

A general understanding of shape grammar for the application in architectural design

Graduation thesis master Architecture

Nina M. Verkerk

TU Delft, faculty of Architecture, Urbanism and Building Sciences, the Netherlands. Graduation studio: Explorelab 17,

e-mail: ninaverkerk@gmail.com

March 2014

Abstract

Shape grammars are systems of transformational rules that describe the design of a shape. Most studies towards the application of shape grammar are analytical in describing a specific building style. Recently, studies towards a generic application of grammars are being developed. This study gives a general understanding of the formal terms, a generic approach of rule systems, and a possible application in the architectural design process. The goal of this project is to make the theorem of shape grammar easier to understand and more accessible in the design process.

The formal terms developed by Stiny (George Stiny, 2006) will improve a general understanding of the subject. The background of the subject will be mentioned through a short history and the current notion and developments. The main part of this research will describe a comparison of the rule systems and rule structures of four different grammars: the Prairie house, Queen Anne house, Palladian villa, and Malagueira house. This comparison leads to a generic rule system that can be used as basis for creating an own grammar. To span the gap between the abstract knowledge and practice, a start towards the application of the learned theorem in an own design process will be made. Part of this research will contain small studies regarding tests towards different rule structures. Because this paper is finished before the design is fully developed, some expectations for the remaining process of the application in architectural design will be declared.

Keywords

architecture, mathematics, shape grammar, generic rule system, rule structure, design process

Introduction

This paper will give an overview of the application of shape grammar in architecture and is the result of an extensive study to shape grammar. Here, first the structure of this paper and then the structure behind the research will be given.

In the following chapters, first the fundamentals of the theorem of shape grammar will be shortly explored. This chapter will provide the foundation necessary to understand the rest of the paper. The current notion and application of shape grammar is then given; the main function of this chapter is to contextualize the subject. The third chapter makes a step towards developing a generic system of shape grammar in use of architectural design. Here different architectural shape grammars are analyzed and compared¹. The fourth chapter provides a bridge between the found theorem and practice. Here, the possibilities for architectural design will be named. Finally, in a short conclusion and discussion the found knowledge will be evaluated. Attached is some background information about the research².

Shape grammars are rule systems containing a basic shape and transformational shape rules. By applying those shape rules recursively to the basic shape, a set of shapes that are part of the same family or belong to a certain style can be generated (George Stiny, 1980).

Current use of shape grammars in architectural design can be distinguished in four stages, as visualized in image 1. With a focus on the translation of specific designs into specific grammars, the value of the application of shape grammar for architecture does not extend beyond specific scientific research and a small application in teaching. I contend that a more generic understanding of the theorem of shape grammar can help to develop an architectural design.

¹ The analysis of the grammars is summarized onto one page per grammar. In Appendix C1-C4, the complete analysis is put into diagrams and extensively described.

² Appendix A: a glossary of shape grammar, appendices B1-B3: summaries of conversations with experts; appendices C1-C4: more extensive analysis of specific grammars; appendix D: studies of rule systems; and finally, appendix E: development of a specific grammar.

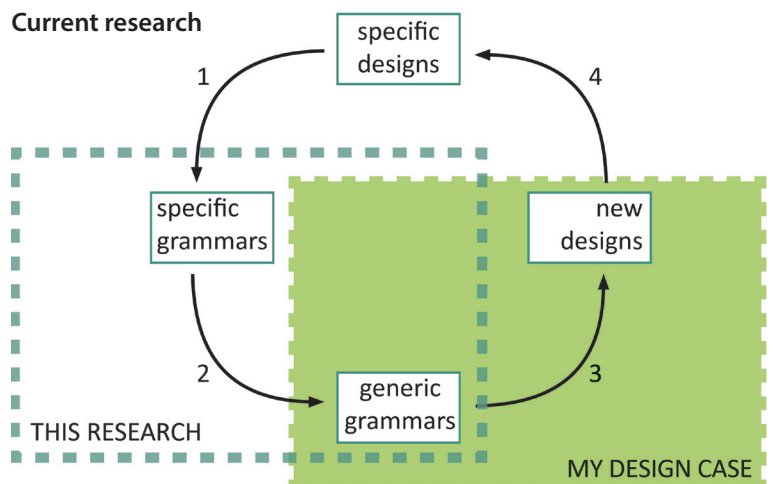

image 1: Circle of current research about shape grammar based on the information of the course by J.P. Duarte

(1) analyze an existing building or style by creating a specific grammar, (2) develop a new (generic) grammar by adapting the found specific grammar, (3) create different design variations in the same language, and at last (4) develop a new specific design based on those grammars.

The goal of this project is to make the theorem of shape grammar easier to understand and more accessible in the architectural design process. To this end, I have a focus on the formal terms and origins of shape grammar, and the application in current grammars. While traditional research mostly has a focus on specific designs translated into specific grammars (image 1, arrow one), this research differs by having a focus on arrows two and three. Firstly, this research focusses on the translation of an amount of specific shape grammars into a generic system (arrow two). Secondly, this research focuses on the translation of this generic system into the architectural design process (arrow three).

Therefore, my research question is construed as following:

To what extent can a general understanding and generic system of shape grammar be applied in the architectural design process?

To develop a general understanding of shape grammar one needs to familiarize himself with the formal terms of shape grammar: elements, spatial relations, transformations, operators and rules. Different specific grammars need to be studied and compared in terms of the construction of rules and rule systems in order to develop the knowledge of the rule system behind shape grammars. These specific rule systems can be summarized into a generic system, which makes the theorem easier to apply in terms of architecture. Finally, in order to investigate to what extent this knowledge can be applied in architectural design, this generic system will be tested in an own architectural design process³ for a secondary Montessori school in Amersfoort, the Netherlands⁴.

To become familiar with the subject I have read and summarized literature about the topic and attended an online class about shape grammar at the University of Architecture in Lisbon. With specific questions I have consulted experts in the topic of mathematics, and shape grammar and architecture. To analyze the abstract theorem of shape grammar I have made lists of formal terms, diagrams of transformations, and drawings and physical models of spatial relations. To research the topic in relation to my research question and find new information, I have studied different precedents: four specific shape grammars. Therefore I also have made lists of different applied rules, diagrams of the way rules are applied and abstract drawings of those rules and matching spatial relations. Finally, to link the theoretical research to practice, I will test my found knowledge in an own design process.

³Two things should be noted about the testing of the knowledge behind shape grammar.

Firstly, this research and paper is finished before my architectural design. Therefore, this part also contains some general ideas and personal expectations about the possibilities for an architectural design process.

Secondly, as the design process is an intuitive process, the studies where I test shape grammar in the architectural design are therefore done as best as possible. Another student could approach it completely differently.

⁴The choice for this design exercise is made due to the following reasons.

Firstly, shape grammar is a systematical approach of design, therefore a design exercise with repetition in the program should be a good fit.

Secondly, the design program gives enough variation to scale (building, cluster and classroom) to test different approaches in grammar.

Lastly, it was also an intuitive choice between different possible design exercises in which this one proved to be closest to my own experience and knowledge.

Formal theorem

⁵ George Stiny (George Stiny, 2006) makes a difference between elements: basic, maximal, and boundary elements. For the understanding of this paper, there is no need to explain the differences and similarities in-depth. For an extensive description I refer to the book 'Shape, talking about seeing and doing' or the notes in the appendix. In short, elements (or shapes) can be constructed by more different elements (p178), while a basic element can only be constructed of shapes in the same dimension (p164). Maximal elements are the smallest number of biggest thing that combine to form a shape (p183). And the boundary of an element is one dimension lower than the original element and is reduced to maximal elements (p196).



Image 2: Example of algebra of shape: an addition of the basic element plane.

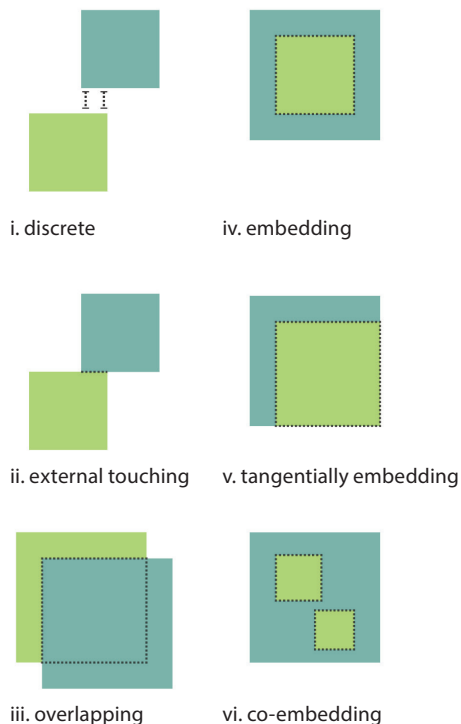

Image 3: Spatial relations visualized by two-dimensional planes.

In this part the fundamentals of shape grammar will be explored and explained in short. Shape grammar is formally defined by algebras of shapes: elements¹ or shapes, a Boolean operator and Euclidean transformations. Or, in other words, to construct a spatial grammar there is need of three things: the elements to which the rules apply, the rules constructed by a type of (Euclidean) transformation, and a Boolean operator². First the dimensional elements in connection to spatial and part relations will be explained. Then will be explained how the operators and transformations are related to the elements in different dimensions. Lastly, the link to the construction of rules and labels will be made.

In this universe elements in four different dimensions can be observed; 0: points (or units), 1: lines, 2: planes, and 3: solids. Shapes can be constructed by a different amount of various kinds of elements. Between those elements, spatial and part relations can occur.

A spatial relation describes the relations among different shapes, while the part relation describes the relation of smaller parts into the whole shape. It is important to understand the possible relations, because from the spatial and part relations, spatial rules can be constructed. Examples of spatial relations are *discrete*, *overlap/touch*, *touch externally* or *embedding* (as visualized in image 3). It should be noted that the spatial relations work differently in the different dimensions. For example, in the case of points there is no difference between the relation overlap and embedding, because points are units and have no dimension. Spatial relations in the third dimension can be hard to visualize and understand in paper view; therefore studies with blocks can help to develop these spatial skills (image 25, 26).

A big part of the theorem of shape grammar relies on embedding. The part relation embedding expands the possibilities of shape grammar: through the *ambiguity* that comes with it, creativity is possible despite the systematic process of shape grammar. The power of ambiguity is that it is possible to construct a bigger shape from an infinite amount of possible smaller shapes. Therefore, anything is possible: By transforming one of those smaller shapes (parts), a new version of the original shape can be created. But a whole different shape could be created if this same transformation was applied to another embedded part of the same shape.

As was explained, shapes can appear in different dimensions, but transformations can be applied in the same four different dimensions as well. The basic transformations are the Euclidean transformations as visualized in image 4: translation, rotation, reflection, scale and identity.

Transformations can be applied in different dimensions and on different kind of shapes. But not every transformation can be applied in every dimension. For example, a rotation can only take place in the second and third dimension; and scale can only take place in the dimension of the shape, because otherwise the shape will be stretched. To develop a good sense of dimensions of shapes and transformations drawing and studying with three dimensional blocks will prove to be helpful.

Next to possible transformations, Boolean operators can be used to apply transformations to a shape. The four possible operators are addition (sum), subtraction (difference), product, and symmetric difference. The operators work mostly in combination with one or more (Euclidean) transformations. For example the transformation in image 2 is a combination of translation and addition. In the architectural grammar Boolean operators are also used in combination with one another. For example: by transforming parts of a shape, embedded parts can be subtracted and replaced (addition) with other shapes. More about the actual connection to architecture will be explained later on in this paper.

A shape grammar exists of rules that can be applied recursively onto a shape which results in new shapes. These rules are based on spatial relations between the original shape and new ones, or on part relations between embedded shapes towards the original shape and a possible transformation of this embedded part. In other words, a shape grammar needs an original shape and spatial rules. Those rules are constructed in a "before and after" situation. Before: shapes that are embedded in the original or transformed shape; and after: the transformed shape based upon a transformation and operator.

To control the use of the rules in the grammar, labels can be assigned to shapes or parts of shapes. With those assigned labels a rule can only be applied if the same label can be found in the shape, as visualized in image 5. Labels can have different appearances; for example of letters, numbers or dots.

To conclude, the shape grammar formalism exists of labelled shapes and rules constructed of a specific transformation and operator. The appearance of a rule is based on the desired spatial or part relation of the components of the shape. What makes shape grammar a strong design tool is the ambiguity of the part relation embedding: different rules are possible to apply to different parts of the shape to generate a family of shapes. Because of the ambiguity, the designer can work creative and intuitive in developing a rule system. Labels can be added in the rules to control the algorithm.

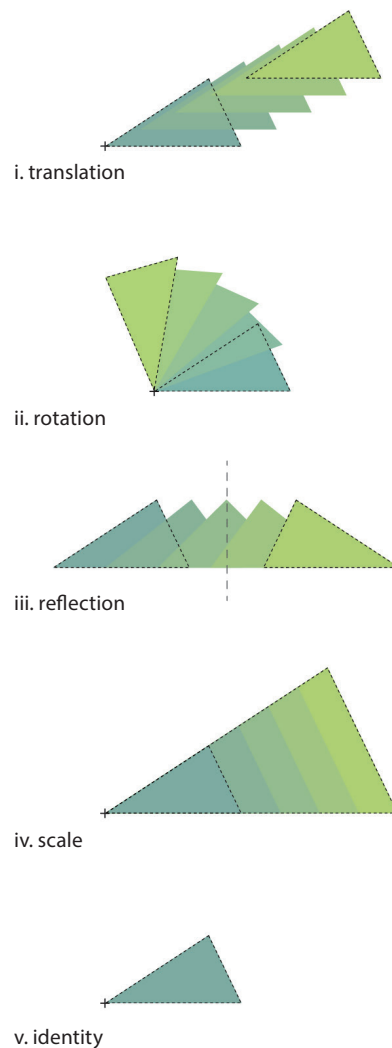

Image 4: Euclidean transformations in the second dimension.

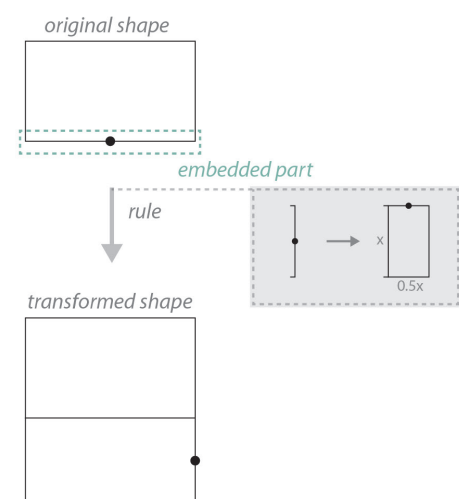

Image 5: Rules can be controlled by adding labels.

Bridge I: context of the subject

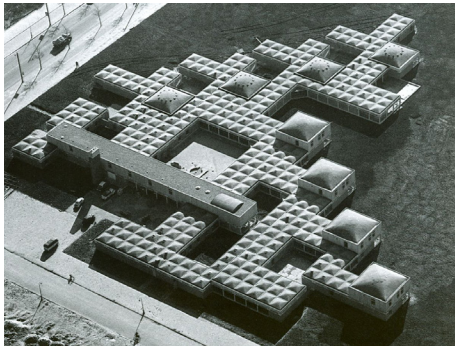

Image 6: Orphanage: Burgerweeshuis Amsterdam, 1960 (www.poly-xelor.com)



Image 7: Apartment complex: Habitat '67, 1967 (www.inhabitat.com)

This part has the goal to place the theorem of shape grammar into context. Firstly, the history of shape grammar towards architecture and the current notion will be explained briefly. Furthermore, an enumeration of examples of the analytical application of shape grammar in the academic setting will be given. Finally, the developments of shape grammar in practice (education and design) will be explained.

In the second half of the last century a movement of a more systematic approach of architectural design emerged (Alexander, 1967; 1977). In the well-known 'A Pattern Language', design problems can be solved using design patterns. Structuralism is another systematic approach to architecture. For example: Van Eyck's 'burgerweeshuis Amsterdam' (image 6), Safdie's Habitat '67 (image 7), and Hertzberger's 'Centraal Beheer'. Just like these approaches, shape grammar describes a systematic language to describe building designs.

In 1971 Stiny and Gips published their first paper about the shape grammar formalism (Stiny & Gips, 1971). In the years after and still today, different grammars that have an analytical function in describing a specific (architectural) style have been developed (Stiny & Mitchell, 1978; Koning & Eizenberg, 1981; Flemming, 1987; Knight, 1989; Duarte, 2005). Also the roles of shape grammar applications in education and practice have been studied (Knight, 1999). Recently there is a movement towards a development of a more generic approach of shape grammar in the application of design (Beirão, Duarte, & Stouffs, 2011; Benrós, Hanna, & Duarte, 2012). This paper follows in the last developments towards a generic understanding and the application of rule systems in the design process.

⁶ For example: architecture of Giuseppe Terragni, Frank Lloyd Wright, Glenn Murcutt, Christopher Wren, Irving Gill, Japanese tearooms, bungalows of Buffalo, Queen Anne houses, Taiwanese traditional houses, landscape architecture of Mughul gardens (T. Knight, 1999), Siza houses (Duarte, 2005).

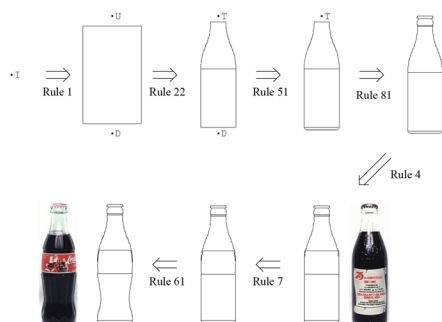

Image 8: Shape computation for two existing Coca-Cola bottles. (Chau et al., 2004)

The focus of shape grammar application was mostly focused on the analysis of existing building types for the first two decades since its development. With a set of rules, compositional designs can be captured into a grammar. Within the same language new compositions of designs can be created based on that grammar. Dozens of specific grammars have been created that describe a specific style or evaluation of style. The Palladian grammar (Stiny & Mitchell, 1978) was the first in a row of complex shape grammars for various architectural styles⁶; four of those grammars will be analyzed further on in this paper. Also other designs as paintings from 'de Stijl', chair designs of Hepplewhite, or ancient Greek pottery (Knight, 1999) and more recently the evaluation of a Coca-Cola bottle (image 8) and a Head & Shoulder bottle (Chau, Chen, McKay, & Pennington, 2004) could be captured in a grammar.

Even more recently there is a focus on a more generic approach of shape grammar. Beirão developed a generic urban grammar from different case studies, from which specific grammars can be created depending on the specific situation (Beirão et al.,

2011). Benrós is developing a generic grammar for the Palladian Villa, Malagueira house and Prairie house (Benrós, Hanna, et al., 2012).

Shape grammar can also be applied in education and design. The report on Shape Computation (Knight, 1999), states that there are three different approaches possible for shape grammar in use of architectural education and design: analysis of existing designs, creating original designs, or a combination of the two.

According to Knight, analysis through shape grammar can help teach students about styles and languages of designs. The students create their own grammar that reveals simplicity or regularities behind designs that seem complex or random at first.

The Kindergarten approach developed by Stiny (Stiny, 1980b) is an approach that creates designs from scratch through shape grammar. Through Froebelian (image 9) building blocks shape grammars and designs can be created in terms of spatial relations, shape rules and initial shape. Creating original designs with shape grammars can help in teaching composition and visually correlates as proportion and symmetry. Knight describes two points of Stiny's Kindergarten paper that are important for education: firstly, that rules can make design ideas explicit so that they can be examined, changed and discussed⁷. Secondly, that rules make multiple design solutions possible. Van Dooren (Van Dooren et al., 2013) describes the importance of making the design and design process explicit. In five generic elements she describes the design process, of which experimenting is an important element: making variations in design solutions. Rule systems can help develop those variations.

In practice shape grammars are not created from scratch, but from a combination of analysis and the creation of original design. Knight (Knight, 1981) developed a method for creating new design languages on the basis of existing ones. First a known style is analyzed by creating a grammar, and then the rules of the grammar are transformed. Those new rules are the basis for a new grammar. In this way, students learn both the work of designers and developing their own work (Knight, 1999).

Shape grammar as a formalism and rule set does not have to be implemented on a computer tool (Benrós, Duarte, & Hanna, 2012), but nonetheless there is a development in computer implementation of rule sets. In this case, mostly the rules are simplified: graph grammars, or non-parametric grammars (App. B2). The pros of a computer implementation is that it is a fast and efficient way to develop the possible design solutions (Benrós, Duarte, et al., 2012); the cons are that a computer implementation misses the ambiguity of a person and therefore there is no emergence (App. B2).



Image 9: Froebel's third, fourth, fifth and sixth Gift. Building blocks for children to learn about spatial relations. (www.thearchitectureofearlychildhood.com)

⁷ Knight tested the abstract method of creating designs by experimenting with spatial relations and color grammars (T. Knight, 1991). An important finding was that the students had a better understanding of their own design than with a traditional trial and error studio method.

Towards a generic system



Image 10: Robie house, 1909
(www.architecture.about.com)



Image 11: Queen anne style house
(www.stupic.com)



Image 12: La Malcontenta
(www.timbuktu.ws)



Image 13: Houses at Malagueira
(www.casafeita.blogspot.nl)

In this part the construction of the rule system behind a specific shape grammar will be analyzed by comparing four different grammars. The goal is to discern what is fixed and what is flexible in a grammar, so that a generic system could be developed. The first focus is on the organization behind the grammar by posing questions as: which components are translated into grammar? How many rules are there in how many stages? And how are the stages related towards each other? Secondly, I will focus on the structure behind the rules by studying the specific grammar through the formal theorem.

The four grammars as case study are: the Prairie house (image 10) grammar by Koning and Eizenberg (Koning & Eizenberg, 1981), the Queen Anne house (image 11) grammar by Flemming (Flemming, 1987), the original Palladian (image 12) grammar⁸ by Stiny and Mitchell (G. Stiny & Mitchell, 1978), and lastly the Siza house (image 13) grammar by Duarte (Duarte, 2005).

Roughly there are three different rule structures to develop a basic composition⁹ (T. Knight, 1999): addition around a focal point (image 14i), subdivision (image 14ii), and a transformation of a predefined grid (image 14iii). Benrós (Benrós, Hanna, & Duarte, 2012) developed a generic shape grammar in 2012, with the structure of subdivision for plans based on all three rule systems.

The additional rule structure is based on a focal point; usually this is the origin shape of the grammar. Based on spatial relations, new shapes can be added around the origin shape. The added shapes have fixed dimensions and can have a specific function in architectural design. To control the additions, labels can be changed during the generation (as explained in the part about the formal theorem), therefore only a fixed number of rules can be applied and there will be no double functions in the layout. Abstract examples of an additional rule system are 'the Game of life' by John Conway (Johnston, 2013), where with four different rules and an origin composition of blocks, a composition can be created. Both the Prairie house grammar by Koning and Eizenberg and the Queen Anne house grammar by Flemming generate a basic composition by means of addition around a focal point.

The subdivision rule structure is based on an origin shape and divisional rules with fixed proportions (and in architectural design also functions). By dividing the original shape, new zones with new proportions appear. Therefore created zones and rooms have no fixed dimensions, but a preferable number of square meters. This can also be controlled by labels and a list with (allocated) functions. An abstract example of this kind of rule system is the grammar developed for the paintings of *De Stijl* art (Knight, 1989). In this paper the transformations of the paintings over the years are put down in a

subdivision grammar. The grammar that creates basic composition of a Malagueira house is based on a subdivision rule system.

The rule structure that uses a grid starts with the definition of the proportions and dimensions of the grid. When this grid is defined, (Euclidean) transformations can be applied where the abstract grid will be transformed into a floor plan defining zones and rooms, divided by walls. The original Palladian grammar by Stiny and Mitchell is based on a grid and the transformation of that grid. In this case the basic grid can be generated by addition of shapes into a grid.

Not just the basic composition of a building could be designed using shape grammar. Rules that create openings, porticos or porches, and roof design can also be composed. Those rules are transformational, which are mostly a combined process of the Boolean operator's subtraction and addition. For example the rule that creates openings in walls: the subtraction of the mid sections of a wall and the addition of the doors or window frames (Appendix B3: mailconversation Deborah Benrós).

In the next pages, a short description of the four case studies is given, completed with the visualization of the application of a rule typical for the described grammar. A more extended analysis of the case studies can be found in appendix C.

⁸ In 2012 an alternative grammar for the original Palladian grammar is developed by Benrós, Duarte and Hanna (Benrós, Duarte, & Hanna, 2012), where the original grammar is based upon a grid, the alternative grammar is based upon sub division.

⁹ The basic composition is the functional layout or compositional plan of a design.

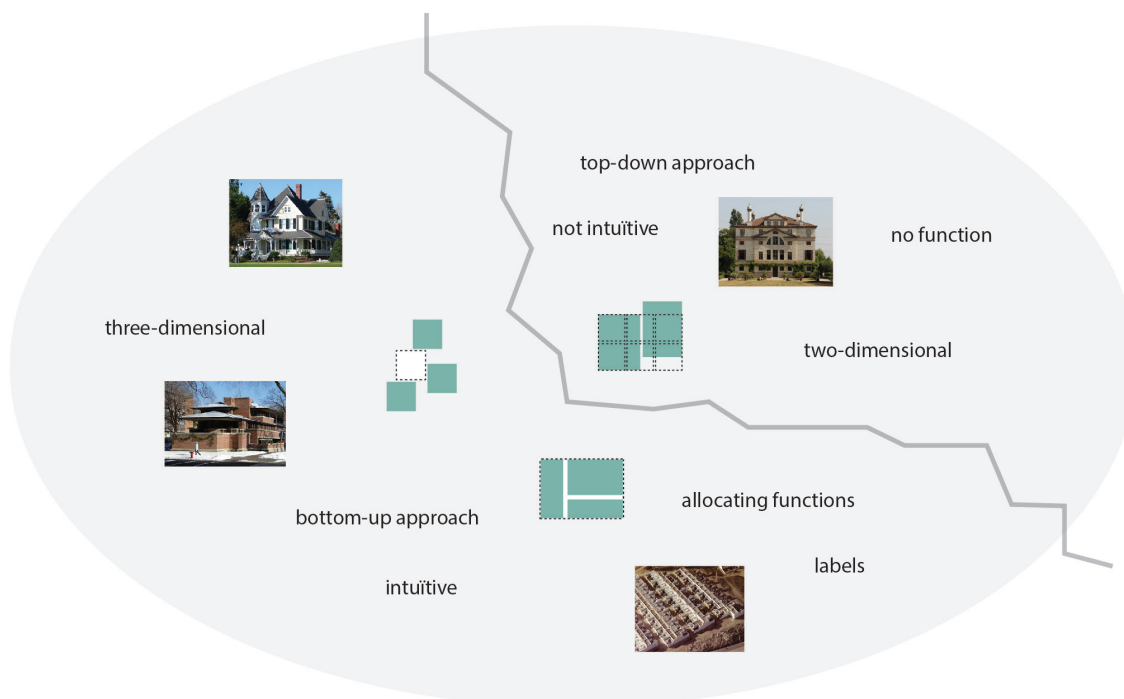
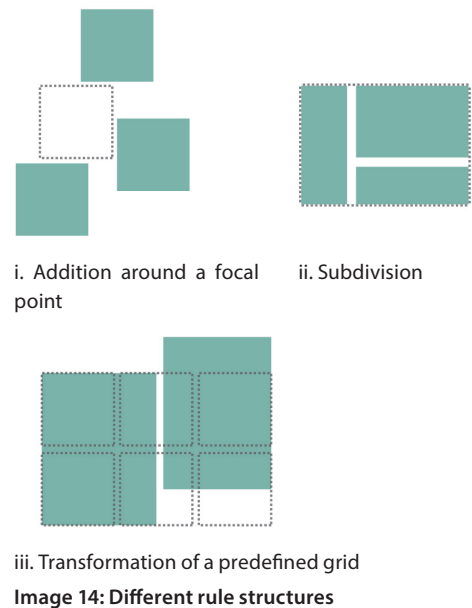

Image 15: grammars positioned towards one another. Notable is that the Palladian grammar differs a lot from approach, while the other three are more similar.

Prairie house grammar

The prairie house grammar (Koning & Eizenberg, 1981) can generate a basic composition and the ornamentation of the composition of a typical Frank Lloyd Wright prairie house.

The part of the grammar that creates the *basic composition* works very clearly. With a few simple and straightforward rules, spread out over five stages, the layout of a prairie house can be created. The fireplace is the generating center of the prairie house, therefore these rules are all constructed as addition around a focal point (as visualized in image 16, 17). Blocks are added around the fireplace in two axes to produce the basic composition of a house.

The rules in the subsequent nineteen stages that generate the *ornamentation of the basic composition* are less straightforward. For example, there are different stages in which porches, terraces and balconies are generated. Also, the roof is constructed over more stages and is interrupted by the generation of balconies and the erasing of nonterminal labels. The rules that create the details are based on the transformation, or subtraction of embedded parts of the composition. Extensions as for instance a balcony are created by additional rules. Almost all rules in these nineteen stages must be applied during the generation. In spite of this these rules can create variations, because the rules can be applied to different parts of the generated composition.

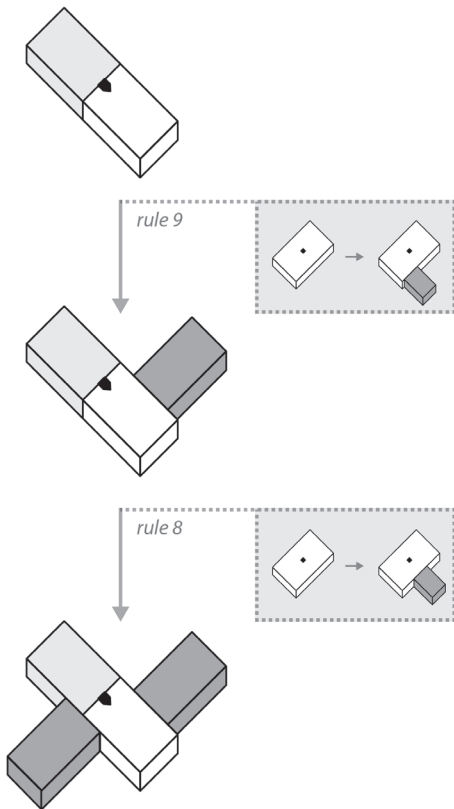
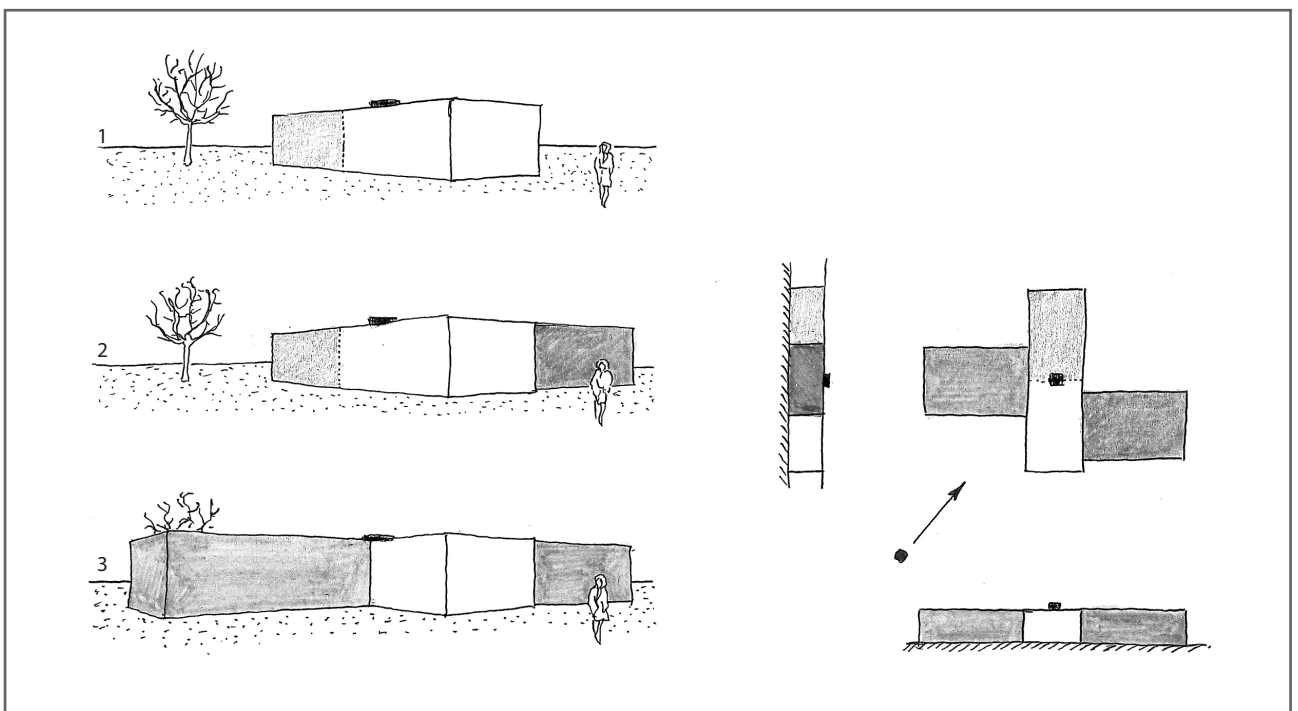

Image 16: A part of the generation of the basic composition: Additional rule 9 and 8 in the fourth stage: the so called obligatory extensions.

Image 17: application of the rules in perspective



Queen Anne house grammar

The Queen Anne House grammar (Flemming, 1987) could be used to generate a basic type of a Queen Anne House: it is possible to explain its overall geometry and to demonstrate how the various parts and features of a house are related to each other. On the contrary, the grammar cannot generate a complete house in detail. The grammar designer selected some typical aspects of a house and developed a grammar especially for these aspects. Some parts of the Queen Anne houses (as the picturesque aesthetics) are too difficult to catch in a set of rules, and can more easily be added by the designer himself.

The first five stages of the grammar generate the *interior* and therefore the relations between spaces, while the second five stages generate the *exterior* of the house. For the interior part shapes containing a function (stairs, kitchen, dining room and pantry) are added around a focal point: the hall. Other type of rooms like bathrooms and sleeping rooms are excluded from the grammar. In the exterior part the walls, the roof, the porches (as visualized in image 18, 19) and chimney breasts can be generated, but subtracting openings as windows are excluded from the grammar.

Two things about this grammar are unique compared to the other grammars. First, the intention of this grammar is to define some typical aspects into a grammar, not to generate a complete typical Queen Anne house. Secondly, the first part of this grammar is two-dimensional while the second part is defined in the third dimension. All the other grammars operate in just one dimension.

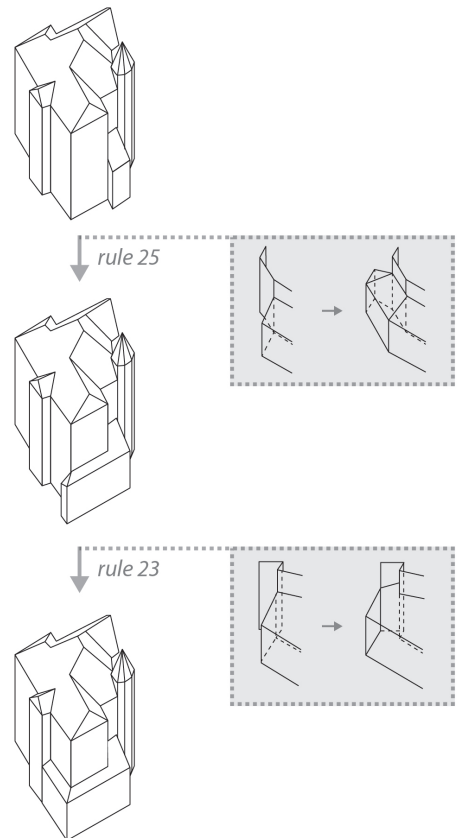
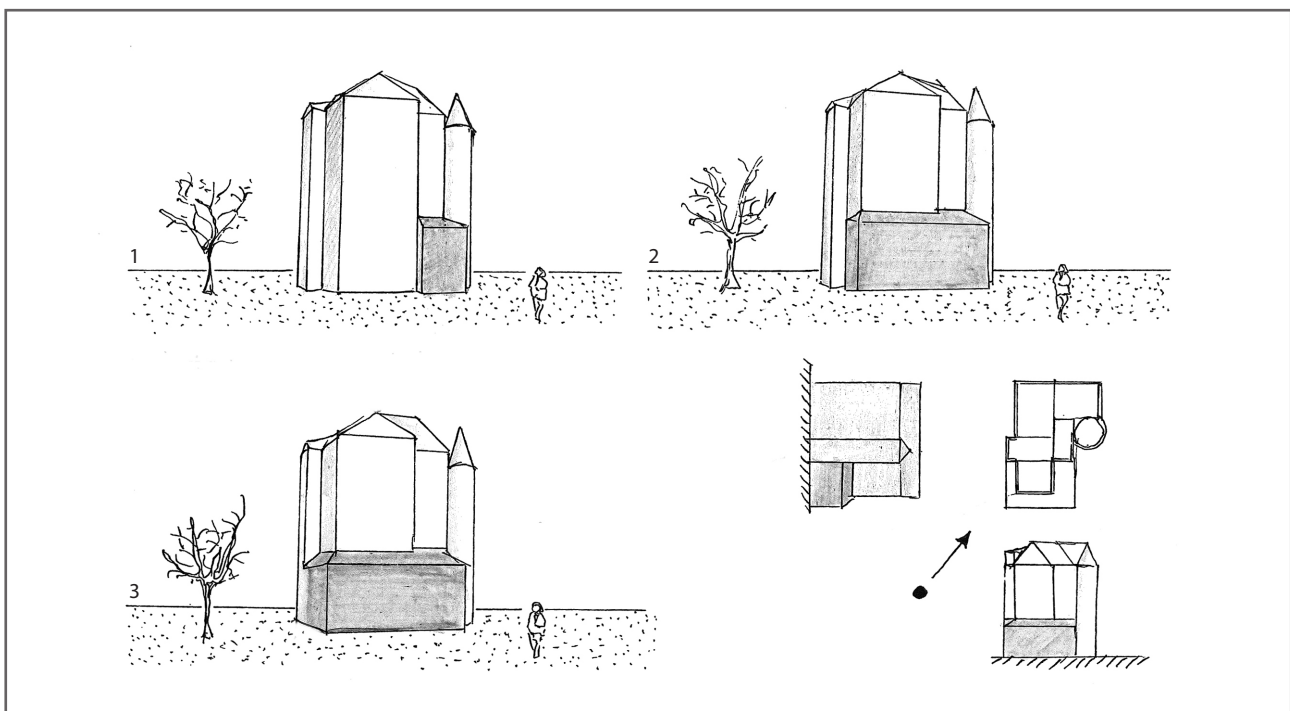
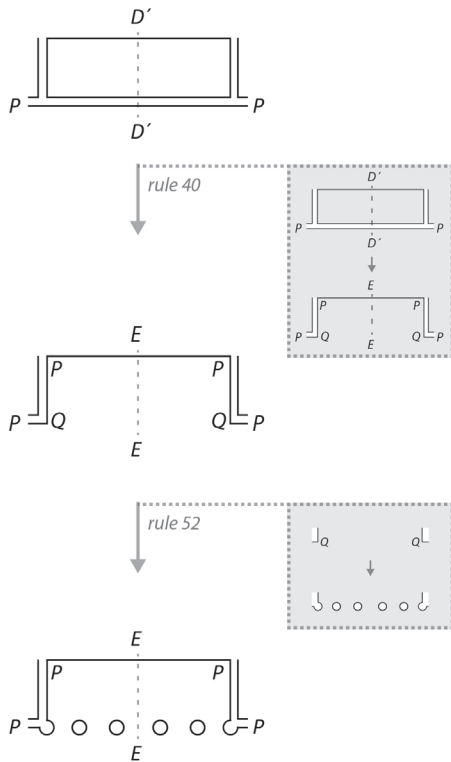

Image 18: A part of the generation of the exterior: growing porches. Additional rule 25 and 24 from stage 2.4 let the porch grow around the exterior walls.

Image 19: application of the rules in perspective



Palladian villa grammar



The original Palladian grammar (Stiny & Mitchell, 1978) is a parametric shape grammar that generates the ground plans in definition of the Palladian style. The grammar is based on the information of the geometry of Palladio's villas in *Quattro Libri dell'Architettura* by Palladio. The grammar is both additional and transformational.

The first part of the grammar exists of four stages that generate the abstract layout of the villa. First a grid is created by adding polygons, followed by stages where the grid is transformed. The next part exists of four stages where specific details are generated: the entrance and its ornamentation (as visualized in image 20, 21), and the subtraction of openings as doors and windows. These rules are based on a system that subtract embedded parts and replace those with new shapes. In the last stage labels that are used to control the transformations are terminated.

The grammar works two-dimensional and only generates a ground plan; the grammar therefore only creates a partial definition of the Palladian style. The definition of the façade or the system of proportion by Palladio is ignored in the grammar.

Image 20: Typical for the Palladian grammar is the transformation of the grid, by subtracting embedded parts and adding new shapes. Rules 40 and 52 create an *inantis portico* by first subtracting the front wall and adding columns.

Image 21: application of the rules in perspective

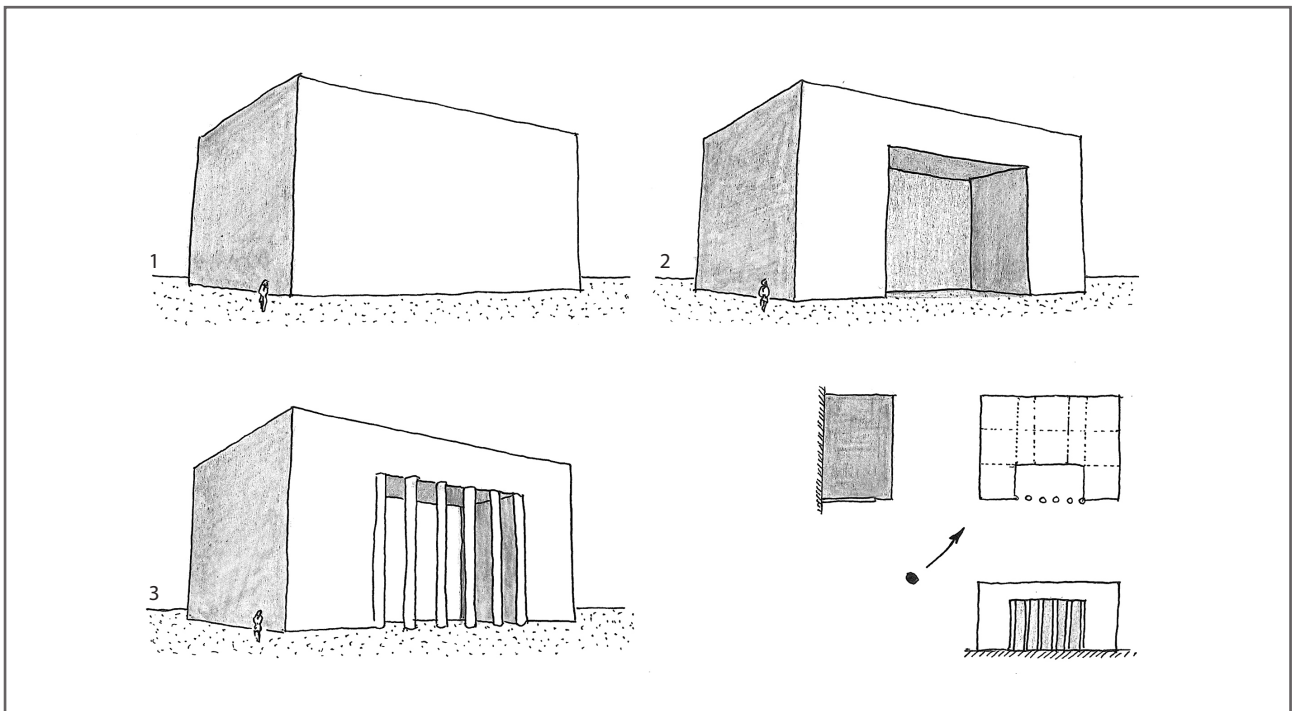

Malagueira house grammar

The Malagueira house grammar (Duarte, 2005) is a functional shape grammar that generates the typical Siza houses at Malagueira. The grammar exists of three stages where in following sequence the first, second floor and terrace can be generated. The grammar is constructed two-dimensional. Floor plans, sections and elevations are generated by applying the rules. Also, the final generation is represented in axonometric view. As the the generation proceeds, shapes and labels are placed at the representational images.

The stages always start with introducing and enclosing the origin shape by adding new shapes and labels, and always end with erasing the unnecessary labels. In between, first functional rooms and circulation zones are located (as visualized in image 22, 23). Rules in this stage are dimensional: by dividing, connecting, and adding shapes; and functional: by adding, changing and permuting labels. Then the details and openings are introduced. The rules in this stage are transformational for embedded parts of shapes and have no influence on the allocated functions.

Three things about this grammar should be mentioned. Firstly, next to shape transformations, this grammar has a focus on applying the right function. Secondly, the grammar goes into great functional detail, for example by transforming the space under the stairs into a closet and assigning the laundry zone. Finally the grammar is unique by representing almost a complete design in plans, sections, elevations and axonometric view.

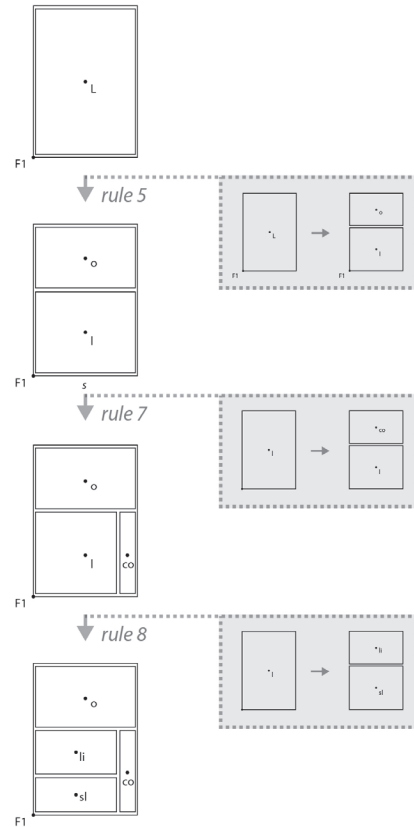
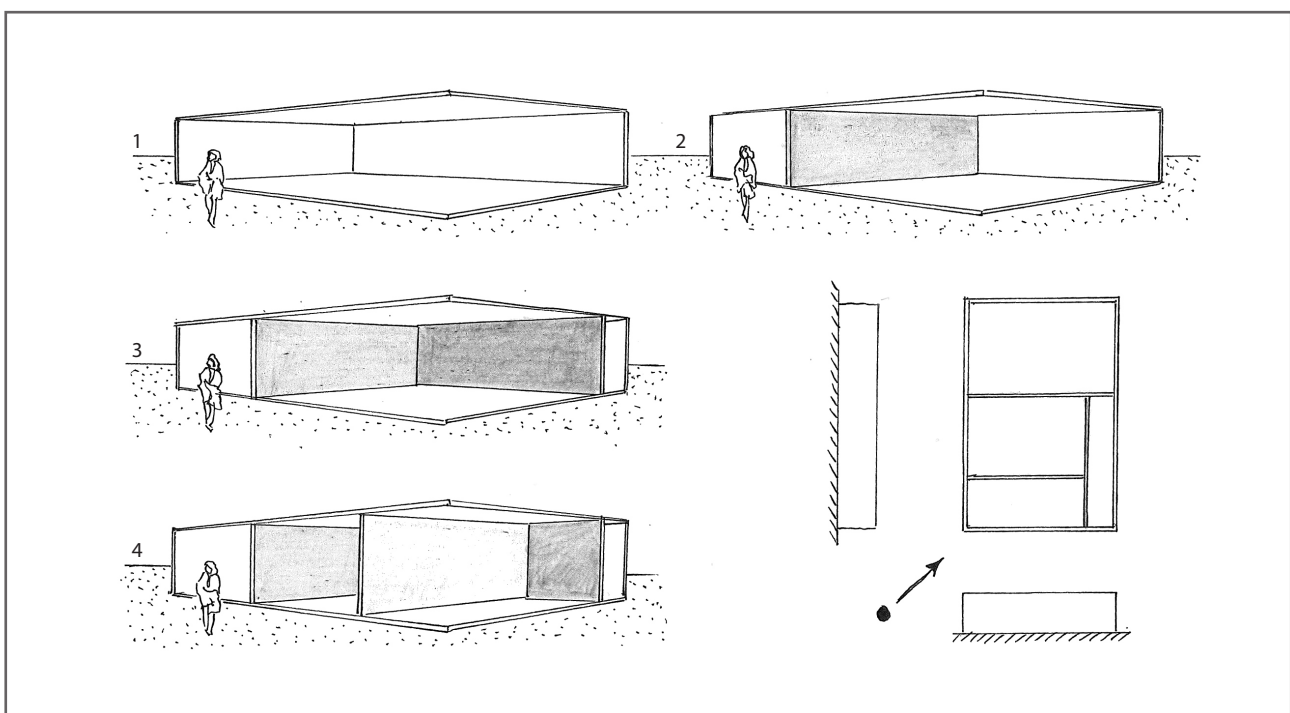

Image 22: The Malagueira grammar is based on a sub divisional method. These rules allocate the outside and living zone (rule 5), corridor (rule 7), and sleeping zone (rule 8), by dividing the original shape into smaller parts.

Image 23: application of the rules in perspective



Synthesis

¹⁰Not all parts can be generated with grammar

Every specific grammar analyzed does not cover a whole building design.

The grammar for the Siza houses at Malagueira is the closest one to generating a whole building design: The grammar covers the functional arrangement of zones and rooms, wall thickness, openings (windows and doors), and placing the stairs. This all is visualized two-dimensionally in plans, elevations and a cross and longitude section, and in the third dimension with in axonometric view.

The other grammars do not cover a whole building design. For example the Palladian grammar states nothing about the building in the third dimension (height) and about the functional arrangement of the created spaces. The computation is only visualized in floor plans. The Prairie house grammar does not cover placing the stairs, and does not provide openings and the computation is only visualized in axonometric view. The final plans are made with traditional design knowledge. Finally, the Queen Anne house grammar does not define all functions in the rooms and does not generate openings as windows and doors. The grammar does not provide a final complete variation of design, but gives some examples of the results of the grammar of details like entrances and chimneys.

¹¹ Differences between the scheme and the specific grammars

The four stages are a simplification of the information found in the specific grammars. Therefore, the specific structures are not completely similar to this simplification: Some stages seem to flow into each other.

For example the Prairie house grammar, after generating the basic composition or functional room layout, also adds some new spaces like the bedroom floor or balconies during the next stage.

Another example is the Malagueira house grammar. The Siza house grammar walks through this scheme more than once: the first time to generate the first floor, the second time to generate the second floor and the third time to generate the terrace.

In this part similarities and differences between the overall structures and the application of rule systems of the grammars come together into a generic system.

One of the most important findings is that most grammars cannot generate a whole building design¹⁰. Except for the Malagueira house grammar, the other grammars only describe the generation of the most important features of an architectural building style. Also most generations are only visualized in one way; therefore the generation is no building design, just an abstraction of the typical spatial features of that building style.

All grammars can be subdivided in a flexible amount of stages and sub stages. In every stage a number of rules are offered from which the designer can choose. In one stage or sub stage, a specific part or component of a design can be developed. Rules can only have a spatial function, but can also allocate functional zones. To control the transformations, labels can be included in the transformational rule, through the process labels can be added, changed or terminated. After finishing a stage it is not possible to go back to an earlier stage, because of the changed labels.

The following stages can be found in every grammar¹¹.

Stage 0: Origin

All grammars start with the generation of an original shape. Most times this is called stage 0 including rule 0, sometimes it includes more rules.

Stage 1: Functional layout

All grammars create a functional layout. This is done by different rule systems in a flexible amount of sub stages. For example with addition rules as the Palladian, Queen Anne house and Prairie house grammar. Another method is with subdivision rules as the Siza house grammar and the alternative Palladian grammar of Benrós.

This can result in a connection between polygons including functions or just a connection between polygons. This stage can be divided into more stages where different parts of the layout are constructed. An example of a connection between polygons including functions in different steps is the Queen Anne grammar where first zones around the hall are allocated followed by the kitchen and stairs. An example where the room layout has no function is the Palladian grammar where first a grid and walls are created, followed by transformations of the created shapes.

Stage 2: Specific parts

When the global layout of the building is created, some specific parts can be generated. This stage can also contain different sub stages and can generate anything specific for the architectural design of style¹². For example the addition or transformation of functional

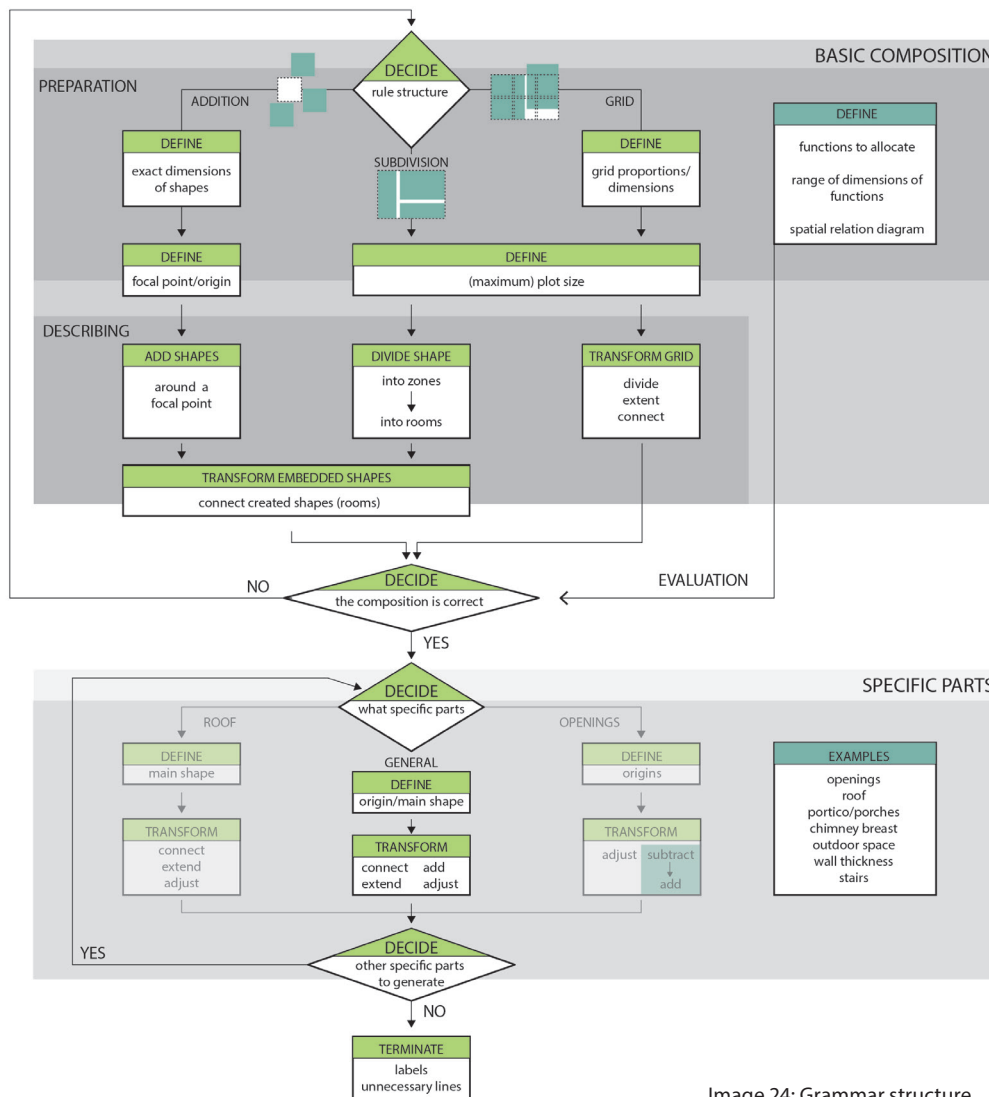

Image 24: Grammar structure

spaces, the transformation of spatial details: chimneys, wall thickness or openings, or an addition of the roof in relation to the basic layout.

Stage 3: Termination of labels

The most stages end with the termination or changing of labels, and the computation can therefore continue in the next stage or finish. Some grammars have a specific stage with specific rules that terminate the rules, like the Palladian or Siza house grammar, whereas the Prairie house and Queen Anne grammars seem to skip this stage. It should be noted that during the other stages and sub stages, also termination and change label rules can be applied.

In conclusion, all grammars have in common that first a basic composition is generated. This can be done by different rule systems: addition (around a focal point), grid and subdivision grammars. Then components or elements specific for the building style are translated into a shape grammar¹⁰. The rules in this stage are mostly transformational: a combination of subtracting embedded parts and adding new parts. In the rules, labels are used to control the transformations and change stages¹³.

¹²Examples of possible specific parts are:

The Prairie house grammar focuses on the addition of functional spaces like generating terraces, bedroom floors and balconies; and the transformation of details as chimneys; and finally generating the roof in relation to the basic layout.

The Queen Anne house grammar focuses on some aspects on the exterior of the house, where first the walls are generated, then the roof, porches and at last in great detail the chimney breasts.

The Palladian grammar focuses on the generation of the entrances with or without columns followed by the generation of the openings like windows and doors.

The Siza houses grammar also focuses on some details like placing the chimney, stairs and adjusting the wall thickness. At last it generates openings like doors and windows.

¹³ By making lists of the functions that need to be allocated and that are already allocated, the grammar makes sure there are no double functions. (Appendix B1: Skype conversation José Duarte)

Bridge II: implementation in the design process

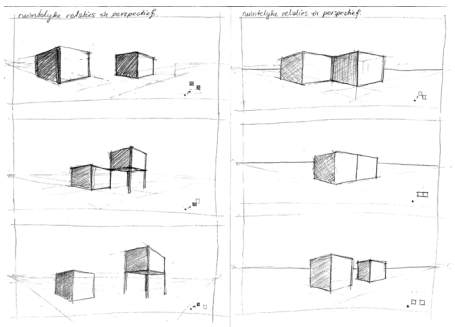
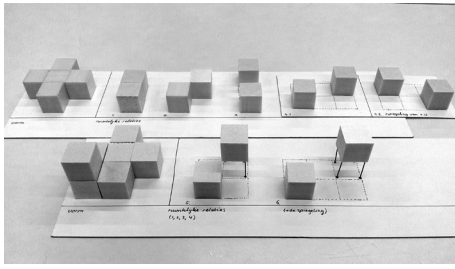

Image 25: Spatial relations of two building blocks in a composition visualized through physical models and perspective view.

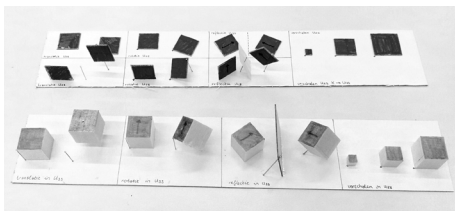

Image 26: Euclidean transformations of a plane and solid in various dimensions.

¹⁴ For the testing of the three systems in the design of a Secondary Montessori School, I choose to test this with a smaller cluster (about 5 classrooms, 2 toilets and circulation space), to simplify the exercise to a recognizable scale. For first tests, working in two dimensions (plans) works intuitively.

In this paragraph it will be explained how the found theorem can be used into my own design process for a secondary Montessori school. First will be described how experts use rule systems in design, and how I tried to implement the information. Finally, because this paper is finished before the end of the design process, some expectations for future design steps are given.

Different approaches to rule systems of shape grammar are possible for the application in architectural design. Stiny (George Stiny, 2011) describes in 'What rule(s) should I use?', that you can use any rule you want. That shape grammar formalism is an open-ended process and one can always try another rule. Benrós (Benrós, Hanna, et al., 2012) describes that researchers usually try to create the most elegant grammar: the one with the smaller number of rules. Duarte (App. B1) describes two options to create rules for design: the first one uses abstract type of rules and the second one uses spatial qualities and spatial relations of precedents. The last one is also described in terms of spatial relations of an architectural style by Knight (T. Knight, 1981). To become familiar with spatial relations and transformations, I studied different spatial relations between two blocks (image 25) and transformations of a plane and solid (image 26) in an early phase of the research.

One of the results of the analysis of the specific grammars is that not everything can be generated through shape grammar. Stouffs (App. B2) also recommends describing the desired design process in stages and choosing specific stages to test the application of shape grammar. Another result of the analysis is that always the basic composition of the house is generated, and some of the specific spatial qualities of the style.

The basic composition is created by one of the possible rule systems: addition (around a focal point), subdivision, or transformation of a predefined grid. To become familiar with those three systems in terms of designing instead of analyzing, I tested the systems in developing the basic composition of the design¹⁴ (App. D). Almost instantly an important difference between working towards an analysis and a design occurred: with designing every final result is possible, while with making an analysis there is a fixed image. Therefore the designer needs to define a lot of information before starting the generation.

Some conclusions from working with these systems are:

- Addition rules incline towards symmetry. Addition rules need to predefine dimensions, and less original compositions occur because of fixed dimensions.

- Grids also need to be predefined; the dimensions of the grid totally control the playfulness and originality of the end results. Different levels of grids in different axes help to prevent a messy

end result but keep originality possible. The designer needs to keep thinking about scale because nothing is fixed yet. Because nothing is fixed, more different end results are possible than with addition rules.

- Using only subdivision rules makes the design plan very inflexible. During the design process, if a division is made, it is difficult to take a step back. Scale and dimension are intuitive in the process of division because the maximum plot is the starting point. Also, variable dimensions of shapes develop through the process of division.

An interesting combination of systems is to use a maximum plot and divide this in the required amount of shapes, then start to translate and rotate the embedded shapes to create a more flexible plan (image 27). Transforming a basic composition of shapes results in new compositions that are more original and flexible.

I noticed that it is probable that someone will keep working on an abstract level for too long. Therefore the next step was to develop a specific building design at a location. Armed with a spatial concept, relation diagram, location analysis and some spatial precedents, I developed a first design for a school (image 28). Even so I did not purposely apply the theorem of shape grammar into a design, consistency and transformations of shapes are clearly implemented in the first plans.

In the remaining part of the design process I will analyze the created design in terms of rules. With those rules, new compositions of the first design will be generated. One of the compositions will be developed through traditional designing methods of trial and error. Some specifics of the design will be explored in possible variations through shape grammar. This way I will apply shape grammar in the best way it is used: as an analytical tool, but at the same time use this analysis to keep designing.

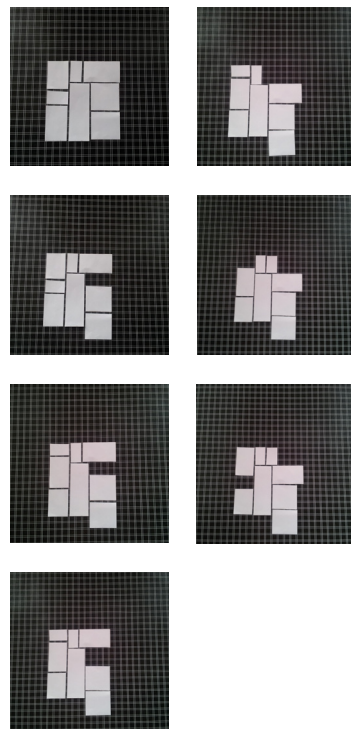
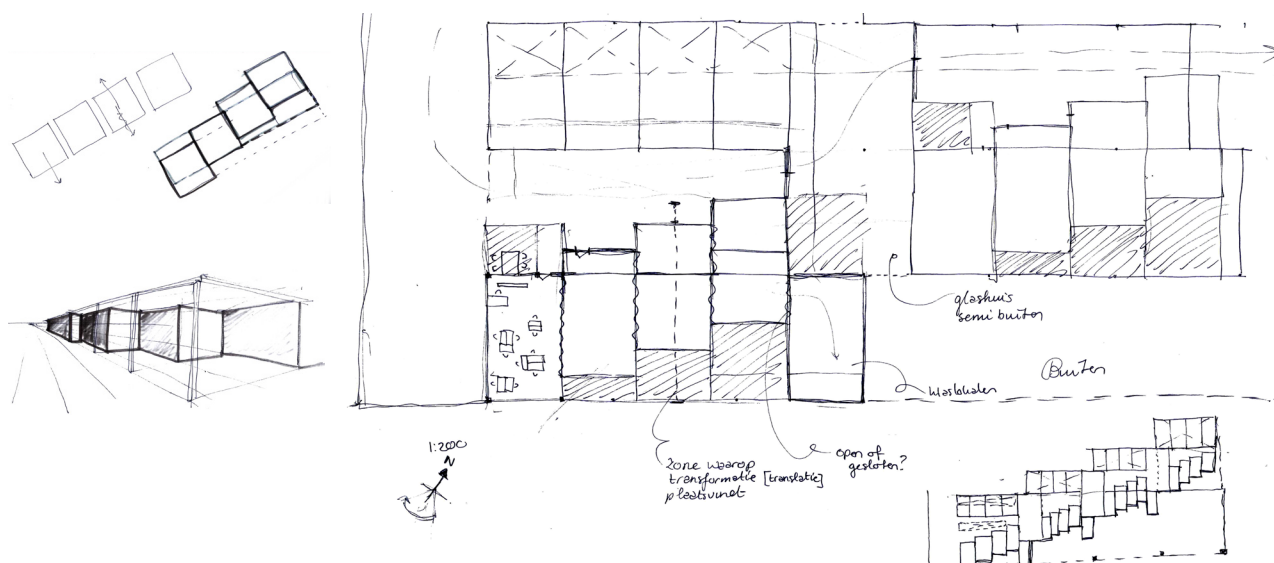

Image 27: Combination of systems
Starting point: subdivision of an original plot.
Transformation rules: translation and rotation.

Image 28: First design sketches
Composition of different clusters. Translation of shapes in different scales (cluster, classroom).
Visualized in plans and perspective view.



Conclusion

The goal of this research is to make the theorem of shape grammar accessible for the architectural design process. This goal is achieved by researching to what extent a general understanding and generic system of shape grammar can be applied in the architectural design process. The general understanding is developed by studying the formal theorem, and becoming familiar with the terms by translating this to the third dimension through models. The generic system is developed by analyzing and comparing different specific grammars. To research to what extent the knowledge could be applied during the design process, background information about the application of shape grammar and own studies towards the implementation have been done. At this moment the research is not definite because the design process continues after finishing this paper. Therefore in the next paragraphs, some assumptions and expectations about the application in the design process will be given.

Studying the formal theorem led to a certain general knowledge about (spatial) relations between form, dimensions and transformations. I developed a consciousness of shape, the possibilities of transformations of shapes, and the effects for compositions. To fully understand shape grammar one has to take theory into practice. Just studying abstract theorem will not lead to master the skill of shape and transformations. The best way to learn and use the system is playing around with it. Therefore I found it satisfactory to develop variations of spatial compositions based on the knowledge about spatial relations and transformations, and developing a simple grammar (Appendix E). I expect that in later phases of the design, a relation between shape (the complete design plan) and embedded parts (clusters or parts of the plan) will be established because of the developed feeling for spatial relations.

Furthermore, the analysis and comparison of different specific grammars teaches us that there is a generic rule system for grammars. Firstly, all the analyzed grammars are constructed in a comparable way: generated in different stages and sub stages. Secondly, all the analyzed grammars generate a basic composition of the analyzed style, based on one of the three rule structures. Finally, none of the grammars generate a complete building design, but describe specific characteristics of the building style in terms of transformational rules.

The main difference between shape grammar as analytic or design tool is that the first one has a clear end point. The goal is to create a grammar for a specific style, based on a set of plans. As design tool the final image is not yet fixed, therefore everything is possible and creating rules out of nothing is a demanding task. Therefore the designer needs to define his wishes in terms of spatial relations before rules can be created.

Describing a basic composition of a building style is something that all analyzed grammars do. Therefore I used the

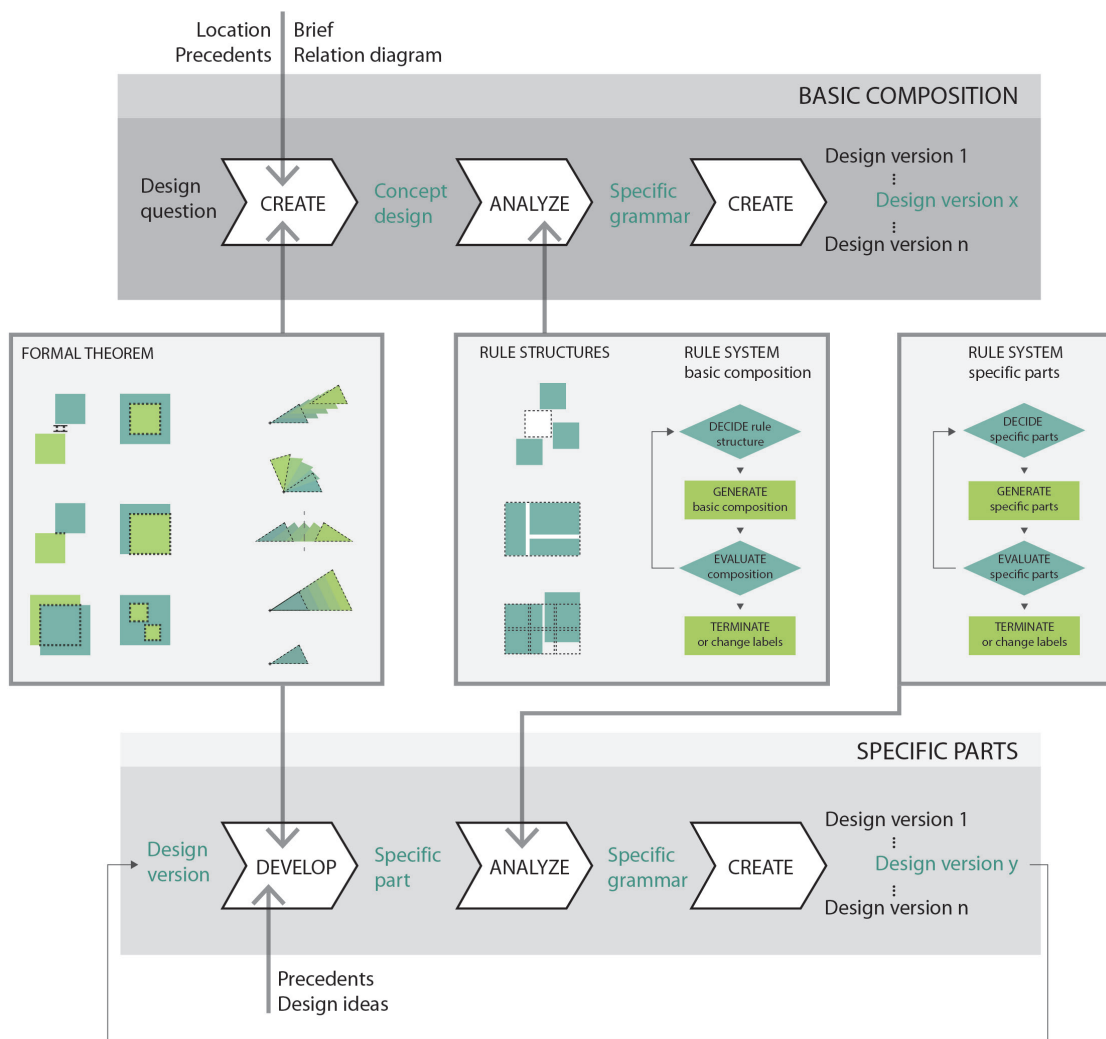

Image 29: Possible implementation of the formal theorem of shape grammar and the rule system in the design process.

three specific rule structures as basis to develop variations in a basic composition of a design. Starting points were fixed dimensions and relations between rooms (shapes). The next step is to analyze a developed concept design in terms of spatial and functional rules. I expect to generate several consequent yet varied possible design plans by applying those rules.

At this moment, the design process is not yet at the point that specific characteristics of the design can be described in spatial rules. Later in the design process I expect to develop a specific characteristic (probably the roof, and/or façade openings) in terms of rules and design variations. This way I apply shape grammar in the best way it is used: as an analytical tool, but at the same time use this analysis to keep designing.

In conclusion, the general knowledge of shape grammar can help to develop an aptitude for spatial relations, as designing tool. It is too soon to describe the precise function on which a generic system can help during a design process, but it is my expectation that it will work in the way as described in the previous paragraph. A lot of further research is possible for the implementation of the system in the design process¹⁵.

¹⁵ Possible subjects could be: the development of rules through spatial objectives or contextual starting points, computational implementation of a generic system, development of a shape grammar editing tool or computer program to make the application of grammars in design more practical and utilizable.

Acknowledgements

I want to thank the following people for developing my research:

My research mentor Dr.ir. Martijn Stellingwerff (*TU Delft, faculty of Architecture, Urbanism and Building Sciences*) for the useful discussions about the possibilities of shape grammar, keeping me focused on the subject and introducing me to experts.

Professor José Pinto Duarte (*President of the University of Lisbon, faculty of Architecture*) for allowing me to join the course about shape grammar online, and presenting me with (the latest) papers about the subject.

Dr. Joost de Groot (*TU Delft, faculty of Applied Mathematics, Mathematical Physics*) for helping me understand the mathematical facets and the approach of shape grammar, and for reminding me to keep a critical attitude.

Dr.ir. Rudi Stouffs (*National University of Singapore, Architecture and Urbanism, computational methods*) for the possibility to brainstorm about the subject and possible (computational) application.

Deborah Benrós (*PhD candidate University College London*) for presenting me with her latest papers and helping me understand the theorem and application of the subject.

Sander Mulders MSc (*TU Delft, faculty of Architecture*) for objective and practical remarks.

Finally, Simon Tiemersma (*graduate student master Architecture, TU Delft*) for useful conversations, substantive remarks on the structure of the paper and mental support, and Caya Commerell MA for editing.

About the author



Nina (Malinda) Verkerk has a bachelor degree in Architecture (TU Delft) and studied a year of Applied Mathematics (TU Delft). Since secondary school, she has an interest in both, creative design and the systematics behind mathematics. In the master graduation studio Explorelab (faculty of Architecture, TU Delft) it was possible to combine both interest, by studying the subject Shape Grammar.

Bibliography

- Alexander, C. (1967). *Notes on a synthesis of form*. Oxford: Oxford University Press.
- Alexander, C. (1977). *A pattern language*. Oxford: Oxford University Press.
- Beirão, J. N., Duarte, J. P., & Stouffs, R. (2011). Creating Specific Grammars with Generic Grammars: Towards Flexible Urban Design. *Nexus Network Journal*, 13(1), 73-111.
- Benrós, D., Duarte, J. P., & Hanna, S. (2012). A New Palladian Shape Grammar. *International journal of architectural computing*, 10(04), 521 - 540.
- Benrós, D., Hanna, S., & Duarte, J. P. (2012). A generic shape grammar for the Palladian Villa, Malagueira House and Prairie House. *Design Computing and Cognition DCC'12*.
- Chau, H. H., Chen, X., McKay, A., & Pennington, A. d. (2004). Evaluation of a 3D shape grammar implementation *Design Computing and Cognition'04* (pp. 357-376). Dordrecht: Kluwer Academic publishers.
- Van Dooren, E., Boshuizen, E., Van Merriënboer, J., Asselbergs, T., & Dorst, M. v. (2013). Making explicit in design education: generic elements in the design process. *International Journal of Technology and Design Education*.
- Duarte, J. P. (2005). Towards the mass customization of housing: the grammar of Siza's houses at Malagueira. *Environment and Planning B*, 32, 347-380.
- Flemming, U. (1987). More than the sum of parts: the grammar of Queen Anne houses. *Environment and Planning B*, 14, 323-350.
- Johnston, N. (2013). A community for Conway's Game of Life and related cellular automata. Retrieved 10-03, 2014, from <http://conwaylife.com/>
- Knight, T. (1981). Languages of designs: from known to new. *Environment and Planning B*, 8, 213-238.
- Knight, T. (1991). Designing with Grammars. *CAAD futures Digital Proceedings*, 33-48.
- Knight, T. (1999). *Applications in Architectural design, and education and practice*. Cambridge: Massachusetts Institute of Technology.
- Knight, T. (1989). Transformations of De Stijl art: the paintings of Georges Vantongerloo and Fritz Glarner. *Environment and Planning B: Planning and Design*, 16, 51-98.
- Koning, H., & Eizenberg, J. (1981). The language of the prairie: Frank Lloyd Wright's prairie houses. *Environment and Planning B*, 8, 295 - 323.
- Stiny, G. (1980a). Introduction to shape and shape grammars. *Environment and Planning B*, 7, 343-351.
- Stiny, G. (1980b). Kindergarten grammars: designing with Froebel's building gifts. *Environment and Planning B*, 7, 409-462.
- Stiny, G. (2006). *Shape, Talking about Seeing and Doing*. Cambridge, Massachusetts: The MIT Press.
- Stiny, G. (2011). What Rule(s) Should I Use? *Nexus Network Journal*, 13(1), 15-47.
- Stiny, G., & Gips, J. (1971). Shape grammars and the generative specification of Painting and Sculpture. *The best computer papers of 1971*.
- Stiny, G., & Mitchell, W. J. (1978). The Palladian grammar. *Environment and Planning B*, 5, 5-18.

Appendices

Appendix A:
Glossary shape grammar.

Appendix B1:
Skype conversation prof. José P. Duarte, 21th of Februari 2014.

Appendix B2:
Skype conversation Dr.ir. Rudi Stouffs, 26th of Februari 2014.

Appendix B3:
Mail conversation PhD candidate Deborah Benros, 2014.

Appendix C1:
Analysis of the Prairie house (Frank Lloyd Wright) grammar by Koning and Eizenberg.

Appendix C2:
Analysis of the Queen Anne house grammar by Flemming.

Appendix C3:
Analysis of the Palladian villa grammar by Stiny and Mitchell.

Appendix C4:
Analysis of the Siza houses at Malagueira grammar by Duarte.

Appendix D:
Studies of the rule systems.

Appendix E:
Development of a specific grammar.

Appendix A: Glossary

Algebras of shape Constructed of three things: elements or shapes, a Boolean operator and Euclidean transformations.



(Boolean) operator Possible operators: addition (sum), subtraction (difference), product, and symmetric difference

(Euclidean) transformation Possible transformations: translation, rotation, reflection, scale and identity.

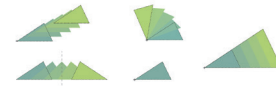

Ambiguity Equivocal: seeing things differently.

Boundary element One dimension lower than the original element, and reduced to maximal elements.

Element Possible elements in different dimensions: 0, points (or units); 1, lines; 2, planes; and 3, solids.



Embedding Something is part of something else.



Maximal element The smallest number of biggest thing that combine to form a shape .



Part relation The relation of smaller parts into the whole shape.

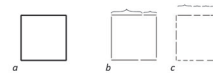

Relation Possible relations: discrete, overlap/touch, touch externally or embedding.



Rule structure How a rule is constructed. For example: addition (around a focal point), subdivision, transformation of a grid.



Rule system Different rules together based on the same rule structure.

Shape Constructed by more different elements .

Spatial relation Relations among different shapes.

Transformation Rule structure. For example: divide, extend, connect, adjust (subtract x add)

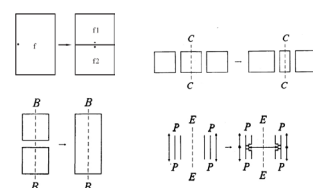

Appendix B1:

Skype conversation prof. José P. Duarte, 21th of Februari 2014.

NV: How do you generally use shape grammar in the architectural design process?

JD: A method to make a shape grammar for a design is to combine the qualities of a program and the site with a relevant precedent. For example, this can be done by a classification of buildings and spatial qualities. It can help to define your grammar when you compare the specific problem with a problem where you are already familiar with, or what already is solved.

NV: I would like to focus on a general understanding of shape grammar and the translation in a grammar useful for architectural design.

JD: Nothing comes from nothing. We always start with some knowledge. For example the knowledge from exercises that you have done before can be a starting point. I recommend you to read the article from Rivka Oxman in Design Studies.

Your task is to design a school. So define for yourself what qualities you would like to achieve and search for schools with those qualities. Then analyze how those qualities can be achieved by spatial properties. Search for the connection between form and the qualities of affordance.

NV: How can I construct the rules of the grammar? How do I decide what is good or not?

JD: There are two options. The first option is to use abstract rule types and the second option is to look into specific grammars. The rules of a grammar can be constructed based on the spatial relations found in precedents. Read a paper of George Stiny, that is published at the Nexus Conference in 2010 in Porto. You have to link the spatial features to the qualities or design goal you want to achieve. The trick is to understand spatial relations.

NV: How do you choose which rules to apply (when more are possible) by applying a grammar? Is this random or are there qualities which the choices are based on?

JD: For this you should look into Artificial Intelligent algorithms (but this is a PhD in special). This uses something called: best for search. What you need to define is a design goal and during the generation, you need to use the rule that brings you closer to your design goal. So evaluate the design during the generation. But this strategy is not always successful, so you sometimes you need to guess. Donald Schön wrote the reflective practitioner, about evaluating during the design process: so you draw something, then look to it and draw again.

NV: What about the passageway? How do you apply this in the grammar?

JD: The type of circulation is very important in the design. The circulation type defines the building type and therefore it depends on the building type you want to use for your design. For example: if you want to design a U-shape, you get a corridor.

NV: How can I make variations during the process of generation? By hand or computer program? What kind of program?

JD: You can do both. For a computer program you can use Rhino. Mario Barros did research on grammars during a course and he found that sometimes the same grammar can need more different computer programs.

NV: Are there any conferences or organizations (For example linkedIn groups) I can join to keep up with shape grammar during my study and following career?

JD: Environment & Planning B, Cummincad, eCAADe, SiGradi, CAADRIA, ACADIA, ASCAAD, CAAD Futures, DSS.

NV: Can the Siza grammar also generate designs that are not in line with the designs of Siza?

JD: There are 4 possible cases:

The grammar generates designs that Siza already designed;

The grammar generates designs that Siza didn't designed, but that he could have designed;

The grammar generates designs that Siza didn't designed, and he wouldn't design, but that he accepted that other people would design it for the Malaguiera houses;

The grammar generates designs that Siza does not accept that anyone could design at all.

The grammar for the houses at Malaguiera can generate the first, second and third, but not the last one.

NV: How could you make sure that no houses could be generated that Siza would never designed?

JD: You have to guess a bit by creating the rules, and also have a good understanding of the designer. For example, there is a rule that places the stairs. While creating this rule out of the analysis of the houses, Siza never had placed the stairs in the bed room. But when I talked with Siza about this, and said that it would be possible in the grammar to place the stairs also in the bed room, Siza said that would also be logic. And after our conversation he designed a new Malagueira house where the stairs were in the bed room.

NV: How do the rules work in function?

JD: You have to make several lists:

A list of required spaces, based on the design brief;

A list of spaces that still need to be placed into the design;

A list of already allocated spaces

.
During the design generation, the evolving design, allocated spaces are removed from the second list and placed on the third list. For example, if the kitchen is allocated, there is no need to place a second kitchen, so the 'place a kitchen' rule cannot be applied anymore if it is not in the second list anymore.

NV: thank you for your time for this conversation.

Appendix B2:

Skype conversation Dr.ir. Rudi Stouffs, 26th of Februari 2014.

Dit gesprek begon met de uitleg van mijn onderzoek en ontwerp doel. Na mijn uitleg spraken we over specifieke uitdagingen die ik tegenkom nu het onderzoek en het ontwerp samen moeten komen.

NV: Hoe kan ik ontwerpvarianten (digitaal) genereren?

RS: De meeste grammatica's zijn gemaakt met de hand. Dit is omdat er een probleem is met het digitaal genereren door middel van regels. Dit is omdat shape grammar regels niet alles definiëren, er is een vrijheid. Bijvoorbeeld, wanneer je een lijn tekent kan dit nog van alles worden op elke schaal. In regels moet dit direct vastgelegd worden. Wel zijn sommige grammatica's die zijn ontwikkeld, achteraf versimpeld in een computer programma verwerkt. Echter is dit nooit exact of accuraat. Bijvoorbeeld is de Queen Anne grammar, dat een graph grammar is, versimpeld door het niet ondersteunen van emergence.

[Een graph grammar is in plaats van een grammar van vormen, een netwerk van relaties en knooppunten hiertussen.]

Als je een rechthoek tekent in een niet parametrische grammar, dan liggen de verhoudingen (lengte/breedte) van die rechthoek vast. Dit kun je alleen uniform schalen. In een parametrische grammar, als je een rechthoek tekent (aan de linkerzijde van de pijl) dan bedoel je daarmee, eendert welke rechthoek, het maakt niet uit welke verhouding. Bijvoorbeeld de Palladiaanse grammar werkt met een grid en de eigenlijke verhouding van de afmetingen van de ruimte doen er eigenlijk niet toe. Er worden gewoon regels gemaakt dat je rasteronderdelen kan samenvoegen tot een rechthoek, maar welke verhoudingen een rechthoek heeft, daar wordt niet bij stilgestaan. Het probleem met parametrische grammars, is dat deze nog veel moeilijker zijn. De enige implementaties die er tot voorkort waren die lossen het probleem dusdanig niet op. Die gebruiken bijvoorbeeld graph grammars om het probleem uit de weg te gaan. Recentelijk heeft één van Stiny's studenten wat vooruitgang geboekt en ook in Georgia Tech zijn ze bezig om een systeem te ontwikkelen voor parametrische grammars. Dus dat is een probleem, in die zin is het gemakkelijk om het met de hand te doen. Alleen weet ik niet wat jij voor ogen hebt.

NV: Toen ik mijn onderzoek begon, hoopte ik dat ik dat zou uitvinden tijdens mijn onderzoek. Nu merk ik dat dit lastig kan zijn. Op het moment wil ik een testomgeving creëren in Rhino - Grasshopper waarbij ik additieve regels kan testen, met vaste proporties.

RS: Dat is zeker mogelijk. Ik ken een paar voorbeelden.

Een promovendus van Duarte en mij; José Beirao heeft ook een grammar ontwikkeld die het ontwerpen ondersteund in de stedenbouw. Om die een structuur te geven die hij kon gebruiken in het ontwerpproces, heeft hij gebruik gemaakt van Alexanders patterns. Als je in de stedenbouw iets bedenkt of wilt toevoegen kun je kiezen uit een aantal patronen die kan worden uitgewerkt door een aantal regels. Dus eigenlijk heb je een grammar waarbij je niet regel per regel kiest, maar werkt op basis van patronen. Dit is het ene punt, maar het is natuurlijk heel moeilijk om dit rechtstreeks te vertalen naar architectuur. Het andere punt is dat hij het helemaal heeft uitgewerkt als een grammatica en gedeeltelijk heeft geïmplementeerd in AutoCAD. Maar heeft achteraf met een medestudent en versie gemaakt in grasshopper. Deze versie is opzich geen grammatica, want je kunt de regels niet onderscheiden, maar qua beleving en gebruik zit er wel heel veel gelijkenissen tussen. Het is op basis van parameters natuurlijk, maar er zit een vrij belangrijk aantal parameters in

waarmee je op een vrij groot niveau de resultaten kunt beïnvloeden zoals je dat in een grammatica zou kunnen doen.

Een ander voorbeeld is van een promovendus van MIT in 2001, die over de Chinese constructie van huizen gezien over de geschiedenis, een soort Alberti maar dan van China. Op basis van de beschrijvingen van die woningen heeft hij een grammatica ontwikkeld. Nu heel recent is er iemand bezig om dit via een parametrisch model te doen. Het is natuurlijk heel erg analytisch, je weet waar je naar toe wil werken en deze persoon is gewoon de vertaling van de beschrijving aan het maken naar een parametrisch model.

Ik heb zelf een oefeningetje van vijf regels gemaakt in grasshopper, en dat gaat redelijk goed. Het is natuurlijk zo dat je de gegevens moet doorgeven van de ene regel naar de andere. Ik heb het model echt willen vormgeven als een grammatica, en je kunt de outputs van de ene regel als input van de volgende regel doen. Ik geef hier niet de kubus door aan de volgende regel, maar een punt door, waar vervolgens een nieuwe kubus bij wordt gemaakt. Dat gaat over het implementeren als het ware.

Het andere wat ik wilde melden is dat er natuurlijk veel meer onderzoek is gedaan naar analytische grammatica's, zoals de voorbeelden die je aangegeven hebt. Maar er wordt ook wel wat onderzoek gedaan naar de grammatica's van het ontwerpen, en vooral in het onderwijs. Eigenlijk zijn er geen voorbeelden van grammatica's die gebruikt zijn als ontwerphulpmiddel, tenzij in het onderwijs. José Duarte, Terry Knight, José Beirao en Andrew Li. De voorbeelden van Terry Knight en Andrew Li kunnen eventueel interessant zijn voor je, omdat ze meestal grammatica's gebruiken in het onderwijs om studenten te leren begrip te hebben van regels en een grammatica. Het gaat er minder om om echt een gebouw te ontwerpen, maar meer om een tekening te ontwerpen. Je werkt met een heel sterke abstractie wat een gebouw zou kunnen zijn. Maar in zekere zin kan het toch eventueel interessant voor je zijn.

Er zijn wel wat onderzoeken die meer gericht zijn op het ontwikkelen van een algemene ontwerptool, maar dan meestal op het ontwikkelen van een lay-out. Daar is wel enige logica in natuurlijk. De meeste voorbeelden zijn zoals bij de huizen van Siza, waarbij uitgegaan wordt van een rechthoek die wordt onderverdeeld. Maar dit is natuurlijk niet de enige manier om tot een plot te komen.

- Duarte heeft de basisregels gemaakt voor de Siza grammar, genaamd PAHP grammar, die is gebaseerd op de Portugese regelgeving van woningen. Het lijkt op de Siza grammar, maar is niet gebaseerd op het oeuvre van een bepaalde architect.

- De andere gaat over het onderverdelen van rechthoeken: rectangular dissections. Hier zijn een paar papers over verschenen in Environment and Planning in de jaren '80. Het gaat er over hoe je rechthoeken kunt onderverdelen in kleinere rechthoeken. Maar er is op zekere hoogte een relatie te leggen met planvorming.

NV: Hoe kan ik het beste mijn regels opstellen en hierbij mijn ontwerpdoelstellingen in verwerken?

RS: Dit is een onderwerp waar veel onderzoek naar gedaan wordt, maar waar ze nog niet helemaal over uit zijn hoe je dit het beste kunt doen. Er zijn twee mogelijkheden.

1) Op bepaalde momenten een evaluatie doen. Als ik me niet vergis heeft Terry Knight hier ooit eens een abstract voorstel voor gedaan: hoe je zulke functies die een evaluatie doen binnen een grammatica kunt verwerken. Op bepaalde momenten heb je in je grammatica regels die bepaalde functies oproepen die je gebouw kunnen evalueren.

2) De andere methode heeft José Beirao gehanteerd. Stel je hebt een grammar om een plan te ontwikkelen, en je hebt een optimale lengte van je gebouw. Maar de regels voegen telkens een nieuwe ruimte toe. Dan weet je pas op een bepaald moment of je die maat bereikt hebt of

niet. In de onderzoeken van José Beirao en José Duarte, worden die doelstellingen als parameters meegenomen in de regels, om die op gepaste wijze op te roepen en te controleren. Het gaat hier bij wel om eenvoudige controles. De manier waarop zij voorstellen dit te doen is om de grafische regels te complementeren met de description rules. [Stiny heeft hier ooit een korte paper over geschreven, 'A note on the description of designs'. Description rules zijn: tekstuele regels die bepaalde informatie genereert of bijhoudt, die ook van interesse is maar die je niet zomaar in de geometrie kunt plaatsen. In zijn geval werd dit altijd afgeleid, dus het was een soort beschrijving die je genereerde tegelijk met het plan.] Maar in de voorbeelden van José Duarte zijn die beschrijvingen van het begin al ingevuld, en worden gebruikt ter controle.

Dus dat kun je doen, maar de meeste voorbeelden die ik ken hebben dit niet geïmplementeerd, en doen dit met de hand. Alleen José Duarte en José Beirao hebben dit op een heel specifieke manier geïmplementeerd. Als je zou willen beschrijven hoe dit kan gebeuren, kan dit met de description rules, maar dat je dat niet noodzakelijk probeert te implementeren, maar zegt: op die manier kun je bepaalde informatie meenemen in je ontwerp die niet zuiver geometrisch is.

NV: Bij Duarte is dat welke ruimtes een plekje hebben gekregen en welke niet.

RS: Exact, en bij Beirao gaat het erover voor hoeveel mensen je het wilt ontwerpen en dergelijke. Informatie die je dus niet in de geometrie kwijt kunt. Eventueel zou dit ook met labels kunnen, maar die maakt de geometrie alleen maar ingewikkeld.

RS: Als ik een algemene raad kan geven, mijn mening, dan zou ik zeggen dat het interessant kan zijn als jij bijvoorbeeld die fasering conceptueel zou kunnen uitwerken. Dus welke fases zijn er in ontwerp en welke afhankelijkheden zijn er in ontwerp. Dus een zinvolle fasering met afhankelijkheden. En dat je dan zegt dat je hier één of twee fases uit wilt pikken en daar regels voor definieert, die veel gedetailleerder gaan. Die dus echt tonen hoe die fase doorlopen zou kunnen worden. Zonder alle andere fases te moeten uitwerken. Dus eigenlijk heb je een aantal oefeningen binnen je ontwerp die gebruik maken van de grammatica. Die dan niet helemaal los staan van elkaar maar ingebed zitten in het grotere concept van die fasering.

NV: Zou u me aanraden de fasering van een ontwerpproces of de grammatica fasering te halen?

RS: Ik zou een ontwerpproces dat jij voor ogen wilt hebben proberen te vertalen naar grammatica. Vanuit de optiek van een grammatica is het natuurlijk simpeler om alle ramen en deuren in één fase te doen, maar misschien hoeft dit wel helemaal niet. Misschien kun je daar een veel interessantere fasering voor bedenken. Dan zit je dus met het probleem dat er in je fasering onderdelen zitten die je sneller kan uittypen in een grammatica en andere fases die wat moeilijker zijn om uit te diepen in een grammatica. Maar dat je nog wel het volledige concept kan neerleggen, zonder dat je een duizendtal regels moet neerleggen en uitwerken om het ontwerp van punt nul tot het resultaat uit te werken. Als je dat vertaald naar grasshopper kan dat op dezelfde manier. Je kunt één fase uitwerken. Je kunt een hiërarchie van fases en deelfases maken. Je hebt de volledige controle over hoeveel en hoe verregaand je de grammatica uitwerkt, zonder dat je in de problemen hoeft te komen zonder tijdsgebrek.

NV: Heel erg bedankt voor uw tijd en dat u zo snel kon afspreken via skype.

Appendix B3:

Mail conversation PhD candidate Deborah Benros, 2014.

7th of January 2014

Dear Deborah Benrós,

I found out about your research on Palladian Grammar and email adress through prof. Duarte because I'm graduating in Architecture at the TU Delft (Netherlands) on the topic of shape grammars. I'm focussing on different type of rules (kind of transformations and operations) that can be found in additional grammar and subdivision grammar, and how this can be used in architectural design. Therefore, I find your research very interesting.

I was hoping you could answer some questions about the paper:

- 1) About what kind of shapes do you write, about lines or spaces (like rooms or walls)?
- 2) In stage 3 of the original Palladian grammar, you define the rules as UNION. But how can the combination of more than one discrete shape be a union? Shouldn't the shapes be connected to be able to be unified?
- 3) You define stage 7 as subdivision, (probably because of the addition of the arrow), but the addition of openings in the wall; do you define that also as a subdivision? Or do you call that something else? I find it hard to define transformations of a line (like making a corner in a line) in terms of (euclidean) transformations or operations. I hope you can tell me your vision about it and help me in understanding your method.

Kind regards,

Nina Verkerk

[attached are the drawings that can clarify my questions]

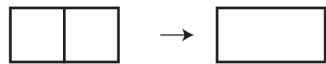
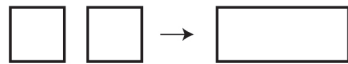

question 2: union ?

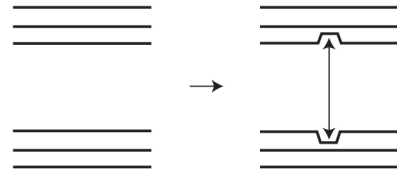

question 3: subdivision ?

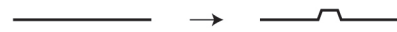

question 3: kind of transformation?

10th of January 2014

Dear Nina,

Thanks for your kind email.

Hopefully you will find below the answers to your questions otherwise feel free to contact me with any additional clarifications.

1) mostly i refer to shapes. By shapes i mean enclosed polygons that later in the generation process can be converted into spaces or rooms

2) in stage 3 is discussed borders manipulation. Most of the manipulation is performed by concatenation processes. By concatenation it can be interpreted as space merging or union. This process is attained by deletion of sides of adjacent polygons. These have to be adjacent with coincident sides

3) stage 7 proposes specific detailing. In the case of the palladian grammar most of the detailing performed has to do with punctuating openings (doors an windows) The method is based on a combined process subtraction of the mid sections and addition of the doors or window frames.

Kind regards,

Deborah

25th of February 2014

Dear Deborah,

once again, thank you for the papers.

Today I read your paper: 'A generic shape grammar for the Palladian Villa, Malagueira House and Prairie House'. Which is very helpful for my own research (graduation thesis), because I also studied those three grammars (plus the Queen Anne house grammar), and I'm also focussing on a more generic way of using grammars into architectural design, therefore I really liked reading your paper.

I've collected some questions about the paper and hoped you could answer them. If you prefer mail that is OK for me, but maybe it are too many questions to answer by mail, and would an appointment using Skype better.

Thank you so much for your help already.

Kind regards,

Nina Verkerk

Questions about 'A generic shape grammar for the Palladian villa, Malagueira House and Prairie house':

- 1) According to the paper, incorrect use of the grammar could lead to something between a palladian villa or for example a prairie house. But how do you exactly make sure that this would not happen if you use the grammar correctly? Is this implemented in the rules? Or are there some moments during the generation process that controls this?
- 2) How do you generate the plans of the designs? Do you apply the rules by hand or do you use a computer program? In the conclusion you say that future work will also focus on computerised implementation. Does this already work?
- 3) I've a question according to proportions in the plans. The proportions between spaces in the plans of the three grammars do differ. But in the first steps of the generation process always rule 2 and 3, the division rules, are used. How do you make sure, the copied maximal lines will be placed at the 'right' place in the grammar?
- 4) How many rules does this generic shape grammar have? I saw rule 1 - 9, but you also talk about rule 10 and in the figure that generates a Malagueira house you use A, B, C ...
- 5) What does rule 10 look like?
- 6) In figure 7 (Palladio's Villa generation), step 6 you apply rule 3 (the division rule), but what happens in this step in this figure, isn't that shape concatenation?
- 7) How do you exactly implement the allocation of spatial functions in the grammar?
- 8) Do you use labels to control the generation process?

3th of March 2014

Hi Nina,

It took me more time than predicted to respond to your questions. Hopefully this is what you are looking for. Below you will find my answers to your questions:

1) The paper discusses a generic grammar that enables the generation of Palladian, prairie 'or' Malagueira houses. It is important to note 'or' instead of 'and'. The rules to generate any of these examples are the same. What changes is the parameterisation. Each shape rule has three sets of parameters respectively customised to either style. This will avoid hybrid solutions.

I do mention that hybrids will be possible if the grammar is misused. This means that the user is using the grammar, rules and parameterisation incorrectly. This can be avoided by the computer implementation that will not allow it by conditioning the available parameters in each rule.

2) The grammar is illustrated and structured so it can be used freely by hand. I do mention the computer implementation which is something that at the time of the paper was published was still a work in progress. Both (computer and conventional) implementation do the same and generate the same results given the same original input. The only difference is the automation of the grammar and having an aiding tool.

3) This is linked with the parameterisation. By parameterisation I mean there is a set of three algebraic expressions that describe how the rule can be applied and between each interval. This is specific to each style and for instance the Palladian grammar shows usually a preference for 1:1 1:2, 2:3 and other specific proportions of space. This is incorporated in the algebraic expressions conditioning the relation between the X and Y (length and height e.g.). The division rules and other rules that follow observe the same principle.

4) The paper does not go into the specificities... It only focused on what I called the common branch of the grammar. Rule 1 to 9 present rules that are truly generic. To this point, and disregarding the overall proportions it is difficult to distinguish in abstract the type house generated up to here.

5) Rule 10 is illustrated and attached for you. Rules 10 and the rest focus on the particular stylistic elements such as functional distribution, detailing and specific elements of style. This is further on discussed on my PhD which I am finishing writing currently. The following rules are cater to each style

6) That's correct, it is a typo that no one picked up, apologies for that

7) Spatial functions are covered in the particular part of the grammar, rules 10 on. These are particular to each style. An analysis was made of the basic spatial relations between rooms for each type or style. These principles were simply described using shape rules. I am attaching a two images to illustrate it. Rule 10 illustrates for instance the central room in the Palladian villa. This is always an entertainment space (labelled with 'E'). In addition other labels are included like the central axis marks which shows the application conditions. If the space has a 'T' shape, occupies the centre of the building, then qualifies to host the entertainment space function.

8) Yes, labels illustrate the application conditions. There are spatial/function labels, location labels, such as access point, centre, symmetry axis for example.

I hope this is clear to you now.

D

Appendix C1:

Analysis of the Prairie house (Frank Lloyd Wright) grammar by Koning and Eizenberg.

Grammar

The paper (Koning & Eizenberg, 1981) developed a shape grammar that generates prairie houses in the style of Frank Lloyd Wright. The following characteristics can be mentioned. The fireplace is the generating center of the prairie house. Around the fireplace, Froebelian – type blocks are added in two axes of growth to produce the basic compositions. The basic compositions that follows after applying the first five type of rules, see to a balance in the prairie-style houses. The ornamentation of the basic composition that follows up the rules applied before, secures a third axis of growth and completes the design by simple arrange new layers of blocks around the fireplace. (Koning & Eizenberg, 1981, p. 322)

With a total of 99 rules it is possible to create typical compositions of the prairie houses of Frank Lloyd Wright. The first 18 rules, spread out over five stages, generates the basic composition. This part makes the variations between possible prairie houses. The remaining rules, spread out over nineteen stages, generate the ornamentation of the basic composition. Were the rules in the first part creates a composition by adding new shapes, the rules in this part always works on embedded shapes and the addition or transformation to create details. Almost all rules of this part must be applied during the generation; in spite of this also these rules can create variations by applying the rules on different parts of the composition.

Rules

In the next paragraphs I analyze the type of rules per stage of the Prairie house grammar. Hereby I relate the construction of the rules to the formal theorem of the first chapter. I also explain explicitly how some important typical rules work and why some rules or labels are indispensable for the grammar.

The rules of the grammar are drawn in U33, but the rules in stages 0 – 1.5 and 2.1 – 2.3 could also have been drawn in U22, because the transformations work two dimensional. The following stages, 2.4 – 2.9 and 2.10 – 2.19 refer to a basement, a second floor, a roof or a connection between floors. Therefore, these rules only work in the third dimension.

Stage 0 – 1.5: creating the basic composition

The first two rules locate the fireplace, we choose one, and exist of adding a block and some labels in the origin. Rule 3 – 6 add a living zone next to the fireplace, we choose one of the four rules to apply. The label A would be erased and replaced by some new possible labels. Rule 7 completes the core unit and is obligatory to apply. Rule 8 – 11 makes some obligatory extensions; adding new blocks to the existing composition, with or without label. We choose a combination of rules [footnote: this may or may not be two times the same rule, but applied on another embedded shape] and apply them to the generated composition. Finally rule 12 – 18 assign functions to the created zones, therefore these rules only changes labels. To conclude, these stages contain rules that add new blocks and make a composition.

Stage 2.1 – 2.19: ornamentation of basic compositions

The remaining stages and rules generate the ornamentation of compositional forms. Some of the rules are in some cases obligatory to apply, for example; those that add roofs. Also all prairie-style designs, with the exception of those with double height living spaces, must have basements. Other rules are optional to apply, for example; those that add porches, terraces, or extra blocks to corners of basic compositions. (Koning & Eizenberg, 1981, pp. 306, 314)

stage	rule number	rules	type
0	1 -- 2	locating the fireplace	LABEL + ADD (origin)
1.1	3 -- 6	adding a livingzone	LABEL + ADD
1.2	7	completing the core unit	ADD
1.3	8 -- 11	the obligatory extensions	ADD
1.4	12 -- 18	assigning function zones	LABEL
2.1	19 -- 22	adding to concave corners	ADD
2.2	23 -- 25	adding porches	ADD
2.3	26 -- 34	interior details: main floor	TRANSFORM (extend, connect, divide)
2.4	35 -- 40	basement formation	TRANSFORM (extend)
2.5	41 -- 47	adding terraces	ADD + TRANSFORM (extend)
2.6	48 -- 53	exterior details: main floor	TRANSFORM (adjust)
2.7	54 -- 55	creating portes cocheres	LABEL (assign) + TRANSFORM (subtract)
2.8	56 -- 60	erasing main-floor nonterminal labels	LABEL
2.9	61 -- 62	establishing the bedroom floor	LABEL + ADD
2.10	63 -- 64	bedroom-floor extensions	ADD
2.11	65 -- 66	details: bedroom floor	TRANSFORM (extend, adjust)
2.12	67 -- 73	making double-height living rooms	TRANSFORM (connect, adjust)
2.13	74	erasing bedroom-floor nonterminal labels	LABEL
2.14	75 -- 82	establishing roof eave lines	TRANSFORM (adjust)
2.15	83 -- 84	creating balconies	ADD
2.16	85 -- 86	erasing nonterminal labels	LABEL
2.17	87 -- 97	roof formation	TRANSFORM (adjust)
2.18	98	details	TRANSFORM (adjust)
2.19	99	extending the chimney through the roof	TRANSFORM (extend)

Stage 2.1 – 2.9: ornamentation of the basic composition of the main floor

Rule 19 – 56 generates the detailing of the main floor. The structures of the rules are mutually divergent. For example addition: addition of new rooms by the stages of concave corners and porches, addition of new smaller elements in the stage of the basement formation. But also some rules are a transformation of an embedded element: the stage of the addition of terraces contains an extension or subtraction of a part of the shape. And also the stage of the exterior details contains transformations by subtracting a part of a line (or plane in U33) and replacing it with something else. Rule 56 – 60 erases the left over labels for the main floor. (Koning & Eizenberg, 1981, pp. 310 - 311)

Stage 2.10: establishing the bedroom floor

This stage exists of two rules where the first one (rule 61) is obligatory and adds a bedroom floor on top of the core unit. The second one (rule 62) is optional and transforms the bedroom floor.

Stage 2.11 – 2.19: finishing the ornamentation of the remaining composition

These stages switch between adding new shapes or details, transforming existing shapes by extending, and erasing labels. Some stages exists of rules that extents and connects existing spaces and walls (planes) horizontally or vertically, and adds details by transforming existing walls (planes) like balconies or chimneys. Stage 2.11 – 2.13 generates the detailing of the spaces by extending spaces or connecting different spaces. There are two stages which generate the roof of the prairie house; stage 2.14 establishes roof eave lines and 2.17 forms the roof. In between is stage 2.15 that creates balconies and 2.16 that erases labels. Finally, rule 98 and 99 that also makes a detail and extends the chimney through the roof.

Conclusion

The generation of the basic composition (stage 0 – 1.4) works very clearly. With a few simple and straight forward rules, the layout or grid of a prairie house can be created. The rules in the following stages are a bit tangled up. The rules of different parts of the composition are blended; for example, there are different stages in which porches, terraces and balconies are generated. Also, the roof is not constructed in one stage but is interrupted by the generation of balconies and erasing of nonterminal labels.

Appendix C2:

Analysis of the Queen Anne house grammar by Flemming.

Flemming analyzed the Queen Anne houses by means of shape grammar. He demonstrated a grammar by which it is possible to create a basic type of a Queen Anne house. It was possible to demonstrate how the various parts and features of a house related to each other and to explain its overall geometry. He acknowledges that the picturesque aesthetics are simplified, but that it is possible to use the basic framework developed by Flemming, and add the richness of the patterns easily yourself. (Flemming, 1987, p. 349)

Grammar

The grammar of the Queen Anne houses contains two parts. The first part focusses on the interior and relations between spaces, while the second part focusses on the exterior of the house. The first 17 rules can be divided in the first five stages. In this part functional labels as hall (H), front (F), back (B), rooms (R), kitchen (K), parlor (P), dining room (D), pantry (Pt) and stairs (S) are important. The second part exists of 32 different rules and can be distinguished in the second five stages in the table. Were in the first part rules are defined in U12, the rules in the second part are defined in U33. Some parts of the Queen Anne houses were too difficult to catch in a set of rules. For that reason, the Picturesque aesthetic is not in the grammar and there are no rules concerning the service stairs.

The maker of the grammar states that there are three types of elements that have expressive power over the Queen Anne houses: windows, chimneys, and porches. In the grammar presented in the paper he only focusses on the last two.

Rules

Table: analysis of the grammar that generates the Queen Anne houses (own analysis, based on the information of 'More than the sum of parts: the grammar of Queen Anne houses (Flemming, 1987, pp. 330 - 348)).

Stage 0: locating the hall

The grammar starts with an addition of a shape at the origin. This shape gets some labels as back and front, and a functional label (H) that stands for hall. Also the stage of the grammar changes by changing the original H into R, therefore the first rule cannot be applied again and a loop is prevented.

Stage 1: defining the interior

The first stage is divided into four sub stages and generates the interior of the house. The rules of stage 1.1, 1.2 and 1.3 are all defined in V22, because all shapes are two-dimensional and labelled. Stage 1.3 translates the created layout in V22 to the third dimension.

Stage 1.1: allocate spaces around hall

Rule 1 – 5 locates zones, by adding new shapes, around the original shape (hall). All new zones are uniformly labelled R, leaving a more precise label for next sub stages. The rules contain labels B, F and X, where X can be both B and F, and therefore can be applied on different sides of the original shape. These rules are all additional.

Stage 1.2: allocate kitchen

Rule 6 – 12 place the kitchen (K), dining room (D) and optional pantry (Pt). Rule 6 - 8 only change the already assigned label R into a K or D. But rule 10 and 11 directly adds a new shape and corresponding label K, and rule 9 and 12 were an already existing labelled shape is divided and provided with a new label. These rules are both, additional and sub divisional in relation with assigning functions.

Stage 1.3: allocate main stair

Rule 13 – 15 place the stairs (S) into the composition. All rules assume an existing labelled rectangle (this can be any label). The rectangle will be divided into new zones and directly gets a corresponding

stage	rule number	rules	type
0	0	locating the hall	LABEL + ADD (origin)
1.1	1 -- 5	locate zones around the hall	ADD
1.2	6 -- 12	allocate kitchen	LABEL + TRANSFORM (divide) + ADD
1.3	13 -- 15	allocate main stair	LABEL + TRANSFORM (divide)
1.4	16 -- 17	create a second floor	TRANSFORM (sum + translate, extend)
2.1	1 -- 8	create front, back and side walls	ADD
2.2	9	locate roof	ADD (origin)
2.3	10 -- 13	transform roof to body created by 1 - 5	TRANSFORM (adjust, extend)
2.4	18 -- 25	adding porches	ADD
2.5	26 -- 32	generate bottom ends of chimney breasts	TRANSFORM (adjust, extend)

label from which one is a S. These rules are sub divisional in relation with assigning functions.

Stage 1.4: create a second floor

Rule 16 and 17 are extrusion rules where the first floor can be copied into a second floor, and the staircase can be extruded to the two levels of the floor. At this moment in the grammar, the two-dimensional visualization of the house is translated to the third dimension. The product at the end of this stage is a composition of blocks with some distance between each block.

Stage 2: defining the exterior

The second stage is divided into five sub stages and defines the exterior of the house. The original paper starts counting the rules all over again. To be in line with the original paper, I will also start counting the rules from one again. The rules in this stage are defined in the third dimension and labelled, therefore we work in: V33.

Stage 2.1: create walls

Rule 1 – 8 are rules that generate front, back and side walls around the composition generated in the first stage. Planes are folded around the composition of blocks, with some distance from each block. Every side of the plane that points to the original B gets a label B or B'. The same takes effect on the F or S sides. Small corners that are given from the 'folding' gets the label A.

Stage 2.2: locate roof

Rule 9 locates the roof. This rule is obligatory, because otherwise the rules in the next stage cannot be applied. The roof will be located from the labels R that are assigned to the corners of the composition. This rule is similar to the generation of the initial shape in stage 0.

Stage 2.3: generate roof

Rule 10 – 17 generates the roof by adjusting the basic roof towards the composition underneath. New parts of roof are added, and roof lines are adjusted by making it less or more pointy. These rules are all of a transformational kind and controlled by labels.

Stage 2.4: add porches

Porches of Queen Anne houses can be very different: small, extend over the entire front or even turn around a corner and wrap a portion of the first floor. Rule 18 – 25 generates the porch of the house. Rule 18 allocates the minimal porch in front of the entrance hall, while rule 19 – 21 recognize and label the closed and open side of the added porch. Rule 22 – 25 control the growing of the porch around the house, therefore the porch can stay very small, but also grow around the house. Rule 18, 22 – 25 are of an additional kind, while rule 19 – 21 just reassign labels.

Stage 2.5: generate chimney breasts

In the final stage rule 26 – 32 generate the bottom ends of chimney breasts. Rule 26 prepares a chimney breast for elaboration by cutting off its bottom part. Then rule 27 and 28 can be applied repeatedly, which divides the chimney breast in steps. Finally, rule 29 – 32 can be applied that stops and finalize the generation of the chimney breast. These rules transform a part of the wall by extruding some embedded parts.

Conclusion

The grammar is not very specific and complete. Flemming chooses to focus on turning some typical aspects of Queen Anne houses into a grammar, and is aware that this grammar is not complete. For the interior aspect is only the hall, stairs, kitchen, dining room (and optionally pantry) defined. Other type of rooms like bathrooms and sleeping rooms, are excluded from the grammar. Also the arranging of windows and doors (both interior and exterior) are not included.

In contrary, because Flemming focused on some parts and not he could make a grammar where he could say something about the Queen Anne houses in a lot of different levels of detail. For example: on the level of functional and spatial relations between rooms, the roof and the porch can be generated, and finally the chimney breast can be generated in a level of high detail. In other words, this grammar cannot generate the whole house, but some specific parts can be generated in detail.

Appendix C3:

Analysis of the Palladian villa grammar by Stiny and Mitchell.

The original Palladian grammar is developed by G. Stiny and W.J. Mitchell in 1978. Recently D. Benrós developed an alternative grammar for the original Palladian grammar (Benrós, Duarte, & Hanna, 2012). The difference between both grammars is in the first stage of the grammar, where the original one uses an additional system while the alternative grammar uses a sub divisional grammar, as visible in the grammar tree.

Grammar

In 1978 G. Stiny and W.J. Mitchell published a paper presenting 'The Palladian grammar'. This paper presents a parametric shape grammar that generates the ground plans of Palladio's villas in definition of the classical architectural style. Based on the information of the geometry of Palladio's villas in *Quattro Libri dell'Architettura* by Palladio, the ground plan is systematized in a grammar. The grammar and its rules exist of polygons, and is defined in a two-dimensional coordinate system U22. [footnote: in some stages maximal lines of the polygons are used to make a transformation, therefore it is debatable if some rules work in U12] The grammar of the plans consists of eight stages which are applied in one sequence: (1) grid definition; (2) exterior-wall definition; (3) room layout; (4) interior-wall realignment; (5) principal entrances; (6) exterior ornamentation – columns; (7) windows and doors; and finally (8) termination. (G. Stiny & Mitchell, 1978, pp. 5-6)

Rules

In the next paragraphs I analyze the type of rules per stage of the Palladian grammar. Hereby I relate the construction of the rules to the formal theorem of chapter 1. I also explain explicitly how some important typical rules work and why some rules or labels are indispensable for the grammar.

Stage 1: defining the grid

In stage 1, rules 1 – 10 can be applied to define the underlying structure of the villa. The rules in this stage are all additional. There is only one rule that introduces the origin or original shape [rule 1]. In this rule, the direction of the expansions of the grid is fixed by the labels A, A' and O. What exactly happens in the following rules in different directions and sequences is: take the maximal lines of the original square, copy [sum] some of the maximal lines and translate them over a fixed distance [for example rule 3 and 7]. By using labels, like the •, A or A', the grammar controls which rules can be applied in what direction and prevent an endless use of rules, like a loop.

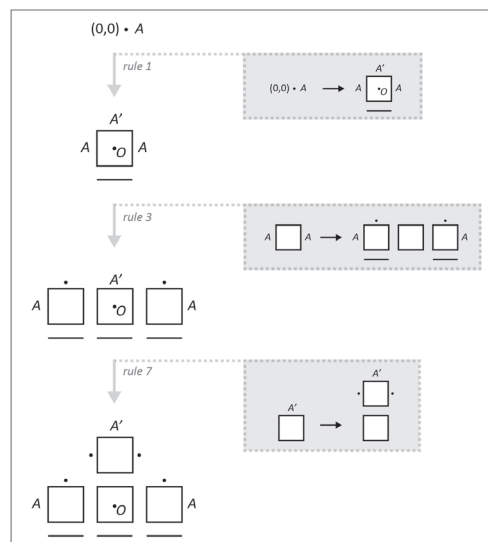

Stage 2: exterior-wall definition

This stage only exists of rule 11, and must be applied to create the outside walls. This rule adds a new outside line and also new labels (B and P) that are needed for stage 3 and make sure that the plan becomes symmetrical.

Stage 3: room layout

This stage connects different polygons by subtracting maximal lines and adding new lines by connecting existing ones, these kind of rules are transformational because embedded parts of the total shape are transformed. Labels are changed during the shape transformations, and rule 19 is

specially construed to transform the remaining 'B's into 'C's, therefore the rules cannot be applied infinitely. All rules in this stages are construed in such a way that the plan stays symmetrical.

Stage 4: interior-wall realignment

This stage is an optional operation. The vertical dashed line between the two C's means that the C doesn't have to stand exactly at that place above the polygon, so the operation can be applied in the middle, on the back or the front of the plan. In this stage walls are translated to rescale rooms.

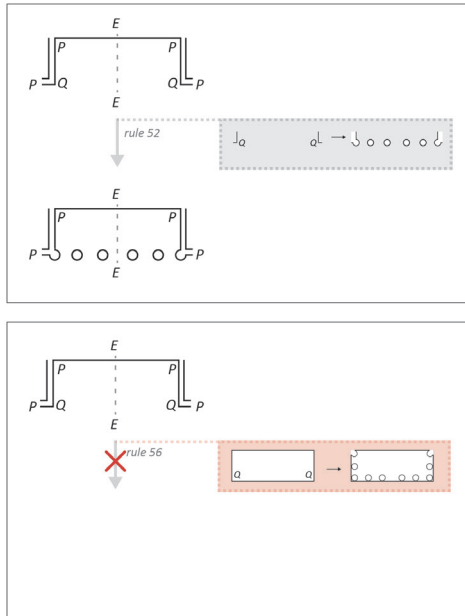

Stage 5: principal entrances – porticos and exterior-wall inflections

This stage has different type of rules and labels to control shaping the entrances. The rules are all applicable in the symmetry of the ground plan. The first rule of stage 5 (rule 26) is to change all label C into D. It is obliged to apply this rule; otherwise the other rules of stage 5 cannot be applied. Rule 27 – 34 and rule 40 – 45 make an 'in antis' portico, while rule 35 – 39 can be used to make a 'prostyle' portico. It is only possible to choose and apply one rule from rule 27 – 45, to the ground plan. The rules itself prevent a loop by changing labels. Rule 46 – 48 can be used to in- or decrease the wall thickness of the backside of the ground plan. Finally, rule 49 erases all P' and 50 changes all label D into E, therefore we can continue to stage 6.

Stage 6: exterior ornamentation

Rule 51 – 57 place columns into the just created portico. The shape transformations are the addition of rounded columns (circles), where sometimes a part of an existing line would be replaced by an arc of three quarters circle. Dependent on the applied rule in stage 5 some rules of stage 6 can or cannot be applied, as visualized in figure.

Stage 7: windows and doors

All openings, windows and doors have to be placed symmetrical, the dotted symmetry axis and label E in the shape and possible rules ensure this. Rule 58 and 59 ensure that no opening would be placed upon the plan's axis of symmetry. The grammar makes it obligatory to insert a window for each nonaxial external wall segment in the plan. Rule 60 and 61 ensures the placing of symmetrical interior doors, while rule 66 places an interior door on the axis of symmetry. Finally, rule 62 – 65 provide exterior doors on the plan's axis of symmetry.

In abstract terms what happens with the rules in this stage is that mid sections of lines would be subtracted and replaced by new lines that represent a door or window. The placing of new axes in rule 58 and 59 ensure the possibility to apply rule 60 and 61 on those new formed line crossings.

Stage 8: termination

The last stage of the Palladian grammar erases the left over labels and labelled line segments that were used to guide the generation process of the ground plan. Taken into the generation of the termination rules is that they can only be applied if the plans have been correctly generated in the previous seven stages. This means that only plans that missed no steps in the earlier stages can finish this stage.

stage	rule number	rules	type
0	1	introduce initial shape	ADD (origin)
1	2 -- 10	creating grids with bilateral symmetry	ADD (translate, shapes, maximal lines)
2	11	creating exterior walls	ADD (scale, translate)
3	12 -- 19	room layout	TRANSFORM (connect)
4	20 -- 25	realigning interior walls	TRANSFORM (extend)
5	26 -- 50	adding porticos and wall inflections	TRANSFORM (subtract)
6	51 -- 57	finishing porticos by addition of columns	ADD
7	58 -- 66	locating windows and doors in plans	TRANSFORM (adjust)
8	67 -- 72	termination	LABEL

Appendix C4:

Analysis of the Siza houses at Malagueira grammar by Duarte.

Grammar

J.P. Duarte developed a functional shape grammar that generates typical Siza's houses at Malagueira. (Duarte, 2005) In three successful stages one house can be formed where rooms and functions, stairs, walls, openings as doors and windows are generated. In the first stage the first floor is generated, in the second stage the second floor and in the third stage the terrace. The first two stages exist of the same seven sub stages and the third of four sub stages (figure).



- E - enclosing floor
- L - locating functional zones
- C - defining circulation scheme
- D - dividing zones into rooms
- A - adding details
- O - piercing openings
- R - erasing unnecessary labels and changing stage

Figure: Stages of the grammar of Siza's houses at Malagueira (Duarte, 1999)

Before starting the first stage that defines the first floor, an initial shape will be introduced by rule 0. The seven sub stages; (E) Enclosing floor, (L) Locating functional zones, (C) Defining circulation scheme, (D) dividing zones into rooms, (A) adding details, (O) piercing openings and (R) erasing unnecessary labels and changing stage, are applied in stage one and two that generates the first and second floor. The last stage generates the terrace and exists merely of four stages; (E) enclosing floor, (L) locating functional zones, (A) adding details and finally (R) erasing unnecessary labels and changing stage. In the next paragraph I will explain the seven sub stages and its rules.

Rule 1 – 109 are applied in stage 1 that generates the first floor. Rule 2, 81 – 97, and 110 – 148 can be applied in stage 2 that generates the second floor. Finally, rule 2, and 149 – 164 can be applied in the last stage

that generates the terrace. We see that despite the first and second floor can be generated in the same type of stages, the most of the rules for the first and the second floor differ. The exception is the application of rule 2, that introduces enclosing walls or with other words the maximal space that the stage can be applied to, and 81 – 97, that introduces openings in walls.

The grammar is constructed in a two-dimensional way were floor plans and elevations are generated by applying the rules. The floor plans and elevations are used for the three-dimensional visualization of the design. The grammar contains a label F0, F1, F2 or F3 for the level of the floor plan where the grammar is applied. If the generation of the first floor proceeds, labels are placed on the second floor and in the elevation. When we work in stage 0, the first floor is visualized by a dotted square, and when we work in the first floor, the second floor is visualized by a dotted square with labels, etcetera.

Rules specific

The rules in the grammar contain a lot of labels that control the transformations. Rules are described in both dimension and functional zones. Both are visualized in diagram and abstract function containing letters and mathematical code.

All rules are constructed the following way (Duarte, 2005, p. 357):

$R_i: \langle F_n; f_b, f_r, f_f, f_l; f; Z \rangle \rightarrow \langle F_n; f_b, f_r, f_f, f_l; f_1; f_2; Z - [f_1, f_2] \rangle.$

In this expression the letters represent the following:

R_i: rule number (For example: R₉ is rule number 9)

F_n: stage number (n= 0, 1, 2, 3) (For example: F₁ is stage number 1 where the first floor is generated)

F_b, f_r, f_f, f_l: functions associated with adjacent rectangles at back, right side, front side and left side of the unit.

F: function of the zone or space. (a specific function is not yet assigned)

F1, F2: specific functions (For example: instead of F1 there could be li for living room)

Z: set of required zones

Z – [f1, f2]: set of required zones without allocated zones

Example (rule 10 applied):

R10: < F1, fb, fr, ff, fl, li; o; Z > → < F1, fb, fr, ff, fl, li, o; y, se; Z – {y, se} >; y, se in Z.

Note that it can differ what is before the arrow, depending on what kind of rules are already applied before rule 10. At least we need an outside zone (o) because here the rule has effect. We further see that rule 10 can be applied in the first stage (F1) and has effect on the outside zone (o) by introducing a yard (y) and service zone (se). The livingzone (li) is already allocated, so nothing happens here. Because in this rule the yard and service zone is introduced they are subtracted from the required zones (Z).

Stage 0: introduce the initial shape

This is a stage where the initial shape is introduced and exists only of the obligatory rule 0. This rule contains strict dimensions in width and length and introduces labels on which the other rules in the next shape can be applied. The labels: fb, fr, fl and ff that stand for back, right, left and front, are introduced so that in later stages functions can be associated with that rectangles. The label Q1 specifies in which ways the lot can be split into halves.

Stage 1: define the first floor

This stage as the next exists of seven sub stages: (E) Enclosing floor, (L) Locating functional zones, (C) Defining circulation scheme, (D) dividing zones into rooms, (A) adding details, (O) piercing openings and (R) erasing unnecessary labels and changing stage.

Stage 1.1: Enclosing floor

This stage exists of rule 1 – 4, and prepares the unit for the transformations in the next stages by introducing ‘walls’ and adjusting the ‘wall thickness’. Or what happens abstract: introduce a double line and translate a maximal line therefore a new distance between both lines arises.

Stage 1.2: Locating functional zones

This stage exists of rule 5 – 12, and divides the unit into zones: outside, living, sleeping, service zone, and yard. Dependent on if the outside zone is defined at the front of the back side, a corridor will be introduced. What happens abstract is that squares are divided by copying and translating maximal lines. Always double lines are placed; therefore wall thickness is already attended to.

Stage 1.3: Define circulation zones

Rule 13 – 18 generates the circulation zones, first the main entrance and the place of the staircase in connection to the living zone is introduced. Depending on the place of the outside zone is in front or back, the main entrance will be placed in front or at the corridor. In an abstract way a point (label) is added between two lines and a dotted line in line with the place of the staircase. At the place reserved for the staircase, new lines and an arrow is placed.

Stage 1.4: Dividing zones into rooms

Different rooms have to be placed in the already assigned functional zones. The computation starts with the set obligatory and desired rooms R'. The computation stops when this set becomes empty or continues until the set R'', the set of optional rooms, becomes empty too. Rule 19 – 61 can be applied to generate the rooms and its desired relation in between. Rule 19 – 39 divide a functional zone into two new zones with a fixed proportion between both. Abstract: both, dividing and extending rules are used, and new functions (labels) are introduced. Rule 48 – 57 ensures that there is no zone that is not assigned to a function by creating the last required room or an optional room (from the set R''). These rules have only functional (assigning label) properties. Rule 58 – 60 are some remaining rules;

that create a closet under the stairs, connect rooms with the same or related function that share a wall from at least 1.2 meters, and locate a laundry. Rule 61 is an obligatory and an indispensable rule that permutes double functions.

Stage 1.5: Introduce details

Rule 62 – 78 introduces the chimney, details of the stairs, adjusts wall thickness and heights. In a two-dimensional view, embedded parts of lines are copied, translated and/or connected.

Stage 1.6: Introduce openings

Rule 79 – 107 introduce openings in walls (double lines). Rule 79 – 93 pierces exterior and rule 94 – 99 interior openings. Axes of symmetry are introduced to place the openings in the front. Rule 100 – 107 introduces the frames.

Stage 1.7: Erasing unnecessary labels and changing stage

Rule 108 erases the left over labels at the level of the first floor. While rule 109 changes the stage from F1 into F2. Both rules are obligatory to proceed to go to the next stage. These rules only apply on labels and have no effect on the appearing shape.

Stage 2: define the second floor

This stage is also divided into the same sub stages as the first stage. The rules are quite similar to the rules applied in the first stage. But there is a significant difference between the two stages, because it has already assigned a series of labels from the derivation of the first floor; for example the stairs, chimney and place of the openings.

The first sub stage introduces the slab (rule 110), enclosing walls (rule 2) and adjusts wall thickness rules 111 – 113. The second sub stage replicates the dissections of the first floor using rules 114 – 118. The third sub stage extends the staircase and basic circulation scheme using rules 119 – 124. The fourth sub stage assigns functional labels to the assigned zones, based on the first floor using rules 125 – 137. The fifth and six sub stage introduces details using rules 138 – 146, and the openings using rules 81 – 97. The last sub stage exists of rule 147 that erases left over labels, and rule 148 that changes the stage from F2 into F3.

Stage 3: define the terrace

This stage exists of four sub stages. As for the other stages, the first sub stage introduces the slab (rule 149) and encloses the terrace (rule 2). The second sub stage works like stage 2.2, were a replica of the functional division of the lot is introduced (rule 150 – 155). The third sub stage adds details of the chimney (rule 156 – 159) and the patio walls (rule 160 – 162). The fourth and last step erases the unnecessary labels (rule 163) and applies the termination rule 164 to complete the generation of the house.

Rules in general

The stages always start with introducing and enclosing the origin shape. These rules add new shapes and labels. The stages always end with erasing the unnecessary labels and changing the stage, these rules only apply on labels. In between, first the functional rooms and circulation zones are located in sub stages. Rules are dimensional; dividing the shape into smaller ones, connecting shapes, adding stairs; and functional; adding, changing and permuting labels. Then the details and openings are introduced in sub stages. Rules are transformational for parts of shapes, and have no effect on functional rooms.

Conclusion

The grammar of the Siza houses at Malaguiera is quite mathematical and has next to the shape transformations, a focus on applying the right function. The grammar goes into great functional detail by for example creating the space under the stairs into a closet (rule 58) and assigning the laundry zone (rule 60) in the yard.

stage	rule number	rules	type
0	0	introduce initial shape	ADD (origin)
1.1	1 -- 4	start	LABEL + TRANSFORM (divide)
1.2	5 -- 12	locate functional zones	LABEL + TRANSFORM (divide)
1.3	13 -- 18	define circulation zones	LABEL + TRANSFORM (divide)
1.4	19 -- 61	devide zones into rooms	LABEL (assign, permute) + TRANSFORM (divide, extend, connect)
1.5	62 -- 78	introduce details	TRANSFORM (adjust)
1.6	79 -- 107	introduce openings	TRANSFORM (subtraction)
1.7	108 -- 109	terminate	LABEL
2.1	2, 110 -- 113	define second floor, start	ADD (origin)
2.2	114 -- 118	replicate dissections first floor	LABEL + TRANSFORM (sum + translate)
2.3	119 -- 124	define circulation zones	LABEL + TRANSFORM (sum, extend)
2.4	125 -- 137	divide remaining zones into rooms	LABEL + TRANSFORM (divide)
2.5	138 -- 146	introduce details	TRANSFORM (adjust)
2.6	81 -- 97	introduce openings	TRANSFORM (subtract)
2.7	147 -- 148	terminate	LABEL
3.1	2, 149	define terrace, start	ADD (origin)
3.2	150 -- 155	division zones	TRANSFORM (divide)
3.3	156 -- 162	introducing details	TRANSFORM (adjust, extend)
3.4	163 -- 164	terminate	LABEL

Appendix D: Studies of the rule systems

1. addition around focal point

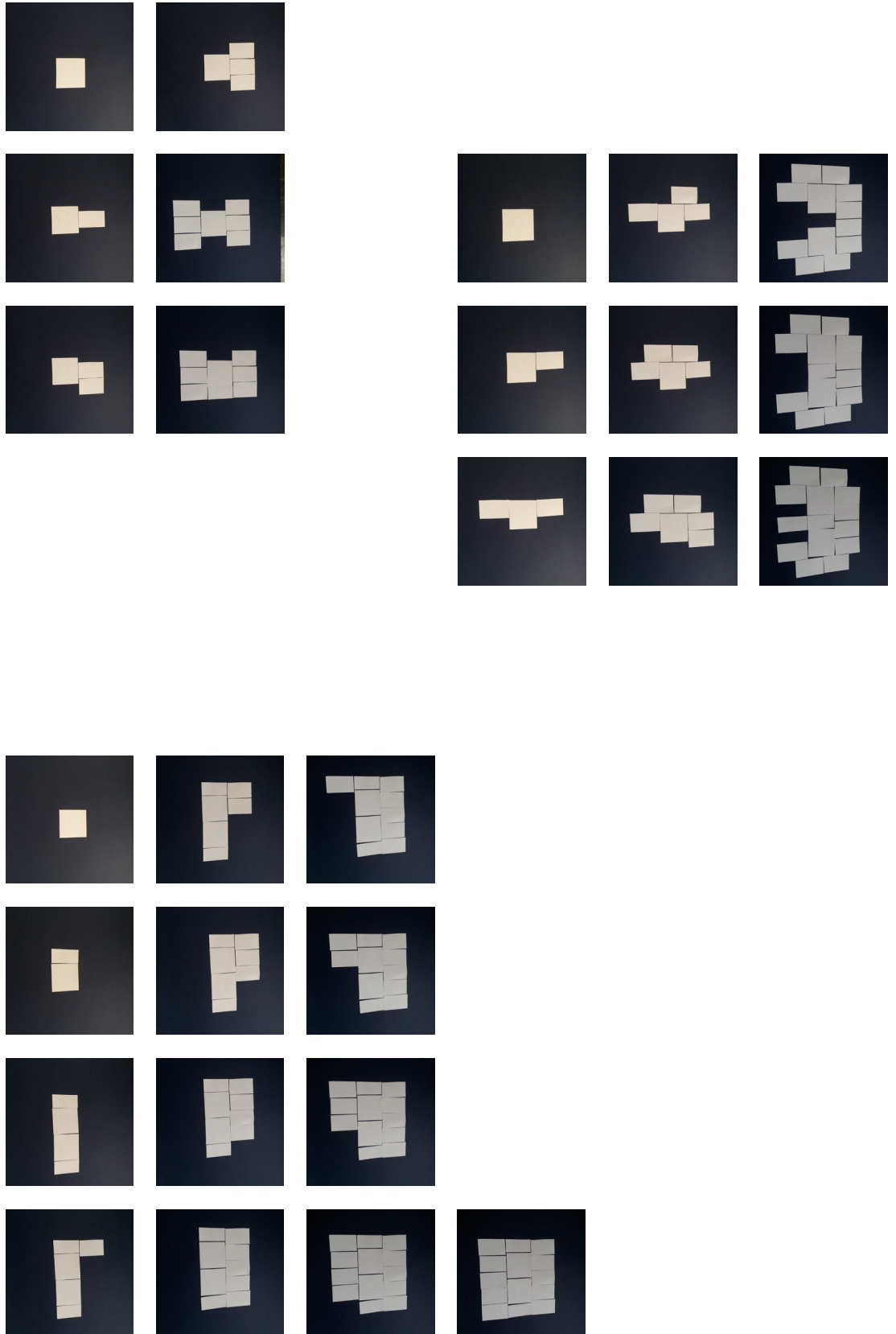

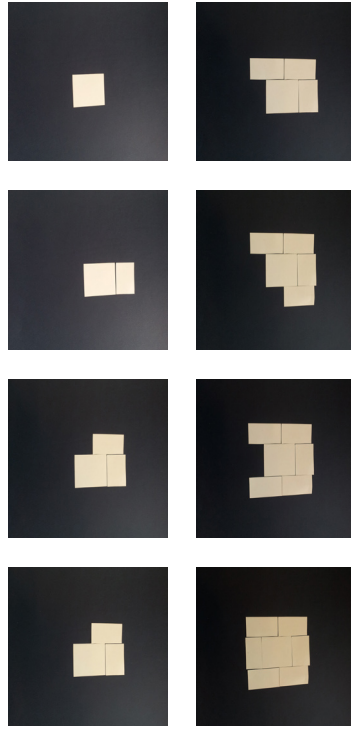
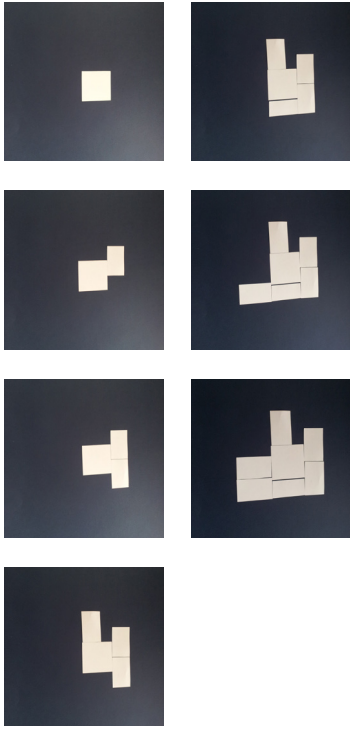

2. subdivison

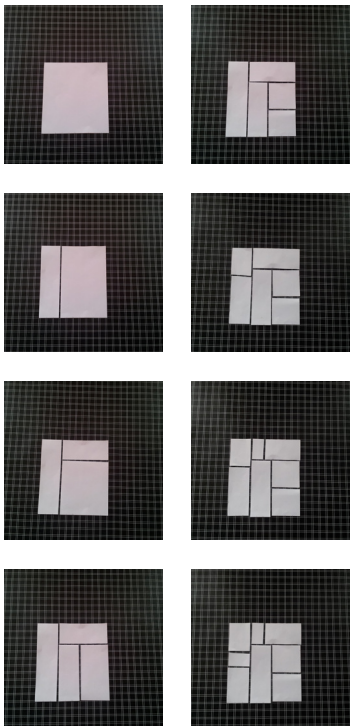

3. transformation of a grid

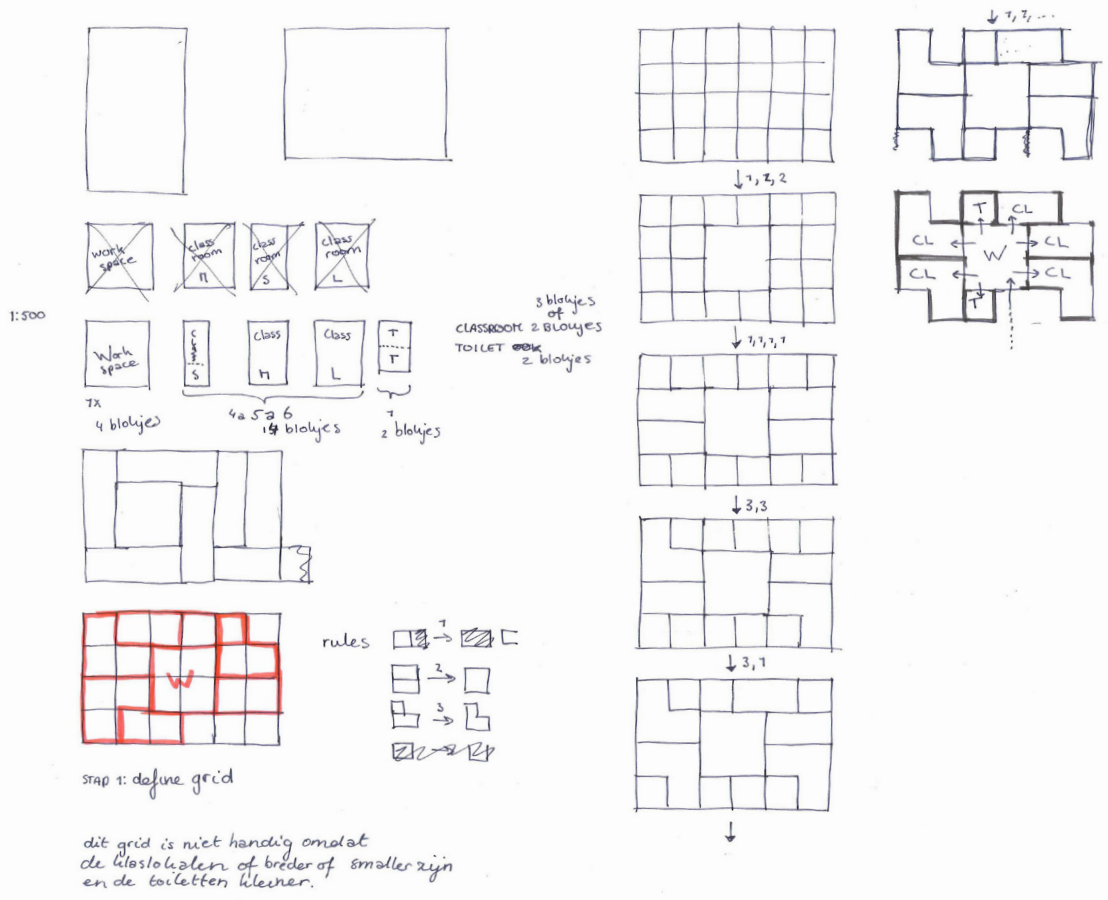

4. transformation of a basic composition.

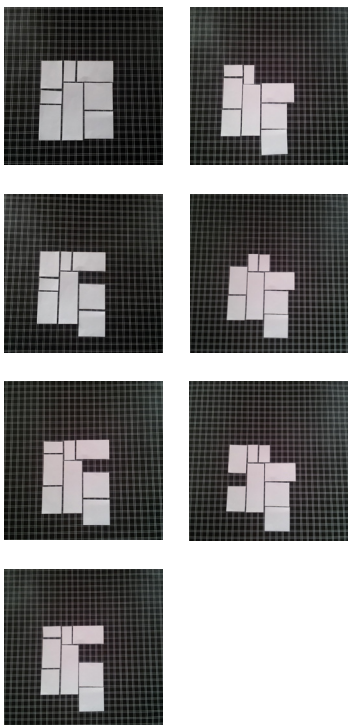
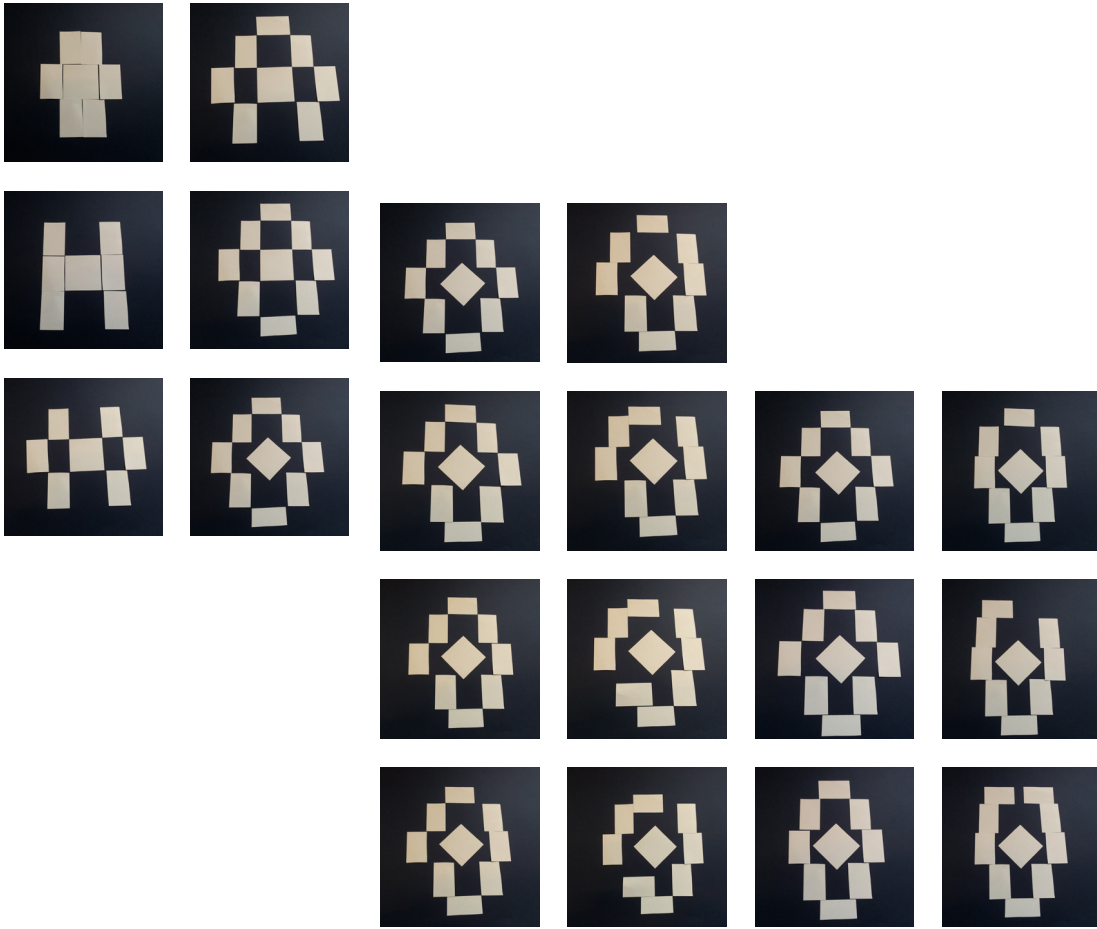

Appendix E: Development of a specific grammar

Montessori School Delft - Herman Hertzberger

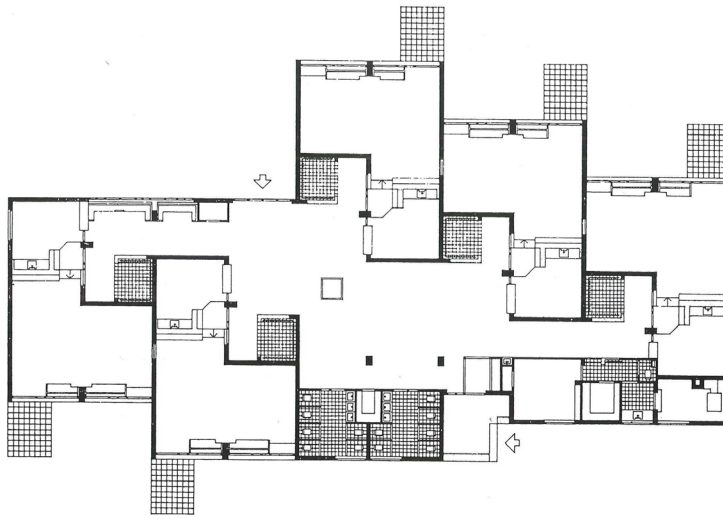

Plan of the school

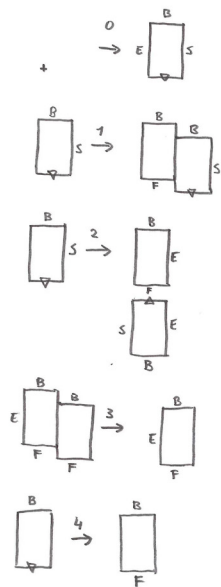

Compositional rules

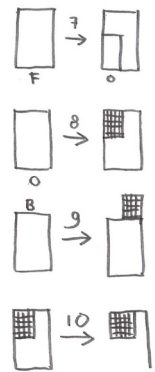
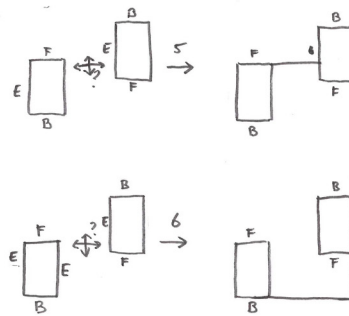

Rules specific part: classroom

Generation of the design by applying rules

