

The Design of a Cooling Garment for Olympic Sailors



Master Thesis
Integrated Product Design

Emiel Janssen

Delft, November 2019

The Design of a Cooling Garment for Olympic Sailors

Master Thesis

Emiel Sebastiaan Janssen

6 November, 2019

Master Thesis

MSc Integrated Product Design Faculty
of Industrial Design Engineering

Supervisory team

Prof dr. ir. K.M.B. Jansen

Dr. L.P.J. Teunissen

Delft University of Technology

Faculty of Industrial Design Engineering

Landbergstraat 5

2628 CE Delft

The Netherlands

Emiel Janssen

Delft, November 2019

Preface

In front of you lies the process report of 'The Design of a Cooling Garment for Olympic Sailors'. This document describes design and research activities that lead to a cooling garment. A cooling vest that is tailored to competitive sailing, and which can be produced before the 2020 Olympics in Tokyo.

The report is kept as visual as possible. More than half of the space available is covered with imagery. Nevertheless it can be heavy to read all sections. The report is split into six sections, not all are equally valuable to every reader. The following text gives a quick overview of what information can be found where.

The first section gives a summary of the **discovered** knowledge. Which included information from papers, persons and videos. This chapter is interesting if you are new to cooling garments and/or sailing.

The information acquired in the first chapter formed a good basis, but there were some knowledge gaps. Expertise on the subject was **expanded** to be able to come to a good result. Read this part if you want to know more about phase change materials.

The third chapter is a two page summary of all insights, **structured** in a list of requirements. This list forms the ground work for the design process.

The many insights were **integrated** using an iterative approach with many prototypes. This chapter describes the process of designing, creating and testing a total of seven prototypes.

Ultimately the iterations **resulted** in a design optimized for Olympic sailors. Compromises were necessary to make the design producible.

At the end of the report an extensive **evaluation** is provided. The cooling power and duration is estimated for both the proposed and producible design. This chapter is concluded with an indication of the effect the vest can have on sailing performance.

Furthermore, the report contains chapters that can be expected in a master thesis. Such as an executive summary, recommendations, a reflection and acknowledgements.

I hope you enjoy your reading,

Emiel Janssen

Glossary

Acronyms

PCM = Phase Change Material

TPU = Thermoplastic PolyUrethane

SIC = Sailing Innovation Center

CBT = Core Body Temperature

WBGT = Wet Bulb Globe Temperature

RH = Relative Humidity

RIB = Rigid Inflatable Boat

Terms

Hyperthermia

If the CBT rises above the normal range (CBT > 38,0°C) one speaks of hyperthermia.

Heat stress

Heat stress is any situation which, if uncompensated by thermoregulation, would result in hyperthermia.

Wet Bulb Globe Temperature

This is an apparent temperature indicator that takes temperature, humidity, wind speed and radiation into account.

Latent heat

Amount of energy needed to change the phase of 1 kg of PCM. This is closely related to the cooling capacity of the PCM.

Hiking

Is the action of moving ones weight upwind, in order to keep the boat as level as possible.

Tacking

Briefly, tacking is a sailing maneuver where the boat changes direction in such a way that the wind comes from the other side.

Hotplate

Measurement device that can measure cooling power. It does so by logging how much power is needed to keep its measurement surface at a constant temperature.

Neoprene

Durable and elastic synthetic rubber. Often used as closed-cell foam in wetsuits because it insulates very well even when submerged.

Pre Cooling, Per Cooling, Post Cooling

Cooling strategy applied before, during or after exercise.

FIXME

Had to be removed in the final edit, due to mysterious circumstances there are always some FIXMEs that persevere.

Readability

Figures are numbered per spread (2 pages). In case a reference is made to a picture that is not on the same spread the page on which the picture is shown is provided as well.

The following icons are used throughout the project:



Design insight, information that will have impact on the design of the product.



Requirement, information that creates a boundary condition for the design.



Design choice, based on design insights and requirements a design choice can be formulated.



Ideation, the creative process leading to new design ideas.



Design, translating ideas into a realistic and tangible form.



Prototype, materializing the design as good as possible with the available materials and prototyping techniques.



Test, evaluation of the prototype to gain new insights.

The following four icons indicate a particular PCM.



H₂neO, not really a PCM on itself but a combination of water/ice covered with a thin insulation layer made with Neoprene rubber. (**H₂O** + **NeO**prene)



Inu 15, a paraffin based PCM with a phase change temperature of 15°C sold by Inuteq.



Inu 6,5, a paraffin based PCM with a phase change temperature of 6,5°C sold by Inuteq.



IZI 24, a salt-hydrate PCM with a phase change temperature of 24°C sold by IZI-Bodycooling.



Proposed design

Compared to other cooling vests the proposed design, the so called 'CoolKeeper' has the following unique features:

- 1 The hexagon pattern gives the right balance between rigidity and flexibility. Making it comfortable to wear and easy to handle.
- 2 The vest can easily be put on and off without the need to remove sailing clothing.
- 3 The H2neO combination has the highest cooling capacity and duration per unit weight, compared to PCMs that are commonly used for personal cooling garments.
- 4 Transporting the vest is easy, it can be filled with tapwater at location.

Specifications

When filled, the vest weighs approximately 1,3 kg and has a thickness of 10 mm. The vest can provide 95W cooling power for 45 minutes.

Producible design

Compared to other cooling vests the producible version of the CoolKeeper has the following unique features:

- 1 The vest is producible by Inuteq on very short notice.
- 2 The vest can easily be put on and off without the need to remove sailing clothing.
- 3 The vest has a high cooling power without causing frostbite.
- 4 The vest can be recharged in a coolbox.

Specifications

The vest weighs 1,3 kg and has a thickness of 10 mm. The vest can provide 150W cooling power for 20 minutes.



Executive Summary

The 2020 Olympics will take place in Tokyo. The expected heat and humidity will cause severe heat stress for athletes. To improve safety and performance of Dutch athletes during the Olympics the project "Thermo Tokyo – Beat the Heat" was started. This is a multidisciplinary project in which multiple universities, companies, sports organizations and sport innovator centers take part.

Sailors are prone to heat issues because they are obliged to wear an insulating flotation aid. And they are not sheltered from the sun. The Sailing Innovation Center came with the proposition to design a cooling garment for Dutch sailors that are competing in the 2020 Olympics.

The sailing context was analyzed. The best option for sailors is a cooling vest that can be applied underneath the flotation aid. Sailing regulations forbid wearing a cooling vest during a race because of the added weight around the torso. A cooling vest can still be worn before and in between races. According to literature, pre-cooling can have a positive effect on exercise performance in hot and humid conditions.

Using a Phase Change Material (PCM) is the best cooling technique for the sailing context. PCMs do not require special equipment, only a freezer for recharging and a coolbox for transport are needed. Also, the cooling power of a PCM is independent from the environment. Project partner Inuteq provided PCMs for the project.

Multiple PCMs were analyzed. A paraffin based PCM with a phase change temperature of 6,5°C is best for short and intense cooling. Combining ice with a thin layer of Neoprene is the best option if cooling duration is important.

Laser sealing TPU sheets made it possible to create custom shaped cooling packs quick and easy. Multiple forms were tried. A raster of hexagons showed the right balance between flexibility and rigidity.

Seven iterations of ideating, designing, prototyping and testing were executed. This led to the design of a cooling vest that is easy to use at sea. It can be applied quickly underneath sailing clothing. And it can be stored in a medium sized coolbox.

The design as proposed can not be produced on short notice by partner Inuteq. With some compromise the most important features of the design were transferred to a design that is producible well before the Olympics.

The design as proposed and the design as produced are shown on the left, together with their key features.

The cooling power and duration of the vests is estimated by combining results from lab and exercise tests. The method used to make this estimation does not require a thermal mannequin. And it can be used for a variety of cooling vests.

The vest is compared to other vests previously evaluated in literature. It is almost certain that the vest will have a positive impact on exercise performance in hot and humid conditions.

It is hard to compare sailing to the exercise protocols used to measure the effect of cooling garments on sport performance. Nevertheless, it is likely that sailors can benefit from using a cooling vest during the 2020 Olympics if weather conditions are as expected.

Contents

Preface	4
Glossary	6
Executive Summary	8
Table of Contents	10
1 Discover	13
1.1 Introduction	14
1.2 Approach	16
1.3 Thermoregulation and exercise performance	18
1.4 Cooling techniques	20
1.5 Olympic sailing	24
2 Expand	35
2.1 PCM research	36
2.2 PCM comparison	42
2.3 PCM selection	52
2.4 PCM packaging	54
3 Structure	61
3.1 List of requirements	62

4 Integrate	65
4.1 Rapid prototyping	66
4.2 Prototype 1	68
4.7 Prototype 6	78
4.8 User test 1	80
4.9 Prototype 7	82
4.10 User test 2	84
5 Result	87
5.1 Proposed design	88
5.2 Producible design	90
5.3 Image gallery	92
6 Evaluate	95
6.1 Method	96
6.2 Lab test	98
6.3 Exercise test	102
6.4 Cooling power and duration	106
6.5 Effect on sport performance	110
6.6 Recommendations	112
6.7 Coolbox and freezer advice	116
6.8 Reflection	122
Acknowledgments	125
References	126
Appendices	133



Discover

Nothing is built from scratch. There is always plenty of information available to form a good basis for a project. The first chapter gives a quick overview of the background information used during the project. First the project brief is dissected briefly, and the approach used to solve the design challenge is explained. The chapter proceeds with the following three sections, the first explains the basis of thermoregulation and the effect on exercise performance. The second gives an overview of the cooling possibilities available. The last part of this chapter gives an overview of the world of Olympic sailors, and shows several implications of this context on the design of a cooling garment.

1.1 Introduction

The 2020 summer Olympics will take place in Tokyo. The weather conditions will be harsh for athletes because of the expected heat and humidity (Kakamu et al. 2017). The wet bulb globe temperature (WBGT) is expected to be $28.6 \pm 2.8^\circ\text{C}$ during the hottest moment of the day (13:00h). (Gerret et al. 2019) The wet bulb globe temperature (WBGT) is an apparent temperature indicator that takes temperature, humidity, wind speed and radiation into account.

For safety reasons there are WBGT threshold values that indicate the risk of heat-related illnesses. Figure 1 shows the recommended threshold values for risk of heat-related illnesses from different international organizations.

The orange bar shows the expected WBGT at 13:00 h during the Olympics, indicating that the danger of heat disorders is high. It is advised to stop endurance exercise events. If an event continues, rest periods and water replenishment are necessary. (Armstrong et al. 2007, Asayama 2009)

The weather conditions during the Olympics will affect exercise performance and might lead to heat stress related injuries.

To improve safety and performance of the Dutch athletes during the Olympics the project "Thermo Tokyo – Beat the Heat" was started. This is a multidisciplinary project in which multiple universities, companies, sports organizations and sport innovator centers take part.

The goal of the project is to find solutions in the form of acclimatization and cooling strategies for safety and performance issues caused by hot and humid conditions. The Emerging Materials group at the faculty of industrial design engineering of the TU Delft is looking to develop dedicated cooling garments for Olympic Sailors in collaboration with the Sailing Innovation Center (SIC), Inuteq and the Watersportverbond. These cooling garments can help athletes withstand the heat during the 2020 Olympics in Tokyo. Parallel to this project there are other projects focused on cooling garments and strategies for other sport categories.

From the Sailing Innovation Center and Watersportverbond, two main partners within Thermo Tokyo, came the request to develop a cooling solution that can be used by sailors while at sea. Sailors are prone to heat issues because they are not sheltered from the sun, increasing heat gain via radiation and they are obliged to wear swimming vests which inhibit sweat evaporation from the torso.

The solution could be either in the form of a physical attachment to the coach boat, like a sun canopy to offer shadow to the sailors, or in the form of a cooling garment developed to be used on the water during a race day. This graduation project is about the development of a personal cooling garment that can improve sailing performance in hot and humid conditions.

The design goal of this project is formulated as follows:

Design a cooling garment for Dutch sailors that are competing in the 2020 Olympics.

In the next chapter this goal is dissected and a suitable approach for this challenge is presented.

Industrial & Military Guidelines for Heat Stress

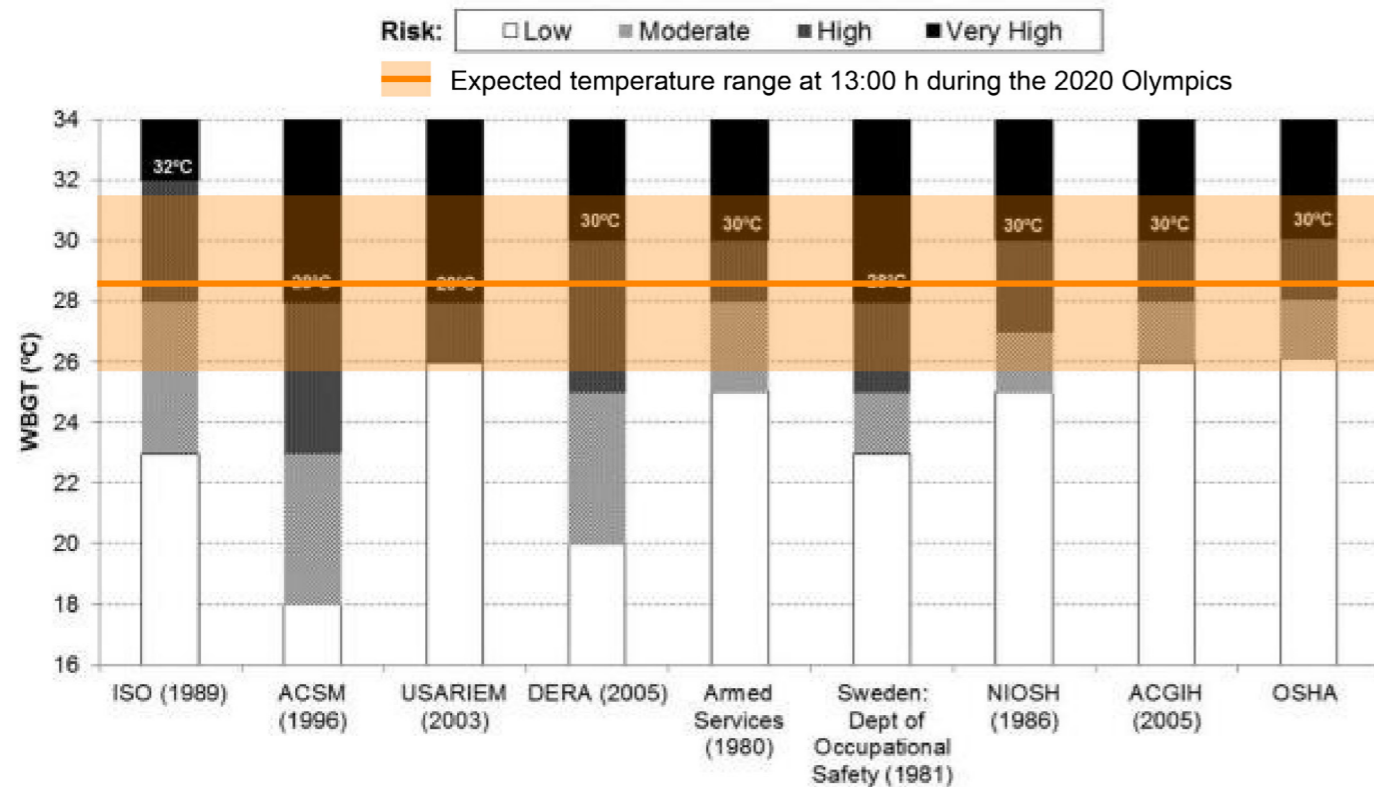

Figure 1: Summary of recommended wet bulb globe temperature (WBGT) threshold values for low, moderate, high, and very high risk of heat-related illnesses from different international organizations. ACGIH, American Conference of Government Industrial Hygiene; ACSM, American College of Sports Medicine; DERA, Defence Evaluation and Research Agency; NIOSH, National Institute for Occupational Safety and Health; OSHA, Occupational Safety and Health Administration; USARIEM, US Army Research Institute of Environmental Medicine (Cheung et al. 2016).



1.2 Approach

Designing a cooling garment involves foremost the human body and flexible materials. Both are unpredictable, therefore an iterative and parallel approach is used for this project. Multiple iterations make it possible to converge on a proper solution, while giving the chance to correct missteps. The method is based on the basic design cycle, as described in the Delft Design Guide (Boeijen, Daalhuizen, Schoor, & Zijlstra, 2014, p. 19), but altered with inspiration from the SCRUM method. SCRUM is often used in digital product design agencies. It is a method that takes an agile and iterative approach on design. The process is split in so called sprints; a sprint is a short period at the end of which a minimum viable product (MVP) must be delivered. At the start of the sprint the functionality of this MVP is defined, and at the end of the sprint this MVP is evaluated. Usually SCRUM is used for software development. In this domain it is viable to reach an MVP after every couple of weeks. For designing physical products this is usually an issue, but with rapid prototyping and relatively affordable materials it was possible to make multiple iterations in a short amount of time. In addition, this is a solo project, the additional planning, communication and role division were not needed. This gives more flexibility to the length of the sprints. SCRUM is similar to the basic design cycle with as major difference that instead of trying to design the whole product at once the goal is to design smaller parts and keep on improving with each iteration. With the basic design cycle, one must decide whether another iteration (or step back) is needed. With SCRUM it is already known that the MVP will be far from perfect, the point where a significant decision must be made comes after several smaller iterations. This is illustrated with Figure 1.

The design goal can be split in four categories as shown in Figure 2; function, form, persona and context. An iterative approach was taken on every topic, continuously building knowledge and empathy. Starting with rough pilot tests, and later evaluated with more accurate methods. An infographic of the method, with examples of methods used per category, is shown in Figure 3.

Design a **cooling garment** for **Dutch sailors** that are competing in **the 2020 Olympics**

Function **Form** **Persona** **Context**

Figure 2: Design goal split in four categories.

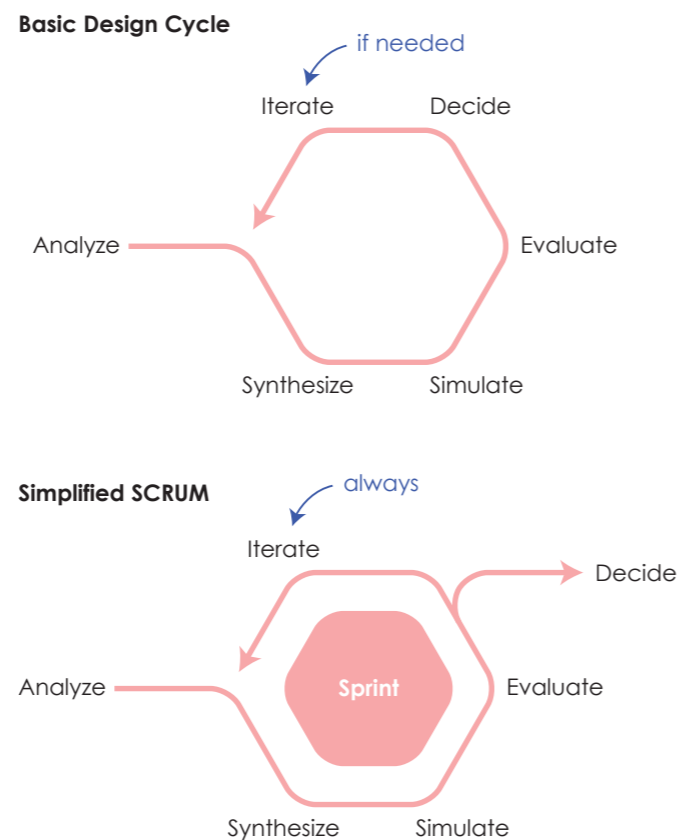

Figure 1: Basic desing cycle compared to SCRUM

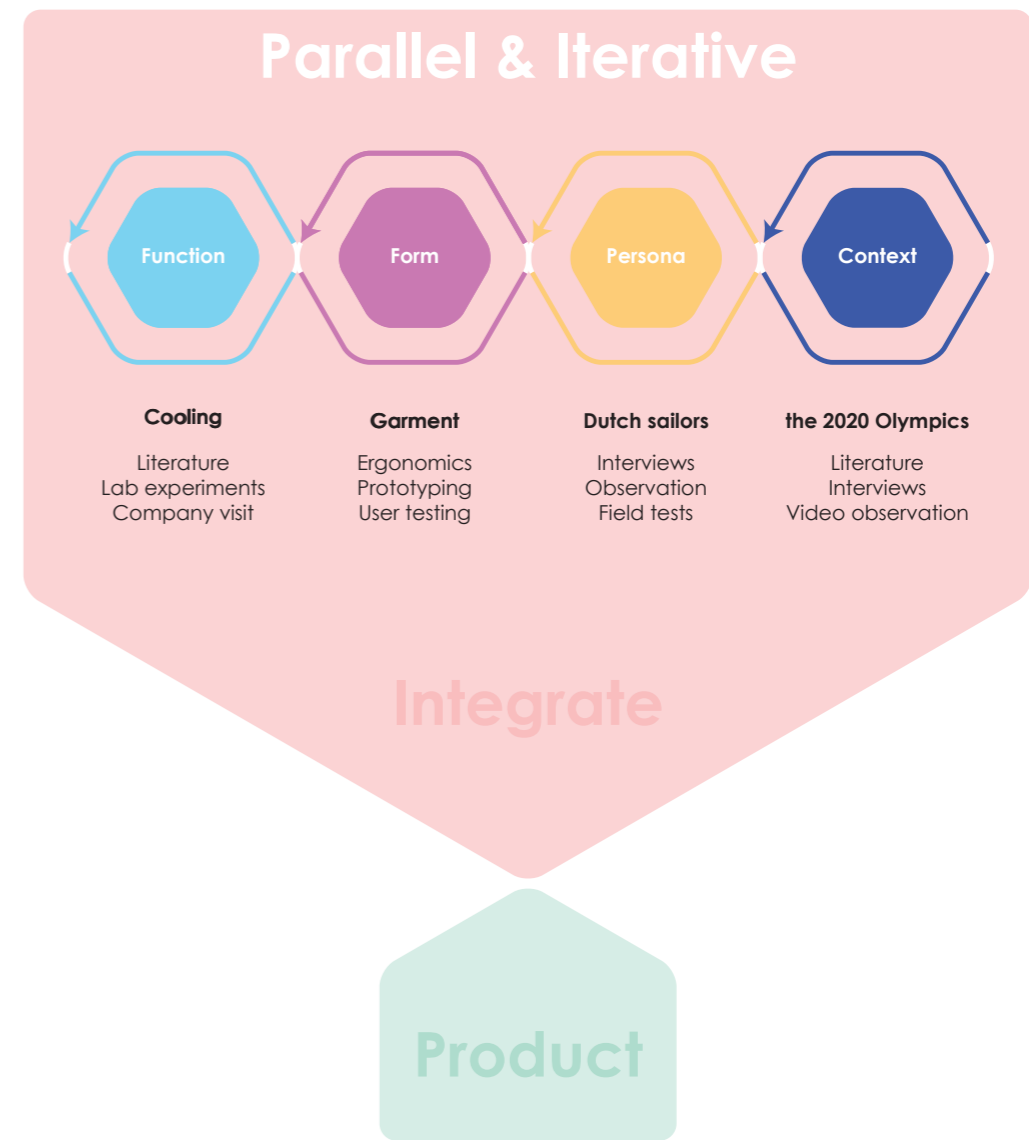

Figure 3: Overview of the approach of the project, with examples of methods used for each part.

Results are presented in a structure which is not strictly chronological, because many processes took place in parallel. Therefore, it might seem that some decisions in the second half of the report are somewhat backwards, because the knowledge presented in the first few chapters was not readily available at the time. A reflection of the methodology used is given in chapter 6.7.

Side note:
To keep track of all things happening the software OneNote was used. This is a cross-platform digital note taking application with the possibility to quickly insert photos and notes of activities from either phone or computer. This proved to be very useful for the approach used.

1.3 Thermoregulation and exercise performance

Thermoregulation is the ability of organisms to regulate their own temperature. Thermoregulation and exercise performance are related, because muscle activity generates heat.

Heat balance of the human body

Humans are endothermic mammals which can survive in a wide variety of climates. To do so the human body has several features to keep its core temperature constant. In thermophysiology the core body temperature is the temperature of the blood around the heart and brain, when at rest this is about 36.8°C. The temperature of peripheral areas and the skin is, depending on the climate, lower than the core temperature (Figure 1, Tamura 2018).

The temperature of the human body is stable when the heat balance is in equilibrium, the heat balance of the human body is as follows:

$$M \pm C \pm R - E = S$$

With:

M: Metabolism

C: Convection & Conduction

R: Radiation

E: Evaporation

S: Storage

Note that C and R can be both positive or negative, depending on ambient temperature and radiation. E can only be negative since evaporation will always withdraw heat. If the left-hand side of the equation is larger than zero, heat is stored in the human body. This will cause a rise in body temperature.

Metabolism depends mostly on how much muscle power is required. By shivering the body can increase power output when in rest to 4-5 times rest metabolism (Teunissen, 2012). Muscle tissue efficiency differs per muscle type but is generally not larger than 20% (Smith et al. 2005), this means that 80% of power is released as heat. Therefore, during intensive exercise, a lot of heat is produced. To avoid a too high body temperature, heat must be lost to the environment.

Heat loss via convection and conduction can be influenced by clothing (insulation) or by direct contact with an external material like water. Radiation from and to the body can be blocked with a material that either reflects or absorbs

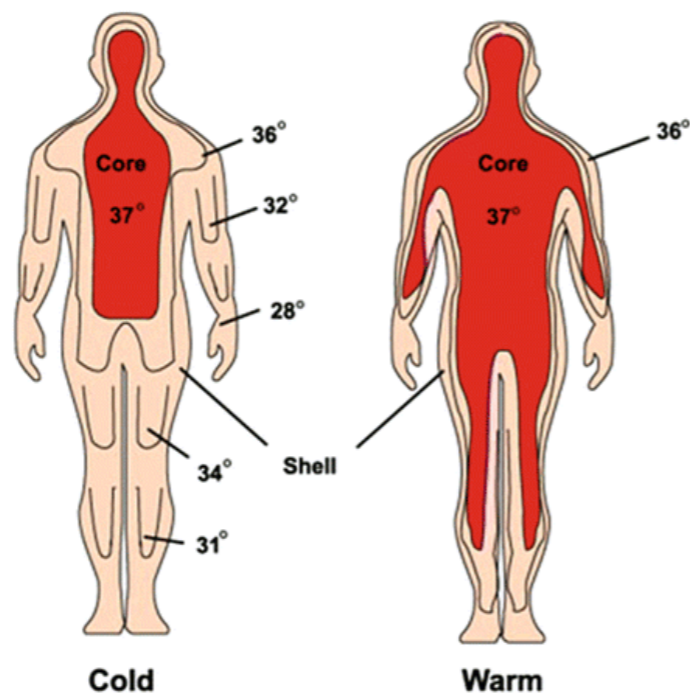

Figure 1: Body temperature (Tamura 2018)

radiation. If the material absorbs the radiation it will become hot itself and transfer heat back to the body via convection, conduction or radiation.

Evaporation is the most powerful cooling mechanism of the human body. Evaporating a liquid requires energy, the human body uses this effect via sweating. At peak moments around 3 liters of sweat per hour can be produced. This has a cooling power of around 2400W. (Teunissen, 2019) A very humid environment reduces the evaporation rate, evaporation works best in hot and dry environments. The sweating rate is not consistent across the human body. Most sweat is produced at the torso, especially the lumbar region. The outer regions like hands and feet sweat the least. (Smith & Havenith 2011) Figure 2 shows how sweating power is spread out over the human body.

Heat can only be lost to the environment via the skin. To improve the cooling efficiency vasodilation can take place, this is the widening of blood vessels close to the skin. The skin's blood flow is highly associated with local sweating rate and heat exchange. (Rowell 1977)

Normally the core body temperature (CBT) is in a narrow range around 36.8 °C. When heat is accumulated the CBT will rise. If the CBT rises above the normal range (CBT > 38,0°C) one speaks of hyperthermia. Heat stress is any situation which, if uncompensated by thermoregulation, would result in hyperthermia.

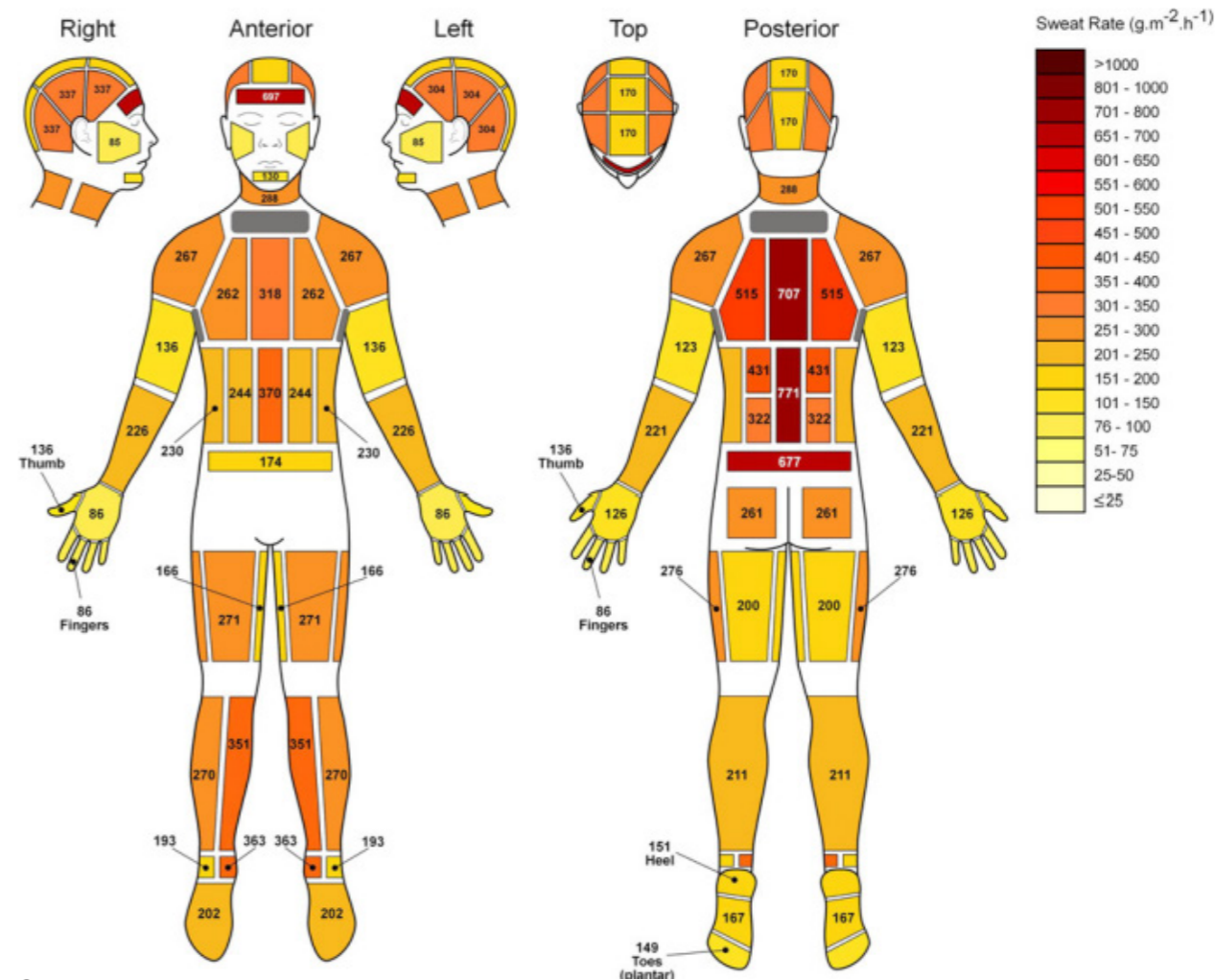

Figure 2:

Absolute regional median sweat rates of male athletes when exercising (55% of VO₂max). (Smith & Havenith 2011)

Effect of hyperthermia on exercise performance

The amount of heat the human body can safely store is limited. When this limit is reached the human body will lower exercise performance to keep the heat balance. It is unclear if there is a specific critical core temperature at which hyperthermic fatigue is induced. (Ely et al. 2009) However, whole-body hyperthermia is highly associated with reduced performance caused by failure of the cardiovascular system to maintain oxygen delivery to the exercising muscles. During prolonged hyperthermic exercise, the brain's ability to sufficiently activate skeletal muscles will also degrade causing reduced performance. (Nybo 2008, 2012)

Hyperthermia is related to reduced muscle, nerve and brain performance.

Causation of heat stress (WBGT)

The factors that cause a high WBGT are high ambient temperature, high humidity, harsh solar radiation and low wind speeds. These factors make it difficult to release heat via convection and conduction because of the high ambient temperature. It makes heat loss via evaporation difficult due to low wind speeds and high humidity. And finally, it indicates a big energy input via radiation.

It can be concluded that the WBGT during the 2020 Olympics will induce severe levels of heat strain resulting in reduced sport performance. (Cheung et al. 2016, Ely et al. 2006, Hargreaves 2006, Marino 2008, Nybo 2008, Nybo 2010, Tatterson 2012, Maughan 2012, Galloway 1997) Helping athletes to literally keep their head (and body) cool will reduce the negative impact of heat stress on exercise performance (Marino 2002, Bongers et al. 2017) It is hard to put a number on the impact cooling will have on exercise in practice because most research is done in a lab environment. Sailing is very different to cycling or running on an exercise machine. The power output is far from constant and depends wildly on the weather conditions and the sailing class. Hiking and tacking are physically most strenuous. Another big difference is that sailing requires a big mental effort, choosing the right tactics while keeping track of opponents, wind and waves requires full concentration. Even though sailing is different it is likely that cooling will help.

Cooling interventions help to reduce thermal strain and improve exercise performance.

1.4 Cooling techniques

Cooling the athlete's body can be done before (pre) during (per) or after (post) exercise. Pre-cooling decreases the body temperature before exercise, increasing the heat storage reserve at the start of a race. Per-cooling helps cooling the body during exercise. Post-cooling is done to speed up recovery after a race.

There are internal and external cooling possibilities. Internal cooling involves ingesting cold consumables. External cooling can for example be in the form of a garment or water immersion. This reduces the skin temperature which increases the temperature gradient and improves thermal perception.

There are multiple cooling strategies. An overview with the effectivity of each cooling strategy for pre-, per- and post-cooling is provided in Figure 1.

This graduation project focuses on pre- and per-cooling in the form of a cooling garment. The other categories are either less suited for sailing or do not require a newly designed product. There are multiple techniques available for cooling garments that can be divided into five categories that are shown in Table 1.

For sailing air, liquid and thermoelectric cooling are not suitable because these garments require bulky and relatively vulnerable equipment with an external power source. Additional argumentation why this does not fit in the sailing context is given in chapter 1.5. PCM and evaporative cooling garments are better suited because of their simplicity. These techniques are therefore relatively cheap, faster to develop and easy to use. The speed of development is of an important criterion for this project since the product should be ready before spring 2020.

Cooling using PCMs or evaporation is most promising. 



Figure 1: Infographic of the feasibility and effectivity of pre-, per- and post-cooling strategies. The effectivity of cooling techniques is classified as small (+), moderate (++) or large (+++). Based on (Bongers et al. 2017)

Type	Working principle	Advantages	Disadvantages
Air	Increase sweat evaporation by increasing air flow	Does not require tight body fit.	Requires power source, often not very portable.
Liquid	Heat pump cycle with heat sink	High cooling capacity at no physiological cost.	Expensive equipment, requires a power source.
Evaporative	Evaporation of water	Cheap, easy to reactivate.	Uncomfortable, effectiveness depends on environmental humidity.
PCM	Latent heat storage of a phase change material (PCM)	No power source needed, cooling power independent of environment.	Cooling time is proportionate to PCM weight, needs to be recharged in a freezer, may inhibit sweat evaporation.
Thermoelectric	Thermoelectric elements	Relatively thin and flexible.	Expensive, requires power source, application in a cooling garment is still in its infancy.

Table 1: Types of cooling garments based on Yazdi et al. 2014; Sarkar & Kothari 2013; Ravindran et al. 2016.

Evaporative cooling

The evaporation of water requires energy. This energy is partially withdrawn from the skin subsequently cooling down the skin creating a cool sensation. The effectiveness of evaporation is dependent on the vapor pressure of water at the fabric's surface temperature, the vapor pressure of water in the surrounding air and the thermal resistance of the fabric, the boundary layer and the air-gap between the fabric and the skin (Sarkar & Kothari 2013). The difference in vapor pressure is influenced by the relative humidity. The relative humidity at 13:00h during the Olympics is around 60% and rises to 80% at 05:00h (Gerret et al. 2019). This is quite high but when sailing at sea there is a lot of wind most of the time, increasing evaporative performance. Evaporative cooling already happens due to natural sweating, an evaporative cooling garment can be an extension to sweating. Evaporative cooling fabrics have most effect when they are applied at skin areas where sweat rate

is relatively low. To conclude, evaporative cooling in the form of special extra clothing can support the evaporative cooling ability of the human body.

For evaporative cooling there are numerous solutions on the market (Figure 1, next spread). Inuteq, one of the partners in Thermo Tokyo provides cooling towels made from materials that can soak up water while allowing easy evaporation. These products can form handy additions to the gear that is present in the coach boat. There is little difference in power withdrawal when soaking them in cold (drinking) water or lukewarm sea water. There will be a small initial (conductive) cooling burst, but the evaporative cooling effect remains the same. (Mane, 2019)



There are drawbacks in the sailing context: evaporative cooling garments will not work underneath the padding of the floatation aid because the foam blocks do not breathe. Also, moving while wearing wet clothing might cause discomfort. Cotton is not used in sailing clothing because it soaks up water making it heavy and not tightly fit the wearers body (Douwe, personal communication, April 1, 2019 & Emma, personal communication, May 2, 2019). But on the other hand, it is really easy to reactivate an evaporative cooling garment at sea.

Evaporative cooling garments will:
 - not work underneath a flotation aid.
 - cause discomfort.



A material used for evaporative cooling garments is Polyvinyl Alcohol (PVA). Research of colleague student Mane (2019) indicates that the evaporation rate of water from PVA is about equal to the evaporation rate of sweat from skin. Athletes are sweating excessively when exercising in hot conditions, in this situation PVA is not beneficial. Evaporative cooling garments are more suited for situations in which people do not sweat a lot, for example during mild exercise or for people with a handicap that reduces their sweating capability.

Evaporative cooling garments support- but do not outperform natural sweating significantly.



Unpublished test results of our lab showed that evaporative cooling power decreases linearly with relative humidity (Teunissen, 2019). Tests were performed with a PVA fabric at in a climatic chamber set at 35° while varying the relative humidity. Test results are included in Appendix A.

Evaporative cooling garments are not very effective in a very humid environment.



Phase Change Materials

Phase change materials use the latent heat of melting to cool the skin. Power is withdrawn from the skin while the PCM stays at a fixed temperature. The most common example of a PCM is water; when water changes phase from ice to liquid it absorbs energy while maintaining the same temperature. For personal cooling there are PCMs that change phase at more



Figure 1: Examples of evaporative cooling products available. Two vests, a towel and arm sleeves.

comfortable temperatures with a large heat of fusion. The company Inuteq produces oils that changes phase from solid to liquid at respectively 6.5, 15, 21, 24 or 29°C. The brand name is INUTEQ-PAC. For a cold sensation the 6,5 and 15°C variants are most practical. The oil is bio-based and not toxic to humans. Latent heat storage in these oils is 177-190 kJ/kg. Further details of the product can be found on Inuteq's website and on the material safety sheets in Appendix B.

Besides materials that change phase from solid to liquid, there are hydrated inorganic salts that can store latent heat. An example often found in literature is Glauber's Salt. When the salt is cooled to temperature lower than the saturation point a supersaturated solution appears. Subsequent crystal growth in the solution explains the heat absorption process. (Mondal 2007) The chemical reaction in the case of Glauber's Salt is:

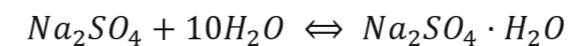

To the left is exothermic (PCM is recharged) and to the right is endothermic (PCM is cooling).

The phase change temperature of Glauber's Salt is 31,5°C which is too high for personal cooling. It is possible to lower the phase change temperature by adding Table salt (NaCl) to about 22,7°C.

The company IZI-Bodycooling produces these PCM-salts. An advantage of these PCMs is that they remain flexible when cooled. A drawback is that their phase change temperature is quite high for personal body cooling, IZI-Bodycooling produces PCM packs that change phase at 24 or 30 °C.

The PCM will cool the skin helping the body to get rid of excessive heat. Heat transfer will be fastest when the temperature difference between the PCM and the skin is largest. However, if the temperature difference is big sudden local cooling will cause local vasoconstriction (Johnson & Kellog 2010) increasing the thermal resistance of the skin. In other words; when a PCM is too cold this will impair its cooling effectiveness.

The temperature difference between skin- and the PCM's phase change -temperature is related to the heat flux but not linearly because of vasoconstriction.

PCMs must be contained in impermeable bags. This inhibits sweat evaporation reducing the overall cooling effect. In hot and dry conditions sweating is very effective, therefore PCM cooling vests are not efficient in these conditions. On the other hand, in hot and humid conditions sweat does not evaporate as fast. In this case PCM cooling garments do offer significantly improved cooling (Zhao et al. 2013).

PCM packaging inhibits sweat evaporation.



The amount of latent heat available is directly correlated to the PCM's weight. Long term cooling requires more weight which might be uncomfortable or restrict movement.

There is a tradeoff between cooling capacity and weight.



Underneath the floatation aid evaporation is limited. PCM cooling provides a good opportunity here. The PCM packages are heavy and could restrict movement, proper placement should be analyzed but wearing weight around the torso is likely to cause the least nuisance while moving because this is close to a human's center of gravity. Besides comfort, the location of the cooling pads affects the cooling garment's efficiency. The skin's surface area, local heat production, tissue insulation, vascularity and maintenance of heat exchange will affect the cooling capacity (Nunneley 1970). When looking at the sweating rate per body area, the torso has the highest sweating rate (Smith & Havenith 2011). Since evolution tries to be as efficient as possible it is likely that cooling here is most important and/or efficient. The floatation aid hinders evaporation of sweat around the torso, extra cooling in the form of PCM packs underneath the floatation aid can make up for this loss of cooling performance.

PCM placement must include the area underneath the floatation aid around the torso.



Conclusion

When looking at the techniques available for personal cooling garments the use of PCMs is most promising for this project. The best place to add PCM packages is underneath the floatation aid. There are multiple PCMs available. The process of choosing the best suitable PCM is described in chapter 2.2.

1.5 Olympic sailing

To better understand the future users and context interviews were held, clothing was analyzed, and experiments were executed. Not everything is directly correlated to the design process but exploring broadly helped in substantiating design decisions, directions and priorities. A summary of the findings is given in this paragraph. Much of the following insights are gathered in collaboration with the Sailing Innovation Center in the Hague. An excursion and personal communication with embedded scientist D. Broekens helped a lot in understanding the potential user and context. Since much of the information comes from a single source, two interviews with external people (B. Bouwer, E. van Welij) were conducted to reduce bias.

The Netherlands have a long and close relationship with water. The combination of water and a lot of wealthy people that can afford a sailing boat creates a big community of sailors. Quantity seems to breed quality resulting in a lot of Dutch podium finishes for the European Championships, World Championships and Olympics.

There are nine Dutch sailors that are likely to race during the 2020 Olympics in Tokyo in six different sailing classes. Six females and three males, ages vary from 24 to 38 years old. Body length from 1,61 to 1,96 m and weight from 57 to 96 kg, quite a big variety of body types. A full list is provided in Appendix C.

! *The product must fit a wide variety of body types.*

There are plenty of differences and similarities per sailing class. Observing and analyzing YouTube videos from sailing races helped in getting a good understanding of the context and the different classes. Findings are used throughout this chapter. However, videos of races are focused on the racing itself, not so much on the auxiliary activities. There is a lot more happening during a race day than just sailing the races. The classes 49er(-FX) and RS:X sail three races per day, the other classes two. During World cup events, European Championships and World Championships there are usually 5 sailing days without rest days in between.



Nicholas Heiner - Finn



Marit Bouwmeester - Laser Radial



Kiran Badloe - RS:X



Annemiek Bekkering & Annette Duetz - 49'er FX



Afrodite Zegers & Lobke Berkhout - 470 Women



Dorian van Rijsselberghe - RS:X



Lilian de Geus - RS:X

The images on this spread show the Dutch sailors that are going to the Olympics while sailing their respective classes. TeamNL does not take part in the Laser, 49'er and Nacra 17 classes. The laser and 49'er classes are the male variant of the Laser Radial and 49'er FX classes with as main difference a larger mainsail area (respectively +1,3 and +2,3 m²) The Nacra 17 is added to the Olympic classes in 2012 in the multihull category. Even though there are no Dutch athletes competing in these three classes during the 2020 Olympics there are plenty of Dutch sailors that from time to time have to sail these classes in a hot and humid environment.

! *The vest should be useable in all current Olympic classes.*



N.A. - Nacra 17

The racing schedule of the 2020 Olympics is not known yet. The racing schedule of the 2016 Olympics was provided by D. Broekens (personal communication, April 16, 2019). A typical race day is visualized in Figure 1 together with the expected WBGT during the day based on the data from (Gerret et al. 2020).

As can be seen the WBGT is highest during the races. To put into perspective, during a heat wave in the Netherlands the WBGT is usually around 27 (30°C, 70% RH). Note that Figure 1 shows the planned times, there is a good chance races will be delayed extending the race day. This can be due to a false start, wind changes or other unforeseen circumstances.

According to D. Broekens it regularly happens that a race day is extended with one or two hours. This was confirmed by talent coach A Sign (personal communication, June 7, 2019), a short day would be around three to four hours but days that are six to seven hours long are not uncommon.

Cooling vests must stay cold in storage for at least six hours. 

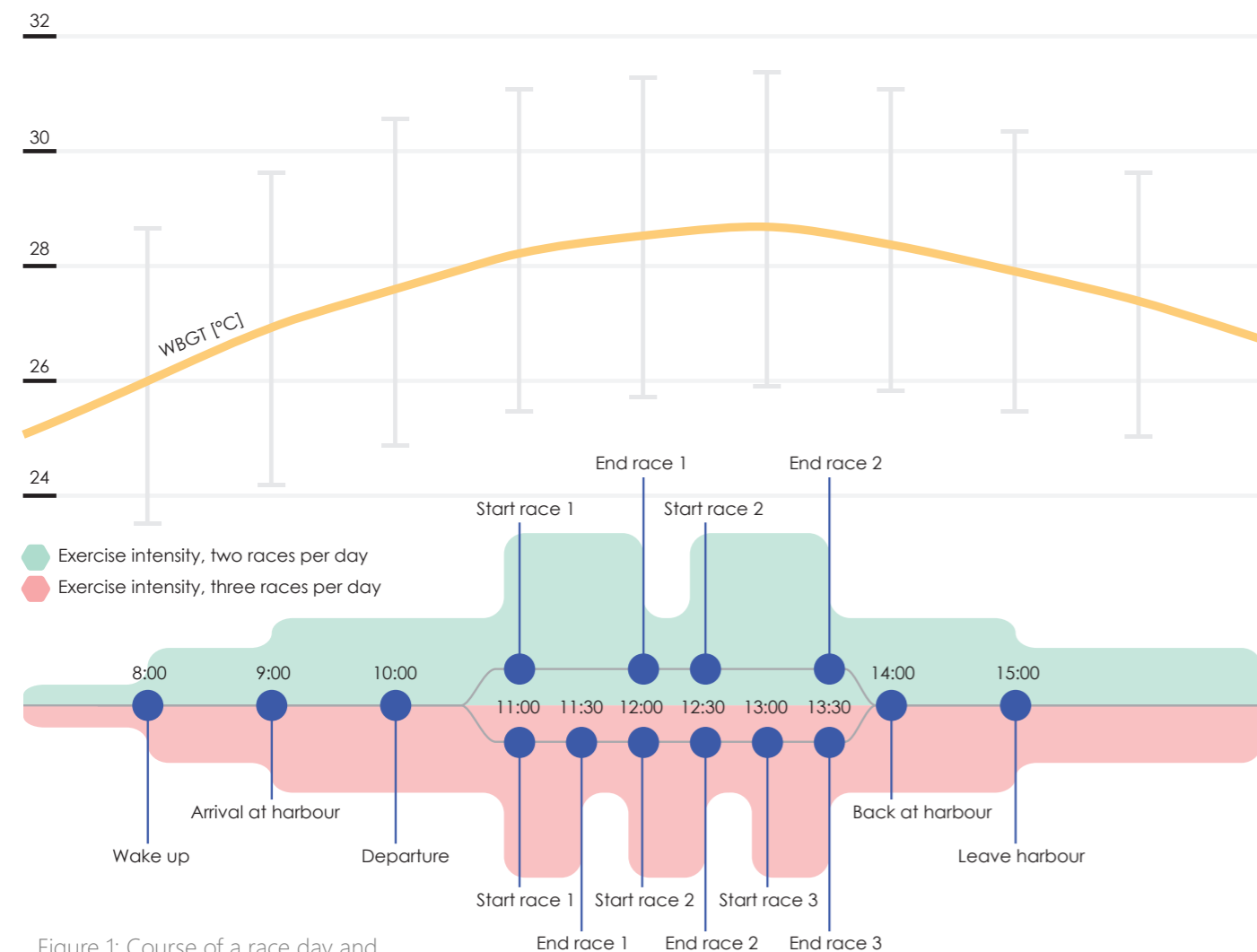



Figure 1: Course of a race day and WBGT.

Cooling window

Due to regulations it is not allowed to wear clothing with the purpose to increase the sailor's weight. This would be advantageous in windy conditions because the sailor can exert more force when hiking. Even though a cooling garment's main purpose is not to increase weight it would not be allowed during a race.* A cooling vest is comparable to wearing a CamelBak (water bladder) during a sailing race. The purpose is hydration but because of the extra weight around the torso this is not allowed.

Cooling can take place before, in between and after races. Webster et al. (2007) studied the effect of a cooling vest applied prior and after a 30-minute running exercise in a hot and humid environment and found that light-weight cooling vests provide a significant thermoregulatory advantage. Similar results were achieved by (Falkner, 2012): time trial performance increased with 4,8% when pre-cooling with an ice vest.

 **The product will be used for pre-cooling; before and in between races.***

A benefit of this conclusion is that there are more design possibilities if sailors do not have to do competitive sailing while wearing the garment.

 **Weight and freedom of movement are not a bottleneck.**

*Side note:

At the end of the project a representative of the SIC was in conversation with World Sailing to figure out if cooling vests are allowed. There is a chance that it is allowed to wear a cooling vest while racing, but it then has to be worn during all races. Also, extra weight would be detrimental towards sailing performance during races with little wind.

Sailing from the harbor to the starting line takes approximately 60 minutes and according to coach A. Sign (personal communication, June 7, 2019) a cooling vest can be applied between 10 and 60 minutes in between races depending on the circumstances. D. Broekens stated that a cooling garment should cool for around 30 minutes (personal communication, June 7, 2019).

A cooling vest should cool for at least 30 and preferably around 60 minutes. 

There are three or four windows at which a cooling vest could be applied. During the races there cannot be physical contact between the sailor and the coach boat. The last moment of contact between sailor and coach boat is 10 minutes before a race, at this moment the cooling vest should be removed.

A vest should be put on and off three to four times. 

To get a good overview of what happens with a cooling vest during the Olympics a visual product journey is made. A draft version was made and evaluated with the SIC's embedded scientist D. Broekens and with B. Bouwer who went to youth Olympics in 2016 in Rio. Based on the draft version a new version was made which is shown on the next page.

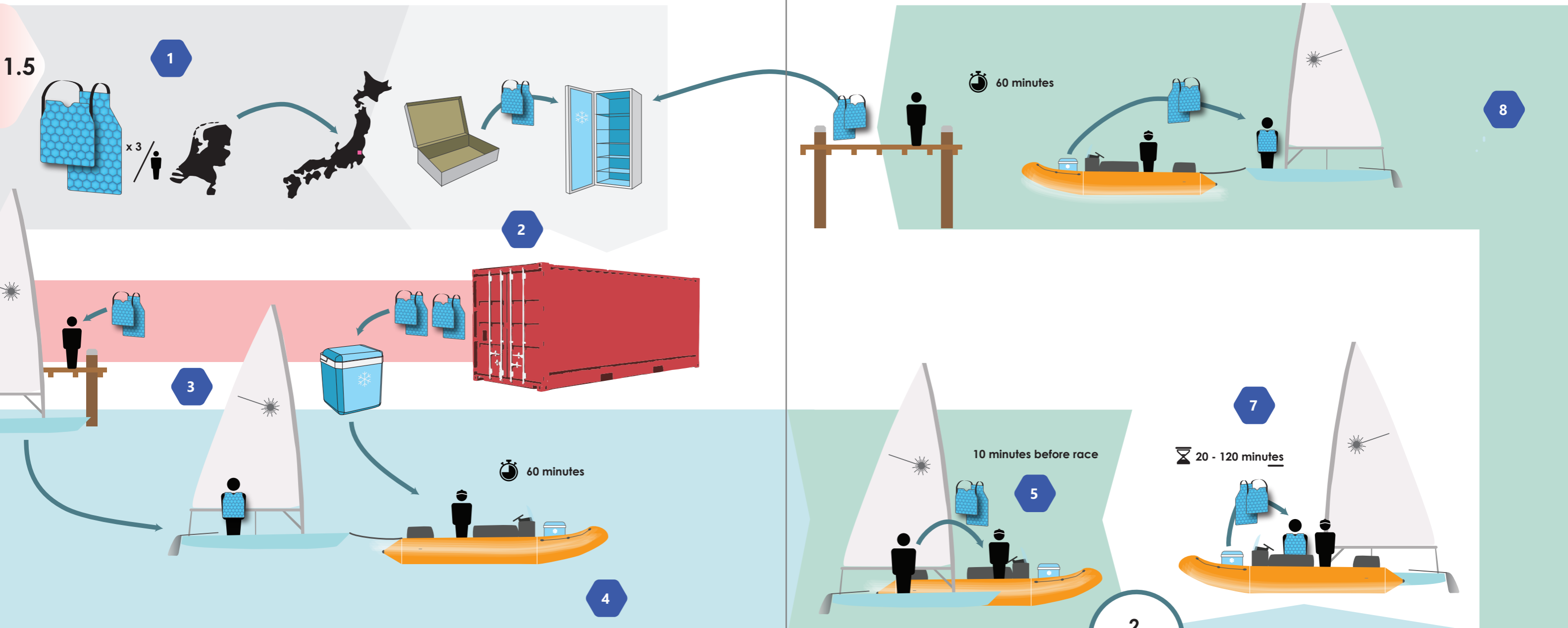

Figure 1: Visualization of the use of a cooling vest during a race day.

Product Journey

Figure 1 shows the course of a sailing day. In this product journey a vest is used as example of a cooling product. The following text accompanies the visual, the numbers 1 to 8 refer to the picture.

1. The vests are be transported from the Netherlands to Japan, three vests per person are needed.
2. The vests are stored in a deep freezer in the container that stands in the containerpark close to the harbour.
3. Just before the sailors leave the harbour to the starting line three vests are taken from storage. Two are put in a coolbox on the RIB with the coach and one is worn by the sailor.
4. During the tow towards the starting line the sailor is cooled by the first cooling vest.
5. The last moment of contact between the coach and sailor is ten minutes before the start of the race, at this time the vest is removed and stored on the RIB.

6. The first race takes place. After approximately sixty minutes the sailors finish. Afterwards the athlete sails back to the coach boat.
7. In between the races there is time to put on a cooling vest, to eat and drink and to evaluate and prepare the next race. Depending on the weather circumstances the time between races can be 30 to 120 minutes.
8. After the second race sailor and coach travel back to docks. A cooling vest can be used to speed up recovery during this period (post-cooling). At the end of the day the depleted cooling vests must be placed in the freezer to recharge over night.

Side note:
For sailing classes that sail three races per day, races take 30 in stead of 60 minutes. Waiting times are unaffected. An extra cooling vest is needed for the second break.



Figure 1: Sailor communicating with coach before a race.

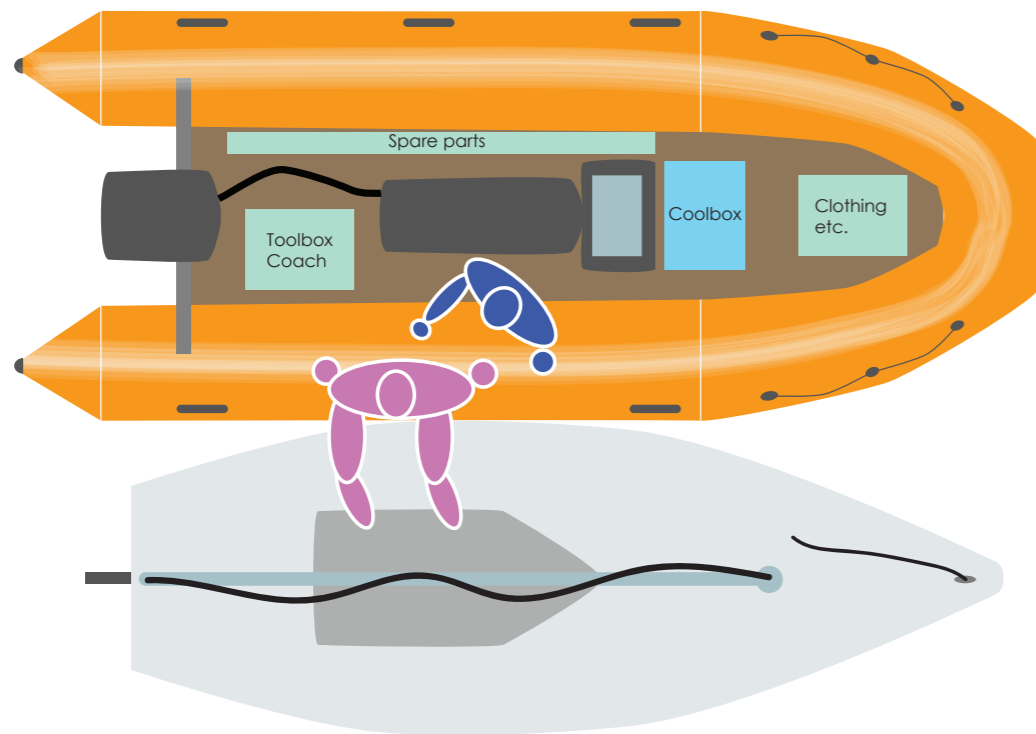

Figure 2: Top view coach boat with supplies indicated.



Figure 3: Video stills of sailors during a break alongside the coachboat. (From Youtube)

Equipment

When on the water sailors are accompanied by their coach in the coach boat (Figure 1), this is a small rib with outboard engine. The coach boat has all supplies needed during a race day such as food, water, clothing, tools and spare parts for the sailing boat. A quick overview is given in Figure 2. There is not much space left aboard the RIB, there is enough space for an extra coolbox but not for huge auxiliaries.

The garment should preferably be storable in a medium sized coolbox.

Contact between coach and sailor goes via shouting and gestures. During breaks sailors are usually sitting on the sides of the RIB (Figure 4). During a break on the RIB the following activities take place:

1. Water and food
2. Evaluation of last race
3. Preparation of next race

There is some time to add 'putting a cooling vest on and off' but this should take minimal time and effort. This was confirmed by coach A. Sign: *'It should be something I can quickly give to them without any hassle'*

It is allowed to remove the personal flotation aid temporarily to adjust clothing, but this is quite a hassle. The coach can help with adjusting the garment if necessary.

Putting the vest on and off quick and easy is very important, the coach can help if needed.

During an excursion it was found that the RIB will dance on the waves, fidgeting with small knobs or cords can be annoying but in general this is not an issue in weather conditions acceptable for a sailing race.

Communication from the competition organization goes via flags (Figure 5). Sailors wear a sailing clock with timer to keep track of time. Ten minutes before the race the coach races towards the athlete to exchange the last supplies, from four minutes before the start of a race it is forbidden to have contact between coach and sailor. A summary of sailing regulations that are of importance for this design project can be found in Appendix D.



Figure 4: During a break sailors often sit aboard the coachboat.



Figure 5: Rack with communication flags.

Sailing clothing

From 10:00h till at least 14:00h sailors are on the water and wear their sailing outfit including the obligatory flotation aid. Figure 2 shows the different clothing items sailors often use. Because of the expected hot weather, the shirt and top over will be made of thin Lycra. Lycra is a fabric made from thin, durable and very elastic Polyurethane yarn. The pants and hiking boots have Neoprene patches because they need to be protective and durable. Neoprene is a synthetic rubber produced by the polymerization of Chloroprene. It can be foamed during production to form a closed-cell foam that insulates very well even when wet. All clothing is rather stretchable and fits tight around the body.

There are multiple sailing classes. From the classes in which Dutch athletes take part the RS:X, 470 and 49er-FX have a trapeze. A trapeze is a steel wire attached to the mast that can be used to hike further outwards. To be able to use the trapeze sailors wear a trapeze harness underneath their flotation aid. RS:X (Surfboard) sailors also use a harness but this one is smaller and fits around the hips. The harnesses are shown below in Figure 1.

The cooling vest should be useable while wearing a harness. ⓘ



Figure 1: Hiking in the 49'er FX (above) and RS:X (below) classes with corresponding harnesses used.



Figure 2: Overview of the gear usually worn by sailors.

Conclusion

The cooling vest will be used before and in between races. It must give sufficient cooling power for at least 30 minutes. Sailors are very busy during a race day, so the vest should be very easy to put on and off.

The RIB is a crowded place, preferably the cooling vest does not require any auxiliaries that are not readily available.

There are multiple classes for which the product should be useable. The requirements of a cooling vest do not differ significantly per class, except that the vest should be compatible with two types of hiking harnesses.

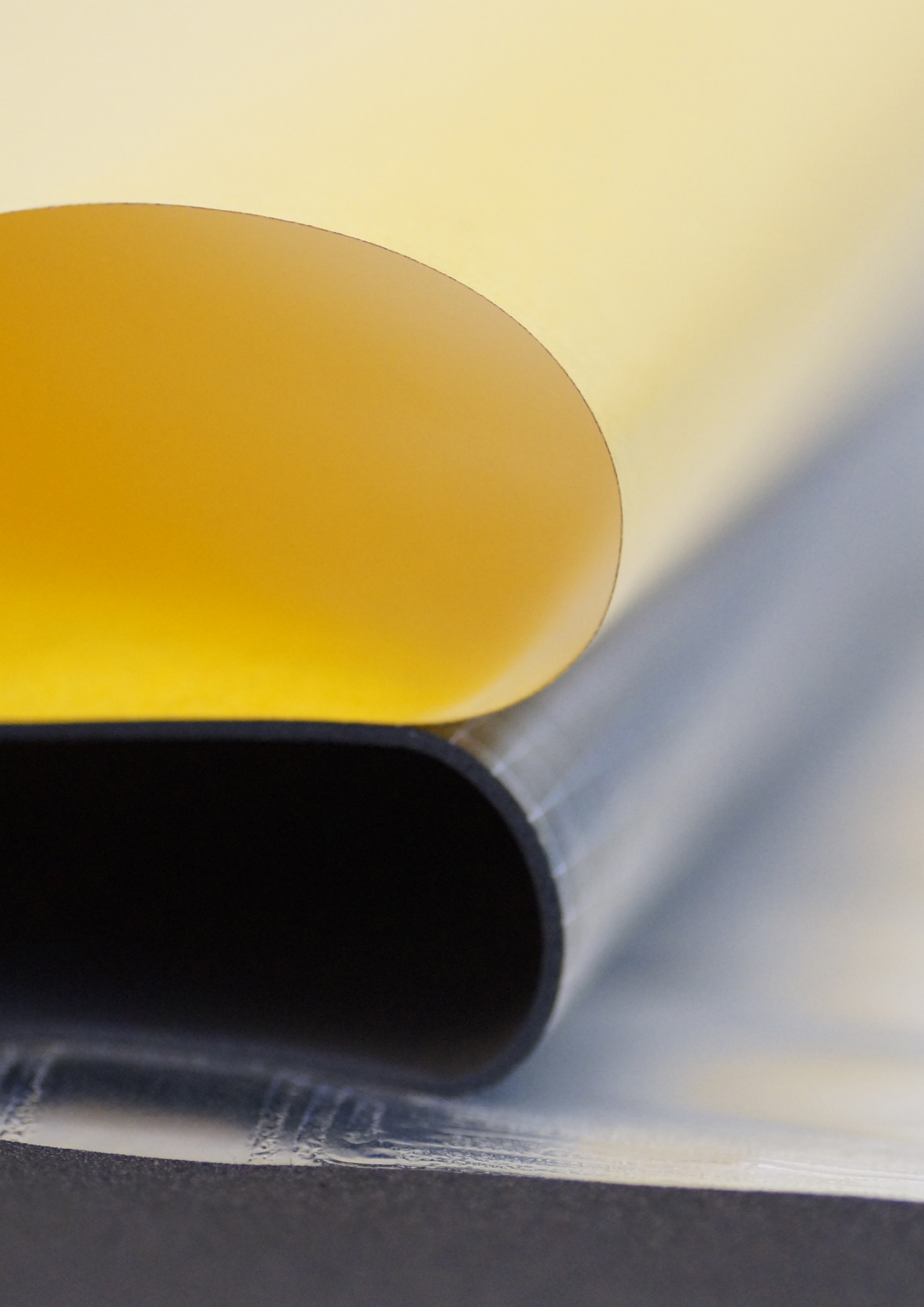

Expand

The previous chapter gave many insights on the requirements and desires for a cooling garment. It became clear that cooling with a PCM is the most viable option. This chapter is about expanding knowledge and possibilities. Experimentation with PCMs and possible packaging materials lead to new possibilities. The second part of this chapter is about comparing and choosing the right PCM for the design of a cooling garment for sailors.

2.1 PCM research

There are three types of PCM commonly used for personal cooling: water, paraffin and salt-hydrates. Water has a very large heat capacity, but because of its low phase change temperature it causes extreme cooling which will cause vasoconstriction and even frostbite when applied for too long. A small case study confirmed that ice is uncomfortable and even painful over time (Appendix E).

Using ice as PCM (0°C) is very uncomfortable.

Except for the extreme cooling effect ice has very good PCM properties therefore the following research goal was set:

Find a way to use ice as PCM without severe discomfort.

Paraffin based PCM does not have this extreme cooling issue because the phase change temperature is higher. A drawback is that the latent heat of paraffin based PCM is around two times lower than the latent heat of water. Both paraffin based PCM and water are solid when frozen, this lack of flexibility makes it hard to create a tight fit. Salt-based PCM do remain flexible. However, the minimum phase change temperature of salt hydrate PCM offered by IZI-Bodycooling is 24°C. This temperature gradient between the PCM and skin is of importance, the bigger it is the more heat will be withdrawn from the body. Faulkner (2012) researched the effect of two different cooling vests on cycling performance. In this research participants had to cycle in hot conditions till a specified work threshold. The COLD condition theoretically had 169W more cooling power than the COOL condition. The results indicate that performance improvement could be related to the strength of cooling. Figure 1 shows how the required time till completion decreases with more intense cooling.

Bogerd (2010) also found that more intense cooling gives a bigger performance advantage despite the increase of vasoconstriction.

It is likely that the magnitude of the cooling power is related to sport performance improvement.

In other words, a low phase change temperature is preferred but the PCM should not cause severe discomfort due to extreme cooling as is the case with ice (0°C).

Oil and water based PCMs are solid when frozen, when worn close to the skin these solid blocks will cause annoying pressure points. Flexible PCMs do not have this issue but they generally have a higher phase change temperature. Therefore the following research goal was set:

Find a flexible PCM that has a phase change temperature between 5 and 20°C

The company Inuteq offers PCMs based on organic paraffin with a phase change temperature of 6,5°C or 15°C. They also offer PCMs with a higher phase change temperature but in this case the PCM by IZI-Bodycooling is more alluring because it is flexible and has a phase change temperature of 24°C.

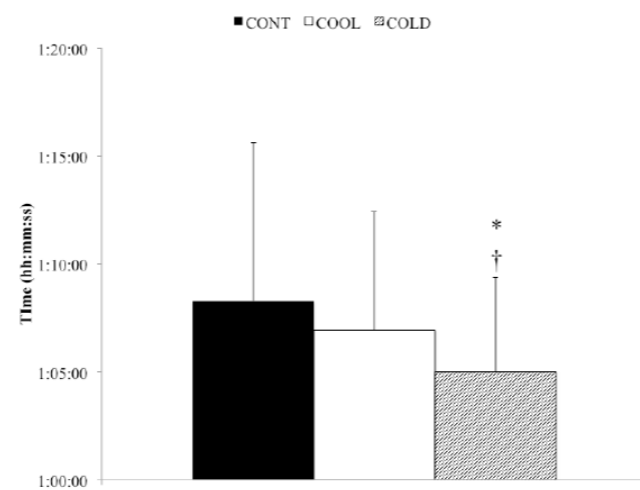

Figure 1: Mean time to complete target workload for each condition. Data presented as mean \pm SD (n=9) from (Faulkner 2012, page 118)

PCM Experimentation: Flexibility

The PCMs from Inuteq have a good phase change temperature but are solid when frozen. Wearing hard blocks of frozen PCM on your skin is not comfortable. To improve the flexibility of PCMs multiple mixtures were tried and tested. Preliminary experimentation and tests were already performed by L. Teunissen and L. Plaude before the start of this graduation project. Their work jumpstarted experimentation.

Inuteq's PCMs are made from an organic oil, therefore the following two methods were tried to make oil flexible while frozen.

Oil absorption grains

To avoid the oil from becoming one solid the PCM oil can be mixed with Polyurethane oil absorption grains. These grains can contain the oil while still being able to move freely around each other in frozen state.

By crushing and grinding the grain size was reduced (Figure 2) Mixing this with PCM oil created a flexible cooling material (Figure 3). Preliminary results were promising, the sample did retain a cool temperature for a long time when heated in an oven. A sample was made to include in the PCM evaluation that is described in chapter 2.2.



Figure 2: Crushing oil absorption grains with a mortar.

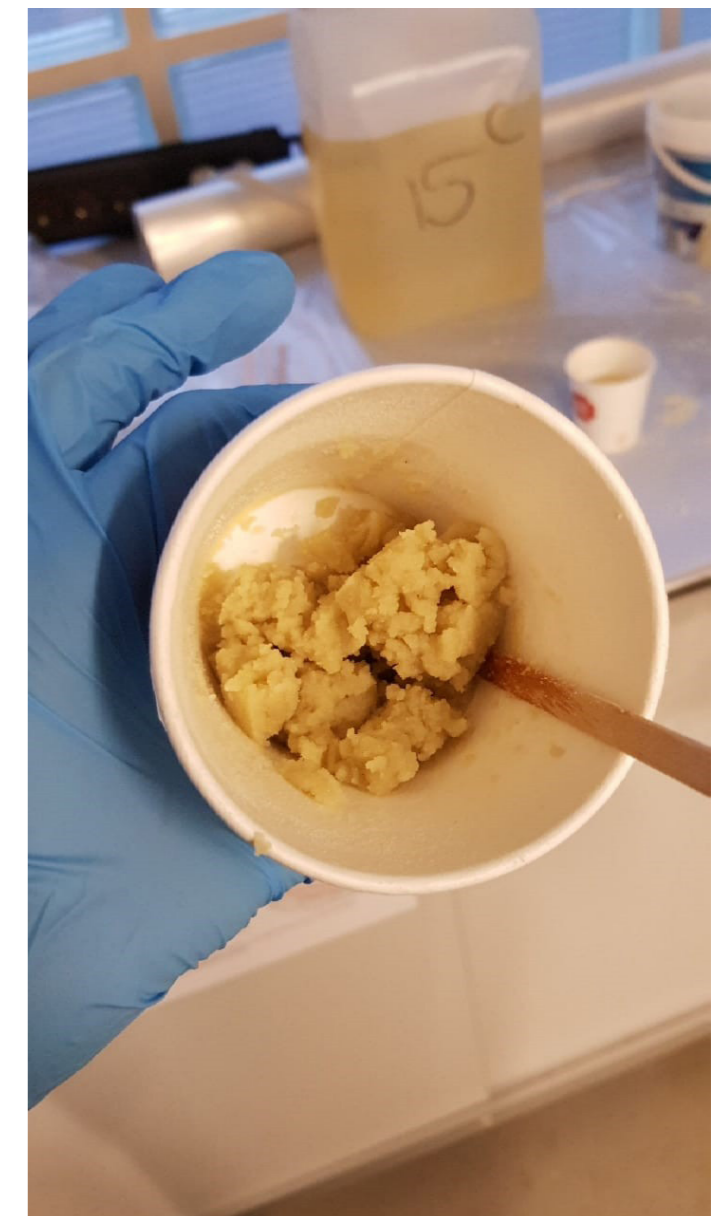

Figure 3: Slush made by mixing Inu 15 PCM with oil absorption grains.

Emulsion with water

A second way that could improve flexibility is by emulsifying PCM oil with water. The underlying idea is that porosity decreases material strength. In concrete porosity reduces compressive strength (Lian et al. 2012). The magnitude of this effect in concrete is visualized in Figure 1.

If it were possible to make the PCM porous in frozen condition it could reduce its rigidity significantly. A way to create a similar condition as porosity in a PCM would be to create a water in oil emulsion as illustrated in Figure 2. Instead of tiny air bubbles there will be liquid water droplets in the still frozen solid part.

The quest to find the right emulsifier and the results of a preliminary strength test can be found in Appendix F. This tests indicated that a higher water fraction results in less strong PCM packages. The makeshift test as described in Appendix F was however very imprecise. To validate the result a proper test was performed using a tensile strength tester.

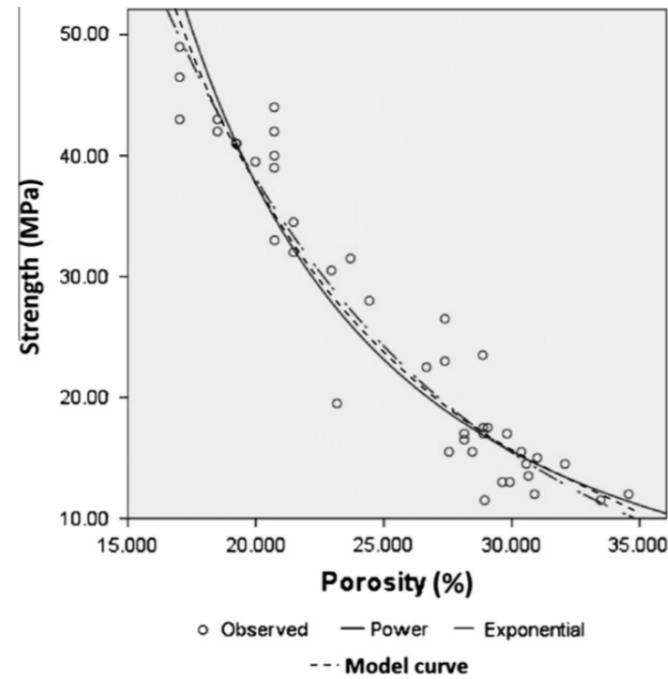

Figure 1: Model for compressive strength versus porosity in concrete from (Lian et al. 2012)

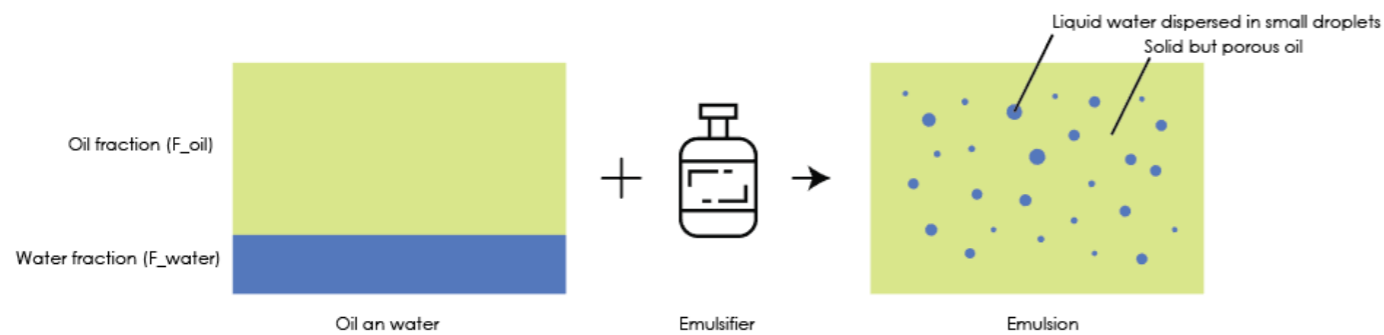

Figure 2: Illustration on how an emulsion would render a porous PCM structure.

Four samples with respectively 0%, 5%, 10% and 20% water emulsified in INUTEQ PAC 15°C were tested five times. The packages were the same as the ones used for the PCM cooling performance evaluation (Chapter 2.2), their size is 144 x 118 mm and 20±1 mm thick. All samples were cooled in a fridge till 4°C while being compressed between two plates. At 4°C the PCM fraction is frozen while the emulsified water droplets are still liquid.

Samples were tested with a 3-point flexural test on a Zwick Z010 tensile tester. The bottom supports are set 80 mm apart. Figure 3 shows the situation at the end of a test.



Figure 3: Sample at the end of a three point flexural test on the tensile tester.

All measurements show a comparable force - displacement curve as illustrated in Figure 4. At point A the sample breaks, the force drops and shortly after rises again (B). This is because the TPU foil around the package stretches when it is bent.

MATLAB was used to find the yield forces. All results including graphs can be found in Appendix G. The spread is too high to make a general statement about the material properties of the emulsions. The results are consistent enough to compare the samples. Hence, the strength of the emulsified samples is indicated as the fraction of the pure sample in Table 1.

The conclusion of this test is that emulsifying 20% water in the PCM decreases the strength of the sample notably. However, adding 20% water does decrease the theoretically available cooling capacity. This is not desirable but in case extra comfort is needed emulsifying 20% water in the oil based PCM can be a solution at the cost of a reduced cooling capacity.

Emulsifying 20% water can be a solution if wearing comfort severely affected by PCM's solidness.

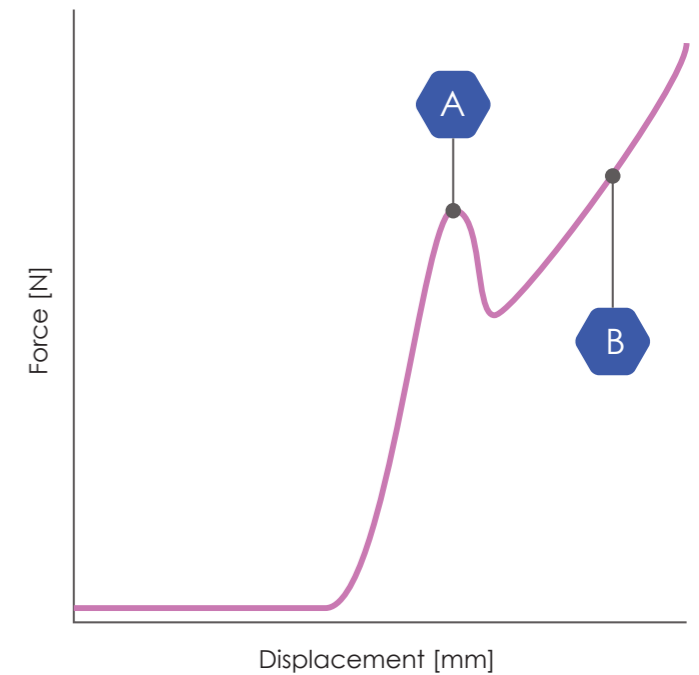

Figure 4: Typical force - displacement curve of a test of an emulsion sample on the tensile tester.

Sample:	5% Water	10% Water	20% Water
Minimal	95%	49%	47%
Average strength:	116%	96%	65%
Maximal	164%	145%	77%

Table 1: Strength of emulsified samples compared to pure PCM (n=5)

Side note:

If the PCM is frozen in a deep freezer instead of a fridge the water fraction will be frozen as well. This would likely diminish the effect on the strength/wearing comfort. Nevertheless, the water part could function as a buffer for the PCM fraction. If this ice-buffer is then depleted, e.g. due to transport in a coolbox, the emulsion-sample would regain its comfort advantage.

PCM Experimentation: Making Ice comfortable

Besides the flexibility, a second branch to explore is the cooling duration of a PCM. Compared to water all PCMs have a relatively low latent heat capacity. This chapter shows two experiments to create packaging that allows the use of water as PCM without the drawback of potential frostbite.

Ice with insulation

Wearing ice packs directly on skin is not comfortable and can even lead to frostbite. This is the reason why a towel needs to be placed between a cooling pack and skin when treating injuries. This can also work with the cooling vest, adding a layer of insulation will reduce the cooling power.

Sweating underneath a PCM package will soak the material between the package and the skin. Most insulating fabrics do not insulate very well when they are wet. Closed cell Neoprene rubber meets the material properties needed for an insulating layer. It does not soak up water, is flexible, durable and with a thermal conductivity of 0,05 W/(mK) it insulates very well.

A drawback of using ice is that it will start to melt above 0°C. It is difficult to keep such a low temperature inside a coolbox. Experimenting with ice packs and a thin Neoprene wetsuit gave promising results. The ice would still feel rather cold, but the cold would not start to feel annoying or painful over time. The ice-Neoprene combination was added to the list of samples to be compared.

A 0,8 mm thick Neoprene foam rubber sheet was acquired. This material comes with an adhesive layer to ensure optimal connection between the rubber and the PCM's packaging. It is sufficiently flexible but can still tear from the edges.

Ice can be used as a PCM when covered with a thin layer of Neoprene rubber.



Figure 1: Ice with a Neoprene shirt feels about equally as cold as PCM Inu 15°C.

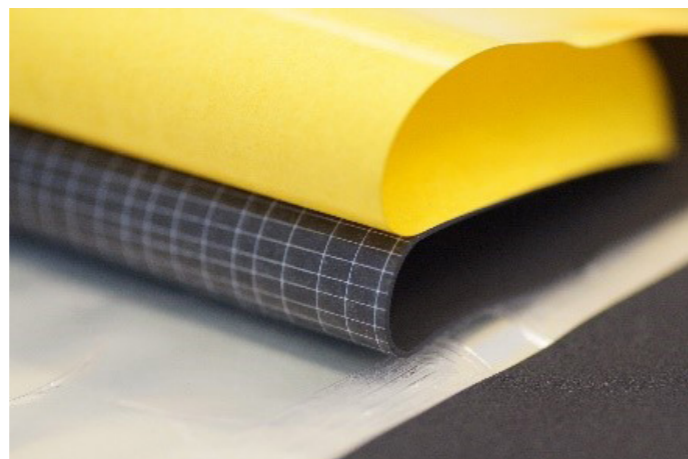

Figure 2: 0,8 mm thick Neoprene foam with self-adhesive layer.

Two-phase PCM packaging

Water has a large latent heat but is too cold to be applied directly to the skin. Inu 15°C has the right temperature but has a much lower latent heat capacity. A composite PCM could incorporate best of both worlds. In this case the ice layer would function as energy storage layer while the Inu 15°C keeps the extreme cold away from the skin as illustrated in Figure 3. The insulating floatation aid prevents the ice from melting due to heat from the outside.

In chapter 2.4 is described how two sheets of TPU foil can be welded using a laser cutter. With the laser cutter it is also possible to weld three layers of TPU together by sealing from both sides. Forming a container for two different PCMs separated by a layer of TPU.

A few samples were made but in practice it turned out to be very impractical to create durable full-scale prototypes with this method. It was not possible to create a good enough sample to add to the Hotplate test described in the next chapter. More about experimentation with triple layer sealing can be read in Appendix H.

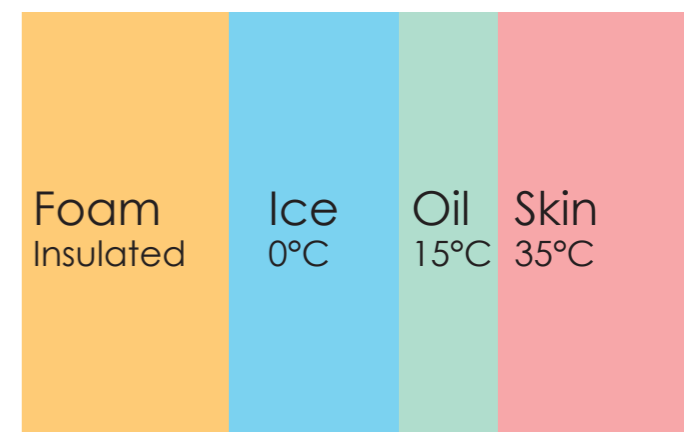

Figure 3: Illustration of composite PCM



Figure 4: Triple layer specimen.

2.2 PCM comparison

Eleven PCM configurations are available to use in the cooling vest. The cooling power and duration of eleven samples is measured to be able to compare them. The results help in deciding which PCM is most suitable for the sailing context.

Cooling power measurement apparatus; the Hotplate

To measure the heat flux a special device was used. This device will be referred to as the Hotplate in this report. The Hotplate is a measurement device that measures the power input required to keep an aluminum plate at the top of the device at a set temperature. When something is cooling the Hotplate the device registers a temperature drop and subsequently heats the plate with a certain power input until it reaches the set temperature again.

This is a simplified model of the human skin. When skin is cooled the human body warms the skin via blood flow. There are major differences between the Hotplate and real skin as explained in the note on the right side of this page. Nevertheless, for the purpose of comparing different PCMs in terms of cooling power, capacity and time the device is very useful.

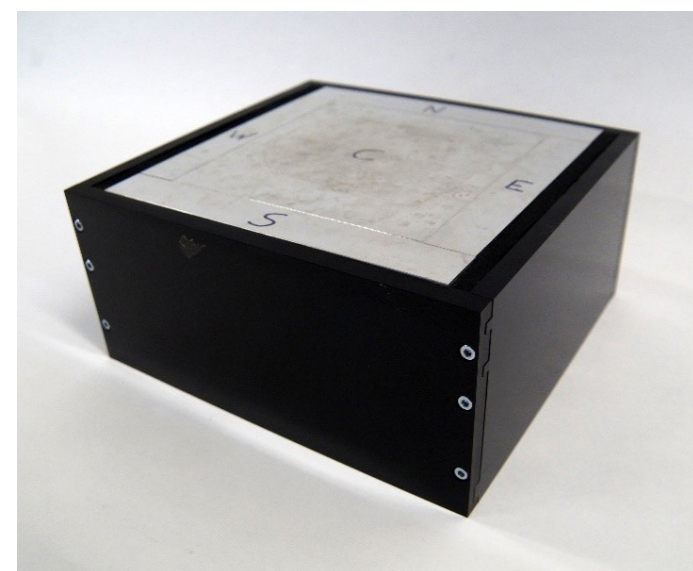

Figure 1: Hotplate cooling power measurement device

Side note:

The following text explains important differences between the Hotplate and human skin.

The first difference is the lack of vasoconstriction in the model, when skin is cooled the blood flow to this skin area is restricted to reduce heat losses. The skin's surface temperature will lower reducing the temperature difference causing a decrease in heat transfer. The amount of vasoconstriction depends on multiple variables and is therefore hard to predict. The Hotplate simulates a situation in which the body can supply enough energy to keep the skin temperature constant. This will melt the PCM packages faster than real skin would.

Secondly, the Hotplate is rigid and human body is flexible. This flexibility makes a good contact between skin and solid PCM possible. Without this flexibility there will be places where there is air between the sample and the Hotplate's surface, this reduces the area of contact between PCM and Hotplate making the PCM melt slower. However, once a part of the PCM changes phase the liquid part will fill the gaps increasing the area of contact.

A third difference is that testing on the Hotplate is static while athletes will be using the PCM packages while moving. Moving kneads the PCM in its packaging, this kneading will mix the PCM and can break solid pieces into smaller pieces. Both will increase the heat flux towards the skin.

Finally, the Hotplate hardware is capped to deliver a maximum of 42 Watts. If this power limit is exceeded the temperature of the Hotplate goes down. Skin also can not deliver an unlimited amount of power and will react in a similar way but not likely at the same power limit.

PCM samples

Eleven samples were made to be tested on the Hotplate. IZI-Bodycooling has PCMs packaged in a special highly conductive foil that is said to improve the PCM's performance. The packages are sized (118 x 144 mm) and weigh approximately 250 grams. With the available facilities it is not possible to reproduce IZI-Bodycooling's packaging.

Therefore all other samples are made identical in size and weight to IZI-Bodycooling's PCM packages. Eleven test-samples were made, packaged in 0,1 mm thick TPU and filled with 250 grams of PCM. A picture of all samples is shown in Figure 2. From now on the icons and abbreviations used in this picture (in bold) will be used to describe the different PCMs in the report.



Figure 2: Overview of the PCM samples that were tested on the Hotplate.

Method

Samples are frozen to -20°C in a fridge pressed between two Perspex plates, to create an as flat as possible surface area. This is shown in Figure 1.

The Hotplate is placed in a bench-top temperature and humidity chamber (Espec SH-661) to create a controlled environment. The climate chamber has a big fan that cannot be switched off. The air flow in the chamber influences the cooling performance of the PCM packages. The continuous flow of warm air melts them from the top. In practice, the cooling packs are worn underneath a flotation aid. In this case there is no air flow but a thick block of insulation. To create similar conditions an insulating ($\lambda = 0,035 \text{ W}/(\text{mK})$) Styropor cover with a thickness of 10mm is made (Figure 2). It that can be placed on top of the Hotplate. This cover can shield the Hotplate and the sample from the surrounding airflow (Figure 3 and 4).

Mairiaux (1987) measured average skin temperatures of around 35°C in hot conditions. Therefore the temperature of the Hotplate was set to 35°C . The foam cover will simulate the flotation aid. The inside of the flotation aid will also be around the skin temperature (35°C). Therefore, the climate chamber is set to 35°C . The temperature of the surroundings and the foam block will then also be 35°C . During the 2020 Olympics temperatures of 35°C are not unlikely. A benefit from this setting is that no heat is withdrawn from the hot plate due to the surrounding air temperature. The humidity should not significantly influence the results because they do not rely on the evaporation of water. However, to keep the environment as controlled as possible the climate chamber is set to a relative humidity of 65%. This is the expected average relative humidity during the 2020 Olympics (Gerret et al. 2019).



Figure 1: Cooling of samples while compressed between two Perspex plates



Figure 2: Image of styropor cover

The test is stopped when the power withdrawal of the sample has fallen below 5W. In this situation the PCM is completely molten and the last bit of cooling power comes from slowly heating up the PCM, at this point the PCM does not feel cool anymore. 5W is approximately the same cooling power as would be achieved by evaporative cooling with an equal surface area and the same environmental conditions. The data used for this approximation can be found in Appendix A. (Teunissen, unpublished data)

Data from the Hotplate is aggregated with LabVIEW and visualized using MATLAB and Excel. The cooling capacity is calculated by integrating measurements over the period where the power is above the threshold value of 5 Watts. The average cooling power is calculated over the same period.

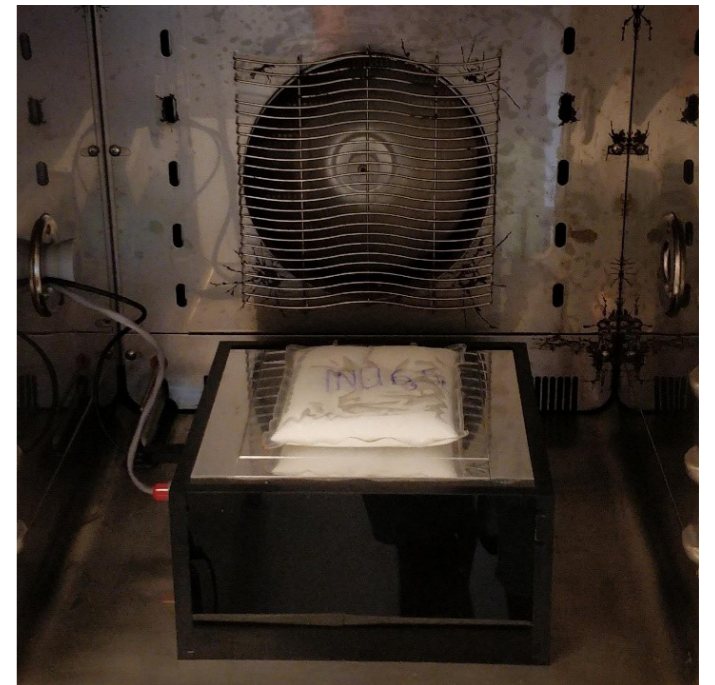

Figure 3: Sample placement on Hotplate, not shielded from the climate chamber's fan.



Figure 4: Test setup.

Results & Discussion

The results paragraph is split into two parts. First sample specifications and raw measurements are presented and discussed. Afterwards the cooling performance of the different PCMs is given in three properties; cooling power, capacity and duration, for easier comparison.

Measured cooling power over time

Figure 2 shows how much cooling power each different sample exerted on the Hotplate. The graphed data is the average over three measurements per sample. IZI 24 (—) and Inu 15 gel (---) give a short burst of cooling but their cooling power quickly decreases. Inu 15 sorb (·····) performs rather badly, after the test there is a big temperature difference (9°C) between the top and the bottom of this sample. It is likely that the added PU grains insulate the Inu 15 oil inhibiting the heat flow within the sample. Inu 15 gel also has this issue, for this sample the temperature difference after a test was approximately 7°C.

Inu 15 (—), Inu 6,5 (—) and H2neO (—) provide a good amount of cooling power over a longer period of time. Inu 6,5 gives more intense cooling over a shorter period of time, this can be explained by its low phase change temperature. The cooling power of Inu 15 and H2neO is similar. The phase change temperature of H2neO is much lower, but the cooling power is limited by the insulating Neoprene layer. The saw-tooth shape of the power curves of Inu 6,5 and Inu 15 is unexpected. An explanation could be that the solid frozen part inside the package breaks into multiple smaller pieces when melting. This increases the surface area of the frozen parts resulting in a larger the heat flux.

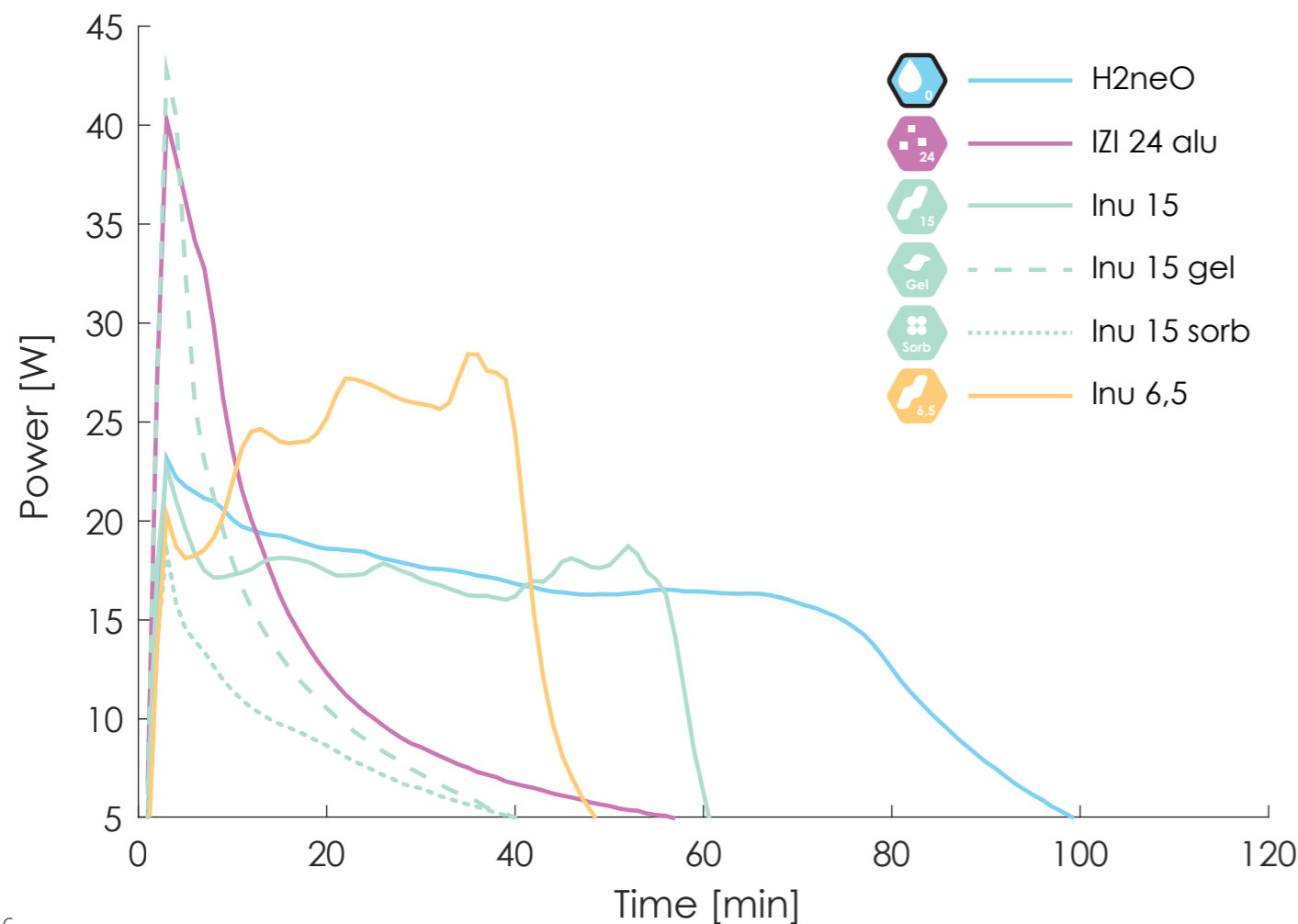

46 Figure 2: Cooling power over time for six different PCM samples.

H2O causes intense cooling: the cooling power of the sample is greater than the maximum power the Hotplate can deliver to the sample. This causes the Hotplate's temperature to drop, it will keep on providing its maximum power output (43W) until the set temperature is reached again. The actual cooling power of the H2O sample is higher than 43 Watts. The cooling time would also be shorter if the Hotplate could deliver more power. Pure H2O is not suited as a PCM because placing ice packs directly on skin will cause frostbite over time. Insulating the package, in this case with a thin layer of Neoprene, greatly spreads the cooling power over a longer period of time as can be seen in Figure 1.

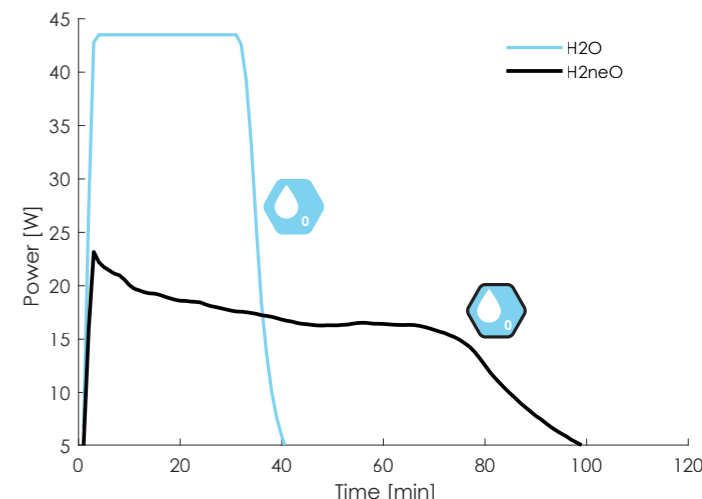

Figure 1: The effect of insulation on cooling power

Figure 2 shows the cooling power course of the emulsions of Inu 15 and water. The water part is respectively 0%, 5%, 10% and 20%. The emulsions combine the characteristics of H2O and Inu 15. The ice causes a cooling power spike, and after the water part has molten the course follows the trend of Inu 15. Adding water decreases the cooling time. For the vest Inu 15 is preferred because it gives slightly longer more stable cooling. However, if more flexibility is needed, emulsifying 20% water would be an option.

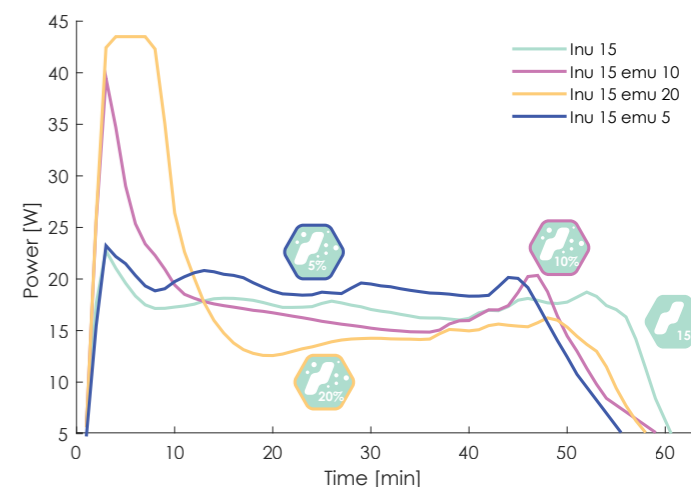

Figure 2: Inu 15 emulsions' performance

IZI Bodycooling stressed that their packaging material outperforms plastic packaging because it has a very low thermal resistance. Their packaging seems to be based on aluminum. Test results are presented in Figure 3, they show a marginal difference between the TPU and aluminum packaging.

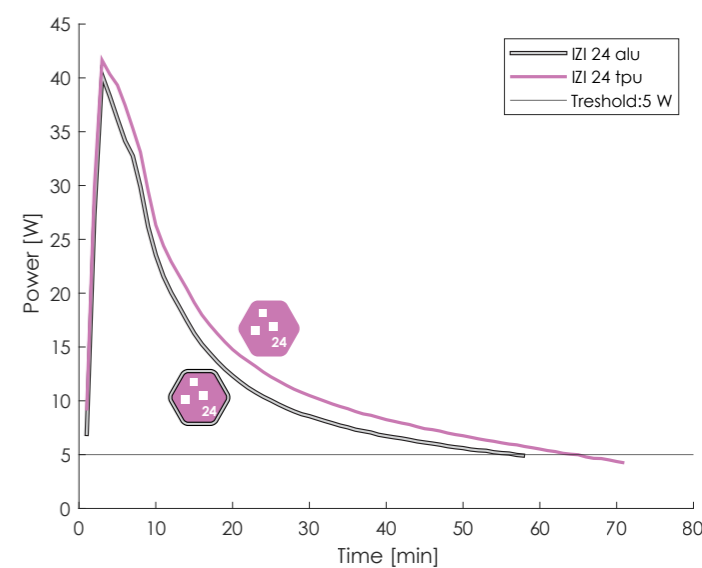

Figure 3: IZI 24 packaging comparison

👁️ *There is no need for a highly conductive packaging material as long as it is very thin.*

Conclusions from unprocessed data

IZI 24 is abandoned in this project because it does not deliver constant cooling. Also, it is difficult to prototype with IZI 24 because it is quite unstable and irritating for skin and eyes. This is a major drawback since this project required a lot of prototypes as described in chapter 4.1.

➡️ *IZI 24 will not be used as PCM in this project.*

Because of the packaging described in chapter 2.4 the rigidity of a PCM did not pose a problem for the design. Therefore the Inu 15 emulsion were abandoned as well.

Theoretical cooling power over time

The cooling power over time is interesting for the design of a cooling garment. Preferably a cooling vest should withdraw a constant amount of power, a high peak in cooling could result in vasoconstriction increasing the skin's insulative capability reducing the vests effectiveness.

The course of the power over time can be predicted. When a PCM changes phase its temperature is constant, the temperature of the hot plate and the surroundings is constant as well. Therefore the power withdrawal during the phase change will be constant. Before and after the phase change the material does absorb energy as well, when it is absorbing energy the temperature of the sample rises. The temperature difference between the sample and the Hotplate decreases, the heat flow to the sample will decrease proportionally according to Fourier's law:

$$q = \frac{k}{s} * A * (T_{Hotplate} - T_{Sample})$$

$$q = \text{heat flux} \left[\frac{J}{s} \right]$$

$$k = \text{thermal conductivity} \left[\frac{W}{m K} \right]$$

$$s = \text{material thickness} [m]$$

$$A = \text{heat transfer area} [m^2]$$

$$T_{Hotplate} - T_{Sample} = \text{temperature difference} [K]$$

k, s and A are constant.* Therefore the heat flux depends on the temperature difference which depends on the heat flux. The course of the graph will decay exponentially.

In short the cooling power will decay exponentially until the phase changes, during the phase change the power will be constant and afterwards the cooling power will decay exponentially once more. This is illustrated in Figure 1 A.

The specific heat influences the ramp of the exponential decay and the latent heat influences the duration of the phase change (Figure 1 B). The length of the phase change is also influenced by the phase change temperature. If the phase change temperature is low the temperature difference is large during the phase change resulting in more intense and shorter cooling. (Figure 1 C).

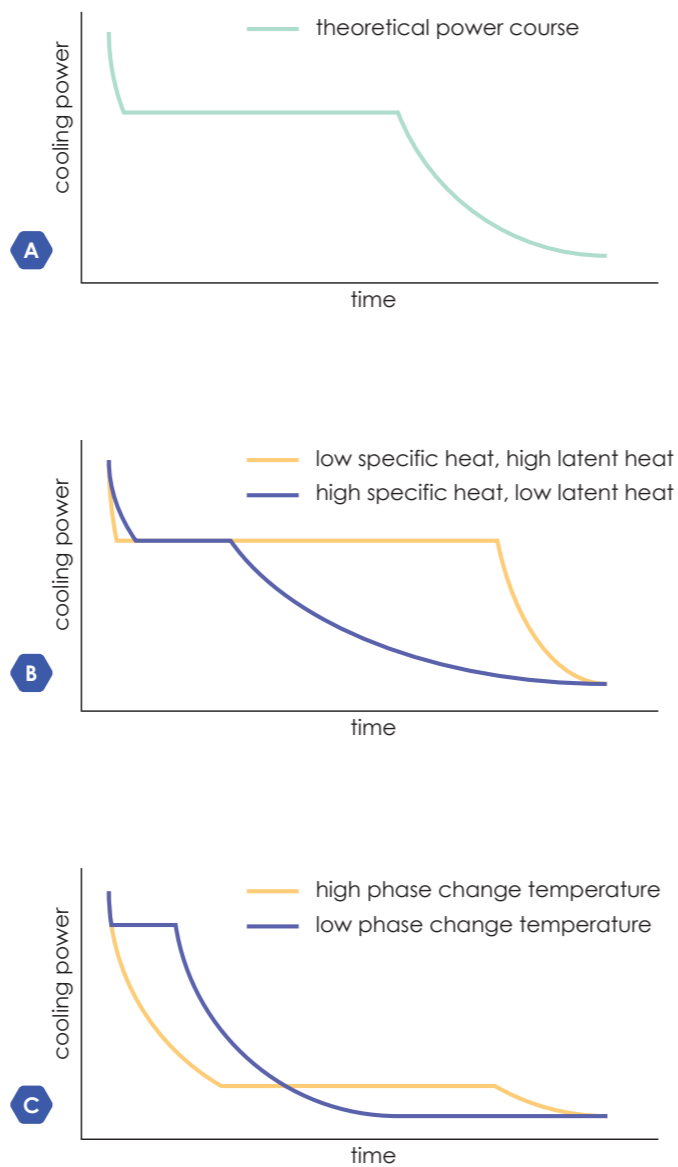

Figure 1: Theoretical power courses. A: standard power course. B: effect of specific and latent heat. C: effect of phase change temperature.

*Side note:

Theoretically, the insulative barrier between the sample and the Hotplate is the thin packaging layer. But in practice it does not work out if the thermal conductivity and thickness of the TPU sheet are used. Likely because the PCM itself also has thermal resistance which limits the heat flux. Also, the area of contact is never perfect, there are minute air pockets on the sample - hotplate interface. On top of that the heating element inside the hotplate does not heat the PCM sample on top completely homogenous.

Processed PCM data

Figures 4, 5 and 6 (on the next page) show the cooling capacity, power and duration of each sample.

The cooling duration is the time it takes until the threshold of 5W is reached.

The cooling capacity is defined as the total measured power withdrawal until the threshold of 5W is reached. It is calculated by integrating the power curve over this period with MATLAB.

The cooling power is the average cooling power over the same period.

A complete overview of the measured and processed data can be found in Appendix I.

The green bars in Figure 4 show the time it takes until the sample is depleted. In this case the obvious winner is H2neO with a cooling duration of almost 100 minutes. The cooling time of IZI24 and Inu 15 is quite similar.

Figure 5 shows the average cooling power of each sample. There is clear relation between the PCM's phase change temperature and the cooling power. With H2neO and Inu 15 sorb as exceptions, both have been altered with an insulating material. This significantly reduces the cooling power of the sample. In H2neO's case this is a good thing since H2O provides too much cooling power.

Sample Cooling Duration

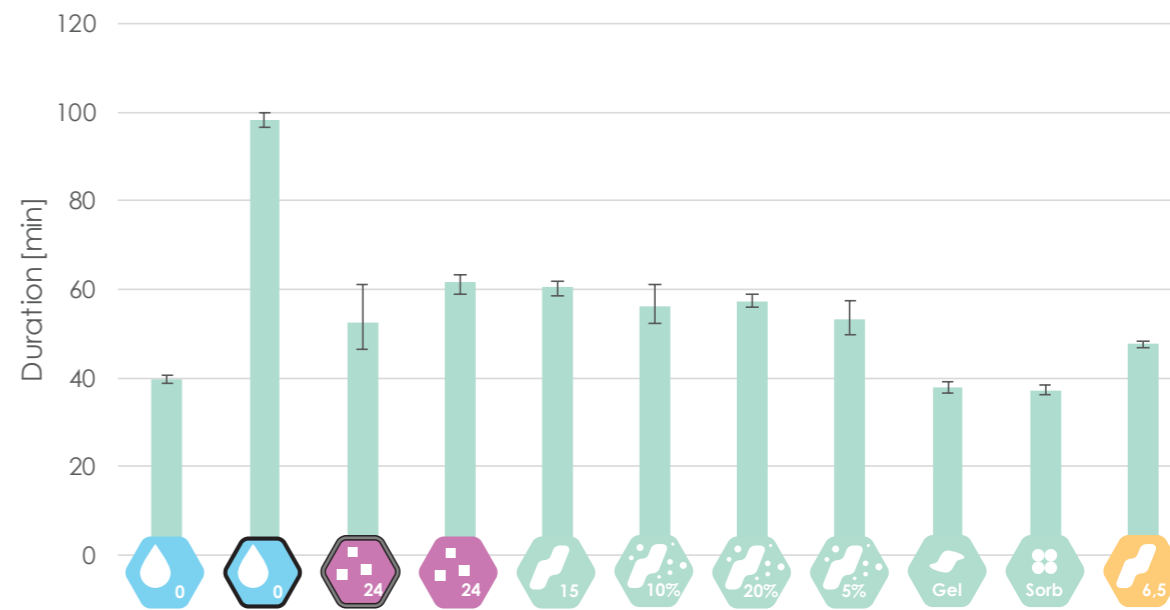

Figure 4: Cooling duration per sample, green = cooling duration, black T= spread (n=3)

Sample Cooling Power

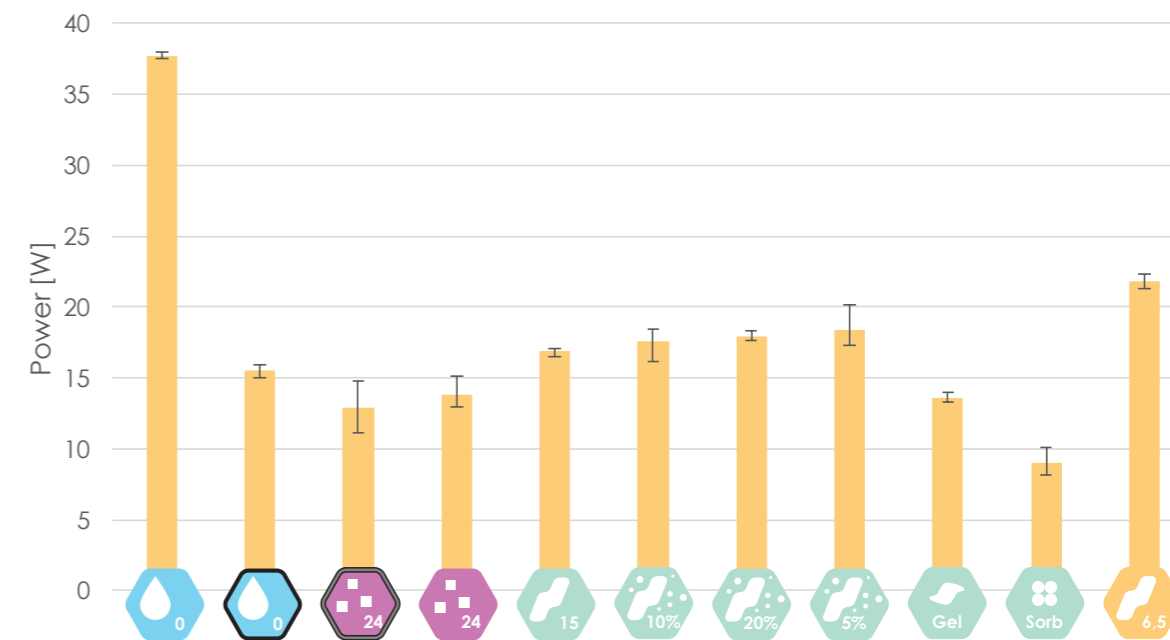

Figure 5: Average cooling power per sample, orange = cooling power, black T= spread (n=3)

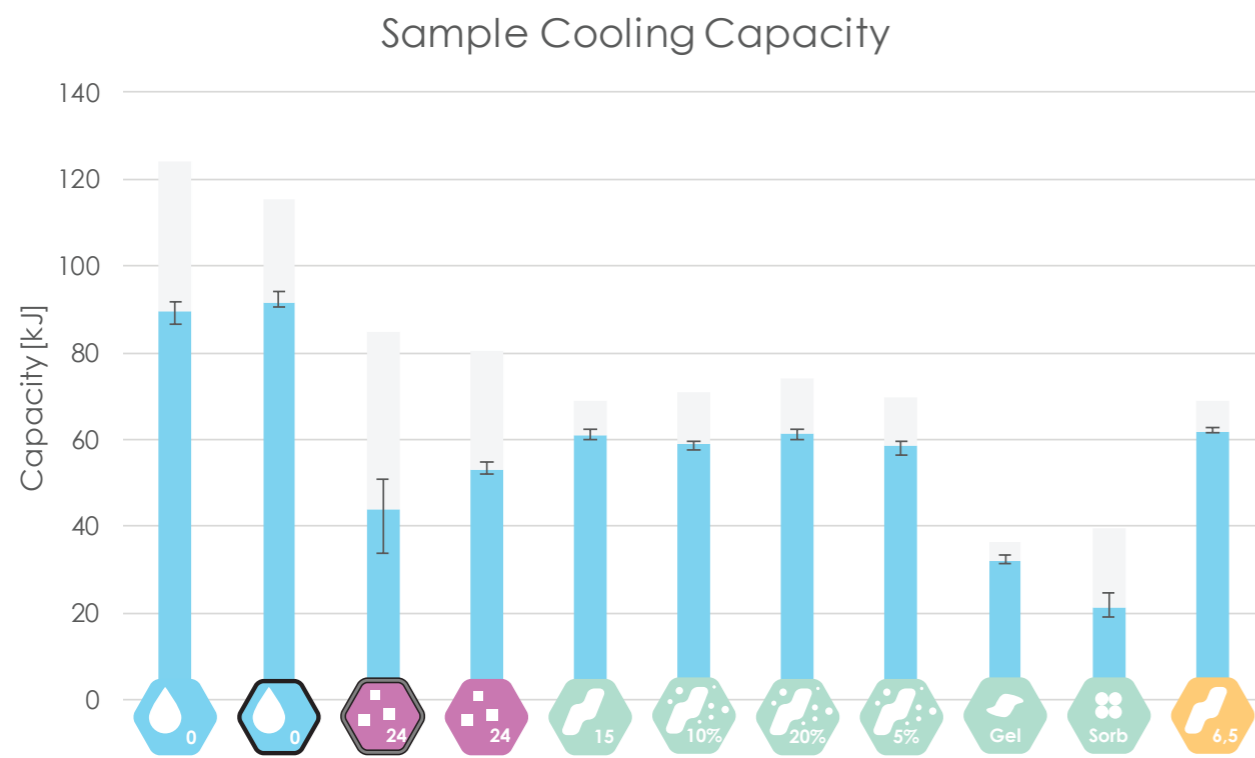

Figure 6: Cooling power per sample, blue = cooling capacity, black T= spread (n=3), grey = theoretical cooling capacity

$$E = L_m * m + c_s * m * (T_{pc} - T_{start}) + c_l * m * (T_{end} - T_{pc})$$

$E = \text{potential cooling energy [kJ]}$	Amount of energy stored that can be used for cooling
$L_m = \text{latent heat } \left[\frac{\text{kJ}}{\text{kg}} \right]$	Amount of energy that is needed to melt 1 kg of product
$m = \text{mass [kg]}$	Mass of the sample (packaging excluded)
$c_l = \text{specific heat liquid } \left[\frac{\text{kJ}}{\text{kg}\cdot\text{K}} \right]$	Energy needed to raise 1 kg of liquid product with 1 Kelvin
$c_s = \text{specific heat solid } \left[\frac{\text{kJ}}{\text{kg}\cdot\text{K}} \right]$	Energy needed to raise 1 kg of solid product with 1 Kelvin
$T_{start} = \text{Initial temperature } [^{\circ}\text{C}]$	Sample's temperature in the freezer
$T_{pc} = \text{phase change temperature } [^{\circ}\text{C}]$	Sample's phase change temperature
$T_{end} = \text{Final temperature } [^{\circ}\text{C}]$	Sample's temperature at the end of the test

Figure 7: Formula used to calculate the theoretical heat capacity of each sample.

As you can see in Figure 6 the cooling capacity of water is highest, followed by Inuteq's PCMs trailed by IZI-Bodycooling's salt hydrates. The experimental Inu 15 gel and Inu 15 sorb contain a relatively small part PCM resulting in a low cooling capacity.

From these results IZI 24 and Inu 15 seem to be quite on par. However, there is a major difference in how these PCMs release their cooling power over time as was described in the previous paragraph. Inu 15 has favourable stable power curve.

Discussion

Most test results are in line with what could be expected from the corresponding PCM. What is strange though is that the theoretical cooling capacity (grey bars Figure 6) is larger than the measured cooling capacity (blue bars Figure 6). The theoretical cooling capacity is calculated with the formula shown in Figure 7.

Except for the In 15 sorb sample the temperature of each sample changes from around -20°C , the temperature of the freezer, till $30 \pm 2^{\circ}\text{C}$ at the end of the test when the cooling power reaches the threshold of 5W. Temperature after a test was measured using an infrared thermometer. The temperature change used for predicting the potential cooling energy is $30 - -20 = 50^{\circ}\text{C}$

The predicted cooling capacity (grey bars) is higher than the measured cooling capacity (blue bars) for every sample. It is likely that somehow cooling energy is lost to the environment. This could be due to condensation of water from the air underneath the styropor cover. Also, when the threshold of 5 Watts is reached the temperature of the sample is not exactly 30°C . Also, the sample's temperature is not homogenous. Nevertheless, a deviation 2°C at the end of the test would only account for 3% difference in theoretical heat capacity.

The difference between predicted and measured cooling capacity is not consistent for all samples. For the Inu samples it gives a decent approximation, the deviation is $14 \pm 3\%$. But for the other samples the deviation goes up to 48%. Especially the prediction for the salt-hydrates does not seem to stroke with reality.

The measured and theoretical heat capacity of Inu 15 sorb

is very different. It could be that the PCM is still changing phase when the threshold value of 5 Watts is reached. The measured outside temperatures are respectively $28,5^{\circ}\text{C}$ and $19,8^{\circ}\text{C}$ at bottom and top. The inside of the package could still be below the phase change temperature. The same reasoning could be applied to the IZI24 samples even though the outside temperature was measured in the $30 \pm 2^{\circ}\text{C}$ range. Also, after kneading the PCM to create a more homogenous temperature the measured outside temperature did not change significantly.

The difference between the theoretical and measured heat capacity of H₂O can be due to the Hotplate not being able to provide enough power to keep the temperature at 35°C . The mass of every sample should have been 250 grams (excluding the packaging) however filling the packages was a tedious process hence a variety in sample weight. Also, the Inu 15 sorb mixture has a relatively low density, it was not possible to package 250 grams in a similar sized package. Therefore, it weighs only 190 grams.

The cooling power of water is in reality higher than 38 Watts, but the Hotplate hardware is capped to deliver a maximum of 42 Watts to the sample. If this power limit is exceeded the temperature of the Hotplate goes down. The Hotplate will keep on feeding the maximum power until the temperature balance is restored. This will be after the water sample has changed phase.

Lastly, when freezing a sample thermal shrinkage sometimes lead to a slightly curved surface of the sample. This could have influenced the measurements even though the liquid phase would fill up the gap between the sample and the Hotplate after the PCM has partially molten.

Conclusion

All in all the tests led to the choice of three PCMs that are most suitable for a cooling garment for Olympic sailors. They all have their specific characteristics that can be of help depending on the situation. They are presented on the next page.

2.3 PCM selection

The test results presented in the previous paragraph showed that Inu 15, Inu 6,5 and H2neO have the best combination of cooling capacity, duration and power. They offer good and stable cooling power over a decent period.

H2neO offers the longest cooling duration, but a relatively low cooling power.

Inu 6,5 on the other hand offers plenty of cooling power, but for half the time.

Inu 15 offers the same capacity as Inu 6,5, but the cooling power is spread over a slightly longer period.

The main advantage of Inu 15 is that it will always stay sufficiently frozen anywhere in a normal coolbox while this could be an issue for Inu 6,5 and especially for H2neO, because of their lower phase change temperatures.

On the right a short summary of the findings in this chapter is given. In general the results of this chapter are suitable for cross-checking the PCMs to decide which one is most suitable for a certain situation. They are not suited for predicting the cooling power someone will experience when exposed to one of the PCMs.

In chapter six the cooling power and duration of the designed vest is estimated. To do so the cooling power and duration of the PCM on human skin is determined with an exercise test. Even though only one PCM is chosen for the final design the theoretical cooling power and duration of a whole vest is given for all three PCMs. The whole process is described in chapter six.

1. Inuteq 15°C PCM oil

The main advantage of this PCM is that it will stay frozen up to fifteen degrees Celsius and can therefore easily be stored and recharged in a normal coolbox with ice. This PCM is used during the qualitative user tests. These tests showed that Inu 15 does not cool strong enough for athletes. Nevertheless, the PCM is suitable for staff and coaches because they require comfort, not extreme cooling for performance improvement.

2. Ice with Neoprene

The main advantage of using water as a PCM is that it has a very large latent heat capacity. Experiments indicated that H2neO cooling packs can cool up to twice as long compared to Inu 6,5 cooling packs with the same volume. This PCM is used during the qualitative user tests and physiological evaluation. In a normal coolbox with ice it is somewhat hard to keep the vest sufficiently frozen.*

3. Inuteq 6,5°C PCM oil

First, this PCM was discarded because it is depleted quite fast. But, after doing qualitative user research, this PCM is back in the race. Sailors commented that they felt that the Inuteq 15°C PCM did not offer enough cooling power. This PCM is used during the physiological evaluation. It offers the strongest cooling which could result in a greater sport performance improvement. Inu 6,5 can be kept frozen and even be recharged in a normal coolbox with ice.*

*Side note:

This is true for a coolbox with only ice. If salt is added the melting temperature of water lowers making it possible to reduce the temperature in the coolbox significantly. Preliminary tests indicated that the temperature at the bottom of the box can go to -10°C easily. Chapter 6.7 describes these tests, one outcome is that H2neO might be better suitable for coolbox-recharging than Inu 6,5 despite the lower phase change temperature. This however needs to be confirmed with more tests.

1. H2neO Ice +Neoprene

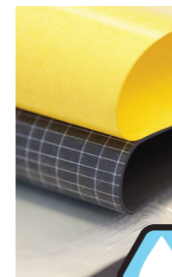

2. Inu 15 INUTEQ-PAC 15°C



3. Inu 6,5 INUTEQ-PAC 6,5°C

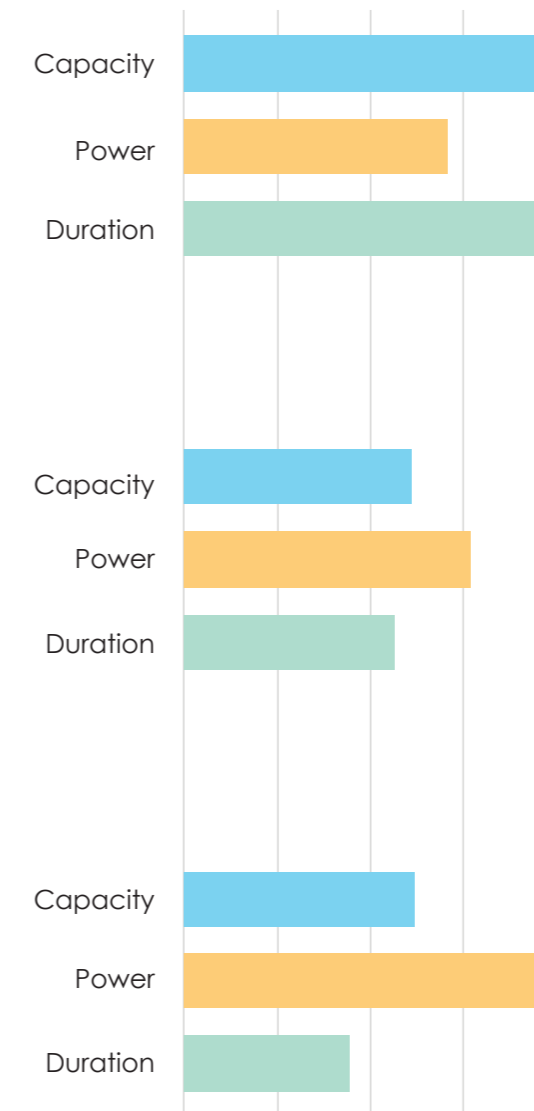

2.4 PCM packaging



Parallel with experimenting, evaluating and choosing the right PCM for the garment, a way to package it was researched. The goal was to find a way of packaging that is sturdy, flexible and easy to prototype with.

Company visit: Inuteq

A partner of the overarching Thermo Tokyo project is Inuteq. Inuteq sells cooling garments and accessories. Most production of garments is sourced out in China. In the Netherlands Inuteq has machinery to package the PCM oil in a special TPU (Thermoplastic Polyurethane) sheets. A visit to their production site at May 5, 2019 showed their PCM packaging possibilities.

The core product is an 8-cell PCM package that contains 300 grams of PCM. A vest can carry 4 of these packs in small mesh-like bags. A machine automatically fills and seals these packs. The little Velcro at the top of the packs keeps the packs in place in the vest, it is welded to the TPU foil with an ultrasonic welding machine shown in Figure 1. A vest with four 300 gram 15°C PCM packages is supposed to cool the wearer for about an hour according to Inuteq co-owner R. Bokslag (personal communication, May 5 2019). There is no scientific data on how long they exactly work. The cooling time depends wildly on the environmental en excersice conditions.

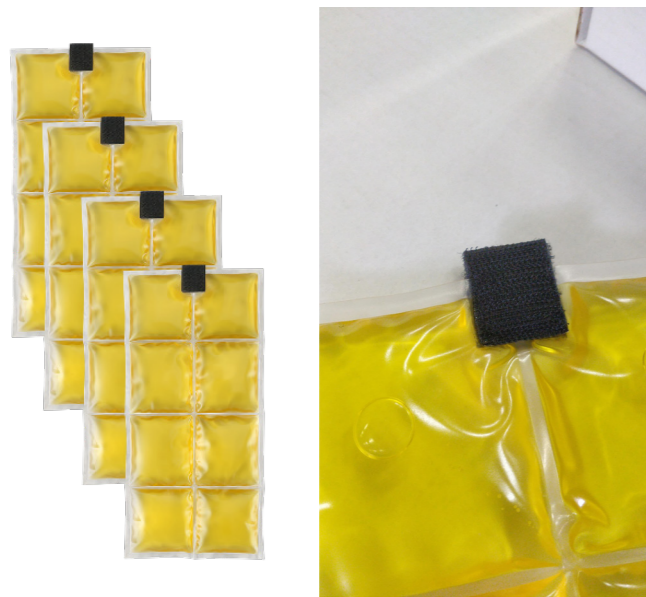

Besides the automated production of PCM packages they are also able to produce packs with a custom shape. This is done with aluminum molds and a heat press. First the outline is sealed (Figure 3 A) next the bag is filled with the right amount of PCM. Third the bag with PCM is placed in an aluminum mold (Figure 3 B) underneath a heat press. This seals the foils together through the PCM creating a custom shaped package with multiple cells (Figure 3 C). The custom package shown is meant to be placed in a back protector used by motorcyclists.

Figure 1: 8-cell PCM packages and ultrasonic welding machine used to attach Velcro.

Laser sealing

A drawback of these custom shaped packages is that the production is much more expensive because it requires custom tooling and production is much more labor-intensive. Inuteq uses a heat press or an ultrasonic welding machine to seal the sheets of TPU together. At the faculty of industrial design engineering these facilities are not present. At the start of the project some samples were made using an iron and a baking sheet. This does work but is very labor intensive and the quality of the seal not consistent.

S. Calish (2012), student at MIT, mentioned on his blog that he could weld TPU foils using a laser cutter. This was tried in the lab as well with a 80W CO2 laser. (Merlin, Lion Lasers) The lowest power setting of the laser is however still too powerful, this problem is solved by defocusing the laser. The power is then spread over a wider area melting the foil together without burning through it. The coaxial gas flow provides enough pressure to create a good airtight seal. A more elaborate explanation of the laser sealing procedure can be found in Appendix J. It is worthwhile to read this Appendix if you want to try laser sealing TPU yourself.



Figure 2: Laser cutter used for sealing and a close up photograph of the laser head above sealed foil.

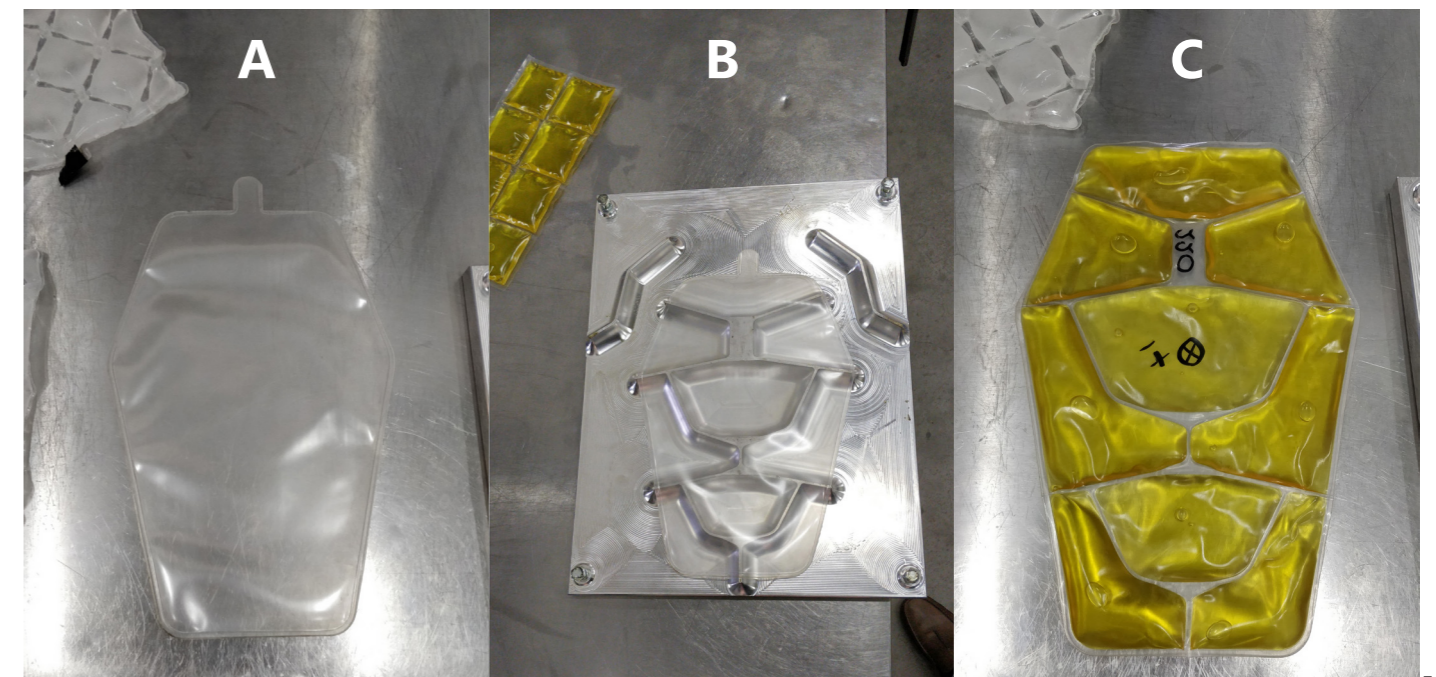

Figure 3: Three steps towards a custom shapes PCM pack.

Packaging form

The stock PCM packaging of Inuteq, the squares, is good but there is room for improvement. With the laser sealing technique it is possible to create a wide variety of custom shapes.

Several different shapes and patterns were prototyped and tested, three versions are shown in Figure 2. In the end a hexagon pattern proved to have the best balance between flexibility and rigidity. The hexagon pattern has enough flexibility to bend around body curves, and has enough rigidity to not be too flimsy when handling a sample. Other shapes would fold too easily when trying to push them underneath clothing. Figure 1 shows the different axis around which the hexagon pattern can bend.

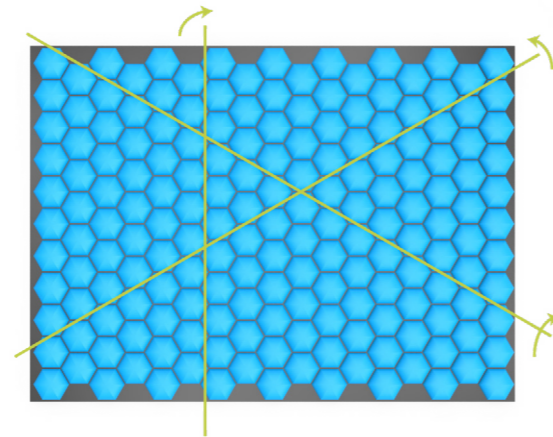

Figure 1: Axis around which a hexagon pattern can bend.

A hexagon pattern will be used, this forms a lattice of solid parts that has the right balance between flexibility and rigidity.

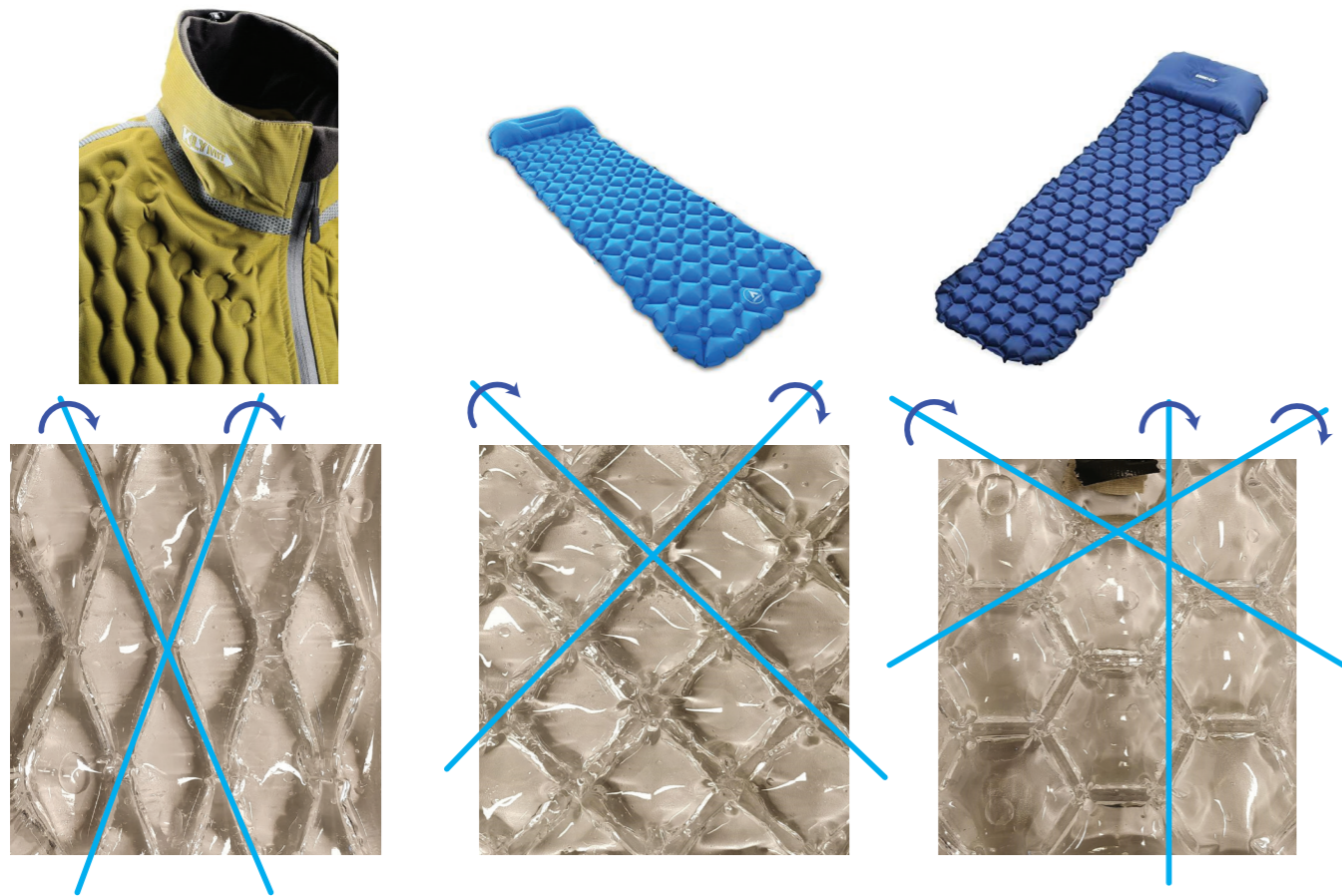

Figure 2: Three packaging patterns with accompanying inspiration. The blue lines indicate the axis around which the sample can fold.

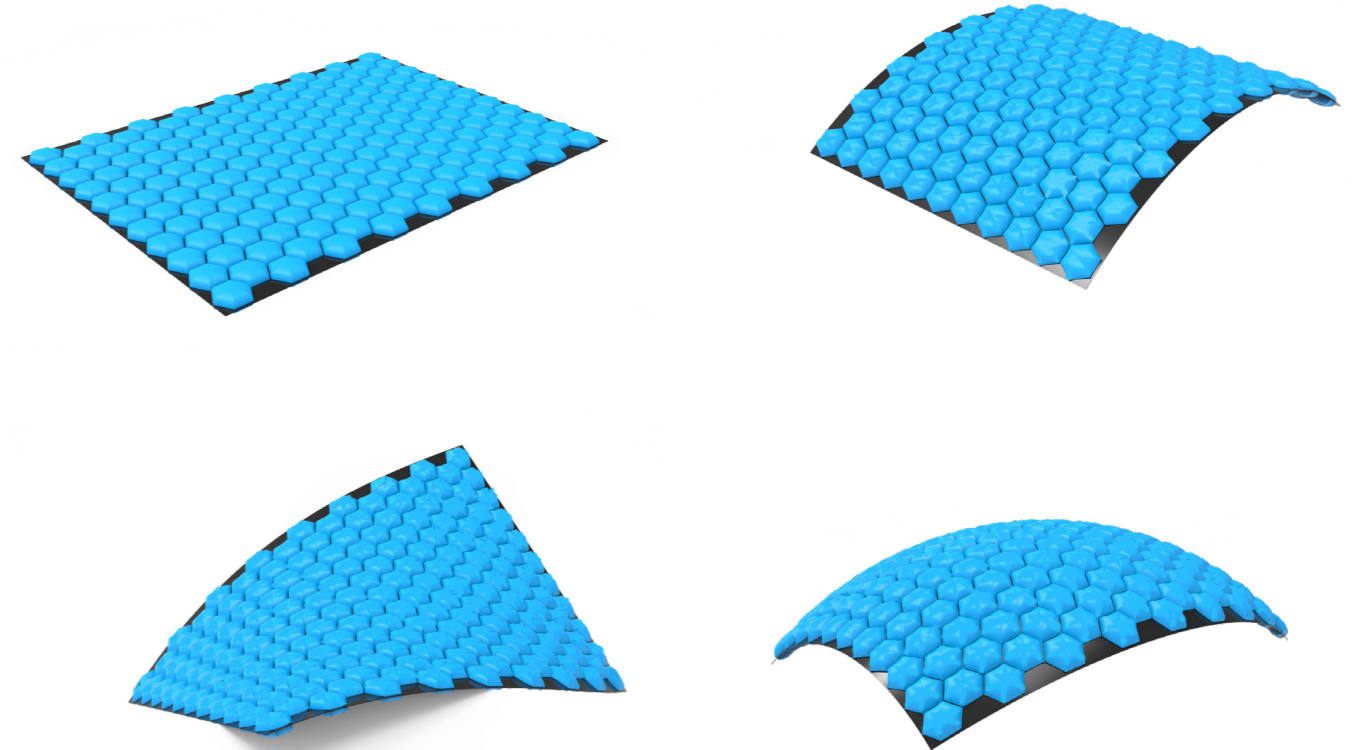

Figure 3: Bending possibilities of the hexagon pattern.

One prerequisite of prototyping with the laser cutter is that the enclosed volume should be continuous. Then the PCM can be inserted from one filler hole and spread through the whole pack. It would be tedious to have to fill and seal every volume separately. This is the reason that inflatables formed a good source of inspiration (Figure 2).

The lines to create the hexagon sample have evolved to maximize the total seal length to improve burst strength, with as boundary condition that the PCM can flow freely from cell to cell (Figure 4). An advantage of this free-flow design is that, if there is a pressure point, the excess PCM can flow to another cell. The same principle can be a disadvantage because the PCM can spread unevenly over the package. In practice this was not an issue because the channels are narrow and offer enough resistance. The blue sealing pattern is used in the proposed design as described in paragraph 5.1.

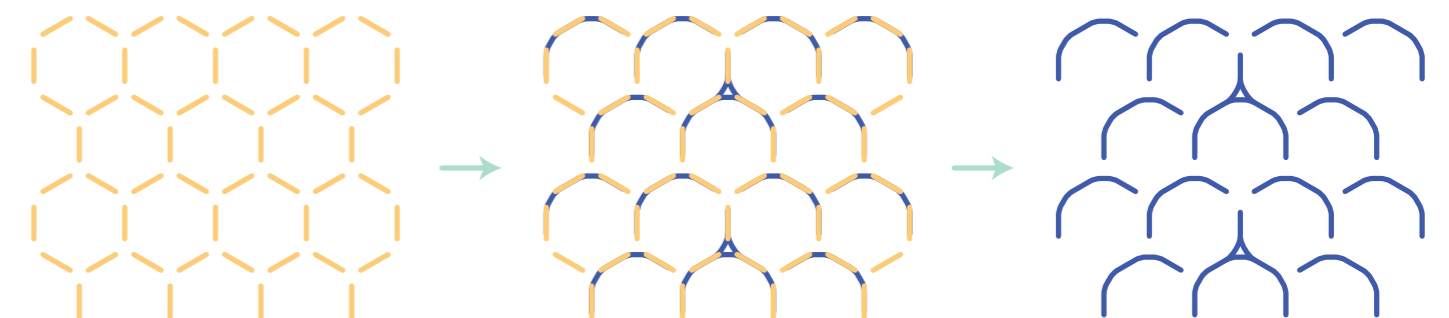

Figure 4 evolution of the hexagon pattern to seal.

Packaging Thickness

A pragmatic test showed that the vest's thickness would not be limited by the ergonomically available space underneath the flotation aid. A description of the test can be found in Appendix K.

Cooling time relies mainly on mass per surface area which in turn is mainly influenced by the thickness of the PCM package. It is hard to predict the thickness of a sample based on the dimensions of a seal pattern. Attempts to find a formula to estimate the thickness of a hexagon package based on the rib length did not succeed. The attempts and results of the validation experiments can be found in Appendix L.

The square PCM samples tested on the Hotplate (Chapter 2.2) were approximately 2 cm thick and weighed 250 grams. These packages had sufficient cooling time. Empirically, packages with different hexagon sizes were made to approach the same characteristics as the PCM samples. A rib-length of 25 or 30 mm gives be a good balance between capacity and wearing comfort. 40 mm results in too big bubbles causing discomfort (Prototype 1, Chapter 4.2) and 17 mm does not provide enough volume for PCM.

Materials & Methods

Six samples were made (Table 1) and tested with the same protocol as used for the PCM evaluation described in chapter 2.2. Every sample was tested three times.





Rib Length	H2neO	Inu 15	Inu 6,5
30 mm	 Weight: 135 gram Thickness: 10±1mm	 Weight: 139 gram Thickness: 10±1mm	 Weight: 136 gram Thickness: 10±1mm
25 mm	 Weight: 181 gram Thickness: 16±1mm	 Weight: 173 gram Thickness: 15±1mm	 Weight: 176 gram Thickness: 15±1mm

Table 1: Six hexagon samples used to evaluate their cooling power and duration.

Result

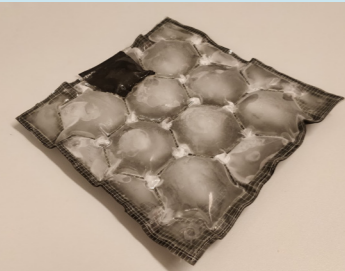
The average of three measurements per sample is calculated and plotted in Figure 1. The threshold at which the sample is less effective than evaporative cooling under the same conditions is 8 Watt. This is different than the threshold used in chapter 2.2 for the square samples. This is because the hexagon samples cover a larger area of the Hotplate. This is further explained in Appendix A.

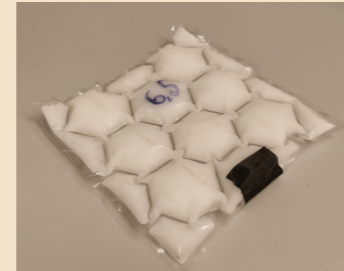
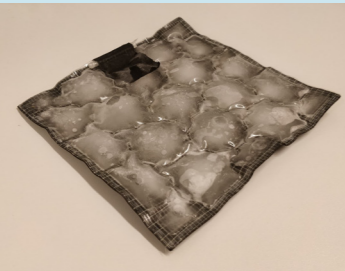
The cooling duration should be at least 30 minutes. From these results a hexagon size of 30 mm seems best in terms of wearing comfort and cooling time for Inu 15 and Inu 6,5. A size of 25 mm is enough for H2neO. 30 mm does give a longer cooling duration but this makes the package unnecessary heavy.

Discussion

Internal stress caused by thermal expansion due freezing made it difficult to ensure good contact between the sample and the Hotplate. Some tests had to be repeated multiple times to provide useable data.

The Hotplate is solid, human tissue is soft and can form around the solid hexagon pieces. This will enlarge the area of contact resulting in a larger heat flux. On the other hand human tissue has a much larger thermal resistance than the material of which the Hotplate is made. It is difficult to estimate the magnitude of these two factors.

All in all the results gives a good enough indication of the cooling durations that can be expected from the hexagon packages to be able to continue the design process. All data is available in Appendix R.

Lab tests indicate that a hexagon pattern with a rib length of 30mm is a good starting point for prototypes with Inu 15 and Inu 6,5. A rib length of 25mm is enough for H2neO.

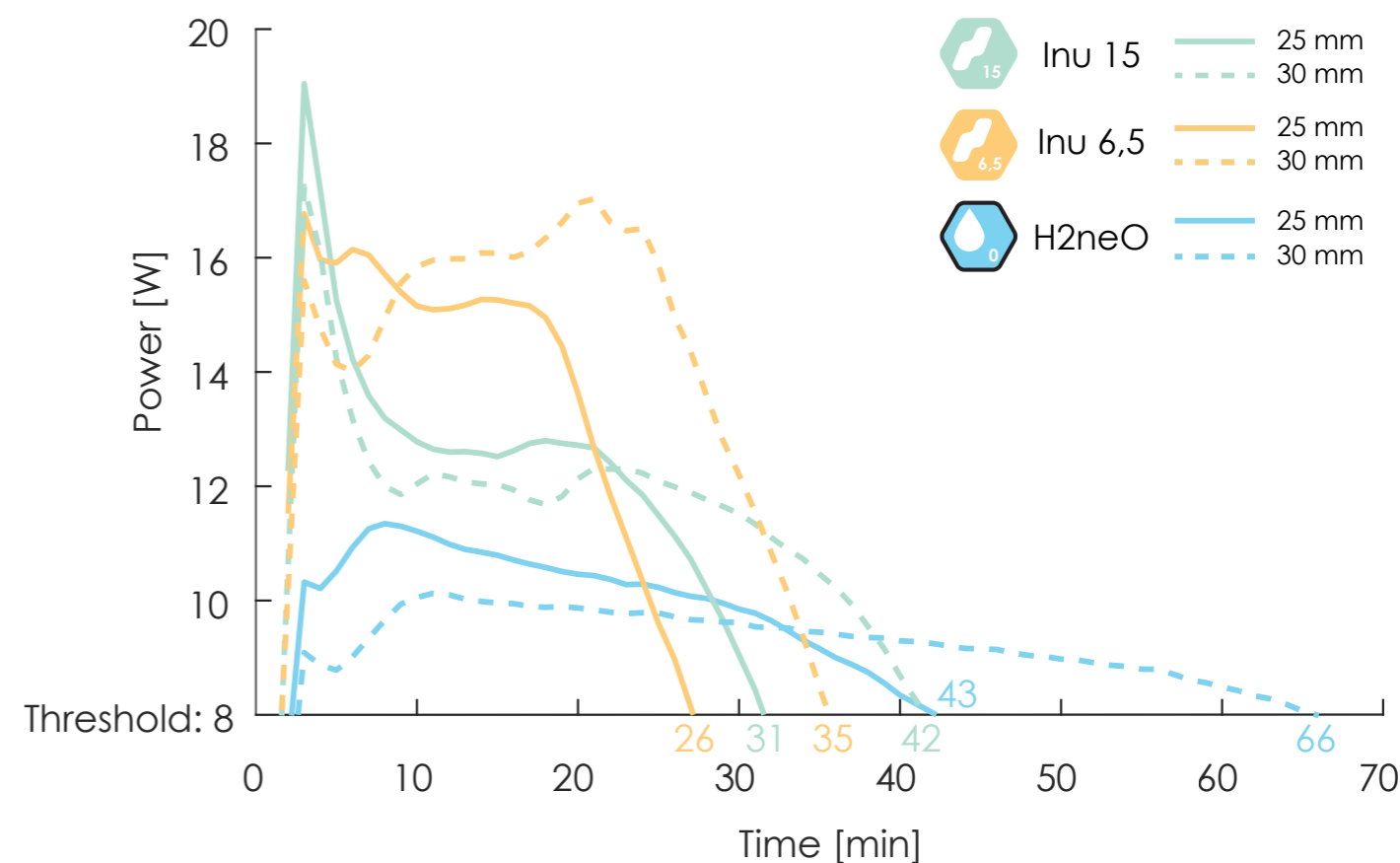

Figure 1: Average (n=3) cooling power over time of the Hex-samples shown in Table 1.

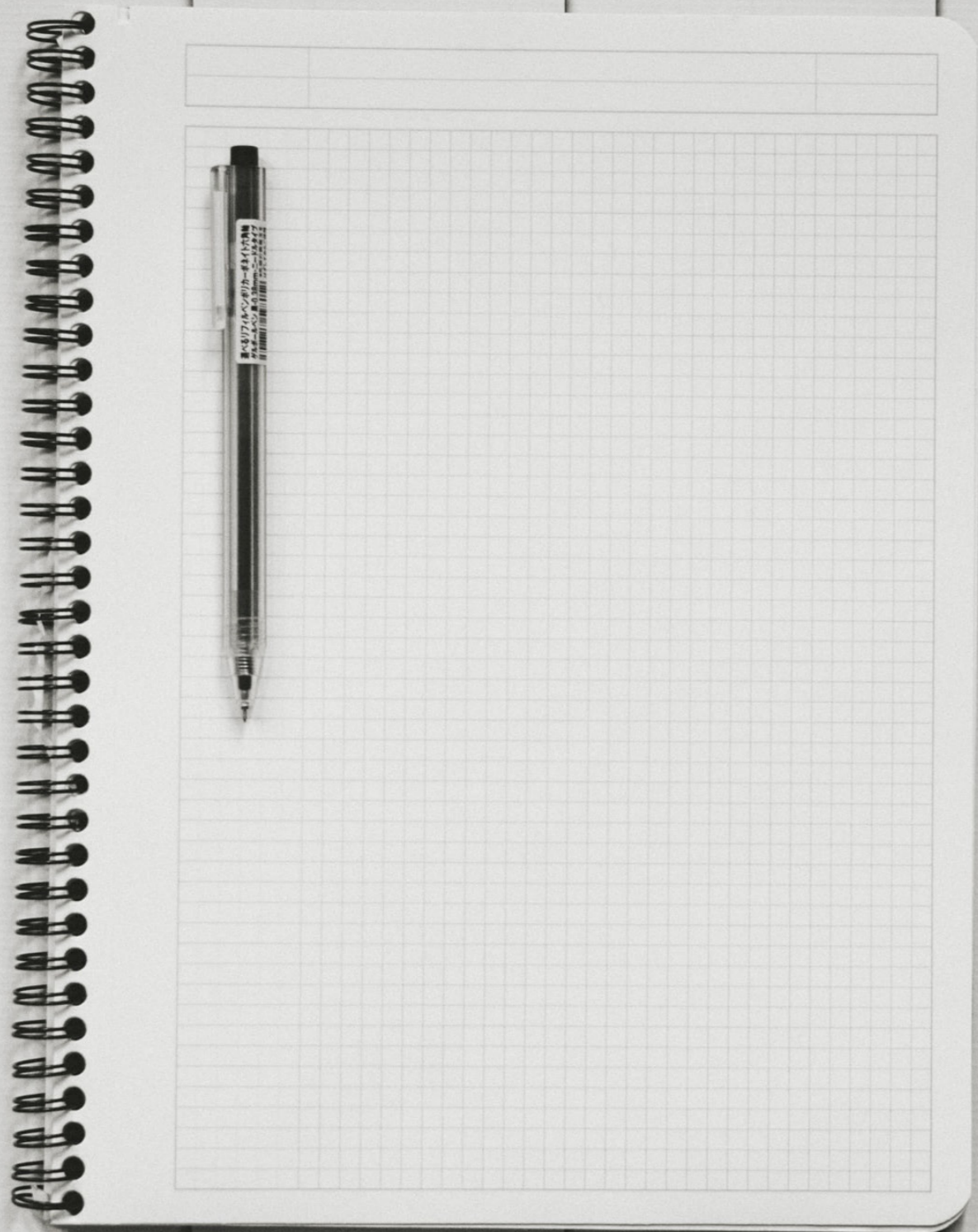

Photo by Kelly Sikkema
on Unsplash



Structure

With desk and lab research a good understanding of cooling garments, Olympic sailing and especially phase change materials is established. There are many findings from different sources. In the first two chapters all design insights, requirements and choices are highlighted. This chapter is a summary of all these findings. The findings are funneled into a list of requirements. This list formed a useable to guide for the design process, and a way to evaluate the result afterwards.

List of requirements

In the first two chapters many design insights, requirements and decisions are deducted from literature and lab research. To keep the gathered knowledge workable, a list of requirements is made. First a quick recap of the knowledge gathered so far is given. This formed the basis for the list of requirements.

Knowledge recap

The following text is a short recap of all design insights, requirements and decisions that have been presented chapters one and two of this report.

Hyperthermia is related to reduced muscle, nerve and brain performance. Cooling interventions help to reduce thermal strain and improve exercise performance. Cooling using PCMs is most promising, because evaporative cooling garments will not work underneath a flotation aid and cause discomfort. Also, they evaporation is not an effective cooling mechanism in a very humid environment.

It is likely that the magnitude of the cooling power is related to sport performance improvement. The temperature difference between skin and the PCM's phase change temperature is related to the heat flux. This relationship is not linear because of vasoconstriction. Using ice as PCM (0°C) is very uncomfortable. ICE can be used as a PCM when covered with a thin layer of Neoprene rubber.

With PCMs there is a tradeoff between cooling capacity and weight. Also, PCM packaging inhibits sweat evaporation. The best place for PCM placement is the area underneath the flotation aid around the torso. Good contact between skin and PCM is important, paraffin based PCMs are solid when frozen, emulsifying 20% water can be a solution if wearing comfort is critical. However, weight and freedom of movement are not a bottleneck, because the product will be used for pre-cooling; before and in between races.

The vest should be versatile. It must fit a wide variety of body types, and be useable in all current Olympic classes. The cooling vest should be useable while wearing a hiking harness.

A vest should be put on and off three to four times. Therefore, putting the vest on and off quick and easy is very important, the coach can help if needed. If not in use the garment should preferably be storable in a medium sized coolbox. Cooling vests should stay cold in storage for at least six hours.

The garment should give consistent cooling power for at least 30 and preferably around 60 minutes. Inu 6,5, Inu 15 and H2neO are the most promising PCMs.

List of requirements

To be able to evaluate the product, a list of requirements is set up. Setting up a list of requirements might impede the creative process (Boeijen et al. 2014, p. 103). However, I believe that having limitations is necessary for a good creative process. Limitations create challenges that spark creative thoughts. Also, the requirements help to limit the scope of the project. A clear and bounded challenge is more likely to have a concrete and good solution.

The requirements are set based on literature, lab and user research. The list is a living document and was continuously updated when new insights occurred. The list is split into demands and wishes. Demands are necessities, wishes should be covered if they do not require extensive resources. When possible, a requirement is assigned a unit and a way to measure if the product meets the requirement. Also, a short reasoning per requirement is provided. The list is kept as short as possible to keep it practicable.

A summary of the list is shown on the right. The full version with reasoning and categorization can be found in Appendix M.

Demands

- 1 Put on in 20 Seconds
- 2 Put off in 10 Seconds
- 3 Tight fit around body
- 4 No restriction in movement
- 5 Cool sensation for at least 30 minutes
- 6 Sufficient cooling power for at least 30 minutes
- 7 At least 3 vests must be storeable in a coolbox
- 8 Withstand impact without bursting.
- 9 Not toxic/harmful for the environment
- 10 Suitable for male and female body type
- 11 Weigh no more than 3 kg
- 12 Can be worn together with existing clothing
- 13 Can be used in combination with a hiking harness
- 14 Can be used in all current Olympic classes
- 15 Can withstand temperatures from -25 till +40°C
- 16 It must be possible to produce 30 units before the 2020 Olympics.
- 17 The use of the product must be in compliance with international sailing legislation
- 18 The product should not come loose unintended
- 19 The product must always be removeable from the body
- 20 The product should not degrade when exposed to sea water
- 21 Production cost is maximum 100€

Wishes

- 22 Should float when dropped in the water
- 23 Easy to throw and catch
- 24 Minimally restrict sweat evaporation
- 25 Added thickness is maximum 20 mm
- 26 Producibile with existing equipment at Inuteq
- 27 The product should have an high tech and effective appearance
- 28 Broken parts should be easy to replace
- 29 Rechargeable in a cool box at sea
- 30 Take up a minimum amount of weight and space for flight transport



4

Integrate

Prototyping was done parallel to the lab experiments and desk research. This formed a nice synergy. Prototyping and user testing exposed knowledge gaps, that in turn could be covered by lab and desk research. When laser sealing TPU sheets became somewhat viable the first prototype was made. This was the first of a large series of prototypes that evolved into the proposed design at the end of this project. Multiple iterations allowed for many tests and helped to keep client and users involved.

This chapter gives an overview of all versions and how they came to be. Some decisions made for earlier prototypes might seem backwards if you have read the previous chapters. Nevertheless, it can be interesting to see how the results of lab and desk research influenced prototyping.

4.1 Rapid prototyping

After having acquired enough information from interviews, lab- and literature research the design phase started. During the design phase many more insights into the context were gathered.

An agile and iterative approach was chosen because of multiple reasons. The first reason being that there were a lot of uncertainties. The human body is difficult to model, and the required flexible materials show unpredictable behavior. Secondly, prototyping with the laser cutter gives a lot of freedom. It is relatively affordable and fast. This makes it possible to create multiple prototypes in a short amount of time. Thirdly, with many iterations it is easy to involve people in an early stage of the design. They can interact with a physical prototype, a design on paper is hard to convey. Also, since no cooling vest are used by Sailors prior to this project, this will help creating support for using such products. Lastly, the iterative approach suits my personal working style. In my enthusiasm I want to reach a goal fast, and I quickly become a bit careless. Multiple iterations make it possible to fix problems that are overlooked.

The method used is based on the SCRUM method with as primary driver: 'Fail fast and fail cheap.' Quick cycles of designing, prototyping and testing were executed. Every cycle rendered new insights and challenges. During the process the SCAMPER method (Boeijen et al. 2014, p. 123) is implicitly used. By Substituting Combining and Putting things to other use the design evolved.

Every iteration can be divided roughly in the following four phases:

1. Ideate
Convert previous insights into potential ideas and solutions.
2. Design
Incorporate new ideas in the design.
3. Prototype
Materialize the design and its functionality.
4. Test
Check if assumptions are true by testing the prototype.

These phases are illustrated with the icons shown in Figure 1. With every iteration the prototype improved. Quality of testing also improved every step. Starting with wearing the prototype as a researching, till doing a user test with world's number one sailor and her coach. Since iterations had to be quick, testing and results are qualitative.

Please take note that the knowledge presented in the previous paragraphs was mostly not available when making the first few designs and prototypes. Some of the decisions made in the beginning might seem backward in hindsight. At the time they were a logical step to explore the possibilities.

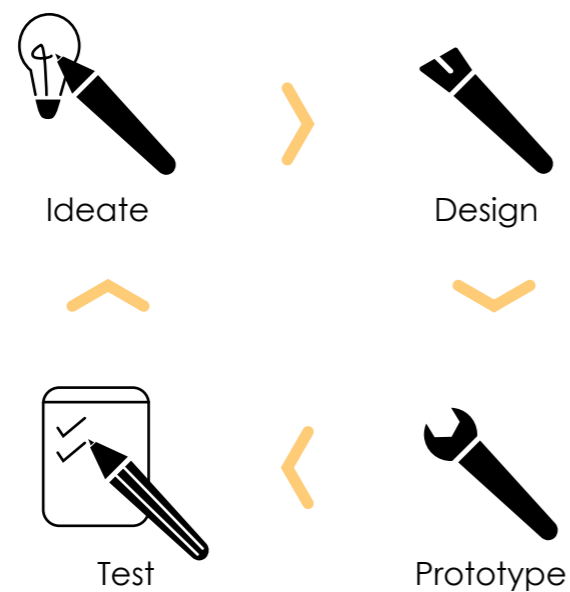
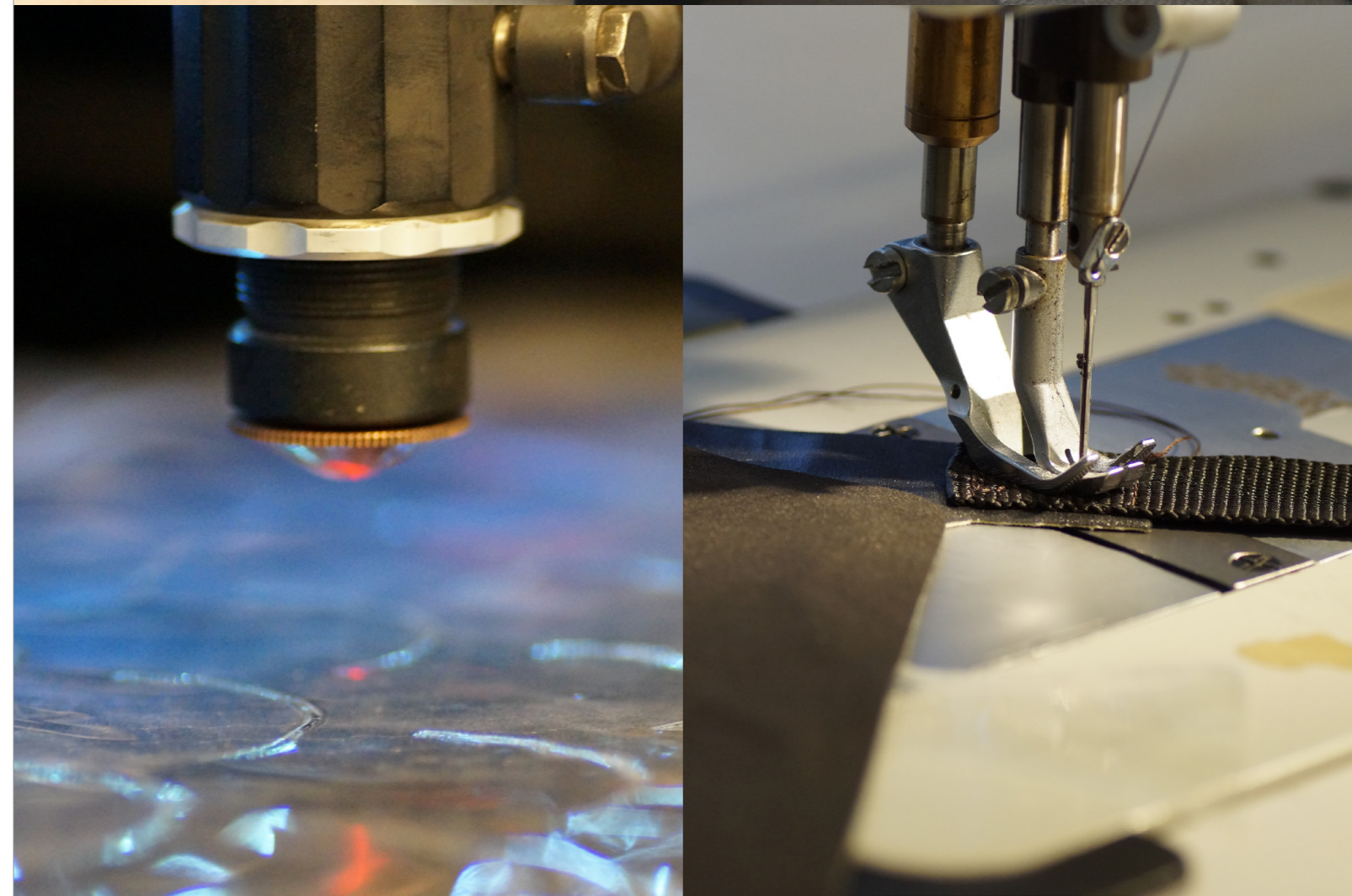

Figure 1: Icons used to indicate the four phases per iteration.



4.2 Prototype 1

The first prototype was made just after laser sealing proved to be a potential prototyping technique. The first prototype did not follow the design cycle as explained on the previous page. There are actually two smaller iterations for the front and rear part of the vest.



Ideate

The goal of the first prototype was to find out how to apply a cooling vest without the need to remove clothing items. Ideation rendered plenty ideas but most of them are not applicable or unnecessary hassle. Sliding in a front and back part from the bottom seemed most promising.

The vest can be applied underneath clothing by sliding in from below.



Design: Rear pack

Designing the first version was focussed on how to create a sealing pattern that is strong, and can contain a big amount of PCM. This to achieve the highest possible cooling duration. The dimensions were based on how much space is available underneath the flotation aid, this was assessed with the test shown in Appendix K. And on the size of the foam blocks inside the flotation aid.

The rear pack was designed to be 650 x 450 mm and with a hexagon radius of 41 mm.

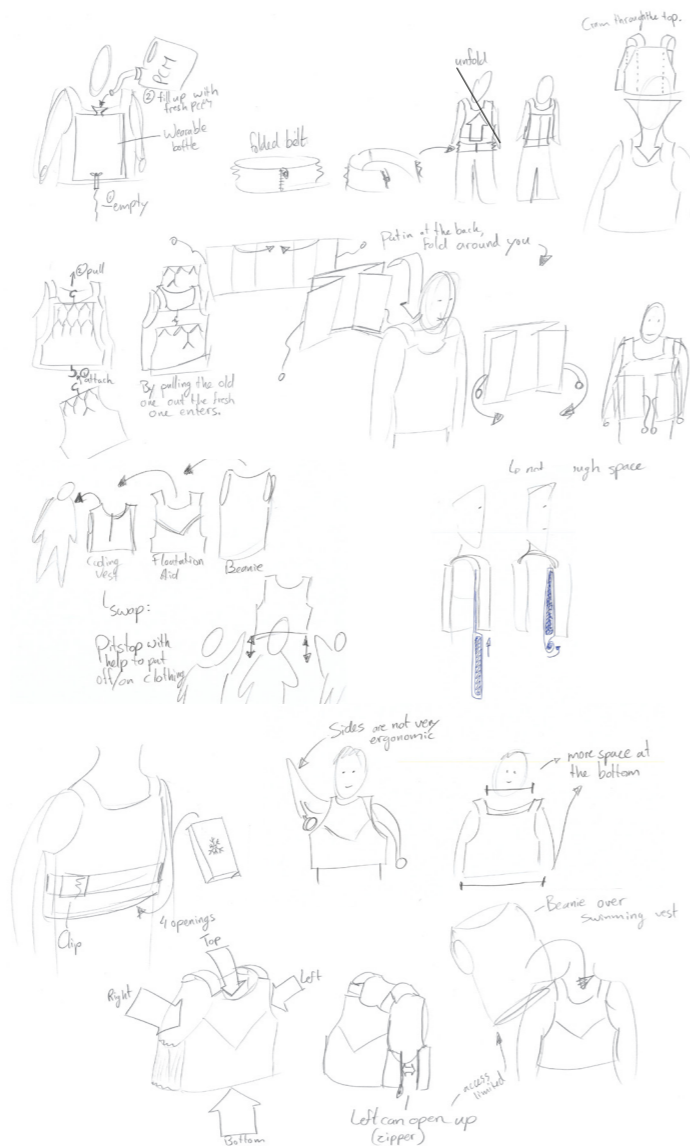
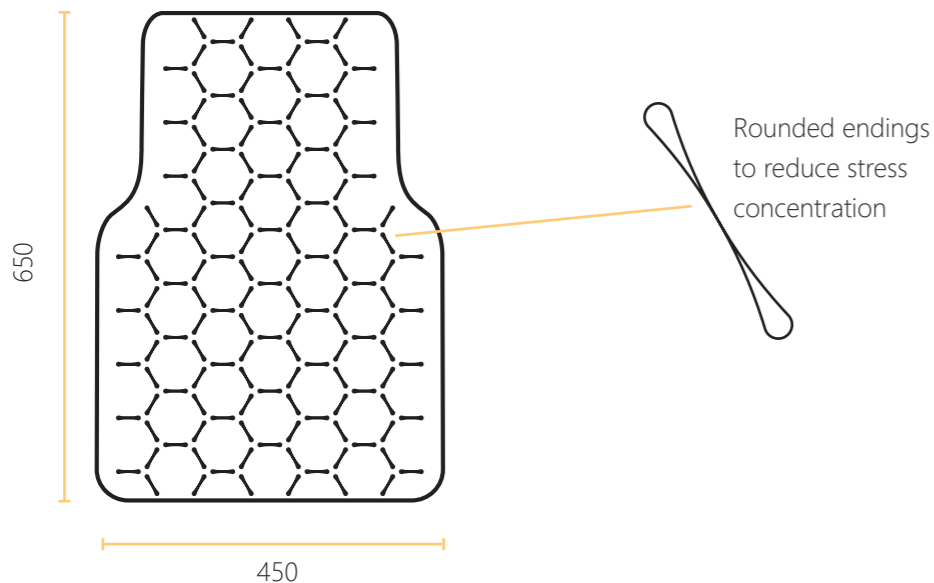

Prototype: Rear pack

This was the first time a sealed package of such a big size was made. After multiple attempts the rear side succeeded. The rounded endings trick did not work because sealing twice over the same area weakens the TPU sheets too much. The sample was leaking badly but it was good enough to evaluate that the pack was way too heavy. It should be much thinner.



Design: Front pack

The hexagons were reduced to a size of 25 mm. Also, the rounded endings trick was not applied. The front pack's size was based on the size of the front foam block of the flotation aid. It measures 500 x 500 mm.



Prototype: Front pack

The prototype succeeded. The edges were leaking but with some tape it could be frozen and tested.



Test

The prototype was tested by myself. Sliding in the pack from below went well while wearing all sailing clothing. The pack's width and height were too big. Especially the front part was too long; bending forwards would give annoying pressure at the stomach area.

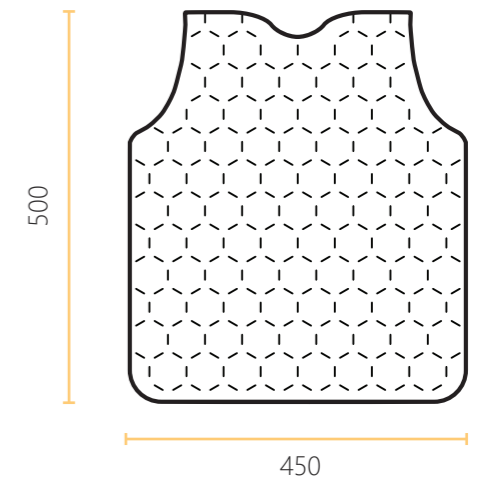
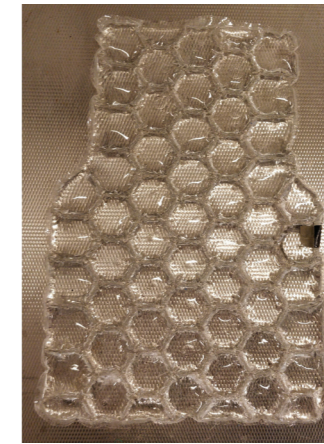

4.3 Prototype 2

The second prototype focussed on improving the shape of the packs and to improve the laser sealing's reliability.



Ideate

An insight from wearing the sailing clothing was that the elastic band of the overtop could be used to press a cooling pack against the wearer's body. This would make it possible to enlarge the rear part of the vest without the need of adding fasteners.



Design

The front pack has been shortened. The rear pack has a more convenient shape to slide in and a ridge has been added in which the can elastic band of the overtop can fit.

The front pack was designed to be 360 x 400 mm and the rear 600 x 400 mm, both with a hexagon radius of 30 mm.

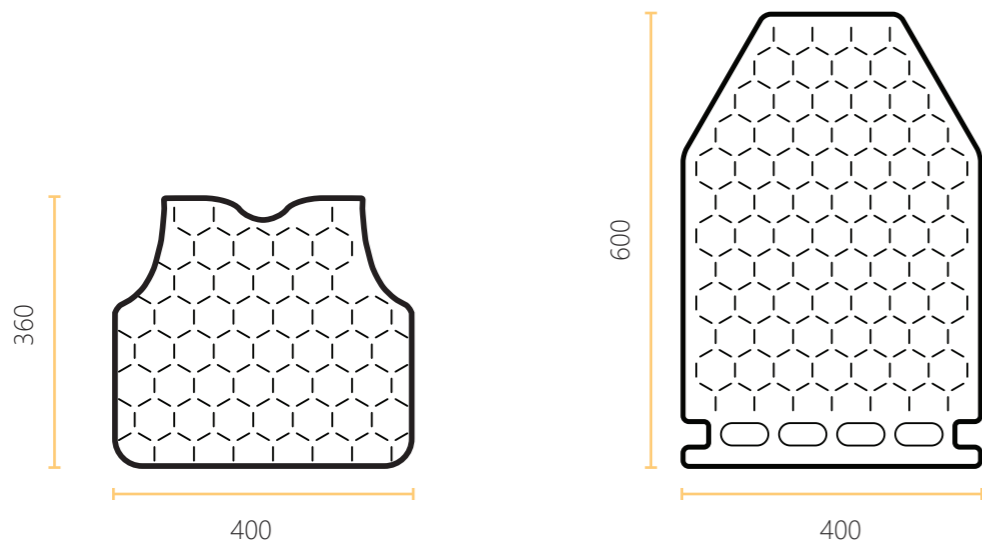
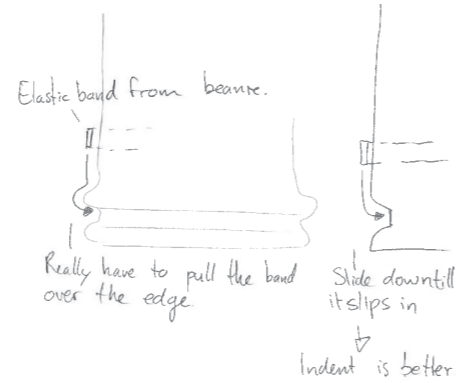
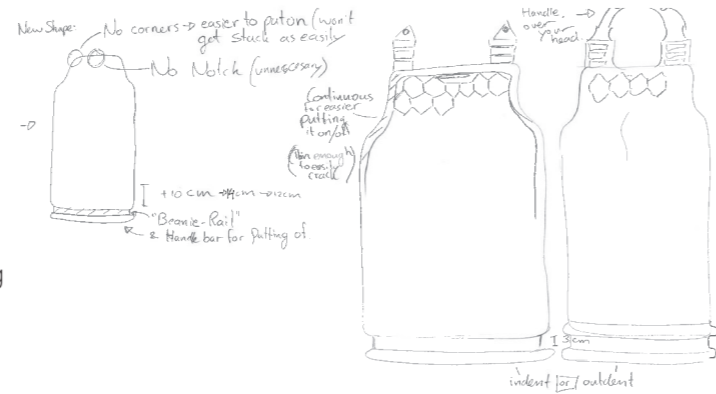

Prototype

Prototyping went much better because laser settings and the way of mounting the sheets on the laser bed had been further refined. This was the first prototype that was not leaking.

When filling the sample the total surface shrinks. This is less so at places where there are less sealing lines. This caused the sample to crumple at the edges. This is especially notable at the lower band (Figure 1)



Test

The prototype was tested by myself. The thickness of the packs is good. The size of the front part as well. The rear part works as well but the crumpled edges hinder sliding the pack underneath the flotation aid.

The prototype was used to do some preliminary tests on how to add straps to help handling the packs and to fixate them to the wearer. The flotation aid is too flexible to attach a heavy cooling pack (Figure 2) A better way is to attach both packs together over the shoulder (Figure 3)



Figure 1: Crumpled band due to filling the pack.



Figure 2: The shoulder bands of the flotation aid are too flexible to carry an ice pack.

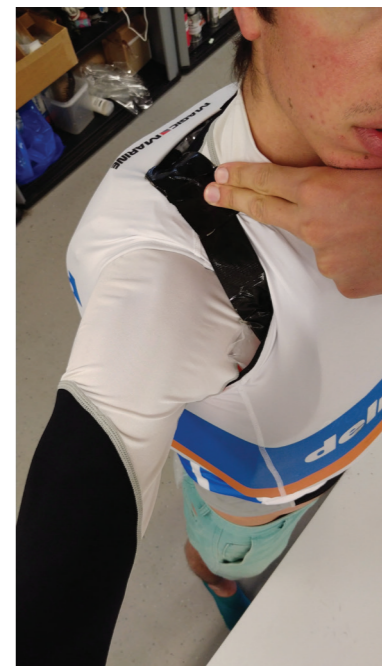
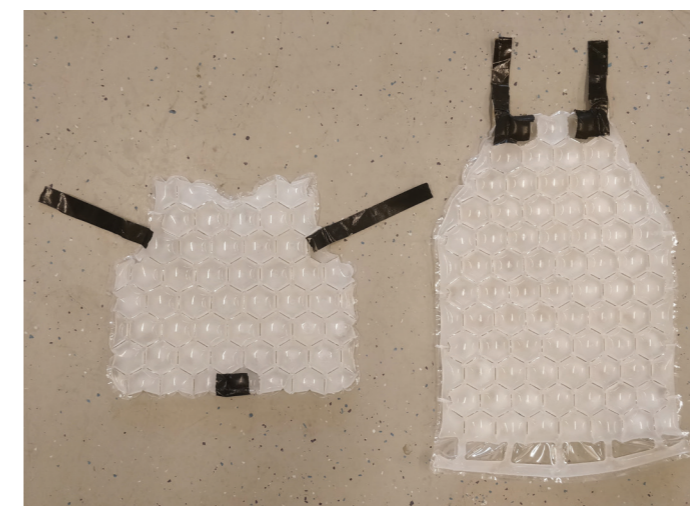

Figure 3: Attachment over the shoulder keeps both packs well in place.

4.4 Prototype 3

The third prototype focussed on improving the ease of applying the packs underneath the flotation aid and to fixate them.



Ideate

First a way to put on the rear pack yourself was to be found. This proved harder than it seemed. Applying the rear pack yourself is barely possible. The best solution is that the coach or a fellow sailor helps with pulling the rear pack through the flotation aid.

Someone has to help with applying the rear pack.

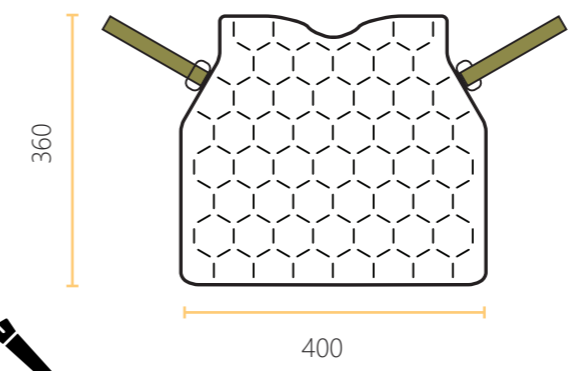
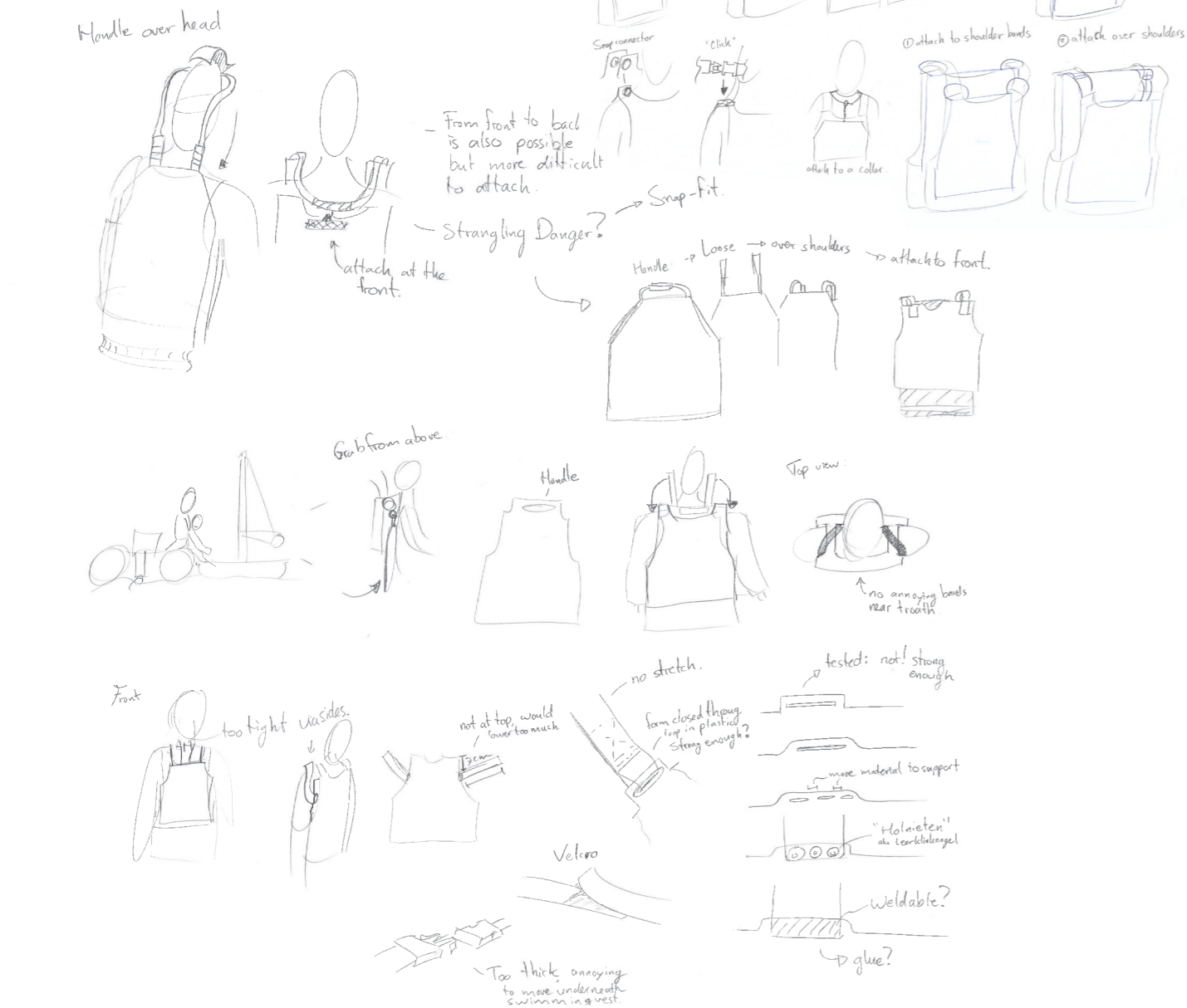

Design

Straps have been added to the packs. The ones at the front are not directly at the top so it is more convenient to pull it up as far as needed. The rear straps can form a handle that can be used to pull the pack upwards. A section at the top has been added that could function as a grip when grabbing the rear pack.



Prototype

The prototype is quite similar to the previous version (2). Straps have been added, they are 25 mm polypropylene straps. They are sewn to the TPU sheets, at the place they are attached the TPU sheets are reinforced with strong waterproof tape.



Test

The handlebar indent at the top of the rear pack does not offer an advantage. Joining the straps together at the top does give a very good handlebar. Straps can be attached back to front over the shoulderpieces of the flotation aid, this works well and keeps everything in place nicely.

The straps of the rear pack can form a nice handlebar.

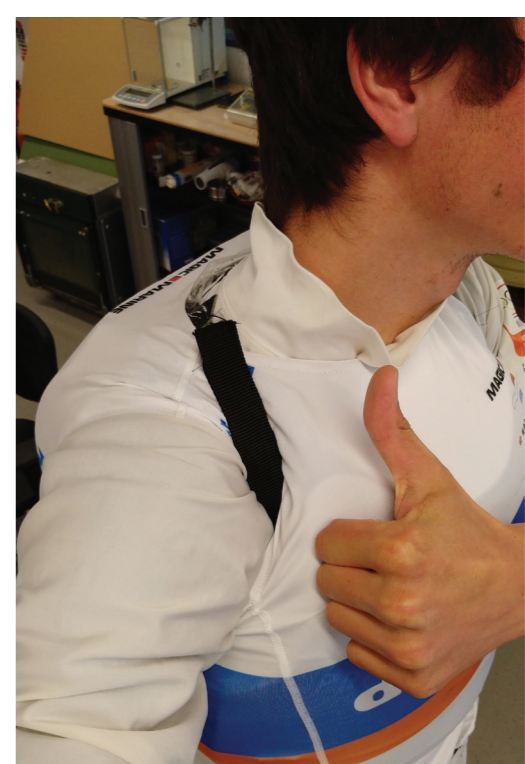
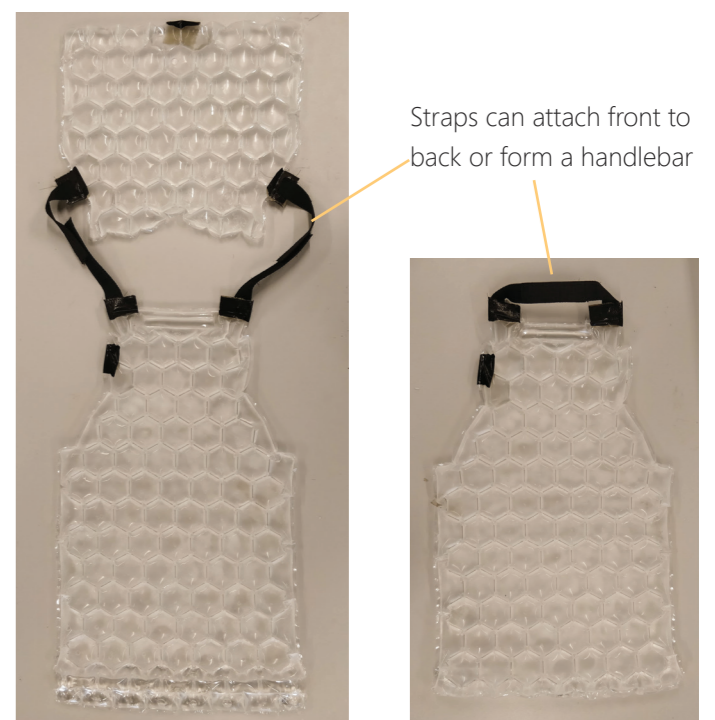
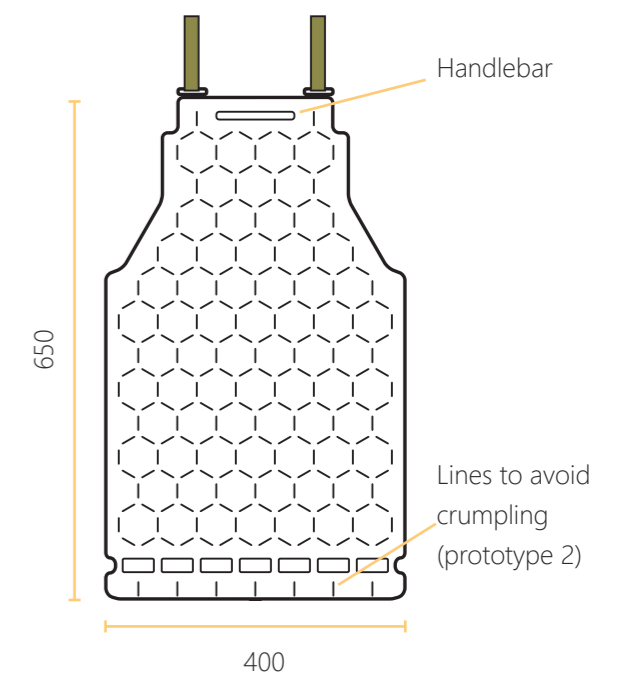

4.5 Prototype 4

The fourth prototype grasped the insights of the previous three prototypes and was reliable enough for a low key ergonomics test with external people.



Ideate

Not much ideation took place, the design is a wrapup of the insights gathered with previous prototypes and research.



Design

The straps of the front pack have been reduced in size, they are more attachment points for the rear straps. The front and back are very long to check if it is possible to cover such a large area with PCM without becoming too uncomfortable.

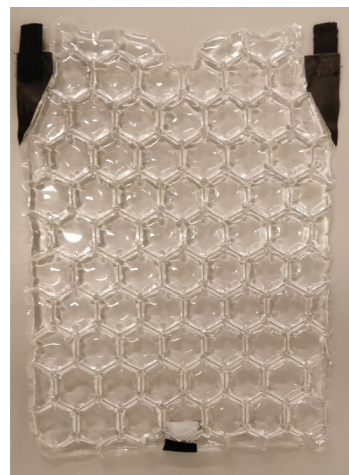
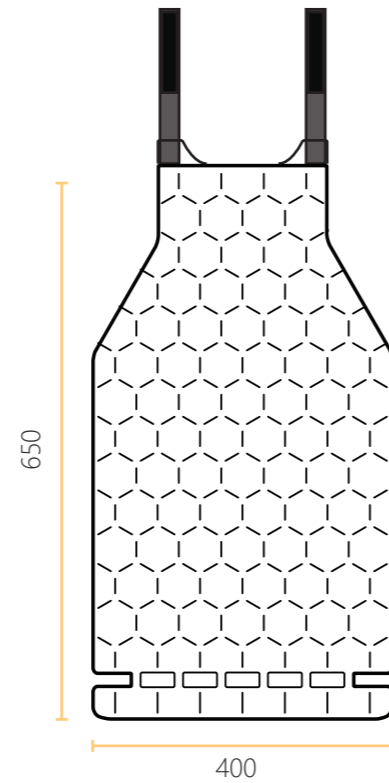
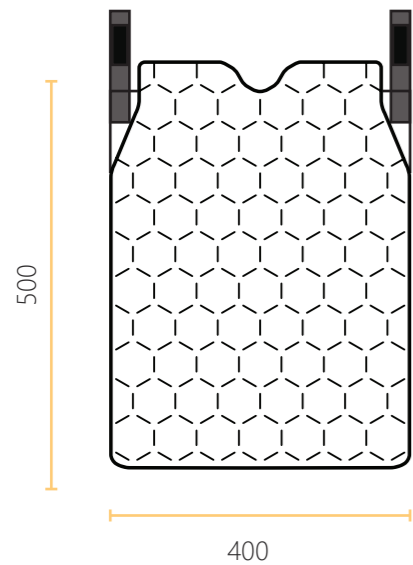

Prototype

Prototyping succeeded very well. Good tape and velcro helped to get a decent prototype. Letting the sealing lines of the hexagon pattern continue to the edges did stop crumpling but it also made the edges more prone to leakages. The prototypes were strong enough to survive a few small tests.



Test

The previous prototypes were only tested with my own body. Two people were approached to try to put on the prototype, one male and one female. The prototype did fit fine for both with reasonable comfort. The length of the packs did not pose an issue but the width was a bit too large. Both participants commented that the elastic band of the tocover did not apply enough force at the lower part of the rear pack (Figure 3).

When observing the participants both tried to pull the front pack upwards in stead of shoving it in from below (Figure 2). To accomodate this behaviour a small handle at the front was prototyped (Figure 1), this feature was further developed and included in the successive prototype.

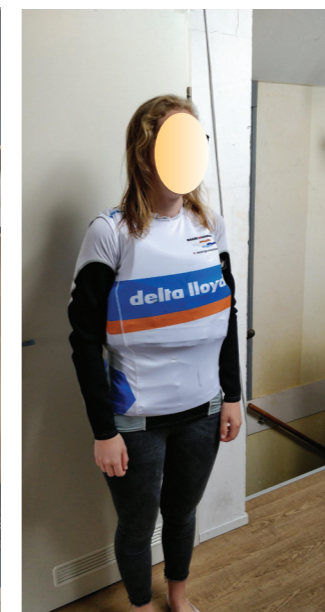

Figure 1: Prototyped handle

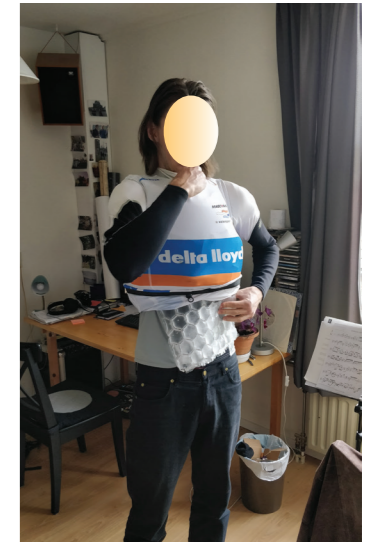

Figure 2: Participant looking for handle



Figure 3: Elastic band exerting pressure on the ice pack.

4.6 Prototype 5

Not much changed with the fifth prototype except that the results of the PCM analysis (Chapter 2.3) were included. Two versions are made; one with Inu 15 and one with H2neO as cooling material. Ideation was not necessary.



Design

Form-wise, only marginal changes took place. A small handle has been added to the front pack. The front straps are now only patches of velcro on which the rear straps can be attached. The outer edges have been smoothed to accommodate the hexagon pattern to avoid leakages. For H2neO a 25 mm hex grid was used and for Inu 15 a 30 mm grid.

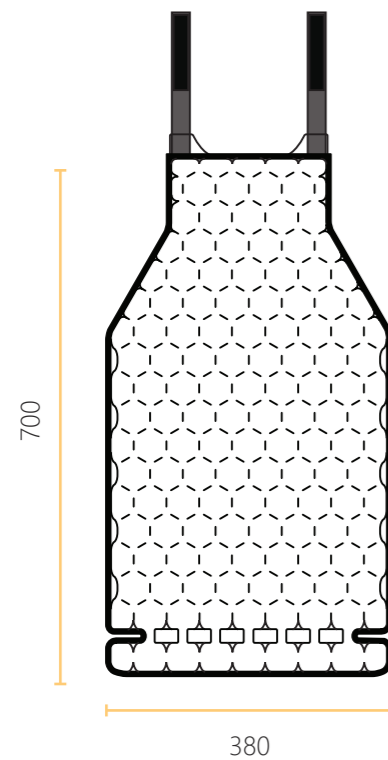
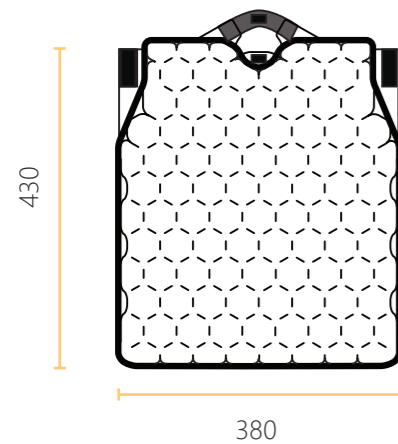

Prototype

Filling the prototype with Inu 15 was harder than with water, the distance between seals had to be enlarged. Also, properly applying the Neoprene layer to the sealed TPU proved to be quite a hassle. Eventually, prototypes were ready to be shown to the client.



Test

The H2neO version is more comfortable than the Inu 15 version. At first it feels about equally as cold as the Inu 15 version, but after a while it starts to feel colder.

The prototypes were brought to an excursion at the Sailing Innovation Centre in Scheveningen (Figure 1). Unfortunately, it was not possible to do a field test at the time. The vests were presented to the client (D. Broekens) and to a coach (A. Sign). Both were quite positive about the result so far. The comments Broekens and Sign made while discussing the prototypes showed that they were mostly worried about the ease of use of the product. The focus of the project so far had been very much on the prototype itself, and not so much on how it must fit in the whole context. In terms of effectivity, they mainly cared about if the vest would cool long enough. They were not very interested in the total cooling power.



Figure 1: Observing 49'er FX sailors during an excursion.

Eye icon: Ease of use overrules effectivity.

This insight was supported by Dr. Ir. A. Jansen, he motivated to focus on usage in a broader sense en to search for solutions beyond cooling vests. One of these solutions is described in Appendix N.

After experiencing the situation on the RIB during an excursion it became clear that adding supplementary equipment for cooling vests would be very unwelcome. At most an extra coolbox could be added.

Arrow icon: The vest should easily fit in a medium sized coolbox.



Figure 3: The current vest does not neatly fit in a medium sized coolbox.



Figure 2: The coach boat (RIB) is a crowded place..

4.7 Prototype 6

The sixth prototype was designed to explore a broader range of cooling possibilities, and to improve the use in a broader sense. The prototype was tested during a training event by Olympic champion Marit Bouwmeester.



Ideate

Ideation mainly focussed on extra products that could be an addition to the front and rear pack. Another important point was how the packs should be transported. The idea to make side-packs that would also function as cooling elements to optimally use the space available in a coolbox, was deemed worthwhile to include in the sixth prototype. The ideation towards this concept is shown in Figure 1.

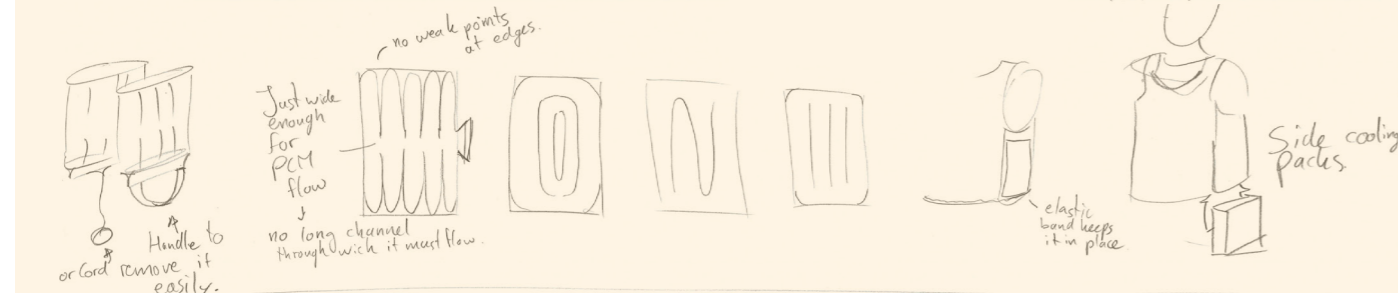
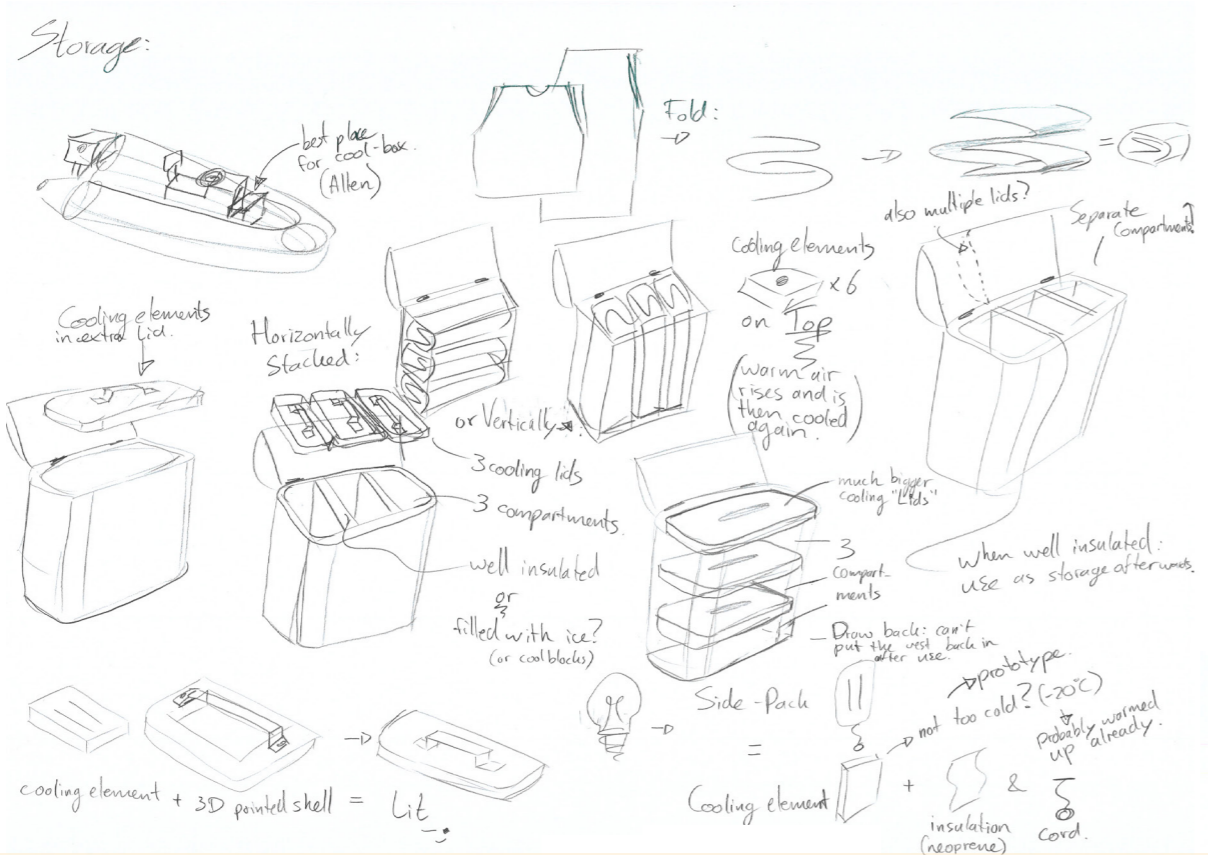
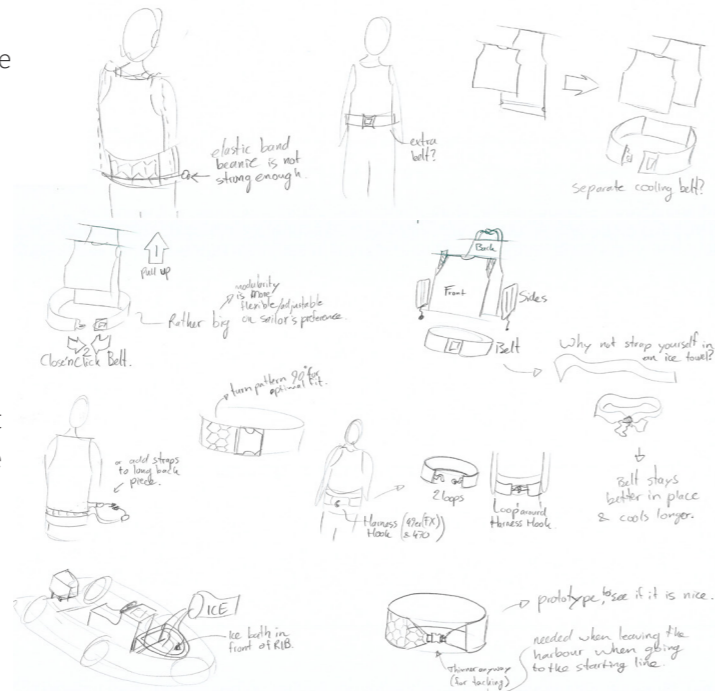

78 Figure 1: Ideation towards side and neck pack.



Design

The front and rear packs are smaller to fit in a medium sized coolbox. Ridges are added to ease folding the packs for placement in freezer or coolbox without crumpling the pack. A side pack has been designed that can be placed on the left and right side of the flotation aid (Figure 2). Together with the extra pack that can be worn around your neck (Figure 3) the three extra packs also function as cooling elements in the coolbox. They are filled with saline water that has a melting point of -5°C.

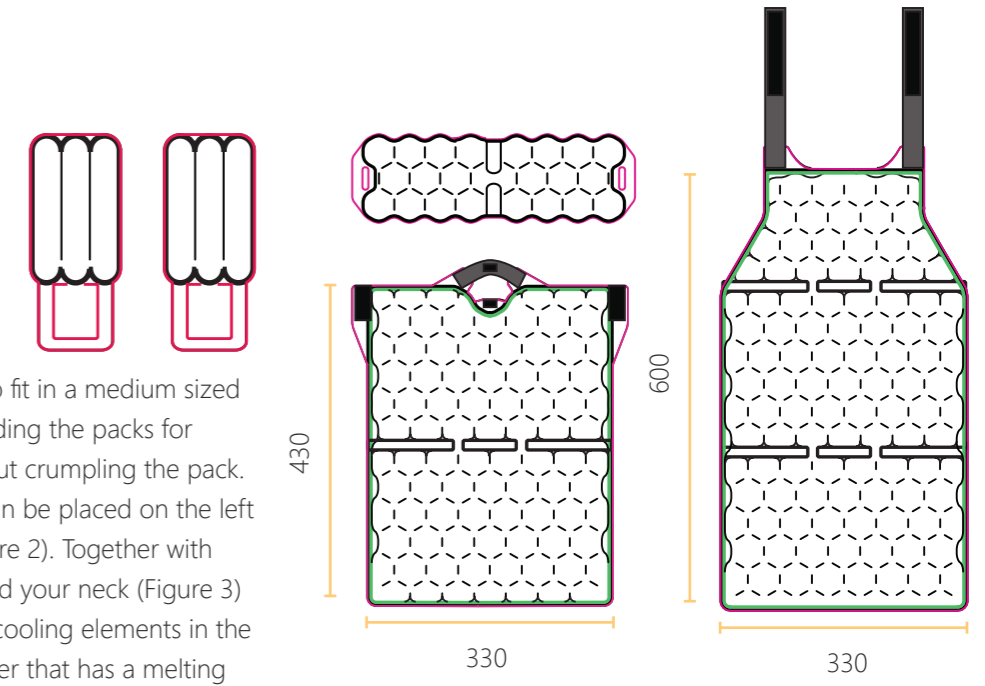

Figure 2: Evolution of the side packs.



Figure 3: Design of neck-pack.



Prototype

The new side packs went through a series of iterations to optimize their form and size (Figure 2). Two main prototypes were made, one with Inu 15 and one with H2neO (Figure 4). Colorants were added to indicate the different packages and to emphasize their different melting points.



79 Figure 4: Prototype 6, the version with H2neO (blue) is shown on the left, together with the side (red) and neck (yellow) packs. The inu 15 version (transparent) is shown on the right.

4.8 User test 1



The sixth prototype was brought to the Sailing Innovation Center in Scheveningen on a warm day at the end of June. The average temperature that day was 24,6°C with RH 65%, the maximal temperature was 32,1°C at Hoek van Holland (KNMI).

Side and neck packs

The side and neck pack were redundant and too much of a hassle. They obstruct grabbing the front and rear parts from the cool box. Also, the chance that they get loose and lost is too big according to Douwe.

H2neO

Douwe wore the H2neO (Figure 2) variant while on the RIB at sea for 50 minutes. From 13:10h till 14:00h, when putting it of it was still sufficiently cold. Douwe commented that the vest was very cold for the present weather conditions.

Inu 15

Marit Bouwmeester tried the Inu 15 variant while sailing from the harbour to the starting line (Figure 1 & 4). The vest was used from 13:00h till approximately 13:40h. She commented that the initial cold quickly fades. Also, at places where the PCM is not pressed against the skin it does not feel cold.

👁️ *Packs do not feel cold without pressure.*

She said the cooling intensity is acceptable for Dutch conditions. She would prefer more intense cooling is for Tokyo conditions.

👁️ *Inu 15 does not feel cold enough.*

After wearing the vest Marit mentioned that the vest should not be thicker than it is (15 mm).

👁️ *15 mm is close to the maximum comfortable thickness.*

A big part of the vest was still frozen after usage.

Pull on- and off

The fifth prototype was used to check how putting on- and off the vest would go when at sea. Coach Roelof aided Marit with putting the vest on and off (Figure 5 & 6). Observing the situation lead to multiple insights. A lot is hapening in a small window of time during a break at the RIB. During the bustle the front part of the vest was applied backwards. And when removing the vest Roelof tried to pull the vest out upwards, this did not fit and the handle tore (Figure 8).

🚫 *All actions must be utterly intuitive.*

After removing the vest the packs were thrown on the RIB's console and Roelof speeded away to the starting line (Figure 7). Shortly after the vest was thrown back into the coolbox. The vests are not meant to be recharged in the coolbox, a separate storage solution is needed.*

🚫 *A storage solution for depleted vests is needed.*

Other comments

Both H2neO and Inu 15 stayed frozen in the coolbox for the entire day until 18:00h. During the excursion only Laser sailors were present, it came to mind that the vests were not tried by sailors that use a trapeze.

During the day one of the referees showed interest in the H2neO vest, and tried it for half an hour. He commented that it felt nice and cool.

👁️ *Inu 15 can be suitable for auxiliary personnel.*

*Side note:

At the end of the project this assumption changed. It might actually be realistic to recharge a vest in a coolbox. More on this can be read in chapter 6.7

Figure 1: Marit trying the Inu 15 version.



Figure 2: Douwe wearing the H2neO version.



Figure 3: Side packs were tried but considered redundant.

Figure 4: Marit sailing out of the harbour with cooling vest.

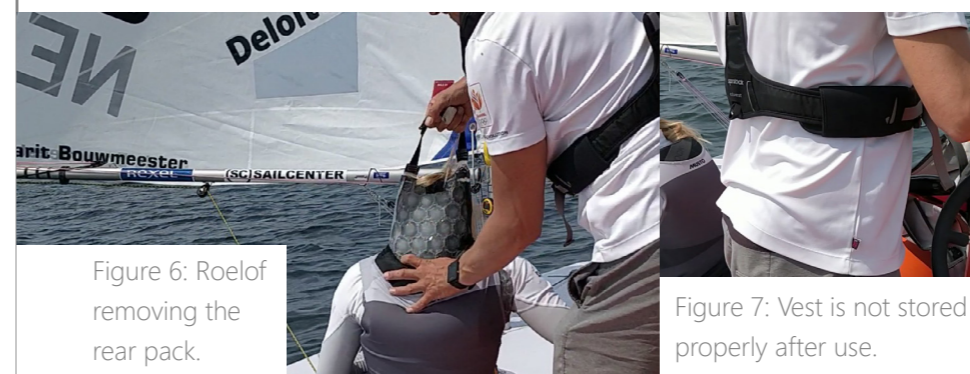
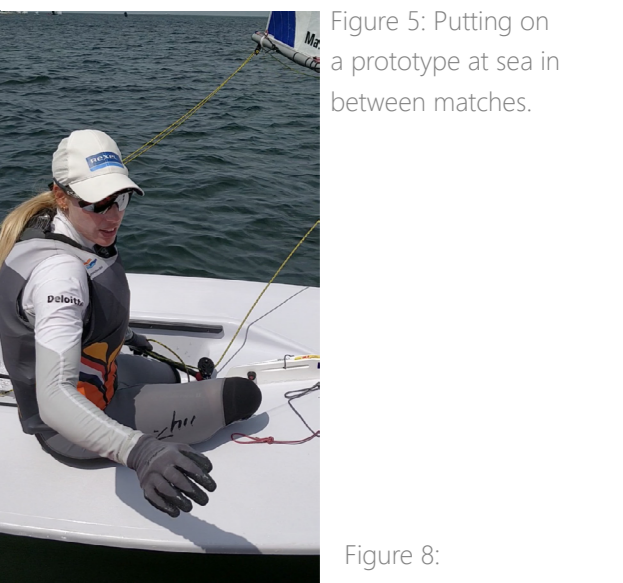

Figure 6: Roelof removing the rear pack.

Figure 7: Vest is not stored properly after use.

Figure 8: Torn handle after use.

4.9 Prototype 7

The seventh prototype was design-wise a small iteration on the sixth. The main challenge was to make two prototypes sturdy enough to survive the summer in Japan.



Design

It came to my attention that Inuteq would provide vests with Inu 15 and Inu 6. Therefore, in agreement with Douwe, it was decided to continue with the H2neO. This way three different PCMs could be tested in Japan.

The front and back have been shortened so they do not stick out from underneath the flotation aid. A different pattern was used to create the hexagons, this pattern has more sealing area and is therefore less prone too bursting. The side and neck packs are abandoned.



Prototype

The prototypes were finished in time. Bright blue velcro was used to make it easier to glimpse where to attach the straps. Figure 3 shows how to put on the packs. Accompanying the prototype a manual was made to instruct coaches and sailors. This manual is provided in Appendix N.

The vest can be worn in two different ways; with the water/ice side towards your body and with the insulated Neoprene side against your body. Which is preferred depends on the situation. For a small intense burst of cooling the water side is good, and for timid long duration cooling the insulated side is the better choice.



82 Figure 1: Prototype when folded

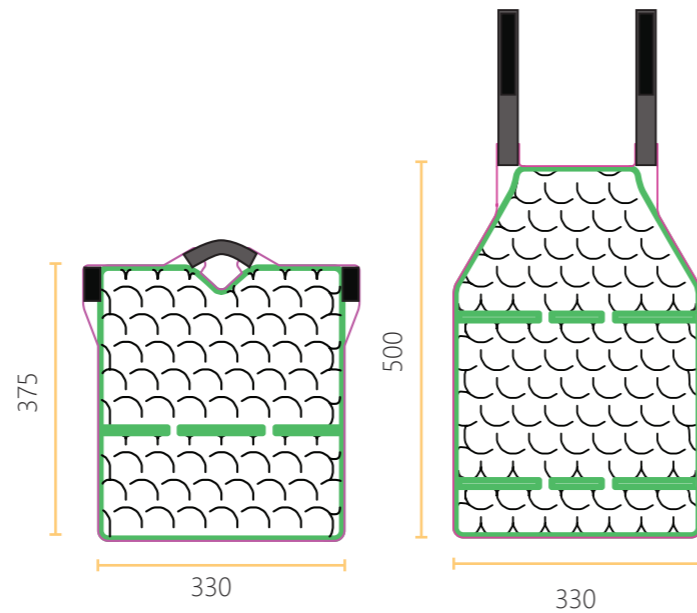

Figure 1: Prototype used for evaluation in Japan



Figure 3: Illustration on how to put on the vest.

4.10 User test 2



The second user test was done remotely. Two vests were taken to Japan to be used during the Olympic test event (15 - 22 aug) in Enoshima. A third vest was taken by Marit Bouwmeester to the World Championships at Sakaiminato City (16-24 July).

Three other types of cooling vests were taken to the trainings in Japan as well. Four different vests were tried and evaluated to some degree with sailors. A small picture of each vest is shown in Figure 2.

Since the evaluation took place in Enoshima data had to be collected from a distance. To do so a clear set of instructions, a manual (Appendix N) and a questionnaire were made to guide the use and evaluation of the prototype. In practice, remote user testing did not work out as well as expected. The researcher and users were more focused on using and comparing the prototypes for themselves. They wanted to find out which one they liked best and were less interested in evaluating the design.

Due to miscommunications not all vests were tried by all sailors. Also, in Japan the sailors did not fill out a single questionnaire. Afterwards, insights were gathered via a shortened questionnaire and via Douwe whom evaluated the whole training week including the vests with each sailor separately.

Result

Four sailors filled in the questionnaire about the prototype. The results are visualized in Figure 1. In general the cooling intensity is good all be it somewhat on the high side. The cooling duration is too short. The wearing comfort is very good and the ease of putting the vest on and off is outstanding. The question if the vest was easy to use when not wearing it (e.g. transport, freezer, coolbox) did not give an unambiguous result.

'We forgot that we were wearing the prototype after a while.' - Annette Duetz, Olympian 49'er FX

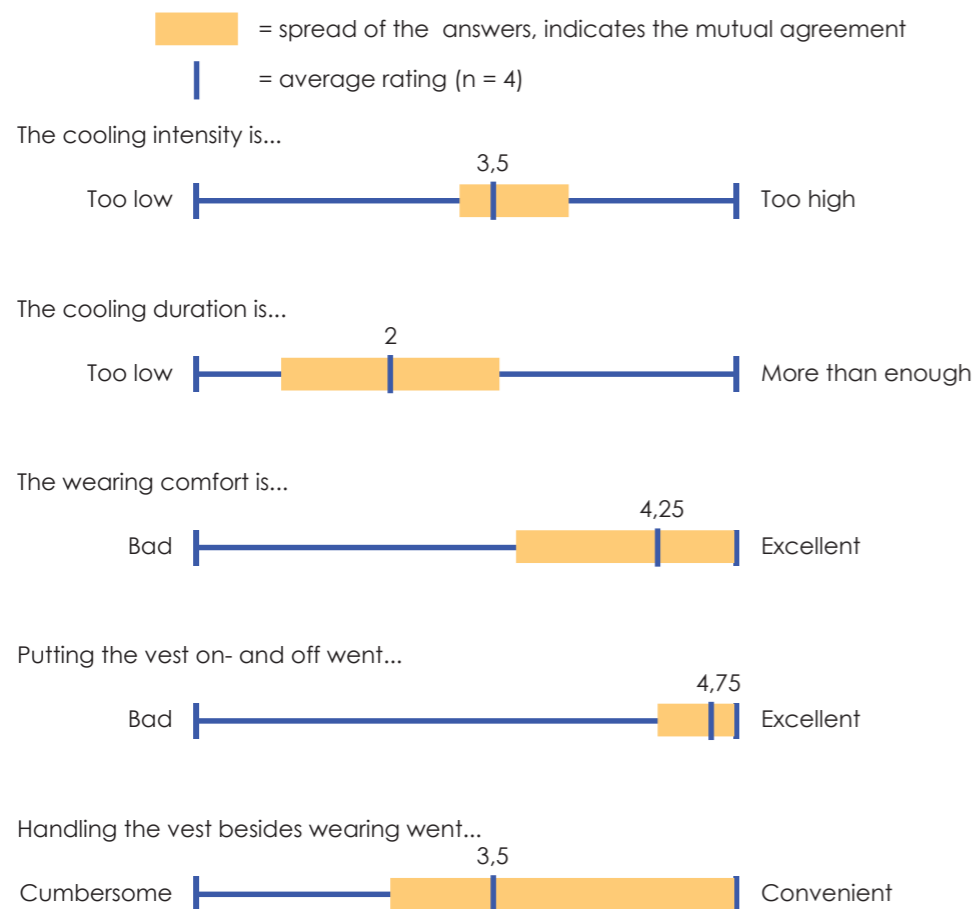

Figure 1: Visualization of the results of the questionnaire filled in by 4 sailors.

Besides ratings, general comments were gathered. A positive feature is that the vest is easy to fit in fridge or cool box. The straps that could for a handle were appreciated, they should however be bigger, so they are easier to grab and attach. The handle at the front tickles your chin and was deemed superfluous.

A negative comment is that it was hard to keep the vest solidly frozen in a coolbox. It would be very handy if the vest could be recharged in a coolbox. The current design is meant to be single use, multiple vests are therefore needed during the day but there were not enough prototypes.

Sailors expect that a single vest can be used throughout the day.

The vest was tried by Annette and Annemiek while wearing a trapeze harness, the harness did not prevent the use of the vest. It did however make it a bit more difficult to put on and off.

From the other vests that were tested (Figure 2), the white version (Inuteq 6,5°C) was appreciated the most. It gives good cooling power. An advantage of this vest is that it can be (partially) recharged in a cool box with ice water. The vest's PCM patches that cover the shoulder were considered annoying.

The cooling power of the Inuteq 15°C and IZlbodycooling 24°C vests was considered to be too weak by the sailors.

Inu 15 PCM is definitely not cold enough for Athletes

Unfortunately, none of the prototypes came back from Japan. They were left behind because luggage weight is a big issue when traveling for Sailors. Being able to fill the prototype with water yourself proved to be a very handy feature for transporting the vests.

Transport weight is a big issue for international sailing.

Figure 2: The four prototypes tested in Japan

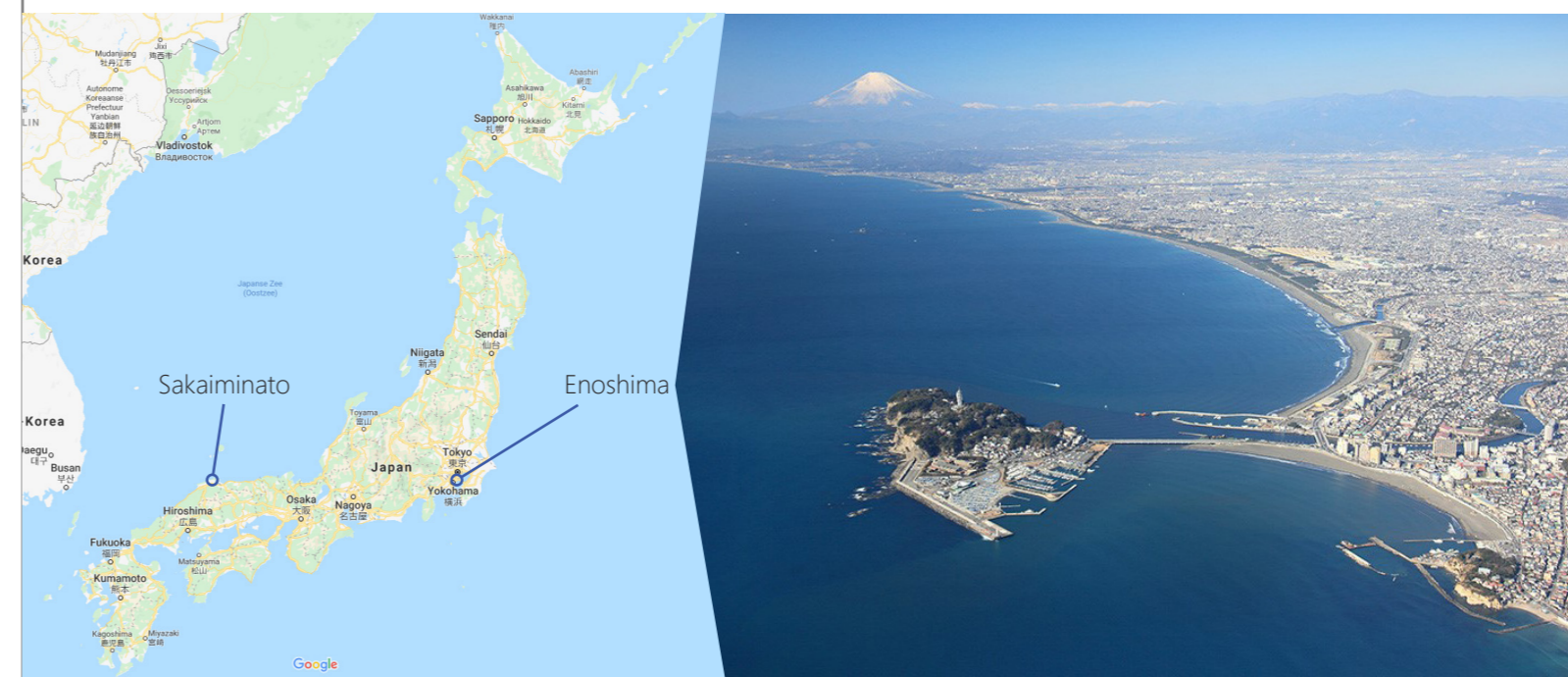
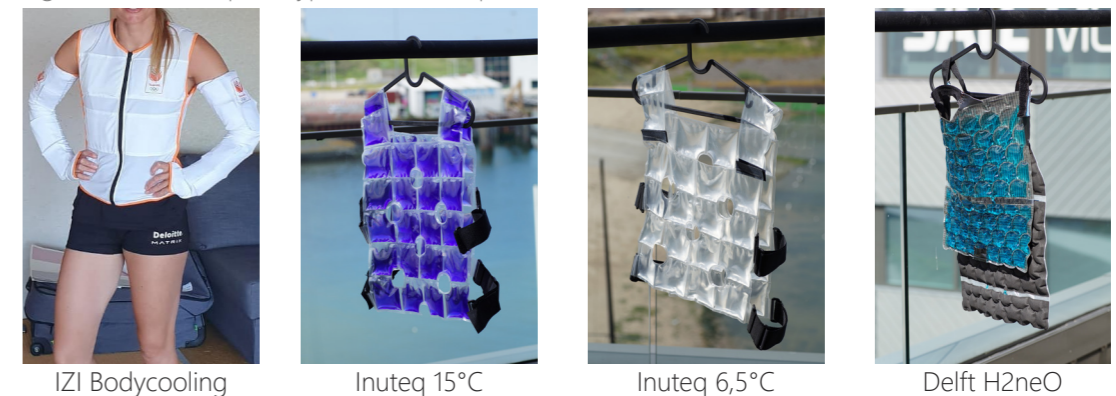



Result

After the evaluation in Japan enough information was available to make one more iteration. Resulting in the final design, which satisfies all important criteria for the cooling garment. It might be possible to further optimize the design in the future but this will be out of the scope of this project.

The design as proposed has one drawback; it is not producible by Inuteq at the moment. Because the Olympic sailors want to train with the garment it should be ready as soon as possible. Therefore the design has been transformed into a version that is producible by Inuteq on short notice. Both the proposed and produced design are presented in this chapter.

5.1 Proposed design

Based on the second user test some small design changes were implemented. A prototype was made for demonstration purposes.



Design

To improve the filling operation two things have changed. First the spout is adapted so that it is possible to open and close it without tape (Figure 1). Second, the pattern that forms the hexagons has changed. It is now symmetric and shaped in such a way that water can flow in, while air flows to the top. This makes filling and emptying the vest with tap water much easier.

Another change is that straps and velcro patches are now 40 mm in stead of 25 mm wide for easier attachment. The small handle that can be annoying to the chin is removed.



Prototype

This design will not be tested anymore. Still a prototype was made for demonstration purposes. Mainly because the other three presentable prototypes were left behind in Japan.

The prototype was presented during a Thermo Tokyo meeting in Papendal (16-9-2019). After the presentation the prototype was discussed with the client (Douwe, SIC) and manufacturer (Rein, Inuteq), to define the final product. Many features did not make it into the production phase. Nevertheless some key aspects could be translated into a vest that is produceable with the given time and production facilities. This is further explained in the next chapter.

Nevertheless, the design shown on this page has much potential. It is not possible to produce it on short notice but it can be good inspiration for future products.

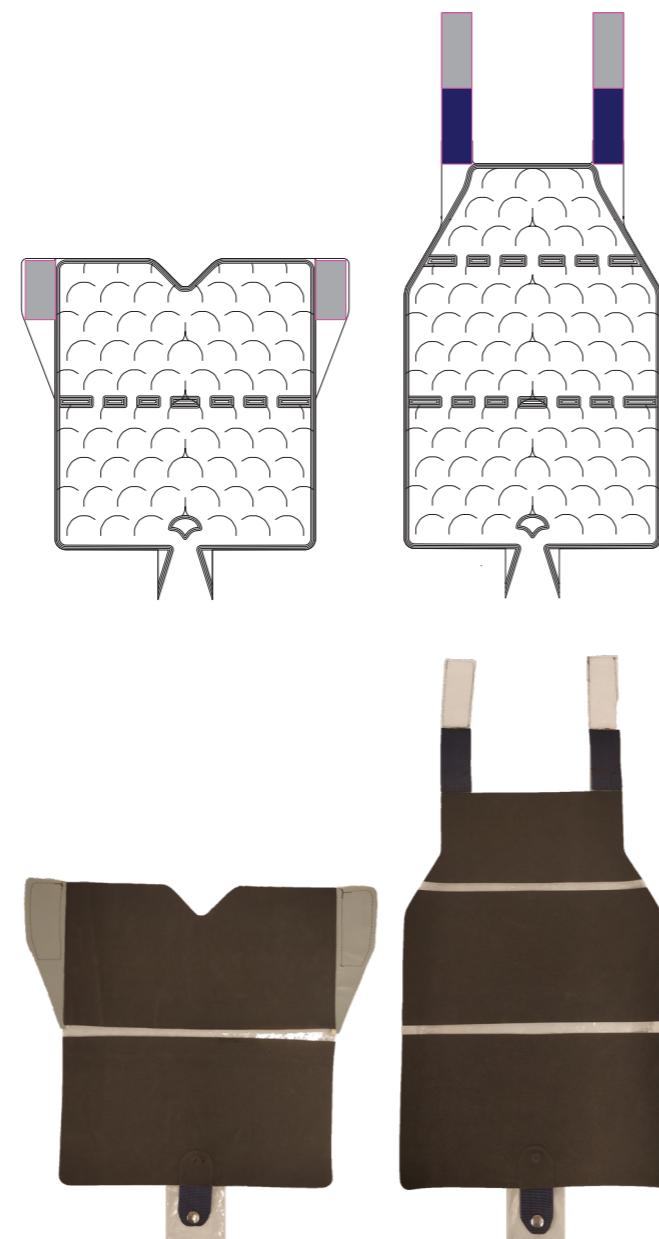

Sizing

There is quite a variety of body types, the smallest Olympic sailor has shirt size 8 and the largest 18. Prototypes are built for size 14. From testing the prototypes, it became clear that one size fits all. The length of flotation aides does not change much per size.

Unique selling points

Compared to other cooling vests the proposed design, the so called 'CoolKeeper' has the following unique features:

- ★ 1 The hexagon pattern gives the right balance between rigidity and flexibility. Making it comfortable to wear and easy to handle.
- ★ 2 The vest can easily be put on and off without the need to remove sailing clothing.
- ★ 3 The H₂neO combination has the highest cooling capacity and duration per unit weight, compared to PCMs that are commonly used for personal cooling garments.
- ★ 4 Transporting the vest is easy, it can be filled with tapwater at location.

Specifications

When filled, the vest weighs approximately 1,3 kg and has a thickness of 10 mm. The vest can provide 95W cooling power for 45 minutes.



5.2 Producible design

The ninth prototype was designed to be producible by Inuteq within a short time frame with the present production facilities. The goal was to incorporate the 'best of both worlds' from the CoolKeeper (Figure 1, left) and the CoolOver (Figure 2, right) in a new design that has the most essential features for sailing and is cost effective in production.



Design

The biggest adaption is the change from the ingenious hexagon pattern towards straight line seals that can be made by machine or hand. Inuteq has automated facilities to produce 70 x 70 mm squares (Figure 2), therefore most of the new design consists of these squares with some adapted shapes attached that can be sealed by hand.



Prototype

The design on the right was prototyped to check if the squares would pose issues. In terms of comfort the squares are fine because the packs are smaller and therefore only cover areas of the body that are relatively planar.

There was an issue when putting the rear vest on and of. The vest can fold very easily over the long line seals. When pulling the rear pack between the flotation aid and body the sides would often fold inwards. Once applied it is a hassle to reposition the doubled up parts.

The prototype was also discussed with the client (Douwe, SIC) and manufacturer (Rein, Inuteq) to come to agreement over the final shape of the cooling vest.



Design

The form of top section of the rear part was changed to keep the vest from folding when putting it on. The front was adjusted to be slightly shorter based on feedback from Douwe. Lastly, the design of the straps is adjusted. The rear straps are now 25 mm wide. The front patches on which they need to be attached are now 50 mm wide and placed at a better reachable spot.



Figure 1: The CoolKeeper and CoolOver.



Inu 6,5 will be used in stead of H2neO. With H2neO it was clear which side should be pointed towards the body and which side towards the flotation aid. This is not the case with the Inu 6,5 version. A solution to this came from an adaption used in one of the earliest prototypes. With smart velcro placement the front and rear can be made rotation symmetric. This is useful because now it is not possible to put on one of the packs the wrong way around. Figure 3 shows a stepwise instruction on how the front and rear pack can be made.

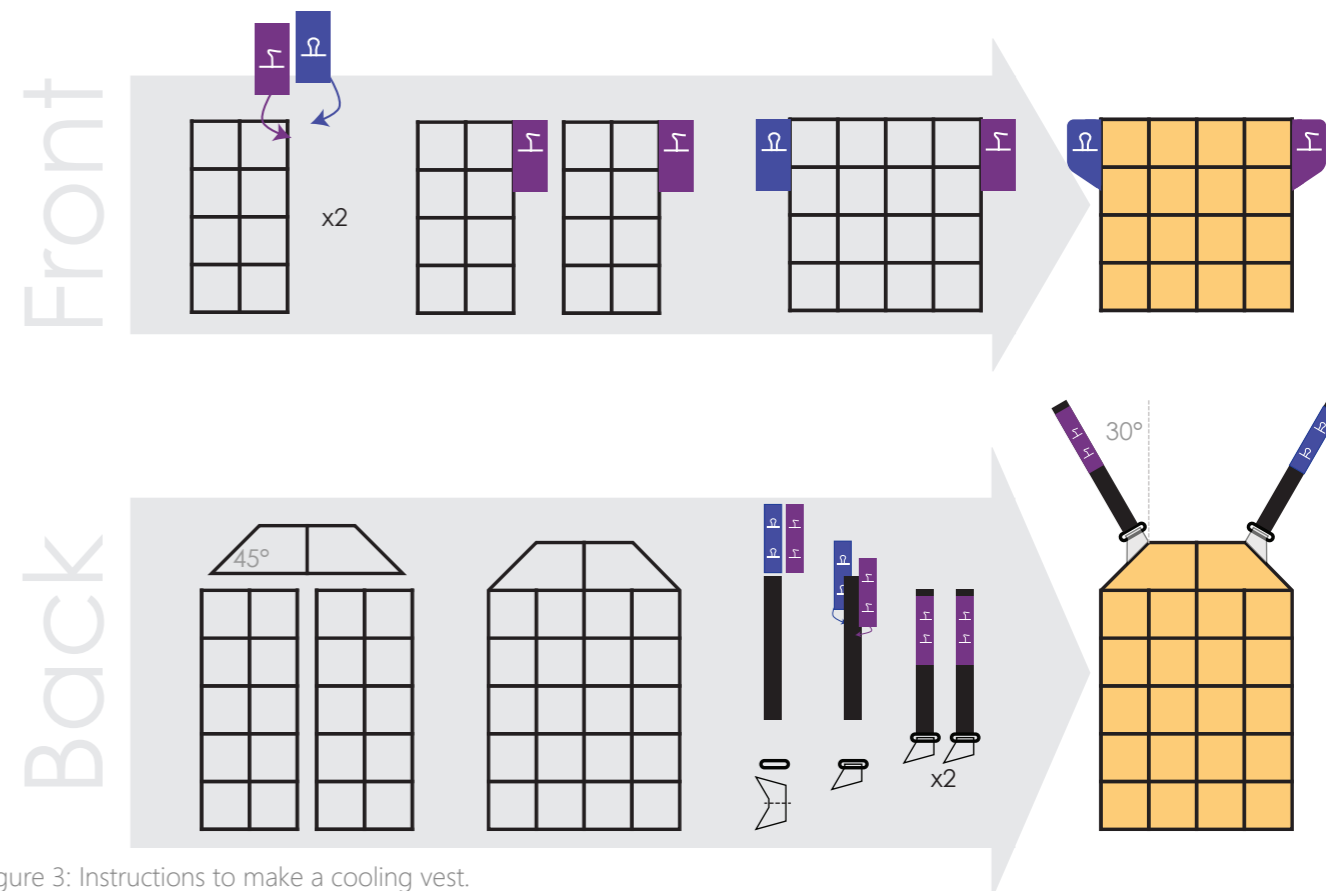
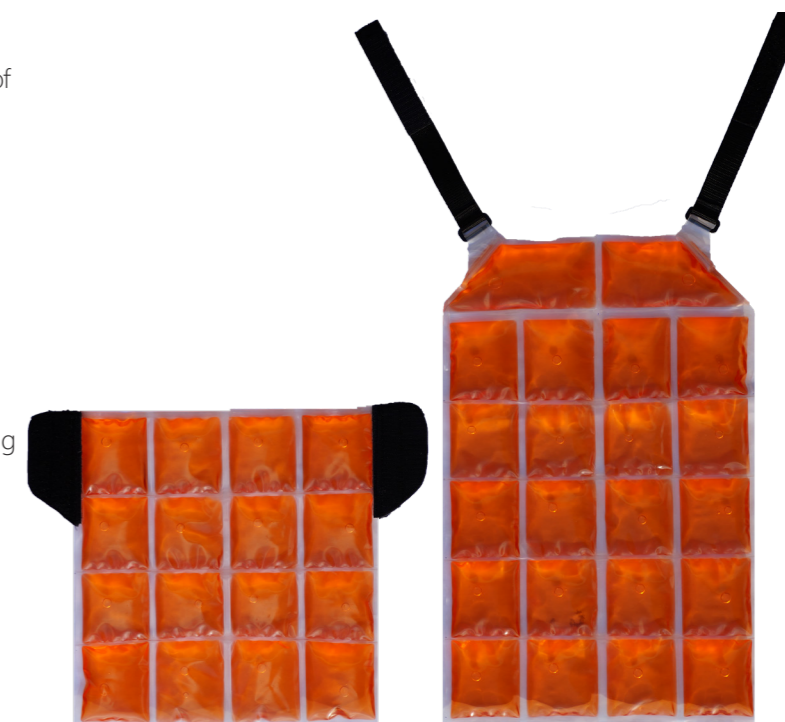

Figure 3: Instructions to make a cooling vest.

Unique Selling Points

Compared to other cooling vests the producible version of the CoolKeeper has the following unique features:

- 1 The vest is producible by Inuteq on very short notice.
- 2 The vest can easily be put on and off without the need to remove sailing clothing.
- 3 The vest has a high cooling power without causing frostbite.
- 4 The vest can be recharged in a coolbox.



Specifications

The vest weighs 1,3 kg and has a thickness of 10 mm. The vest can provide 150W cooling power for 20 minutes. These are estimations from chapter 6.4.



5.3 Image gallery

This page contains imagery of the vest as proposed and of the vest as produced.

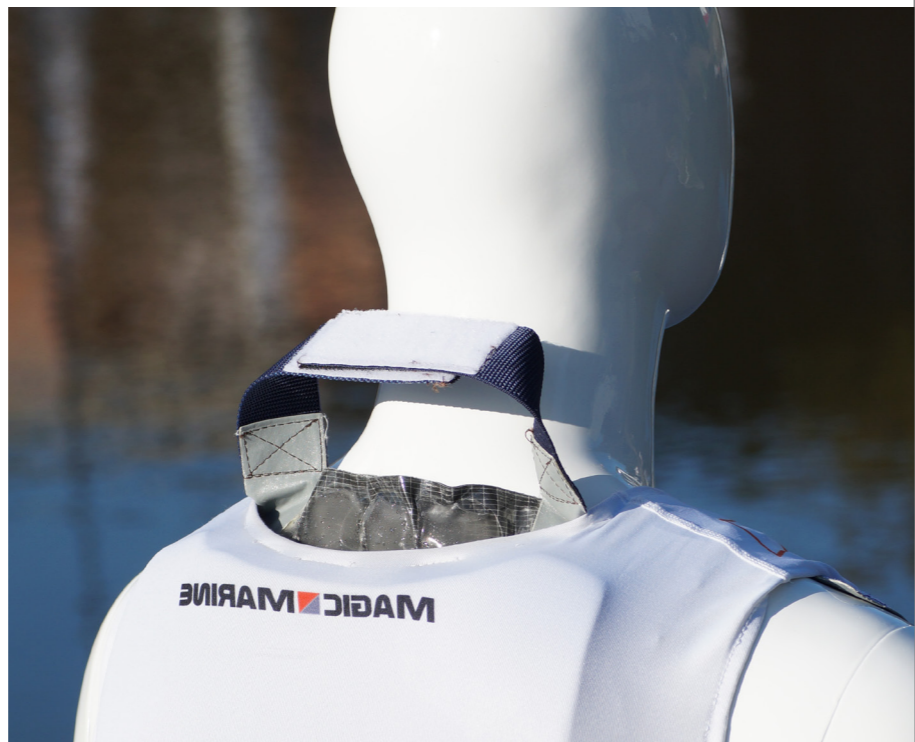
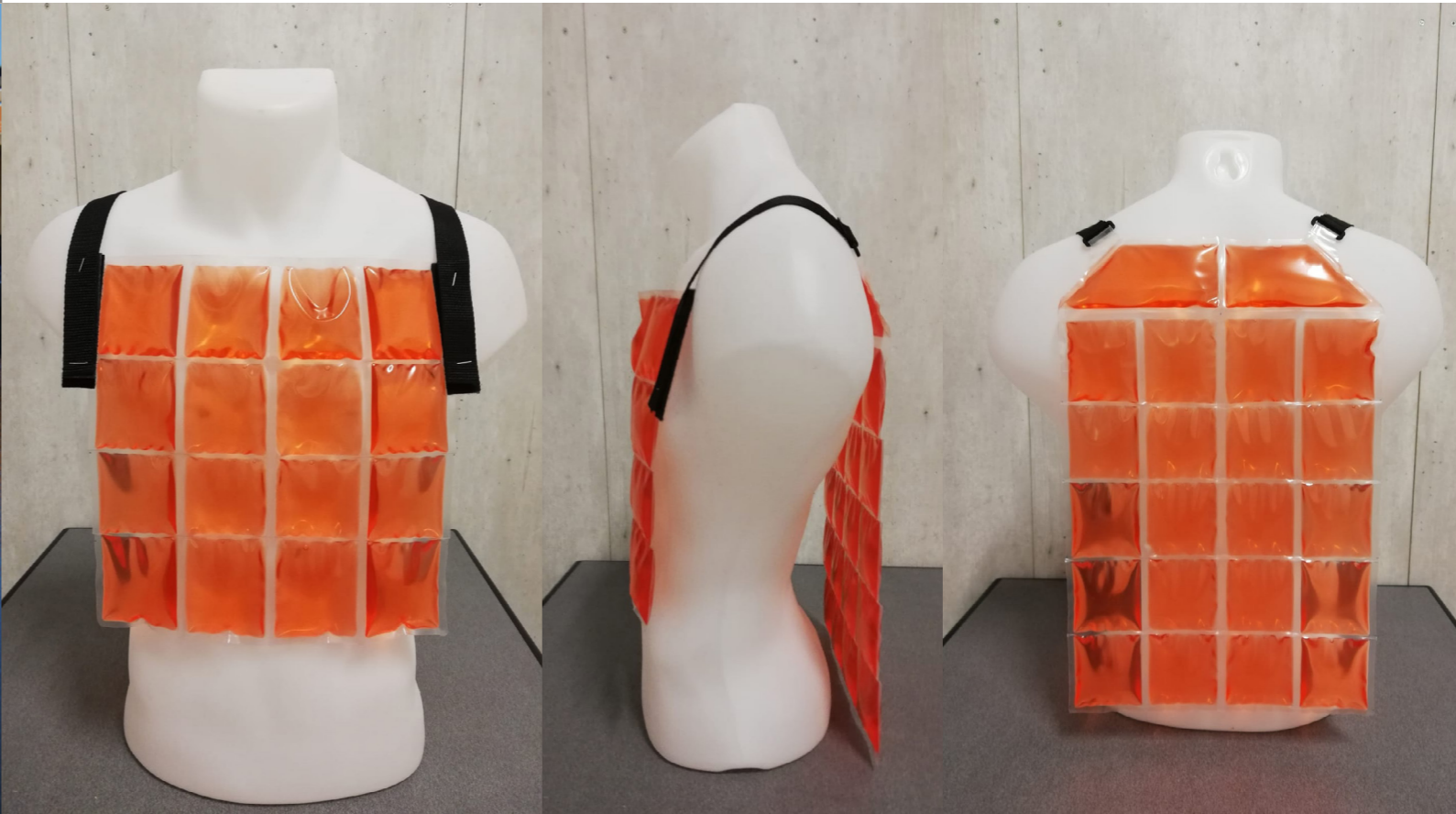



Evaluate

The previous chapters lead to the design of a cooling vest for Olympic sailors. The form and the use of the vest have been evaluated during the prototyping phase (Chapter 4.10). The impact the vest might have on sailing performance is hard to estimate. In this chapter the vest's cooling power and duration are estimated. Subsequently, the CoolKeeper is compared to vests evaluated in literature. And an assessment of the vest's possible impact on sailing performance is made.

This chapter is concluded with recommendations and a general evaluation of the project. Also, practical advice is given on how to handle charging the vest. A small case study about recharging a vest in a coolbox with ice and salt showed interesting results.

6.1 Method

Chapter 6.1, 6.2 and 6.3 describe the tests performed that were needed to make an educated guess on the vest's cooling power and duration (Chapter 6.4). In chapter 6.5 these figures are compared to vests examined in literature to be able to make a statement about the effect on sailing performance.

Model of thought

There are standardized methods for measuring the heat removal of a cooling vest, such as the ASTM F2371 – 10 test method. Unfortunately, these methods generally require a sweating heated manikin, which is very costly. To be able to give a good estimation of the theoretical cooling power of the vest, the model shown in Figure 1 is proposed. The following text accompanies the infographic:

The cooling power and duration can be measured on the hotplate for a square sample (C) and for a hexagon sample

(D). With an exercise test the cooling power and duration of a sample on human skin (A) can be defined. Assuming that the relation between square and hexagon samples is the same for the Hotplate (C & D) and for human skin (A & B), the cooling power and duration of a hexagon sample on human skin can be calculated.

Cooling power and duration are linearly related to the dimensions of a sample. An estimation of the vest's cooling power and duration (E) can be made by comparing the surface area of the whole vest to the surface area of the hexagon sample.

This cooling power can then be compared to the cooling power of vests evaluated in literature (F). The performance results achieved in literature can then be used to predict the impact the designed vest can have on exercise performance (G).

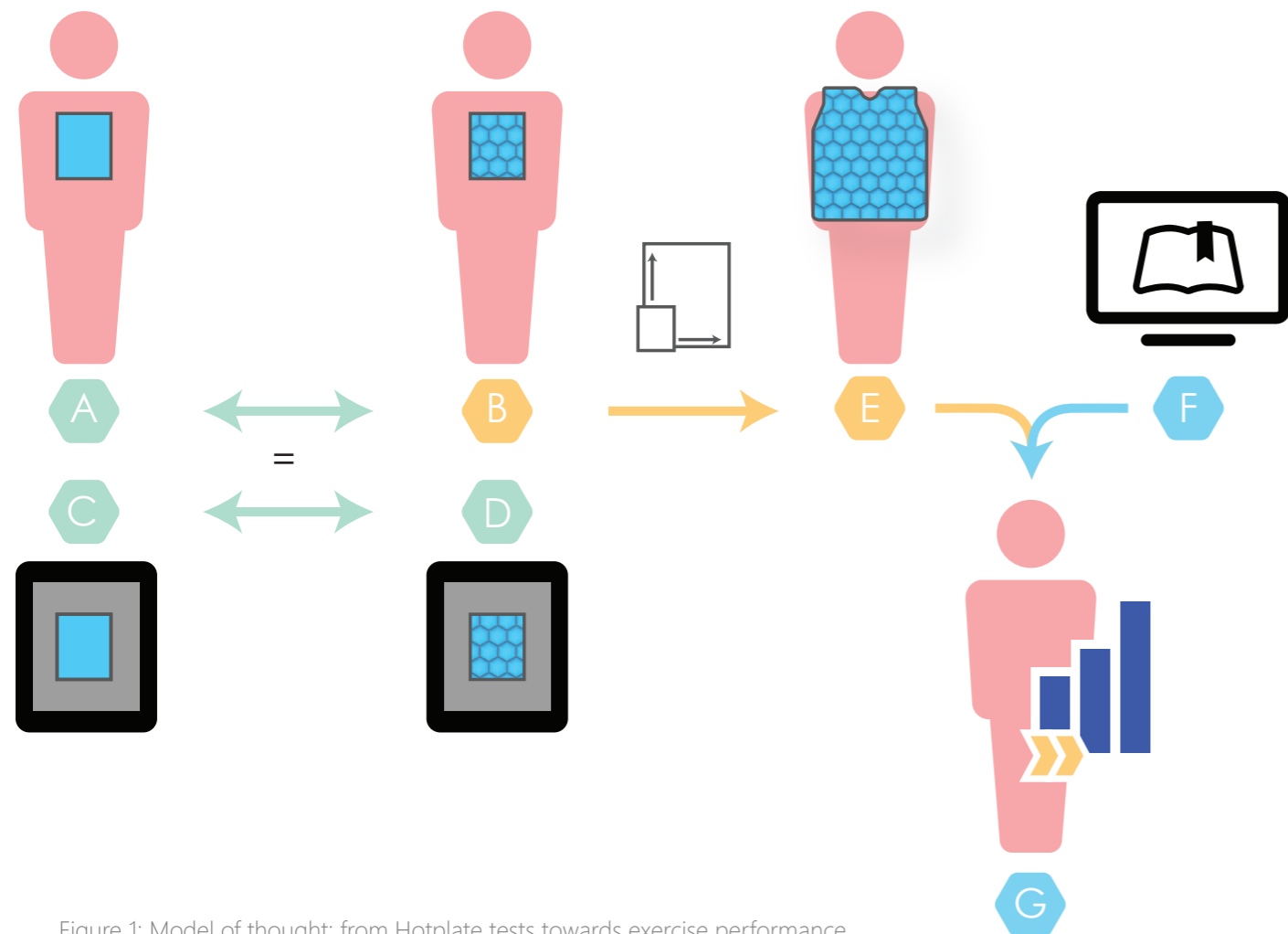

Figure 1: Model of thought; from Hotplate tests towards exercise performance.

Testing square samples on the Hotplate (C) is described in chapter 6.2. Testing the same samples on human skin (A) in chapter 6.3. The performance of the hexagon samples on the Hotplate (D) is provided at the end of chapter 2.4.

PCM Samples for model

The samples used in the PCM evaluation (Chapter 2.2) could not be used to measure cooling duration on human skin. New samples with temperature sensors were made to be able to relate cooling power to temperature measurements.

The PCMs Inu 6,5, Inu 15 and H2neO were selected as the most suitable PCMs (Chapter 2.3). These three PCMs are undergoing further research in this chapter. New samples were made with two differences.

H2neO lasts 98 minutes on the hotplate till the power threshold of 5W is reached, asking a test person to exercise for such a long time in a hot and humid climate chamber is undesirable. Therefore, the samples are scaled down. Instead of 250 gram PCM they are filled with 125 gram PCM, since the surface area stays the same, the cooling duration is halved.

It is not possible to directly measure the cooling power the PCM package exerts on human skin. To be able to judge when a package is depleted the interface temperature and the core temperature of the PCM package are logged. This is done by attaching two thermocouples per PCM sample. One is attached to the surface and the other is inserted into the PCM package (Figure 2). The thermocouples are made from 150 mm long pieces of Type-T wire (-75°C to 250°C). A small piece of foam keeps the sensitive element in the middle of the PCM package (Figure 2).

Temperature readings from the thermocouples are logged every second with a SQ2020 data logger by Grant Instruments.

In the freezer the samples are compressed between two Perspex plates to ensure a flat surface area (Figure 3). In total there are two samples per PCM, making a total of six samples (Figure 4).

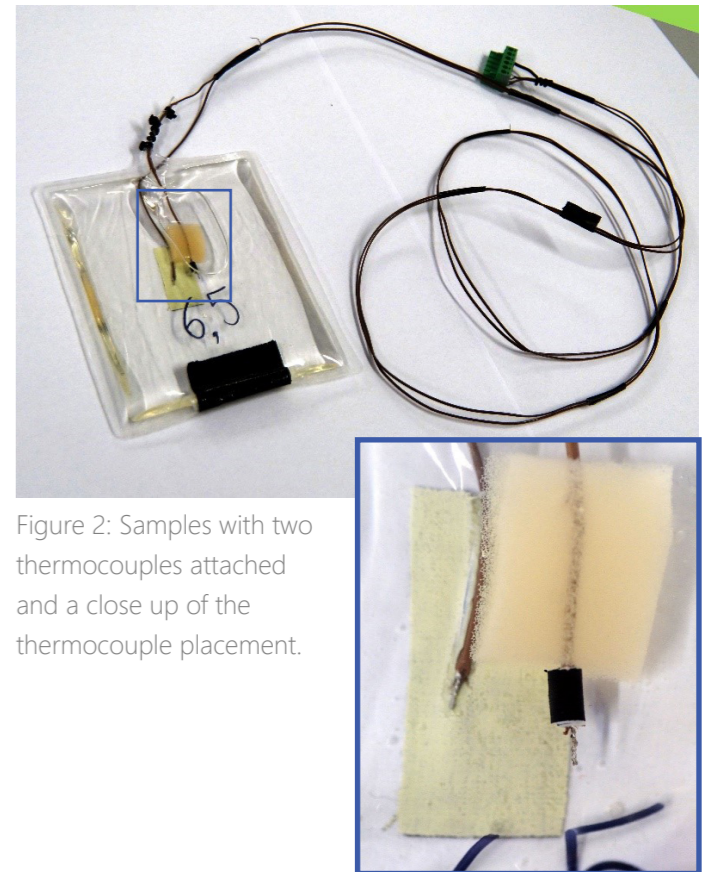

Figure 2: Samples with two thermocouples attached and a close up of the thermocouple placement.



Figure 3: Samples placed in freezer.



Figure 4: Six samples with a thermocouple in the center and at the surface.

6.2 Lab test

First the samples were tested on the Hotplate in the lab. The same protocol as used in chapter 2.2 is used. The samples were placed on the Hotplate underneath a styropor cover in a climate chamber (Figure 1). Temperature and cooling power were logged every second. The main goal of this test was to find a relation between the temperature and power readings.

The test was executed a total of twelve times, resulting in four data sets per PCM. The results of the test are analyzed with MATLAB to find the relation between the Hotplate power readings and thermocouple temperature data.

In theory the sample's temperature will rise to the phase change temperature, stay constant during the phase change, and rise again after the sample has changed phase. The cooling power should be constant as well while the temperature is constant. The temperature and power curves should resemble Figure 2.

There are two things the results should show. The first is the time it takes until the PCM has changed phase (A). This can be deduced from both the temperature and the power curve. The second is the sample's temperature when the power threshold of 5W is met (B).

Phase change duration

The end of the phase change is defined as the point on the graph where the curvature is highest. This point is calculated by taking the maximal absolute value of the second order derivative of the curves. The end of phase change points are calculated for the power, core temperature and interface temperature curve as illustrated with Figure 3. The averages per sample are presented in Table 1.*

Temperature at threshold

The second goal of the lab test is to find how interface and core temperatures relate to the power threshold. This is indicated with B in Figure 2. The averages per sample are presented in Table 2.*

Results

A summary of the results is given in Table 1 and 2. Detailed results, such as the graphs of every lab tests, are included in Appendix P.

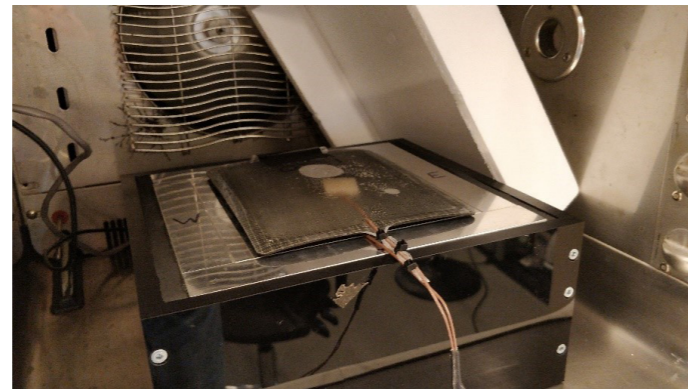

Figure 1: Sample on Hotplate.

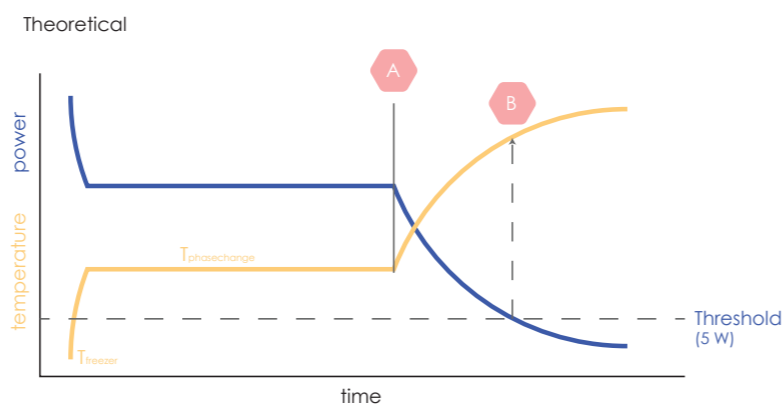

Figure 2: Theoretical power and temperature curves.

*Side note:

Averaging the results of four measurements per sample is a bit blunt. Because with a sample size of four it can not be determined if the results are normally distributed. The values as presented here are an indication only. The standard deviation is given to give an indication on the accuracy of the results.

A more academic way to present the results would be to show the maximum, minimum and median value. With a sample size of four this would mean that almost all values are included. This would be inconvenient to present. Therefore it is decided to show the average and standard deviation here and to include detailed results in Appendix O.

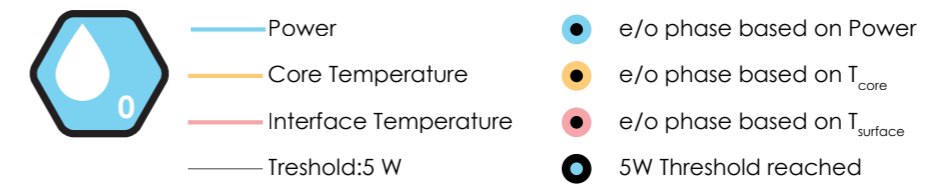

Figure 3: Power and temperature curves resulting from testing an H2neO sample.

Phase changed after (...) minutes based on...

PCM	...Power curve [min]	...Core temperature curve [min]	...Interface temperature curve [min]
H2neO	41 ±3	35 ±3	39 ±1
Inu 15	21 ±2	21 ±3	22 ±3
Inu 6,5	16 ±3	15 ±3	17 ±1

Table 1: Time it takes till the end of the phase change of three different PCM samples. Rounded on full minutes. (±stdev, n=4)

PCM	Capacity [kJ]	Time till power threshold [min]	Core temperature at power threshold [°C]	Interface temperature at power threshold [°C]
H2neO	46 ±3	53 ±2	26 ±1	31 ±1
Inu 15	28 ±1	29 ±3	28 ±2	30 ±1
Inu 6,5	28 ±0	22 ±1	27 ±1	28 ±2

Table 2: Measured capacity, time it takes till the power threshold is reached and the corresponding core and interface temperatures at that time of three different PCM samples. Rounded on full units. (±stdev, n=4)

Discussion

Most samples show a response as in figure 3 on the previous page. From such a response the phase change points can be calculated easily. However, some samples show a response that is not. One of these cases is shown in Figure 1. There are multiple bends that could indicate the end of the phase change. The sample does not change phase homogeneously. In other words, there will be both solid and liquid parts present during the phase change. The thermocouples only measure local temperature. It can happen that the core of the sample, where temperature is measured, is molten while there are plenty of frozen pieces left elsewhere in the sample or vice versa. This can make it hard to deduct the end of the phase change from the curves. Nevertheless, the average times till the end of the phase change based on the power, core temperature or interface temperature correspond relatively well per PCM (Table 1). The only exception is the time based on the core temperature of H2neO (Table 1, row 1 column 2). This is likely because of the insulative Neoprene layer. It acts as a dampener causing a delay. It takes a while before the cooling power drops after the sample has been depleted. The interface temperature

sensor is connected at the outside of the Neoprene layer, therefore it does not show this delay towards the cooling power (Table 1, row 1).

Predicting the time till the power threshold is reached from only the sample's temperature is unreliable because the sample's temperature does not change much around the power threshold. If the threshold is set to 4 or 6 Watt in stead of 5 Watt the accompanying average temperatures differ only 0,5-1°C from the values at 5 Watt. At 5 Watt the maximal spread is ±2°C. This is more than the difference to 4 or 6 Watt. Therefore, it is hard to predict the time till the power threshold from only the temperature data. Especially for a single measurement, the accuracy improves when averaging multiple measurements.

Conclusion

With these measurements part C (Figure 2) of the model of thought towards exercise performance is completed. Part D has been covered in chapter 2.4 where the thickness of the hexagon packaging was established. Now the cooling powers and durations of the square sample and the hexagon sample can be compared. This will be described in chapter 6.4 after the exercise test (A) which follows in the next chapter.



PCM	Phase changed after (...) minutes based on...		
	...Power curve [min]	...Core temperature curve [min]	...Interface temperature curve [min]
 H2neO	41 ±3	35 ±3	39 ±1
 Inu 15	21 ±2	21 ±3	22 ±3
 Inu 6,5	16 ±3	15 ±3	17 ±1

Table 1: Time it takes till the end of the phase change of three different PCM samples. Rounded on full minutes. (±stdev, n=4) With highlight for discussion.

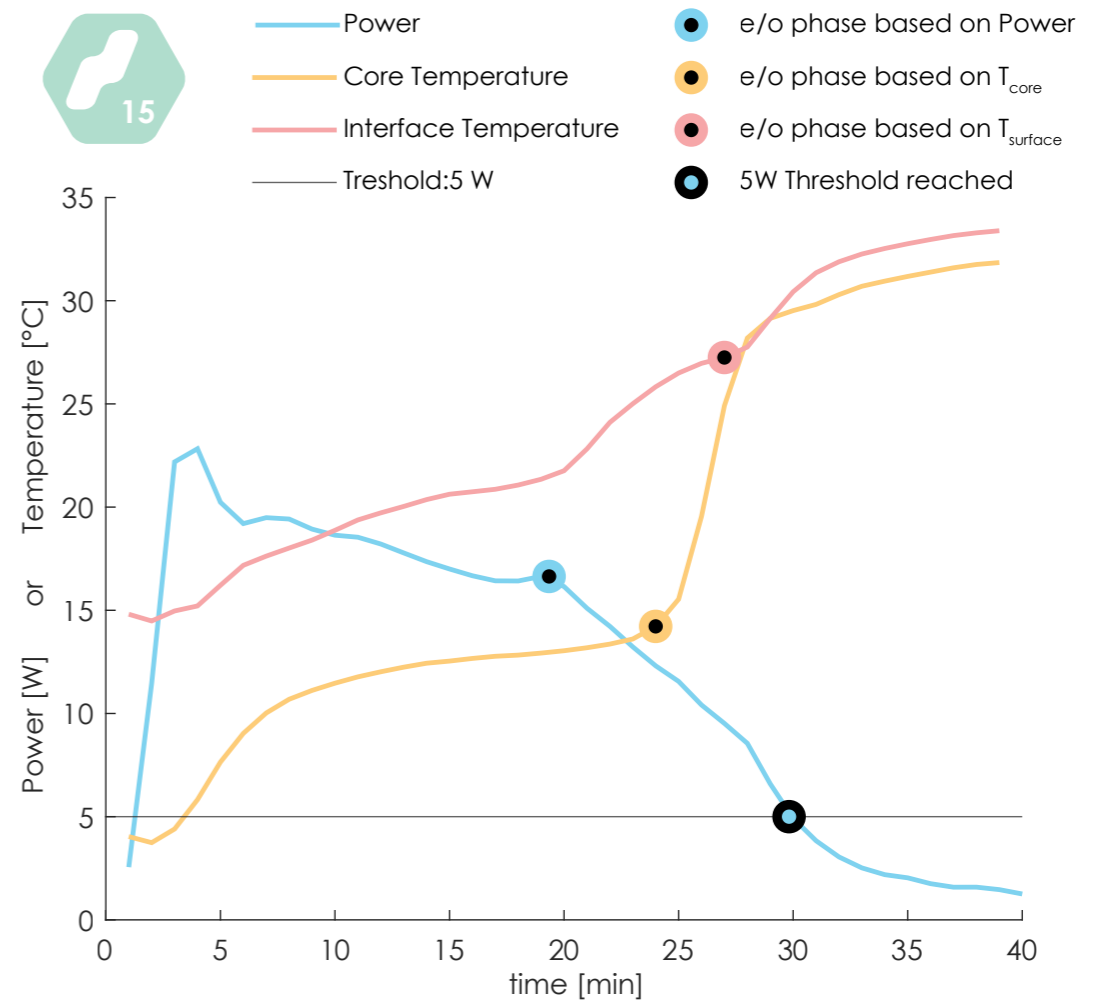

Figure 1: Power and temperature curves resulting from testing an Inu 15 sample.

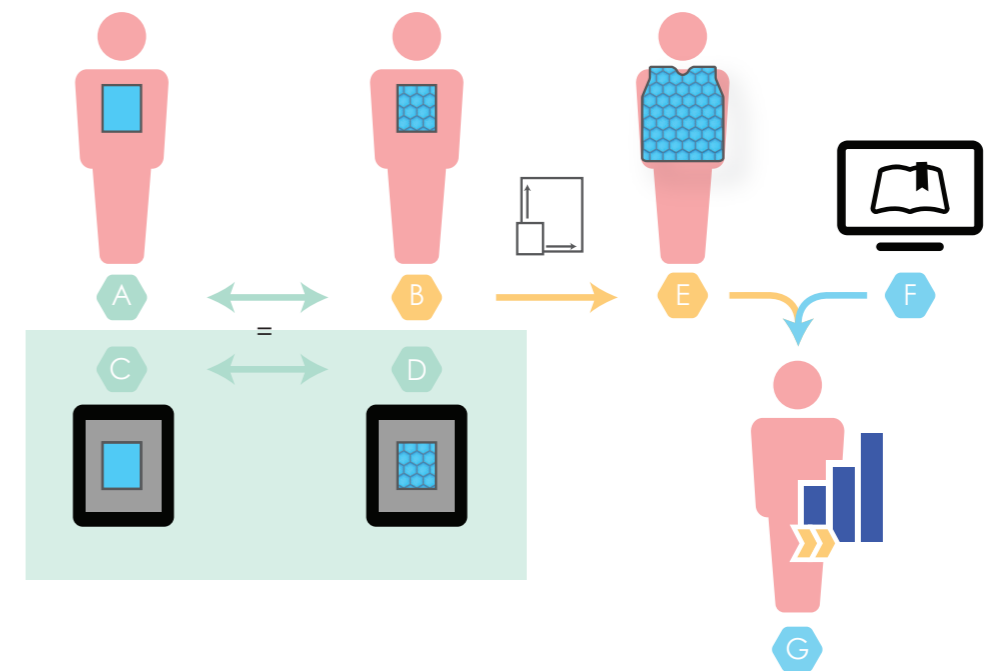

Figure 2: Model of thought; from Hotplate tests towards exercise performance.

6.3 Exercise test

Three PCMs were tested on human skin to be able to relate the Hotplate measurements to a real life situation. The main goal was to see how fast human skin can deplete PCM packages when exercising in expected Tokyo weather conditions.

Materials & Methods

The same samples that were tested on the Hotplate were used for the exercise test. The samples are applied at the back of the participant as in Figure 1. Two in the middle and one above. A band with two pockets for samples was made to ease sample attachment. A third package did not fit in this band and needed to be added with tape.

The tests took place in a climatic chamber at topsport centre Papendal (Figure 3). It was set to 32°C and 75% RH. These are the conditions frequently used for simulating Tokyo climate at sport center Papendal. (Linders, personal communication, October 11, 2019)

Involving external participants would require an extensive ethical procedure. Exercising in a hot and humid environment is not without risk. To expedite the testing process the test was performed by myself and my coach L. Teunissen. The test is focussed on the behaviour of the PCMs, not on the physiological response of the body on these PCMs. Therefore, a varied participant poule is not as important.

The exercise protocol is shown in Table 1. Four iButtons are placed before the test, these measure skin temperature at four places. The average of these four sensors is the skin temperature. The participant enters the climatic chamber 15 minutes before the start. Acclimatizing for around 15 minutes will bring the skin temperature to 35±1°C, equal to the setting of the Hotplate during the lab tests.



Figure 1: Location of samples applied.

Time	Activity
-20	Apply iButtons (Neck, Scapula right, Hand left, Shin right)
-15	Enter climatic chamber Habituate till $T_{\text{skin}} = 35^{\circ}\text{C} \pm 1^{\circ}\text{C}$
-7	Put on waist-band with samples, attach third sample with tape Put on flotation aid and beanie
-2	Arm Datalogger, take place at bike trainer
0	Start Cycling; 80W
~60	End of test when all samples are depleted Or if terminated by participant for any reason

Table 1: Protocol of the exercise test.

7 Minutes before the start of the test the samples are removed from the freezer and applied. 2 Minutes before the test they are connected to the datalogger and the temperature recordings start.

After the samples are applied the participant puts on a flotation aid and sailing topover. When everything is set up the participant takes place at the bike trainer and starts cycling.

The cyclometer is set to a constant power input of 80W. This is comparable to cycling approximately 20 km/h. 80W external power would relate to 320W heat production, ample to heat the samples, sweat significantly and keep the average skin temperature at 35°C.

A standing fan simulates a gentle breeze. The test ends if the temperature of the samples rises above the temperature corresponding to the 5W power threshold as defined in the previous chapter. For H2neO this 26°C, for Inu 15 28°C and for Inu 6,5 27°C (from Table 2, page 99). If a participant wants to stop for any reason the test is terminated as well.

To be prepared two pilot tests took place with improvised equipment. A small room with a big radiant heater, wet laundry and a fan functioned as a makeshift climate chamber (Figure 2). A Tacx bike trainer was used as exercise machine. Temperature could be controlled between 32 and 35°C and relative humidity between 50 and 70%.



Figure 2: Test in makeshift climate chamber.

Figure 3: Test 2 in progress in the climatic chamber.



Results

Ambient and skin temperatures are similar per test (Table 1). There is no big difference between the tests at Papendal and the pilots. Therefore, the data from all four tests is used to calculate the averages.

Figure 1 shows a graph of the data collected with the first test in the climate chamber. The temperature course of the cores of the three PCM samples is shown with a solid line, the temperature of the skin - PCM interface is shown with a dashed line. The end of the phase change is the spot where the curvature is steepest, this is indicated per curve with a black circle with a border that corresponds to the color of the PCM's icon.

The time till the end of the phase change or threshold can be based on core or interface temperature. From now on the core temperature will be guiding because the interface temperature of the H2neO did not reach the threshold in three out of four tests.

The points where the core temperatures reach the core temperatures that are associated with 5W cooling power on the Hotplate are indicated with a colored circle with a black border. For H2neO this threshold is 26°C, for Inu 15 28°C and for Inu 6,5 27°C (from Table 2, page 99).

The average time till the end of the phase change and time till the power threshold are given in Table 2 for each PCM.

Again the average and standarddeviation are presented in stead of the median, maximum and minimum value for the same reasons as in chapter 6.2. Graphs of the separate tests and all numerical data can be found in Appendix Q.

In terms of qualitative data, participants indicated that Inu 6,5 felt coldest, followed by H2neO and then Inu 15. It was hard to say if a sample was still active based on thermal sensation. Samples very quickly did not feel cold anymore. The cold quickly becomes familiar. However, one could still note the sample's cold with a hand. This held true for all three PCMs.

It is not possible to indicate if a sample is depleted based on thermal sensation.

Discussion

For the individual durations the spread is quite large, up to 16 minutes for Inu 15's time till the power threshold (Table 2, column 3, row 2). The maximal and minimal values per PCM are included in Appendix Q.

Inu 15 lasts 7 minutes longer than Inu 6,5 till the end of the phase change. The time till the power threshold is the same. This could be explained by the difference in thermal resistance. Inu 6,5 has a higher thermal resistance than Inu 15. Therefore, Inu 15's temperature rises faster after the phase change than Inu 6,5's.

The results per test are comparable, no unequivocal difference between the different test persons or ambient conditions can be derived from the test results.

The sample placement could have affected the melting times for three reasons. First, the sample applied with tape is in direct contact with the skin. There is a thin layer of cotton in between the other two other and the skin. Even though the cotton layer is quickly soaked with sweat, reducing its thermal resistance, this layer has some thermal resistance. Secondly, the pressure exerted by the flotation aid on the different samples could not be controlled. Lastly, the skin's heat exchange capability differs per body area. Despite these effects, the data available does not show a causality between sample placement and cooling duration.

It takes much longer for a sample to deplete during the exercise test then during the Hotplate test. The capacity of each sample is the same therefore the cooling power must be lower. While the threshold temperatures do correspond to 5W cooling power on the Hotplate, it is unlikely they equal to 5W cooling power on real skin.

Conclusion

With these results the cooling duration of a PCM on skin can be approximated. The cooling capacity of the samples was measured on the Hotplate. Combining these values gives the average cooling power of the sample on human skin. This is described in the next chapter.

	Ambient temperature [°C]	Average skin temperature [°C]
Test 1	31,5	35,3
Test 2	32,2	34,8
Pilot 1	32,7	35
Pilot 2	33,4	34,8

Table 1: Average ambient and skin temperatures per test.

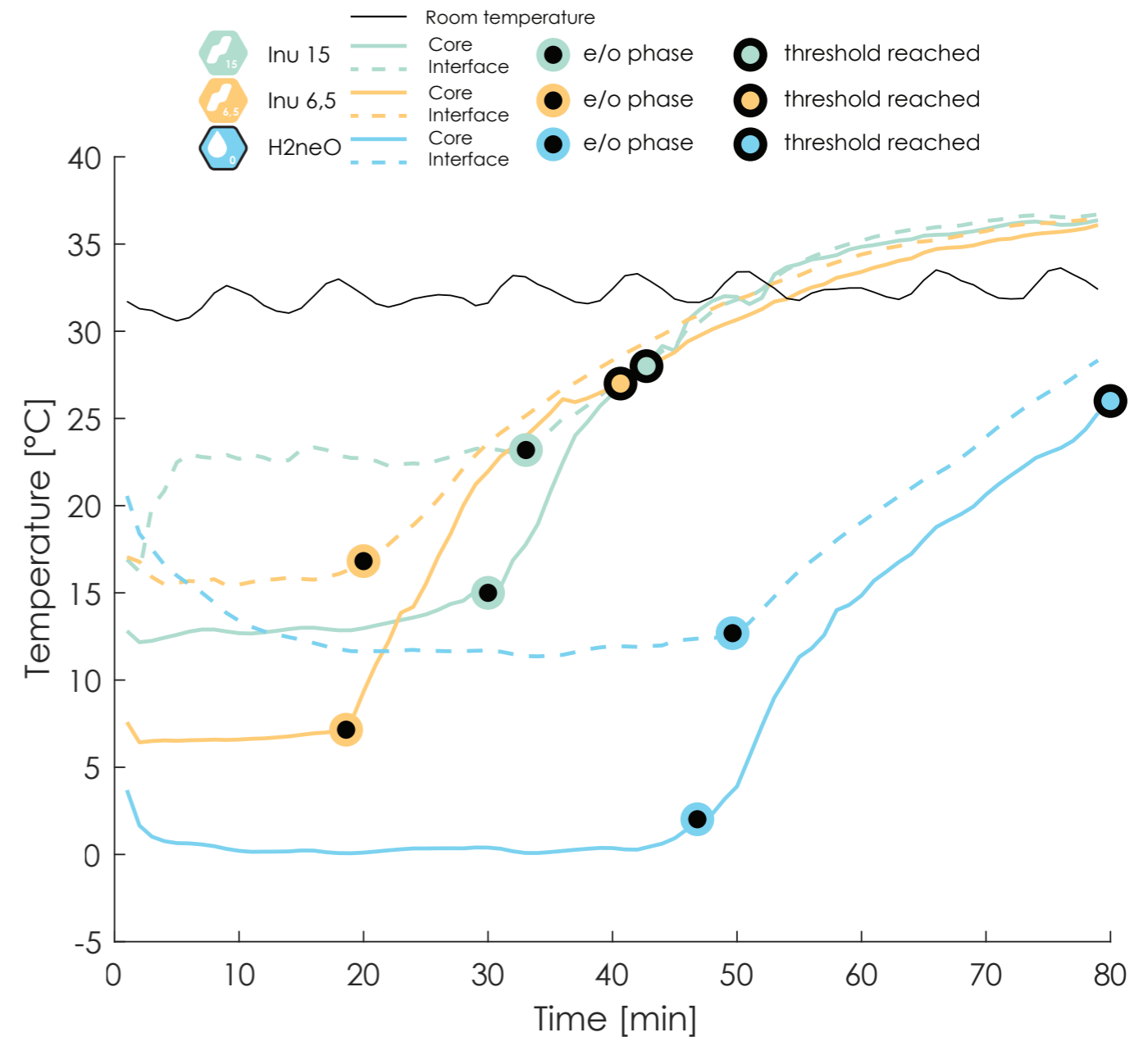

Figure 1: Temperature curves from one exercise test with markers that indicate the end of a phase change or reaching the Threshold temperature.

PCM	Time till end of phase change [min]	Time till power threshold [min]
H2neO	43 ±6	78 ±6
Inu 15	28 ±4	44 ±7
Inu 6,5	21 ±3	44 ±6

Table 2: Time till end of phase change and power threshold of three different PCM samples based on the sample core temperatures. Rounded on full units. (±stdev, n=4)

6.4 Cooling power and duration

The square samples have been analyzed on the Hotplate and human skin. Now all data required to estimate the total cooling power and duration of the vest (Figure 2) is available. The measured and calculated values for each condition are presented in Figure 3. The following text will explain what the numbers mean and how they were determined.

The cooling power and duration of three PCMs (H2neO, Inu 15 and Inu 6,5) is defined for conditions A to E (Figure 1).

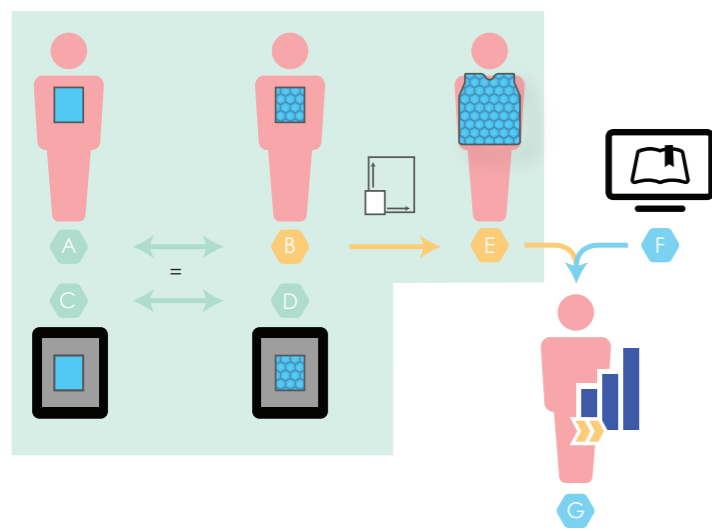

- A** A square PCM sample on human skin, the temperature curve is measured during an exercise test. (Chapter 6.3)
- B** A hexagon pattern sample on human skin.
- C** A square sample tested on the Hotplate, power and temperature curves are measured in the lab. (Chapter 6.2)
- D** A hexagon sample tested on the Hotplate, the power curve is measured in the lab. (Chapter 2.4)
- E** The proposed cooling vest (Figure 2) worn by an Athlete.

Figure 1: Model of thought; from Hotplate tests towards exercise performance. The green area is the subject of this chapter.



Figure 2: The vest of which the cooling power and duration are estimated.

These five conditions have similarities and differences. By finding the ratios between them condition E can be approximated.

How to interpret cooling power and duration

The cooling power is the cooling power of the sample till the PCM has changed phase. The end of the phase change is the minimal cooling duration. After this point the PCM's temperature rises quickly and the cooling power will drop. The maximum cooling duration is the time it takes for the PCM to be less effective than evaporative cooling in Tokyo conditions. After this point the vest becomes a burden rather than a relief.

Connections between conditions

The power of condition A can be calculated by dividing the sample's capacity by the duration. The capacity of each sample was measured on the Hotplate (Condition C).

By assuming that the linear relation between the square and hexagon sample extracted from Hotplate tests also holds for a sample on human skin the theoretical cooling power and duration of a Hexagon sample on human skin can be calculated.

According to Fourier's law the cooling power is proportional to the surface area:

$$q = \frac{k}{s} * A * (T_{Hotplate} - T_{Sample})$$

The cooling power of the whole vest can be calculated by the ratio between the surface areas:

$$P_{vest} = P_{sample} * \frac{A_{vest}}{A_{hotplate}}$$

The duration depends on the capacity and the cooling power. The cooling power scales with the surface area. The capacity also scales with the surface area because the thickness stays the same. Therefore, the cooling duration does not change from condition B to E.

The values in the Table are averages, these averages were used to predict the vest's specifications. Since every set of measurements has a spread the accuracy is affected by the multiplications. All data with the maxima and minima per PCM per condition are included in Appendix S. Accompanied by a more elaborate explanation of the formulas used to calculate the values for condition A, B and E.

Human Skin	Square sample			Hexagon sample			Vest		
	Power [W]	Duration Min [min]	Duration Max [min]	Power [W]	Duration Min [min]	Duration Max [min]	Power [W]	Duration Min [min]	Duration Max [min]
H2neO	14	43	78	8	45	63	95	45	63
Inu 15	14	28	44	10	31	48	112	31	48
Inu 6,5	16	21	44	10	26	51	118	26	51

Hotplate	Square sample			Hexagon sample		
	Power [W]	Duration Min [min]	Duration Max [min]	Power [W]	Duration Min [min]	Duration Max [min]
H2neO	17	35	53	10	37	43
Inu 15	19	21	29	13	23	31
Inu 6,5	22	15	22	15	18	26

Legend:
Bold = Measured value
Regular = Calculated value

Figure 3: The cooling power and duration values as measured or calculated for all five conditions.

6.4 Coolkeeper specifications

The cooling power, minimal and maximal duration of the design as proposed (Chapter 5.1) are visualized in figures 2 and 3. The black bars show the spread of the result. The spread is calculated by combining maxima and minima, from the data available, to give the highest and lowest possible values. The spread is rather large because of the calculation steps, each step made the uncertainty-window grow.

The minimal duration is the time it takes for the PCM to fully change phase. The maximal duration is the time it takes till the vest is less effective than evaporative cooling.

With the reasoning described on the previous page the cooling power of the produced design (Chapter 5.2) can be deducted. In this case the step of translating from the square samples to the hexagon shape can be skipped, because the square pouches of the produced vest are very close to scaled versions of the square sample. The model of thought for the produced vest's performance is shown in Figure 1. The result is shown in Figures 4 and 5.

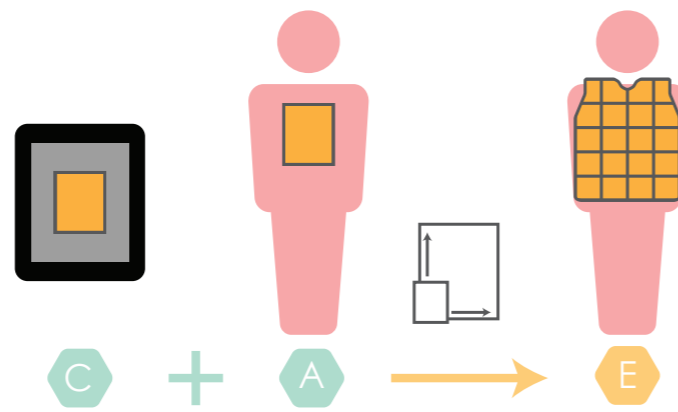

Figure 1: Simplified model of thought; from Hotplate tests towards vest performance.

All numerical data used for the charts on this page is included in Appendix S. Accompanied by the formulas used to deduct the produced vest's cooling power and duration.

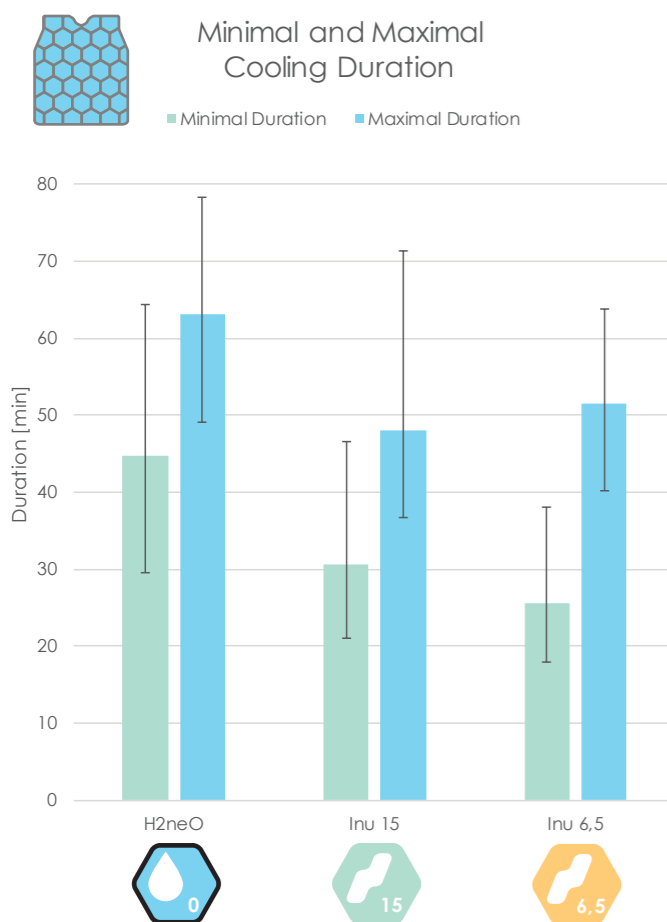

Figure 2: Minimal and maximal cooling duration of the vest as proposed (Chapter 5.1). The values are given for a vest with H2neO, Inu 15 or Inu 6,5 as PCM

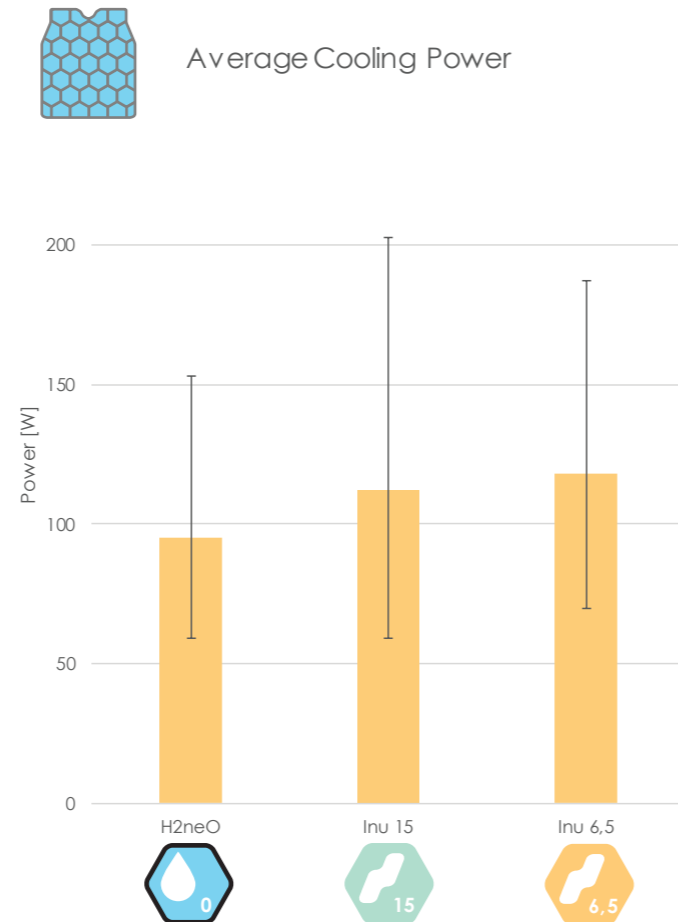

Figure 3: Average cooling power till the minimal cooling duration of the vest as proposed (Chapter 5.1). The value is given for a vest with H2neO, Inu 15 or Inu 6,5 as PCM.

Discussion

The results show that it doesn't matter too much if Inu 6,5 or Inu 15 is used as PCM. Inu 6,5 has a slightly larger cooling power resulting in a slightly shorter cooling duration. H2neO has a lower cooling power but a significantly longer cooling duration. The time it takes till H2neO has changed phase, the minimal cooling duration, is almost twice as long as Inu 6,5's time.

The method used is disadvantageous for the hexagon form. From these results it looks like the squares give a higher cooling power. This is likely because the hexagon form performs quite badly on the Hotplate. The lack of a flat surface makes good contact between the solid Hotplate and a hexagon sample difficult. It is likely that the area of contact on soft human tissue is much larger which increases the cooling power. In practice, the performance of both vests should be close because both vests have almost the same surface area and weight.

Conclusion

The proposed method leaves much room for measurement errors, but it is the best estimation available with the available time and equipment.

The implication of the cooling durations is that Inuteq's PCMs will not last a long time. During pre-cooling this is not a big issue because there is enough time to replace a vest. If it is not desirable to replace a vest, such as during a race, it is better to use H2neO which will last significantly longer with the same weight.

The numerical value of the cooling power is of little value to athletes. In the next chapter the vests are compared to vests previously evaluated in literature. Concluded with an indication of the vest's impact on sport performance.

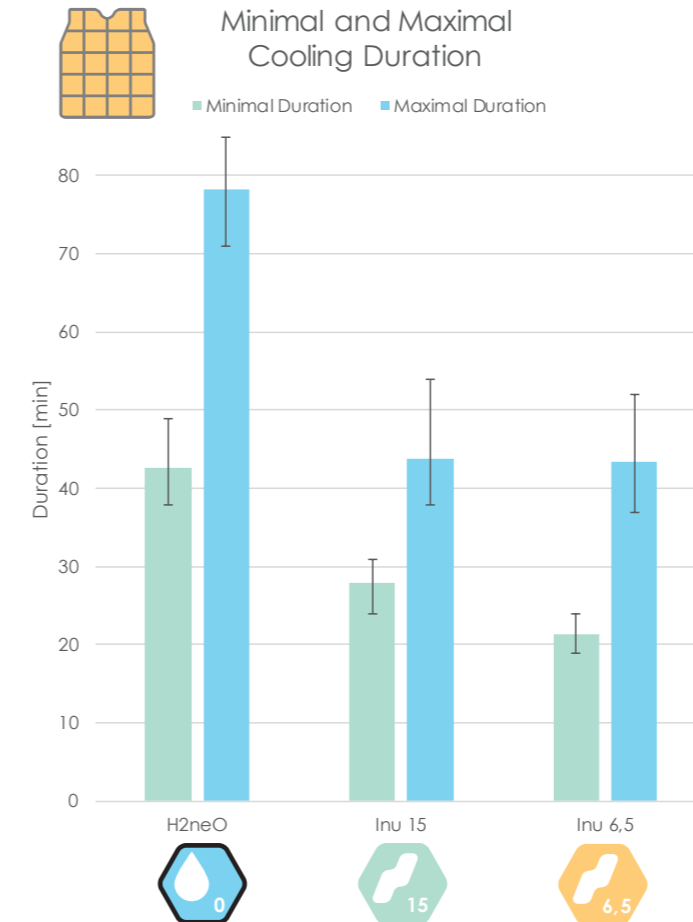

Figure 4: Minimal and maximal cooling duration of the vest as produced (Chapter 5.2). The values are given for a vest with H2neO, Inu 15 or Inu 6,5 as PCM

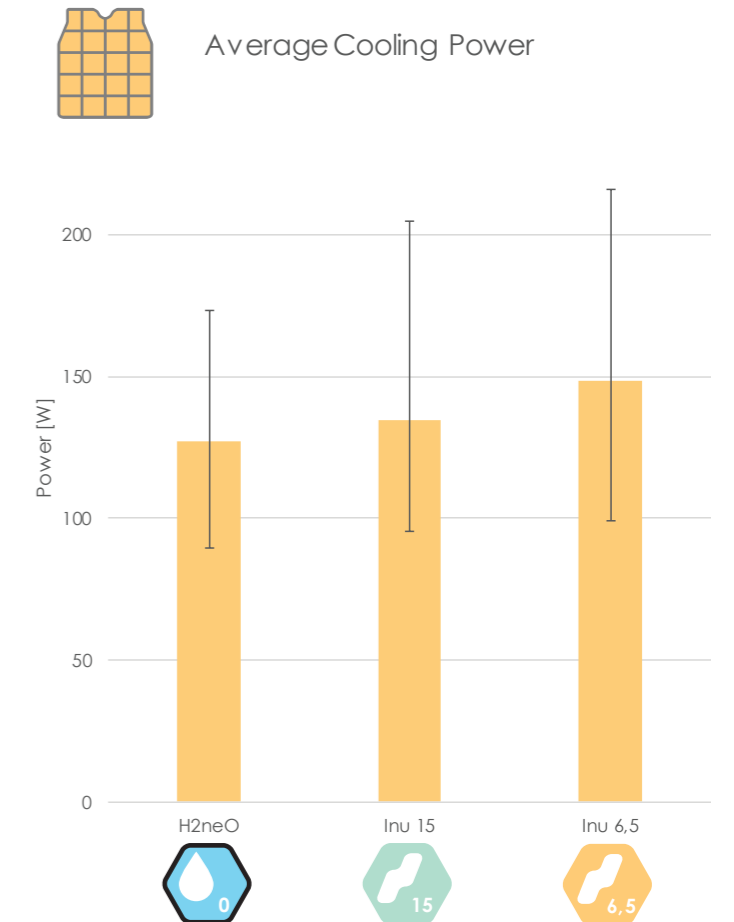

Figure 5: Average cooling power till the minimal cooling duration of the vest as produced (Chapter 5.2). The value is given for a vest with H2neO, Inu 15 or Inu 6,5 as PCM.

6.5 Effect on sport performance

In the previous chapters the CoolKeeper's cooling power is analyzed. This cooling power is hard to translate to exercise performance benefits. For some vests on the market the effect on exercise performance is tested. In this chapter the vest is compared to vests previously evaluated in literature.

Approach

There are plenty of papers published about the effect of cooling garments on sport performance. The following selection criteria were applied to find suitable papers. First, some vest specifications must be available like the cooling power, phase change temperature and surface area. Second, the performance tests should have taken place in hot and humid conditions similar to the once that can be expected in Tokyo. Also, in mild conditions cooling vests are known to be of little effect. (Ross et al. 2013) Third, the effect on exercise performance should be included. Often papers only show data of physiological parameters like heart rates, skin and core temperatures. These are interesting, but eventually coaches and athletes just want to know the effect on exercise performance. In other words:

The scientific paper should contain:

1. An indication of vest specifications
2. A test in hot and humid conditions.
3. The effect on sport performance.

Eight suitable papers in which twelve vests are tested were selected. An overview of the important information from the papers is given in Table 1. A textual summary of the papers can be read in Appendix T, this Appendix also contains a more extensive version of Table 1.

Result

The literature review rendered the following insights: Mild cooling has negligible effect in mild or hot conditions (Faulkner, 2012). Mild cooling can help in extremely humid conditions (Bogerd, 2010). Strong cooling has a notable effect, especially in improving time till exhaustion (Luomala 2012, Webster 2005, Bogerd 2010, Cuttel et al. 2016, Uckert & Joch 2006). On endurance exercise cooling has some, but little effect (Faulkner 2012, Arngrimsson 2003).

The specifications of the vests used in literature are almost always lacking, or hard to interpret. The values available are inconsistent and provided in different units that are hard to compare (Table 1, column 3). It is often not possible to estimate the total cooling power that is received by the athlete.

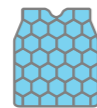

The CoolKeeper with H2neO can best be compared to the vest used by Luomala et al. (2012) because it uses a similar cooling principle: Ice with a thin insulative layer between the ice and skin. Theoretically, the CoolKeeper should be able to achieve a comparable physical performance improvement (21%), when worn during exercise under the same conditions.



The produced vest with Inu 6,5 can best be compared to the vests used by Bogerd (2010), Cuttel et al. (2016) and Uckert & Joch (2006). The cooling power of the produced vest per unit area is lower because the vests in literature contains ice in stead of Inu 6,5. However, the produced vest has a much larger cooling area. Assuming that these differences nullify eachother, a physical performance improvement between 7 and 17% can be expected, if conditions are comparable to the ones used by Bogerd (2010), Cuttel et al. (2016) or Uckert & Joch (2006).

Relation to sailing performance

Biggest performance improvements when using cooling vests are shown when testing time till exhaustion. It is hard to say how this relates to sailing performance. Especially because the exercise regime is different per sailing class. Olympic sailors can roughly be divided into three exercise categories (Bojsen-Møler et al. 2015):

Category:	Classes:
Hikers	Laser, Laser Radial, Finn, 470 helmsman
Trapezing sailors	49'er, 49'erFX, Nacra 17, 470 crew
Board sailors	RS:X

Board sailors are likely to benefit the most from cooling vests, because continuously pumping the sail requires a lot of power. From the three categories board sailors have the largest aerobic (endurance) capacity (De Vito et al. 1997; Vogiatzis et al. 2002; Castagna et al. 2007; 2008) Sport

Author	Vest				Condition				
	Type	Cooling Power	Before/During exercise	Cooling time [min]	Activity	Till	Temperature [°C]	Relative Humidity [%]	Performance improvement
Faulkner, 2012	Evaporation	170 W/m2	Before	30	Running	5K	25	50	-1%
	Evaporation	190 W/m2	Before	30	Running	5K	25	50	0%
	Evaporation	170 W/m2	Before	30	Cycling	Work treshold	35	50	2%
	Evaporation & PCM	170 W/m2 + 169 W	Before	30	Cycling	Work treshold	35	50	5%
Quod et al., 2008	PCM 20°C	?	Before	40	Cycling	Work treshold	34	41	1%
Arngrimsson, 2003	Ice	?	Before	38	Running	5K	32	50	1%
Luomala et al., 2012	Ice*	?	During	**	Cycling	Exhaustion	30	40	21%
Webster, 2005	PCM	1,53 [°C/100g]	Before	35	Running	Exhaustion***	37	50	43%
Bogerd, 2010	Evaporation	27 W/m2; 6,3W	Before	45	Cycling	Exhaustion	29	80	11%
	Ice	49 W/m2; 11,5W	Before	45	Cycling	Exhaustion	29	80	17%
Cuttel et al., 2016	Ice	49 W/m2; 11,5W	During	-	Cycling	Exhaustion	35	50	7%
Uckert & Joch, 2006	Ice	49 W/m2; 11,5W	Before	20	Running	Exhaustion	31	50	7%

Table 1: Summary of findings in literature. *Ice with a thin layer of insulation. **The vest is applied after 30 minutes of exercise. ***Time till exhaustion of a final sprint after 30 minutes of running.

disciplines with a similar exercise intensity are for example cycling, running or cross-country skiing (Bojsen-Møler et al. 2015).

RS:X, 49'er, 49'er FX and Nacra 17 class races are 30 minutes. The protocols used by Bogerd (2010), Cuttel et al. (2016) and Uckert & Joch (2006) rendered times till exhaustion of around 45, 30 and 30 minutes respectively, these times improved with 7 to 17%. Bay & Larsson (2013) found that sailors of the Nacra 17 class approached maximum heart rate values at the end of a simulated race. This indicates that competitive sailors will go all in to win a race, which is likely close to exhaustion. Therefore, it is likely that a cooling vest can help improve physical sailing performance in hot and humid conditions. Physical performance plays a big role for board and trapezing sailors. (Bojsen-Møler et al. 2015).

Laser, Laser Radial, Finn and 470 races are 60 minutes. Even though this duration is more fitting to an endurance sport, the exercise intensity is very dynamic due to tacking and wind changes. Especially hiking requires a lot of physical power. When looking at anaerobic (sprint) performance

the anaerobic capacity of elite sailors can be compared to swimmers and middle-distance runners. Anaerobic capacity is likely to be correlated with the performance ranking of a sailor (Vangelakoudi et al., 2007). A cooling vest can help to improve sailing race times if conditions are such that the hiking performance is limited by severe hyperthermia. Body temperatures tend to climb during exercise, Webster (2005) showed that final sprint duration after 30 minutes of running can improve with 43%.

Conclusion

Olympic sailors will go all in to win a race. This will take a big physical effort. Cooling vests can improve physical performance in hot and humid conditions, especially if used in combination with other cooling methods. In particular board sailors and trapezing sailors can benefit from pre-cooling. Hikers will also benefit from pre-cooling but possibly to a slightly lesser extent. It is not possible to quantify the effect of cooling vests on sailing performance with the current state of knowledge.

6.6 Recommendations

In practice, doing more research does not reduce the amount of loose end. New opportunities worth investigating keep popping up during the process. A compilation of these topics is given in this chapter, they are split in three categories. First recommendations to improve the design of the product are given, followed by practical advice on how to implement the product. At the end, four topics that could form the basis for research projects are proposed.

Design

The design as proposed meets almost all demands that are included in the list of requirements (Appendix M). The design does not meet two requirements because it is not producible with existing equipment at Inuteq and outsourcing will likely increase the production cost too much.

The design of the vest as produced does comply with these two requirements. However, it does not confidently meet requirement number six: 'Sufficient cooling power for 30 minutes.'

To make the vest producible well before the 2020 Olympics a compromise had to be made. The swap from H2neO hexagons to Inu 6,5 squares made the vest easy to produce but the cooling duration and wearing comfort suffered from this decision (Figure 1).

There is still room for improvement. Some improvements can be made before the 2020 Olympics. Other more rigorous improvements will likely take too much time.

First the vest as produced should be tested by sailors. If in practice the cooling duration is indeed too short, there are two options.

The first option is straightforward: Bring more cooling vests, and possibly an extra coolbox. Continuously swapping the vests should make it possible to cool for a long time. If a vest is depleted a second vest can be worn while the depleted vest recharges in the coolbox, the number of vests necessary to complete the circle depends on how long it takes for a vest to recharge. This can be explored empirically.

The second option would be to produce the same vest with H2neO instead of Inu 6,5. It should be possible to do this by hand with the equipment available.

The shape and way of putting the vest on and off seem to be in order. The vest is optimized for the sailing context and meant to be used underneath a flotation aid. It could be an option to add tightening straps to the sides to make it possible to wear the vest without a flotation aid. This would add to the versatility. On the other hand, other cooling vests would work as well in this case.

The three PCMs evaluated in the last chapter each have their own characteristics. They can be applied for different reasons. Based on the experience gained from this project the following applications are suggested.

H2neO can best be used if cooling duration and weight are important. If a vest were to be used during exercise and especially during a race H2neO is the best option.

Inu 6,5 provides a high cooling power for a relatively short duration. The high cooling power makes it the best choice for pre-cooling at sea. The short cooling duration can be overcome by frequently swapping the vest which can be a hassle.

Inu 15 gives mild cooling for a modest amount of time.

Due to the high phase change temperature it is possible to quickly recharge this PCM in a regular coolbox. An example of a suitable application is a cooling vest for a coach or referee. It is best for people that want to stay cool but do not need to do intensive exercise.

PCMs with a higher phase change temperature have not been extensively investigated in this project. It is a bit presumptuous, but it seems there is little demand for PCMs with a phase change temperature above $\sim 20^{\circ}\text{C}$ in the sporting world.

PCM cooling is a good option for sailors because the flotation aid inhibits sweat evaporation. There are other sport disciplines where protective garments limit sweating efficiency. An adapted version of the cooling vest could be beneficial for horse riders, hockey goalies, mountain bikers or fencers among others.

After the 2020 Olympics

There were rumors that there are plans for a new production facility at Inuteq that would make it much easier to create custom shaped cooling packs. This would give numerous opportunities to improve the way PCMs are packaged. This would also make it possible to create the sealing pattern used for the final prototype. There is a notable comfort difference between the squares and the hexagons. And the possibility to fill a vest with tap water is a very handy feature for transport and storage.

Also, if a vest can be refilled with tap water, it does not matter if water is lost while wearing the vest. It would be an option to make the outer layer out of Gore-Tex. The fabric Gore-Tex is impermeable for liquid water but does allow gaseous water molecules to pass through it. In other words; the melt water can evaporate. This way PCM and evaporative cooling can be combined in a single garment.

Implementation

The cooling duration of the vest is estimated, a field test should confirm if the estimate is valid.

Humans are sensitive for temperature changes, not necessarily to constant temperatures. After wearing a vest for a while, it might seem that it is not cold anymore while it is still delivering plenty of cooling power. The vest delivers its maximum cooling power for as long as the PCM is partially solid. Afterwards the temperature rises, and the cooling power drops. The vest's temperature can best be felt by touching it with an uncooled hand.

A set of cooling products that offer the best cooling experience can be composed by trying different materials and products during trainings. Possibilities are for example sunshades, cooling towels, ice slurries, caps and portable fans. An option could be to do intensive pre-cooling in an ice bath at the harbor. Afterwards, a cooling vest can help retain the cooling benefit from the pre-cooling session during the tow from the harbor towards the start of the first race.

Naturally, athletes pace their exercise intensity to keep their bodies from overheating. If a cooling intervention is used this heat regulation system must adapt to the new situation. It could for example be that an athlete under- or overestimates the environmental conditions, because the cooling vest skews their heat perception. Therefore, it is very important to use cooling vests often during trainings.

It is worthwhile to experiment with salt and ice to optimize recharging vests in a coolbox. Freezing a mixture of salt and water instead of adding salt afterwards is a good option if plenty of freezer space is available. Otherwise crushed ice with salt will also work well. It might be necessary to bring an extra coolbox for drinks and food unless an ice cream diet is desirable. More on this is described in chapter 6.7.

Lastly, if vests can be worn during a race and weight is an issue, I would suggest to only wear the rear part of the vest and not the front. Simulations from Itani (2016) show that the back is more sensitive to cooling than the front of the torso.

Before the 2020 Olympics

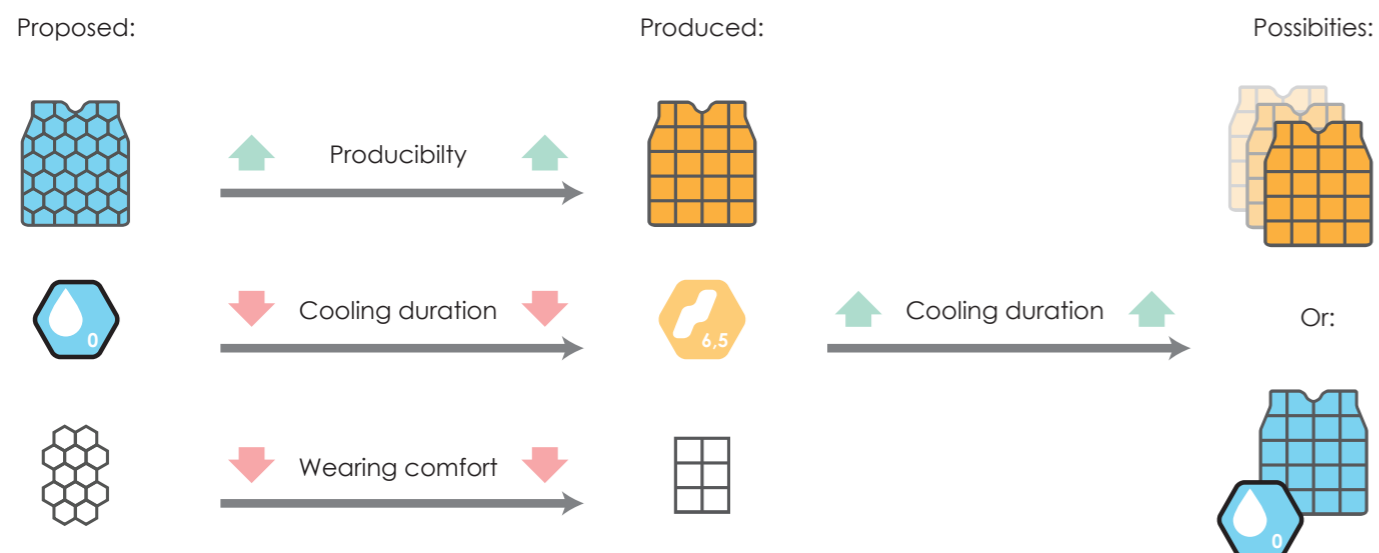

112 Figure 1: Effect of the compromise made to make the proposed design producible (left). And the two possible solutions to the cooling duration (right).

Research

Most tests were focused on gaining insights to justify design decisions. There is scientific potential in many case studies, but often there was not enough time to expand these into more generic findings that can be applied in a wider sense. There are four research topics worth looking in to.

Hotplate improvement

The Hotplate is a very useful device to measure cooling power. The measured power is not the same as the cooling power a sample would exert on human skin. It is possible to translate these values to cooling power on human skin. A relationship between the Hotplate and real skin could be extracted from experiments like the exercise test in chapter 6.3. The durations measured on human skin are longer than on the Hotplate. A simple intervention, like adding a thin layer of insulation on top of the aluminum plate, can improve the realism of the Hotplate. Another option would be to set up a model to convert the cooling power. In that case vasoconstriction can also be included in the model.

Cooling experience

No quantitative data was collected on perceived cooling during this project. Qualitative data from user tests gave a good enough understanding to continue the design process. Nevertheless, it would be interesting to find out how perceived cooling relates to a PCM's temperature and cooling power. By changing cooling power and temperature over time the cooling experience can be improved. The cooling experience was not crucial in this project, because of the assumption that athletes are more interested in performance than experience. For other target groups it would be worthwhile to focus more on experience than performance.

Cooling power vs Exercise performance

In literature about the effect of cooling garments on exercise performance, the documentation of the products used is almost always lacking. I would vouch for the creation of a model that can be used to predict a cooling vest's cooling power without the need of expensive equipment like a thermal mannequin. This way, it becomes much easier to relate cooling power and duration to physiological parameters. For now, the only conclusion from literature is that cooling vests can help in certain conditions. This is far from enough for athletes to decide what type of cooling vest they should use. Also, it is unclear when- and how they should use a cooling vest for optimal results.

Initially, the plan was to evaluate the cooling effectiveness of the prototype with a physiological test. Multiple test persons would wear different cooling vests while exercising in a climate chamber. This is very time consuming. The biggest issue is to have multiple participants do a relatively long and unpleasant exercise test multiple times. On top of that, participants should be available at the same time of day on at least three different days that are more than five days apart to minimize the influence of circadian rhythms and heat acclimation. Before arriving at this conclusion, a test plan and ethics documents were already written, they can be found in Appendix U. They can be used as a basis for future research.

Laser sealing opportunity

Ou et al. (2016) researched pneumatically driven soft shape-changing materials in the project *aeroMorph*. The paper describes some universal bending mechanisms that can be used to design shape-changing inflatables (Figure 1). Custom inflatables were made by hand, heat press or CNC sealing apparatus. Their demonstrator, a crane bird, looks very interesting (Figure 3). Yao et al. (2013) did a similar project with silicon cast inflatables.

The laser sealing method used in this project creates airtight seals, it and can be used to make TPU inflatables quick and cheap. This could form the basis for a (graduation) project on shape changing inflatables. Maybe it is possible to incorporate this project in the field of soft robotics.

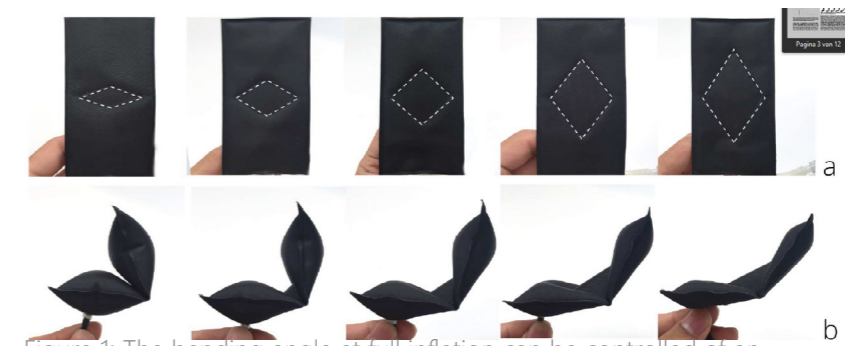

Figure 1: The bending angle at full inflation can be controlled of an inflatable hinge. (Picture from Ou et al. 2016)

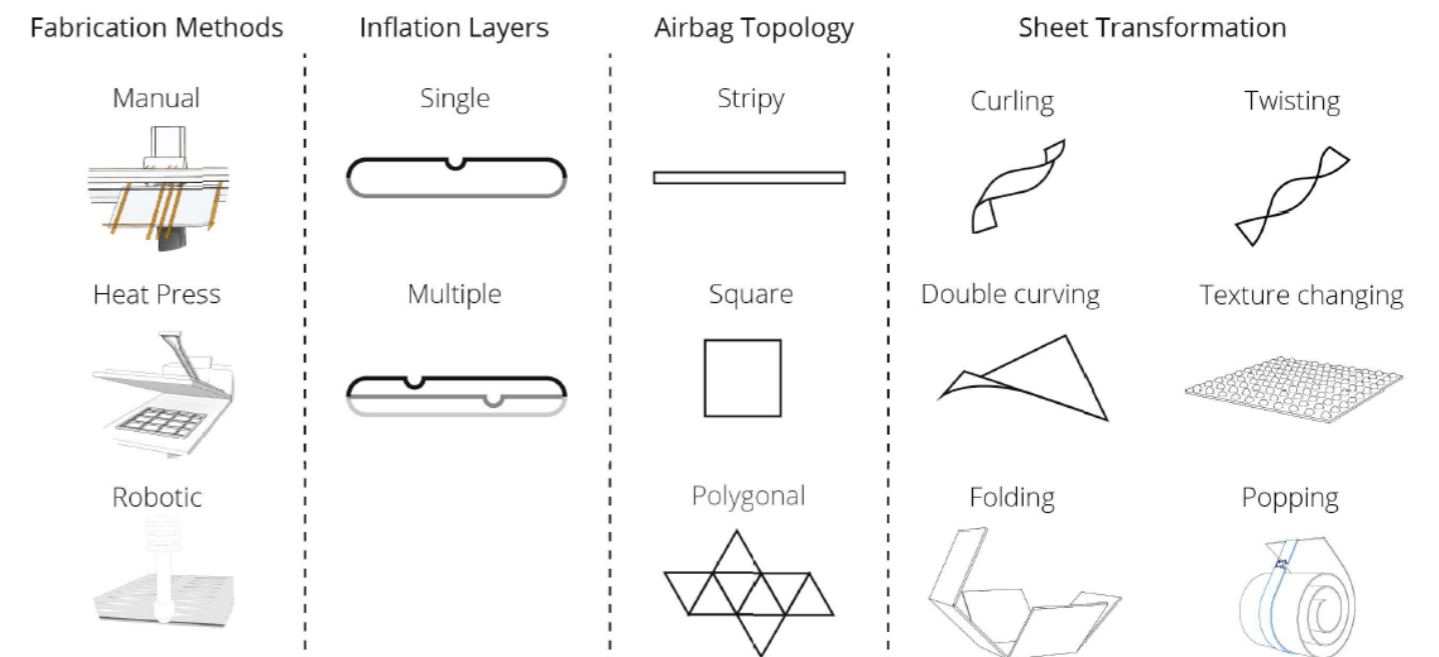

Figure 2: Four dimensions of the design space of custom inflatable shape-changing composites as presented by Ou et al. (2016).



Figure 3: Demonstrator model of a shape changing inflatable by Ou et al. (2016)

6.7 Coolbox and freezer advice

Recharging the packs on shore and keeping them cool at sea requires some attention and equipment. This chapter provides some considerations that can help setting up the right equipment.

On shore: Deep freezer

If many vests need to be recharged over night a powerful freezer is a must.

Normal consumer freezers have a freezing capacity of around 4 kg per 24 hours. This is not enough to recharge enough cooling vests after a race day. There are freezers on the market with a decent cooling capacity for a good price. For example the Zanussi ZFC25401WA (Figure 1) can be bought for around €380,- and can freeze up to 27 kg water per 24 hours. Catering freezers (Figure 2) with active cooling fans are more powerful but also more expensive.



Figure 1: Consumer freezer



Figure 2: Catering freezer

If freezing the cooling packs in time is an issue, a blast chiller could be used (Figure 3). These are powerful small freezers used in restaurants to quickly freeze hot meals. Depending on their size and quality they can freeze around 8 kg of food from +70°C to -18°C in only four hours. A drawback is that they have a smaller volume and they carry a hefty price tag.



Figure 3: Blast chiller

At sea: Coolbox

In the container park there is a freezer to store the vests. At the harbor and on the water there is not. During the day the vests must be kept cool in a medium sized coolbox. A passive coolbox is preferred over an active one. Active coolboxes are more expensive, fragile, and need to be wired to the RIBs battery. Also, active coolboxes that run on 12 Volt are not very powerful (ANWB Koelboxtest 2012). A suitable coolbox is for example the coolbox used during this project. The Campinggaz Icetime 30L is affordable, durable and has decent dimensions. A Bigger coolbox could be handy but would become very heavy to carry when filled with cooling vests and ice.



Brand	Campinggaz
Dimensions	41×47×32 cm
Weight	2,6 kg
Capacity	30L

Figure 4: Coolbox used during this project

The temperature course over time in the coolbox was analyzed to find if it would be possible to keep the cooling packs frozen in the coolbox during the day. The temperature at the top of the coolbox is much higher than at the bottom. Inu 15°C will stay frozen anywhere in the coolbox but H2neO vests should be placed on the bottom with cooling elements or ice water on top.

The second user test (Chapter 4.10) showed that a coolbox with cooling elements can keep an ice vest sufficiently frozen during a full day in hot and windy conditions. During the second user test in Japan ice water was used instead of cooling elements, this also worked well.

Adding salt

Vests will remain sufficiently frozen in a coolbox with cooling elements or ice. But the temperature inside is too high to recharge vests quickly. There is a way to lower the temperature in a coolbox.

A trick inspired by the way ice cream was made in a time before refrigerators were invented can be used to achieve lower temperatures inside a coolbox. In the past artisans would pour ice and salt in a big barrel, and put ice cream batter in a smaller barrel. Which is then placed inside the big barrel. The salt makes the ice around the batter melt faster and at a lower temperature. This effect subsequently freezes

the batter forming delicious icecream.

The same principle can be applied to cooling vests in a coolbox. To evaluate this principle the temperature of the coolbox was logged using iButton temperature sensors at three places; suspended in the air in the middle of the coolbox, on top of the ice blocks, and at the bottom of the coolbox submerged in melt water. At the start 3 kg of ice was placed in the box, after three hours 200-gram kitchen salt was added. The resulting temperature courses are shown in Figure 5.

Adding salt does lower the temperature of the melt water at the bottom of the coolbox a lot, up to -12°C. The air temperature does lower a bit as well but not as much. If vests were to be recharged in a coolbox they should be placed at the bottom of the coolbox in the melting water.

Adding salt to ice lowers the coolbox' temperature, this helps keeping vests fully frozen.

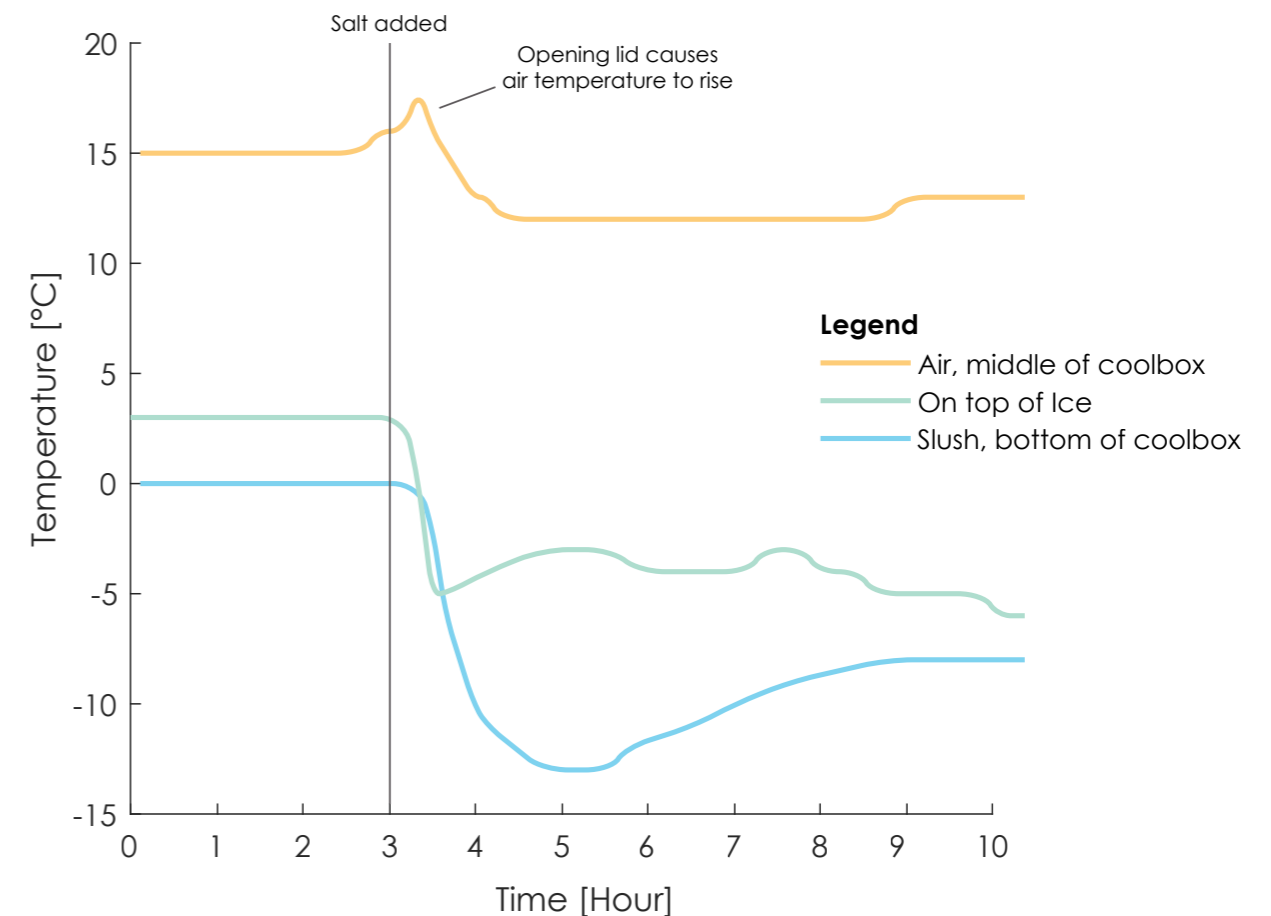

Figure 5: Temperature course in a coolbox measured at three places; (1) suspended in the middle of the coolbox, (2) on top of ice blocks and (3) submerged in melt water at the bottom of the coolbox.

Recharge time in coolbox

At first, recharging a vest while at sea was not necessary. Because of the assumption that one would bring multiple vests to have enough cooling charges for the whole day. At the end of the project D. Broekens indicated that after all recharging at sea is a very handy feature. This was one of the reasons why Inu 6,5 was chosen as PCM for the final version of the cooling vest.

i The possibility to recharge a vest in a coolbox is important.

A vest needs to be recharged during a race to be available in the break afterwards. A race takes approximately 60 minutes. This is quite short, especially since it takes multiple hours to fully recharge a vest in a deep freezer. The coolbox does have one advantage; the heat exchange from melt water to a vest is much larger than from cold air to a vest.

There was enough time for a small case study, the results are such that it is worthwhile to present them here and to give advice on future research.

A thermocouple was taped to the bottom of the coolbox and another one was taped to the inside of the lid of the coolbox. At the start 2 kg ice, 500 mL tap water and 200 g salt were put in the coolbox. After 15 minutes the ice was crushed and stirred. After 45 minutes three samples were added. The samples the ones used for the lab and exercise tes described in chapter 6. They weigh 125 gram and a thermocouple is placed in the middle of the samples. The measured temperature course over time is shown in Figure 1.

Interpretation of the measurements

The black continuous line is the temperature measured at the bottom of the coolbox. When the samples are added it rises. What is interesting is that the temperature of the samples' core temperature drops below the coolbox bottom temperature after 25 minutes. Since temperature is only measured at a single point it is not a good representation of the average temperature in the coolbox. For this test it is assumed that the minimum temperature attained by the core of H2neO is close to the average temperature of the melt water.

A sample is recharged when its core temperature drops below its phase change temperature. The colored arrows show the time it takes for the different samples to change phase.

As expected Inu 15 recharges faster than Inu 6,5 because it has a higher phase change temperature. What is not expected is that H2neO recharges the fastest. One explanation could be the difference in thermal conductivity.

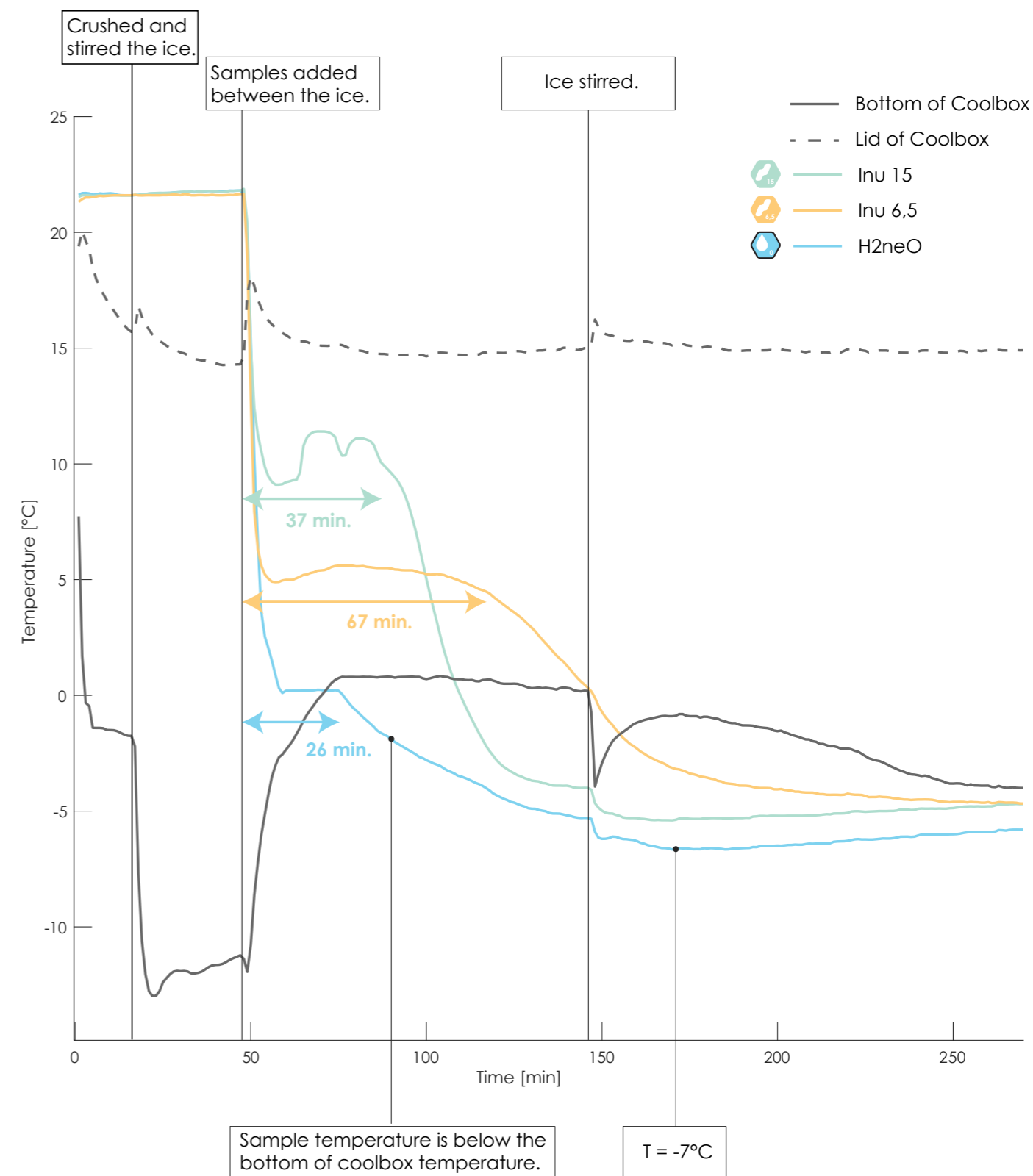

Figure 1: Temperature course in a coolbox measured at five places. (1) at the bottom of the coolbox, (2) at the inside of the lid of the coolbox, and in the cores of an Inu 15 (3), an Inu 6,5 (4) and an H2neO sample (5).

If the dimensions of each sample are equal and the sample starts freezing at the interface the duration of the phase change depends on:

- a. The latent heat capacity (L) [kJ/kg]
- b. The temperature difference ($T_{\text{phasechange}} - T_{\text{coolbox}}$) [K]
- c. The thermal conductivity when frozen (k_{solid}) [W/mK]

When looking at how these material properties differ per PCM the following relationship between PCM A and B can be extracted:

$$\text{Duration}_A : \text{Duration}_B =$$

$$\frac{L_A}{(T_{\text{phasechange}_A} - T_{\text{coolbox}}) * k_{\text{solid}_A}} : \frac{L_B}{(T_{\text{phasechange}_B} - T_{\text{coolbox}}) * k_{\text{solid}_B}}$$

This relationship seems to fit the measured results very well, the measured and predicted durations are shown in the rightmost columns of Table 1.

Another explanation to the difference in recharge time could be that the thermocouple in the H2neO sample did not stay put in the middle, and thus was not measuring the core temperature. Nevertheless, it is interesting to set up a proper experiment to test the hypothesis presented.

Sample	Thermal conductivity when solid [W/(mK)]	Phase change temperature [°C]	Temperature of melting water [°C]	Latent heat capacity [kJ/kg]	Ratio to H2neO*	Measured duration [min]	Calculated using ratio [min]
H2neO	2,2	0	-7	334	1,0	26	26
Inu 6,5	0,2	6,5	-7	177	2,5	67	66
Inu 15	0,3	15	-7	184	1,3	37	35

Table 1: PCM properties with measured and calculated recharge duration.

* The ratios are determined using the formula shown in the text.

If these results are valid then the low thermal conductivity of Inu 6,5 and 15 seems to be the bottleneck for recharging in a coolbox. This could mean that H2neO is better suited than Inu 6,5 for recharging in a coolbox. More research is necessary to verify the results and to find out if the effect holds for PCM packages as big as a whole cooling vest.

A pilot test indicates that H2neO is more suited for recharging in a coolbox than Inu 6,5 and Inu 15.

A second case study was done while moving the coolbox around in a car, this stirred the ice-salt mixture in the box. The result is shown in Figure 1. The salt was added at the same time as the samples, therefore the temperature of the coolbox did not reach as low as in the previous study. Inu 15 and 6,5 froze much faster, the phase change took respectively 15 and 25 minutes. The temperature in the box was not cold enough to quickly freeze the H2neO sample, this took 65 minutes.

Freezing the PCMs will happen much faster if the ice in the box is continuously stirred, which is the case aboard the RIB at sea.

Conclusion

The vest's design has approximately the same thickness as the PCM samples used in the case studies. Therefore, the time it will take to recharge a full vest can be close to the time it takes to recharge a sample. A big practical difference is the ratio of melt water to PCM. A full vest is close to 10 times as big as a sample. It would be hard to completely surround the vest with sufficient melt water in a medium sized coolbox. Nevertheless, with the right coolbox setup it should be possible to recharge a vest with any of the three PCMs within the duration of a one hour race.

A very cold coolbox is beneficial, especially if H2neO needs to be recharged. If powerful freezers are available it could be a solution to make ice from a salt-solution with a melting temperature of around -10°C. This saline ice can then be used to supercool a coolbox. However, this would require plenty of freezer space because it will take a long time for the salt-solution to fully freeze.

Recharging a vest in a coolbox at sea is realistic. Practical experimentation is needed to find the right cooling set up.

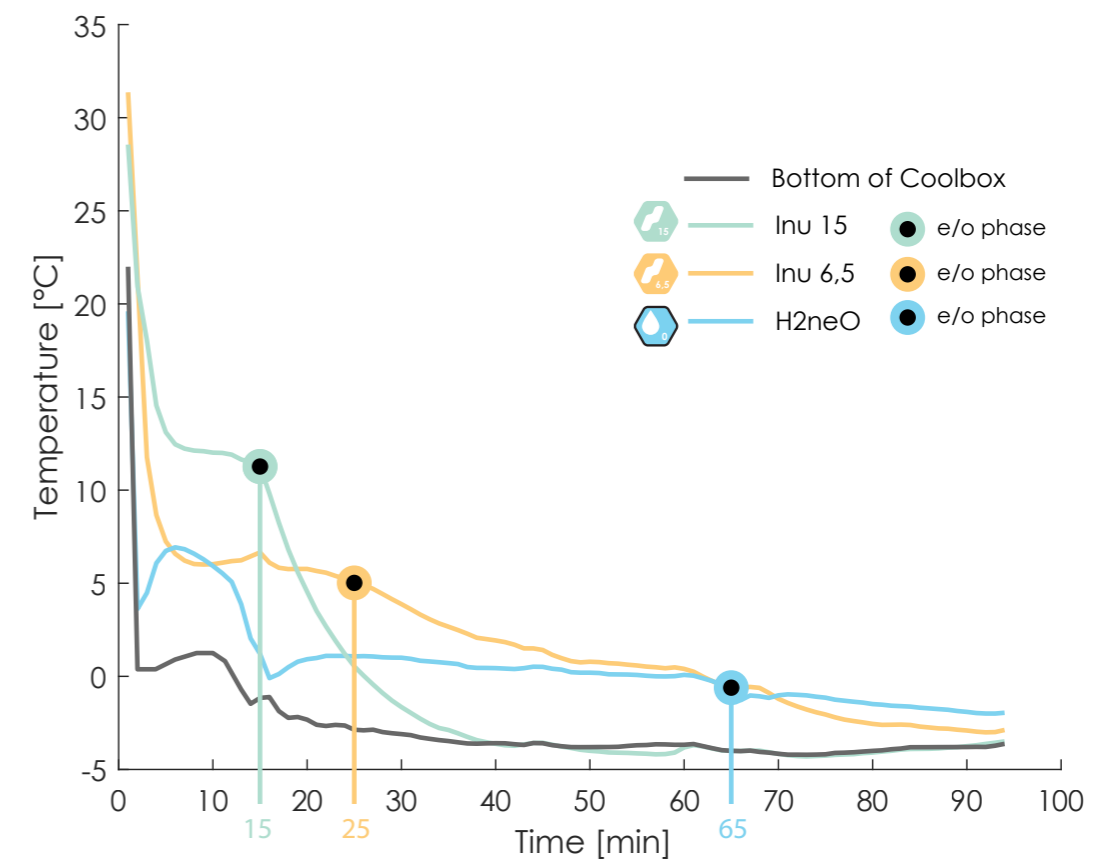

Figure 1: Temperature course in a coolbox measured at four places. (1) at the bottom of the coolbox and (2, 3, 4) in the cores of an Inu 15, an Inu 6,5 and an H2neO sample. Salt and samples were added simultaneously.

6.8 Reflection

This chapter is a general reflection. More specific reflective thoughts can be found in the discussions of their respective topics. The reflection is split into three parts. First the contribution of the project to the IDE-faculty's triple-P strategy is described. Followed by a reflection on the approach and concluded with a personal reflection.

People planet profit

Graduation projects must be related to the *people, planet, profit* strategy of the faculty of Industrial Design at the TU Delft.

The cooling vest will help *people* in achieving better sport performance in hot and humid conditions. Besides aiding top athletes, the vest can help amateur athletes train more safely and comfortably during hot summer months.

The product will not save the *planet*. However, the warming planet is affecting people that are prone to thermoregulatory issues like elderly or disabled people. The findings in this report can be used in designing solutions for such people. Lastly the category *profit*. The product is designed for a niche market. To make the product more profitable the target group can be expanded. When looking outside the sports world there are a lot of professions where people wear clothing that gives heat stress in hot environments. A more profitable product can be made by adjusting the product, such that it becomes interesting for e.g. policemen, military forces or welders.

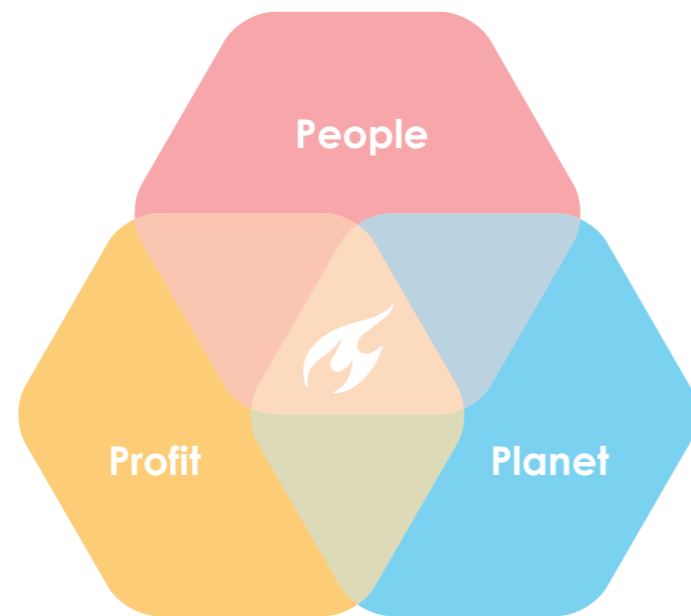

Approach

The parallel approach made it possible to use time effectively, not much time was wasted while waiting till tests were completed, repair of the laser cutter or delivery of materials. The iterative 'fail fast and cheap' approach did give a nice flow. However, going from minimum viable product, to minimum viable test-setup often lead to a minimum viable result. The small sample sizes and rough test set-ups rendered insights, but often tests did not meet the scientific requirements. It did cost quite some time to redo tests to be able to present more convincing data to stakeholders. During the project there were many small decision moments, there was no classic moment in which three concepts were presented from which had to be chosen. A pity, because this is a good chance to involve the client in the design process. Even though this moment did not take place I think that the client was well involved in the project. Presenting many

prototypes gave the possibility to steer the project into the desired direction. The numerous small user tests gave useful unforeseen insights. Next time I would like to do this even more early in the project. Desk and lab research mainly draw on previous insights. User tests are less influenceable by the researcher, this can lead to unexplored domains. Which in turn can be further explored with desk and lab research. This is visualized in Figure 1. I did find that an iterative approach is more suited for improving instead of disrupting. Steps are small and therefore steps into crazy directions are small as well. Since the project was focused on a short-term functional solution this did not matter too much. For more emotion driven or futuristic design projects I think this approach is less suited.

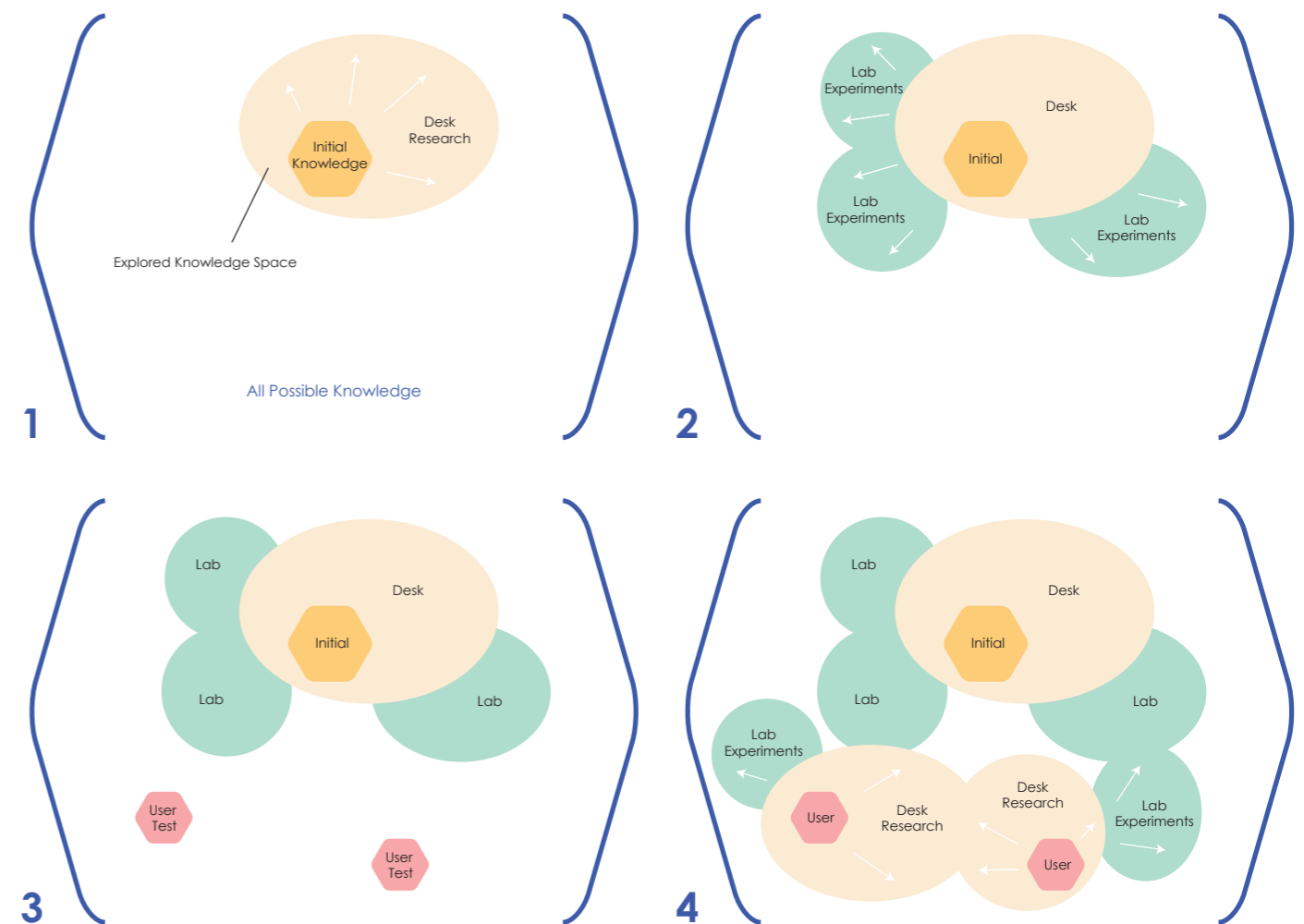

Figure 1: Infographic explaining the benefit of early user tests on the knowledge coverage.

During this project I often evaluated things by experiencing first-hand. In my opinion the best sensor is your own body. There is however a major drawback; determining the magnitude of findings. This makes it hard to explain results to others. Also, validation with other people is required to reduce bias. I found out that measuring is relatively easy, knowing what you are measuring is not. Especially with temperature, there are many variables that must be known to be able to interpret measurements. This is particularly hard when it comes to the human body. A whole graduation project can be set up just to test one assumption of the physiological response of a human to a particular cooling garment.

Personal

At the start of the project I focused too much on the cooling materials. I tried to underpin decisions by formulas and results of lab experiments with well-defined boundary conditions. Even though this was insightful in how the materials work and behave, as well as giving me a broad understanding of what is happening when cooling a human body, it did not help as much as I hoped it would help in designing the product. When moving more towards interviews, context and iterative prototyping I found this was a more effective way of designing. With my background as a mechanical engineer I tend to overthink things. In this project it helped to just go and evaluate afterwards. Iterative design proved to be critical in getting to a result in time.

Because this project was solo, I did not feel the need to properly structure and document everything all the time. I did take a lot of pictures as reminders of what I did. In a group it is necessary to explain and argument choices. Sometimes not having to do this was a blessing, and helped me to get a lot work done in little time. Other times it led to some weird intuitive decisions that I found hard to argument afterwards.

Working with soft materials is both frustrating and fun. There is much freedom in working and designing with fabrics. Many things can be done that are not possible with steel and wood. However, I found it hard to predict how a form would behave. The boundary conditions and material's behavior are much less predictable. This made prototyping both exiting and frustrating. Working in the lab helped in the frustrating moments. Other people's projects and the different devices available provided inspiration and solutions.

At the start of the project I investigated a lot of literature about thermophysiology. I would have liked to be able to use more of this knowledge in the design. There is a lot of knowledge on how the human body works. However, it is very hard to translate this biological knowledge into concrete statements that are useable for product designers. Also, the variety in humans makes it very hard to offer a universal solution.

I enjoyed working on a university project because it gave me the chance to go all in on optimizing the product for a niche market. There was no need to pay much attention to marketing or a business plan around the product. All in all, I liked working on a clearly defined project brief. I got the chance to go from scratch towards a handmade product in only six months.

Acknowledgments

In 2012 I started as a freshman in Delft to become a mechanical engineer. At the time I never would have thought to end my career as a student with the design of a cooling vest. During my studies I found out that I like to study a wide variety of subjects. To do so I think I have found the perfect place at Integrated Product Design. There are so many inspiring projects, the IDE faculty is the perfect incubator for allround problem solvers.

First I want to thank my supervisory team, consisting of Kaspar Jansen and Lennart Teunissen, for the opportunity to do this project. Your enthusiasm for your field caught me and helped to get the project on the road. There was a great balance in letting me figure things out myself and nudging me in the right direction during the frequent meetings. It was great that you were very invested in the project and always supportive. It really felt like we were working towards a common goal.

I want to thank Linda for learning me how to work with fabrics and to give valuable advice on material choices. Your patience and good mood make the sewing space a pleasurable and inviting environment to work.

I would like to thank all sailors and coaches that helped with testing or interviews for their extremely valuable input for this design project. Your friendly and open personalities made the user centered design approach a blast. In particular I want to thank Douwe for his insights and for making it possible to test prototypes with top athletes multiple times.

I want to say thanks to Rein and Stefan from Inuteq for their help with and their practical insights for designing a cooling garment. Your openness about the materials and production techniques helps a lot with innovation.

I also want to state my gratitude towards the applied Labs' staff and graduates for their readiness to help and for the good working ambience in general. Especially Martin and Tessa often helped with solving practical challenges.

Second to last, I would like to thank the Schnekkerts, the inhabitants of Kasteel Zaire and Renske for listening to my endless jabbering about the project, and for the essential coffee breaks and other activities to unwind after studying a bit too hard.

This chapter would not be complete without thanking my family for their mental support, and for making it possible for me to study as carefree as possible. Thanks mom, for calling often to check if I did not burn out yet.

Lastly, thank you reader, for taking an interest in this thesis.

With gratitude,

Emiel Sebastiaan Janssen

References

1. Arngrimsson, S. A. (2004). Cooling vest worn during active warm-up improves 5-km run performance in the heat. *Journal of Applied Physiology*, 96. doi:086.083.102.112
2. Bay & B Larsson, J. (2013). *En fysiologisk performance test for 49'er gaster. [A Physiological Performance test for 49'er crewmen]* (Unpublished master's thesis). University of Copenhagen, Copenhagen, Danmark.
3. Boeijen, A. V., Daalhuizen, J., Schoor, R. V., & Zijlstra, J. (2014). *Delft Design Guide: Design Strategies and Methods*. Bis Pub.
4. Bogerd, N. (2010). The effect of precooling intensity on cooling efficiency and exercise performance. *Journal of Sports Sciences*, 28(7). Retrieved from <http://dx.doi.org/10.1080/02640411003716942>
5. Bojsen-Møller, J. (2015). Physical requirements in Olympic sailing. *European Journal of Sport Science*, 15(3). Retrieved from <http://dx.doi.org/10.1080/17461391.2014.955130>
6. Bongers, C. C., Hopman, M. T., & Eijssvoegels, T. M. (2017). Cooling interventions for athletes: An overview of effectiveness, physiological mechanisms, and practical considerations. *Temperature*, 4(1), 60-78. doi:10.1080/23328940.2016.1277003
7. Calish, S. (2012). Geometric folding algorithms. Retrieved November 1, 2019, from <http://www.mit.edu/~calisch/fold/www/welding.html>
8. Castagna, O., Brisswalter, J., Lacour, J., & Vogiatzis, I. (2008). Physiological demands of different sailing techniques of the new Olympic windsurfing class. *European Journal of Applied Physiology*, 104(6), 1061-1067. doi:10.1007/s00421-008-0863-y
9. Castagna, O., Vaz Pardal, C., & Brisswalter, J. (2007). The assessment of energy demand in the new olympic windsurf board: Neilpryde RS:X®. *European Journal of Applied Physiology*, 100(2), 247-252. doi:10.1007/s00421-007-0403-1
10. Cheung, S. S., Lee, J. K., & Oksa, J. (2016). Thermal stress, human performance, and physical employment standards. *Applied Physiology, Nutrition, and Metabolism*, 41(6 (Suppl. 2)), S148-S164. doi:10.1139/apnm-2015-0518
11. Cuttell, S. A., Kiri, V., & Tyler, C. (2016). A Comparison of 2 Practical Cooling Methods on Cycling Capacity in the Heat. *Journal of Athletic Training*, 51(7), 525-532. doi:10.4085/1062-6050-51.8.07
12. De Vito, G. (1996). Assessment of energetic cost in Laser and Mistral Sailors. *Sports Cardiol*, 5(55).
13. Ely, B. R., Ely, M. R., Cheuvront, S. N., Kenefick, R. W., DeGroot, D. W., & Montain, S. J. (2009). Evidence against a 40°C core temperature threshold for fatigue in humans. *Journal of Applied Physiology*, 107(5), 1519-1525. doi:10.1152/jappphysiol.00577.2009
14. Ely, M. R., Cheuvront, S. N., Roberts, W. O., & Montain, S. J. (2007). Impact of Weather on Marathon-Running Performance. *Medicine & Science in Sports & Exercise*, 39(3), 487-493. doi:10.1249/mss.0b013e31802d3aba
15. Faulkner, S. H. (2012). *Body temperature manipulation and exercise performance in athletically trained males* (Doctoral dissertation, Loughborough University, Loughborough, United Kingdom). Retrieved from https://repository.lboro.ac.uk/articles/Body_temperature_manipulation_and_exercise_performance_in_athletically_trained_males/9355127
16. Galloway, S. D., & Maughan, R. J. (1997). Effects of ambient temperature on the capacity to perform prolonged cycle exercise in man. *Medicine & Science in Sports & Exercise*, 29(9), 1240-1249. doi:10.1097/00005768-199709000-00018

17. Gerrett, N., Kingma, B. R., Sluijter, R., & Daanen, H. A. (2019). Ambient Conditions Prior to Tokyo 2020 Olympic and Paralympic Games: Considerations for Acclimation or Acclimatization Strategies. *Frontiers in Physiology, 10*. doi:10.3389/fphys.2019.00414
18. Hargreaves, M. (2008). Physiological limits to exercise performance in the heat. *Journal of Science and Medicine in Sport, 11*(1), 66-71. doi:10.1016/j.jsams.2007.07.002
19. Lian, C., Zhuge, Y., & Beecham, S. (2011). The relationship between porosity and strength for porous concrete. *Construction and Building Materials, 25*(11), 4294-4298. doi:10.1016/j.conbuildmat.2011.05.005
20. Luomala, M. J., Oksa, J., Salmi, J. A., Linna-mo, V., Holmér, I., Smolander, J., & Dugué, B. (2012). Adding a cooling vest during cycling improves performance in warm and humid conditions. *Journal of Thermal Biology, 37*(1), 47-55. doi:10.1016/j.jtherbio.2011.10.009
21. Mane, S. (2019). *Application of Polyvinyl Alcohol (PVA) Fabric for Cycling Clothing* (Master's thesis, Technical University of Delft, Delft, Netherlands). Retrieved from <https://repository.tudelft.nl/islandora/object/uuid%3A845ca9cc-9d11-49f0-9d93-ff1693f23f6c?collection=education>
22. Marino, F. E. (2002). Methods, advantages, and limitations of body cooling for exercise performance. *British Journal of Sports Medicine, 36*(2), 89-94. doi:10.1136/bjism.36.2.89
23. Marino, F. E. (2008). The Evolutionary Basis of Thermoregulation and Exercise Performance. *Thermoregulation and Human Performance, 1-13*. doi:10.1159/000151545
24. Maughan, R. J., Otani, H., & Watson, P. (2011). Influence of relative humidity on prolonged exercise capacity in a warm environment. *European Journal of Applied Physiology, 112*(6), 2313-2321. doi:10.1007/s00421-011-2206-7
25. Mokhtari Yazdi, M., & Sheikhzadeh, M. (2014). Personal cooling garments: a review. *The Journal of The Textile Institute, 105*(12), 1231-1250. doi:10.1080/00405000.2014.895088
26. Mondal, S. (2008). Phase change materials for smart textiles – An overview. *Applied Thermal Engineering, 28*(11-12), 1536-1550. doi:10.1016/j.applthermaleng.2007.08.009
27. Nunneley, S. A. (1970). Water cooled garments: A review. *Space Life Sciences, 2*(3), 335-360. doi:10.1007/bf00929293
28. Nybo, L. (2008). Hyperthermia and fatigue. *Journal of Applied Physiology, 104*(3), 871-878. doi:10.1152/jappphysiol.00910.2007
29. Nybo, L. (2010). Cycling in the heat: performance perspectives and cerebral challenges. *Scandinavian Journal of Medicine & Science in Sports, 20*, 71-79. doi:10.1111/j.1600-0838.2010.01211.x
30. Nybo, L. (2012). Brain temperature and exercise performance. *Experimental Physiology, 97*(3), 333-339. doi:10.1113/expphysiol.2011.062273
31. Ou, J., Skouras, M., Vlavianos, N., Heibeck, F., Cheng, C., Peters, J., & Ishii, H. (2016). aeroMorph - Heat-sealing Inflatable Shape-change Materials for Interaction Design. *Proceedings of the 29th Annual Symposium on User Interface Software and Technology - UIST '16*. doi:10.1145/2984511.2984520
32. Ravindran, S. (2016). *Thermoelectrically cooled jacket* (Unpublished doctoral dissertation). Hindustan Institute of technology, Padur, India.
33. Ross, M., Abbiss, C., Laursen, P., Martin, D., & Burke, L. (2013). Precooling Methods and Their Effects on Athletic Performance. *Sports Medicine, 43*(3), 207-225. doi:10.1007/s40279-012-0014-9

34. Rowell, L. B. (1977). Reflex Control of the Cutaneous Vasculature. *Journal of Investigative Dermatology*, 69(1), 154-166. doi:10.1111/1523-1747.ep12497938
35. Rowell, L. B. (1977). Reflex Control of the Cutaneous Vasculature. *Journal of Investigative Dermatology*, 69(1), 154-166. doi:10.1111/1523-1747.ep12497938
36. Smith, C. J., & Havenith, G. (2010). Body mapping of sweating patterns in male athletes in mild exercise-induced hyperthermia. *European Journal of Applied Physiology*, 111(7), 1391-1404. doi:10.1007/s00421-010-1744-8
37. Smith, N. P., Barclay, C. J., & Loiselle, D. S. (2005). The efficiency of muscle contraction. *Progress in Biophysics and Molecular Biology*, 88(1), 1-58. doi:10.1016/j.pbiomolbio.2003.11.014
38. Tamura, T., & Chen, W. (2017). *Seamless Healthcare Monitoring: Advancements in Wearable, Attachable, and Invisible Devices*. Basingstoke, England: Springer.
39. Tattersson, A. J., Hahn, A. G., Martini, D. T., & Febbraio, M. A. (2000). Effects of heat stress on physiological responses and exercise performance in elite cyclists. *Journal of Science and Medicine in Sport*, 3(2), 186-193. doi:10.1016/s1440-2440(00)80080-8
40. Teunissen, L. (2019). *Thermophysiology introduction* [PDF].
41. Teunissen, L. P., & Daanen, H. A. (2011). Infrared thermal imaging of the inner canthus of the eye as an estimator of body core temperature. *Journal of Medical Engineering & Technology*, 35(3-4), 134-138. doi:10.3109/03091902.2011.554595
42. Uckert, S., & Joch, W. (2007). Effects of warm-up and precooling on endurance performance in the heat. *British Journal of Sports Medicine*, 41(6), 380-384. doi:10.1136/bjism.2006.032292
43. Vangelakoudi, A., Vogiatzis, I., & Gelas, N. (2007). Anaerobic capacity, isometric endurance, and Laser sailing performance. *Journal of Sports Sciences*, 25(10), 1095-1100. doi:10.1080/02640410601165288
44. Vogiatzis, I., Spurway, N. C., Jennett, S., Wilson, J., & Sinclair, J. (1996). Changes in ventilation related to changes in electromyograph activity during repetitive bouts of isometric exercise in simulated sailing. *European Journal of Applied Physiology and Occupational Physiology*, 72(3), 195-203. doi:10.1007/bf00838638
45. Webster, J., Holland, E., Sleivert, G., Laing, R., & Niven, B. (2005). A light-weight cooling vest enhances performance of athletes in the heat. *Ergonomics*, 48(7), 821-837. doi:10.1080/00140130500122276
46. Yao, L., Niiyama, R., Ou, J., Follmer, S., Della Silva, C., & Ishii, H. (2013). PnUI. *Proceedings of the 26th annual ACM symposium on User interface software and technology - UIST '13*. doi:10.1145/2501988.2502037
47. Zhao, M., Gao, C., Wang, F., Kuklane, K., Holmér, I., & Li, J. (2012). The torso cooling of vests incorporated with phase change materials: a sweat evaporation perspective. *Textile Research Journal*, 83(4), 418-425. doi:10.1177/0040517512460294



Appendices

The chapter 'appendices' speaks for itself. It is the big knowledge dump of everything that did not make the cut. For some information it was hard to decide if it was worthy to be in the main report. If you really enjoyed reading everything so far, you can continue your peculiar obsession in the appendix.

Contents

A	Evaporative cooling power vs humidity	136
B	Inuteq PAC PCM material safety sheets	137
C	Detailed characteristics of Olympic sailors	139
D	Relevant sailing regulations	140
E	Case study: Ice packs under flotation aid	141
F	Water in oil emulsion as PCM	142
G	Data from emulsion breaking strength test	144
H	Laser sealing three layers	146
I	Data from from Hotplate for PCM comparison (Chapter 2.2)	149
J	Laser sealing procedure	152
K	Case study: Available space underneath flotation aid	154
L	Attempts to estimate hexagon thickness	156
M	List of requirements	158
N	Alternative solution: Cold water from below	162
O	Cooling vest's manual for testing in Japan	164
P	All power and temperature data from Lab test (Chapter 6.2)	165
Q	All power and temperature data from Exercise test (Chapter 6.3)	168
R	All power data from Hexagon hotplate test	171
S	Values used for vest's cooling power and duration estimation	173
T	Supplement for literature review	175
U	Preparatory documents for future physiological study	178

Evaporative cooling power vs humidity

The following data has been collected by L. Teunissen, it shows how evaporative cooling power changes with relative humidity. This data has not been published. (personal communication, September 26, 2019)

The average relative humidity in Tokyo will be around 65%. The average cooling power between the two tests at 65% RH is $7,98 \approx 8$ W.

This is the cooling power over the Hotplate's surface of 150 x 150 mm.

The threshold used for the hexagon samples that cover the whole Hotplate is therefore also 8 W.

The square samples are smaller, the evaporative cooling power over the square sample's surface is:

$$8/A_1 \cdot A_2 = 4,6 \approx 5[W]$$

With:

$$A_1 = 150 \times 150mm$$

$$A_2 = 100 \times 130mm$$

	Relative Humidity [%]	Evaporation rate [gr/hr/m2]	Cooling power [W]
Test 1	40,8	1120	11,04
	50,5	980	10,85
	60,8	890	10,11
	69,7	645	6,3
	79,8	450	4,45
	89,7	285	3,35

	Relative Humidity [%]	Evaporation rate [gr/hr/m2]	Cooling power [W]
Test 2	36,6	1050	13,55
	50,6	760	9,97
	60,7	650	8,37
	70,1	545	7,13
	80	400	4,76
	89,6	270	3,28

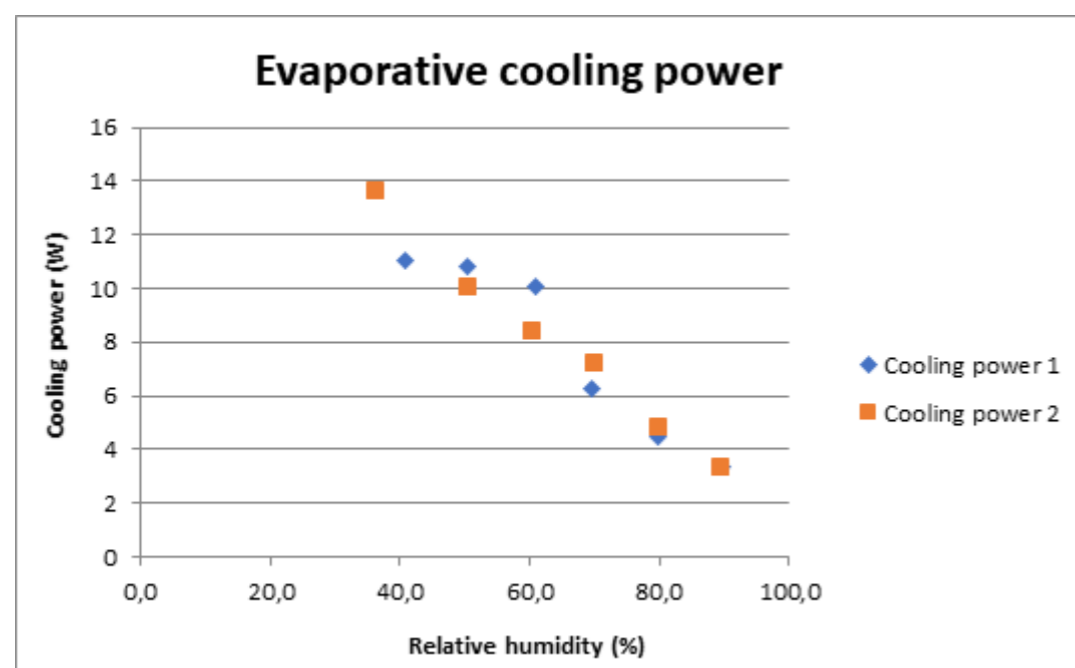

Inuteq PAC PCM material safety sheets

This Appendix contains part of the material safety sheets of the products from Inuteq that have been used during prototyping. This information can be handy if you want to design with Inuteq PAC PCMs. Or if you want to compare it with another PCM.



INUTEQ-PAC™ 15

Ambient temperature phase change material

INUTEQ-PAC 15 is a water insoluble organic phase change material derived from plant-based feed stocks and has the form of a crystalline wax or oily liquid (depending on temperature).

INUTEQ-PAC 15 has low flammability, is readily biodegradable and non-toxic.

Typical properties

Test	Typical Value	Units
Melting temperature	15	°C
Latent heat, melting	177	kJ/kg
Crystallization temperature	9.7	°C
Latent heat, crystallization	-176	kJ/kg
Specific heat capacity, solid	2.0	kJ/(kg·°C)
Specific heat capacity, liquid	1.9	kJ/(kg·°C)
Volumetric heat capacity, solid	1.79	MJ/(m ³ ·°C)
Volumetric heat capacity, liquid	1.63	MJ/(m ³ ·°C)
Thermal conductivity, solid	0.29	W/(m·°C)
Thermal conductivity, liquid	0.10	W/(m·°C)
Flash point	206	°C
Density at 10°C (liquid)	896	kg/m ³
Density at 20°C (liquid)	859	kg/m ³
Thermal expansion	4.3	% Volume



INUTEQ-PAC™ 6.5

Low temperature phase change material

INUTEQ-PAC 6.5 is a water insoluble organic phase change material derived from plant-based feed stocks and has the form of a crystalline wax or oily liquid (depending on temperature).

INUTEQ-PAC 6.5 has low flammability, is readily biodegradable and non-toxic.

Typical properties

Test	Typical Value	Units
Melting temperature	6.8	°C
Latent heat, melting	184	kJ/kg
Crystallization temperature	2.5	°C
Latent heat, crystallization	-182	kJ/kg
Specific heat capacity, solid	1.6	kJ/(kg·°C)
Specific heat capacity, liquid	2.1	kJ/(kg·°C)
Volumetric heat capacity, solid	1.6	MJ/(m ³ ·°C)
Volumetric heat capacity, liquid	1.6	MJ/(m ³ ·°C)
Thermal conductivity, solid	0.24	W/(m·°C)
Thermal conductivity, liquid	0.15	W/(m·°C)
Flash point	200	°C
Density at 3°C (solid)	958	kg/m ³
Density at 25 °C (liquid)	857	kg/m ³
Thermal expansion	11.8	% Volume

Detailed characteristics of Olympic sailors

The Table below shows the characteristics of the sailors that form the user group of this project.

	Gender	Age	Length	Weight	Shirt size	Class
Marit Bouwmeester	F	31	1,77	68	12	Laser Radial
Lilian de Geus	F	27	1,64	57	8	RS:X Women
Afrodite Zegers	F	27	1,61	58	10	470 Women
Lobke Berkhout	F	38	1,83	70	14	470 Women
Dorian van Rijsselberghe	M	30	1,89	75	16	RS:X
Kiran Badloe	M	24	1,96	73	16	RS:X
Nicholas Heiner	M	30	1,86	96	18	Finn
Annemiek Bekkering	F	28	1,62	54	10	49er-FX
Annette Duetz	F	26	1,8	74	12	49er-FX

Relevant sailing regulations

The following sailing rules are of interest to the design of a cooling garment. They are from the Racing Rules of Sailing 2017-2020 (World Sailing 2017)

It is allowed to not briefly wear a personal flotation device to change or adjust clothing or personal equipment. (rule 40)

It is not allowed to wear or carry clothing or equipment for the purpose of increasing weight. (rule 43.1a)

Clothing and equipment shall weigh no more than 8 kilograms, excluding hiking or trapeze equipment. This might differ a bit per class. (rule 43.1b)

It is not allowed to add equipment on board after the preparatory signal. (rule 47.1)

It is not allowed to intentionally throw something overboard. (rule 55)

Flag Y below is shown when it is obliged to wear a flotation aid. Flag P below is shown when a race is about to start.



Y Wear a personal flotation device (see rule 40).



P Preparatory signal.

Case study: Ice packs under flotation aid

To experience the effect of using ice as PCM in a cooling garment myself I put two ice packs underneath a flotation aid (Figure 1 a). Next, I put on warm clothing and did an intensive cycle ride of 20 minutes (Figure 1 b). Afterwards my skin felt very cold and was white and red (Figure 1 c). The ice packs did not feel comfortable. The temperature felt too cold and the blocks of ice caused uncomfortable pressure points especially at my scapula.



Figure 1: Trying ice packs underneath flotation aide while cycling.

Water in oil emulsion as PCM

To create a stable water in oil emulsion multiple emulsifiers were tried. First dishwashing detergent (Dreft) was used, this resulted in a lot of foam and did not give a stable emulsion. (Figure 1)

To avoid the foam 'Groene Zeep' was tried as an emulsifier. This is a typical soap that grannies use for almost everything. The result improved but the emulsions were still unstable over time. It is hard to predict the stability of an emulsion if it were to change phase, thawing can cause an emulsion to break. (Josh & Coupland 2008) Figure 2 illustrates this process.

A good emulsifier should be able to retain a stable emulsion when freezing and thawing.

The behavior of an emulsifier is characterized by its Hydrophilic-Lipophilic balance (HLB). For a good water in oil emulsion an HLB value between three and six is preferred.

Source: "Pharmaceutics: The Science of Dosage Form Design" 2nd edition, Michael E. Aulton. Churchill Livingstone, 2002. p. 96"

The emulsifier Polyglyceryl-3 polyricinoleate has an HLB value between four and five. It is sold under the brand name 'Dermofeel PR' and advertised to create stable water in oil emulsions with up to 80% water. (Bought at: <https://www.jojoli.nl/dermofeel-pr.html>)

Within the emulsion the emulsifier should cover the surface of the microscopic drops of water dispersed in the oil. For stability the emulsifier needs to cover the surface of the droplets completely. A rule of thumb is to add 25% emulsifier to the phase to be dispersed. (Source: <http://makingskincare.com/emulsions-stability/>, retrieved may 2019)



Figure 1: Emulsions with different fractions of water with Dreft as emulsifier.

Three samples were made with respectively 5%, 10% and 20% emulsion (Table 1).

These proportions provided stable milk-white emulsions.

First a draft test was performed to see whether or not the effect of the emulsion could be notable. The test setup is shown in Figure 4. Despite the large measurement error there seems to be test seems to indicate that the samples with an emulsion break more easily than pure PCM (Figure 3).

A more thorough test with a tensile strength tester was performed to get proper data on the yield strength of the different emulsion samples, this test and the results are described in chapter 2.1.

Optical micrographs of a coarse 40 wt% n-hexadecane emulsion from (Ghosh & Coupland 2008)

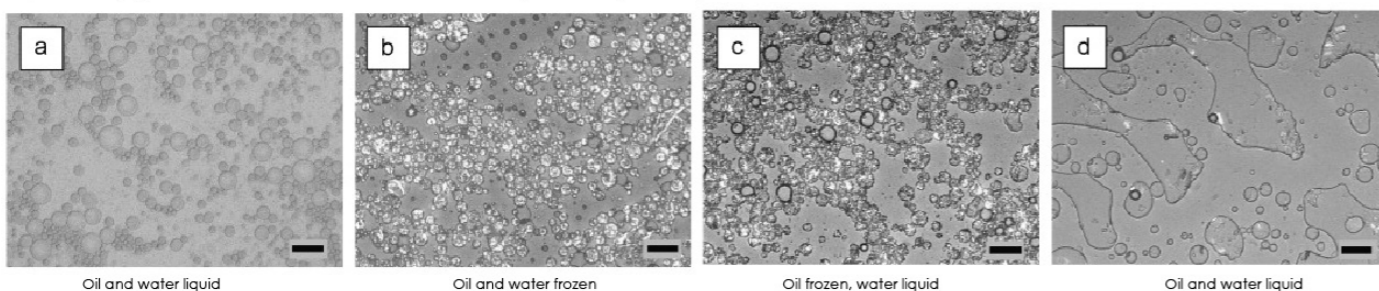

Figure 2: Micrographs of the thawing of an oil in water emulsion from Josh & Coupland (2008)

Phase:	5% emulsion, 300 mL	10% emulsion, 300 mL	20% emulsion, 300 mL
Oil	285 mL	270 mL	240 mL
Water	11,25 mL	22,5 mL	45 mL
Emulsifier	3,75 mL	7,5 mL	15 mL

Table 1: Contents of the samples.

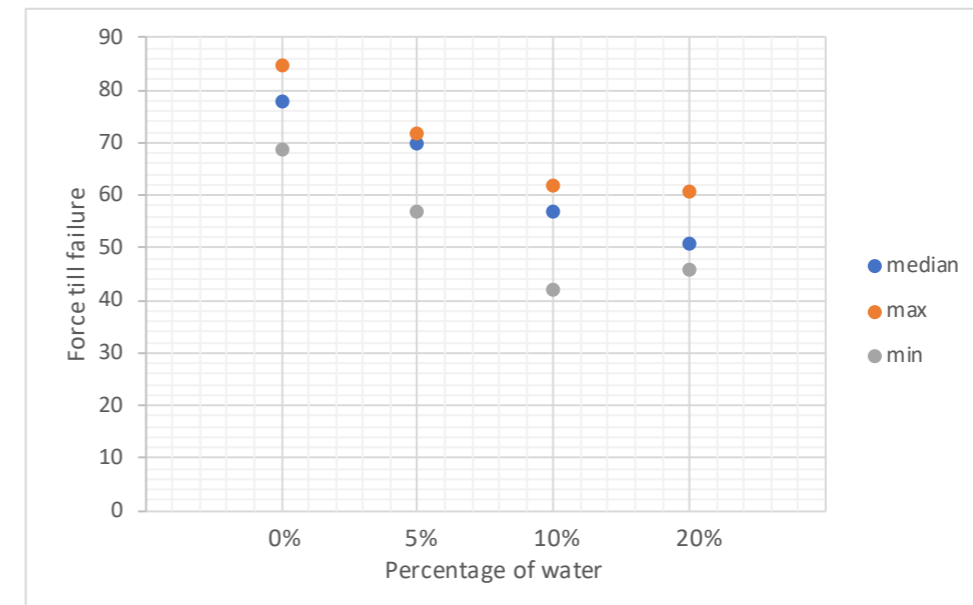

Figure 3: Preliminary results of strength test of emulsion samples

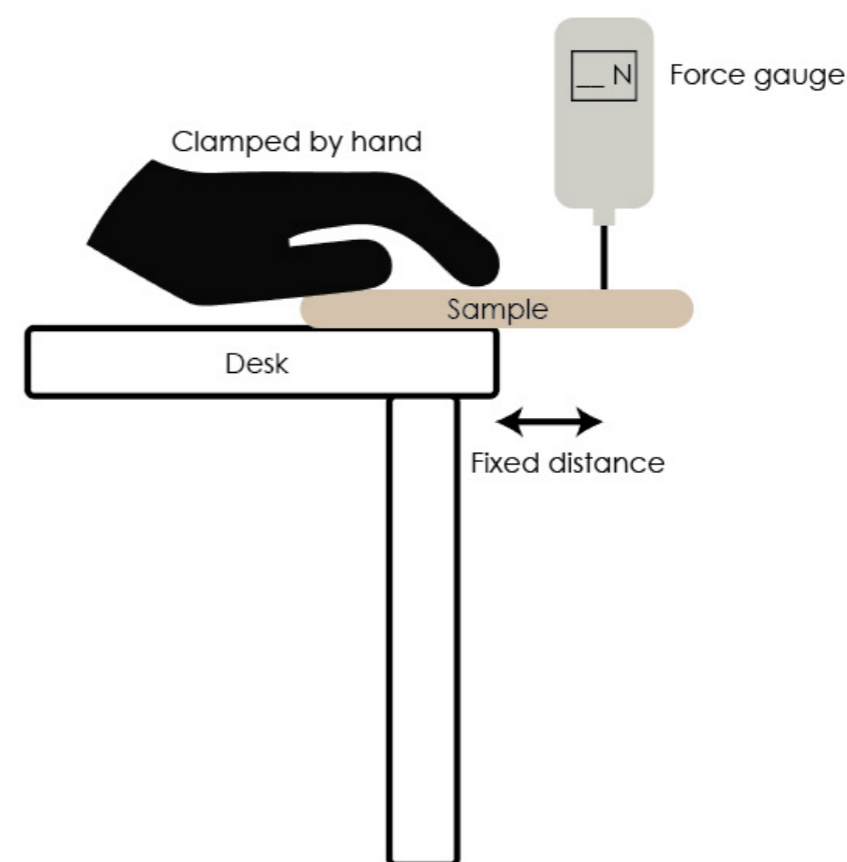

Figure 4: Draft test setup



Data from emulsion breaking strength test

The Table on the right shows all yield forces of every sample of each of the five tests. The graphs on the right page show the force - displacement curves as measured by the Zwick tensile tester. As you can see the results differ quite a lot.

Emu 5 and emu 10's strength is close to the strength of emu 0, sometimes larger sometimes smaller. This really depends on how the sample has frozen up and is very unpredictable.

Emu 20 on the other hand is in all cases the smallest.

Test #	Yield force [N]			
	emu 0	emu 5	emu 10	emu 20
1	161	263	233	119
2	150	174	156	107
3	189	180	170	117
4	243	285	271	188
5	236	236	115	110
Average	196	228	189	128

Test #	Fractions of pure PCM (emu 0):			
	emu 0	emu 5	emu 10	emu 20
1	1	1,64	1,45	0,74
2	1	1,16	1,04	0,71
3	1	0,95	0,90	0,62
4	1	1,18	1,12	0,77
5	1	1,00	0,49	0,47
Average	1	1,16	0,96	0,65

	Compared to pure PCM (emu 0)			
	emu 0	emu 5	emu 10	emu 20
Max	100%	95%	90%	47%
Average	100%	116%	96%	65%
Min	100%	164%	145%	77%

*One outlier that has a strength of 49% of the pure sample is excluded.

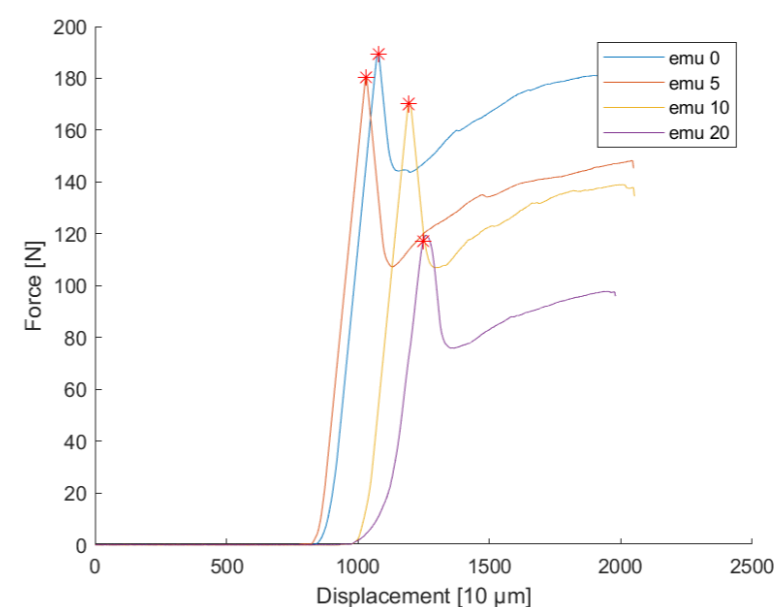
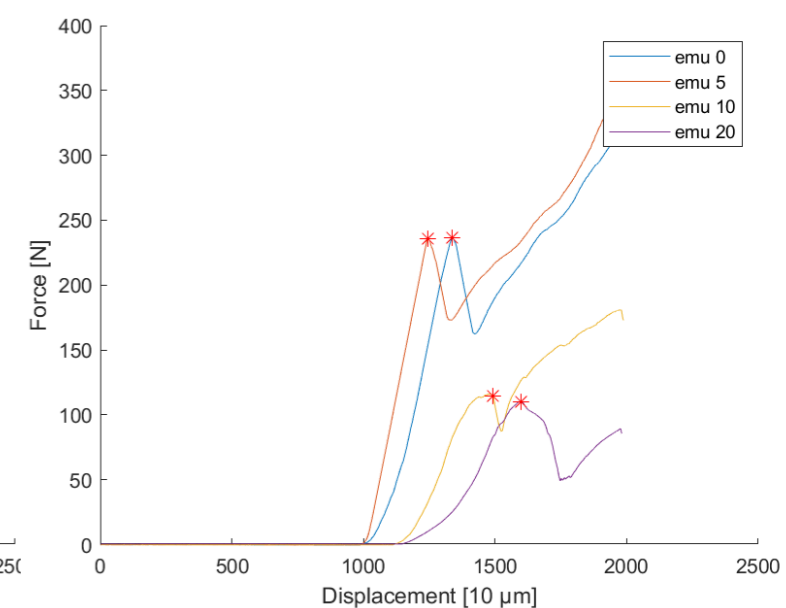
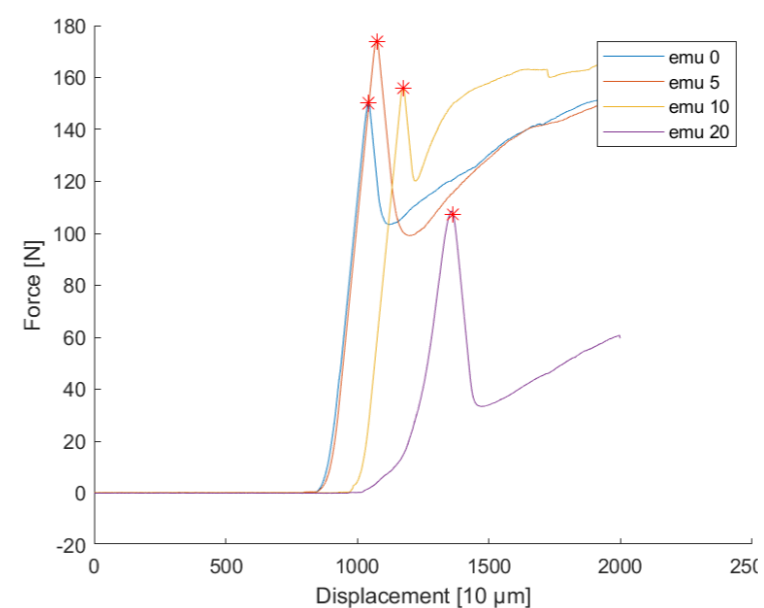
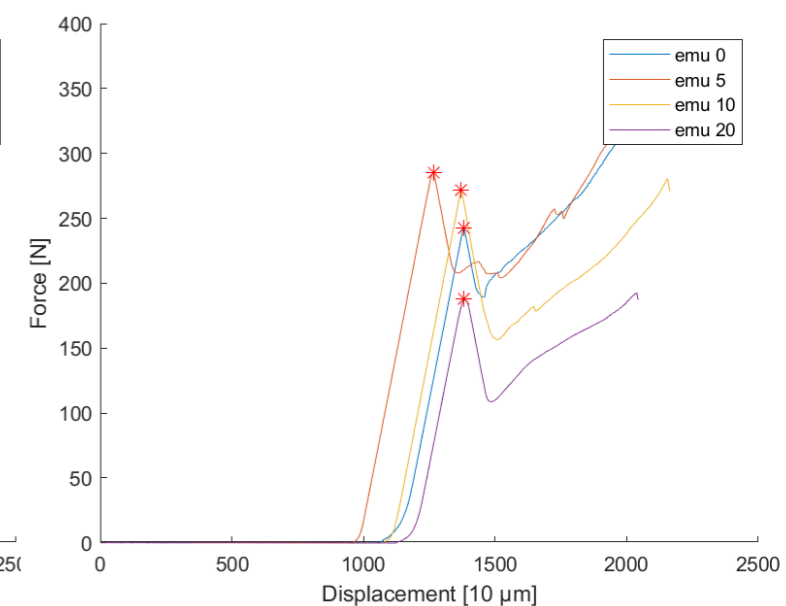
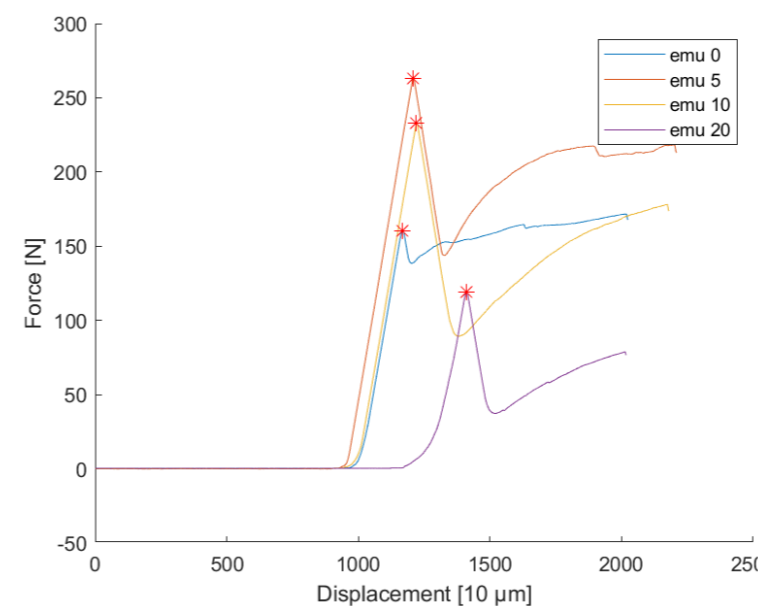

Laser sealing three layers

Water has a large latent heat but is too cold to be applied directly to the skin. Inu 15°C has the right temperature but has a much lower latent heat capacity. A composite PCM could incorporate best of both worlds as illustrated in the figure on the right. In this case the ice layer would function as energy storage layer while the Inu 15°C keeps the extreme cold away from the skin. The insulating floatation aid prevents the ice from melting due to heat from the outside.

With the laser cutter it is possible to weld three layers of TPU together by sealing from both sides (Figure 2), this could form a container for two different PCMs separated by a layer of TPU.

A test sample showed that it is possible to make a triple layer bag, it can be seen in Figure 1. In this case the sample is filled with water and a different colorant per side. A drawback is that the hexagon pockets are not filled with equal parts yellow and blue. The middle layer buckles against one of the two outer layers and does not stay neatly in the middle. (Figure 4)

It turned out to be possible to seal at different places from both sides, the third layer would not weld to the second layer. Only the topmost two layers are welded together properly, the third one merely sticks to the layer above it. This makes it possible to seal an alternating pattern as illustrated in Figure 3.

Figure 1: Triple layer sample with yellow and blue colorants.

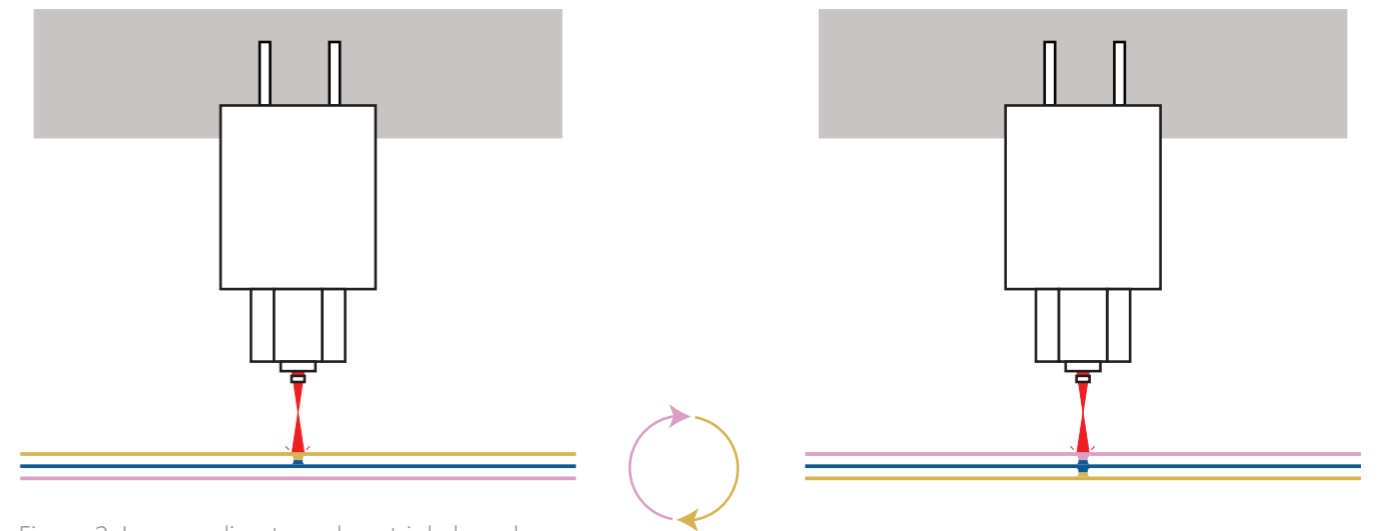

Figure 2: Laser sealing to make a triple layer bag

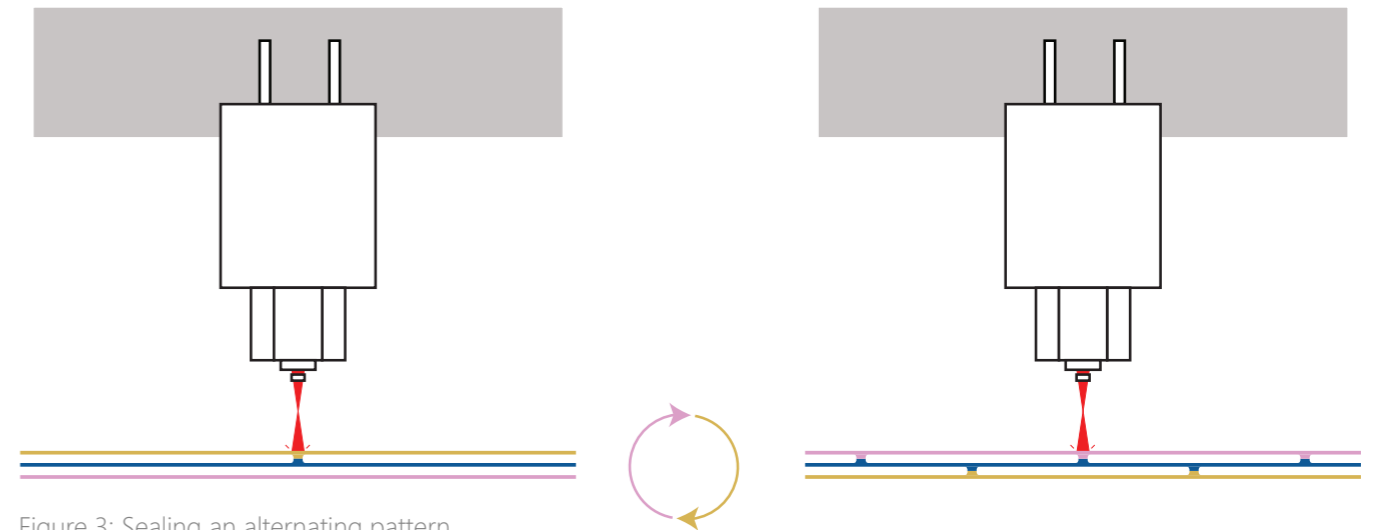

Figure 3: Sealing an alternating pattern.

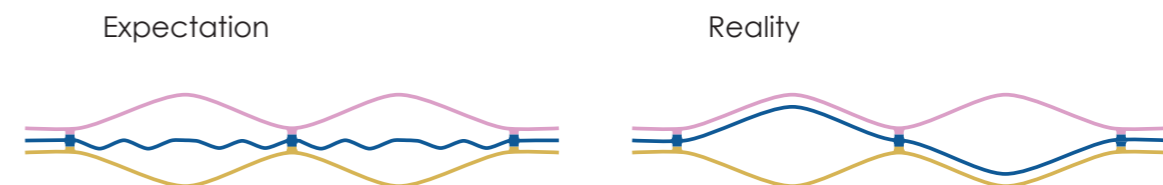

Figure 4: Expected result with triple layer bag and how the sample behaved in reality.

It turned out to be quite hard to release the third layer from the upper two layers after welding. Eventually a sample succeeded (Figure 1). The two phases did disperse more equal over the sample, but the two layers do not sit neatly on top of each other. The liquid moves towards where there is a seal in the other compartment. The liquid moves towards where there is a seal in the other compartment.

Next a version was made with point seals instead of lines for a more equal dispersion of the two phases. It is filled with two PCMs; water and Inu 15°C oil. In Figure 2 you can see the sample after it had been in a fridge, the oil is frozen while the water phase is still liquid. After being deep frozen the temperature of each side rose to approximately its phase change temperature.

The concept works but with the prototyping facilities available it was not possible to scale the triple layer bag sealing to the desired product size. The combination of ice with a layer of Neoprene proved to be working and is much easier to prototype, therefore experimenting with a two phase PCM package was discontinued.

Figure 1: Triple layer sample with alternating pattern.



Figure 2: Triple layer sample with water and Inu 15°C



Data from from Hotplate for PCM comparison (Chapter 2.2)

This Appendix contains more elaborate details of the data acquired via the Hotplate tests. The Table below shows the different samples with their constituents, theoretical cooling capacity and the measured data averaged over three measurements.

Sample name	Sample number	Measured Duration (fill Threshold 5W) [min]	Average cooling power fill threshold [W]	Measured / Theoretical	Measured capacity (fill Threshold 5W) [kJ]	Theoretical capacity [kJ]	Specific heat (Liquid) [kJ/kgK]	Specific heat (Solid) [kJ/kgK]	Latent heat [kJ/kg]	Content [g]	Phase change temperature [°C]
1 H2O	Water	40	38	72%	89	124	4,2	2,1	334	247	0
2 H2neO	Water	98	16	79%	92	115	4,2	2,1	334	230	0
3 IZI 24 alu IZI FLEXIBLE PCM		53	13	52%	44	85	1,9	2,1	228	256	24
4 IZI 24 tpu IZI FLEXIBLE PCM		62	14	66%	53	80	1,9	2,1	228	242	24
5 Inu 15	INUTEQ-PAC15C	60	17	88%	61	69	1,9	2	177	250	15
6 emu 10	90% INUTEQ-PAC15C, 10% Water	56	18	83%	59	71	NA*	NA*	192,7*	240	15 & 0
7 emu 20	80% INUTEQ-PAC15C, 20% Water	57	18	83%	61	74	NA*	NA*	208,4*	239	15 & 0
8 emu 5	95% INUTEQ-PAC15C, 5% Water	53	18	84%	58	70	NA*	NA*	184,85*	243	15 & 0
9 gel	30% INUTEQ-PAC15C 70% Unknown**	38	14	88%	32	36	1,9	2	53	239	15
10 sorb	60% INUTEQ-PAC15C, 40% PU***	37	9	54%	21	40	NA*	NA*	106	190	15
11 Inu 6.5	INUTEQ-PAC6.5C	48	22	90%	62	69	2,1	1,6	184	250	6,8

*Latent or specific heat is a combination of Inu 15 and water.

**The product is based on Inu 15, the other part is added to make it flexible. The material specifications of Inu 15 are used.

***PU (PolyUrethane) functions as an absorbent of the PCM, it does not change phase and does not contribute to the latent heat capacity

Every sample was tested a total of three times. For all samples the three times show the same trend. The Inu samples show a jagged line, this is quite unpredictable. It does seem that there is a power spike right before the sample is depleted. All graphs are shown here.

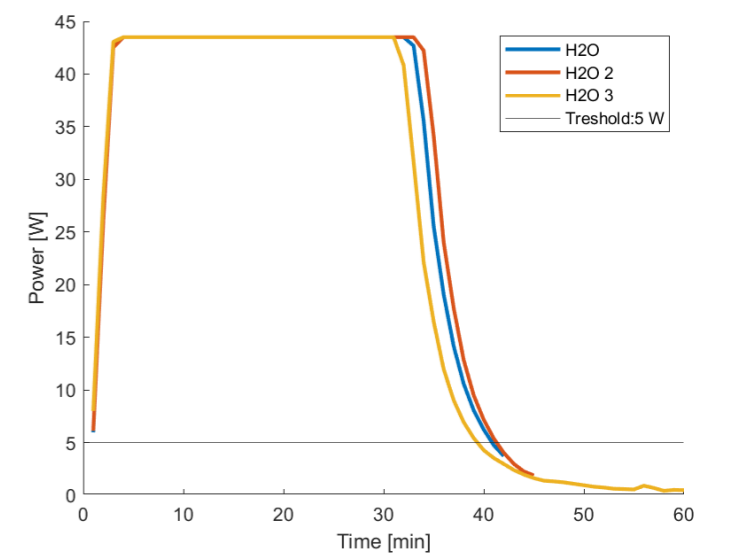
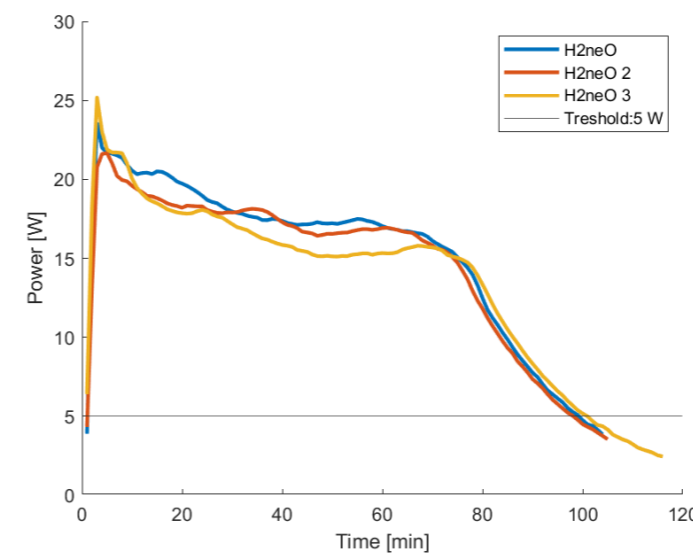
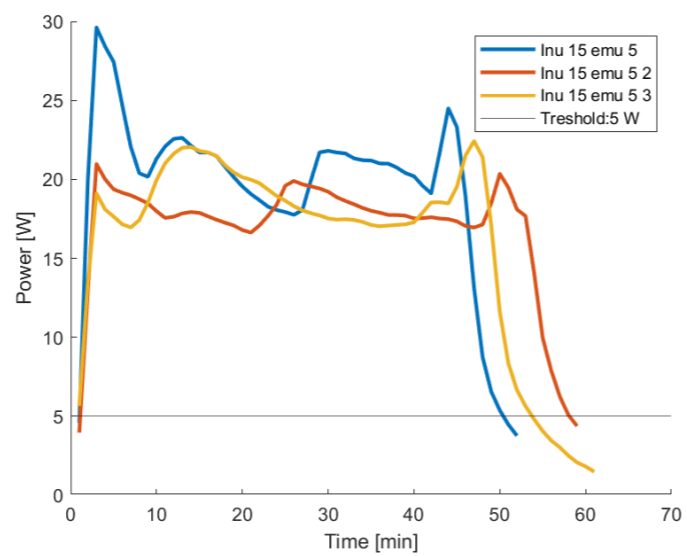
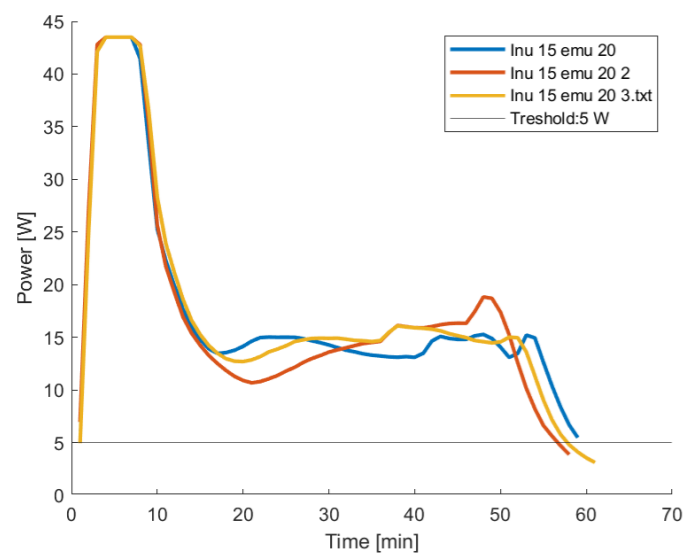
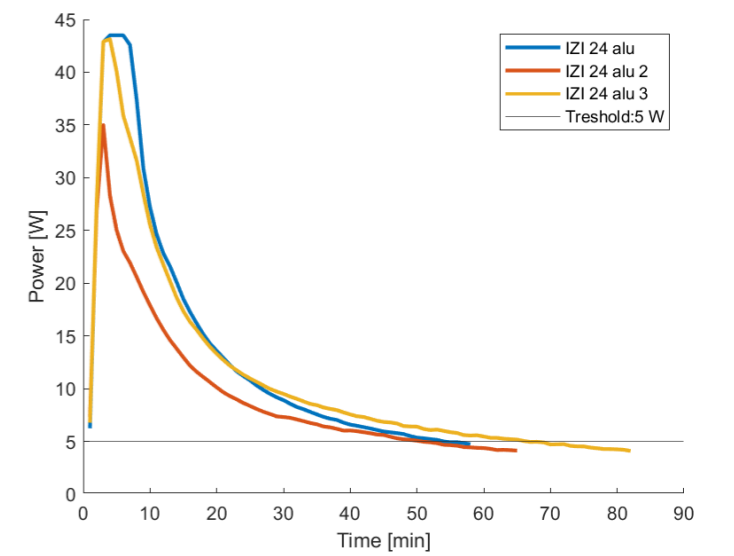
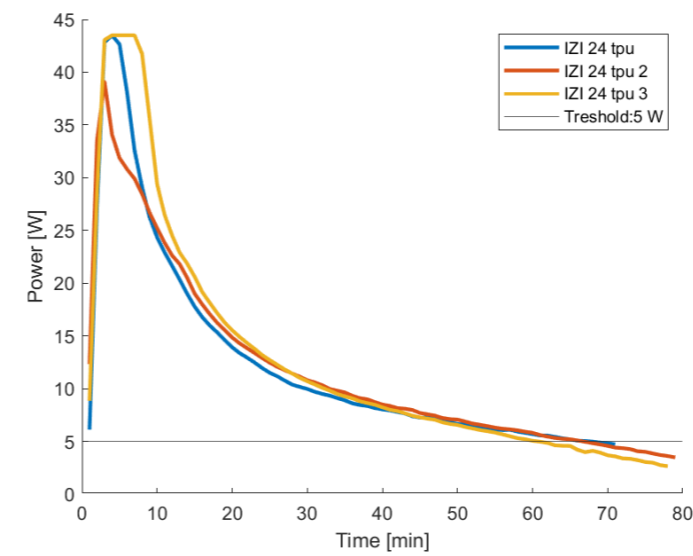
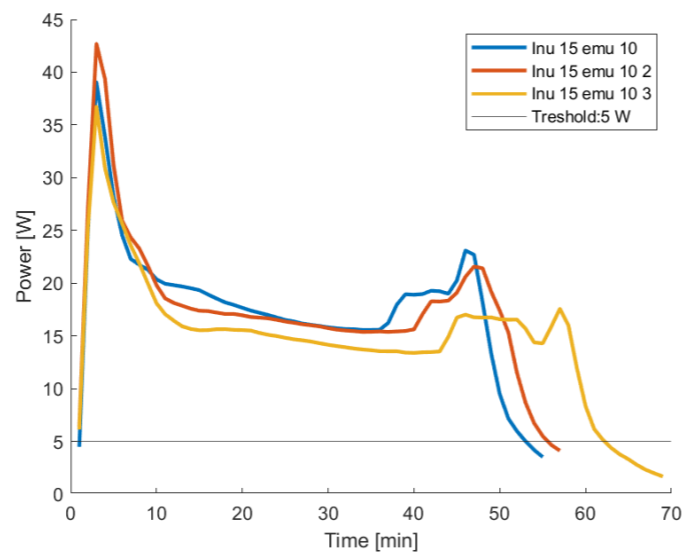
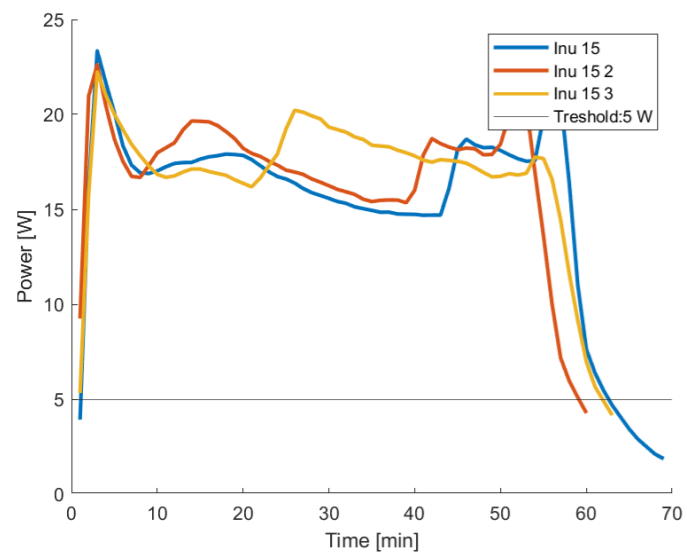
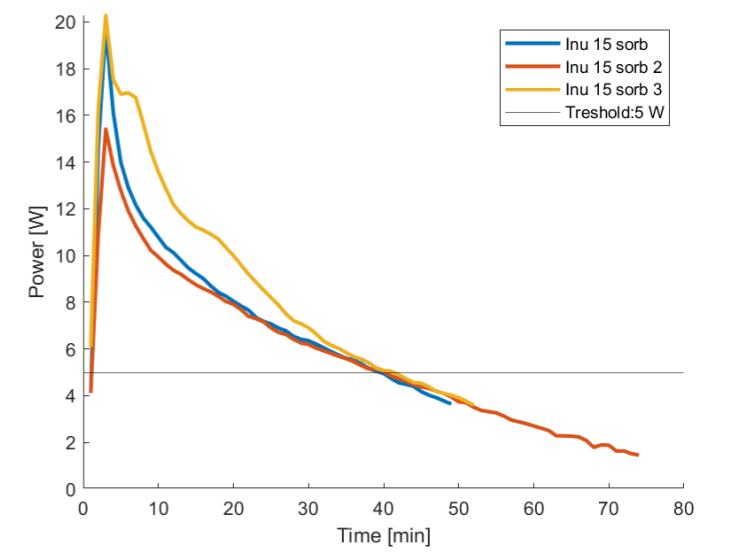
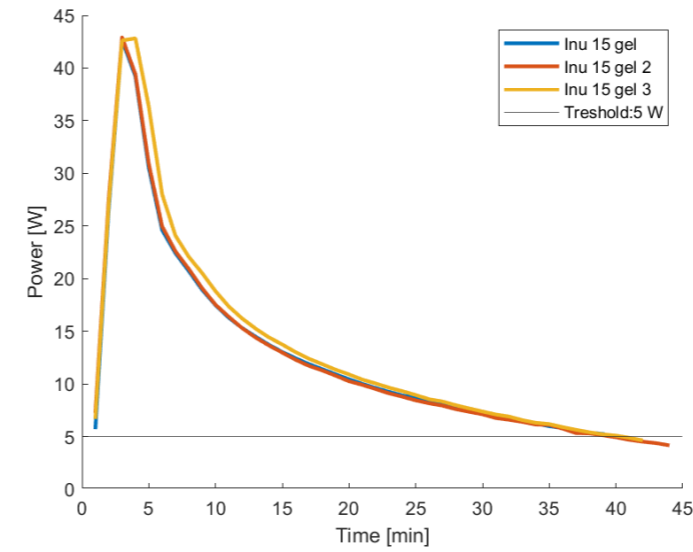
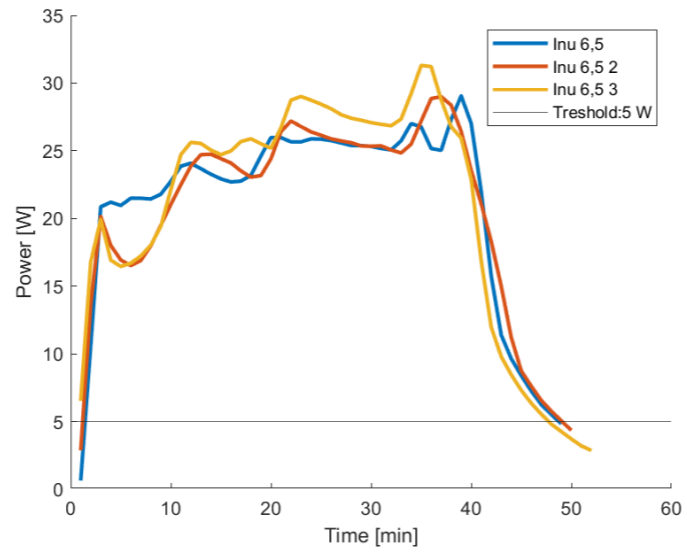

Laser sealing procedure

A laser cutter is able to seal two thin sheets of transparent TPU together. This Appendix describes the process.

A laser cutter can produce a consistent beam of heat, I hypothesized that it would be possible to seal two plastic foils together using the laser cutter at the Applied Labs. MIT Student Sam Calisch managed to create laser-sealed inflatables with PU foil. (<http://www.mit.edu/~calisch/fold/www/welding.html>)

If duplicating this production technique would be possible in the lab it would be of great use in prototyping custom shaped cooling packs. There is little to no data available online on which settings are to be used, by trial and error the right laser setup was found to create water-tight transparent plastic bags.

The lowest power setting of the laser is still too powerful, this problem is solved by defocusing the laser. The power is spread over a wider area melting the foil together. The coaxial gas flows that is cooling the material helps in pressing foils together. When creating smaller samples (< 30 x 30 cm) this works well but when samples get larger this does not always tightly press the foils together. Therefore, it is important to create a double or triple line seal at the edges of the sample to ensure it is watertight. Counterintuitively it is better to not use tape to strap down the foil on the laser bed. When the foils are fixed, they cannot move freely and wrinkle more when being sealed. When they are not they can move a bit and the coaxial gas flow together with the moving seal sort of irons the creases out of the foils during the process.

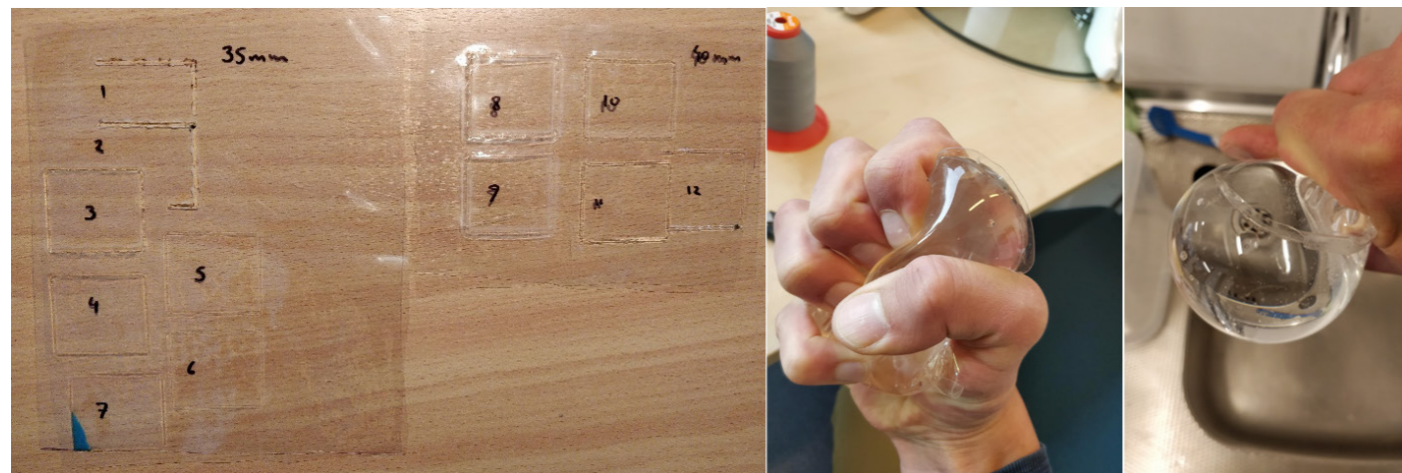

Two laser passes might weaken the foil too much, an offset of 2 mm ensures that seals do not cross each other.

S. Calisch mentions on his blog that fillets in all corners are necessary to ensure a continuous laser speed. The laser at applied labs does not have this issue, it is possible to seal sharp corners as well.

During the prototyping phase the laser cutter broke down. After it was repaired the settings did not work anymore, it seems that the repair made the laser a bit more powerful. After plenty of failed samples the settings in the Table below gave reliable results.

For sealing transparent TPU fabric sheets are used. The TPU foil from Inuteq cannot be welded with a laser because it's lack of transparency. The top layer will melt too much before attaching to the bottom layer, the material around the seals will tear very easily.

Laser sealing TPU sheets is suited for prototyping. In case the product ever comes to the stage of production, the company Covestro can laser-seal TPU films on an industrial scale. <https://www.films.covestro.com/en/Technologies/Welding>

Laser		Lion Lasers: Merlin https://www.lionlasers.com/machines/Merlin-lasers Laser: 80W CO2 Wavelength: 10640nm	
Foil		Transparent TPU foil, can be bought at Tessuti (070-4065809) Thickness 100±50 µm	
Time of prototyping		May 2019	Sep-19
Focal length		45 mm	40 mm
Laser settings	Power	10	10
	Speed	40	32
	Acceleration	1200	1200
	Corner acceleration	1800	1400
	Coaxial gas pressure	5 bar	5 bar

Case study: Available space underneath flotation aid

The human body is not easily modelled. To find out what dimensions the cooling packs can have underneath the flotation aid it was inlaid with floral foam (Figure 1). This foam crushes easily, the goal was to wear the swimming vest with foam inside to find out where the foam would be damaged. I put on the vest myself and mimicked movements a sailor makes when tacking. Watching videos of sailing competitions showed that this is the movement that requires most agility.

I found that torsional movement around my spine when turning around caused most pressure on the blocks. Afterwards the blocks were analyzed, none of them was badly damaged. The differences in damage are shown in Figure 2

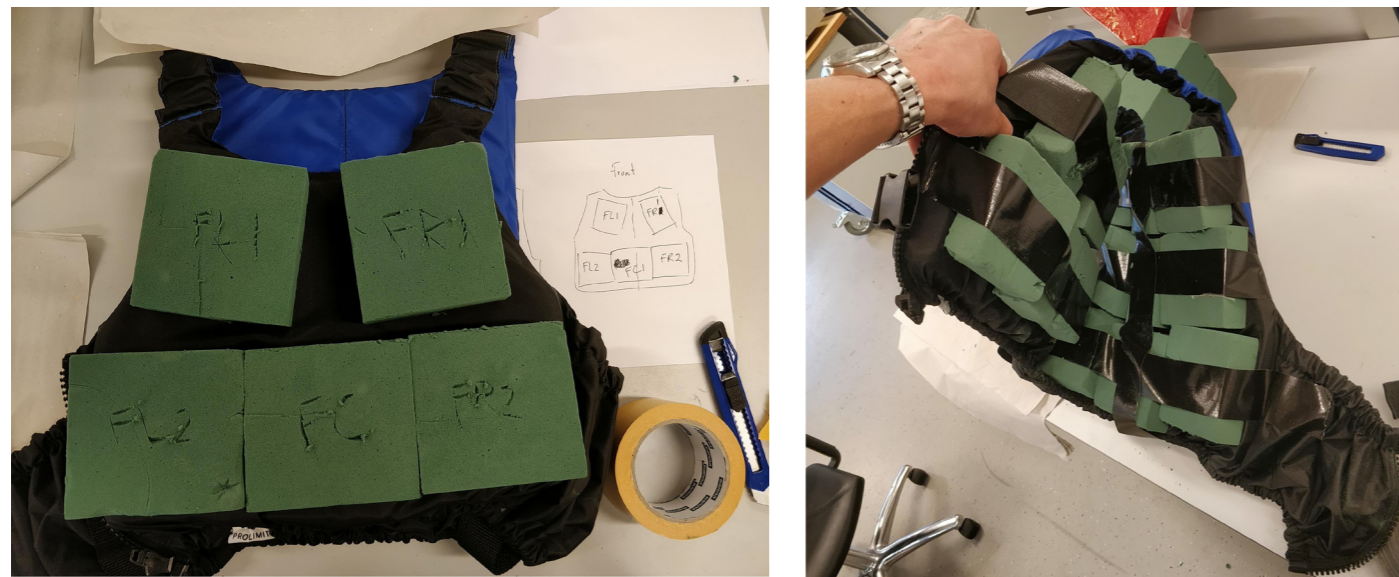
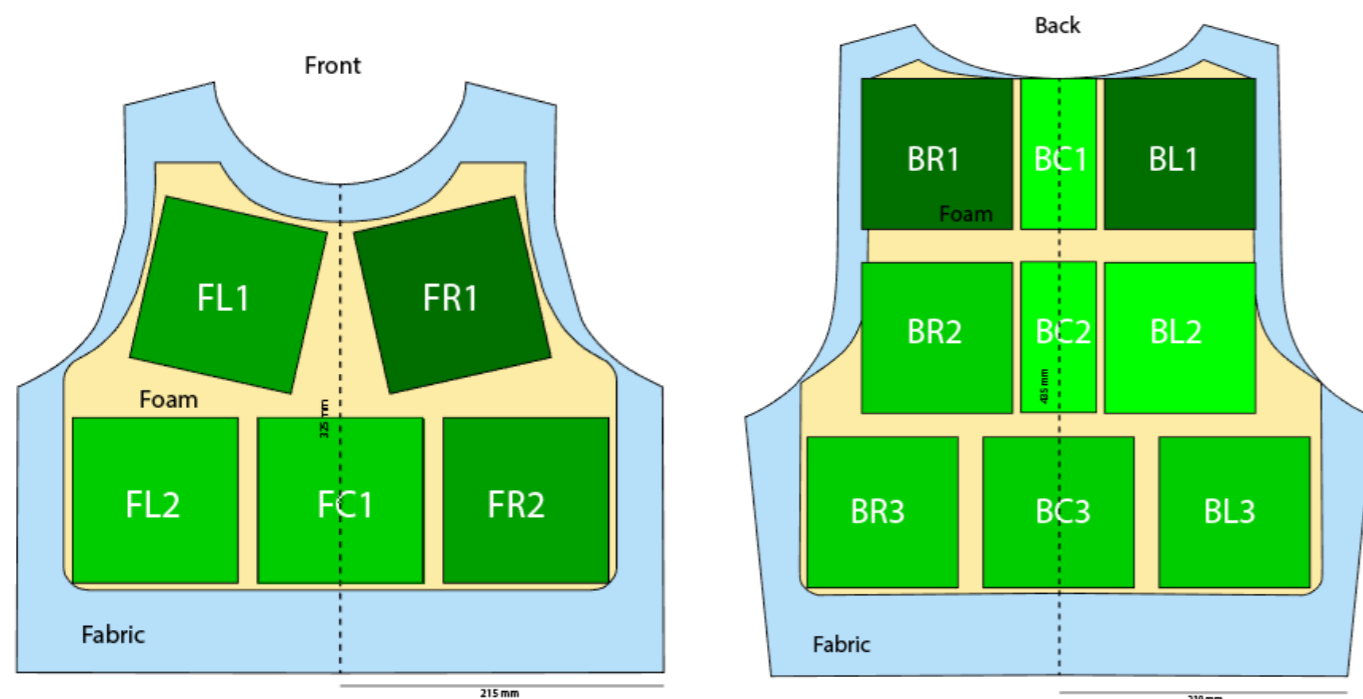

Figure 1: Flotation aid covered with floral foam.



154 Figure 2: Floral foam damage after wearing the vest and moving around, darker green = more damage.

It must be noted that even the most damaged blocks were barely damaged. The conclusion of this experiment is that the clothing worn by the sailors is rather flexible and leaves ample space for a cooling pack. Most spacious is the area around the spine, around the scapula less so. The foam blocks were 37mm thick, this was not very comfortable, it should be possible to place packs with a thickness up to around 30mm quite comfortably.

Based on the foam test results an ice pack with a thickness of 30 mm was made. Next, the vest was worn with this custom ice pack underneath as shown in Figure 3. The bubbles of the hexagon ice pack are too big. The thickest points are uncomfortably pressing against ribs and scapula. A finer grid would reduce this issue. When the packs were worn for a while the pressure would more evenly spread reducing the annoying pressure points. A hexagon pattern of 30 mm thick has too big hexagons (75mm).

To conclude, the thickness of the cooling packages is not limited by the space underneath the swimming vest. It is limited by the geometry of the package; pressure points are often more pronounced with larger thicknesses. Also weight becomes an issue quite quickly with very thick packs.



Attempts to estimate hexagon thickness

The hexagon pattern is great for making flexible patches of solid blocks. It is quite difficult to estimate until what thickness a produced bag will expand when filled with water. A series of tests was done to get a better understanding of the relationship between drawn and real dimensions.

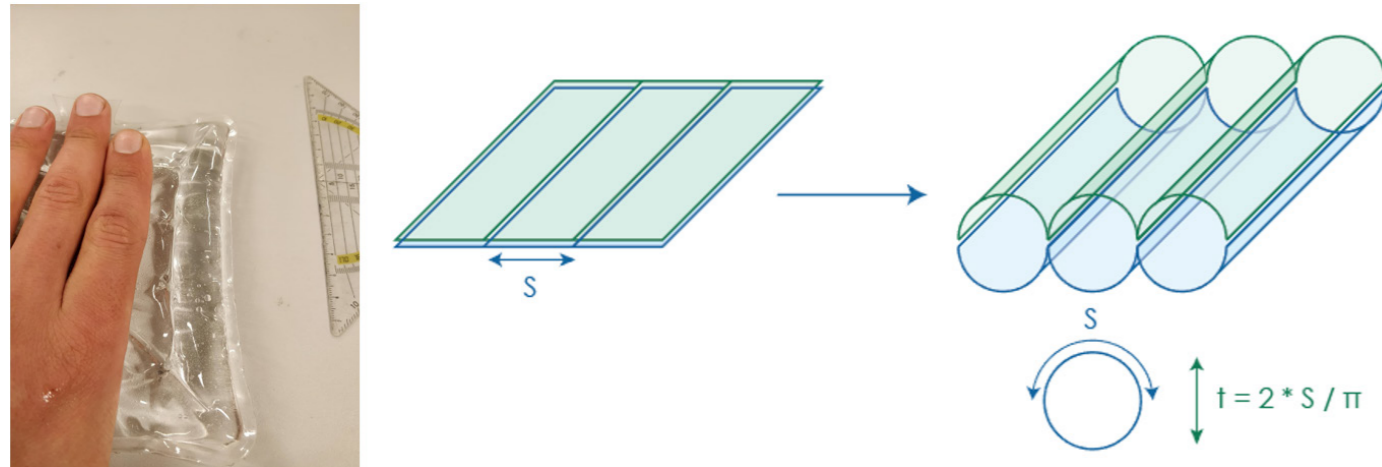

Figure 1: Proposed relationship between seal distance and sample thickness.

Figure 1 shows the reasoning behind the translation from seal distance to sample thickness for tubular packages. Three samples with different spacings were made and measured. The results are shown in the Table on the right.

Spacing	Calculated thickness	Measured thickness
30mm	$30 \cdot 2 / \pi = 19 \text{ mm}$	18 mm
50mm	$50 \cdot 2 / \pi = 32 \text{ mm}$	35 mm
75mm	$75 \cdot 2 / \pi = 48 \text{ mm}$	50 mm

For these three cases the relationship holds. Next a solution for the hexagon packages was proposed as can be seen in Figure 2 and 3. The first relationship simplifies the hexagons into circles which in turn are expanded into globes. The surface of the two foils when flat must be equal to the surface of the globe. The second relationship simplifies the hexagons into small tubular parts. The relationship can then be calculated in as shown in Figure 1.

Four hexagon samples were made (Figure 4) to validate the methods. Method 2 outperforms method 1, but both do a bad job in predicting the thicknesses. The relationship between rib length and thickness is not linear for the tested samples, no easy formula was found. Also, the thickness depends wildly on the amount of water that is put into a sample.

Rib length [mm]	Calculated thickness Method 1 [mm]	Calculated thickness Method 2 [mm]	Measured thickness
17,3 mm	27	11	9
25 mm	40	16	15
30 mm	47	19	24
45 mm	71	29	35

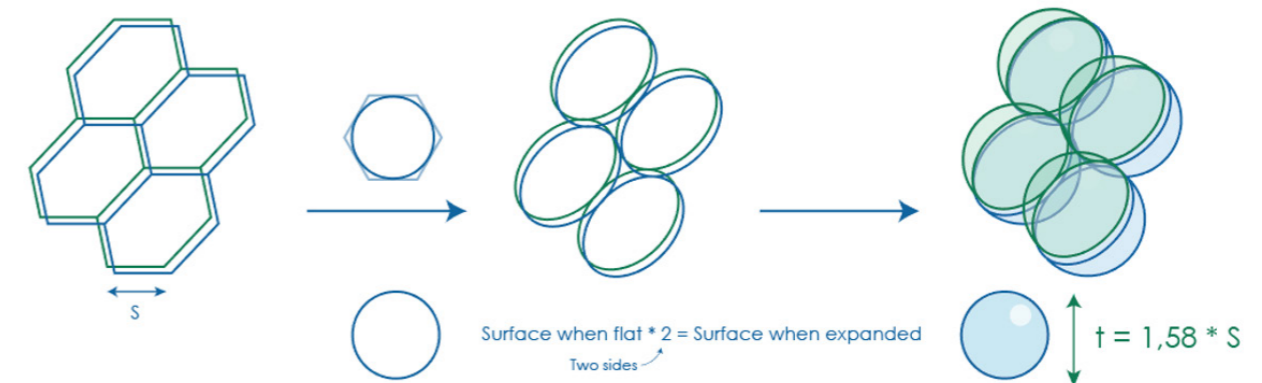

The surface of the 2D circle is equal to the surface of the 3D sphere.
 The thickness of the sample is twice the radius of the 3D sphere.
 The radius of the circle is equal to the length of a rib of the hexagon.
 Now the thickness can be calculated from the rib-length.

$$2 * \pi * r_{circle}^2 = 4 * \pi * r_{sphere}^2$$

$$\frac{thickness}{2} = r_{sphere} = \sqrt{\frac{1}{2} * r_{circle}^2}$$

$$thickness = 2 * 0,71 * \sqrt{Rib^2 + \left(\frac{Rib}{2}\right)^2}$$

$$thickness = 1,58 * Rib$$

Figure 2: Proposed relationship between Hexagon size and sample thickness. (Method 1)

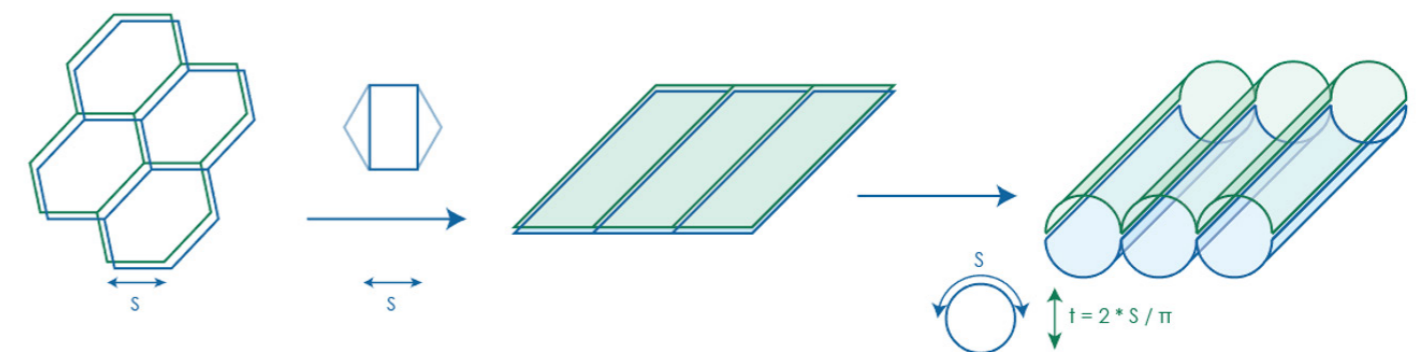

Figure 3: Proposed relationship between Hexagon size and sample thickness. (Method 2)

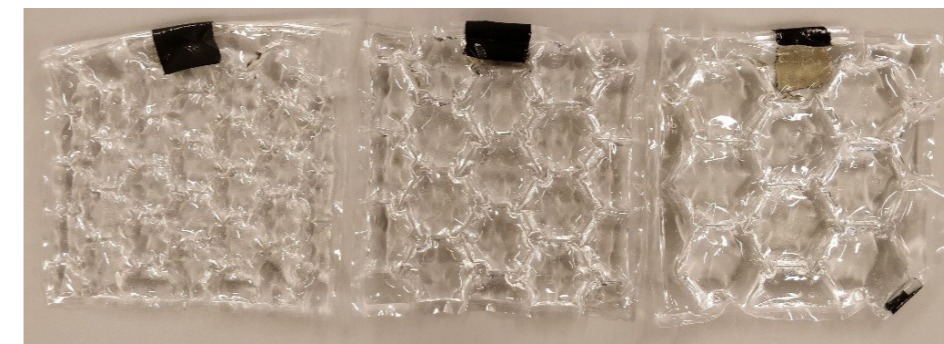

Figure 4: Three of the four samples used to validate the thickness estimation method.

List of requirements

v	= Design meets requirement.
?	= Requirement has not been evaluated.
-	= It is debatable if the design meets the requirement.
x	= The design does not meet the requirement.

#	Categorie	Requirement	Unit	How to measure	Reasoning	Proposed design	Produced vest
Demands:							
1	Use	Put on in 20 Seconds	20 s	User test	Ease of use, the product should not be a burden.	v	v
2	Use	Put off in 10 Seconds	10 s	User test	Ease of use, the product should not be a burden.	v	v
3	Ergonomics	Tight fit around body		User test	A tight fit ensures optimal contact for conduction of heat from body to coolpacks.	v	v
4	Ergonomics	No restriction in movement		User test	Could influence sailing behaviour causing negative performance effects.	v	v
5	Cooling	Cool sensation for 30 minutes	30 minutes	Hot plate, User testing: interviewing	Time between races, before the first race this is one hour then coolpacks have to be swapped once.	?	?
6	Cooling	Sufficient cooling power for 30 minutes	30 minutes	Hot plate, Temperature measurement	Time between races, before the first race this is one hour then coolpacks have to be swapped once.	v	-
7	Storage	At least 3 vests must be storeable in a coolbox	fit 3 vests in coolbox	Dimensions	There a coolbox on the coachboat, one sailor will need 4 to 6 recharges for a normal sailing day.	v	v
8	Durability	Withstand impact without bursting.		Lab test, material data	The PCM packages should not burst when an impact occurs.	v	v
9	Environment	Not toxic/harmfull for the environment	Toxicity	From material data	It could be that a cooling vest is lost on the water.	-	-
10	Ergonomics	Suitable for male and female body type		User test	There will be male and female athletes.	v	?

11	Ergonomics	Weigh no more than 3 kg	3 kg	Scale	Weight should be in an acceptable range.	v	v
12	Compatibility	Can be worn together with existing clothing		User test	Existing clothing is necessary during the races, the cooling vest should be an add-on.	v	v
13	Compatibility	Can be used in combination with a hiking harness		User test	It might not be ideal but the vest should at least be useable in combination with a hiking harness.	v	v
14	Compatibility	Can be used in all current Olympic classes		User test	Dutch athletes will compete in a wide variety of classes.	v	v
15	Durability	Can withstand temperatures from -25 till +40°C	-25°C till 50°C	Testing, material properties.	A deep freezer till a very hot day temperature.	v	v
16	Production	It must be possible to produce 30 units before the 2020 Olympics.	30 units	Produceability evaluation	Three per Dutch sailors at the 2020 Olympics.	?	v
17	Legislation	The use of the product must be in compliance with international sailing legislation		Consultation	During races a cooling vest will likely not be allowed, in between races there are less rules but even so the product should comply.	v	v
18	Use	The product should not come loose unintended		User test	Clothing should work the way you want it to.	v	v
19	Use	The product must always be removeable from the body		User test	Before a race it should be quick and easy to put of the cooling vest.	v	v
20	Durability	The product should not degrade when exposed to sea water		Material properties	Salt water can corrode, the product should not be susceptible to corrossion due to salt water exposure.	v	v

Whishes:						
21	Use	Should float when dropped in the water		Floatation test	If the vest would sink it might get lost in the water.	v v
22	Use	Easy to throw and catch		User test	The sailor might want to throw the vest from the sailing boat to the coach boat.	v v
23	Ergonomics	Minimally restrict sweat evaporation		User test	Even tough the skin is cooled there is still sweat production, it is not comfortable if this can not be dissipated.	v v
24	Ergonomics	Added thickness is maximum 20 mm	20 mm	Measure with a Calliper	The added thickness should be kept to a minimum, extra thickness is likely to restrict movement.	v v
25	Production	Production cost is maximum 100€	€ 100	Cost price analysis	Comparable vests have a retail price of 200€. Assuming a total margin of 50% the production costs can be 100€.	x -
26	Production	Producible with existing equipment at Inuteq		Consultation	It would be beneficial if Inuteq could produce the the vests to reduce the time till production.	x v
27	Experience	The product should have an high tech and effective appearance		Interview	Besides physical effectivity the perception of cooling and placebo effect is also of importance.	? ?
28	Durability	Broken parts should be easy to replace		Lab test	If a unit breaks during the Olympics it should be easy to repair with minimal equipment.	- -
29	Use	Rechargable in a cool box at sea		Lab test	If a vest can be recharged in a coolbox aboard the RIB during a race less vests are needed per day.	v v
30	Storage	Take up a minimum amount of weight and space for on flight transport.		Measure weight and volume	Transport space- and especially weight is scarce because sailors travel by plane.	v x

Comments:

req. 5:

The cooling power has been evaluated, the cooling sensation not. It is likely that the cooling power is related to the cooling sensation.

req. 9:

The vest does not contain chemicals that are very harmful for the environment. Nevertheless the vest is made of TPU plastic that will take years to degrade in sea water.

req. 25:

At the end of the project the design as proposed is not producible for less than 100€. Nevertheless, with some optimization and a much larger production batch the cost can probably come down to acceptable levels.

The vest produced by inuteq is sold for around 250€, slightly higher than vests currently on the market. For Olympic sailors this is not an issue for a small number of vests.

req. 28:

The vests can not easily be repaired if they start leaking. A temporary solution is to clean the pack and fix it with tape. If a strap comes loose it can be welded or sewn back on depending on the point of breaking.

Alternative solution: Cold water from below

An idea that popped up was to cool down sailors with cold water. The surface water is too warm to have much effect. But deeper layers of water could be sufficiently cold for a nice fresh spray. (Figure 3)

However, ocean water is well stirred due to tidal forces and wind. The first 200 meters are called the epipelagic zone in which the temperature is relatively constant. After 200m the temperature drops quickly (Figure 2).

Source: <https://oceanservice.noaa.gov/facts/thermocline.html>

In theory it could be possible to pump this cold water to the surface but in practice the material needed to get to 200 meters deep would be impossible to transport on a small RIB.

In august the sea temperature at Onjuku is around 25°C. (Figure 1, Source: <http://www.surf-forecast.com/breaks/Onjuku/seatemp>)

When at rest a water temperature of 25°C still feels quite cool.
Source: <https://www.zwemmanalyse.nl/zwemmen-koud-water/>

Taking a swim could be a way to cool down. However, this is not preferred by sailors because all clothing will get wet and heavy. Salt from evaporated sea water is also uncomfortable.

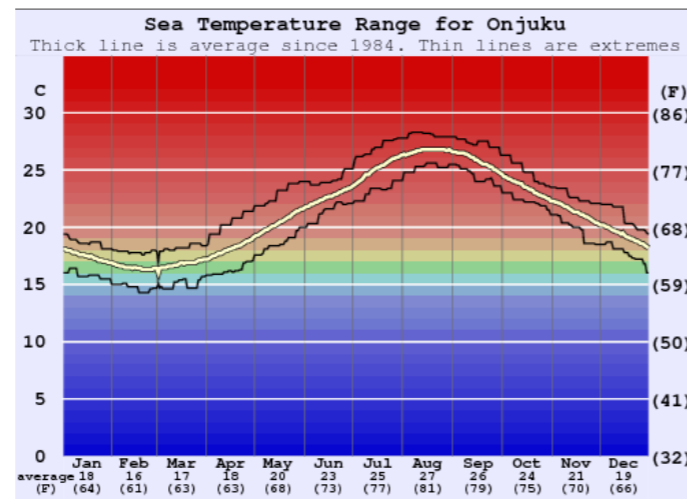

Figure 1: Sea water temperature at Onjuku

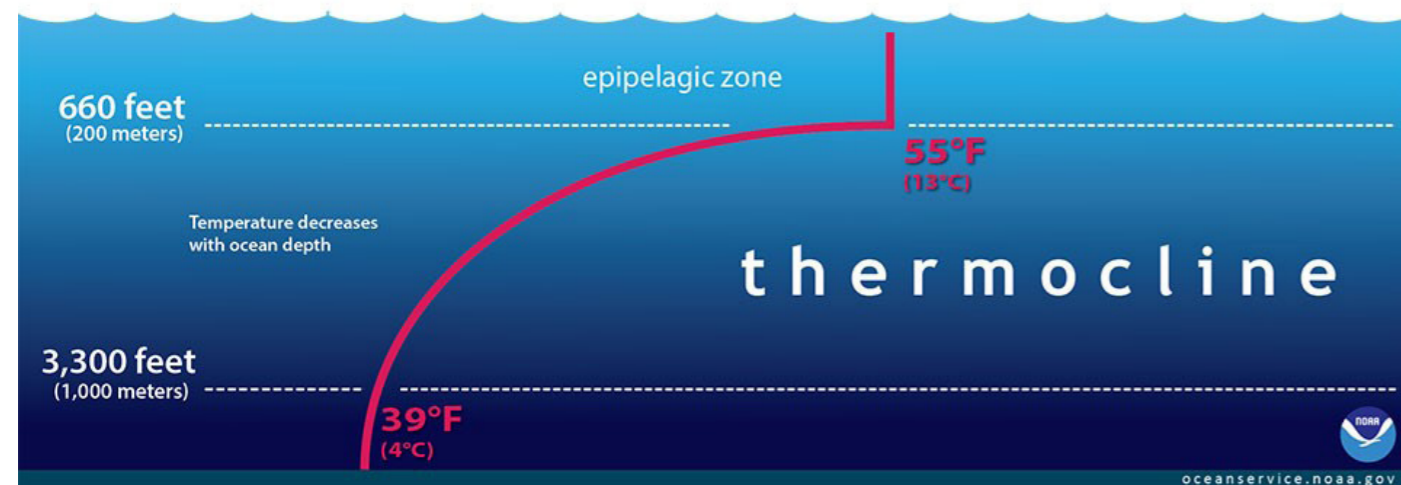

Figure 2: Sea water temperature change with depth.

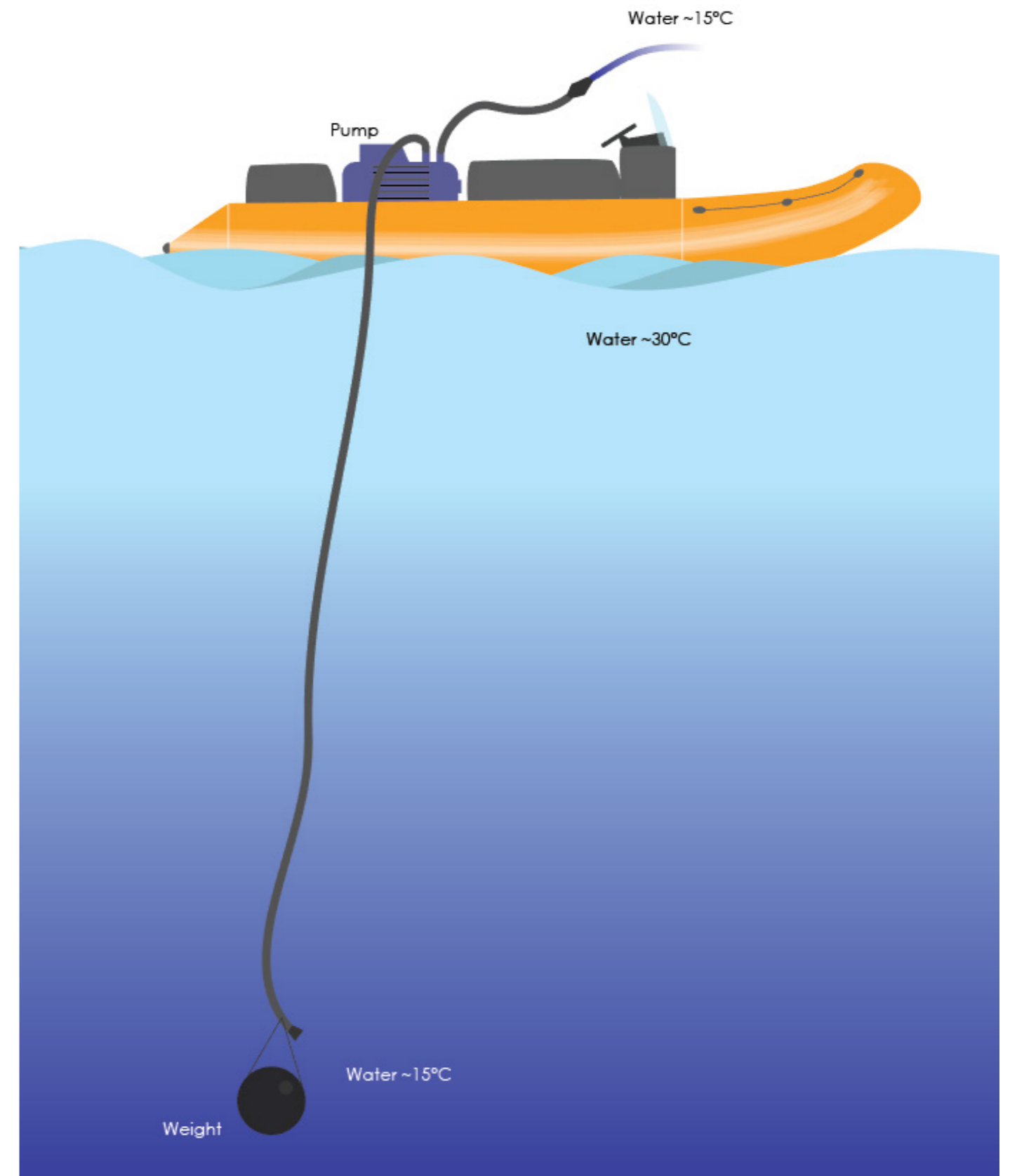

Figure 3: Pumping cool water to the surface idea.

Cooling vest's manual for testing in Japan

Prototype CoolKeeper



The cooling vest is made out of two parts, one at the front and one at the back. Both contain frozen water and are covered with a thin layer of flexible rubber that reduces the cooling intensity.

Both packs can be slid underneath the flotation aid from the bottom. The rear pack should be pulled upwards with help from another person.

Depending on the circumstances the vest can cool for around 60 minutes.

When the straps are joined together they form a handle that can be used to pull the rear pack through the flotation aid.

Subsequently they can be re-attached over the shoulders to the front pack to keep the packs in place.

Note: The straps go diagonally over the shoulder straps of the flotation aid.



The **water side** against the body provides intense cooling.
 ⚠ This could lead to frostbite when applied too long.

The **rubber side** against the body provides more mellow cooling over a longer time.

When placing the cooling packs in a deep freezer they must be folded along the folding lines.

Tip: Because of the insulating layer of rubber the packs should be placed:
 - With the water layer to the outside in the freezer.
 - With the rubber layer to the outside in the cool box.



This is a prototype and it is quite fragile. Please handle with care and keep away from sharp objects.
Using the prototype is at your own risk.



Emiel Janssen 2019

All power and temperature data from Lab test (Chapter 6.2)

The Table below shows all the values resulting from the Matlab script. The accompanying plots are shown on the next pages.

Data based on power threshold:

PCM	#	Time till power threshold [min]	Core	Interface	Average power till threshold [kJ]	Capacity till power threshold [kJ]
			temperature at power threshold [°C]	temperature at power threshold [°C]		
H2neO	1	51	26	30	14	44
	2	53	27	31	15	48
	3	55	25	30	13	44
	4	54	26	32	15	49
Average:		53	26	31	15	46
Inu 15	1	29	29	29	16	27
	2	31	30	32	16	30
	3	29	27	30	16	27
	4	25	27	29	20	29
Average:		29	28	30	17	28
Inu 6,5	1	22	27	28	23	28
	2	22	25	26	22	28
	3	23	28	29	21	28
	4	22	27	30	22	28
Average:		22	27	28	22	28

Data based on phase change:

PCM	#	Phase changed after (...) minutes based on...			Average power till: e/o phase based on T_core [W]	Capacity till: e/o phase based on T_core [kJ]
		...Power curve [min]	...Core temperature curve [min]	...Interface temperature curve [min]		
H2neO	1	40	32	40	17	31
	2	39	34	38	17	35
	3	45	34	39	15	31
	4	41	40	38	18	41
Average:		41	35	39	17	35
Inu 15	1	19	24	27	18	24
	2	21	18	20	19	21
	3	24	24	20	18	25
	4	21	18	21	22	23
Average:		21	21	22	19	23
Inu 6,5	1	12	12	16	24	18
	2	16	18	18	21	25
	3	17	16	17	22	22
	4	18	14	16	22	19
Average:		16	15	17	22	21

All graphs that form the basis for the Table on the previous page are shown here. As you can see not all curves show a neat place at which the phase change is over. Nevertheless, the averages (shown in the Table at the previous page) are closely related (Except for the average of the e/o phase indications of the core temperature curves of H2neO).

Legend

- Power
- Core Temperature
- Interface Temperature
- Treshold: 5 W
- * e/o phase Power
- * e/o phase Tcore
- * e/o phase Tsurface

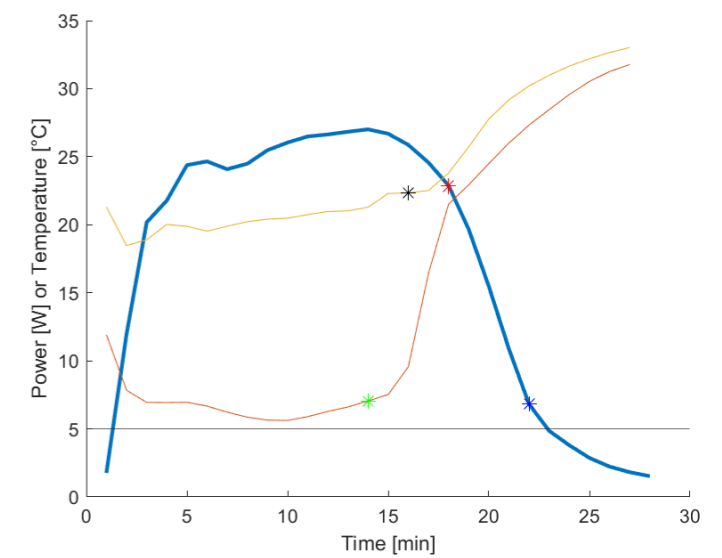
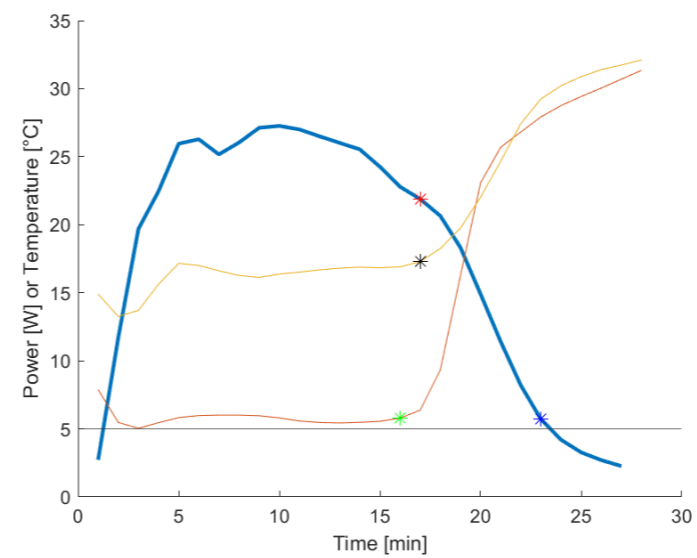
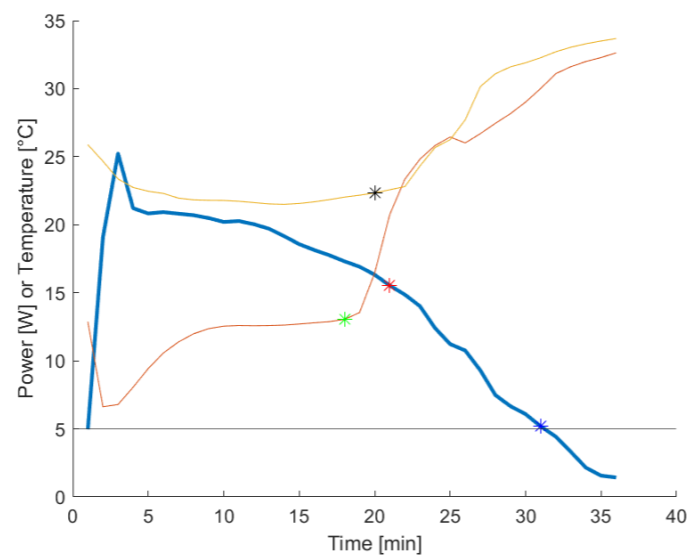
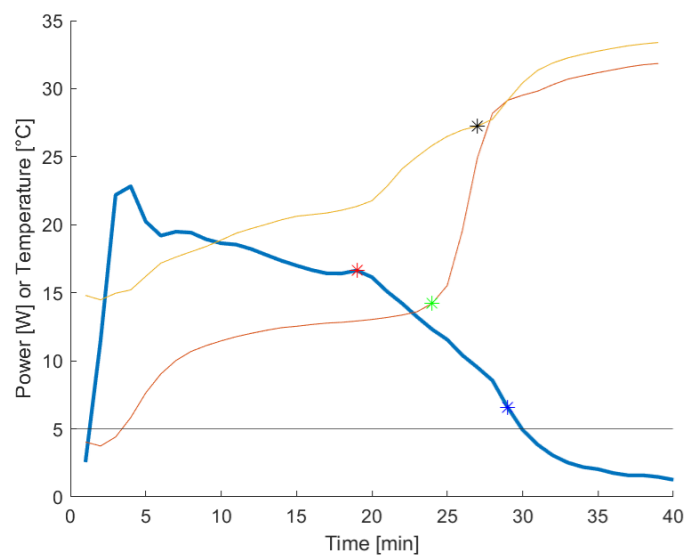
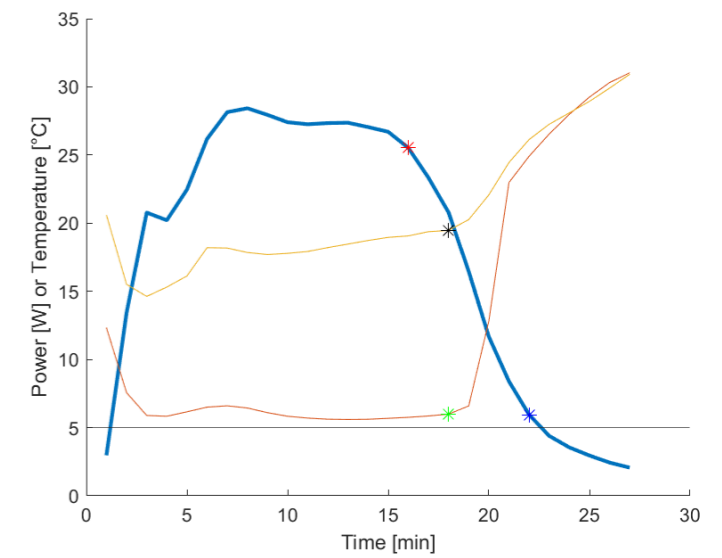
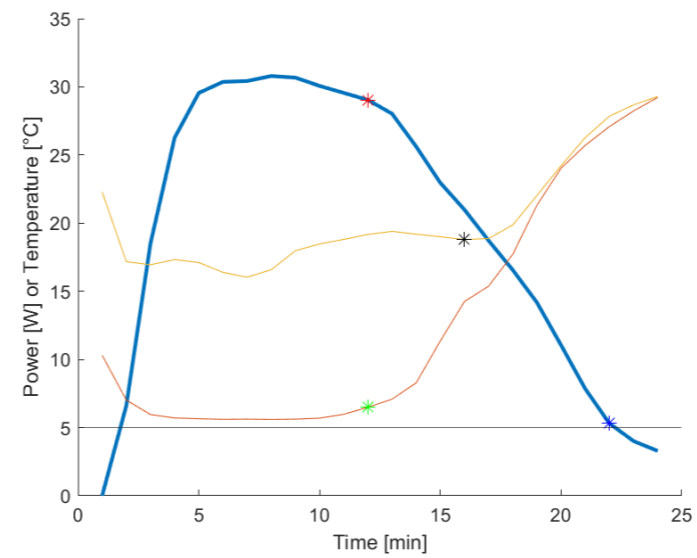
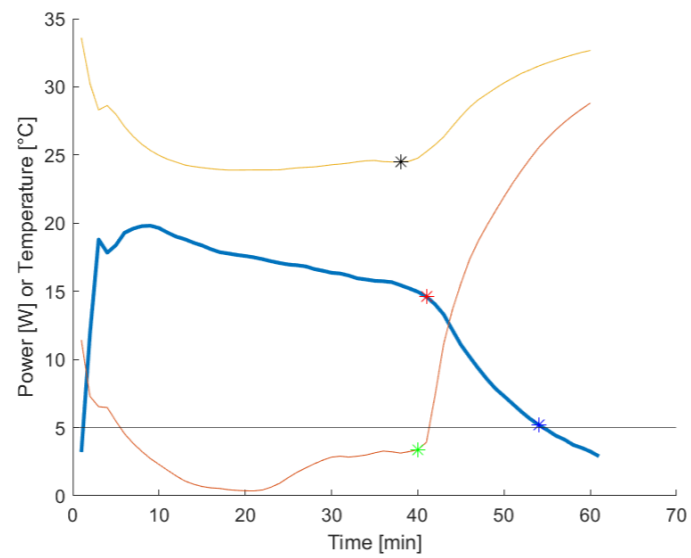
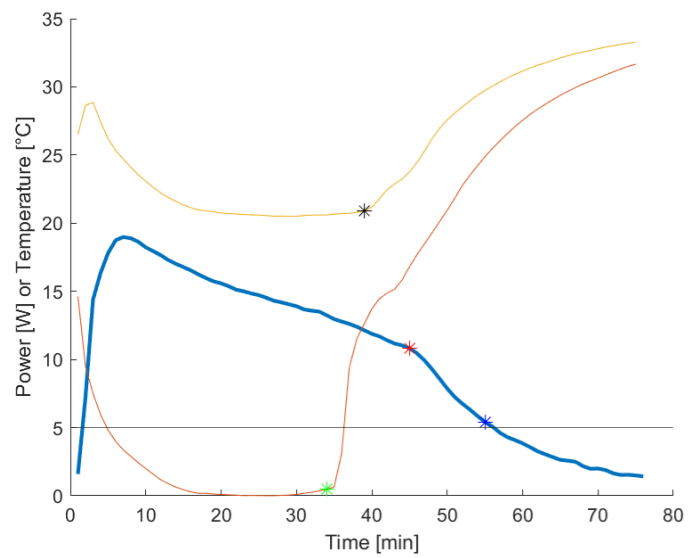
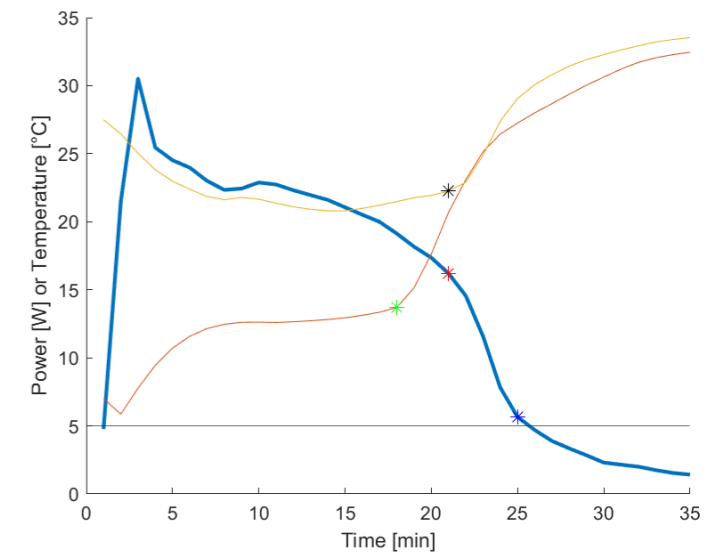
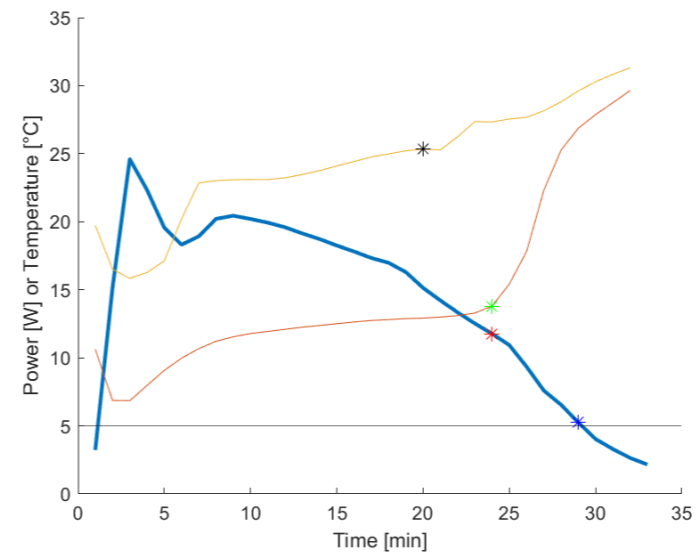
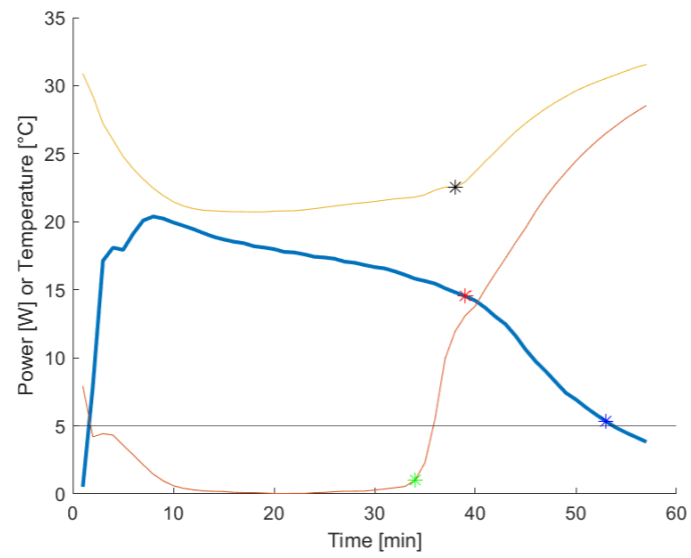
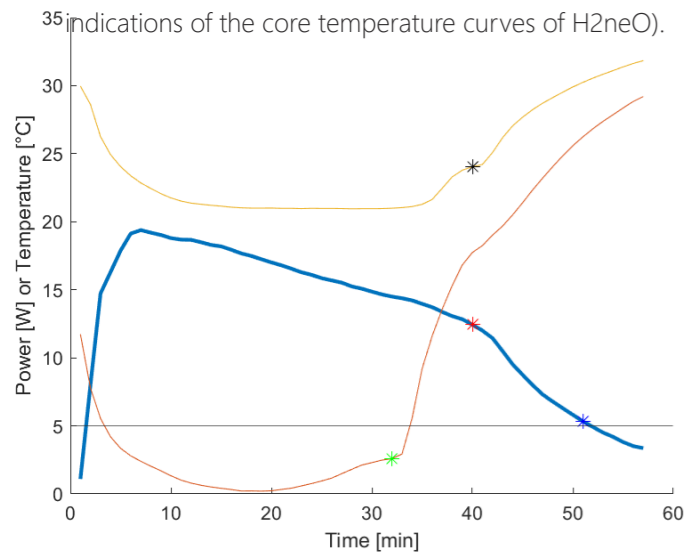

All power and temperature data from Exercise test (Chapter 6.3)

All temperature data from the exercise test was analyzed with Matlab, all results are shown in the Table below.

The temperature courses over time are shown in the graphs on the next two pages.

	Time till e/o Phase based on (...) temperature		Time till Power threshold based on (...) temperature	
	Core	Interface	Core	Interface
H2neO:				
Pilot 1	49	52	85	not available
Pilot 2	38	46	71	74
Test 1	38	39	77	not available
Test 2	46	50	80	not available
Average	43	47	78	
Stdev	6	6	6	
Max	49	52	85	
Min	38	39	71	
Inu 15:				
Pilot 1	26	30	40	42
Pilot 2	31	35	54	57
Test 1	24	25	38	40
Test 2	31	33	43	45
Average	28	31	44	46
Stdev	4	4	7	8
Max	31	35	54	57
Min	24	25	38	40
Inu 6,5:				
Pilot 1	24	20	44	42
Pilot 2	23	23	52	53
Test 1	19	23	37	38
Test 2	19	21	41	43
Average	21	22	44	44
Stdev	3	2	6	6
Max	24	23	52	53
Min	19	20	37	38

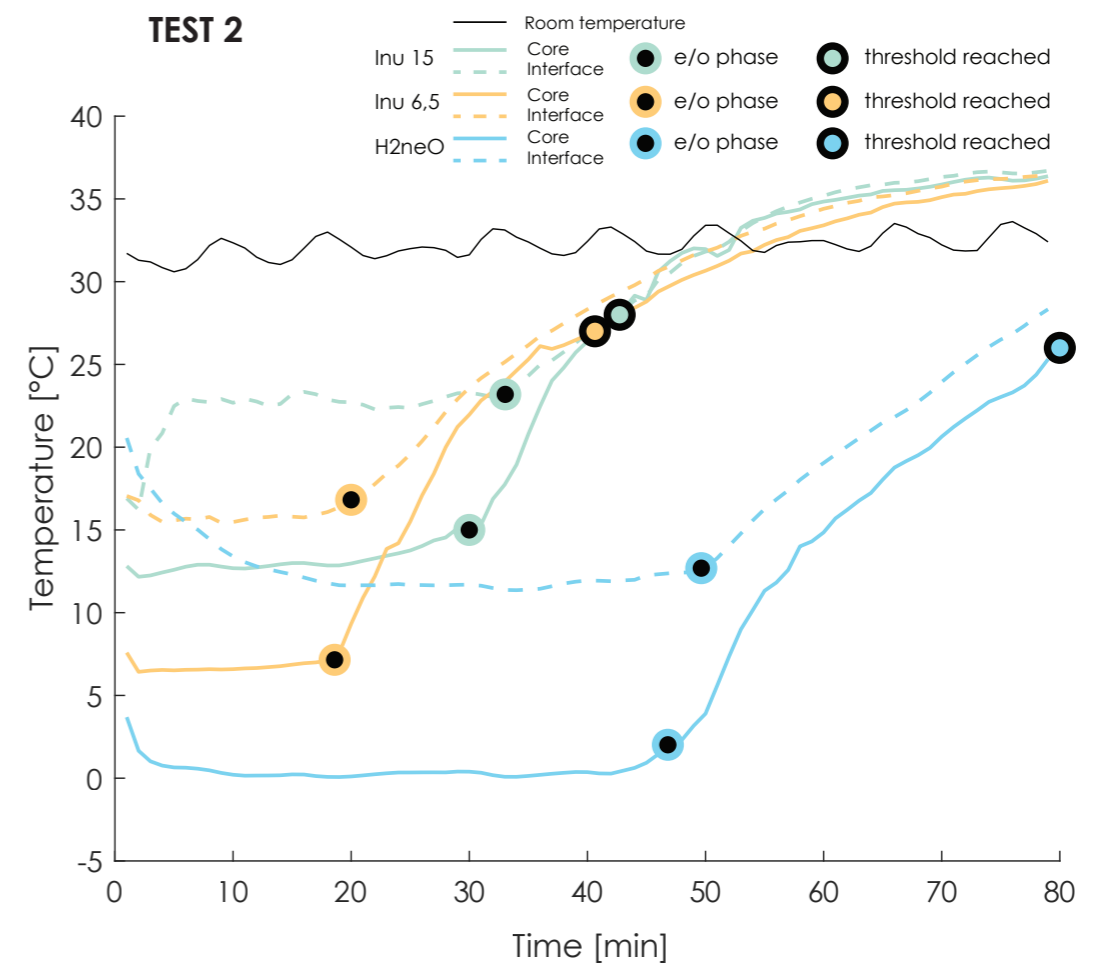
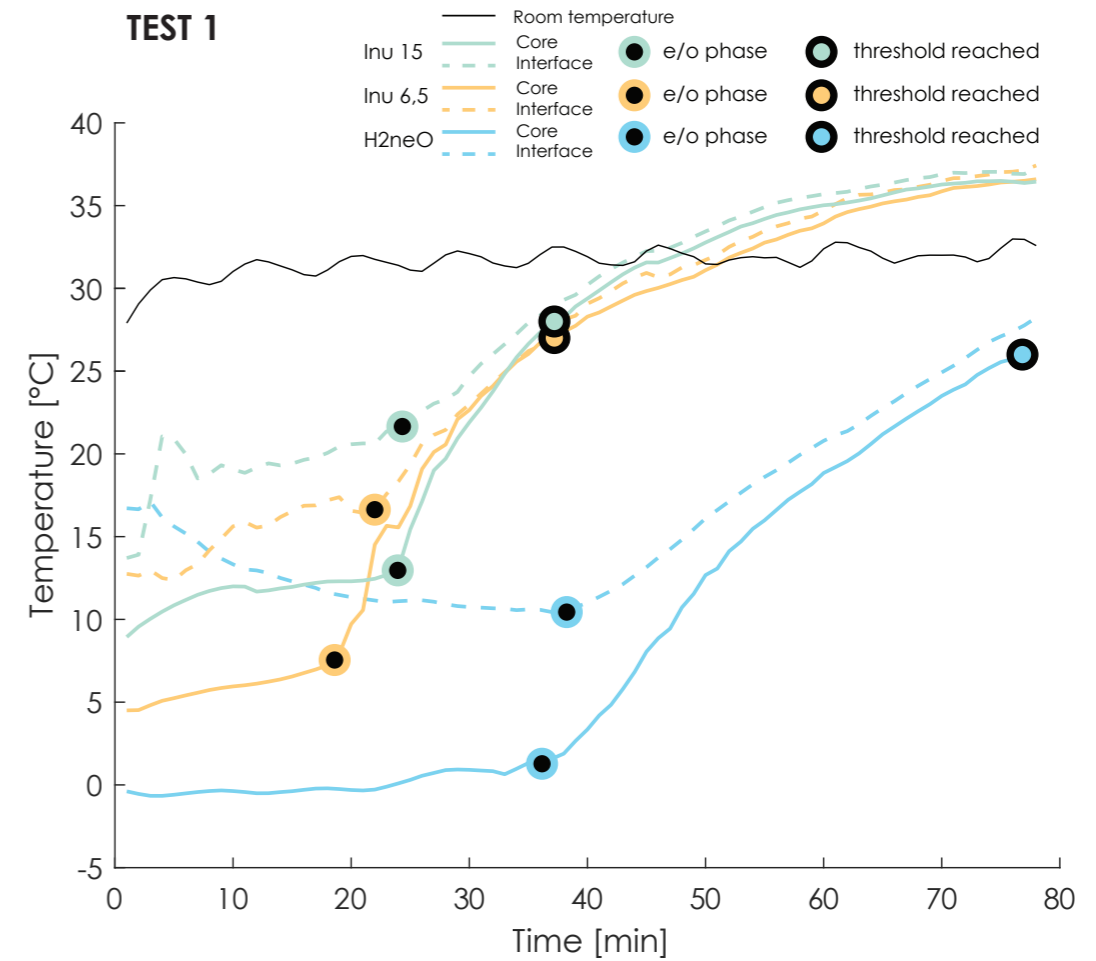

All power data from Hexagon hotplate test

All values of the cooling power measurements on the Hotplate are shown in the Table below, accompanying graphs are included on the next two pages.

These values are used in chapter 2.4 and to calculate the vest's total cooling power in chapter 6.4

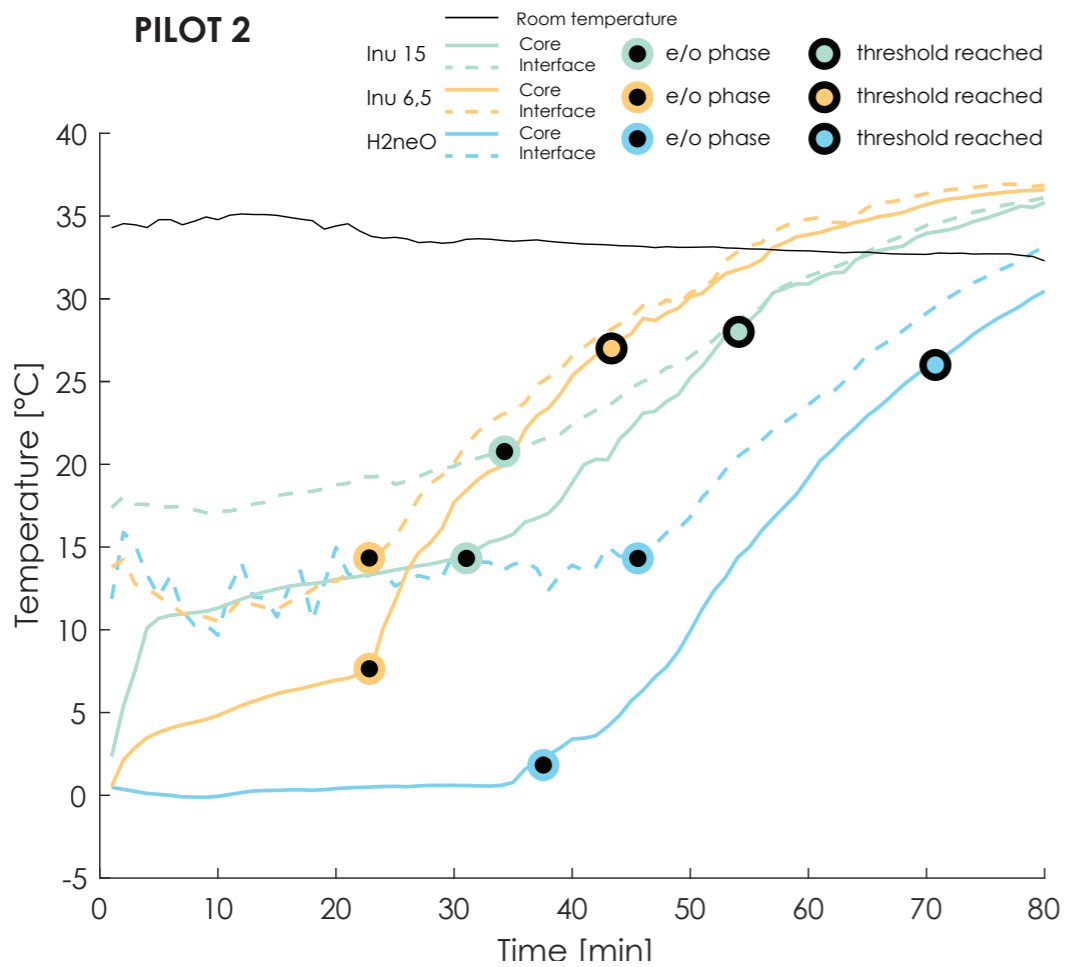
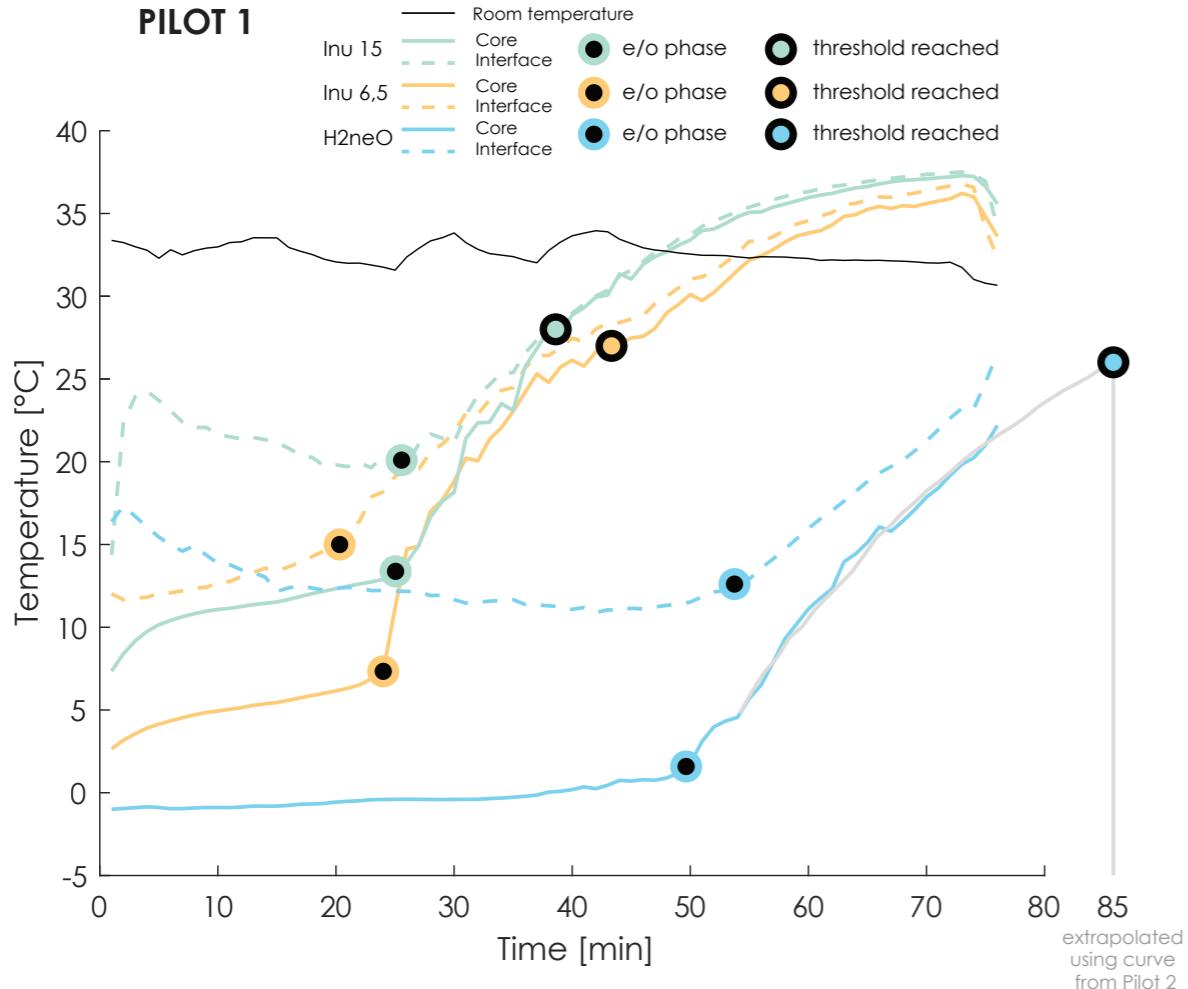

PCM	#	Time till 8W threshold [min]	Average power till 8W threshold [W]	Capacity till 8W threshold [W]	Time till e/o phase [min]	Average power till e/o phase [W]	Capacity till e/o phase [kJ]
Hexagon RIB length: 25 mm							
H2neO	1	47	7	27	42	9	24
	2	44	7	27	37	10	23
	3	38	7	24	31	11	20
	Average	43	7	26	37	10	22
Inu 15	1	30	10	24	21	14	17
	2	33	8	22	27	11	18
	3	31	10	25	21	14	18
	Average	31	10	23	23	13	18
Inu 6,5	1	27	10	22	17	14	14
	2	27	11	23	18	15	16
	3	25	12	21	19	15	17
	Average	26	11	22	18	15	16
Hexagon RIB length: 30 mm							
H2neO	1	66	6	35	70	9	37
	2	70	6	38	70	9	38
	3	64	7	37	56	10	33
	Average	67	6	37	65	9	36
Inu 15	1	41	8	27	28	12	19
	2	39	11	31	26	14	22
	3	32	11	27	26	15	23
	Average	37	10	29	27	14	21
Inu 6,5	1	37	7	28	27	13	21
	2	28	11	25	21	16	20
	3	30	12	27	24	16	23
	Average	32	10	27	24	15	21

- Legend:**
- Power test 1
 - Power test 2
 - Power test 3
 - Threshold (8W)
 - * Marker: Threshold reached
 - * Marker: End of phase change

25 mm H2neO

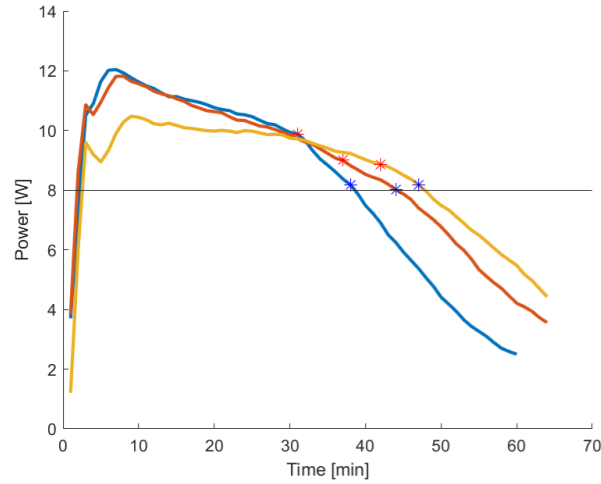

30 mm H2neO

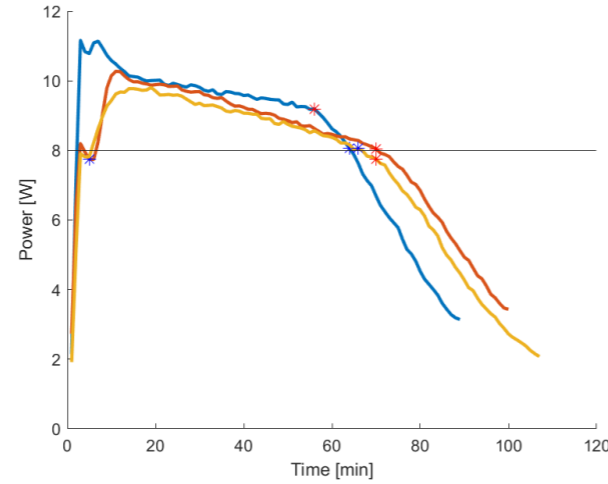

25 mm Inu 15

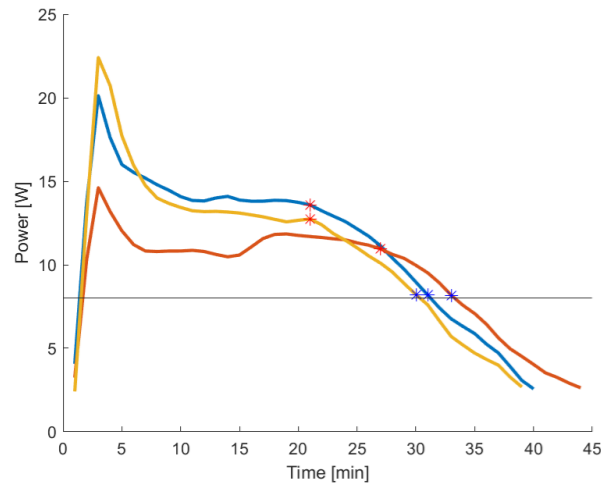

30 mm Inu 15

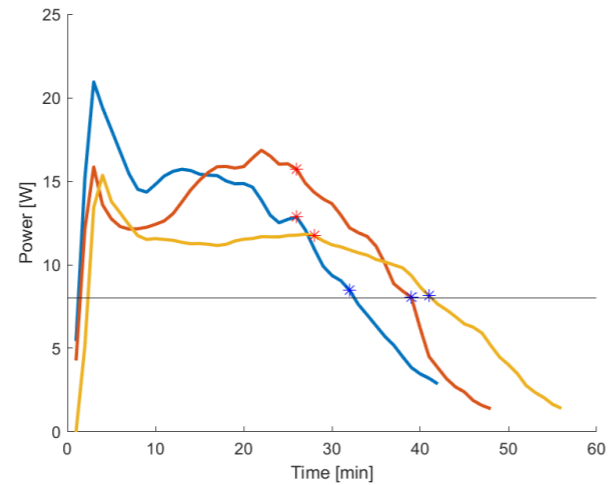

25 mm Inu 6

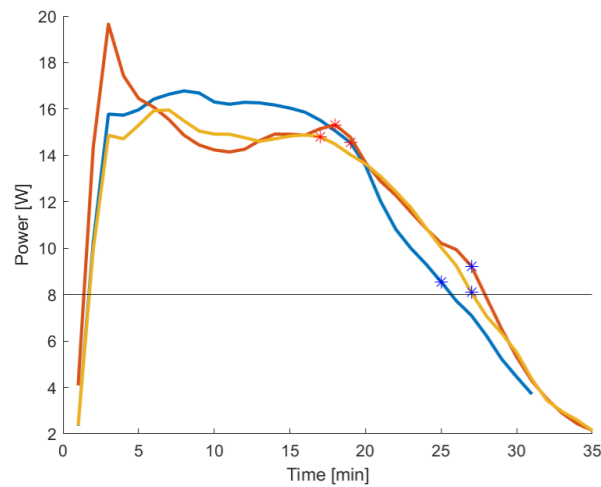

30 mm Inu 6

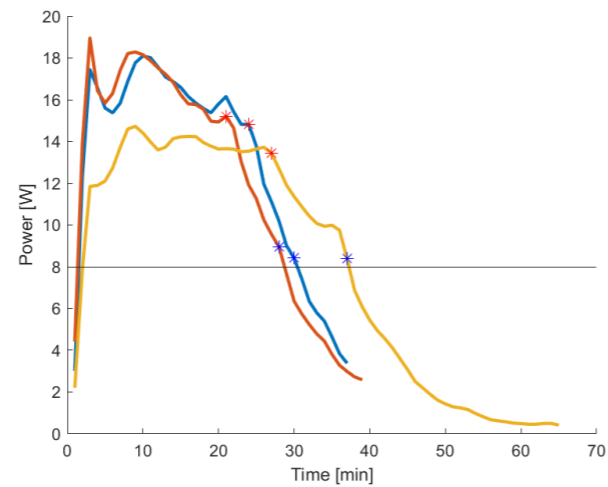

Values used for vest's cooling power and duration estimation

The values in the Table on the right are used to predict the vest's total cooling power and duration.

The following reasoning was applied to calculate all values that could not be measured.

The same samples are used for the hotplate and exercise test, therefore the capacity stays the same. With this knowledge the cooling power of the sample on human skin can be calculated:

$$Capacity = P * t$$

$$P_{body} = \frac{t_{hotplate}}{t_{body}} * P_{hotplate}$$

When assuming that the ratio of the flat to the hex sample is the same when tested on the body or the hotplate:

$$\frac{HEX_{Hotplate}}{FLAT_{Hotplate}} = \frac{HEX_{body}}{FLAT_{body}}$$

Then the power of the hex sample on body can be calculated:

$$P_{hotplate,HEX} = \frac{P_{body,HEX}}{P_{body,FLAT}} * P_{hotplate,FLAT}$$

As well as the duration:

$$t_{hotplate,HEX} = \frac{t_{body,HEX}}{t_{body,FLAT}} * t_{hotplate,FLAT}$$

The cooling power of the whole vest can be calculated by scaling accordingly:

$$P_{vest} = \frac{A_{vest}}{A_{sample}} * P_{sample}$$

$$A_{vest} = 2579 \text{ cm}^2$$

$$A_{sample} = 225 \text{ cm}^2$$

	C		A		B		D		E			
	Hotplate, flat	Body, flat	Hotplate, hex (25 mm)	Body, hex	Body, vest	Power [W]	Duration	Power [W]	Duration	Power [W]	Duration	
	Min [min]	Max [min]	Min [min]	Max [min]	Min [min]	Max [min]	Min [min]	Max [min]	Min [min]	Max [min]	Min [min]	Max [min]
H2neO	17	35	43	78	10	37	43	8	45	95	63	63
stddev	1	3	6	6	1	6	5			153	78	78
Max	18	40	49	85	11	42	47			59	49	49
Min	15	32	38	71	9	31	38			112	31	48
Inu 15	19	21	28	44	13	23	31	10	31	203	47	71
stddev	2	3	4	7	2	3	2			59	29	37
Max	22	24	31	54	14	27	33			118	26	51
Min	18	18	24	38	11	21	30			187	38	64
Inu 6,5	22	15	21	44	15	18	26	10	26	70	18	40
stddev	1	3	3	6	1	1	1					
Max	24	18	24	52	15	19	27					
Min	21	12	19	37	14	17	25					

Light italic = Calculated value

Bold = Measured value

For the Inu square vest similar relations can be used to predict the cooling power and duration:

$$P_{vest} = \frac{A_{vest}}{A_{sample}} * P_{sample}$$

With:

$$A_{vest} = 1755 \text{ cm}^2$$

$$A_{sample} = 187 \text{ cm}^2$$

The cooling duration would be different if the vest does not have the same capacity per unit area. By pure coincidence the vest has almost the same capacity per unit area. The capacity is linearly related to the weight, the following ratios are found between weight and surface area:

$$\frac{m_{vest}}{A_{vest}} = 6,7$$

$$\frac{m_{sample}}{A_{sample}} = 6,7$$

Therefore, the cooling duration is the same for the vest and the sample.

	C			A			E		
	Hotplate, flat			Body, flat			Body, INU SQUARE VEST		
	Duration			Duration			Duration		
PCM	Power [W]	Min [min]	Max [min]	Power [W]	Min [min]	Max [min]	Power [W]	Min [min]	Max [min]
H2neO	17	35	53	<i>14</i>	43	78	<i>127</i>	43	78
stddev	1	3	2		6	6			
Max	18	40	55	<i>18</i>	49	85	<i>173</i>	49	85
Min	15	32	51	<i>10</i>	38	71	<i>90</i>	38	71
Inu 15	19	21	29	<i>14</i>	28	44	<i>135</i>	28	44
stddev	2	3	3		4	7			
Max	22	24	31	<i>22</i>	31	54	<i>205</i>	31	54
Min	18	18	25	<i>10</i>	24	38	<i>95</i>	24	38
Inu 6,5	22	15	22	<i>16</i>	21	44	<i>148</i>	21	43
stddev	1	3	1		3	6			
Max	24	18	23	<i>23</i>	24	52	<i>216</i>	24	52
Min	21	12	22	<i>11</i>	19	37	<i>99</i>	19	37

Light italic = Calculated value

Bold = Measured value

Supplement for literature review

The Table on the right summarizes the vests, conditions and performance results of twelve tests. The text on the following pages is a textual description of the findings in the different papers. Pictures of the vests are included when these were available.

Faulkner (2012) researched the effect of a wearing a cooling vest in combination with cooling forearm sleeves 30 minutes prior exercise. With both running 5K at 25°C 50% RH and cycling at 35°C 50% RH.



Figure 1: Custom vest and sleeves used by Faulkner (2012)

The vest consists of a breathable mesh body with hydrophilic silica gel packs at the grey areas.

The vest was tested for a COOL (15°C), and COLD (5°C) condition. The average and peak cooling power were measured using a thermal mannequin (Table 1). The peak cooling power occurred 15 minutes after wearing and declined steadily afterwards.

For running 5K at 25°C there was no significant improvement in performance.

The test was repeated with cycling and now the vest for the cold condition was frozen. For cycling a time trial at 35°C there was an improvement of 4,8% for the COLD condition and there seems to be a relation between the strength of cooling and performance improvement (Figure 2).

Condition	Initial temperature	Average cooling power, over 60 minutes [W/m ²]	Peak cooling power, occurred after 15 minutes [W/m ²]
COOL, running and cycling	Evaporation and conduction, soaked at 15°C	170	211
COLD, running	Evaporative and conduction, soaked at 5°C	190	220
COLD, cycling	Ice and evaporation -20°C (PC at 0°C)	COOL + 169W	

Table 1: Cooling power of garment used by Faulkner.

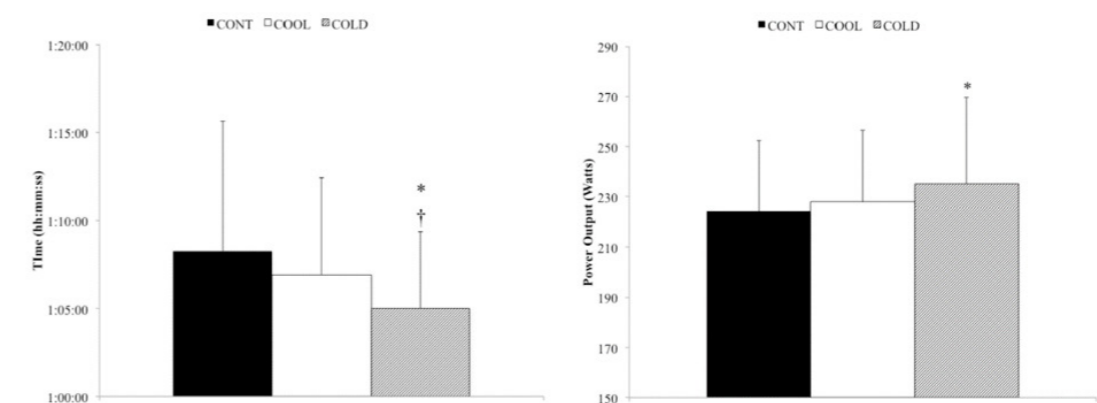

Figure 2: Results of performance on cycling trial (Faulkner, 2012)

Webster et al. 2005 studied the effect of three different PCM vests (Table 2) on cycling time till exhaustion in 37°C and 50% RH. Vest B improved the time till exhaustion with 49 seconds, for vests A and C the effect was not significant. Vests were worn 35 minutes before the actual exercise trial during rest and warm up. Too bad that vest specifications are not given in SI units and therefore quite useless to compare to.

Arngrimsson (2003) researched the effect of wearing an ice vest during warm up (38 minutes) on a 5-km run in a hot and humid environment (32°C 50%RH). This improved the run time with 13 seconds. The vest worn was a cooling vest developed by the Australian Institute of Sport for use by Australian Olympic Athletes. The vest has eight pockets for ice packs (450–500 ml each): four at the front and four at the back. The average ice content is 3,8 kg and is capable of absorbing 1270 kJ of heat.

Tate et al. (2008) designed a jacket filled with a 20°C PCM (Figure 1) and compared it to the same ice vest as Arngrimsson (2003) used. They concluded that their vest achieved comparable cooling performance. It must be said that the data they present seems to be quite inconclusive.



Figure 1: Prototype of vest designed by Tate et al. 2008

Bogerd (2010) researched the difference between mild and strong cooling (Table 1). Participants were asked to cycle till exhaustion in 29°C with 80% RH. The average time till exhaustion increased for both mild and strong cooling with 5:09 minutes and 7:46 minutes respectively.

Their conclusion was that even though strong cooling causes more vasoconstriction the larger heat sink gives a bigger thermophysiological advantage. Vests were worn 45 minutes before exercise.

Cuttel et al. 2016 also researched the effect of wearing an ice vest during cycling by comparing cycling times till exhaustion in hot and humid conditions (35°C, 50% RH). Cycling time improved from 30,0 minutes to 32,2 minutes. The vest was soaked and frozen in a deep freezer, the cooling patches cover 5% of the estimated body surface area (Figure 2). The average BSA is 1,9 m² (Women and men combined, source https://en.wikipedia.org/wiki/Body_surface_area) Which leaves a surface area of 1,9*0,05 = 0,1 m² covered with ice by the vest.



Figure 2: Vest by Arctic Heat used by Cuttel et al. 2016, Uckert & Joch 2006 and Bogerd 2010

Condition	Initial temperature	Average cooling power [W/m ²]
COOL	Evaporation and conduction, soaked at 20°C	27
COLD	PCM at 0°C (Arctic Heat)	49

Table 1: Cooling power of vest used by Bogerd (2010) (Figure 2)

Uckert & Joch (2006) also analyzed the effect of the vest by Arctic Heat but this time with pre cooling (20 minutes) and on running performance instead of cycling. They also analyzed the effect of warming up before exercise in hot and humid conditions. The running time till exhaustion was 30,3 minutes without warm up or cooling vest. Warming up reduced performance till 26,9 minutes. Wearing the vest 20 minutes before exercising increased the running time to 32,5 minutes. Tests were performed at 31°C, 50% RH.

Luomala (2012) researched the effect of wearing an ice vest during exercise on cycling performance. The vest has pockets for ice covered in a thin insulative fabric to avoid frostbite. This is similar to the H2neO PCM packages. The cooling surface area is 0,20 m² and one vest lasted approximately 30 minutes. Exercise time improved significantly from 61:29 min to 74:14 min. Conditions were warm (30°C) and moderately humid (40% RH)



Figure 3: Vest used by Luomala (2012)

Quod et al. (2008) researched the effect of wearing a cooling jacket with 20°C PCM for 40 minutes before exercise. They did find a small (1,5%) but not significant performance improvement. On average, the participants were able to finish the set trial in 1080 instead of 1097 seconds with a temperature of 34°C and 41% RH. They hint that a jacket might not be suitable as a pre-cooling method but that it is more appropriate to use as an external heat sink to keep the benefits from pre-cooling while doing a warm-up before exercise. The cooling vest used is different but comparable to the one designed by Tate et al. 2008.

Table 2: Specifications of cooling vests used by Webster et al. 2005

Vest type	Mass g			Rate of melting °C·(100g) ⁻¹	Heat capacity* cal·g ⁻¹
	Vest	Coolant	Total		
A	359.07	2450.82	2809.89	1.44	134.3
B	443.65	2555.76	2999.41	1.53	142.6
C	675.35	2145.65	2821.00	0.86	79.9

*Assumes skin temperature of 36°C (Coleman 1989)



Preparatory documents for future physiological study

Physiological evaluation

There are two versions of the cooling vest that seem suited for the Olympics. There are drawbacks and advantages to both. To be able to come to a better decision the vests are evaluated on how much they help in recovering from heat stress after a race.

From previous tests the conclusion was that the Inu 6,5 and H2neO vests feel more or less equally effective. Hot plate tests show that Inu 6,5 has more cooling power per surface area even though the PCM's temperature is higher than that of H2neO (0°C).

The human body's heat balance relies on the exchange of heat (power) with the environment. The Inu 6,5 vest withdraws heat faster, therefore the hypothesis is that the Inu 6,5 vest can release heat stress faster than the H2neO vest. And theoretically both vests should outperform the control group wearing no vest.

A full scale research on the exact effectiveness is not feasible because of the lack of resources and time. A pilot is set up with internal participants. In this case there is no need for an extensive ethical allowance procedure.

Introduction

The 2020 Olympics will be in hot and humid conditions. When exercising in these conditions heat stress is induced. Reducing heat stress for sailors in between races can improve their thermal comfort and exercise performance. To speed up the process of recovering from heat stress after exercise a cooling vest is designed. This pilot is done to evaluate the effectiveness of two different versions of the cooling vest.



Location

Climate chamber with the following settings

Temperature	33	°C
Relative humidity	75	%
Wind speed		

Materials

Sailing outfit consisting of: Lycra long-sleeve, flotation aid, lycra bottom.
H2neO cooling vest (one per participant per day)
Inu 6,5 cooling vest (one per participant per day)
Cool box with ice water/cooling elements

Stationary bicycle

Note: With a rowing ergometer more core muscles are used, this relates better to sailing. However, it is not likely that all test persons are acquainted with using a rowing ergometer.

Sensors:

- Heart rate (HR) monitor
- Skin temperature sensors (iButtons)
- Core temperature (My Temp Pills)
- Stopwatch

Data collection forms.

Measurements

Continuously:

Heart rate
Skin temperature
Core temperature

Periodically (Every five minutes from -5 till 30):

Experienced exercise intensity (RPE, rate of perceived exertion)

Borg scale; <https://www.hsph.harvard.edu/nutritionsource/borg-scale/>

Thermal sensation (TS):

- General
- Upper body

Hot	Warm	Slightly warm	Neutral	Slightly cool	Cool	Cold
-----	------	---------------	---------	---------------	------	------

Thermal comfort (TC):

- General
- Upper body

Very comfortable	Comfortable	Neutral	Uncomfortable	Very Uncomfortable
------------------	-------------	---------	---------------	--------------------



Design

Four recreationally trained subjects (m/f) will perform three 30-min submaximal cycling trials in Tokyo climate with simulated wind.

Each trial will be performed on a different day with a different condition at the same time of day.

Conditions

Each test, subjects will be wearing one of two versions of a cooling vest underneath the flotation aid during recovery after the cycling trial.

1. Cooling vest with ice and a neoprene insulation layer [H2neO]
2. Cooling vest with Inuteq PAC 6.5C PCM [Inu 6,5]
3. Control without cooling vest [Control]

Protocol

	Read information sheet and sign consent form
-180	Swallow temperature pill
-20	Attach iButtons and HR monitor; put on sailing outfit
-15	Enter climatic chamber; habituate/rest not yet wearing cycling jersey
-5	Note TS, TC & RPE
0	Cycling 2.0 W/kg; note TS/TC/RPE every 5 min
20	Put on cooling vest [Control, Inu 6,5 or H2neO]
	Recovery; note TS/TC/RPE every 5 min
35	Remove cooling vest
	Cycling 2.0 W/kg; note TS/TC/RPE every 5 min
55	Recovery
60	End of test

Early termination when the participant does not feel well at any point during the test.

Total time required at location: 80 minutes + 10 minutes for showering etc.

Participants

#	1	2	3	4
Age				
Gender				
Weight				
Fitness				
Etc (?)				



Evaluation of cooling vest's effectiveness on heat stress recovery

Adult Participant Information Sheet

Investigators Details:

Emiel Janssen (Student), Delft University of Technology, e.s.janssen@student.tudelft.nl

Dr. Lennart Teunissen (Academic Tutor), Delft University of Technology, L.P.J.Teunissen@tudelft.nl

I would like to invite you to take part in my study. Before you decide I would like you to understand why the research is being done and what it would involve for you. I will go through the information sheet with you and answer any questions you have. Talk to others about the study before deciding if you wish.

What is the purpose of the study?

The purpose of this study is to gathering insights into the effectiveness of two cooling vests on the recovery from heat stress in a hot and humid environment to inform the development of new products to improve exercise performance. The vests are designed to be used by sailors but the test results can be applied in other sports as well.

Who is doing this research and why?

This study is part of a graduation project supported by Delft University of Technology. The research will be carried out by Emiel Janssen supervised by Prof. Dr. Ir. Kaspar Jansen and Dr. Lennart Teunissen.

Are there any exclusion criteria?

People with health problems that might give an issue when exercising in a hot and humid environment should not take part in this research. If you are aware of any condition that negatively influences your thermoregulation performance please let us know.

What will I be asked to do?

You will be asked to do a series of trials that will consist of 20 minutes cycling, 15 minutes recovery followed by another 20 minutes of cycling. During recovery there are three different conditions: Wearing cooling vest A, wearing cooling vest B and without a cooling vest. The trial will take place in a climate chamber in which a hot and humid climate is simulated. Every 5 minutes you will be asked to rate your thermal sensation, thermal comfort and experienced exercise intensity. Sensors to measure heart rate and skin temperature will be placed. To measure your core body temperature a MyTemp capsule must be swallowed 180 minutes before the trial. (<http://mytemp.eu>)



Once I take part, can I change my mind?

Yes. After you have read this information and asked any questions you may have if you are happy to participate we will ask you to complete an Informed Consent Form, however if at any time, before, during or after the sessions you wish to withdraw from the study please just contact the main investigator. You can withdraw at any time, for any reason and you will not be asked to explain your reasons for withdrawing.

Will I be asked to attend any sessions and where will these be?

There will be three sessions on different days, they will take place at Sportcentrum Papendal near Arnhem. (Papendallaan 8, 6816 VD Arnhem)

How long will it take?

The test will take a total of 80 minutes. This is excluding changing/shower time.

Are there any disadvantages or risks in participating?

Exercising in hot and humid conditions will lead to heat stress. Excessive heat stress can be dangerous. The test can be stopped at any time if you do not feel well during a test.

What personal information will be collected from me?

Identifiable personal information including for example your name, age, ethnicity and fitness may be collected.

Will my taking part in this study be kept confidential?

Personal information collected about me that can identify me, such as my name or where I live, will not be shared beyond the student and Academic tutors. Participants will be allocated a code to separate any identifiable information from their data. No individual will be identifiable in any report, presentation or publication.

Will my data be shared with others?

Identifiable personal information can be shared with the Academic tutors and potentially the External Examiner for the student's programme of study. Anonymous data can be used for scientific research, publications and presentations.

I have some more questions; who should I contact?

In the first instance please raise any queries with Emiel Janssen alternatively you may speak directly to the Academic Tutor Dr Lennart Teunissen.



Evaluation of cooling vest's effectiveness on heat stress recovery

INFORMED CONSENT FORM
(to be completed after Participant Information Sheet has been read)

Taking Part

The purpose and details of this study have been explained to me. I understand that this study is designed to further scientific knowledge.

I have read and understood the information sheet and this consent form.

I have had an opportunity to ask questions about my participation.

I understand that taking part in the project will involve interviews and physiological measurements. (e.g. Heart rate, skin- and core body temperature)

I understand that I am under no obligation to take part in the study, have the right to withdraw from this study at any stage for any reason, and will not be required to explain my reasons for withdrawing.

Use of Information

I understand that information I provide can be used for scientific- research, publications and presentations.

I understand that personal information collected about me that can identify me, such as my name or where I live, will not be shared beyond the study team.

I agree that information I provide can be quoted anonymously

I voluntarily agree to take part in this study.

Name of participant Signature Date

Researcher Signature Date