

Document Version

Final published version

Licence

CC BY-NC-ND

Citation (APA)

Fernández-Dacosta, C., Shen, L., Schakel, W., Ramirez, A., & Kramer, G. J. (2019). Potential and challenges of low-carbon energy options: Comparative assessment of alternative fuels for the transport sector. *Applied Energy*, 236, 590-606. <https://doi.org/10.1016/j.apenergy.2018.11.055>

Important note

To cite this publication, please use the final published version (if applicable). Please check the document version above.

Copyright

In case the licence states "Dutch Copyright Act (Article 25fa)", this publication was made available Green Open Access via the TU Delft Institutional Repository pursuant to Dutch Copyright Act (Article 25fa, the Taverne amendment). This provision does not affect copyright ownership. Unless copyright is transferred by contract or statute, it remains with the copyright holder.

Sharing and reuse

Other than for strictly personal use, it is not permitted to download, forward or distribute the text or part of it, without the consent of the author(s) and/or copyright holder(s), unless the work is under an open content license such as Creative Commons.

Takedown policy

Please contact us and provide details if you believe this document breaches copyrights. We will remove access to the work immediately and investigate your claim.

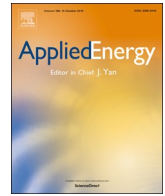

Potential and challenges of low-carbon energy options: Comparative assessment of alternative fuels for the transport sector

Cora Fernández-Dacosta^a, Li Shen^{a,*}, Wouter Schakel^a, Andrea Ramirez^b, Gert Jan Kramer^a

^a Copernicus Institute of Sustainable Development, Utrecht University, Princetonlaan 8a, 3584CB Utrecht, the Netherlands

^b Department of Engineering, Systems and Services, Faculty of Technology, Policy and Management, Delft University of Technology, Jaffalaan 5, 2628 BX Delft, the Netherlands

HIGHLIGHTS

- Comparing alternative fuels with potential for low-carbon intensities.
- Technical process design and economic assessment of hydrogen and CO₂-based fuels.
- Environmental life-cycle assessment considering the full carbon cycle.
- Identification of methodological challenges in carbon accounting of CO₂-fuels.

GRAPHICAL ABSTRACT

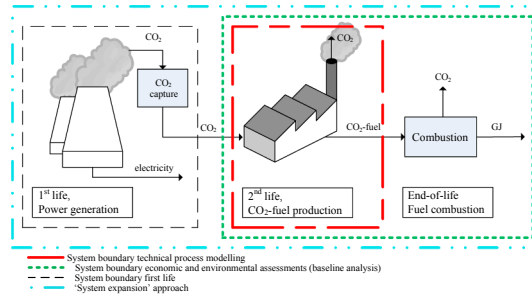

ARTICLE INFO

Keywords:

CO₂-based fuel
 Hydrogen
 Climate change mitigation
 Carbon capture and utilisation (CCU)
 Life cycle assessment (LCA)
 Prospective technology assessment

ABSTRACT

The deployment of low-emission alternative fuels is crucial to decarbonise the transport sector. A number of alternatives like hydrogen or dimethyl ether/methanol synthesised using CO₂ as feedstock for fuel production (hereafter refer to “CO₂-based fuels”) have been proposed to combat climate change. However, the decarbonisation potential of CO₂-based fuels is under debate because CO₂ is re-emitted to the atmosphere when the fuel is combusted; and the majority of hydrogen still relies on fossil resources, which makes its prospects of being a low-carbon fuel dependent on its manufacturing process.

First, this paper investigates the relative economic and environmental performance of hydrogen (produced from conventional steam methane reforming and produced via electrolysis using renewable energy), and CO₂-based fuels (dimethyl ether and methanol), considering the full carbon cycle. The results reveal that hydrogen produced from steam methane reforming is the most economical option and that hydrogen produced via electrolysis using renewables has the best environmental profile. Whereas the idea of CO₂-based fuels has recently gained much interest, it has for the foreseeable future rather limited practical relevance since there is no favourable combination of cost and environmental performance. This will only change in the long run and requires that CO₂ is of non-fossil origin, i.e. from biomass combustion or captured from air.

Second, this paper address unresolved methodological issues in the assessment of CO₂-based fuels, such as the possible allocation of emissions to the different sectors involved. The outcomes indicate that implementing different allocation approaches substantially influences the carbon footprint of CO₂-based fuels. To avoid allocation issues, expanding the boundaries including the entire system and is therefore recommended.

* Corresponding author.

E-mail addresses: C.FernandezDacosta@uu.nl (C. Fernández-Dacosta), L.Shen@uu.nl (L. Shen), c.a.ramirezramirez@tudelft.nl (A. Ramirez), g.j.kramer@uu.nl (G.J. Kramer).

<https://doi.org/10.1016/j.apenergy.2018.11.055>

Received 23 May 2018; Received in revised form 23 October 2018; Accepted 16 November 2018

0306-2619/ © 2018 The Authors. Published by Elsevier Ltd. This is an open access article under the CC BY-NC-ND license (<http://creativecommons.org/licenses/by-nc-nd/4.0/>).

1. Introduction

The transport sector accounted for 24% of the greenhouse gas (GHG) emissions, 33% of the final energy consumption in the European Union in 2015 [1], and it has been the only major sector with growing GHG emissions since 1990 [2]. Within this sector, road transport contributes to 73% of the CO₂ emission from fuel combustion [1]. The strong need to decarbonise the road transport sector has been taken into account in the European emission reduction targets: 60% reduction of transport GHG emissions by 2050 compared to 1990 and 20% emissions reduction by 2030 compared to 2008 [3,4]. To achieve these targets, one key component of the current Commission's low-emission mobility strategy is to replace fossil fuels by accelerating the deployment of low-emission alternative fuels [2].

One alternative of low-emission fuels are those based on CO₂ (i.e. CO₂-based fuels, using captured CO₂ as feedstock for their production). The concept of CO₂-to-fuel has been investigated in the last decade as one climate change mitigation option. With increasing number of projects on large-scale CO₂ capture from power plants or industrial facilities (17 currently operating and five under construction worldwide [5]), large amounts of captured CO₂ will be transported and stored in geological formations. Besides carbon capture and storage (CCS), captured CO₂ could be used in the synthesis of chemicals and fuels. In contrast to CCS, carbon capture and utilisation (CCU) can generate revenue that can partially compensate high costs of capturing CO₂. Moreover, utilising CO₂ into fuels can contribute to the transitioning to a circular economy, which aims to close material and energy loops to minimise resource input, waste, and emissions. However, the decarbonisation potential of CO₂-based fuels is currently under debate [6]. The reasons are the additional energy that is required for the transformation of CO₂ into fuels and the short storage time of the CO₂ in the fuel (the CO₂ is re-emitted to the atmosphere when the fuel is combusted).

There are many different CO₂-based fuel routes under development, including methane, slurry hydrogen, formic acid, sodium borohydride, or metal hydrides. CO₂ hydrogenation into methanol is currently one of the options most extensively researched [7,8] and already demonstrated at bench- and pilot-scale plants in Asia and Europe ([9,10,11]). Other studies have suggested dimethyl-ether (DME) as a preferable CCU alternative because it can be used as a direct and cleaner alternative to diesel [12,13] and its market will likely grow [14–16]. Due to their different technology readiness level (TRL,¹ 8 in the case of CO₂-methanol and 4–5 in the case of CO₂-DME) and their likeliness to replace conventional fossil fuels, this paper elaborates on the potential of CO₂-based methanol and CO₂-based DME as alternative transportation fuels. The list of CO₂-based fuels included in this paper is by no means exhaustive but examining all the different options is beyond the scope of the work.

In regard to the environmental performance of CCU technologies [19], there is currently scarce and dispersed information. Previous research [20–23] has concluded that CO₂-based fuels have indeed the potential to offer emission reduction compared to their fossil-based counterparts, but the significance of the potential differs between studies (Table 1). Comparing the results of these studies is very difficult or even inconsistent, because they are based on different assumptions and use different system boundaries and carbon metrics (Table 1). Although the CO₂ capture unit is not always included inside the boundaries of the system under assessment, it is usual to take into account a carbon credit from the CO₂ utilised in the production of the fuels. Important to mention is that none of the previous work considered the end-of-life emissions, when carbon is re-emitted during fuel combustion (Table 1). Hence, the previous analyses did not close the full carbon cycle. This calls for a consistent comparison among different alternative fuel

options, based on the same assumptions, using uniform system boundaries, equal metrics and closing the carbon cycle.

Besides CO₂-based fuels, hydrogen is another alternative that has been extensively investigated. Today, 192 fuel cell electric vehicles are running in demonstration projects in Europe and 350,000 are planned to be on the road by 2020 [24]. However, the majority (96%) of hydrogen still relies on fossil fuels. In 2008, steam methane reforming (SMR) of natural gas accounted for 48% of the global hydrogen production, 30% was produced during petroleum refining processes and 18% came from coal gasification [25]. Vehicles running on fossil-fuel based hydrogen could result in large indirect fossil carbon emissions. Earlier studies estimated that hydrogen production via conventional SMR produces 75 kg CO₂eq/GJ [26], 81 kg CO₂eq/GJ [81], 99 kg CO₂eq/GJ [82] or 67–112 kg CO₂eq/GJ [83]. Non-fossil based hydrogen only accounts for 4% of total hydrogen production (via water electrolysis). Literature values of the carbon footprint of hydrogen production via electrolysis range from 21 to 25 kg CO₂eq/GJ (Bhandari et al., 2013) to 37 kg CO₂eq/GJ [26]. However, compared to SMR for instance, electrolysis plants have seven times smaller capacity [27]. Due to the modular nature of the electrolysers, electrolysis of water does not benefit from economies of scale. Given the size and scalability of this option, it is not clear how much will contribute to climate change mitigation.

To the best of our knowledge, no previous study has explored the potential that CO₂-based fuels have to compete with other alternative fuels. Besides one-to-one comparisons with their fossil-based counterparts, it still remains unclear what are the most cost- and environmental-effective alternative fuels for the transport sector. The first goal of this paper is to *investigate the relative economic and environmental performance of alternative fuels for the transport sector*: i.e. hydrogen and CO₂-based fuels (DME and methanol) using a coherent approach and considering the end-of-life emissions. Although other alternative fuels could be investigated, the four options selected allow gaining insights into main bottlenecks and key hotspots that influence the relative performance of alternative fuels for the transport sector.

Furthermore, from a methodological perspective, alternative fuel systems can be equally or more complex than current fossil-based fuels. An aspect inherent to such complexity in CO₂-to-fuel systems is the potential allocation of emissions to the different sectors involved. For instance, allocation of emissions to the power sector producing the emissions or to the CO₂ processing sector, converting the CO₂ into fuels. The potential impacts of different allocation approaches have not been previously discussed in the literature and remain a blind spot in the performance analysis of CO₂ utilisation concepts. The second goal of this paper is to *evaluate the implications of different approaches for carbon accounting in CO₂-based fuels*, followed by recommendations from the perspectives of technology developers, policy makers and life-cycle assessment (LCA) practitioners.

2. Methodology

To achieve the goals of this study, four alternative fuel routes are investigated:

- Dimethyl ether (DME) produced from CO₂ (CO₂-DME)
- Methanol produced from CO₂ (CO₂-methanol)
- Hydrogen produced from steam methane reforming (SMR-H₂)
- Hydrogen produced from water electrolysis using renewable energy (electrolysis-H₂)

Fig. 1 shows an overview of the different assessments performed in this study and how the two specific research goals are achieved. To address the first goal of this study, i.e. *assess the relative economic and environmental performance of alternative transportation fuels*, a technical process design is developed and modelled for each alternative fuel route (Section 2.1). The outcomes from process modelling are used as basis

¹ TRL: method of estimating technology maturity during the acquisition process based on a scale from 1 to 9, being 9 the most mature technology [17], [18].

Table 1
Overview of previous environmental assessments on CO₂-based fuels.

Utilisation product	CO ₂ capture	CO ₂ credit	End-of-life	Environmental metric			Study
Ethanol	Yes	Yes	No	Global warming	–25	kgCO _{2eq} /GJ	Christodoulou et al. [20]
Methanol	Yes	Yes	No	Global warming	–28	kgCO _{2eq} /GJ	Christodoulou et al. [20]
Formic acid	Yes	Yes	No	Global warming	–69	kgCO _{2eq} /GJ	Christodoulou et al. [20]
Methanol	Yes	Yes	No	CO ₂ abatement	60–80	kgCO ₂ /GJ	van-Dal and Bouallou [21]
Methanol	No	Yes	No	CO ₂ not-produced	27	kgCO ₂ /GJ	Pérez-Fortes et al. [22]
Methanol	No	Yes	No	CO ₂ avoided	100	kgCO ₂ /GJ	Pérez-Fortes et al. [22]
Formic acid	No	Yes	No	CO ₂ not-emitted	363	kgCO ₂ /GJ	Pérez-Fortes et al. [23]

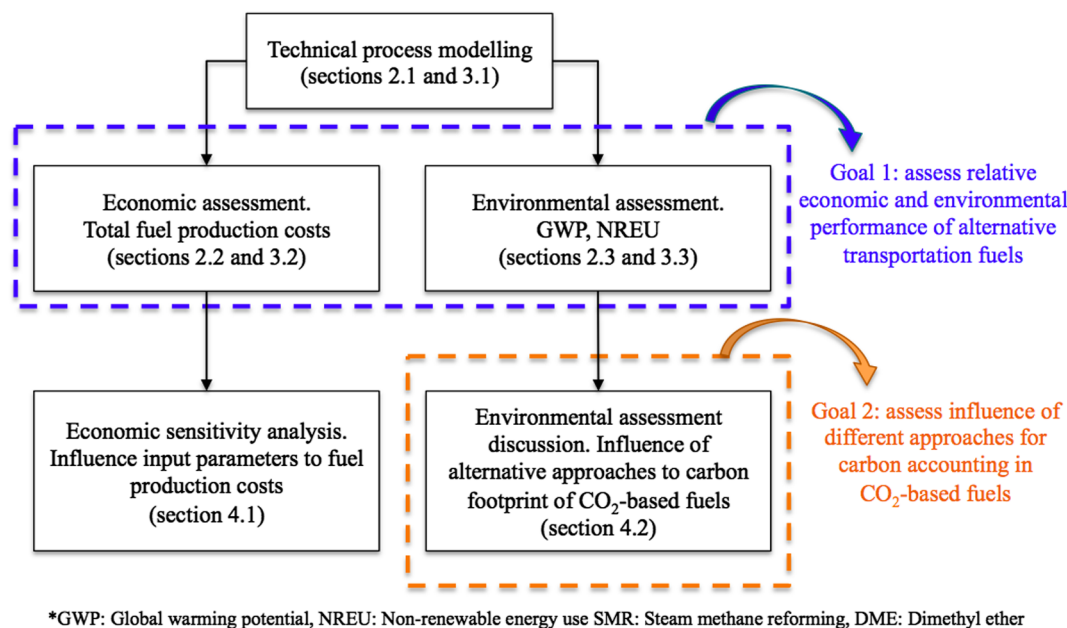

Fig. 1. Overview of the assessments carried out in this study and the specific research goals.

for a comparative assessment, which includes economic aspects (total fuel production costs, see [Section 2.2](#) for details in the methodology) and environmental aspects (global warming potential (GWP), non-renewable energy use (NREU), see [Section 2.3](#) for details in the methodology). This integrated approach allows identifying trade-offs among the costs and environmental burdens of the four alternative fuels investigated.

For the purpose of this analysis, the geographical location is assumed to be the Netherlands and the energy content of each fuel, i.e. 1 GJ of fuel produced delivered at the factory gate is selected as basis for the comparison. In order to explore the total impact in GHG emission reduction, the system boundary for the economic and environmental assessments includes the fuel production plant (“cradle-to-factory gate”) plus the end-of-life phase for all four alternative routes investigated.

Defining the system boundaries in the assessment of primary production is straightforward. The system boundaries in the hydrogen routes include the “cradle” stage, i.e. extraction and transportation of raw materials, energy production and supply, conversion steps until the product is delivered at the factory gate and also the end-of-life emission, which is zero in the case of hydrogen. However, defining the system boundaries and the “cradle” stage of CO₂ utilisation options is usually a challenge. CO₂ utilisation technologies are not stand-alone but part of a system ([Fig. 2](#)). In CO₂-to-fuel systems, “waste” CO₂ is emitted in a first life (e.g. a power plant) and then used as the carbon source in a second life (CO₂ utilisation process, i.e. converting CO₂ into fuels). The value chain for this study assumes that the CO₂ is the by-product of an industrial process, e.g. production of electricity in a power plant. Thus means that CO₂ would be emitted during electricity production

regardless of the demand of CO₂-based fuel. The CO₂-based fuel therefore uses CO₂ that would be produced anyway, thereby avoiding extraction of “fresh” fossil fuel.

The first life (CO₂ capture at a point source, e.g. a power plant) is out of the scope of the baseline analysis of CO₂-based fuels (details in [Section 2.3.1](#)). To address the second goal of this study, i.e. *assess the influence of different approaches for carbon accounting in CO₂-based fuels*, the effect of considering the first life (e.g. electricity production in a power plant) in the carbon accounting of CO₂-based fuels is explored the discussion [Section 4.2](#).

2.1. Technical process modelling

The mass and energy balances and the equipment list of each fuel production plant are obtained from process modelling. The production processes of SMR-hydrogen, CO₂-DME and CO₂-methanol are modelled in Aspen Plus software. Electrolysis efficiency and electricity consumption per kW of hydrogen produced are used to develop the spreadsheet model of hydrogen production via electrolysis ([Section 2.1.2](#)).

2.1.1. Hydrogen via steam methane reforming (SMR)

In the steam methane reforming (SMR) process, steam and natural gas react at high temperature to yield carbon monoxide and hydrogen ([R.1](#)). In a water gas shift reaction ([R.2](#)) additional hydrogen is recovered and CO₂ is produced.

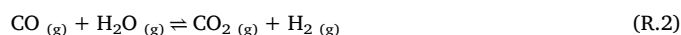
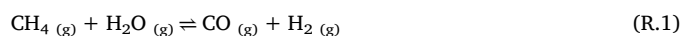

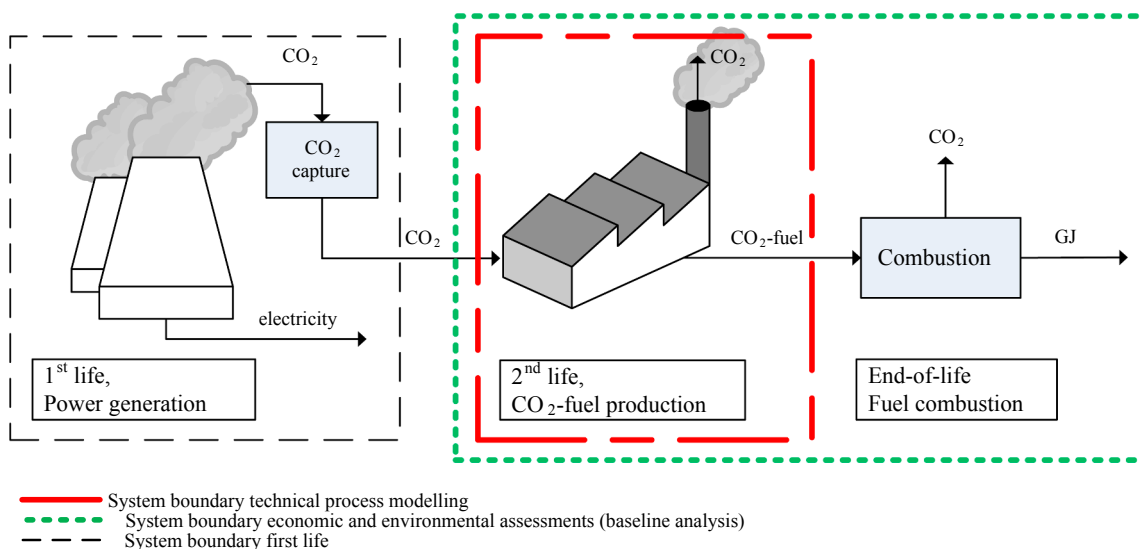

Fig. 2. Assessment of CO₂-based fuels. In this paper (see Section 2. Methodology), technical process modelling is carried out for the fuel production plant. The system boundary for the economic and environmental assessments in the baseline analysis includes the fuel production plant plus the emission at the end-of-life. The first life is out of the scope of the comparative assessment in the baseline analysis.

There is a wide range of reported capacities of large-scale SMR plants (8–360 kt/a, [27]). A previous in-house model [28] of a hydrogen-manufacturing unit with a typical industrial capacity of 59 kt/a [29] and validated with confidential data from a real refinery is used in this study. Fig. 3 shows the scheme of the process modelling carried out in Aspen Plus. Natural gas and steam are pre-heated to 410 °C and fed to the pre-reformer, which operates at 560 °C and 30 bar. After the pre-reformer, the gas stream is heated to 650 °C and fed to the reformer for further catalytic conversion at 25 bar. The reformer products are cooled to 350 °C, delivering steam as a by-product. The water gas shift is carried out at 25 bar in a high temperature reactor (400 °C) and in a low temperature reactor (220 °C).

Water is removed before the reaction products are fed to a pressure swing adsorption (PSA) unit (40 °C, 25 bar), where 90% of the hydrogen is recovered at high purity (99.99 wt%). Heat integration is carried out by feeding the PSA off gas into the furnace section of the reformer and burned to aid the endothermic reaction. Moreover, the extra heat available from the reformer flue gas is used to pre-heat the feed streams and for steam generation. After heat integration, the flue gas is emitted to the atmosphere.

2.1.2. Hydrogen via electrolysis

In an electrolysis process, water dissociates into hydrogen and oxygen by applying a direct electric current (R.3). Hydrogen is obtained

at 20 °C, 30 bar and high purity (99%) [29]. Also oxygen is obtained at high purity, which allows its sale without any further conditioning [21,23]).



Large-scale electrolysis plants produce about 20 kt/a of hydrogen [27,30], which is approximately 35% of the production capacity of the SMR unit (59 kt/a, [29]). Alkaline electrolyzers are considered a mature technology for large systems [23,27]. A large-scale electrolysis plant with an output capacity of 125 MW, 80% of hydrogen mass efficiency and electricity consumption of 1.43 kWe/kW H₂ [27] is modelled in a spreadsheet. It is estimated that this electrolysis plant delivers 21 kt/a of hydrogen and 166 kt/a of oxygen.

To be a true zero-emission process, the electricity used in hydrogen production via electrolysis needs to come from a renewable source. In the process model for electrolysis-hydrogen, it is assumed that electricity is produced from photovoltaics (PV) and bought from the market, thus the PV panels are not included in the modelling. PV-electricity is only produced during the hours that there is solar energy, and therefore storage systems are required to ensure continuous hydrogen delivery when no sunlight is available. Weather data in the Netherlands from 35 meteorological stations [31] is used to estimate the number of hours of sunshine per day. Based on the irradiance measurements and the values of sunshine duration per hour reported, a

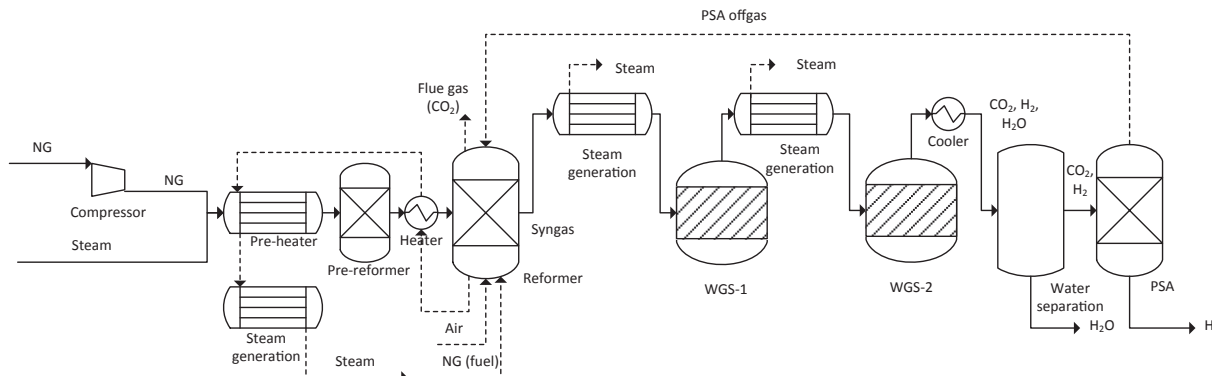
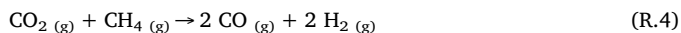

Fig. 3. Hydrogen production via steam methane reforming. Process model developed in Aspen Plus. NG: natural gas; PSA: pressure swing absorption; WGS: water gas shift.

yearly average of six hours of sunshine per day is calculated. As hydrogen is produced during six hours a day, storage of 18 h a-day is needed to ensure its continuous delivery. A block diagram and a detailed description of the storage system are available in the [supplementary information \(SI. 1\)](#).

2.1.3. CO₂-based Dimethyl-ether (CO₂-DME)

CO₂-based DME can be produced in a two-step process based on dry reforming of methane and CO₂ to syngas (R.4) followed by direct synthesis of DME as described in the model of Schakel et al. [32].



Four simultaneous reactions occur in the direct synthesis of DME i.e., conversion of syngas to methanol (R.5) and (R.6), water gas shift reaction (R.7) and methanol dehydration (R.8). In the direct synthesis process, efficient conversion to DME is achieved at a H₂/CO ratio close to 1 in the syngas. Methanol produced is directly converted to DME, which induces extra methanol conversion and facilitates hydrogen production in the water gas shift reaction. This allows a higher syngas conversion rate than when only methanol synthesis is considered [33,34].

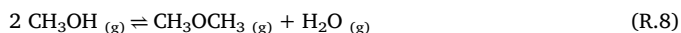
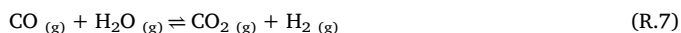
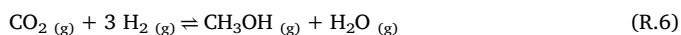

Fig. 4 shows the modelling flow diagram of the synthesis of CO₂-based DME as modelled in Aspen Plus [32]. CO₂ and methane are pre-heated to 800 °C and fed to the dry reformer reactor. The syngas generated is compressed in three stages with intermediate cooling and water removal to 79 bar and 250 °C. DME is produced in the direct synthesis reactor without addition of extra heat. Impurities such as methanol, water, CO₂, CO, methane and hydrogen are present in the stream outflowing the direct synthesis reactor. In a first distillation step at 10 bar, CO₂, CH₄, CO and H₂ are separated at the top of the distillation column. A refrigeration cycle is needed to reach the low temperature of operation in the condenser and meet the separation targets. In a second distillation step, water and methanol are separated at the bottoms. 188 kt/a of highly pure DME (> 99.5%) are obtained. The capacity of the CO₂-DME process is limited by the large volumetric gas flow compressed. The impurities separated in the distillation columns are burnt in a furnace for heat recovery. The exhaust gases (> 1500 °C) are used to pre-heat the CO₂ and methane feed and to provide the heat for the dry reforming reaction. The flue gases from the furnace are emitted to the atmosphere.

This model was developed as part of the EDDiCCUT project [35], which was carried out together with partners belonging to academia and industry. The model was subjected to a process of verification by

discussing in detail the assumptions and results with industrial partners, which resulted in modifications of the original models.

2.1.4. CO₂-based methanol (CO₂-methanol)

In this route, methanol is produced via hydrogenation of CO₂ (R.9). Part of the CO₂ and hydrogen feed are consumed in a side reaction towards CO and H₂O (R.10). High selectivity is reached by recycling back to the reactor the unreacted hydrogen and CO₂.

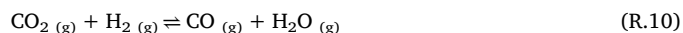
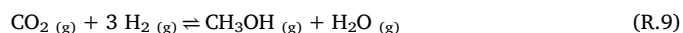

Fig. 5 shows the process modelling developed in Aspen Plus for the synthesis of CO₂-methanol. In this process model, the CO₂ stream is compressed to 78 bar in a four-stage compression train with intermediate cooling and water removal. H₂ from electrolysis at 30 bar is compressed to 78 bar and fed together with the CO₂ to the methanol synthesis reactor. The heat released in the exothermic reaction is used to pre-heat the feed stream to the reaction temperature (210 °C). After exchange heat with the feed streams, the reaction products are further cooled down to 30 °C and separated in a flash step. Unreacted hydrogen and CO₂ recovered at the top of the flash vessel are recycled to the reactor for further conversion. In a second flash step at atmospheric pressure, further gas is separated. This off gas is burned in a furnace for electricity production, which is used for feedstock compression. Water and methanol are recovered as liquids at the bottoms of the flash separation. Methanol is purified to 99.7 wt% in a distillation column (1.2 bar, 30 °C).

The model of CO₂-based methanol was also developed as part of the EDDiCCUT project [35], and verified with industrial partners.

A typical commercial-scale methanol plant has a capacity of about 450 kt/a of methanol [36], and demands about 90 kt/a of hydrogen as feedstock. To contribute to CO₂ emission reduction, the hydrogen used for CO₂-methanol synthesis must be provided from a carbon free source, such as water electrolysis using renewables [22]. However, there is a clear mismatch between the amount of hydrogen that an electrolysis plant can deliver (i.e. up to 20 kt/a, [27,30]) and the amount of hydrogen that a methanol plant demands as feedstock (i.e. 90 kt/a). Commercial-scale methanol production will require distributed electrolysis-hydrogen production with long distance transport of hydrogen to the methanol plant. However, to become a cost-effective option, the hydrogen needed for methanol synthesis should be produced on-site [7]. Another option to produce the amount of hydrogen needed for commercial-scale methanol production is to have several large-scale dedicated electrolysis plants on-site. However, this also raises economic challenges because electrolyzers are modular equipment and therefore they do not benefit from economies of scale. Following a conservative approach, the modelling choice in this study is to establish the capacity of the methanol process based on the amount of carbon-free hydrogen available from one large-scale electrolysis plant (Section 2.1.2).

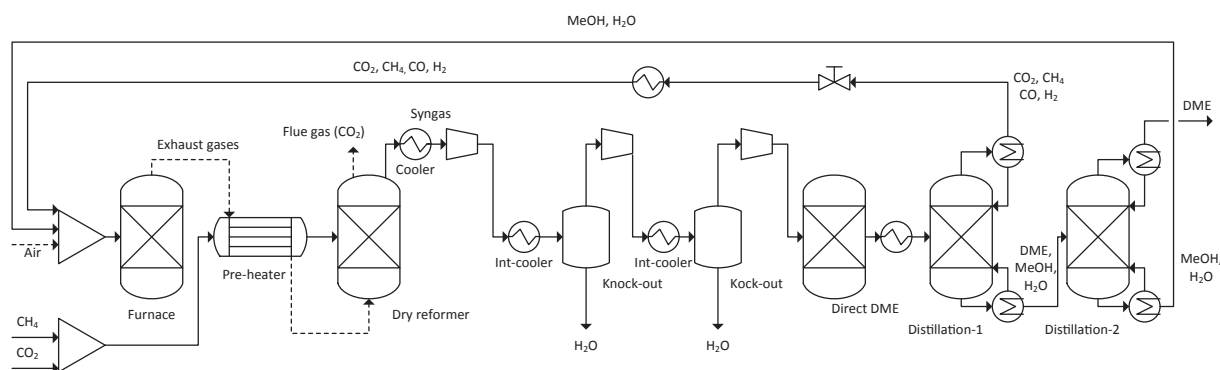

Fig. 4. CO₂-DME production process. Process model developed in Aspen Plus [32].

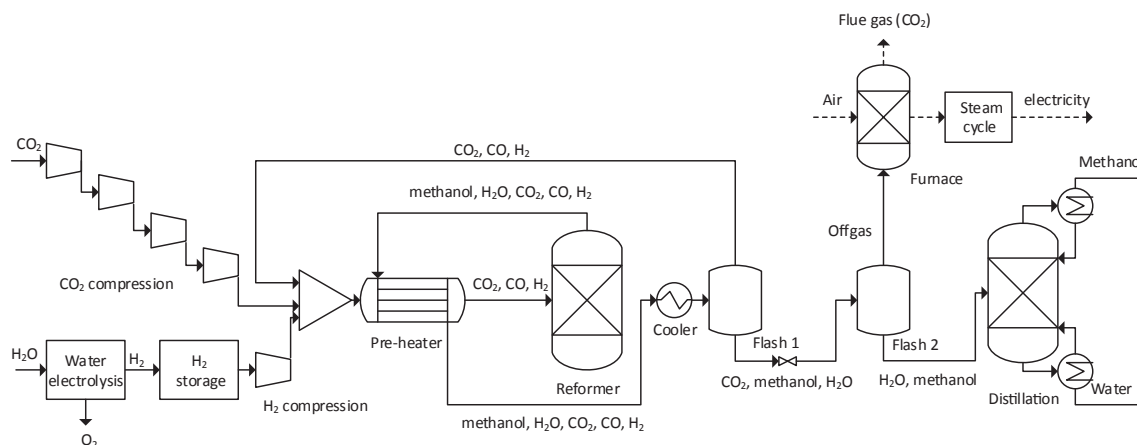

Fig. 5. CO₂-methanol production process. Process model developed in Aspen Plus.

Assuming that the electrolysis plant has the largest reported capacity (125 MW, 20 kt/a [27]), a methanol plant of 102 kt/a is modelled.

2.2. Economic assessment

The production costs per GJ of fuel output are estimated as the sum of the annualised capital expenditure (Capex), the operational expenditure (Opex) plus a tax from the CO₂ emission (including the direct emission during the fuel production process and the end-of-life emission):

$$\text{Fuel production costs} = \text{Annualised Capex} + \text{Opex} + \text{tax CO}_2 \text{ emission} \quad (1)$$

Capex estimates for chemical process plants are often based on the purchase equipment cost (PEC) of the major equipment items required for the process. In this study, equipment sizes and process conditions from the technical models developed in Aspen Plus are the basis to estimate the PEC, which is calculated using the Aspen Capital Cost Estimator software. The contribution of each of the other costs to the Capex is calculated by multiplying the PEC by an appropriate factor (i.e. the factorial method of cost estimation, [37]). These factors are based on the process industry experience and take into account typical contributions of the installation of equipment costs, the costs of design, engineering, contractor's fee or project contingency costs. The factorial method is here implemented using factors reported in chemical engineering design literature [37]. Specific factors used in this study are in the SI.2. The Capex is annualised assuming a plant lifetime (n) of 25 years and a discount rate (d) of 7.5% [38]:

$$\text{Annualised Capex} = \frac{d * (1 + d)^n}{(1 + d)^n - 1} * \text{Capex} \quad (2)$$

Electrolysers are not typical equipment of the chemical process industry and therefore Aspen Capital Cost Estimator is not used in the estimation of their costs. For the large-scale electrolysers for hydrogen production, an investment cost of 1200 €/kW and an operational lifetime of 15 years are assumed [39].

The Opex is the second component of the fuel production costs, and includes the costs of raw materials, utilities, labour and other cost items such as maintenance, plant overheads or capital charges:

$$\text{Opex} = \text{Rawmaterials} + \text{Utilities} + \text{Labour} + \text{Rest} \quad (3)$$

Raw materials and utilities costs are estimated based on the mass and energy flows from the simulation models and the prices reported in Table 2. An explanation to the choice of these values and a complete list of the prices of catalysts and auxiliary materials is included in the SI.2. The influence in the fuel production costs to variations of these one-point prices is explored in the discussion Section 4.1. All prices used are in €₂₀₁₅ and adjusted for inflation (HCPI, [40]). A fixed exchange rate of

Table 2

Materials and utility prices used for the baseline economic assessment. The influence in the fuel production costs to variations of these one-point prices is explored in the discussion section.

Material/utility	Unit	Price	Source
CO ₂ , as feedstock	€/2015/tonne	11.4	[44]
Natural gas	€/2015/GJ	10.8	[78]
Oxygen	€/2015/tonne	54.2	[23]
Electricity grid	€/2015/MWh	90	[79]
Electricity PV	€/2015/MWh	77.71	[80]
Cooling water	€/2015/m ³	0.03	[38]
Steam high pressure	€/2015/tonne	34.0	[38]
Steam low pressure	€/2015/tonne	27.5	[38]
Feed water	€/2015/tonne	0.8	[38]
Wastewater treatment	€/2015/m ³	1.1	[38]
Solid waste	€/2015/kg	0.04	[38]

1.1095 USD/€ [41] is used. Furthermore, it is assumed that the by-products generated (low pressure steam in SMR-H₂ and oxygen in electrolysis-H₂ routes, Section 2.1) are of enough quality to be sold without any further conditioning. The revenues obtained by selling the by-products are deducted from the total fuel production costs. Labour costs included in the Opex are calculated based on the salaries of operators and engineers in the Netherlands in 2015 [42,43], being the number of operators and engineers needed estimated in Aspen Plus based on the process flow sheet, type and pieces of equipment (SI.2). The costs of the rest of the items contributing to the Opex are estimated applying typical factors from the process industry [37]. Specific factors applied are in SI.2.

The costs of CO₂ used as feedstock for the production of the CO₂-based fuels are also part of the Opex. While all the other materials and utilities prices can be obtained from literature and statistics (Table 2), estimating the price of CO₂ utilised as feedstock is not straightforward because processes utilising CO₂ as feedstock are still under development. The price of bulk CO₂ is typically agreed through private negotiations between parties and in general it is not publically available [44]. The price of CO₂ used as feedstock in the baseline is assumed at the average of reported market prices (11.4 €/tonne, being the range of reported values 2.3–19.5 €/tonne CO₂, [44]). These CO₂ market prices do not include the costs of carbon capture neither carbon taxes but typically they include the costs of CO₂ transportation.

The CO₂ source (for instance, a power plant) is outside the CO₂-fuel system boundaries in the baseline analysis (Fig. 2). The baseline assumes that the power plant pays for the capture of waste CO₂ to reduce its emission and obtains revenues from selling this CO₂. Large-scale facilities such as power plants that install a capture unit are probable price-takers in the market for CO₂, particularly when there is a carbon

tax on emissions [44]. However, leaving the capture unit outside the CO₂-fuel system boundaries in the baseline is a debatable choice. CO₂ is needed for the synthesis of DME and methanol, which in turn can provide revenues to the fuel producer when they are sold as transportation fuels. Therefore, it can be argued that the fuel producer is interested in making the effort to capture CO₂, and therefore should pay for the capture costs. The effect of shifting boundaries including the capture unit inside the CO₂-fuel system, and therefore shifting the capture unit costs to the CO₂-based fuel is explored in the discussion Section 4.1.

The third component of the fuel production costs (next to Capex and Opex) is the tax from the CO₂ emission. These are the direct emissions during the fuel production process (result of the technical modelling) and the emissions at the end-of-life (based on combustion reactions). The current emission allowance price (8.15 €/tonne CO₂ emitted; [45]) is used as CO₂ tax price in the baseline calculation. However, CO₂ tax prices are expected to increase in the future as a consequence of more rigid policy scenarios [46]. The effect of higher CO₂ emission tax to the fuel production costs is studied in the discussion Section 4.1.

2.3. Environmental assessment

Ex-ante life cycle assessment (LCA) is carried out according to ISO 14040-14044 standards [47,48]. The goals of the LCA are to compare the relative environmental performance of the CO₂-fuels and hydrogen and to investigate their potential to offer low-carbon intensities in the transport sector. The functional unit selected is the energy content of each fuel, i.e. 1 GJ of fuel produced. The scope is defined from cradle-to-factory gate plus end-of-life phase (see Section 2.3.1). A life cycle inventory is derived from the mass and energy balances of the technical process modelling (SI.4). The background data are taken from the *ecoinvent* v3.3 database [49], being the choices documented in the SI.3. Current technology level is used for the background technological coverage [49]. For the four product systems studied, global warming potential (GWP) [50] and non-renewable energy use (NREU) [51] are estimated.

Similarly as applied within the economic assessment, it is assumed that the by-products generated are of enough quality to be used without any further processing. Therefore the environmental impacts that would have arisen from their production are considered as environmental credits and directly deducted from the GWP and NREU. Impacts of chemical plant infrastructure are excluded from the analysis because they typically represent a minor share [52]. However, for the case of hydrogen production via electrolysis using PV, the impact from the manufacture of PV infrastructure may be significant [53]. The effect of including PV infrastructure impacts is therefore explored in the discussion Section 4.2. Due to lack of data, the impact of the electrolyser infrastructure is not taken into account in the environmental assessment.

2.3.1. Methodological choices for the carbon footprint assessment of CO₂-based fuels

The assessment of the carbon footprint of CO₂-based fuels is not straightforward. The partitioning of the carbon credit and the end-of-life carbon emission burden when the lifetime of the carbon is extended has been debated for long time when modelling the carbon footprint of recycled products. However, life cycle assessment (LCA) practitioners and its stakeholders have still not found a clear agreement [54,55].

The most common practice in assessing recycle products is to apply the so-called “cut-off” approach ([51]; e.g. paper and aluminium recycling, [56,57] production of bioethanol from waste paper, [58]). In the “cut-off” approach, the first and second lives are treated as separated product systems with their own boundaries and do not interact (Fig. 2). Studies on CO₂ utilisation products typically implemented this “cut-off” approach (e.g. production of calcium carbonate, [59] production of formic acid, [22]; production of methanol, [23]). When “cut-

off” is applied, the impact of capturing the carbon used as feedstock is allocated to the CO₂ source (e.g. a power plant). CO₂ available to produce fuels is free of environmental burdens. Furthermore, when “cut-off” is applied the first life does not receive any credit for re-using the “waste” CO₂ [60]. Former research (see Table 1) has frequently assumed that the CO₂ utilisation product receives a carbon credit for the CO₂ stored in the product but has not considered the end-of-life emission, which can lead to inconsistency in the results.

For the assessment of the carbon footprint of CO₂-based fuels in the baseline of this study the conventional “cut-off” approach is selected. In addition, it is assumed that the CO₂-based fuels receive the carbon credit from the carbon (temporarily) stored in the fuels, as commonly done in the assessment of CO₂ utilisation technologies (e.g. [20,21,59]). In contrast to previous research on CO₂ utilisation technologies, the emission from the end-of-life is taken into account in the present study. Following the “cut-off” approach, the baseline considers that the entire carbon burden from the end-of-life emission (fuel combustion) is allocated to the CO₂-fuel.

The common practice of earlier studies on CO₂ utilisation products is subjected to discussion, explained as follows:

- Allocating the impact of CO₂ capture to the first life is a consequence of the common “cut-off” approach. However, the installation of a capture unit is needed to obtain the CO₂ used as feedstock in the synthesis of CO₂-based fuels. Therefore, it can be sustained that the CO₂-fuel producer is pleased to make the effort to capture CO₂, and thus the capture impacts should be allocated to the CO₂-based fuel.
- The usual assumption that CO₂-based fuels receive a carbon credit from the carbon (temporarily) stored in the fuels is controversial. On the one hand, it follows “carbon removal” defined by PAS 2050 [61], if CO₂ is considered a “waste”; this is also in line with the argument that the physical flow of the carbon stays in the technosphere (i.e. the carbon is not emitted to the environment). On the other hand, this decision is inconsistent with the “cut-off” approach, where the physical flow of carbon should also be cut-off. A further argument of this inconsistency could be seen from the assumption that the impact of CO₂ capture is allocated to the first life. When a power plant installs a capture unit to lower its CO₂ emission, it is supposed to benefit from the no-CO₂-emission, power production. If the CO₂ credit is also attributed to the fuels, the credit is actually double counted. Double counting is a frequent error in modelling of recycled products [19,54].
- By utilising CO₂, it is possible to retain carbon within a cycle. However, neglecting the end-of-life emission in the assessment of CO₂-based fuels can be questioned because of the short lifetime of fuels. CO₂ is almost immediately re-emitted to the atmosphere, when the fuels are combusted in the engine of the car.

Variations of these methodological decisions could substantially affect the final carbon performance of the CO₂-based fuels studied. To assess the second goal of this paper, different approaches related to carbon accounting and their influence on the carbon footprint of CO₂-based fuels are investigated in the discussion Section 4.2. Briefly described here (this is more elaborated in Section 4.2), the different approaches investigated include:

- The CO₂-fuel system boundary is shifted and contains the CO₂ capture. Thus, the capture unit impacts are allocated to the CO₂-based fuel.
- The carbon credits are allocated to the first life (a power plant). Thus, the CO₂-fuel does not receive any carbon credit.
- The end-of-life burden is shared between the first life (power plant) and the second life (CO₂-fuel) because the CO₂ source is the first life.
- A “system expansion” approach is applied. The power plant, the CO₂ capture unit and the CO₂-fuel are included inside the system boundaries. With the “system expansion” approach, allocation of carbon credits, capture unit impacts and end-of-life burden is avoided.

Table 3
Mass and energy balances per GJ fuel delivered at gate.

Parameter	Units	SMR-H ₂	electrolysis-H ₂	CO ₂ -DME	CO ₂ -methanol
Output capacity	GJ _{LHV} /a	7.1·10 ⁶	2.5·10 ⁶	5.4·10 ⁶	2.1·10 ⁶
By-product Oxygen	kg/GJ	0	66.6	0	80.2
By-product steam, LP	GJ/GJ	0.3	–	0.007	0.2
Input materials					
Steam HP, as feedstock	kg/GJ	85.1	–	–	–
Natural gas, as feedstock	kg/GJ	25.9	–	22.2	–
Water, as feedstock	kg/GJ	–	93.6	–	112.8
CO ₂ , as feedstock	kg/GJ	–	–	60.8	73.0
Other materials ^a	kg/GJ	0.03	–	0.0003	0.004
Input energy					
Electricity grid	kWh/GJ	0.6	–	28	7
Electricity PV	kWh/GJ	–	479	–	397
Boiling water	m ³ /GJ	0.098	–	–	–
Natural gas fuel	GJ/GJ	0.2	–	–	–
Cooling water	m ³ /GJ	1.5	–	2.7	3.5
Refrigerant	kg/GJ	–	–	3·10 ^{−6}	–
Direct emission and process waste					
CO ₂ direct emission	kg/GJ	73.5	0	55.5	5.1
Wastewater treatment	m ³ /GJ	0.04	0.02	0.001	0.03
Solid waste to landfill	kg/GJ	0.03	–	0.0003	0.004

^a Other materials: Catalysts; catalysts and zeolite in SMR-H₂; HP: high pressure; LHV: low heating value; LP: low pressure

3. Results

3.1. Technical process modelling

Table 3 shows the output capacity (GJ/a) and the mass and energy balances per GJ of fuel delivered at the plant gate of the four fuel technologies, resulting from the process modelling. The process output capacity in energy terms (GJ/a) of electrolysis-H₂ and CO₂-methanol are about half of the output capacity of CO₂-DME and one third of the output capacity of SMR-H₂ (see Section 2.1 for details on each process output capacity). Larger systems are probably more efficient, i.e. they consume lower amounts of input material and energy per GJ, which could have a positive impact in their economic and environmental performance (economic and environmental assessment results are presented in Sections 3.2 and 3.3). Nonetheless, in the case of electrolysis-H₂ and CO₂-methanol the main input material is water and the main energy input is electricity from PV using renewable energy. In contrast, SMR-H₂ and CO₂-DME are based on fossil resources, i.e. natural gas is used as feedstock in both processes.

A significant difference between the four processes is the amount of electricity from the grid used. CO₂-DME shows four times higher electricity demand than CO₂-methanol, even when both processes require high pressure for the synthesis reaction (79 bar and 78 bar, respectively). The reasons are the larger volumetric gas flow that needs to be compressed in the CO₂-DME process and onsite electricity production after burning off gas in the CO₂-methanol process, which partially covers the electricity demand for CO₂-methanol production. Most important, the CO₂ direct emission substantially differs in the four alternative fuels investigated. The direct CO₂-emission in the production of SMR-H₂ and CO₂-DME is more than ten times the direct CO₂-emission in CO₂-methanol. CO₂ is emitted in SMR-H₂ and CO₂-DME processes after burning off gases for heat recovery (Figs. 3 and 4).

3.2. Economic assessment

Fuel production costs per GJ of fuel delivered at the plant gate are shown in Table 4. SMR-H₂ and CO₂-DME have comparable costs. From an economic perspective, CO₂-DME could be considered a promising CO₂-fuel route. In contrast, the fuel production costs of electrolysis-H₂ and CO₂-methanol are more than twofold the costs of SMR-H₂. The CO₂-methanol route has the highest costs because it uses electrolysis-H₂ as feedstock to convert CO₂ to methanol. After hydrogen production via electrolysis, the

Table 4

Production costs per GJ fuel delivered at the plant gate. Capex, Opex and CO₂ emission taxes.

Parameter	Units	SMR-H ₂	electrolysis-H ₂	CO ₂ -DME	CO ₂ -methanol
Capex	€	1.9	7.5	2.1	12.9
Opex	€	23.5	48.1	23.6	72.3
CO ₂ tax, process	€	0.6	–	0.5	0.0
CO ₂ tax, end-of-life	€	–	–	0.5	0.6
Fuel production costs	€	26.0	55.6	26.3	85.8

CO₂-methanol route requires extra pieces of equipment and energy input, which increases both Capex and Opex. Fuel production costs are dominated by the Opex rather than by the Capex for all four alternatives investigated.

Fuel production costs also include taxes from the CO₂ emission. The share of the CO₂ tax to fuel production costs is irrelevant at the current tax price. Taxes from process and end-of-life emissions are < 4% of the production costs of SMR-H₂, CO₂-DME and CO₂-methanol. The International Energy Agency (IEA) estimates that the CO₂ tax price will increase if more stringent policies are implemented to achieve emissions reduction targets [46]. The influence of higher carbon tax to the fuel production costs is investigated in the discussion Section 4.1.

A breakdown of the Capex is shown in Fig. 6. The Capex of CO₂-DME is comparable to the Capex of SMR-H₂. However, the Capex of the electrolysis-H₂ technology is four times higher than the Capex of SMR-H₂ and CO₂-DME; the Capex of CO₂-methanol technology is six times higher than the Capex of SMR-H₂ and CO₂-DME. Electrolysers are the largest contributors to the Capex of the electrolysis-H₂ and CO₂-methanol processes (91% and 64%, respectively) because they are modular equipment that do not benefit from economies of scale. The value of the capital investment assumed for the electrolysers in the base case is varied in the discussion Section 4.1 to quantify its impacts to the fuel production costs. The contribution of pumps and compressors is significant to the Capex of CO₂-DME and CO₂-methanol (49% and 13%, respectively). CO₂-DME and CO₂-methanol synthesis reactions are carried out at high pressure, which requires several compressing stages.

Fig. 7 shows the breakdown of the Opex. Likewise the Capex, the Opex of CO₂-DME and SMR-H₂ are comparable; the Opex of electrolysis-H₂ is twofold the Opex of SMR-H₂ and CO₂-DME. CO₂-methanol shows the highest Opex among all alternatives studied. Electricity from photovoltaics used in water electrolysis has the highest share to the Opex of electrolysis-

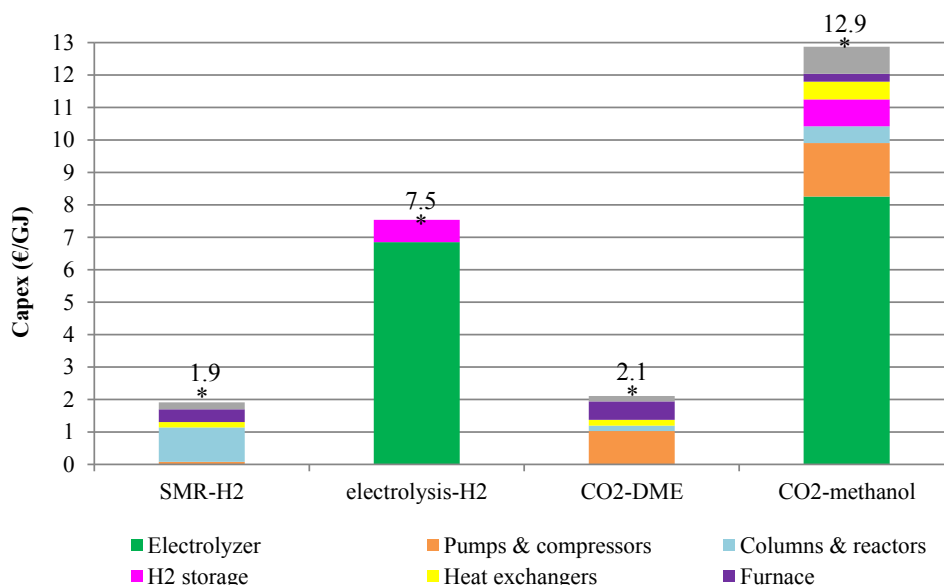

Fig. 6. Comparison of the Capex breakdown of the studied alternative fuels.

H₂ and CO₂-methanol technologies. Capital charges are other important contribution to the Opex of electrolysis-H₂ and CO₂-methanol, as a direct consequence of the high capital investment of the electrolyzers.

Natural gas used as feedstock in the synthesis of SMR-H₂ and CO₂-DME routes is the biggest contributor to the Opex of both processes. The prices of natural gas and electricity from photovoltaics are varied in the discussion Section 4.1. The contribution of CO₂ as feedstock to the production costs of CO₂-DME and CO₂-methanol is not relevant at the CO₂ feedstock price assumed in the baseline. The effect of higher CO₂ feedstock price to the production costs of the CO₂-fuels is quantified in the discussion Section 4.1.

The economic results of the present study are compared with fuel

prices from the market and the literature (a review of these fuel prices is available in SI.2).

- SMR-H₂ costs estimated in this study (26 €/GJ) are higher than the costs reported in the literature (19 €/GJ reported in [26] and expected to be stable until 2030; 19 €/GJ is also the average of the values reported in [27], being the range 18–23 €/GJ). A stand-alone hydrogen unit with heat integration inside the hydrogen unit was modelled in this study. In reality, hydrogen is produced in refineries, and benefits from process and energy integration with the rest of the operations inside the refinery. Moreover, in the economic assessment the market price of natural gas and steam feedstocks was used.

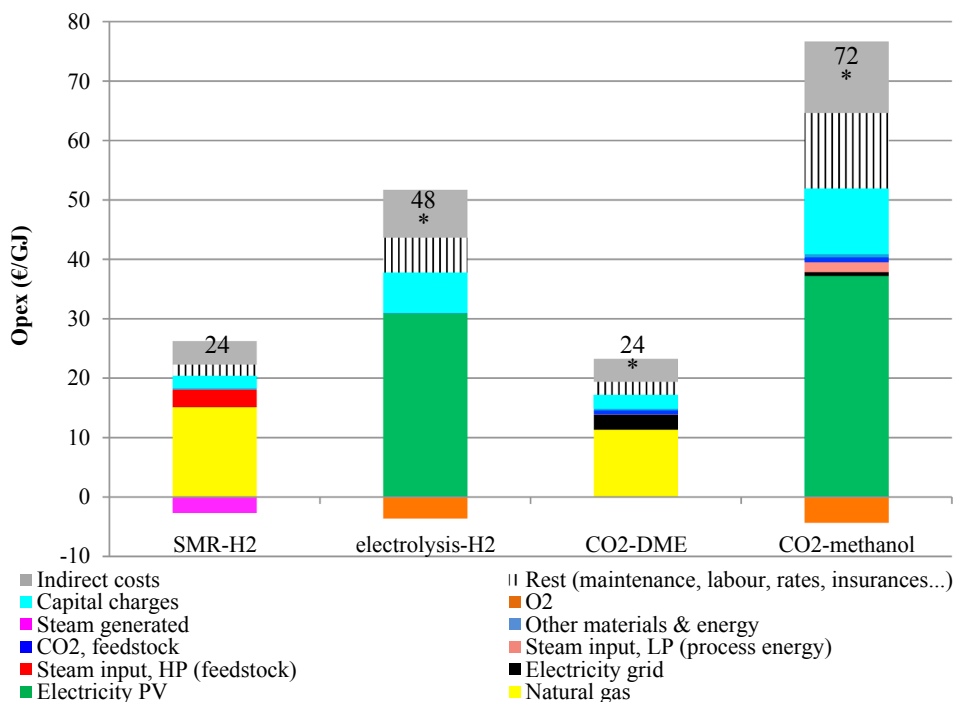
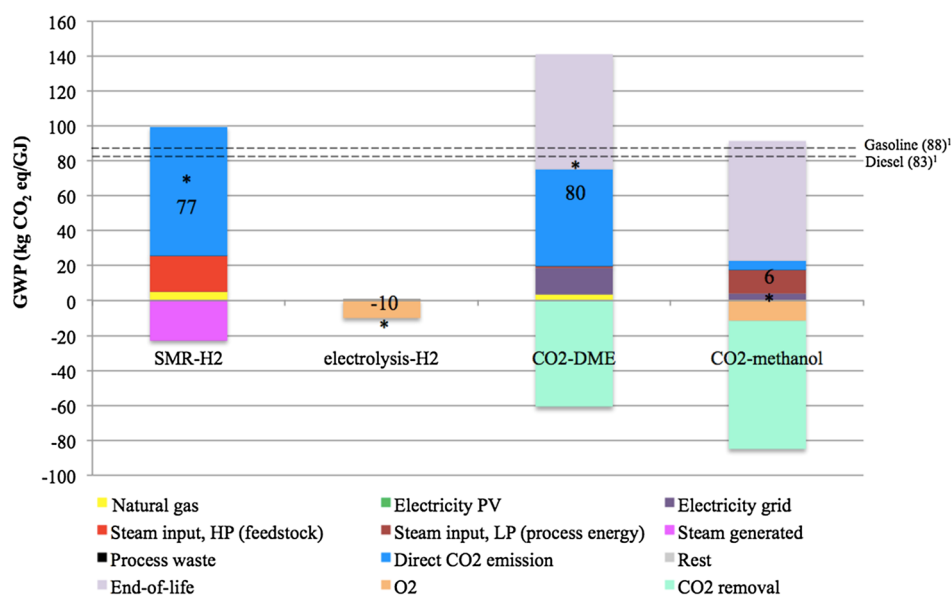

Fig. 7. Comparison of the Opex breakdown and (*) the net Opex of the studied alternative fuels. HP: High pressure; LP: Low pressure.



¹GWP of gasoline and diesel including end-of-life. Production data of gasoline and diesel taken fromecoinvent 3, end-of-life based on combustion reactions

Fig. 8. Cradle-to-factory gate plus the end-of-life phase global warming potential (GWP) of studied alternative fuels. Comparison of the GWP breakdown and (*) the net GWP. HP: High pressure; LP: Low pressure.

In a real refinery, natural gas and steam are often available based on long-term contracts at lower prices.

- For electrolysis-H₂ costs, a wide range of values is reported in the literature (35–66 €/GJ; [26,27,30]). The costs of electrolysis-H₂ estimated in the current study (56 €/GJ) are within this range, although close to the high end.
- The use of DME as fuel could replace diesel given the similarities in the characteristics of both fuels. Conventional DME and diesel market price are similar (33–40 €/GJ, [62,63]). In this study, CO₂-DME costs are estimated at 26 €/GJ. CO₂-DME can be an economically interesting alternative fuel under the baseline assumptions. The economic competitiveness of CO₂-DME could somehow be reduced at higher CO₂ feedstock and emission tax prices. The influence of CO₂ feedstock and emission tax prices to CO₂-DME production costs is quantified in the discussion Section 4.1.
- Methanol could potentially replace gasoline. Conventional methanol price is half of the gasoline price (16–22 €/GJ, [64] €/GJ [63], respectively). CO₂-methanol costs estimated in this study (86 €/GJ) are higher than gasoline price and four times the market price of conventional methanol. The reason for the high CO₂-methanol costs estimated in this study is the use of renewable hydrogen as feedstock. Synthesis of CO₂-methanol from renewable-hydrogen is not an economic viable alternative fuel at the current prices of electrolyzers and electricity from photovoltaics. The electrolyzers capital investment and PV-electricity price are varied in the discussion Section 4.1.

3.3. Environmental assessment

Fig. 8 shows a breakdown of the GWP of the four alternative fuel options investigated per GJ of fuel delivered at the factory gate plus the end-of-life phase. The results are compared with the GWP per GJ of gasoline and diesel produced and also including end-of-life emission.

From Fig. 8 it can be appreciated that in both CO₂-fuel options i.e. DME and methanol, the CO₂ removal almost equals² the CO₂ emission

² The carbon balance is closed considering that (i) in the synthesis reaction of CO₂-DME also natural gas is used, (ii) reaction efficiencies are not 100% and (iii) there is direct CO₂ emission from the process flue gases.

at the end-of-life. The direct CO₂ emission during the production process has an important share in the GWP of SMR-H₂ and CO₂-DME. The net GWP of CO₂-DME is similar to the GWP of fossil-based SMR-H₂, gasoline and diesel. From a climate change perspective, there is no advantage in introducing CO₂-DME as alternative fuel. The GWP of CO₂-methanol is less than 10% of the GWP of SMR-H₂, gasoline and diesel, but higher than the GWP of electrolysis-H₂. CO₂-methanol shows emission reduction potential compared to SMR-H₂, gasoline and diesel. However, the use of electrolysis-H₂ as fuel is preferred than further conversion of electrolysis-H₂ into methanol. Under the baseline assumptions, electrolysis-H₂ shows a negative GWP due to the credits from the generation of high quality oxygen by-product.

With the methodology used in the baseline, the CO₂-fuels are exempt from capture unit impacts, receive a credit from the carbon removals and take the burden from the end-of-life emission (see Section 2.3.1). As shown in Fig. 8, CO₂ removals and end-of-life emission are major contributors to the net carbon footprint of CO₂-DME and CO₂-methanol. Different methodological choices can therefore cause a significant variation in the carbon footprints of both CO₂-fuels. The influence of alternative approaches in open-loop³ recycling to the carbon footprint of CO₂-fuels is elaborated in the discussion Section 4.2.

Fig. 9 shows the non-renewable energy use (NREU) of the four alternative fuels investigated. The net NREU values of SMR-H₂ and CO₂-DME are almost equal to each other and higher than the NREUs of gasoline and diesel. The NREUs of SMR-H₂ and CO₂-DME are dominated by natural gas used as feedstock. Electrolysis-H₂ and CO₂-methanol have negative and nearly zero NREU, benefiting from the credit of the oxygen by-product. In terms of NREU, electrolysis-H₂ is the preferred choice.

3.4. Relative performance of alternative fuels

This paper aimed to compare the economic and environmental performance of alternative transportation fuels. Table 5 qualitatively

³ Open-loop recycling refers to those situations in which the material of the product system considered is partly or fully recycled into another product system [65].

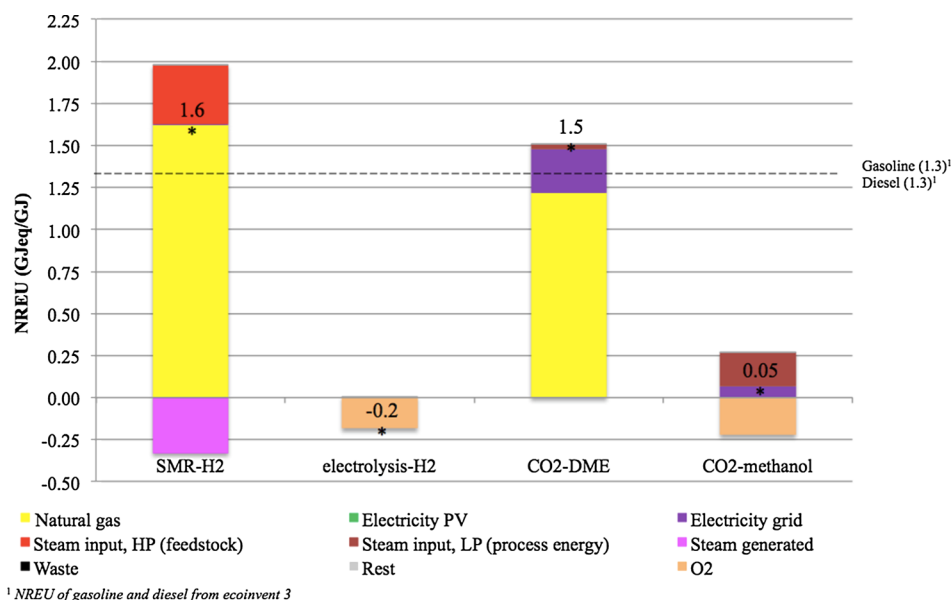

Fig. 9. Cradle-to-factory gate plus the end-of-life phase non-renewable energy use (NREU) of studied alternative fuels. Comparison of the NREU breakdown of and (*) the net NREU. HP: High pressure; LP: Low pressure.

Table 5

Assessment of alternative fuels for the transport sector in comparison to the conventional fuels gasoline and diesel. The arrows indicate an increase or decrease in the parameters compared to conventional fuels.

Parameter	Units	SMR-H ₂	electrolysis-H ₂	CO ₂ -DME	CO ₂ -methanol
Costs	€	0	↑↑	↓	↑↑↑
GWP	kg CO ₂ eq	↓	↓↓↓↓	0	↓↓↓
NREU	GJ eq	↑	↓↓↓↓	↑	↓↓↓

summarises the outcomes of the economic and environmental assessments, taking as reference conventional fuels gasoline and diesel. The arrows indicate an increase or reduction in a parameter with respect to the value of the same parameter for the conventional fuels. The number of arrows indicates the magnitude of the difference in the parameter between each alternative fuel option investigated and the conventional fuels. When there is no significant difference, a zero is given.

Table 5 shows that all systems except CO₂-DME offer GWP reduction potentials and two of them, electrolysis-H₂ and CO₂-methanol, both offer substantial NREU saving potentials. Nevertheless, there is no clear winner. From the results of this paper none of these four alternative fuel options appear as the clear replacement to gasoline and diesel. The results also indicate evident trade-offs between their economic and environmental performance, which could explain their limited potential deployment. This also could explain why the present development trend in practice bets on electricity, rather than on these alternative fuels [66–70]. Note that the focus of this paper was on the potential for decarbonisation option, measured through GWP and NREU. While the work does not only include CO₂ but also other GHG, potential trade-offs in other environmental categories (e.g., water, toxicity, raw material use) were not analysed. In this regard, more research is needed to identify and further develop alternative fuel options for the transport sector with apparent improved performance in both economic and environmental aspects than current conventional fuels.

4. Discussion

A common challenge to ex-ante analysis is the lack of high-quality data. Due to the exploratory character of this research, several assumptions were taken to develop the baseline when there was no information available. Although this increases the degree of uncertainty,

the use of data uncertain in nature is justified for the purpose of exploring new concepts, comparing different alternatives and identifying potentialities and bottlenecks of novel fuel options prior to commercialisation. In this section, the most critical assumptions are varied to understand their influence to the relative performance of the four alternative fuels studied. To address the second research goal of this study, methodological concerns related to carbon accounting in CO₂-fuels are investigated and alternative approaches are explored.

4.1. Economic sensitivity analysis: Influence of economic input parameters to fuel production costs

The energy prices, the CO₂ tax and the electrolysers costs assumed in the baseline are subjected to change with time. Moreover, the price of CO₂ used as feedstock in the CO₂-fuel systems is different when the capture unit is included inside the boundary. A sensitivity analysis of the fuel production costs is carried out varying economic input parameters (Table 6):

- Natural gas price can decrease as a consequence of the abundant production of shale gas after the emergence of new supplies. Shale gas price [71] is used for the lower range of natural gas price in this sensitivity analysis. However, natural gas price can also very well increase. Industrial natural gas prices reported by IEA from 2009 were reviewed (SI.2). This review shows a difference of 30% between the highest and lowest prices. Thus, for the high range of the sensitivity analysis, the natural gas price is set at +30% relative to the value assumed in the baseline.

Table 6

Sensitivity analysis to economic input parameters. Range of values used.

Parameter	Units	Baseline value	Low range sensitivity	High range sensitivity
Natural gas price	€/GJ	10.8	3.7	14.1
Electricity grid price	€/MWh	90.0	63.0	152
Electricity PV price	€/MWh	77.7	20.0	–
Electrolyser investment costs	ME	150	105	225
CO ₂ tax	€/tonne CO ₂	8.15	–	45.0
CO ₂ , feedstock price	€/tonne CO ₂	11.4	2.3	52.8

- Electricity price increases about 60–80% when CCS is applied to all power plants. An average of the increase in costs of different power plants including CCS [72] is used as high range value for the sensitivity analysis. A review of the electricity price for industry shows a variability of 30% since 2009 (SI.2). The low range value of the sensitivity analysis for the price of the electricity from the grid is fixed at -30% of the value used in the baseline.
- Previous prospective studies indicate that the price of electricity from photovoltaics will decrease very fast. A review of PV-electricity prices in 2015 and projected prices until 2050 is included in SI.2. A value of 20 €/MWh of PV-electricity is used in the sensitivity analysis to account for the reduction in PV-electricity price for large-scale industrial use in 2050⁴ [73].
- The high Capex of electrolysis-H₂ and CO₂-methanol processes is due to the investment costs of the electrolyzers. The value assumed for the investment of the electrolyzers is varied in the sensitivity analysis by -30%/+50% because this is the inaccuracy range of the value used in the base case [74].
- CO₂ tax price is expected to increase in the future as a consequence of more strict policy scenarios [46]. In addition to CO₂ tax schemes already in place, the IEA “New Policies Scenario” includes the introduction of new carbon pricing instruments where these have been announced but not yet introduced. The CO₂ tax price estimated for Europe in 2040 in the IEA “New Policies Scenario” [46] is used in this sensitivity analysis.
- In the baseline, CO₂ capture is outside the CO₂-fuel system boundaries. It is assumed that the CO₂ feedstock required for the synthesis of DME and methanol is bought at the average market price. However, the prospect is that the market price for CO₂ will decrease due to the likelihood of a growing global CO₂ supply surplus as the carbon tax increases with strict emission regulation [44]. The lowest reported value for CO₂ market price is used as low range value in the sensitivity analysis.
- When the CO₂-fuel system boundaries are shifted and include the capture unit, capture costs are also shifted and allocated to the CO₂-fuel. The costs of CO₂ capture vary from 28 to 109 €/tonne CO₂ depending on the type of power plant and the technology applied. The average of CO₂ capture costs included in an exhaustive report on CCS demonstration projects that utilises data provided by the industrial and utility members of the Zero Emission Platform [75] is selected as high range value for the price of CO₂ as feedstock.

The sensitivity of fuel production costs to variations of economic input parameters is shown in Fig. 10 (see SI.5 for complete results). Electrolysis-H₂ could become an economically plausible fuel alternative, given that PV-electricity prices decrease as expected. Lower electrolysis-H₂ costs are also achieved at reduced electrolyzers investment costs. CO₂-methanol fuel production costs are also sensitive to PV-electricity price and electrolyser investment costs. However, even at the at the lowest PV-electricity price and electrolyser costs assumed in this sensitivity, the production costs of CO₂-methanol are two to three times higher than the costs estimated for SMR-H₂ and CO₂-DME in the baseline. CO₂-DME production costs grow to 29 €/GJ when the capture unit is inside the CO₂-fuel system boundaries and to 31 €/GJ when the CO₂ tax increases to 45 €/tonne CO₂. Shifting capture costs to the CO₂-fuel or higher CO₂ taxes in the future do not play a role in the economic

⁴ Scenario developed with a wide range of experts in three workshops. Estimation based on: large-scale, ground mounted systems (> 100 MWp); 5% (real) weighted average cost of capital; duplication of module efficiency (35%) and largely PV-based energy system (PV provides 40% of global electricity demand) in 2050. This is considered a conservative scenario of future cost for PV electricity because it is based on crystalline silicon technology, which is currently the most widely deployed technology in terms of installed capacity. Possible technological breakthroughs in other solar photovoltaic technologies might lead to lower cost.

competitiveness of CO₂-DME because its production costs remain lower than the range of conventional DME and diesel market prices (33–40 €/GJ, [62–63]). The rest of the parameters investigated in the sensitivity analysis do not show a noteworthy influence to the production costs of any of the alternative fuels included in this study.

4.2. Environmental assessment discussion. Influence of alternative approaches in open-loop recycling to the carbon footprint of CO₂-based fuels

The conventional “cut-off” applied in the baseline environmental assessment derives into allocation issues, and the choices made for the baseline can be challenged (see Section 2.3.1). In this section, the second research goal of this study is addressed by discussing three methodological concerns when estimating the carbon footprint of CO₂-fuels:

- is it justified to include the carbon credit in the GWP of the CO₂-fuel?
- how to allocate the impacts of the carbon capture unit between the power plant and the CO₂-fuel?
- how to allocate the end-of-life burden between the power plant and the CO₂-fuel?

To investigate the influence of different approaches in open-loop recycling, the GWP of electricity production at a power plant with CO₂ capture (first life) and the GWP of CO₂-methanol (second life) are estimated. A “system expansion” approach is here used to understand the consequences of the introduced changes. With system expansion, the two life cycles are included inside one system. Thus, the functional unit following “system expansion” includes the two products of the system. For this exercise, the functional unit is defined as 1 GJ of CO₂-methanol plus 0.3 GJ of electricity production. The definition of the functional unit is based on the amount of CO₂ needed to produce 1 GJ of methanol (73 kg CO₂ as feedstock, Table 2). This amount of CO₂ can be captured during the production of 0.3 GJ of electricity at a power plant (based on the models of [76]).

Fig. 11 depicts a scheme of the entire system including 0.3 GJ of electricity produced at the power plant, the capture unit, 1 GJ of CO₂-methanol production and the end-of-life emission. Fig. 11 outlines possible allocation approaches inside the individual product systems, i.e. electricity production at the power plant and CO₂-methanol production. Capture impacts, carbon credits and end-of-life burden could be distributed between the first and second lives as follows:

- A. The power plant makes the effort to capture CO₂ with the goal to reduce its emission. The impacts of the capture unit are allocated to the power plant and hence, it benefits from the carbon credit. Compared to the baseline, CO₂-methanol does not benefit from any carbon credit. Besides, approach A assumes that the power plant disengages after providing the CO₂ to the fuel producer. Thus, the CO₂-methanol producer is responsible for any emission that occurs downstream the capture unit at the power plant. The entire end-of-life burden is allocated to CO₂-methanol.
- B. The CO₂-methanol producer makes the effort to capture CO₂ because it is needed as feedstock for methanol synthesis. Thus, the capture unit is included inside the boundaries of the CO₂-methanol system. The impacts of the capture unit are allocated to CO₂-methanol, and also the carbon credit. The burden from the CO₂ emitted at the end-of-life is also allocated to CO₂-methanol because the fuel producer enjoyed the use of CO₂ as feedstock.
- C. The effort of capturing CO₂ is shared between the power plant and the CO₂-methanol producer. The impacts of the capture unit and the carbon credit are therefore distributed between both. The end-of-life burden is also shared because the CO₂ source is the power plant and the CO₂ is used in fuel production. It is here arbitrarily assumed that the capture unit impact, the carbon credit and the end-of-life burden

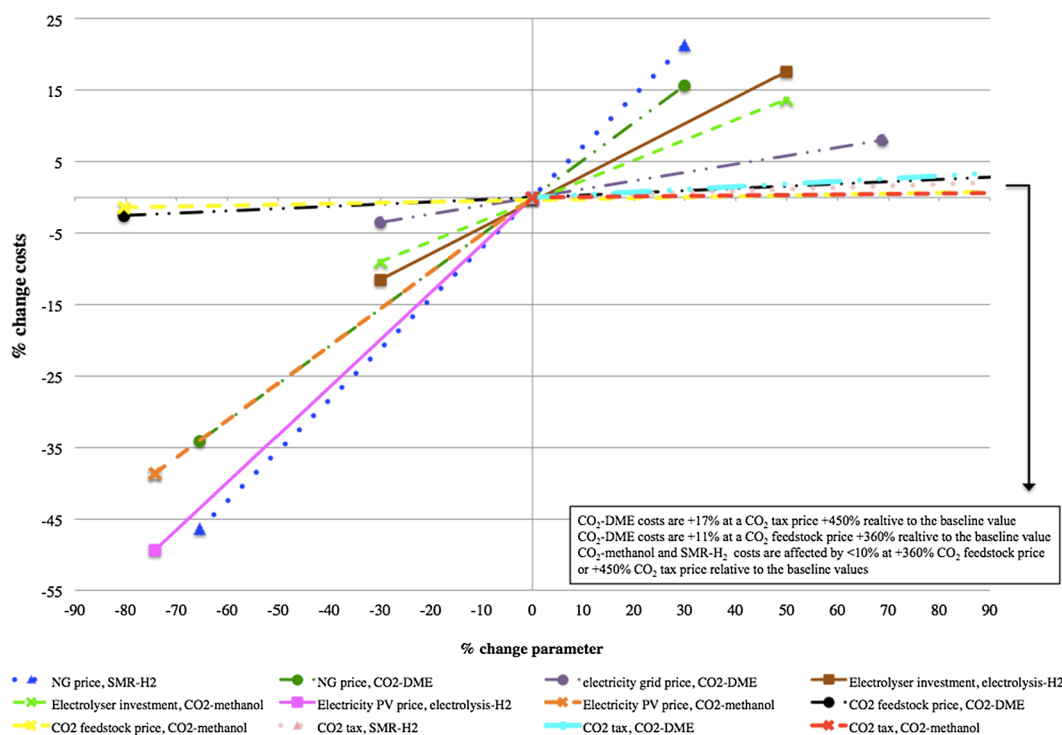

Fig. 10. Influence of the economic input parameters to fuel production costs.

are equally shared. Thus, an allocation factor of 50% is used.

To contextualize the results of this exercise, the GWP of the baseline and approaches A, B and C are compared to the GWP of business-as-usual over the full life cycle, i.e. electricity production without carbon capture and gasoline production. In addition, the results are also compared to the GWP of electricity production at a power plant with CCS and gasoline production. For consistency, the same functional unit is used, i.e. 0.3 GJ of electricity (with and without CCS) and 1 GJ of fuel (gasoline). The end-of-life emission from gasoline combustion is also taken into account in the analysis. Full details of this exercise are described in the SI.5.

The results of this exercise are shown in Fig. 12. At first glance, it can be seen that the total carbon footprint for the entire system (power with CO₂ capture and CO₂-methanol) is the same regardless the approach taken (baseline, A, B or C). However, different approaches for the allocation of the capture unit impact, carbon credits and end-of-life burden between the first and second life products significantly influence the individual carbon footprints (power or CO₂-methanol):

BASELINE. Allocation of carbon credits to the CO₂-fuel in the baseline inevitably derives into either double counting or into higher carbon burden upstream. Double counting is a common error when modelling recycled products [54], and lacks of logic from a physical point of view. There is only one CO₂ stream and therefore it cannot be removed twice, once by the power plant and once by the CO₂-fuel producer. Since double counting cannot be justified, under the baseline assumptions the power plant makes the effort to capture CO₂ but it cannot benefit from the no-CO₂-emission power production (because the credit has been assigned to the CO₂-fuel). This would most likely not be accepted by the power plant.

A. From a power plant perspective, it is reasonable to benefit from the carbon credit because it is the one making the effort of capturing CO₂. Compared to the baseline, the GWP of CO₂-methanol increases when it does not benefit from the carbon credit and covers the entire end-of-life burden. The GWP of CO₂-methanol following this approach is similar to the GWP of gasoline.

B. From a CO₂-fuel producer standpoint, it would be preferable to accept the capture unit impact but be eligible to benefit from the carbon credit. The GWP of CO₂-methanol would be higher than in the baseline but lower than following approach A.

C. When the power plant and the CO₂-fuel are both responsible of the carbon credit and burdens, the GWP of CO₂-methanol increases respect to the baseline but lowers relative to approaches A and B.

Furthermore, Fig. 12 shows that a system including power plus CO₂-methanol production (baseline, A, B and C) provides 42% emission reduction compared to business-as-usual, i.e. power without CO₂ capture plus gasoline production. Compared to power with CCS plus gasoline, the CO₂-to-methanol system provides small emission reduction (−8%), which might be overcome by the uncertainty in the analysis. Note that these results are obtained excluding the impacts of PV infrastructure, as in the baseline the impact of the infrastructure for the rest of the processes was also excluded (Section 2.3). However, Fig. 12 indicates that the GWP of CO₂-methanol is highly sensitive to including the impacts of PV infrastructure.

When PV infrastructure impacts are taken into account, the CO₂-to-methanol system shows only 14% emission reduction compared to business-as-usual, and 35% higher emissions compared to power with CCS plus gasoline. This large variation is due to the indirect emissions related to the production of PV panels. The electricity supply option assumed for PV production has been already identified as the most influential parameter to the carbon footprint of PV-electricity, followed by the heat input (Reich et al., 2011). The carbon footprint of PV-electricity has a range of 0.06–200 gCO₂eq/kWh depending on whether the electricity input in PV production is based on renewables or fossil fuels, and the heat input is obtained from combustion of fossil fuels [84]. Other studies (e.g. [53]) estimate that the carbon intensity of PV-electricity varies from 20 to 40 gCO₂eq/kWh when PV panels are produced in Europe to 80 gCO₂eq/kWh when they are produced in a coal-dominated economy like China. To investigate the influence of including the impacts of PV infrastructure in the analysis (dashed squares in Fig. 12), a value of 100 gCO₂eq/kWh PV-electricity produced in the Netherlands including infrastructure was considered [49], which

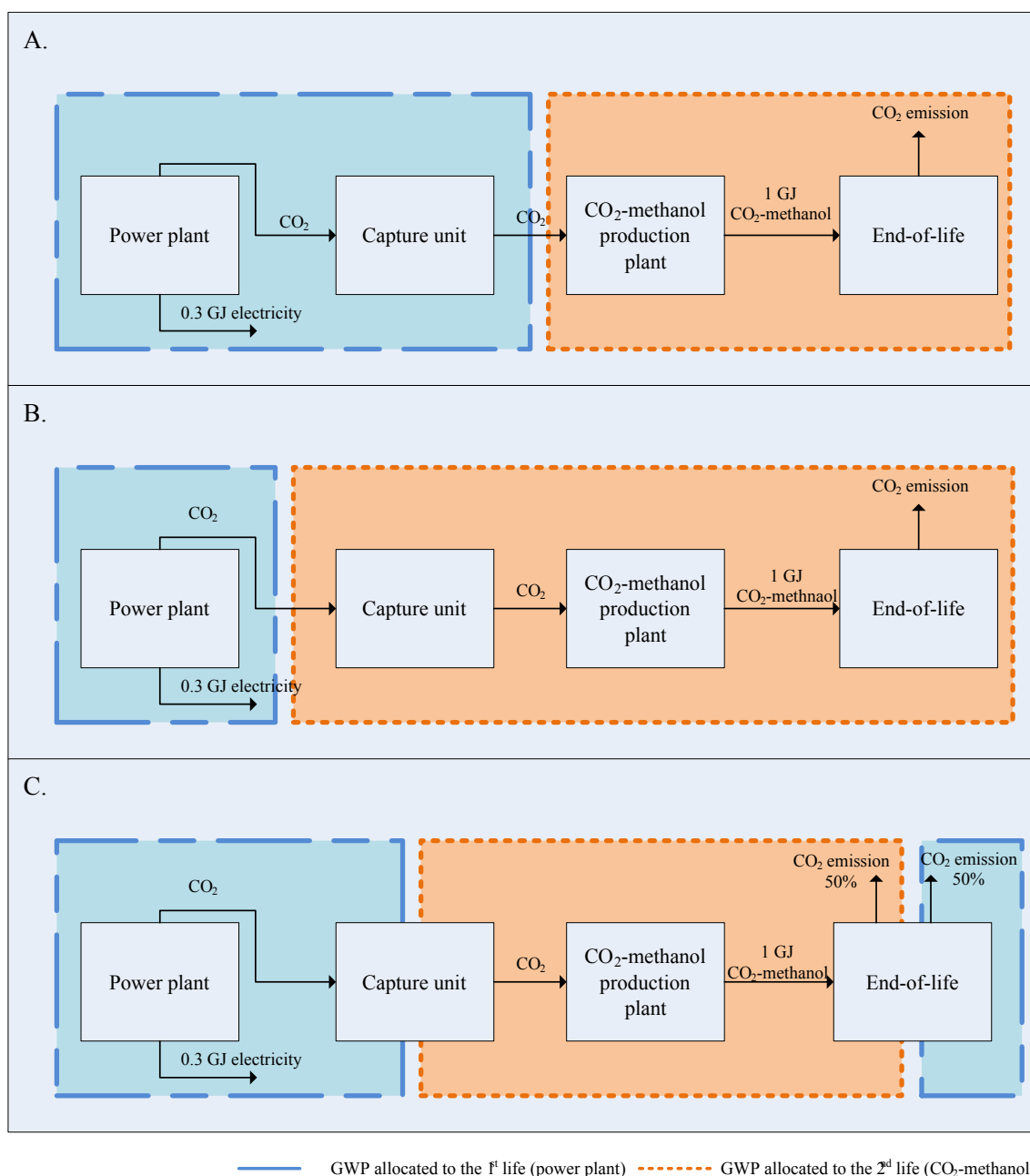

Fig. 11. “System expansion” including electricity production at a power plant (first life), CO₂ capture unit, CO₂ utilisation in methanol synthesis (second life) and end-of-life emission. Functional unit: 0.3 GJ of electricity plus 1 GJ of CO₂-methanol. Alternative approaches inside individual product systems in open-loop recycling: (A) capture impacts and carbon credit allocated to the power plant. End-of-life burden allocated to CO₂-methanol; (B) capture unit impacts, carbon credit and end-of-life burden allocated to the CO₂-methanol; (C) shared capture unit impacts, carbon credit and end-of-life burden between the power plant and CO₂-methanol.

falls within the ranges reported in the literature. PV panels used in the Netherlands (geographical scope assumed for this study) are mainly manufactured in energy-intensive processes in China using hard coal electricity and heat [49]. Note that the effect of incorporating PV infrastructure impacts to the GWP of CO₂-methanol could be minor at other locations when using cleaner electricity and heat sources.

Finally, it is important to mention that this exercise was carried out using the CO₂-methanol route. CO₂-DME has substantially higher carbon footprint than CO₂-methanol and similar to diesel (Fig. 8). Therefore, under the assumptions taken in this study, a system including power and CO₂-DME production has 2% higher emissions than business-as-usual (electricity plus diesel), and 56% higher emissions than power with CCS plus diesel (full results are in SI.5).

The benefits and drawbacks of the different allocation approaches (Fig. 11) can be exploited by stakeholders to fit different purposes. For instance:

- From a CO₂-utilisation developer’s perspective, the priority is to reduce the carbon footprint of the CO₂-fuel technology. The “cut-off” approach corresponds to the business boundary. It focuses on the CO₂-fuel product system, does not require data outside the CO₂-fuel production process itself, and it can be easily implemented and communicated. However, it simplifies open-loop allocation issues, especially overlooking the implications to the first life (e.g. where and how CO₂ is captured). In this exercise, CO₂-methanol technology innovation will be promoted following the baseline and

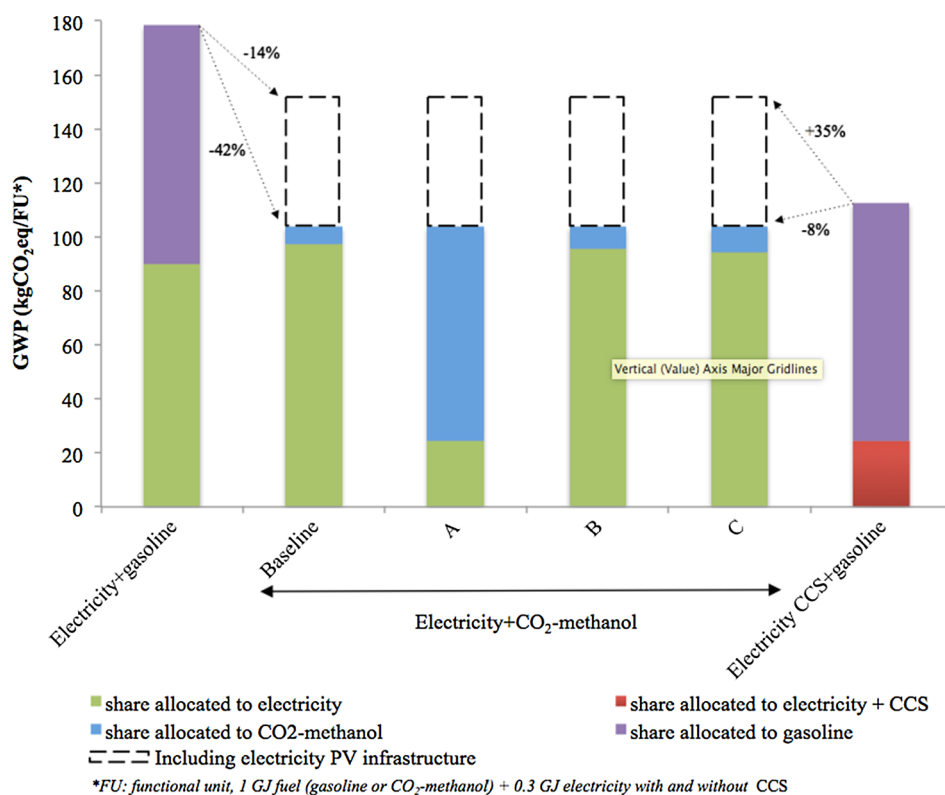

Fig. 12. Cradle to grave GWP of 0.3 GJ electricity and 1GJ CO₂-methanol transportation fuel. Comparing the CO₂ utilisation cases including the baseline and approaches A, B, C, with two reference cases without CO₂ utilisation. The GWP of the CO₂ utilisation cases is estimated both excluding and including the impacts of PV infrastructure.

approaches B and C, but not under approach A because it has a GWP similar to the GWP of gasoline.

- From a policy maker's perspective, the ultimate goal is overall emission reduction. Existing trading schemes use principles are analogous to the “cut-off” approach. Emissions are recorded from individual producers and consequently responsibilities are particularly assigned. In a “system expansion” approach, the entire value chain is considered and therefore the efficiency of the overall emission reduction can be analysed. In the CO₂-to-methanol system, the overall emission is reduced compared to business-as-usual but it is similar to the reduction achieved by applying CCS and keeping gasoline as standard transportation fuel. As a major downside, implementation of the “system expansion” method in a policy context is not straightforward since it requires data from outside the business boundaries and therefore cooperation between different sectors. Nevertheless, the use of comparisons at system level in the development of environmental policy strategies is here suggested.
- From the LCA community's perspective, this exercise highlights that the common practice in the assessment of CO₂ utilisation systems should be carefully examined. The “system expansion” is recommended by the environmental specification PAS 2050 [61], ILCD Handbook [54] or PEF guide [65]. With “system expansion”, the entire system (power plant, capture unit, CO₂ fuel production and end-of-life) is taken into account in the carbon accounting, thus the full carbon cycle is assessed. The use of the “system expansion” method in open-loop recycling is here encouraged, as it follows a life-cycle-thinking perspective, avoids allocation issues raised when applying “cut-off” and allows quantifying the real environmental gains or impacts of incorporating utilisation options to established systems.

4.3. Limitations and recommendations for further research

The results of this study serve as a preliminary indication of the feasibility of alternative fuels with prospects for low carbon intensities and help understanding their relative economic and environmental

performance. Nevertheless, the following limitations in this study are acknowledged:

- The value chain in this study assumes that the CO₂ is the by-product electricity production in a power plant. Thus, electricity is the main product and the CO₂-based fuel uses CO₂ that would be produced anyway. The comparison of potential implications of main product vs. by product was outside of the scope of the current paper. Further research could make this comparison, since it is quite interesting and not straightforward, especially from a consequential (LCA) point of view.
- Modelling fuel transport and distribution infrastructure was out of the scope of this study. CO₂-DME and CO₂-methanol can use slightly modified existing infrastructure because they are liquid fuels with similar behaviour of conventional fuels. However, transport losses can become relevant in the case of hydrogen. In addition, there are currently few distribution networks for hydrogen, which makes its transport and distribution costs extremely high [77]. As the use of hydrogen becomes more spread, established distribution networks will be available and costs will reduce to the level of conventional fuels [77]. Further research could investigate hydrogen transport losses and costs, and their variation in the future.
- This study only took into account the theoretical emission for the end-of-life; the actual emission is related to the type of engine. Compared to combustion engines, hydrogen is converted at higher efficiency in a fuel cell. The high efficiency of the fuel cell could compensate hydrogen losses during transport. The engine efficiency for CO₂-DME and CO₂-methanol is expected to be similar to each other and to conventional engine efficiencies. Therefore the conclusions of this study about the decarbonisation effect of the CO₂-based fuels evaluating the full carbon cycle are not affected by assuming a theoretical emission.
- This study assumed that the oxygen generated as a by-product during water electrolysis was of enough quality to be used in industrial processes without any further conditioning. Based on that, it was assumed that the oxygen by-product provided economic and

environmental credits. Future research should investigate whether the purity of oxygen from water electrolysis meets the specifications to be competitive against industrial oxygen production.

- The impact of the electrolyser infrastructure was not taken into account in the environmental assessment due to lack of data. Further research is needed to assess the influence of the electrolyser infrastructure in the environmental performance of hydrogen production via electrolysis.
- Post-combustion CO₂ capture at a fossil fuel power plant was used as illustrative example. Using alternative carbon capture technologies and other potential sources of CO₂ for the synthesis of fuels could be further investigated. When the CO₂ is of non-fossil origin, e.g. from biomass or from direct air capture there is no burden from the end-of-life emission. The economic viability of these options remains to be examined.
- The impact of renewable energy intermittencies in the electrolysis plant operation (start-up times) was disregarded in this study. Furthermore, the yearly average approach is questionable for the Netherlands (other locations might not be that affected). During Dutch winter, there is virtually no PV-electricity production; all output is concentrated in summer. To accommodate a continuous production, large storage systems will be needed. The technical and economic feasibility of large energy storage systems deserves further research.

5. Conclusions

This study aimed first to gain insights into the relative economic and environmental performance of CO₂-based fuels (dimethyl ether and methanol) and fuel hydrogen produced via conventional steam methane reforming or via electrolysis using renewables, considering the full carbon cycle by taking into account the emission at the end-of-life, when the fuel is combusted. The results show that among all the four fuel options investigated, hydrogen production via steam methane reforming is the alternative with the lowest costs. Using electrolysis-H₂ as transportation fuel is the most carbon- and energy- effective option, being the challenges for a wide implementation of electrolysis-H₂ economic in nature. This study concludes that whereas the idea of synthesising CO₂-based renewable fuels has recently gained much interest, it has for the foreseeable future rather limited practical relevance since there is no favourable combination of cost and environmental performance. This will only change in the long run and requires that CO₂ is of non-fossil origin, i.e. from biomass combustion or captured from air.

The second goal of this study was to elaborate the methodological challenges of carbon accounting in CO₂-based fuels, when the lifetime of the carbon is extended. In the conventional “cut-off” approach the first life (CO₂ source, e.g. a power plant) and the second life (CO₂-fuel production) are cut into two independent product systems that do not interact. The “cut-off” approach has the advantage that fits well with the business boundary, it is easy to implement and communicate. However, following the “cut-off” approach only a part of the carbon cycle is taken into account, leaving the CO₂ source and the capture unit outside the CO₂-fuel system boundary. In practice, this will mean that a power plant that installs a capture unit needs to cover all capture impacts but cannot benefit from emission reduction because the carbon credit has been assigned to the CO₂-based fuel.

Different approaches to allocate the capture impacts, the carbon credit and the end-of-life emission between the first life (e.g. power plant) and the second life (CO₂-fuel production) were explored. The outcomes of this study indicate that the approach taken highly influences the carbon footprint of the individual products (power **or** CO₂-fuel production). Alternatively, the “system expansion” approach includes the two life cycles in one system (power **and** CO₂-fuel production) and thus avoids allocation issues. The results based on the “system expansion” approach show that the overall carbon footprint of a system including power plus CO₂-fuel production remains invariable. Based on these results, the use of the “system expansion” approach is encouraged in the investigation of CO₂ utilisation options. With

this approach, the results can be contextualised and compared against other systems with/without CO₂ utilisation. Thus, the “system expansion” approach allows a critical analysis of the potential emission reduction of different CO₂ utilisation options, which fits with the broader context of global climate change mitigation.

Acknowledgments

This research was carried out as part of the EDDiCCUT project (www.eddiccut.com). EDDiCCUT was a 4-year research project (2012–2016) supported by the Norwegian Research Council under grant number 218952 and by an industrial consortium (Bharat Petroleum, Uniper, and Norske Shell).

Appendix A. Supplementary material

Supplementary data to this article can be found online at <https://doi.org/10.1016/j.apenergy.2018.11.055>.

References

- [1] EC. EU transport in figures – statistical pocketbook 2017; 2017. ISBN 978-92-79-62312-7; ISSN 2363-2739. <https://www.doi.org/10.2832/041248MI-AA-16-002-EN-N>.
- [2] EC. Climate action. Reducing emissions from transport. European Commission. Policy; 2017.
- [3] EC. White paper. Roadmap to a Single European Transport Area – Towards a competitive and resource efficient transport system. European Commission, COM 2011. 144; 2011.
- [4] EC. Roadmap. Communication on decarbonising the transport sector. European Commission; 2016.
- [5] Global CCS institute; 2018. < <https://www.globalccsinstitute.com/projects/large-scale-ccs-projects> > [accessed 2 August 2018].
- [6] Mac Dowell N, Fennell PS, Shah N, Maitland GC. The role of CO₂ capture and utilization in mitigating climate change. *Nat Clim Change* 2017;7:243–9. <https://doi.org/10.1038/nclimate3231>.
- [7] Dimitriou I, García-Gutiérrez P, Elder RH, Cuéllar-Franca RM, Azapagic A, Allena RWK. Carbon dioxide utilisation for production of transport fuels: process and economic analysis. *Energy Environ Sci* 2015;8:1775.
- [8] Quadrelli EA, Centi G, Duplan JL, Perathoner S. Carbon dioxide recycling: emerging large-scale technologies with industrial potential. *ChemSusChem* 2011;4(9):1194–215. <https://doi.org/10.1002/cssc.201100473>.
- [9] Mitsui Chemicals; 2014. < <http://http://www.mitsuichem.com/> > [accessed January 2018].
- [10] Joo O, Jung K, Jung Y. *Stud surf sci catal. Elsevier*; 2004.
- [11] Carbon Recycling International; 2014. < <http://www.carbonrecycling.is/> > [accessed November 2017].
- [12] Olah GA, Goepfert A, Prakash GKS. Chemical recycling of carbon dioxide to methanol and dimethyl ether: from greenhouse gas to renewable, environmentally carbon neutral fuels and synthetic hydrocarbons. *J Org Chem* 2011;74(2):487–98. <https://doi.org/10.1021/jo801260f>.
- [13] Takeishi K, Akaike Y. Direct synthesis of dimethyl ether (DME) from syngas. *Recent Adv Energy Environ* 2010:408–11.
- [14] Semelsberger TA, Borup RL, Greene HL. Dimethyl ether (DME) as an alternative fuel. *J Power Sources* 2006;156(2):497–511. <https://doi.org/10.1016/j.jpowsour.2005.05.082>.
- [15] MarketsandMarkets. Dimethyl Ether Market by Raw Materials (Coal, Methanol, Natural gas and Bio-based feedstock), by Applications (Aerosol Propellant, LPG Blending, Transportation fuel and Others), and by Region - Trends & forecasts to 2020; 2015.
- [16] Global Market Insights. Dimethyl Ether (DME) Market Size, Share, Prize, Report 2024. Report ID: GM185; 2016.
- [17] DOE. U.S. Department of energy, Technology Readiness Assessment Guide, DOE 413.3-4, Washington, D.C., 20585; 2009.
- [18] EARTO. European Association of Research and Technology Organisations. Recommendations, The TRL Scale as a Research & Innovation Policy Tool; 2014.
- [19] EC. Novel carbon capture and utilisation technologies. European Commission Group of Chief Scientific Advisors. Opinion 4/2018; 2018. <https://www.doi.org/10.2777/01532>.
- [20] Christodoulou X, Okoroafora T, Parry S, Velasquez-Orta SB. The use of carbon dioxide in microbial electrosynthesis: advancements, sustainability and economic feasibility. *J CO₂ Utilization* 2017;18:390–9.
- [21] van-Dal ES, Bouallou C. Design and simulation of a methanol production plant from CO₂ hydrogenation. *J Cleaner Prod* 2013;57:38–45.
- [22] Pérez-Fortes M, Schöneberger J, Boulamanti A, Tzimas E. Methanol synthesis using captured CO₂ as raw material: techno-economic and environmental assessment. *Appl Energy* 2016;161:718–32.
- [23] Pérez-Fortes M, Schöneberger JC, Boulamanti A, Gillian Harrison G, Tzimas E. Formic acid synthesis using CO₂ as raw material: techno-economic and environmental evaluation and market potential. *Int J Hydrogen Energy* 2016;41(37):16444–62.
- [24] IEA. Technology roadmap hydrogen and fuel cells. International Energy Agency;

- 2015.
- [25] Decourt B, Lajoie B, Debarre R, Soupa O. Hydrogen-based energy conversion, more than storage: system flexibility. Paris: SBC Energy Institute; 2014.
- [26] ZEP. Commercial scale feasibility of clean hydrogen. European Zero Emission Technology and Innovation Platform; 2017.
- [27] Bolat P, Thiel C. Hydrogen supply chain architecture for bottom-up energy systems models. Part 2: Techno-economic inputs for hydrogen production pathways. *Int J Hydrogen Energy* 2014;39:8898–925.
- [28] Fernández-Dacosta C, Stojcheva V, Ramirez A. Closing carbon cycles: evaluating the performance of multi-product CO₂ utilisation and storage configurations in a refinery. *J CO₂ Utilization* 2018;23:128–42. <https://doi.org/10.1016/j.jcou.2017.11.008>.
- [29] Ullmann. Ullmann's Encyclopedia of industrial chemistry. Hydrogen section §4.1.3.3 steam reforming plant. John Wiley and Sons, Inc; 2007.
- [30] DOE. Hydrogen Production Cost From PEM Electrolysis. DOE Hydrogen and Fuel Cells Program Record; 2014.
- [31] KNMI. Koninkrijk Nederlanden Meteorologisch Instituut; 2017. < <http://projects.knmi.nl/klimatologie/uurgegevens/selectie.cgi> > [accessed June 2017].
- [32] Schakel W, Oreggioni GD, Singh B, Strømman AH, Ramirez A. Assessing the techno-environmental performance of CO₂ utilization via dry reforming of methane for the production of dimethyl ether. *J CO₂ Utilization* 2016;16:138–49.
- [33] Lebarbier VM, Dagle RA, Kovarik L, Lizarazo-Adarme JA, King DL, Palo DR. Synthesis of methanol and dimethyl ether from syngas over Pd/ZnO/Al₂O₃ catalysts. *Catal Sci Technol* 2012;2(10):2116. <https://doi.org/10.1039/c2cy20315d>.
- [34] Lee S, Sardesai A. Liquid phase methanol and dimethyl ether synthesis from syngas. *Top Catal* 2005;32(3–4):197–207. <https://doi.org/10.1007/s11244-005-2891-8>.
- [35] EDDiCCUT; 2018. < <https://www.eddiccut.com/> > .
- [36] Pérez-Fortes M, Tzimas E. Techno-economic and environmental evaluation of CO₂ utilisation for fuel production: synthesis of methanol and formic acid. Joint Research Centre Institute for Energy and Transport; 2016. EUR 27629 EN. doi:10.2790/981669.
- [37] Sinnot R. Chemical engineering design Vol. 6. Coulson and Richardson's Chemical Engineering; 2005.
- [38] Towler, Sinnot. Chemical engineering design. Principles, practice and economics of plant and process design. Elsevier; 2008.
- [39] Mansilla C, Louyrette J, Albou S, Bourasseau C, Dautremont S. Economic competitiveness of off-peak hydrogen production today – a European comparison. *Energy* 2013;55:996–1001.
- [40] Eurostat; 2017. < http://ec.europa.eu/eurostat/data/database?node_code=prc_hicp_midx > .
- [41] Eurostat; 2016. < [http://ec.europa.eu/eurostat/statistics-explained/index.php/File:Exchange_rates_against_the_euro_2005%E2%80%932015_\(1_EUR_%3D_%E2%80%A6_national_currency\).YB16.png](http://ec.europa.eu/eurostat/statistics-explained/index.php/File:Exchange_rates_against_the_euro_2005%E2%80%932015_(1_EUR_%3D_%E2%80%A6_national_currency).YB16.png) > [accessed September 2017].
- [42] Eurostat; 2015. < http://ec.europa.eu/eurostat/statistics-explained/index.php/File:Hourly_labour_costs_by_selection_of_NACE_industries_compared_to_the_national_level_-_LCS_2012.png > [accessed September 2017].
- [43] CBS. Centraal Bureau voor Statistiek; 2017. < <http://statline.cbs.nl/statweb/publication/?vw=t&dm=sln&pa=70957ned&d1=a&d2=0-1.l&d3=0&d4=a&d5=0&d6=a&hd=080523-1743&hdr=g2,g4,t,g5&stb=g1,g3> > [accessed September 2017].
- [44] Global CCS institute. Accelerating the uptake of CCS: industrial use of captured carbon dioxide. Parsons Brinckerhoff; 2011.
- [45] EEX. European Energy Exchange AG; 2017. < <https://www.eex.com/en/market-data/environmental-markets/spot-market/european-emission-allowances#!/2017/12/22> > [accessed 23 December 2017].
- [46] IEA. World energy outlook 2016. International Energy Agency; 2016.
- [47] ISO. ISO 14040:2006, Environmental management. Life cycle assessment. Principles and framework. International Standards Organization; 2006.
- [48] ISO. ISO 14044:2006, Environmental management. Life cycle assessment. Requirements and guidelines. International Standards Organization; 2006.
- [49] Ecoinvent data v.3.3, 2016. < www.ecoinvent.ch > [accessed June 2017].
- [50] IPCC. The physical science basis. Cambridge, United Kingdom and New York, NY, USA: Cambridge University Press; 2013. p. 1535.
- [51] Frischknecht R, Niels Jungbluth N, Althaus H-J, Bauer C, Doka G, Dones R, et al. Implementation of Life Cycle Impact Assessment Methods. Data v2.0. Ecoinvent report No. 3. Dübendorf; 2007.
- [52] Frischknecht R, Althaus H-J, Bauer C, Doka G, Heck T, Jungbluth N, et al. The environmental relevance of capital goods in life cycle assessments of products and services. *Int J LCA* 2007;12(Special Issue):7–17.
- [53] Nelson J, Gambhir A, Ekins-Daukes N. Solar power for CO₂ mitigation. Imperial College London, Grantham Institute for Climate Change, Briefing paper No 11; 2014.
- [54] EC. European Commission - Joint Research Centre - Institute for Environment and Sustainability: International Reference Life Cycle Data System (ILCD) Handbook - General guide for Life Cycle Assessment - Detailed guidance. 1st ed. EUR 24708 EN. Luxembourg; 2010.
- [55] NL Agency. Usability of Life Cycle Assessment for Cradle to Cradle purposes. Position Paper. NL Environment and NL Energy and Climate, Dutch Ministry of Infrastructure and the Environment. Publication-nr. 1AFVA1106; 2011.
- [56] Merrild H, Damgaard A, Christensen TH. Life cycle assessment of waste paper management: the importance of technology data and system boundaries in assessing recycling and incineration. *Resour Conserv Recycl* 2008;52(12):1391–8.
- [57] Laurijssen J, Marsidi M, Westenbroek A, Worrell E, Faaij A. Paper and biomass for energy?: the impact of paper recycling on energy and CO₂ emissions. *Resour Conserv Recycl* 2010;54(12):1208–18.
- [58] Wang L, Templer R, Murphy RJ. A Life Cycle Assessment (LCA) comparison of three management options for waste papers: bioethanol production, recycling and incineration with energy recovery. *Bioresour Technol* 2012;120:89–98. <https://doi.org/10.1016/j.biortech.2012.05.130>.
- [59] Teir S, Kotiranta T, Pakarinen J, Mattila H-P. Case study for production of calcium carbonate from carbon dioxide in flue gases and steelmaking slag. *J CO₂ Utilization* 2016;14:37–46.
- [60] Ecoinvent; 2017. < <https://www.ecoinvent.org/database/system-models-in-ecoinvent-3/cut-off-system-model/allocation-cut-off-by-classification.html> > [accessed March 2018].
- [61] BSI. PAS 2050:2011 Specification for the assessment of the life cycle greenhouse gas emissions of goods and services. ICS code: 13.020.40; 2011.
- [62] IDA. International DME association; 2017. < <https://www.aboutdme.org/index.asp?bid=234#Q6> > [accessed October 2017].
- [63] MyLPG; 2017. < <https://www.mylpg.eu/stations/netherlands/> > [accessed October 2017].
- [64] Methanex. Methanex Monthly Average Regional Posted Contract Price History; 2017.
- [65] Manfredi S, Allacker K, Chomkhamri K, Pelletier N, Maia de Souza D. Product Environmental Footprint (PEF) Guide. European Commission (EC), Joint Research Centre (JRC). Institute for Environment and Sustainability (IES), Sustainability Assessment Unit. No N 070307/2009/552517. Ref. Ares(2012)873782 - 17/07/2012; 2012.
- [66] Chen F, Taylor N, Kringos N. Electrification of roads: opportunities and challenges. *Appl Energy* 2015;150:109–19. <https://doi.org/10.1016/j.apenergy.2015.03.067>.
- [67] Du J, Ouyang D. Progress of Chinese electric vehicles industrialization in 2015: a review. *Appl Energy* 2017;188:529–46. <https://doi.org/10.1016/j.apenergy.2016.11.129>.
- [68] Ferrero E, Alessandrini S, Balanzino A. Impact of the electric vehicles on the air pollution from a highway. *Appl Energy* 2016;169:450–9. <https://doi.org/10.1016/j.apenergy.2016.01.098>.
- [69] He X, Wu Y, Zhang S, Tamor MA, Wallington TJ, Shen W, et al. Individual trip chain distributions for passenger cars: implications for market acceptance of battery electric vehicles and energy consumption by plug-in hybrid electric vehicles. *Appl Energy* 2016;180:650–60. <https://doi.org/10.1016/j.apenergy.2016.08.021>.
- [70] Rocco MV, Casalegno A, Colombo E. Modelling road transport technologies in future scenarios: Theoretical comparison and application of Well-to-Wheels and Input-Output analyses. *Appl Energy* 2018;232:583–97. <https://doi.org/10.1016/j.apenergy.2018.09.222>.
- [71] EIA; 2017. < <https://www.eia.gov/dnav/ng/hist/n3035us3m.htm> > [accessed September 2017].
- [72] van der Spek M, Sanchez Fernandez E, Eldrup NH, Skagestad R, Ramirez A, Faaij A. Unravelling uncertainty and variability in early stage techno-economic assessments of carbon capture technologies. *Int J Greenhouse Gas Control* 2017;56:221–36.
- [73] Fraunhofer ISE. Current and Future Cost of Photovoltaics. Long-term Scenarios for Market Development, System Prices and LCOE of Utility-Scale PV Systems. Study on behalf of Agora Energiewende; 2015.
- [74] Christensen Dysert P, Dysert LR. AACE International Recommended Practice. 18R-97 – Cost Estimate Classification System – As Applied in Engineering, Procurement, and Construction for the Process Industries, Morgantown, West Virginia; 2005.
- [75] ZEP. The costs of CO₂ capture. Post-demonstration CCS in the EU. Zero Emissions Platform; 2011.
- [76] van der Spek M, Ramirez A, Faaij A. Improving model uncertainty evaluation by using pedigree matrices. A case study on CO₂ capture with monoethanolamine. *Comput Chem Eng* 2016;85:1–15.
- [77] Cazzola P, Morrison G, Kaneko H, Cuenot F, Ghandi A, Fulton L. Production costs of alternative transportation fuels. Influence of Crude Oil Price and Technology Maturity. International Energy Agency; 2013.
- [78] Eurostat; 2017. < [http://ec.europa.eu/eurostat/statistics-explained/index.php/File:Half-yearly_gas_prices_\(EUR\).png](http://ec.europa.eu/eurostat/statistics-explained/index.php/File:Half-yearly_gas_prices_(EUR).png) > [accessed September 2017].
- [79] Eurostat; 2016. < [http://ec.europa.eu/eurostat/statistics-explained/index.php/File:Half-yearly_electricity_and_gas_prices_\(EUR\).png](http://ec.europa.eu/eurostat/statistics-explained/index.php/File:Half-yearly_electricity_and_gas_prices_(EUR).png) > [accessed September 2017].
- [80] Chiantorre PV, Gordon I, Hoffmann W, Perezagua E, Philipps S, Roman E, et al. Future renewable energy costs: solar photovoltaics. How technology innovation is anticipated to reduce the cost of energy from European photovoltaic installations. KIC-InnoEnergy; 2015.
- [81] Markevich M, Sonnemann GW, Castells F, Montané D. Life cycle inventory analysis of hydrogen production by the steam-reforming process: comparison between vegetable oils and fossil fuels as feedstock. *Green Chemistry* 2002;4:414–23. <https://doi.org/10.1039/b203742b>.
- [82] Spath PL, Mann MK. Life cycle assessment of hydrogen production via natural gas steam reforming. Technical report NREL/TP-570-27637. U.S. Department of energy laboratory, Midwest Research Institute, National Renewable Energy Laboratory, 2001. < <http://www.doe.gov/bridge> > .
- [83] Bhandari R, Trudewind CA, Zapp P. Life cycle assessment of hydrogen production methods – A review. STE research report. Forschungszentrum Jülich, Institute of Energy and Climate Research - Systems Analysis and Technology Evaluation (IEK-STE), D-52425 2013. Jülich, Germany.
- [84] Reich NH, Alsema EA, van Sark WJHM, Tukenburg WC, Sinke WC. Greenhouse gas emissions associated with photovoltaic electricity from crystalline silicon modules under various energy supply options. Progress in Photovoltaics Research and Applications 2011;19(5). <https://doi.org/10.1002/pip.1066>.