

Enhancing [Spatial] Creativity

Enhancing creativity of architects by applying unconventional virtual environments (UVEs)

Mahdizadeh Hakak, Alireza

DOI

[10.7480/abe.2017.7](https://doi.org/10.7480/abe.2017.7)

Publication date

2017

Document Version

Final published version

Citation (APA)

Mahdizadeh Hakak, A. (2017). *Enhancing [Spatial] Creativity: Enhancing creativity of architects by applying unconventional virtual environments (UVEs)*. [Dissertation (TU Delft), Delft University of Technology]. A+BÉ | Architecture and the Built Environment. <https://doi.org/10.7480/abe.2017.7>

Important note

To cite this publication, please use the final published version (if applicable). Please check the document version above.

Copyright

Other than for strictly personal use, it is not permitted to download, forward or distribute the text or part of it, without the consent of the author(s) and/or copyright holder(s), unless the work is under an open content license such as Creative Commons.

Takedown policy

Please contact us and provide details if you believe this document breaches copyrights. We will remove access to the work immediately and investigate your claim.

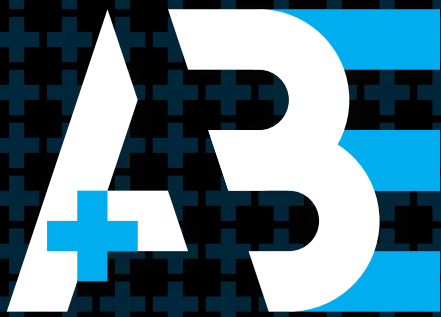

Architecture
and the
Built environment

#07
2017



Enhancing [Spatial] Creativity

Enhancing creativity of architects by applying unconventional virtual environments (UVEs)

Alireza Mahdizadeh Hakak

Enhancing [Spatial] Creativity

**Enhancing creativity of architects by applying
unconventional virtual environments (UVEs)**

Alireza Mahdizadeh Hakak

*Delft University of Technology, Faculty of Architecture and the Built Environment,
Department of Architectural engineering + Technology*

Design: Sirene Ontwerpers, Rotterdam

ISBN 978-94-92516-64-0

ISSN 2212-3202

© 2017 Alireza Mahdizadeh Hakak

All rights reserved. No part of the material protected by this copyright notice may be reproduced or utilized in any form or by any means, electronic or mechanical, including photocopying, recording or by any information storage and retrieval system, without written permission from the author.

Unless otherwise specified, all the photographs in this thesis were taken by the author. For the use of illustrations effort has been made to ask permission for the legal owners as far as possible. We apologize for those cases in which we did not succeed. These legal owners are kindly requested to contact the publisher.

Enhancing [Spatial] Creativity

Enhancing creativity of architects by applying
unconventional virtual environments (UVEs)

Proefschrift

ter verkrijging van de graad van doctor
aan de Technische Universiteit Delft,
op gezag van de Rector Magnificus prof. ir. K.C.A.M. Luyben,
voorzitter van het College voor Promoties,
in het openbaar te verdedigen op dinsdag, 4 juli 2017 om 10:00 uur

door

Alireza MAHDIZADEH HAKAK

MSc in Architecture Engineering
geboren te Mashhad, Iran

Dit proefschrift is goedgekeurd door de

promotor: Prof. ir. Kas Oosterhuis
copromotor: Dr. ir. N.M. Bioria

Samenstelling promotiecommissie bestaat uit

Rector Magnificus,	voorzitter
Prof. dr. ir. Kas Oosterhuis	promotor
Dr. ir. N.M. Bioria	copromotor

Onafhankelijke leden

Prof. dr. A. Saggio	University of Rome
Prof. ir. J. Van Erp	Delft University of Technology
Assist. Prof. dr. S. Ritter	Radboud University Nijmegen
Dr. ir. M.S. Kleinsmann	Delft University of Technology
Prof. dr. P.G. Badke-Schaub	Delft University of Technology

This research was partly funded by the **Visionair** (A world-class infrastructure for advanced 3D visualization-based research) through FP7 program



تقدیم به روح پدرم عبدالرضا

و مادر عزیزم زهرا

و همسر همراهم ارمغان

To my mother, Zahra,

my wife, Armaghan

And in memory of my father, Abdolreza

Contents

List of figures	12
List of tables	14
Summary	15
Samenvatting	17
خلاصه رساله	19

1	Introduction	21
1.1	General introduction:	21
1.2	Terminology	22
1.2.1	Creativity	22
1.2.2	Abstract design	22
1.2.3	Unconventional Virtual Environments (UVEs)	23
1.3	Research aims and questions	24
1.4	Boundary condition	25
1.5	Research questions	26
1.6	Research Method	28
1.6.1	Research steps and approaches	28
1.6.2	Research tools	29
1.6.2.1	Computer design and simulation tools	29
1.6.2.2	Analysis tools	29
1.6.2.3	Technical devices	30
1.7	Dissertation outline	32
7	Contents	

2	Literature review	33
<hr/>		
2.1	Introduction to creativity and effective parameters correlated with creativity in architectural design	33
<hr/>		
2.2	Creativity in architecture - A review on effective parameters correlated with creativity in architectural design	34
<hr/>		
2.2.1	Introduction	35
2.2.2	What Is Creativity?	35
2.2.3	Where do creative ideas come from?	36
2.2.4	Types of creativity	39
2.2.5	Shifting to Impossible conceptual blending in architecture	39
2.2.6	The Relationship between Tolerance of Ambiguity and Creativity	40
2.2.7	The Creative Cognition Approach	41
2.2.8	Discussion	42
2.2.9	Conclusion	45
<hr/>		
3	2D vs. 3D	47
<hr/>		
	Starting the design process from a higher dimension	
<hr/>		
3.1	Exploring the impact on creativity of architects: Designing using a 2d environment (pen and paper) vs. starting from a 3D interface	47
<hr/>		
3.2	“Thinking Out of the Box” from Out of the Box!	48
<hr/>		
	Increasing the Dimension of “Starting Point” Case study: Architecture students	
<hr/>		
3.2.1	Introduction	48
3.2.2	Where do creative ideas come from?	49
3.2.3	Flatland VS. Spaceland	50
3.2.4	Experiment:	53
3.2.4.1	Instruction	54
3.2.4.2	Judgment criterion	55
3.2.4.3	Reliability and validity	56
3.2.4.4	Analysis	57
3.2.5	Other advantages of 3D workspaces	60
3.2.6	Conclusion	61

4	Implementing UVEs	63
	<hr/>	
	In architecture pedagogy	
4.1	Hypothesizing implementation of UVEs in architectural pedagogy	63
	<hr/>	
4.2	Implementing unconventional virtual environments for enhancing creativity in Architecture pedagogy	64
	<hr/>	
4.2.1	Introduction	65
4.2.2	What Is Creativity?	68
4.2.3	Types of creativity	69
4.2.4	The Creative Cognition Approach	70
4.2.5	Experiencing unconventional virtual environments and the role of creativity	70
4.2.6	Implementation in pedagogy	73
4.2.7	Conclusion	75
	<hr/>	
5	Proto-fuse project	79
	<hr/>	
	Methods to boost [spatial] creativity	
5.1	Experimental approaches to derive two methods for boosting spatial creativity	79
	<hr/>	
5.2	The Proto-Fuse Project: Methods to boost creativity for architects	80
	<hr/>	
5.2.1	Introduction	81
5.2.2	Where do creative ideas come from?	82
5.2.3	Types of creativity	84
5.2.4	Shifting to Impossible conceptual blending in architecture	85
5.2.5	The Relationship between Tolerance of Ambiguity and Creativity	87
5.2.6	Implementation in "pedagogy" of architecture	88
5.2.7	Proto-Fuse method	89
5.2.7.1	Navigating in Unconventional Virtual Environments (UVEs)	90
5.2.7.2	Extracts of Local Distance	91
5.2.8	Designing a NSA (non-standard architecture) to enhance Impossible creativity	94
5.2.9	Discussion and Conclusion	98

6	Differences in human perception	101
6.1	Differences in human perception, while observing three different environments, and their [possible] relationship with creativity	101
6.2	Navigating abstract virtual environment: An electroencephalography (eeg) study	102
6.2.1	Introduction:	103
6.2.2	Materials and Methods	106
6.2.2.1	Participants	106
6.2.2.2	Stimuli	107
6.2.2.3	Experimental procedure	107
6.2.2.4	EEG recordings	108
6.2.2.5	EEG pre-processing	108
6.2.2.6	EEG source localization	109
6.2.3	Results:	110
6.2.3.1	Behavioural responses	110
6.2.3.2	Buzzwords responses	111
6.2.3.3	EEG power analysis	113
6.2.3.4	EEG source localization	113
6.2.4	Discussion	115
6.2.5	Conclusion	117
7	Sample UVE	121
7.1	Creating a practical UVE	121
7.1.1	Introduction	121
7.1.2	Building the UVE	122
7.1.3	Instruction for the participants:	123
7.1.4	Feedback of the participants	125
7.1.5	Specification of the tools for the experiment	128
7.1.5.1	3D projector	128
7.1.5.2	3D goggle	129
7.1.5.3	3D stereoscopic interface	129
7.1.5.4	3D navigation tool	130

8	Conclusion	131
8.1	Introduction	131
8.2	Answers to research question	131
8.2.1	Question number 1 (answered in chapter 2)	132
8.2.2	Question number 2 (answered in chapter 3)	132
8.2.3	Question number 3 (answered in chapter 4)	133
8.2.4	Question number 4 (answered in chapter 5)	134
8.2.5	Question number 5 (answered in chapter 6)	134
8.3	Application recommendation based on results:	135
8.3.1	Apply UVE in the pedagogy of architectural education:	135
8.3.2	Start designing from a higher dimension	135
8.3.3	Train the brain to tolerate more ambiguity:	136
8.3.4	Do not mix design and problem-solving modes of the brain:	136
8.4	Recommendations:	136
8.4.1	Recommendation for future research:	136
8.4.2	Recommendation for the market:	137
8.5	Value of this dissertation:	137
	Acknowledgements	139
	Curriculum vitae	141
	List of publications:	143

List of figures

- [Figure 1.1](#) Abstract environment by Alireza Mahdizadeh Hakak 23
- [Figure 1.2](#) Sample of Unconventional virtual environment by Marcos Novak 24
- [Figure 1.3](#) 3D stereoscopic projector 30
- [Figure 1.4](#) XPAND 3D Goggle 31
- [Figure 1.5](#) 3DConexxion mouse 31
- [Figure 2.1](#) The model of human mental structure after Jones (2012). 37
- [Figure 2.2](#) V4D_Visio4D by Marcos Novak-Used with permission 42
- [Figure 2.3](#) V4D_Visio4D by Marcos Novak-Used with permission 42
- [Figure 2.4](#) Screenshot (authors) – new cognitive perception of virtual environments 43
- [Figure 2.5](#) Screenshot (authors) – new cognitive perception of virtual environments 43
- [Figure 3.1](#) The model of human mental structure after Jones (2012). 50
- [Figure 3.2](#) Conventional 2D interface, Pen and Paper 51
- [Figure 3.3](#) 3D interface, Point cloud 51
- [Figure 3.4](#) Point cloud 52
- [Figure 3.5](#) Saltwater Pavilion by ONL 52
- [Figure 3.6](#) Kinetic Sculpture, BMW Museum Munich 2008 53
- [Figure 3.7](#) Students while doing the experiment 53
- [Figure 3.8](#) Some of the sketches of students 55
- [Figure 3.9](#) Sample 1 59
- [Figure 3.10](#) Sample 2 59
- [Figure 3.11](#) Sample 3 60
- [Figure 4.1](#) V4D_Visio4D by Marcos Novak-Used with permission 66
- [Figure 4.2](#) V4D_Visio4D by Marcos Novak-Used with permission 66
- [Figure 4.3](#) Unconventional virtual environment -©2008-Marco De Gregorio, used with permission 71
- [Figure 4.4](#) Unconventional virtual environment -©2008-Marco De Gregorio, used with permission 71
- [Figure 4.5](#) Screenshot (authors) – new cognitive perception of virtual environments 72
- [Figure 4.6](#) Screenshot (authors) – new cognitive perception of virtual environments 72
- [Figure 5.1](#) The three layered model of human mental structure after Jones (2012). In this model, the upper layer, Observer-Reasoner, is in the conscious mind, the middle layer, Censor, is in the subconscious mind, and the lower layer, Random Idea Generator, is in the unconscious mind. The horizontal lines schematically depict ideas/representations and the bold line demarcates the consciousness. 82
- [Figure 5.2](#) V4D_Visio4D by Marcos Novak 86
- [Figure 5.3](#) UVEs by authours 90
- [Figure 5.4](#) UVEs by authours 90
- [Figure 5.5](#) Extracts Of Local Distance Project (used with permission) 91
- [Figure 5.6](#) A normal building in 3d-max interface 95
- [Figure 5.7](#) screenshots of transformed building, designed by students 96

[Figure 6.1](#) Sample abstract environment. Courtesy of Marcos Novak-V4D_Visio4D [106](#)

[Figure 6.2](#) Samples of three different types of design environment: fully designed (left panel), semi-designed (middle), and abstract design (right). Here only a snapshot of individual design is shown and in the actual experiment we presented a short video (1 min long) in each category. [107](#)

[Figure 6.3](#) List of buzz-words. At the end of each video, participants were instructed to choose five words from this list that they would consider best fit to the environment. [108](#)

[Figure 6.4](#) Mean responses on the ease (of navigation), creativity and liking of the three types of design environments, full, semi and abstract. [110](#)

[Figure 6.5](#) Scatter plots of ease of navigation vs liking for three design environments. Note only the abstract designed environment shows a clear relationship ($r = .54$). [111](#)

[Figure 6.6](#) Distribution of buzzwords selected to represent three types of design environments: fully designed (top panel), semi designed (middle panel), and abstract designed (bottom panel). [113](#)

[Figure 6.7](#) Activation of the precentral gyrus in the fully designed condition vs. the abstract condition [114](#)

[Figure 6.8](#) Activation of the dorsolateral prefrontal cortex in the abstract condition [114](#)

[Figure 7.1](#) Participant wearing a 3D goggle [123](#)

[Figure 7.2](#) Instruction for using 3D Conexxion [124](#)

[Figure 7.3](#) Participant while navigating in a UVE [125](#)

[Figure 7.4](#) 3D stereoscopic projector [128](#)

[Figure 7.5](#) XPAND 3D Goggle [129](#)

[Figure 7.6](#) 3DConexxion mouse [130](#)

List of tables

[Table 3.1](#) Summary of experiment and interviews 58

[Table 3.2](#) Percentage of change 58

[Table 5.1](#) Summary of comments from each participant's feedback, on "Extracting local distance project" 93

[Table 5.2](#) Summary of comments from each participant's interview in the middle of experiment 97

[Table 5.3](#) Summary of comments from each participant's interview after the experiment 97

[Table 6.1](#) List of correlation values between different three ratings in three different types of designs. 111

[Table 6.2](#) Summary results of three comparisons based on sLORETA findings. 115

[Table 7.1](#) Post experiment feedback 128

Summary

Potentials of virtual environment for enhancing creativity of architects have shaped this research. There is no singular definition of creativity. In fact, there are more than 100 different definitions for creativity according to different contexts and disciplines. Nevertheless, it is possible to confine the boundaries of definitions and address creativity within a confined framework.

The first practical step was thus to perform an in-depth literature survey to define a boundary condition for the widespread topic of “creativity” and identify vital research questions pertaining to creativity. In this regard, personality and behavior of creative people; mood, state, temper, intelligence vs. creativity, motivation and so forth were ignored. Instead, cognitive aspects of creativity such as thinking patterns, conceptual blending, idea expansion and tolerance of ambiguity have been focused upon.

The second step was to test whether starting a design procedure with a 2 or a 3-dimensional mode of thinking has any correlation with creativity. An experiment pertaining to this test was designed in which participants were asked to perform the same design task once with 2D tools and environments (e.g. traditional pen and paper) and the next time by applying 3D tools and environments (e.g. 3D software). A jury of experts in the field of design subjectively compared the results and arrived at a conclusion that participants generated more creative ideas by implementing 3D environments/tools.

The third step, involved the introduction of unconventional virtual environments (UVEs), which subsequently lead to the creation of a hypothesis. This hypothesis tries to connect navigation in UVEs with the enhancement of creativity. Characteristics of UVEs and theoretical arguments around the hypothesis were also discussed.

The fourth step, involved a discussion on two effective parameters of creativity:

- 1- Tolerance of ambiguity
- 2- Conceptual blending

Attempts to verify these parameters, lead to the formulation of two separate experiments. The conclusions of these experiments were as follows:

- 1- Tolerance of ambiguity has a direct relationship with creativity. Architects deal with multiple parameters during a typical design process. The ability to meaningfully process the relationships between such a multitude of parameters has also trained architects to possess a higher level of tolerance of ambiguity aiding them in postponing making hasty judgements.

2- By combining different ideas, one can formulate newer and much novel ideas. Ideas tend to become creative when more remote ideas are combined and synthesized. In order to prevent repetitive and self-similar ideas, the unconscious mind needs to be fed with more ideas, which the mind has not been exposed to. These new ideas/ experiences can be generated by exposing one's self to UVEs, since UVEs can expose one to situations and experiences which the brain cannot experience in the physical world.

The fifth step, aims at understanding how the brain perceives different environments. Three different environments were chosen for an experimental study pertaining to the same: 1- Abstract environment 2- Semi-designed environment and 3- Fully designed environment. Participants were asked to provide a feedback by answering a questionnaire after navigating each of these environments. Simultaneously, their brain activity patterns were recorded via a professional neuropsychology apparatus. After analyzing the brain activities, in conjunction with the questionnaire, it became clear that perception of an abstract environment is completely different from the perception of a Semi-designed or Fully designed environment. This experiment consolidated the hypothesis that UVEs as abstract designed environments activate parts of the brain that are correlate with creativity.

The sixth step, involved putting the hypothesis to a final test. A conclusive experiment was thus designed. The experiment won the Visionair fund of FP7 and was conducted in Italy. A UVE was designed using the software 3D max and was converted to 3D stereoscopic mode using a specific software: GIOVE; developed in ITIA-CNR, Italy. Using a 3D goggle and 6 axis mouse, a group of 20 participants were asked to navigate the UVE. They were asked to provide a written feedback pertaining to their feelings, expectations, strategy of navigation and in general, their experience. Their responses were collected and analyzed.

The final step, involved answering the formulated research questions and discussing the final results.

Samenvatting

Dit onderzoek wordt vorm gegeven door de potenties die ontstaan wanneer architecten gebruik maken van virtuele omgevingen om hun creativiteit te verbeteren. Er is geen duidelijke definitie voor creativiteit. Door de verschillende contexten en vakgebieden zijn er al meer dan 100 verschillende definities. Desondanks is het mogelijk om de meest geschikte definitie van creativiteit vast te stellen binnen een gespecificeerde kader. In dit onderzoek wordt geprobeerd de perceptie van omgeving en haar processen te verkennen in samenhang met de onbewuste geest. Het doel is om tot passieve oplossingen te komen die een ontwerper creatiever maken.

De eerste stap is bestaat uit een literatuurstudie en het inkaderen van de definities voor "creativiteit". In die zin: de persoonlijkheid en het gedrag van creatieve mensen, het humeur, toestand, temperament, intelligentie vs. creativiteit, de motivatie enzovoorts, zijn genegeerd. In plaats daarvan is er gefocust op; de cognitieve aspecten van creativiteit -inclusief denkpatronen-, het kunnen combineren van concepten, het verrijken van ideeën en de toleranties m.b.t. tot dubbelzinnigheden

In de volgende stap wordt gekeken of er een correlatie is tussen de dimensie van het ontwerp proces (zoals 2D vs 3D) en creativiteit. De opzet van het experiment is als volgt: de deelnemers worden eerst gevraagd een ontwerp te maken 2D gereedschappen en omgevingen (zoals pen en papier) te gebruiken. Vervolgens moeten zij het ontwerp opnieuw maken met 3D gereedschappen en omgevingen (bijvoorbeeld 3D software). Hierna gaan een jury van deskundigen op het gebied van ontwerpen de resultaten subjectief vergelijken. De conclusie die hieruit volgt was dat deelnemers meer creatieve ideeën generen door toepassing van 3D gereedschappen. In de derde stap wordt een hypothese geformuleerd door de introductie van 'unconventional virtual environments' (UVEs). Deze hypothese probeert een verband vast te stellen tussen navigatie in UVEs en de verbetering van creativiteit. Daarnaast worden kenmerken van UVEs en theoretische argumenten besproken. In de vierde stap worden twee belangrijke en effectieve parameters van creativiteit besproken:

- 1- Tolerantie van dubbelzinnigheid
- 2- Conceptuele combinatie

In een poging om deze parameters te verifiëren, zijn twee afzonderlijke experimenten uitgevoerd. De resultaten van de experimenten zijn:

1- Tolerantie van dubbelzinnigheid heeft een directe relatie met creativiteit. Ontwerpers leren omgaan met de ambiguiteit en het zo lang mogelijk uitstellen van hun oordeel aangezien het architectuur discipline vaak te maken heeft met een groot aantal parameters in het ontwerp proces.

2- Door ideeën te combineren ontstaan nieuwe ideeën. De meest creatief ideeën ontstaan wanneer ogenschijnlijk vergezochte ideeën worden gecombineerd. Om te voorkomen dat dezelfde of gelijksoortige ideeën steeds worden herhaald moeten we steeds ideeën verstreken aan de onbewuste geest. Deze nieuwe ideeën / ervaringen kunnen afkomstig zijn van UVEs omdat UVEs kenmerken heeft die de hersenen niet kunnen ervaren in de fysieke wereld.

In de vijfde stap, waarin de aard van perceptie van de hersenen wordt vastgesteld, zijn drie verschillende omgevingen gekozen: 1 abstracte omgevingen, 2 semi-ontworpen omgevingen en 3 volledig ontworpen omgevingen. Deelnemers die door alle omgevingen hebben genavigeerd worden gevraagd om een feedback te geven middels het beantwoorden van een vragenlijst. Ondertussen worden hun hersenactiviteiten geregistreerd door middel van professionele neuropsychologie apparaten. Na het bestuderen van de hersenactiviteiten en de vragenlijsten begint het steeds duidelijker te worden dat de perceptie van een abstracte omgeving totaal verschillend is van de perceptie van de semi-ontworpen of volledig ontworpen omgevingen. Dit experiment versterkt de hypothese dat UVEs als abstract ontworpen omgevingen de delen van de hersenen activeren die een correlatie hebben met creativiteit.

In de laatste stap van dit onderzoek, worden alle theorieën toegepast in het laatste experiment. Het experiment won de Visionair fonds van het KP7 en de uitvoering wordt gefinancierd om in Italië plaats te vinden. Een UVE was ontworpen in de software 3D-max en vervolgens 3D stereoscopisch gemaakt in een specifieke software genaamd GIOVE. De multi-disciplinaire interface is ontwikkeld door ITIA-CNR in Italië. Met behulp van een 3D bril en een 6 assen muis wordt een groep van 20 deelnemers gevraagd om door de virtuele omgeving te navigeren. Hierna worden zij gevraagd om schriftelijk feedback te geven over hun gevoelens, de verwachtingen, hun strategie van navigeren door de simulaties en hun ervaring in het algemeen. Hun reacties worden verzameld en geanalyseerd.

In het laatste hoofdstuk worden de onderzoeksvragen beantwoord en worden de definitieve resultaten besproken.

خلاصه رساله

پتانسیل های فضاهای مجازی برای افزایش خلاقیت و همچنین محافظه کار شدن و از دست دادن خلاقیت طراحان با گذشت زمان، دو موضوع اصلی شکل گیری این رساله می باشند. کودکان نسبت به بزرگترها خلاق تر هستند چون به محدودیت ها فکر نمی کنند، بر عکس آن بزرگسالان و بخصوص طراحان تمایل دارند هر دفعه روشهای تکراری گذشته را برای هرگونه موضوع طراحی به کار گیرند.

هیچ تعریف جامع و مانعی برای خلاقیت وجود ندارد. بیش از ۱۰۰ تعریف متفاوت با توجه به زمینه ی رشته ای که خلاقیت در آن تعریف می شود موجود است. با این وجود آنچه بین همه این تعاریف مشترک است این است که خلاقیت ترکیب جدیدی از تمامی چیزهای قبلا تجربه شده است. در این تحقیق تلاش شده است تا بررسی کاملی بر روی روشهای شناخت ضمیر ناخودآگاه از محیط اطرافش و روند درک فضا، همچنین روشهای مختلف تحریک خلاقیت در ضمیر ناخود آگاه بررسی گردد تا بتوان با گسترده تر کردن دامنه تجربیات اندوخته شده در ضمیر ناخودآگاه به تعداد بیشتری از ایده های خلاقانه رسید.

در اولین گام عملی پس از فاز مطالعات چندین فضای مجازی غیر متعارف طراحی گردید و بازخورد مقدماتی متخصصان جمع آوری گردید. در گام بعدی دو پارامتر اثرگذار در خلاقیت معماری شناسایی گردیدند و برای شناخت هر کدام از آنها، یک آزمایش مجزا طراحی گردید :

- تحمل پیچیدگی و ابهام

- ترکیب ایده ها

در این آزمایش ها بازخورد شرکت کنندگان در مواجهه با هر یک از این دو مقوله دریافت شده و آنالیز گردید. نتایج این آزمایشات به دو سوال پاسخ دادند:

الف : تحمل پیچیدگی و ابهام ارتباط مستقیمی با خلاقیت دارد و دانشجویان رشته معماری با توجه به ماهیت رشته معماری و پارامترهای زیاد موثر در طراحی بیش از باقی رشته های مهندسی، آموخته اند که پیچیدگی و ابهام را تحمل کرده و قضاوت خود را به تاخیر بیندازند.

ب : با ترکیب ایده ها می توان به ایده های جدید رسید. هرچه ایده های دورتر و با ماهیت متفاوت تر در ناخودآگاه با هم ترکیب شوند، ایده جدید خلاقانه تر خواهد بود. برای جلوگیری از تولید ایده تکراری، ضمیر ناخودآگاه احتیاج به داده های بیشتر و متفاوت تر و غیرتکراری دارد. این نوآوری در نوع داده های ورودی هنگامی که فضاهای مجازی غیر متعارف را بکار می بریم ممکن می شود.

در گام سوم آزمایشی طراحی گردید تا مقایسه ای بین بعد ابزار و زمینه طراحی صورت گیرد، به این مفهوم که از شرکت کنندگان درخواست گردید تا یک موضوع طراحی را یک باز با استفاده از فضا و ابزار دو بعدی (قلم و کاغذ) طراحی کرده و بار دیگر همان موضوع را با استفاده از فضای سه بعدی کامپیوتری طراحی نمایند. یک گروه داور متخصص در طراحی، میزان تفاوت در خلاقیت را بررسی کردند و به این نتیجه رسیدند که شرکت کنندگان هنگام طراحی در فضای سه بعدی و با ابزار سه بعدی، ایده های خلاقانه تری را ارائه نمودند.

در گام چهارم برای شناخت ماهیت درک فضا برای مغز انسان، سه گونه فضای استعاری، تا حدی طراحی شده و کاملاً طراحی شده انتخاب گردیدند. از شرکت کنندگان درخواست گردید پس از مشاهده هر فضا بازخورد خود را در قالب پاسخ به یک پرسشنامه اعلام نمایند. امواج مغزی شرکت کنندگان همزمان با تجربه حرکت در آن فضاها ثبت گردیدند. پس از آنالیز نتیجه ها مشاهده گردید که روند شناختی مغز برای درک فضایی که استعاری است و مغز هیچگونه سابقه شناختی راجع به آن ندارد با یک فضای فیزیکی قبلاً دیده شده یا تا حدی مشابه آن کاملاً متفاوت است.

در گام پنجم برای اینکه تایید کنیم در هنگام تقلای مغز برای شناخت فضای استعاری مجازی غیر متعارف، قسمتهایی از مغز فعال می شوند که مربوط به خلاقیت است، آزمایش پایانی این مطالعه طراحی گردید. این آزمایش که با بودجه اتحادیه اروپا تامین مالی گردیده و در ایتالیا به انجام رسید، یک فضای مجازی غیر متعارف در محیط نرم افزار تری دی مکس طراحی گردید و توسط نرم افزار واسط دیگری به نام "جیاوه" که توسط تیم میزبان (مرکز تحقیقات ملی ایتالیا) طراحی و توسعه پیدا کرده بود، سه بعدی گردید. شرکت کنندگان با استفاده از عینک سه بعدی و موس شش محوره در آن حرکت کرده و با فضا تعامل می کردند. همانند آزمایش قبلی امواج مغزی شرکت کنندگان در حین حرکت در فضا ثبت گردید. پس از آنالیز نتیجه ها مشخص گردید قسمتهای یکسانی از مغز که قبلاً در آزمایشهای استاندارد مرتبط با خلاقیت تحریک شده بود، شروع به فعالیت کردند. این نتیجه، ایده اولیه این تحقیق را در مورد تحریک خلاقیت با استفاده از فضای مجازی به تایید رساند.

1 Introduction

§ 1.1 General introduction:

Creative potential of human spearheads their civilization. In fact, progress in every sphere of our lives crucially depends on our creativity. Emphasizing the role of creativity in design even more than other disciplines pushes one to explore understanding of creativity as a key role player in Architecture. Furthermore, by identifying the basic principles of our ingenuity/creativity, researchers might be able to enhance these abilities in the future.

But how can we define creativity? Though creativity is the hallmark of human cognition, and therefore a topic of enormous scientific importance, yet not a single definition of creativity exists that is universally accepted by creativity researchers, and the scenario hasn't changed much in the last fifty years. Nevertheless, any creative output (be it an idea, product, or performance) should have, at least, three characteristics: novelty (it is original), usefulness (it is functional and adaptive), and surprising (it is non-obvious, therefore eliciting an aesthetical or affective response).

Many architects confess that, very gradually and unconsciously they tend to inherit and hold on to conventional design approaches, because slowly confinements in construction and conventional stereotypes impose on them, dominate them and prevent them to think innovatively. Now, it is seemingly logical that if you get a chance to see and explore some innovative notions in virtual environments, devoid of any physical limitation, then it will lead to conceptual expansion, since diverse pictures/ inspirations shall be added to pre-conceived design ideas. This will help designers to expand their conceptual boundaries and thus eventually help them to enhance their creativity. Being in varied or miscellaneous environments can help train individuals to encode information in multiple ways, building a myriad of associations between diverse concepts.

§ 1.2 Terminology

§ 1.2.1 Creativity

Creativity is a vague term, and its definition is totally pertaining to the context of study and the discipline. As far back as 1959, Taylor surveyed about 100 definitions in his attempt to clarify the creative process (Taylor 1959). The definitions vary significantly by the content and complexity. Nevertheless, there are two commonly “universal” attributes of creativity: novelty and appropriateness. Any creative output (be it an idea, product, or performance) should have, at least, three characteristics: novelty (it is original), usefulness (it is functional and adaptive), and surprising (it is non-obvious, therefore eliciting an aesthetical or affective response) (Simonton, 1999). For the purpose of this research, we will consider creativity as a cognitive process that generates new concepts, which are novel and unconventional.

§ 1.2.2 Abstract design

Abstraction is the process of taking away or removing characteristics from something in order to reduce it to a set of essential characteristics. In other words, it is the act of considering something as a general quality or characteristic, apart from concrete realities, specific objects, or actual instances (Langer, 1953). Narrowing down the concept of abstraction to architectural space, the definition can be modified to: Abstract architectural environments are those, which, use a visual language of form, color and line to create a composition which may exist with a degree of independence from visual references in the physical world. For the sake of this research, “degree of independence” is considered as “not complying with physical rules, e.g. lack of gravity, infinite depth, continuous change and whatever that is not perceivable in the physical world.

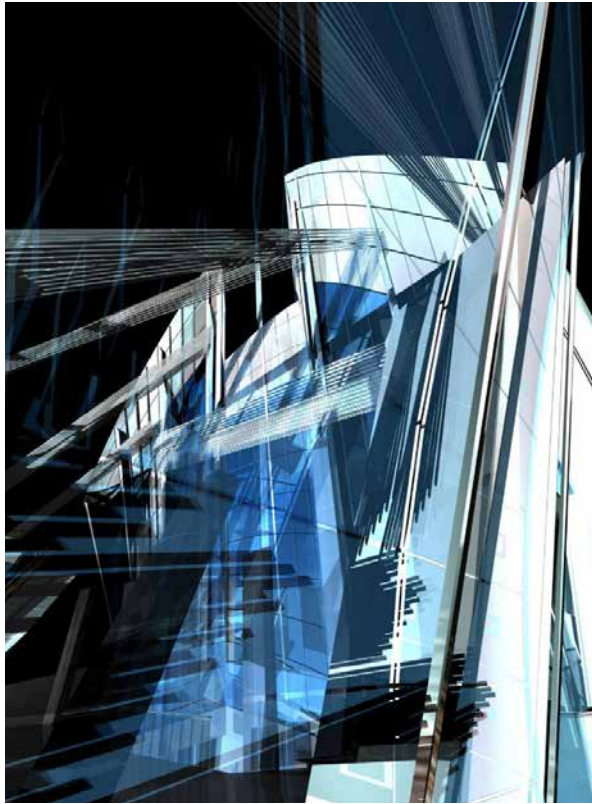

FIGURE 1.1 Abstract environment by Alireza Mahdizadeh Hakak

§ 1.2.3 Unconventional Virtual Environments (UVEs)

A UVE is an abstract environment which designed with a degree of independence from rules of physical world, e.g. lack of gravity, infinite depth, continuous change, etc. A UVE can be sophisticated, complicated and fully detailed, but still apart from concrete realities, specific objects, or actual instances.



FIGURE 1.2 Sample of Unconventional virtual environment by Marcos Novak

§ 1.3 Research aims and questions

As a designer, I was always curious as to why children tend to be more creative than adults. They always have a solution for every problem. I did spend a lot of time observing their behavior to try to find a pattern or reasonable answer to my questions. And besides, after spending 8 years in practice and dealing with almost all aspects of the discipline of architecture (as a lecturer at a University, an Architect with consulting engineers, as a Project Manager handling different scales of projects and as a Construction Supervisor), and interviewing a variety of different designers and architects with different backgrounds, ages, sex and expertise coming from different contexts, I can summarize subjectively, the problems related with the discipline of architecture as follows:

- 1. Gradually thinking out of box becomes a very difficult task for the designer*
- 2. Designers tend to follow the same design methodology each time (Irrespective of the differences in Content and Context)*
- 3. Construction related constrains impose upon designers and restrict them from exploring unconventional design solutions*
- 4. Designers find it difficult to update themselves with new technologies not only due to the cost of new technologies, the learning curve involved as well as the fear of swaying away from their set methodology of operation but also since the brain, in the long run tends not to think divergently.*
- 5. Tendency to deploy convergent thinking means instead of divergent thinking during the early stages of design*

Considering the aforementioned problems and context, this dissertation explores the application of Unconventional virtual environments (UVEs) for enhancing creativity in the domains of architecture pedagogy and practice. Besides finding parameters which are correlated with creativity in architecture design, the two main primary objectives driving this research are the following:

- 1. Is it possible to reverse the process of diminishing creativity by providing new visual feed/stimulus to the brain by exploring UVEs? Does the combination of this new visual feed with the previous knowledge of space and geometry, help the brain in generating creative ideas? Does the mutation in combination of ideas happen?*
- 2. Does starting the design process from a higher dimension help the designer generate more creative ideas? Does changing the medium and design tools help the architect to be more creative? If the answer is positive how this can be implemented in architecture practice?*

§ 1.4 Boundary condition

This research is narrowed down based on two different boundary conditions that make it more specific.

Firstly, since there is no global definition for creativity and it changes from context to context and there are more than 100 different definitions according to different disciplines, this study embraces the definition of David Jones and the idea of “Conceptual Blending” by Arthur Koestler.

Secondly, creativity has different aspects to be compared; due to the vagueness of the topic according to different contexts. The scope of this research has thus been narrowed down to creativity in architecture/design and all other aspects of creativity including personality and behavior of creative people, mood, state, temper, intelligence vs. creativity, motivation, prediction of the brain and so forth have been ignored. Instead, cognitive aspects of creativity including thinking patterns, conceptual blending, idea expansion and tolerance of ambiguity have been focused upon.

§ 1.5 Research questions

From these main objectives, the following main research questions arise:

1. *What are effective parameters correlated with creativity in architectural design?*
2. *Does changing the tool and changing the dimension of design process (from an analogue 2D pen and paper to 3D software interface) help in enhancing creativity?*
3. *Theoretically, how can unconventional virtual environments (UVEs) be helpful for enhancing creativity?*
4. *Are there any methods to boost [spatial] creativity in architecture?*
5. *Does the human brain detect any difference while perceiving different spatial environments? (E.g. Abstract designed, Semi designed and Fully designed environment). Can we provide an objective empirical evidence of this difference in perception?*

Research question 1) is addressed after an in-depth literature review to find effective parameters correlated with creativity in architectural design. This question is answered via a scientific journal paper, published in Journal of civil engineering and architecture (JCEA) with the following title:

CREATIVITY IN ARCHITECTURE -A REVIEW ON EFFECTIVE PARAMETERS CORRELATED WITH CREATIVITY IN ARCHITECTURAL DESIGN

Research question 2) is addressed in chapter 3 via a research experiment. In this experiment a group of architects were asked to perform the same design task using two different mediums, tools and dimensions: once using a 2D pen and paper and the next time by using a 3D software interface. The question is answered via a scientific journal paper, published in "Scientific Research Publishing" with the following title:

"THINKING OUT OF THE BOX" FROM OUT OF THE BOX! INCREASING THE DIMENSION OF "STARTING POINT"

Research question 3) is answered in chapter 4. The chapter also has a complete/detailed elaboration of the hypothesis:

- What types of virtual environments are needed for enhancing creative performance?
- Will surfing/exploring UVEs enhance creative performance and creativity-supporting cognitive processes (e.g., recruitment of different ideas and retrieval of unconventional knowledge)
- How can UVEs contribute towards developing a pedagogy of architecture

The Research question 3) is answered via a scientific journal paper published in The International Journal of Virtual and Personal Learning Environments (IJVPLE) with the following title:

IMPLEMENTING UNCONVENTIONAL VIRTUAL ENVIRONMENTS FOR ENHANCING CREATIVITY IN ARCHITECTURE PEDAGOGY

Research question 4) is answered in chapter 5. In this chapter an experimental research project has been introduced: Proto-fuse. In this project conceptual blending and tolerance of ambiguity have been addressed. The project and its findings are introduced via a scientific journal paper published in The International Journal of Design Creativity and Innovation (IJDCI) with the following title:

THE PROTO-FUSE PROJECT: METHODS TO BOOST CREATIVITY FOR ARCHITECTS

Research question 5) is answered in the chapter 6. This chapter elaborates upon experiments which have been conducted to analyze the differences between human perception while observing three different environments:

- 1- Abstract environment
- 2- Semi-designed environment
- 3- Fully-designed environment

The results of these experiments have been published in a scientific journal paper published in the journal of Cognitive Neurodynamics with the following title:

NAVIGATING ABSTRACT VIRTUAL ENVIRONMENT: AN EEG STUDY

§ 1.6 Research Method

§ 1.6.1 Research steps and approaches

This dissertation is an exploratory research that tests the hypothesis of using unconventional virtual environments (UVEs) for enhancing creativity of architects. Therefore, different parameters which were correlated with creativity in architecture were studied from the available literature. Since creativity is a multi-faceted topic, which can be approached from different angles and viewpoints, a boundary condition has been subsequently defined for this dissertation as the first step.

After reviewing relevant literature, a hypothesis has been defined clearly and the potentials for implementing UVEs in pedagogy of architecture have been outlined as the second step. Yet there is no clear road map which has been defined, since one needs to conduct more explorative experimentations to recognize better the characteristics of human perception, the role of the unconscious mind, and creativity supporting tools. For this reason, three different experiments have been designed to address each of these questions separately as the third step.

As the fourth step, a sample UVE has been designed and tested by a group of unbiased participants. The facilities and fund, tools and the ground for the last experiment has been provided by Visionair (<http://www.infra-visionair.eu/>) as a part of an FP7 program. This experiment was conducted in ITIA-CNR of Italy. For creating this environment, 3D max software was interfaced with a 3D interface Glove, in order to develop a 3D stereoscopic environment. A Conexxion 3D navigation mouse and 3D Goggle were used to create a highly immersive environment. Group of 20 participants subsequently provided feedback after navigating in this UVE.

Fifth and final step is the conclusion. In this chapter all the question were answered. Besides, suggestion for future researches and recommendation for application in practice were also provided.

§ 1.6.2 Research tools

In this research, computer simulations, experiments and analysis were done. The tools used are described here in three categories: simulation software, analysis software and technical devices.

§ 1.6.2.1 Computer design and simulation tools

3ds Max - Autodesk:

Autodesk 3ds Max, formerly 3D Studio, then 3D Studio Max is a professional 3D computer graphics program for making 3D animations, models, games and images. The software is used to create the design environment of UVE for the experiment.

Giove

GIOVE stands for: “Graphics and Interaction for OpenGL-based Virtual Environments” and is a set of software libraries (SDK Software Development Kit) written in C and C++ for developing applications that use real time 3D graphics. GIOVE was specifically used for creating stereoscopic environments in this research. ITIA-CNR (National Research Council: Institute of Industrial Technologies and Automation) of Italy had developed this stereoscopic interface for its internal research. GIOVE is an internal “product”, it does not have any licenses, it is not open source either. GIOVE is based on OpenGL (www.opengl.org) and is compatible with Windows. It can load 3d models in 3DS and Obj format. FBX and DXF formats are under development depending on the demand of the projects in progress. For utility purposes there is an application called “GIOVE-Viewer”, an application for loading 3D models and that allows various basic operations including navigating in the scene, positioning/rotating models, taking screenshots, adding lights, customizing observer’s point of views, and enabling real time shadows and so forth.

§ 1.6.2.2 Analysis tools

sLORETA

sLORETA is a method that computes images of electric neuronal activity from EEG and MEG. For this research, sLORETA as a software package was specifically used for analyzing EEG patterns. Publically available free academic software at: <http://www.>

Uzh.ch/keyinst/loreta.htm, has been successfully used in a number of recent EEG studies. The software provides a 3d map of the activated parts of the brain and has powerful capabilities of data normalization, baseline correction, etc.

EEGLAB

EEGLAB is an interactive Matlab toolbox for processing continuous and event-related EEG, MEG and other electrophysiological data incorporating independent component analysis (ICA), time/frequency analysis, artifact rejection, event-related statistics, and several useful modes of visualization of the averaged and single-trial data.

§ 1.6.2.3 Technical devices

3D projector:

The projector used in this experiment was EX762, XGA - 4000 ANSI Lumens. Using the inherent speed of DLP technology, The Optima EX762 can output video and images at the rate of 120Hz, allowing one to project in full screen, full color, stereoscopic 3D. The 3D effect is generated by splitting one signal into two standard video streams, one for each eye. Using DLP® Link™ technology, the 3D glasses synchronize with the image on screen to filter each stream to the correct eye. The brain then combines the two streams. The 3D features of the EX762 can only be used with compatible 3D content (Figure 2).



FIGURE 1.3 3D stereoscopic projector

3D goggle:

DLP (Digital light processing) technology uses millions of microscopic, digital mirrors that reflect light to create a picture for projectors. This imaging technology is so fast, it can actually produce TWO images on the screen at the same time: One for the “left” eye and

one for the “right” eye. To create the 3D effect, you need 3D Glasses that combine the two images (Figure 3). For the sake of an experiment we decided to use XPAND 3rd generation of DLP® Link™ 3D Glasses: XPAND Edux 3 3D Glasses (X103-EDUX3 / X103-EDUX3-R1).



FIGURE 1.4 XPAND 3D Goggle

3D navigation tool:

3Dconnexion was employed to navigate virtual environment. Commonly utilized in CAD applications, 3D modeling, animation, 3D visualization and product visualization, users can manipulate the controller’s pressure-sensitive handle (historically referred to as either a cap, ball, mouse or knob) to fly through 3D environments or manipulate 3D models within an application. 3Dconnexion patented 6-degrees-of-freedom (6DoF) technology – smooth and intuitive control of 3D models and environments. The appeal of these devices over a mouse and keyboard is the ability to pan, zoom and rotate 3D imagery simultaneously, without stopping to change directions using keyboard shortcuts or a software interface giving the participants a clear sense of immersion in virtual space.



FIGURE 1.5 3DConnexion mouse

§ 1.7 Dissertation outline

This dissertation has three main parts:

Part A is based on literature review. All different effective parameters correlated with creativity in architectural design have been reviewed. Other related parameters of creativity which may not directly related to design and were more into personal behavior, were dismissed (chapter 2).

Part B demonstrates series of experiments to investigate different aspects of human perception, creativity, tools which can enhance creativity. (Chapters 3-5). Also, two sample experiment have been introduced which can increase tolerance of ambiguity and also help for mutation in conceptual blending (chapter 6). Both concepts will indirectly enhance creativity.

Part C presents a sample designed UVE which has empirically approved that by navigating in that sample environment [spatial] creativity of the user will improve.

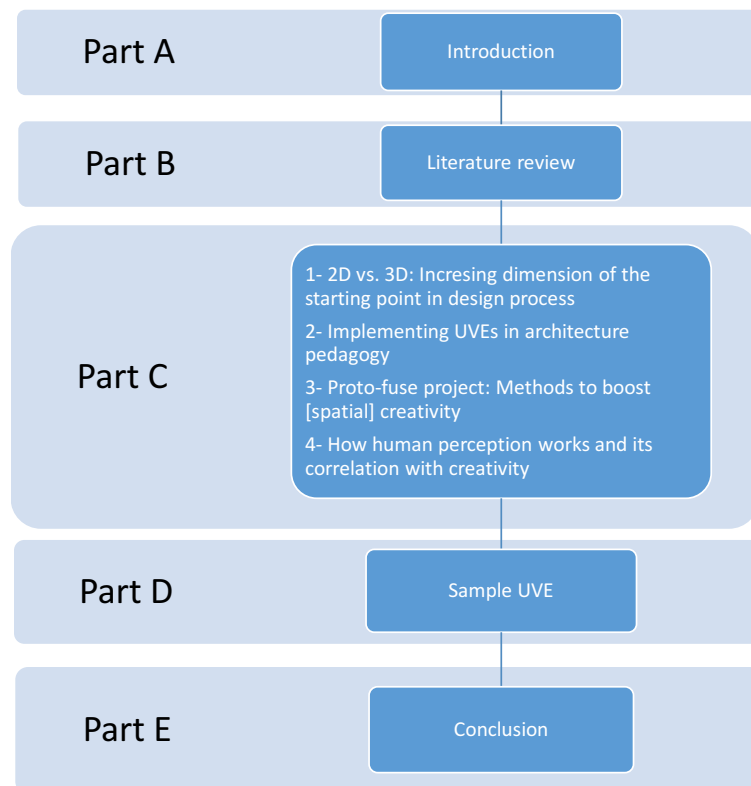

2 Literature review

§ 2.1 Introduction to creativity and effective parameters correlated with creativity in architectural design

A pivotal target of this thesis is 'how to enhance creativity'. This chapter reviews effective parameters correlated with creativity in architectural design. The Chapter starts with the definition of creativity and investigates where creative ideas come from. Further on, it also elaborates upon types of creativity and touches upon the relationship between tolerance of ambiguity and creativity.

To narrow down the widespread topic of creativity and focus on creativity in architecture, the research ignores aspects of creativity which focus on personality and behavior of creative people, their mood, their state and their temper, intelligence vs. creativity, motivation and so forth. Instead, the research focuses on cognitive aspects such as thinking patterns, conceptual blending, idea expansion and tolerance of ambiguity.

These aspects are elaborated in the first journal article: "Creativity in architecture -A review on effective parameters correlated with creativity in architectural design" in the Journal of civil engineering and architecture, ISSN 1934-7359, USA, Nov. 2014, Volume 8, No. 11 (Serial No. 84), pp. 1371-1379.

§ 2.2 Creativity in architecture - A review on effective parameters correlated with creativity in architectural design*

Alireza Mahdizadeh Hakak¹, Nimish Bioria¹ and Armaghan Ahmadi Venhari²

¹Faculty of Architecture, TU Delft University, Delft, The Netherlands

²Faculty of Architecture, Shahid Beheshti University of Iran, Tehran, Iran

Abstract. Human civilization can be ameliorated by human creativity. Innovation and progress of human civilization results from a change in our thinking patterns, thus, potentially transforming the present into a creative future. Accentuating the role of creativity in design even more than other disciplines pushes one to underpin the understanding of creativity as a key role player in Architecture. Furthermore by identifying the basic principles of our ingenuity/creativity, researchers might be able to enhance this ability in the future. A key point in “creativity” is the role of previously gained experiences, which cause expanding the inventory of experiences. According to accepted definition in different disciplines, creativity is no more than new combinations of previous ideas. The paper explores different effectual parameters correlated with creativity in architectural design including notion of conceptual blending, improbableist and impossibleist creativity, tolerance of ambiguity and its correlation with creativity and creativity aided tools and interfaces. At the end we will suggest necessary experiments to obtain empirical results for some speculations that are discussed in the paper. Also practical approaches will be suggested to apply the results in pedagogy of architecture.

Keywords. Virtual Environment, Experience, Creativity, Conceptual blending, Tolerance of ambiguity

* Published as: Mahdizadeh Hakak A., Bioria N, Ahmadi Venhari A. (2014), “Creativity in architecture - A review on effective parameters correlated with creativity in architectural design”, Journal of civil engineering and architecture, ISSN 1934-7359, USA, Nov. 2014, Volume 8, No. 11 (Serial No. 84), pp. 1371-1379

§ 2.2.1 Introduction

The human civilization is spearheaded by human's creative potential. In fact, progress at every sphere of our lives crucially depends on our creativity. Accentuating the role of creativity in design even more than other disciplines pushes one to underpin the understanding of creativity as a key role player in Architecture. Furthermore by identifying the basic principles of our ingenuity/creativity, researchers might be able to enhance these abilities in future.

But how can we define creativity? Though creativity is the hallmark of human cognition, and therefore a topic of enormous scientific importance, yet not a single definition of creativity exists that is universally accepted by creativity researchers, and the scenario hasn't changed much in the last fifty years (Runco, 2004; I. A. Taylor, 1959). Nevertheless, any creative output (be it an idea, product, or performance) should have, at least, three characteristics: novelty (it is original), usefulness (it is functional and adaptive), and surprising (it is non-obvious, therefore eliciting an aesthetical or affective response)(Simonton, 1999).

Many architects confess that, very gradually and unconsciously they stock in some conventional design approaches, because slowly confinements in construction and conventional stereotypes and rules of the physical world impose on them, dominate them and prevent them from thinking innovatively. In this paper, after reviewing the related literature on creativity in design, methods will be proposed to boost creativity and reverse the process of losing it.

§ 2.2.2 What Is Creativity?

Creativity is typically defined as the process of bringing into being something that is both novel and useful (Amabile, 1996; Sawyer, 2012; Sternberg & O'HARA, 1999). The creative process is often a mysterious phenomenon, with sudden insights seeming to work at an unconscious and inaccessible level (Schooler & Melcher, 1995). The magical "aha" moment of discovery, the point at which an idea leaps into consciousness, is part of what makes creativity seem sudden, without logic, and elusive (Leung, Maddux, Galinsky, & Chiu, 2008).

Because of its apparent unpredictability and elusiveness, creativity may seem difficult to study scientifically and systematically. However, psychology based literature now can provide a wealth of evidence depicting the psychological factors that facilitate creativity; elements of personality, affect, cognition, and motivation can either

facilitate or impair creativity (Amabile, 1996; Csikszentmihalyi, 2009; Sawyer, 2012). For example, personality studies have demonstrated that creative people tend to be nonconforming, independent, intrinsically motivated, open to new experiences, and risk seeking (Simonton, 1999). Large-scale studies and meta-analyses have found that intelligence, tolerance of ambiguity, self-confidence, and cognitive flexibility also tend to be found in creative people (Feist, 1998; MacKinnon, 1978). Now, it seems logical that if we consider an approach from the other side of the spectrum - we push designers to encounter new experiences - we can enhance their thresholds of ambiguity, self-confidence, cognitive flexibility, etc. It has been proven that a number of contextual factors related to motivation, cognition and affect facilitate creativity. Individuals who pursue tasks for intrinsic rather than extrinsic purposes show enhanced creativity (Amabile, 1985, 1996; Amabile, Hennessey, & Grossman, 1986; Hennessey & Amabile, 1998). Especially in design we consider it largely intrinsic rather than extrinsic. A distant future focus, compared to a near future focus, has been shown to lead to more creative negotiation outcomes (Okhuysen, Galinsky, & Uptigrove, 2003) and to enhanced creative insight (Förster, Friedman, & Liberman, 2004). Focusing on potential gains rather than losses increases the accessibility of unconventional ideas and thus enhances fluency in generating creative ideas (Friedman & Förster, 2001; LAM & CHIU, 2002). Finally, creativity seems to flourish when people are in positive or neutral affective states rather than negative affective states (Amabile, Barsade, Mueller, & Staw, 2005; Fredrickson, 2001).

To narrow down the scope of this research to creativity in architecture, we will ignore all other aspects of creativity including personality and behavior of creative people, mood, state and temper of them, intelligence vs. creativity, motivation and so forth and instead we will focus on cognitive aspects including thinking patterns, conceptual blending, idea expansion and tolerance of ambiguity.

§ 2.2.3 Where do creative ideas come from?

How can we get new ideas? In his book “The AHA! Moment” David Jones (Jones, 2012) takes a bold stance by claiming that we cannot have a truly new idea, the best we can do is to make combinations of different ideas already known to us. Therefore one needs a vast subconscious mass of remembered data in order to increase the likelihood of combination of ideas.

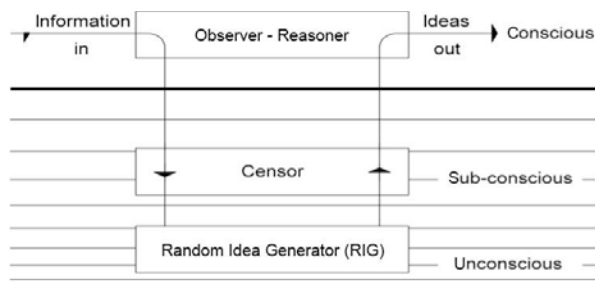

FIGURE 2.1 The model of human mental structure after Jones (2012).

Jones' theory of creativity is based on a three-tiered model of human mental structure (Figure 1). The top level is the Observer-Reasoner, the conscious part of our mind that is involved with planning, execution and action. It is also involved with reasoning, argument and conscious deliberation. The mid-level is the Censor, the subconscious part that houses our implicit knowledge (e.g., procedural skills, linguistic skills). It allows rapid access of stored knowledge or information, and also protects the Observer-Reasoner from constant perturbations. The lowermost level is the unconscious mind, the creative part of it is termed as the Random-Idea-Generator (RIG) that combines randomly, without any rule/supervision, ideas or information stored in the unconscious and preconscious mind. Due to the inherent randomness in the combinatorial process, most of the RIG ideas are wrong or not functionally useful and therefore blocked by the Censor before it could reach the uppermost conscious level, the Reason-Observer. If a creative RIG idea manages to pass the Censor and finally reaches the conscious level, it is likely to be perceived as a flash of sudden insight, known as Aha!

This model, though quite appealing due to its inherent simplicity, does not provide much insight into how the ideas are combined. Even for a random combination to occur by the RIG, there has to be a mapping procedure by which ideas or concepts belonging to different domains or disciplines are allowed to merge with each other. The theory of 'conceptual blending' provides such a mechanism (Turner, 1998). In his book "The Literary Mind" Mark Turner states: "Conceptual blending is a fundamental instrument of the everyday mind, used in our basic construal of all our realities, from the social to the scientific." The theory posits that elements and vital relations from diverse scenarios are "blended" into a subconscious process known as Conceptual Blending, which is assumed to be ubiquitous to everyday thought and language. If two concepts are similar, simpler strategy is used to combine them and the resultant concept is less novel and offers limited surprise. However, for very different or remote concepts, complex strategies of structural mapping are required to fuse them and this results in most novel, innovative concepts. The more mutually remote the concepts are, the more surprising and creative the blended concept is. Indeed one of the classic laboratory tests on creativity is termed as remote associate test, which is based on this very idea that creativity involves remote associations between concepts (Mednick, 1962).

Insights obtained from these blends constitute the products of creative thinking. Arthur Koestler, demonstrate this idea in his 1967 book *The Act of Creation* and identified a common pattern in creative achievements in art, science and humor, which he called “bisociation” (Koestler, 1964). After analyzing and comparing varied instances of inventions and discoveries he concluded that fusing two unrelated elements coming from two different ideas/categories can be seen in an evolving matrix of meaning by way of a process applying analogies, comparisons, abstraction and metaphors. Indeed throughout history there are many examples of creative individuals who possessed expertise in multiple professions, thereby allowing the successful combination and cross-fertilization between different disciplines.

Good bodies of literatures consolidate and extend the above notion. Being in varied or diverse environments can train individuals to encode information in multiple ways, building a myriad of associations between concepts. For instance, bilinguals, who have been exposed to two languages, are more creative than monolinguals (Leung et al., 2008; Simonton, 1999). Creativity is found at relatively high rates for individuals who are first or second generation immigrants and for individuals who are ethnically diverse or ethnically marginalized (Lambert, Tucker, & d’Anglejan, 1973). At the group level, creativity is facilitated within collaborative groups that contain diverse members (Guimerà, Uzzi, Spiro, & Amaral, 2005; Levine & Moreland, 2004) and in groups in which heterogeneous opinions are expressed (Nemeth & Wachtler, 1983). Even at the societal level, creativity increases after civilizations open themselves to outside influences and when geographic areas are politically fragmented and relatively diverse (Simonton, 1997).

The current study also accentuates ‘experience’, its way of operation and points out its existence and relevance in creativity. Experiences indirectly affect creativity. The larger the inventory of experiences, the more and better combination of ideas is possible. Further, the more diverse and unusual the experiences, the higher the likelihood of creativity. For example, recent research suggests a link between multicultural experiences (e.g., learning a new language, multicultural exposure) and creative thinking (Leung et al., 2008). The exposure to and engagement with unusual experiences and/or situations may lead to a better cognitive flexibility by breaking the fixed cognitive patterns, a source of functional fixedness, and thereby, promoting creative associations between distant ideas. In fact, a recent research shows that after actively experiencing unusual virtual scenarios participants score higher on unusual uses task, a widely applied measure of creativity leading the authors to suggest a causal role of unusual and unexpected experiences in creativity (Guilford, 1967; Ritter et al., 2012). In this paper we attempt to extrapolate and connect this concept of “variety and extensiveness of experiences” to discipline of architecture.

§ 2.2.4 Types of creativity

Boden (M. A. Boden, 2003) has suggested two broad types of creativity: improbableist and impossibilist. The improbableist creativity involves new or unlikely, therefore improbable in nature, combinations of existing ideas, which is similar to the earlier concept discussed by David Jones. This is also the current working definition of creativity in architecture. Though this is not a universally accepted definition of creativity, however, informally this is the usual creative process, which architects follow. On the other hand, the impossibilist creativity is a deeper type involving the mapping, exploration and transformation of conceptual spaces. Therefore the two types differ in the mode of the creative thinking.(M. A. Boden, 2003). Improbabilist creativity specifies thinking in the associative mode, while respecting the logics, (physical) rules, and boundaries and constraints (Fauconnier & Turner, 1998).

If we extrapolate this definition to architecture, obeying conventional rules and the role of confinements in architecture in terms of material, technology, even perception of new spaces become clear. Impossibilist creativity is subject to the bisociative mode, in which the conceptual space is transformed, possibly at the expense of existing rules and disciplinary boundaries, and therefore affords higher autonomy in the procedure (Koestler, 1964). It is literally presumed that a product of impossibilist creativity needs mutation and transformation of the corresponding conceptual spaces (M. Boden, 1995). The first step relevant for creativity in design will be an enhancement of the perception of spaces. Since our visual perception is overly used to (and therefore constrained by) the environment around us in term of scale, depth, dimension, etc., changing the characteristics of the conventional environment around us might pave the way towards transformation of the corresponding conceptual spaces (Bubic, Von Cramon, & Schubotz, 2010).

§ 2.2.5 Shifting to Impossibilist conceptual blending in architecture

In the same logical vein as above, we expect to find similar outcome in the architecture discipline in design processes. The question here is how we transform improbableist creativity to impossibilist creativity in architecture. Since the information feed of the brain is limited to what has been provided by the senses (e.g., hearing, seeing, tactile) and the experiences that can be accumulated from experiencing the physical world too are limited or constrained by the environment around us, in terms of its scale, depth, dimension, etc (Bubic et al., 2010). Transformation of the corresponding conceptual space needs mutation that seems farfetched with the available information feed.

Therefore changing the characteristics of the conventional environment around us may provide an alternative route for transformation of the corresponding conceptual space.

Digital era allows for new possibilities of architectural experience. It is assumed that new designs in virtual environments can be created that go beyond the mere accommodation of literal functions, and that affect human experiences. Detaching from the real one in sense of time and matter, enables the designers to cross the borderline between reality and fiction and expand their inventory. This new kind of architecture can create emotionally rich architectural experiences through the dynamic and precise manipulation of abstract visual forms in virtual space (Hakak, Bilorja, & Rahimi, 2012). In this stage the inventory of experiences is expanding and we can expect that by blending new data with the old ones, mutations are bound to happen. From a cognitive point of view extensiveness of experience gained by surfing in unconventional virtual environments can positively be related to both creative performance (enhance interactivity, lateral thinking, idea generation, etc) and creativity-supporting cognitive processes (retrieval of unconventional knowledge, recruitment of ideas from unconfined virtual environment for creative idea expansion). Eventually with new languages and forms we can stimulate our creativity (Bartle, 2004; Castronova, 2008; Cherbakov, Brunner, Smart, & Lu, 2009; Novak, 2004).

§ 2.2.6 The Relationship between Tolerance of Ambiguity and Creativity

A large number of literature studies suggest a possible link between tolerance of ambiguity and creativity. A creative individual should have the ability, will and desire to deal with ambiguous and open-ended situations and suspend his/her immediate judgments to allow various possibilities to emerge; in fact, Taylor (C. W. Taylor & Barron, 1963) listed a liking for abstraction with considerable tolerance of (cognitive) ambiguity as one of the key traits of a creative scientist. Amabile (Amabile, 1996) too, illustrates the judgment suspension as “keeping response option open as long as possible” as well as tendency to break down the conventional rules/methods whenever necessary. Intrinsic motivation is also connected to creative achievements (Amabile, 1985, 1996; Hennessey & Amabile, 1998). We argue here that tolerance of ambiguity is related to creativity because it “empowers the intrinsically motivated exploration of novel, unusual, or complex stimuli”. Zanasni and Barron (Barron & Harrington, 1981; Zanasni, Besançon, & Lubart, 2008) show that creative achievers tend to be attracted towards complexity. Dacey (Dacey, 1989) describes: “The first characteristic of the creative person is tolerance of incongruity, which could be called tolerance of ambiguity. Its opposite could be called fear of the unknown or unfamiliar.” Eysenck (Eysenck, 1993) illustrates that highly creative individuals, “can live with doubt and uncertainty, even enjoying risks and seeking out instabilities in the world.”

Amabile (Amabile, 1996) also emphasizes the ability of divergent thinking and using wide and flexible categories. Individuals, who cannot tolerate ambiguity, tend to seek the solution through available options and rigid categories and tend to close the situation prematurely (Kenny & Ginsberg, 1958). However one should not confuse creativity with intelligence, as Kenny and Ginsberg (Kenny & Ginsberg, 1958) found that individuals with high levels of intelligence but low levels of creativity tended to be “intolerant of unlikely, unconventional types of hypothesizing about the world.”

These literatures altogether conspicuously suggest a positive association between creativity and tolerance of ambiguity (Amabile, 1985, 1996; Sternberg, 1985; Sternberg & O’HARA, 1999; C. W. Taylor & Barron, 1963; Zenasni et al., 2008).

§ 2.2.7 The Creative Cognition Approach

Recently, a scientific approach to studying creativity—the creative cognition approach—was proposed for understanding and specifying the cognitive processes that produce creative ideas (Amabile, 1996; Bink & Marsh, 2000; Finke, Ward, & Smith, 1992; Runco & Chand, 1995; Wan & CHIU, 2002). The central argument of this approach is that creative processes are not much different from those cognitive processes that produce our everyday mundane activities.

Every person has the potential to become creative as long as he or she effectively utilizes ordinary cognitive processes to produce extraordinary creative outcomes (Finke et al., 1992; Thomas B Ward, Smith, & Vaid, 1997; Weisberg, 1993). Specifically, the creative cognition approach identifies two kinds of cognitive processes implicated in creative thinking—generative processes and exploratory processes (Finke et al., 1992). First, people actively retrieve or seek out relevant information to generate candidate ideas with differing creative potential (the generative processes). Next, they survey these candidate ideas to determine which ones should receive further processing, such as modification, elaboration, and transformation (the explorative processes) (Leung et al., 2008). One strategy that makes effective use of generative processes is conceptual expansion, which takes place when attributes of seemingly irrelevant concepts are added to an existing concept to extend its conceptual boundary (Hampton, 1987; T.B. Ward, Patterson, Sifonis, Dodds, & Saunders, 2002; Thomas B Ward et al., 1997).

§ 2.2.8 Discussion

Unconventional Virtual Environments (UVEs) can be designed in a way that variety of spatially intriguing concepts such as: Ambiguity, Multiple dimensions, Dematerialization, Infinite depth, Continuous change, multiple scales etc. can be experimented with. These concepts and their visualization can render cognition and perception a new meaning owing to the fact that the brain has not experienced and comprehended such concepts before and is thus not pre-conditioned to interpret them (Figure 2.2,2.3).

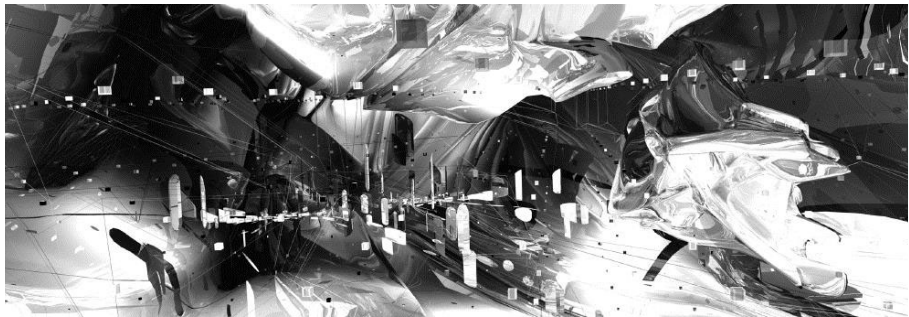

FIGURE 2.2 V4D_Visio4D by Marcos Novak-Used with permission



FIGURE 2.3 V4D_Visio4D by Marcos Novak-Used with permission

Although this shock has its dark side, once the initial, difficult adaptation stages have passed, it can also provide a great opportunity for acquiring new perspectives to approaching various tasks and learning new ways of thinking. Whereas old, conventional design approaches may constrain creativity, the experience of virtual environments may foster the creative expansion of ideas. Thus, we hypothesize that virtual environment experiences can contribute to creative expansion in at least four ways:

(1) Architects learn new ideas and concepts from exploring and designing in these environments. Through these experiences, people are also exposed to a range of behavioral and cognitive scripts for situations and problems. These new ideas, concepts, and scripts can be the inputs for the creative expansion processes because the more new ideas people have, the more likely they are to come up with novel combinations (Weisberg, 1993).

(2) Although architectural pedagogy established conceptions and conventions provide the architect with structured and routine responses to design, these cognitive structures may be destabilized as people to acquire alternative conceptions through their experiences in another environment, in terms of new perception and cognition and interaction with it, particularly as people adapt their own thoughts and behaviors to the new environment. Immersing in multiple virtual environments may even lead individuals to access unconventional knowledge when back in the physical world (Figure 2.4, 2.5).

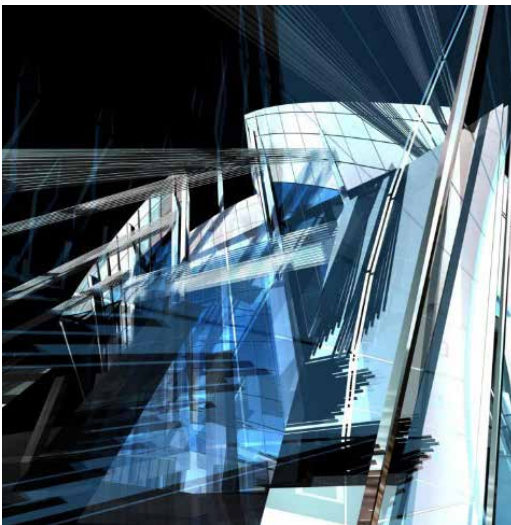

FIGURE 2.4 Screenshot (authors) – new cognitive perception of virtual environments

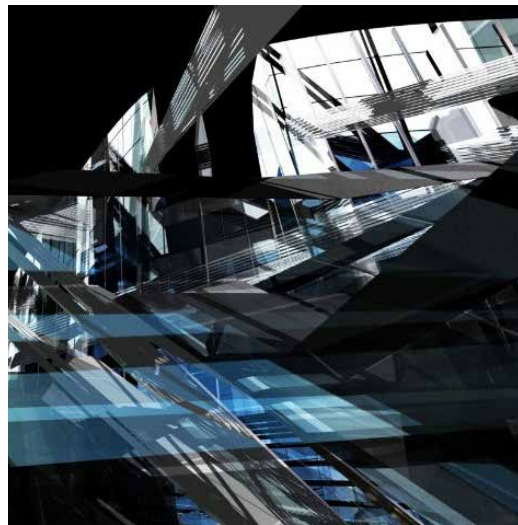

FIGURE 2.5 Screenshot (authors) – new cognitive perception of virtual environments

(3) Having acquired and successfully applied incongruent ideas from these new experiences, designers may show an increase in psychological readiness to recruit and seek out ideas from diverse sources and use them as inputs in the creative process, allowing for continued exposure to a wide range of new ideas, norms, and practices.

(4) It is obvious that implementing formal shapes, characteristics, etc., directly in the physical world is not the purpose, however, incongruent concepts provoke exploration into their interrelations, the process of implementing incongruent ideas may lead to greater cognitive complexity, this challenge finally helps them to think out of the box. In short, the experience of virtual environments may foster creativity by:

- a. Providing direct access to novel ideas and concepts in (unconventional) virtual environments.
- b. Creating the ability to see multiple underlying functions behind the same form.
- c. Destabilizing conventional knowledge structures (design approach), thereby increasing the accessibility of normally inaccessible knowledge
- d. Creating a psychological readiness to recruit ideas from unfamiliar sources and places.
- e. Supporting synthesis of seemingly incompatible ideas from another environment.

Suggested future research will focus on empirically proving that applying UVEs would enhance creativity. Recording the brain waves by EEG (electroencephalography) would be an appropriate measuring tool. While the participant is navigating in UVE, the brain waves will be recorded to see whether there is a correlation between activated parts of the brain with the activated parts on previous standard creativity experiments. The similarities between patterns of thinking will help in understanding the procedure and enhancing the creativity. In case of finding empirical evidence, the following questions may emerge and will need to be answered:

- a. What types of virtual environments are needed for enhancing creative performance?
- b. How does exploring a virtual environment benefit creativity?
- c. How does the brain perceive such immersive environments? (Does it use a reductionist point of view or is it an emergent phenomenon?)

§ 2.2.9 Conclusion

The review demonstrates that virtual environment experiences predict both creative outcomes and creative processes. Virtual environment experiences are positively related to the conceptual boundary in design that requires insight into producing creative ideas without being confined to the widely known. It also predicts creativity supporting processes such as the tendency to access unconventional knowledge from memory and to recruit ideas from new experiences for creative idea expansion. Dealing with the ambiguity of the UVEs helps to enhance tolerance of these environments that positively correlates with creativity. Moreover, it is conspicuous that the relationship between virtual environment experience and creativity is stronger when people adapt and are open to these new experiences. Also, shifting from improbableist creativity to impossibleist creativity is possible when navigating in UVEs.

References

- Amabile, T. M. (1985). Motivation and creativity: Effects of motivational orientation on creative writers. *Journal of personality and social psychology*, 48(2), 393.
- Amabile, T. M. (1996). *Creativity in context*: Westview Press.
- Amabile, T. M., Barsade, S. G., Mueller, J. S., & Staw, B. M. (2005). Affect and creativity at work. *Administrative science quarterly*, 50(3), 367-403.
- Amabile, T. M., Hennessey, B. A., & Grossman, B. S. (1986). Social influences on creativity: the effects of contracted-for reward. *Journal of personality and social psychology*, 50(1), 14.
- Barron, F., & Harrington, D. M. (1981). Creativity, intelligence, and personality. *Annual review of psychology*, 32(1), 439-476.
- Bartle, R. A. (2004). *Designing virtual worlds*: New Riders Pub.
- Bink, M. L., & Marsh, R. L. (2000). Cognitive regularities in creative activity. *Review of General Psychology*, 4(1), 59.
- Boden, M. (1995). Creativity and unpredictability. *Constructions of the Mind: Artificial Intelligence and the Humanities*. *Stanford Electronic Humanities Review*, 4(2).
- Boden, M. A. (2003). *The creative mind: Myths and mechanisms*: Routledge.
- Bubic, A., Von Cramon, D. Y., & Schubotz, R. I. (2010). Prediction, cognition and the brain. *Frontiers in human neuroscience*, 4.
- Castronova, E. (2008). A test of the law of demand in a virtual world: Exploring the petri dish approach to social science.
- Cherbakov, L., Brunner, R., Smart, R., & Lu, C. (2009). *Virtual spaces: enabling immersive collaborative enterprise, part 1: introduction to the opportunities and technologies*. IBM Developer Works, Armonk, NY.
- Csikszentmihalyi, M. (2009). *Creativity: Flow and the Psychology of Discovery and*: HarperCollins.
- Dacey, J. S. (1989). *Fundamentals of creative thinking*: Lexington books Lexington, MA.
- Eysenck, M. W. (1993). *Principles of cognitive psychology*: Lawrence Erlbaum Associates, Inc.
- Fauconnier, G., & Turner, M. (1998). Conceptual integration networks. *Cognitive science*, 22(2), 133-187.
- Feist, G. J. (1998). A meta-analysis of personality in scientific and artistic creativity. *Personality and Social Psychology Review*, 2(4), 290-309.
- Finke, R. A., Ward, T. B., & Smith, S. M. (1992). *Creative cognition: Theory, research, and applications*: MIT press Cambridge, MA.
- Förster, J., Friedman, R. S., & Liberman, N. (2004). Temporal construal effects on abstract and concrete thinking: consequences for insight and creative cognition. *Journal of personality and social psychology*, 87(2), 177.
- Fredrickson, B. L. (2001). The role of positive emotions in positive psychology: The broaden-and-build theory of positive emotions. *American Psychologist*, 56(3), 218.

- Friedman, R. S., & Förster, J. (2001). The effects of promotion and prevention cues on creativity. *Journal of personality and social psychology*, 81(6), 1001.
- Guilford, J. P. (1967). *The nature of human intelligence*: McGraw-Hill.
- Guimerà, R., Uzzi, B., Spiro, J., & Amaral, L. A. N. (2005). Team assembly mechanisms determine collaboration network structure and team performance. *Science*, 308(5722), 697-702.
- Hakak, A. M., Biloria, N., & Rahimi, M. R. (2012). Implementing Unconventional Virtual Environments for Enhancing Creativity in Architecture Pedagogy. *International Journal of Virtual and Personal Learning Environments (IJVPLE)*, 3(4), 41-52.
- Hampton, J. A. (1987). Inheritance of attributes in natural concept conjunctions. *Memory & Cognition*, 15(1), 55-71.
- Hennessey, B. A., & Amabile, T. M. (1998). Reality, intrinsic motivation, and creativity.
- Jones, D. (2012). *The Aha! Moment: A Scientist's Take on Creativity*: JHU Press.
- Kenny, D. T., & Ginsberg, R. (1958). The specificity of intolerance of ambiguity measures. *The Journal of Abnormal and Social Psychology*, 56(3), 300.
- Koestler, A. (1964). *The act of creation*: Hutchinson & Co.
- LAM, T. W. H., & CHIU, C. Y. (2002). The motivational function of regulatory focus in creativity. *The Journal of Creative Behavior*, 36(2), 138-150.
- Lambert, W. E., Tucker, G. R., & d'Anglejan, A. (1973). Cognitive and attitudinal consequences of bilingual schooling. *Journal of Educational Psychology*, 65(2), 141.
- Leung, A. K.-y., Maddux, W. W., Galinsky, A. D., & Chiu, C.-y. (2008). Multicultural experience enhances creativity: the when and how. *American Psychologist*, 63(3), 169.
- Levine, J. M., & Moreland, R. L. (2004). Collaboration: The social context of theory development. *Personality and Social Psychology Review*, 8(2), 164-172.
- MacKinnon, D. W. (1978). *In search of human effectiveness*: Creative Education Foundation Buffalo, NY.
- Mednick, S. (1962). The associative basis of the creative process. *Psychological review*, 69(3), 220.
- Nemeth, C. J., & Wachtler, J. (1983). Creative problem solving as a result of majority vs minority influence. *European Journal of Social Psychology*, 13(1), 45-55.
- Novak, M. (2004). *Marcos Novak Interview*. interview by Alessandro Ludovico (4/2001), at Neural. it electronic magazine: <http://www.neural.it/english/marcosnovak.htm>, accessed, 10(1).
- Okhuysen, G. A., Galinsky, A. D., & Uptigrove, T. A. (2003). Saving the worst for last: The effect of time horizon on the efficiency of negotiating benefits and burdens. *Organizational Behavior and Human Decision Processes*, 91(2), 269-279.
- Ritter, S. M., Damian, R. I., Simonton, D. K., van Baaren, R. B., Strick, M., Derks, J., & Dijksterhuis, A. (2012). Diversifying experiences enhance cognitive flexibility. *Journal of Experimental Social Psychology*, 48(4), 961-964.
- Runco, M. A. (2004). *Everyone Has Creative Potential*.
- Runco, M. A., & Chand, I. (1995). Cognition and creativity. *Educational psychology review*, 7(3), 243-267.
- Sawyer, R. K. (2012). *Explaining creativity: The science of human innovation*: Oxford University Press.
- Schooler, J. W., & Melcher, J. (1995). The ineffability of insight.
- Simonton, D. K. (1997). Foreign influence and national achievement: The impact of open milieus on Japanese civilization. *Journal of personality and social psychology*, 72(1), 86.
- Simonton, D. K. (1999). *Origins of genius: Darwinian perspectives on creativity*: Oxford University Press.
- Sternberg, R. J. (1985). *Beyond IQ: A triarchic theory of human intelligence*: CUP Archive.
- Sternberg, R. J., & O'HARA, L. A. (1999). 13 Creativity and Intelligence. *Handbook of creativity*, 251.
- Taylor, C. W., & Barron, F. E. (1963). *Scientific creativity: Its recognition and development*: John Wiley.
- Taylor, I. A. (1959). The nature of the creative process. *Creativity*, 51-82.
- Turner, M. (1998). *The literary mind: The origins of thought and language*: Oxford University Press.
- Wan, W. W., & CHIU, C. Y. (2002). Effects of novel conceptual combination on creativity. *The Journal of Creative Behavior*, 36(4), 227-240.
- Ward, T. B., Patterson, M. J., Sifonis, C. M., Dodds, R. A., & Saunders, K. N. (2002). The role of graded category structure in imaginative thought. *Memory & Cognition*, 30(2), 199-216.
- Ward, T. B., Smith, S. M., & Vaid, J. (1997). Conceptual structures and processes in creative thought.
- Weisberg, R. W. (1993). *Creativity: Beyond the myth of genius*: WH Freeman New York.
- Zenasni, F., Besançon, M., & Lubart, T. (2008). Creativity and tolerance of ambiguity: An empirical study. *The Journal of Creative Behavior*, 42(1), 61-73.

3 2D vs. 3D

Starting the design process from a higher dimension

§ 3.1 Exploring the impact on creativity of architects: Designing using a 2d environment (pen and paper) vs. starting from a 3D interface

One of the main targets of this research is to find methods and tools for enhancing creativity. This chapter compares the results of an experiment focusing on the starting phase of a design process from two different dimensions: analogue 2D vs. digital 3D. The experiment involves providing the same design task to a group of students using two different starting points: first, with a lower dimension of analogue 2D (pen and paper) and the next time with a higher dimension using 3D software. Students, in their last semester of Bachelor's, who were quite familiar with architecture and design were used as test subjects.

A group of architecture experts were assigned as jurors, who subjectively judged whether the creative performance of the students had been enhanced after experimenting with the higher dimension 3d environment.

This part of the research is elaborated in the second journal article "Thinking Out of the Box" from Out of the Box! Increasing the Dimension of Starting Point, Case study: Architecture students", Scientific research publishing, 2016

§ 3.2 “Thinking Out of the Box” from Out of the Box!

Increasing the Dimension of “Starting Point” Case study: Architecture students *

Alireza Mahdizadeh Hakak¹, Nimish Bilorla¹, Amirmasoud Dabbagh², Armaghan Ahmadi Venhari³

¹ Faculty of Architecture, TU Delft University, Delft, The Netherlands

² Azad Islamic University, Science and Research Branch, Iran

³ Department of Urban Design, Faculty of Architecture, Shahid Beheshti University of Iran

Abstract. To start a design process with plan and section in 2D environment (pen and paper) will exclude thousands of possibilities, which the designer will never be able to consider them. The 2D designer will never touch upon the rich world of complexity.. Starting the design from higher dimension is the solution to get rid of old conventional designing methods. Adding extra dimension to the “starting point” is applying CAD (computer aided architectural design) software not to extrude the 2D lines, but thinking from a higher dimension. Now thinking out of the box from out of the box becomes possible. To prove the hypothesis, authors decided to conduct an experiment and asked a group of architecture students to design a same architectural task with different dimensions. First the conventional pen and paper in 2D and the second time applying 3D environment interface of their own choice for the same task. The jury of experts concluded that students were more creative when they chose a 3D interface (higher dimension).

Keywords. Creativity, Thinking out of the box, design, dimension, pedagogy

§ 3.2.1 Introduction

“Thinking outside the box” is more than just a business cliché. It is a metaphor that means to think differently, unconventionally or from a new perspective. This phrase often refers to creativity and creative thinking. A simplified analogy is “the box”, in the commonly used phrase “thinking outside the box”, where the word “inside the box”

* Published as: Mahdizadeh Hakak A., Bilorla N, Dabbagh A., Ahmadi Venhari A. (2016), ““Thinking Out of the Box” from Out of the Box! Increasing the Dimension of Starting Point, Case study: Architecture students”, Scientific research publishing, 2016

is analogous with the current, conventional methods. Creative thinking acknowledges and rejects the accepted paradigm to come up with new ideas.

Human's creative potential spearheads the human civilization. In fact, progress at every aspect of our lives crucially depends on our creativity. Emphasizing the role of creativity in design even more than other disciplines pushes one to acknowledge the understanding of creativity as a key role player in Architecture. Furthermore by identifying the basic principles of our ingenuity/creativity, researchers might be able to enhance these abilities in future.

But how can we define creativity? Though creativity is the hallmark of human cognition, and therefore a topic of enormous scientific importance, yet not a single definition of creativity exists that is universally accepted by creativity researchers, and the scenario hasn't changed much in the last fifty years (Runco, 2004; Taylor & Barron, 1963). Nevertheless, any creative output (be it an idea, product, or performance) should have, at least, three characteristics: novelty (it is original), usefulness (it is functional and adaptive), and surprising (it is non-obvious, therefore eliciting an aesthetical or affective response) (Simonton, 1999).

The current study suggests new methods for starting a design procedure. Ignoring conventional approaches and dare to apply 3d computer interfaces for early architectural sketches. The paper has two different theoretical sections. Talking about creativity and how to reach to creative ideas in the first section and differences between "flatland" and "spaceland" in the second sections. In the third section we bridged between two previous parts and create our Hypothesis: Does starting a design from a higher dimension helps us to be more creative? To prove the hypothesis a group of architectural students have been asked to perform one architectural task with two different methods. Once start a design with pen and paper and the next time use a 3D environment. Since judgment of creativity is quite subjective a group of experts in architecture (University professors) have been considered as a jury and they subjectively did the evaluation. The results, analysis and comparisons are coming afterwards.

§ 3.2.2 Where do creative ideas come from?

As mentioned earlier, a necessary condition of creativity is novelty, but how can we get new ideas? In his book "The AHA! Moment" David Jones takes a bold stance by claiming that we cannot have a truly new idea, the best we can do is to make combinations of different ideas already known to us (Jones, 2012). Therefore one needs a vast subconscious mass of remembered data in order to increase the likelihood of combination of ideas.

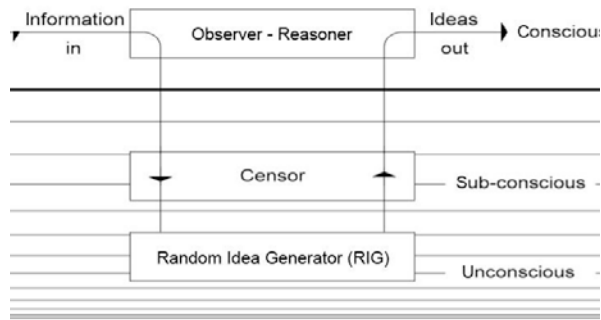

FIGURE 3.1 The model of human mental structure after Jones (2012).

Jones' theory of creativity is based on a three-tiered model of human mental structure (Figure 3.1). The top level is the Observer-Reasoner, the conscious part of our mind that is involved with planning, execution and action. It is also involved with reasoning, argument and conscious deliberation. The mid-level is the Censor, the subconscious part that houses our implicit knowledge (e.g., procedural skills, linguistic skills). It allows rapid access of stored knowledge or information, and also protects the Observer-Reasoner from constant perturbations. The lowermost level is the unconscious mind, the creative part of it is termed as the Random-Idea-Generator (RIG) that combines randomly, without any rule/supervision, ideas or information stored in the unconscious and preconscious mind. Due to the inherent randomness in the combinatorial process, most of the RIG ideas are wrong or not functionally useful and therefore blocked by the Censor before it could reach the uppermost conscious level, the Reason-Observer. If a creative RIG idea manages to pass the Censor and finally reaches the conscious level, it is likely to be perceived as a flash of sudden insight, known as Aha!

So far importance of creativity and how to reach to creative ideas have been explored. Now we try to explain methods to expand the unconscious mass of data and feed it differently.

§ 3.2.3 Flatland VS. Spaceland

"Thinking outside the box" starts well before we're "boxed in". That is, well before we confront a design task and start forcing it into a familiar "box": Using Pen and Paper to start a design! Kas Oosterhuis denotes it in his book "Toward a new kind of building" as: inclusion and exclusion (Oosterhuis, 2011). To start a design process with plan and section in an exclusive approach is so poor. It excludes thousands of possibilities, and

so the designer will never be able to consider these possibilities. The Flatland-based designer will never touch upon the rich world of complexity. Space-landers can observe the flat-landers without any problem and flat-landers can see line-landers and line-landers can easily internalize the life of point-landers (Oosterhuis, 2011). Starting with a point cloud is a first solution to get rid of old conventional methods and aiming for inclusion (Figure 3.2, 3.3).



FIGURE 3.2 Conventional 2D interface, Pen and Paper



FIGURE 3.3 3D interface, Point cloud

Kas Oosterhuis (2011) defines his approach and definition of the point cloud in this way:

My personal design universe consists of an interacting population of groups of points in space, wirelessly connected by force fields that are aware of themselves, communicating with their immediate neighbours... My design universe includes interacting point clouds, in which each point behaves as if it is in the centre of the world, even though it is just 'somewhere', as our Earth is just somewhere in the Milky way... Each point is an actor; always busy measuring and adjusting its position in relation to its peers. Each point is an actuator, triggering the execution of its internal program. Each point is a receiver, processor and a sender in one. Each point of my personal design point cloud displays behaviour, it has character and style. Each point of the point cloud is a microscopic instrument to be played, a game to be unfolded (figure 3.4).

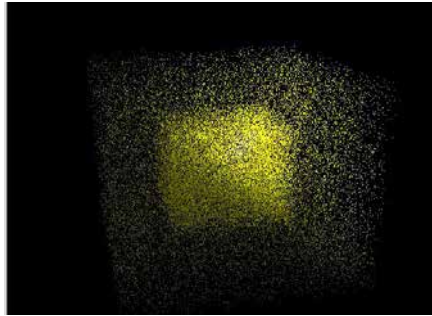

FIGURE 3.4 Point cloud

Oosterhuis implement this approach in real practice. He explains the procedure of his design for the saltwater pavilion: “The saltwater pavilion has evolved from the very beginning of the design process as a three-dimensional computer model. We kneaded, stretched, bent, rescaled, morphed, styled and polished. We no longer accept the domination of platonic volumes, the simplistic geometry of cube, sphere, cylinder and cone as the basic elements of architecture; that resolution is much too low. Our computers allow us to command millions of coordinates describing far more complex geometries” (Figure 3.5). (<http://www.oosterhuis.nl/quickstart/index.php?id=saltwater-pavillion>).

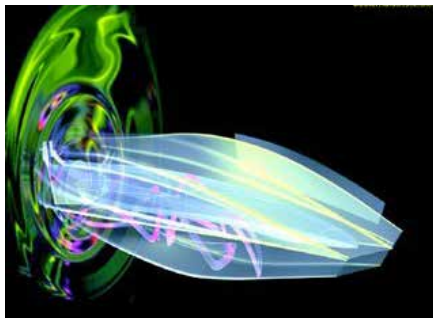

FIGURE 3.5 Saltwater Pavilion by ONL

Adding extra dimension to the “starting point” is the point. Starting with a cloud of points floating in endless space and establishing a behavioural relation between those points as birds in the swarm is a proper method (Figure 3.6). Implementing a point cloud in a 2d interface helps a lot, even though it is still confined. Starting to manipulate a point cloud in an immersive 3d virtual environment is starting from a progressive point, since it is already out of the box. Now thinking out of the box from out of the box becomes possible. Experiments in this scope of action have already been started, as mentioned before, this is an on-going project.



FIGURE 3.6 Kinetic Sculpture, BMW Museum Munich 2008

§ 3.2.4 Experiment:

The experiment has been held in Architecture faculty of Shahid Rajayee University in Tehran/Iran. The chosen group were on the last year of Bachelors studies, included 18 students, 3 male and 15 female (figure 3.7)..



FIGURE 3.7 Students while doing the experiment

§ 3.2.4.1 Instruction

The experiment started with a small presentation on what is the criterion for creativity evaluation. The summary of the presentation is as follow: In architecture the designer deals with many parameters including:

- Find an innovative form
- Fit in the context
- Respect the user and their culture
- Find a better material
- Find a better detail
- Solve ecological aspects
- Optimize the building and make it sustainable
- Etc.

If the architect can solve any of aforementioned parameters in an innovative way, then the project is a creative one. That is why the creativity of Tadao Ando for instance is different from Zaha Hadid. For the sake of this experiment, if the creativity parameters would be too much, the evaluation was almost impossible, thus for obtaining reliable results at the end of the experiment, the students have been asked to focus only on an innovative form (form-finding) and ignore other architectural parameters for now.

The task was to design a mall around 10000 m², free of any confining regulations. They encouraged not focusing too much on the structural, mechanical and any other technical issue. They asked to be as innovative as possible and they were free to design any double curve, blobby shapes, Euclidean/non Euclidean geometry, etc.

The students have been asked to design once with pen and paper and start design form 2D and afterwards start again using a 3D interface. In the morning session student started to design with pen and paper, however since students had a lot of problem with sketching abilities they couldn't finish the experiment in the designated time or even tend to choose simple geometry to have the possibility of sketching them (Figure 3.8). In the afternoon session, students started to design in a 3D environment.

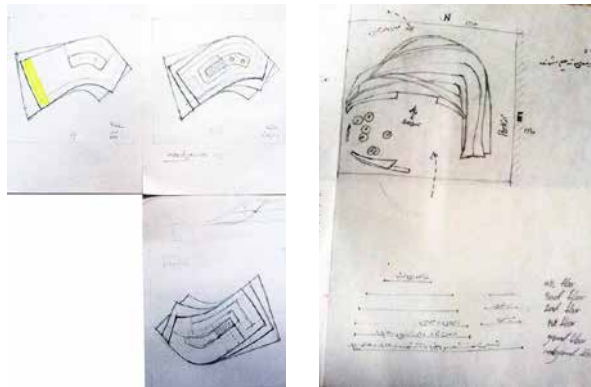

FIGURE 3.8 Some of the sketches of students

They were free to choose their 3D software. 39% of students chose Sketch up, 27% of them chose 3D max and 33% did with Autodesk Revit. There was a semi-structured interview at the end of experiment to capture feedback from the participants.

§ 3.2.4.2 Judgment criterion

In discussions about the quality of a design and of a designer, the concept of creativity is a dominant factor. Ignoring the functionality criterion, the result of this design activity is expected to be original and adding value to the existing world of design. In design awards, and in the field of architecture, creativity assessment relies on human judgments. This article raises the question of whether creativity in architecture design can be judged in a valid and reliable way or not? There exists enormous amount of research in the last decades highlighting the lack of objective methods of evaluation. One reason for this lack is that the need for objectivity by formalizing the measurement leads to a reduction of the features that are quantifiable (Hofstee, 1985). Features that are related to the subjective decisions of the designer, on the whole, be neglected. Another possible reason is that, such concepts as creativity and quality have, according to Hofstee, an emergent character; that is, they are defined again and again on the basis of new creations, so that there is no possibility for previous programming. Only a human judge can make estimates of the originality of a product. The fact that there would be mistakes in the decisions is not suffice to kick the judge out of the system. When estimating the creativity of an architectural design we have to rely on human judgment. In all studies thus far the question has been how to overcome subjectivity within these assessments.

§ 3.2.4.3 Reliability and validity

Most creativity assessment studies, relying on human judgment, have been performed in the domain of art, and only a few in design (Teresa M. Amabile, 1983; Ward & Cox, 1974). The results of the art studies show considerable variation in inter-rater reliability based on correlations between judges (Christiaans, 2002). Because they are at different levels of subjectivity, the question is whether artwork judgment can be compared with design work judgment. The design of products always builds on previous designs and on the archetype of the designed device (Christiaans, 2002). Ensuring that the functionality of the product is recognized by the user often takes precedence over aesthetic values. Therefore, objective judgments would seem to be more possible in design work than in artwork. However, although the judging of designs is daily practice in real life, playing an important role in decisions about production and in the awarding of prizes, no controlled experiments have been found to confirm this assumption. The reliability of intersubjective measurement seems also to depend on the expertise of the judges.

In the field of art, professionals or trained observers are presumed to be more reliable than naive observers (Hekkert & Van Wieringen, 1996; Runco, McCarthy, & Svenson, 1994). Amabile (1982) argued that “appropriate” (familiar with the domain) observers are able to judge creativity (Teresa M Amabile et al., 2002). This would apply to any domain in which creativity is a valuable criterion. The assumption is that, based on general cultural values within a society, consistencies will underlie the assessments of judges (Child & Cordasco, 1970). In the assessment of both the aesthetic preference (Temme, 1983) and the level of creativity of artworks and designs, a higher level of agreement will be shown among people who have similar learning experiences in the area of art or design. Problems have arisen, however, regarding the idiosyncratic standards of professional judges. A number of studies report that in the judging of artworks the level of agreement among lay judges is often higher than among experts (Getzels & Csikszentmihalyi, 1976; Gordon, 1956; Hekkert & Van Wieringen, 1996; Runco & Charles, 1993). Runco et al. suggested that expert judges rely on high-level, esoteric, idiosyncratic standards (Runco & Charles, 1993). This makes for less awareness of differences among artworks than is found in groups of judges with lower expertise. Getzels and Csikszentmihalyi argued that experts have more difficulty assessing products in terms of their fundamental attributes than judges with an intermediate level of expertise (Getzels & Csikszentmihalyi, 1976). They assumed that experts are much too involved in objects as aesthetic wholes and therefore consider differentiation between attributes as spurious abstractions. Their findings were confirmed by Hekkert and Van Wieringen (Hekkert & Van Wieringen, 1996). Correlations between mean ratings on originality and other criteria are much higher among experts than among nonexperts. The validity of subjective judgment is also open to question. An indication of validity might be that judges apparently have no difficulty in distinguishing between various assessment criteria; however, the results

of correlational analysis in several studies do not confirm any clear distinction between them. The aesthetic value of the product seems to be strongly related to originality and creativity (Teresa M. Amabile, 1983; Getzels & Csikszentmihalyi, 1976). Findings regarding the relationship between creativity and technical quality are contradictory. In the study of Trowbridge and Charles, the hypothesis that creativity and technical competence can be separated into two distinct variables is confirmed with a correlation of nearly zero (Trowbridge & Charles, 1966). In contrast, in the studies of Getzels and Csikszentmihalyi (1976) and in most of Amabile's (1983) studies, the relationship between the two is quite strong. Although many studies show that creativity is interrelated with such concepts as aesthetic appeal, appropriateness, and (technical) quality, some authors still claim that creativity can be considered a separate construct (Teresa M. Amabile, 1983).

In this study we tried to find evidence to prove this assumption—that is, that creativity and other aesthetic criteria are different constructs—by introducing a discriminating variable called prototypical value. Based on information processing theory, Attractiveness of a stimulus increases the more it resembles the prototypical representation of that stimulus (Crozier & Chapman, 1984). If this theory holds well, then objects that, because they are original and unexpected, are by definition far from being prototypical representations, will be less attractive because of their divergence from the prototype. Because creativity is also characterized by concepts such as originality, the distance between a creative object and the prototypical representation, based on membership of the category of similar objects, is also by definition large, larger than the distance between the aesthetic appeal and the prototypical value.

To sum up all above we assigned 5 experts in field of architecture, 3 assistant professors, 1 associate professor and 1 full professor. They were all staff of Shahid Rajayee University. The group have been asked to score from scale of 1 to 10 to each of the projects and the mean of their score have been assigned to the student's design.

§ 3.2.4.4 Analysis

All the students who finished the task with Sketch up confessed that the software is not appropriate to create complex geometries (double curves, non-standard architecture (NSA), non-Euclidean geometry, etc.) therefore they all had somehow similar results with two different mediums and that was different composition of Euclidean geometry. In the table of results it have been mentioned that this is the limitation of the software that they cannot create complex geometry (Table 1). By decision of the jury, among six students who have been used Sketch up the results of three students out of six were more creative. The other four received "The same results as pen and Paper" therefore they received "No change" on comparing the results in the table (Table 3.1).

Among five students who have been chosen 3D max, four of them were more creative and one of them received “NO change” in results. The remaining six chose Revit for their design and among them two students received “No change” and the other four were more creative (Table 3.2).

No	Name	Software	Subjective opinion in competency in software	Ability to create complex geometry using 3D software	Why didn't you choose more complex geometry?	Judge's decision on the results of switching between 2D and 3D
1	Z. Badamchi	R	70%	Yes	Subjective	Yes
2	M. Rahou	R	50%	No	Not expert	Yes
3	A. Souki	3D	30%	No	Not expert	No change
4	Y. Asemi	3D	50%	No	Subjective	Yes
5	P. Zarghami	S	90%	No (SL)	SL	Yes
6	F. Jafari	3D	80%	Yes	Subjective	Yes
7	P. Zamannejad	S	90%	No (SL)	SL	Yes
8	M. Mohamadi	R	70%	No	Not expert	Yes
9	D. Faturechi	S	70%	No (SL)	SL	No change
10	Sh. Ebrahimi	S	50%	No (SL)	SL	No change
11	Z. Dehghani	S	50%	No (SL)	SL	Yes
12	F. Jabari	3D	40%	No	Not expert	Yes
13	E. Taghavi	S	70%	No (SL)	SL	Yes
14	E. Akbari	R	80%	Yes	Subjective	Yes
15	A. Aynevand	R	70%	Yes	Subjective	No change
16	J. Mousavi	S	80%	No (SL)	SL	Yes
17	M. Makki	3D	90%	Yes	Subjective	Yes
18	M. Ozgoli	R	80%	Yes	Subjective	No change

TABLE 3.1 Summary of experiment and interviews

SL: Software limitation, R: Revit, S: Sketch up, 3D: 3D Max

SOFTWARE	Percent of students who are more creative after changing the medium
3D max	83.4 %
Sketch up	42.9 %
Revit	66.7 %

TABLE 3.2 Percentage of change

In general, 11 students out of 18 were more creative (61.1%). 42.9 % of the students who chose Sketch up received the lowest score in being creative and people who chose 3D max had the best results: 83.4% , and finally 66.7% of students who worked with Revit were more creative (Table 2).

Sapmles of sketches by studetns are af follows (3.9, 3.10, 3.11).

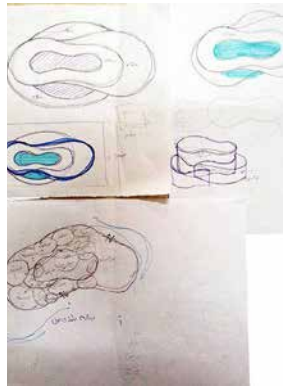

FIGURE 3.9 Sample 1

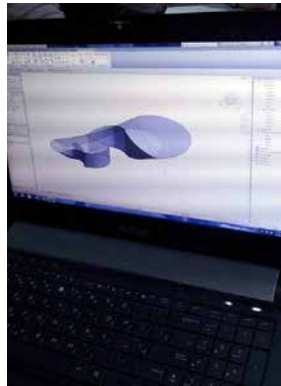
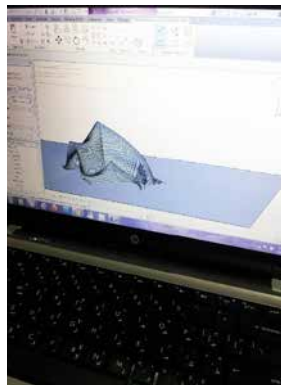

FIGURE 3.10 Sample 2



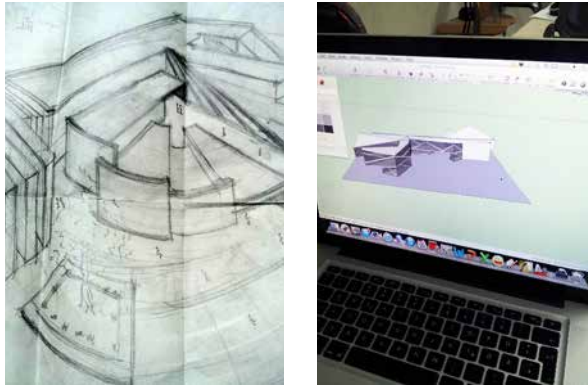

FIGURE 3.11 Sample 3

§ 3.2.5 Other advantages of 3D workspaces

Beside the aforementioned advantage of switching to 3D environment, ceasing use of 2D pen and paper and turn to 2D and 3D computer interface will have plenty of other advantages:

- Better visualization: We live in a 3D world and the brain get used to visualize objects in 3D. When it comes to communicating with a design, we naturally prefer a 3D images, models, or animation for better perception over a 2D technical drawing. In the 2D world, the brain should capture different 2d angels and fuse them mentally and create a 3d visualization in order to perceive the image. It takes a lot of effort and especially the task becomes almost impossible when it comes to non-Euclidian geometries and NSA (non-standard architecture).
- Eliminate manual updates: In 2D, upon each change in design the current drawing view will be disconnected from the other two. You have to manually update every drawing view whenever a change occurs. Change one part and you not only have to include that change in each of the three drawing views for the part, you must also change every view of every assembly in which that part is used. Therefore, updating the design for each drawing view is one of the benefits of working in 3D workspaces.
- Reuse existing designs and modifiability: The unique aspects of 3d environment will allow you to make easy and extensive reuse of existing designs (by saving the file!) As discussed earlier, “associativity” means when you change a design model, the change automatically goes through all the other places where that

model is used. Modifiability let you reuse existing designs to create new versions or configurations easily.

- Advance development cycles with quick simulations and virtual testing: Another benefits of working in 3d workspace are the agile ability for simulations, virtual testing, analysis, and optimization. For instance Autodesk® Vasari with integrated analysis for energy and carbon, providing design insights in early stages of decision making. Vasari is focused on conceptual building design using both geometric and parametric modelling. It supports performance-based design via integrated energy modelling and analysis features.
- F2F (File to Factory) for rapid prototyping: New fabrication techniques enormously rely on 3D CAD model. CAM (computer aided modelling) will help us create a faster production process and components and tooling with more precise dimensions and material consistency.

It is always suggested that an architect student should be master of all the tools he/she has, whether a 2D tool or 3D interface. This shouldn't be implied for the above experiment that the architects should ignore pen and paper, always a combination of all the tools together can have the best answer. However, because of the powerful effects of CAAD tools for idea generation, it is wise to implement specific workshop in architecture pedagogy to enhance their implication of CAAD in the design process. The more students get familiar with 3D CAAD interfaces, the more creative ideas they can reach to.

§ 3.2.6 Conclusion

Following the ideas of Edwin Abbott Abbott the writer of "Flatland" and also Kas Oosterhuis in his book "Towards a new kind of building", authors considered a hypothesis: If we increase the dimension of the starting point of design from flatland (pen and paper) to Spaceland (3D environment) we will have more creative results. Base on this premise an experiment have been designed and group of 18 students have been asked to design an architectural task once with pen and paper and the next time with a 3D environment of their own choice. The jury (group of 5 experts in field of architecture) compared the results and decided among them 61.1% of students have more creative results when they changed their dimension of starting point. Students who chose Sketch up as their 3D environment got the least score because of software limitation on creating complex geometries and students who chose 3D max had the best results. Level of proficiency of students in software is important for choosing

complex geometries and students with less skill tend to stick to conventional Euclidean geometry.

References:

- Amabile, T. M. (1983). The social psychology of creativity: A componential conceptualization. *Journal of personality and social psychology*, 45(2), 357.
- Amabile, T. M., Mueller, J. S., Simpson, W. B., Hadley, C. N., Kramer, S. J., & Fleming, L. (2002). Time pressure and creativity in organizations: A longitudinal field study.
- Child, I. L., & Cordasco, F. (1970). Italian Or American?: The 2. *Generation in Conflict: Russell [and] Russell*.
- Christiaans, H. H. (2002). Creativity as a design criterion. *Communication Research Journal*, 14(1), 41-54.
- Crozier, W. R., & Chapman, A. J. (1984). *Cognitive processes in the perception of art*: Elsevier.
- Getzels, J. W., & Csikszentmihalyi, M. (1976). The creative vision: A longitudinal study of problem finding in art.
- Gordon, D. A. (1956). Individual differences in the evaluation of art and the nature of art standards. *The Journal of Educational Research*, 50(1), 17-30.
- Hekkert, P., & Van Wieringen, P. C. (1996). Beauty in the eye of expert and nonexpert beholders: A study in the appraisal of art. *The American Journal of Psychology*, 389-407.
- Hofstee, W. K. B. (1985). Limits on the objectivity principle in assessment and selection. *Dutch Journal of Psychology (Nederlands Tijdschrift voor de Psychologie)*, 40, 459-473.
- Jones, D. (2012). *The Aha! Moment: A Scientist's Take on Creativity*: JHU Press.
- Oosterhuis, K. (2011). *Towards a New Kind of Building: A Designers Guide for Non-Standard Architecture*: NAI Uitgevers/Publishers Stichting.
- Runco, M. A. (2004). *Everyone Has Creative Potential*.
- Runco, M. A., & Charles, R. E. (1993). Judgments of originality and appropriateness as predictors of creativity. *Personality and Individual Differences*, 15(5), 537-546.
- Runco, M. A., McCarthy, K. A., & Svenson, E. (1994). Judgments of the creativity of artwork from students and professional artists. *The Journal of Psychology*, 128(1), 23-31.
- Simonton, D. K. (1999). *Origins of genius: Darwinian perspectives on creativity*: Oxford University Press.
- Taylor, C. W., & Barron, F. E. (1963). *Scientific creativity: Its recognition and development*.
- Temme, N. (1983). The numerical computation of the confluent hypergeometric function $U(a, b, z)$. *Numerische Mathematik*, 41(1), 63-82.
- Trowbridge, N., & Charles, D. C. (1966). Creativity in art students. *The Journal of Genetic Psychology*, 109(2), 281-289.
- Ward, W. C., & Cox, P. W. (1974). A field study of nonverbal creativity. *Journal of personality*, 42(2), 202-219.

4 Implementing UVEs

In architecture pedagogy

§ 4.1 Hypothesizing implementation of UVEs in architectural pedagogy

This chapter introduces unconventional virtual environments (UVEs) in the context of this research. The characteristics, types and parameters of UVEs are defined. Moreover, the role of experience and its efficacy on idea expansion and divergent thinking are also discussed in this Chapter.

The brain possesses existing knowledge of architectural space, styles and physical world. By exposure to UVE, previously unknown data feed can be added to this existing knowledgebase. The brain tries to digest this new feed by connecting them to the previous/existing knowledge of space. It is hypothesized that the challenge of the brain to digest new feeds, indirectly stimulate creativity. To prove this hypothesis, more research experiments were designed. These, are discussed in the following chapters.

After examining the hypothesis, a possible implementation of UVEs within architectural pedagogy is also discussed. It is also suggested to provide workshops for developing UVEs and let students navigate and interact with them during their education in order to expand their inventory of experiences. The more they can expand their experiences, the more combination of ideas is made possible, which, will indirectly influence their creativity.

Respective research findings have been published in the third journal article: "Implementing unconventional virtual environments for enhancing creativity in Architecture pedagogy", IGI Global Publisher, Volume 3, Issue 4, 2012, pp. 41-52.

§ 4.2 Implementing unconventional virtual environments for enhancing creativity in Architecture pedagogy*

Alireza Mahdizadeh Hakak, Nimish Bilorla¹, Mozhgan Raouf Rahimi²

¹Faculty of Architecture, TU Delft University, Delft, The Netherlands

²Azad Islamic University, Parand Branch, Iran

Abstract. What is common definition amongst near 100 different definitions of creativity according to different disciplines is: Creativity is a new combination of what you have in your inventory of experiences + intuition. Now we can consider expanding the inventory of experiences, gradually helps better combination of elements inside. Surfing in a virtual environment with specific unconventional characteristics stands to be an interesting move. Detached from the real one in sense of time and matter, enables the designer to cross the borderline of reality and expand this inventory.

The authors hypothesis in cognitive point of view is extensiveness of experience gained by surfing in unconventional virtual environments can positively be related to both creative performance (enhance interactivity, lateral thinking, idea generation, etc) and creativity-supporting cognitive processes (retrieval of unconventional knowledge, recruitment of ideas from unconfined virtual environment for creative idea expansion). Authors also believe that creating a new perception of environment in the first steps of architecture pedagogy would be a broad help on expanding educator's ideas. As a practical suggestion we suggest workshops beside the main curriculum in which designers can design, surf, play, manipulate unconventional virtual environment totally free of any constrains in an immersive, interactive virtual environments.

Keywords: Virtual Environment, Experience, Creativity and Pedagogy

* Published as: Mahdizadeh Hakak A., Bilorla N, Raouf Rahimi M., (2012), "Implementing unconventional virtual environments for enhancing creativity in Architecture pedagogy", IGI Global Publisher, Volume 3, Issue 4, 2012, pp. 41-52.

§ 4.2.1 Introduction

Many of the architects confess that, very gradually and unconsciously they stock in some conventional design approaches, because slowly confinements in construction and conventional stereotypes impose on them, dominate them and prevent them to think innovatively. Now, it is seemingly logical if you got a chance to see and explore some innovative notions in virtual environments, totally free of any limitation, causes a conceptual expansion, since irrelevant pictures are added to old design approaches. This will reverse the process and the confinements; stereotype, etc. diminish gradually; helping designers to expand their conceptual boundaries and thus eventually help them to enhance their creativity.

Creativity on the other hand is a vague term, and its definition is totally pertaining to the context of study and the discipline. As far back as 1959, Taylor surveyed about 100 definitions in his attempt to clarify the creative process (Taylor 1959). The definitions vary significantly by the content and complexity. Nevertheless, there are two commonly “universal” attributes of creativity: novelty and appropriateness. For the purpose of this paper, we will consider creativity as a cognitive process that generates new concepts, which are novel and unconventional. This study accentuates the experience. Identifying its way of operation and pointing out its existence and relevance. Experiences indirectly affect creativity. The more inventory of experiences, the more and better combination of ideas are possible.

Being in varied or diverse environments can train individuals to encode information in multiple ways, building a myriad of associations between concepts. For example, bilinguals, who have been exposed to two languages, are more creative than monolinguals (Nemeth & Kwan, 1987; Simonton, 1999). Creativity is found at relatively high rates for individuals who are first or second generation immigrants and for individuals who are ethnically diverse or ethnically marginalized (Lambert, Tucker, & d’Anglejan, 1973; Simonton, 1997, 1999). At the group level, creativity is facilitated within collaborative groups that contain diverse members (Guimera, et al., 2005; J. M. Levine & Moreland, 2004) and in groups in which heterogeneous opinions are expressed (Nemeth & Wachtler, 1983; Simonton, 2003). Even at the societal level, creativity increases after civilizations open themselves to outside influences and when geographic areas are politically fragmented and relatively diverse (Simonton, 1997).

Considering the brief introduction on creativity and role of experience and diversity, the authors propose designers, surfing in virtual environment to

gain novel experiences, and broaden their perception of environment to enhance their creativity. In this article, we define the Virtual Environment as a real-time interactive and fully immersive virtual 3d environment. In contrast to the definition of Virtual Reality which is somehow an imitation of the physical world (consider flight simulation). Also emphasizing on the unconventional virtual environments within which an emergent spatial pattern can dynamically evolve in time with respect to user interactions, a variety of spatially intriguing concepts such as: Multiple dimensions, Dematerialization, Infinite depth, Continuous change, Multiple scales etc. can be experimented with (Figure 4.1, 4.2).

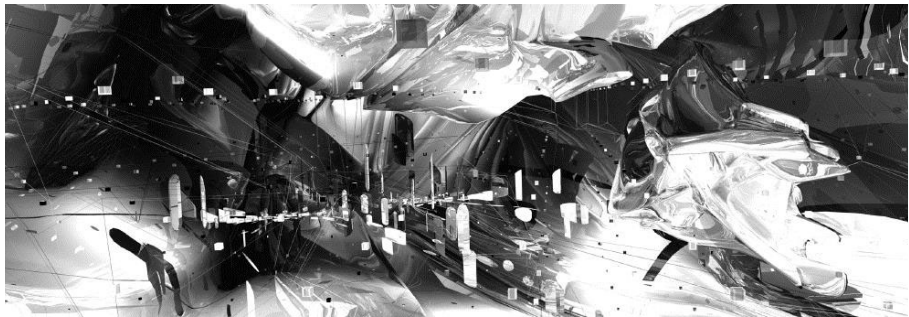

FIGURE 4.1 V4D_Visio4D by Marcos Novak-Used with permission



FIGURE 4.2 V4D_Visio4D by Marcos Novak-Used with permission

Another important role of implementing virtual environment in design is trying to define a new criterion for evaluating architecture. It has been widely believed that what are now important in architecture discipline are unified concepts and objects clear function and performance. Reality, ironically, compels partiality, discontinuity of space, discontinuity of experience and conciseness. Finally, constructability, speed of procedures, etc. in designing in physical world are

evaluating parameters for architecture. Following this criterion in designing, adding to variety of constraints imposed on the architect and building close architect's hands. Designing in virtual environments uses the same tool of expression as architecture, however it is free from the consequence of the built, technology, material etc. As such it can suggest an opposing value system: interaction, immersion, fragmentary, adventure, joy, innate stimulus, infinity, continuous change, etc. Thus virtual environment positioned in opposition to realistic architecture, as polemical, critical and experimental.

Designing in virtual environments is an ongoing practice that is built into the language of architecture. The utilitarian discipline of architecture requires a system to value them especially in a paradoxical way, negative or dichotomy to its main development course, though it can refurbish itself. Also the new evaluation criterion can be a stimulus to push designers think out of box. Since defining this criterion deeply related to cognitive aspects and perception of environment, it is out of scope of this paper.

The speculation on the relationship between experiencing virtual environments and creativity is expected to answer the following questions:

- a. What types of virtual environments are needed for enhancing creative performance?
- b. How does surfing in virtual environment benefit creativity?
- c. How does the brain perceive such immersive environments? (Does it use a reductionist point of view or is it an emergent phenomenon?)
- d. In terms of topology, can this mathematical term be applicable in visual perception of environment? (Can the brain define certain characteristics of space even when the space deforms?)

As an overview of the major speculations in this paper, we are seeking to prove that:

- a. Surfing/Exploring Virtual environment enhances creative performance and creativity-supporting cognitive processes (e.g., recruitment of different ideas and retrieval of unconventional knowledge);
- b. The connection between experiencing virtual environments and creativity is most apparent when individuals have had the experience of deeply "immersing" themselves in virtual environment and "interacting" with the environment;

- c. Adapting and opening themselves to new experiences and actively interact and compare the differences they encounter between unconventional environments and the physical world can boost the benefits of this experiencing;
- d. A weaker relationship between experiencing virtual environments and creativity emerges in contexts where one confines themselves to limitations of the physical world, such as: construction limitations, material limitations etc.

§ 4.2.2 What Is Creativity?

Creativity is typically defined as the process of bringing into being something that is both novel and useful (Sawyer, 2006; Sternberg & O'Hara, 1999; see also Amabile, 1996). The creative process is often a mysterious phenomenon, with sudden insights seeming to work at an unconscious and inaccessible level (Schooler & Melcher, 1994). The magical “aha” moment of discovery, the point at which an idea leaps into consciousness, is part of what makes creativity seem sudden, without logic, and elusive (Leung, Maddux, Galinsky, Chiu, 2008).

Because of its apparent unpredictability and elusiveness, creativity may seem difficult to study scientifically and systematically. However, psychology based literature now can provide a wealth of evidence depicting the psychological factors that facilitate creativity; elements of personality, affect, cognition, and motivation can either facilitate or impair creativity (see Amabile, 1996; Csikszentmihalyi, 1996; Sawyer, 2006). For example, personality studies have demonstrated that creative people tend to be nonconforming, independent, intrinsically motivated, open to new experiences, and risk seeking (for reviews, see Simonton, 2000, 2003). Large-scale studies and meta-analyses have found that intelligence, tolerance of ambiguity, self-confidence, and cognitive flexibility also tend to be found in creative people (Feist, 1998; MacKinnon, 1978). Now, it seems logical that if we approach from the other side of the spectrum - we push designers to encounter new experiences - we can enhance their thresholds of ambiguity, self-confidence, cognitive flexibility, etc. It has been proved that a number of contextual factors related to motivation, cognition, and affect, facilitate creativity. Individuals who pursue tasks for intrinsic rather than extrinsic purposes show enhanced creativity (Amabile, 1985, 1996; Amabile, Hennessey, & Grossman, 1986; Eisenberger & Cameron, 1996; Hennessey & Amabile, 1998). Especially in

design we consider it largely intrinsic rather than extrinsic. A distant future focus, compared to a near future focus, has been shown to lead to more creative negotiation outcomes (Okhuysen, Galinsky & Uptigrove, 2003) and to enhanced creative insight (Foerster, Friedman, & Liberman, 2004). Focusing on potential gains rather than losses increases the accessibility of unconventional ideas and thus enhances fluency in generating creative ideas (Friedman & Foerster, 2001; Lam & Chiu, 2002). Finally, creativity seems to flourish when people are in positive or neutral affective states rather than negative affective states (Amabile, Barsade, Mueller, & Staw, 2005; Fredrickson, 2001; Fong, 2006).

§ 4.2.3 Types of creativity

There are two main types of creativity (Boden, 1990): 1) improbabilist that assumes that nothing has to be created *de novo* but existing elements are brought into a distinctive relation to each other by establishing new connections among them, which is the current definition of creativity in architecture, indeed this is not a defined accepted definition of creativity, however informally this is the way creative architects follow, and 2) impossibilist – a deeper type that is based on transformation of conceptual spaces. The difference between these types is determined by the mode of creative thinking. Improbabilist creativity stipulates thinking in the associative mode, adherence to rules, logic, and boundaries of the current conceptual (mental) space that is a conceptual packet or network built up for purposes of local understanding and action (Fauconnier, 1985). If we extrapolate this definition to architecture, obeying conventional rules and the role of confinements in architecture in terms of material, technology, even perception of new spaces become clear. Impossibilist creativity is subject to the bisociative mode, in which the conceptual space is transformed, yet frequently regardless of the existing rules and disciplinary boundaries (Koestler, 1967). As Boden puts it in “Creativity and unpredictability” a theory of creativity is to be a theory about the exploration, mapping, and transformation of conceptual spaces (Boden, 1995). It is presumed that a product of impossibilist creativity cannot be generated without transformation of the corresponding conceptual space. The first step here for creativity in design is enhancing the perception of space. Since we are used to the environment around us in term of scale, depth, dimension, etc., changing the characteristics of the conventional environment around us would be the right choice for transformation of the corresponding conceptual space.

§ 4.2.4 The Creative Cognition Approach

Recently, a scientific approach to studying creativity—the creative cognition approach—was proposed for understanding and specifying the cognitive processes that produce creative ideas (Amabile, 1996; Bink & Marsh, 2000; Finke, Ward, & Smith, 1992; Runco & Chand, 1995; Wan & Chiu, 2002). The central argument of this approach is that creative processes are not much different from those cognitive processes that produce our everyday mundane activities.

Every person has the potential to become creative as long as he or she effectively utilizes ordinary cognitive processes to produce extraordinary creative outcomes (Finke et al., 1992; Ward T.B., Smith, & Vaid, 1997; Weisberg, 1993). Specifically, the creative cognition approach identifies two kinds of cognitive processes implicated in creative thinking—generative processes and exploratory processes (Finke et al., 1992). First, people actively retrieve or seek out relevant information to generate candidate ideas with differing creative potential (the generative processes). Next, they survey these candidate ideas to determine which ones should receive further processing, such as modification, elaboration, and transformation (the explorative processes), (Leung, Maddux, Galinsky, Chiu, 2008). One strategy that makes effective use of generative processes is conceptual expansion, which takes place when attributes of seemingly irrelevant concepts are added to an existing concept to extend its conceptual boundary (Hampton, 1987; Wan & Chiu, 2002; Ward, T. B., Patterson, Sifonis, Dodds, & Saunders, 2002, Ward, T. B et al., 1997).

§ 4.2.5 Experiencing unconventional virtual environments and the role of creativity

As mentioned before, defining the term creativity is a hard task. Every designer has the bias that he/she is creative. Now, there is not an objective measurement or measurement tool to evaluate the creativity. On the other hand, it seems obvious that the learned routines and conventional knowledge of that discipline may limit his or her creative conceptual expansion. Prior knowledge and highly accessible exemplars are a major constraint on imagination and creative conceptual expansion (Ward, T.B., 1994). For instance, when people generate exemplars in a novel conceptual domain (e.g., animals on the planet Mars), even the most creative examples resemble highly accessible exemplars (e.g., animals on Earth with eyes and legs or

known science fiction exemplars; (see Kray, Galinsky, & Wong, 2006; Rubin & Kontis, 1983; Ward, T.B., 1994; Ward, T.B. et al., 2002). It happens exactly on design process as well. Thinking out of box would become an impossible task. To overcome the constrains, experiencing virtual environments is a solution. When individuals encounter an unconventional virtual environment, they may experience a shock, anxious feeling and disorientation in the absence of spatial perception, scale, depth, material etc, which are generally all conventional norms. People typically take these familiar things for granted can thus suddenly become lost and inaccessible when people are immersed in virtual environment.(figure 4.3, 4.4).



FIGURE 4.3 Unconventional virtual environment - ©2008- Marco De Gregorio, used with permission



FIGURE 4.4 Unconventional virtual environment - ©2008- Marco De Gregorio, used with permission

Although this shock has its dark side, once the initial, difficult adaptation stages have passed, it can also provide a great opportunity for acquiring new perspectives to approaching various tasks and learning new ways of thinking. Whereas old, conventional design approaches may constrain creativity, the experience of virtual environments may foster the creative expansion of ideas. Thus, we hypothesize that virtual environment experiences can contribute to creative expansion in at least four ways:

First, architects learn new ideas and concepts from surfing and designing in these environments. Through these experiences, people are also exposed to a range of behavioral and cognitive scripts for situations and problems. These new ideas, concepts, and scripts can be the inputs for the creative expansion processes because the more new ideas people have, the more likely they are to come up with novel combinations (Weisberg, 1999).

Second, although architecture pedagogy established conceptions and conventions provide the architect with structured and routine responses to the design, these cognitive structures may be destabilized as people acquire alternative conceptions through their experiences in other environment, in terms of new perception and cognition and interaction with it, particularly as people adapt their own thoughts and behaviors to the new environment. Immersing in multiple virtual environments may even lead individuals to access unconventional knowledge when back in physical world (.

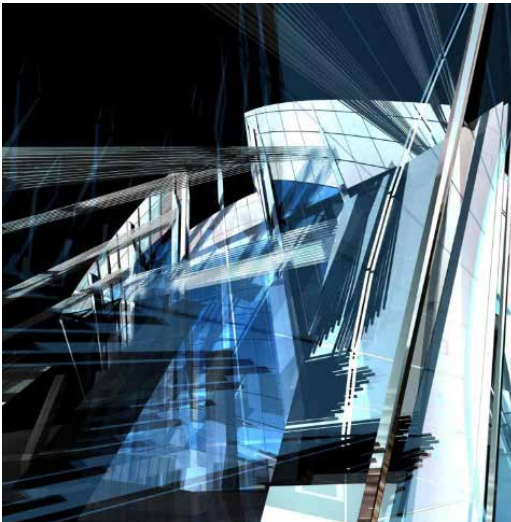

FIGURE 4.5 Screenshot (authors) – new cognitive perception of virtual environments

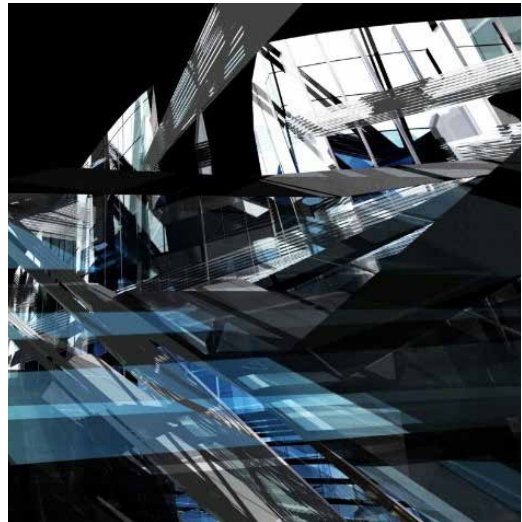

FIGURE 4.6 Screenshot (authors) – new cognitive perception of virtual environments

Third, having acquired and successfully applied incongruent ideas from these new experiences, designers may show an increase in psychological readiness to recruit and seek out ideas from diverse sources and use them as inputs in the creative process, allowing for continued exposure to a wide range of new ideas, norms, and practices.

Forth, it is obvious that implementing formal shape, characteristics, etc. directly in physical world is not the purpose, however incongruent concepts provoke exploration into their interrelations, the process of implementing incongruent ideas may lead to greater cognitive complexity, this challenge finally help them to think out of box. Higher creativity is most likely when the two concepts involved in conceptual expansion are not normally seen as overlapping with each other seemingly non-overlapping concepts sometimes being associated with two distinct worlds (Hampton, 1987; Wan & Chiu, 2002). In short, the experience of virtual environments may foster creativity by (a) providing direct access to novel ideas and concepts in (unconventional) virtual environments, (b) creating the ability to see multiple underlying functions behind the same form, (c) destabilizing conventional knowledge structures (design approach), thereby increasing the accessibility of normally inaccessible knowledge, (d) creating a psychological readiness to recruit ideas from unfamiliar sources and places, and (e) supporting synthesis of seemingly incompatible ideas from another environment.

§ 4.2.6 Implementation in pedagogy

Design thinking harnesses tacit knowledge rather than the explicit knowledge of logically expressed thoughts. Designers operate at a level of complexity in the synthesis of constraints where it is more effective to learn by doing, allowing the subconscious mind to inform intuitions that guide actions. Perhaps the mind is like an iceberg, with just a small proportion of the overall amount protruding above the water. If we operate above the water line, we only have a small volume to use, but if we allow ourselves to use the whole submerged mass, we have a lot more to work with. If a problem has a large number of constraints, the conscious mind starts to get confused, but the subconscious mind has a much larger capacity. Designers have the ability and the training to harness the tacit knowledge of the unconscious mind, rather than being limited to working with explicit knowledge. This makes them good at synthesizing complex problems with large numbers of constraints; it also makes them bad at explaining or defining what they are doing or thinking. They

will describe process and results because they are not consciously aware of their own rationale (Designing interactions by Bill Moggridge).

In his book *To Understand Is to Invent* Piaget said the basic principle of active methods can be expressed as follows: "to understand is to discover, or reconstruct by rediscovery, and such conditions must be complied with if in the future individuals are to be formed who are capable of production and creativity and not simply repetition. Humans generate knowledge and meaning from an interaction between their experiences and their ideas (Jean Piaget)". Accentuating the role experience in education, the virtual environment exploring, totally fits in educational program.

In form of some interactive workshops, which participants first build their environments with specific software like Max/Msp/Jitter/Cosm, Virtools, Blender or even by scripting, and then manipulate their environment as they follow the path of their choice. It is important to achieve the right balance between the degree of structure and flexibility that is built into the learning process. Savery (1994) contends that the more structured the learning environment, the harder it is for the learners to construct meaning based on their conceptual understandings. Instructors first introduce the basic approaches that give life and form to any unconventional designs in virtual environments, and then revisit and build upon these repeatedly. Each group examines different tasks in terms of material, depth, interactivity, etc...which is their personal subjective interpretation of the unconventional. In next step groups exchange their environments with each other and try to perceive environments of other groups. Since explaining some cognitive science seems boring, theoretical and not understandable in some cases, involving students directly is a proper idea. In this way students become active participants instead of passive sponges and the teacher takes on the role of facilitator as he/she gave them guidance in their creation. Learners should constantly be challenged with tasks that refer to skills and knowledge just beyond their current level of mastery. This captures their motivation and builds on previous successes to enhance learner confidence (Brownstein 2001). Of course proper discussion methods and exchanging ideas like Edward Harkness method would be implemented in between and students become familiar with each other approaches and senses.

§ 4.2.7 Conclusion

This paper speculations reviewed here demonstrate that virtual environment experience predicts both creative outcomes and creative processes. Virtual environment experience is positively related to conceptual boundary design that requires insight to produce creative ideas without being confined to the widely known. It also predicts creativity supporting processes such as the tendency to access unconventional knowledge from memory and to recruit ideas from new experiences for creative idea expansion. Moreover, it is conspicuous that the relationship between virtual environment experience and creativity is stronger when people adapt and are open to these new experiences. Also authors believe that creating a new perception of environment in the first steps of architecture pedagogy would be a broad help on expanding educator's ideas.

References

- Amabile, T. M. (1985). Motivation and creativity: Effects of motivational orientation on creative writers. *Journal of Personality and Social Psychology*, 48, 393–399.
- Amabile, T. M. (1996). *Creativity in context*. Boulder, CO: Westview Press.
- Amabile, T. M., Barsade, S. G., Mueller, J. S., & Staw, B. M. (2005). Affect and creativity at work. *Administrative Science Quarterly*, 50, 367–403.
- Amabile, T. M., Hennessey, B. A., & Grossman, B. S. (1986). Social influences on creativity: The effects of contracted-for reward. *Journal of Personality and Social Psychology*, 50, 14–23.
- Barsalou, L. W. (1985). Ideals, central tendency, and frequency of instantiation as determinants of graded structure in categories. *Journal of Experimental Psychology: Learning, Memory, and Cognition*, 11, 629–654.
- Bink, M. L., & Marsh, R. L. (2000). Cognitive regularities in creative activity. *Review of General Psychology*, 4, 59–78.
- Boden M., *The creative mind: myths and mechanism*. London: Weidenfeld and Nicholson, 1990.
- Boden M., *Creativity and unpredictability*, Stanford Humanities Rev 1995
- Chen, S., & Andersen, S. M. (1999). Relationships from the past in the present: Significant-other representations and transference in interpersonal life. In M. P. Zanna (Ed.), *Advances in experimental social psychology* (Vol. 31, pp. 123–190). San Diego, CA: Academic Press.
- Chiu, C-y. (in press). Multicultural psychology. In D. Matsumoto (Ed.) *Dictionary of psychology*. Cambridge, England: Cambridge University Press.
- Chiu, C-y., & Cheng, S. Y-y. (2007). Toward a social psychology of culture and globalization: Some social cognitive consequences of activating two cultures simultaneously. *Social and Personality Psychology Compass*, 1, 84–100.
- Chiu, C-y., & Leung, A. K-y. (2007). Do multicultural experiences make people more creative? If so, how? Retrieved January 3, 2008, from <http://www.in-mind.org/special-issue/do-multicultural-experiences-make-people-more-creative-if-so.html>.
- Chiu, C-y., Morris, M. W., Hong, Y-y., & Menon, T. (2000). Motivated cultural cognition: The impact of implicit cultural theories on dispositional attribution varies as a function of need for closure. *Journal of Personality and Social Psychology*, 78, 247–259.
- Costa, R. T., & McCrae, R. R. (1992). *Revised NEO Personality Inventory (NEO PI-R) and NEO Five-Factor Inventory (NEO-FFI) professional manual*. Odessa, FL: Psychological Assessment Resources.
- Csikszentmihalyi, M. (1996). *Creativity: Flow and the psychology of discovery and invention*. New York: Harper-Collins.
- Duncker, K. (1945). On problem solving. *Psychological Monographs*, 58(5, Whole No. 270).

- Earley, P. C., & Ang, S. (2003). *Cultural intelligence: Individual interactions across cultures*. Palo Alto, CA: Stanford University Press.
- Earley, P. C., & Mosakowski, E. (2004, October). Cultural intelligence. *Harvard Business Review*, 139–146.
- Eisenberger, R., & Cameron, J. (1996). Detrimental effects of reward: Reality or myth? *American Psychologist*, 51, 1153–1166.
- Fauconnier G. *Mental spaces*. Cambridge, MA: MIT press, 1985
- Feist, G. J. (1998). A meta-analysis of the impact of personality on scientific and artistic creativity. *Personality and Social Psychological Review*, 2, 290–309.
- Feist, G. J., & Brady, T. R. (2004). Openness to experience, non-conformity, and the preference for abstract art. *Empirical Studies of the Arts*, 22, 77–89.
- Finke, R. A., Ward, T. B., & Smith, S. M. (1992). *Creative cognition: Theory, research, and applications*. Cambridge, MA: MIT Press.
- Fong, T. T. (2006). The effects of emotional ambiguity on creativity. *Academy of Management Journal*, 49, 1016–1030.
- Förster, J., Friedman, R. S., & Liberman, N. (2004). Temporal construal effects on abstract and concrete thinking: Consequences for insight and creative cognition. *Journal of Personality and Social Psychology*, 87, 177–189.
- Fredrickson, B. L. (2001). The role of positive emotions in positive psychology: The broaden-and-build theory of positive emotions. *American Psychologist*, 56, 218–226.
- Friedman, R. S., & Förster, J. (2001). The effects of promotion and prevention cues on creativity. *Journal of Personality and Social Psychology*, 81, 1001–1013.
- Fu, H-y., Morris, M. W., Lee, S-l., Chao, M-c., Chiu, C-y., & Hong, Y-y. (2007). Epistemic motives and cultural conformity: Need for closure, culture, and context as determinants of conflict judgments. *Journal of Personality and Social Psychology*, 92, 191–207.
- Galinsky, A. D., Maddux, W. W., & Ku, G. (2006). The view from the other side of the table: Getting inside your counterpart's head can increase the value of the deal you walk away with. Here's how to do it. *Negotiation*, 9, 1–5.
- Glover, J. A., Ronning, R. R., & Reynolds, C. R. (Eds.). (1989). *Handbook of creativity*. New York: Plenum.
- Grant, A. M., Langer, E. J., Falk, E., & Capodilupo, C. (2004). Mindful creativity: Drawing to draw distinctions. *Journal of Creativity Research*, 16, 261–265.
- Guilford, J. P. (1959). Traits of creativity. In H. H. Anderson (Ed.), *Creativity and its cultivation* (pp. 142–161). New York: Harper.
- Guimera, R., Uzzi, B., Spiro, J., & Amaral, L. A. N. (2005). Team assembly mechanisms determine collaboration network structure and team performance. *Science*, 308, 697–702.
- Hampton, J. A. (1987). Inheritance of attributes in natural Hennessey, B. A., & Amabile, T. M. (1998). Reality, intrinsic motivation, and creativity. *American Psychologist*, 53, 674–675.
- Hong, Y., Wan, C., No, S., & Chiu, C-y. (2007). Multicultural identities. In S. Kitayama & D. Cohen (Eds.), *Handbook of cultural psychology* (pp. 323–346). New York: Guilford Press.
- Ip, G. W-m., Chen, J., & Chiu, C-y. (2006). The relationship of promotion focus, need for cognitive closure, and categorical accessibility in American and Hong Kong Chinese university students. *Journal of Creative Behavior*, 40, 201–205.
- Jost, J. T., Glaser, J., Sulloway, F., & Kruglanski, A. W. (2003). Political conservatism as motivated social cognition. *Psychological Bulletin*, 129, 339–375.
- Koestler A., *The act of creation*. New York: Mcmillan, 1967.
- Kray, L. J., Galinsky, A. D., & Wong, E. (2006). Thinking within the box: The relational processing style elicited by counterfactual mind-sets. *Journal of Personality and Social Psychology*, 91, 33–48.
- Ku, G., Galinsky, A. D., & Murnighan, J. K. (2006). Starting low but ending high: A reversal of the anchoring effect in auctions. *Journal of Personality and Social Psychology*, 90, 975–986.
- Lam, T. W., & Chiu, C-y. (2002). The motivational function of regulatory focus in creativity. *Journal of Creative Behavior*, 36, 138–150.
- Lambert, W. E., Tucker, G. R., & d'Anglejan, A. (1973). Cognitive and attitudinal consequences of bilingual schooling: The St. Lambert project through grade five. *Journal of Educational Psychology*, 65, 141–159.
- Langer, E. (2000). Mindful learning. *Current Directions in Psychological Science*, 9, 220–223.
- Levine, J. M., & Moreland, R. L. (2004). Collaborations: The social context of theory development. *Personality and Social Psychology Review*, 8, 164–172.
- Leung, A.K., Maddux, W., Galinsky, A., Chiu, C. (2008). Multi cultural experience enhances creativity, *American Psychologist*

- MacKinnon, D. (1978). In search of human effectiveness. Buffalo, NY: Bearly.
- McCrae, R. R., & Costa, P. T. (1987). Validation of the five-factor model of personality across instruments and observers. *Journal of Personality and Social Psychology*, 52, 81–90.
- Nemeth, C., & Kwan, J. (1987). Minority influence, divergent thinking and detection of correct solutions. *Journal of Applied Social Psychology*, 17, 788–799.
- Nemeth, C., & Wachtler, J. (1983). Creative problem solving as a result of majority vs. minority influence. *European Journal of Social Psychology*, 13, 45–55.
- Okhuysen, G. A., Galinsky, A. D., & Uptigrove, T. A. (2003). Saving the worst for last: The effect of time horizon on the efficiency of negotiating benefits and burdens. *Organizational Behavior and Human Decision Processes*, 91, 269–279.
- Rubin, D. C., & Kontis, T. C. (1983). A schema for common cents. *Memory & Cognition*, 11, 335–341.
- Runco, M. A., & Chand, I. (1995). Cognition and creativity. *Educational Psychology Review*, 7, 243–267.
- Sawyer, K. (2006). *Explaining creativity: The science of human motivation*. New York: Oxford University Press.
- Schooler, J., & Melcher, J. (1994). The ineffability of insight. In S. M. Smith, T. B. Ward, & R. A. Finke (Eds.), *The creative cognition approach* (pp. 97–133). Cambridge, MA: MIT Press.
- Simonton, D. K. (1997). Foreign influence and national achievement: The impact of open milieu on Japanese civilization. *Journal of Personality and Social Psychology*, 72, 86–94.
- Simonton, D. K. (1999). *Origins of genius: Darwinian perspectives on creativity*. New York: Oxford University Press.
- Simonton, D. K. (2000). Creativity: Cognitive, personal, developmental, and social aspects. *American Psychologist*, 55, 151–158.
- Simonton, D. K. (2003). Scientific creativity as constrained stochastic behavior: The integration of product, person, and process perspectives. *Psychological Bulletin*, 129, 475–494.
- Sternberg, R. J., & O'Hara, L. A. (1999). Creativity and intelligence. In R. J. Sternberg (Ed.), *Handbook of creativity* (pp. 251–272). New York: Cambridge University Press.
- The diversification of psychology: A multicultural revolution. *American Psychologist*, 54, 1061–1069.
- Tadmor, C. T., & Tetlock, P. E. (2006). Biculturalism: A model of the effects of second-culture exposure on integrative complexity. *Journal of Cross-Cultural Psychology*, 37, 173–190.
- Taylor AI. The nature of the creative process. In: Smith P editor. *Creativity: an examination of the creative process*. New York: Hastling House, 1959. P. 51-82
- Torrance, E. P. (1974). *Torrance Tests of Creativity Thinking*. Lexington, MA: Personnel Press.
- Wan, W., & Chiu, C-y. (2002). Effects of novel conceptual combination on creativity. *Journal of Creative Behavior*, 36, 227–241.
- Ward, C., Bochner, S., & Furnham, A. (2001). *The psychology of culture shock*. London: Routledge.
- Ward, T. B. (1994). Structured imagination: The role of conceptual structure in exemplar generation. *Cognitive Psychology*, 27, 1–40.
- Weisberg, R. W. (1993). *Creativity: Beyond the myth of genius*. New York: W. H. Freeman.
- Weisberg, R. W. (1999). Creativity and knowledge: A challenge to theories. In R. J. Sternberg (Ed.), *Handbook of creativity* (pp. 226–250). Cambridge, England: Cambridge University Press.

5 Proto-fuse project

Methods to boost [spatial] creativity

§ 5.1 Experimental approaches to derive two methods for boosting spatial creativity

This chapter, via two experiments, focuses on proving the hypothesis with empirical evidences. Two separate experiments were conducted under the title: The Proto-fuse project. In each of these experiments the following two concepts and their correlation with creativity have been addressed:

- 1- Conceptual blending
- 2- Tolerance of ambiguity

The experiments firstly aim to identify the relationship between conceptual blending and navigating UVEs and secondly aim to identify the importance of tolerances of ambiguity in the discipline of architecture and engineering.

The empirical evidences are published in the fourth journal article: "The Proto-Fuse project: methods to boost creativity for architects", International Journal of Design Creativity and Innovation, Taylor & Francis publisher, pp. 1-16.

§ 5.2 The Proto-Fuse Project: Methods to boost creativity for architects*

Alireza Mahdizadeh Hakak ¹, Joydeep Bhattacharya ², Nimish Bilorla ¹, Armaghan Ahmadi Venhari ³

¹ Faculty of Architecture, TU Delft University, Delft, The Netherlands

² Faculty of Psychology, Goldsmiths University of London, London, United Kingdom

³ Faculty of Architecture, Shahid Beheshti University of Iran, Tehran, Iran

Abstract. Human civilization can be ameliorated by human creativity. Innovation and progress of human civilization results from a change in our thinking patterns, thus, potentially transforming the present into a creative future. Accentuating the role of creativity in design even more than other disciplines pushes one to underpin the understanding of creativity as a key role player in Architecture. Furthermore by identifying the basic principles of our ingenuity/creativity, researchers might be able to enhance this ability in the future.

The digital era allows for a new domain of architectural experience. It is assumed that new designs in virtual environments can be created that go beyond the mere accommodation of literal functions, and affect human experiences. This paper presents the role of a method developed by the authors: 'Proto-Fuse', experimented with, as an artwork for the survey of cognitive perception of humans, specifically targeting enhancement of spatial creativity. The logic behind this method is based on two psychological concepts: 1- Conceptual blending, 2-Tolerance of ambiguity. Two experimental projects were conducted for exploring the Proto Fuse method: a. "Unconventional Virtual Environments (UVEs)" to improve conceptual blending and b. "Extracting local distance" to enhance tolerance of ambiguity.

The paper concludes with an implementation scenario of the Proto-Fuse method in the pedagogy of architecture and elaborates on the results of the projects and analysis of the feedbacks received during the project session.

Keywords. Creativity; Architecture; Pedagogy; Education; Conceptual Blending

* Published as: Mahdizadeh Hakak A., Bhattacharya J., Bilorla N., Ahmadi Venhari A., (2015), "The Proto-Fuse project: methods to boost creativity for architects", International Journal of Design Creativity and Innovation, Taylor & Francis publisher, pp. 1-16

§ 5.2.1 Introduction

Creative potential of human spearheads their civilization. In fact, progress at every sphere of our lives crucially depends on our creativity. Emphasizing the role of creativity in design even more than other disciplines pushes one to underpin the understanding of creativity as a key role player in Architecture. Furthermore by identifying the basic principles of our ingenuity/creativity, researchers might be able to enhance these abilities in future.

But how can we define creativity? Though creativity is the hallmark of human cognition, and therefore a topic of enormous scientific importance, yet not a single definition of creativity exists that is universally accepted by creativity researchers, and the scenario hasn't changed much in the last fifty years (Runco, 2004). Nevertheless, any creative output (be it an idea, product, or performance) should have, at least, three characteristics: novelty (it is original), usefulness (it is functional and adaptive), and surprising (it is non-obvious, therefore eliciting an aesthetical or affective response) (Simonton, 1999).

The current study focuses on 'experience', its way of operation and points out its existence and relevance in creativity. Experiences indirectly affect creativity. The larger the inventory of experiences, the more and better combination of ideas is possible. Further, the more diverse and unusual the experiences are, the higher the likelihood of creativity. For example, recent research suggests a link between multicultural experiences (e.g., learning a new language, multicultural exposure) and creative thinking (Maddux & Galinsky, 2009). The exposure to and engagement with unusual experiences and/or situations may lead to a better cognitive flexibility by breaking the fixed cognitive patterns, a source of functional fixedness, and thereby, promotes creative associations between remote or distant ideas. In fact, a recent research shows that after actively experiencing unusual virtual scenarios participants score higher on unusual use tasks, a widely applied measure of (divergent) creativity (Guilford, 1967), leading the authors to suggest a causal role of unusual and unexpected experiences in creativity (Ritter et al., 2012). Therefore, in this paper we attempt to extrapolate and connect this concept of "variety and extensiveness of experiences" to the discipline of architecture and apply it to a pedagogy of architecture as a practical creativity enhancing application.

Many architects confess that, very gradually and unconsciously they tend to stock in some conventional design approaches, because slowly confinements in construction and conventional stereotypes and rules of the physical world impose on them, dominate them and prevent them from thinking innovatively.

Considering this context, in the paper, two methods are proposed to boost creativity and reverse the process of losing it.

§ 5.2.2 Where do creative ideas come from?

As mentioned earlier, a necessary condition of creativity is the novelty aspect: a creative product or idea should not exist previously in the same form; but how can we get new ideas? In his book “The AHA! Moment” David Jones takes a bold stance by claiming that we cannot have a truly new idea, the best we can do is to make combinations of different ideas already known to us (Jones, 2012). Therefore one needs a vast subconscious mass of remembered data in order to increase the likelihood of combination of ideas.

Jones’ theory is based on a three-tiered model of human mental structure. In the following spaces, we outline briefly the salient features of this model (figure 5.1).

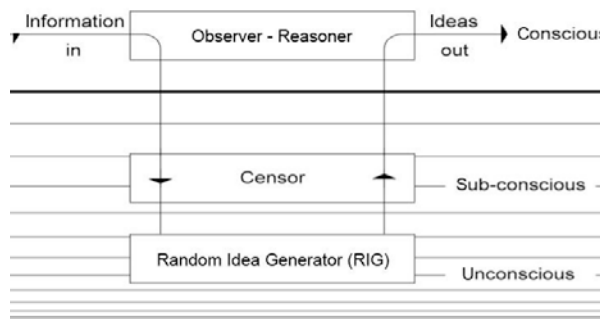

FIGURE 5.1 The three layered model of human mental structure after Jones (2012). In this model, the upper layer, Observer-Reasoner, is in the conscious mind, the middle layer, Censor, is in the subconscious mind, and the lower layer, Random Idea Generator, is in the unconscious mind. The horizontal lines schematically depict ideas/representations and the bold line demarcates the consciousness.

The top level is the Observer-Reasoner, the conscious part of our mind that is involved with planning, execution and action. It is also involved with reasoning, argument and conscious deliberation. In short, it processes incoming data gathered from the senses and from the lower levels, critically evaluates the ideas and formed representations, and finally plans our subsequent actions.

The mid-level is the Censor, the subconscious part that houses our implicit knowledge (e.g., procedural skills, linguistic skills). It allows rapid access of stored knowledge or information. For example, our language related skills are subconscious and we can constantly access our relevant knowledge from the subconscious during writing or speaking without much delay. The Censor also protects the Observer-Reasoner from constant perturbations by preventing non-sensical absurd or uninformative ideas reaching the uppermost level. Therefore, if it is too restrictive, it impairs creativity, and if it is too permissive, the Observer-Reasoner will be flooded with meaningless ideas. The lowermost level is the unconscious mind, the creative part of it is termed as the Random-Idea-Generator (RIG) that combines randomly, without any rule/supervision, ideas or information stored in the unconscious and preconscious mind. Due to the inherent randomness in the combinatorial process, most of the RIG ideas are wrong or not functionally useful and therefore blocked by the Censor before it can reach the uppermost conscious level, the Reason-Observer. For a simple problem (such as arranging the books on a shelf), the RIG generates ideas almost on demand and pushes them up as quickly as the Observer-Reasoner can evaluate them. But for a complex problem (such as designing an office complex), the whole process may take for years. And once a creative RIG idea manages to pass the Censor and finally reaches the conscious level, it is likely to be perceived as a flash of sudden insight, known as Aha! It is to be noted that the RIG is rather immune from influences of the intellectual critical self, rather is strongly tied with the emotional self. Jones (Jones, 2012, Chapter 3) has listed various factors (such as time, expertise, social skills, gender) that interact with the RIG.

The role of unconscious processing of information in creativity is widely known. For example, in Wallas four-stage description of creative process (Wallas, 1926), the second stage is incubation, the time period during which the unconscious mental processes are active; it is also claimed that during incubation “associative processes are at work and are free from the censorship of the conscious mind” (Runco, 2014). However, this does not mean that the mental information processing below the level of conscious awareness is passive, and in fact, they can be active and goal driven (Ritter & Dijksterhuis, 2014). Recently, a possible candidate mechanism is proposed by which the transition from preconscious to conscious creativity is managed (Wiggins & Bhattacharya, 2014).

This mental model, though quite appealing due to its inherent simplicity, does not provide much insight into how ideas are combined. Even for a random combination to occur by the RIG, there has to be a mapping procedure by which ideas or concepts belonging to different domains or disciplines are allowed to merge with each other. The theory of ‘conceptual blending’ provides such

a mechanism (Turner, 1998). In his book “The Literary Mind” Mark Turner states: “Conceptual blending is a fundamental instrument of the everyday mind, used in our basic construal of all our realities, from the social to the scientific.” The theory posits that elements and vital relations from diverse scenarios are “blended” into a subconscious process known as Conceptual Blending (Fauconnier & Turner, 2008) which is assumed to be ubiquitous to everyday thought, language, metaphor and reasoning. If two concepts are similar, a simpler strategy is used to combine them and the resultant concept is less novel and offers limited surprise. However, for very different or remote concepts, complex strategies of structural mapping are required to fuse them, resulting in most novel, innovative concepts. The more mutually remote the concepts are, the more surprising and creative the blended concept is. Indeed one of the classical laboratory tests on (convergent) creativity is termed as remote associate test, which is based on this very idea that creativity involves remote associations between concepts (Mednick, 1962); see (Pereira & Cardoso, 2002) for a computational framework relating conceptual blending to convergent creative processes.

Insights obtained from these blends constitute the products of creative thinking. Arthur Koestler, championed this idea in his 1964 book *The Act of Creation* and identified a common pattern in creative achievements in art, science and humour, which he called “bisociation” (Koestler, 1964). After analysing and comparing varied instances of inventions and discoveries he concluded that fusing two unrelated elements coming from two different ideas/categories can be seen in an evolving matrix of meaning by way of a process applying analogies, comparisons, abstraction and metaphors. Indeed throughout history there are many examples of creative individuals who possessed expertise in multiple professions, thereby allowing the successful combination and cross-fertilization between different disciplines (Johansson, 2004); see also (Dubitzky, Kötter, Schmidt, & Berthold, 2012) for a recent attempt on the computational implementation of bisociation in creativity.

So far we can assume that creativity is about blending concepts, however, we can blend the ideas in different ways, and different modes of thinking, that lead us to two different types of creativity.

§ 5.2.3 Types of creativity

Boden has suggested two broad types of creativity: improbableist and impossibilist (M. A. Boden, 1994). The improbableist creativity involves new

or unlikely, therefore improbable in nature, combinations of existing ideas, which is similar to the earlier concept discussed by David Jones. This is also the current working definition of creativity in architecture. Though this is not a universally accepted definition of creativity, however, informally this is the usual creative process, which architects follow. On the other hand, the impossibilist creativity is a deeper type involving the mapping, exploration and transformation of conceptual spaces. Therefore the two types differ in the mode of the creative thinking. Improbabilist creativity specifies thinking in the associative mode, while respecting the logics, (physical) rules, and boundaries and constraints. If we extrapolate this definition to architecture, obeying conventional rules and the role of confinements in architecture in terms of material, technology, even perception of new spaces become clear. Impossibilist creativity involves the spontaneous generation of new states with new properties. Gabora provides a mathematical description of impossibilist creativity using an example of a torch (Gabora & Aerts, 2002). This example involves the spontaneous appearance of a new state (the state of mind that conceives of the torch) with a new property (the property of being able to move fire). Impossibilist creativity is subject to the bisociative mode, in which the conceptual space is transformed, possibly at the expense of existing rules and disciplinary boundaries, and therefore affords higher autonomy in the procedure (Koestler, 1964). It is literally presumed that a product of impossibilist creativity needs mutation and transformation of the corresponding conceptual spaces (M. Boden, 1995). Impossibilist creativity in architecture can be associated with ignoring the physical rules (e.g. gravity), ignoring structured Euclidean geometry and move to non-Euclidean fluidity, while creatively distorting and blending scale, material limitations and essentially reverse engineering the very act of conceiving space etc.

The first step relevant for creativity in design is quintessentially an enhancement of the perception of spaces itself. Since our visual perception is overly used to (and therefore constrained by) the environment around us in term of scale, depth, dimension, etc., changing the characteristics of the conventional environment around us might pave the way towards transformation of the corresponding conceptual spaces.

§ 5.2.4 Shifting to Impossibilist conceptual blending in architecture

In the same logical vein as above, we expect to find similar outcome in the architecture discipline in design processes. The question here is how we transform improbable creativity to impossibilist creativity in architecture.

Since the information feed of the brain is limited to what has been provided by the senses (e.g., hearing, seeing, touch), the experiences that can be accumulated from experiencing the physical world are limited or constrained by the environment around us, in terms of its scale, depth, dimension, etc. Transformation of the corresponding conceptual space needs mutation that seems farfetched with the available information feed. Therefore changing the characteristics of the conventional environment around us may provide an alternative route for transformation of the corresponding conceptual space.

The digital era allows for new possibilities of architectural experience. It is assumed that new designs in virtual environments can be created that go beyond the mere accommodation of literal functions, and that affect human experiences. Detached from the real one in sense of time and matter, they enable the designers to cross the boundary between reality and fiction, thus expanding their inventory. This new kind of architecture can create emotionally rich architectural experiences through dynamic and precise manipulation of abstract visual forms in virtual space.

Unconventional Virtual Environments (UVEs) can be designed, within which, spatial patterns can dynamically evolve in time with respect to user interactions. A variety of spatially intriguing concepts such as: Multiple dimensions, Dematerialization, Infinite depth, Continuous change, Multiple scales etc. can thus be experimented with. These concepts and their visualization can render cognition and perception a new meaning owing to the fact that the brain has not experienced and comprehended such concepts before and is thus not pre-conditioned to interpret them (Figure 2).

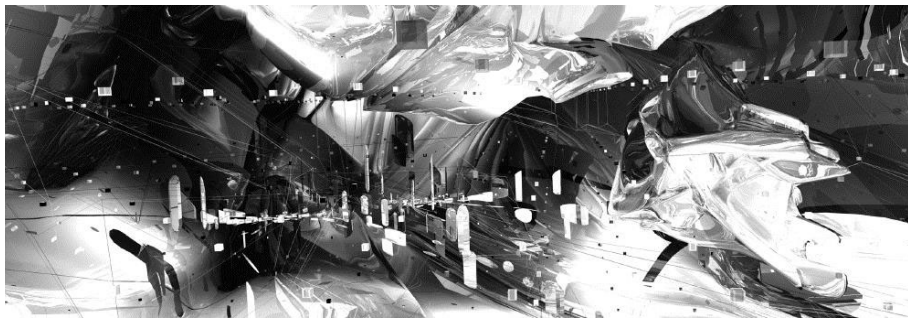

FIGURE 5.2 V4D_Visio4D by Marcos Novak

In this stage the inventory of experiences is constantly expanding and we can expect by blending new data with the old ones mutations are bound to happen.

From a cognitive point of view extensiveness of experience gained by surfing in unconventional virtual environments can positively be related to both creative performance (enhance interactivity, lateral thinking, idea generation, etc.) and creativity-supporting cognitive processes (retrieval of unconventional knowledge, recruitment of ideas from unconfined virtual environment for creative idea expansion). Eventually with new languages and forms we can stimulate our creativity (Bartle, 2004).

§ 5.2.5 The Relationship between Tolerance of Ambiguity and Creativity

A substantial body of literature suggests a possible link between tolerance of ambiguity and creativity. A creative individual should have the ability, will and desire to deal with ambiguous and open-ended situations and suspend his/her immediate judgments to allow various possibilities to emerge (GOLANN, 1962; Stoycheva, 2003). Taylor and Barton listed a liking for abstraction with considerable tolerance of (cognitive) ambiguity as one of the key traits of a creative scientists (Taylor & Barron, 1963). A positive correlation was indeed observed between the tolerance of ambiguity scale and certain measure of creativity (Tegano, 1990). In fact, an influential model of creativity, the investment approach, has considered the tolerance of ambiguity as one of the most crucial attributes of creative personality (Lubart & Sternberg, 1995). Amabile illustrates the judgment suspension as “keeping response option open as long as possible” as well as tendency to break down the conventional rules/methods whenever necessary (Amabile, 1996). Intrinsic motivation is also connected to creative achievements (Hennessey & Amabile, 1998). We argue here that tolerance of ambiguity is related to creativity because it “empowers the intrinsically motivated exploration of novel, unusual, or complex stimuli” (Zenasni, Besançon, & Lubart, 2008). Barron and Harrington show that creative achievers tend to be attracted towards complexity (Barron & Harrington, 1981). Dacey describes as: “The first characteristic of the creative person is tolerance of incongruity, which could be called tolerance of ambiguity (Dacey, 1989). Its opposite could be called fear of the unknown or unfamiliar.” Eysenck illustrates that highly creative individuals, “can live with doubt and uncertainty, even enjoying risks and seeking out instabilities in the world” (Eysenck, 1993).

Amabile also emphasizes the ability of divergent thinking and using wide and flexible categories (Amabile, 1996). Individuals, who cannot tolerate ambiguity, tend to seek the solution through available options and rigid categories and tend to close the situation prematurely (Kenny & Ginsberg, 1958). However one

should not confuse creativity with intelligence, as Kenny and Ginsberg found that individuals with high levels of intelligence but low levels of creativity tended to be “intolerant of unlikely, unconventional types of hypothesizing about the world” (Kenny & Ginsberg, 1958).

These literatures altogether conspicuously suggest a positive association between creativity and tolerance of ambiguity (Taylor & Barron, 1963) .

§ 5.2.6 Implementation in “pedagogy” of architecture

Referring back to the human mental structure as proposed by David Jones (Figure 1), we consider the model to be quite appropriate for designers, especially considering the supposed role of unconscious RIG in generating creative ideas and concept. Design thinking uses more of tacit knowledge of the unconscious mind rather than explicit knowledge of the conscious mind. A physical metaphor will be an iceberg, the small portion outside the water representing the conscious mind, the big submerged part represents the unconscious mind and the surface of the water is the censor line. It is immediately obvious that the capacities are not comparable: the unconscious mind is vastly superior in terms of information processing capacity therefore the capacity limitation of the conscious mind slows down the mind’s performance in complex, multi parameter based processing with a large number of constraints.

Problem solving procedure in architecture also involves many stakeholders from other disciplines: structural engineering, mechanical/electrical issues, energy saving, material properties, cost efficiency, social aspects of the inhabitants, interaction with the context, neighborhood and city and so forth, therefore dealing with all aspects of the design at the same time makes the mind rather confused, much sooner. However the unconscious mind has a large capacity to incorporate these aspects in mind and find a proper solution. Designers are trained to harness the tacit knowledge of the unconscious, instead of the explicit knowledge of the conscious mind. This ability helps architects to relate and optimize multiple parameters and find apt solutions that meet their requirements. Meanwhile, this also entails the inability to rationalize the design process in a fully explainable manner, since many of the solutions are discerned from an “Aha! Moment”, and are thus not describable.

§ 5.2.7 Proto-Fuse method

Summarizing, the aforementioned context, we can effectively extract two important parameters pertinent to creativity:

- Conceptual blending and impossibilist creativity
- Tolerance of ambiguity

This paper elaborates the role the Proto-Fuse method, tested as an artwork for the survey of cognitive perception of humans, targeting the enhancement of spatial creativity. Simply put, it can be considered as a method of transiently altering our visual environment in order to promote two critical functions: (i) a mutation in unconscious and (hypothetical) RIG (see Figure 1), and (ii) improvement of tolerance of ambiguity, with the final aim to enhance creativity.

The recent propagation of inexpensive, at hand, high performance computing is driving scientists to generate larger, more complex data sets from the simulations they develop. This can also be said of modern artworks that take place in virtual environments, where the audience can manipulate, and explore it interactively. We find this approach appropriate to extend human experience/perception of space. It is designed for the purpose of gaining insight and developing intuition about environments in which the brain cannot venture because of constraints of the physical world: N-dimensional information spaces, the worlds of the very small or very large, from nanotechnology to cosmology, from neurophysiology to new media, even imaginary virtual worlds in which the characteristics of physical world are not dominant e.g. zero gravity or continuous change.

The paper focuses on this method to blend new ideas in the unconscious mind following the idea of conceptual blending and expects mutation in random idea generation (RIG), which subsequently will help to shift from improbableist creativity to impossibilist creativity. For reaching this aim two approaches are proposed and explained:

- Navigating in UVEs (helping conceptual blending mutation)
- Extracts of local distance (helping tolerance of ambiguity)

§ 5.2.7.1 Navigating in Unconventional Virtual Environments (UVEs)

Art is unhindered by the strict practicalities that result from purely scientific pursuits and thus makes a good test bed for experiencing some qualities that do not exist in rule-based physical universe. Art is firmly embedded in the history of immersive virtual reality spaces. Indeed, Cave Automated Virtual Environments (CAVEs) are now an established medium for artists. CAVEs provide a space where art can be dynamic, interactive, immersive, and multimodal.

The Chair of Hyperbody at the TU Delft previously conceived such a space: The Virtual Operation Room as a future self-diagnostic tool and auto-curing health game. The goal is to locate and exterminate cancerous cells, thus healing the patient embodied in the avatar. This virtual environment was developed for an exhibition at the Delft Museum of Technology. Actual architectural concepts like e-motive architecture, time-based architecture, programmable architecture, freeform styling, coupled with computational techniques involving complexity sciences (swarm behavior and genetic algorithms) come together in UVEs. The science of virtual reality has contributed to the world of art; however, the contribution of art to the science of virtual reality and the development of the software and hardware infrastructure of these spaces has received little attention. Virtual reality artworks often challenge the capabilities of the spaces in which they are installed. Since no specific software system or interactive design was in place for the target of Proto-Fusion, there was ample opportunity to allow the art to drive the technological design (figures 5.3,5,4).



FIGURE 5.3 UVEs by authors

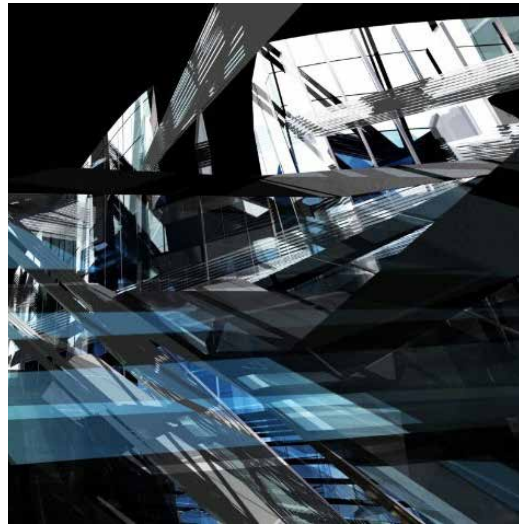

FIGURE 5.4 UVEs by authors

§ 5.2.7.2 Extracts of Local Distance

“FELD - studio for digital crafts” initiated a project named “Extracts Of Local Distance”. In collaboration with the studio, we used this project as a test bench for experimenting tolerance of ambiguity through a group of participants. The description of the project borrowed from their website (<http://www.localdistance.org/process.php#process>) is as follows:

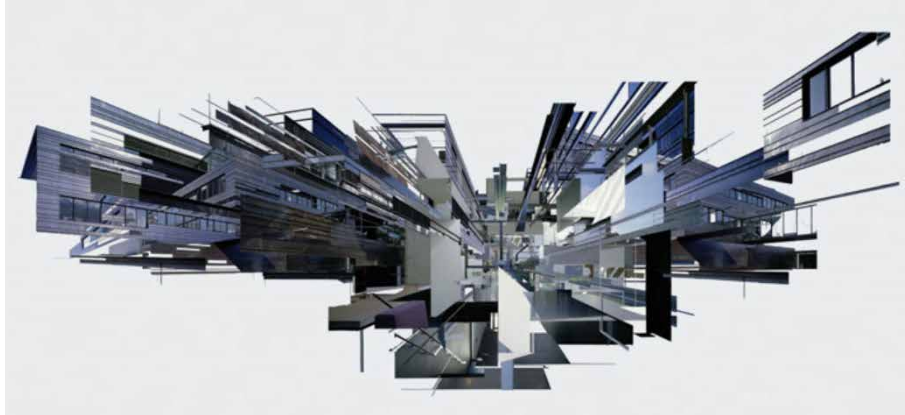

FIGURE 5.5 Extracts Of Local Distance Project (used with permission)

“There is a strong bias regarding image composition in architecture photographs. Perspective foreshortening and vanishing lines dominate the overall impression of the image. This realization lead to experiments in automated extraction of said features in the image data. The medium used for the result is just one of the many possibilities. The method also bears the potential for further experimentation and can be considered a work in progress.

Countless fragments of existing architectural photography are merged into multi-layered shapes. The resulting collages introduce a third abstract point of view next to the original ones of architect and photographer. Digital scans of analogue architectural photography form tiny pieces of a large resulting puzzle. The original pictures are being analyzed and categorized according to their vanishing points and shapes. Based on this analysis, slices are being extracted from the source image. These slices retain the information of their position corresponding to their original vanishing point and thus form a large pool of pieces, ready to be applied to new perspectives and shapes.

Using the extracted image segments, it is now possible to form collages of originally different pictures with a new common perspective. In order to compose a collage, a perspective-grid is defined and a lining of matching image segments is being applied. The segments are not altered to match the frame but fitting ones are chosen from the sheer mass of possible pieces. By defining additional keywords that describe the content of the original photographs, the selection of segments used for the final composition can be influenced. Thus a contextual layer is added through the semantic linking with the source material. The resulting fine-art prints are entirely unique each time."

To see the impact of these images on different groups of participants, a small experiment was designed. A crowd sourcing method was used for this experiment. An interface with clear instructions was designed, and students were asked to participate in the experiment via social networking sites. The instructions were spread and shared by people using Facebook and participants were asked to send their response as a private message, to avoid being influenced by other respondents. More than 130 different feedbacks were collected in one week and we stopped collecting data afterwards. Since more than 80 percent of the participants were from Architecture/Engineering background and to specify more the target of the experiment was aiming to narrow down the target groups as much as possible, we decided to remove about 20% of the responses from people who were from disciplines other than architecture and engineering (medicine, law, chemistry, literature, etc.). Eventually, 102 participants were chosen and were distributed in groups of two students, one from Architecture and one from Engineering.

The groups were asked to give their feedback about their immediate feeling after watching a series of images that were taken from "Extracts Of Local Distance Project". Proportion of the participants in terms of male and female was almost the same (53 female and 49 male) and the average age of the group was 26 years (from 18 to 36). Responses obtained from some of the participants are shown below (table 5.1):

1	M	Architect	A science-fiction feeling. Sounds ridiculous, but I see it as a dream where you can choose whatever you desire, a puzzle that you can create with whatever you like out of the assemblage
2	F	Architect	It's a mess, A tornado passed by a room and created chaos. I feel speed, like watching from the window of a moving train. The lack of logical connection between elements is because of motion. It is not a static still image, it is moving....
3	F	Engineer	I can say my opinion in some words: Perspective, order, disorder, technology, future, earth, loneliness...
4	M	Engineer	The picture is fragmented, does not give me any special feeling. I do not hate it; I do not like it though.
5	F	Architect	On the first look it give me a headache, stress and rush and I do not want to stay there anymore. On the second look though, I can see layers and layers beneath. Each time I am exploring something new. I enjoy exploring...
6	M	Architect	I enjoy ambiguous environments, especially those that engage the brain and stimulate it.
7	M	Engineer	I am not patient to dig in the image and explore them. I cannot stand them.
8	F	Architect	I use a lot of collage and sketches in my designs; I love to be a journalist architect....
9	F	Architect	If I had not seen the word ambiguous in the instruction, I would not consider this images as ambiguous. They are not ambiguous...
10	M	Architect	What I remember from any space I have been is like these images; they are not ambiguous.
11	M	Engineer	It is like a modern art which does not necessarily give me good feeling. I do not understand the shape of the building. The ones from inside are more interesting though.
12	M	Engineer	It is not comforting for me, especially ones with big scale, in which you lose your human scale or ones with more than one vanishing point.
13	F	Engineer	I try to find an order in the chaos, Try to find a route/way through the vanishing point...
14	F	Architect	My eyes look at different local points and create a perception, but I cannot combine them and create a holistic image. I think the more I can tolerate these local points without connecting them, I am more creative...

TABLE 5.1 Summary of comments from each participant's feedback, on "Extracting local distance project"

At first glance one notices two different approaches to define the images: convergent approach and divergent one. Mostly students with engineering background tend to simplify the image as soon as possible, following guidelines, protocol and rules to analyze the image and reach to a conclusion/perception. This might be due to a general tendency towards a lack of suspension of their judgment and finalizing their responses immediately without waiting for further deliberations; alternatively it also could be due to a lack of personal engagement with the images due to the content of the images. On the other hand, the architecture students seem to explore more through layers, dig more and find more meanings out of that. This offers preliminary

evidence supporting the fact that architecture students are more trained in terms of dealing with different parameters and variety of conditions in a design/problem solving task.

Extrapolating the same logic, we can expect that by providing new ground or visual environment for architects, we may enhance their tolerance of ambiguity, suspend their judgments and ultimately help them become more creative.

§ 5.2.8 Designing a NSA (non-standard architecture) to enhance Impossibilist creativity

We can start by defining what Non-Standard architecture is. Non-standard Architecture (NSA) is defined as an architecture that departs from modernist, repetitive, mass-production principles in order to address complexity, variation, and mass-customization.

To reach these qualities we can implement virtual environments within the design process. Hakak explained in a recent paper about the application of interactive unconventional virtual environment (UVEs) workshops, in which students can navigate in UVEs and gain novel experiences (Hakak, Biloria, & Rahimi, 2012). Following the same idea but with suitable extension, in a designed workshop we asked students not only to navigate in UVEs, but also to design one of them. In collaboration with Islamic Azad University, Mashhad branch, Faculty of Art and Architecture (<http://en.mshdiau.ac.ir/>), a group of twenty students were asked to transform a normal conventional building to a Non Standard Architecture, using the 3d max interface (figure 5.6). All the participants were chosen from a Bachelors class and there were 12 female and 8 male students, all of them in the age of 20-22. We chose the pool of participants from Bachelors students because they were still developing design-thinking abilities and were thus more prone to absorb novel modes of design processes.

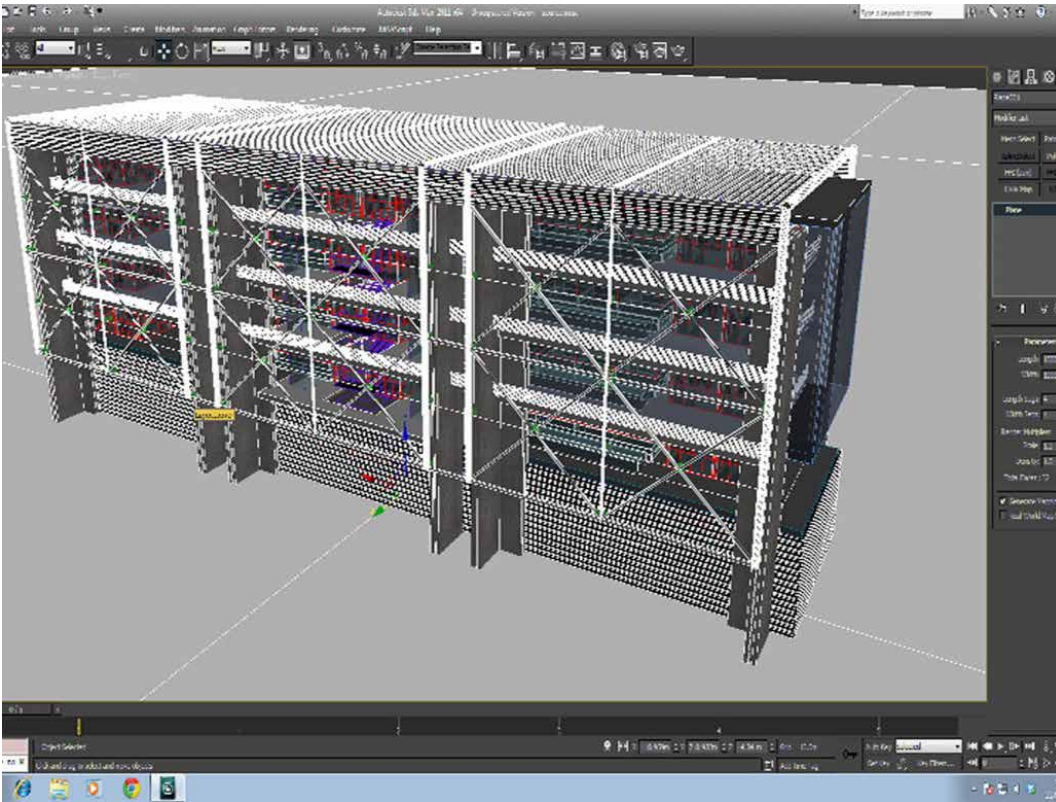

FIGURE 5.6 A normal building in 3d-max interface

The task was to use some simple commands of 3d max software (FFD box, bend, scale, etc.) and transform a conventional building (a modern repetitive, mass production design) to an unconventional (non-standard, mass customization, interactive) one, almost an alien. The definition of alien was subjective for students. Some considered a “Sci-Fi, futuristic building”, some interpret it as “what does not exist in reality” or “as weird as possible”. They were free of any confinements of the physical world, e.g. gravity, material limitation, cost, etc. (figure 5.7). Two semi-structured interviews were conducted with each participant: the first interview after the first hour of the experiment (before demonstrating any sample works of any kind), and the second interview after presenting some sample works of NSA and also after explaining the logic of conceptual blending behind the experiment.

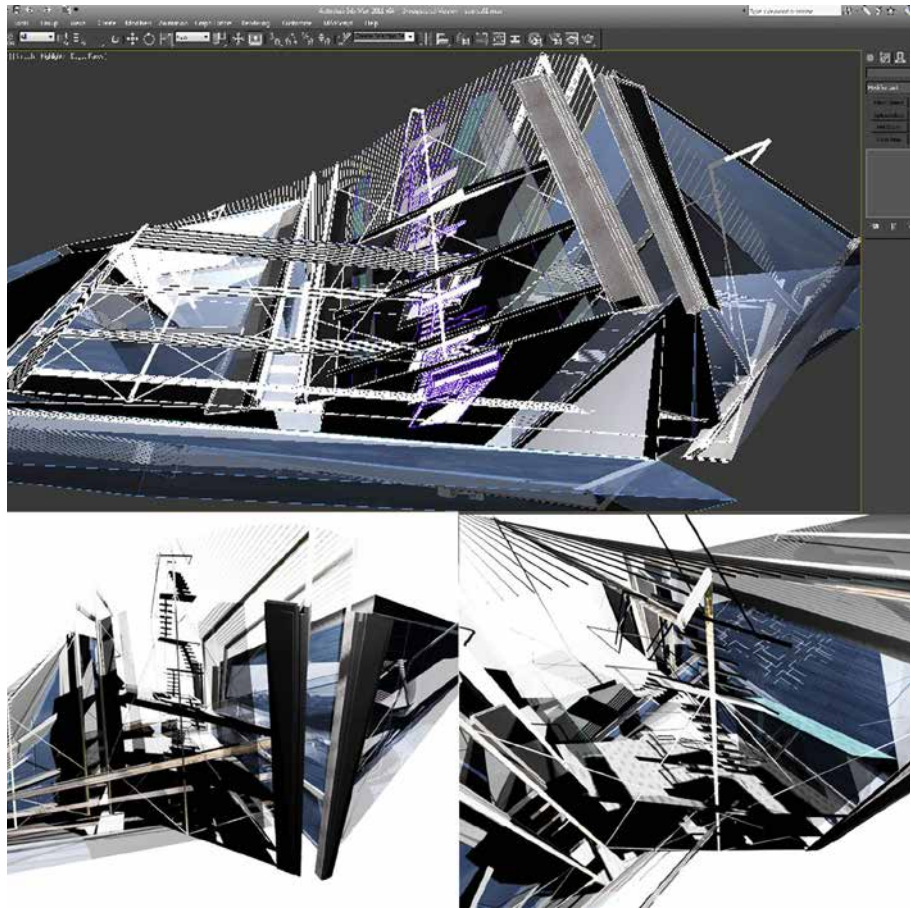

FIGURE 5.7 screenshots of transformed building, designed by students

As we expected after the first hour, students were wondering or even confused. They struggled to find where to start, what to do, potentials of discarding constrains, etc. However after explaining the logic and watching the samples they arrived at some interesting results (Tables 5.2 , 5.3).

1	Constraints help me to organize my ideas
2	Constraints give me a starting point, I do not know where to start where to go
3	Takes time to get used to this kind of design approach, I have a lot of liberty; do not know what to do though.
4	Non-sense, what is the point of this experiment? This is not Architecture
5	Unconsciously I tend to use/think in conventional methods. I do not know how to get rid of that
6	I am enjoying, the more I go further, the more I explore and enjoy
7	I am wandering
8	I need a starting point, conventionally I start with analysis of the site and get ideas from the constraints, I can not design context free
9	Confused
10	What is the point of designing something that cannot be built?

TABLE 5.2 Summary of comments from each participant's interview in the middle of experiment

1	I have to change my design approach. There is no starting point. I play with the given object and meanwhile the design appears.
2	There is no "where to go" in this project, you can stop whenever you want, there is no start and end
3	I am getting used to it, I prefer to see a lot of samples though.
4	It is architecture but not in physical world. I keep asking myself if we are going to design a future scene in a futuristic movie, who is going to design that? Director? Screenwriter? Architects should do this!
5	You have to learn to think out of the box
6	I'm getting even better!
7	When I saw the samples, I have some ideas where to go, but still I'm biased with the Images I've seen.
8	I do not dare to leave my conventional approach yet, I afraid I'd get lost in this new way of thinking
9	I am trying to get rid of conventional approaches and embrace a new method
10	Now I know it is not about building something, it is about being creative

TABLE 5.3 Summary of comments from each participant's interview after the experiment

As we can see in the tables, in the second interview, students begin to leave their conventional design approaches and think differently, they also tend to leave the conventional standards, regulations and physical rules. What we define as a conventional design approach is a Euclidian geometry in which the load transfer is through beams and columns to the foundation, angles tend to be rectangular and moreover, there are restricted rules on seismic regulations and structure of the design. Many other parameters including the sustainability, costs, exploitation comfort for residents of the building, accessibility of the materials and so forth are all parts of the conventional design approach. However, there was not any problem-solving or real architectural design task.

Referring again on the results of the workshop, we can see that students dare to leave the conventional method which they have learnt in their schools. Angles are not linear anymore, no physical constrains on the structure or materials can be seen. The cost and also possibility of construction is totally neglected. The aim of the workshop was only to train students and help them become familiar with new geometrical qualities and spatial expressions that were unknown to them. By this freedom of thought we can thus state that we initiated the very first steps towards a new method in architecture pedagogy.

§ 5.2.9 Discussion and Conclusion

Two different approaches have been utilized to define the images of the first experiment: Convergent and Divergent. Engineers tend to follow the convergent approach, simplify the image as soon as possible, follow guidelines, rules and converge all of them to reach to conclusion, unlike architects, who have been trained during their education to include as many parameters as possible in their design and suspend their judgment as much as possible. Architects also tend to dig more, through deeper layers and dare to suspend their judgment. The divergent approach, that they apply help them to deal with different parameters and variety of conditions in a design/problem solving task. Through this paper, the authors suggest to include “tolerance of ambiguity workshops” in the pedagogy of architecture to train them even more.

In the second experiment students learnt to leave their conventional design approaches, conventional standards, regulations and physical rules and dare to look at the task from a totally different angle. Moreover, via the experiment new unconventional feed/stimulus was provided for the unconscious mind to play with. Also, with this unconventional experiment, their inventory of experiences was expanded and we can expect that in the near future, mutations would happened in their RIG, subsequently resulting in new ideas to crop up in their minds.

To be creative we need to blend concepts, that are remotely connected and preferably unfamiliar, and this conceptual blending often occurs in our unconscious mind. To have a new blending we need mutations; combination of concepts. To reach a state of mutation, the sensory feed of the brain can be changed by something that is novel for the brain, thereby stimulating the brain to perceive the new surroundings, forging new connections between abstract representations. This idea of conceptual blending is quite relevant in

architecture as well. Improbabilist creativity can turn to impossibilist creativity by applying unconventional virtual environments to attain the mutation of ideas. In this article we thus suggest that creating a new perception of the environment itself, as the first step of architectural pedagogy will be a positive step towards expanding an educator's ideas, resulting in a transition from an improbabilist to an impossibilist mode of creativity.

Training future students of architecture to tolerate more ambiguities during their design process, by designing specific ambiguous experiences and training them gradually for more ambiguous situations, can provide a suitable springing board for implementation of the Proto-fuse concept. Providing virtual reality workshops for students, where they can navigate, interact and explore unconventional virtual environments will add new and unique opportunities to enhance their inventory of experiences, subsequently leading to novel ideas generation ability. Authors also believe that late years of the Bachelors period for students before their Masters would be a suitable time, since students are already familiar with basics, rules and regulations of the architecture discipline and with these workshops they train to think out of the box.

Students in our pilot experiment showed considerable interest and attained intriguing results at the end, thereby providing a first, though preliminary evidence of the potential of our approach in architecture pedagogy.

References

- Amabile, T. M. (1996). *Creativity in context*: Westview Press.
- Barron, F., & Harrington, D. M. (1981). Creativity, intelligence, and personality. *Annual review of psychology*, 32(1), 439-476.
- Bartle, R. A. (2004). *Designing virtual worlds*: New Riders Pub.
- Boden, M. (1995). Creativity and unpredictability. *Constructions of the Mind: Artificial Intelligence and the Humanities*. *Stanford Electronic Humanities Review*, 4(2).
- Boden, M. A. (1994). *Precis of the creative mind: Myths and mechanisms*. *Behavioral and Brain Sciences*, 17(3), 519-531.
- Dacey, J. S. (1989). *Fundamentals of creative thinking*: Lexington books Lexington, MA.
- Dubitzky, W., Kötter, T., Schmidt, O., & Berthold, M. R. (2012). Towards creative information exploration based on Koestler's concept of bisociation (M. R. Berthold Ed.). *Biosociative knowledge discovery*: Springer.
- Eysenck, M. W. (1993). *Principles of cognitive psychology*: Lawrence Erlbaum Associates, Inc.
- Fauconnier, G., & Turner, M. (2008). *The way we think: Conceptual blending and the mind's hidden complexities*: Basic Books.
- Gabora, L., & Aerts, D. (2002). *Contextualizing Concepts*. Paper presented at the FLAIRS Conference.
- GOLANN, S. E. (1962). The creative motive. *Journal of personality and social psychology*, 30, 588-600.
- Guilford, J. P. (1967). *The nature of human intelligence*: McGraw-Hill.
- Hakak, A. M., Biloria, N., & Rahimi, M. R. (2012). Implementing Unconventional Virtual Environments for Enhancing Creativity in Architecture Pedagogy. *International Journal of Virtual and Personal Learning Environments (IJVPLE)*, 3(4), 41-52.
- Hennessey, B. A., & Amabile, T. M. (1998). Reality, intrinsic motivation, and creativity.

- Johansson, F. (2004). *The medici effect: Breakthrough insights at the intersection of ideas, concepts, and cultures*: Harvard Business review Press.
- Jones, D. (2012). *The Aha! Moment: A Scientist's Take on Creativity*: JHU Press.
- Kenny, D. T., & Ginsberg, R. (1958). The specificity of intolerance of ambiguity measures. *The Journal of Abnormal and Social Psychology*, 56(3), 300.
- Koestler, A. (1964). *The act of creation*: Hutchinson & Co.
- Lubart, T. I., & Sternberg, R. J. (1995). An investment approach to creativity: Theory and data. *The creative cognition approach*, 269-302.
- Maddux, W. W., & Galinsky, A. D. (2009). Cultural borders and mental barriers: the relationship between living abroad and creativity. *Journal of personality and social psychology*, 96(5), 1047.
- Mednick, S. (1962). The associative basis of the creative process. *Psychological review*, 69(3), 220.
- Pereira, F. C., & Cardoso, A. (2002). Conceptual blending and the quest for the holy creative process. Paper presented at the Workshop on Creative Systems. [en línea] <http://eden.dei.uc.pt/~camara/files/Quest-CRC.pdf>.
- Ritter, S. M., Damian, R. I., Simonton, D. K., van Baaren, R. B., Strick, M., Derks, J., & Dijksterhuis, A. (2012). Diversifying experiences enhance cognitive flexibility. *Journal of Experimental Social Psychology*, 48(4), 961-964.
- Ritter, S. M., & Dijksterhuis, A. (2014). Creativity—the unconscious foundations of the incubation period. *Frontiers in human neuroscience*, 8.
- Runco, M. A. (2004). Everyone has creative potential. *Creativity: From potential to realization*, 21-30.
- Runco, M. A. (2014). *Creativity: Theories and themes: Research, development, and practice*. Amsterdam: Elsevier.
- Simonton, D. K. (1999). *Origins of genius: Darwinian perspectives on creativity*: Oxford University Press.
- Stoycheva, K. (2003). Talent, Science and Education: How Do We Cope with Uncertainty and Ambiguities? P. CSERMELY & L. LEDERMAN (Eds), 31-43.
- Taylor, C. W., & Barron, F. E. (1963). *Scientific creativity: Its recognition and development*: John Wiley.
- Tegano, D. W. (1990). Relationship of tolerance of ambiguity and playfulness to creativity. *Psychological Reports*, 66(3), 1047-1056.
- Turner, M. (1998). *The literary mind: The origins of thought and language*: Oxford University Press.
- Wallas, G. (1926). *The art of thought*: Harcourt Brace, New York. .
- Wiggins, G. A., & Bhattacharya, J. (2014). Mind the gap: an attempt to bridge computational and neuroscientific approaches to study creativity. *Frontiers in human neuroscience*, 8.
- Zenasni, F., Besançon, M., & Lubart, T. (2008). Creativity and tolerance of ambiguity: An empirical study. *The Journal of Creative Behavior*, 42(1), 61-73.

6 Differences in human perception

§ 6.1 Differences in human perception, while observing three different environments, and their [possible] relationship with creativity

Spatial navigation involves dynamic and intricate brain functions, fundamentally required to locate oneself in space, which is vital for any human's survival in their daily life. Sensorimotor abilities are quintessential for spatial navigation wherein subjects associate external sensory stimuli with sensori commands. Individuals for instance process external stimuli such as buildings in the environment and pathways between the buildings and internally create spatial information in their brain and use this information to navigate in the environment (Brunsdon, Nickels, & Coltheart, 2007; Davis, 1999; Farah, 1989). Therefore, individuals create a mental image of the environment which they are navigating and with respect to their target, they manipulate their current position (Palermo, Iaria, & Guariglia, 2008).

The Chapter identifies the difference in human perception of different spatial environments via analyzing activated parts of the brain [of the participants in the experiment], as they encounter three different types of environments:

- Fully-designed environment
- Semi-designed environments
- Abstract-environment

The aim of the experiment was to prove that human perception is different in abstract environments as comparison to fully designed and semi designed environments. Since an abstract environment, has multiple degrees of freedom as compared to the physical world and is thus unlike a fully-designed or a semi-designed environment, the difference in perception of these kinds of environments can be related to creativity and divergent thinking. The experiment was conducted at The Goldsmiths University, London in collaboration with the Faculty of Psychology, under the supervision of Professor Joydeep Bhattacharya.

The findings have been published in the fifth journal paper “Navigating abstract virtual environment: an eeg study”. Cognitive Neurodynamics, 1-10, Springer publisher, New York, USA

§ 6.2 Navigating abstract virtual environment: An electroencephalography (eeg) study*

Alireza Mahdizadeh Hakak¹, Joydeep Bhattacharya², Nimish Bilorla¹, Roy de Kleijn³, Fanak Shah-Mohammadi⁴

¹ Faculty of Architecture, TU Delft University, Delft, The Netherlands

² Faculty of Psychology, Goldsmiths University of London, London, United Kingdom

³ Faculty of Psychology, Leiden University, The Netherlands

⁴ Azad Islamic University, Tehran Shomal Branch, Iran

Abstract. Perceptions of different environments are different for different people. An abstract designed environment, with a degree of freedom from any visual reference in the physical world requests a completely different perception than a fully or semi-designed environment that has some correlation with the physical world. Maximal evidence on the manner in which the human brain is involved/operates in dealing with such novel perception comes from neuropsychology. Harnessing the tools and techniques involved in the domain of neuropsychology, the paper presents new evidence on the role of pre-central gyrus in the perception of abstract spatial environments. In order to do so, the research team developed three different categories of designed environment with different characteristics: 1-Abstract environment, 2-Semi-designed environment, 3- Fully designed environment, as experimental sample environments.

Perception of Fully-designed and semi-designed environments is almost the same, [maybe] since the brain can find a correlation between designed environments and already experienced physical world. In addition to this, the response to questionnaires accompanied with a list of buzzwords that

* Published as: Hakak, A. M., Bhattacharya, J., Bilorla, N., de Kleijn, R., & Shah-Mohammadi, F. (2016). “Navigating abstract virtual environment: an eeg study”. Cognitive Neurodynamics, 1-10, Springer publisher, New York, USA

have been provided after the experiments, also describe the characteristics of the chosen sample environments. Additionally, these results confirm the suitability of continuous electroencephalography (EEG) for studying Perception from the perspective of architectural environments.

Keywords. EEG, Abstract environments, fully designed, Semi-designed, Perception

§ 6.2.1 Introduction:

Spatial navigation is a dynamic and intricate brain function required to locate oneself in space, which is vital for human's survival in daily life. Integration of sensorimotor information is required for navigation: subject will associate external sensory stimuli with sensori commands. Individuals for instance receive external stimuli such as building and pathways and internally create mental representations of spatial maps and subsequently use this information to navigate in the environment (Brunsdon, Nickels, & Coltheart, 2007; Davis, 1999; Farah, 1989). Therefore, individuals are required to create a mental image of the environment which they are navigating and with respect to their target, they manipulate their current position (Palermo, Iaria, & Guariglia, 2008). This suggests that the neural computation to output motor command required for spatial navigation activates various cortical regions distributed over the brain. Recent noninvasive studies using virtual environments have highlighted the brain regions related to spatial information processing and navigation; the hippocampus, parahippocampal gyrus, posterior cingulate gyrus, temporal cortex, insula, superior and inferior parietal cortex, precuneus, dorsolateral prefrontal cortex, medial prefrontal cortex, premotor area and supplemental motor area are all activated during these tasks (Aguirre & D'Esposito, 1997; Burgess, Maguire, Spiers, & O'Keefe, 2001; Hartley, Maguire, Spiers, & Burgess, 2003; Iseki, Hanakawa, Shinozaki, Nankaku, & Fukuyama, 2008; MacEvoy & Epstein, 2007; Maguire et al., 1998; H. Spiers & E. Maguire, 2007; H. J. Spiers & E. A. Maguire, 2007a, 2007b; Wolbers, Wiener, Mallot, & Büchel, 2007). Simultaneous activation of many cortical regions inferred from navigation, could be integrated and functionally connected as coherent activity across different brain areas is important for cognition and action (Singer, 1999; Varela, Lachaux, Rodriguez, & Martinerie, 2001).

This new-found knowledge about the understanding of brain network underlying spatial navigation acquired by the advent of modern neuroimaging techniques has greatly stimulated the field of Architecture (Eberhard, 2008).

For example, a typical question a [spatial] designer, namely an architect, has to consider even before starting the design process is how humans, i.e. the users of the designed environment, will perceive the environment. Given that a significant portion of our time is usually consumed in built environments, a better understanding of human brain's responses to different designed environments would invariably improve the efficacy and intended purpose of the design. This is the primary motivation of our study in which we monitored large scale electrical activities of humans while they were virtually perceiving/ navigating in three different designed environments, fully-designed, semi-designed and abstract design environment.

Architecture is a multi-faceted and multi-function discipline, which involves the act of visualizing, designing and problem solving as an iterative process. Studying the manner in which architects operate reveals the prevalence of a divergent approach during the phase of form finding as opposed to a convergent approach being employed during the problem-solving phase in order to narrow down appropriate design solutions and for subsequently finding the best one. The neural correlates of these two design phases, divergent and convergent, are different (see for example, (Limb & Braun, 2008) on divergent/convergent thinking in the context of musical improvisation) and it would be of benefit to an architect to discover this difference in the brain's functioning so that they can combine the respective potentials in the most appropriate and efficient manner. For example, it could be expected that exposure to an abstract environment at the early stages of design could help the designer suspending variety of potential solutions and therefore promoting divergent thinking (Ritter et al., 2012).

There has been a rich body of literature available on perception, i.e. how sensory information are interpreted in order to represent and understand the environment (see for a review, (Schacter, Gilbert, & Wegner, 2011)). It is widely acknowledged that perception is not just a passive registration of the sensory input, but it involves an active reconstruction procedure involving learning, memory, expectation, and attention (Bernstein, 2013). Jerome Bruner breaks down the process of perception in to three steps (Bruner, 1973):

Encountering an unfamiliar target/space/environment, we are open to different informational cues and want to learn more about the target.

One tries to collect more information about the target/space/environment. Gradually, looking for some familiar cues to help him/her categorize the target or perceive the environment.

The cues become less open and selective. We are looking for those cues which affirm his/her categorization of the target. We also actively ignore and even distort cues that violate our initial perceptions. Our perception becomes more selective and we finally paint a consistent picture of the target or perceive an environment.

Extrapolating and interfacing Bruner's process to perception of environments, a question surfaces: How does the brain react while navigating in an unconventional virtual environment, which possesses none of the qualities of the conventional physical world and which, the brain cannot find any cues to correlate with previous knowledge of space? This question is addressed in the current study.

Abstraction is the process of taking away or removing characteristics from something in order to reduce it to a set of essential characteristics. In other words, it is an act of considering something as a general quality or characteristic, apart from concrete realities, specific objects, or actual instances (Langer, 1953). The 'Object', which remains, after abstraction in Abstract artworks is a representation of the original, with unwanted detail omitted. In his classical book "Visual Thinking" Rudolph Arnheim explains "Abstract art" as a visual language of form, color and line to create a composition which may exist with a degree of independence from visual references in the world (Arnheim, 1969). Narrowing down the concept of abstraction to architectural space, the definition can be modified as follows: Abstract architectural environments are those, which use a visual language of form, color and line to create a composition which may exist with a degree of independence from visual references in the physical world. In the current research context, "degree of independence" is considered as "not complying with physical rules, e.g. lack of gravity, infinite depth, continuous change and whatever that is not perceivable in the physical world. Abstract environments are subjective. They may be interpreted and perceived in more than one way and lack one unique perception. Seeing all abstract environments typically lack scale and no clear measure to understand the environment clearly (figure 6.1).

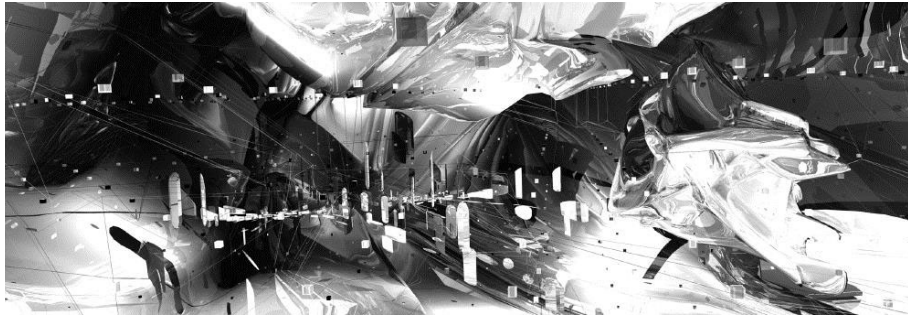

FIGURE 6.1 Sample abstract environment. Courtesy of Marcos Novak-V4D_Visio4D

In this research we experimented with three different designed environments: abstract, semi-designed and fully designed. Healthy human adults virtually navigated in these three types of design environments while their brain responses were recorded. We predicted distinct brain responses in higher order brain areas, typically associated with planning and executive functions, would be differentially engaged with navigating in these three designed environments.

§ 6.2.2 Materials and Methods

§ 6.2.2.1 Participants

Twenty one healthy human adults (aged 18-39 years, mean 23 years, 17 female) with normal hearing (self-reported) and normal or corrected-to-normal vision participated in the experiment. All participants were recruited from the campus at Goldsmiths, University of London. None of the participants had any architectural background, however some of them were from the department of Design. All participants were in good mental health, and had no past history of neurological illness. Data from one participant was discarded due to poor quality of the EEG signals. All participants provided written informed consent before starting the experiment. The study was approved by the local Ethics Committee of the Department of Psychology at Goldsmiths and conducted in accordance with the Declaration of Helsinki.

§ 6.2.2.2 Stimuli

The stimuli consisted of fifteen videos of architectural environments, simulating three design categories; fully designed, semi-designed and abstract design. Figure 6.2 shows an individual sample of the three categories. There were five videos for each category and the duration of each video was 1 min.

The architectural simulations have been created by different 3D software, e.g. 3Ds Max, Revit, Rhino and Grasshopper. The differences in the 3D interfaces were not the intention of the authors as long as the content conforms to the categories. Having the same resolution, all videos were transformed to the VGA format (640*480 pixels). Choosing the videos and categorization happened subjectively by the authors.



FIGURE 6.2 Samples of three different types of design environment: fully designed (left panel), semi-designed (middle), and abstract design (right). Here only a snapshot of individual design is shown and in the actual experiment we presented a short video (1 min long) in each category.

§ 6.2.2.3 Experimental procedure

Participants were seated in front of a computer in a dimly lit room. The experimenter placed an EEG cap on their head to monitor their brain's electrical activity during the experiment. The participants were informed that they would be presented with different design videos and were instructed to look at the video carefully. The order of the video was randomized across participants. At the end of each video, the participants were instructed to rate, on a 7-point Likert scale, three aspects of the design environment as follows: (i) the ease of navigation within the environment, (ii) the creativity of the design, and (iii) their personal liking of the environment. Further, participants were asked to choose around five words from the list of buzzwords (Figure 6.3), which would best describe the qualities and characteristics of the environment of the video shown immediately before. They were also allowed to add their own words if they could not find any appropriate word from the presented list

to describe the environment of the video. The participants were presented with a practice video at the beginning to get them familiarized with the experimental procedure.

elusive carved space bio-mimic
open-ended ambiguous
complex farfetched smart
organic brutal logical
fluxing simple complicated live creature
mutate metamorphosis noisy conventional
suspend rebellious alien arrogant
ecosystem creative vague swarm

FIGURE 6.3 List of buzz-words. At the end of each video, participants were instructed to choose five words from this list that they would consider best fit to the environment.

§ 6.2.2.4 EEG recordings

The EEG signals were recorded by placing Ag-AgCl electrodes on 32 scalp locations according to the extended International 10-20 electrode placement system (Jasper, 1958). The electrode AFz was used as ground. The EEG signals were amplified (Synamps Amplifiers, Neuroscan Inc.), filtered (dc to 100 Hz), and sampled at 500 Hz. EEG data were re-referenced to the arithmetic mean of the left and right earlobe electrodes (Essl & Rappelsberger, 1998). The vertical and horizontal electro-oculograms were recorded in bipolar fashion to monitor eye blinks and eye movements. All electrode impedances were kept below 5 k-Ohm.

§ 6.2.2.5 EEG pre-processing

Prior to analysis, EEG signals were first visually inspected for identification of large artifacts (e.g., excessive muscular artifacts). Next we applied Independent Component Analysis (ICA), a blind source separation method

(Jung et al., 2001; Lee, Girolami, & Sejnowski, 1999; Naganawa et al., 2005), to transform EEG signals into maximally statistical independent components (ICs). We removed those ICs that are primarily related to vertical eye-blinks and horizontal saccades and re-transformed back to the EEG signal space. Afterwards, epochs with the duration of 1 min for viewing individual design environment were extracted, and finally subdivided into non-overlapping 10 segments each with 10 s long. All preprocessing were done by the Matlab Toolbox EEGLAB (Delorme & Makeig, 2004)

§ 6.2.2.6 EEG source localization

The standard low-resolution brain electromagnetic tomography (sLORETA) was used to compute the cortical three-dimensional distribution of current density. It computes the inverse solution by using a realistic head model based on the MNI152 template (Mazziotta et al., 2001), with the three-dimensional solution space restricted to cortical gray matter, as determined by the probabilistic Talairach atlas (Lancaster et al., 2000). A spatial resolution of 5 mm was used, producing 6239 voxels. Thus the sLORETA image represented the standardized electrical activity at each voxel in neuro anatomic Montreal Neurological institute (MNI) space as the exact magnitude of the estimated current density (Musso, Brinkmeyer, Mobascher, Warbrick, & Winterer, 2010).

The sLORETA software package (Pascual-Marqui, 2002) was used to compute average cross-spectral matrices for 8 standard EEG frequency bands: delta (1.5-6 Hz), theta (6.5-8 Hz), alpha1 (8.5-10 Hz), alpha2 (8.5-10 Hz), beta1 (12.5-18 Hz), beta2 (18.5-21 Hz), and beta3 (21.5-30 Hz), providing a single cross-spectral matrix for each participant, frequency band and design condition, from which we computed the current source density (CSD). Subsequently, CSD values were log-transformed. Next, we performed three pairwise statistical comparisons to explore the differences in brain activation patterns separately for fully designed vs abstract, abstract vs semi designed, and semi designed vs fully designed. For each comparison, we performed non-parametric statistical analysis, which was based on estimating the empirical probability distribution of the maximum t statistic under the null hypothesis of no differences, via 5000 randomization, and corrected for multiple comparisons of all 6239 voxels (see (Nichols & Holmes, 2002)), for details on this statistical permutation procedure).

§ 6.2.3 Results:

§ 6.2.3.1 Behavioural responses

First, we analysed the three behavioural ratings (on the ease of navigation, creativity and liking) provided by the participants at the end of each video. Figure 6.4 shows the mean responses of these three ratings three types of design environments. A 3x3 within-subjects factorial ANOVA was performed with the following factors, design (3 levels: full, semi, and abstract) and response (3 levels: ease of navigation, creativity and liking). There were main effects of design ($F(2,38) = 5.40$, $p = .01$) and response ($F(2,38) = 10.05$, $p = .002$) and an interaction effect between design and response ($F(4,76) = 24.18$, $p < .001$). Follow up tests suggests that fully designed environments, as expected, were rated easier to navigate than both semi ($F(1,19) = 54.41$, $p < .001$) and abstract ($F(1,19) = 46.98$, $p < .001$) design environments, whereas the semi designed environments were judged as slightly more easier to navigate than the abstract ($F(1,19) = 6.66$, $p = .02$) ones. However, fully designed environments were judged as less creative than the other two ones ($p < .01$), but the differences in creative rating between the semi and abstract design environments were not statistically significant ($F(1,19) = 3.44$, $p = .08$). The semi design environments were subjectively most liked by our participants followed by fully design and abstract design environments.

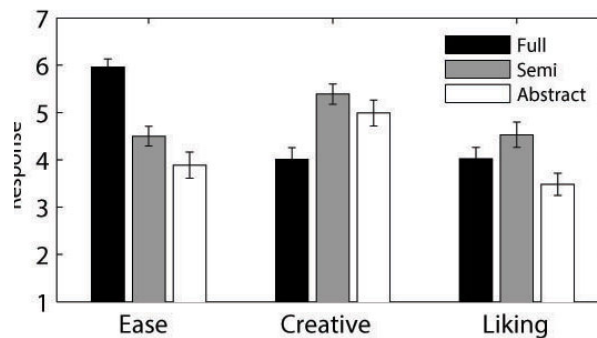

FIGURE 6.4 Mean responses on the ease (of navigation), creativity and liking of the three types of design environments, full, semi and abstract.

Next we studied the interrelationships between these three responses by performing pairwise Pearson's product-moment correlations and the correlation values are listed in the Table 6.1. We found that the ease of

navigation within an environment was not related with the creativity judgment. However, if a design environment was judged to be more creative it was also more liked and vice versa, and this relationship was slightly stronger in the full and semi design environments than the abstract ones. The most surprising observation was that the ease of navigation was not related to the liking judgment for both full and semi design environments, yet a strong relationship was found for abstract design (figure 6.5).

	FULLY DESIGNED	SEMI-DESIGNED	ABSTRACT DESIGNED
Ease * Creative	-.03	-.04	.05
Ease * Liking	.03	.03	.54
Liking * Creative	.74	.75	.62

TABLE 6.1 List of correlation values between different three ratings in three different types of designs.

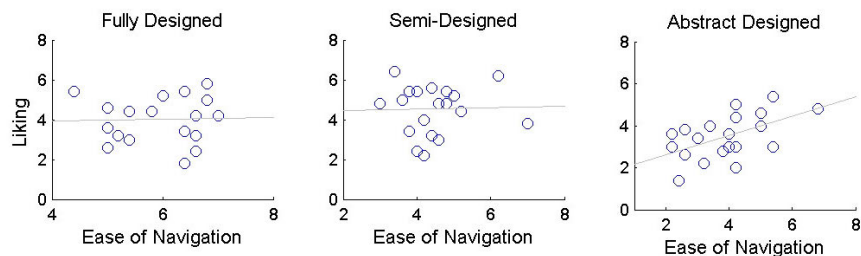
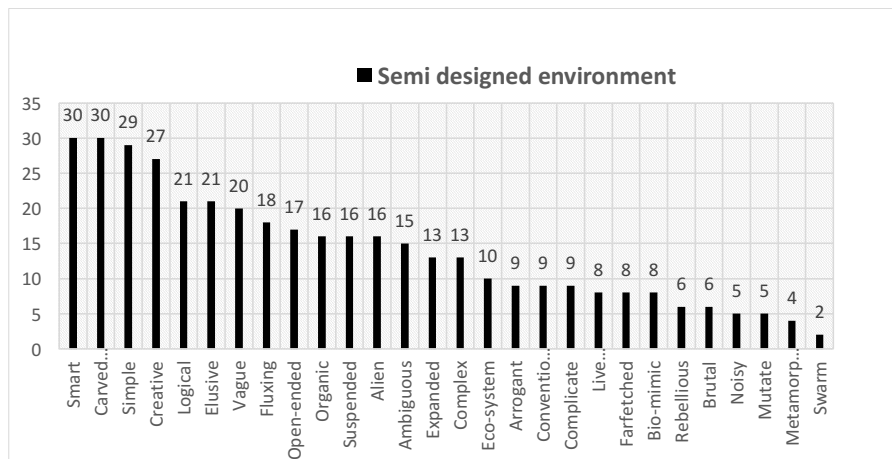
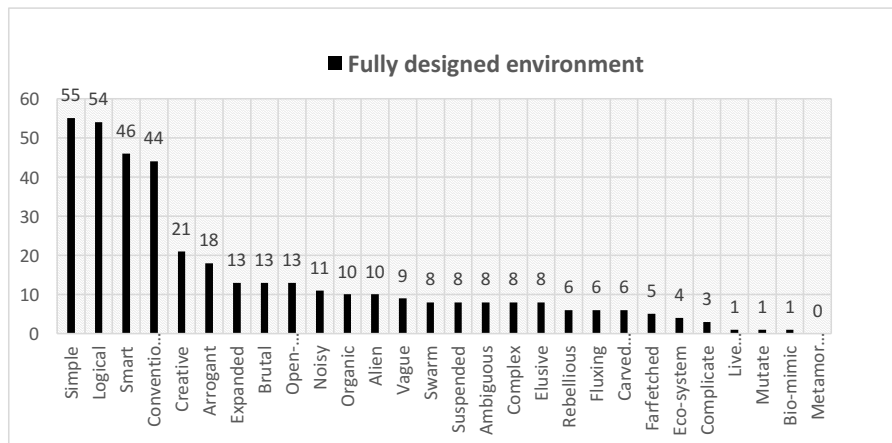

FIGURE 6.5 Scatter plots of ease of navigation vs liking for three design environments. Note only the abstract designed environment shows a clear relationship ($r = .54$).

§ 6.2.3.2 Buzzwords responses

Next we looked at the selection of buzzwords for the three design environments (figure 6.6). The number of buzzwords used for each category describes the characteristics of that environment. Participants chose “simple, logical, smart and conventional and less metamorphosis, mutate and bio-mimic” traits for a fully designed environment. These environments were not open to different interpretations. Further, participants were quite consistent with their selections in representing the fully designed environment (as reflected by a sharp fall after four buzzwords). For the semi designed environment, participants frequently chose “smart, carved space, simple and creative and less swarm, metamorphosis and mutate.” The abstract design environment was associated with buzzwords such as “alien, complex, bio-mimetic, lively

creature mutation, and ambiguous” and much less frequently other buzzwords such as “conventional and logical”. Interestingly, among the three design environments, semi design one was associated with more varied response across participants (as reflected by a stronger trend towards a uniform distribution). Altogether, these observations fit well with the distinction between abstract, fully designed and semi-designed environments that were targeted in our experimental design. The data also showed that the abstract environments require more interpretation (rather than receiving more details, dimensions, scale, etc. in a fully and semi designed environments) and associated with dynamical attributes that are further biologically rooted.



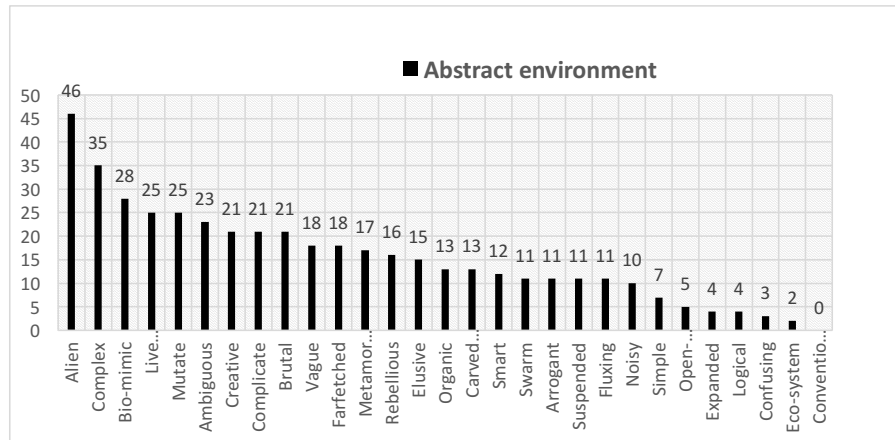

FIGURE 6.6 Distribution of buzzwords selected to represent three types of design environments: fully designed (top panel), semi designed (middle panel), and abstract designed (bottom panel).

§ 6.2.3.3 EEG power analysis

A three-way repeated-measures ANOVA with the following factors, electrode location (32 channels), condition (abstract, semi-designed, fully designed), and frequency band (delta, theta, alpha, beta) as within-subjects factors on average EEG power showed significant main effects of location ($F(5.09, 96.64) = 11.33, p < .001$), frequency ($F(1.14, 21.58) = 444.76, p < .001$), and a location \times frequency interaction ($F(5.67, 107.60) = 17.01, p < .001$).

Analysis of variance over all 7 frequency bands (delta, theta, alpha1, alpha2, beta1, beta2, and beta3) showed a main effect of condition on absolute global power, $F(2, 57) = 3.22, p = .047$. Post-hoc testing showed that this effect was strongest for the beta2 frequency band, $F(2, 57) = 8.27, p < .001$.

§ 6.2.3.4 EEG source localization

Source reconstruction at the whole brain level was performed using the sLORETA method, and statistical comparisons were performed pair-wise between any two conditions. For the fully designed vs abstract designed comparison, we detected a decrease in the beta2 activity primarily in the precentral gyrus (Brodmann area 4), followed by activation from the anterior cingulate (BA 24). Beta3 activation showed a somewhat smaller difference between the two environments ($t = -.264, p = .02$), and was located more

anterior, potentially originating in the superior prefrontal gyrus (BA 6). These areas showed more activity in the fully designed condition than in the abstract condition. We did not find significant results in any other frequency band (figure 6.7).

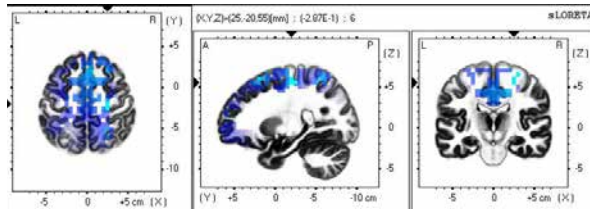

FIGURE 6.7 Activation of the precentral gyrus in the fully designed condition vs. the abstract condition

- Abstract vs. Semi-designed

Similar to the fully designed vs. abstract environment comparison, the biggest difference in activation was found in the precentral gyrus (BA 6), but this time in both beta2 as well as beta3 frequency bands ($t = -.466$, $p = .001$).

Also, the dorsolateral prefrontal cortex (BA 9) showed more beta3 activity in the abstract condition compared to the semi-abstract condition ($t = -.465$, $p = .001$, see Figure 6.8). We did not find significant results in any other frequency band.

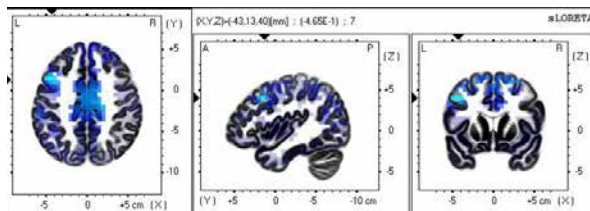

FIGURE 6.8 Activation of the dorsolateral prefrontal cortex in the abstract condition

- Semi vs. full

No robust significant differences were observed between the semi-abstract and full conditions (all $p > .097$).

The results of different comparisons are summarized in the Table 6.2.

	DELTA	THETA	ALPHA1	ALPHA2	BETA1	BETA2	BETA3
Fully designed vs. Abstract	-	-	-	-	-	precentral gyrus (BA4) - anterior cingulate cortex	superior prefrontal gyrus (BA6)
Semi designed vs. Abstract	-	-	-	-	-	precentral gyrus (BA6)	precentral gyrus (BA6)-dorsolateral prefrontal cortex (BA9)
Fully designed vs. Semi designed	-	-	-	-	-	No significant difference	No significant difference

TABLE 6.2 Summary results of three comparisons based on sLORETA findings.

§ 6.2.4 Discussion

Architecture is a multi-faceted discipline, which involves the act of visualizing, designing (divergent thinking) and problem solving (convergent thinking) as an iterative process. It is important for a designed to understand how our brains navigate in a designed environment, as the understanding is inextricably linked to the whole design procedure. By navigating in three different virtual environments, the perception of abstract virtual environment is different from fully designed or semi designed environment. Applying abstract design in early stages of design procedure may help the brain to think as divergent a possible and ease the visualization and form-finding.

Across the studied standard seven EEG frequency bands, the most robust differences across all three comparisons were found in the beta2 and beta3 frequency bands. Synchronized neuronal oscillations at the broad beta frequency band (13 – 30 Hz), covering both the beta2 and beta3 bands, are usually prominent in the human motor system, including somatosensory cortex, basal ganglia and the cerebellar network (Jenkinson & Brown, 2011). Therefore, beta oscillations are often linked to diverse range of sensorimotor functions such as planning, preparation and execution of movements (Pfurtscheller, Stancak, & Neuper, 1996; Salmelin, Hämäläinen, Kajola, & Hari, 1995); (Pavlidou, Schnitzler, & Lange, 2014). Further, sensorimotor beta oscillations are also involved with observation and imagination of biological movements (Muthukumaraswamy & Johnson, 2004; Schnitzler, Salenius,

Salmelin, Jousmäki, & Hari, 1997) These evidence have led to the suggestion that oscillatory beta activity over the sensorimotor network represents a matching mechanism to internally stored mental representations of actions, and subsequently provides the substrates for the functional integration of visual and sensorimotor brain regions (Pavildou et al, 2014). Altogether this also confirms the appropriateness of the designed environments presented in our study.

We also found consistent differences in brain activation patterns in the motor network involving precentral gyrus associated with perceiving abstract design environments. This is in line with the body of literature demonstrating the role of sensorimotor areas in aesthetical appreciations, especially of abstract art (Freedberg & Gallese, 2007; Hagerhall et al., 2008; Jacobsen, Schubotz, Höfel, & Cramon, 2006; Umiltà, Berchio, Sestito, Freedberg, & Gallese, 2012). We could not speculate on the artistic value of our abstract design environment, but it is likely that the total unfamiliarity of the presented environment might have led the observer, i.e. our participants, to consider more similar to an abstract art form. This further substantiates the notion of embodied cognition in the context of viewing design environments. Unlike previous studies demonstrating the role of sensorimotor network in observation and imagery of various actions (Muthukumaraswamy and Johnson, 2004; Salmelin et al, 1995; Schnitzler et al, 1997), our results show that viewing different types of design environments with varying degree of abstractness would differentially impact on viewer's cortical motor system. Do note though that we do not claim that such motor activation is causally related to the aesthetic experience of the viewer, instead we suggest that this spontaneously evoked cortical motor activation reflects some sort of embodied simulation of the presented environment (Gallese, 2005; Gallese & Sinigaglia, 2011).

In addition to the cortical motor network, we observed differential activations in other brain area, primarily in the prefrontal cortex, and this includes anterior cingulate cortex (ACC), dorsolateral prefrontal cortex (dLPFC) and superior prefrontal gyrus.

Activation of the anterior cingulate cortex (ACC) while navigating fully designed vs abstract designed environments may suggest an increased involvement of higher level cognitive functions such as attention (Weissman, Gopalakrishnan, Hazlett, & Woldorff, 2005), error detection and conflict monitoring (Bush, Luu, & Posner, 2000). Further, activation of dLPFC while navigating in an abstract environment could potentially reflect conflict-induced behavioral adjustment (Mansouri et al already found connections between them in their research (Mansouri, Buckley, & Tanaka, 2007). Since characteristics of the abstract environment are totally different from the familiar fully- or semi-

designed environments, conflicts and rule violations would be the norm while viewing an abstract environment, yet it is also crucial to resolve these conflicts in a dynamic and adaptive fashion in order to ensure an appropriate mental simulation of the abstract environment.

There are two principal limitations of the current study. First, the selection of the three types of design environments could be considered a bit arbitrary. Although we have carefully tried to choose and categorize the three environments, the selection process happened subjectively as there is no known objective way to categorize the environments in the desired category. Further, the concept of abstractness may be on a continuum yet we considered only three snapshots on this continuous scale of abstractness. Secondly, it is not clear whether the reported differences in large scale brain activity while navigating abstract virtual environment is any way related to the aesthetics and/or creativity of the presented design.

§ 6.2.5 Conclusion

Architecture is a multi-faceted discipline and the design process is always seen as an iteration cycle between design and problem solving. The functioning of the brain is completely different while doing these two tasks and therefore it is important for an architect to know the mechanisms of his/her brain in order to find efficient and more effective combinations between these two tasks. The brain function is different while perceiving an abstract environment as compared to the perception of a fully designed or semi-designed environment. Navigating abstract virtual environment requires more precentral efforts comparing with fully or semi-designed environment. Therefore, starting the early stages of design with an abstract environment with a degree of freedom from all physical rules, restrictions and confinements may help one to think as divergent as possible and thus be more creative during the idea generation phase of architectural design.

References:

- Aguirre, G. K., & D'Esposito, M. (1997). Environmental knowledge is subserved by separable dorsal/ventral neural areas. *The Journal of neuroscience*, 17(7), 2512-2518.
- Arnheim, R. (1969). *Visual thinking*: Univ of California Press.
- Bernstein, D. (2013). *Essentials of psychology*: Cengage Learning.
- Bruner, J. S. (1973). *Beyond the information given: Studies in the psychology of knowing*: WW Norton.
- Brunsdon, R., Nickels, L., & Coltheart, M. (2007). Topographical disorientation: Towards an integrated framework for assessment. *Neuropsychological rehabilitation*, 17(1), 34-52.
- Burgess, N., Maguire, E. A., Spiers, H. J., & O'Keefe, J. (2001). A temporoparietal and prefrontal network for retrieving the spatial context of lifelike events. *Neuroimage*, 14(2), 439-453.
- Bush, G., Luu, P., & Posner, M. I. (2000). Cognitive and emotional influences in anterior cingulate cortex. *Trends in cognitive sciences*, 4(6), 215-222.
- Davis, S. J. (1999). Rehabilitation of topographical disorientation: An experimental single case study. *Neuropsychological rehabilitation*, 9(1), 1-30.
- Delorme, A., & Makeig, S. (2004). EEGLAB: an open source toolbox for analysis of single-trial EEG dynamics including independent component analysis. *Journal of Neuroscience Methods*, 134(1), 9-21.
- Eberhard, J. P. (2008). *Brain landscape the coexistence of neuroscience and architecture*: Oxford University Press.
- Essl, M. M., & Rappelsberger, P. (1998). EEG coherence and reference signals: experimental results and mathematical explanations. *Medical and Biological Engineering and Computing*, 36(4), 399-406.
- Farah, M. J. (1989). The neural basis of mental imagery. *Trends in neurosciences*, 12(10), 395-399.
- Freedberg, D., & Gallese, V. (2007). Motion, emotion and empathy in esthetic experience. *Trends in cognitive sciences*, 11(5), 197-203.
- Gallese, V. (2005). Embodied simulation: From neurons to phenomenal experience. *Phenomenology and the cognitive sciences*, 4(1), 23-48.
- Gallese, V., & Sinigaglia, C. (2011). What is so special about embodied simulation? *Trends in cognitive sciences*, 15(11), 512-519.
- Hagerhall, C. M., Laike, T., Taylor, R. P., Küller, M., Küller, R., & Martin, T. P. (2008). Investigations of human EEG response to viewing fractal patterns. *Perception*, 37(10), 1488-1494.
- Hartley, T., Maguire, E. A., Spiers, H. J., & Burgess, N. (2003). The well-worn route and the path less traveled: distinct neural bases of route following and wayfinding in humans. *Neuron*, 37(5), 877-888.
- Iseki, K., Hanakawa, T., Shinozaki, J., Nankaku, M., & Fukuyama, H. (2008). Neural mechanisms involved in mental imagery and observation of gait. *Neuroimage*, 41(3), 1021-1031.
- Jacobsen, T., Schubotz, R. I., Höfel, L., & Cramon, D. Y. v. (2006). Brain correlates of aesthetic judgment of beauty. *Neuroimage*, 29(1), 276-285.
- Jasper, H. H. (1958). The ten twenty electrode system of the international federation. *Electroencephalography and clinical neurophysiology*, 10, 371-375.
- Jenkinson, N., & Brown, P. (2011). New insights into the relationship between dopamine, beta oscillations and motor function. *Trends in neurosciences*, 34(12), 611-618.
- Jung, T. P., Makeig, S., Westerfield, M., Townsend, J., Courchesne, E., & Sejnowski, T. J. (2001). Analysis and visualization of single trial event related potentials. *Human Brain Mapping*, 14(3), 166-185.
- Lancaster, J. L., Woldorff, M. G., Parsons, L. M., Liotti, M., Freitas, C. S., Rainey, L., . . . Fox, P. T. (2000). Automated Talairach atlas labels for functional brain mapping. *Human Brain Mapping*, 10(3), 120-131.
- Langer, S. K. (1953). *Feeling and form*.
- Lee, T.-W., Girolami, M., & Sejnowski, T. J. (1999). Independent component analysis using an extended infomax algorithm for mixed subgaussian and supergaussian sources. *Neural computation*, 11(2), 417-441.
- Limb, C. J., & Braun, A. R. (2008). Neural substrates of spontaneous musical performance: An fMRI study of jazz improvisation.
- MacEvoy, S. P., & Epstein, R. A. (2007). Position selectivity in scene- and object-responsive occipitotemporal regions. *Journal of Neurophysiology*, 98(4), 2089-2098.
- Maguire, E. A., Burgess, N., Donnett, J. G., Frackowiak, R. S., Frith, C. D., & O'Keefe, J. (1998). Knowing where and getting there: a human navigation network. *Science*, 280(5365), 921-924.
- Mansouri, F. A., Buckley, M. J., & Tanaka, K. (2007). Mnemonic function of the dorsolateral prefrontal cortex in conflict-induced behavioral adjustment. *Science*, 318(5852), 987-990.

- Mazziotta, J., Toga, A., Evans, A., Fox, P., Lancaster, J., Zilles, K., . . . Pike, B. (2001). A probabilistic atlas and reference system for the human brain: International Consortium for Brain Mapping (ICBM). *Philosophical Transactions of the Royal Society of London. Series B: Biological Sciences*, 356(1412), 1293-1322.
- Musso, F., Brinkmeyer, J., Mobascher, A., Warbrick, T., & Winterer, G. (2010). Spontaneous brain activity and EEG microstates. A novel EEG/fMRI analysis approach to explore resting-state networks. *Neuroimage*, 52(4), 1149-1161.
- Muthukumaraswamy, S. D., & Johnson, B. W. (2004). Primary motor cortex activation during action observation revealed by wavelet analysis of the EEG. *Clinical Neurophysiology*, 115(8), 1760-1766.
- Naganawa, M., Kimura, Y., Ishii, K., Oda, K., Ishiwata, K., & Matani, A. (2005). Extraction of a plasma time-activity curve from dynamic brain PET images based on independent component analysis. *Biomedical Engineering, IEEE Transactions on*, 52(2), 201-210.
- Nichols, T. E., & Holmes, A. P. (2002). Nonparametric permutation tests for functional neuroimaging: a primer with examples. *Human Brain Mapping*, 15(1), 1-25.
- Palermo, L., Iaria, G., & Guariglia, C. (2008). Mental imagery skills and topographical orientation in humans: a correlation study. *Behavioural Brain Research*, 192(2), 248-253.
- Pascual-Marqui, R. (2002). Standardized low-resolution brain electromagnetic tomography (sLORETA): technical details. *Methods Find Exp Clin Pharmacol*, 24(Suppl D), 5-12.
- Pavlidou, A., Schnitzler, A., & Lange, J. (2014). Beta oscillations and their functional role in movement perception. *Translational Neuroscience*, 5(4), 286-292.
- Pfurtscheller, G., Stancak, A., & Neuper, C. (1996). Post-movement beta synchronization. A correlate of an idling motor area? *Electroencephalography and clinical neurophysiology*, 98(4), 281-293.
- Ritter, S. M., Damian, R. I., Simonton, D. K., van Baaren, R. B., Strick, M., Derks, J., & Dijksterhuis, A. (2012). Diversifying experiences enhance cognitive flexibility. *Journal of Experimental Social Psychology*, 48(4), 961-964.
- Salmelin, R., Hämäläinen, M., Kajola, M., & Hari, R. (1995). Functional segregation of movement-related rhythmic activity in the human brain. *Neuroimage*, 2(4), 237-243.
- Schacter, D., Gilbert, D., & Wegner, D. (2011). *Sensation and Perception*. Charles Linsmeiser. Psychology. Worth Publishers. p. 158, 159.
- Schnitzler, A., Salenius, S., Salmelin, R., Jousmäki, V., & Hari, R. (1997). Involvement of primary motor cortex in motor imagery: a neuromagnetic study. *Neuroimage*, 6(3), 201-208.
- Singer, W. (1999). Neuronal synchrony: a versatile code for the definition of relations? *Neuron*, 24(1), 49-65.
- Spiers, H., & Maguire, E. (2007). The neuroscience of remote spatial memory: a tale of two cities. *Neuroscience*, 149(1), 7-27.
- Spiers, H. J., & Maguire, E. A. (2007a). A navigational guidance system in the human brain. *Hippocampus*, 17(8), 618-626.
- Spiers, H. J., & Maguire, E. A. (2007b). Neural substrates of driving behaviour. *Neuroimage*, 36(1), 245-255.
- Umla, M. A., Berchio, C., Sestito, M., Freedberg, D., & Gallese, V. (2012). Abstract art and cortical motor activation: an EEG study. *Frontiers in human neuroscience*, 6, 311.
- Varela, F., Lachaux, J.-P., Rodriguez, E., & Martinerie, J. (2001). The brainweb: phase synchronization and large-scale integration. *Nature reviews neuroscience*, 2(4), 229-239.
- Weissman, D. H., Gopalakrishnan, A., Hazlett, C., & Woldorff, M. (2005). Dorsal anterior cingulate cortex resolves conflict from distracting stimuli by boosting attention toward relevant events. *Cerebral Cortex*, 15(2), 229-237.
- Wolbers, T., Wiener, J. M., Mallot, H. A., & Büchel, C. (2007). Differential recruitment of the hippocampus, medial prefrontal cortex, and the human motion complex during path integration in humans. *The Journal of neuroscience*, 27(35), 9408-9416.

7 Sample UVE

§ 7.1 Creating a practical UVE

An open competition, organized by Visionair, provided for the support required for creating this real/practical UVE. Visionair is an acronym for “VISION Advanced Infrastructure for Research”. Visionair applies European infrastructure for high level visualisation facilities that are open to research communities across Europe and around the world. By integrating existing facilities, Visionair aims for conducting state-of-the-art research in visualization, thus significantly enhancing the attractiveness and visibility of the European Research Areas (ERA). With over 20 members across Europe participating, VISIONAIR offers facilities for Virtual Reality, Scientific Visualization, Ultra High Definition, Augmented Reality and Virtual Services. The fund for Visionair activities is provided by Fp7 (Framework Program for Research and Technological Development).

ITIA-CNR (<http://www.itia.cnr.it/en/>), Italy, was assigned via the Visionair funding body, as the chosen authority to provide the virtual reality (VR) facilities. The experiment was subsequently conducted in December 2013. The results of the experiment were presented in the Visionair conference in Rennes, France in 2014.

After creating the UVE, a group of 20 participants were asked to navigate in the environment. They were asked to provide a written feedback pertaining to their feelings, expectations, strategy of navigation and in general, their experience.

§ 7.1.1 Introduction

By applying virtual environments in design processes, architects can expect a variety of solutions, as compared to conventional methods despite the problems with visual perception or mental workload or frequency of iteration between creation and modification (Schnabel & Kvan, 2003).

Designers use different tools to communicate and express their thoughts. Although some architects visualize their design decisions through large-scale models, modelling

is always limited by the overall dimensions, scale, resource constraints and material restrictions. To overcome these constraints, architects implement virtual environments (Bertol & Foell, 1997). Although virtual environments can be easily found everywhere, immersive virtual environments (IVE) are typically found in research-laboratories or universities. Recent progression in technology provided the ground for IVEs to be implemented in the consumer electronics sector such as the gaming industry (Leach, 2002). The story is the same in the discipline of architecture and opportunities for applying VEs in architectural design are still developing (Stuart, 2001). VEs are employed successfully to study, communicate, collaborate, and present architectural designs but are rarely used for the actual act of creation and form-finding in the field of architecture (Maze, 2002).

In this chapter another application of the IVEs is proposed: to create an immersive UVE. This application is not developed for the purpose of visualization or form finding, but specifically for enhancing creativity.

§ 7.1.2 Building the UVE

The UVE has been built using the 3D Max software platform. Attempts have been made to implement all the [unconventional] qualities for separating the virtual environment from the physical world as much as possible. With the help of a 3D physical interface, termed Giove, developed in ITIA-CNR, the 3D max environment, is converted into an interactive, 3D stereoscopic environment. This allowed the participants to navigate the UVE by wearing a 3D goggle (figure7.1).



FIGURE 7.1 Participant wearing a 3D goggle

§ 7.1.3 Instruction for the participants:

The participants were asked to navigate the UVE using the 3Dconnexion (Figure 7.2). They were asked to consider that they are in a real environment when they are walking/navigating through the simulation (Figure 7.3). After the experiment, the participants were asked to write down their opinions about the experiment such as their most prominent feelings, strategies to navigate the environment etc.



FIGURE 7.2 Instruction for using 3D Conexxion

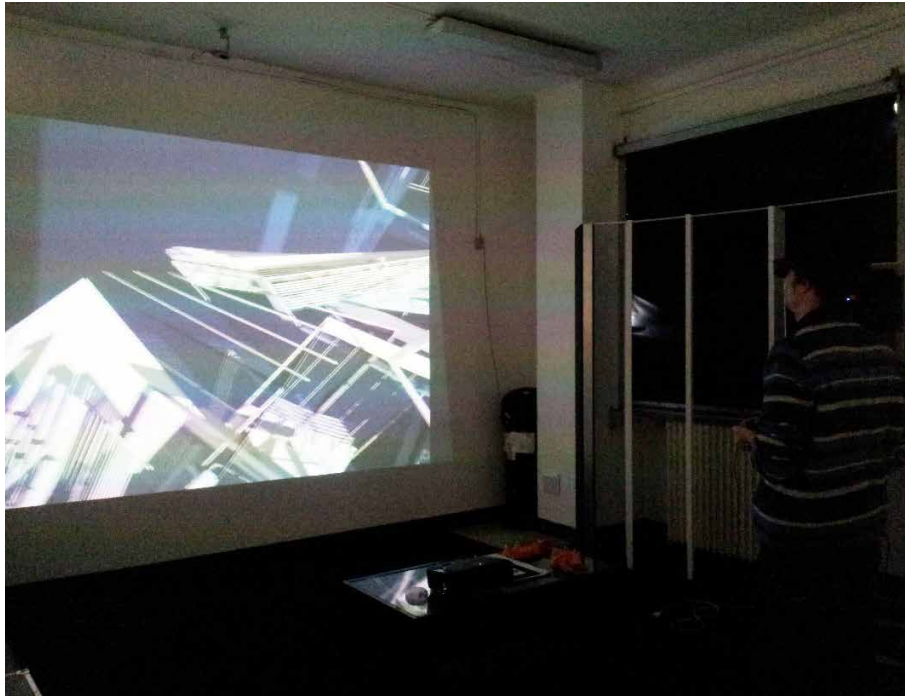

FIGURE 7.3 Participant while navigating in a UVE

§ 7.1.4 Feedback of the participants

The post-experiment analysis of the participant's comments, suggest that almost all of them have the similar feelings of confusion, dis-orientation and dizziness while they begin the navigation process, however, after a while they get used to the navigation process and develop a feeling of excitement and enjoyment. Smaller groups of participants also commented on the time required for navigation. Some, found it "boring" after the second minute while some preferred to voluntarily spend time inside the UVE to perform a task, rather than pure exploration. All comments of the participants (unedited) have been listed in Table 7.1. These comments will be considered for future experiments to optimize the experiment duration and interaction.

POST EXPERIMENT FEEDBACK

PP1(M)	<p>The dominant feeling during the first minute (or so) was confusion as the brain was trying to establish a clear relation between the subspaces (i.e. lines and planes) to define relative position and perspective in general. Then the confusion gradually developed itself into curiosity as these relations were explored more, but this process was not as fast as expected maybe due to erratic spaces and non-familiar alignments (as opposed to those familiar features in the daily life). Afterwards came the amusement as the curiosity was fulfilled (or may have worn out). Weightlessness played an important role in this stage (which is I guess is irreverent to the purpose of this study). If one defines fear as something that hinders curiosity and ruins amusement, it can be associated with the dark space surrounding the "playground". Once getting lost into this space it was not that easy finding your way back.</p>
PP2(F)	<p>The environment seems like an island lost in the empty space. No people can live there, only pointed objects. Not really dangerous but not comfortable because nothing is soft or warm there. The color is also cold on the black surface.</p> <p>Curiosity for sure, but sometimes confusion took over passing over different levels of the environment was not leading to clarity. I am Interested anyhow to explore these boundaries and understand the general view or shape of the space.</p>
PP3 (M)	<p>I was not fully comfortable with the controller since I could not easily distinguish between moving forward/backward and rotate upward/downward. I improved during the test but was not fully satisfied.</p> <p>While moving in the virtual environment I felt curious at the beginning but after a while I felt the need for an objective or a task to accomplish, because I was "just moving around". I focused on "building-like" elements on the left, but I would be more involved if I had something to find, or a purpose, alongside free exploration. So I tried to "give a meaning" to the environment by first having overall views and then focusing on details.</p>
PP4 (M)	<p>The environment reminded, in some of its aspects, a common building or a common house in which rooms and corridors can be identified even if these are not clearly defined. In some other aspects it was like a ruined building where the corridors were interrupt and the floors were destroyed. It wasn't clear where the environment ends and I had to be careful to not lose myself.</p> <p>The prominent feeling was one of curiosity to understand the environment configuration and in which way a real person could navigate in it and if there was some logical construction and it was possible to navigate in it as if I were walking in a real palace. Navigate through the walls and fly over the environment has been a funny experience.</p>
PP5 (M)	<p>Before going through your experiment I imagined something different: a more colored and dreamlike environment. Instead I found a quite dark and well-ordered architecture.</p> <p>Anyway my prominent feeling during the whole experiment was curiosity. During my exploration I tried to figure realistic architectural components: gates, stairs, flats etc.</p>
PP6 (M)	<p>The experiment is very interesting and I am very curious about the results. Is an unconventional-spatial environment really effective to stimulate creativity?</p> <p>Did immersive VR really influence the user's status?</p> <p>From the environment point of view, I found it very captivating. The disorientation was for a very few moments, after that I was very interested in finding out a path towards an incredible 3D space.</p> <p>As said I was very curious to discover the environment while I was also trying to rationalize it.</p>
PP7 (F)	<p>The non-common environment, which I was asked to navigate through, is very strange and confusing: the absence of orthogonal planes and classic perspective creates disorientation.</p> <p>The main structure appears like a post-apocalyptic environment, a wooden world after a cataclysm or a giant-size of pick-up sticks.</p> <p>While I was navigating, I felt the necessity to search and follow a clear path, moving along what seemed to me more "stable", avoiding the intersecting structures.</p> <p>The main problem of that strategy was the unexpected interruption of those elements and the consequent access into the darker zones.</p> <p>Then my principal intent became to reach the main structure again. I don't know exactly why, maybe the reduced interest to that darker part or maybe the sense of vacuity.</p>

>>>

POST EXPERIMENT FEEDBACK

PP8 (M)	<p>First of all, thank you for having involved me in your experiment, it has been great!</p> <p>I have been fascinated by your experiment mostly because I was allowed to freely navigate in a 3D environment, which was completely new for me.</p> <p>The entire environment resembled a giant contemporary architecture and I was mostly attracted by the light grey shapes because they were like the parts lit by the sun.</p> <p>The other part on which my eyes focused a lot was that one modeled like a kind of footbridge because I was attracted by the parallel lines. I found the navigation system easy to use and understand, but two or three times I lost my way trying to look around me because of a low velocity on the rotation around the vertical axis of the 3D mouse. I am a curious person so I was excited by the chance to navigate in a completely new environment. I was not frightened nor confused by the modeled structure, but I am really convinced that my feelings would be different with another background color, maybe a light one. But I have to say that the dark grey background helped me to recognize shapes, shadows and volumes.</p>
PP9 (F)	<p>I already had experience with 3D environments and the use of 3D mouse, therefore it wasn't something completely new. Anyway, I was not used to navigate in an unstructured 3D scene.</p> <p>After a quick initial exploration of the 3D environment, the navigation was a bit boring because I couldn't find a goal to lead my movements in the space.</p>
PP10 (M)	<p>I found the experiment curious, annoying, disorienting and relaxing. In the first part of the trial, I was curious to navigate inside the environment understanding what it was and I wasn't able to. With the time elapsing I felt a bit annoyed because of a sense of disorientation (entering some area too dark I lost the orientation) and of a decreased sense of presence (since I could pass through objects). Then I decided to watch the environment from the outside and I found it relaxing.</p>
PP11 (F)	<p>I think that the experiment is very interesting and innovative.</p> <p>During the navigation, (after understanding how to use the joystick!), I felt very curious about the environment, and I didn't feel frightened or confused.</p> <p>I also noticed that, at the beginning of the experiment, I tried to relate the shapes of the virtual environment with the shapes of the real world which are, of course, more familiar to me. But then, since I wasn't able to find an association for every virtual object, I only continue to navigate without this kind of "preoccupations" and it was really funny, mainly because it seemed like I was flying!</p> <p>I wished for the experiment to last longer!</p>
PP12 (F)	<p>I would like to mention 2 comments about the experiment performed yesterday. On the one hand, I want to highlight my particular interest in the colors of the environment. I don't know if these were intentionally selected but I guess that they influenced my feelings when I was moving around these colors. I associated the white color as a possible exit point, so I focused on trying to find possible paths for getting out of there. So I think that I can use the word anxiety to describe what I felt in the experiment.</p> <p>On the other hand, I will like to mention that the devices used to perform the experiment, specially the glasses are heavy and uncomfortable, I think that these might have some influence in the experience of walking around the environment.</p>
PP13 (F)	<p>While I was navigating, my prominent feeling was curiosity. I thought I was going into a building and I was discovering how it was made.</p> <p>Some details in your structure made me think there were conventional elements in it, like stairs, windows, walls, etc. Because of this feeling, what I intended to do was try to discover if what I thought to be a specific buildings element (stairs for instance) was that element indeed.</p> <p>Of course, I realized that none of them was something conventional. Therefore, I navigated to try and identify how these unconventional structures were made.</p> <p>I think it is a nice experiment, and it stimulates my curiosity. It was challenging to try to find out how the structure was built.</p>

>>>

POST EXPERIMENT FEEDBACK

PP15 (M)	Before doing the experiment I was sceptic about the virtual environment (also because of ignorance about the specific research field), mainly because it made no sense to me, with all those strange shapes apparently assembled together in a chaotic way. During the experiment I put aside these thoughts and just navigated while concentrating on exploring this new world as an archeologist does the first time he visits a new cavern. The feeling was curiosity and "contemplation", let the mind absorb what it is actually seeing and feeling. I found that, whatever my orientation and /or navigation direction were, there were always geometrical shapes that made my actual orientation "correct" or, better. It was a sort of property of "isotropy of the feelings" maybe caused by the space. In my opinion it would be useful/interesting to build a more extended virtual environment
PP16 (F)	In my personal experience, I felt very relaxed and curious to discover the virtual environment, I sometimes lost my orientation and got lost in the space but maybe this was because I was curious to discover the environment around me. I hope that this account of my experience will be useful for you.

TABLE 7.1 Post experiment feedback

§ 7.1.5 Specification of the tools for the experiment

§ 7.1.5.1 3D projector

The projector used in this experiment was EX762, XGA - 4000 ANSI Lumens.

Using the inherent speed of DLP technology, The Optoma EX762 can output video and images at rate of 120Hz, allowing one to show full screen, full color, and stereoscopic 3D. The 3D effect is generated by splitting this signal into two standard video streams, one for each eye. Using DLP® Link™ technology, the 3D glasses synchronize with the image on the screen to filter each stream to the correct eye. The brain then combines the two streams. The 3D features of the EX762 can only be used with compatible 3D content.



FIGURE 7.4 3D stereoscopic projector

§ 7.1.5.2 3D goggle

DLP (Digital light processing) technology uses millions of microscopic, digital mirrors that reflect light to create a picture for projectors. This imaging technology is so fast, it can actually produce TWO images on the screen at the same time: One for the “left” eye and one for the “right” eye. To create the 3D effect, you need 3D Glasses that combine the two images. For the sake of this experiment we decided to use XPAND 3rd generation of DLP® Link™ 3D Glasses: XPAND Edux 3 3D Glasses (X103-EDUX3 / X103-EDUX3-R1).



FIGURE 7.5 XPAND 3D Goggle

§ 7.1.5.3 3D stereoscopic interface

For creating stereoscopic environment, we applied GIOVE. GIOVE stands for: “Graphics and Interaction for OpenGL-based Virtual Environments” and is a set of software libraries (SDK Software Development Kit) written in C and C++ for developing applications that use real time 3D graphics. ITIA-CNR (National Research Council: Institute of Industrial Technologies and Automation) of Italy developed the interface for its own research but since various research projects within ITIA typically have different targets and applicative contexts, it was difficult to focus on just one commercial platform for development. GIOVE is an internal “product”, it does not have any licenses, it is not open source either. GIOVE is based on OpenGL (www.opengl.org) and it works with Windows operating system. It can load 3d models in .3DS and .Obj format. The FBX and DXF formats are under development depending on the demand of the projects in progress.

For utility purposes an application called “GIOVE-Viewer”: an application for loading 3D models and that allows various basic operations including navigating in the scene, positioning/rotating models, taking screenshots, add lights, customize observers point of views, enable real time shadows and so forth was used.

§ 7.1.5.4 3D navigation tool

3Dconnexion was employed to navigate the virtual environment. Commonly utilized in CAD applications, 3D modeling, animation, 3D visualization and product visualization, users can manipulate the controller's pressure-sensitive handle (historically referred to as either a cap, ball, mouse or knob) to fly through 3D environments or manipulate 3D models within an application. 3Dconnexion patented 6-degrees-of-freedom (6DoF) technology for smooth and intuitive control of 3D models and environments. The appeal of these devices over a mouse and keyboard is the ability to pan, zoom and rotate 3D imagery simultaneously, without stopping to change directions using keyboard shortcuts or a software interface giving the participants a clear sense of immersion in virtual space.



FIGURE 7.6 3Dconnexion mouse

8 Conclusion

§ 8.1 Introduction

The research focused on cognitive aspects of creativity, including thinking patterns, conceptual blending, idea expansion and tolerance of ambiguity instead of personality and behavior of creative people, their mood, state, temper, motivation and so forth.

It was also found that “conceptual blending” and “tolerance of ambiguity” are related to creativity. Multiplicity of experiences may help for divergent thinking and indirectly affects creativity.

Starting the design from a higher dimension (3D interface) may yield to more creative ideas comparing to lower dimension (2D pen and paper), due to the fact that 3D interfaces provide a better perception of non-Euclidean geometry.

It is also found that the brain function is different in different environments. More creative parts of the brain activates while the brain tries to perceive an “abstract” environment in comparison with “fully or semi” designed environments.

Each of the above finding is discussed in detail by answering the research questions:

§ 8.2 Answers to research question

This section gives detailed answers, firstly to the sub research questions and subsequently, to the two main questions posed in chapter 1.

To narrow down the widespread topic of creativity and focus on creativity in architecture, the research ignores aspects of creativity which focus on personality and behavior of creative people, their mood, their state and their temper, intelligence vs. creativity, motivation and so forth. Instead, the research focuses on cognitive aspects such as thinking patterns, conceptual blending, idea expansion and tolerance of ambiguity.

§ 8.2.1 Question number 1 (answered in chapter 2)

What are the effective parameters correlated with creativity in architectural design?

The chapter expanded upon the understanding of creativity and narrowed down upon a definition of creativity pertaining to the scope of this research. The Chapter also, discusses where creative ideas come from in accordance with theories of David Jones. The Chapter further, elaborates upon types of creativity and correlates it with the architecture discipline. A clear focus on cognitive aspects of creativity such as thinking patterns, conceptual blending, idea expansion and tolerance of ambiguity have been focused upon. In short, it can be summarized that the following parameters are correlated with [spatial] creativity:

1. Multiplicity of experiences helps in the process of idea expansion and divergent thinking. The same Divergent thinking is directly related to creativity.
2. Conceptual blending is influential in training the brain to blend remote ideas. The more remote ideas are available for blending, the more the chances of generating creative ideas.
3. Tolerance of ambiguity, helps in postponing one's judgment and allows for considering as many parameters as possible. This ability is pertinent to creativity.
4. A change in thinking pattern is emphasized on. This implies shifting from probabilistic creativity towards impossibilistic creativity.

§ 8.2.2 Question number 2 (answered in chapter 3)

Are tools and changing the dimension of design process (from 2D pen and paper to 3D interface) effective in the enhancement of creativity?

Inspired by the book "Towards a new kind of building", written by my promoter Kas Oosterhuis, an experiment was conducted to address this question. In the experiment, the same design task was provided to a group of architecture students [in the last year of their Bachelors studies]. The design task was to design the same spatial environment once using an analogue traditional interface of a 2D pen and paper and the next time using a 3D software platform. A group of 5 experts [University Professors] subjectively decided whether there was any enhancement of creativity in their designs or not.

The jury decided that the students who used 3D max platform as their modeling interface had the best results with 83.4 % improvement in their performance. Only 42.9% of the students had improved by choosing Sketch up as their interface and this was mainly due to software limitations for producing complex geometries. Students who applied Revit as their 3D interface gained 66.7% improvement.

In summary, tools have a direct effect on the brain's ability and aid it to think out of the box. Starting design from a higher dimension thus helps the designer to include all the possible design options, both Euclidian and non-Euclidean.

§ 8.2.3 Question number 3 (answered in chapter 4)

Theoretically, how can unconventional virtual environments (UVEs) be helpful for enhancing creativity?

This question has been expanded upon and elaborated in chapter 4. After defining the characteristics of a UVE, the hypothesis has been broken down and discussed in detail. In summary the following arguments have been arrived at:

1. Surfing/Exploring an UVE enhances creative performance and creativity-supporting cognitive processes (e.g., recruitment of different ideas and retrieval of unconventional knowledge);
2. The connection between experiencing UVEs and creativity is most apparent when individuals have had the experience of deeply "immersing" themselves in virtual environments and "interacting" with these environments;
3. Adapting and opening themselves to new experiences and actively interacting and comparing the differences they encounter between unconventional virtual environments and the physical world can boost the benefits of this experience;
4. A weaker relationship between experiencing virtual environments and creativity emerges in contexts where one confines themselves to limitations of the physical world, such as: construction limitations, material limitations etc.

§ 8.2.4 Question number 4 (answered in chapter 5)

Are there any methods to boost [spatial] creativity in architecture?

This question is answered in Chapter 5. In Chapter two, pertinent parameters on creativity have been tested under the unique name: Proto-fuse project. These parameters are 1) Conceptual blending and 2) Tolerance of ambiguity. For each of these parameters a separate experiment has been designed:

1. Navigating in UVEs (aiding conceptual blending mutation)
2. Extracts of local distance (aiding tolerance of ambiguity)

These two experiments not only verified the linkage of these two concepts to creativity, but also clarified how these can be implemented in the pedagogy of architecture to enhance creativity in praxis as well as academia. The Proto-fuse project can help architects to increase their tolerance of ambiguity and expand their inventory of experiences. Improbabilist creativity can turn to impossibilist creativity by applying UVEs to attain the mutation of ideas.

Training students of architecture to enhance their tolerance of ambiguity during the design process, by designing ambiguous experiences and training the mind gradually for more ambiguous situations, can provide a suitable springing board for implementation of the Proto-fuse concept. Providing virtual reality workshops for students, where they can navigate, interact and explore UVEs adds new and unique opportunities to enhance their inventory of experiences, subsequently leading to the generation of novel ideas and should thus be surely encouraged.

§ 8.2.5 Question number 5 (answered in chapter 6)

Is there any difference between perceiving different environments? (E.g. Abstract, semi designed and fully designed environment). If the answer is positive, can we provide an objective empirical evidence for it?

This question is addressed in Chapter 6. A marked difference is observed by analyzing the differences in the perception of different environments. The experiment was conducted with three different environments: 1) Abstract-designed environment, 2) Fully-designed environment and Semi-designed environment. The results show that

the brain activity patterns during perceiving abstract environments is different from the brain activity patterns while perceiving a fully designed or semi-designed environment.

It is also discussed that this difference is [possibly] related to creativity. The difference observed while perceiving abstract virtual environments, owing to its being free from physical rules/world, maybe related to divergent thinking, expanding inventory of experiences, thinking out of the box and in general to different aspect of creativity. The empirical evidences for these claims have been acquired with an electroencephalography (EEG) study.

§ 8.3 Application recommendation based on results:

The designated audiences of this dissertation are architects, industrial designers, (3D) game designers and so forth. The application may thus vary for different target groups. The following applications are nevertheless speculated:

§ 8.3.1 Apply UVE in the pedagogy of architectural education:

UVEs can be implemented in the pedagogy of architectural education, specifically in the early years as part of the curriculum. By designing, navigating and interacting with UVEs, students shall add new data to their unconscious mind. Their brains shall thus witness a higher possibility of conceptual blending and passively becoming more creative.

§ 8.3.2 Start designing from a higher dimension

Unlike the traditional recommendation of architecture schools to start designing with pen and paper in a 2D environment and then shifting to a computer, there should be no obligation on the order or the kind of design tools. It is even recommended to start designs from a higher dimension e.g. 3D computer interfaces or an even higher dimension such as starting a design from a virtual reality point-cloud.

§ 8.3.3 Train the brain to tolerate more ambiguity:

It is recommended to confront one's self with complex ambiguous situations/images/problems and try to suspend making rational judgments as much as possible. Try decoding ambiguity as much as possible from different perspectives. It is suggested that introducing the proposed UVE's based exposure to induce ambiguity in the architectural curriculum can help train students to enhance tolerating ambiguity as much as possible.

§ 8.3.4 Do not mix design and problem-solving modes of the brain:

Opposed to the popular belief amongst designers, that they can think as a designer (for form-finding) and problem solver (technical issues) at the same time, it was observed that the brain cannot perform both tasks at the same time. It is thus recommended to iteratively pursue a design process (form-finding, problem solving), focusing on these two aspects of design one at a time.

§ 8.4 Recommendations:

§ 8.4.1 Recommendation for future research:

This dissertation and its findings suggests two topics for further research:

In the experiment presented in chapter three, two different starting point dimensions were considered: 2D vs. 3D. The comparison was between pen and paper and a 3D interface. Such a comparison would become more interesting if we can compare the same task using another higher dimension: A 3D interface (by using 3D software platforms on the computer) with an interactive 3D point cloud accompanied with 3D goggles and motion detector gloves. It could still be hypothesized that the results of the interactive 3D environment will be more creative as compared to a lower dimension starting point.

The second recommendation is drawn from the experiments in chapter seven. In this Chapter a sample UVE was created and participants interactively navigated in this environment wearing a 3D goggle. It is suggested that one records the brain functions of the participants while they are navigating the UVE. The results would help to see whether the creativity correlated parts of their brain are being activated while the users are navigating the UVE's or not. There are nearly 60 different experiments already conducted in the whole world in connection with creativity and brain function (using EEG, fMRI). The results of such an experiment can be compared to the results of these previous experiments and comparatively analyzed for similarities and differences in the recorded data.

§ 8.4.2 Recommendation for the market:

Enhancement of creativity of designers [especially architects] and applying more creativity supporting tools comprised the broader aim of this research. The research thus specifically focused on methods which can passively increase creativity. At the moment there is no specific game engine for designing interactive virtual environments. The next generation of architects will apply creativity supporting tools more and more in their design procedure. Therefore, powerful design engines can be developed in the market which can be of great use for the design community. Moreover, interfaces which can transform a 3D environment to stereoscopic 3D would also be a welcome move from the industry.

Better tools for interacting with virtual environments are also very vital a for the future development of such immersive VR based methods. Next generation of motion detectors, 3D goggle, 3D navigating tools, 3D sound, 3D soundscapes, 3D projectors etc. with intuitive interfaces for a richer experience are thus much needed. It is thus suggested that the industry invests in developing up to date supporting tools for such creative/cutting edge design/pedagogy developing procedures.

§ 8.5 Value of this dissertation:

This dissertation has provided a set of unique and original results regarding human creativity, perception and the functioning of the human Brain. These results are driven by scientific simulations, experiments, interviews and observations conducted

in The Netherlands, United Kingdom, Italy and Iran and have been peer reviewed by Internationally reputed scientific Journals.

The most important factor of this research is its multidisciplinary perspective on creativity and design. While there is no consensus on the definition of creativity and each of these disciplines (design, psychology and neurology) has its own approach, definition and associated research, this research managed to cover all three domains.

Architecture is a subjective and context oriented discipline. While there is no global design approach accepted by all architects and each of them have their own approach and design methodology, this research found empirical evidence on brain functions during design procedures, which is not subjective but objective in nature. Such empirical evidence on brain function can help architects to re-design/re-think their methods and approaches via enhancing their creativity.

At the end, this dissertation serves society in general because it helps to improve the creativity of human kind, which, is the fountainhead of human civilization.

Acknowledgements

First and foremost, I would like to express my gratitude to my promoter, Professor Kas Oosterhuis for his guidance and supervision on this research. His ingenuity and vision made me motivated to reach my goals. I'm also grateful to my co-promoter, Dr. Nimish Bioria. I was very lucky to have him as a supervisor who has patiently supported me in my journey and helped me during the way. I would like to thank Dr. Darab Diba who trusted me, support me and motivated me to start a PhD. I would like to extend my gratitude to Prof. Dr. Joydeep Bhattacharya for providing me the opportunity to work in his research Lab at Goldsmiths university of London and for his co-operation for co-authoring two journal papers. I also acknowledge the efforts of my other co-authors in the journal papers: Dr. Roy de Kleijn, Dr. Amirmasoud Dabbagh, Dr. Armaghan Ahmadi Venhari, Fanak Shahmohammadi and Mojgan Rauf Rahimi.

Besides my advisors and co-authors, I particularly acknowledge the rest of my defense committee for their encouragement, constructive comments and insightful questions.

I would like to thank the scholars who helped me through this research; Dr. Henriette Bier, Dr. Marco Sacco, Stefano Mottura, Dr. Job Lindsen. I am also thankful to Dr. Frank van der Hoeven for his support.

I really enjoyed working with warm and intimate colleagues and friends from the first year of my work; Achilleas, Chris, Christian, Han, Jelle, Jia-Rey, Sina, Tomek, Vera and Xin. I also had great times with friends in other chairs of BK; Babak, Jurek, Giancarlo, Mauricio, Ahmed, Alejandro, Irem etc. There is no word that can describe my gratitude to Mohammad, and Azadeh for their support and sympathy in all my PhD challenges. I would like to thank Shuai, Michiel for their friendship and support and thanks to Barbara, Bo, Danielle, Françoise and Shaïda.

I would like to thank my family for all their love and encouragement. I would also like to thank my mother and my late father who raised me with a love for science and sisters who supported me in all my pursuits. And finally my dear wife Armaghan who was beside me during this journey and patiently provided the warm environment at home and supported me in finishing my PhD.

Curriculum vitae

Alireza Mahdizadeh Hakak was born on 16 September 1980 in Mashhad, Iran. After obtaining a Master of Science in architecture from Azad University of Tehran in 2006, he has worked as a freelance architect with several consulting Engineering firms in Tehran. He also won more than 10 different national and international architectural competitions many of them published by well-known publishers (including Archdaily). He has been a lecturer in Azad University (2007-2008) and a member of the editorial board of "Architecture and Urbanism" magazine in Iran (2006). Following his interest in spatial creativity he joined TU Delft as a PhD researcher in 2011.

During his interdisciplinary research between architecture and neuropsychology, he collaborated with Goldsmiths University, London, UK as a visiting scholar in 2012 and performed his first experiment in a neuropsychology department. This opportunity made it possible for him be familiar with neuropsychology and be successful to pursue his interdisciplinary research. In the same year, his proposal was accepted in Visionair (part of FP7 program) and the EU FP7 funded his next experiment in Italy, which was conducted in ITIA-CNR. Applying cutting edge facilities of their labs, enhanced the accuracy of the results and made them more reliable. He extended his collaboration with Iranian universities and conducted several experiments in Tehran and Mashhad. The published results of all experiments in reputed journals gradually build up the chapters of his [journal paper based] doctoral thesis.

List of publications:

- Hakak, A. M., et al. (2016). "Navigating abstract virtual environment: an eeg study." *Cognitive Neurodynamics* 10(6): 471-480.
- Hakak, A. M., et al. (2016). "'Thinking Out of the Box' from Out of the Box! Increasing the Dimension of 'Starting Point' Case Study: Architecture Students." *Psychology* 7(03): 345.
- Hakak, A. M., et al. (2012). "Implementing unconventional virtual environments for enhancing creativity in architecture pedagogy." *International Journal of Virtual and Personal Learning Environments (IJVPLE)* 3(4): 41-52.
- Hakak, A. M., et al. (2014). "Creativity in Architecture-A Review on Effective Parameters Correlated with Creativity in Architectural Design." *Journal of Civil Engineering and Architecture* 8(11).
- Hakak, M. and N. Biloria (2011). "New perception of virtual environments, Enhancement of creativity." Ljubljana: Proceedings of eCAADe: 967-975.
- Mahdzadeh Hakak, A., et al. (2016). "The Proto-Fuse project: methods to boost creativity for architects." *International Journal of Design Creativity and Innovation* 4(3-4): 206-221.

