

URBAN STRATEGY AND SITE PLAN

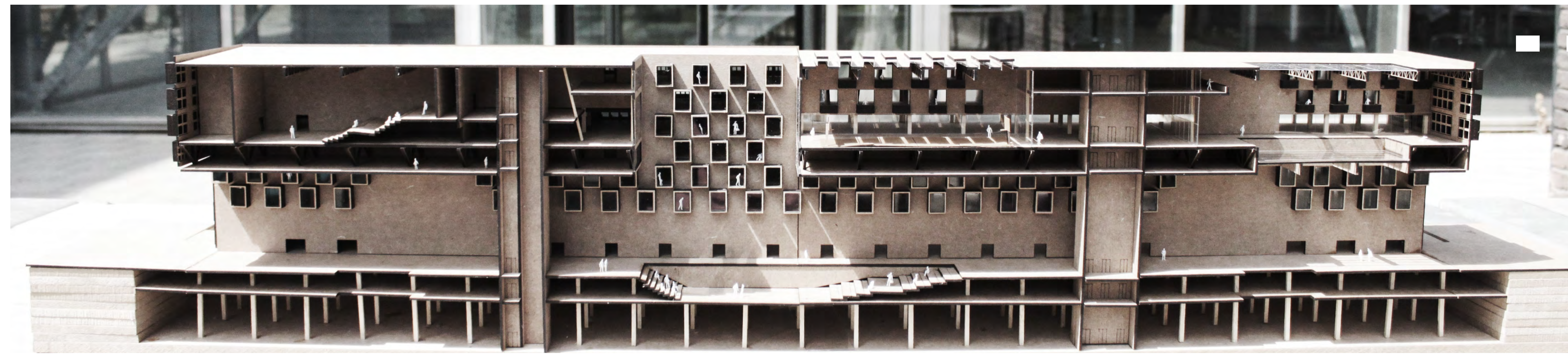

SITE PLAN 1:2000



URBAN SITUATION

SITE IN RELATION WITH BUILDING CONCEPT

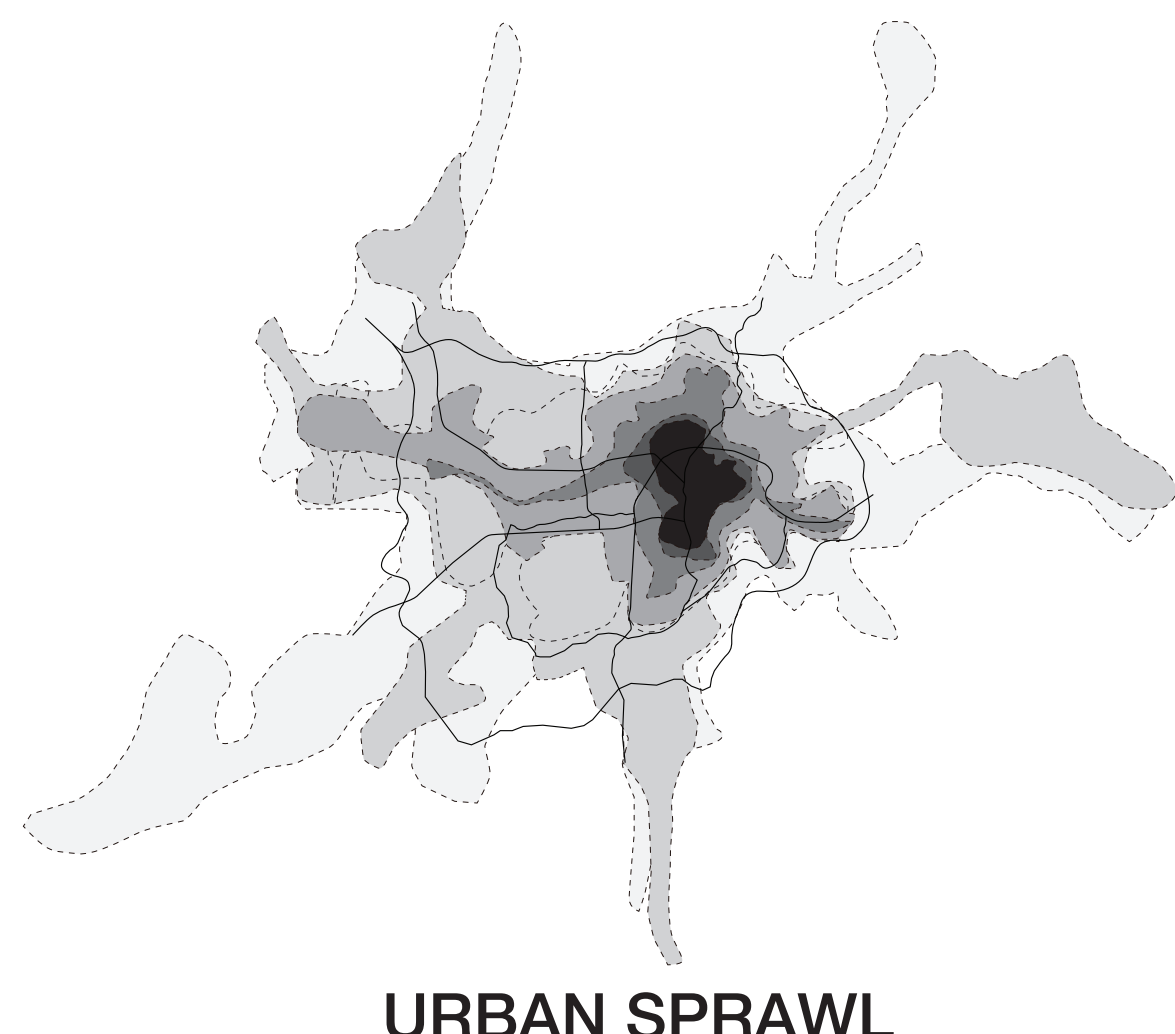

URBAN SPRAWL

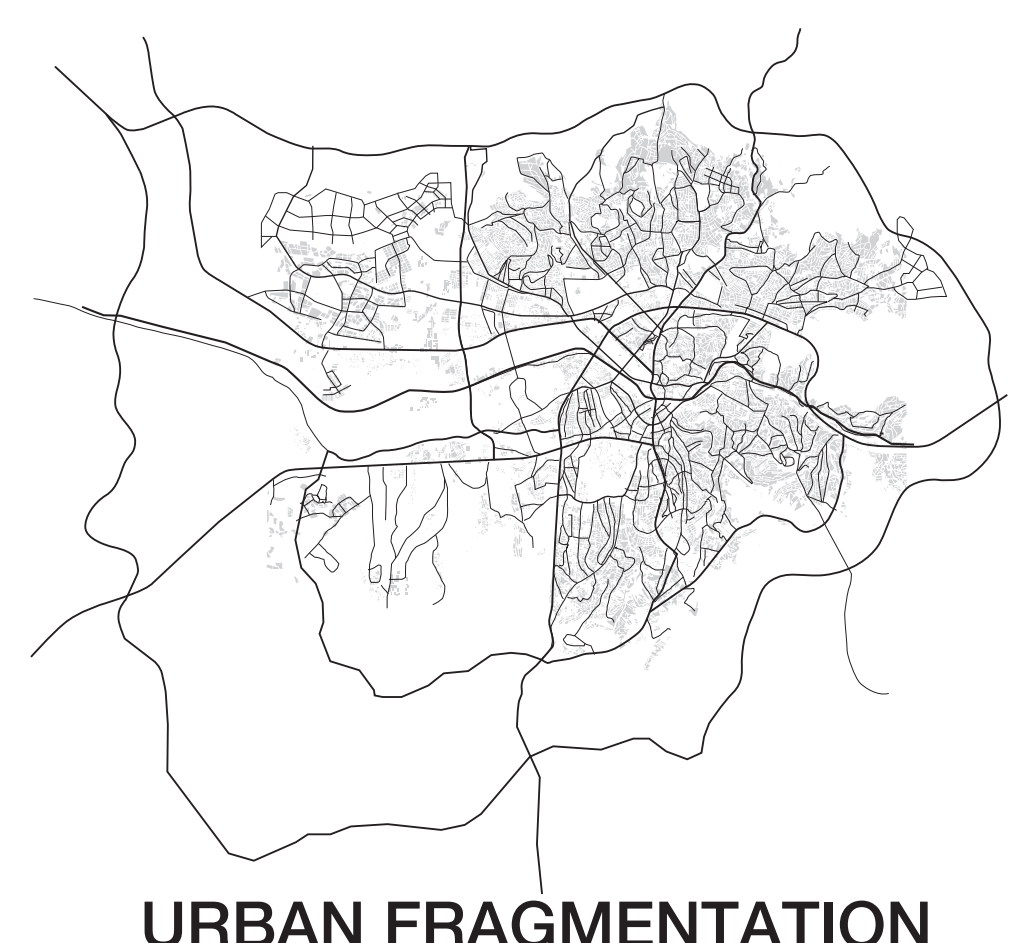

URBAN FRAGMENTATION

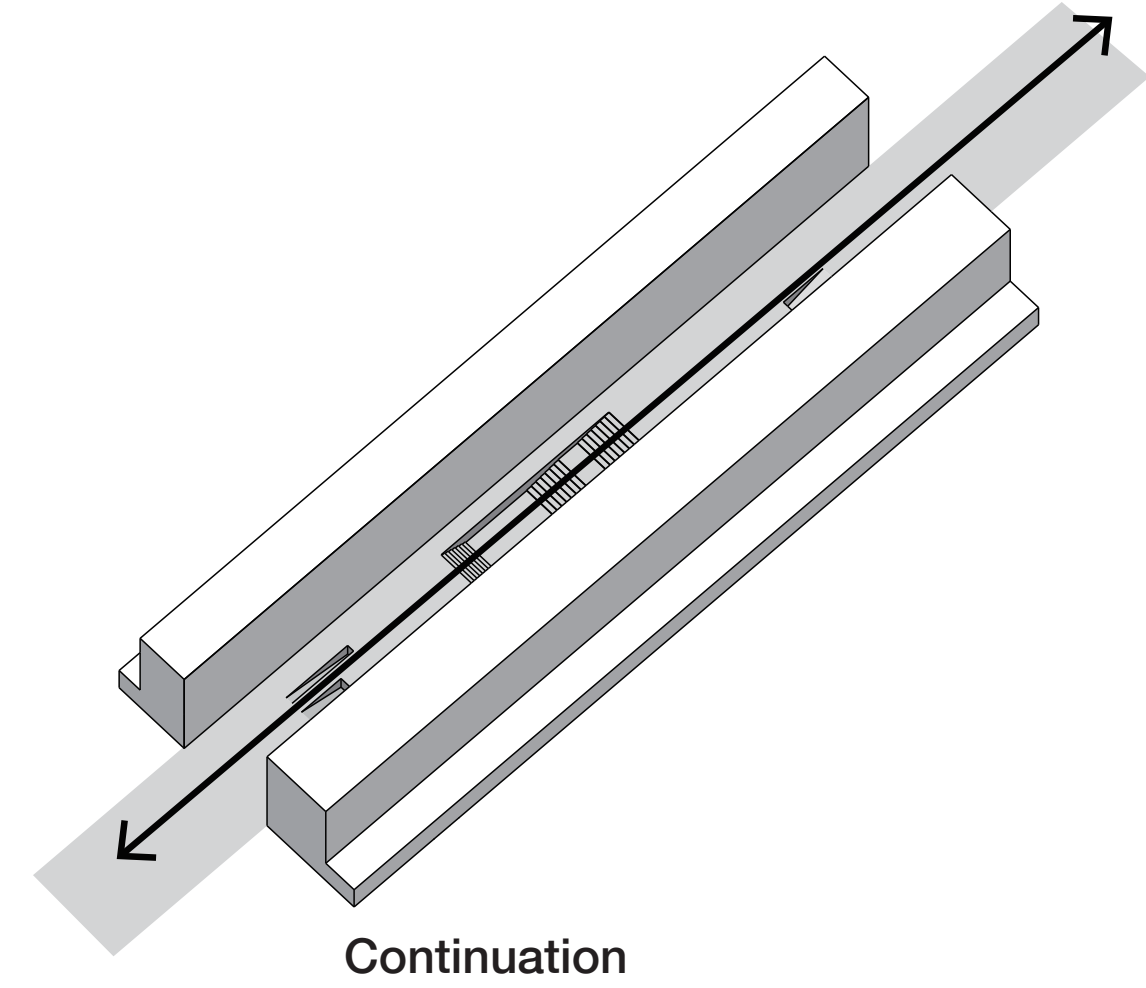

Continuation

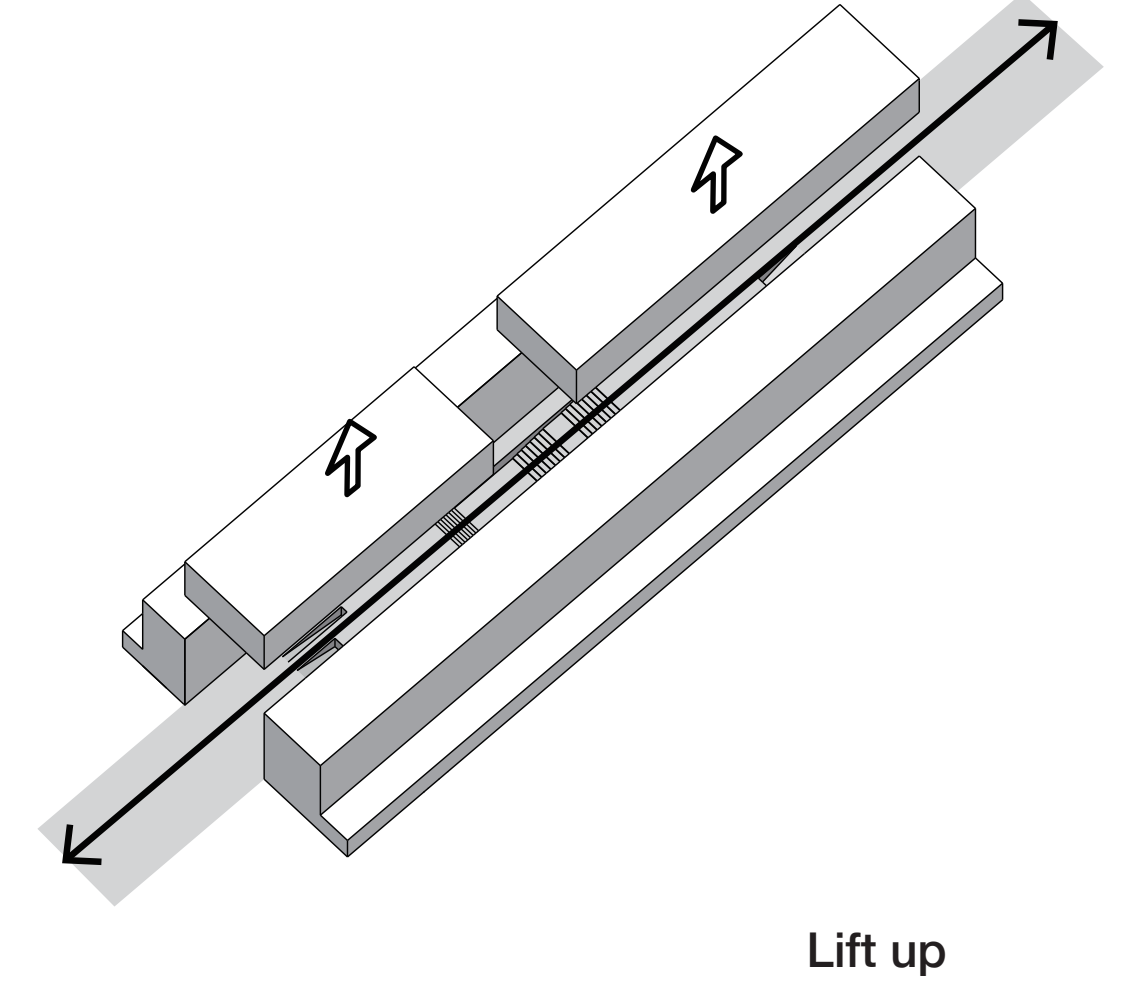

Lift up

URBAN STRATEGY

PROGRAM DISTRIBUTION



URBAN GREEN AND INFRASTRUCTURE



INNER CITY LOOP

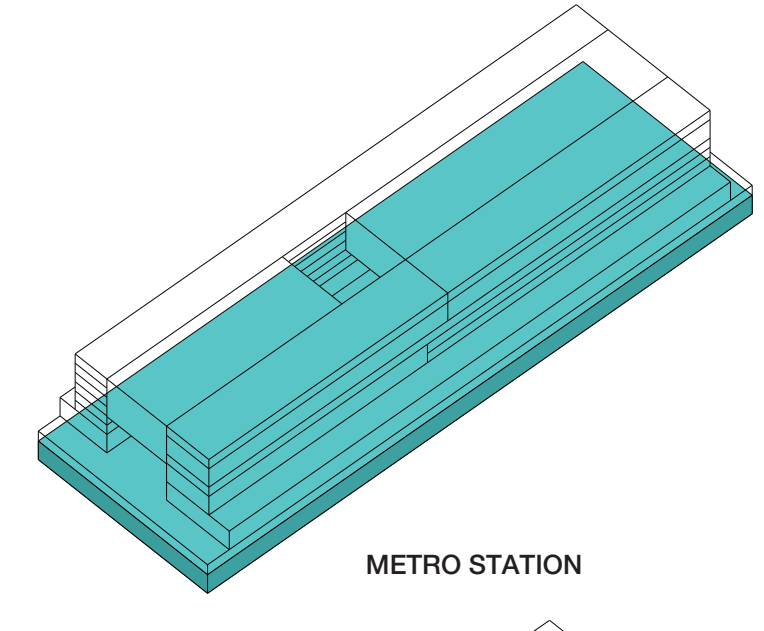

METRO STATION

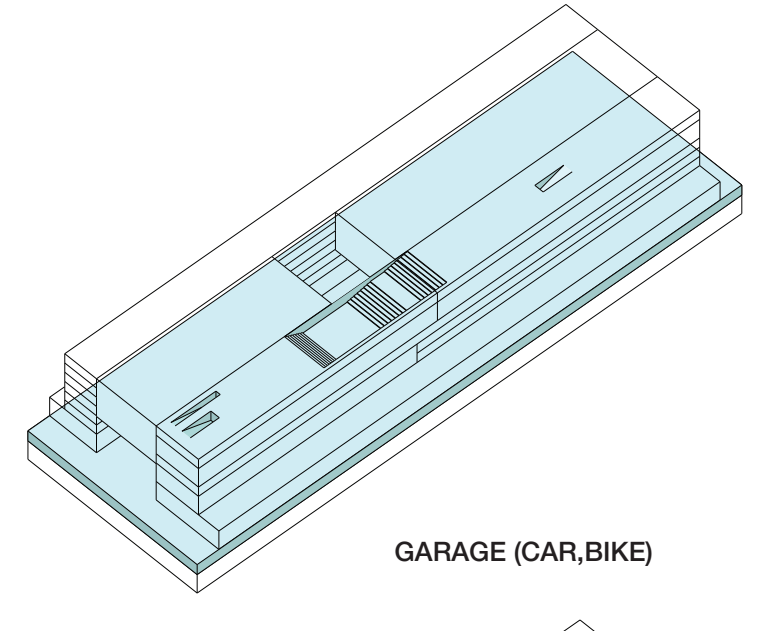

GARAGE (CAR, BIKE)

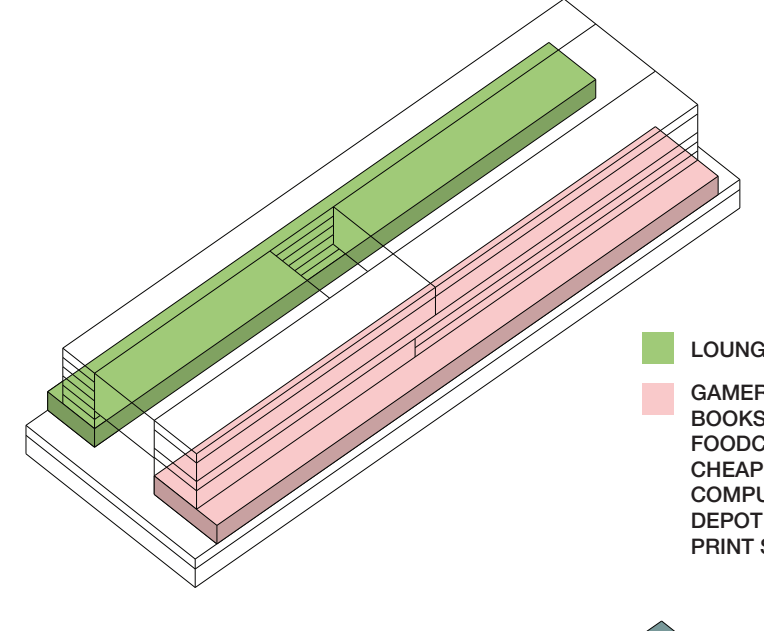

LOUNGES

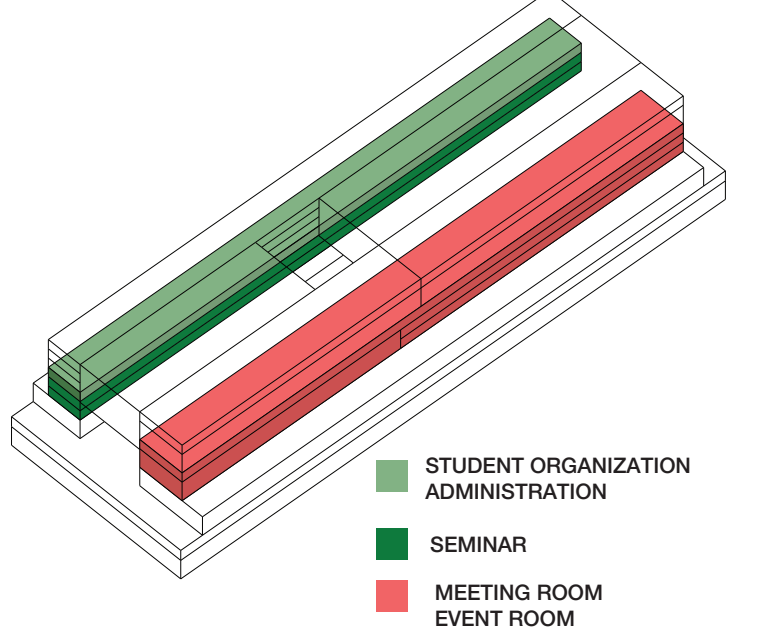

STUDENT ORGANIZATION ADMINISTRATION

SEMINAR

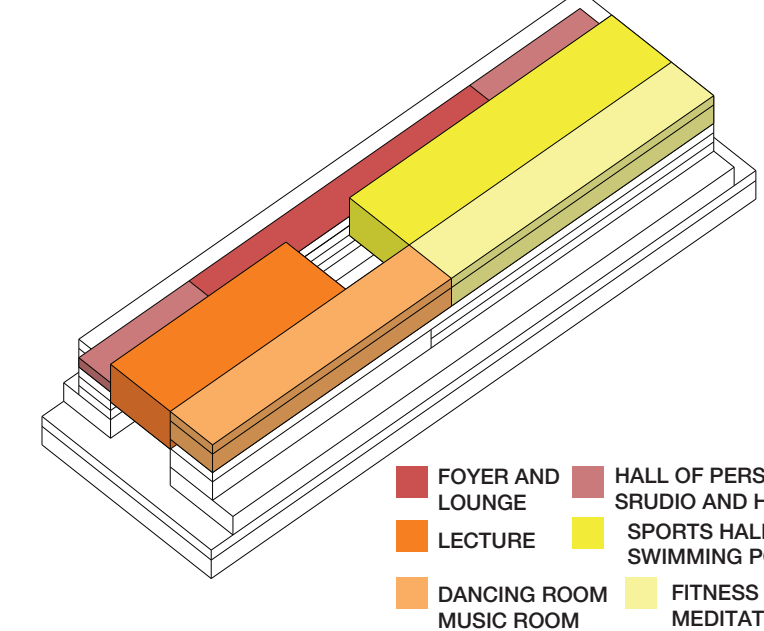

FOYER AND LOUNGE

LECTURE

DANCING ROOM

MUSIC ROOM

CHAIR

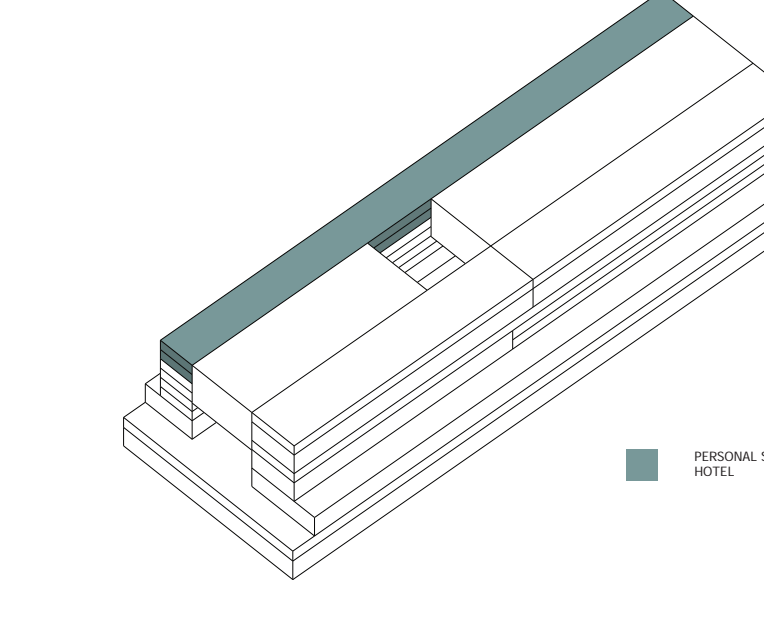

GAMER ROOM

BOOKSHOP

FOODCOURT

CHEAP MARKET

SEAT

PRINT SHOP

PLANS

Fragment 1

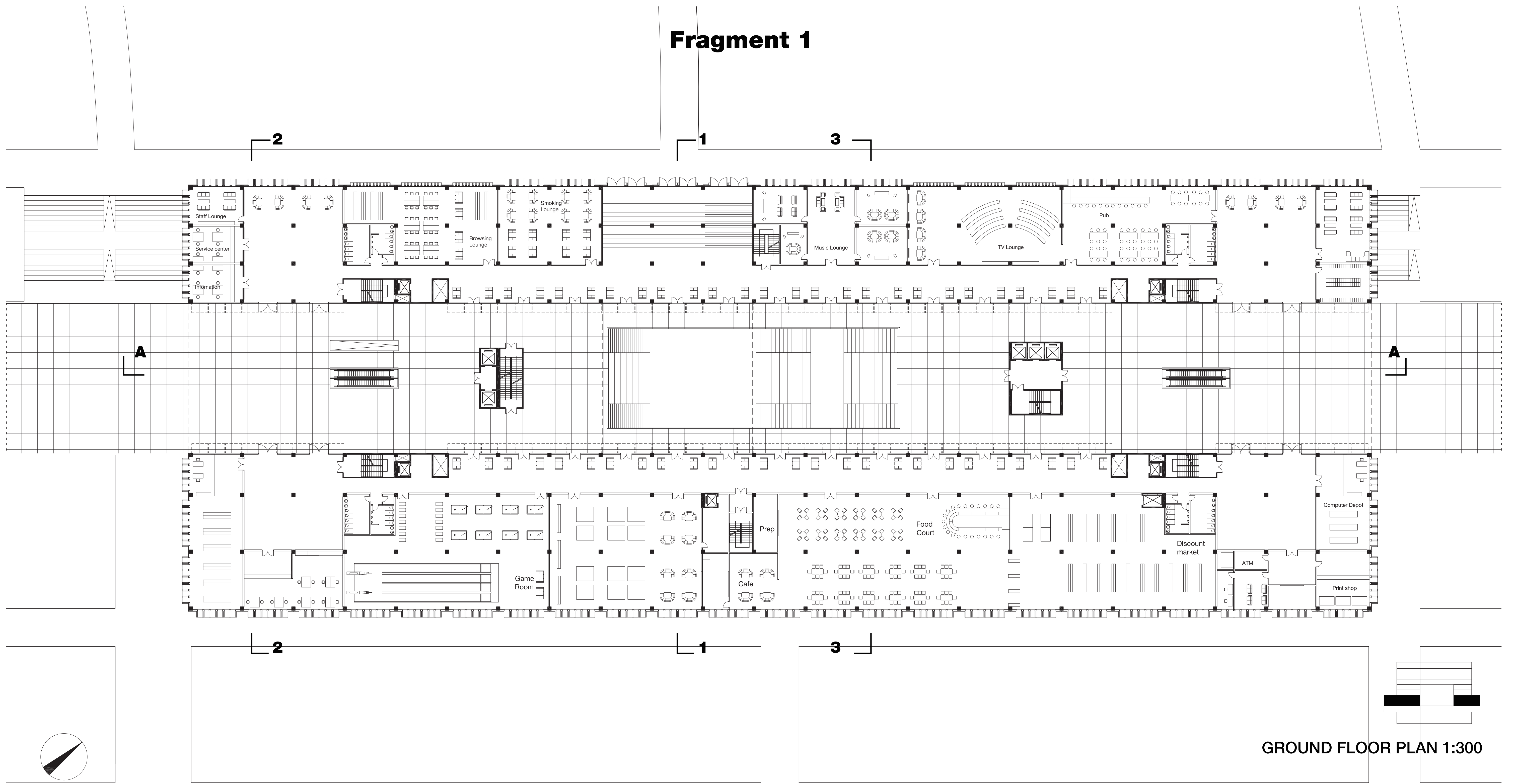

GROUND FLOOR PLAN 1:300

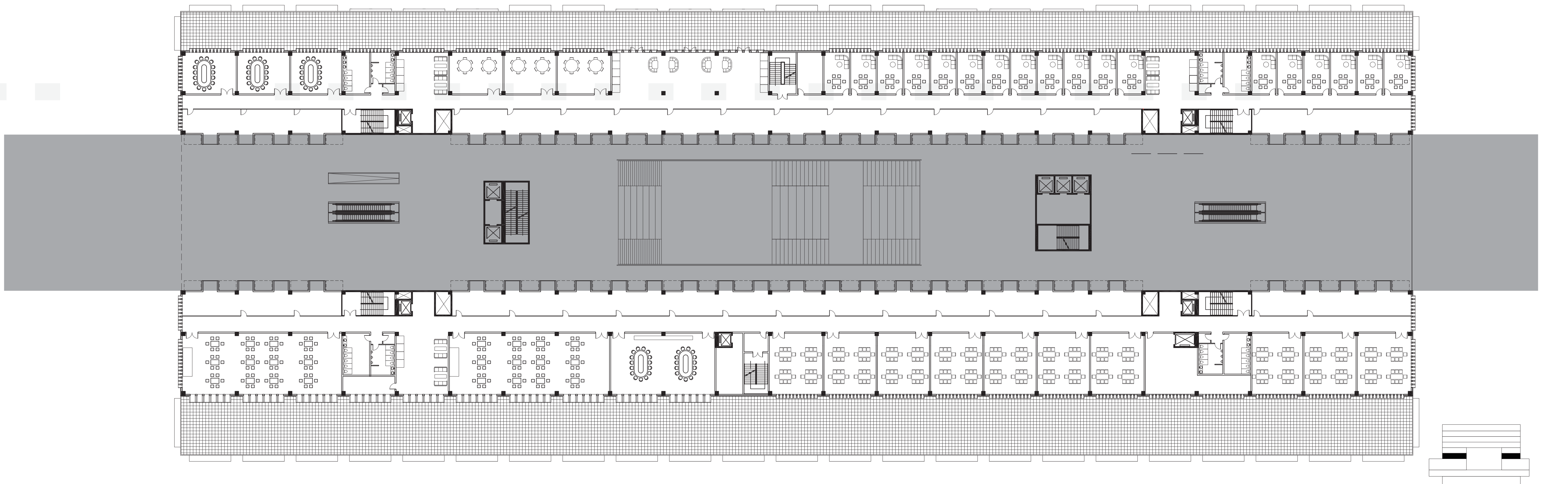

1ST FLOOR PLAN 1:300

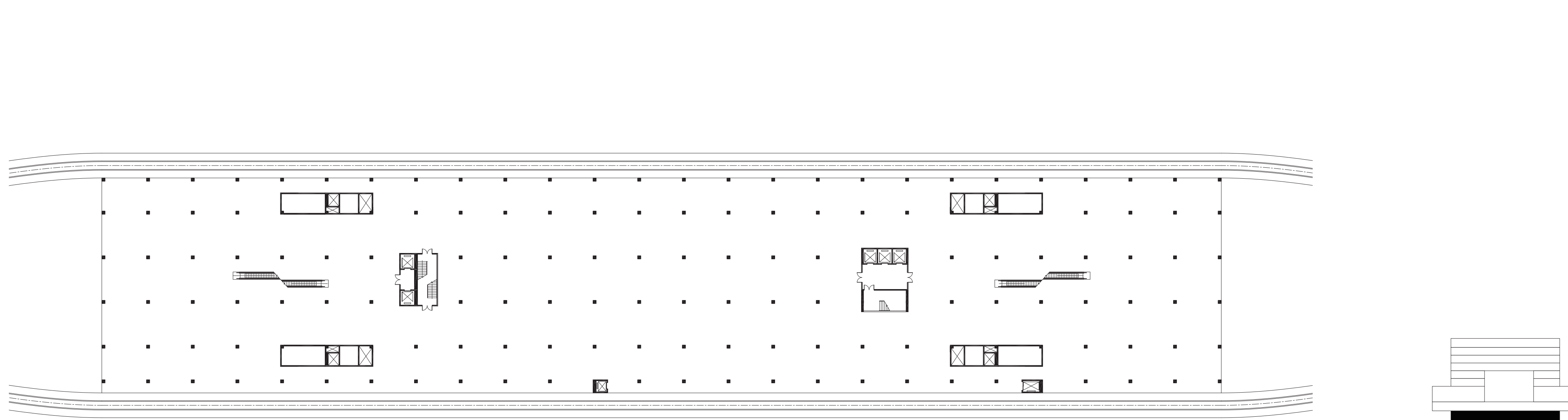

METRO STATION PLAN 1:500

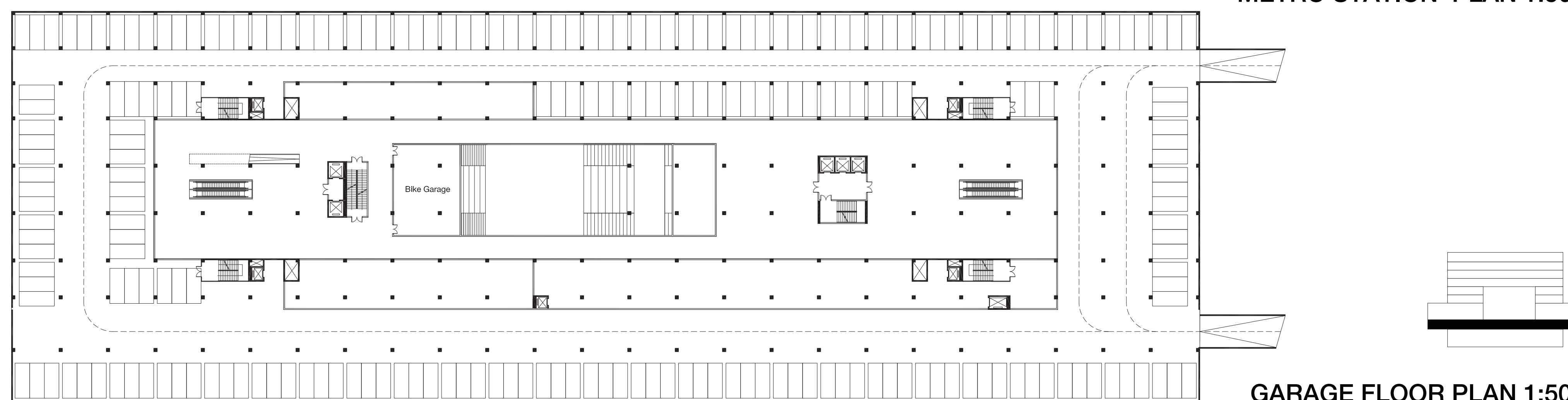

GARAGE FLOOR PLAN 1:500

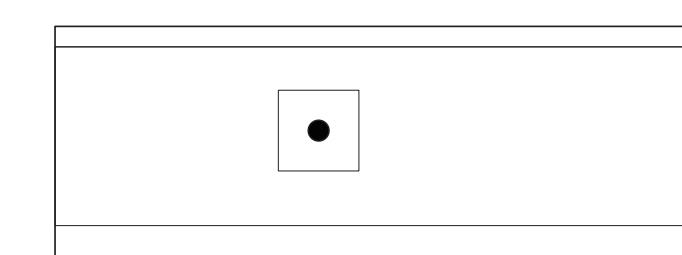

Open concert, lecture



See the open event from above

PLANS

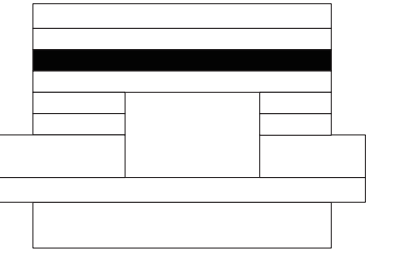
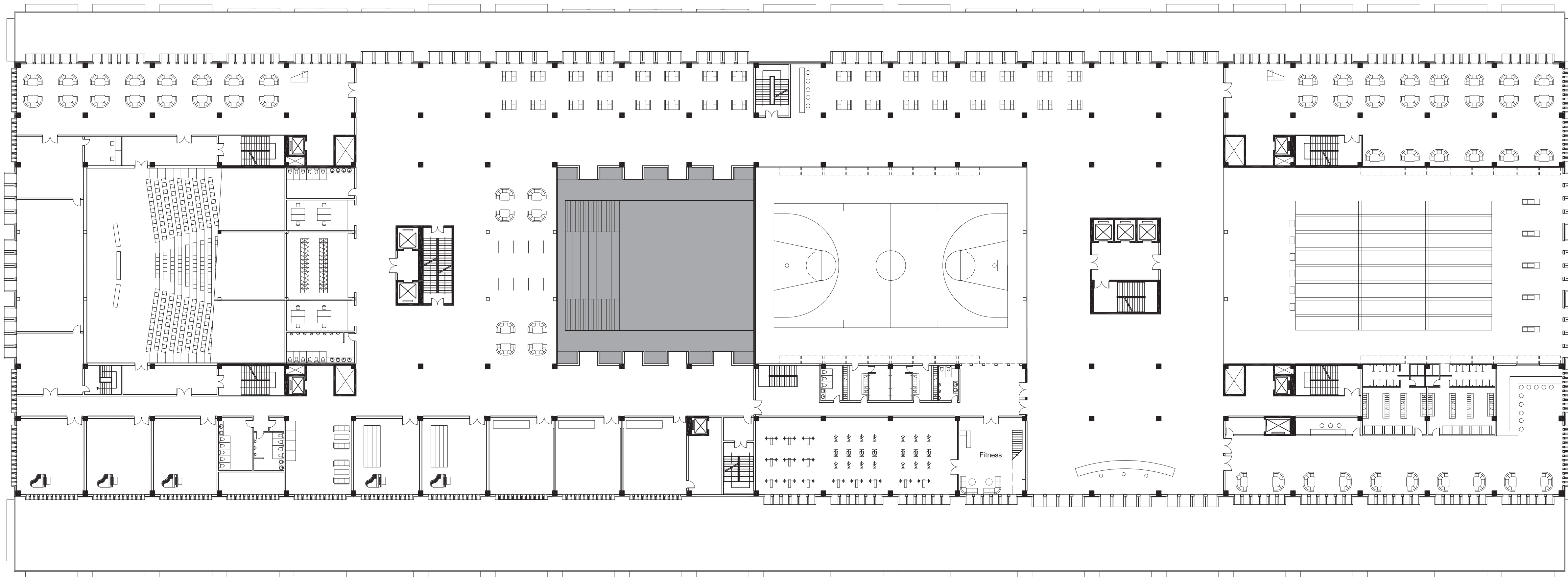

4TH FLOOR PLAN 1:300

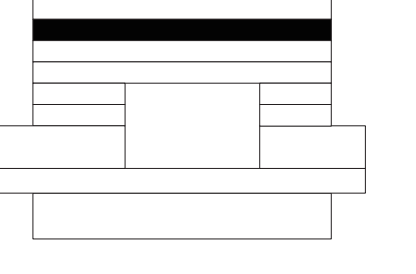
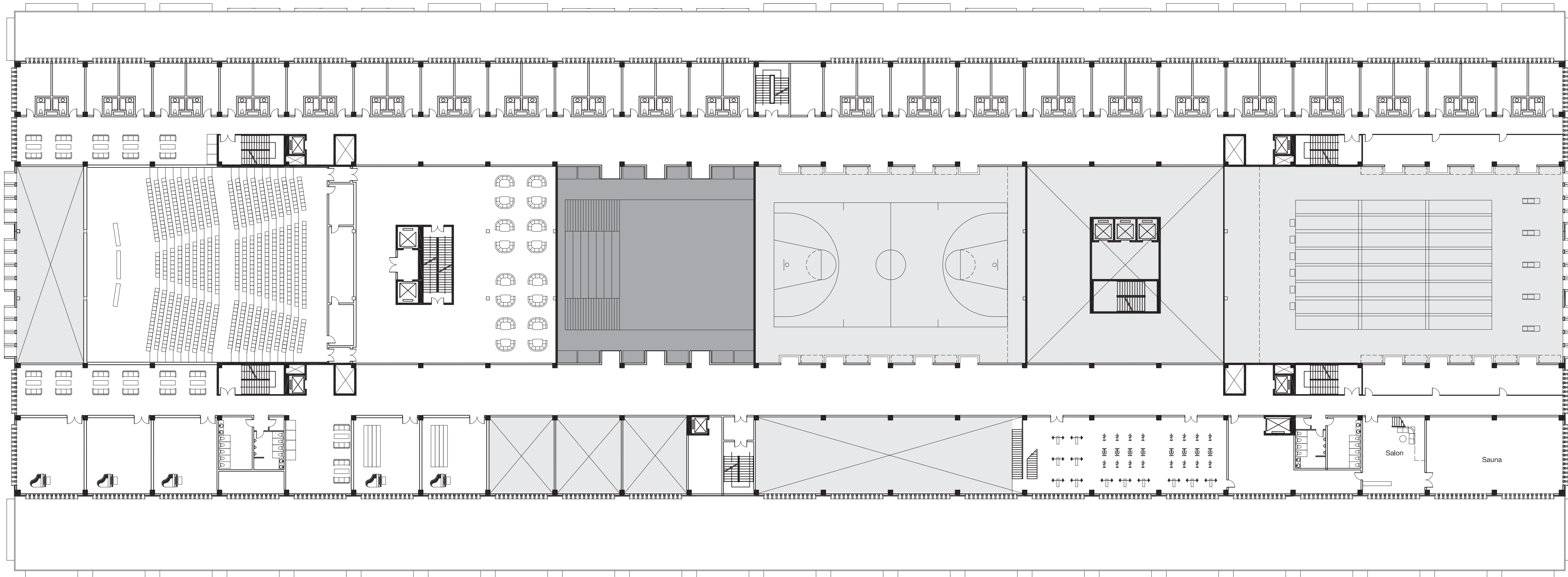

5TH FLOOR PLAN 1:300

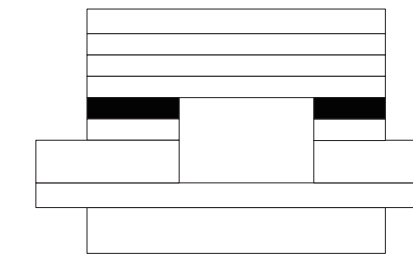
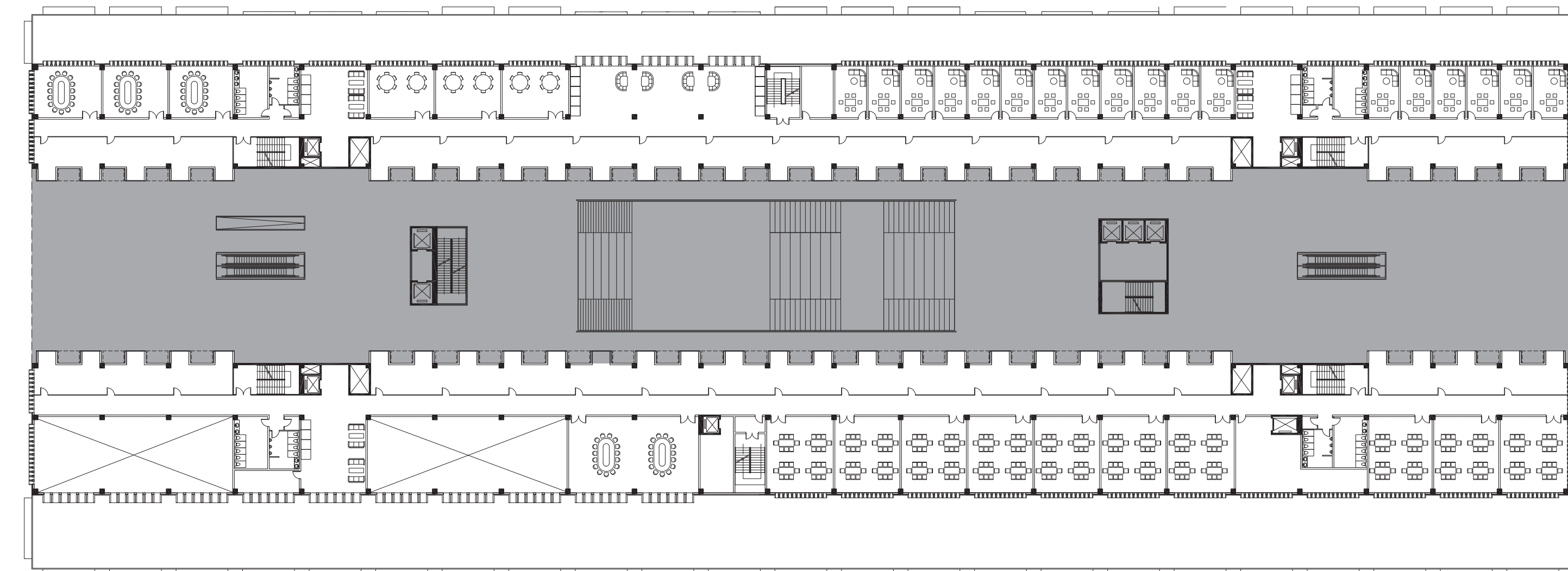

2ND FLOOR PLAN 1:500

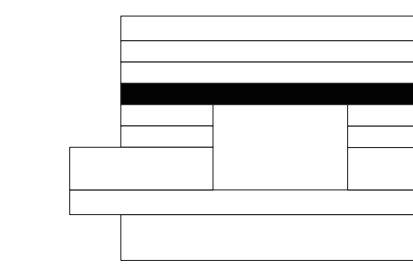
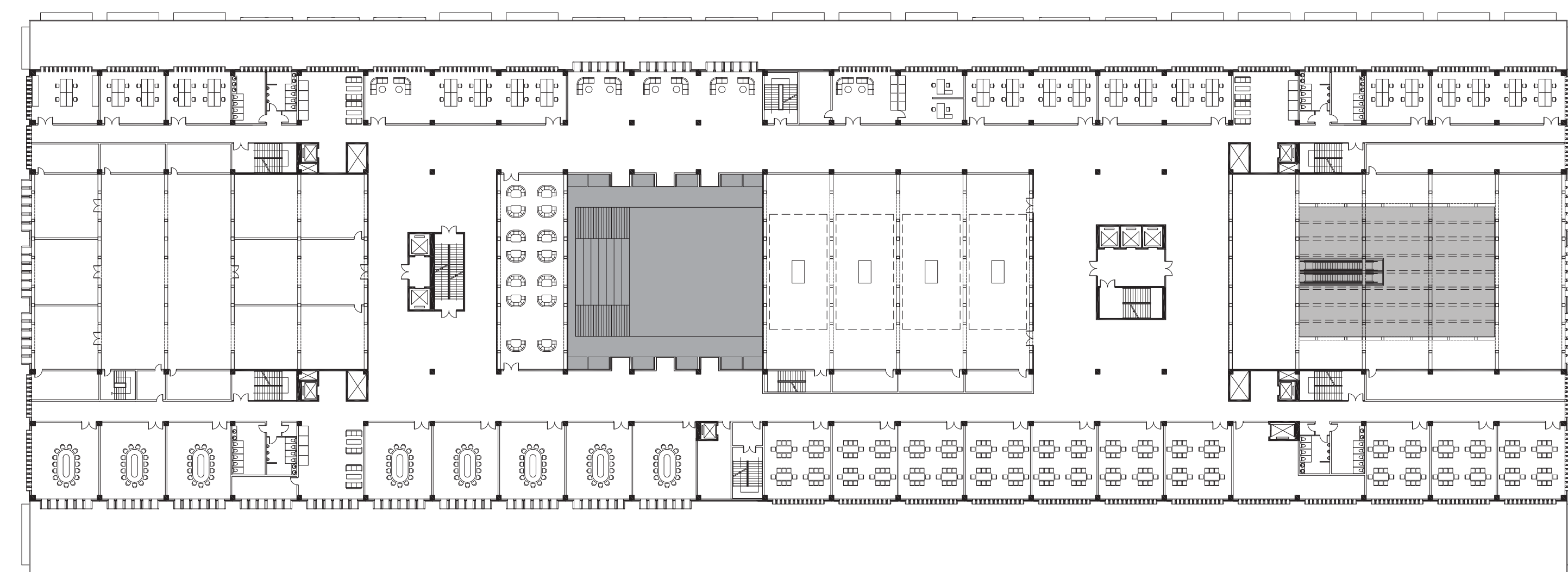

3RD FLOOR PLAN 1:500

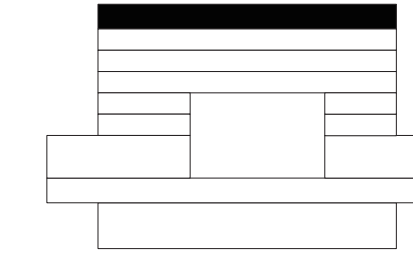
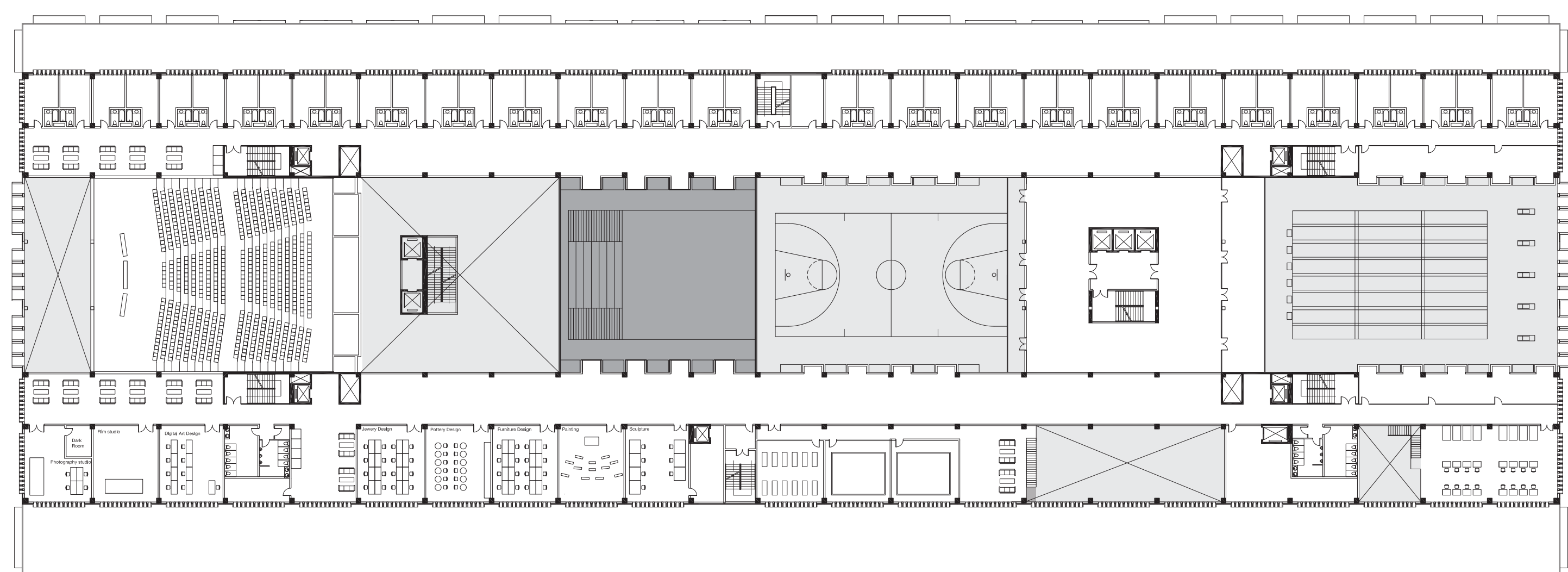

6TH FLOOR PLAN 1:500



Lecture Hall



Basketball Hall



Glass bottom Swimming Pool



People in the open street can see the other people swim above

SECTION

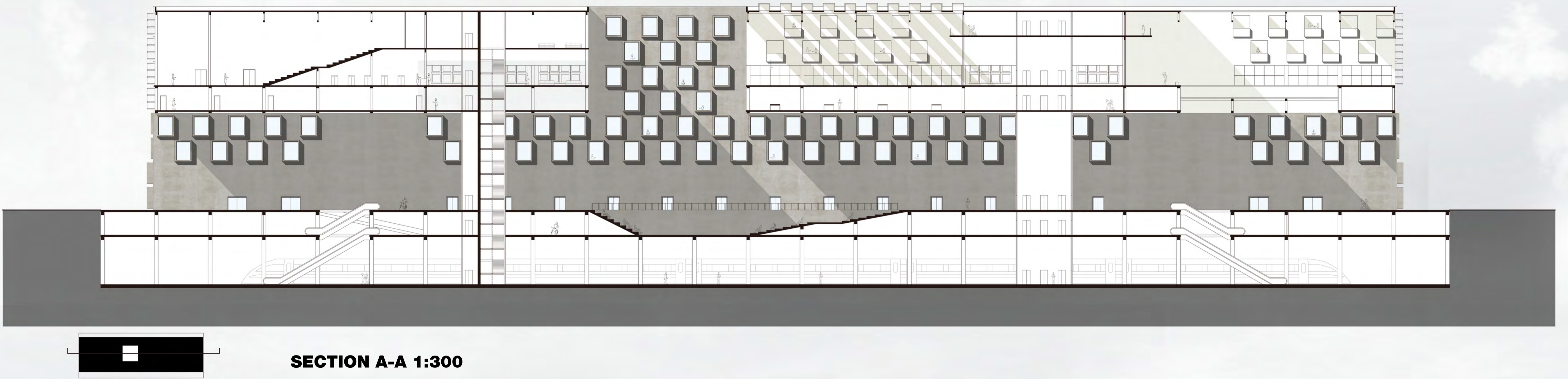
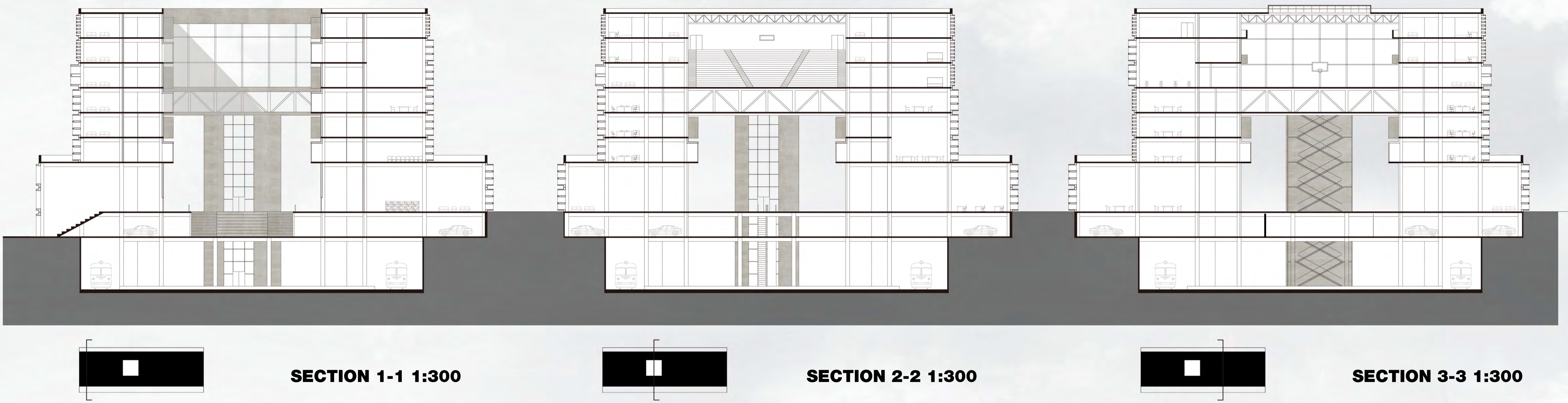

ELEVATION

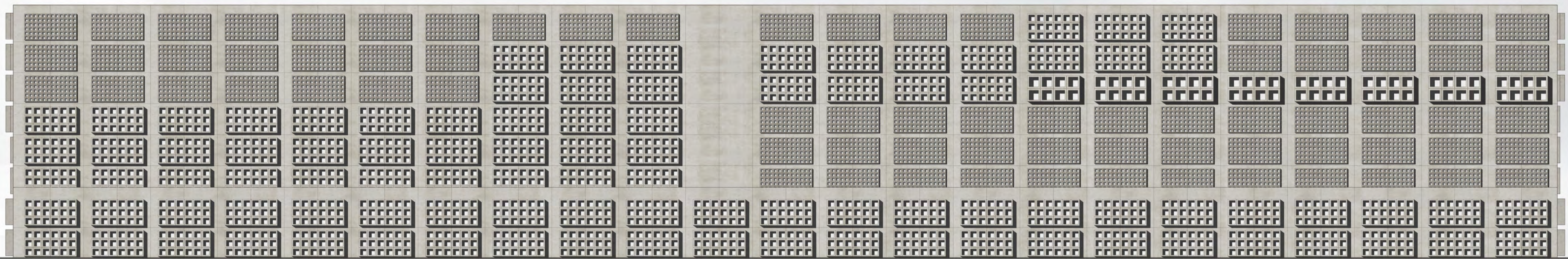

SOUTHEAST ELEVATION 1:300

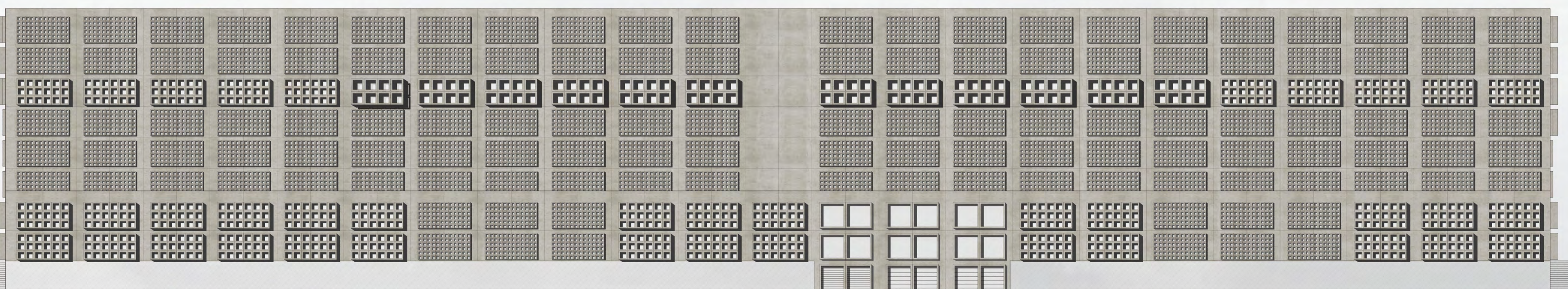

NORTHWEST ELEVATION 1:300



SOUTHWEST ELEVATION 1:300

NORTHEAST ELEVATION 1:300

FRAGMENT AND DETAIL

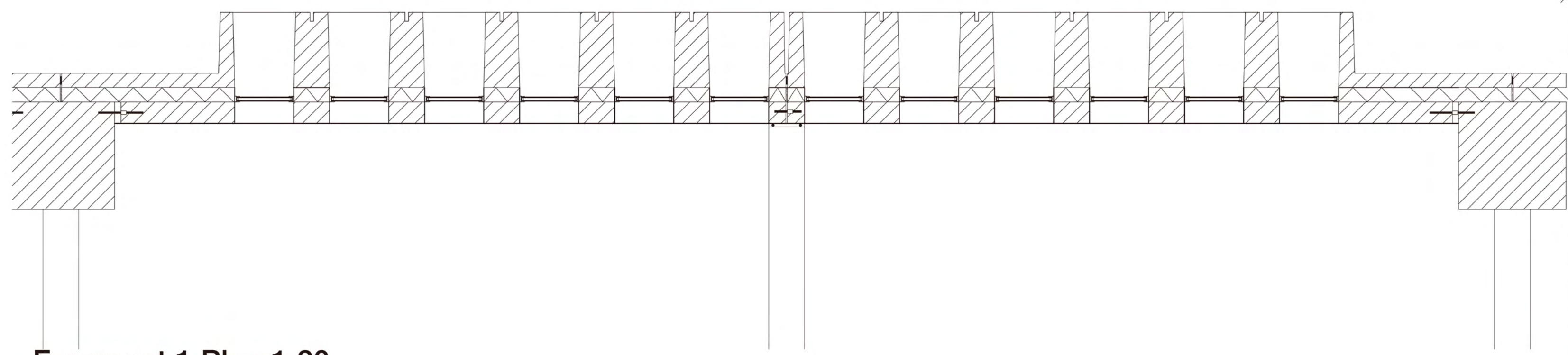

Fragment 1 Plan 1:20

Fragment 1 Elevation 1:20

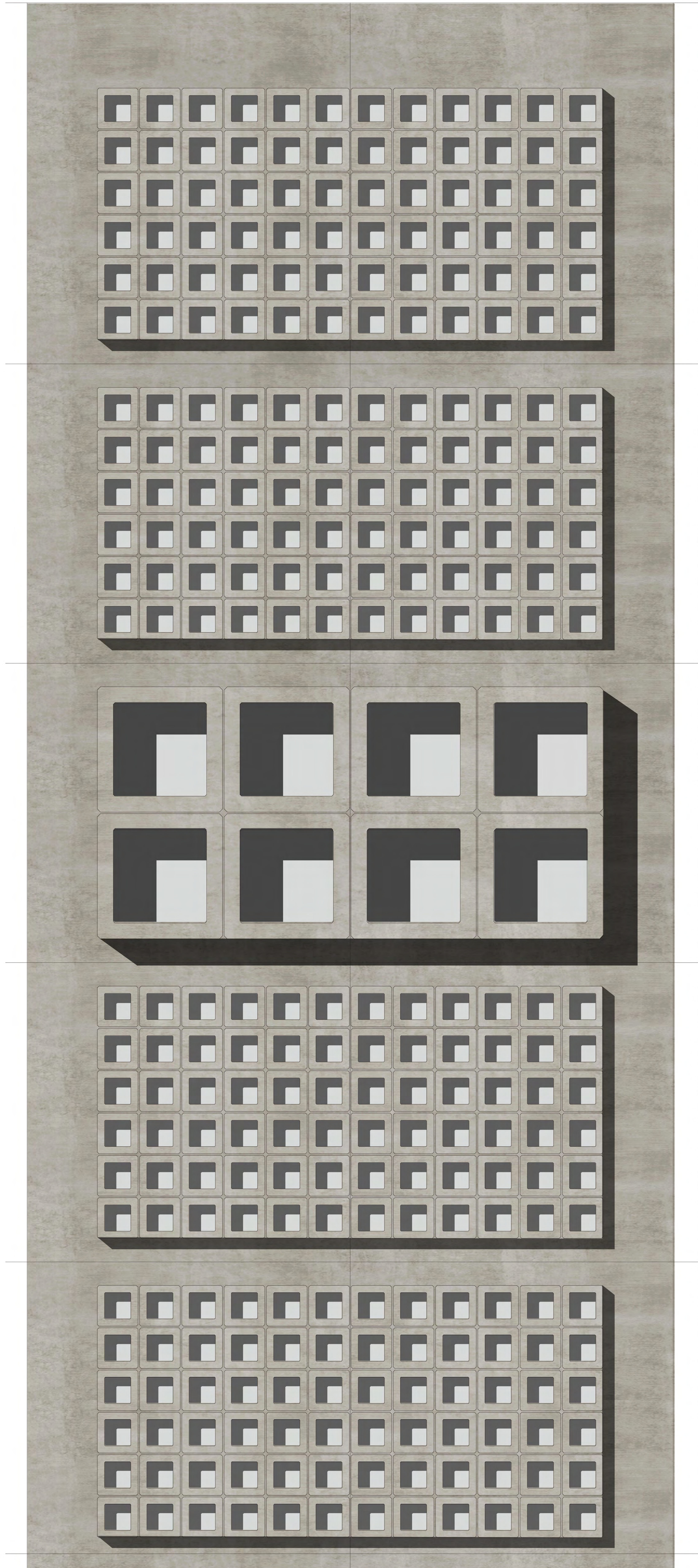

- 1 Prefabricated sandwich facade element
- 2 Insulation
- 3 Inner concrete wall
- 4 Vapor barrier
- 5 Anchor
- 6 Hollow core slab
- 7 Mortar
- 8 Polyurethane foam

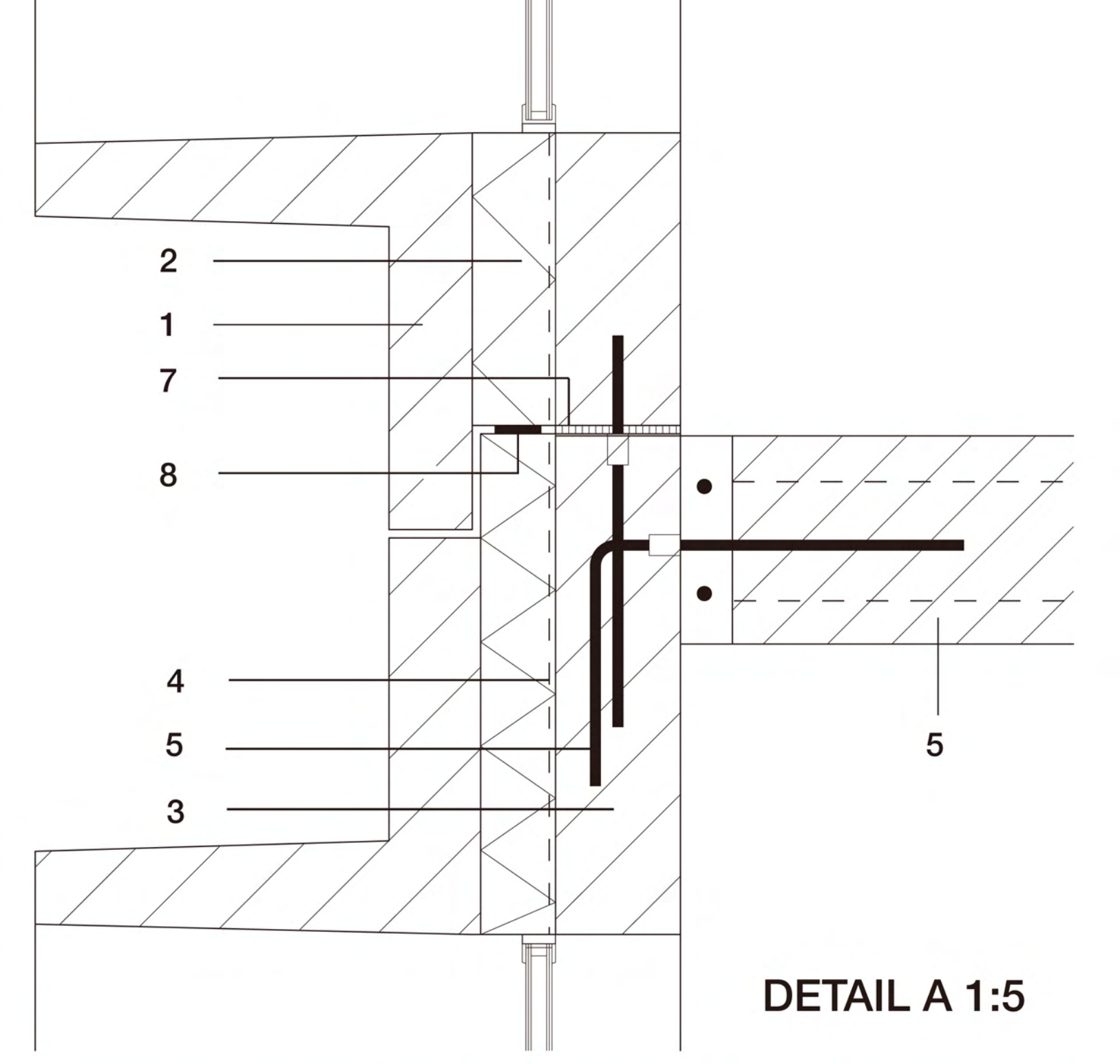

DETAIL A 1:5

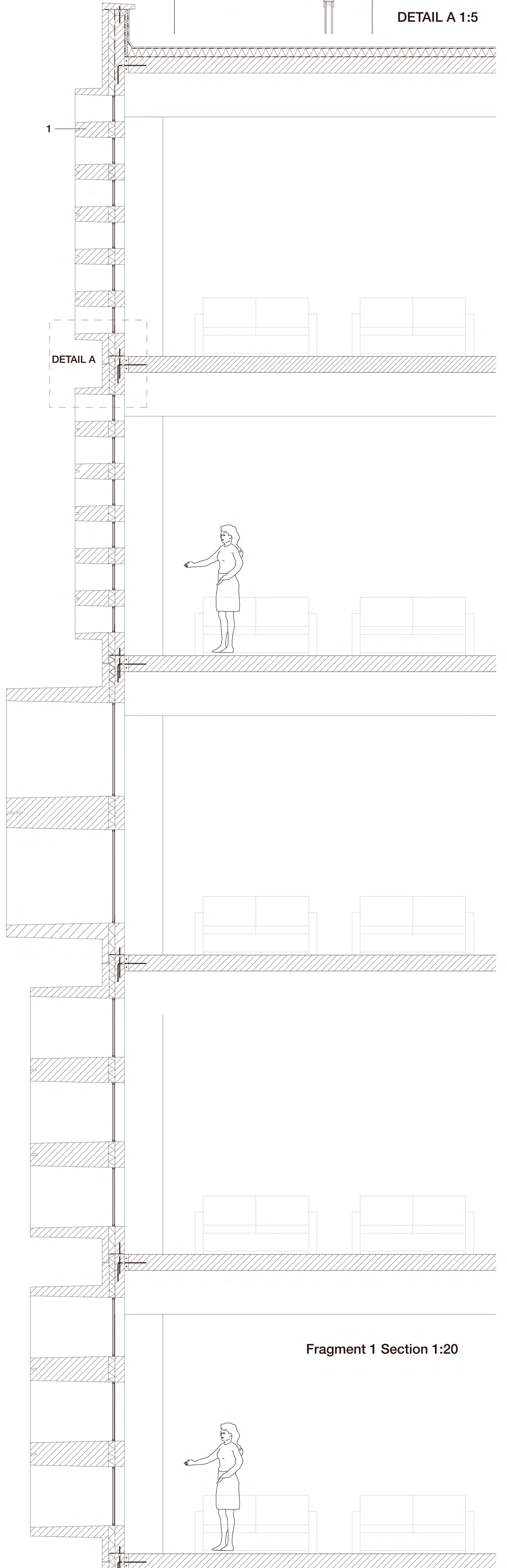

Fragment 1 Section 1:20