

Document Version

Final published version

Licence

CC BY-NC-SA

Citation (APA)

Quist, P., Lansen, A. J., Koedijk, O. C., Verheij, H. J., van Koningsveld, M., & de Vriend, H. J. (2021). Part II - Ch 5 Other terminal types. In M. V. Koningsveld, H. J. Verheij, P. Taneja, & H. J. de Vriend (Eds.), *Ports and Waterways: Navigating a changing world* (pp. 161-191). TU Delft OPEN Publishing.

Important note

To cite this publication, please use the final published version (if applicable). Please check the document version above.

Copyright

In case the licence states "Dutch Copyright Act (Article 25fa)", this publication was made available Green Open Access via the TU Delft Institutional Repository pursuant to Dutch Copyright Act (Article 25fa, the Taverne amendment). This provision does not affect copyright ownership. Unless copyright is transferred by contract or statute, it remains with the copyright holder.

Sharing and reuse

Other than for strictly personal use, it is not permitted to download, forward or distribute the text or part of it, without the consent of the author(s) and/or copyright holder(s), unless the work is under an open content license such as Creative Commons.

Takedown policy

Please contact us and provide details if you believe this document breaches copyrights. We will remove access to the work immediately and investigate your claim.

5 Other terminal types

¹As mentioned in Chapter 3, there are many types of other terminals, apart from container terminals. Each of these has its own specific design requirements and operational procedures. In this chapter we will briefly summarise the most important aspects of a number of these other terminals. The reader is referred to Ligteringen (2017) and the relevant PIANC manuals for more detail.

5.1 Liquid bulk terminals

Liquid bulk refers to cargo that is unpackaged and in liquid form. It can be crude oil, oil products, chemical products, vegetable oil and liquefied gases (LNG, LPG, hydrogen, et cetera). Important discriminating properties for shipping are the density and the temperature and pressure under which the material is transported. These three properties are mutually dependent, following the physical laws of Boyle and Gay-Lussac. Crude oil, which is transported under atmospheric pressure and temperature, has a density of $0.85 \div 0.97 \text{ ton/m}^3$, liquefied gas of $0.4 \div 0.6 \text{ ton/m}^3$, depending on temperature and pressure. Liquid hydrogen has a density of only 0.07 ton/m^3 , but has to be transported at a very low temperature (-253°C). Clearly, these different types of liquid bulk put different demands on vessel designs and port facilities.

5.1.1 Oil terminals

Crude oil is won from onshore or offshore wells. It is transported from these upstream wells to the export terminal, where it is stored and loaded into crude carriers. These carriers transport the crude oil to overseas (downstream) import terminals, where it is stored for onward transport to a refinery (see Figure 5.1).

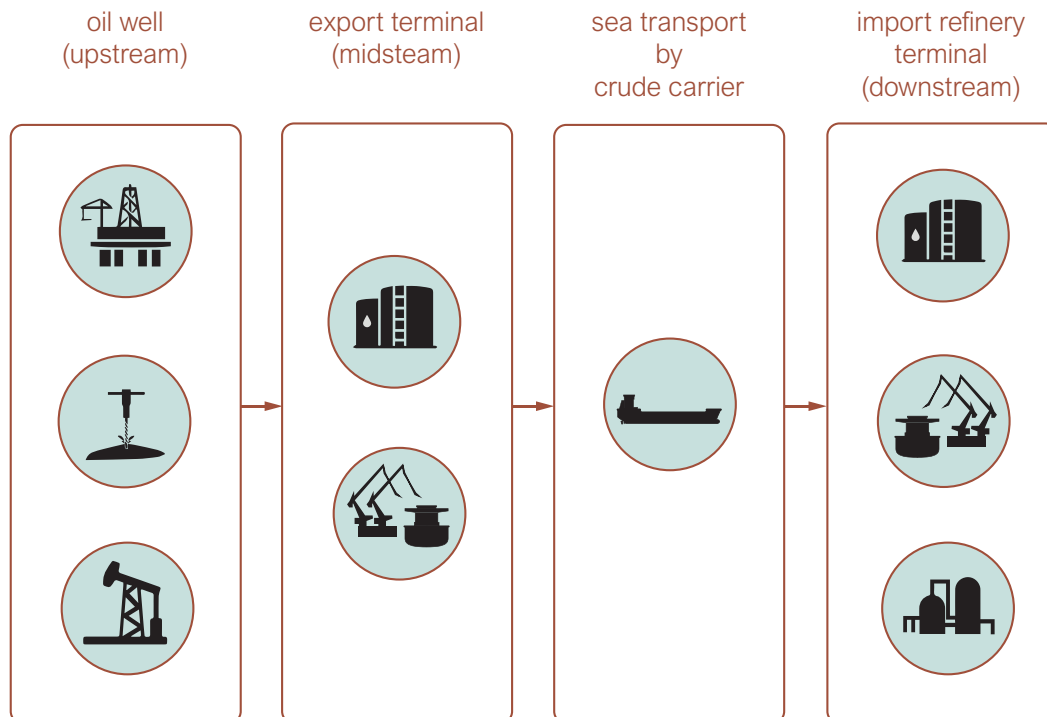

Figure 5.1: Schematic of a crude oil supply chain (by TU Delft – Ports and Waterways is licenced under CC BY-NC-SA 4.0).

¹This chapter made use of lecture slides (Quist, 2019) for the Ports and Waterways course CIE5306 at TU Delft

Refining transforms the crude into a variety of oil products, which are subsequently distributed overseas by seagoing tankers, or to the hinterland through pipelines, or by barge, rail or truck. At the refinery the oil products can also be blended, by adding bio-ethanol, for instance.

Before focusing on the terminals (boxes two and four in [Figure 5.1](#)), we have to know more about the carriers. Like in the case of container vessels, the size of crude oil carriers has increased over the years. [Figure 5.2](#) gives the most important characteristics of typical oil tanker classes.

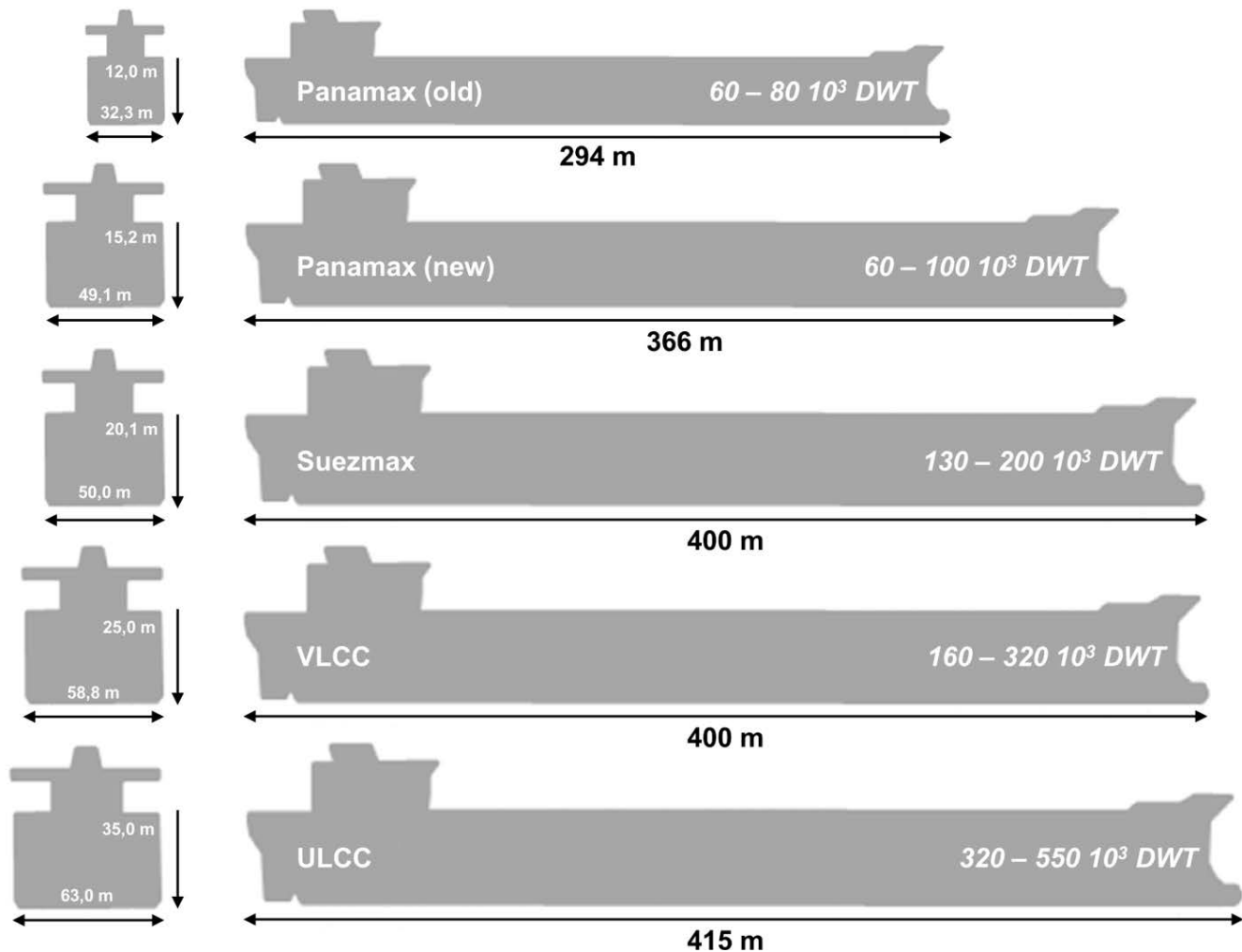

Figure 5.2: Typical oil tanker classes; lengths and widths are to scale, draughts are not (modified from [Maximum ship sizes for the Panama and Suez canals, Strait of Malacca](#) by U.S. EIA; Surveyor (2002); Maritime Connector is licenced under CC0 1.0).

The largest crude carrier ever built, the Seawise Giant with a capacity of 564,763 DWT and a length of more than 458 m (built in 1979), could not reach some major ports when fully loaded, was subsequently reduced to a permanently moored storage tank and has now been scrapped. Present-day ULCCs are not much longer than 400 m.

This illustrates that tanker dimensions are limited by the route taken. Vessels in the New Panamax class, for instance, are the largest that can pass Panama Canal, while the Suezmax class is dimensioned for the Suez Canal.

Liquid bulk cargo, crude oil, is generally loaded and unloaded via a manifold, which is placed midships and consists of a number of pipes, each connected with a different onboard storage tank ([Figure 5.3](#), left). Loading and unloading takes place via one or more loading arms or flexible hoses connected to the manifold ([Figure 5.3](#), right). This arrangement concentrates the points for loading and unloading, such that the equipment does not have to move alongside the ship. Consequently, the jetty or quay does not have to extend over the full length of the ship, a relatively small service platform is sufficient. It should be just large enough for the support of the marine loading arms and auxiliary facilities such as an operator's box, a gangway tower and firefighting equipment.



Figure 5.3: Liquid bulk (un)loading facilities; left: manifold (*Maya OBO carrier 3* by Herv Cozanet is licenced under CC BY-SA 3.0); right: (un)loading arms (*Marine Loading Arm KLEa* by Ljl.kanon is licenced under CC BY-SA 3.0).

This is reflected in the design of the jetty, which only has to connect the service platform with the shore and provide the possibility for the ship to be safely moored. Figure 5.4 outlines a conventional jetty design, with a service platform, breasting dolphins to support the vessel and mooring dolphins to fasten the mooring lines. The shore connection consists of an access bridge and a pipe bridge connecting the loading arms or the hoses with the terminal storage tanks.

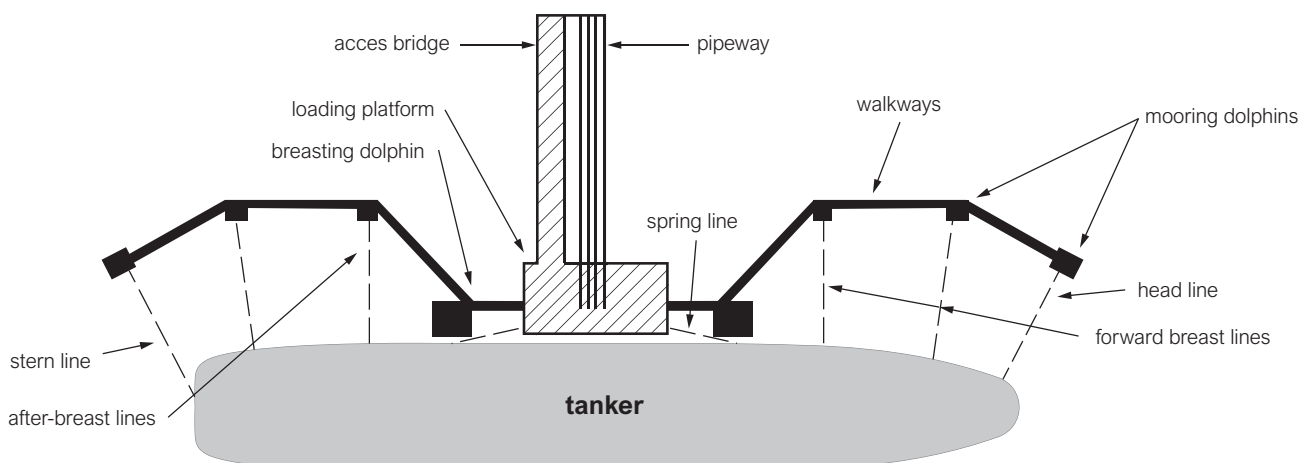

Figure 5.4: Conventional T-jetty design (modified from Thoresen, 2018, image by TU Delft – Ports and Waterways is licenced under CC BY-NC-SA 4.0).

Next to the T-jetty shown in Figure 5.4, other conventional jetty types are the L-jetty (for a single vessel) and the finger jetty (for two vessels, see Figure 5.5, left). These conventional jetties are usually located in sheltered port basins and are characterised by a high loading and unloading capacity.

Another type of loading and unloading facility is buoy mooring, either to a single buoy or to multiple buoys. Buoy mooring can be applied at more exposed locations outside the port complex, as it can operate under higher wave conditions. A tanker attaches its mooring lines to the buoy system and a hose to the offloading buoy (Figure 5.5, right). Via a submerged pipeline the cargo is pumped to the onshore terminal and stored there. The advantage of a buoy system is that it can be located in deep water, such that a deep draught access channel to the port is not necessary. On the other hand, buoy systems generally have a lower capacity, more downtime and higher maintenance costs than a conventional jetty system.

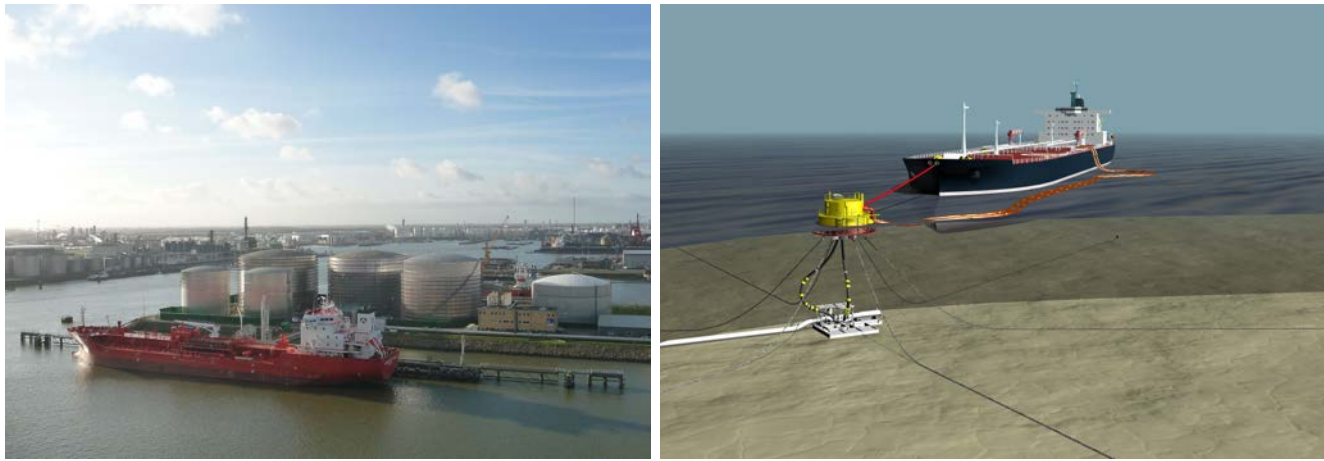

Figure 5.5: Tanker mooring arrangements; left: T-jetty mooring in Botlek, Rotterdam, the Netherlands (by BoH is licenced under CC BY-SA 3.0); right: single point buoy mooring (Functional SPM (Turret Buoy) by BluewaterPR is licenced under CC BY-SA 4.0).

Design objectives for an oil terminal are throughput, storage and safety, under the constraint of a limited waiting time for the vessels waiting to be served. Note, however, that tankers are not always waiting to be served: if the market collapses, like during the 2020 Corona pandemic, ships are just kept waiting for the right moment to put the cargo into the market.

One of the determining parameters in the design is the berth productivity, which can be estimated by:

$$C_b = p \cdot n_h \cdot n_d \cdot m_b \quad (5.1)$$

in which:

C_b	=	berth productivity [ton/year],
p	=	pump capacity [ton/hour],
n_h	=	number of operational hours per day [hours/day],
n_d	=	number of operational days per year [days/year],
m_b	=	berth occupancy [-].

In order to maintain sufficient pressure, shore-based pumps are used for loading, the tanker's pumps for unloading. VLCCs have typical pump capacity of $5,000 \text{ m}^3/\text{hr}$ per pump, but have 3 pumps so in total $10,000 \text{ m}^3/\text{hr} \sim 15,000 \text{ m}^3/\text{hr}$ for the largest vessel. The density of the product and pipeline sizing onshore has impact on the offloading capacity. As a rule of thumb the total tanker pump capacity is about 10% of the tanker's deadweight tonnage per hour. Normally, the maximum acceptable service time is 1 to 1.5 day, depending on the size. As a rule of thumb, the acceptable berth occupancy lies between 40% for a single berth and 80% for four berths. This may suffice as a first estimate in the early design phase, but later phases require more accurate calculations. A more detailed assessment of the required number of berths, unloading equipment and storage tanks can be made by following the steps described in Section 3.3.3 (see Section 4.4 for their application to a container terminal).

Safety is a special point of attention when designing liquid bulk terminals. In the case of oil, spills and fires are particular hazards. Apart from double-hull vessels, safety equipment and an operational safety regime, safety is also realised by applying safe distances between loading platforms, between berths and from navigation channels. In the storage area special precautions need to be taken, like sufficient distance between storage tanks, and a containment basin in case a tank starts leaking (required basin volume at least 1.1 times the volume of the largest tank). Figure 5.6 shows an aerial picture of containment bunds around oil storage tanks at the Maasvlakte Oil Terminal in the Port of Rotterdam.

Safe mooring is another point of attention in the terminal design. To that end, the Oil Companies International Forum developed the 'Mooring Equipment Guidelines' (OCIMF, 2018). Following these guidelines one can design



Figure 5.6: Containment bunds around oil storage tanks at the Maasvlakte Oil Terminal in the Port of Rotterdam (from www.vopak.com, *Maasvlakte Olie Terminal (Rotterdam)* by Vopak. Copyrights 2021 Royal Vopak.).

a safe and optimum mooring arrangement (Figure 5.7). The mooring lines are attached to bollards or quick release hooks (Figure 5.8, left) that are installed on top of the mooring and breasting dolphins. In this arrangement the spring lines are attached to mooring points on the deck of the loading platform. Breasting points are located within $0.25 \div 0.40 L_{OA}$ around the midship axis, in order to make sure that the breasting points are in the parallel body of the tanker. The breasting points can be integrated with the platform, but are often realised by separate breasting dolphins, so that in the event of overloading the platform with the expensive equipment on top of it remains undamaged.

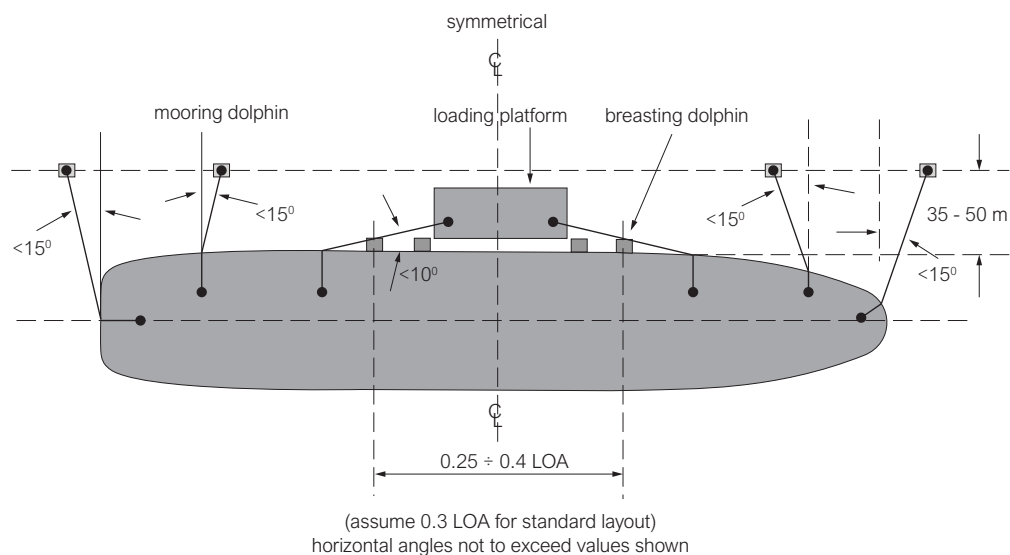

Figure 5.7: Optimal mooring arrangement for a liquid bulk carrier (reworked from OCIMF, 2018, by TU Delft – Ports and Waterways is licenced under CC BY-NC-SA 4.0).

Apart from the mooring arrangement, fendering also contributes to safe berthing. An adequate fender plan is therefore a prerequisite for liquid bulk jetties. Installed on the breasting dolphins (Figure 5.8, left), the fenders support the tanker and absorb berthing energy by deformation. Normally jetties accommodate a range of tankers, so additional fender points may be required.

For further reading see also:

- PIANC (2012a) – PIANC Report N°116 “Safety Aspects Affecting the Berthing Operations of Tankers to Oil and Gas Terminals”
- PIANC (2016d) – PIANC Report N°153 “Recommendations for the design and assessment of marine Marine Oil and Petrochemical terminals”
- Ligteringen (2017) – “Ports and Terminals”, Chapter 10
- OCIMF (2018) – “Mooring Equipment Guidelines (MEG4)”



Figure 5.8: Mooring equipment; left: quick release hook; right: breasting point fender (source: Trelleborg catalogue safe berthing and mooring, 2008).

5.1.2 Gas terminals

The LNG supply chain has a certain similarity with the crude oil supply chain (Figure 5.9). Before being cost-effectively transportable the gas needs to be liquefied, which reduces its volume by a factor 600. This is done at a liquefaction plant, where the gas is liquefied by refrigeration and/or pressure. Under atmospheric pressure natural gas can only be liquefied by cooling it to a temperature around -163°C . The liquefaction plant and storage tanks are normally located at a marine export terminal where LNG tankers can berth and be loaded. The tankers transport the LNG to the overseas import terminal, where the cargo is unloaded and stored in LNG storage tanks. At the import terminal a re-gasification plant vaporises the LNG by heating it, for instance with warm water from a nearby power plant. After re-gasification the gas is added to the distribution system, often a pipeline system. Some LNG import terminals also have hinterland connections by truck, railway or IWT.

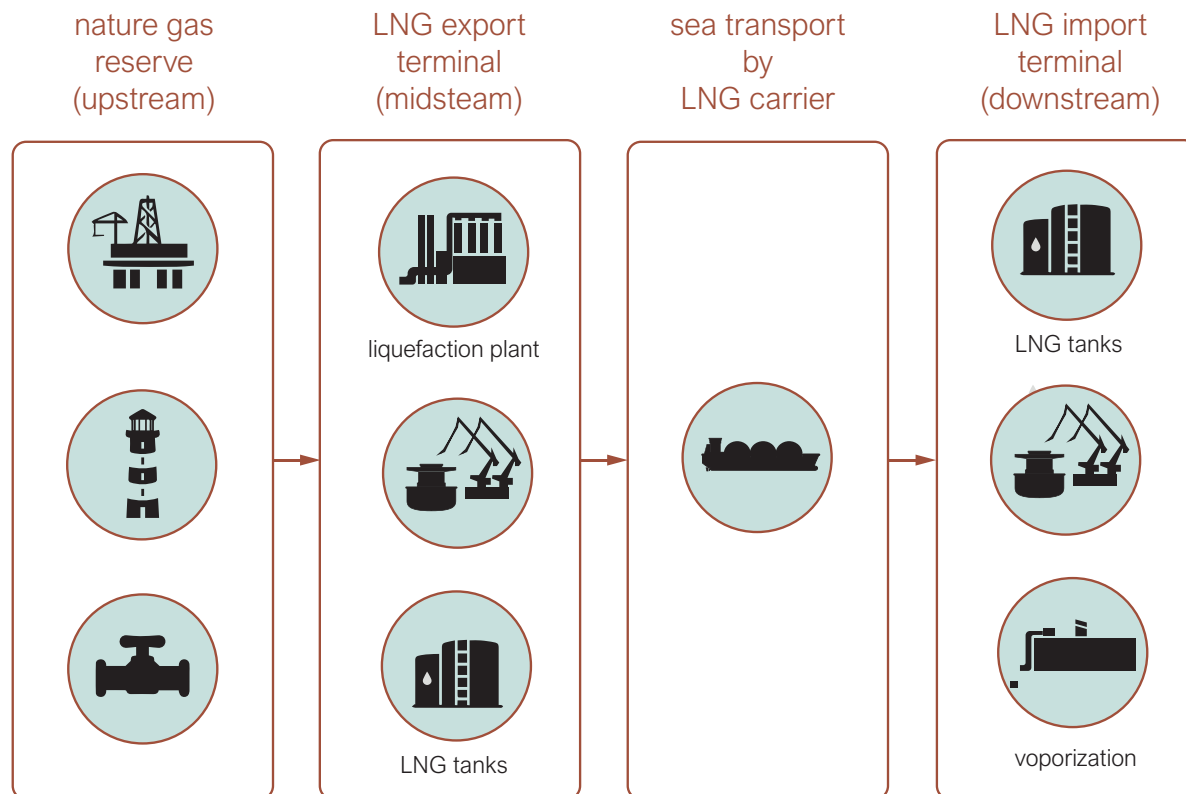

Figure 5.9: Schematic of the LNG supply chain (by TU Delft – Ports and Waterways is licenced under CC BY-NC-SA 4.0).

Because of the lower density, LNG and LPG carriers have a smaller range of DWT and a higher freeboard, so more windage than crude carriers. Table 5.1 from Puertos del Estado (2007) gives an overview of their dimensions.

DWT (t)	Δ_m (t)	L_{oa} (m)	L_{pp} (m)	B (m)	T (m)	C_B (t)	Min. Lateral Windage: Fully Loaded (m ²)	Max. Lateral Windage: In Ballast (m ²)	Approx. Capacity (m ³)
LNG Carriers (Prismatic)									
125,000	175,000	345.0	333.0	55.0	12.0	0.78	8,400	9,300	267,000
97,000	141,000	315.0	303.0	50.0	12.0	0.76	7,000	7,700	218,000
90,000	120,000	298.0	285.0	46.0	11.8	0.76	6,200	6,800	177,000
80,000	100,000	280.0	268.8	43.4	11.4	0.73	6,000	6,500	140,000
52,000	58,000	247.3	231.0	34.8	9.5	0.74	4,150	4,600	75,000
27,000	40,000	207.8	196.0	29.3	9.2	0.74	2,900	3,300	40,000
LNG Carriers (Spheres, Moss)									
75,000	117,000	288.0	274.0	49.0	11.5	0.74	8,300	8,800	145,000
58,000	99,000	274.0	262.0	42.0	11.3	0.78	7,550	8,000	125,000
51,000	71,000	249.5	237.0	40.0	10.6	0.69	5,650	6,000	90,000
LPG Carriers									
60,000	95,000	265.0	245.0	42.2	13.5	0.66	5,600	6,200	
50,000	80,000	248.0	238.0	39.0	12.9	0.65	5,250	5,800	
40,000	65,000	240.0	230.0	35.2	12.3	0.64	4,600	5,100	
30,000	49,000	226.0	216.0	32.4	11.2	0.61	4,150	4,600	
20,000	33,000	207.0	197.0	26.8	10.6	0.58	3,500	3,900	
10,000	17,000	160.0	152.0	21.1	9.3	0.56	2,150	2,500	
5,000	8,800	134.0	126.0	16.0	8.1	0.53	1,500	1,700	
3,000	5,500	116.0	110.0	13.3	7.0	0.52	1,050	1,200	

Note: Dimensions given in the tables may vary up to $\pm 10\%$ depending on construction and country of origin.

Table 5.1: Typical dimensions of LNG and LPG tankers (from: Puertos del Estado, 2007).

The terminal concepts are similar to those of oil terminals: jetties or offshore buoy systems. Storage can be in special cryogenic tanks onshore, but also in in so-called Floating LNG Storage and Re-gasification Units (FSRUs), permanently moored vessels where tankers come alongside for unloading liquefied or loading re-gasified LNG (Figure 5.10).



Figure 5.10: Offshore moored FSRU with an LNG-tanker alongside, West Java, Indonesia (Offshore LNG import terminal mooring in Indonesia by Royal HaskoningDHV is licenced under CC BY-NC-SA 4.0).

LNG and LPG terminals come with a risk of gas explosions. Ligteringen (2017) refers to a TNO study of the effects of a main LPG tank failure: “If a 28,000 m³ tank of an LPG carrier is ruptured and ignites, a column of fire will develop with a diameter of 600 m and a height of 550 m for a duration of 6 min; first-degree burns will be sustained up to a distance of 2200 m. With delayed ignition, an explosion may occur (with LPG, but not with LNG) which, under unfavorable weather conditions, leads to a loss of 10% of the living quarters at a distance as far away as 7 to 11 km.”. Clearly, prevention by adequate precautionary measures is the only way to deal with this kind of extreme events.

Therefore, these types of terminals are often located at a place where the associated risk is acceptable. This requires a detailed study by safety experts, which usually leads to a map of risk contours (also see Part I – Section 2.2.5).

Example box 5.1 describes the safety zones for a gas terminal.

Example box 5.1: Exclusion zones around a gas terminal

Non-Ignition Zone (NIZ) – area where non-essential people and vessel movements are not allowed, use of Personal Protective Equipment (PPE) is obligatory and ignition sources must be avoided or strictly controlled. The NIZ may be determined by national regulations and/or as part of a Quantitative Risk Assessment (QRA). A wide range of radii for Safety and Security Zones (SSZs) is found in literature, as a result of different company or national regulations.

Safety and Security Zone (SSZ) – area where only authorized vessels are allowed, specifically on business associated with the terminal, to avoid unnecessary risk in case of incidents at the terminal. The final SSZ size shall be determined with Hazard and Operability (HAZOP) and QRA during further terminal development.

Marine Zone (MZ) – this is the exclusion zone around the terminal where in principle no other ships should sail, with exception of vessels serving the terminal. If this is not possible, due to site limitations, this is the area where all passing vessels need to be closely monitored. The marine (exclusion) zone is established to minimise collision risks from sailing ships that need to pass the terminal. The final radius of the MZ will be determined with local Maritime Authorities, depending on the size of the vessels transiting and the speed allowed at the limit of the MZ.

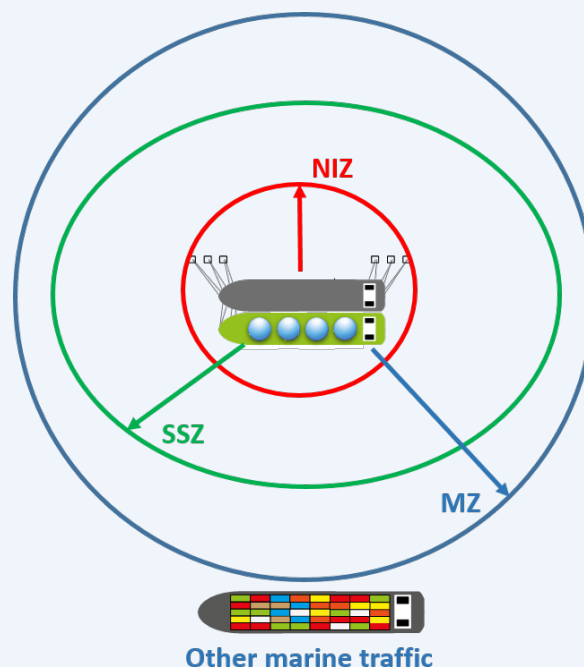

Figure 1. Safety zones for a gas terminal (by TU Delft – Ports and Waterways is licenced under CC BY-NC-SA 4.0).

For further reading see also:

- [SIGTTO \(1997\)](#) – “Site Selection and Design for LNG Ports and Jetties”
- [PIANC \(2012a\)](#) – PIANC Report N°116 “Safety Aspects Affecting the Berthing Operations of Tankers to Oil and Gas Terminals”
- [PIANC \(2016b\)](#) – PIANC Report N°153 “Recommendations for the design and assessment of marine Marine Oil and Petrochemical terminals”

Liquid chemicals are transported under various conditions of temperature and pressure, depending on the type. [Figure 5.11](#) gives a summary for a number of often transported chemicals. In this figure the critical temperature is the temperature above which the material cannot be liquefied, no matter what pressure is applied. The diagram shows that ammonia, propane and butane can be transported at atmospheric temperature (Type 1 and Type 2 vessels), whereas methane, for instance, requires deep cooling, but can be transported under atmospheric pressure.

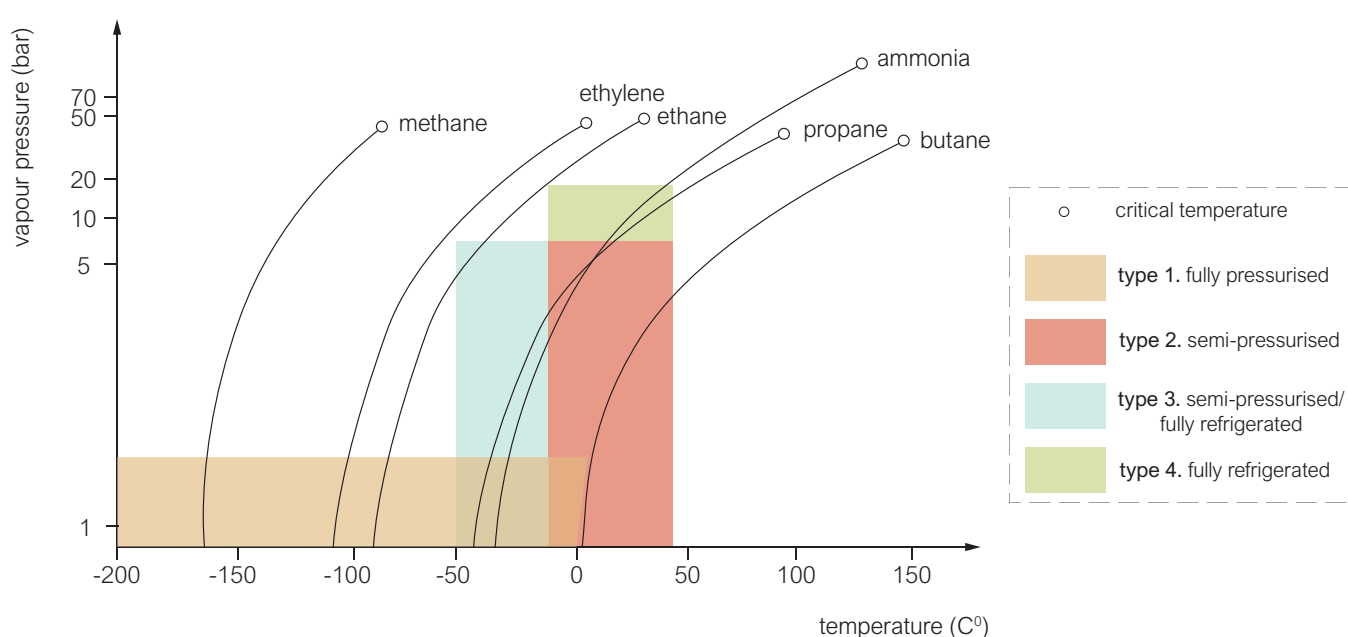

Figure 5.11: Transport conditions for different chemicals (reworked from [Ligteringen, 2017](#), by TU Delft – Ports and Waterways is licenced under CC BY-NC-SA 4.0).

The typology shown in [Figure 5.11](#) is linked to the risk involved in the chemicals they transport:

- *Type 1* – for products with very serious environmental and safety hazards, requiring maximum preventive measures against leakage of cargo.
- *Type 2* – for products with appreciably severe environmental and safety hazards, requiring significant preventive measures against an escape of cargo.
- *Type 3* – for products with sufficiently severe environmental and safety hazards to require a moderate degree of containment, to increase survival capability in a damaged condition.

Most tankers are of Type 2 and 3, as highly hazardous chemicals are usually transported in small quantities.

5.1.3 Liquid chemicals terminal

Compared to the oil and the gas supply chains the liquid chemicals supply chain includes some additional elements, such as the production of the chemicals and the cleaning of the tanks after unloading ([Figure 5.12](#)). Tank degassing and cleaning is extremely important, because chemical gasses may involve health risks and the next cargo may consist of different chemicals.

The size of oceangoing chemical tankers ranges from 5,000 DWT to 35,000 DWT. They are smaller than other tankers, due to the nature of their cargo and the size restrictions imposed by the port terminals. They usually have

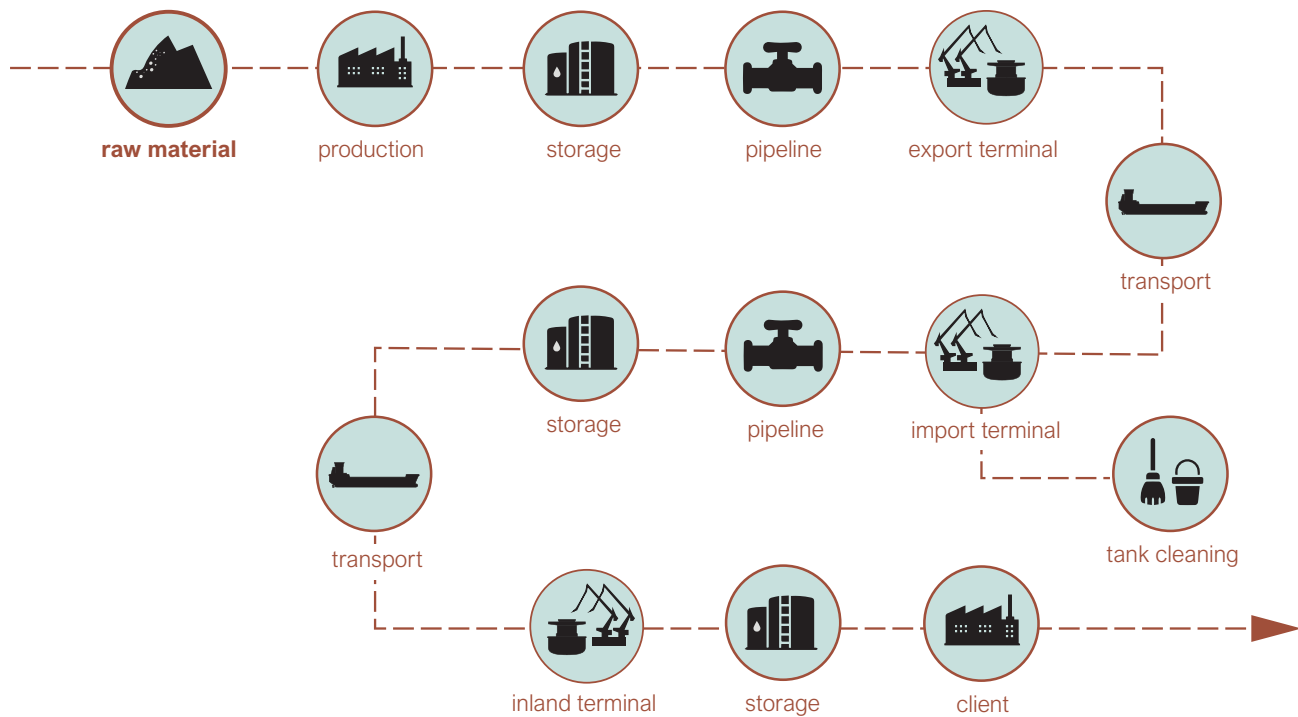

Figure 5.12: Schematic of the liquid chemicals supply chain (by TU Delft – Ports and Waterways is licenced under CC BY-NC-SA 4.0).

several fully separated tanks, each with its own loading and unloading pipelines. Thus they can transport different types of chemicals during the same voyage and deliver different chemicals at different ports during a roundtrip. Like in the case of container vessels on a roundtrip, this requires careful planning of port services.

Because of the emphasis on cleaning after unloading, the inside of the tanks on board of liquid gas carriers is kept as smooth as possible, in order to make them easier to clean with onboard tank cleaning machines. As a consequence, transverse stiffeners on deck must provide the vessel with sufficient stiffness (Figure 5.13). Before being cleaned, the tanks must be degassed and ventilated, in order to be made free of explosive gases. In order to prevent explosions, filled as well as empty chemical cargo tanks are normally protected by a blanket of inert gas, often nitrogen.



Figure 5.13: Chemical tanker at sea; note the transverse stiffeners on deck (GULF OF ADEN (Dec. 13, 2007) by U.S. Navy photo by Cmdr. M. Junge is licenced under CC0 1.0).

The nature of liquid chemical cargo also puts special demands on the terminal equipment. The jetty needs additional pipelines for vapour return and scrubber systems for tanker cleaning. Hazardous gases need to be stored and treated. Storage tanks have to be double-walled, often with a concrete outer wall. As accidents may lead to dangerous gas clouds, exclusion zones have to be defined on the basis of a risk analysis. Blending may be needed before further transport to the hinterland. Some ports also offer laboratory services, in order to determine key specifications of the products handled (e.g. composition, purity, specific density, viscosity, pH).

For further reading see also:

- [Ligteringen \(2017\)](#) – “Ports and Terminals”

5.1.4 Hydrogen terminals

Hydrogen is expected to become an important carrier of clean and renewable energy and port authorities are already considering what role they wish to play in the hydrogen supply chain ([Figure 5.14](#)).

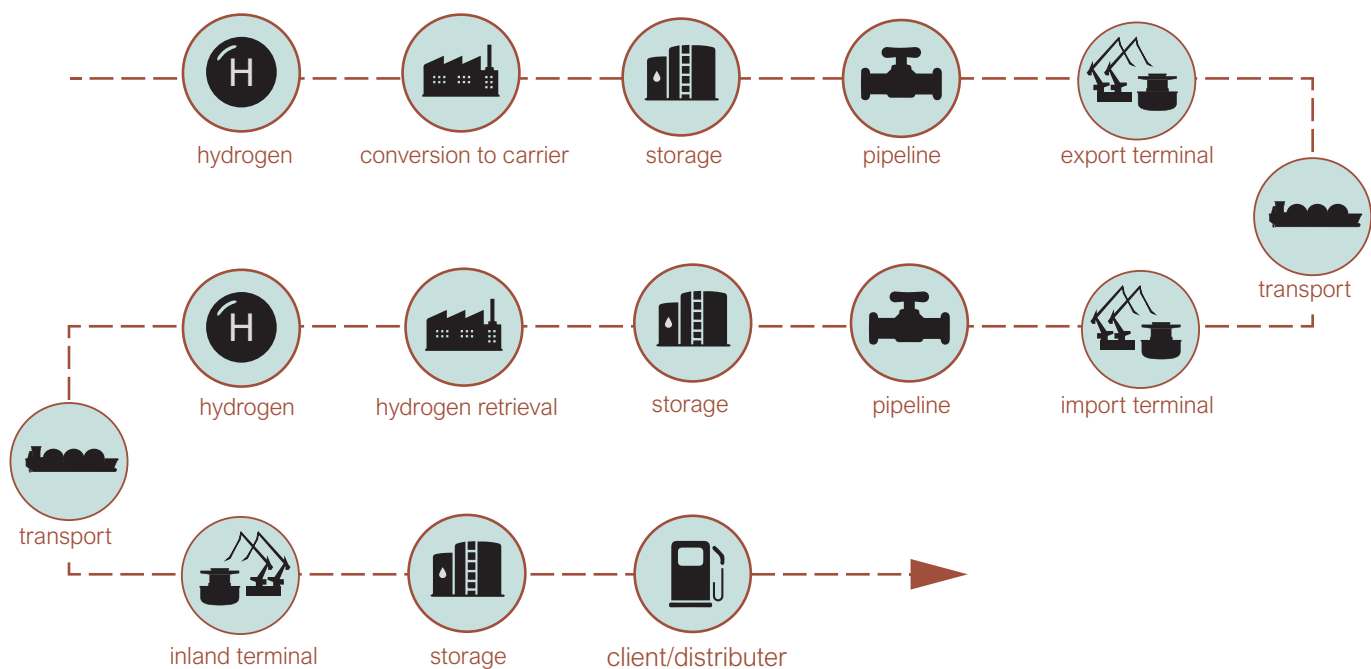

Figure 5.14: Schematic of a hydrogen supply chain (modified from [Lanphen, 2019](#), by TU Delft – Ports and Waterways is licenced under CC BY-NC-SA 4.0).

The hydrogen supply chain is somewhat more complex than the one of crude oil or liquefied gas. Hydrogen can be produced from different sources, among which fossil fuels and natural gas, but also from water (via electrolysis). At the moment, production from natural gas is the most cost-effective. This may change if the by-product CO_2 has to be captured and stored, or if CO_2 prices are raised.

Hydrogen can be stored and transported in different forms, called carriers (gaseous, liquefied, or chemically bound). Depending on the carrier and the location, long-distance transport can take place by ship or by pipeline. Because of the low density and the low boiling point under atmospheric conditions, gaseous hydrogen has to be stored and transported under high pressure. Liquefied hydrogen is stored and transported at a temperature of -253°C , but even then the density is relatively low (0.07 ton/m^3). Chemically bound hydrogen, e.g. in the form of ammonia (NH_3) or methylcyclohexane (MCH), can be stored and transported under less extreme conditions, but involves efficiency losses due to the chemical binding and retrieval processes.

The development of hydrogen supply chains is still in its infancy and common practice still has to settle. [Figure 5.14](#) shows that many actors have to agree about the choices to be made. Although there may be power differences, none of these actors can decide on its own, they are all interdependent. For the port authorities of the exporting and the importing port, for instance, it makes a lot of difference in which form the hydrogen is transported. This determines important choices for the processing plant, for the terminal type (liquid or dry bulk), for the safety

zones and for the facilities and the storage capacity at the terminal. They cannot independently optimise, however, on these investments and their timing: the plans and interests of the other parties involved have to be taken into account. This requires not only a good overview of what, where, when, who and how in the supply chain, but also a certain degree of coordination and collaboration.

The same goes for the vessels. Since the first hydrogen vessel has just been built (Figure 5.15), there are no vessel standards or classifications. This makes it difficult to design terminal facilities. Yet, rapid developments in this field are to be expected in the near future.

For further reading see also:

- Lanphen (2019) – “Hydrogen import terminal. Elaborating the supply chains of a hydrogen import terminal, and its corresponding investment decisions.”



Figure 5.15: The world’s first liquefied hydrogen carrier, the Suiso Frontier, launched December 2019 (© Kawasaki Heavy Industries).

5.2 Dry bulk terminals

5.2.1 Types of cargo

Dry bulk refers to cargo that is unpackaged and in granular, particulate form, as a mass of relatively small solids. For efficiency reasons it is generally transported in loose form and encompasses a wide range of commodities. Table 5.2 gives an overview of the evolution of dry bulk seaborne trade over the years 2013 - 2017.

Annual World Dry Bulk Seaborne Trade (Unit: Mtpa)						
Product	Category	2013	2014	2015	2016	2017
Major Bulk						
Iron Ore	Ore	1,189	1,338	1,363	1,410	1,478
Coal	Ore	1,184	1,218	1,144	1,410	1,193
Grain	Organic	392	432	495	480	505
	Total major bulk	2,765	2,988	2,966	3,030	3,176
Minor Bulk						

Table 5.2 – Continued on next page

Table 5.2 – continued from previous page

Agribulks	Organic	148	161	165	163	170
Sugar	Organic	56	54	56	62	59
Fertilisers	Processed product	143	154	155	150	162
Coke & Pet. Coke	Processed product	76	82	85	85	88
Bauxite	Ore	108	72	94	81	93
Alumina	Processed product	32	35	34	33	34
Manganese Ore	Ore	25	26	26	25	30
Anthracite Coal	Ore	63	52	48	50	39
Cement	Processed product	104	108	103	110	109
Salt	Mineral	45	49	49	43	47
Nickel Ore	Ore	80	56	44	41	42
Copper Concentrate	Processed product	23	24	26	29	29
Scrap Iron	Processed product	106	104	101	101	110
Other	Various	121	125	128	131	140
	Total minor bulk	1,130	1,105	1,114	1,104	1,152
	Total all	3,895	4,093	4,080	4,134	4,328

Table 5.2: Seaborne bulk trade 2013 - 2017 (PIANC, 2019b).

Table 5.2 shows that dry bulk commodities can be categorised as:

- *major bulk* – such as iron ore, coal, grain, phosphate or bauxite, and
- *minor bulk* – such as sugar, rice, bentonite, gypsum, wood chips, salt or copra.

Before going into vessels and terminals, we first give a brief description of a number of major commodities, because their properties determine to a large extent the way they are handled and stored at the terminal.

Iron ore

Table 5.2 shows that iron ore is the most important dry bulk commodity, representing about one third of the total dry cargo shipment by weight. When shipped, the ore has a stowage factor between 0.30 and 0.52 m³/ton, on average 0.4 m³/ton. Sometimes the ore is concentrated and baked into small spheres or pellets.

Iron ore is generally dusty, so dust extraction is normally necessary. The density may be a limiting factor for stacking, because of the limited bearing capacity of the ground. The angle of repose is usually less than 40°.

Coal

Coal is the second most import dry bulk commodity. According to Table 5.2 it represents some 27% of the total dry cargo shipment by weight. The stowage factor of coal varies from 1.2 to 2 m³/ton. The angle of repose varies between 30 and 45°.

Coal of all types may exhibit spontaneous combustion, as it absorbs oxygen when heated. The sensitivity, however, depends on the type. This sensitivity may limit the maximum allowable height of the stockpile. Dust nuisance can generally be controlled by water sprays, during unloading and transfer and when stored.

Grain

Different types of grain (wheat, barley, oats, rye, tapioca, quinoa, etc.) have different densities and properties, hence different storage and handling requirements. In the grain trade, variation in seasonal conditions results in large fluctuations in transport requirements. Various types of vessels of different sizes are used, including combined carriers. Some products, such as soybeans, are more and more containerised, in order to keep sight of the provenance.

Since grain is a perishable commodity, it is necessary to have proper ventilation and protection against weather conditions and pests during shipping and storage.

Phosphate

Phosphate rock is the main raw material for the fertiliser industry. It is very dusty and absorbs moisture rapidly, which can create problems for unloading. The average stowage factor is 0.92 – 1.0 m³ per ton. Practically all shipments are in the form of a powdery concentrate. The material is very fine, and special provisions have to be made to prevent dust problems, including irritation and dust explosions.

Bauxite/alumina

Bauxite ore, when processed into alumina (Al₂O₃), is used as a raw material in aluminium industry. Bauxite and alumina differ significantly in bulk density: 0.80 to 0.88 m³/ton for bauxite and 0.6 m³/ton for alumina. There is a trend towards conversion of bauxite at the source, as this halves the transport load. Alumina in particular is dusty and requires precautions against inhalation, soil and air pollution.

As an illustration of the extent of worldwide trade in bulk goods, Figure 5.16 gives an overview of the global trade flows in some important agricultural products.

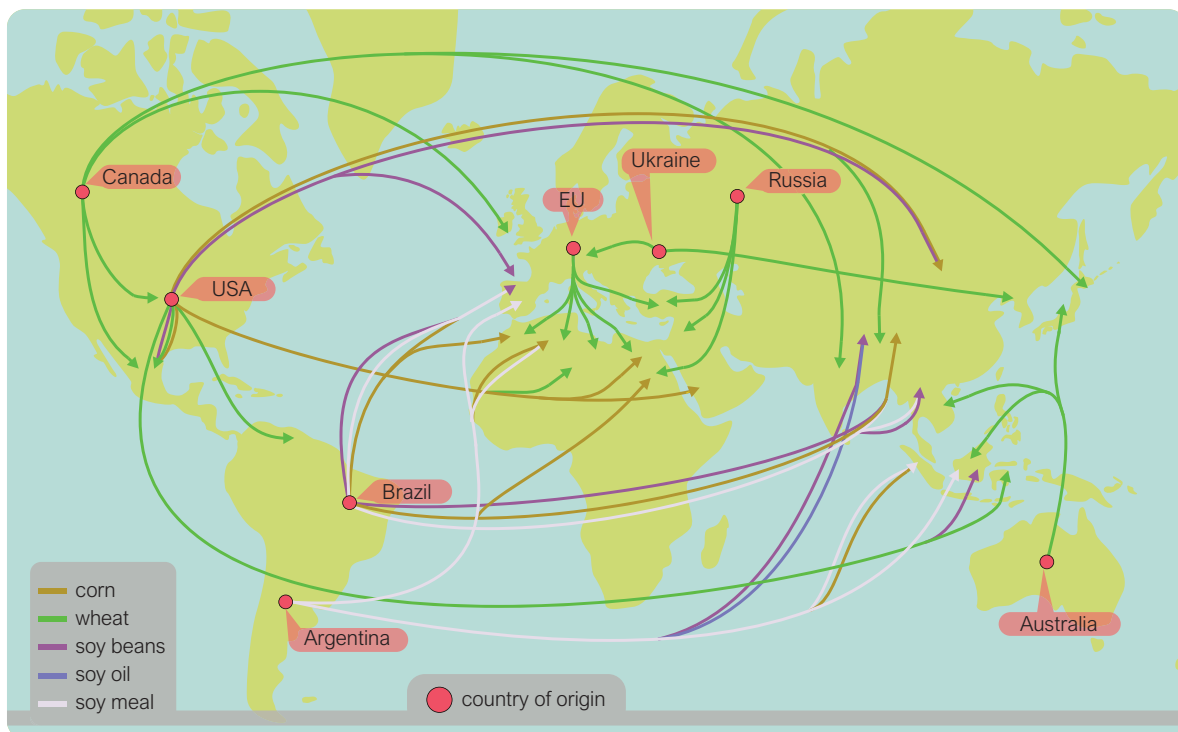

Figure 5.16: Global trade flows of some important agro-products (modified from <https://www.bunge.com/our-businesses/managing-physical-flows> by TU Delft – Ports and Waterways is licenced under CC BY-NC-SA 4.0).

5.2.2 Types of vessels

Fleet and vessel sizes for dry bulk transport have grown over the years. In the past carriers have also been built for the transport of both dry and liquid bulk cargo. One example are the so-called **Ore-Bulk-Oil (OBO)** carriers, which were designed to carry both wet and dry cargoes. The idea of such combination carriers was to reduce the number of empty (ballast) voyages. Neither **OBO**, nor other types of combination carriers have been used at a large scale, and new ones are no longer built. In recent years the primary driver in vessel development was to

achieve a greater economy of scale. The total fleet capacity, for example, has more than doubled between 2005 and 2015. [Table 5.3](#) summarises present vessel characteristics.

Category	Limiting factor	Maximum dimensions (m)			kDWT
		L_s	B_s	D_s	
Chinamax	large port access	375	65	24	400
Valemax	large port access	375	65	24	400
Malaccamax	Strait Malacca	400	59	20	300
Suezmax	Suez Canal	300	50	20	200
Capesize	large port access	330	42	19	200
Newcastlemax	Port of Newcastle	300	47	17	185
Dunkirkmax	Port of Dunkirk	289	45	16	175
Neo-Panamax	Panama Canal (new)	366	49	15.2	120
Panamax	Panama Canal (old)	295	32.3	12	80
Kamsarmax	Port of Kamsar	229	32.2	14.4	70
Seawaymax	St. Lawrence Seaway locks	226	23	7.92	25.5
Handymax	small port access	175	28	11	55
Handysize	small port access	140	21	9	35

Table 5.3: Dry bulk vessel categories (by TU Delft – Ports and Waterways is licenced under CC BY-NC-SA 4.0).

Like container and liquid bulk carriers, dry bulk carriers have been adapted to the navigability restrictions on the routes on which they operate or the ports at which they call. This has led to the classification shown in [Table 5.3](#). Note that the Valemax ([Figure 5.17](#)) is a subcategory of the Chinamax, named after the Vale mine company in Brazil.



Figure 5.17: The Vale Sohar, a 400,000 DWT dry bulk carrier of the Valemax class (Vale Sohar in Nantong by Dmitriy Lakhtikov is licenced under CC BY-SA 3.0).

Bulk carriers can also be distinguished by the way they are unloaded. Like loading, unloading is commonly done with shore-based equipment, but for unloading also ship-based equipment can be used. In that case, there are so-called geared bulk carriers and self-unloaders. Geared carriers are equipped with deck-mounted grab cranes, generally one for every hold ([Figure 5.18](#), left). Self-unloaders are equipped with a continuous unloading system consisting of horizontal and vertical conveyors ([Figure 5.18](#), right; also see [Youtube: How does a self unloader work?](#)).



Figure 5.18: Dry bulk carriers with on-board unloading equipment; left: geared Handysize carrier (*Polish Bulk Carrier Kociewie in the Port of Hamburg* by Buonasera is licenced under CC BY-SA 3.0); right: self-unloader (*CSL Trimnes* by Cavernia is licenced under CC BY-SA 4.0).

5.2.3 Types of terminals

The berth configuration varies with the carrier type, but also between export and import terminals. Dry bulk terminals are seldom import and export terminal at the same time. In the next subsections we discuss several types of dry bulk terminals.

Export terminals

Export terminals are often dedicated to a single product, such as coal, ore or grain. Their location is generally close to the mine or the process plant. If direct loading is not feasible because a suitable port is too far away, the cargo may first be loaded into barges which bring it to deep water that can accommodate large carriers.

Loading is always done with shore-based equipment, either travelling along the ship, or serving the ship from a fixed point with a swaying arm. The latter requires less of a quay structure, but the loading equipment itself is more complex. In any case, the loading equipment must be able to reach each hold of the ship, but spreading the cargo over the hold is not necessary, gravity helping out. Figure 5.19 shows some examples of loading arrangements.

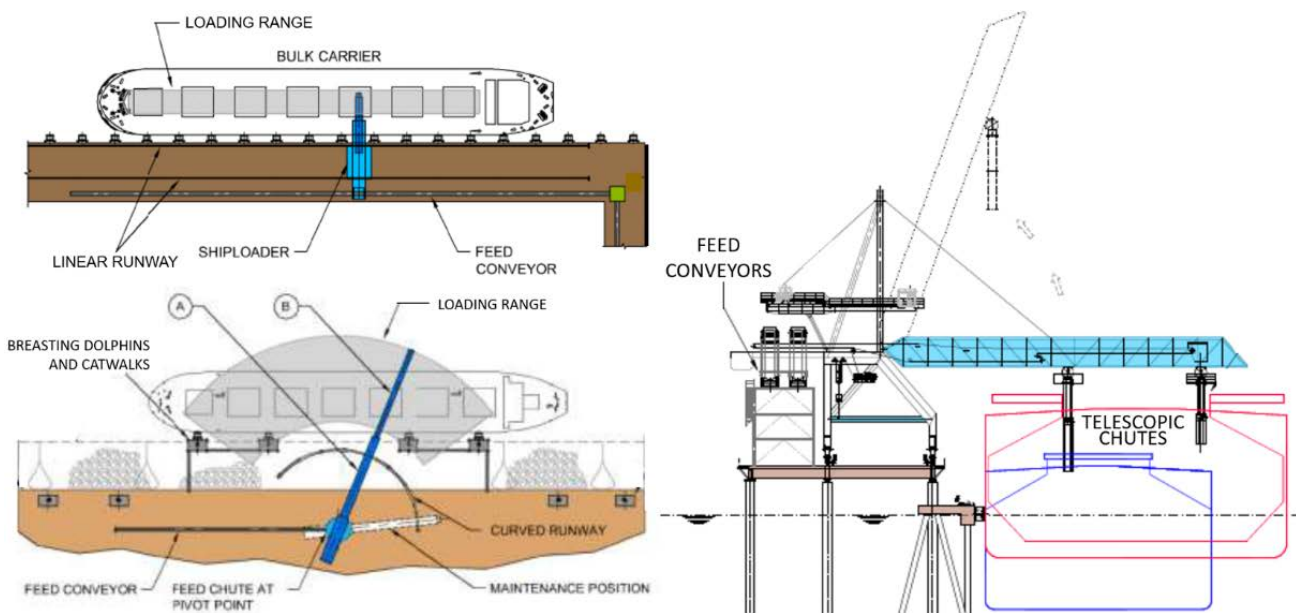

Figure 5.19: Examples of dry bulk loading equipment; top left: shuttle boom shiploader; bottom left: quadrant radial shiploader; right: long travelling shiploader (PIANC, 2019b).

Figure 5.20 shows an example of a combined import and export jetty for iron ore in the deep-water port of Sohar, Oman. At import side (right at the photo), the world's largest ore carriers can be accommodated for unloading. At the export side (left at the photo), smaller transshipment vessels can be loaded, either with ore or with iron pellets produced at the terminal.



Figure 5.20: Iron ore terminal, Port of Sohar, Oman (*Bulk IJzerertsterminal in de haven van Sohar (Oman)* by Royal HaskoningDHV is licenced under CC BY-NC-SA 4.0).

Import terminals

Most import terminals consist of linear single-sided berths with unloading machines of different types, either ship-mounted or land-based. Most commonly, they deliver the product to a terminal buffer stockpile, from where it is loaded into trucks, trains or inland vessels. PIANC (2019b) distinguishes three types of unloaders, as summarised in Figure 5.21. Figure 5.22 shows four examples of continuous unloaders.

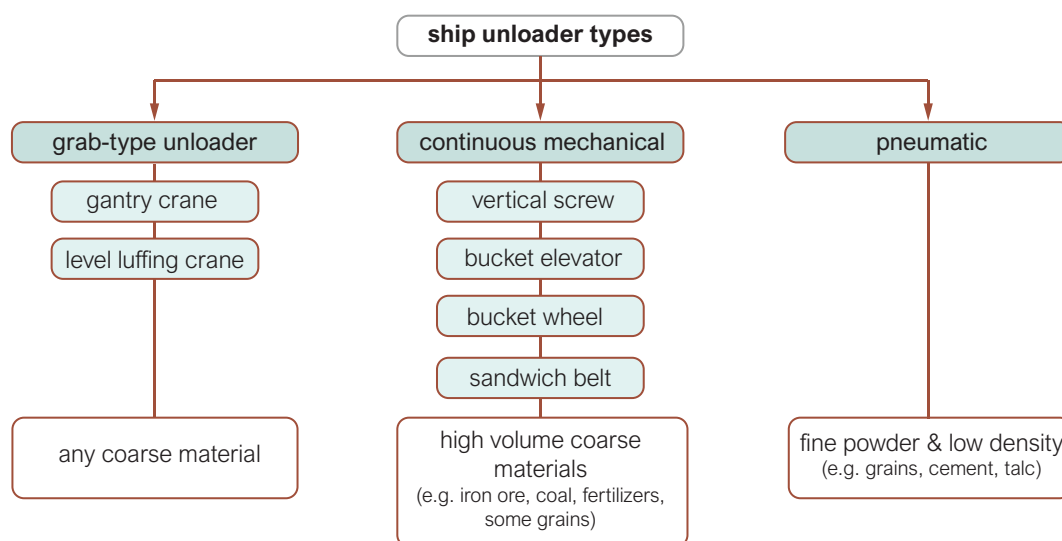

Figure 5.21: Ship unloader types (reworked from PIANC, 2019b, by TU Delft – Ports and Waterways is licenced under CC BY-NC-SA 4.0).

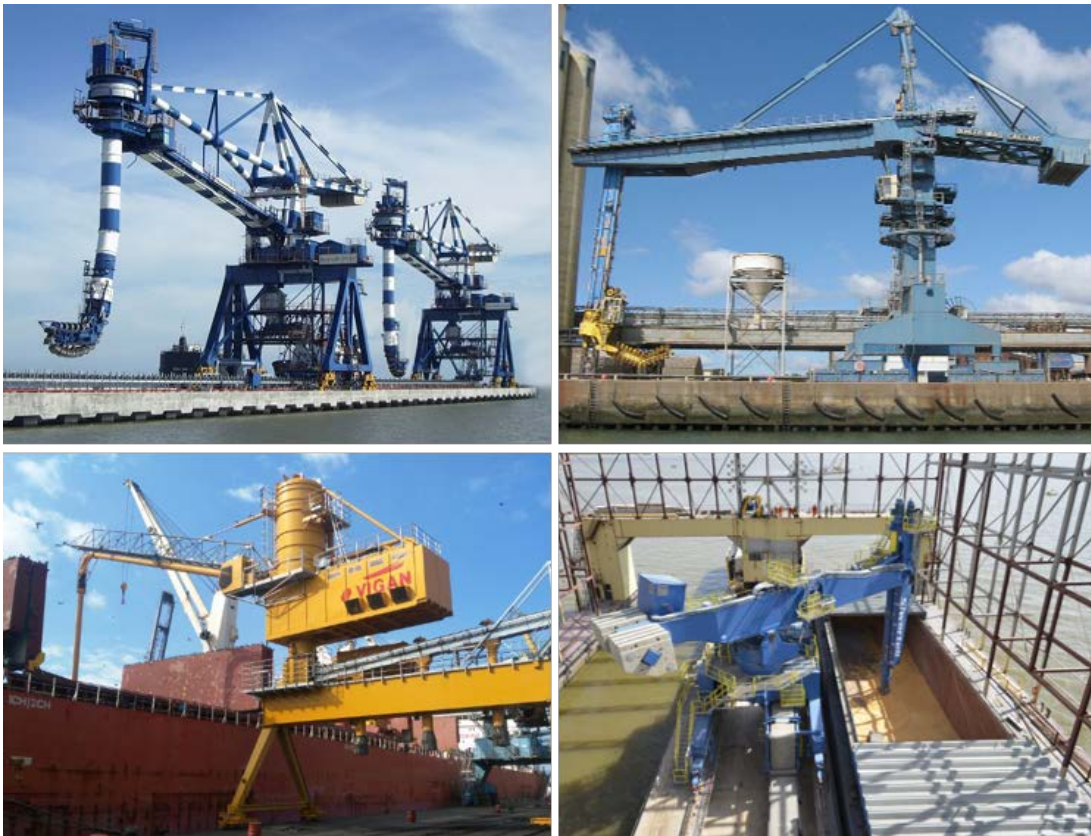

Figure 5.22: Continuous unloaders; top left: bucket elevator type; top right: chain type; bottom left: pneumatic type; bottom right: screw type (images by [PIANC, 2019b](#), are licenced under CC BY-NC-SA 4.0, [Port-de-commerce-de-Lorient](#) by [Pline](#) is licenced under CC BY SA 3.0).

These unloaders determine the requirements to the onshore part of the terminal. A gantry crane with a grab unloader, for instance, has to travel over a quay structure over the entire length of the moored vessel. A self-unloader, on the other hand, can do with a simple dolphin mooring, because it can deliver the cargo at a single point ([Figure 5.23](#)).

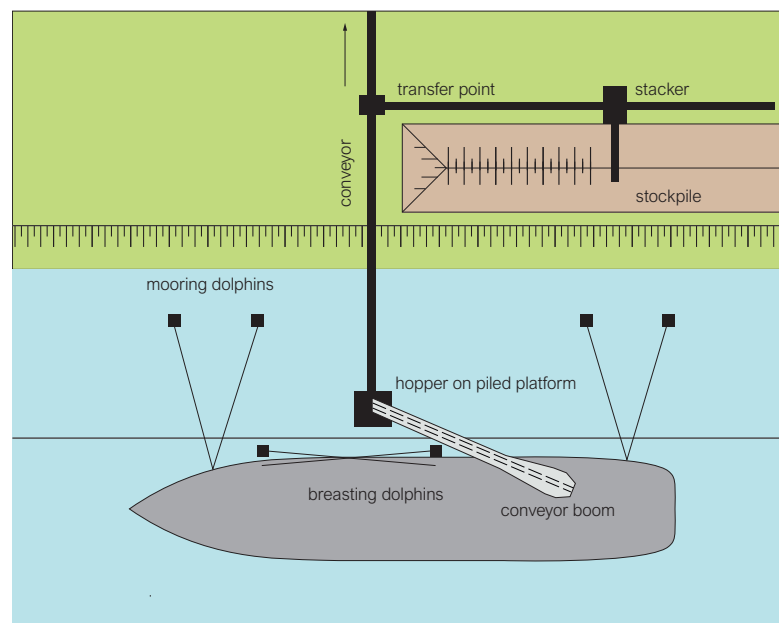

Figure 5.23: Self-unloading arrangement (by [TU Delft – Ports and Waterways](#) is licenced under CC BY-NC-SA 4.0).

The capacity of the unloading equipment generally determines the terminal throughput capacity. The unloading capacity depends not only on the equipment, but also on the conditions (full hold, experienced operator, start of the shift) and the degree to which the hold has been unloaded (Figure 5.24). Therefore, different types of capacity are distinguished:

- Peak capacity (optimum circumstances, free digging); this should be the design capacity for all downstream equipment and plant facilities (conveyors, weighing equipment, stackers, stockage, et cetera).
- Nominal (rated) capacity, free digging rate under average conditions over an extended period.
- Effective capacity, average hourly rate for entire ship load, including trimming, cleaning, moving between holds, et cetera).

An unloading grab crane at the EMO-terminal in the Port of Rotterdam, for instance, has a grab volume of 45 ton and can make 100 cycles per hour. The corresponding capacities are:

- Peak capacity 4,200 ton/hr,
- Rated capacity 3,400 ton/hr, and
- Effective capacity 1,700 ton/hr.

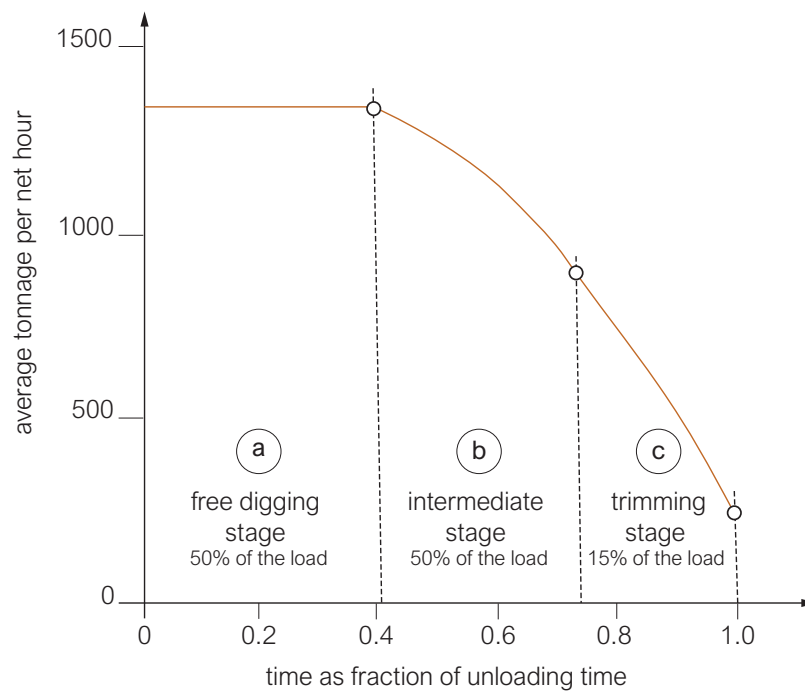

Figure 5.24: Unloading capacity as a function of time (reworked from Ligteringen, 2017, by TU Delft – Ports and Waterways is licenced under CC BY-NC-SA 4.0).

As a first approximation, the capacity of a berth follows from:

$$C_b = p \cdot t_{\text{eff}} \cdot m_b \quad (5.2)$$

in which:

- p = effective capacity of the (un)loading equipment,
- t_{eff} = effective number of operational hours per year,
- m_b = estimated berth occupancy rate.

A more detailed assessment of the required number of berths, unloading equipment and storage silo's and warehouses can be made by following the steps described in Section 3.3.3 (see Section 4.4 for their application to a container terminal). Queueing theory and simulation models can be applied to further study the extent to which the design meets throughput requirements and waiting time limitations.

A special point of attention is hold cleaning after unloading. Hold cleaning, which is necessary to prevent cargo contamination, corrosion, et cetera, is strictly overseen. A vessel may even be held in port if it does not comply with the hold cleaning rules. If the cleaning takes place while the vessel is at berth, this will reduce the berth capacity.

The overall terminal layout varies between cargo types: requirements to stocking iron ore or coal are different from those to stocking grain or sugar (Figure 5.25). PIANC (2019b) gives a number of examples of terminal designs.

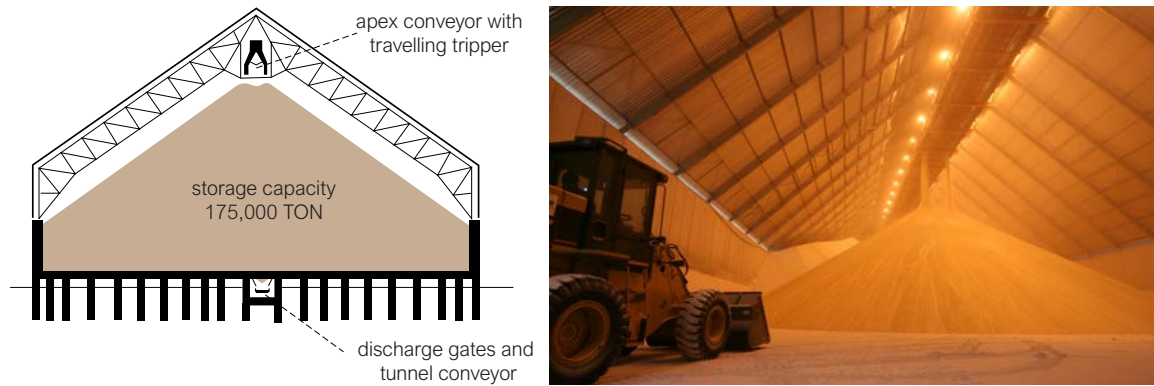

Figure 5.25: Stacking, storage and reclaiming of sugar (left: image by TU Delft – Ports and Waterways is licenced under CC BY-NC-SA 4.0, right: Terminal Graneleiro em Operacao - Sugar Mill Santos Harbor by Sabino Freitas Correa is licenced under CC BY-SA 4.0).

5.2.4 Transshipment terminals

Although most dry bulk terminals are either import or export terminals, there are also transshipment terminals for further transport by short sea shipping and/or IWT. One example is the EMO-terminal for coal and iron ore (throughput 40 mio ton/yr) in the Port of Rotterdam (Figure 5.26). This terminal has separate quays for large carriers, short sea vessels and IWT barges.



Figure 5.26: EMO-terminal for coal and iron ore, Rotterdam (PIANC, 2019b): (1) large carrier unloading quay; (2) short sea vessel loading quay; (3) barge loading quay.

If a port is not accessible to large ocean-going carriers, the cargo is sometimes reloaded into smaller ships at a deep-water offshore terminal (Figure 5.27). Another way of dealing with a too shallow access is to unload part of the cargo onto smaller vessels. This is done, for instance, with bulk carriers on the Western Scheldt, on their way to the Port of Antwerp.



Figure 5.27: Offshore salt terminal, Porto-Ilha de Areia Branca, Brazil (*Salt ship loading* by Marcus Guimares is licenced under CC BY 2.0).

For further reading see also:

- [PIANC \(2019b\)](#) – PIANC Report N°184 “Design principles for dry bulk marine terminals”

5.3 Cruise terminals

Cruise shipping is a rapidly growing branch of the port and shipping industry. This applies to ocean-going as well as inland cruising. Ports adapt to this trend by increasing their cruise terminal capacity. On the other hand, this market is rather volatile, as has become clear during the 2020 Corona pandemic (Figure 5.28).



Figure 5.28: Large cruise ships waiting for business off the Weymouth Bay (UK), summer 2020 (*Cruise Ships from the Air* by Andrew Bone is licenced under CC BY 2.0).

Figure 5.29 outlines the ‘supply chain’ of the cruise shipping industry. Clearly, cruise terminals differ from container, liquid and dry bulk terminals.

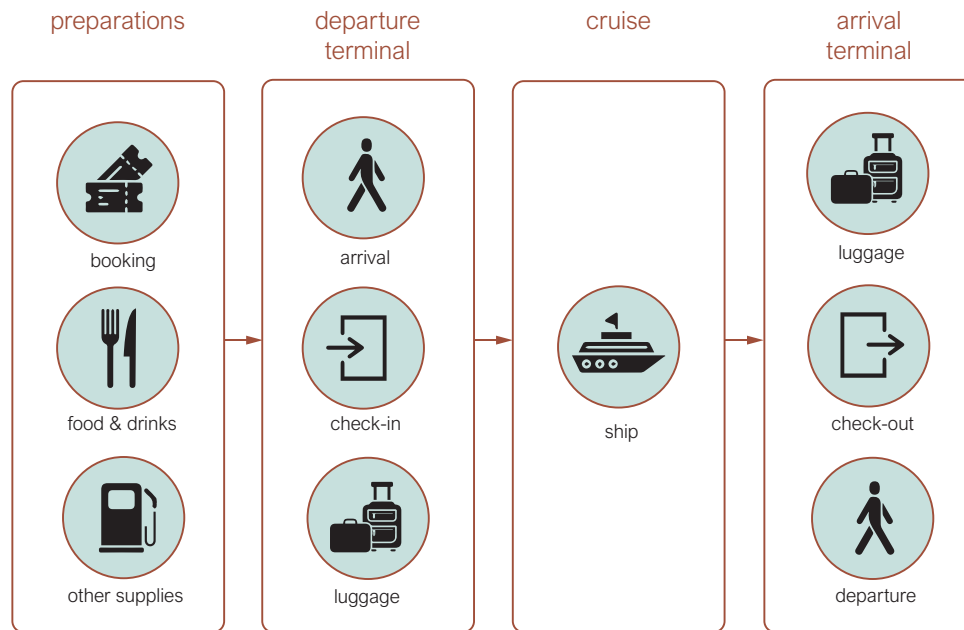

Figure 5.29: Schematic of the cruise shipping process (by TU Delft – Ports and Waterways is licenced under CC BY-NC-SA 4.0).

Along with the increasing demand, cruise vessels have increased in size. At the moment, the largest ones are not much smaller than other large ships (Figure 5.30, left). The largest cruise ship at the moment is the Symphony of the Sea, measuring 360 x 65.7 x 9.32 m, with a gross tonnage of 228,081 and accommodating up to 6,680 passengers.



Figure 5.30: Ocean-going cruise ships, no longer much smaller than other ships; left: the world’s longest ships (Bateaux comparaison2 with Allure by Delphine Ménard and Tupsumato is licenced under CC BY-SA 2.0); right: the Symphony of the Sea (SymphonyOfTheSeas by Darthvadrouw is licenced under CC BY-SA 4.0).

Apart from a terminal building for passenger handling, a cruise terminal generally provides long-duration parking space and facilities to accommodate passengers while waiting, such as a restaurant. Sometimes the terminal buildings include facilities for other activities, such as meetings and conferences. The Cruise Terminal Rotterdam, for instance, has a famous restaurant, a congress centre, meeting rooms, a dancing hall and a fair and exposition hall.

River cruise ships also tend to grow ever larger. The biggest ones at the moment are 135 m long and can accommodate more than 200 passengers (Figure 5.31). River cruise terminals are generally less extensive than the ones for ocean-going cruise ships, but the bigger ones still offer a range of facilities, such as a parking, shops, a restaurant and a tourist information office.



Figure 5.31: The A-Rosa-Aqua, one of the largest river cruise ships. (*A-Rosa Aqua (ship, 2009)* by Rolf Heinrich, Köln is licenced under CC BY-SA 3.0).

For further reading see also:

- [PIANC \(2016c\)](#) – PIANC Report N°152 “Guidelines for Cruise Terminals”
- [Ligteringen \(2017\)](#) – “Ports and Terminals”

5.4 Other port and terminal types

In terms of cargo volume the most important terminal types are: container terminals (Chapter 4), liquid bulk terminals (Section 5.1) and dry bulk terminals (Section 5.2). A brief description of cruise terminals was given in the previous section as an illustration of how its process differs significantly from the other terminal types. Obviously there is a range of other terminal types that we have not yet discussed:

- *Ro-Ro terminals* – Roll-on/Roll-off terminals are designed to handle wheeled cargo that is driven on and off the ship on their own wheels (i.e. cars, trucks, semi-trailer trucks, trailers) or using a platform vehicle (i.e. a self-propelled modular transporter). This is in contrast to Lift-on/Lift-off (LoLo) vessels, which use a crane to load and unload cargo. The Ro-Ro terminals need facilities to accommodate the (un)loading ramps of the vessels, and generally large amounts of parking space. As such, designing a Ro-Ro terminal requires similar considerations when it comes to the number of terminal elements that are needed for a target capacity, and their order-of-magnitude dimensions.
- *General cargo or break bulk terminals* – Break bulk differs from containers and (liquid and dry) bulk in the sense that the cargo are goods that must be loaded individually. An important distinction with containers is that break bulk does not have standardised dimensions to facilitate (un)loading and storage. Break bulk cargo is, for example, transported in bags, boxes, crates, drums, barrels and packed pallets. One of the challenges of designing a general cargo terminal is making sure that the terminal is flexible in handling and safely storing the potentially large variety of goods. Other than that, similar challenges are faced when it comes to making cargo forecasts, estimating the fleet composition and deriving the required number of terminal elements and their order-of-magnitude dimensions to meet the forecasted demand.
- *Fisheries ports* – Fishing ports are designed for landing, temporarily storing and distributing fish. This may take place in a recreational facility, but is usually commercial. The type of fisheries that the port caters to affects its layout. A fisheries port that caters to vessels that fish locally (days), needs different facilities than

a port that caters to vessels that fish remote grounds (days – weeks). Not only are the dimensions of the vessels quite different in both cases, also the amount of fish that is potentially brought in per arrival. Again the design challenge is to estimate the terminal elements required to handle the projected payload. But also ensuring proper connections to markets is key. The balance between access to fishing grounds and access to markets was one of the core issues of the 2020 Brexit negotiations.

- *Marinas* – A marina typically caters to yachts and small boats. Security and on-site facilities like, parking spaces, toilets, showers, electricity, running water, small shops, restaurants, etc., can make a marina more attractive. But in some cases also access to, and attractiveness of, the region around the marina can be a factor of attraction. Typical design challenges are of course to arrange optimal facilities on the available scarce area. Again the expected vessel mix the marina should cater for is influential. The expected client will have a great influence on the service levels that need to be provided. Furthermore, making sure that the marina design is such that customers can safely enter/leave the marina, and conditions while moored are as comfortable as possible, is important.

The above bullet list only lists a number of aspects that are important for a small selection of port and terminal types. Obviously there is much more to consider for the ports and terminals mentioned. Also the list of port and terminal types could have been much longer. Detailing aspects associated with each port and terminal type is outside the scope of this book. For more information on ports and terminals the reader is referred to [Ligteringen \(2017\)](#).

5.5 Inland ports

A type of port that we do consider to be in scope for more detailed discussion in this book is the inland port or harbour. Inland ports play an important role in the supply chain as transfer points in the hinterland distribution of cargo; exporting from a production site or importing towards the end users, with the ‘last mile’ often covered by trucks or rail. This section discusses the *IWT*-terminals at inland ports and along river or canal banks, but it also pays attention to facilities required in overnight harbours.

5.5.1 Typology and change

Inland ports range from sophisticated multiple-basin complexes with up-to-date handling equipment, to simple one-berth terminals along the bank of a river or canal for incidental loading or unloading of goods or passengers. The city of Nijmegen, situated on the Waal, in the Netherlands, provides examples of this diversity within a stretch of 4 km (see [Figure 5.32](#)). From East to West we see the (a) Lindenberghaven, (b) the Waalhaven and (c) the Oostkanaalhaven.

The Lindenberghaven, which is a marina (port for pleasure crafts), is situated *on* the river Waal. It is positioned in the outer bend, and the marina opening is facing down stream. The quay directly bordering it to the west, the Waalkade, marks the edge of a location known as the ‘old harbour’ (in Dutch: ‘Oude haven’). This was the location of the city’s port for centuries, up to the 1850s when the city authorities decided to fill in the harbour basins and construct a new harbour outside the city walls. An important reason for this was to prevent the inner city from being flooded by the River Waal. The Waalkade is nowadays mainly used for recreational purposes.

The Waalhaven is the ‘new harbour’ that was constructed following the decision to fill in the ‘old harbour’ in the 1850’s. It is positioned *next to* the river Waal, with an open connection and placed right next to the rail network. From the 1850’s up to the 1990’s this was the industrial port of Nijmegen. Due to space limitations additional port space was developed, starting in the 1950’s, a bit further west at the position of the current Oostkanaalhaven. Since the 1990’s all industrial activities moved from the ‘new harbour’ to the Oostkanaalhaven. Eversince the ‘new harbour’ is mainly used as an overnight harbour for *IWT* vessels.

The Oostkanaalhaven is an example of a modern multi-basin industrial port. Its two main water areas were constructed in the 1950’s. It is well connected to the wider *IWT* network through its positioning on the Maas-Waal canal. The connection to the Waal is via a lock, preventing changing water levels in the Waal to affect the port operations directly. The port is furthermore well-connected to the wider road network and situated closely to rail connections.

The ports in the city of Nijmegen provide a nice example of the diversity of inland ports, but their evolution over time is also an example of the trend to move port facilities away from city centres more to the fringe where more space is available (see also [Figure 2.1](#)). Another driver for this trend has been the growth in ship size.



Figure 5.32: Variety of inland ports in the city of Nijmegen, the Netherlands, (a) the Lindenberghaven, (b) the Waalhaven, and (c) the Oostkanaalhaven (aerial imagery by the National Georegister (NGR) is licenced under CC BY 4.0).

5.5.2 Challenges of inland port planning

As indicated in [Part I – Chapter 2](#), ports need to adapt to never ending triggers of change. This is true for sea ports but also for inland ports. The Nijmegen example already illustrates how ports need to move to grow, among others in response to changes in society. But other triggers of change also apply.

Economic and political changes can have consequences as well. One example is the history of the Twente kanalen in the East of the Netherlands: triggered by Belgian independence in 1830 and the opportunities provided by the industrial revolution, the textile industry in the region of Twente developed spectacularly during the second half of the 19th century. The population of Enschede, for example, multiplied by a factor five in the period between 1870 and 1900. To stimulate the supply of cotton, and coal from the mines in the South of the Netherlands, a canal network was constructed in the 1930s to connect Almelo, Hengelo and Enschede to the IJssel and the further [IWT](#)-network. This stimulated the textile industry to grow even further. But several economic and political changes

triggered a dramatic decline from the 1960s onwards: economic developments caused the prices of textile products to drop (i.e. overproduction, changing markets), workers wanted to earn higher wages causing labour shortages and further erosion of competitiveness, the discovery of natural gas in North of the Netherlands led to the political decision to close the mines in the South, et cetera. All these developments together caused the textile industry, which employed approximately 43,000 people in the mid 1960s, to collapse to approximately 8,700 employees in the 1990s. All this of course had its impact on cargo flows and associated port activity. Nowadays the main cargo in the port of Hengelo is salt, which is still mined in the region in ground layers between 300 and 3,000 m down.

Also extreme conditions can have a significant effect on the [IWT](#) transport mode and inland ports. An episode of extremely low discharge on the River Rhine in 2018 caused water levels to drop significantly below the [Agreed Low Waterlevel \(ALW\)](#) for navigation during several months. Consequently, vessels needed to limit their load to lessen their draught (see: [Van Dorsser et al., 2020](#)). This caused transport costs of the [IWT](#) mode to rise, while road and rail transport remained largely unaffected. At the most extreme discharge lows, several ports even became inaccessible. If climate change causes such droughts to occur more frequently, this constitutes not only a challenge for the inland port infrastructure, but it also raises concerns about a modal shift away from [IWT](#).

Besides threats there are also opportunities. In the upcoming energy transition [IWT](#) has the potential to have a smaller environmental footprint than other transport modes. Whereas road networks tend to become more congested, [IWT](#)-networks still have room for growth. Furthermore, the steady increase of container transport creates opportunities for the further development of inland container ports.

The above examples are meant to underline uncertainties that [IWT](#) and inland ports need to deal with. Careful planning under conditions of uncertainty is of vital importance, and the paradigm of Adaptive Port Planning applies. The steps described in [Chapter 2](#) are used for inland port planning as well. A Port Master Plan is needed and any decision should be based on a careful estimate of future cargo flows and vessels that the port should be able to handle. For a greenfield inland port site selection is crucial: it requires a delicate mix between access to various transport networks (road, rail, [IWT](#), pipeline) and proximity to production locations and/or end users. Once future demands are estimated and the anticipated vessel mix is defined, a port layout can be developed; conceptual at first, more detailed later on.

5.5.3 Inland port layout

Preceding any port layout effort, location selection is one of the most important outcomes of the port planning process. Apart from economical and logistical considerations, which are obviously very important from a feasibility perspective, a number of civil engineering aspects is essential as well:

- Inland ports are preferably located at the outer bend of a river, where the water depth is the largest. [Part III – Section 2.4](#) shows examples of different types of ports: open ports, ports closed off with a lock from the river, etc.
- Quays located along a river bank may experience high current velocities. A berth should preferably be located at deep water and in line with currents, but at such locations the current velocities can be high. A small inclination ($>5^\circ$) of a moored vessel's axis with respect to the current direction may already lead to high mooring forces.
- Rivers may carry high sediment loads, which can give rise to access channel blockage or basin sedimentation. This may even jeopardise the feasibility of the port. As river morphology can be complex and very dynamic, a port should be located on a morphologically stable part of the river. Maintenance dredging in very dynamic rivers may not be economically feasible for small ports.
- River ports should be sufficiently protected from floods, for instance by placing them on a landfill. If this sticks out into the river bed, however, it may negatively influence the river's flood conveyance capacity.

[Part III – Section 2.4](#) gives more detailed guidelines for the dimensioning of water areas in inland ports. They concern, for instance, the width of the access channel entrance and the dimensions of turning basins and port water bodies, but also the preferred berthing arrangements.

Here we will focus on ports and terminals in commercial inland ports or at quays (terminals along river or canal banks), among which we can distinguish:

- *general-purpose ports* – multi-user interfaces between [IWT](#) and other modes of transport (road, rail), gener-

- ally offering storage facilities; see for example [Figure 5.32c](#) and [Part III – Figure 2.55](#);
- *dedicated ports* – for containers or other cargo, sometimes multi-user, sometimes single-user; see for example [Figure 5.33](#) – left, but also [Part I – Figure 1.21](#);
- *industrial ports* – they are generally the end of the transport line, where raw materials and (half-)finished products reach their final destination and end-products are loaded directly from the factory; see for example [Figure 5.33](#) – right.

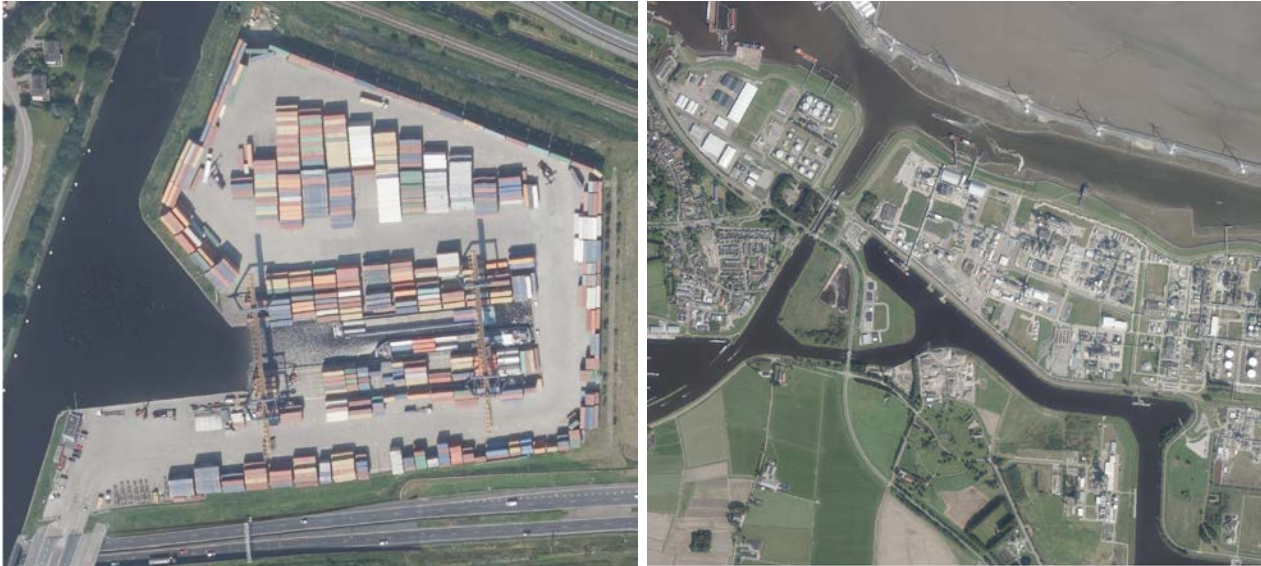

Figure 5.33: Left: dedicated container terminal on the Gouwe canal, Alphen aan de Rijn, exporting mainly Heineken beer via barge to Rotterdam and Antwerp; right: chemical industry terminal Delfzijl, connected to sea via the river Eems and to the hinterland via the Eemskanaal (aerial imagery by the National Georegister (NGR) is licenced under CC BY 4.0).

Compared with sea ports the available space on which the different inland port functions can be planned is generally much more limited. Furthermore since inland ports are often located in or near cities, and bordering along existing rivers or canal networks, the space that *is* available is often not ideally shaped, with odd angles and curves (see for example [Figure 5.33](#)). Despite these complications the development of a port layout at master plan level is quite similar to sea ports (see [Section 3.2](#)).

5.5.4 Inland port terminals

Terminal services and components

Like in the case of seaports, services provided in inland ports will differ per commodity. In general the following facilities will be available:

- mooring facilities,
- quay side cargo transfer equipment and terminal transport equipment,
- storage facilities,
- interfaces to other modalities (road, rail, and
- terminal support services (shore power, offices, workshops, security, etc.)

Mooring facilities

In ports with a more or less constant water level, such as canal ports or closed river ports with a ship lock (see [Part III – Section 2.4](#)), vessels can be moored along quays. In open river ports, however, the water level may vary too much for a fixed quay, so there one has to find another solution, such as a movable jetty with a floating pontoon ([Figure 5.34](#)).

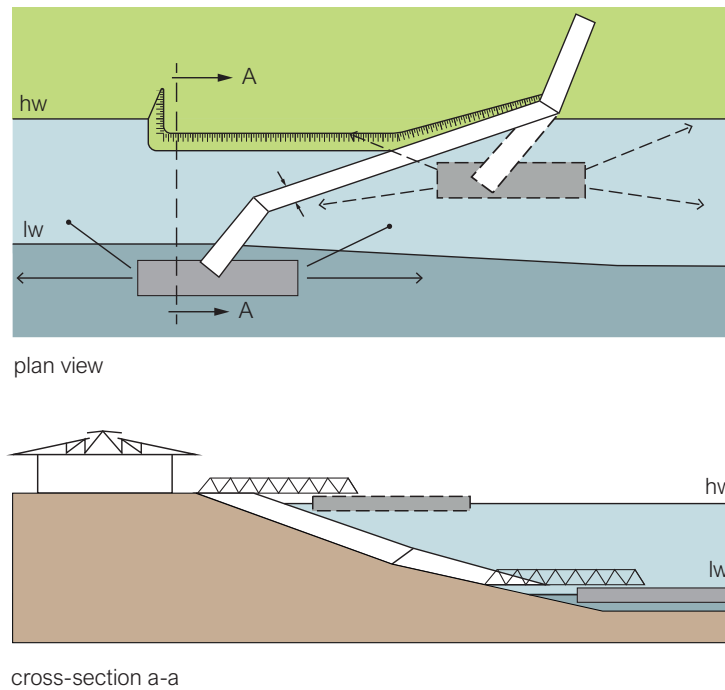

Figure 5.34: Layout movable jetty with floating pontoon (by TU Delft – Ports and Waterways is licenced under CC BY-NC-SA 4.0).

Whatever the form (quay wall, fixed jetty, floating jetty), a berth must withstand the forces exerted on it (Figure 5.35). These forces may fluctuate considerably and vary from one location to another, so a thorough analysis is needed. Particular attention should be given to sudden changes of the water pressure caused by passing ships.

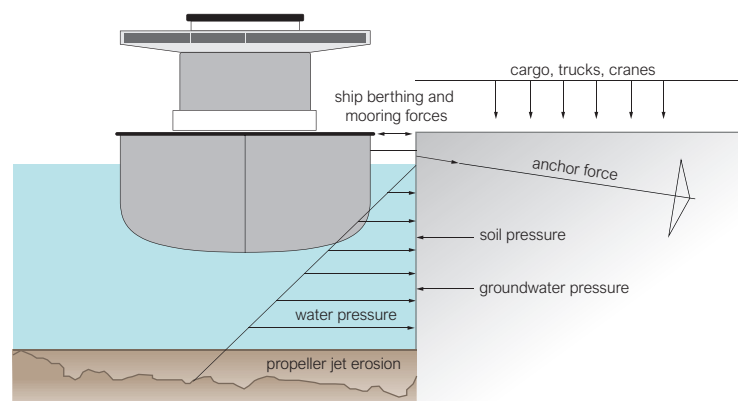

Figure 5.35: Forces acting on a quay wall (by TU Delft – Ports and Waterways is licenced under CC BY-NC-SA 4.0).

Ship impacts may be considerable, e.g. in case of a failing manoeuvre leading to significant kinetic energy to be absorbed (see Part III – Chapter 5). The extent to which rough berthing manoeuvres are taken into account in the analysis is subjective. In that respect there is a difference between rigid structures and structures with a flexible fendering. In the latter case, the impact load will be smaller. RVW (2020) presents guidelines for the rope forces that can be expected at bollards as a function of the ship class.

Near a berth, ships will often be manoeuvring. Consequently, the risk of erosion due to propeller or bowthruster induced jets is relatively high, and should be given due attention. To prevent stability problems, sheet piles should be given some extra length, or a bed protection should be considered. Repair of structures and revetments in this

kind of situations is generally rather costly. In [Part III – Section 4.3](#) we present some first ideas. More details can be found in PIANC-report 180 ([PIANC, 2015](#)). For a further discussion of design aspects and relevant guidelines on quay wall design, we refer to EAU 2012 ([Cywiński and Grabe, 2005](#)).

Quayside cargo transfer equipment

The type of cargo determines the port equipment: cranes, overhead ropeway systems, cable-suspended drag buckets, various types of grab or continuous barge unloaders, et cetera. [Figure 5.36](#) gives a number of examples, but many more exist.

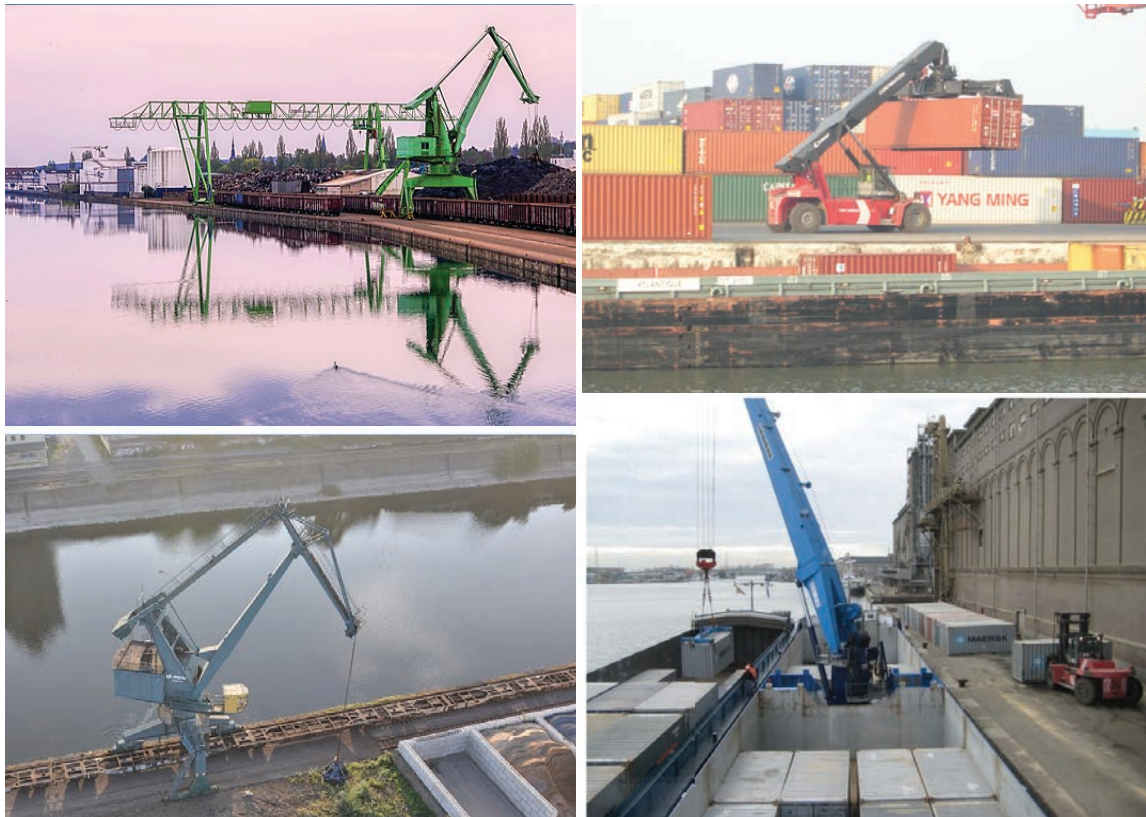

Figure 5.36: Examples of (un)loading facilities; upper left: gantry crane by Jürgen Striewski is licenced under CC BY-SA 4.0, upper right: reach stacker by Lundex is licenced under CC BY-SA 2.5, lower left: quay mounted crane by Atamari is licenced under CC BY-SA 3.0, lower right: vessel mounted crane (from www.slideshare.net, “Crane Barges”, Copyright by Mercurius Shipping Group).

IWT container terminals require one or more container cranes with a lifting capacity of about 40 ton. Since the beam of **IWT** vessels or barges is much smaller than that of sea-going container ships, the crane’s outreach from the quay edge can be less. As the trolley and hoisting speeds are usually lower, as well, the investment in container handling equipment is significantly less than in a seaport, though still substantial in **IWT** terms.

In developing countries, (un)loading of barges is sometimes still done manually. In most cases, however, some form of mechanisation, or partial mechanisation, has been introduced. From an engineering point of view, mechanisation of cargo handling makes a considerable difference for the design of a terminal and, especially, for the design of the jetty.

Storage

Compared to seaports, inland ports generally have to cope with less space. As a consequence, rather than having large container stacks that are optimised for efficiency, storage arrangements are designed to make optimum use of the space available.

Clearly, required storage facilities depend on the type of cargo: tanks for liquid bulk, for instance, or closed storage sheds for dry bulk (agri products, minerals, iron ore). Containers are generally stored at the terminal and can serve as a sound wall (see [Figure 5.33](#)). Like in sea ports, an efficient system for managing the storage is required, though the different optimisation criteria may lead to different choices.

Interfaces with other modalities

Because of the space restrictions, transfer of cargo from storage facilities (tanks, sheds, container stacks) to rail or truck or vice versa requires special attention when developing the layout of an inland port. Gates for further transport of containers by truck can be used in combination with an [Automatic Equipment Identification System \(AEIS\)](#). Trucks or other terminal transport facilities are also necessary to transfer containers to rail. In case of dry or liquid bulk a system measuring the quantities entering or leaving the terminal to truck, rail or pipeline should also be available.

5.5.5 Facilities in overnight stay harbours

To enable crews to have rest periods, overnight stay harbours should be situated at regular distances along the waterway. Depending on the duration, the facilities will differ: just a safe mooring at a mooring pile for one night without disembarkation, or a mooring along a disembarkation facility, for example via a floating or fixed landing stage ([Figure 5.37](#)).

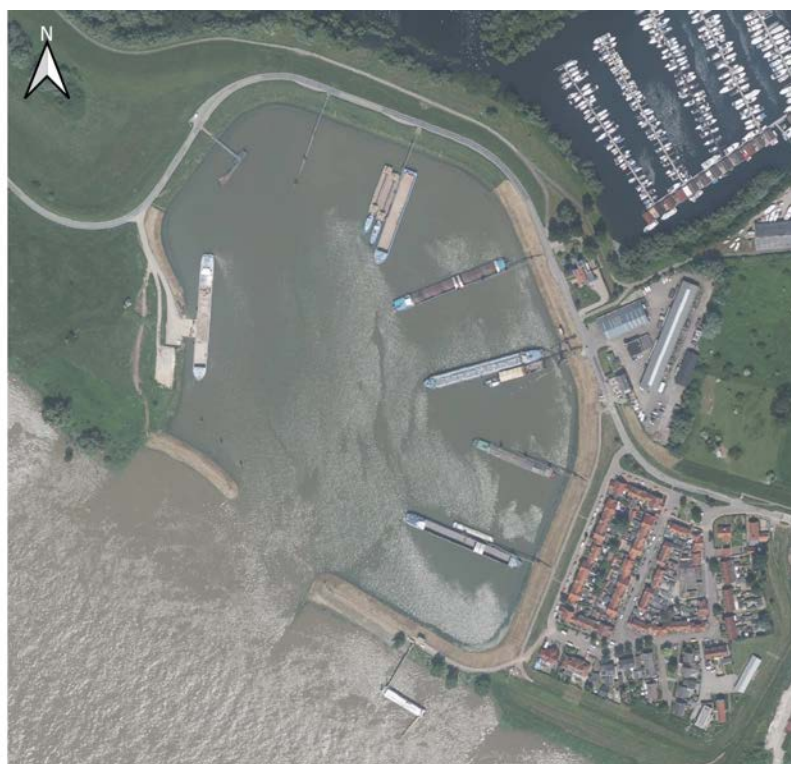

Figure 5.37: Lobith (NL), overnight harbour with floating landing stages (aerial imagery by the National Georegister (NGR) is licenced under CC BY 4.0).

A growing number of vessels have spuds (cf. [Part III – Figure 1.31](#)). They do not need mooring structures, but the spuds can damage bed protections. Harbour authorities can designate certain areas for vessels that will use their spuds.

In addition to a disembarkation facility, overnight stay harbours require some specific facilities, such as shore-side electricity, drinking water, and a car boarding facility ([Figure 5.38](#)). The car boarding facility can be a jetty or a pontoon. More details can be found in [RVW \(2020\)](#).

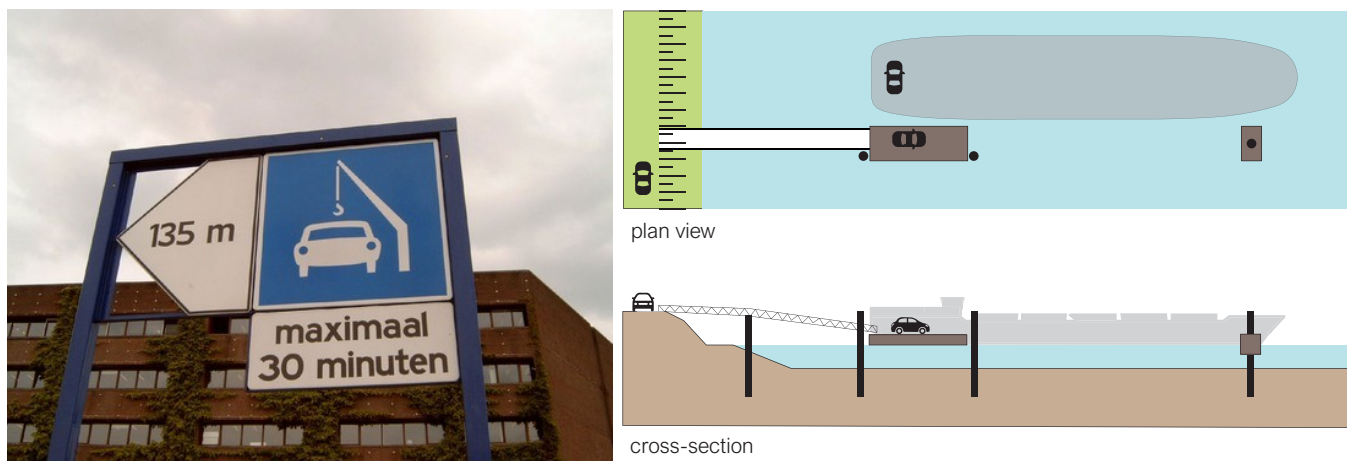

Figure 5.38: Car boarding facility with pontoon or landing stage for variable water levels (left: *Indication for a car drop-off point* by G.A.T. van Meegen, Nijmegen is licenced under CC BY-NC-SA 4.0, right: image by TU Delft – Ports and Waterways is licenced under CC BY-NC-SA 4.0).

Apart from that, there are harbours providing temporary shelter, such as harbours of refuge (for wind and waves, floods, ice, or in case of machine breakdown), and service harbours (for survey vessels, contractor equipment, etc.). Further information can also be found in [Part III – Section 2.4](#).