

aE GRADUATION STUDIO | AR3AE100

P5 - PLAY WELL FLEXIBLE PARTICIPATORY HOUSING | JACEK BACZKOWSKI

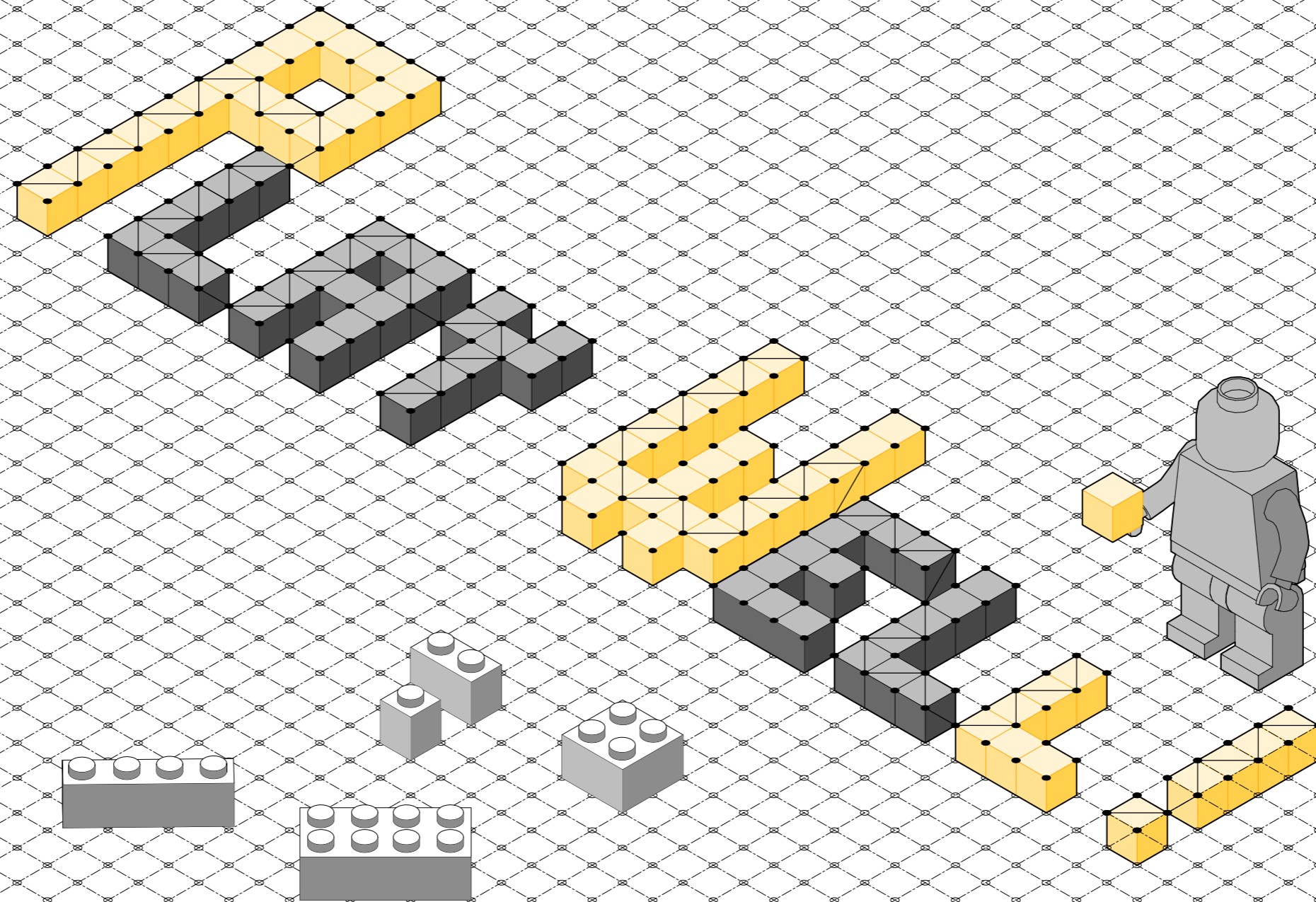

MENTORS:

ROEL VAN DE PAS

PADDY TOMESSEN

PIROUZ NOURIAN

P5 - PLAY WELL FLEXIBLE HOUSING

00.PROBLEM STATEMENT - 1 MILION HOMES



Housing sector and municipalities call for 1 million new homes by 2031

“THERE IS AN URGENT NEED FOR AFFORDABLE HOUSING SOLUTIONS IN THE NETHERLANDS BEFORE 2030. HOWEVER, THE FOCUS SHOULD NOT ONLY BE ON PRODUCING NEW DWELLINGS, BUT RATHER ON CREATING HOMES AND NEIGHBOURHOODS THAT MEET THE NEEDS OF THE FUTURE POPULATION”

“AN ENTIRE GENERATION IS IN DANGER OF LOSING CONNECTION TO THE HOUSING MARKET”

P5 - PLAY WELL FLEXIBLE HOUSING

00.PROBLEM STATEMENT - HOUSING AFFORDABILITY:

LEADING TO **GENERATION RENT!**

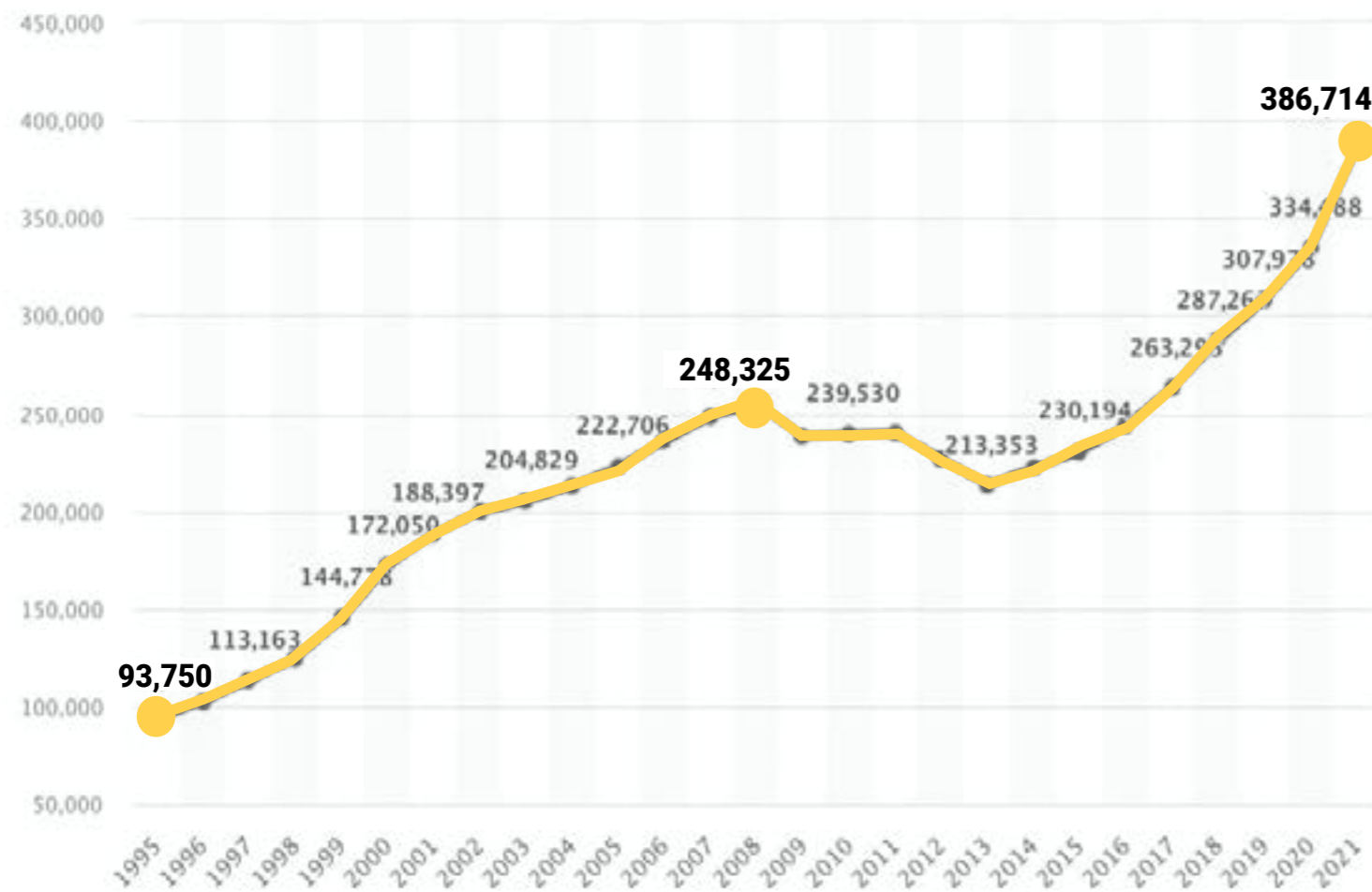

HOUSE PRICE INCREASE - NETHERLANDS

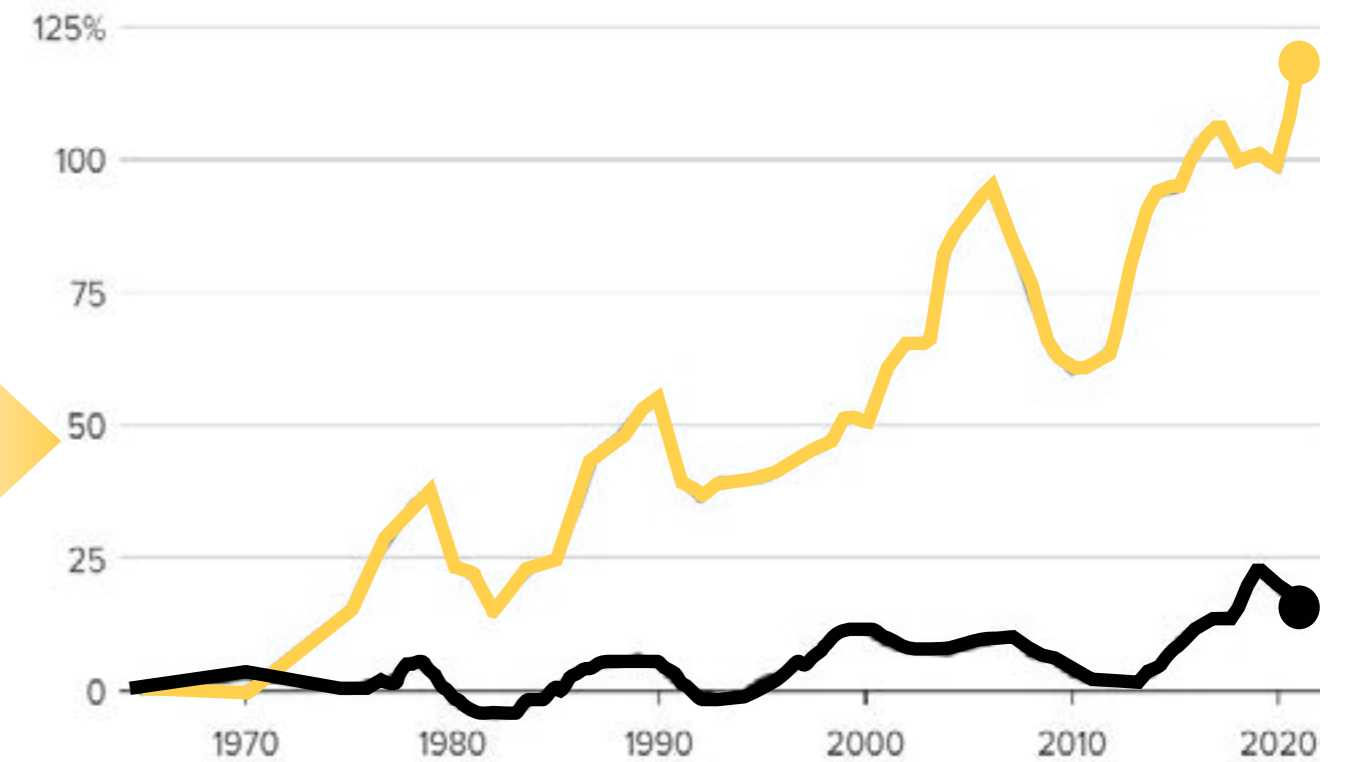

MEDIAN **HOUSE VALUE** TO **MEDIAN WAGE** GROWTH



ACCORDING TO THE GUARDIAN IN 2020 IN UK INHERITANCE REPLACED WORK AS MAIN ROUTE TO HOME OWNERSHIP.

P5 - PLAY WELL FLEXIBLE HOUSING

00.PROBLEM STATEMENT - CONSTRUCTION INEFFICIENCY:

EXACERBATING **UNAFFORDABILITY!**

Productivity in manufacturing has nearly doubled, whereas in construction it has remained flat.

Overview of productivity improvement over time

Productivity (value added per worker), real, \$ 2005

— Manufacturing
— Construction

\$ thousand per worker

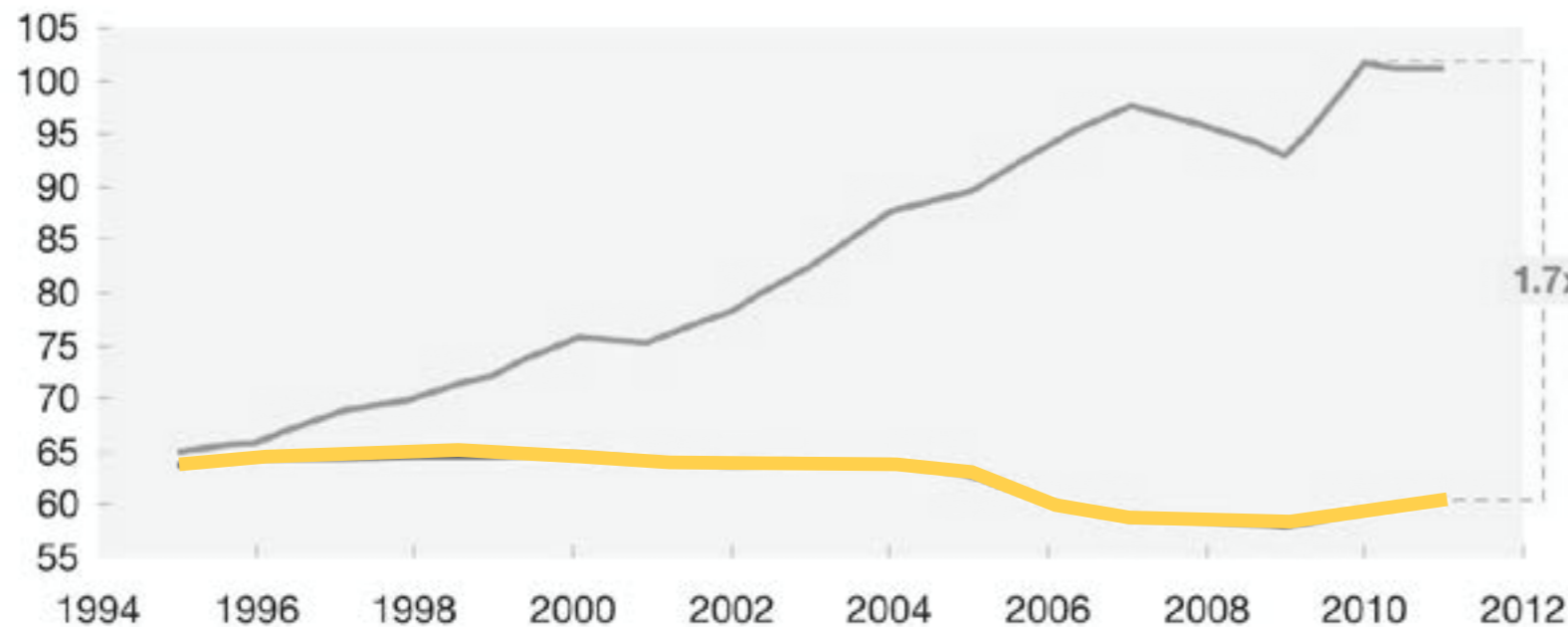

The same sectors tend to be at the frontier—and also lagging behind—in the United States and Europe.

MGI Industry Digitization Index, United States vs European nations¹, Select sectors²



¹Index is based only on asset and labor components and thus may not align with heat maps displayed elsewhere.
²Due to accounting differences between the United States and Europe, not all sectors can be fairly compared.
³Information communications technology.

MANUFACTURING VS CONSTRUCTION PRODUCTIVITY



DIGITIZATION IN INDUSTRIES

P5 - PLAY WELL FLEXIBLE HOUSING

00.PROBLEM STATEMENT - THE ARCHITECTURE FOR 95% VS 5%

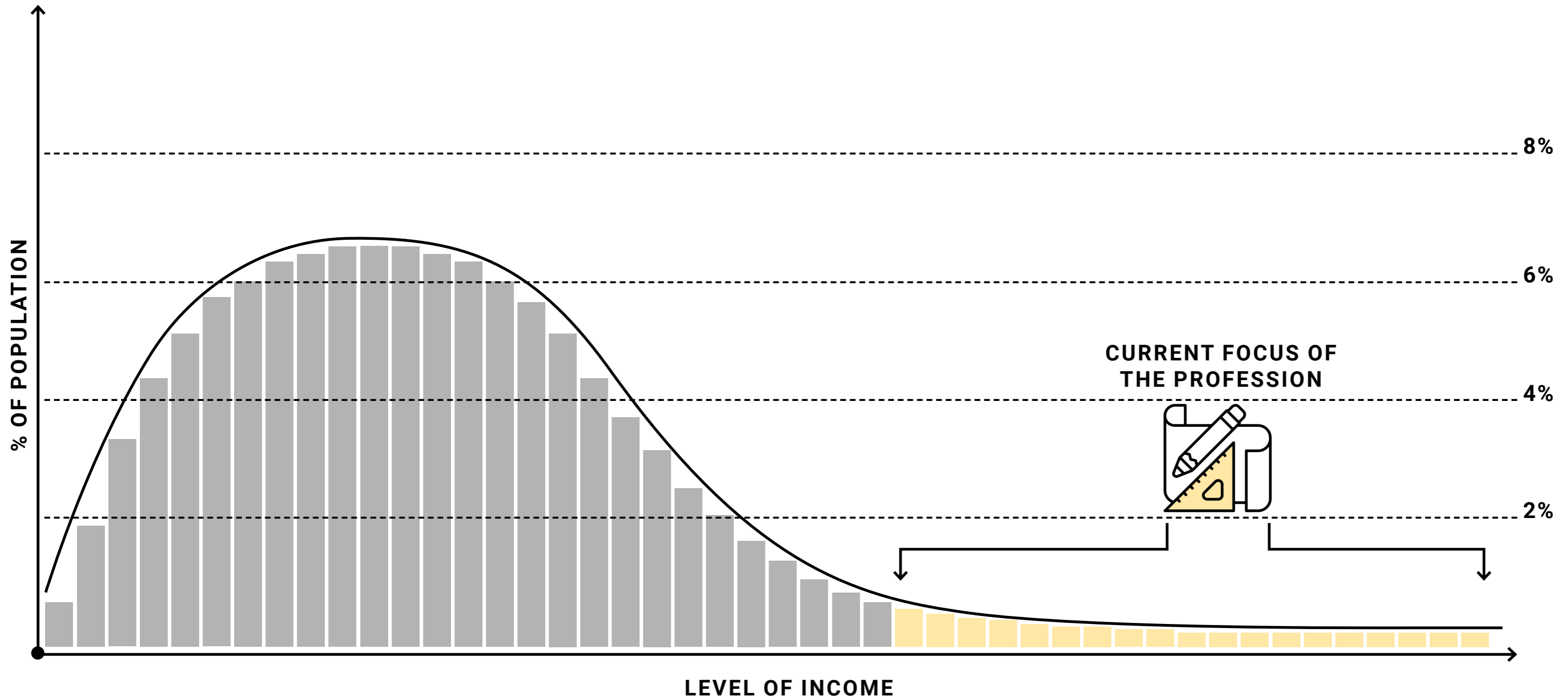

P5 - PLAY WELL FLEXIBLE HOUSING

00.PROBLEM STATEMENT - THE ARCHITECTURE FOR 95% VS 5%

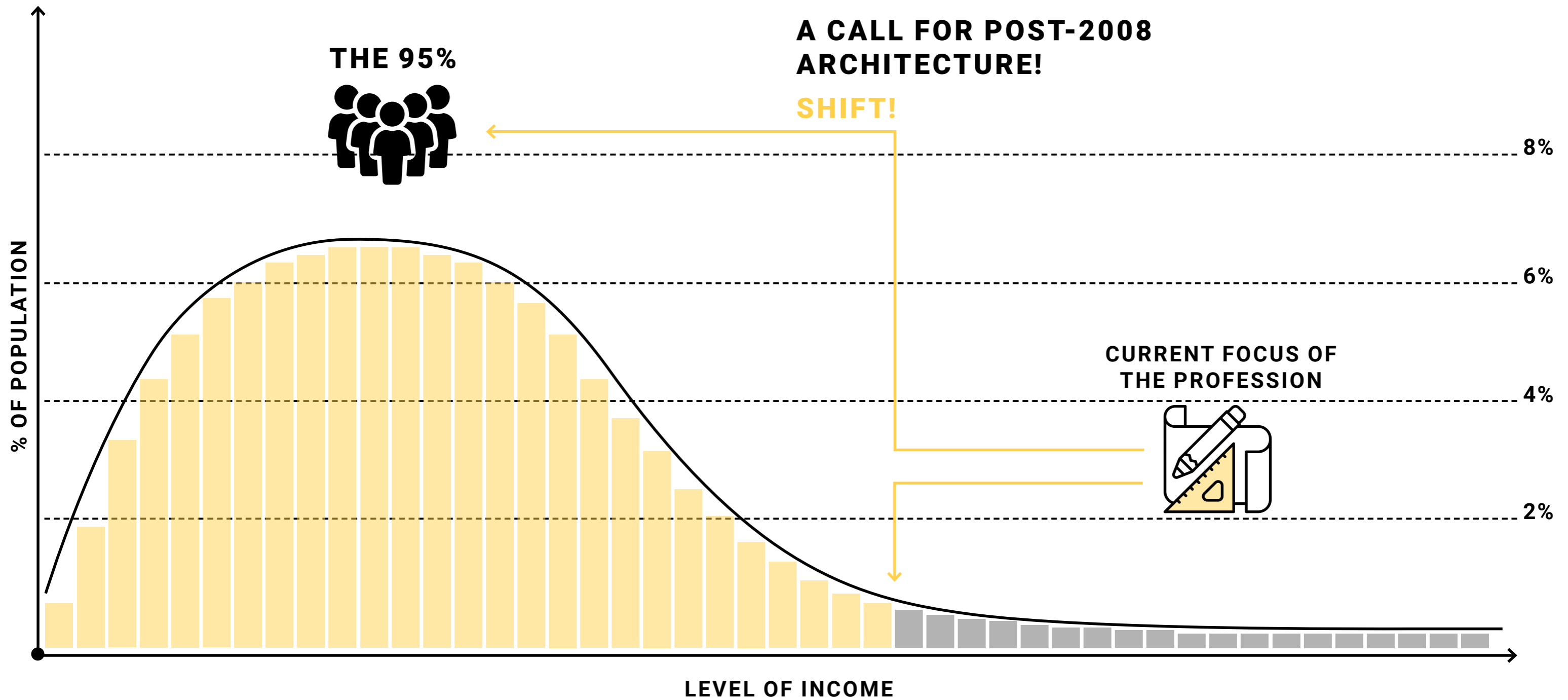

P5 - PLAY WELL FLEXIBLE HOUSING

00. PROBLEM STATEMENT - BIGGEST HOUSING INDUSTRY PROBLEMS:



GENERIC | DEHUMANIZING

35% OF EU CITIZENS DON'T FEEL ATTACHED TO THEIR LIVING SPACE!



WASTEFUL | RESOURCE INTENSIVE.

40% OF ENERGY CONSUMPTION AND 36% OF CO2 EMISSIONS IN THE EU!



UNATTAINABLE | UNAFFORDABLE

IN EU 20.0 % OF INCOME WAS DEDICATED TO HOUSING COSTS. RENT PRICES INCREASED BY 15% BETWEEN 2010 AND 2019!



LOW ON-SITE CONSTRUCTION QUALITY

98 % OF UK NEW HOME OCCUPANTS REPORT DEFECT OF SOME KIND!

PROBLEM OF **DISREGARD FOR THE NEEDS** OF THE BIGGEST POTENTIAL CUSTOMER OF ARCHITECTURE. I.E THE MASSES.

SOCIO-ECONOMIC PROBLEMS

PROBLEM OF THE **INEFFICIENCY AND WASTE** IN CONSTRUCTION INDUSTRY.

TECHNOLOGICAL PROBLEMS

P5 - PLAY WELL FLEXIBLE HOUSING

00. PROBLEM STATEMENT - HYPOTHESIS POTENTIAL SOLUTIONS:

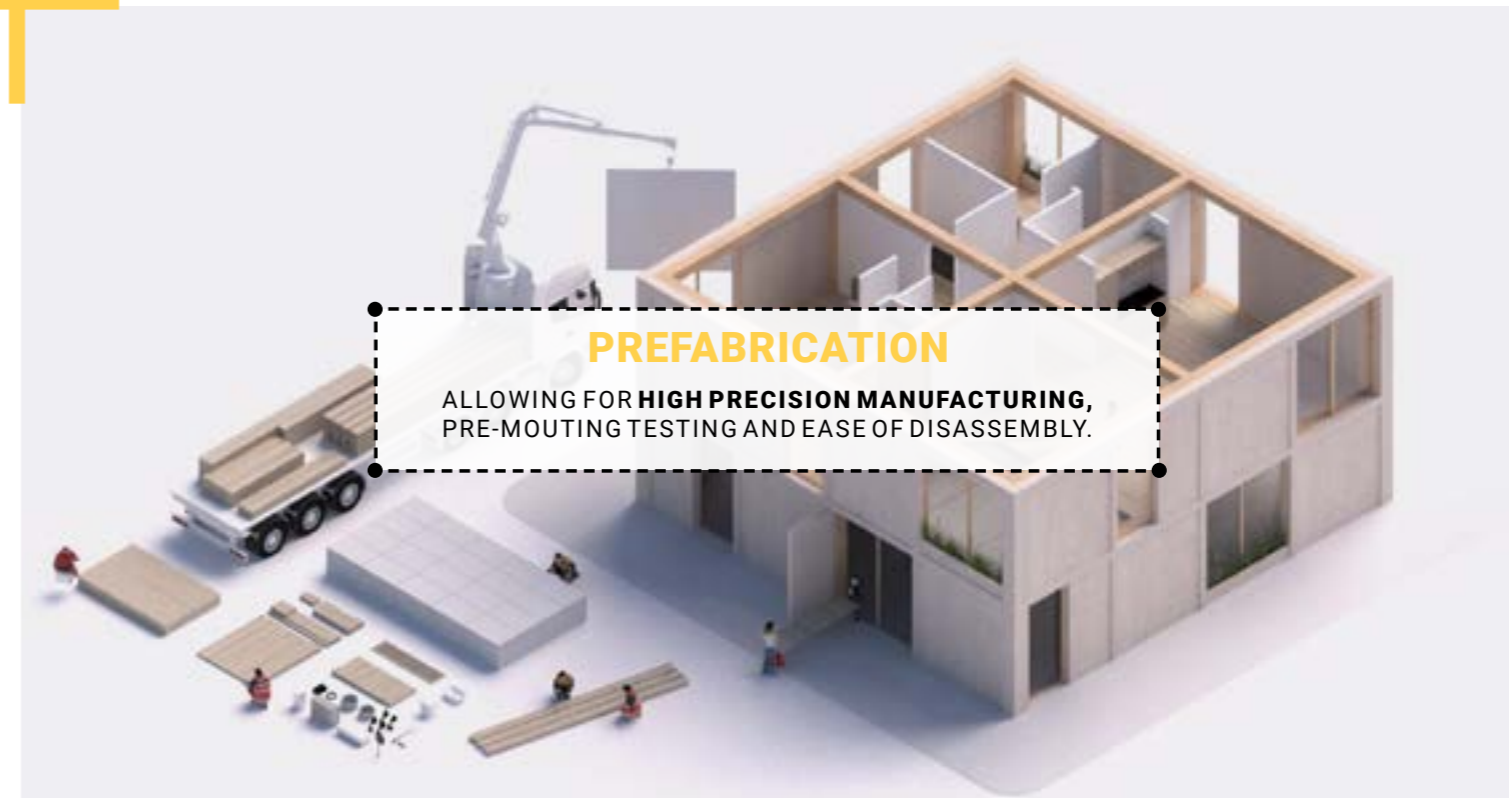
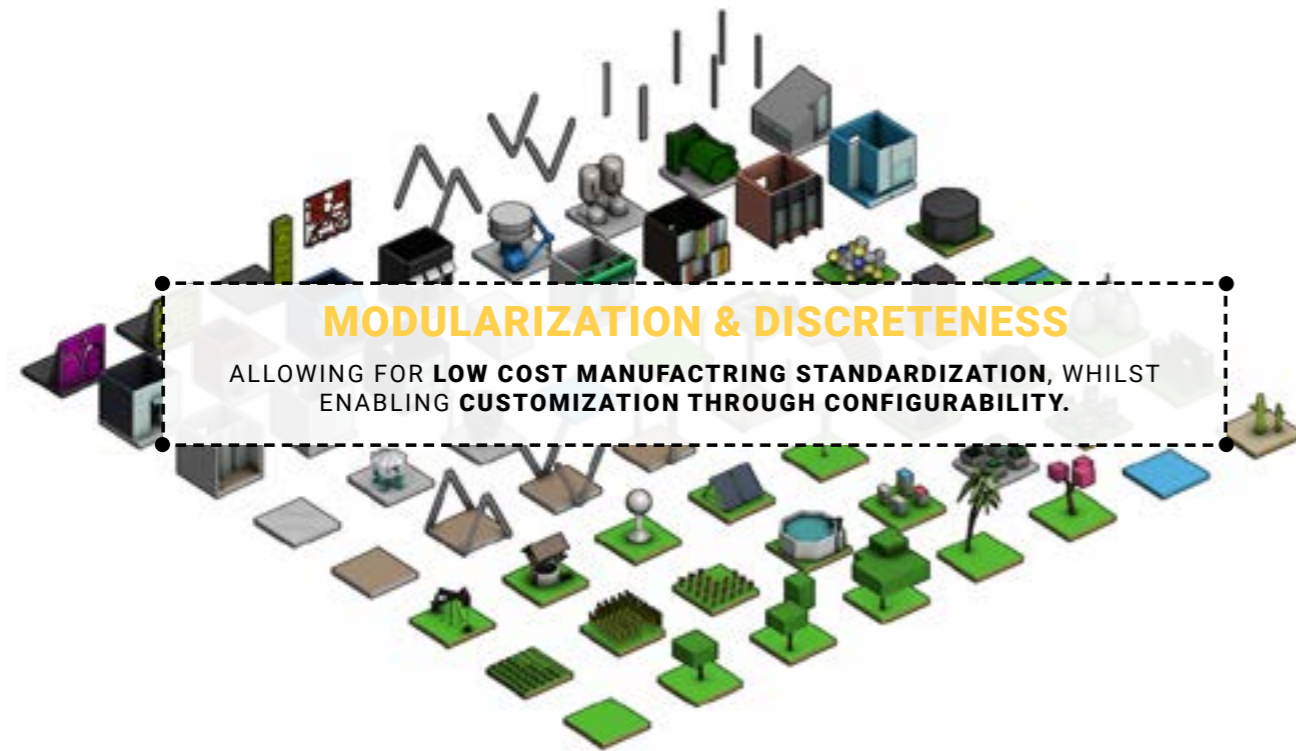
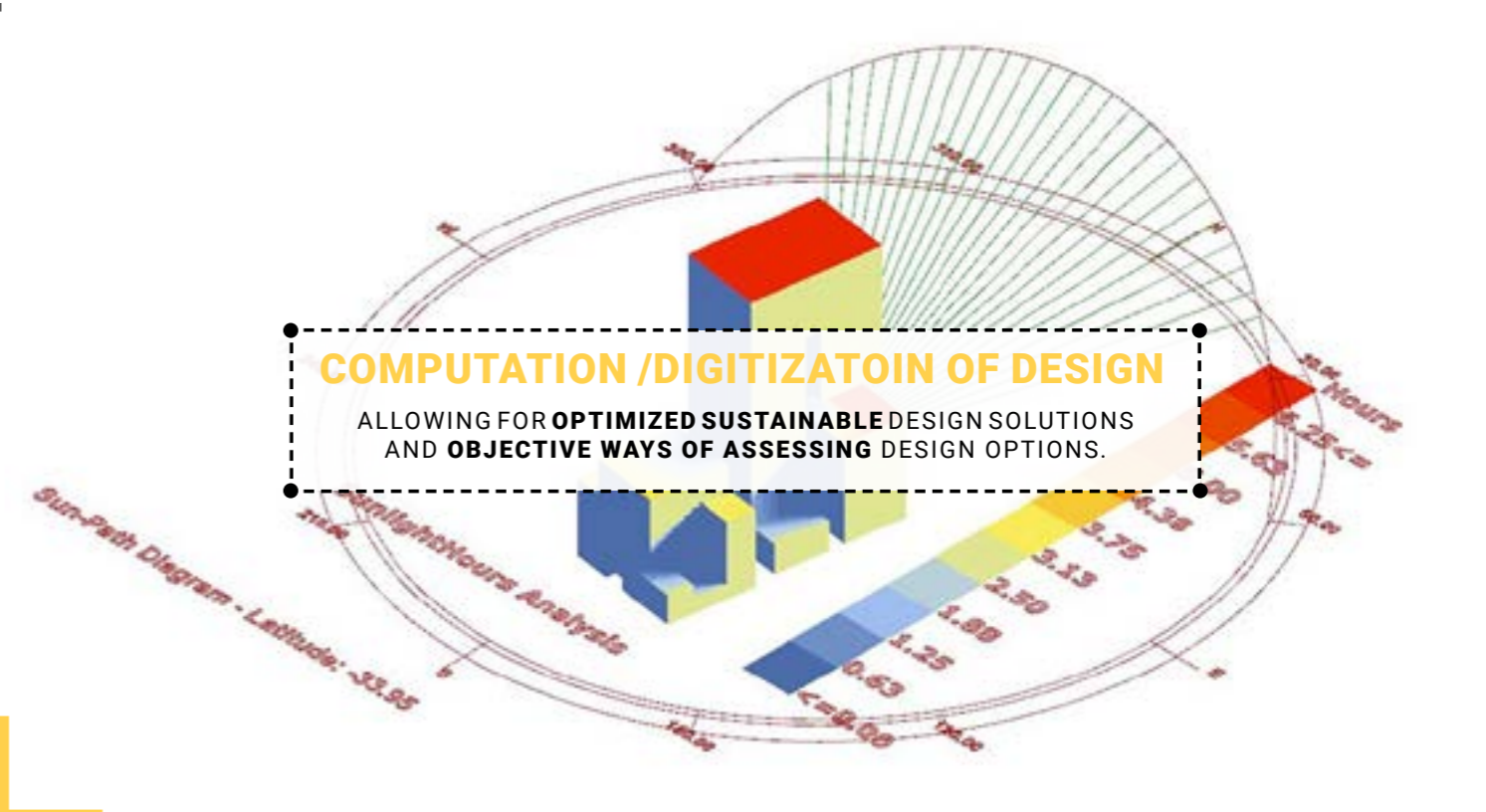

PROBLEM OF **DISREGARD FOR THE NEEDS** OF THE BIGGEST POTENTIAL CUSTOMER OF ARCHITECTURE. I.E THE MASSES.

PROBLEM OF THE **INEFFICIENCY AND WASTE** IN CONSTRUCTION INDUSTRY.

P5 - PLAY WELL FLEXIBLE HOUSING

01. RESEARCH BACKGROUND - HOUSING INNOVATION ECOSYSTEM APPROACH PRINCIPLES:

UB



nabr

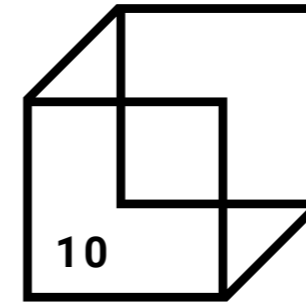

juno



01. URBAN BETA

+ SPATIAL VOXEL BASED CONFIGURATOR FOR BUILDING CONFIGURATIONS CREATION.



GAMIFICATION



02. NABR

+ PRODUCTIZED APPROACH TO HOUSING - END USER HAS THE POSSIBILITY TO SELECT FEATURES.



PRODUCTIZATION

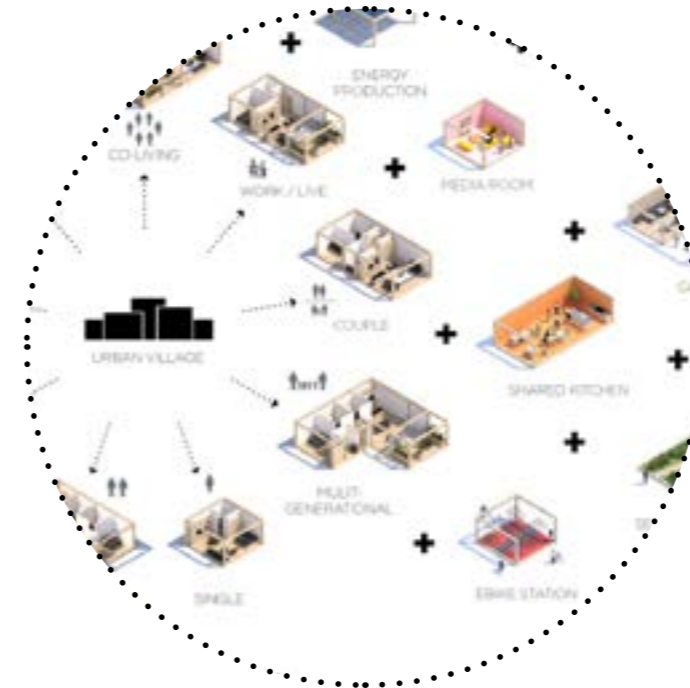

03. URBAN VILLAGE

+ CATALOGUE OF PRE-CONFIGURED SPACES TO BE UTILIZED WITHIN THE SYSTEM.



CATALOGIZATION

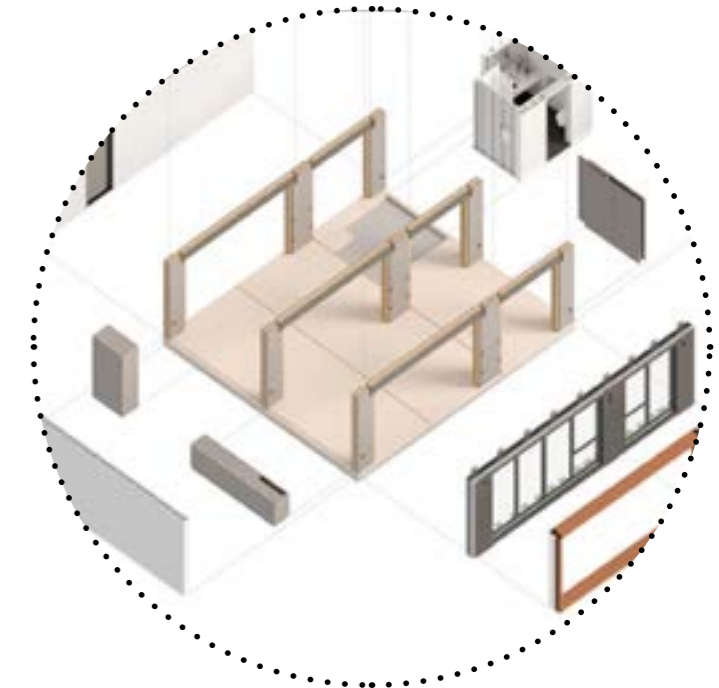

04. JUNO

+ CREATED A COMPONENT-BASED DESIGN PROCESS THAT BRINGS PRECISION AND SIMPLICITY.
+ ENTIRE SYSTEM COMPRISES OF 30 PRE-FABRICATED ELEMENTS.



COMPONENTIZATION

P5 - PLAY WELL FLEXIBLE HOUSING

01. RESEARCH BACKGROUND - HOUSING INNOVATION ECOSYSTEM APPROACH PRINCIPLES:

UB

nabr

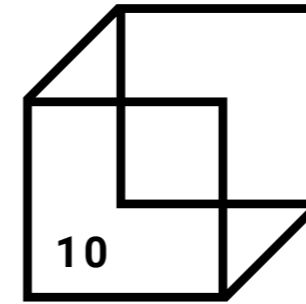

juno

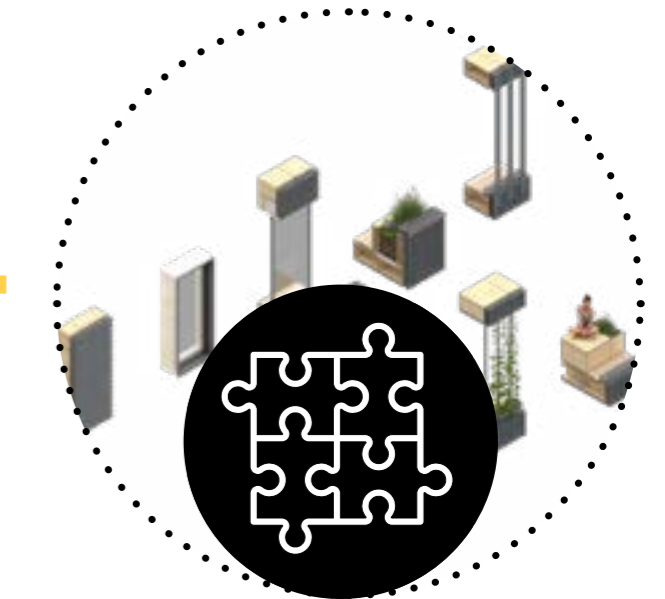
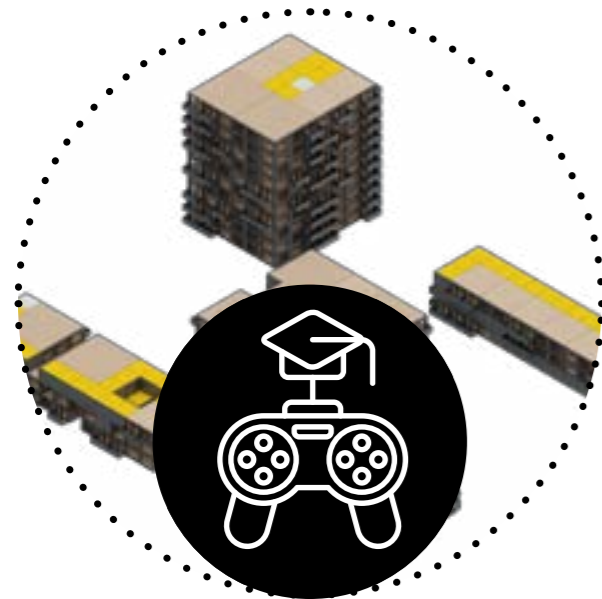

GAMIFICATION

ALLOWING FOR
DESIGN PROCESS
PARTICIPATION.

PRODUCTIZATION

ALLOWING FOR
ATTUNING TO VARIOUS
NEEDS AND FINANCIAL
CAPACITIES.

CATALOGIZATION

ALLOWING FOR
CONSTANT STOCK
IMPROVEMENT
AND EASY OPTIONS
COMPARISON.

COMPONENTIZATION

ALLOWING FOR MASS
CUSTOMIZATION OF
DESIGN.

P5 - PLAY WELL FLEXIBLE HOUSING

01. RESEARCH BACKGROUND - HOUSING INNOVATION ECOSYSTEM
BOOM DEVELOPMENT SYSTEM:



Boom

BOOM DEVELOPED A MODEL FOR THE CONSTRUCTION INDUSTRY THAT MINIMIZES THE TIME AND COST REQUIRED TO START CONSTRUCTION ON NEW HOUSING. AT THE HEART OF THIS SYSTEM IS A CATALOGUE OF **WOOD-BASED HOUSING ARCHETYPES** THAT ARE **FLEXIBLE AND EASILY ADAPTABLE TO DIFFERENT CONTEXTS**. - CATALOGUE OF OPTIONS.

- CUSTOM-MADE LIVING FOR EVERYONE!
- READY-MADE ARCHITECTURE FOR A BETTER WORLD!
- CATALOGUIZED DEVELOPMENT SYSTEM FOR THE FUTURE OF LIVING

MVRDV

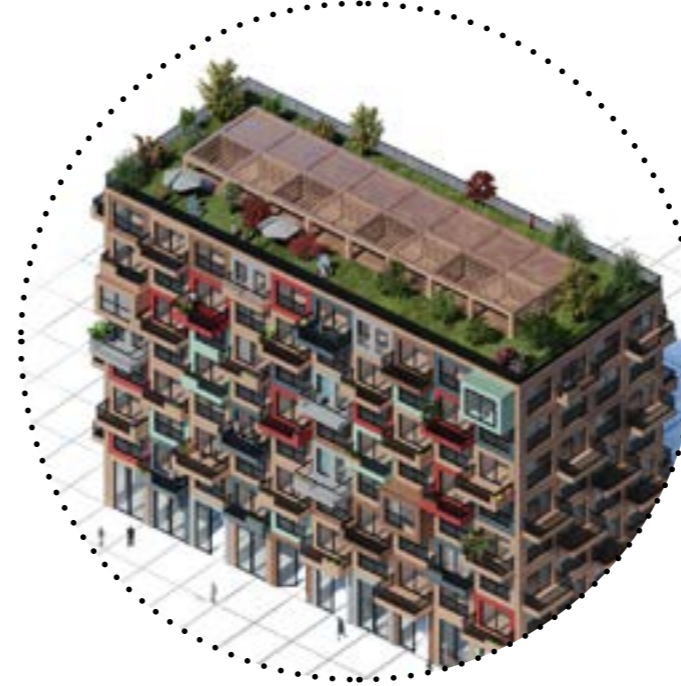

FLEX BLOCK

SPACE&MATTER



PUZL

+

+



MOVA

+



CORE

P5 - PLAY WELL FLEXIBLE HOUSING

01. RESEARCH BACKGROUND - THE DEFENSE OF THE BOX - MODULARITY:

THERE IS A MOUNTAIN RANGE OF EVIDENCE, DOES NOT THE BOX'S RESILIENCE ALSO PROVE ITS OWN INEVITABILITY? ITS ABILITY TO EFFORTLESSLY REPEAT MAKES IT SO SUCCESSFUL.

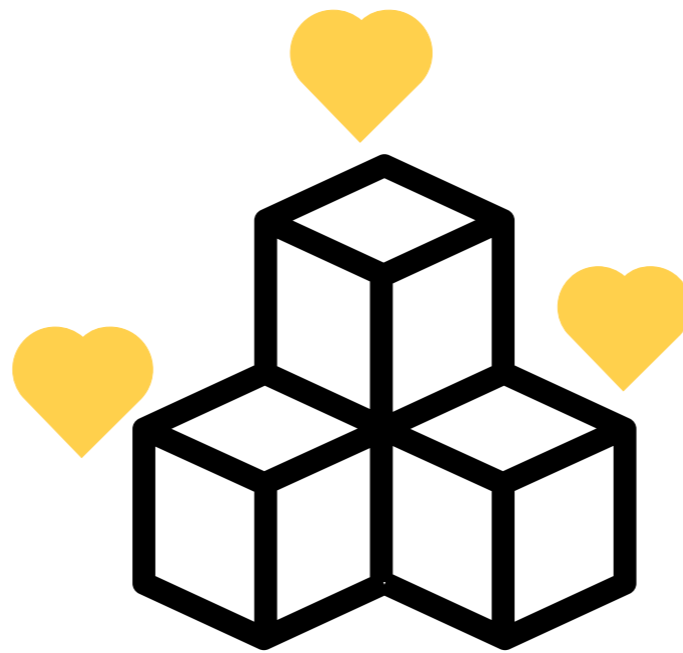

THE BOX IS A NATURAL OUTCOME OF ALL THE RATIONAL PARAMETERS COMBINED, THE FORM IN WHICH GEOMETRY AND ECONOMY MEET IN PERFECT SYNC. THE BOX DOESN'T RESIST; IT COMPLIES. IT'S EASY. IT SUITS ANY USE AND ANY SIZE. IT OFFERS MULTIPLE OPTIONS TO EXPAND.

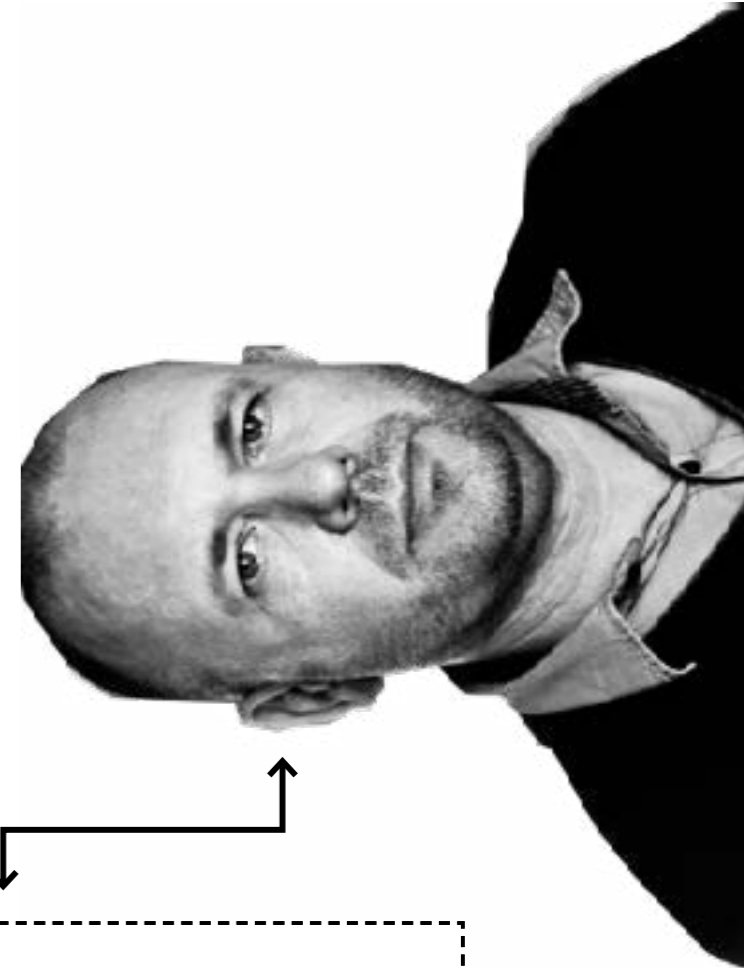

P5 - PLAY WELL FLEXIBLE HOUSING

01. RESEARCH BACKGROUND - SERIOUS GAMES:



DIGITAL PARTICIPATORY GAMES

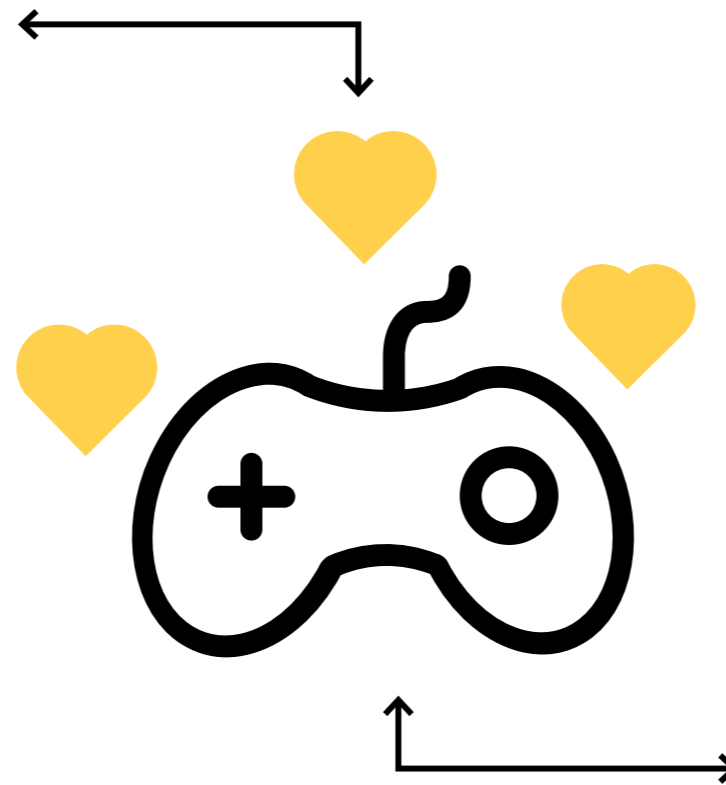

PHYSICAL COLLABORATIVE GAMES



P5 - PLAY WELL FLEXIBLE HOUSING

01. RESEARCH BACKGROUND - MODULAR CONSTRUCTION & SERIOUS GAMES MARKETS:

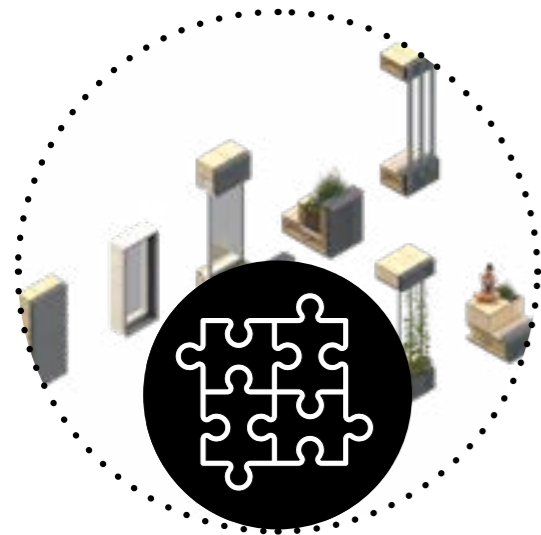

MODULAR CONSTRUCTION

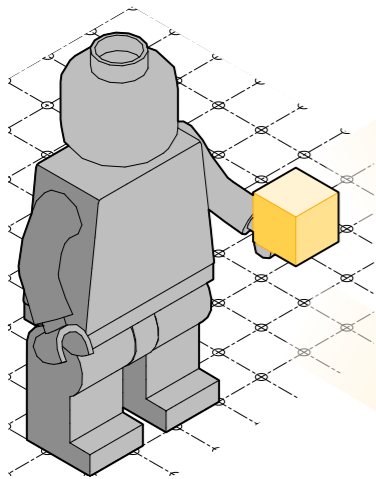

SERIOUS GAMES

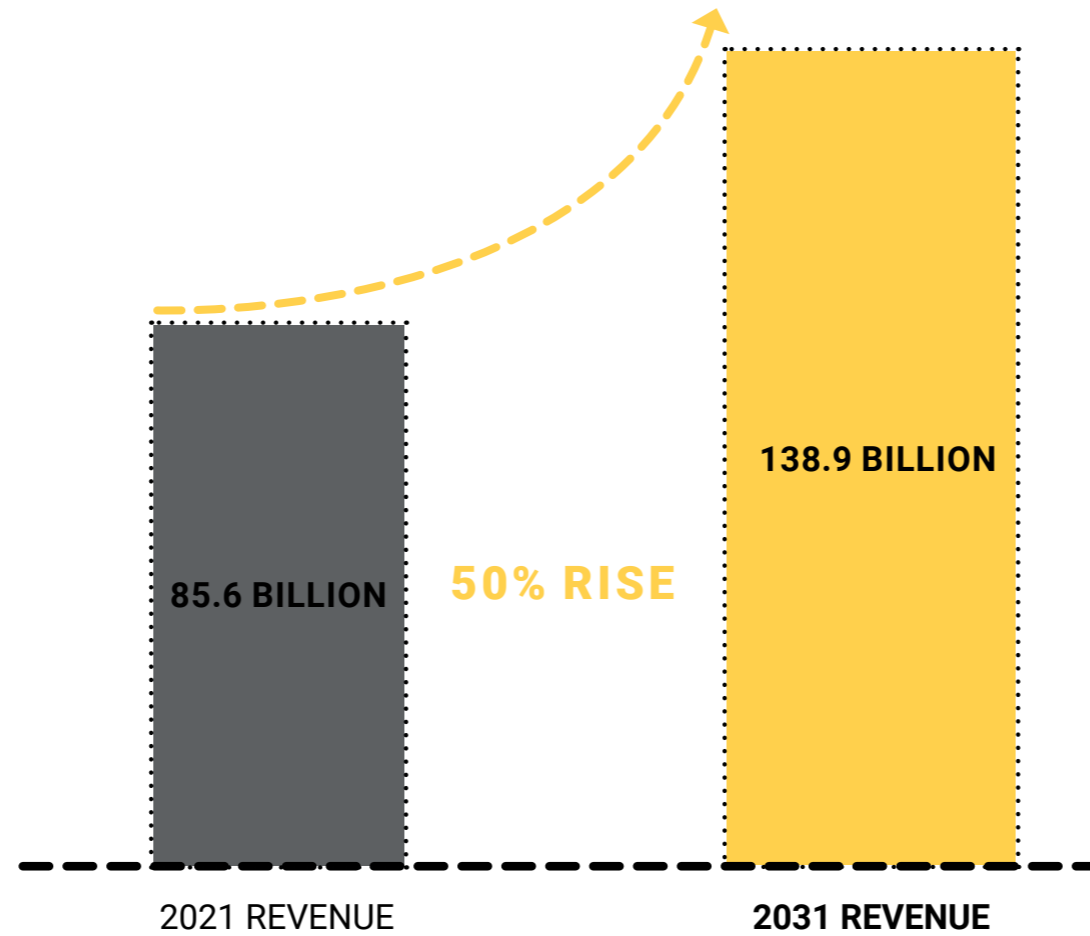

GVRESEARCH MARKET ANALYSIS

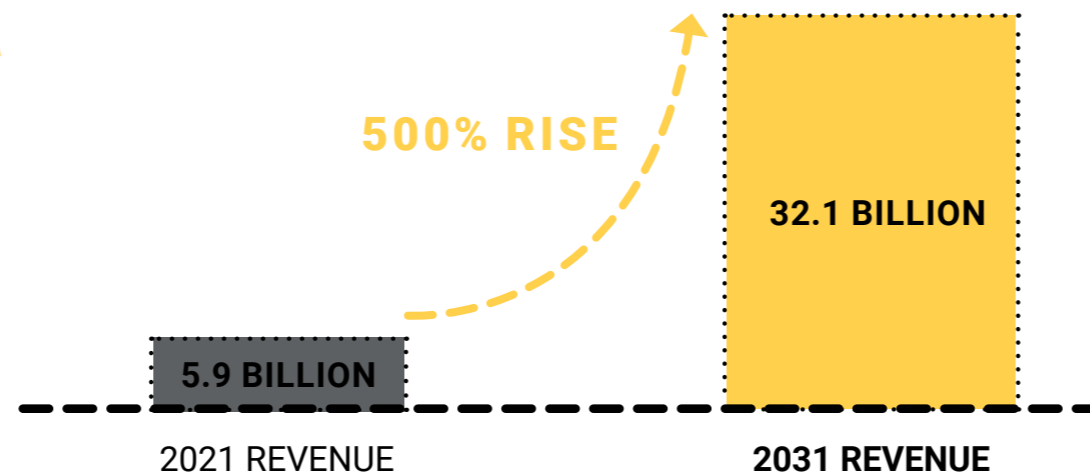

AMR MARKET ANALYSIS



P5 - PLAY WELL FLEXIBLE HOUSING

02. MODULAR CONSTRUCTION SYSTEM - WHAT IS PLAY WELL?

DIGITAL HOUSING SYNTAX

RELATIONSHIPS:

WORDS:

DESIGN PARTICIPATORY SYSTEM/ PLATFORM!

KIT-OF-PARTS CATALOGUE FOR MASS CUSTOMIZABLE DESIGN!

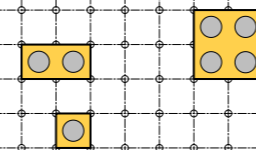
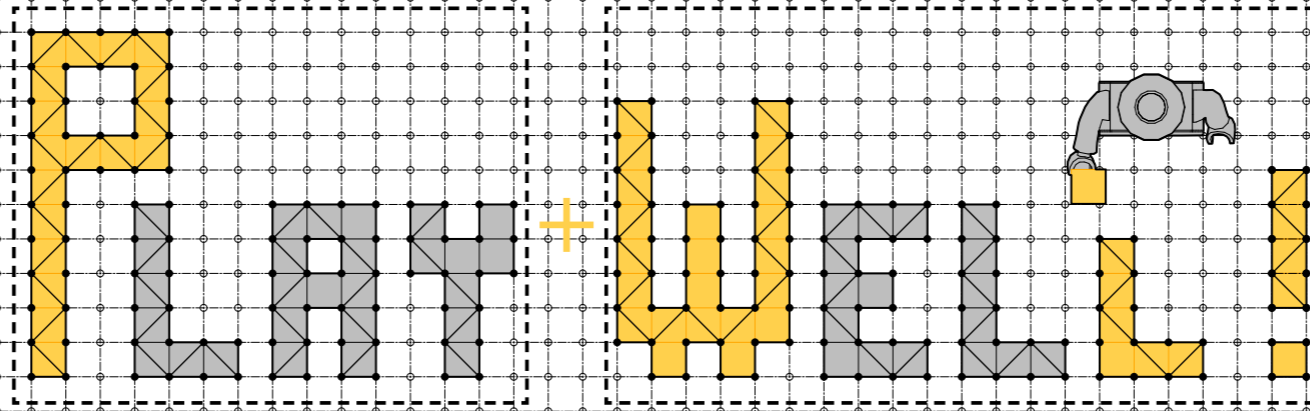

PROBLEM OF DISREGARD FOR THE NEEDS OF THE BIGGEST POTENTIAL CUSTOMER.

REDEFINITION OF FRAMEWORK FOR 21ST CENTURY HOUSING DESIGN: FROM MACHINE FOR LIVING TO AN ECOSYSTEM FOR LIVING.

FOR HOUSING AFFORDABILITY, PERFORMANCE, AND FIT FOR PURPOSE DESIGN.

PROBLEM OF THE INEFFICIENCY AND WASTE IN CONSTRUCTION INDUSTRY.

LEGO - LEG GODT (DAN.) - PLAY WELL!

P5 - PLAY WELL FLEXIBLE HOUSING

02.PLAY-WELL - BLOCK CONSTRUCTION SYSTEM:

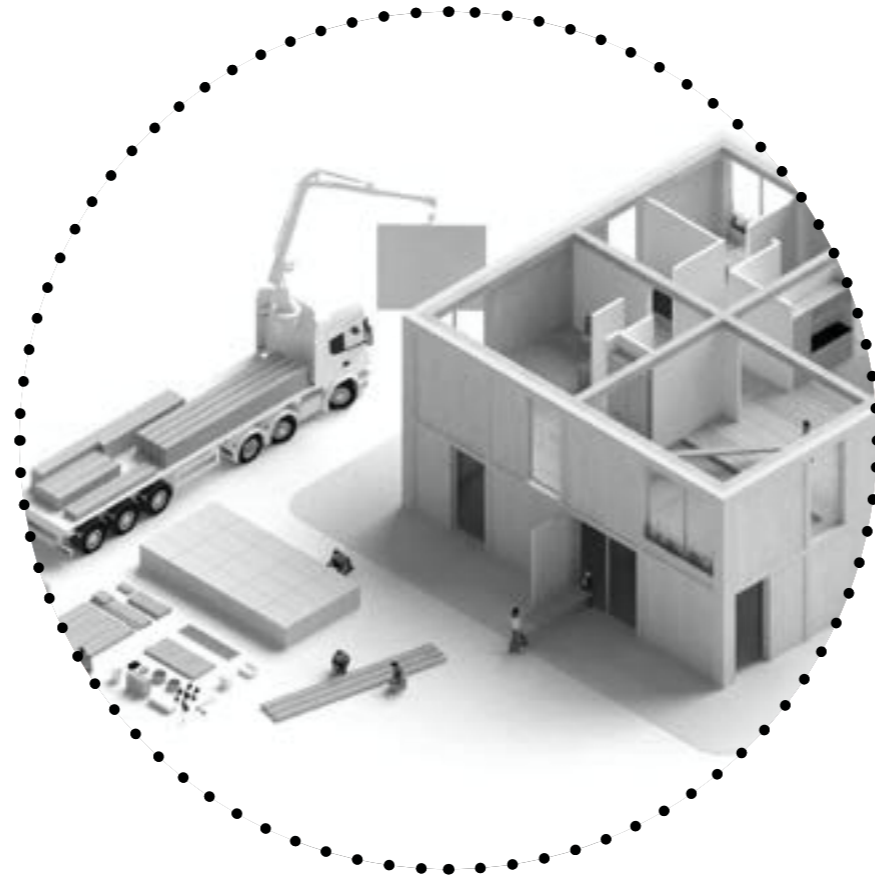

MODULAR BLOCKS SYSTEM RESEARCH!

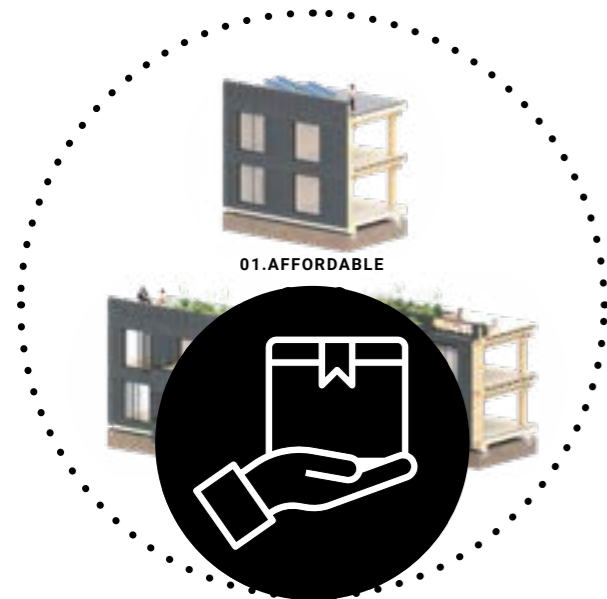

PRODUCTIZATION

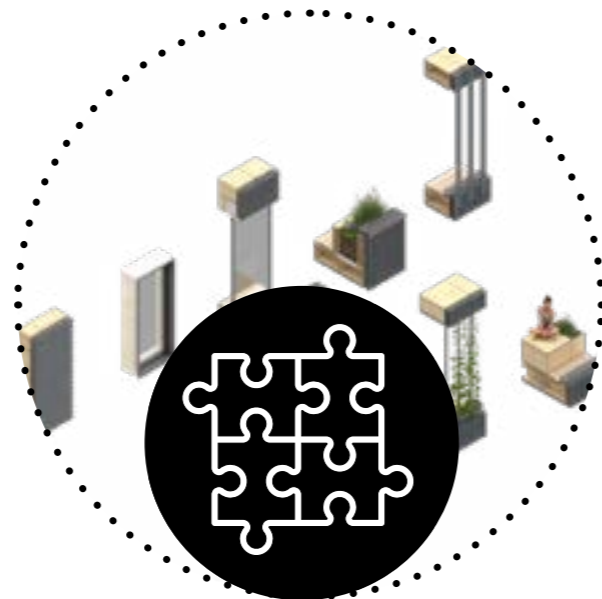

COMPONENTIZATION



DOUGHNUT ECONOMY

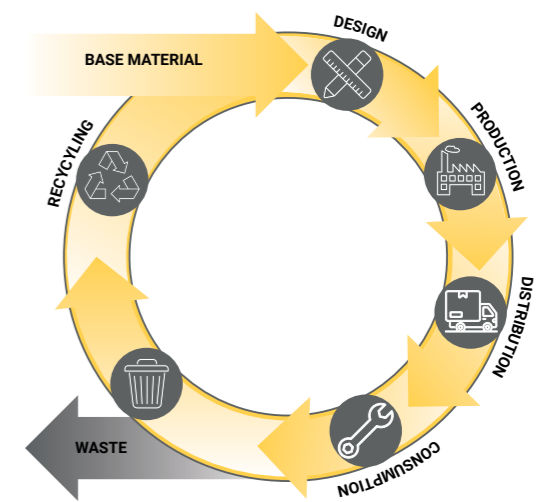

CIRCULAR ECONOMY

P5 - PLAY WELL FLEXIBLE HOUSING

02.BLOK CONSTRUCTION SYSTEM - MODULAR CONSTRUCTION TYPES:

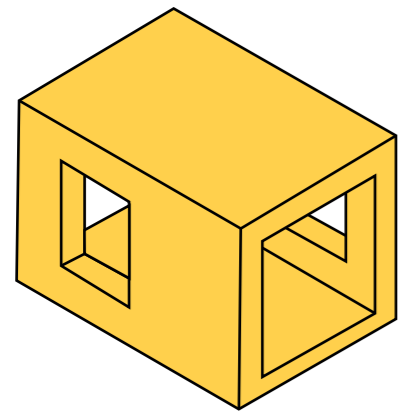

VOLUMETRIC

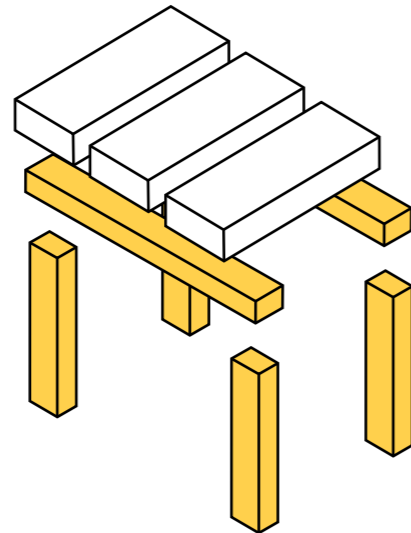

POST&BEAM

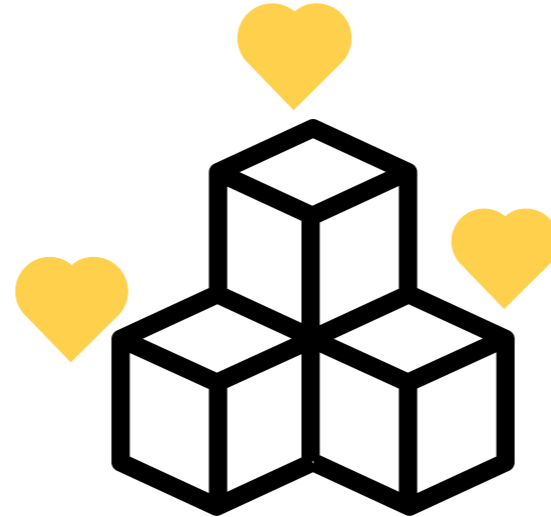

SECTIONAL

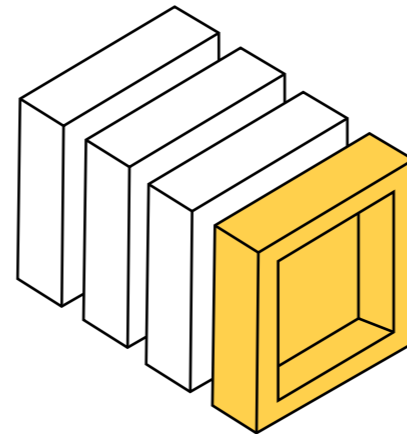

PLANAR

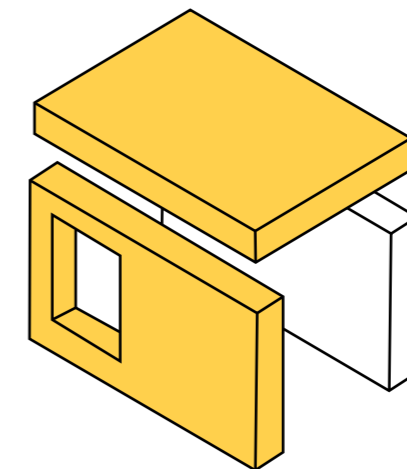
A 3D isometric drawing of a yellow grid-like block system placed on top of a yellow frame structure, enclosed in a dashed box.

- BLOCK SYSTEM**
- + VERSATILE
- + POSSIBLE TO EMULATE BENEFITS OTHERS - PREASSEMBLE
- + CUSTOMIZATION THROUGH CONFIGURATION
- + PARTICIPATION ENABLING

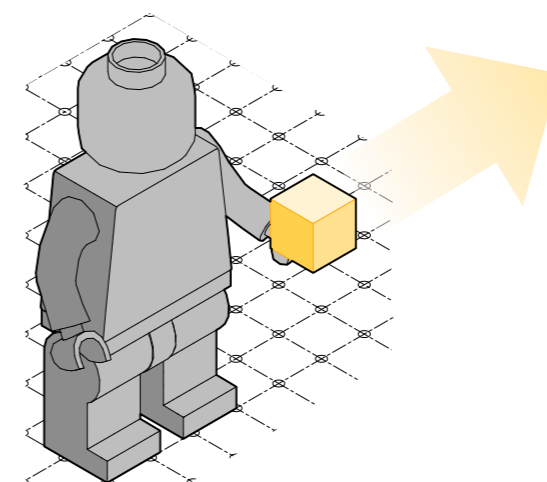

+ MOST LEGO-LIKE!

P5 - PLAY WELL FLEXIBLE HOUSING

02.BLOK CONSTRUCTION SYSTEM - METHODOICAL PROCESS FLOWCHART

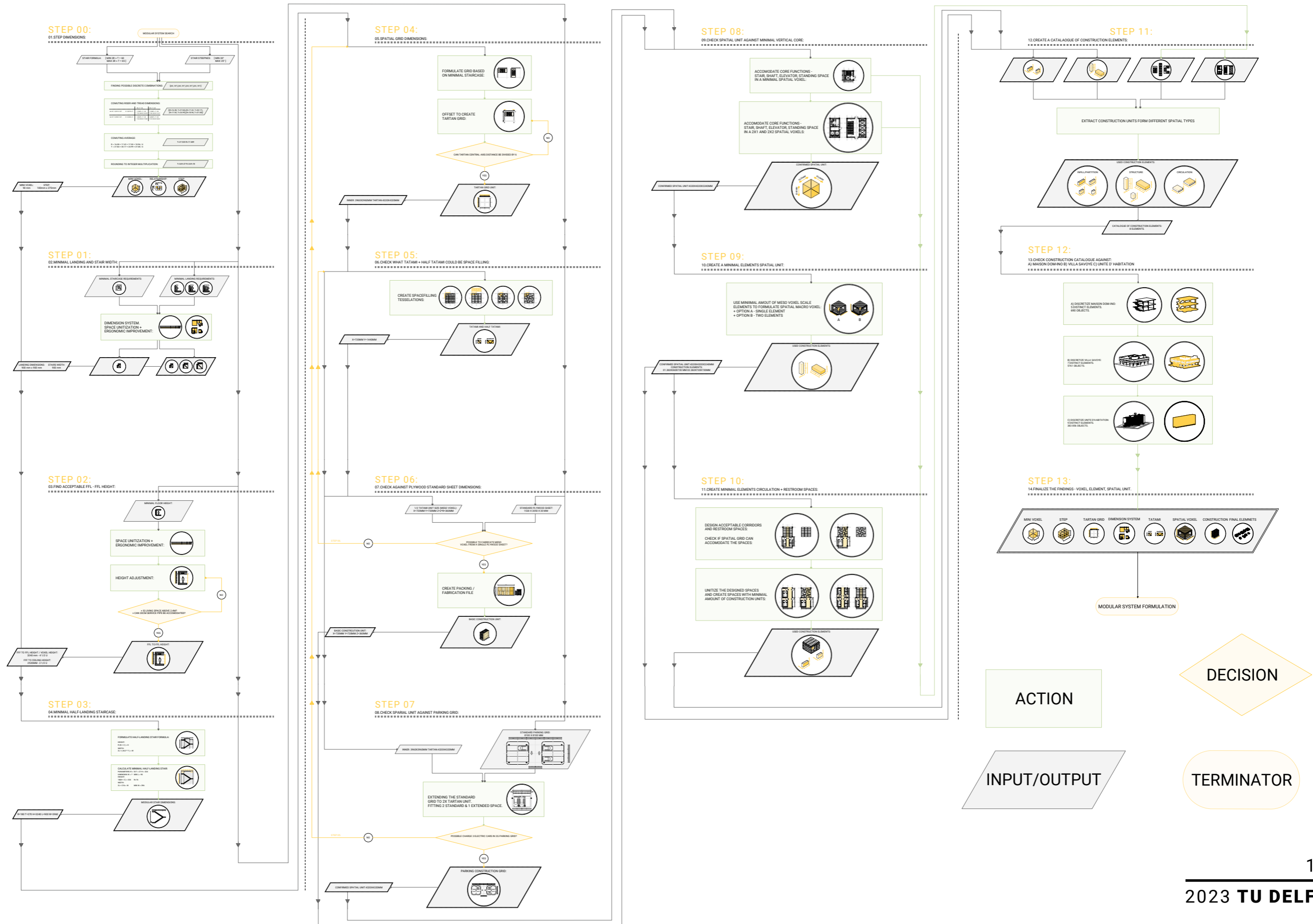

P5 - PLAY WELL FLEXIBLE HOUSING

02.BLOK CONSTRUCTION SYSTEM - PROCESS STEP 00

STEP 00:

01.STEP DIMENSIONS:

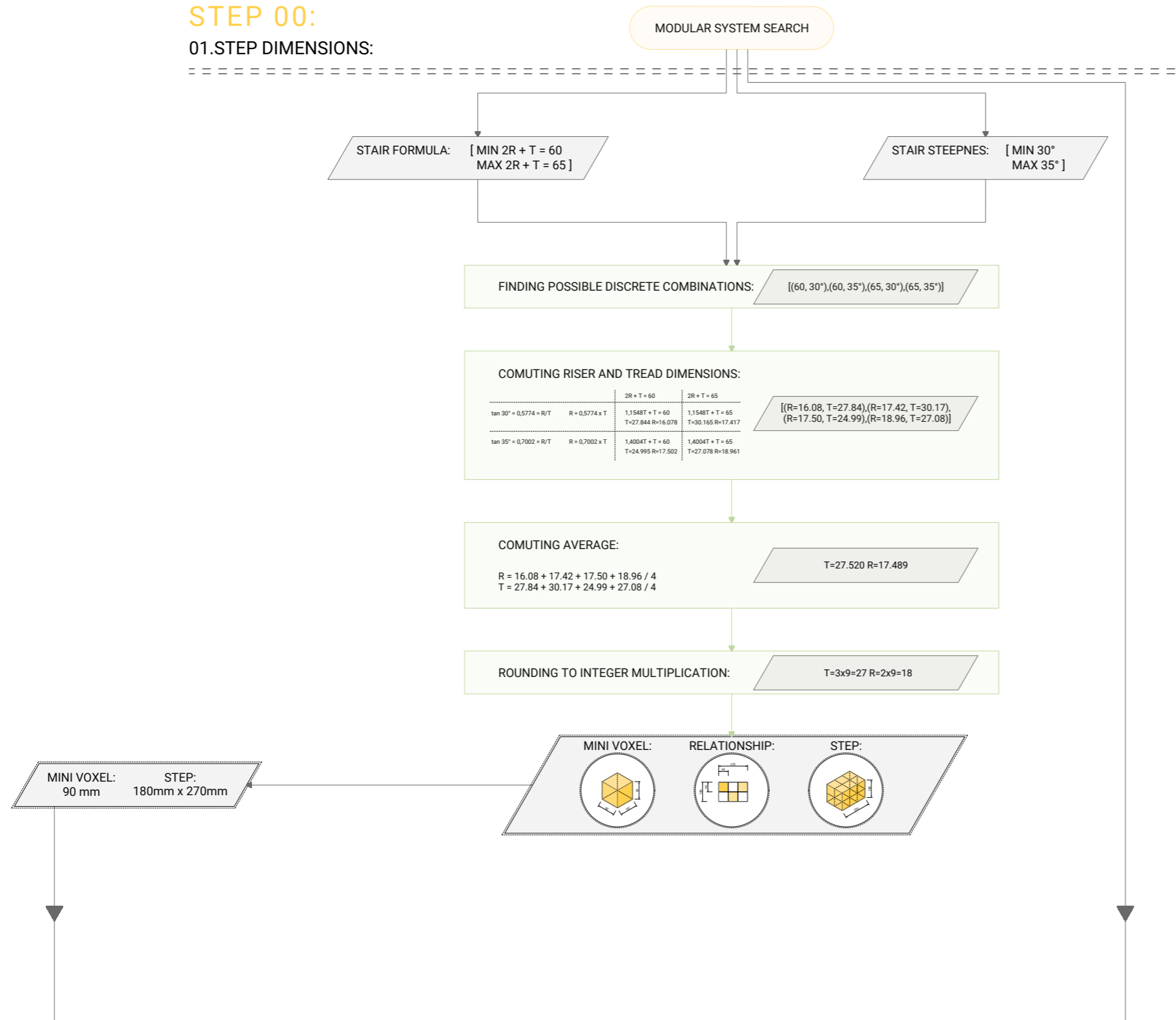

STEP 00: - STEP DIMENSIONS.

STEP 01: - ACCEPTABLE LANDING AND STAIR WIDTH.

STEP 02: - ACCEPTABLE FFL TO FFL HEIGHT (ERGONOMIC LIVING + SERVICES + STRUCTURE PROVISION).

STEP 03: - FIND A MINIMAL HALF LANDING STAIRCASE.

STEP 04: - CREATE A TARTAN SPATIAL GRID BASED ON STAIRCASE DIMENSIONS.

STEP 05: - CHECK WHAT TATAMI + HALF TATAMI MESO VOXELS COULD BE SPACE FILLING IN THE GRID.

P5 - PLAY WELL FLEXIBLE HOUSING

02.BLOK CONSTRUCTION SYSTEM - PROCESS STEP 09

STEP 09:

10.CREATE A MINIMAL ELEMENTS SPATIAL UNIT:

USE MINIMAL AMOUNT OF MESO VOXEL SCALE ELEMENTS TO FORMULATE SPATIAL MACRO VOXEL:
+ OPTION A - SINGLE ELEMENT
+ OPTION B - TWO ELEMENTS

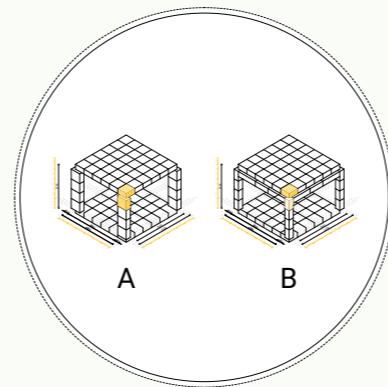

USED CONSTRUCTION ELEMENTS:

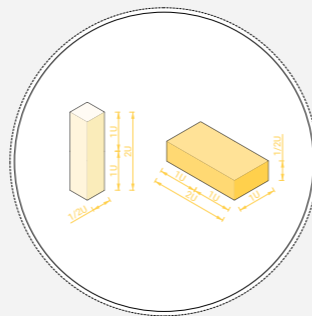

CONFIRMED SPATIAL UNIT:4320X4320X3240MM
CONSTRUCTION ELEMENTS:
01.360X360X720 MM 02.360X720X720MM

STEP 06: - CHECK MESO VOXEL AGAINST STRUCTURAL PLYWOOD SHEET FOR FABRICATION.

STEP 07: - CHECK SPATIAL GRID FOR PARKING PROVISION CAPACITY.

STEP 08: - CHECK SPATIAL GRID AGAINST REQUIREMENTS OF VERTICAL CORES.

STEP 09: - CREATE A SPATIAL UNIT WITH MINIMAL ELEMENT USAGE.

STEP 10: - CREATE A CIRCULATION + RESTROOM/TECHNICAL UNITS WITH MINIMAL ELEMENTN USAGE.

P5 - PLAY WELL FLEXIBLE HOUSING

02.BLOK CONSTRUCTION SYSTEM - PROCESS STEP 11



P5 - PLAY WELL FLEXIBLE HOUSING

02.BLOK CONSTRUCTION SYSTEM - PROCESS STEP 12

STEP 12:

13.CHECK CONSTRUCTION CATALOGUE AGAINST:
A) MAISON DOM-INO B) VILLA SAVOYE C) UNITE D' HABITACION

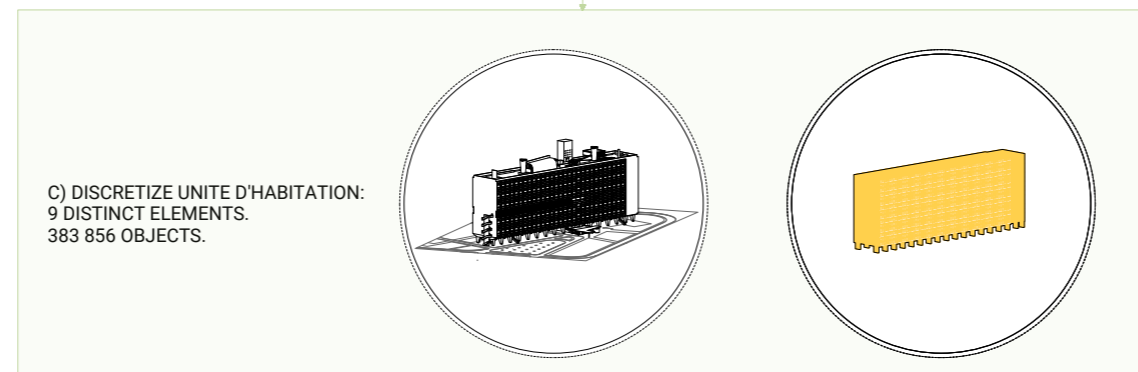
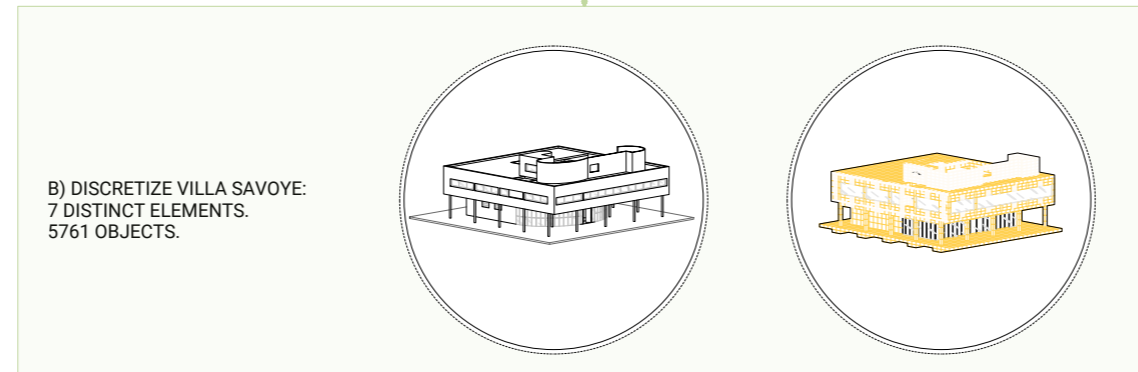
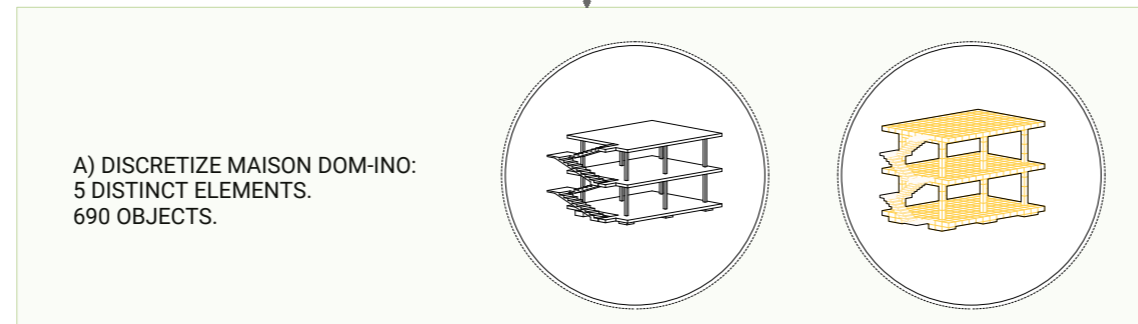

STEP 12: - CHECK THE CONCLUDED
CONSTRUCTION BLOCKS AGAINST
MODERNIST CLASSICS: DOMINO,
SAVOYE, UNITE D'HABITACION.

P5 - PLAY WELL FLEXIBLE HOUSING

02.BLOK CONSTRUCTION SYSTEM - SUMMARY:

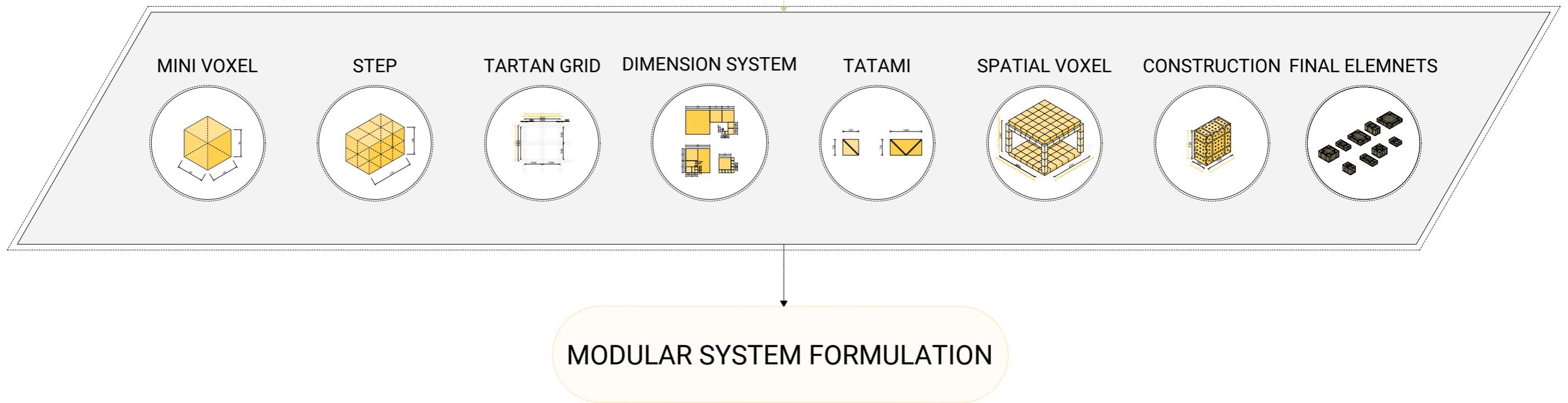
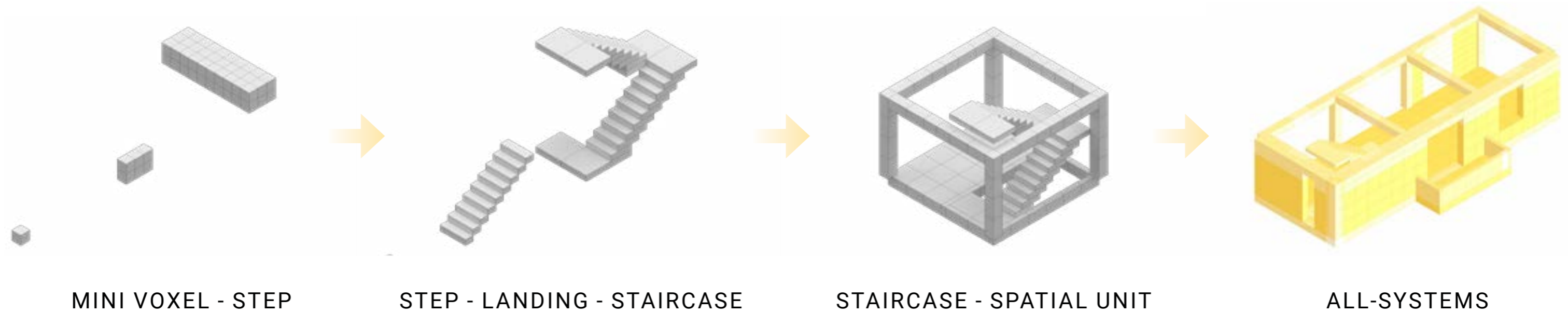

P5 - PLAY WELL FLEXIBLE HOUSING

02.BLOK CONSTRUCTION SYSTEM - MODERNIST ICONS TRANSFORMATION:

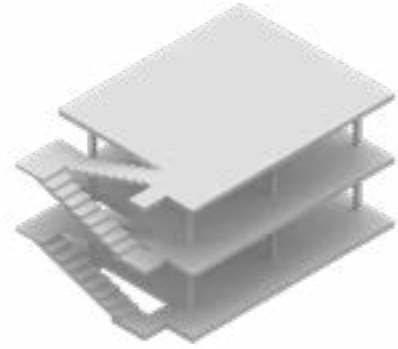

MAISON DOMINO:
+ 5 DISTINCT ELEMENTS
+ 690 OBJECTS

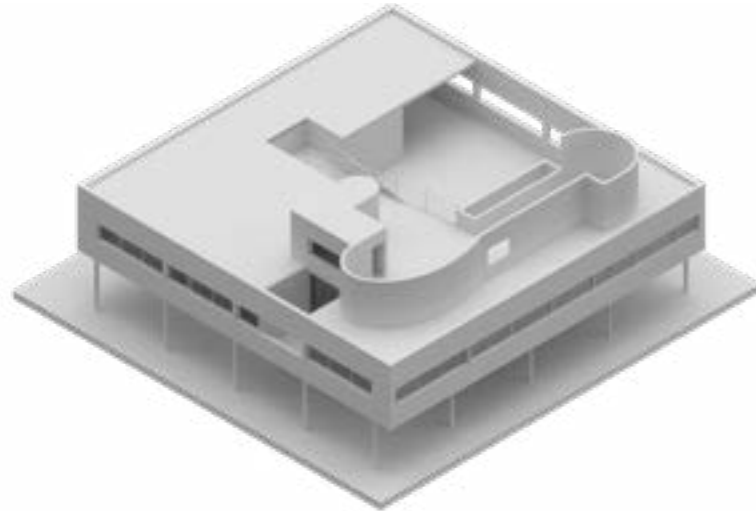

VILLA SAVOYE:
+ 7 DISTINCT ELEMENTS
+ 5762 OBJECTS

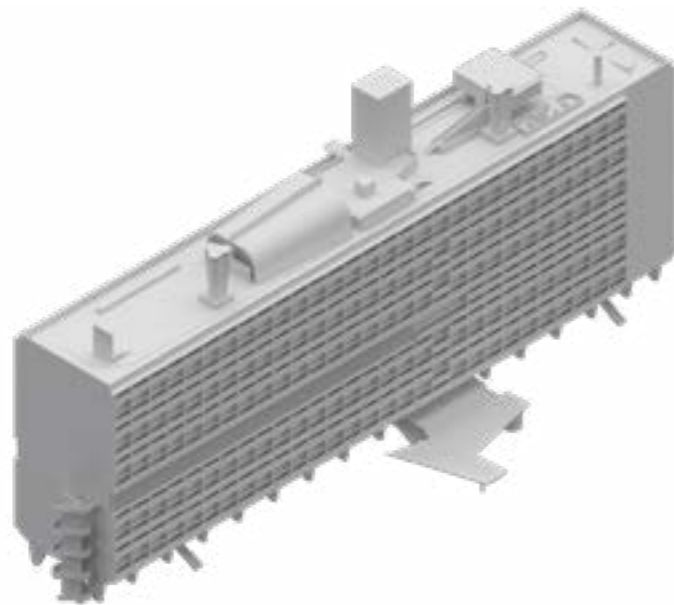

UNITE D' HABITATION:
+ 9 DISTINCT ELEMENTS
+ 383 856 OBJECTS

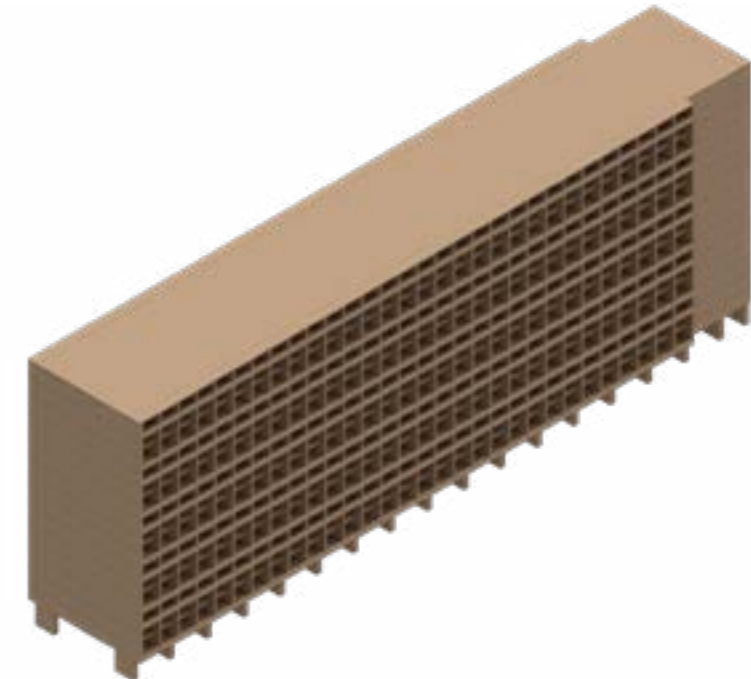

P5 - PLAY WELL FLEXIBLE HOUSING

02.SYSTEM IMPLEMENTATION AUTOMATION TESTS - OVERVIEW:

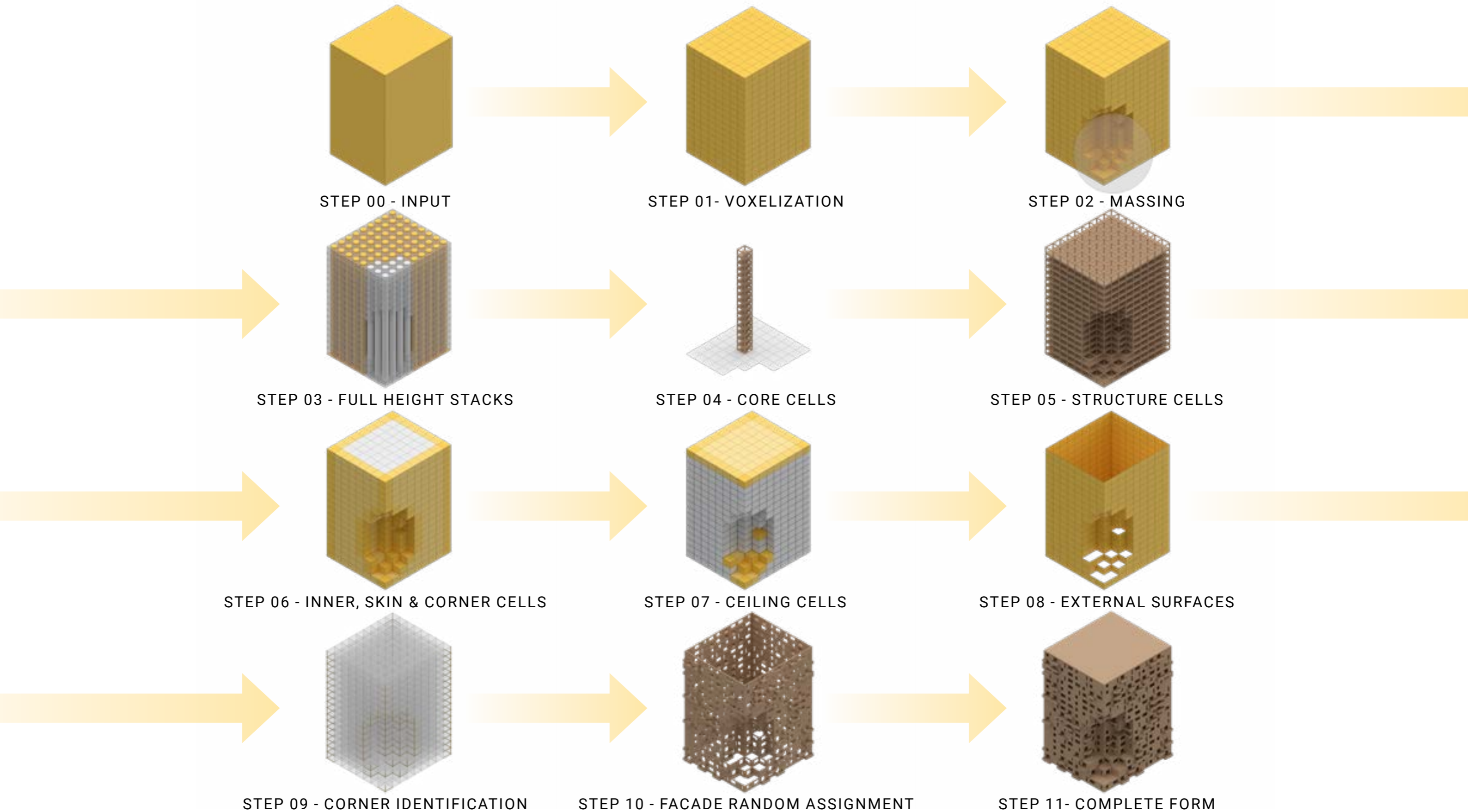

P5 - PLAY WELL FLEXIBLE HOUSING

02.SYSTEM IMPLEMENTATION AUTOMATION - CODE OVERVIEW + VARIOUS MASSING TESTS:

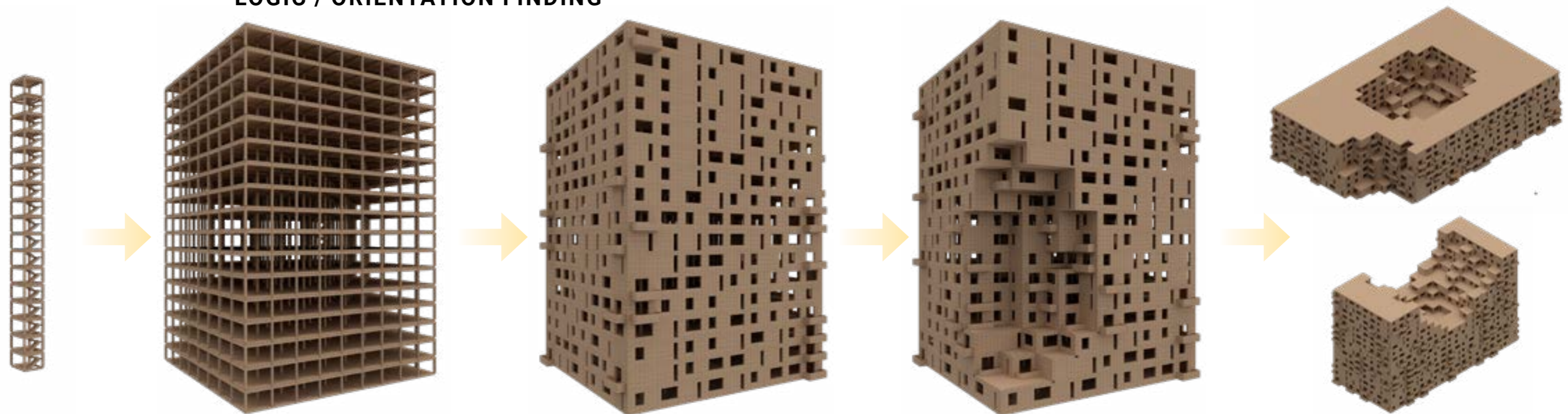
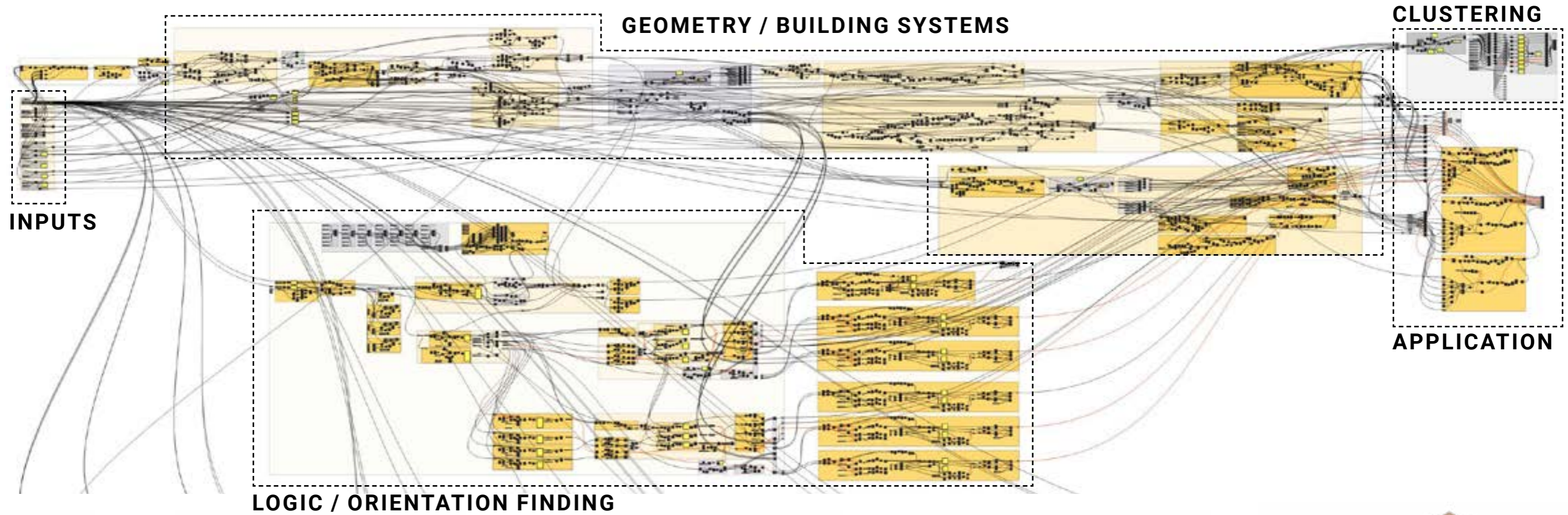

P5 - PLAY WELL FLEXIBLE HOUSING

02.SYSTEM IMPLEMENTATION AUTOMATION - UNIQUE BUILDING BLOCKS:

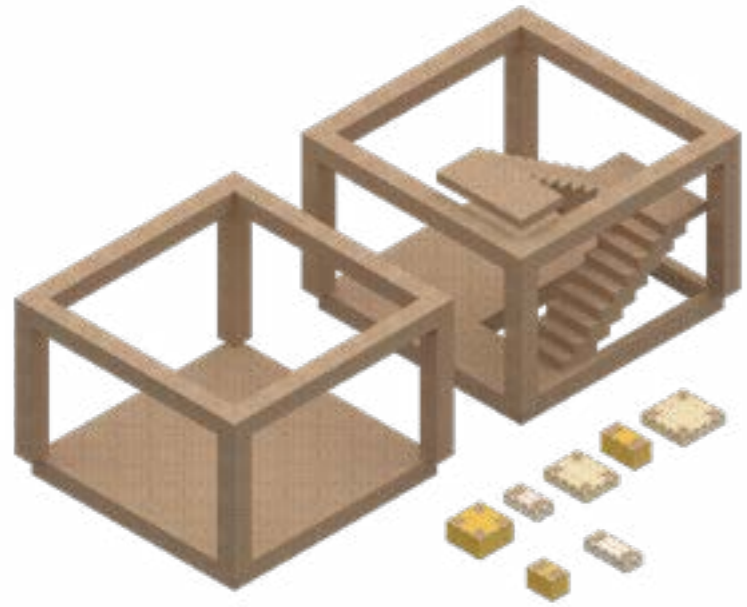

STRUCTURE + CIRCULATION



ROOF



FACADE + BALCONIES

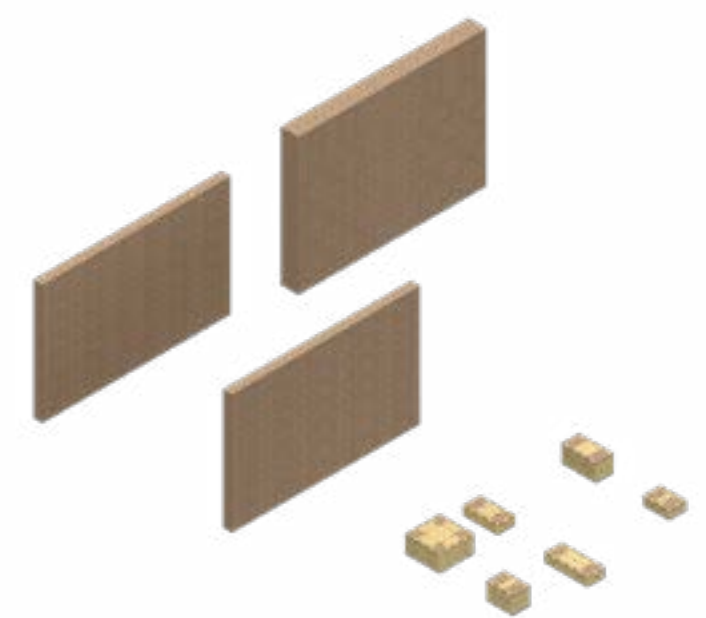

WALLS + PARTITIONS

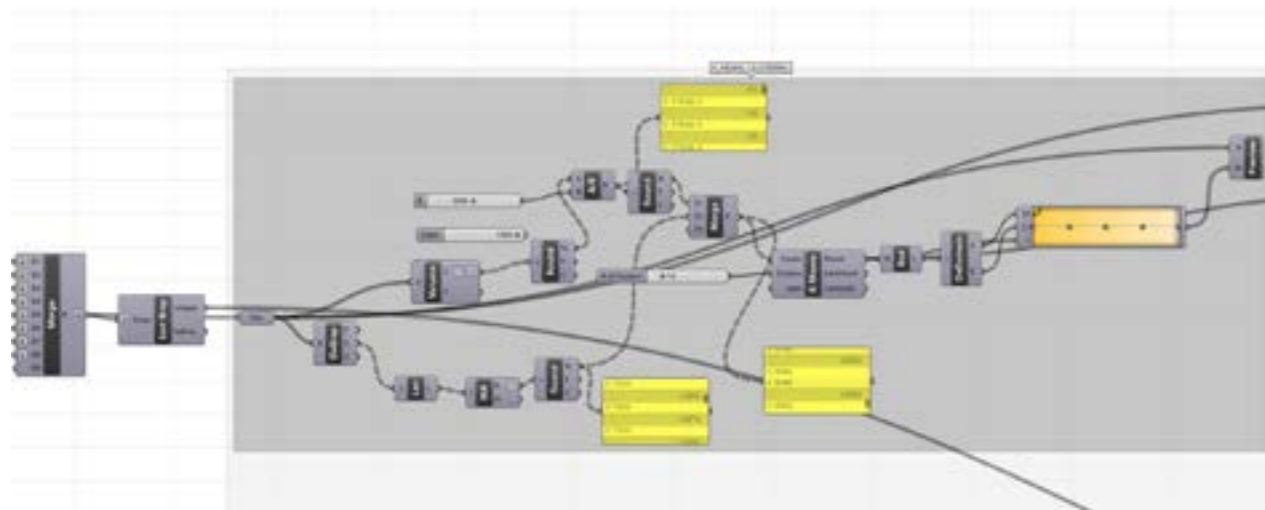

+

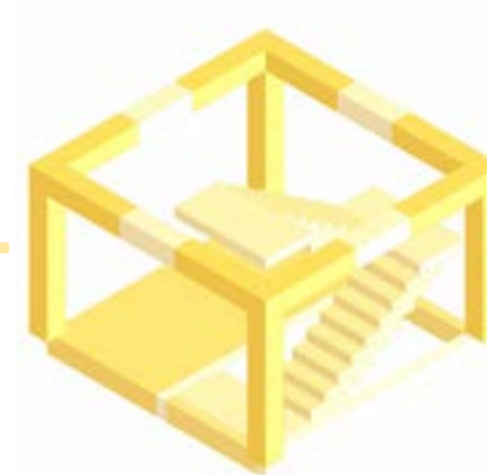

+

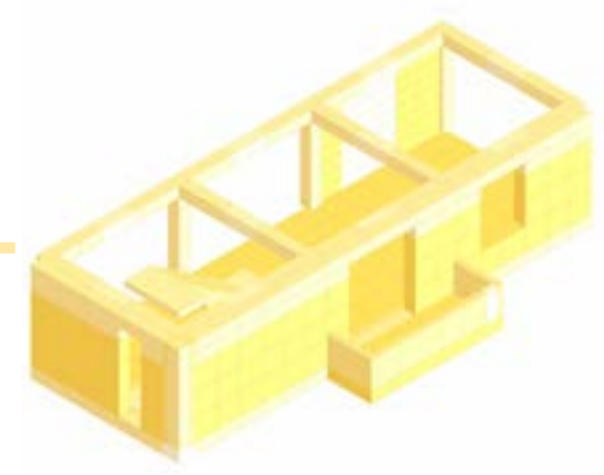

P5 - PLAY WELL FLEXIBLE HOUSING

02.SYSTEM FABRICATION & CONSTRUCTIBILITY - AUTOMATIC FABRICATION FILE GENERATION:

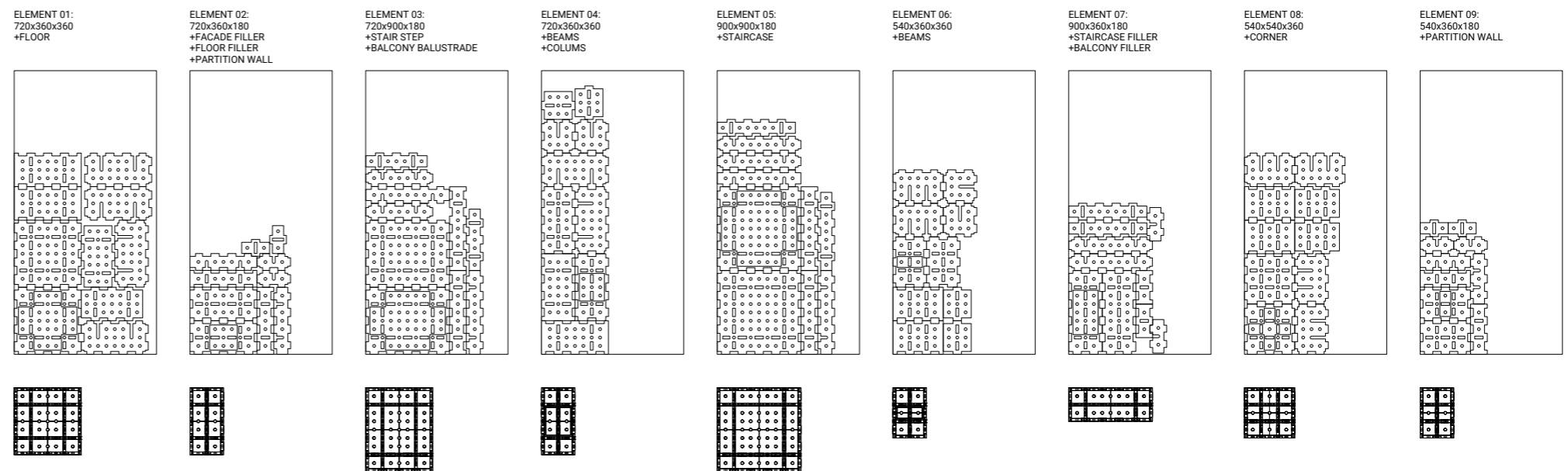
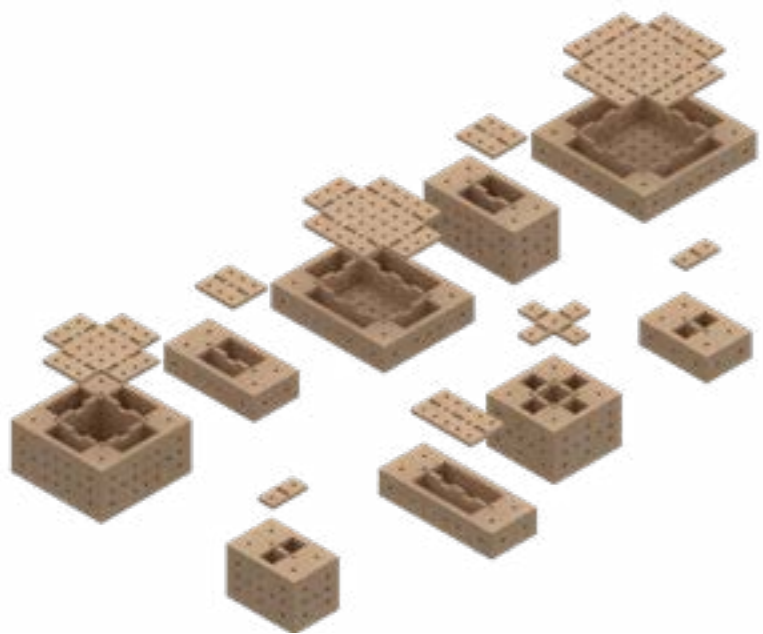
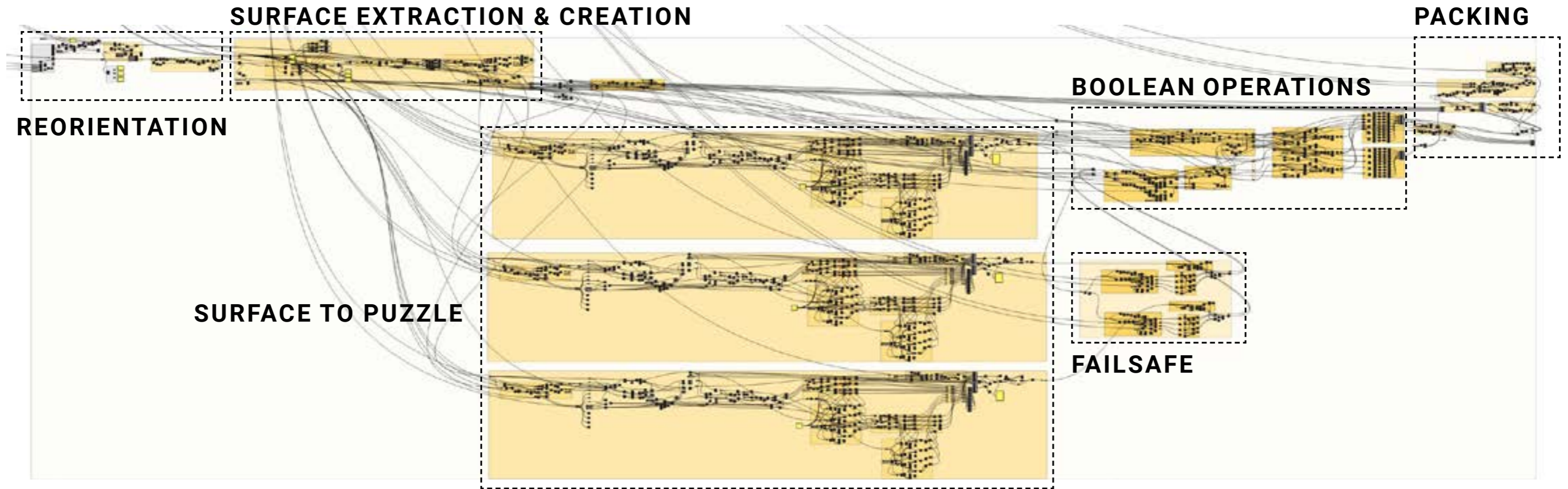

P5 - PLAY WELL FLEXIBLE HOUSING

03.GAMIFICATION / CONFIGURABILITY RESEARCH:

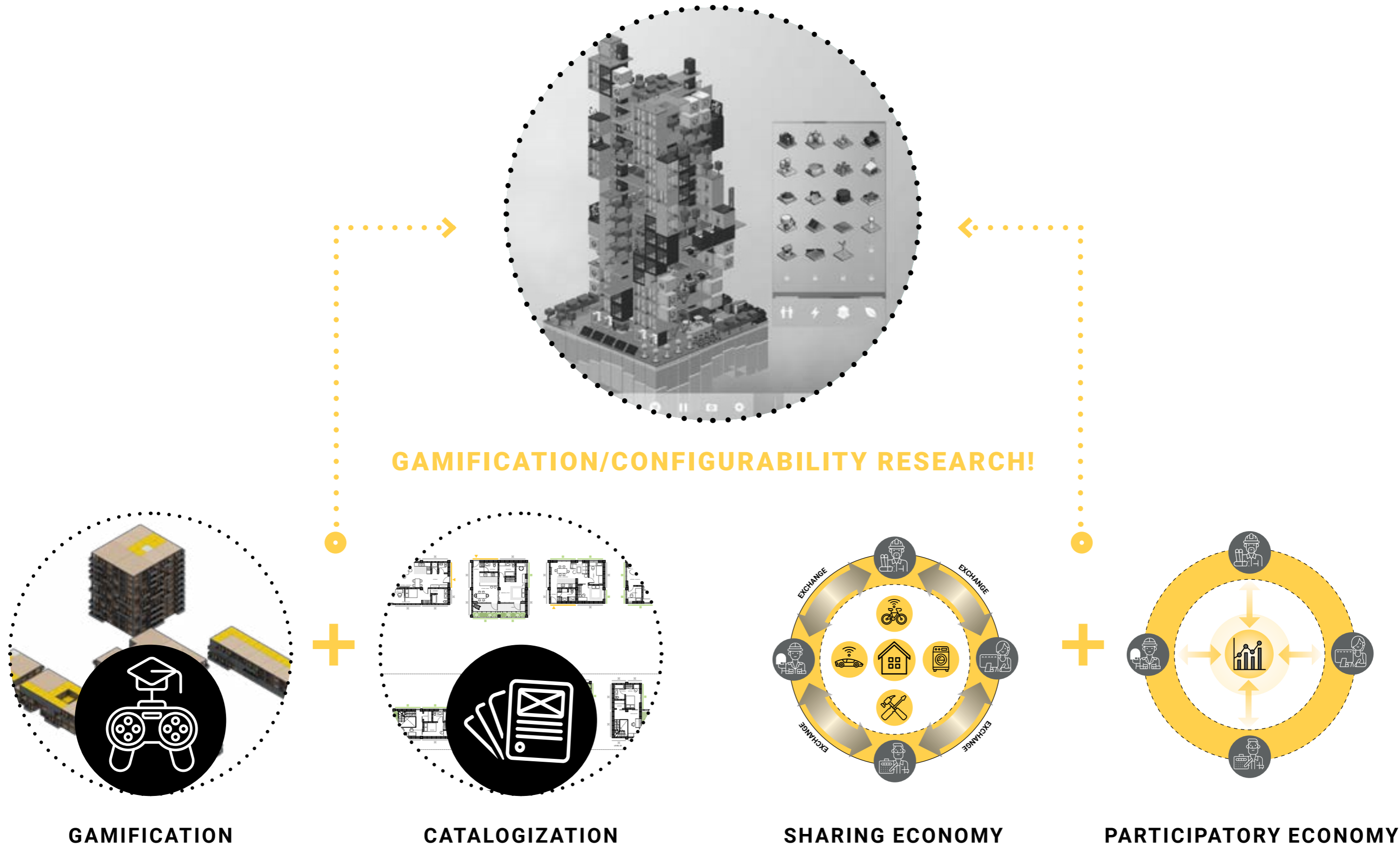

P5 - PLAY WELL FLEXIBLE HOUSING

03.GAMIFICATION / CONFIGURABILITY RESEARCH - WAVE FUNCTION COLLAPSE:

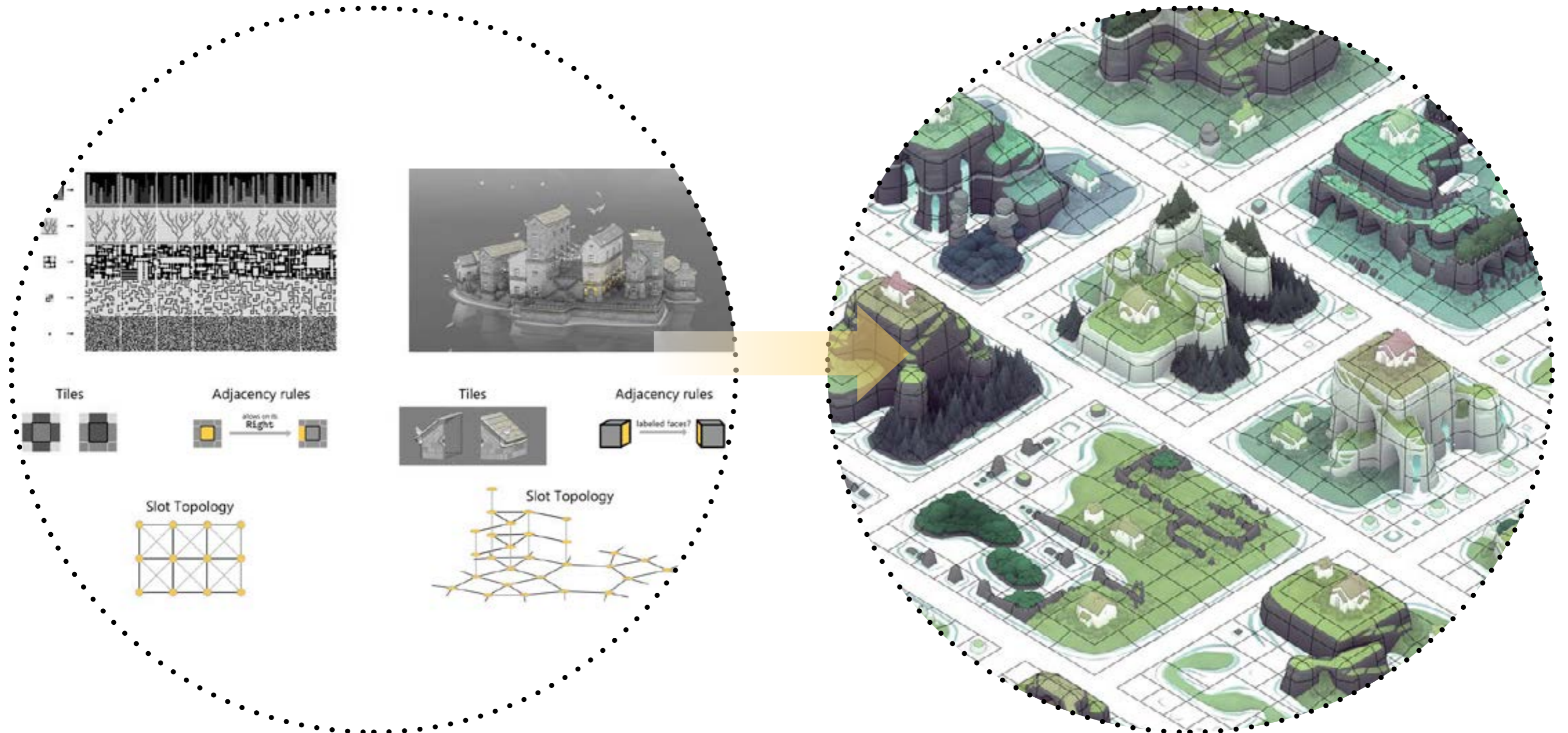

TILESETS + ADJACENCY RULES

INSPIRED BY **QUANTUM PHYSICS**

PROCEDURALLY GENERATED WORLDS

USED FOR PROCEDURAL GENERATION OF TRaversable **ENVIRONMENTS**

P5 - PLAY WELL FLEXIBLE HOUSING

03.GAMIFICATION / CONFIGURABILITY RESEARCH - WAVE FUNCTION COLLAPSE:

WFC BEHAVIOR PRINCIPLES:

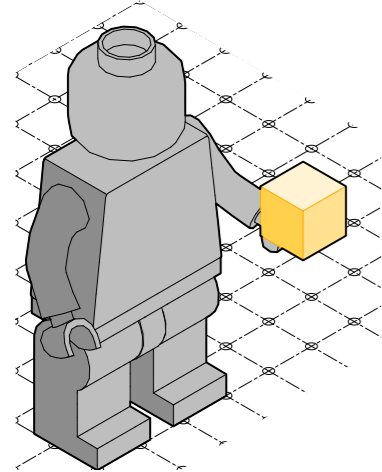

1. MODULES:



2. RULESET:

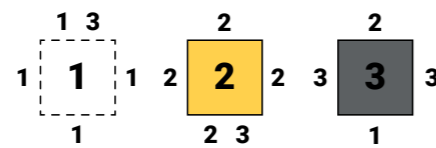

5. PROPAGATION:

1,2,3	1,2,3	1,2,3	1,2,3	1,2,3
1,2,3	1,2,3	2	1,2,3	1,2,3
1,2,3	3	3	3	1,2,3
1,2,3	1,2,3	1	1,2,3	1,2,3
1,2,3	1,2,3	1,2,3	1,2,3	1,2,3

1,2,3	1,2,3	2	1,2,3	1,2,3
1,2,3	2	2	2	1,2,3
3	3	3	3	3
1,2,3	1	1	1	1,2,3
1,2,3	1,2,3	1	1,2,3	1,2,3

3. INITIAL STATE:

1,2,3	1,2,3	1,2,3	1,2,3	1,2,3
1,2,3	1,2,3	1,2,3	1,2,3	1,2,3
1,2,3	1,2,3	1,2,3	1,2,3	1,2,3
1,2,3	1,2,3	1,2,3	1,2,3	1,2,3
1,2,3	1,2,3	1,2,3	1,2,3	1,2,3

4. OBSERVATION:

1,2,3	1,2,3	1,2,3	1,2,3	1,2,3
1,2,3	1,2,3	1,2,3	1,2,3	1,2,3
1,2,3	1,2,3	3	1,2,3	1,2,3
1,2,3	1,2,3	1,2,3	1,2,3	1,2,3
1,2,3	1,2,3	1,2,3	1,2,3	1,2,3

1,2,3	2	2	2	1,2,3
2	2	2	2	2
3	3	3	3	3
1	1	1	1	1
1,2,3	1	1	1	1,2,3

2	2	2	2	2
2	2	2	2	2
3	3	3	3	3
1	1	1	1	1
1	1	1	1	1

PRINCIPLES TRANSLATED INTO SPATIAL DESIGN:

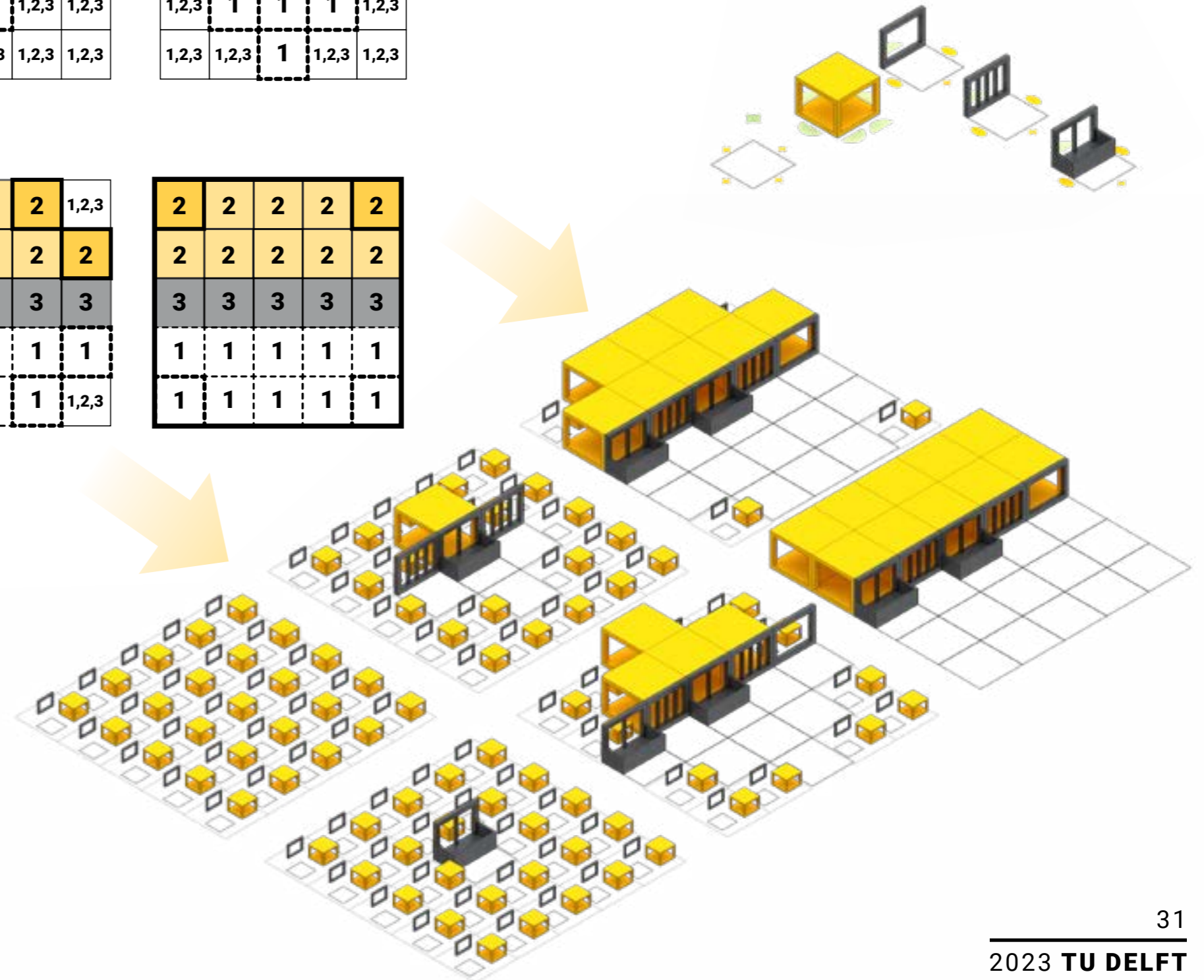

P5 - PLAY WELL FLEXIBLE HOUSING

03.GAMIFICATION / CONFIGURABILITY - CONFIGURATIVE SCRIPT:

BOUNDARY CONSTRAINTS

CONFIGURATIVE SOLVER

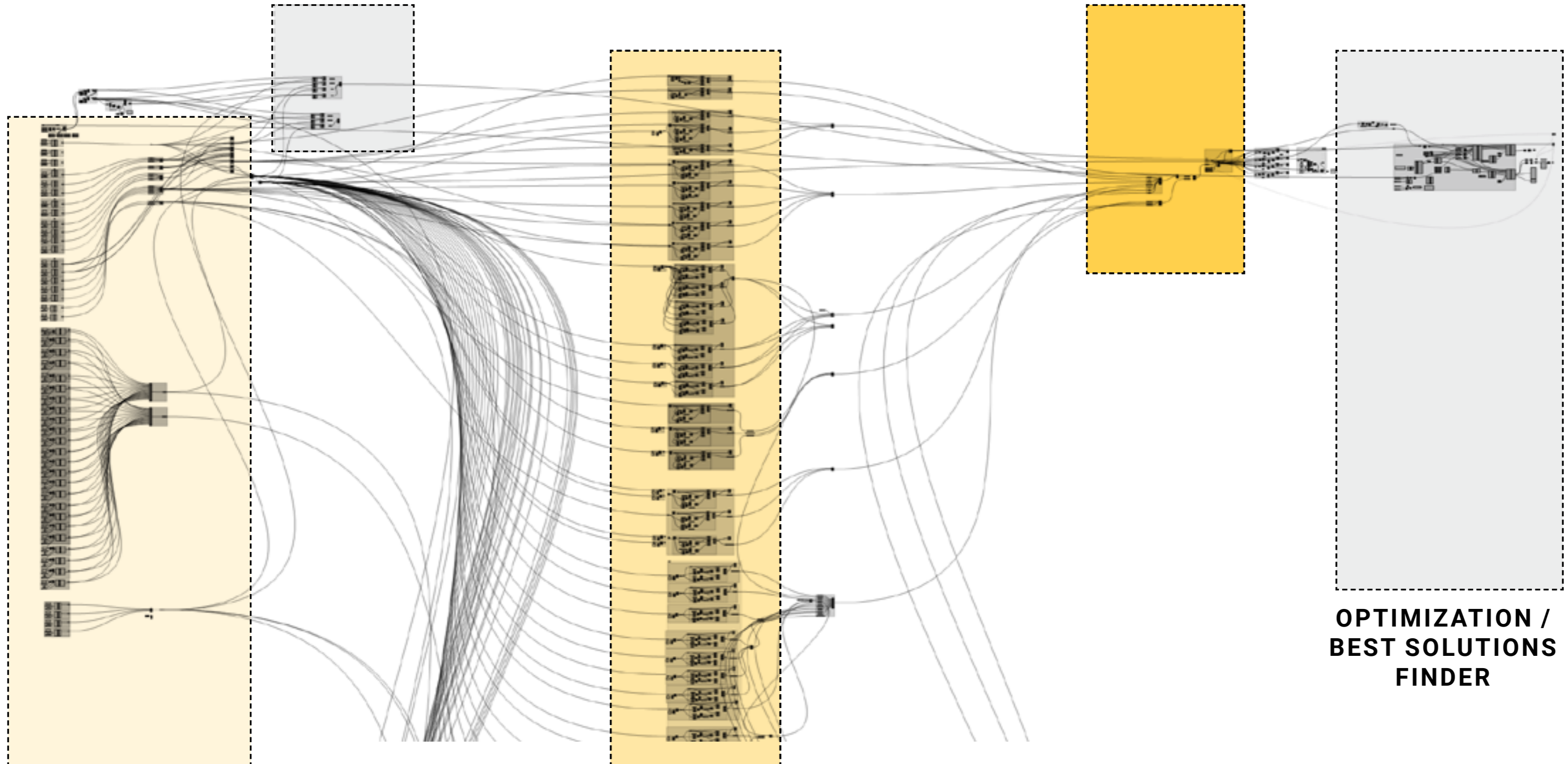

**OPTIMIZATION /
BEST SOLUTIONS
FINDER**

MODULES DEFINITION

RULESET FORMULATION

P5 - PLAY WELL FLEXIBLE HOUSING

03.GAMIFICATION / CONFIGURABILITY - PRELIMINARY FACADE GAME:

END GOAL: UNDERSTANDING ALL THE FACADE PRINCIPLES

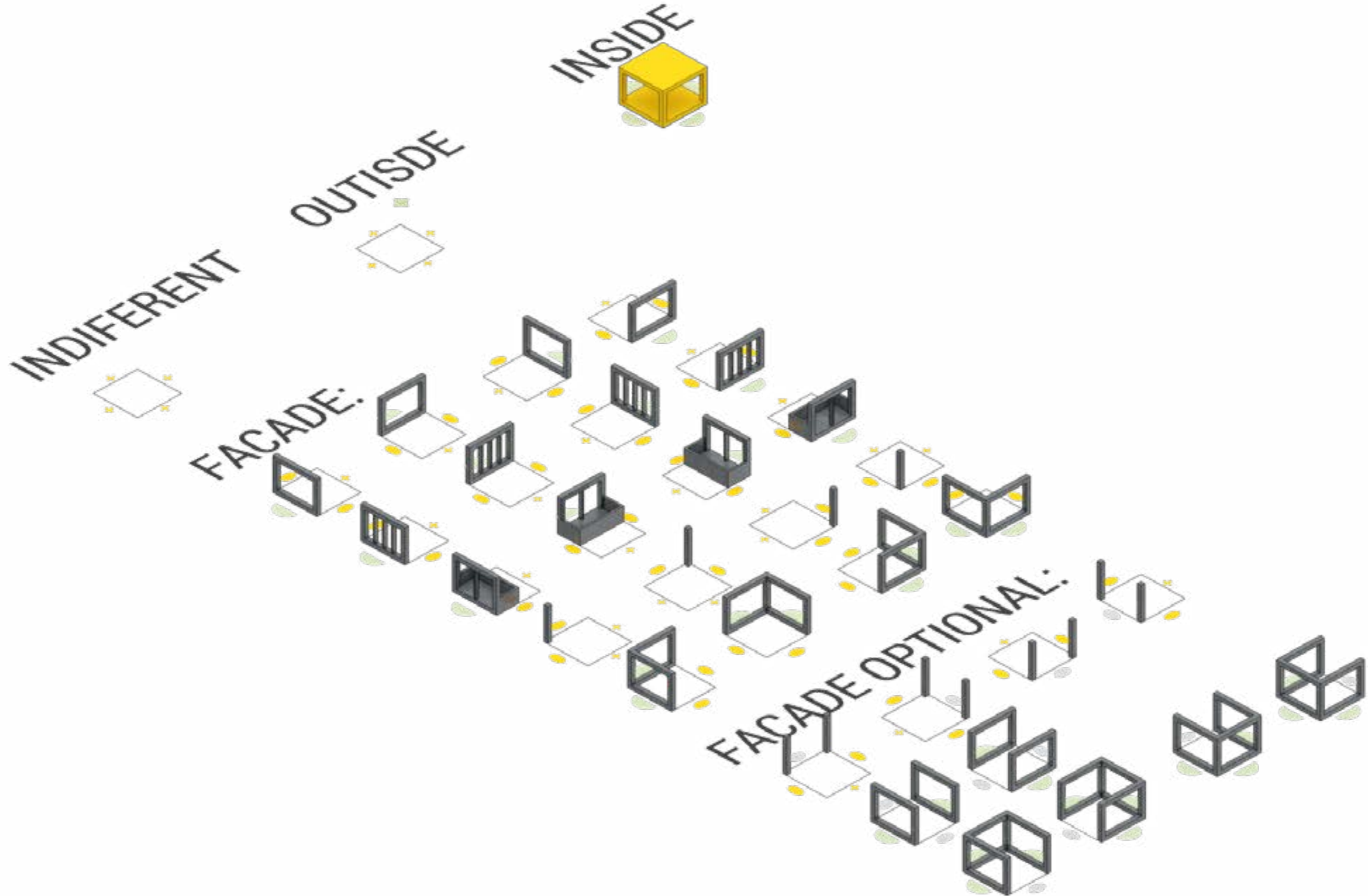

P5 - PLAY WELL FLEXIBLE HOUSING

03.GAMIFICATION / CONFIGURABILITY - PRELIMINARY FACADE GAME **PRIMARY TEST:**

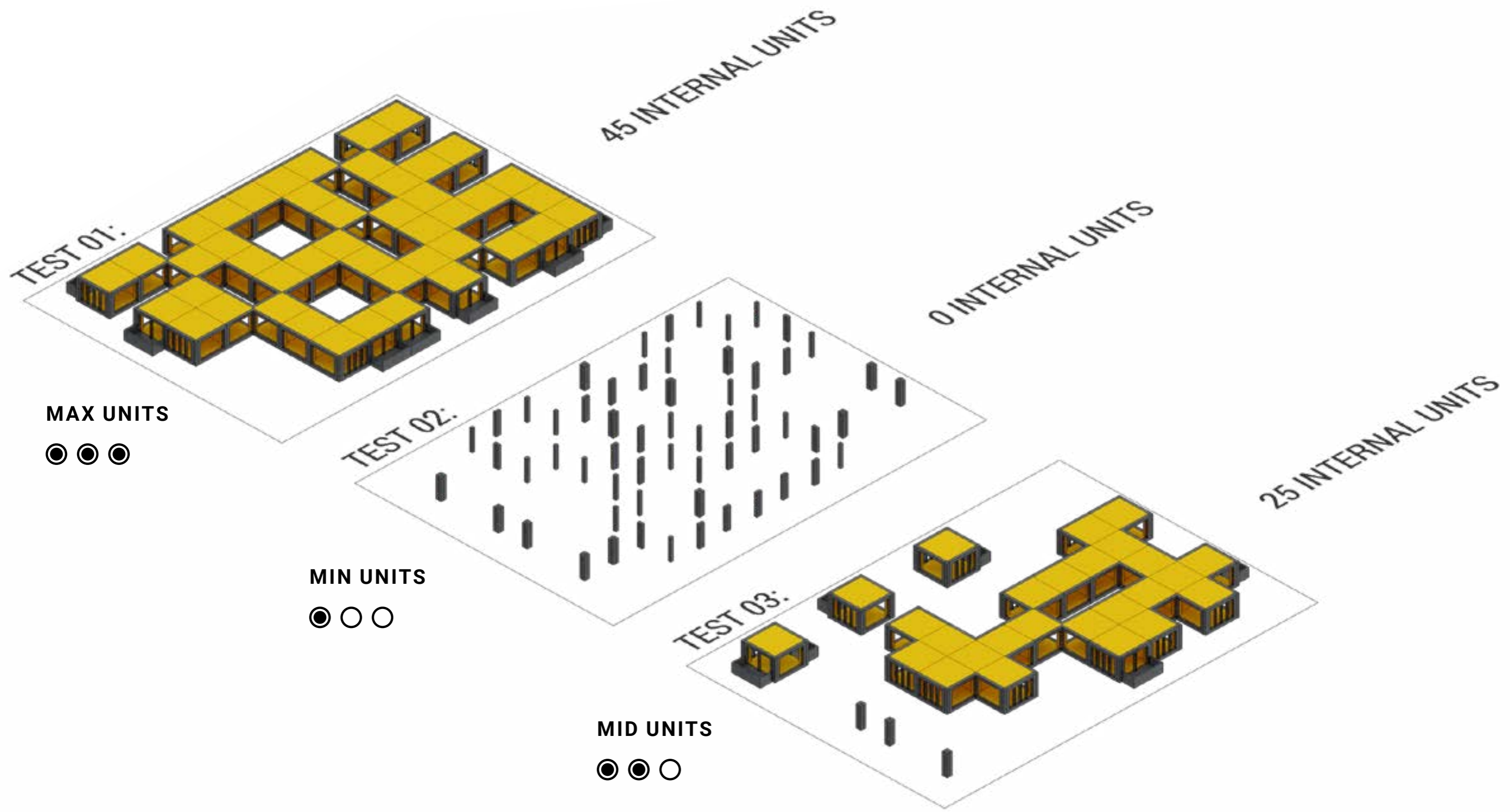

P5 - PLAY WELL FLEXIBLE HOUSING

03.GAMIFICATION / CONFIGURABILITY - PRELIMINARY FACADE GAME CONCLUSIONS:

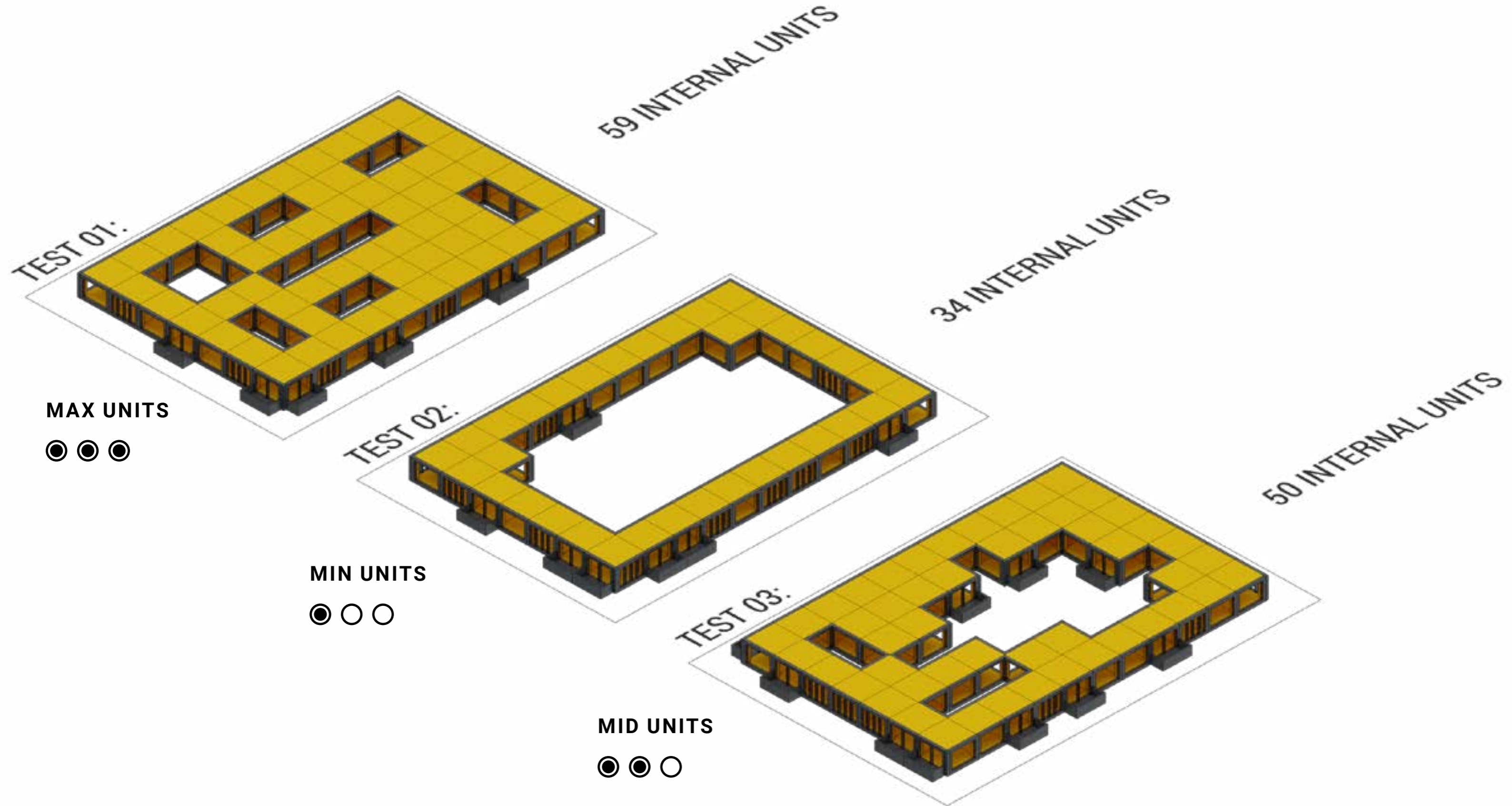

P5 - PLAY WELL FLEXIBLE HOUSING

03.GAMIFICATION / CONFIGURABILITY - PRELIMINARY CORRIDOR GAME:

FACADE_TO_WALL_MODULES:



FACADE_TO_WALL_OPTIONAL:

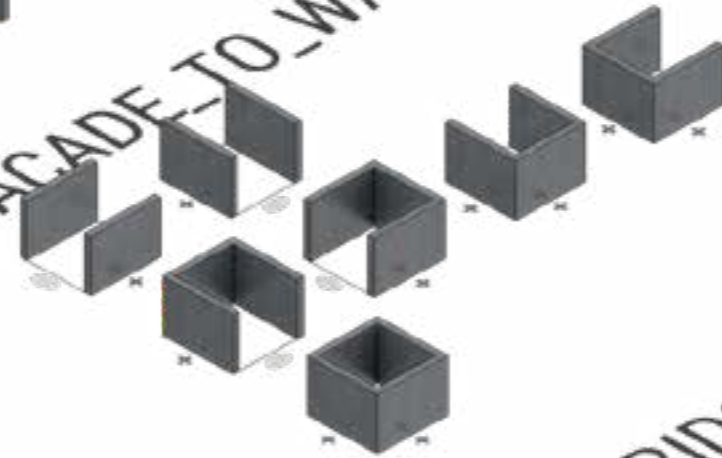

CORRIDOR_MODULES:

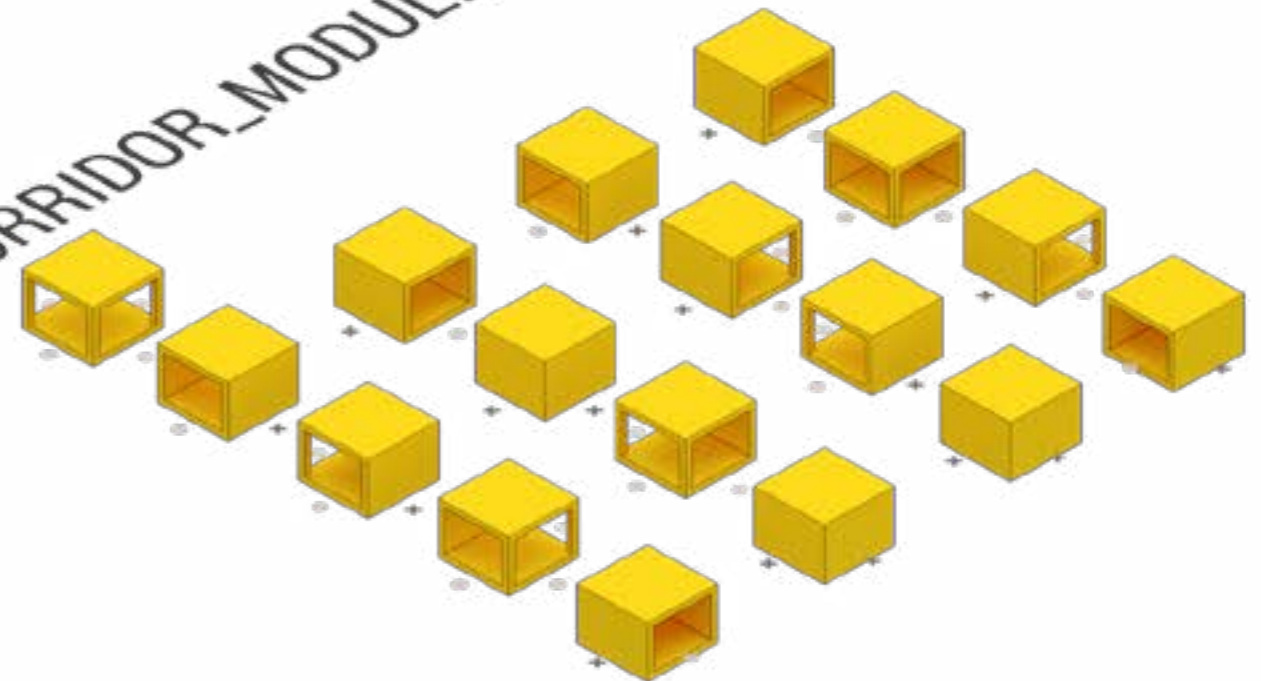

P5 - PLAY WELL FLEXIBLE HOUSING

03.GAMIFICATION / CONFIGURABILITY - PRELIMINARY CORRIDOR GAME **PRIMARY TEST:**
END GOAL: CONSTRUCTING CORRIDORS THAT ARE SINGLE LANE AND GO IN ALL DIRECTIONS

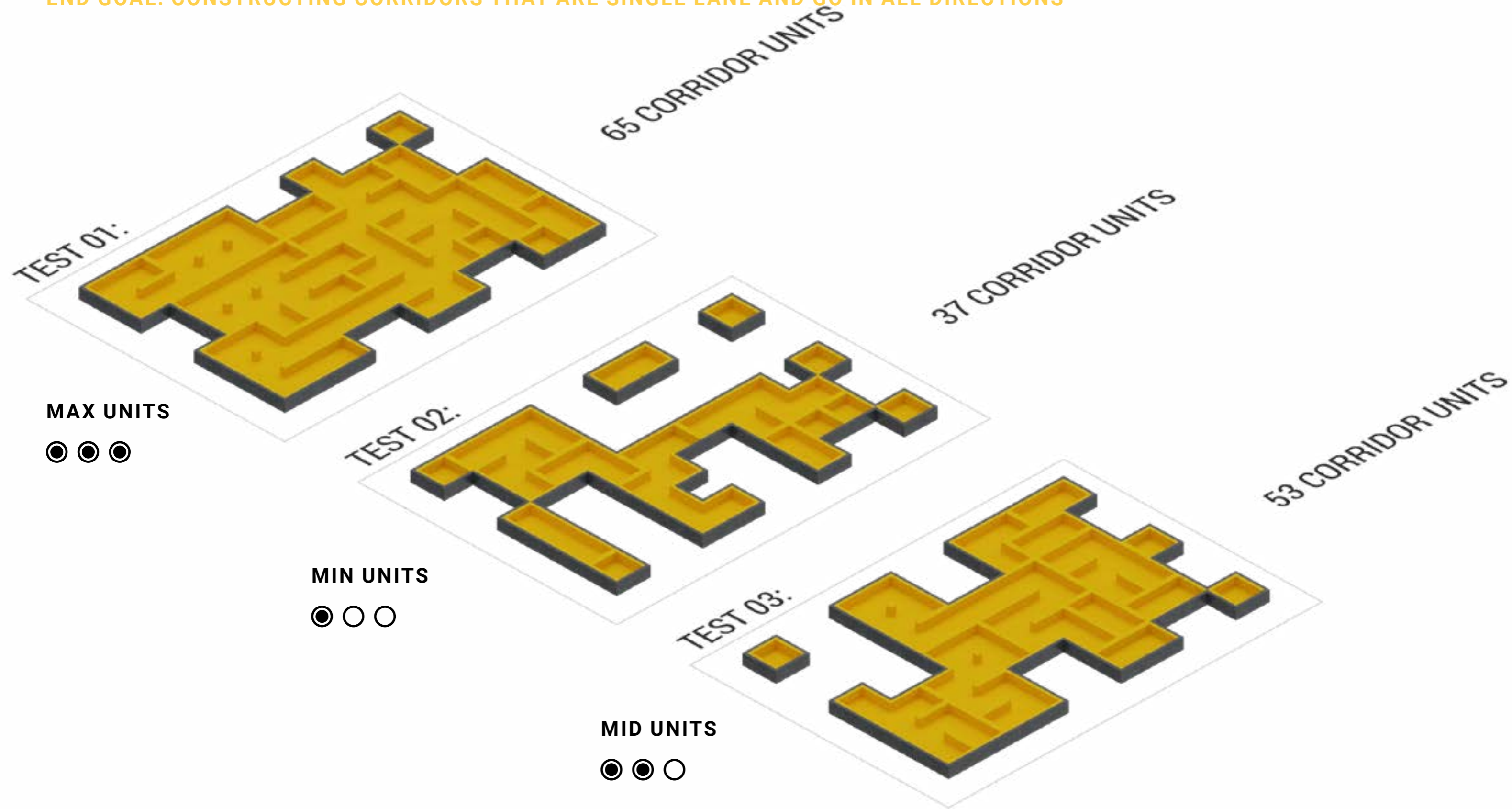

P5 - PLAY WELL FLEXIBLE HOUSING

03.GAMIFICATION / CONFIGURABILITY - PRELIMINARY CORRIDOR GAME CONCLUSIONS:

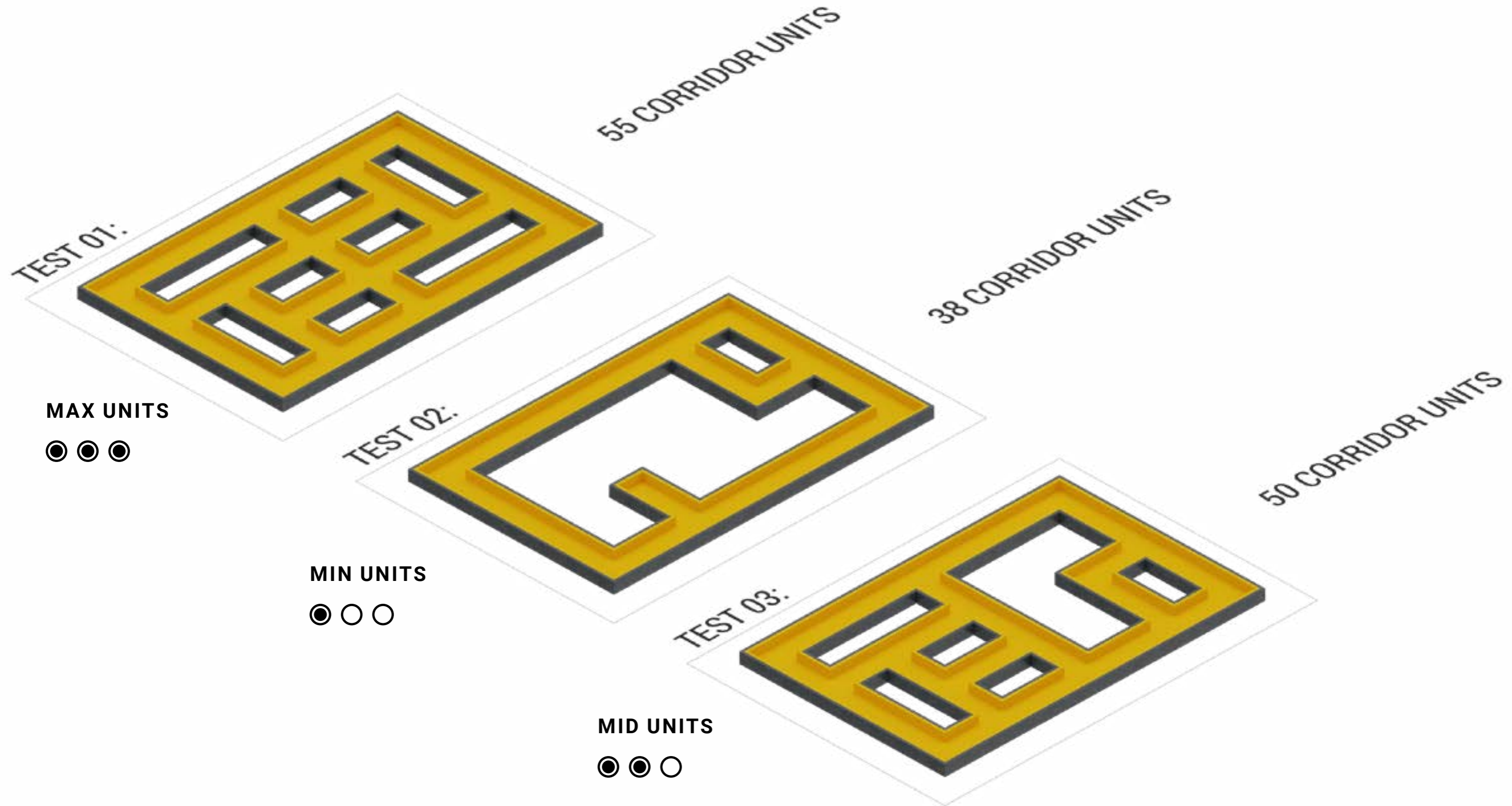

P5 - PLAY WELL FLEXIBLE HOUSING

03.GAMIFICATION / CONFIGURABILITY - FINAL MODULE SET:

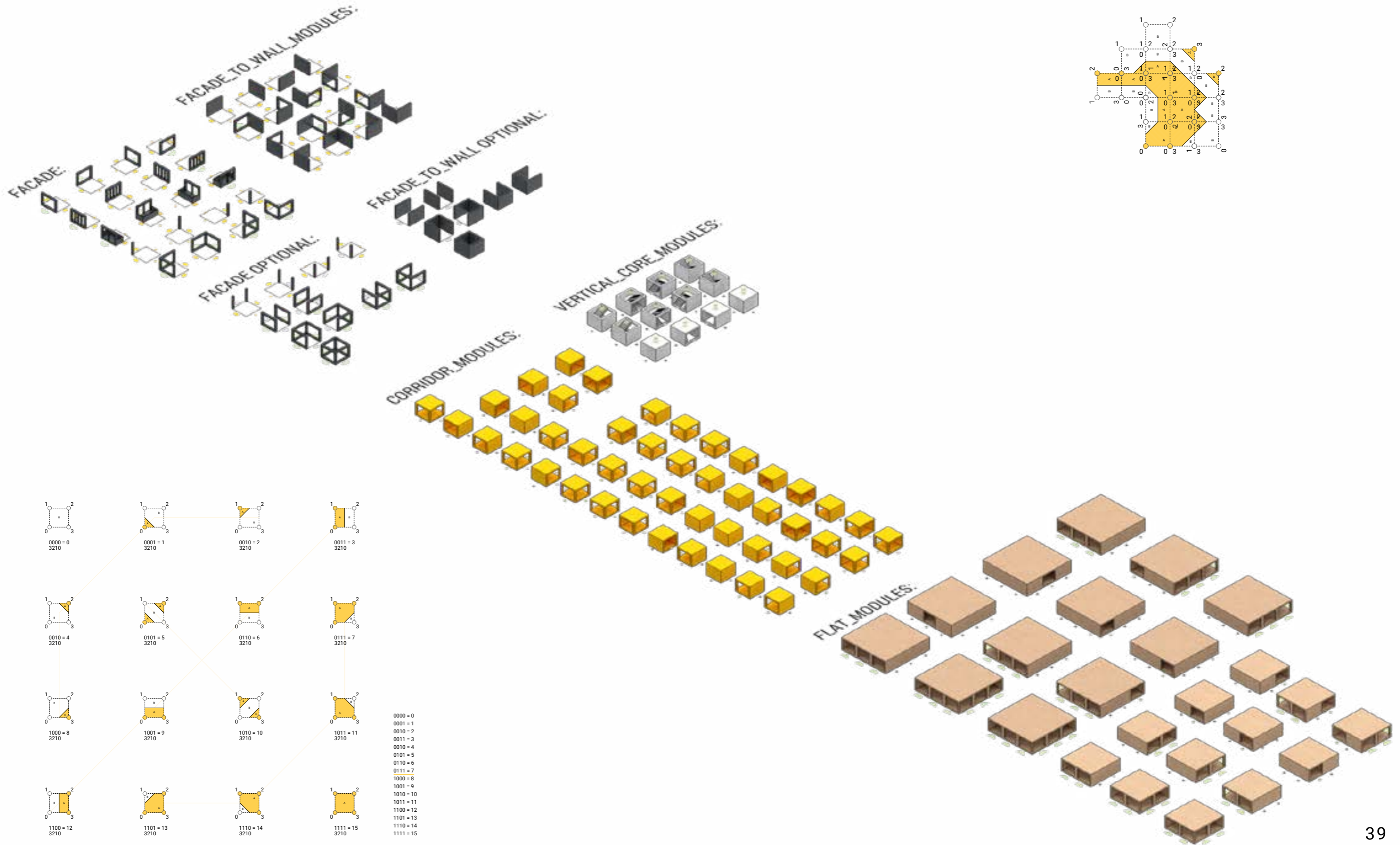

P5 - PLAY WELL FLEXIBLE HOUSING

03.GAMIFICATION / CONFIGURABILITY - RULESET DEVELOPMENT TESTS:

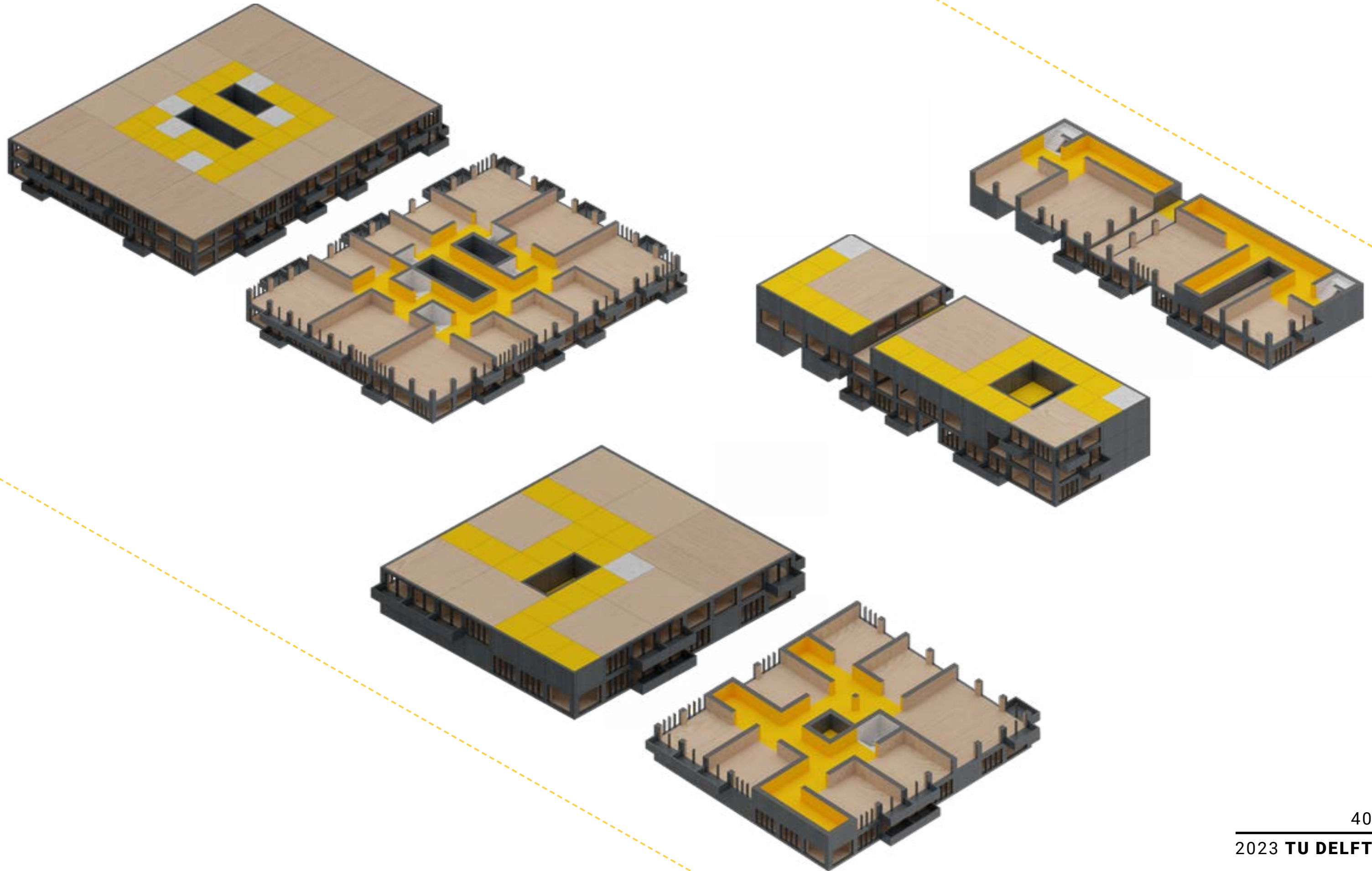

P5 - PLAY WELL FLEXIBLE HOUSING

03.GAMIFICATION / CONFIGURABILITY - FROM CHAOS TO CONTROL:

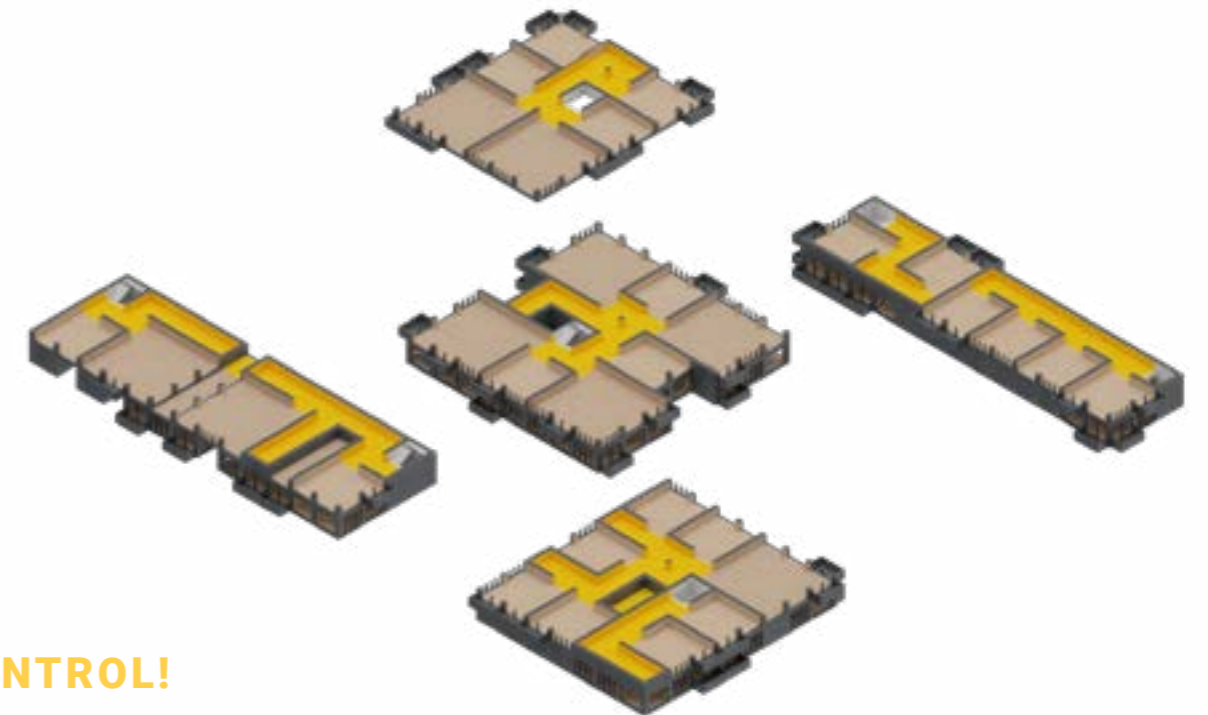
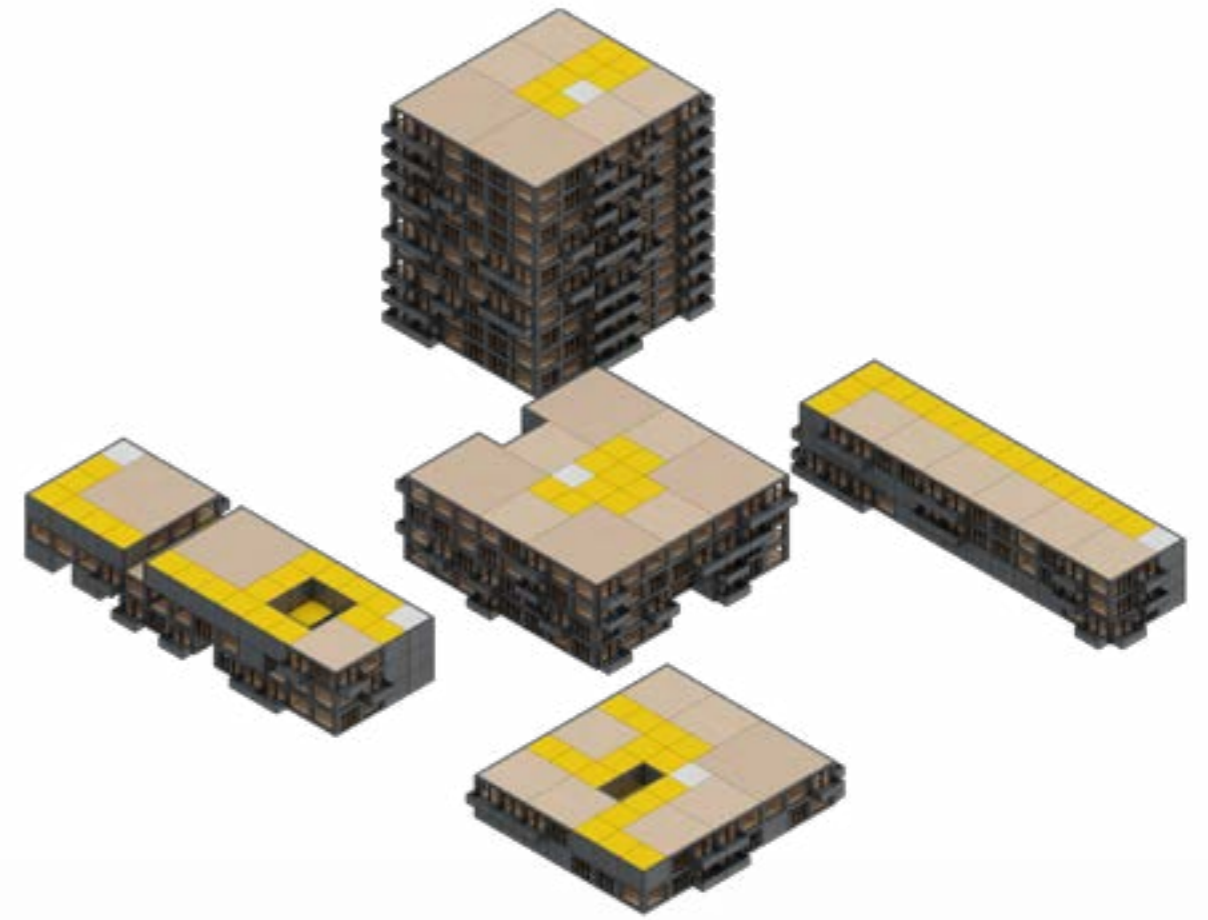
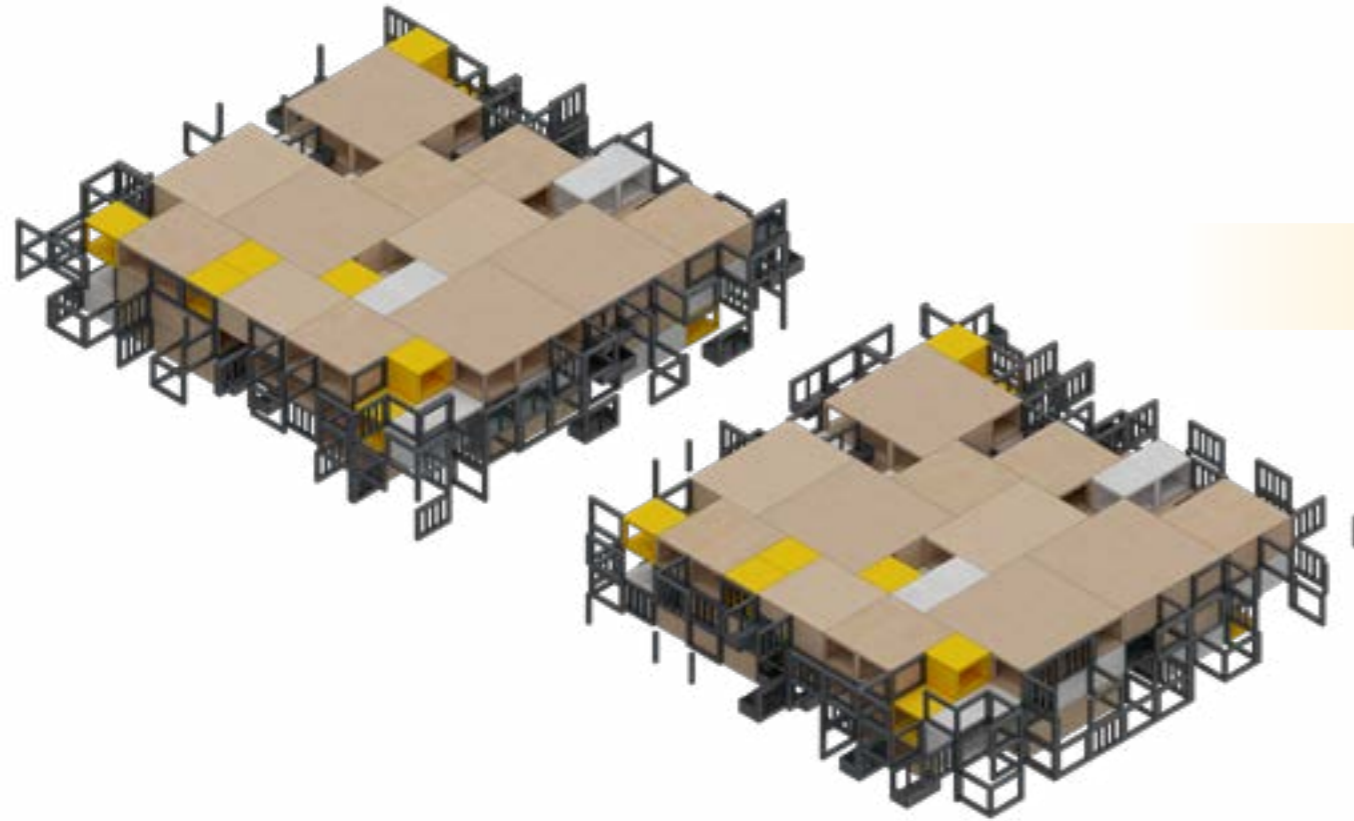

FROM CHAOS!

TO **CONTROL!**

ARCHITECTURALLY VALID
RESULTS GENERATION!

P5 - PLAY WELL FLEXIBLE HOUSING

03.GAMIFICATION / CONFIGURABILITY - BIGGEST BENEFITS / POTENTIALS:

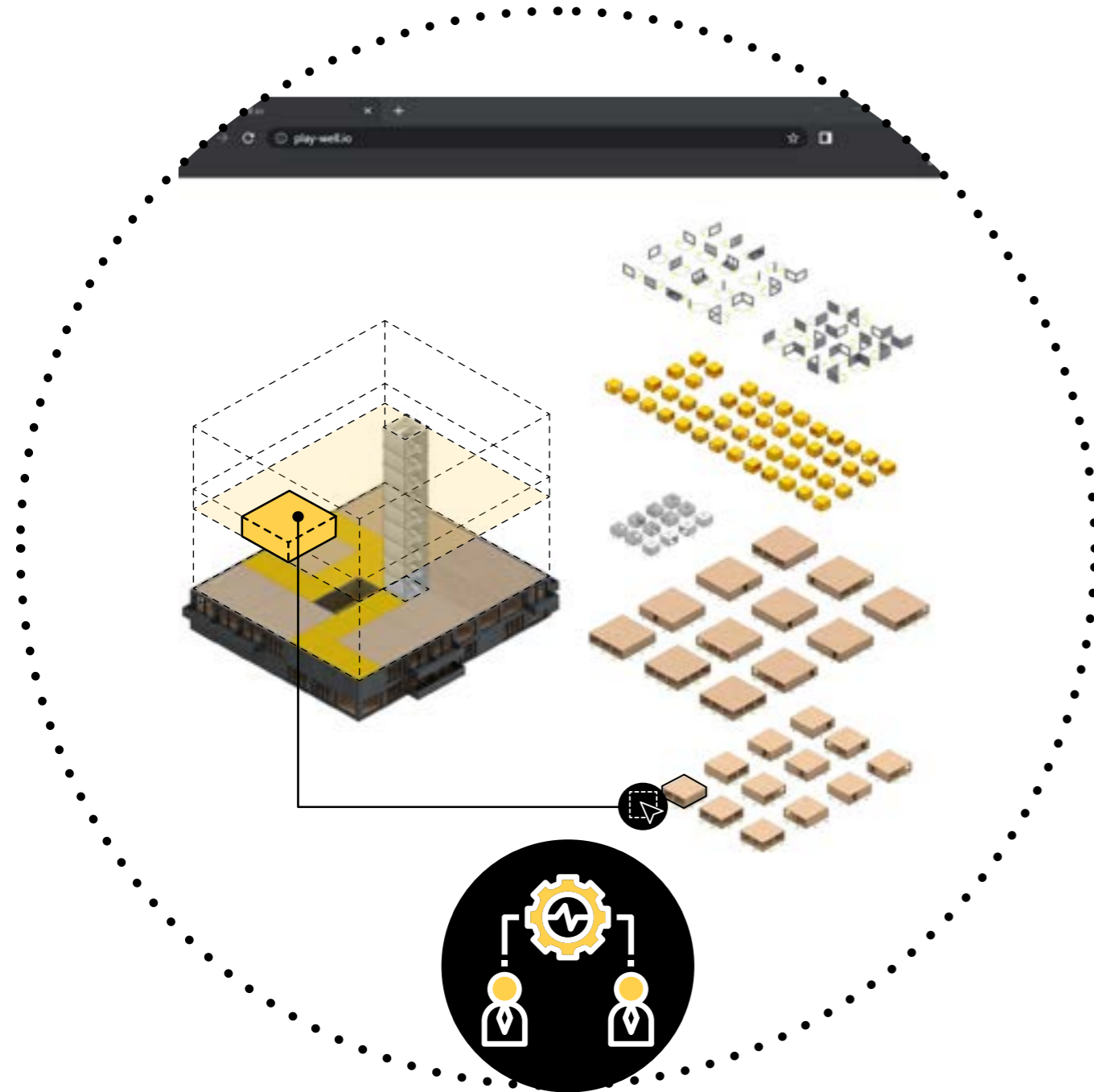

CONFIGURATIVE PARTICIPATION

+ ABILITY TO TEST AND VALIDATE THE RULESET TO ALLOW FOR FREEDOM OF CONFIGURATIVE PARTICIPATION.

+ MACHINE IS STILL INHERENTLY DEVOID OF INTELLIGENCE - IF IT PRODUCES VALID RESULTS **ANY PLAYER WILL!**

+ GAMIFICATION AS **MEANS OF FAILSAFE.**

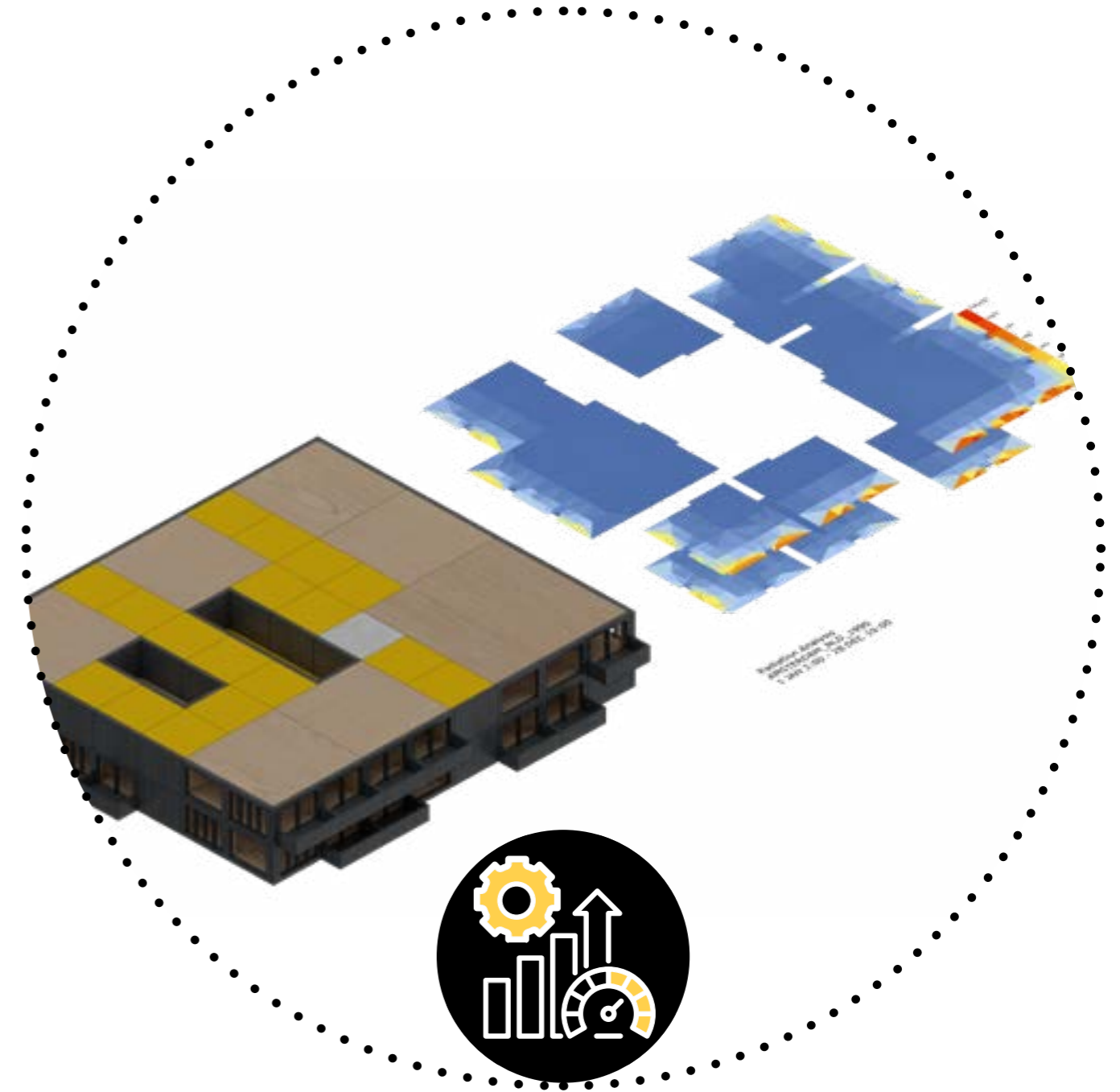

PERFORMANCE OPTIMIZATION

+ ABILITY TO SEARCH FOR BEST OUT OF MILLIONS OF VALID OPTIONS.

+ IF ANY OPTION CREATED BY ALGORITHM IS VALID THANKS TO ROBUST RULESET WE CAN SCOUR THE LANDSCAPE FOR **THE MOST FITTING ONES!**

P5 - PLAY WELL FLEXIBLE HOUSING

04.URBAN BLOCK UNDERSTANDING & DESIGN



URBAN BLOCK UNDERSTANDING!

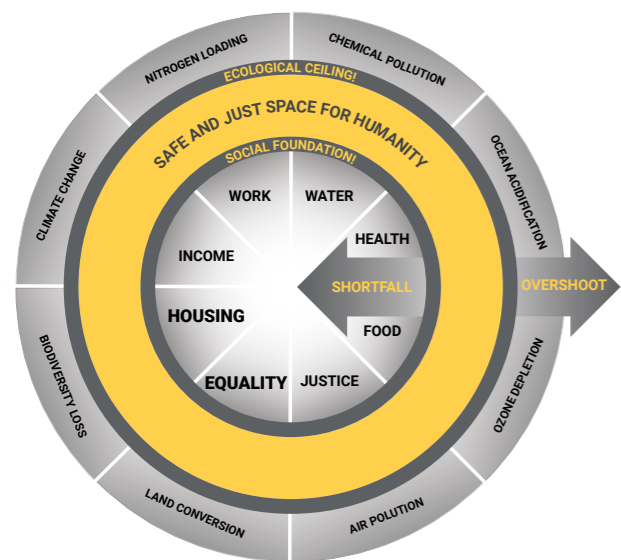

DOUGHNUT ECONOMY

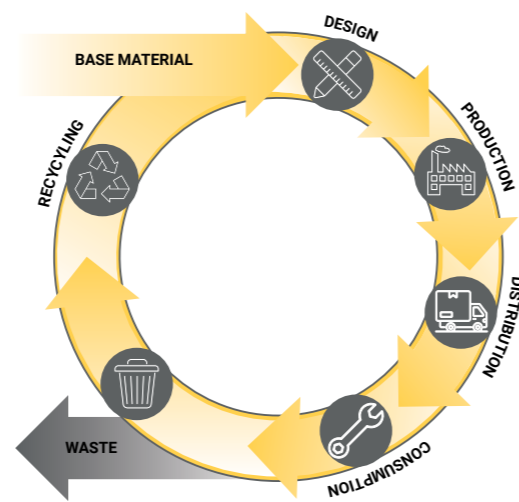

CIRCULAR ECONOMY

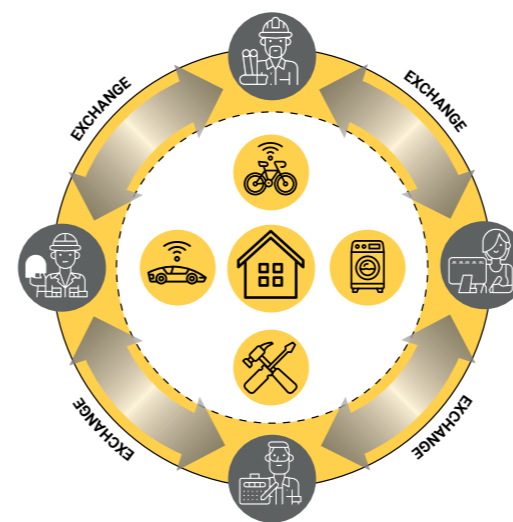

SHARING ECONOMY

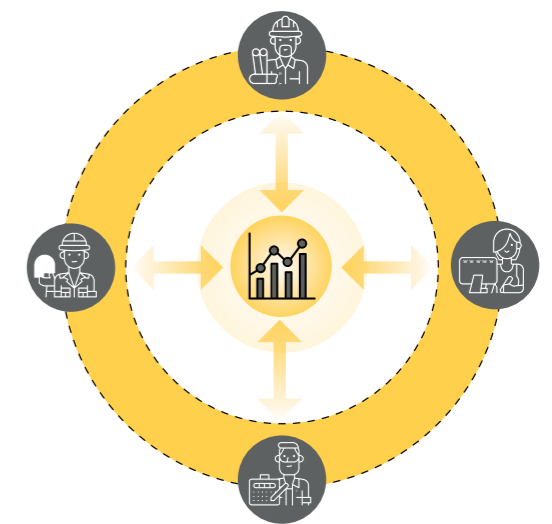

PARTICIPATORY ECONOMY

P5 - PLAY WELL FLEXIBLE HOUSING

04.URBAN BLOCK UNDERSTANDING - POTENTIAL SITES - ROTTERDAM:



POTENTIAL SITES IN URBAN CORE PROXIMITY

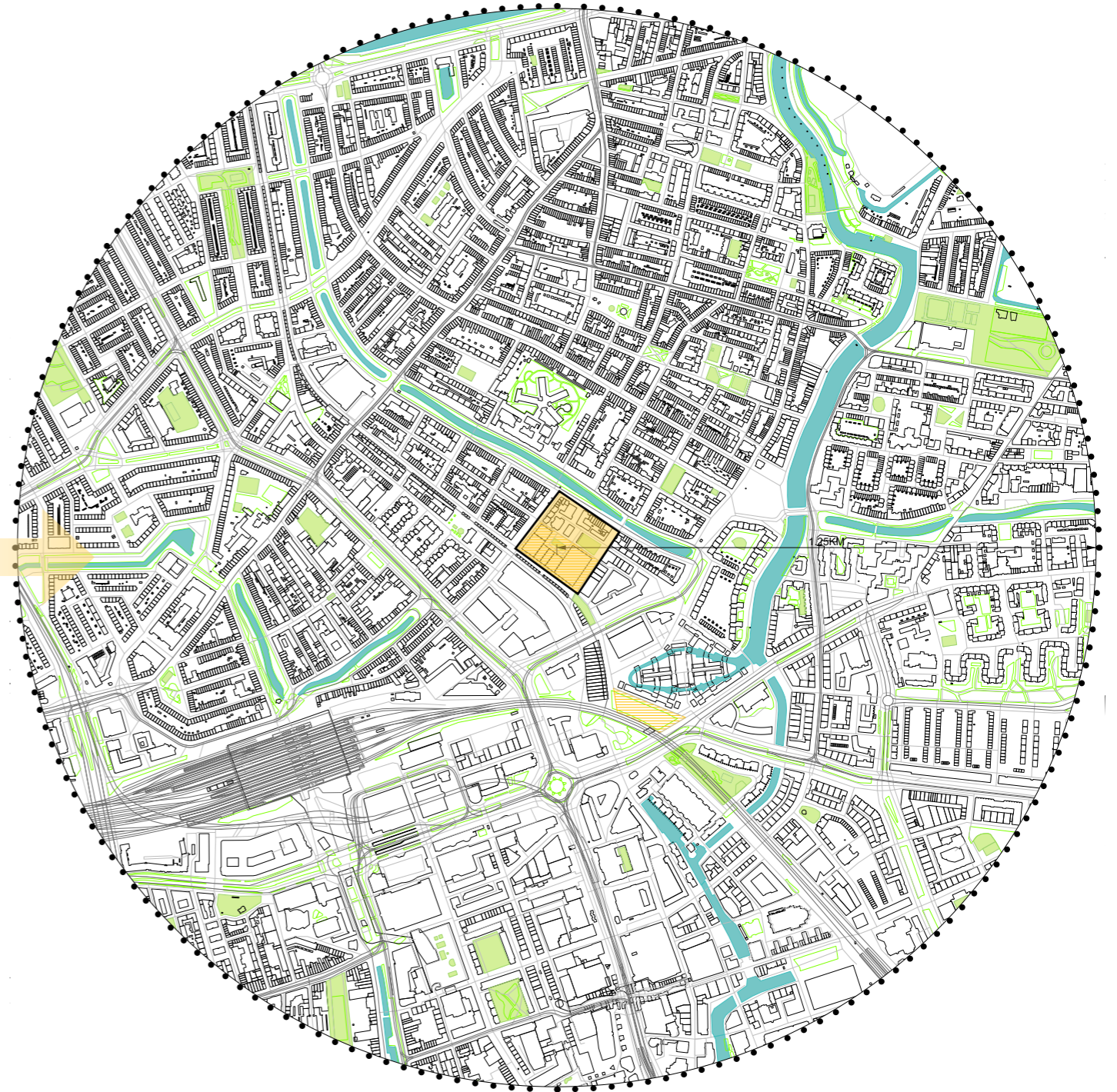

SITE OF EXPLORATION:

- + POTENTIAL OF URBAN CORE DENSIFICATION.
- + POTENTIAL OF CULTIVATING VIBRANT NEIGHBORHOOD.
- + POTENTIAL OF EXPANDING EXISTING BUSINESS.

P5 - PLAY WELL FLEXIBLE HOUSING

04.URBAN BLOCK UNDERSTANDING - CURRENT MASTER PLAN PROPOSAL (ECHO DESIGN):



MASTER PLAN MARQUETTE

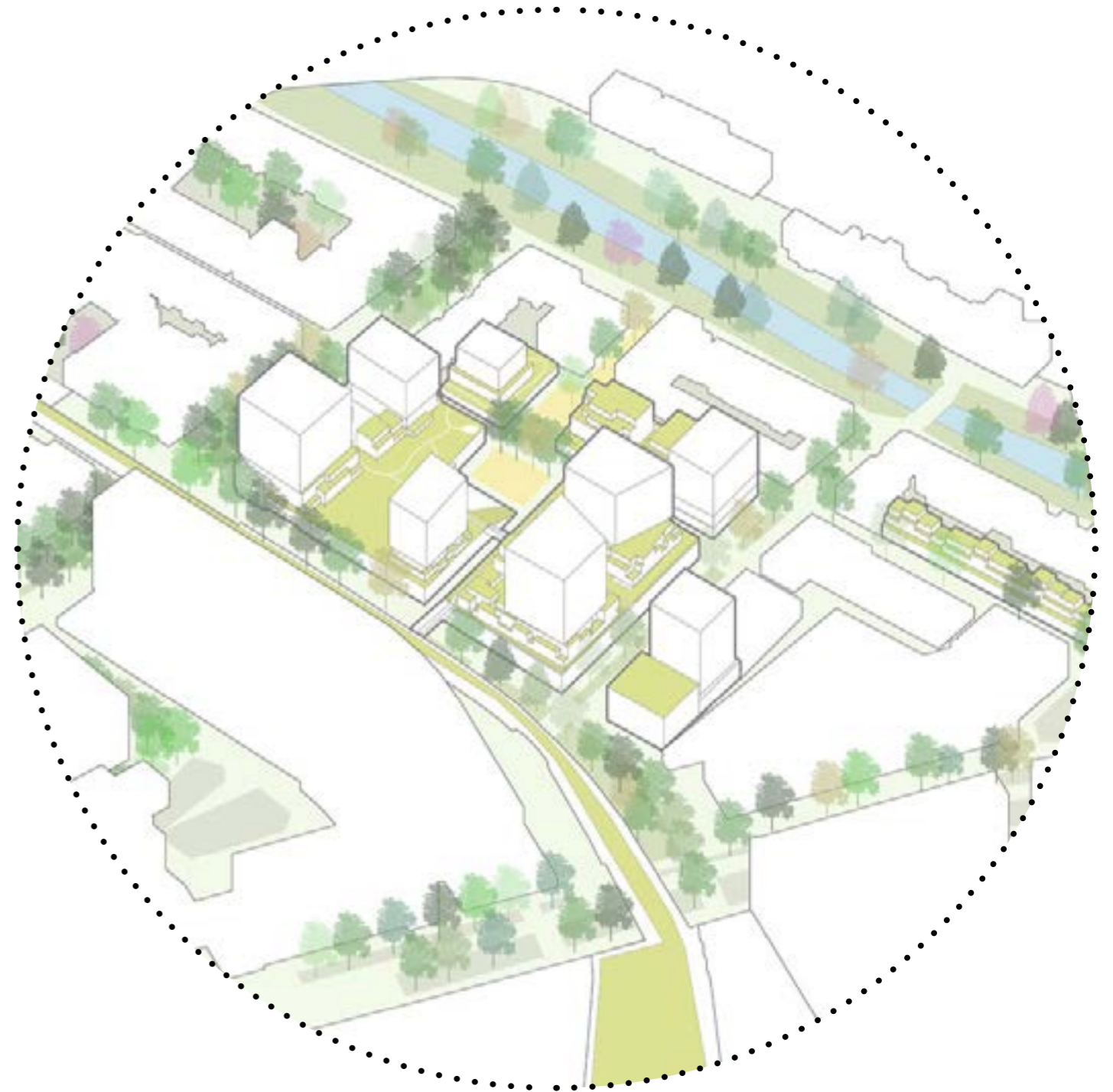

MASTER PLAN DIAGRAM

P5 - PLAY WELL FLEXIBLE HOUSING

04.URBAN BLOCK UNDERSTANDING & DESIGN - SITE ANALYSIS - CLIMATE:

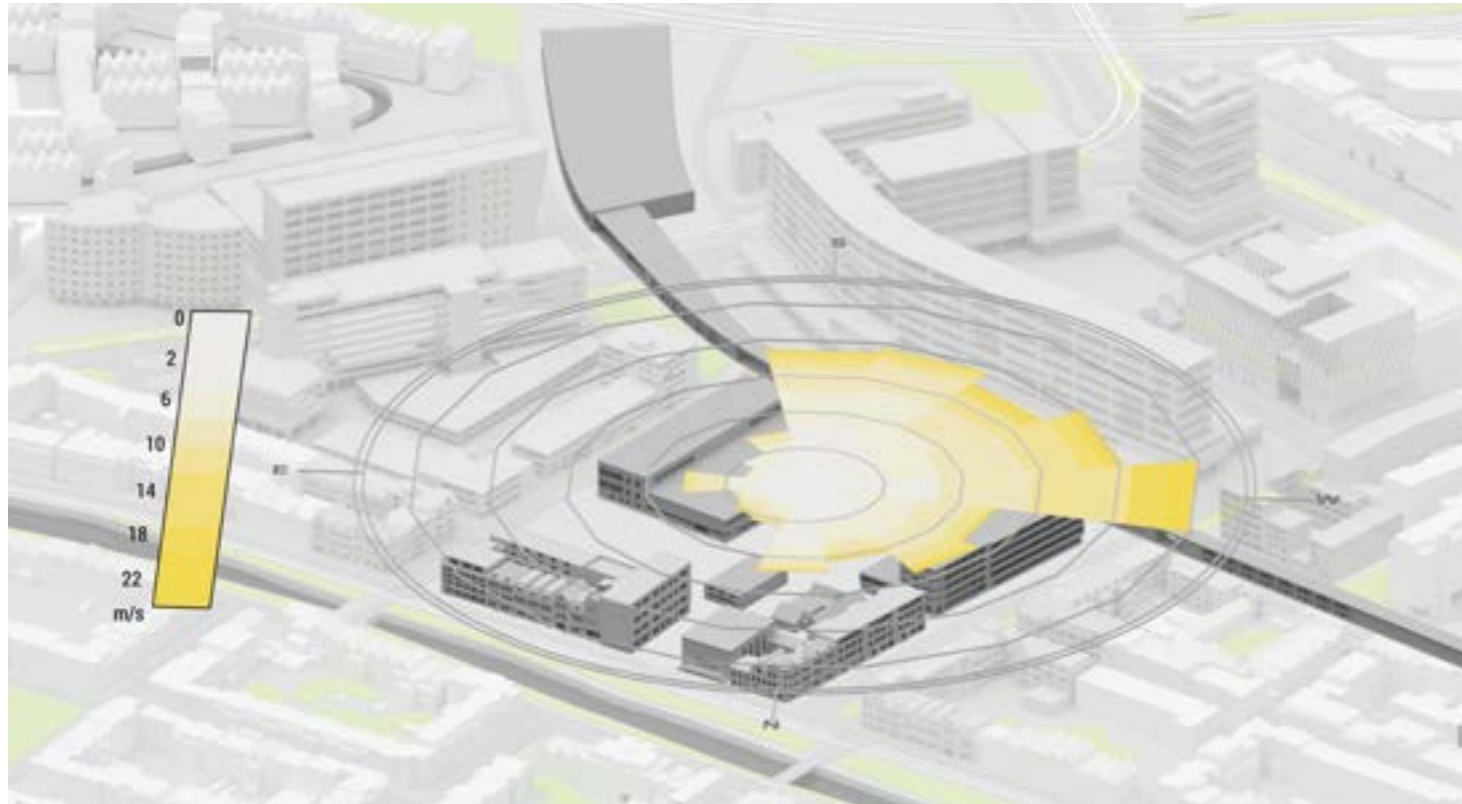

00.PREVAILING WINDS STATISTICS.

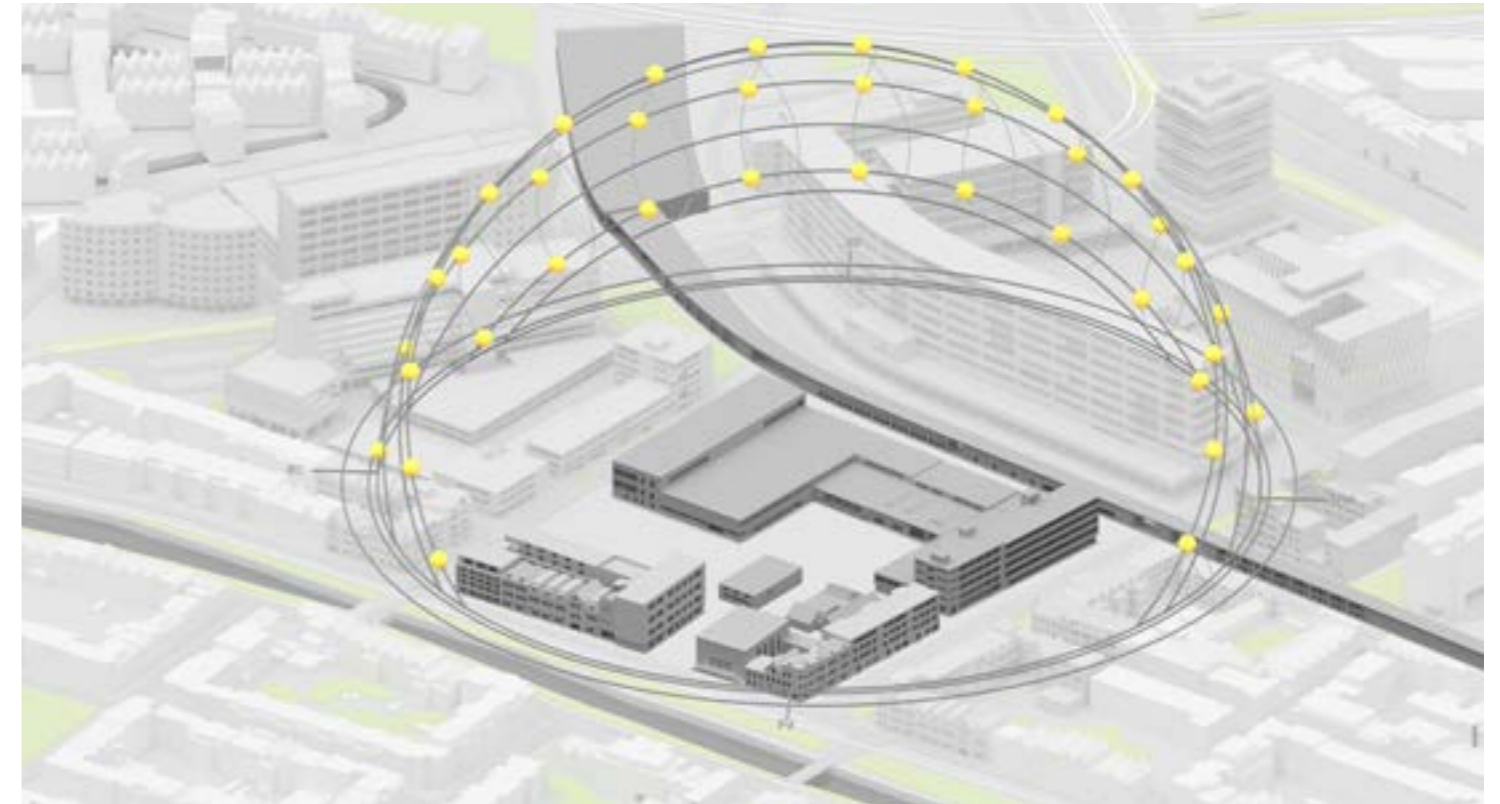

01.AVERAGE YEARLY SUNPATH.



02.KWH SOLAR GAINS PER M2.

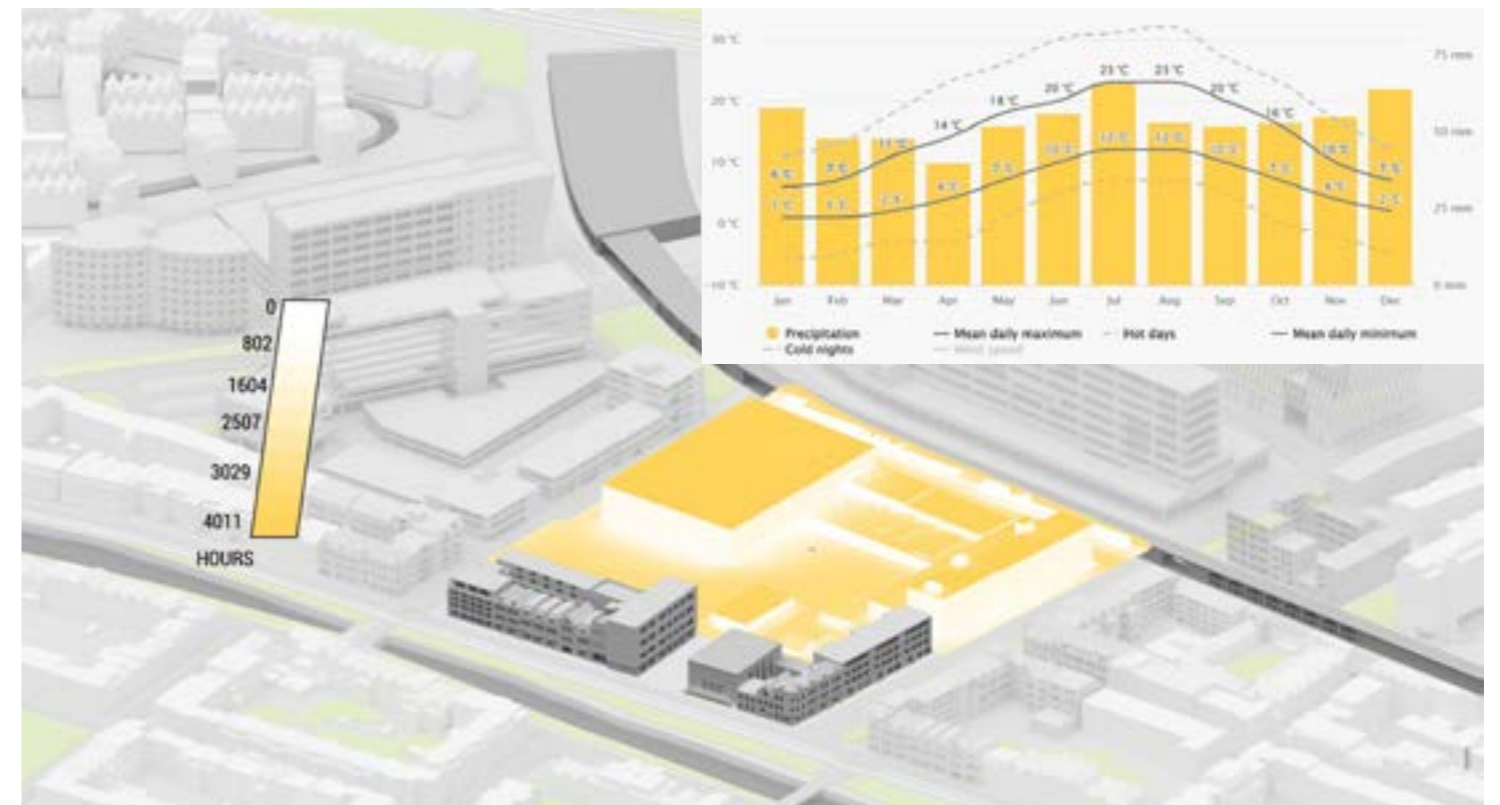

03.SOLAR EXPOASURE RATIO + CLIMATE STATISTICS.

P5 - PLAY WELL FLEXIBLE HOUSING

04.URBAN BLOCK UNDERSTANDING & DESIGN - SITE ANALYSIS - CONDITIONS:

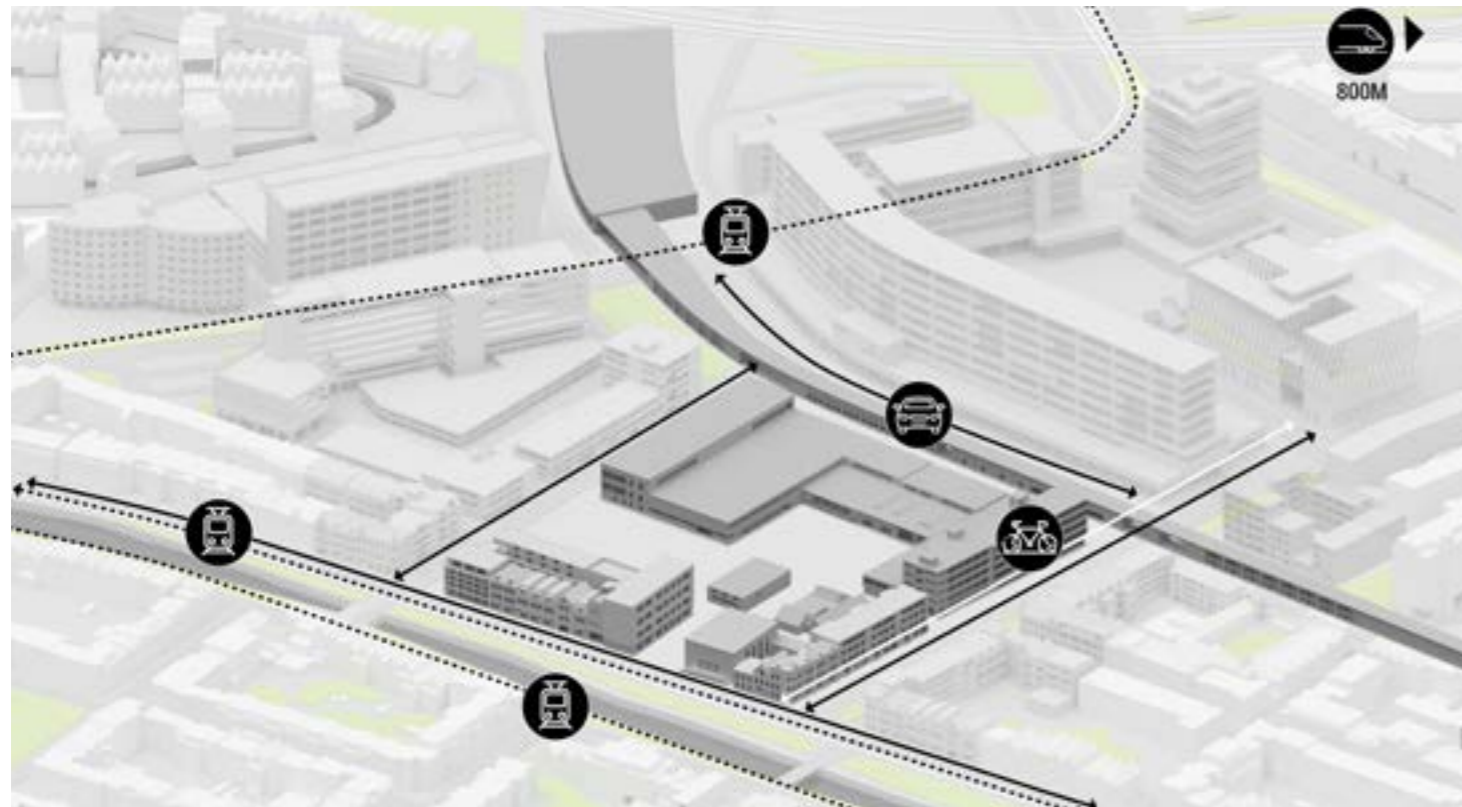

04.MAIN MEANS OF TRANSPORT / CONNECTIVITY.



05.IMPORTANT PUBLIC ASSETS / GREEN PASSAGES.

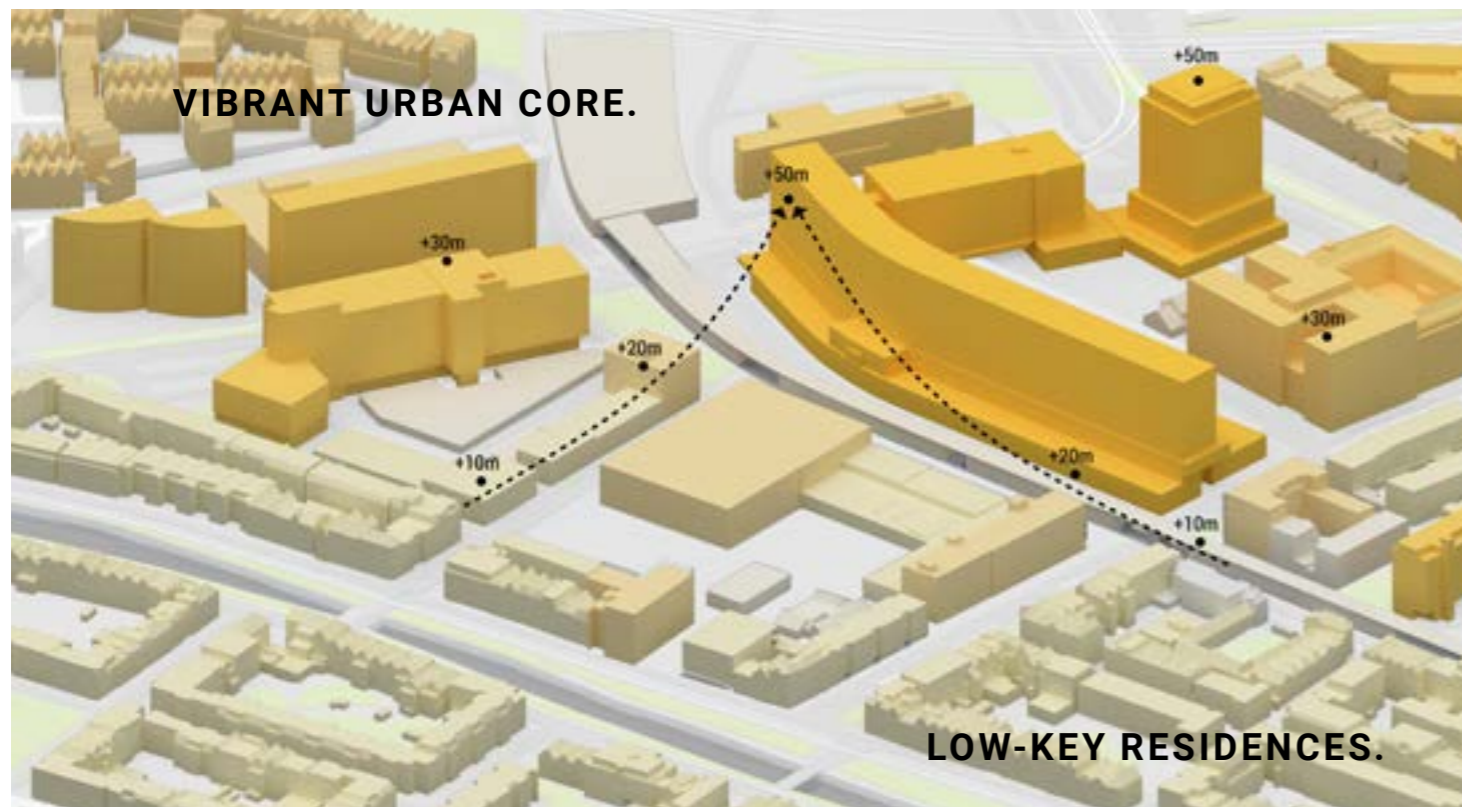

06.HEIGHT GRADIENT TRANSITION.

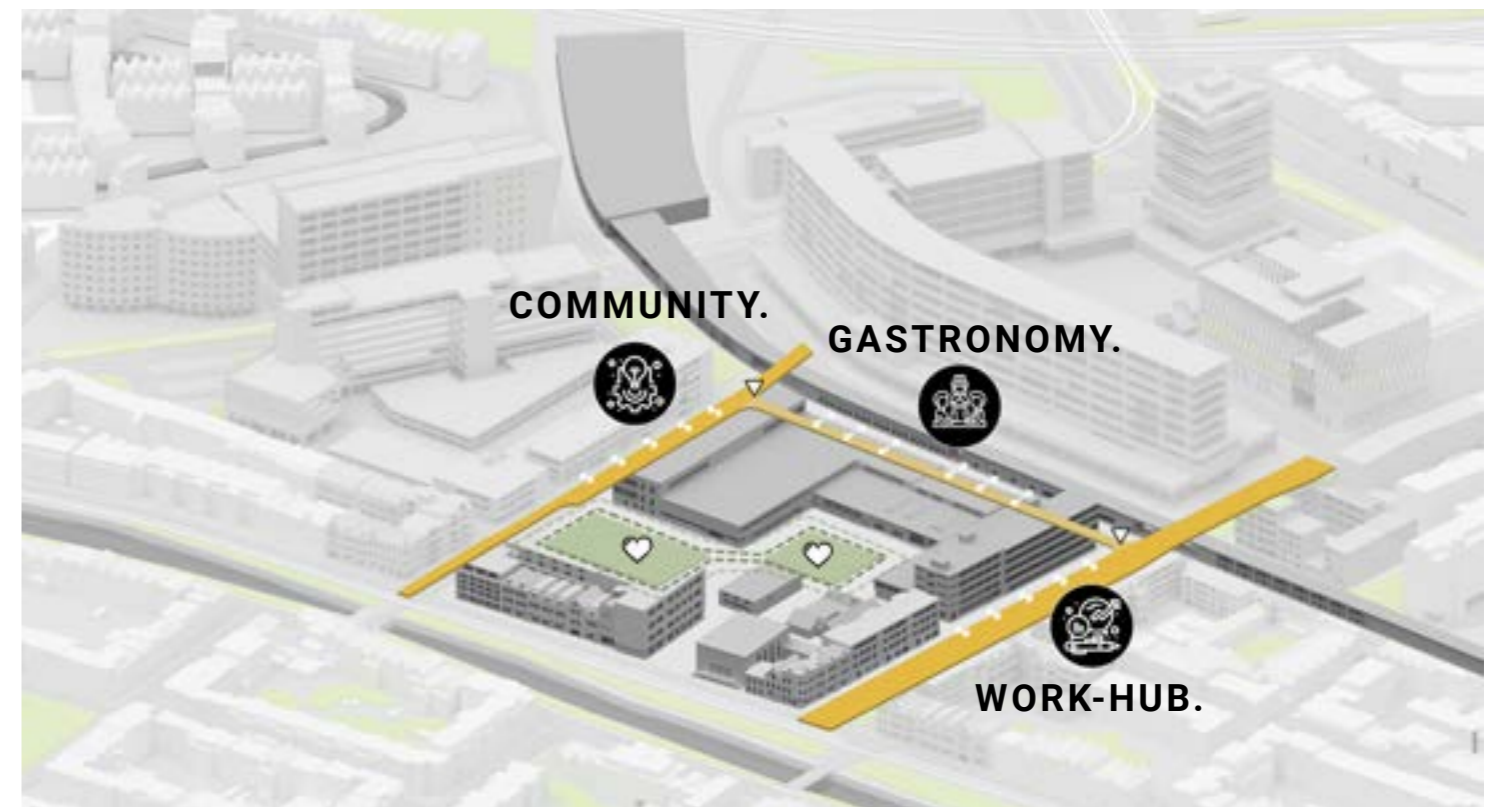

07.ACTIVATION POTENTIAL - COMMUNITY/CATERING/WORK.

P5 - PLAY WELL FLEXIBLE HOUSING

04.URBAN BLOCK UNDERSTANDING & DESIGN - LOCAL FEELING / VALUE:



+ LOCAL **BUSINESS.**



+ VIBRANT **STREET-LIFE CULTURE.**



+ CHARACTERISTIC **VISUAL IDENTITY.**



+ OUTDOOR/**SPORTS CULTURE.**

P5 - PLAY WELL FLEXIBLE HOUSING

04.URBAN BLOCK UNDERSTANDING & DESIGN - LOCAL CHARACTERS:



WILLIE - 40S - WORKOUTCLUBNL



EWALD - 60S - HEINDE & VERRE



JORRE 30S - BONZA CAFFEE



WORK:

WILLIE FOUNDED A PERSONAL TRAINING CLUB, WITH FEW LOCATIONS AROUND ROTTERDAM.



HEINDE & VERRE

EWALD RUNS A RECOGNIZED CHOCOLATE ROASTERY.



JORRE IS A BARISTA AT BONZA KOFFIE, HE ALSO HEADS THE LOCAL COFFEE ROASTERY.

LIFE:

WILLIE IS IN HER LATE 40S. SHE HAS TWO KIDS AND A DOG. SHE PREFERS ACTIVE, BUT MAINLY LOCAL LIFESTYLE.

EWALD ENTERED HIS 60S. HE IS SINGLE. LOVES HIS COMFORT AND LOOKS FOR UNIQUE EXPERIENCES IN LIFE.

JORRE IS A STARTER, HE DREAMS OF EXPANDING HIS ROSTERY. HE HAS A YOUNGER GIRLFRIEND WITH WHOM HE TRAVELS A LOT.

NEIGHBORHOOD:

WOULD WANT TO START A DAY WITH A TRAINING WITH NEIGHBORS AND A DOG WALK. ENJOYS AN OCCASIONAL RESTAURANT GATHERING WITH FRIENDS .

LOVES TO TO HIS GROCERY IN LOCAL NEIGHBORHOOD STORES. WHEN NOT WORKING IN ROSTERY HE PREFERS THE COMPANY OF PEOPLE IN CO-WORKING SETUPS.

HE'S ALL INTO TEAM SPORTS IN HIS SPARE TIME, LIKES TO TINKER WITH ELECTRONICS AND A PINT OF CRAFT-BEER WITH FRIENDS AFTER HOURS.

HOUSING:

WOULD ENJOY A LARGE APARTMENT WITH VERANDAS AND SEPARATE BEDROOMS FOR HER KIDS. LOTS OF LIGHT LOTS OF GREENERY.

PREFERS MODESTY WITH STYLE AND WOULD ENJOY A MID-SIZE LOFT TYPOLOGY WITH DOUBLE HEIGHT PARTS.

WOULD BE HAPPY WITH A COMFORTABLE STUDIO IN THE CITY CENTER.

P5 - PLAY WELL FLEXIBLE HOUSING

04.URBAN BLOCK UNDERSTANDING & DESIGN - PROGRAM TOPOLOGICAL MAP:

COMMUNICATION:	0	00.ENTRANCE/STREET
	1	01.ATRIUM/HUB
	2	02.COURTYARD
	3	03.CORRIDOR
HOUSING:	4	04.STUDENT HOUSING (80units)
	5	05.STARTER HOUSING (100units)
	6	06.ASSISTED HOUSING (30units)
	7	07.COMMUNAL KITCHENS
7B	07B.COMMUNAL ROOMS	
WORKING:	8	08.LIBRARY
	9	09.WORKSHOPS
	10	10.MAKER SPACES/FAB-LABS
	11	11.OFFICES
12	12.CO-WORKING	
RECREATION/LEISURE:	13	13.CINEMATHEQUE
	14	14.ARCADE
	15	15.CAFÉ
	16	16.RESTAURANT
	17	17.PUB
	18	18.GYM
19	19.COMMUNITY CENTERS	
	20	20.COMMUNITY GARDENS
FACILITIES/UTILITIES:	21	21.SUPERMARKET
	22	22.LAUNDRY ROOM
	23	23.BICYCLE PARKING
	24	24.CAR PARKING
	25	25.TOOLSHOP
	26	26.LOCAL STORES

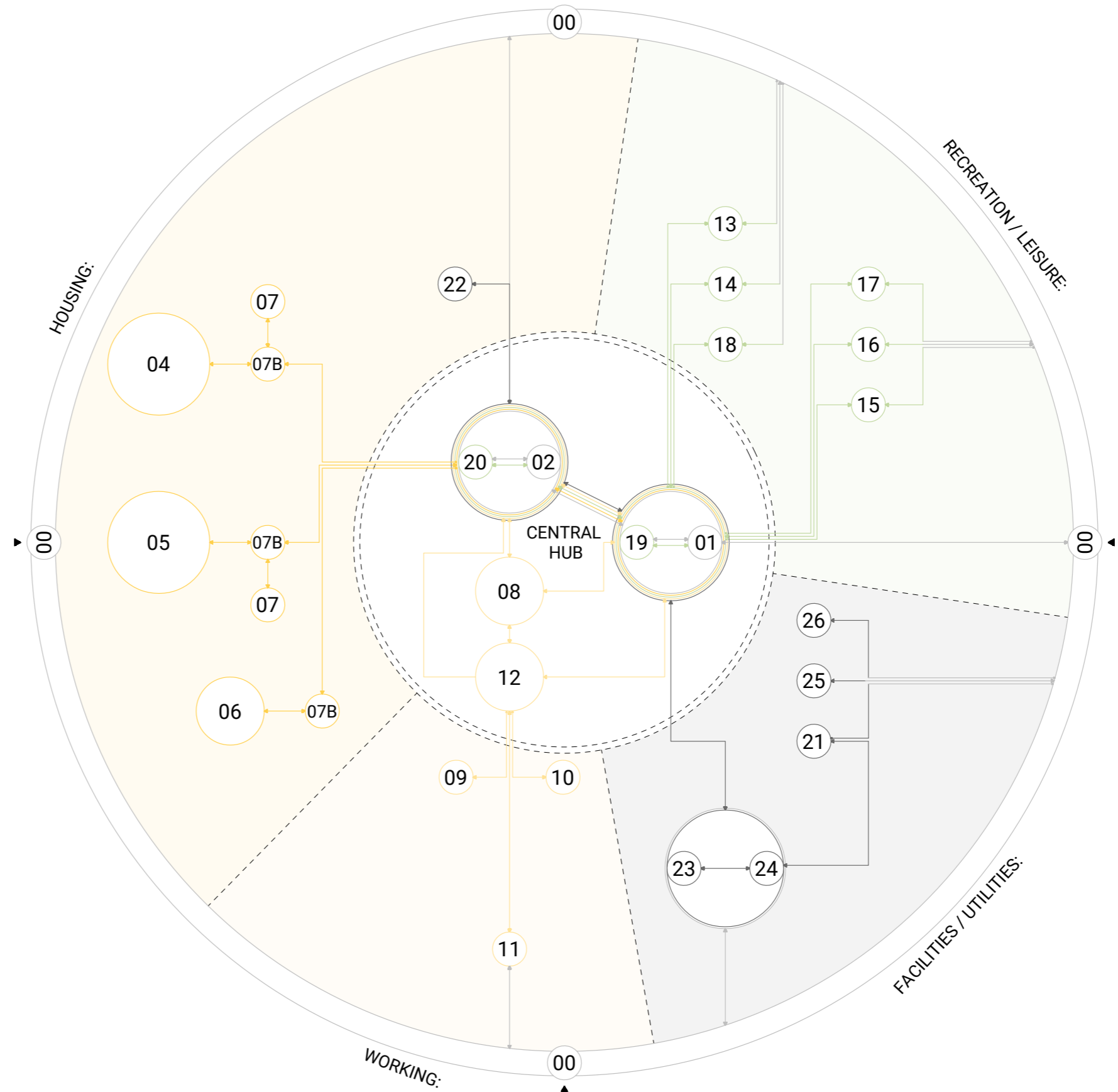

P5 - PLAY WELL FLEXIBLE HOUSING

04.URBAN BLOCK UNDERSTANDING & DESIGN - DESIGN STEPS:



00.RECOGNIZING THE HEARTH OF THE NEIGHBORHOOD.

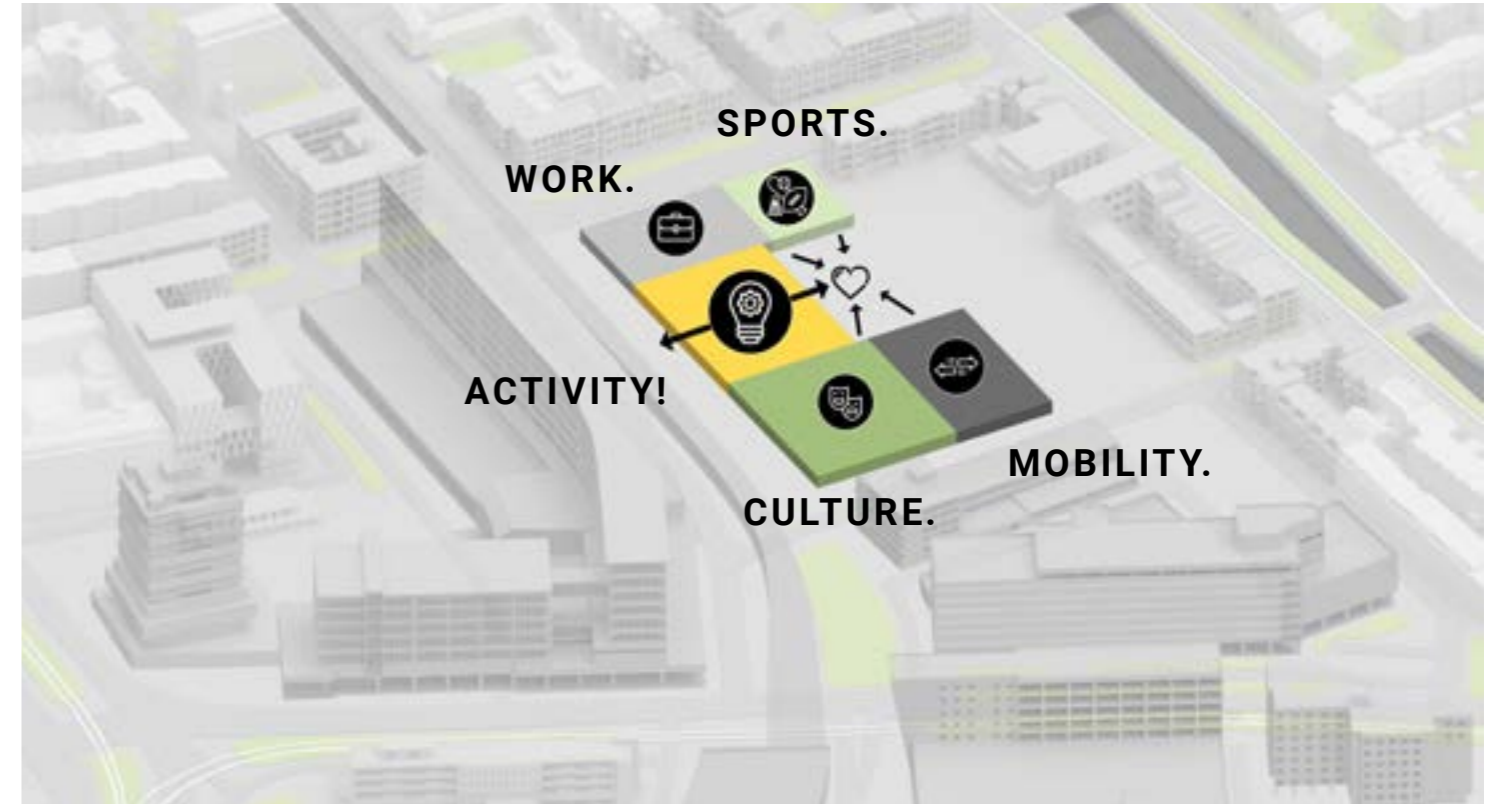

01.UTILIZING THE EXISTING VALUE.

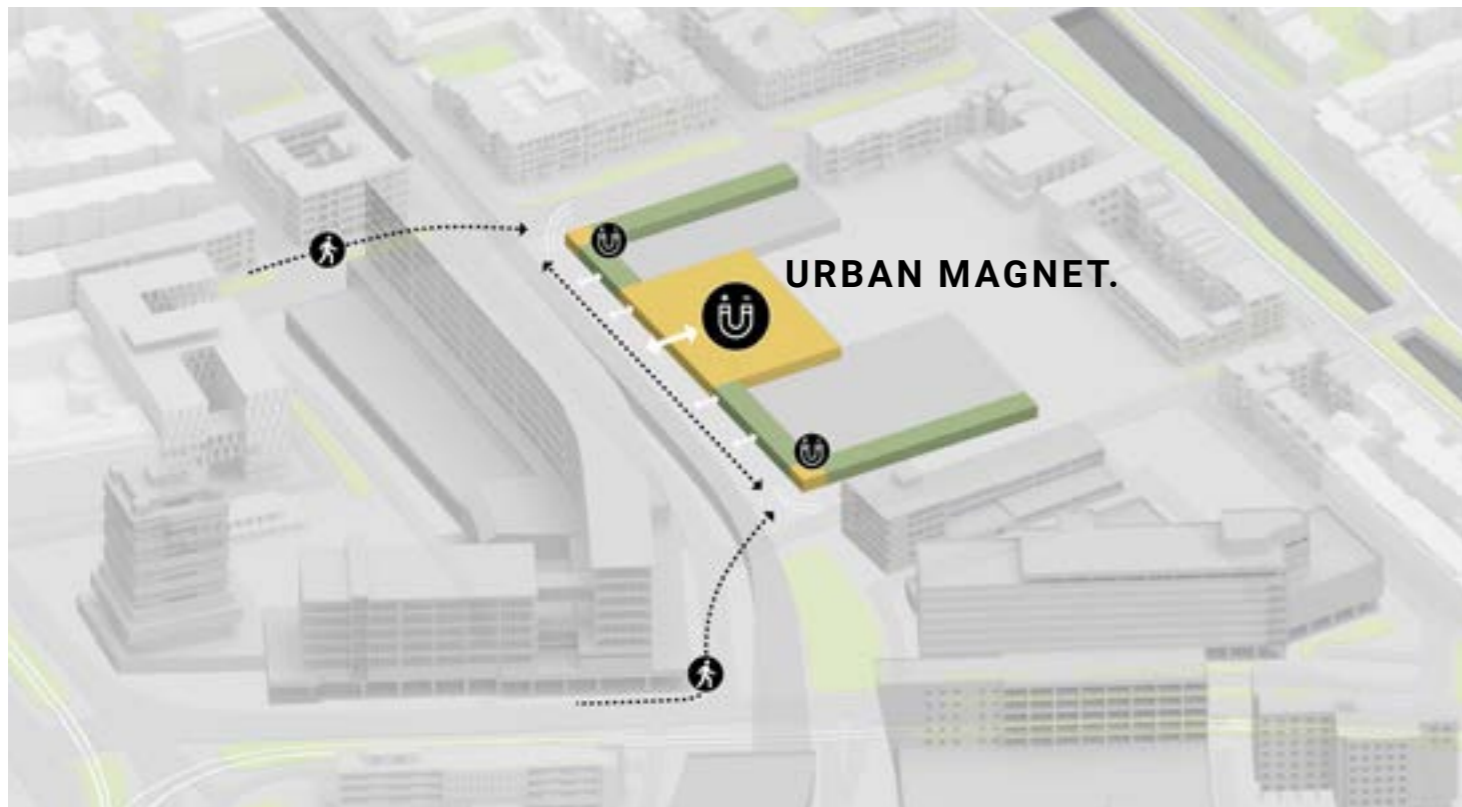

02.ACTIVATING THE STREET FRONTAGES.

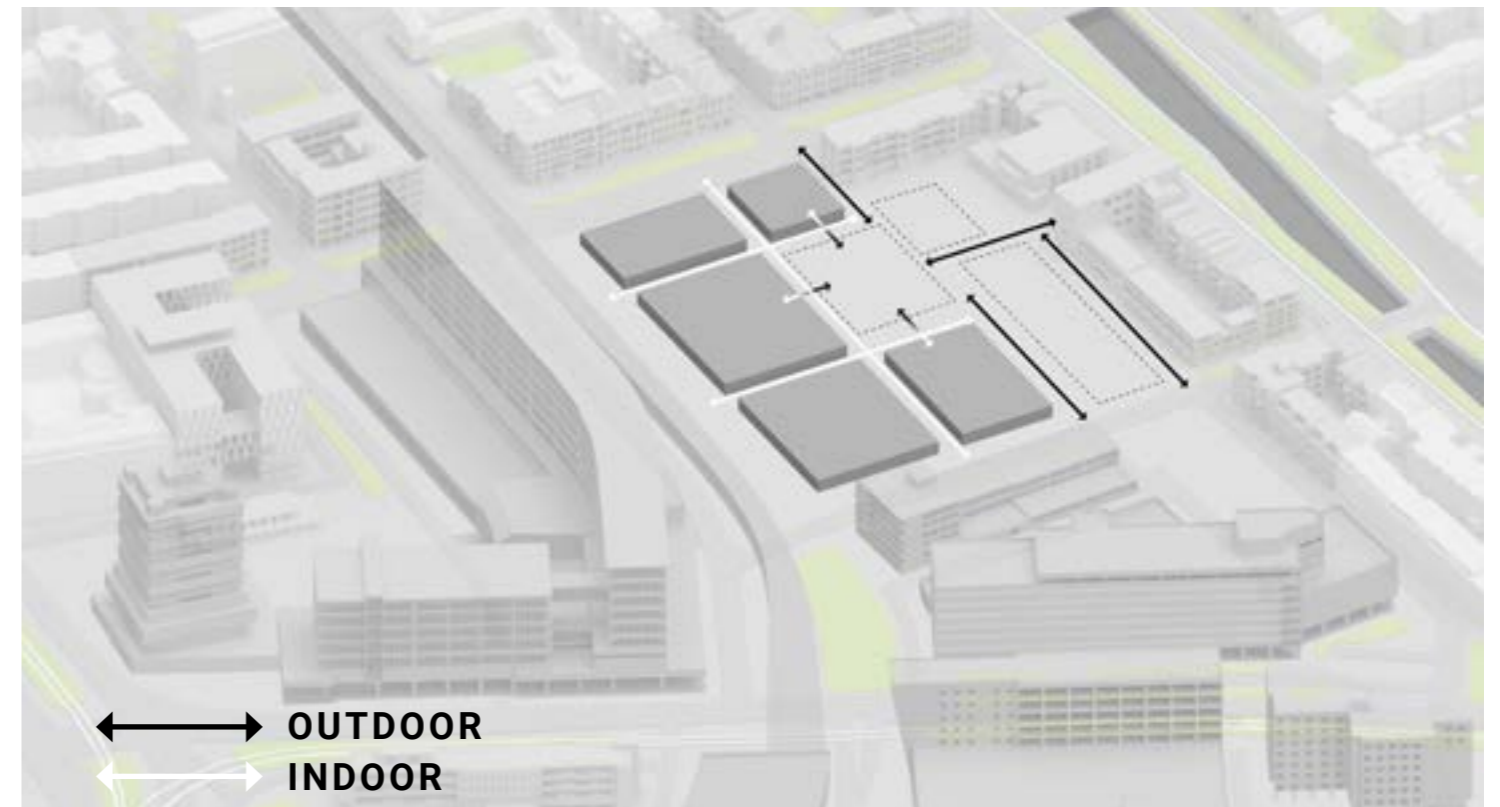

03.FACILITATING CONNECTION + PROLONGING EXISTING.

P5 - PLAY WELL FLEXIBLE HOUSING

04.URBAN BLOCK UNDERSTANDING & DESIGN - DESIGN STEPS:



04.ADDING SUPPORT PROGRAM.

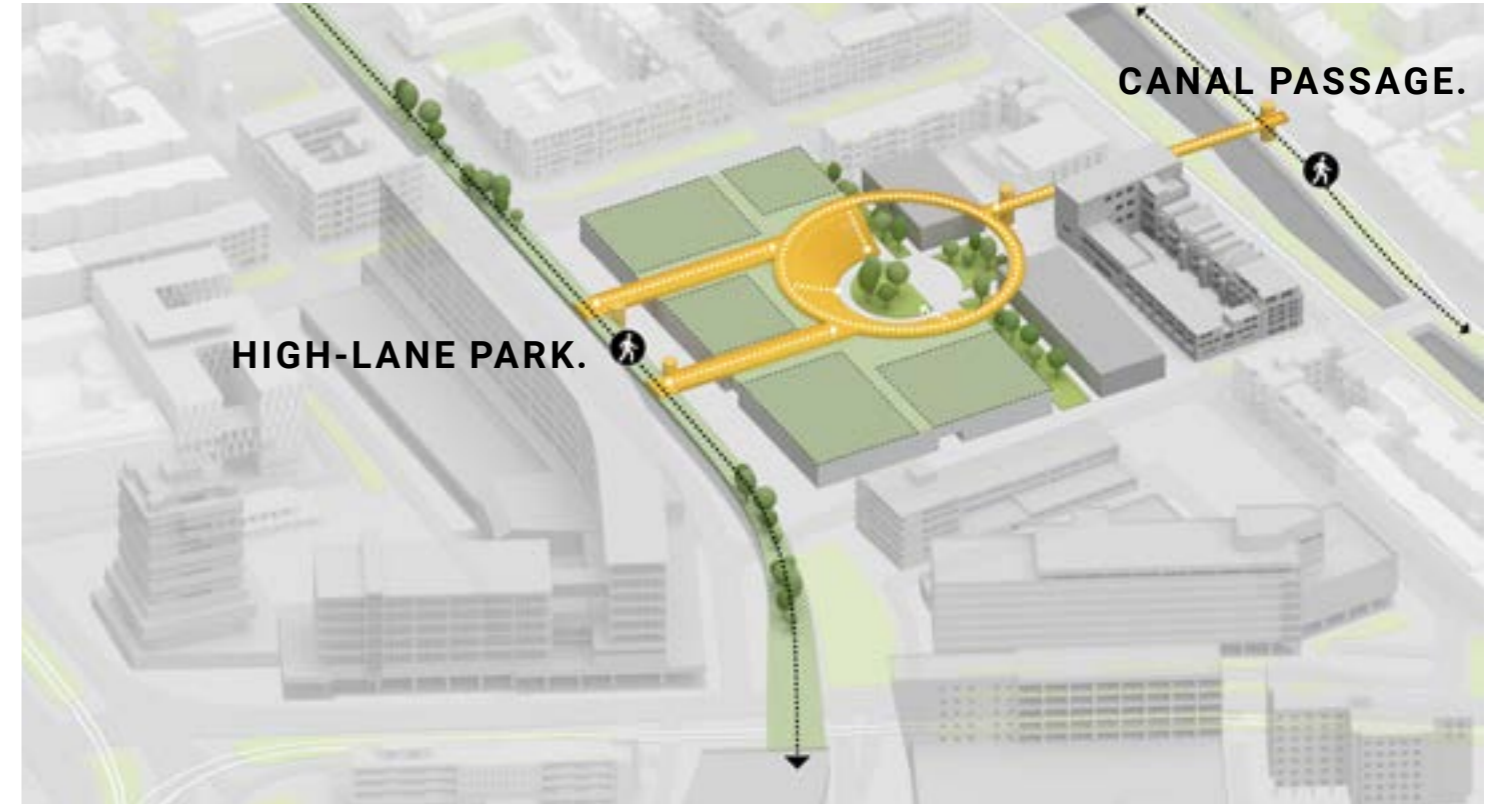

05.BRIDGING PUBLIC ASSETS. CREATING THE HEARTH.



06. BRINGING PARK VALLEYS UP WITH PROGRAM BLOCKS.



07. DENSIFYING THE NEIGHBORHOOD. THEMED BLOCKS.

P5 - PLAY WELL FLEXIBLE HOUSING

04.URBAN BLOCK UNDERSTANDING & DESIGN - FINAL STEP - HEIGHT CONTEXT ADJUSTMENT:



08. ADJUSTING THE MASSING HEIGHTS TO CORRESPOND WITH SURROUNDINGS.

P5 - PLAY WELL FLEXIBLE HOUSING

04.URBAN BLOCK UNDERSTANDING & DESIGN - VOLUMETRIC OUTLINE:

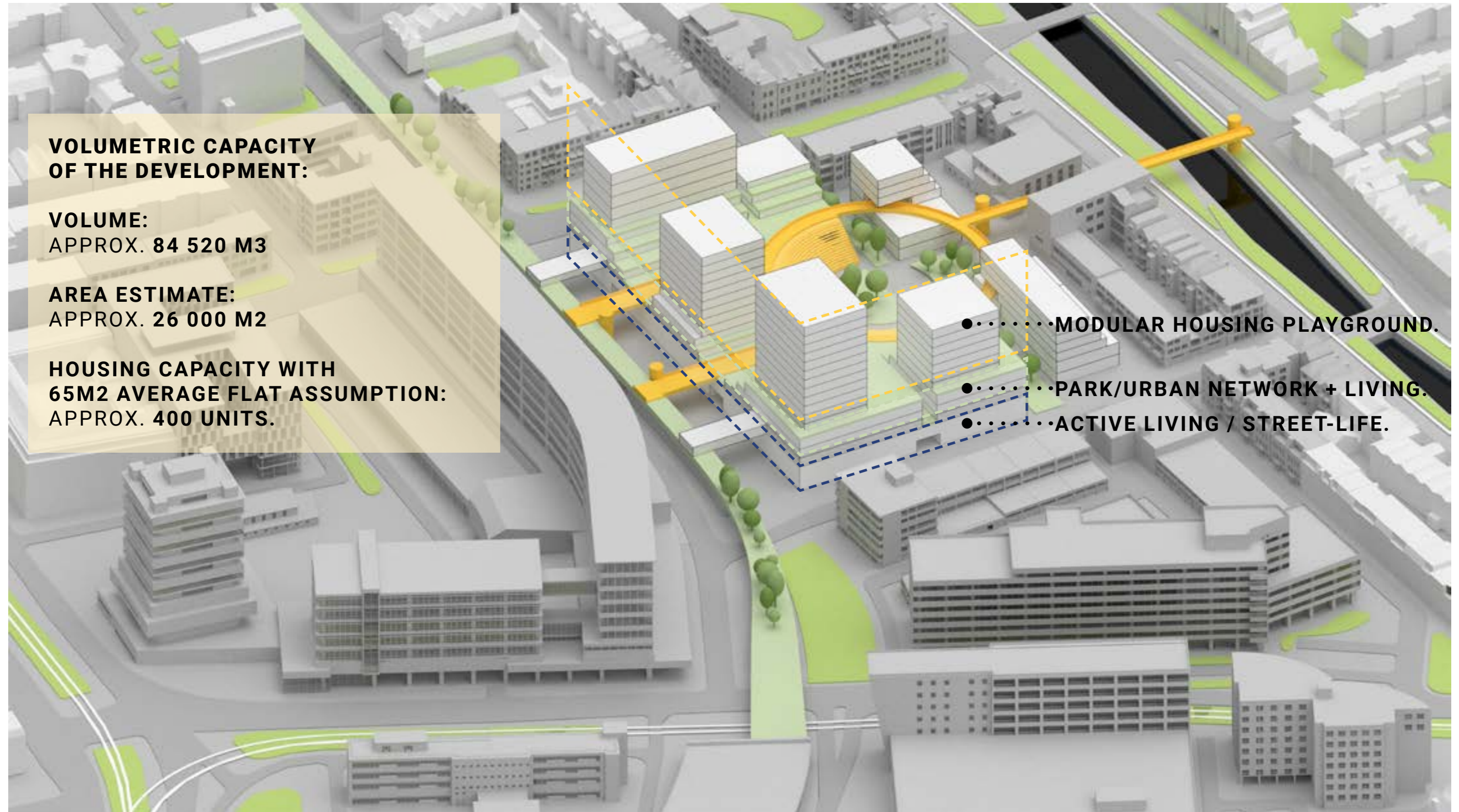

P5 - PLAY WELL FLEXIBLE HOUSING

05.CATALOGUIZATION / PRODUCTIZATION / COMPONENTIZATION.

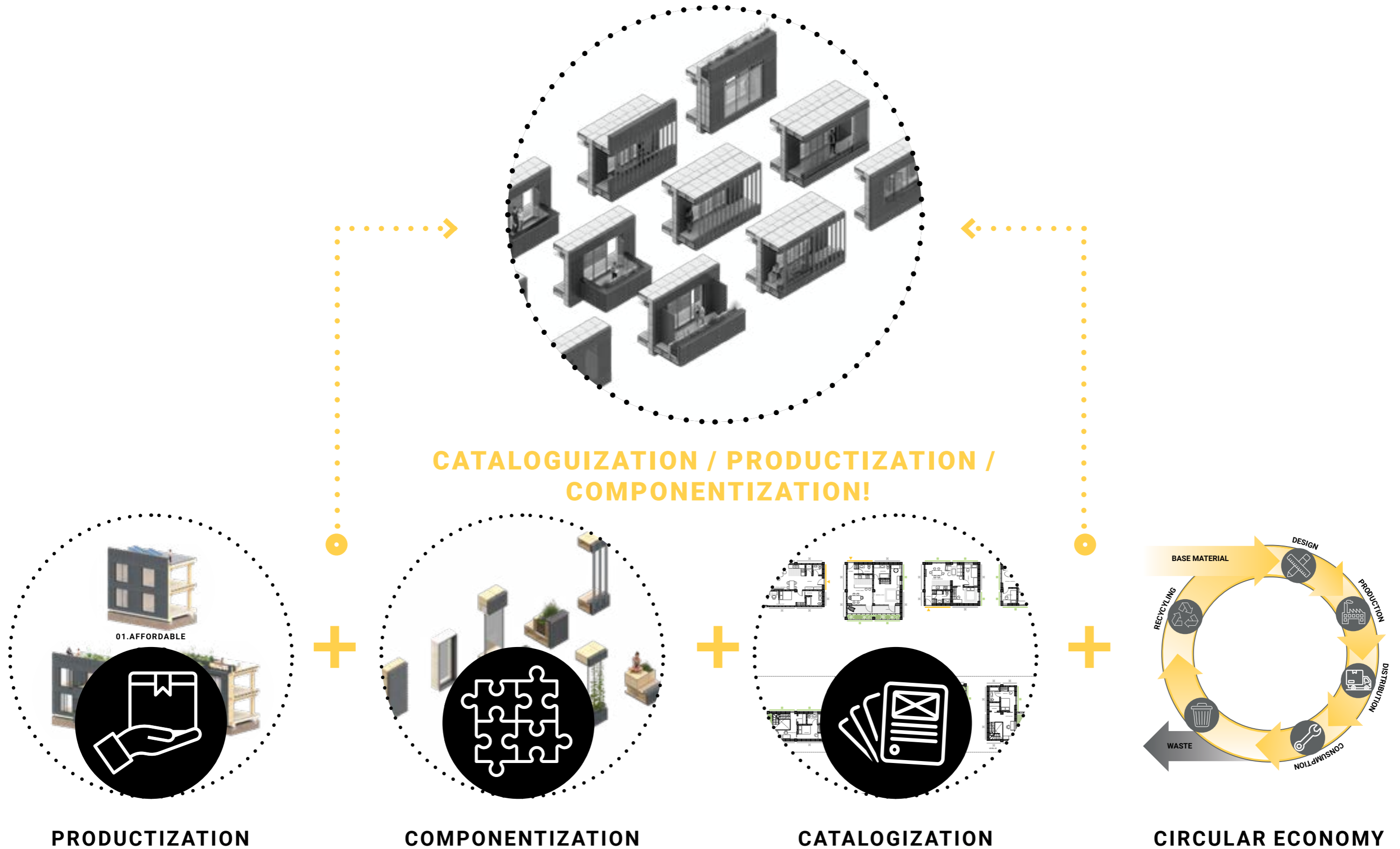

P5 - PLAY WELL FLEXIBLE HOUSING

05.CATALOGUIZATION / PRODUCTIZATION / COMPONENTIZATION - PRECEDENTS BLOCK SYSTEMS:



P5 - PLAY WELL FLEXIBLE HOUSING

05.CATALOGUIZATION / PRODUCTIZATION / COMPONENTIZATION - 01.BLOK BUILD:

BlokBuild



01.JUNCTION DETAILING
STEEL ROD JOINTS



02.POSSIBLE SPANS
OF APPROX 7M

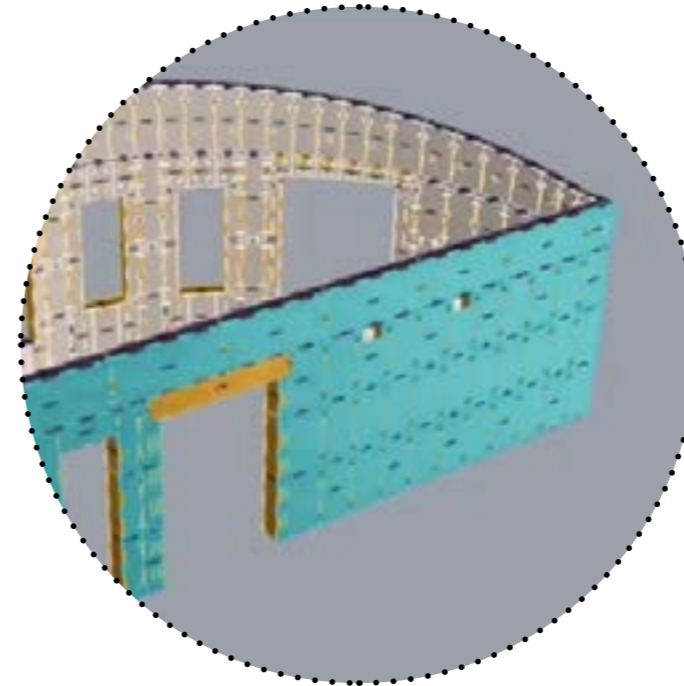

03.FULL DIGITIZATION OF
PROCESS AND ELEMENTS
CATALOGIZATION



04.SPRAY AIR TIGHT LAYER
/ ADDITIONAL STRUCTURE
FIRE PROOFING

P5 - PLAY WELL FLEXIBLE HOUSING

05.CATALOGUIZATION / PRODUCTIZATION / COMPONENTIZATION - 02.U-BUILD:

U-Build[®]



**01.AIRTIGHTNESS
MEMBRANE + TAPE**



**02.BOX VARIABLE
INFILL**



03.FACADE CLADDING



**04.FACADE FINISH
PANELIZED**

P5 - PLAY WELL FLEXIBLE HOUSING

05.CATALOGUIZATION / PRODUCTIZATION / COMPONENTIZATION - 03.AUAR:

au ar

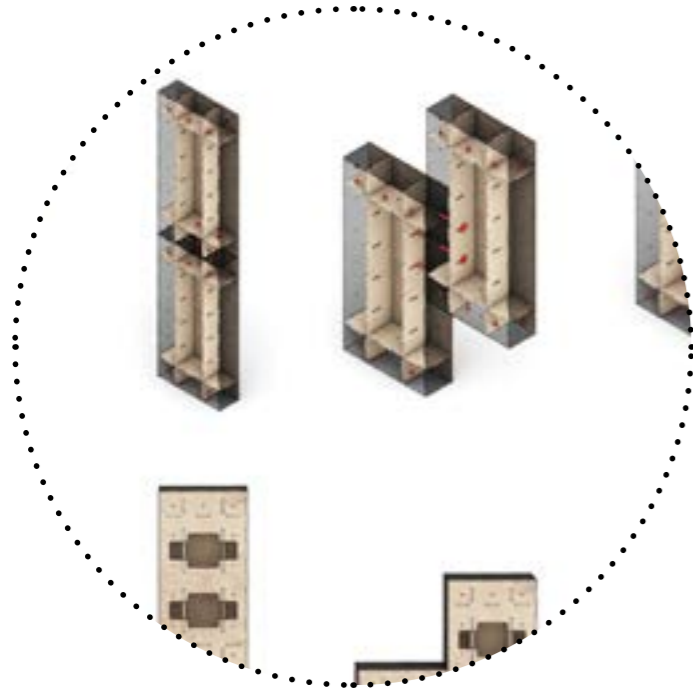

**01.JUNCTION DETAILING
CABLE SYSTEM**



**02.POTENTIAL OF
VARIABILITY**

**USING THE BOX TO
THE MAXIMUM**



**03.AUTOMATION OF
CONSTRUCTION**

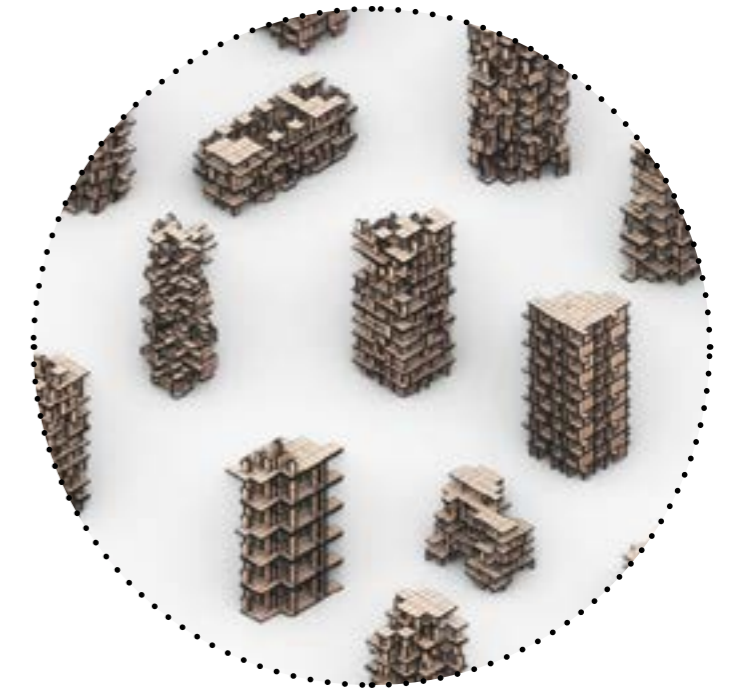

**04.ASSEMBLY AND
REASSEMBLY**

SCALE OF ADOPTION

P5 - PLAY WELL FLEXIBLE HOUSING

05.CATALOGUIZATION / PRODUCTIZATION / COMPONENTIZATION - 04.WIKI HOUSE:

WikiHouse

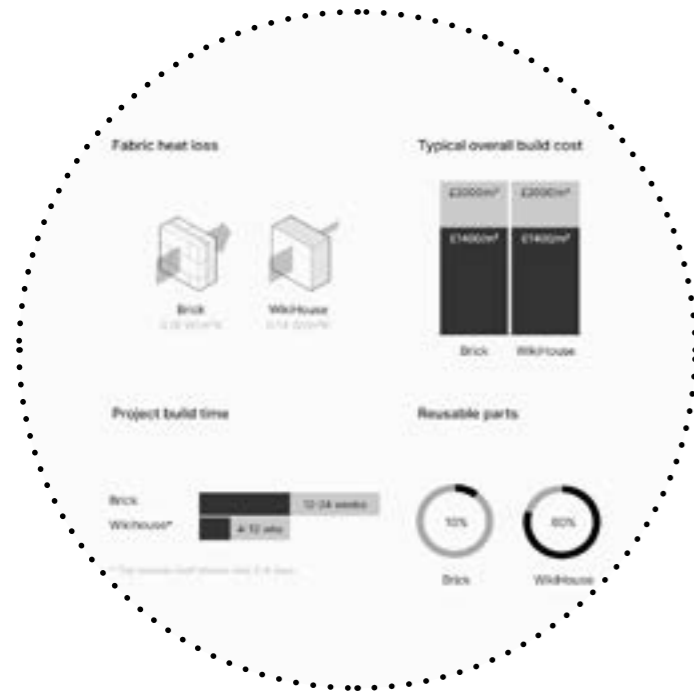

01. BENEFITS OF WOOD BLOCK CONSTRUCTION SYSTEM:

- + PARTS RE-USABILITY
- + HEAT LOSS
- + BUILDING COST
- + BUILDING TIME



02. AIR-TIGHTNESS ADDITIONAL INTERNAL LAYER FOR PASSIVE HOUSE 1.5 ACH

WALL U-VALUE:
0.15 W/(M²K)

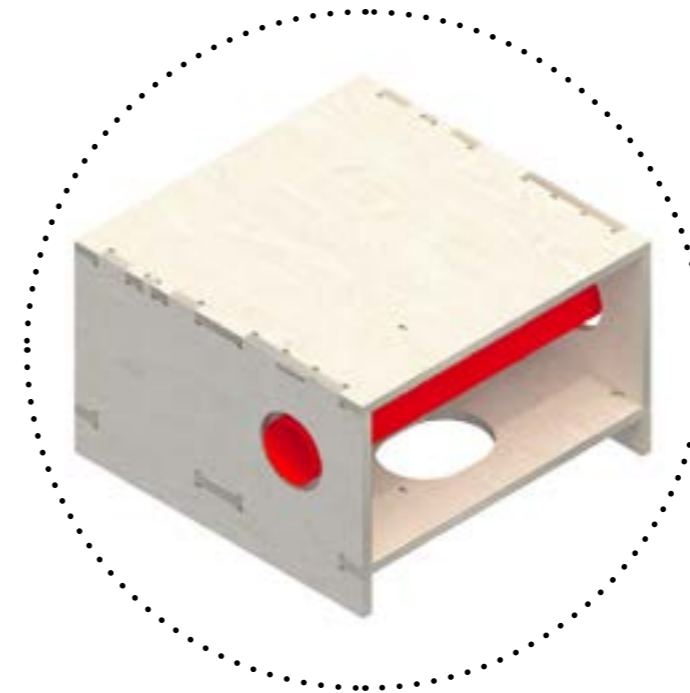

03. BOX PRE-DRILLING FOR SERVICES INTEGRATION

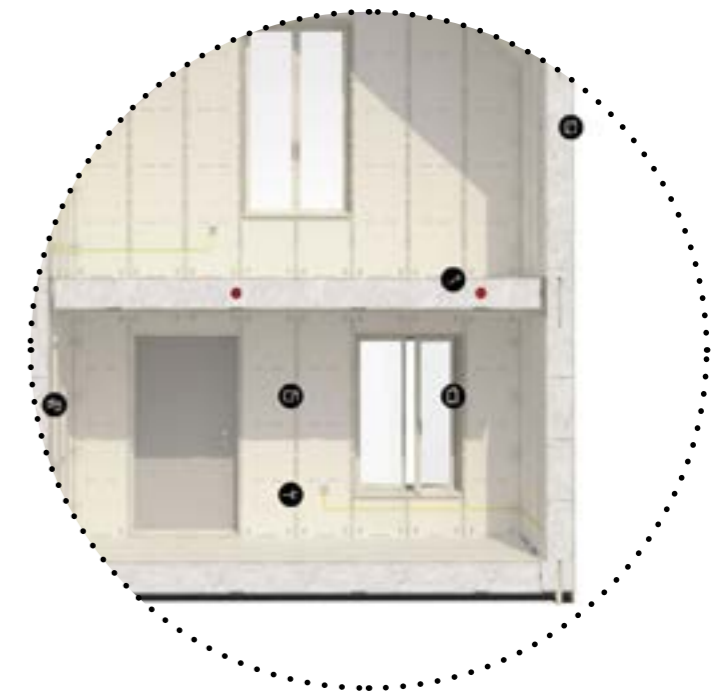

04. SYSTEMS INTEGRATION

DOCUMENTATION STATING
POSSIBILITY OF CREATING
MID-RISE BUILDINGS

P5 - PLAY WELL FLEXIBLE HOUSING

05.DETAILING PRINCIPLES BASIS - PASSIVE HOUSE + OPEN BUILDING

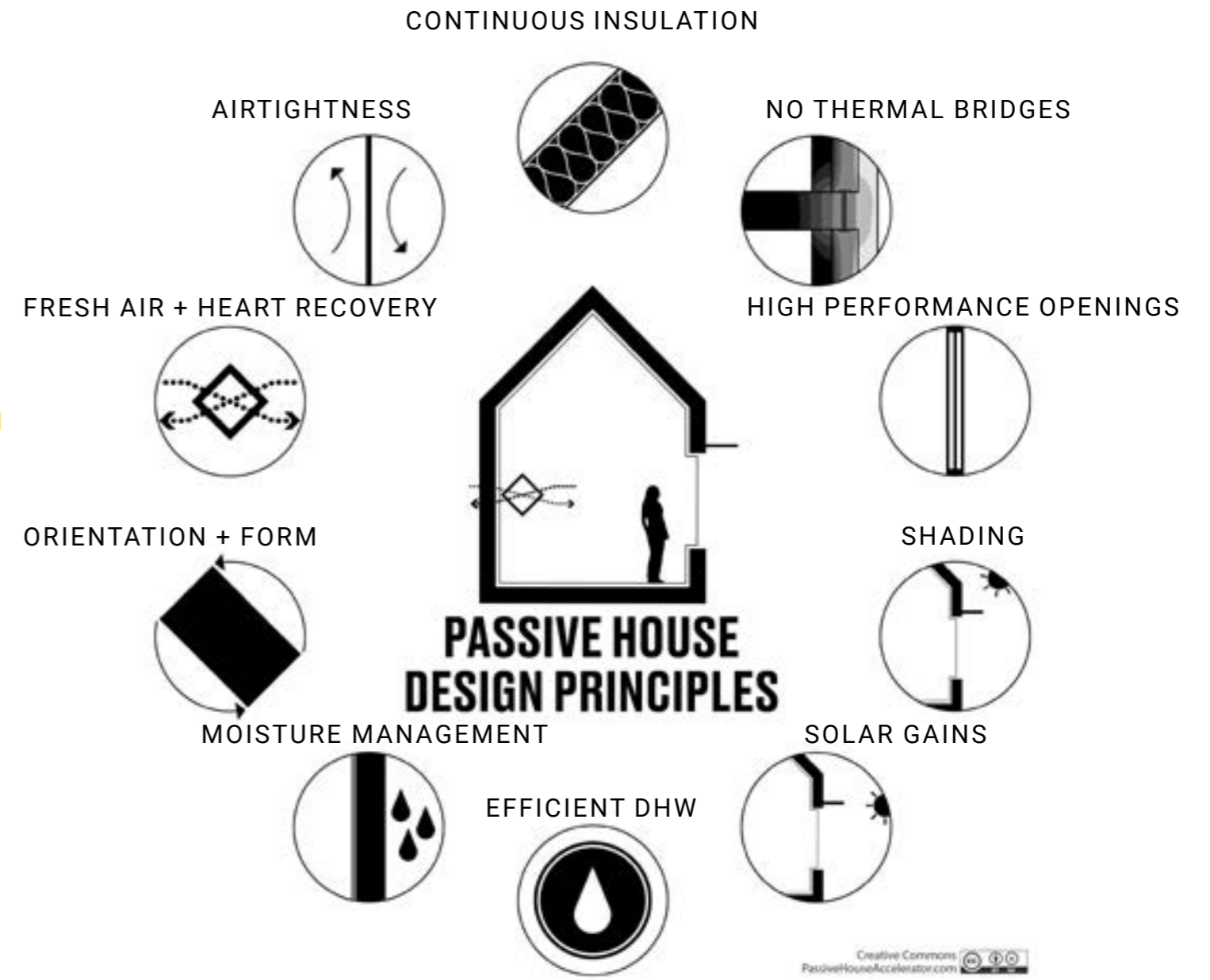
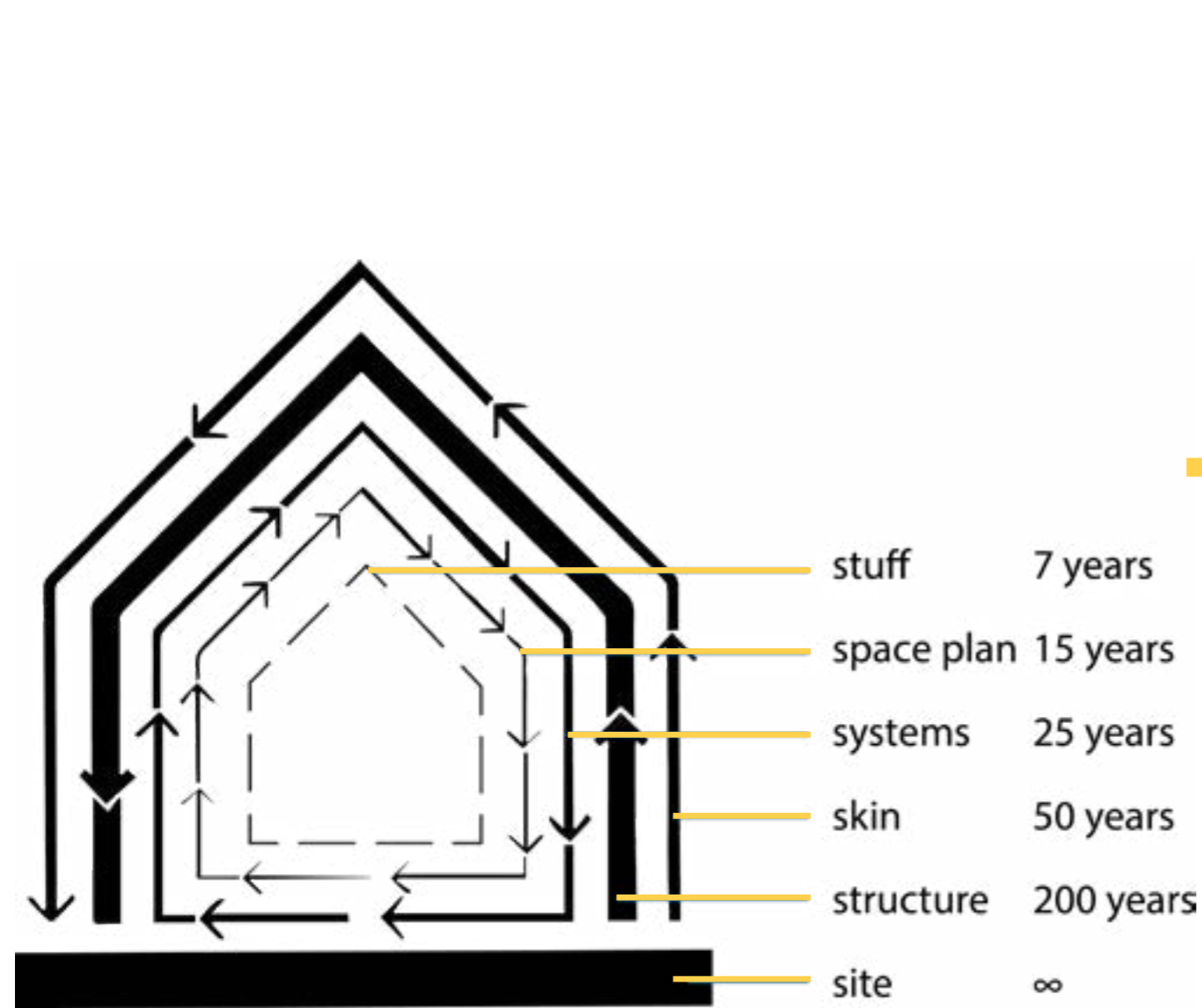

OPEN BUILDING

- + SYSTEMS: DEMOUNTABLE, SEPARATED FROM THE SUPPORT.
- + SKIN: COLLAGE: FREEDOM OF APPEARANCE PER DWELLING OR A CLUSTER OF UNITS.
- + SKIN: DEMOUNTABLE AND DRY MOUNTED.
- + SPACE PLAN: CIRCULAR MATERIALS AND SYSTEMS.
- + SPACE PLAN: DEMOUNTABLE, FLEXIBLE ADJUSTABLE

PASSIVE HOUSE

- + CONTINUOUS INSULATION.
- + NO THERMAL BRIDGES.
- + HIGH PERFORMANCE OPENINGS.
- + FRESH AIR + HEART RECOVERY.
- + AIRTIGHTNESS.
- + SOLAR SHARING.

P5 - PLAY WELL FLEXIBLE HOUSING

05.CATALOGUIZATION / PRODUCTIZATION / COMPONENTIZATION - SCENARIO SECTIONS:

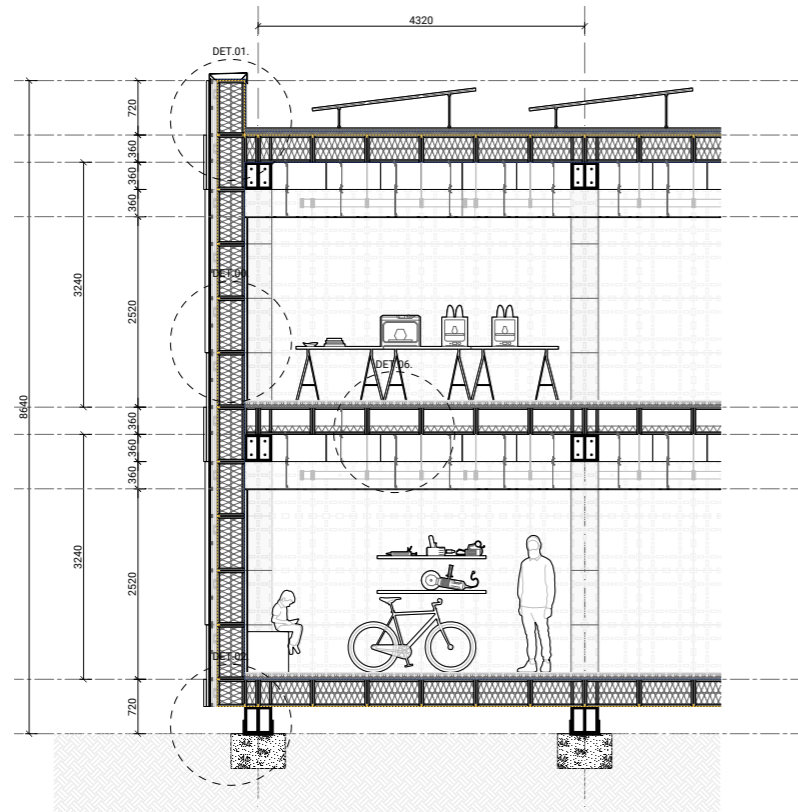

SCENARIO 01 - ENCLOSED WALL + PV PANELS ROOF

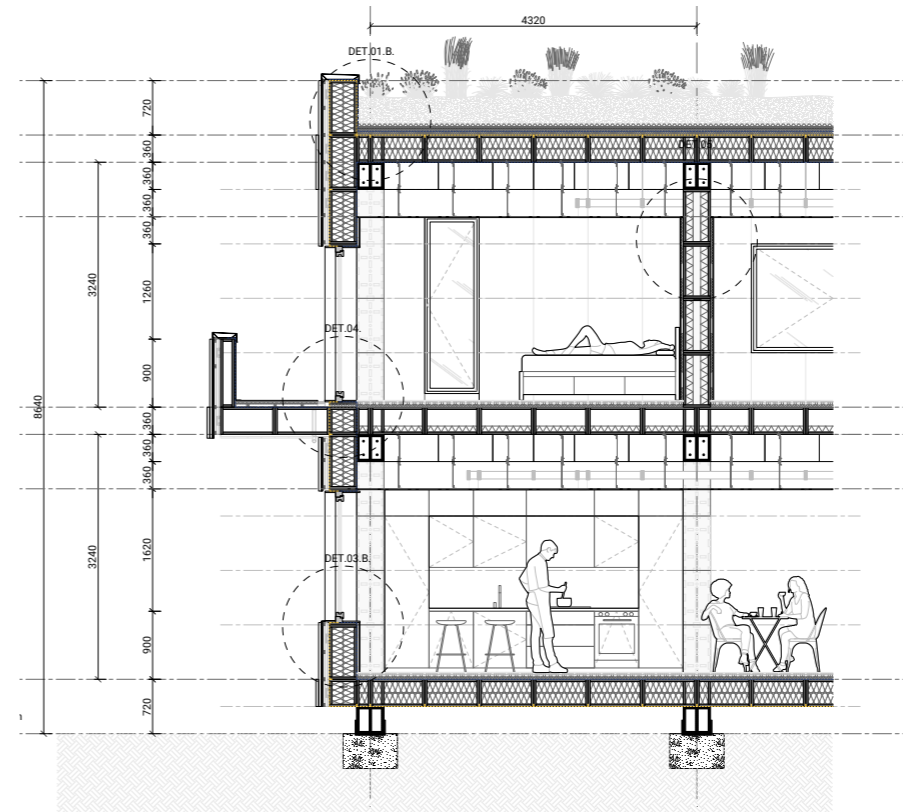

SCENARIO 02 - BALCONY/WINDOW + GREEN ROOF

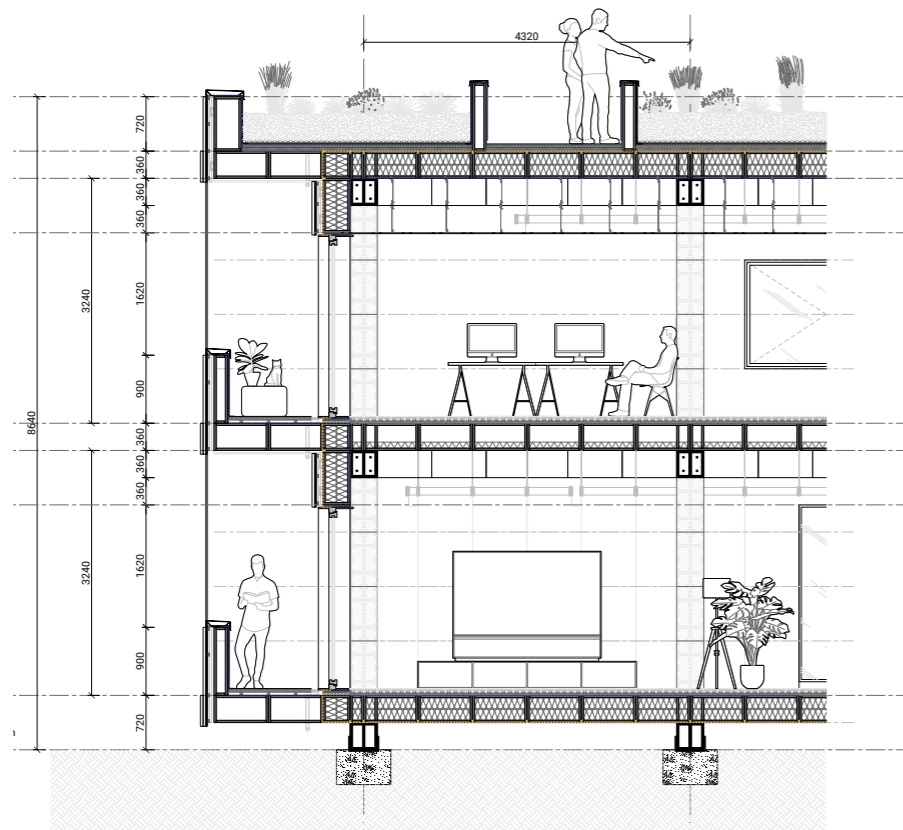

SCENARIO 03 - LOGGIA WITH SHADERS + ACCESSIBLE ROOF

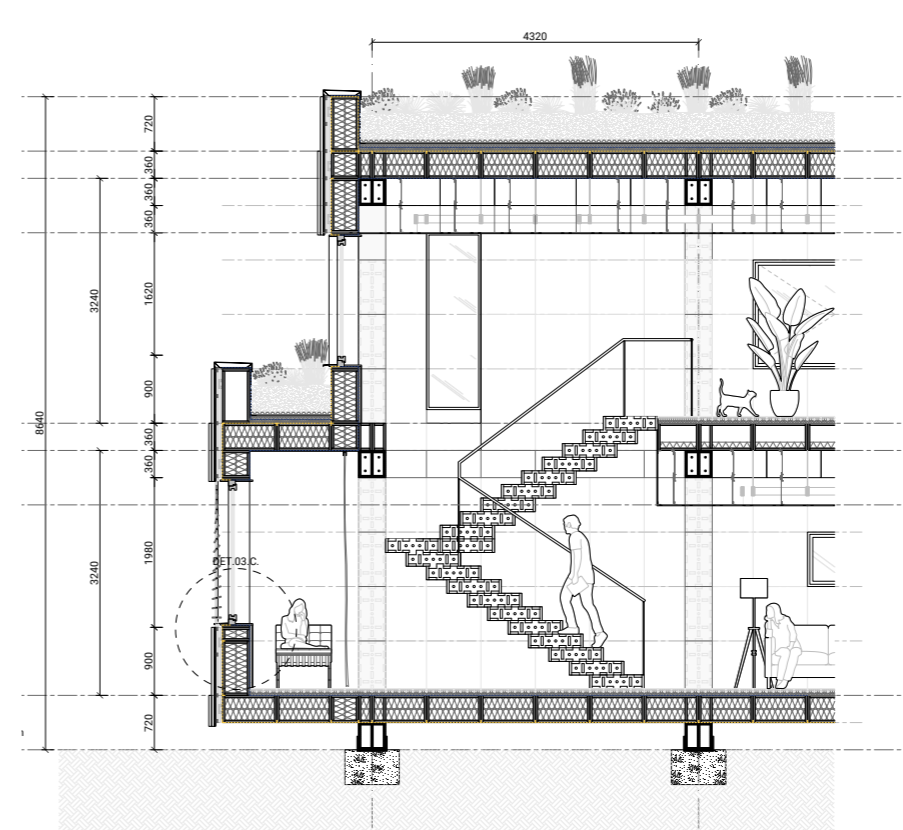

SCENARIO 04 - DORMER WINDOW + GREEN PLANTERS

P5 - PLAY WELL FLEXIBLE HOUSING

05.DETAILED EXPLORATION: CATALOGUE OF DETAILS.

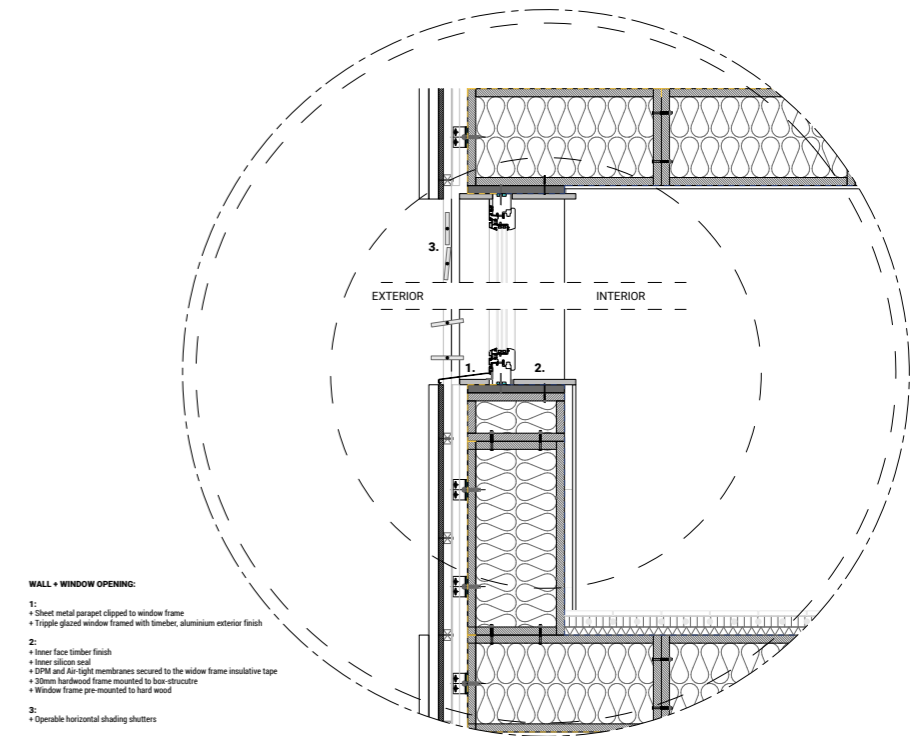
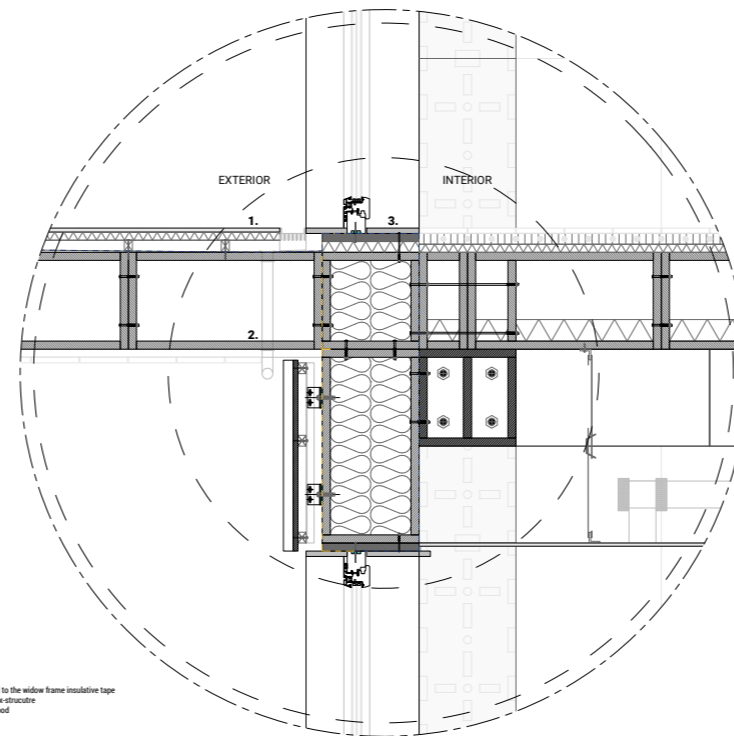
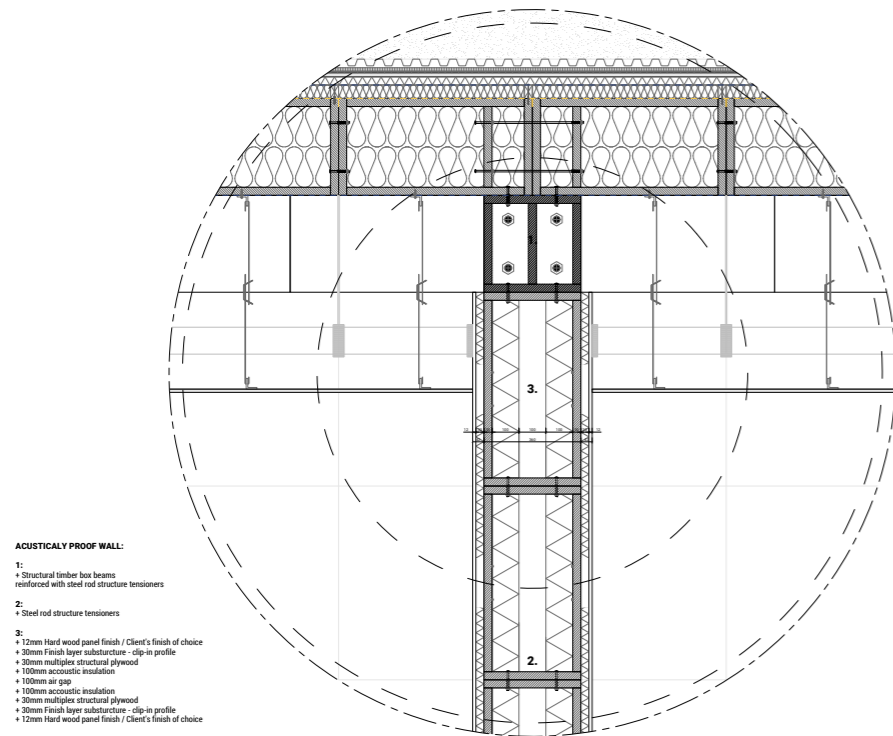
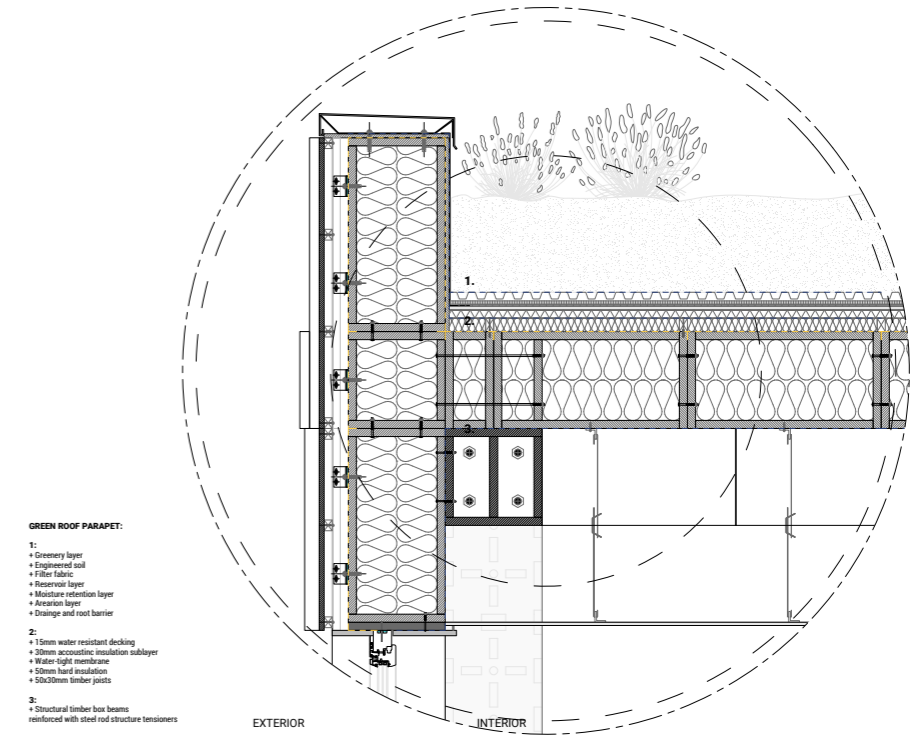
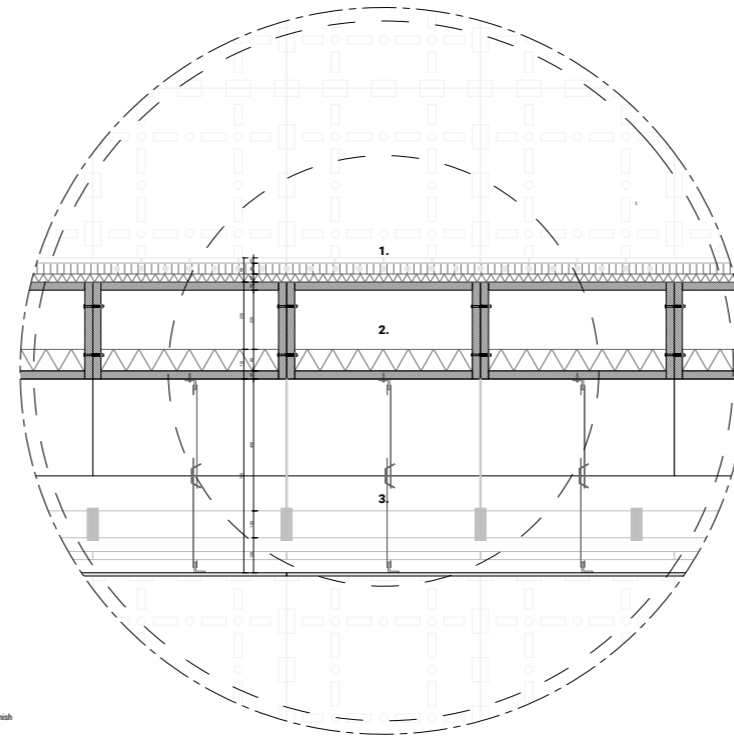
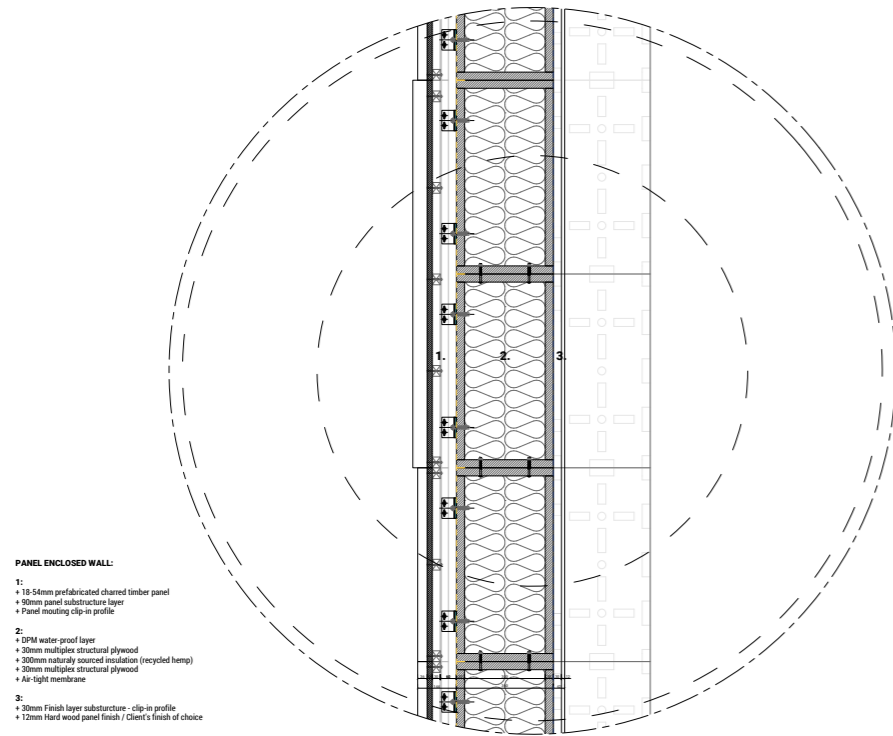

P5 - PLAY WELL FLEXIBLE HOUSING

05.CATALOGUE OF FACADE SOLUTIONS:

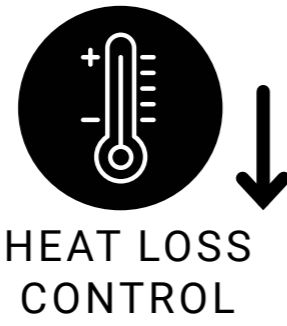

HEAT LOSS
CONTROL

RAINSCREEN

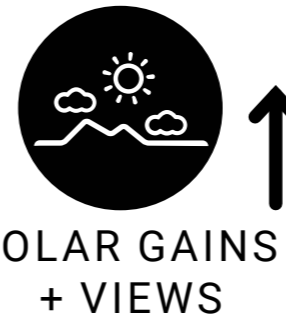

SOLAR GAINS
+ VIEWS

WINDOW OPENING



RECREATION
+ VIEWS

BALCONY MODULE



BIODIVERSITY

PLANTER MODULE



GLARE LIMIT

VERTICAL LOUVERS

P5 - PLAY WELL FLEXIBLE HOUSING

05. CATALOGUE OF FACADE SOLUTIONS:

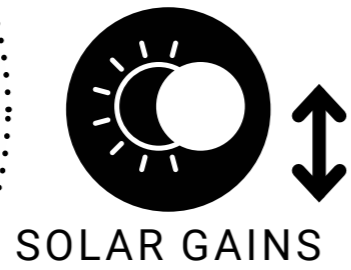
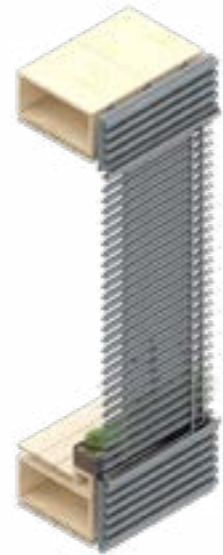

SOLAR GAINS

OPERABLE HORIZONTAL SHADERS

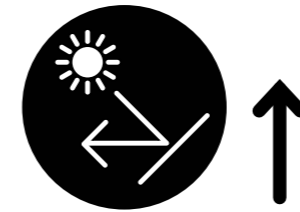

SHADING

OPERABLE WINDOW BLINDS



BIODIVERSITY

GREENERY TRELLIS

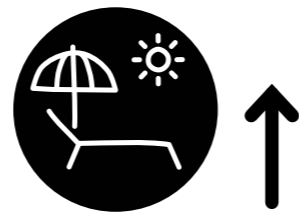

RECREATION

SEATING MODULE



VENTILATION

DOUBLE SKIN FACADE

P5 - PLAY WELL FLEXIBLE HOUSING

05.CATALOGUE OF ROOF SOLUTIONS:



GREEN ROOF



GREENIFICATION

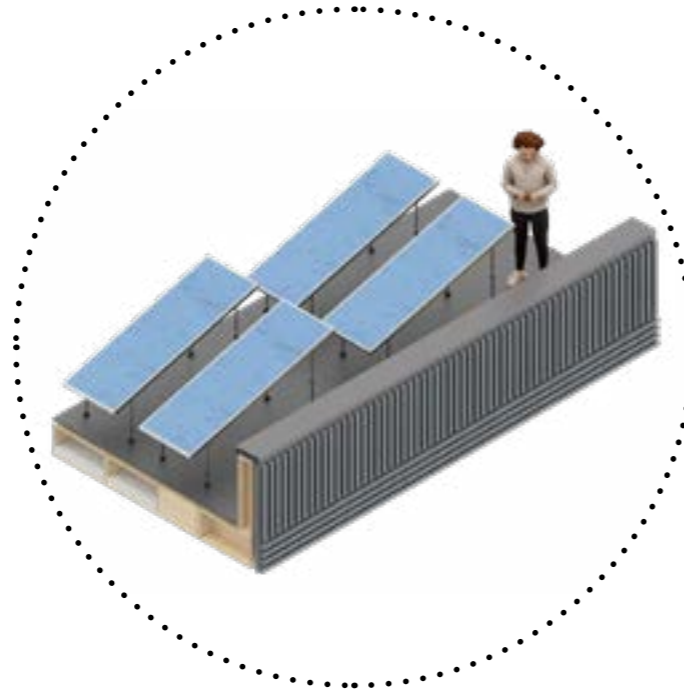

PV PANELS

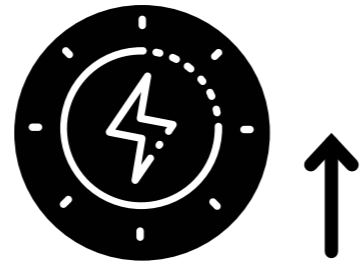

ENERGY COLLECTION



**RELAXATION /
ACCESS**



PUBLIC AMENITIES



**WATER COLLECTION /
BIODIVERSITY**

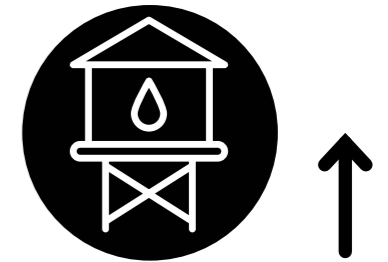

RESOURCES CAPTURE

P5 - PLAY WELL FLEXIBLE HOUSING

0.5 CATALOGUE OF FACADE SOLUTIONS

GAMIFICATION - FACADE FINISH - USER PARTICIPATION:

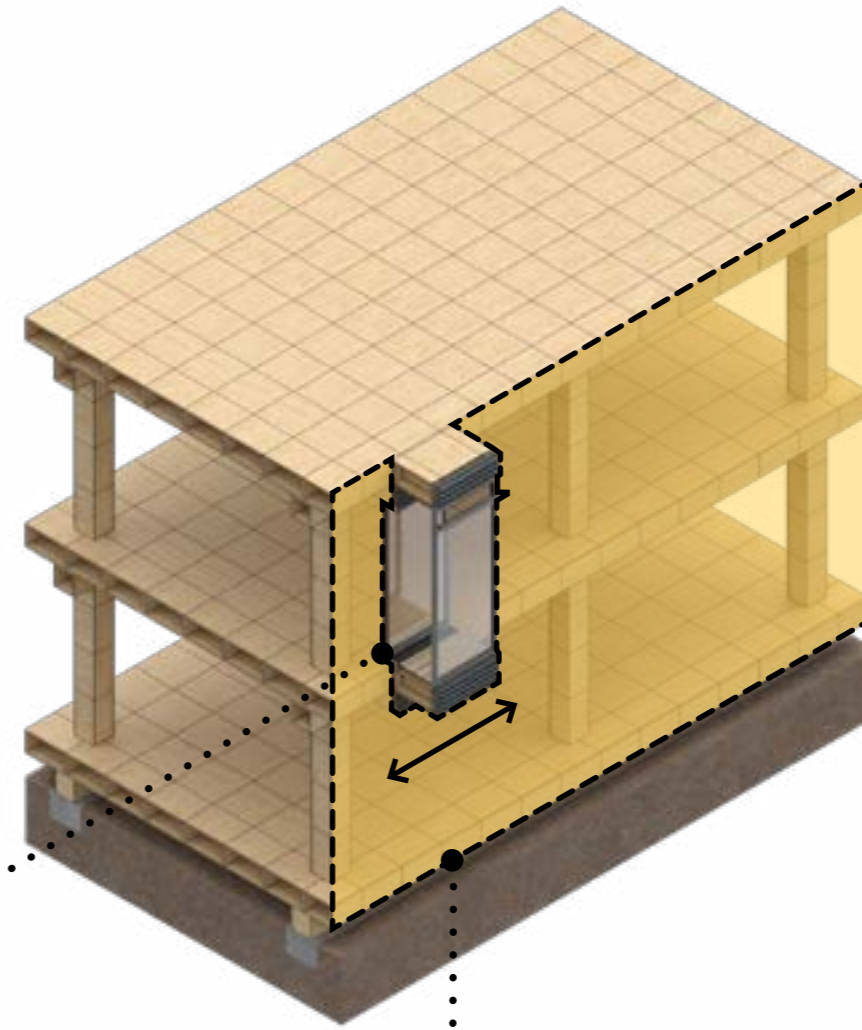
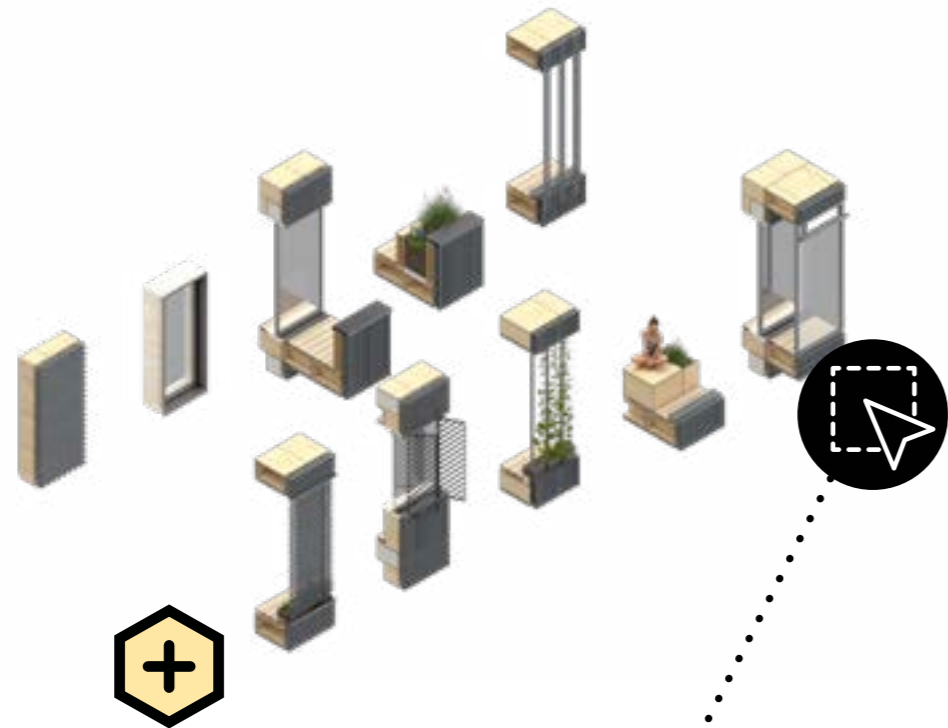

BIODIVERSITY



SOLAR GAINS
+ VIEWS



HEAT LOSS
CONTROL



VENTILATION



P5 - PLAY WELL FLEXIBLE HOUSING

05.CATALOGUE OF FACADE SOLUTIONS:

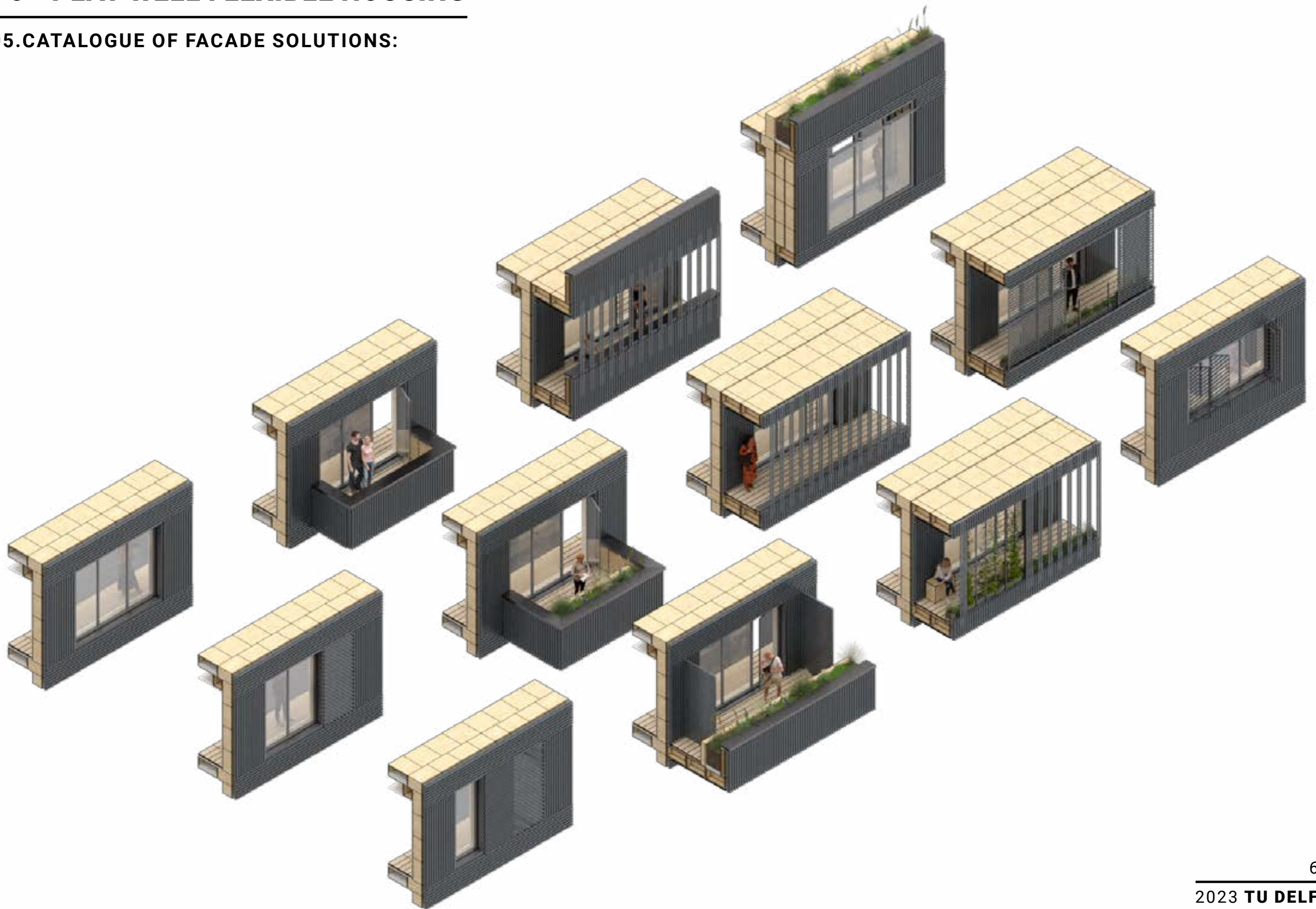

P5 - PLAY WELL FLEXIBLE HOUSING

05.DEVELOPMENT SCENARIOS / FINISH TIERS:



00.STRUCTURE

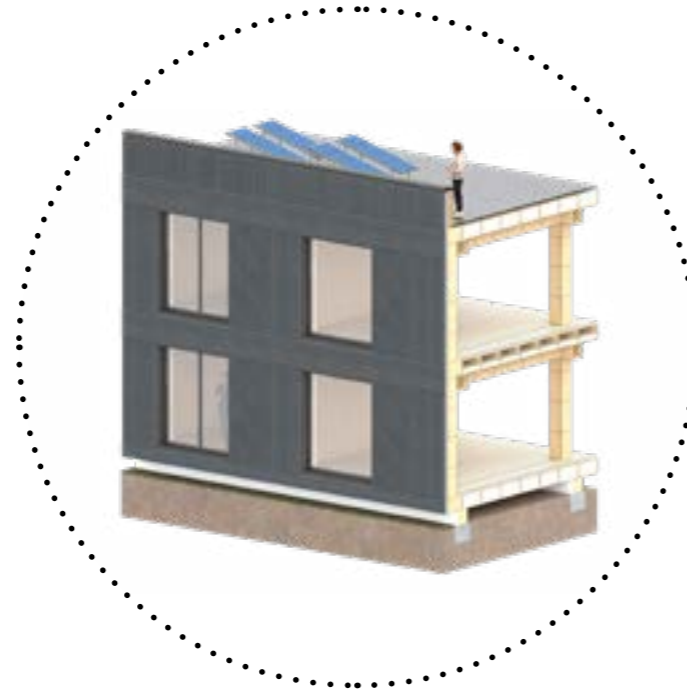

01.AFFORDABLE



02.MID-RANGE



03.ADVANCED



P5 - PLAY WELL FLEXIBLE HOUSING

05.DEVELOPMENT SCENARIOS / FINISH TIERS:

TIER 01 - AFFORDABLE



NEW ELEMENTS:

- + SIMPLE RAIN SCREEN FACADE FINISH.
- + WINDOW OPENINGS INTEGRATION.
- + OPEN SERVICES INCLUSION.
- + DECKING FLOOR FINISH WITH ACOUSTIC INSULATION.
- + PHOTOVOLTAIC PANELS.

CATERING FOR BASIC NEEDS:

SHELTER



LIGHT



SOUND

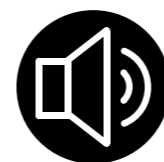

TEMPERATURE



ENERGY



P5 - PLAY WELL FLEXIBLE HOUSING

05.DEVELOPMENT SCENARIOS / FINISH TIERS: TIER 02 - MID-RANGE



NEW ELEMENTS:

- + BALCONIES & LOGGIAS.
- + WINDOW SHADERS.
- + INTERNAL WALL FINISH WITH LAYER OF AIR-TIGHTNESS.
- + FLOOR HEATING INTRODUCTION.
- + GREENIFICATION PLANTERS.

P5 - PLAY WELL FLEXIBLE HOUSING

05.DEVELOPMENT SCENARIOS / FINISH TIERS: TIER 03 - ADVANCED



NEW ELEMENTS:

- + GREENIFICATION TRELLIS.
- + DOUBLE SKIN FACADE.
- + FULL INTERIOR FINISH.
- + FLOOR HEATING INTRODUCTION.
- + FURNISHED ROOFTOP TERRACES.

P5 - PLAY WELL FLEXIBLE HOUSING

05.DEVELOPMENT SCENARIOS / INTERIOR FINISH TIERS:



01.AFFORDABLE



02.FURNITURE BRAND



03.HIGH-END DESIGNER



P5 - PLAY WELL FLEXIBLE HOUSING

05.DEVELOPMENT SCENARIOS INDUSTRIAL PARTICIPATION:

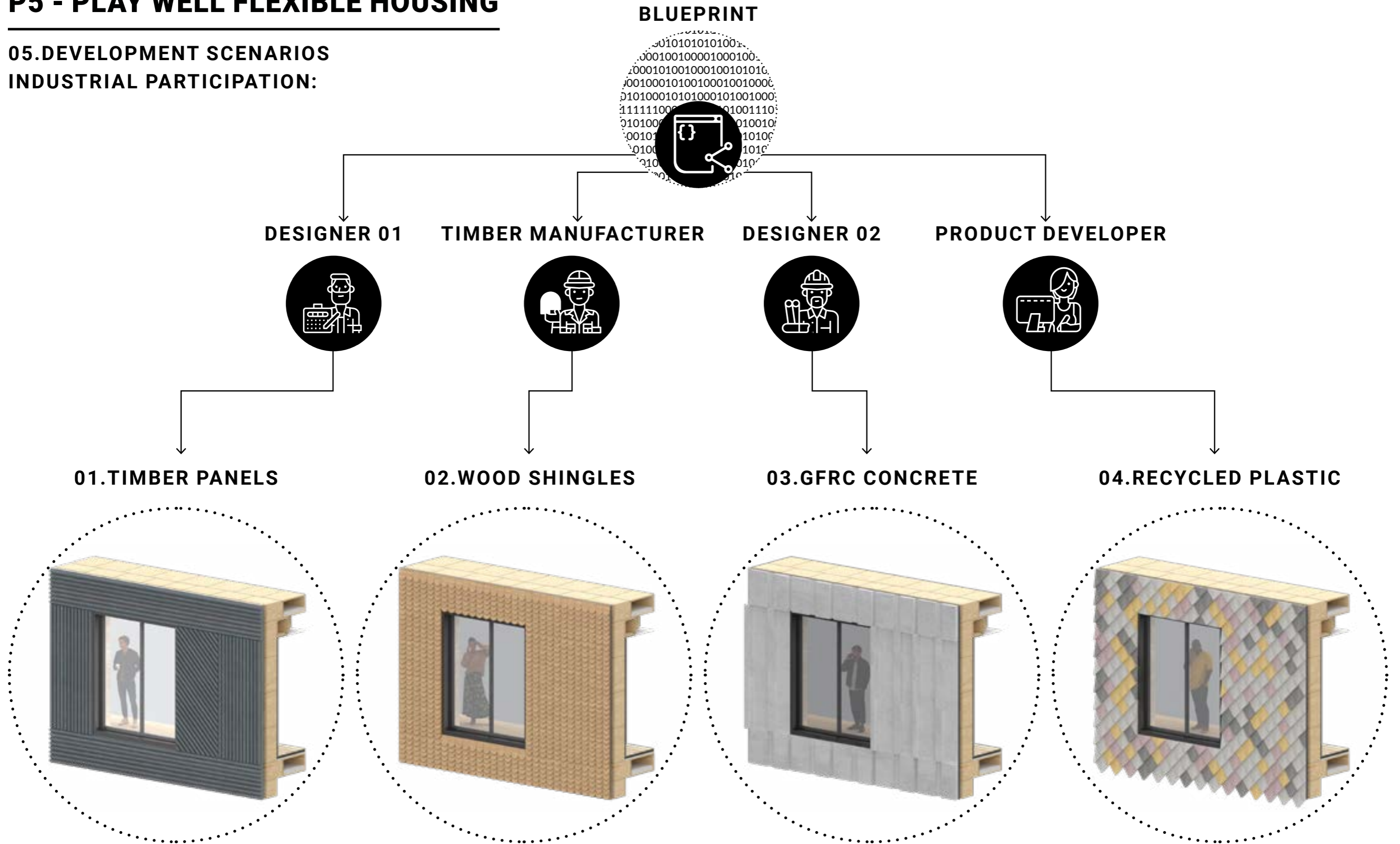

P5 - PLAY WELL FLEXIBLE HOUSING

05.CATALOGUIZATION / PRODUCTIZATION / COMPONENTIZATION - BENEFITS OF USE:
FOR SOCIETY:

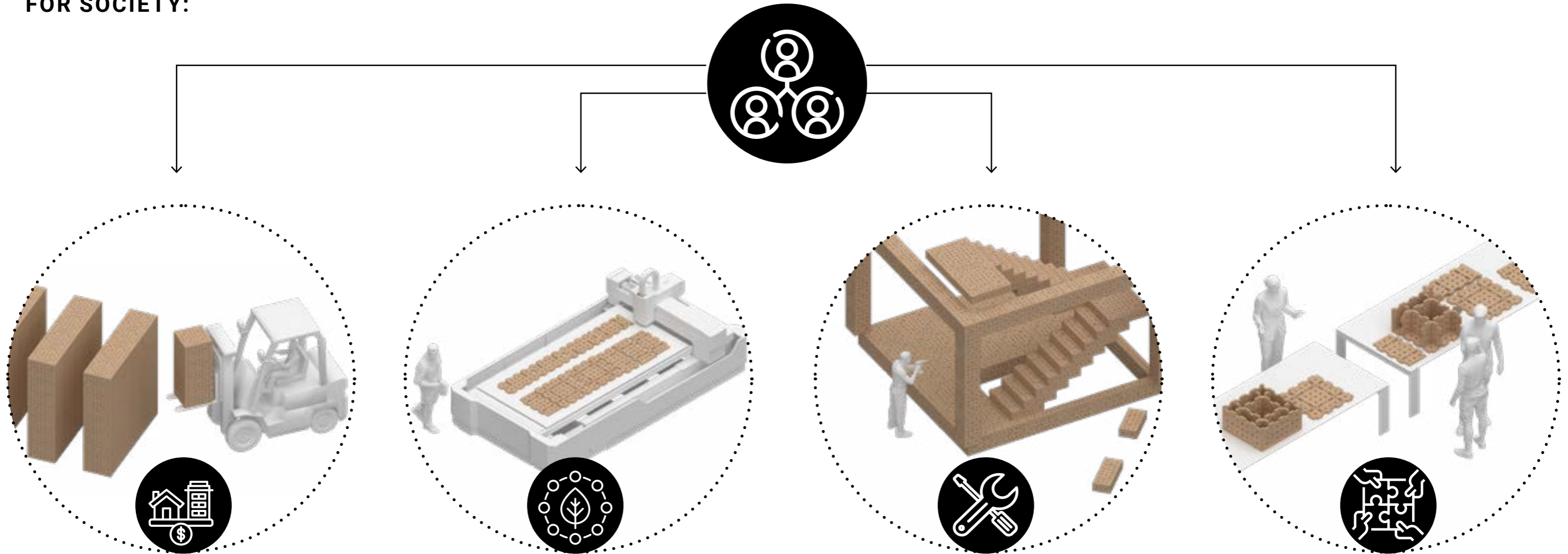

01.AFFORDABLE

+ THE EFFECTS OF SCALE AND MASS PRODUCTION ALLOW FOR PRICE REDUCTION.

02.SUSTAINABLE

+ STRUCTURAL TIMBER AS THE MAIN MATERIAL UTILIZED IS A CARBON SINK.
+ THE DEMOUNTABILITY ALLOWS FOR RECYCLABILITY OF RESOURCES.
+ WELL-DETAILED TO THE LEVELS OF PASSIVE HOUSE - ENSURES ENERGY EFFICIENCY.
+ MINIMIZING WASTE.

03.EASY TO MAINTAIN

+ DEMOUNTABILITY OF ELEMENTS - DRY MOUNTING BASED CONNECTIONS ALLOW FOR PARTS REPLACEMENT.

04.PARTICIPATORY

+ SIMPLICITY OF THE SYSTEM AND THE CATALOGUE OF PRE-CONFIGURED SPACES ALLOW FOR HANDS ON USER PARTICIPATION.

P5 - PLAY WELL FLEXIBLE HOUSING

05.CATALOGUIZATION / PRODUCTIZATION / COMPONENTIZATION - BENEFITS OF USE: FOR ARCHITECTS:

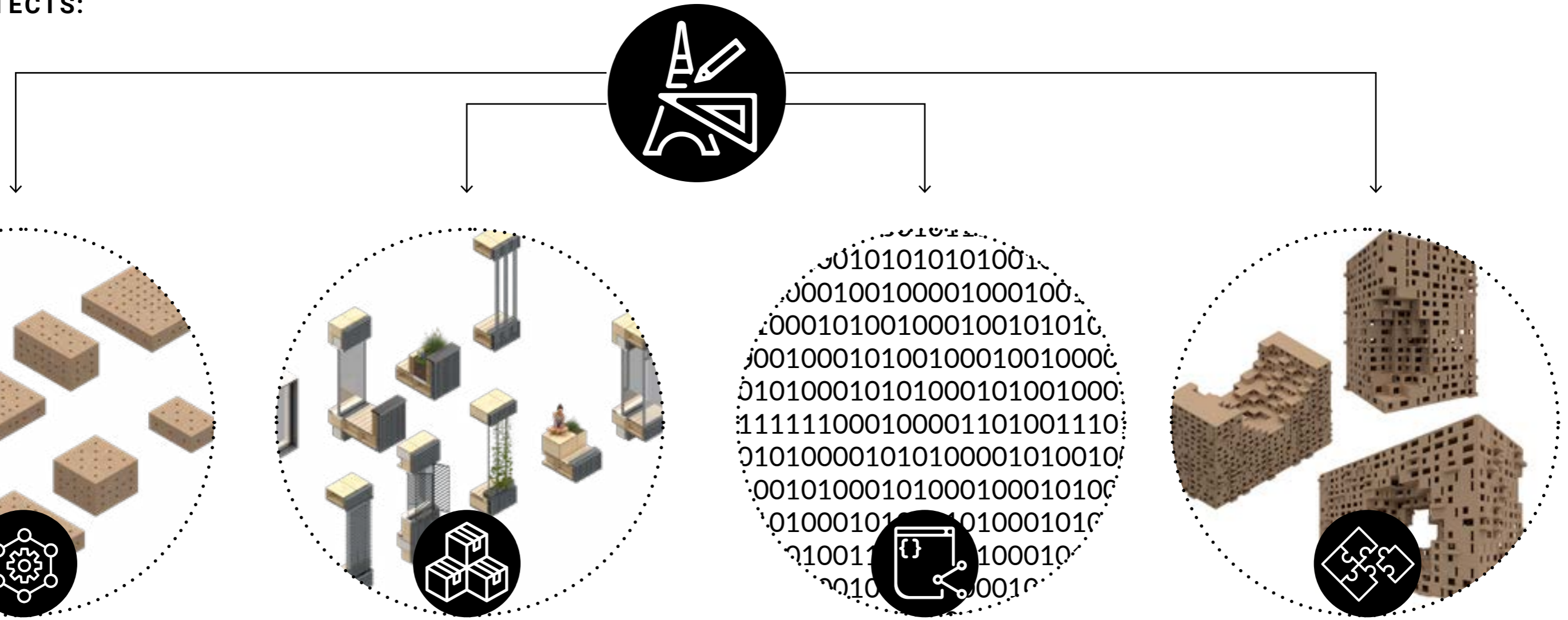

01.SYSTEMATIZED

+ THE SYSTEM OF CONSTRUCTION DEPENDS ON ERGONOMICS AND PROPORTIONS. ENSURES COMFORT OF END USERS

02.PRODUCTIZED

+ THE SYSTEM MINIMIZES THE AMOUNT OF UTILIZED COMPONENTS.
+ IT RELIES ON CATALOGUE OF READILY AVAILABLE SOLUTIONS.

03.OPEN SOURCE - OPEN FOR ADAPTATION

+BLUEPRINTS OF DIMENSIONS ARE AVAILABLE OPEN SOURCE AND READY FOR IMPROVEMENTS AND ADAPTATIONS.

04.CONFIGURABLE / VERSATILE

+THE SYSTEM IS AN OPEN ONE - PROVIDES POSSIBILITIES FOR RE-CONFIGURATION AND CREATIVITY.

P5 - PLAY WELL FLEXIBLE HOUSING

06. BUILDING SCHEME IMPLEMENTATION.

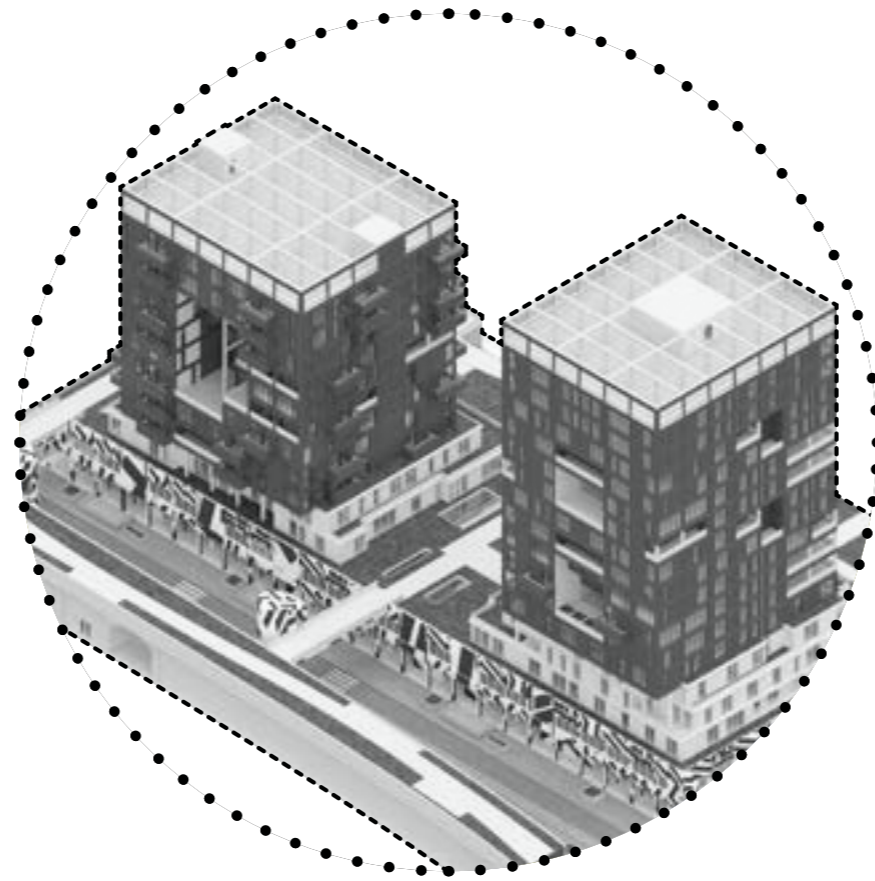

BUILDING SCHEME IMPLEMENTATION!



GAMIFICATION

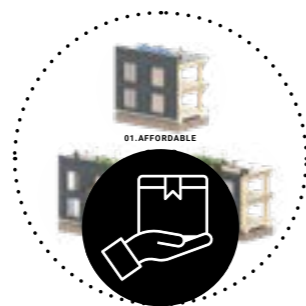

PRODUCTIZATION

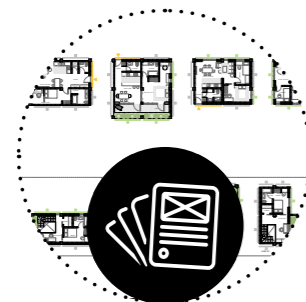

CATALOGIZATION

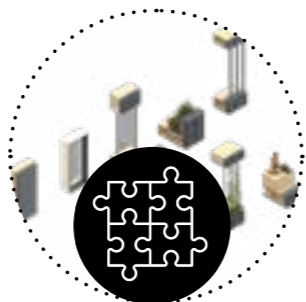

COMPONENTIZATION



DOUGHNUT ECONOMY

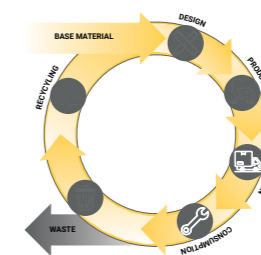

CIRCULAR ECONOMY

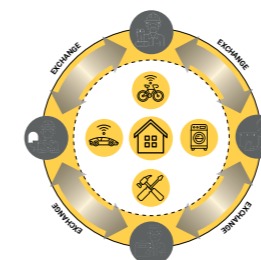

SHARING ECONOMY



PARTICIPATORY ECONOMY

P5 - PLAY WELL FLEXIBLE HOUSING

06.IMPLEMENTATION - 4X4X2 SYSTEM EVOLUTION - 4 STUDIOS:



LEVEL 01



LEVEL 02

+ SPACE PLAN: DEMOUNTABLE, FLEXIBLE ADJUSTABLE

P5 - PLAY WELL FLEXIBLE HOUSING

06.IMPLEMENTATION - 4X4X2 SYSTEM EVOLUTION - 2 SINGLE FAMILY FLATS:



LEVEL 01



LEVEL 02

+ SPACE PLAN: DEMOUNTABLE, FLEXIBLE ADJUSTABLE

P5 - PLAY WELL FLEXIBLE HOUSING

06.IMPLEMENTATION - 4X4X2 SYSTEM EVOLUTION - SUPERLOFT + STUDIOS:



LEVEL 01

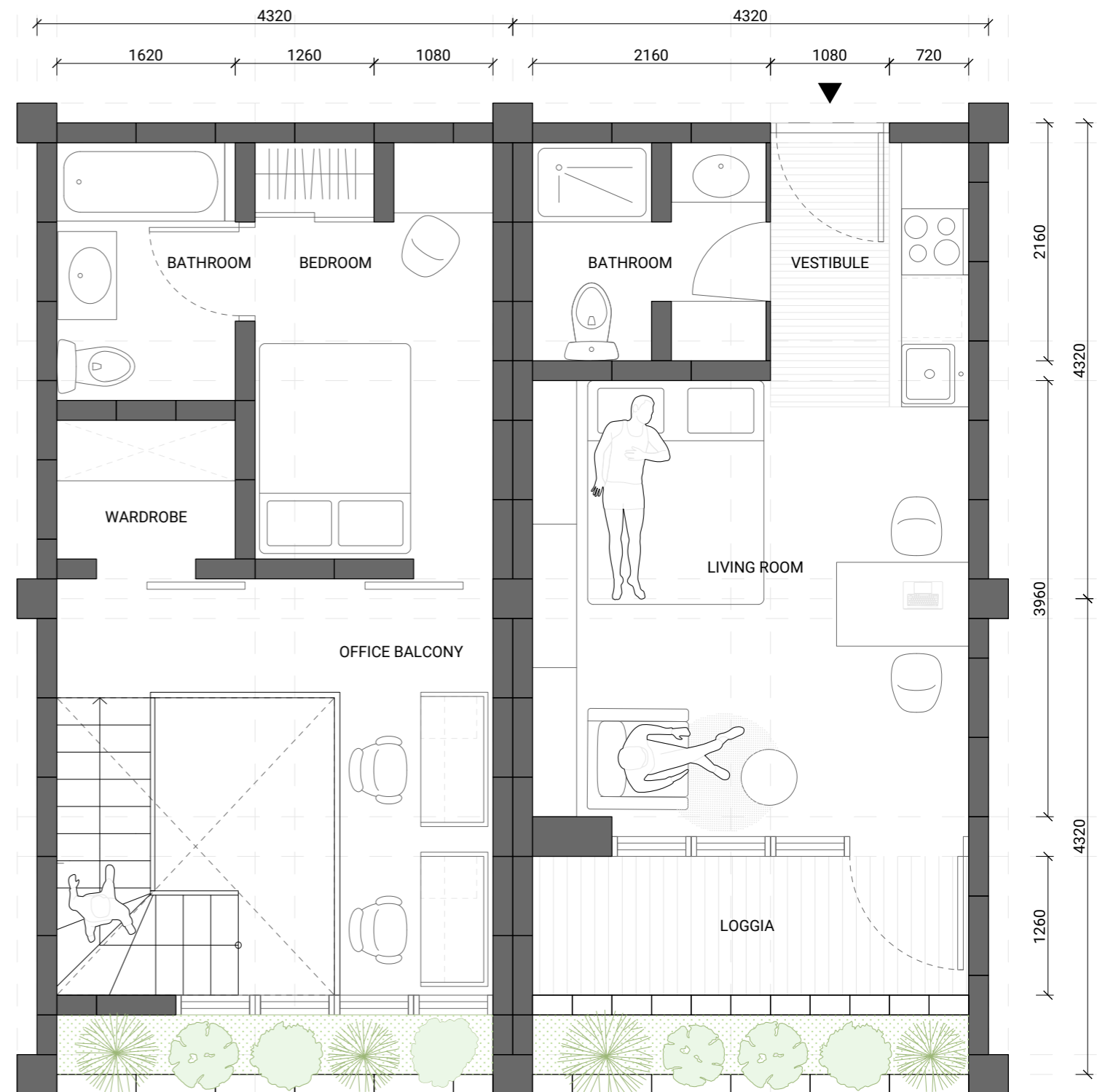

LEVEL 02

+ SPACE PLAN: DEMOUNTABLE, FLEXIBLE ADJUSTABLE

P5 - PLAY WELL FLEXIBLE HOUSING

06.IMPLEMENTATION - 4X4X2 SYSTEM EVOLUTION - MULTIGENERATIONAL HOUSE:

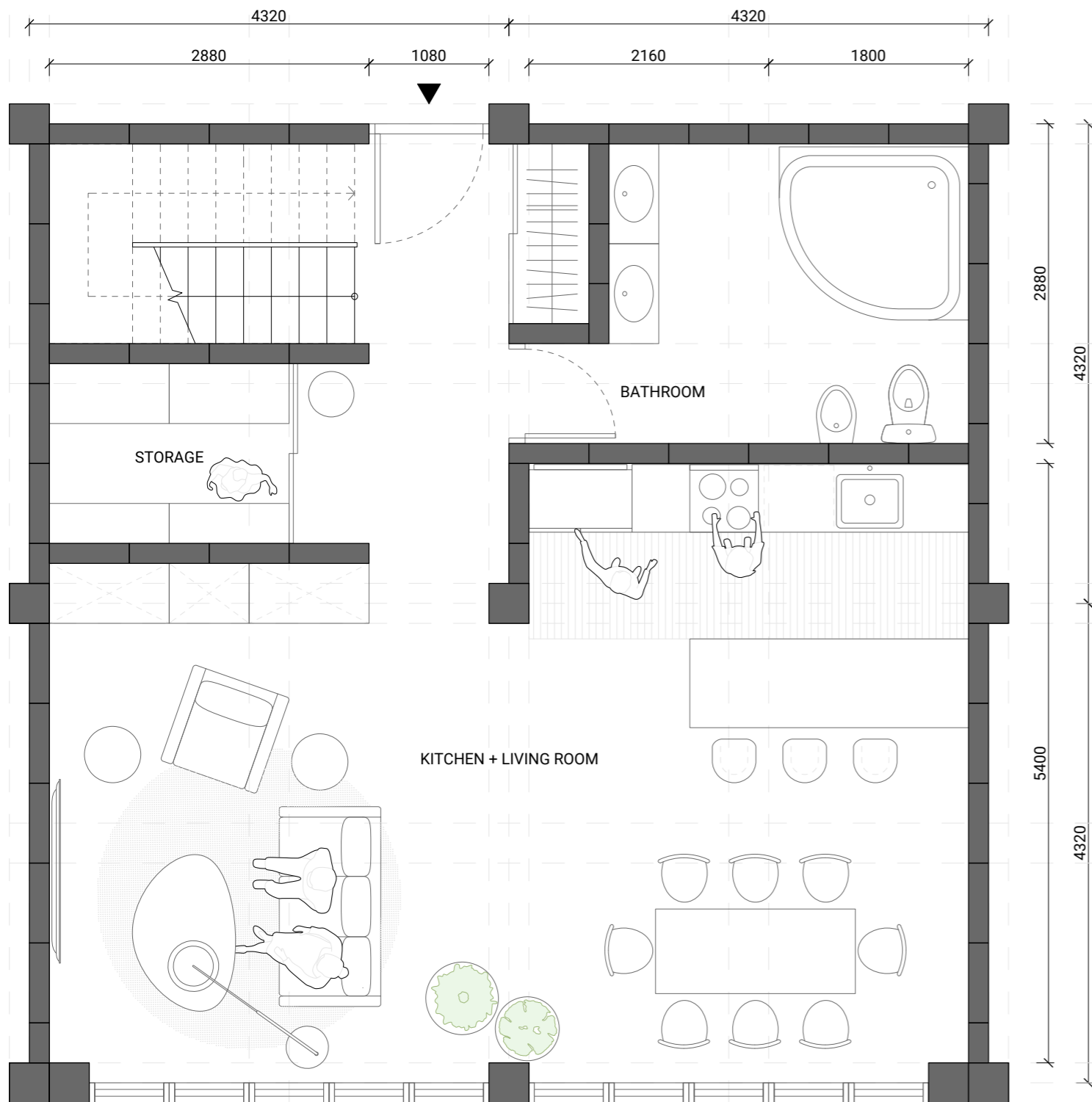

LEVEL 01

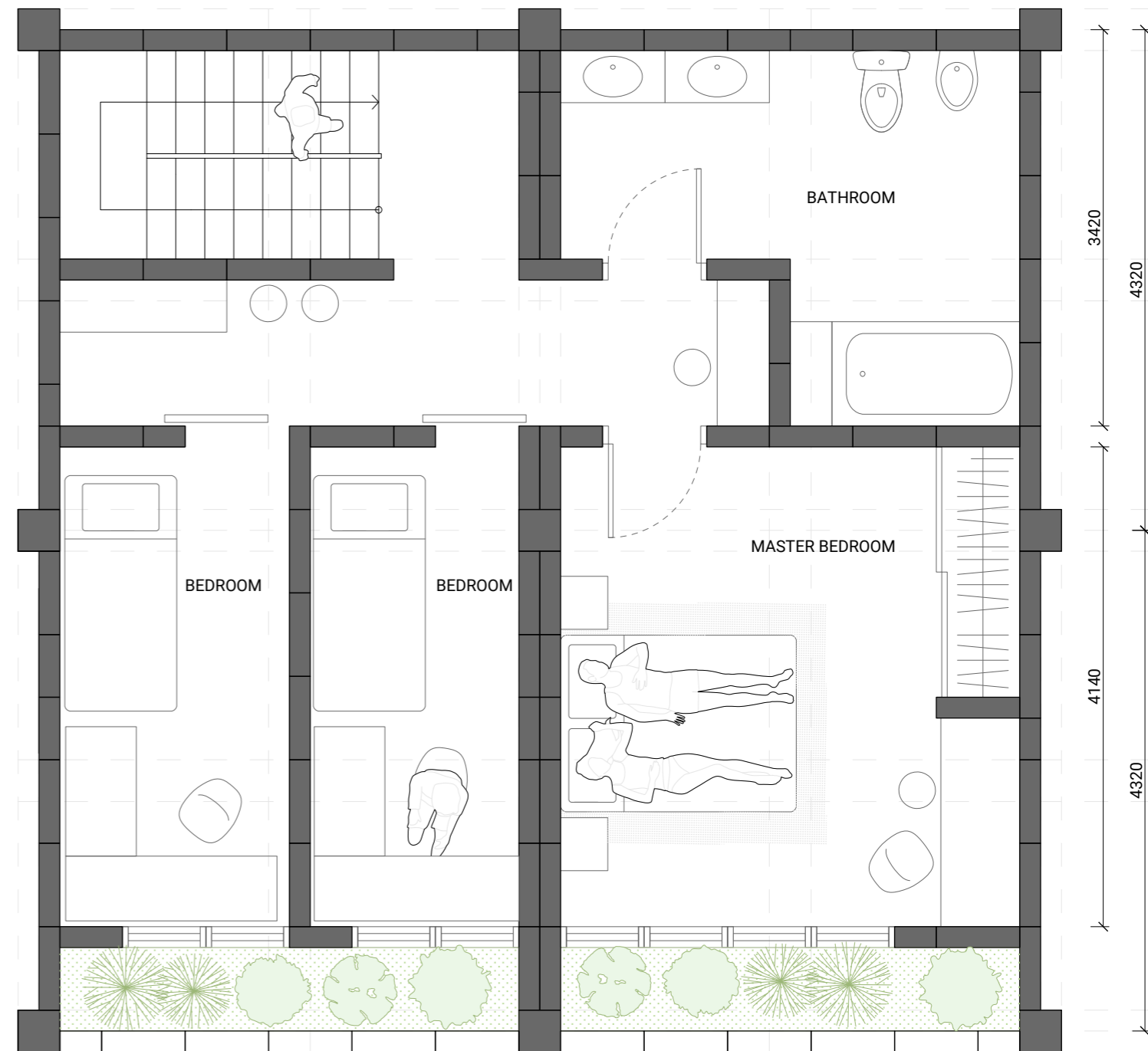

LEVEL 02

+ SPACE PLAN: DEMOUNTABLE, FLEXIBLE ADJUSTABLE

P5 - PLAY WELL FLEXIBLE HOUSING

06. IMPLEMENTATION - SPATIAL CATALOGUE OF AVAILABLE FLATS: SMALL FLATS:

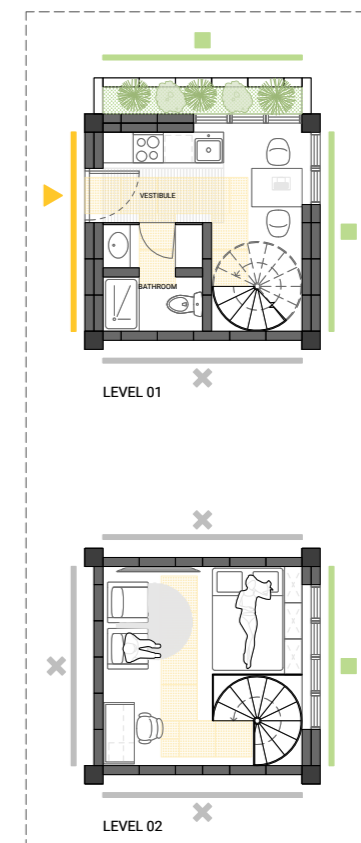
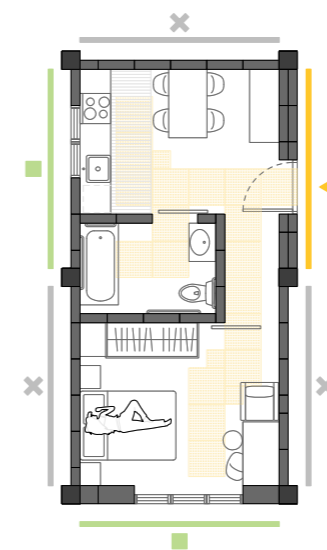
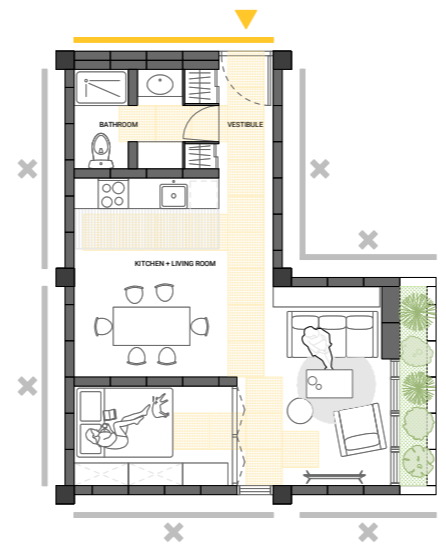
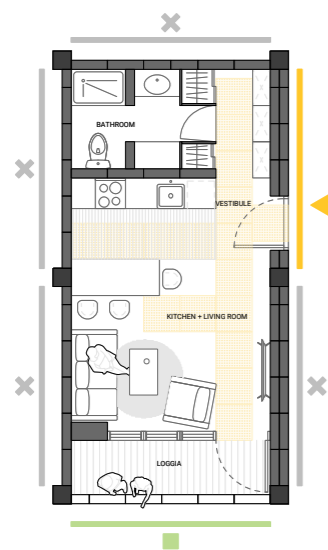
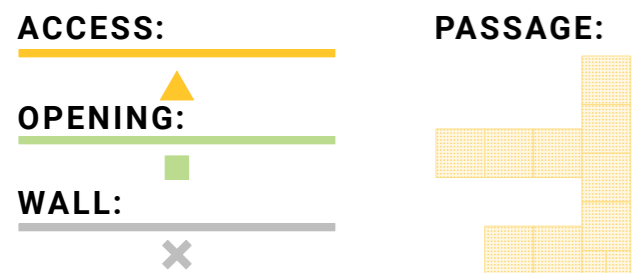
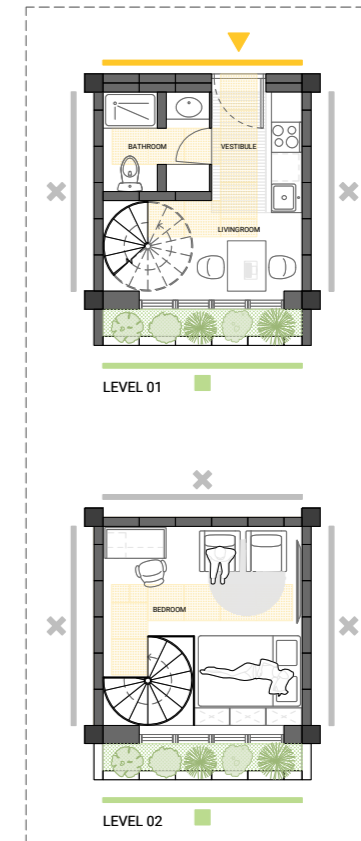
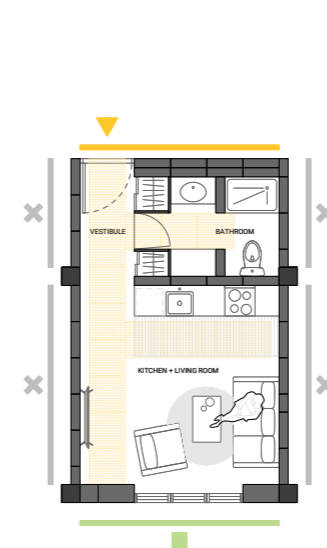
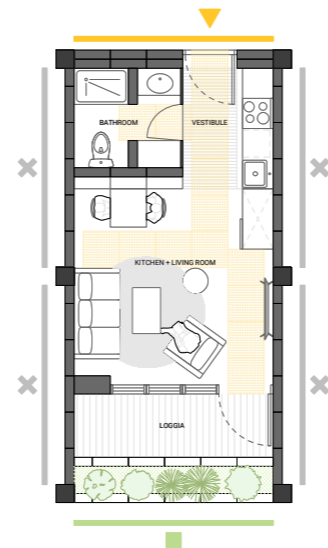
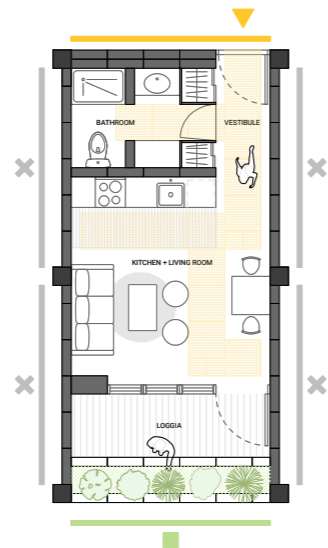
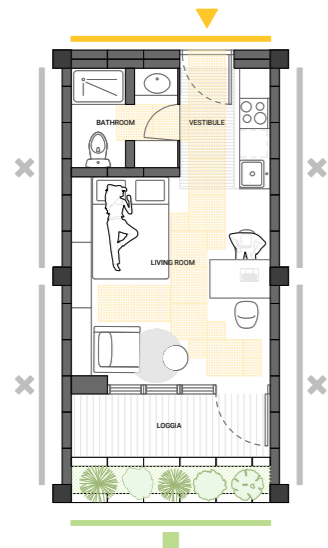

P5 - PLAY WELL FLEXIBLE HOUSING

06. IMPLEMENTATION - SPATIAL CATALOGUE OF AVAILABLE FLATS: MEDIUM FLATS:



P5 - PLAY WELL FLEXIBLE HOUSING

06. IMPLEMENTATION - SPATIAL CATALOGUE OF AVAILABLE FLATS: LARGE FLATS:



P5 - PLAY WELL FLEXIBLE HOUSING

06. IMPLEMENTATION - URBAN BLOCK OVERVIEW:

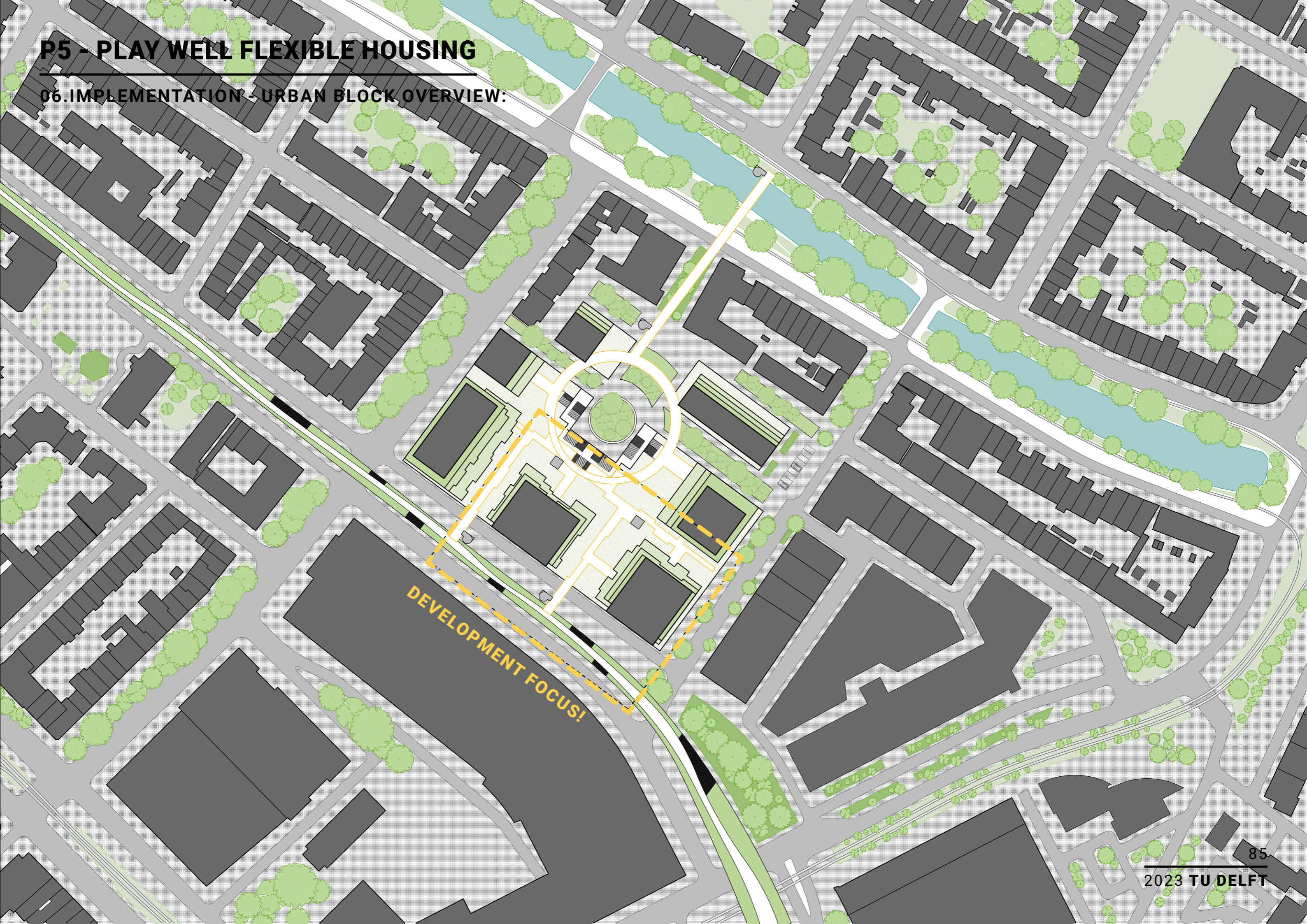

DEVELOPMENT FOCUS!

P5 - PLAY WELL FLEXIBLE HOUSING

06.IMPLEMENTATION - URBAN BLOCK OVERVIEW:

SHORT TERM FOCUSED:



NEIGHBORHOOD FOCUSED:



ELDERLY FOCUSED:



FAMILY FOCUSED:



P5 - PLAY WELL FLEXIBLE HOUSING

06. IMPLEMENTATION - URBAN BLOCK OVERVIEW:

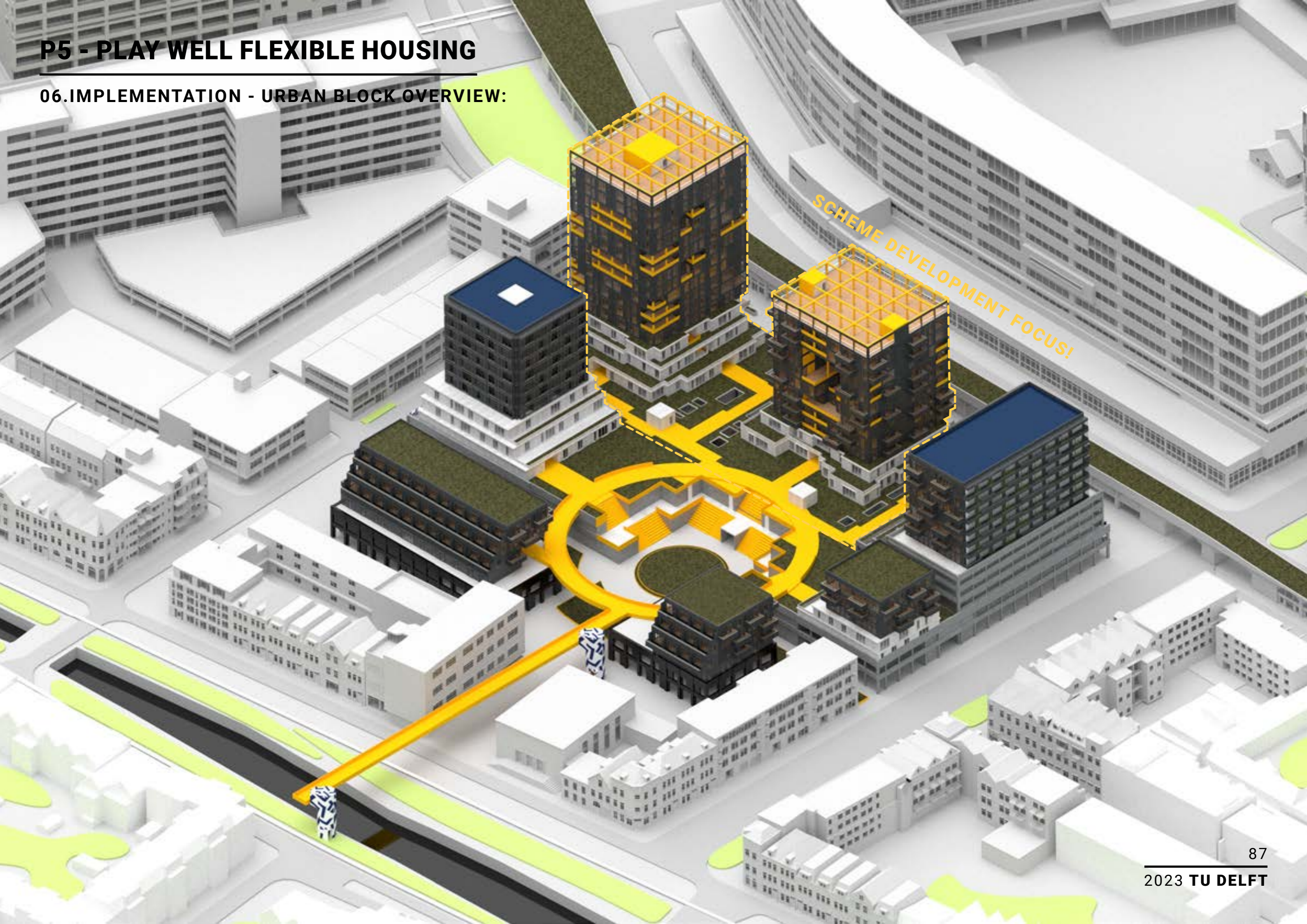

P5 - PLAY WELL FLEXIBLE HOUSING

06. IMPLEMENTATION - SCHEME STEPS:

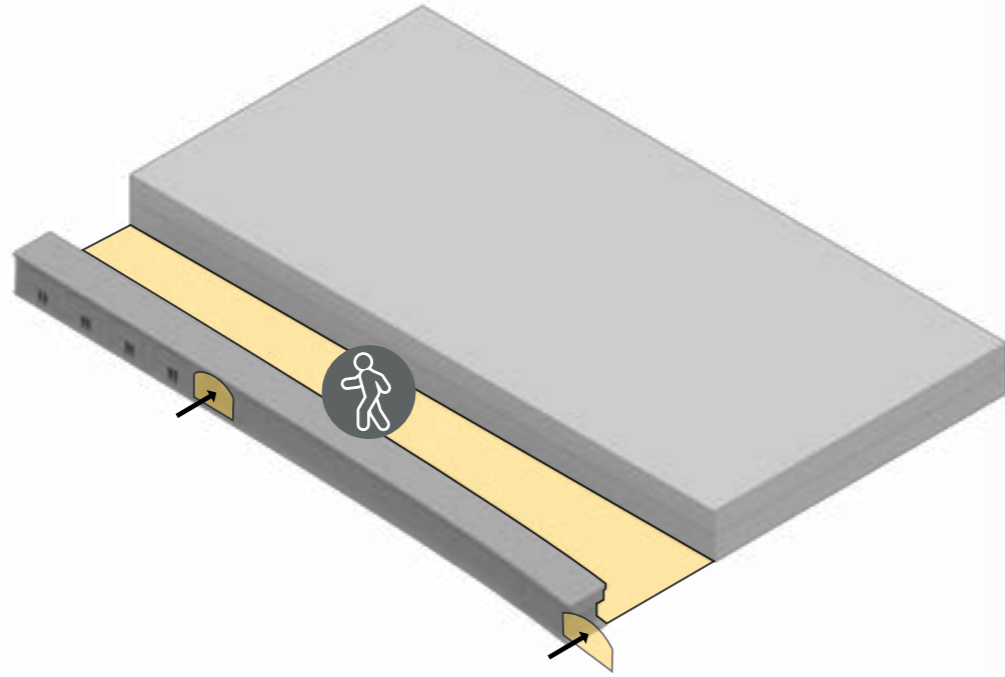

00. CATERING FOR ACTIVE STREET-LIFE.

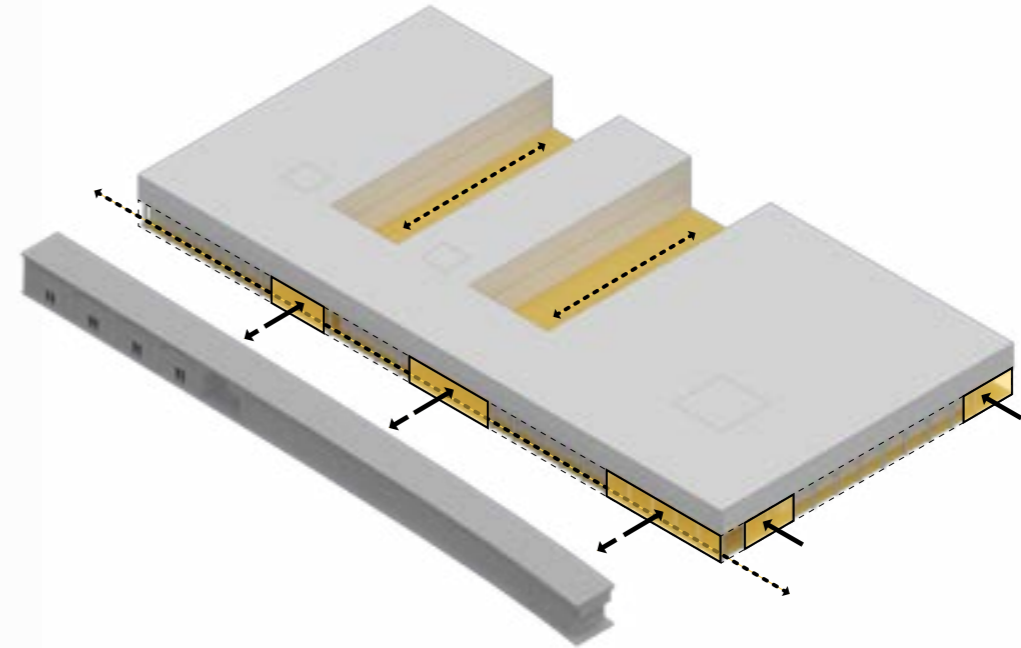

01. ACTIVATING THE FORNTS. INVITING ACTIVITY INSIDE.

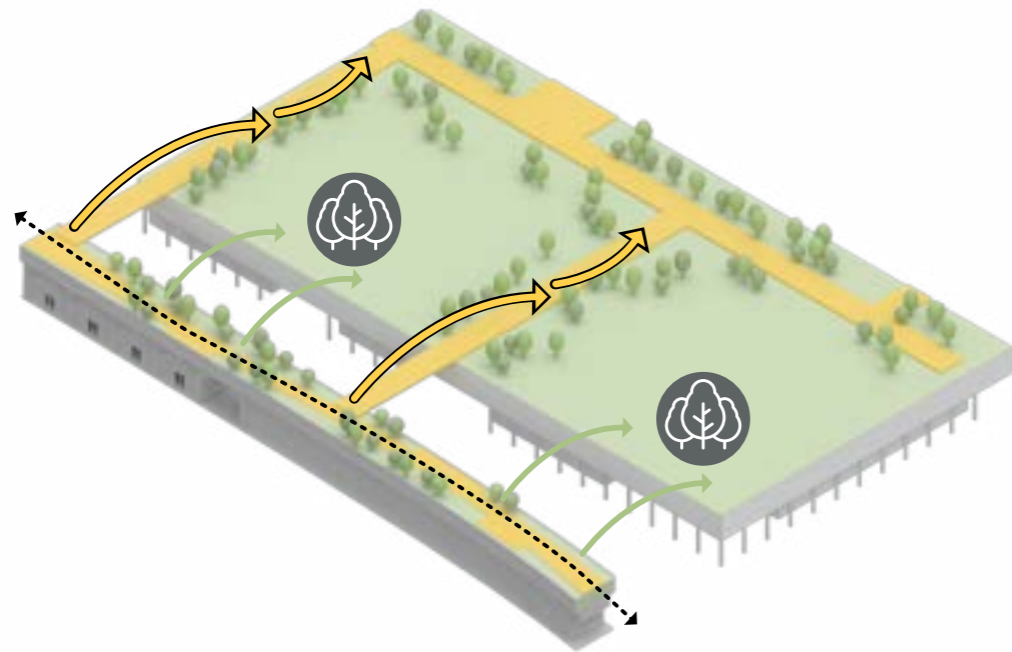

02. CONNECTING THE PASSAGES & GREENERY.

SEGMENT A : 19 HOMES.
SEGMENT B : 12 HOMES.

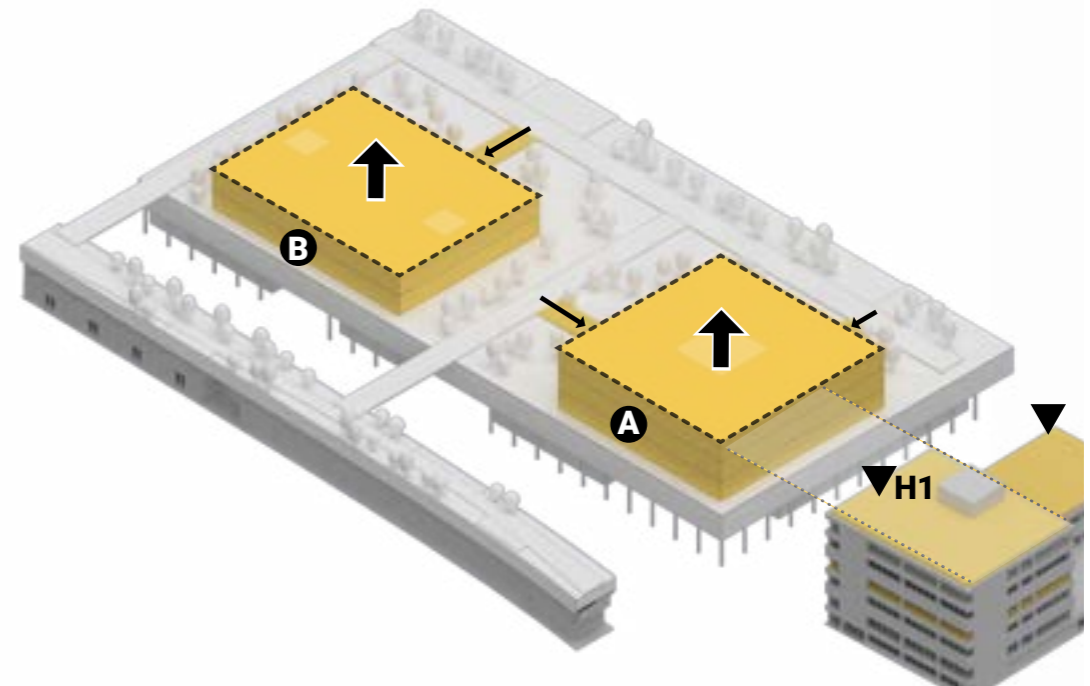

03. RISING PARK LIVING BASED ON NEIGHBORHOOD HEIGHTS.

P5 - PLAY WELL FLEXIBLE HOUSING

06. IMPLEMENTATION - SCHEME STEPS:

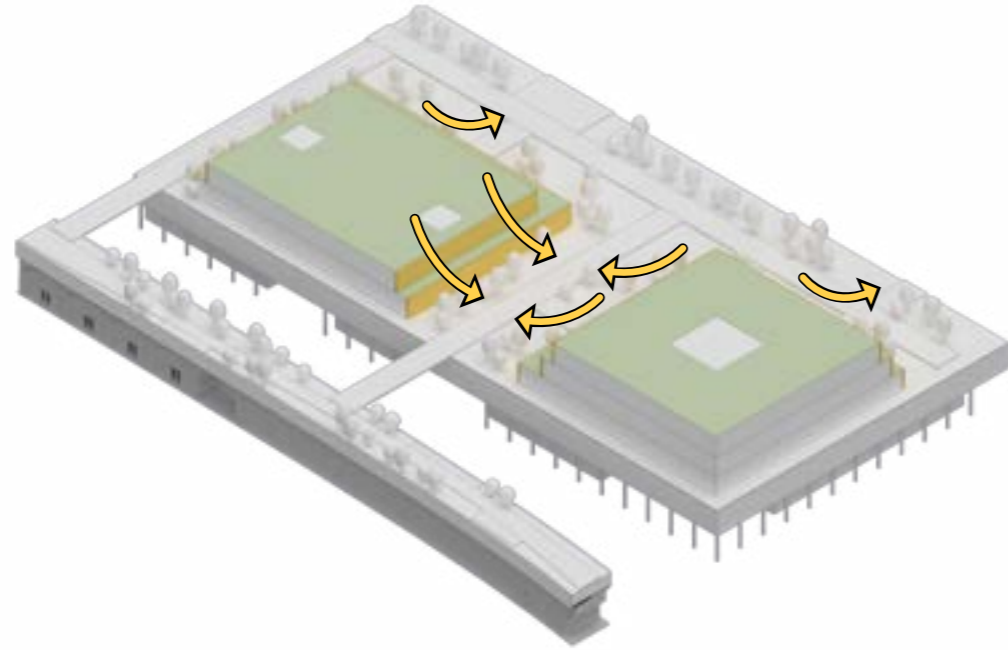

04. BREAKING DOWN THE VOLUME WITH VALLEYS.

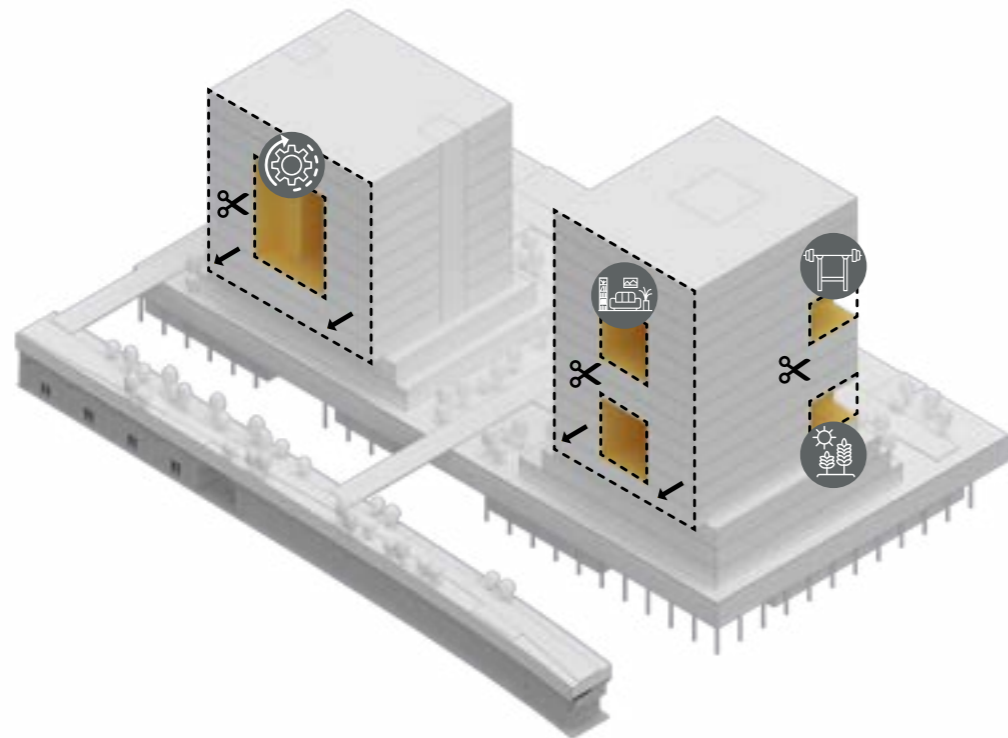

06. POROSITY FOR THE UNEXPECTED AND THE PUBLIC.

SEGMENT A : TOTAL: 94 UNITS.
SEGMENT B : TOTAL: 70 UNITS.

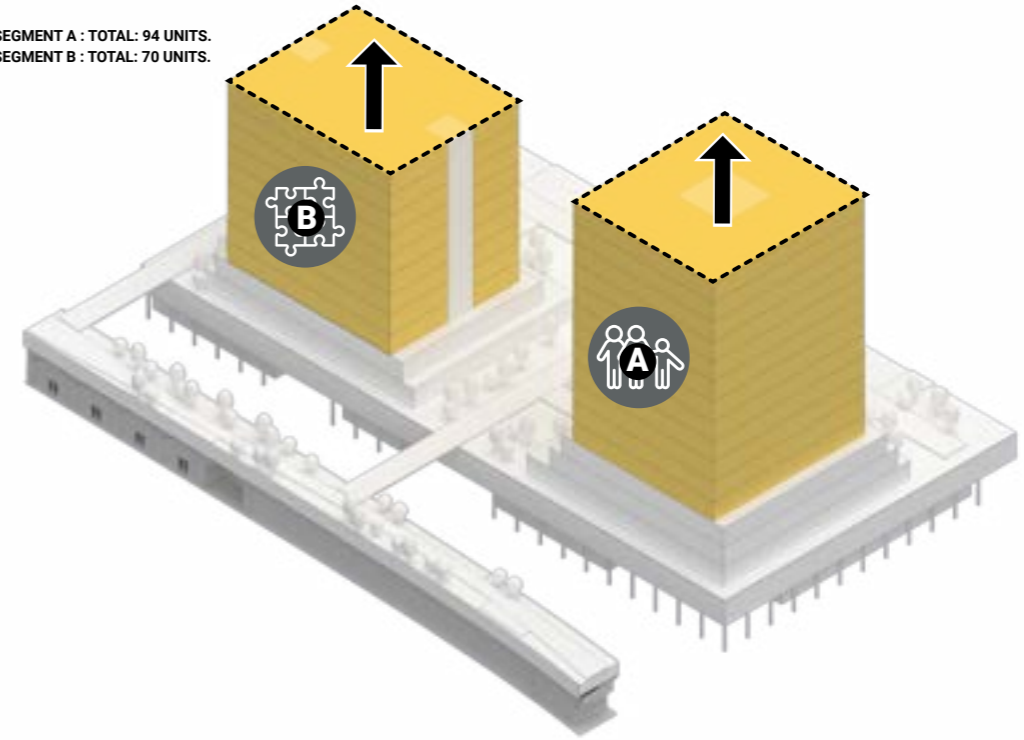

05. RAISING THE OPEN AND COMMUNITY LIVING BLOCKS.

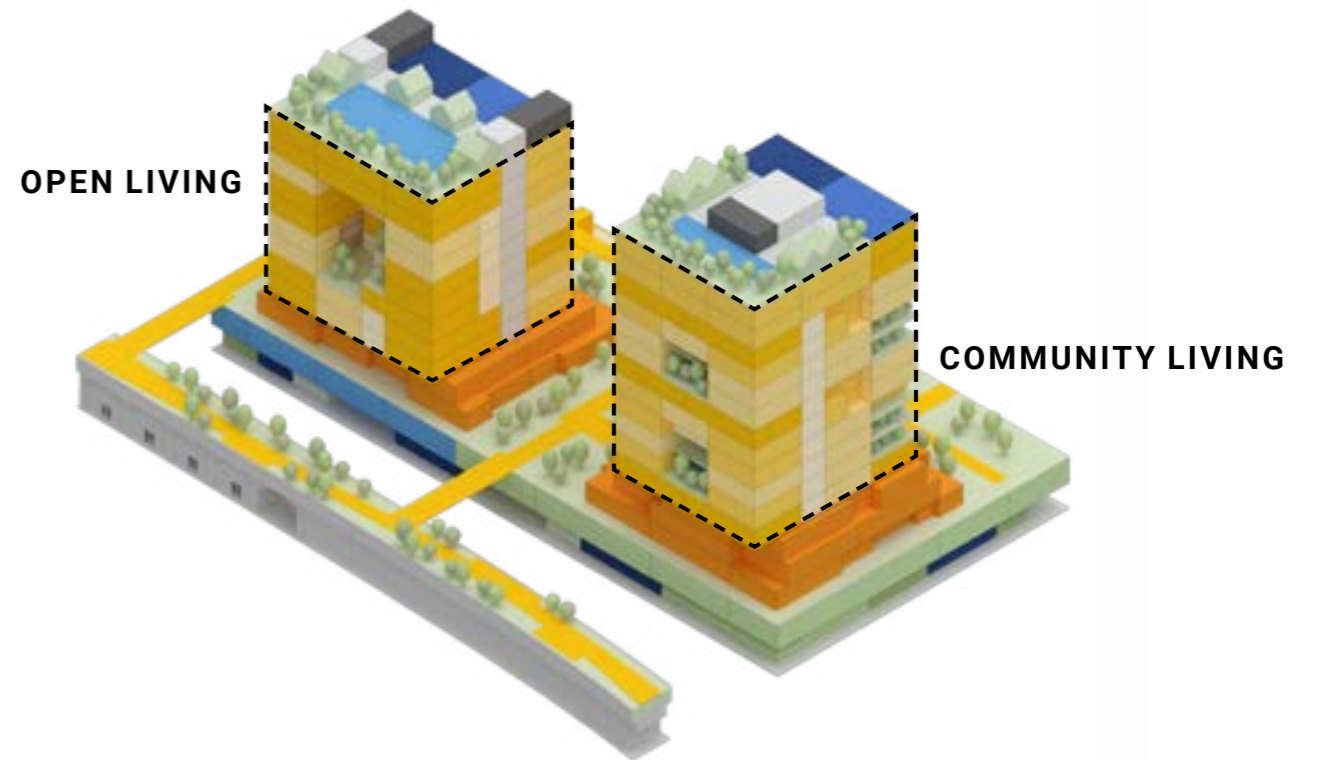

07. COMPLETING PROGRAM ALLOCATION.

P5 - PLAY WELL FLEXIBLE HOUSING

06. IMPLEMENTATION - PROGRAM APPROACH - NEIGHBORHOOD LIVING + ACTIVE PASSAGES:

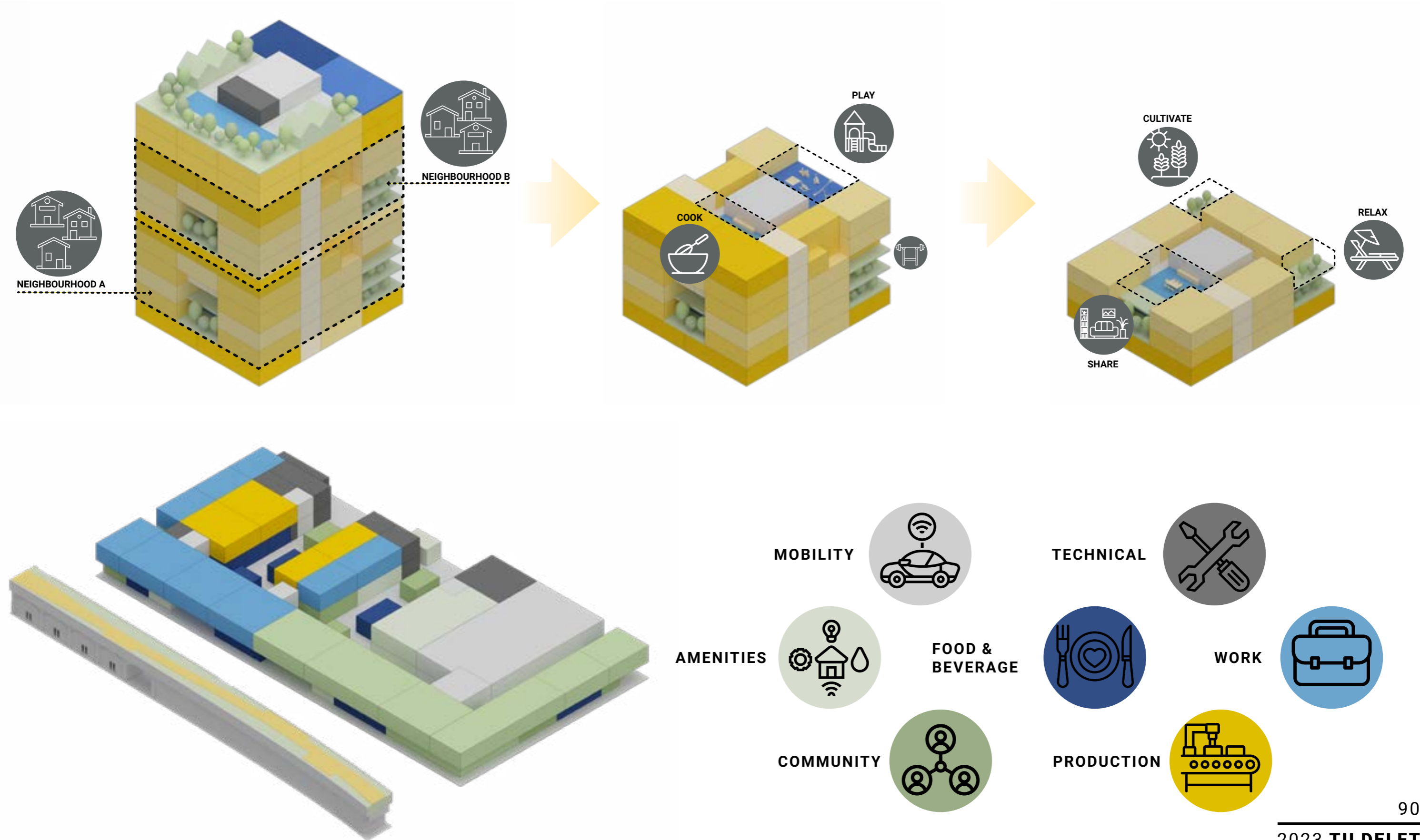

P5 - PLAY WELL FLEXIBLE HOUSING

06. IMPLEMENTATION - SCHEME OVERVIEW:

OPEN HOUSING:

- SMALL FLATS: 19 UNITS.
- MEDIUM FLATS: 20 UNITS.
- LARGE FLATS: 14 UNITS.
- XLARGE FLATS: 17 UNITS.
- SEGMENT B TOTAL: 70 UNITS.

PARK LIVING:

- SEGMENT B : 12 HOMES.

FAMILY + STARTER HOUSING:

- SMALL FLATS: 22 UNITS.
- MEDIUM FLATS: 36 UNITS.
- LARGE FLATS: 24 UNITS.
- XLARGE FLATS: 12 UNITS.
- SEGMENT A TOTAL: 94 UNITS.

PARK LIVING:

- SEGMENT A : 19 HOMES.



03. MODULAR LIVING



02. PARK LIVING



01. ACTIVE LIVING



P5 - PLAY WELL FLEXIBLE HOUSING

04.URBAN BLOCK UNDERSTANDING & DESIGN - LOCAL CHARACTERS:



WILLIE - 40S - WORKOUTCLUBNL



EWALD - 60S - HEINDE & VERRE



JORRE 30S - BONZA CAFFEE



WORK:

WILLIE FOUNDED A PERSONAL TRAINING CLUB, WITH FEW LOCATIONS AROUND ROTTERDAM.



HEINDE & VERRE

EWALD RUNS A RECOGNIZED CHOCOLATE ROASTERY.



JORRE IS A BARISTA AT BONZA KOFFIE, HE ALSO HEADS THE LOCAL COFFEE ROASTERY.

LIFE:

WILLIE IS IN HER LATE 40S. SHE HAS TWO KIDS AND A DOG. SHE PREFERS ACTIVE, BUT MAINLY LOCAL LIFESTYLE.

EWALD ENTERED HIS 60S. HE IS SINGLE. LOVES HIS COMFORT AND LOOKS FOR UNIQUE EXPERIENCES IN LIFE.

JORRE IS A STARTER, HE DREAMS OF EXPANDING HIS ROSTERY. HE HAS A YOUNGER GIRLFRIEND WITH WHOM HE TRAVELS A LOT.

NEIGHBORHOOD:

WOULD WANT TO START A DAY WITH A TRAINING WITH NEIGHBORS AND A DOG WALK. ENJOYS AN OCCASIONAL RESTAURANT GATHERING WITH FRIENDS .

LOVES TO TO HIS GROCERY IN LOCAL NEIGHBORHOOD STORES. WHEN NOT WORKING IN ROSTERY HE PREFERS THE COMPANY OF PEOPLE IN CO-WORKING SETUPS.

HE'S ALL INTO TEAM SPORTS IN HIS SPARE TIME, LIKES TO TINKER WITH ELECTRONICS AND A PINT OF CRAFT-BEER WITH FRIENDS AFTER HOURS.

HOUSING:

WOULD ENJOY A LARGE APARTMENT WITH VERANDAS AND SEPARATE BEDROOMS FOR HER KIDS. LOTS OF LIGHT LOTS OF GREENERY.

PREFERS MODESTY WITH STYLE AND WOULD ENJOY A MID-SIZE LOFT TYPOLOGY WITH DOUBLE HEIGHT PARTS.

WOULD BE HAPPY WITH A COMFORTABLE STUDIO IN THE CITY CENTER.

P5 - PLAY WELL FLEXIBLE HOUSING

06. IMPLEMENTATION - ACTIVE LIVING:

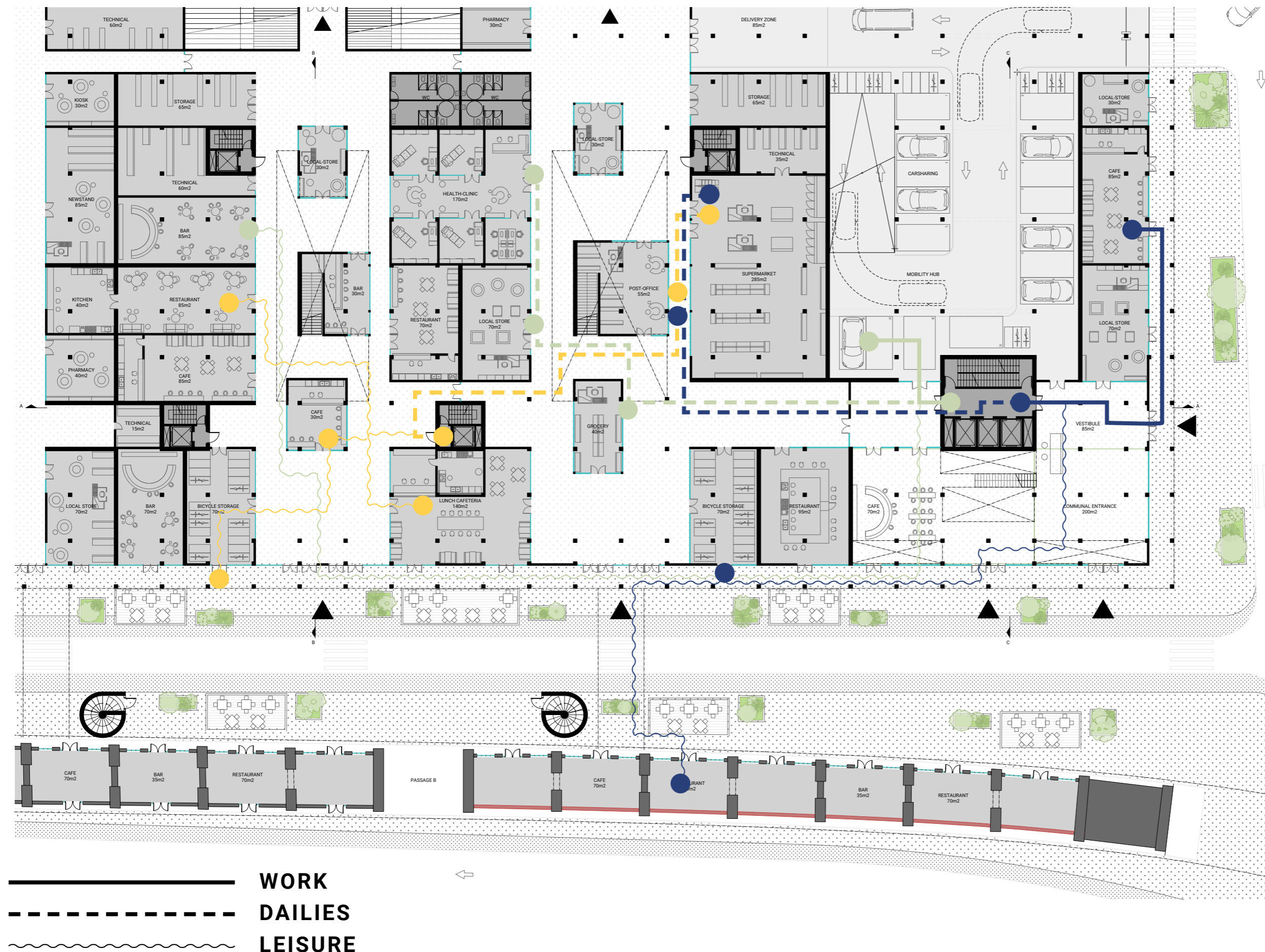

WILLIE



EWALD



JORRE

P5 - PLAY WELL FLEXIBLE HOUSING

06. IMPLEMENTATION - ACTIVE LIVING:



WILLIE



EWALD



JORRE

P5 - PLAY WELL FLEXIBLE HOUSING

06. IMPLEMENTATION - PARK LIVING:

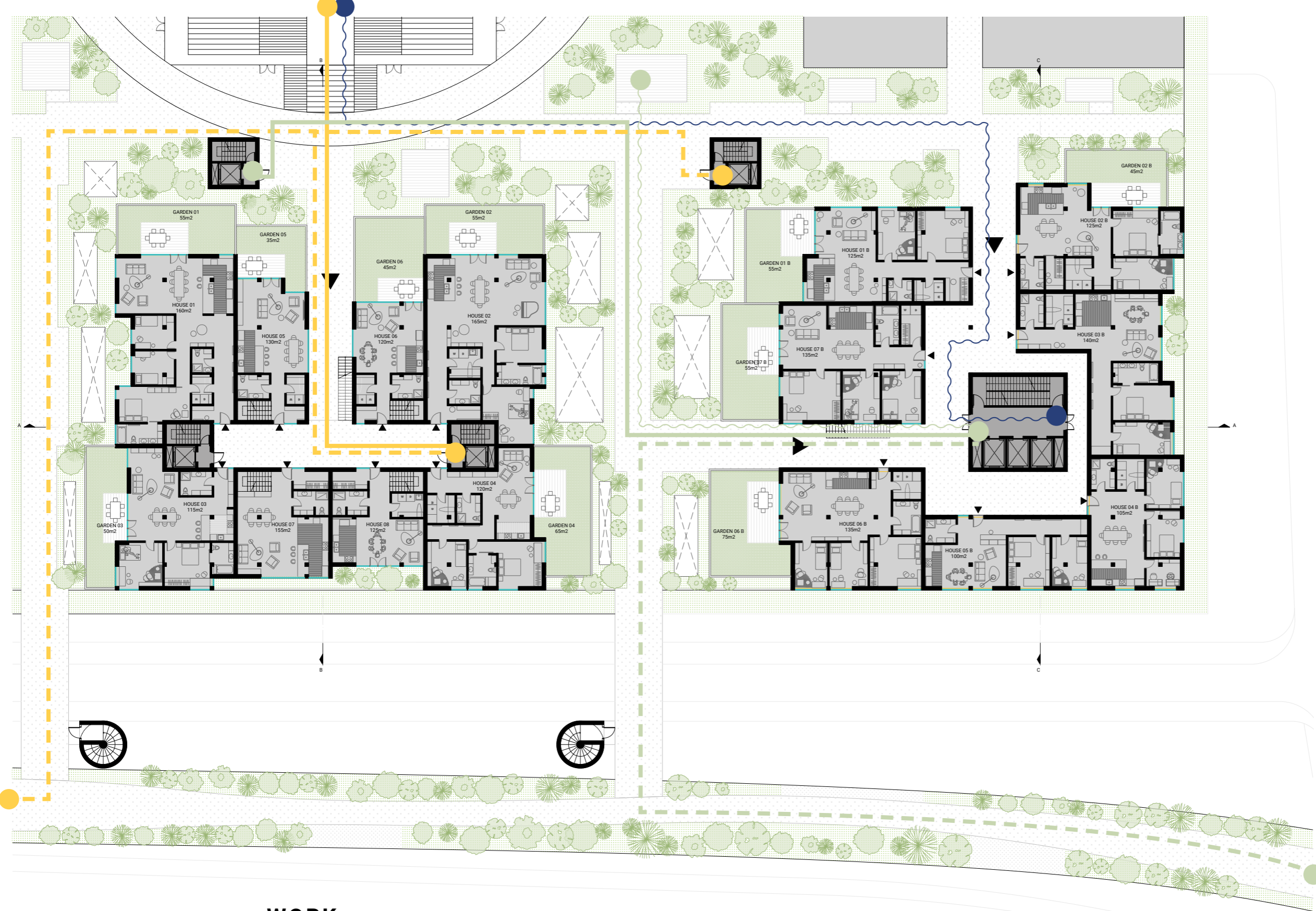

WILLIE



EWALD



JORRE

- WORK
- DAILIES
- LEISURE

P5 - PLAY WELL FLEXIBLE HOUSING

06. IMPLEMENTATION - JORRE'S HOME:

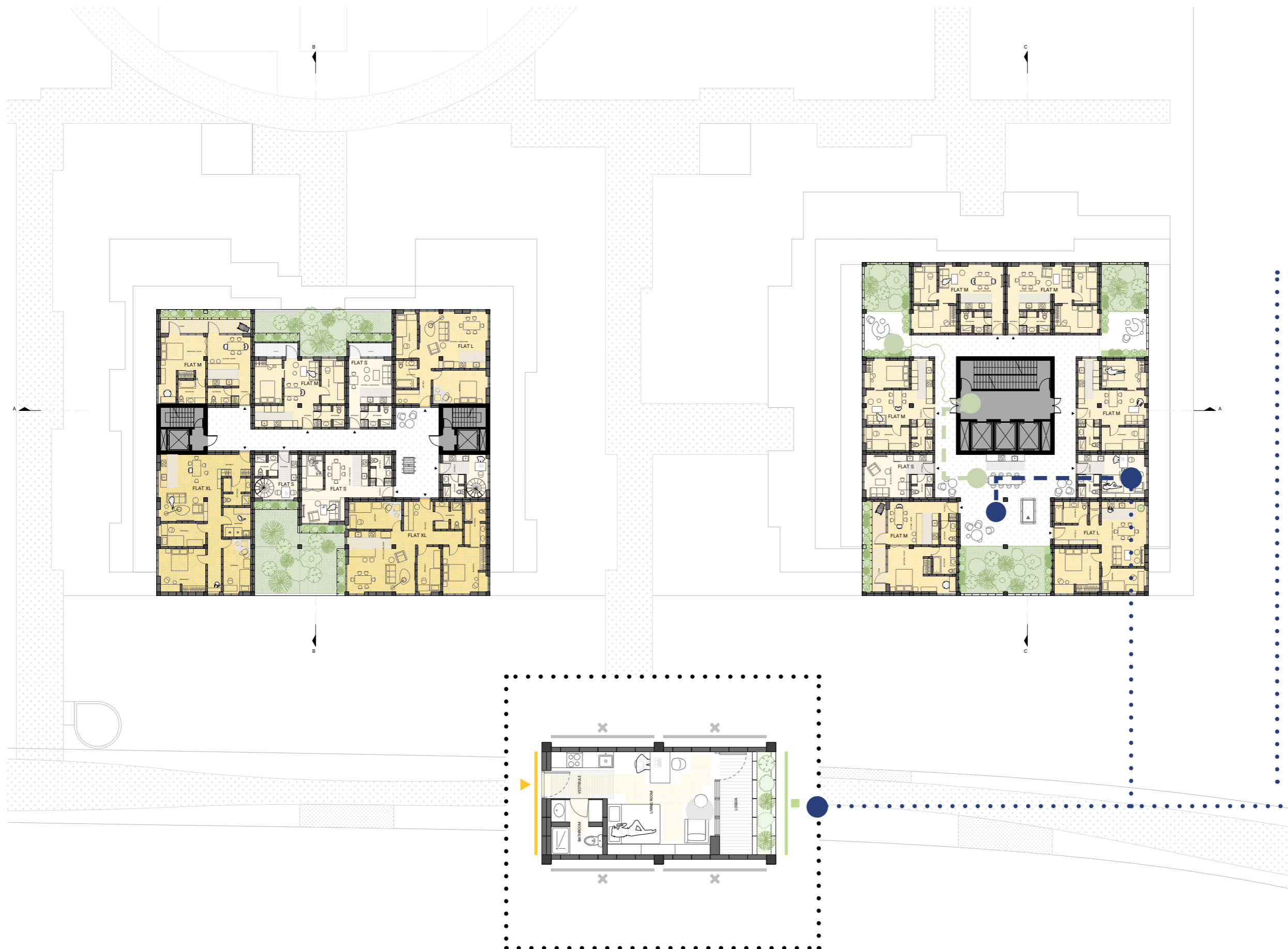

AFFORDABLE



FURNITURE BRAND



JORRE

S CATALOGUE STUDIO

P5 - PLAY WELL FLEXIBLE HOUSING

06.IMPLEMENTATION - EWALD'S HOME:

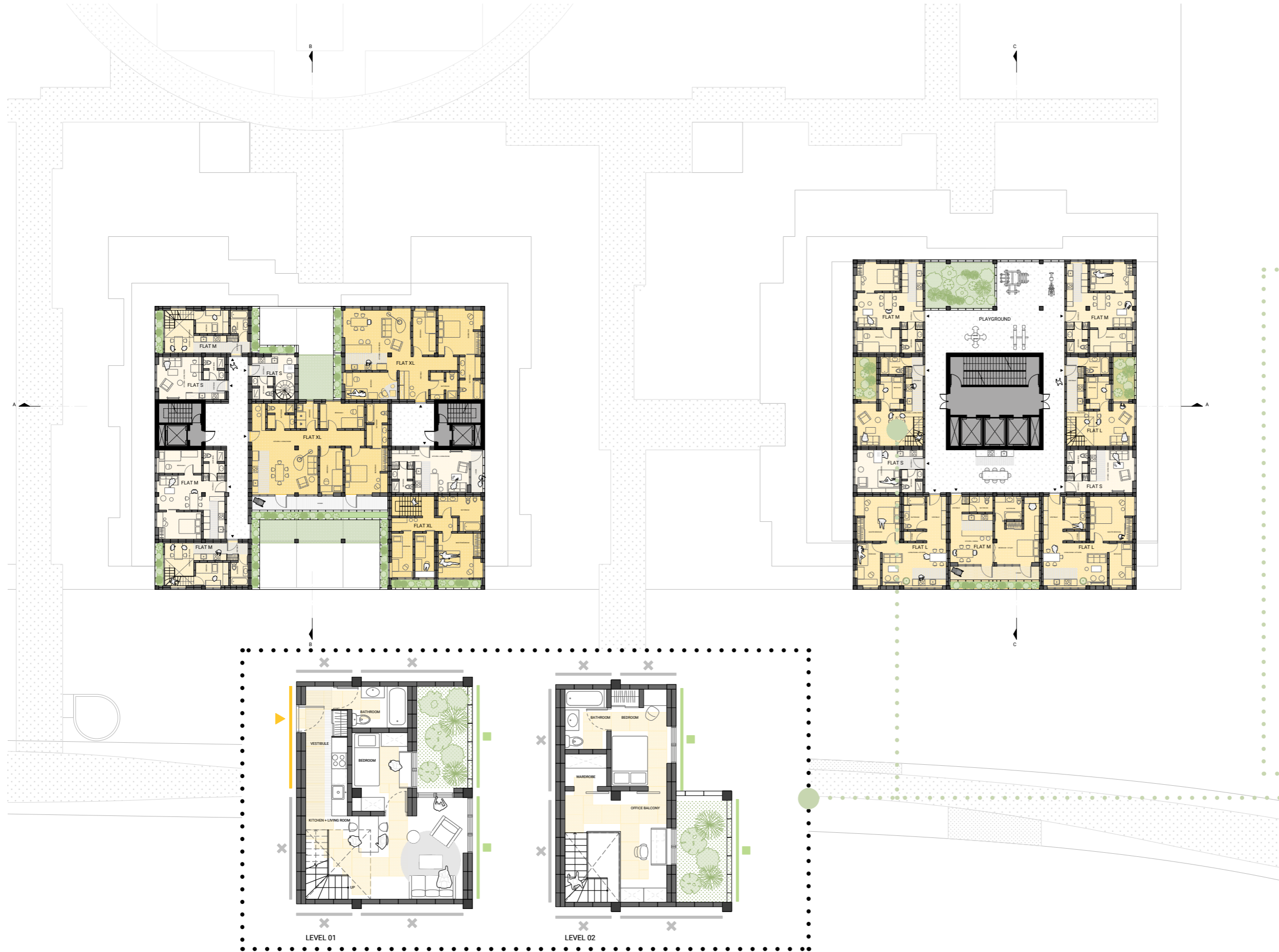

MID-RANGE



KATTY SCHIE BECK

HIGH-END DESIGN



EWALD

P5 - PLAY WELL FLEXIBLE HOUSING

06. IMPLEMENTATION - WILLIE'S HOME:

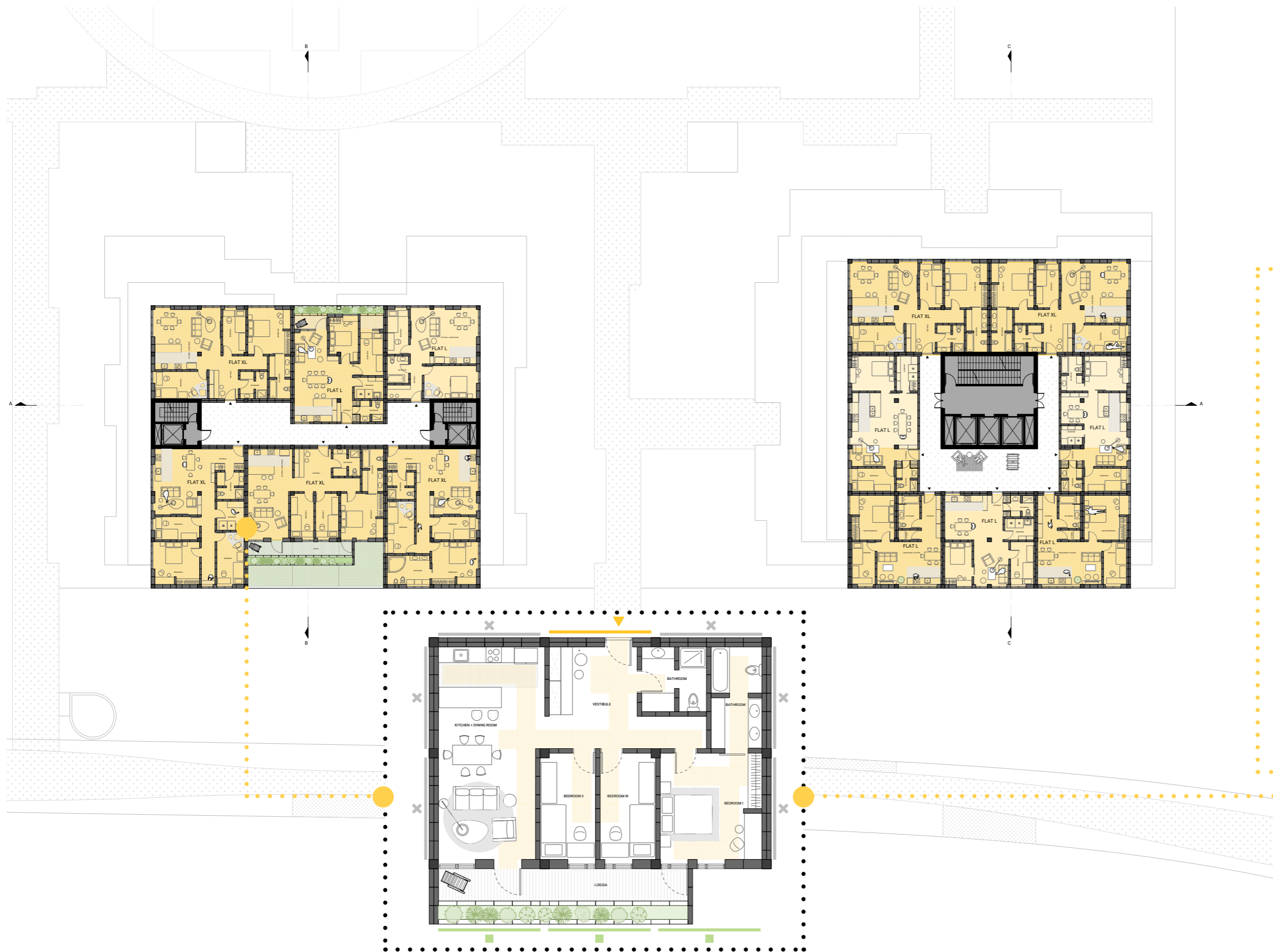

ADVANCED



HIGH-END DESIGN



WILLIE

L CATALOGUE APARTMENT

P5 - PLAY WELL FLEXIBLE HOUSING

06. THE FUTURE OF ACCESSIBLE HOUSING:

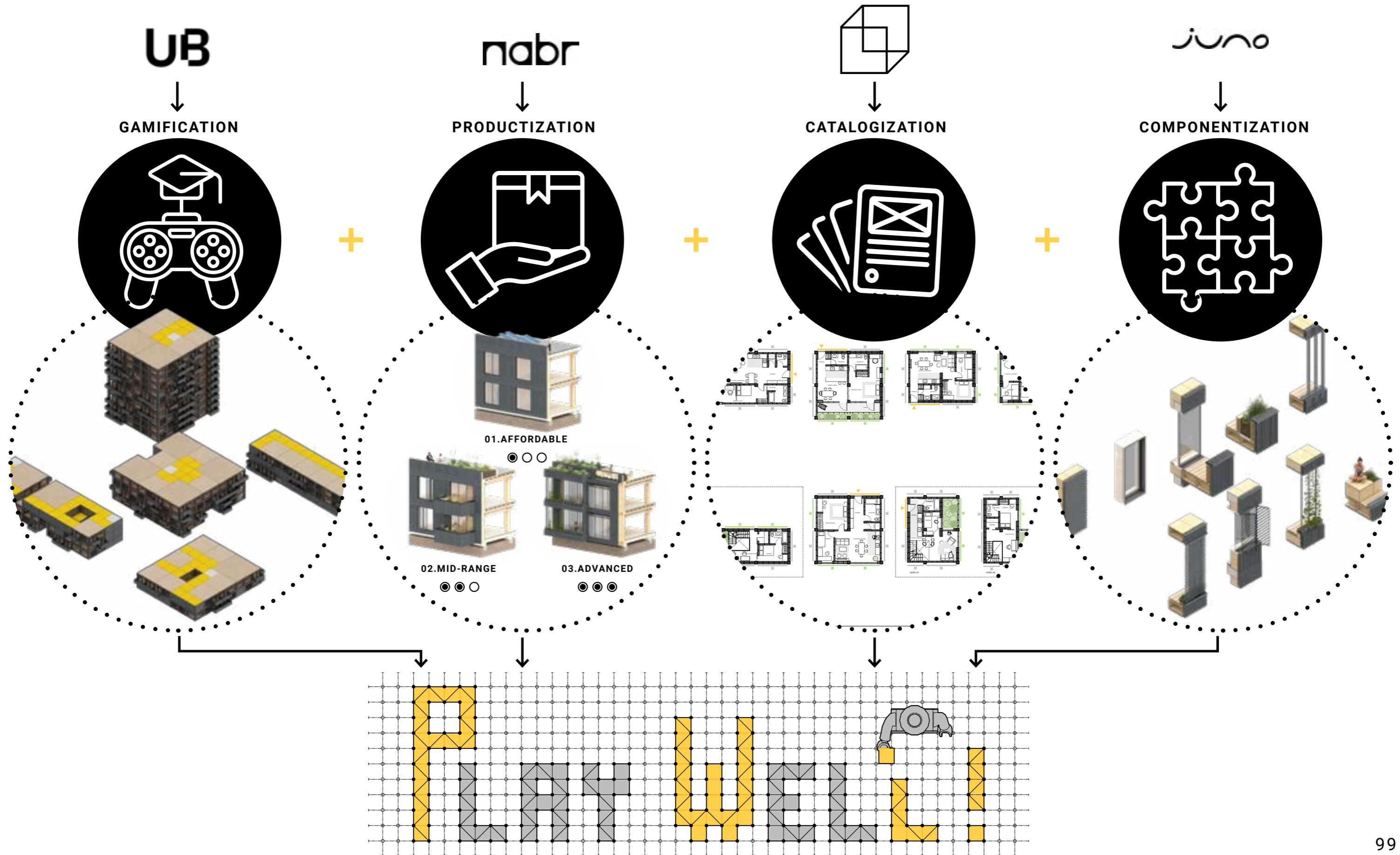

PLAY WELL!

THANK YOU!

TO ROEL - FOR ALWAYS ENCOURAGING ME TO PUSH FORWARD, AND BEING A CAREFUL LISTENER OF MY CHAOTIC RANTS.

TO PADDY - FOR ALWAYS PRESSING WHERE IT HURTS, AND CHALLENGING ME TO THINK AT EVERY STEP. EVEN, OR ESPECIALLY WHEN I WANTED TO 'JUST GET IT DONE'.

TO PIROUZ - FOR ALWAYS BRINGING IN THE SPARK OF PASSION, AND PROVIDING THE ESSENTIAL EXPERTISE AND HELPING ME CONNECT THE DOTS.

PLAY-WELL.IO