

Thesis for the Degree Master of Science

TU Delft Supervisor: Ronald Dekker

Philips Supervisor: Jaap Haartsen

**Delft University of Technology**

Faculty of Mechanical, Maritime and Materials Engineering

Department of BioMedical Engineering

# Wearable Ultrasound for Respiratory Monitoring in the Intensive Care Unit

---

THE DESIGN OF A PLACING SYSTEM FOR ULTRASOUND PATCHES

Annemijn Hintzen

PHILIPS | TU DELFT | 4443608

NOVEMBER 2022

# PLACING SYSTEM FOR ULTRASOUND PATCHES

Focused on respiratory monitoring in ICU patients

Philips Lumify or  
another preferred  
transducer



**Adapter:**  
bridge between  
transducer and gel  
pad holder

**Gel pad holder:**  
contains a solid  
ultrasound gel pad to  
transfer signal, a  
plaster, and  
protection sheet

**Pod:**  
transducer that  
monitors for up to 72  
hours

## Use existing transducer to find desired monitoring location



1. Click transducer in adapter



2. Click both in gel pad holder and  
perform ultrasound examination



3. At the desired location, release  
protection sheet



4. Press ring down to stick to  
skin



5. Release adapter from gel  
pad holder



6. Attach pod to gel pad holder.  
Leave for max. 72 hours

## One patch, many solutions

- for both imaging and non-imaging pods
- beyond respiratory: bladder, hemodynamic, renal

## Focus on usability

- use of known transducer leads to faster acceptance
- designed to place patches with minimal actions, in minimal time

## Modular design

- recyclable pod
- customizable gel pad holder and adapter for different applications and transducers

# Abstract

---

Elongated mechanical ventilation is associated with ventilator-induced lung injury (VILI), diaphragmatic muscle atrophy, patient discomfort, increased mortality rates and higher healthcare costs. However, hospitals are lacking in user-friendly, affordable and accurate methods to measure the decline the respiratory condition. Computed tomography (CT) is often used for visualization of the thorax, but it is expensive, time-consuming and uses unsafe ionizing radiation. Healthcare staff from the LUMC has expressed their need for a monitoring device using user-friendly, safe, affordable and accurate technology.

Current developments in ultrasound technology are resulting in smaller, cheaper and higher quality ultrasound devices. Micro-electro-mechanical (MEMS) ultrasound also allows for wearable solutions, such as patches attached to the skin. Besides, ultrasound does not use ionizing radiation and is therefore safer to use than CT.

Since ultrasound patches are already in development for other applications, for instance hemodynamic and bladder monitoring, the possibility of using it for respiratory monitoring for mechanically ventilated patients is investigated. In this report, the possibilities of using ultrasound patches for continuous respiratory monitoring for mechanically ventilated patients are explored. The focus points are usability and workflow design.

The design of a placing system is proposed, which allows the user to properly place the patches on the right location. This system is based on using an existing ultrasound transducer, in this case the Philips Lumify L12-4, to generate a full image. Then, the patch can be placed. This system allows for the use of both imaging and non-imaging patches. The electronics are reusable. The other parts can be adapted for the use with different transducers and applications, beyond respiratory monitoring.

# Introduction

---

This thesis is a design report on how wearable ultrasound devices can be used to monitor the respiratory system. Over the course of nine months, the project has evolved from problem analysis to a prototype of a device system that enables place finding for ultrasound patches. The report is divided in four parts, according to the Basic Design Cycle method described in the Delft Design Guide.

The first part of the report is Analysis, which is the research phase. In this part, information on surrounding factors is gathered to create a problem statement. For Part Two, a literature review on wearable ultrasound for several respiratory applications is performed. At this point, a problem statement can be defined, and the design phase is started. This is described in Part Three: Synthesis and Simulation. It contains the process from scope definition to brainstorming, and from prototyping to concept details. Finally, Part Four: Evaluation finishes the report. This is a reflection on the design, including recommendations and future prospects.

# Acknowledgment

---

The achievements accomplished in this project would not have been possible without the support and guidance of my supervisors.

Ronald Dekker, who never runs out of ideas. His infectious enthusiasm makes everyone around him believe in the projects he believes in. It was a pleasure to be able to work on one of his projects.

Jaap Haartsen, who always was available for discussions whenever I was stuck. His guidance and kindness made the many train rides to Eindhoven worth the while.

Next to them, I am also very grateful for all the others who helped me during this project:

- David van Westerloo of the LUMC, whose enthusiasm gave the project an incentive;
- Mariska Paap, who let me experience a day as a nurse in the ICU, which was a very emotional experience. I have a lot of respect for the work you and your coworkers do every day.
- Ed Berben, who helped me with the 3D printing and the plaster design;
- André Immink, for the advice on the electronics;
- Bas Jacobs, for his design of pod interior;
- Jacco Eerden, for his consult as a design expert;
- Petra Macova, for her consult as a business expert;
- Shin Kawasaki and Maarten Bakker of TNO, for their help with the plaster design;
- Jeffrey Visser, for his help with understanding his thesis:).

And all the people who took the time to have a conversation with me during the first eight weeks of the project: Hoa Pham, Hans Huiberts, Roland van de Molengraaf, Johan Klootwijk, Sabina Manzari, Jeroen van den Brand, Reinout Woltjer, Petra Rietveld, Willem Snoep, and Tom Goos.

Last but not least, I would like to thank my family. My mother for always welcoming me with a glass of wine and a borrelplank on Tuesdays, my dad who is always available for brainstorm sessions over 3D printed steaks, my sister who will have to work on a Saturday to accompany my defense, and my boyfriend for always remembering that everything will be alright. His move to the USA during this project, made me motivated to finish the project and follow him.

I hope you have as much fun reading this report as I had during the several Eureka moments, visits to the LUMC and conversations with my supervisors Jaap and Ronald, which mostly (not always, of course 😊) led to fruitful results.

Annemijn Hintzen

November 2022

Abstract.....	2
Introduction .....	3
Acknowledgment.....	4
<b>Part One: Analysis</b>	
Introduction .....	7
Analysis .....	12
Requirements.....	22
Conclusion.....	23
<b>Part Two: Literature review (separate)</b>	
<b>Part Three: Synthesis and Simulation</b>	
Literature review.....	26
Problem statement .....	26
Updated scope.....	26
Function analysis .....	29
Ideation .....	31
Idea and concept generation.....	34
Concept generation.....	35
Prototyping.....	42
Final concept.....	58
<b>Part Four: Evaluation</b>	
Requirements.....	69
User tests and feedback .....	69
Recommendations.....	72
Future.....	73
Conclusion.....	74
Appendices .....	75

# Part One: Analysis

# Introduction

---

The initial project description was to ‘walk through the use case of wearable ultrasound for lung monitoring’. To comprehend the meaning of this project, a problem analysis is performed. In this process, information was obtained from conversations with stakeholders, literature, and a visit to the Leids Universitair Medisch Centrum (LUMC).

## Background

This project is a continuation of the graduation thesis of Jeffrey Visser, a Technical Medicine student who had finished his graduation research at Philips and the LUMC before the starting date of this research. The thesis revealed a need for continuous monitoring of the lungs for mechanical ventilated patients, to prevent lung damage caused by the ventilator. Since ultrasound is a non-invasive, non-radiating and relatively cheap imaging method, it is a possible solution for monitoring the lungs. An indication of healthy and thus non-damaged lungs is lung sliding, which is the movement of the visceral and parietal lung pleura sliding against one another during respiration. Overdistention of the lung, which is damage caused often by the mechanical ventilator, results in a reduction of lung sliding. Therefore, detecting lung sliding is valuable for assessing the state of the lungs. An algorithm was developed to quantify lung sliding using ultrasound images. The algorithm turned out to detect the lung sliding sufficiently, and thus, ultrasound has the potential to be an imaging technology for lung monitoring.

The development of MEMS ultrasound, which is based on using chips rather than bulky crystals to create ultrasound, creates the possibility to make smaller, cheaper and smarter ultrasound transducers. This is an opportunity for developing wearable ultrasound devices that Philips can use. Finally, the Covid-19 pandemic induces the need for respiratory monitoring.

## Incentive

### Clinical need

Several respiratory conditions may lead to patients not able to breath on their own, like lung consolidations, atelectasis or acute respiratory distress syndrome (ARDS). Whenever this occurs, there is a large chance the patient will end up in the intensive care unit (ICU) and put on mechanical ventilation (MV). Mechanical ventilation is used to open damaged parts of the lungs and provide proper gas exchange in the whole lung. Even though mechanical ventilation can be necessary for saving the life of a patient, it is known to potentially harm the lungs as well. This damage is called ventilator-induced lung injury (VILI) [1].

In healthy lungs, an inhalation starts with the diaphragm contracting, which opens the lung space and creates a negative air pressure. This causes air to flow into the lungs, where gas exchange can take place. During exhalation, the diaphragm relaxes, and the air is pushed out. For the inhalation, no positive pressure is occurring in the lungs. Mechanical ventilation, however, pushes air into the lungs and therefore creates a positive pressure. By applying the pressure, the ill, contracted parts of the lungs are opened. However, the healthy parts also experience a higher pressure, which causes overdistention. Overdistention is linked to volutrauma (injury caused by overdistention) and barotrauma (caused by too high pressure).



These two, together with atelectrauma (high shear forces), bio-trauma (inflammatory response) and shear strain, can cause VILI [2].

Presence of lung abnormalities will in turn lead to a more uneven pressure distribution, as more pressure flows into the healthy lung parts and can lead to death of tissue [3]. For this reason, it is important that MV is applied within a therapeutic window. Since ARDS patients have a 27-60% mortality rate, the optimal ventilation strategy should represent a compromise between alveolar recruitment (opening of collapsed alveoli) and preventing lung overinflation. The ventilator settings are determined by the patient's weight, age and course of illness. However, since every patient is different, these aspects turn out to be not enough to achieve the delicate compromise [4].

Overdistention in healthy parts of the lungs can be monitored using Computed Tomography (CT). Before starting a treatment using mechanical ventilation, a CT scan is performed. Whenever a suspicion for lung difficulties exists, another lung CT is made to compare the images. CT is known for providing clear lung images and therefore provide much information on the lung's condition. Nevertheless, the scans are costly, timely, and use ionizing radiation. Another option is to use electrical impedance tomography (EIT), which measures the tomography throughout the lungs and therefore can take a picture of the lungs. However, EIT requires expensive machines costing around €25-45.000, which makes it unavailable in most hospitals [5][6]. Point-of-care ultrasound (POCUS), the use of handheld ultrasonography transducers, is currently the easiest and cheapest method to examine the lungs non-invasively [1]. As mentioned before, reduction of lung sliding is an indication of lung overdistention and can be detected using handheld ultrasound probes. However, according to the LUMC intensivists, these examinations are only performed once a day due to their timely character. This makes them incapable of providing a complete image of the lung state.

## LUMC

The thesis by Jeffrey was in collaboration with the LUMC, and a close collaboration with research intensivists David van Westerloo, Jorge Lopez Matta and Bram Schoe. From them, a wish was expressed to create a device that monitors lungs continuously.

According to these intensivists, there is currently no proper way of knowing if the ventilator is operating at the optimal settings. The pressure in the lungs is measured using an esophageal balloon, but that can only provide an estimation of the general pressure within the lungs, and not the desired regional pressures for indicating overdistention. Also, the balloon is an invasive device, which brings the risk of contamination. As mentioned before, CT machines are experienced as too harmful and inconvenient, and EIT is not available in the LUMC. Doctors currently use point-of-care ultrasound to quantify the conditions of the lungs, a task that takes about 15-20 minutes a day per patient. These measurements provide an image of the lungs at a specific time and therefore are not sufficient for providing a complete image [6].

## Philips

Having started as a lightbulb company in the small city of Eindhoven in the 1890s, Philips has grown into a world leader in healthcare and patient-centered solutions. According to Philips'

website, their goal is to advance ultrasound technology to more intelligent solutions, allowing more people in more places to make faster and better decisions [7][8].

Philips is commonly mentioned as one of the market leaders in ultrasonography, but always amongst other global leaders such as Siemens and GE Healthcare [9-13]. It is necessary to continue to improve in order to remain one of the market leaders in ultrasonography, making novel applications for ultrasound are an opportunity for Philips. They are currently researching the use of MEMS ultrasound to create new applications for small

## Ultrasound patches

An ultrasound patch is an ultrasound transducer that is integrated within a patch, a wearable device that sticks to the skin and monitors the patient. Patches are already used in the medical world as contraception, allergy tests and smoking withdrawal help. An example of a contraceptive patch is given in Fig. 1.1.



Figure 1.1: Contraceptive patch [1]

Because of the Covid-19 pandemic, the demand for solutions that require as little nurse-patient contact as possible has risen. Therefore, Philips is discovering the possibility to design patches for multiple applications, among others, to minimize ventilator-induced lung damage. This is where Philips, Jeffrey's research and the LUMC come together.

## Monitoring versus imaging

An important difference between existing ultrasound and patches is the difference between monitoring and imaging. Ultrasound transducers are used for imaging, which is producing a complete image of organs with a rate of multiple frames per second. Monitoring however, does not require the production of an image. In combination with artificial intelligence, frames are taken with a larger interval and less ultrasound beams. AI is integrated for the following functions:

1. Reduce data: AI will reduce the number of measurements and ultrasound beams. For imaging purposes, a full image is produced with 25 images per second. Using AI, the data can be reduced. For instance, for diaphragm thickness monitoring, a measurement could

be done every other second using only one beam, rather than continuously imaging the diaphragm.

2. Obtain relevant information from data: intelligent software can draw a conclusion from less data than doctors.
3. Interpret data: the role of the skilled specialist will be less time intensive. Since the AI will take care of processing the data, the doctor can use that information to decide whether to adapt the treatment plan.

This difference is important, since it divides current ultrasound devices from the desired monitoring device.

## Problem Statement

Mechanical ventilation is used to open lungs of ill patients, but often also harms the healthy parts of the lungs. Too high pressures lead to overdistention and therefore lung damage. Defining the ventilation strategy is a complicated balance, since doctors are forced to use trial and error methods to find the optimum. A device that provides information on the condition of a specific part of the lungs can give feedback on the current settings and find the optimum.

Commonly used lung imaging techniques are CT, EIT and point-of-care ultrasound. Because those are either intravenous, not accurate enough, too expensive, too time-consuming or using ionizing radiation, doctors at the LUMC have expressed their wish for a new monitoring device. Together with the quick development of MEMS ultrasound technology and the opportunity for Philips to stay an ultrasound market leader, the idea for personal ultrasound monitoring arises.

To effectively make personal ultrasound monitoring accessible for use in the ICU, it is important that a device is designed that aims to decrease the harm done by the ventilator and/or aims to shorten the stay on the ICU, that will fit in the hospital's budget, that is designed specifically to fit in the settings of the ICU and will not cause any patient harm itself. Together with Philips and the LUMC, this project aims to propose a device that will fulfill the needs of getting insights on optimal ventilator settings.

## Scope

This project will be focused on the use, implementation and form factor of a device that enables personal ultrasound for lung monitoring. The focus will be on usability and workflow design. Therefore, the technical aspects of the transducer itself and data processing will be left out of the scope. The project ends with a working prototype of the form factor and a recommendation report for the further course of the project. The prototype will focus on usability aspects mainly. It will take years to make a fully working prototype that can be clinically tested, which is why the project will end with a report on recommendations for the future, so the project can be continued within Philips.

## Structure

This design process follows the course of the Basic Design Cycle as described in the Delft Design Guide that was developed by Roozenburg and Eekels [14][15]. This process consists of four main stages: Analysis, Synthesis, Simulation and Evaluation, which eventually leads to Decision. The Analysis stage is about background research, including mapping out the project, formulating the problem statement, performing a literature study and having conversations with experts and relevant stakeholders. The Analysis stage will end with criteria for the design. The Synthesis and Simulation stage are combined in this report. In this part, the full design process from brainstorming to prototyping can be conceptualized. In the Evaluation stage, the user test takes place. The expected properties are compared to the desired properties listed in the design specifications. The value of the design is evaluated, after which a decision can be made whether to continue finalizing the product or going back to the beginning.

As can be seen in Fig. 1.2 and as can be guessed from the name, the basic cycle is no straight line. In between phases and throughout the project, many iterations will be made. The design process is a process of 'trial-and-error', which allows for a design that has been evaluated repeatedly.

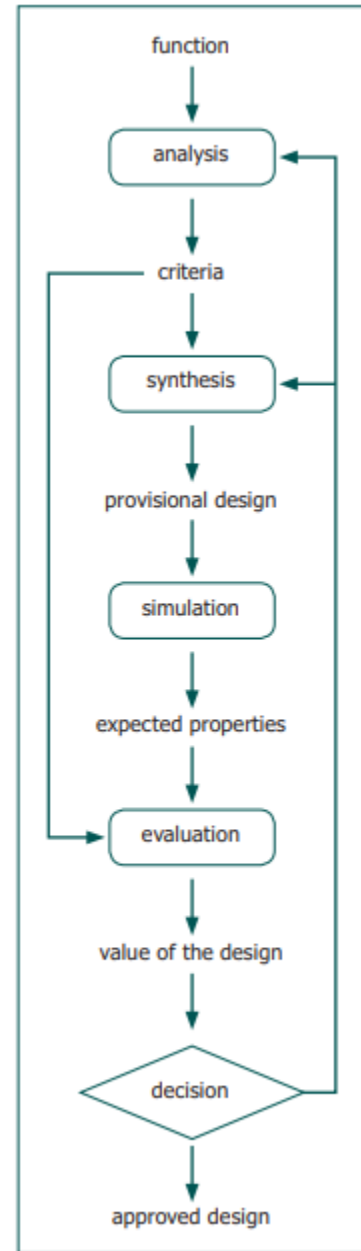

Figure 1.2: Basic Design Cycle

# Analysis

---

## Ultrasound

Using sound as a method to visualize an environment has been first discovered in the 19<sup>th</sup> century. SONAR (Sound Navigation And Ranging) is a popular method for both submarines and antisubmarine ships to obtain information on other ships. However, it wasn't until the 1930s that ultrasound was started being used for medical applications, beginning with imaging the human brain. Since then, ultrasound has become one of the most used imaging techniques in healthcare [16].

Medical ultrasound has several advantages over other medical imaging techniques. It is non-invasive and does not produce harmful ionizing radiation. It is used for both diagnostic and therapeutic purposes. For diagnostic use, the ultrasound probes, called transducers, produce sound waves with frequencies in the megahertz range, which is much above the hearing threshold for humans, 20 kHz. A transducer both produces and receives sound waves it transmits. In most cases, the active elements in the transducers are piezoelectric crystals that vibrate when electric current is applied, but also produce an electric signal when reflected sound hits them. Calculating the different time periods that a signal needs to return to the transducer, an image of the human body can be created. The most known medical application is fetal ultrasound, to monitor the growth and development of a fetus during pregnancy, but it is also widely used for many other purposes: imaging the heart, blood vessels, abdominal organs, skin, muscles, brain and eyes [17].

Ultrasound waves pass well through tissues containing water, but cannot transfer through every medium. For instance, bone will generate a bright white image and does not show anything behind the bone, and air will block the waves and return a black image. During an ultrasound exam, gel is applied to the patient's skin to prevent air pockets between the transducer and the skin that block the waves [17].

The original ultrasound machines were large and costly. In 1998, the first point-of-care ultrasound (POCUS) was introduced. POCUS enables machines to become smaller and cheaper, and investigations to be faster [18]. Tradeoffs are concerning image quality; however, current developments are showing that POCUS solutions such as the Philips Lumify provide just as high-quality images as the older, large machines [6]. The latest development is MEMS ultrasound, based on chips rather than crystals. This project will also be based on the MEMS ultrasound potential to create smaller and cheaper ultrasound.

## Lung ultrasound

Lichtenstein et al. were the first to come up with a protocol to perform ultrasound on lungs, called the BLUE protocol [19].

The BLUE protocol is based on three measurements:

1. The number of B-lines present: B-lines are vertical, comet-like stripes that indicate fluid in the lungs. A-lines, however, are horizontal and indicate a normal lung.

2. Pleural movement and the thickening of the pleura: an absence of lung sliding indicates stiffened lungs. A thickened or fraying pleural line is also an indication of unhealthy lungs.
3. The presence of lung consolidations, non-ventilated areas that resemble liver tissue. [19]

Figs. 1.3a and 1.3b show ultrasound images of the lung and associated ultrasound characteristics.

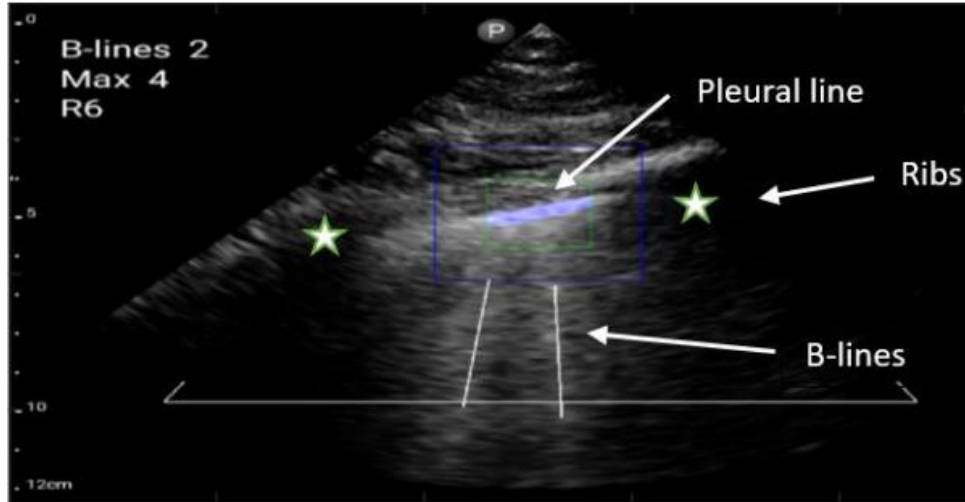

Figure 1.3A: Lung ultrasound image, screenshot taken by Jeffrey. The stars represent the location of the ribs, which project an ultrasound shadow on the picture. The pleural line is partly colored blue. B-lines indicate interstitial pulmonary edema: a higher number of B-lines indicates more fluid upbuild [1]

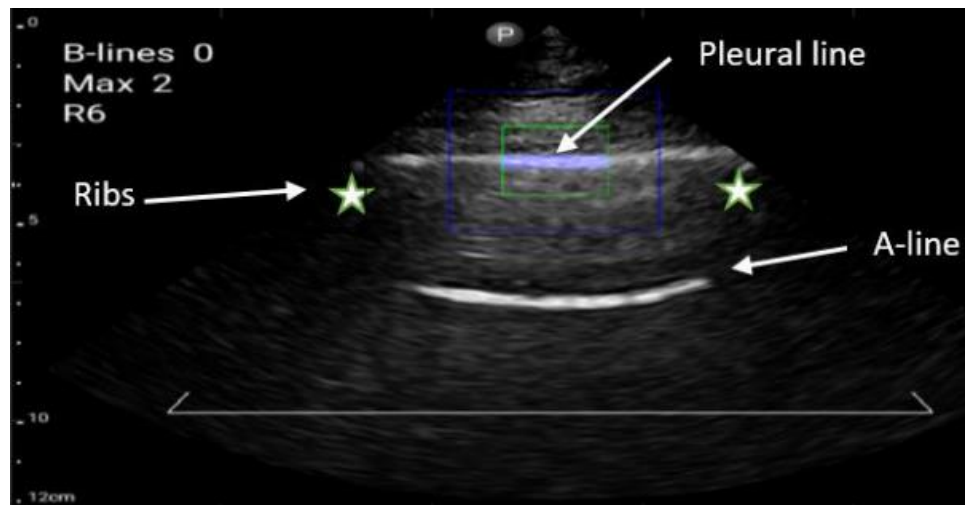

Figure 1.3B: Another ultrasound image. In this case, no B-lines are detected. The presence of an A-line indicates there is no edema, and the lung is well aerated [1]

To correctly assess the lung condition, all lung areas should be evaluated. A regular lung ultrasound examination from the study of Dargent et al. [20] shows that 6 areas are imaged in each lung, as can be seen in Fig. 3 below. According to the LUMC doctors, zone (R/L)1 and zone (R/L)2 are most interesting to monitor, as overdinflation occurs in these zones first. The division of the lung areas is shown in Fig. 1.4.

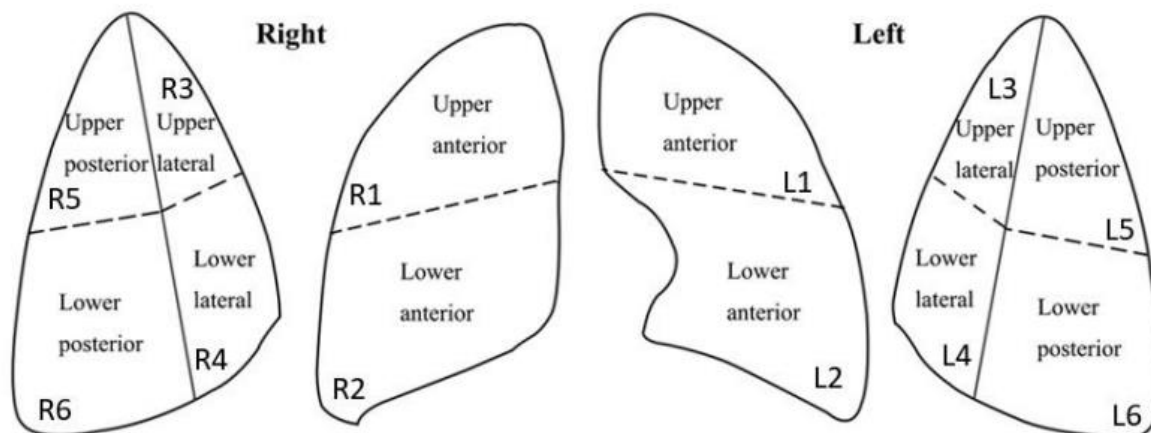

Figure 1.4: The 12 zones of the lung for ultrasound examination [20]

The currently used ultrasound is based on imaging. That does not mean that the patches themselves will need to provide the same images as well. With the integration of AI, less data is needed to obtain a complete image of the lungs. For instance, a single beam produced every other minute can be used to assess the thickness of a membrane. AI can in turn draw a conclusion from the available data and suggest a clinical review from a doctor.

## Ultrasound market

Philips is a strong competitor in high-end medical imaging machines and thus a market leader for high-end ultrasound machines. However, for simpler exams, devices are preferred that are smaller, less costly and easier to operate [21].

The demand for more intelligent and versatile ultrasound is worldwide. According to market research, the global ultrasound market is expected to grow between 5-7% in the next 10 years. Some factors that induce this growth are: adoption of ultrasound devices for diagnostic imaging and treatment; the rising demand for minimally invasive surgery; technological advancements in ultrasound imaging; and the integration of AI, which saves valuable time for skilled sonographers. Next to that, the Covid-19 pandemic also induced the general need for handheld devices, because of the speed, portability and ease of use they offer for lung monitoring [9-13].

## POCUS

Point-of-care ultrasound is the most direct competitor of patches, as it is currently the cheapest and most portable ultrasound solution. Due to the surging geriatric population, the increasing prevalence of chronic diseases and technological advancements, the POCUS market growth rate is expected to be 7.9% worldwide from 2021 to 2030 [22].

Philips's Point-of-care ultrasound device is the Lumify, pictured in Fig. 1.5. It is based on a set of three different portable probes that can be connected to a tablet. According to market research on the point-of-care ultrasound, Philips is a key player among Siemens, Samsung, General Electric, Braun, Fujifilm, Canon and more [22].



Figure 1.5: Philips Lumify plus tablet [23]

Another notable competitor is Butterfly, a relative new company that has presented the world's first handheld whole-body ultrasound system, specifically based on bringing ultrasound to developing areas. Earlier in 2022, Butterfly was also promising the development of a wearable ultrasound patch to be developed in 2023. However, in October 2022, this future plan is nowhere visible anymore. This can mean that either they have abandoned the project, or that it has become confidential. The Butterfly iQ+ transducer is pictured in Fig. 6 [24-25].



Figure 1.6: Butterfly iQ+ POCUS [24]

## Patches

Ultrasound patches were first mentioned in research in 2010 as a novel solution for healing damaged tendons using low-frequency ultrasound waves. Since then, ultrasound patches have been developed for several applications, such as soft tissue imaging, bladder monitoring and



hemodynamic monitoring. A patch for bladder monitoring by Dutch-based company Novioscan is shown in Fig. 1.7 [26-30].



*Figure 1.7: A bladder monitoring patch by company Novioscan helps children with potty training [29]*

Especially for hemodynamic monitoring, the development of ultrasound patches has progressed. In 2018, researchers from the University of California developed thin silicone elastomer sheets consisting of electrodes and piezoelectric transducers to form small patches that are flexible enough to stick to and move along with a finger. However, the patch is still in development since the processor, power source and wireless communication system have not been integrated yet. An image of the patch by University of California is shown in Fig. 8 [33].



*Figure 1.8: the wireless, flexible silicone patch for hemodynamic monitoring by the University of California. This is a non-working prototype, the patch still requires wires for power [30].*

The Canadian company Flosionics Medical claims to have designed the world's first wireless and wearable device to perform doppler assessments in the carotid artery. Already a working prototype exists. This patch is located on the left side of the neck, where it can accurately measure the carotid artery blood flow. Fig. 1.9 shows the Flopatch prototype [31-32].

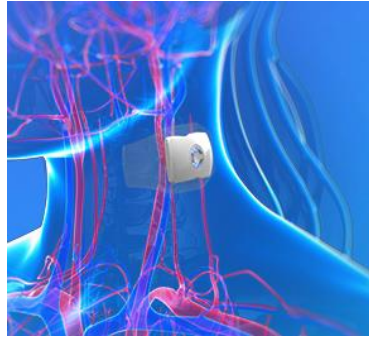

Figure 1.9: The Flosionics Flopatch [32]

Patches developed so far claim to reduce time-consuming tasks and improve the patient's outcome, by reducing the need of radiating scans, inconvenient bedside ultrasound examinations and long-term treatment plans. However, none of the patches in literature is focusing on thoracic measurements. The existing patches are based on superficial measurements rather than the more complicated and deeper images needed for lung assessment. An exception is a patch designed for diaphragm monitoring by Shanshahani et al. They showed a PTZ transducer, applied in the zone of apposition at the right side of the body. The patch is used to measure the diaphragm to detect respiratory disorders and is tested with promising results [34]. Images of this patch are shown in Fig. 1.10.

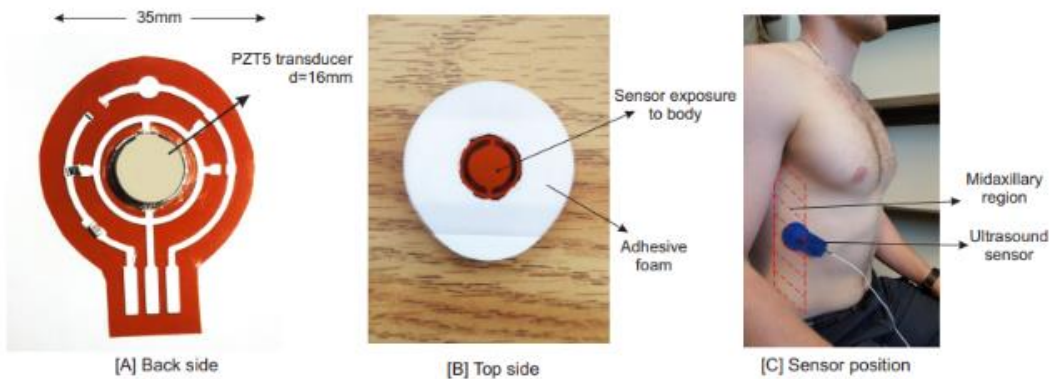

Figure 1.10: patch by Shanshahani et al. [34]

Philips is already working on patches for carotid and fetal monitoring. Especially the hemodynamic group is developing quickly, presenting a prototype that has already been tested on pigs. The prototype consists of a deconstructed Lumify. However, for this project, the focus is to work with MEMS technology and therefore, the Lumify components will not be used for the patch itself. This is desirable for creating a smaller and cheaper patch.

## Environment: The Intensive Care Unit (ICU)

The Intensive Care Unit (ICU) is the department of the hospital or health care facility that provides intensive care for critically ill or injured patients. It is staffed with specifically trained medical personnel and has equipment that allows for monitoring and life support.

Two visits to the ICU provided information on the hospital settings. The first visit was a walkthrough with intensivists, the second visit a walk-in day together with a nurse.

## Inside the ICU room

No pictures were taken during the visit due to the sensitive nature of the environment. However, the VieCuri Medical Center in Venlo provides a clear overview of the equipment that is present. The separate components are shown in Figs 1.11-1.17.



Figure 1.11: An ICU room [35]

## The bed

An ICU room in the Netherlands consists of either 1 or 2 beds plus working stations. The beds are controlled electrically, can be adjusted in position and moved around throughout the hospitals because of the wheels underneath. The mattresses are anti decubitus mattresses, which lowers the probability of bedsores. When a patient is mechanically ventilated, they are often put in prone position for parts of the day. Laying in prone position helps the lungs to fill up with air easier, but patients cannot be in that position for more than 16 hours straight and should be turned around regularly [35].

## Breathing tube or mask

Air is administered either through a breathing tube or a mask. Patients who are ventilated, are not able to talk, eat, or walk around freely.



Figure 1.12 (left): Breathing tube and breathing mask. Figure 1.13 (right): Bedside patient monitor

## Bedside patient monitor

This monitor continuously provides information on the patient's blood pressure, oxygen saturation, heart rate and other bodily functions. These monitors are also present in at the nurse desks, which allows nurses to watch the patient's statistics from down the hall. An alarm rings any time values deviate from normal on all available monitors in the department, to ensure it is heard.

## Ventilator monitor

This monitor provides information on the mechanical ventilation. Settings of the ventilator can be adjusted using this monitor. Intensivists have pointed out the opportunity to place a screen next to the ventilator screen, since there is space available.



Figure 1.14 (left): Ventilator monitor

Figure 1.15 (right): Perfusers

## Perfusors

Perfusors are injection pumps. There are multiple perfusors attached to the bedside of a patient, which are all programmed to administer different medicines at different rates. Patients on the ICU are connected to at least one catheter providing fluid, which makes it necessary to take the perfusion tower with them when leaving the bed.

## Gastric tube

A gastric tube is inserted when a patient cannot take food themselves or is severely weakened. The tube travels from the nose through the stomach. Next to food, also medicines can be administered. Patients on MV always need a gastric tube.



Figure 1.16 (left): Gastric tube      Figure 1.17 (right): Arterial line

## Arterial line

Most patients on the ICU have an arterial line, which is an IV in the wrist vein. With this line, the blood pressure is continuously monitored, and blood samples are regularly taken.

## Staff

Every ICU nurse is responsible for a maximum of two patients at a time. During a shift, the nurse either is working in the patient's room or sitting behind the nurses' desk in the hallway. At the desk, all patient monitors are present to make sure no signal is missed.

An observation by the intensivists pointed out the use of ultrasound probes. Apparently, the Lumify device is not always stored correctly. Often, they are forgotten to be charged. These remarks should be used for the device design.

## ECG

Many patients in the ICU are also monitored with electrocardiography (ECG). When designing an ultrasound device, the placement of ECG patches should be considered, since they will take up an important place of the chest. Placement of the ECG stickers are shown in Fig. 1.18.

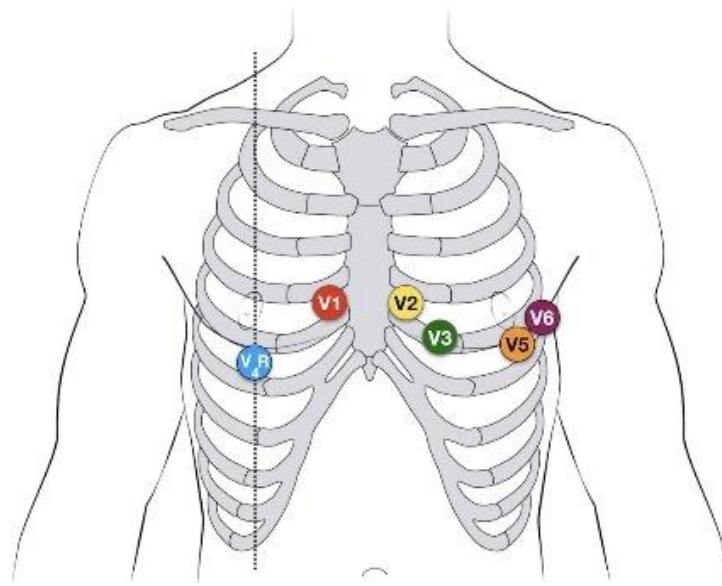

Figure 1.18: placement of ECG [36]

## Other applications

During the LUMC visit, possible applications for using ultrasound were discussed, next to detecting lung sliding. A prevalent issue called fluid overload or ‘overfilling’ of the lungs is dangerous, but quickly assessable using ultrasound. At the admission of a patient to the ICU, fluid is immediately administered using an IV to fight dehydration. This is called ‘filling’. However, the balance can be delicate, and a patient is quickly overfilled, with the possibility of causing renal failure. Ultrasound monitoring can be used to detect B-lines, the sign of fluid upbuild in organs [6][37].

Another application is diaphragm monitoring. The diaphragm is a fibrous muscle in the shape of a parachute that runs between the chest and the abdomen, separating these two cavities. It is the most important muscle of respiration. During respiration, it is moving longitudinally, but is also changing in thickness. By monitoring the thickness change, conclusions can be drawn on the patient’s ability to breathe on their own. Also, asynchronies between the ventilator and patient’s breathing cycle can be determined [6].

Other applications are explained in the Literature Review.

## Market share

For determining the market share, a rough estimation was made based on information about ICU occupation and assumptions.

Contradicting information exists on the amount of ICU patients in the Netherlands. In general, de Nederlandse Overheid, de Stichting Nationale Intensive Care Evaluation (NICE) and the Nederlandse Vereniging voor Intensive Care (NVIC) state there were a total of 1032-1208 beds available before the COVID-19 outbreak, of which normally 70-75% is occupied. From LUMC information, it appears that about 50% of these patients are mechanically ventilated. If all these patients would have a monitoring patch, this is about 400 people each day, and 150.000 patch

days in total each year. Since the patch can stay on for 3 days, this is a total of 50.000 patches per year in the Netherlands [30-32]. If the market is shared with Germany, Belgium, Luxembourg and France, expecting those countries need proportionally as many patches as can be expected from population numbers, this adds up to 500.000 patches each year. During a pandemic, this amount can easily go up to twice the amount, which is one million a year.

## Requirements

---

A first version of the design requirements is stated in a list in Appendix A. A design must fit all these requirements to be suitable. However, the list is far from complete and will be completed later in the process, when more information is available.

### Use

The use requirements are mainly obtained from a walk-in day at the IC of the LUMC. Most important was the wish expressed by nurses to reduce the amount of extra work that the new device requires. It must fit in the existing workflow. Another important insight was the placement of patches. Unless they are as thin as a regular medical plaster, nothing can be placed on the back. Therefore, a solution is needed that will work with only the frontal and lateral lung zones.

### Cleaning

The requirements for cleaning the reusable part of the device should be the same as used for the Lumify. In the LUMC, the Lumify is disinfected using alcohol wipes. Also, in the official guidelines Philips provides along the Lumify is stated that the device should be cleaned either by soaking in a disinfectant bath or using alcohol wipes. Therefore, the reusable part should withstand alcohol wipes. The parts that touch the skin are disposable and therefore do not have cleaning requirements [41].

Cleaning the patient is another important aspect. Patients are bathed using water-based cleaning wipes for the skin. The patch should be able to resist those. Also, the patch cannot cover places that are important to clean, such as armpits or the pubic area.

### Function

The patches will be used to monitor several lung zones, not necessarily all at the same time. This requires a modular system with communicating patches. The patches must keep working when the patient is turned sideways for cleaning or examinations.

### Price

The price aspect is compared to the biggest competitor, the EIT. Therefore, one full device system should be able to retail for less than €25.000.

### Safety

The device must not harm the patient permanently and must be considered comfortable to wear. The device cannot cause wounds or bedsores and must not worsen the patient's condition.

## End of life

The device will contain valuable electronics. Therefore, it is desirable that the part containing the electronics can be reused. The part that touches the skin must be either disposed or thoroughly disinfected. At the end of life, the device must be disposed using the regular hospital waste streams.

## Conclusion

---

Following the analysis and stakeholder conversations, the following gaps were found to be interesting to explore.

### **Market needs**

LUMC doctors have expressed the wish for a monitoring device. However, that is no guarantee for a market-wide demand. The current situation involves doctors performing an ultrasound exam with a handheld probe, taking up 15-20 minutes a day. To make sure the patch is a valuable addition to the usual exams, the patches should have a positive impact on more than eliminating this time. This value could be added by shorter ICU stay, a higher survival rate or less lung damage. Therefore, it is chosen to perform a literature on the added value of patches for different application.

### **Technological issues**

Although CMUT patches are in development within Philips, the specific technological application should be determined. Continuous imaging is not needed for monitoring, but it must be pictured what data is enough to perform monitoring in combination with what AI. The application zones of the patches are important in this decision as well, since the needed data will have to be application- and location-specific.

Even though all 12 lung zones are interesting to monitor, it is expected to be redundant to make a solution that administers all 12 at the same time. Therefore, modular solutions focused on only interesting lung zones are an option. From the literature review, the interesting lung zones must be determined as well.

### **Data interpretation**

A device interpreting medical signals and drawing conclusions is a huge liability risk and therefore not desirable. The patches should be able to detect lung issues and always alert a doctor before acting on its own. Therefore, a fully autonomous patch is currently not in line with expectations.

## Next steps

Next, the above-mentioned literature review will be performed. The goal of this review is to find in what area the device will be valuable. After the literature review, Phase Three: Synthesis and Simulation can start.



# Part 2: Literature review

Added as a separate document due to conflicting layout

# Part 3: Synthesis and Simulation

The Synthesis and Simulation phase can also be called the Design phase, as it will be a description of the full design process, starting from problem statement to detailed concept information.

## Literature Review

---

The Literature Review showed that no clear conclusion can be drawn about the added value of ultrasound patches in terms of shorter ICU stay, a higher survival rate and/or less lung damage. However, the review also pointed out a potential for improving several issues caused by mechanical ventilation that may be resolved by monitoring. Therefore, the focus of this project is to focus on creating a simple design that can contribute to the development of patches and research their potential.

## Problem statement

---

Following Part One: Analysis and the Literature Review, an adapted problem statement is defined.

**Problem:** Elongated mechanical ventilation is associated with ventilator-induced lung injury (VILI), diaphragmatic muscle atrophy, patient discomfort, increased mortality rates and higher healthcare costs. However, hospitals are lacking in user-friendly, affordable and accurate methods to measure the decline the respiratory condition. Computed tomography (CT) is often used for visualization of the thorax, but it is expensive, time-consuming and uses unsafe ionizing radiation. Healthcare staff from the LUMC has expressed their need for a monitoring device using user-friendly, safe, affordable and accurate technology.

**Opportunity:** Current developments in ultrasound technology are resulting in smaller, cheaper and higher quality ultrasound devices. Micro-electro-mechanical (MEMS) ultrasound also allows for wearable solutions, such as patches attached to the skin. Besides, ultrasound does not use ionizing radiation and is therefore safer to use than CT.

**Vision:** Since ultrasound patches are already in development for other applications, such as hemodynamic and bladder monitoring, the possibility of using it for respiratory monitoring for mechanically ventilated patients can be investigated.

**Objectives:** The purpose of this research is to explore how ultrasound patches can be used for continuous respiratory monitoring of mechanically ventilated patients in the ICU.

## Updated scope

---

Following the Delft Design Guide, the scope is defined once more. Now more information is obtained about the problem, a more detailed version of the scope is determined.

## Locations

Based on the literature review, the scope for the applications for monitoring patches was determined. An overview of those applications and the corresponding patch locations is shown in Table 1 and Fig. 3.1.

Application	Number of Patches	Position	Image
<b>Lung sliding</b>	2-8	Two upper anterior zones	Lack of movement
<b>Pleural effusion</b>	1-2	Lateral zones (for lying down)	B-lines
<b>Pneumonia</b>	1-8	In risk zones or all zones	Consolidations
<b>Atelectasis</b>	1-4	Risk zones, anterior zones	Primary signs: lung sliding changes into lung pules. Delayed signs: consolidations, heart suddenly visible on anterior wall
<b>Asynchronies</b>	1	Zone of apposition, right	Nonsynchronous contractility with ventilator
<b>Weaning prediction</b>	1	Zone of apposition, right	Diaphragm thickness, muscle contractility
<b>Diaphragm dysfunction</b>	1	Zone of apposition, right	Diaphragm thickness, muscle contractility

Table 1: application zones for different use cases, from literature review

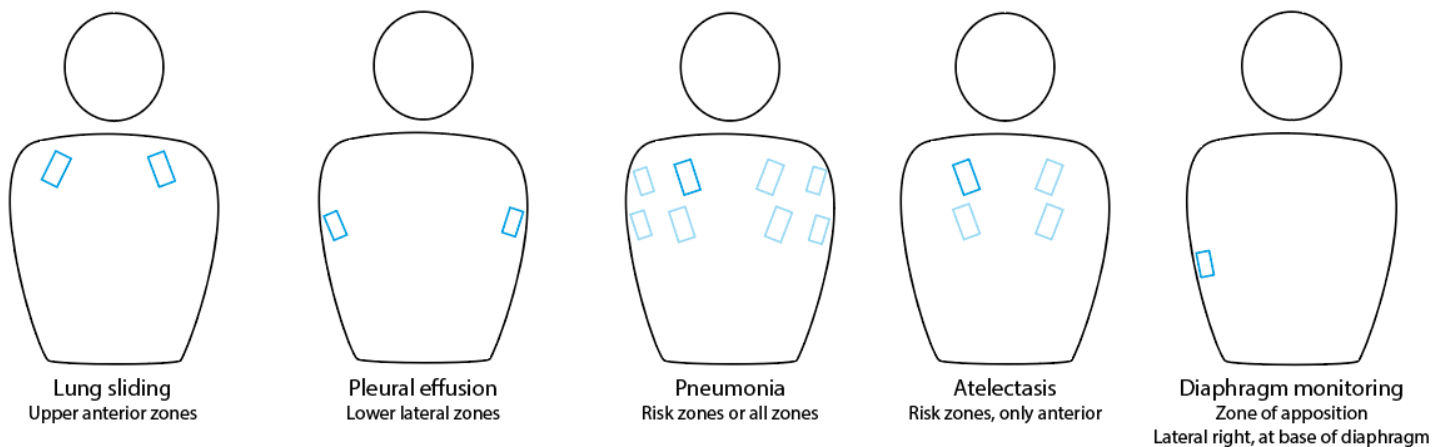

Figure 3.1: visualization of patch locations. The darker colored ‘patches’ represent the locations for the number of patches needed. The lighter colored ‘patches’ represent the possible locations when more are needed.

## Scope analysis

A word cloud was created as a brainstorming technique to represent all aspects of the patch design. Of this word cloud, a division is made of which aspects will be included and which not. The word cloud is shown in Fig. 3.2.

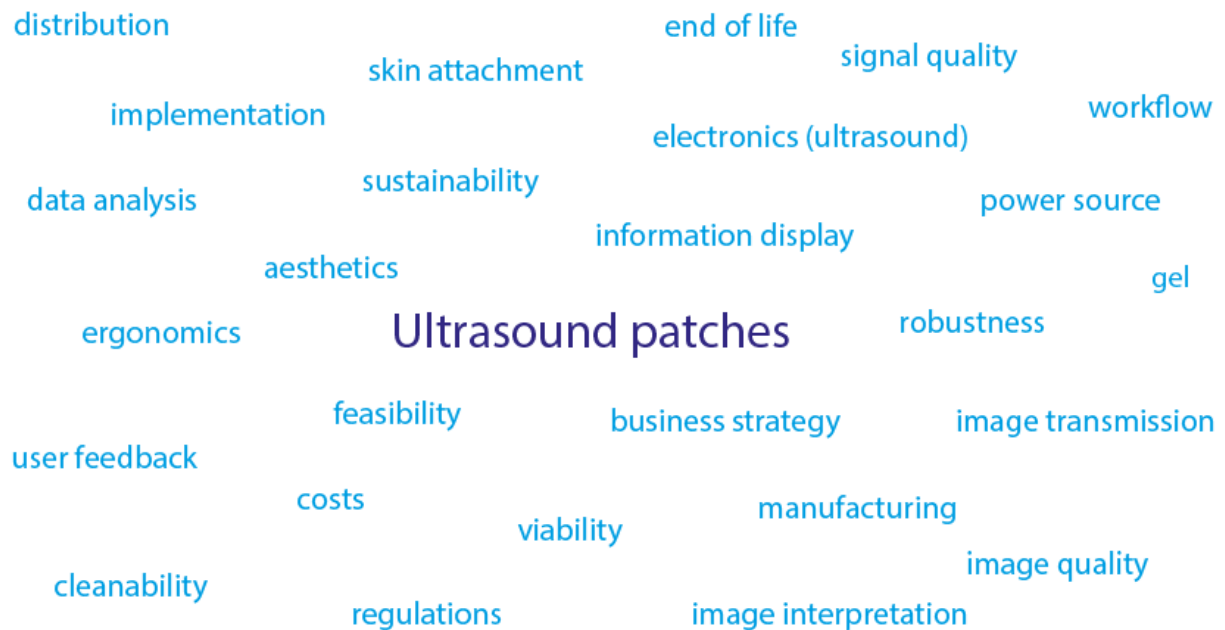

Figure 3.2: Word cloud association ultrasound patches

Client research of the Philips team working on hemodynamic monitoring patches showed that data quality is most important to users, followed by usability. This project will be focused on usability mainly, because of the following reasons:

1. Personal experience with product and usability design, opposed to little experience with electronics and data management;
2. A tangible prototype can create momentum, which is needed for the continuation of the project;
3. It can be said with certainty that this approach a prototype can be finished within the time frame.

The aspects that are considered in the scope, are listed below in Fig. 3.3.

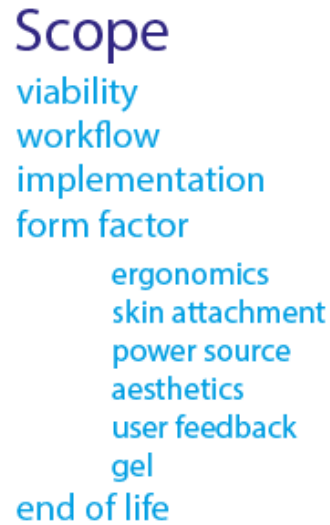

Figure 3.3: Scope list

The scope elements are explained below.

## Viability

It was chosen to work with the minimal viable design (MVP) approach. A minimal viable product means that the simplest design options are chosen in order to quickly get to a functional concept. To release an MVP early, a project is more likely to get enthusiasm. Once a first version is created, a more complicated product can be developed if there is demand.

## Workflow

Both client and user research pointed out that usability is an important aspect. Because hospital staff are always busy, a new product must fit the operations that are already being performed. In addition, good workflow integration also ensures earlier product acceptance.

## Form factor

The form factor considers the whole system, including aesthetics, ergonomics considering both user and patient, wires, user feedback and use of (an alternative to) ultrasound gel.

## End of Life

The end of the product's lifecycle will also be considered. Reuse, Reduce and Recycle are the goals for this part of the problem.

## Function analysis

---

The primary function of the patches is to monitor the respiratory system. In addition, the patches will also have secondary functions, which are described here. Inspired by the Delft Design Guide, a storyboard is made to discover the subfunctions of the system.

## Storyboard list

A storyboard is created to create an image of the use and find possible opportunities for improvement. Here, list of the sequential tasks from user perspective is presented.

1. A patient is in the ICU on mechanical ventilation;
2. Nurse or doctor notices an issue;
3. Ultrasound exam is performed using Lumify or other ultrasound machine;
4. Nurse or doctor decides on placing a patch;
5. Patch is retrieved from storage;
6. Location for placing patch is determined;
7. Patch is placed on patient;
8. Patch is connected to any other patches and monitoring system;
9. Patch signals;
10. Nurse checks for issue;
11. If needed, nurse summons doctor;
12. Doctor decides whether to change the treatment plan or not;
13. Potentially: change treatment plan;
14. Every 72 hours: change patch;
15. Disposable parts (if any) are disposed;
16. Reusable parts are disinfected using alcohol wipes;
17. Reusable parts are put away in designated area.

## Functions

From this story board list, subfunctions are determined. These are presented in the list shown in Fig. 3.4.

### What should the patch do?

blue = within scope

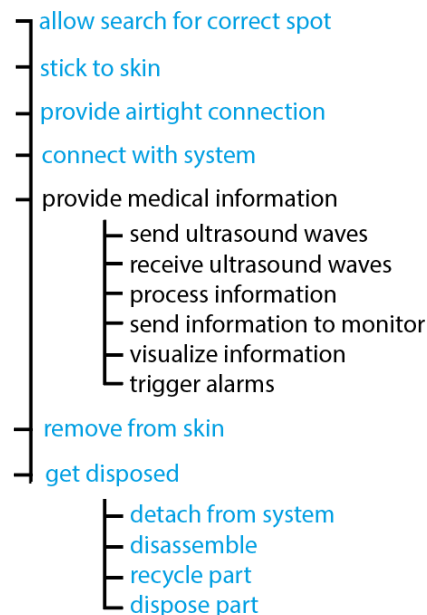

# Ideation

---

## How to's

'How to's' are problem statements written in the form of "How to .....". It is a method for ideation described in the Delft Design Guide and is used to create a wide variety of problem descriptions from different perspectives.

The following How to's were used for ideation:

1. How to search for the correct spot?
2. How to stick a patch to the skin?
3. How to provide an airtight connection?
  - a. How to replace the ultrasound gel?
  - b. How to keep a device close to the skin?
4. How to connect multiple devices together?
5. How to remove a patch from the skin?

Of these brainstorm questions, three were decided to be most interesting to design for. These aspects are believed to be essential to patches.

1. How to search for the correct spot? → Due to fact that bone blocks ultrasound, accurate placement of patches on the chest is essential.
2. How to stick and stay closely stuck to the skin? → Since ultrasound image quality is highly dependent on airless wave transduction, it is important the patch stays in close contact to the skin. for some applications, such as heart monitoring and patients with more body fat, it is important that the patch stays pressed to the body.
3. How to connect to the system? → LUMC staff expressed their wishes for a wireless solution. However, it is believed this is not possible for a minimal viable product. Therefore, options with wires are also discussed.

The results of this brainstorm round are pictured in the following morphological chart.

## Morphological chart

A morphological chart is a method to generate ideas in a systematic and analytical manner, usually starting with product subfunctions. By combining ideas from different rows and columns, a concept can be created. For this morphological chart, the 'search', 'stick' and 'connect' functions are used. The chart is shown in Fig. 3.5. On the next page, the drawings are explained.













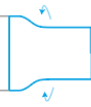

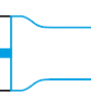
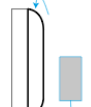
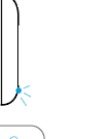

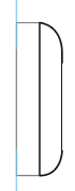
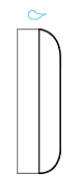
Search	 <p>Use Lumify for search</p>	 <p>Use Lumify and mark spot</p>	 <p>Use Lumify, patch blocks one beam to find location</p>	 <p>Direct image from patch</p>	 <p>Patch navigates through lights</p>			
Stick	 <p>Plaster over patch</p>	 <p>Plaster under patch</p>	 <p>Glue</p>	 <p>Vacuum</p>	 <p>Spring</p>	 <p>Elastic band</p>		
Connect	 <p>Connected with wires in series</p>	 <p>Adjustable cables</p>	 <p>Connected through one point</p>	 <p>Connected through vest</p>	 <p>Another type of adjustable vest</p>	 <p>Wireless connection</p>	 <p>Connect through elastic band</p>	 <p>Modular system with different connection types</p>

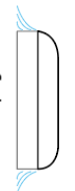
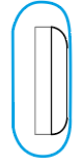
Figure 3.5: Morphological chart

## Search

Ideas for searching the correct spot are:

1. Using the Lumify for place detection in combination with a bottom part that will stay on the body;
2. Using the Lumify for place detection in combination with some sort of marker;
3. Using the Lumify for place detection. The Lumify will be positioned on a patch that transmits most of the Lumify's ultrasound signal. One spot where the signal is blocked, will be the exact place the patch will be monitoring itself. Once the blind spot is at the place where monitoring should happen, the Lumify is taken off again. Idea originating from supervisor Jaap.
4. Using the patch itself for place detection, connected to a monitor;
5. Using the patch itself for place detection, in combination with software that recognize certain tissues and thus the desired spot. Little lights indicate the desired direction. Idea originating from supervisor Ronald.

## Stick

Ideas for sticking the patch to the body are:

1. Using a sticker that goes around the perimeter of the patch;
2. Using a sticker only on the parts that sticks to the body;
3. Using biomedical glue;
4. Using a vacuum system that extracts the air underneath the patch to make a solid connection;
5. Incorporating a spring system in the patch model that pulls the surrounding skin upwards. This idea is originating from the Philips Hemodynamic patch team;
6. Adding an elastic band to press the patch firmly to the body.

## Connect

Ideas for patch connection are:

1. Connect the patches using wires in series;
2. Connect the patches using adjustable cables, possibly using a spring system, a belt adjustment or something else;
3. Connect the patches using wires, but connect them in one point;
4. Connect the patches in a vest containing wire connections. The vest will be elastic and one-size-fits-all;
5. Connect the patches in a vest containing wire connections. This vest will be adjustable using buckles and is adjustable for most patients;
6. Wireless connection, possibly sharing data over Bluetooth;
7. Connect the wires in an elastic band, possibly the same that is used for pressing the patches towards the body;
8. Connecting through a 'plug and play'-system, using cables of different lengths and colors for different application. Some applications require one cable for data transmission, whereas other applications also require inter-patch connection.

Several combinations of these ideas can be combined to create potential concepts.

# Idea and concept generation

Reviewing the morphological chart with the team, the idea of using the Lumify to find the correct location for the patch is found to be interesting. In this idea, the Lumify will be connected to an ultrasound gel containing adapter, so-called 'gel pad holder'. When the correct location is determined, the gel pad holder is stuck to the skin and the Lumify is disconnected. After that, the 'ultrasound pod', the reusable part containing electronics, is attached to the gel pad holder. An idea description containing images is shown in Fig. 3.6.

## Idea

Use Lumify probe to find correct spot

Three components:

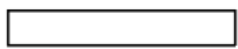

Gel pad holder that connects with both Lumify and pod

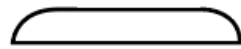

Ultrasound pod



Lumify

## Workflow

Step by step

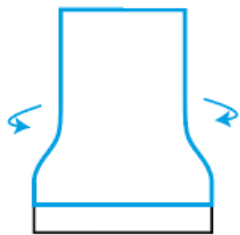

1. Use Lumify to find correct spot



2. Lock gel pad, stick to skin

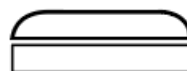

3. Place ultrasound pod on gel pad

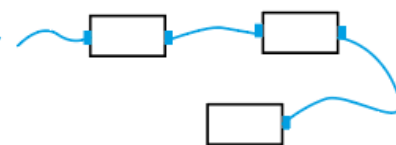

4. Connect to system

## Advantages

1. Reusable electronics
2. Work with existing probe (shorter and easier implementation)
3. Different user interface (gel pad) for different applications

Figure 3.6: idea explanation

This idea has several advantages:

1. It allows for recyclability of the electronic, as the pod is not in direct contact with the patient;
2. It uses an already used device to determine the proper location. This will lower the acceptance barrier, since no new equipment has to be learned by the staff for the application;
3. Because of the modularity of the idea, the system can be adapted for different applications by redesigning only the cheaper plastic parts such as the gel pad holder. For all applications, only one version of the expensive pod is needed;
4. Additionally, it has an advantage for the course of this project: it is a novel idea that fits within the 'minimal viable product' idea that can be finished and tested within 9 months.

## Philips Design

To discuss the idea and get feedback from the Philips Design department, a meeting with Jacco Eerden was scheduled. This session showed that Jacco was very enthusiastic about the integration of usability and workflow aspects. In doing so, he pointed out the advantage of being able to design for different applications, even beyond the respiratory area. The advice was to start creating by using simple household materials and, above all, be critical of your own idea and ask yourself if this product is worth using.

## Search

For the concept generation, this is the main subject. The challenge is to create a steady connection between the gel pad holder to both the Lumify and the pod, and simultaneously provide an easy option to disconnect.

## Stick

Because the gel pad holder will be stuck to the skin while the Lumify is still connected, the sticker cannot be interfering with the Lumify or pod. The decision on the sticking mechanism will be made at a later stage.

## Connect

This solution works for a single patch and is therefore difficult to reconcile with the vest options. Wires are still a potential. Because, according to the team, wireless patches are not a solution in the near future, wired patches are assumed to belong to the minimal viable product for now.

# Concept generation

---

Essential for the search idea, is the click system. During the process, several new subproblems appeared.

## Methods

The following methods are used for concept generation:

- Three-dimensional models: household materials such as clay, rope and cardboard are used for model generation. The clay is used to imitate the shape of the Lumify and the possible

form factors for both the gel pad and pods. This method is used because of the possibility to immediately see and feel the shapes, and how it fits within the system.

- Design drawing: idea generation for connecting and disconnecting the various parts is visualized in simple drawings. At a later stage, more detailed drawings are made. Design drawing is a quick and easy method to get an understanding of a concept. Especially detailed drawings force the creator to rethink their concept.
- 3D modeling: once a decision is made on a concept, it will be recreated using 3D drawing software Solidworks 2021. This software was chosen because of previous experience and the provision by TU Delft.
- 3D printing: this method is chosen for prototyping because it allows for precise fits and quick iteration.

Shapes and concepts can be tested and immediately adapted. During the process, both Philips printers and a private printer were used. The printers at Philips are Ultimaker 2+ Connect, printing with 2.85mm PLA filament. The private printer is the Easythreed Nano, printing with 1.75mm PLA filament. The Easythreed Nano is of far lower quality, but was very valuable for quick idea testing at home. The used 3D printing software is Cura and Nano3D, the latter one being the private Easythreed software.

## Lumify

In the research performed by Jeffrey Visser, a Lumify S4-1 Phased Array transducer was used for detecting lung sliding. However, since it was noted the Lumify L12-4 Linear Array transducer is preferred in the LUMC, the first prototype will be based on the linear L12-4 transducer. However, the device will not be based solely on this transducer, as that would limit its range of use. For the future product, it is desired to integrate an attachment for S4-1 transducer to fit the gel pad holder and pod.

Both transducers are shown in Fig. 3.7.



Figure 3.7a (left) and 3.7b (right). On the left, the S4-1 transducer, on the right, the L12-4 transducer that will be used as a model for the prototype. Both are used often in the LUMC [43]

## Three-dimensional models

The concept generation started with building mockup models from clay, rope and cardboard. Some pictures of the process are featured below in Figs. 3.8-3.13.



Figure 3.8: measuring Lumify for clay model

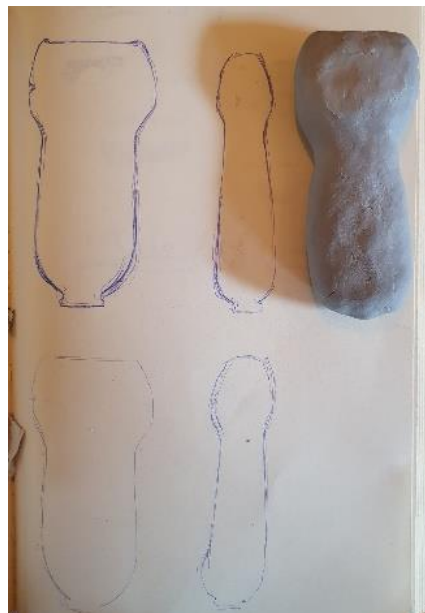

Figure 3.9: clay Lumify model based on outlines. No Lumify casing was available yet to take home.

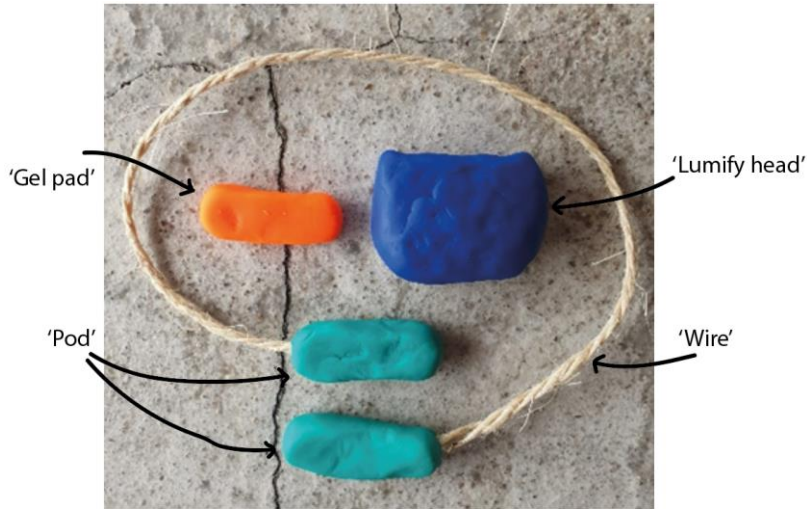

Figure 3.10: example of system set, made out of play doh. Blue: Lumify head. Orange: gel pad. Green: pods, including rope as a wire.



Figure 3.11: ideation drawings of how to connect the Lumify to the gel pad, and how to disconnect again. To allow for attachment and detachment, some kind of elastic force should be used. These drawing ideas were translated to cardboard mockups.



Figure 3.12a t/m d: recreating ideas from cardboard, clay and hairbands. The models showed there is no place for wires in this design. Therefore, a hole was made. However, these tests pointed out that a design containing elastic bands is not providing a secure fit.

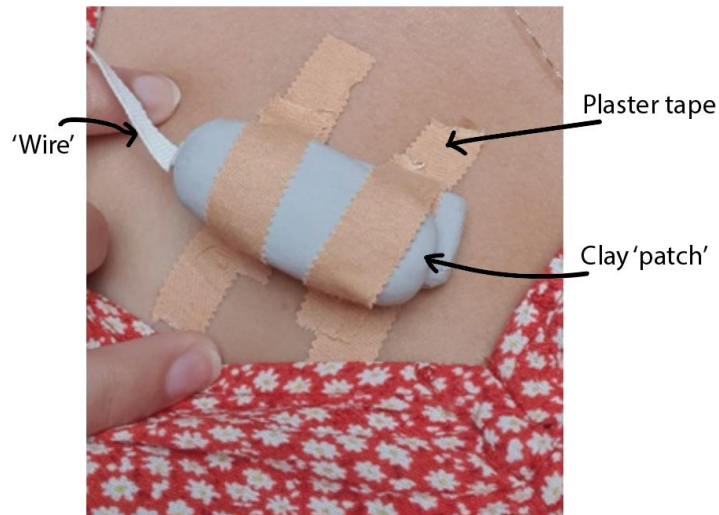

Figure 3.13: testing the comfort of wearing the mockups. The size, fit and weight seemed okay, however, this was a severe simplification.

## Lumify adapter

During these tests it became clear that the Lumify had a difficult shape to attach anything to, as there were few possible grip points on the device itself. However, to ensure proper ultrasound transmission, a solid connection between the Lumify/pod and gel pad holder is needed. Since the Lumify has a fixed shape, an adapter that either slides or snaps in the gel pad holder must be designed to enable the connection.



## Connections

Research for simple, 3D printable reversible connections, resulted in many ideas. Because sliding joints often cause a lot of resistance, it was chosen to work with reversible snap fits. The results of internet searches are shown in Appendix B. After evaluation, the following two snap fit ideas using hooks are the two connection concepts chosen for further development, see Figs. 3.14 and 3.15. [44-46]

Concept A: Downwards hook

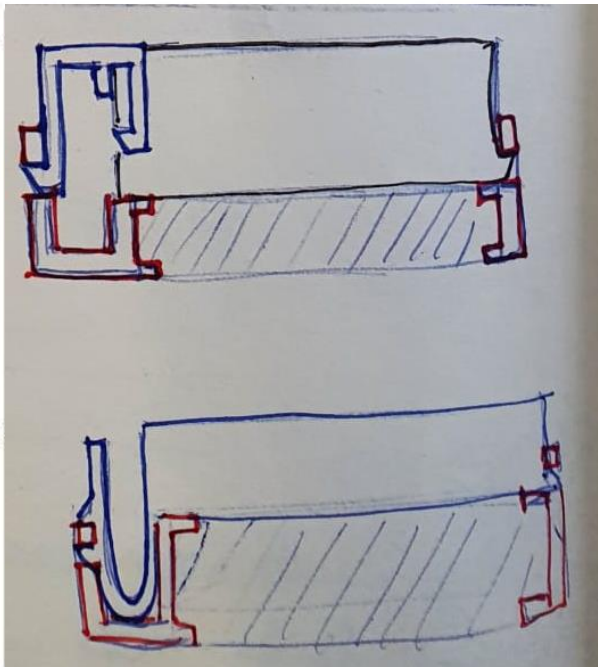

Blue/upper part: Adapter  
Red/bottom part: Gel pad holder  
Shaded: Ultrasound gel

Concept B: Upwards hook

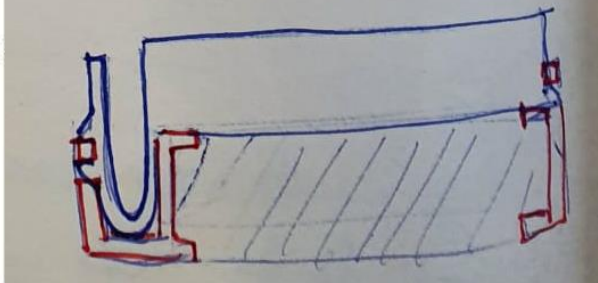
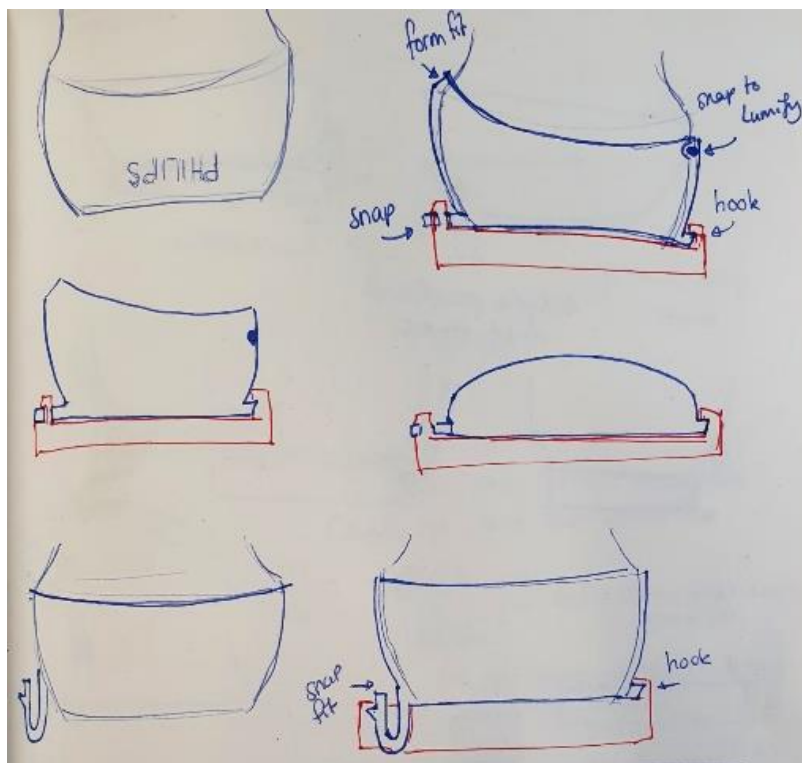

Figure 3.14, snap fit hook concepts. In red: gel pad holder. In blue: Lumify adapter. Shaded: the ultrasound gel. On the right is a hook that will fit in a destined place and is the turning point for the system. On the left, the



hook will snap into the bottom part.

Figure 3.15: Ideation in context of the Lumify

# Prototyping

## Adapter

After the Solidworks model of the Lumify L12-4 was made available by Philips Ultrasound, a perfectly fitting adapter was designed. The offset of the adapter to the Lumify was 0.5 mm and the wall thickness was 1.5 mm. The maximum dimensions were 60x32x26 mm. This combination allowed for a light and firm piece, with a snug fit. As is shown in Fig. 3.16, the Lumify contained a notch on the side. This notch was used to shape the adapter around. On the other side of the adapter, an overhang was made. The first iterations were based on snap fit mechanisms shown in Fig. 3.15. The hook is designed and printed separately so that the adapter did not have to be reprinted each time a change to the hook was needed. The hook was connected to the adapter

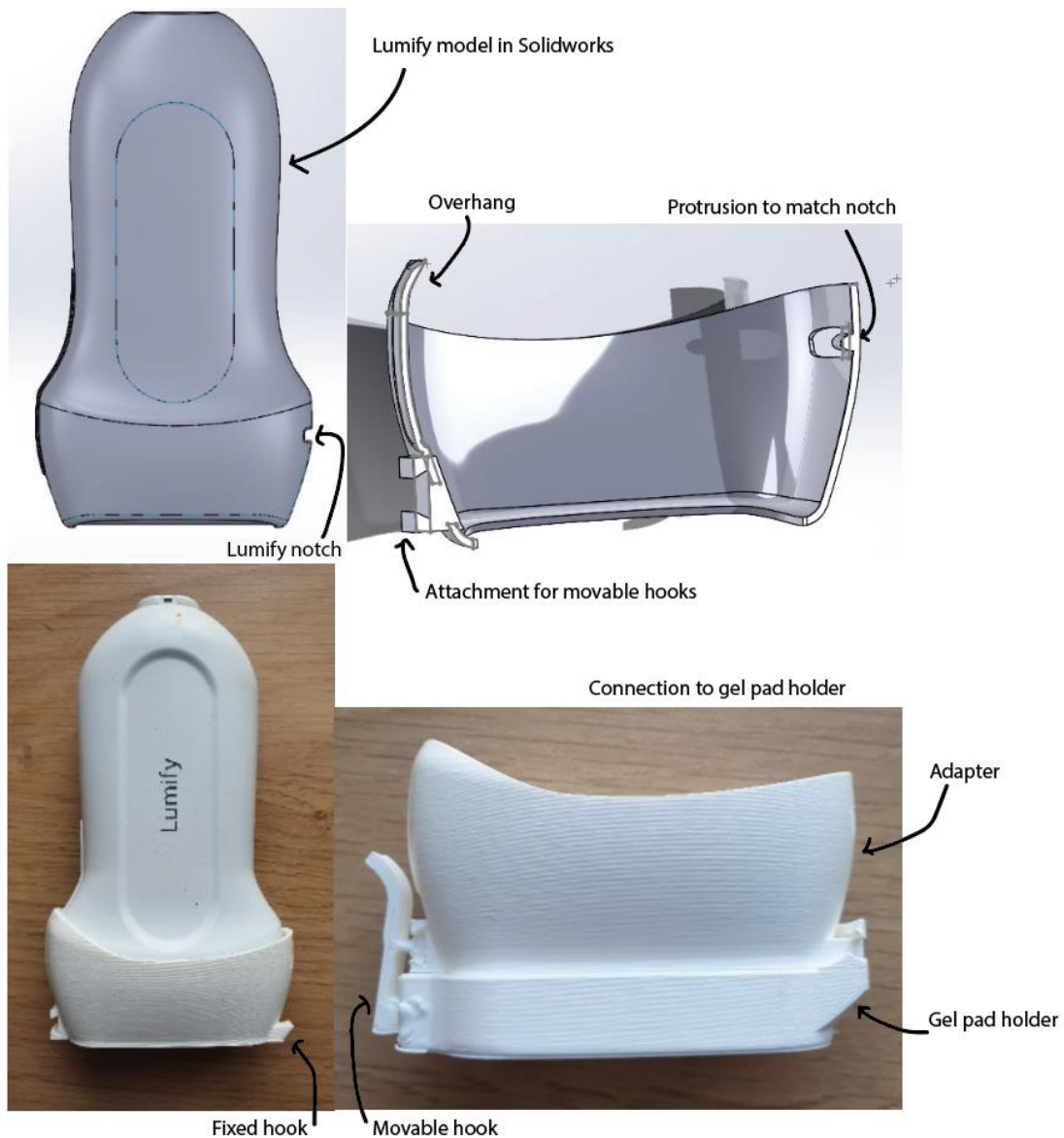

using a dovetail connection. Figs. 3.17-3.19 show the hook models.

Figures 3.16-3.19: Solidworks design with hook; 3D print with the Lumify; hook iteration

While testing the click system, a crack appeared in the adapter due to large stresses. To solve this issue, a split was designed in the adapter. This addition led to more elasticity in the piece and brought the extra benefit of showing the marker line of the Lumify, seen in Fig. 3.20.

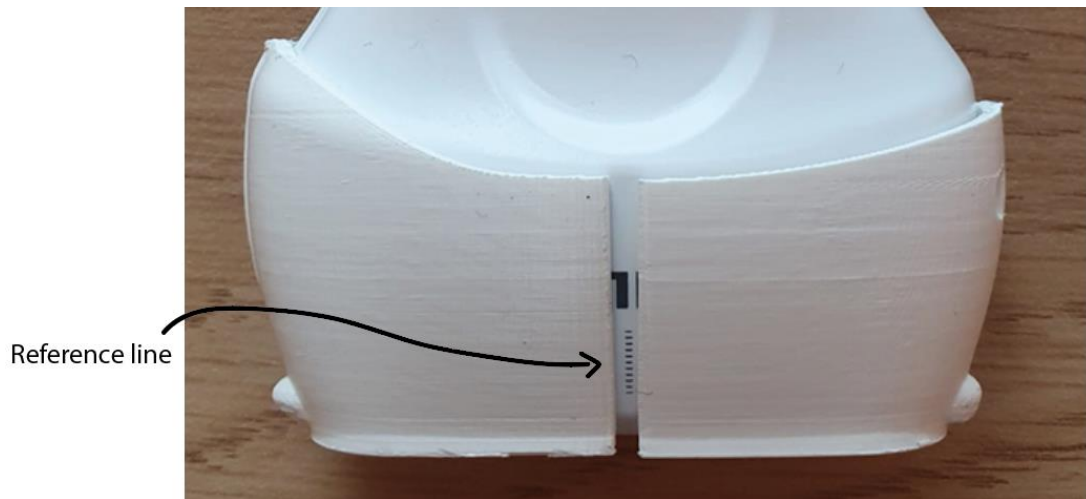
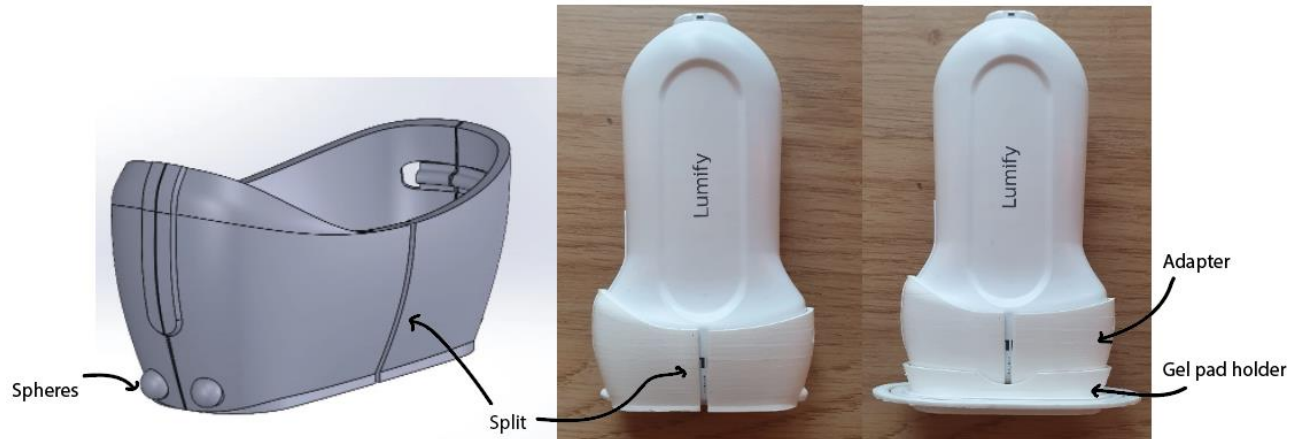

Figure 3.20: The split did not only release stresses, it also now shows the Lumify's reference line

Although the adapter fitted the Lumify, the connection between the adapter and gel pad holder was wobbly. The movable hook that was supposed to stick in the gel pad holder did not provide enough stability and the rigid hooks on the other side did not move smoothly in the notches. The several designs printed for the hooks all did not suffice, since they did not provide the necessary rotational movement. Also changing the amount of connection points between the two parts from two to three did still not result in a firm system. At this time, a novel click system was devised, based on small spheres on the adapter that would fit into holes in the gel pad holder. The idea behind this invention is that spheres have no sharp corners in all directions, and therefore click both easily in and out of a notch. This solution worked very well, providing easy and reproducible connection and disconnection using a single hand. After a few iterations, the spheres ended up being sized 3mm in diameter.

A disadvantage of this design was the dependency on the Lumify shape. To accommodate for different-shaped transducers, the adapter should be redesigned for each different transducer head. Images of the design are shown in Figs. 3.21-3.23.



Figures 3.21-3.23: Final design of the casing in Solidworks; the final 3D print attached to the Lumify.

## Gel pad holder

With the changes to the adapter, the gel pad holder has obviously changed as well. At first, it consisted of notches for both the hooks. The final version contained notches for the spheres, a flat surrounding ring to accommodate for sticking the device to the skin, protrusions to fix the ultrasound gel and notches for gripping the pod. The holder is shaped around the adapter. The maximum dimensions were 87x46x12 mm and the wall thickness was 1.5 mm. Images of the first and final version are shown in Figs. 3.24 and 3.25. An image of all the 3D printed component

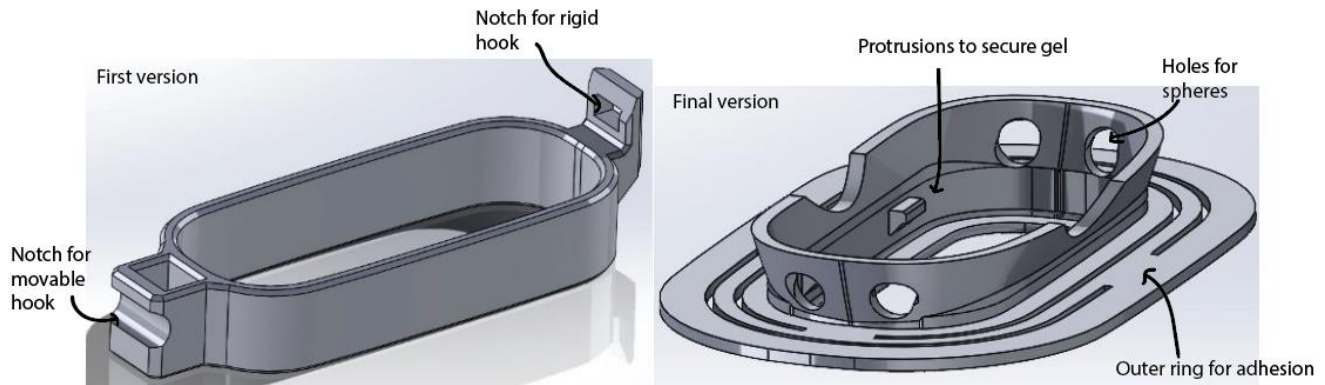

iterations is included in Fig. 3.26.

Figures 3.24 and 3.25: first and final gel pad holder design

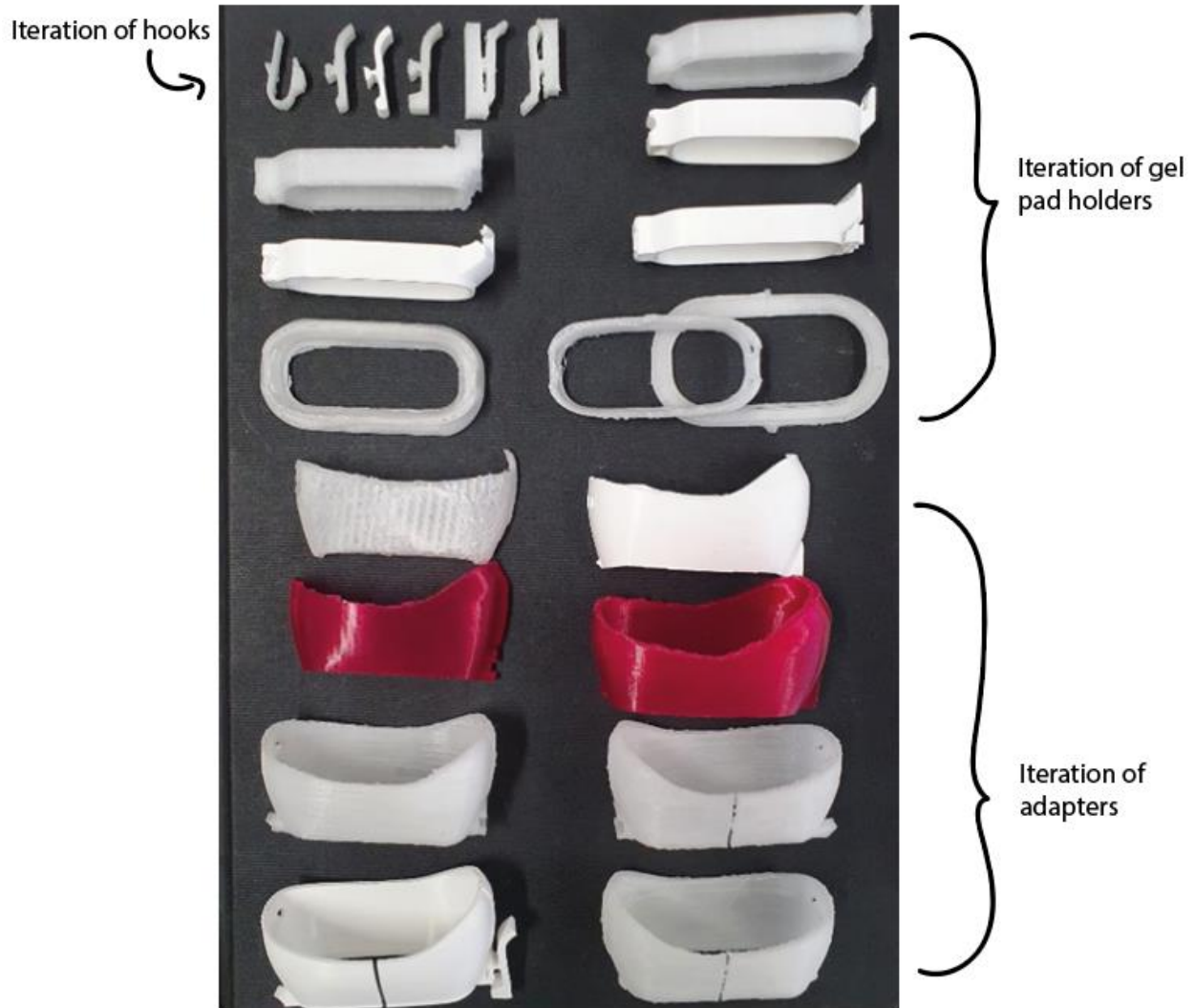

Figure 3.26: 3D printing allows for iterative design, prints made between August 15<sup>th</sup> and September 8<sup>th</sup>

## Gel

A solid ultrasound pad was chosen for two reasons: solid gel is easier to contain in the gel pad holder, and it does not vaporize within 72 hours. Because of availability in the Philips office, the Aquaflex Ultrasound Gel Pad was chosen. This is a bacteriostatic and disposable solid gel sold by Parker Laboratories BV, an ISO13485:2016 certified company. A gel pad holder containing the gel is shown in Fig. 3.27.

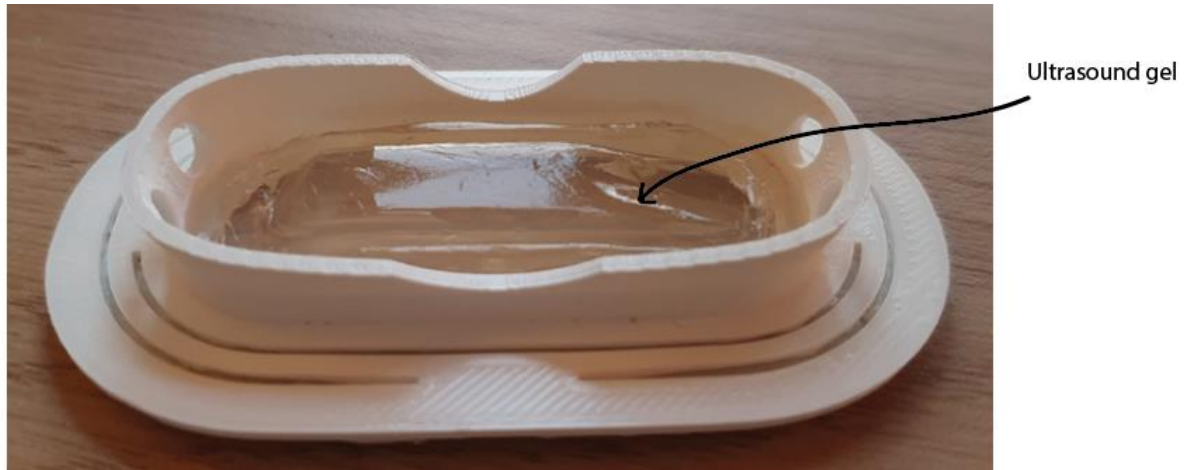

Figure 3.27: Gel pad holder containing gel

## Plaster

Underneath the ring of the gel pad holder, a plaster is attached. For the plaster design, the following requirements were considered:

1. The plaster must be limited to the size of the gel pad holder;
2. The plaster must stick for 72 hours to the skin of an ICU patient and the gel pad holder;
  - a. For testing: the gel pad holder including plaster must stick for 24 hours to a subject's skin;
3. The plaster must only stick to the skin at the moment the desired location is found;
4. The sticking must be done using minimal actions, time and force, and without lifting the gel pad holder from the skin.

To make sure the plaster does not stick too early, either a protective sheet must be added, or the plaster should not make skin contact until it is pushed downwards. Those two ideas are pictured in Fig. 3.33. The Figure also contains option C, which is the current solution used for the hemodynamic Philips patches.

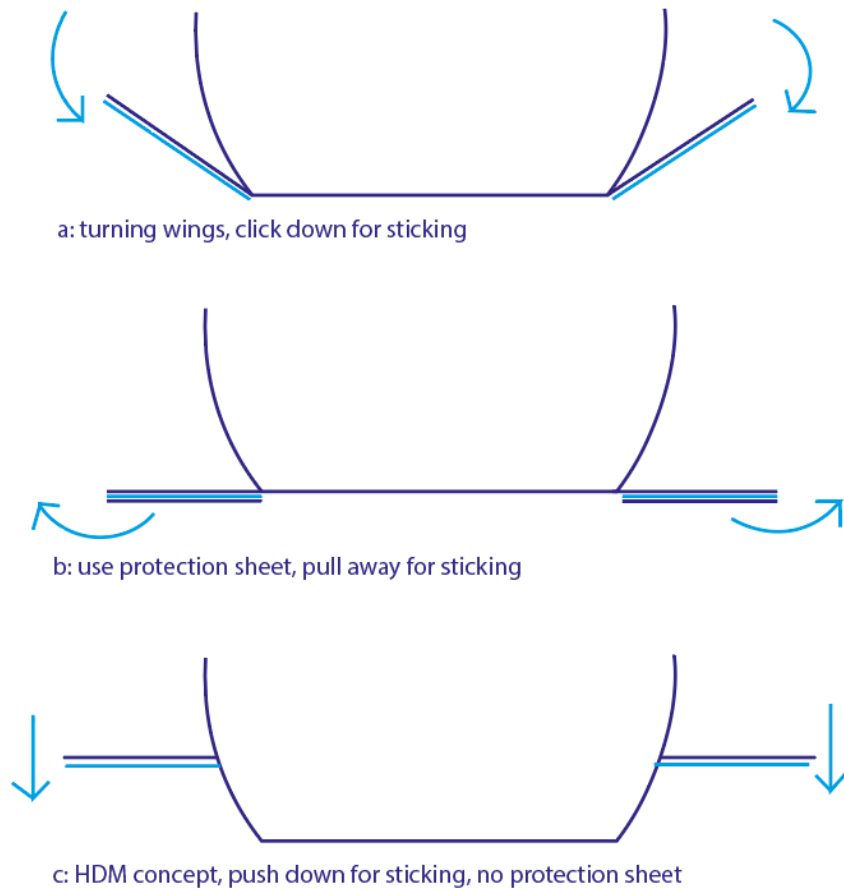

Figure 3.33: Adhesive idea

The first one, idea A, is based on a moving ring that turns around the bottom part of the gel pad holder. Once the correct place is determined, the ring can be pushed down, and the device will stick to the skin.

Idea B is based on a flat ring containing a plaster on the bottom side, and a liner to prevent early sticking.

Concept C, the HDM solution, is based on a ring at approximately 1cm above the patient's skin. It is placed by pushing the outer ring down, which works as a spring. This flexible feature is made possible by cut-outs in the ring. This is pictured in Fig. 3.34.



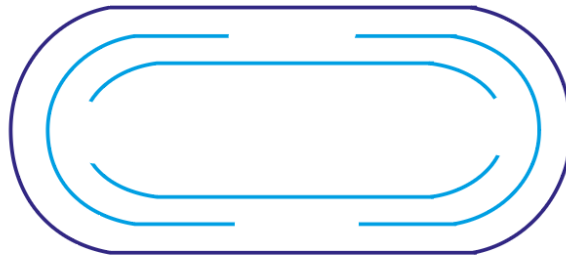

cutouts in gel pad holder ring allow for spring mechanism

Figure 3.34, spring cutouts

A combination of idea B and the HDM concept are chosen for the patch concept developed in this thesis. This decision was made based on the fact that a protection sheet not only prevents early sticking, but also protects the plaster from attracting dirt.

Idea C, which contains the 1 cm high ring, is not believed to be enough to prevent early sticking. In practice, often body fat and hair will prevent the patch from moving freely. Therefore, it is believed a protection sheet is essential for successful sticking. The height of the ring can be reduced from 1 cm to 3 mm, because less height is needed now the protection sheet is added. This height was considered enough to release stresses on the spring system, while still remaining the spring force.

## Protection sheet

Pulling the protection sheet was a bigger problem than expected. Pulling a protection sheet from a plaster regularly happens in perpendicular direction. Because the plaster is positioned parallel and close to the skin, perpendicular pulling is not an option. Therefore, a solution for pulling the liner of in parallel positioned must be designed. An important aspect of this was that the protection sheet must not block the window of the transducer, and thus must be pulled in two parts. In Fig. 3.35, the idea iterations are pictured. The left views are side views of the gel pad holder in longitudinal direction, the right views are top views of the liner.

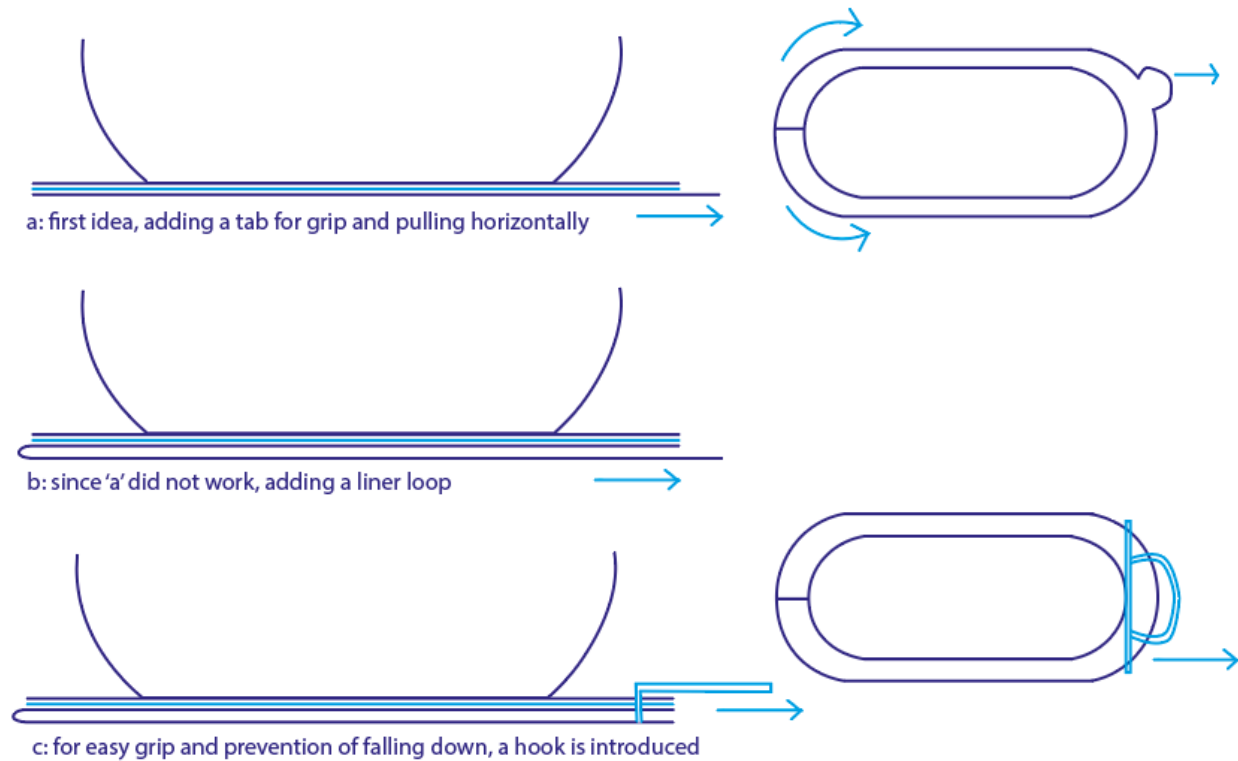

Figure 3.35: liner design ideation

Initially, a tab was added. Unfortunately, the sheet was not removed because still a more perpendicular pulling force was needed. Therefore, a loop was added to make sure the pulling force was coming from the back and in perpendicular direction. To increase the user's grip, a hook was designed. An additional benefit of this solution was that the hook kept the protection sheet close to the gel pad holder. The hook design is based on the opening mechanism of soda cans.

The first prototypes were made using Tesa Universal Carpet Tape, since this tape was double-sided, thin and available at the local do-it-yourself store. However, this tape was not suitable for medical purpose. Maarten Bakker and Shin Kawasaki from TNO provided two types of medical approved plasters for prototyping: an acrylic DuploMED 22507 and a silicone Avery Dennison MED 6503SI. Since only a few samples were available, the first tests were performed using the carpet tape.

An issue encountered during prototyping was the fact that protection sheets are naturally resistant to adhesion, and therefore it is hard to attach anything to it. Many iterations involving paperclips, needle and thread, press studs, and gallery hooks were tested. The main issue was the thickness of all these materials, which was in the way of the pivot movement of the sheet, and the tendency of the liner to rip. Pictures of the tests are shown in Figs. 3.36-3.43.

Protection sheet ripping was a common issue



Paperclips were used to pull, this also ripped the sheet



Painting hooks were too large and could not make the turn.



Press studs were too large in diameter and interfere with skin when the sheet is pulled



Avery Dennison tape in combination with plaster tape. This tape would not stay on the skin.



DuploMED tape in combination with plaster tape and superglue. This protection sheet was too rigid and therefore could not make the turn.

Figures 3.36-3.41 different materials and methods used to test the protection sheet pulling system



Figure 3.42: First, it was tried to pull the sheet using tabs. However, this only worked for perpendicular tensile forces, which were impossible to perform in practice

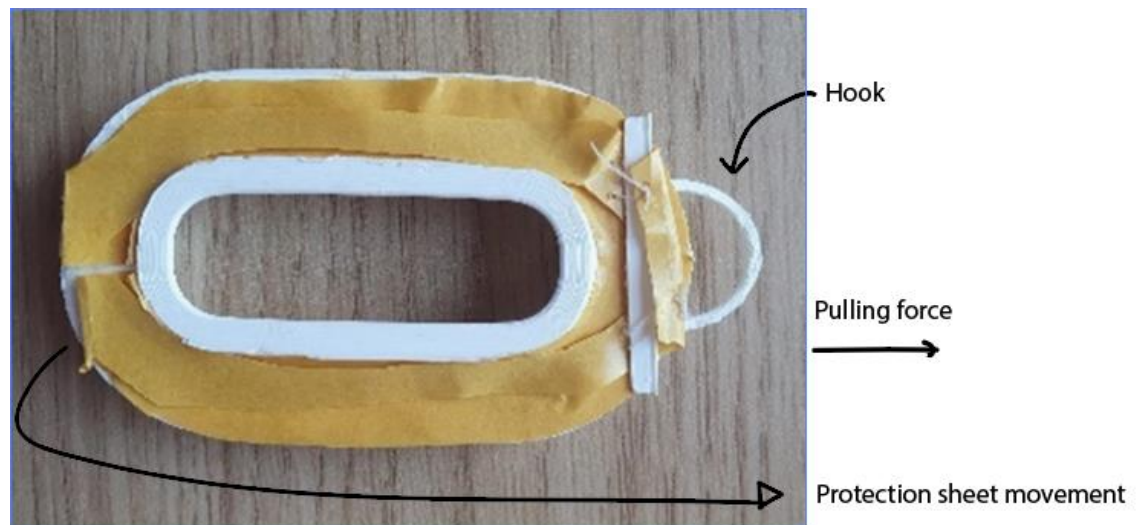

Figure 3.43: A hook was added in combination with a double, looped, protection sheet. The hook is connected to the protection sheet using needle and thread.

The strongest connection was realized by looping the sheet and not attaching another material to it. The downside of this solution is that quite some plaster material is wasted, since for half of the protection sheet the plaster must be cut away. Two final-design gel pad holders, including either one of the TNO prototyping adhesives, were placed on a test person's chest on Tuesday 11<sup>th</sup> October at 16:30 and left there until the next morning. The silicone Avery Dennison adhesive released from the skin after an hour. It still stuck to the device. The acrylic DuploMED stucked firmly to the skin the next morning but released from the device itself.

Even though the DuploMED performed best out of the two, its protection sheet was too rigid to pull. Therefore, another plaster was needed. Within Philips, the Avery Dennison MED 6371U adhesive was available. This adhesive was not silicone based and therefore, stronger than the previously tested Avery Dennison.

To attach the hook to the protection sheet, a combination of sanding paper and super glue was used. When the surfaced is sanded, it allows for glue attachment. Figs. 3.44-3.47 show images of

the plaster and protection sheet. Cutouts in the protection sheet are made to allow the double-struck layer to attach to the plaster, and prevent it from dragging over the patient's skin.

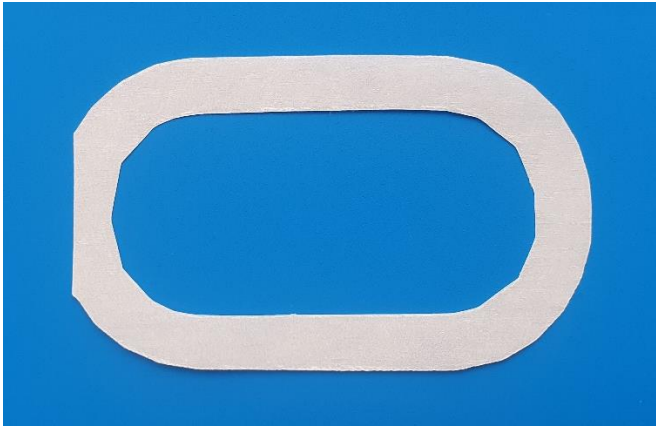

Figure 3.44: Plaster

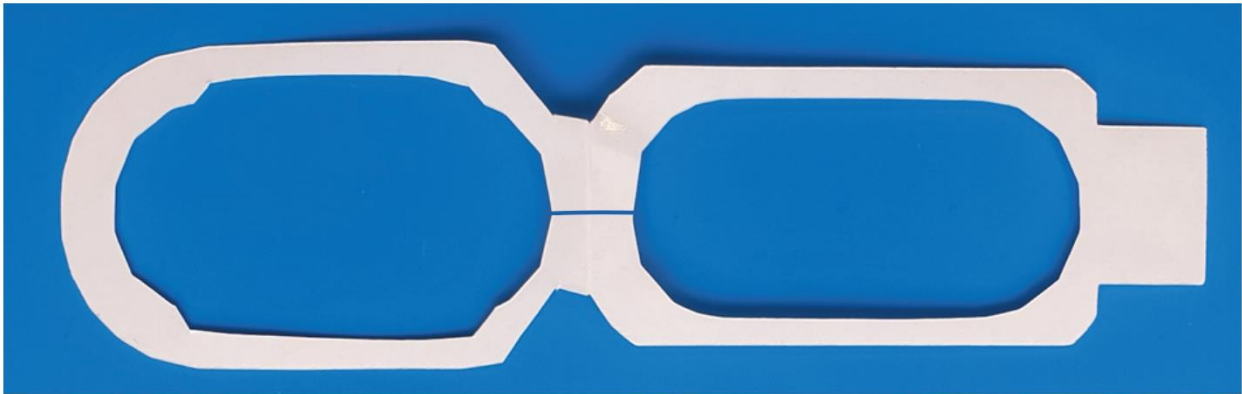

Figure 3.45: Protection sheet

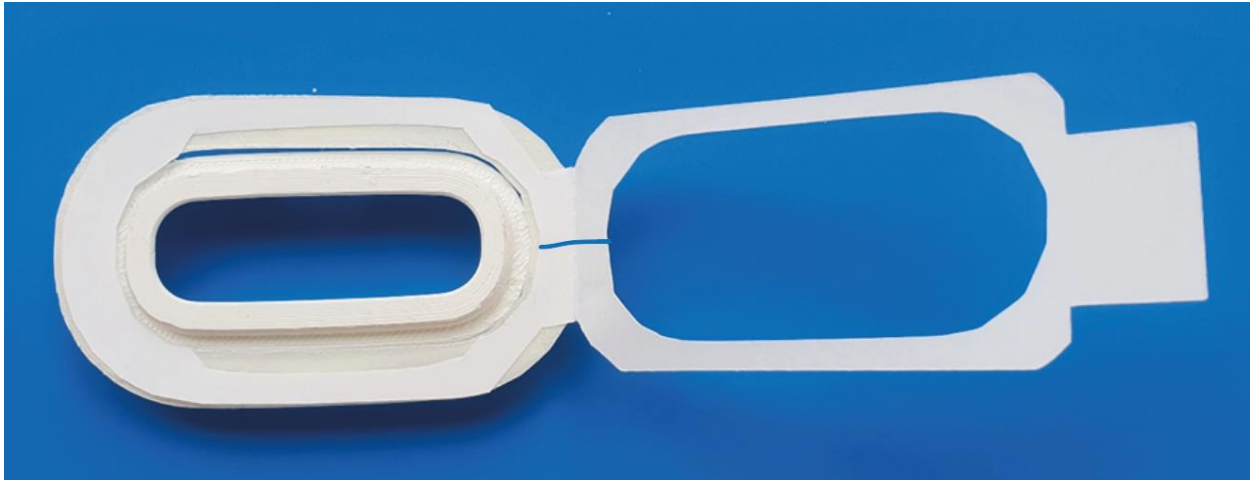

Figure 3.46: Plaster plus protection sheet on gel pad holder. The cutouts in the left part of the protection sheet leave part of the plaster open, which will keep the double-struck part of the sheet close to the holder.



Figure 3.47: Plaster and protection sheet on gel pad holder. The double-struck part of the protection sheet attached to the plaster because of the cutouts in the other half of the protection sheet.

Figs. 3.48-3.52 show the protection sheet pulling mechanism.



Figure 3.48 (left) and Figure 3.49 (right): Plaster plus protection sheet and hook on gel pad holder

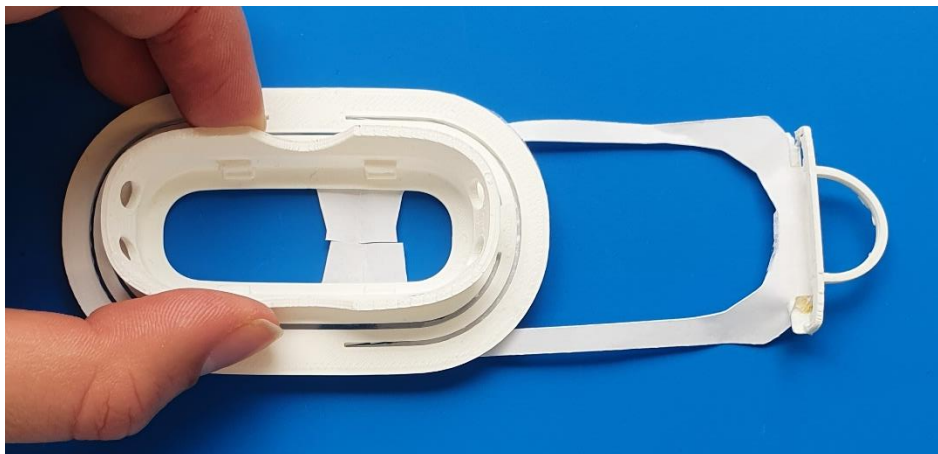

Figure 3.50: Pulling the protection sheet

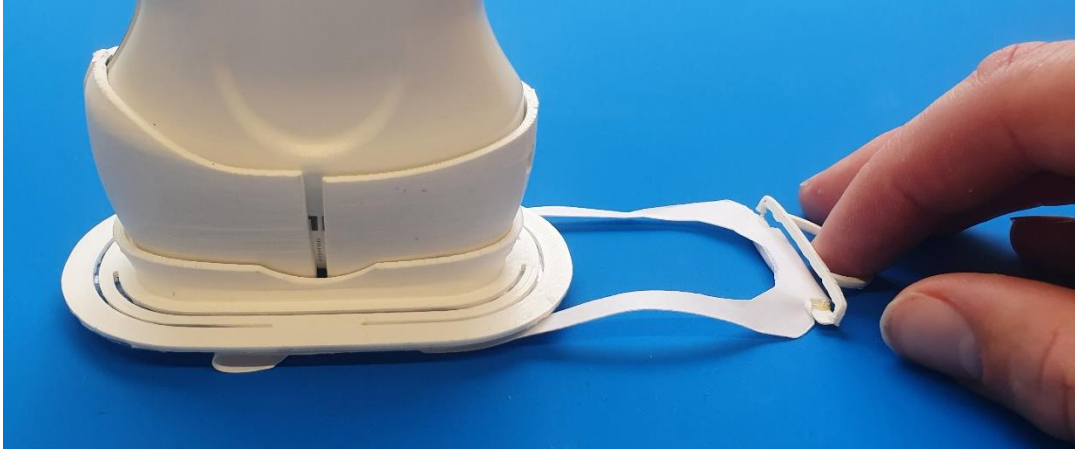

Figure 3.51: Pulling sheet from underneath Lumify



Figure 3.52: Pulling sheet

## Pod

The electronic components of the patch were not available yet at the time of writing. However, after a meeting with André Immink, System Architect at Philips, the required components could be determined. Even though a patch capable of imaging would require wires for a minimal viable product, for a patch capable of monitoring a wireless patch suffices. For monitoring, an ultrasound signal every so many seconds is enough, in combination with AI, to assess the condition of the lungs and/or diaphragm. This is opposed to imaging, which requires around 25 fully interpretable images per second. According to previous research by André, a patch that takes an ultrasound image every other second can be powered using a 20mm button cell battery. Especially the patches that can not image, are valuable for the place finding system. Therefore, it can be assumed a wireless patch is technically feasible. The pod is based on

A schematic image of the required components is pictured in Fig. 3.53.

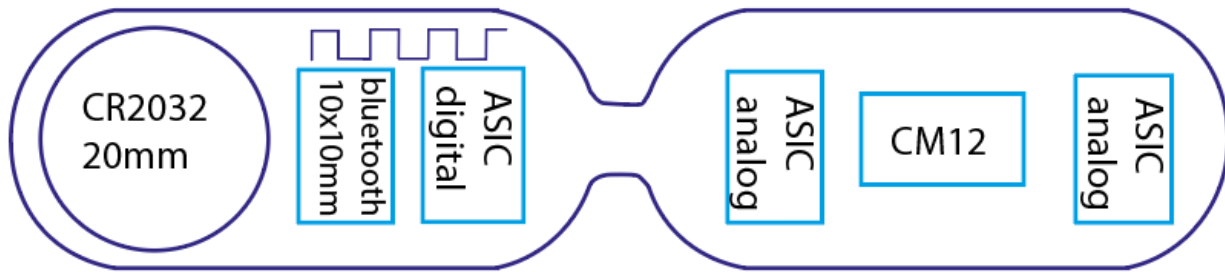

Figure 3.53: schematic overview of patch components

The required components are:

- Flex circuit film (dark blue outline) which connects the components. It is folded at the narrow section in the middle to reduce pod size;
- Button cell CR2032 (diameter 20mm), that is capable of powering the patch for up to 5 days;
- Bluetooth chip for connection with screen;
- ASIC digital chip to process information;
- Two ASIC analog chips;
- Last but not least: the CM12 chip, which is responsible for producing the ultrasound signal.

3D images of the electronic components were provided by Bas Jacobs, another System Architect of Philips. The system is designed for easy assembly. Because all the components are attached on the same side of the film, assembly will be quicker and easier. Images of components on the film and in the pod body are shown in Figs. 3.54-3.57.

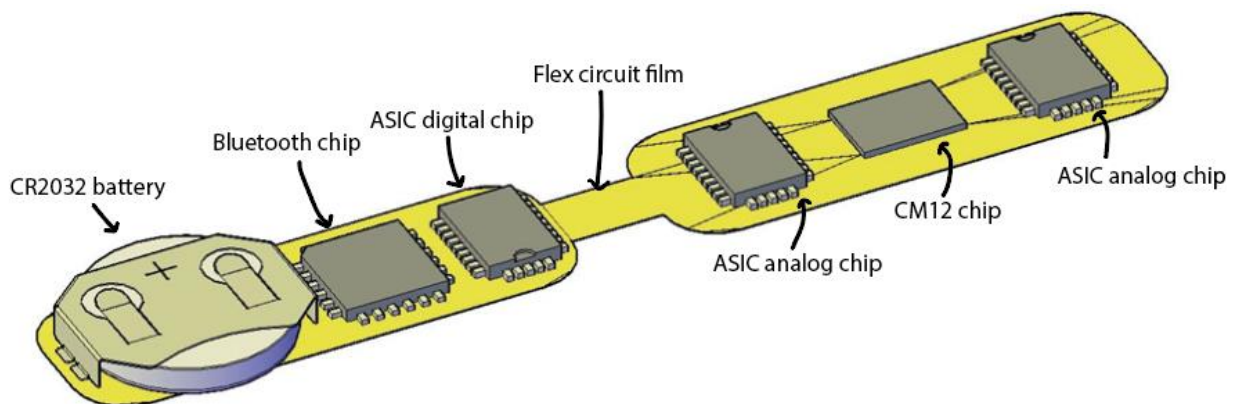

Figure 3.54: Electronic components, layout flex film



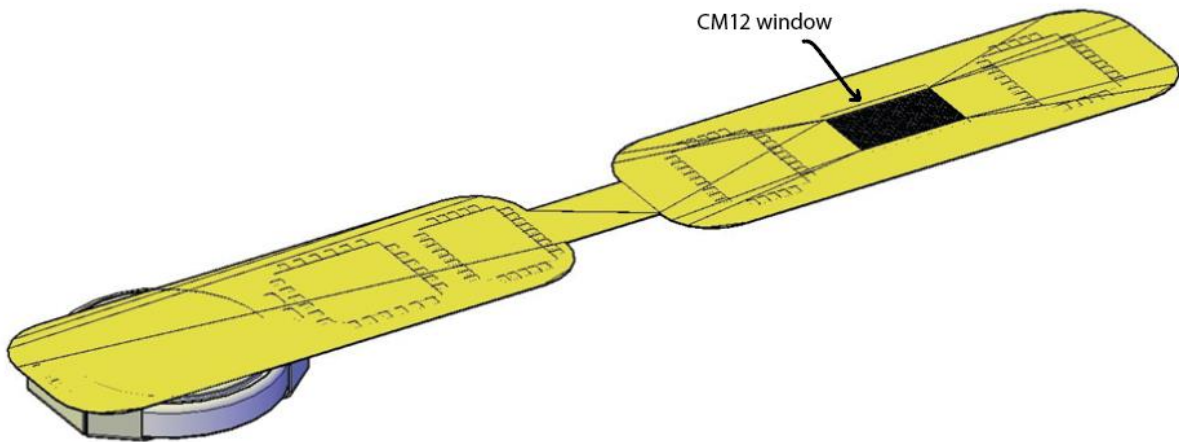

Figure 3.55: Back of flex circuit film, window for CM12

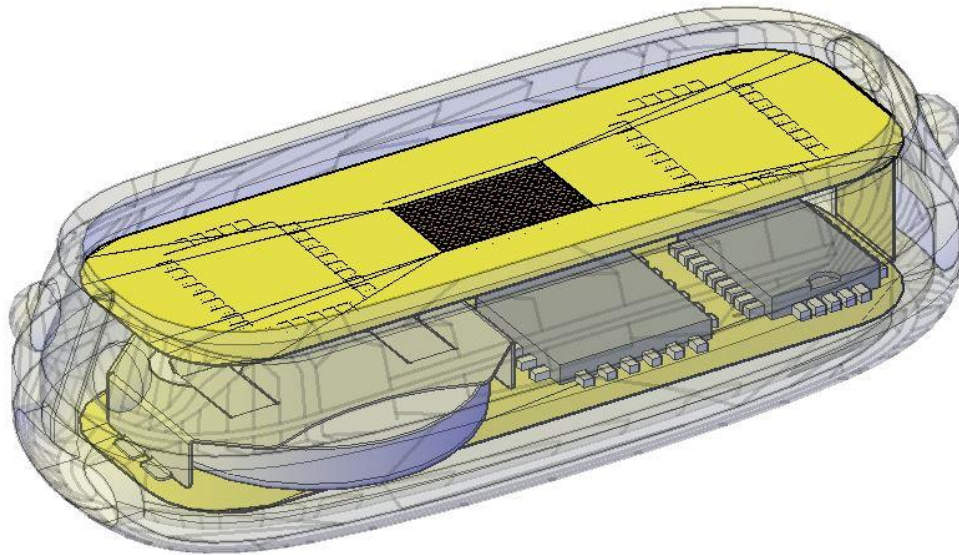

Figure 3.56: Components fitted in Pod body

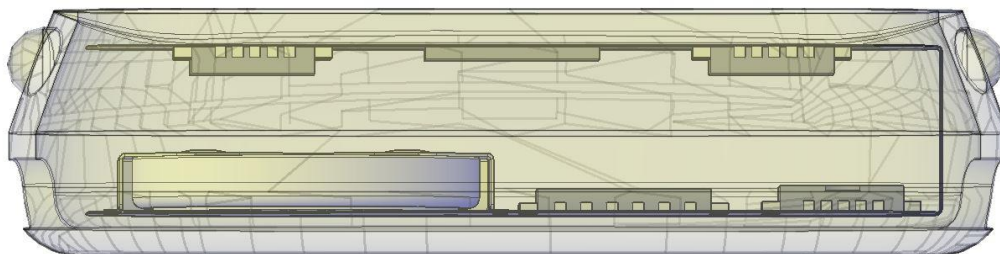

Figure 3.57: Components fitted in Pod body, side view

These components are fitted in a pod which will click in the gel pad holder using the same click mechanism as the adapter. The pod is the most valuable part of the system because it contains the electronics. Therefore, the shape of the pod will remain the same for different applications and transducers, and the other components will be designed around it. Thus, only one type of pod is needed in the hospital for multiple applications, which can save costs. The maximum dimensions of the pod are 56x24x14 mm. Images of the pod are shown in Figs. 3.58-3.60.

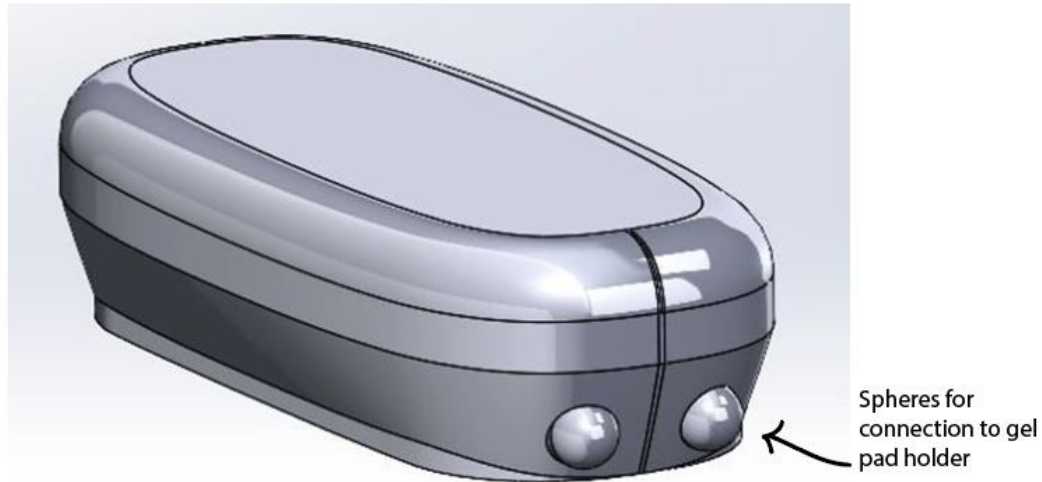

Figure 3.58: Pod design in Solidworks



Figures 3.59-3.60: Pods clicked into gel pad holder

An image of the three 3D printed prototypes together with the Lumify is pictured in Fig. 3.61. Line drawings are presented in Appendices D to I.



Figure 3.61: The whole 3D-printed system

## Final concept

### Main elements

The invention is based on the minimal viable product (MVP), which means it is based on creating the simplest and most cost-efficient solution to implement monitoring patches in hospitals. It is a placing mechanism using an existing handheld ultrasound transducer to enable correct placement of patches.

The proposed solution comprises a system and a method. The system consists of the following components, pictured in Fig. 3.62:

- Handheld ultrasound transducer, in this case Lumify L12-4;
- Transducer adapter to bridge the shape of transducer and gel pad holder;
- Gel pad holder, which holds the gel and accommodates the skin adhesion. On the bottom part it contains a plaster with a protection sheet. A hook is attached to this sheet to pull away the protection sheet;

- Ultrasound pod responsible for the monitoring. It can be used wirelessly.

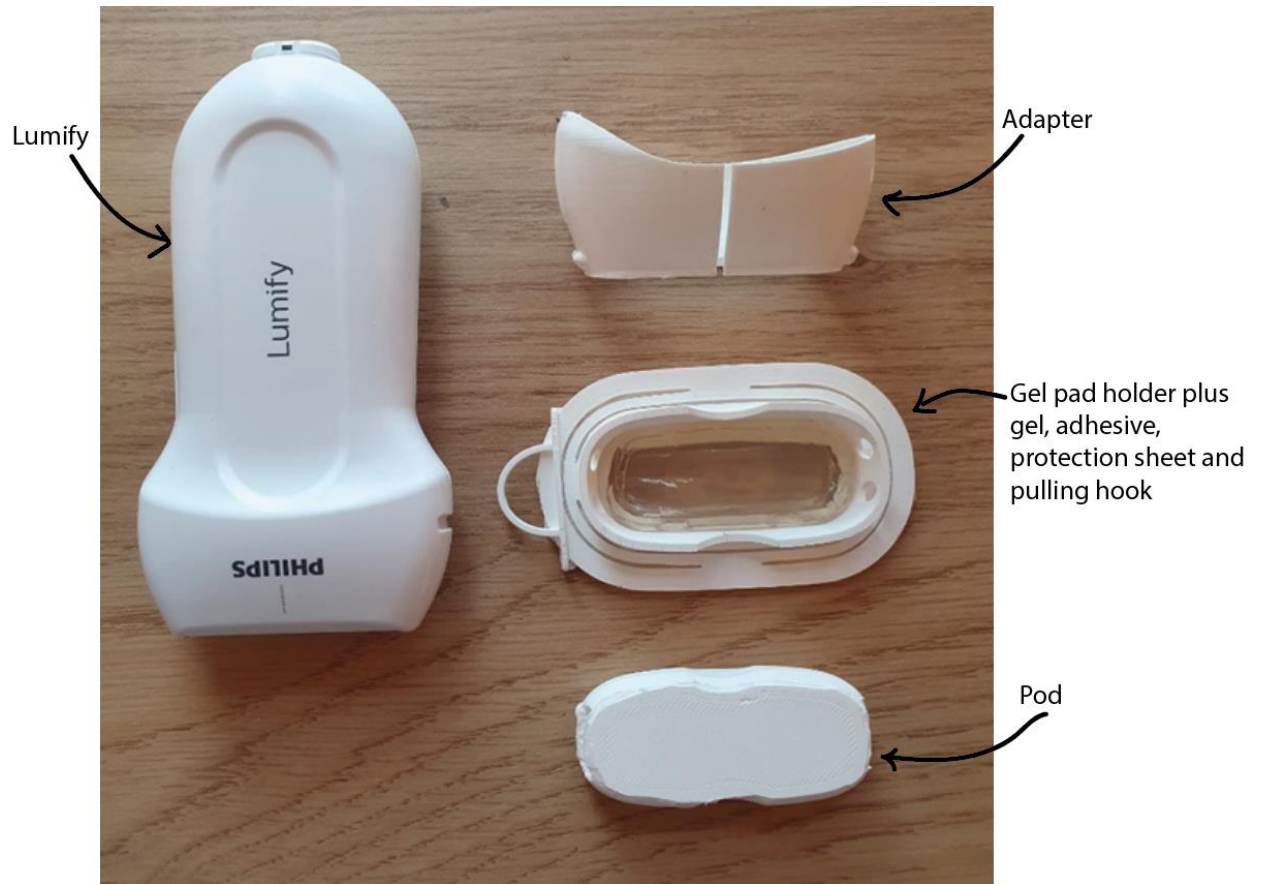

Figure 3.62: system elements. Left: Lumify L12-4 transducer. Right, from top to bottom: Attachment, gel pad holder and patch.

The method comprises the following steps (Figs. 3.63-3.70):



1. Figure 3.63: Lumify clicked in attachment. Fits in indent on right side, shapes over curve on left side. Gap in middle creates spring-like effect, allows for easy snap fit while holding on tightly.



2. Figure 3.64: Transducer assembly, containing transducer, attachment, and gel pad



holder

3. Figure 3.65: When desired spot is found, liner can be taken off without lifting the system from the skin



4. Figure 3.66: Push outer ring, with adhesive underneath, down to lock device



5. Figure 3.67: Take off transducer plus attachment



6. Figure 3.68: Gel pad holder including gel is in place



7. Figure 3.69: Click in patch



8. Figure 3.70: Monitoring can start. Patch can stay in place for 72 hours.

## Design options

The following design options are available for this concept:

- Different applications: the system allows for more than monitoring, due to its modular character. Therefore, other possible applications are:
  - Hemodynamic monitoring, during surgery;
  - Bladder monitoring, for bladder training;
  - Renal monitoring, checking for overfilling in ICU settings.
- Different transducers: the system is not limited to the Lumify L12-4 in its current shape. The system is designed with the idea that the most valuable part, the pod, always has the same form factor. The less valuable pieces, the attachment and gel pad holder, will be shaped around the pod and can be altered based on application-specific requirements.

## Manufacturing

Both 3D printing, which is used for prototyping, and injection molding are suitable production processes, and both have their advantages. 3D printing allows for creating complex shapes and easy modification of the shape, which is convenient for the different design options. Injection molding, however, provides the most consistent quality and is by far the cheapest process for large quantities. A comparing list is shown in Table 3.2.

<b>Injection molding</b>	<b>3D printing</b>
Parts must be printed in separate parts due to needed injection mold geometry	Allows for complex shapes
Expensive to make changes	Easy to adapt model
Once started, quick production	Slower production
Little post-processing, smooth surfaces	Post processing and rough surfaces, especially for gel pad holder
Easier to recycle	Harder to recycle
Expensive for small batches	Cheap for small batches

Table 3.2: Injection molding versus 3D printing [49-50]

An important fact to base the decision on, was the expected production quantities. In the Analysis Phase, a calculation for the market share was made. In the Netherlands, there is a market opportunity for 150.000 patches each year, not taking in consideration a pandemic. Even though the production numbers will probably be lower than this, the production can be targeted at tens of thousands of pieces. Since injection molding starts getting more affordable from 10.000 pieces, this is in favor of injection molding.

Another important aspect is the post-processing. During prototyping, removing 3D-printed supports from the gel pad holders was a timely task that did not seldomly resulted in finger cuts. Even though the adapter and pod have easily 3D-printable shapes, the post-processing of the gel pad holders is timely. Next to that, injection molding provides a far more smooth surface finish, which is preferable in hospital settings where more rough surfaces attract germs.

Therefore, injection molding will be the chosen production process.

## Assembly

To minimize assembly costs, the pod design should be specifically altered for quick assembly. This will also be of use during disposal since the electronics can easily be taken out as well. The casing of the pod is split in two parts over the longitudinal axis. Notches on the split line will allow for easily putting the two parts together. The split will also result in a cheaper injection mold, as the original shape cannot be taken out of a regular mold due to its closed geometry. Fig. 3.71 shows a section view of the pod.



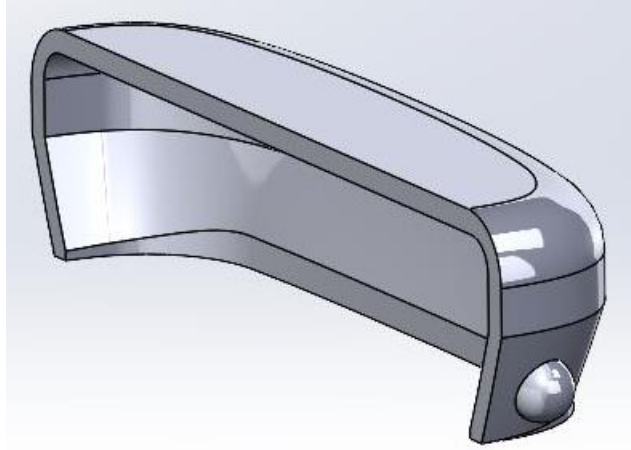

Figure 3.71: Section view of pod

## Materials

The material used for the 3D printed prototype is polylactic acid (PLA). PLA is known to be a safe, non-toxic, biodegradable material that is widely used for both 3D printing and injection molding. However, PLA is not suitable for regular contact with solutions such as water or alcohol. This makes it not suitable for a wearable ultrasound device. [51]

Therefore, it is proposed to make the injection molded parts out of high-density polyethylene (HDPE). PE is inert, extremely resistant to fresh and salt water, food, and alcohol, and FDA approved for medical devices. It is cheap (around €1,20/kg) and easy to mold and fabricate. Also, it is strong and flexible enough to allow for slight bending, as is needed for the product. [48][51]

The gel used is the Aquaflex solid ultrasound gel mentioned in Prototyping, earlier this report.

## Electronics

Even though at first, the electronics were out of scope, it is an important aspect to determine the feasibility of the patches. To repeat, the required electronic components are:

- CM12 chip;
- 2x ASIC analog chip;
- ASIC digital chip;
- Bluetooth chip;
- Button cell CR2032;
- Electronics film to connect the parts;

A 1D array is used to create a 2D image, which suffices for all mentioned use cases.

## Charging

The patch is powered by a rechargeable button cell battery. Similar to electrical toothbrushes, the pod will be charged with an induction charger. The chargers will be stationed at the place where the Lumify transducers are charged in the hospital. After a patch is used for 72 hours, it will be cleaned and put in the chargers. If a patient needs further monitoring after the 72 hours, the whole patch is replaced by a new one.

## Heat development

According to regulations IEC60601, a medical device that is in contact with the skin should not exceed a heat limit of 48 degrees Celsius at the area of contact. It is expected the patch will not exceed this limit, for the following reasons:

- The limited required power, due to data reduction in combination with AI, will cause less heat than regular imaging transducers;
- The ultrasound gel works as a barrier for the heat transfer.

The ultrasound gel has another advantage for the device. Due to its flexible nature, it shapes around an object that is pushed into it. Therefore, the pod will be pushed closely to the gel and complicated designs to eliminate air pockets between the electronics and the gel are not needed.

## Costs

### Material costs

The costs for the electronic components are estimated to be between €100-150 per patch. This is based on the following assumptions:

- ASIC&CMUT chips, around €20 each = €80
- Other components: around €40
- Total: €120

The Aquaflex gel is sold online costing €60 for 6 boxes. Each box contains enough gel to make 6 gel pads, thus €1,68 each. Assuming the gel will be bought in bulk in more efficient shapes than the current disc-shape packages, the gel costs will be €1,00 per patch. PE costs around €1,20/kg. Estimating a total of 50 grams of plastic per system is needed, the material costs will be €0,30. The adhesive and the liner are estimated to cost about €1-€2 per product. This will bring the material costs to a total of €110-160.

### Additional costs

For injection molding, expenses include making the mold and operating the machine. An Excel sheet obtained from an injection molding company gave insight in the production costs of a single part. If 50.000 patches are produced in a 4-cavity mold, the cost will be around €0,16 per piece, including material costs. Assuming that the casing and gel pad holder are produced in batches of 10.000 of the same size, the costs will be around €5,00 per piece. Therefore, it makes much more sense to unify the shapes as much as possible or print in larger batches [52].

Assembly costs should be taken into consideration as well. The electronics are expected to be responsible for the largest part of these costs, since the assembly requires precision work. The assembly costs are estimated to be €10,00 per patch. For other costs, for instance distribution and packaging, another €5,00 is estimated.

This brings the total patch system costs to €130-€190 for the bill of materials.

## Distribution

The patches will be distributed using the existing Philips distribution channels. They can be bought in combination with the Lumify transducers or separately. The system is packaged in

three parts: the adapter, the gel pad holder equipped with the plaster, gel and hook, and the pod are separately bought, due to their different lifetimes. The gel pad holder will be used once for a maximum lifetime of 72 hours, the pod is assumed to live as long as a regular transducer, and the adapter can be cleaned and used until it breaks, gets lost, or gets dirty.

The packaging of the gel pad holder must be airtight to keep the ultrasound gel moist. A dried ultrasound gel will shrink and does not transfer the signal.

## Cleaning

All parts can be cleaned using alcohol wipes. The patch itself is reusable and will be cleaned using the same guidelines as the Lumify, which is first cleaning with wet wipes before disinfecting with alcohol wipes [41]. Eliminating the USB-c ports has the major advantage of improving the cleanability. This is also the reason to use induction charging.

## End of life

The patch is designed to monitor for 72 hours. If a patient needs further monitoring after that time, the full patch must be replaced.

### Pod

The pod is cleaned and connected to a charger. The charging stations for the pods are next to the POCUS transducers. A pod is expected to be in use for as long as the Lumify can be in use. In the LUMC, it was revealed that cables were the first component of Lumify transducers to break. Another issue was that the transducers, because they are small and portable, are sometimes accidentally thrown away. An idea to elongate the pod's lifetime is to add a noticeable and expensive-looking color to the device. Therefore, it will hopefully be noticed before thrown away. Since the pod does not have wires, the breaking wires are no issue anymore.

At the final end of use, the pod must be recyclable. The pod consists of an electronic core and a plastic casing. For easy manufacturing, assembly and disassembly, the pod casing is split in two parts. Therefore, the pod is opened easily, and the electronics can be taken out. According to hospital guidelines, rechargeable batteries must be disinfected using disinfectant wipes before placed in the designated recycling bin.

The other electronics can be easily taken out of the pod case and then gathered in a recycling waste bin. Together with other non-contaminated electronic waste, it can be transferred to a partner that can sort the waste and possibly use it for new applications.

The casing itself must be disinfected using the alcohol wipes and placed in the plastic recycle bin. After disinfection, it does not have to be disposed of with the hazardous waste. This creates the possibility for recycling the PE. Depending on the hospital's waste line, dedicated PE disposal bins may be around.

### Gel pad holder and adapter

The adapter is only used during the placing process. Therefore, after use it is cleaned and stored in a designated storage space for adapters. The gel pad holders on the other hand are in contact with the patient and will be disposed of after every use. The protection sheet accompanied by the

hook will be thrown away immediately. After use of the gel pad holder, the plaster and ultrasound gel are removed from the plastic part and disposed of. The plastic part will be put in the recycling bin for plastic parts, preferably specifically for PE.

# Part 4: Evaluation

Finally, the concept will be evaluated. In this stage, the concept and prototype are tested on usability and functionality and evaluated along the initial requirements. Also, the concept shortages and recommendations will be pointed out. This part concludes with a proposition for the next steps.

## Requirements

In the first part of this report, the Analysis phase, a list of requirements was included. In the course of the project, requirements were adapted and added, which lead to a final list of requirements. The final concept is tested along this final requirements list. The full test and updated list of requirements is attached in Appendix C. Out of the 46 requirements, 35 requirements are fully met, and 11 are either partially met or require more research. In Table 4.1, the noteworthy details are discussed.

1.4	Must stay on for 72 hours		Not tested, but probable because of HDM data
1.5	Must fit all 12 lung zones		Anything on the back causes bedsores, however, the system is designed for applying to many use cases
1.9	Must be able to be placed correctly or corrected after placing		This is not possible, but the need is eliminated because the placing mechanism allows for finding the right spot
5.3	Reusable for 20 cycles		This is an interesting one to test if the patch is ready
6.2	Not limited to L12-4 probe		In theory this is true, but the concept designs have not been made yet
6.8	At least 2 novelties in design		There are even 3! The use of Lumify, click system and liner
2.4	Monitor continuously		This is possible, even wireless, although this would not mean continuous imaging. Interesting to find out in the future.

Table 4.1: Noteworthy details of requirement test

## User tests and feedback

The concept was presented at the LUMC intensivists to gather final feedback. The system was tested with a working Lumify transducer to determine the effectiveness. A user test was planned, where the system was tested on a fellow TU Delft student by another TU Delft student who was experienced in ultrasound examinations.

### The test

Since medical regulations do not allow testing on actual subjects, the user test was performed in a small group of TU Delft students who had been practicing ultrasound on each other as part of their studies. This test was focused on the diaphragm, as this is an easy organ to visualize, and valuable for the use case. The test had the following protocol:

1. First, the project and goals are described, as well as the user instructions for using the patch system.
2. The Lumify is switched on and connected to the tablet, the lung settings were chosen.

3. A normal ultrasound image is produced, to compare what the image in combination with the device looks like. Ultrasound gel is applied to the skin, and the Lumify is used as it normally would be.
4. The gel is cleaned off the body.
5. The other components are provided: adapter, gel pad holder already containing gel and the pod.
6. The user is asked to perform the tasks of searching for the correct spot, pulling off the protection sheet, sticking the gel pad holder to the skin, taking off the Lumify and adapter, and attaching the pod.
7. Meanwhile, pictures are taken.
8. Afterwards, the feedback is discussed.

The user test went well, with the most reassuring results being that the image was clear, and the protection sheet released easily. However, the students did provide some feedback:

- The gel pad holder released from the skin too easily. Although the subject student was skinny and therefore there was less skin to attach to, this should be improved. A stronger tape is needed for the attachment.
- The students suggested to change the material of the spring ring to a more flexible material. This will be investigated. However, this may be counter-productive for the spring mechanism and therefore, should first be researched.

Images of the used test are shown in Figs. 4.1-4.5



Figure 4.1: Diaphragm visible in Lumify image, measured while connected to gel pad holder

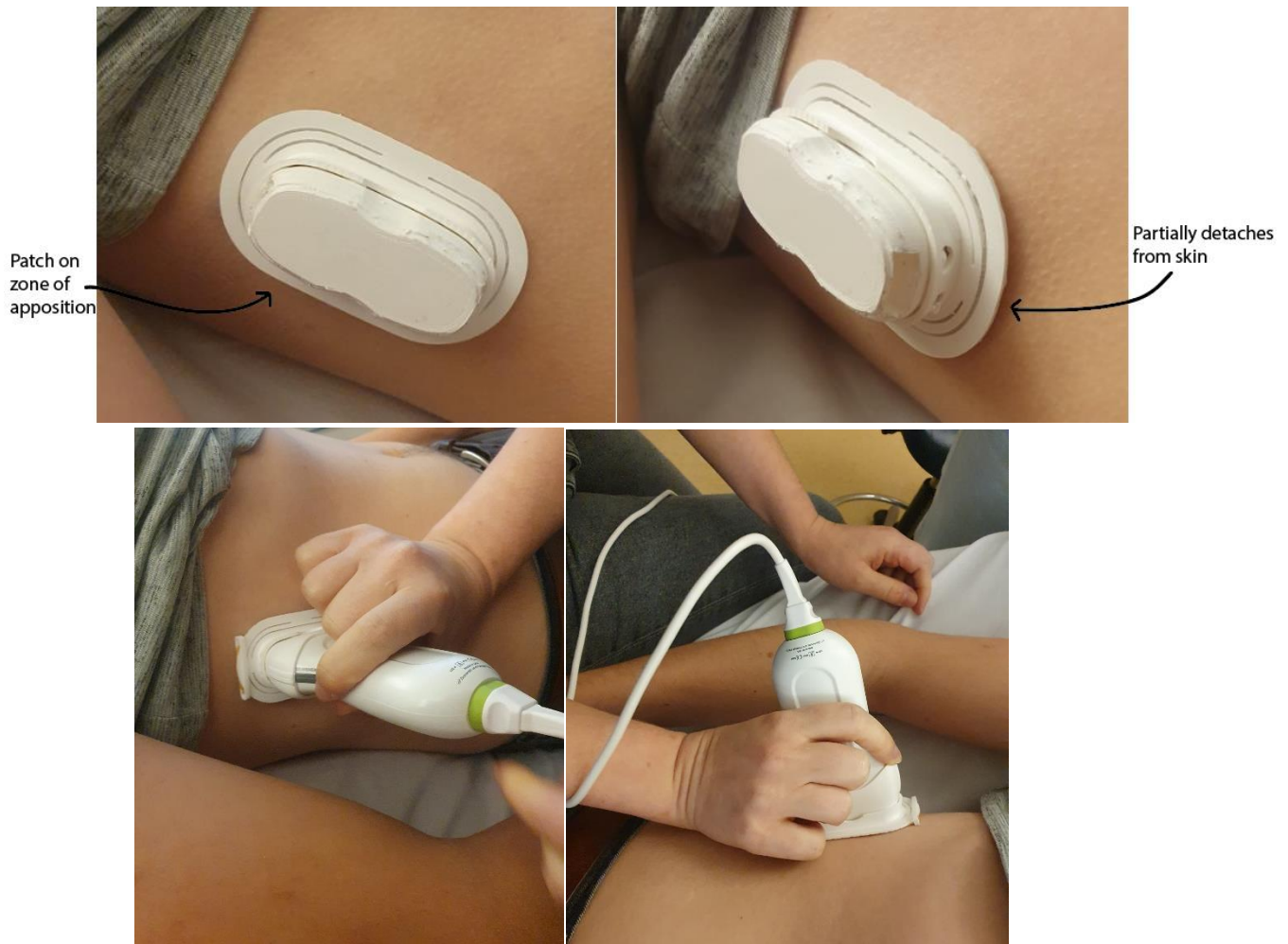

Figures 4.2-4.5: testing the device

Since the images were as clear using the gel pad holder as they were without, the image quality is confirmed. Also, the students found the design intuitive. The point of improvement is the adhesive strength; in the current design, it let loose of the body. Either another adhesive should be used, or another shape of the gel pad holder.

The intensivists provided feedback as well. Overall, it is believed this system can solve an issue and make implementing patches possible. However, it must be proven it works also for different use cases, for multiple days and patients with different bodies. Their suggestions are listed below:

- Especially for cardiac monitoring, which is an application that is believed by the intensivists to be very valuable, a large pressure is needed to create an image. It is believed the spring system will not accommodate for such forces. Therefore, this should be tested, preferably on subjects with more body fat. Also, the opportunity of integrating a rubber band around the body should be explored.
- For some applications, for instance heart monitoring, the angle of measurement is important. By using the gel pad holder and accompanying ring, changing the measurement angle is more complicated and perhaps not possible. For these applications,



the current system should be tested. A redesign of the gel pad holder should be made when the results are not sufficient.

## Recommendations

---

The concept was received well both at Philips and at the LUMC. However, there are improvements to make. The following aspects are recommendations for future development:

- Wearability 1: The device detached from the patient in the user test. New tests with different adhesives and perhaps different material of the outer ring should be performed to find the balance between rigidity and flexibility.
- Wearability 2: The gel pad holder is pressed firmly to the skin. However, this could harm the patient when the device is worn for 72 hours. More flexible materials for the part that touches the skin should be explored.
- Usability 1: The current design works for providing an image of the diaphragm in a person with little body fat but may not work for other use cases like heart monitoring. This requires much pressure to obtain a clear image. The possibility of adding a band around the body to keep the device close to the patient should be explored.
- Usability 2: More experiments should be performed to test the usability of the current system while measuring under different angles.
- Usability 3: Other use cases should be tested which leads to improved design for each use case, such as carotid and renal monitoring.
- Usability 4: The gel pad still falls out of the gel pad holder. Something must be made up for that. Also, no exact measurements are made for the gel pad, nor a convenient way to mold the gel. The idea to create a mold for the gel should be explored.
- Usability 5: The gel pad holder shape will probably be unsuitable for some applications and patients, for instance with a different BMI. A study must be performed to find out what is needed and what gel pad holder is suitable for each application.
- Opportunity 1: In conversations at Philips, the possibility to use ultrasound monitoring for knee implant design was discussed. First concepts of other companies already exist using bulky ultrasound systems which gather information about the shape of the knee. Patches could be a better solution for both hip and knee replacements.
- Opportunity 2: Another opportunity lies in the veterinary industry. Prize winning horses may benefit from ultrasound monitoring. As for the medical device regulations, veterinary medical devices are easier to validate than regular medical devices.
- Technology 1: A team should be gathered to create the electronic components and build a working patch.
- Technology 2: Technical requirements for each opportunity must be thought out. An example is the technical requirements for diaphragm asynchrony monitoring. It must be determined how many images are needed at what time interval to receive enough information about the natural breathing cycle.
- Development 1: An investigation must be started to determine what is needed to gain support for the course of this project.

# Gaps

---

During the research, some aspects were out of scope and therefore are gaps in the solution. The following aspects are crucial to the final solution and valuable for future research.

- Data analysis: currently, graduate student Suus van Westerloo is working on the data analysis of ultrasound monitoring of the diaphragm. The AI is crucial for patches, since the measurements require data processing to draw conclusions. In this report, no developments have been made on the software part.
- Information display/user feedback: if the algorithm spots an abnormality, what is done with the information? It can be presented in the way of an alarm, a showcase of the abnormal image, or perhaps the patch could light up. It is important to think about the display of information and how the users are informed action should be undertaken. Setting up user requirements is a part of this research. What are the current alarms in the ICU and how do the ICU staff want to be approached?
- Signal transfer: the electronics model is made by Bas Jacobs, but the device is still lacking information. The CM12 window must be seamlessly connected to the gel. In a new design, a firm connection must be realized to ensure the ultrasound transfer to the body.
- Skin attachment: on behalf of the Philips hemodynamic patch team, TNO Holst has performed research on what adhesive is needed for sticking the patch to the skin. Our patch designs are different and therefore, another adhesive research is valuable.
- Regulations: the device is not designed to meet regulations considering medical monitoring devices, but it is important to know what they are. A device that processes information and draws conclusions that result in decisions for a treatment is an enormous liability risk. The feedback a patch provides should always be suggestive, not stating a solution.

# Future

---

One of the goals for this project was to create a tangible concept to enthuse Philips employees about the development of patches. Therefore, it is important to communicate the findings with the stakeholders within Philips, and also enthuse the people who are responsible for the project budgets. To show what the concept is about, a one-pager will be made containing the important information.

## Successor

A successor intern is an interesting idea for the continuation of the project. This intern can focus on one or more of the recommendations mentioned above. Already the continuation and a new insight on the current project may induce the energy and find ways to push it into a real product. After that, a permanent team can be established.

## Technology

It was pointed out by the system architects that the technical feasibility is not the problem, but the people at Philips are. For creating the working patch, the following steps should be performed:

1. Build the electronic circuit, show that the patch works;
2. Optimize the patch digitally;
3. Integrate the system further technically.

However, step 3 is said to be a complicated since collaboration from higher levels within Philips is needed. When, however, the realization of the patch is started, it is believed it will be finished within 2 years.

## Conclusion

---

In the past nine months, a placing mechanism is designed for ultrasound patches with the focus on usability and workflow. The goal was to end with a testable prototype and a document with recommendations for the further steps: it is safe to say those goals have been achieved. However, it is still a concept and not near a finished product. To gain support from Philips, it is important to show the working principles of the patch and combine it with the insights on the technical medicine side, provided by Jeffrey and Suus. A successor that likes to pull the cart and has knowledge about electronics, medical device design and perhaps even politics (we have to get things done! 😊), will potentially lead to better monitoring in the ICU.

# References

---

- [1] From the seashore to the stratosphere, a step closer to continuous lung monitoring using wearable ultrasound. Lung sliding quantification - master thesis. (2022, March). Jeffrey Visser.
- [2] Beitler JR, Malhotra A, Thompson BT. Ventilator-induced Lung Injury. *Clin Chest Med*. 2016 Dec;37(4):633-646. doi: 10.1016/j.ccm.2016.07.004. Epub 2016 Oct 14. PMID: 27842744; PMCID: PMC5131805.
- [3] Radermacher P, Maggiore SM, Mercat A. Fifty Years of Research in ARDS. Gas Exchange in Acute Respiratory Distress Syndrome. *Am J Respir Crit Care Med*. 2017 Oct 15;196(8):964-984. doi: 10.1164/rccm.201610-2156SO. Erratum in: *Am J Respir Crit Care Med*. 2017 Dec 15;196(12):1619. PMID: 28406724.
- [4] Rouby JJ, Constantin JM, Roberto De A Girardi C, Zhang M, Lu Q. Mechanical ventilation in patients with acute respiratory distress syndrome. *Anesthesiology*. 2004 Jul;101(1):228-34. doi: 10.1097/00000542-200407000-00033. PMID: 15220794.
- [5] Hahn G, Niewenhuis J, Just A, Tonetti T, Behnemann T, Rapetti F, Collino F, Vasques F, Maiolo G, Romitti F, Gattinoni L, Quintel M, Moerer O. Monitoring lung impedance changes during long-term ventilator-induced lung injury ventilation using electrical impedance tomography. *Physiol Meas*. 2020 Oct 9;41(9):095011. doi: 10.1088/1361-6579/abb1fb. PMID: 33035199.
- [6] Own conversations, ask for notes
- [7] Echografie | Philips Healthcare. (2022). Philips. Retrieved April 2022, from <https://www.philips.nl/healthcare/solutions/ultrasound?msclkid=8ac1e425ba3d11ec9a27ef648d1b56bb>
- [8] Our history. (2022). Philips. Retrieved April 2022, from <https://www.philips.com/a-w/about/our-history.html?msclkid=85a3eb72ba3c11ecb2d3a64073cd3cac>
- [9] Future Market Insights. (2022, March 31). Cardiac Ultrasound Systems Market is predicted that sales will increase at a CAGR of 5.0% between 2021 and 2031. Digital Journal. <https://www.digitaljournal.com/pr/cardiac-ultrasound-systems-market-is-predicted-that-sales-will-increase-at-a-cagr-of-5-0-between-2021-and-2031>
- [10] Medical Ultrasound Probe Market Size In 2022 : 3.4% CAGR with Top Countries Data, Which product segment is expected to garner highest traction within the Medical Ultrasound Probe Industry? | In-depth 116 Pages Report. (2022, March 29). MarketWatch. <https://www.marketwatch.com/press-release/medical-ultrasound-probe-market-size-in-2022-34-cagr-with-top-countries-data-which-product-segment-is-expected-to-garner-highest-traction-within-the-medical-ultrasound-probe-industry-in-depth-116-pages-report-2022-03-28>
- [11] Global Ultrasound Device Market Size Report 2022–2030. (2021). Grand View Research. <https://www.grandviewresearch.com/industry-analysis/ultrasound-device-market>

- [12] Ltd, M. D. F. (2022). Portable Ultrasound Market Size, Industry Growth | 2022 to 2027. Market Data Forecast. <https://www.marketdataforecast.com/market-reports/portable-ultrasound-market>
- [13] Ltd, M. D. F. (2022b). Ultrasound Market Size, Share, Growth, Industry Trends | 2022 to 2027. Market Data Forecast. <https://www.marketdataforecast.com/market-reports/ultrasound-market>
- [14] Boeijen, V. A., Daalhuizen, J., der Schoor, V. R., & Zijlstra, J. (2014). Delft Design Guide: Design Strategies and Methods. Laurence King Publishing.
- [15] Roozenburg, N. F. M., & Eekels, J. (1995). Product Design: Fundamentals and Methods (Product Development: Planning, Design, Engineering). Wiley.
- [16] Newman, P. G., & Rozycki, G. S. (1998). THE HISTORY OF ULTRASOUND. *Surgical Clinics of North America*, 78(2), 179–195. [https://doi.org/10.1016/s0039-6109\(05\)70308-x](https://doi.org/10.1016/s0039-6109(05)70308-x)
- [17] Ultrasound. (2022). National Institutes of Health. <https://www.nibib.nih.gov/>
- [18] Lee, L., DeCara, J.M. Point-of-Care Ultrasound. *Curr Cardiol Rep* 22, 149 (2020). <https://doi-org.tudelft.idm.oclc.org/10.1007/s11886-020-01394-y>
- [19] Lichtenstein DA, Mezière GA. Relevance of lung ultrasound in the diagnosis of acute respiratory failure: the BLUE protocol. *Chest*. 2008;134(1):117-25.
- [20] Dargent A, Chatelain E, Kreitmann L, Quenot J-P, Cour M, Argaud L, et al. Lung ultrasound score to monitor COVID-19 pneumonia progression in patients with ARDS. *PLoS One*. 2020;15(7):e0236312-e
- [21] The best premium general imaging ultrasound machines: (2021). UltrasoundSupply. Retrieved April 2022, from <https://www.ultrasoundSupply.com/guides/general-imaging-ultrasound-machines>
- [22] Point-of-Care-Ultrasound Device Market. (2021, August 5). P&S Intelligence. <https://www.psmarketresearch.com/market-analysis/pocus-device-market>
- [23] Lumify Exceptional portable ultrasound from your Android device | Ultrasound Systems | Emergency Medicine | Ultrasound | Philips Global Category | Philips Healthcare Shop Netherlands. (2022). Philips. <https://www.healthcare.shop.philips.nl/Philips-Global-Category/ultrasound/ultrasound-emergency-medicine/ultrasound-systems/lumify/p/795005?salesOrg=NL90>
- [24] Handheld portable ultrasound machine, advanced POCUS solutions. (n.d.). Retrieved October 28, 2022, from <https://www.butterflynetwork.com/>
- [25] Butterfly iQ+ Ultrasound System. (2021, September 2). Medical Device Network. <https://www.medicaldevice-network.com/projects/butterfly-iq-ultrasound-system/>
- [26] Adahan, H. M., Sharon, H., & Siev-Ner, I. (2010). A Sound Solution to Tendonitis: Healing Tendon Tears With a Novel Low-Intensity, Low-Frequency Surface Acoustic Ultrasound Patch. *PM&R*, 2(7), 685–687. <https://doi.org/10.1016/j.pmrj.2010.04.028>

- [27] Massachusetts Institute of Technology. (2021, June). Multi Array, Conformable Ultrasound Patch for Soft Tissue Imaging. Mejorado III, David. <https://hdl.handle.net/1721.1/139326>
- [28] Lee, H.-S. (2021). 2020 Annual Research Report. Massachusetts Institute of Technology. <https://cics.mit.edu/wp-content/uploads/2021/05/CICS-Research-Abstracts-2020-MTL-Annual-Report.pdf#page=12>
- [29] Novioscan. (2022, June 8). How it works - SENS-U KIDS Bladder Sensor. <https://novioscan.com/how-it-works/>
- [30] Kenny, J. M. S. (2021). Functional Hemodynamic Monitoring With a Wireless Ultrasound Patch. *Journal of Cardiothoracic and Vascular Anesthesia*, 35(5), 1509–1515. <https://doi.org/10.1053/j.jvca.2021.01.040>
- [31] Munding, C., Acconcia, C., Elfarnawany, M., Eibl, J., Verrecchia, P., Leonard, P., Boyes, A., Yang, Z., Atoui, R., & Demore, C. (2021). In vitro and clinical demonstration of relative velocity measurements with the Flopatch™: A wearable Doppler ultrasound patch. 2021 IEEE International Ultrasonics Symposium (IUS). <https://doi.org/10.1109/ius52206.2021.9593456>
- [32] Flosionics Medical. (2022, May 20). Homepage. <https://flosionicsmedical.com/>
- [33] Wearable ultrasound patch tracks blood pressure. (2018, October 16). National Institutes of Health. <https://www-nih-gov.tudelft.idm.oclc.org/news-events/nih-research-matters/wearable-ultrasound-patch-tracks-blood-pressure>
- [34] Shahshahani, A., Laverdiere, C., Bhadra, S., & Zilic, Z. (2018). Ultrasound Sensors for Diaphragm Motion Tracking: An Application in Non-Invasive Respiratory Monitoring. *Sensors*, 18(8), 2617. <https://doi.org/10.3390/s18082617>
- [35] Onze specialismen. (2019). VieCurie. [https://www.viecuri.nl/onze-specialismen/intensive-care/een-kijkje-op-de-ic-kamer/?fbclid=IwAR1Ebm9awz9LjQ-xvfuLU0QtFv80YryV9QZKb4PLgIO8r2\\_XIUicpcAJug](https://www.viecuri.nl/onze-specialismen/intensive-care/een-kijkje-op-de-ic-kamer/?fbclid=IwAR1Ebm9awz9LjQ-xvfuLU0QtFv80YryV9QZKb4PLgIO8r2_XIUicpcAJug)
- [36] Buttner, R. (2021, September 8). Inferior STEMI. *Life in the Fast Lane • LITFL*. <https://litfl.com/inferior-stemi-ecg-library/>
- [37] Claire-Del Granado, R., Mehta, R.L. Fluid overload in the ICU: evaluation and management. *BMC Nephrol* 17, 109 (2016). <https://bmcnephrol.biomedcentral.com/articles/10.1186/s12882-016-0323-6>
- [38] wetten.nl - Regeling - Subsidieregeling opschaling curatieve zorg COVID-19 - BWBR0044273. (2020, October 31). <https://wetten.overheid.nl/BWBR0044273/2020-10-31/1>
- [39] Wetten, B. van. (2022, September 28). NVIC. <https://www.nvic.nl/>
- [40] Data in beeld. (n.d.). Retrieved October 27, 2022, from <https://www.stichting-nice.nl/datainbeeld/public>
- [41] Transducer and System Care and Cleaning (2013), Koninklijke Philips N.V. Reference number: 4535 617 39361 Rev B <https://www.philips.nl/c-dam/b2bhc/us/feature-details/transducer-care/Transducer-care-cleaning-english.pdf>

- [42] Boeijen, V. A., Daalhuizen, J., Schoor, V. R. der, & Zijlstra, J. (2014, April 1). Delft Design Guide: Design Strategies and Methods. Laurence King Publishing.
- [43] Philips Healthcare shop (2022) <https://www.healthcare.shop.philips.com.au/Philips-Global-Category/ultrasound/point-of-care-ultrasound/point-of-care-ultrasound-systems/lumify-s4-1-phased-array-transducer/p/795005FUS6884?salesOrg=AU90>
- [44] Design for Manufacturing and Assembly (2022) Snap Fit Design Consideration. | <http://courses.nus.edu.sg/course/mpeleeks/personal/ME3263%20eBook/chap3.22.html>
- [45] Snap Fit Design: Types of Snap Fits and Best Practices | RapidDirect Blog. (2022, August 2). Rapiddirect. Retrieved October 20, 2022, from <https://www.rapiddirect.com/blog/snap-fit-design/>
- [46] Richardot, A. (2018, April 25). How to connect two parts with 3D printed joints and snap fits. 3D Printing Blog: Tutorials, News, Trends and Resources | Sculpteo. Retrieved October 20, 2022, from <https://www.sculpteo.com/blog/2018/04/25/how-to-connect-two-parts-with-3d-printed-joints-and-snap-fits/>
- [47] DeStefano, V., Khan, S., & Tabada, A. (2020). Applications of PLA in modern medicine. *Engineered Regeneration*, 1, 76–87. <https://doi.org/10.1016/j.engreg.2020.08.002>
- [48] Mittal, A. (2022, July 2). Injection Molding in Medical Industry | The Pros of Medical Device Injection Molding | The Importance of Medical Injection Molding. PlasticRanger. Retrieved October 20, 2022, from <https://plasticranger.com/injection-molding-in-medical-industry/>
- [49] Radius, F. (2022, August 25). Injection molding vs. 3D printing: all you need to know. Fast Radius. Retrieved October 20, 2022, from <https://www.fastradius.com/resources/injection-molding-vs-3d-printing/>
- [50] Flynt, J. (2021, July 22). 3D Printing vs Injection Molding: Which Technique is Better? 3D Insider. Retrieved October 20, 2022, <https://3dinsider.com/3d-printing-vs-injection-molding/>
- [51] (2020) Ansys Granta Edupack 2020, Cambridge: Granta.
- [52] Cost of Injection Molding | (includes calculator .xlsx). (n.d.). Micromolding. Retrieved October 27, 2022, from <https://www.micromolds.eu/cost-of-injection-molding>

# Appendices

---

## A: List of requirements, part one

### 1 Use

- 1.1 Must not hinder ECG measurements
- 1.2 Must fit within the setting and workflow of ICU
- 1.3 Must work for 72 hours
- 1.4 Must be usable for all frontal and lateral lung zones
- 1.5 Must be usable for current ICU healthcare staff
- 1.6 Must be rated 'comfortable' by patient
- 1.7 Must be able to place correctly or correct after placing
- 1.8 Must be able to use for patients between p5 and p95 who are admitted to the ICU in terms of age and BMI
- 1.9 Must not be painful to remove from body
- 1.10 Application to the body must not take longer than 30 seconds

### 2 Cleaning

- 2.1 Must be cleanable using cleaning wipes
- 2.2 Must be disinfectable using alcohol wipes
- 2.3 Must not hinder patient cleaning

### 3 Function

- 3.1 Must be able to detect lung sliding
- 3.2 Must be able to detect B-lines
- 3.3 Must be able to compare to older measurements
- 3.4 Must be able to connect to other patches
- 3.5 Must work also during unexpected movements of the patient

### 4 Price

- 4.1 Must be possible to retail for under €25.000

### 5 Safety

- 5.1 Must follow regulations of FDA and CE
- 5.2 Must not cause permanent damage to the body
- 5.3 Must not cause severe skin irritations
- 5.4 Must not cause bedsores
- 5.5 Must not cause wounds

### 6 End of life

- 6.1 Electronics must be reusable
- 6.2 Parts in contact with skin must be either disposable or disinfectable
- 6.3 Disposal must be according regular hospital waste lines
- 6.4 Reusable parts must be used for at least 20 cycles



# B: Snap fits for 3D printing

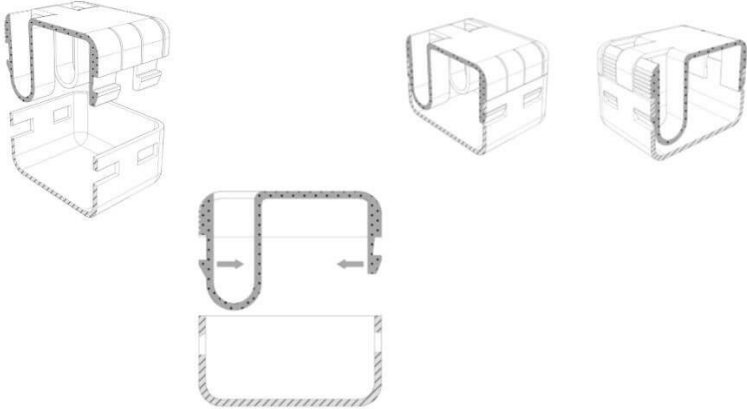
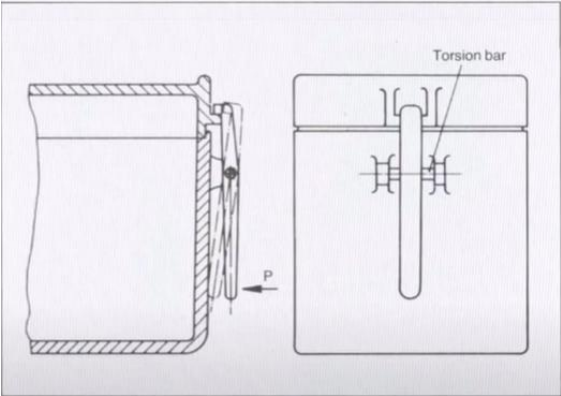
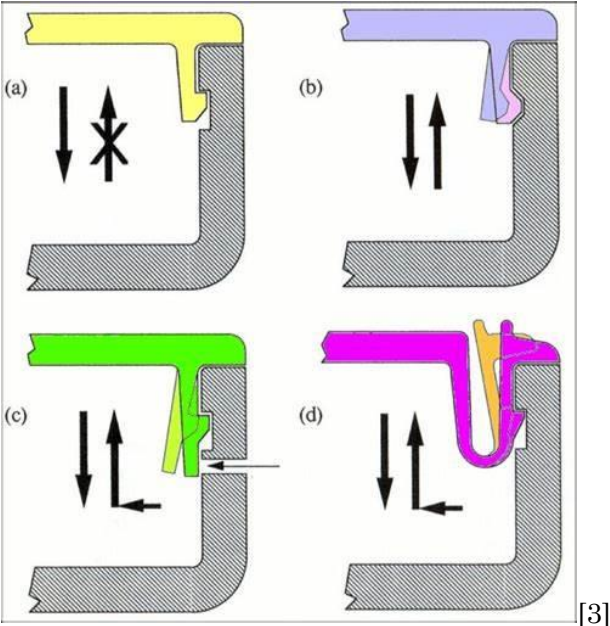

[4]

[5]

## C: Updated list of requirements B: Line drawings

1 Use		
1.1 Must not hinder ECG measurements		
1.2 Must fit within the setting and workflow of ICU		
1.3 Must work for 72 hours		Not tested yet. The battery will survive, it is not sure if the gel pad holder will stick that long.
1.4 Must be usable for all frontal and lateral lung zones		
1.5 Must be usable for current ICU healthcare staff		
1.6 Must be rated 'comfortable' by patient		Not tested for a longer time. Sleeping with the gel pad holder was considered 'comfortable'.
1.7 Must be able to place correctly or correct after placing		
1.8 Must be able to use for patients between p5 and p95 who are admitted to the ICU in terms of age		Not tested, needs research.
1.9 Must not be painful to remove from body		
1.10 Application to the body must not take longer than 30 seconds		
2 Cleaning		
2.1 Must be cleanable using cleaning wipes		
2.2 Must be disinfected using alcohol wipes		
2.3 Must not hinder patient cleaning		
3 Function		All the functional requirements need testing.
3.1 Must be able to detect lung sliding		
3.2 Must be able to detect B-lines		
3.3 Must be able to compare to older measurements		
3.4 Must be able to connect to other patches		
3.5 Must work also during unexpected movements of the patient		
4 Price		
4.1 Must be possible to retail for under €25.000		The retail price is depending not only on costs, but also demand. However, seen the cost price, this is possible.
5 Safety		
5.1 Must follow regulations of FDA and CE		Validation process has not started yet.
5.2 Must not cause permanent damage to the body		
5.3 Must not cause severe skin irritations		
5.4 Must not cause bedsores		
5.5 Must not cause wounds		
6 End of life		
6.1 Electronics must be reusable		
6.2 Parts in contact with skin must be either disposable or disinfected		
6.3 Disposal must be according regular hospital waste lines		
6.4 Reusable parts must be used for at least 20 cycles		
6 Design requirements		
6.1 The concept must be used in combination with the linear Lumify L12-4 probe		
6.2 The concept is not limited to the L12-4 probe		In theory this is true, but no actual prints have been made.
6.3 The concept must have a steady connection with the L12-4		
6.4 The concept is mostly made out of 1 material		
6.5 The concept is 3D printable		
6.6 The concept withstands 20 cycles of clicking in and out of other parts		
6.7 The concept contains solid ultrasound gel		
6.8 The concept contains at least 2 novel elements compared to the HDM patch and all other known patches		Even 3 novel concepts were achieved: use of lumify, click system, liner mechanism.
6.9 The patch must have the same form factor for different applications and transducers		
6.10 The product must be used in the least amount of time, using the least amount of user actions		
7 Patch specific		
7.1 The patch contains two USB-c ports to allow for wire connection		
7.2 The patch must stay in the exact same place for 72 hours		
7.3 All electrical components must fit in the patch		
8 Adhesive specific		
8.1 The adhesive must be limited to the size of the gel pad holder		
8.2 The adhesive must hold for 72 hours to the skin and the device on an bed-ridden patient * for testing: the adhesive must hold for 24 hours on my own skin during normal activities		Not tested.
8.3 The adhesive must only stick to the skin when wanted by the user		
8.4 The sticking must be done without lifting the device		
9 Materials		
9.1 All external materials must be approved by CE and FDA for class 1 medical devices		

D: Line drawings pod

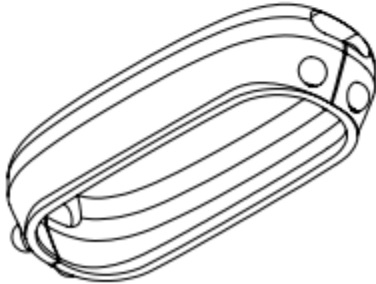
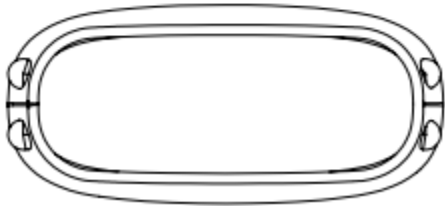
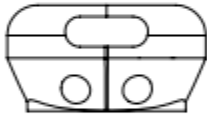
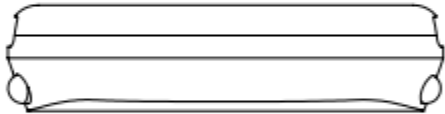
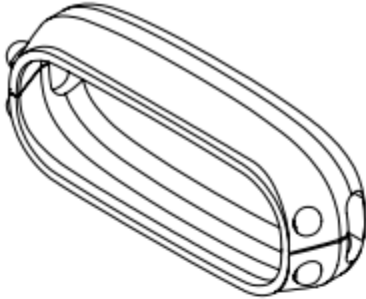
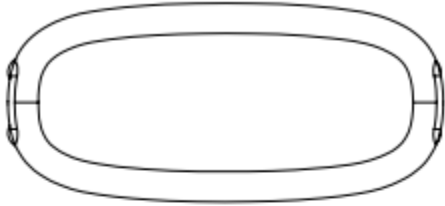

E: Line drawings gel pad holder

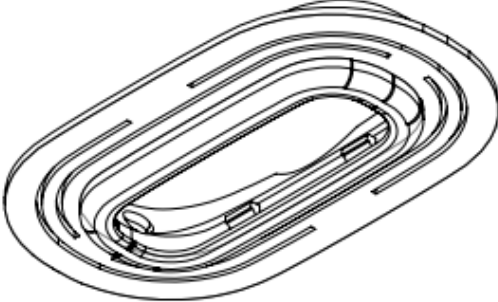
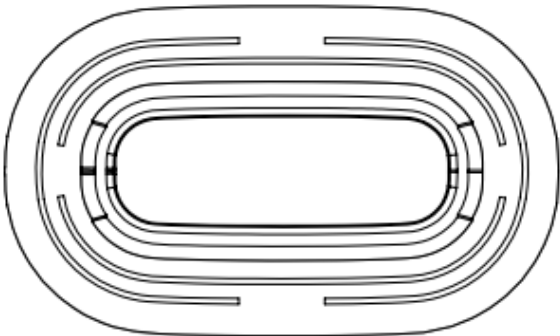
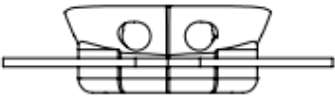
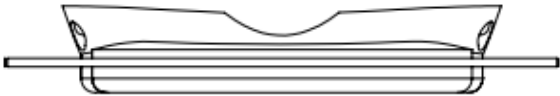
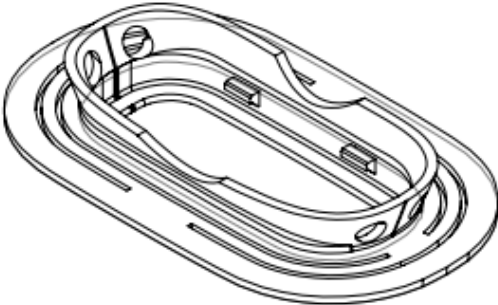
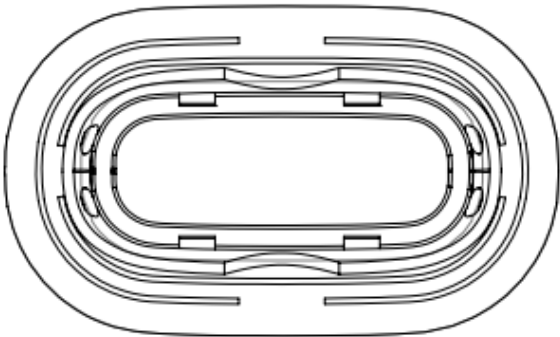

F: Line drawings adapter

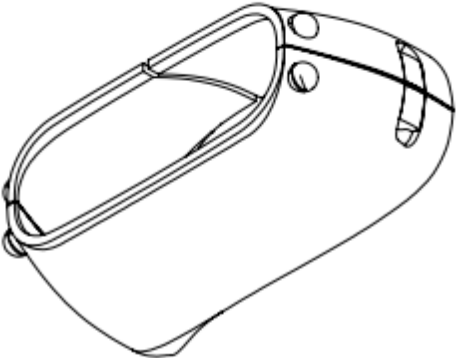
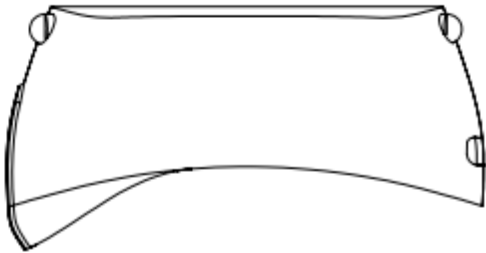
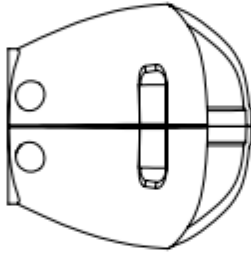
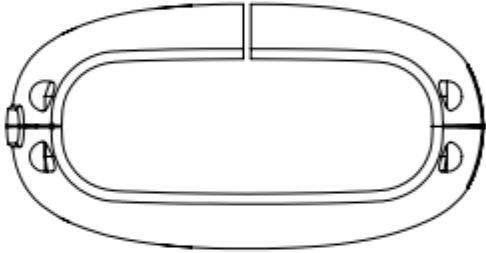
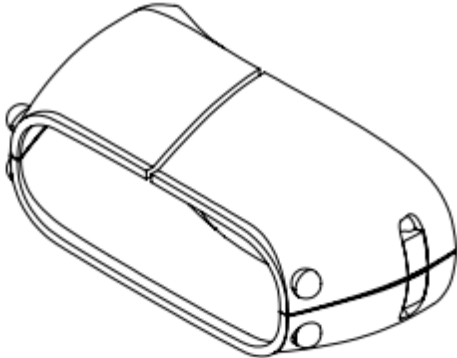
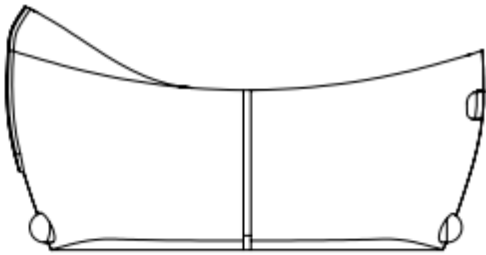

G: Line drawings plaster hook

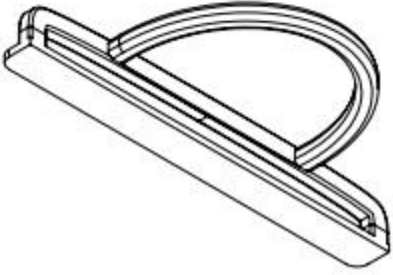
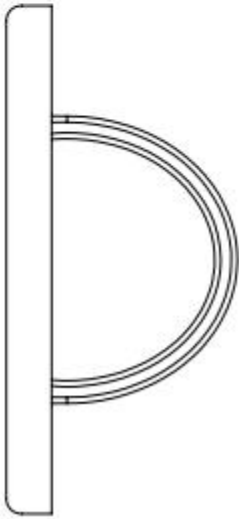
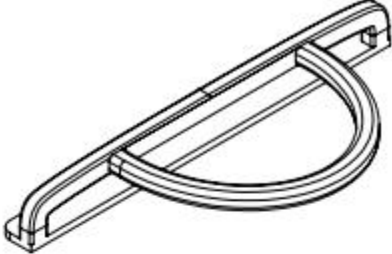
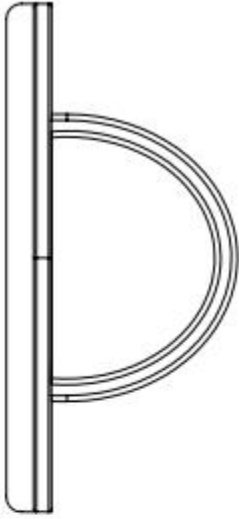

H: Line drawings assembly Pod

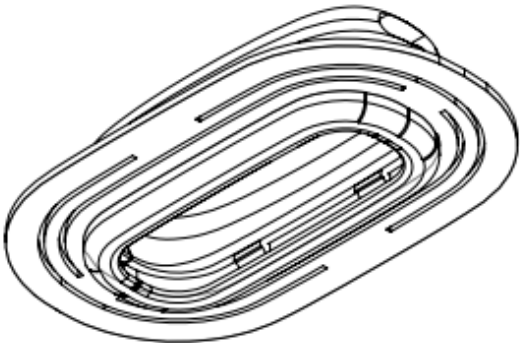
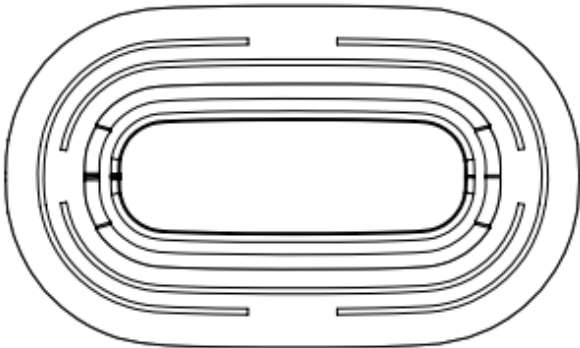
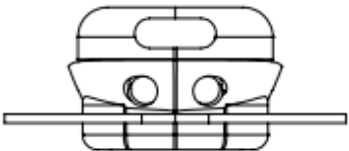
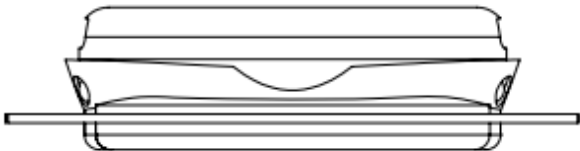
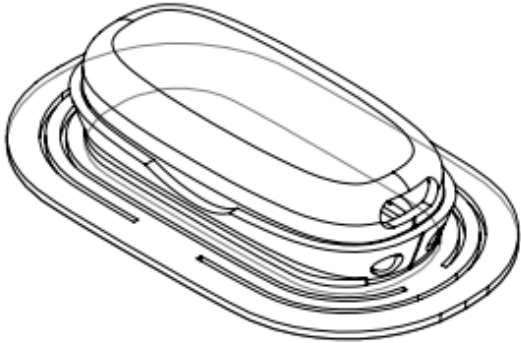
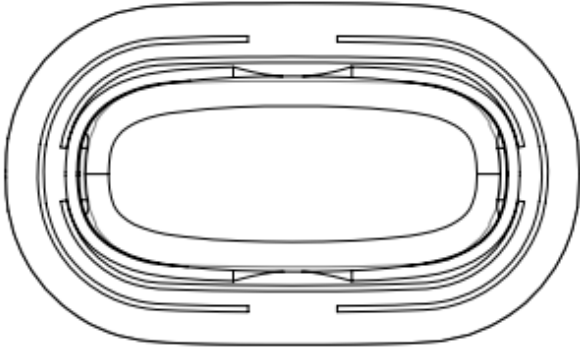

I: Line drawings assembly Lumify

