

Grandstand Design for Disassembly

Joël Klerks

Research Report: June 6th, 2014

Graduation date: January 30th, 2015



Architectural Engineering + Technology
Faculty of Architecture
Delft University of Technology



*One thing is certain: building on its current foundations of flexibility, sustainability
and the ability to create the extraordinary:
temporary architecture is a discipline with an exciting future.*

John Borrow, Populous

© Copyright 2015 Joël Klerks, Delft University of Technology, Delft, The Netherlands

All rights reserved. No part of this document may be reproduced for commercial purposes without written consent from the author. Permission is granted to reproduce for personal and educational use only with the use of proper citation. Commercial copying, hiring, lending and selling is prohibited without written consent from the author. For inquiries regarding this thesis please contact the author via e-mail: joelklerks@gmail.com.

Disclaimer

The images which were used for this report were found from different sources around the Internet. I do not own the right of any of these images .

Colophon

Student information

Student Joël Klerks
Student number 1502905
E-mail address joelklerks@gmail.com
Date P2-report June 6th, 2014
Date P2-presentation June 20th, 2014
Date P5-graduation January 30th, 2015

Address Markt 12
2611 GT Delft
The Netherlands

University information

University Delft University of Technology
Faculty Architecture
Master Architecture, Urbanism and Building Sciences
Studio Architectural Engineering + Technology
Address Julianalaan 134
2628 BL, Delft
The Netherlands
Website <http://www.bk.tudelft.nl/>

Committee information

Research tutor prof. ir. Rob Nijse
Structural and Building Engineering
Senior Advisor at ABT consultancy
R.Nijse@tudelft.nl

Design tutor ir. Job Schroën
Architectural Engineering
Architect at September
jschroen@septemberarchitectuur.nl

Building Technology tutor ir. Pierre Jennen
Building Technology
Architect at OvO associates
P.H.M.Jennen@tudelft.nl

Table of contents

I	Abstract	6		
II	Introduction	7		
III	Research Method	9		
1	Context			
1.1	Stadium relevance.....	11	3.4	Materials & properties
1.2	Media in the stadia	11	3.4.1	Materials
1.3	Sponsoring	12	3.4.1.1	Metals
1.4	Temporary events	12	3.4.1.2	Composites
1.4.1	Football	12	3.4.1.3	Plastics
1.4.2	Ice skating.....	14	3.4.1.4	Woods
1.4.3	Tennis.....	14	3.4.2	Material properties
1.4.4	Racing sports	14	3.5	Design for disassembly.....
1.4.5	Extreme sports	15	3.5.1	Bolts
1.4.6	Olympic Games.....	15	3.5.2	Tensile elements
1.5	Future challenges.....	16	3.5.3	Boltless connections.....
1.6	Business case	17	3.6	Structure.....
1.7	Conclusions.....	19	3.6.1	Base
			3.6.1.1	Concrete elements
			3.6.1.2	Scaffolding principle
2	Program		3.6.2	Seats
2.1	Functions.....	21	3.6.3	Patents
2.1.1	Seating accommodation.....	21	3.6.4	New designs
2.1.1.1	Visibility.....	21	3.6.5	Roof
2.1.1.2	Lighting.....	22	3.7	A new way of thinking
2.1.1.3	Acoustics.....	22	3.7.1	Form and composition
2.1.1.4	Roof as protection.....	22	3.7.2	Component dimensions
2.1.2	Media facilities.....	22	3.7.3	Build-up sequence
2.1.3	Kiosks and shops.....	23	3.8	Logistics
2.1.4	Toilets.....	23	3.8.1	Transport
2.2	Circulation.....	24	3.8.2	Handling
2.3	Fire engineering.....	26	3.8.3	Packaging
2.3.1	Precautions.....	26	3.9	Conclusions
2.3.2	Safety.....	26		
2.4	Conclusions.....	27	4	Research Conclusions
3	Technique		5	The Design
3.1	Foundations.....	30	5.1	Concepts.....
3.2	Structural performance.....	32	5.2	Design.....
3.2.1	Ultimate limit states	32	5.3	Design for disassembly.....
3.2.2	Design strength	32		
3.2.3	Factored load	32	6	Drawings and Model
3.3	Loads	32	6.1	Section for poster 1:20.....
3.3.1	Dead loads	32	6.2	Details 1:10.....
3.3.2	Live loads	32	6.3	3D model 1:100
3.3.3	Wind loads	33		
3.3.4	Horizontal loads.....	34		
3.3.5	Vibrations	34		
A	Reflection	85		
B	Case studies	87		
C	Bibliography	93		
D	Appendices	97		

Abstract

The need for a building or structure for a temporary event such as a sports tournament or match, contradicts with the thought of creating new permanent buildings every time such event occurs at a different location. Such expensive investments can become white elephants after their thriving starts, never to be used to the full extent as they were built for again. For this report, a research is done on how a temporary structure can be beneficial for onetime events. The emphasis is on the structural and aesthetical possibilities, since the research will form a base for an architectural design. Via an extensive literature research and some research by design, the following aims will be leading for the design:

- The intentional idea of only creating a grandstand as an extension for current stadia is obsolete.
- The structure will be demountable and transportable by sea or road.
- The grandstand can function as a hireable product by event organisers.
- A maximum timeframe of four functional weeks will be the aim for the design, with a maximum construction time in mind.
- The structure will be flexible in height, seat capacity, and functions, according to the preferences and demands.
- Certain measures and precautions must be taken to ensure structural safety.
- Bolts, tensile elements, and boltless connections can accelerate the erection and disassembly time.
- A cantilevered roof will be attractive for building speed, material savings, and an unobstructed view from the grandstand.
- The building element size will depend on transportation possibilities.

Keywords: Design for disassembly, grandstands, transportability, structural design.

Introduction



This research paper was written for my graduation project at the faculty of Architecture at the Delft University of Technology. In the studio of Architectural Engineering + Technology students learn about integrating technology in architecture in the fields like sustainability, climate, energy efficiency transformation, and reuse. This specific work focusses on the structural design of a building. The type of structure that is chosen to research and design is a grandstand with optional additional functions. The problem with events like sports and shows is that not every event in a stadium is visited by the same amount of people. Sometimes the smaller stadia with smaller viewer capacities think about expanding the stadium or even building a new one, which will bring lots of costs for the club and possibly its city. Also tonnes of materials will have to be used to create the building elements to form these structures. When it is finally erected, it doesn't necessarily mean that it will always be filled to the brim with every event, so most of the times lots of empty spots can be seen in the stadia which will also mean the atmosphere in the stadium will drop. The great discrepancy is the varying demand of viewer capacity per sports event and the decision to build definitive structures.

The objective for the graduation process is to design demountable grandstands which can be applied on demand, so organisations of the events can anticipate on the varying amount of people coming to the event. A wide range of problems must be solved for this issue, like variable heights and loads, acoustics, sightlines of the grandstands, demount possibilities and transport, differing aesthetics of the stadia, environmental protectiveness, fire safety, and so on. The ideal would be that the portable grandstand can be applied for any event which is visited by spectators and which can house a numerous amount of functions. The overall research question is:

How can a demountable grandstand with possible extra functions be applied on any desired location to be transported to and constructed on the site of the event, with simple feasible means in a short amount of time, fulfilling the wishes of the event organiser?

The subject was chosen out of interest in large structures which endure several types of loads, but also for the specific archetype of the stadium. The fact that the building can be a site with which spectators can build a relationship with during its lifetime out of support for the club fascinates me, just as other buildings from other types can become part of the memories of people.

The relevance of the research and the design lies in sustainable use of building structures. Reusability of structures is of importance to save materials, energy, resources, and building effort. The question of what to do with empty stadia is no longer of the essence, because with the new design they can simply be demounted, transported, and located elsewhere. A flexible design allows smaller and bigger options so that its number of possible event types will be broad. Temporary (sports) event types can be Olympic Games, World Cups of football, tennis matches, hockey matches, Moto GP's and Formula 1 races, air races, and so on.

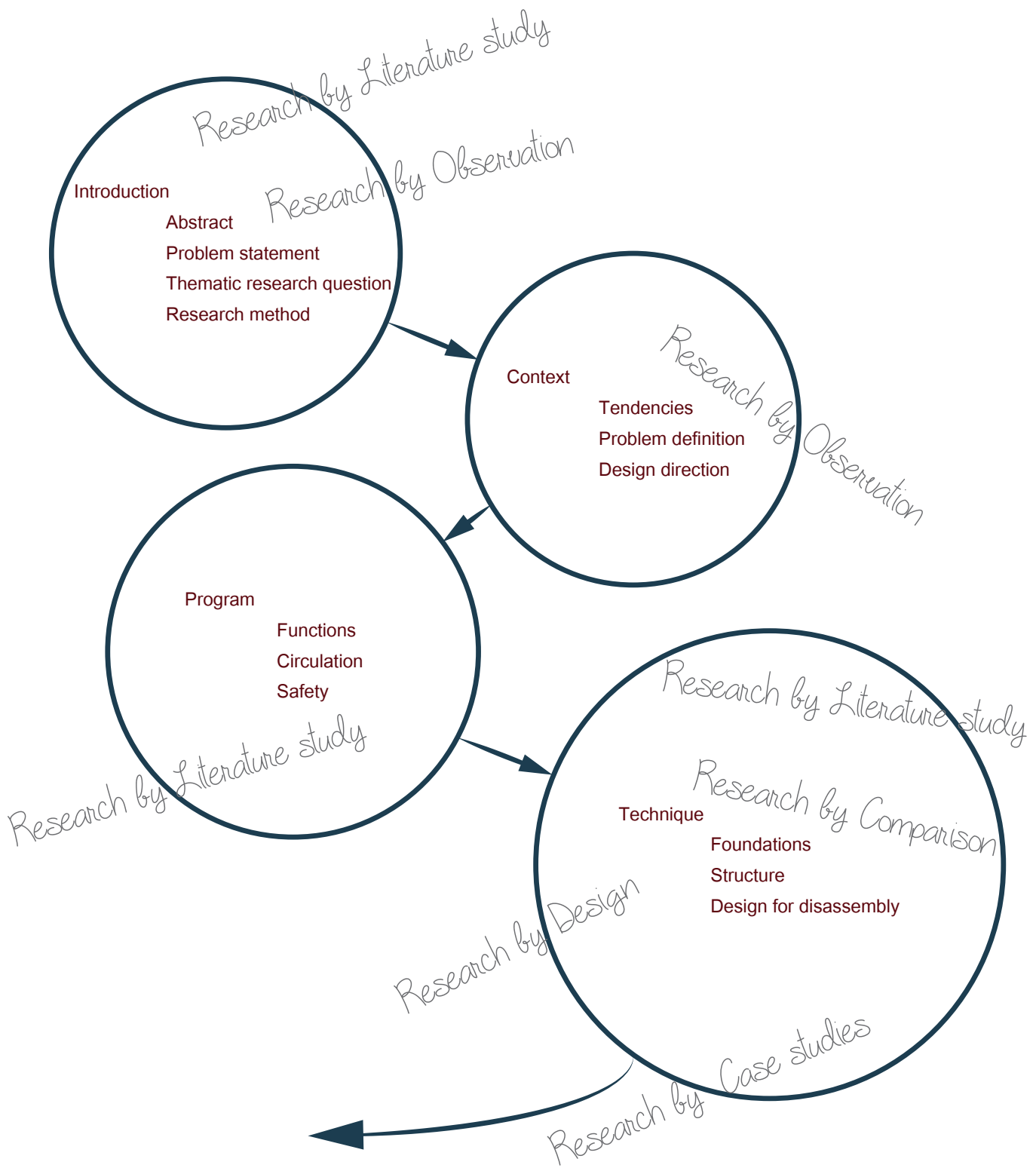

Research methodology



For this research a certain research methodology was used. This methodology can schematically be seen on the left page. The first step in the research was to define a structure which would guide me through the process. This structure embraces the three main subjects that we learned at the studio of Architectural Engineering + Technology, which are context, program, and technique. The first step was to define a main fascination for the graduation project, and for this fascination a structure for the research was drafted within the subjects of context, program, and technique. The main research methods used were research by literature studies, research by observations, research by comparisons, research by design, and research by case studies.

Research by observations

The observations done for the research consisted mainly out of figuring out what the current tendencies were in architecture and the use of stadia and their structures, and finding out if the first direction for this research (extensions of football stadium) was relevant. After observing that this was not the case, a shift in graduation topic occurred to temporary demountable grandstands and supporting facilities.

Research by literature studies

The research which was done in the literature consisted out of reading books and papers on the internet about the subjects that were part of the research structure. Especially for the part about 'technique' a lot of books were found at the central library of the Delft University of Technology. Papers and patents could be found on the internet.

Research by case studies

A new design cannot be done without examining older realised projects within the same typology. For the research, examination was done to older patents, realised designs, and newer designs for future applications, with the aim of understanding design problems, and defining difficulties and obstacles for the design process. Also much can be learned from these case studies in knowing what is possible for realisation.

Research by design

A small part of this research consists out of research by design, which is actually a collection of sketches that are made after literature readings and observations. These ideas were drawn on paper, to be analysed and possibly compared with one another. These options can be used as a base for the design process.

Research by comparisons

With the knowledge of case studies and the designed possibilities, comparisons can be made to determine the positive and negative sides of the options. By determining these points these 'tools' can be used for the design process which will follow after the research process.

At the end of the report the research question is answered, along with a summary of the conclusions throughout the report.



1.1 Stadium relevance

Stadia can be expensive buildings, but can also generate substantial revenues. Not only for the clubs or stadium owners themselves, but also the city around it or even the country. Examples for this statement are the greater Olympic Games or other big tournaments and matches where surrounding hotels, bars and night clubs benefit from the activities which are held in the stadia. That is why they can be a key ingredient in the marketing of cities, and even nations. The stadiums become work suppliers like a small city. Not only the players, spectators and club owner(s) are members of this 'society'. Cleaners, office workers, merchandise sellers and shopkeepers, snack sellers and ticket sellers and barkeepers are all doing jobs there to make money.

The challenge in obtaining and maintaining a stadium lies in the cost making and earning parts. Great costs have to be made like for building the structure itself, maintaining the building and paying its employees. Money can be made out of ticket selling, renting the pitch or its locations to external parties, and profit from the earnings of TV rights. In comparison with the potential revenue from sponsorship, the sale of naming rights of teams and stadia, the lease of VIP boxes, TV rights and merchandising, the sum of gate receipts is negligible (Zinganel, 2010, p. 78).

1.2 Media in the stadia

The gladiator fights in the arenas of the Roman Empire and the plays about gods in the ancient Greek theatres were visited by many people from different parts of the country or even different parts of the continent. People would never know how immense the Coliseum was, as it was one the first great structures man has ever built, until they would actually see the arena with their own eyes when they visited the site. The next thing was that they watched the spectacle inside the stadium, with the conformation that at that moment they were the only ones who would see the action at that specific time.

With the great developments in technology we are nowadays able to see a live match from thousands of kilometres away right away on our TV screens with commentary, and interviews with the players. These changes in scale also meant different kinds of income for the stadium and its owners. The stadia were no longer reliable on the amount of visitors inside and the possible club who is paying to play there, but their income was also based on the TV rights they could sell with the placement of cameras and media locations in the stadium.

The so-called fourth generation of stadia is coming up. The role of the television and the internet is increasing. The challenge for the future is to offer more detailed, or specialised coverage of events to a wider, or more specialist audience. There is no doubt the future of sports coverage is digital. Stadia will become studios of their own. Two different kinds of buildings are created, on one hand a sports and entertainment centre providing action for the live audience, on the other hand a studio serving the remote audience (Sheard, 2000, p. 13).

There can be no guarantee that future generations will find live sports as attractive as the present generation, and the move to provide better information to the spectator is essential if attendance at live events is to be maintained (John et al., 2007, p. 24). It is a fact that the quality of the viewing possibilities in stadia stays the same, whilst the quality of watching a match at home is increasing significantly. From the early days of black and white TV, we went over to colour TV and even live broadcasts. The regular square TV's were replaced by widescreens, later the wide- and flat screens got the ability to show its images in High Definition quality. Latest techniques even featured 3D TV, but also on a social media level changes can be seen in the technologies of sport. The possibilities of following one or several matches at home are not only far more diverse as one would find in the stadium, they are also much cheaper. For some matches nowadays people have to pay from 20 to 60 or even 100 euro for a ticket in the stadium, where a match can be watched at home for free or some small additional costs for the cable provider. A rise in demand for live or recorded images of the event in the stadium also meant a rise in facilities for the media. In chapter 2.1.2 *Media facilities* this will be further discussed.

The AT&T stadium, home of the Dallas cowboys. It is the biggest indoor stadium in the world with a capacity of 80.000 seats

1.3 Sponsoring

Unlike the classic stadium with its horrendous construction and running costs, the 'new stadium' creates a new revenue stream. Instead of persuading sponsors to place its advertising in what maybe unfavourable spots, the new stadium simply packs itself up and goes wherever the sponsor wants it. The architecture of the new stadium corresponds to whatever a film director or camera operator momentarily requires (Zinganel, 2010, pp. 89-90). There are of course sponsor deals which are meant for the event visitors only. This can be seen for example in free gadgets which are distributed among the people during the event, company logos on tickets and merchandise, and specific beverage brands that can be bought in the kiosks. The greater sponsor earnings however can be earned by the borders around the pitch, the signs along the race tracks and the commercials during live feeds of television. The reason for that is that the number of viewers at home is much greater as live spectators, so wherever the camera lens goes in the live event, the eye of the viewers at home will go as well. Strategic positions for sponsoring can rise the value of the structure.

1.4 Temporary events

The need for temporary structures will differ for the type of event. In the following part the types of events will be discussed to investigate for what sorts of events the temporary grandstands can be beneficial. The sports events that will be discussed are football, ice skating, tennis, and racing sports, because they are the most viewed sports on the Dutch TV. The other events are extreme sports which are meant for entertainment and display, which has a slight competitive touch to it. Examples for this category are air races, crashed ice, snow events, and stunt shows.

1.4.1 Football

Is there actually a need for temporary grandstands to increase the capacity for the football stadiums and if yes, will that also be beneficial? The question here lies in the ratio viewers/income for the club, and if they are able to hire the grandstand for a certain amount of time. The standard costs of building and demounting remain for the lessor, while it doesn't cost him extra while the stand is up. It is therefore financially more attractive to hire the grandstand for a longer period.

There are several problems which lie in the application of the grandstand as an extension of the current state of the stadium. The first one lies in the attractiveness of the matches in the time that the grandstand is hired. It is a known fact that the better and more known clubs have more fans and viewers during their matches, that is why you can see a relationship between the size of the stadium and their rankings in the competitions they play in; the higher the ranking, the bigger the viewer capacity is of the tiers. This has the following meanings:

1. The biggest clubs have the biggest stadiums, which are physically hardly able to expand without changing its current structure;
2. The middle sized clubs already have a certain height of the grandstands. The problem is that an extension will have blocked visibility lines because of the current roofs they already have;
3. The smaller clubs do also have roofs but they can be demounted.

The football stadium of FC Emmen. Just like an arsenal of other smaller stadia in the Netherlands the surroundings give the opportunity for temporary stadium expansion, the only thing what have to be done is to remove the light steel roof. The problem is that figures do not say that there is a need for temporary expansions.



The problem for the smaller clubs is that because of the little interest by viewers they have they commonly do not want to expand. Temporary grandstands can come in handy but only for certain events with higher viewer capacity demands, like promotion possibilities in a division, or important matches such as those for the championship, cup matches and in very rare cases league matches (just like the small PEC Zwolle is going to play in the Europa League because of their accomplishments for the Dutch cup).

A short research was done on the smaller stadiums in the Netherlands and their possible opportunities to temporarily upgrade their viewer capacity by adding an extra structure behind the current grandstands. This can be seen in Appedix 4. The following conclusions can be drawn from this research:

1. Almost every club has some space behind at least one and up to three of their current grandstands. However it does demand for some adjustments to the spaces. In most of the cases the land must me flattened and some vegetation has to make way.
2. All the small stadiums have only one tier. This tier is in every case covered by a roof structure. They all have in common that it consists out of a steel structure with light cladding, in most of the times a corrugated plating material. The roofs will actually block the sight lines of the extra visitors whom are seating on the new structures. The



advice is to look for possibilities of demounting these roofs. After the period of usage of the temporary grandstands, they must be reinstalled to protect the visitors against the weather conditions. This is for every stadium different, but common knowledge about steel structures can give insight of how to handle the situation for every site.

So in physical terms, it is actually possible to apply extra grandstands in most of the locations for the Dutch football stadiums behind the current tiers, in case extra space is created and the decision is made to demount the current roofs and place it back when the temporary stands are gone (also replacing the roof by a new light structure which is easily mounted on the current stadium is a possibility).

The question is also when these stands are necessary throughout the football season and for which period(s). It seems that for the longer periods throughout the year the amount of visitors is pretty decent in comparison with other European countries (Lenders, 2013a). The percentage of visitors vary from 60 until almost 100 percent of the stadiums capacities. It must also be said that these numbers are about the 15 clubs whom are playing in the highest division in the Netherlands, the Dutch Eredivisie. For the second division, the Jupiler League, the number of visitors is worse. Infostrada Sports calculated that in the first half of the season 2012/'13 the average amount of visitors was only 55.3% of all stadiums capacities, 3,595 / 6500 Table of these numbers (Infostrada Sports & Blauw Research, 2013). According to Ter Haar, this number is decreasing. He stated that in the year 2012/'13 the number of visitors was on an average of 3,457 per match, and it even decreased to 2,978 in the first half of the season he reported it (Ter Haar, 2013).

As for other events in the Dutch leagues where the smaller clubs also participate (because the impossibility to create extra tiers behind the current largest stadia only the smaller ones are considered) it was also necessary to check if the stadiums were filled or not. One of the examples of such events are the play-offs at the end of the season, where a few matches between the number 16 and 17 of the Eredivisie will play with the period champions of the Jupiler League to decide who promotes and who relegates. It seemed that the average amount of viewers was somewhat higher as throughout the whole year for the whole competition, but still the same for the clubs themselves with an average of 63.3%. See self made excel sheet with wikipedia as source.

Another different competition for the Dutch teams is just like in other countries where they play for the national's cup, in the Netherlands the 'KNVB-cup'. With the viewer count information of Transfermarkt.nl a table was made with a calculation of the attendance of viewers in these matches, where even smaller clubs as in the Jupiler league also played (Transfermarkt.nl, 2014). This table can be found in Appendix 1. The percentage of attendance was calculated at 40.7%. A side note must be mentioned here about the standing or seating possibilities for the smaller pitches. It is more common that they give a certain capacity for their stadia, like 4000, but most of these are standing places. Normal seating comes to a maximum of 20% of this number, so these seats are all taken during such matches. An extension of these seats can mean that these will be filled as well, so people no longer have to stand during the match.

As a conclusion it can be stated that temporary extra seating is not necessary for the clubs in the Dutch Eredivisie, Jupiler League or for the KNVB cup in current times. An estimation for future years cannot be based on earlier ones.

However, a demountable grandstand can function as a part of a temporary stadium. Temporary football events can be like the World Cup, held anywhere on the world. The problem some cities had after they hosted the World Cups were the empty mono-functional stadia, where never again the global matches would be played again. It is important if such application is desired to design for repetition, so that a whole stadium can be built with the same building principle.

"It is a golden rule never to increase stadium capacity beyond that which is known to be necessary, and can be demonstrated to be affordable both in capital cost and running cost. The factors which will lead to a preliminary estimation of ground capacity are the functions, area around the stadium, owners, history of the site and practical limitations. The implications of seating numbers must be carefully checked against considerations such as the quality of the view, the possibility of a roof, the aesthetic character, inside and outside, the cost of the structure and running costs, and the possibility of support facilities." (John, Sheard, & Vickery, 2007, p. 127)

The figures for the mean amount of visitors in the Dutch stadia, throughout the football seasons of 2010 - 2013. It is clearly visible that only nine clubs reach a percentage higher as 90%, and none of the stadia is sold-out every match.

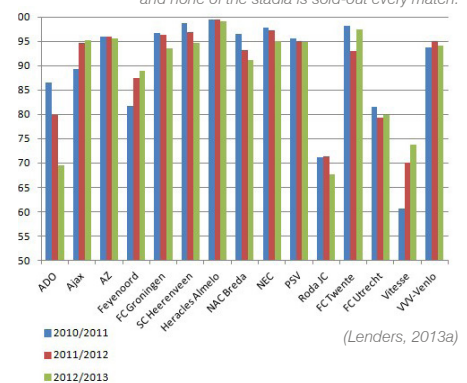

(Lenders, 2013a)

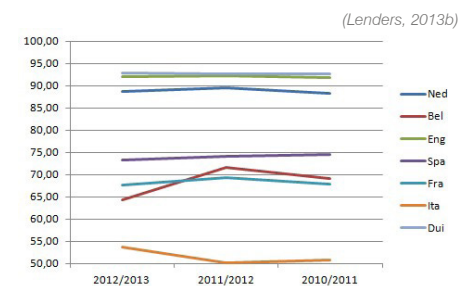

(Lenders, 2013b)

The attendance of football supporters in the rest of Europe throughout the football seasons. The highest number occur in the Netherlands, Germany and England, whilst for the rest of Europe the attendances are much lower.



A design for a temporary stadium expansion by na-ma architects and Tom Bergevoet architects.

1.4.2 Ice skating

In contrast to the open aired football plays, a lot of ice skating and especially the short to medium long distances (10 km) are held inside in a great sports centre. The regulations to keep the ice well enough demand so in this Dutch variable climate. It is therefore impossible to apply extra demountable grandstands since the tracks are location inside huge covered buildings. It happens sometimes that the ice skating events are held outside, to gain popularity and add an extra competitive component to the matches. The Olympic Stadium in Amsterdam had the honour to host the Dutch Championships. The three days were almost every day sold out (Brouwer, 2014), so for this event it may be possible to install temporary extra grandstands for the people, but also for the media who can report and film on site.

As a conclusion it can be stated that there is some need for temporary seating and media facilities, but only for short periods of time like for the national championships (three days) in outside conditions where the stadium offers possibilities as well. Longer periods of grandstands and tiers for outside usage did not occur yet for ice skating. Because of the same sizes of the Amsterdam Olympic Stadium, other European open air stadiums can also be looked into for expansion possibilities. This doesn't have to be particularly for ice skating, but can be for athletics as well since they also take place in open air stadia.

1.4.3 Tennis

Tennis is also a sport which is widely viewed in the Netherlands. The problem is that the Dutch sportsmen themselves do not achieve much lately, and there are not many big tennis events happening in the country. The biggest of these are the ATP in the Ahoy in Rotterdam and the Rosmalen Open, where the ATP is a tournament which takes place inside and the Rosmalen Open outside on grass. The standard amount of seats which are needed for the tournament are usually normal seats, but do give opportunity for something extra with integrated facilities.

The other tennis events in the Netherlands are the Davis Cup matches, which only take place a few times of the year. The locations for these matches differ, depending on the type of ground the players want to play on. Sometimes it is held in a current stadium, but sometimes it is held outside in a temporary one. The event takes place over three days, and depending on the number of visitors to such an event the size of the temporary stadium is determined.

In international terms, tennis is also a big sport. There are loads of tournaments in Europe where the best players of the world compete in ATP's, futures and challengers, and the biggest matches of the year are held in London and Paris on the Grand Slams. These events do not need large viewer capacities throughout the year, but with these peak moments they certainly will give extra value to the locations.



Tennis tournaments are held all over the world on differing locations. Most of the times the tennis courts and the supporting facilities are temporary.

1.4.4 Racing sports

There are different sports which are under this category. The two events which are mostly watched on TV are the Moto GP and the Formula 1, but other racing sports do also have a lot of live supporters because of the scarcity of these events in every region. The grand prix races are international, meaning they also have a great variety of viewers in different countries. For the Formula 1, the top five countries where it is watched are Germany, Italy, China, Spain and Great Britain, where Brazil is an upcoming country as 6th. Viewer numbers fluctuate every year, from 600 million (2009), to 520 million (2010), up to 527 million (2011) and just over 500 million for the 2012 season (a season has 19 GP's so the average per GP is around 26 million per GP) (Sylt, 2013). The Moto GP is somewhat behind with 280 million viewers for the whole season, but is getting more and more viewers each year (Mustafa, 2014).

The opportunities for integrated grandstands and their facilities lie in the building time, material savings and relatively low costs. The GP's of Valencia, Monaco, Sochi and Singapore and future others are special, because they are held in the streets of cities. Not only they have a need for grandstands, but also other demands like media facilities and probable food areas, since the racing tracks are so big that it is infeasible to concentrate them all in one spot. The building and demounting time is essential, since every extra minute less will save money because of the saved costs to the city. It can also be possible for normal GP's to make use of the temporary grandstands with possible other functions.

The Grand Prix of Monaco, a yearly returning race for the Formula 1.



1.4.5 Extreme sports

The rise in number of extreme events has increased in the last few years. The variety in sports is very broad, with broadcasted events of aerial races, BMX, crashed ice, creativity dancing, FMX, mountain biking and surf events on the beach. A great sponsor and organiser of these type of events is Red Bull, the brand of an energy drink. They organise events all over the world, demanding great varieties of locations for their sports. These are held on all terrains like on water, on ice, on snow, dirt, grass and in the city, but also in the air like with their Red Bull air races. The resemblance in these events is that they are most of the times only held once at a specific location, only to be relocated in other times of the year.

These events also demand viewer capacities and the possibilities for media to film, photograph, report and broadcast. The advantage of temporary structures is that these can travel with the events to their locations. With the knowledge of constructing the demountable structures, time, money and effort can be saved.

1.4.6 Olympic Games

An interesting context for the demountable grandstands would be the Olympic Games. With prefab components for a structure where people can sit and view events but which also houses different facilities, any location is possible. The great advantage of this is that it can be transported to all locations around the world by seas and roads, so every future Olympic city can benefit from the temporary structures. It would be no longer a problem to designate other functions for the buildings, but they can simply be demounted and reused elsewhere. The used ground for the Olympic events can be used for other purposes in the future after it has fulfilled its function.

The desired flexibility of the system is to hold any capacity needed for the event. Smaller outdoor games may not demand a high spectator capacity where bigger sports with more viewers do. Just like for activities such as World Cups for football it should be possible to form entire stadia with the repetitive design.

From the analyses some conclusions can we drawn. First of all, football stadiums in the Netherlands do not really need to expand definitively. At least this counts for the smaller clubs, because of last seasons' occupancy of the seats in the stadia. If they eventually do, their current structures of the roofs and their locations give certainly possibilities for temporary or definitive structures, provided that some changes must be brought to the surroundings of the stadium. Examples are deleting some near vegetation and preparing the ground for founding and/or standing of the new structure. Also the roofs must be taken of temporarily or replaced by easy-to-fix new temporary roofs.

As for the second best viewed sport in the Netherlands, ice skating, it is a fact that the indoor arenas cannot easily be expanded with grandstands, left alone temporary ones. Outdoor arena's such as the Olympic Stadium in Amsterdam do give the opportunity for these grandstands, but are mostly used only a few days as such. This fact can also be translated to other open air activities and sports such as athletics which also take place in stadia. It is not bound to just the Netherlands, it can also be transported and used elsewhere in Europe. When the travelling distance becomes larger, a great chance is that it will not be feasible anymore.

Also for tennis the outdoor activities are limited in the Netherlands. The sport has far more tournaments in other countries, and the viewer demands are only high during these events. The erection of temporary tennis stadia can mean that every city is free to organise the top tennis tournaments, with the added value of media and/or VIP boxes integrated.

The 'F1 circus' travels around the world with all the racing teams, cars and spare components they have. The GP locations differ from existing tracks to temporary tracks in the city. With the high viewer demands from all over the world and the live viewer capacities needed, one could think of integrated temporary designs as mentioned earlier.



Red Bull Air Races are popular events which are held in the bigger cities of the world. The events are temporary, and a lot of visitors come to visit every time when the event is held.

1.5 Future challenges

According to David Chernushenko, who wrote for Stadia Magazine in 2002 *“the age of rented equipment and temporary facilities has arrived”* (Chernushenko, 2002, p. 1). Savings will be brought in constructing periods, no damage will be done to the environment, and no permanent facilities have to be taken care of or maintained after their temporary function for a main event. A realistic projection is to build stadia with a temporary large seating capacity that can be retracted in size/capacity after the big event. A greater challenge would be fluctuating a stadiums capacity according to the demands of the events, so costs can be minimized and sell-out crowds maximised. This is because the amount of sports viewers are not a constant, the numbers differ per match, per season, per decade and so on. Temporary fields, tracks, flooring and seating can all be put to good use, ensuring the long-term viability and regular use of outdoor and indoor facilities. It is even possible to combine permanent with temporary structures, so permanent ones can be complimented with temporary extra facilities and seats to host major events.

Upsides (Chernushenko, 2002)	Challenges (Chernushenko, 2002)	Solutions?
<p>Economical</p> <p>Avoided capital and maintenance costs.</p> <p>Additional revenue from infill seating in existing facilities.</p>	<p>Absence of industry-wide standards can impede true competitive bidding and require additional time and expense for design work.</p> <p>The limited number of qualified vendors in some parts of the world adds additional transportation costs and reduces competition.</p>	<p>An increase of temporary stadia can lead to industry-wide standards, making it possible for architects to design within these standards.</p> <p>When event organisers discover the benefits of temporary facilities, an increase of demands can possibly result in more vendors. On the other hand it can be an option to design components for a minimum amount of shipping containers.</p>
<p>Environmental</p> <p>Reduced overall site 'footprint'.</p> <p>Less waste created and energy consumed in construction/erection.</p> <p>Near perfect reuse/recycling of materials and equipment.</p>	<p>High energy use to transport equipment from one continent to the next.</p> <p>Harm to fragile sites if facilities are rapidly erected and dismantled without the same precautions as for permanent construction.</p>	<p>This may offset against the massive cost savings for new materials. Also, strategic location storing of the building components can reduce the distance to travel.</p> <p>Decent soil research must be done before erecting the stadium on a location. After dismantling, the ground must be brought to its original state.</p>
<p>Social</p> <p>No residual impact on the host community.</p> <p>No long-term debt or operating expenses for the taxpayer.</p>	<p>Taking care to design a temporary facility that will not be aesthetically obtrusive, create serious traffic problems or in other ways disrupt local communities.</p> <p>Providing a similar quality of experience for users as a permanent facility (seating comfort, visual, warmth and 'feel'.</p>	<p>It is the task for the architect to design for the experience of the supporters and give his insights for this building type.</p>

1.6 Business case

The financial feasibility of temporary grandstands on a location lies on various factors, as already stated at the beginning of this chapter if it is translated from a stadium by Zinganel (2010). In all cases, the involved parties want to benefit from the event which is held at the location. They therefore also have to make pay other parties. On the next page, a money flow chart with possible expenses/incomes from the involved parties is displayed, where the amount of money differs per event. The main rules of thumb are the more people watching it on TV, the more money can be made with selling TV rights, and the more expenses can be done by renting the temporary grandstands.

As for a more financial approach, this scheme can be divided by separate researches. The four main categories can be: I. Stadium and media economics; how they can complement each other (a market research), II. Optimization of stadium income due to visitors, III. Choosing the right site for a one time event, IV. Financial feasibility of temporary grandstands. These are all shown in the money flow chart.

Because of the technical and background this report embraces, no further research will be done on the first three. The fourth one is actually done for a whole temporary stadium instead of a single grandstand unit by a student of Civil Engineering and Geosciences for his master thesis. In "*Preliminary structural design and financial feasibility study of a transportable multi-functional stadium*" Marcel Klomp (2013) discusses how a demountable stadium can be feasible with the following main assumptions, estimations, and boundary conditions about the use, incomes and expenses (others are not mentioned but can be viewed in his thesis):

The demountable stadium

- Lifespan of 30 years.
- 8 big events, such as World Cup football matches.
- Break even after these 8 events.
- The first 2 years will be used for the design, manufacturing and erecting the stadium.
- €4000,- per seat, 50.000 seats in total
- Maintenance costs of 5% of the initial costs every 10 years
- After each assembly/disassembly 5% of the initial costs are unforeseen damage costs.
- The cost division are 18% for transportation, assembly and disassembly, and 82% for the materials. He has derived this from an interview he had with Hollandia (2013) and two master theses, namely from Den Hollander (2010) and Loosjes (2011). Den Hollander stated the cost division on 70% material, 25% assembly and 5% transportation, but Loosjes was according to Klomp very ideal at 95% material, 5% assembly and 2% transportation.

His conclusions were that building new stadiums for one time events were inefficient. For a whole stadium, the costs of a transportable one for big venues lie in the lease fees, which are determined on 22% of the price of a permanent one which has no use after the one time event. If the results of the market research should turn out positive, then a transportable stadium is feasible (Klomp, 2013).

The research of Klomp (2013) has similarities and differences with the aim of this research. For example, the type of structure is a whole stadium compared to a single grandstand unit. For a single unit the costs will significantly be lower, just as the assembly/disassembly time and the number of materials, and therefore the structure is less complex. The number of uses is lower for the whole structure as for one single unit since the unit can be applied to numerous of activities because of its flexibility in context. The stadium is designed for the great games of World Cups and the Olympics, which occur every four years, while a single unit can be applied throughout the whole year on a great variety of locations, depending on its construction time. Also, the aim for the temporary design is to add other facilities instead of only seats to watch the game.

Similarities lie in structural demands and safety demands and demountable properties.

3. Companies make money out of the products which they display on the commercials.

1. The viewer at home watches the event, but commercials are also shown.

2. Sometimes extra money must be paid for live sports and events.

5. The television broadcasters want to film on site to report the event and broadcast it on tv. They therefore have to pay the organiser of the event or the owner of the stadium for standing places, rights, broadcast boxes and camera positions.

4. The companies must pay the television broadcasters in order to commercialise their products. The costs will rise in correspondence to the popularity of the program or event on tv, where more viewers will watch.

8. Sometimes the organisation of the event must pay local authorities to keep the event in the city, or it will hire the location.

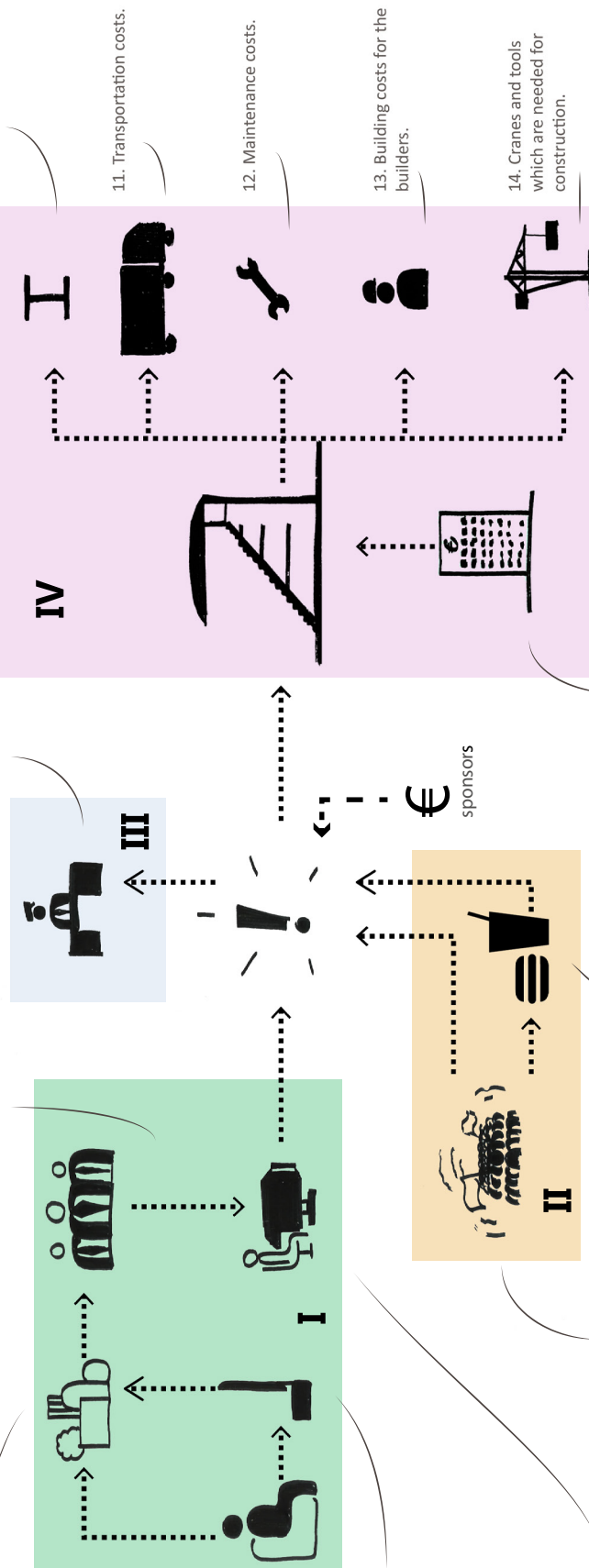

6. Live viewers will pay for snacks and drink inside the stadium, and sometimes merchandise.

7. External snack and food companies can sometimes hire selling locations at the event or in the stadium.

9. The initial costs for the construction and the materials for the grandstand must be loaned by the bank and have to pay off after several years.

1.7 Conclusions

A stadium belongs to a building typology that does not seem to extinct since its beginning of existence when sports emerged as entertainment events for the people. There's a great variety in types of sports and events where great numbers of people come to spectate the sportsmen and women. Recent sports and events are not necessarily held in the larger stadia, more and more the tendency leads to urban streets, rural areas, and nation's waters. With the choice of the locations the events are constraint to temporary timeslots. This was already the case for the bigger tournaments like World Cups and Olympic Games, but now also smaller events and tournaments are held at new locations, only to last as long as necessary. The discrepancy between building permanent structures for temporary events must be discouraged, and temporary buildings for grandstands and supporting facilities can be a solution for the problem. The direct effects are materials savings, shorter construction periods, fewer harms to the environment, and the of white elephants after stadium's temporary thriving periods.



2.1 Functions

Every building has its main function and its associated program. A program can be a collection of functions within a building which support the building and the users' needs. As concluded in the first chapter, the temporary demountable grandstand must be designed to fulfil its function as grand seating place for spectators of an event, where the type of event depends on the hirer of the modules. Thereby it must be possible to place other kinds of functions as supporting facilities. It can therefore be possible to arrange multiple modules next to one another, forming a collection of tiers. The supporting facilities can be chosen out of regulations, luxury, or financial reasons. Most of the times are the regulations leading, and the financial reasons give the organiser the urge to realise extra facilities around a stadium or grandstand. In this chapter the main possible functions are discovered with the obligatory dimensions, arrangements, and materials/applications.

2.1.1 Seating accommodation

Normally, seating places arranged in rows need to be permanently fixed, but in case of a temporary set-up, seats in each row need to be firmly linked. Generally speaking, seats should be comfortable, safe, easy to clean and easy to maintain. As a guideline can be stated that the minimum dimensions are seat widths between 450 – 500mm, placed on treads measuring between 760 and 800mm deep. A wider tread depth means more room for the knees and legs. A safety factor is the number of permissible seats in a row, which is 28 in the United Kingdom but in other countries up to 40 (Sheard, 2000, p. 48).

The main demands for the seats are that they have back with a minimum height of 300mm, are vandalism-proof and are made of climate resistant and inflammable materials (Nixdorf, 2008).

2.1.1.1 Visibility

The design aim is to provide seats or standing places for the number of spectators required by the brief, and to do so in such a way that the spectators have a clear view of the event, and are comfortable and safe (John et al., 2007, p. 123)

As a supporter or user of a grandstand, spectators' viewing standards essentially depend on three factors, namely the distance to the pitch, the ability to see past the heads of the people in front of you and not having the view impeded by obstructions. So the way the roof or upper tiers are designed are also influenced by these criteria, since beams, barriers, fences and columns are not allowed to stand in the way. For each individual sport there is a recognised maximum viewing distance. This is based on the fact that the eye finds it difficult to perceive anything clearly that's subtends an angle of less than about 0.4 degrees, particularly if the object is like a ball is moving rapidly (John et al., 2007, p. 128). Together with the boundary of the minimum amount of -0.5 square meters of surface per spectator, the form of the tiers can be designed. The maximum viewer distance should no more be than 190m from the furthest corners of the pitch, and the optimum is 150m (Sheard, 2000, p. 46).

The quality of sightlines is determined by the C-value. This is defined by the height of a spectator's eye line above the eye of the spectator in front. It is necessary to find a compromise between the angle of the C-value and the angle of ascension (35-42 degrees) according to the Building Regulations (no more than 34 degrees). The formulas which are given for this C-value have the following variables:

- C = Viewing standard
 - D = Horizontal Distance from eye point to point of focus, namely the touchline of the pitch
 - R = Riser height, or the vertical distance from the eye point of focus till the ground floor
 - T = Tread distance
 - N = Riser distance
- (Sheard, 2000, p. 47)

With computer aided design, a stadium plan can be modelled to optimize the seating capacity according to specific values which are desired/obliged in the stadium. A C-value with a minimum of 90mm is ideal for a new design.

The interior of the Lord's Media Centre at the stadium of Lord's Cricket Ground.

The important C-factor can be calculated by knowing or deciding the distances to the pitch, the riser height, the tread and riser distance, and the horizontal distance.

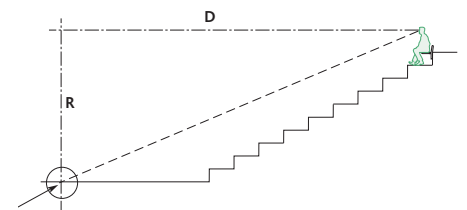

$$N = \frac{(R+C) \times (D+T)}{D} - R$$

$$C = \frac{D(N+R)}{D+T} - R$$

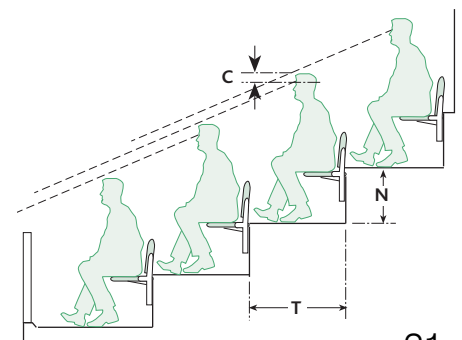



Well chosen and placed stadium lighting can cause a greater atmosphere in the stadium.

2.1.1.2 Lighting

An overriding aspect of stadia design should be to allow as much daylight as possible into the building, thus avoiding the use of artificial lighting as much as possible. Translucent roofs can provide daylight to the spectator areas and this is not only beneficial from an energy point of view but is also preferred by spectators, providing a more pleasant outdoor 'ambience' for the user. The stadium is, after all, a building which has its origins in outdoor sports.

Lighting units require huge amounts of electricity. Floodlighting comes from giant lighting towers which require up to 150 MWh/year. Savings can be made in the light fittings, rationalized lighting levels, improved distribution, maintenance and control systems (John et al., 2007, p. 246). A challenge for the design can be a possible obstruction of the new temporary grandstands with the current lighting systems in the stadia. It may be necessary to apply lighting systems in the design to create more light on the pitch, but it is the question on how far this question needs to be answered in terms of framing the design question into one subject.

2.1.1.3 Acoustics

For acoustics design in stadium engineering, one must consider the functions which will be on the pitch. If it is only about football, the desire to hear the sounds from the field will not be as great as if there's a concert playing where visitors especially will come for the music. There has been an increasing demand of acoustic consultants in stadium engineering, and the acoustic issues can have fundamental effects on the design itself. In stadium design, the following noise sources can be considered; construction and demolition, range of events, audience, public address system, mechanical and electrical plant and transportation noise (Griffiths, 2002, p. 174). For the subject of demountable grandstands without regarding what function there will be on the pitch, the following elements can be of importance:

- Acoustics in (de)constructing
- Audience
- Integrated installations

The roof of the Dragon Stadium designed by Toyo Ito powers the whole stadium. It also gives shading to the visitors on sunny days.



2.1.1.4 Roof as protection

The main argument to design a roof for a grandstand is to protect the people from the weather conditions, like snow, rain, hail and wind, but possibly also from directly looking into the sun when the tiers are facing its direction. In case of the presence of a grass pitch, the pitch must be in the sun as much as possible, with also some allowance for some wind to go over the pitch. In the case of demountable grandstands, it is less applicable to design with the last fact, since its locations will differ, as the orientation of the pitch and the position of the grandstand as well. There are several design criteria which must be considered when designing a roof for a stadium:

- *Structure*; as we saw in the case of visibility, columns and other elements which can obstruct the view must be avoided. This will be discussed in 3.6.5 *Roof*.
- *Wind*; not only is the approach of the back or the sides of an issue, if the wind approaches the roof from the front it can also create an uplift. In "Stadia: A design and development guide" (John et al., 2007, p. 63) it is even stated that *more grandstand roofs have failed from destructive uplift than from collapse*. Lightweight structures will have insufficient mass to naturally dampen the 'bounce' of gusts and the up and down going of the roof. Adequately stiffening the structure with special braces and combining the structure's elements so that they will function together as one system to control the vibrations.
- *Height and size*; The appearance and its functionality will be discussed in the technical part of this report in 3.6.5 *Roof*.

The Lord's Media Centre, with great visibility for commentators and analysts.



2.1.2 Media facilities

Facilities for the media are an integral part of stadium design, involving the press, radio and television. It is prescribed that the media facilities should be grouped together at the same side of the team's dressing rooms, but also be accessible from the parking zone and the broadcast vehicles with their own reserved places (John et al., 2007, p. 189). The three different work areas for the media are 1. On the stand (TV, radio, print media, photographers), 2. Beneath the stand (press conference, TV studios, commentators' point and TV control room, media centre), 3. Outside the stadium (parking spaces and set-up areas, media transfer point).

The seats for commentators require specific dimensions, including tables where

monitors can be put on. The CCR or Commentary Control Room is for a full stadium expected at 150m². For a full sized stadium according to the FIFA standards the TV studio must be at least 50m² with a minimum height of 4m. The main or lead camera for a football match is situated on the main stand, with the technical recommendations of the FIFA for the camera angles: first touchline 27° - 36°, centre spot 16° to 20°, penalty sport to be see above crossbar 12° to 15° (Nixdorf, 2008). For other activities the specific angles must be looked into before determining the camera positions.

2.1.3 Kiosks and shops

Refreshment stalls should be placed in a clean and attractive environment and be easily accessible and evenly distributed throughout all sectors (Nixdorf, 2008, p. 38) The snack shops cater for customers before, during breaks and after an event, and in most of the times they are even open during the event. The selling points are integrated into the stadium structure, where the queuing customers should not conflict with the circulation routes (see also chapter 2.2 Circulation). The aim for the stand employees is to work swift to keep the queue to a minimum. The minimum required space is 35 – 45 m² for preparing and selling foods and drinks. A derivation of Table E in StadiumATLAS: Technical Recommendations for Grandstands in Modern Stadia by Nixdorf (2008, p. 70) gives the mean for twelve German stadia for the following values: 47 customers per catering area per m², with the useful depth of 4.2m.



Long queues can cause congestions in the halls of stadia.

2.1.4 Toilets

The number of toilet groups differs in the type of people which will have to make use of these toilets in a specific part of the building. Players and referees are off course separated from the crowds, just as the management or VIPS are separated from the workers in the stadium. It will depend on which functions the demountable grandstand will contain. The Workplace Regulations state that workers on a location need their own sanitation areas, separated from the visitors. Also hot and cold washing should be provided for food handlers (Health and Safety Executive, 1999, p. 92).

The number of toilets is hard to predict for grandstands. Again, it will depend if the function of the stadium is football only or also for different purposes which will be visited by more women. There are several guidelines for the amount of toilets in stadia, concert halls, cinemas and similar buildings, but a division must be made in the function and its sources.

	Minimum recommendations for cinemas, concert halls and similar buildings (John et al., 2007, p. 180)	The UK Football Stadia Design Advisory Council's minimum recommendations for sports stadia and stands (John et al., 2007, p. 181)	Chapter 14: Sanitary Facilities in The Event Safety Guide (Health and Safety Executive, 1999, p. 90)
Men			
Urinals	2 per 100. If more: 1 per 80.	1 per 70	1 per 175
WC's	1 per 250. If more: 1 per 500	1 per 600	1 per 600
Women	3 per 100 If more: 1 per 40	1 per 35	1 per 120

As an overall indication, sport clubs use the ratio of 80:20 for men/women.

2.2 Circulation



With a decent amount of excitement the visitors wait in queues before they can enter the stadium. The fact that they are in advance of the event is less worrisome as for leaving after the event. In that case a swift evacuation must be paramount.

The movement of people in a building between its different points and locations can also be called the circulation in a building. For the design of tiers which are elevated above the ground, where the height will differ depending on its location, it is difficult to design for disabled people as well. Lifts are a possibility to design, as well as a platform where they can sit or position their wheelchairs. This will result in extra material, costs and volume for the grandstand.

The geometry of stadium structures should be sufficiently open and clear to allow spectators always to see where they are going, and to see alternative routes if the obvious path is blocked. Awareness of what lies ahead is vital to crowd safety. The special clarity should be reinforced with an equally clear and visible signage system. Lay-bys will function as quiet out of the main stream of traffic, where people can stop, think, wait for their friends or perhaps to change course without obstructing the people (Sheard, 2000, p. 42)

For stadium design, getting the pedestrian circulation right is of paramount importance. The consequences of getting it wrong can be severe. The four key time periods that need to be considered are the pre-match arrival, half time, post-match egress and the potential calamity and an emergency evacuation.

For the arrival, it differs per activity which is held in the stadium. Since the aim is for football matches, a differentiation can also be seen in the type of match. A normal weekly match can have an arrival time of 90 minutes before the match, but for cup finals or matches with events before the match, spectator arrival profiles can spread out over more than three hours. When designing for premium seating areas the queuing time must be reduced to a minimum. For the other parts of the grandstands care must be taken into separation of the home and away teams and their accessibility within the stadium.

For half time, there are other things that must be thought of. The density of the crowd, concourses and their direction are important. Examples of facilities are the toilets and snack bars. If these locations are designed wrong the consequences could be jams and congestions in all other queues. The time between the two halves in football is fifteen minutes, so the aim will be to design for this time interval (Gooch, 2005, p. 78). Queuing can be a great nuisance for the supporters, especially when going to the loos or when waiting for some food. People queue more happily in spaces that are commodious, light and airy, and with surfaces finished in materials, textures and colours that are interesting and stimulating. The width will also have decisive influences for the type of queue. That will depend on the amount of people, the point of movement along the queue, the purpose of walking (waiting or just wanting to pass by). Boredom can be reduced or prevented with things to look at, things to listen to or strategically located respites (Sheard, 2000, pp. 38-40).

For the end of the match, when most people want to leave the stadium and the tiers, a maximum of amount of time to leave can function as a guide to design to. Also the season ticket holders with specific places in the stadium and the locations of their parking spots can optimize the exit flow.

As for evacuation, the time will vary between 2.5 and 8 minutes, depending upon the level of risk associated with that area. It mainly depends on the combustible material which increase the possibilities of fire spread (Gooch, 2005, pp. 77-78).

As a general principal, people tend to leave the stadium the same way as they come in. Optimizing the divisions for entries when reaching the stadium can lead to an optimization for leaving or evacuating as well.

The capacity of an exit system can be calculated by assessing for each element in the system the number of persons who can pass the limiting point in that element in eight minutes. The calculation is made as follows (Harris, 2005, p. 88):

$$\frac{\text{width of element} \times \text{appropriate flow rate} \times \text{appropriate time}}{\text{unit width (0.550 – 0.600 m)}}$$

Sufficient exits from each section of viewing accommodation should be provided so that all spectators can leave that area and pass into a free-flowing exit route system within eight minutes or less.

Wide lanes and passages are not clearly visible in this image of the Michigan stadium. In stadium design, the exit routes must clearly be visible for the visitor, so he or she knows exactly where to go in case of an emergency. People bound to go the same way as they came in.



Timed exit analysis or TEA-calculation (John et al., 2007, p. 163)

1. Take the worst case part of the stadium
2. Calculate the distance in meters to the temporary and permanent safe zone
3. Spectators move at 150m per minute, down stairways at 30m per minute.
40 people per minute can pass through one exit width of 600mm
4. Add up walking times from vomitory to the external circulation outside the stadium
5. Subtract this from the 'escape period' defined by the regulations
6. Calculate all widths in units of 600 mm and check it. If they cannot exit well enough the widths must be increased
7. Do this for all subdivisions in the stadium

Horizontal circulation elements (John et al., 2007, p. 166)

- Entrances. The number of people passing through gates or turnstiles should be limited to a certain maximum to prevent bottlenecks.
- Exits. 40-60 people per minute passing through one unit exit width of 600 mm.
- Passageways. Results of TEA-calculations.
- Areas of particular congestion. Toilets, eating/drinking facilities, ticket windows etc. at least 10m away from entrances and exits and allow circulation space.

Stairways

The intermediate landings have the disadvantage that they consume floor space and add to the expense of a stairway. The advantages are that they function as rest points in the ascension, but also give allowance for changing in direction in the circulation on the grandstand itself. More important is the possibility of a user to fall down along the stairway. An intermediate landing will prevent the fall from extending all the way to the foot of the stairs.

Safety stair treads and landings are available in (stainless) steel, aluminium, fibreglass and other materials including, as required, appropriate backings and boned surfaces (Culley & Pascoe, 2009, p. 217).

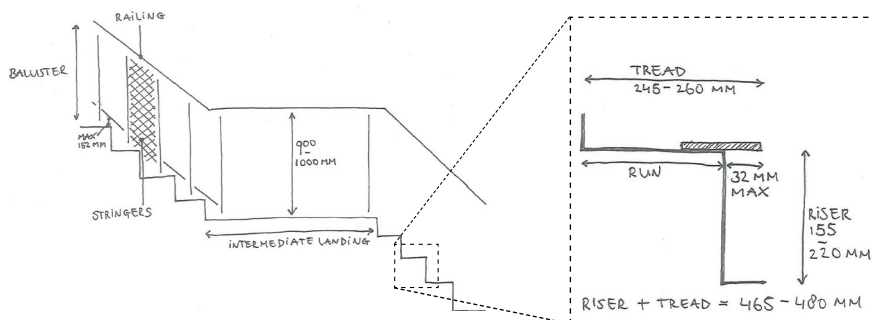

Some indications of stairway dimensions, described by Culley & Pascoe (2009)



Supporters with torch-like fireworks can endanger themselves and the surrounding crowd. Precautions must be taken in stadium design to prevent disasters.

2.3 Fire Engineering

When buildings are designed for any purpose, safety comes first as in any other situation. This is no other for stadium or grandstand engineering. Large quantities of people will be concentrated in the same area, and precautions must be taken to ensure people's safety in case of an emergency. Of course, fire engineering is well documented and legislated. The architect will have to design his fire safety according to the regulations en legislations which are given by law. For this report there are multiple sources used to determine the safety for sports stadia. Some are more general and others more specific. These determinations are important to secure a safe design for the graduation process. Caution must be taken in the type of sources used for this report. Because of the international possibilities the design will have in the future, English Building Regulations are used for the safety determination. In other words, according to the English Department for Culture, Media and Sport. The regulations are functional rather than prescriptive, they will outline what is required but will also leave the designer free in how to meet these requirements. In case of the fire safety in a building, the Building Regulations of 1991 state that *"The building shall be designed and constructed so that, in the event of fire, its stability will be maintained for a reasonable period"* (Dowling, Kirby, Smith, & Green, 2005, p. 38).

In terms of structural stability, fire safety engineering is aimed at adopting a rational, scientific approach to address specific problems in particular situations. There are usually three steps to be addressed in a full assessment (Dowling et al., 2005, p. 39):

1. Predicting the likely fire scenario, which include the quality and type of combustible material, the ventilation available and the thermal characteristics of the compartment linings.
2. Predicting the temperature of the structural members, which include the temperatures and duration of the fire the location and size of the structural element and any protection applied.
3. Predicting the stability of the structure, which include the effects of the high temperatures on the weakest parts of the structure.

The structural fire engineering assessment can be called sufficient if the structure will not collapse within the maximum amount of time to flee the part of calamity.

2.3.1 Precautions

There are two aims with applying fire precautions at any location, which are inhibiting the growth of the fire and to restrict its spread. These precautions are in case of a fire, so with the assumption the fire is already there. Some major precautions which are too important to not be mentioned are (Culley & Pascoe, 2009, p. 210):

- Adequate and appropriate provision means of escape
- Access for fire fighters
- Compartmentalisation and separation within the building
- Active fire extinguishing installations to detect and/or contain fire in its early stages
- Limitation of flame spread by selective use of materials

Fire detectors are designed to detect heat, smoke or radiation. Radiation (flame) detectors work best in tall, open, interior spaces and in open exterior spaces. Smoke and heat detectors are ineffective in most external locations. Building occupants must be able to make a quick, safe escape from the building. Emergency lighting must be available to illuminate escape routes (Culley & Pascoe, 2009, p. 211).

The ability to escape the site will be defined by the number of the escape routes, as well as their dimensions. The Building Regulations describe for 500 building users at least two escape routes, and three for 1000 users. It increases to eight escape routes for 16.000 or more users. Where a storey has two or more exits it is assumed that one exit will be disabled by a fire. It is therefore recommended that the remaining exit(s) be of sufficient width to facilitate evacuation of all people on that storey, safe and quickly. Exit width is determinant in stairway design, because the stairs have to be the same width as the exit leading onto them (Culley & Pascoe, 2009, p. 102).

2.3.2 Safety

The spectators must not only be safe in any situation in the stadium, an important thing is that they must also feel safe. Especially in the case of this building type this will form a challenge for the designer because of challenging aspects, like the stepped tiers, ramps and stairs, and possibly boisterous crowds who will not stay seated during the whole event. This last aspect will be discussed in the chapter 'Dynamic Performance'.



The great fire in the Bradford stadium happened after cigarette ignited a collection of trash under the stands. The disaster was live on TV, and in just a few minutes the whole grandstand was on fire. 56 people died, and over 200 got injured.

2.4 Conclusions

As concluded in the first chapter: Context, the design will not only be about demountable grandstands. The structure will have to become flexible, and programmable according to the event organisers wishes. This includes variation possibilities in seats, but also other facilities. For the seats, certain dimensions are important in order for the people to sit comfortably and walk along without falling easily. To view the event with best possibilities, the designer must take the C-value into account. This can be calculated by a formula, where the designer considers the horizontal distance from eye point to point of focus, the riser height, the tread distance, and the riser distance.

The roof will be an important part of the structure and it will protect the people from the natural environment. Its structure will be looked into in another chapter. Media facilities do not only require space for the staff, but also space has to be reserved for cameras, and broadcasting areas. Kiosks and shop sizes will depend on what they are selling, but there are some standards for the snack shops.

The circulation will become an important part in the design to prevent queues, get people into safety if necessary and to empty the structure in a matter of minutes. Also important precautions must be taken to prevent fires and in case of fire.



In this chapter several technical aspects considering the design are mentioned, in order to generate knowledge about the building methodology and technology for the architectural design. These technical aspects are aimed at structural design, where the challenge lies in temporary structures and assembly/disassembly. The main strategies are component reprocessing, component reusing, and building relocation. Within these strategies the following recommendations obtain (Crowther, 1999):

- Strategies for component reprocessing

Try to minimise the number of different types of components, use a minimum number of wearing parts and use mechanical connections. With these recommendations, one can simplify the process of sorting on site, reduce the number of maintenances or number of parts which need to be replaced, and allow easy separation and connection of components.

- Strategies for component reuse

For the reuse of components, use an open building system which allows alterations in the building layout through the relocation of components. Also common assembly technologies are advised so no specialist labour is required. The tolerances for the details must allow for movement during disassembly, where a minimum amount of connectors is recommended as well.

- Strategies for building relocation

Standardized parts with multiple applications for an infinite variety of the whole allows minor alterations, and time can also be saved if they are applied in a standard structural grid. The use of lightweight materials and components will make handling easier, quicker, and less costly.

Within all these recommendations and strategies the structural safety is paramount, and throughout this chapter this will be broadly discussed.

3.1 Foundations

Temporary demountable structures can be built on a variety of locations. The main condition is that they do not have a strong and deep foundation in the ground like most buildings and their settlements. This would take too much time, energy and material per assembly, and since such assemblies are executed multiple times on multiple locations it would be inefficient to do the foundations deep in the ground. Shallow foundations will be the main choice for the temporary design. "A shallow footing is defined as one which has a width equal to or greater than its depth" (Tomlinson, 2001, p. 137).

The loadings of the demountable structures should be distributed so that any bearing pressures and differential settlement are within acceptable limits. The types of soil will differ per location, and for challenging softer soils a competent person must determine the allowing bearing capacity. The structures should be supported on foundations such a size that the bearing pressures do not exceed allowable values. Point loads must be avoided, the forces must be tried to be divided in planar loads with for example base-plates. Higher structures cause bigger loads, in these cases a grillage of suitable spreaders (e.g. railway sleepers) is needed to adequately spread the load to the supporting ground. For regular reuse at the same location, permanent concrete pads with holding down bolts within covered manholes can be an advantage, provided that they are positioned below the superficial layers where frost and shrinkage will not be problematic.

The greatest risk of foundation failure is of soft spots due to peat, unconsolidated fill, cavities, land drains, previous excavations etc. The allowable bearing pressure involves recognising both the ultimate and the serviceability limit states (Institution of Structural Engineers, 2007, pp. 36-37).

Indicative values of allowable bearing pressures for foundations of structures in place for less than 28 days:

Bearing material (immediately below superficial layers)	Allowable bearing pressure (kN/m ²)	
Dense sand	200	
Medium dense sand	150	300
Loose sand	75	100
Hard clays	300	600
Stiff clays	150	300
Firm clays	75	150

(Institution of Structural Engineers, 2007, p. 38)

(Walley et al., 1989, p. 11)

(Simons & Menzies, 2000)

Caution must be taken when choosing the right material type for the shallow foundations. Concrete cannot be exposed to soils which contain acids or sulphurous salts. Steel foundations can corrode due to a combination of air and water. Wooden foundations are vulnerable for aerobic bacteria and fungi in the presence of oxygen. Plastic foundations degrade due to UV-exposure or a combination of temperature and stress. The following types of foundations are considered shallow: Spread footings, strip footings, combined footings, conventional slab-on-grade, post-tensioned slab-on-grade, raised wood floor, and mat foundation (Day, 2010).

Because of possible irregular weight distribution and abnormal wind loads, one also must to take the possibility of falling over into account when designing a demountable grandstand. Under the worst possible loading combination, the righting moment should be less than $1.5 \times$ overturning moment (Walley et al., 1989, p. 6). Some soils allow the opportunity to apply ground anchors and fixings to preclude the overturning moments, but when types like asphalt and concrete are the main bases for the structure, counterweights can be applied to resist the uplift forces.

Site drainage is important. The site should be chosen so that it is not liable to flooding because the load-bearing capacity could then be reduced or the ground under the supports could be washed away. If this is not possible, a hard foundation should be prepared to prevent it being undermined during the time the structure is erected. Also rainwater pipes should discharge well away from the main structural supports.

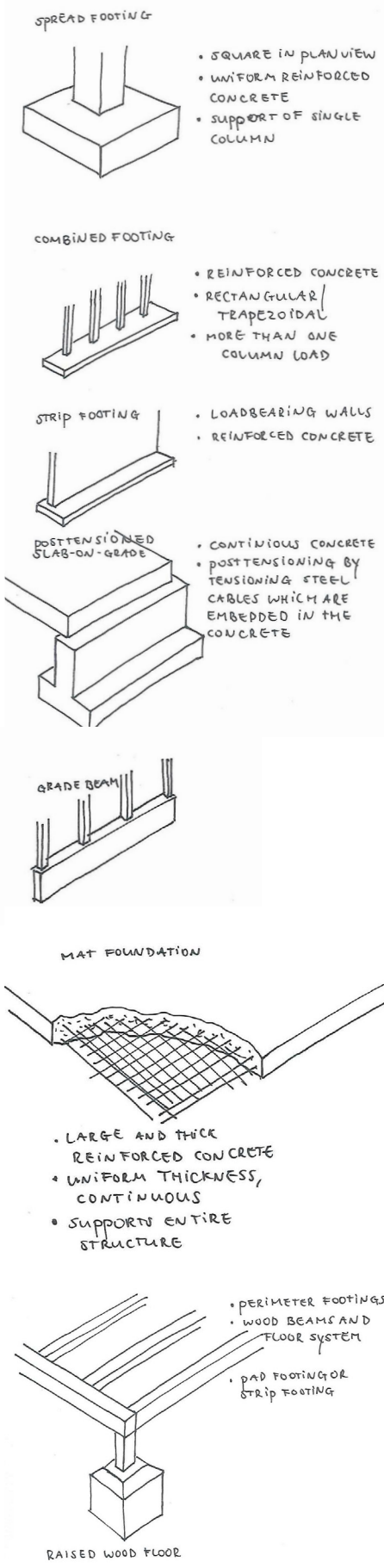

Examples of how shallow foundations can be realised with concrete elements.

BEARING CAPACITY FOR SHALLOW FOUNDATIONS

EQUATION

$$q_{ult} = \frac{Q_{ult}}{BL} = cN_c + \frac{1}{2} \gamma_f B N_\gamma + \gamma_f D_f N_q$$

q_{ult} = ULTIMATE BEARING CAPACITY FOR A STRIP FOOTING (kPa)

Q_{ult} = VERTICAL CENTRIC LOAD CAUSING A GENERAL SHEAR FAILURE OF THE UNDERLYING SOIL (kN)

B = WIDTH OF THE STRIP FOOTING (m)

L = LENGTH OF THE STRIP FOOTING (m)

γ_f = TOTAL UNIT WEIGHT OF THE SOIL (kN/m³)

D_f = VERTICAL DISTANCE FROM GROUND SURFACE TO BOTTOM OF STRIP FOOTING (m)

c = COHESION OF THE SOIL UNDERLYING THE STRIP FOOTING (kPa)

N_c, N_γ, N_q = DIMENSIONLESS BEARING CAPACITY FACTORS

cN_c = COHESIVE SHEAR STRENGTH OF THE SOIL

$\frac{1}{2} \gamma_f B N_\gamma$ = FRICTIONAL SHEAR STRENGTH OF THE SOIL

$\gamma_f D_f N_q$ = SOIL LOCATED ABOVE THE BOTTOM OF THE FOOTING

$$q_{all} = \frac{q_{ult}}{F}$$

q_{all} = ALLOWABLE BEARING CAPACITY (kPa)

q_{ult} = ULTIMATE BEARING CAPACITY (kPa)

F = SAFETY FACTOR = 3

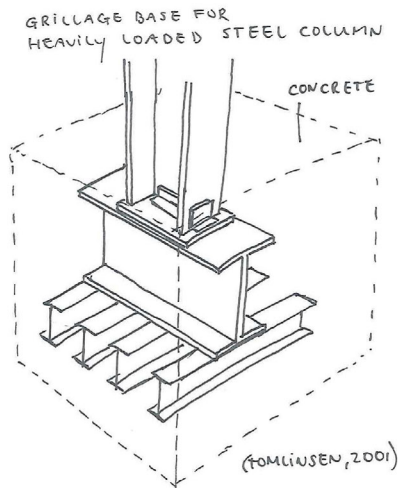
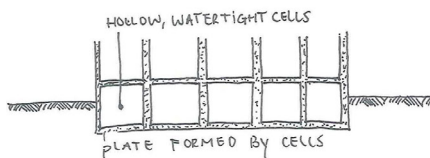
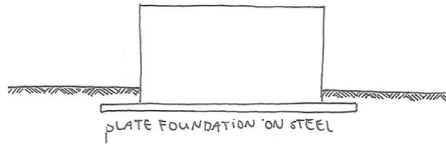

3.2 Structural performance

A structure like a grandstand copes with different kinds of forces in the system. The main forces which will determine the carrying load are the weight of the structure itself, the visitors and users of the building, their possible movement and jumping on the structure and the wind forces. If these forces are defined it is possible to design a structure consisting out of specific materials to support these loads. The following values must be checked and verified to ensure a stable structure (Walley et al., 1989, p. 7):

3.2.1 Ultimate limit states

- Limit state of strength

Strength and stability of the structure. The loads must be multiplied by the relevant γ_f factors:

Loading	factor, γ_f
Dead load (G_k)	1.4
Dead load restraining uplift or overturning	1.0
Dead load acting with wind and live loads combined ($G_k + W_k + Q_k$)	1.2
Live load (Q_k)	1.6
Live load acting with wind load ($Q_k + W_k$)	1.2
Wind load (W_k)	1.4

These values are applicable to limit-state design of grandstands constructed from constructional steelwork. For other materials these factors are no longer applicable.

- Stability limit state

The structure should be adequately stiff against sway in both the transverse and longitudinal directions, where the loads should be increased by the relevant γ_f factors.

3.2.2 Design strength

Y_S = Yield strength

U_S = Ultimate tensile strength

Yield strength of the material multiplied by the appropriate safety factor. For steel, the design strength may be taken as $1.0 \times Y_S$, but not greater than $0.84 U_S$.

3.2.3 Factored load

The factored load is the specific load, multiplied by the relevant γ_f factor from the table.

3.3 Loads

3.3.1 Dead load / Self weight

The dead load can be calculated by summing up the weights of all components of the structure. The total mass of the structure must then be multiplied by the gravitational acceleration the earth causes.

3.3.2 Live loads / Imposed loads

The imposed loads in the structure are of short duration. They are caused by objects which take not a permanent part in the structure such as all equipment in the snack kiosks, but also the people who utilise the structure. The imposed loads are higher than for a different building like a dwelling or an office, since the concentration of people will be higher on the grandstand.

Source	Safety Considerations for the Design and Erection of Demountable Grandstands (Walley et al., 1989)	Eurocode 1 (Comité Européen de Normalisation, 2012) recommended values in bold
q_k seats	4.0 <u>kN/m²</u>	3.0 - 4.0 kN/m²
q_k corridors, stairs, passageways	5.0 <u>kN/m²</u>	5.0 - 7.5 kN/m²
Concentrated load Q_k	4.5 <u>kN</u>	7 kN

3.3.3 Wind loads

Wind is a potential hazard during erection/dismantling stages and during the operational phase. The difference of temporary grandstands with permanent structures is the inability to apply foundations which can take up the compressive forces (negative) and the uplifting forces (positive). As discussed in 3.1 Ground and site conditions for temporary demountable structures, measures can be taken like kentledges and ground anchors. These measures must be taken if calculations show negative reactions in the supporting legs. (Institution of Structural Engineers, 2007).

The wind loads are very unpredictable. Not only does the wind speed differs from day to day, the position of the structure also essential to determine the wind speeds and loads. The wind velocity and velocity pressure are composed of a mean and a fluctuating component. The Euro Code EN-1991 1-4en prescribes several formulas to calculate the wind load on structures. In the design phase of the project, computer analyses will be used to calculate the effects of the wind on the structure.

The following table describes wind speed ranges for short and long term exposure in sitting or standing location, where the Bx number refers to the Beaufort scale (Institution of Structural Engineers, 2007, p. 52):

Activity	Tolerable	Unpleasant	Dangerous
Short exposure	B4 5/5 – 7.9m/s	B5 8.0 – 10.7m/s	B8 17.2 – 20.7 m/s
Long exposure	B3 3.4 – 5.4 m/s	B4 5.5 – 7.9 m/s	B8 17.2 – 20.7 m/s

Roughly speaking, the wind pressure equals $P_w = \frac{1}{2} \times \rho_{air} \times v_{wind}^2$ (KNMI, 2009). The wind speed is not the same at the same height. An operation wind speed of 25 m/s at 10m above ground level means the following operation speeds for the different heights (Institution of Structural Engineers, 2007, p. 55):

Height (m)	Wind speed (m/s)
5	21.5
10	25
15	26
20	26.5
30	27.5



An analysis after a roof collapsed of the Sultan Mizan Zainal Abidin Stadium in Malaysia concluded that inappropriate materials and design were two factors why the accident happened. The wind took care of the fatale movement in the structure.

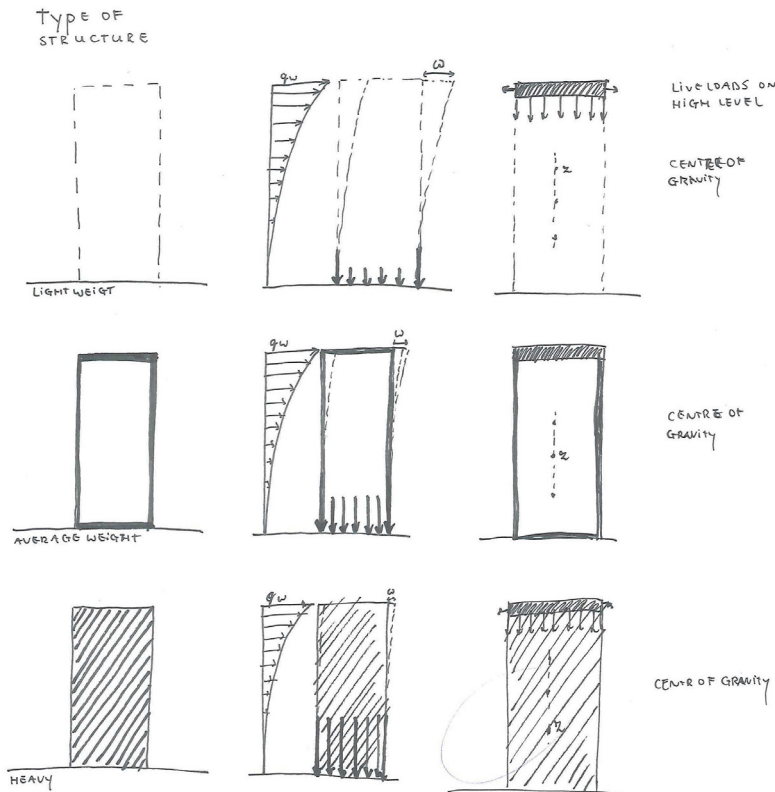



Forces not only have to be carried in vertical direction. Movements of the crowds will also cause in horizontal forces. That is why grandstand structures should be braced properly.

3.3.4 Horizontal loads

Not all the loads the structure has to take are vertical. Not only because of the wind loads, but also because of the movement of the spectators, the demountable grandstands have to take up horizontal loads. There are different sources who advise specific percentages of live loads for the structure to cope with. According to Walley et al. (1989) the overall stability can be assured by providing adequate strength to resist sway. The horizontal force is then equal to 5% of the vertical imposed load in addition to the wind load. Also the Institution of Structural Engineers (2007) states allowance should be made for notional horizontal loads if there's a combination of dead, imposed and wind loads. The horizontal loads are also to take account of geometrical imperfections of frames, such as lack of alignment of vertical members which transfer the loads from the deck to the ground. The horizontal sway deflection should not exceed height/300 under the combined loads. The category of spectator movement for sports is 2, where the notional horizontal load is 7,5% of the load combination.

3.3.5 Vibrations

Safety for the user means safety in the structure. Grandstands and tiers are categorised in the highest level (CC3) of safety concerning public buildings and their consequences in failure, next to high rise buildings, theatres and music halls (Banga, 2012, p. 57).

There are great contradictions in the desires to design with light materials, create clear sightlines from the stands and achieve maximum viewer capacities on cantilevering structures, and the regulations of moving possibilities for the structure. These movements in the structure are of course caused by the supporters, who in some cases can move up and down in significant amount of frequencies.

For the English Regulations, BS 6399 Part1:1996 requires the dynamic responses of structures with natural frequencies below 8.4Hz in the vertical direction and 4.0Hz in the horizontal direction. GSSG2007 states respectively 6Hz and 3Hz. The frequencies are in cycles by second. It all depends eventually on that the vibration levels should not bring discomfort to members of the audience. Together the vibrations form harmonic forces which are sometimes expressed as 'dynamic load factors' or DLF's, defined as the magnitude of the harmonic force divided by the weight of the group of persons engaged in the activity. A dynamic load factor of 0.5 means that the dynamic force amplitude at a particular frequency is equal to half of the weight of the persons producing it.

The greatest variable vertical forces are produced by humans while they jump simultaneously up and down. Individuals can jump at rates to 3,5 Hz of 4,0 Hz, but bigger groups find it difficult to jump at the same frequency, and will not go above 2,75Hz. That is why the total dynamic force of crowd activity will not increase linearly (Wilford, 2005, pp. 46-48).

In the Dutch Building Decree however, one says that the Dutch supporters may jump more in an organized matter. It is stated that the highest frequency which can be made possible by humans is 5Hz for jumping. The natural frequency of the floor is not allowed to be lower than 5Hz in the case of floors where people can jump and dance on (Banga, 2012, p. 79). However, Wilford states that even with a natural frequency of 7Hz in the vertical direction and 1.75Hz in the horizontal direction there should be no concern. The highest DNF's are around 2 with a frequency of 2Hz (Ellis & T., 2004; Pernica, 1990; Wilford, 2005).

Since the temporary grandstand or stadium module is not only excluded for sports events, but for any organiser who desires to upgrade his spectator possibility with excellent sight lines and supporting facilities, one must also take events into account where the jumping of crowds can be more coordinated. Pop concerts are for example events where the rhythms and beats stimulate and coordinate the spectators to jump simultaneously, contradictory to sports matches where a single goal or chanting will be less effective. The extra force which is created by the jumping of visitors equals the mass times g, plus an extra percentage which is created by the ultimate moment of the vibration. Littler, Ellis, and Ji (2001) found after a research on 50 demountable grandstands of fifteen different types a load model which defines different activities involving jumping. The damping value has to be estimated. Excessive vibrations can be improved by using a more efficient bracing system.



You don't have to explain the fans of the Dutch club Ajax what vibrations are. Whole stands move up and down while the supporters move on the beat one of the supporters makes. However, it still is difficult to coordinate the whole crowd to move at the same time up and down.

3.4 Materials & properties

Not every type of desired material can be used for a structure in structural design. Some materials are very commonly used in stadium or grandstand design, like (reinforced) concrete and (stainless) steel. In this chapter some materials will be discussed in order to research which will be suitable for the design. The research emphasizes several aspects and properties which will be important for the design. These aspects are first briefly discussed.

3.4.1 Materials

There is a wide variety of materials used in architecture for different reasons. Some of those reasons are for aesthetical purposes like cladding and interior finishes, others are more functional like for structural or for convenient use (indirectly quoting Vitruvius' *venustas, utilitas and firmitas*). For this part of the research within the theme of technique, a small study has been done in terms of structural capabilities of some materials, with other properties which may be important for the design. The materials will briefly be discussed in this part (3.4.1), and the material properties will be discussed in the next (3.4.2). The four groups of materials which will be discussed are metals, composites, plastics and woods. In these categories the most commonly used types which are used for architecture are chosen. From these, the composites (namely the resin-fibre composites) are relatively new in the fields of civil engineering and building construction. The source for the information in this part is from the student program of CES EduPack 2013, created by Granta Design. This database of materials is the main source of information for architecture students at the Delft University of Technology.

3.4.1.1 Metals

The three metals which will be compared with the other materials are stainless steel, low carbon steel and aluminium. Stainless steels are alloys of iron with chromium, nickel, and often four or five other elements. Most stainless steels resist corrosion in normal environments, and have a high strength. Low carbon steel is the most commonly used steel for almost every structure. Bridges, railroads, building structures are just a few examples of how low carbon steel is applied, because of its high strength but also because of the low costs. Aluminium is also used for buildings, but rather for claddings and window frames as for structural elements. It is a light metal which doesn't corrode.

3.4.1.2 Composites

The composites which will be compared are the fibre reinforced polymers, and concretes. FRP's consist out of fibres which can take up great tensile forces, depending on the fibre type. The three fibre types which are mainly used are glass, aramid and carbon fibres. The glass fibres are the ones which are used more often for the built environment, since they have a relative high strength and relative low costs (Mamlouk & Zaniewski, 1999). The most common type of glass fibre is made of E-glass. The alignment of the fibres determines the final constructive properties. If all fibres are aligned, the component is very strong along the aligned fibres. Perpendicular to it, it will delaminate or break easily due the anisotropic material properties. To prevent this, arbitrary aligned fibres or a woven sheet with the desired alignment of these fibres, can be used (Callister, 2007). The matrix in a polymeric composite can be regarded as both a structural and a protective component. Resin is a generic term used to designate the polymer, polymer precursor material, and/or mixture of formulation thereof with various additives of chemically reactive components. There are two different types of resins, as there are plastics: Thermosetting resins (polyester, epoxy, vinyl ester) harden upon application of heat and a catalyst, and are irreversibly formed thus cannot be re-liquefied. Thermoplastic resins (PEEK, PPS and PSUL, respectively polyether ether ketone, polyphenylene sulphide, polysulfone) liquefy upon heating and solidify by cooling (Motavalli, Czaderski, Schumacher, & Gsell, 2010). Concluding, it all depends on the combination resin-fibre which properties the composite has, where the direction of the fibres also have to be taken into account.

For the comparison of materials, the available data in the CES EduPack was used. A graph was plotted to compare the frp's against each other. The results for the strongest frp's in compression and for Yield strength showed differences. Not all of these materials were options to be chosen for the design, because some of these composites were not used in architecture or for civil structures. A lot of these high strength frp's are applied for the aircraft industry, because of the high strengths and low weights. The three composites which can be applied for the built environment are the polyester/E-glass fibre pultruded rods (unidirectional laminated), Glass/epoxy unidirectional composites and

the Epoxy-E-glass fibred woven fabric composites (biaxial lamina). In the comparison a carbon fibre reinforces polymer is also shown, but only as reference. This fibre is pretty expensive and not yet used in architecture.

The other composite material which will be compared is concrete, because it is widely used for building structures. It is the most used material to construct stadiums in the world. Concrete is composed of water, coarse granular material embedded in a hard matrix of material that fills the space among the aggregate particles and glues them together.. For this research, structural lightweight concrete and high performance concrete are examined. The material properties of the two concretes are shown without reinforcement bars.

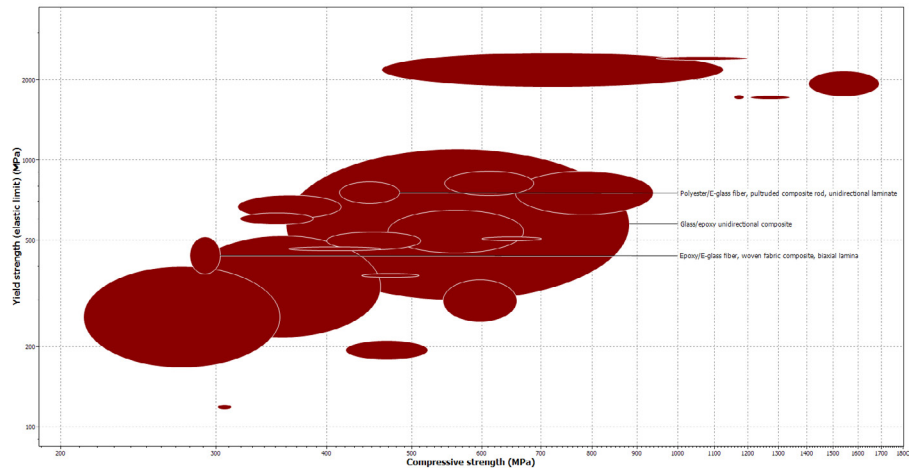

A strength comparison between fibre reinforced polymers.

3.4.1.3 Plastics

Plastics are also chosen for the comparison because they can be applied for the design as light materials which will be easy to transport. Polycarbonates have optical transparency and good toughness and rigidity. They are mainly used for product design, but are also applied for buildings in the form of cladding panels. If they are applied as the like, the percentage of optical transparency reduces with the increase of its thickness.

Polyesters are plastics that are also more applied in industrial design than for architecture. Most polyester thermosets are used in glass fibre/polyester composites. They are less stiff and strong as epoxies, but also considerably cheaper. A common application for polyester is for stadium seats.

PTFE, or better known as Teflon, is an extremely stable and water repellent material. It comes in large sheets which can be used for tent constructions. The sheets are spanned between structural elements of another material.

ETFE is from the fluorplastic family and has high chemical resistance, low and high temperature capability, and is resistant to weathering. ETFE was introduced to provide a material with both corrosion resistance and mechanical strength over a wide temperature range.

3.4.1.4 Woods

Wood offers a combination of favourable properties like low weight, an acceptable stiffness and strength parallel to the grain, it is cheap as well as renewable. Hard woods are used for construction like for bridges and buildings structures. Glulam is a structural timber manufactured by gluing together individual pieces of dimension lumber under controlled conditions. It is used to realise bigger spans with wood than normal. Plywood is also laminated wood but so that the grain in successive layers are at right angles, so that the stiffness and strength is in both directions.

3.4.2 Material properties

Density (kg/m³)

Description : The density of a material defines the weight of a material per volume. A low density means that the material is light for its volume, and combined with high strength properties this means that a light material can be used for structural components. For a temporary structure it is an aim to keep the weight as low as possible, so less effort is needed for assembly and disassembly.

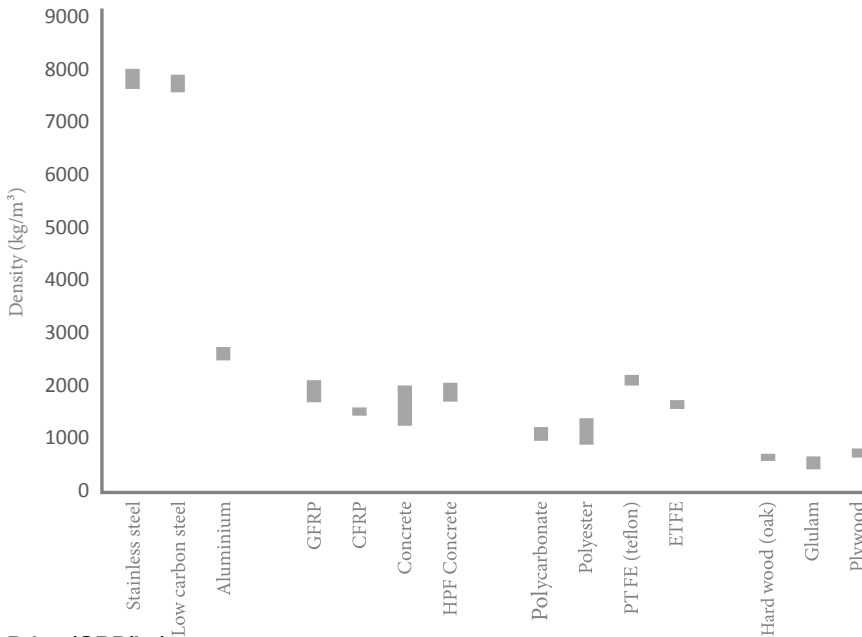

Price (GBP/kg)

Description : The aim is to design with low priced materials, because the structure will be used as a product as described in chapter 1.5 Money flow chart for stadiums as a business (with renting temporary grandstands), so lower investments for the same results will result in higher profits.

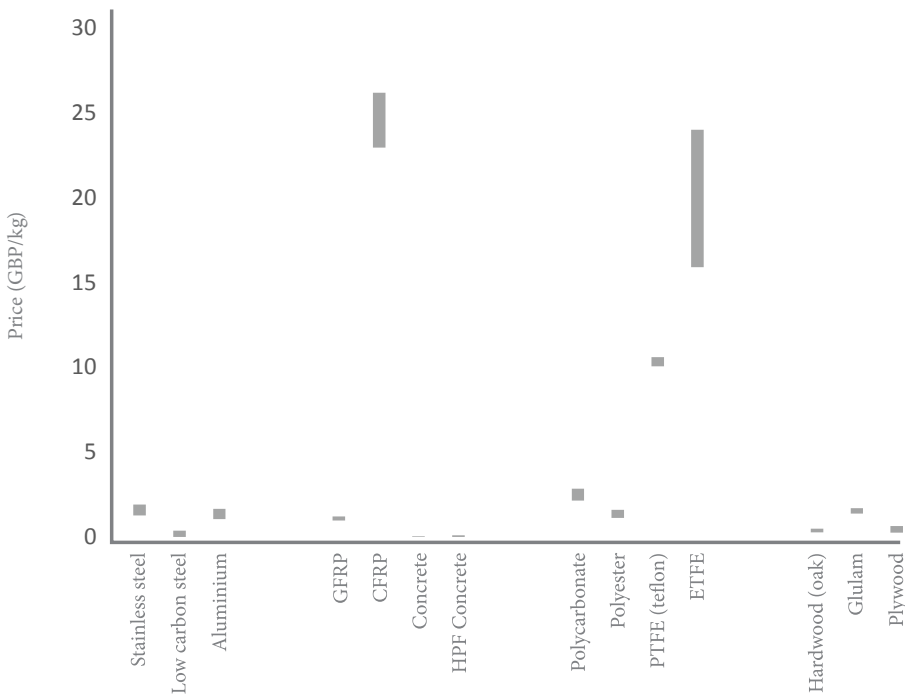

Young's modulus E (GPa or kN/mm²)

Description : The Young's Modulus or Elastic Modulus is a measure of the stiffness of an elastic isotropic material. It defines the slope of the initial, linear elastic part of the stress-strain curve in tension or compression. A material with a high Young's modulus is rigid.

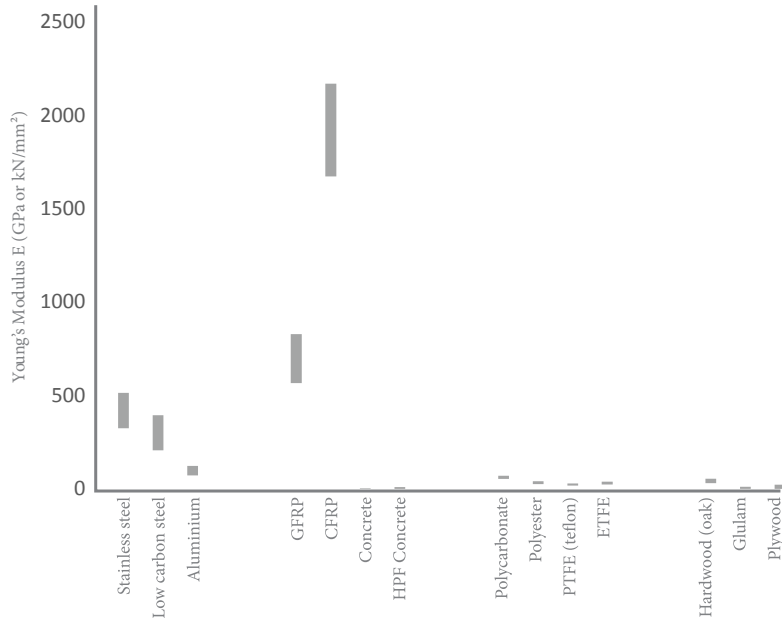

Poisson's ratio ν

Description : When a material is stretched in one direction, a material generally contracts in the other two directions. The Poisson's ratio is the negative of the ratio of the lateral or transverse strain, to the axial strain, in tensile loading. This value is important to calculate the structural performance of a material later in the design.

Yield strength σ_y (MPa)

Description : The Yield strength is the stress at which it first suffers permanent (inelastic) deformation in tension. For a structure a high Yield strength is desired so no permanent deformation will occur under low tensile forces.

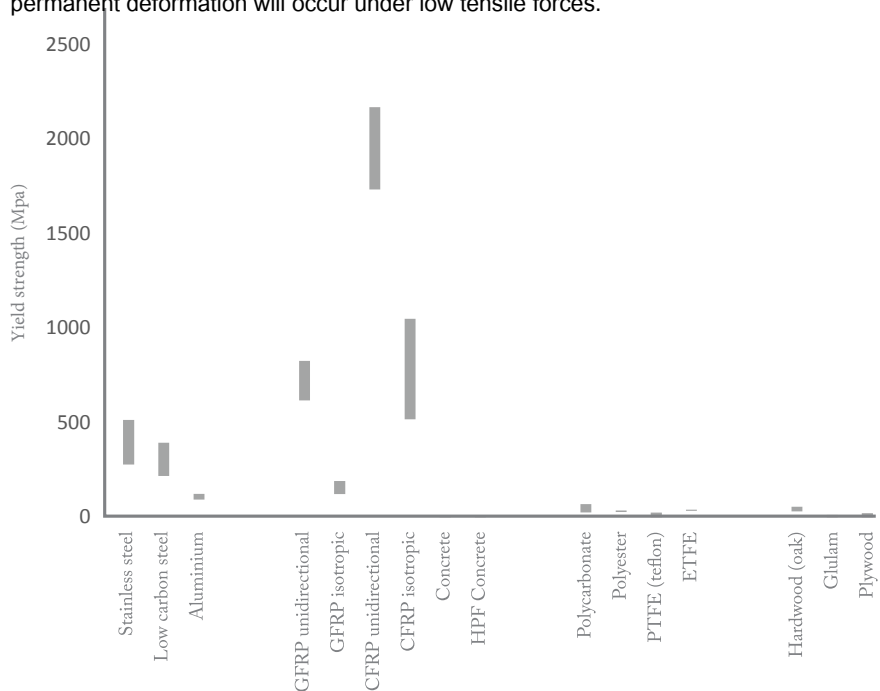

Tensile strength σ_{tS} (MPa)

Description : The tensile strength of a material defines how much force in tension on a round bar of this material must be put to separate it. For brittle materials it is equal to the Elastic limit. For metals it will be larger than the Elastic limit since they are elastic materials. Separation is definitely not desired for a structure, but also deformations must be prevented in order to reuse the materials for other assemblies. Since deformations occur in an earlier stage as separations (for elastic materials that is), the Yield strength will be leading in calculations with tensile forces.

Compressive strength σ_C (MPa)

Description : The compressive strength is the stress at which it first suffers permanent (inelastic) deformation in compression.

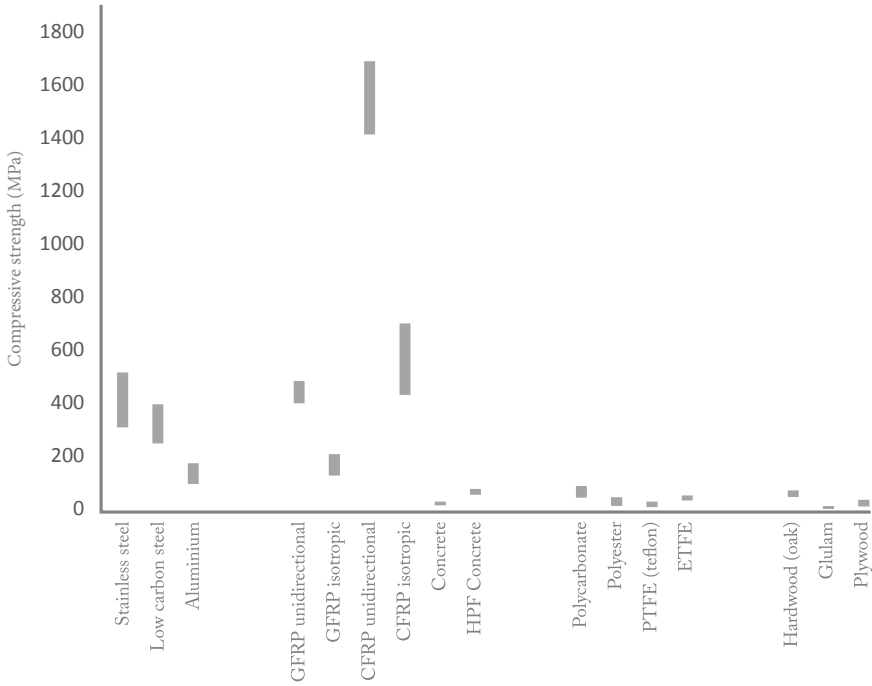

Fracture toughness K_c (MPa.m^{1/2})

Description : The fracture toughness is a measure of the resistance of a material to the propagation of a crack. The lower the fracture toughness is, the earlier a crack appears when bumped onto with a sharp edge. This property is also of the essence since demountable structures are assembled and disassembled various times, and chances are due to human errors that elements are more likely to bump onto other elements during construction.

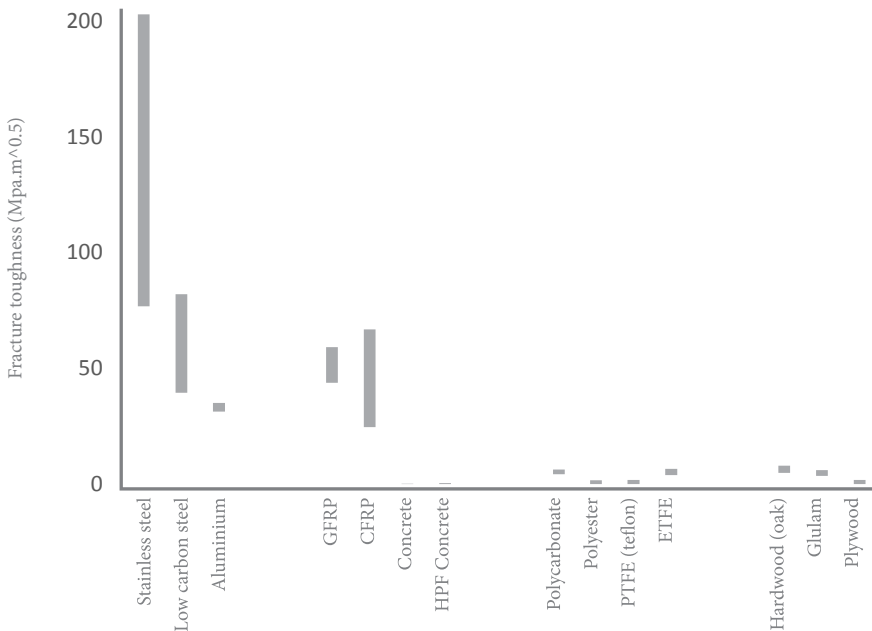

Durability (wear)

Description : The durability of a material embraces several categories such as natural elements and acids. Materials with a higher durability withstand more external elements such as fresh and salt water, UV radiation and strong and weak acids.

Embodied energy, primary production (MJ/kg)

Description : The embodied energy is the energy to make 1kg of the material from its ores/origins. The aim is to design with materials that need few energy for their production processes because of environmental reasons.

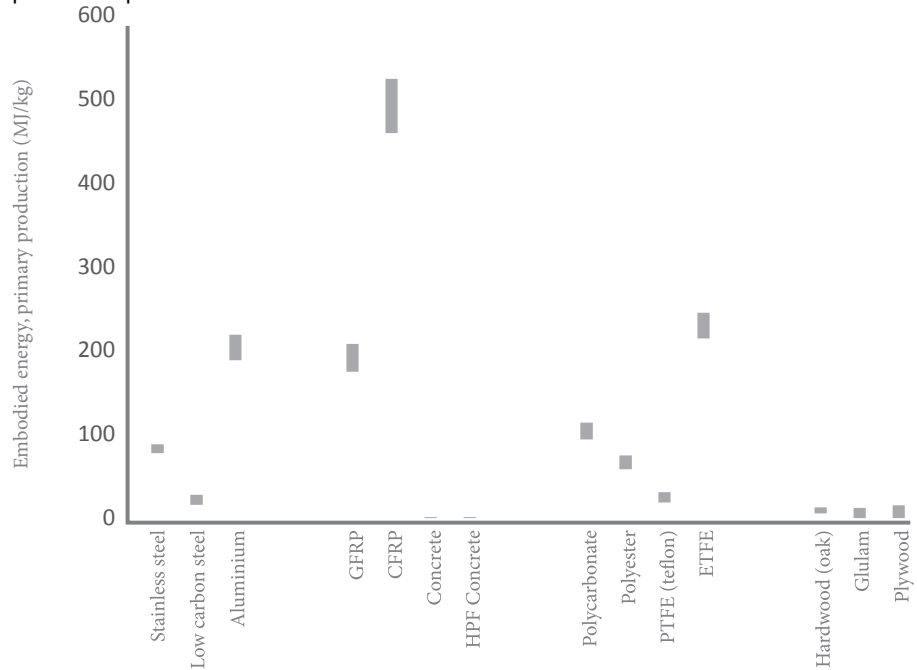

CO2 footprint, primary production (kg/kg)

Description : The amount of CO2 that is released into the atmosphere because of the production process of the material is called the CO2 footprint. The aim is to design with materials that have a low CO2 footprint to cause less harm to the environment, because CO2 emissions increase the global heating effect.

Recycle

Description : The ability to recycle the material can be interesting for a materials when it is near its end of life.

	Stainless Steel	Low carbon steel	Aluminium	GFRP unidirectional	GFRP isotropic	CFRP unidirectional	CFRP isotropic	Concrete	High Performance Concrete	Polycarbonate	Polyester	PTFE (Teflon)	ETFE	Hardwood (oak)	Glulam	Plywood
Young's Modulus	+	+	+	++		++		-	-	--	--	--	--	-	-	-
Yield Strength	+	+	0	++		++		--	--	--	--	--	--	--	--	--
Compressive Strength	+	+	0	+		++		-	-	-	-	-	-	-	-	-
Fracture toughness	++	+	+	+		+		--	--	-	-	-	-	-	-	-
Density	--	--	+	+		+		+	+	++	++	+	+	++	++	++
Price	++	++	++	+		--		++	++	+	+	--	--	++	++	++
Embodied Energy	0	+	-	-		--		++	++	-	0	+	-	++	++	++
CO2 Footprint	++	++	++	+		--		++	++	+	+	--	--	++	++	++

	Young's modulus E (GPa or kN/mm ²)				Poisson's ratio				Yield strength (Mpa)		Tensile strength (Mpa)		Compressive strength (Mpa)		Fracture toughness (Mpa.m ^{0.5})	
	low		high		low		high		low		high		low		high	
	low	high	low	high	low	high	low	high	low	high	low	high	low	high	low	high
Metals																
Stainless steel	189	197	0.27	0.28	310	515	585	860	310	515	77	203				
Low carbon steel	200	215	0.29	0.3	250	395	345	580	250	395	41	82				
Aluminium	68	71.5	0.33	0.34	103	124	172	241	97	172	34	35				
Composites																
GFRP	35	45	0.33	0.35	690	828	692	828	414	483	48.4	59.2				
CFRP	129	154	0.32	0.34	1740	2170	1740	2170	1410	1690	22.8	66.9				
Concrete	11	21	0.17	0.2	1.1	2.8	1.1	2.8	11.3	28	0.04	0.07				
HPF concrete	25	27	0.22	0.25	6	10	6	9	55	75.8	0.1	0.4				
Plastics																
Polycarbonate	2	2.44	0.39	0.41	59	70	60	72.4	69	87	2.1	4.6				
Polyester	2.1	4.4	0.38	0.4	33	40	41	90	36	44	1.1	1.69				
PTFE (teflon)	0.4	0.55	0.44	0.46	15	25	20	30	16.5	27.5	1.3	1.8				
ETFE	0.8	1.5	0.42	0.43	34.2	37.7	42	47	46.6	51.4	3.1	6.5				
Woods																
Hardwood (oak)	13.2	13.9	0.37	0.48	43	55	110	140	49	70	6.5	8				
Glulam	12	14	0.25	0.3	9	12	9.7	12.4	8.3	11	4	6				
Plywood	6.9	13	0.2	0.3	9	22	10	28	27	34	1	1.8				
					Embodied energy, primary production (MJ/kg)				CO2 Footprint (kg/kg)		Wear resistance from 1 to 4		Recycle			
	Density (kg/m ³)		Price (GBP/kg)		low		high		low		high					
	low	high	low	high	low	high	low	high	low	high	low	high				
Metals																
Stainless steel	7800	8010	1.74	1.91	80	88	4.7	5.2	3	yes						
Low carbon steel	7800	7900	0.35	0.38	25	27.7	1.7	1.9	4	yes						
Aluminium	2700	2730	1.5	1.66	198	219	12.2	13.5	2	yes						
Composites																
GFRP	1900	2100	1.1	1.2	188	208	8.4	9.2		no						
CFRP	1550	1580	23.6	26.2	474	524	25.3	28		no						
Concrete	1400	2000	0.03	0.04	1	1.3	0.1	0.1	2							
HPF concrete	2500	2700	0.05	0.107	1	1.3	0.1	0.1	2	yes						
Plastics																
Polycarbonate	1140	1210	2.58	2.84	103	114	5.7	6.4	2	yes						
Polyester	1040	1400	1.45	1.59	68	75	2.8	3.1	2	no						
PTFE (teflon)	2140	2200	9.29	10.6	27.9	30.9	3	3.3	3	yes						
ETFE	1680	1720	16.7	24	222	245	16.4	18.1	2	yes						
Woods																
Hardwood (oak)	660	700	0.43	0.48	9.8	10.9	0.8	0.9	1	no						
Glulam	500	650	1.13	1.69	11.2	12.4	0.8	0.9	1	no						
Plywood	700	800	0.21	0.64	13.8	15.2	0.8	0.9	1	no						

Conclusion

With the results of the graphs and tables, the comparison on the left page can be made. It is visible that some materials are more attractive in price and sustainability instead of their strength (woods). Others are extremely strong in compressive and yield strength, but cost more and are harmful for the environment (CFRP's). There are also materials which are a bit in between all the properties, and seem the right choices for the design (Metals and GFRP's). However, better properties will not always determine the choice for the design. Otherwise every building would have the same materials for cladding, structure and others. It will always be the architect who decides the aesthetics of the building, and therefore determines the materialisation. It will be an architectural engineer who designs with the knowledge of the properties of the materials to form an aesthetic building that performs structurally, and building physically.

3.5 Design for disassembly

“Demountable building is a building method in which the structural connections are made in such way that components of the structure can be demounted without any destruction, and qualify for reuse. One must strive to save energy and fuels, reduce the noise and dust nuisance when demolishing, and reduce the waste and substances problems.”
Research Committee D7 (1990)

When designing for disassembly, one must take some factors into account which are not always of the essence when designing a normal building. The most important factors are the connecting elements in the structure. When disassembling a demountable building the components must stay intact without wearing off, inflecting or bending permanently thus having to be replaced every time the disassembly takes place. This has consequences for the connection material(s) and their types. The material does also have to withstand natural elements like rain, frost, UV radiation and temperature differences because it is used on an exterior site.

The joints can rely on the materials they have to join. Joints for wooden construction for example can be made with screws, nails and glues, but if they just have to fit into each other one can use butt joints, halving joints, dovetails and others. For temporary grandstand design they are unsuitable because screws and nails cause permanent damages to the material, glues are permanent and the fitting joints are not suitable for movement in the structure. When the structure moves too much, the moments in the connections can damage the wood.

Joints in metal can be made by brazing, soldering, welding or using rivets. The first three are semi-permanent joints, because they actually can be undone by applying the same process (heating the metals to melt them and attach/detach them). This will cause damages and irregularities to the metals, so they are unsuitable for demountable design as well.

3.5.1 Bolts

The most common type of temporary fixing involves components with a screw thread, such as screws, nuts, bolts and knock down fixings. The best suitable material for these type of connections is stainless steel because of its strength, durability and the fact that it does not wear off after being reused multiple times. The nuts and bolts are also being produced in titanium but this is a very expensive material.

Bolting is the usual method for forming site connections, and its term is used in generic sense as assembly of bolt, nut and possible washer. Normally black bolts can be used, but not for grandstands. Black bolts are untensioned bolts in a clearance hole which is 2 or 3 mm larger than the bolt dependent upon diameter. They cannot be used for grandstands because they are vibration-prone structures. Black bolts can also not be applied for rigid connections, impact- and fatigue-prone structures and for connections subject to stress reversal. For these cases High-strength friction grip, or HSFG bolts should be used. (Hayward, Weare, & Oakhill, 2011, p. 20).

Bolting can be done with hand or power wrenches. Power wrenches are more economical since they accelerate the building process. Some space around the nuts must be taken into account when the nuts have to be attached to the bolts because of the space the tools need to attach the bolts. Specific bolts with high strengths must be chosen to withstand high loads in the structure. The two types of bolts which are mentioned in several books for structural steel design are A325 and A490 bolts for the American version (American Institute of Steel Construction, 1966) and grade 4.8 and grade 8.8 for British and European specifications (with 8.8S and 10.9S as HSFG bolts) (Bangash, 2000).

Parts of the Bolt Assembly

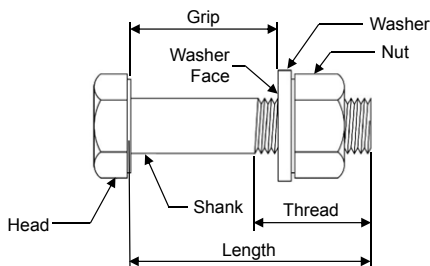

The parts of a bolt.

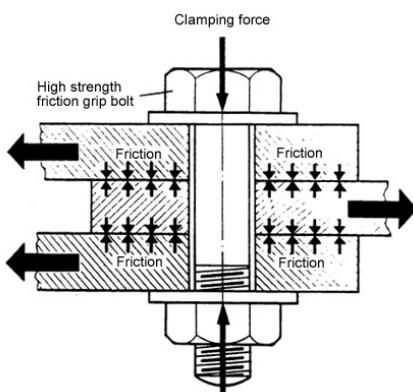

A High Strength Friction Grip Bolt with the way the forces run.

3.5.2 Tensile elements

The dimensions of the surface elements are exceptionally two-dimensional. Linear load-bearing elements are used to transfer loading to the edge. The materials for tensile surface structures can be coated fabrics, films, wire ropes and KEder (plastic) cords.

Ropes consist essentially of wires, cores and strands. Bundled ropes which are used for construction are also called cables, and are predominantly made of steel. Cables with fibre cores are also possible. Cables can only take up loads in tension and are usually preferred above other structural elements like trusses or beams when only tension has to be taken up.

Wire rope clamps and clips can attach two cables and transfer the loads. The nuts must be tightened and the connection relies on friction. It depends on the diameter and the amount of forces flowing through the connection on how many clips or clamps are needed.

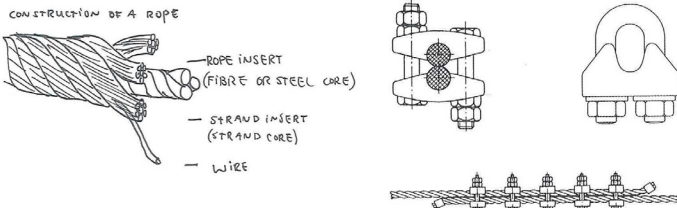

To transmit forces to other construction elements, forces must be transferred into and out of the relatively thin wires of the rope with anchorages as short as possible. For detachable end connections can wire rope clips be used, but for material bonded connections is cast metal or plastic also an option.

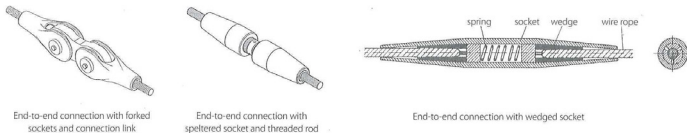

The ropes are anchored in conical sockets by molten zinc which hardens while it cools. If rotation is desired in the system, the following connections can be used: fork fittings, eye fittings, threaded stud fittings, end sleeves, forks with turn-buckles and eyes with turn-buckles.

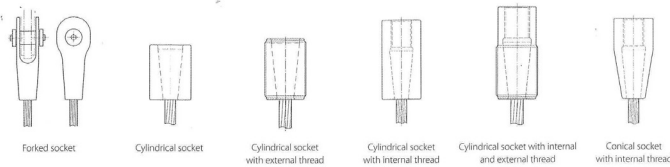

At the end of the tension structural element, the forces must be transferred to other elements like columns, edge beams or the ground. Clearly, if the forces run to the ground anchorage, a proper tension anchorage must run into the subsoil.



If the distances or specific tightness must be adjusted for the cables, it can be done with tolerances adjustments for highly loaded cables or electrical winches.

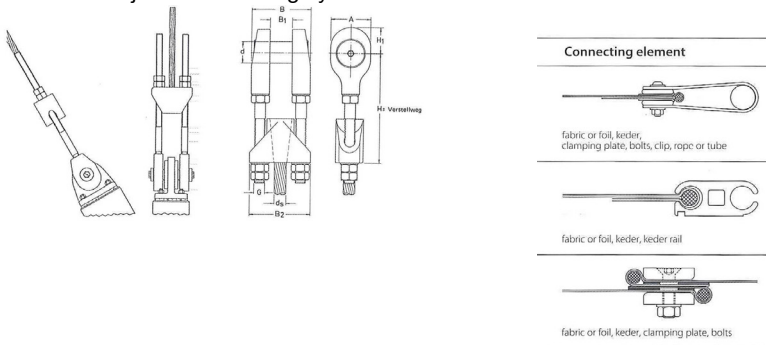

Fabrics can temporary be attached onto the cables with different types of connections, with the similar property of Keder around the membrane.

3.5.3 Boltless connections

Connections between elements in a structure do not always have to be joined or mounted together with other materials or elements like adhesives, bolts, nails, and etcetera. Interlocking principles can also be applied to fit elements into each other and connect them. Multiple examples can be found in woodworking, where the Japanese mastered this technique for hundreds of years.

The Japanese have always preferred wood construction above masonry and the use of stones for their buildings. Causes lie in the great availability of the wood and bamboo and the fact that Japan lies in a seismic area. According to the Japanese the wooden components were easier to adjust and interlock with each other, where the stones would just break or fall over during an earthquake. The Japanese have always given great value to nature, its trees and the use of wood, and according to tradition a carpenter incurs a moral debt when he cuts down a tree. A carpenter must put a tree to uses that assure its continued existence, preferably as a thing of beauty to be treasured for centuries. (Azby Brown, 1989).

Historically a Japanese carpenter is an architect, as well as an engineer and joiner. The ancient Japanese buildings are therefore designed and constructed by the same men, who had the knowledge and control over the whole project. Since iron, bronze, and steel were very costly or not even invented, the joints were developed without the use of nails or other metals. In the following images some connections are shown which are categorized under 'Japanese joinery'. They all have in common that they directly or indirectly interlock. Pins can be used to lock two structural components in their place.

The knowledge of these boltless connections can be used for the design of the demountable grandstands. As mentioned at the beginning of this chapter the aim is to minimize the amount of connections. In one joint there can be multiple bolted connections, but by interlocking two or more components via the Japanese way, bolts can be reduced to just one pin.

There are a few disadvantages or problems which have to be overcome if this way of connecting is used for the design. One disadvantage of this system is that for the old system wood is used. The Japanese did not invent this type of joinery for designs for disassembly. Wood easily gets damaged. They designed their joinery for wood only, including the tolerances for creep and expansion. If the joinery techniques will be applied in the design for the demountable grandstand, they will be made out of another material, probably stainless steel because of several properties which were discussed in 3.4 *Materials and properties*.

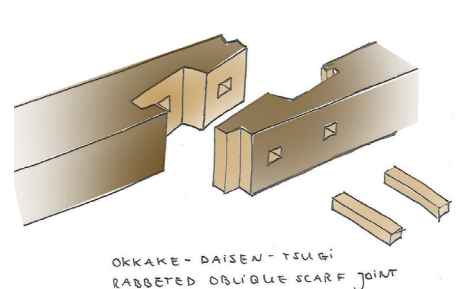
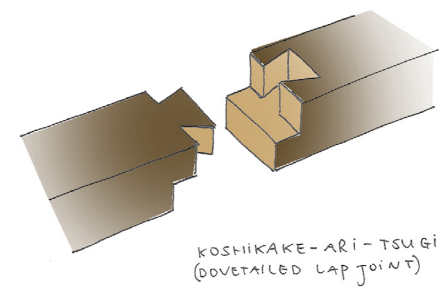
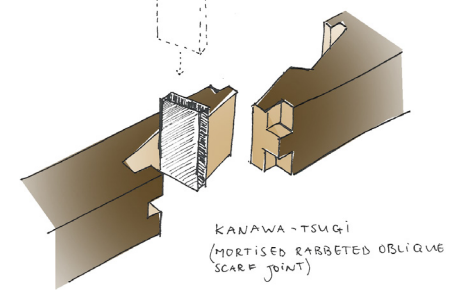
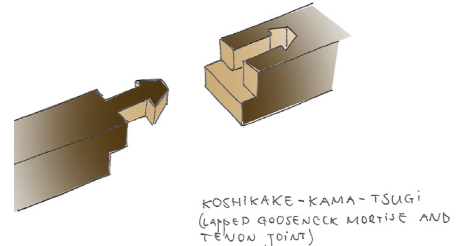
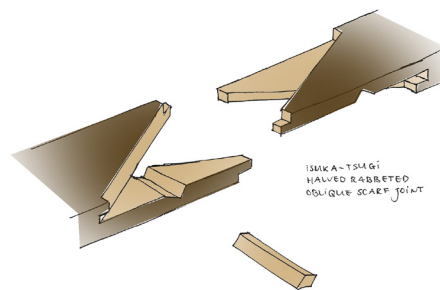
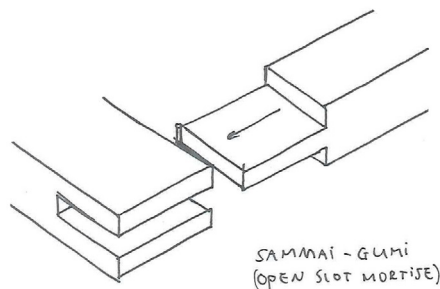
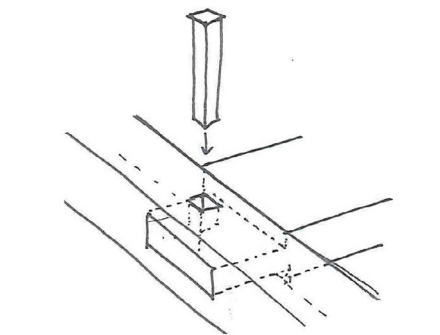
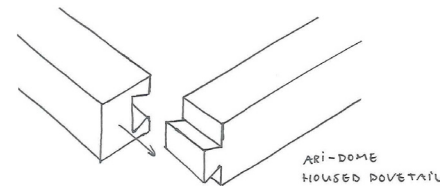
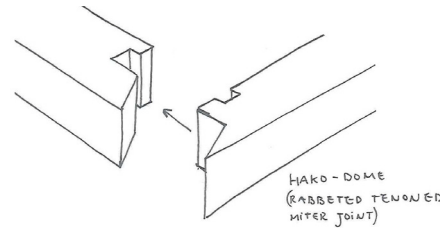
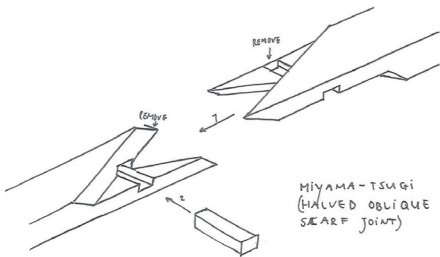
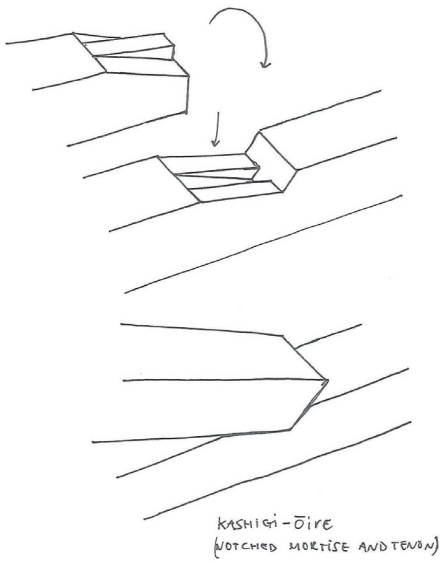

3.6 Structure

3.6.1 Base

Before designing a new type of structure for a demountable grandstand, one must first understand the current possibilities of constructing such object. By defining and learning from its capabilities and weaknesses, one can use this knowledge for the new design.

3.6.1.1 Concrete elements

The first demountable grandstands were the grandstands of the Automotive Stadium or Autostade in Montreal, designed for the World Exposition of 1967. One grandstand unit was made of pre-cast, seat supporting units which rested on pre-stressed columns and beams. Unfortunately it was never replaced so its dismantling function was not used. The interlocking forms of the concrete components made the connections possible. The columns were attached with bolts to its foundations (Stockl, 2008).

Because of the enormous dimensions of the structure and the choice for the material of concrete, relocation would have taken quite some effort. Heavy machinery had to be applied to transport the components, where it would have been easier to relocate lighter materials in smaller sizes.

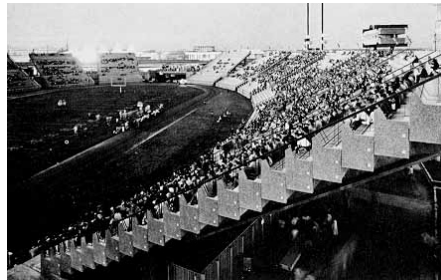

An overview of the Automotive Stadium of the Montreal Expo in 1967. The segments had the same form,

The concrete elements were demountable and could be placed on a different location. Unfortunately this never happened, and the structure was demolished.

3.6.1.2 Scaffolding principle

The main construction method of how demountable structures are built nowadays is with a scaffolding like principle. The most recent form was introduced in the 20's, with aluminium pipes and metal-formed or –cast clamps. The basic structural components are the pipes with has fairly thick walls to enable thread cutting at the ends. See drawing scaffolding. In the 40's the concept of welding pieces of pipe into prefabricated frames simplified the building process (Ratay, 2012).

The temporary grandstands are built this way because of a number of reasons. First of all, the structure is a repetitive system so the number of proceedings is minimal. Secondly, the structure is light and the parts can easily be carried by workers. Thirdly, the detailing is easy and adjustable, and thus perfect for sites with irregular ground surface heights. The main components of the temporary grandstands are steel trusses, post-ledger-braces, deck units, base jacks and seat units (Pakar Seating, 2010).

A disadvantage of the system is the loss of space underneath the structure. The trusses are placed in a grid with relatively small distances between the vertical elements. Another disadvantage is the lack of aesthetical value. The structure is purely functional, and gives from the back a sober impression. Opportunities lie in creating space underneath, with the threat of the angled form of the grandstand.

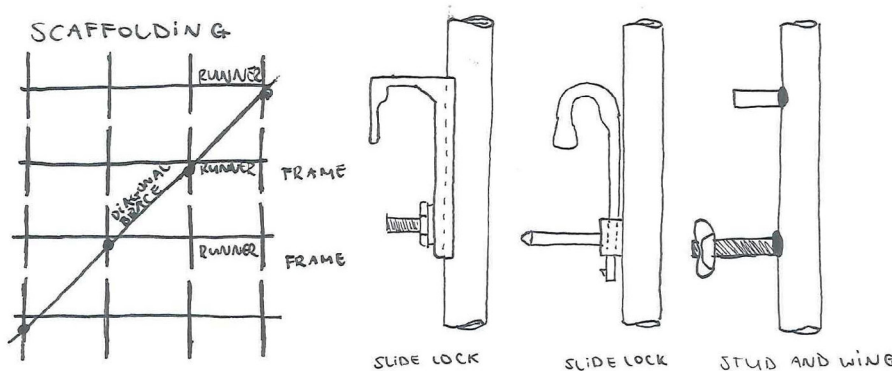

A schematic view of the scaffolding principle.

Three possible details in scaffolding, with how to tighten the connections.

3.6.2 Seats

This section is rather about the structural possibilities for the seats instead of the ways to sit, as already earlier described in section 2.1.1 Seating accommodation. The horizontal steps and vertical risers of the grandstand must carry loads, and the distribution of forces can be taken up with different kinds of spans. Retractable seats are also applied, but mainly indoors to protect the mechanical system.

The span for the seats as larger elements run from girder to girder. This technique is widely applied for concrete structures. Depending on the material, the elements will bend due to vertical loads. The deformation will be largest in the middle of the span.

The second possibility for the span is also to run from beam to beam, but in a different direction as the previous. The beams are stepped just as the ratio riser-tread. If some risers and treads are connected together they will function as elements, spanning over a diagonal distance (Klomp, 2013).

The different spans the seats can have on the underlying construction

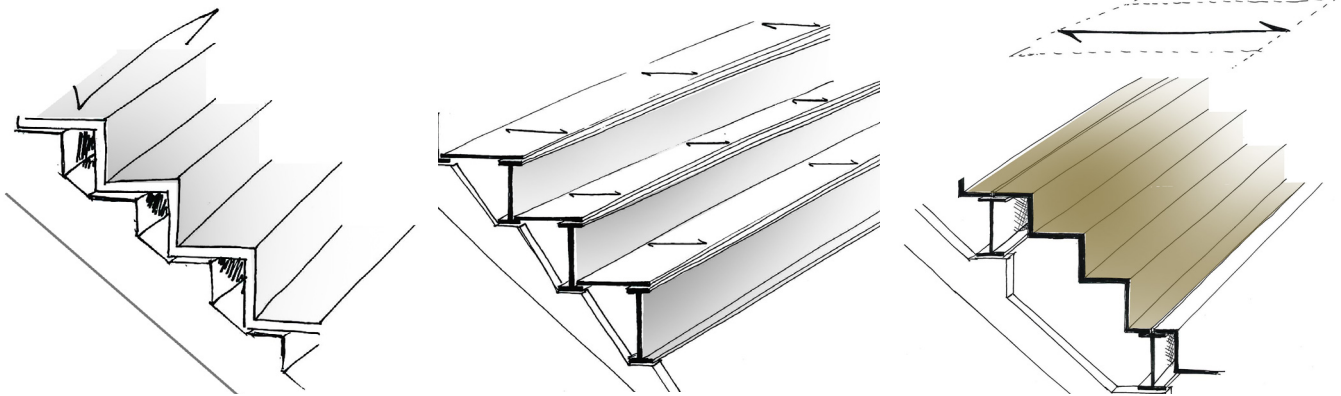

Tread fixed

Riser fixed

Nose fixed

Typical seat

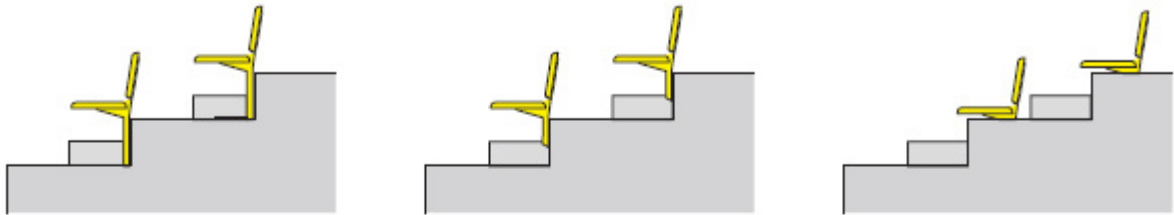

The three possibilities of how the seats can be fixed onto the underlying structure.

Retractable seats

Retractable seats are mostly used indoors in order to save space by converting in form from a grandstand to a retracted unit which does not take up a lot of space. It can even be hidden behind a wall so it can be taken out of sight of the space it is in. The technique is based on rolling units which all fit in each other when retracted, but are also strong enough to carry the loads it has to take. The main material is steel for the construction, but aluminium profiles can also be used. The main reason why they're mostly used inside is because things like dirt and leaves can jam the system. In combination with rain water they go to holes and edges where they have to be cleaned again. It is advised to use as less movement for an outside structure as possible.

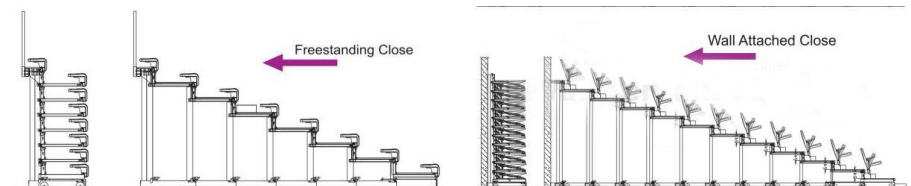

Two examples of how retractable seats can function as space saving wall elements.

3.6.3 Patents

In this section some patents are mentioned which define current possibilities for (demountable) grandstand design. After the descriptions of these current system, a small analysis will be made to compare the techniques with aspects like comfort, flexibility, safety, and others.

1. The patent of C.H. Wetzel, 'Grandstand Construction', was filed on September 23rd, 1933. It describes a structure which exists out of triangular elements which are prefabricated joint together by bolts. To construct these elements together to form the grandstand's structure however, one does not need extra materials for the connections. The connections are based on an interlocking principle, where three triangular elements come together and are held rigid due to this principle. The rest of the structure can be built with this principle, and different sizes of elements are possible to vary with length, depth and width (Wetzel, 1936).

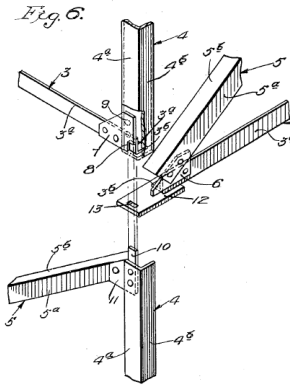
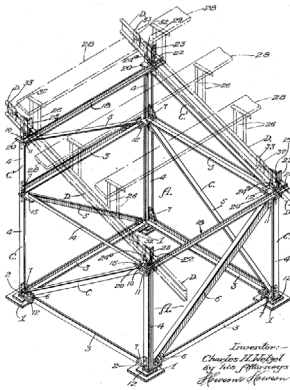

An element of the demountable grandstand of C.H. Wetzel. The patent was innovating because of the boltless connections.

A detail of the design from 1933. The parts slide in one another and hold each other in place.

2. B.J. Lambert filed on April 13th 1938 his construction principle for 'Grandstand Construction'. It consists of prefabricated parts which can be assembled at any desired place. With the invention the inventor states that a maximum strength can be reached through the formation of the parts, but it will also be cost saving. The main elements are the supporting girders, the treads and risers (which are attached to each other), and the benches. The connections are welded construction clips which are permanently attached on the girders. The tread-riser elements can be mounted on site to these clips with bolts, where after the benches can also be bolted on.

Since the invention aimed for a permanent structure, most of the connections are advised to be welded, but it also states that bolting is possible to design for disassembly (Lambert, 1939).

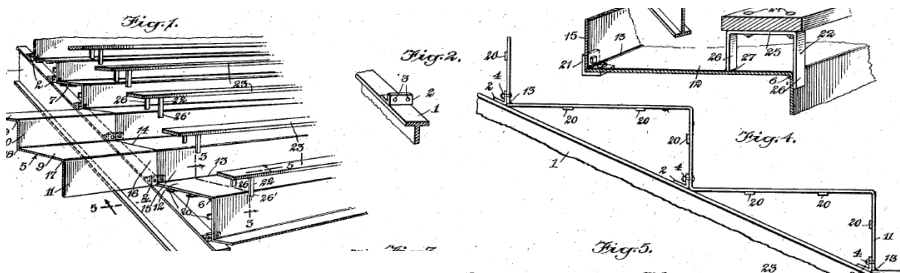

A schematic view of the grandstand and its demountable connection by B.J. Lambert.

In the sideview of the design it can be seen that the risers and treads are made to stack on one another. This is space saving when the elements have to be transported to another site.

3. 'Portable Grandstand' is the name of a patent from July 1940 from R.W. Page and J.F. Roney. The aim was to design for portable grandstands which can be built to any desired height with the intention of increasing seating capacity. The danger of collapse is reduced to a minimum.

The structure is made with a scaffolding principle, with braces as connections. Some braces are pre-welded to form connections with axes in multiple directions (over the x-, y- and z-axis). The distances are not defined, since the diameters of the posts and beams are not defined as well. Greater thicknesses mean higher structural capabilities as well, resulting in greater spans of the seats. Some areas underneath the higher arranged seats can be used for other functions due to the space which is created (Page & Roney, 1942).

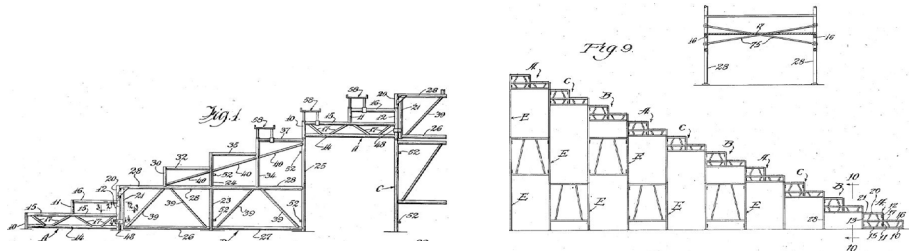

The Portable Grandstand as a scaffolding, braced against horizontal forces. It is designed to be built to any desired height.

4. The 'Portable Grandstand or Bleacher' from R.A. Uecker, D.E. Beatty and L.C. Oertle from 1940 describes a repetitive mounting system, where the only differing elements are the lengths of the vertical posts to increase the height of the grandstand. Meanwhile this must be shored with diagonal elements to ensure its structural safety (Uecker, Beatty, & Oertle, 1942).

5. In the year of 1980, B.M.F. Jarvis invented a 'Modular Stand Construction System' with seat modules which can be folded in its own structure to save space for transportation. This was revolutionary, because all the patents for demountable grandstands before did not contain foldable chairs with backs. This type does need more space for transportation due to the greater volume it has in comparison with the old bleachers seats/planks, but was more comfortable for the user (Jarvis, 1980).

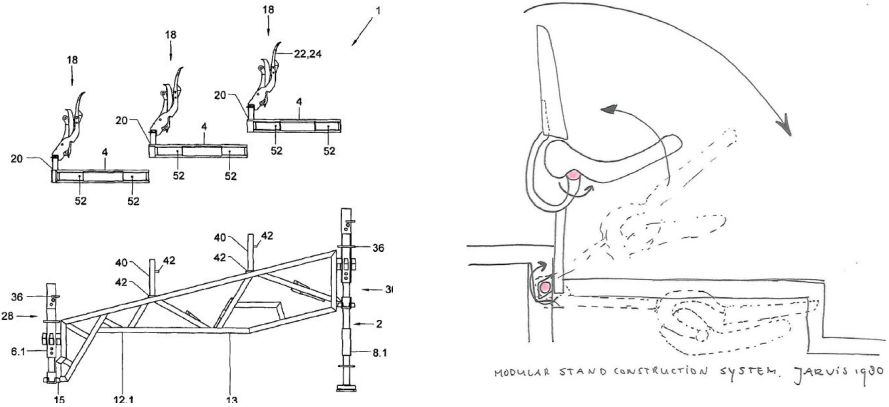

The seats for this patent were able to be folded within the walkways, to save space during transportation.

6. The founder of the most recent technique for demountable grandstands which has been patented is a Dutch company, Van Stokkum Holding Vlijmen B.V. which is located in Elshout. Their invention consists out of two main elements, namely the seats on their treads and risers, and the steel structure as a base. The seats are attached to each other in a row and can be demounted from the structure for transport. They are designed to be folded into each other to save as much space as possible for transportation, but also to reduce the effort when assembling it on the next location (Van Stokkum, 2014).

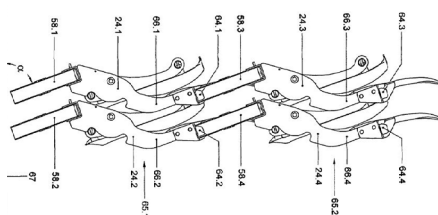

For the Dutch design of demountable grandstands space saving is paramount, together with seating comfort. The seating elements can be stacked on top of each other.

3.6.4 New designs

The idea of transporting complete stadia is not new. It started with the small temporary grandstands, but evolved in sustainable intentions for upcoming world football cups. The first world cup where these ideas really get into practice is Qatar 2022. This report is not political and the fact that Qatar is chosen to host a world sports event will not be questioned, it can only be stated that it will be a great challenge to design stadia which will be cooled via carbon neutral techniques in a climate where the summer temperatures can reach up to 50 degrees. Realizing that the enormous stadia will not be used efficiently enough for future events, Qatar challenged architecture firms to design demountable stadia. The easiest way to transport the building components would be by sea, because Qatar is a coastal country and because the stadia need to be transported to all parts of the world. The use of shipping containers is economic and they give protection to the components while being transported.

Master theses concerning demountable stadia

At the Delft University of Technology, multiple disciplines are educated and practiced. Next to Architecture and the Built Environment, the faculty of Civil Engineering and Geosciences also embraces structures of large objects, possibly even more than the faculty of Architecture. Several students already research the possibilities of demountable stadia, whereof A. den Hollander, M. Loosjes and M. Klomp were the most recent students in this field of interest. In this part the designs and preliminary options are analysed with their specific build up (Den Hollander and Loosjes worked on the same project, the design of Zwarts & Jansma).

Den Hollander, option 1. Retractable truss in accordion structure

Multiple trusses are applied for this option. The challenge was to have stable trusses when they were erected, but when dismantled they have to be folded in for easy transport. The structural principle were slideable braces which were able to move up and down and therefor allow the diagonals going up and down. If this principle was used the vertical columns could move towards one another so less volume is used for transport. When multiple trusses are connected, they can form one big truss. To enable stabilisation this principle was formed in an accordion way.

Den Hollander, option 2. Dimensional stability, 2D-retractable columns

The main principle of this option is a stable triangle as base for the giant truss. The triangles of the first truss are not aligned and for the second truss they are, enabling stability in the whole system.

Den Hollander option 3. Foldable, dimensional, stable V-feet

With the principle of a stable three legged pyramid this structure can be realised. When the pyramid is turned upside down, the triangle components can be used as so called 'V-feet'. These base support the main girder, but to ensure stability of the structure these feet are not aligned relatively to each other. This last option was chosen for the final design. The main girder is erected at one side from the ground. Due to the hinges which will provide rotation over two axes the bases are able to fold out. Because of this principle the structural components are tubular elements.

(Den Hollander, 2010)

Klomp. Main design

The design of Klomp is straightforward. The aim was to design as feasible as possible, using a repetitive system for the whole stadium. Standardized beams and girders are applied for the design. The design itself meets the standard requirements for stadium or grandstand design. The main advantage is its advantageous transportability possibilities, demanding only the use of 51 containers to transport the whole structure. Not much is said about the architectural perspectives such as function, route, aesthetical value, its placement in a city or in a landscape, etcetera.

(Klomp, 2013)

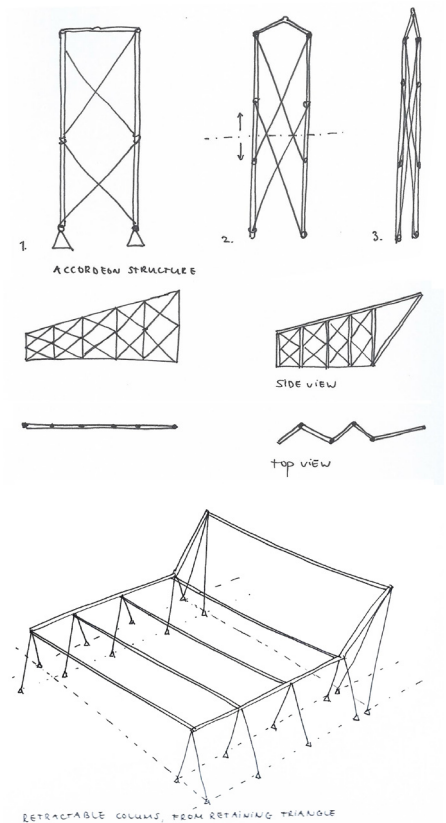

Different types of demountable grandstands, designed for construction ease and speed.

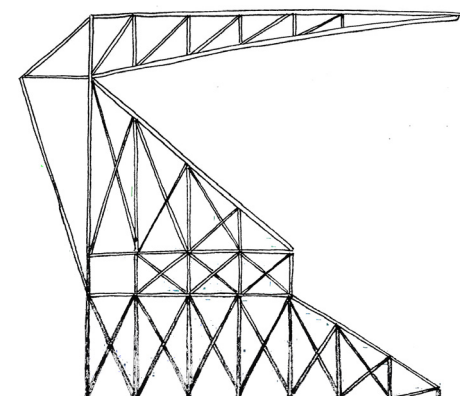
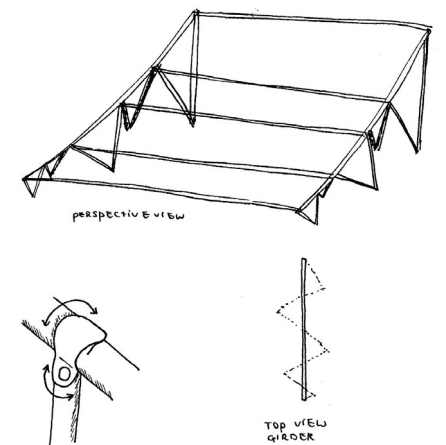

Wolff, Mobile Grandstand

The industrial designer Jesper Wolff posted in 2012 his version of a demountable grandstand on his website. He states that most of the elements can be put into containers, but not all of them. The slender structure gives the possibility to be upgraded with volumes underneath which can house specific functions. In the images of his design the roof looks very lightweight. It all seems a decent design which fulfils its function well, but not much is stated about the functions like the entrance, shops, VIP-boxes, and etcetera. It is only a grandstand meant for ground level.

A roof covered grandstand, seemingly erected with ease. Designed by Jesper Wolff.



Typical cantilevered roof structures, with the red supporting systems and their directions.

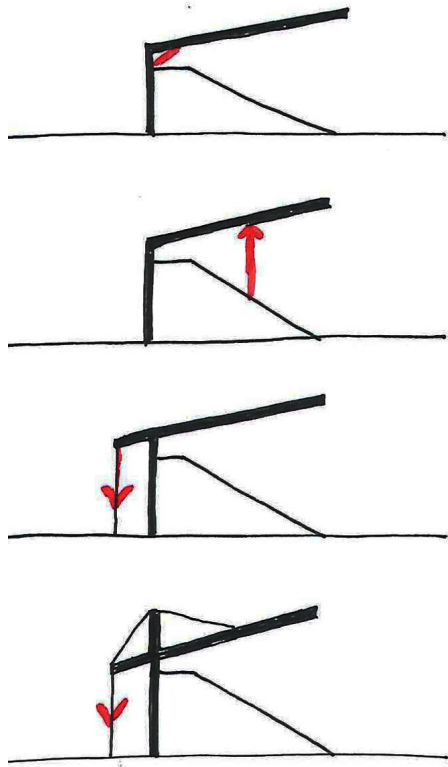

3.6.5 Roof

For stadium design there are multiple types of structural systems for the roof. With gaining knowledge about these types one can choose suitable ones to design with in the design phase for the temporary grandstand. The roof types are 1) post and beam structures, 2) goal post structure 3) cantilever structures, 4) concrete shell structures, 5) compression/tension rings, 6) tension structures, 7) air-supported roofs, 8) space frames and 9) opening roofs (John et al., 2007, pp. 63-72). These types can be categorized in the following categories for structural systems: linear systems, 'simulated' spatial systems and 'true' spatial systems. The 'simulated' spatial systems and 'true' spatial systems emphasize roof systems which function as a whole, meaning their elements work together in as stadium as a whole (in 3 dimensions). This type is not suitable for the temporary grandstands, since they will not be constructed as a stadium but as separate units. The logical choice would be of linear systems (Nixdorf, 2008).

One of the advantages for the linear cantilevered roof is achieving an unobstructed view for virtually any length of stand while spanning depths of 45m or even more, the limiting factor being cost rather than technology. Another advantage is that they can be very dramatic, exploiting the excitement engendered by structure with no apparent means of support (John et al., 2007).

For cantilevered roofs, there are few main options to transfer the loads. At first, to decrease the bending moment in the corner of the structure, a diagonal element can be placed. This is mainly for older wooden or steel roofs with a relatively short cantilever distance. The longer the cantilever gets, the higher the bending moment will be. A post can also take up the loads but will block the view of the people on the grandstand. A couple like structure can be achieved to extend the cantilever beyond the rotation point and connect this part via a cable to a type of anchoring. Another possibility would to run this also from the top like a crane.

Examples of cantilevered structures of German stadia.

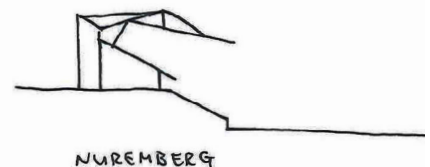
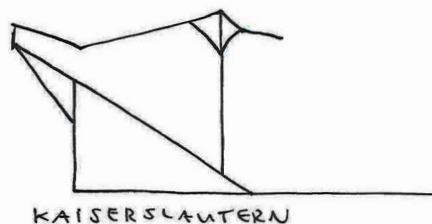
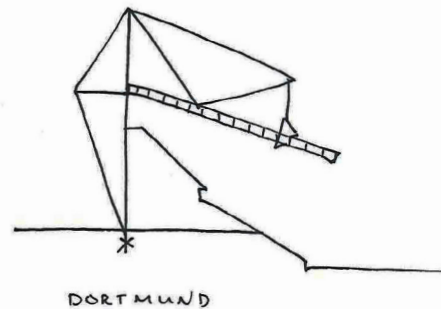
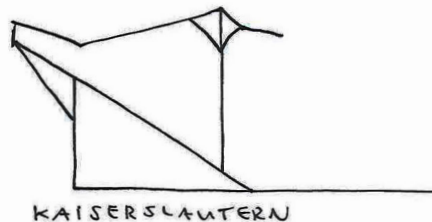
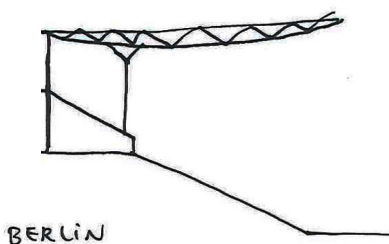

3.7 Towards a new design

Up to this point, much was stated about the context of the design, as well as the program and the technique of how to create this. With this knowledge, design specific techniques can be thought of in order to form a base to start the design with. This base of the design will be divided in the following categories: form and composition, component dimension scale, and build-up sequence. These categories are actually a follow-up from each other, zooming in from a bigger scale to a smaller one.

3.7.1 Form and composition

The research for the context and its program lead to the following conclusions as guidance for the design:

1. The grandstand needs to be transportable
2. The structure has to facilitate multiple functions, depending on the demands and locations
3. The structure has to be expandable and repetitive, thus the size and its capacity must fulfil the needs of the event

These conclusions determine several aspects in the design. The fact that there is not a definitive form is one of the examples. The form and size of the object depends on what is demanded. A small event such as a local outdoor theatre shows in a village will demand a grandstand capacity of 1000 spectators tops, while the main grandstands of a Formula 1 city race require 8000 spectators, and facilities like media areas, VIP-lounges, toilets, and etcetera. Because the design has to be transportable, it must also be flexible in size and capacity.

The words in **bold** refer to the forms of the structures which can be seen here on the right. A **standard** sized seating consists out of seats, arranged according to the right C-values that is, possibly covered with a roof. The optional roof accounts for all possibilities. The extra costs they bring must be compensated by the event organiser, but in return they give the spectators protection against rain, snow, sun, and will reduce the wind speeds. The organiser can therefore charge more for the seats. Depending on the desires of the organiser, the angle of the grandstand must also be changeable. Some events require a steeper incline than others, where for an air show the incline is less important as for an event on a short distance, such as a skateboard competition on a half-pipe.

The amount of facilities must also be optional, and according to the architect or structure letter the right sequence or position of these facilities must be advised. The facilities can be arranged behind the seating areas, but if a **lifted** grandstand is desired the facilities can also be placed underneath. Accessibility of the building will be a problem to solve for the design phase as well.

It is not always of paramount importance to aim 'the eyes' only for the event. With the term 'the eyes' is also the direction meant of the structure's face or aim. Where one would normally define a stadiums front the part where the viewers would spectate the event, and the back the part where one would go out and in, can the new design aim in both ways, for example by creating a **boulevard** on top of one of the facility areas. This open space can have different types of purposes. It can function as a terrace for a restaurant, a play area for smaller children, or a market where they sell merchandise and snacks during the event. Also this area can be protected with a roof if desired.

The number of grandstand areas for one section is not predefined. Multiples are possible, also with the correct C-values and slopes it can have. These must be possible to realise with or without facilities. Possible solutions can be seen here on the right with the names of **double, double +facilities, and triple**.

If a structure is desired for a location where it would function as an extension of a current stadium, for example a smaller football stadium or the Olympic stadium in Amsterdam, a **high** structure will come in handy without the necessity of having facilities in its structure. Depending on the location, the height can be adjusted, as well as the angle for the seating arrangements.

Eventually the maximum height will be determined by the ground's load-bearing capabilities and necessity for the event. Not many sports events require a grandstand with a height over 50 metres, the viewing distance would simply be too far to spectate the action. There are some stadia for horse races however where the facilities within the structure are as much as important as sitting on the tiers. **Quadruple high or stacked structures** are not uncommon there.

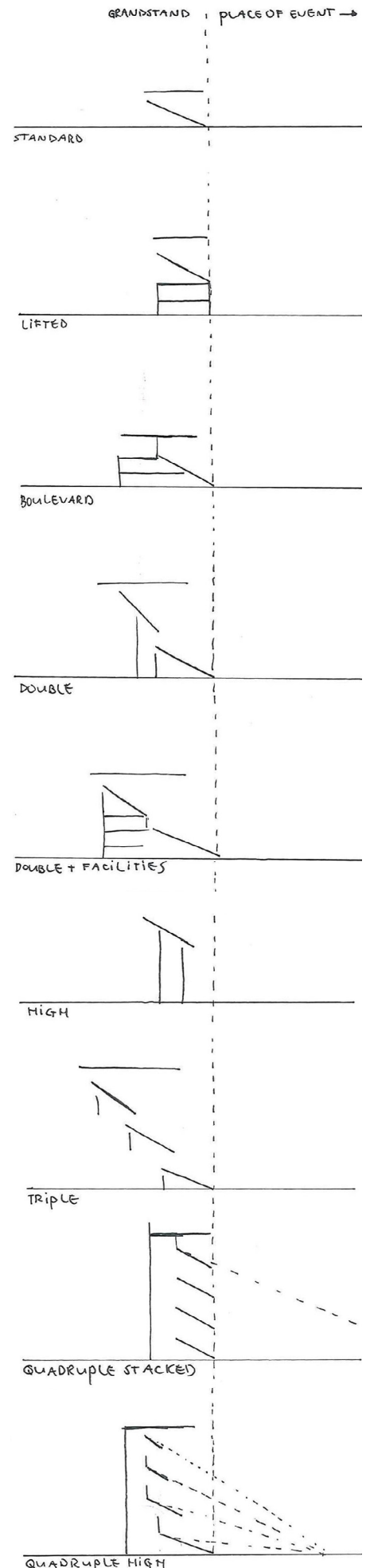



The Ascot Racecourse Stadium, with seating parts stacked on top of one another. It was designed for horserace matches.

The principle of optional areas and therefore building volumes is schematically shown here. This configuration is one possibility of many, which have to be worked out in the design phase of the project. The angled parts are the parts where the seats will come, each volume with a different angle for the right C-values and its own spectator capacity. The blocks underneath the structure houses facilities which can be ordered by the event organiser. Depending on its function and place in the structure, the blocks can differ in dimensions. The optional roof must maybe give the opportunity to vary in its angle, depending on the organiser's demands and location and orientation of the grandstand.

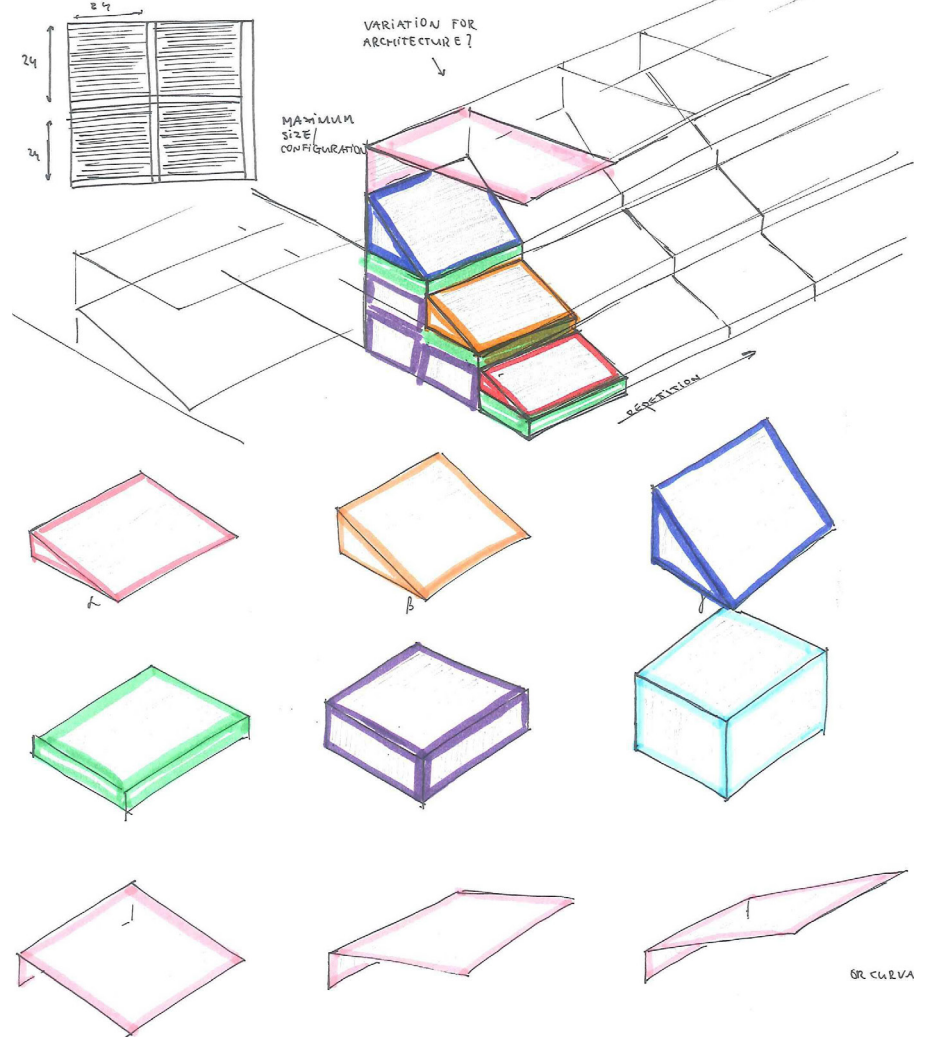

Research by design: creating elements which can be hired on selection and demand by an event organiser. Together they can be stacked or placed within the structure however the organiser desires, of course with the advise of the architect.

Construction types and component dimensions.

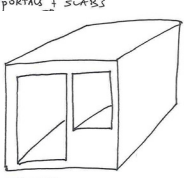
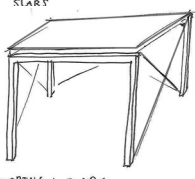
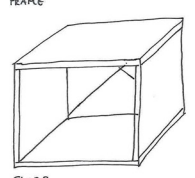
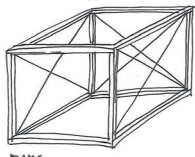

3.7.2 Component dimensions

The component dimension scale has influence of two major aspects in the assembly and disassembly process. It will influence the transportability and building effort. The larger and more complete the building components are, the less effort has to be put in constructing and assembling the parts on site. There will possibly be less connections and joinery, and larger components are more likely to be assembled directly in their places instead of being mixed up between other parts or lost in the great heap of elements. On the other hand the larger components will be heavier than smaller ones, and it will take more force to put these elements into place. The consequences for tolerances are bigger as for the smaller components.

For smaller components the complete opposites of the factors apply as for the larger ones. On the positive side, the smaller components can be transported with less means. The amount of containers can be brought to a minimum, as already showed by Klomp (2013). The elements are lighter and do not directly need heavy machinery to be lifted up at the construction site. On the negative side, the smaller components need more joints as the larger components. A large amount of joints require a simple repetitive joining technique to reduce the complexity of the system.

With these options in mind one can globally look at the component dimension scales, which are indicated on the left side of this page. A combination of these options is of course also possible, where a symbioses has to be found between transportability and construction boundaries and possibilities.

3.7.3 Build-up sequence

An important boundary in the design of the transportable grandstand is the way the elements are put together to form the structure. The building sequence can be performed on multiple ways, where each way had its own pros and cons. In this section the possible building sequences are shown and explained in order to research which building sequence suits best for the design.

The first principle is about constructing the structure piece by piece. The elements are connected onto one another step after step, where the structure has to be build up first and where after the floors and seating elements can be joint. This building sequence is very common in constructing buildings, and shouldn't be too much of a problem for building workers. A mini crane can be used to lift the elements to the upper floors.

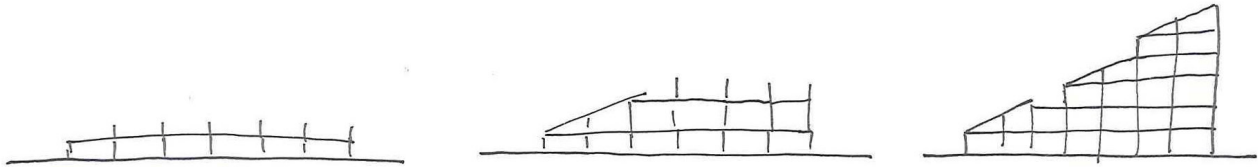

The second principle uses engines to lift the floors and seating spans to the higher areas of the structure. The towers which have to be built must be strong enough to divide the loads on the whole structure. The advantage of this principle is that there is no need to hire cranes to lift the elements. Also the elements don't have to be demounted so their maximum dimensions are defined by the maximum sizes for transport. Challenges will lie in connecting the bigger elements to the towers.

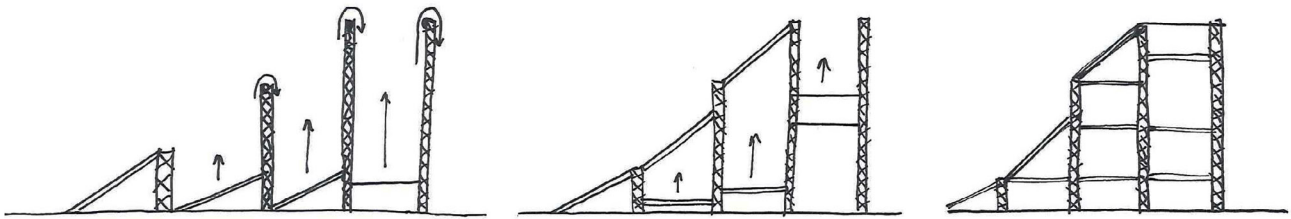

The third principle is constructing the main parts on the ground, and by using a jack-up technique the parts can be lifted up. An example for jacking-up is the scissor technique, which is also used for smaller platforms to lift workers who have to work on ceilings for pipes and lamps. A problem for this principle can be the amount of force the hydraulic system has to deliver to lift the seating and the floors up, since they will be heavy elements. Another problem will be the danger of swaying, because the structure will be top heavy and light in the lower regions (Fransen, 2012).

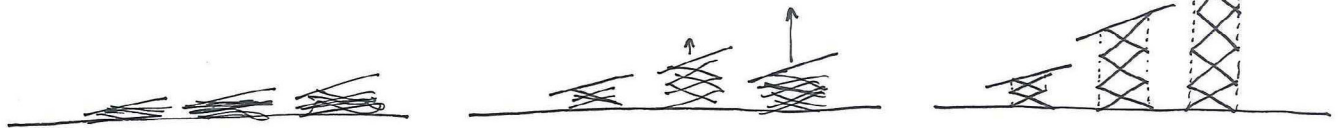

The fourth principle uses a stacking method to stack volumes on top of each other. These volumes can exist out of one element with dimension restrictions according to transport regulations, or can be built on site at ground level. If the volumes are built on ground level it is not necessary to lift all separate elements to the upper floors but only for the whole volumes. The question is if these volumes are closed or somewhat open, because there will be great differences in the program of the building for open and closed areas. Halls, walkways and stair areas will be very open to ensure top overview and visibility, but VIP-lounges, media facilities and food selling points will be more closed to ensure privacy and safety.

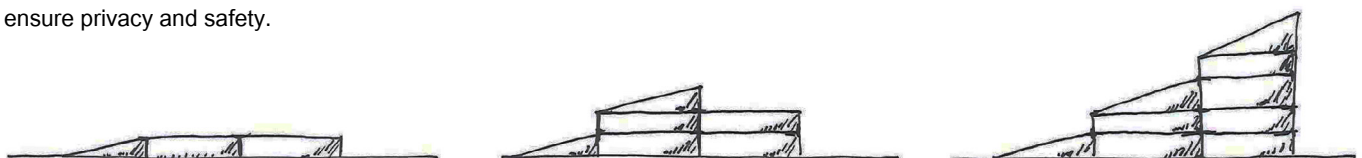

The fifth principle is about a folding method to fold the columns and beams on their correct places. This method was introduced by Zwartz & Jansma and worked out by Den Hollander (2010) and Loosjes (2011). There are multiple ways to use a folding method. For the design it will be of importance what will be leading; the form and composition or the folding principle. If the folding principle is leading, the design will be according to the folding 'rules'. If the design is leading, a suiting folding principle can be applied accordingly.

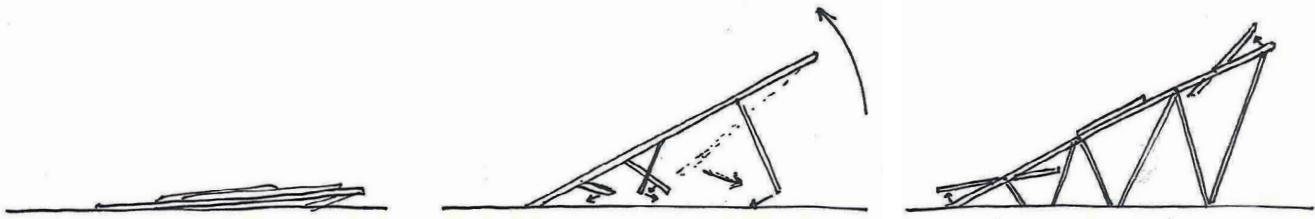

The sixth principle consists of a combination between elements and volumes, where the elements have to be mounted to form the supporting structure, and the volumes can be slid in via a drawer-like method. The advantage of this system is that the speed of the building process is accelerated, because multiple parts can be built at the same time. Once all parts are separately built, they can be joint and connected to form the structure in a small amount of time.

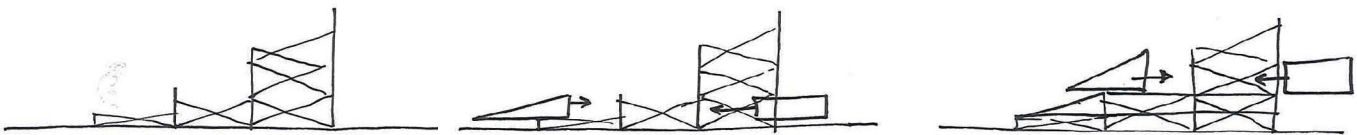

A comparison between the optional building sequence principles. The dots represent a scale from negative to positive. The more dots a score has, the more positive it is for the design.

- Elements;** more elements mean more joinery equals longer building time.
- Element size;** a smaller size means more can transported per shipping container. That is a positive issue.
- Building time;** the shorter the period of building, the better for the design.
- Safety;** The safer a structure is for the builders and the eventual spectators, the more dots it will get in this comparison.
- Tolerances;** getting bigger elements at higher areas can mean swaying of the structure, whereby the tolerances can get greater. Great tolerances can mean an unsafe structure.
- Complexity;** represents how difficult it is to build the structure up with the principle. The easier it is, the more dots it will get.
- Size building area;** the desire is to have a small building area, so there won't be any conflict with possible nearby built environment.
- Design liberty;** when a structure is not reliable on it's building sequence, the design liberty is great. When the design has to follow the leads of the principle, it may not be totally free of form.
- Number of workers;** lesser workers means less costs for erecting the building. It may result in longer building periods.

	1	2	3	4	5	6
Amount of elements	●	●●●	●●●●	●●●●●	●●●	●●●
Element size	●●●●●	●●●	●●	●	●●●●	●●●
Building time	●●	●●●●	●●●●	●●●●●	●●●	●●●●
Safety	●●●●	●●●	●	●●●●	●●●	●●●
Tolerances	●●●●●	●●●	●●	●●●●	●●●	●●●●
Complexity	●●●	●●	●●●	●●●●	●●●●	●●●
Size building area	●●●●●	●●●●	●●●●	●●	●●	●●
Design liberty	●●●●●	●	●●	●●●●	●●	●●
Number of workers	●●●	●●●●	●●●●	●●●	●●●	●●

● very bad ●● bad ●●● average ●●●● good ●●●●● very good

3.8 Logistics

When designing for a transportable structure, one of the most important themes in the design is the transportation itself. Next to that are the handling and stocking of the materials. These subjects have great influences on the design, the structure and how it is constructed or built on site, because they give boundaries to the building components. The boundaries vary in the range of weight, size, weak points in the components, and sorting ways to fasten the construction time.

“At a well organised construction site all transports scheduled, are time slots to load and unload materials with the correct cranes and goods hoists, are lorries diverted to a special lorry car park and are the transports called in just in time.” (Danielse, 2013, p. 91)

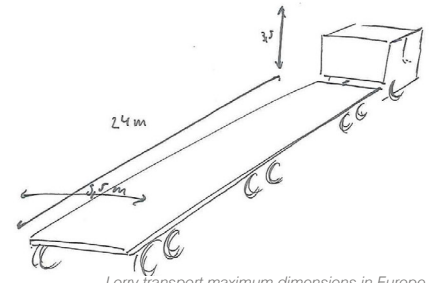

Lorry transport maximum dimensions in Europe.

3.8.1 Transport

Of course, different possibilities lie in the transportation types to transport the components to the building sites, for example by train, plane or boat, but transporting by vehicles on the roads is the most effective of all. This is because the locations are very diverse and are not always near cities, railway tracks, waters or airports. When lorries transport components by road, they are restricted by legislations which determine the maximum dimensions and weights. Special permits are needed for larger dimensions. The European Commission (2009) says the following for the dimensions without needing a permit or escort for all roads:

Maximum width: 3.5 m Maximum length: 24 m Maximum height: 3.5 m

For more protection of the products during the trip, shipping containers can be used. Typical inner dimensions are for a 40 feet container 12 m x 2.35 m x 2.39 m.



A standard 40 feet shipping container, 12x2.35x2.39 m.

3.8.2 Handling

Handling materials

- *Manual handling.* For a single person the weight restrictions run to 20kg per person, and objects heavier than 50kg are not allowed to be carried by any number of workers.

The following handling materials are available in different sizes with different strengths. The weights and distances mentioned here below are those of the strongest in their types.

- *Forklifts.* With a self-weight of eighteen tonnes it can lift elements from up to ten tonnes.
- *Mobile crane.* A hydraulic powered crane, with lifting height possibilities from 44m up to 188m
- *Telescopic loader.* Lift capacity of 3,100 kg, maximum lift height of 7m.
- *Goods hoist.* Max carrying capacity of 2,000 kg, with platform dimensions of 3.30 x 1.50 x 2.30m.
- *(Tower)Crane.* Limited use, low accuracy, high costs. Special areas: corners, roof screens. However, the variety of cranes is great and great heights can be achieved and heavy loads can be lifted.
- *Spider / Mini crane.* These cranes are used from the upper floors where they are flexible and quick. Their lifting capabilities vary with the applied extension, with the maximum capacity of 3,000 kg
- *Loading platforms.* Max width of around 3000mm, with a max load of 2-3 tonnes.

(Danielse, 2013)

3.8.3 Packaging

- Profiles: profile containers can be handled by cranes, forklifts and pallet trucks. They must be fully protected and can be up to 6 or 7 meters long.
- Glass: Glass must be transported on A-frames, and can also be handled by cranes, forklifts and pallet trucks. The maximum load is 2000kg.
- Panels: Can be transported on A-frames, by forklifts and pallet trucks, and must be protected as well.
- Unitized panels: Must be handled individually, and can be transported on steel or wooden frames and in crates. Horizontal transportation is advised.
- Panellised precast panels can be transported on large A-frames as well as U-shaped lorries, and will need a crane for the lifting work.
- Loose components like joints and connectors are transported in crates, fully protected against the environment.

(Danielse, 2013)



A forklift.



A spider or mini crane. Used on upper floors.



A mobile crane.

3.9 Conclusions

The main aims for designing for disassembly are component –reprocessing and –reusing, and building relocation. For a temporary structure, a shallow foundation is efficient in terms of time saving and material costs. A soil research must be done to determine the loadbearing capacity of the soil, and depending on the amount a foundation surface area can be determined. The relevant loads are determined as base for the structural design, because the form, the materials, and the component sizes are dependant of the loads to ensure the structure its safety. Several materials are investigated with their associated properties to determine which ones are suitable for the design. The aim is to design with light, strong materials that preferably last long in harsh conditions. For the joinery, several details are looked into. Bolted and boltless connections seem attractive for the design, with the possible extra application of tensile elements. Known techniques in demountable grandstand building are examined to gain knowledge for the design phase of the project, as well as new designs made by an architecture firm, a product designer, and graduation students. The designs are the results of choices between efficiency in component sizes and build-up sequences. The grandstand its roof will probably a cantilever due to structural boundaries and material savings. The structure of the building itself will not be predetermined, but will depend in size and amount of facilities to the demand of the event organiser. For the design process a build-up sequence still has to be made, but the first options are already explained and compared. Components sizes are limited to transport possibilities and construction machines and their capabilities.

Research Conclusions

4

How can a demountable grandstand with possible extra functions be applied on any desired location to be transported to and constructed on the site of the event, with simple feasible means in a short amount of time, fulfilling the wishes of the event organiser?

Sports events are organised all around the world. They are reoccurring, that is for sure, but most definitely not permanent. More and more we see a shift towards sports events on new sites and in different cities, but we can also see a rise of new sports and the interests they get from the people. To provide seat capacity at the temporary locations of such events, a temporary demountable grandstand can be applied on site. Nowadays these structures are purely functional without any aesthetical value, and much space is lost underneath its scaffolding structure. If a permanent structure is built for a temporary event, like the Bird's Nest stadium for the Olympic Games, much money is put in the design for the aesthetical value and the facilitating functions. A risk is that after the use the building will not be used anymore to its full extent. Therefore, temporary demountable grandstands provided with extra functions can be applied for larger and smaller events. Depending on the size of the event and its seat capacity, it must be possible to form a stadium with this structure.

In order to transport the structure to the event site and construct it with simple and feasible means, choices have to be made during the design phase of the process. Facts are that the components can be transported in standard sized shipping containers, otherwise the component sizes will depend on the maximum allowed dimensions for road transport. Via road transport, the structure can reach almost every location. A soil research must be performed to determine the load bearing capacity, shallow foundations can distribute the forces of the structure to the ground. To accelerate the building process and thereby shorten the construction time, stainless steel bolted connections are best for fastening. Boltless connections can be an option when the components are slid into each other to fasten the connection in two axes, to be secured with a pin to fasten the connection in the third axis. The aim is to design with light, strong materials that preferably last long in harsh conditions. Construction sequences can be with folding, stacking, lifting, jacking, and sliding principles, apart from building it piece by piece. The flexibility from the structure comes from the freedom the event organiser has to compose the grandstand with the functions and capacity he desires.



The Design

5



5.1 Design concepts

After the research, the following conclusions were leading in the design phase of the graduation project: the structure should be temporary, for visitors of all kinds of sports events, on a great variety of locations, with spaces for all types of functions. These statements had consequences for the design and the way the structure has to be built.



A few concepts are set as main goals for the design to reach. Firstly, from an architectural point of view, the concept is to get rid of closed hallways, dark and closed areas which still exist in some large (for example concrete) stadiums. View possibilities have to be in all directions, inside the stadium as well as from outside the stadium and vice versa. With all the possible functions in the structure it has to become a lively and open place to eat, drink, relax, interact, and possibly buy the merchandise of their favourite clubs. The times before, during, and after the events are the times when the building is truly lively and this has to be visible for the people attending as well as the people outside.

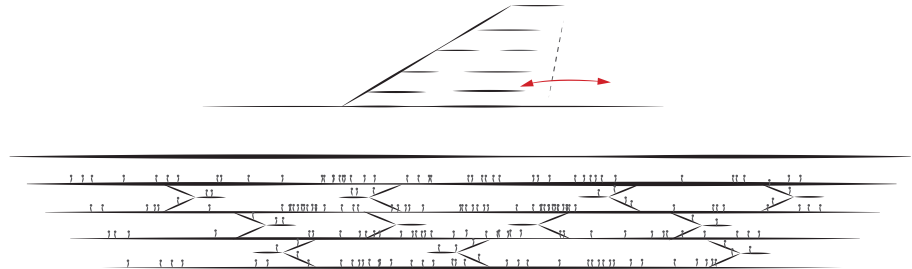

As for the constructional concept, the design for disassembly principles have to be as simplified as much as possible. The materials and building components have to be prefabricated, in order to save time during the assembly and disassembly phase of the project. Thereby the goal is to sort the components in groups to accelerate the building process, skipping the process of sorting the components on site. After the fabrication and sortation phase, the building parts must be saved in a consolidation centre, where they can be stored, cleaned, and replaced in case they are damaged. The transportation has to be conventional for large elements, and able to go by roads, railways and seas. The (dis) assembly period must be short thus it can be beneficial to apply the structure on multiple locations where time is of the issue. This can be reached by a repetitive building process, with a reduced amount of building elements and methods.

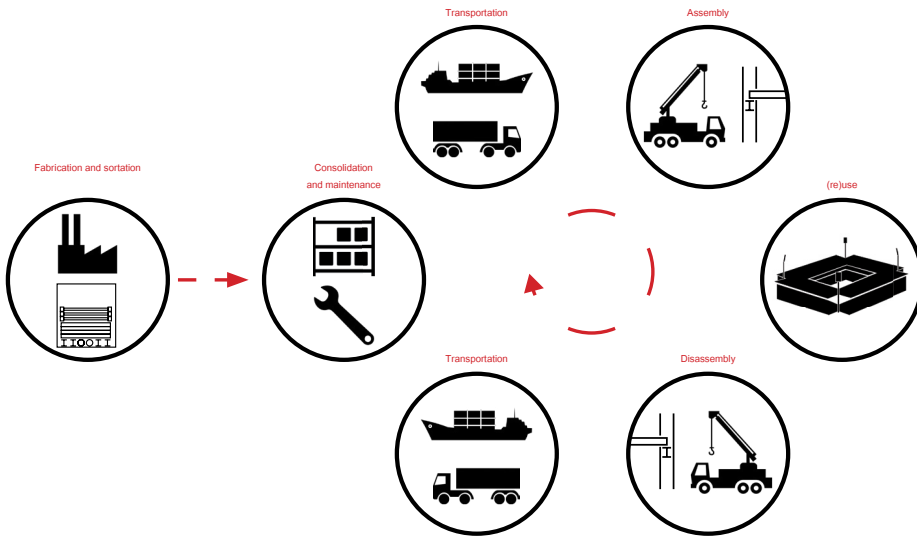

The modular concept has to reach the goal to apply the structure for different capacities, with different forms as well. The different sports each have their own dimensions for the pitches and tracks, and with a modular concept various arrangements can be made possible to stand next to the events and function as grandstands. The various modules must be reduced in numbers because different modules mean more building methods, which means more building complication. With just two modules, one can vary with the configuration for every specific location. With the same 'stacking' principle, higher capacities can be reached just until the point the viewing distance becomes too great for the supporter to catch the event.

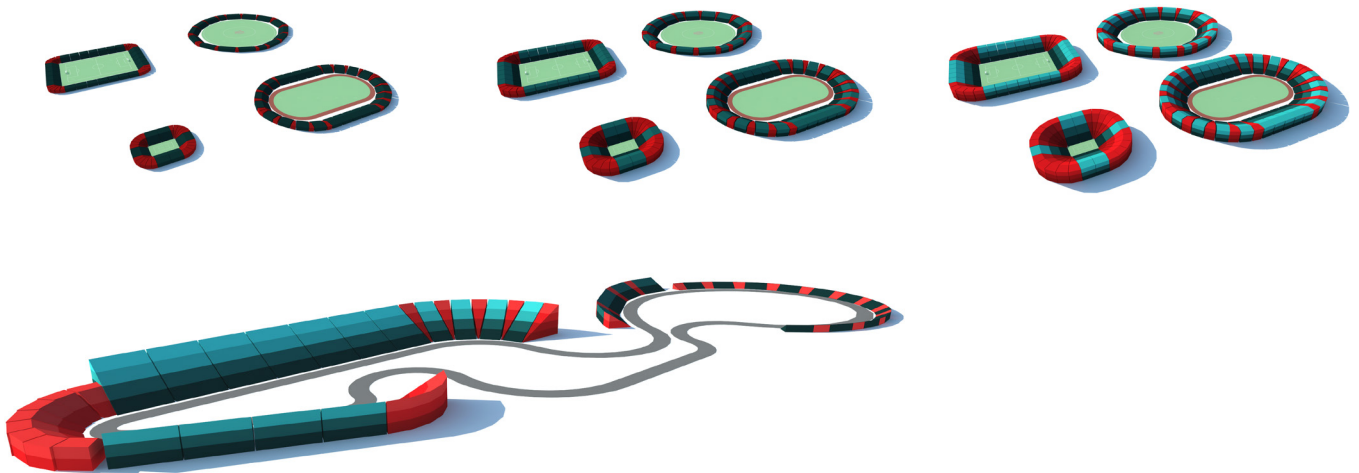

The last concept embraces more the appearance of the building to the outside world. The goal is to use the building multiple times over a longer period using the same materials, but any event organiser must be able to show location specific colours on his building, but even advertisements and commercials or interactive images for the people to see. This must not contradict with the visibility concept, namely the way the people can see the outside from inside and vice versa.



5.2 The Design

One of the two modules is discussed in the following part. It is the main part where the straight sections can be built with. Firstly, displayed in its largest configuration with four floors, it is built up of four sections with grid dimensions of 10,8m and 5,4m. The bigger span part consists of a grandstand and the designated space underneath, the interior infrastructure or routing, and the functional spaces. The smaller span is meant as routing part of the module, with grandstand elements and technical installations at the side of the grandstand. The structure can be provided with a roof, façade, and plinth if the event organisers requires so. The smaller configurations consist of one, two, or three floor(s).

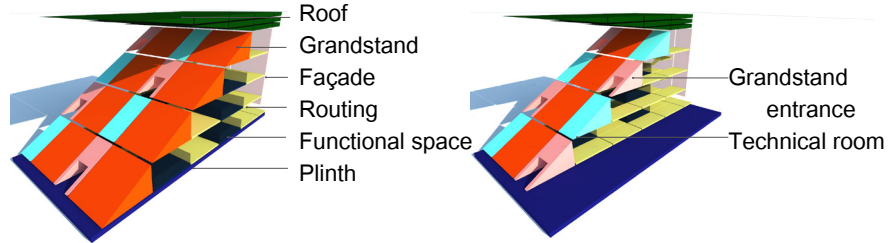
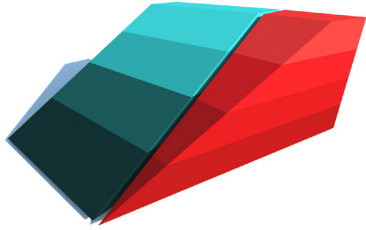

With the design of the grandstand part the building, visibility and safety requirements were considered. One of the flaws in the design is that there is a setback each floor, creating a path for escape when there is a calamity. This has the consequence that people on the first row(s) of the grandstand elements have lesser visibility as prescribed. Unfortunately this flaw was found near the end of the design process, where it wasn't possible anymore to change the plan of the grandstand.

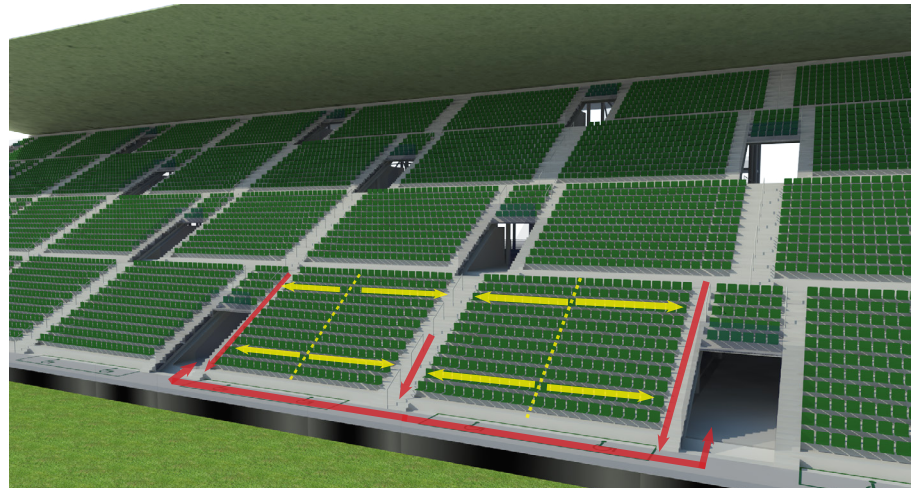

The grandstand unit can be provided with several functions underneath the seating elements. The main examples are toilets, a point of making and selling snacks and drinks, a storage room, or installation room.

The main demands are the reachability of the toilets in terms of walking distance and the correct amount of required toilets for sports events. The positions of the toilets had not to be in conflict with the concept, where interior visibility and interaction with the environment was prior. They are therefore positioned underneath the grandstand units, where the ability of opening on three sides is possible since the spaces next to it vary with functional spaces and routing.

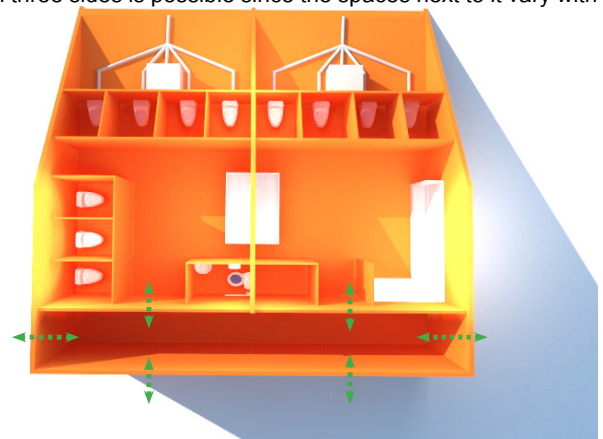

The main demands for the functions is that the designated areas are to be hired b companies which have the interest to do so. They can hire areas at the top location to sell their products like beverages, foods, clothing and merchandises, and any other type of product they wish to sell. Another way is for companies to hire spaces for small offices and lounges, where their employees can gather and meet. For the design, the functions mentioned are not binding. It can even be possible to let out the spaces for these functions as vides, so that sight lines are created in diagonal ways as well, or multiple other types of functions which can be decided by the event organiser or the companies hiring them.

The functional space can be open or closed, meaning in closed appearance they can be climatized as well, since the open spaces are all outside. Climatized means with regulatable temperature, ventilation, and lights.

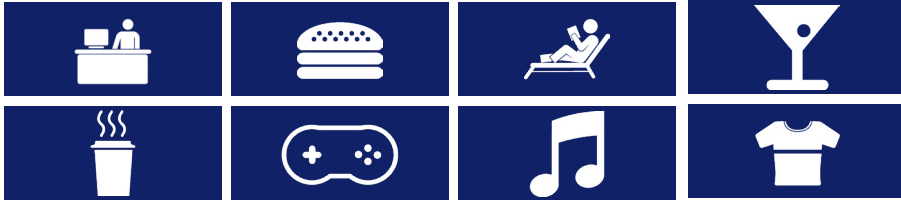

Different identities or characters must be created, in accordance with the type of functions which is being held on the platform. This demand is realised by altering the height of the platforms. If a platform is at the same level as the hallways, the entering of the platforms is effortless, meaning during busy times greater amounts of people can enter and leave the platform at the same time. This is suitable if the platform is made for a fast-food point of selling, bar, or merchandise shop. Lowering the height can mean a more quiet part inside the building, separated from the traffic and the walking people who are travelling via the routes. A coffee area, lounge, or children's play area are options which can be situated on these lowered platforms. If a more private platform is requested, also away from the continuous stream of people on the hallways, it can be situated somewhat higher above the rest. Examples of functions on this platform can be an office or a stage for artists to perform.

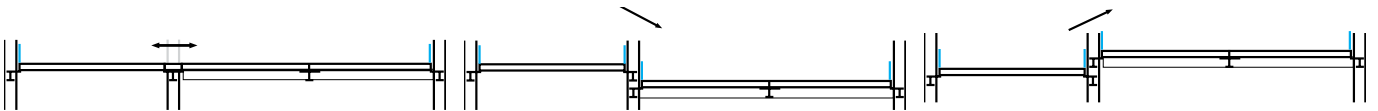



The demands for the routing result from the concept of sightlines and visibility, which should be on all floors ensuring great visibility, also to the exterior. For the walking paths safe escape ways must be obvious, with the widths of the hallways so that great numbers of people can pass simultaneously. The stairs are positioned throughout the structure, ensuring multiple ways to rise and descent to get to the floors.

The plinth is created as an awareness for the people that they are entering a building, but in a gradual way. A few steps up have to be taken, and before entering the building the visitor finds himself on an intermediate space between the building and the outside. People with disabilities are welcomed as well, in the form of ramps and great positions to view the event at the front of the grandstand. The lifted plinth at the side of the event can function as a LED-screen for advertisement or even foam cushions where speed skaters can fall into if they can't hold their balance any longer during a race.

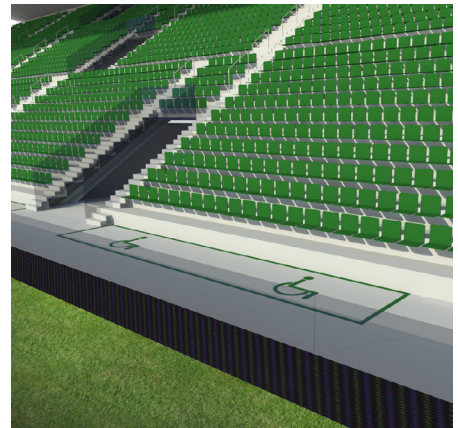

As mentioned earlier the demands for the façade are its changeability per location using the same building principle. It thereby had to be interactive, representing whatever the event organisers wants, still meeting the conceptual goals. Lastly, it was important for the material to be transported to the sites with little effort.

During the design phase of the project, several options were looked into to choose a suiting material for the façade. The statement was made that the structure itself was still an outside area, thus the façade did not have to have insulating properties. A LED-screen consists out of steel cables, where each cable had multiple LED-lights. Together with the right software and energy supply, building users are able to show whatever they want on the façade which then functions as a screen. Because this screen has hundreds if not thousands of different LED's, the number of replacements is also high because the LED's will break over time. This option is therefore not suitable for a demountable building.

Another option which came past the mind was to use a foil, lightweight and responsive to lights from a distance. In the case of ETFE-foil, applied onto the Allianz Arena in Munich, durability was guaranteed as well, because the material lasts for decades. The unfortunate thing is that it costs a great deal of effort to install and uninstall the parts onto the building. The other thing is that it does not coincides with the concept of being able to look inside the building from the outside. The same accounts for the Polli-brick façade.

Textiles however do allow a great variety of prints, opacities, and translucencies, but can also function as a projection screen in front of the building during the evening and night time when the contrast is high enough. Textile are also lightweight materials, they can easily be transported, and can easily be assembled. They thereby cover a great surface for the volume in which they are moved in, since they can be rolled up onto a big roll.

Another advantage of the material is that is also possible to keep the interior of the building somewhat cooler in hot and dry climates. The textile functions as a screen where water can run down from the top where it is sprayed on, whereupon hot winds flow through the screen. The energy level of the wind is lowered at it used to vaporize the water on the façade. The temperature of the wind is much lower as before when it has entered the building. This evaporative cooling principle is applied in the graduation thesis of Naji (2014) bron. The water which isn't vaporized is collected at the bottom in the normal drainage.

The textile rolls can be hanged onto the steel structure of the building, tensioned by strong springs. The hanging principle at the top allows variations of the length of the façade, applicable for multiple storeys.

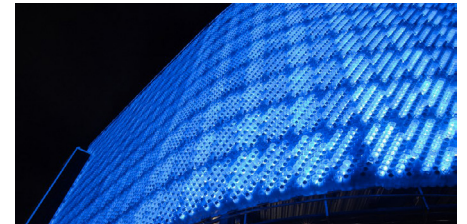
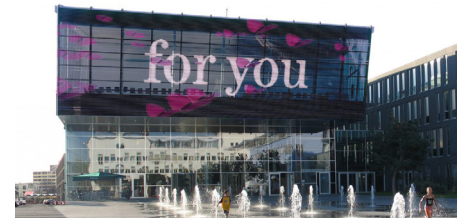

The curvature of the grandstand's configuration is made possible by a pie shaped module, formed out of the same grid relations of the straight module, but then curved by creating a radial grid with an angle of 18 degrees. Therefore five of these module can create an angle of 90 degrees. It is possible to create a gentler curve by alternating curved modules with straight modules, or applying top curvature parts on lower levels.

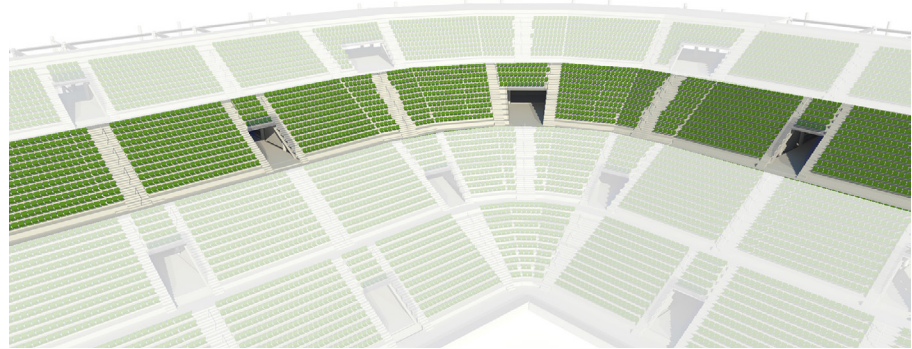
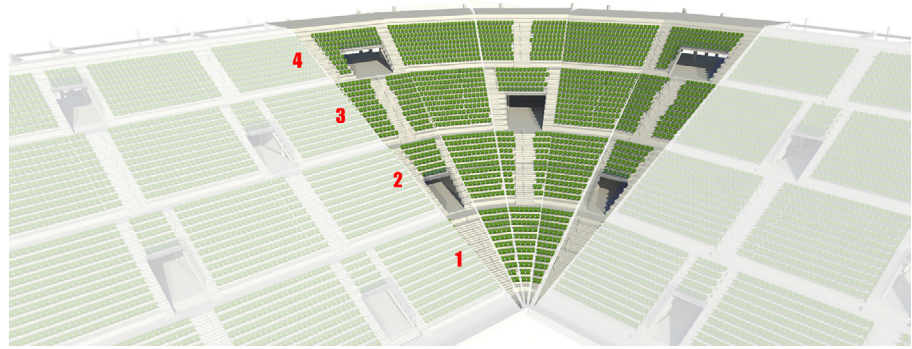

In this part the aims for the design for disassembly will be from an architectural and engineering perspective. The main aims are considering the building materials, transportation, and the building process itself.

An example where the demountable grandstand can be applied is for a street race of the Formula 1, preceded by races for Porsche and other supercars, meaning it will be more beneficial for a multiday/week event. The existing grandstand has a doubtful roof as shown in the following picture, where water drainage is not clearly visible and possibly not present at all. The roof itself protects the people from the sun, but it does not appear to withstand strong winds. The columns underneath the structure also block some visibility. The grandstand itself is next to start/finish, where normally the VIPs and wealthy people have the best seats. The scaffolding does not have the aesthetical value to suit the appearance of the special guests. Also places like the toilets, VIP areas, shops and food courts are not nearby for all the visitors of the spectacle.



With the design of the demountable grandstand, a roof can be created which does not block the view of the supporters, is strong enough to withstand heavy winds, collects the rainwater, but also can be created with a printed textile to show the nations colours or any other desired print. All kinds of functions can be realised underneath the grandstand, and on places where there isn't a roof it can function as a place where people can have drinks and watch the race from above. Also spots are created for the disabled people, of course with the warning to bring the best ear protection.

The functions inside this grandstand can look as following. In this image the following building elements and their materials are discussed; the structure, the floor panels, and the railings and window panels. Steel is used for the structure because of the best price, durability, strength and size ratio, as researched in chapter 3.4. The floor panels are made of glass fibre reinforced polymer sandwich panels, with an insulating foam core which also contributes to the panel's strength and stability. These panels can be integrated with installations like ventilation, sprinklers, and electricity sockets, proven by Van Stormbroek (2008) from whom designed these for 25m long bridge elements. They can even be designed with LED-lighting bars, and as complete panels these only have to be lifted onto the structure and connected with the pipes and wires. With the knowledge and application of these panels for closed areas the spaces can be climatised.

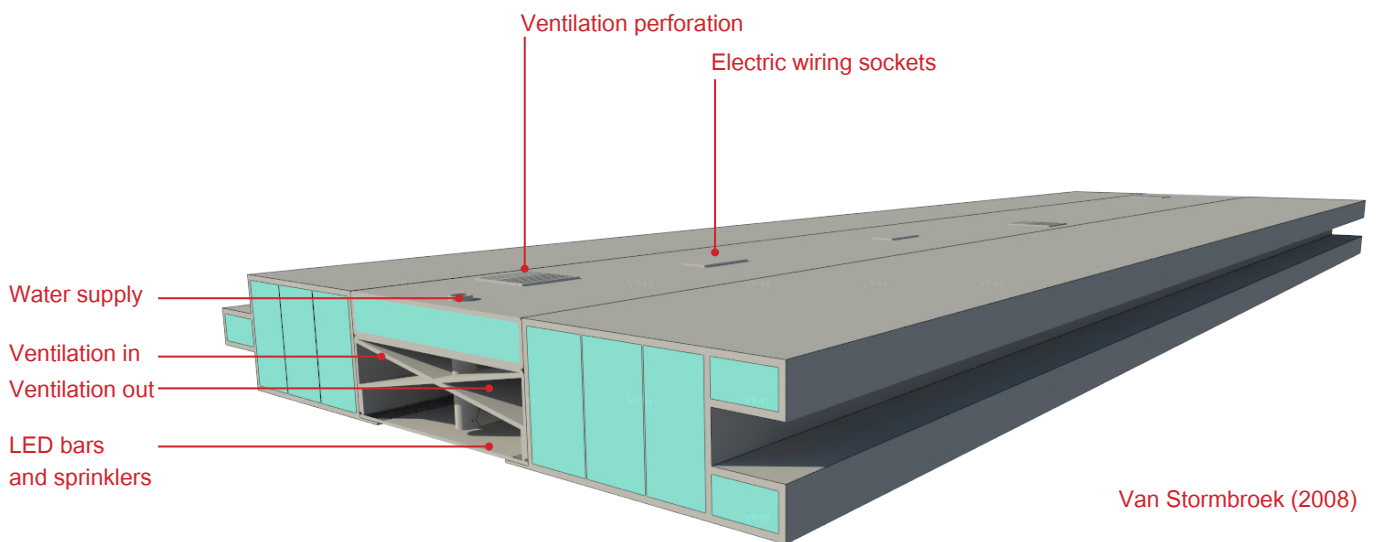
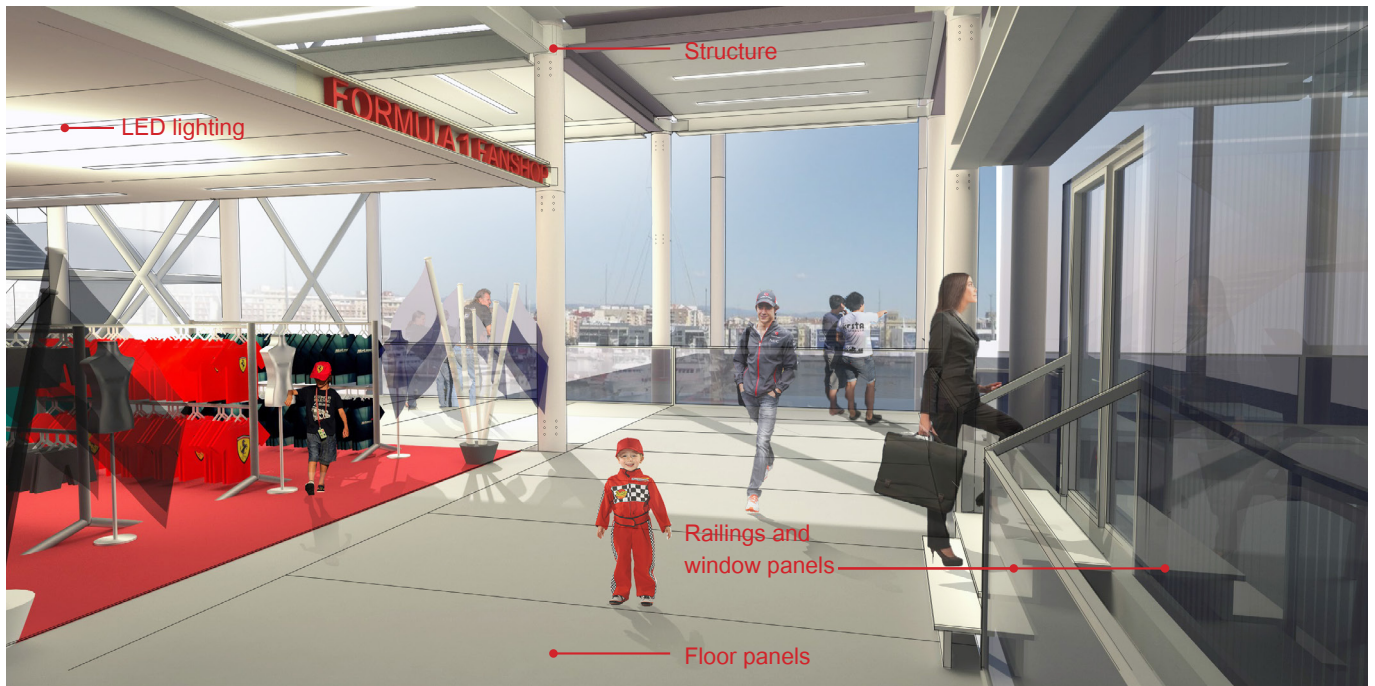

Van Stormbroek (2008)

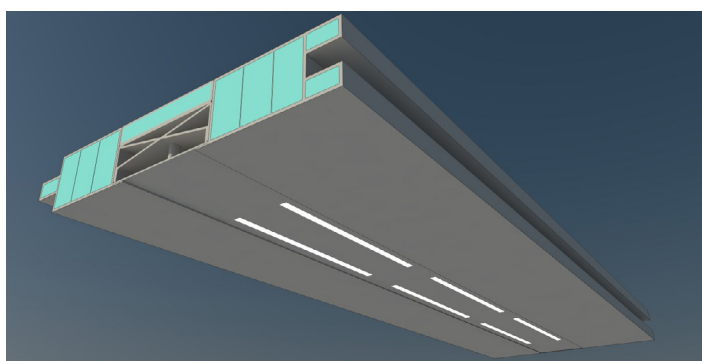

As for the railings and transparent parts of the design, glass, acrylic glass, and polycarbonate were looked into to be applied. Glass is too heavy to be assembled and disassembled multiple times, as it is also too brittle and vulnerable. The idea was to utilize acrylic glasses, as they can be transparent and created in any desired colour. The switch was eventually made to polycarbonate, since acrylic glass is dangerously vulnerable for fire. For the railings single layered polycarbonate is used to maximize the transparency. For the climatized areas, multi-layered polycarbonate panels are used to guarantee an insulating value. The polycarbonate panels have glass fibre reinforced polymer extruded frames, with which the durability of the system is longer as for more vulnerable materials.

After a short research on which transportation possibilities to use for the transportable structure, the choice was made to transport the building elements in shipping containers. The containers can be transported by sea, roads, and railways, thus a great percentage of the world's locations can be reached. The dimensions and weight restrictions of the containers mean limitations for the weight and size of the building elements. After a research in different span lengths, panel heights and weights, and girder heights and weights, an optimum was found to fill the containers as well as for the dimensions as for the weight. This optimum was needed to reduce the total number of containers to a minimum, saving transportation time and energy.

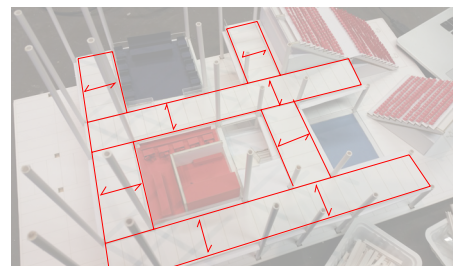
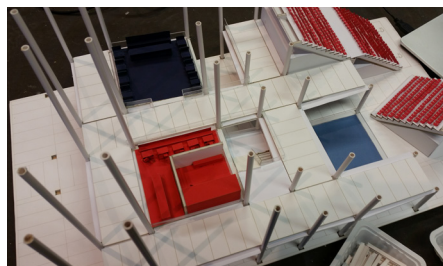
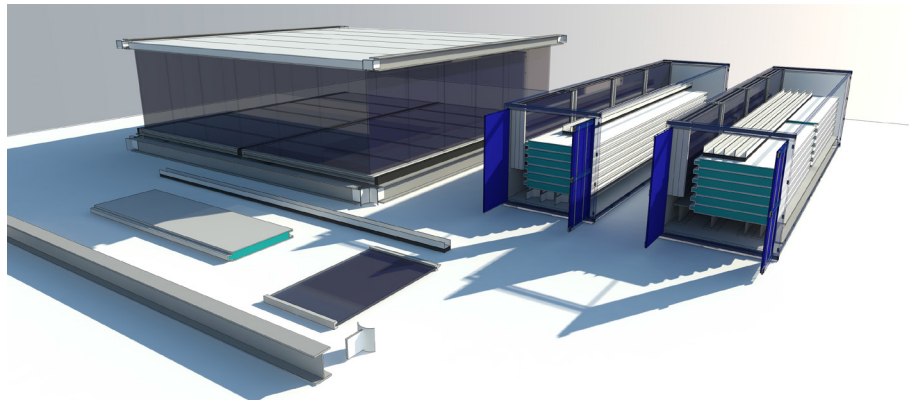

The demands for the building process are to be repetitive, have a small amount of building elements, and have a reduced amount of building methods. The columns are round in order to be neutral in any direction, and feature multiple screw holes to connect steel elements onto to be connected with screw-threads. After the insertion of the top column into the bottom one, the joints are attached as reinforcement of the system, and as possibility to hang the girders on.

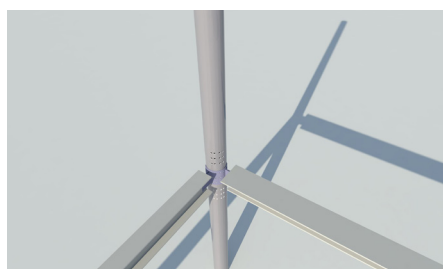
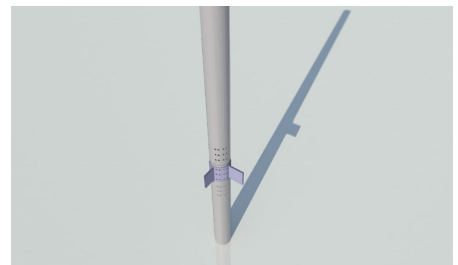

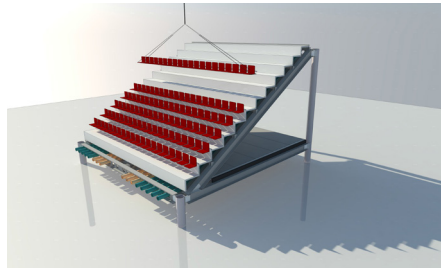
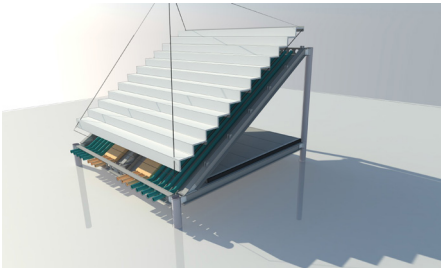
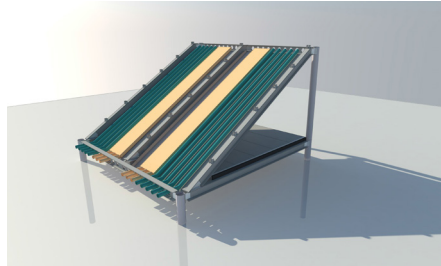
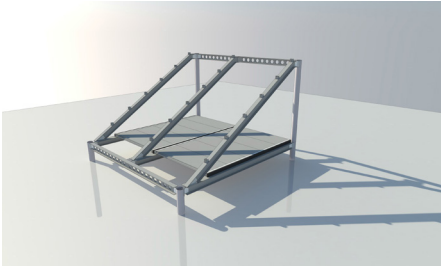
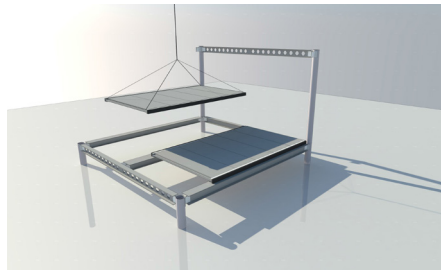
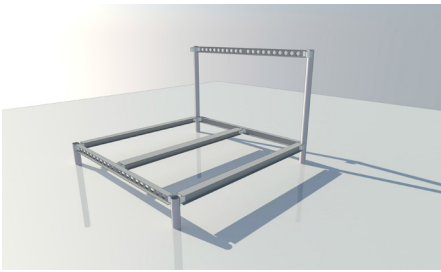

The FRP floor panels are on ground level connected as a rigid floor, and lifted onto its position by a mobile crane. The diagonal girder are then attached to the columns, whereupon prefabricated pipe-packages are installed onto the girders. The grandstand risers have to be connected together on ground level, whereupon they are lifted onto the structure. The seating elements are lifted per row out of the shipping container onto the GFRP risers.

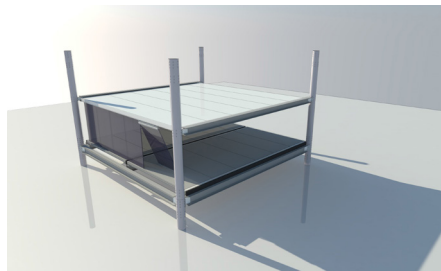
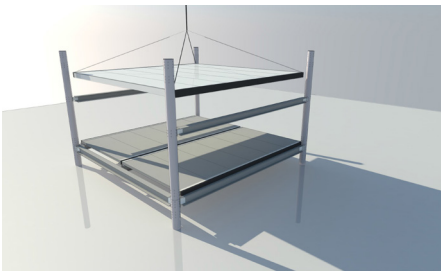

With the same principle for the floor as for the grandstand elements, they are constructed on ground level and lifted onto the positions on the steel girders. The polycarbonate panels are installed with a simple lift-turn-and-release technique. Their lightweight allows them to be installed by two persons manually.

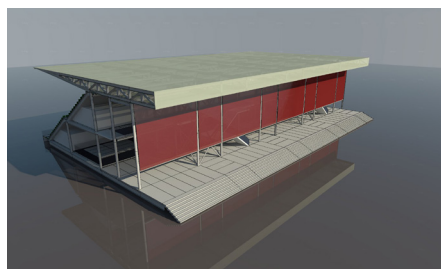
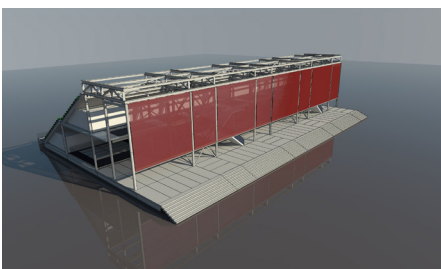
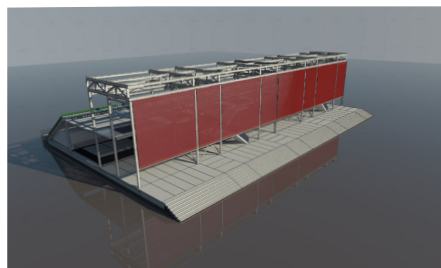
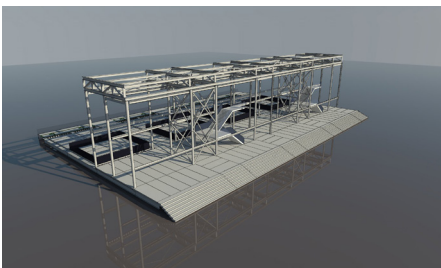
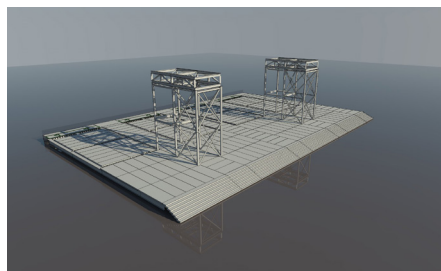
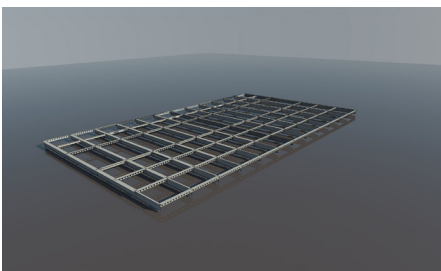

As for the structure on large scale, the plinth rests on the foundation which has to be determined per location, since the soil differs as well as the size and thus weight of the structure itself. The forces and load distributions determine whether shallow foundations complies, or a pole foundation is needed to ensure the structure will not fail. In the case of two grandstand modules with functions next to each other two stable towers have to be built which form the rigid cores of the structure. The cores are then connected with a steel structure and bracings, whereupon the grandstand elements can be built. All floors are lifted into their positions and stabilise the structure because their stabilizing properties in two directions. Eventually the roof, which was built on ground level first, gets lifted onto its position.

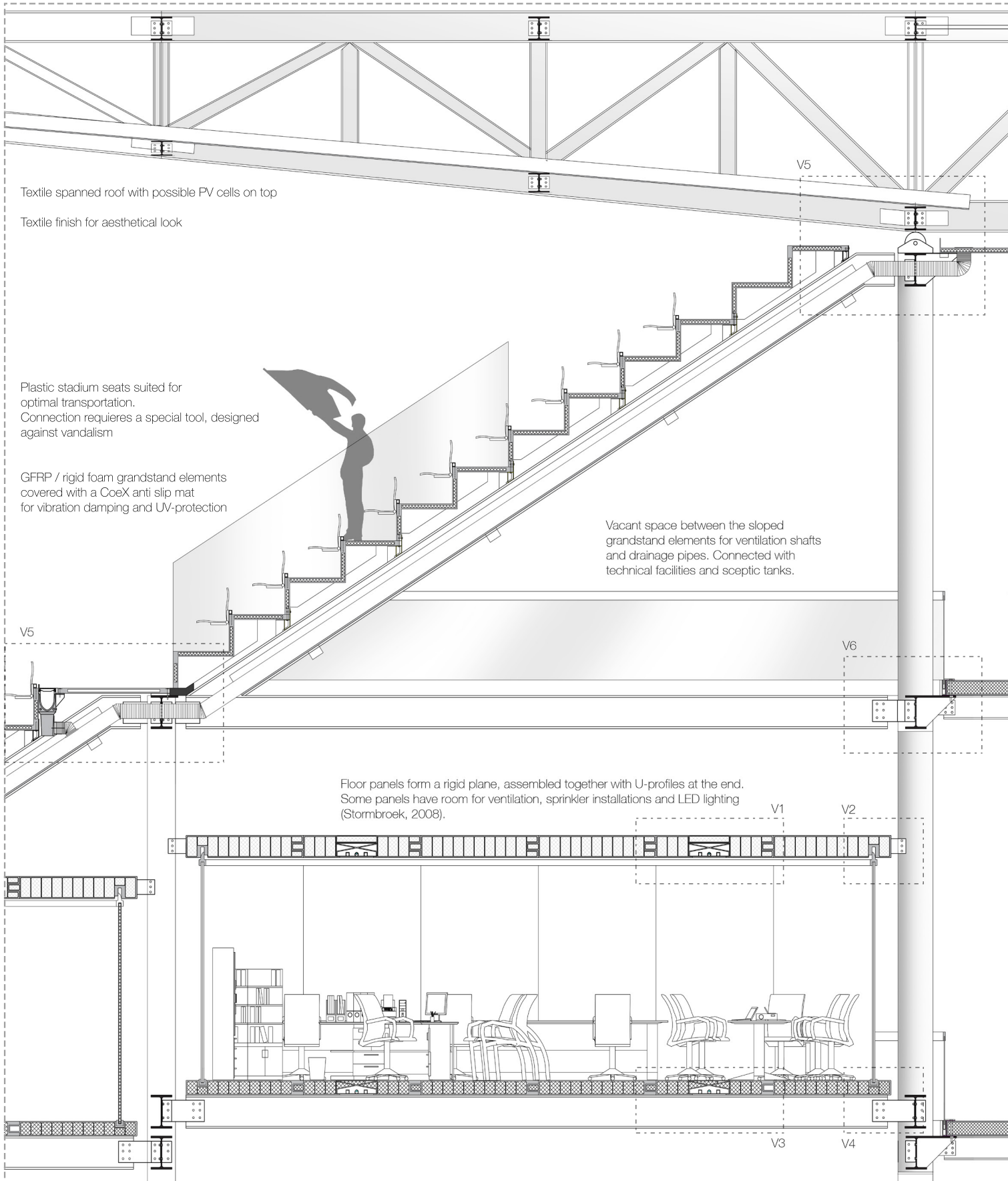

Textile spanned roof with possible PV cells on top
Textile finish for aesthetical look

Plastic stadium seats suited for optimal transportation. Connection requires a special tool, designed against vandalism

GFRP / rigid foam grandstand elements covered with a CoeX anti slip mat for vibration damping and UV-protection

Vacant space between the sloped grandstand elements for ventilation shafts and drainage pipes. Connected with technical facilities and septic tanks.

Floor panels form a rigid plane, assembled together with U-profiles at the end. Some panels have room for ventilation, sprinkler installations and LED lighting (Stormbroek, 2008).

Drawings and Model

6

6.1 Drawing for poster 1:20
Not to scale in this image

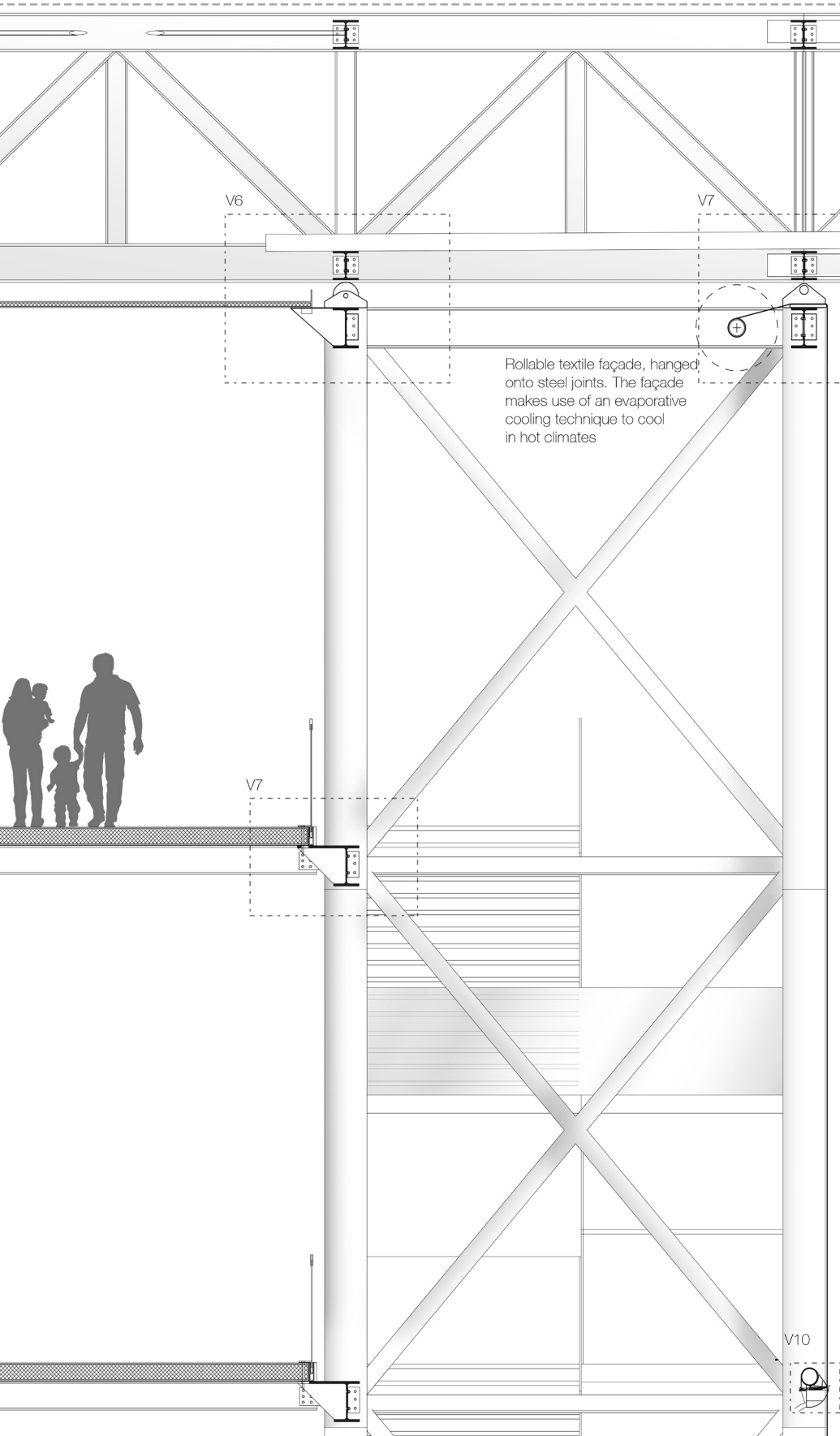

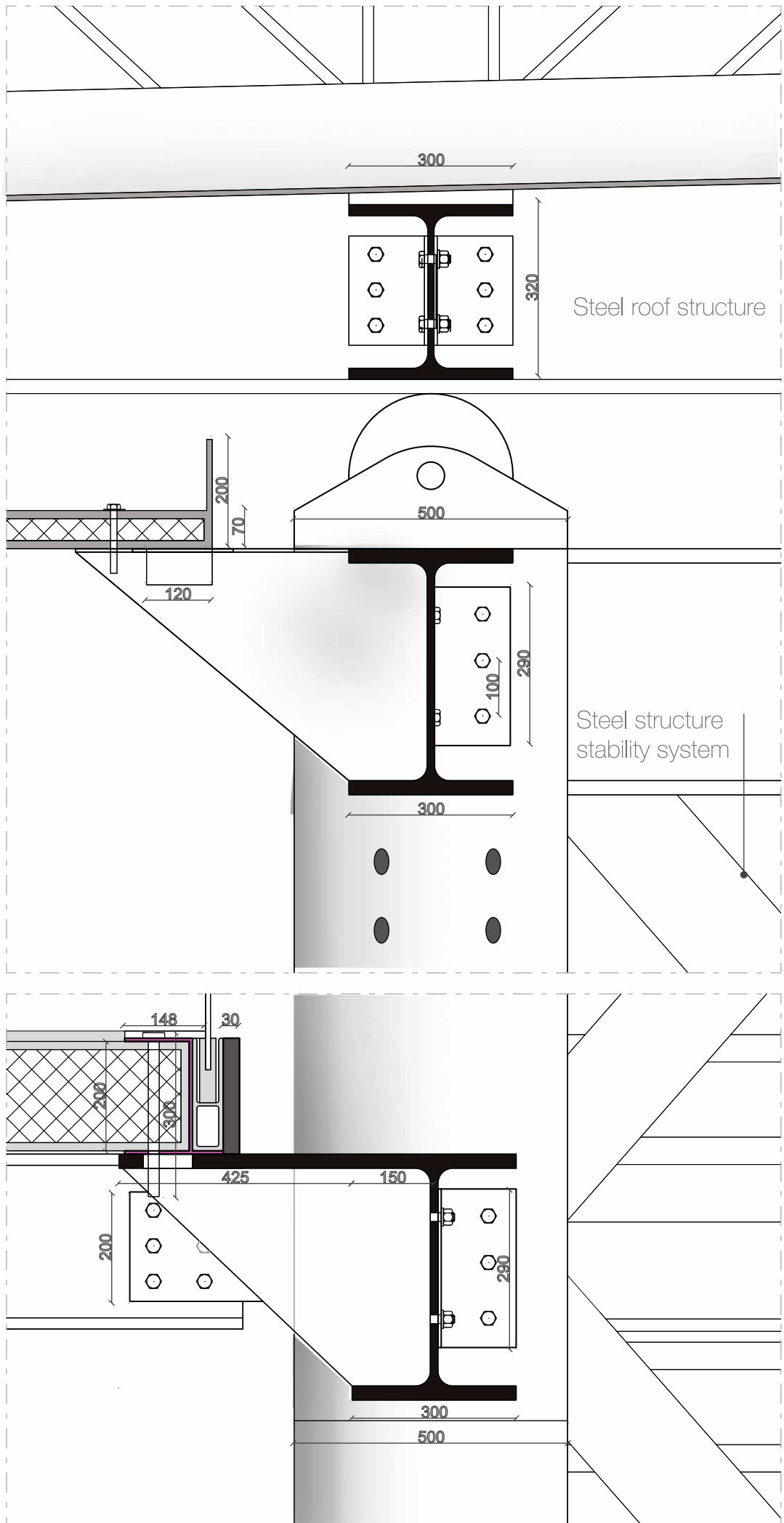

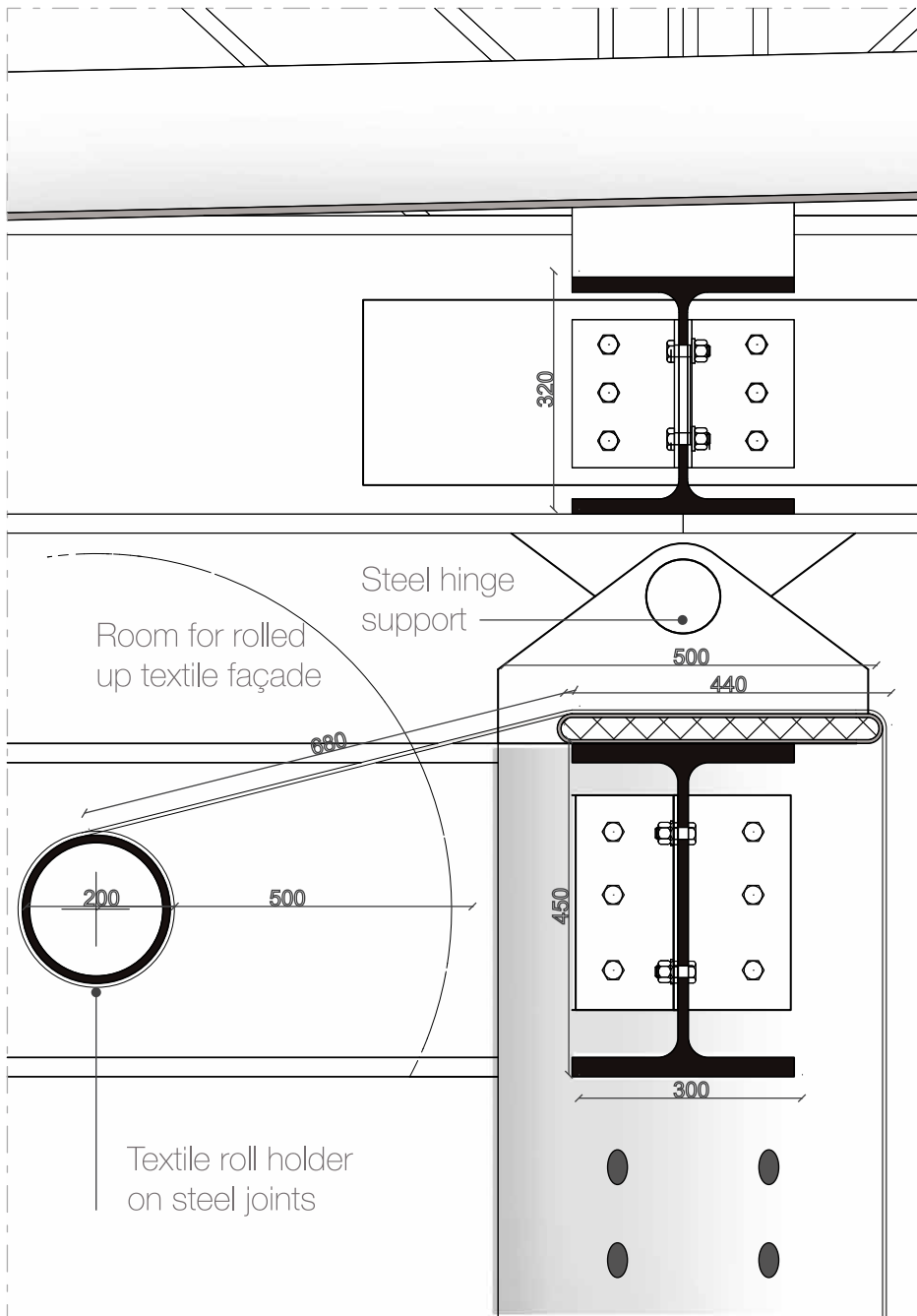

6.2 Details 1:10

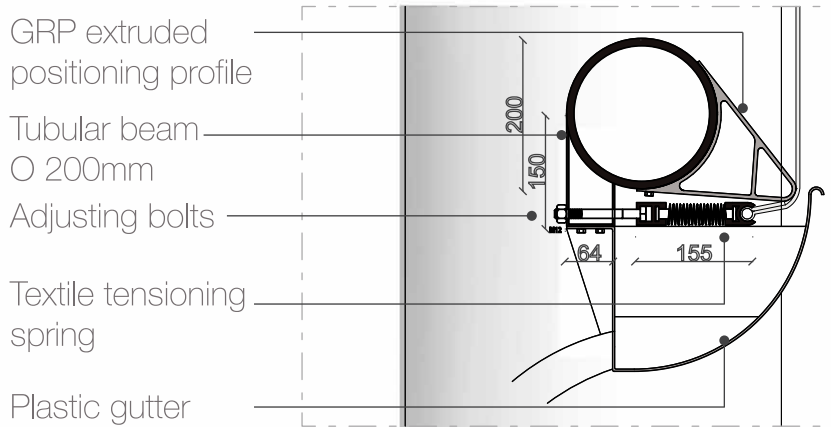

GRP roof sheets

Steel modular roof structure

Textile cover

GFRP / rigid foam sandwich grandstand elements 15/40/15 mm

Steel fitting bar

Diagonal HEB 450

Drainage / room for ventilation shafts
O max = 200mm

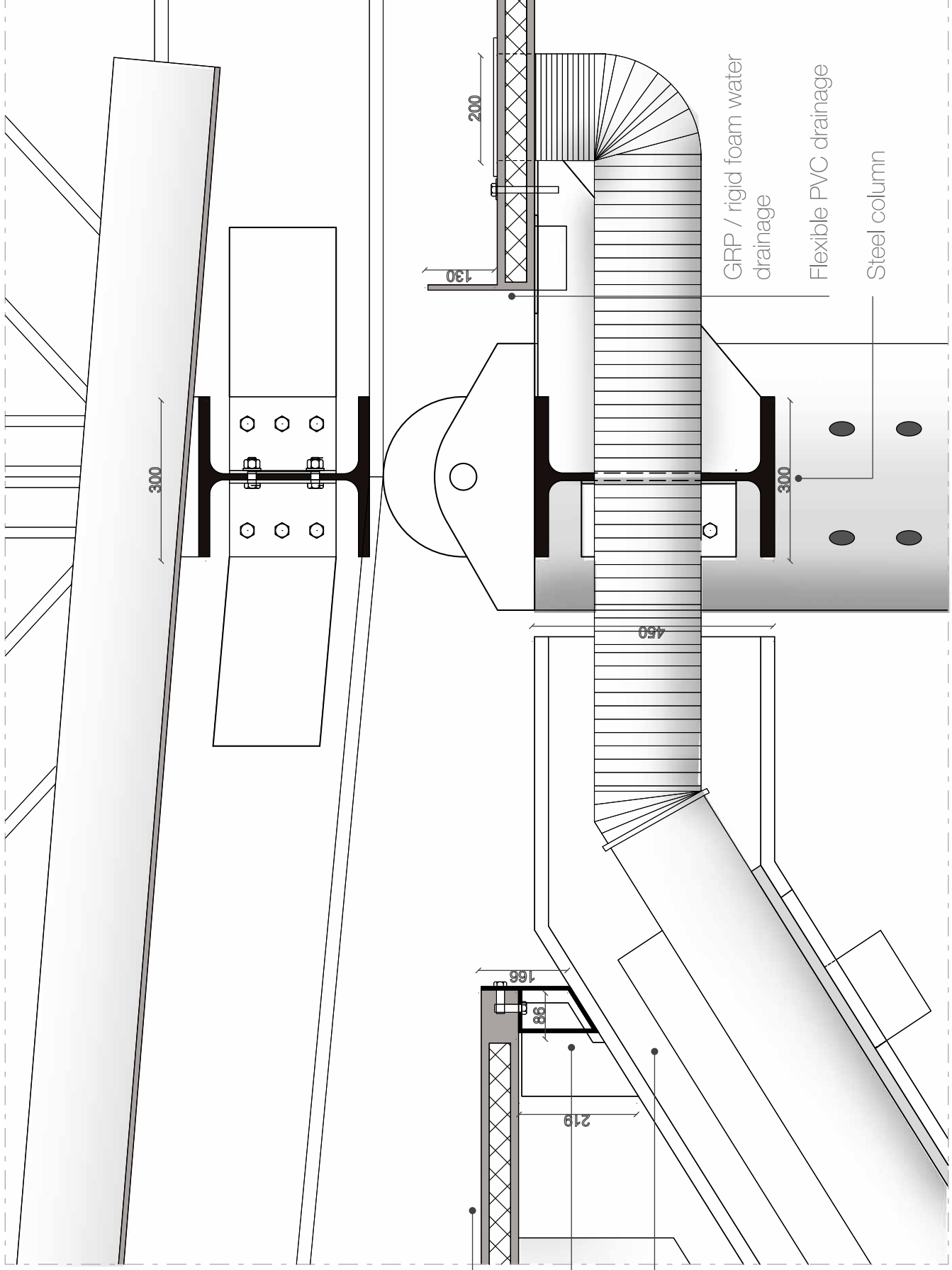

GRP / rigid foam water drainage

Flexible PVC drainage

Steel column

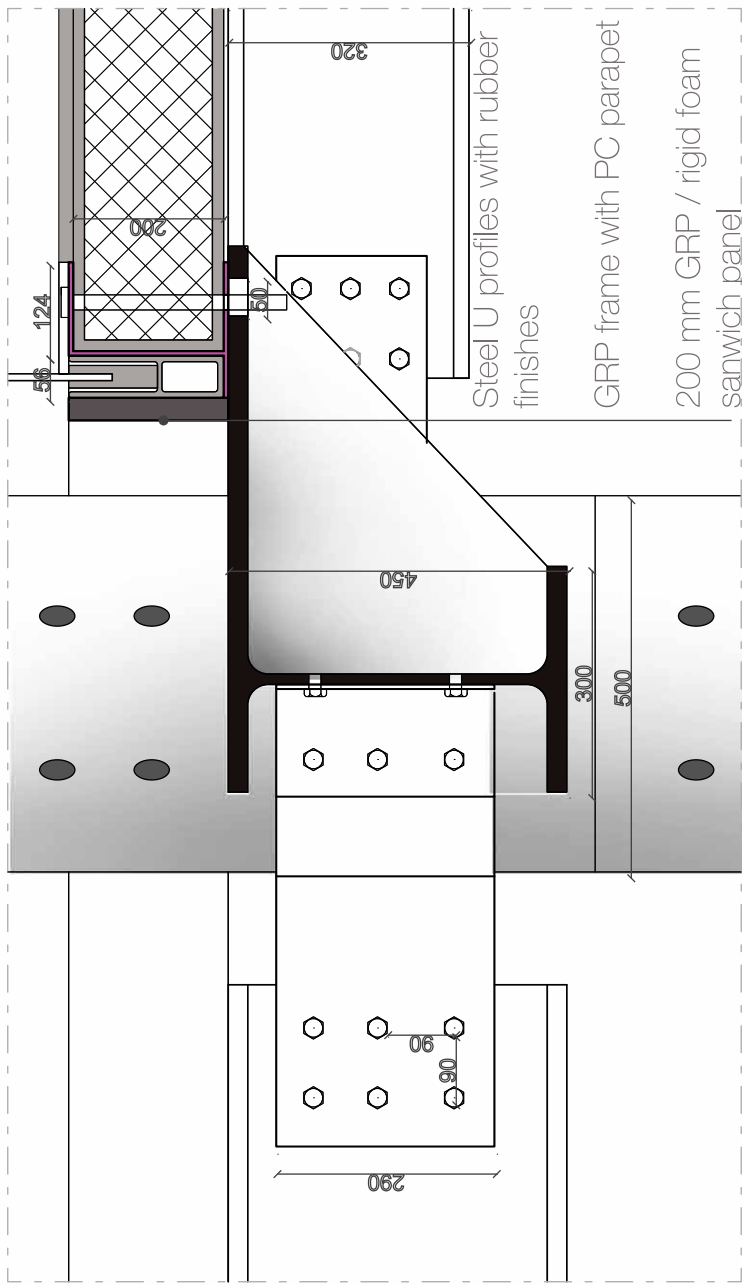

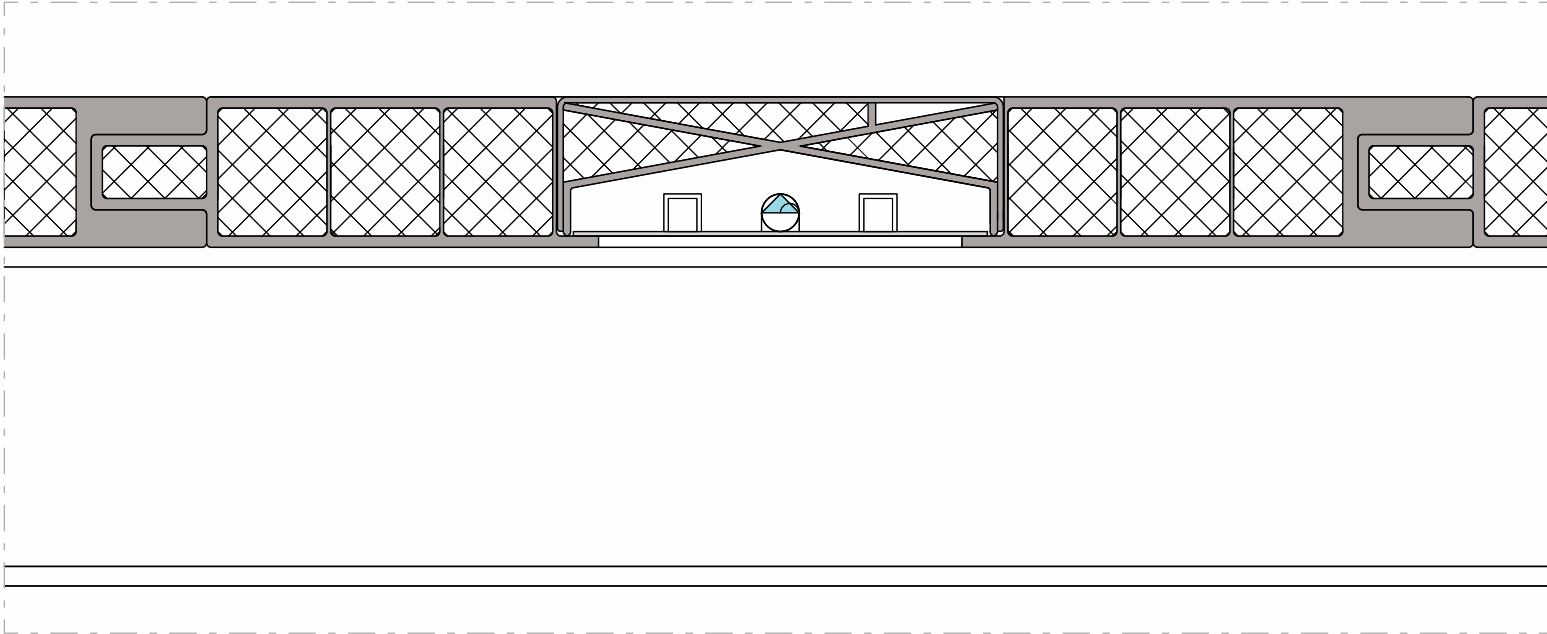
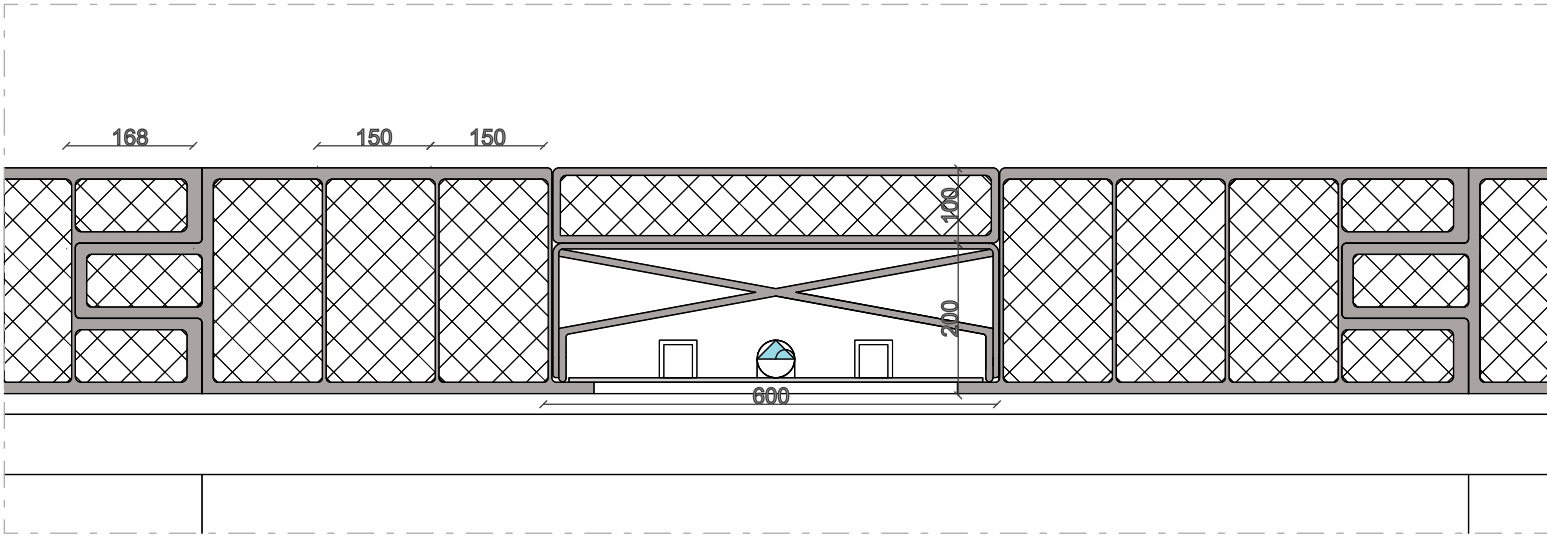

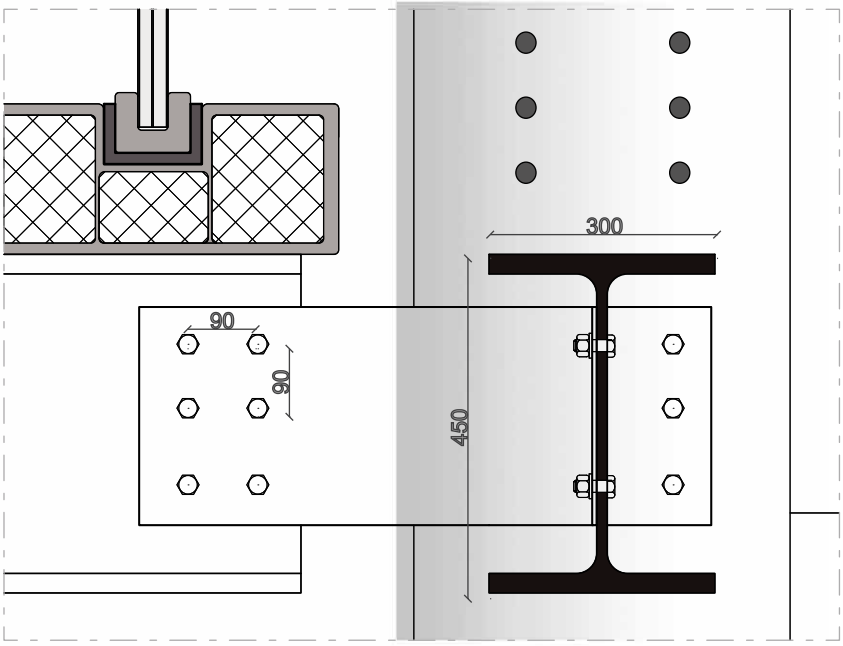
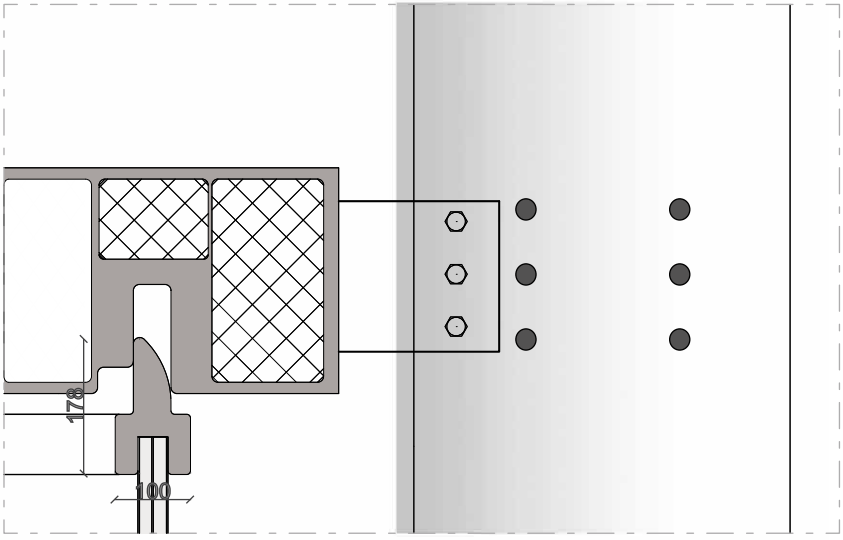

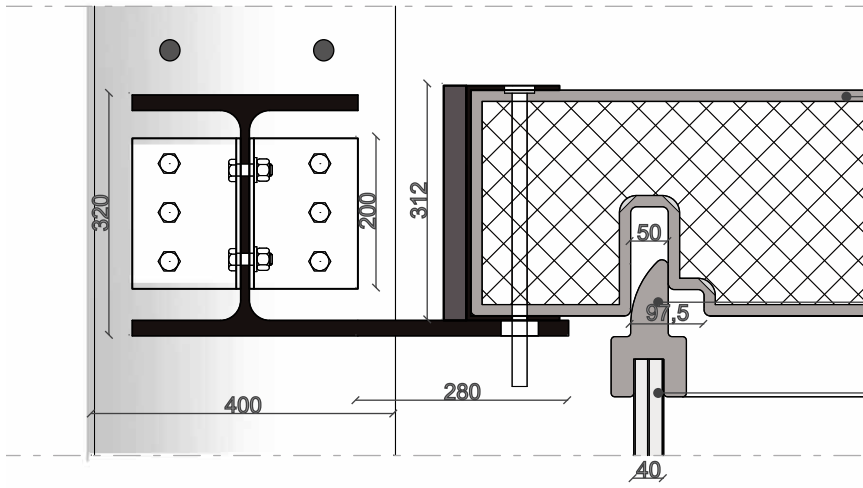

GFRP sandwich panel with rigid foam core

Extruded GRP frame

Polycarbonate window

Rubber adjusting bumpers

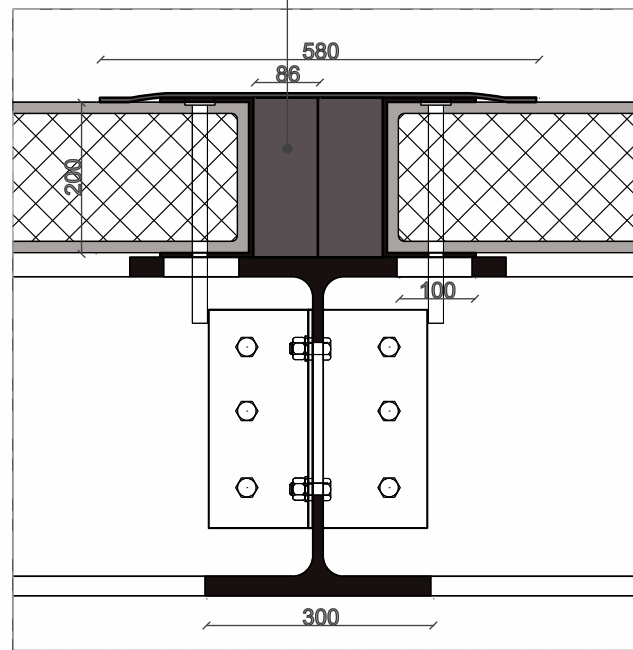
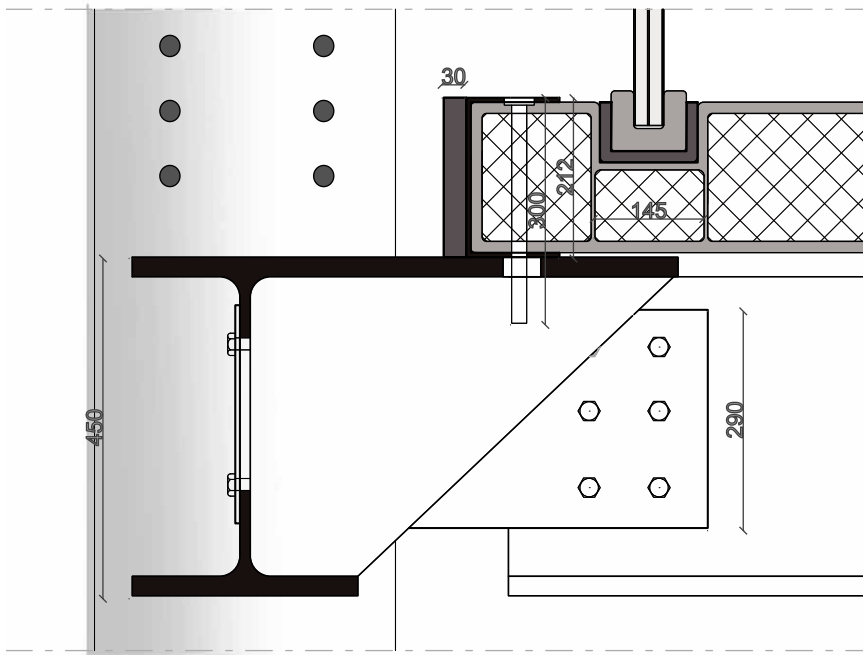



6.3 3D model, scale 1:100

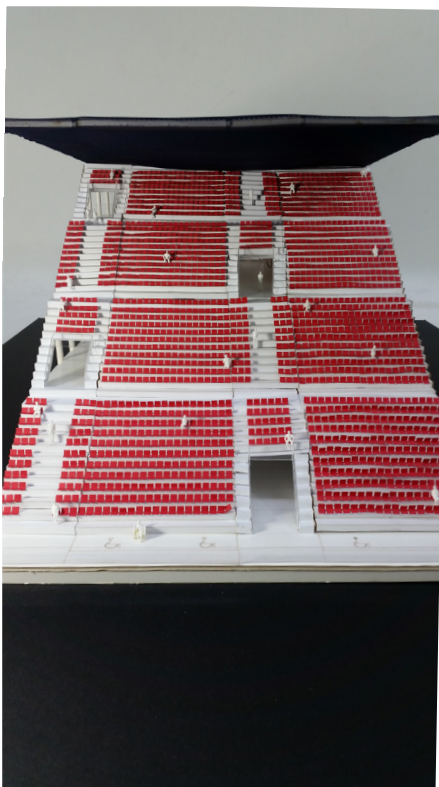

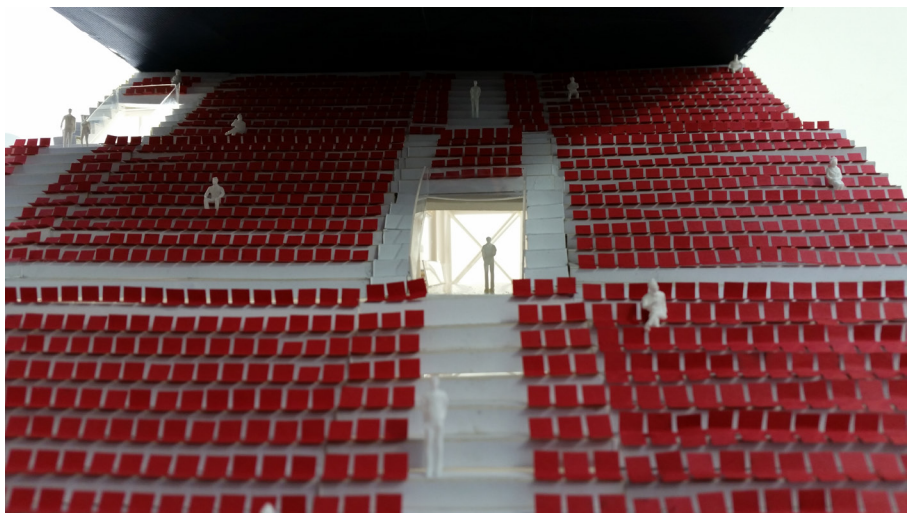

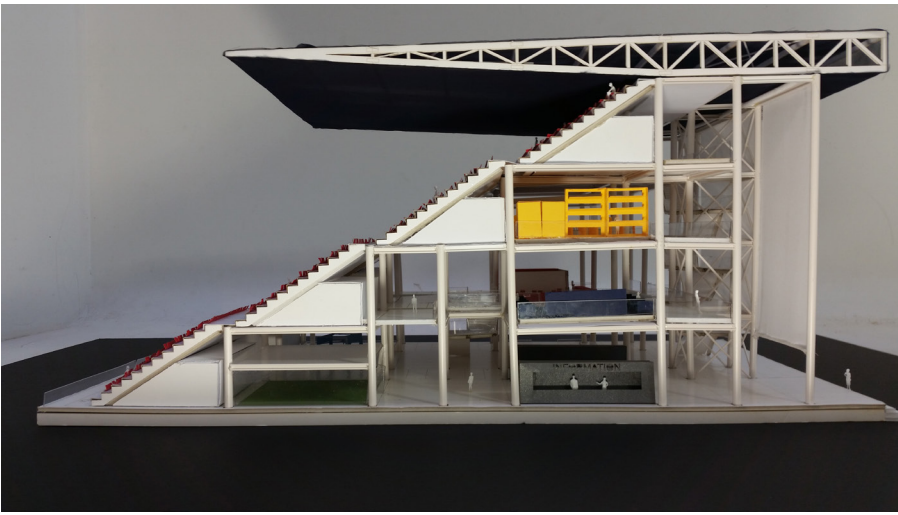

Reflection



The relationship between the theme of the studio and the subject that was chosen for the design is quite clear. I will first analyse the track, where after an explanation will be given about the project and what the exact relationship is between these two.

The name of the studio actually says a lot about its content; it embraces the architectural as well as engineering concepts regarding the design of buildings and the built environment. Architecture itself stands for deliberate choices made in order to design for a cause, client, or mean. It is an embracing term containing a wide scale of aspects. Environment, history, function, aesthetics, structure, climate, legacy, and durability are just some of the terms which take part to form architecture.

Some of these terms coincide with the broad subject of engineering. Everything we use or desire to use as humans in order to make life easier, faster, and better, and also in order to educate ourselves and make us smarter and develops us as a species, we can call engineering. The main terms which describe engineering are the improvement, the design, and maintenance of all devices, materials, and processes we know. The built environment and its context belong therefore under the category engineering as well, because it meets the requirements mentioned above.

The two terms together form the improvement, the design, and maintenance concerning all terms which fall under architecture. The engineering part of designing the built environment considers how with scientific knowledge and knowhow the directive can be analysed, where after this underlying research forms a base for the designer to design spaces and living environments with its creativity. One cannot design without knowledge about the elements with what he designs, as a sculptor cannot create a sculpture without any materials or knowing how to use them. In the specific architectural engineering track this can be recognised with a research semester where the student performs a scientific research which will form the base for his design. With especially the research containing engineering aspects like structural behaviour, material properties, build-up possibilities, climatological possibilities, in order to pursuit a better and more sustainable future, an architectural engineer can truly distinguish himself from a regular architect.

The research and the design coincide parallel to mentioned terms and aspects. A demountable stadium can become a part of the built environment, but embraces multiple engineering aspects as well. In short, the architectural engineering is translated for this specific project to 'design for disassembly'. The design part speaks for itself, where the disassembly part contains every aspect of the engineering and its possibilities. The relevance of the research and the design lies in sustainable use of building structures. Reusability of structures is of importance to save materials, energy, resources, and building effort. The question of what to do with empty stadia is no longer of the essence, because with the new design they can simply be demounted, transported, and located elsewhere. A flexible design allows smaller and bigger options so that its number of possible event types will be broad. Temporary (sports) event types can be Olympic Games, World Cups of football, tennis matches, hockey matches, Moto GP's and Formula1 races, air races, and so on.

Concerning a wider social context, building demountable can truly be the best building method in a great part of the future-to-build buildings and structures. Materials can be saved and reused if they save energy in comparison to new ones. The life cycle assessment of every element which we as humans will use from now on can and must be examined, to make the right choices as well as for sustainability and durability in the future, as for what the design will benefit from at that specific moment.

During the research process and thereafter the design process, I continuously switched between the design and the technologies concerning my aims. They were never fully inseparable from each other as they completed one another as they formed bases for the other's inspirations and continuations.

London 2012 Olympic Stadium

Populous

With just a few key points as a strategy for the design of the 2012 Olympic Stadium of London, the whole project can be described; Build less, build temporary, design for dismantling, specify to reduce embodied energy (Hartman, 2012, p. 85). The aim was to build a stadium with a capacity of 80,000 for the games, but was able to shrink to 25,000 with the removal of the temporary second ring. The 25,000 lower part is a permanent concrete bowl. The upper ring is a steel structure, designed for disassembly. The connections were visually expressed which also meant easy dismantling. Removable glass reinforced concrete caps ('hedgehogs') enclosed joints at ground level. Individual seats clip onto aluminium rails.

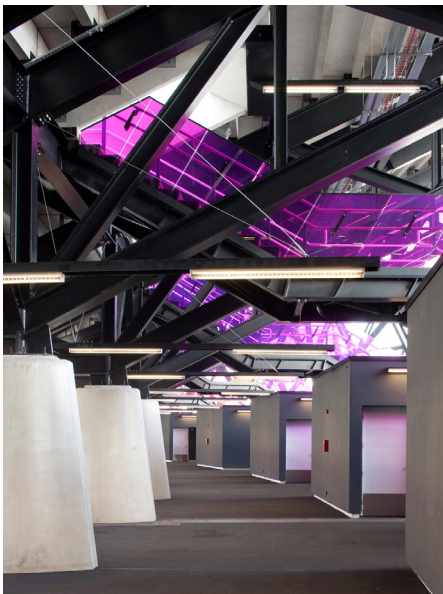
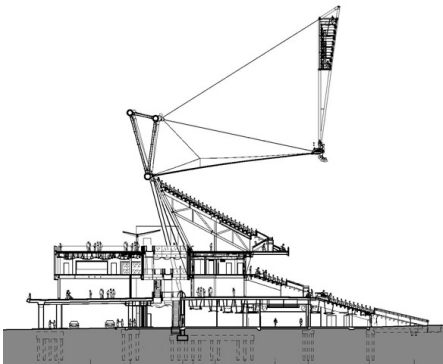

- 1 Sportslight towers
- 2 Access gantries over roof fabric for access, maintenance and ceremonies activities
- 3 Roof tension ring
- 4 PVC coated polyester fabric membrane roof supported by cable net structure
- 5 336 Wrap fabric panels, each 25m high and 2.5m wide twisted by 90°
- 6 Upper tier, gross capacity: 55,000
- 7 Large format video screens and scoreboards
- 8 Upper tier supporting steel structure
- 9 Stairs to the upper tier from concourse level
- 10 Lower tier, gross capacity: 25,000
- 11 Field of play access tunnels for athletes, officials and ceremonies
- 12 Athletics field of play
- 13 Head-on photographers' platform
- 14 Internal toilet pods
- 15 External 'Pod Village' for spectator concessions, being developed by Locog
- 16 Public circulation podium
- 17 Level 02 concourse and hospitality terrace
- 18 West stand external escape stairs
- 19 Tensile fabric canopy over the escalator void areas for hospitality and VIP
- 20 River Lea
- 21 Venue entrance bridge

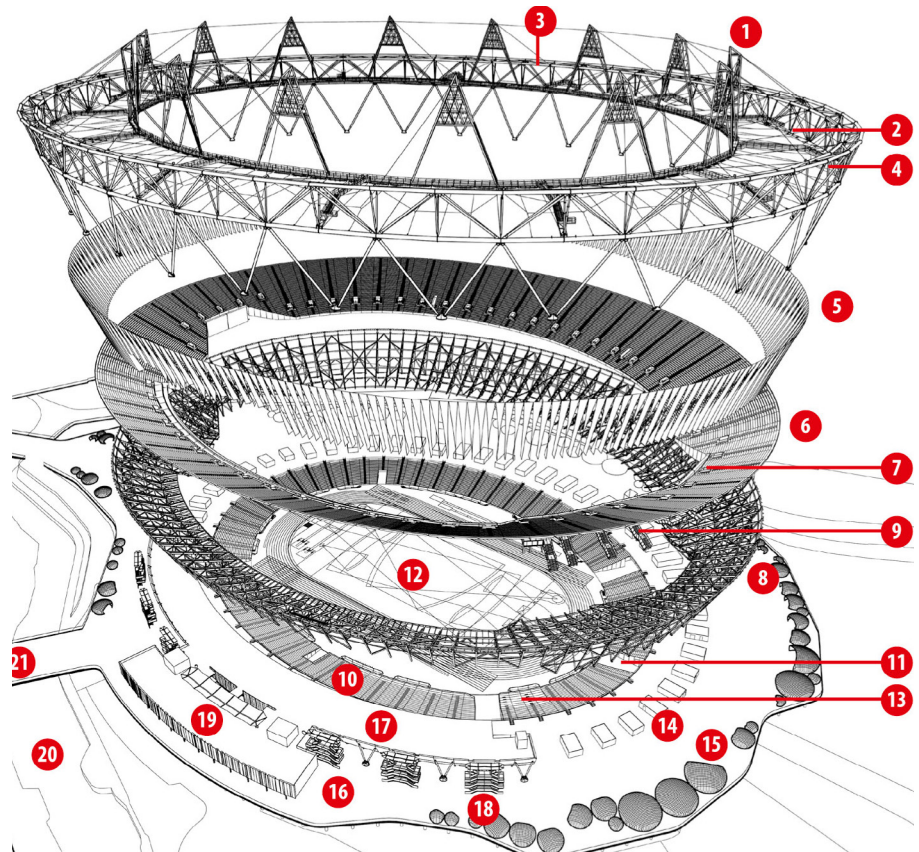

Reference projects

London 2012 Aquatics Centre

Zaha Hadid Architects

Just as the Olympic Stadium, the Aquatics Centre also used the strategy of temporary seats to vary its capacity for the Games and post-Olympic venues. It was the first application for an Aquatic Centre to both use a permanent building as well as a temporary extension. There wasn't a specific plan for the steel temporary structure yet, but it can easily be dismantled and reused. The structure was only covered by a PVC wrap as a cover up (Hartman, 2012).

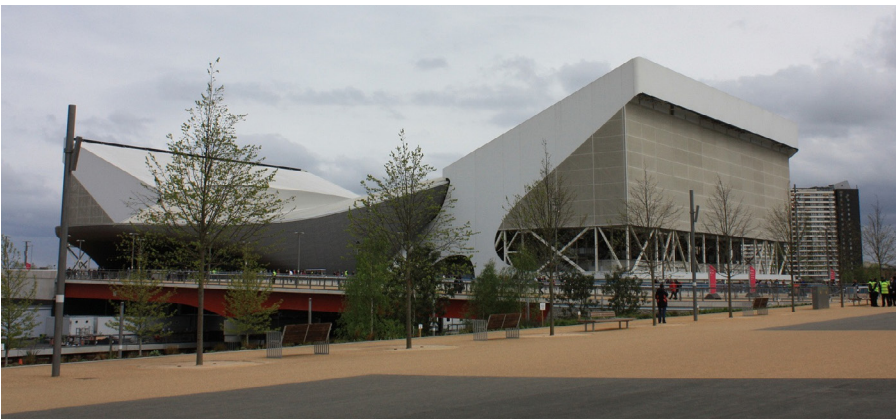
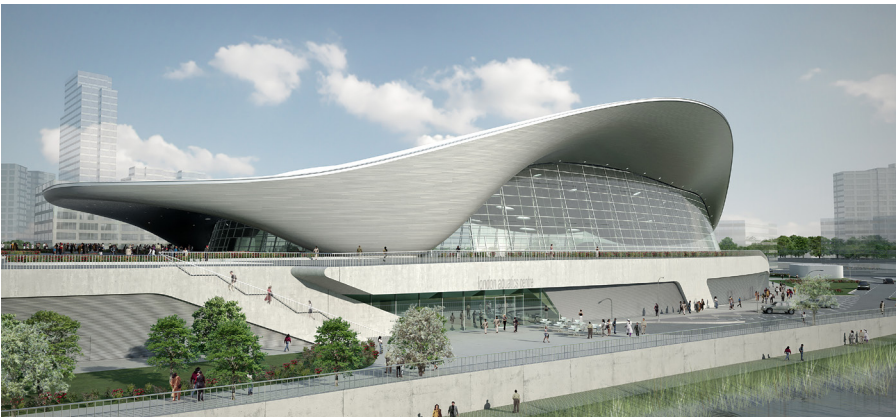

London 2012 Water Polo Arena

David Morley Architects

The Water Polo Arena is a rectangular building with off-the-shelf structural elements and seating stands available directly from the hire market. They can be reused after the Games. Also here was PVC used as a cover up for the buildings temporary structure which saved costs. The PVC was chosen after a research to light plastics and their properties in a scheme. The steel off-the-shelf trusses ensure a light structure that is also easy to transport when it is disassembled in parts.



AMI Stadium

Populous

An earthquake in New Zealand damaged some larger sports stadia. During the decision time of what to do with the damaged stadium of Christchurch, the government decided to build a cost effective temporary stadium. It was built in less than 100 days and had a capacity of 18,000 seats. The main construction type was scaffolding, and some building components were reused from other venues around New Zealand. The temporary seating for example has come from Eden Park, as it was no longer required following the Rugby World Cup. It has a lifespan of 3-5 years. (Populous, 2012)



NUSSLI

Event construction, temporary structures and booth construction.



There are several big companies in the world who rent demountable grandstands or stadium modules to event organisers. A short search on the internet gives loads of results like mobile-grandstands.com, grandstandsworldwide.com, arenagroup.com, vanstokkum.com, and others. One of the international companies is NUSSLI, who specialises in event construction, temporary structures and booth construction. On their website they posted 37 projects under stadium construction, where some of them are permanent and some temporary. Some of the projects are also an expansion of a current stadium or arena. They try to build the projects as quick as possible because of the short periods of time the events last and to fulfil the needs and necessities of the event organisers. On their site they explain their projects and what they did to realise them. In the following table these properties are included: number of seats per stadium/expansion, number of employees who worked during the building period, the construction time in days, the tons of material, and the amount of containers which was used for the structure to be transported to the site. Not all these properties were given on the site, thus these are not shown in the table.

Viewer capacity and days of construction NUSSLI grandstands

Location	Project name	number of seats	number of employees	construction time in days	removal in days	tons material	transport in containers
Sydney	Beach Volleyball Arena Bondi Beach	10000		90		300	
Sydney	Olympic Summer Games Sydney, Velodrome	3000		60			
Berlin	adidas "World of Football"	10000	28			1150	65
Paderborn	stadium extension	1500				40	
Wiesbaden	BRITA Arena	13000		112			
Cottbus	FC Energy Cottbus	8000		42		350	
Doha	Sony Ericsson tennis	3500	120	28			
Benghazi	Football Stadium Benghazi Libya 2008	10500	40	150		1050	85
Vienna	SC Magna Wiener Neustadt expansion	2100		2.5		70	
Cape Town	stadium extension	13000				450	
Granada	extension Los Cármenes stadium	3088	14	16		260	13
San Francisco	Temporary grandstands for California Golden	6000	18	2	1		
Bata	Estadio de Bata expansion	15000	120				275
Aalen	Scholz Arena Grandstand expansion	2088	12	7		130	
Sandhausen	Hardtwald Stadium expansion	1200		50			
Regensburg	SSV Jahn Regensburg expansion	3000	20				13
Alcoy	Alcoyano	1500	10		2	100	
Atlanta	ATP	4500	15				16
Garmisch Partenkirchen	Audi FIS Ski Weltcup 2013	2300	10	10		165	22
Vancouver	Empire field temporary	27500		90		2500	160
Burgdorf	Swiss "Schwing und Alpler" Festiva	52000	110	56	21		
Caribbean	ICC Cricket World Cup West Indies 2007	16500	25		30	750	50

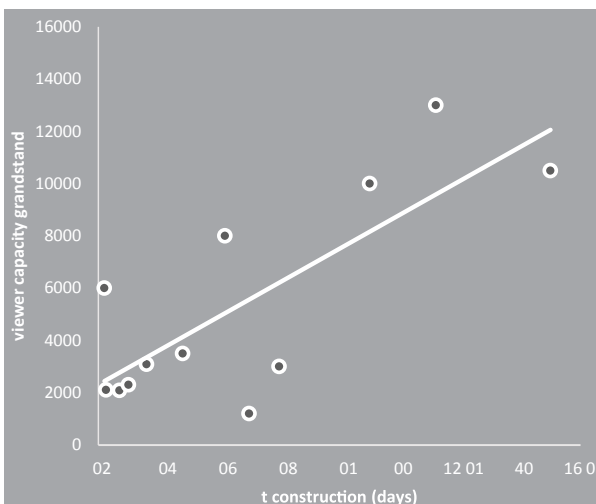

Bibliography



- American Institute of Steel Construction. (1966). *Structural Steel Detailing*. New York: American Institute of Steel Construction,.
- Azby Brown, S. (1989). *The Genius of Japanese Carpentry* (Vol. 1). Tokyo: Kodansha International.
- Praktijkgids Bouwbesluit Constructieve Veiligheid (2012).
- Bangash, M. Y. H. (2000). *Structural Detailing in Steel*. London: Thomas Telford.
- Brouwer, G. (2014). *De Coolste Baan van Nederland schrijft geschiedenis*. Retrieved April 17th, 2014, from http://www.sportnext.nl/berichten/de_coolste_baan_van_nederland_schrijft_geschiedenis
- Callister, W. D. (2007). *Materials Science and Engineering: An Introduction, 7th Edition*. Hoboken, New Jersey: Wiley.
- Chernushenko, D. (2002). *Here Today... Temporary Facilities and Seating Structures*. Stadia Magazine (july).
- Crowther, P. (1999). *Design for Disassembly*. Environmental Design Guide.
- Culley, P., & Pascoe, J. (2009). *Sports Facilities and Technologies*. New York: Routledge.
- Danielse, A. (2013). Lecture: Facades, logistics and construction [powerpoint slides]. Course: *Technoledge Facade Design*. Nieuwegein: Kennis Centrum Gevelbouw.
- Day, R. W. (2010). *Foundation Engineering Handbook* (Vol. 2). New York: McGraw-Hill.
- Den Hollander, A. H. (2010). *Structural feasibility study and design for a Portable stadium*. (Masters), Delft University of Technology, Delft.
- Dowling, J., Kirby, B., Smith, I., & Green, M. (2005). Fire Engineering in Sports Stadia. In P. Culley & J. Pascoe (Eds.), *Stadium Engineering*. London: Thomas Telford Limited.
- Ellis, B. R., & Ji, T. (2004). *Loads generated by jumping crowds: numerical modelling*. The Structural Engineer, 7 september.
- European Best Practice Guidelines for Abnormal Road Transports (2009).
- Fransen, R. (2012). *Innovative Stadium Design*. Delft University of Technology, Delft.
- Gooch, A. (2005). Stadium Circulation. In P. Culley & J. Pascoe (Eds.), *Stadium Engineering*. London: Thomas Telford Limited.
- Griffiths, J. (2002). Sound, noise and acoustics in stadium design. In P. Thompson, J. Tolloczko & N. Clarke (Eds.), *Stadia, Arenas and Grandstands: Design, Construction and Operation*. London: Taylor & Francis.
- Harris, G. (2005). Crowd Safety and Control. In P. Culley & J. Pascoe (Eds.), *Stadium Engineering*. London: Thomas Telford Limited.

- Hartman, H. (2012). *London 2012 Sustainable design; Delivering a Games Legacy*: John Wiley & Sons.
- Hayward, A., Weare, F., & Oakhill, A. (2011). *Steel Detailers' Manual* (3 ed.). West Sussex: John Wiley & Sons.
- The Event Safety Guide: A guide to health, safety and welfare at music and similar events (1999).
- Infostrada Sports, & Blauw Research. (2013). Bezettingsgraad Jupiler League clubs tot de winterstop (23-12-2012). Seizoen 2012/'13. In J. L. F. onderzoek (Ed.): KNVB Expertise,.
- Institution of Structural Engineers. (2007). *Temporary Demountable Structures - Guidance on Procurement, Design and Use* (3 ed.). London: Institution of Structural Engineers.
- Jarvis, B. M. F. (1980). United States of America Patent No. 4,195,451.
- John, G., Sheard, R., & Vickery, B. (2007). *Stadia: A design and development guide* (Vol. 4). Oxford: Elsevier.
- Klomp, M. (2013). *Preliminary structural design and financial feasibility study of a transportable multi-functional stadium*. (Masters), Delft University of Technology, Delft.
- KNMI. (2009). Wind Speed and Wind pressure. Retrieved April 29th, 2014, from <http://www.knmi.nl/samenw/hydra/faq/press.html>
- Lambert, B. J. (1939). United States of America Patent No. 2,180,986.
- Lenders, R. (2013a). Eredivisie trekt volle zalen. In: tussendelnieis.
- Lenders, R. (2013b). Eredivisie trekt volle zalen. Retrieved April 17th, 2014
- Little, J. D., Ellis, B. R., & Ji, T. (2001). The response of grandstands to dynamic crowd loads. *Proc. Instn Civ. Engrs Structs & Bldgs*, 140(November), 355-365.
- Loosjes, M. (2011). *Preliminary structural design of a demountable stadium based on the architectural design of Zwarts & Jansma architects*. (Masters), Delft University of Technology, Delft.
- Mamlouk, M. S., & Zaniewski, J. P. (1999). *Materials for civil and construction engineers*. Menlo Park: Addison Wesley Longman, Inc.
- Motavalli, M., Czaderski, C., Schumacher, A., & Gsell, D. (2010). Fibre reinforced polymer composite materials for building and construction. In G. Pohl (Ed.), *Textiles, polymers and composites for buildings* (pp. 69 -128). Empa: Woodhead Publishing Limited.
- Mustafa, F. (2014). The rise of MotoGP. Retrieved April 18th, 2014, from <http://highlife.ba.com/Curious/the-rise-of-MotoGP.html?PageNumber=1>
- Naji, O. (2014). Aquarena: The coolest stadium in the world(cup). (Masters), Delft University of Technology, Delft.
- Nixdorf, S. (2008). *StadiumATLAS: Technical Recommendations for Grandstands in Modern Stadia*. Berlin: Ernst & Sohn.
- Page, R. W., & Roney, J. F. (1942). United States of America Patent No. 2,287,561.
- Pakar Seating. (2010). Materials. Retrieved May 1st, 2014, from http://pakar-seating.com/Materials_19_1.htm

- Pernica, G. (1990). Dynamic Load Factors for Pedestrian Movements and Rhythmic Exercises. *Canadian Acoustics / Acoustique Canadienne*, 18(2), 3-18.
- Populous. (2012). AMI Stadium. Retrieved June 2nd, 2014, from <http://populous.com/project/ami-stadium/>
- Ratay, R. T. (2012). *Temporary Structures in Construction* (3 ed.). New York: McGraw Hill.
- Research Committee D7 , Demontabel Bouwen",. (1990). Rapport 135 Demontabel Bouwen. Delft: Civieltechnisch Centrum itvoering Research en Regelgeving.
- Seidel, M., & Sturge, D. S. (2009). *Tensile Surface Structures: A Practical Guide to Cable and Membrane Construction*. Londen: Wiley.
- Sheard, R. (2000). *Sports Architecture*. London: Taylor & Francis.
- Simons, N., & Menzies, B. (2000). *A Short Course in Foundation Engineering* (Vol. 2). London: Thomas Telford Limited.
- Stockl, J. (2008). The Automotive Stadium. Retrieved May 1st, 2014, from <http://expolounge.blogspot.nl/2008/04/automotive-stadium.html>
- Sylt, C. (2013). Formula One TV viewing hits the skids. Retrieved April 18th, 2014, from <http://www.theguardian.com/media/2013/feb/15/formula-one-tv>
- Ter Haar, J. (2013). Toeschouwersaantal loopt fors terug in de Jupiler League. April 14th, 2014, from http://www.soccernews.nl/news/215728/Toeschouwersaantal_loopt_fors_terug_in_de_Jupiler_League
- Tienhoven, G. (2014). Spongebob scoort nog beter dan FOX Voetbal, *Algemeen Dagblad*. Retrieved from <http://www.ad.nl/ad/nl/5601/TV-Radio/article/detail/3600455/2014/02/20/Spongebob-scoort-nog-beter-dan-FOX-Voetbal.dhtml>
- Tomlinson, M. J. (2001). *Foundation Design and Construction* (Vol. 7). Pearson Educated Limited.
- Transfermarkt.nl. (2014). Bezoekersaantallen KNVB beker Nederland. In *Bezoekersaantallen* (Ed.): Transfermarkt.
- Uecker, R. A., Beatty, D. E., & Oertle, L. C. (1942). United States of America Patent No. 2,295,311.
- Van Stokkum, C. A. J. (2014). United States of America Patent No. 8,627,608.
- Van Stormbroek, J. (2008). Development of a floor made from fiber reinforced polymers (FRP) with integrated installations. (Masters), Delft University of Technology, Delft.
- Walley, F., Brackley, S. W., Breeze, A. J., Dickie, J. F., Kaye, D., Lovering, D. W., . . . Milne, R. J. W. (1989). *Safety Considerations for the Design and Erection of Demountable Grandstands*. London: Institution of Structural Engineers.
- Wetzel, C. H. (1936). United States of America Patent No. 2,060,436.
- Wilford, M. (2005). Dynamic Performance of Stands. In P. Culley & J. Pascoe (Eds.), *Stadium Engineering*. London: Thomas Telford Limited.
- Zinganel, M. (2010). The Stadium as Cash Machine. In F. Sybille & S. Steets (Eds.), *Stadium Worlds - Football, space and the built environment*. New York: Routledge.

http://nl.wikipedia.org/wiki/PEC_Zwolle

http://nl.wikipedia.org/wiki/Heracles_Almelo
http://nl.wikipedia.org/wiki/SC_Cambuur

<http://nl.soccerway.com/teams/netherlands/kozakken-boys/4660/venue/>
http://nl.wikipedia.org/wiki/VV_IJsselmeervogels
http://nl.wikipedia.org/wiki/Excelsior_%2731

http://nl.wikipedia.org/wiki/JVC_Cuijk
http://nl.wikipedia.org/wiki/BV_De_Graafschap
<http://nl.wikipedia.org/wiki/GVVV>
http://nl.wikipedia.org/wiki/RKC_waalwijk
http://nl.wikipedia.org/wiki/Excelsior_Rotterdam
http://nl.wikipedia.org/wiki/VV_Smitshoek
http://nl.wikipedia.org/wiki/FC_emmen
http://nl.wikipedia.org/wiki/Harkemase_Boys
<http://nl.soccerway.com/venues/netherlands/sportpark-ridderkerk/v2139/>
<http://nl.soccerway.com/venues/netherlands/sportpark-zuid-dvs-33/v10783/>
http://nl.wikipedia.org/wiki/Jan_Louwersstadion
http://nl.wikipedia.org/wiki/Amsterdamsche_Football_Club
http://nl.wikipedia.org/wiki/Amsterdamsche_Football_Club
<http://www.voetbaluitslagen.nl/stadions/sportpark-de-lok/>
<http://nl.soccerway.com/teams/netherlands/ehc-hoensbroek/11170/venue/>
http://nl.wikipedia.org/wiki/Vv_Katwijk
http://nl.wikipedia.org/wiki/FC_Oss
http://nl.wikipedia.org/wiki/Vv_Capelle
<http://www.bvvbarendrecht.nl/website/index.php/5227-animatie-nieuwe-tribune-beschikbaar>
http://nl.wikipedia.org/wiki/Sportpark_De_Heikant

play-offs

http://nl.wikipedia.org/wiki/Play-offs_Nederlands voetbal_2013

2013

Teams	FC Dordrecht	Go Ahead Eagles	De Graafschap	Fortuna Sittard	Go Ahead Eagles	VVV-Venlo
Visitors	2546	4028	6100	4250	4873	6200
Max. in stadium	4235	8011	12600	12000	8011	8000
Percentage	60.1%	50.3%	48.4%	35.4%	60.8%	77.5%

Teams	MVV	FC Volendam	De Graafschap	Roda JC	Helmond Sport	Sparta
Visitors	4648	3128	6507	15091	3228	7100
Max. in stadium	10000	7384	12600	19979	4200	11000
Percentage	46.5%	42.4%	51.6%	75.5%	76.9%	64.5%

Teams	Go Ahead Eagles	FC Volendam	Sparta	Roda JC	total
Visitors	6031	4793	8014	17463	104000
Max. in stadium	8011	7384	11000	19979	164394
Percentage	75.3%	64.9%	72.9%	87.4%	63.3%

http://www.transfermarkt.nl/nl/knvb-beker/besucherzahlen/pokalwettbewerb_NLP.html





	capacity	bought tickets	mean	matches	% visitors
Ajax Amsterdam	Amsterdam ArenA	95.916	31.972	3	
Feyenoord Rotterdam	De Kuip	49000	24500	2	
PSV Eindhoven	Philips Stadion	34000	17000	2	
sc Heerenveen	Abe Lenstra Stadion	25000	12500	2	
AZ Alkmaar	AFAS Stadion	47150	117880	4	
FC Groningen	Euroborg	19790	9895	2	
FC Utrecht	Stadion Galgenwaard	855	8550	1	
Roda JC Kerkrade	Parkstad Limburg Stadion	15173	7587	2	
PEC Zwolle	IJsseldelta Stadion	12500	29482	4	59.0%
Vitesse Arnhem	Gelredome	6210	6210	1	
NEC Nijmegen	Goffertstadion	6021	6021	1	
Heracles Almelo	Polman Stadion	8500	6012	1	70.7%
SC Cambuur-Leeuwarden	Cambuurstadion	10000	10818	2	54.1%
MVV Maastricht	De Geusselt	10000	4770	1	47.7%
Kozakken Boys	Sportpark De Zwaaijer	4000	4000	1	100.0%
VV IJsselmeervogels	Sportpark De Westmaat	8000	10600	3	44.2%
Excelsior '31 Rijssen	Sportpark de Koerbelt	3150	5250	2	83.3%
	Gemeentelijk Sportpark De				
JVC Cuijk	Groenendijkse Kampen	3500	4700	2	67.1%
De Graafschap Doetinchem	De Vijverberg	12600	2.305	1	18.3%
GVVV Veenendaal	Sportpark Panhuis	3500	2250	1	64.3%
RKC Waalwijk	Mandemakers Stadion	7508	2178	1	29.0%
Excelsior Rotterdam	Woudestein	3531	4220	2	59.8%
VV Smitshoek	Sportpark Smitshoek	2000	2000	1	100.0%
FC Emmen	Univé Stadion	8600	2000	1	23.3%
Harkemase Boys	De Bosk	5500	2000	1	36.4%
RVVH Ridderkerk	Sportpark Ridderkerk	3000	1600	1	53.3%
DVS '33 Ermelo	Sportpark Zuid DVS '33	5000	1500	1	30.0%
FC Eindhoven	Jan Louwers Stadion	4600	1314	1	28.6%
AFC Amsterdam	Sportpark Goed Genoeg	2000	1250	1	62.5%
VV TEC Tiel	Sportpark De Lok	1500	1000	1	66.7%
Rijnsburgse Boys	Sportpark Middelmors	6100	1000	1	16.4%
EHC Hoensbroek	Sportpark De Dem	3000	825	1	27.5%
VV Katwijk	Sportpark de Krom	6000	800	1	13.3%
FC Oss	Frans Heesen Stadion	4700	711	1	15.1%
VV Capelle	Sportpark 't Slot	4000	600	1	15.0%
BVV Barendrecht	Sportpark De Bongerd	544	500	1	91.9%
Achilles '29	Sportpark De Heikant	4500	450	1	10.0%

135333

55092

40.7%

BEZETTINGSGRAAD JUPILER LEAGUE CLUBS TOT DE WINTERSTOP (23-12-2012). SEIZOEN 2012/'13

	Aantal thuiswedstrijden	Gemiddeld aantal toeschouwers	Stadion capaciteit	Bezettingsgraad
Go Ahead Eagles 	8	4.861	6.700	72,55%
Helmond Sport 	10	3.021	4.200	71,94%
Excelsior 	9	2.312	3.561	64,93%
AGOVV Apeldoorn 	9	2.037	3.159	64,48%
MVV Maastricht 	8	5.657	8.800	64,28%
Sparta Rotterdam 	9	6.743	10.599	63,62%
FC Dordrecht 	9	2.562	4.100	62,49%
FC Eindhoven 	9	2.731	4.373	62,46%
De Graafschap 	8	7.741	12.600	61,44%
SC Cambuur 	10	5.617	9.500	59,13%
Telstar 	8	1.653	3.063	53,97%
Fortuna Sittard 	8	4.853	10.200	47,58%
SC Veendam 	10	3.076	6.500	47,33%
FC Den Bosch 	9	3.989	8.500	46,93%
FC Oss 	9	1.977	4.547	43,49%
Almere City FC 	9	1.167	2.690	43,39%
FC Volendam 	9	2.833	7.200	39,35%
FC Emmen 	7	2.223	8.500	26,15%
Gemiddeld	8,78	3.595		55,31%



NAC Breda. Middle high stadium, roof covered. The lower parts are obstructing the possibility as a standing place for an extra structure.



The light roof can be dismantled if desired. An engineer will have to investigate of how to put it back on its place when the extra grandstand isn't necessary anymore. This is also the case for all upcoming roofs of the stadia.



RKC Waalwijk. The long side of the stadium actually gives opportunity for bigger structures to stand.



Also here, the steel roof structure must be dismantled to enable viewing lines from the extra stands.



Willem II. With some adjustments on the location, it can be possible to add temporary extra tiers around the stadium.



Again, also the roof must be demounted and after that if desired, put back on again.



De Graafschap. With some site adjustments it can be possible for temporary grandstands to locate behind the current situation.



The light roof structure gives possibilities for openings.



NEC Nijmegen. With some adjustments like flattening the surroundings it can be made possible to build large structures behind the current tiers.



The corrugated plates must be disassembled and so does its supporting structure.



Sparta. On the shorts sides of the stadium is more space for extra structures than on the long sides. The towers of 'the castle' are somewhat in the way.



Steel cantilevers must be made into temporary ones.



PEC Zwolle. Because of the built surroundings of the stadium, extra structures are not possible. Only on the short side there is some room.



Also here, the roof is an obstruction but it seems that is can easily be dismantled.

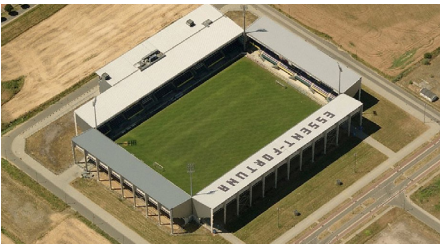

Fortuna Sittard. A middle high structure with columns around supporting the tiers and the roof. No adjustments of the land have to be made and extra tiers can be possible around three sides.



Also here a conflict can be observed between the sight lines of the extra structure and the current roof.



MVV. Extra seating can only made possible on the long and short side of the stadium. The major adjustments which must be made are making way for these new grandstands by removing some trees and creating a pavement around.



The structure of the current roof is not clear in this image and must be looked into further for demounting possibilities.



FC Den Bosch. The current stadium is being replaced by a temporary and demountable structure designed by Zwarts & Jansma. For this stadium, extra tiers weren't possible due to the stadium as a building.





FC Emmen. The possibilities for extra stands are behind one long side and one short side.



A light roof structure does give replacing possibilities.



VVV Venlo. With some changes to the land of the site, extra seating can definitely be made possible.



The roof which is supported by columns seems easily replaceable.



Go Ahead Eagles. Actually the smallest stadium in the highest football division in the Netherlands. Only on the long side of the stadium extra places can be created by a large structure.

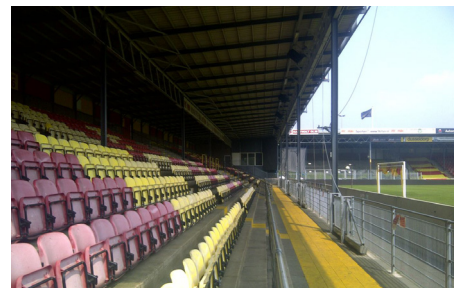

FC Eindhoven. A small stadium with on the two short sides and one long side standing opportunities.



Here is also a light steel cantilevered roof structure visible.

