

A framework for assessing information quality in asset management of flood defences

Klerk, W. J.; Pot, R.; Van Der Hammen, J. M.; Wojciechowska, K.

Publication date

2019

Document Version

Accepted author manuscript

Published in

Life-Cycle Analysis and Assessment in Civil Engineering

Citation (APA)

Klerk, W. J., Pot, R., Van Der Hammen, J. M., & Wojciechowska, K. (2019). A framework for assessing information quality in asset management of flood defences. In D. M. Frangopol, R. Caspeele, & L. Taerwe (Eds.), *Life-Cycle Analysis and Assessment in Civil Engineering: Towards an Integrated Vision - Proceedings of the 6th International Symposium on Life-Cycle Civil Engineering, IALCCE 2018* (pp. 673-680). CRC Press / Balkema - Taylor & Francis Group.

Important note

To cite this publication, please use the final published version (if applicable).
Please check the document version above.

Copyright

Other than for strictly personal use, it is not permitted to download, forward or distribute the text or part of it, without the consent of the author(s) and/or copyright holder(s), unless the work is under an open content license such as Creative Commons.

Takedown policy

Please contact us and provide details if you believe this document breaches copyrights.
We will remove access to the work immediately and investigate your claim.

A framework for assessing information quality in asset management of flood defences

W.J. Klerk

Deltares, Delft, The Netherlands

Dept. of Hydraulic Engineering, Delft University of Technology, Delft, The Netherlands

R. Pot

Fugro N.V., Leidschendam, The Netherlands

J.M. van der Hammen

Nelen & Schuurmans, Utrecht, The Netherlands

K. Wojciechowska

Deltares, Delft, The Netherlands

ABSTRACT: For asset management of flood defences a pivotal aspect is the quality and accessibility of available data and information. In the management of flood defences in The Netherlands, safety assessments are conducted every twelve years. To assure the quality and consistency of these safety assessments, flood defence engineers have to make use of a comprehensive toolbox and a set of guidelines (WBI 2017). The safety assessment is one of the main starting points for the different asset management processes such as day-to-day maintenance and reinforcement/reconstruction. However, there is no clear method available to assess whether the underlying information is sufficient as a basis for decision making. In this study a framework has been developed that consists of methods for an assessment of the quality of information, an assessment of the use and accessibility of information, and a rational framework for assessing the costs and benefits of obtaining additional information. Whereas many frameworks for information management start from the information itself, here the starting point is the extent to which the behavior of a flood defence is understood, in relation to the decision or management process considered. The applicability of the framework is illustrated using various cases and has been tested in multiple workshops with experts in the field.

1 INTRODUCTION

Flood defences in the Netherlands have to meet safety requirements defined as a minimal annual probability of flooding or failure probability (Kind 2014). These safety standards have been derived using risk analysis of loss-of-life as well as economic damage. In order to monitor the safety a statutory assessment is carried out every 12 years (?). In the meantime water authorities have to ensure that their last safety assessment is still valid, meaning that the flood defence still satisfies the requirement ('duty-of-care') (Kok et al. 2017). In order to do so inspections and maintenance are carried out. In the last decade there is also more and more emphasis on use of monitoring techniques and (big) data analysis for inspections. Some examples are monitoring of pore pressures (see e.g. Klerk et al. (2016)), groundwater monitoring, infrared measure-

ments, radar measurements and measurement of deformation using satellites (see e.g. Özer et al. (2016)). This has motivated many water authorities to start initiatives to improve their data management, but up to now it is not very well defined what that should consist of. This mostly leads to slightly unstructured approaches that take the available data as the starting point rather than the goal and use of that data (i.e. supporting decision making). A consequence is that the impact on decision making is still unclear.

A second trend is that asset or life-cycle management is more and more common practice at water authorities (and other infrastructure management organizations) (Jonkman et al. 2018). There is an increased focus on integrating various phases of the life-cycle, for which a shared base of information is pivotal. From an asset management perspective, sound asset information would consist of precisely that in-

formation needed for support of decision making in all phases of the life-cycle. For performance based asset management, the required level of asset information is such that a dike manager is able to make rational (optimal) decisions on maintenance, repair and reconstructions.

This paper presents a framework for intuitively deciding on the usability and quality of available information, and for what aspects new data and information should be acquired in order to support decision making. This paper presents a framework to support asset owners and flood defence engineers in the following three aspects:

- a) Deriving the quality and adequateness of available information;
- b) Determining the level of utilization of information in various life-cycle management aspects;
- c) Making a rational consideration on further data collection, based on the Value of Information.

The applicability of the framework is assessed by various case study applications and experiences in workshops with professionals in the field.

2 CONTEXT

2.1 *Data, information, knowledge and wisdom*

In order to grasp the relation between information and its impact on decision making an understanding of general information concepts is of importance. For this we use the DIKW hierarchy as discussed by Rowley (2007). In this section we discuss the terminology of data, information, knowledge and wisdom and how this can be related to decisions in flood defence asset management. The DIKW framework is shown in Figure 1. It is represented as a pyramid, although there is debate whether a pyramid is an accurate representation (Frické 2009). For these study we have defined definitions of the DIKW terms that are generally aligned with the definitions as used by Rowley (2007), however these are put from a perspective of decision quality as introduced by Howard (1988). This is of specific relevance as the aim of this study is to connect quality of information to decision making.

Data is the bottom level of the pyramid. Rowley (2007) defines this as objective facts, signals or observations (e.g. measurements). It lacks meaning or value and is in principle unorganized. It has to be noted that this definition does not define erroneous data, while in decision making this can have a large influence. Typically without aggregation data can not be used to make decisions.

Information is generally defined as an upgrade of data or data aggregation. Information is processed, organized and structured data. To process data into reliable and usable information, context and analysis of

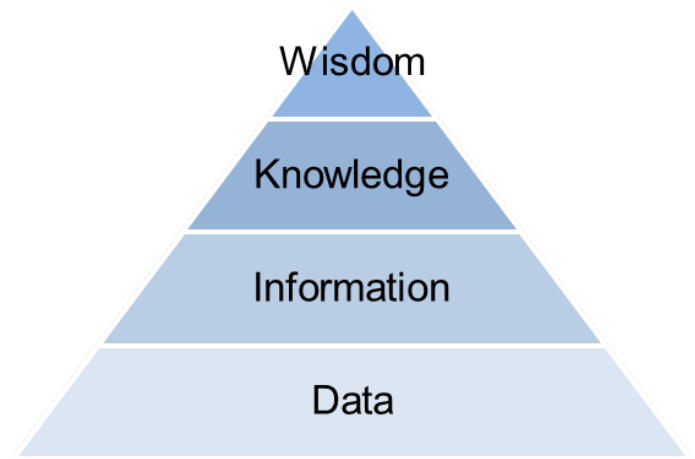

Figure 1: The Data-Information-Knowledge-Wisdom pyramid.

the data are essential. Data becomes of value to the recipient when it is processed so that it is meaningful (Bocij et al. 2003). Also it should have a certain degree of reliability and be based on suitable data, or be of good quality (see e.g. ?, ?) and ?). The definition of information, and its position in the hierarchy is actually one of the major critiques of the DIKW pyramid. It is argued that aggregating data to information already requires knowledge so that they are unjustly separated (Frické 2009). However this does not impede the use of the term information to denote aggregated data.

Where the definitions for data and information are generally accepted, the definition of *knowledge* is much more diffuse. Rowley (2007) defines knowledge as the know-how needed to translate information into instructions but the literature review presented is not unambiguous. In this study we define knowledge as the capability to translate data and information into decision making. An important aspect of knowledge is that there is a distinction between implicit and explicit knowledge (Laudon and Laudon 2015). Explicit knowledge can be recorded in information systems and is therefore accessible and divisible. Implicit knowledge cannot be recorded and is therefore hard to access. Therefore especially implicit knowledge is a challenge in achieving transparent decision making and knowledge sharing with other decision making processes.

Wisdom is the most vague concept in this hierarchy. Wisdom is also considered as a property of a human being, or as the accumulation of knowledge that enables thinking on an abstract and conceptual level (Rowley 2007). Within the context of asset management we define wisdom as the following: wisdom is the ability to act critically and pragmatically in every situation, even beyond the horizon of the directly available knowledge.

Eventually all the aspects together determine the quality of a decision that is taken: the quality and amount of data available, the extent to which this is translated to insightful information, the know-how that is connected to it and the degree to which this is

critically reviewed and tested. In the next section we will illustrate the importance of this for flood defence management decisions.

2.2 Information in flood defence decision making

In the Netherlands the tasks for asset management of flood defences are generally separated in three work processes: regular inspection & maintenance, the statutory safety assessment every 12 years and the strengthening (or renovation) of the flood defence (Kok et al. 2017). Decisions in crisis management situations, such as where to prioritize emergency measures (see e.g. Lendering et al. (2016)), and other decisions in the life-cycle such as when to strengthen the flood defence, are based on the information made accessible in these work processes. Therefore a crucial boundary condition for making informed decisions is the availability of reliable information as well as insight into the remaining uncertainty. In the following subsections we discuss some simplified business cases for reliable information for flood defence management.

2.2.1 Assessment, prioritization and reinforcement

When flood defences are disapproved in the statutory safety assessment, they are prioritized for reinforcement in the national Flood Protection Program, a national program that manages the reinforcement of all primary flood defences in the Netherlands (Kok et al. 2017). Here reinforcements are programmed for the coming decade, as it is not feasible to reinforce everything at once. If flood defences are assessed based on inadequate information this has consequences for the prioritization. This is illustrated by the following example: Consider a stylized case where 25 identical dike sections all have to be reinforced, but the capacity of the contractor is only 1 section per year. In order to minimize the risk during the 25 years that the reinforcements will take, a prioritization is made based on the estimated risk. However, not all estimates are correct: we assume that in 1/3rd of the cases the risk is overestimated by a factor 2, in 1/3rd of the cases it is underestimated by a factor 2 and for the remainder of the sections the risk is correctly estimated. All dike sections have an Expected Annual Damage (EAD) between 1 and 25 M. In Figure 2 a comparison is made for the risk for the chosen strategy compared to the optimal strategy. Economic growth, inflation and discount rate are not considered. It can be clearly seen that the risk for the chosen strategy is much higher (e.g. about 50 % in year 10). This difference is one of the contributions to the cost of inadequate information.

Next to higher risks inadequate information can also lead to higher reinforcement costs. We showed in the previous example that delayed reinforcements

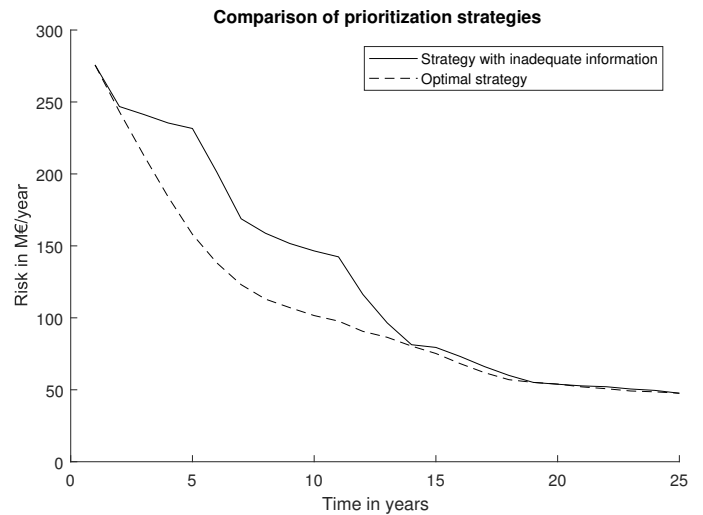

Figure 2: Effect of inadequate information on prioritization of flood defence reinforcements. The dashed line shows the optimal strategy for risk reduction, the solid line the strategy followed with inadequate information.

can result in high risk. On the other hand early reinforcements lead to higher costs. If we consider the Present Value of a reinforcement that is carried out 10 years earlier than optimal due to underestimated reliability would increase costs by approximately 30 % if we use the standard discount rate of 3% (Werkgroep Discontovoet 2015). Additionally, as especially in urbanized areas available space is limited, the reinforcement costs might be significantly higher as one might have to resort to expensive structural measures (De Grave & Baarse 2011).

2.2.2 Maintenance, inspection and crisis management

While the processes of assessment and reinforcement were covered in the preceding section, information is also of importance in day to day maintenance and inspection. Here the same reasoning as for reinforcements can be used: bad information might result in incorrectly (not) applying maintenance, resulting in larger costs and risks. Crisis management is also part of the daily work of a water authority. In crisis management accessible and correct information is of the utmost importance as often decisions have to be taken in very short time frames (Lendering et al. 2016). This can be illustrated by the conceptual case shown in Figure 3. Here we consider the probability of failure given a predicted water level and the information available for an emergency situation. The dike manager has to decide which section to reinforce with sandbags. In the left panel only low quality information is available for section A, resulting in a large uncertainty interval for the estimated probability. If that information is improved (right panel) the distinction in confidence intervals is clear and the dike manager can immediately pick section A for reinforcement with sand bags. This decision could not be made with confidence in the case shown in the left panel. This emphasizes the importance of having clear and

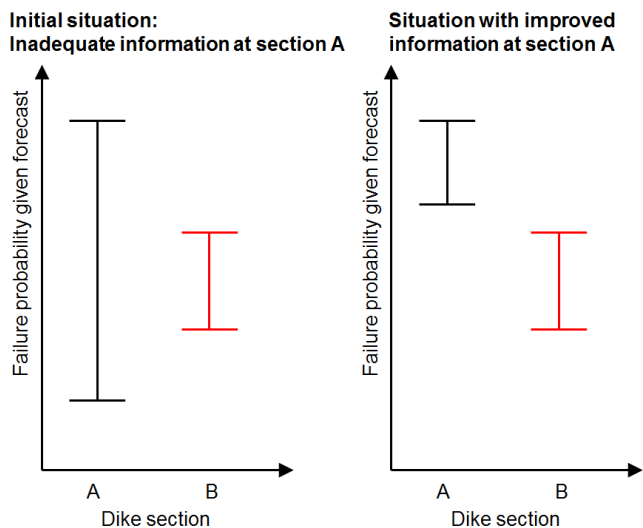

Figure 3: Effect of inadequate information on crisis management given a failure probability forecast. The left panel indicates the situation with inadequate information. In the right panel the situation with improved information is shown

high quality information in such situations and decreasing uncertainties to a level that an informed decision can be made.

2.3 Current status of information in flood defence management

Based on the examples in the preceding sections the importance of information in life cycle management of flood defences is clear. An investigation by IHW, an organisation focusing on data exchange and availability in water management in The Netherlands, investigated the state of information and data management at water authorities (IHW 2015). They found that:

- In general, data on height and location of flood defences is accessible from a central database.
- Less than 20 % of the water authorities store their information on the subsoil in a central database. For inspection results and data on revetments this is less than 40 %.
- At more than 50 % of the water authorities subsoil, inspection and revetment information is only accessible to a limited user group.
- More than 60 % of the water authorities have no standard procedure for processing data and information.

This shows that currently at most water authorities a consistent base of information is not available. This is one of the reasons to also include use of information as an aspect in the framework in Section 3. It has to be noted that there is considerable attention to data management and many initiatives are on-going to improve the situation. Also in all official regulations the care for data management is stressed, since this directly reflects the management of the safety standards. For instance, a technical maintenance register

and ledger is mandatory for all primary flood defences in the Netherlands (Kok et al. 2017). Asset owners have the task to take care of the availability and timeliness of the data. However, despite these regulations and initiatives data and information management are not yet at the required level.

3 A FRAMEWORK FOR ASSESSING DIKE INFORMATION

The proposed framework provides a tool to assess to what extent the available information on the strength properties of a flood defence is sufficient for making informed decisions. Its main goal is to provide an accessible tool for taking into account data and information quality in asset management decisions, which is achieved by providing a transparent way of communicating technical knowledge on the quality of information amongst and towards non-technical asset managers. The framework comprises a three step approach to assess:

1. Quality of information;
2. Use of information in the various decision making processes;
3. The Value of (additional) Information.

3.1 Assessing quality of information

The quality of information is assessed using score performance cards and awarded a score between 1 and 5 stars. The different levels and their descriptions are shown in Table 1. The different scores can be interpreted in line with the DIKW definitions. E.g. for a score of 2 stars information is available but not yet coupled to knowledge. This is done in the sensitivity analysis with which 3 stars can be obtained. The 5 star score corresponds to optimal insight, which can be interpreted as 'wisdom'. The scorecard does not explicitly state what criteria should be met for each level. It is for instance not sharply defined when data can be considered validated, but guidance is, amongst others, given in the ISO standards on data quality models (ISO/IEC 2008) and measurement of data quality (ISO/IEC 2015). Also, to obtain 3 stars a sensitivity analysis has to be carried out. The scope of the sensitivity analysis should be determined by expert judgement and should cover all relevant uncertainties. The reason for not specifying requirements in exact terms is that the intended application of the framework covers a broad range of situations and is highly dependent on the type of flood defence, the important failure mechanisms, the decision problem and the location. With the formulation that is chosen the framework is versatile in its application, as will be illustrated by the case studies in Section 4.

Table 1: Score performance card for information quality with descriptions for every score.

Score	Description
* <i>Insufficient data available</i>	The quality and usability of data is not assessed, insufficient and not validated.
** <i>Validated data available</i>	Quality of the available data is known, described and validated with different independent sources.
*** <i>Insight in flood defence behaviour</i>	Based on the information and knowledge of the flood defence a sensitivity analysis has been carried out that has revealed the major uncertainties.
**** <i>Capable of informed decision making</i>	The relevant uncertainties for decision making have been reduced and do not (significantly) influence the decisions to be taken.
***** <i>Optimal insight</i>	Based on a Cost-Benefit analysis of the different options for additional data collection the economically optimal insight into dike strength has been obtained.

Table 2: Score performance card for use of information with descriptions for every score

Score	Description
* <i>Low data accessibility</i>	Lack of (structured) metadata, information is not digitalized and takes considerable time to access.
** <i>Accessible, non-georeferenced data</i>	Information is digitalized but not geographically referenced or organized.
*** <i>Geo-referenced data</i>	Data is available and traceable to a specific location. A single base of information is available to professionals within the organization.
**** <i>Centrally available data</i>	There is a centrally accessible information system with information that can be accessed from the field (e.g. during inspections).
***** <i>Single Point of Truth</i>	Information is up to date and disseminated using a decision support system that tailors the information to specific decisions and processes. The information is a general starting point for all decisions and processes.

3.2 Assessing the use of information in decision making

In Section 2.3 it was outlined that also the use of information and the way it is organized is a point of continuous attention. For that reason the score performance card for use of information as shown in Table 2 was developed. Again the outline of the DIKW-pyramid can be recognized: at 1 star the data is badly accessible but also incomplete and unstructured, thus hampering a transformation to actionable information. At 5 stars the information is structured, widely used but also disseminated using specific knowledge on relevant aspects for different decision problems and asset management processes.

3.3 Rational decisions on the Value of Information

The assessment whether the acquired information is sufficient is an economic decision problem where the costs are the cost for acquiring additional information. The benefits are for instance:

- Lower dike reinforcement costs due to improved insight;
- An increased action perspective (i.e. better insight in what measures might be effective);

- Better insight in risks resulting in more optimal risk-based investment decisions.

It has to be noted that not all benefits are easily expressed in tangible values. For instance the added value of extra information in a crisis situation is hard to quantify, contrary to the reduction in reinforcement costs. Generally it should be attempted to make all benefits as tangible as possible to approach the actual Value of Information (VOI). As this is not always easy or possible, the framework uses a three-step approach for the rational decision making framework:

1. A *simple* approach that is mainly based on expert judgement of the estimated benefits and costs;
2. A *detailed* approach that is based on an explicit cost-benefit analysis;
3. An *advanced* approach based on a pre-posterior Bayesian decision analysis.

It has to be noted that this framework is applied before the action is carried out, therefore the costs can be estimated with relative confidence but the benefits are uncertain. In this paper we will focus on the simple and detailed approaches as these are most practical and illustrative for the general approach in the framework. For the advanced approach ample examples are available in literature, see for instance Schweckendiek (2014), (?), Klerk et al. (2015) and Goulet et al. (2015).

The simple approach comprises the following steps:

1. Estimate costs for obtaining additional dike information;
2. Estimate benefits from using the additional information:
 - (a) What is the effect of the additional information on the costs of e.g. maintenance or dike reinforcement?
 - (b) What is the effect of the additional information on the risks (e.g. reduction of the number of fatalities and economic damage per year)?
3. Verify whether the benefits (step 2) exceed the cost (step 1).

The goal of this approach is to structure the decision problem and to give rapid insight in the costs and benefits of the considered action. If the problem is relatively straightforward this will be sufficient as basis for decision making. In other cases a detailed approach is recommended. It has to be noted that especially in estimating the benefits it is important to involve responsible persons from the different dike management processes in order to get an overview of all the benefits throughout the life-cycle.

The detailed approach is illustrated in Figure 4. Here an event tree approach is used to distinguish be-

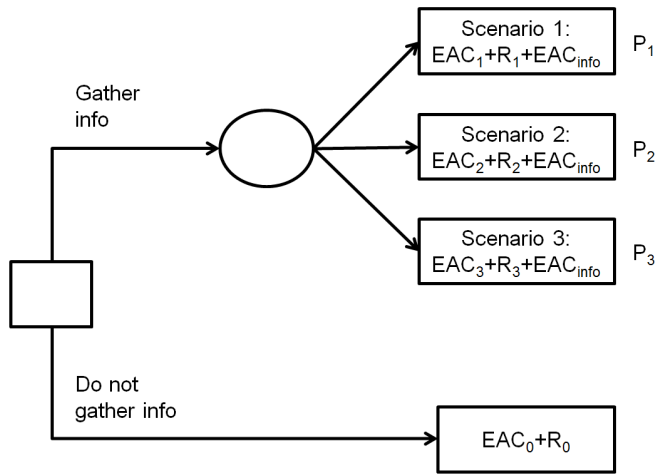

Figure 4: Decision tree for gathering additional information in the detailed approach.

tween the effect of (not taking the action). To evaluate this event tree, first the Equivalent Annual Cost (EAC_i) has to be calculated for each measure i :

$$EAC_i = C_i/A_i \quad (1)$$

$$A_i = \frac{1 - \frac{1}{1+r}^t}{r} \quad (2)$$

The EAC_i is the Present Value of the investment i per year (Schoemaker et al. 2016), A_i is the annuity factor that is governed by discount rate r and lifespan of the investment t_i , C_i is the total cost of the measure. Using this the total benefits (B) can be calculated using:

$$B = (EAC_0 + R_0) - \sum_{i=1}^3 P_i \cdot (EAC_i + R_i) \quad (3)$$

$$B/EAC_{info} > 1 \quad (4)$$

P_i is the estimated probability of scenario i . EAC_i is the equivalent annual cost for measure i and R_i is the risk in scenario i (both in e/yr). EAC_{info} is the equivalent annual cost of obtaining additional information. If the ratio in Eq. 4 is larger than 1, information should be obtained. An important aspect is that it has to be defined what the scenarios and their corresponding benefits are. In principle these scenarios should represent an unfavourable, favourable and neutral outcome. As the outcome is not known beforehand this can be slightly subjective. The advanced approach based on an actual preposterior analysis provides a more structured and objective way that is also based on scenarios (see e.g. Klerk et al. (2016)).

4 CASE STUDIES & APPLICATIONS

In order to test the framework and especially the performance score system for quality of information the framework was applied to two case studies and tested in workshops with experts in the field. In the following sections the findings are discussed.

4.1 Regional flood defence

In this example the framework is applied to assess the quality of information underlying the safety assessment of a 120 m long dike section protecting the Beemster polder, a regional flood defence in the northwest of the Netherlands. In the safety assessment four dike failure mechanisms were considered: inner slope stability, outer slope stability, microstability and piping (Kok et al. 2017). The dike section did not pass the assessment for outer slope stability, whereas satisfactory results were obtained for the remaining three mechanisms. For the framework one star is always awarded as the starting point. The following procedure demonstrates how the framework facilitates information quality assessment for each level:

- *Availability and validation of data (two stars)*: various measurements (e.g. soil probing, cone penetration tests (CPT) and borings) and studies show that the soil structure of dikes around the polder is homogeneous (this can be explained by the fact that the dikes were built around the same time). The homogeneity entails that the measurements are also mutually validated. In the considered dike section, CPT's were conducted at two locations. Given the homogeneity, also within other neighbouring sections, there is no reason to suspect that the number of test locations should be increased or that additional studies are needed. Two stars can therefore be given for the information quality.
- *Sensitivity analysis (three stars)*: the dike section passed the piping assessment due to a thick blanket layer that prevents seepage (presence of the layer was confirmed with measurements). Even with a significantly thinner layer seepage was still prevented. There were no other sensitivities found and hence three stars can be given to the quality of piping information. The slope stability assessments were performed with the software package D-GeoStability. In the assessment no sensitivity analysis of the underlying strength parameters was performed. Therefore no more than two stars can be given to the quality of slope stability information (both inner and outer). For microstability, it was assumed that no sand transport can take place in the considered dike section (because there is no sand) and hence the mechanism cannot take place. This contradicts other locations where a sand layer was found (in the vicinity of the A7 highway). The hypothesis is that the sand originates from the road cunet. Although it is therefore likely that microstability will not occur in the considered dike, a small study should be performed to confirm this. This is why at most two stars can be given to the quality of microstability information.
- *Explicit uncertainties (four stars)*: concerning

the piping assessment, the relevant uncertainties were quantified and found sufficiently small for an unambiguous assessment (i.e. dike section was approved). Thus the considered decision could be taken and hence four stars are given to the quality of piping information.

- *Rational decision making (five stars):* It has been found that there is a large safety margin for piping. Following the simple approach of the framework for rational decision making it follows that additional information would not improve decision making in this case as the benefits are very limited. Therefore, five stars can be awarded for piping information.

Summarizing for this dike section two stars can be given for the assessment of stability of the inner and outer slope and microstability, five stars can be given for the information quality of the piping assessment. The main experience from the case was that the framework provides an intuitive means for assessing information quality. However at the same time in some cases the judgement can be a bit subjective (e.g. on whether a sensitivity analysis is needed for microstability). In order to investigate the subjectiveness of the framework it was also applied in workshops with various experts, this is reported in Section 4. It also has to be noted that in some cases a small analysis could improve the score (e.g. for microstability). This is a consequence following from the different approach towards information quality in this framework compared to the standard safety assessment.

4.2 Dunes

The second case study considers a dune section in the Netherlands. The main goals of this case are to show that an analysis of information quality can be very straightforward and that the framework is applicable to a broad range of flood defence types. At most locations the Dutch dune coast is very wide, consisting of multiple dune rows, a beach and a shallow coast line. The failure mechanism considered in the safety assessment is dune erosion, which considers the erosion of a critical dune profile. If the width of the dunes is verified with two sources (e.g. a DTM and open data) and found to be significantly wider than the critical profile four stars can already be awarded as there are no important sensitivities. Also there is not much data that can add value to that assessment, meaning that a cost-benefit analysis is also straightforward. Therefore five stars can be awarded. This shows that with relatively simple reasoning and without thorough quantitative analysis a high level of information quality can be proven, depending on the complexness of the problem and whether the current state is at a critical level for decision making (e.g. just around the safety standard).

4.3 Application in workshops

In order to assess whether the framework was sufficiently unambiguous it was tested in several workshops during development. In total 3 workshops with 4 sessions were carried out, both with individual experts and groups of experts. In these workshops a set of 6 practical cases were assessed by the participants. Table 3 shows the results for the different workshops. The participants were asset owners and engineers from government, water authorities, engineering firms and knowledge institutes. The workshops were carried out in chronological order, workshop 1 was therefore also used to improve the definition of the different cases. Also, in that stage the definitions of the different levels were ambiguous and improved for the second and third workshop. A notable difference is between the individual scores in part I of workshop 1, and the group scores in the other workshops. It was found to be valuable to discuss the cases with people from various disciplines and perspectives, which also appears from the scores. Based on that it was chosen to work solely in groups in workshops 2 and 3. In all workshops the majority of the groups came to the expected result which shows that the framework is stable and reasonably objective. It is notable that especially the first case shows a large deviation, but for the other cases very stable results are found. This can be due to the fact that the first case was not clearly defined, but from the discussions it was also found that a little practice is needed to get a better understanding of the framework.

After the workshops questionnaires were handed out to participants. Although the framework was still under development during the time of the workshops, one third of the participants stated that the framework could directly be of value for current projects. There was a wide recognition on the importance of information quality and it was stated that the framework would raise awareness about that importance. It was also explicitly rewarded that the framework not only gives an assessment, but also gives directions for improving the score.

5 CONCLUSIONS & RECOMMENDATIONS

In this paper an intuitive approach has been presented for explicitly evaluating quality of information in decisions throughout the life cycle of flood defences. Using case studies the practical applicability has been demonstrated. Results from workshops with experts in the field show that the framework provides stable results for a variety of realistic cases. In these workshops it was also emphasized, both by the results and comments of participants, that involving multiple experts with different perspectives helped in assessing the quality of information. In order to further improve the quality of the framework it is recommended to further test the framework on additional cases and then

Table 3: Scores for the different workshops. Columns with E indicate the fraction that scored the expected value, columns with Δ indicate the differences with the expected value in terms of number of stars (difference of 1 or more than 1).

Case	Workshop 1 part I 9 participants Individual			Workshop 1 part II 10 participants 3 groups			Workshop 2 35 participants 6 groups			Workshop 3 35 participants 7 groups			Overall		
	E	$\Delta = 1$	$\Delta > 1$	E	$\Delta = 1$	$\Delta > 1$	E	$\Delta = 1$	$\Delta > 1$	E	$\Delta = 1$	$\Delta > 1$	E	$\Delta = 1$	$\Delta > 1$
1	0	0.75	0.25	1	0	0	0	0.5	0.5	0	0.57	0.43	0	0.54	0.46
2	0	0.56	0.44	0.67	0.33	0	1	0	0	1	0	0	1	0	0
3	0	0.89	0.11	0.33	0.67	0	1	0	0	0.71	0.29	0	0.85	0.15	0
4	0.67	0.33	0	1	0	0	0.67	0.33	0	0.71	0.29	0	0.69	0.31	0
5	0.22	0.44	0.33	1	0	0	0.83	0.17	0	-	-	-	0.83	0.17	0
6	-	-	-	1	0	0	-	-	-	-	-	-	-	-	-
Average	0.18	0.59	0.23	0.83	0.17	0	0.7	0.2	0.1	0.60	0.29	0.11	0.67	0.23	0.09

implement it as a standard tool to be used in flood defence decision making. This will ensure a solid base for information driven flood defence asset management and will aid water authorities in transparently explaining their efforts to protect society from flooding.

ACKNOWLEDGEMENTS

This work has been financially supported by STOWA, the Dutch Flood Protection programme and Rijkswaterstaat.

REFERENCES

Bocij, P., D. Chaffey, A. Greasley, & S. Hickie (2003). *Business Information Systems: Technology, Development and Management for the e-Business*. FT Prentice Hall, Harlow.

De Grave, P. & G. Baarse (2011). Kosten van maatregelen - Informatie ten behoeve van het project Waterveiligheid 21e eeuw. Technical report, Technical Report, Deltares, Delft, The Netherlands.

Frické, M. (2009). The knowledge pyramid: A critique of the DIKW hierarchy. *Journal of Information Science* 35(2), 131–142.

Goulet, J.-A., A. Der Kiureghian, & B. Li (2015). Pre-posterior optimization of sequence of measurement and intervention actions under structural reliability constraint. *Structural Safety* 52, 1–9.

Howard, R. A. (1988). Decision Analysis: Practice And Promise. *Management Science* 34(6), 679–695.

IHW (2015). Quickscan gegevenshuishouding Nederlandse Waterbeheerders. Technical report, Informatiehuis Water (in Dutch).

ISO/IEC (2008). ISO/IEC 25012:2008 Software engineering – Software product Quality Requirements and Evaluation (SQuaRE) – Data quality model.

ISO/IEC (2015). ISO/IEC 25024 (2015) - Systems and software engineering – Systems and software Quality Requirements and Evaluation (SQuaRE) – Measurement of data quality.

Jonkman, S. N., H. G. Voortman, W. J. Klerk, & S. van Vuren (2018). Developments in the management of flood defences and hydraulic infrastructure in the Netherlands. *Structure and Infrastructure Engineering*, 1–16.

Kind, J. (2014). Economically efficient flood protection standards for the Netherlands. *Journal of Flood Risk Management* 7(2), 103–117.

Klerk, W. J., F. d. Heijer, & T. Schweckendiek (2015). Value of information in life-cycle management of flood defences. In *Safety and Reliability of Complex Engineered Systems*, Zurich, Switzerland, pp. 931–938. CRC Press.

Klerk, W. J., W. Kanning, M. van der Meer, & J. Nieuwenhuis (2016). Structural health monitoring in life-cycle management of dikes: a case study in the north of the Netherlands.

Life-Cycle of Engineering Systems: Emphasis on Sustainable Civil Infrastructure: Proceedings of the Fifth International Symposium on Life-Cycle Civil Engineering (IALCCE 2016).

Kok, M., R. Jongejan, M. Nieuwjaar, & I. Tanczos (2017). Fundamentals of Flood Protection.

Laudon, K. & J. Laudon (2015). *Management Information Systems: Managing The Digital Firm* (14 ed.). Upper Saddle River, NJ, USA: Prentice Hall Press.

Lendering, K. T., S. N. Jonkman, & M. Kok (2016). Effectiveness of emergency measures for flood prevention. *Journal of Flood Risk Management* 9(4), 320–334.

Özer, I. E., M. van Damme, T. Schweckendiek, & S. N. Jonkman (2016). On the importance of analyzing flood defense failures. *E3S Web of Conferences* 7, 03013.

Rowley, J. (2007). The wisdom hierarchy: Representations of the DIKW hierarchy. *Journal of Information Science* 33(2), 163–180.

Schoemaker, M. A., J. G. Verlaan, R. Vos, & M. Kok (2016). The use of equivalent annual cost for cost-benefit analyses in flood risk reduction strategies. In *FLOODRisk 2016*, Volume 20005.

Schweckendiek, T. (2014). On reducing piping uncertainties: A Bayesian decision approach.

Werkgroep Discontovoet (2015). Rapport werkgroep discontovoet 2015. pp. 95.