

Designing Stone Pitchings

LECTURE NOTE

By

C.J. Dorst MSC

Senior Project Manager Coastal Engineering

Ministry of Transport, Public Works and Water Management

Directorate-General of Public Works and Water Management

Civil Engineering Division

Hydraulic Engineering Branch, Hydraulic Engineering Department

(Ministerie van Verkeer en Waterstaat, Bouwdienst Rijkswaterstaat, afdeling Natte Waterbouw)

University of Technology DELFT
March 2004.

Contents

1. Applications of stone pitchings	4
2. The construction.....	5
2.1 Top layer	5
2.2 Fill layer / construction layer and filter layer	12
2.3 Under layer / base material.....	13
2.4 Some other related armour layers.....	14
2.5 Other construction parts	15
2.5.1 Toe protection.....	15
2.5.2 Toe construction	15
2.5.3 Transition construction	16
2.5.4 Connecting constructions.....	16
3. Failure mechanisms.....	17
3.1 Instability of top layer	17
3.1.1 Current.....	17
3.1.2 Wave load: maximum wave withdrawal.....	18
3.1.3 Wave load: wave impact.....	18
3.1.4. Wave run-up	19
3.2 Transport from materials from the under layers.....	19
3.2.1 Transport from the base to granular (fill) layer.....	19
3.2.2 Transport of material from fill layer through top layer.....	20
3.3. Sliding	21
3.4 Failure of toe, transitions and connections	22
4. Stability of individual elements.....	23
4.1 Current.....	23
4.1 Wave load: simplistic empirical method	23
4.2 Wave load: detailed, analytical method.....	24
4.2.1 Leakage length.....	24
4.2.2 Permeability of granular layer	24
4.2.3 Permeability of the top layer.....	26
4.2.4 Schematization of the pressure head front	29
4.2.5 The influence factor Γ	30
5. Transport of material.....	33
5.1 Some principles of filter design.....	33
5.2 Necessity of filters and choice between granular filter or geofabric	33
5.3 Design rules.....	34
5.3.1 Geofabrics.....	34
5.3.2 Granular filters.....	34
5.3.3 Transport of material from the granular layer.....	34
5.3.4 Internal stability granular material.....	35
6. Sliding.....	36
7. Design of other construction parts	39
7.1 Toe protection	39
7.2 Toe construction.....	40
7.3 Transition constructions and connecting constructions.....	40
7.4 Pitchings on and above berms.....	43
7.5 Zone of wave run-up	44
7.6 Crest and inner slope.....	45
8. Required parameters	46
8.1 Hydraulic Loads.....	46
8.1.1 Wind waves	46
8.1.2. Ships induced waves.....	46
8.1.3 Water level.....	46
8.1.4 Horizontal currents	47
8.1.5 Density of water.....	47
8.1.6 Breaker parameter.....	47
8.1.7 Wave run-up	48
8.2 Properties of pitchings.....	48
8.2.1 Fill material of top layer	48
8.2.2 Open space in top layer.....	48

8.2.3 Height or thickness of the top layer.....	48
8.2.4 Density of the elements	48
8.2.5 Thickness of granular layer	48
8.2.6 Properties of granular layer	49
8.2.7 Slope angle	49
9. Useful Literature	50
10. Useful Computer Programs.....	50

1. Applications of stone pitchings

Comparison of rock, pitchings and slab revetments:

Rock versus pitchings:

- Rock: weight of individual stones is larger;
- Rock: total weight of the revetment is larger;
- Rock must be transported from abroad;
- Rock is more simply to apply;
- Rock can be applied under water;

Slab revetments of concrete are not flexible;

Slab revetments of asphalt can only be applied above the water level, above the tidal zone;

Slab revetments of asphalt or concrete are impermeable, so high pressure differences over the cover layer can occur.

Pitchings are applied on dikes, dams and banks if soft (grass, dunes) protections are not wanted or impossible. Reasons for this can be:

- unfavorable daily circumstances (constant wave loads, to often drown, salty environment);
- pitchings need less maintenance;
- the heavy loads combined with rather steep slopes.

The heaviest type of concrete column (0.5 m / 2900 kg/m³) can be applied under:

- current velocities of 4.5 m/s.
- combinations of wave height and period as given in the table below (calculated with $s_{0p}=3.5\%$):

Slope [-]	1:2½	1:3	1:3½	1:4	1:4½
Wave height [m]	3.2	3.7	4.1	4.5	4.8
Wave period [s]	7.7	8.2	8.7	9.1	9.4

Combinations of wave heights, wave periods and slopes, for which a column 0.5 / 2900 is stable

2. The construction

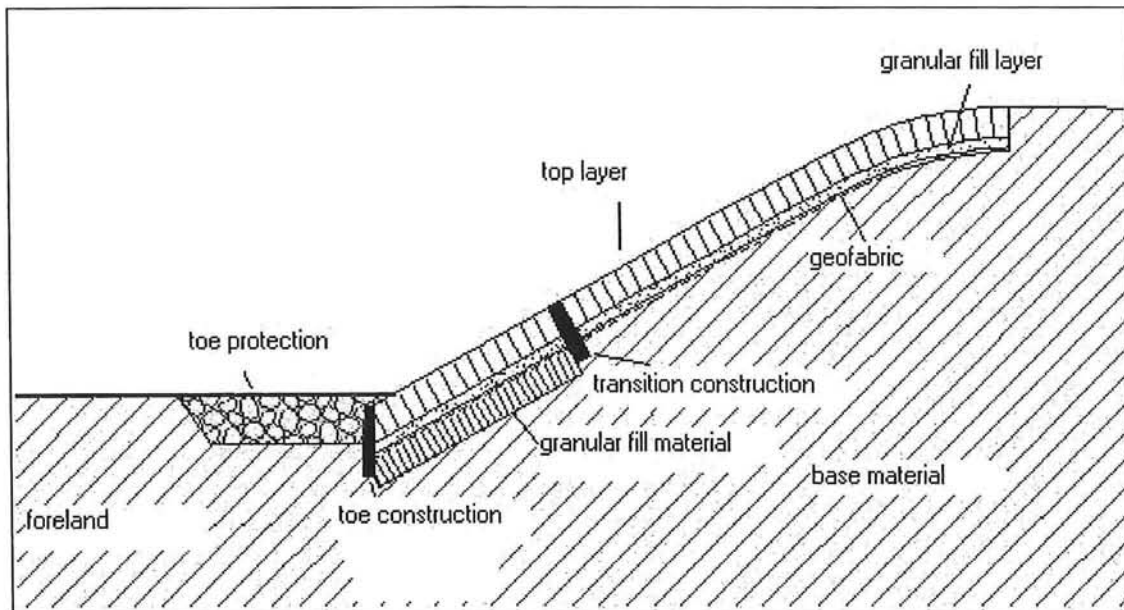

Schematization of the composition of a pitching

2.1 Top layer

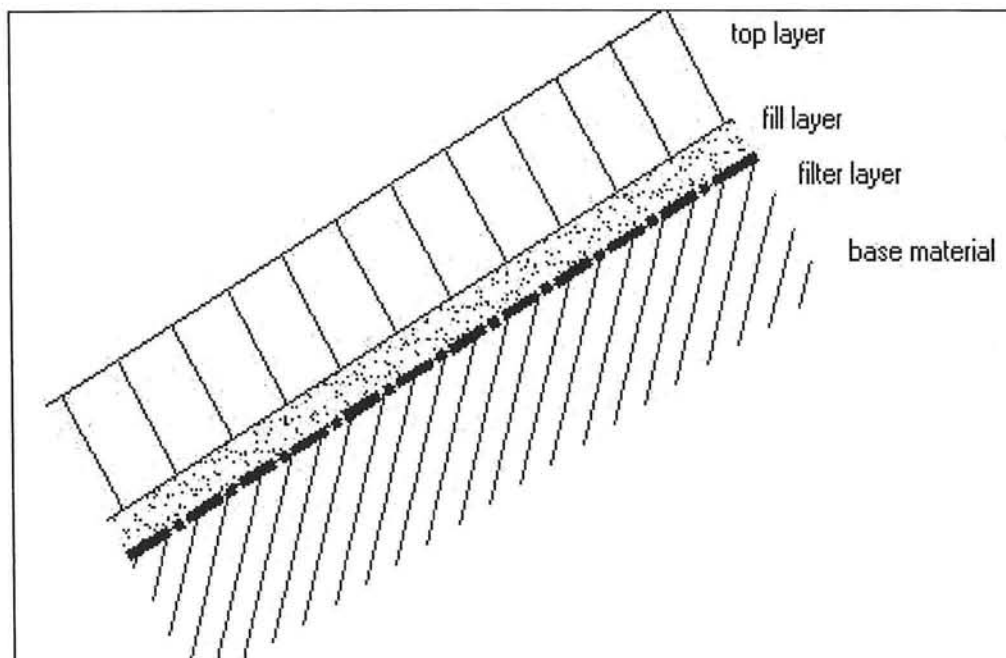

Schematization of a pitching

	Blocks	Columns	New / re-use
Concrete	Concrete	Concrete	New + re-use
Natural stone	Granite	Basalt columns	Re-use
Rest products	"Koperslak" blocks	C-fix	Re-use (blocks) New (columns)

Elements which can be used in a new pitching

	Blocks	Columns
Joint width	Rather constant	Variable
Shape	Rather regular, square, rectangular, or six-angular	Irregular or regular, angular
Open space	Less, comparing to columns	More, comparing to blocks
Coherence	Less, comparing to columns	More, comparing to blocks
Stability of cover layer	Less, comparing to columns	More, comparing to blocks

Differences between blocks and columns

NB: The relationship between heights and surfaces of the elements doesn't determine the differences between blocks and columns.

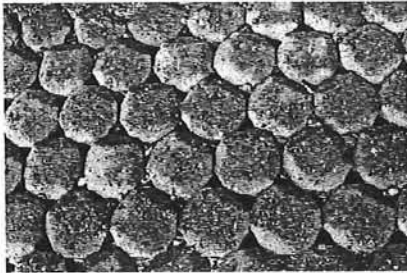

PIT-Polygon columns

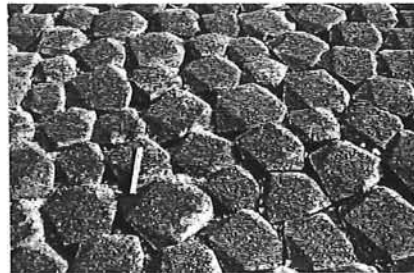

Basalton

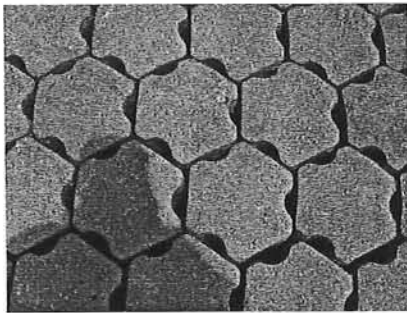

Ronaton

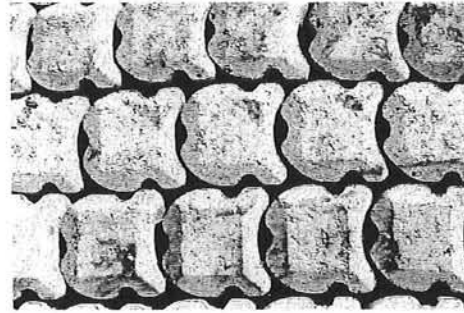

HydroBlock

Four types of concrete columns

Concrete columns of different densities and heights are available:

- density: 2300 – 2900 kg/m³ (in steps of 100 kg/m³)
- height: 0.15 – 0.50 m (in steps of 0.05 m)



Concrete blocks



Polish Granite blocks



"Koperslak" blocks

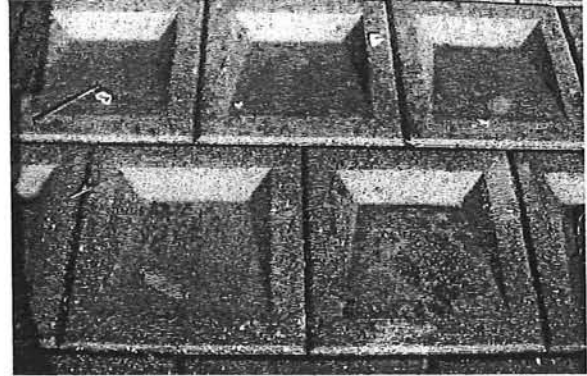

"Haringman" concrete blocks



Concrete columns with "eco-top"

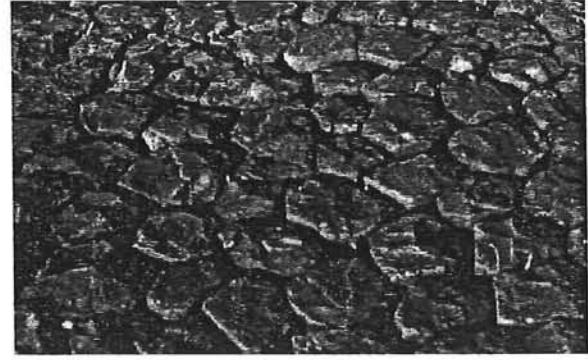

Basalt columns



Re-use of concrete blocks, turned on the side



(Petit) Granite blocks

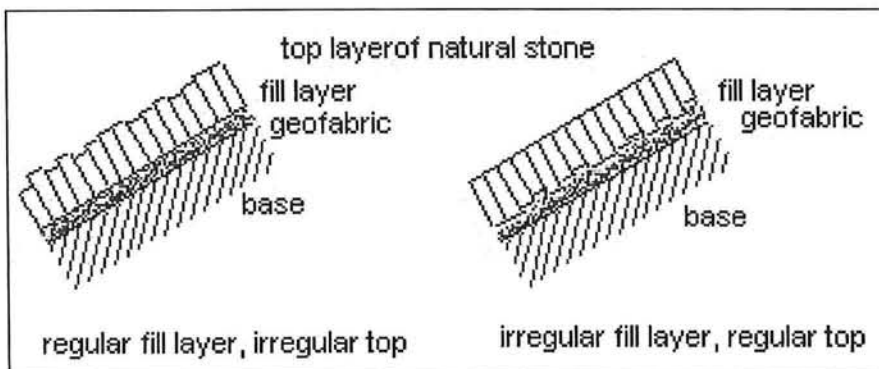

Two ways of placing elements (with differences in heights f.i. natural stones) on an granular layer

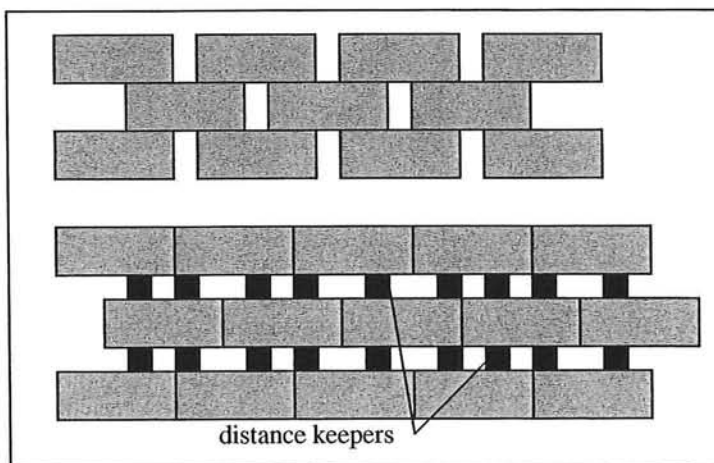

Two ways to enlarge the open space of the top layer (only possible with regular blocks)



Re-use of granite block on regular granular fill layer



"Doornikse" blocks (an old type of pitching)



"Vilvoordse" stone (an old type of pitching)



Bricks (on old type of pitching)



Granite boulders (an old type of pitching, found on the dikes along the IJsselmeer)



"Diabool" concrete blocks (an old type of pitching, to reduce wave run-up)

Some considerations:

Placing by hand or mechanically.

All regular concrete blocks and new concrete columns can be placed mechanically.

Natural stones must be placed by special trained workers.

Execution in curves.

Concrete blocks are not very well applicable when the radius of the curve is less than 100 m. Than hand placed elements or mechanical placed concrete columns must be applied.

Perceptibility of damage.

It is important that damage is perceptible as soon as possible. Also the washing out of materials must be noticed in an early stage. Therefore the pitching must be flexible and smooth: on a dike where settlement can occur, a convex camber is dissuaded and natural stones (with different sizes) should be placed on a uneven, irregular granular layer, resulting in a smooth top of the pitching.

Costs.

The costs depend very much on the circumstances. The purchase of the elements is dominant. A pitching of new elements, mechanically placed, is the most expensive. Re-use of manual placed elements is about a factor 3 cheaper and re-use of elements, mechanically placed a factor 6 – 8.

Choice of pitching type.

Not only technical aspects determine the type of pitching which is applied. F.i. the following actors/aspects can influence the choice:

- The owner of the dike (f.i. a water board) - maintenance aspects;
- Environmental groups – environmental aspects;
- Ecologists – possibilities for special vegetation and small animals;
- Landscape experts – insertion of the pitching into the landscape;
- Culture and history experts – values of old pitchings / archeology;
- Recreation – possibilities for multipurpose uses.

In most cases one should make more than one technically possible designs in the process of decision making.

2.2 Fill layer / construction layer and filter layer

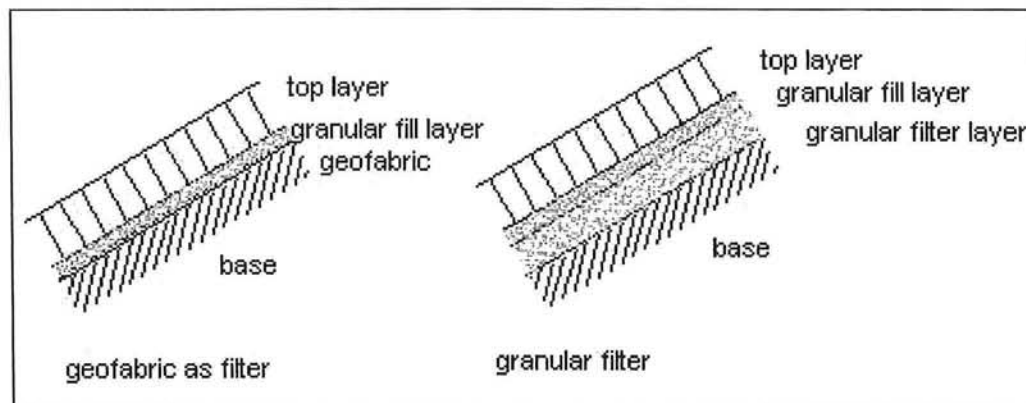

Two types of filter layers

Geofabrics are often used: as a separation layer, for the filter function. Usually:

- clay: non-woven
- sand: woven

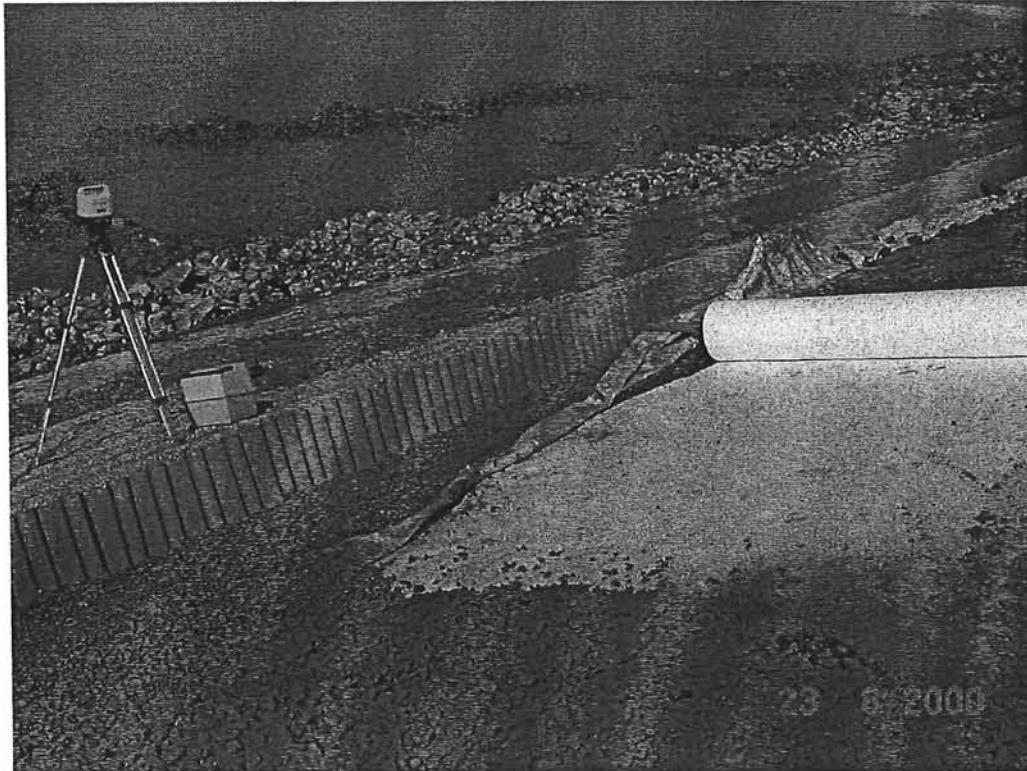

Application of a geofabric and a fill layer

2.3 Under layer / base material

Sometimes it is necessary to fill up the base material (clay dikes) before the new filter and cover layers can be constructed (f.i. soil improvement, removal of a sand inclusion, adaptation of the slope (increase of the slope angle)). Below the water level, f.i. in the tidal zone, clay can not be applied. Broad gradated granular material (containing also small particles) which is also intern stable will satisfy, f.i. mine stone (rest product of coal mining), silex (rest product of cement industry) or concrete debris or rubble (0-40 mm). Granular material containing the 0-fraction is called: unsorted.

The base material of the pitching is the upper layer of the earth body of the dike, dam or bank. In case the core consists of clay this often is also the base material. In case of a sand core, sometimes the sand is the base material, sometimes the sand is covered by a layer of clay (or mine stone) to reduce infiltration of water and to keep the phreatic line within the dike relative low (necessary for micro stability). Due to the cohesive property of clay it also gives the revetments some rest-strength in case the cover layer collapses.

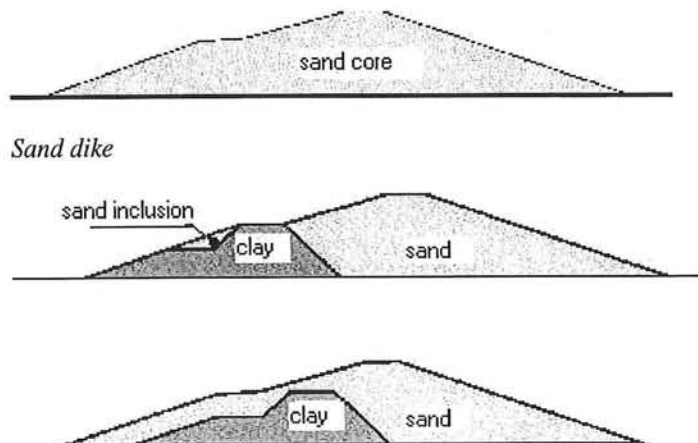

An example of adaptation of the old dikes in Sealand after the storm surge in 1953

2.4 Some other related armour layers

1. Block mattresses

Concrete blocks connected with cables or geofabric. About 10% extra stability comparing non-connected elements. Stability of edges is a weak point and often a problem. It is solvable by connecting the individual mattresses. Block mattresses can be placed under water.

2. Open grass blocks

Concrete block with gaps, in which grass can grow through. The elements have an open surface of about 20-30% and are mostly placed directly on clay. The gaps are filled with soil (clay) and sowed. Mostly used on dikes in the transition area from soft to hard cover layers, preventing damage of traffic and sheep. From investigations in England open grass blocks appear to have more strength than a grass cover. The concrete reduces the development of a horizontal root structure but reduces on the other hand the damage propagation speed. Comparing a uniform grass cover, damage occurs more early, but the final damage is less. It is recommended to use open grass blocks only if it is useful for conservation and only under loads of wave run-up and overflow (not wave impact).

3. Grouted pitchings

Sometimes applied to make possible the re-use of elements which are normally too light. It is always necessary to place the re-used elements again, to make sure that the gaps are clean so that the grout (mostly asphalt mastic) can infiltrate deeply.

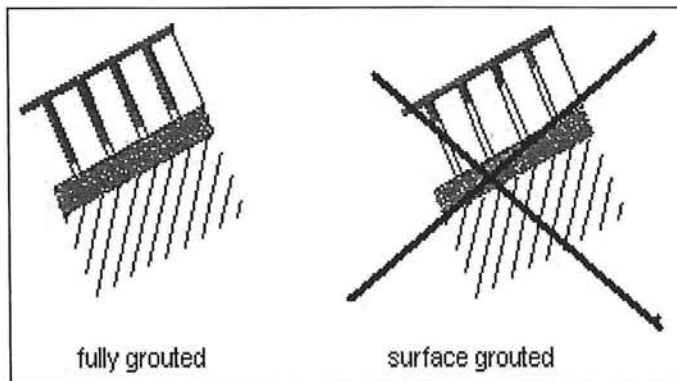

Two types of grouting

There are not yet design rules available.

4. A covering layer of rock

Is often applied in situations where the below part of the pitching is insufficient and the pitching above is ok. Then it is not necessary to demolish the whole pitching.

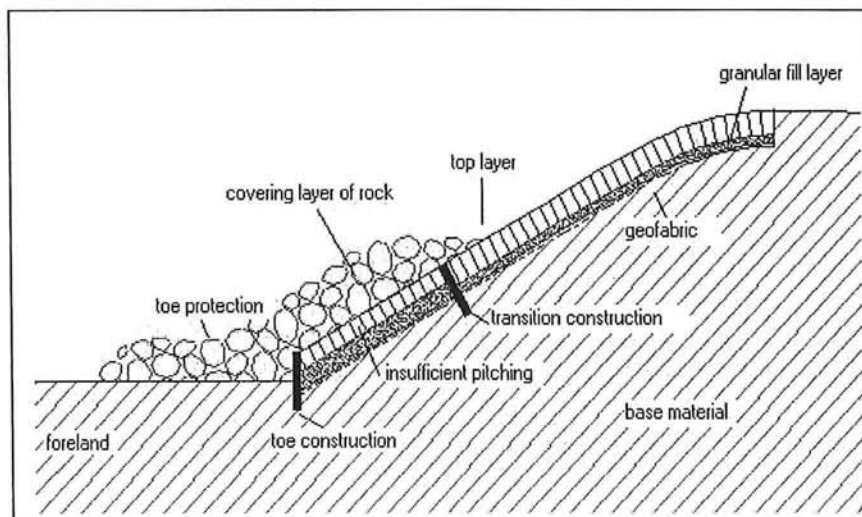

Covering an insufficient pitching with loose rock

Three variants are possible:

1. loose rock
2. pattern penetrated rock
3. fully penetrated rock

Design rules for a covering layer of loose rock, are derived from "Van der Meer's formula" but result in a heavier armour layer (comparing to the normal "Van der Meer's formula"), because the covering layer experiences an extra load from the water which runs down from the slope.

The design rules are not discussed in this lecture note (See [1]).

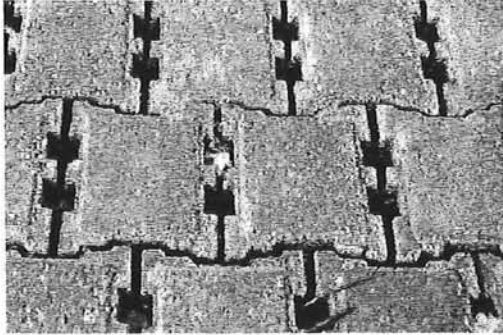

Block mattresses

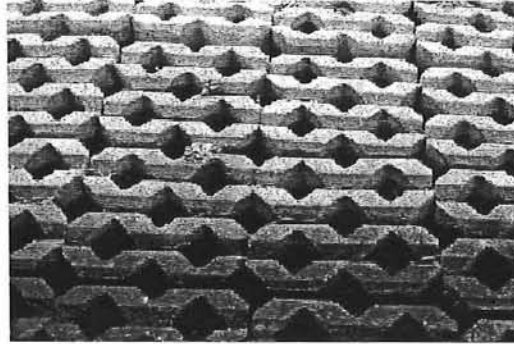

Open grass blocks

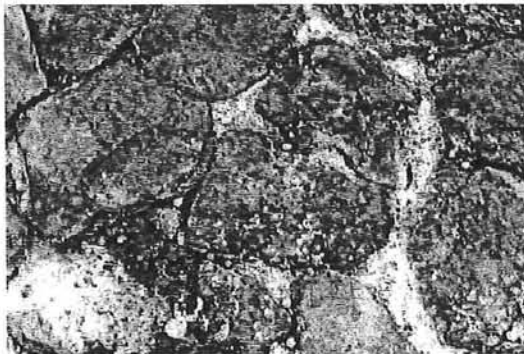

Grouted pitching



Covering layer of penetrated rock

2.5 Other construction parts

2.5.1 Toe protection

The toe protection sustains the toe construction and protects it against erosion.

Two variants:

1. loose rock or re-use of pitching elements if possible
2. pattern penetrated rock

2.5.2 Toe construction

The demands for the toe construction depend to a high degree on the situation and the pitching above. Toe constructions must be well founded, impenetrable for soil (and the granular (fill) layer) and should form a rather straight line.

- Row of stakes with board
- Sheet piling
- Prefab concrete constructions

2.5.3 Transition construction

Makes possible the transition between different types of pitchings, horizontally and vertically.

Aspects:

1. must be stable itself
2. pay extra attention to transport of material
3. must give a straight line if the pitching above is placed mechanically
4. has sometimes negative influences on the pitching below

2.5.4 Connecting constructions

Makes possible the connection between a pitching and other constructions (f.i. sheet pilings, concrete walls of buildings). Same aspects as transition constructions.

2.5.5. Berms

Are applied to reduce wave run-up. In many cases a maintenance road or bicycle paths are applied.

- Slope < 1:9
- $H_s < \text{width} < 2 H_s$
- Below design water level
- Water level combinations: $0.5 \leq d_b / H_s \leq 2.2$ (d_b = water depth above the berm)

Also dike crossings (road or path leading from the outer toe to the maintenance road on the berm or to the land side of the dike) with a certain width, should be considered as berms in the calculations.

3. Failure mechanisms

The main function of a stone pitching is: protecting the earth body of the dike against erosion.

Chances of exceeding per year of the normative storm, are given by law.

- Overload: when the loads (f.i. waves, currents and water levels) exceed a defined design value of the strength;
- Failure: when the pitching cannot fulfil the main function anymore. It occurs when the load exceeds the actual strength;
- Collapse: loss of coherence / large changes of geometry.

Primary failure mechanisms:

A stone pitching can fail due to three main mechanisms:

1. instability of the top layer: loss of stability of individual elements;
2. sliding of the revetment and/or under layers;
3. washing/transport of materials from the under layers

3.1 Instability of top layer

The rest-strength of the under layers (granular material and clay) is not taken into account. Especially in old existing dikes one can not be certain about the presence, quality and thickness of the clay layer. Therefore one assumes that failure of the top layer lead to failure of the dike; so the top layer must be calculated on the normative design level.

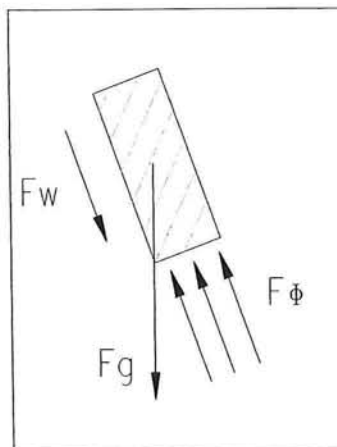

F_w = friction force
 F_g = gravity force
 F_ϕ = force as a result of the difference of pressure head

Forces on an individual element

Four types of loads can lead to failure of a pitching:

- Current
- Wave load at the moment of maximum wave withdrawal
- Wave load, wave impact
- Wave run-up

3.1.1 Current

Is important when the current velocity > 2 m/s or high turbulent.

Parameters	worse
Current velocity u	↑
Turbulence	↑
Weight of top layer ΔD	↓
Clamping between individual elements	↓

3.1.2 Wave load: maximum wave withdrawal

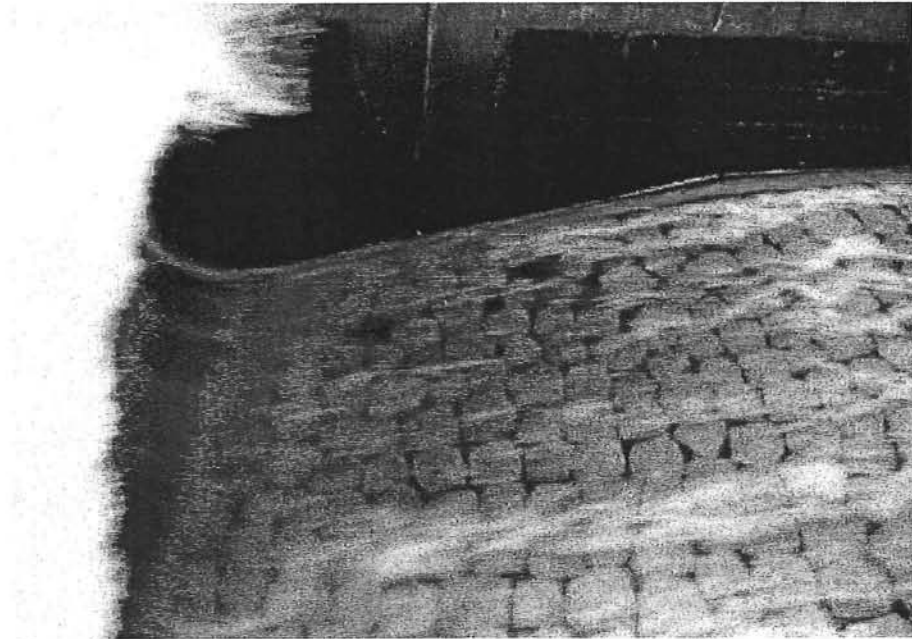

Start of damage on Basalton columns, at the moment of wave withdrawal

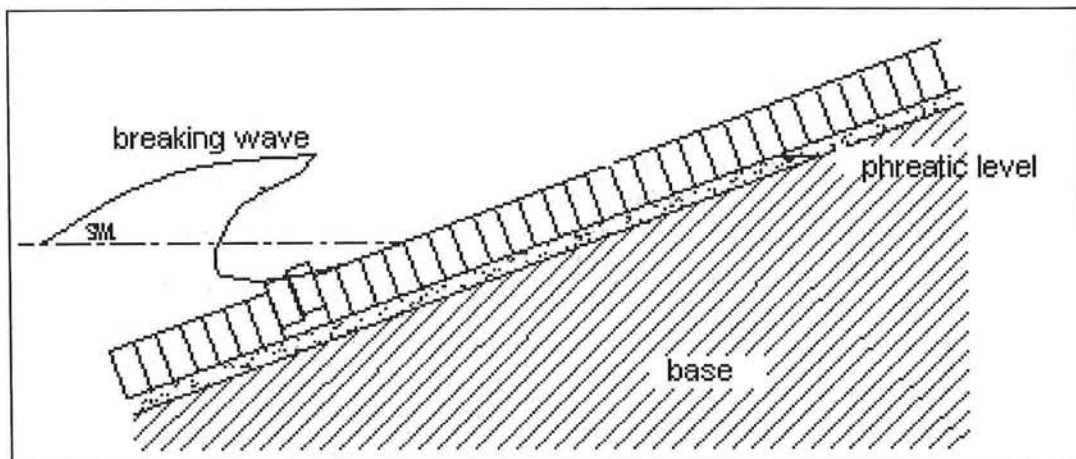

Instability of top layer: maximum wave withdrawal

Parameters	worse
Wave height H	↑
Wave period T	↑ with maximum
Permeability top layer k'	↓
Permeability granular under layer k	↑
Thickness granular under layer b	↑
Weight of top layer ΔD	↓
Clamping between individual elements	↓
Slope angle (cot)	↓

3.1.3 Wave load: wave impact

Occurs when the pitching exists of:

- A relative large permeable top layer (columns and concrete blocks on the side with distance keepers)
- A very thin granular under layer (< 5 cm)

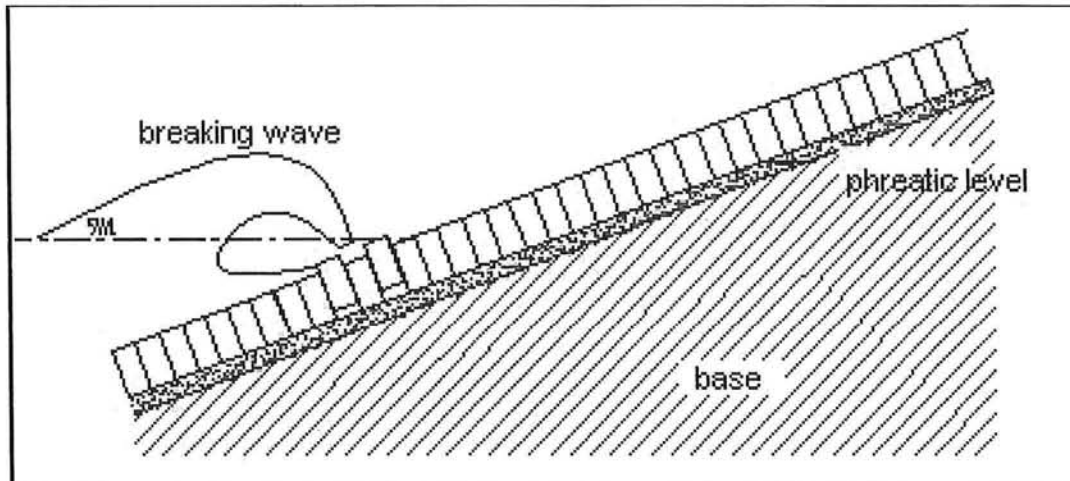

Instability of top layer: wave impact

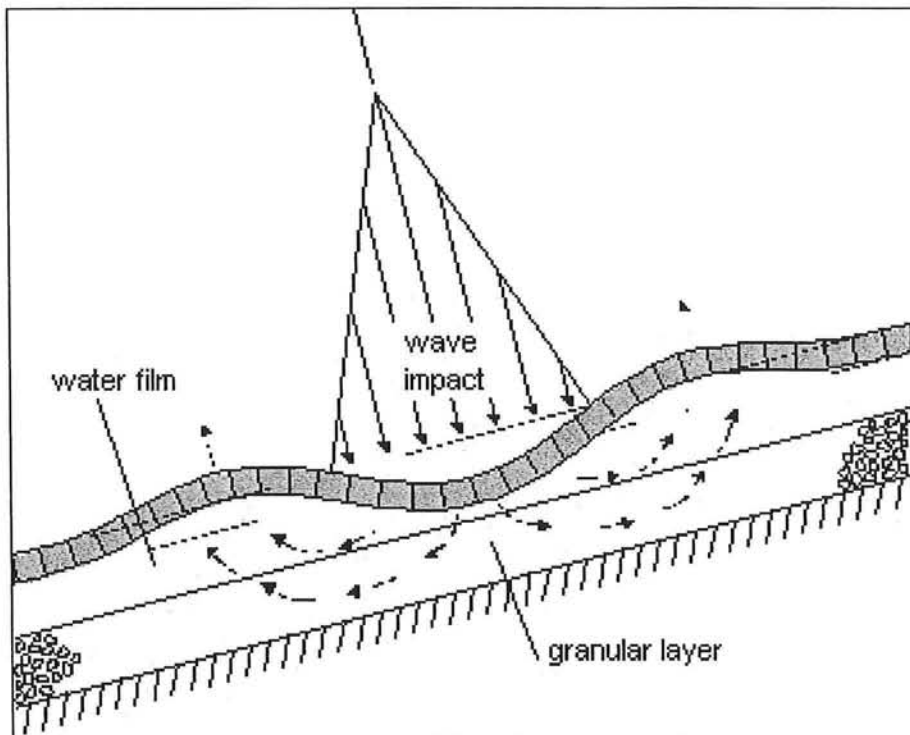

Deformation of the pitching due to wave impact

Same parameters as 'wave load at time of maximum wave withdrawal'.

3.1.4. Wave run-up

Only normative above design water level.
No design rules available yet.

3.2 Transport from materials from the under layers

3.2.1 Transport from the base to granular (fill) layer

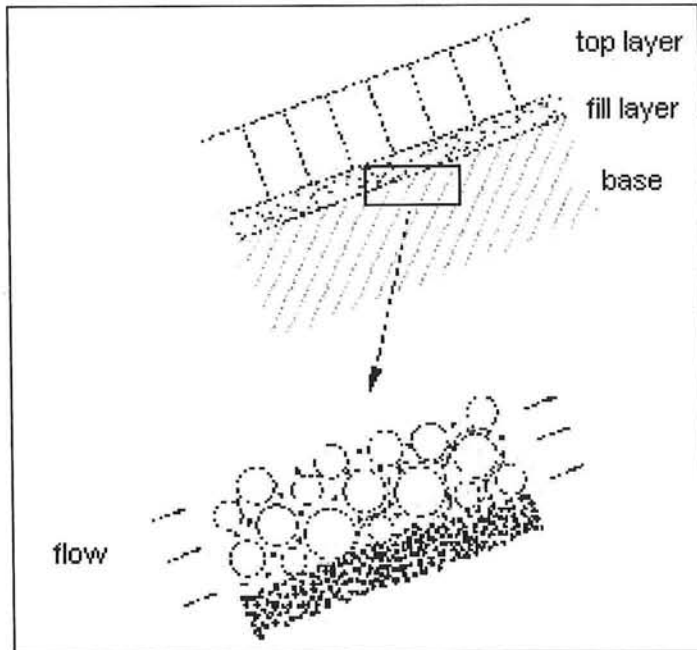

Wash of materials from base

Slow process: not leading directly to failure. Hollow spaces, loss of coherence, local settlements. Increasing upward pressure due to increasing permeability of under layers.

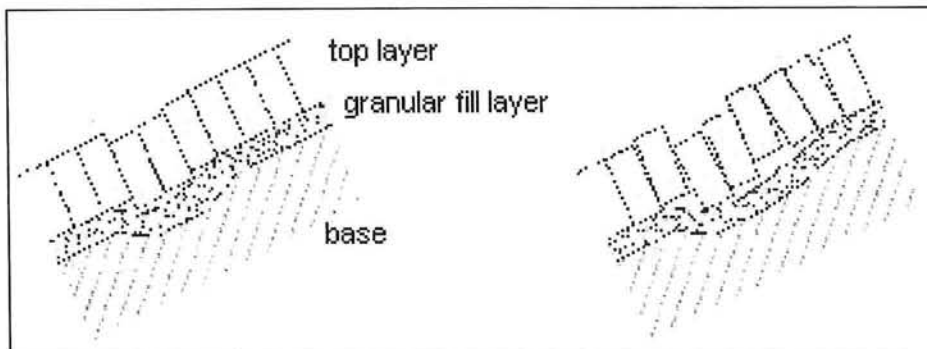

Damage development due to transport of base material

<i>Parameters</i>	<i>worse</i>
Openings in filter O_{90} or D_{15}	↑
Grain size of base material D_{50} or D_{90}	↓
Wave height H	↑
Permeability / thickness top layer k'/D	↓
Transmittivity (product of permeability and thickness granular layer) $k b$	↑
Slope angle (cot)	↓

3.2.2 Transport of material from fill layer through top layer

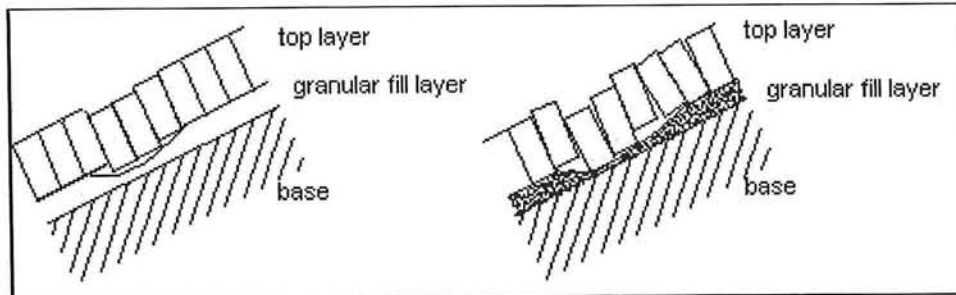

Development of damage by transport of material from the granular layer

<i>Parameters</i>	<i>worse</i>
Openings in top layer, gap diameter G	↑
Grain size of granular material D_{50} or D_{90}	↓
Wave height H	↑
Thickness of top layer	↓

3.3. Sliding

Induced by static water pressures at times of wave withdrawal or drop of the water level.

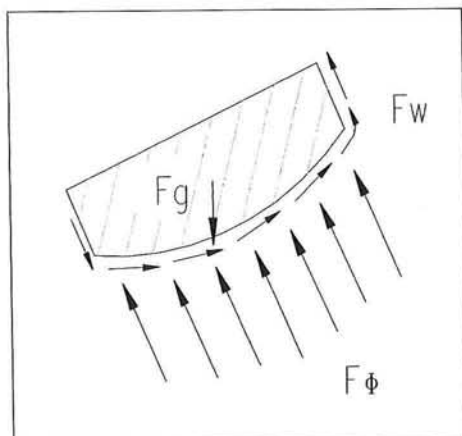

F_w = friction force
 F_g = gravity force
 F_ϕ = force as a result of the difference of pressure head

Equilibrium of forces (sliding)

Location of sliding plane:

- Just beneath top layer
- Deep in base material (sand)

Magnitude:

- Part of the cover layer kinks out
- Sliding of whole slope, collapsing of toe construction

Design rules are based on local sliding in the base material sand (worst case).

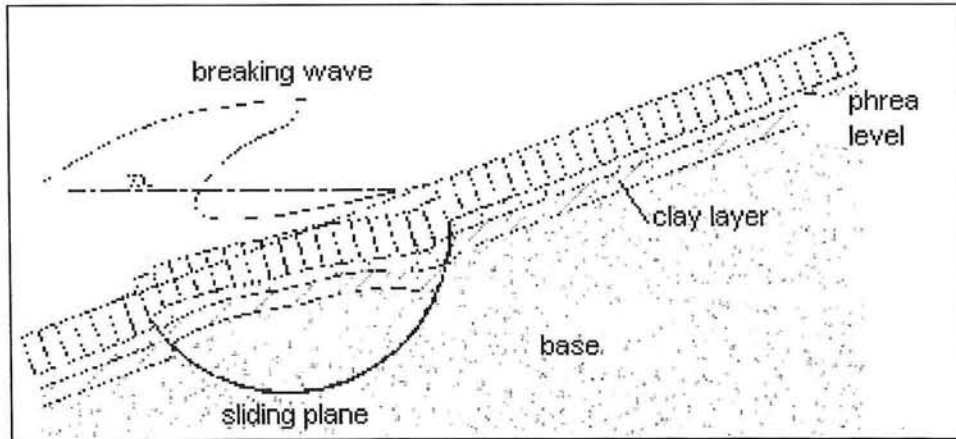

Deep local sliding

Parameters	worse
Wave height H	↑
Wave steepness H/L	↓
Thickness of top and under layers $D+b_{\text{filter}}+b_{\text{clay}}$	↓
Slope angle (cot)	↓
Granular size base material sand D_{15}	↓
Density of top layer ρ_{te}	↓

3.4 Failure of toe, transitions and connections

There are three ways in which the presence of a toe, transition or connecting construction can influence the stability of the pitching:

1. construction itself must be stable, because collapsing can lead to failure of the pitching as a whole;
2. a transition construction under design water level can influence the stability of the top layer in a negative way;
3. a discontinuity is often a weak point in a revetment: extra attention must be paid to design and execution. If not other failure mechanisms can be introduced.

See chapter 7.3 Transition constructions and connecting constructions.

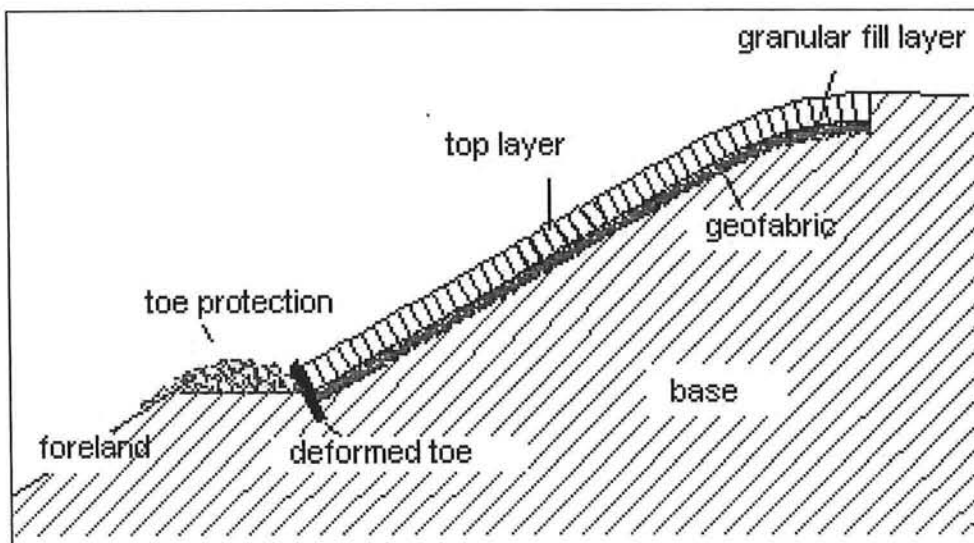

Failure of toe construction

4. Stability of individual elements

4.1 Current

A rough design rule for pitching elements under horizontal currents is:

$$\Delta D \geq 0,44 \cdot \frac{u^2}{g}$$

In which:

Δ	= relative density of the elements	[-]
D	= thickness of top layer = height of the elements	[m]
u	= mean current velocity over the water depth at the toe	[m/s]
g	= acceleration of gravity	[m/s ²]

In many situations the flow pattern is very complex. Than further investigation f.i. scale modeling is necessary. This is also the case for combinations of current and waves.

4.1 Wave load: simplistic empirical method

The simplistic method is often used for tests and rough checks.

For elements on a granular layer, use of this method will not lead to the most optimum design; for elements directly on clay (or comparable material) it is the only available method.

Construction types:

1. pitching on geofabric on sand or clay
2. pitching on proper erosion resistant clay
- 3a. positive construction: relatively open top layer combined with relatively thin granular layer with relatively fine grains
 - percentage open top layer: $\Omega > 3\%$, **and**
 - relatively thin granular layer: $b_g < 0.5 \times D$, **and**
 - relatively fine granular material: $D_{15} < 10$ mm.
- 3b. normal construction
 - thin granular (fill) layer: $b_g < 0.5 \times D$, **or**
 - rather thick granular layer consisting of fine grains: $b_g \geq 0.5 \times D$ and $D_{15} < 5$ mm, **or**
 - rather thick granular layer but relatively open top layer: $b_g \geq 0.5 \times D$ and $\Omega > 2\%$, **or**
 - thick granular layer, but very fine material: $b_g \geq 0.7 \times D$ **and** $D_{15} < 3$ mm.
- 3c. rather bad construction: other conditions than types 3a en 3b.

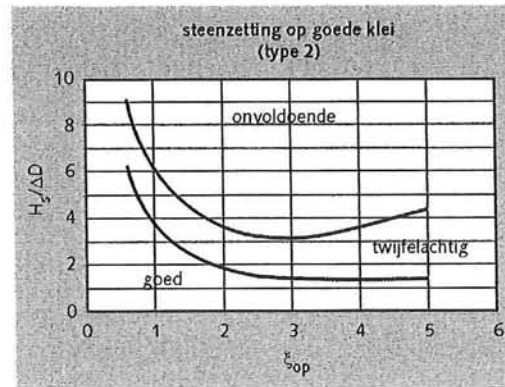
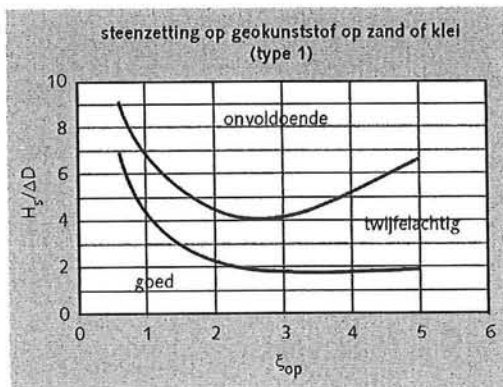

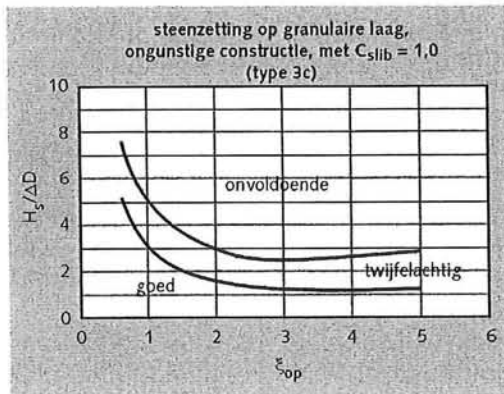
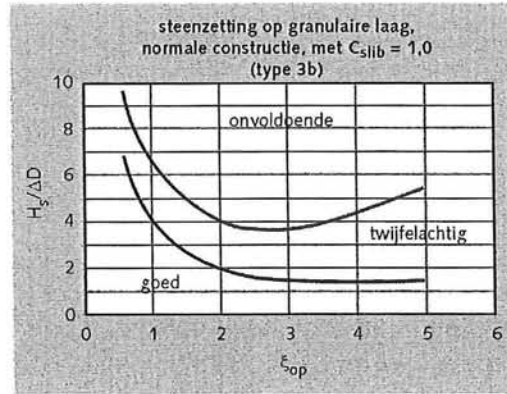
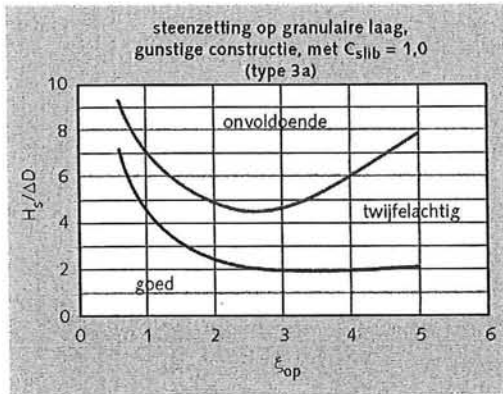

4.2 Wave load: detailed, analytical method

4.2.1 Leakage length

The stability of the top layer increases, if the water is hardly able to flow through the granular layer, but can easily flow through the top layer. Important parameters are:

- Transmittivity: kb : the ease for water to flow parallel on the slope through the granular layer;
- D/k' : the ease for water to flow perpendicular on the slope through the top layer

The leakage length combines the transmittivity and D/k' :

$$\Lambda = \sqrt{\frac{D}{k'} kb}$$

In which:

Λ	=	Leakage length	[m]
D	=	Thickness of top layer	[m]
k'	=	Permeability of top layer	[m/s]
k	=	Permeability of granular layer	[m/s]
b	=	Thickness of granular layer	[m]

4.2.2 Permeability of granular layer

The permeability of the granular layer mainly depends on the porosity n and on the presence or absence of small particles in the granular layer. According to Forchheimer the relationship between the (energy) gradient i and the specific discharge q (filter velocity) is characterized by a linear component and a quadratic turbulent component:

$$i = a_f q + b_f q^2$$

in which:

i	= (energy) gradient	[-]
q	= Filter velocity or specific discharge = discharge per m^2 (incl. the grains)	[m/s]
a_f	= Linear resistance coefficient of the granular layer	[-]
b_f	= Turbulent resistance coefficient of the granular layer	[-]

According to Darcy ($q = k i$) the permeability k can be written (in linearized form) as a function of the gradient i :

$$k = \frac{-a_f + \sqrt{a_f^2 + 4b_f i}}{2b_f i}$$

Measures gave for the coefficients a_f and b_f the following values:

$$a_f = 160 \frac{\nu (1-n)^2}{g n^3 D_{15}^2}$$

$$b_f = \frac{2,2}{g n^2 D_{15}}$$

in which:

ν	= cinematic viscosity = 1.2×10^{-6}	[m ² /s]
n	= porosity of the granular layer	[-]

The relationship between k , n and the fine particles of the material is given in the next figure with $i = 0.3$. The left part of the figure ($D_{15} < 10$ mm) concerns laminar flow, the right part the turbulent flow.

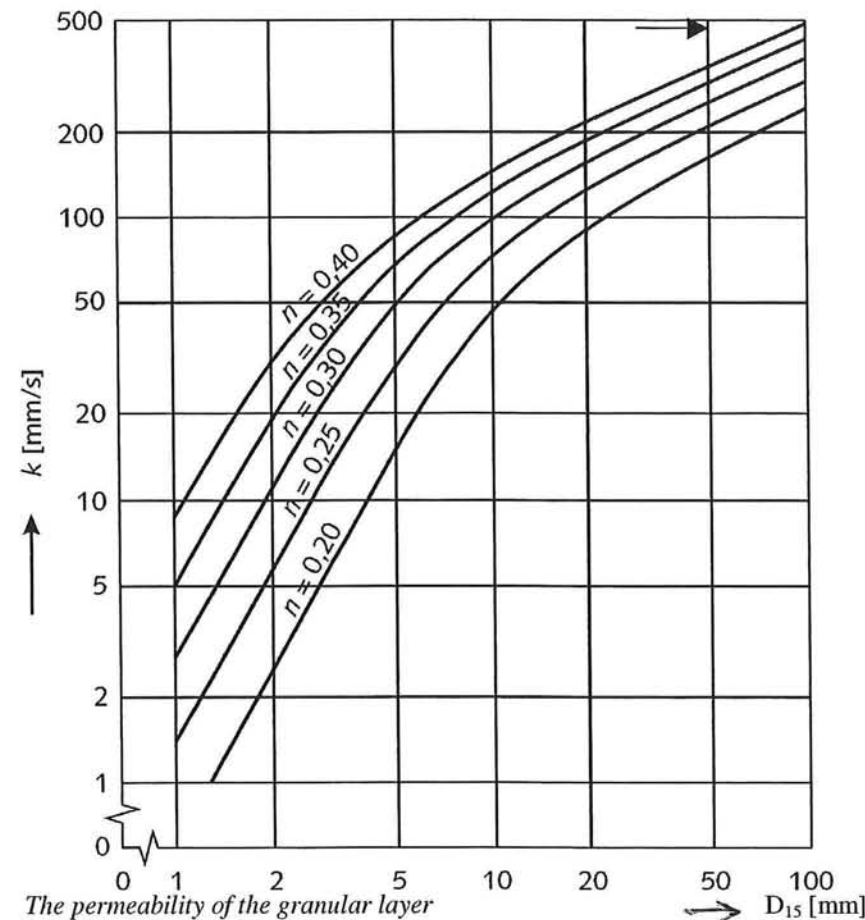

4.2.3 Permeability of the top layer

The relative open surface Ω , can be determined for rectangular blocks with:

$$\Omega = \frac{s(B+L)}{BL}$$

in which:

B	=	Width of the block	[m]
L	=	Length of the block	[m]
Ω	=	Relative open surface or open space percentage of the top layer	[-]
s	=	Joint width in the top layer	[m]

In case of columns one should determine the equivalent widths and lengths of the elements:

$$B = L = \sqrt{A}$$

in which:

B	=	Equivalent width of the block	[m]
L	=	Equivalent length of the block	[m]
A	=	Mean surface of column	[-]

The joint width s for columns is given by:

$$s = \frac{\Omega\sqrt{A}}{2}$$

A [m ²]	BxL [m ²]	Joint width s [mm]		
		$\Omega = 0.05$	$\Omega = 0.10$	$\Omega = 0.15$
0.040	0.20 x 0.20	5.0	10.0	15.0
0.063	0.25 x 0.25	6.3	12.5	18.8
0.090	0.30 x 0.30	7.5	15.0	22.5
0.123	0.35 x 0.35	8.8	17.5	26.3
0.160	0.40 x 0.40	10.0	20.0	30.0
0.250	0.50 x 0.50	12.5	25.0	37.5

Equivalent joint width s for columns

The permeability of the top layer is furthermore determined by four flow resistances, causing reduction of influence of the pressure head differences:

1. $\Delta\phi_r$: the flow through the granular layer is assumed to be parallel on the slope but near the openings in the top layer contraction takes place.
2. $\Delta\phi_g$: takes place when the water must flow out of the granular layer through a geofabric (block mattresses f.i.).
3. $\Delta\phi_a$: loss due to changes in the wet cross section at the in- and out flow side of the top layer (entrance and exit losses).
4. $\Delta\phi_w$: wall friction along the elements of the top layer.

The total resistance is given by the sum of the four contributions. One found, with the Forchheimer and Darcy relations, the following formula:

$$k' = \frac{-a' + \sqrt{(a')^2 + 4b'i}}{2b'i}$$

in which:

a'	=	linear resistance coefficient of the top layer	[-]
b'	=	turbulent resistance coefficient of the top layer	[-]

And:

$$a' = \frac{12v}{gs^2\Omega} + \frac{sa_f}{\Omega\pi D} \ln\left(\frac{s}{\Omega r_{\min} e}\right) + \frac{a_g T_g}{\Omega D}$$

$$b' = \frac{1}{2g\Omega^2} \left[\left(\frac{1}{n} - 1\right)^2 + 1 \right] + \frac{sb_f}{\Omega\pi D} \left(\frac{s}{\Omega r_{\min}}\right) + \frac{b_g T_g}{\Omega^2 D}$$

in which:

a_f	=	Linear resistance coefficient of the granular layer	[-]
D	=	Thickness of the top layer	[m]
r_{\min}	=	The maximum of $\frac{1}{2} D_{f15}$ and 0.4 s	[m]
a_g	=	Linear resistance coefficient of the geofabric	[-]
T_g	=	Thickness of the geofabric	[m]
n	=	Porosity of the granular layer	[-]
b_f	=	Turbulent resistance coefficient of the granular layer	[-]
b_g	=	Turbulent resistance coefficient of the geofabric	[-]

	k' [mm/s]	top layer type
Very large k'	60 – 100	Blocks with many gaps / holes
Large k'	5 – 20	Columns with filled gaps (with gravel/grit)
Small k'	3 – 10	Large blocks, no holes
Very small k'	≤ 1	Blocks or columns with clogged joints and gaps

Indication for the permeability k' of the top layer on a granular layer

See also next figure for $i = 1.0$.

no joint filling with joint filling

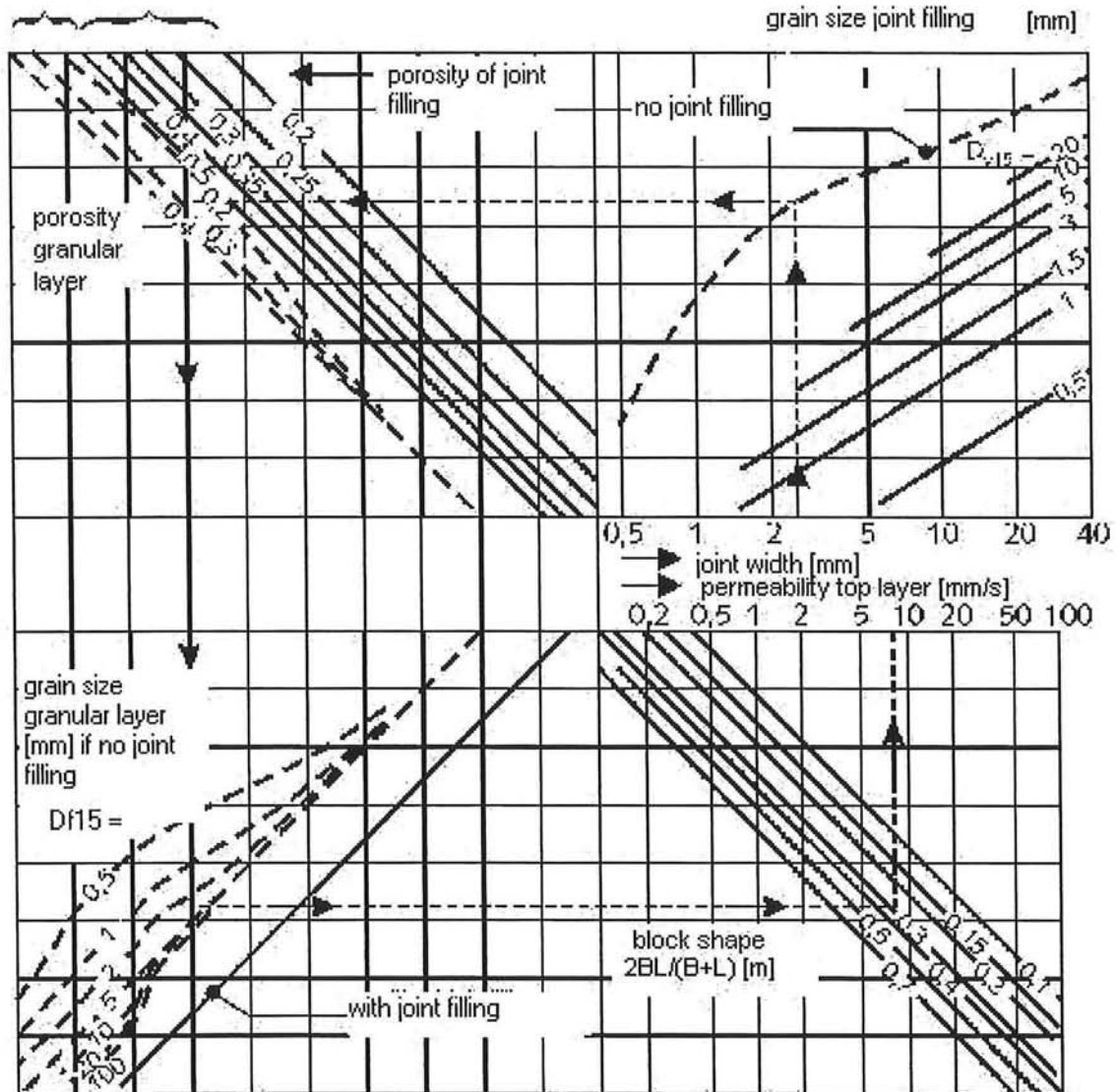

Permeability k' of the top layer having only joints

In case there are more granular layers, the leakage length is given by:

$$\Lambda = \sqrt{\frac{D}{k'}(k_1 b_1 + k_2 b_2 + \dots)}$$

The graph below shows for which value for H_s movement of individual elements occurs. Comparing the simplistic method, the design line now depends on the parameter $\Gamma^{1.25} \sqrt{(\Delta D / \Lambda)}$.

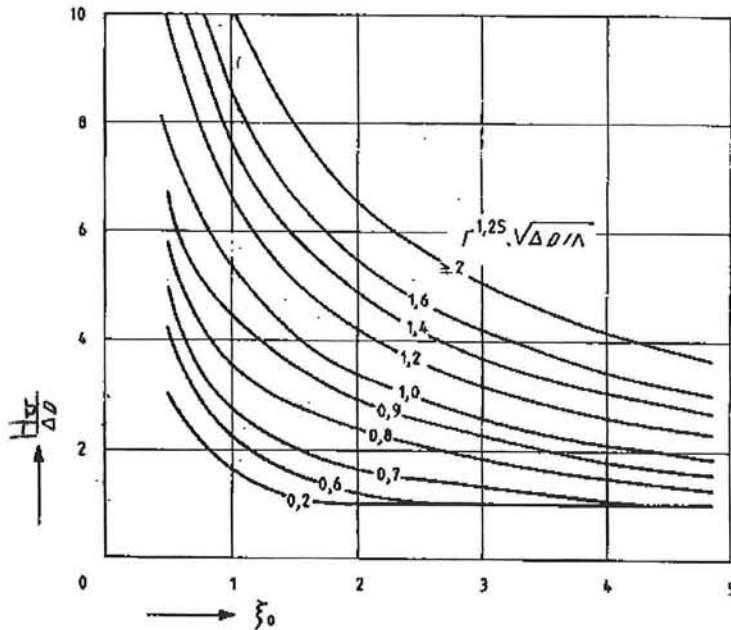

Critical wave height with respect to the uplifting of an individual element (H_{cr})

4.2.4 Schematization of the pressure head front

Physical processes used in the analytical approach are normative for pitchings with relative high leakage lengths (top layer has relative small gaps f.i. concrete blocks). Model experiments showed that this theory also can be used for other pitchings (with relative small leakage lengths f.i. columns).

The normative pressure head on the slope can be calculated with two different approaches:

1. straight front. Based on model experiments with regular waves. Using the principle that every individual wave gives a load which hardly depends on the preceding wave, one showed that this approach also can be used for irregular waves.
2. Round shaped front. Based on model experiments with irregular waves.

The first method is subsumed in the computer program ANAMOS and is used most cases. The second approach is not yet fully developed for application.

The straight pressure head front is schematized with slope θ and height ϕ_b . The base of the front lies on a depth d_s under the still water level.

$$\frac{\phi_b}{H} = \min \left\{ 0,36 \frac{\xi_0}{\sqrt{\tan \alpha}} ; 2,2 \right\}$$

$$\tan \theta = 5,88 \sqrt{H / L_0}$$

$$\frac{d_s}{H} = \max \left\{ -0,11 \left(\frac{\tan \alpha}{H / L_0} \right)^{0,8} ; -1,5 \right\}$$

in which:

ϕ_b	=	Height of the pressure head front	[m]
H	=	Wave height (H = H _s for significant load; H = 1,4·H _s for the 2%-load)	[m]
ξ_0	=	Breaker parameter for deep water (= tan α /√(H/L ₀))	[-]
α	=	Slope angle	[°]
θ	=	Front angle	[°]
L ₀	=	Wave length on deep water (= gT ² /(2π) ≈ 1,56T ²)	[m]
T	=	Wave period (often T _p is used)	[s]
d _s	=	Depth of the base with respect to the still water level	[m]

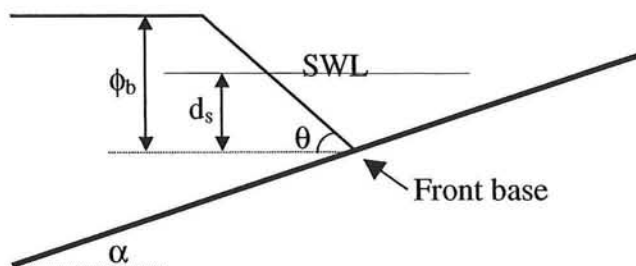

Schematization of the straight front

Het maximale stijghoogteverschil wordt met de volgende formule berekend:

$$\frac{\phi_w}{\Lambda} = \left(\frac{\cos \alpha \tan \theta}{2} \left[1 - \exp\left(\frac{-\phi_b}{\Lambda \cos \alpha \tan \theta}\right) \right] + \frac{\sin \alpha}{2} \right) \left(1 - \exp\left(\frac{-2z_f}{\Lambda \sin \alpha}\right) \right)$$

in which:

ϕ_w	=	Maximum pressure head difference over the top layer	[m]
Λ	=	Leakage length = √(kbD/k')	[m]
k	=	Permeability of the granular under layer	[m/s]
k'	=	Permeability of top layer	[m/s]
D	=	Thickness of top layer	[m]
b	=	Thickness of granular under layer	[m]
z _f	=	Level of the phreatic line compared to the front base (≈φ _b)	[m]

4.2.5 The influence factor Γ

In the analytical approach three stability criteria are used:

1. No movement of individual elements allowed due to H_s in the design circumstance;
2. Maximum displacement of 10 % of the thickness of an individual element due to individual waves H_{2%} (= 1,4 H_s) in design circumstance;
3. Stability limit: H_s/(ΔD) ≤ 6ξ^{-2/3}.

Criterion 1: no movement for H = H_s

For the first criterion the factor of influence Γ is determined completely by the friction between individual elements Γ_1 . So: $\Gamma = \Gamma_1$.

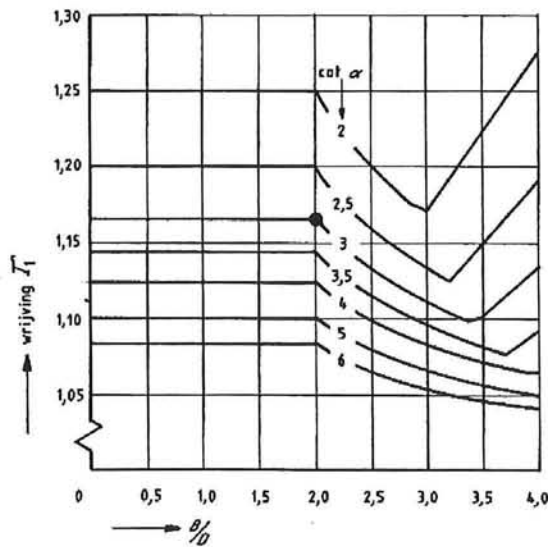

Influence factor Γ_1 for the friction of an individual element

Criterion 2: Maximum displacement of 0.1 D for $H = H_{2\%}$

The factor of influence Γ is not only determined by friction (Γ_1) but also by mass inertia (Γ_2) and hindered flow towards the space under the lifted element (Γ_3): $\Gamma = \Gamma_1 + \Gamma_2 + \Gamma_3$. Determining Γ en ξ_{op} one should use $H_{2\%} = 1,4 \times H_s$.

For Γ_1 see criterion 1.

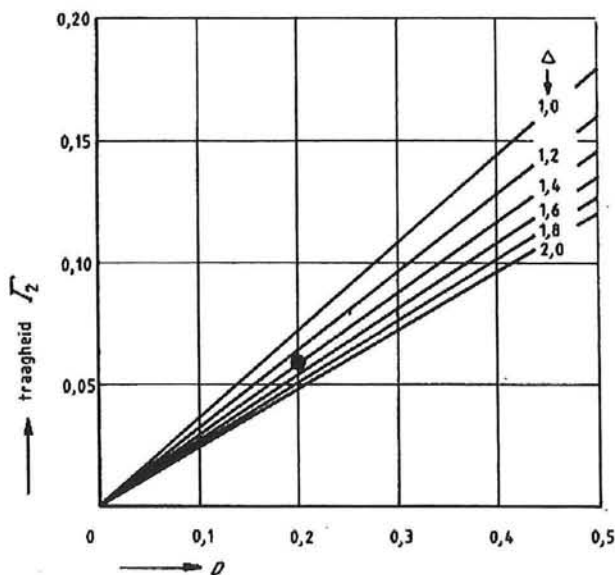

Influence factor for the inertia of mass Γ_2 , if the stone movement is permissible

When an individual element lifts up, the space under the element must be filled by water. If this flow is hindered and the water cannot flow fast enough to this location, the pressure under the element decreases; the element is suck tight.

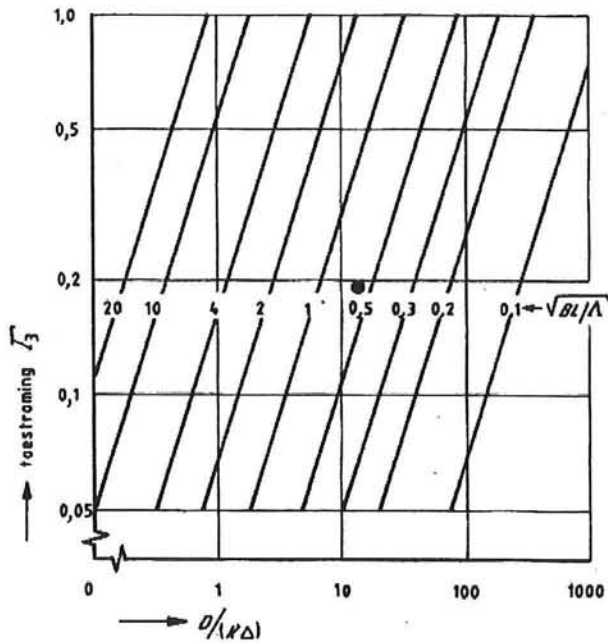

Influence factor for the flow Γ_3 , if the stone movement is permissible

Criterion 3: The "6 ξ rule"

For certain combinations of parameters (f.i. very thin granular under layer consisting of fine material in combination with very open top layer) a very high stability is calculated, but unrealistic comparing the results from model tests. The reason for this is the fact that the failure mechanism instability of top layer induced by wave loads at the time of maximum wave withdrawn, is not valid anymore.

The upper stability limit:

$$\frac{H_s}{\Delta D} \leq 6\xi^{-2/3}$$

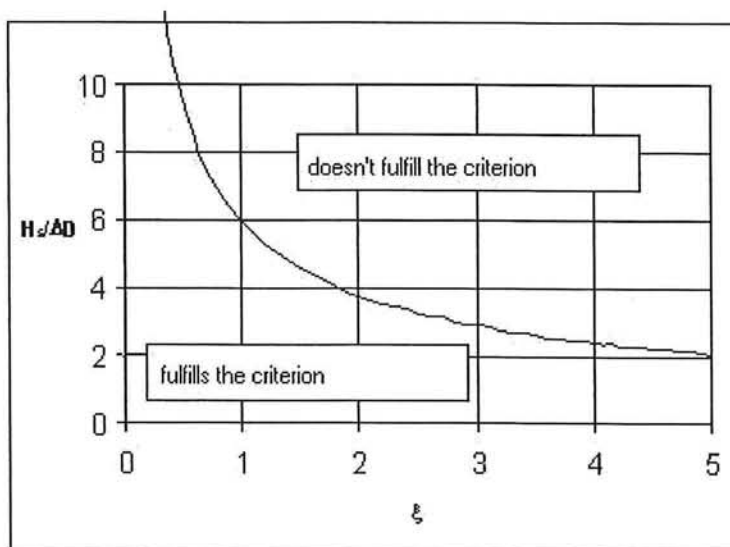

The upper stability limit

5. Transport of material

5.1 Some principles of filter design

Filters should be soil tight and permeable for water.

Geofabrics must have certain strength (for execution) and lifespan (50 years?)

One distinguishes:

- Geometrical sand tight: grains of under layer are physically larger than the layer above. Independent of the hydraulic loads, transport is not possible. (Always hydraulical sand tight);
- Geometrical sand open: grains of upper layer are so much bigger than the smaller grains of the under layer, that transport is possible;
- Hydraulical sand tight: during the design load no transport takes place. (can be geometric open);
- Hydraulical sand open: the loads can cause transport.

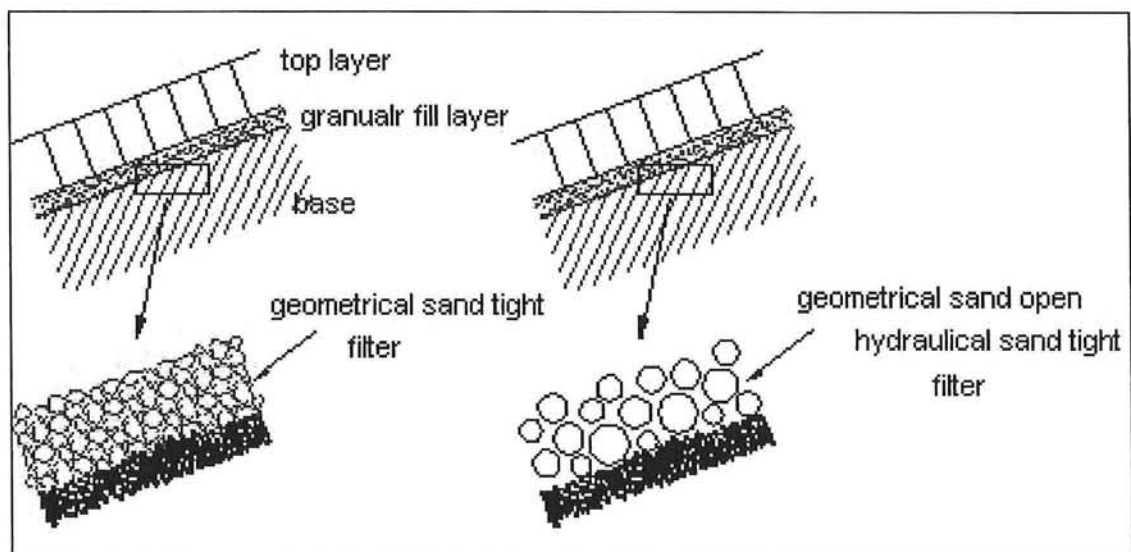

Geometrical and hydraulical sand tight granular filters

Granular filters also should be internal stable.

In many cases more layers with different sized granular material are needed.

5.2 Necessity of filters and choice between granular filter or geofabric

Pitchings without filters are only possible occasionally: very small loads (waves < 0.5 m) and a subsoil which gives resistance against erosion (f.i. clay) and very small openings in the top layer and the revetment doesn't play a very important role in the safety against inundation.

Aspects which influence the choice between granular filters or geofabrics:

Aspect	Granular filter		Geofabric	
		disadvantage		disadvantage
Thickness	large	<ul style="list-style-type: none"> • Difficult to fit in in an existing construction • More expensive • Has negative influence on the stability of top layer 	small	<ul style="list-style-type: none"> • Doesn't contribute to stability against sliding
Execution		<ul style="list-style-type: none"> • Difficult to construct thin layers under water 		
Durability	large		smaller	<ul style="list-style-type: none"> • Uncertain (50 years ?)
Costs	high		low	
Application	only on sand		On sand and clay	

Geofabrics:

- Non-woven. Less permeable for soil, less strong and more elastic than wovens.
- Woven
- Foils. Are impermeable for water (only applicable above water level) and are very slippery (possible inducing sliding for slopes steeper than 1:4).

5.3 Design rules

The design method for filters is extensively described in [8].

5.3.1 Geofabrics

Geometrical sand tight:

Geofabric on clay:

$$O_{90} < 10 \times D_{50} \text{ and } O_{90} < D_{90} \text{ and } O_{90} < 0.1 \text{ mm}$$

Geofabric on sand:

$$O_{90} < D_{50}$$

With a granular filter on the geofabric: $O_{90} < D_{90}$

Hydraulic sand tight: not described in this lecture note.

5.3.2 Granular filters

Geometrical sand tight: $D_{f15} \leq 5 \times D_{b50}$ (f = filter, b = base material)

Hydraulic sand tight: not discussed in this lecture note.

5.3.3 Transport of material from the granular layer

Geometrical sand tight: $D_{15} < \text{width of joints or diameter of gaps top layer.}$

Hydraulic sand tight: $Y < 0.5 D$

$$\text{for } G \geq 0.1 \text{ m: } Y > 0,23G \cdot (H_s / D_{50})^{0,33}$$

$$\text{for } G < 0.1 \text{ m: } Y > 0,04G \cdot \sqrt{H_s / D_{50}} \cdot \Omega^{-0,75}$$

in which:

G	=	Diameter of gap	[m]
D	=	Thickness of top layer	[m]
H _s	=	Significant wave height	[m]
D ₅₀	=	Mean grain size of granular material	[m]
Ω	=	Percentage open space of top layer	[-]

5.3.4 Internal stability granular material

For every grain size between D_{fx} between D_{f0} and D_{f20} one should determine the grain size D_{fy} which is 4xD_{fx}. Percentages of underspend can be found: 0 ≤ x ≤ 20 and 0 ≤ y ≤ 80.

Granular material is internal stable if: $(y/x)_{\min} > 2,3$ met $x \leq 20$ %

In which:

D _{fx}	=	Grain size with percentage of underspend ≤ 20 %	[m]
D _{fy}	=	4 D _{fx}	[m]
x	=	Percentage of underspend of D _{fx} (x ≤ 20 %)	[%]
y	=	Percentage of underspend of D _{fy}	[%]

6. Sliding

Sliding does not occur if the pitching (including the granular fill layer and/or filter layer) is directly placed on the clay core of the dike; a sand layer is absent.

To prevent high static water pressures an eventual sand inclusion should be removed.

First check: if the thick ness of the clay layer $> H_s$, than sliding does not occur.

The resistance against sliding is good enough if: (not valid for slopes steeper than 1:2.7)

$$\Delta D + b_f + b_k > \min \left\{ 0.16 H_s^{0.2} T_p^{1.6} (\tan \alpha)^{0.8}; 1.5 H_s \right\} - 1334 \cdot (1 - 1.19 \cdot \tan \alpha) D_{15} \sqrt{T_p}$$

in which:

Δ	=	Relative density of top layer	[-]
D	=	Thickness of top layer	[m]
b_f	=	Thickness of granular layer	[m]
b_k	=	Thickness of clay layer	[m]
α	=	Local slope angle	[°]
D_{15}	=	Representative grain size of sand	[m]

In graphs:

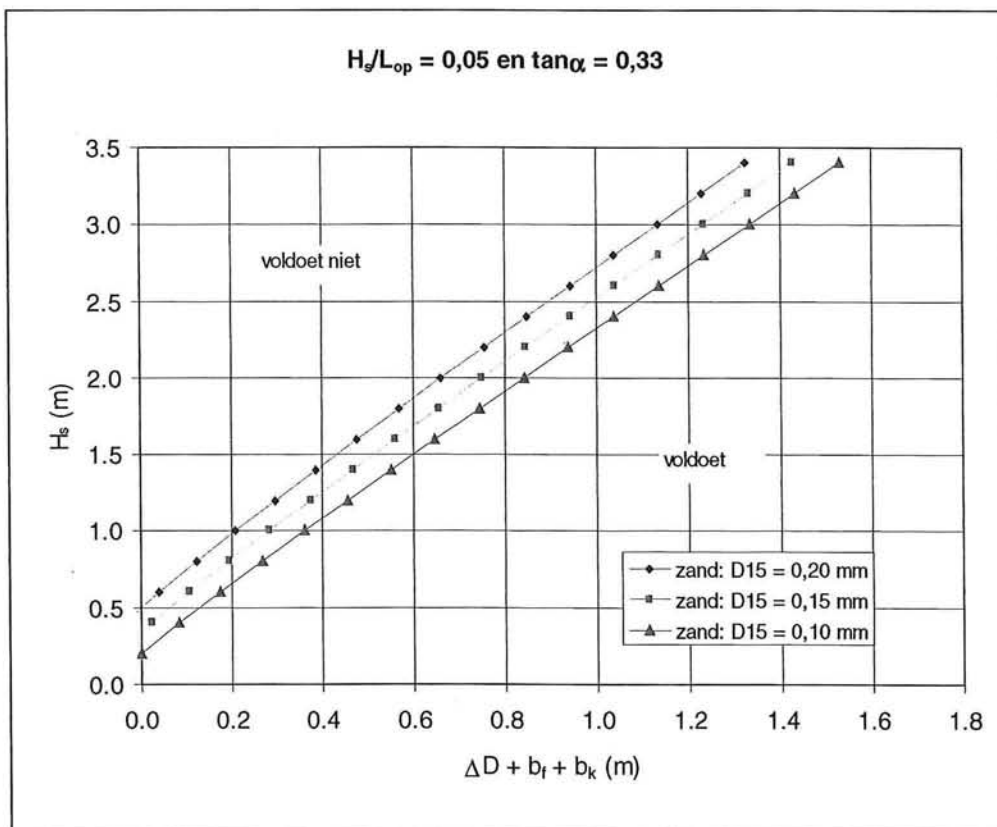

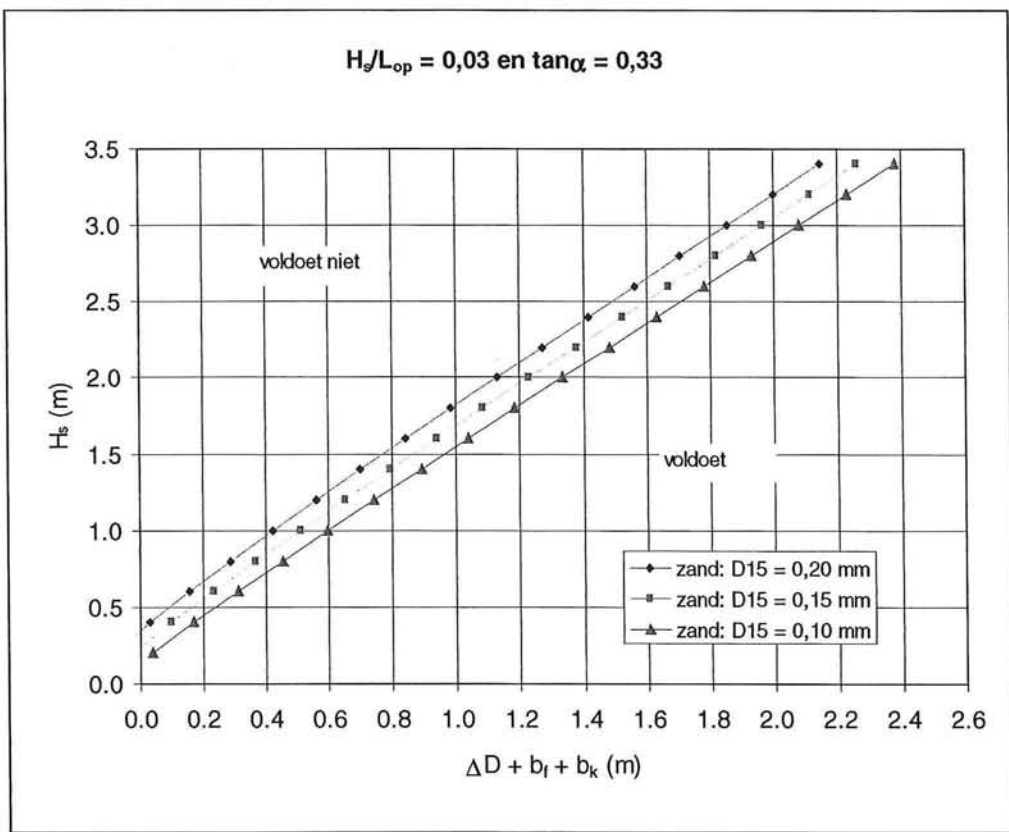
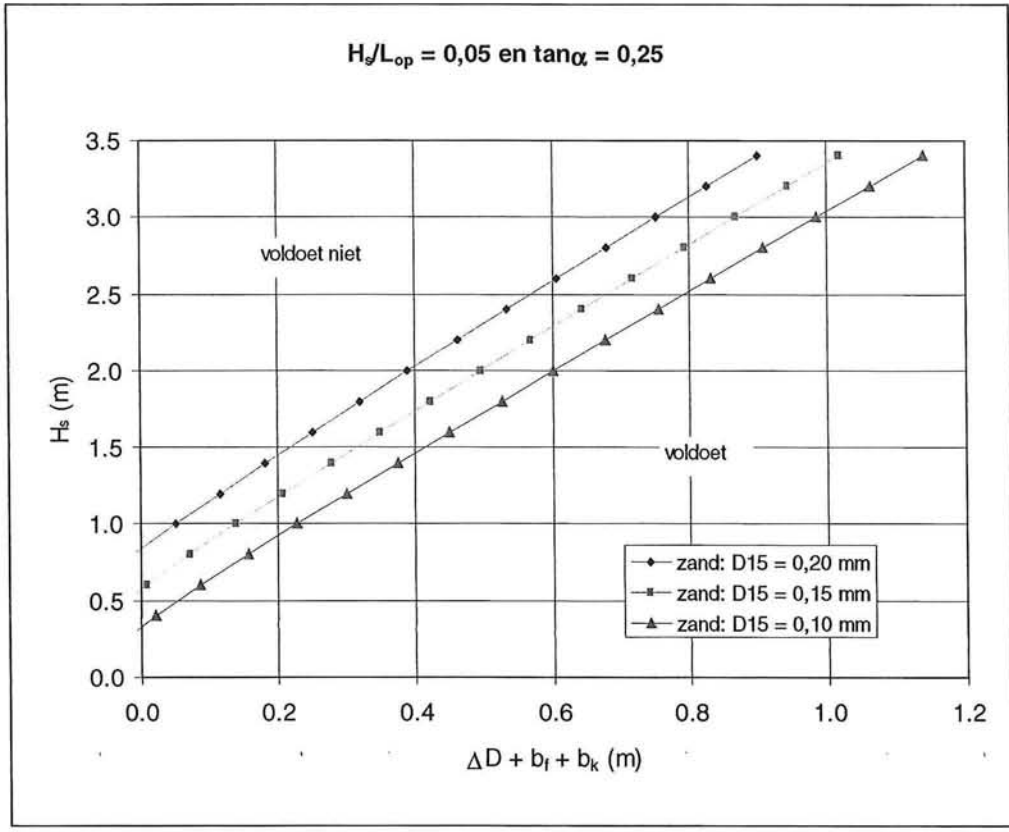

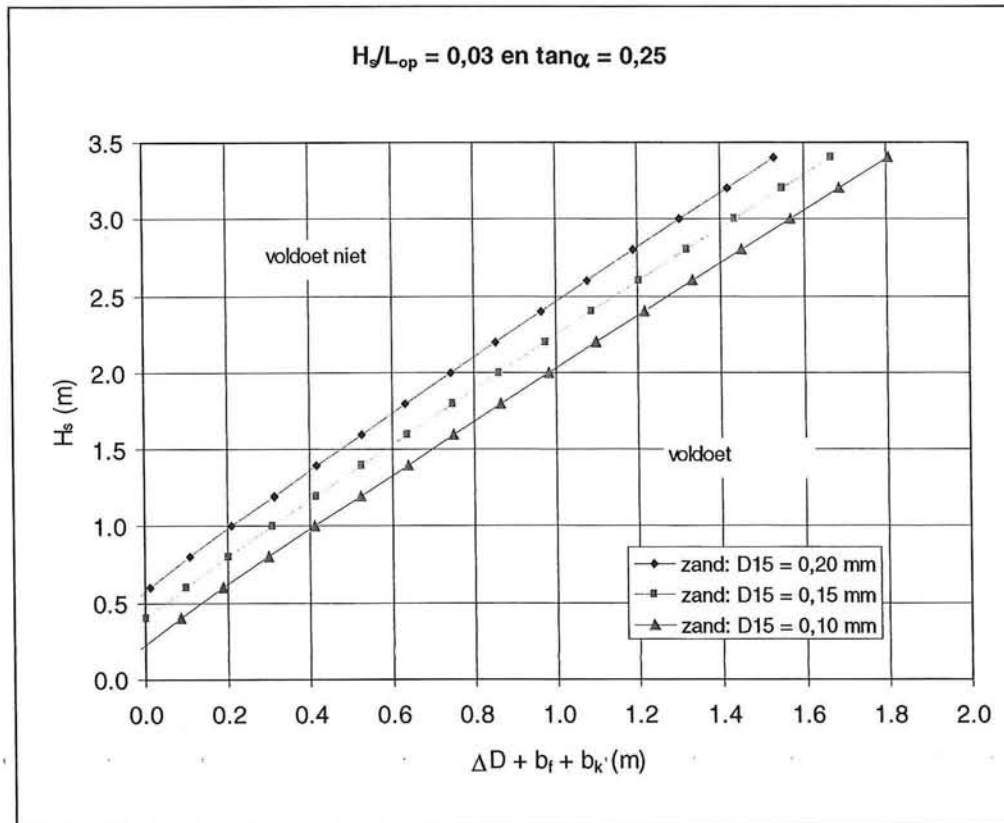

Resistance against sliding

The thickness of the clay layer is also important for the micro stability of the dike, influencing the phreatic level in the dike. In many cases one demands $b_k > 0.8$ m. The resistance against sliding can be improved by enlarging the thickness of the top layer, granular layer, granular supplements and clay layer.

7. Design of other construction parts

7.1 Toe protection

Compared to f.i. block mattresses, which are fixed on the dike slope at the top side, pitchings need to be shored at the bottom by a toe construction. Large deformations of this construction is very unwanted because it will lead to severe damage of the pitching. To prevent this kind of deformation, the toe constructions often are protected by a toe protection of rock. The toe protection holds erosion on a certain distance from the toe and gives the toe construction extra strength.

Toe protection always are applied in case the toe construction is located within the tidal range (seadikes) or close to the (mean) water level (lake dikes).

In most cases loose rock can be applied but sometimes in case of heavy loads a penetration of the rock (f.i. with asphalt) is necessary. In case of relative small loads sometimes also re-use of old pitching elements is possible.

Design method

For penetrated rock, see [6].

For loose rock, one should distinguish two situations:

1. presence of a long and shallow foreland on which the incoming waves break
2. deep water just before the dike

The first situation is not discussed in this lecture note; in most cases rock 10-60 kg will be sufficient.

In the second situations it is presumed that the toe protection is directly attacked by incoming waves. The required rock size can be calculated by Van der Meer's formula which is programmed in BREAKWAT or CRESS, using slope 1:5 and damage parameter $S=3$. The minimum rock grading is 10-60 kg. Re-use is possible if the required weight according to Van der Meer (M_{50}) is sufficient.

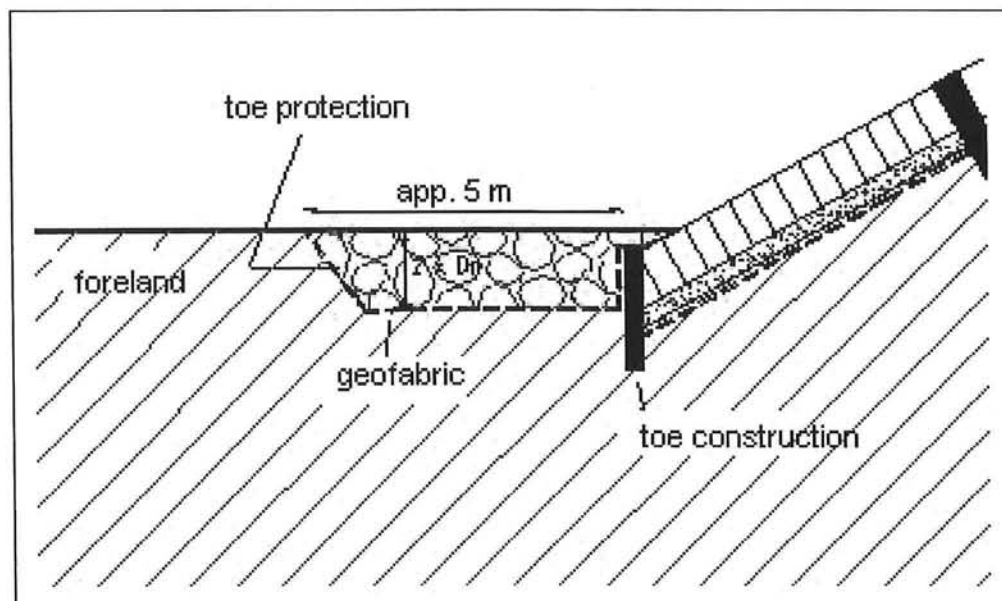

Example of toe protection of rock 10-60 kg

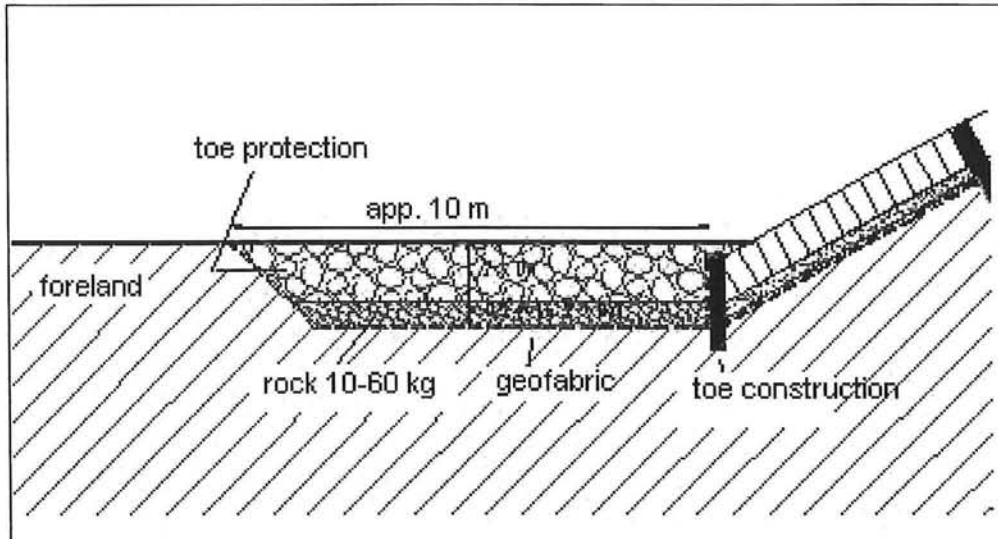

Example of toe protection of rock from 60-300 kg

7.2 Toe construction

The most common kinds of toe constructions are:

- Row of stakes with boards
- Sheet pilings
- Prefab concrete constructions

The choice is mainly based on experience and costs. Also the design is mainly based on experience.

Examples:

- Wooden stakes with a length of 1.8 m, 3-5 stakes per m¹ and boards against it; usable in sandy material and clay.
- Concrete sheet pilings with a length of 1.5 m; it can be hard to apply in sand.

One should pay extra attention to prevent washing out and transport of material.

7.3 Transition constructions and connecting constructions

Transition constructions often are made from stakes and concrete curbs.

Transitions should be applied only if necessary, because a transition is always a weak part of the revetment !

For horizontally placed transitions the following diagram can be used to determine the type of construction.

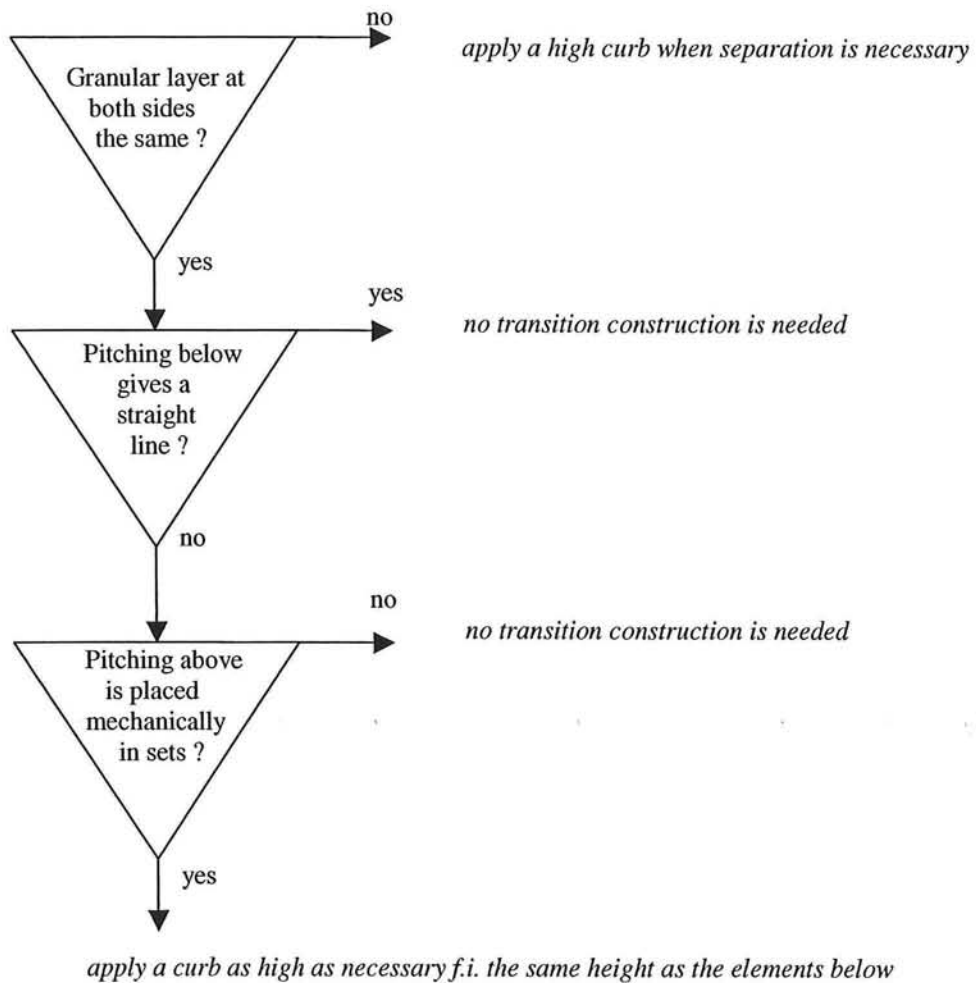

In case the transition construction is located below design water level, it can influence the stability of the pitching negatively, in two situations:

1. if the granular layer is interrupted by the transition construction, the propagation of pressures is blocked. The negative influence concerns the pitching below. This negative influence can be taken into account by introducing an influence factor Γ_0 . This is no further discussed in this lecture note.
2. if the leakage lengths of the pitchings below and above differs more than 20%. The negative influence is applicable to the pitching with the smallest leakage length (just below or above the transition) in a zone with a width equals the leakage length but with a minimum of 0.5 m. Not always, but very often in this situation the influence is negative and measures must be taken.

Due to bad connections, there is a risk for transport of material, loss of friction and clamping.

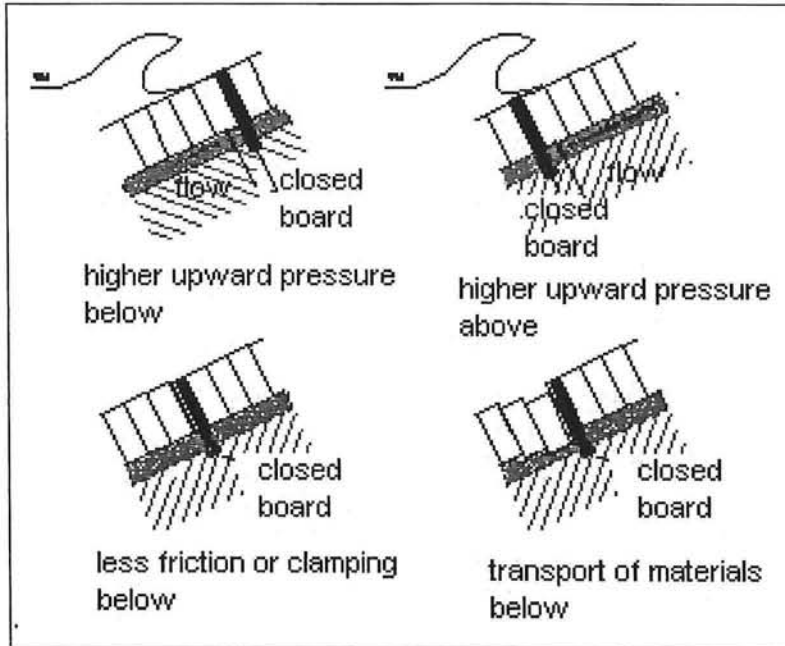

Negative influence of the transition construction

Kinds of measures:

1. Apply heavier elements in three rows just below the transition (situation 1) and in the concerned zone below or above the transition (situation 2);
2. Grout the chink just below the transition (situation 1) or the concerned zone below or above the transition (situation 2) f.i. with asphalt. The penetration material should also penetrate the granular layer and the penetrated zone must be as narrow as necessary, to prevent the manifestation of water pressures under the top layer. Penetration is only possible in case the gaps in the top layer are not yet filled with gravel/grit (or other material).
3. Bring the transition construction to a lower level (further downward on the slope) where the loads are less heavy;

In most cases the chink just below the transition is penetrated with asphalt to give the upper elements of this pitching more strength. One should monitor the development of the chink, induced by irregular settlements.

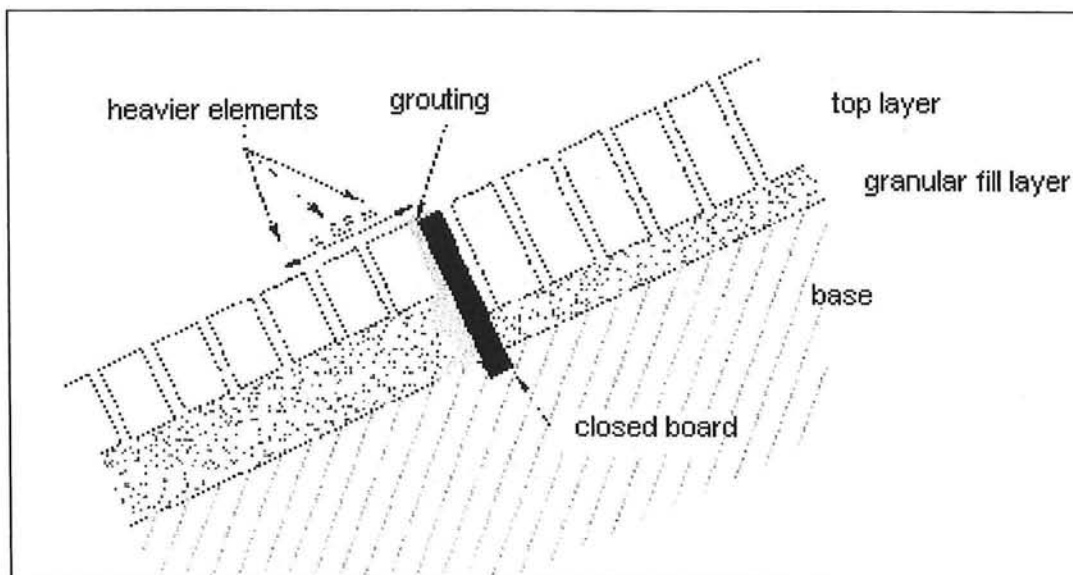

Measures to strengthen the pitching just below a transition construction

7.4 Pitchings on and above berms

One considers berms if:

- Slope < 1:9
- $H_s < \text{width} < 2 H_s$
- Below design water level
- Water level combinations: $0,5 \leq d_b / H_s \leq 2,2$ (d_b = water depth above the berm)

Possible top layers:

- Grass if applicable. Depend on loads (f.i. water, traffic);
- Asphalt or concrete are often applied in case the berm is used as (maintenance) road;
- Pitchings. To prevent transition constructions. Also passable for maintenance equipment.

If the berm is located relatively low with respect to the design water level, the loads on a berm are higher compared to a normal slope. Also the strength of a pitching on a berm can be less (less friction). In these situations the elements on the berm must be heavier.

The design method for pitchings on berms differs from pitchings on normal slopes, and is rather complicated. Simplified and not very wrong:

1. Determine the thickness of an element on berm level, using the steepest slope (comparing the slope below and above the berm);
2. Multiply the thickness with the berm factor, which can be found in the graphs below. For values in between, linear interpolation is allowed.

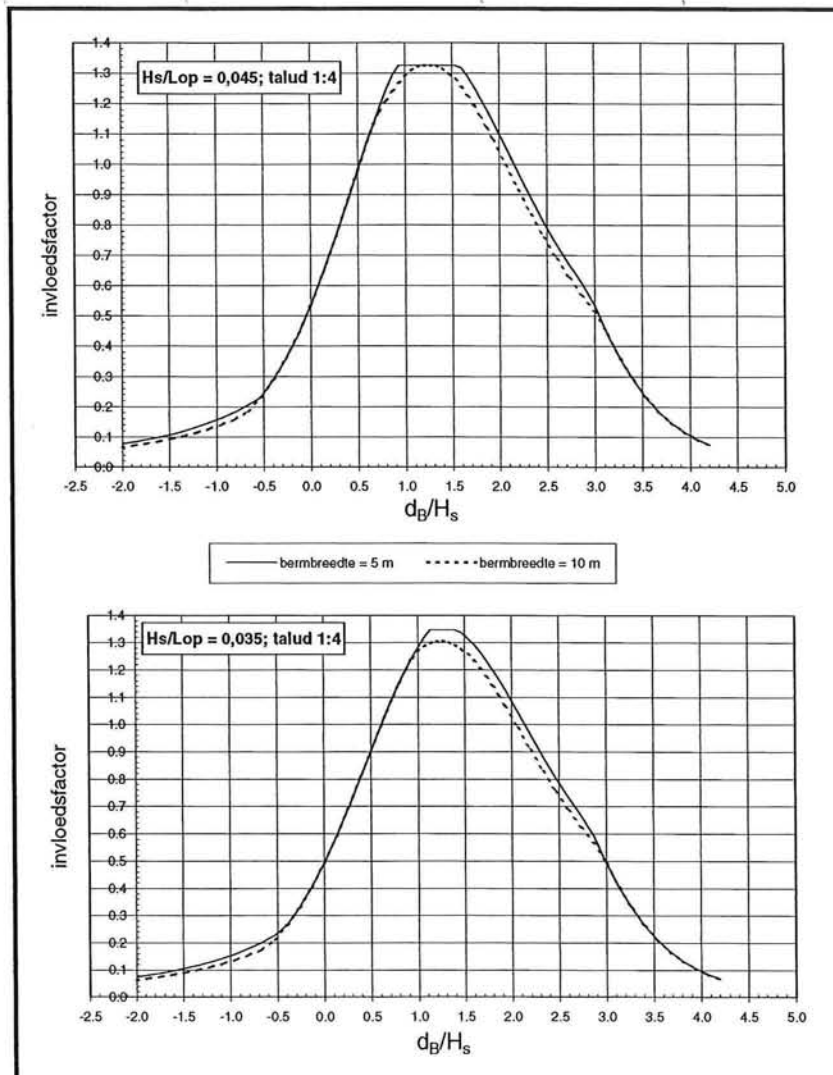

Berm factor for slopes 1:4

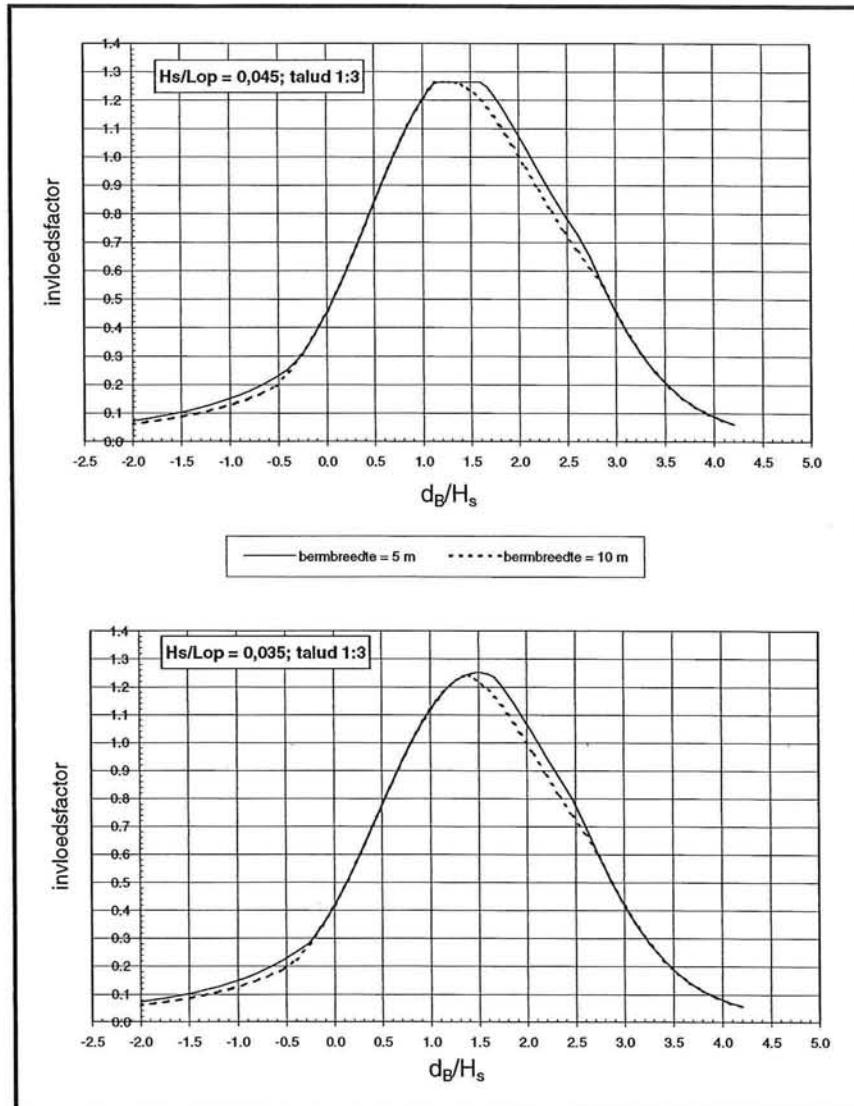

Berm factor for slopes 1:3

Transition from normal slope into berm slope must be gradually and must not be bent (f.i. radius about 10 m).

In some cases the presence of a berm determines the loads and therefore also the design method of the pitching above. One can distinguish three situations:

1. A relatively low berm with level $<$ (design water level minus $H_{s, \text{design water level}}$) does not influence the stability of the pitching above. The pitching above the berm can be calculated in the normal way.
2. (Design water level minus $H_{s, \text{design water level}}$) $<$ berm level $<$ design water level. The pitching above the berm is the minimum demand, comparing the required thickness of the elements on the berm and in the (fictitious) case the berm is absent.
3. berm level $>$ design water level. The pitching above the berm has the same dimensions as the pitching on the berm.

7.5 Zone of wave run-up

Design method:

- Zone $<$ design water level $+ 1/2z_{2\%}$: the required thickness of the pitching is 80% of the required thickness in the zone just below design water level.
- Zone $>$ design water level $+ 1/2z_{2\%}$: concrete elements 0.2 m / 2300 kg/m³ are sufficient.

7.6 Crest and inner slope

Not discussed in this lecture note.

8. Required parameters

8.1 Hydraulic Loads

8.1.1 Wind waves

In the design methods often H_s must be used. For breaking waves H_s equals the mean value of the highest 1/3rd part of the waves. For non breaking waves on relative deep water H_s equals the wave height which is exceeded by 13.5 % of the waves.

In the design methods often T_p (peak period) must be used. T_p equals the wave period which belongs to the peak of the wave spectrum. The formula of Van der Meer uses T_m (mean period) which is about 10% – 30% smaller than T_p .

On a relative shallow fore shore waves will break. The maximum wave height equals 0.5 x water depth. The accompanying wave period for breaking waves, only valid for pitchings, $T_p = 3,4 \times \sqrt{d}$ in which d = water depth on a distance $\frac{1}{2} L_{0p}$ from the toe.

In the design method mostly L_0 , the deep water wave length, should be used ($L_0 = gT^2/(2\pi)$). The deep water wave length belonging to T_p is L_{0p} . A derivative parameter is the wave steepness $s = H_s/L$.

Can be determined by:

- Bretschneider
- Computer package HYDRA for IJsselmeer and Markermeer;
- Computer package SWAN
- “Randvoorwaardenboek”

8.1.2. Ships induced waves

Secondary waves and primary waves are about 0.5 m, sometimes up to 1 m. Wave period is about 2 – 5 s.

Can be determined by:

- Computer package DIPRO

Wave type	Output DIPRO	Input design methods
Front waves	Wave height Δh_f	$\Delta h_f = H_s$
	Wave steepness i_f	$i_f = H_s/L_{0p}$ $= H_s/(gT_p^2/2\pi)$
Decline of water level	Δh	$\Delta h = H_s$
Stern wave	Wave height z_{max}	$z_{max} = H_s$
	Wave steepness i_{max}	$i_{max} = H_s/L_{0p}$ $= H_s/(gT_p^2/2\pi)$
Secondary waves	Wave height H_i	$H_i = H_s$
	Wave period T_i	$T_i = T_p$

Parameters of ships induced water movement used for design methods

8.1.3 Water level

Until the upper limit of the wave impact zone (= the design water level), a revetment is attacked by wave impact and wave run-up; above this level only wave run-up occurs.

Every horizontal row of pitching elements has a normative water level on a value y_s (or often also called d_s) above it.

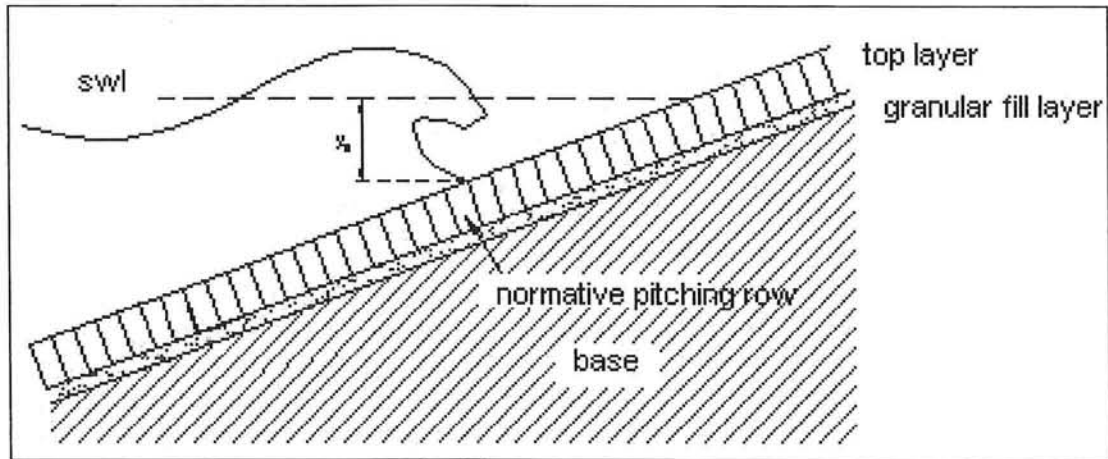

Determination of the normative water level for a certain location on the slope

The value for y_s depends on the wave parameters and the slope angle:

$$y_s = 0,11 \cdot H_s \cdot \left(\frac{1,56 \cdot T_p^2 \cdot \tan \alpha}{H_s} \right)^{0,8} ; \text{maximum: } y_s = 1,5 \times H_s$$

in which:

y_s	=	distance above a certain location on the slope on which the normative water level is found for this location	[m]
H_s	=	significant wave height	[m]
α	=	slope angle	[°]
T_p	=	peak period	[s]

8.1.4 Horizontal currents

In the design method the mean current over the water depth at the toe should be used. For currents induced by ships DIPRO can be used.

8.1.5 Density of water

In the design methods the relative density of the elements is used: $\Delta = (\rho_{te} - \rho_w) / \rho_w$.

in which:

Δ	=	relative density	[-]
ρ_{te}	=	density of the armour elements	[kg/m ³]
ρ_w	=	density of water (1025 for salty water)	[kg/m ³]

8.1.6 Breaker parameter

Also called the surf similarity parameter: $\xi = \tan \alpha / \sqrt{H_s / L}$

in which:

ξ	=	breaker parameter	[-]
α	=	mean slope angle	[°]
H_s	=	significant wave height	[m]
L	=	wave length	[m]

8.1.7 Wave run-up

The wave run-up level $z_{2\%}$ is the level above the still water level which is exceeded by 2% of the waves.

A simply formula is the so called "Delftse formula": $z_{2\%} = 8H_s \tan \alpha$

8.2 Properties of pitchings

8.2.1 Fill material of top layer

Pitchings with relative large joints or spaces between the individual elements (columns and blocks with distance keepers) are filled with gravel or grit (f.i. gradation 16-32 mm (for columns)), about 50 kg/m². The advantage of introducing extra friction between the elements is bigger than the disadvantage of a decreasing permeability of the top layer. (This is only valid for columns, because the extra friction at straight block is minor).

8.2.2 Open space in top layer

Columns: open space Ω = percentage open space in relation to the total surface. The design method is valid for $\Omega_{\max} = 15\%$. In the calculations of transport of material also the diameter of the gaps (G) is used.

Blocks: use block lengths (L) and block widths (B) and joint widths s. In the calculations of transport of material G = joint width.

Type	Ω / joint width
Columns	10 – 15 %
Concrete blocks	1 – 4 mm
Granite blocks	3 – 30 mm

Some default values for Ω and the joint width s

8.2.3 Height or thickness of the top layer

Use a margin on the height of elements of natural stone, f.i. 5 cm, because the worker will sort the elements without measuring.

8.2.4 Density of the elements

Type	Density [kg/m ³]
Concrete columns	2300 – 3000
Concrete blocks (re-use)	2300 - 2500
Basalt columns	2900 – 3100
Granite blocks	2600 – 2700
"koperslak" blocks	2500 - 2700

Some default values for the density

8.2.5 Thickness of granular layer

In case a geofabric is used as a filter, a granular fill layer is needed. Considering the negative influence of a thick granular layer on the stability of the top layer, one should minimize the thickness of the granular layer (about 10 cm). In the design one should take into account a margin of 5 – 10 cm, depending on the difficulty of constructing, or even more in case of re-use of irregular blocks of natural stone.

8.2.6 Properties of granular layer

For granular material in the fill layer often grit 16-32 mm or 20-40 mm is used. De value of the porosity $n \approx 0.35$.

8.2.7 Slope angle

In many cases the slope is applied with a camber. In The Netherlands a convex camber is usual, while in Germany often a concave camber is applied. In the calculations the adaptation of the slope angle for camber should be taken into account.

9. Useful Literature

- [1] Technisch Rapport Steenzettingen, TAW, November 2003.
- [2] Leidraad Zee- en Meerdijken, TAW, december 1999.
- [3] Keuzemodel kust- en oeverwerken, Rijkswaterstaat DWW.
- [4] Technisch Rapport Waterkerende Grondconstructies, TAW, Juni 2001.
- [5] Technisch Rapport Golfoploop en golfoverslag bij dijken, Rijkswaterstaat DWW, 2000.
- [6] Technisch Rapport Asfalt voor Waterkeren, TAW, 2002.
- [7] Voorschrift Toetsen op Veiligheid, TAW, 2003.
- [8] Filters in de Waterbouw, Rapport CUR 161, juni 1993.
- [9] Handboek voor dimensionering van gezette talubekledingen, Rapport CUR 155, maart 1992.

10. Useful Computer Programs

- [A] ANAMOS
- [B] CRESS
- [C] BREAKWAT
- [D] PCOVERSLAG