

5

# THE PRESCRIPTION

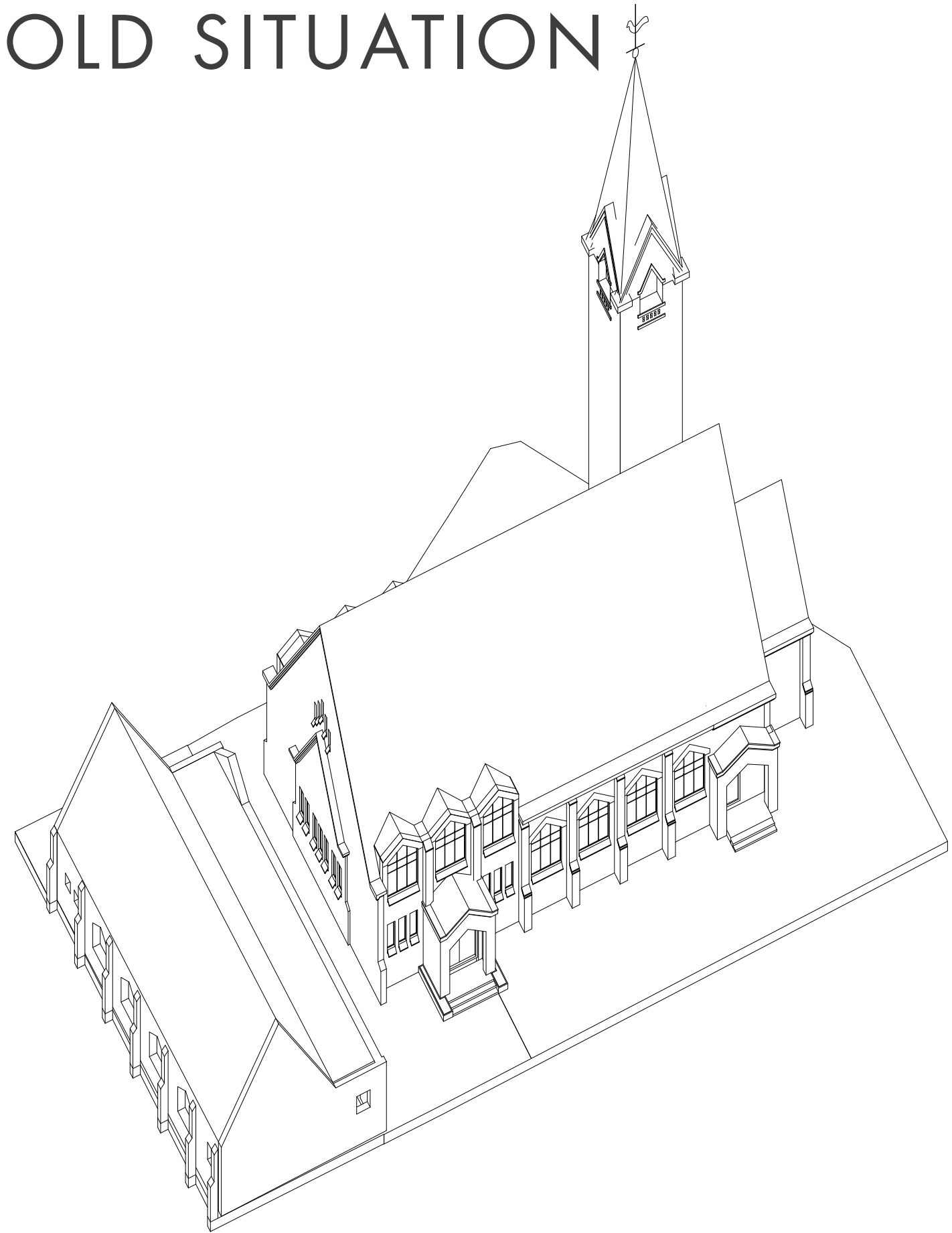

# OLD SITUATION



82



# PRIOR TO IGNITION

After 10 years of vacant  
an end to public ... from 1930 onwards

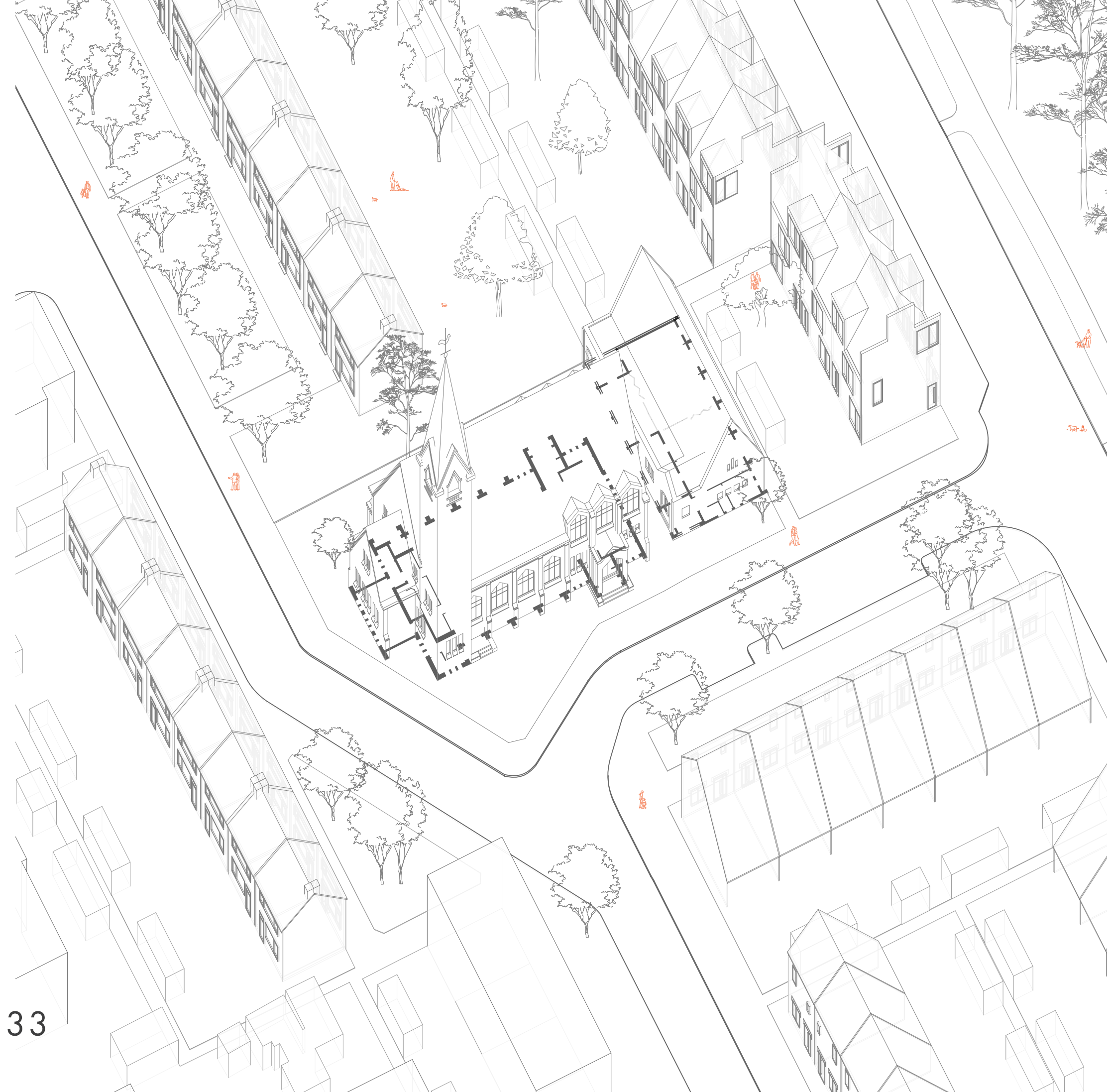





Julianachurch (May, 2017)



# FIRST PLANS AND FUNKY MONKS

FUNKY 1. DIFFERENT BUT COOL

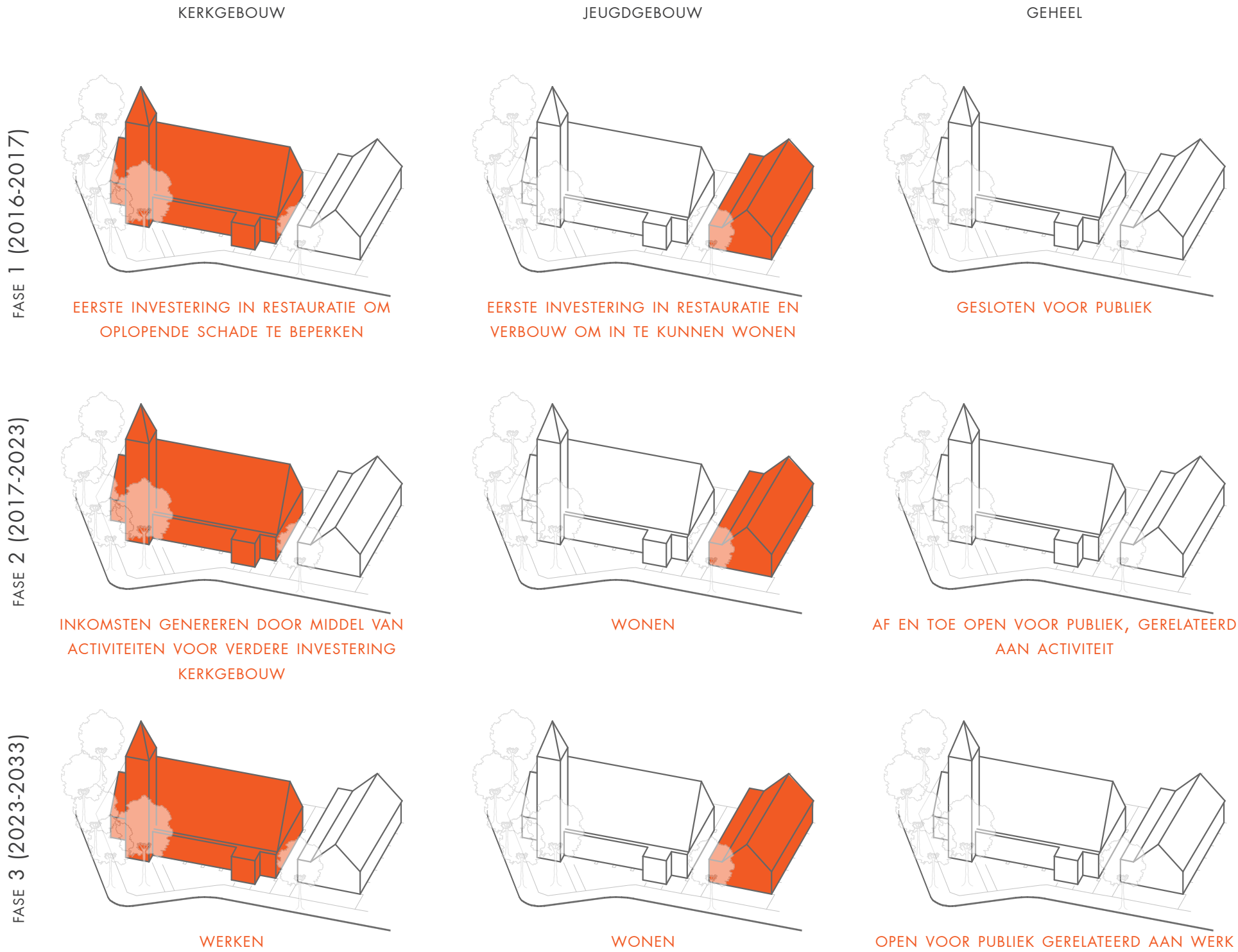
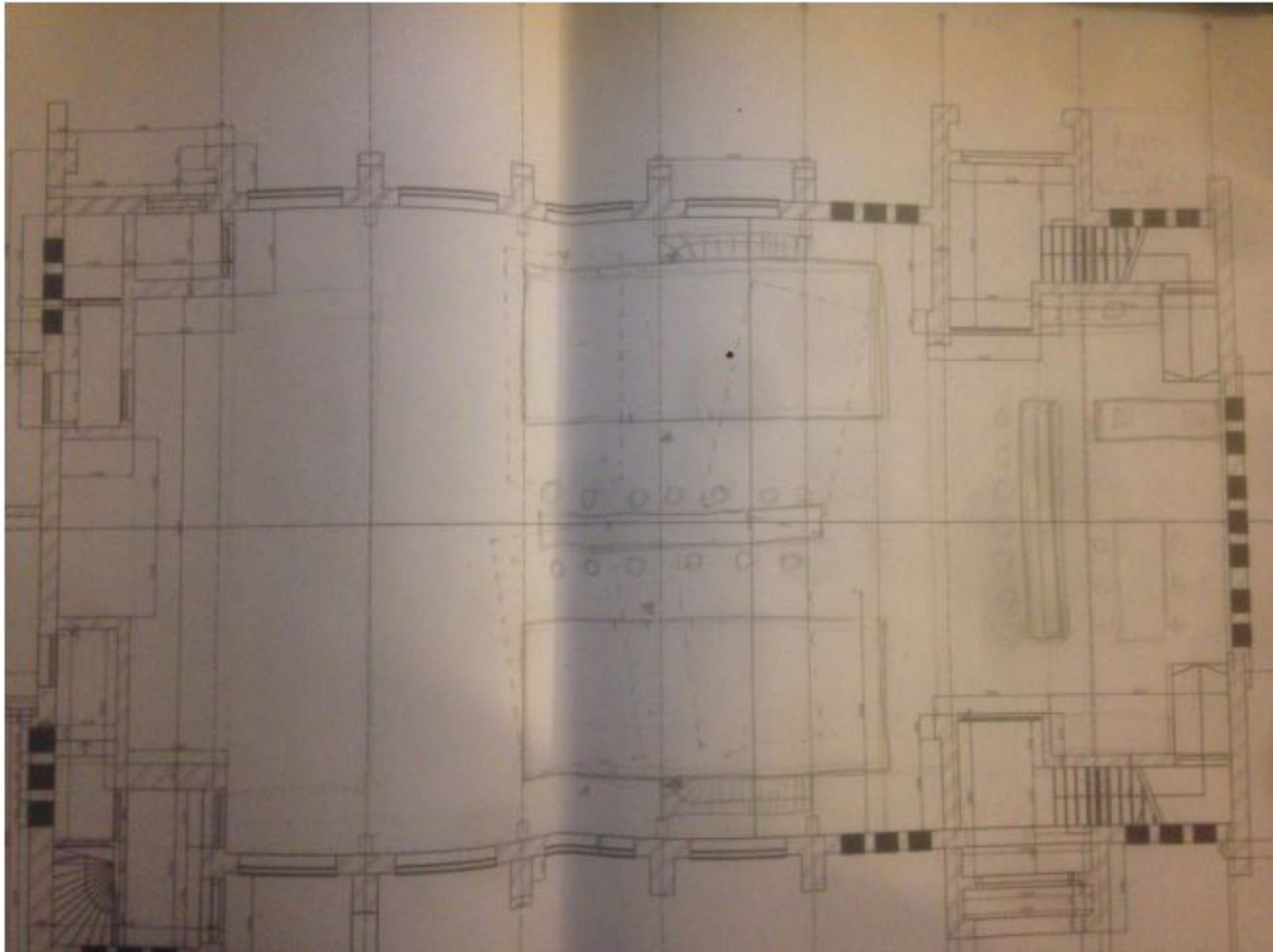



# IGNITION

The current situation is that about 70% of the brick facade is left behind, including a tower, leaving a big and open square.







Julianachurch burns down on the night of the 6th of august 2017 (ANP, 2017)



# POST IGINATION

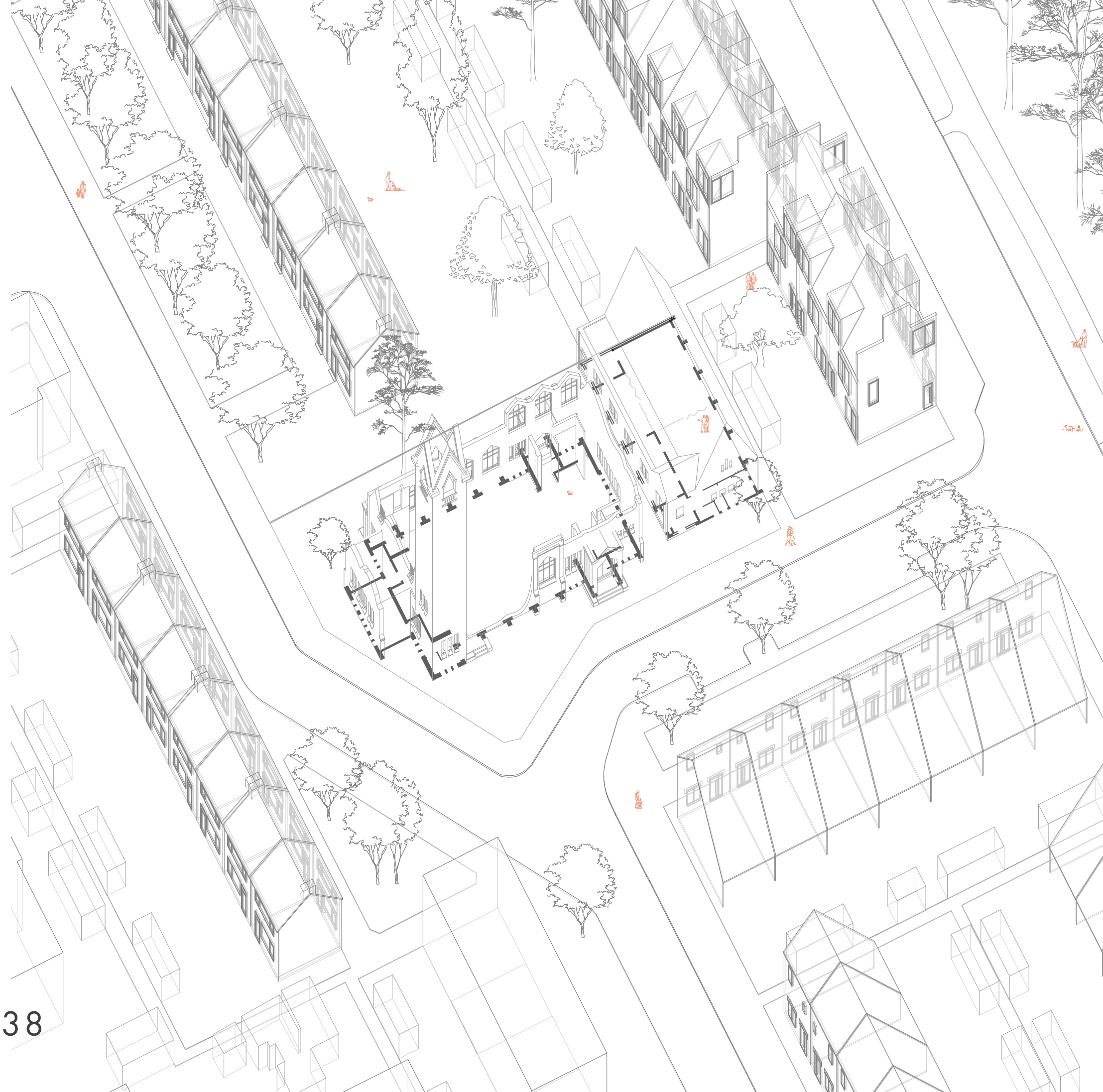
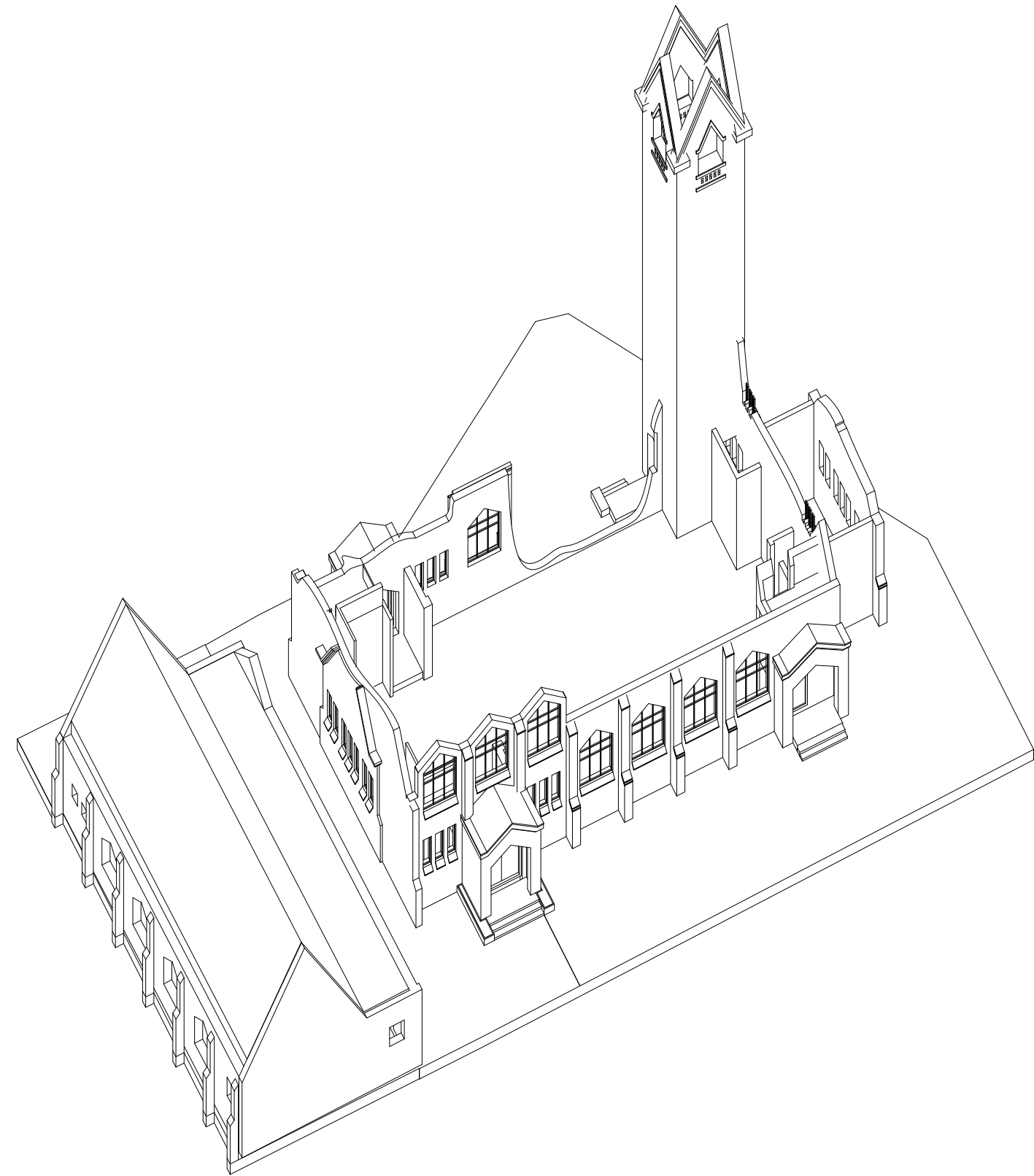



The current situation is that about 70% of the brick facade is left behind, including a tower, leaving a big and open square. "The bricks that are left are good for about 90%".



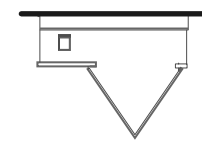
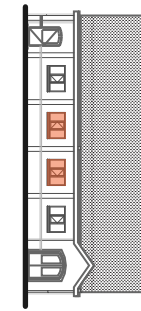
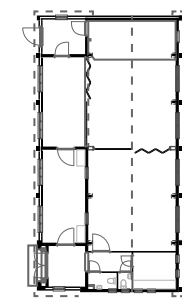
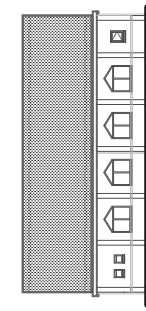
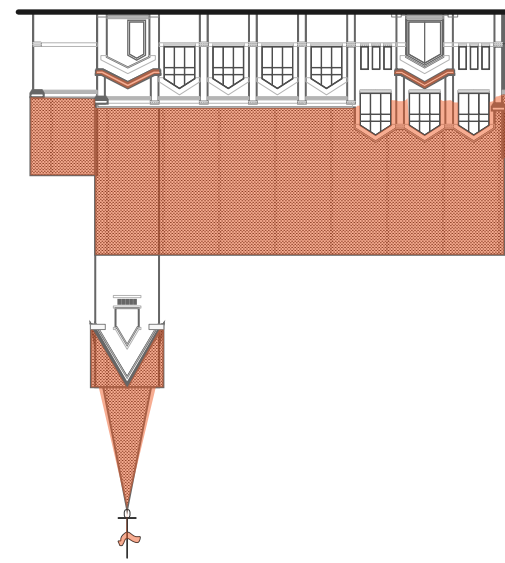
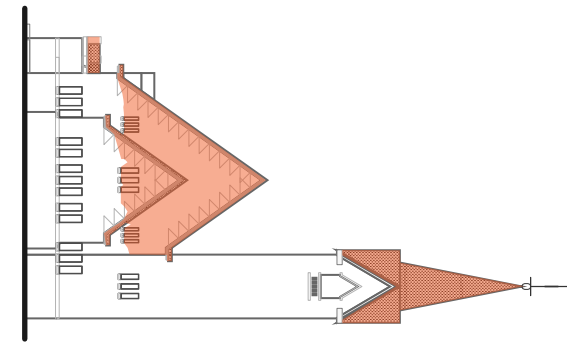
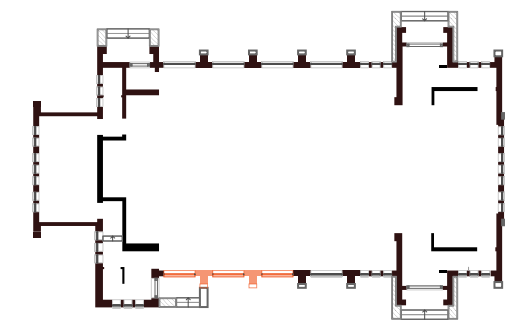
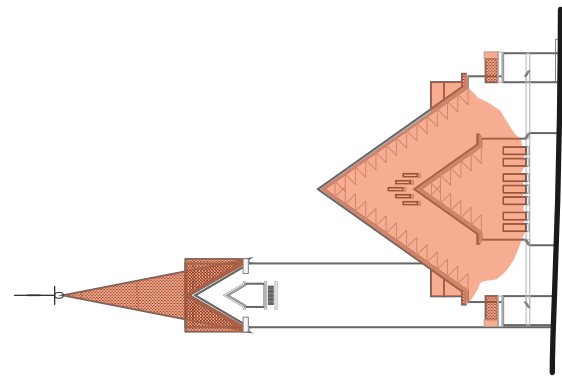
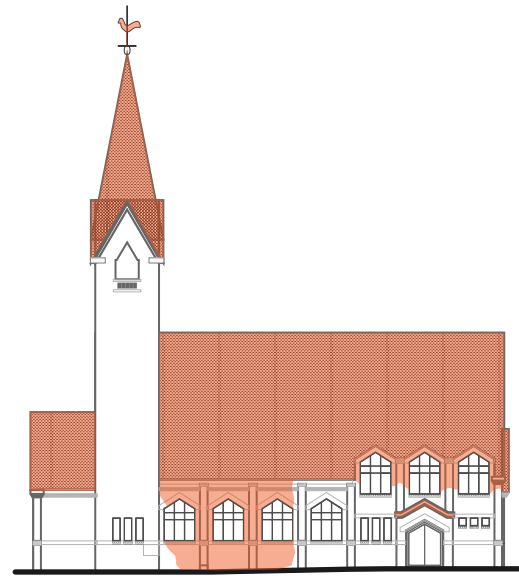

damage and demolition until structurally safe





Julionachurch after the fire, prior to cleaning





Julianochurch after the fire, after cleaning



# TEMPORALITY AS A BASIS FOR THINKING AND BEING

Hoewel Heijplaat op een afgelegen plek lijkt te liggen binnen Rotterdam is het toch goed bereikbaar via de watertaxi in combinatie met een fiets. Verder is het RDM campus ook op het "schiereiland" gelegen, een centrum vol bouwkundige kennis met een (beginnende) aantrekkingskracht voor jonge mensen en ondernemers. Dit kan een goede basis zijn voor mogelijke

2018 - 2019





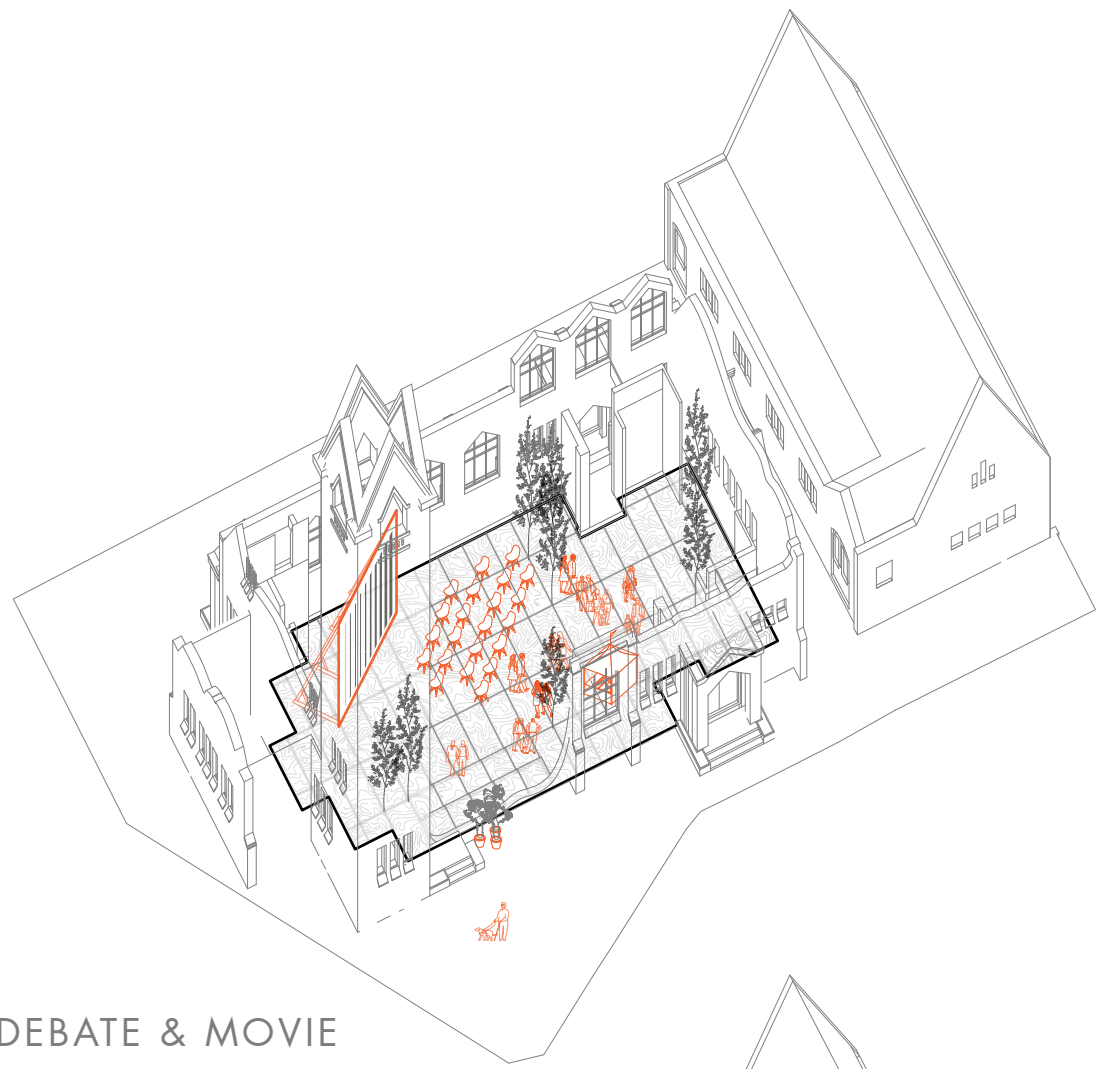

DEBATE & MOVIE



EAT, DRINK, MEET

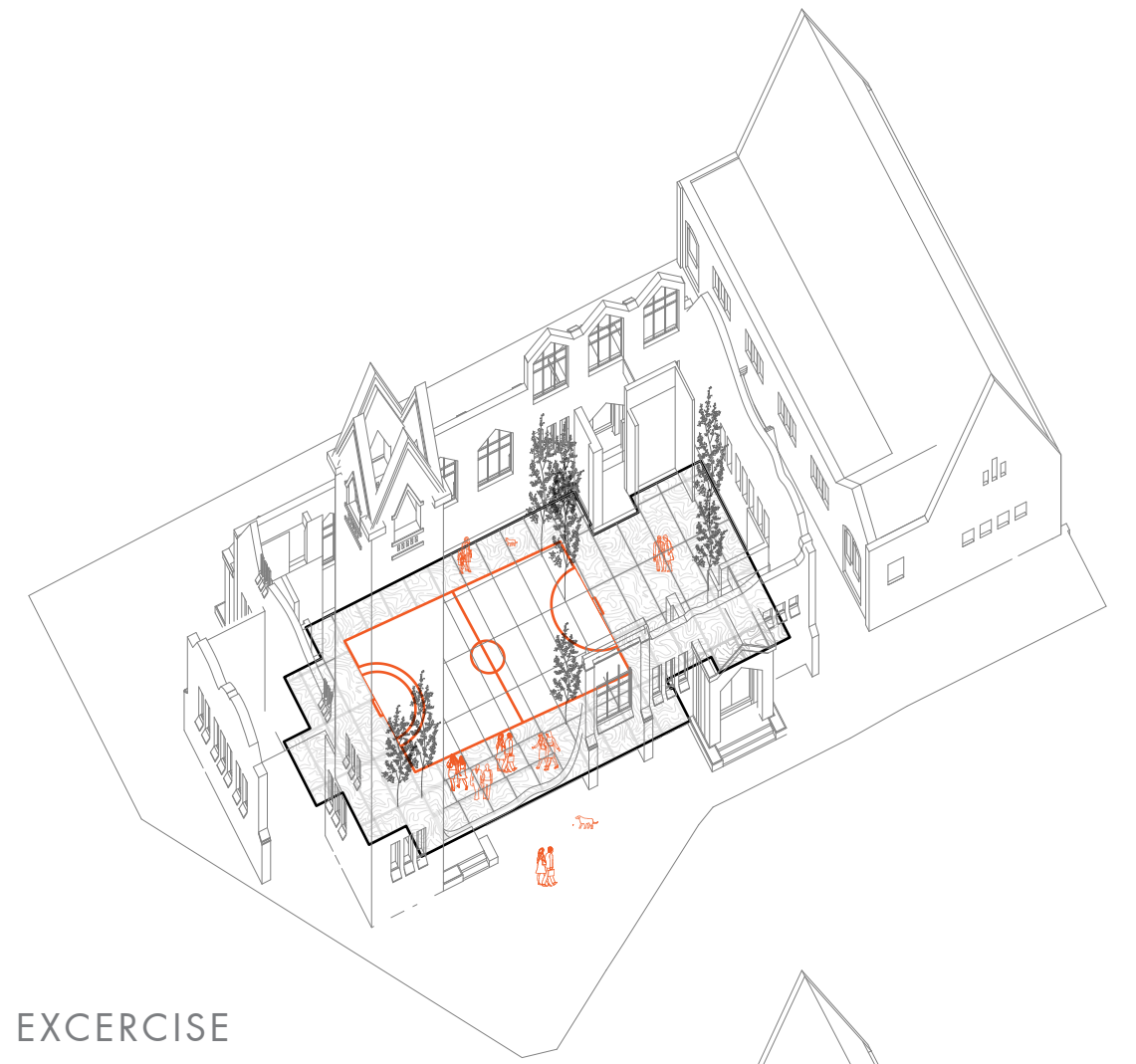

EXCERCISE

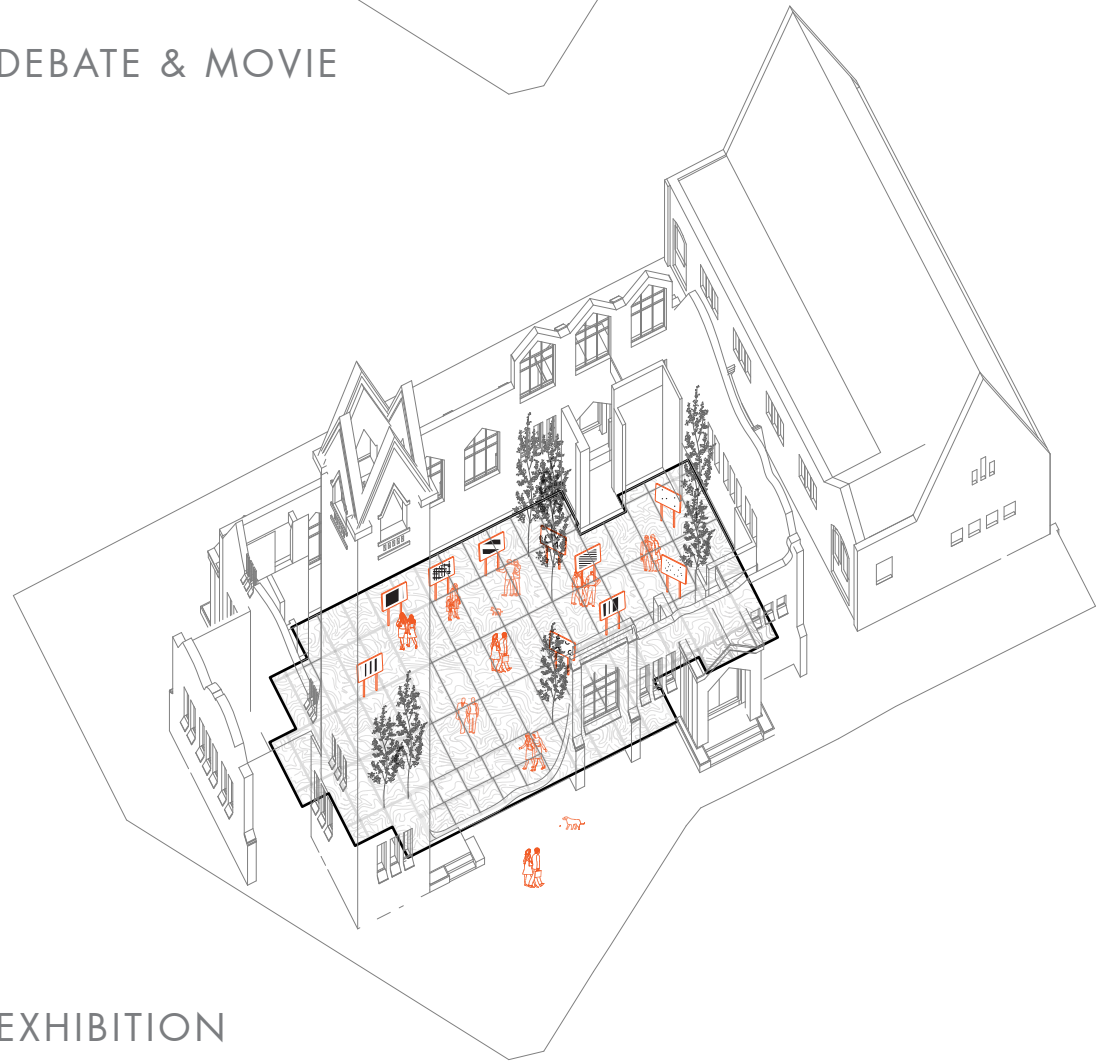

EXHIBITION

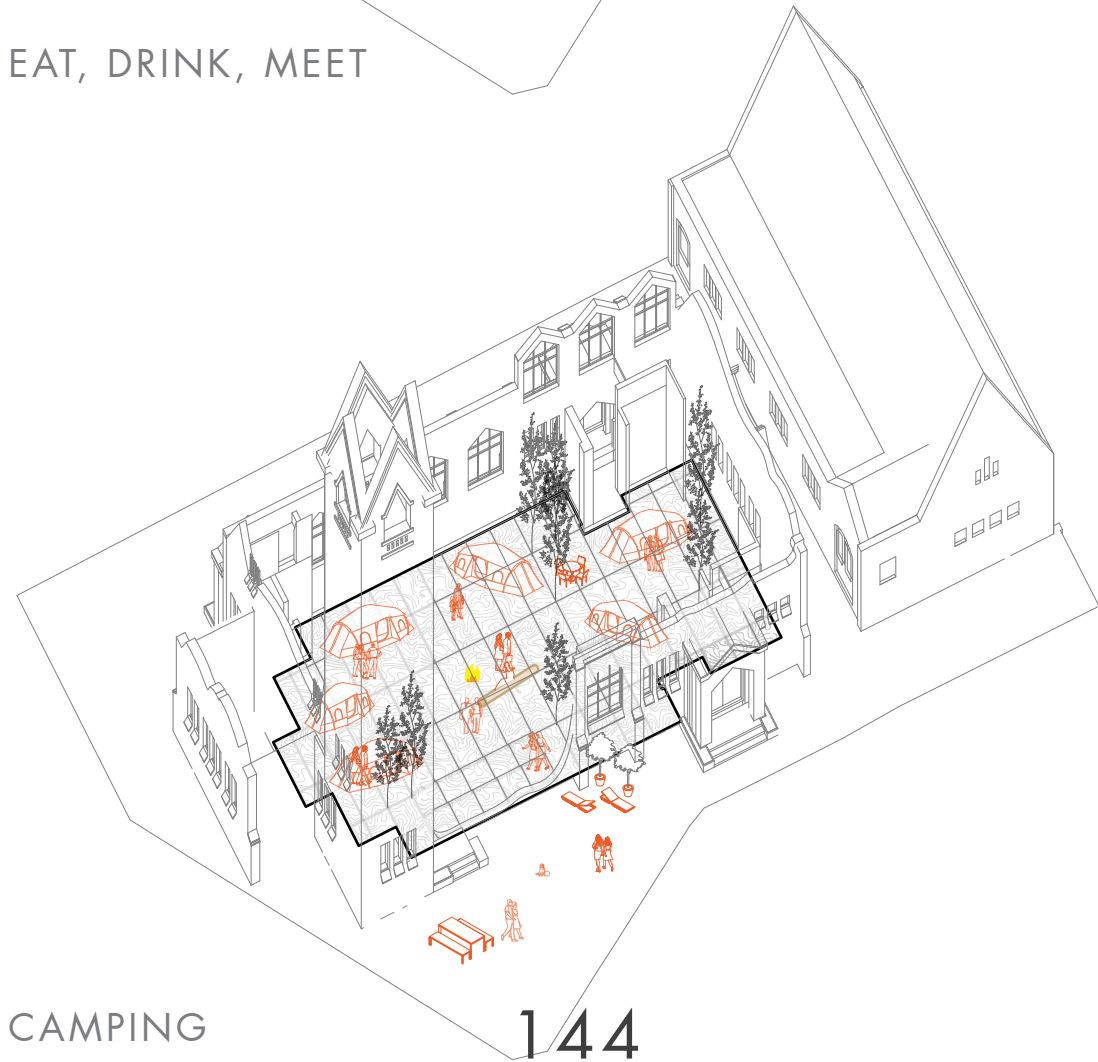

CAMPING

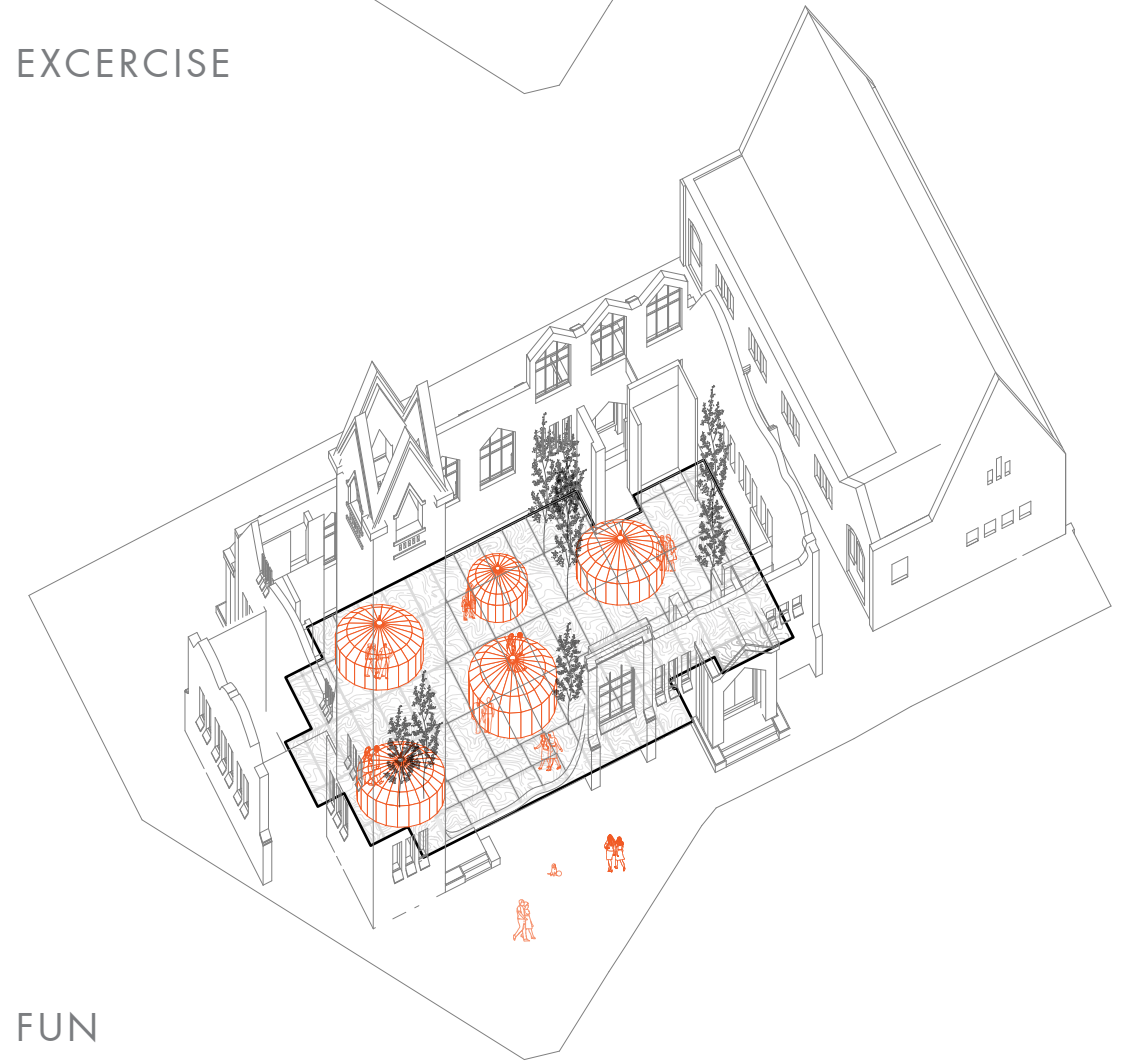

FUN





Public square





Proces plan (social-event)



Proces plan (movie-night)



# URBAN RECONSTRUCTION

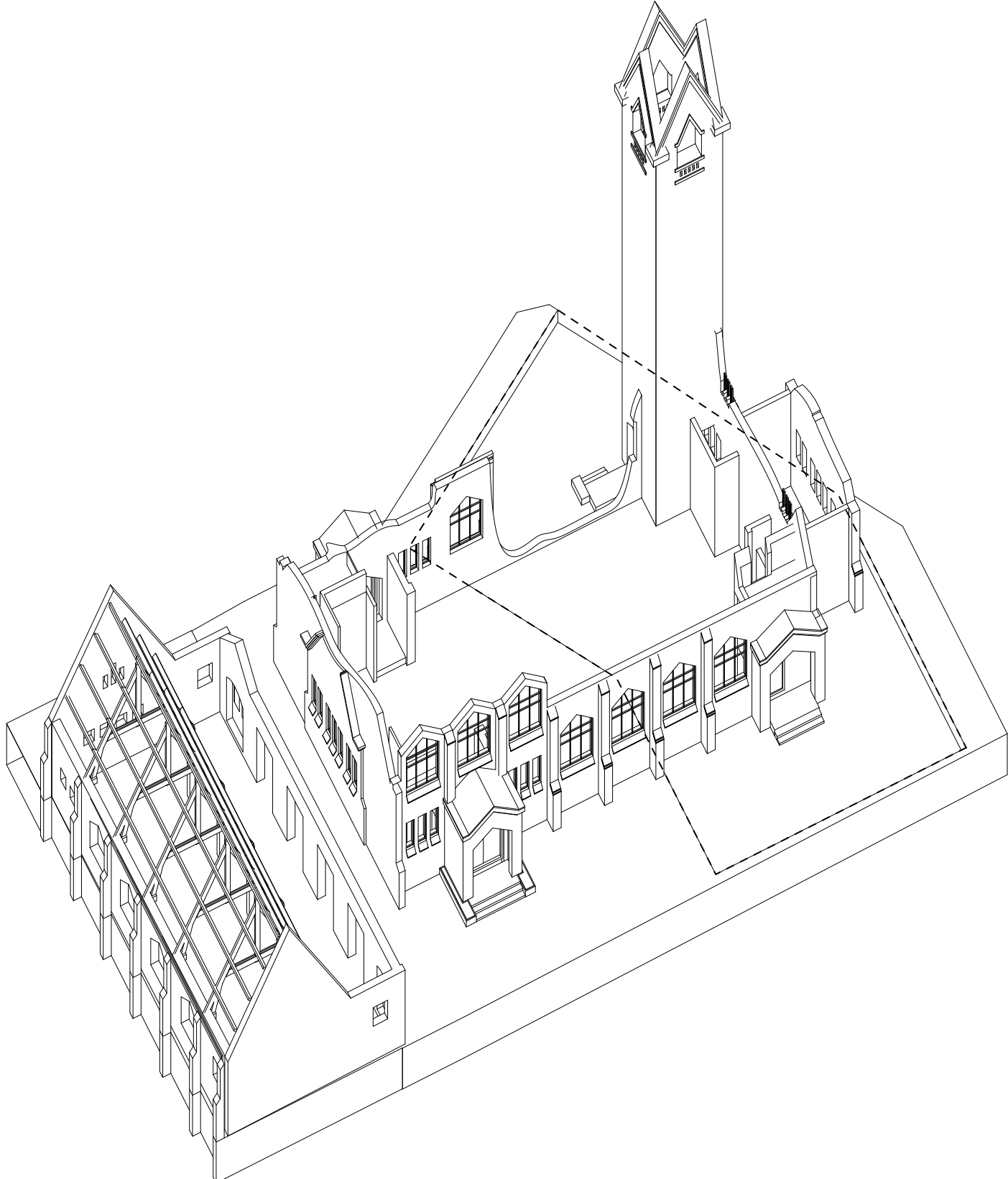



# URBAN RECONSTRUCTION

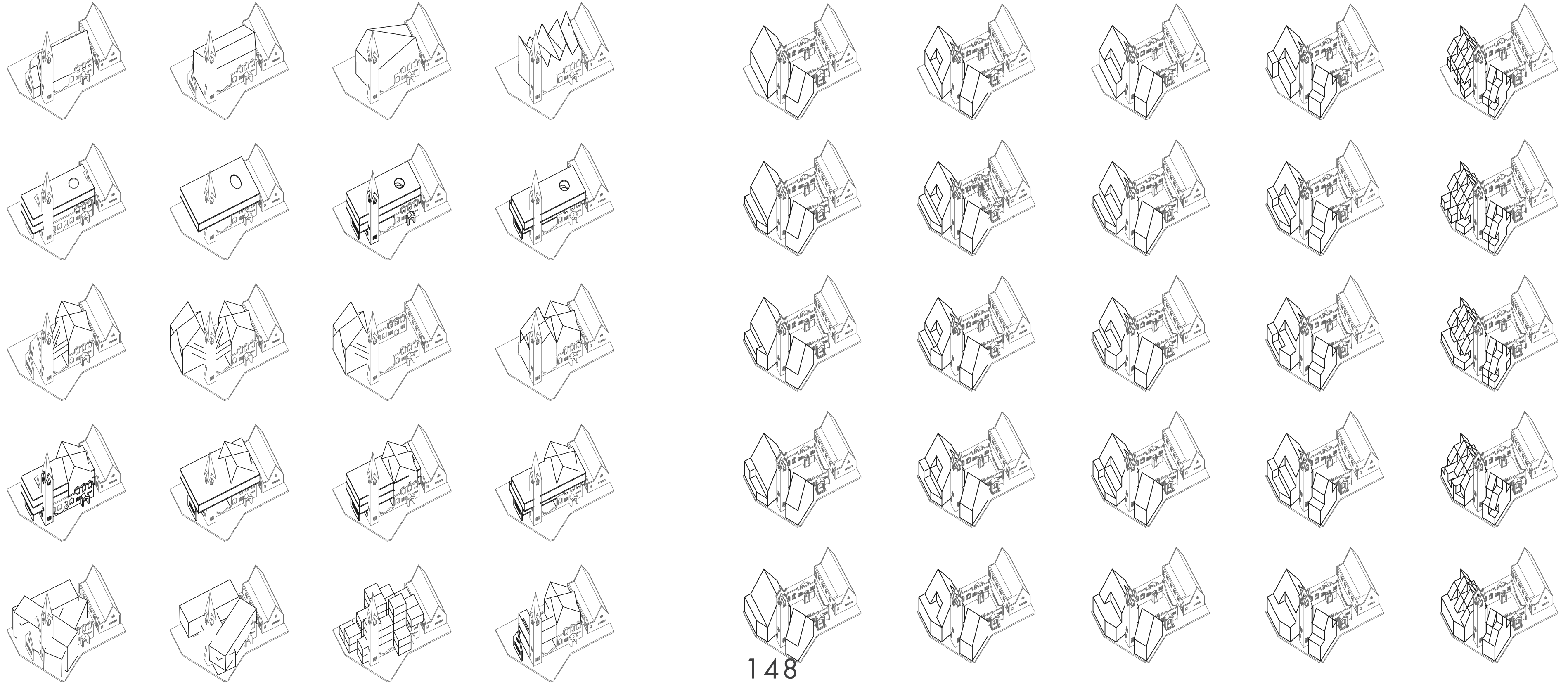



# URBAN RECONSTRUCTION

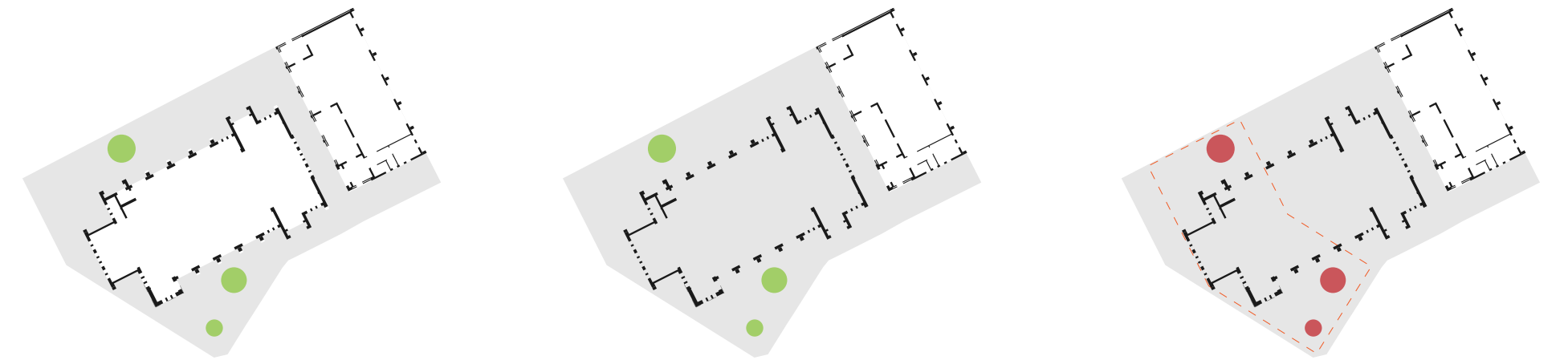
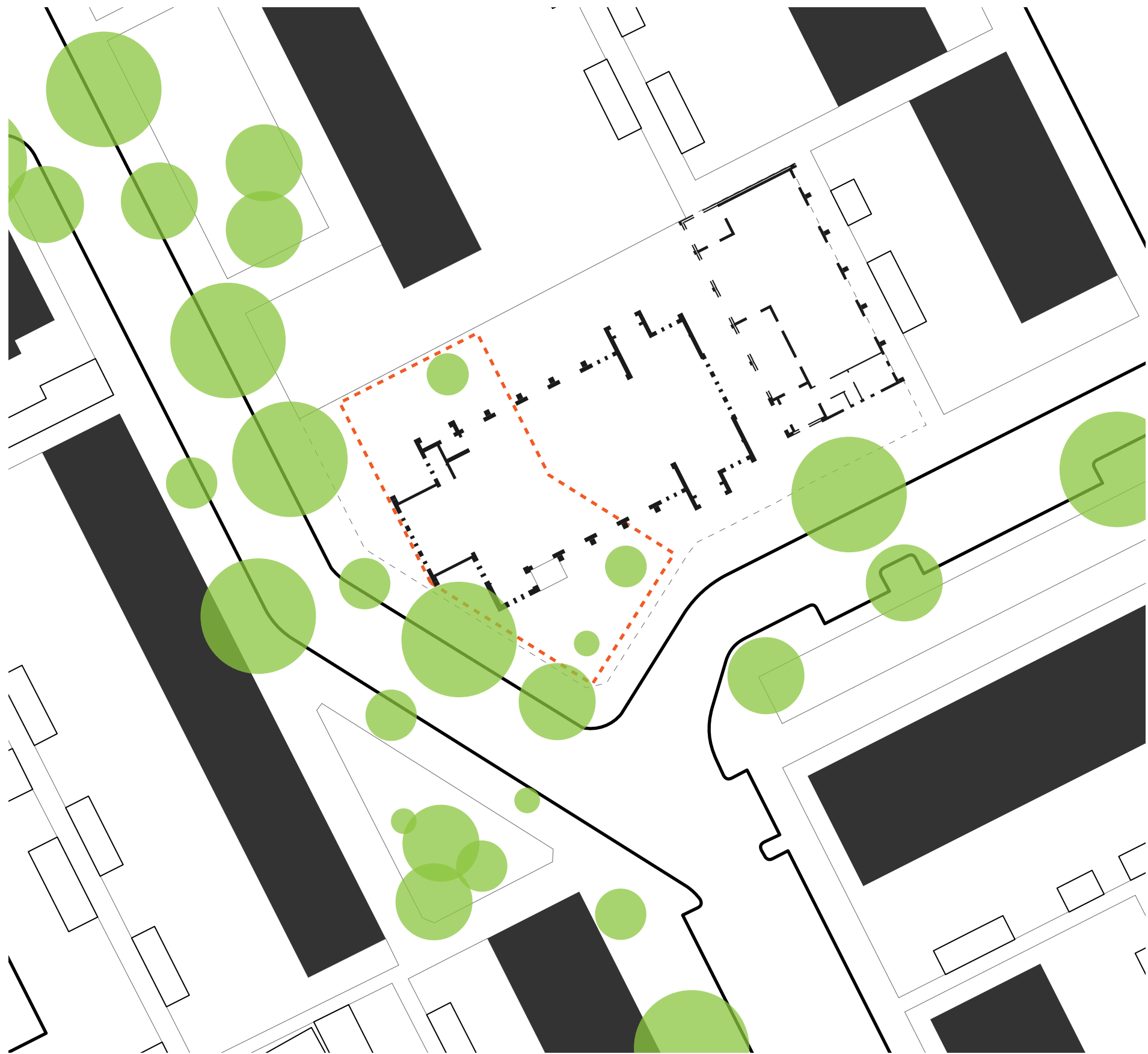

START

FIRE

NEW OUTLINE

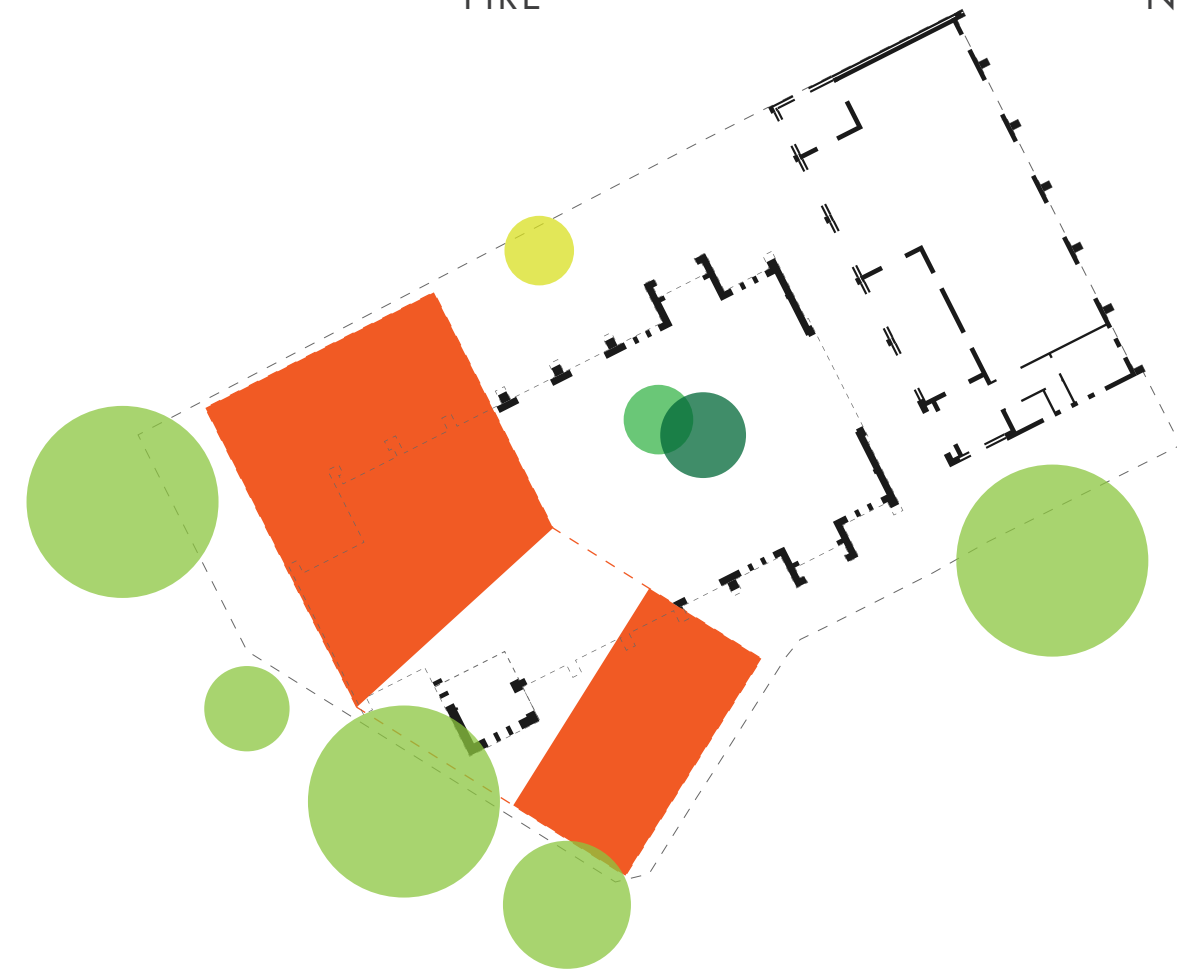

DEMOLISH

CONNECTION

CONCENTRATE SPACES



# SUN STUDY

OLD

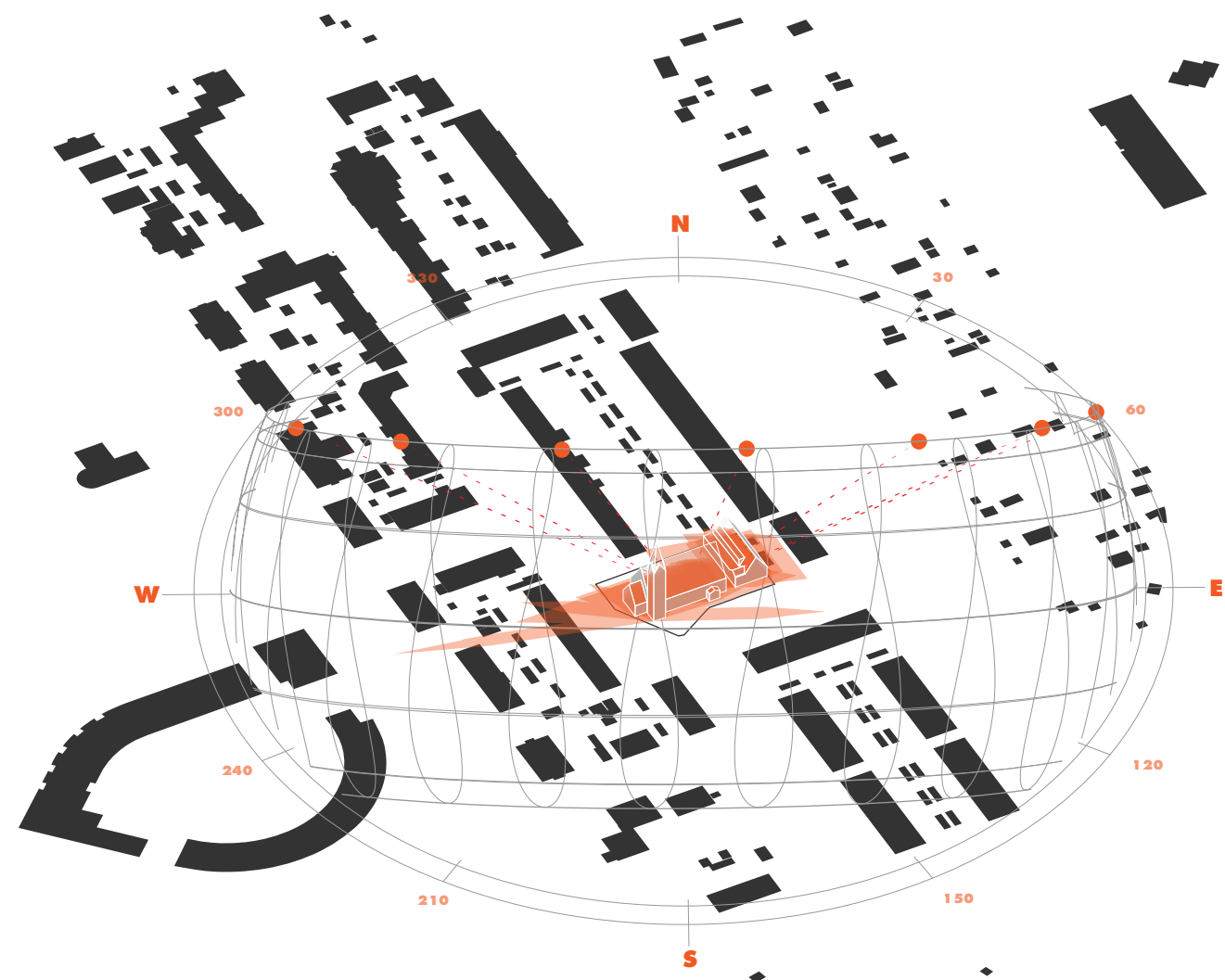

NEW

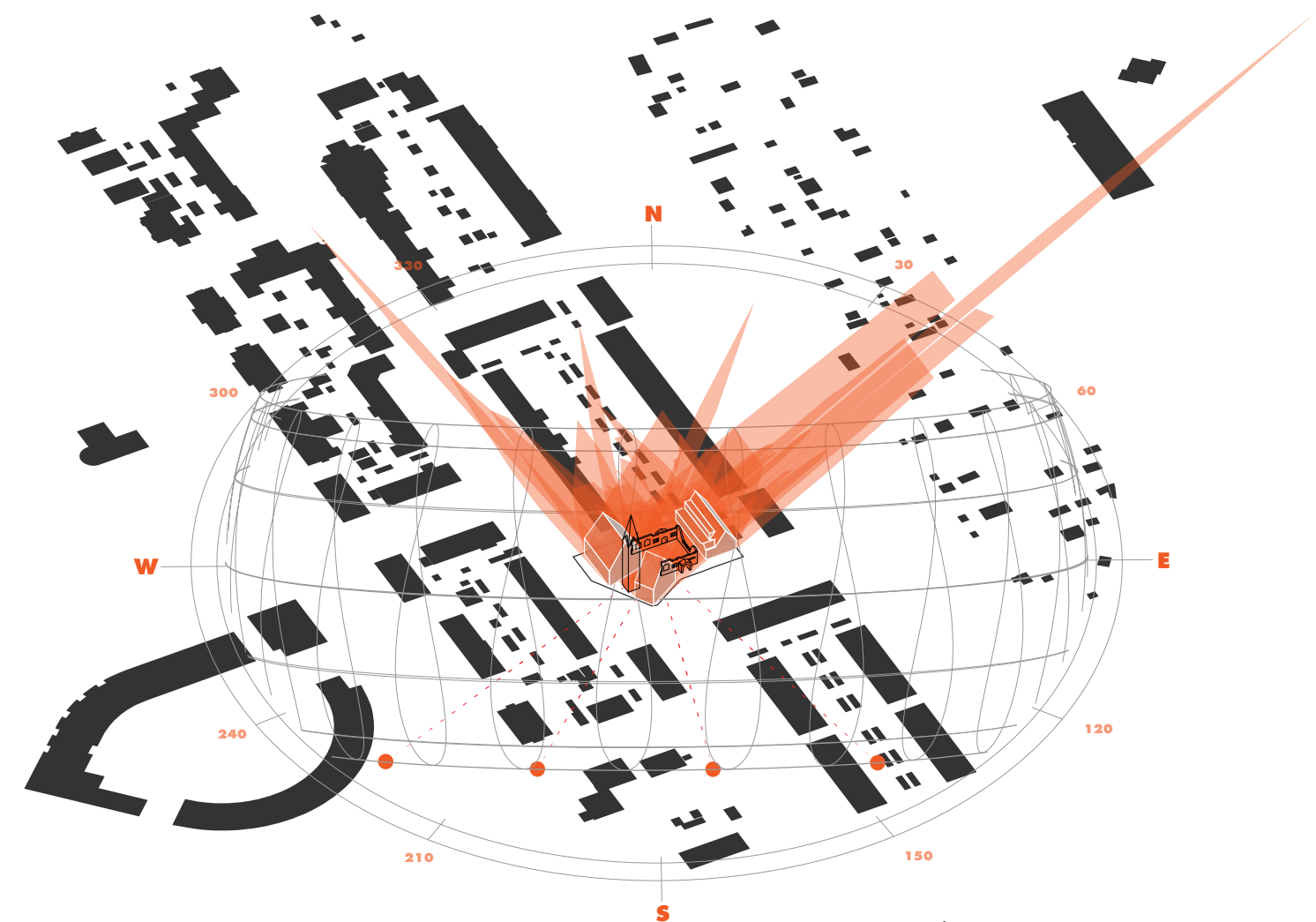
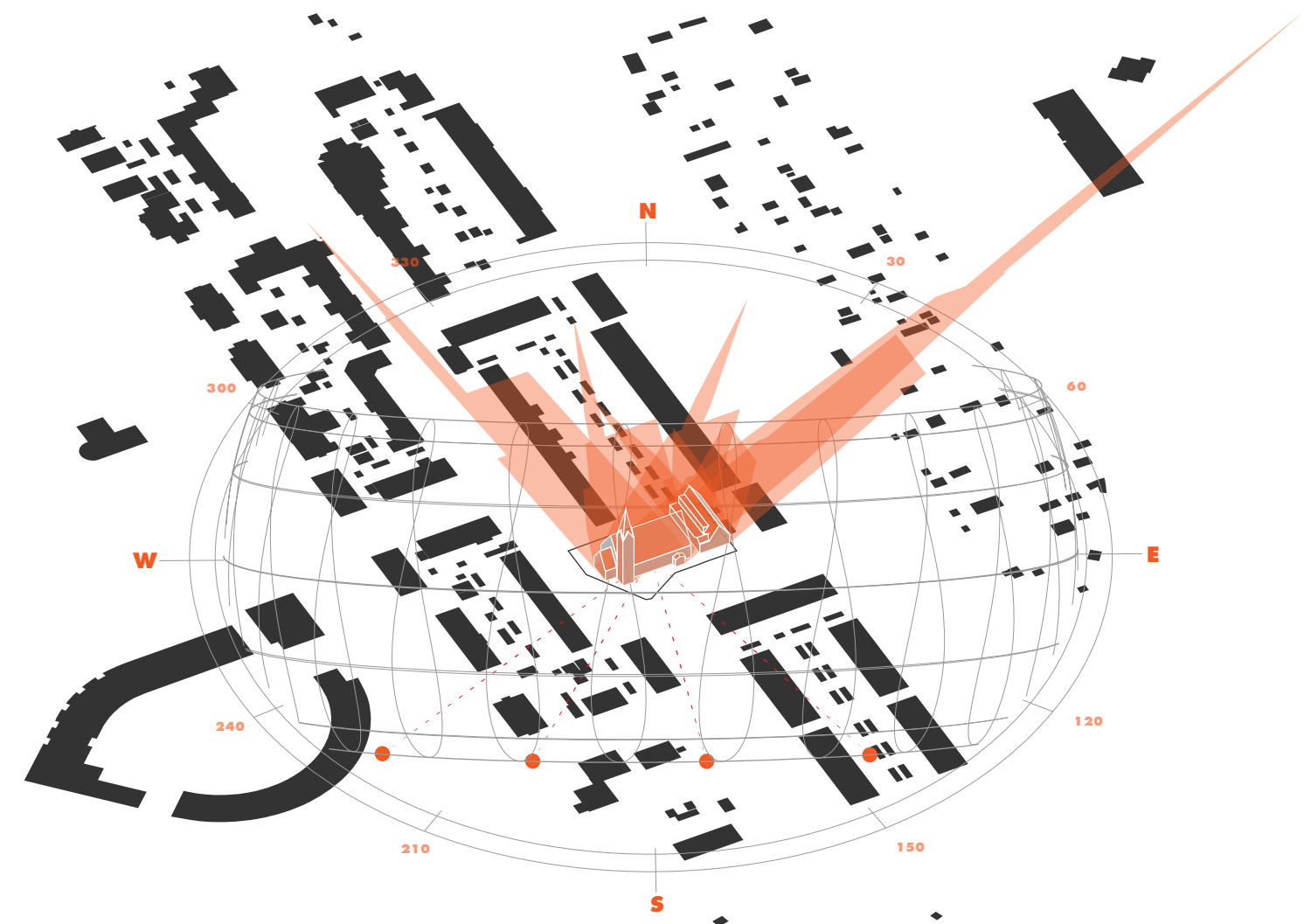
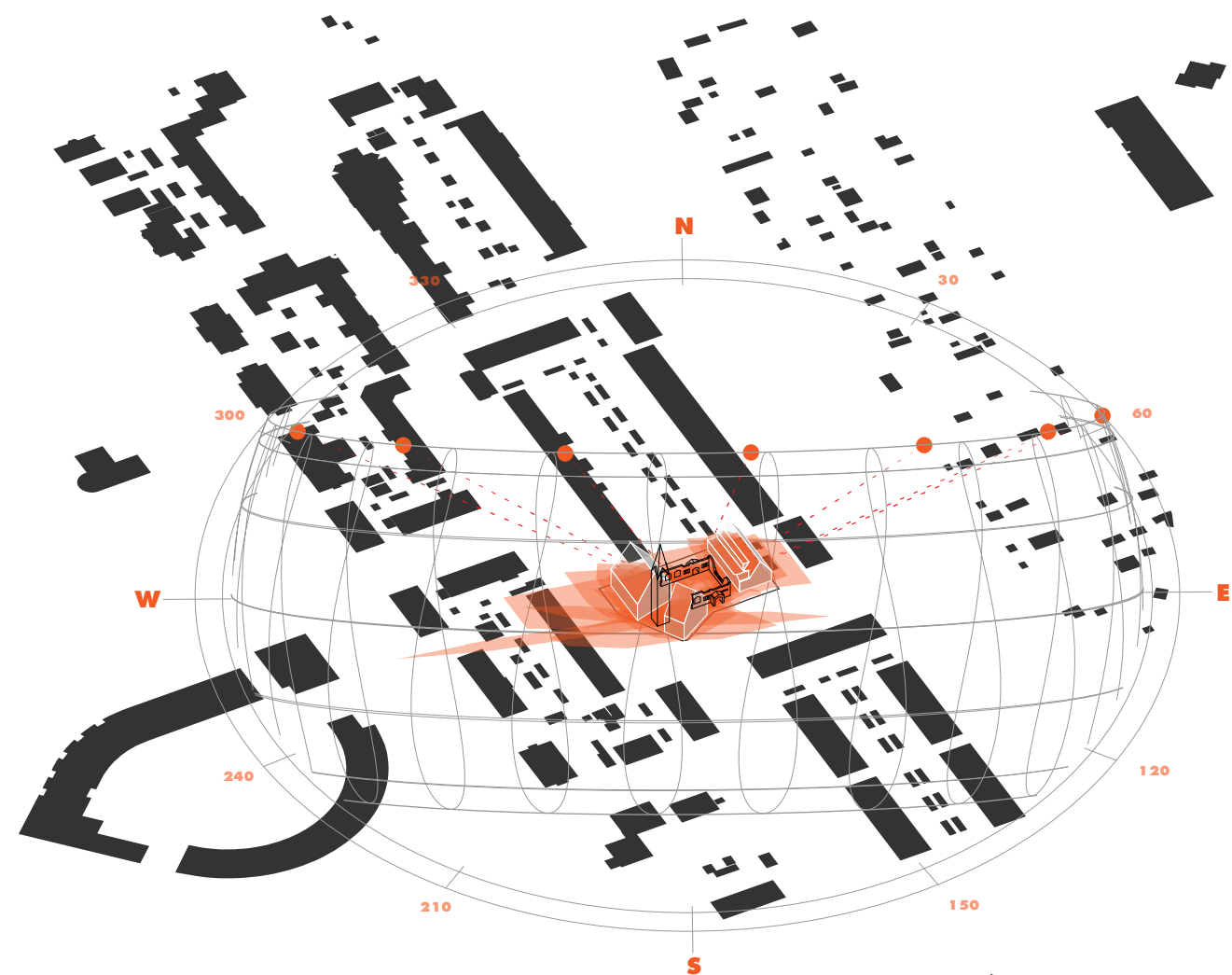











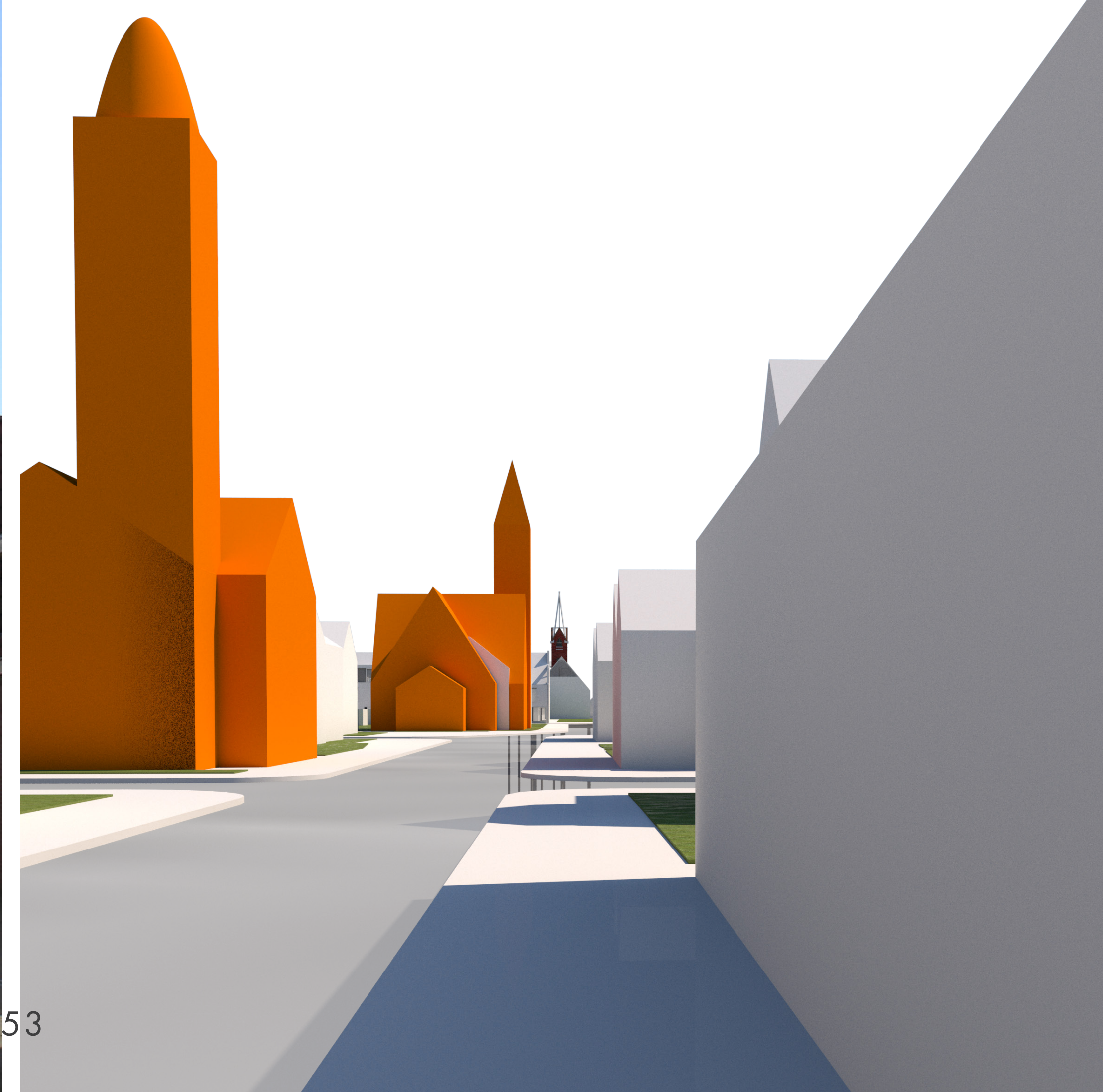



# NEW FOUNDATION

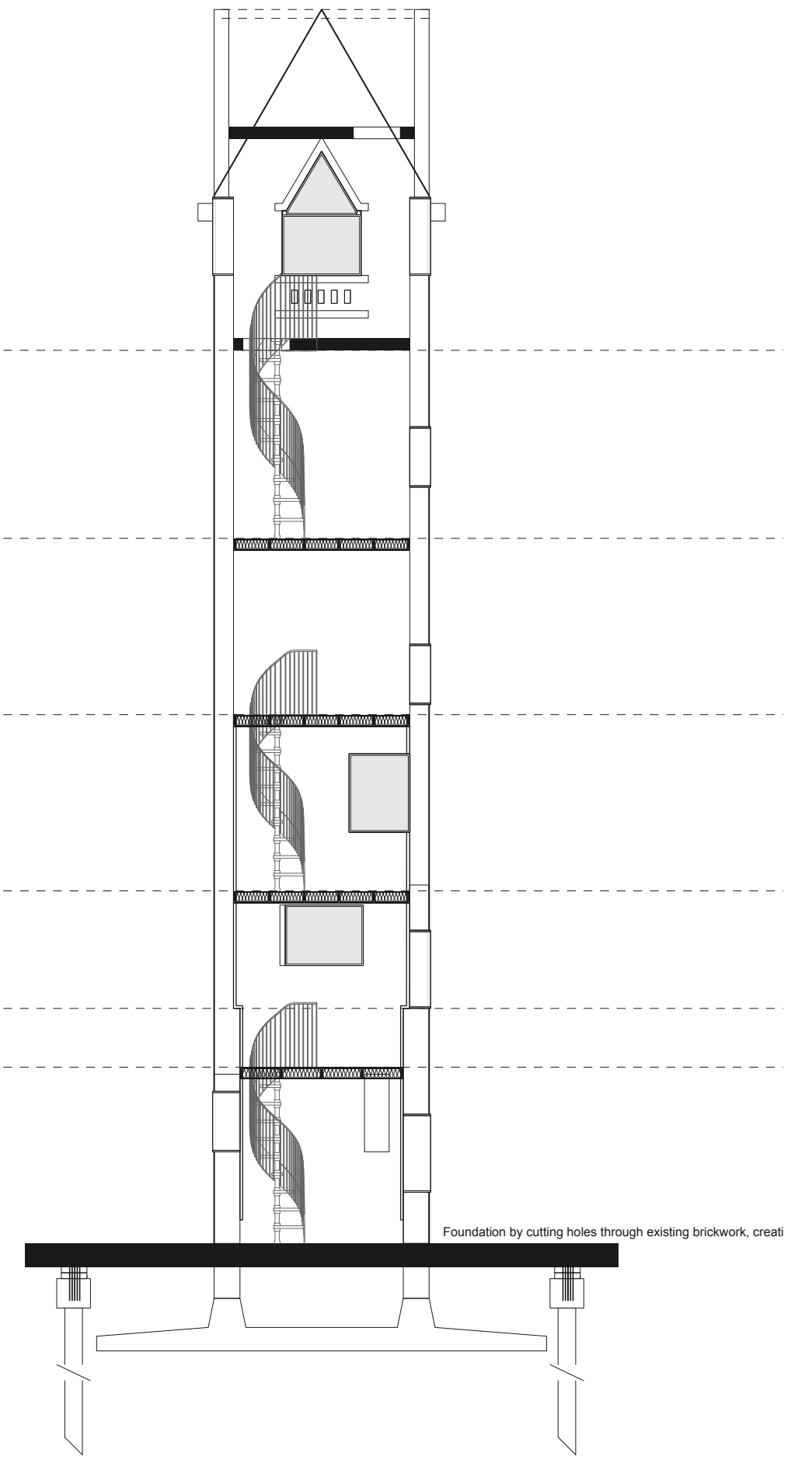
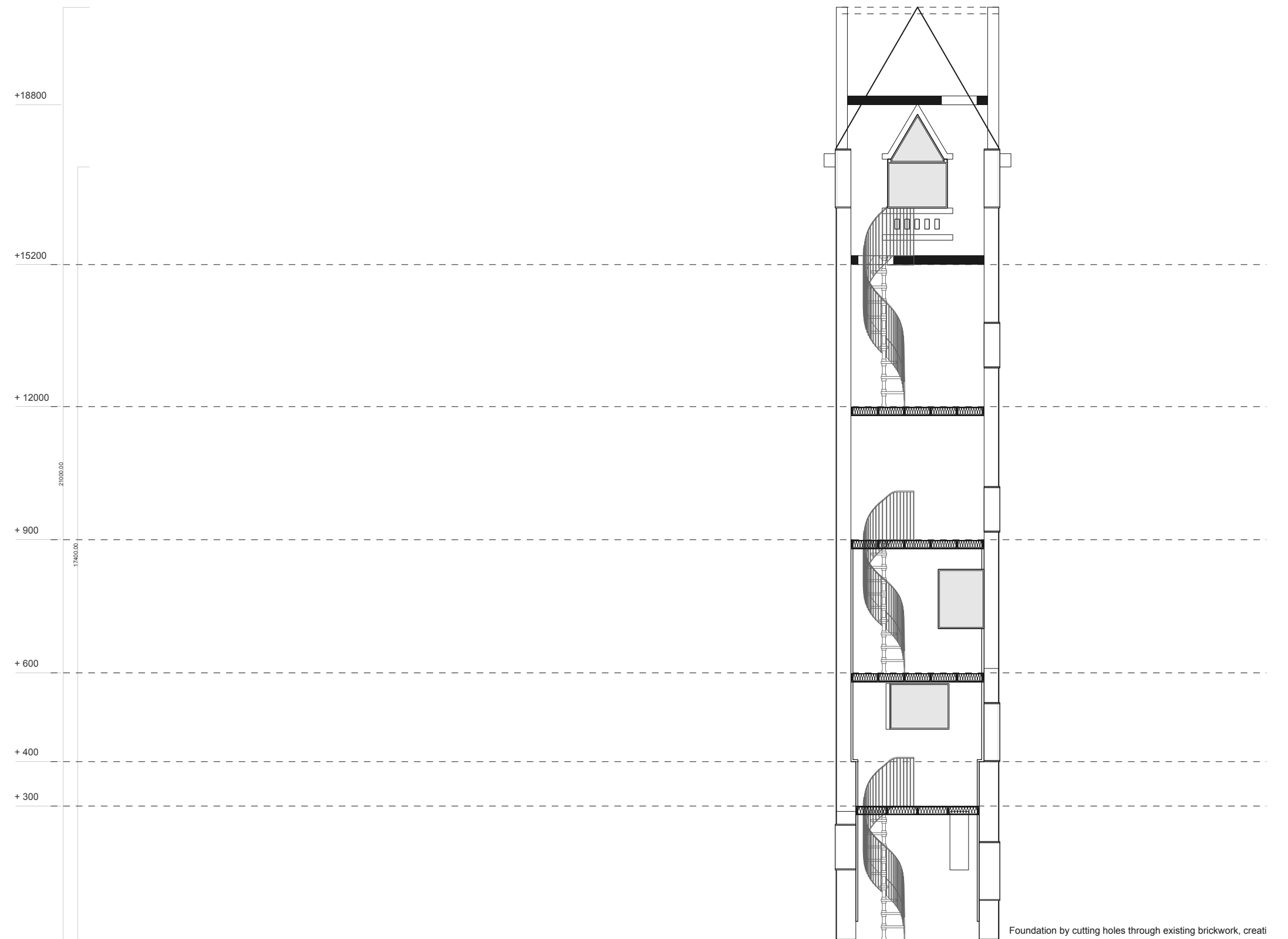
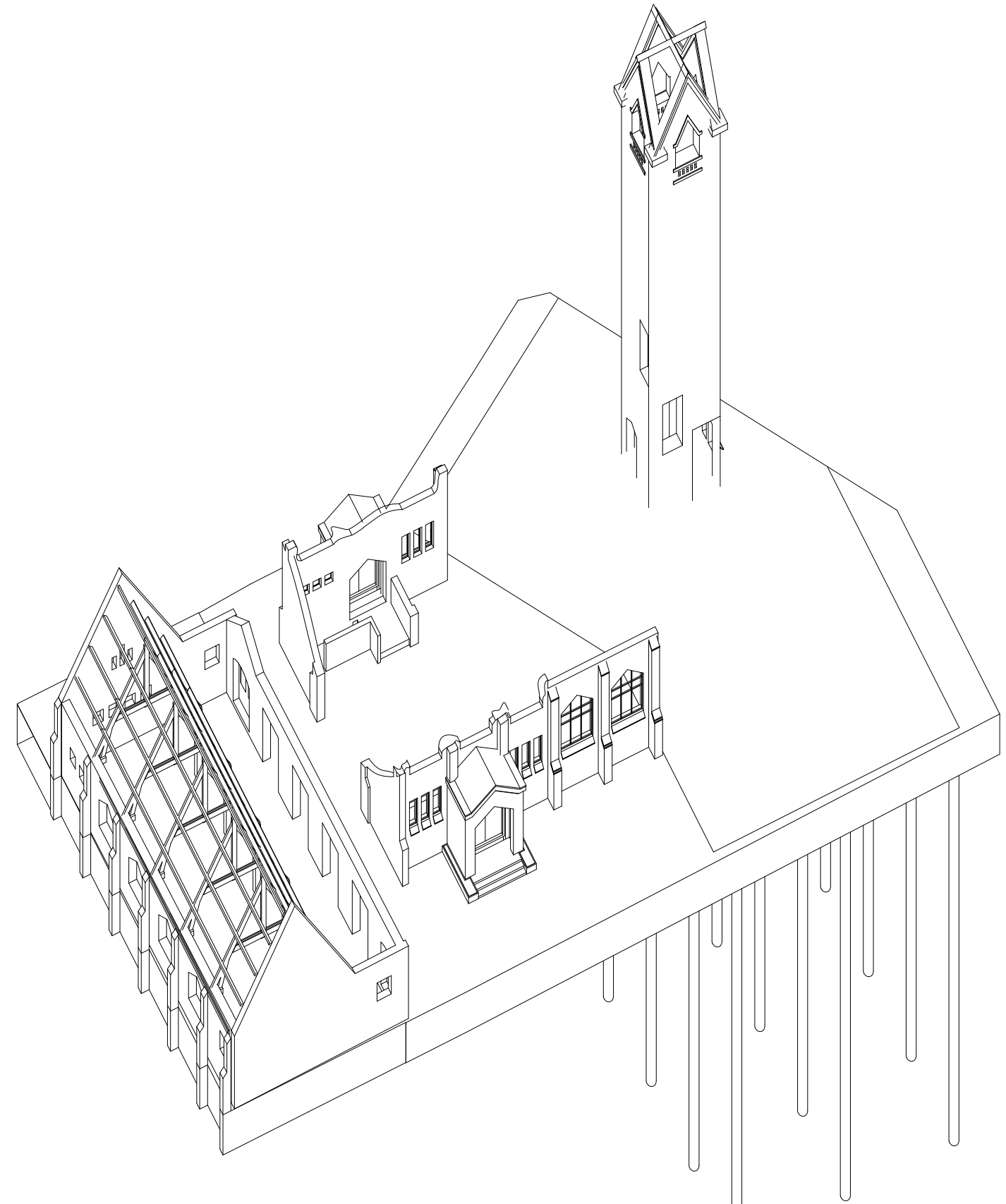



# RESTORE AND RENOVATE

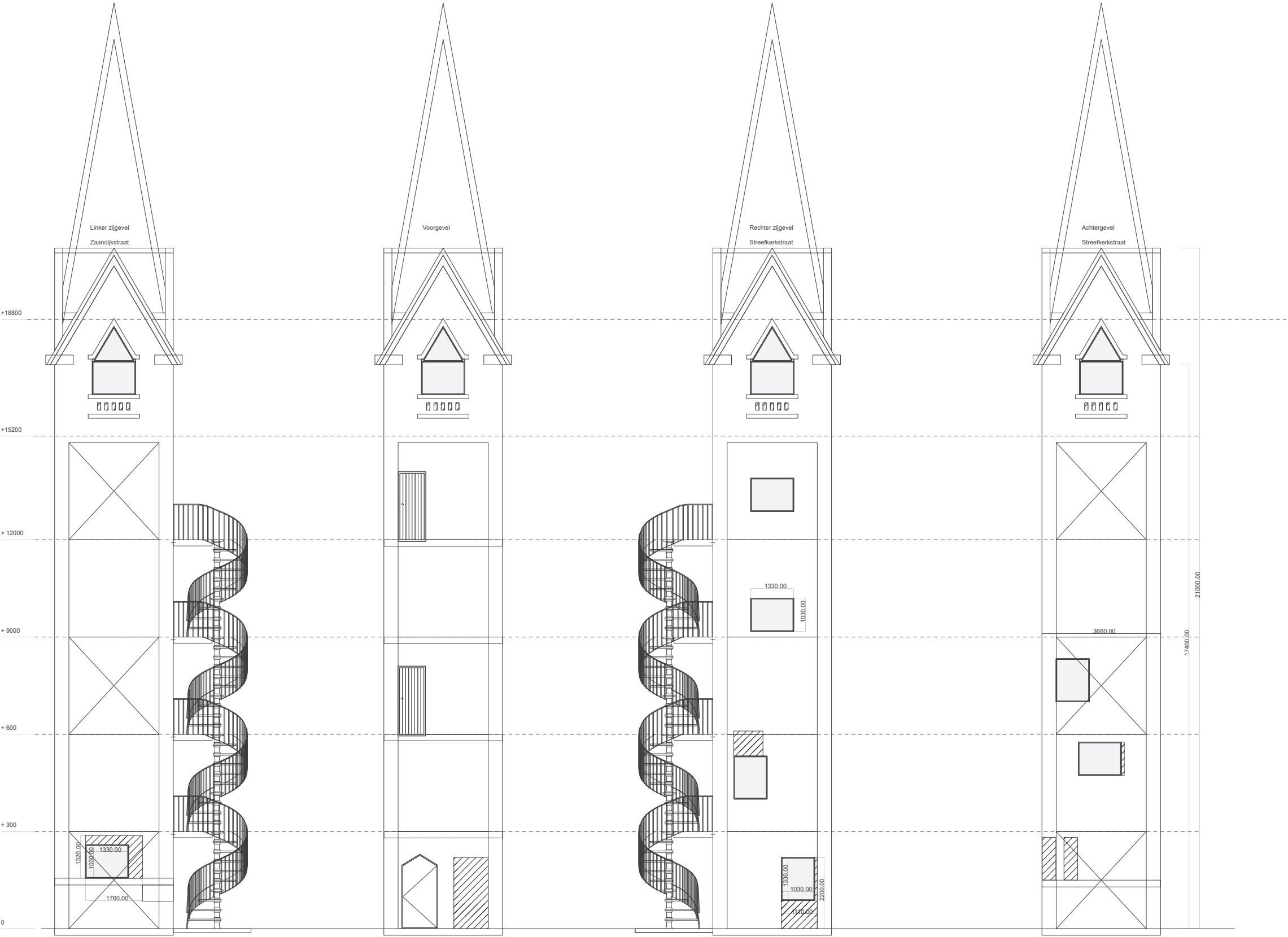
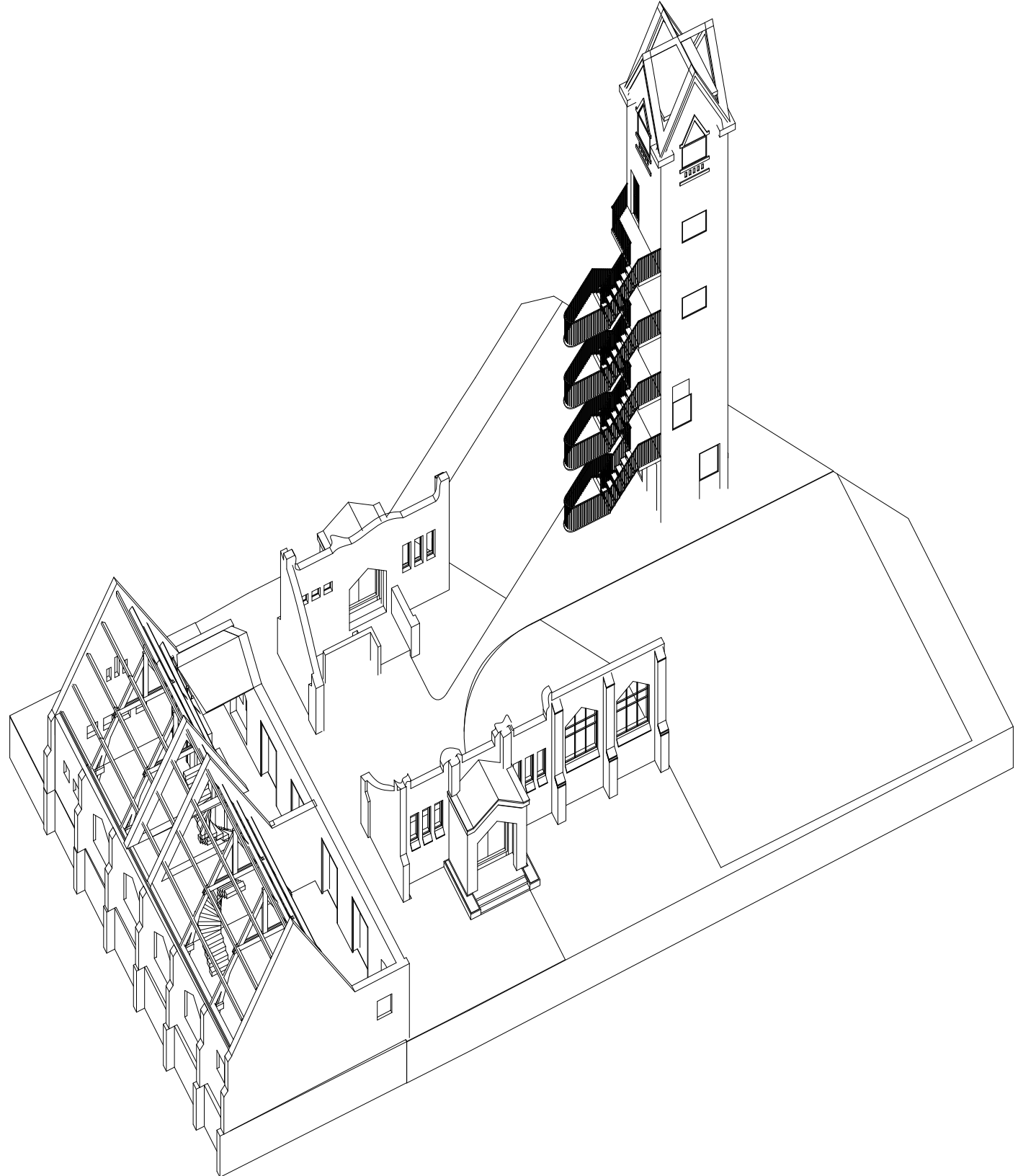



# FINAL PROGRAMME



STC, Franklin, Ampelman  
Temporary workers RDM  
3 Studio Units  
3-4 temporary workers  
rent

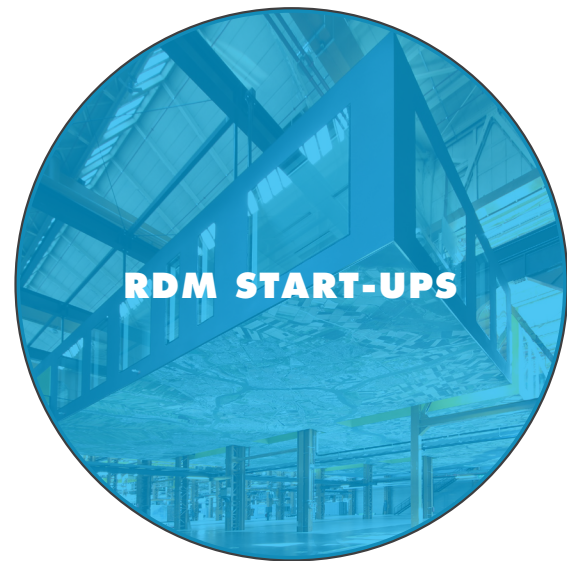

Start-ups/Starters  
RDM  
7 Apartment Units  
7 starters (+ baby/spous)  
sell



Students  
RavB, Automotive  
1 Student house  
~5 students  
rent

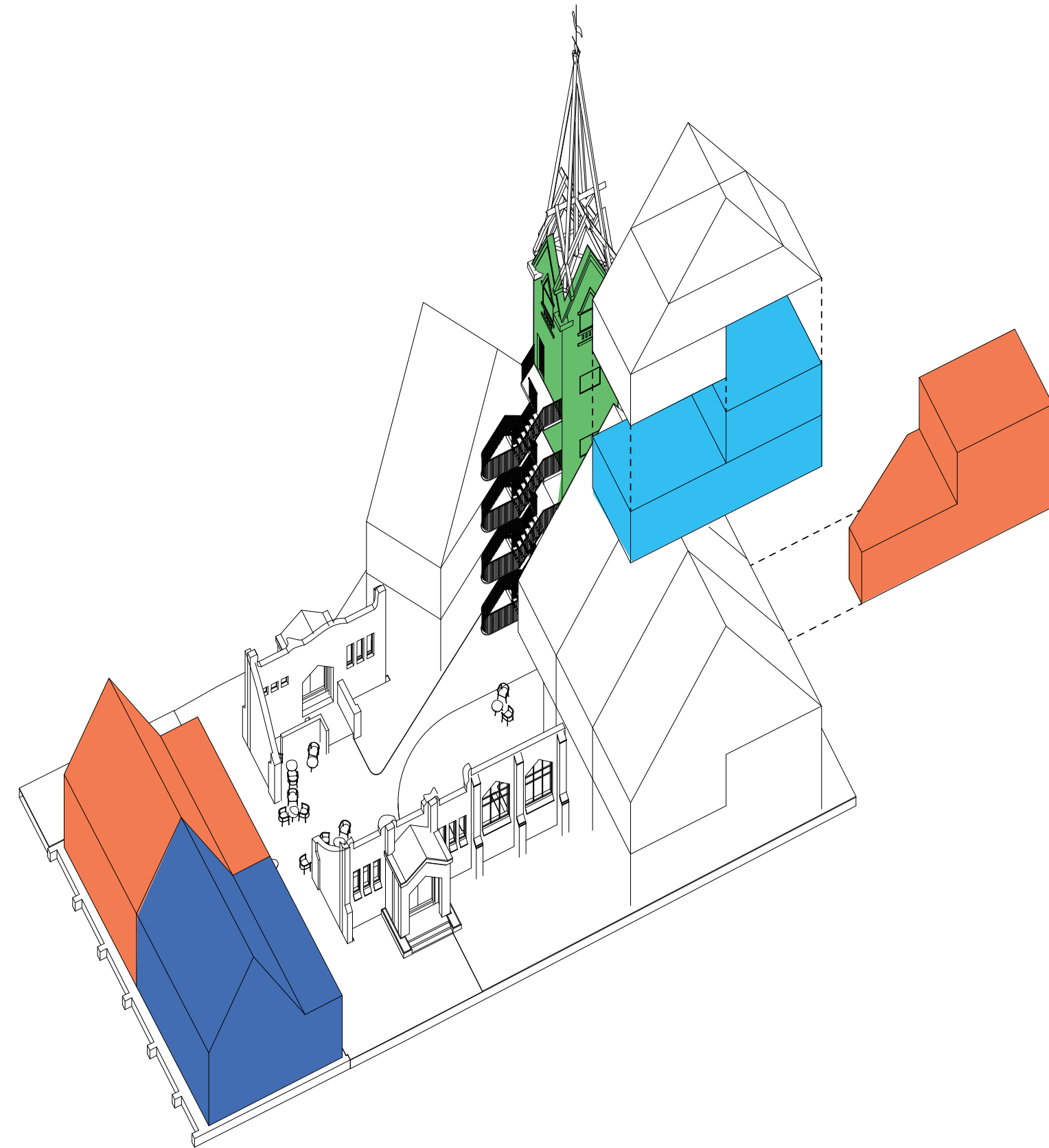



# FINAL PROGRAMME

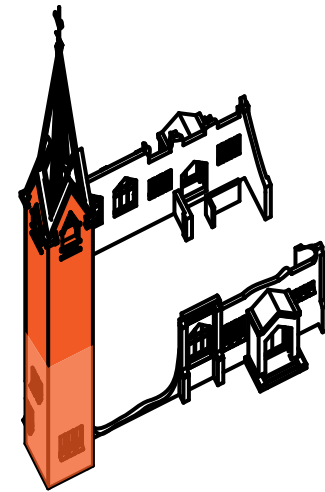

HOTEL  
PUBLIC

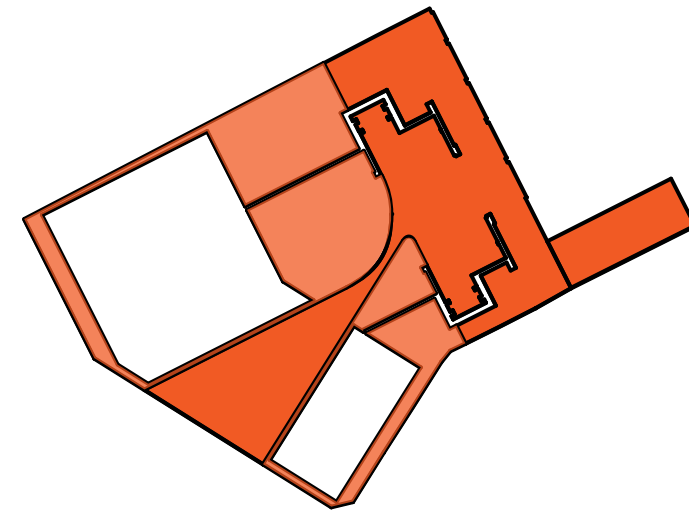

MOTOR  
(SEMI) PUBLIC

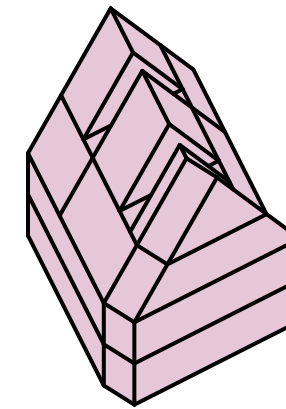

LIVING  
PRIVATE

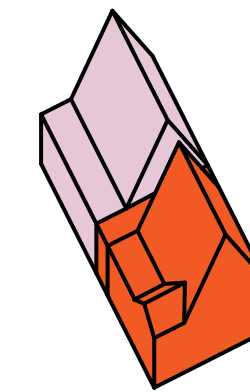
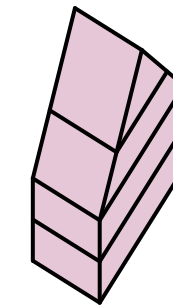

PAVILION/  
LIVING  
PUBLIC/  
PRIVATE



# DESIGN MATERIALIZATION

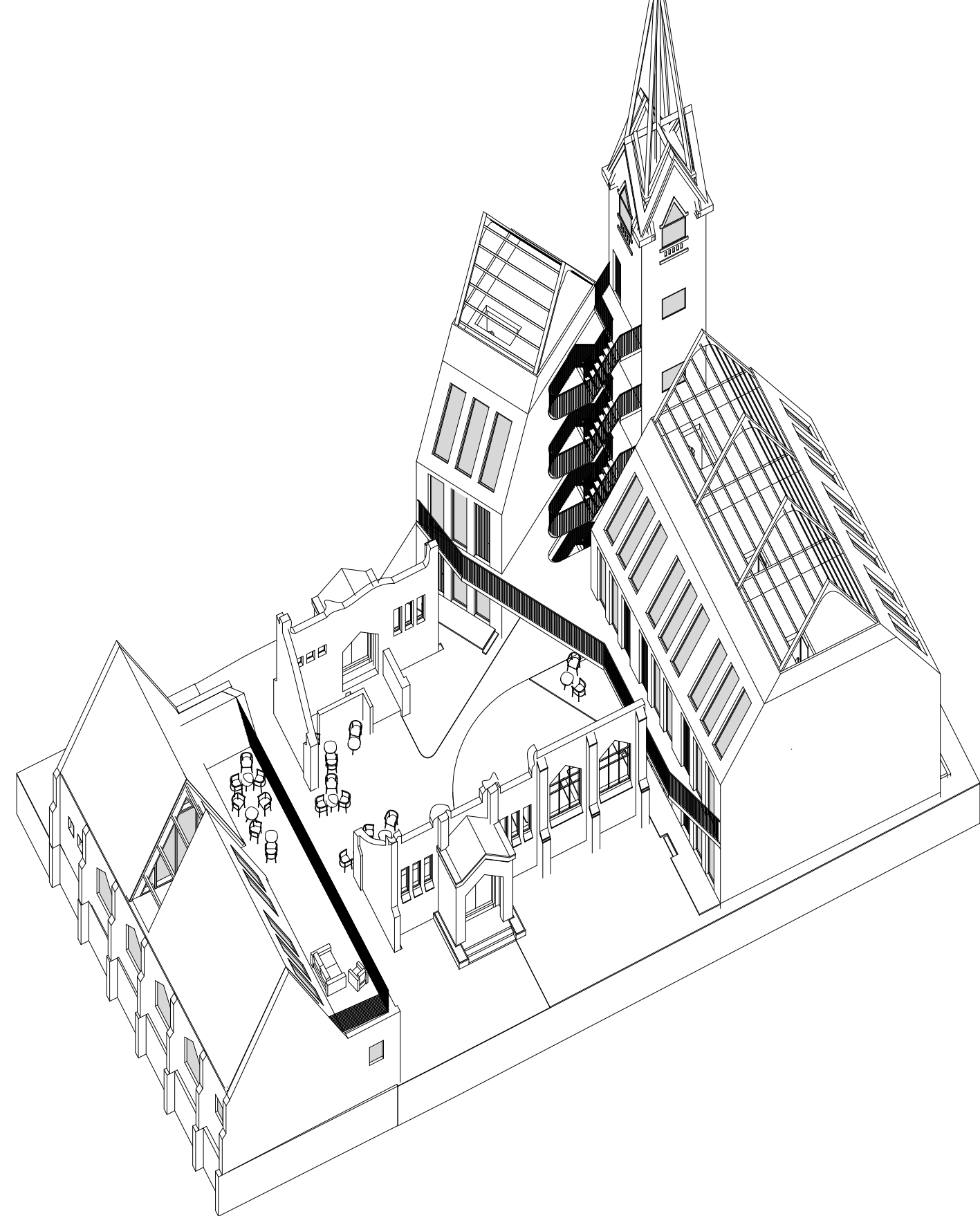

Re-used bricks  
through terrazo

Flooring garden

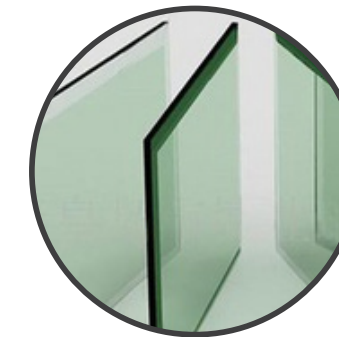

HR++ Glass (3  
dubbel)

Openings



Steel plate finishing  
white

Main Volumes

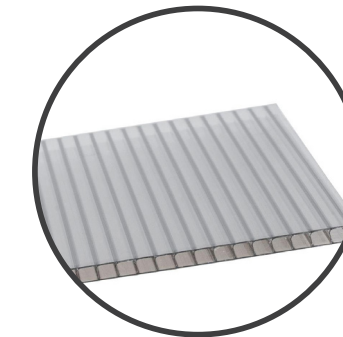

Polycarbonate

doors and highlights



Steel cables

Bridges and Tower



Cross laminated  
timber

primary structure



wood

construction  
elements for roof



steel

window frames and  
doors



natural isolation

recycled cotton



Greenery

highlights tower and  
garden

70% BRICKS



10% BRICKS



20% CEMENT





# FACADE

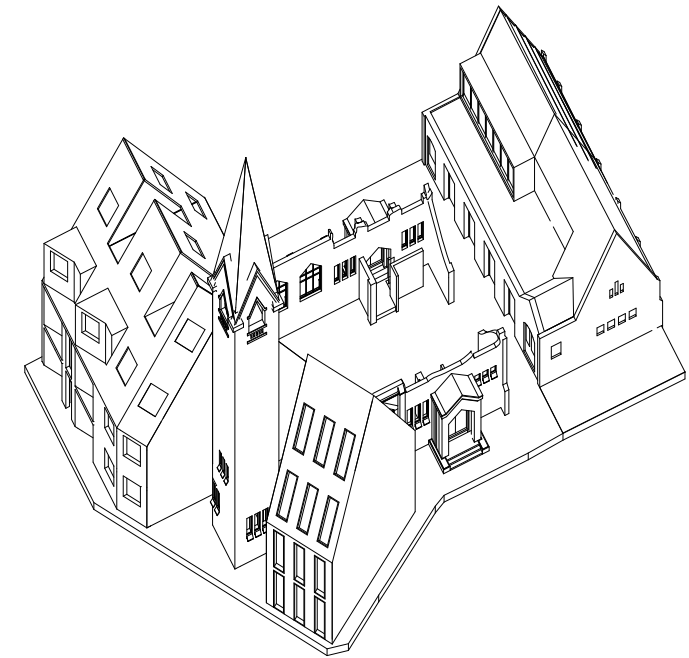
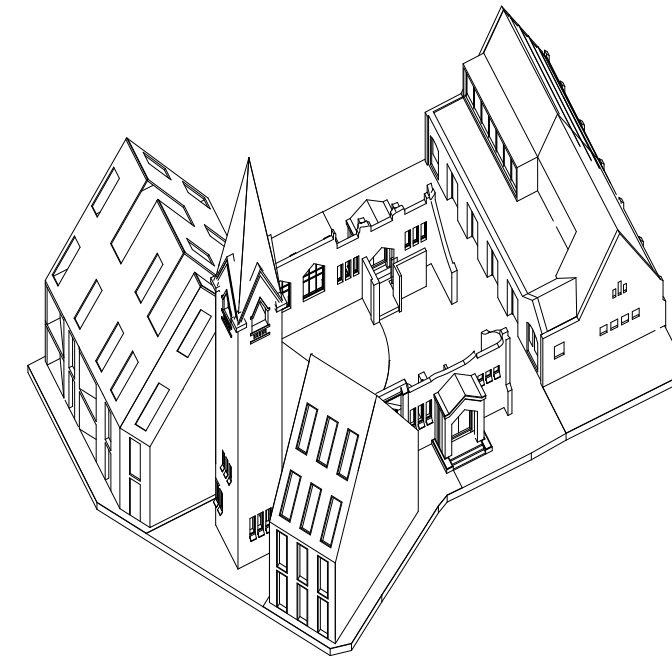
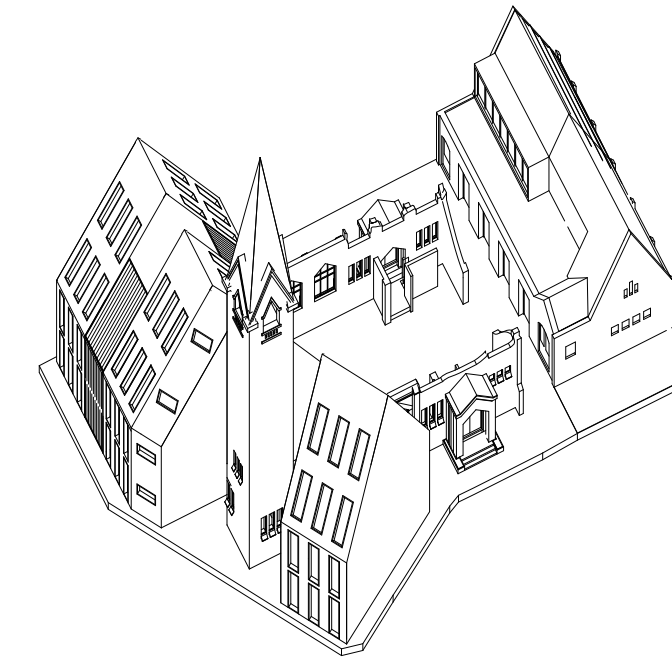
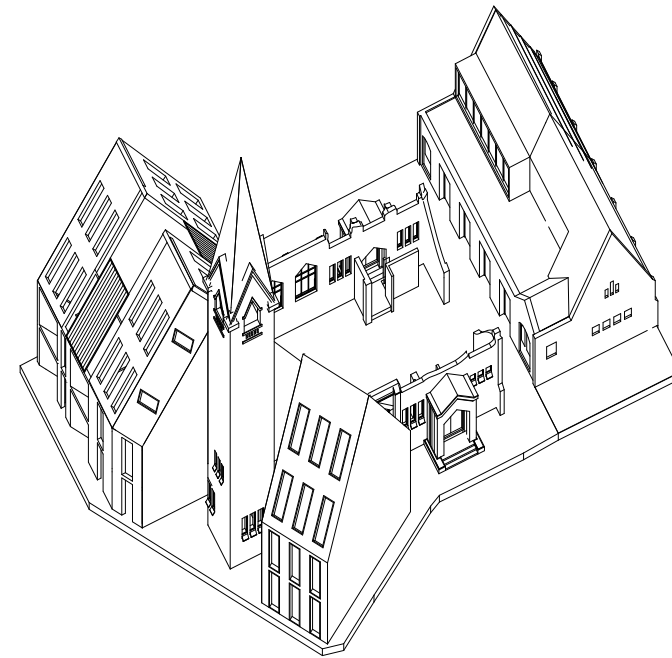
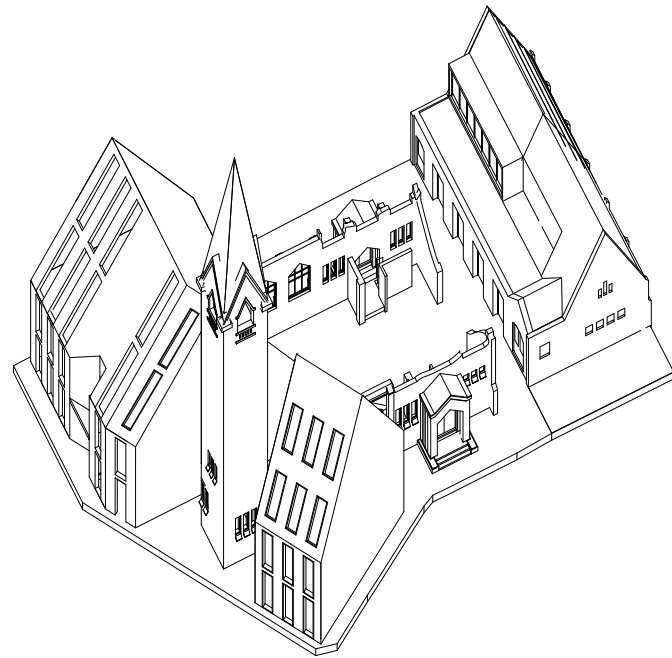
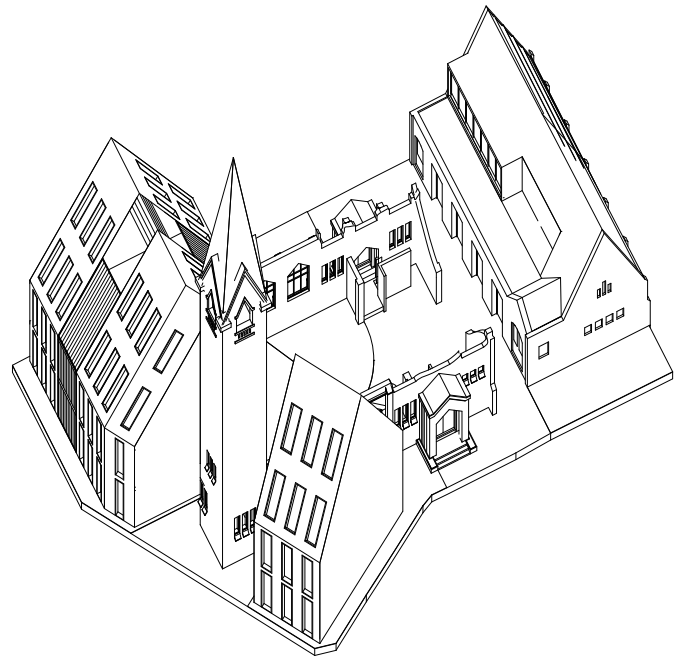
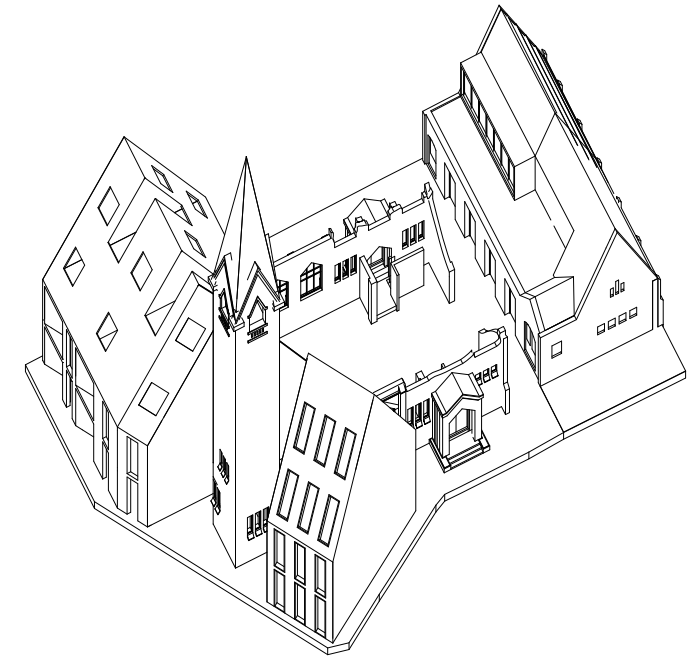
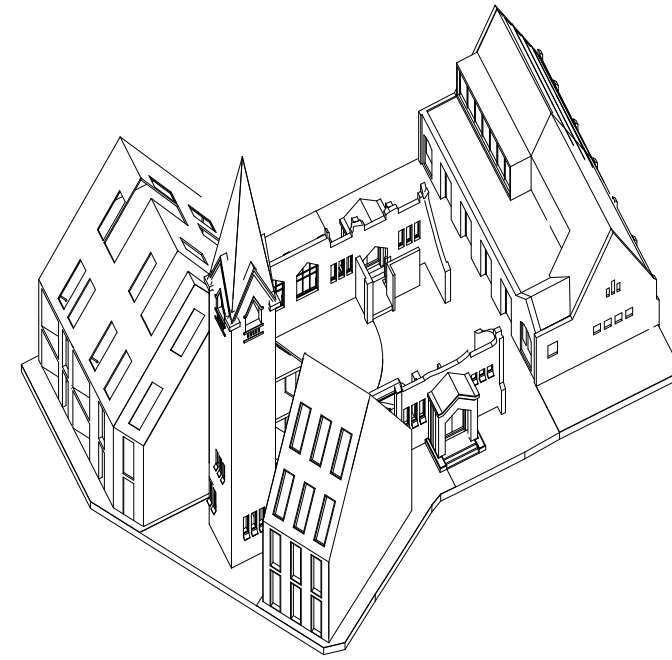
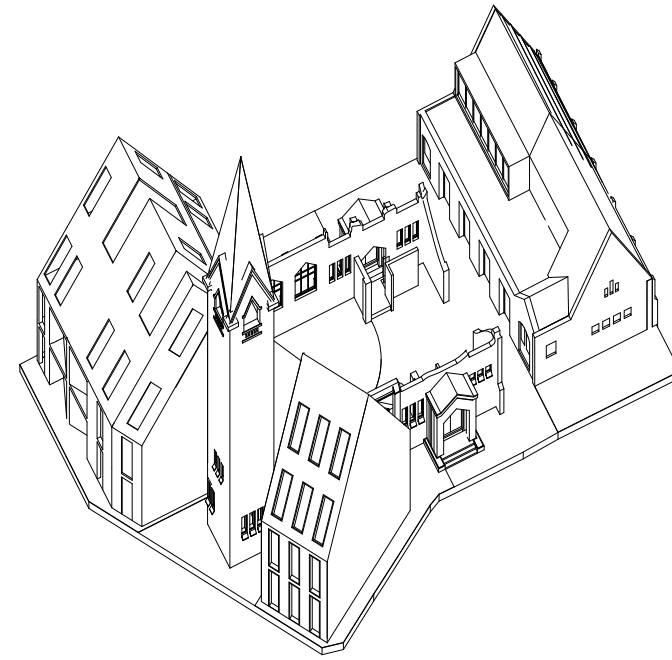
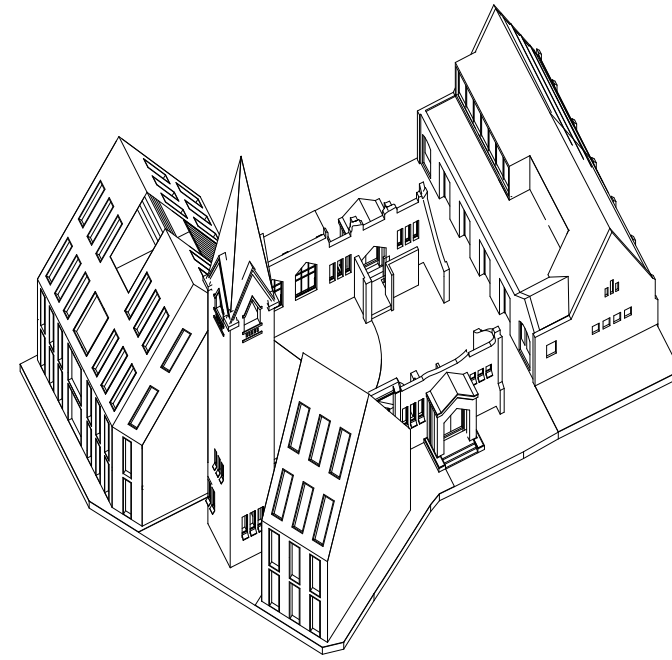
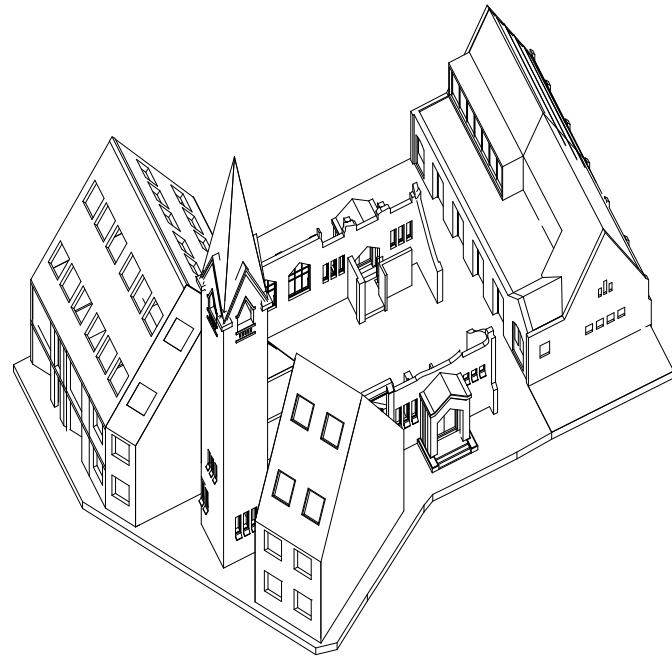
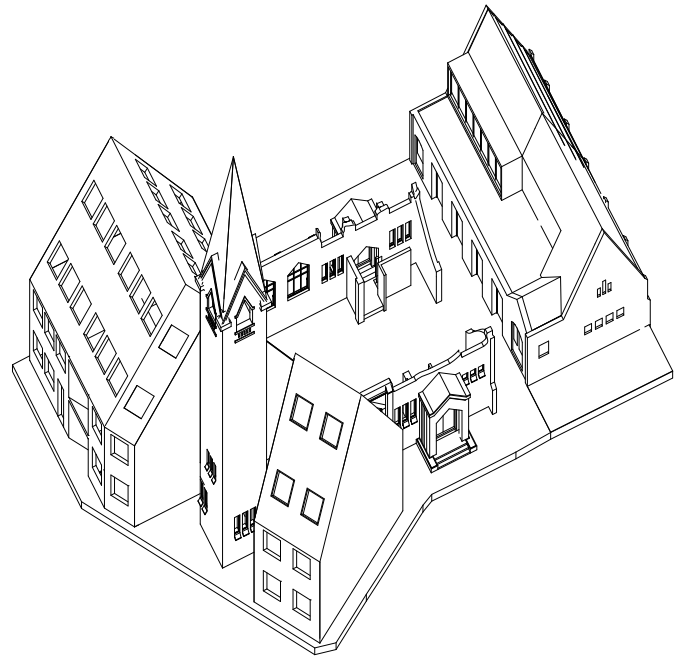



# FACADE

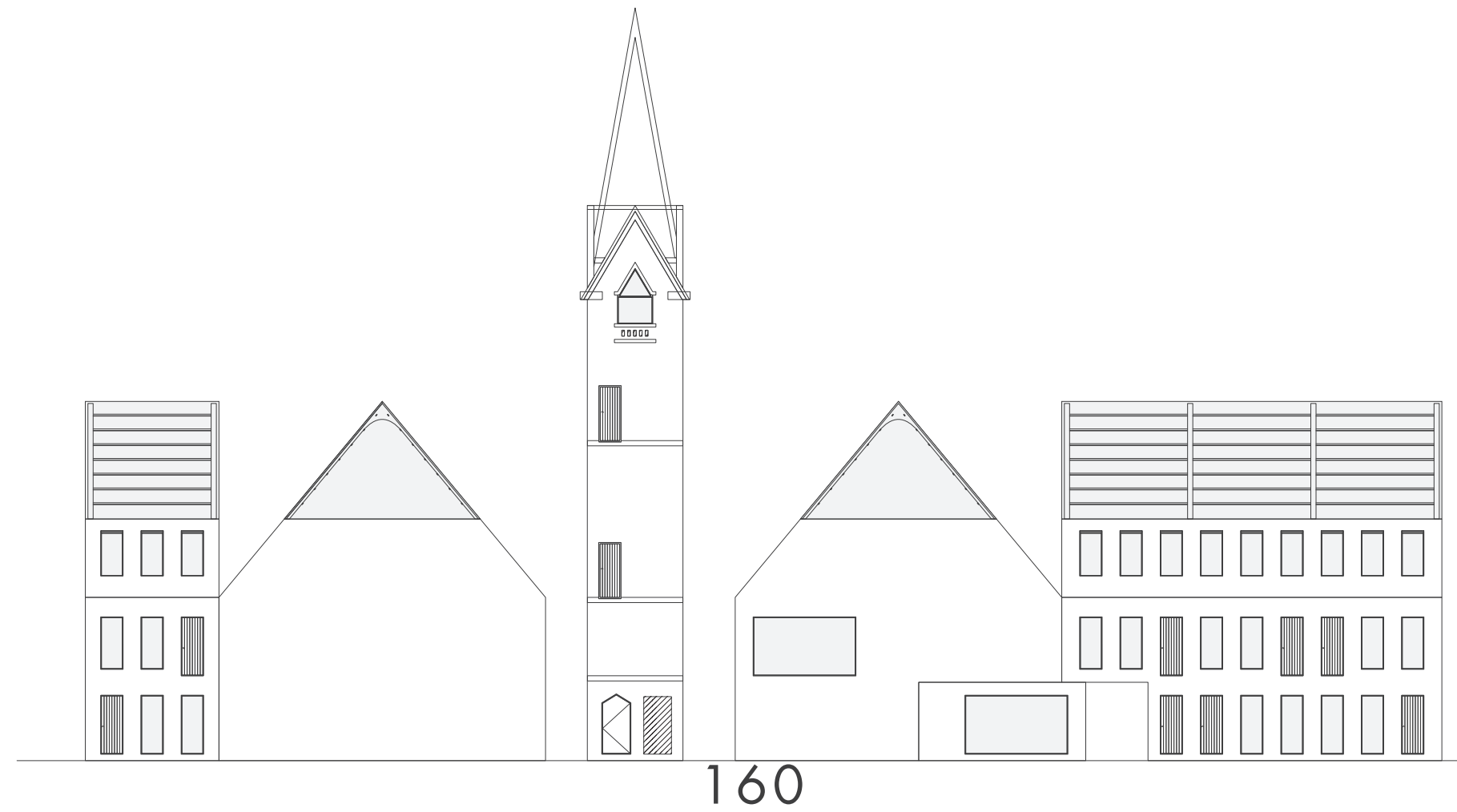
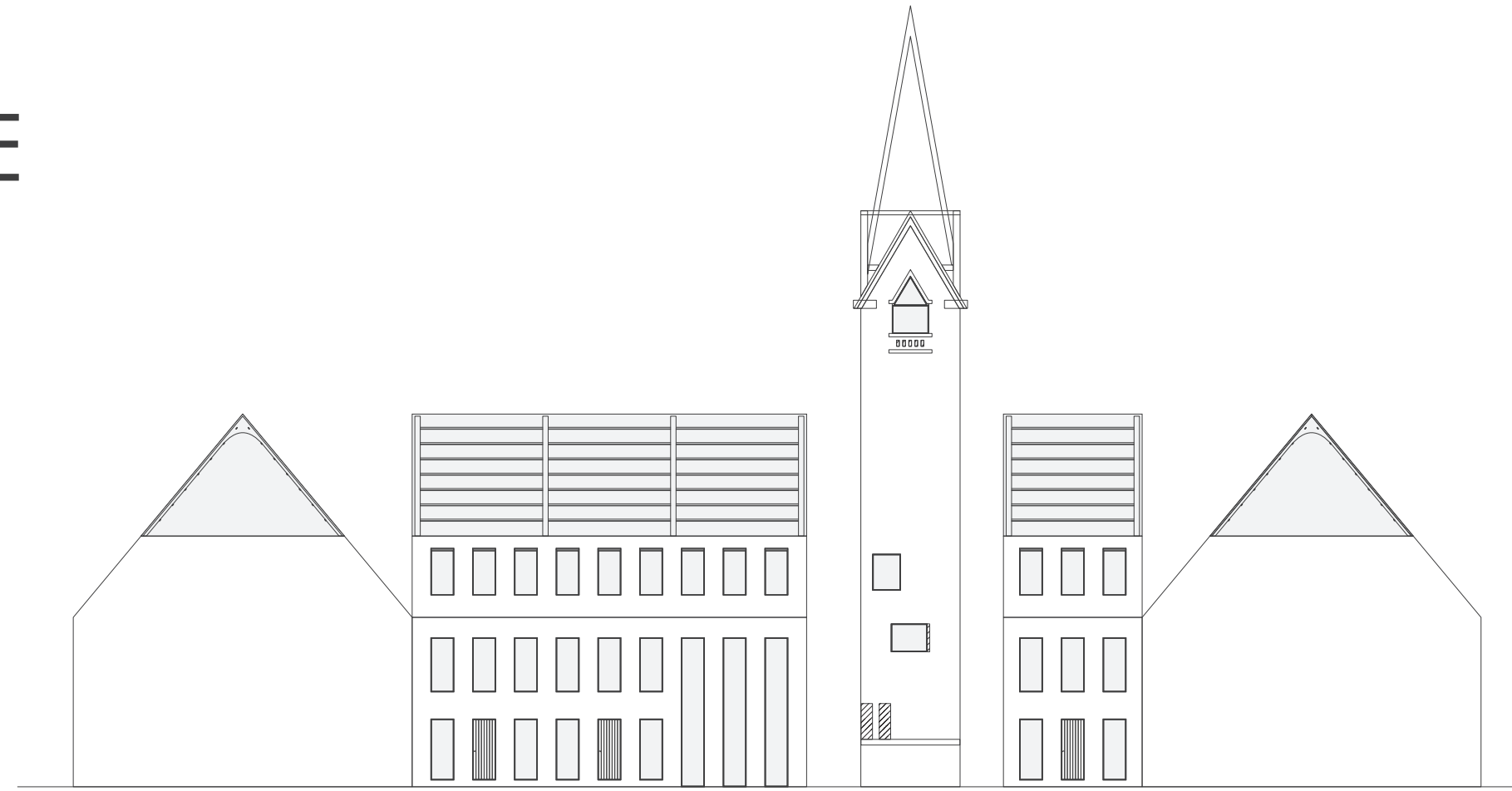

160



FINAL

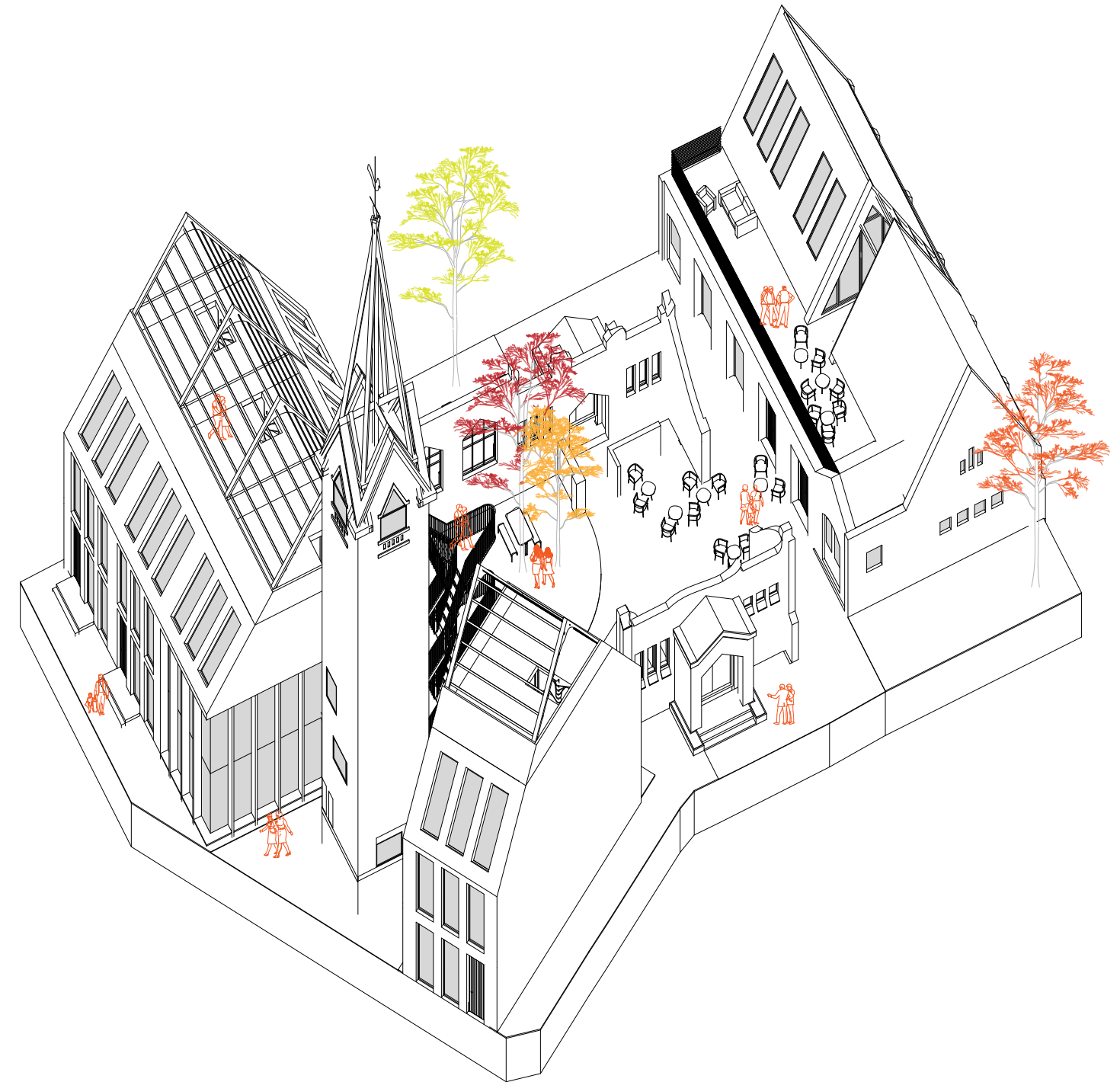
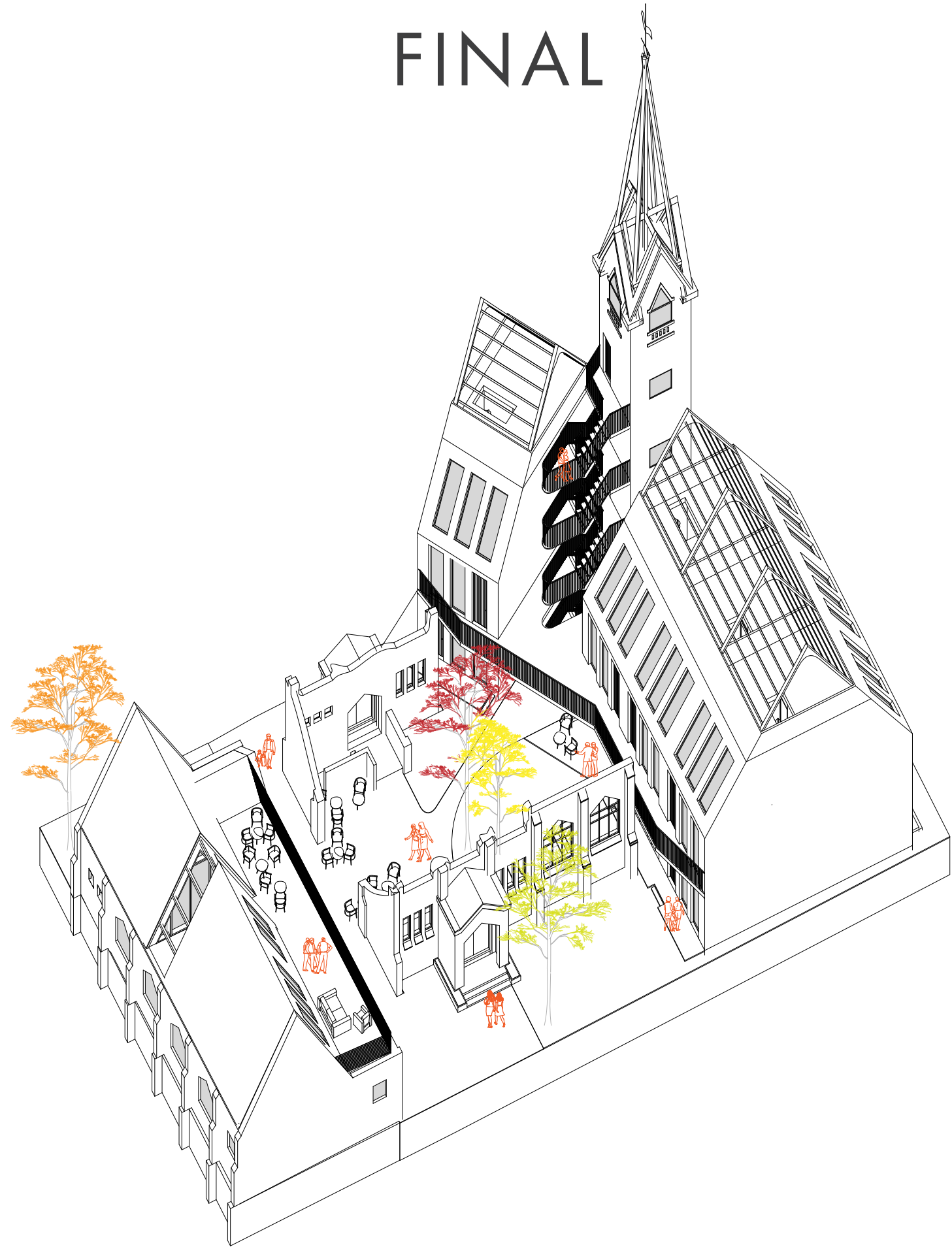



# PLANS





# PLANS

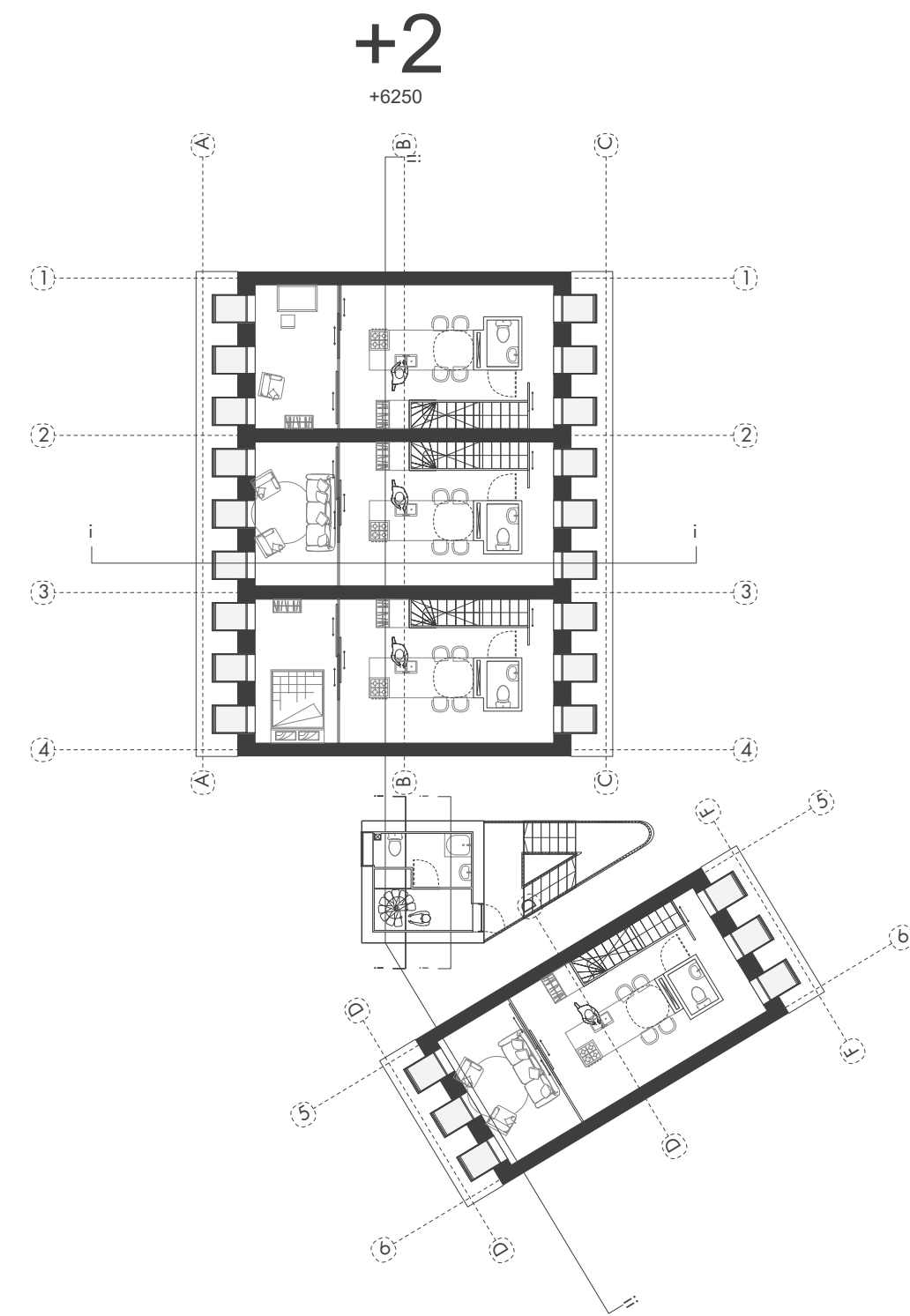
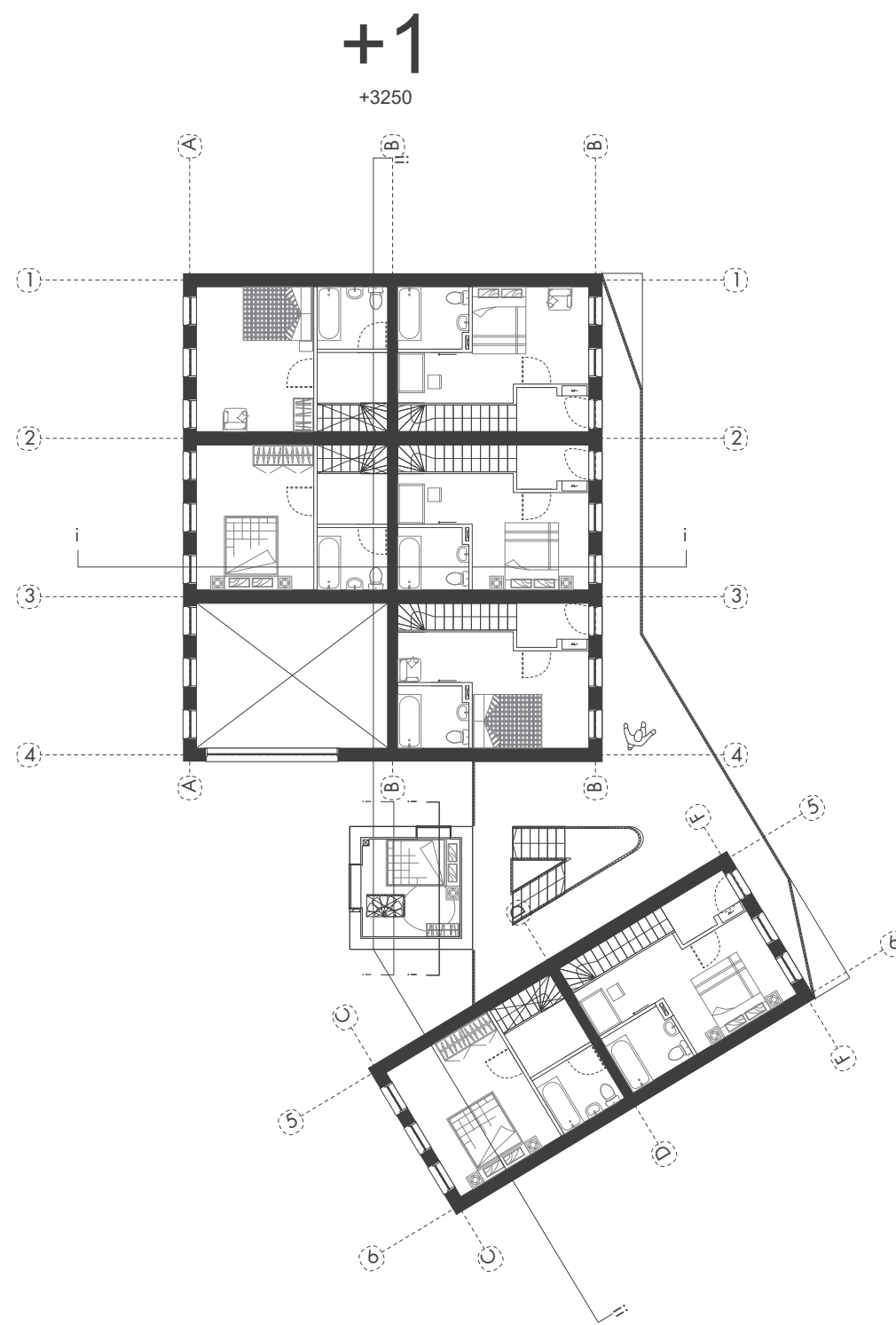
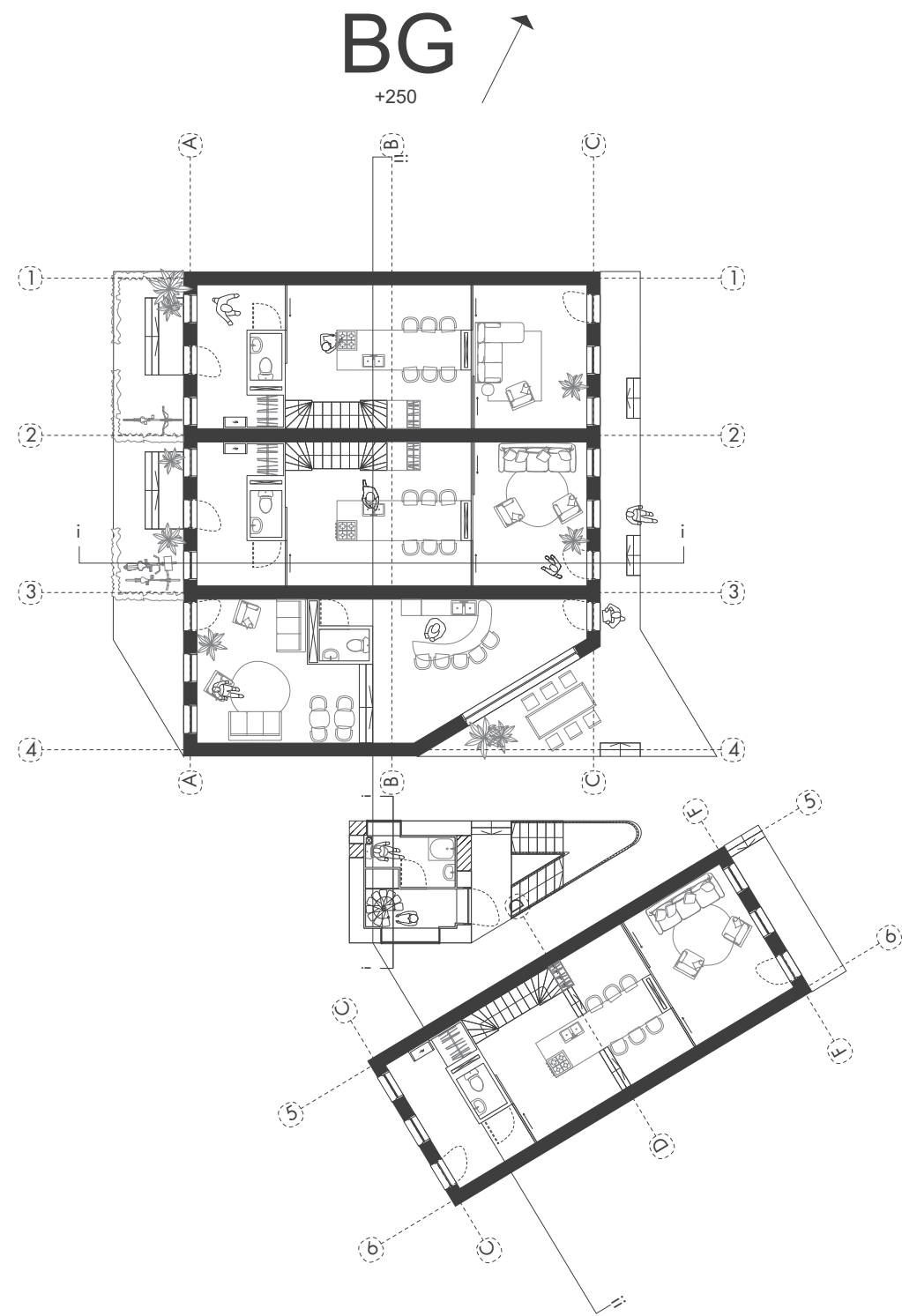



# PLANS

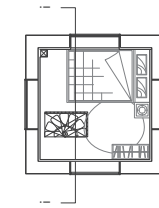
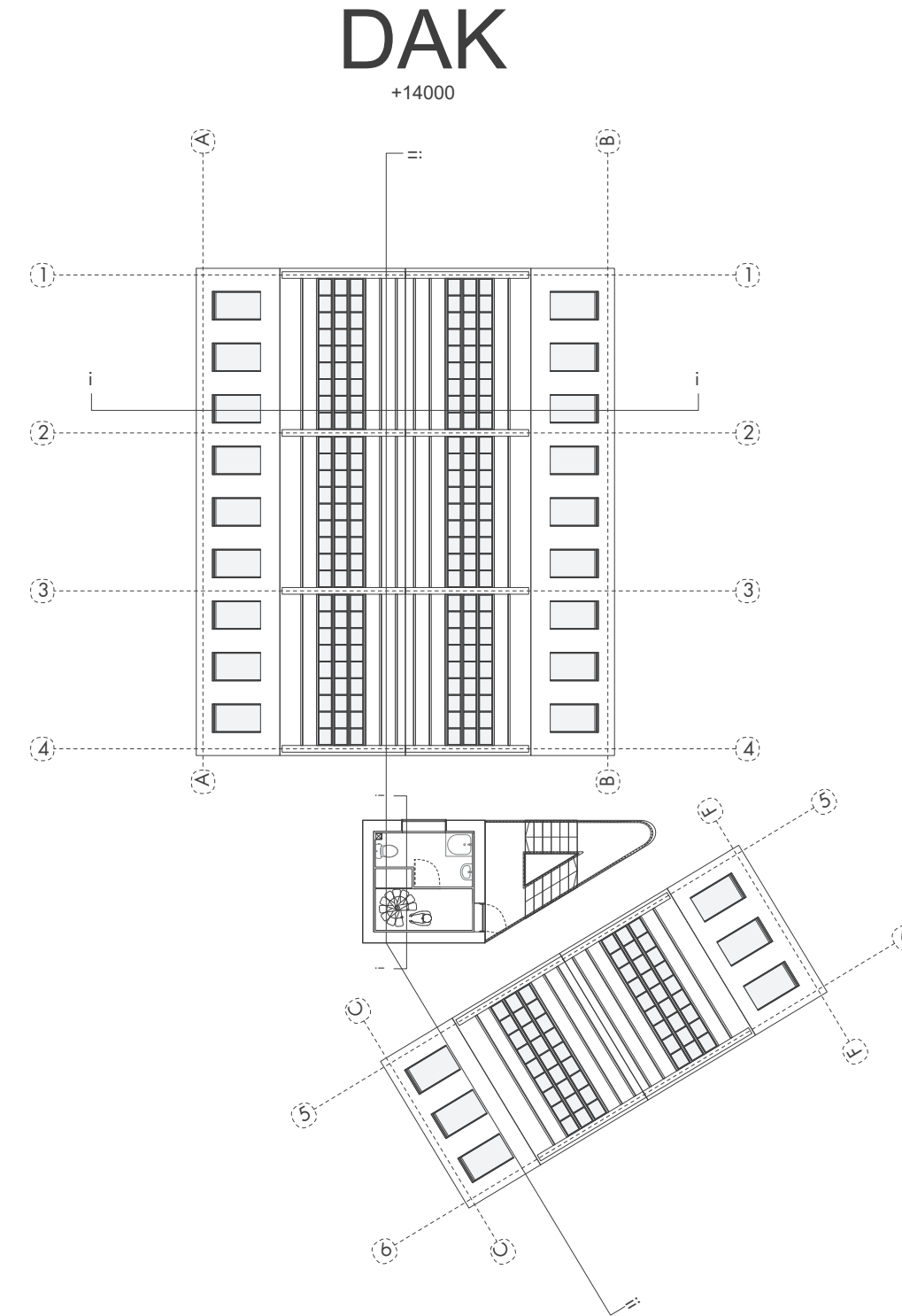
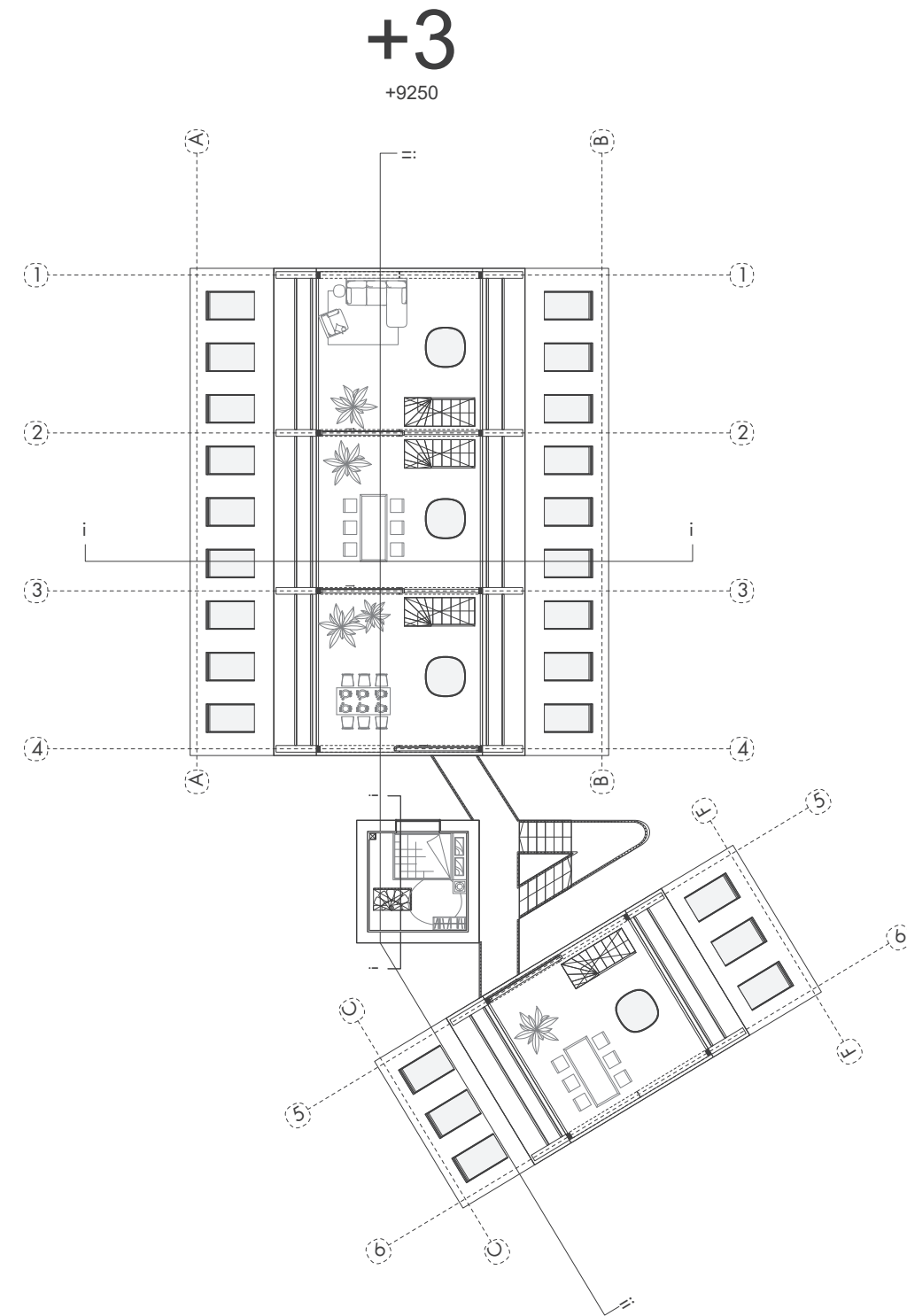



# PLANS

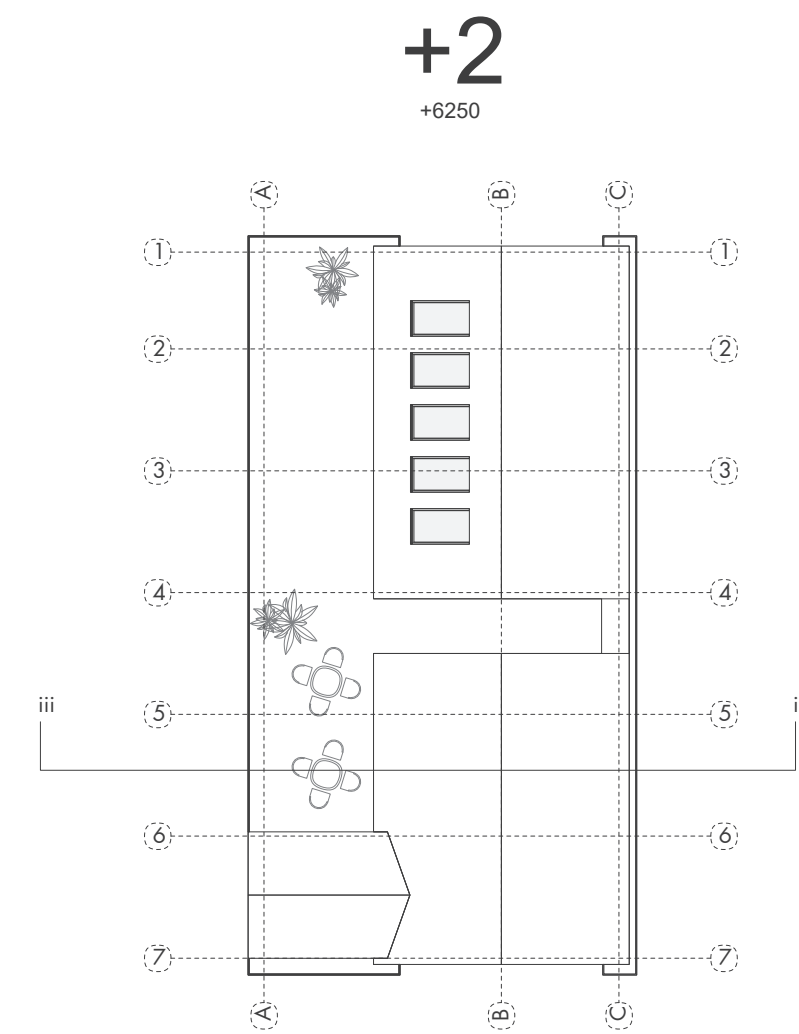
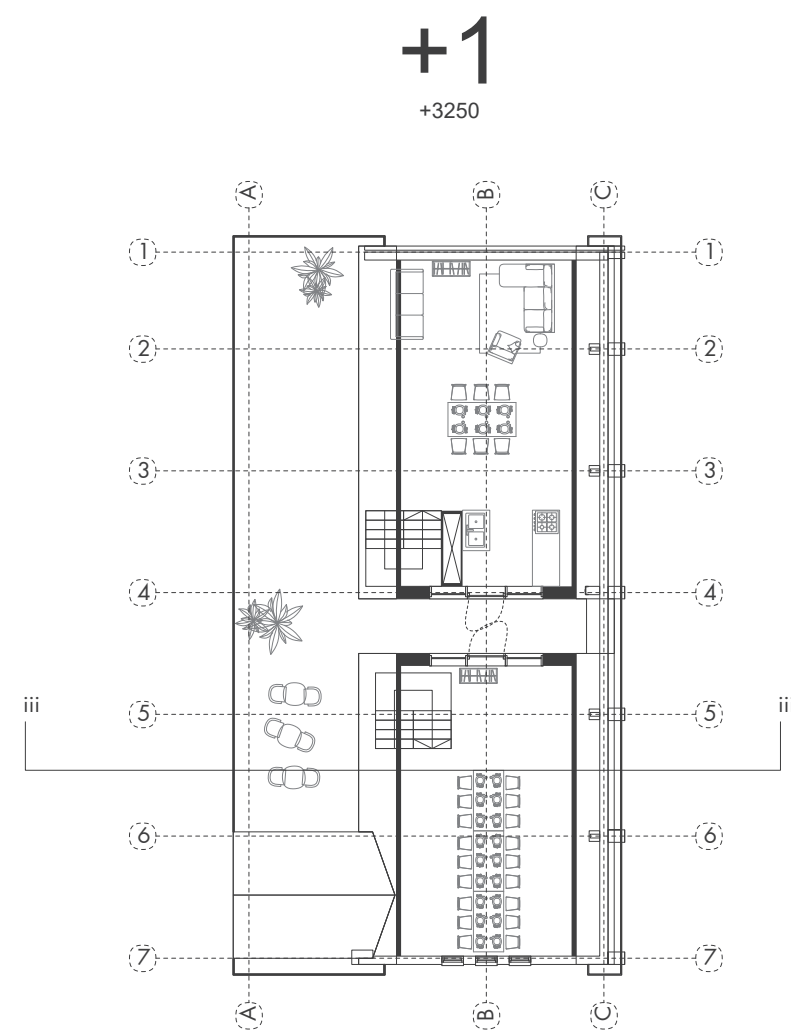
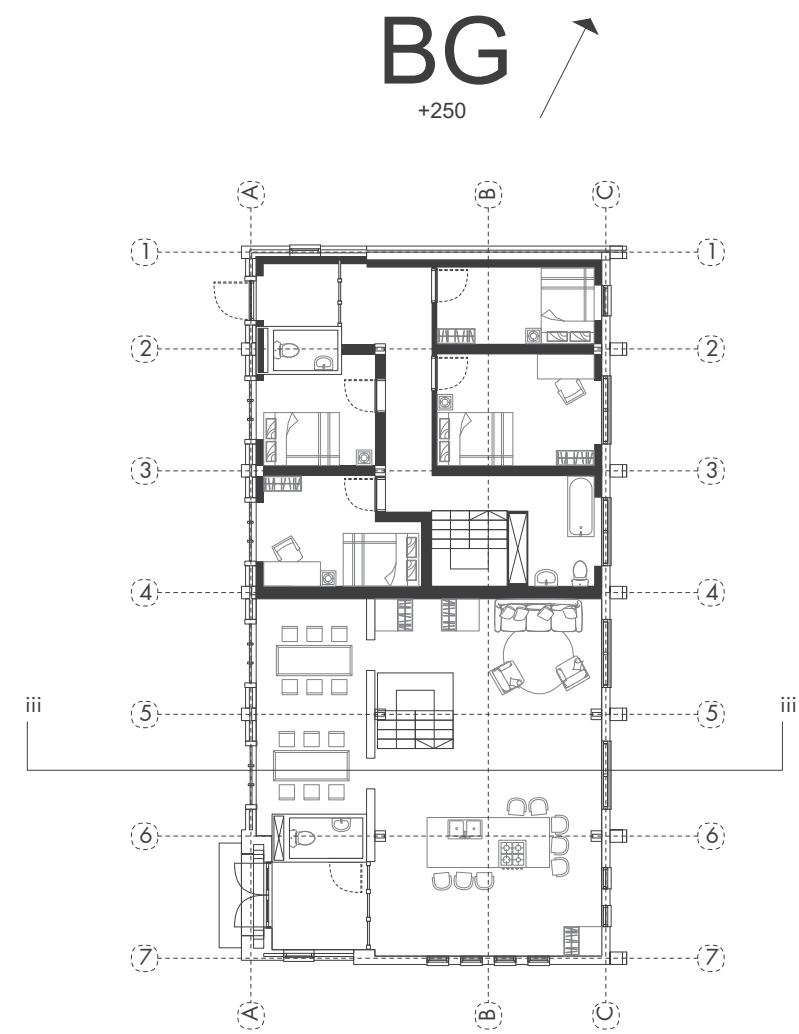



# SECTIONS

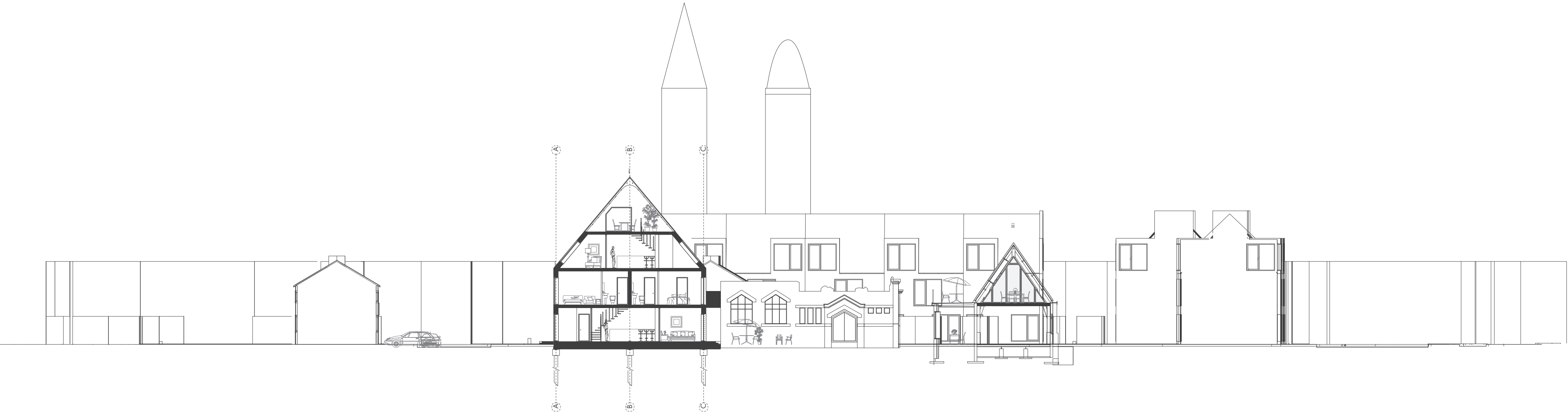



# SECTIONS

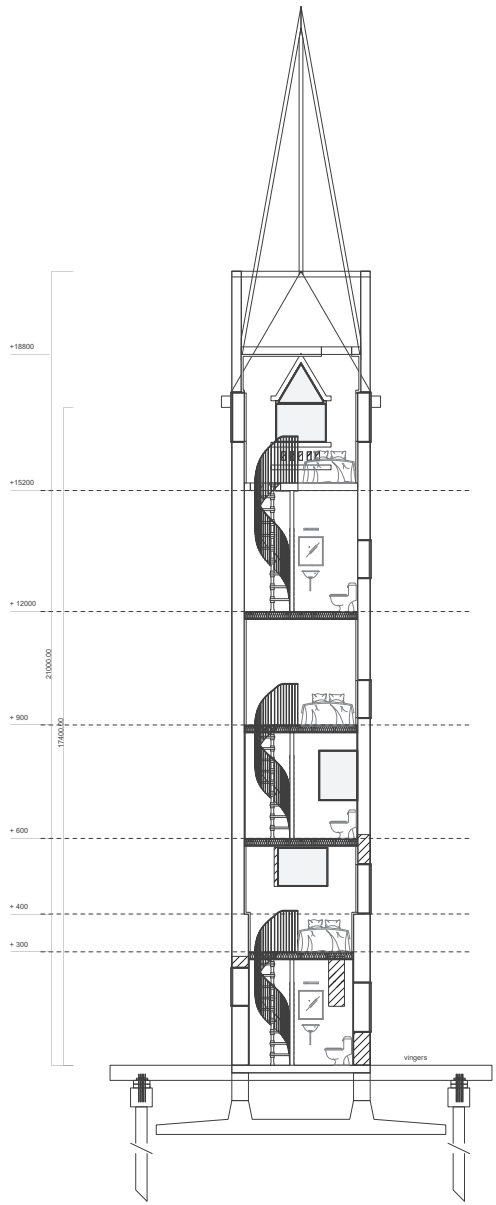
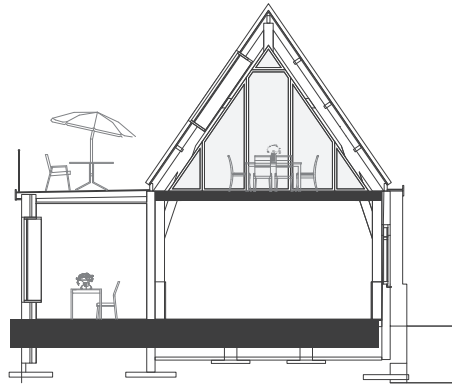
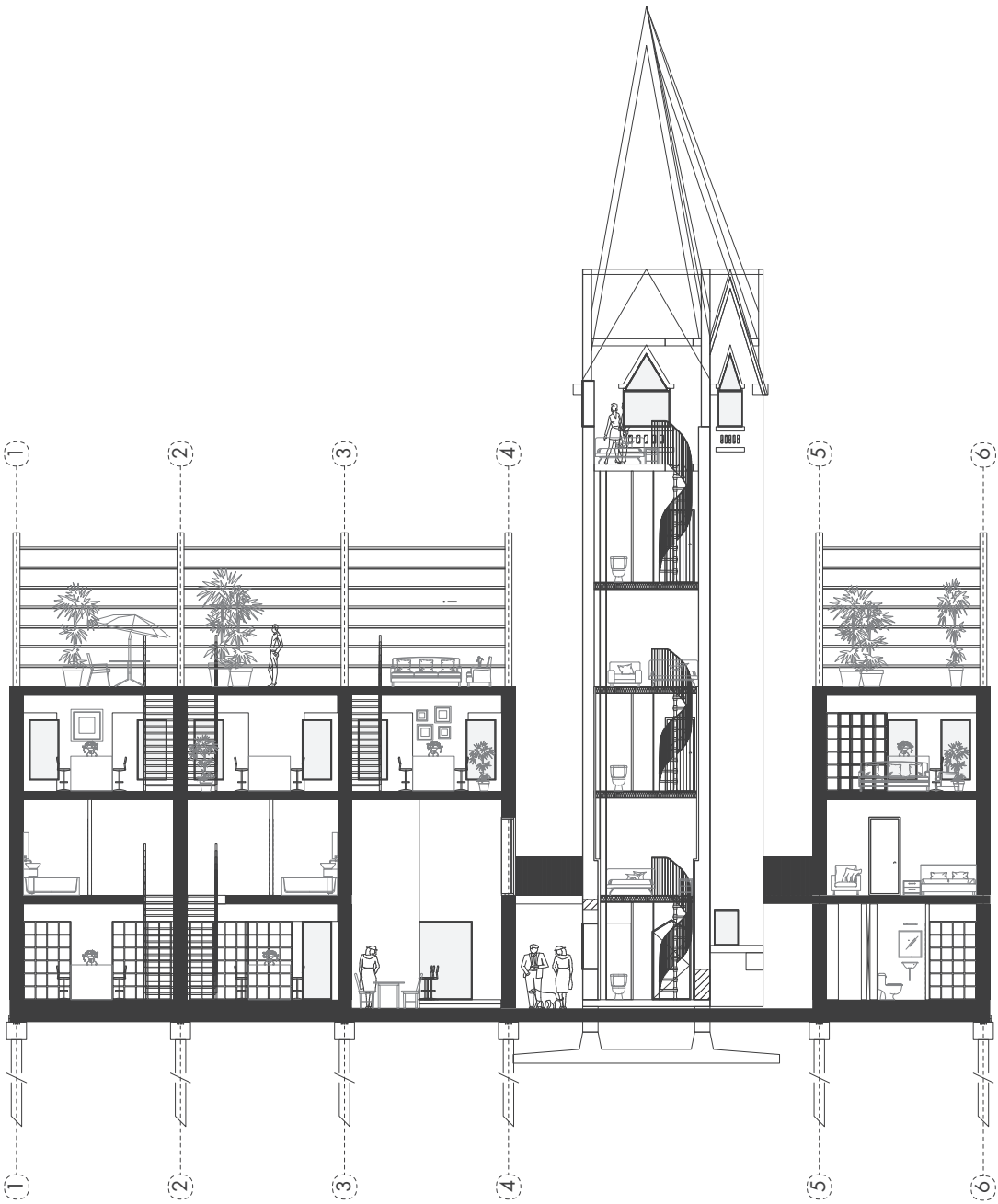
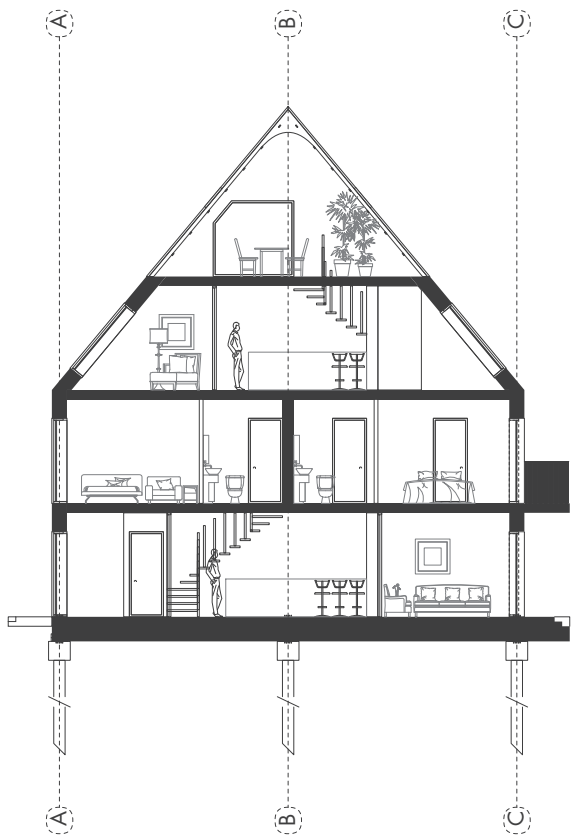





168



## ZOMER

- hoogwaardige thermische schil houdt warmte buiten
- natuurlijke ventilatie tbv verkoeling en gezonde leefomgeving
- zonwering (reflecterend) zorgt voor verminderde warmtelast
- weinig opwarming door geringe hoeveelheid open gevel
- activatie PV

## HERGERBUIK

Hergebruik baksteen in pleinvloer en waar mogelijk hergebruik van bestaande kerk en jeugdgebouw



## WINTER

- hoogwaardige thermische schil zorgt voor weinig thermisch verlies
- langgerekte gevelopeningen zorgen voor opwarming door zon
- gebruik restwarmte industrie Heijplaat
- activatie PV

## CLT

- hernieuwbare grondstof
- thermisch en akoestisch extra isolerend
- gezond binnenklimaat
- lichtere fundering
- aanpasbaar (levensduur + flexibiliteit)
- ruwbouw = afbouw

## MOBILITEIT EN FUNCTIONALITEIT

-  ELEKTRISCH DEELAUTO
-  DEELFIETS (elektrisch)
-  GEDEELDE SERVICES

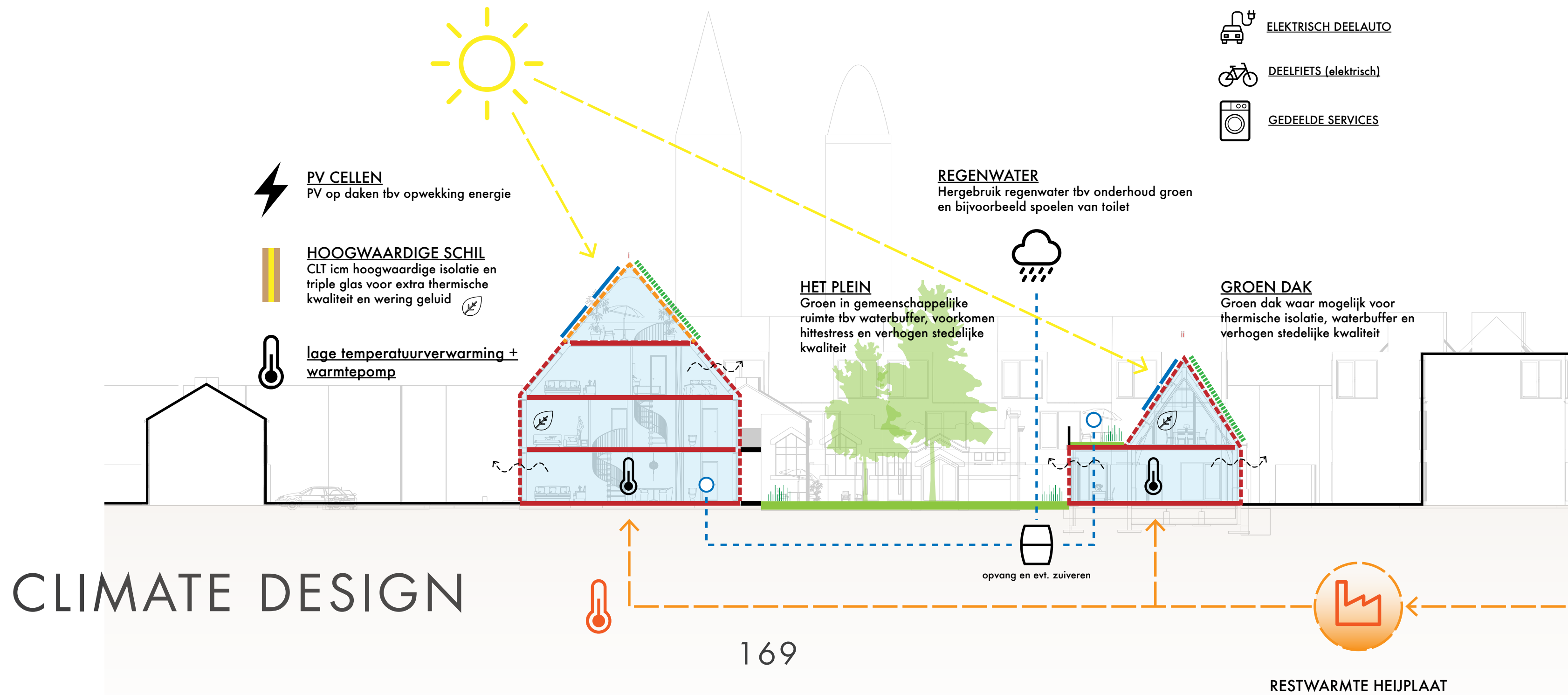



# START MAIN CONSTRUCTION

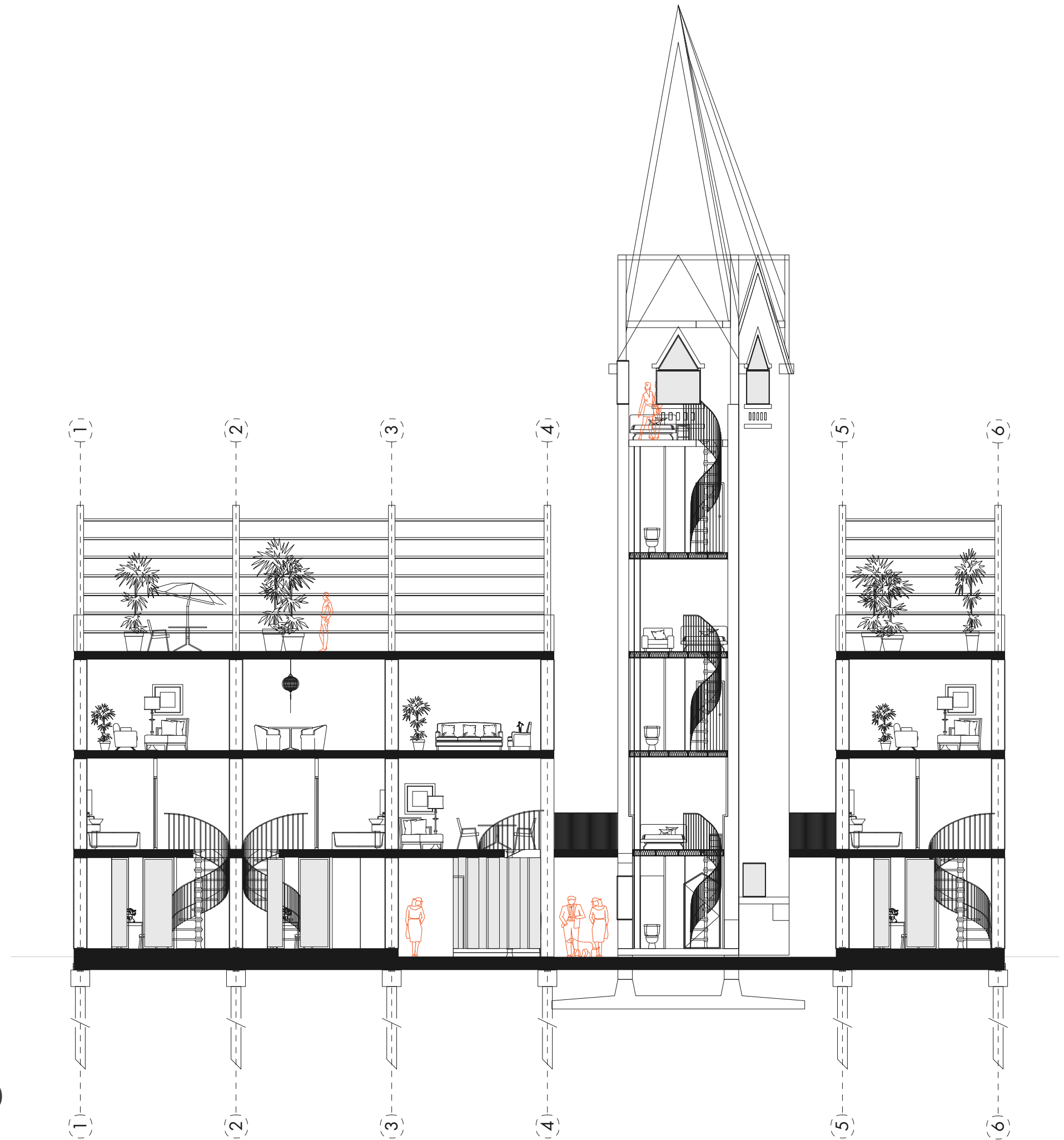
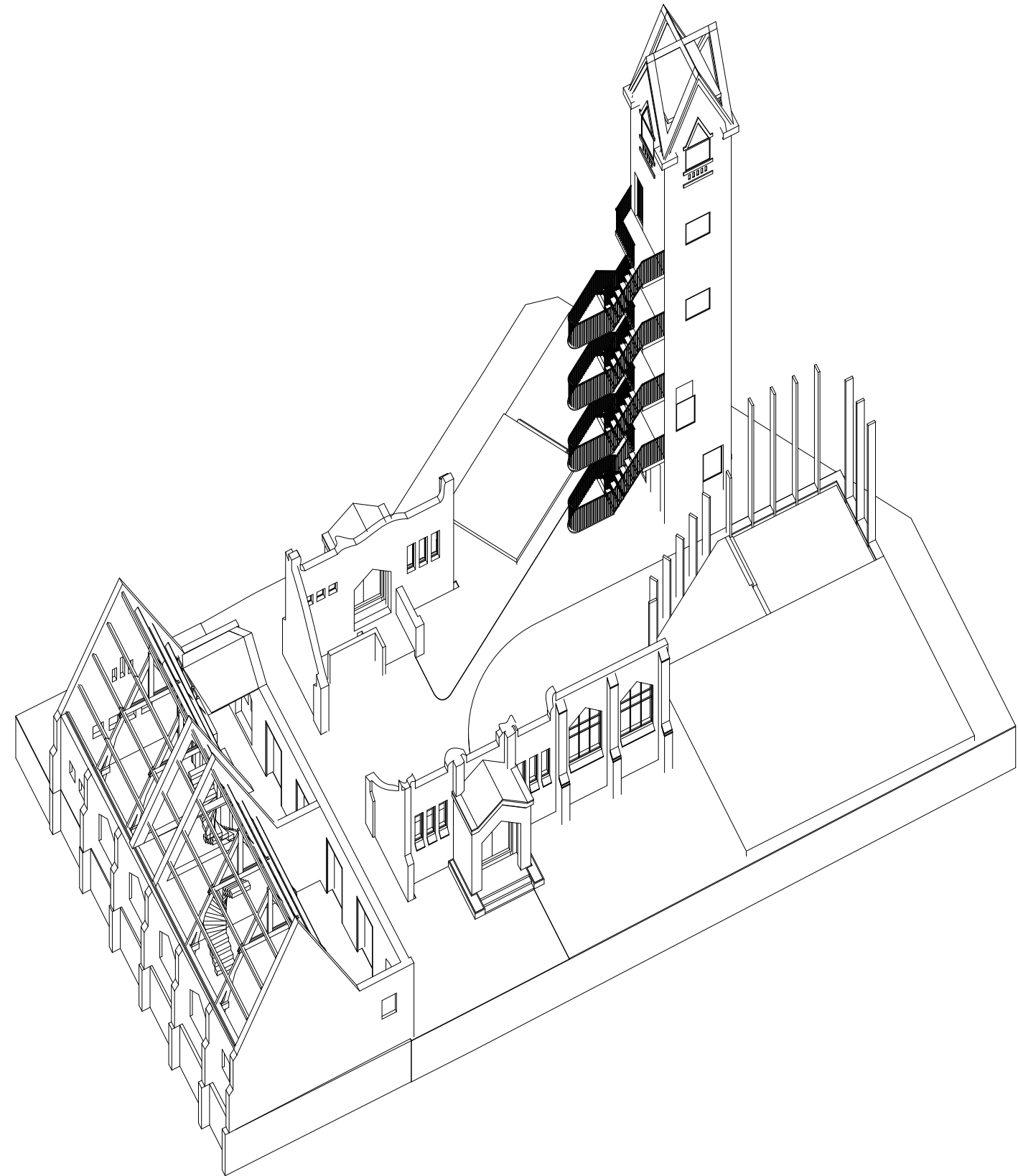



# MAIN STRUCTURE

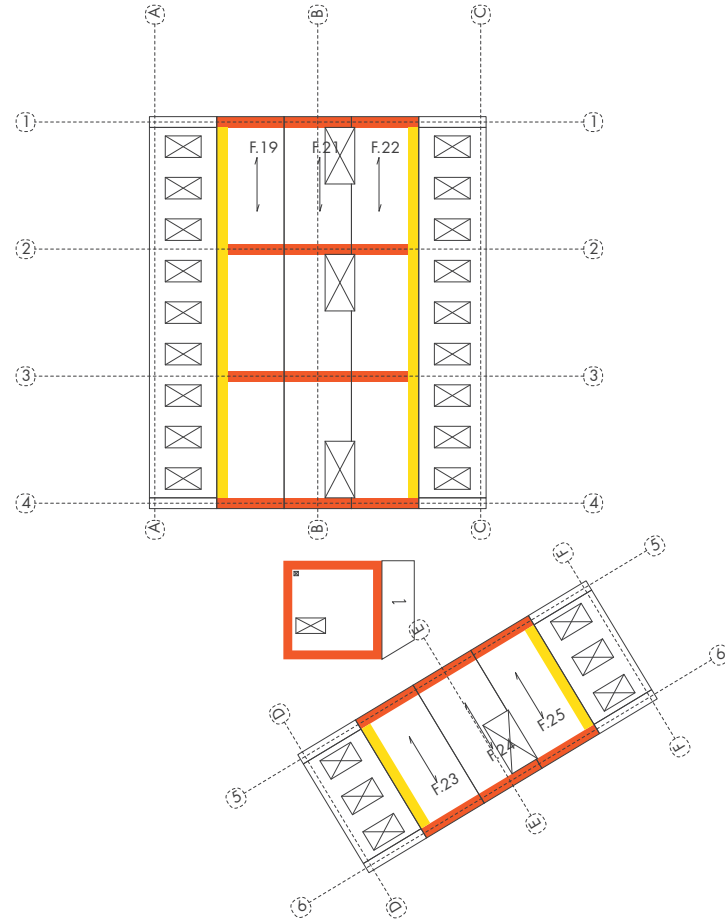
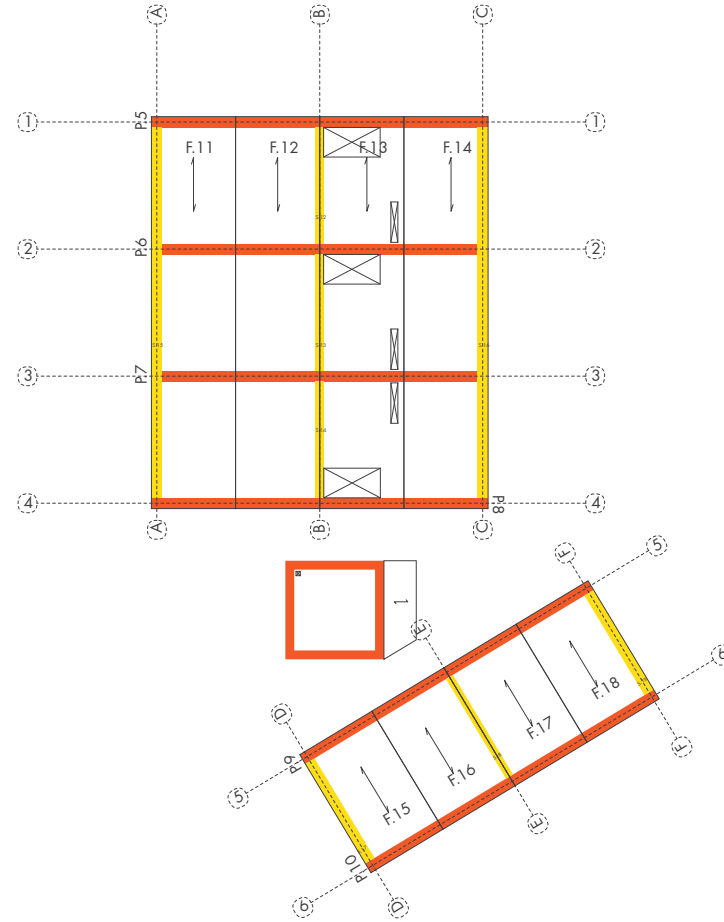
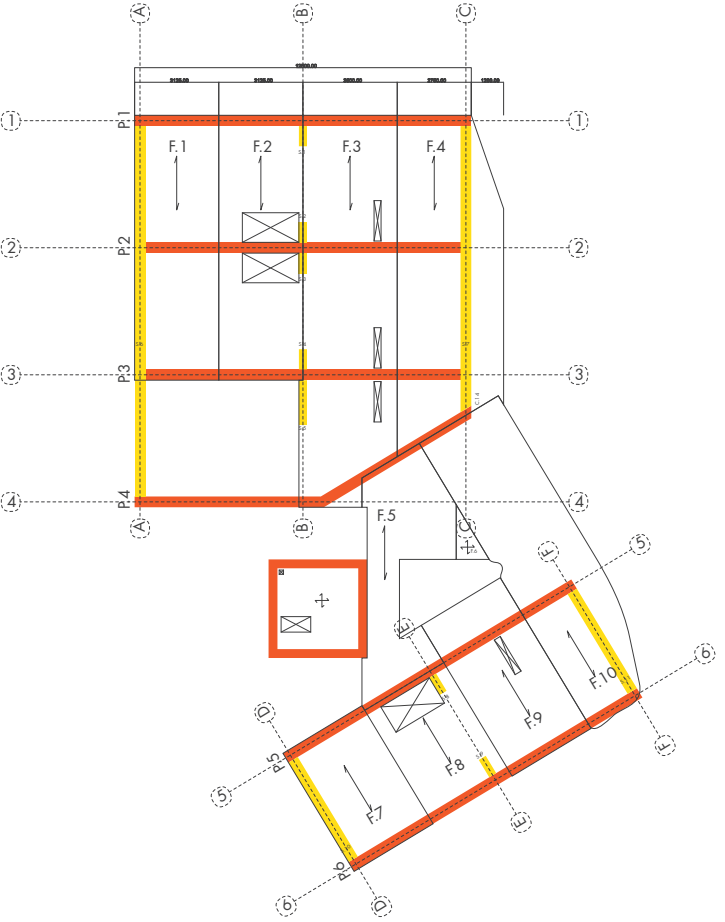
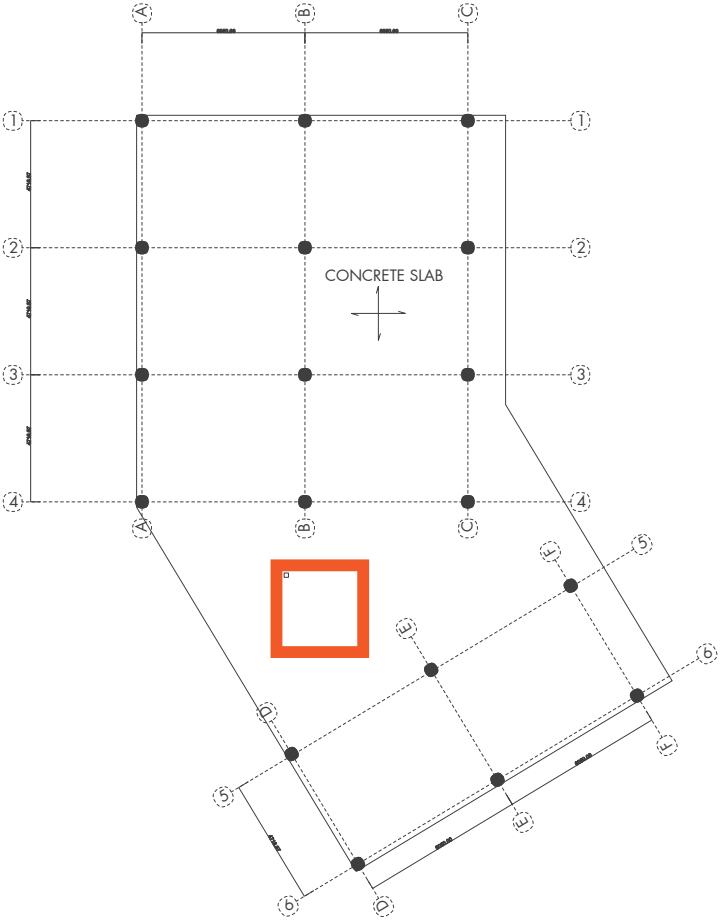
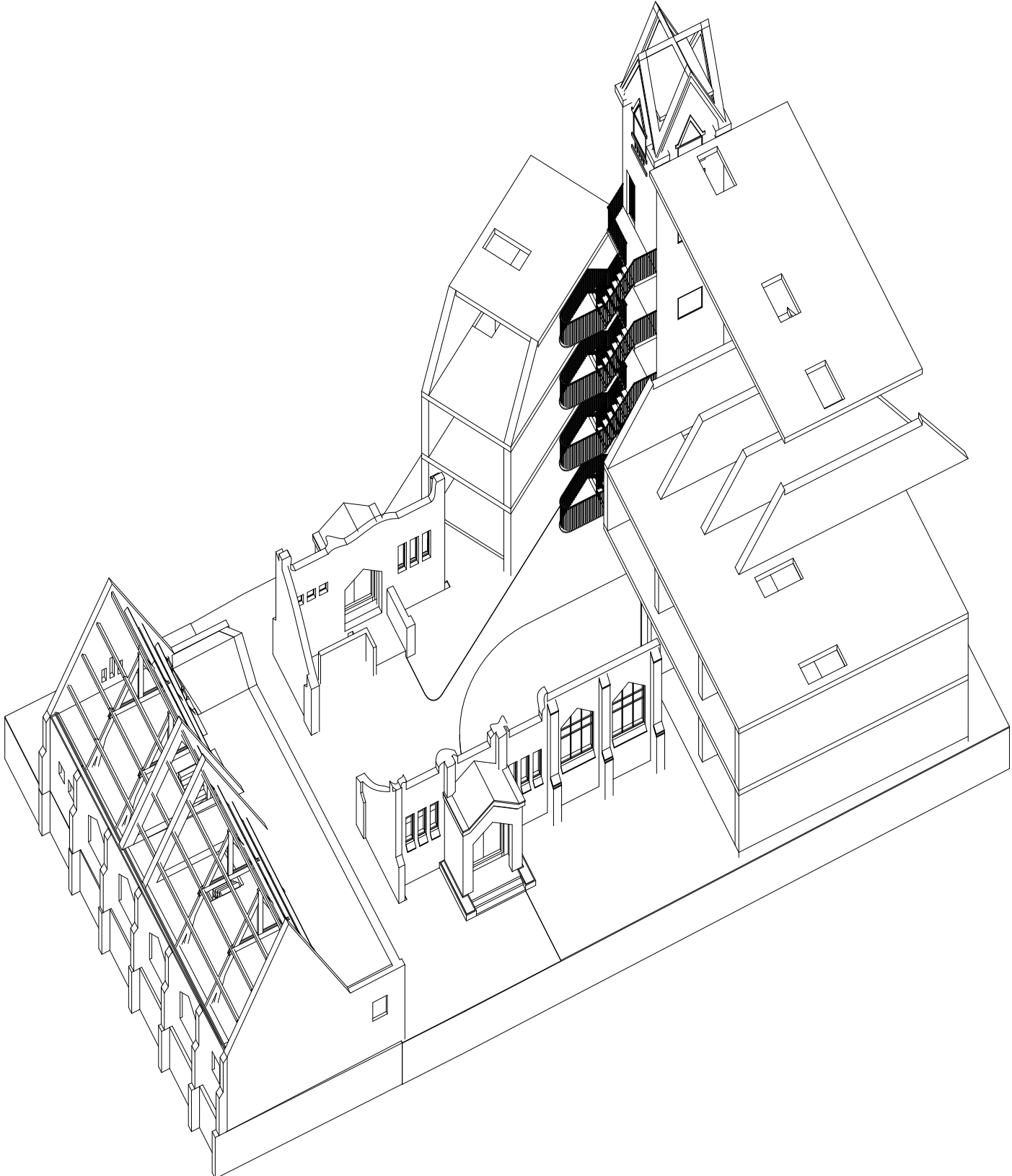



# ADD INNER WALLS AND STAIRS

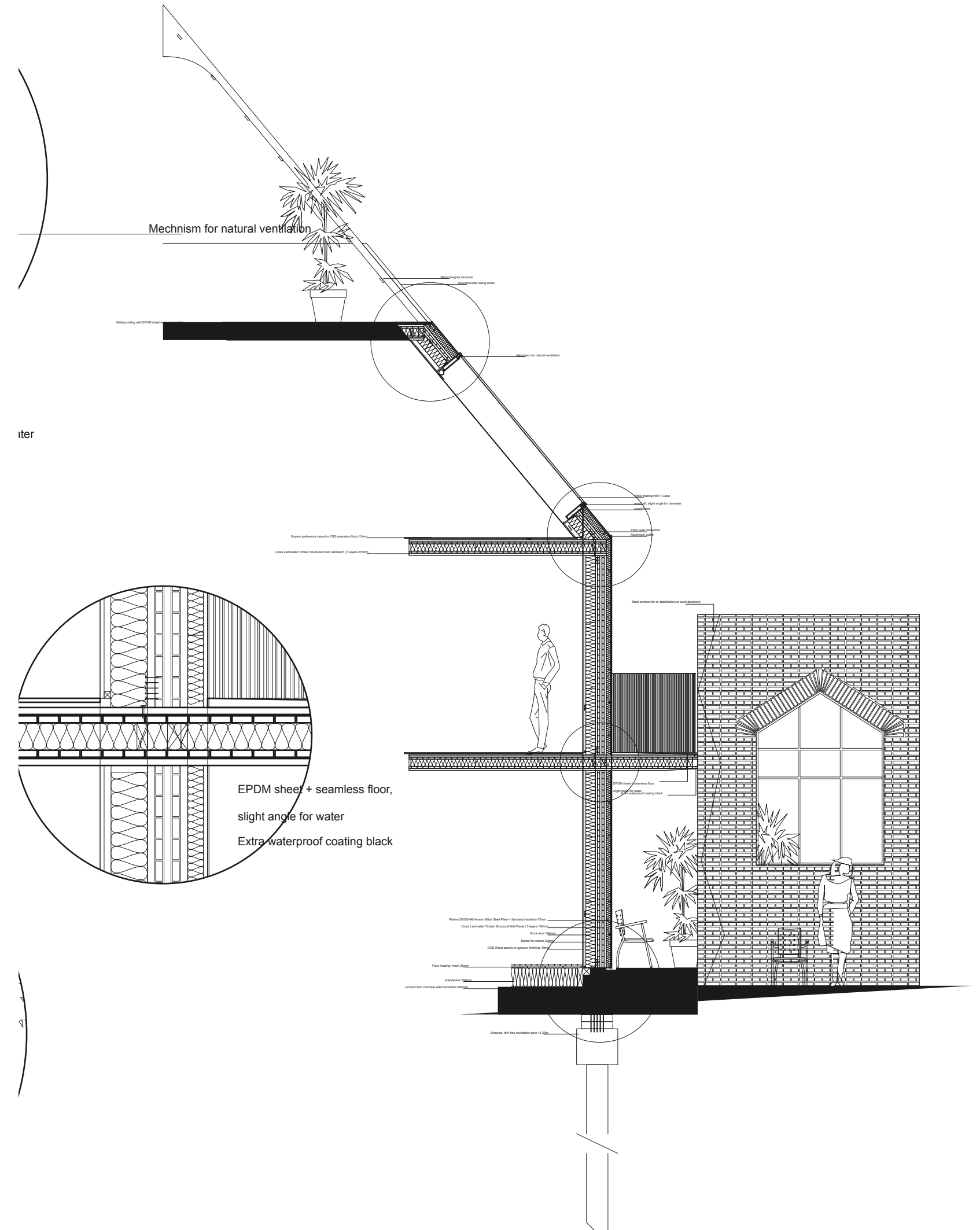
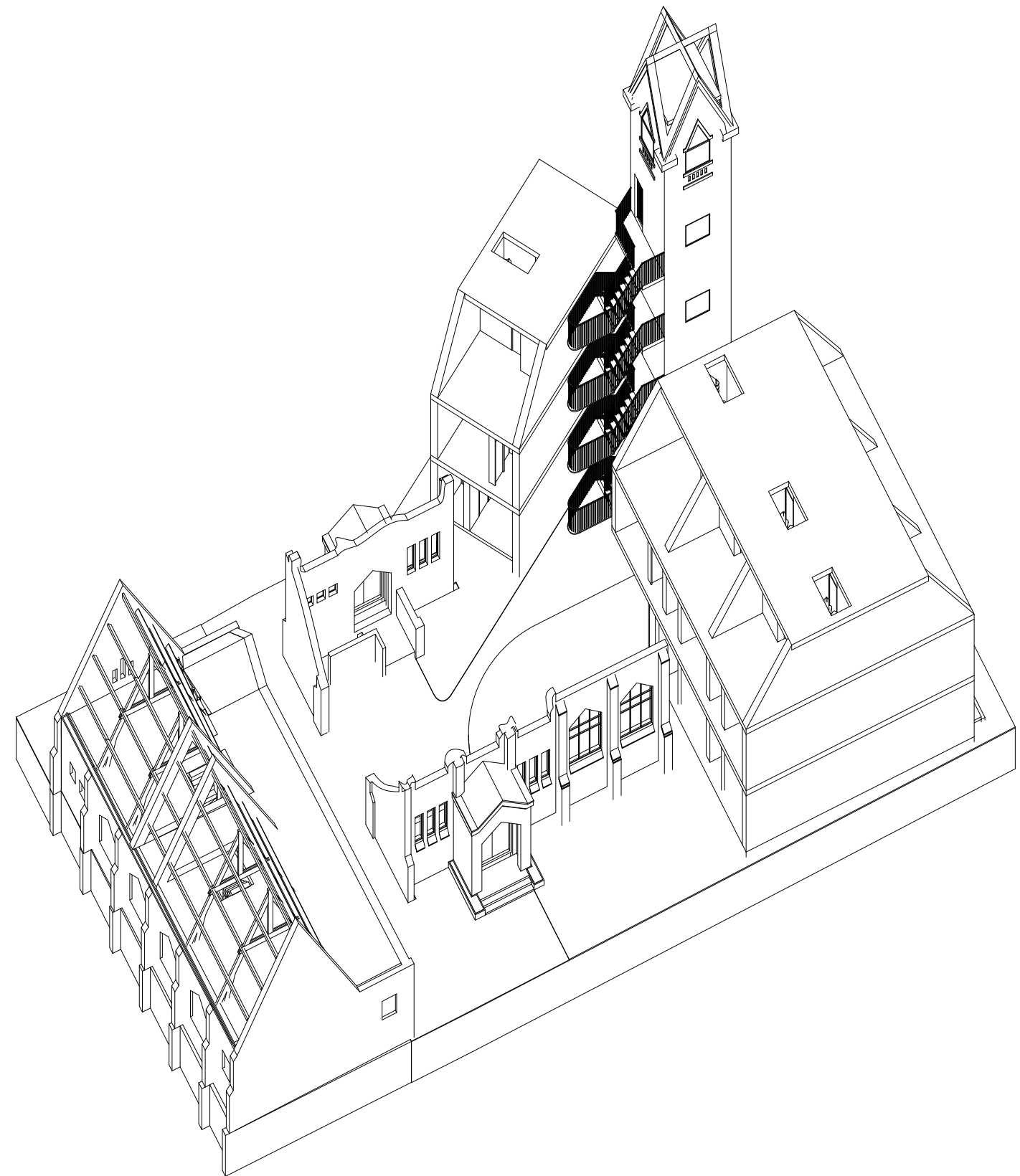



# FINAL STURCTURE

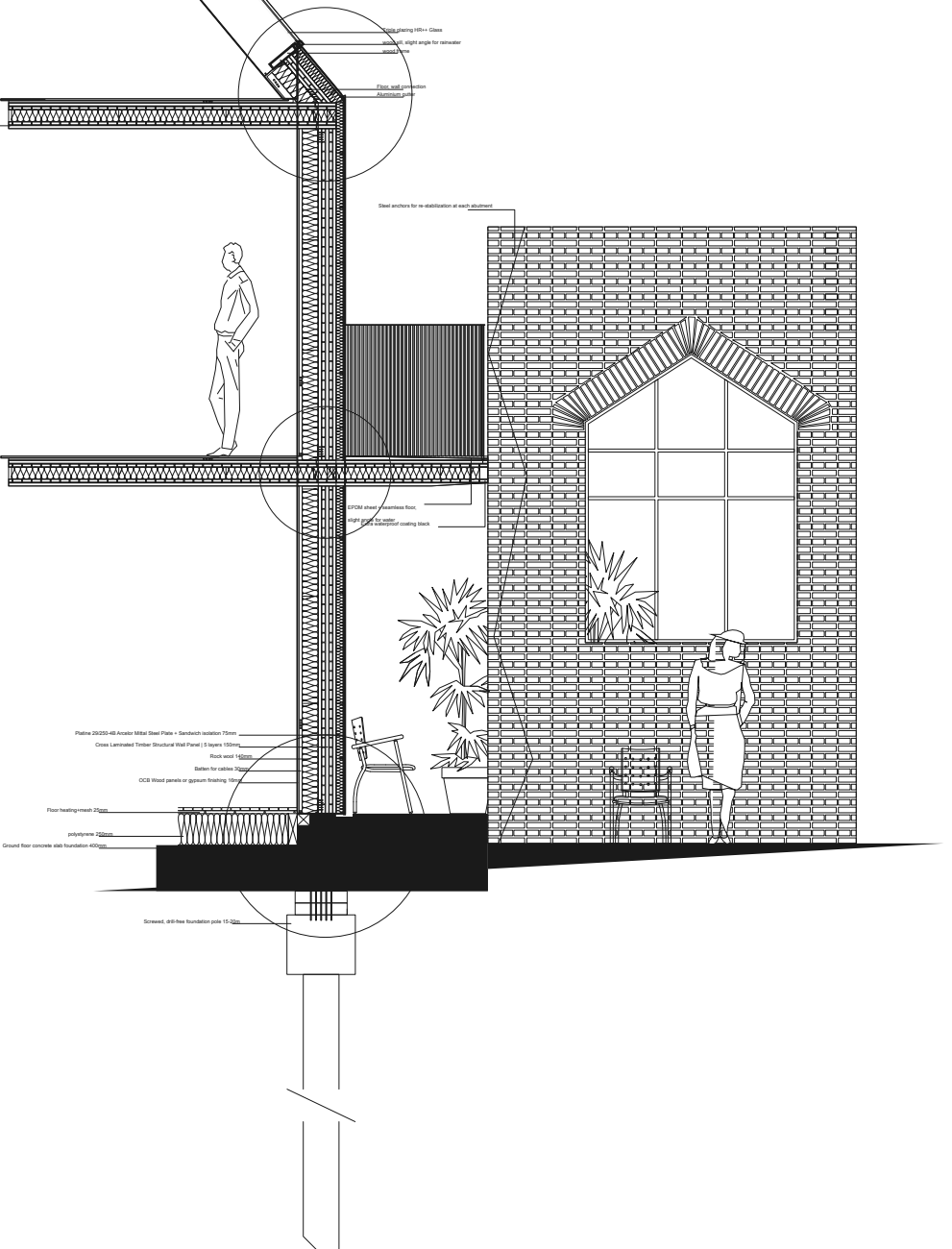
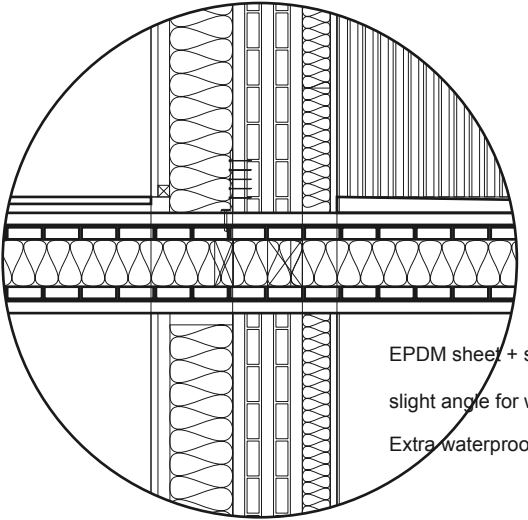
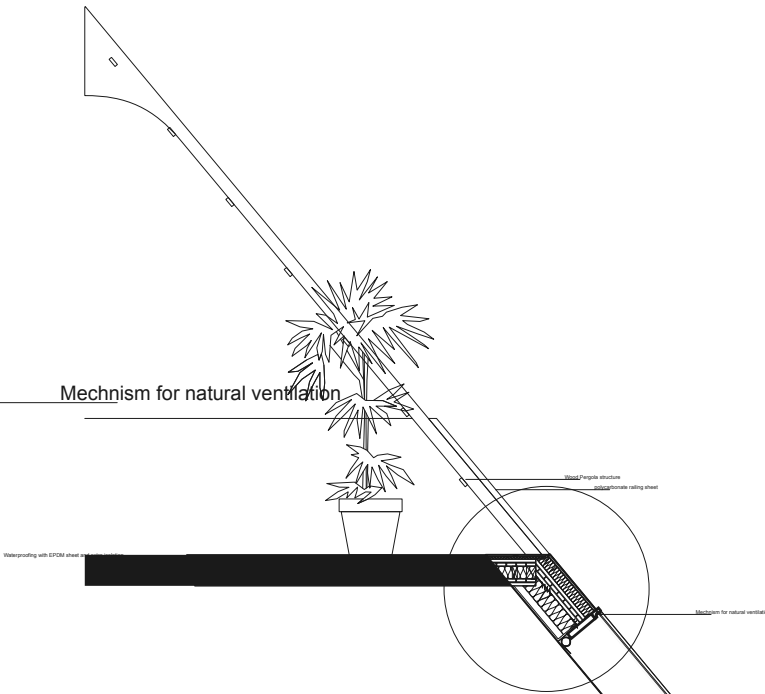
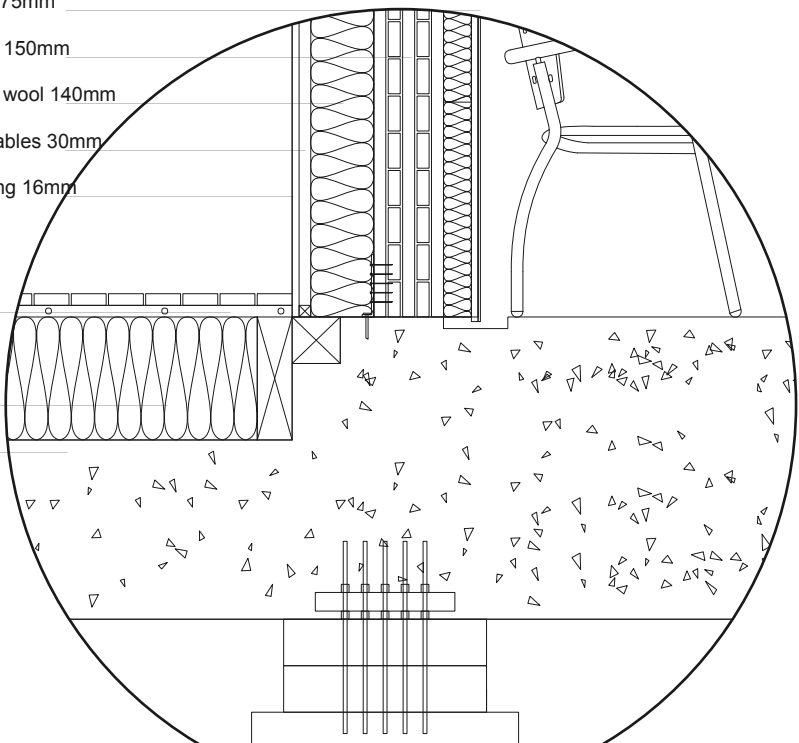
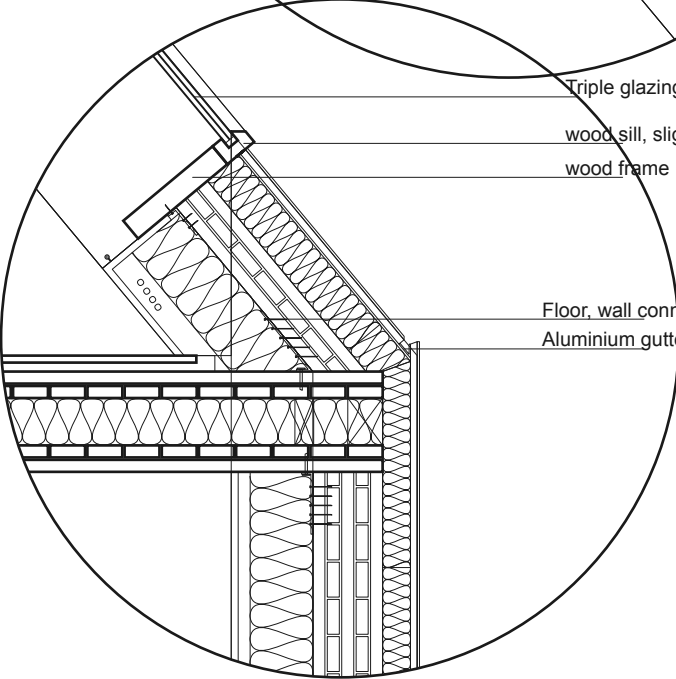
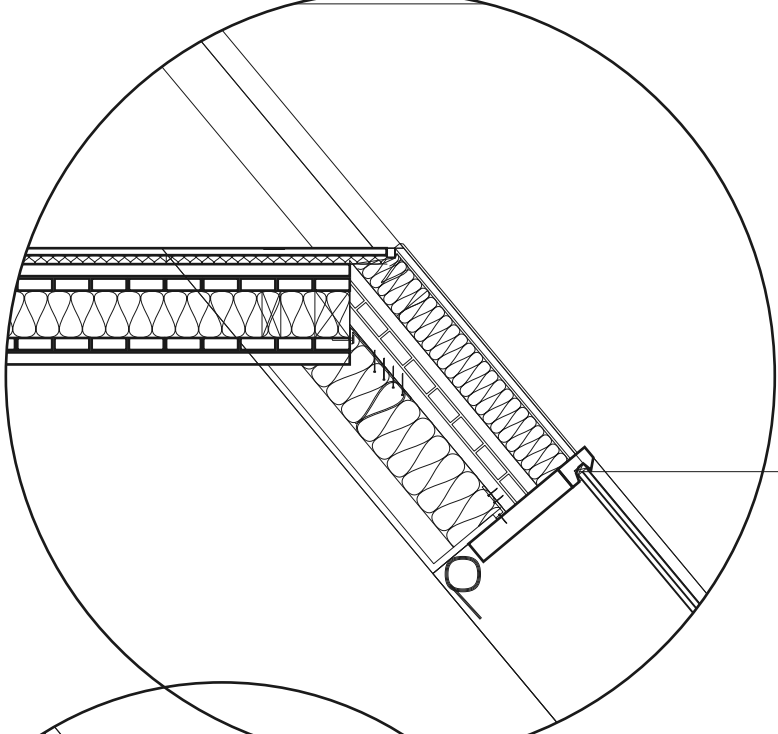
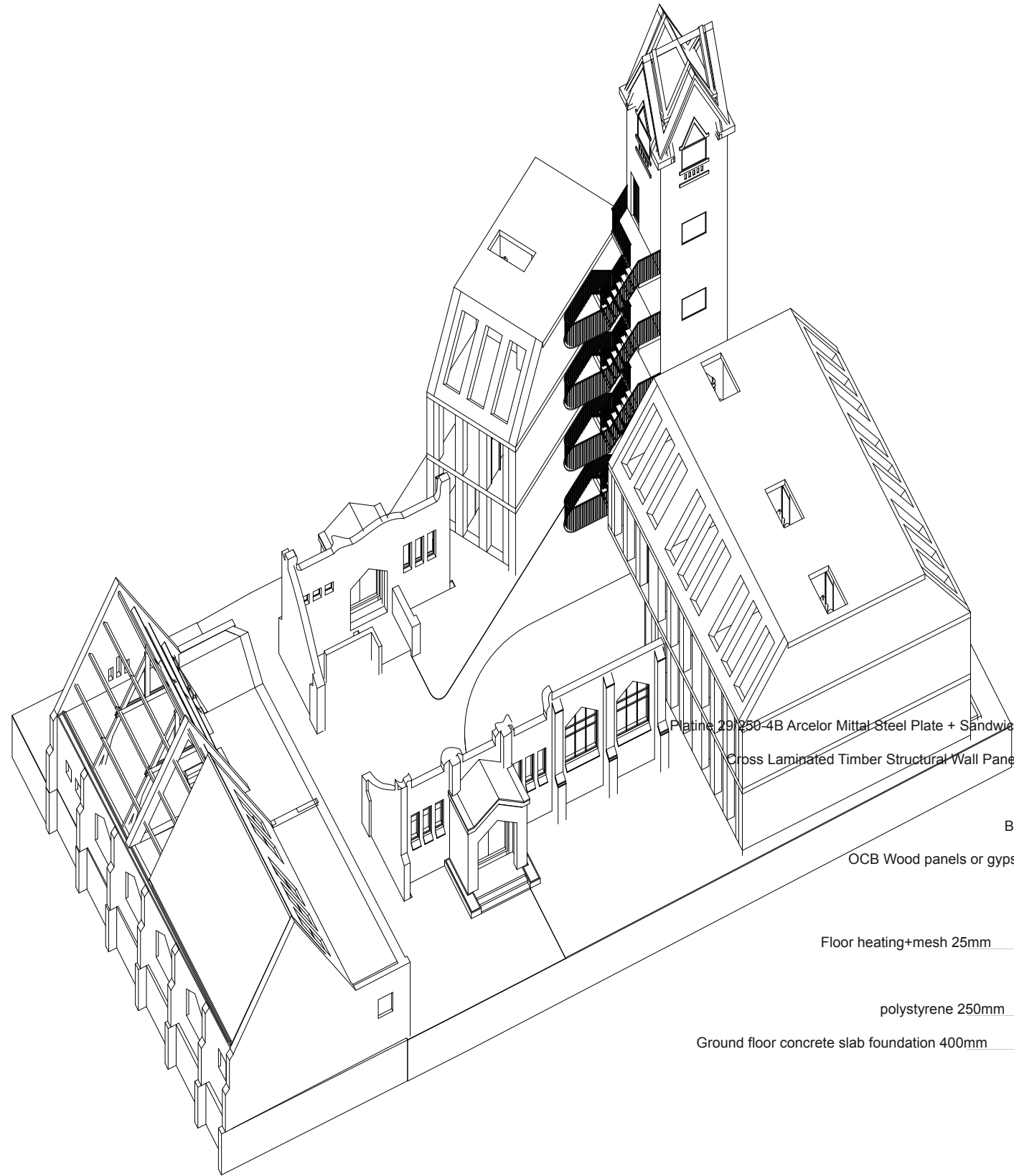

- Platine 29/250-4B Arcelor Mittal Steel Plate + Sandwich isolation 75mm
- Cross Laminated Timber Structural Wall Panel | 5 layers 150mm
- Rock wool 140mm
- Batten for cables 30mm
- OCB Wood panels or gypsum finishing 16mm
- Floor heating+mesh 25mm
- polystyrene 250mm
- Ground floor concrete slab foundation 400mm

Triple glazing HR++ Glass  
wood sill, slight angle for rainwater  
wood frame

Floor, wall connection  
Aluminium gutter

EPDM sheet + seamless floor,  
slight angle for water  
Extra waterproof coating black

Mechanism for natural ventilation



# 5.8 PRESCRIPTIVE EVENTS



1. THE OPENING



2. THE WINE MIXER



3. ONE NIGHT IN HEIJPLAAT

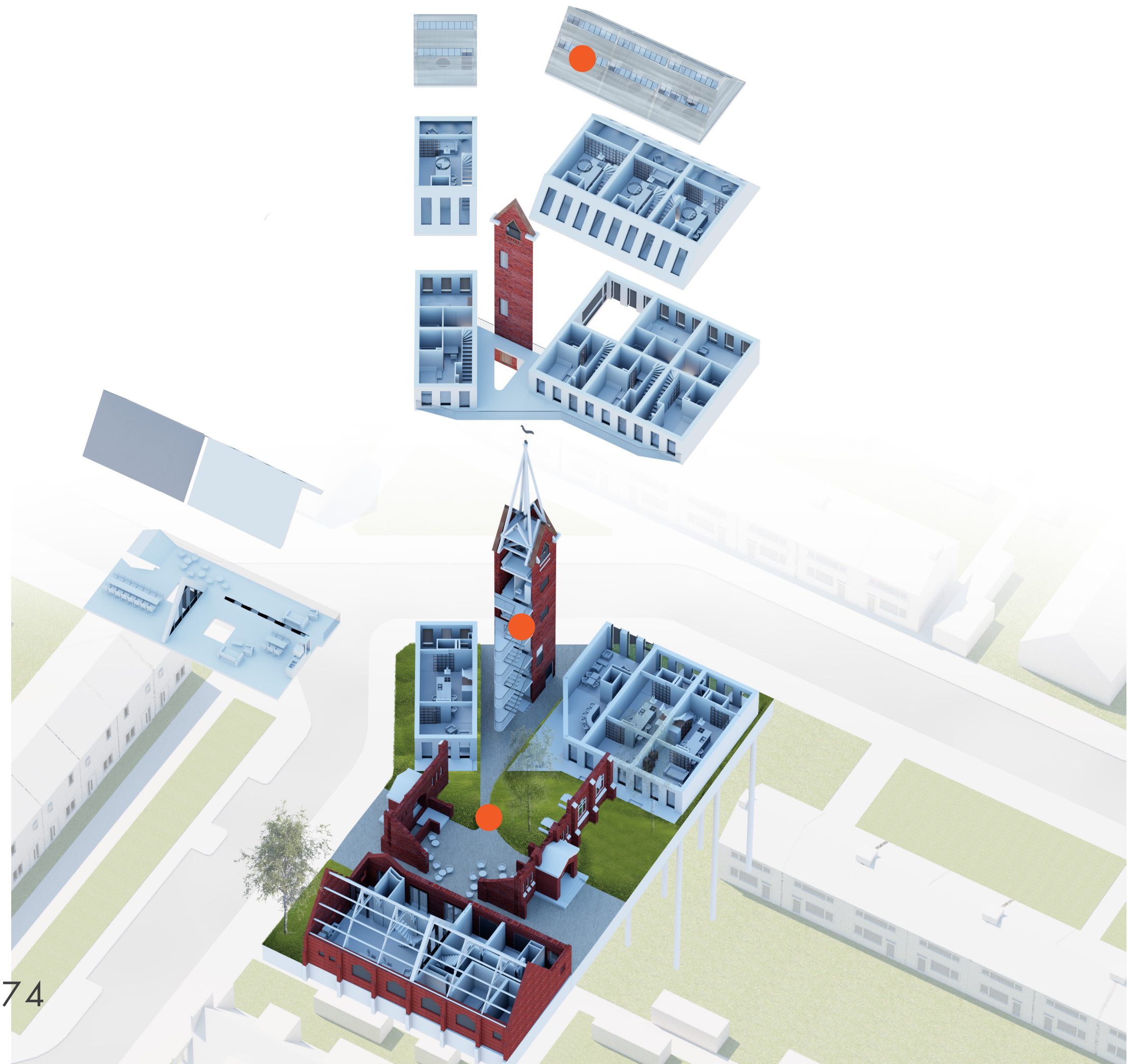



**EVENT 1.  
THE OPENING**

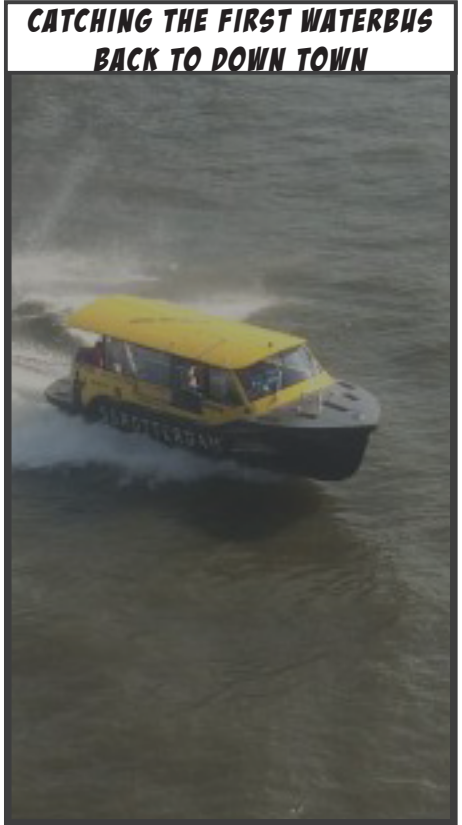

**I'M GOING  
THE SUN'S ALREADY OUT!**

**BUT I ALREADY BOOKED  
THE ROOM..**

**ONE MORE DRINK?**

**SHIT, THAT HURTS!**

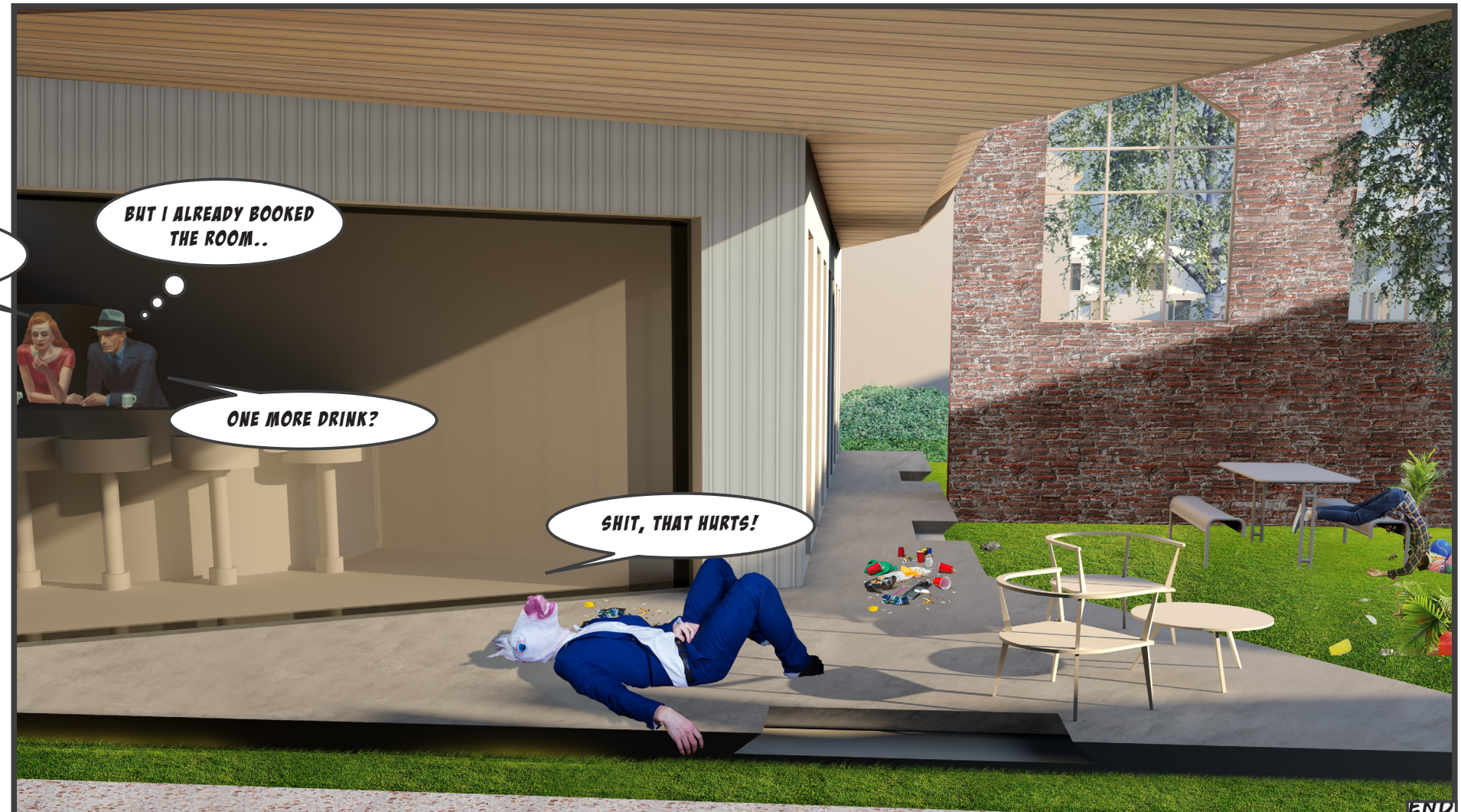



**EVENT 2.**  
**THE CATALINA**  
**WINE-MIXER**

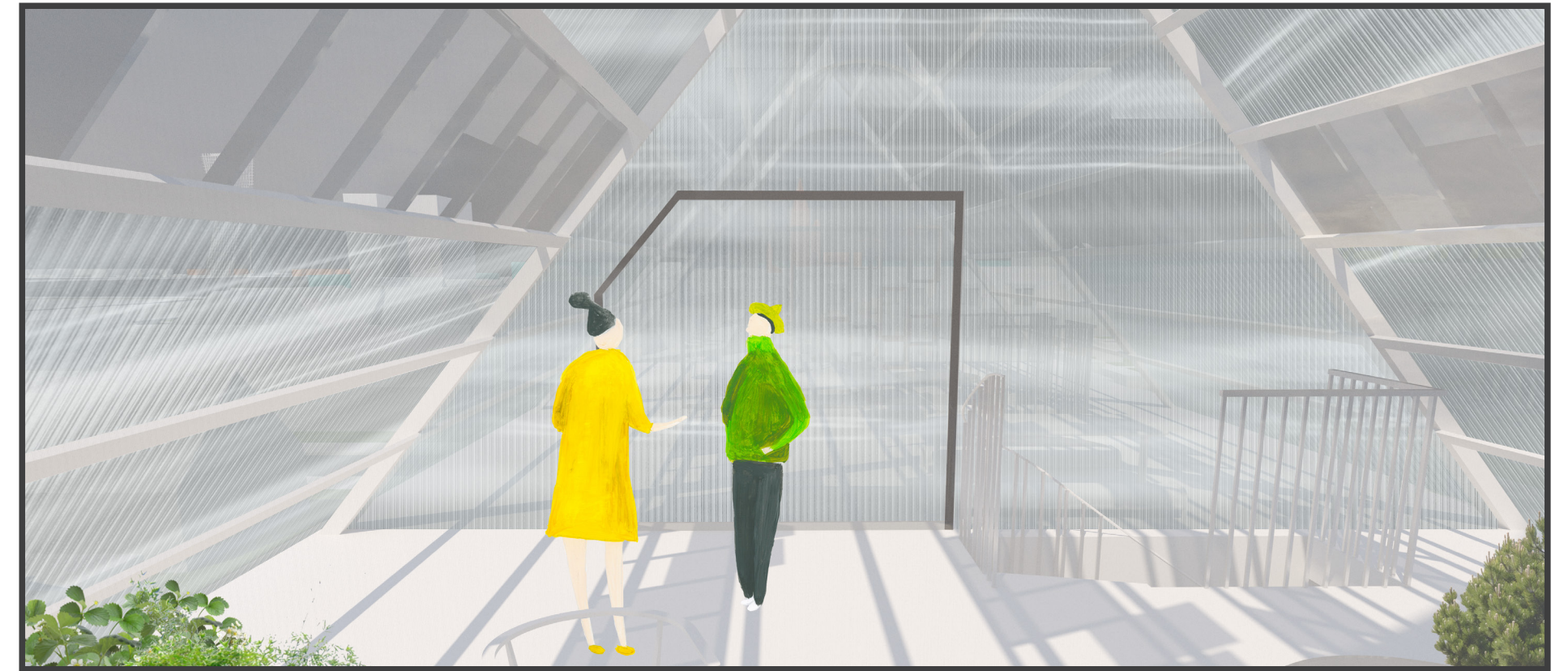
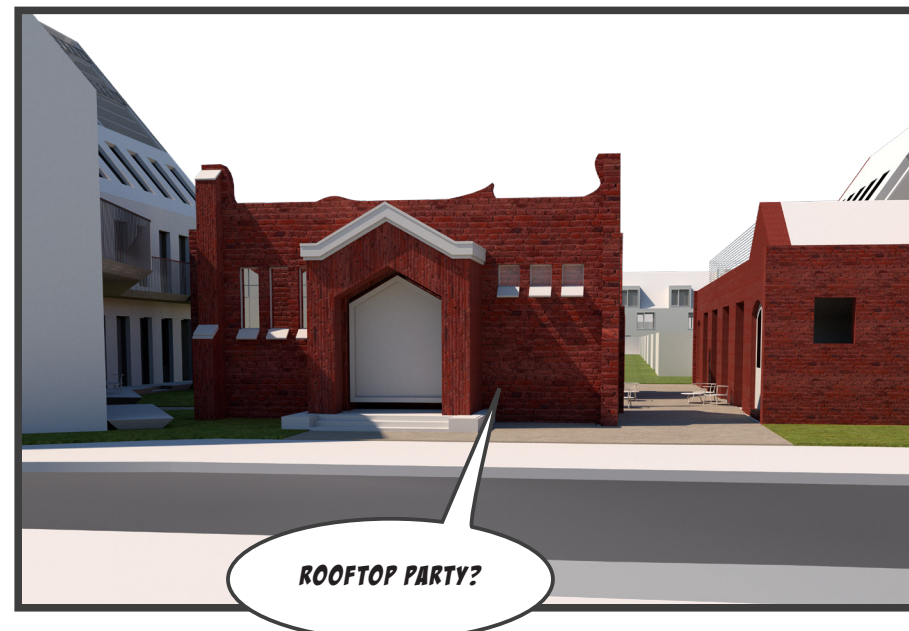



**EVENT 3.**  
**ONE NIGHT AT THE**  
**RDM'INN**





# 1.2 GRADUATION CONTENT

1.	IGNITION	1
1.1	ACKNOWLEDGEMENTS	2
1.2	GRADUATION CONTENT	3
1.3	PROJECT DESCRIPTION	4
1.4	INVENTORY	7
1.5	ESSAY 1   SOCIAL MONUMENTALITY	11
2.	GARDEN CITY HEIJPLAAT AND ITS UNCONVIVIAL TRUTH	18
2.1	HISTORY	19
2.2	CURRENT SITUATION	32
2.3	EVENTS	41
2.4	PRESCRIPTIVE EVENTS	55
2.5	ESSAY 2   GARDEN CITY HEIJPLAAT AND ITS CONVIVIAL FUTURE	61
3.	REDEVELOPING RELIGIOUS HERITAGE   CONFLICTS AND RECOMMENDATIONS IN PRIVATE AND PUBLIC BUILDING LAW	67
3.1	INTRODUCTION	68
3.2	PURCHASE	70
3.3	GROUND LEASE	77
3.4	STATUS OF MONUMENTALITY	80
3.5	RE-PURPOSING	85
3.6	TEMPORALITIES	93
3.7	ESSAY 3   SUMMARY	97
4.	THINKING BY BEING (THERE)	104
4.1	ROLE OF THE ARCHITECT	105
4.2	CASE STUDIES	108
4.3	DESIGN PROCESS	112
4.4	ESSAY 4   CONSIDERING THE ARCHITECT AS ONE WHO MOUNTS THE BODY OF KNOWLEDGE	127
5.	THE PRESCRIPTION   THE ACTUAL DESIGN	132
5.1	GENERAL	133
5.2	PRIOR TO IGNITION	134
5.3	IGNITION	136
5.4	POST IGNITION	138
5.5	TEMPORALITIES	143
5.6	URBAN RECONSTRUCTION	147
5.7	DRAWINGS	158
5.8	PRESCRIPTIVE EVENTS	174
5.9	ESSAY 5	178







# ESSAY 5

## SOCIAL MONUMENTALITY

### REFLECTION

During this project I have looked for a way to build upon the social monumentality of a place. Specifically that of the former Julianachurch in Heijplaat, Rotterdam that was destroyed by a fire. By understanding social monumentality in the first place, within the past academic discussions on monumentality, presence of history, involuntary memory and transgression/value gave me a philosophical base to work with.

Through my understanding of social monumentality I have focused my research on the past and (possible) future events of a place rather than the physical assembly. This basically means: what has happened and what conditions are needed in order to have an intervention that is valuable (and convivial)? Especially for the existing groups and new groups in Heijplaat/RDM. Of course, through a new structure on the place of the burned down church. My research takes the stance that the “presence of history” that Zumthor speaks about – within a new project - cannot be solely considered through the (surrounding) bricks, or physical forms, but should rather also consider the existing and past social structures and events.

Conducting research by simply ‘doing’ architectural design is increasingly important to architecture, and represents an academic recognition of alternatives to the production and consumption of literature as ways of thinking. This is often expressed as the idea of ‘thinking by doing.’” If ‘thinking by doing’ can be considered a method for research; the research conducted for my graduation project can be described as ‘thinking by being (there)’ as my main source of information has been through field research, putting an emphasis on exploring existing social structures rather than the physical structures. This is very much in line with the core values and method of the Veldacadmie, the studio in which I am graduating.

Personal believe that practicing architecture within the common structures of today increasingly enables one to put forward interventions that add value to a site. Therefore

it is necessary to find more ways to deal with clientship, ownership and competition/commission-based designs. Therefore I have found it of great importance to spend time on the legal/formal aspects of redeveloping a site, in this specific case religious heritage. Herein I have looked at what effects/conflicts the purchase, land lease, monumentality, repurposing, and temporalities can have on the trajectory of realizing goals that are set throughout the process and what a way would be to optimize them. Although this a parallel research it does effect the end-result of the design as the formal constraints and possibilities are understood better.

I have used a method to document my architectural research that compresses the information I gathered by conducting interviews, conversations, questionnaires, books, (newspapers) and archival research. Whilst doing this I have put emphasis at the past events in and around Heijplaat/RDM in order to understand how the place has come to be as it is today. This resulted in (1) series of informal products: comics that explain the place through an unseemingly, but connected narrative and a (2) series of formal products that are a general compilation of findings.

The conclusions I have drawn from here are that the people that value this place the most are not living, carrying or leading Heijplaat at the moment. These people have other living needs and therefore the intervention should address this issue.

My opinion is that (1) the urban reconstruction of the site, (2) the assembly of program, (3) the volume in relation to the ruin (4) the division of spaces, breathe the results and understanding of my research.

Also I am confident that the design (of interactions) that has been researched through description and prescriptive narration with drawings as a background and interactions as a foreground has a strong physical relation with the social. The façade design and materials used are simple and straightforward, only emphasizing and underlining the social ambitions of this project, but contrasting the existing situation.

I am confident that this graduation has become a coherent and (very) complete project. The holes in my project are mostly in tying the booklets together, but with the time that is left I am much invested in tying the ends together.

The building does not make us. We make the building.

### SHIFT TO SECULARIZATION AND EMPTY SPACE

#### FUNKY MONKS AND THE COMMON EXPERIMENT

“Commonality is not an everyday term. The quality of being jointly owned or shared 2) the quality of working together or of being united...According to Louis Kahn the reason we are moved by ancient constructions is because we are connected to one another by things deep within us that transcend time and place, and these things are commonalities.” (Atelier Bow-Wow, 2014)

For this reason it is intensified by the fire, which results in the ruin that is there today. “This psychotic approach of appreciation of a fire comes close to the way Bernard Tschumi talks about transgression and the way architecture may really be appreciated by committing a murder or at least have the space witness one. To explain it in more humanly acceptable terms I would say it is in line with why the worn down jeans are worn by practically everyone. Because it makes the suggestion that these jeans have lived, that they are experienced and reliable jeans. It is the same reason why an architect that has designed a house before is more likely to get another job designing a house (whilst one who hasnt designed one yet might be better at it).

### THE ESSENTIAL CHALLENGE OF EMBEDDING THE

### RUINS

For these reasons it is essential to keep the ruins, although it does not have any structural qualities anymore.

Do not return toward an origin, transform towards the needs of the now.

In In Search of Lost Time (also known as Remembrance of Things Past), author Marcel Proust uses madeleines to contrast involuntary memory with voluntary memory. The latter designates memories retrieved by “intelligence,” that is, memories produced by putting conscious effort into remembering events, people, and places. Proust’s narrator laments that such memories are inevitably partial, and do not bear the “essence” of the past. The most famous instance of involuntary memory by Proust is known as the “episode of the madeleine,”

The smell of fire does not go away. Building with a perfume.

### THE SHIFT FROM A HIGHLY DICTATED PUBLIC SPACE TO A SOFTLY DICTATED PUBLIC SQUARE

Margaret Crawford talks about everyday space. “everyday space is the connective tissue that binds daily lives together, amorphous and so persuasive that it is difficult even to perceive. In spite of its ubiquity every space is nearly invisible in the professional discourse of the city. Everyday space is like everyday life...Trivial, obvious but invisible, everywhere and nowhere.” (Crawford, 1999)

The temporary square is as much opposite of these kind of public spaces as can be as it becomes the most conscious way to enter a new space.

“ Trivial and common-place, vacant lots, sidewalks, frony yards, parks and parking lots are begin claimed for new



uses and meanings by the poor, the recently immigrated, the homeless and even the middle class. These spaces exist physically somewhere in the junctures between private, commercial and domestic. Ambiguous and unstable, they blur our established understandings of these categories in often paradoxical ways. They contain multiple constantly shifting meanings rather than clarity of function. In the absence of a distinct identity of their own these spaces can be shaped and redefined by the transitory activities they accommodate. Unrestricted by the dictates of built form, they become venues for the expression of new meanings through the individuals and groups who appropriate the spaces for their own purposes. Apparently empty of meaning, they acquire constantly changing meanings - social, aesthetic, political, economic - as users reorganize and reinterpret them.” (Crawford, 1999)

“Temporally, everyday spaces exist in between past and future uses, often with a no-longer-but-not-yet-their-own-status, in a holding pattern of real-estate values that might one day rise. The temporary activities that take place there also follow distinct temporal patterns. Without fixed schedules, they produce their own cycles, appearing, reappearing, or disappearing with the rhythms of everyday life. Use and activity vary according to the seasons, vanishing in winter, born again in spring.” (Crawford, 1999)

“ Despite different owners, each building anticipates in shaping the town landscape or urban space with their roofs and facades, forming a collective whole that transcends private ownership.” (Atelier Bow-Wow, 2014)

The space is not democratic. The owner decides.

In principle, no-one will be denied access to the space, one is only perhaps not feeling welcome because it doesn't share the same rituals, feelings, etc.

liberation, everyone is taking photos, even tourists with cameras. If the ruins become public this will be even stronger.

more powerful than the existing Rondoplein, because of the events that have taken place and the intensification of the space.

## DEFINITION OF PROGRAM

## COLLABORATIVE USE OF SPACE

## NOTES

People are ultra-aware of the space/place, more than normally

when I prescribe a movie night. The movie night itself is a transcription again. Then I need to decide if a new prescription is needed.



# APPENDIX, CONVERSATIONS

placemaking



# CONVERSATIONS

Die norm is al zeker dertig jaar 2350 patiënten per fulltime huisarts  
"Huisartsenpraktijk Boute in Charlois" Amarant Troost

HUISARTS

Die norm is al zeker dertig jaar 2350 patiënten per fulltime huisarts  
"Huisartsenpraktijk Boute in Charlois" Amarant Troost

VINCENT TAAPKEN | NEW INDUSTRIES, DEVELOPER



Die norm is al zeker dertig jaar 2350 patiënten per fulltime huisarts  
"Huisartsenpraktijk Boute in Charlois" Amarant Troost

ANALOGUE BRIEF | 4 JANUARI 2018

Betreft: Aankondiging opruimwerkzaamheden Julianakerk  
Beste burens,  
het duurde een tijdje, maar met het begin van het nieuwe jaar zit schot in de zaak! Kruiswijk BV begint maandag 8 januari met puinruimen in de afgebrande Julianakerk. De werkzaamheden zullen enkele weken in beslag nemen. Kruiswerk werkt in principe van 7u 's ochtends tot 4u 's middags.  
De kerk is onderzocht op schadelijke stoffen. Er zijn geen schadelijke stoffen geconstateerd, op een klein plaatje asbest in de voormalige meterkast na. Dit zal eerst verwijderd worden volgens de normen. Daarna wordt begonnen het verwijderen van de rest van het puin.  
Uiteraard probeert Kruiswijk zo min mogelijk overlast te veroorzaken. Mocht je alsnog veel last hebben van de werkzaamheden, gaan we proberen een oplossing te zoeken. We zijn bereikbaar via onderstaande nummers.  
Na het opruimen zijn de restanten van de kerk een stuk veiliger, en kan er grondig onderzoek worden gedaan naar de bouwkundige staat. We houden de bakstenen die nog goed zijn apart voor een mogelijke herbouw van de gevel. Na het opruimen kunnen we ook beoordelen of een deel van de hekken weggehaald kan worden. Het mooiste zou zijn een tijdelijk pleintje in de ruïne te maken, maar het moet nog blijken of dit een realistische optie is. Na de opruimwerkzaamheden zijn jullie van harte welkom om een kijkje te komen nemen, een drankje te drinken en mee te denken over de toekomst. Een uitnodiging hiervoor volgt.  
Groetjes, Nima & David  
Nima Morkoc: 06-250 553 21  
David Demper: 06-270 173 83  
Op de hoogte blijven van de ontwikkelingen? Volg ons op [facebook.com/JuulvanRotterdam](https://www.facebook.com/JuulvanRotterdam)  
PS. Sorry voor het kekke kleurtje, printer was leeg;)

CORRESPONDENTIE WIJK