

Industrial housing in India

The Wall as an Industrial Craft Flyash 'Stackcrete'



Graduation Report
Final

Prashanth Raghunath
TU Delft
Building Technology
International Facade Master

Foreword

I always wanted to be able to use whatever I learnt here at the TU Delft in a context in India in future. Graduation provides me the perfect platform to explore this. The social, political and climatic context in India provides a good challenge to analyse and develop a technology to satisfy the housing demands, by means of what has been already done in the developed countries.

This report shall be a documentation of the work done for my Graduation in TU Delft as part of the Facade Masters Programme.

I would like to take this opportunity to thank my mentors- ir. Arie Bergsma, Dr. ir. Arjan Van Timmeren and ir. H.R. Schipper for their continuous guidance through out the project. I would also like to extend my thanks to Mr. Kees and Mr. Tom of Stevin Labs in CiTG for providing the space, material and equipment to make the mockup. Special thanks to Mar Munoz Catalina for helping me in transporting the mockup panels from CiTG to the Faculty of Architecture. I would like to finally thank my family and friends for their support in producing this work. Lastly, I would like to thank TU Delft, for providing me this opportunity to pursue this masters research.

Prashanth Raghunath

Personal information: **Prashanth Raghunath**
Student no.: 4129253
Building technology
"international facade master"
Email: P.Raghunath@student.tudelft.nl
Address: Roland Holstlaan 721,
2624 HV, Delft
Tel no: 0031-617055521

First Mentor: **ir. Arie Bergsma**
Building Technology "facade design"
Email: a.c.bergsma@tudelft.nl

Second Mentor: **Dr. ir. Arjan Van Timmeren**
Building Technology "product design"
Email: a.vantimmeren@tudelft.nl

Third Mentor: **ir. H.R. Schipper**
CiTG "design and construction"
Email: h.r.schipper@tudelft.nl

Abstract

The building industry in the developing countries, today, is confused between technological developments and the vernacular. The values imbibed in tradition, and colonial hegemony in India have had deep impacts in the psychological perception of the vernacular. Unfortunately, in today's circumstances, where in population explosion and rapid urbanisation have resulted in severe housing shortages and demands, the advantages which can be borrowed from the technological advancements in the developed countries cannot be ignored. The meaning of 'traditional' itself is mistaken today, where the construction practice is no longer vernacular, but utilizing manpower at large on site to produce buildings is being termed as 'traditional'. The cultural values associated with what has been termed as 'traditional' building methods are so deeply rooted that, even though all the stake holders are aware that the 'traditional' building methods are no longer viable solutions for present day demands, it is still continued at large, due to lack of much research on what values technology could add to the building methods for housing. Though it must be mentioned that the scene is not the same for commercial projects, where technology is slowly catching up.

This trend, is weighing heavily on the housing industry. Therefore the need of the hour is to come up ideas, systems, strategies of utilizing the potentials of what technology can offer to benefit in supplying quicker, better quality housing. This is absolutely essential from the point of not only housing demands, but also there is a deep decline in the percentage of skilled labour available for making good quality 'traditional' craftsmanship. So it is better to channelise the 'unskilled' labour into a more productive chain of work, to develop new crafts- 'industrial' crafts.

This report documents a brief investigation of the present housing scenario in India, the existing construction alternatives, what possibilities industrialization can offer, case studies on a few systems to help arrive at a good system to be developed, and finally ends with a development of a product which can be used to address the housing needs in India, with further research. Parallely a study of fly-ash is presented, the under-utilization of which is seen as the second problem in this research work. So the product/system proposed and developed is one utilizing a good percentage of flyash as its main ingredient. The Flyash 'Stack-crete' as I would call it, is a prefinished load bearing wall element, which can be stacked up to make up a load bearing facade, for a low rise. The report culminates with a discussion on a mockup, the potentials of the product and possible constraints.

It should be mentioned here, that, industrialization offers several possibilities as noted in the report. Product and system development is one way of addressing it, and is definitely an important step in the whole process. So the flyash based prefabricated product proposed is one of the ways of addressing the housing needs in India in a sustainable way. I shall by no means make a claim that it is the best way of solving the housing problems, but can conclude that it is a viable option under Indian circumstances to address the housing needs with further research.

Contents_

<i>1. The Problem</i>	1.1 Housing scenario in India 1.2 Existing Housing supply mechanism 1.3 Conclusion- the need for Prefab	<i>7. Construction Research</i>	7.1 Introduction 7.2 Production process 7.3 Transport/ stacking 7.4 Lifting method(s) 7.5 Assemblage/ temporary supports 7.6 The end product
<i>2. Preliminary Research</i>	2.1 Introduction 2.2 Industrialisation in Building Industry 2.3 Typologies in Prefab 2.4 The Indian Context and Pre requisites for Prefab 2.5 Prevalent Prefab techniques in India 2.6 The demand for Low rise 2.7 The sustainability question and the problem of flyash 2.8 Climate of India 2.9 Conclusions	<i>8. Mockup</i>	8.1 Introduction 8.2 The Manufacturing Process 8.3 Conclusions
<i>3. Research Focus</i>	3.1 The final Problem and research goal 3.2 Requirements 3.3 Research Method	<i>9. Opportunities and constraints</i>	9.1 Opportunities 9.2 Constraints 9.3 A typical case study
<i>4. Research on Flyash</i>	4.1 Introduction 4.2 History of Flyash use 4.3 Types of puzzolans/ fly ash 4.4 Effects of replacing cement with partly / fully flyash in concrete 4.5 Design and Construction considerations 4.6 Sintered Fly ash aggregates- a case study of specimens 4.7 Effect of replacing sand with flyash 4.8 Conclusions	<i>10. Conclusions</i>	10.1 Reflection 10.2 Conclusions and Recommendations
<i>5. Case Studies- Component based Prefab systems</i>	5.1 Introduction 5.2 Modular co-ordination and Type standardisation 5.3 Danish Housing system 5.4 Precast Sandwich Wall Panels 5.5 ARXX Insulated Concrete forms 5.6 Calcium Silicate Masonry 5.7 Conclusions	<i>11. References</i>	
<i>6. Preliminary Design</i>	6.1 Introduction 6.2 Concept directions 6.3 Study of dimensions- breaking the 'wall' down 6.4 Design of Panel/ structure 6.5 Joints 6.6 Details and systems 6.7 Panel composition and infill mix- a study of flyash 6.8 Thermal properties	<i>12. Appendix</i>	Appendix 1- housing demand statistics Appendix 2- Geography and climatic data of india Appendix 3- flyash data Appendix 4- structural calculations Appendix 5- thermal conductivity of design mix



In this chapter we will try to establish a basic problem in India which needs attention. And the problem will be something, which I as a Building Technology researcher, can find a role in contributing towards addressing the problem.

One thing which all of us as human beings strive for, is to have a good quality of life. The quality of living is influenced by many factors. In the developing countries the housing problem are manifold and key factor in influencing quality living. The mainstream formal housing needs a faster production system of housing maintaining quality of houses and economy to overcome the huge shortage. Government's role has been changed to enabler from provider during last couple of decades and that is reflected in national plans. Overall 12% household (H/H) do not have livable house. Existing housing supply mechanism could not fulfill only 15% on an average of total housing need per decade including the backlog and additional need for population increase. National Housing and Habitat Policy (NHHP) mentioned about the necessity of a faster housing supply and focused on prefabricated system built housing. Scope for appropriate prefabricated building system to fulfill the housing shortage in India must be reassessed in present context.¹

This chapter analyses the housing shortage and supply system, identifies the need of a faster system of housing delivery.

		1961	1971	1981	1991	2001
Population (in cr)	Urban	7.89	10.91	15.95	21.76	28.61
	Rural	36.03	43.91	52.38	62.87	74.25
	Total	43.92	54.82	68.33	84.63	102.86
Housing Shortage in Crore, (10 million)	Urban	0.36	0.3	0.7	0.82	1.06
	Rural	1.16	1.16	1.63	1.47	1.41
	Total	1.52	1.46	2.33	2.29	2.47
Shortage as a percentage of Total H/H (in %age)	Urban	20.40	12.29	19.62	16.84	16.56
	Rural	16.58	13.61	16.03	12.04	9.78
	Total	17.35	13.31	16.96	13.41	11.86

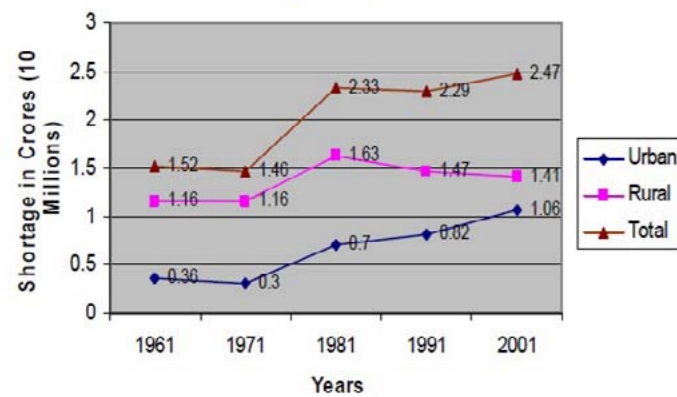
Fig 1: Table, Housing shortage in figures¹Fig 2: Graph, Housing shortage in figures¹

Housing Shortage, Supply and Issues

There is around 24.7 million-house shortage in India on an average (National Building Organization, NBO & NHHP 2007).

Fig. 1 shows, that housing shortage in absolute number is not decreasing. i.e. existing gap in housing stock from 1981, 1991 to 2001 could not be filled up by conventional housing supply system. Whereas, housing shortage in urban areas is increasing. i.e. demand for new housing is growing at higher pace in urban areas and supply is not adequate (Fig. 1). Housing shortage in rural areas could be reduced in absolute numbers. Since combined effort from public as well as private housing providers could not fulfill the gap, existing housing supply have to be speedier to achieve the fulfillment of this additional shortage. Proportionately 1 out of 10 H/H in rural areas do not have livable house. Whereas for urban areas the corresponding figures is 1 out of 6.¹

Housing Shortage, Need and Stock

Exact data on supply of housing stock is not available. However to calculate for convenience of study housing supply is calculated from the following simple equation and presented in the table. It may be mentioned that for determining additional requirement of housing additional population is divided by average household size. Hence, the figure is indicative and based on average household size of recent plan period.

Existing housing supply mechanism could increase the stock for only 15% on an average of total housing need including the backlog and additional need for population increase in a decade. Even during fifth and sixth plan, absolute housing supply, which was far below the combined need and newly dilapidated houses, which increased manifold, resulted a negative increase in housing stock. The successive years could not ensure more supply and it definitely shows that faster system of housing delivery has to be envisaged to overcome the total shortage.¹

Key Issues in non-Achievement of Housing Supply in Public Plan & Policies

Based on the study of performance during 5 year plans the key issues are identified as below and a marking has been done based on the analysis during the specific plan period. Major issues have been enumerated from 20 to 10 according to qualitative assessment during plan period. Accumulating the whole, speedier housing system and affordability resembles the most prominent issues, which need to be addressed. (fig. 3)

It is seen from the table that speedier technology and housing supply is the prime barriers (90) followed by the affordability and availability of housing finance (85). In developed as well as developing countries, prefabricated system of housing has been envisaged as a viable option for speedier supply of housing since it offers cost effective and faster production of housing. In the country like India problem remained in various aspects, which needs due attention.

Issues/Barriers	1961-71 Third and fourth plan	71-81 Fifth and sixth plan	81-91 Sixth and seventh plan	91-2001 Eight and ninth plan	2001-11 Tenth and Eleventh plan	Total marks
Housing finance and affordability	20	20	20	15	10	85
Institutional and policy framework	15	15	10	10	10	60
Availability of land for housing	10	20	15	15	10	70
Advancement and availability of building materials	15	10	15	20	20	80
Speedier technology and housing system	20	15	15	20	20	90
Supply of skilled and unskilled labor	10	10	15	10	20	65

Fig 3: Table, Key issues in non achievement of housing supplies¹



Construction system

Traditional construction techniques involve the use of timber moulds or shuttering for roof spans and other structural systems. These temporary timber structures have a short lifespan and due to the volume of construction in the peak seasons of spring and summer for larger well-funded projects are often unavailable. This hinders construction schedules and does not allow projects to be completed before cooler or rainy seasons begin. However, construction does not stop in the summer despite the lack of proper equipment and material. Instead, using makeshift methods for construction on site leads to inappropriate means and hence a substandard quality of construction in finished buildings.

Primarily housing in Urban areas today are done with in-situ RCC frame with infill of concrete blockwork, then plastering, then services and then finishing. So it has an established protocol of one thing having to wait for another thing to get over and most of the things get controlled by site conditions, labour force and climatic conditions, which often results in poor quality and extreme delays due to uncontrollable situations.

In a current scenario, housing as an industry is still hand crafted and heavily depended on unskilled labour and on site construction. This results in large amount of material wastage and labour in efficiency, leaving aside the quality and thermal comfort level.

Fig 4-8: A typical example of conventional construction of housing, in Bangalore

Participants in India's housing construction industry

The construction industry consists of numerous fragmented firms. Developers engage main contractors who, in order to maintain minimal overheads, subcontract most of the construction tasks to smaller, non-registered groups of workers. Although these subcontracted (mostly blue-collar) workers have some specialisation in their respective trades, almost none of them provides truly professional and specialised services to construction firms. The industry then is made up of developers, contractors, subcontractors and workers.²

1. Developers: Property developers, typically small landowners, start the construction process by commissioning construction work to contractors. The government and big corporations account for only a small share of housing construction as they develop large projects of multi-storied buildings. Developers devote most of their efforts to procuring land and obtaining building permits, cutting through multiple layers of red tape.

2. Contractors: Main contractors, mostly small registered companies, are responsible for construction work at the site. After receiving the contract from the developer, main contractors typically subcontract all construction work and concentrate on top-level supervision and material procurement. In the case of individually built houses, the contractor's function is typically undertaken by the house-owner.

3. Labour subcontractors: Labour subcontractors, mostly individual, non-registered entities, directly procure and engage the labour required at the site. Labour subcontractors are typically construction workers who have established themselves by enhancing their reputation in their local area or by following a main contractor from site to site. Although labour subcontractors are organised by trade, high labour turnover and lack of formal training severely limits their ability to provide truly specialised services.

4. Workers: Workers are often recruited directly from villages by labour subcontractors who facilitate their migration to cities by providing finance and assuring employment. These workers often leave their families and small landholdings behind and return to their villages during the monsoon to participate in agricultural activities.

Lack of Labour Productivity

The housing construction sector in India is unproductive at the moment. The sector contributes only 1 per cent of GDP in India. Labour productivity in the sector is less than one-fifth its potential.

There are two key reasons for the poor productivity performance of the sector:

1. The first is the artificial scarcity of land created by various distortions in the land market (which is beyond the scope of this research).

2. The second is the lack of standards for building materials and the poor enforcement of the standards that exist.

These factors create a situation where competition in housing construction is not based on construction costs, but is instead based on securing access to land and managing material costs. As a result, players are profitable despite the inefficient and unproductive construction practices.²

At the operational level, poor organisation of functions and tasks (OFT), inefficient design for manufacturing (DFM) and lack of large-scale projects are the key reasons for the low labour productivity in this sector. The industry suffers from a lack of price-based competition. As a result, players are complacent and do not feel motivated enough to cut construction costs or improve productivity. This has resulted in poor operational efficiency. For instance, in the MFH segment, all players along the production chain, from developers onwards, are focusing their attention on issues such as gaining access to land and cutting material costs, rather than focusing on productivity at the sites. This decreases any incentive for the contractors and labour subcontractors to improve operations.²

A distinct lack of standards as far as building materials are concerned and also ineffective enforcement of the few standards exists. Maintaining and enforcing material standards would facilitate the dissemination of best practices and create greater transparency in the housing market thereby allowing consumers to compare prices. It would also make it more difficult for contractors to profit by sourcing cheap and sub-standard materials and compel them to focus on earning their profits by lowering labour costs. The nature of the building materials used also sometimes limits the scope of design for manufacturing (DFM), organisation of functions and tasks (OFT) and viable capital improvements. Materials such as mud, straw and cow dung are not amenable to standardisation, making task specialisation and modularisation of building design difficult.²

Lack of viable investments: Inadequate investment in construction equipment. It is the contractors who typically decide the equipment to be used in a project. Basic hand tools and small equipment are rarely used in Indian construction even though investment in this equipment is economically viable despite current low labour costs. For example, most material in India is currently transported on the heads of the workers as opposed to wheelbarrows. In shuttering, most of the wood used is prepared using manual tools instead of the more efficient circular saws and electric surface planers. In painting, exterior walls are still painted with standard brushes rather than roll-brushes or paint sprayers. When confronted with the savings potential of adopting such tools, the typical response of Indian managers interviewed is, "Nobody thinks about saving labour in this business".²

M4I Sustainability Indicator	Effect of Using Prefabrication
Operational Energy	Positive – Improvements in build quality should ensure consistent standards of insulation and service installation.
Embodied Energy	Positive – Reduced waste and increased recycling in off-site manufacture should reduce the embodied energy associate with the manufacture of a given part.
Transport Energy	Negative – Movement of prefabricated components will necessitate the transport of some additional volumes of air (particularly for volumetric solutions
Waste	Positive – Manufacture of components in a factory environment should reduce much of the waste currently associated with site activity.
Water	Positive – Manufacture of components that require water in their manufacture in a factory environment should allow more control, and potential for water recycling than would be found on site.
Species per hectare	Positive – Reduction of pollution on site by undertaking manufacture in a controlled environment should limit the impact on existing species on site. However, the design and landscaping of the proposed development is likely to be very important and unaffected by the choice of prefabrication or not.

Fig 9: Table, M4I sustainability index²⁷

The prefabricated alternative to roof construction removes the issues of timber moulds and shuttering. Prefabrication in Indian housing improves uniformity and brings unskilled labour inside where work is supervised, monitored and controlled. Lets discuss briefly how prefab is a better way to address housing in India:

Why Prefab?

- Quick execution of work:**
The housing demand in India at the moment needs fast execution. Pre-manufacture of components and assembly on site ensure work can go on parallel off-site during the season of rain and bad weather also, resulting in faster execution of the project. Unlike in Europe, where a layered construction is necessary to avoid cold-bridging, in India an integrated wall element is sufficient without a distinct insulation layer and cavity, prefabrication of which will increase the speed.
- Quality control:**
Offsite production in a controlled environment under skilled supervision ensures better quality of work in terms of precision; material optimisation; finish; performance is ensured limited only to the proper handling of joints on site. It also improves the control of the work which finally gets executed, as there is a change in the Protocol, whereby technical skilled people control the project more than the unskilled labour force on site, by means of prefabrication. An industrialised building system component produces higher quality of components attainable through careful selection of materials, use of advanced technology and strict quality assurance control
- Cleaner Construction Site:**
This is an important factor. The conventional insitu construction results in messy site conditions, unhygienic and unhealthy atmosphere for the workers and the neighbouring localities. Prefab ensures the site remains clean and healthy for most part of the construction periods. Un-necessary scaffolding work can be avoided.
- The labour problem:**
Although there is no dearth of human resource in India, there is severe dearth of skilled labour force to work with traditional craft. If this problem can be addressed more holistically then it can be beneficial. Large production output and standardisation of precast elements allow a high degree of labour specialisation with the production process. The process can be subdivided into a large number of small homogenous tasks. In such working condition, workers are exposed to their work repetitiously with higher productivity level.

So holistically speaking, Prefab is a good way of addressing the mass housing problem in India. What kind of Prefab is suitable for Indian conditions? This question shall be addressed methodically in the subsequent chapters, to arrive at something which is critically missing but having a good potential, worthy of research.

In this chapter we do a literature study on the existing scenario prevalent prefabrication, and housing in India, to arrive at a more concrete focus point of research. This is essential, as the research on developing an entire prefab system for housing is a very vast topic, and one can easily get lost in this ocean, and be able to come up with something productive in the time frame of a Masters Graduation.

The various topic covered in the chapter are:

2.2 Industrialisation in building Industry

This is a introduction to the various processes involved in industrialisation

2.3 Typologies in Prefab

Here we study the different categories of prefab systems, based on size, weight, and design decisions. The advantages and disadvantages of each, on a broad level

2.3 The Indian Context and Pre requisites for Prefab

Here we try to define the critical issues which affect the process of prefabrication in India, on a broader level, and conclude on kinds of approach is favourable

2.4 Prevalent Prefab techniques in India

This sub-chapter we try to look at most of the pre-fab (semi-prefab) techniques being experimented on housing in India already, and establish what is lacking.

2.5 Demand for Low-rise housing

In this sub-chapter, we establish the fact the demand for low-rise housing is on a high, following the economic recession.

2.6 The sustainability question and the problem of flyash

Here we try to look at how 'sustainability' aspects can be addressed for housing on a broad level, and look at facts relating to an industry waste called flyash

2.7 Climate of India

A vast country like India, will have several climatic zones. So it is important to broadly study the classification and focus on one typology. It also concludes with the typology of housing suitable for the chosen climate.

The chapter shall end with a summary on all these sub-chapters to arrive at one/few focus points for research, which shall be narrated in the next chapter.

Introduction

Industrialisation in Building Industry is multi-dimensional. It is quite a complex process, which involves several stake holders and methodologies that can influence the process. Crudely, the following are some of the different directions (most of them related to one another) involved in this:

1. Governmental policy to industrialise.
2. Establishment of Industries to manufacture by investors and technocrats.
3. Developing an automation program.
4. Developing industrial products/ building systems.
5. Restructuring labour organisation.
6. Shift Building industry planning protocol.
7. Developing mechanisation methods on site, like developing a simple tool to help lay mortar for example.

We can contribute to the step of industrialization through any of the above steps or even by many of them. I have focussed my research work on Industrial products/ building systems for this graduation.

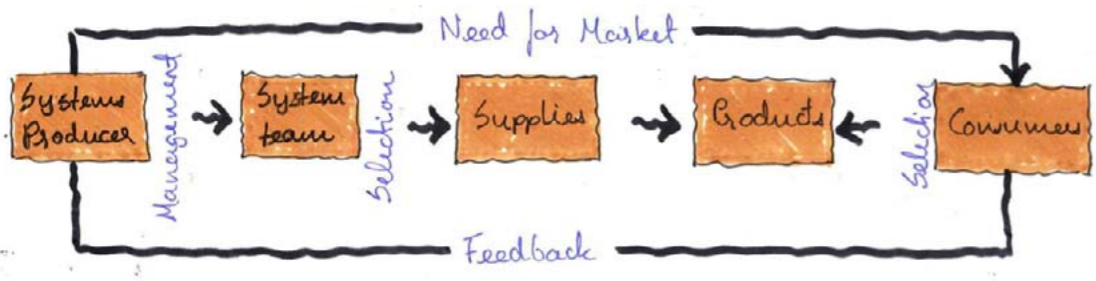

Fig 10: Closed system

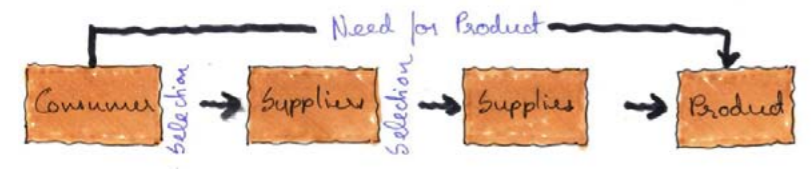

Fig 11: Open system

Industrial building system (definitions)

Industrialised Building Systems in the construction industry includes the industrialised process by which components of a building are conceived, planned, fabricated, transported and erected on site. The system includes a balanced combination between the software and hardware components. The software elements include system design, which is a complex process of studying the requirement of the end user, market analysis, development of standardised components, establishment of manufacturing and assembly layout and process, allocation of resources and materials and definition of a building designer conceptual framework. The software elements provide a prerequisite to create the conducive environment for industrialised to expand.⁴

Esa and Nuruddin (1998) asserted that an IBS is a continuum beginning from utilising craftsmen for every aspect of construction to a system that make use of manufacturing production in order to minimise resource wastage and enhance value for end users.⁴

Warswaski (1999) expounded that an industrialisation process is an investment in equipment, facilities, and technology with the objective of maximising production output, minimising labour resource, and improving quality while a building system is defined as a set of interconnected element that joint together to enable the designated performance of a building.⁴

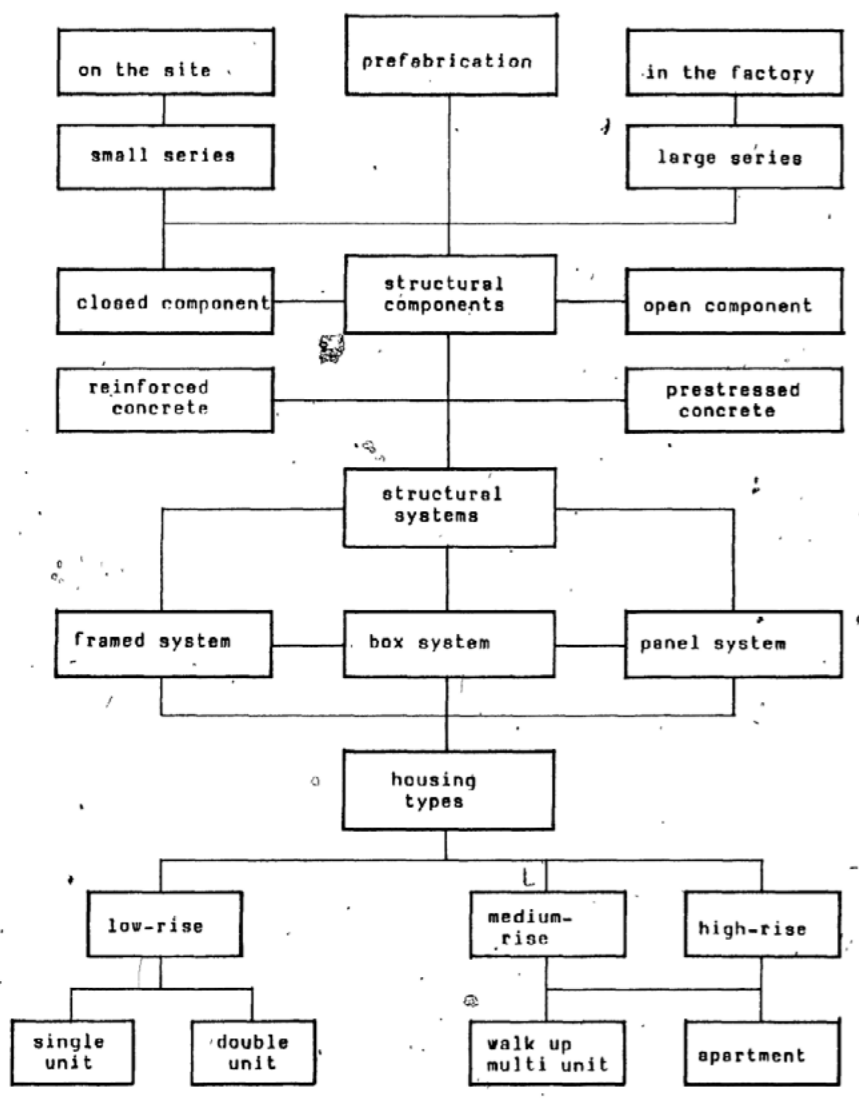
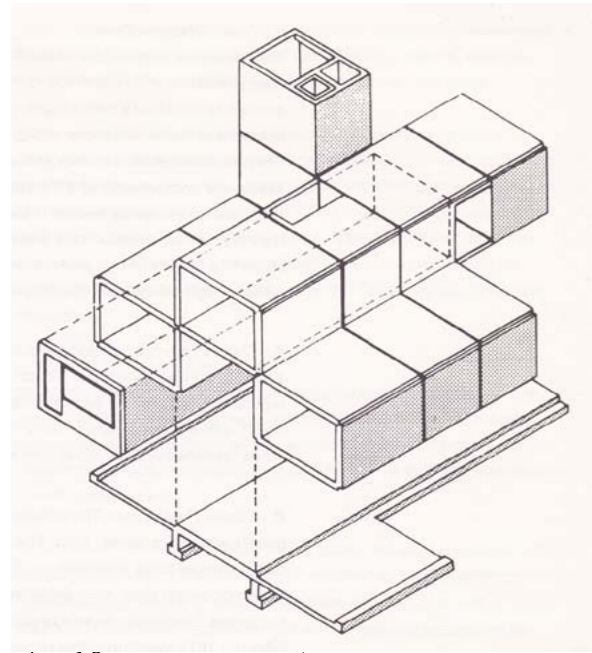
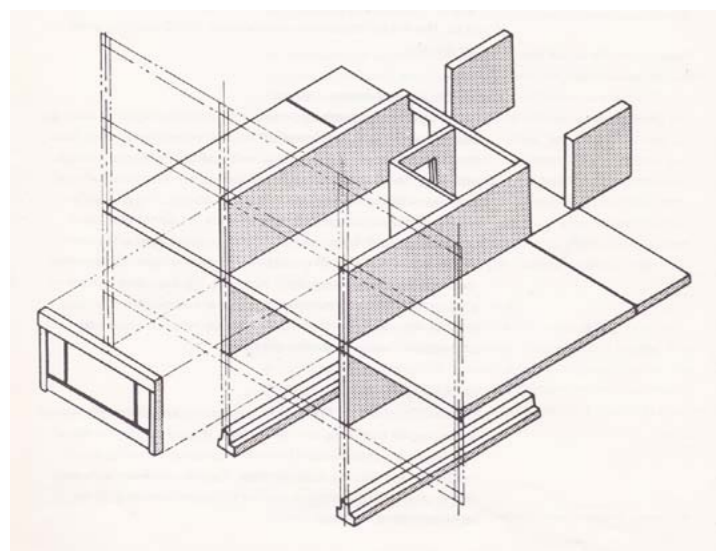
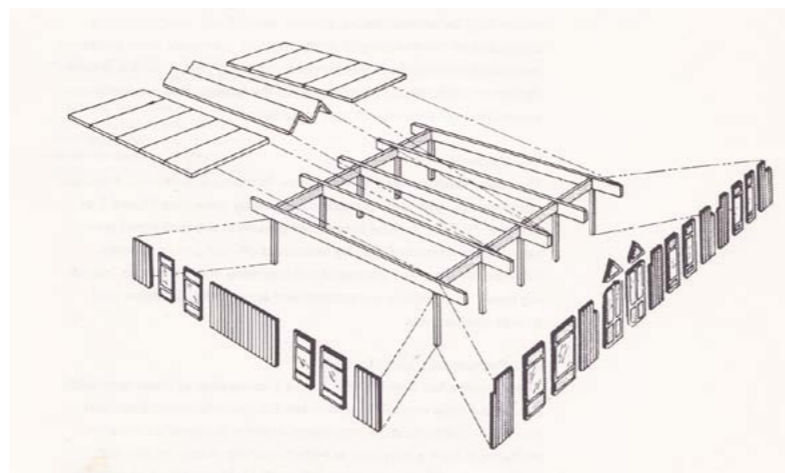

Fig 12: Broad Classification of prefabrication⁴

Typologies based size and scale of manufacture

Fig 13: Box system³Fig 15: Panel system³Fig 16: Component system³

1. Monolithic Unit: Boxes

Monolithic units (Figure 13) are generally factory-produced and preassembled volumetric elements with a high degree of finish and a minimum amount of required site erection time (utility connections). They may be further categorized as a function of their relative degree of self-containment.

A. Lightweight units or mobile-home types: Totally self-contained housing units which can retain their mobility, or be permanently installed and grouped or stacked with the addition of a demountable frame. In most cases mobile homes are completely preassembled and finished, and require only site utility connections for occupancy.

B. Heavyweight or volumetric components: Room-size (or smaller) volumes of concrete, steel sandwich, wood- or fiber-reinforced plastic, which can be grouped horizontally and/or stacked vertically (if bearing) and dry connected to form single-family or multifamily attached or detached housing. In some cases, these volumes may be incorporated in traditional structural/mechanical space grids to provide high-rise multifamily housing. Stacked bearing units often avoid the necessity of producing six-sided volumes by wall and slab sharing, and, in some cases, bonus room units are acquired by checkerboard stacking. Other types of systems employ discontinuous room units to provide for mechanical chases, sound insulation, and structural fireproofing.

Basically, monolithic units are restricted by travel radius from the plant (action radius); they are also extremely costly to handle. They are usually to be considered "closed" systems because it is not possible to mass the volumes in very many different ways; thus, monolithic systems restrict the flexibility of urban designs dependent upon them.³

2. Total Systems: Panels

Total systems (Figure 15) are usually large concrete slabs or otherwise panelized units not made in the form of a box, but often large enough to constitute entire walls, partitions, and floors, or substantial parts of floors and roofs, which form boxes when put together. They are fabricated in a shop and assembled at the site. In some cases, the components of different manufacturers can be incorporated within the same system if the components are "open" in that they provide for modular coordination options for subsystems. Panels come in a variety of materials; some examples are heavyweight (concrete) or lightweight (sandwich) pieces.³

3. Components

The industrialized production of materials and components (Figure 16) is nothing more than the rationalization and the application of modular coordination and assembly line techniques to traditional craft technology (windows, floors, panels, etc.). Such coordination is applicable to the grouping of units that had previously been produced and distributed separately (heart units or utility cores), with a greater portion of production accomplished at the factory. It is generally accompanied by the use of new materials.³

No	General System	System	Production Material
1	Frame system	Light weight frame	Wood, light gage metals
		Medium light weight frame	Metal, reinforced plastics, laminated wood
		Heavy weight frame	Heavy steel, concrete
2	Panel system	Light and medium weight panel	Wood frame, metal frame, and composite materials
		Heavy weight panel (factory produced)	Concrete
		Heavy weight panel (tilt up – produced on site)	Concrete
3	Box system (modules)	Medium weight box (mobile)	Wood frame, light gage metal, composite
		Medium weight box (sectional)	Wood frame, light gage metal, composite
		Heavy weight box (factory produced)	Concrete
		Heavy box (tunnel produced on site)	Concrete

Fig 17: Table, classification based on material and production method³

The term "pieces" refers to smaller units than big panels, usually columns, beams, and floor slabs, assembled at the site to provide the structure into which are inserted nonstructural panels or field-fabricated parts such as partitions. The line between industrialization and traditional construction can easily become blurred. The objective may be greater flexibility of arrangement with a smaller number of different units than might be possible with big panels, or it may be simpler fabrication equipment in the shop, or simpler and lighter erection equipment, or pieces small enough to be handled by manpower alone. More joints are usually required than with boxes and large panels, but the joints may be simplified by being put at points of low stress. The amount of field finishing and field incorporation of utilities is generally greater than with boxes and big panels, but this can be reduced by careful and ingenious design.³

These approaches are not mutually exclusive, nor do they preclude mixtures of industrialized and traditional methods. The latter is the rule; few, if any, of the new technologies make no use of traditional procedures. Box construction is likely to employ some panels and pieces; the dividing line between big panels and pieces is not sharp; foundations are almost certain to be field fabricated; and it is often more economical to cast floors in place than to use precast slabs, especially when plans are irregular and non-repetitive.³

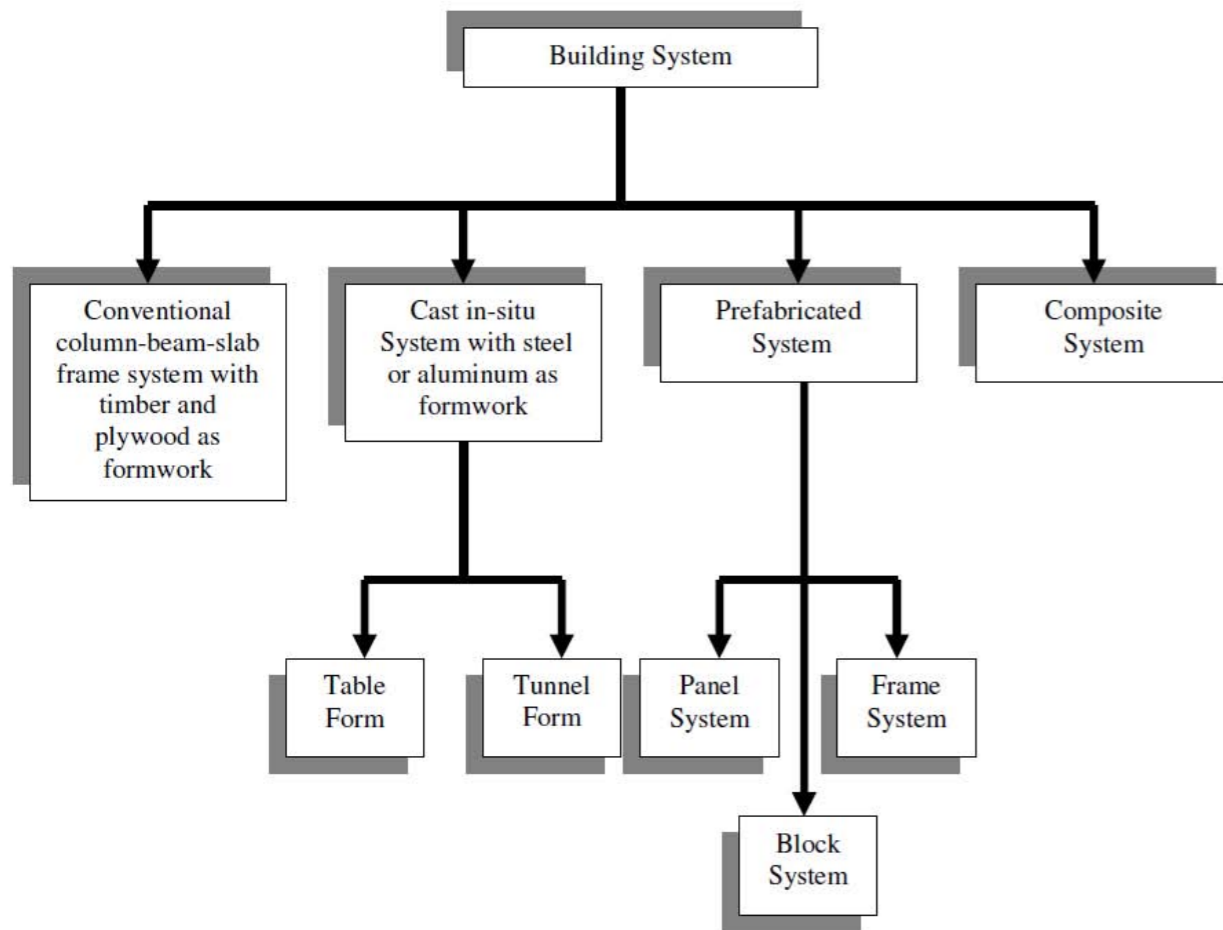

Fig 18: Classification of IBS, malaysian method⁴

Typologies based on design of system

Closed System

A closed system can be classified into two categories, namely production based on client's design and production based on precaster's design. The first category is designed to meet a spatial requirement of the client's, that is the spaces required for various functions in the building as well as the specific architectural design. In this instance, the client's needs are paramount and the precaster is always forced to produce a specific component for a building. On the other hand, the production based on precaster's design includes designing and producing a uniform type of building or a group of building variants, which can be produced with a common assortment of component. Such building includes school, parking garage, gas station, low cost housing, etc. Nevertheless these types of building arrangement can be justified economically only when the following circumstances are observed (Warszawski, 1999).

a) The size of project is large enough to allow for distribution of design and production costs over the extra cost per component incur due to the specific design.

b) The architectural design observes large repetitive element and standardisation. In respect to this, a novel prefabrication system can overcome the requirement of many standardised elements by automating the design and production process.

c) There is a sufficient demand for a typical type of building which could be stereotyped so that a mass production can be obtained.

d) There is an intensive marketing strategy by precaster to enlighten the clients and designer the potential benefit of the system in term of economics and noneconomic aspects.⁴

Open System

In view of the limitations inherent in the closed system, an open system which allows greater flexibility of design and maximum coordination between the designer and precaster has been proposed. This system is plausible because it allow the precaster to produce a limited number of elements with a predetermined range of product and at the same time maintaining architectural aesthetic value.

In spite of many advantages inherent in an open system, its adoption experiences one major setback. For example, joint and connection problem occur when two elements from different system are fixed together. This is because similar connection technology must be observed in order to achieve greater structural performance.⁴

The Indian Context and the pre-requisite for industrial housing

To explore the opportunity to increase housing stock by industrialized housing system the main considerations lies in the process and appropriate form of housing package for different groups. It has to be analyzed thoroughly. Suitability of prerequisite in Indian situation is discussed below:

Availability of Bigger Land for Mass Housing:

Until 2000, bigger land parcels were scarcely specially in urban areas. Recently repeal of Urban Land Ceiling Regulation Act (ULCRA) has been enforced in various states. This has made possible the availability of bigger land. On the other hand where ULCRA is still in enforced, like West Bengal, public private joint venture made large parcels of land available. However, the availability of land for big scale mass industrialized housing is not a barrier now.¹

Private Investment Possibility:

After liberalization and consecutive permission of 100%, Foreign Direct Investment in the large infrastructure and housing projects the investment in housing is also not a big problem. For componentized construction, even smaller manufacturers of building elements can participate. While major real estate projects are meant for higher Income group (HIG) and middle-income group (MIG), recent trend in real estate development shows that developers are keen to invest in housing for MIG and LIG since there is ready demand whereas demand for HIG is in a semi-saturated state in major cities.¹

Formulation, Enforcement of Building Code and Inspection Mechanism for Quality Control:

In a country like India this is something for which a radical strategy and change has to come. The present building regulation and National Building Code (NBC) need more enforcement on behalf of public body. To maintain safety in built environment it will be wiser to start with componentized construction to full-scale industrialization since quality control in componentized construction is much easier than full-scale 3D or 2D unit prefabrication.¹

Offsite Road Infrastructure:

The present condition of road infrastructure in India based on national, state and district high ways. Whereas other than national highways and some selected roads in major state capital cities, largely roads are not capable of taking load of full-scale houses and its careers. Hence, panelized/componentized construction conforms to the road situation, since both of them needs much lesser space, volume and weight. However, componentized construction would be feasible for smaller settlement-road networks, which cater semi urban and rural areas.¹

prerequisites	Weight-age for Suitability of specific system in India condition		
	3D full scale structural elements	2D full scale panelized elements	Componentized construction based on frame structures.
characteristics	Closed	Open/closed	Open
Availability of bigger land	3	3	3
Private Investment Possibility:	1	2	3
building code an inspection mechanism for quality control:	1	2	3
Offsite road infrastructure	1	2	2
Dimensional Coordination and Research in Housing Module:	2	2	3
Skilled manpower requirements	1	2	3
Total score	9	13	17

Note: Scores have been provided as 3-most suitable, 2-suitable, 1-less suitable

Fig 19: table, comparison of the 3 types of prefab in Indian context¹

Dimensional Coordination and Research in Related Area of Housing Module:

The present housing market plays within a wide range of dimensions having little regards to the NBC where a modular dimension of 100 mm (1M) has been proposed. It must be noted here however, that in practice the basic module of 150 is still at large. This is due to the British imperial system in the age old days when 6 inches was a standard measurement. Most residential dimensions still revolve around the 150 module. However, appropriate dimensional coordination and R/D in modular construction must be first step for componentized construction. Similar R & D in 2D or 3D unit load bearing prefabrication more skilled, trained labor is required. Indian scenario does have plenty of unskilled/semiskilled labor, who can be engaged in componentized construction after little or no training.

Considering the situation described above, the suitability of appropriate system of industrialized housing must be explored. A matrix analysis among the various systems (3D Blocks, 2D panel, and framed-components) with the prerequisites as discussed above may be useful to find the appropriate form. The table on the left (fig.19) gives a weighed comparison over a score of 3, between the the 3 systems (as per Ar. Uttam K. Roy, Dr. Madhumita Roy, Prof. Subir Saha)

One can clearly see, that component system is the most suitable. But Panel system is not far behind. It might be worthwhile to fuse the advantages of Panel system into the component system to define a new system, which has its own advantages combining both, and more suitable to Indian context at Present.

So what then is the system we are talking about? It could be an interlocking load bearing Prefab block system, which has all the characteristics of a Component system, but also can perform the function of 'load bearing' Panel system, after assembly. This kind of system can be coined under a 'composite' system perhaps. The low and medium rise demand for housing in India also makes it favourable to investigate load bearing option for prefabrication, for 2 reasons- one is it eliminates the 2 stage process on site of frame and infill, thereby probably reducing time; two, it reduces cost of saving the frame, maximising the use of structural properties of the material concerned.

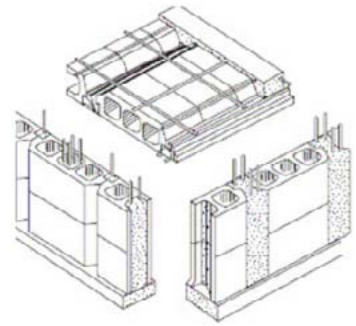

fig. 20 & 21- structural clay joist elements⁵

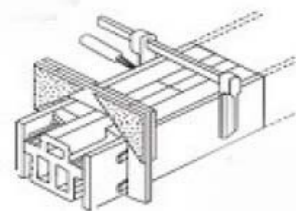
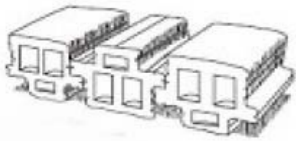

fig. 22- prefabrication of joists⁵

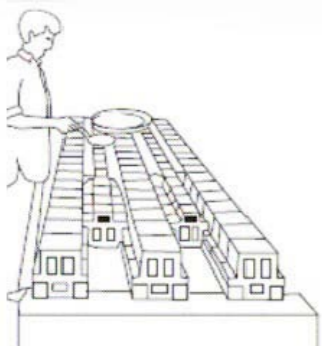

fig. 23- insitu concreting to finish the roof⁵

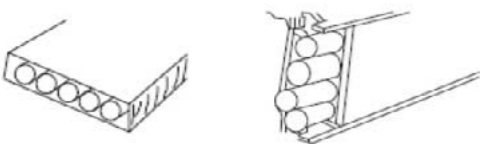

fig. 24- typical hollow core slab and the mould for it⁵

Zipbloc system

This system developed in India, utilizes a single precast element, a hourdi-type hollow block $530 \times 250 \times 140$ mm for walls and roofs.

Pre-stressed slab elements-

This roofing system was developed at the Structural Engineering Research Centre in Chennai. The hollow blocks used are 'Hourdi' or similar blocks, and may be placed in one or more rows. Concrete ribs of at least a four-centimetre width run around the periphery of the row of blocks forming the slab. The prestressing wires are located in these ribs. For units longer than two metres, intermediate ribs with nominal reinforcement are provided in the traverse direction, at spacing that does not exceed two metres. The hollow clay blocks, which have grooves on their surfaces, remain exposed at the top and bottom of the precast element. In situ concrete screed is laid on the top and plastering is done on the underside. The advantage over traditional systems is that the slab elements are about 25% lighter than conventional RCC slabs.⁵

Extruded structural clay joist and filler unit floor/roof

This roofing system was developed by CBRI (Central Building Research Institute), Roorkee, India. The overall dimensions of the unit are $165 \times 150 \times 190$ mm. It has three rectangular cavities, which account for 37% of the total volume, and the outer faces have grooves for better bonding of mortar and concrete.

Prefabrication of joists : This is done by laying the fired clay units end to end on a flat surface, in a row of the desired length, with the wider base below, and joined with a 1:3 cement and sand mortar. Two wooden planks are placed on either side and held by clamps. The gap between clay units and planks is filled with concrete, in which the reinforcing rods are embedded, ensuring good cover from all sides. The joists is manually laid in parallel lines, at distances of 300 mm c/c. The structural clay units, with their wider base below, are laid between the joists as filler units, ensuring that the joints in the joist member and filler units are broken⁵

Hollow floor slabs

This is one more option for material reduction. The overall dimensions of the unit are $3500 \times 600 \times 120$ mm. In this method the steel endpieces with four openings define a trapezium-shaped cross section of the floor slab, so that when finally assembled, the V-shaped gaps between the slabs can be easily filled with concrete. Reinforcement is laid and four GI pipes are pushed lengthwise through the holes in the end. The concrete is poured and compacted simultaneously to ensure that no air pockets are developed around the pipes. The concrete is cast very dry so that it does not collapse when the pipes are removed. The pipes are later pulled out with an electrical winch⁵

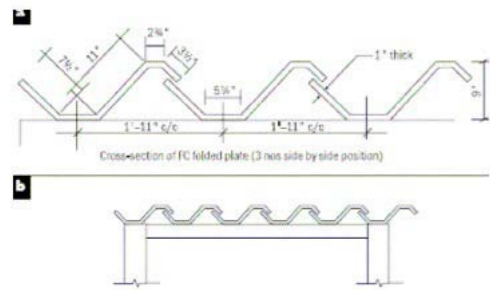

fig. 25- precast ferro cement roofing element⁵

Precast ferro-cement folded plate-roofing element

Folded plates with a trapezoidal cross-section either in the form of a 'hat' or in the form of a trough section give high rigidity and ensure safety. Such a trough section can be conveniently made of ferro-cement. Roofs made of such trough sections can be constructed by simply assembling such precast FCFP (ferro-cement folded plate) elements side by side on supports, which may be of wall or beam with no in-filling. When required it can be shifted and re-erected as desired. The span length of FCFP element up to 12 feet 6 inches (3810 mm) is adopted for the sake of convenience in handling/hoisting and placing without any mechanical aid. Design of a precast FCFP element (with no diaphragm) may be done as an inverted T-beam replacing a trough section. The details of FCFP elements are a six-inch (150 mm) base, eightinch (200mm) depth and thickness of a half to threequarters of an inch (12-18 mm). Tension reinforcement as per the design requirement is provided and transverse reinforcement is also to be provided in the shape of the profile of the trough section. Skeletal reinforcement of two layers of 24-gauge GI wire mesh at the rate of a half-inch (13mm) c/c with a one-third inch (10mm) cover on either side.⁵



fig. 26,27- mivan formwork system- RC box frame construction

Tunnel form construction

The Aluminum Formwork System is a system for forming the cast-in-place concrete structure for a building. It is also a system for scheduling and controlling the work of other construction trades such as steel reinforcement, concrete placement, and mechanical and electrical trades.

The Formwork System of aluminum forms has been used in the construction of thousands of residential units in both low rise and high rise buildings. It has been proven to be very successful in the construction of mass housing projects in various parts of the world. It is fast, simple, adaptable and very cost effective.

This is a unique system because it forms all of the concrete in a building including Columns, Beams, Walls, Floor Slabs, Stair Case, Shafts, Window Hoods, Balconies, Lift Area and most of the decorative features in exact accordance with the architect's design. Unlike other construction systems, the aluminum forms can be erected by unskilled/semi-skilled labours and without the installation of hoisting cranes, as 99% of the equipments are made of hard aluminum, and only 1% comprises of steel. The weighs of each component are kept not more than 30 kilograms which can easily be handled by a single worker. The panels and other sections are secured and fixed by steel pins and wedges with spacer ties and can be assembled by a simple hammer. This eliminates the need for skilled workers.⁵

Conclusions

1. There is considerable research being done on prefabricating the roof system for housing in India
2. The idea of looking at the wall as a prefabricated systems is not yet investigated in the housing sector in India, for multi-family dwellings.



Introduction

Delhi and Bangalore have been seeing a wave of low-rise buildings recently. Sapna Kulshrestha studies the shift in trend that is responsible for gradually changing the capital's skyline.

Delhi has innumerable high-rises with many new ones coming up in and around the city and the National Capital Region (NCR). However, there is an interesting development gradually manifesting itself in the capital city - the rising number of low-rise apartments. Many real estate developers discovered that the option of low-rise apartments was something the public wanted as well. Typically, low-rise apartment units are built on Ground+ 2 floors or a maximum of Ground+3 floors

This trend seems to be a reaction to the slowdown in the economy and the subsequent dampening of the real estate market that happened in the past few years. The situation forced builders and developers to think of different formats so as to attract all types of buyers.

Besides, the construction of low-rise apartments rather than high-rise buildings was an attractive option for lower and middle-income buyers - as the cost of construction is less for such developments and the benefits can be transferred, making the purchase affordable for them.

Vineet Singh, senior vice president-domestic (North, East & West) and international sales of property, www.99acres.com says, "The plotted area concept was what Delhi started with before it moved on to an apartment-style living with multi-storeyed constructions by the DDA (Delhi Development Authority) and later by private developers during the real estate boom. With the slowdown, developers are trying out various formats to attract buyers."⁶

Says Nitesh Kumar, director, marketing, TDI Group: "Building low-rises helps to cut costs as a number of services can be done away with. For instance, fire norms are easier to follow, separate parking space does not need to be created within the structure, there's no need to maintain a basement and elevators are not required. All this amounts to significant savings for the developer."

LOW-RISE PROJECTS LAUNCHED RECENTLY

PROJECT	LOCATION	FLOORS
Unitech Uni Homes	Mohali	Ground+2
BPTP Park Floors-II	Faridabad	Ground+3
Jaypee Lake District	Greater Noida	Ground+3
TDI My Floor	Kundli	Ground+2
Vipul Tatvam Villas	Gurgaon	Villas
Silver Springs	Indore	Villas and Ground+2
The Empyrean	Bengaluru	Villas

Fig 28: table, low rises, projects launched⁶



Fig 29: 'marble-arch' project, Chandigarh³⁹

An erstwhile concept

Delhi already had the concept of registering independent floors in low-rise buildings for freehold properties, later extended even to DDA flats. Now, with Haryana allowing registration of independent floors, the market is flush with independent floor launches which demonstrate the demand for such projects.⁶

Another reason for the increase in low-rise apartments, especially in the suburbs and satellite towns is because the permissible covered area on a plot of land depends on the FSI available in that area.

Thus, while in centralised locations of the city a builder would opt for high-rise buildings to consume all available FSI, for the suburbs, which have lower FSI, a developer would have no choice but to build low-rise projects.⁶

"Low-rise buildings are the forerunners of the Indian residential property sector, and continue to represent its bulk. However, the concept is also highly location-specific and has a lot to do with available FSI in any given location," says Subhankar Mitra, AVP-Strategic Consulting, Jones Lang LaSalle Meghraj.

Experts in urban development also feel that the rising development of satellite townships would further push up the demand for low-rise apartments, which can be an answer to the intense pressure on civic infrastructure in the core areas of cities.

What is Sustainability

Sustainability can have many meanings and is often called "green construction" or "green building."

The U.S. Environmental Protection Agency defines green building as "the practice of creating structures and using processes that are environmentally responsible and resource-efficient throughout a building's life-cycle from siting to design, construction, operation, maintenance, renovation and deconstruction. This practice expands and complements building design concerns of economy, utility, durability, and comfort. A green building is also known as a sustainable or high performance building."⁷

When it comes to residential buildings, the Green Building Council believes that green homes are generally "healthier, more comfortable, more durable, and more energy efficient and have a much smaller environmental footprint than conventional homes." The Sustainable Native Communities Collaborative defines sustainable housing as: "culturally appropriate, green, and affordable."

Benefits of sustainable construction

It is generally accepted that there are environmental, economical, and social benefits to building more sustainably:

Environmental benefits—Sustainable construction enhances and protects biodiversity and ecosystems, improves air and water quality, reduces waste streams, and helps conserve and restore natural resources.

Economic benefits—Green building practices help to reduce operating costs (such as fuel costs); create, expand, and shape markets for green products and services; and optimize life-cycle economic performance of buildings.

Social benefits—Sustainable design practices enhance occupant comfort and health, minimize strain on local infrastructure, and improve overall quality of life.⁷

Categories of Sustainable construction*Energy Efficiency*

ex:

- Façade differentiation designed for passive solar heating/cooling,
- Insulated Concrete Forms
- Straw bale technology
- Adobe
- Geothermal heating/cooling
- Low-E windows (low emissivity windows)
- Heat and Energy Recovery Ventilators
- High efficiency heating and cooling systems (heat pumps)
- Photovoltaic panels (solar panels)
- Solar water heating
- Radiant floor heating

Materiality

ex:

- Long-term, durable materials such as metal roofs, cementitious siding, masonry, etc.
- Recycled/waste products incorporated into construction materials
- Low volatile organic compound (VOC) products and paints
- Use of regional or local materials and labor

Water Efficiency

ex:

- Green roofs
- Landscaping to reduce water usage/plants that thrive in regional conditions
- Gray water systems/wastewater systems
- Rainwater harvesting and storage
- Xeriscaping
- Rain barrels/cisterns
- Permeable pavement
- Bioswales
- Low-flow plumbing fixtures

Site Planning/Synthesis

ex:

- Project on a brownfield site
- Building orientation
- Project near public transportation or car sharing implemented to minimize car trips to and from the site for everyday needs
- Project part of larger master plan that includes other non-residential uses
- Low-impact development
- Soil erosion control
- Plan for future expansion
- Green maintenance plan
- Educational programs for residents, maintenance staff

There is a tremendous scope for sustainable practices for housing in India, if the issue can be addressed holistically, however small the contribution is from each of the participants in the industry. **As part of this research I would like to focus more on the materiality aspect of sustainability, which in a way also relates with energy efficiency. Site planning and water efficiency is beyond the scope of this research at the moment.**

Conventional building materials like cement, steel, brick, stone, wood can no longer be considered sustainable for reasons described in the table xx. On the other hand, there are a lot of industrial waste products, which unless are utilized for some beneficial purposes, can prove harmful to the environment. One of the most heavily produced Industrial waste is Flyash. Lets look at the scene of Flyash in India now.



Aftermath of a retention-pond-wall collapse



View of Fly Ash Spill (approx.1 mile from the retention pond)

Flyash

Fly ash is a fine, glass powder recovered from the gases of burning coal during the production of electricity. These micron-sized earth elements consist primarily of silica, alumina and iron. When mixed with lime and water the fly ash forms a cementitious compound with properties very similar to that of Portland cement. Because of this similarity, fly ash can be used to replace a portion of cement in the concrete, providing some distinct quality advantages. The concrete is denser resulting in a tighter, smoother surface with less bleeding. Fly ash concrete offers a distinct architectural benefit with improved textural consistency and sharper detail. Fly Ash is also known as Coal Ash, Pulverized Flue Ash, Pozzolona.

Present scenario on fly ash in India

- Over 75% of the total installed power generation is coal-based
- 320 - 350 million MT coal is being used every year
- High ash contents varying from 30 to 50%
- More than 170 million MT of ash generated every year
- Presently 65,000 acres of land occupied by ash ponds
- Presently as per the Ministry Of Environment & Forest Figures, 30% of it is being used in Fillings, embankments, construction, block & tiles, etc.

The ash content in Indian coal ranges from 35% to 50%

In India fly ash generation is around 170 million tonnes / year and is set to continue at a high rate into the foreseeable future. Presently majority of the coal ash generated is being handled in wet form and disposed off in ash ponds which is harmful for the environment and moreover ash remains unutilized for gainful applications. India has sufficient coal reserves. In India almost 65-70% of electricity production is dependent on coal which produces a huge quantity of Fly Ash as residue which is allegedly a waste product in Thermal Power Stations.¹¹

Disposal and environmental effects

Most of the ash generated from the power plants is disposed off in the vicinity of the plant as a waste material covering several hectares of valuable land. The dumping of coal-ash, the byproduct of coal-burning power plants, in ponds and landfills endangers environment and ecosystem of the area. Power companies dump large quantity of coal ash in landfills and holding ponds, some of which are located in close proximity to rivers and neighborhoods. In such scenario, dumping of coal ash poses dangers to groundwater or people and in several instances where the activity has led to serious environmental problems in the surrounding areas. Problems arise such as:

- * Leaking arsenic-laced water,
- * Increase in arsenic levels in groundwater on the banks of river and in drinking water limit of the area,
- * A breach in an earthen wall at ash ponds allowed arsenic and nickel to pollute groundwater next to the river, etc.¹¹

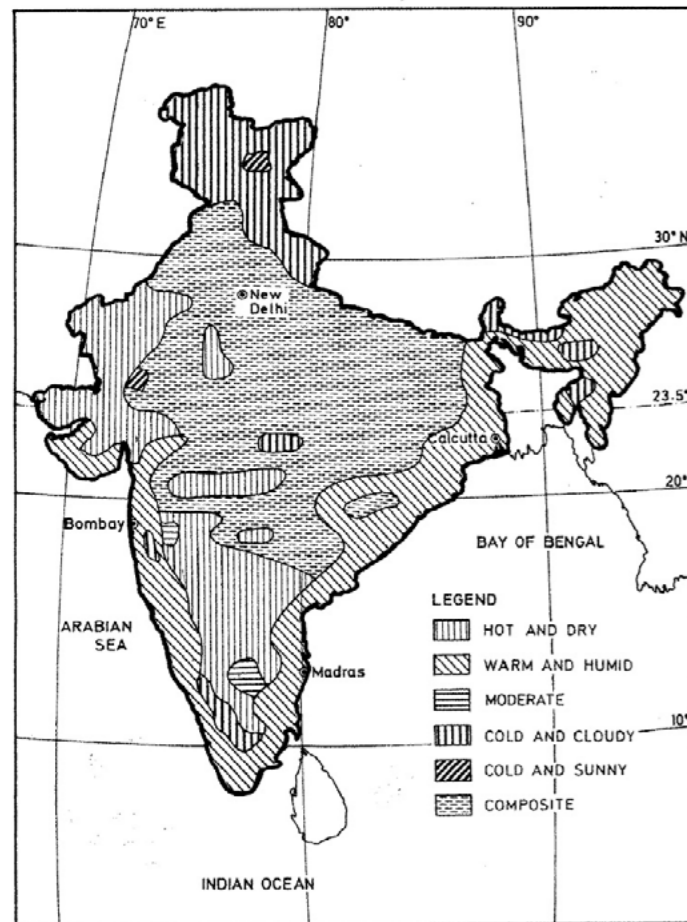

Fig 33: Climatic zones of India¹²

Criteria of Bansal et al. [1]		
Climate	Mean monthly temperature (°C)	Relative humidity (%)
Hot and dry	>30	<55
Warm and humid	>30	>55
Moderate	25-30	<75
Cold and cloudy	<25	>55
Cold and sunny	<25	<55
Composite	This applies, when six months or more do not fall within any of the above categories	

Fig 34: Climatic zones of India¹²

Climatic zones

India being a very vast Country, the climate varies largely over the entire country. The mountain range on the north and the Ocean to the south are the two most significant reasons which influence the climate largely. The movement of the trade winds over the ocean, results in it carrying moisture over large part of the country, which results in a 'rainy season' which is not prevalent in the temperate countries.

The climate is so diverse that, there are parts of north India where six distinct seasons are defined over an year, where as parts of South have only four including the 'rainy' season which is called the monsoon season.

India being quite a vast country, can be divided into a number of climatic zones. Bansal had carried out detailed studies and reported that India can be divided into six climatic zones, namely, hot and dry, warm and humid, moderate, cold and cloudy, cold and sunny, and composite. A place is assigned to one of the first five climatic zones only when the defined conditions prevail there for more than six months. In cases where none of the defined categories can be identified for six months or longer, the climatic zone is called composite. According to a recent code of Bureau of Indian Standards, the country may be divided into five major climatic zones. The recent classification is not very different from the earlier one except that the cold and cloudy, and cold and sunny have been grouped together as cold climate; the moderate climate is renamed as temperate climate. However, a small variation is noticed as far as the land area of the country corresponding to different zones is concerned. In this report, I have followed the former classification. It may be mentioned that each climatic zone does not experience the same climate for the whole year. It has a particular season for more than six months and may experience other seasons for the remaining period.¹²

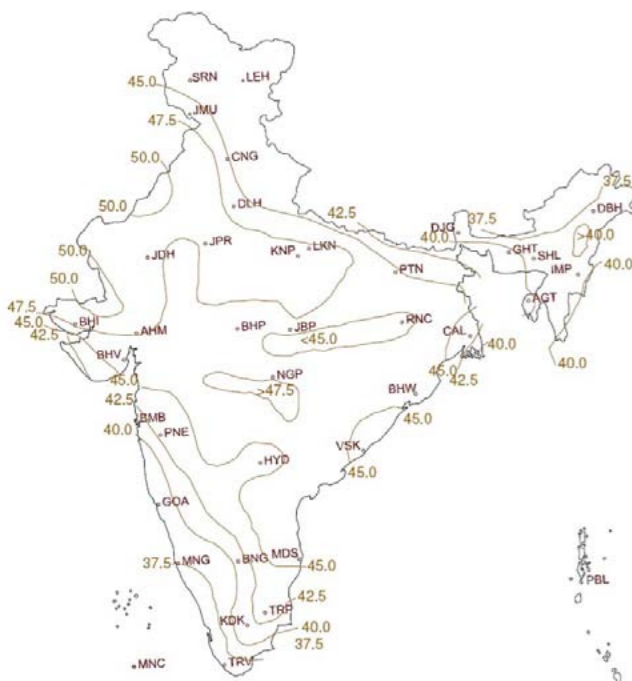

Fig 35: Max temperature isopleths¹²

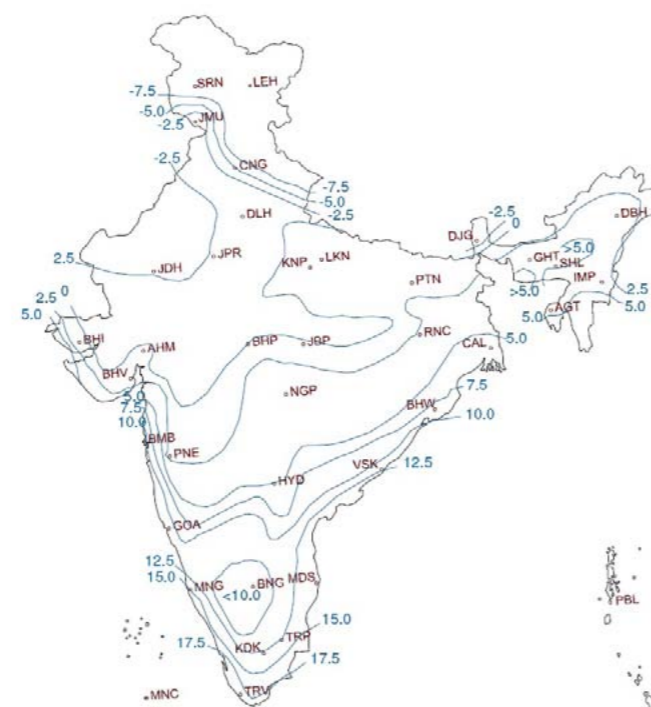

Fig 36: Min temperature isopleths¹²

Urban Climate

Rapid urbanisation and industrialisation has resulted in heavy heat islands. An urban heat island study was carried out in Pune, Mumbai, Kolkata, Delhi, Vishakapatnam, Vijayawada, Bhopal and Chennai; It is seen that, among the cities listed in the table, the heat island intensity is greatest in Pune (about 10 °C) and lowest in Vishakhapatnam (about 0.6°C). In the metropolitan cities of Mumbai, New Delhi, Chennai and Kolkata, the corresponding values are 9.5, 6.0, 4.0 and 4.0oC respectively. Clearly, the values are quite high. The density of the built environment and the extent of tree cover or vegetation primarily affect the heat-island intensity. Pollution and heat due to vehicular traffic, industrialisation and human activities are other contributing factors.¹²

Among the Different Climatic zones I chose to focus my research and design on the Warm and Humid Climate. This is more because, the region I come from India in a way belongs to this zone and also this presents a totally contrasting climatic design challenge than here in Netherlands.

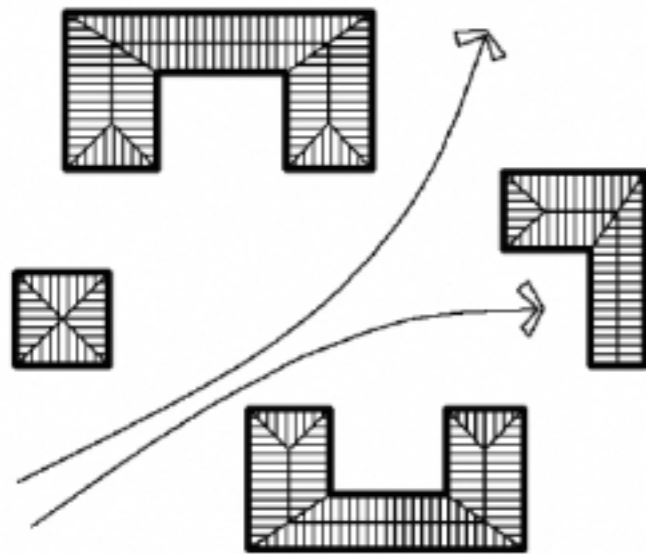

Fig 37: An example for open courtyard plan¹³

Warm and Humid climate

The warm and humid zone covers the coastal parts of the country. Some cities that fall under this zone are Mumbai, Chennai and Kolkata. The diffuse fraction of solar radiation is quite high due to cloud cover, and the radiation can be intense on clear days. The dissipation of the accumulated heat from the earth to the night sky is generally marginal due to the presence of clouds. Hence, the diurnal variation in temperature is quite low. In summer, temperatures can reach as high as 30 - 40°C during the day, and 25 - 30°C at night. In winter, the maximum temperature is between 25 to 30°C during the day and 20 to 25°C at night. Although the temperatures are not excessive, the high humidity causes discomfort. An important characteristic of this region is the relative humidity, which is generally very high, about 70 - 90% throughout the year. The wind is generally from one or two prevailing directions with speeds ranging from extremely low to very high. Wind is desirable in this climate, as it can cause sensible cooling of the body. The main design criteria in the warm and humid region are to reduce heat gain by providing shading, and promote heat loss by maximising cross ventilation. Dissipation of humidity is also essential to reduce discomfort.¹²

Thermal Adaption and impediments

thermal comfort standards are not prescribed in Indian codes. The National Building Code of India (NBC, 2005) specifies two, too narrow temperature ranges for winter (21-23 °C) and summer (23-26 °C) for all building and climate types. Importantly, these are not validated through empirical studies on local subjects, but are prepared from ASHRAE standards (ASHRAE, 2005), developed based on climate chamber studies on Western subjects. A field study was conducted in a few apartments in Hyderabad, in summer and monsoon, involving over 100 occupants in 2008. The analysis returned a comfort temperature of 29.23 °C and the comfort band (26 -32.5°C); way above the Indian standard limits (23- 26 °C). Fanger's PMV grossly overestimated the actual sensation. The occupants' adaptation was limited by economic level, tenure, socio-cultural preferences, fashion, psycho-physical hindrances and attitudes. Higher economic class occupants adopted a non-adaptive lifestyle. This life-style pattern and profligate attitudinal disregard always have overridden the simple behavioural, clothing and metabolic adaptations most necessary to achieve thermal comfort. Conversely, the subjects displaying 'thermal empathy' adapted well exploiting all the adaptive opportunities prior to using high energy intensive environmental controls.¹³

2) Warm and Humid Region	
OBJECTIVES	PHYSICAL MANIFESTATION
1) Resist heat gain	
<ul style="list-style-type: none"> Decrease exposed surface area Increase thermal resistance Increase buffer spaces Increase shading Increase surface reflectivity 	<ul style="list-style-type: none"> Orientation and shape of building Roof insulation and wall insulation. Reflective surface of roof. Balconies and verandahs Walls, glass surfaces protected by overhangs, fins and trees Pale colour, glazed china mosaic tiles, etc.
2) Promote heat loss	
<ul style="list-style-type: none"> Ventilation of appliances Increase air exchange rate (Ventilation throughout the day) Decrease humidity levels 	<ul style="list-style-type: none"> Provide windows/ exhausts Ventilated roof construction. Courtyards, wind towers and arrangement of openings Dehumidifiers/ desiccant cooling

Fig 37: Design guidelines¹²

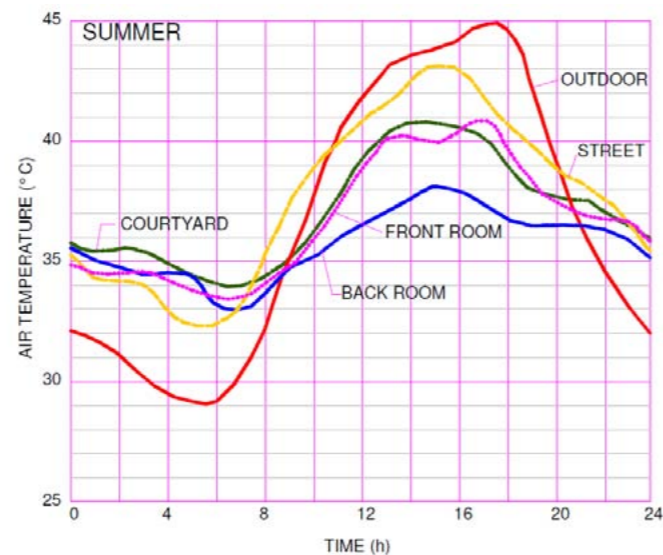

Fig. 2.17 Effect of courtyard [18]

Fig 38: Effect of courtyard on indoor temperatures¹³

Conclusions

1. Since the diurnal variation of temperature is not drastic, a 'thermal break' is not necessary as like temperate countries
2. Warm-humid climate necessitates good cross ventilation in buildings- implying linear configuration of housing is a better choice in terms of climatic design of spaces.
3. Sunshades become integral over openings.
4. The thermal adaptation study, and personal experience in India reveals that an active cooling system is not needed and not affordable for middle class housing. A wall system with a U value of 1 W/m-k or lesser is good enough to maintain comfort standards, with ceiling fan provision inside the volumes to regulate air flow on critically hot and humid days.

The preliminary research work documented in the previous chapter was done with a view of strongly arriving at a focus point for graduation research. In essence to define a narrower problem(s) within the vastness of housing problems, and then carry on the research from there on.

Summary

The following can be summarised from all the preliminary research done:

1. There is a severe housing shortage in India.
2. The housing demand in Urban and semi-urban areas for the middle class and upper middle class society is continuously on the rise.
3. The traditional building system lacks speed, efficiency and quality to address this problem.
4. Industrialization is the way forward in housing industry. It is multi-dimensional and contribution in any of the aspects is useful. My focus would be on building system.
5. Box system of prefab is unsuitable in the Indian scenario to satisfy the housing demand at large.
6. There is considerable research being done on prefab methods for roofing for housing in India. What lacks is a study on making the wall quicker, qualitatively.
7. It would make more sense to explore the wall system as a load bearing one, for a low rise housing, as it would eliminate one process of framing, and also utilise the full potential of the material
8. There is an abundance of fly-ash available in India, which at present is unfortunately being used in land-fills leading to environmental hazards. The same has vast potential for use in Building industry. Not enough is being done in this regard.
9. The climatic needs for Indian context is completely different for those of temperate countries. Since the delta T is not very high, the U value neednt be as low as 0.2. The thermal adaptation findings demonstrate that people can adapt to a comfort temperature of 28-30 deg also in peak summer, implying a U value of around 0.8 to 1.2 w/m-k could be sufficient. Sunshading devices are a must for openings in Warm humid climate

In the next chapter we shall define the focus of research based on this summary.

3. Research Focus

3.1_

The final problem and Research Goal

Introduction

In the previous chapter we examined the current scenario in India, and possible directions to look at and arrived at a few conclusions. Based on that I shall define the Main problem(s) and the Focus of research here.

Problem statement(s)

"A pre-fabricated method of assembling a load bearing wall with prefinished exterior surface for housing is lacking in India, to facilitate quicker supply of low rise housing for middle class and upper middle class in Urban and semi-urban India"

"The potential of Flyash, an industrial waste, is heavily under-utilized at present in building industry"

Now that we have defined the problems to be addressed concisely, it is important to define the goal of the research, which will aim to address the problem(s).

Research Goal

"To develop a prefinished load bearing facade element, maximising the use of flyash, which could be assembled on site for faster supply of housing in urban and semi-urban India"

Background question

1. What are the characteristics of fly-ash as an ingredient in concrete.

Subquestions

1. What is the range of dimensions of the product, to balance between flexibility and practicality?

2. What is the influence of the varying the proportion on flyash in the mix, on the design of the system? What potentials does it offer?

3. What methods of production are suitable for the product under the present Indian scenario?

4. What strategies could be adopted for simple assembly of the product on site? How does structural stability influence its assembly?

5. What are the possible strategies to market the product, and what are its constraints?

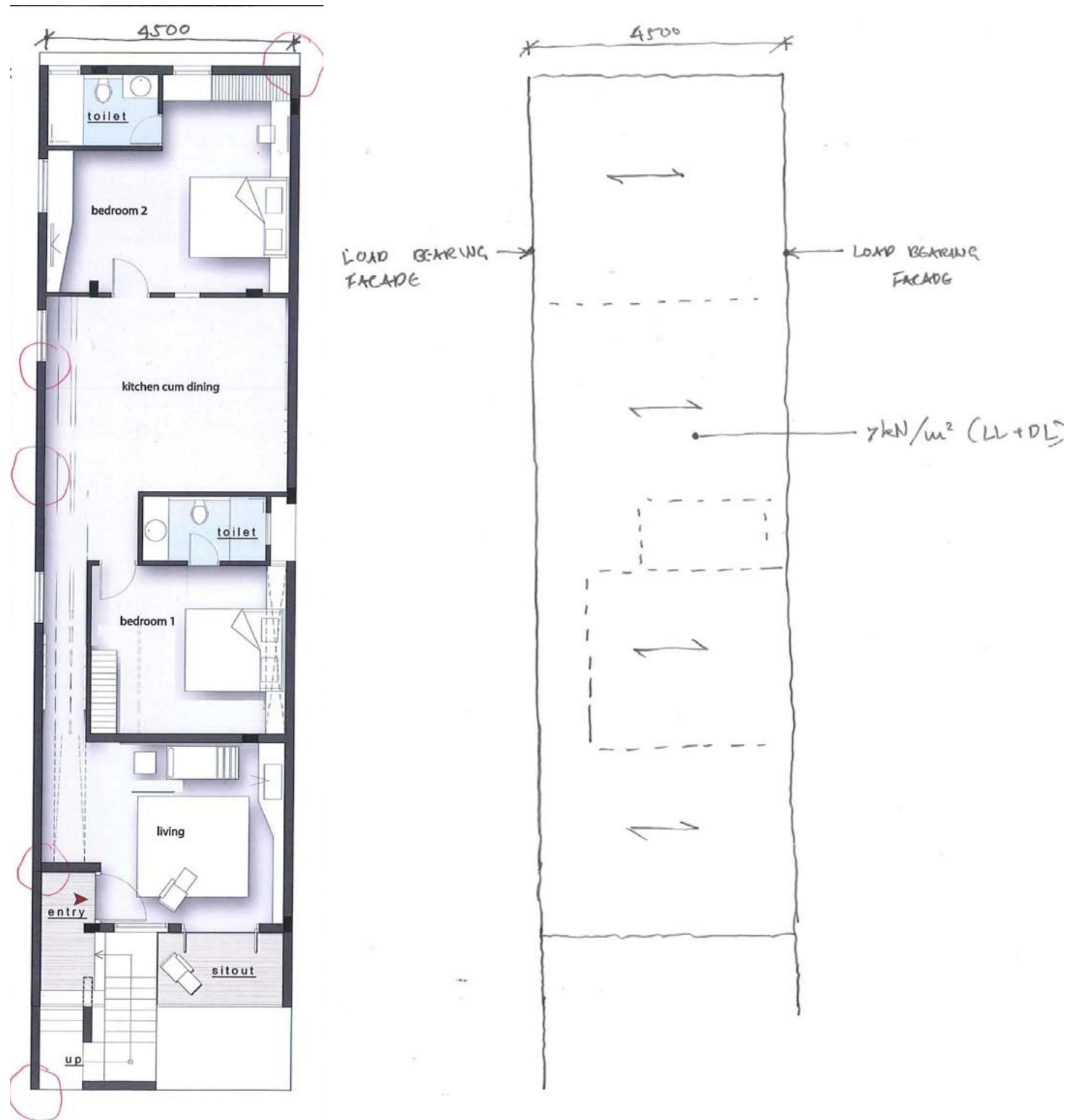

Fig 39: Typical linear housing

Design requirements

To start off on the main research it is important to define the basic design requirements and programme, before developing it and adding further value.

The design requirement is as follows:

1. A prefabricated load bearing facade element(s)

The element shall be an additive component (refer chapter 5.2). The design shall consider that the exterior surface is pre-finished. No/minimal sitework on exterior surface after assembly

2. Design for connection between elements during and after assembly.

The design shall take into consideration ease of assembly on site, feasibility of self alignment, minimal time delays due to site work during assembly. It shall also consider structural load transfer

3. Design of joints

The joint design shall consider water tightness, load transfer bearing areas.

4. Design for end conditions-

strategy for openings- spanning of elements over openings, jamb details

strategy at floor and wall connections, corners

5. Strategy for integration of sunshading elements into the system.

This is important from climatic perspective, as sunshading from outside are important in tropical countries. It is important to consider the means of integrating other architectural features like fins etc, from a different manufacturer into the system.

6. Building physical properties:

The wall section shall have a U value $< 1 \text{ W/m}^2\text{K}$. The material composition of wall shall investigate the possibility of maximum utility of fly-ash.

7. Strategy for production

In a not so industrialised country, it is important to have a simple production strategy to start with, until the establishment gets big enough to make it more sophisticated after considerable success of the product.

8. Design for lift of panels

The lifting strategy is important to be considered during the design of the product itself because, one is the product is expected to be prefinished, and cannot afford to have lifting hooks etc protruding from it after assembly;

9. Marketing strategy

It is important to have good strategies to marketing the product in order to force it into a conservative market, which inherently doesn't perceive the demand and potential of it.

Given/ programme

1. Target group- middle class and upper middle class of Urban and semi-urban India- this target group is a personal choice, although the market demand exists for housing for all classes of people. The reason for this choice of target group, is because of their economical background, this class of people will be able appreciate the qualitiveness of a new system/ product. This I say because, the higher income group, can literally afford anything, to purchase any kind of dwelling want and time usually is not a criteria for them. The economically weaker section, have so many problems of their own that they will accept whatever is given to them by the housing commission. So the evaluation of a new system will happen best for a middle class society.

2. Low rise housing- 4 storeys typically.- the demand for which has been established in chapter 2.5

3. Floor to floor height= 3m is a generic practice in India, no data available to prove the standards.

4. Span between load bearing facades 4.5m, due to the linear configuration suited for warm-humid climate.

5. Floor load (dead load + live load)= 7kN/m² as per national building code of India

6. Wind load= 0.6kN/m² as per national building code of India

7. Generic cill height for walls= 0.75m

There is no reference for this. This is generally accepted to be a good cill height in most parts of India, and is practiced at large.

8. Generic lintel height= 2.1m

This also has no reference as such. It is generally accepted in residences to have lintel at 2.1m, due to anthropological requirements.

In order to have the research work to be successful, it is of primary importance to define a broad research method/ strategy. As we have seen in the preliminary research (chapter 2) was a literature review done as a lead in to arrive at the research goal

The Research method has been based around a number of discrete but linked studies as follows:

1. Literature study of flyash as a material and as an ingredient in building products-

Ideally, it would be best to lay my hands on the real material and explore the possibilities. But due to limited time and finances, I have restricted my research about the material, to literature sources from scientific journals and books. The research on the material is based on the experimental evaluation by a few research institutes in India, Canada and United States.

2. Case studies of a few Panel type and Component type Prefab systems-

A literature and web based study of the technicalities involved in the two types of prefab system, to understand the advantages and disadvantages. To understand what problems might arise while designing, developing the product/ system. The systems are studied in terms of dimension, structure, production, assembly and joints.

3. Design of the system-

Based on the research done so far, and the requirements mentioned previously, a product design and development exercise starts. The product shall be developed as a continuous iterative process of evaluating dimensions, transportability, structural calculations, production techniques, assembly strategies. I have to confess that the evaluation of the system is never sacrosanct, unless tested on a real life project and laboratory tests of product before execution of course. So the design explored here is extremely 'preliminary' in that respect. It will require further research beyond the graduation. What is important is to establish that the research done in this academic work is worthy of further research, and could probably in the near future down the line can actually be implemented with further research.

4. Mockup-

Finally a scaled mockup of the elements shall be tried with concrete and assembled as a demonstration, and a check for ease of connection between elements.

In this chapter we shall study in detail about fly-ash as a material and as an ingredient in making concrete.

Coal fly ash is an abundant industrial waste product that happens to be high in reactive silica, and thus an excellent pozzolan. For this simple reason it is rapidly becoming a common ingredient in concrete all over the world. Of particular interest to the industry is the idea of not just adding fly ash to known concrete mixes, but using large quantities to replace 30%, 50%, or more of the portland cement—the glue—in a concrete mix. Most of the reasons for using fly ash in any proportion are practical, such as increasing strength and durability, decreasing heat of hydration, and decreasing permeability. Those reasons alone make the idea of high fly ash concrete (HFAC) worth considering, but there are many global economic, health, and environmental concerns that make HFAC even more attractive and compelling. The use of fly ash as a performance-enhancing ingredient in concrete is one of the most outstanding examples of industrial ecology—i.e., making effective use of waste resources, and ultimately eliminating the concept of waste altogether. In fact, given the huge (and growing) volume of concrete production needed, the potential for effectively using fly ash makes it one of the key components of an industrial ecology.¹⁵

There is, not surprisingly, disagreement among fly ash experts. The term HVFAC is generally interpreted as referring to concrete in which fly ash replaces about 50% of the cement. However, in some cases 40% or 10% will be more appropriate, and in others 100% replacement is possible. Some experts will argue that 30% replacement is the most one should ever use, while others argue that you won't get the greatest benefits of HFAC until you get up to or over 40% or 50% replacement. The right figure for a project at a location will depend on many things, as will be discussed in the sections to follow.¹⁵

How much Fly-ash replacement makes a product 'green'?

The short answer is: any fly ash in the mix as replacement for cement, up to the limits discussed in the sections to follow, will make for better concrete and reduce the atmospheric carbon load associated with cement production. For example, in many areas, 15% to 20% addition or replacement is already standard practice, and is mandated by such governmental agencies as the California Department of Transportation (CALTRANS). The contention here is that, in most applications, about 50% replacement results in concrete that is better for the builder, for the building owner, and for the planet.¹⁵

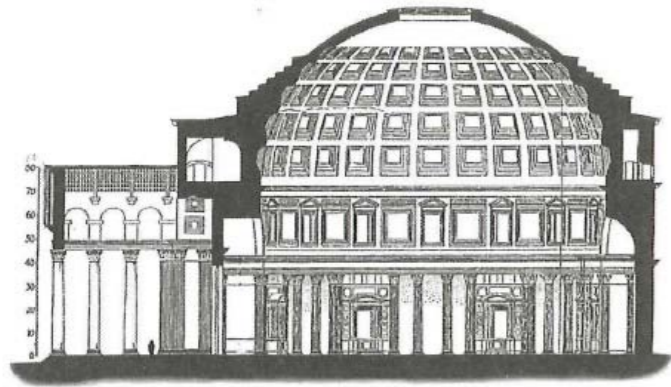

Fig 40: Pantheon, one of the oldest to be constructed with puzzolans¹⁵

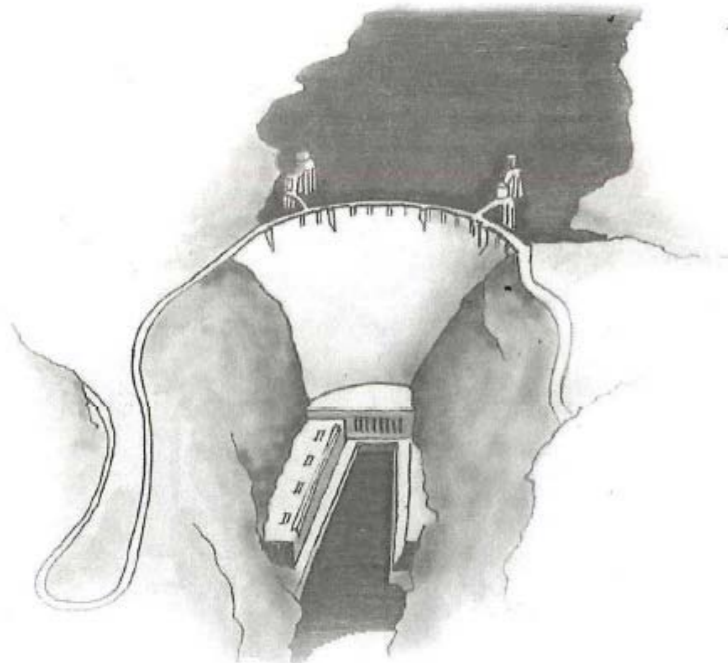

Fig 41: Hooevr dam¹⁵

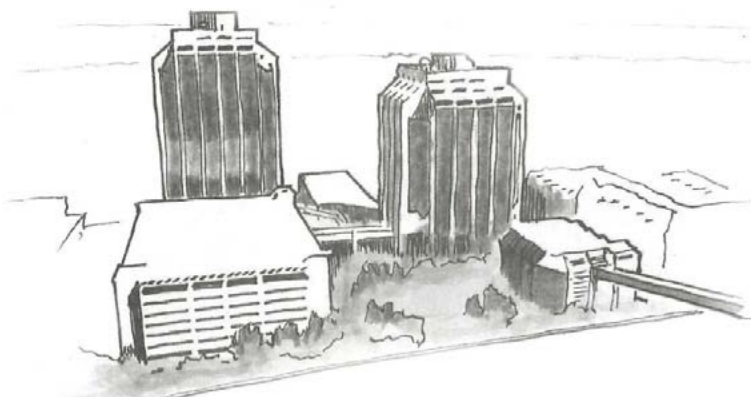
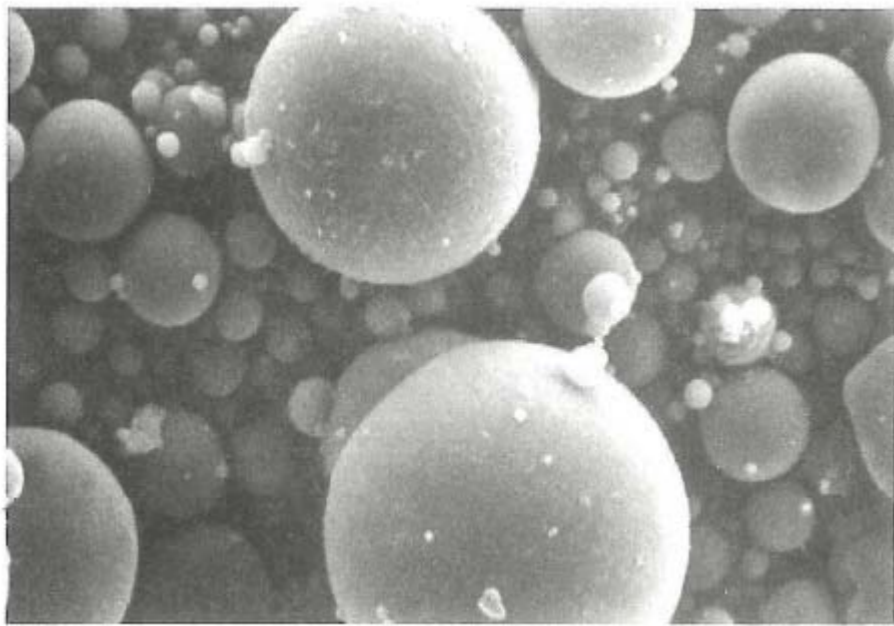
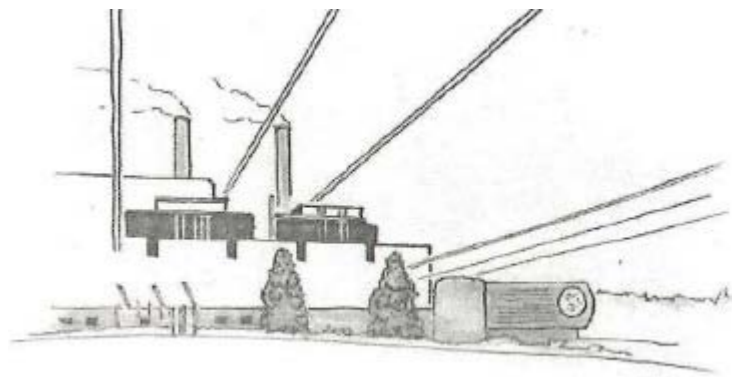

Fig 42: Purdy's Wharf retail center, First use of HVFAC (50%)¹⁵

Fly ash in concrete is nothing new. Seventy years ago, the US Bureau of Reclamation made use of natural pozzolans and fly ash in the construction of the big dams of the American west, primarily to control heat of hydration. The great architect Louis Kahn used fly ash in concrete for the Salk Institute, mainly to lighten its color. Today, growing numbers of major structural concrete projects are being built in Canada and the United States using high volumes of fly ash to increase strength, workability, and durability.

However, the technology for using pozzolans could be said to go back thousands of years, far predating the invention of portland cement in the early 1800s or the coal-fired power plants that generate fly ash. Lime plasters—the precursors to both Roman and modern concrete—date as far back as 2500 BC in India, Mesopotamia, China, and the Mediterranean. No one knows for certain how things started, but probably a large bonfire encircled by limestone rocks reached a high enough temperature to calcine the limestone, turning it unexpectedly into quicklime. Soon enough, rain falling on the quicklime would cause it to hiss, spit, and heat up. Someone eventually discovered that the resulting material could be ground up, mixed with more water, and applied to earthen walls in a paste that hardened to a much greater density and durability than any manmade thing previously known. Lime plaster was born, and concrete would eventually follow.¹⁵

The next step in the development of concrete was to improve the lime by adding reactive silica. The ancients found that ground-up pottery shards (calcined clay—the precursor of the modern pozzolan metakaolin), when mixed with lime, created a much harder plaster that would even cure under water. Later, the Romans were able to produce the same effect by using certain volcanic soils from the region of Pozzuoli, Italy—hence the term pozzolans. The famous Roman concrete which survives to this day is a mixture of lime plaster and pozzolanic soil. In 'The Ten Books of Architecture', Vitruvius explained this in terms of the (then known) primordial elements of earth, water, fire, and air. Nowadays, we explain Roman concrete by saying that hydrated lime reacted with amorphous silica in the pozzolanic soils to provide the "glue" for the concrete. We can describe the effects of adding fly ash to portland cement in a similar way: hydrated lime (remaining from the hydration of portland cement) combines with the reactive silica in fly ash to better hold the concrete together. Of course, it's not all that simple, but the approximation is good to introduce the process.¹⁵

Fig 43: Flyash through microscope¹⁵Fig 44: Thermal plant- artificial means of flyash generation¹⁵Fig 45: Volcano- natural source of pozzolan¹⁵

Pozzolans defined by source and standards organizations

To the concrete industry, Flyash is but one of a broader class of materials called pozzolans, or mineral admixtures, which are primarily characterized by high quantities of reactive silica. Fly ash also contains lesser amounts of iron, alumina, calcium, magnesium, sulfur, potassium, and sodium, often in oxidized forms; it is less dense than cement, with a specific gravity of 1.9 to 2.8, as contrasted with 3.15 for cement.

*Unlike cement and other pozzolans, fly ash particles are spherical, like ball bearings. Along with their electrostatic properties that keep cement particles from clumping, and their ability to fill micropores, this is why fly ash reduces water demand in concrete mixes.*¹⁵

The Pozzolans can be classified based on various characteristics. The most important one is given below:

The American Society for Testing and Materials' Standard ASTM C618 places all pozzolans in one of three categories, which is accepted worldwide:

1. Class N:

Natural pozzolans such as volcanic tuffs and pumicite (what the Romans used), opaline cherts and shales, and diatomaceous earth, as well as calcined (fired) materials such as calcined kaolin clays (Metakaolin).

2. Class C:

Fly ash characterized mainly, and some would say mistakenly, by a calcium oxide (CaO) content above 10%. Some say that that the class of fly ash should be defined more accurately by the sum of the oxides of silica, alumina, and iron. The high calcium content of this makes this highly reactive, and almost totally self-cementing.

3. Class F:

Most coal sources in India produce class F fly ash. The CaO content of Class F fly ash is usually below 16-18%, and often well under 10%. The low amount of Calcium makes it relatively less reactive. The CaO content, if high enough, makes the fly ash self-cementing, but also makes it less resistant to alkali-silica reaction (ASR) and to sulfate attack.¹⁵

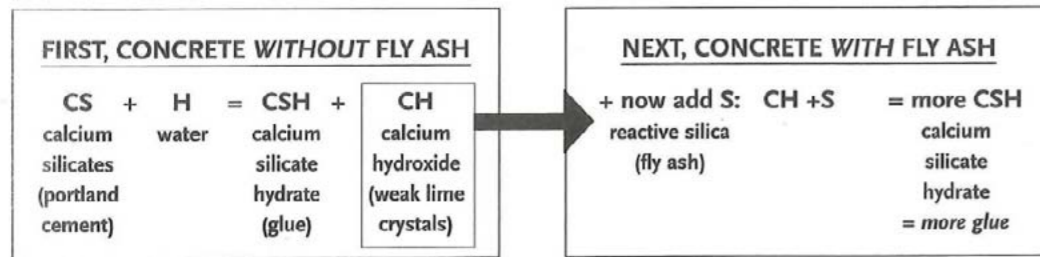
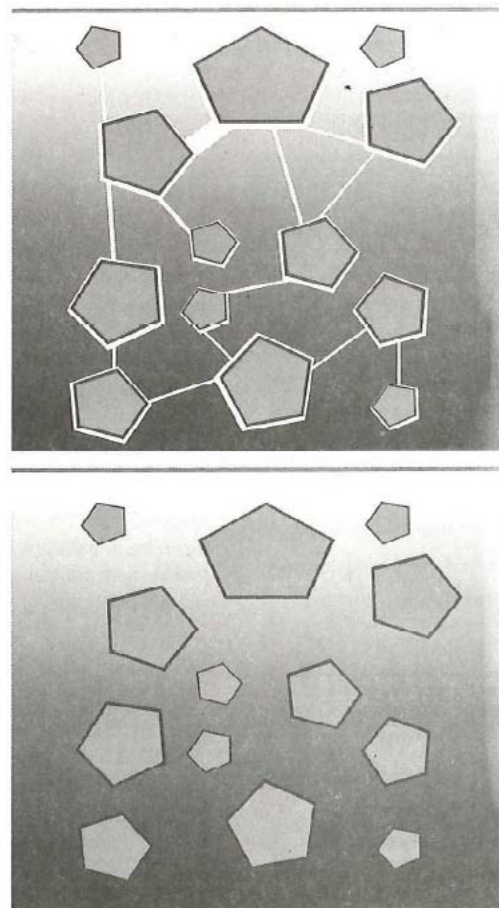
Fig 46 & 47: The cementing action of flyash explained¹⁵

Basic Principle of cementing action

The typical fly ash particle is a microscopic sphere anywhere from 1 to 100 microns in diameter; its particle size distribution is much like that of portland cement. The smaller particles, less than 10 microns in diameter, do most of the pozzolanic work, and are thus what is needed. A typical fly ash has about 40% of its particles in this range, with the average particle being about 20 microns in diameter. Particles over 45 microns in diameter are less useful for pozzolanic activity, so this proposed but controversial standard sets a limit at 20% of particles above this size (ASTM C618 currently limits it to 34%). Some argue that an even distribution of ash particle sizes makes for a beneficial packing effect, just as on a larger scale a well-designed gradation from sand to small aggregate to large aggregate makes for better concrete. However, many reports based on field experience contradict these general guidelines; there is as yet no clear way to correlate an ash's effectiveness with its particle size gradation.¹⁵

When the portland cement in ordinary concrete hydrates—in other words, after we have added water—compounds of calcium, silica, and alumina (calcium silicates, abbreviated below as “CS”) react with the water (abbreviated below as “H”) to create a gel of calcium silicate hydrate (CSH). CSH is the glue that holds everything together and gives concrete its strength and durability. Unfortunately, a lot of the portland cement—often nearly half—in most concrete isn't fated to become CSH, but instead becomes hydrated lime, or calcium hydroxide (CH). That CH tends to show up as brittle crystals that gather on the surface of aggregate particles and rebar, making for a weakened matrix. If, however, we add a source of additional reactive silica like flyash, it will react with that calcium hydroxide in the presence of moisture to become more CSH—glue. In effect, the fly ash takes the weakest link in the chain, CH, and turns it into the strongest link in the chain, CSH.

The calcium hydroxide (CH) that results from cement hydration tends to collect in the bleed water trapped under and around rebar and particles of sand and gravel—the so-called “wall effect.” Eventually the CH dries, primarily in the form of weak, brittle microcrystals. To the extent that this happens—as it typically does in most concrete—the concrete's strength goes down and its permeability goes up.

Now add some reactive silica (S)—such as fly ash. If we proportion the ingredients right, and keep things moist, two good things happen:

1. the fine fly ash particles pack the voids between cement and aggregate particles, making it much harder for the bleed water to move around or form pockets and cracks, and
2. the silica reacts over time with the calcium hydroxide to make more glue: $CH+S = CSH$. Instead of a weak transition zone, we have a strong one; instead of high permeability resulting from a three-dimensional network of microcracks, we have impermeability. Instead of a little bit of glue holding things together, we have a lot of glue.

That is briefly how flyash works conceptually.¹⁵

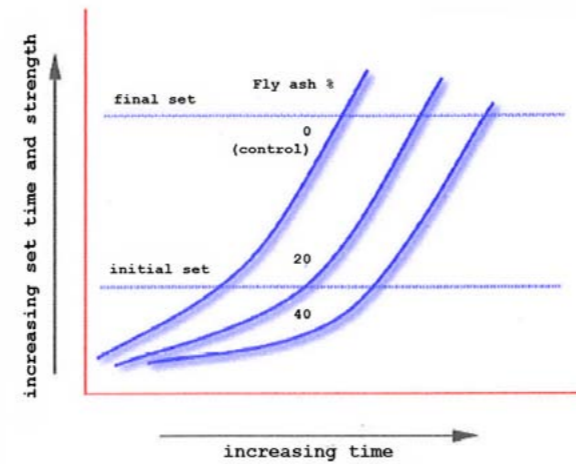
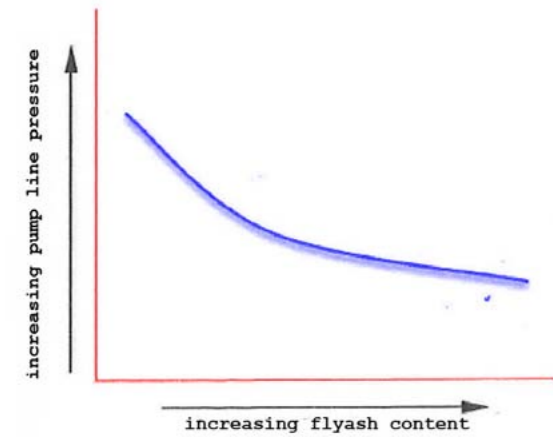
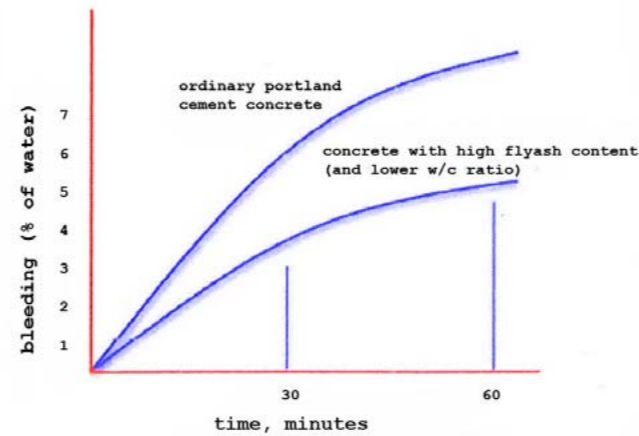
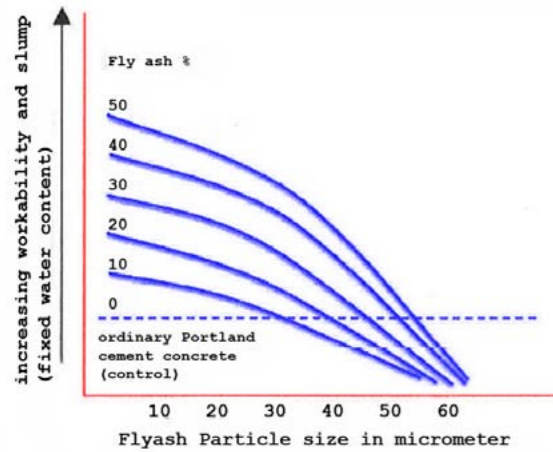

Effects of flyash on fresh concrete

Reduced water demand:

Fly ash has been described as the "poor man's superplasticizer" because it can reduce water demand and increase workability and pumpability.

There are at least three reasons for this:

1. the tiny particles of ash help pack voids between cement particles,
2. fly ash particles are spherically shaped, acting like ball bearings, and
3. probably most important, the ash particles have an electrostatic effect on cement particles that keeps them from clumping (flocculating) - a process that gums up the fresh concrete.

All of this gives fly ash an advantage over other pozzolans, almost all of which tend to increase water demand in fresh concrete. Note, however, that poor-quality ashes with coarse particle sizes or high levels of unburned carbon will usually not have this effect, and may even reverse it (see illustration).¹⁵

Reduced bleed water:

The incorporation of 15% to 60% of quality fly ash will lower the water demand, so there will be less or no bleed (excess) water appearing on the surface of slabs and other pours - and a proportionately greater need to protect surfaces from premature drying. The rate at which bleed water rises is also reduced, so caution is needed to avoid finishing a slab before it's really ready; premature finishing can be followed by a rise in bleed water and consequent weakening of the surface.¹⁵

Increased workability and pumpability:

Laboratory studies and field experience indicate that HFAC is easier to pump and work than its conventional concrete counterpart, all other things being equal. This makes it easier on workers and pumps, and easier to consolidate and get into congested or complex formwork without the need for excessive vibrating, and without segregation or pocketing.¹⁵

Continuing slump:

When subjected to the standard cone test, HFAC will often show a certain slump, only to gain an additional inch or two after some time has passed. The material remains cohesive, but simply continues settling longer than its conventional concrete counterpart.¹⁵

Extended set times:

Initial and final set will be slower by an hour or two in a typical HFAC if the mix is not adjusted to counter this effect. In some cases, such as cool weather or misuse of chemical admixtures, set can be extended as long as overnight. The fact that fly ash provides greater early-age extensibility can be an advantage, as the concrete mass remains more ductile to redistribute forces and reduce plastic cracking.¹⁵

Effects of flyash on plastic concrete

Fig 48,49,50,51: Graphs, Influences of flyash replacing cement on concrete¹⁵

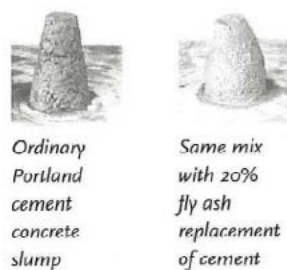
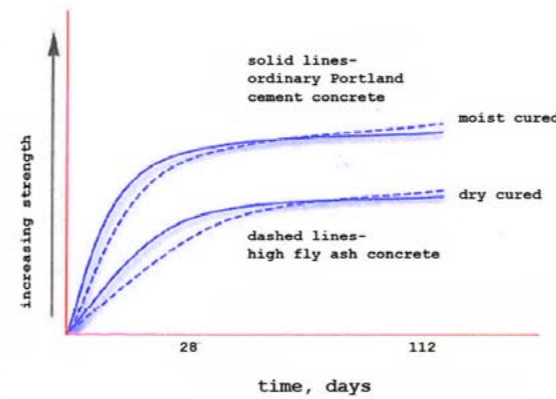
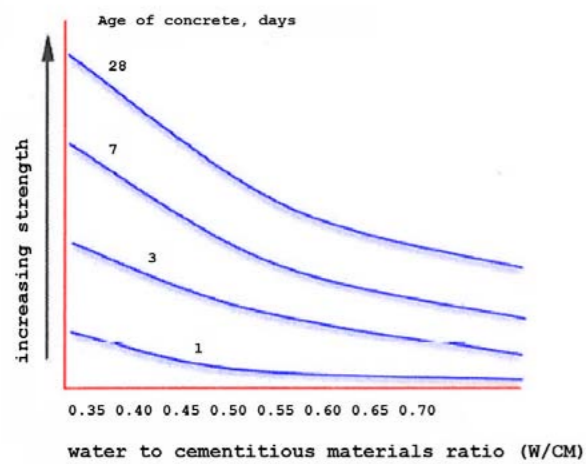
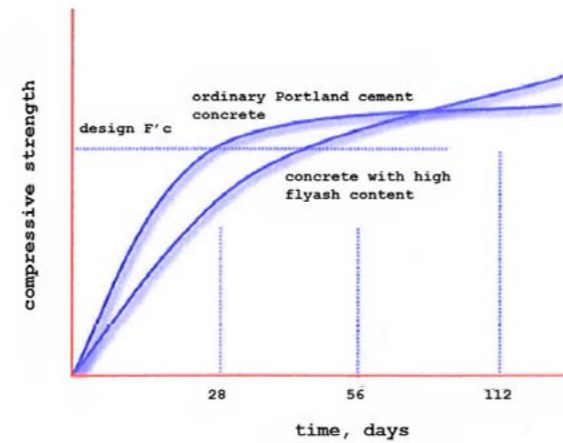
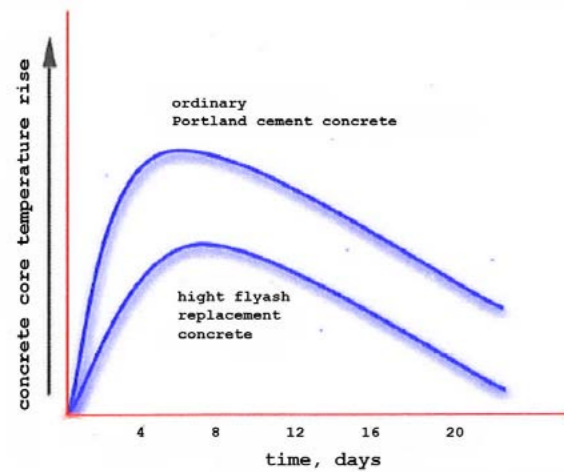

Fig 52: Slump comparison¹⁵



Effects of flyash on hardened concrete

Reduced heat of hydration:

Portland cement gives off heat as it hydrates, especially in the first few days after pouring. In a massive concrete pour, the subsequent surface cooling (relative to the still-warm core) can lead to differential thermal-shrinkage cracking. If you reduce the amount of cement in the mix by replacing it with fly ash, the heat of hydration is reduced and you will have fewer thermal shrinkage cracks. (That is why some of the first uses of high volumes of fly ash in concrete were in dams—purely to reduce thermal cracking.) The fact that fly ash generally retards the rate of strength gain is, in this case, an advantage; the concrete mass remains relatively plastic as it changes size with temperature, and therefore cracks less.

Thermal cracking is not significant for a lot of concrete work, but studies have shown that any concrete pour with a smallest dimension of two or three feet can experience enough thermal change to cause cracking. The problem is not the heating up or cooling down of the concrete mass—generally, we want it quite warm for the first few days—but differential heating or cooling as the material hydrates in the critical first days. We don't want the surface temperatures to be different than the core, and the more the core heats up the more likely it is that there will be a difference.¹⁵

Reduced plastic shrinkage cracking:

The loss of water in the early stages of concrete's life is the main thing that causes the concrete volume to plastically shrink. If the mass is restrained in any way—as it almost always is by rebar, formwork, or the ground under a slab—then that shrinkage causes cracking. In a well-blended HVFAC mix, there is less water and thus less volume change during the plastic phase.¹⁵

Slower rate of strength gain:

Increasing amounts of fly ash as cement replacement will generally slow the rate of strength gain. This tendency is less pronounced with class C ashes, and less pronounced when coarse aggregates are both increased and optimally graded. Slower rate of strength gain may or may not matter, as most concrete (e.g., foundations, columns, and slabs on grade) doesn't need to reach its design strength for at least two or three months after pouring. Flexural strength and Modulus of Elasticity are generally higher than for conventional concrete, depending on many factors.¹⁵

Reduced permeability:

All the elements of the pozzolanic reaction—reduced cracking, a strengthened transition zone, particle packing of voids, and deflocculation of cement particles—contribute to reduced permeability. Increasing and grading coarse aggregates also lowers water demand through reduced aggregate surface area, further reducing permeability through reduction of transition zones.¹⁵

Fig 53,54,55,56: Graphs, Influences of flyash replacing cement on concrete¹⁵

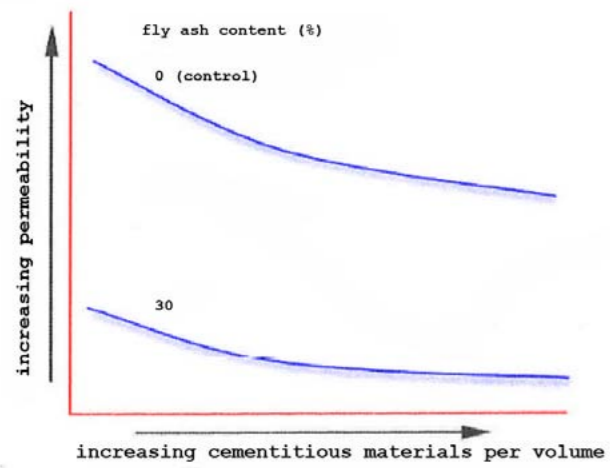

Fig 57: Graph, Influence of flyash replacing cement on concrete¹⁵

Reduced drying shrinkage:

As the illustration shows, drying shrinkage increases with cement and/or water content. Field experience has demonstrated that replacing cement with fly ash reduces shrinkage even when using aggregate prone to high shrinkage. By lowering the water content, shrinkage is further reduced.¹⁵

Resistance to scaling from deicing salts:

Early tests on the scaling resistance to deicing salts of concrete containing high proportions of fly ash and other pozzolans showed very poor results. This is probably why many building codes only address and limit the amount of fly ash in concrete tullen in the presence of deicing salts. By contrast, many field tests of actual sidewalk sections, using high fly ash replacement and exposed to deicing salts and repeated freeze-thaw cycles, have shown good results. As of this writing, the picture is still unclear. Researchers have speculated that the discrepancy appears because ASTM test C672 is in some way excessively conservative, or at least not representative of actual conditions. Testing has shown that the use of curing compounds is beneficial, and that finishing methods can influence the concrete durability.¹⁵

**Flyash Concrete
performance spec-
ifications**

A hundred years ago, someone noticed that concrete will typically attain about 80% of its ultimate strength in a month. Ever since then, engineers have habitually specified required concrete compressive strength (F_c') at 28 days. That number is universally used in the industry as the benchmark for quality control in the field and for inferring other design properties of the concrete (e.g., shear strength and elastic modulus).

As noted in the previous section, HVFAC is initially somewhat slower to gain strength than conventional concrete. But it will continue to gain strength as the months go by, unlike conventional concrete. In other words, the strength of HVFAC at 28 days may be only half its ultimate strength. In most cases, concrete doesn't need full strength for several months and project specifications can simply be changed to F_c' at 56 days. That simple change alone can save a bag or more of cement per cubic yard of concrete, because we have allowed the concrete (and the ready-mix supplier worried about his responsibility) enough time to gain the needed strength. In the specifications, define the construction-phase quality control program—especially if it differs from normal practices, such as basing acceptance on the 56-day compressive strength vs. the usual 28-day strength.¹⁵

In some cases, however, benchmarking 56-day compressive strength isn't good enough. Some concrete does need to gain strength quickly, such as retaining walls slated for immediate backfilling, post-tensioned slabs, and overhead beams or overhead slabs whose formwork can't be left in place for long. In those cases, initial strength gain can be increased through the use of accelerating admixtures, high early strength cement, a high-grade pozzolan (such as silica fume or rice-husk ash), moist/hot curing, water-content reduction, or a combination of these and other tricks.¹⁵

**Design, mix,
place, and test
trial batches**

This is extremely important consideration while using fly-ash. The reason is, each thermal power plant will generate a fly-ash with considerably different properties from another plant. Unlike cement, which is factory 'produced', this is a factory 'residue'. Hence the design mix will vary with the different sources of power plants. Hence it becomes extremely important to make trial mixes, batch them and test samples before final design and production of a product or insitu work starts.

Also, some people in the concrete industry, who have come to describe HVFAC as highperformance concrete, view portland cement itself as an admixture—albeit usually a crucial one. Concretes have been poured with cement contents as low as 20%, 10%, and even 0% by instead using cementitious-pozzolanic minerals, such as slag and class C fly ash. For that matter, the Romans made some of the most beautiful and durable concrete structures in the world, without any portland cement. In other words, it's an open question as to what should or should not go into any particular concrete mix.¹⁵

Fig 58,59: Cold bonded flyash aggregates¹⁶

Table 1. Physical properties of Conventional Fine Aggregate (CFA) and Fly ash fine aggregate (FAFA)

S. No	Properties	CFA	(FAFA)
1	Specific gravity	2.70	1.28
2	Bulk density (Kg/m ³)	1808	838
3	Size (mm)	Below 4.75	Below 4.75
4	Fineness modulus	2.68	2.70

Table 2. Physical properties of Conventional Coarse Aggregate (CCA) and Fly ash Coarse Aggregate (FACA)

S. No	Properties	CCA	FACA
1	Shape	Angular	Spherical
2	Specific gravity	2.75	1.3
3	Bulk density (Kg/ m ³)	1685	913
4	Size (mm)	4.75mm to 20mm	4.75mm to 20mm
5	Crushing value (%)	24.94	25.6
6	Impact Value (%)	23.86	21.6

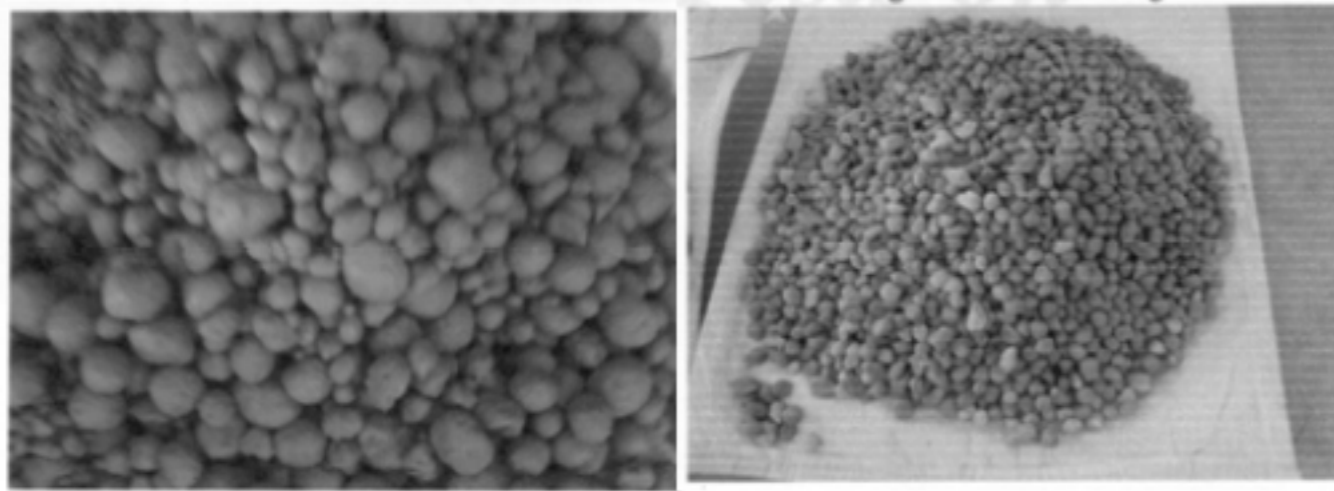
Fig 60,61: tables, physical properties of cold bonded flyash aggregates¹⁶

Introduction

The manufacture of sintered fly ash light-weight aggregates is an appropriate step to utilize a large quantity of fly ash. Many countries like the UK, USA, Germany, Poland and Russia are producing light-weight aggregates commercially under different trade names, such as Terlite, Lytag, Waylite corsonalite, sinterlite, etc. Central Building Research Institute, Roorkee carried out some R&D studies on a pilot plant procured from the UK in the early 1960s. Although R&D results on the feasibility of using sintered fly ash light-weight aggregates are promising, yet the technological results could not be implemented due to initial consumer resistance in adopting to new materials at a little higher cost than the prevailing market rates.¹⁶ For this purpose a case study was done by a group of researchers has been provided here

Formation of light weight aggregates

1. Raw materials:

Fly ash

Fly ash is the prominent raw material required for production of light-weight aggregates. Fly ash substantially contains approx. 10% carbon which is most suited for making aggregates. If the carbon content exceeds 10% in the fly ash, the clay/bentonite may be added in a suitable proportion to dilute it. In case the carbon content is -10% in the fly ash then the coal dust may be added to make the proper mix.

Coal dust

For fly ash containing carbon content -10%, the additional requirement of unburnt carbon is to be compensated with the coal dust. The ground coke breeze may be used.

Clayey soil

Clay is a cheap and appropriate binder to impart cohesive strength to the pelletized nodules. It has been observed that soil containing 25% clay fraction is most suitable for obtaining the binding property. In case the available soil is found unsuitable to impart the binding property to the fly ash particles, then 3.5% bentonite could be admixed in the fly ash.¹⁶

2. Proportions for Fly Ash Aggregates

The constituents like cement, fly ash and water produce the fly ash aggregates. Water is the binding material that paves the way for the function of the aggregate with good bond property. Cement and fly ash are constituents for preparation of the aggregates. Also water is the binder when it is added to increase the workability. Six different proportions of cement and fly ash such as 10:90, 12.5:87.5, 15:85, 17.5:82.5, 20:80 and 22.5:77.5 were tried.¹⁶

Casting of Test Specimens

The Concrete Cubes (control specimens) of size 15cm x 15cm x 15cm were cast by using conventional fine aggregate (CFA) and conventional coarse aggregate (CCA) and using fly ash fine and fly ash coarse aggregates obtained from the above six cement fly ash proportions. The specimens were demoulded after 1 day and immersed in water for 1, 3, 7, 14, 28, 56 and 90days for curing.

Age of testing	Proportion Cement : Fly ash	Compressive Strength in N/mm ²
1 day	10 :90	2.62
	12.5:87.5	2.76
	15 :85	3.84
	17.5:82.5	2.57
	20 :80	2.21
	22.5:77.5	2.13
	Control concrete	3.33
3 days	10 :90	6.41
	12.5:87.5	6.55
	15 :85	9.43
	17.5:82.5	6.81
	20 :80	6.61
	22.5:77.5	6.28
	Control concrete	8.37
7 days	10 :90	11.62
	12.5:87.5	12.89
	15 :85	15.93
	17.5:82.5	13.10
	20 :80	12.90
	22.5:77.5	10.24
	Control	14.34
14 days	10 :90	14.20
	12.5:87.5	15.60
	15 :85	20.24
	17.5:82.5	16.20
	20 :80	15.80
	22.5:77.5	12.60
	Control concrete	17.62
28 days	10 :90	16.30
	12.5:87.5	17.23
	15 :85	23.71
	17.5:82.5	17.90
	20 :80	17.20
	22.5:77.5	14.80
	Control concrete	20.80
56 days	10 :90	17.12
	12.5:87.5	18.26
	15 :85	25.35
	17.5:82.5	19.20
	20 :80	18.32
	22.5:77.5	16.19
	Control concrete	22.44
90 days	10 :90	19.10
	12.5:87.5	19.40
	15 :85	27.03
	17.5:82.5	20.18
	20 :80	19.54
	22.5:77.5	18.64
	Control concrete	24.96

Fig 62: table, flexural strengths for varying proportions¹⁶

Age of testing	Proportion Cement : Fly ash	Flexural Strength in N/mm ²
7 days	10:90	4.10
	12.5:87.5	4.50
	15:85	5.49
	17.5:82.5	4.40
	20:80	4.20
	22.5:77.5	3.95
	Control concrete	4.95
28 days	10:90	4.40
	12.5:87.5	4.75
	15:85	6.22
	17.5:82.5	4.60
	20:80	4.35
	22.5:77.5	4.15
	Control concrete	5.36

Fig 63: table, compressive strengths for varying proportions¹⁶

Compression test results

Fly ash aggregate concrete with fly ash aggregates prepared from cement fly ash proportions 15:85 showed 15%, 13%, 11%, 15%, 14%, 13% and 8% increase in Compressive strength at the ages of 1day, 3days, 7days, 14days, 28days, 56days and 90days respectively over the control concrete. Fly ash aggregate concrete with fly ash aggregates prepared from other cement fly ash proportions 10:90, 12.5:87.5, 17.5:82.5, 20:80 and 22.5:77.5 showed reduction in compressive strength at the ages of 1day, 3days, 7days, 14days, 28days, 56days and 90days respectively over control concrete.¹⁶

Split tensile test results

The fly ash aggregate concrete beam with fly ash aggregate made from cement fly ash proportion 15:85 showed an increase in split tensile strength of 12% and 15% respectively at the ages of 7days and 28days compared with control concrete beam.

The cement fly ash proportions of 10:90, 12.5:87.5, 17.5:82.5, 20:80 and 22.5:77.5 showed reduction in split tensile strength of 35%, 16%, 22%, 26%, and 28%, respectively at the age of curing in 7days and 24%, 15%, 19%, 25%, and 34%, respectively at the age of curing in 28 days than control concrete specimen.¹⁶

Flexural tensile strength test results

The fly ash aggregate concrete containing fly ash aggregate made from cement fly ash proportion 15:85 showed increase in flexural strength of 11% and 16% respectively at the ages of curing in 7days and 28days than the control concrete specimen.

The cement fly ash proportions 10:90, 12.5:87.5, 17.5:82.5, 20:80 and 22.5:77.5 showed reduction in flexural strength of 17%, 9%, 11%, 15%, and 20%, respectively at the age of curing in 7days and 18%, 11%, 14%, 18%, and 23%, respectively at the age of curing in 28days than control concrete specimen.¹⁶

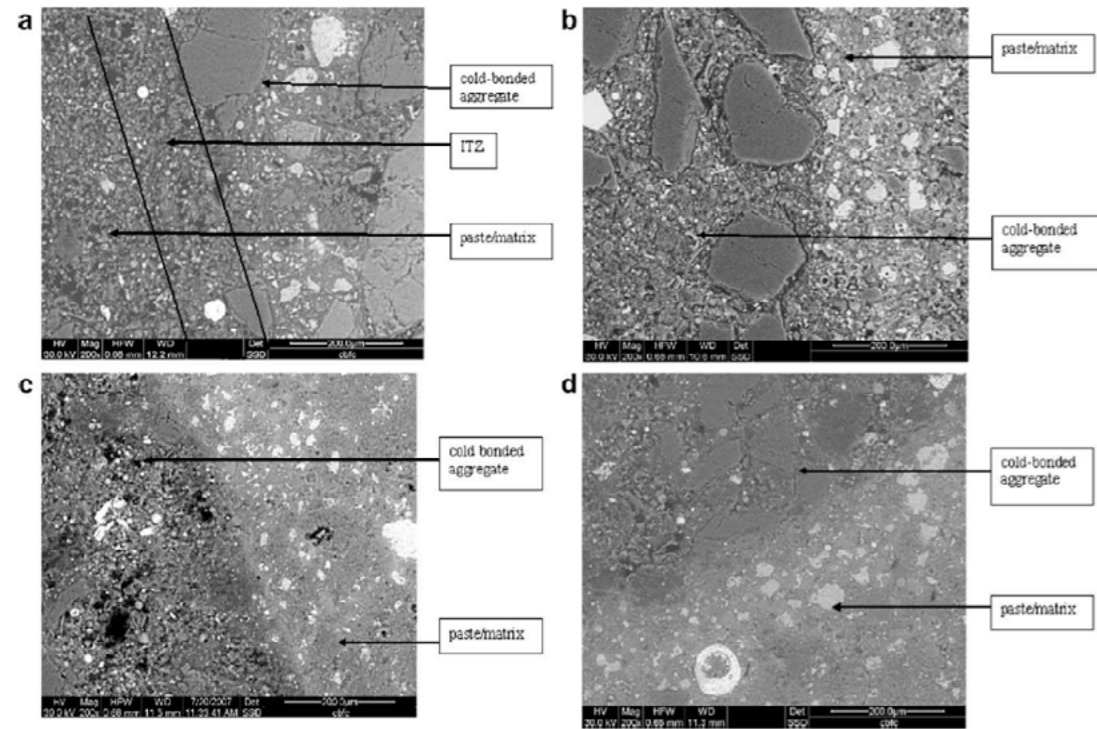

Fig 64: Microscopic view of surface of aggregate with a) flyash 0%, b) flyash 40%, c) flyash 60%, d) flyash 80%¹⁷

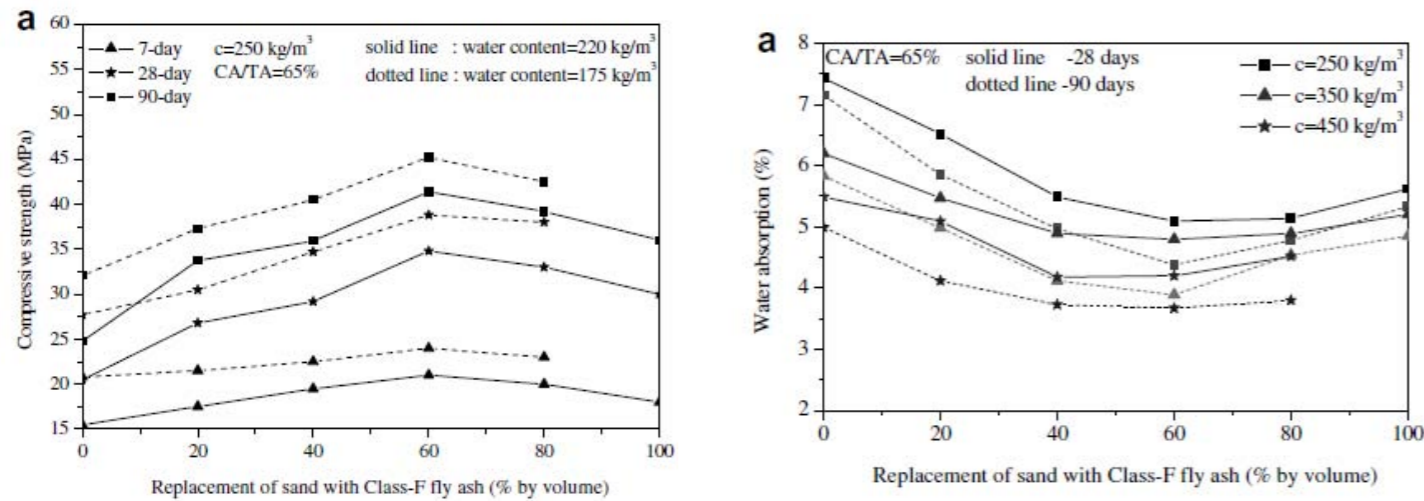

Fig 65,66: Graphs, influences of replacement of sand by flyash aggregates¹⁷

Introduction

Lets consider, flyash pellets are being used as aggregates in a mix. We have now understood that the insulation property increases with that and we can still get strengths adequate enough to make load bearing concrete elements with it. But what we have also understood is, the absorption co-efficient is higher with the flyash pellets being used for LWAC, with a mix of flyash, cement and sand with it.

There has been a technical research done on the effect of replacing sand with flyash, instead of replacing cement, for LWAC. Lets look at what it can give us.

Step 1

The dosage of superplasticizer required for maintaining a constant workability increases with sand replacement by fly ash (Table x), which is attributed to the increase in specific surface of the mix. For each cement content, CA/TA ratio and water content, the maximum sand replacement level was restricted by the limiting admixture dosage recommended by the manufacture. The concrete was cohesive even when the sand is completely replaced with fly ash.¹⁷

Compressive strength

The variation in 28-day compressive strength of cold-bonded aggregate concrete for a range of replacement level of sand with Class-F fly ash is shown in Fig...When sand was replaced with fly ash, the 28-day compressive strength of concrete was higher than the corresponding control mix, owing to the densification of matrix due to combined filler effect and pozzolanic action of fly ash. Higher amount of C-S-H is being produced with an increase in fly ash content inhibiting large CH deposits, contributing to early strength gain. In general, the strength increases up to a sand replacement level of 60-80%. A marginal reduction in strength is observed when the sand is fully replaced with fly ash, but this strength is higher than that of control mix. The strength of concrete at 100% replacement level corresponds to the strength achieved at around 45-60% replacement level. In mixes with a cement content of 250 kg/m³ (low cement content) and when 80% of sand is replaced with fly ash, the fly ash content ranges between 395 and 565 kg/m³ (155-225% of the cement content) for CA/TA ratios of 50% and 65%, respectively. As compared to the corresponding control specimen, the maximum the enhancement in strength (i.e. 40-70%) was achieved at a cement content of 250 kg/m³, while the enhancement was only of the order of 20-40% and 8-18% in mixes with cement content of 350 and 450 kg/m³, respectively. Significant improvement in strength of mixtures of low cement content is mainly due to the improvement in matrix and matrix-aggregate bond which controls the concrete failure. At higher cement content, since the aggregate governs the failure, the strength enhancement is less pronounced. The pores in matrix and interface are finer (<10 micrometer) especially in concrete with fly ash of 60-80%. Unlike mixes with fly ash replacing cement, the density of concrete can be brought down below 1900 kg/m³ when the sand is replaced in the mix with fly ash, which results in a dry density qualifying it as lightweight aggregate concrete.¹⁷

Fig. 8. Influence of replacement of sand with fly ash on water absorption: (a) water content = 220 kg/m³; (b) water content = 175 kg/m³.

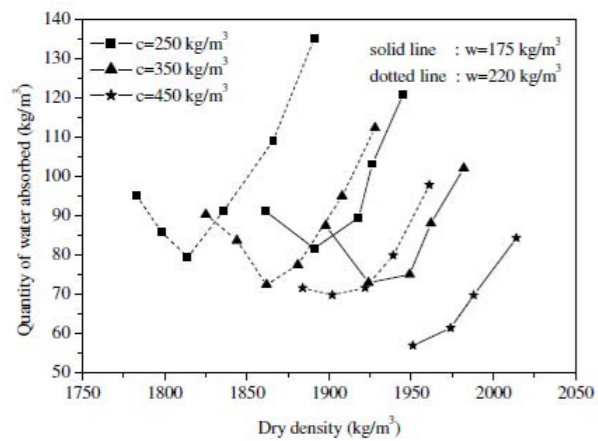

Fig. 9. Influence of density on quantity of water absorbed (replacement of sand with fly ash, 90-day).

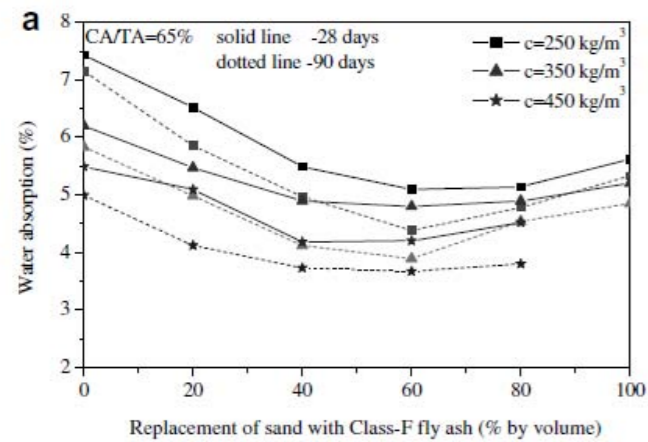

Fig 67,68: Graphs, influences of replacement of sand by flyash aggregates¹⁷

Water absorption

The absorption decreases with an increase in sand replacement (Fig. ..) and reaches a minimum at 60-80% replacement level, which corresponds to the level at which the maximum improvement in strength was observed (Fig. ..). Beyond this replacement level, though the absorption started increasing, the absorption at 100% replacement level was considerably lower than that of corresponding control mix. As sand is replaced with fly ash, an improvement in the microstructure of both matrix and matrix-aggregate interface and formation of discontinuous pores as observed in BSEI (Fig. ..) are attributed for this reduction in water absorption. As expected, for a cement and aggregate content, the effect of curing was more pronounced in mixes with fly ash than control mix due to the extended pozzolanic reaction of fly ash. The influence of fly ash in reducing water absorption was more pronounced in lower cement content mixes. Tests show a steep decrease in the amount of water absorbed by unit volume of concrete with a reduction in density caused by replacement of sand with fly ash. An increase in the strength of concrete is associated with a decrease in water absorption. The R2-value (relationship between compressive strength and water absorption) is higher for concrete with a cement content of 250 kg/m³ (enhancement in strength and the corresponding reduction in water absorption of concrete) as compared those with higher higher cement content (a marginal increase in strength in mixtures of higher cement content could be achieved when sand was replaced with fly ash).¹⁷

Conclusions

1. The workability of cold-bonded fly ash aggregate concrete increased with partial replacement of cement with fly ash, while it decreased when sand was partially replaced with fly ash.
2. The results suggest that the cement replacement levels can be restricted based on the target compressive strength requirement at the desired age.
3. The 28-day compressive strength of mixes with fly ash as replacement for sand was higher than the corresponding control mix. The strength enhancement was higher in mixes with lower cement content (250 kg/m³) along with higher CA/TA ratio.
4. At 90-days, the water absorption and sorptivity of concrete with 30% fly ash replacing cement was lower than that of control mix. The water absorption and sorptivity reduced with an increasing level of sand replacement in the mix with fly ash up to 60-80%. Even at 100% replacement level, the absorption and sorptivity were lower than that of the corresponding control mix.
5. The reduction in water absorption and sorptivity of cold-bonded aggregate concrete sand replacing fly ash was consistent with improvement in compressive strength. Microstructure showed improvement both in matrix and matrix-aggregate interface in concrete with fly ash replacing sand.
6. Replacement of sand with fly ash in cold-bonded aggregate concrete allows high volume utilization (up to 0.6 m³/m³ of concrete) of fly ash with beneficial effect on strength while causing no detrimental effect on sorption behaviour.
7. The permeation behaviour of concrete is reported to depend on the porosity of matrix and the quality of matrix-aggregate interface rather than the porosity of cold-bonded aggregate.¹⁷

component and panel based
prefab systems

In this chapter we shall study 4 different systems developed for industrial housing. I cannot claim that these 4 systems are indeed the ideal case studies for my design. Nevertheless, they are successful systems under various markets and societies. I studied several others also, but found these four to encompass most of the information contained in the others as well. Out of the four, two of them are panel based, and two of them are component based. Before getting into each of them, we shall see the role of modularity and standardisation in prefab. This chapter will provide a strong basis for developing the new system subsequently. To study the advantages, disadvantages of each system, understanding problems in each stage of product development and execution is the goal of this chapter.

In discussions of the large volume of building-particularly housing - projected for the balance of this century, it is often said that we have the necessary technology and that no great improvements are either necessary or likely, but that other factors stand in the way of its full application. It is also said that costs of building, especially housing for low- to moderate-income families, are too high but that technology cannot substantially reduce them, and that they must be brought down in other ways, mainly by financial means such as interest subsidy, preferential tax treatments, and so on.

There seems to be a contradiction here. If costs are too high and technology can not substantially reduce them, then technology is inadequate. It may be true that no great improvements are possible; it may also be true that we need only to utilize fully our existing technology. Perhaps we are in the position of the dirt farmer who refused to send his son to agricultural school because, "we don't farm as good as we know how right now."

There is no single technology; there are many, and none universally applicable to all building situations. We have many traditional methods of construction developed during centuries of trial, and based upon diverse materials, structural principles, and methods of environmental control. When well organized and efficiently carried out, these often still offer the best solutions to given problems. Nevertheless, we are acutely aware that they have their shortcomings in the face of today's situation and tomorrow's demands. The search for improved technologies moves forward on a worldwide scale. We hear much about industrialization, building systems (also called systems building and the systems approach), the performance concept, organization and project control, and how these promise to help solve our problems. We may examine them briefly to see where they stand today, and where they appear to be going.

"Industrialization," as is true of many commonly used words, means different things to different people. To some, it is merely a subterfuge to avoid the bad odour of "prefabrication." To others, it is the panacea for all building ills. As used here it means not only shop. As previously explained in chapter 2, component based prefab systems and Panel based systems are better suited to Indian conditions than the 3d Box system. Ideally with the road infrastructure available, and the flexibility possible with component based systems, it would be good to explore the value of integrating the advantages of panel based system, into a component based system. Hence it would be worthwhile to make case studies of both the types, before trying to combine the utilities.

"Full-scale industrial methods must be applied by introducing standardization of individual components".

Le Corbusier, 1920.

Normalization and Standardization of components

Many industrialized countries have a central bureau or institute to regulate the standardized norms for the building components. The setting of standardized norms prescribes the properties and the quality required of building components. The closed systems need not be standardized for mass production. Only a requirement for a sufficient number of identical units is needed so that an economically satisfactory production can be established. This is why some of the closed housing systems adopted on-site precasting technique with a lower degree of mechanization compared to that applied in a permanent factory. However, standardization may contribute to the success of closed systems in several ways:

1. Less costly when components of closed systems are made in part from standard units;
2. Freedom of choice of finished material obtained from other sources and offered in standard sizes and
3. The use of selected components of closed systems in other applications if they are standardized, thus reducing the cost through increased production.

The gradual evolution of components of closed systems has been considered as a natural and logical approach to the development of open systems. In fully developed open systems, all the components, for housing are available from various sources and they are standardized to fit perfectly together.¹⁸

Modular co-ordination

"Modular coordination", is the name that has been almost universally adopted for an internationally agreed system of uniform dimensioning in the building process. The module is a unit of measurement. All those dimensions of the various components, which are important for their coordination with other components are whole multiples of this basic module. Thus, modular coordination would serve a dimensional guide both to the manufacturers, offering them a limited set of coordinated product sizes, and to designers, offering them an adequate choice of building sizes and planning grid. Normalization and standardization only gives general measures for components, while the modules are exact sizes which both prescribe the dimensions of components, and indicate their position in the system.-

Multimodules and submodules: The size of basic module, is internationally established as 10 centimeters for metric countries and 4 inches for foot-inch countries. For some products, a selection of preferred modular sizes must be made, such as whole multiples of 3 M and 6M which serve as multimodules or a whole fraction of the basic module such as M/4 (2.5 centimeters respectively 1 inch) which serves as a submodule (or a infra-module).

The common multimodules used in the C.M.E.A. (Council for Mutual Economic Assistance) countries are 3M-6M-12M-15M-30M-60M. For the submodule, the United Kingdom modular coordination standards recommend for such sizes up to 30 centimeters, the use of 5 centimeters (M/2) and 2.5 centimeters (in descending order of preference). In the C.M.E.A. countries, the use of 1/2M- 1/5M- 1/10M- 1/20M- 1/50M-1/100M is common.¹⁸

It must be noted here, however that, as mentioned in chapter 2, it is more practical to explore 150mm as M for residences in India.

Single and additive components:

a) Single components:

Components having at least one dimension equal to the functional element which it is intended to create or be a part of, may be called single components. ex: the length of the floor components.

b) Additive components:

Components, which on the building site are added to other components of the same kind so as to form in combination a functional element, may be called additive components. ex: the width of the floor components.

The purpose of single component is for size standardization while the additive components permit them to form, in various combination, all modular dimensions.¹⁸

Type Standardization

Type standardization of material, component, and structure in housing construction gives the possibility of obtaining the greatest degree of repetition of all operations and products in design and production. The reduction of the infinite, variety of types to a small number of types is the first and the most important step towards industrialization. The difficulty of type standardization is that it sets up a completely new pattern of satisfying demand, and affects the client as well as the component manufacturer and designer. Therefore, standardization is rather a psychological attitude before it becomes a technical measure. Speaking of economy and efficiency, the less the types and sizes of component, the cheaper the cost. Meanwhile, type standardization permits a specification of assembly groups acting on the site, implies and decreases the variety of the erecting equipment, which results in considerable economy in the housing cost.¹⁸

This Panel based Precast Concrete housing system was developed in Denmark in the 1960's, and has been in a process of continuous improvisation ever since.

Originally, a block of flat has precast floor components simply supported on load-bearing cross walls, as shown above. Today, we have added spans across the building, spine walls, external and re-entrant corners (angles 90 or more, e.g. 1350) etc., all mixed within the same building, to allow for more flexibility.

Structural system has a few additional components, viz. the load-bearing concrete sandwich facades (gables), the balcony components, and the longitudinal wind-bracing walls (usually at the stairwell). Façade components are not necessarily part of the structural system. The floor components may support light façade components. The concrete sandwich components may be load-bearing (and/or bracing) or just suspended on brackets at the ends of the cross walls. This permits movements due to shrinkage and due to thermal expansion and concentration, of the external leave of concrete.²⁰

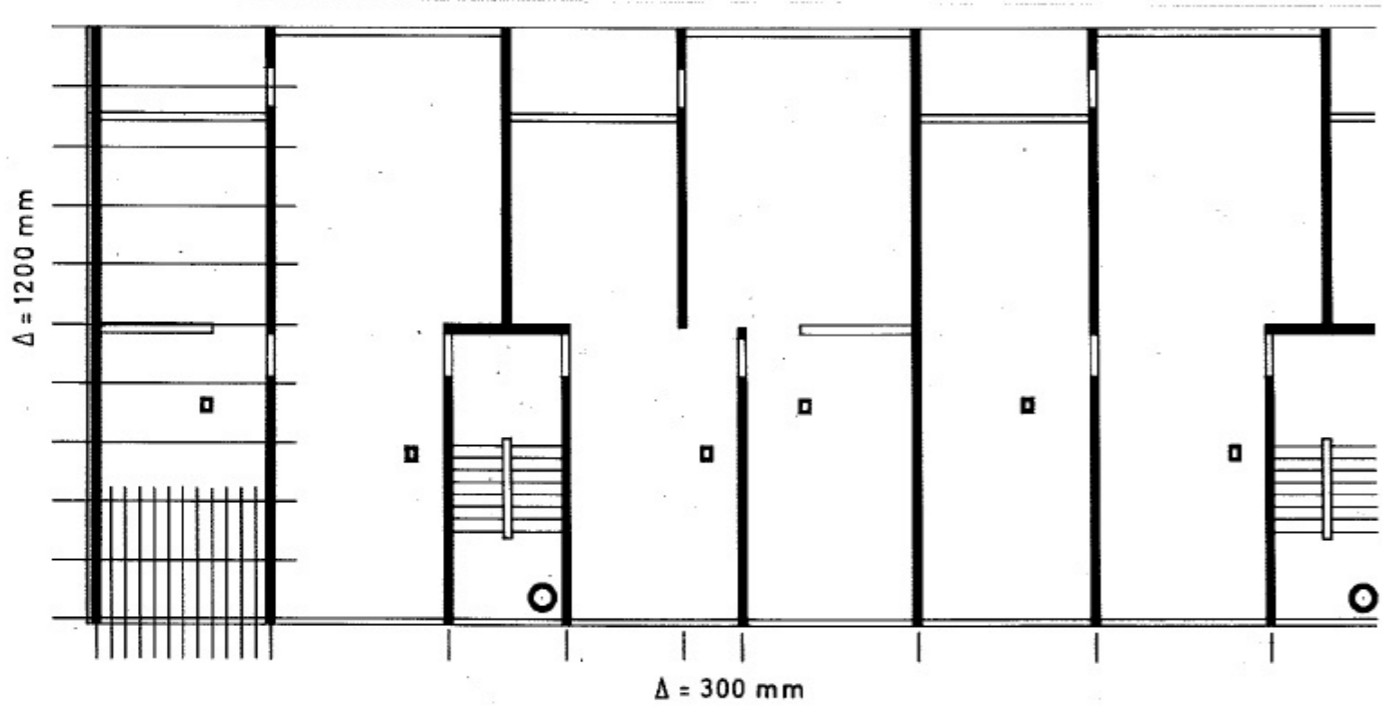

Fig 69: Typical layout of cross wall load bearing system²⁰

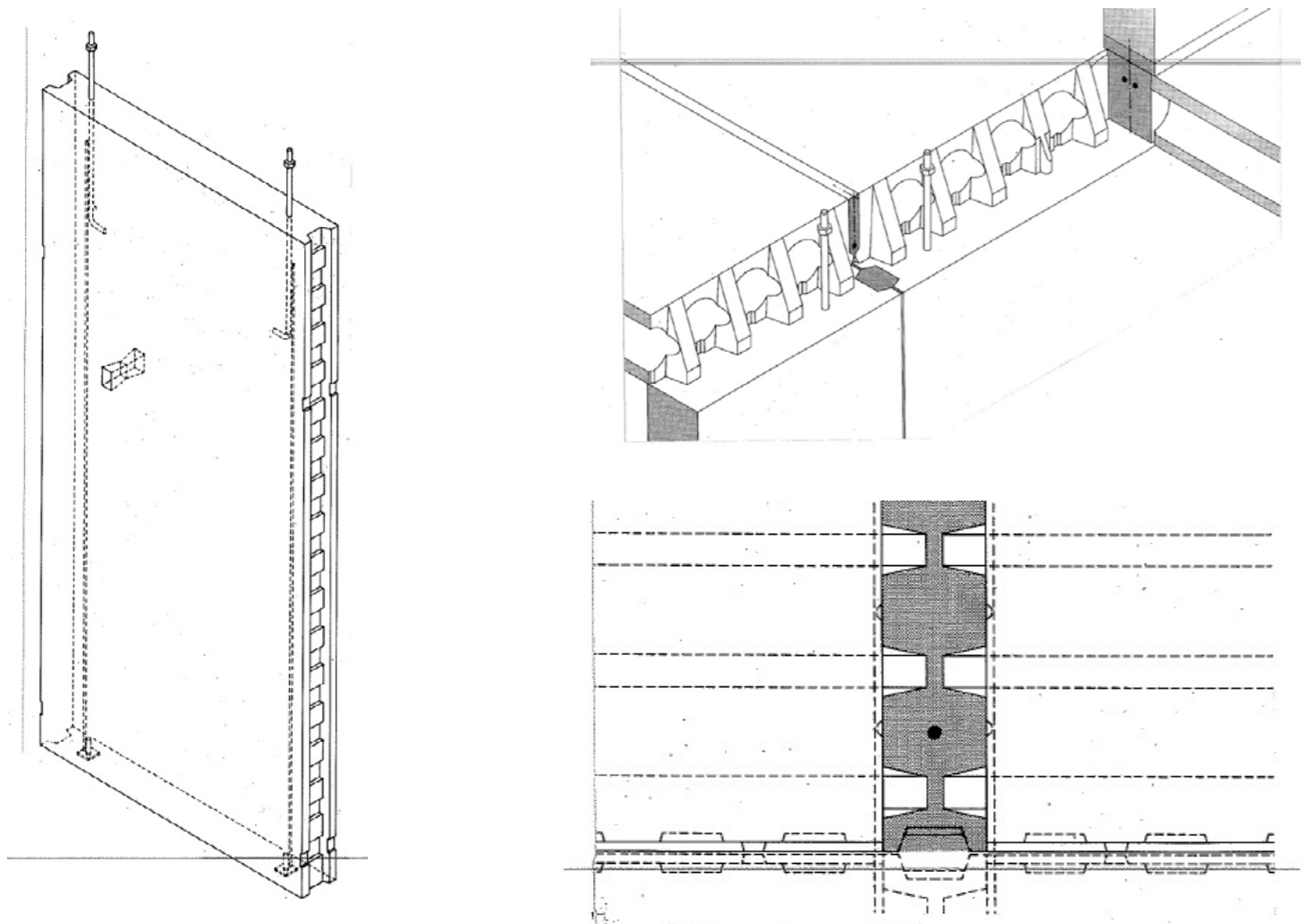

Fig 70: Typical wall element²⁰

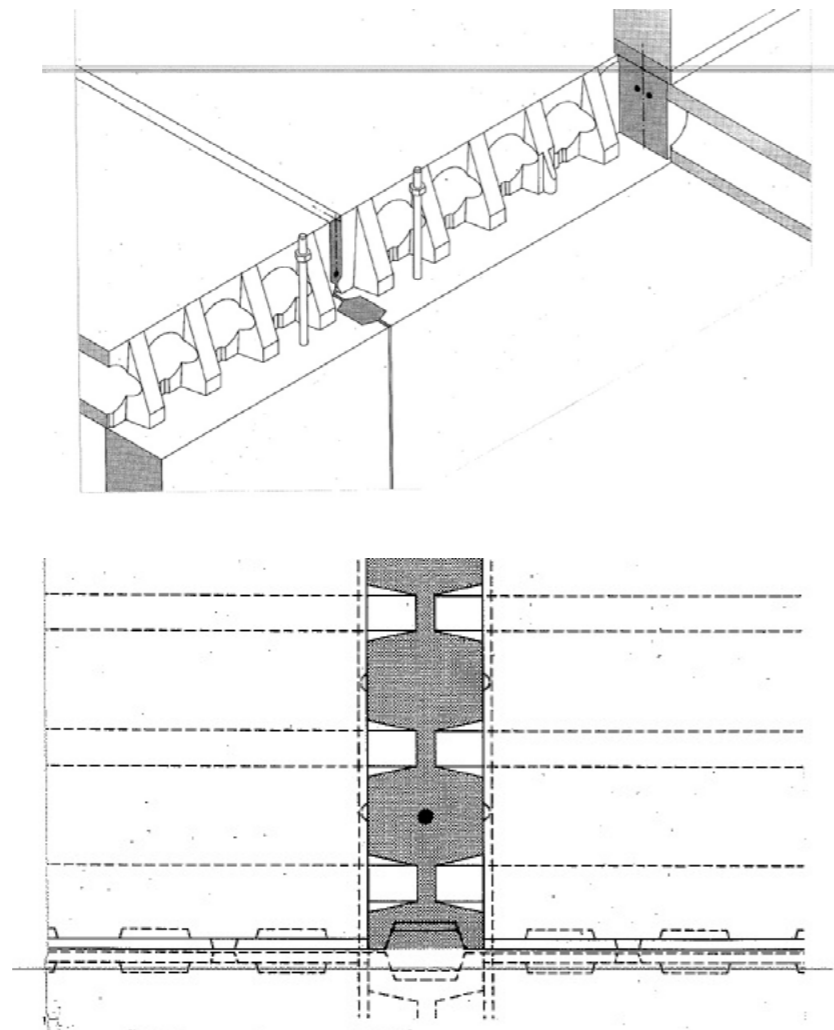

Fig 71,72: Wall floor junction²⁰

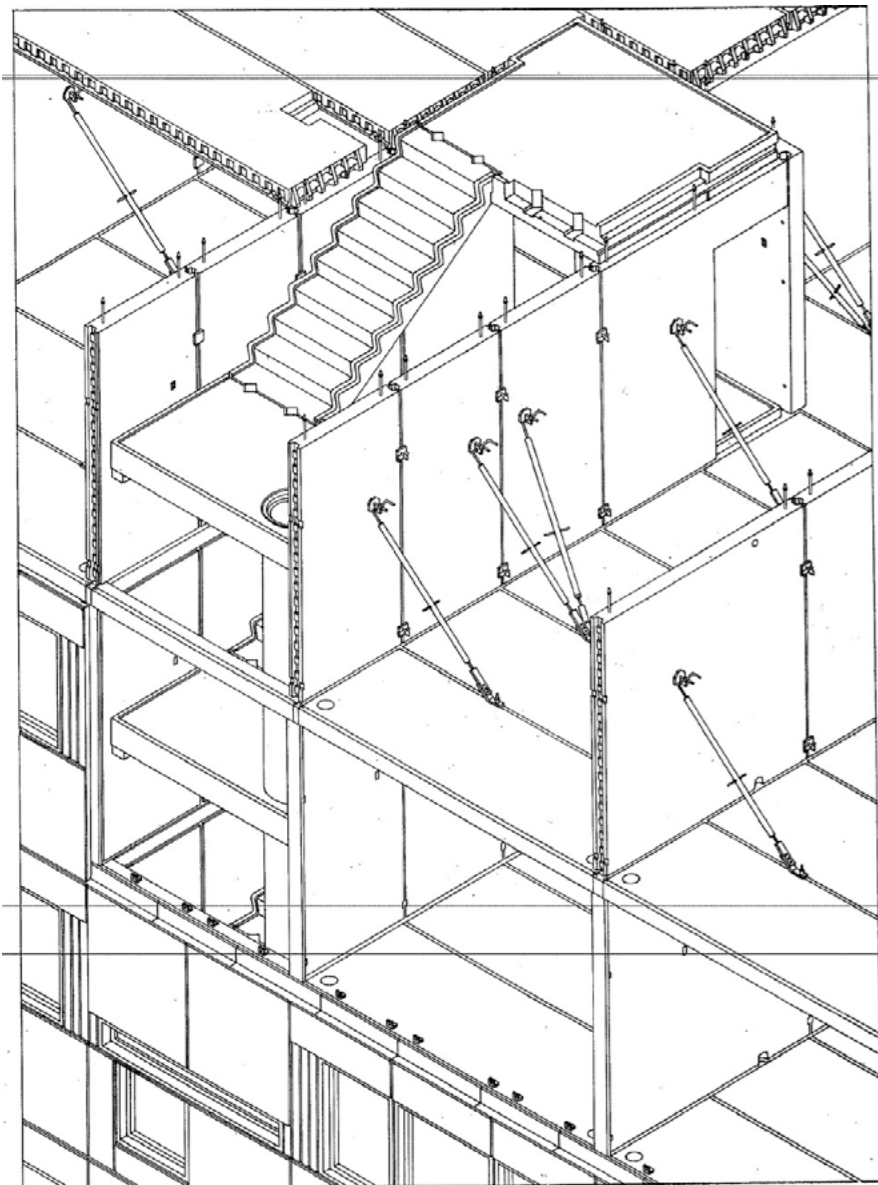

Fig 73: 3d exploded view of assembled components with shoring²⁰

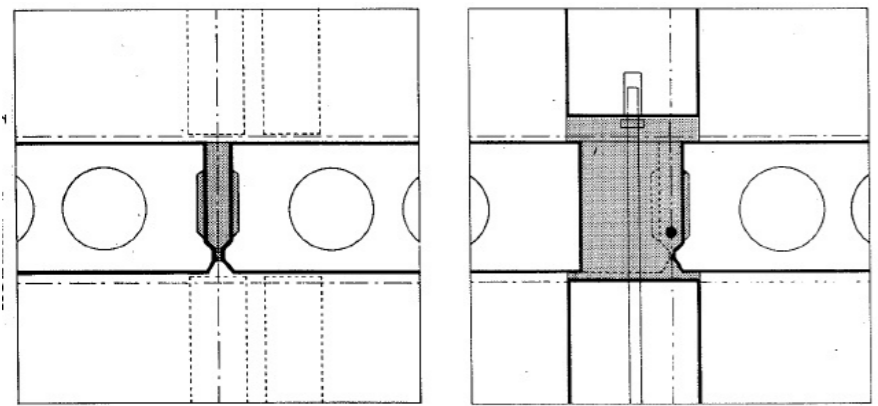
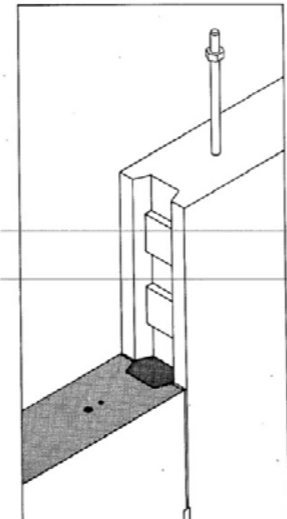
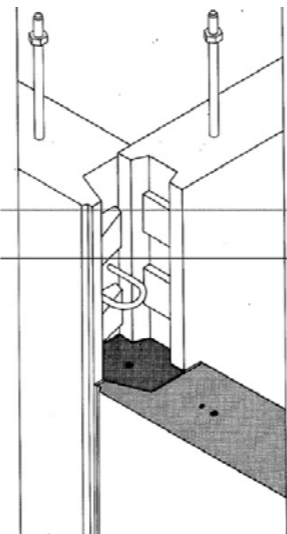
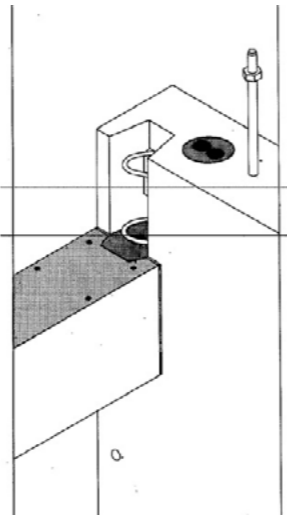

Fig 74-78: junction details, showing teething for grouting²⁰



The vertical forces in the walls cannot be carried through the floor slabs: the floor slabs have hollow cores, and the narrow zones between them cannot take the forces from the fully loaded wall. Furthermore, the floor slabs (to increase speed of erection) rest on a dry joint. Thus the stress distribution is a function of small irregularities in the components' surfaces.

Therefore, the vertical forces must be transmitted directly, i.e. through the cast-in-situ concrete in the joint, the cross-section of which is only slightly less than that of the wall. The load is transmitted centrally and the stress distribution is fairly well known.

The loads from the floor slabs are transmitted to the wall top by a row of cams at 150mm intervals. In practice the slabs do not rest on all the cams, and some are useless because of the openings in the floor slab. Many experiments have shown that the bearing capacity that the reinforcement is carried at least 50mm in over the wall (the most unfavourable combination of production and erection inaccuracies may reduce this to 40mm), i.e. carried through to the end of the cam. Such components have been used for most prefabricated housing in Denmark for the past 25 years. The end face of the form is quite simple, and there is no projecting reinforcement.²⁰

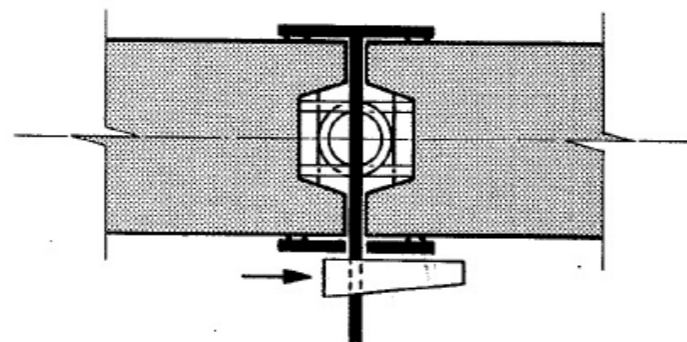
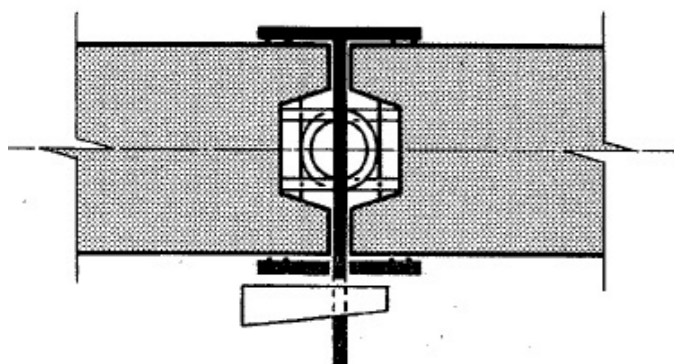
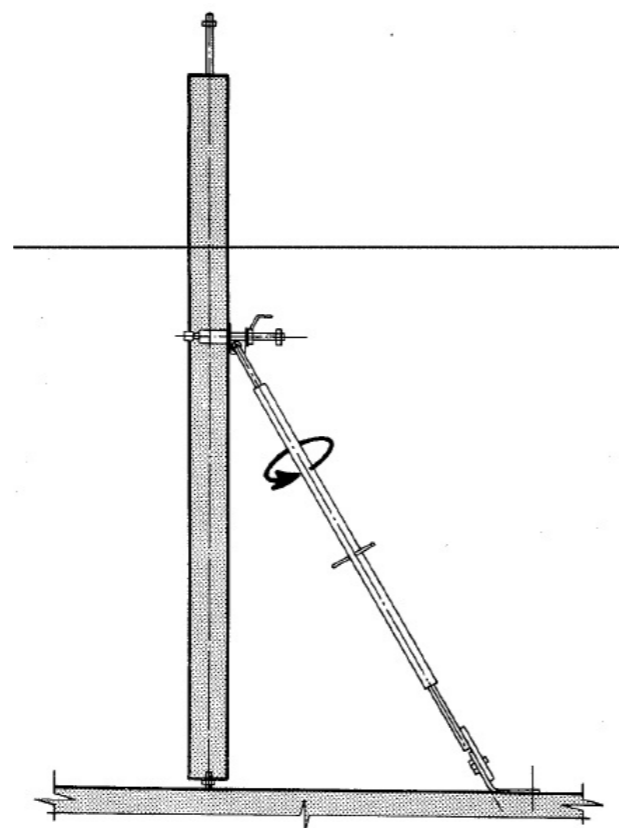
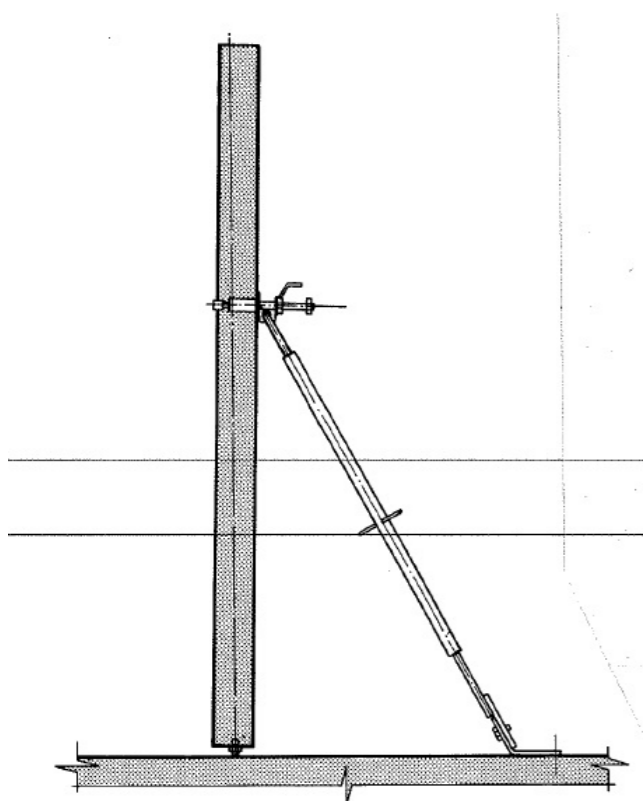
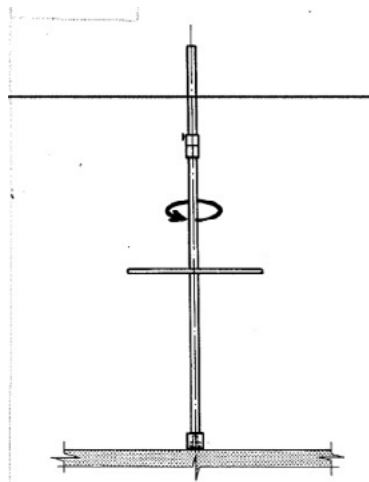

Typically, the erection tempo is two flats per day per crane, and the erection of the structure proceeds as follows: The floor elements are laid in the walls (the joint being dry); the joint reinforcement is placed in position; the facades are erected. In spite of the open joints the building is then sufficiently closed to permit its being temporarily heated in winter, so that the joints can be grouted.

The wall joint likewise requires no formwork, and the edges of the elements are also toothed, so that the entire wall acts as a plate for resisting the wind forces.²⁰

Fig 79-83: Alignment of panel after erection²⁰

Introduction

Precast/prestressed sandwich wall panels are composed of two concrete wythes (layers) separated by a layer of insulation. One of the concrete wythes may be a standard shape, such as a flat slab, hollow-core section, double tee, or any architectural concrete section produced for a single project. In place, sandwich wall panels provide the dual function of transferring load and insulating the structure. They may be used solely for cladding, or they may act as beams, bearing walls, or shear walls. Precast/prestressed concrete sandwich wall panels are used as exterior and interior walls for many types of structures. These panels may readily be attached to any type of structural frame, e.g., structural steel, reinforced concrete, pre-engineered metal and precast/prestressed concrete. The panels are precast at a manufacturing plant, trucked to the project site and erected by cranes. Panels generally span vertically between foundations and floors or roofs to provide the permanent wall system, but may also span horizontally between columns.²¹

Typologies

Non-Composite

A non-composite panel is analyzed, designed, detailed and manufactured so the two concrete wythes act independently. Generally, there is a structural wythe and a non-structural wythe. The structural wythe is the thicker of the two.

Composite Panels

Composite panels are analyzed, designed, detailed and manufactured so that the two concrete wythes act together to resist applied loads. The entire panel acts as a single unit. This is accomplished by providing full shear transfer between the wythes.

Semi-Composite Panels

Semi-composite panels are analyzed and designed as composite or partially composite panels during stripping, shipping and erection, but as non-composite panels for in-place loads. Experience indicates that early bond between certain insulation types and the concrete wythes provides sufficient shear transfer for composite action during handling, but for design purposes this bond is considered unreliable for the long term.²¹

The wythes

The wythe thickness has ranged from a minimum of 40mm to as thick as required by the imposed loads. Strands are generally pulled to normal levels of initial tension and located at the centroid of each wythe so there is no tendency of the wythe to "camber". Composite panels that have wythes of unequal thickness or of unequal section properties have strands normally placed at the centroid of each wythe, but the initial tension is adjusted in one of the wythes so the resultant prestress force coincides with the centroid of the composite section. This is done to eliminate or reduce the initial bow or camber in the panel.

Some designers report success in intentionally introducing an inward bow to composite panels by the use of an eccentric prestress force. The intent of this is to offset the observation that "composite sandwich wall panels always bow outwards." The use of such a design should be carefully thought out because the introduction of an initial bow may create field alignment problems. A uniform strand spacing across the panel width is generally used²¹



Fig 84: An industrial building with sandwich panels²¹



Fig 85: hollow core sandwich panel stacked²¹

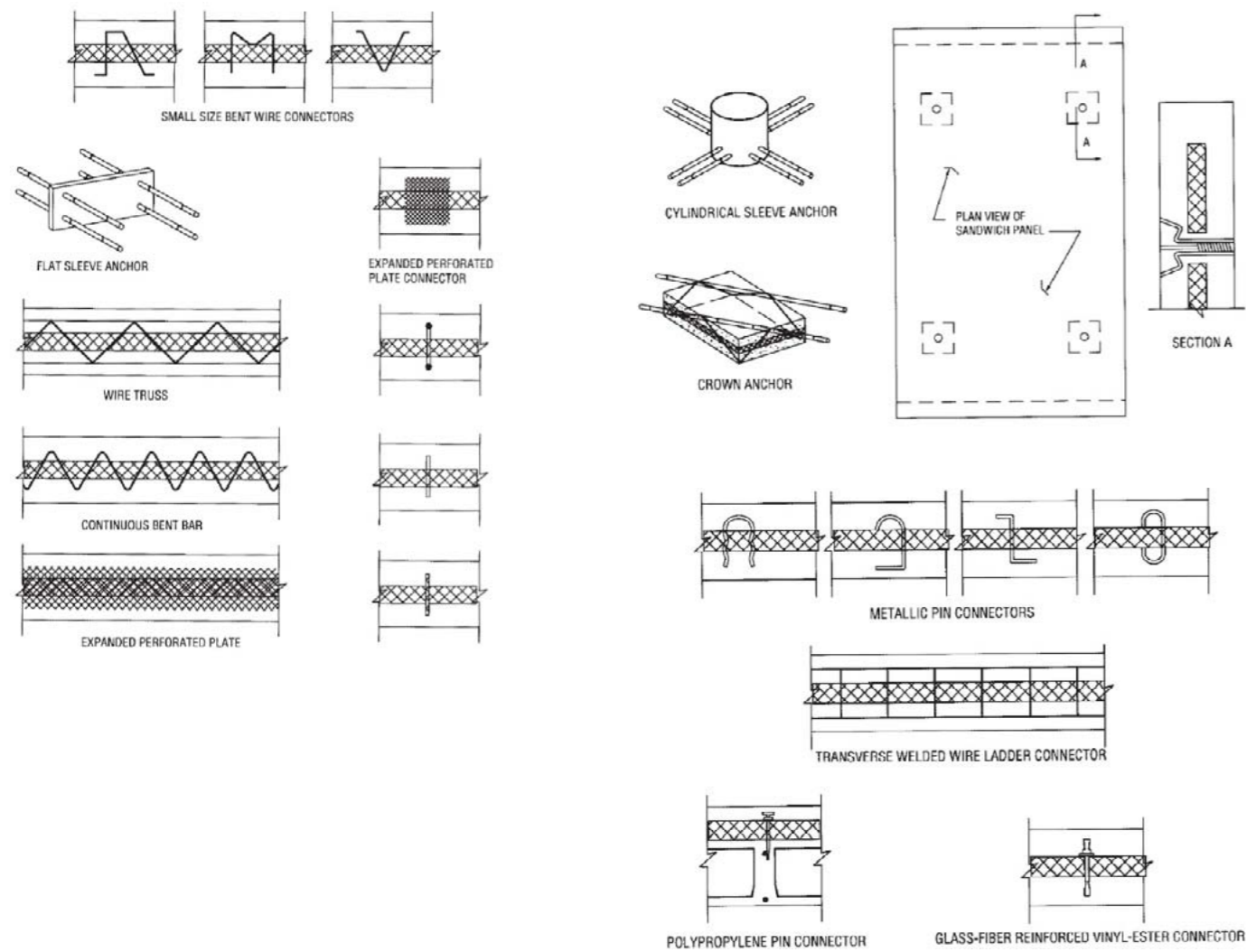

Fig 86: different methods of shear connections between the 2 wythes²¹

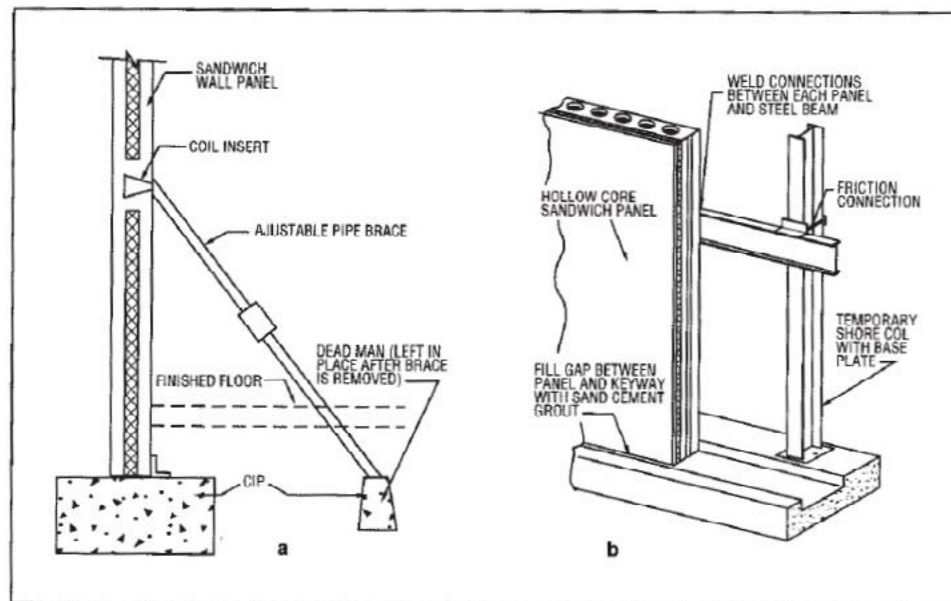

Fig 87: bracing of the first panel above foundations²¹

Shear Connectors

Shear connectors are used to transfer shear forces between two wythes. Because wall panels are usually designed as one-way structural elements, shear forces are generated due to longitudinal bending in the panels. In some cases, the shear connectors may be used to transfer the weight of a non-structural wythe to the structural wythe.

Some shear connectors are stiff in one direction and flexible in the other. These are called one-way shear connectors. Examples of these are longitudinal steel wire trusses, solid ribs of concrete, M-ties, flat sleeve anchors and small diameter bent bars. Care must be taken in the manufacturing process to maintain the intended orientation of the connectors.

Other shear connectors are stiff in at least two perpendicular directions and will consequently transfer both longitudinal and transverse horizontal shears. Examples of these are solid blocks of concrete (often located at lifting points), connection plates, cylindrical sleeve anchors and crown anchors.

Capacities of shear connectors may be obtained from the connector manufacturer or, in some cases, calculated using allowable bond stresses for bending, shear and axial forces. When solid areas of concrete are utilized, a commonly used ultimate shear resistance value is 80 psi (552 kPa).

The insulation between the wythes may in some cases provide a shear resistance between the wythes. Rough faced dense insulation provides more shear transfer than slick faced insulation. Shear resistance that may be available from bonded insulation is considered temporary. In demi-composite panels, the assumption is made that the insulation provides sufficient shear transfer to create composite action during stripping, handling and erection, but the shear transfer is not relied on to provide composite action for resisting service loads.²¹

Bowing

Bowing is a complicated and sometimes controversial topic. The present state-of-the-art is not sufficiently advanced to precisely predict the amount of bow in any given panel.

Reasons for this inability to precisely predict bow are:

- Shrinkage, creep and modulus of elasticity of the concrete cannot be precisely predicted.
- Actual thermal gradients and their shape are not precisely known.
- The degree of restraint provided by external connections is not precisely known.
- The degree of composite action in semi-composite panels is generally not precisely known.
- An exact analytical model for each of the above, or the interaction among them, has not been established.

With all these unknowns, it is still possible for the designer to adequately account for the bowing characteristics of composite and semi-composite panels. In this regard, it is similar to the imprecision in accurately predicting the camber of a double tee. The most important consideration is to realize that bowing will occur and to establish a reasonable value for the magnitude of bowing, often based on experience.²¹

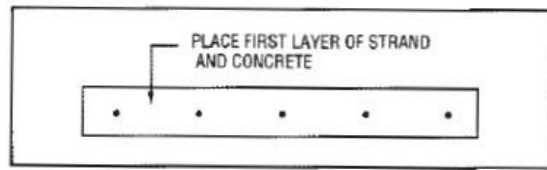

Fig. 4.3.1.a. First step — Place first layer of strand and concrete.

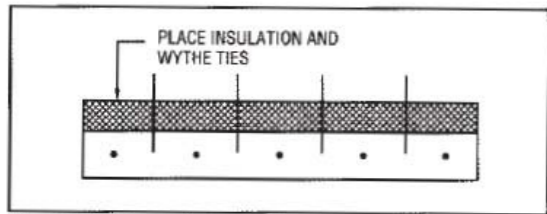

Fig. 4.3.1.b. Second step — Place insulation and wythe ties.

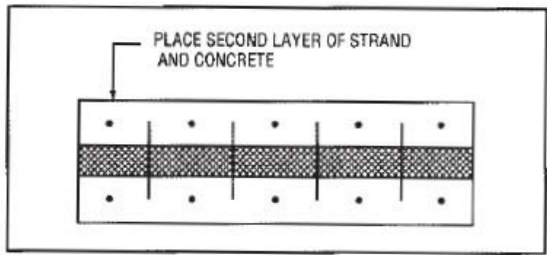

Fig. 4.3.1.c. Third step — Place second layer of strand and concrete.

Fig 88: The production process explained in section²¹

Methods of casting

Wet Cast (Normal Slump)

Sandwich insulated wall panels cast by the "Wet Cast System" are manufactured in long line steel forms with bulkheads separating each panel. The bottom wythe strand, reinforcing steel, embedments and other required materials are placed and the first layer of concrete is introduced and vibrated. Vibration techniques vary. Some commonly used methods are standard "spud" vibrators, vibrating drop screeds, grid vibrators and external form vibrators.

Insulation is then placed with wythe ties that connect the bottom layer of concrete and project into the top layer of concrete.

The top wythe strand, reinforcing steel, and embedments are then placed and the final layer of concrete is cast and finished. Because vibration tends to make the insulation float, some manufacturers use reinforcing bar slugs placed between the top strand and the insulation to hold down the insulation.

Also, some manufacturers stress both the top and bottom strands in the initial production step. The remaining procedures are then the same as described above.²¹

Dry Cast (Zero Slump)

Dry cast refers to panels made with zero slump concrete placed by machines that extrude dry concrete as part of their manufacturing operation. Zero slump products started as hollow-core slabs, and the standard production procedures have been modified to permit the manufacture of sandwich wall panels.²¹

Machine Cast

Manufacturers have developed various machine casting systems to improve the quality and reduce the cost of manufacturing sandwich wall panels. This system utilizes the "Wet Cast System" and/or the "Dry Cast System." Some of the machine-cast panel systems are described in this section.²¹

Corewall (Wet Cast) System

The Corewall Panel System utilizes machinery to produce panels with normal slump concrete or by the wet cast system. Corewall Inc. has developed machinery to place the concrete wythes and create various ribbed finishes in the top surface. After the machinery places the bottom wythe concrete, insulation is then placed with special wythe ties. The Corewall machinery then places the top wythe concrete and finishes the top surface with a proprietary roller system. The rollers can be changed to provide various patterns in the concrete surface. The panels may be formed to length or sawcut to length after curing.²¹

Shipping

Sandwich panels are shipped either on edge or in the flat position. The shipping position is dependent on equipment availability, form face finish requirements, transportation equipment, and the flexural design of the panel.

When panels are shipped on their edge, consideration of localized bearing stresses must be given in order to prevent chipping and spalling. Non-composite panels should be loaded so that only the structural wythe sits on dunnage. Panels receiving a special finish are often edge shipped to prevent damage or staining to the finish.²¹

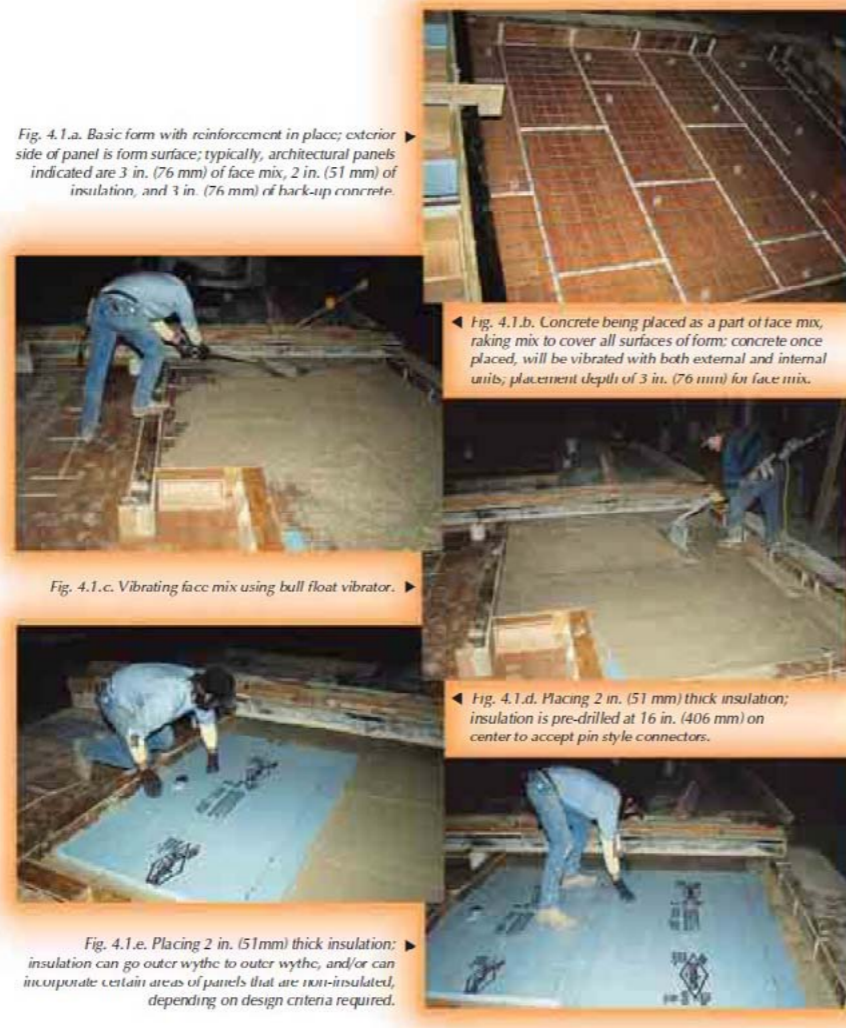

Fig. 4.1.a. Basic form with reinforcement in place; exterior side of panel is form surface; typically, architectural panels indicated are 3 in. (76 mm) of face mix, 2 in. (51 mm) of insulation, and 3 in. (76 mm) of back-up concrete.

Fig. 4.1.b. Concrete being placed as part of face mix, raking mix to cover all surfaces of form; concrete once placed, will be vibrated with both external and internal units; placement depth of 3 in. (76 mm) for face mix.

Fig. 4.1.c. Vibrating face mix using bull float vibrator.

Fig. 4.1.d. Placing 2 in. (51 mm) thick insulation; insulation is pre-drilled at 16 in. (406 mm) on center to accept pin style connectors.

Fig. 4.1.e. Placing 2 in. (51 mm) thick insulation: insulation can go outer wythe to outer wythe, and/or can incorporate certain areas of panels that are non-insulated, depending on design criteria required.

Fig 89: The production process as it happens-1²¹

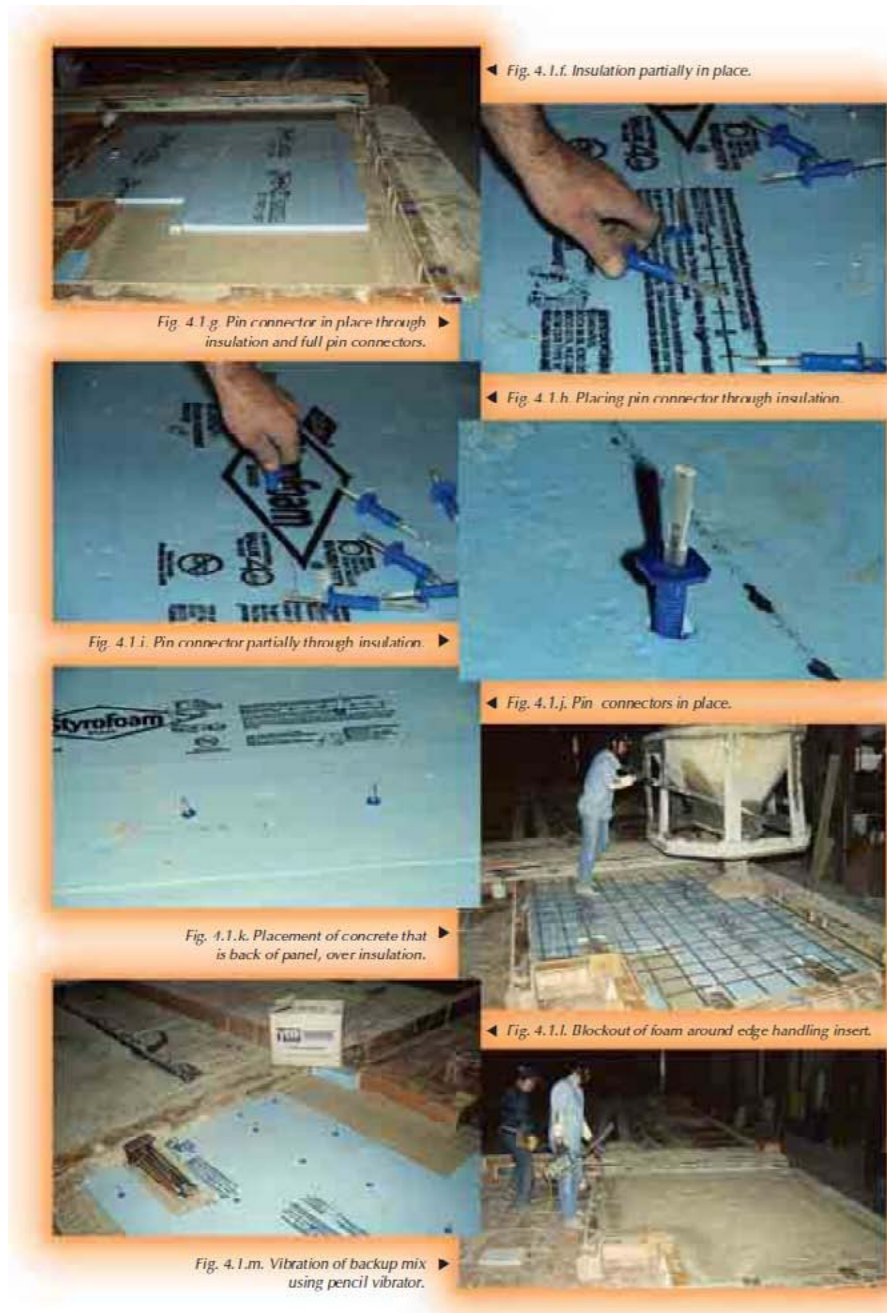

Fig 90: The production process as it happens-2²¹

When panels are shipped in the flat position, more panels can usually be shipped per load. Some items requiring attention are:

- Length of panels vs. length of trailer. If the trailer is flexible (such as a stretch trailer), over-stressing of the panel may result.
- Dunnage is usually positioned at the lift point locations.
- Job site access needs to be such that torsional twist of the trailer and panel is minimized or eliminated.

Panel storage

Panel storage is determined by the method of stripping and/or shipping. Ideally, the panel is stored in the same position in which it is shipped. This reduces handling, thus reducing cost and opportunities for damage.

Job site storage of sandwich panels is undesirable because the panels need to be stored on dunnage resting on clear, firm, flat areas. Areas such as these are not found on most job sites. Job site storage also creates additional handling unless the trailers are "dropped". On most industrial buildings, the general contractor requests that some panels be left out for equipment access during construction. These panels can be leaned against the structure adjacent to their final location, and should be securely tied off to the structure.²¹



Fig 90: View of a typical ICF panel²²



Fig 91-93: extract of images from works in progress listed on website²²

Introduction

Insulated Concrete forms are used to create cast-in-place reinforced concrete walls. An IC form is made up of two panels of high insulating value EPS foam that are held in place by plastic or steel connectors. The cavity or width between the foam panels is variable based on the structural requirements of the building, however the most common concrete core sizes are 6" and 8" for residential construction. Walls of 24" or more can also be created using ICFs. The forms are stacked to create the walls and foundation of the structure. Rebar is placed in the cavity and concrete is then poured in the cavity between the foam panels to create a structurally tough, energy-efficient, air-tight building with greater comfort. The foam panels and concrete act as air and vapor barriers, in addition to adding the high performance insulation factor. This saves substantial heating and cooling costs and will reduce HVAC requirements and up front costs.²²

Walls

ARXX ICF forms have easy to reference cut lines on each side of the block. Use an ARXX ICF saw (or pruning saw) to cut forms to the required size.

When working from an unlevel footing, the simplest correction is to scribe and cut the bottom of the EPS panels to the contour of the footing. When levelling the wall, fill any voids below the form panels with expandable foam or shims.

After the first two courses have been laid and are tied together, the two course wall should be adjusted to make the entire wall perimeter level. Temporary blocking should be fastened to the footing on the outside of the wall to keep the wall in place.

Once the walls are level, plumb and straight, the bottom of the forms can be spot glued on both sides to the concrete with low expansion foam adhesive.

Successive courses of ARXX forms can be installed by following the pattern established in the first two courses.²²

Openings

Door and window openings can be installed simply by placing a frame or buck with the same dimensions as the rough stud opening dimensions.

Bucks are typically made from wood, vinyl or metal. Generally, wood and vinyl bucks are installed in the wall permanently. Some metal bucks are made to be removed and reused.

In addition to creating openings for windows and doors, a buck is also required to provide the fastening points for a window, as well as restrain the concrete in the wall. The buck also supports the ICF forms during the placement of concrete.

Wood bucks can be placed either inside the form panels or across the width of the form. Alternatively, solid lumber or plywood can be used along the base of the frame.

Vinyl buck systems made for ICFs may be used with ARXX forms. These systems are cast-in-place, remain on the wall and provide solid fastening for the windows or doors.²²

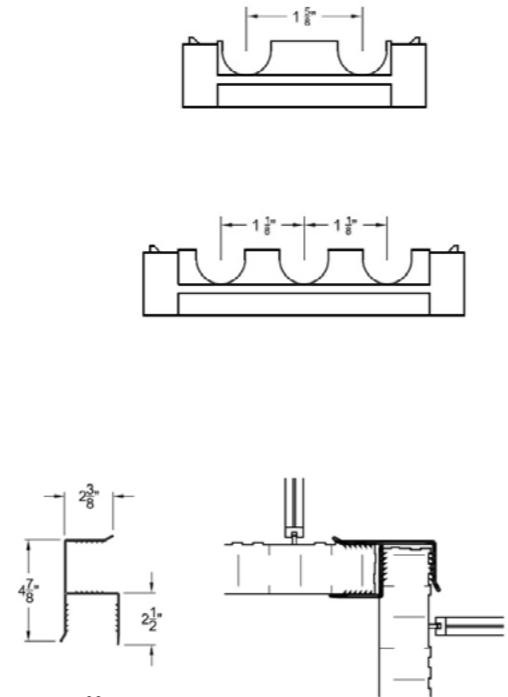
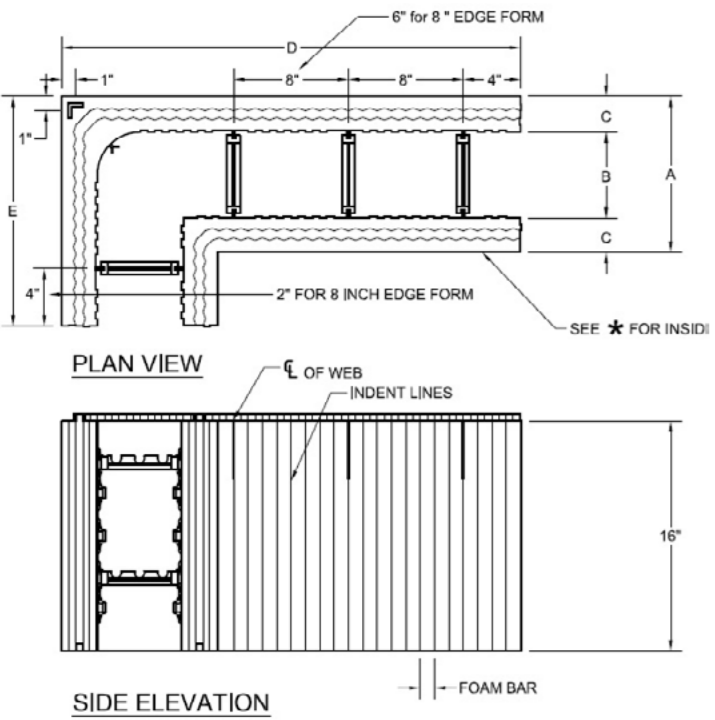
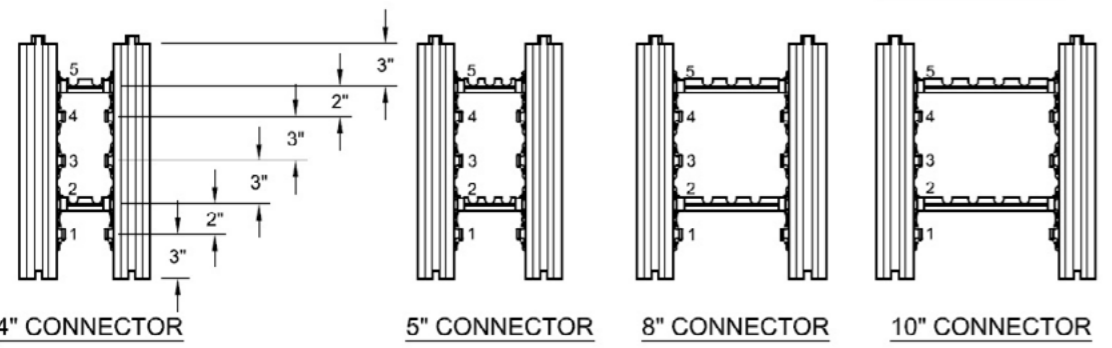
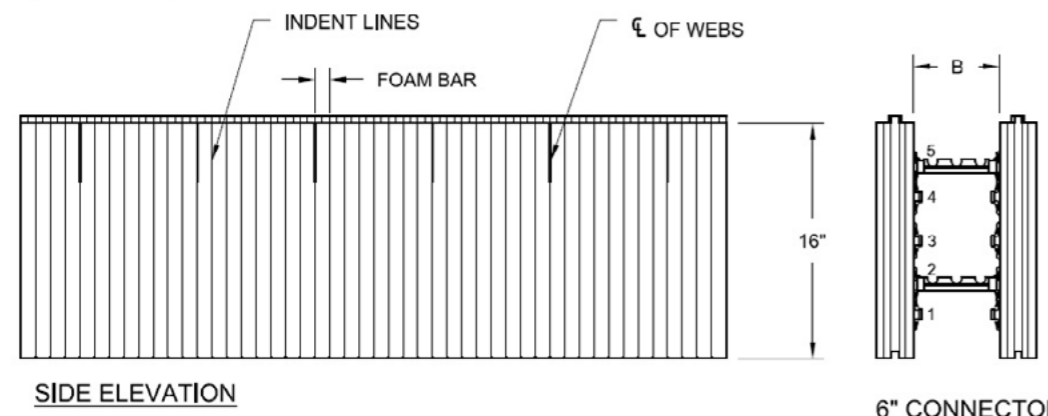
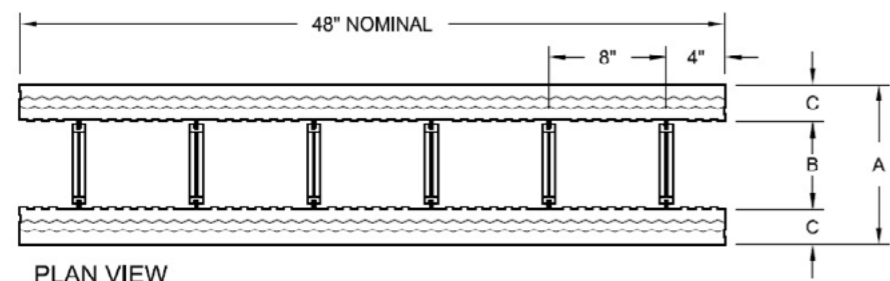

Alignment

An alignment system should be used to help with the construction of ARXX ICF walls and to provide an adjustable device for ensuring the walls are plumb and straight.

An alignment also provides structural bracing for the wall and acts as a scaffolding system for the placement of forms and concrete.

Bracing and alignment systems are designed to efficiently align the wall prior to and directly after placing the concrete. Along with the use of a string line and a level, an alignment system provides fine adjustment to ensure walls are plumb and straight.

The alignment system is normally erected after the third or fourth courses of forms have been installed. The alignment system is typically installed on the inside face of the wall, however it may be installed on either side of the wall when required.²²

Reinforcement

The unique design of ARXX ICFs allows for easy rebar placement from the most basic rebar schedules to complex reinforcement to provide for resistance to seismic events and high winds.

The concrete that makes up the framework of an ARXX structure is recognized as having tremendous compressive strength.

The purpose for steel reinforcement in concrete is to provide tensile strength to the concrete wall. This serves two functions: control of cracks (due to stress caused by temperature or shrinkage) and control of deflection of the wall (due to loads imposed on the concrete caused by backfill, wind, etc.)

Placement of reinforcements must be in accordance with the local standards, regulations, or code. In the United States, the placement and design of reinforcing steel must be in conformance with ACI 318, or ACI 332, or the latest International Residence Code (IRC). In Canada, the placement of reinforcing steel must conform to CSA A23.1; design requirements must be in accordance with CSA A23.3 and the National Building Code of Canada (NBCC).²²

Concrete

Concrete is poured into the wall with the use of a concrete pump or crane and bucket. Internal vibration is used to consolidate the concrete. Most ready-mix concrete plants have developed an ICF mix suitable for ARXX projects.

With ARXX ICFs, concrete can be placed during cold winter months extending the building season in certain regions. As the concrete cures it generates heat, which is retained within the form, eliminating the need for heating or chemical additives to prevent freezing.

ARXX ICFs can also provide better quality concrete in warmer climates. Conventional concrete forming systems are removed as soon as possible, leaving the wall to lose its moisture when exposed, rather than a wall left in a moist curing environment such as inside an ARXX ICF system, which yields a 25% stronger, more durable concrete than conventionally formed walls.

ARXX ICF walls develop a high strength early in the curing process, and they are known to exceed the expected design strength over 28 days.²²

Fig 94: illustrations of the panel, connectors and anchors²²

Services

Electrical, plumbing and mechanical chases are easily cut with ARXX ICFs. The EPS foam can be cut with a hot knife or chainsaw post concrete pour.

Electrical fixture boxes can then be secured to the exposed webs of the ARXX form or directly to the concrete. After concrete has been placed, pipe chases can be cut into the foam to permit running small diameter pipes up to 1.5" diameter beneath the wall finish material. Standard Romex type wire can be tucked into the chase cuts easily, and it will stay in place under friction fit. Either metal or plastic electrical outlet boxes can be used with ARXX forms. Electrical panels can be installed either by face mount or by recessed mount.

Once the concrete is in place, the webs of the ARXX forms may be cut to allow horizontal services. The HVAC system (which can be scaled down due to the high energy efficiency of the ARXX wall assembly) is also installed at this stage.²²

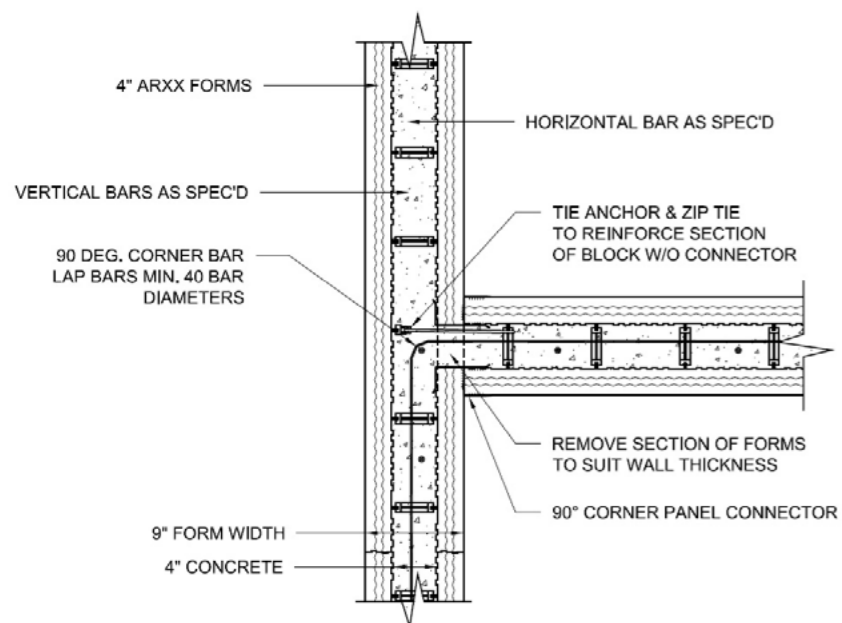
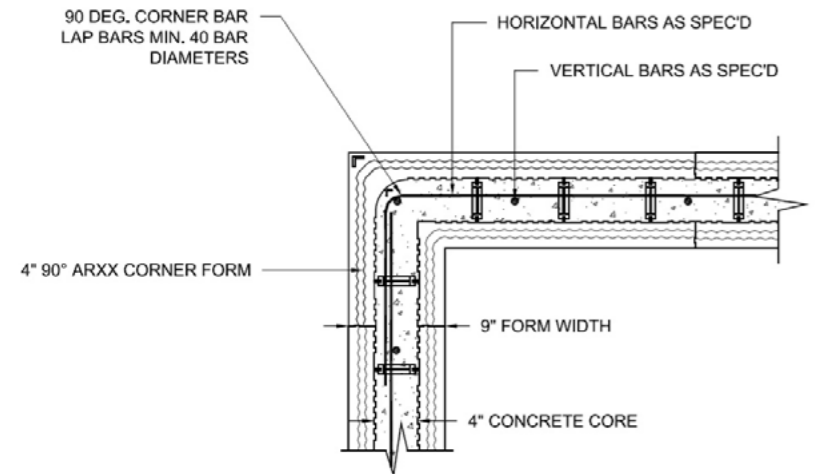
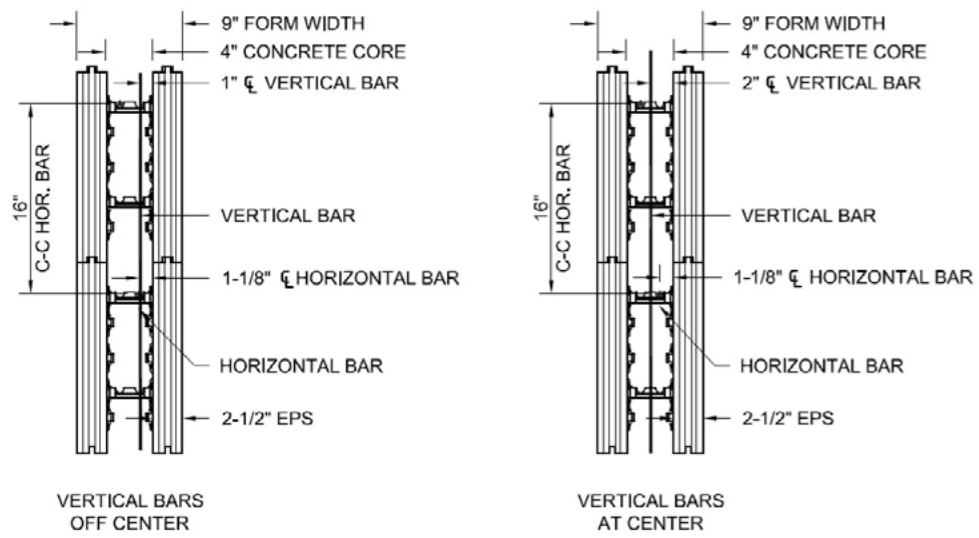

Fig 95: illustrations of the construction details in section and plan²²

Nominal thickness	E100/543	E150/543	E175/543	E214/543	E240/543*	E300/543
Nominal length x height in mm	997 x 543	997 x 543	997 x 543	997 x 543	997 x 543	997 x 543
Working length x height in mm	1000 x 545	1000 x 545	1000 x 545	1000 x 545	1000 x 545	1000 x 545
Working thickness in mm	100	150	175	214	240	300
Number per m ²	1.85	1.85	1.85	1.85	1.85	1.85
Maximum dimensional tolerance	1	1	1	1	1	1
Weight per element in kg	84.74	142.11	165.79	202.74	227.37	284.22
Normalized mean compressive strength f_b in N/mm ²	≥25	≥25	≥25	≥25	≥25	≥25

* On request

Nominal thickness	E100/643	E150/643	E175/643	E214/643	E240/643*	E300/643
Nominal length x height in mm	997 x 643	997 x 643	997 x 643	997 x 643	997 x 643	997 x 643
Working length x height in mm	1000 x 645	1000 x 645	1000 x 645	1000 x 645	1000 x 645	1000 x 645
Working thickness in mm	100	150	175	214	240	300
Number per m ²	1.56	1.56	1.56	1.56	1.56	1.56
Maximum dimensional tolerance	1	1	1	1	1	1
Weight per element in kg	112.19	168.28	196.33	240.08	269.25	336.56
Normalized mean compressive strength f_b in N/mm ²	≥25	≥25	≥25	≥25	≥25	≥25

Remark:
The SILKA elements are not suitable for application in the external leaf of a cavity wall and are also not intended for facework masonry application.

* On request

Fig 96: Overview of SILKA calcium silicate elements²⁴Fig 97: mechanical lifting and placing of a panel²⁴

Introduction

These are large format masonry blocks developed mainly for quick construction. SILKA blocks and elements consist mainly of sand (93 %) the remaining component being lime (7 %). This sand is usually extracted quite close to the production facilities. After extraction, redesign and development of the quarried area is undertaken.²³

Production process

The modern production process starts with the fully automated measuring and mixing of quicklime, sand and water. This mixture is placed in a reactor, where the quicklime is turned into slaked lime within a few hours. This mixture - now called 'mortar' - is transported to the press, where it is processed into 'unfired brick', which is then placed in an autoclave for hardening. This is done by means of steam under high pressure, to obtain the end product. The 'SILKA block' made in this manner does not have any of the qualities of the original raw materials of sand and quicklime, but consists of grains of sand that have been bonded together through calcium silicate hydrate bonds²³

Sizes

The elements come in various thicknesses with a working length of 1000 mm and in heights of 545 mm and 645 mm. SILKA is a lime-sand product, with a very smooth finish, capable of delivering significant onsite time and money savings upon completion.

Clamping devices and dowels

At the top end of each SILKA-element there are 2 holes, every 500 mm, for mechanical lifting and for dowel placement. Dowels:

In the system, dowels are used for simplifying the exact placement of the SILKA elements and to prevent them from 'floating'. The dowels are manufactured from recyclable synthetic material (polypropylene); the blue colour is obtained by adding a cadmium-free colouring agent. A maximum of 1,85 dowels (1 per whole element) is needed per m².²³

Construction methods

SILKA walls are composed of standard elements and cut-to-size blocks in accordance with the previously approved wall drawings. The kicker course consists of smaller calcium silicate blocks (standard heights 70, 85, 100, 115, 130, 145 and 160 mm). This allows wall parts to be supplied as semi-prefabricated packages.

Walls are constructed using

- a crane and useful tools (lump hammer, cold chisel, etc.)
- "thin joint mortar" of traditional composition. With this building method, even smooth walls can be obtained, which are extremely well suited to finishing with:
- a thin layer of plaster
- tiling straight onto the surface.



Fig 100: smaller panel²⁴



Fig 101: shoring²⁴



Fig 99: Partially built walls²⁴



Fig 102: view of unfinished SILKA wall²⁴

Sequence of operation

- adjust the necessary corner uprights;
- kicker course construction;
- setting up the crane;
- mixing the thin joint mortar;
- erecting the wall;
- removing excess mortar and repairing any wall damage with an appropriate filler;
- shoring the walls.

Profile adjustment

Corner uprights are set the same as for laying traditional bricks; the adjusting slats should not interfere with the crane.

Kicker course construction

The kicker course is constructed using SILKA kicker course blocks, specially designed for this purpose as they are completely flat, level and easily adjustable by means of a line, in a general purpose mortar. The vertical joints are filled with thin joint mortar. The kicker course construction should be completely set before placement of the SILKA elements can begin²³

Erecting walls

With a squad consisting of two persons, SILKA calcium silicate elements can be laid mechanically. One person operates the crane, picking up strategically placed elements and bringing them to the wall under construction. The second person sees to the application of thin joint mortar to all joints and ensures that the elements are correctly placed. The application of thin joint mortar must take place with the aid of the mortar applicator; the slide of this applicator must be set to size disposing only of a 2 mm mortar bed. The mortar for the vertical joint is applied with the help of a scoop, from the bottom to the top, on the already adjusted SILKA elements. For elements with a thickness of 300 mm, it is recommended that the mortar is applied by the person operating the crane before he cranes the next block to the wall. If necessary, the placement of the elements could be tightened up with the use of a heavy rubber hammer to close the vertical joint. Excess mortar must be removed with a spack knife after it has slightly hardened.²³

Scaffold work and shoring

The SILKA walls can immediately be erected to the full height of the wall. Depending on weather conditions and the thickness of the walls, it may be necessary to shore walls. The regulations set by health and safety directives must always be adhered with regard to shoring walls as well as scaffolding work. During and after construction, the walls must be prevented from falling down. Walls falling over or sliding down could be caused by wind load (pressure or suction) or because of impact load, which could take place during, for example, assembly of floor slabs. Calculations by 'TGB Steenconstructies en proefnemingen' (according to European Standard) have shown that a wall with a height of up to 2.70 m and a thickness of up to 214 mm should be supported and properly shored every 5.00 m until the floor on top of the walls (or roof construction respectively) has been placed.²³

As mentioned in the beginning of the chapter, several other systems were also studied along with ones given in this report, but I documented only 4 of them, which I thought had most of the information I wanted and which were similar to other systems as well.

Some of the conclusions which can be drawn from this literature study are:

1. Both Panel system and Component based systems have their own merits.
2. Design of Prefabrication starts from detailing and ends with with design most often than often. It goes in a reverse direction to the architectural philosophy, but finally merges at some point.
3. Design for totally manual lifting can be a futile effort of unnecessarily making labourers lift weight, which mechanisation can allow them to perform the task better without the load on them. Unless very light weight materials like EPS is used, the size of the panel/ component is very restricted if manual lifting is a criteria.
4. The design for joinery, connection and assembly are critical in a prefabricated system. Most of them the the joints do have a minor problem, however much it is solved in theory.
5. It is indeed a wise choice to explore the possibility of combining the panel system and component system into one typological system..i.e a load bearing component system, like the calcium silicate blocks for example, for the design intent of low rise housing in India.
6. Design for lifting points become critical when I need a prefinished surface, which cannot have lifting hooks projecting from the surface.
7. Modularity and standardization helps develop the product / system in a co-ordinated way from the start itself. Standards are defined by the system. So there is already a basic rule for dimensioning, which ensures a certain architectural quality to the building from design to execution, when compared to Insitu works.
8. Temporary supports become necessary as the free standing prefab walls are erected till the floor slabs hold them together.

Design Goal

The design goal is to come up with a simple, efficient product with pre finished exterior surface, which can be assembled on site without extra-ordinary technical expertise to form a load bearing facade, using Flyash as a major influence in material properties.

Requirements

The design requirement is as follows:

1. A prefabricated load bearing facade element(s)

The element shall be an additive component (refer chapter 5.2). The design shall consider that the exterior surface is pre-finished. No/minimal sitework on exterior surface after assembly

2. Design for connection between elements during and after assembly.

The design shall take into consideration ease of assembly on site, feasibility of self alignment, minimal time delays due to site work during assembly. It shall also consider structural load transfer

3. Design of joints

The joint design shall consider water tightness, load transfer bearing areas.

4. Design for end conditions-

strategy for openings- spanning of elements over openings, jamb details

strategy at floor and wall connections, corners

5. Strategy for integration of sunshading elements into the system.

This is important from climatic perspective, as sunshading from outside are important in tropical countries. It is important to consider the means of integrating other architectural features like fins etc, from a different manufacturer into the system.

6. Building physical properties:

The wall section shall have a U value $< 1 \text{ W/m}^2\text{K}$. The material composition of wall shall investigate the possibility of maximum utility of fly-ash.

7. Strategy for production

In a not so industrialised country, it is important to have a simple production strategy to start with, until the establishment gets big enough to make it more sophisticated after considerable success of the product.

8. Design for lift of panels

The lifting strategy is important to be considered during the design of the product itself because, one is the product is expected to be prefinished, and cannot afford to have lifting hooks etc protruding from it after assembly;

9. Marketing strategy

It is important to have good strategies to marketing the product in order to force it into a conservative market, which inherently doesn't perceive the demand and potential of it.

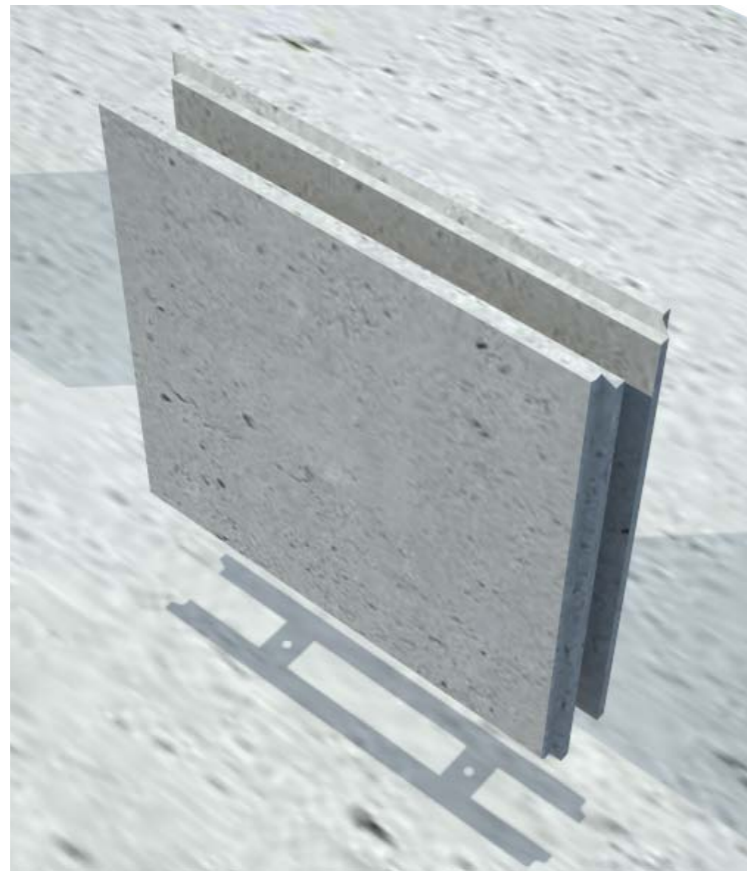

Given/ programme

1. Target group- middle class and upper middle class of Urban and semi-urban India- this target group is a personal choice, as mentioned in chapter 3.3
2. Low rise housing- 4 storeys typically.- the demand for which has been established in chapter 2.5
3. Floor to floor height= 3m is a generic practice in India, no data available to prove the standards.
4. Span between load bearing facades 4.5m, due to the linear configuration suited for warm-humid climate.
5. Floor load (dead load + live load)= 7kN/m² as per national building code of India
6. Wind load= 0.6kN/m² as per national building code of India
7. Generic cill height for walls= 0.75m
There is no reference for this. This is generally accepted to be a good cill height in most parts of India, and is practiced at large.
8. Generic lintel height= 2.1m
This also has no reference as such. It is generally accepted in residences to have lintel at 2.1m, due to anthropological requirements.

What we see is that, although this chapter is divided into a lot of sub-chapters, sequentially, all the subchapters are interlinked, the whole process is iterative, so the product development happens back and forth to arrive at a conclusion. The chapter is closely linked with the next chapter on 'construction research' also. I have tried my best to explain the process sequentially, but it might happen that some aspects still need to be read back and forth, because it is iterative.

Wall section

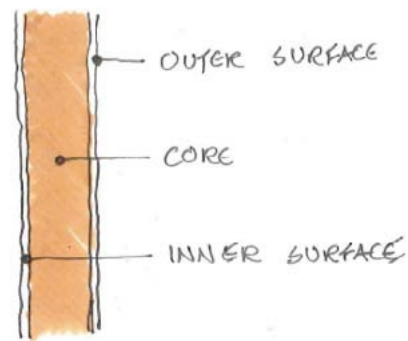

Fig 103: Basic wall section

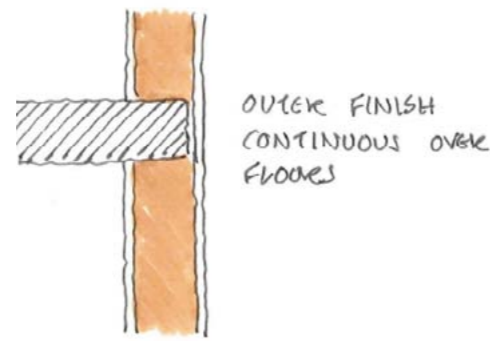

Fig 104: Design requirement

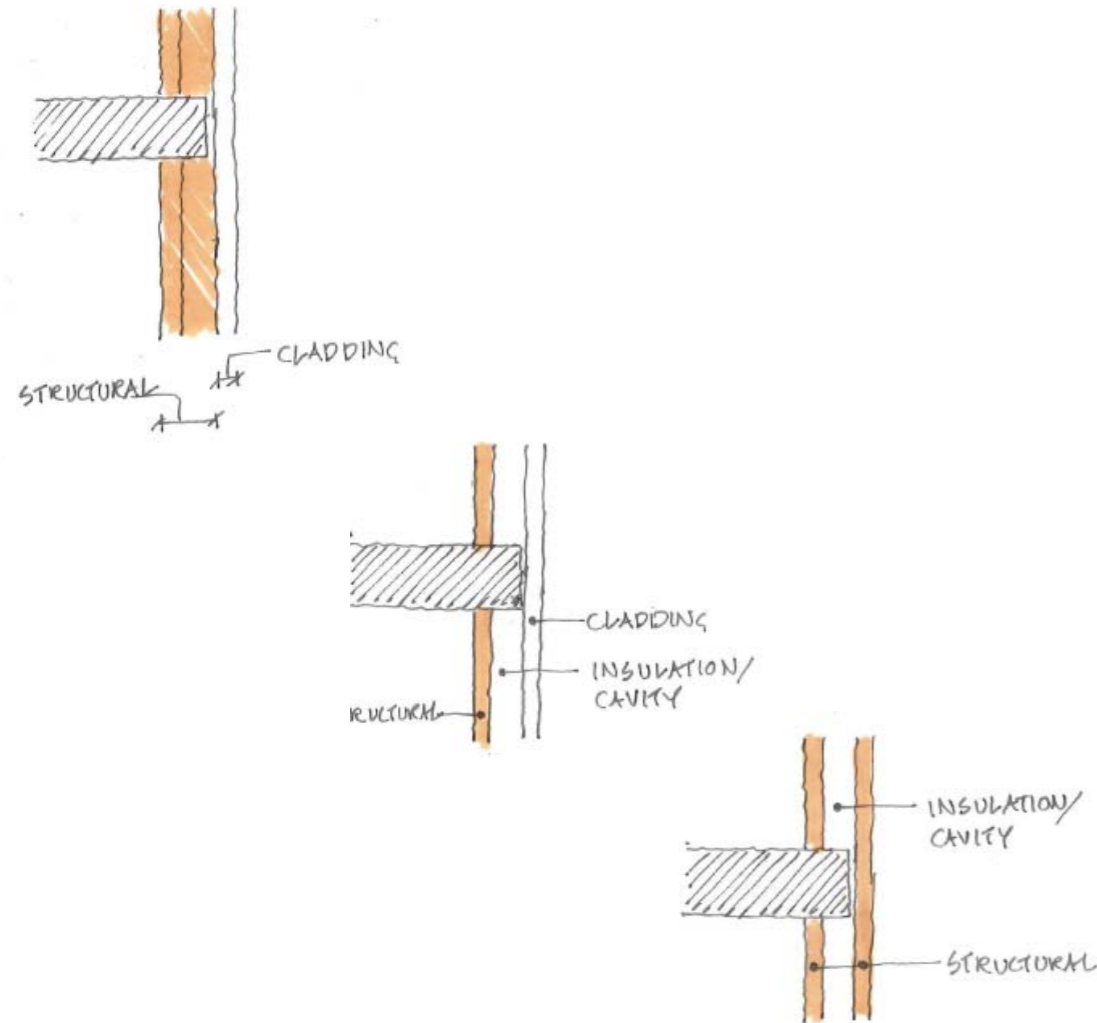

Fig 105: 3 ways of looking at a wall section

The idea of using flyash concrete for the load bearing facade has opened up a new question altogether- What are the different ways of looking at the cross section of the wall itself, before breaking it down into transportable components?

One way is to look at the whole width of the wall section being one of fly ash concrete (could be 100% flyash as well). This is the simplest way of looking at it. It is the most sustainable approach in terms of the use of flyash, but when it comes to breaking the wall into components of smaller size and insulation requirements, this does yield the best possibility. For one, when the whole wall width is consistent, the 'broken-up' components need some additional connectivity when assembled together, which is not provisory within the width of the wall. So the blocks need mortar or glue to hold them together. Second disadvantage is, the component, is unnecessarily over-designed, because the entire width is not needed for axial and bending loads, but is needed only for a limiting slenderness ratio. This problem of weight could be overcome by aerating the product. But aeration has its own limitation in terms of the structural strength possible. In view of these two disadvantages, we should design the wall section more efficiently.

The idea of making the product prefinished, clearly distinguishes 3 different sections of the wall thickness- exterior surface, the core, interior surface. If it were just a product which will get cladded on later, it wouldn't have mattered. But the design goal gives it this distinction. So it would be a wiser to give a thickness to each of these sections within the wall width, and explore what options could be generated by them.

For convenience, let's call the outer thickness as exterior wythe, inner thickness as Interior wythe and the core as core. As seen in chapter 4, flyash being a structural material, it is best to maximum the potential of it. With the design requirement being that the exterior surface to be continuous over the floors (fig...), the wall section has 3 possibilities:

1. Interior wythe and core- load bearing, Exterior wythe- cladding

In this scenario, the inner wythe and core together form the load bearing section of the wall, and the outer layer is free to take up whatever finish and with a minimum thickness. It is a more rational way of looking at the wall, in terms of aesthetic value, but there are disadvantages to this system. The Load bearing part of the wall- inner wythe plus the core, cannot have aeration, due to requirement of minimum compressive strength. This leads to the product adding dead weight onto itself unnecessarily, adding to transportation cost, and added weight for lifting. Also since the core is structural, insulating properties are limited, unless an extra layer is added. Also the structural connections between the panels.

2. Interior wythe- load bearing, Core- free to be cavity of insulated, Exterior wythe- cladding

In this scenario, the problems of insulation and structural connection between the panels can be overcome, by using the 'non-load bearing' core. The inner wythe takes up all the stresses, allowing the core and outer wythe to be free. The core could be filled up by the aerated fly ash concrete, for insulation and structural connection between the panels. The disadvantage of this system,

however, is that the inner wythe has to have a minimum width to exceed the slenderness ratio. This results in an overall increase in the wall thickness, and hence the weight of panel in effect.

3. Interior wythe and exterior wythe- load bearing, Core- free to be cavity or insulation

In this scenario, the outer and inner layers are made to work together by using a composite action between them, using shear connectors. The load is distributed between the 2 layers and the core could be filled in with aerated fly ash concrete for insulation and connection between panels. The advantage of this system, is the we are using the potential of the structural properties of fly ash concrete to a maximum, by using composite action, and the width of the whole panel could be limited just enough for the slenderness ratio. Insulation and connections also seem feasible. So this option seems like the better of the 3 to be explored further.

Once the cross section idea is fixed, the next target is to break down the facade into smaller assemblable components. The purpose of doing this is two-fold

1. The road infrastructure in lot of regions in India, isnt convenient enough to transport floor height panels, as described in chapter two. Atleast one dimension of the panel has to be limited to 1.5m maximum for convenient transport to most of the regions.

2. The breaking down of the wall into smaller components gives the flexibility for an architect to adapt the wall dimensionally for different opening sizes etc. The smaller the size of the component the more th flexibility to adapt. But the smaller it is the more th joints, and more time to assemble defeating the purpose of prefabrication.

So what is the balance between flexibility and prefabrication? What is the dimensional range which can strike that balance? We shall discuss these issues in the next subchapter.

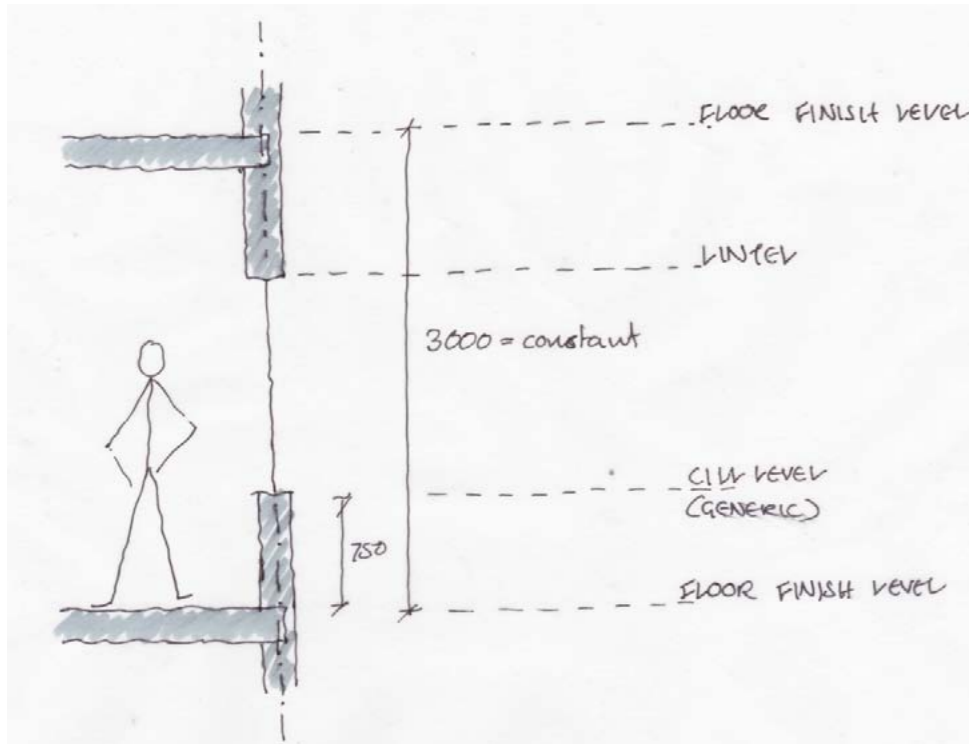

Fig 106: Sectional dimensions of a residential facade

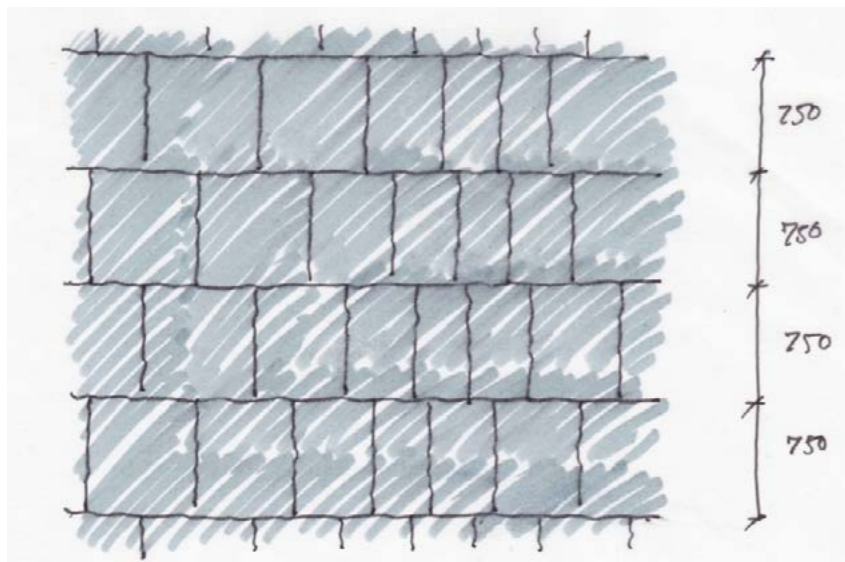

Fig 107: Varied stagger

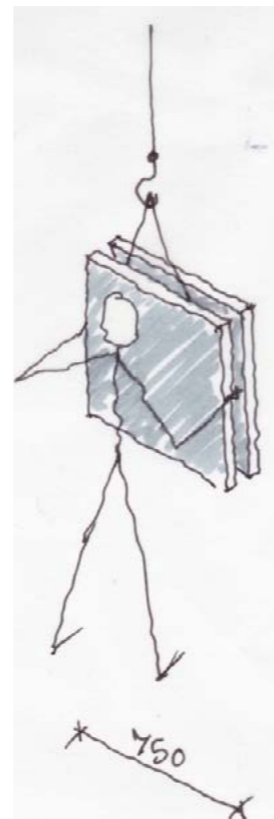

Fig 108: The maximum ergonomic width

As described in the previous sub-chapter, it is important to strike a balance between modular flexibility and and prefabrication.

As mentioned in chapter 2 and 5, although 100mm is a the basic module accepted internationally and in India, in practice 150 is more often seen being used. Most building components like doors, windows cill heights etc are sized as multiples of 150mm. This probably is because the British system is still prevalent in India, and 6" was a standard then, and is being carried forward today, converted into 150mm.

Vertical Breakdown:

As transporting a full storey height panel isnt practical in Indian scenario, the next option is to break it down into 2 parts in the vertical dimension. What does that lead to? Two panels of 1.5m high. Transportation- feasible. But the problem is at openings, it will lead to further change in dimension for a different panel size doe window positions and door positions. This contradicts the idea of standardisation.

The generic cill height in India is 0.75m. The floor to floor height is 3.0m. So, if we consider the cill height as a standard reference for breaking down the wall, it will give rise 4 panels of exactly 0.75m height each. The lintel may then have to be modifies to 2.25m instead of 2.10m, which is fair enough, if a certain standardisation in dimension is achieved. Three joints per floor, is still a compromise, but is much better than the conventional masonry. So for now lets assume the panels are of consistent height of 0.75m from the outside. This can provide flexibility in varying the horizontal width of the panel intead of flexibility bothways due to the limitations in a simple mould for casting, which shall be discussed in subsequent chapters.

Horizontal Breakdown:

The horizontal width of the panel also is be a multiple of 150mm. Lets check what could possibly limit the horizontal width of the 'standard' panel.

1. Panel weight: the simplest calculation shows that a panel of width even 0.3m of 40mm flange widths each, weighs 80 kg for fly-ash concrete. So it is not humane to expect workers to lift them in place manually, when case studies done on project sites demonstrate that an average labour worker can lift 14kg comfortably every 5 minutes (A Guide to Manual Handling published by Taylor and Francis, 1997). Hence we may conclude, some mechanisation is necessary in any case, so the limiting weight for manual lifting is not a wise governing factor here.

2. Handlable width for grip between two hands: Lets propose one worker shud be able to grip the panel while being mechanically helped while lifting and placing. Ergonomic studies have shown the grip width upto 750mm is comfortable for average male adults (according to NIOSH). This could be one governing factor to limit width of panels. One worker per panel could possibly result in labour efficiency on site, however, it needs to tested in real life. For this academic research, let us assume this is valid.

So now we have a standard panel of height 0.75m, and width of maximum 0.75m, but can be manufactured with 0.30, 0.45 and 0.60m widths as well, for various facade compositions as per architectural need for aesthetics.

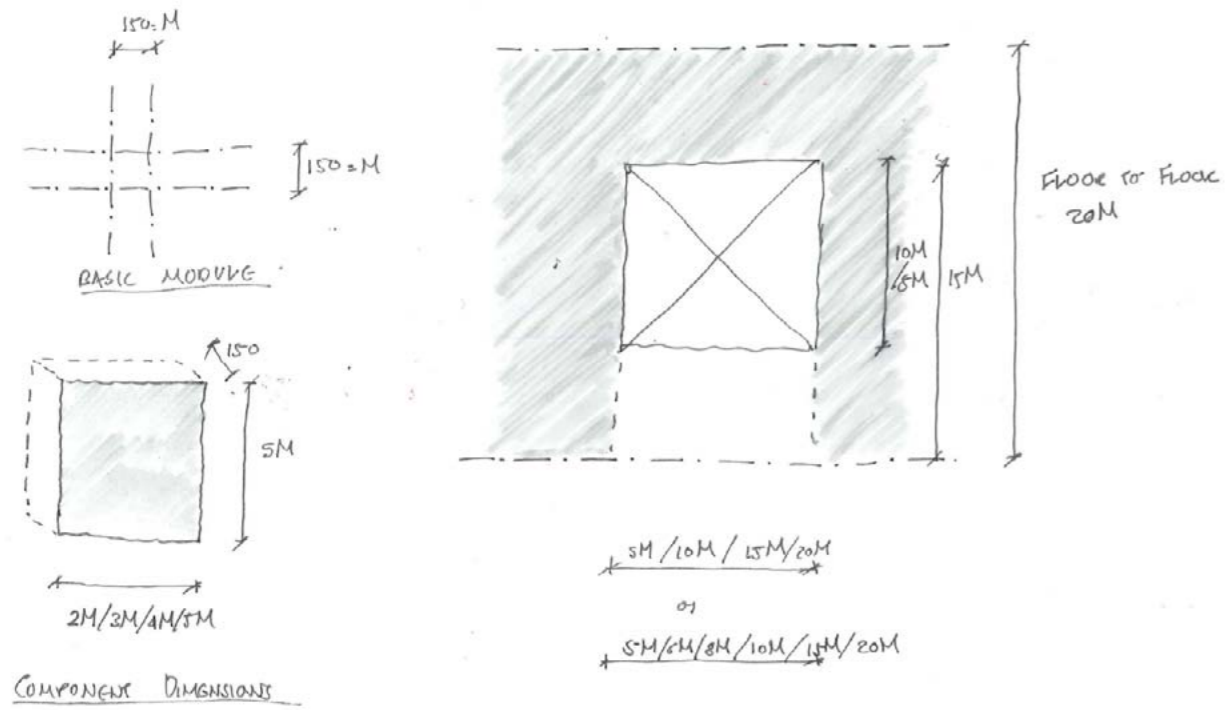

The component is 'additive' in nature (refer chapter 5.2). Atleast 4 elements stacked up are needed to perform the function of a wall.

So now lets define some basic modules from what we have. Lets consider 150mm as the basic module and call it 'M'.

For the component we have vertical dimension with 5M as the standard. For horizontal dimension as well we have 5M as the standard, with sizes possible with 2M, 3M, 4M also.

The vertical storey height is generic and shall be 20M. The room dimensions shall be a minimum of 15M and be 20M, 25M and so forth (although initially architects would expect more flexibility to market the product).

The opening sizes (clearance from only the proposed product) vertically shall be 5M, 10M or 15M. Horizontal widths of the openings shall be 5M, 6M, 8M, 10M, 15M, 20M.

Fig 109: Basic modular co-ordination

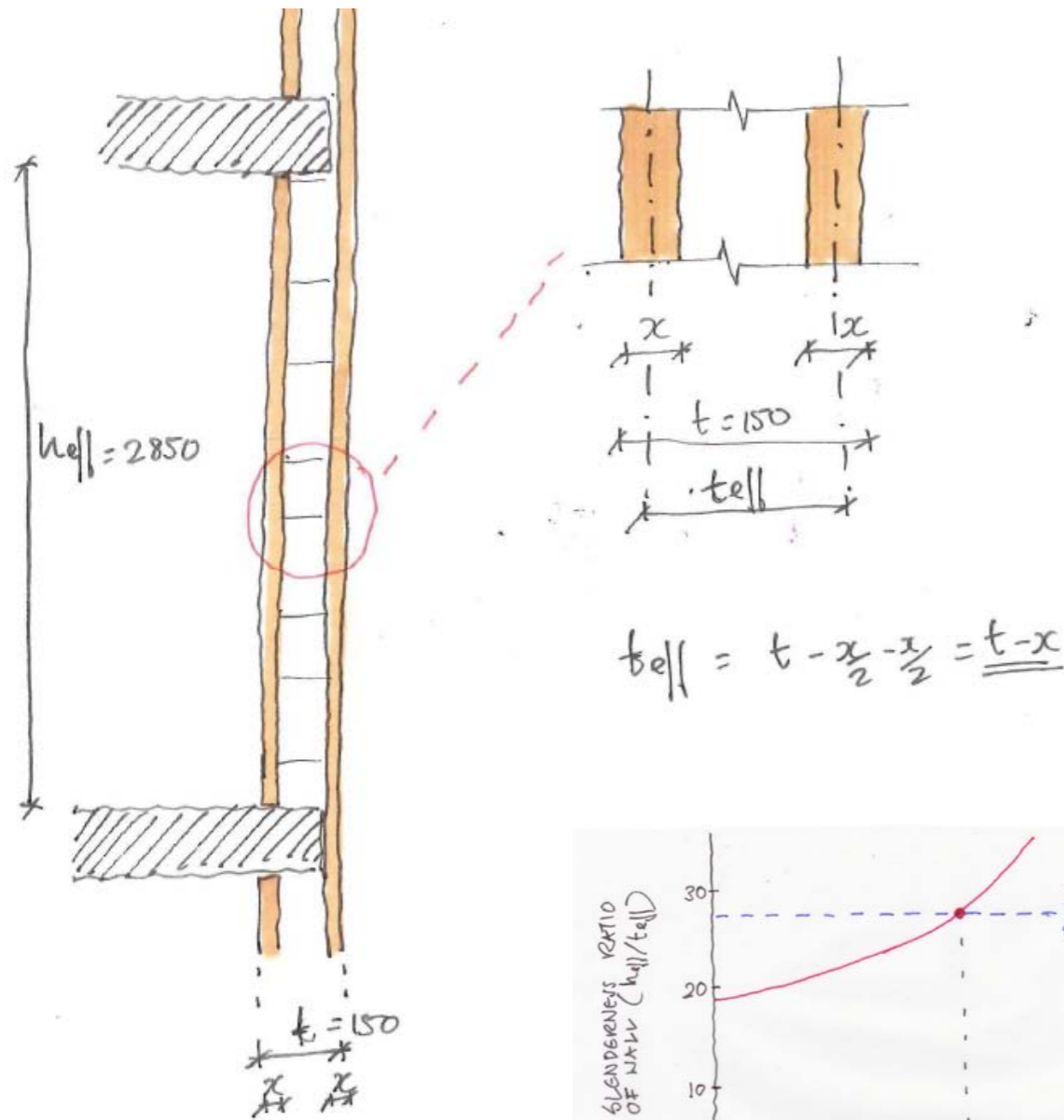

Fig 110: structural width

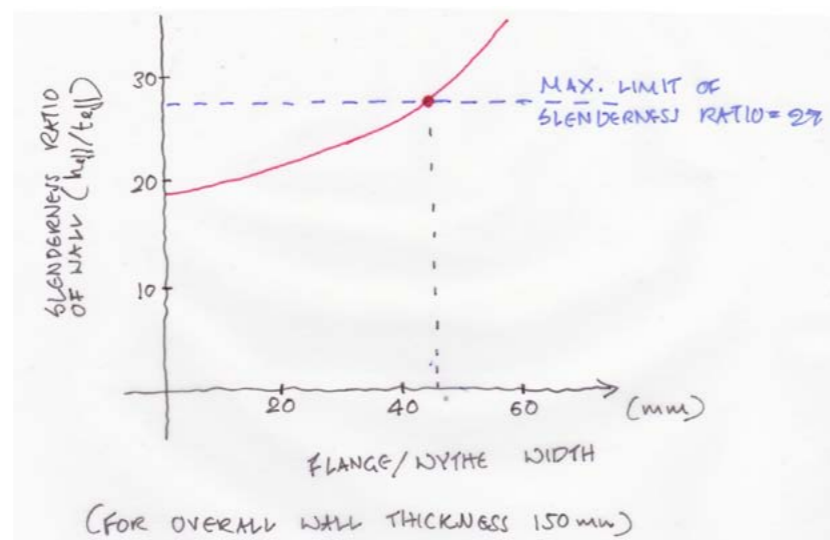

Fig 111: graph illustrating the variation in slenderness ratio with increasing flange width (FOR OVERALL WALL THICKNESS 150 mm)

As already decided, the wall section is broken into external wythe, internal wythe and the core.

Since one of the design goal is speed of execution, it is important to ensure that delay in construction due to insitu works is reduced to a minimum. Thus it is better to design the panels to take up axial load totally, allowing the flyash infill to perform the task of just providing connection between elements, a water proof membrane and give insulating properties to the wall.

Assuming the modular width of 150mm for the overall width of the wall, simple calculations for imposed loads indicate that a thickness of 40mm is sufficient for each wythe (see appendix 4). It is interesting to note that the effective width of the wall will become unsuitable for an unconstrained height of 2850, if the flange width is increased to 50mm, as the slenderness ratio goes beyond the permissible value of 27. The calculations are made assuming complete composite action.

The width of 40mm is slightly over designed for the imposed loads, for practicality in terms workability for getting edges, and avoiding local bowing, it is better to leave it at 40mm for now.

So we have 2 wythes of 40mm. A maximum standard panel size of 750 x 750. Lets propose a 50% flyash blended concrete to start with for the element. It has a density of 2150 kg/m³. So the weight of the standard panel would be around 97kg (excluding shear connections). See appendix 4 for calculations.

Now the next check would be to verify the stability of each panel when placed over the other, before the connection through cavity infill. As per calculations (see appendix 4), the dry stacking without any connection can resist upto a udl of 70N per metre width at any level. So temporary supports maybe needed at top before grouting.

As discussed earlier it is important to come up with a system with a certain level of type standardisation for the product. So assuming a standard panel of 750mm height (the widths could be all 750 or could be 300,450 and 600 even), first 3 layers of the stack are all 750, where as the top layer will have inner wythe 600 high to accomodate the floor system.

As seen on the left the the shear connectors can be designed as 1 way or 2 way. 2 way might be over designed a bit, but it allows the flexibility of rotating the panel 90 degrees while assembling. This might give added advantage to the architectural ideas.

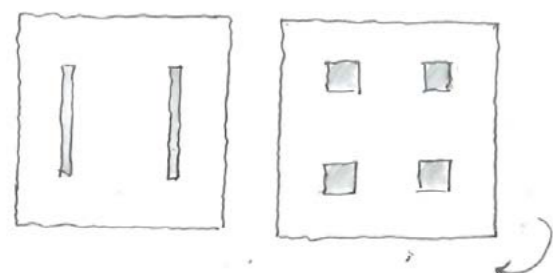

Fig 112: one-way and two-way shear connections

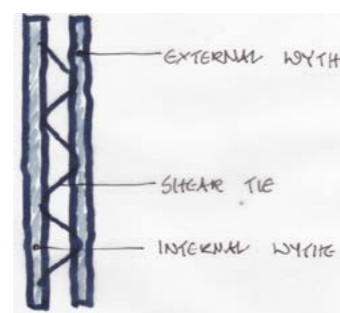

Fig 113: metal shear connection

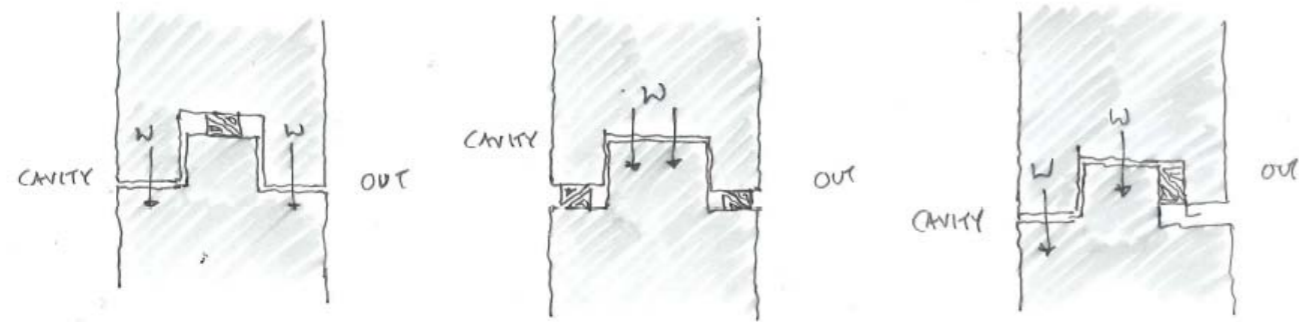
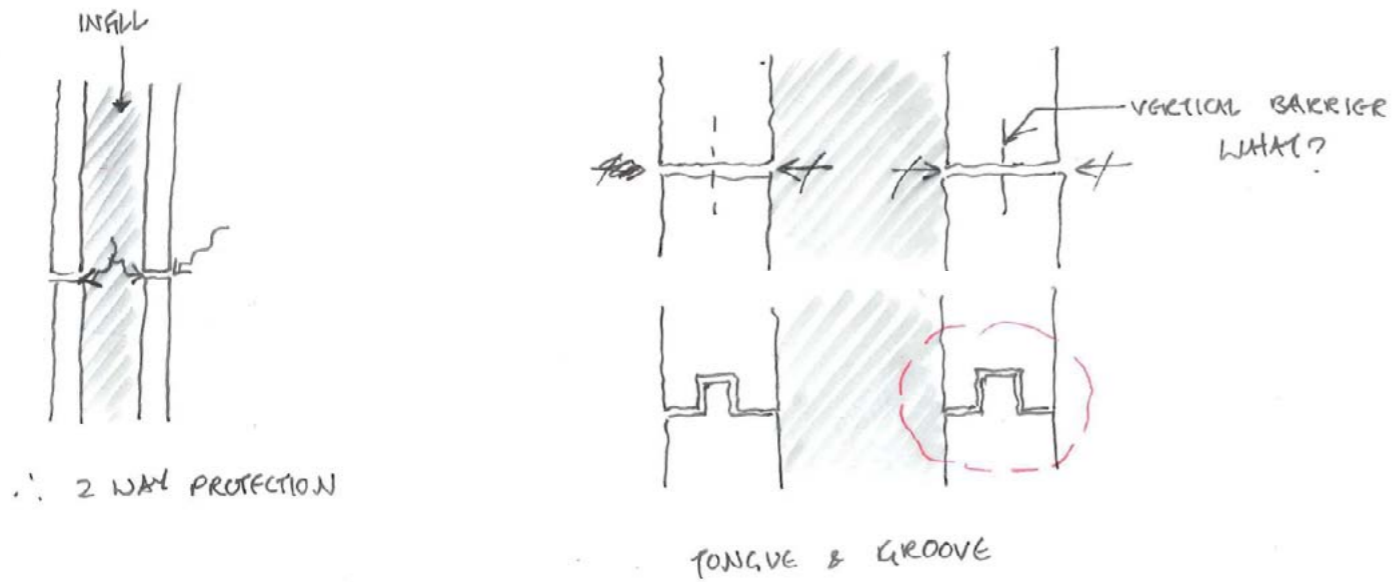

Fig 114: two way protection, tongue and groove joint

2 TIME FRAMES OF JOINT PROTECTION

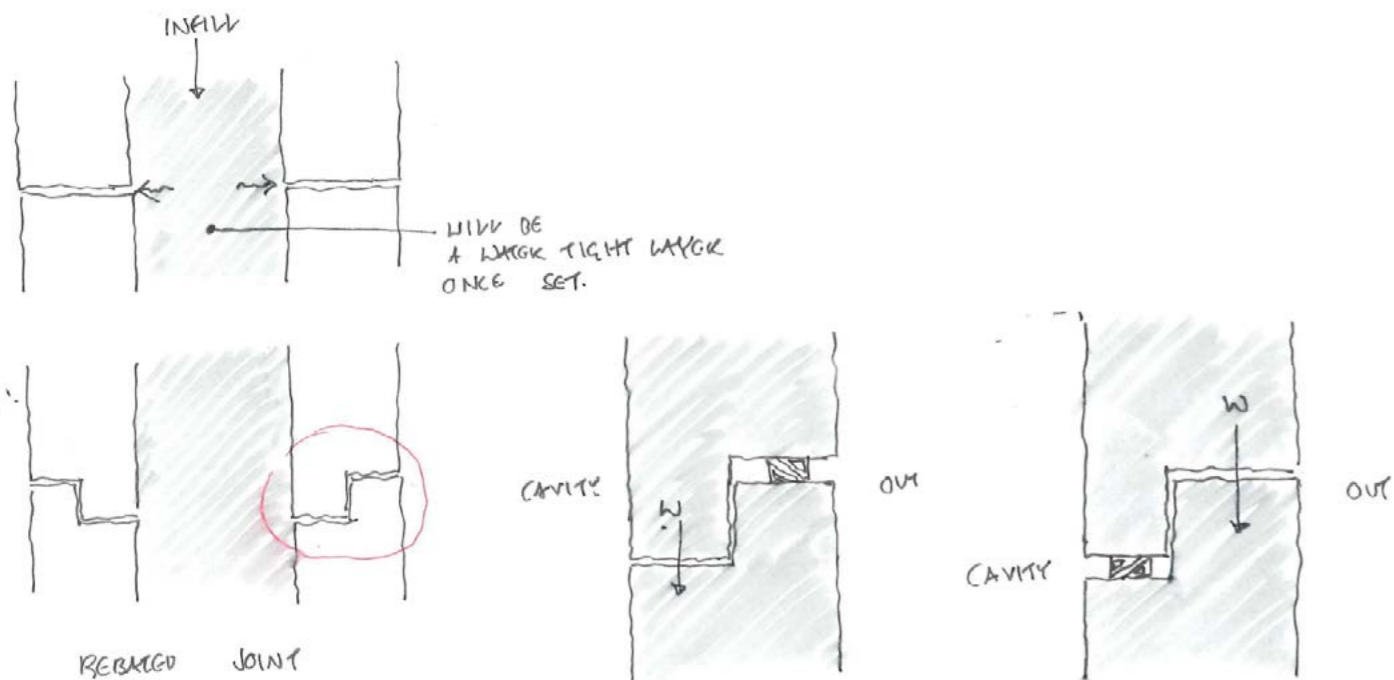

Fig 115: two stage one way protection, rebated joint

Joints serve 3 purposes in general:

1. Water and air seal lines
2. The need to accommodate the bearing surface for load transfer between elements, in case of load bearing element like how it is here.
3. Provision of tolerance- usually more important in case of high rises and cladding panels.

Since it is an attempt to develop a dry construction system to assemble (i.e without mortar) and then grout the cavity, it is important to develop a joint system which is impervious to water penetration from outside, as well as the flyash concrete poured into the cavity.

Tongue and groove joint

The idea of water tightness from both sides gives rise to thought of having a tongue and groove kind of joint system. In this system the edge of panel needs to be divided into the part which transfers the load, and part which has the flexible rubber/ foam strip for water tight layer.

Two ways of looking at it again.

1. Load is transferred along the surfaces of the side edges, and the tongue forms the base for weather proof rubber/ foam
2. Load is transferred through the surface of the tongue and the side edges are free to take up the weather seal. Alternatively one of the sides could also be used along with the tongue for the load transfer, leaving only one side edge free to take up the weather seal.

Both the typologies are illustrated in the figures on the left.

The disadvantages with this type of joint for the product is,

1. The multiple rebates need to make a tongue and groove, necessitates that the wythe of the product cannot be less than a particular width, so that the edges can remain undamaged while deshuttering, transport and erection. This could compromise of the structural optimisation of the product.
2. Experiments with models indicate that tongue and groove for a panel of single wythe is easier to assemble, but with the product having 2 wythes, a minor error in manufacture, or post manufacture deflection, would make the product difficult to assemble, due to minor variations in mm. The tolerance for fitting the tongue into the groove needs to be higher than what is needed for a panel of single wythe, which is a compromise on having this type of penetration joint itself.

Rebated joint

On second thoughts of the product and system of construction, it might be worthwhile to note that the aerated flyash concrete once poured into the cavity of the wall and set, forms an impervious layer to water penetration from outside. This means that the primary purpose of the joints of the product, would be then to prevent the flyash concrete being poured inside the cavity from leaking out. Once this is done the production from outside is already taken care of by the layer in the cavity.

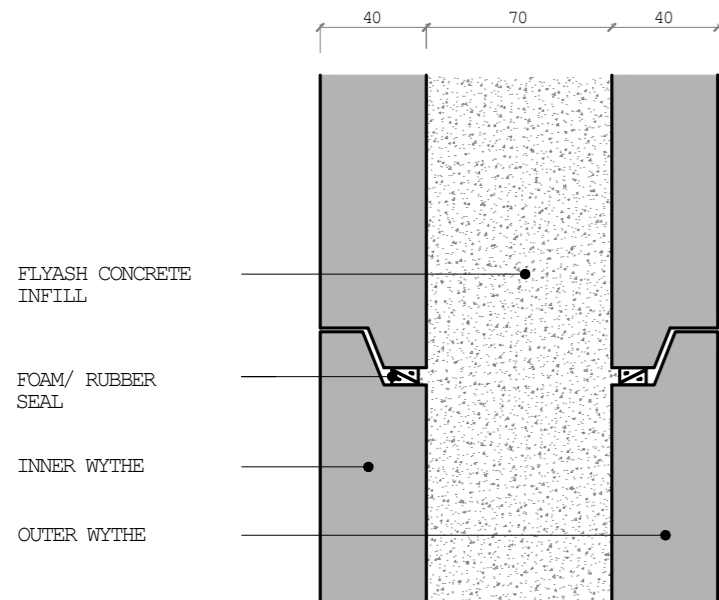

Fig 116: the final proposal of joint

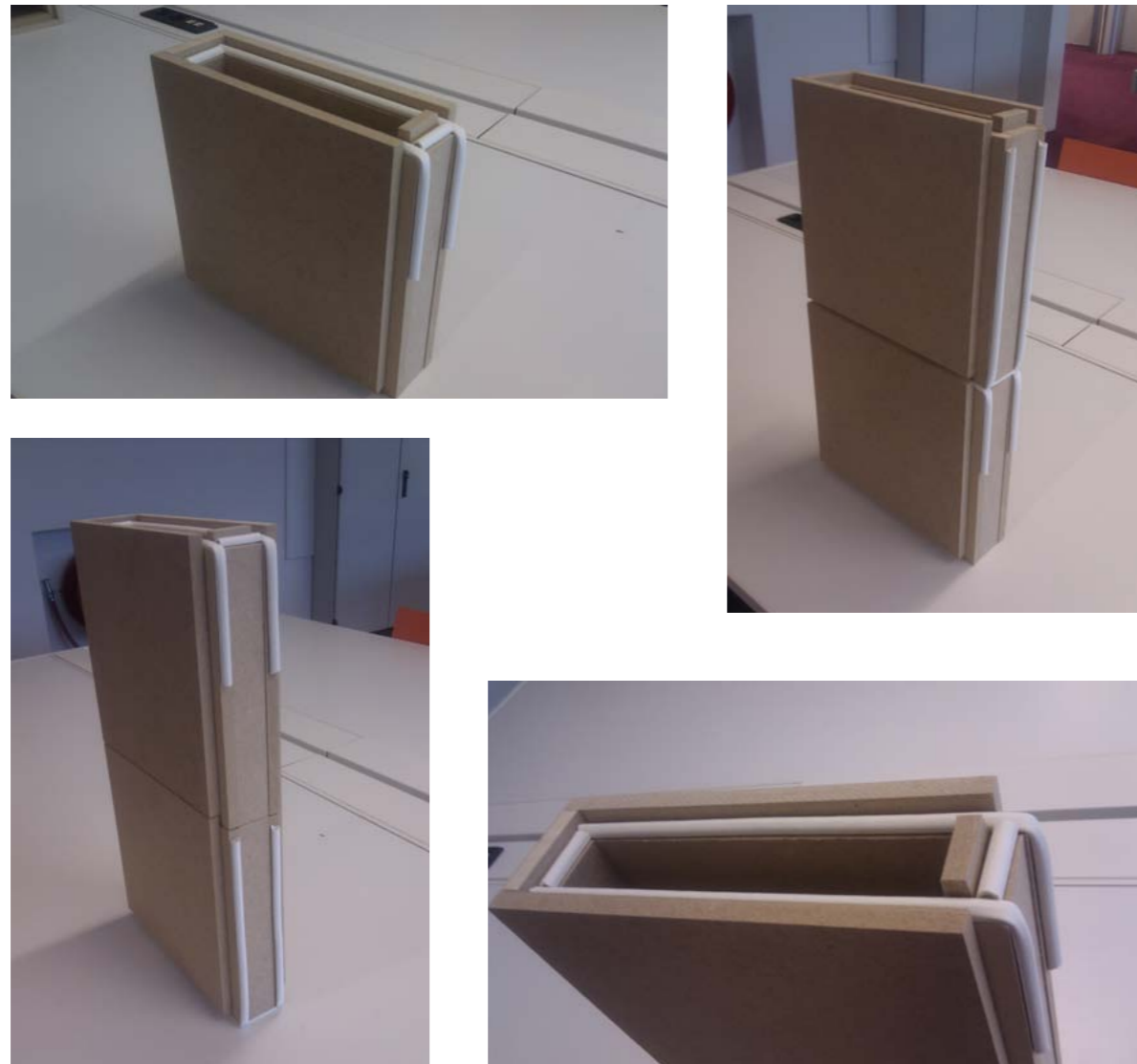

Fig 117-120: test of seal, wooden model

Hence a rebated joint profiled as shown in the figure, might just do the trick. One edge of the rebate could be used for load transfer and the other for holding the weather seal. This type of joint system gives more options for connections between panels in various scenarios of end conditions of panels, with lesser type of panels. Also it overcomes the disadvantages of the tongue and groove system, as there are lesser edges. These advantages shall be illustrated in the next sub-chapter where we get into details.

Seals

Various profiled EPDM rubber and foam gaskets are available in the market. A profiled hollow rubber/ foam gasket may be glued to the edge of each of the panels before hand- either in factory or on site, before assembly. Thus when the panels are assembled together the rubber/ foam from each panel compresses the one on the other to form a water tight joint.

Of course, there are problems with this system, as envisaged, and also what the wooden prototype of a 1:2 sample (picture on the left) demonstrated. They become discontinuous at the corner of each panel with respect to another panel. Also for the prototype, I didnt calculate the thickness required to compress the foam, and it turned out that the weight of the wood was insufficient to compress the foam fully anyway! However, in reality this problem wont happen , the thickness for compressed rubber, will be calculated and provided for within the dimensions of the product, and the weight of flyash concrete will be sufficient (hopefully) to compress the rubber/ foam fully.



Fig 121: interior render, wall panels, precast floor ribs, and floor panels

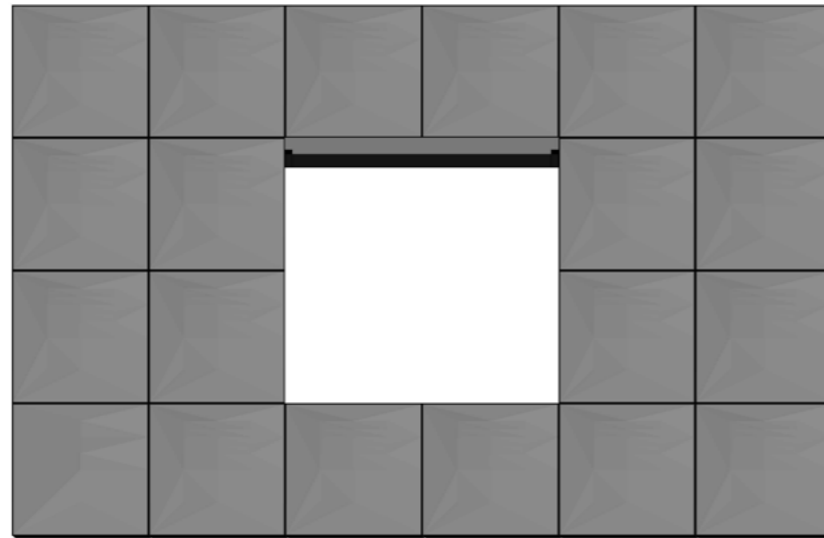

Fig 122: Elevation, Facade fragment

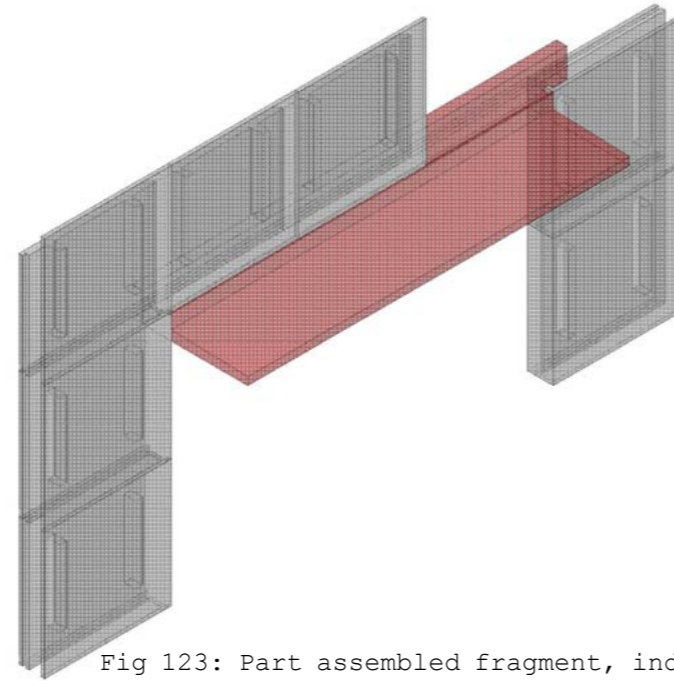

Fig 123: Part assembled fragment, indicating the lintel element

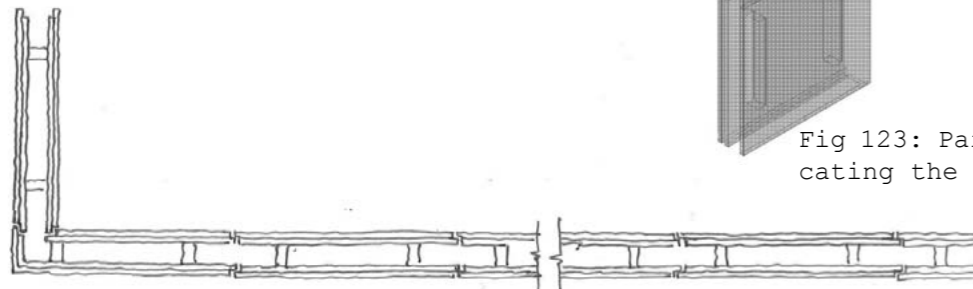

Fig 124: Plan at 2.4m above floor level

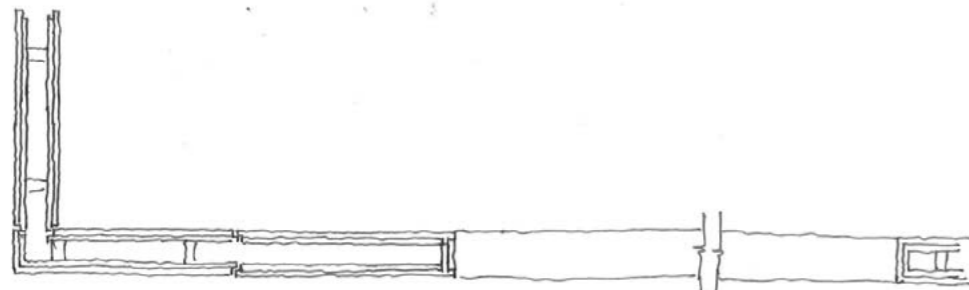

Fig 125: Plan at 1.0m above floor level

Floor Connections

Residential facades, for a middle class housing gives rise to various end conditions. Floor connections, Lintel level, cill level, jambs, corners, are typical and most basic to be addressed in any system of construction first. Improvisations on angles, fins, cantilevers, will add value to the product later on. But the basics need to be addressed first.

The floor systems (although I wanted to design them as well initially, but proved to be beyond the scope of this academic research within the time frame), reset on the inner wythe of the product, allowing the outer wythe to be continuous over the floor depth. The system, designed with a basic module of 150, allows the floor system of 150mm depth to be fit into the system. This thickness is allowed as per Indian Building Codes, as the Indian cultural system as mentioned earlier is to walk bare foot at home, so the structure borne noise is much lesser, doesn't necessitate a cavity.

The Floor system (here assumed to be ribbed flyash concrete panel system) basically rests over the inner wythe as a simply supported system, although later Flyash concrete filling might provide more rigidity to the system. Simply supported system is a sufficient assumption for a low rise residential structural calculations. The level differences have to be adjusted by means of shims provided over the inner wythe of the top facade panel. The decision on whether the system needs to be just simply supported or rigid shall be taken by the specific structural consultant of each project, according to the site conditions and the seismic zone.

The tolerances, as explained in the earlier chapter, maybe adjusted at every floor level by wedging, using plastic shims, as I assume the probabilistic variation in levels with just 4 vertical panels will not be more than 5-10 maximum, for industrially produced products. Alternatively, a turn buckle kind of thread system can be adopted for adjusting the levels at every floor, which is a little complicated for the overall simple assembling process, but can be very accurate if implemented as shown in figure on the next page.

Openings

The lintel level is a critical detail. The idea of using standard type products, at the same time allowing flexibility for architects to deal with openings, encourages a thought of having a concealed lintel in the cavity over which the standard wall panels can rest above. The openings, as mentioned in 6.3, are usually modular 5M, 10M etc. The lintel size is limited to 60mm width and 150mm depth, in order to be embedded with the clearances of the jamb panel and shear connector above. The sunshading element shall be cast along with the lintel as per architectural design (customised). This element shall be rested over the jamb panels. Temporary supports shall be provided under this lintel. The upper panels shall be assembled over this lintel. The flyash infill concrete, shall ensure that these panels and the lintel act together as beam by the shear connection between the top surface of the lintel and the infill concrete, to carry the floor load above. The tolerances for the opening are accommodated by provided a rebate in the jamb panels and the lintel, to allow for the precise aluminium/ upvc or whichever window to be set against it with lateral dimension adjustability while fixing

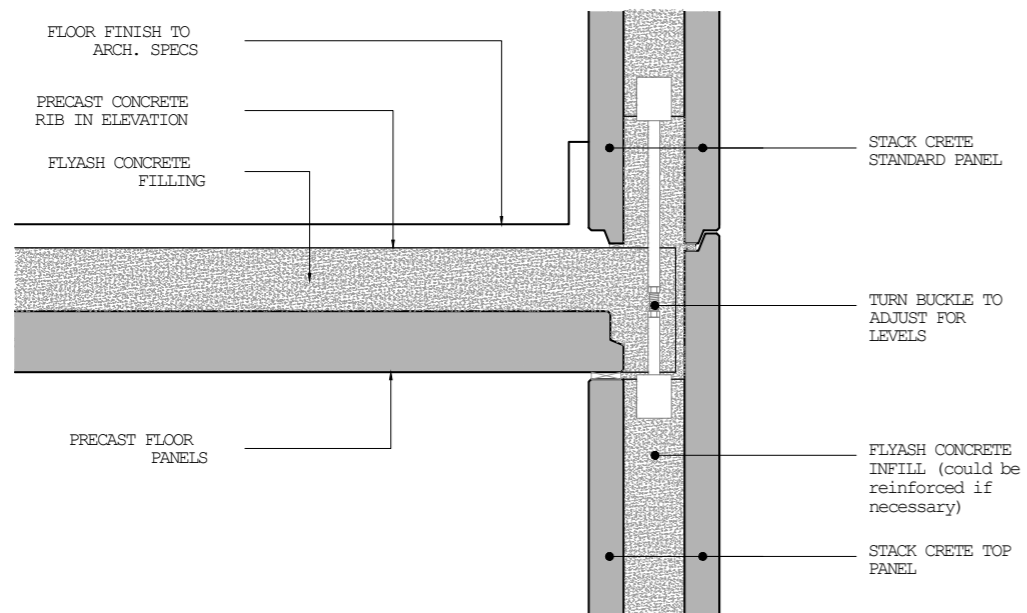

Fig 126: Detail, floor level section

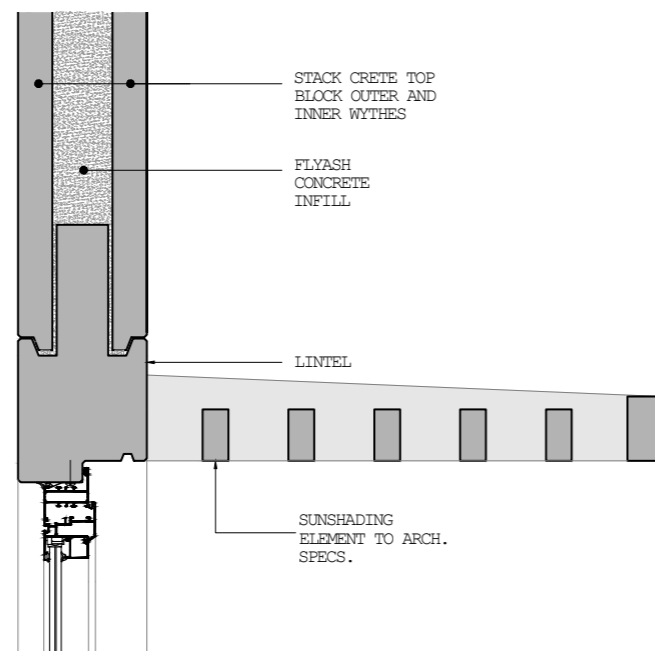

Fig 127: Detail, lintel level section

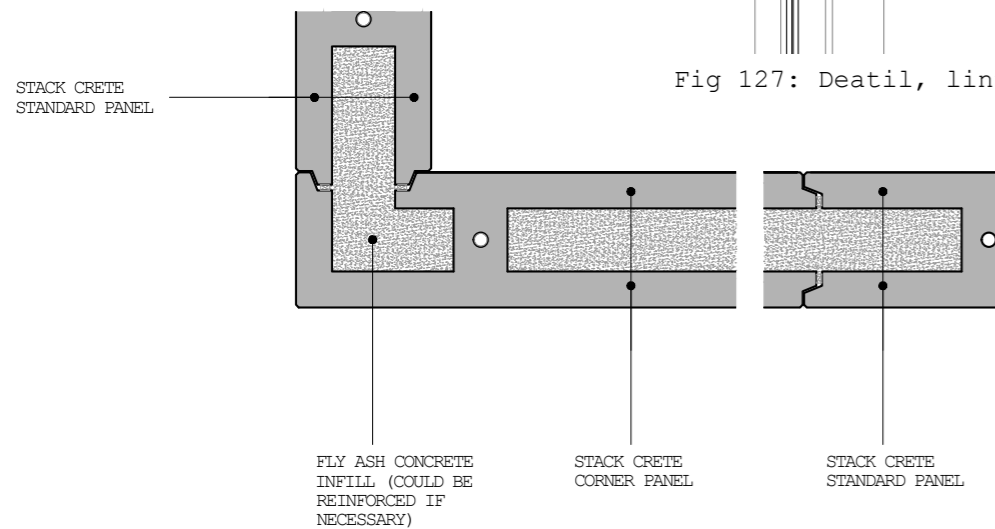

Fig 128: Detail, corner junction plan

Corner panels

The corner panel is a variation of the standard panel to allow for the same rebated connection between the two corner panels. One panel shall be a standard one, the other one will accommodate an extended thickness of wall turned around to house the rebate. This type of panel is arrived at to ensure continuity in the cavity around the corner for lateral connection of panels.

Electrical conduiting

Electrical conduiting could be embedded in the cavity before the infill as per drawing, like any other hollow block masonry. The tap off points can be marked and drilled in the inner wythes wherever necessary later.

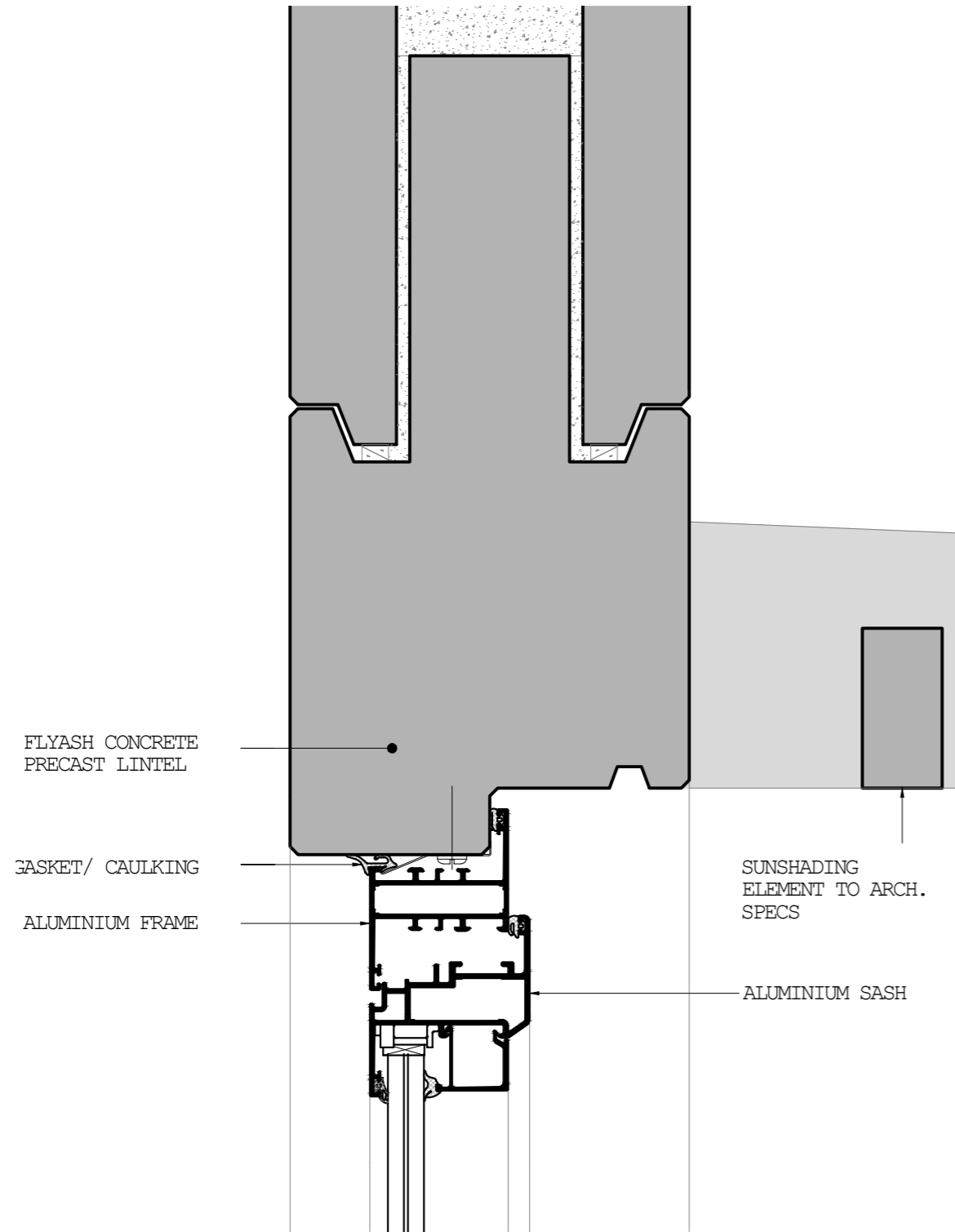

Fig 129: Enlarged detail Lintel level, showing suggestions for accomodating window tolerances

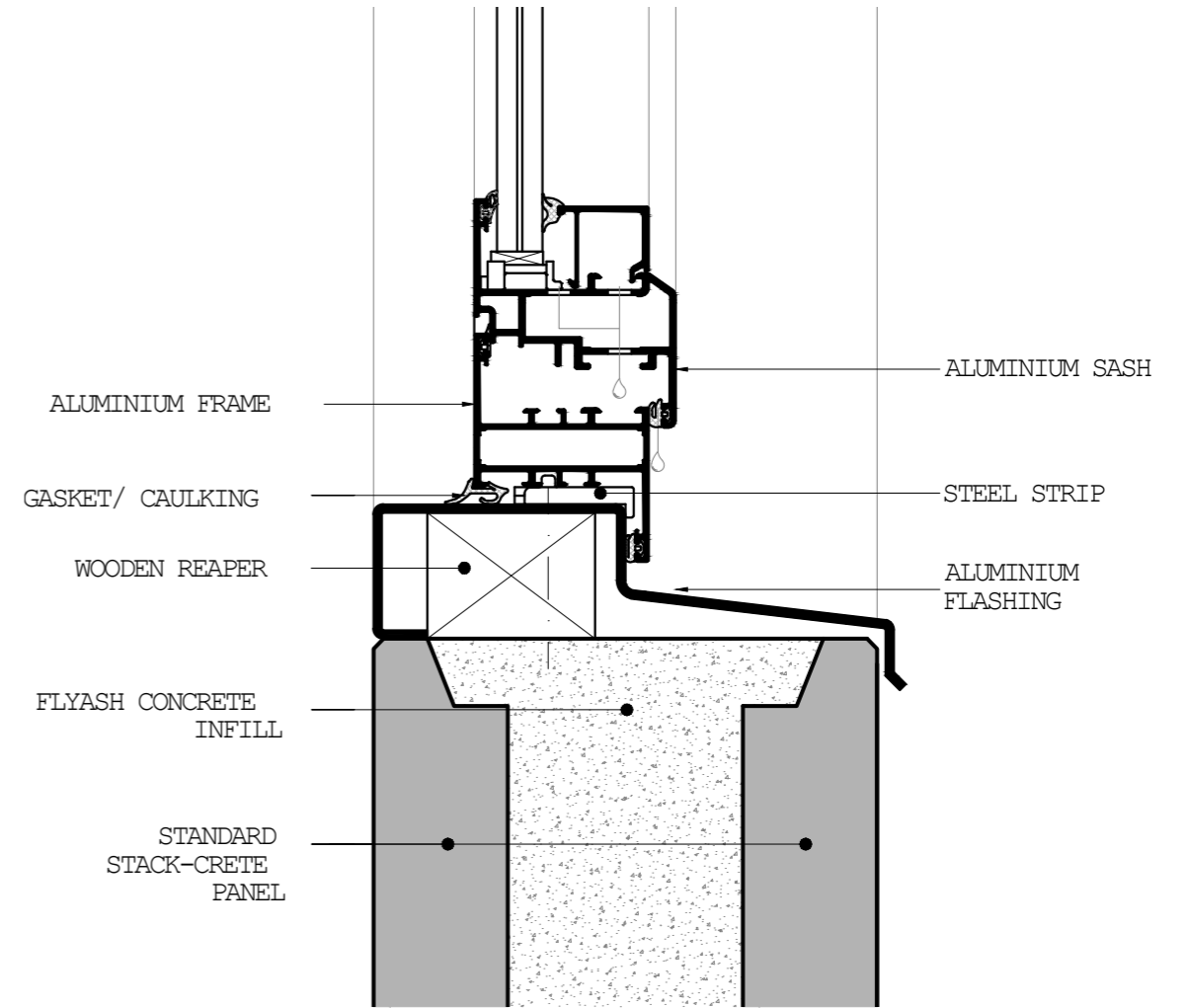

Fig 130: Enlarged detail Cill level, showing suggestions for accomodating window tolerances

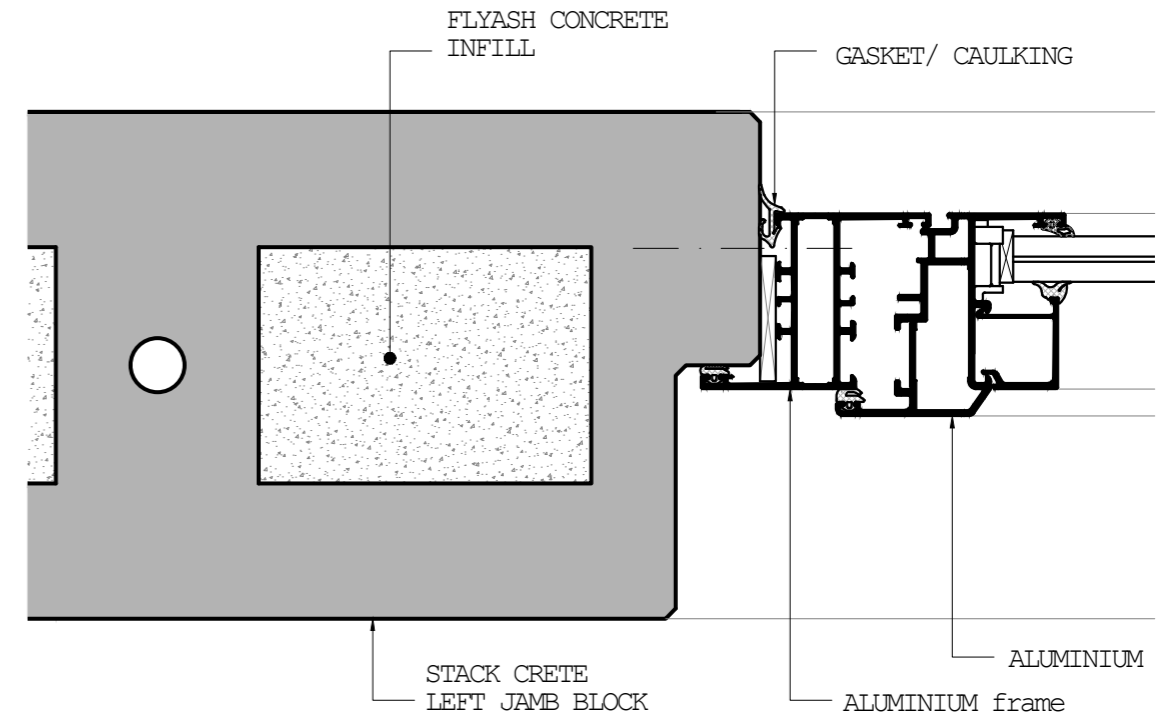

Fig 131: Enlarged detail jamb, showing suggestions for accomodating window tolerances

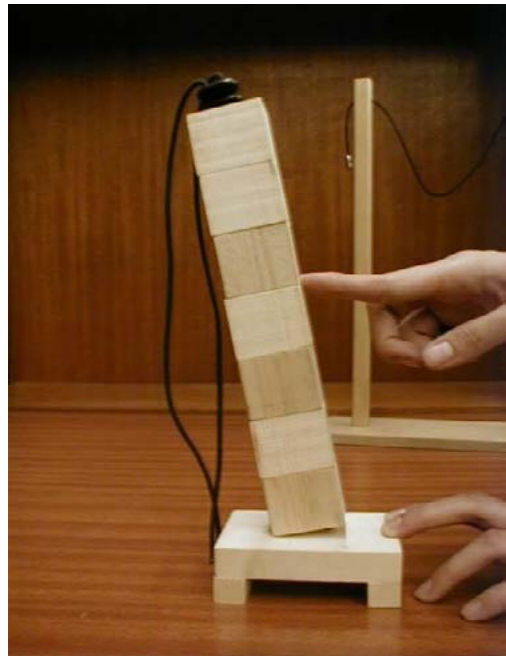
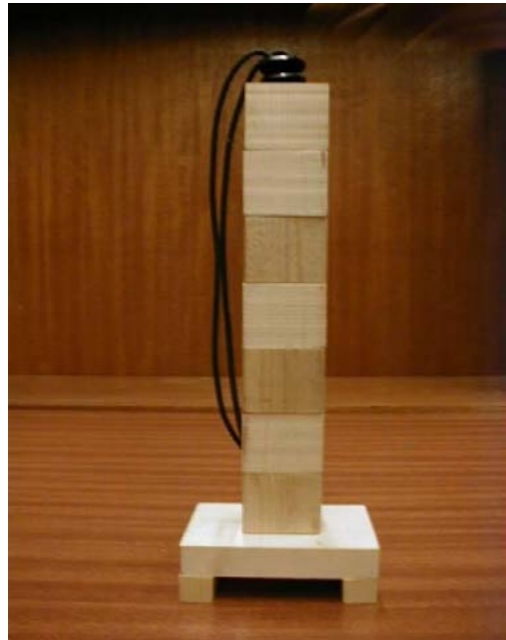
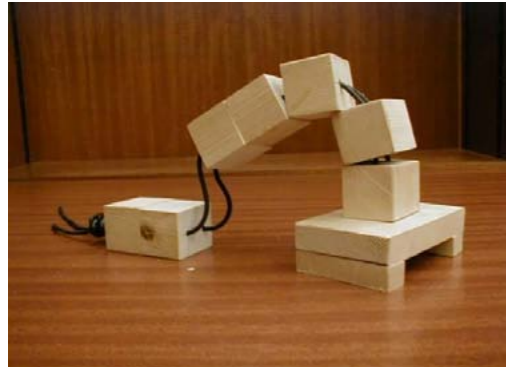

Fig 132: experimenting demonstrating benefit of prestressing
http://www.mace.manchester.ac.uk/project/teaching/civil/structuralconcepts/Statics/prestress/prestress_mod1.php

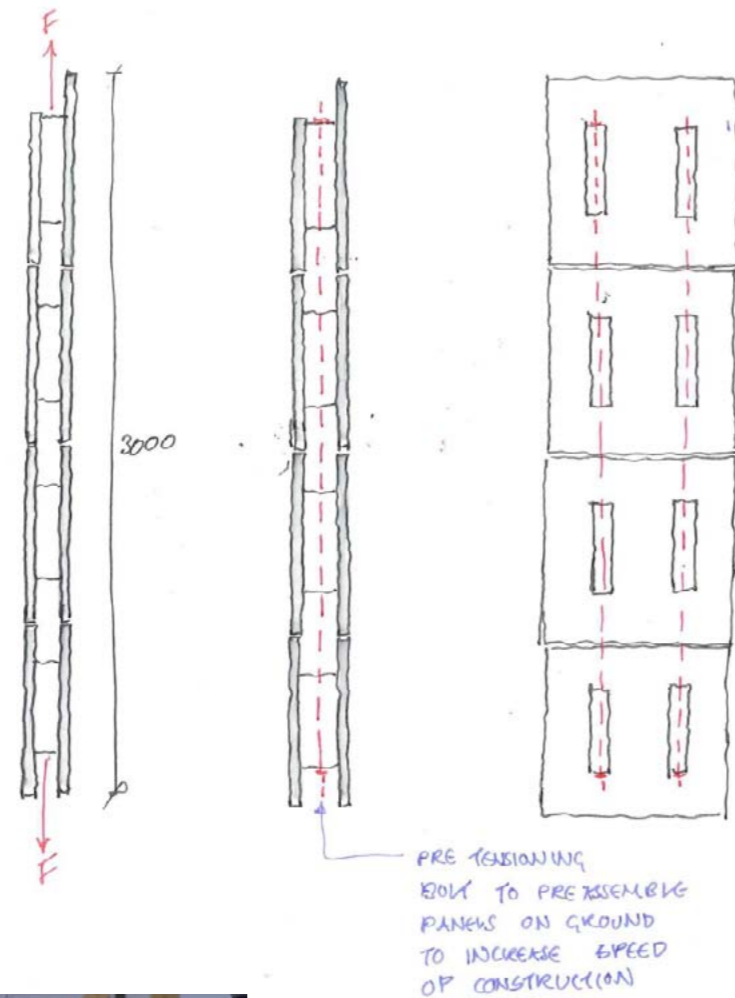

Fig 133: section and elevation illustrating the prestressing of panels with bolts as an idea



Fig 134: 1:5 model with wood demonstrating the principle of prestressing of panels



Fig 135: Sketch of plan of the panel incorporating the sleeve for the bolt in the shear connector

Pretensioning of panels

As noted previously, the panels are standardised into smaller components mainly due to existing offsite road infrastructure. The transport network does not permit the transport of larger panels, stacked in their design load position, to the site.

Now that the transport of panels is sorted out by having smaller sized additive components, we can try adding value to the system by providing an inbuilt option to enhance speed of construction. Pretensioning, or in simple terms bolting is one such good method which can be done. The illustration on the left demonstrates what it can possibly do. We could preassemble 4 panels vertically on ground as a parallel process to actual assembly, and erect them together in place. The idea here is, the shear connector already exists in the cavity zone of the panel, the value of which can be enhanced by adding functional values to it.

The panel, while being cast, could be provided with sleeves in the region of shear connectors. This provides for a bolt which can pass through in all panels. The proposed system is that, panels need to cover one storey height (4 panels) are stacked up on ground, bolted together through the sleeve in the shear connector to provide enough pre tension to make them act like one element, such that the bolt can be unwound and removed from the top after assembly.

These pre-bolted panels can be assembled one next to the other at the required floor. The problem here is of course, if the bolts are left inside, additional precaution needs to be taken to protect the bolt from corrosion by ensuring enough concrete gets packed all around it. But the question is, whether the bolted is needed in place after assembly. The stability check calculations, says the bolts are not needed after assembly. So they can be unwound and removed from the top before concreting the cavity.

This pre-tensioning is a value addition to the system, to increase speed. But it has more architectural potentials like it enables panels to be cantilevered on top of the other, with the prestress in one shear connector providing the counter weight, for example.

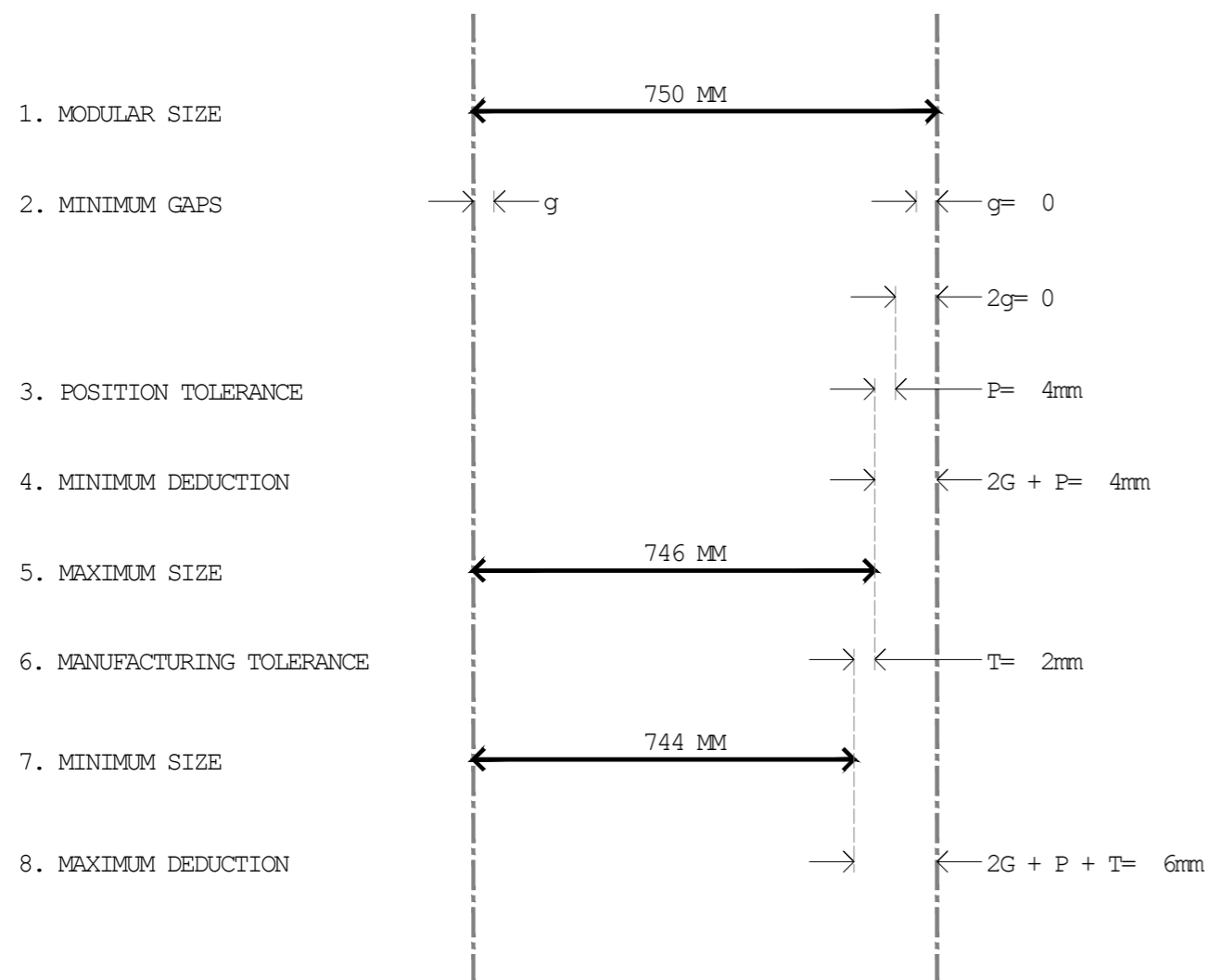

Fig 136: Diagram illustrating the parameters governing the tolerance for the product

Definitions

Modular size:

The basic modular space which the component occupies can be called as the modular size.⁴² Here in our case it is 750mm x 750mm

Minimum gap:

The minimum gap is the minimum usable distance between the component and its nearest modular plane and depends on the nature of the component and the method usually used in making its joints.⁴² Here in our case, since the elements are stacked as load bearing elements, there is no need for 'minimum' gaps, unlike cladding elements. So the minimum gap can be zero.

Position tolerance:

The position tolerance is an allowance for the lack of accuracy which must be accepted for the positioning of a component.⁴² Here in our case, it is difficult to define this as a numerical value, but can be probably given upto 4mm, to account for a minimum overlap of joints.

Minimum deduction:

The minimum deduction is the amount which will have to be deducted from the modular size to obtain the maximum size. This deduction is equal to twice the minimum gap plus the position tolerance.⁴²

Maximum size:

The maximum size is the greatest permissible manufactured size of the component, which by definition occupies a modular space. It is derived from the modular size by subtracting the minimum deduction.⁴² Thus is $750 - 4 = 746\text{mm}$

Manufacturing tolerance:

The manufacturing tolerance is an allowance for the lack of accuracy permitted for the production of the component.⁴² Again, complex to define the value without practical experience, but based on the example of the calcium silicate blocks, the tolerance can be assumed as 2mm.

Minimum size:

The minimum size is the smallest permissible size of the component. It is derived from the maximum size by subtracting the manufactured tolerance.⁴² Thus is $746 - 2 = 744\text{mm}$

When several components, are placed side by side, or one above another to make a functional element, each component should in principle occupy its own assigned modular space which may be shown on drawings by means of modular planes and on the site by suitable equivalent markings and location devices. A manufactured component will naturally be smaller than its corresponding modular space (750mm), and will exceed this space only if it is badly placed. Under such a situation horizontal and vertical positions along the building should be established where the cumulative errors can be accommodated and the placement can restart with a fresh line again from there on. We shall discuss this more on the case study.⁴²

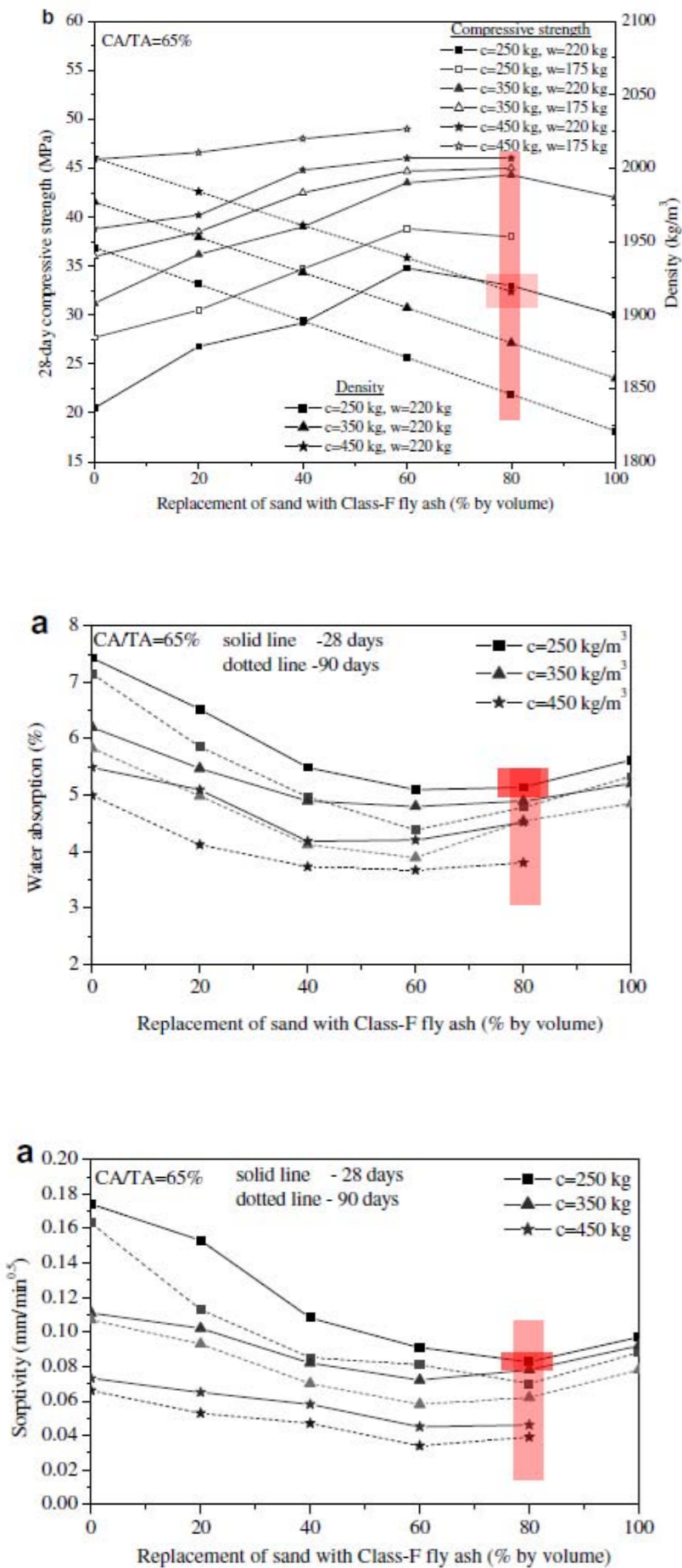

Fig 137, 138, 139: The properties of the mix design of flyash replacement for sand suggested¹⁷

As mentioned in chapter 3, the material intent of the design, is to maximize the utilization of flyash in the product.

Since the system itself has 3 zones, it is important to see what material characteristics each of the 3 zones need.

Functions

1. The exterior and Interior wythes. These are structural, the main load carrying components of the wall. So the flyash mix design is expected to provide atleast 25Mpa of compressive strength as assumed for structural calculations. In addition to structure, these layers need to be less permeable to water, salts from the infill concrete from inside as well as from outside. The surface needs to be able to take up any kind of finish on it, and colour retention to be high on the exterior surface. Insulating property shall be an added value, considering use of utility. The mix shall be highly workable to get good finish with just 40mm thickness, and fine edge details

2. The cavity. The cavity infill, shall just provide bond between adjacent panels structurally. Not necessary to have high compressive strength. The layer shall have a minimum sorptivity, to form a water proof membrane once set. The layer shall have high insulating properties. The mix shall be highly workable to be poured into the cavity.

Composition

Considering the above functional needs, and the design need of maximising the utility of flyash, we can arrive at the following conclusions:

1. Use of cold-bonded flyash aggregates can be taken as a given for both the panel and the wythes- As noted in chapter 4, replacement of gravel by cold-bonded flyash aggregates does not compromise on the strength of concrete. Bulk utilization of flyash is the advantage.
2. The panel can have sand replaced by flyash upto 80%, when the compressive strength reaches the maximum, and the permeability and sorptivity reaches the minimum (chapter 4). With this composition 62.8% of the panel shall be out of flyash (appendix 3 gives all combinations tested in IIT Madras).
3. It must be noted in the above point that, the shear connector also is recommended to have the same mix, not due to the functional need, but mainly due to the production process of wet casting, where one mix can be used.
4. The cavity infill can have the same mix. But to maximise the use of flyash and to improve the insulation properties, no-fines concrete with cold bonded flyash aggregate and 50% flyash replaced cement could be used. No-fines concrete has almost zero sorptivity as noted in chapter 4 and the usual mix ratio is 1:8 by volume of cement: course aggregate. No-fines flyash concrete allows the concrete to be poured into the cavity with less lateral pressure on the wythes in both x and y directions.

Please note that the mix design is only suggestive and is based on the findings by others listed in chapter 4. The properties of flyash varies from plant to plant. So the percentage of flyash in the mix has to be tested depending on the source.

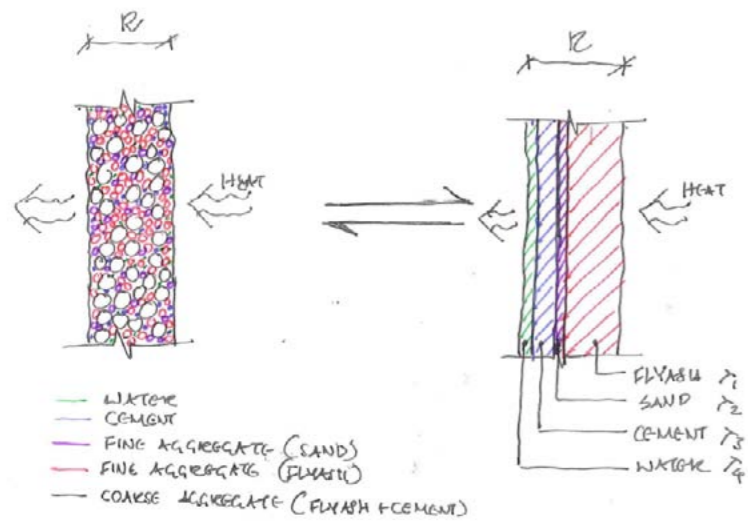

Fig 140: The rule of mixtures, applied to concrete

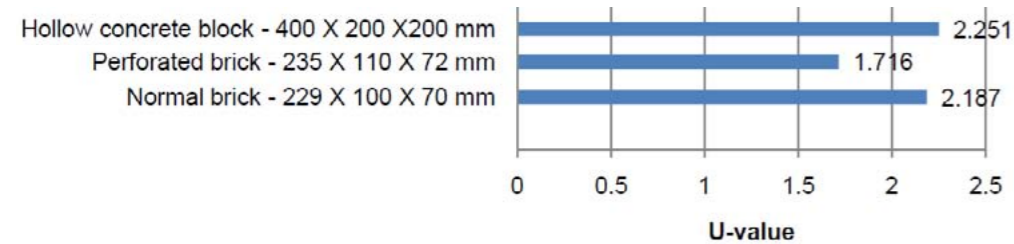

Fig 141, 142: U values of typical conventional walling systems

Fyash Stack-crete
U Value= 0.91- 1.03

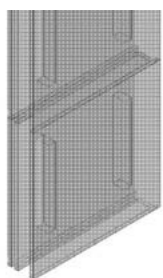

Fig 143: U value of stack crete

One of the design parameters for the research was the climatic context. As noted in Chapter 2 and 3, this product/ system is being designed for warm-humid climate zone in India.

One of the parameters which needs to be checked is the U-value of the product and how does it compare with the conventional construction walling systems in India.

Based on the mix designs mentioned in the previous chapter, an attempt has been made to calculate the thermal resistances across the various layers and the U value of the wall system as a whole.

Since concrete is also a 'composite', the rule of mixtures may probably be applied to calculate the conductivity of the mix per unit volume. The cumulative sum of the products of individual conductivities and volume fractions of each component.

$$\Lambda = \Lambda_1.V_1 + \Lambda_2.V_2 + \Lambda_3.V_3 \dots$$

Appendix 5 gives the calculation of volume fraction etc.

Based on this calculation we get the conductivities of each layer as follows

1. Inner and outer wythes: 0.185 W/mk
2. Cavity infill:
 - 2a) Same mix as wythe: 0.185 W/mk
 - 2b) No-fines flyash concrete: 0.135 W/mk

So resistance across each layer

1. $0.04 / 0.185 = 0.21 \text{ m}^2/\text{k-w}$
- 2a. $0.07 / 0.185 = 0.38 \text{ m}^2/\text{k-w}$
- 2b. $0.07 / 0.11 = 0.51 \text{ m}^2/\text{k-w}$

So net Air to air resistance:

$$\text{Wall system 1} = \text{air} + 1 + 2a + 1 + \text{air} = 0.04 + 0.21 + 0.38 + 0.21 + 0.13 = \mathbf{0.97 \text{ m}^2\text{-k/w}}$$

$$\text{Wall system 2} = \text{air} + 1 + 2b + 1 + \text{air} = 0.04 + 0.21 + 0.51 + 0.21 + 0.13 = \mathbf{1.10 \text{ m}^2\text{-k/w}}$$

So U- values:

$$\text{Wall system 1} = 1/0.97 = \mathbf{1.03 \text{ W/m}^2\text{-k}}$$

$$\text{Wall system 2} = 1/1.23 = \mathbf{0.91 \text{ W/m}^2\text{-k}}$$

So we note here that in both cases the U-value is considerably lower than the conventional counterparts in India. The only better construction element, without a separate insulation layer is AAC blockwall.

Also it must be noted that the calculation is made on the basic functional elements of the wall, the exterior surface has a layer of finish pre-cast onto it, which adds a resistance layer, which is not accounted for here, as it varies with architectural specification for the finish.

The construction process of the product, as a part of the building process, is one which has various stages of specialised activities, which have implications on one another in terms of both time of building as well some balance between time and economy. The construction process, unless defined well, will lead to inefficient making and utilization of the proposed product, which will then end up having a silent death by lack of quality and efficiency, due to lack of proper design and planning in terms of construction process, which isnt the fault of the intent of proposing the product. Hence it is essential to consider the construction process as part of the product development, for carrying out any further research for its success.

The construction process of the product being proposed has been broadly divided into the following sub- processes

1. Production process: the means by which the product gets 'manufactured'.
2. Transportation/ stacking: the means and the precautions that need to be addressed while transporting the product(s) to the actual project site, and the means of stacking them.
3. Lifting strategy: this is a design strategy, rather than a process which follows the transportation activity. Its the possible strategies for lifting the product, for unloading and for erection and precautions needed.
4. Assembly/ temporary supports- the method of erection, sequence of assembling the products, and the need for temporary supports if any, till the core is filled in and initial set is over.
5. Filling the core: This is the last stage critical to operation of the product as a load bearing facade, before construction can proceed further.

Each of these processes shall be discussed in the subsequent sub-chapters. It has to be noted that all the processes can be fully evaluated and improved upon only with execution of a real-time project with the product. This report documents only the level upto which I, as a student of building technology, could evolve from the research on existing processes, their pros and cons with respect to Indian context and the product, on a theoretical level. I must confess though that I do have a little bit of field experience of trying out concrete casting and erection in an extremely crude manner back in India, but yet quite substantial in envisaging the probable problems that might occur.



Fig 144: Sectional perspective of the construction

The Production process is important step, which influences the design of the product, and on a strategic level influences the organisation of the construction industry for housing.

The production process can be evaluated and developed based on various factors, all combined together, or by giving importance to one or more of them. Some of the factors are:

1. Economy- The cost of the method of production will be a key element in a real life scenario. But for this academic research, the cost is beyond the scope of evaluation, and the economy of the process is judged only by intuition and my personal work experience in India.

2. Simplicity in production- this is eventually one of the design goal of the research work , in real life for producing and marketing the product on a mass scale. However for this academic work, a simple production process shall be defined as 'a production process which can be easily transferred from a highly specialised factory to a regional casting yard if need be, with just minor adjustments in techniques'. This is important, considering urban developments happening with very limited road infrastructures around in some places.

3. Production time- This parameter closely relates with economy also. The exact production time of each process cannot be determined in the academic work, but a comparison between the different processes is drawn here.

Dry casting:

Dry casting is a process a where concrete is cast with very little water content in order to render it almost zero slump. This type of casting is beneficial when the deshuttering time has to be almost immediate after placing. Its used in extrusion processes like hollow core slab casting, and press mould castings like concrete block manufacture (solid and hollow). The problem with this process is there is very low workability, and the finish tends to be very crude due to the dryness of concrete, thereby limiting the possibilities of surface finishes needed for the product to be successful. These negative factors dominate over the positive aspects of the process, considering the adavantages of using the highly workable properties of flyash to produce sharper detail. Hence we can rule out this process for this product.

Wet casting:

Wet casting is a process where a more fluid concrete is placed in moulds. The proportion of fluidity is entirely upto the needs and the design specifications of the product. The disadvantage is higher initial setting time, for deshuttering and stacking. But the biggest advantage is using the potential of flyash in terms of its workability to be able to produce shapr details, and good finishes with possibility of preembedded finishes like bricks etc while casting. The compromise of time, needs to adjusted with the production facility, and the number of moulds, size of panel etc. But wet casting is any case preferable to dry casting, for this product.

Now coming to the product itself, the product has 3 parts- the external wythe (flange), the shear connectors, the internal wythe (flange). The external and internal wythes are a given that they are wet cast flyash concrete with whatever finish specified. The shear connector method, is something which also depends on the process of combining the wythes together. It can be looked at in 2 ways:

1. Independent casting of wythes, connected later:

In this method, the wythes (external and internal) are cast independently, simultaneously perhaps, and are connected later together to form the product. The shear connectors in this case could be metal studs with anchoring to the panels. The advantage of this system is, faster production. However, the biggest threat to this system, is the inaccuracies while connecting the wythes together, due to lack of precision is small scale factories at the present setup in India.

2. Two-stage casting of both wythes together are one panel:

This is very much similar to case study of sandwich panel production. The first layer (exterior layer) is cast on the platform, with the reinforcement for shear connector projecting up. After the setting of this layer, a bed of sand maybe poured to the width of the cavity. A layer of foil, and then the second layer of concrete is poured to form an integrated product. The advantage of this process is, due to single mould for the entire product, the product accuracy is much higher, and the shear connector could be the same material as the panel. The disadvantage being, 2 stage casting consumes more time for production.

Both methods are viable. The manufacturer, should be able to decide which is better based on past experience and capital requirements.

Note that in both the methods, the exteriors surface can be lined with any finish while casting. That's the advantage of wet casting over dry casting.

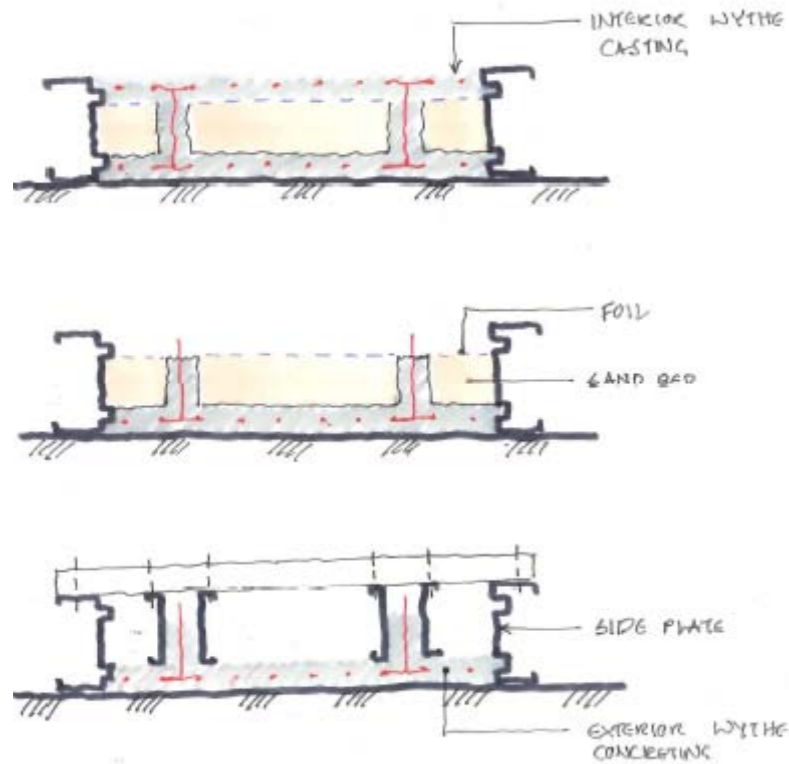

Fig 145: the production process

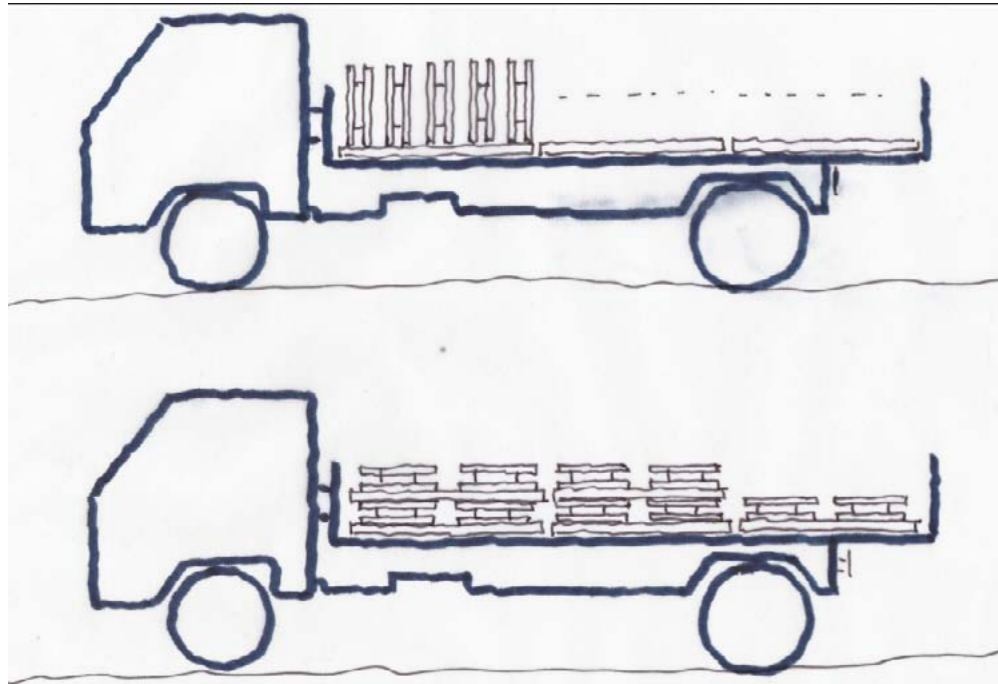

Fig 146: Stacking systems during transport



Fig 147: A typical truck commonly used in India (<http://www.sadgururoadways.com/services.html>)

Since the production happens in a controlled environment, which can almost never be the project site itself (unless a very rare case permits such a thing), it is important to consider the transportation methods, and product handling while transport, and the method of placing the products on site after unloading.

The most common mode of transporting construction products in India, is by a canter truck. A-407 is a smaller truck more suitable to more remote areas of a town.

Horizontal stacking

The most profitable way of transporting the panel would be to stack the panels horizontally on a trailer or truck, as a maximum number of panels can be transported at one time. But this method has several disadvantages.

- It leads to creating 2 stages of lifting. One, to rotate from horizontal to vertical state, and the direct vertical lifting. The panel will have to be over designed for lift loads, and also additional lift points need to be provided perhaps.
- The plates might deflect while placed horizontally in the truck, leading to bowing of the panel, and then lead to difficulty in assembly due to mismatch in edges.
- Since we are talking about prefinished surface, additional precautions need to be taken while transporting the panels horizontally, so as to not damage the surface.

Vertical Stacking

So the next option is to check vertical stacking. This option is slightly less economical, as it can transport slightly lesser number of panels per trip. But in the long run it proves more beneficial.

Advantages-

- Panels lifted in the same direction as they are stacked. So lift points are one and the same.
- Structurally more stable to transport the panels in the same orientation as how they are actually erected on project site. It reduces induced stresses in lateral planes, and possible chances of bowing.
- The finish of the surface can be maintained better during the transport.

Due to the above advantages, I feel it's better to transport the panels vertically stacked, even though there might be a slight compromise on economy. However, this has to be validated by an actual manufacturer.

On site also, it is preferable to stack them vertically on dunnages, before erection. It is best to have the stack time period before erection on site, as minimum as possible.

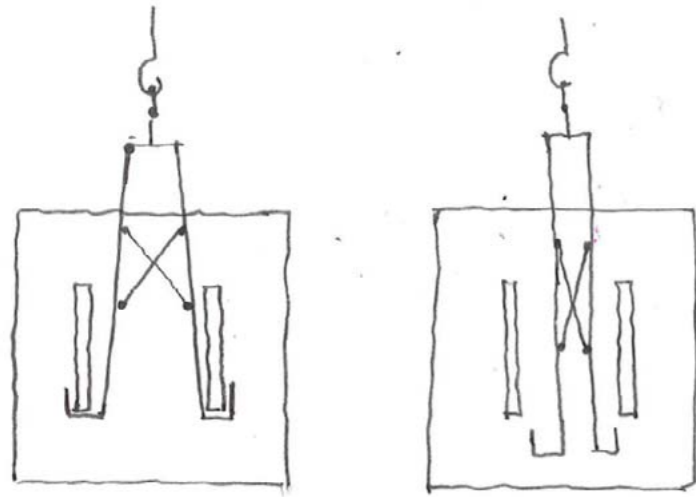

Fig 148: suggestions for lifting systems



Fig 149: a mobile crane with 18m boom



Fig 150: An improvised floor mounted lifting device



source: ANT ENGINEERS INDIA

As we have already seen, the maximum weight of the panels is approximately 95-100 kg. It is not possible for manual lifting to be efficient, even if the strongest men are employed for the task.

It is better to provide mechanical advantage to the labour force on site for lifting and assembly. The labourers can then just manuevre the panel with their hands, while load is taken up by the lifting equipment.

Cradle

The main strengths of the hollowness of this product, is that all supports required for temporary connections, lifting, assembly, etc can take advantage of the shear connectors between the flanges. By using them, we eliminate the need for providing additional lifting hooks and such other temporary provisions, which might have to be otherwise trimmed off after erection. Thus an adjustable cradle like device with a sling could be designed (fig...) which could just clip on to the shear connectors from below, to allow for any lifting equipment to lift the cradle with the panel together. The cradle could be released from the panel immediately after placing the panel in position and aligning it manually.

Lifting equipment

Most civil contractors for urban projects in India, do own mobile cranes with atleast 18m boom length, or atleast can afford to hire one to lift them. But if not possible to find a mobile crane in some remote urban area, a customised floor mounted lifting jig could be used (fig...). The example shown on left can lift upto a weight 500kg. It is more than sufficient to lift the products in place, and equipment can be converted to be portable on floor slabs, demounted and moved to the next level

Specification of the same is as below:

Machine Specification:

Name : ANT PRO 200

Type : Portable and Easy To Shift

Lifting Capacity : Max 200 kg [up to 500 Kg for Custom need]

source: ANT ENGINEERS INDIA

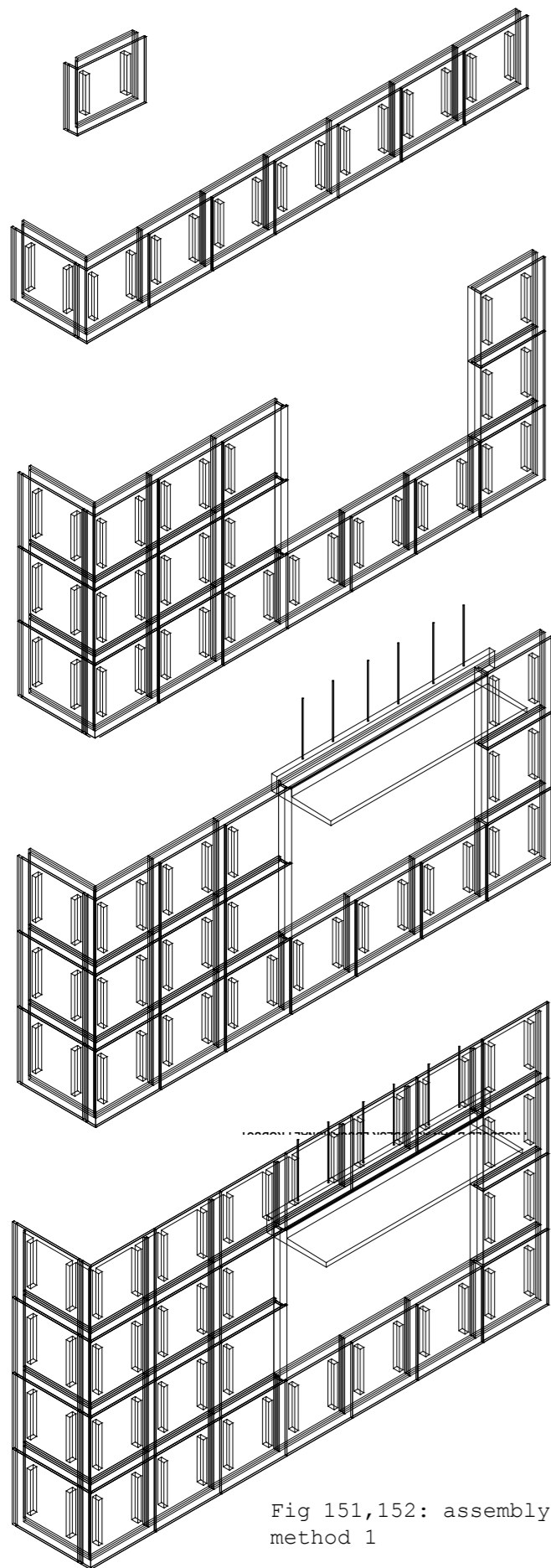
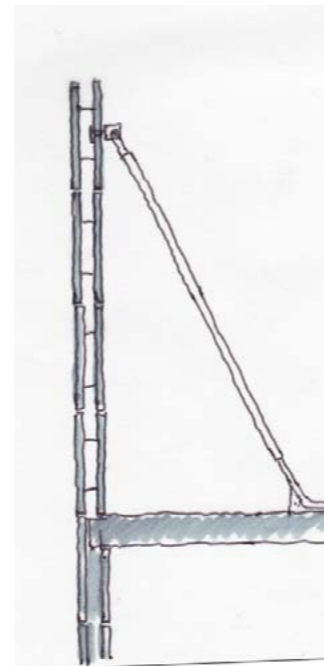
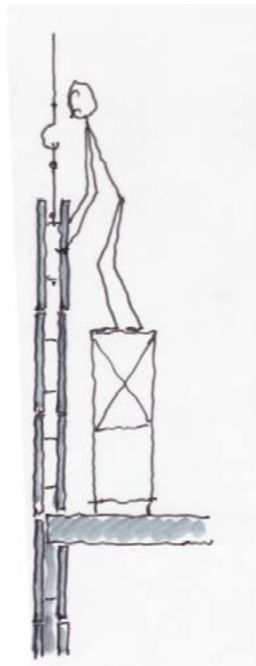

Fig 151,152: assembly sequence of method 1



The sequence of operation - method 1- individual panel assembly

As mentioned in the design of the system subchapter, the product has an option of being assembled individually, or can have a 2 stage assembly, where 4 panels are already assembled together on ground by bolting(pre tensioning) and then erected in place sequentially. The choice is left to the management team on site, and the what suits the site conditions.

1. Wall footings: footings could be done insitu, while the panels are being manufactured in the factory and cured, in case some are custom made.
2. Base aligning anchors- Base aligning anchors are proved to setout the assembly of panels, for dimensional accuracy at the startup. They could be simple angle cleats bolted to the footins at the line of cavity of wall or a simple detail like that, which is validated by the structural consultant on board.
3. Starter panels: The first layer of panels are laid, usually below grade. The height of excavation thus also needs to consider the architectural requirement of what level the ground floor starts.
4. First layer of panels are laid (upto cill): this is a simple assembly.
5. Second layer: The assembly of second layer can happen with the worker still on ground/ floor level. All panels, jamb panels are included.
6. Third layer (upto lintel level): Portable scaffolding is needed before this step, for the worker to stand on to reach the level above 1.5 m. The panels are then assembled, with the jamb panels as well upto 2.25 height. They are assumed to stay in place due to self weight.
7. Placement of lintel/ sunshade element over the shear connector of jambs: the system allows 150 deep lintel to rest over the jamb panels. If the span is larger than 2m, temporary supports maybe be given to the lintel till the next 2 steps.
8. Last layer of panels of the floor: these are assembled over the lower wall panels and over the lintel. The panels over the large span lintel, could be bolted to the lintel over the shear connectors, to provide pretension, make it workm like a deep beam.
9. Temporary supports- Temporary supports shall be installed for lateral support to the wall at the topmost level, till it is grouted.
10. Installation of electrical conduits and reinforcements in the cavity (if needed)
11. Infill of fly ash aggregate concrete in the cavity:
12. Placement of floor system over the walls

And then the process repeats from step 4. Note that step 11 and 12 could be interchanged depending on the structural requirement of the stiffness of floor connection, if the wall is grouted together with the floor, it forms a rigid joint.

Stability calculation checks are provided in appendix 4.

The sequence of operation - method 2- pretensioned assembly

In this method the ground floor can be assembled as per the previous sequence. As this is being done parallelly the panels for upper levels can be pretensioned as discussed in chapter 6.5, to get floor high panels of unit width.

And then the sequence of assembly is as follows

1. Place the first floor to floor high bolted panels. After alignment on floor, the bolt shall be removed from the top.
2. The second layer of panels gets done similarly.
3. Jamb panels- these panels shall be pretensioned upto lintel only and erected together (3 panels together), on either side of the opening, with the cill pieces below the opening erected individually simultaneously.
4. The lintel with sunshade element shall be rested over the web of the jamb panels. Temporary supports shall be provided adequately.
5. The panels over lintel shall be assembled individually over the lintel which goes into the panel cavity width.
6. The erection continues beyond the opening similarly.
7. Electrical conduits are laid in the cavity as per drawings.
8. Flyash infill concrete shall be poured in the cavity.
9. Placement of floor system over the walls.
10. The sequence of operation continues for the subsequent floors. Note that the temporary supports below the lintel shall be removed only after 35 days (as per chapter 4 flyash strength gain requirements).

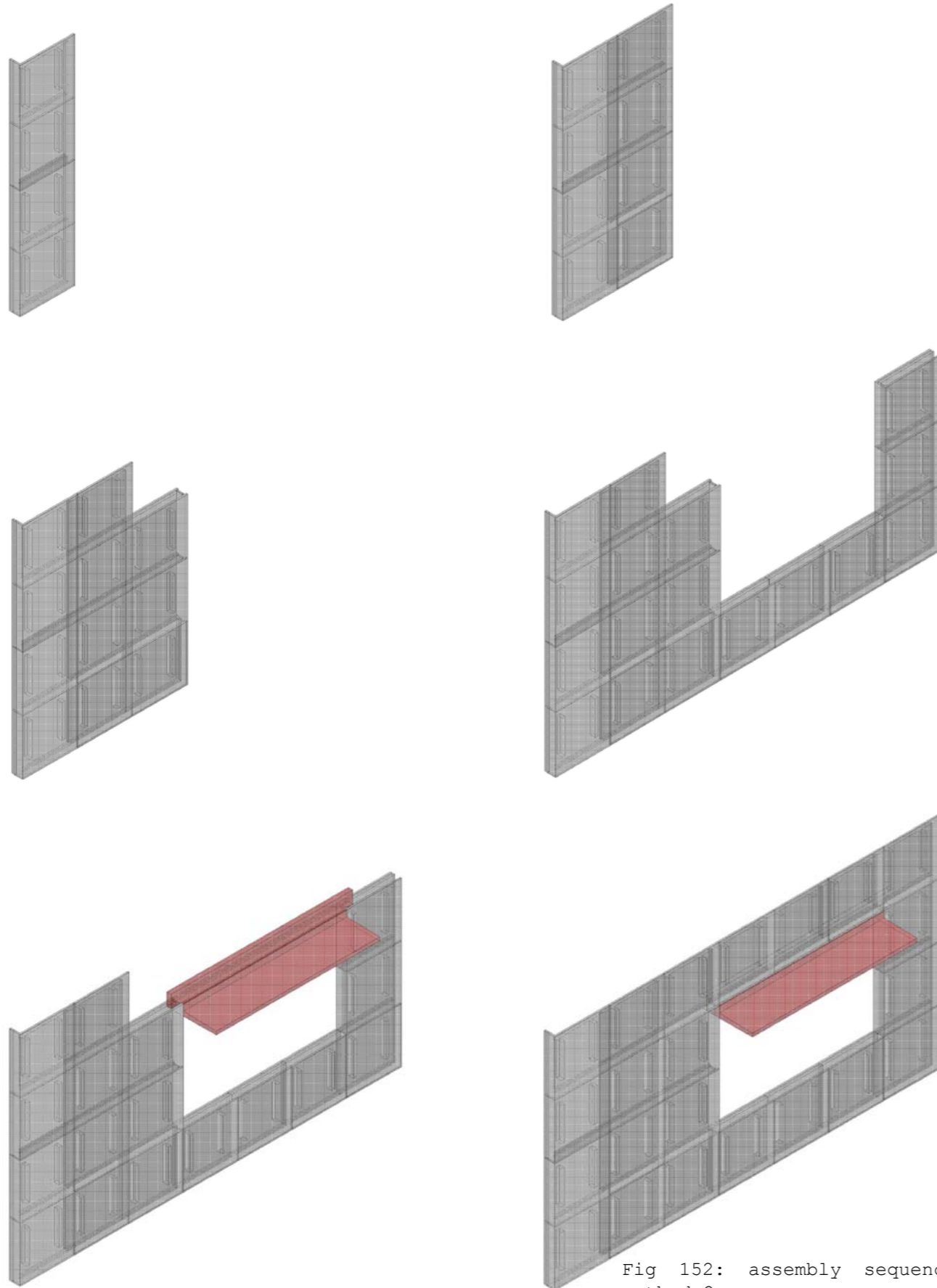
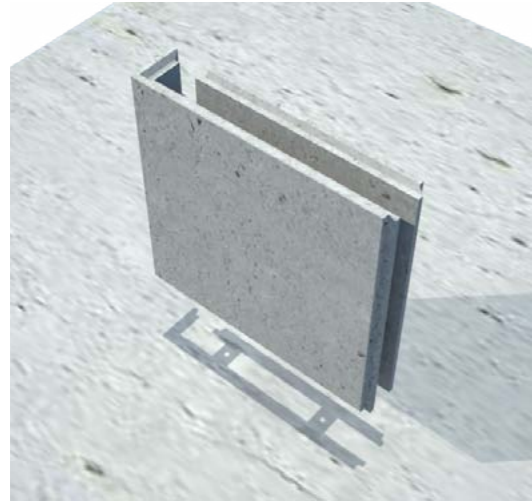
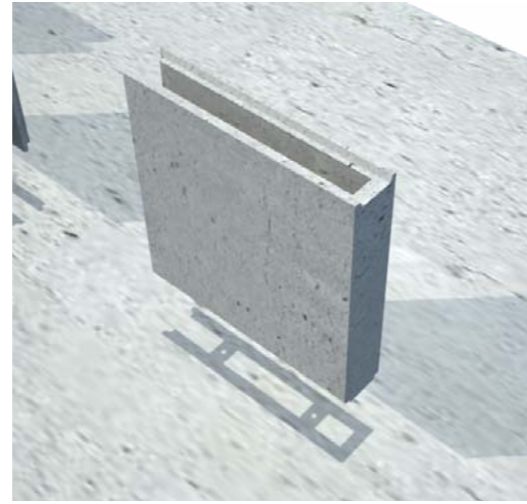

Fig 152: assembly sequence of method 2



corner panel- generic



left jamb panel

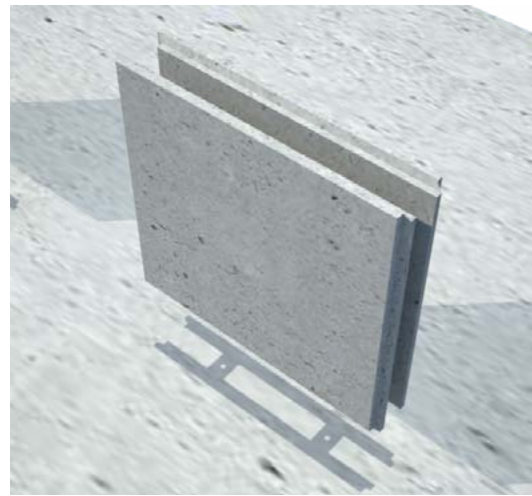

standard panel- generic

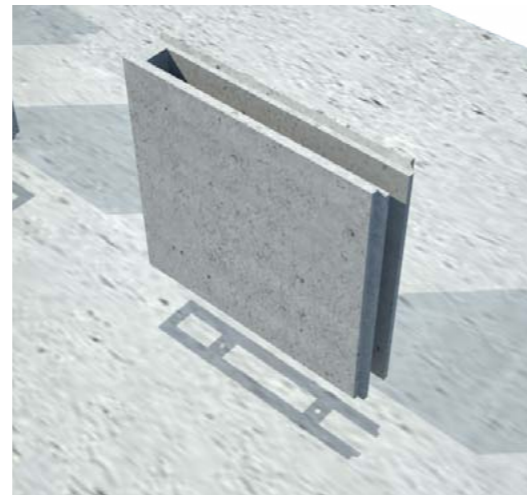

right jamb panel

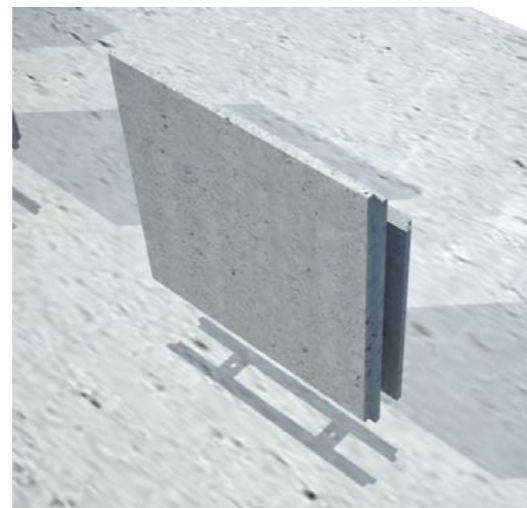

standard panel- above lintel

Fig 153-157: the different stack crete elements

The Product so designed so far, has been totally 'theoretical' in all aspects. So in theory it could be proved by calculations and references that it is a workable solution towards addressing the main problem.

The real evaluation of the product would only be when it is actually tested on a realtime project. However this is beyond the scope of this academic research. On a smaller level, however, the evaluation could be stronger than just theory, if the production of the product is tried out with 'real' materials (almost real, lets say), and the ease of assembly is checked for. With the available facilities in CiTG, it should not be a very difficult task.

The initial intention was to make 8 panels and assemble them. A 1:1 mockup would have been ideal, but considering the overall size after assembly and the difficulties involved in transport from CiTG to BK, and the cost factor ofcourse, we settled for making a 1:2 prototype.

Special thanks to ir. H.R. Schipper for his valuable guidance in this whole process. The labs in CiTG were used for both, making the mould as well as casting the panel. Special thanks to Mr. Kees and Mr. Tom of Stevin lab, for providing the space, material and equipment to make the mockup.

The process and the findings shall be discussed in the subsequent sub chapters.



Fig 158: First trial

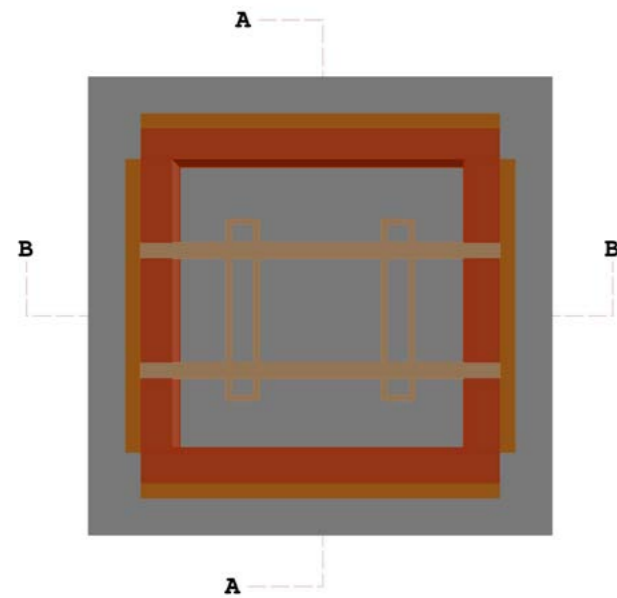

Fig 159: plan of the mould

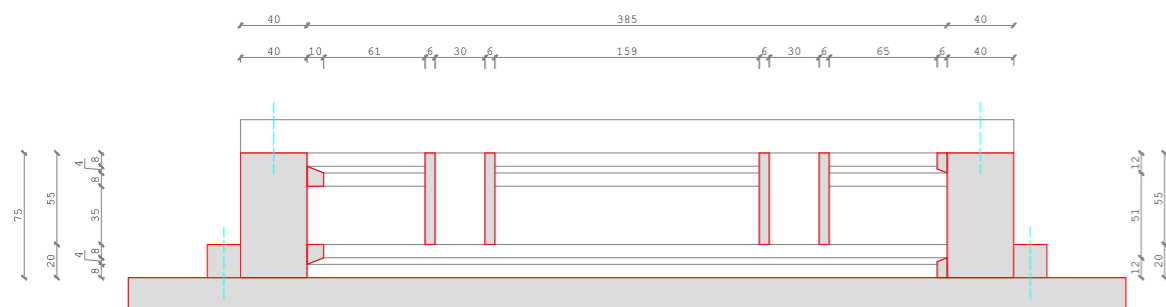

Fig 160: Section BB

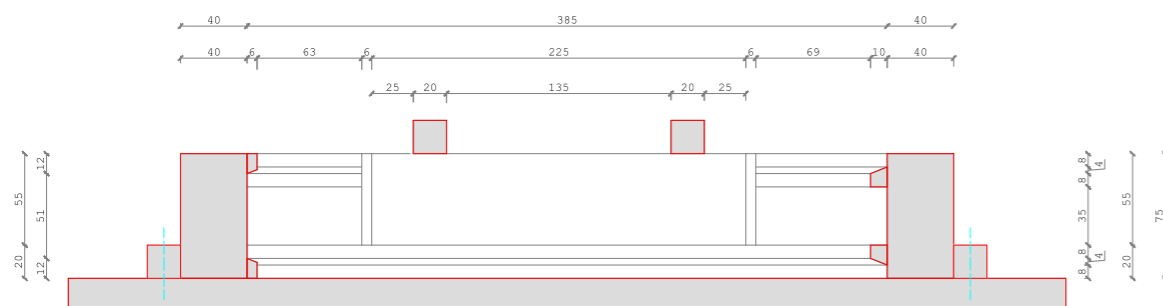

Fig 161: Section AA



Fig 162,163: Views of completed mould

The Mould

The scale being already decided as 1:2, it was time to select the material for the mould. Steel mould would have been ideal, considering the perfection which would be achieved, as also the surface finish and mould releasability. But considering that very few castings are going to be made and the ease of making the mould, wood was chosen to make the mould instead of steel.

The mould consisted of 3 parts.

1. The 18mm plywood base with fair finished veneer
2. The side pieces with mdf profiles glued onto them to get the required rebate in concrete. These side pieces are screwed/ unscrewed individually from the base
3. The formwork for the shear connector part, which is screwed on to the side pieces from the top.

Mix design

The mix design was suggested by ir. H.R. Schipper. The mix included a small percentage of fly-ash. The proportion is given below:

Binders:

Cement:	595.00 kg
Flyash:	164.00 kg

Aggregates (dry):

Sand 0.125- 0.25:	188.42 kg
Sand 0.25 - 0.50:	251.22 kg
Sand 0.50 - 1.00:	376.84 kg
Sand 1.00 - 2.00:	314.00 kg
Sand 2.00 - 4.00:	125.62 kg

Water:	239.55 kg
Super plasticiser:	4.22 kg

Please note that the weights given are per one cubic meter of concrete.

The total volumes required per panel was just about 6.5 litre. Although the volume did not remain very consistent, due to the variation in thicknesses of the sand bed.

Casting process

The casting was tried out exactly as explained in the production process.

1. Side pieces screwed onto the base. The mould is then slightly oiled to facilitate easy deshuttering.
2. Concrete poured to finish upto the thickness of one wythe. (aweld mesh of thin gauge is included in the wythe)
3. The formwork for the shear connector is screwed in position immediately.
4. The concrete is poured into the formwork to fill upto the level of the base of the inner wythe or slightly higher. The metal sleeve for the pretensioning bolt was tried only in the last 2 panels.
5. The concrete is left for a few hours. In 3 castings it was left upto next day morning to release the formwork for the shear connector, as the wood had enough friction with the concrete to not be released easily which slowed down the process.

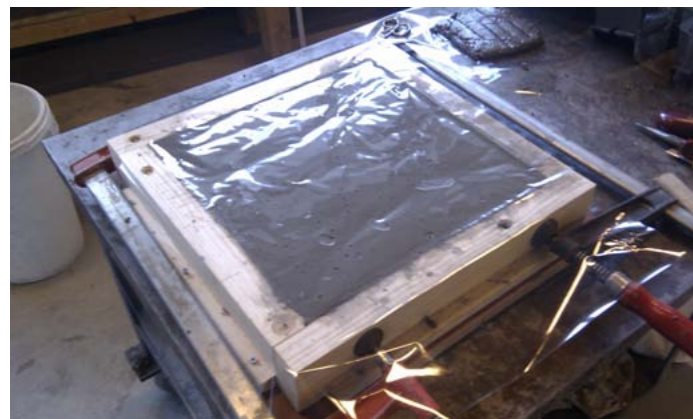

6. After the release of the form for the shear connector, a layer of sand is poured till the level of the base of the inner wythe, and is levelled to the extent possible.

7. A foil cut to profile is placed over the sand, to avoid the draining of water from the concrete above into the sand.

8. The upper layer of concrete is then poured and leveled till the top of the mould. (the mesh is included again). A foil is covered on top to avoid excessive evaporation of water from concrete.

9. The side pieces are released the following day, and the panel is ready to be stacked elsewhere. The sand bed falls off, and is collected and reused for the next castings.

10. The mould is cleaned to the extent possible and prepared for the next casting immediately and the process continued.

With this process, we were able to manage 4 panels, although I had initially intended to make 8.

A few difficulties we faced during the process were:

1. The formwork for the shear connectors, were made in plywood initially and later in mdf again. In both cases it was extremely hard to release them from the concrete, even though the surface was oiled and the edges were tapered in the second attempt. Steel would have eliminated the difficulty perhaps.

2. It was slightly difficult to control the fluidity of concrete each time for such small volumes, although the ingredients were accurately weighed each time. So every panel proves to have a slightly different get up than the other.

3. It was impossible to vibrate the top layer of concrete due to the presence of the sand bed below.

Some of the important findings from the mockup are described in the next sub-chapter.

Fig 164-168: the process of casting the first panel



Fig 169: First panel deshuttered

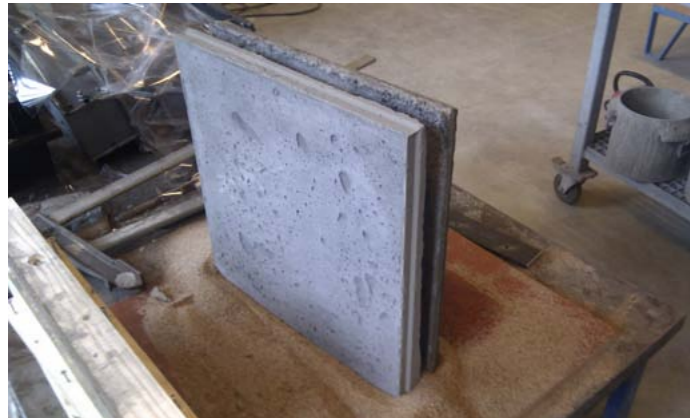

Fig 170: Panel tilted up from the mould



Fig 171: trial of horizontal assembly of 2 panels



Fig 172: assembly of 3 panels type 1



Fig 174, 175: assembly of 3 panels type 2



The following are the findings from the mockup:

1. The design is workable. The panels although cast in two stages, with hardly any metal tie between them, except for one single wire, tying the two meshes, came out as a single piece after deshuttering. The rebates being, fairly accurate and smooth although the thicknesses were extremely thin in the 1:2 scale.

2. The production method using sand fill to cast the second layer is workable and sustainable in terms of reuse of the sand as the whole of it is recoverable while deshuttering. But the method also has many disadvantages. Its very difficult to level the sand perfectly. The sand also does not permit the use of a vibrator for compacting the concrete above as it unsettles the sand layer below. As a result the thickness of the inner wythe of the panel becomes slightly uncontrollable. This although is not a problem in terms of finish, aesthetics and basic structural strength, it results in non-optimal use of materials. Hence probably a 3 part mould could be recommended from this finding to replace the use of sand bed.

3. The self alignment of panels by means of the rebate worked in the mockup. So with panels of twice the scale, it is more likely to perform better, with lesser errors in manufacture.

4. Obviously, as anticipated, the mdf profiles started warping a bit after 2 castings. Thus the mould is very unsuitable for many castings, and steel mould is recommended.

5. The idea behind having the flange width of the standard panel as 40mm, was to have a minimum thickness for workability. But as demonstrated in the mockup of 1:2, the flange of 20mm also is workable with the rebates. So the cavity could be increased for better insulation and pumping of concrete inside. However this assumption has to be validated structurally.

6. The error in the mould, which accounted for a millimeter increase in length for the inner wythe than the outer, first the first 2 panels cast, caused the panels to be very mildly out of plumb when stacked one top of the other. This defect is almost unnoticeable by the naked eye, and with more accurate steel moulds for industrial production, this problem can be totally eliminated.

7. As carried out in the lab for the mockup, the idea of this system can be extended to non-urban areas also, where site manufacture of panels with simple moulds can be possible, when industrial backup is unreachable in the settlements.

8. The panels cast for the mockup could not achieve a consistent finish, as the fluidity of concrete for very small volumes became difficult to be controlled precisely each time. Perhaps in an industrial setup, where manufacture happens at bulk this problem can be overcome.

9. Personally, I found the panel to be quite heavy to handle manually. Although I am proposing the mechanical means of lifting and placing, with labour required to just maneuver the panels in place, It would be wise at researching further on how to making the element lighter in any case.

Speed, Economy and Quality:

The product/ system has the capacity to drive down costs and improve the productivity of the construction industry as noted earlier. However these claims for level of improvement that can be achieved need to be scrutinised and evidence is required to support them. Other selling points for the product are the improvements in quality that can be achieved through factory controlled manufacture of components and the avoidance of problems with site skills shortages, by off-site manufacture.

Sustainable

Environmental legislative pressures on construction activity are likely to continue to grow in the future. If the environmental benefits can be demonstrated for the system in a more clinical and time tested way, then the system should flourish in the future. The bulk utilization of flyash itself is a potential marketing point. If the product is indeed found to be a really potent system after further research, what could be done is regional level factories could be established at the sites close the fly ash land fill areas and the thermal plants, which are actually spread over the country. This can lead to mass production, and a transition zone for the on site labourers into the more productive industrial setup. However capital costs need to be evaluated by prospective investors and manufacturers.

Facade compositions

The system provides an opportunity for architects to explore a new dimensional aesthetics with square panels for housing. The conventional construction methodology never offered a challenge to design with the dimension of individual elements as a standard, for planning or facade composition. This can open up a new dimension of architectural thought process for volumetric planning of residences. The possibility to eliminate staggering of panels by design, offers new possibilities for facade compositions. The play of openings and fenestrations are illustrated on the page on the left.

Materials and Relief

The wet casting method of the product allows the element to take up any kind of relief, form and material on its surface, as a pre finished product. All one needs to do is to have this surface spread over the base of the mould before casting or form the base of the mould with the required profile as rest of the cross section of the element remains the same. The smartness in handling the surface finish is also a means of hiding the construction errors in alignment of joints. The images on the left and next page show some of the various forms the product can be manifested into in terms of the finishes.

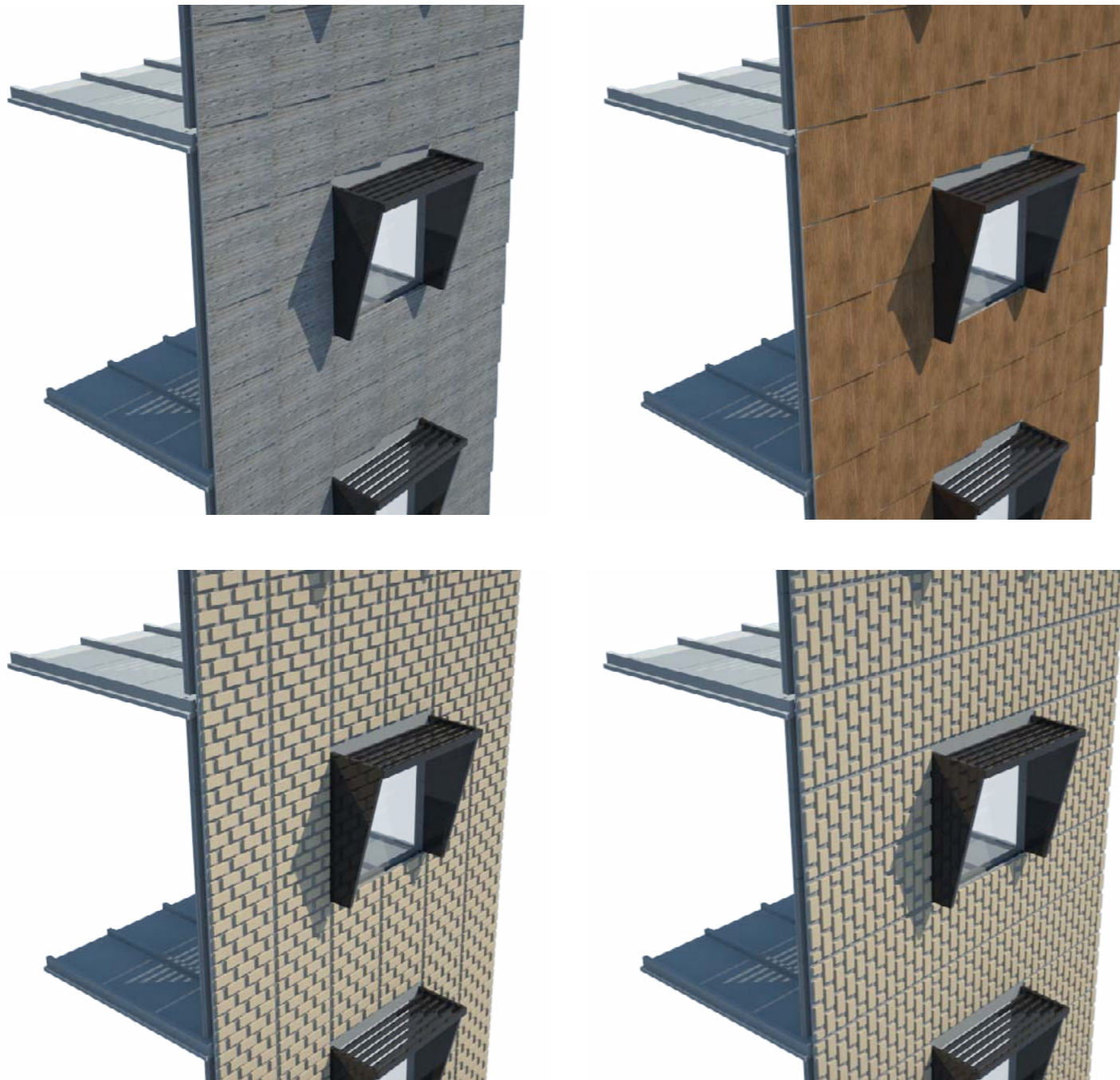
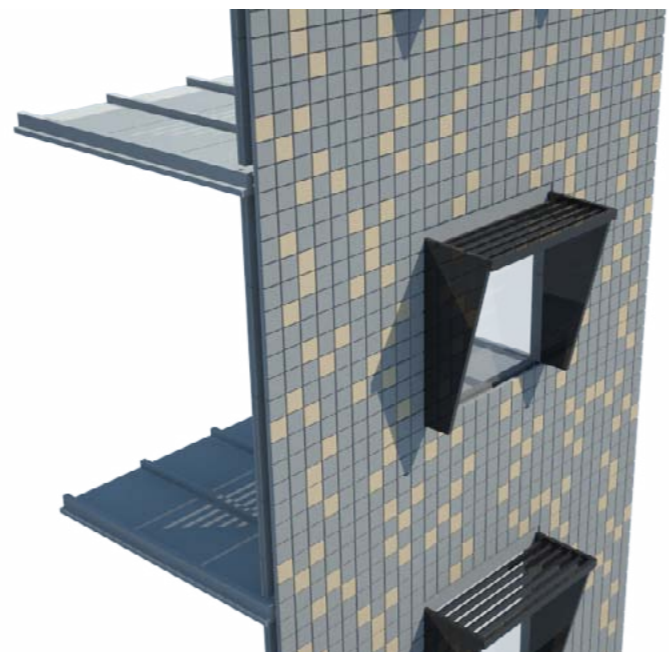
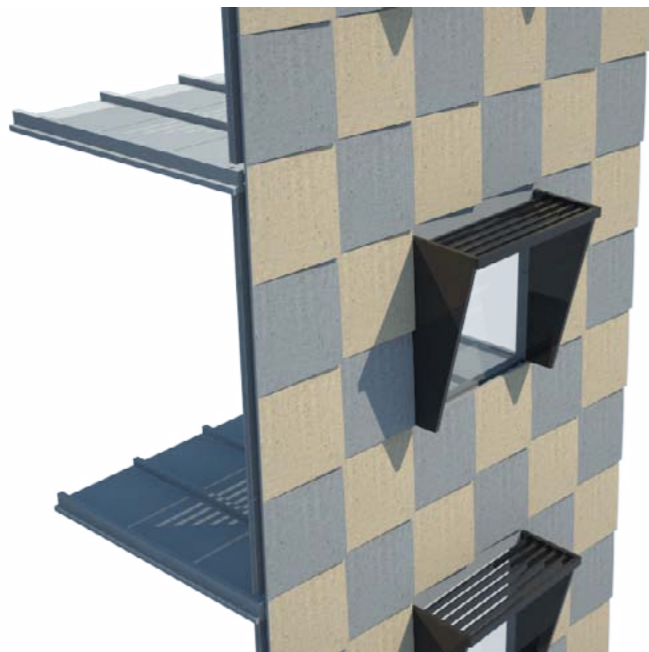

Fig 176-179: renderings of facade with different surface reliefs and materials
172



Some other Potentials:

The Concept of pretensioning with the bolt, combined with the larger size of panels than masonry units, provide them with an opportunity to be used as column and beam elements as well. So there is a possibility of even looking at frame and infill construction with the same system. So the product could then also be experimented with highrises (with probably a different cross sectional thickness if needed)

As carried out in the lab for the mockup, the idea of this system can be extended to non-urban areas also, where site manufacture of panels with simple moulds can be possible, when industrial backup is unreachable in the settlements. The Target group hence might not necessarily be limited to Middle class Urban society as defined earlier. The product could be easily experimented across varied cultural milieu and contexts

Fig 180-183: renderings of facade with different surface reliefs and materials



Fig 184-185: Facade compositions

1. Perceived Performance

Much of prefabrication has been viewed as having a shorter lifespan than that of equivalent traditional buildings. The perception that prefabrication offers a non-permanent solution is one of the potential barriers that exist for its wider acceptance as a mainstream procurement option.

2. Product Awareness

The procurement of prefabricated components for a project is often a matter of designers being aware of the availability of a given system. Designers are unlikely to use a system for which they don't appreciate the benefits for the construction, or for which they don't understand how the system impacts on the design process. So, unless forcefully tried out on a project by a progressive investor, it is very likely that architects would be hesitant to try a new system, which is not tested on a real project.

3. Conservatism and lack of innovation in mass house-building is caused by inertia created by stalemate between:

- a. Developers with a market position to maintain and
- b. Popular cynicism about builders' motives.

We therefore need a new development model to break this deadlock, and market the product

4. Society:

The challenge for prefabrication in the housing sector is to leave behind the association of some types of system with poor quality housing and even social exclusion in some extreme cases. This is at the root of whether prefabrication can be successful or not in the housing sector, and both designers and manufacturers need to come to terms with this. If prefabrication becomes linked again with these problems, then there will be a risk of it being viewed as a socially unacceptable system which, regardless of other technical merits and environmental benefits, will be viewed as a failure.

A good strategy to market the product initially would be to experiment it one more non-conservative ventures like a commercial development such a Hotel or an office building. Try the repetitive parts of the facade in those buildings with these products, so then the people, builders and architects can get a real life feel for the product, and the attitude towards the new system will slowly change, and it will get accepted in the main stream residential market.

Introduction

A simple linear courtyard planning typology is adopted to make a very rough evaluation of, if the product proposed does help in reducing the time for building at all, which was the very first problem identified for the start of this thesis.

The design of the housing, is partially based on the 'marble arch housing' in Chandigarh, by Morphogenesis architects. Although the proposed scheme is very different in terms of dimensions and complexity, the functional planning is sourced from the case study quoted.

the typical setting, is illustrated clearly in the figure on the left. Its a linear block, based on the 750/ 150 module, with just the kitchen wing turning inwards to join with the staircase. The apartment is repeated along the sides and mirrored along the staircases to form a court on the inner side. As explained with the climatic study in chapter 2, this linear planning helps with the air flow needed for warm humid climate, as also suitable for 1 way spanning for precast floor slabs. The stability for the system is provided by the staircase cores. The precast floor slabs might also perform like diaphragms to transfer horizontal forces.

Since we are basically looking at the product as a wall element, the agenda here is to roughly compare the time for building the load bearing wall for 1 apartment with 'stack-crete' with the corresponding time using conventional CMU construction. The wall construction time includes comparable items like finishing time etc, which make a difference to the time of building, overall.



Fig 186: typical plan of 1 apartment

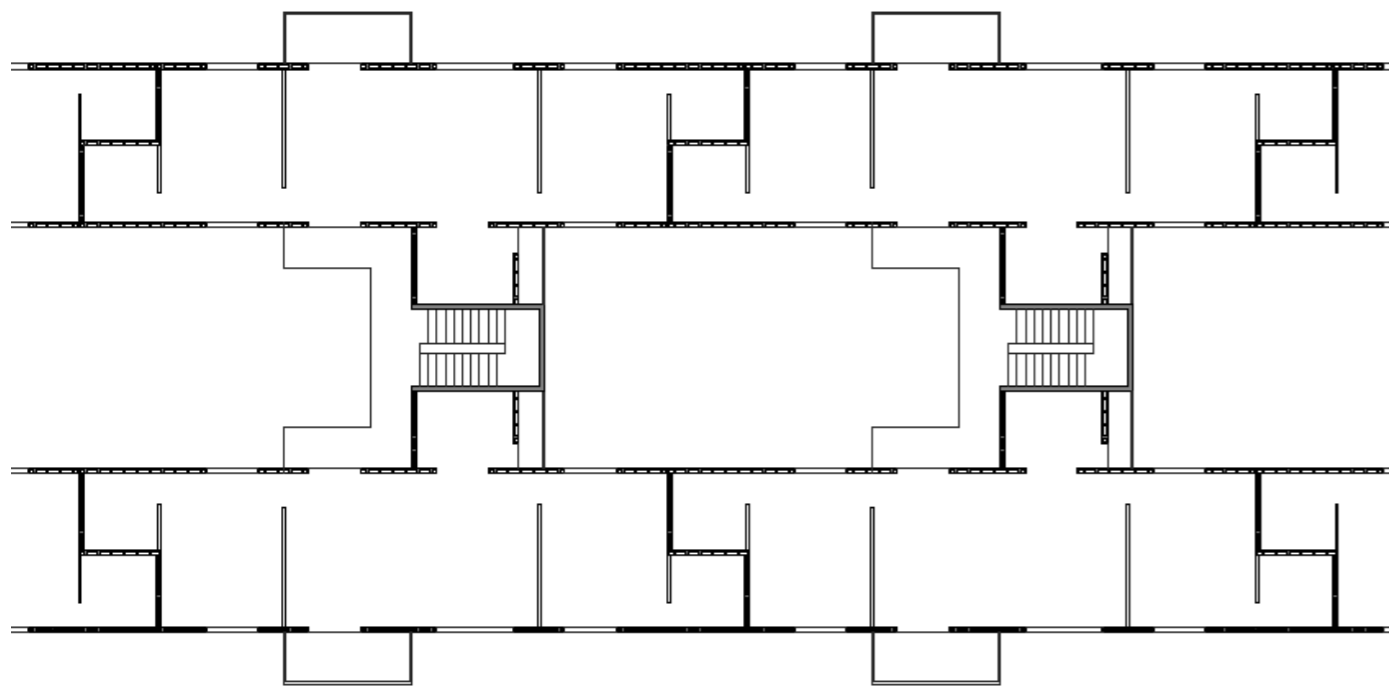

Fig 187: plan of apartment cluster

Total wall surface area: 140 sq.m

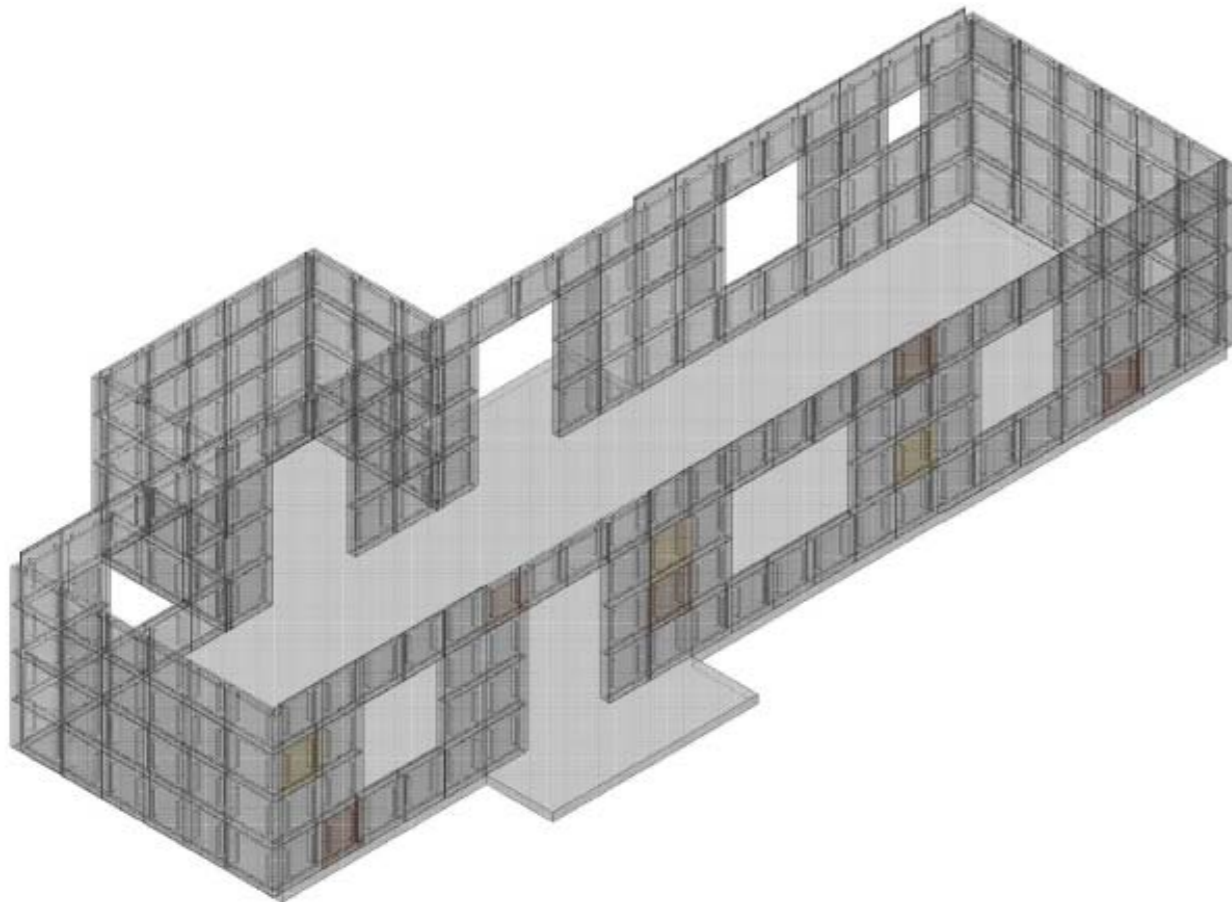

Fig 188: view of a single apartment with walls of stackcrete

	Skilled workers	Unskilled workers	Man hours	Output Sq. m	Total time for entire wall
CMU construction	1	2	8	12	12 days
External plastering	1	2	8	9	16 days
Internal plastering	1	2	8	9	16 days
External painting	2	1	8	40	3.5 days
Internal painting	2	1	8	40	3.5 days

Fig 189: table, illustrating time estimate of wall construction and finishing with conventional CMU

	Skilled workers	Unskilled workers	Man hours	Output Sq. m	Total time for entire wall
Manufacture	-	-	zero	-	-
Panel erection	2	2	8	72	2 days
Cavity concrete fill	2	2	8	100	1.5 days
Curing time if needed (max.)					7 days
Internal painting	2	1	8	40	3.5 days

Fig 190: table, illustrating time estimate of wall construction and finishing with Stack crete

The time

Conventional CMU construction:

As indicated in the table on the left, conventional CMU construction involves, blockwork constructions, then plastering and then painting, to put it in a crude way. The productivity rates are measured up for all three categories. As can be seen in the table, the plastering work consumes a lot of time. The building process is heavily slowed down in the later parts of construction due to this activity.

Stack-crete construction:

The 2nd table on the left, demonstrates the various stages involved for completion of the 'wall'. The manufacture of the product can be industrialised, as well as the stacking process on the site. Both of these can hence be parallel or pre-organised activities which do not impact the time of building the wall after the work has begun. So the assembling time, and cavity filling time is all that matters. The values for concrete pumping are considered on the slower side, to calculate the maximum time it might take in any case. The cavity, for all practical purposes, does not need curing time for construction to proceed further, but worst case scenario, if needed for structural reasons, 1 week of time is added.

Considering all this factors it might be noted that Stack crete proves to take less than half the conventional type for construction for wall alone. Considering the overall building process, that flooring system also does not impede the time for moving up with upper walls, the speed is definitely enhanced, theoretically.

However, this evaluation has to be done on a practical project, and studied with the help of building contractors, to really test how much time is saved, and what teething problems might arise.

Initially, when I came up with the topic, I was being extremely ambitious. I wanted the project to touch upon, and explore all the limits in how industrialisation could radically change the way urban housing is built in India, in terms on quality, speed, better environment, flexibility etc . I even wanted to even study how the prefabrication could be made as a parametric model of allowing plug in systems in 'n' different options as per needs.

But I realised that this was not was not possible within the timeframe I am working with for the graduation programme. Having realised that research on the topic is a continuous process, it doesnt stop with graduation, I slowly narrowed my focus of research into a few aspects which I was more interested in the broad topic. The focus essentially is on 'product- development', an assemble-able product, which as a building system benefits the housing industry in India. Nevertheless, the motivation for doing something which helps in giving me insight into what I could be focussing on in my career when I head back made me focus strongly in depth into what I have worked on for this graduation.

If I look back at the research work, the initial intent of developing a 'prefab' system has eventually materialized into a midway solution between 'prefab' and masonry, but can still be categorized under prefab. What the product also offers is to develop a new 'industrial' craft in the way it can be assembled. This development is obviously a long process, which will evolve over a period of time, tested by time and people.

The Mockup in CiTG was a great experience. Trying out the design with real materials and manufacturing process offered a lot of thrill and a great learning eaperience. It was most satisfying that the results of the mockup were not far from what was predicted in theory. So far it has a satisfyting experience about the various things I have been able to explore during this process, although I can always say 'I could have done more'.

The graduation experience has been fairly successful and has provided me a good launchpad into what I would be looking forward to do in my future as a professional- design and development of Industrial Products in India for building industry, as a step towards a sustainable, flexible industrialization. I must mention here that my crude experiences in practically trying out concrete casting and erection, with my Father a few years back, prompted me to think about this topic for graduation, as also helped me partly envisage the problems that might arise in the development of such a system.

Any research work is always a continuous process. There can be no full-stop to it. This is more so for an academic work, where in you conclude at some point to fulfill academic requirements for graduation. But the conclusion itself will end with scope for further research.

At this point it is only fair to say that I feel that the research work presented here is worthy of further research, more rigorously. Some of the positive conclusions from the research work would be:

Conclusions

1. The proposed product/ system eliminates scaffolding work required required from outside the facade for plastering/ painting/ finishing, as the product is prefinished and the assembly can happen with labour having to move on just plain ground and the floor slabs alone. Thereby reducing time of building.

2. Basic structural calculations prove that self weight of the panel is just enough to maintain the walls stable enough after just dry stacking. The interlocking mechanism provides sufficient self-alignment possibility as observed in the 1:2 mockup.

3. The product, due to its composite action has a high strength-to-weight ratio, making it an efficient one. This effect can be further enhanced than the present design, by making the flange thinner, as demonstrated in the 1:2 mockup that it is workable, unlike assumed otherwise initially. More optimisation is thus possible

4. It is found that, a basic standardisation in architectural planning of residences like floor heights, opening sizes, can offer a good flexibility with larger panel sizes also. Unlike blockwork masonry, which was developed as a generic walling system, the flexibility was offered only by limiting its dimension. Developing a product for a particular building typology offers more flexibility for bigger dimensions.

5. The utilization of high volume flyash in the making of the product, makes the product more energy efficient in terms of reduced embodied energy, lesser impact on raw material sourcing, and high insulation values for similar thicknesses of conventional construction- to name a few.

6. The product can be manufactured with simple production methods. Thereby the establishment of multiple regional factories near to all the fly ash sources is a viable option to reduce transport overheads.

7. As demonstrated earlier, the product can take up almost any finish, relief, form, and texture on the exterior. This being prefinished, makes it a very versatile product to play with for architectural composition of facades.

8. The product, hence, may not necessarily be limited for residential use, although developed with such a target group. It is open to varied interpretation of use by designers.

Recommendations

1. The properties of fly-ash varies from source to source. So under any circumstance the research work should base its study on the technical findings on 'a' particular source of plant, and not generic, for design.
2. What is necessary in Indian scenario today, is for designers (architects) and researchers to work together to improve the product. This relation is severely lacking today, and is weighing down heavily in marketing any new product, where in architect themselves start opposing it.
3. The economics of the product has not been studied in this research. It is essential to study this aspect in detail, can modify to balance it with quality, in order to market it.
4. The fire resistance properties of the product/ system has not been investigated. Although there are no building norms in India for fire safety for low rises, it is important to study the behaviour of the product/ system in case of fire. Acoustical properties of the product is another aspect which hasnt been investigated. It is important to study this aspect, in comparison with conventional construction systems.
5. The joint system as explored in the model, is still not fool proof at the corners as noted in the model. It needs more research, to make it water tight at corners.
6. The method of site prestressing is also worthy of further research. The economics of such a pre-bolted connection system needs to be studied. The behaviour such a wall system in seismic zones needs evaluation.
7. The curing method for the flyash concrete poured into the cavity is not touched upon here. It is important ot test it out in the cavity, and check if any pores are needed in the flanges for escape of air.
8. A protection system for the harmful effects of flyash needs to be worked out. Wearing masks is obviously a pre-requisite, but further steps may be necessary
9. It would be necessary to forcefully test out the system on one or two projects, to see whether it would be welcome by the labour force and the generic public.

11. References

- 01 **Ar. Uttam K. Roy, Dr. Madhumita Roy, Prof. Subir Saha**, *Mass-Industrialized Housing to Combat Consistent Housing Shortage in Developing Countries: Towards an Appropriate System for India*
- 02 ?
- 03 **Albert G.H. Dietz, Laurence S. Cutler**, *Industrialized Building Systems for Housing, MIT Special Summer Sessions- august 1969 and June 1970*
- 04 **W.A.Thanoon, Lee Wah Peng, Mohd Razali Abdul Kadir, Mohd Saleh Jaafar and Mohd Sapuan Salit**, *the essential characteristics of industrialised building system*
- 05 **Dr.Shailesh Kr.Agrawal**, *Innovative Building Materials and Technologies for LowCost Housing, International Conference on Industrialised Building Systems, Kuala Lumpur, Malaysia,10-11 September, 2003*
- 06 *Constructionweekonline.in, The low-rise trend, May 24th 2010*
- 07 **U.S. Department of Housing and Urban Development (HUD), Office of Policy Development and Research (PD&R), in partnership with the Office of Native American Programs (ONAP)**, *Sustainable Construction in Indian Country (SCinIC)*
- 08 **Bolton, G. et al.** (1999) *Housing: an exercise in industrial design, Arup Journal, Autumn*
- 09 **Bottom, D., Gann, D., Groak, S. & Meikle, J.** (1996) *Innovation in Japanese prefabricated house building industries, Special Publication 139, CIRIA, London, UK.*
- 10 **Ryan Smith and Shilpa Narayanamurthy, University of Utah**, *Without a Hitch: New Directions in Prefabrication Architecture; Prefabrication in Developing Countries: A Case Study of India, 2008*
- 11 **CII and Natural resources Canada**, *fly ash status summary report in india*
- 12 **Bansal N.K. and Minke G.**, *Climatic zones and rural housing in India, Kernforschungsanlage, Juelich, Germany, 1988.*
- 13 **Madhavi Indraganti, B. Arch, M.Tech. (IITD), Ph.D.**, *Adapting to Change: New Thinking on Comfort, Thermal Adaption and impediments: Findings from a field study in Hyderabad, India*
- 14 **SP 7:2005, national building code of India 2005**, Bureau of Indian Standards, New Delhi, 2005.
- 15 **Bruce King P.E.**, *Making Better Concrete, Guildelines for Using Fly-ash fir Higher quality Eco-friendly Structures, Green Building Press*
- 16 **C.L. Verma, S.K. Handa, S.K. Jain, R.K. Yadav**, *Techno-commercial perspective study for sintered fly ash light-weight aggregates in India*
- 17 **Glory Joseph, K. Ramamurthy**, *Influence of fly ash on strength and sorption characteristics of cold-bonded fly ash aggregate concrete*
- 18 **Alex H Chu**, *precast concrete panel systems for housing*
- 19 **prof.ir. H.W. Bennenk**, *BFBN - Bouwen in Prefab Beton*
- 20 **Johs F. Munch-Peterson**, *Typical Danish floors, walls and facadees, Technical University of Denmark, 1980*
- 21 *State-of-the-art of precast/prestressed sandwich wall panels, PCI journal march-april 1997,*
- 22 www.arxx.com
- 23 <http://www.xella.com/en/content/silka.php>
- 24 **Kishor S. Jaiswal, Ravi Sinha, Alok Goyal**, *HOUSING REPORT- Reinforced concrete frame building with masonry infill walls designed for gravity loads*
- 25 <http://www.morphogenesis.org/projects/project/?p=0017>
- 26 <http://www.deir.qld.gov.au/workplace/subjects/manualhandling/issues/limits/index.htm>
- 27 **Paul Waskett**, *DTI Construction Industry Directorate Project Report : Current Practice and Potential Uses of Prefabrication*
- 28 **Robert Gordon University, Aberdeen**, *Overcoming Client and Market Resistance to Prefabrication and Standardisation in Housing.*
- 29 **Ellen Baum, Clean Air Task Force, Boston, MA**, *Strategies for Cleaner Walling Material in India*

- 30 **Bansal N.K. and Minke G.**, *Climatic zones and rural housing in India*, Kernforschungsanlage, Juelich, Germany, 1988.
- 31 **Stanley Russell, University of South Florida**, *Without a Hitch: New Directions in Prefabrication Architecture; Metabolism Revisited: Prefabrication and Modularity in 21st Century Urbanism*, 2008
- 32 **Hardingham, Samantha, London**: *A Guide To Recent Architecture*, B. T. Batsford, London, 2002, pp. 294-97
- 33 **Bergdoll, Barry and Peter Christensen**: *Home Delivery. Fabricating the Modern Dwelling*, The Museum of Modern Art (MoMA), New York, 2008
- 34 **Jackson, Leslie**: *The Sixties: Decade of Design Revolution*, Phaidon, London, 2000
- 35 **Linda BrockI and James BrownII**: *The Prefabricated House in the Twenty-First Century: What Can We Learn from Japan? A Case Study of the KST-Hokkaido House*
- 36 **Svetlana Brzev, British Columbia Institute of Technology, Canada**
Teresa Guevara-Perez, Architect, Venezuela- precast concrete construction
- 37 www.pci.org
- 38 www.af-tab.nl
- 39 www.morphogenesis.org/
- 40 <http://www.thehindu.com/news/national/article1159274.ece>
- 41 <http://saferenvironment.wordpress.com/2009/07/02/coal-ash-disposal-becoming-burning-issue-%E2%80%93needs-to-be-resolved-in-eco-friendly-manner/>
- 42 **Organisation for European Economic Co-operation, European Production Agency**: *Modular Co-ordination*, July 1961
- 43 **Hubert Bachmann, Alfred Steinle**: *Precast Concrete Structures*, 2011

Time period	Total housing need including backlog in cr.			Housing shortage in terminal year HI_y^1	Increase in Stock HS_{x-y}
	Initial shortage $(HI_x)^1$	Additional requirements for new population $(IA_y)^2$	Total need $H_y = (HI_x + IA_y)$		
1961-71 Third and fourth plan	1.52	0.221	1.741	1.46	0.281
71-81 Fifth and sixth plan	1.46	0.277	1.737	2.33	-0.593
81-91 Sixth and seventh plan	2.33	0.334	2.664	2.29	0.374
91-2001 Eight and ninth plan	2.29	0.374	2.664	2.47	0.194
2001-11 10 th and 11 th plan	2.47	0.183**	2.653	--	--

Census years	Number of Urban agglomeration/town	1901 2001		
		Total population	Urban population	Rural
1901	1827	238396327	25851873	212544454
1911	1825	252093390	25941633	226151757
1921	1949	251321213	28086167	223235046
1931	2072	278977238	33455989	245521249
1941	2250	318660580	44153297	274507283
1951	2843	361088090	62443709	298644381
1961	2363	439234771	78936603	360298168
1971	2590	598159652	109113977	489045675
1981	3378	683329097	159462547	523866550
1991	3768	844324222	217177625	627146597
2001	5161	1027015247	285354954	741660293

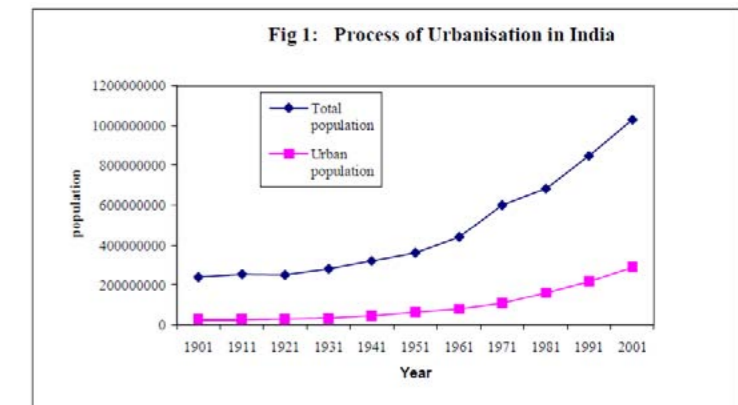

Appendix 2

Indian Geography and Climate



Geographically, India is a land of diversity, situated between $8^{\circ} 4' N$ and $37^{\circ} 6' N$ North Latitude and $68^{\circ} 7' E$ and $97^{\circ} 25' E$ East Longitudes, it occupies a large area of South Asia. The mainland of India has four well defined geographical regions - Mountains, Plains, the deserts and the southern peninsula.

The mountainous region is comprised of the Himalaya, the highest mountain ranges in the World. The glaciers in the Himalaya and the monsoon rains are sources of water for perennial rivers in the plains. During the monsoon season, the heavy water coming out of these rivers causes frequent flooding.

The plains are mainly made up of basins by three main rivers in India - the Indus (also called as Sindhu), the Ganga and the Brahmaputra. These fertile plains run through most of the northern, central and eastern India, while most of the south India is covered by the Deccan Plateau. Besides Deccan Plateau, Malwa Plateau (in the west) and Chota Nagpur Plateau (in the east) are also there.

In the desert area, Thar desert in Rajasthan, Rann of Kutch in Gujarat and the trans-Himalayan cold deserts of Laddakh are important regions of Indian geography.

The Southern Peninsular part of India has mountains or hilly ranges - Western and Eastern Ghats, Nilgiri ranges with coastal areas. The West of India is bordered by the Arabian Sea, whereas there is Bay of Bengal in the East of India and Indian Ocean towards the South.

This unique geography and geology of India strongly influence its climate along with the characteristic monsoon climatic system.

The word climate refers to the weather variation systems of any specific area over a period of time.

Being a vast country, India is divided mainly into four climatic zones. These zones are namely Alpine, Subtropical, Tropical and Arid.

Alpine Zone: This climate zone can be experienced in the high altitudes of Himalaya. In this region there are high climatic fluctuations due to steep altitude variations. Different types of climatic zones can be seen in this region. On the foothills occur subtropical climate whereas on the higher altitudes there is Alpine Tundra Zone.

Sub Tropical: This zone is prevalent in most of the northern and peninsular part of India. It can be called as the typical Indian monsoon climate. Summers are hot and wet with the monsoons precipitating for three to four months while in winter temperature may drop down to freezing point in higher ranges like in northern sections near Himalaya. The coastal regions have moist and humid climate with minimal variations from mean temperatures throughout the year.

Tropical: It can be divided into two sub types viz., Tropical Wet Monsoon and Tropical Dry. The characteristics of Tropical Wet Monsoon include average temperature, which normally does not fall below $18^{\circ}C$, accompanied by average to high rainfall as experienced in Kerala for almost 8 months of the year. The rest of India does not show a typical tropical climate.

Arid: High temperature and low rainfall are marked features of this climatic zone. This climatic zone is prevalent in western part of the country and includes large part of Rajasthan. The temperature in this zone may shoot up to as high as $50^{\circ}C$ in summer.

Due to its geographical position and the climatic conditions, India witnesses different climatic seasons in a year commonly known as - Winter, Summer and Monsoon.

Winter: At this time of the year, days are cold. In some higher ranges of northern India temperature can drop down to below $0^{\circ}C$. Normally winters are dry in northern India. In Southern part, the temperature difference is not so marked due to moderating effect of Indian Ocean, Bay of Bengal and Arabian Sea. Wintertime is observed in almost all parts of India during November to February.

Summer: It is a time period when rays of the sun fall vertically on Indian subcontinent. The average temperature varies region-wise but in northern & western region the maximum temperature can be far above the average. Hot wind, known as 'Loo' is the marked feature of summers in northern India. March, April and May are the summer months in India.

Monsoon (Rainy): In the months of June, July, August and September India gets major part of its share of rain. Rain starts from Andaman-Nicobar then Kerala and advances to almost all parts of the country. The monsoon approaches with moisture laden winds & is marked with violent thunderstorms and lightening, known as 'break' of the monsoon.

In the month of September this monsoon after drenching all of India, begins to retreat, called as Retreating Monsoon. Rainfall begins to decrease and upto November, the monsoon completely goes from major part of India, except for Tamil Nadu and some other southern states.

Indian Meteorological department (IMD) divides the year into four seasons for India, namely winter, premonsoon, and southwest & post monsoon season. Division of these four seasons depends upon Monsoon pattern.

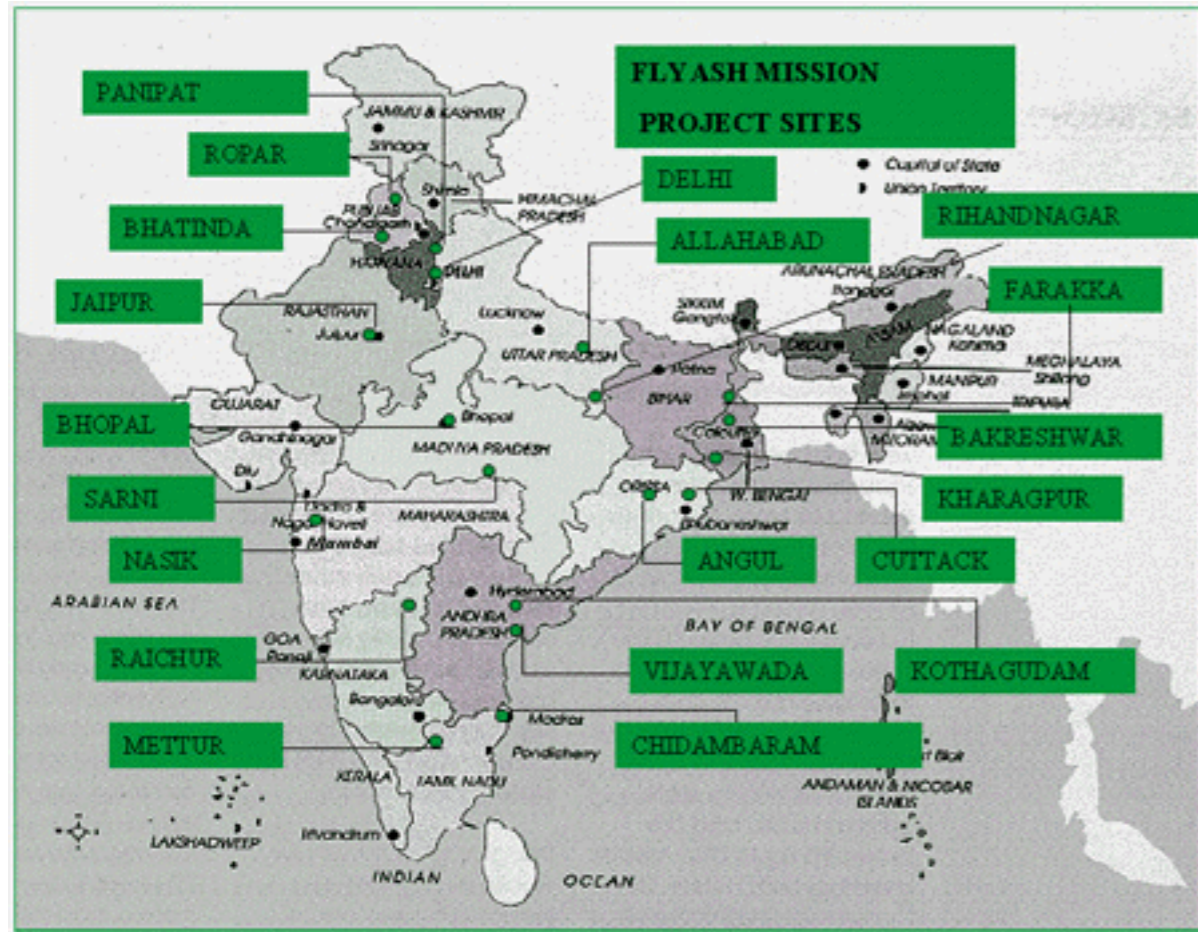

S No	Country	Annual ash production, MT	Ash utilization %
1	India	112	38
2	China	100	45
3	USA	75	65
4	Germany	40	85
5	UK	15	50
6	Australia	10	85
7	Canada	6	75
8	France	3	85
9	Denmark	2	100
10	Italy	2	100
11	Netherlands	2	100

Mixture compositions with fly ash as cement replacement.

Cement (kg/m ³)	Fly ash (kg/m ³)	Water (kg/m ³)	Water-binder ratio	CA/TA (vol.%)	Sand (kg/m ³)	Fresh density (kg/m ³)	Slump (mm)	Total vol. of fly ash (cold-bonded aggregate + fly ash replacing cement) (m ³ /m ³ of concrete)
450	0	175	0.39	50	861	2127	55	0.329
405	45	175	0.39	50	851	2110	60	0.346
315	135	175	0.39	50	832	2077	65	0.382
225	225	175	0.39	50	813	2044	70	0.417
450	0	175	0.39	65	603	2060	85	0.427
405	45	175	0.39	65	596	2045	90	0.444
315	135	175	0.39	65	583	2013	95	0.477
225	225	175	0.39	65	569	1982	110	0.511

Mixture compositions with fly ash as sand replacement.

Cement (kg/m ³)	Water (kg/m ³)	CA/TA (vol.%)	Sand (kg/m ³), Fly ash: 0%	Slump (mm), Fly ash: 0%	Replacement of sand with fly ash (%)	Sand (kg/m ³)	Fly ash (kg/m ³)	Superplasticizer (% by weight of cement + fly ash)	Total vol. of fly ash (m ³ /m ³ of concrete)
450	175	50	861	50	20	689	137	0.3	0.395
					40	517	275	0.5	0.461
					60	361	432	0.6	0.55
350	175	50	902	50	20	722	144	0.25	0.413
					40	541	288	0.4	0.482
					60	361	432	0.6	0.55
250	175	50	944	60	20	755	150	0.22	0.432
					40	566	301	0.35	0.504
					60	378	452	0.55	0.576
450	175	65	603	85	20	482	96	0.25	0.473
					40	362	192	0.45	0.519
					60	241	288	0.65	0.565
350	175	65	632	90	20	505	101	0.2	0.496
					40	379	202	0.35	0.544
					60	253	303	0.55	0.592
250	175	65	661	95	20	529	105	0.15	0.518
					40	397	211	0.25	0.569
					60	264	316	0.4	0.619
450	220	50	802	180	20	642	128	0.25	0.367
					40	481	256	0.45	0.428
					60	321	384	0.7	0.489
350	220	50	844	190	20	675	135	0.2	0.386
					40	506	270	0.35	0.450
					60	337	404	0.65	0.515
250	220	50	885	190	20	708	141	0.15	0.406
					40	531	282	0.3	0.473
					60	354	424	0.5	0.541
450	220	65	561	240	20	449	90	0.2	0.441
					40	337	179	0.4	0.484
					60	225	269	0.6	0.526
350	220	65	590	250	20	472	94	0.15	0.463
					40	354	188	0.3	0.508
					60	236	283	0.55	0.553
250	220	65	620	245	20	496	99	0.1	0.486
					40	372	198	0.25	0.533
					60	248	297	0.4	0.581
					80	124	395	0.65	0.628
					100	-	494	0.9	0.675

Appendix 4 Structural calculations

check for axial compression

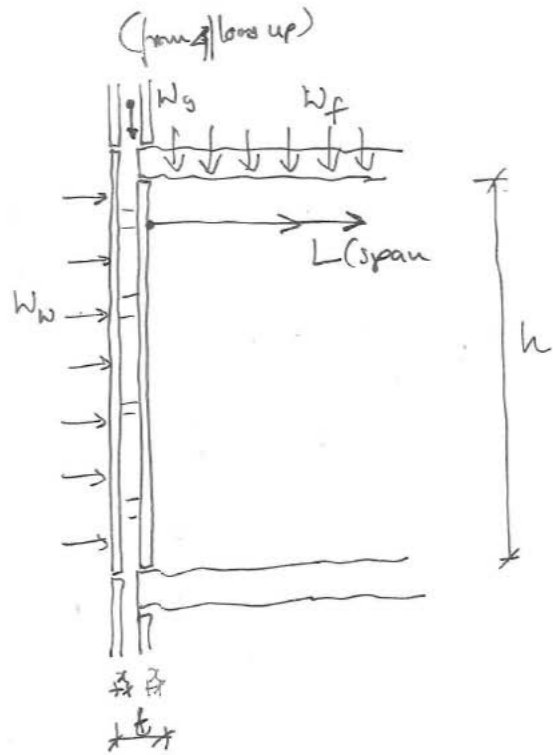

$h = 2.85 \text{ m} = 2880 \text{ mm}$
 $L = \text{span} = 4500 \text{ mm}$
 $t = 150 \text{ mm}$
 $x = \text{flange width} = ?$
 $t_{eff} = (2 \times \frac{x}{2}) + (150 - 2x)$
 $= (150 - x)$
 $W_f = 7 \text{ kN/m}^2$
 $W_w = 0.6 \text{ kN/m}^2$
 $W_g = (4 \times 7 \times 2.25) \times 1.1 = 23.1 \text{ kN/m}$
 $W_y = (4 \times 7 \times 2.25) \times 1.1 = 23.1 \text{ kN/m}$

Slenderness ratio $\lambda \leq 27$

$$\therefore \frac{h_{eff}}{t_{eff}} < 27 \Rightarrow \frac{2850}{t_{eff}} < 27$$

$$\therefore t_{eff} > 105 \text{ mm}$$

$$\Rightarrow x \leq 45 \text{ mm (as } t = 150 \text{ mm)}$$

\therefore Let's consider $x = 40 \text{ mm}$

$$W_{fn} = 1.5 \times 7 \times 4.5 = 23.625 \text{ kN/m}$$

$$W_g = 1.5 \times 7 \times 2.25 = 10.5 \text{ kN/m}$$

Eccentricities

$$V_k = \frac{4500}{150} = 30 \Rightarrow e_x = \frac{t}{2} - \frac{z_k}{2} = \frac{150}{2} - 49 = 55 \text{ mm}$$

Eccentricities

e_x (due to imposed load)

$$V_k = \frac{4500}{150} = 30 \Rightarrow e = \frac{t}{2} - \frac{z_k}{2} = \frac{150}{2} - 49 = 55 \text{ mm}$$

Correction due to loads from above,

$$e_{sc} = \frac{W_f \cdot e}{W_g + W_f} = \frac{23.625 \times 55}{10.5 + 23.625} = 30.18 \approx 15$$

$$\therefore \frac{e_x}{t} = \frac{e + 10}{150} = \frac{0.066}{1}$$

e_w (due to wind)

$$M_w = 1.2 \times 0.6 \times \frac{2.85^2}{8} = 0.72 \text{ kN-m/m}$$

$$e_{wx} = \frac{M_w}{t \cdot W_g} = \frac{0.72 \times 10^3}{150 \times (10.5 + 23.625)} = 0.0324$$

e_a (due to slenderness ratio)

$$e_{ax} = \frac{\lambda^2}{2400} - 0.015 = \frac{27^2}{2400} - 0.015 = 0.025$$

e_m (error)

$$e_m = \max \left\{ 0.066, 0.75(0.066) + 0.0324 + 0.025 \right\} = 0.34$$

$$\therefore \frac{e_m}{t} = 0.34$$

$$\therefore \beta = 1.1 [1 - 2 \times 0.34] = 0.352 \text{ (reduction factor)}$$

Taking f_{ck} of concrete panel as a minimum of 21 N/mm^2

$$N = \frac{\beta f_{ck} \times t}{\gamma_m}$$

where γ_m = material safety factor usually 1.5

$$\therefore N = \frac{0.352 \times 21 \times 150}{1.5} = 315 \text{ kN/m}$$

$$\therefore 315 \text{ kN/m} \geq 128.625 \text{ (imposed load)}$$

\therefore So a wall with a maximum slenderness ratio will still work for a total width of 150 mm.

Please note that increasing the flange width beyond 45 mm will decrease β increase the slenderness ratio also beyond permissible limit of 27

Weight

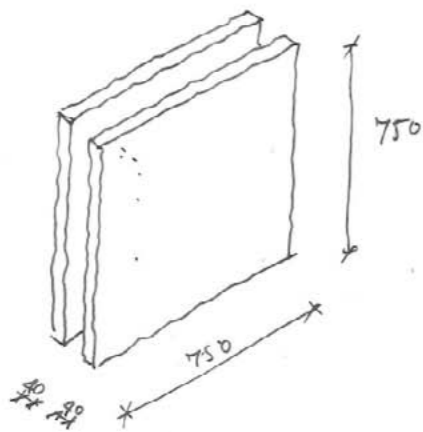

$$\rho = \text{density} \approx 2100 \text{ kg/m}^3$$

$$\therefore \text{Weight of each panel} \approx 0.04 \times 2 \times 0.75 \times 0.75 \times 2100$$

$$= 94.5 \text{ kg}$$

(excluding shear connectors)

So lets say 100 kg approximately maximum weight

Shear connector

Let's suppose we use the same flyash concrete for shear connector. The critical condition would be to examine when a lifted carries the panels above at shear connector (upto a floor height). Shear transfer is ultimate then.

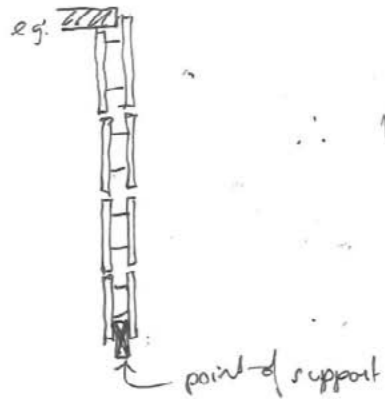

\therefore We may assume for convenience

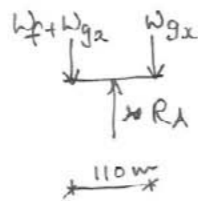

Let's assume there are 2 planes of shear connectors per panel, each spaced at 450 mm c/c

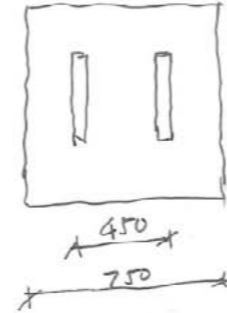

\therefore The reaction & the load will be distributed between the 2 connectors.

Hence we need to calculate the loads imposed on 375 mm width ^(750/2)

$$W_f = 1.5 \times 7 \times 2.25 \times 0.375 = 8.86 \text{ kN}$$

$$W_g = 4 \times 0.04 \times 0.375 \times 0.75 \times 2100 \times 10 = 1.92 \text{ kN}$$

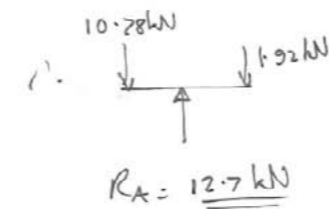

\therefore Shear connector have to be designed for a force of 12.7 kN.

Assuming maximum shear stress in concrete = 552 kPa

$$\text{Area of concrete} = \frac{12.7 \times 10^3}{552} = 0.021 \text{ m}^2$$

Assuming 450 mm depth for the web we need $\frac{0.021}{0.45} = 0.046 \text{ m width}$

\therefore Each web can be 45 x 450 mm

STABILITY CHECK FOR DRY STACKING

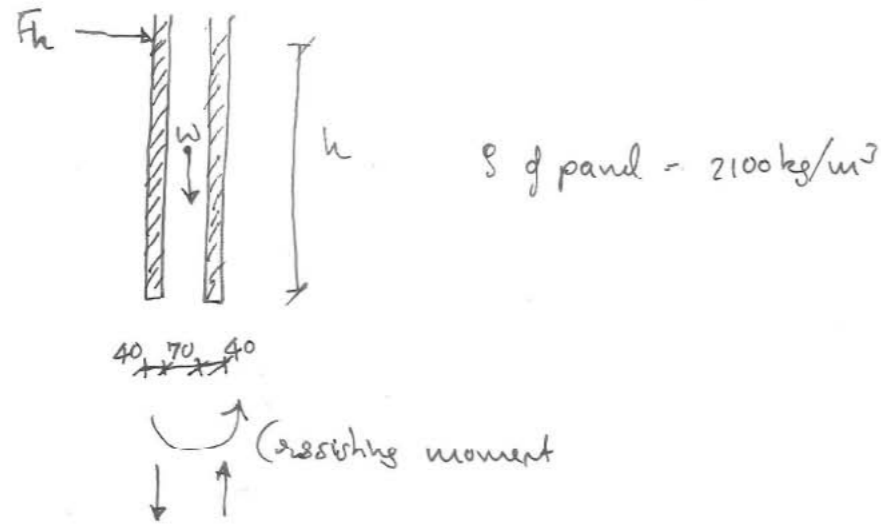

$$\sigma_N = \frac{h \times 0.04 \times 2 \times 21}{0.04 \times 2} = 21 \cdot h \text{ kN/m}$$

$$\sigma_M = \frac{M}{W} = \frac{F_h \cdot h}{\frac{1}{6}(0.15^2 - 0.07^2)} = \frac{F_h \cdot h}{0.0037}$$

For stability $\sigma_N \geq \sigma_M$

$$\therefore 21 \cdot h \geq \frac{F_h \cdot h}{0.0037}$$

$$\Rightarrow h F_h \leq \underline{70 \text{ N}}$$

70 N is quite a nominal limit. Since the stability is independent of the height as we see in the calculation, may be advisable to temporarily support the last layer panels of each floor, before grouting and while it sets.

CALCULATION OF THERMAL CONDUCTIVITY OF MIX

① For WYTHG-① & CAVITY OF SAME MIX (2a)

Cement = $250 \text{ kg/m}^3 = C$
 Water = $0.4C = 100 \text{ kg/m}^3 = W$
 Sand = $124 \text{ kg/m}^3 = S$
 Flyash = $395 \text{ kg/m}^3 = F = 0.628 \text{ m}^3/\text{m}^3$ of mix = given

$\rho_C = 1506 \text{ kg/m}^3$
 $\rho_W = 1000 \text{ kg/m}^3$
 $\rho_S \approx 1600 \text{ kg/m}^3$

\therefore Volume fractions of component.

$$V_C = \frac{250}{1506} = 0.166$$

$$V_W = \frac{100}{1000} = 0.10$$

$$V_F = 0.628$$

$$V_S = 0.106$$

Given

$$\lambda_C = 0.29$$

$$\lambda_W = 0.58$$

$$\lambda_S = 0.25$$

$$\lambda_F = 0.087$$

$$\therefore \lambda_{\text{concrete}} = (\lambda_C V_C) + (\lambda_W V_W) + (\lambda_F V_F) + (\lambda_S V_S)$$

$$= (0.166 \times 0.29) + (0.10 \times 0.58) + (0.628 \times 0.087) + (0.106 \times 0.25)$$

$$\text{or } \lambda_{2a} = \underline{0.185 \text{ W/mK}}$$

② Cavity WITH NO FINES Fly ash CONCRETE (2b)

Cement : Aggregate = 1:8 by Volume
 50% Fly replacement \Rightarrow 1:1:16 Cement : Flyash : aggregate
 Aggregate has 15:85 cement : Flyash.

$$\therefore \text{Net Cement : Flyash} = \underline{21:91}$$

Water = 40% of cement (excluding aggregate)

$$\therefore \text{Net ratio } W:C:F = 3:21:91$$

$$\therefore \lambda_{\text{concrete}} = \frac{0.58 \times 3}{115} + \frac{0.29 \times 21}{115} + \frac{0.087 \times 91}{115}$$

$$\therefore \lambda_{\text{concrete}} \text{ or } \lambda_{2b} = \underline{0.135 \text{ W/mK}}$$