



ESCAPING CASABLANCA

rense kerkvliet
p5 presentation
chair of methods
and analysis

resorting to inversions of everyday life

CONSTRUCTION OF DESIRE

reading la corniche, casablanca's other

TOWARDS SANCTUARIES OF PLAY

introducing the 'holy' day in casablanca

TACTICS FOR INTERVENTION

exploiting casablanca's collective memory of 'holiday'

THREE INSTANCES OF BEACH

materializing the architectural oasis

ESCAPING CASABLANCA

rense kerkvliet
p4 presentation
chair of methods
and analysis

resorting to inversions of everyday life

CONSTRUCTION OF DESIRE
reading la corniche, casablanca's other



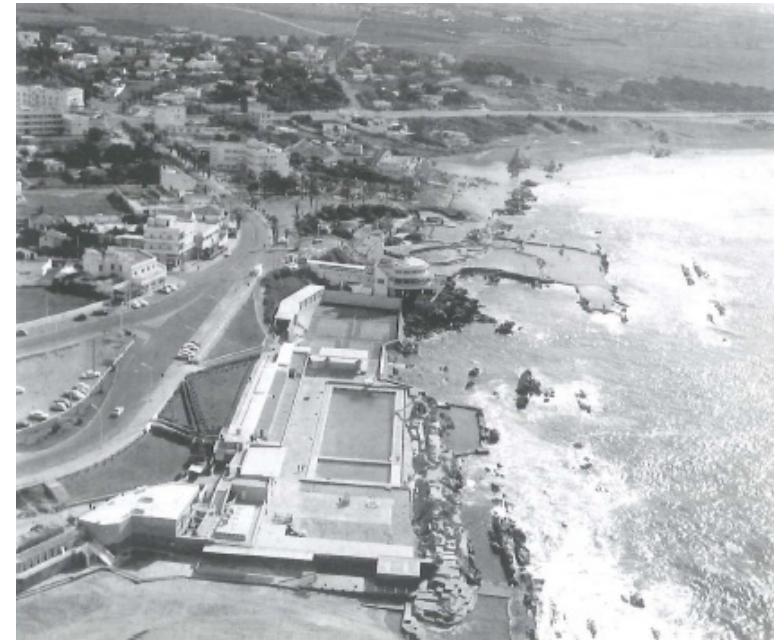
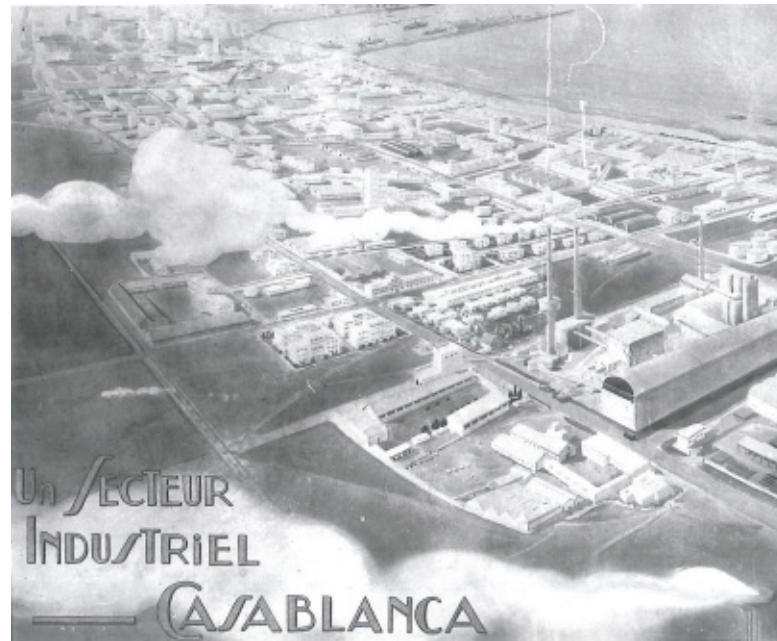

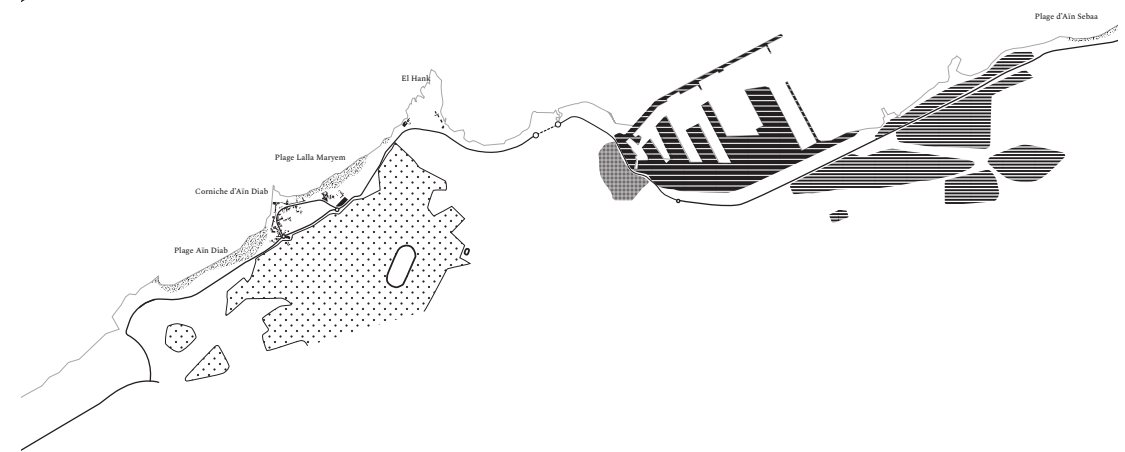
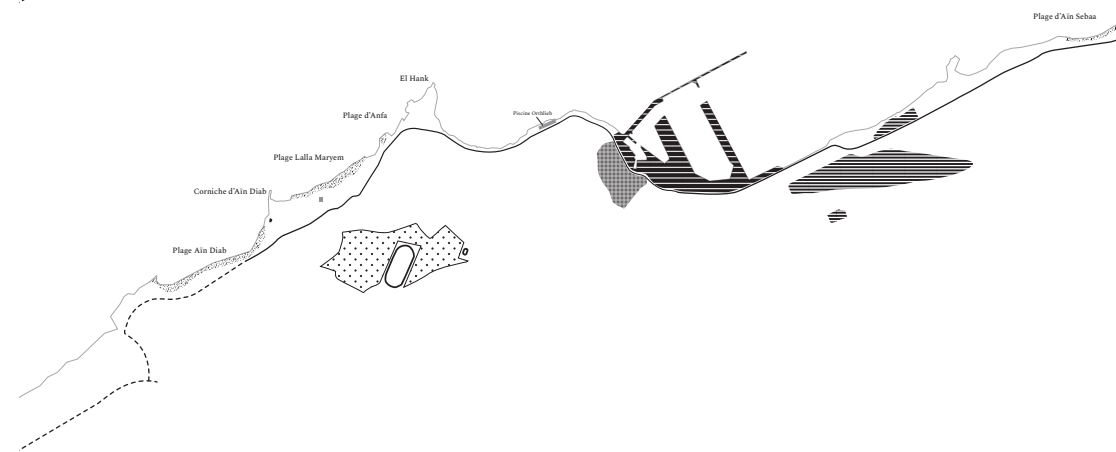
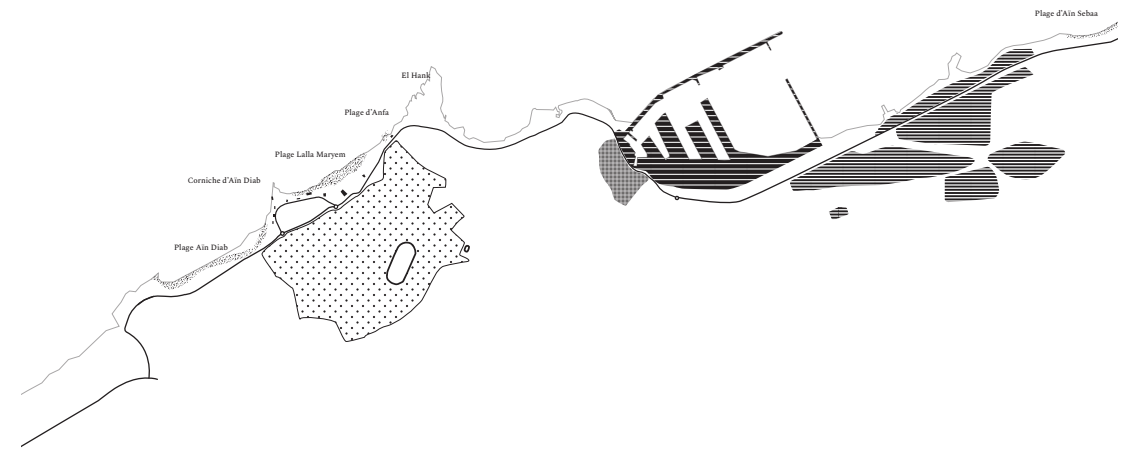
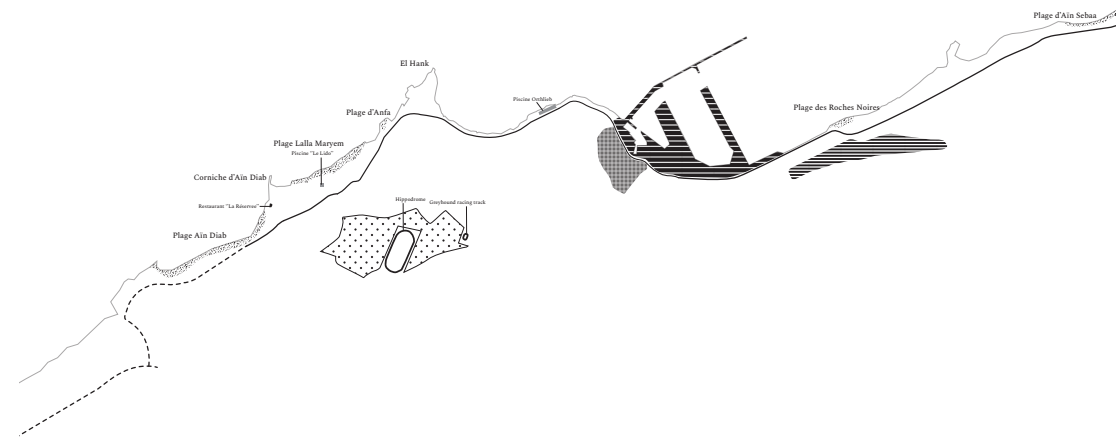
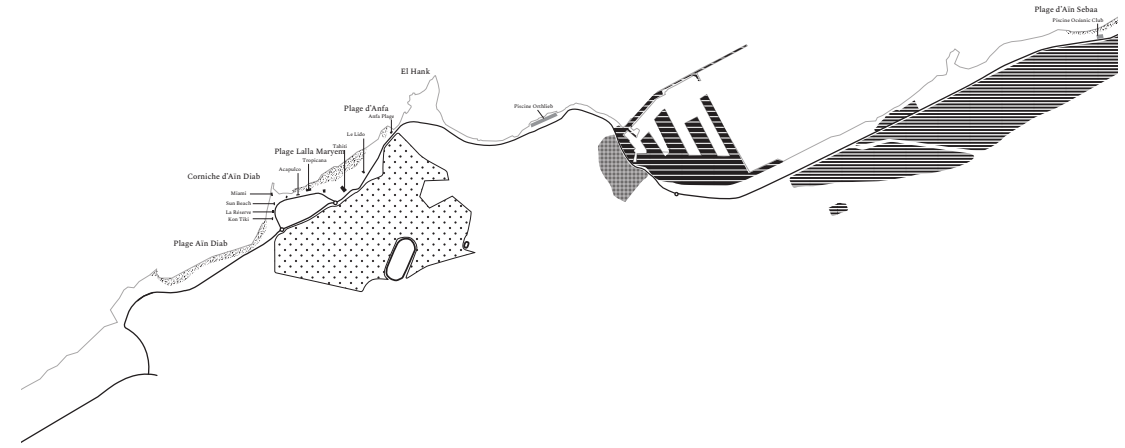
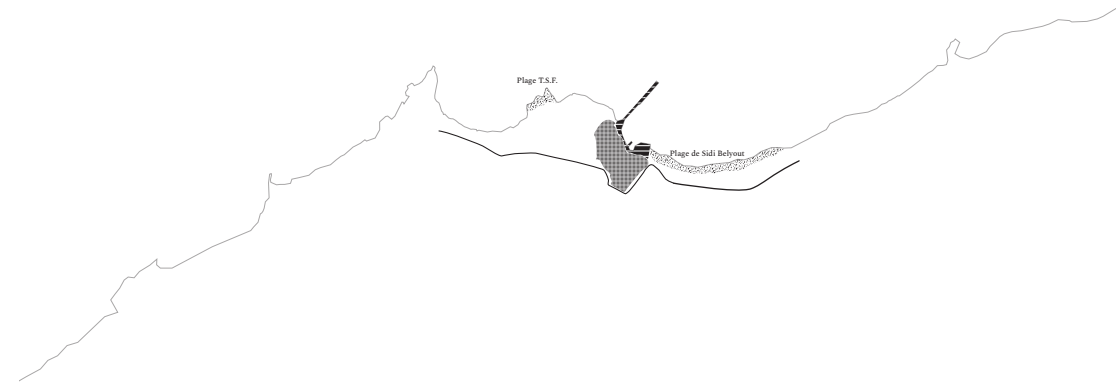



different characters of la Corniche

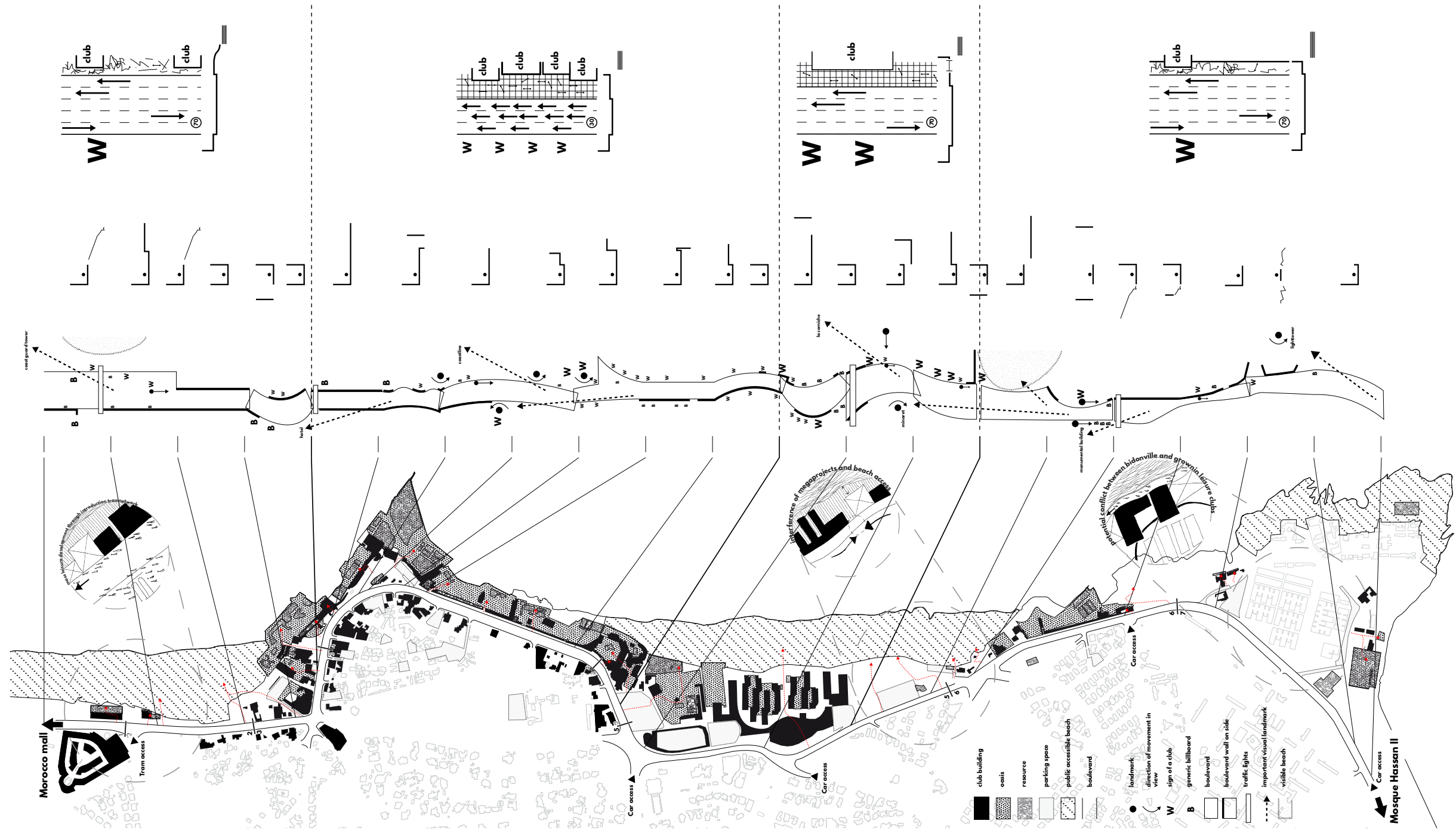

boulevard of la Corniche

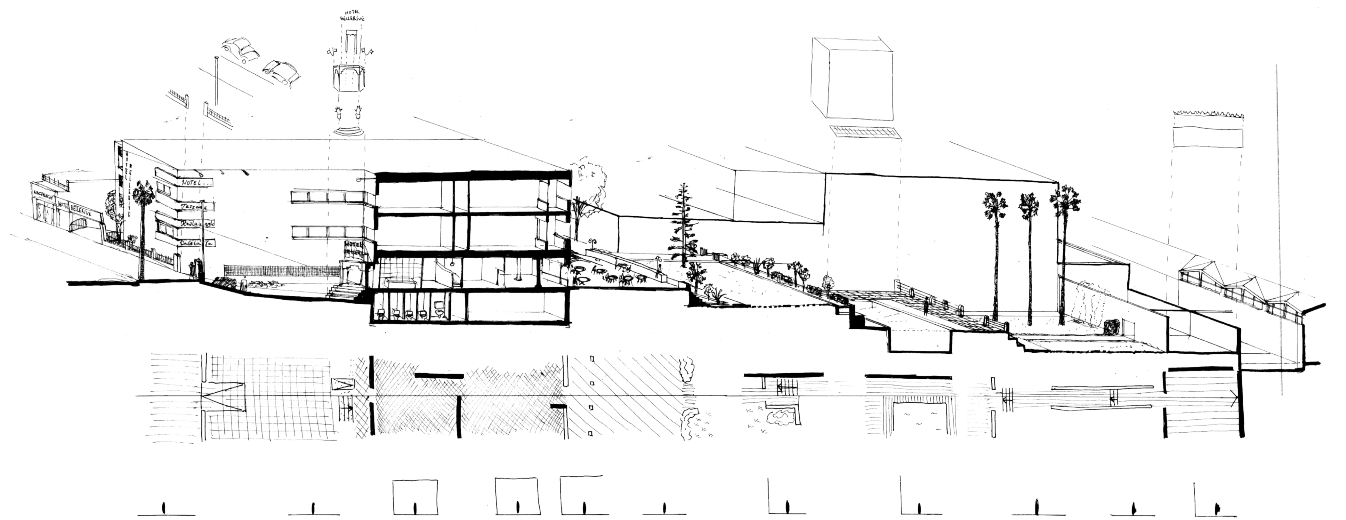
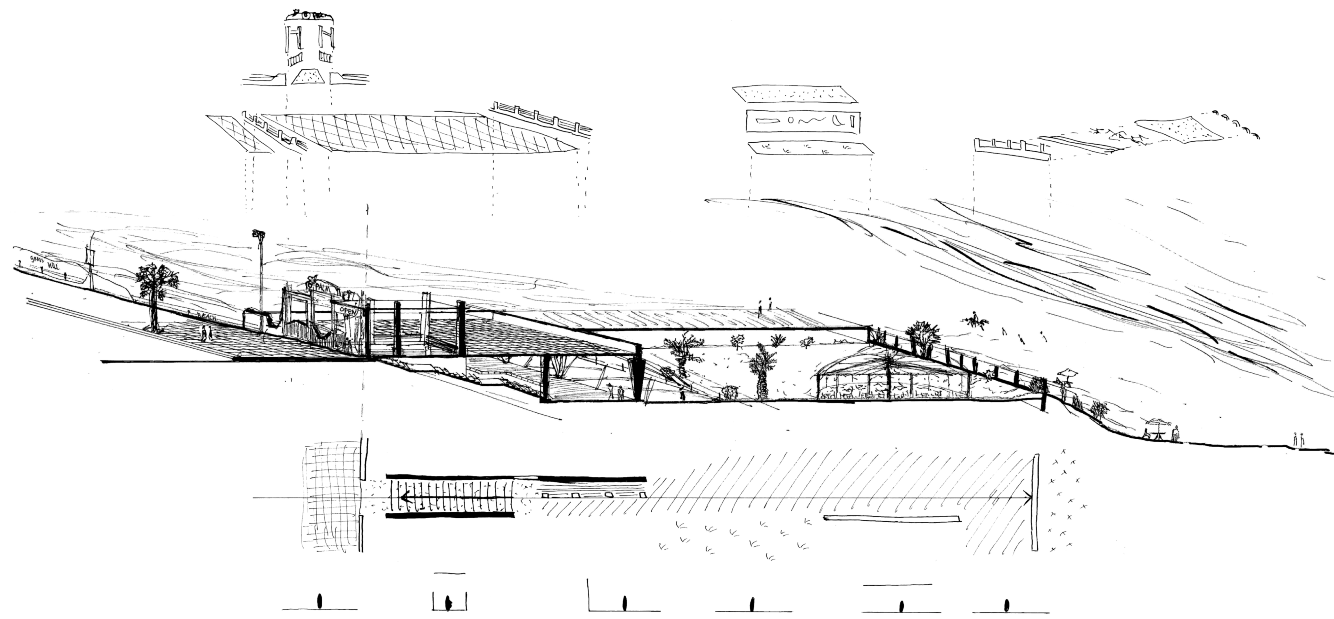
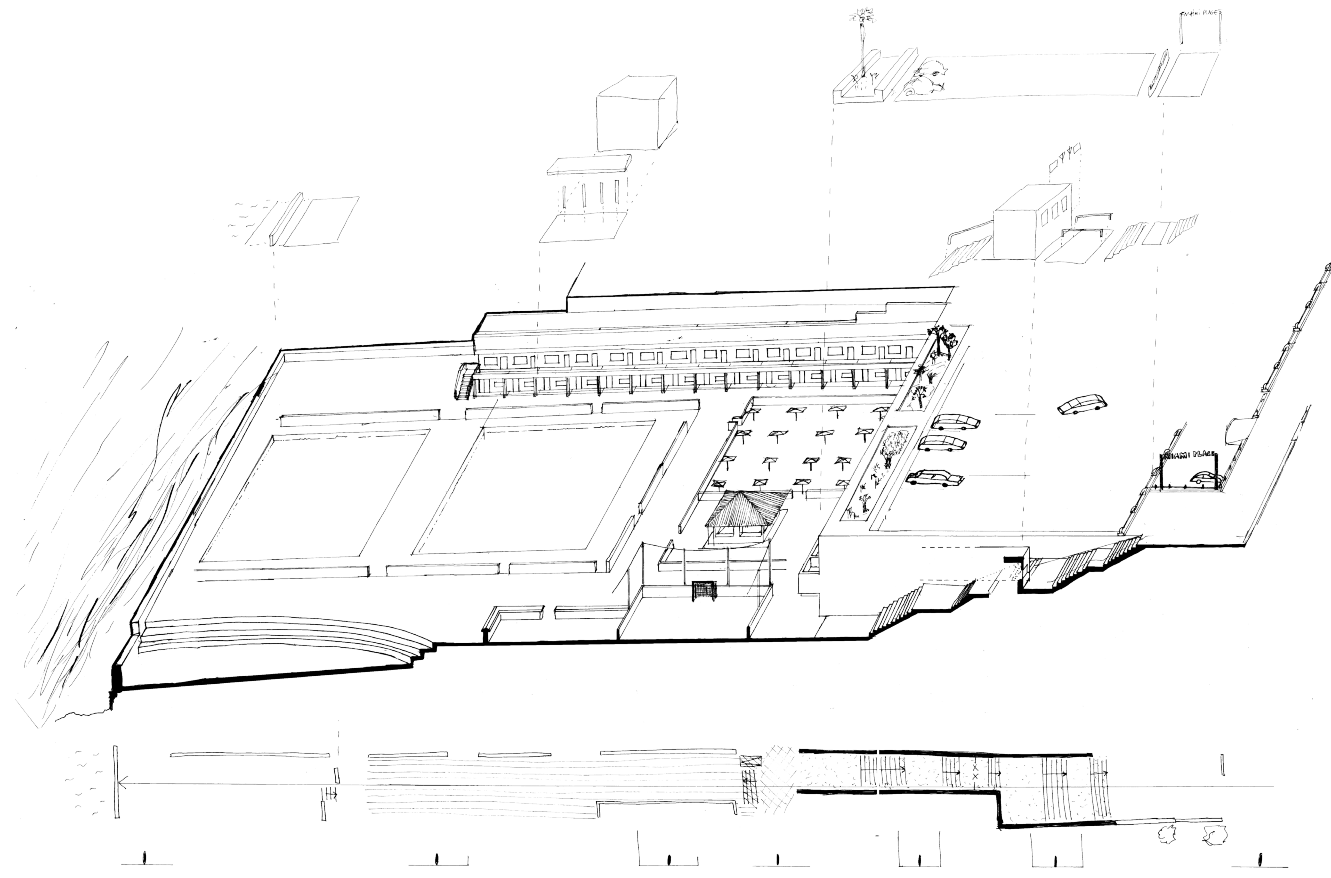

clubs of la Corniche

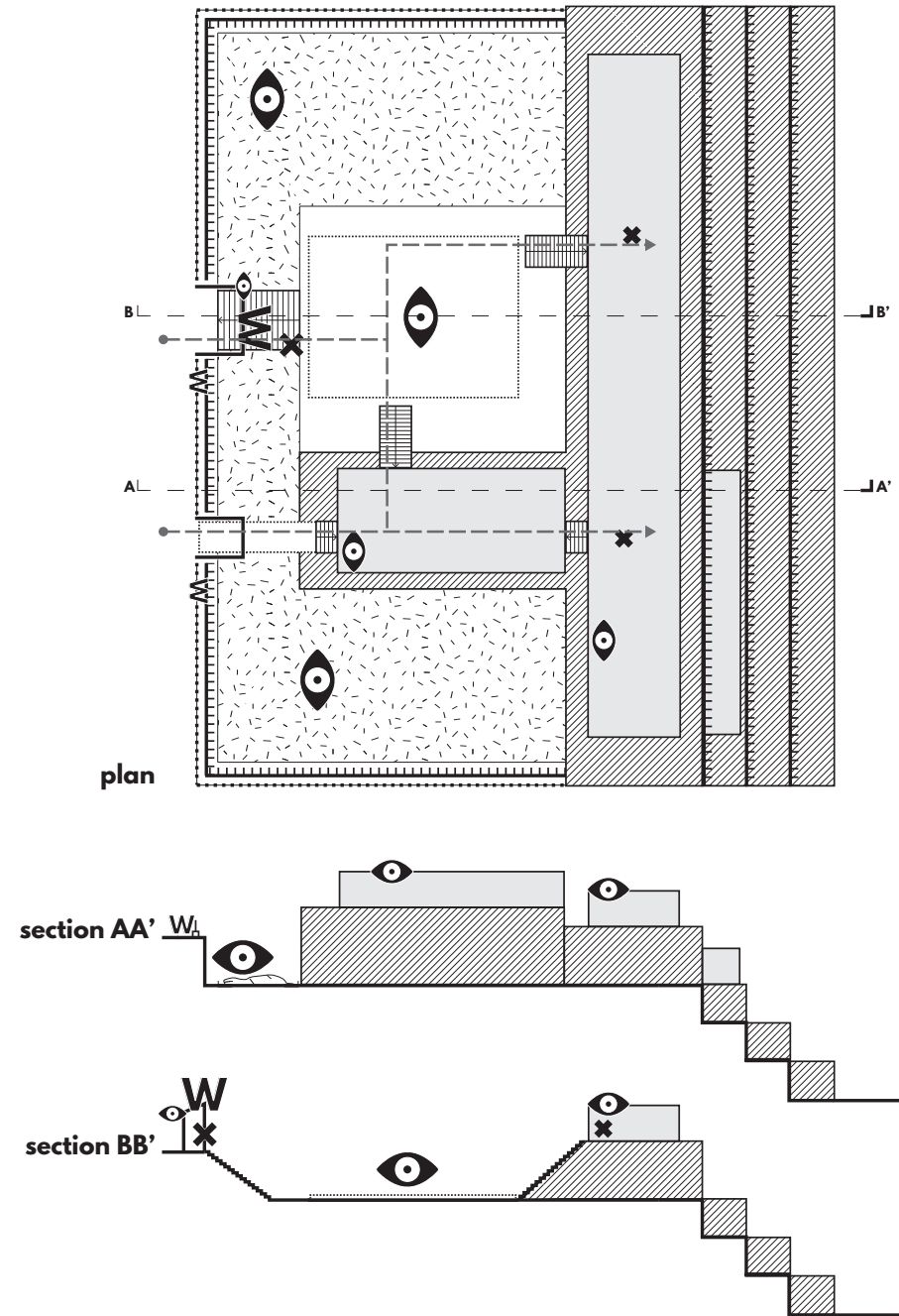
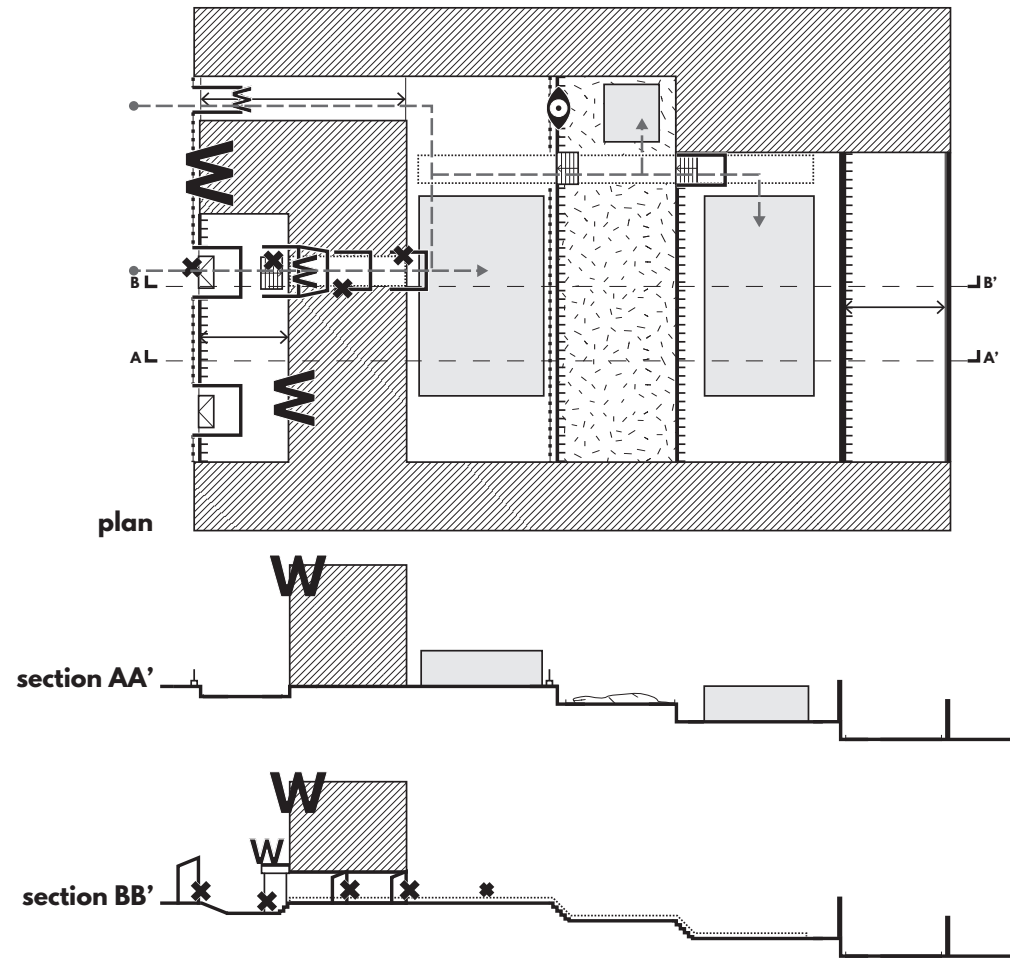

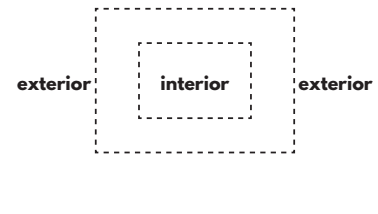
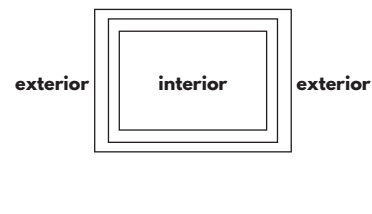
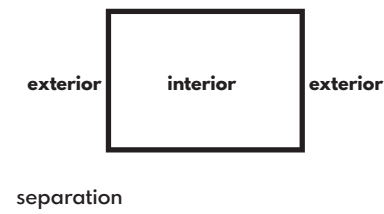
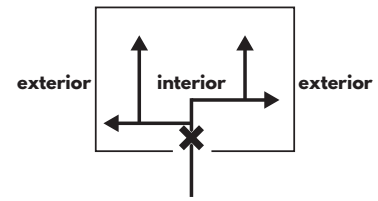
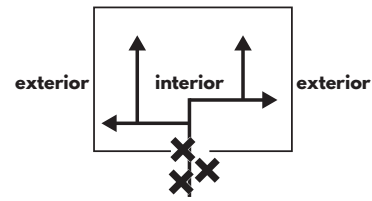
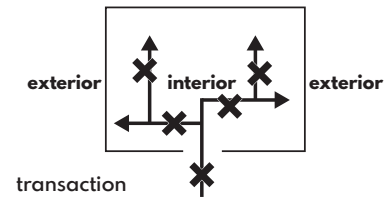
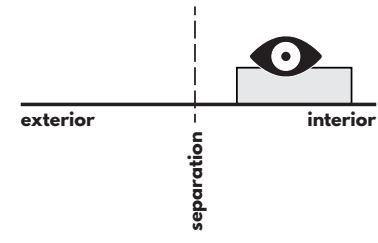
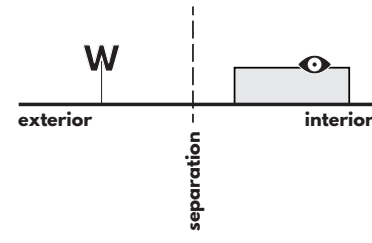
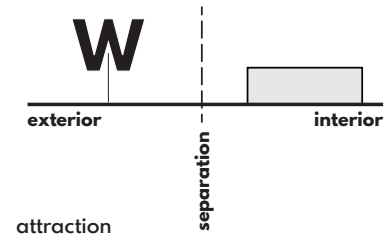
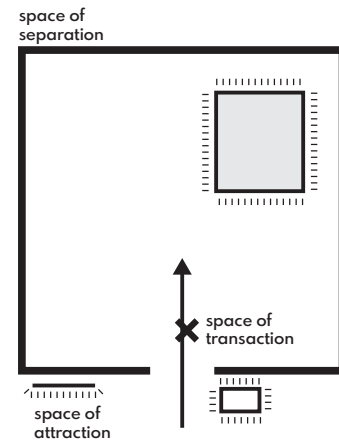

O'Palm

**Nzaha
(day out)**

**Bellerive
(beautiful shore)**

V-Randa

**Crepuscule
(sunset)**

Sun Beach

Miami Plage

Tahiti

Paradise

Anfa Place

**Cascade
(Waterfall)**

Atlantique

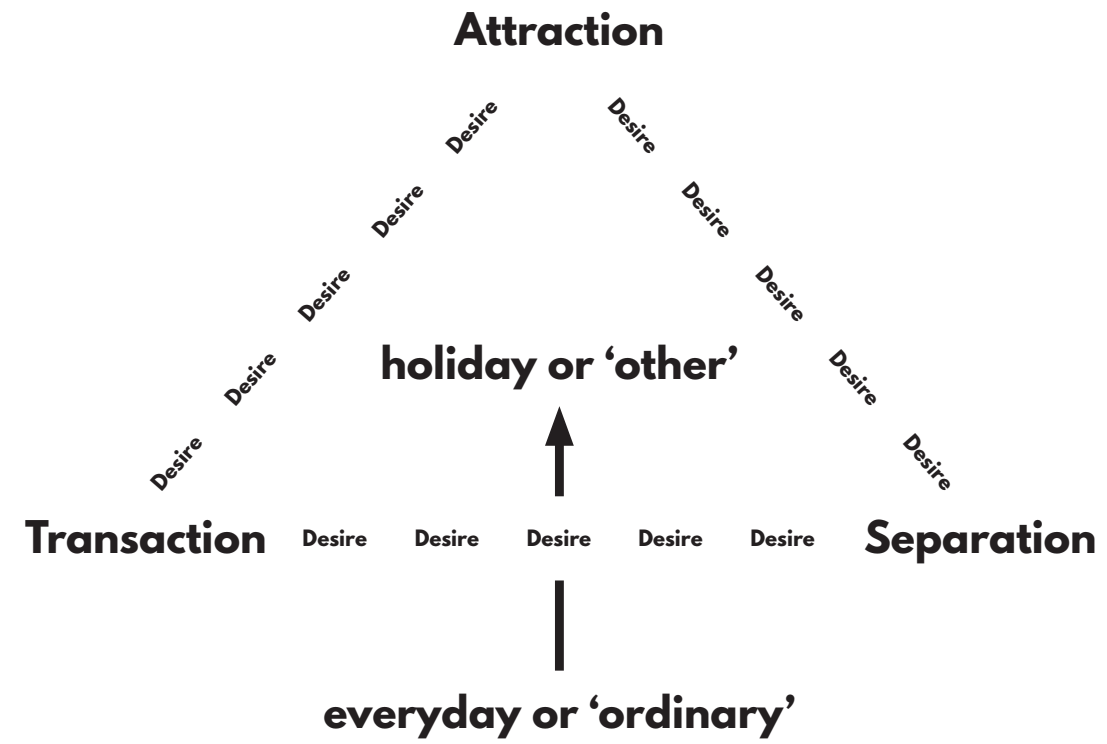

ESCAPING CASABLANCA

rense kerkvliet
p4 presentation
chair of methods
and analysis

resorting to inversions of everyday life

**TOWARDS SANCTUARIES
OF PLAY**
introducing the 'holy' day in casablanca

‘ holiday - holy day ‘ (Hieromènia)

**play detached of work/labour/action
being non-economical &
being non-political**

holiday occurs in:

the space of play

De Cauter, Dehaene (2007)
The space of play

Homo Ludens : Playing man and Heterotopia

exist on same principles:

- **outside the everyday**
- **without direct purpose or material end**
- **unfolds in dedicated space and time**
- **rule bound**
- **associated with a club/specialized society**
- **hidden or disguised**

Huizinga (1938) Homo Ludens

De Cauter, Dehaene (2007)

The space of play

two sides of heterotopia:

**to be expelled forcefully or
to escape voluntarily**

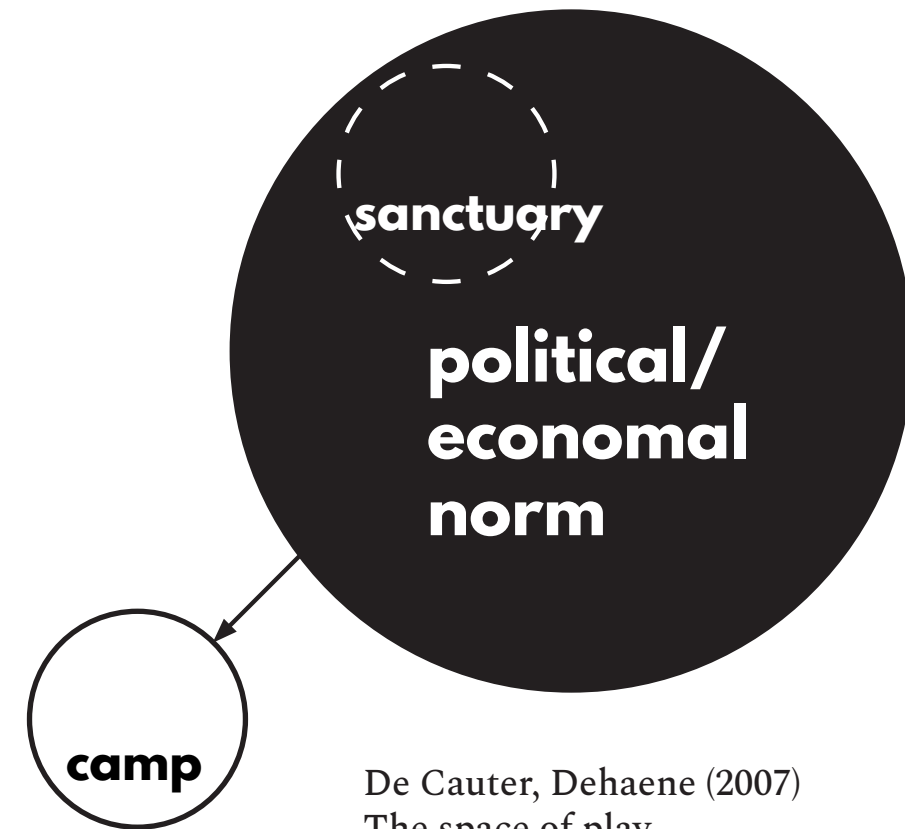

De Cauter, Dehaene (2007)
The space of play

**while the holiday is a suspension in time
from the everyday**

**whereas the sanctuary forms a spatial suspension
from the everyday**

sanctuary; temenos, a 'holy cut-out', literally a discontinuity of the everyday

Sanctuaries of Play



to 'Sanctuarize' a space

how can the figure of the club be transformed into a more inclusive form, creating a sanctuary of play for the 'commons'?

what are sanctuaries of play?

**distinctly other than its surroundings,
providing a holy (day) space protected from
the everyday, while still relating to it, through a
porous border.**

**discontinuities in the city by being 'other',
created by difference in:**

proportion

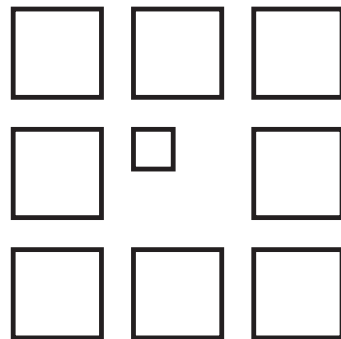

nature

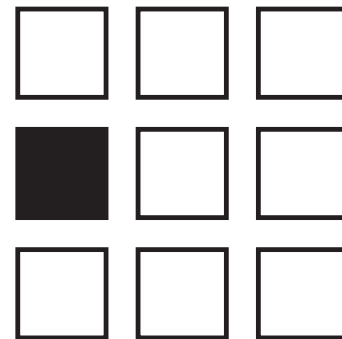

position

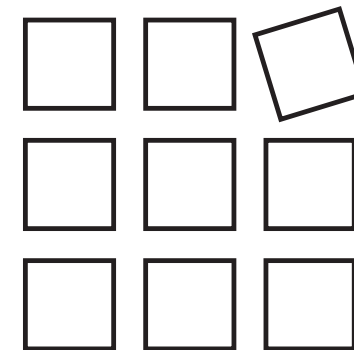

**providing a condition wherein
play can manifest itself
through separating it from
the everyday**

**it is impossible to design
'a' room for play, one can only
provide 'room for play'**

Jones (2014) On South Bank: The
Production of Public Space

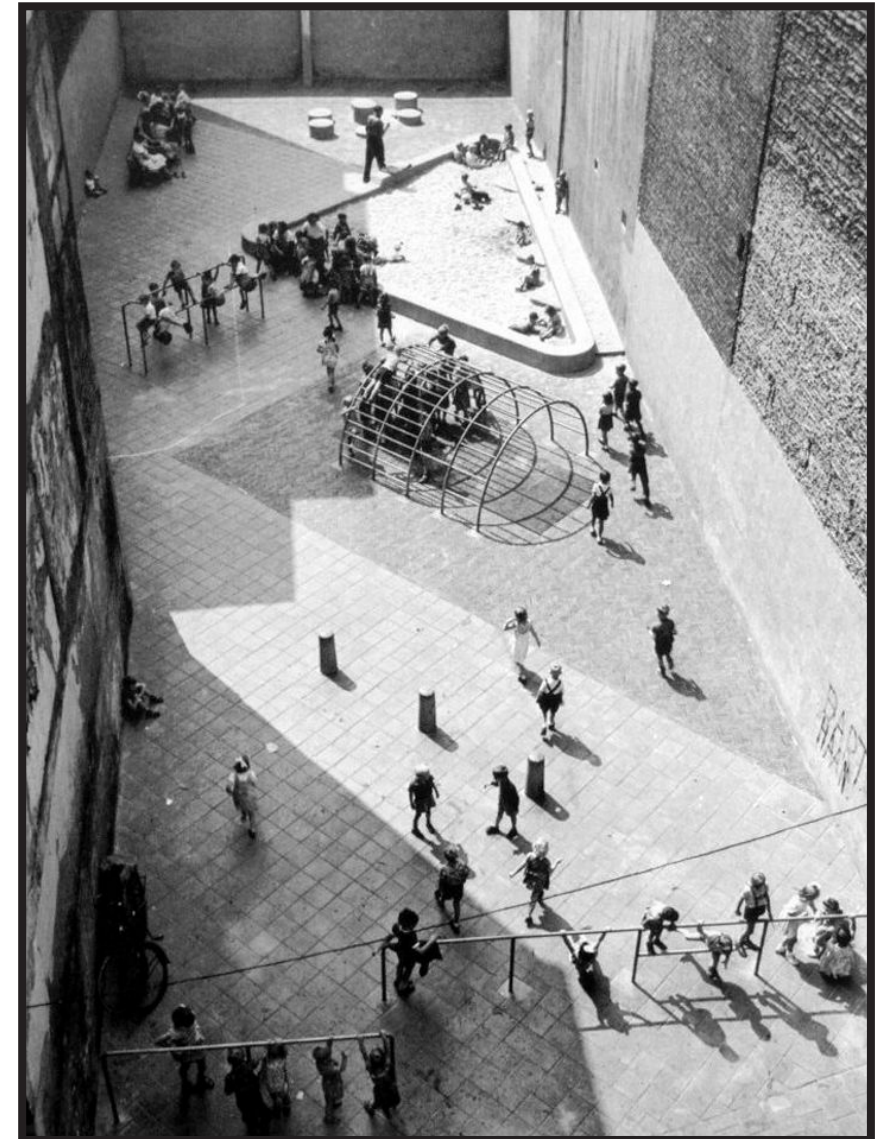

Aldo van Eyck, Dijkstraat Playground, 1954

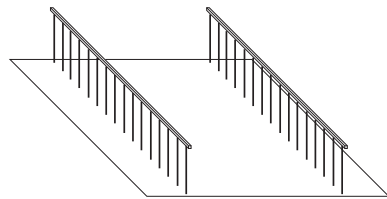
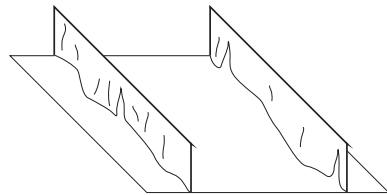
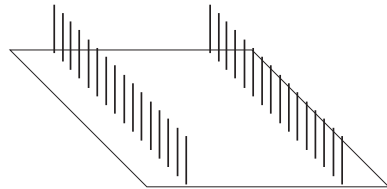
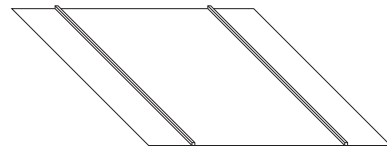
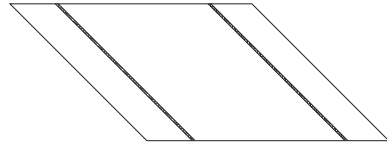
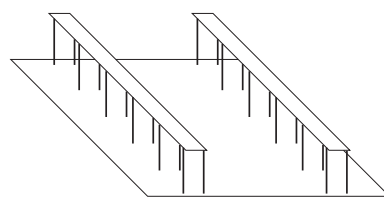
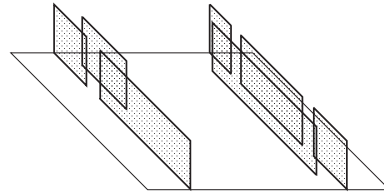
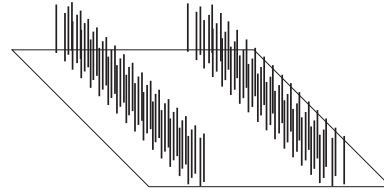
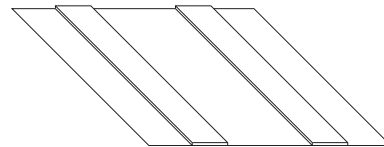
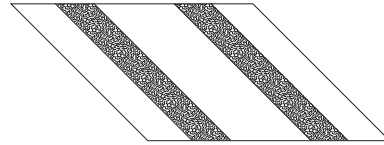
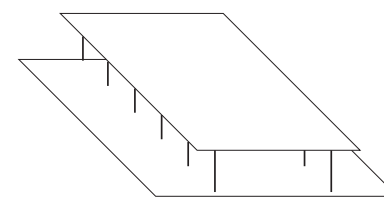
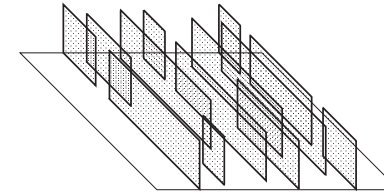
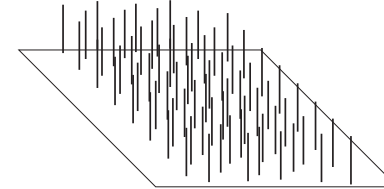
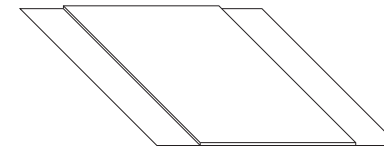
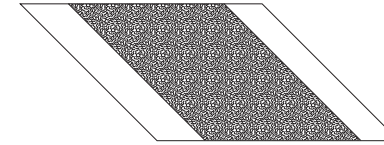
boundary**border****field****material****plateau****column****wall****roof**

**la Corniche is Casablanca's
space of play**



however,

**it is a privileged, exclusive site,
a fortress of play**

proposition of an alternative:



**a Casablanca which is infiltrated
by sanctuaries of play**

**in theory,
many sites in Casablanca can be 'sanctuarized'**

but which sites are appropriate to 'sanctuarize' ?



tram stops as site for intervention

- liminal space : space of waiting**
- autonomous object**
- part of many daily lives**
- common denominator**



a network of potential

ESCAPING CASABLANCA

rense kerkvliet
p4 presentation
chair of methods
and analysis

resorting to inversions of everyday life

TACTICS FOR INTERVENTION
exploiting casablanca's collective memory of 'holiday'



three interventions



les anciennes abbatoirs
single stop, two neighborhoods



hay Mohammadi
single stop, complex intersection



ibn Tachfine
transfer stop, complex intersection



les anciennes abbatoirs
single stop, two neighborhoods



hay Mohammadi
single stop, complex intersection



ibn Tachfine
transfer stop, complex intersection

**how is the site isolated and protected from the everyday?
while at the same time relating to it?**

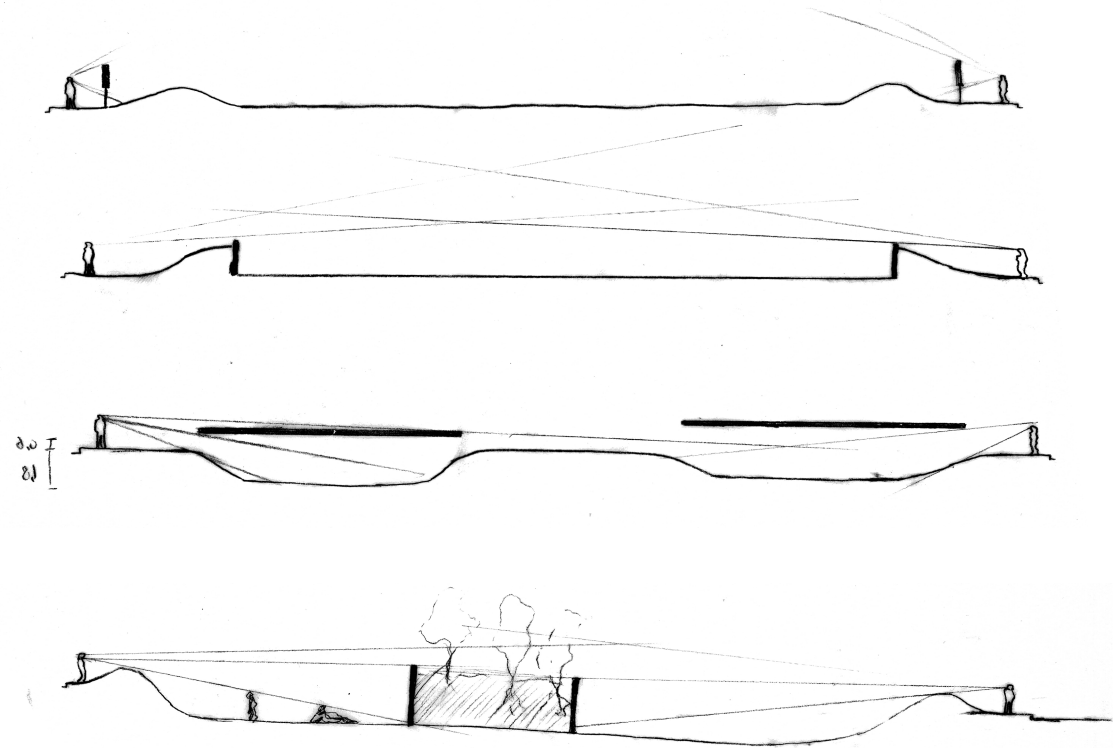

the scheme thus consists out of two elements or projects:

autonomous architectures, which frame and block views

and

the surface, which accommodates the architectures while folding



**in the collective memory,
the holiday is celebrated at the beach**

the scheme aims to exploit this collective memory

**by introducing abstracted elements of casablanca's coast in
architectural form**



Robles Castillo House
quite literal interpretation



Cuadra San Cristóbal
abstracted interpretation



water & acoustics
isolating from the city noise, masking it by
introducing fountains



light, shadow & reflections
catching shadows and reflections of the water
surface



materiality, mimicking & inverting
exploiting the materiality of the natural and
artificial coast



white artificial architectures on a dark natural surface

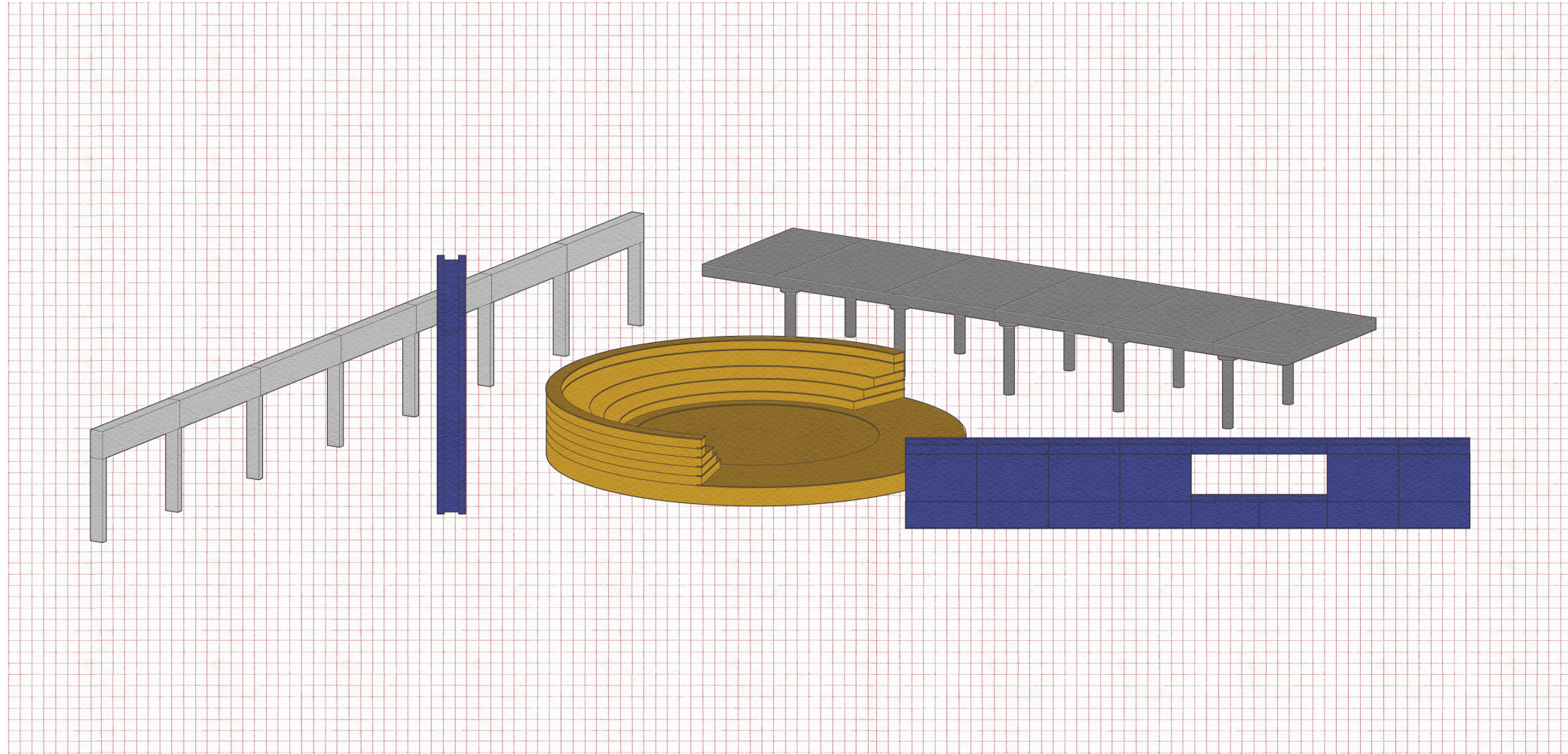

white artificial surface with dark natural architectures

ESCAPING CASABLANCA

rense kerkvliet
p4 presentation
chair of methods
and analysis

resorting to inversions of everyday life

THREE INSTANCES OF BEACH
materializing the architectural oasis

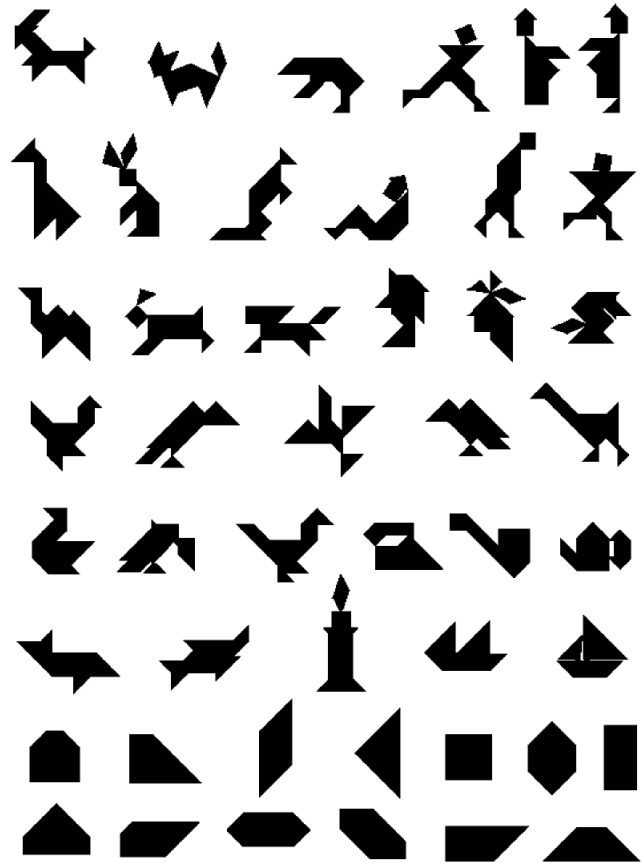

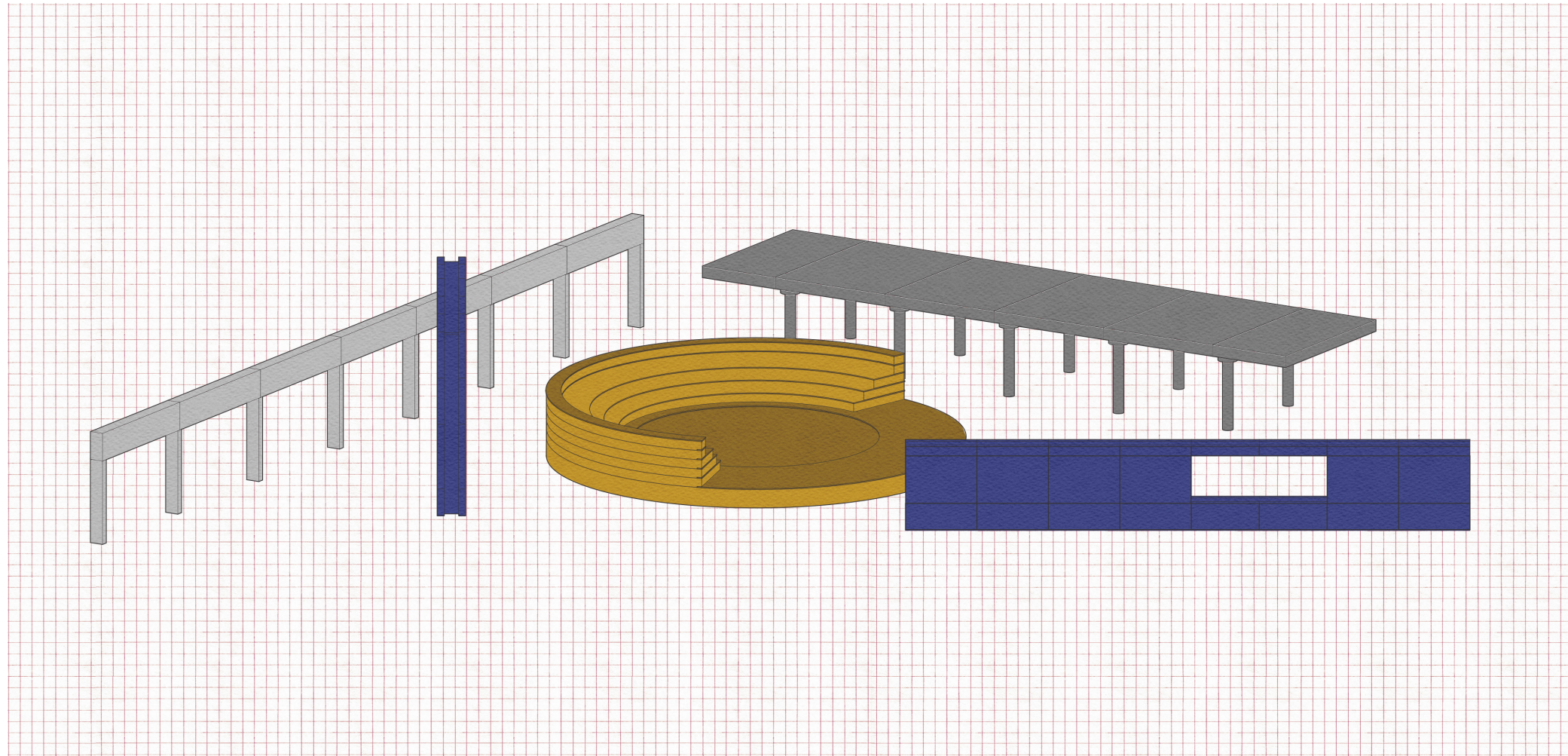

tangram of surface and elements

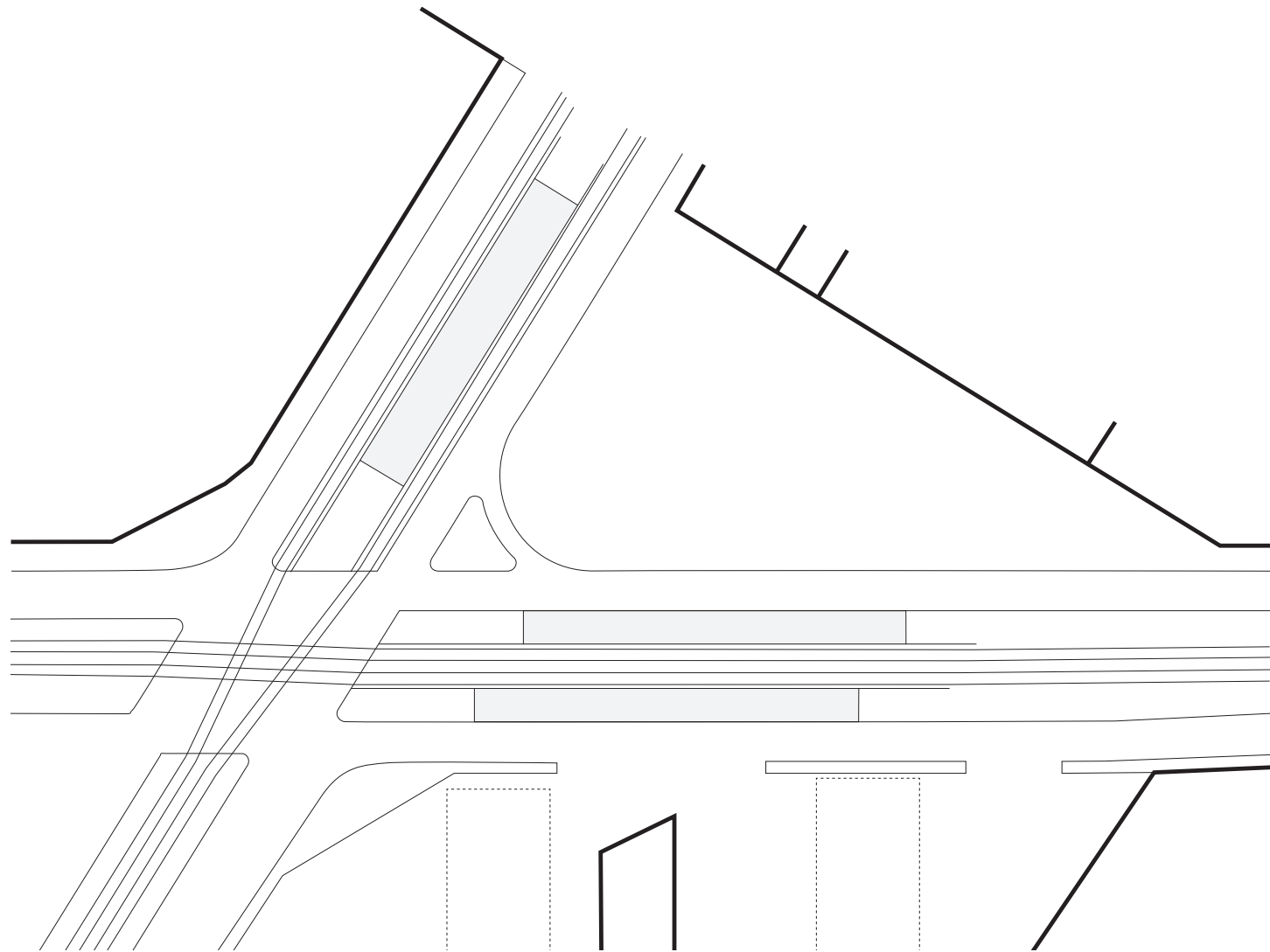

given urban condition

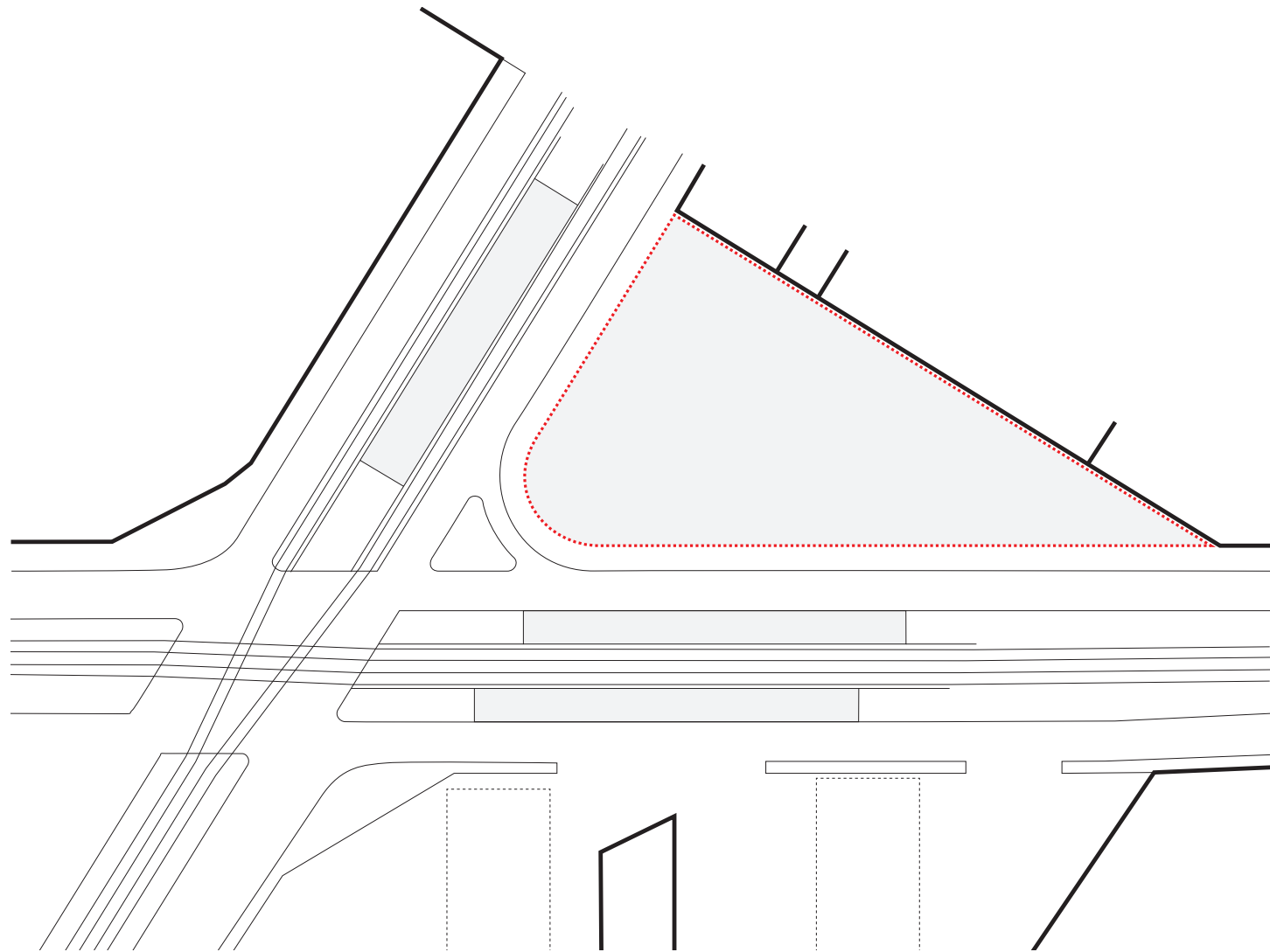

claiming adjacent territory

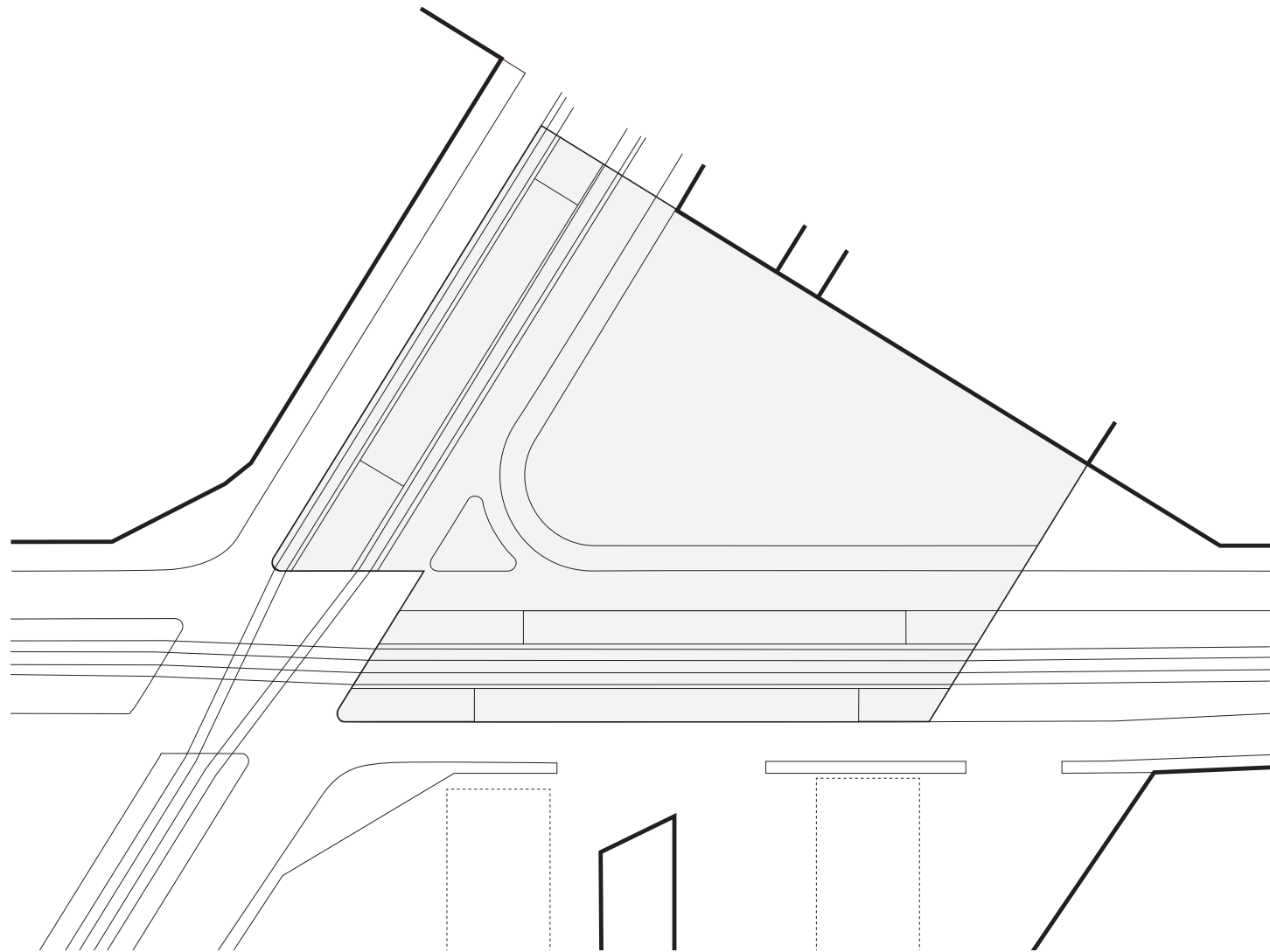

extending the surface

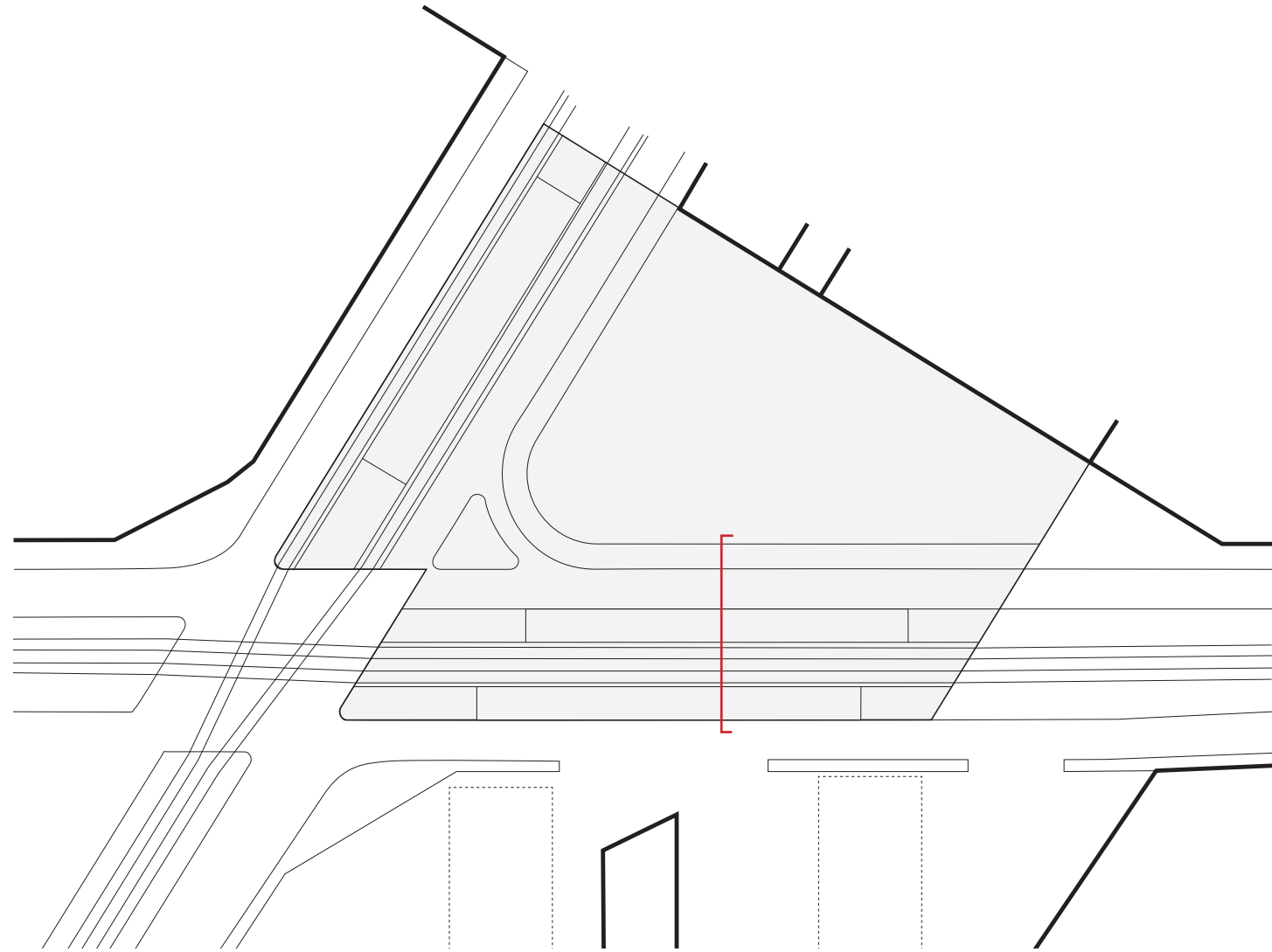

fragment . transition to the oasis

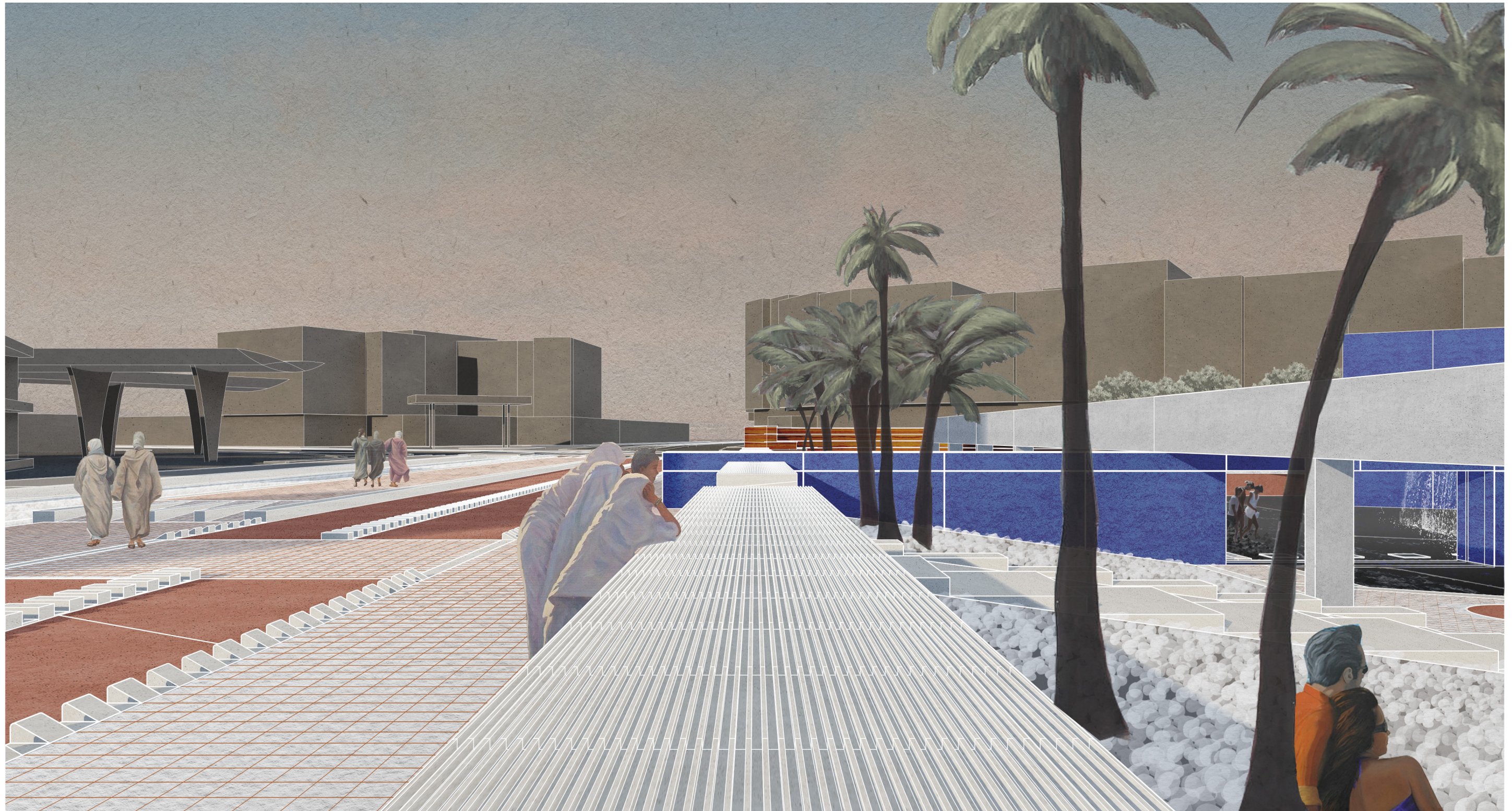

surface . longing for holiday

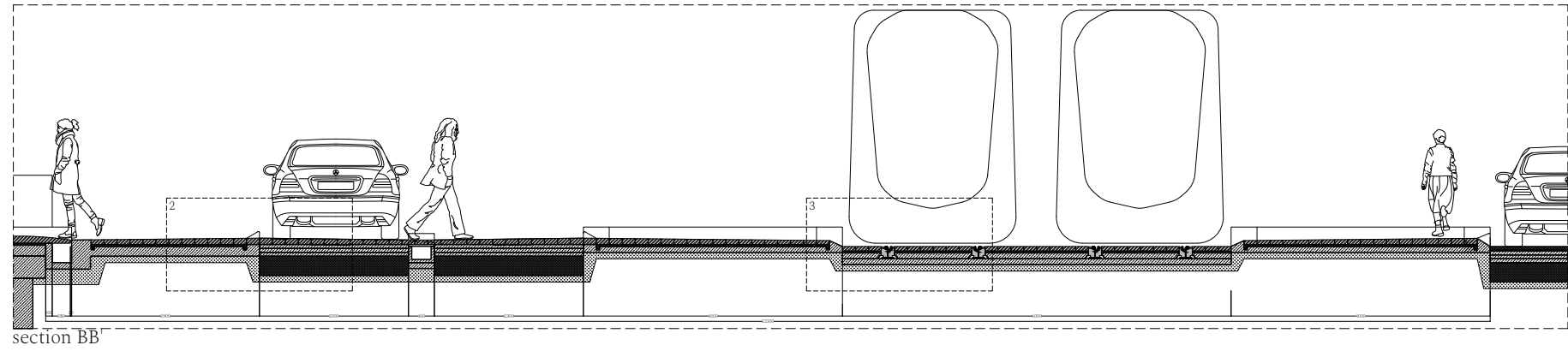
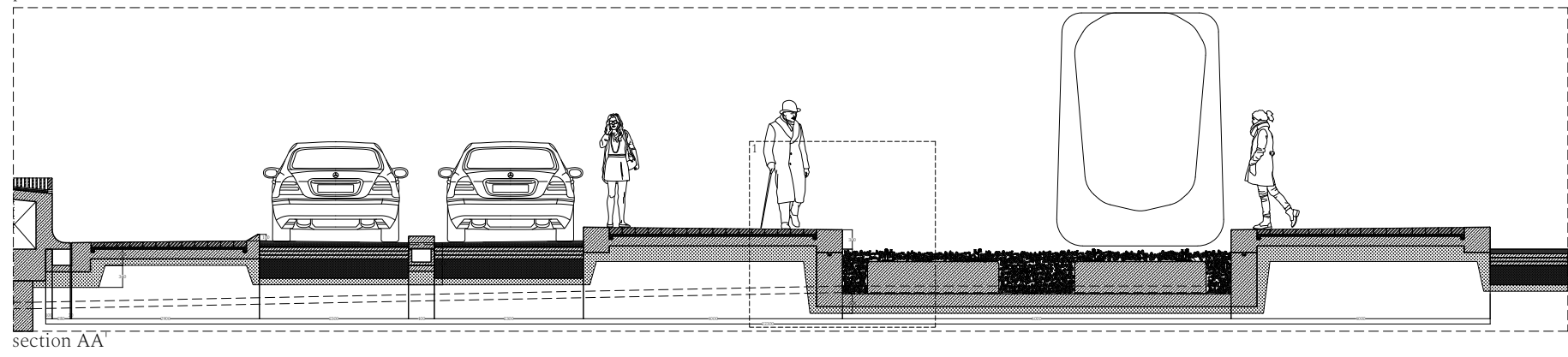
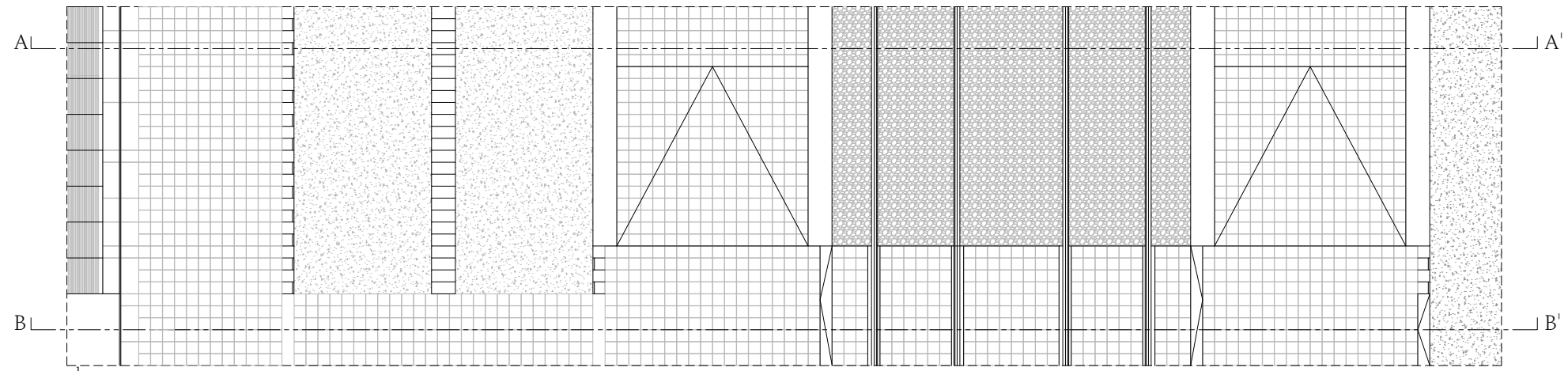

fragment . surface . entrance to oasis



pierre blanche limestone
logic of the beach clubs



**earthy red mortar, asphalt,
concrete**
contrasting the white tiles
(cranbourne botanical gardens)

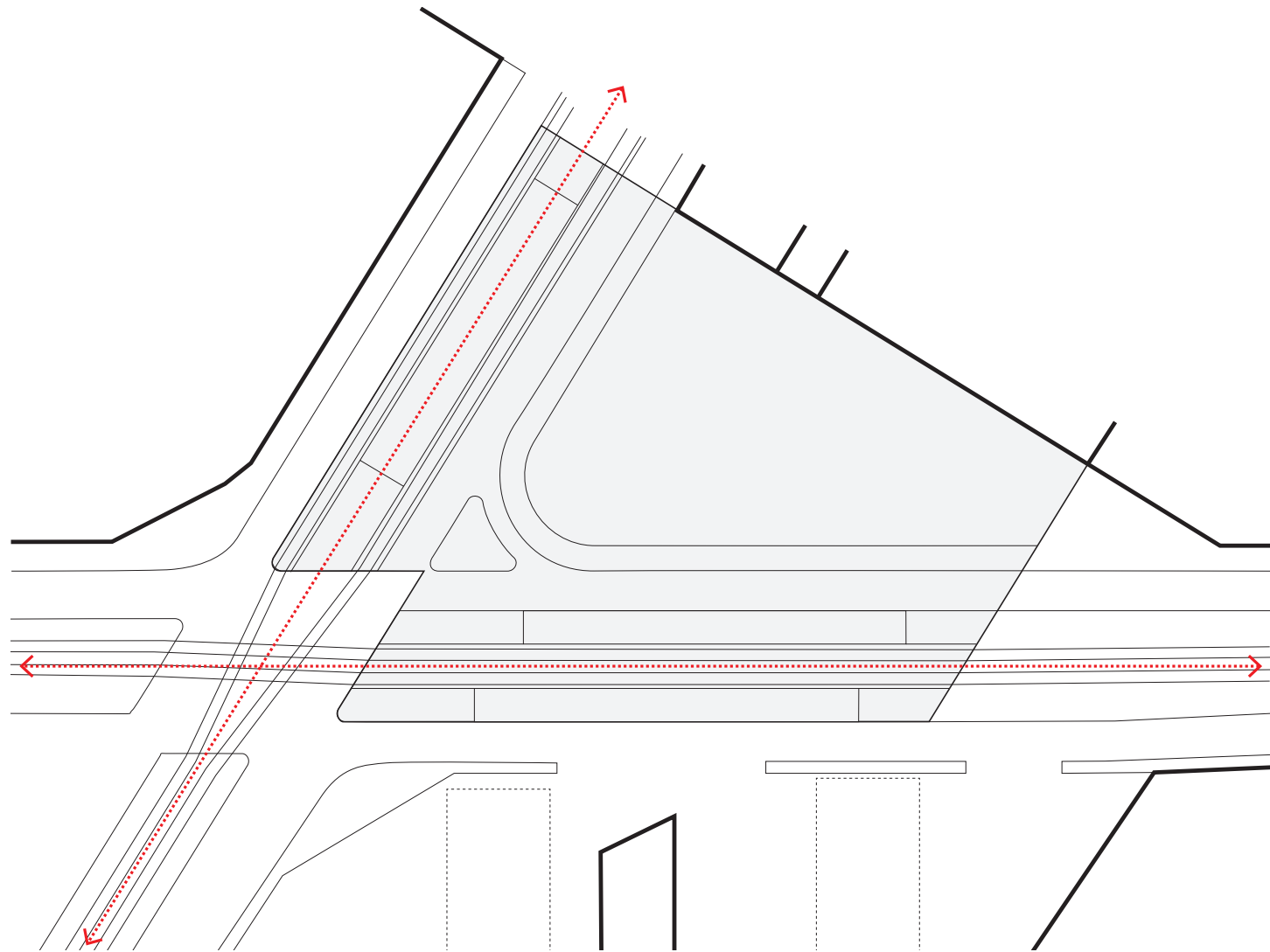

incorporating context diagonals

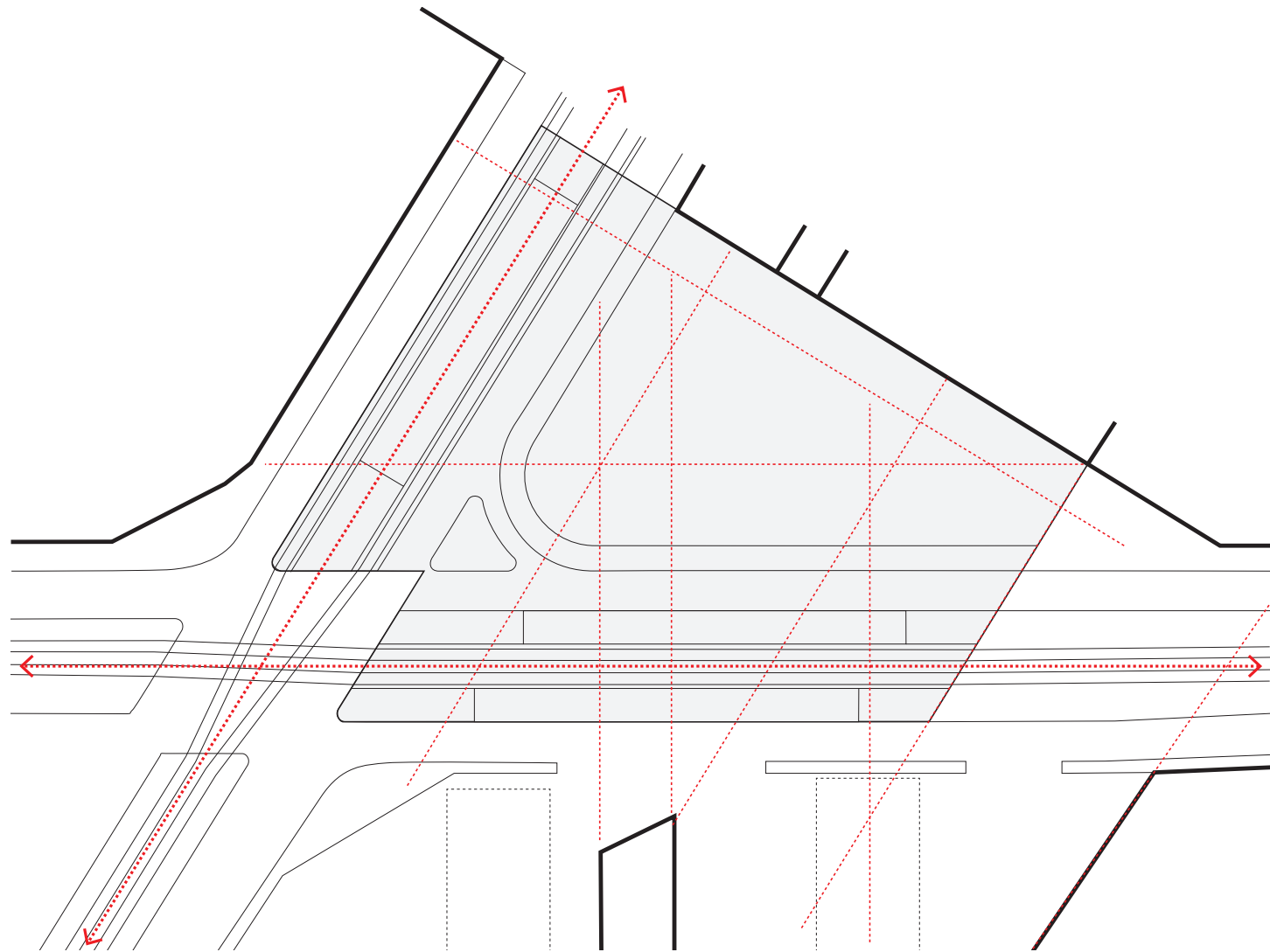

contextual references

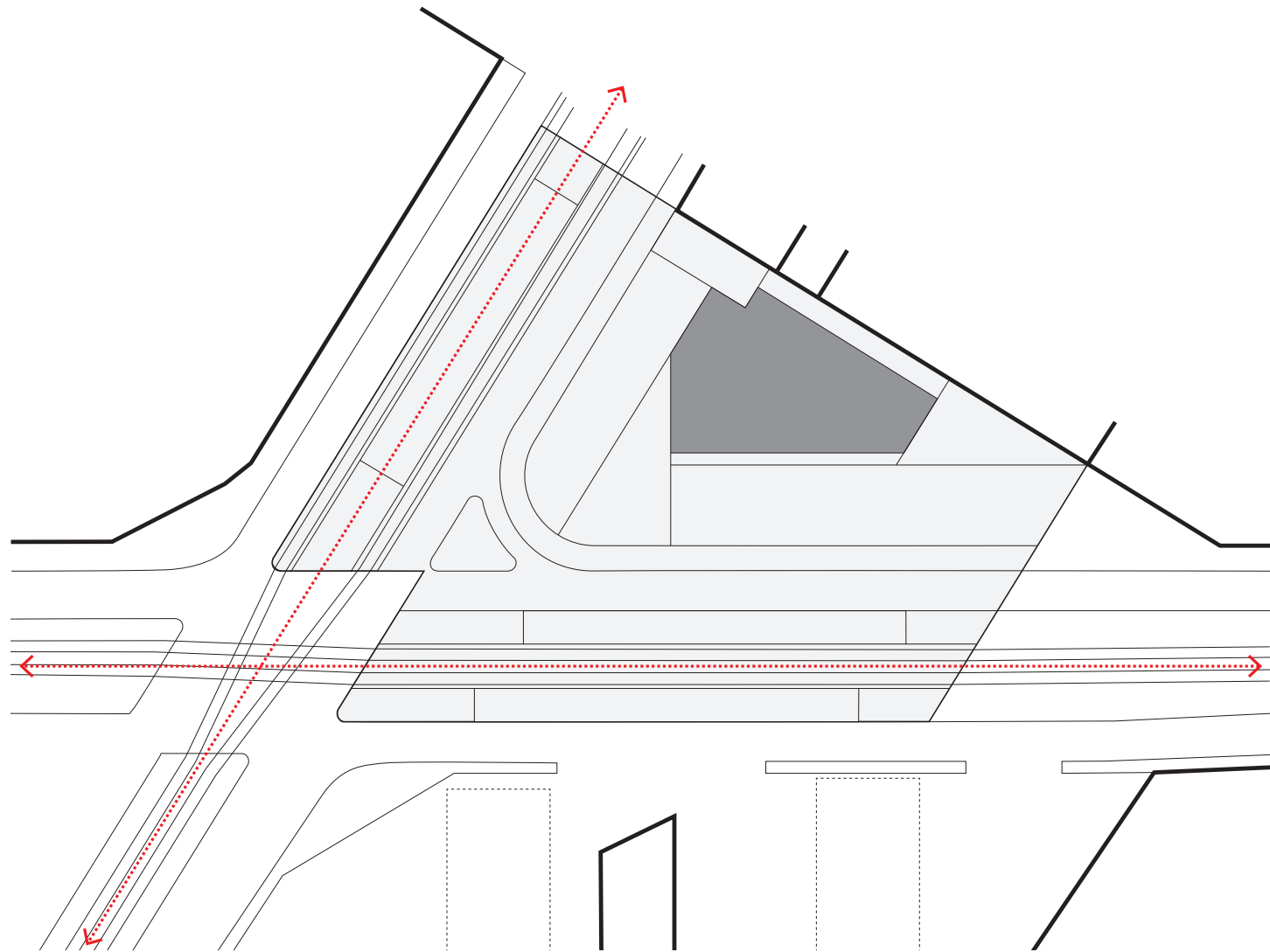

manipulating the surface

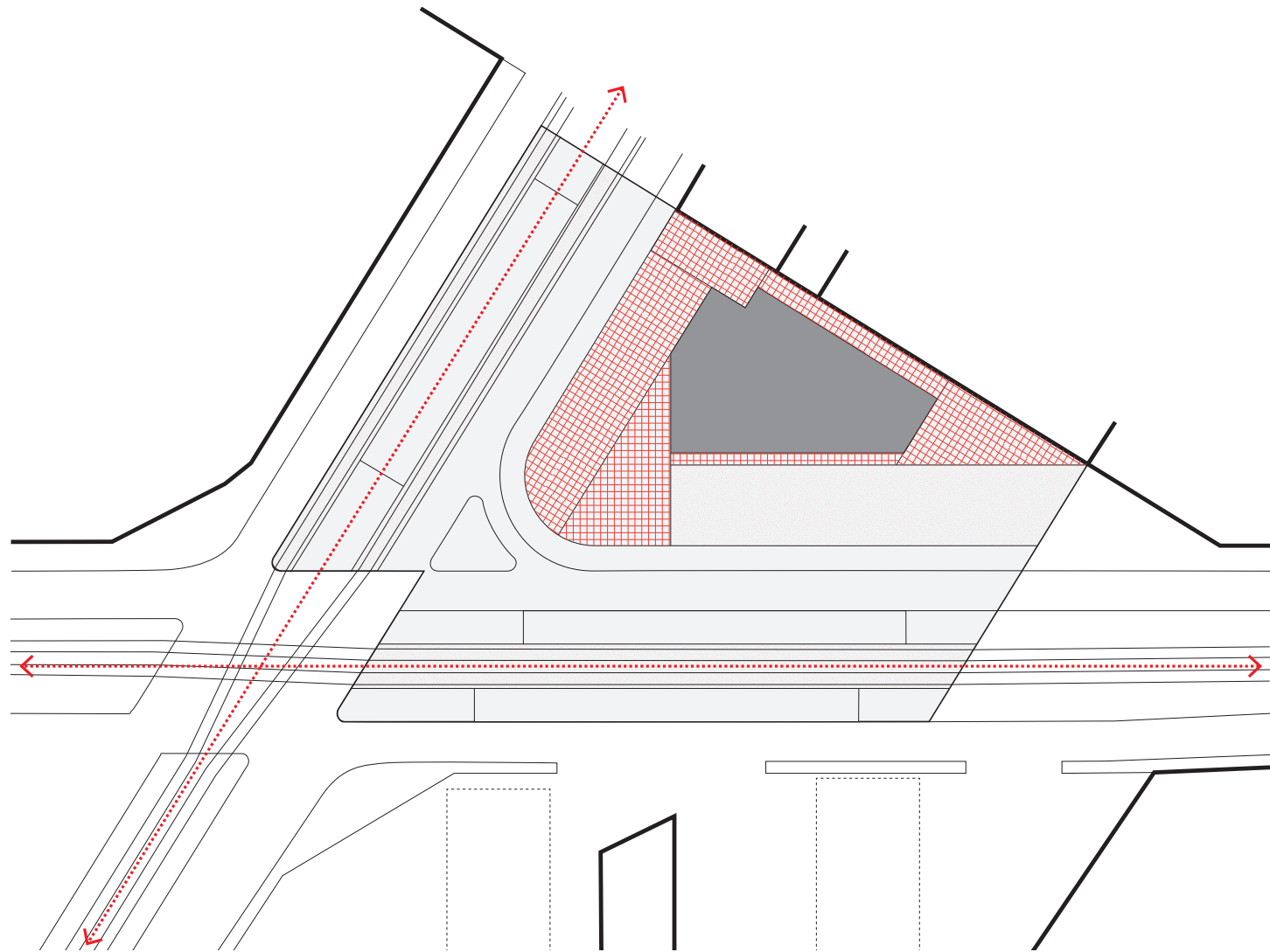

materiality and direction

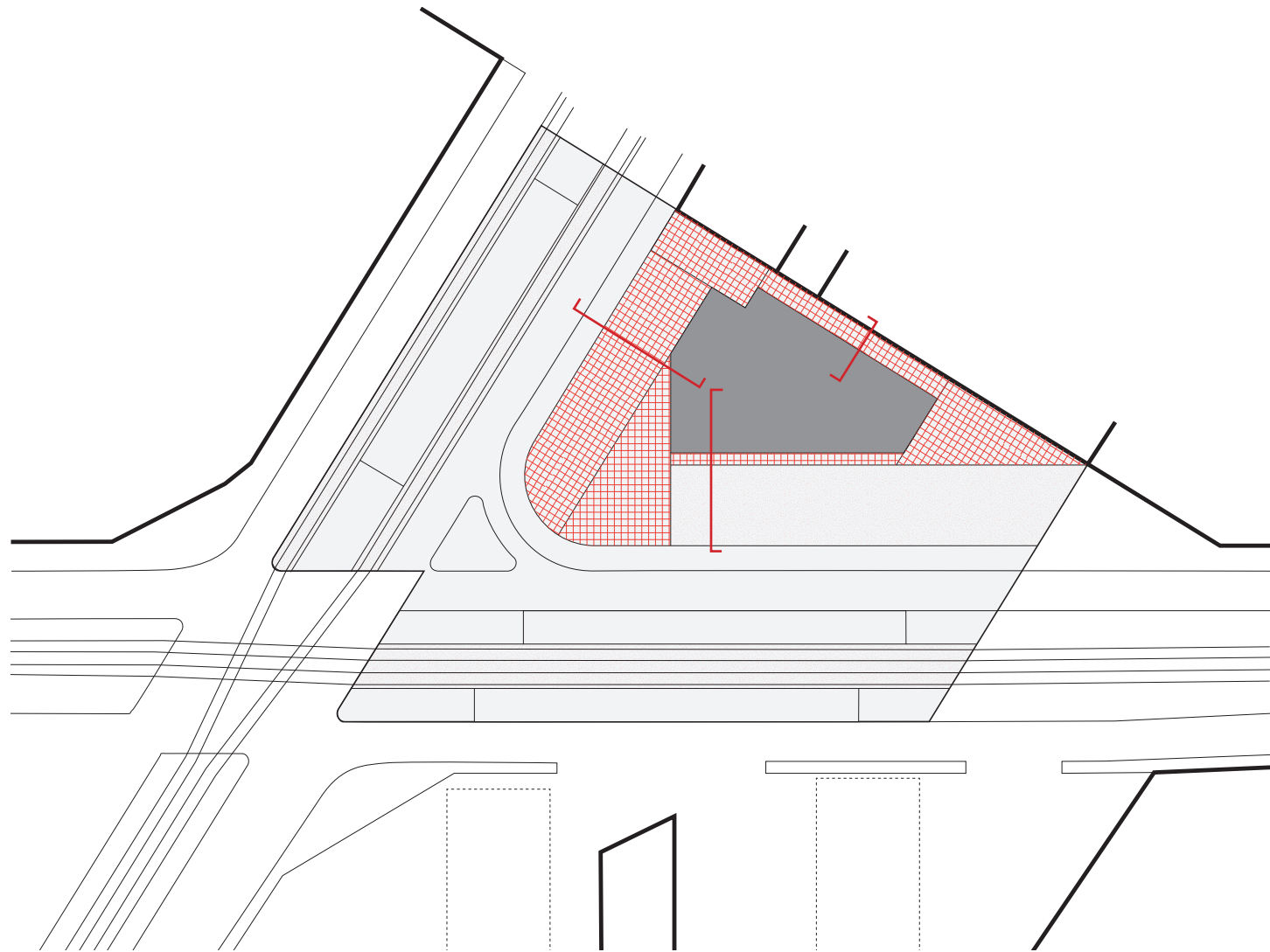

three conditions

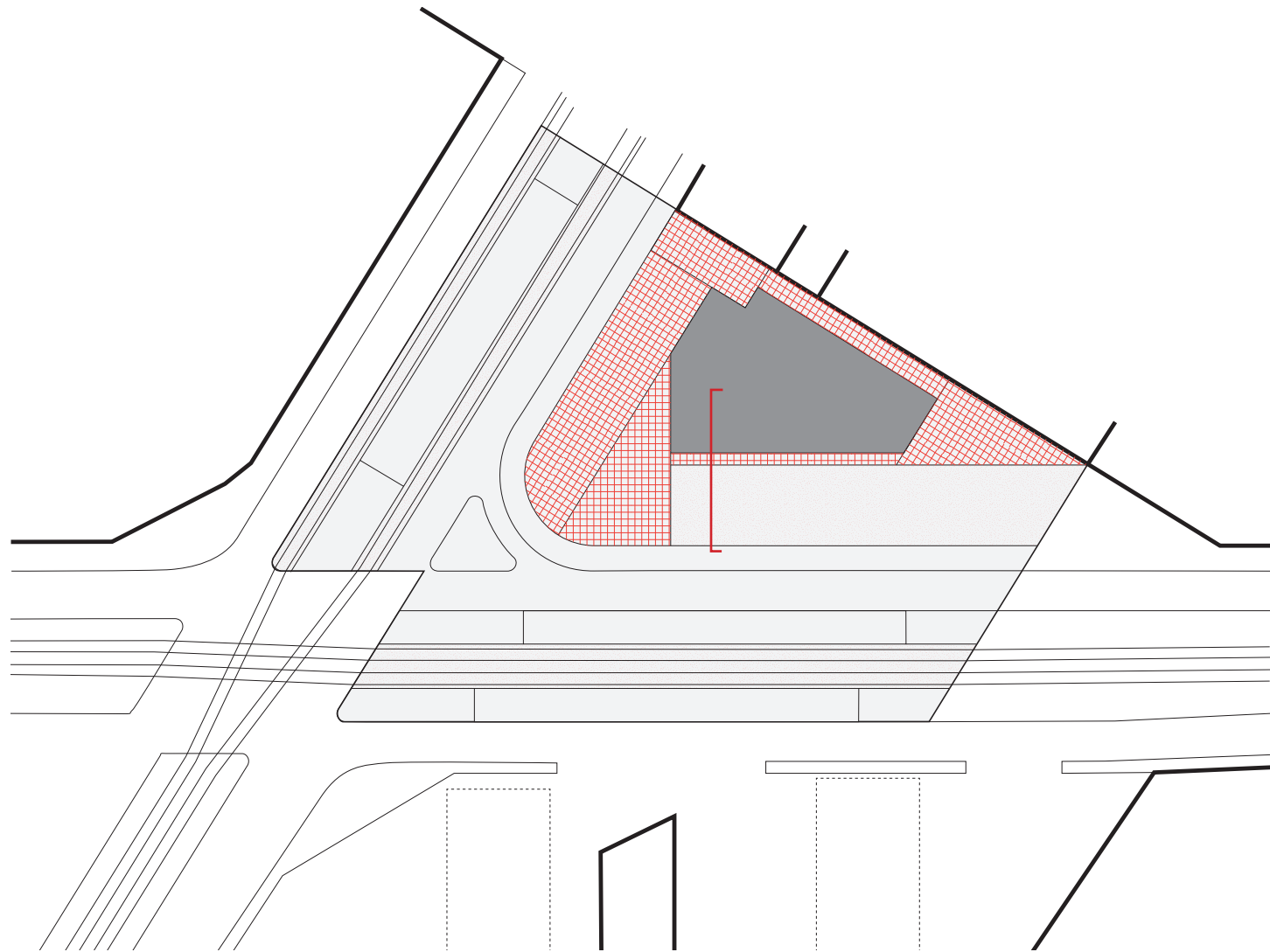

the sloping surface



surface . stroll along the ocean

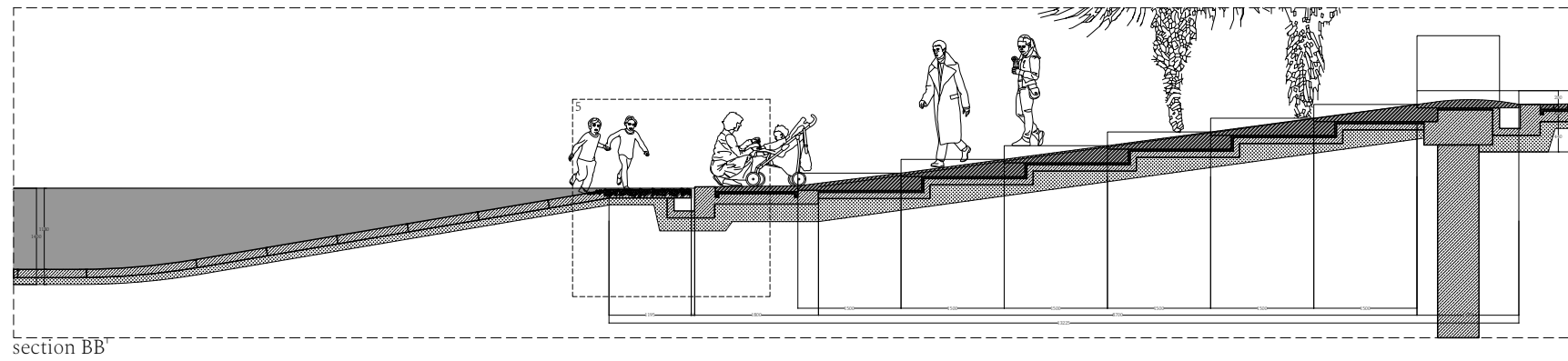
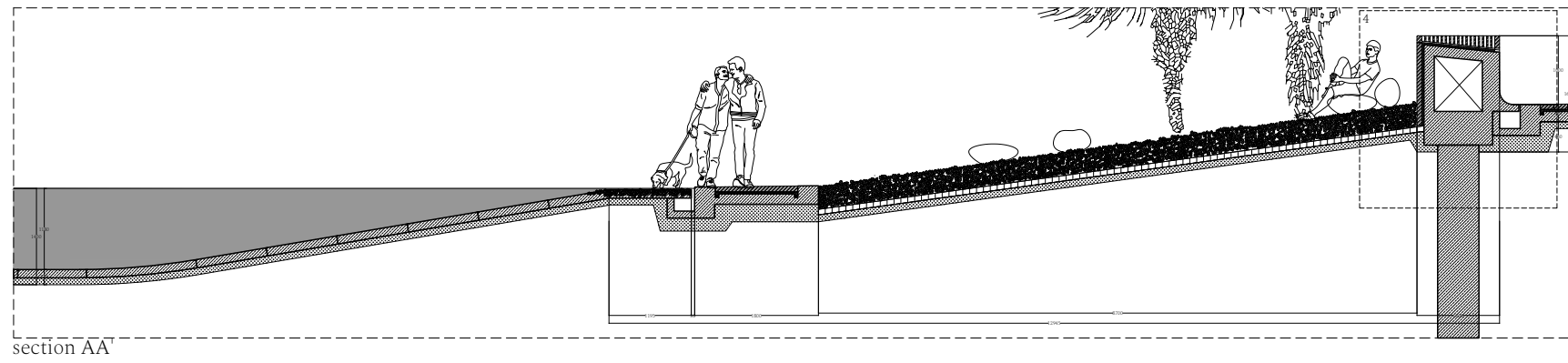
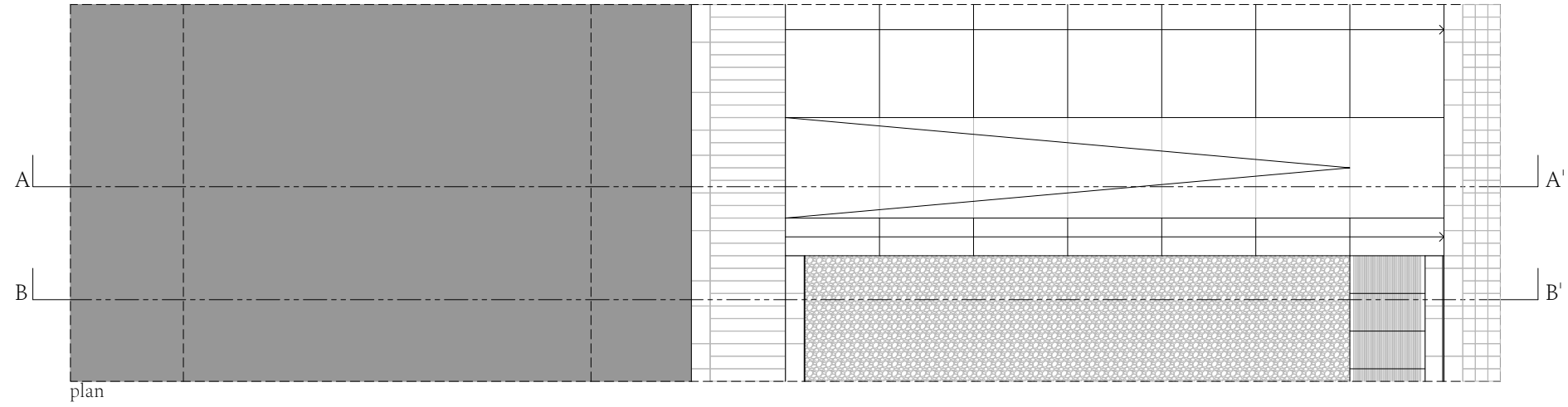



polished bitumen asphalt concrete
dark, threatening underneath the water



white pebbles
soft, bright and reflective

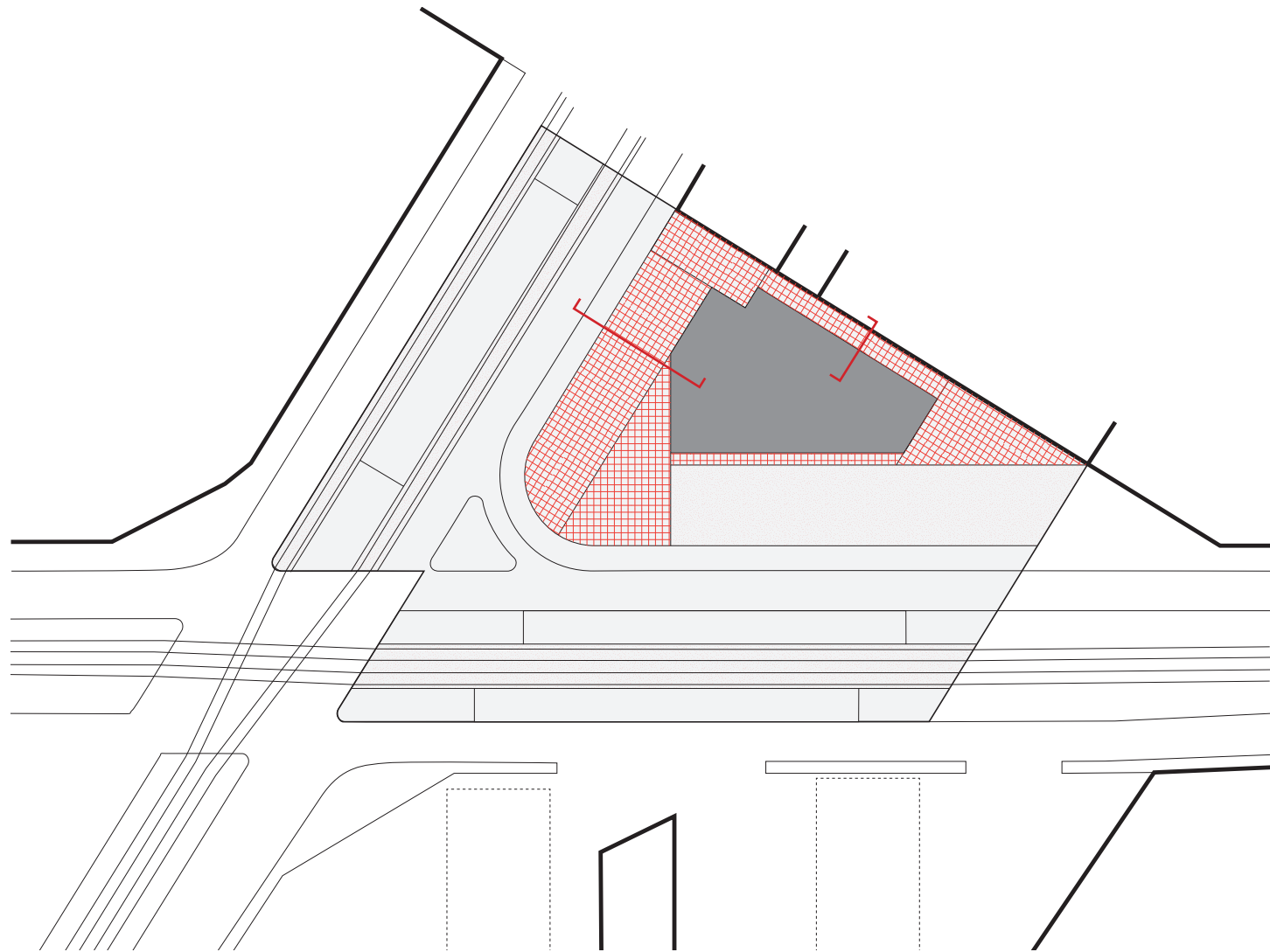

the plaza and the grating floor

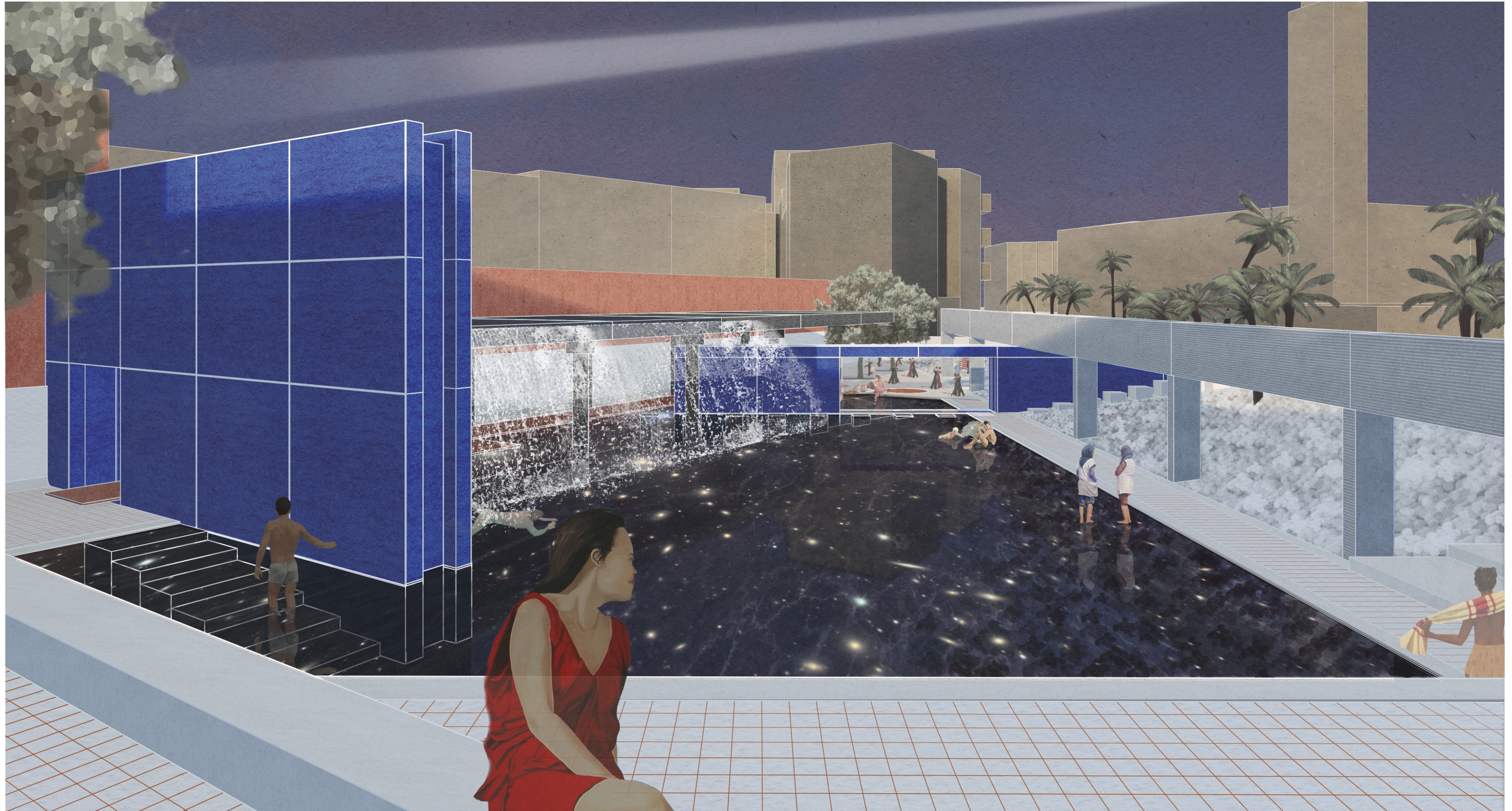

surface . overseeing the whole

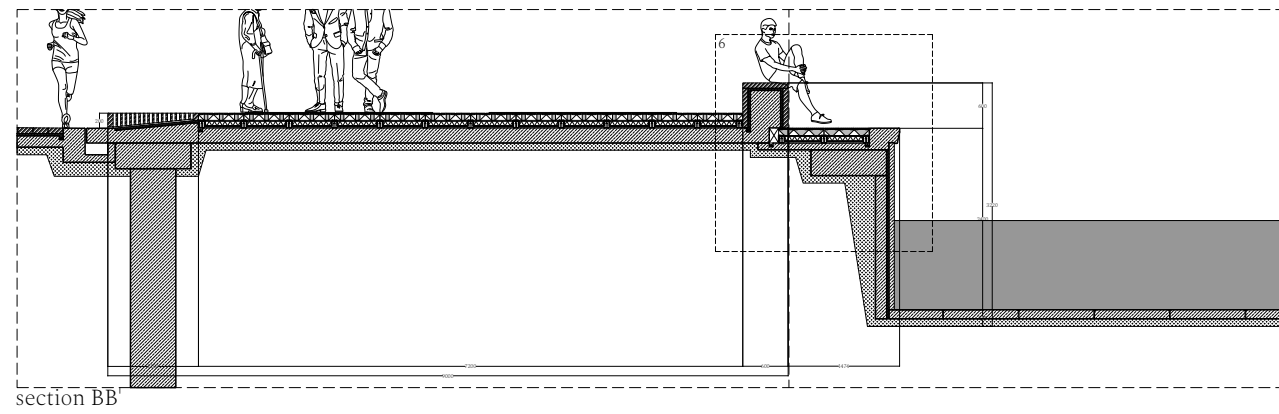
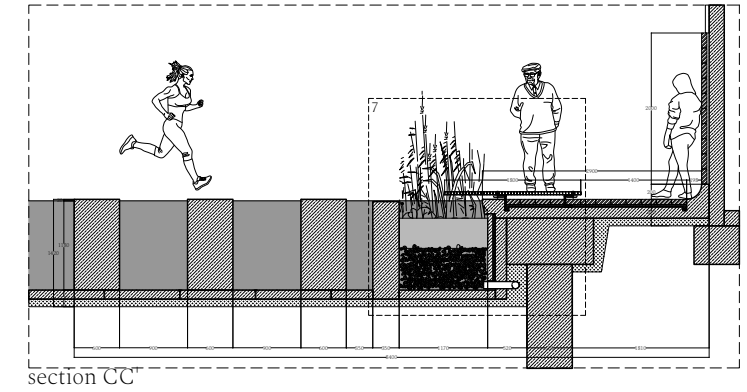
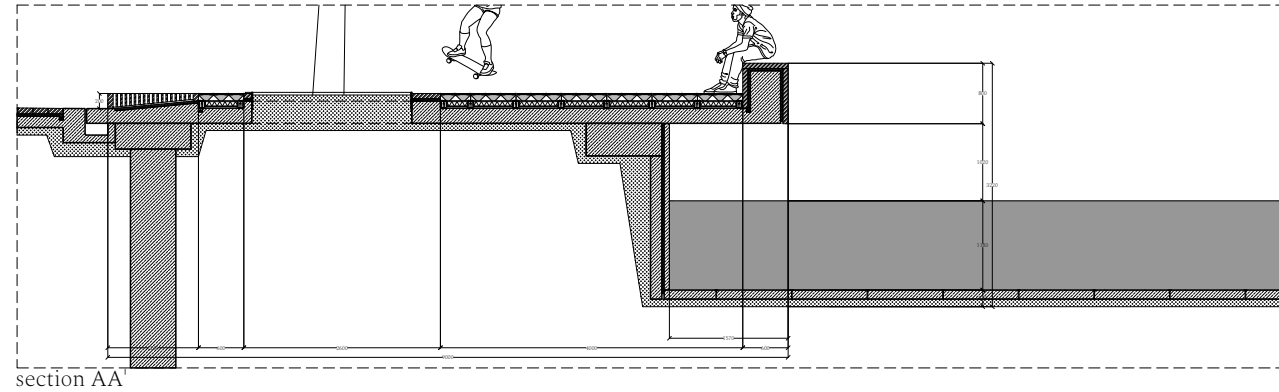
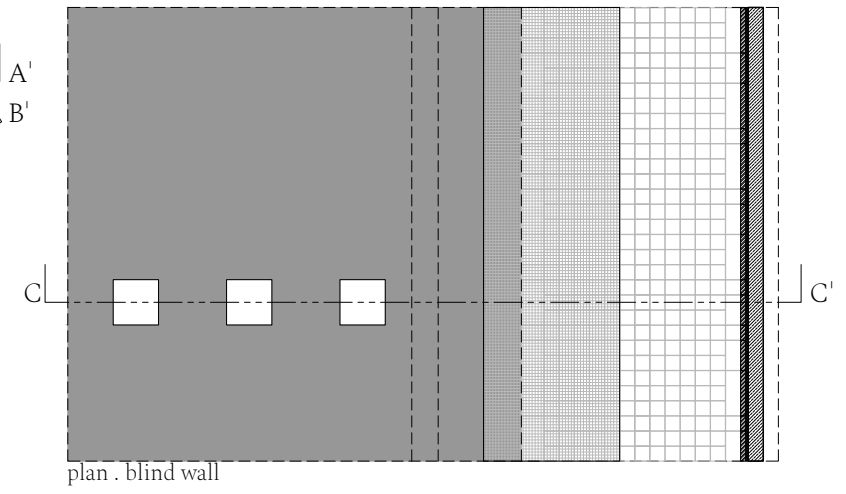
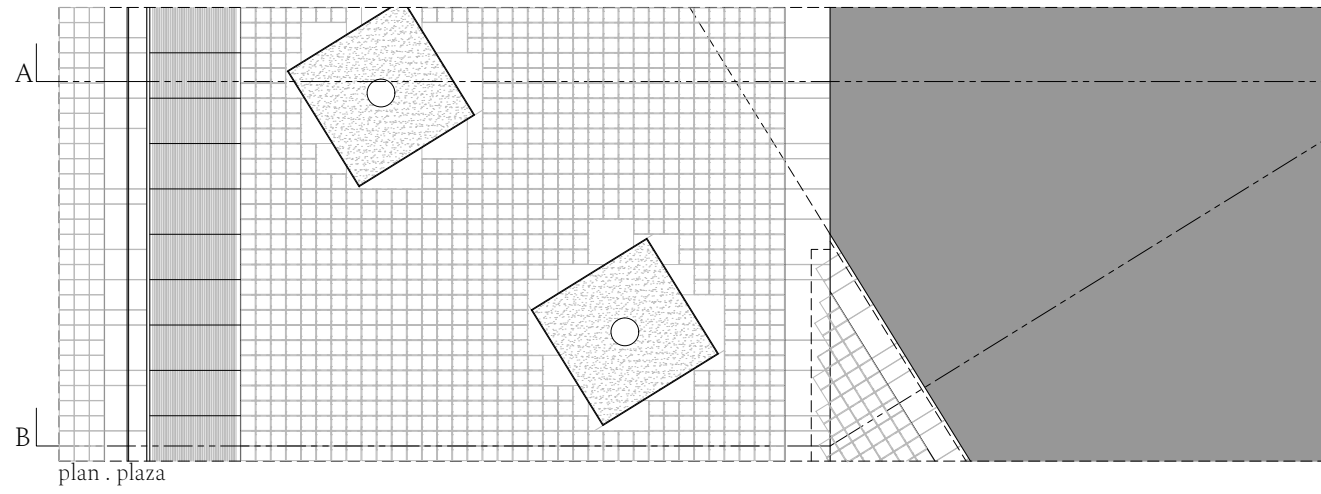

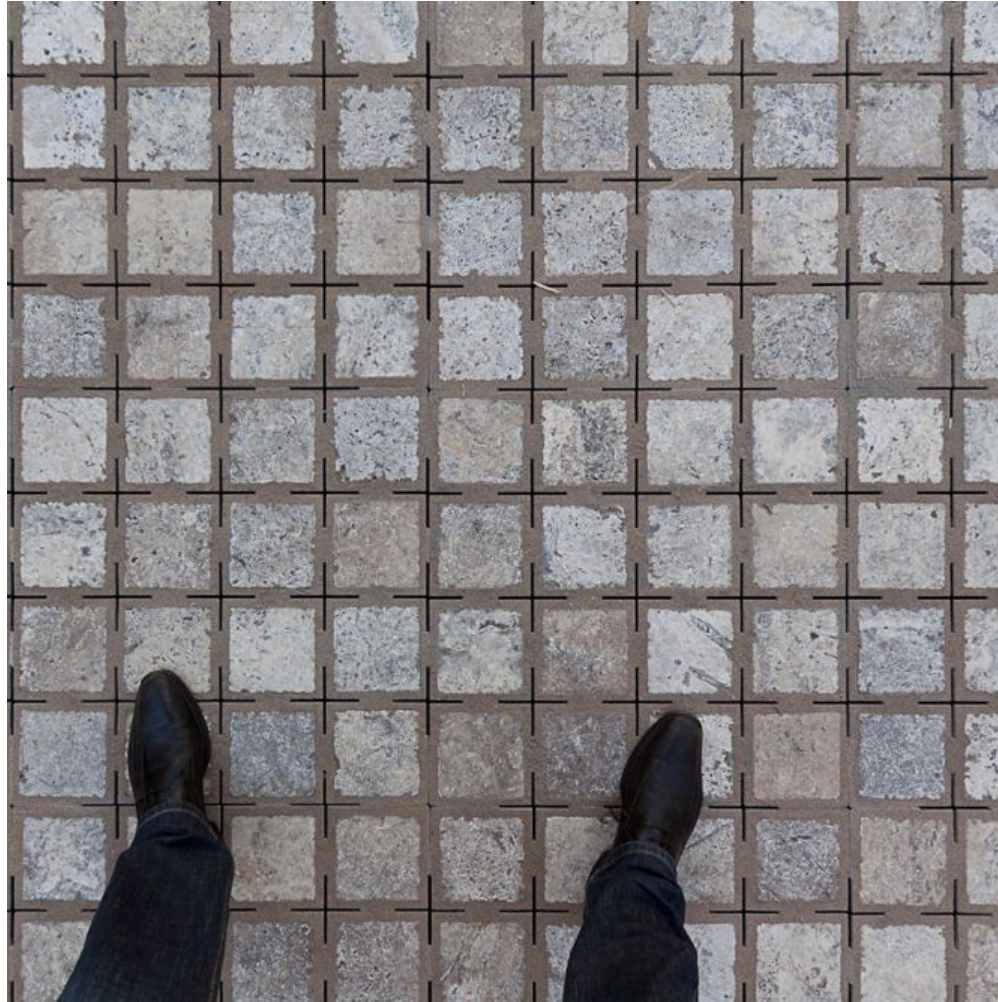

acoustic tiles
noise absorbing floor

(scheepvaartmuseum)

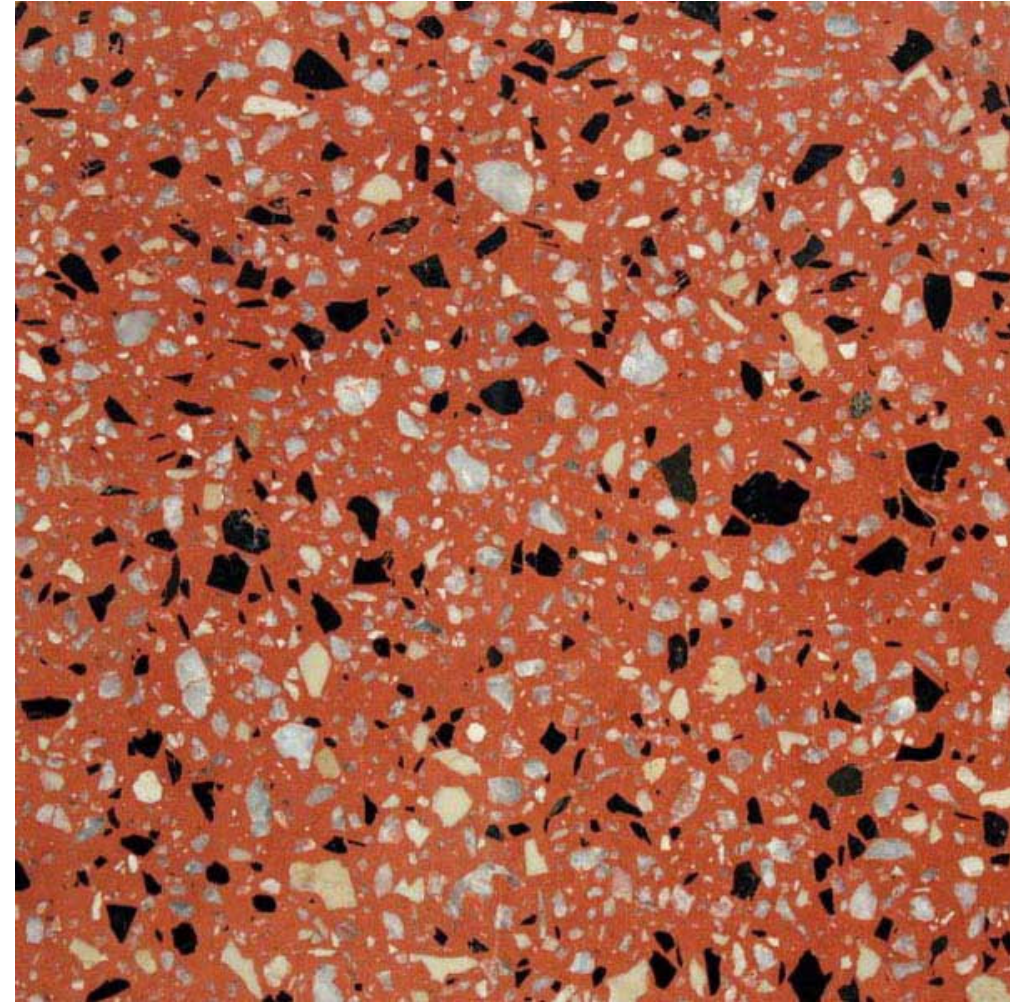

polished earthy terrazzo
rupture in the surface

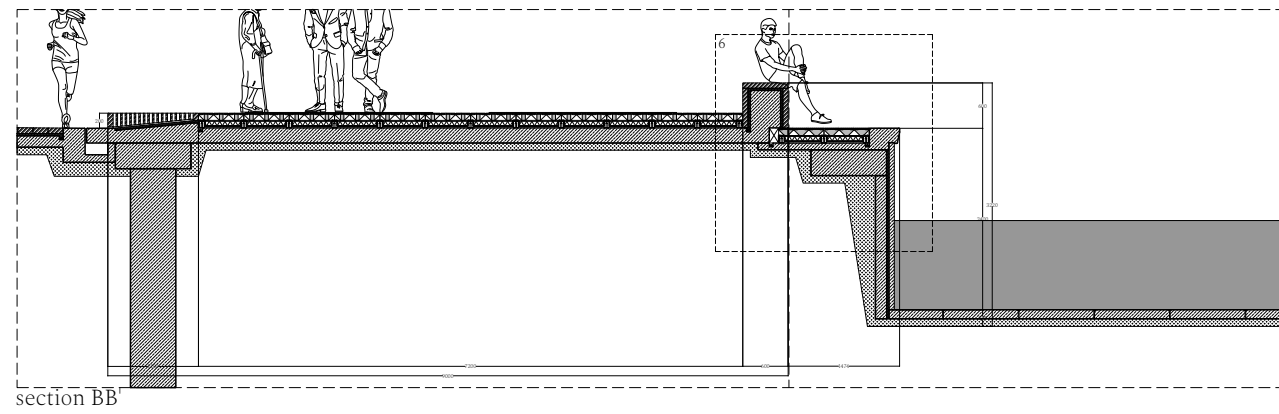
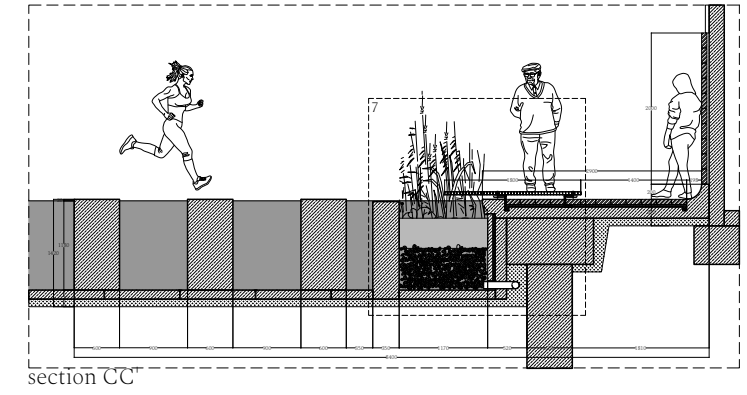
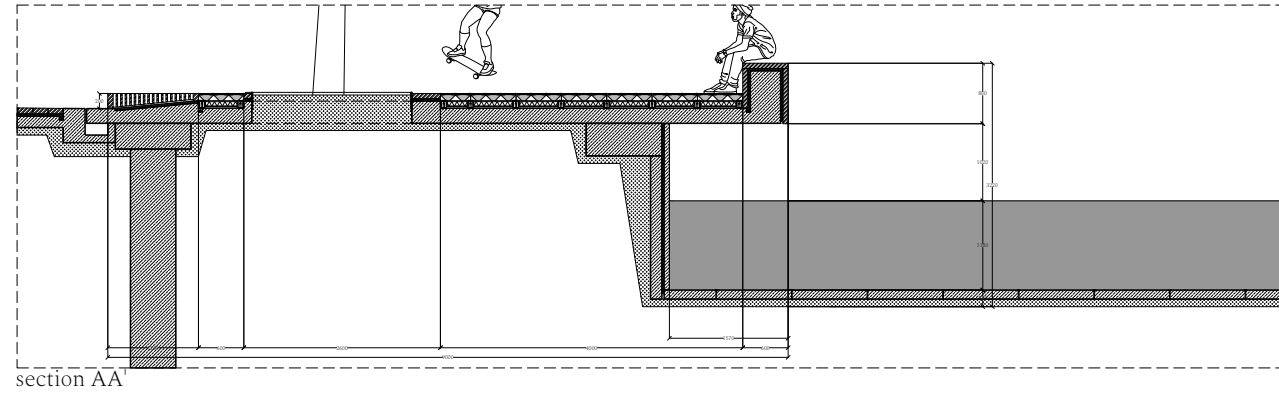
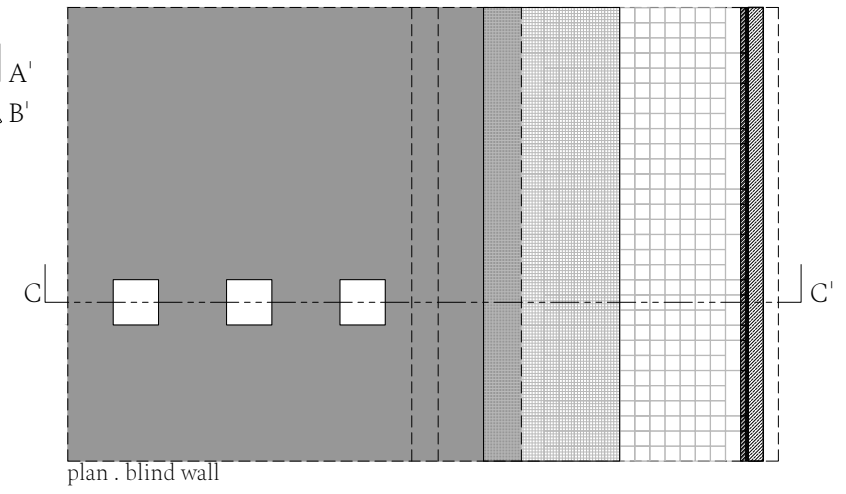
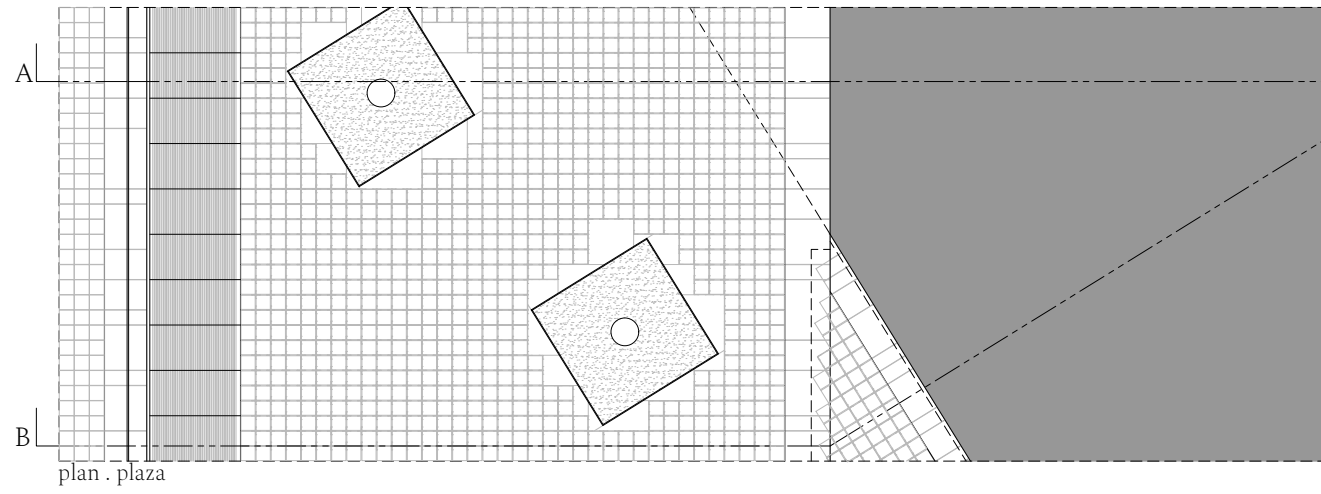



corten steel walkway
absorbing noise



earthy colored loam
rupture in the surface

(guelmim technology school)

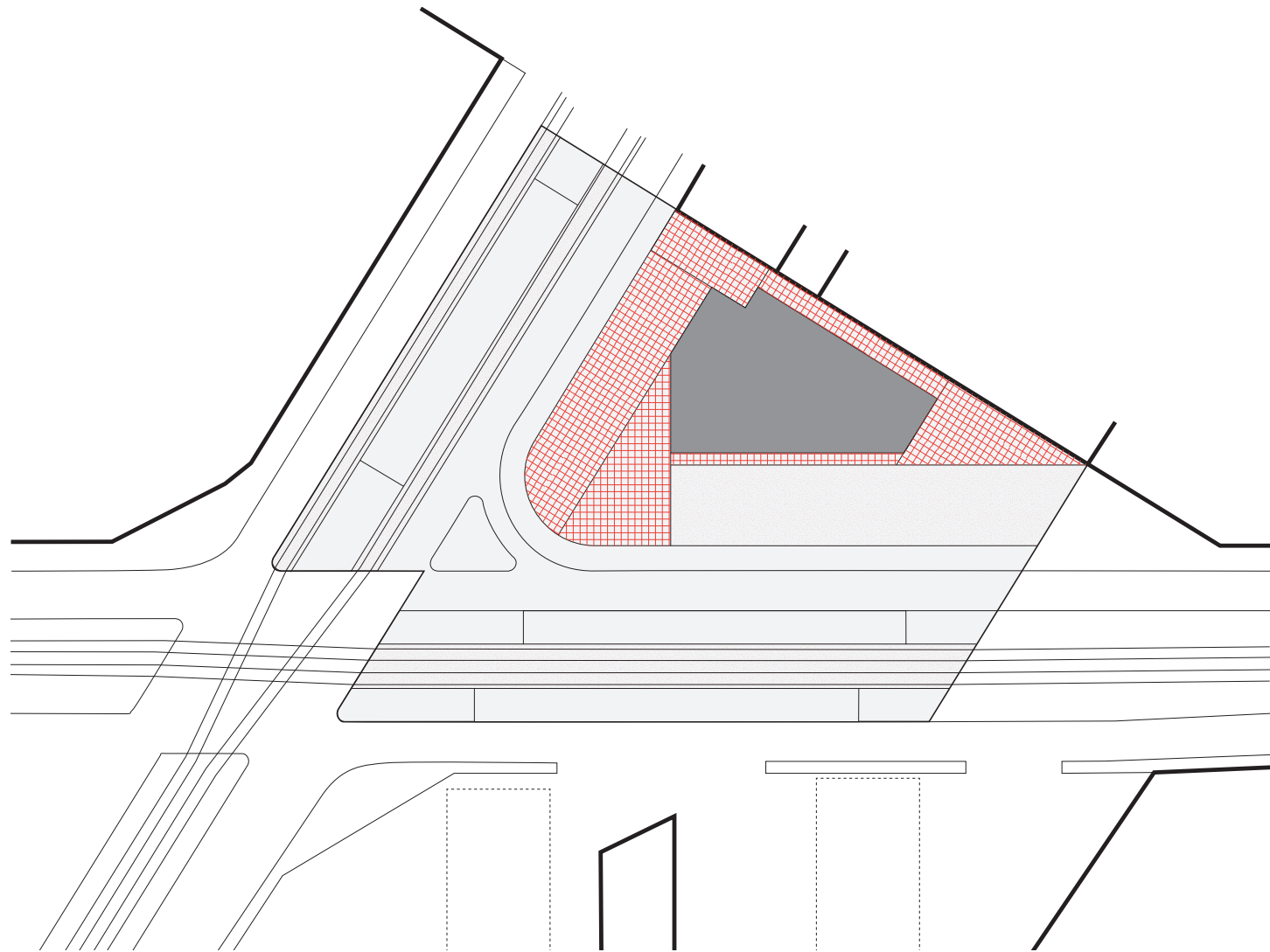

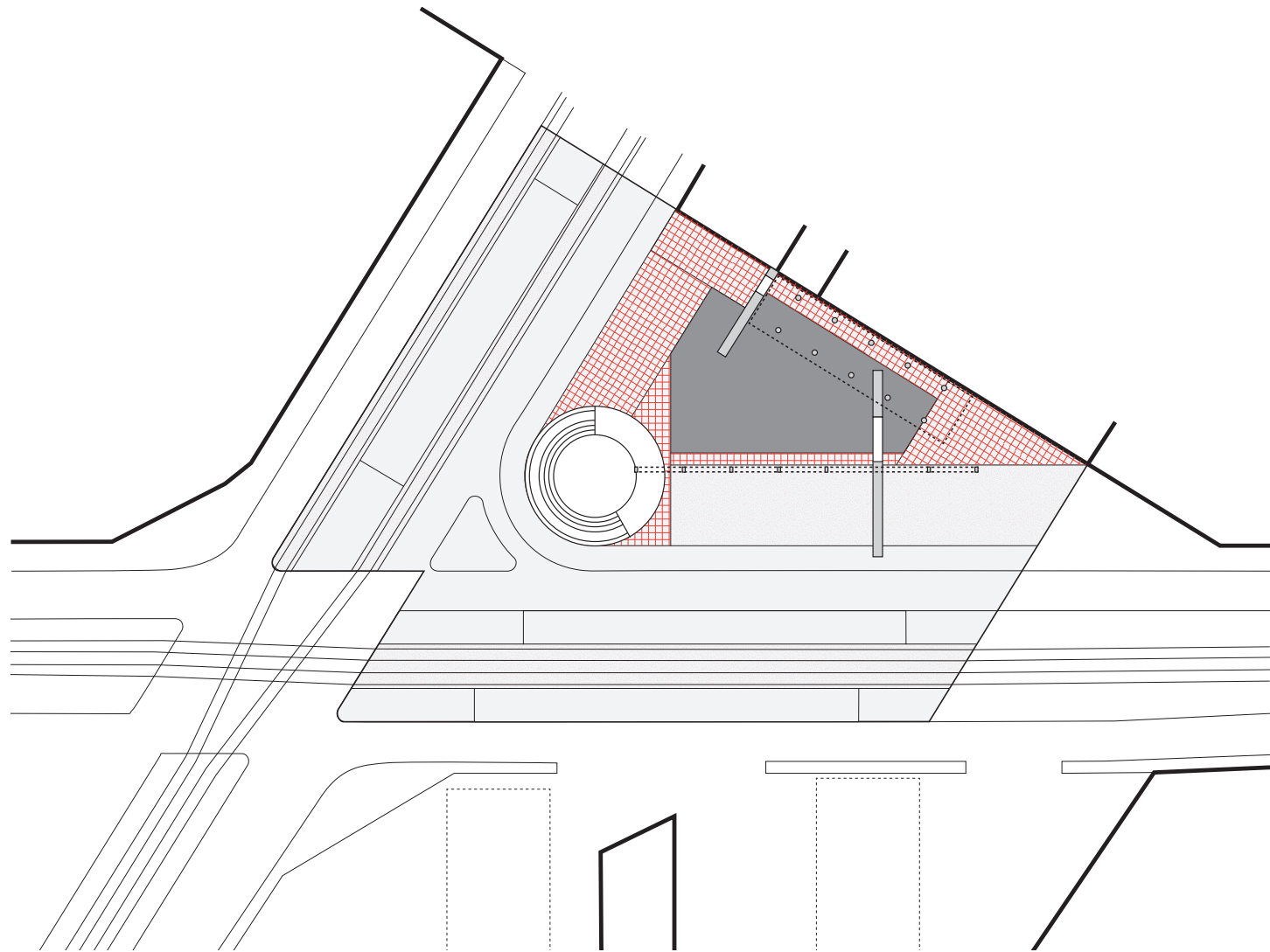

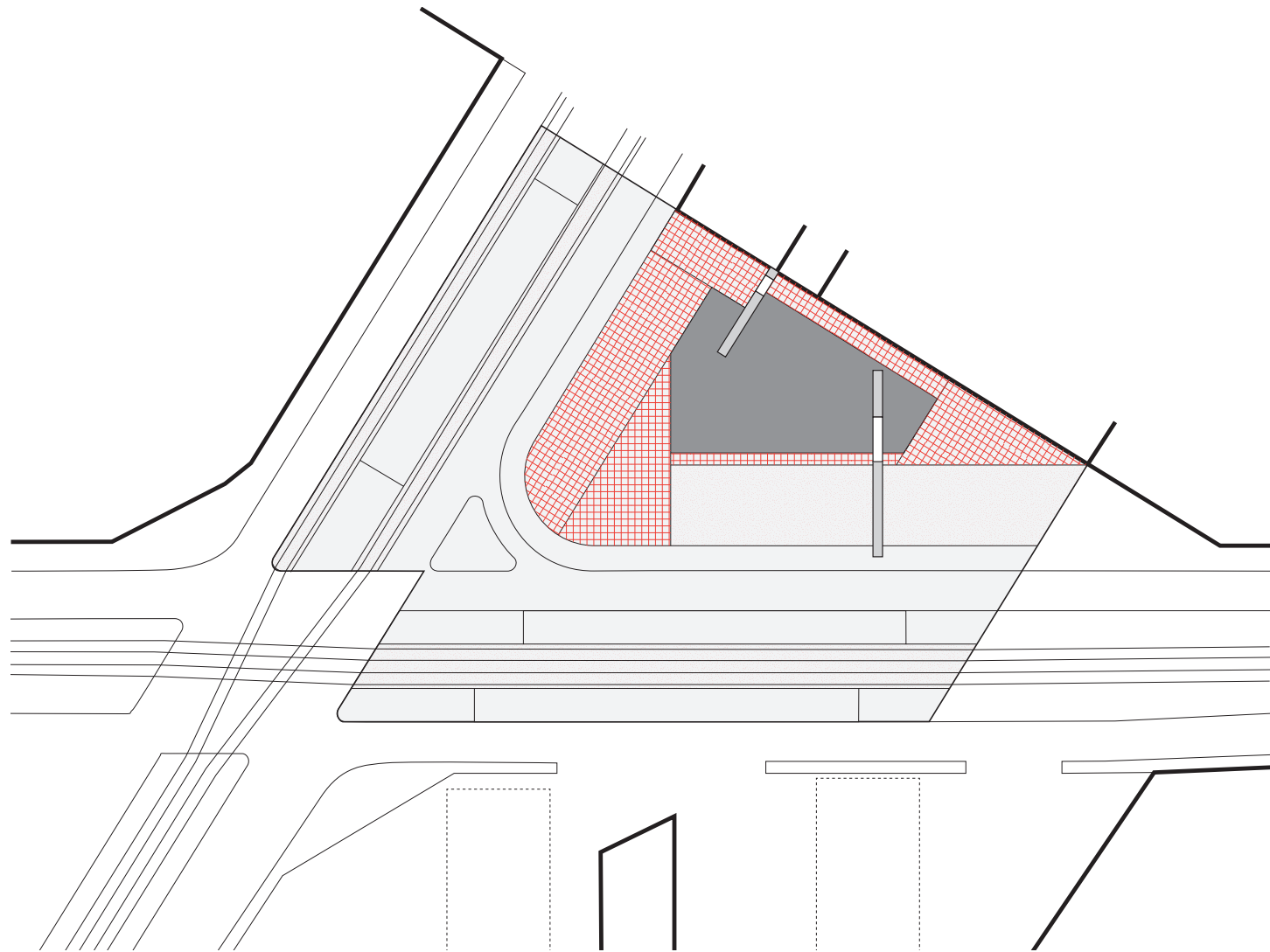

introducing the walls

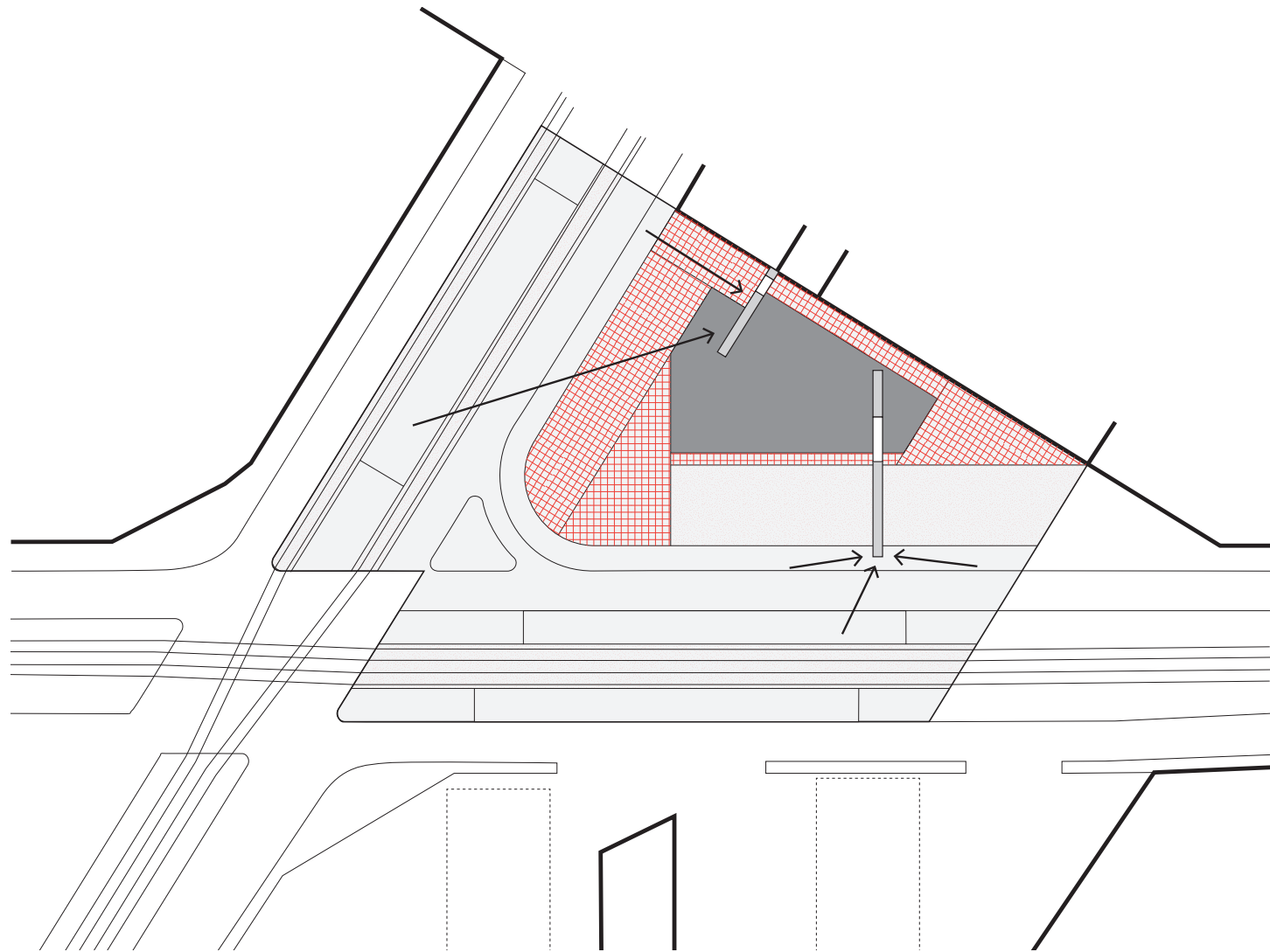

operate as clear signs to the oasis

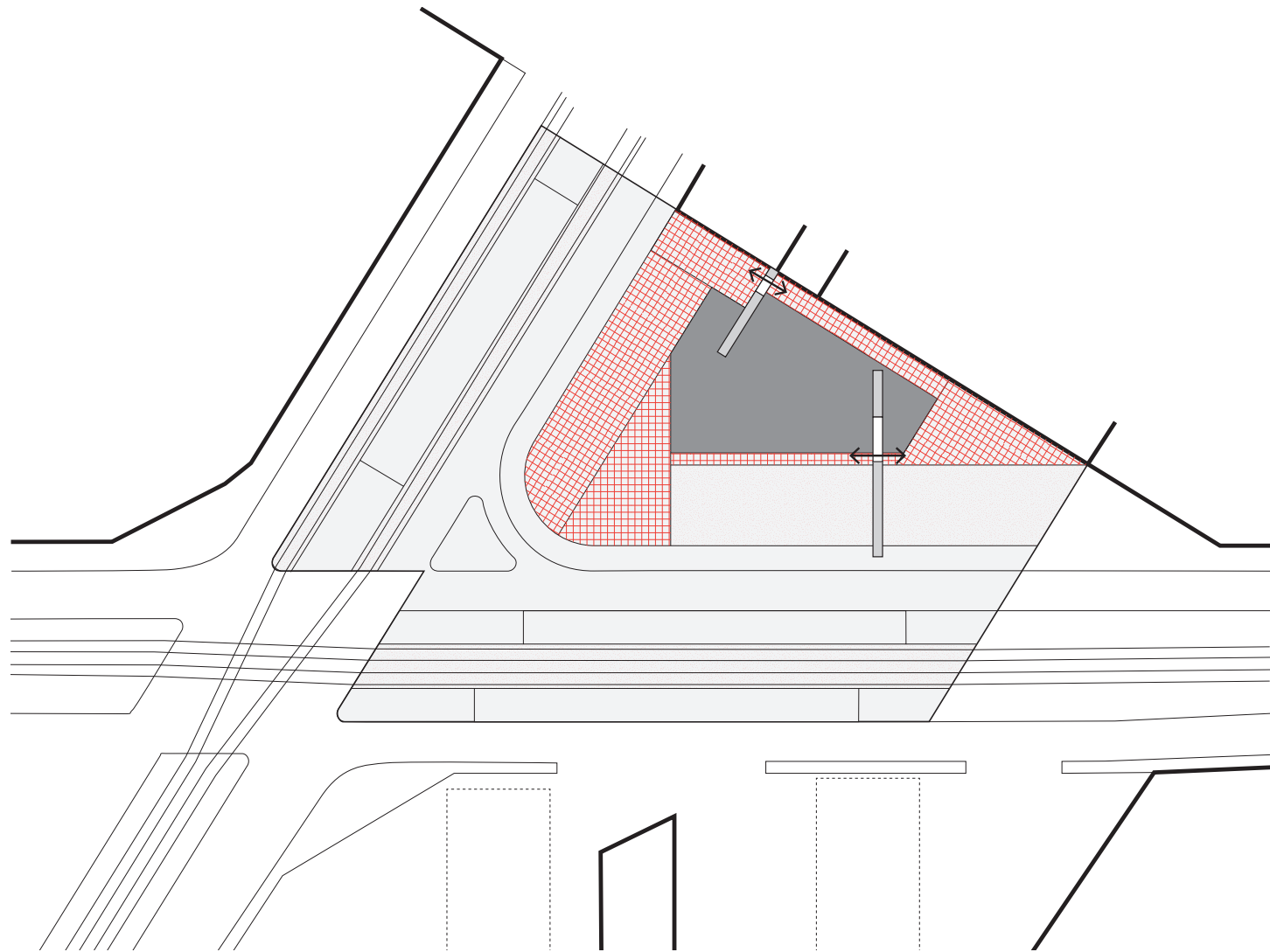

perform as gateways



walls . gate, frame and sign

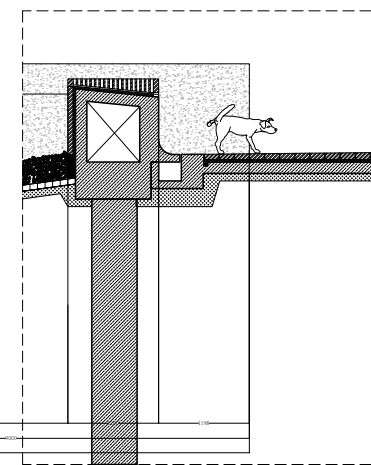
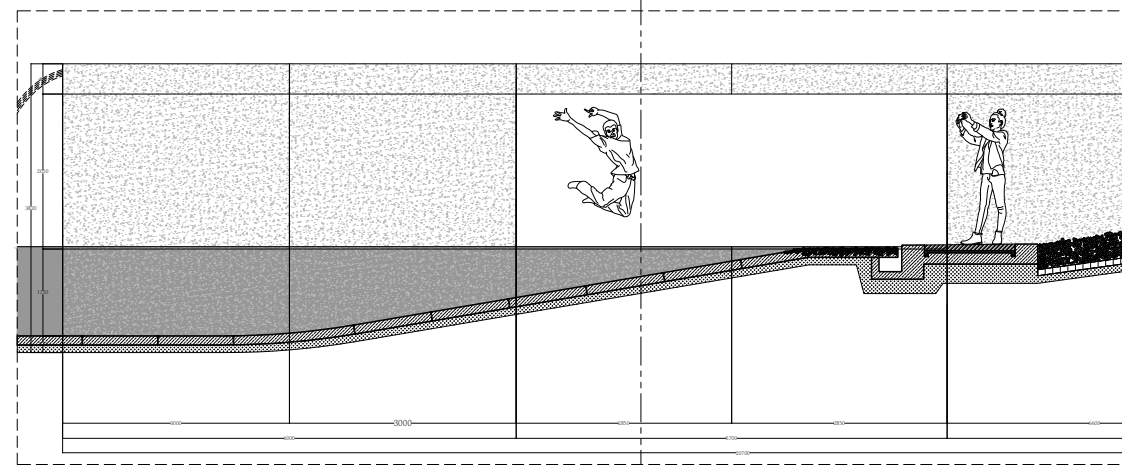
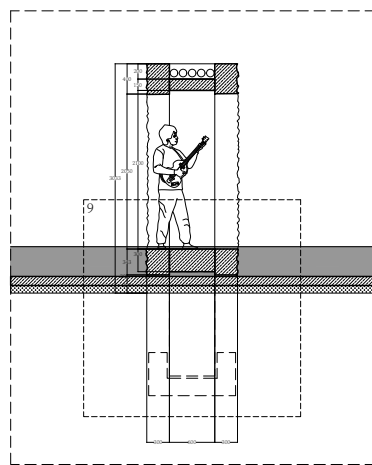
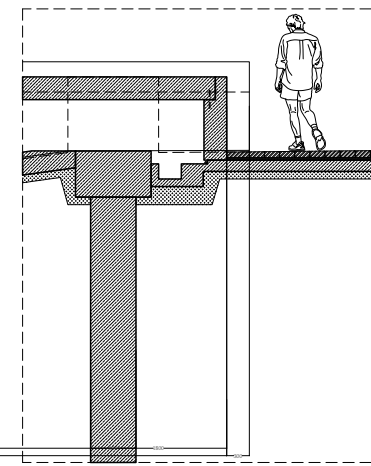
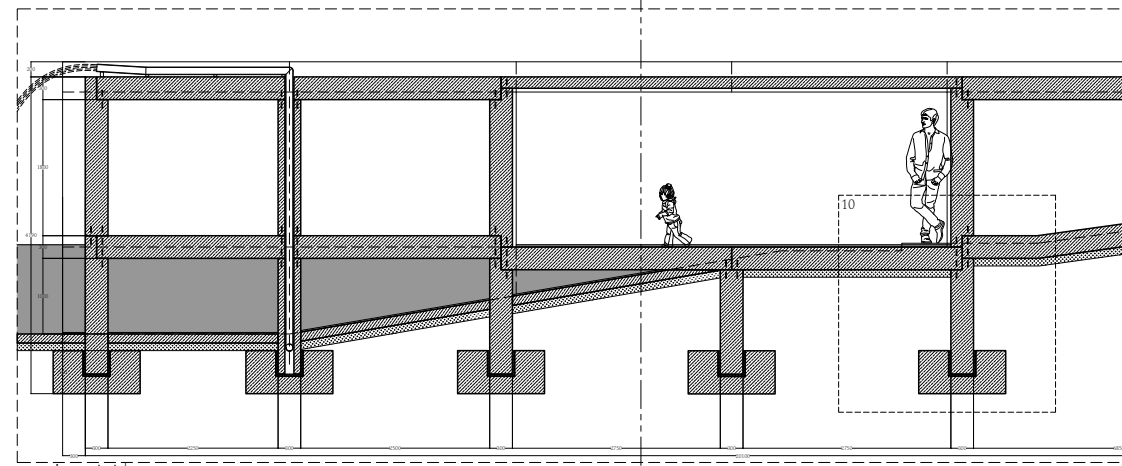
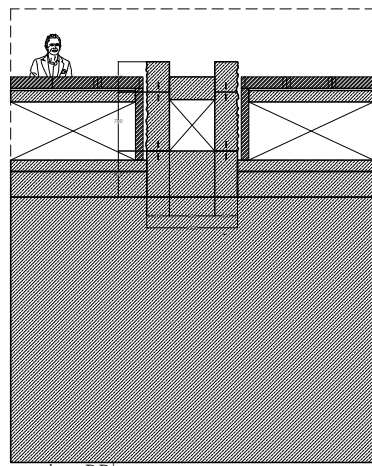
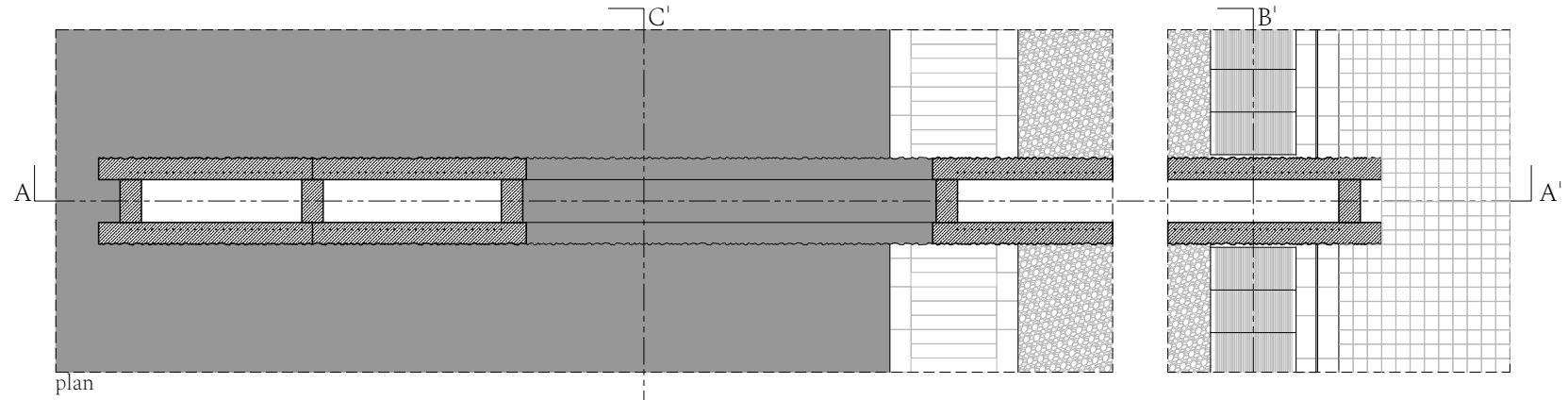
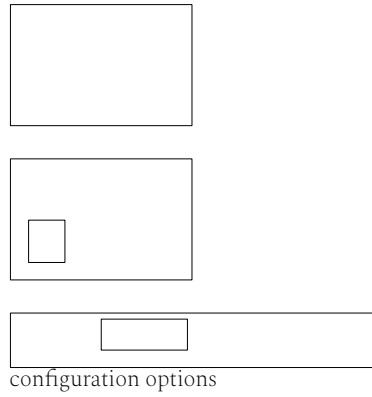



(museum blau)

cobalt pigmented concrete

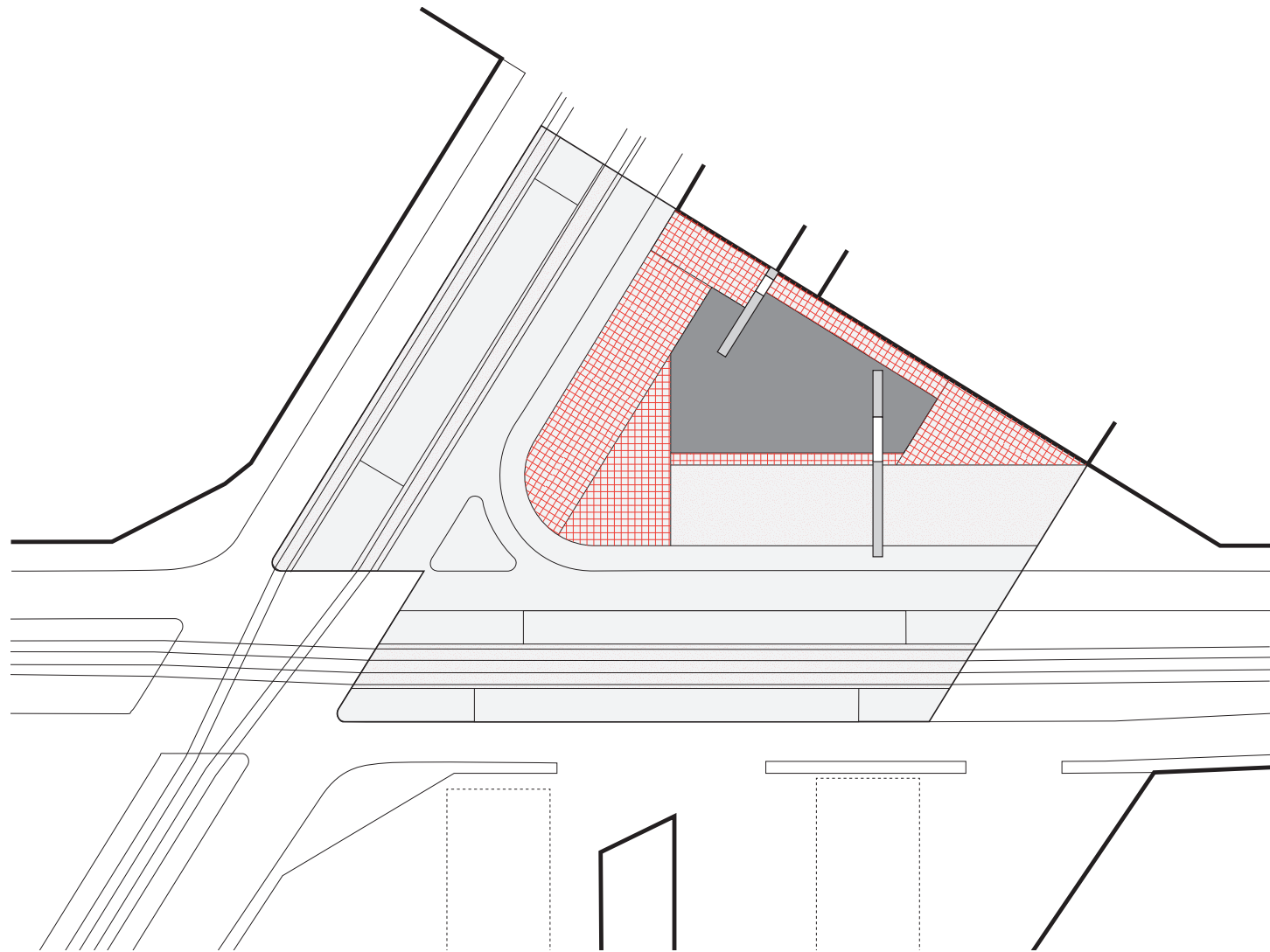

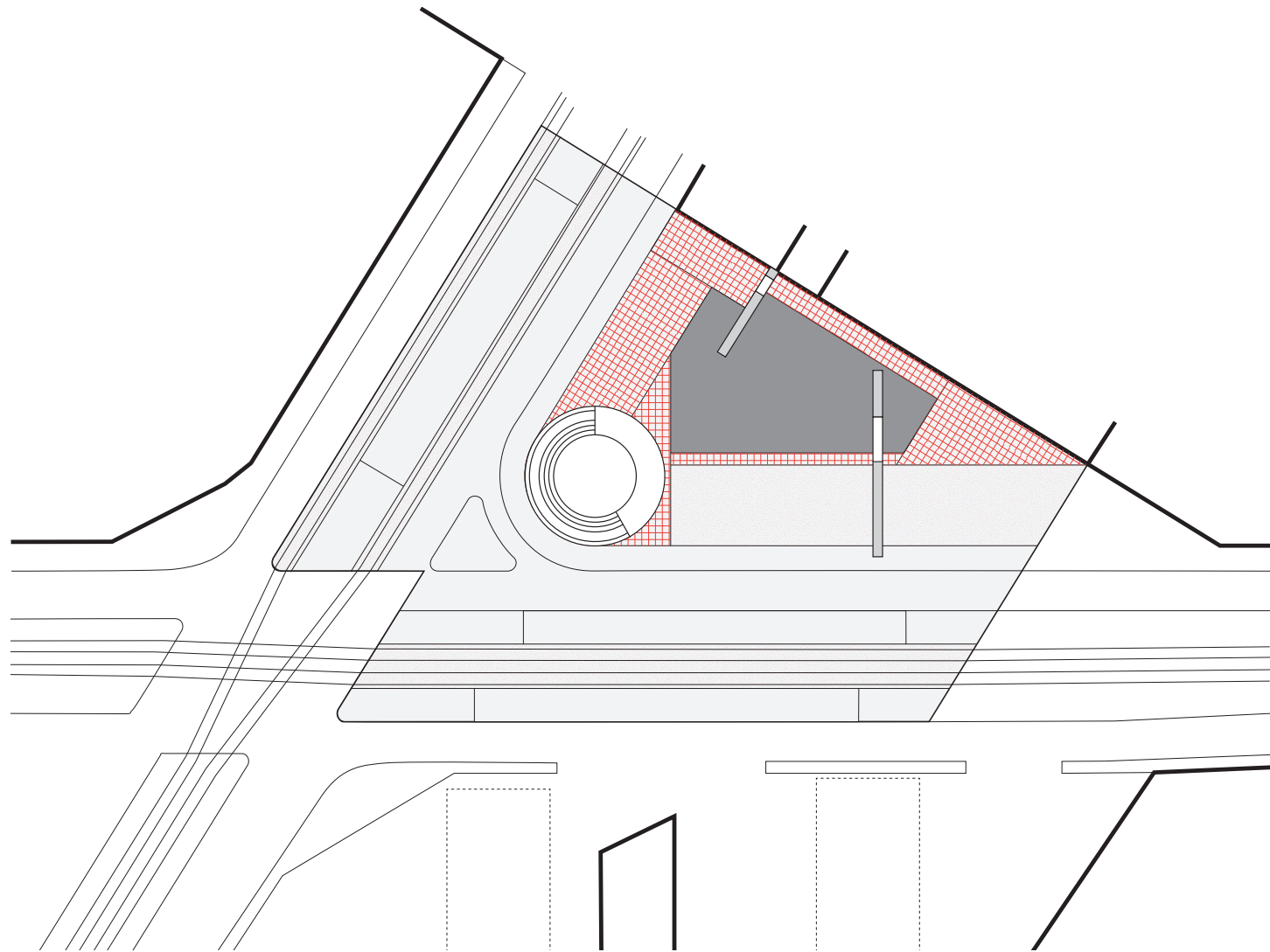

introducing the circle

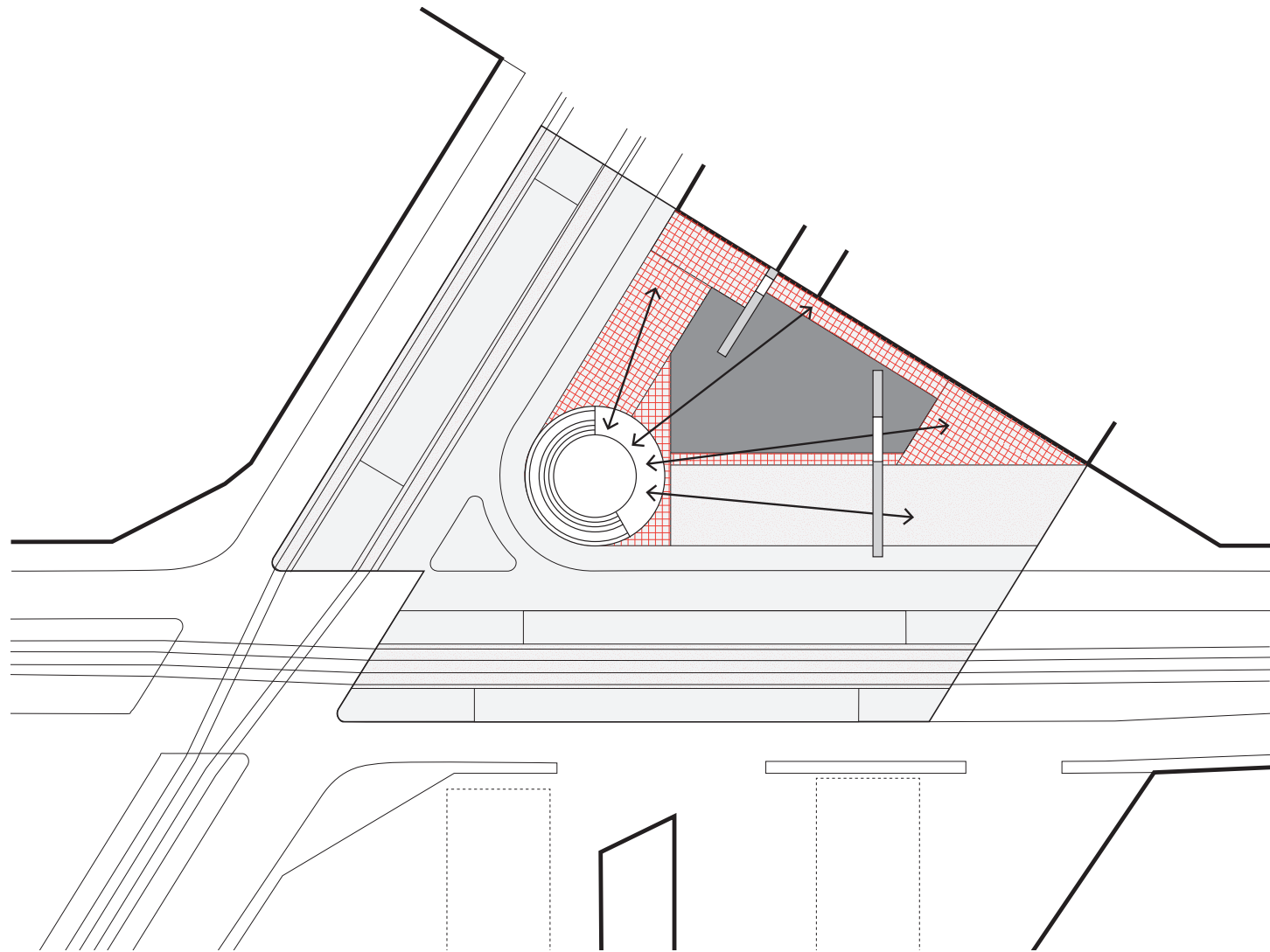

seen and overseen from within the oasis



circle . anticipation of the spectacle

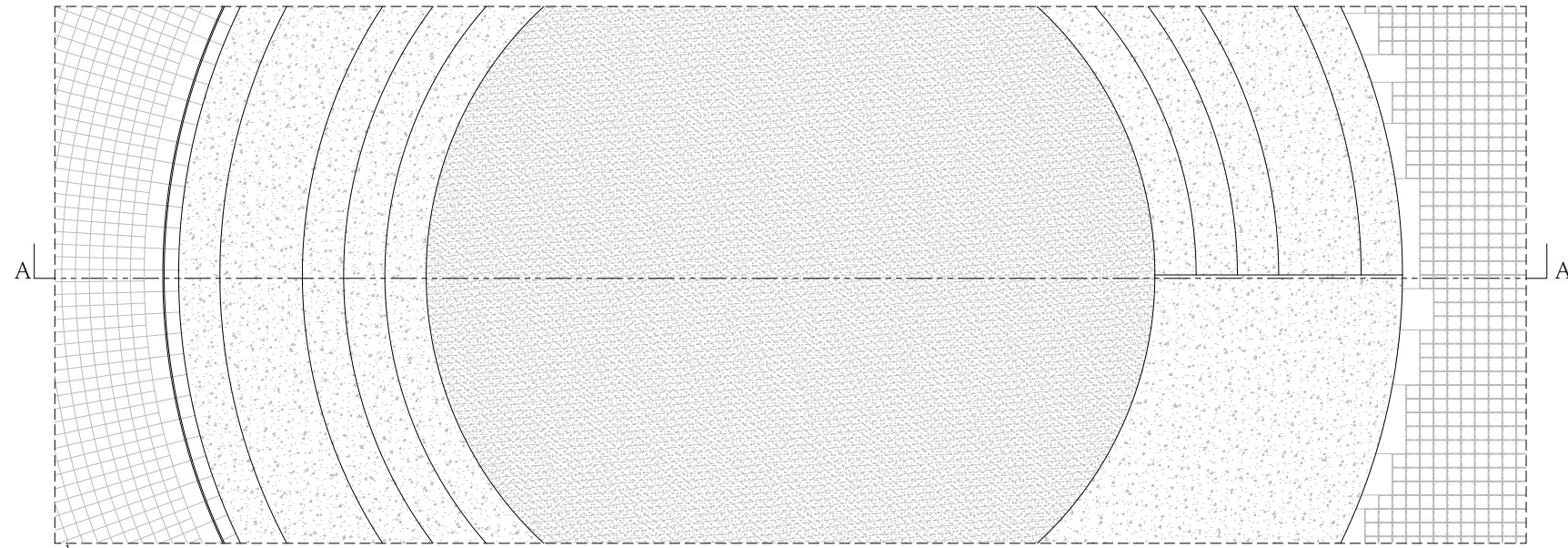

plan

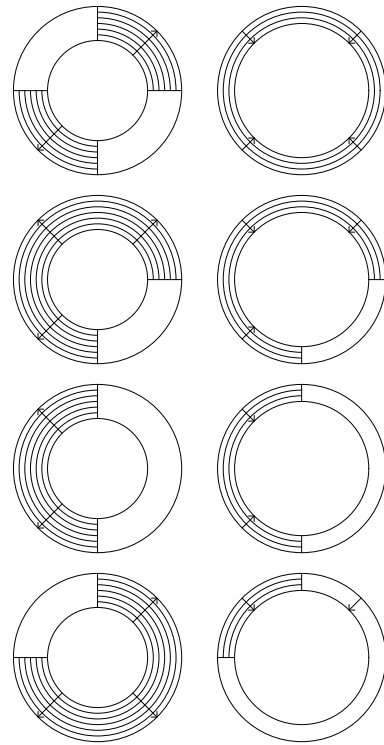

configuration options

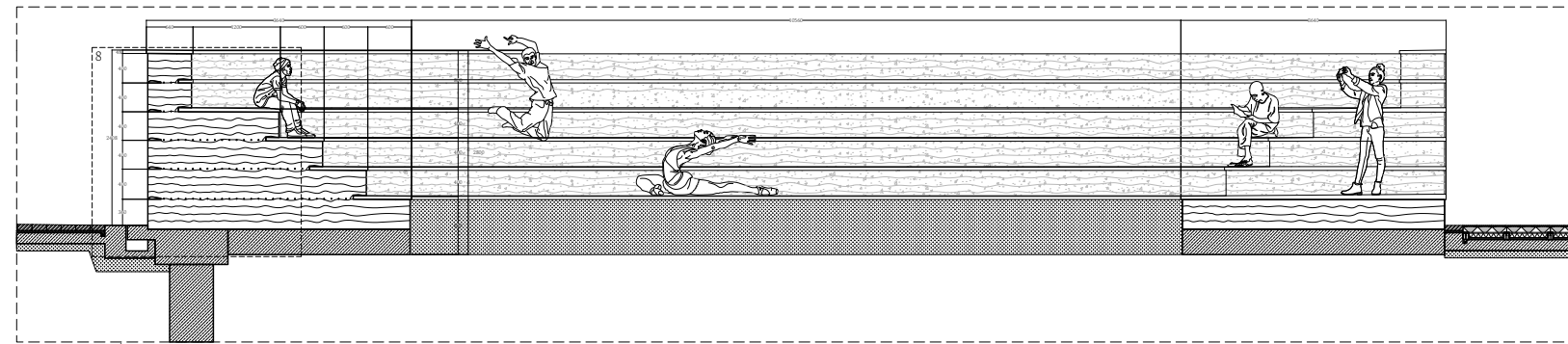

section AA

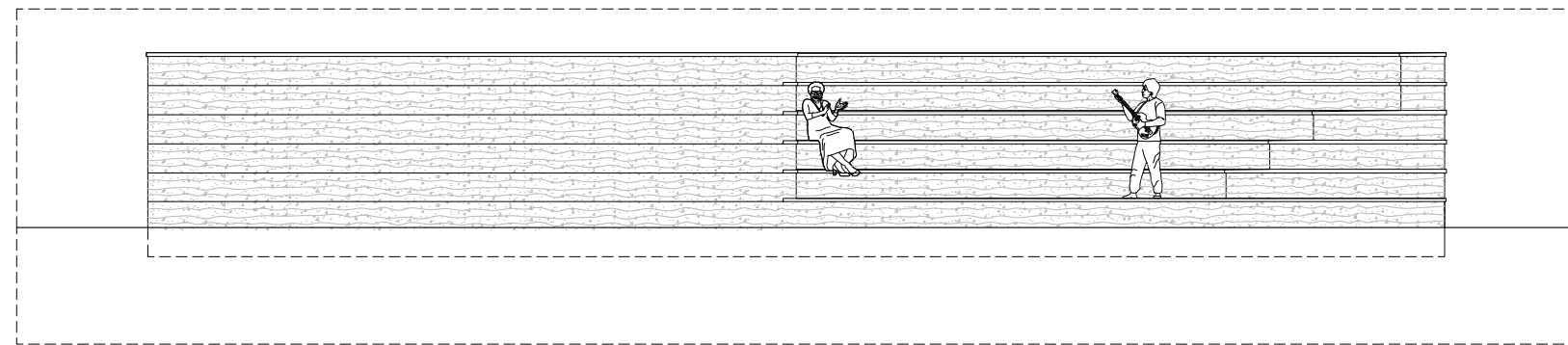

elevation



rammed earth

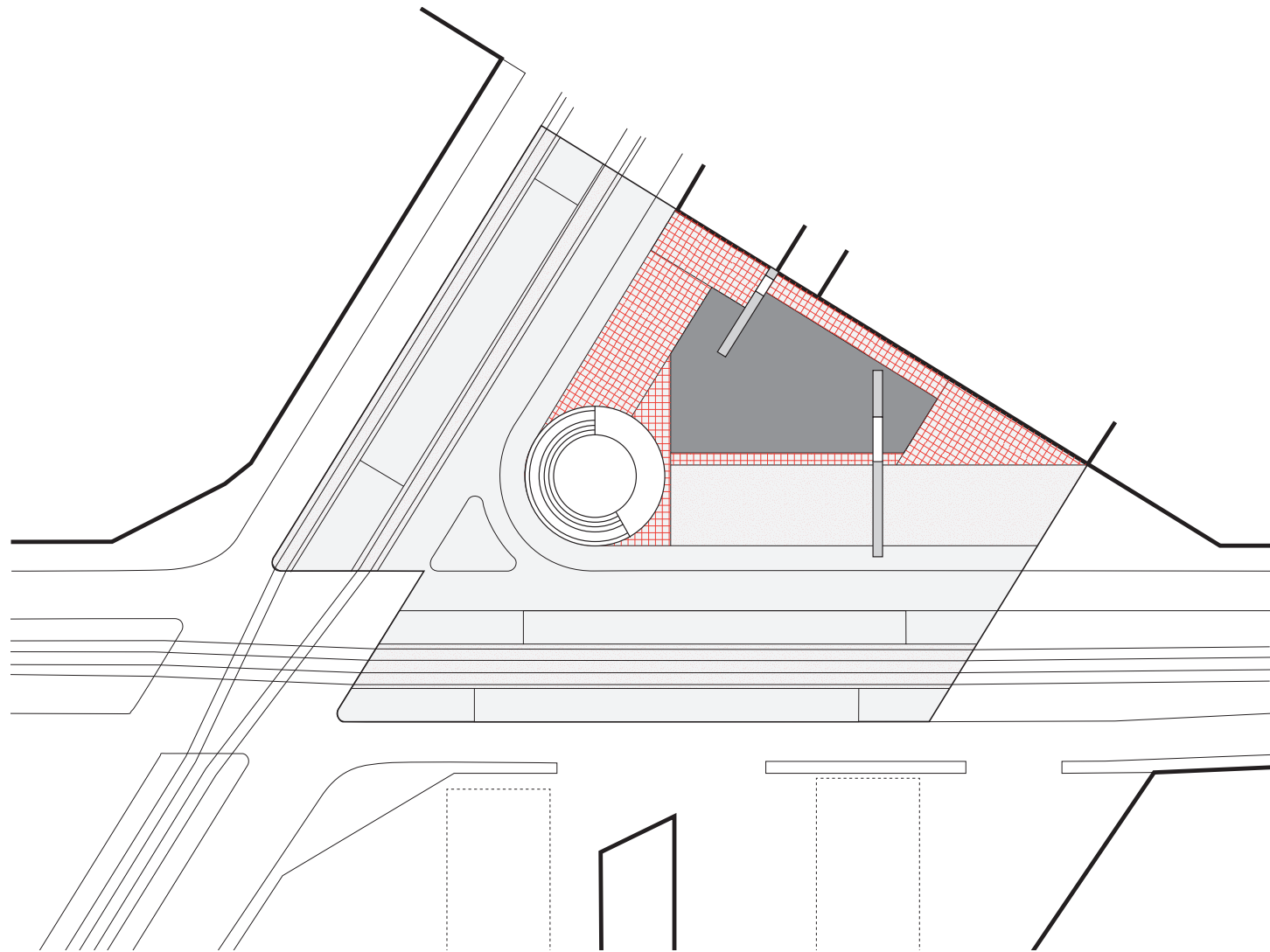

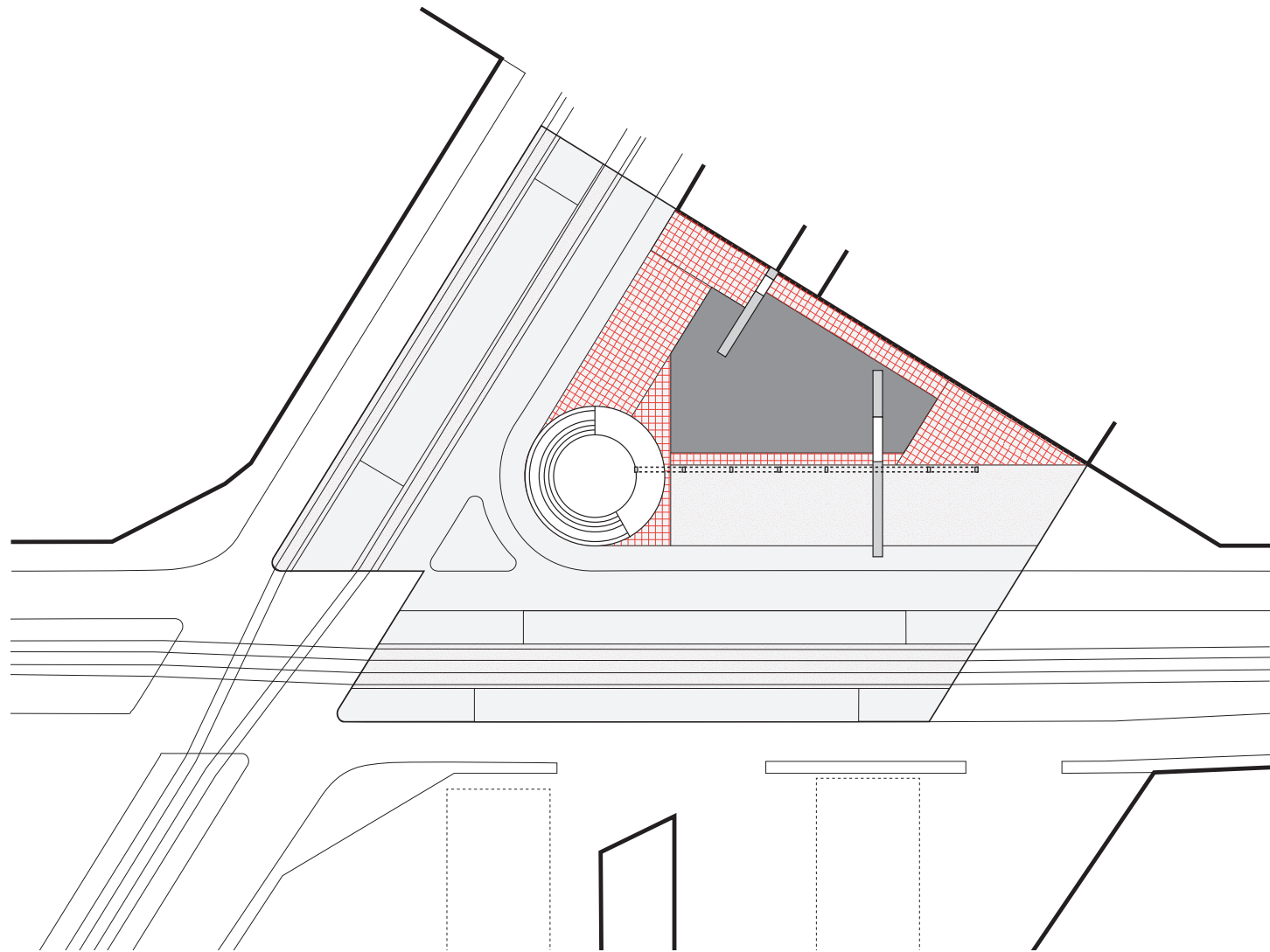

introducing the colonnade

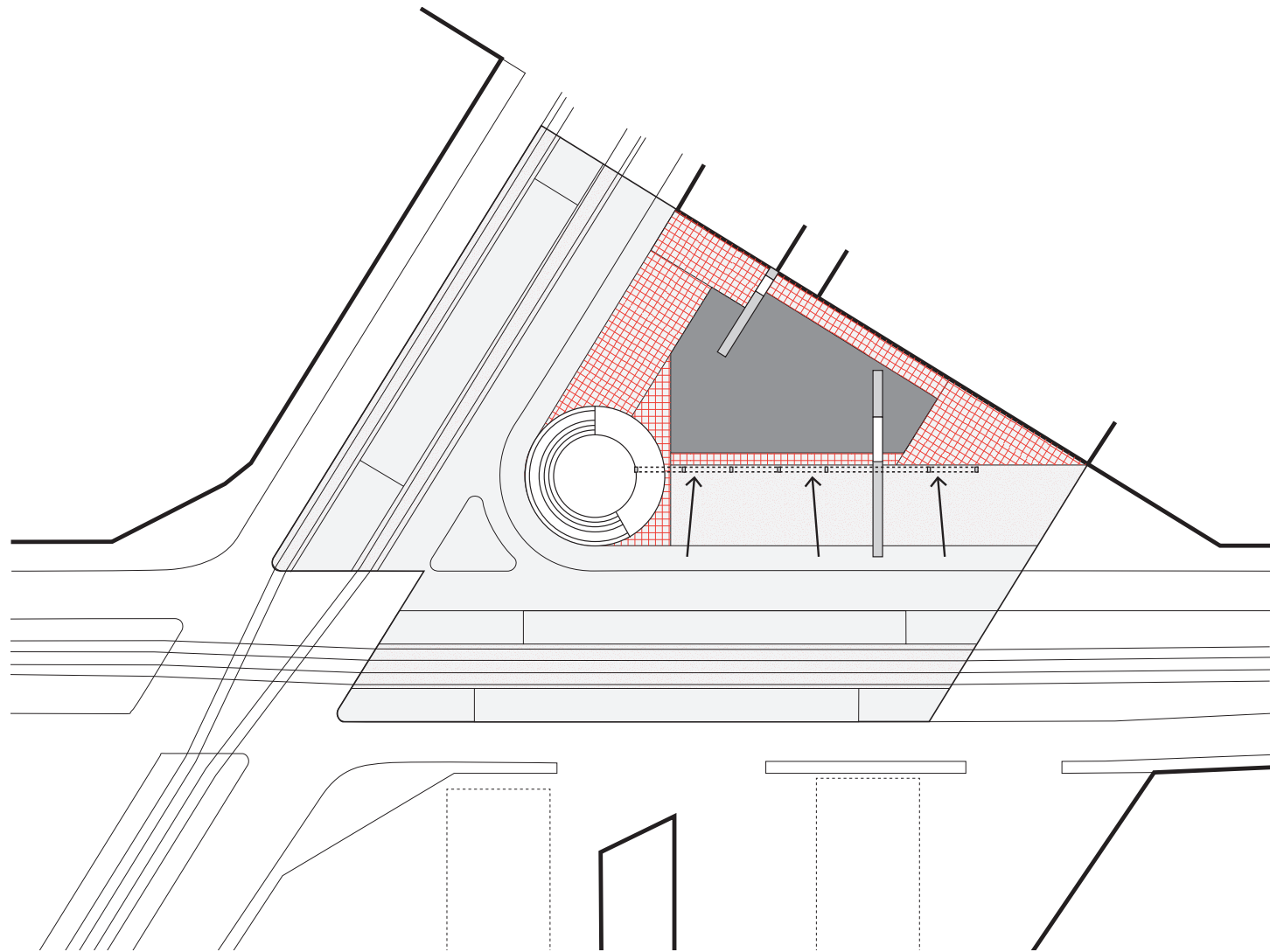

mediating boundary



colonnade . filtering the everyday

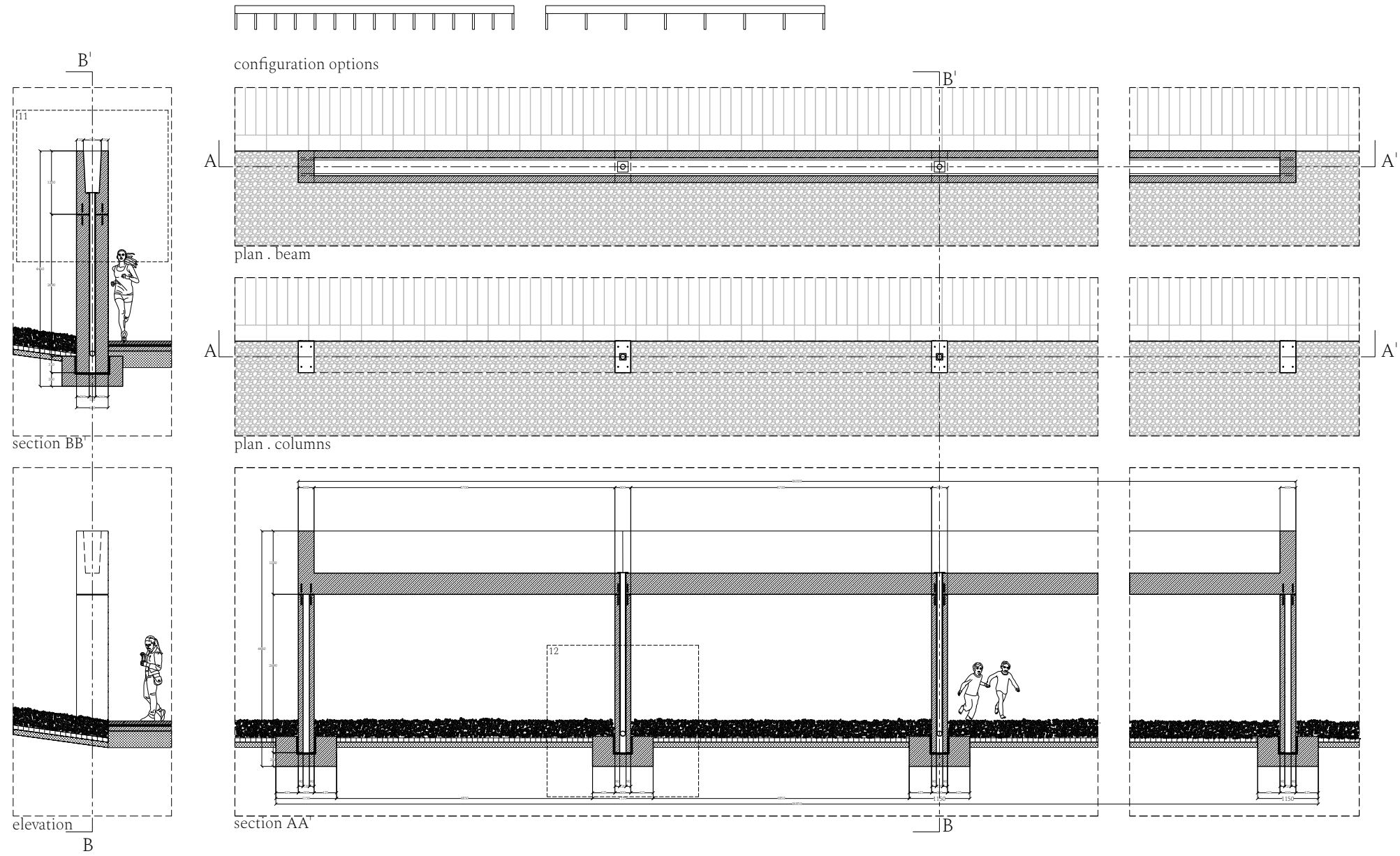

fragment . element . colonnade



(sayamaike historical museum)

textured concrete accumulating stains

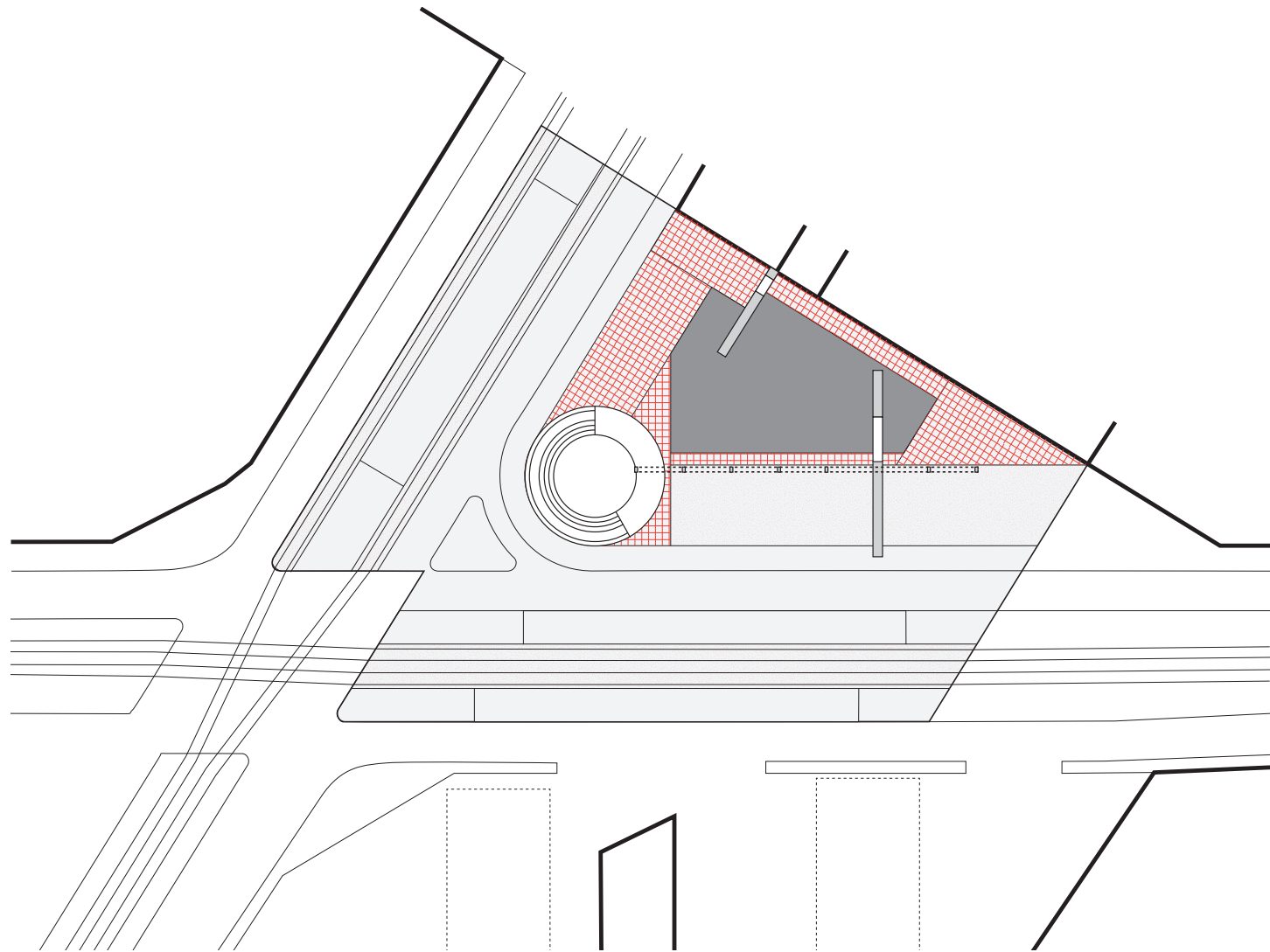

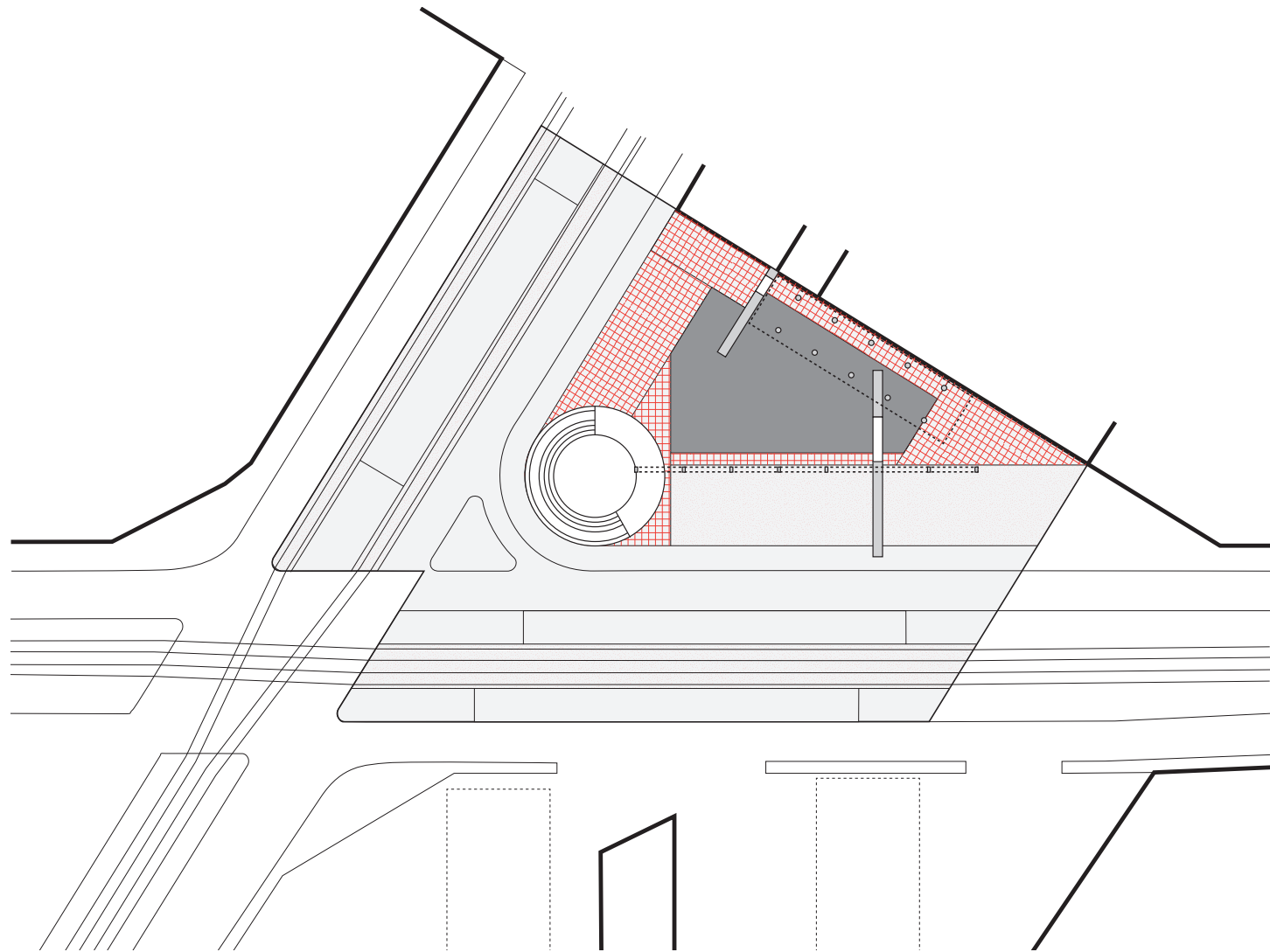

introducing the roof

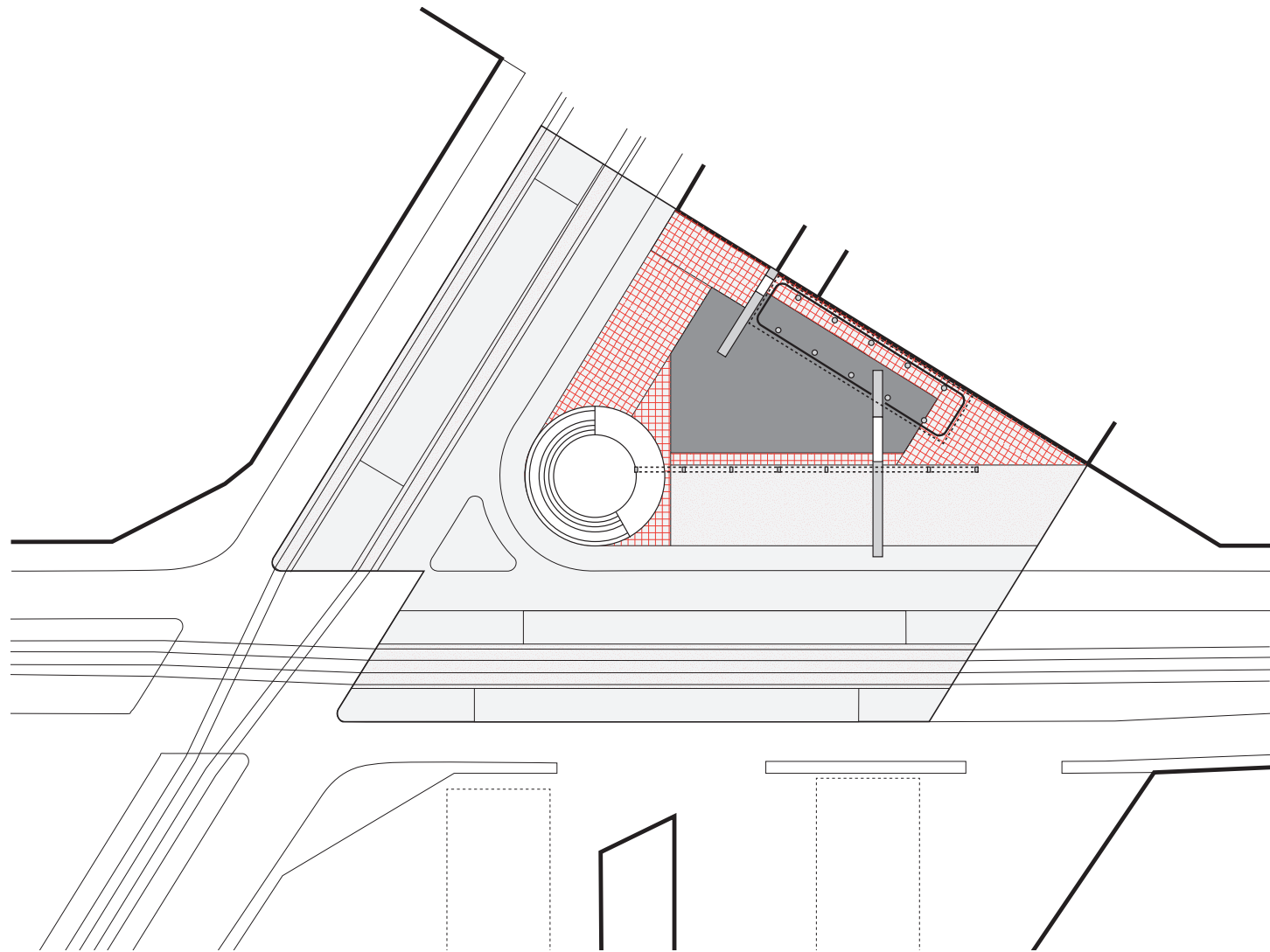

ultimate intimacy

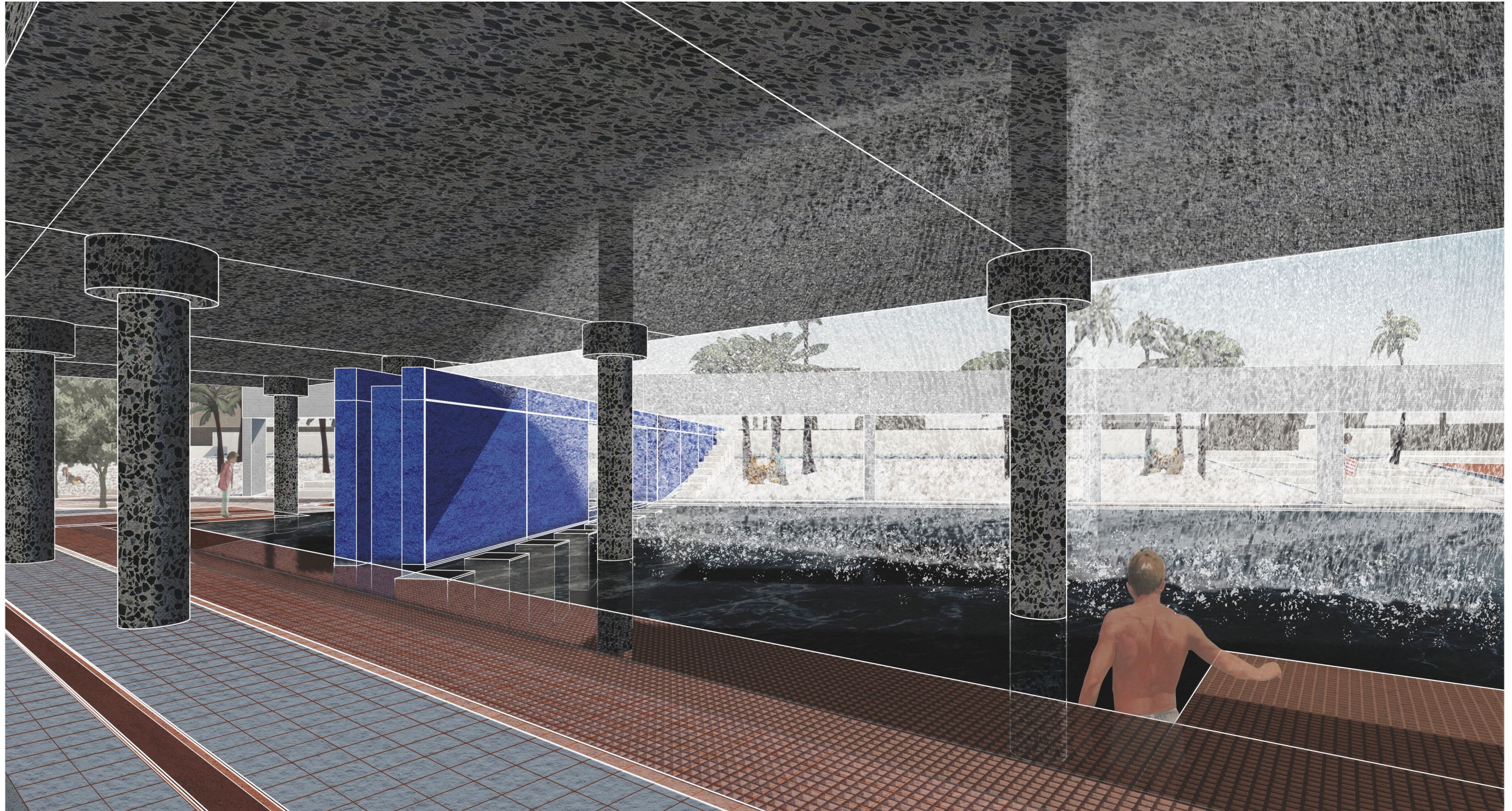

roof . accommodating inner sanctuary

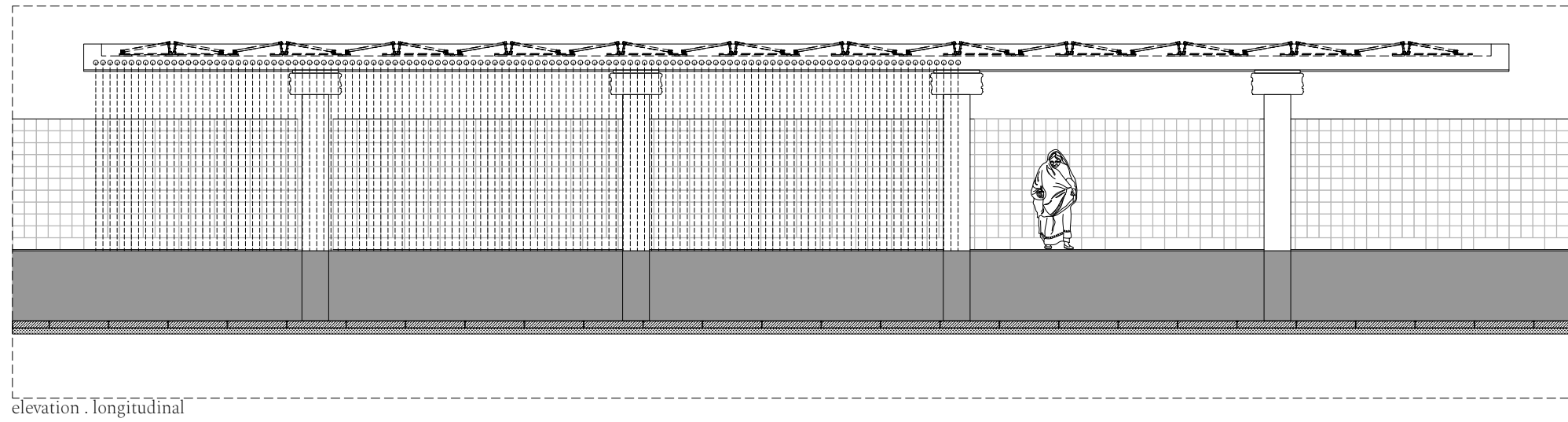
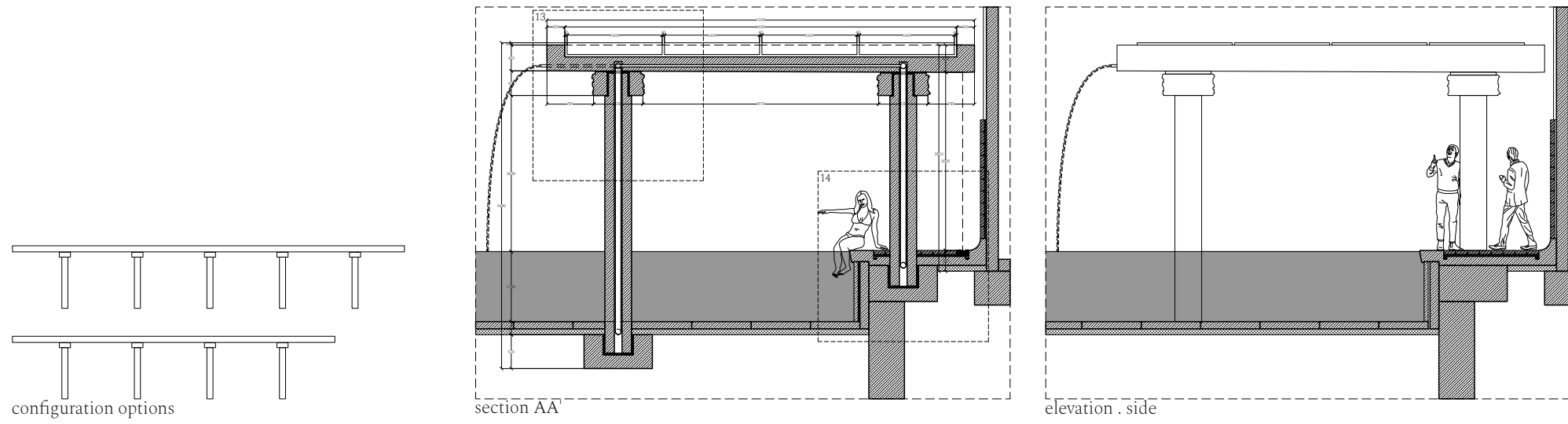

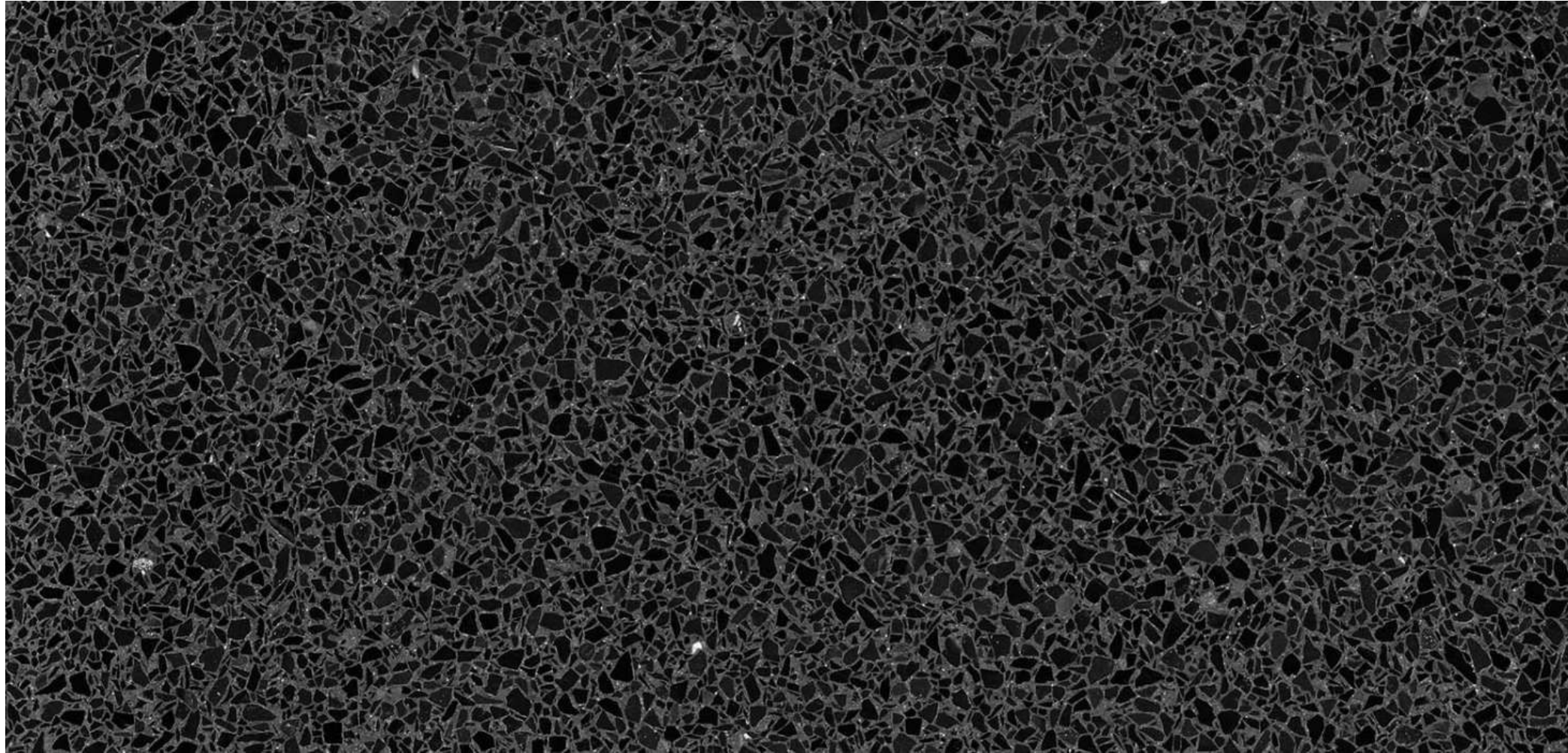

terrazzo with black stone aggregates

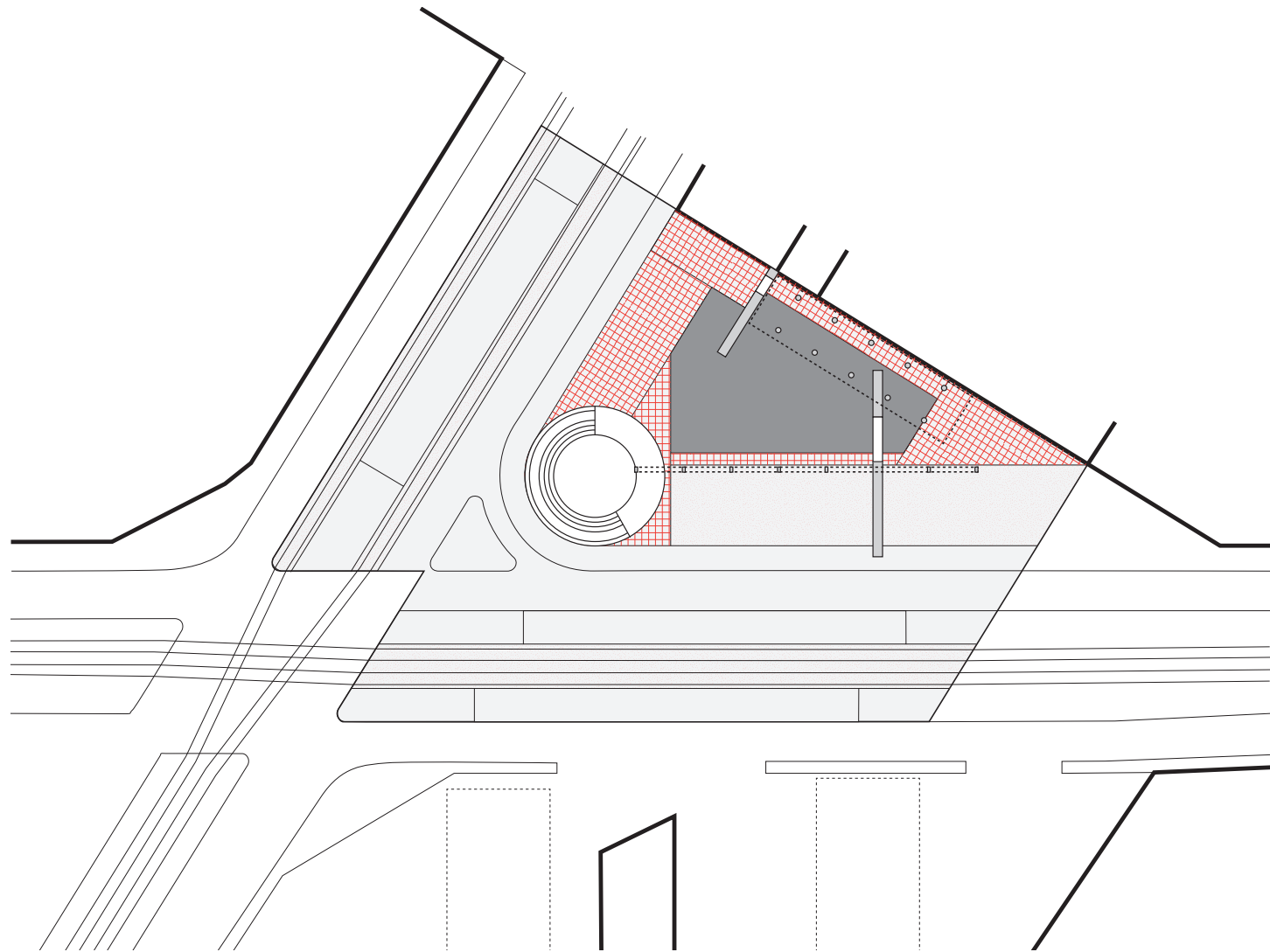

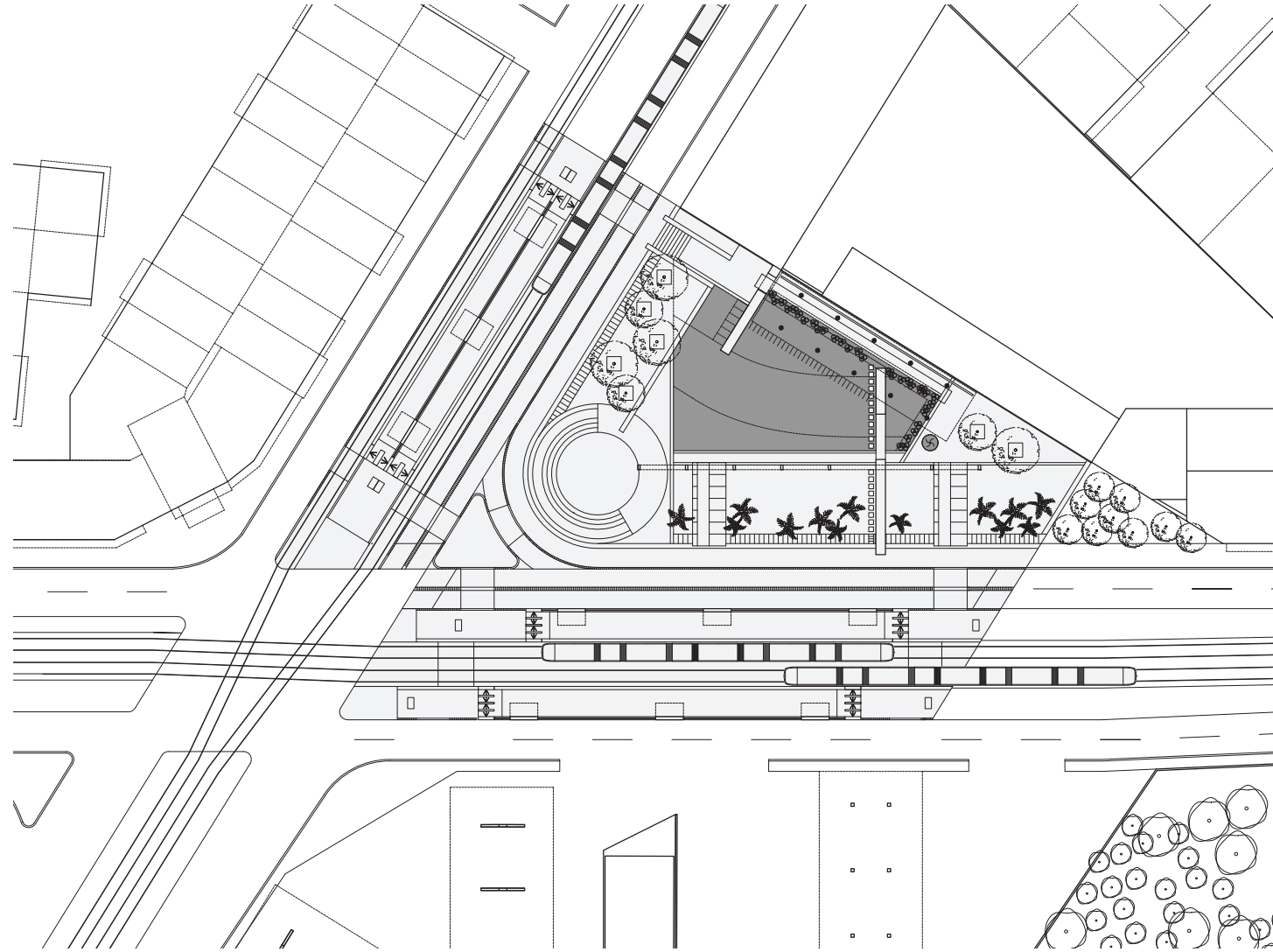

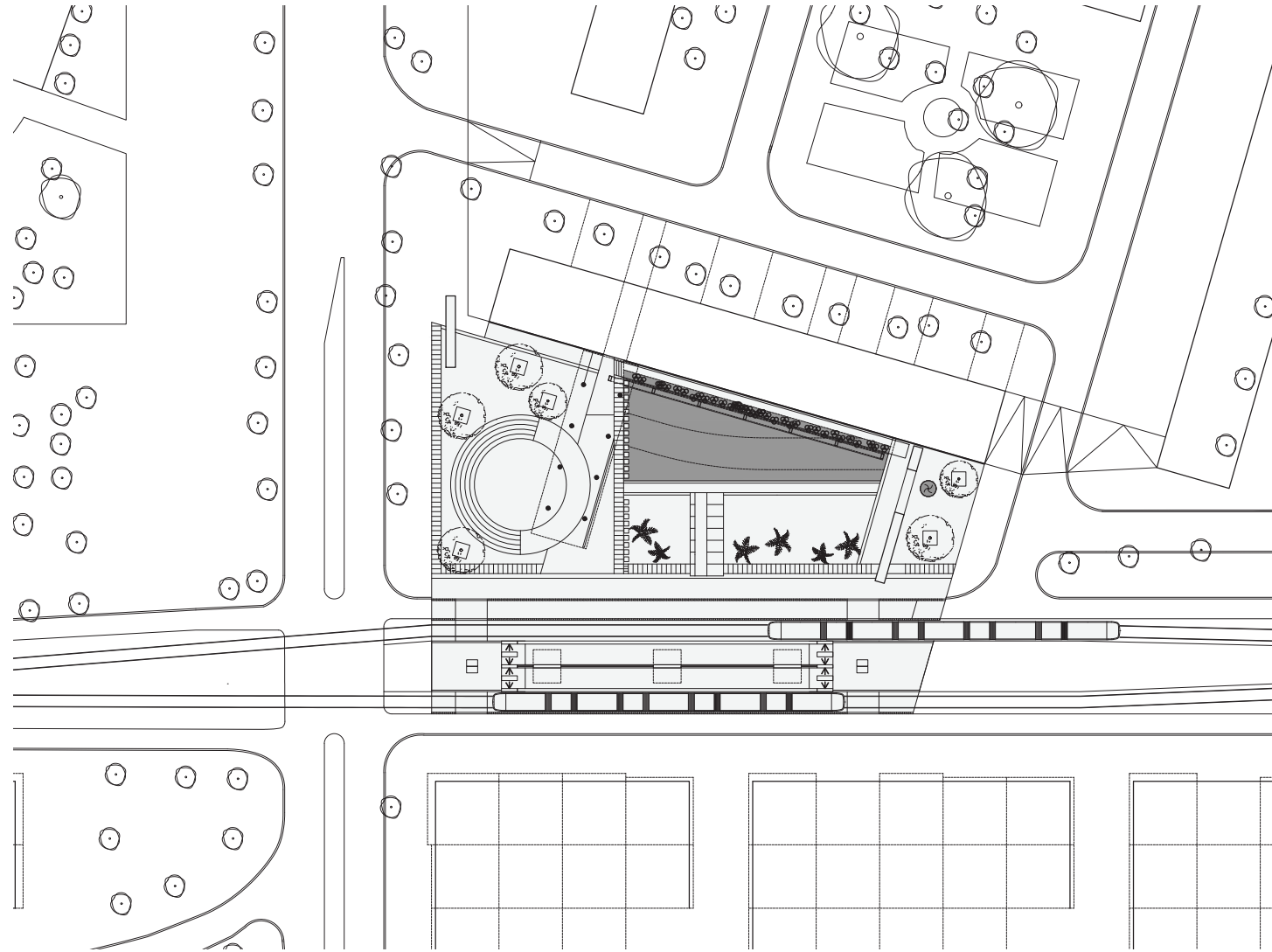

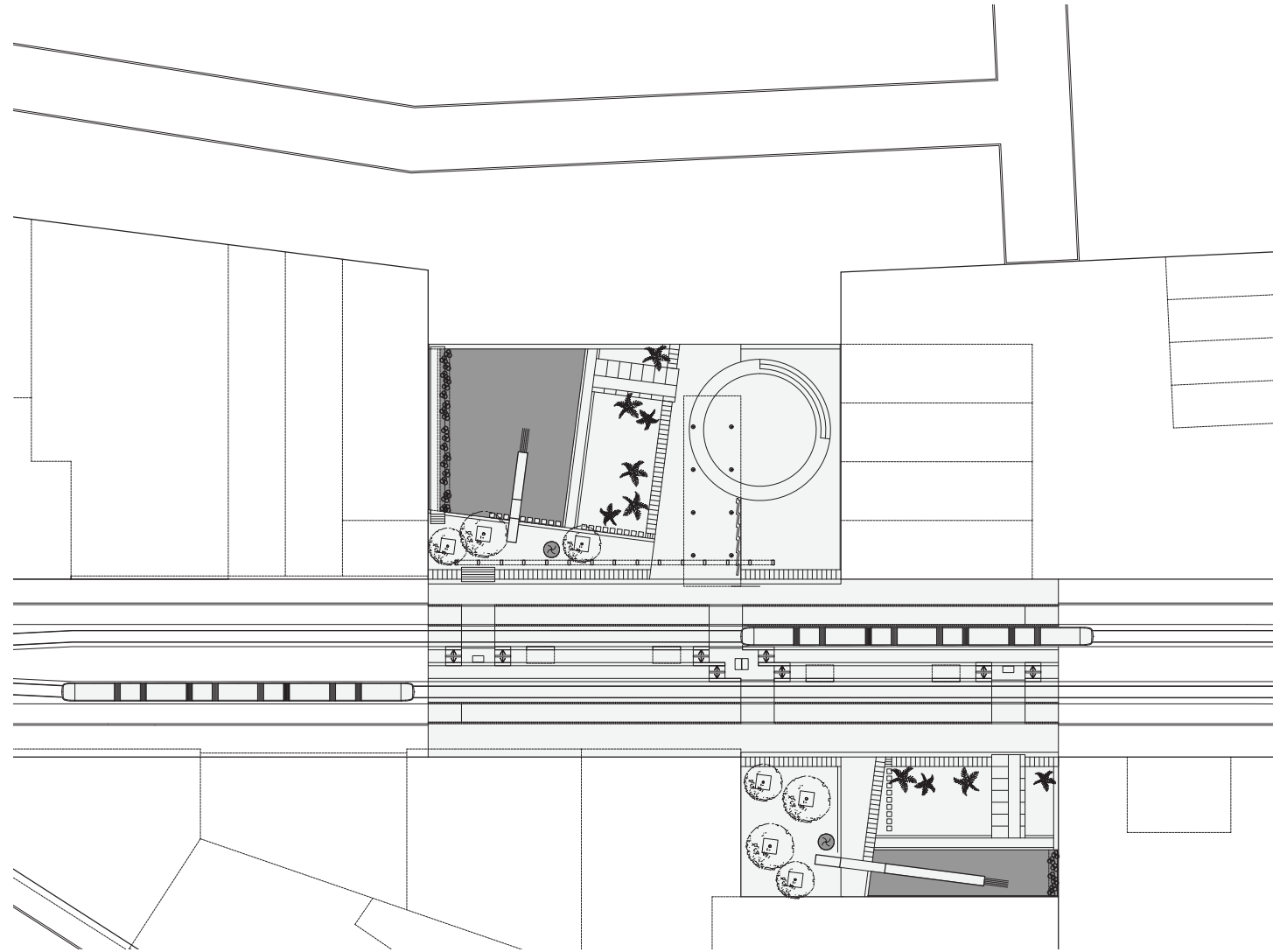



section

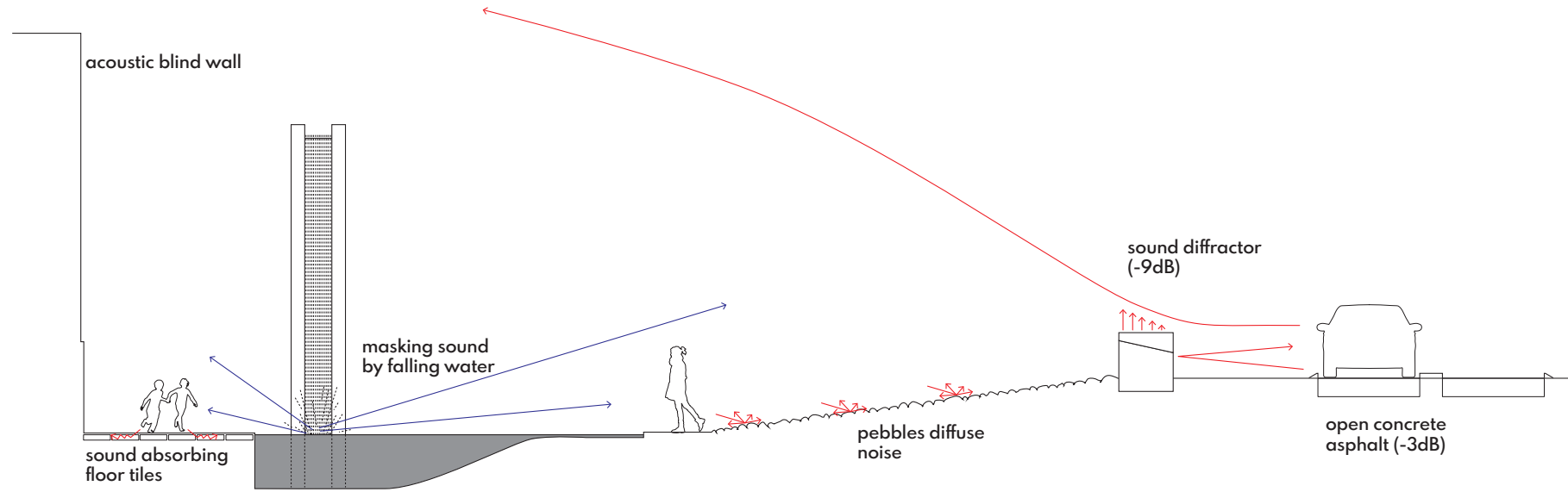

plan

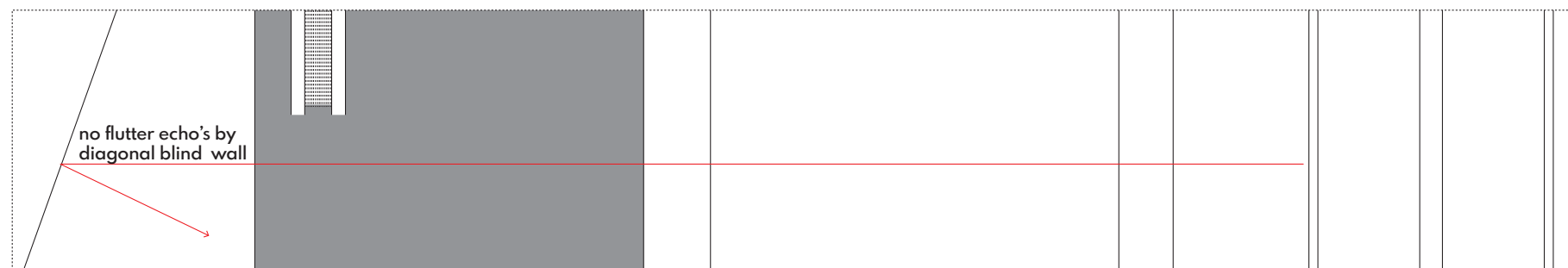

Morocco among Countries Facing Water Scarcity

By Hamza Guessous - February 15, 2018



Rabat- Morocco is now among 45 countries facing water scarcity, according to World Resources Institute water scarcity map, which reveals Morocco's critical situation.

Although Morocco is still far from the "extremely high" ratio of water withdraw to supply, as the case in many Middle Eastern countries, the kingdom is still considered in water deficit.

Morocco's volume of water has dropped by 80 percent to reach 500 cubic meters per inhabitant per year, against 2,500 cubic meters in 1960, according to Food and Agriculture Organization (FAO) and United Nations data.

According to L'Economiste, the establishment of a governmental emergency program that aims to provide drinking water for areas that are mainly reliant on vulnerable water sources and ensure the irrigation of fruit trees



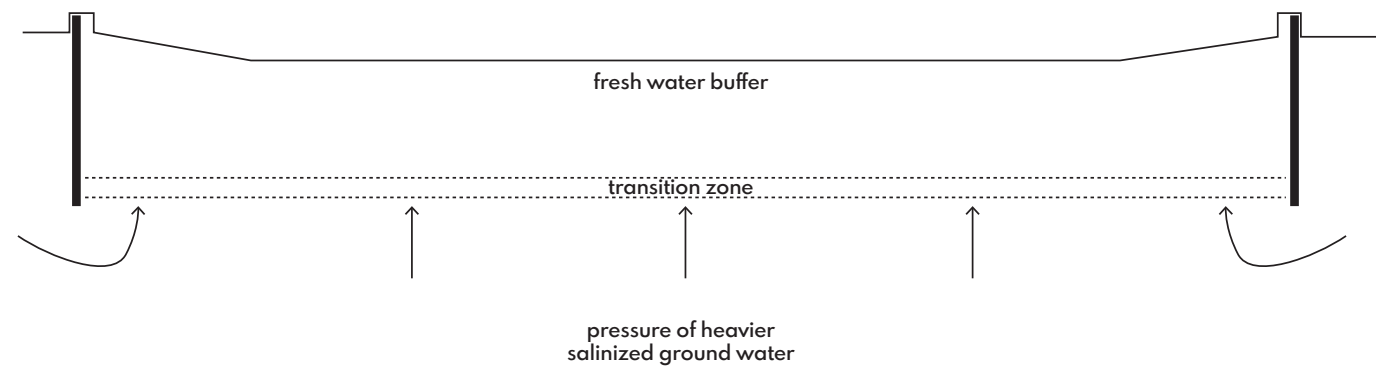

internal water cycle

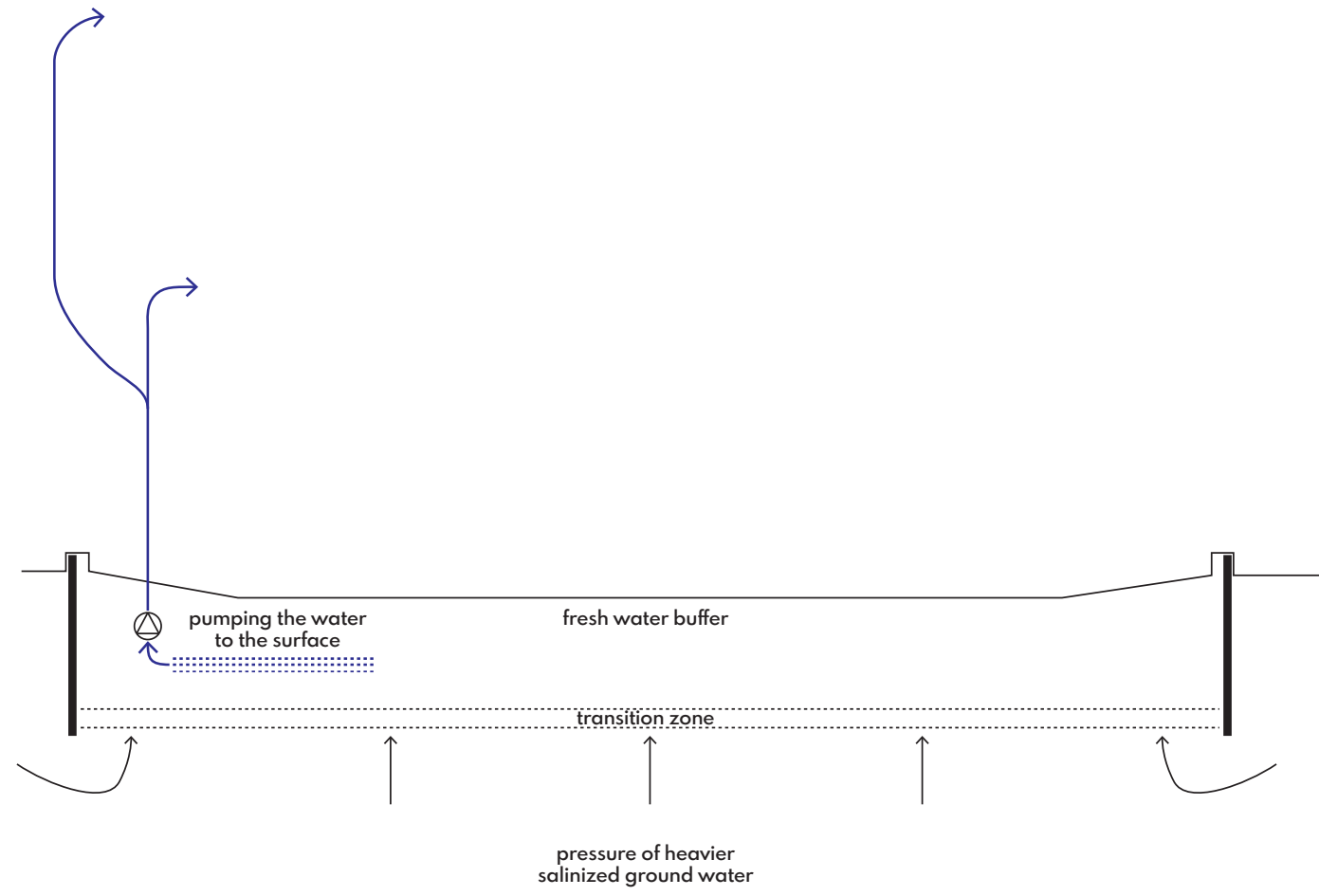

internal water cycle

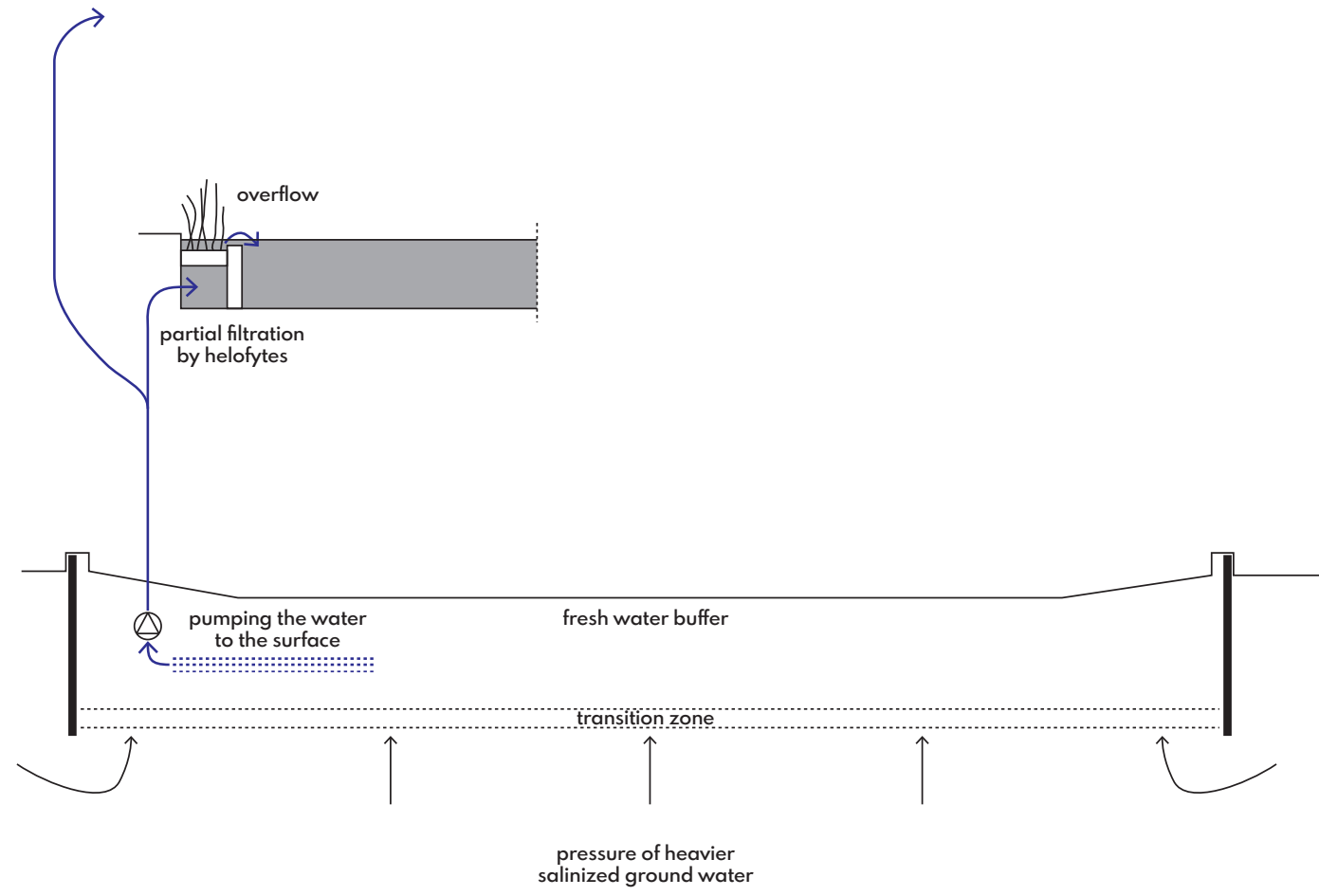

internal water cycle

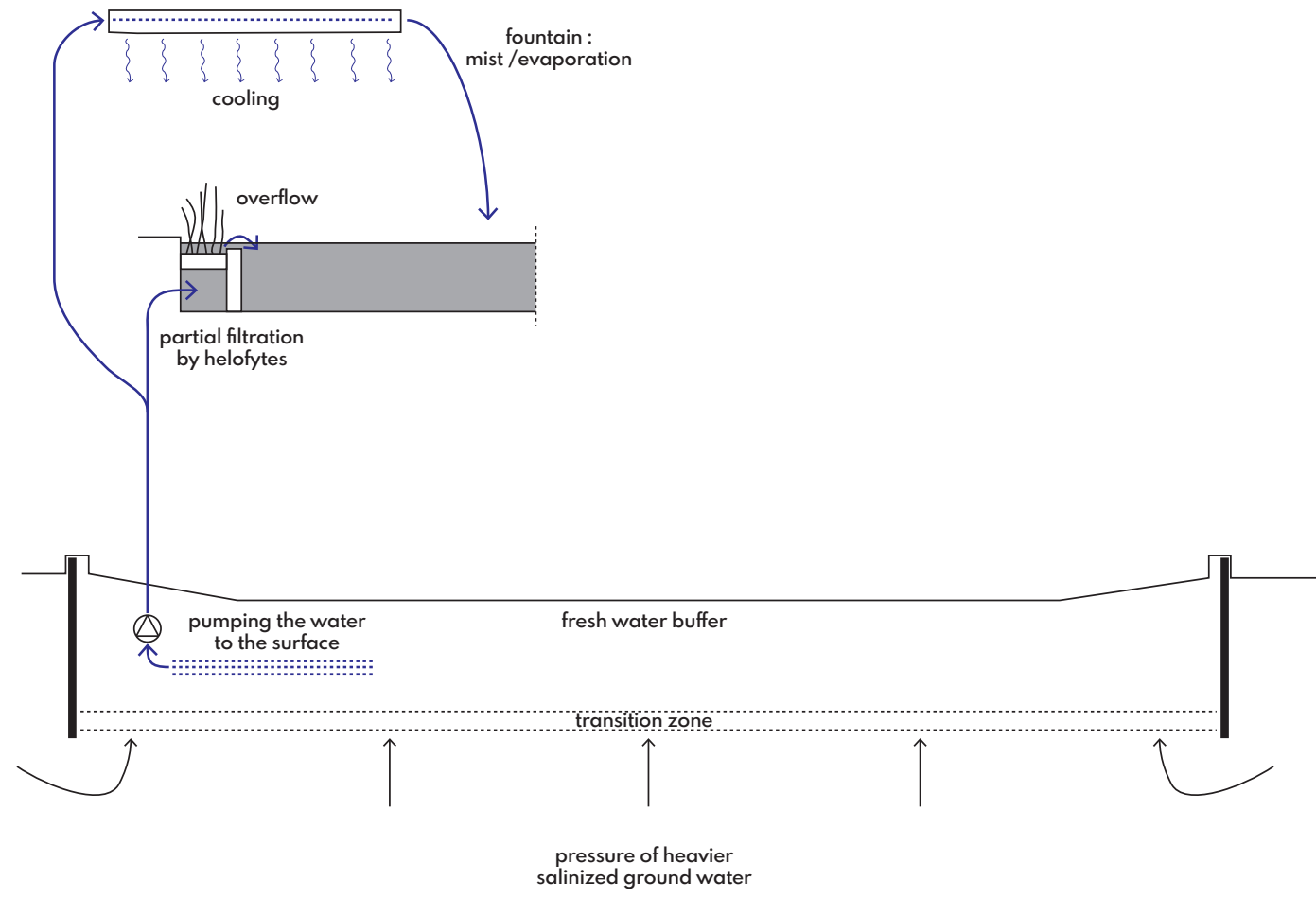

internal water cycle

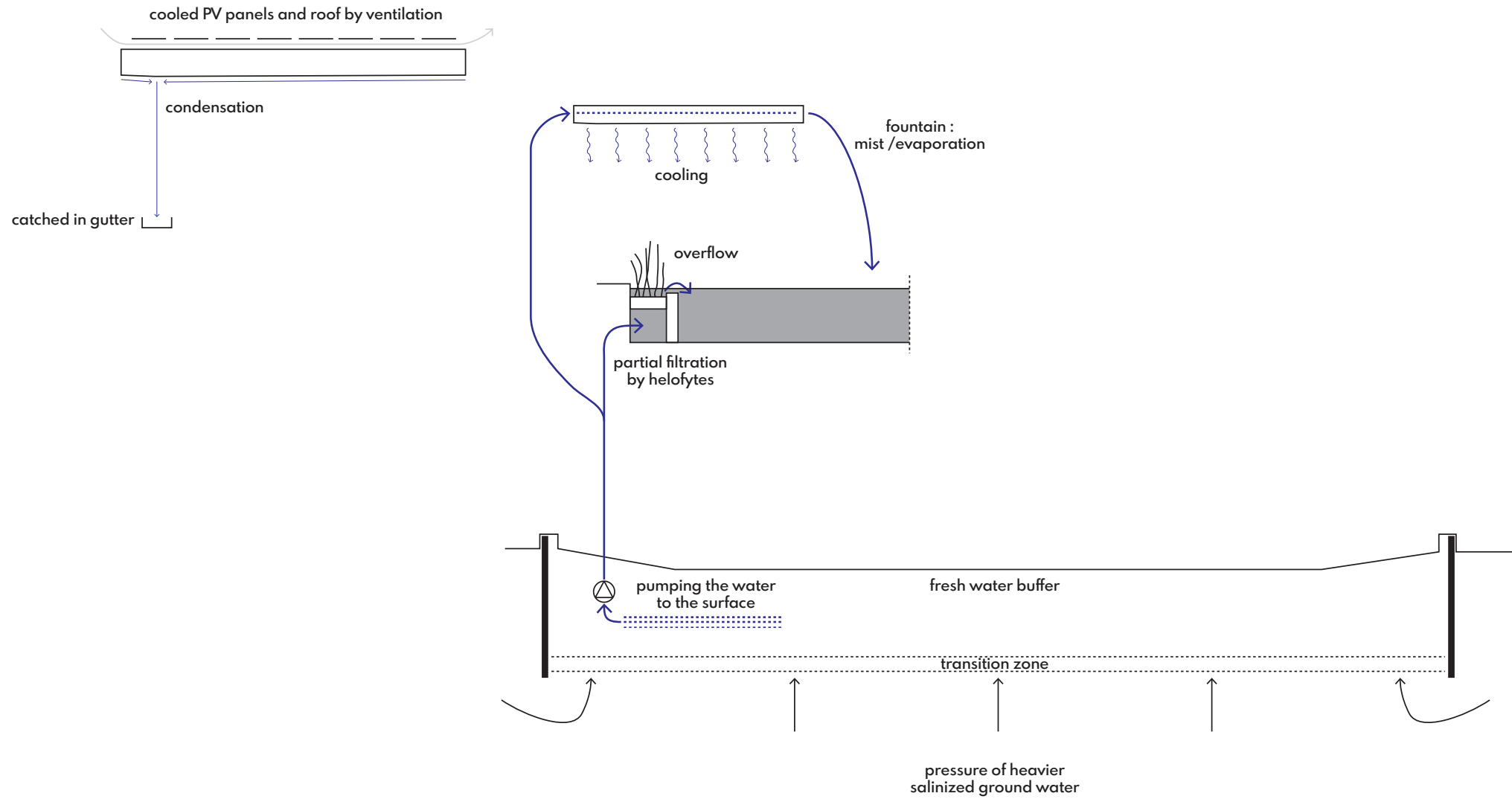

internal water cycle

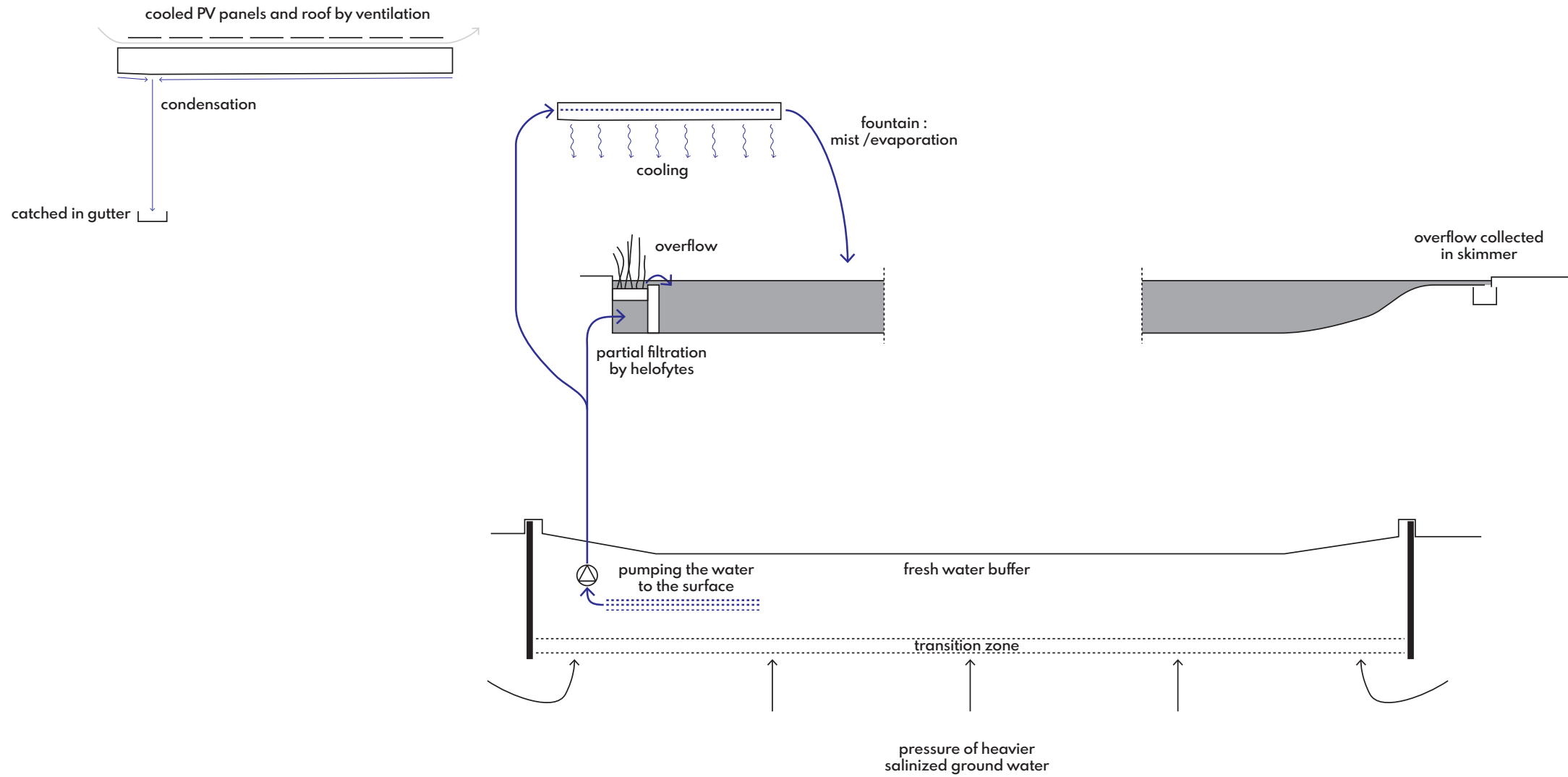

internal water cycle

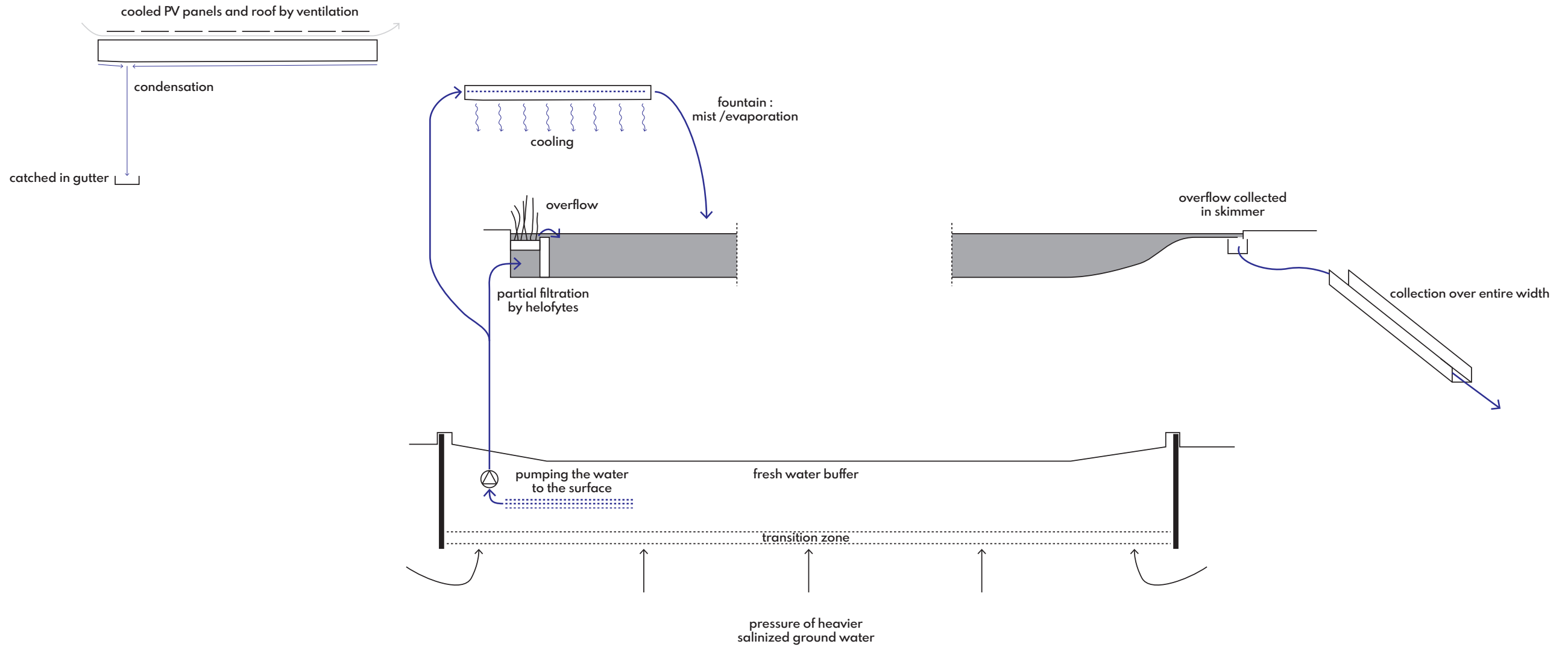

internal water cycle

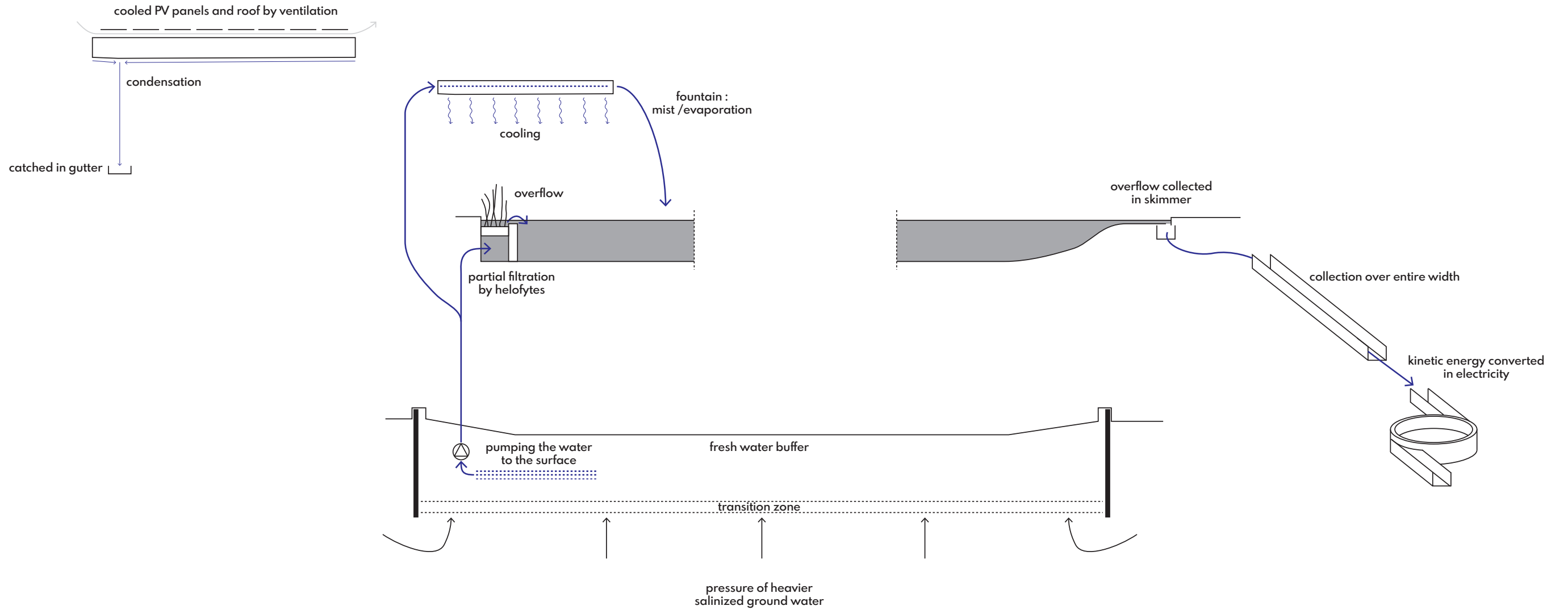

internal water cycle

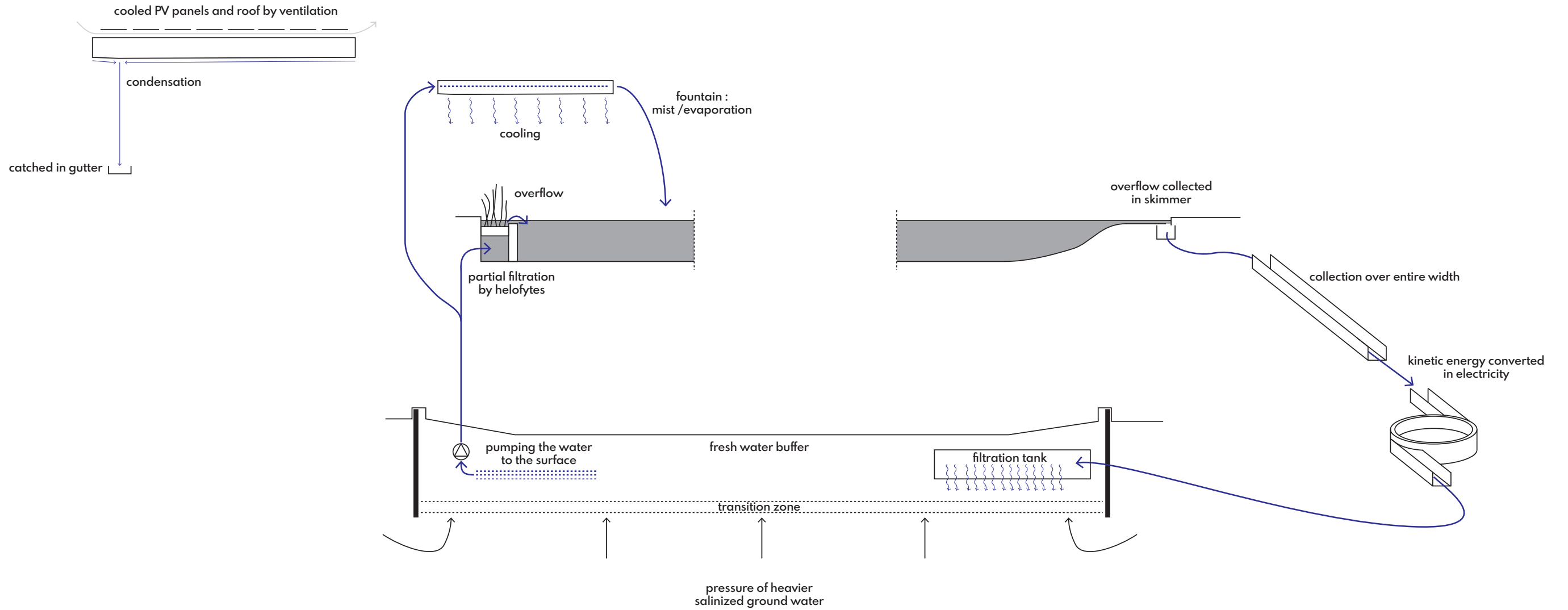

internal water cycle

how can the figure of the club be transformed into a more inclusive form, creating a sanctuary of play for the 'commons'?

