

# Feasibility, beneficiality, and institutional compatibility of a micro-CHP virtual power plant in the Netherlands

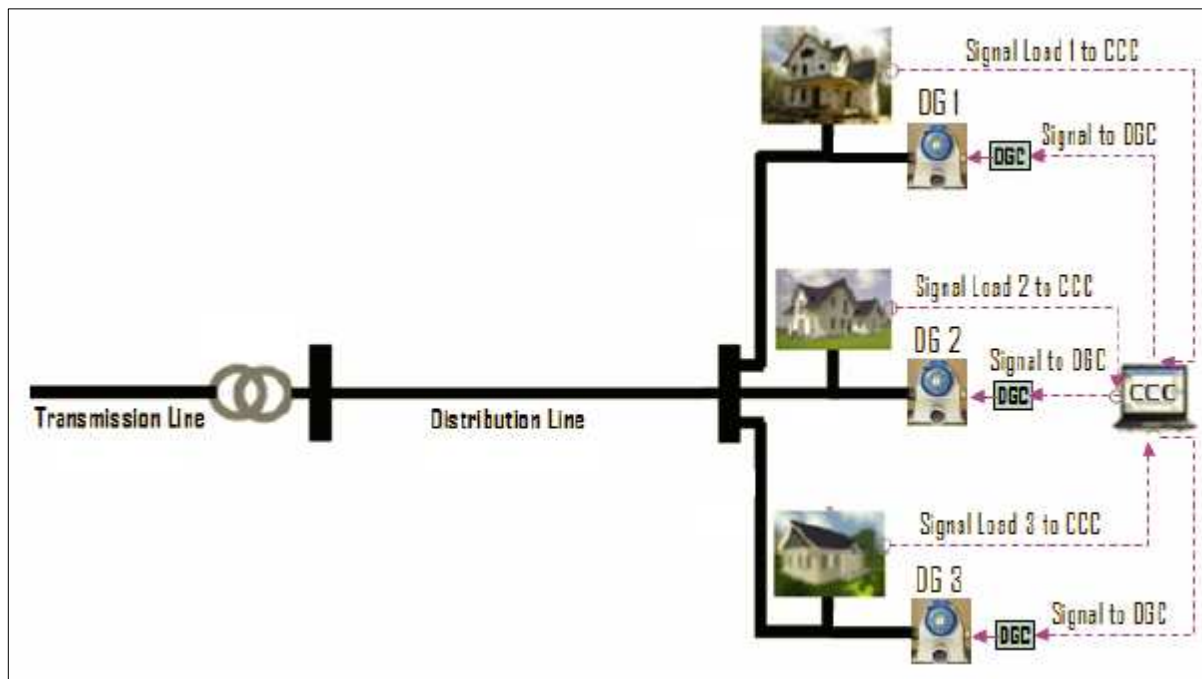

Adapted from (Setiawan, 2007)

*Master thesis - Systems Engineering, Policy Analysis, and Management*

**Patrick Landsbergen, B.Sc. (1015400)**

plandsbergen@hotmail.com

Date: 17-6-09

Version: Final

**Delft University of Technology**

Faculty of Technology, Policy and Management

Department of Economics of Infrastructures

**N.V. Nuon Energy**

Department of Business Development & Projects

Technology & Engineering Services

*Graduation committee*

Prof.dr. J.P.M. Groenewegen (TU Delft, Economics of Infrastructures)

*1st supervisor:* Dr. T.W. Fens (TU Delft, Economics of Infrastructures)

*2nd supervisor:* Dr.ir. I. Bouwmans (TU Delft, Energy & Industry)

*External supervisor:* R.I. Gnutek, M.Sc. (Nuon, BD&P - TES)

## **Preface**

It has been a challenging and intensive 8 months, but in the end I'm happy with the performed research and the report as it now is. I could however not have performed this research without the support of others.

I would like to thank professor John Groenewegen for being the chairman of my graduation committee. Further, I want to thank my university supervisors Theo Fens and Ivo Bouwmans for their useful suggestions and clear feedback, and especially for their advice on making the report more readable. Also I would like to thank Michiel Houwing for answering my questions and providing me with data, advice, and insights in  $\mu$ CHP and VPP.

At Nuon there are also a number of people that helped me during the research. First, I would like to thank my Nuon supervisor Radoslaw Gnutek for his support, feedback, good suggestions and helping me get familiar at Nuon. Involving me in the day to day practice of the department has greatly enriched my graduation project and without his guidance I would not have been able to produce the report as it now is. Further, I would like to thank Robert de Kler for providing me with the opportunity to perform my research at his department and Remôn te Morsche and Ruud Hendriks for providing me with starting points and advice on the economic viability calculations. Also I would like to thank Maurice Vlek for providing me with data and advice on retail related subjects and Jan van den Bor for helping me with energy trade related subjects. Also I would like to thank Renate Meekenkamp for providing me with starting points for the institutional chapter. Last, I would like to thank all my other colleagues for making my experience at Nuon a very pleasant one.

I also got help from people outside Nuon and university. I would like to especially thank Jan Bozelie and Alex Geschiere of Liandon for guiding me through the complex world of electricity networks. Without their feedback and advice I would not have been able to correctly write the network impacts part of the research. I would also like to thank Gerrit-Jan Ruijg of ECN and Jan Uitzinger of the University of Amsterdam for providing me with measured household energy demand profiles. Further, I would like to thank Hans Spaermon and Patrick Donders of Ecolegis for helping me with interpreting the Law on environmental taxes. Last, I would like to thank Jorgen van de Velde ICT Solutions and Simon Kolin and Ferry van Doorn of Homa Software for providing me with more insight in the ICT and software related aspects of my research.

Further, I would like thank all people that I have forgot to mention, but that have participated in interviews, provided me data, or gave me suggestions and advice.

Last, but not least, I would like to thank my parents for their love and support during the research and my study.

## Table of contents

<b>EXECUTIVE SUMMARY .....</b>	<b>6</b>
<b>1 INTRODUCTION .....</b>	<b>10</b>
1.1 BACKGROUND AND MOTIVATION FOR RESEARCH .....	10
1.2 VPP LITERATURE OVERVIEW AND RESEARCH POSSIBILITIES .....	11
1.3 PROBLEM STATEMENT, RESEARCH OBJECTIVE AND PERSPECTIVE .....	12
1.4 RESEARCH FRAMEWORK.....	12
1.5 RESEARCH QUESTIONS AND METHODS .....	13
1.6 THESIS OUTLINE.....	14
<b>2 VIRTUAL POWER PLANT DEFINITION AND MCHP REVIEW.....</b>	<b>15</b>
2.1 VPP DEFINITION AND DESCRIPTION.....	15
2.2 ADVANTAGES AND DISADVANTAGES OF A VPP.....	17
2.3 MCHP REVIEW .....	19
2.4 CONCLUDING .....	19
<b>3 TECHNICAL FEASIBILITY OF A MCHP VPP .....</b>	<b>20</b>
3.1 TECHNICAL PROBLEMS RELATED TO MICRO-CHP UNITS .....	20
3.1.1 <i>Technical limitations of the <math>\mu</math>CHP units.....</i>	20
3.1.2 <i>Seasonal operating limitations of the <math>\mu</math>CHP units.....</i>	21
3.1.3 <i>Solutions to overcome <math>\mu</math>CHP limitations: energy storage and supplementary heating .....</i>	22
3.2 TECHNICAL PROBLEMS RELATED TO THE VPP CONTROL SYSTEM .....	24
3.3 POSSIBLE NETWORK PROBLEMS WHEN CONNECTING MCHP/DG TO ELECTRICITY DISTRIBUTION NETWORKS .....	25
3.3.1 <i>Voltage.....</i>	25
3.3.2 <i>Fault level.....</i>	27
3.3.3 <i>Anti-islanding / loss of main (LOM) protection.....</i>	27
3.3.4 <i>Power quality.....</i>	28
3.3.5 <i>Network stability.....</i>	29
3.4 CONCLUSIONS TECHNICAL FEASIBILITY OF A MCHP VPP .....	30
<b>4 ECONOMIC VIABILITY OF A MCHP VPP.....</b>	<b>32</b>
4.1 BASE, INTERMEDIATE, AND PEAK LOAD OPERATION OF A MCHP VPP .....	32
4.1.1 <i>Heat and electrical output of the <math>\mu</math>CHP VPP vs. the energy demand of a household.....</i>	33
4.1.2 <i>Costs of electricity production of a <math>\mu</math>CHP VPP vs. wholesale and retail electricity prices.....</i>	34
4.2 CALCULATION OF ECONOMIC VIABILITY INDICATORS .....	38
4.2.1 <i>Possible trade revenues on Dutch electricity markets.....</i>	39
4.2.2 <i>NPV, IRR and discounted payback period.....</i>	42
4.2.3 <i>Sensitivity analysis to determine critical parameters.....</i>	44
4.2.4 <i>NPV break even values of most critical parameters.....</i>	45
4.3 OTHER POTENTIAL COSTS AND BENEFITS .....	46
4.4 CONCLUSIONS ECONOMIC VIABILITY MCHP VPP.....	47
<b>5 THE INSTITUTIONAL ENVIRONMENT AND THE IMPACT ON THE FEASIBILITY AND VIABILITY OF A MCHP-VPP .....</b>	<b>49</b>
5.1 INTRODUCTION AND FRAMEWORK AS BASIS FOR ANALYSIS .....	49
5.2 INSTITUTIONAL ENVIRONMENT OF THE MCHP/VPP .....	49
5.2.1 <i>Layer 1: Actors .....</i>	49
5.2.2 <i>Layer 2: Institutional arrangements between the actors.....</i>	50
5.2.3 <i>Layer 3: Formal institutions.....</i>	50
5.2.4 <i>Layer 4: Informal institutions.....</i>	53

5.3	IMPACT OF INSTITUTIONAL ENVIRONMENT ON TECHNICAL FEASIBILITY .....	54
5.4	IMPACT OF INSTITUTIONAL ENVIRONMENT ON ECONOMIC VIABILITY .....	55
5.5	CONCLUSIONS ON THE IMPACT OF THE INSTITUTIONAL ENVIRONMENT ON THE TECHNICAL FEASIBILITY AND ECONOMIC VIABILITY.....	58
<b>6</b>	<b>COMPARISON OF A MCHP VPP WITH EXISTING TECHNOLOGIES FOR THE SUPPLY OF HEAT TO HOUSEHOLDS .....</b>	<b>59</b>
6.1	EXISTING TECHNOLOGIES FOR THE SUPPLY OF HEAT TO HOUSEHOLDS IN THE NETHERLANDS .....	59
6.2	CRITERIA DERIVED FROM ACTOR'S VALUES FOR COMPARING THE MCHP VPP WITH OTHER TECHNOLOGIES .....	59
6.3	THE SCORES OF THE OPTIONS ON THE CRITERIA.....	60
6.4	CONCLUSIONS.....	61
<b>7</b>	<b>CONCLUSIONS, RECOMMENDATIONS, REFLECTION AND FURTHER RESEARCH.....</b>	<b>62</b>
7.1	CONCLUSIONS.....	62
7.2	RECOMMENDATIONS .....	64
7.3	REFLECTION AND FURTHER RESEARCH .....	64
	<b>REFERENCES .....</b>	<b>67</b>
	<b>APPENDIX A GENERATOR TYPES .....</b>	<b>76</b>
	<b>APPENDIX B DETAILED DESCRIPTION OF NETWORK IMPACTS.....</b>	<b>77</b>
	<b>APPENDIX C ECONOMICAL VIABILITY: FORMULAS, ASSUMPTIONS AND CASH FLOWS .....</b>	<b>83</b>
	<b>APPENDIX D TRADE REVENUES ANALYSIS.....</b>	<b>86</b>
	<b>APPENDIX E COMPARISON OF OUTCOMES OF THE MODEL WITH OTHER SOURCES.....</b>	<b>88</b>
	<b>APPENDIX F MONTE CARLO INPUT PARAMETERS AND DATA ANALYSIS .....</b>	<b>89</b>
	<b>APPENDIX G DETAILED DESCRIPTION OF CURRENT INSTITUTIONAL ENVIRONMENT.....</b>	<b>91</b>
	<b>APPENDIX H SCORES ON CRITERIA CALCULATIONS .....</b>	<b>93</b>

## List of tables

Table 1: 2007 household energy consumption and CO2 emissions in comparison to total Dutch energy consumption and emissions (CBS, 2008; EnergieNed, 2008).....	10
Table 2: Overview of price difference between average consumer electricity and gas price (incl. energy and VAT) (EnergieNed, 2007b, 2008).....	11
Table 3: Advantages of a $\mu$ CHP VPP over stand-alone $\mu$ CHP units and central power plants.....	17
Table 4: Disadvantages of a $\mu$ CHP VPP over stand-alone $\mu$ CHP units and central power plants .....	18
Table 5: Assumptions on the Stirling engine and SOFC (CFCL, 2008; De Sanctis, 2007) .....	19
Table 6: Operational limitations of $\mu$ CHP Stirling engine and SOFC (Bozelie, 2009; Topsoe fuel cell, 2008).....	21
Table 7: Allowable penetration levels of DG in existing LV networks without causing voltage limits to be exceeded .....	26
Table 8: Assumptions for economic calculations (based on sellers information and EPRI (2002)) .....	36
Table 9: Consumer and wholesale gas prices (APX data services, 2009; EnergieNed, 2007, 2008).....	36
Table 10: Costs of electricity production of a Stirling engine vs. historical APX and retail electricity prices (APX Data Services, 2008; Energiekamer, 2009; EnergieNed, 2008) .....	37
Table 11: Costs of electricity production of a SOFC vs. historical APX and retail electricity prices (APX Data Services, 2008; Energiekamer, 2009; EnergieNed, 2008).....	38
Table 12: Deviation of outcomes Stirling engine model with outcomes of Houwing's model (see also appendix E) .....	41
Table 13: Deviation of outcomes SOFC model with outcomes of Ruijg and Ribberink (see also appendix E) .....	41
Table 14: Yearly electricity and heat demand per household segment and assumed proportion of total households under VPP control (yellow marked segments are created with profile methodology) .....	42
Table 15: Possible APX revenues Stirling VPP 100,000 units (in million €) .....	42
Table 16: Possible APX revenues SOFC VPP 100,000 units (in million €) .....	42
Table 17: NPV, IRR and discounted payback period based on expected values .....	42
Table 18: Certainty levels and mean values of IRR and discounted payback period.....	44
Table 19: Change of value of single parameters needed to break-even with the investment cost for a Stirling VPP .....	45
Table 20: Change of value of single parameters needed to break-even with the investment cost for a SOFC VPP.....	46
Table 21: Other potential costs and benefits of a $\mu$ CHP VPP system .....	46
Table 22: NPV SOFC base case vs. no energy tax gas.....	57
Table 23: NPV Stirling base case vs. no energy tax gas.....	57
Table 24: Comparison of systems to supply 100,000 households with heat .....	61
Table 25: Differences between large and micro (co)generators .....	76
Table 26: Base case assumptions for the NPV, IRR and discounted payback period calculations .....	83
Table 27: Stirling VPP cash flows.....	85
Table 28: SOFC VPP cash flows*.....	85
Table 29: Yearly household energy demand measured	Table 30: : Yearly household energy demand retail
.....	.....
Table 31: Data analysis of Monte Carlo input parameters (all prices corrected for 2% inflation) (Energiekamer, 2009; EnergieNed, Energie in Nederland 2004 -2008; Gas transport services, 2009) .....	89
Table 32: Inputs for the sensitivity and Monte Carlo analysis (based on historical data analysis and estimations).....	89
Table 33: Requirements for $\mu$ CHP units connected to the low voltage grid .....	91

## List of figures

Figure 1: micro-CHP vs. separate production of heat and electricity (all efficiencies based on LHV).....	10
Figure 2: Research framework.....	13
Figure 3: Commercial virtual power plant concept .....	15
Figure 4: $\mu$ CHP control possibilities, adapted from (Houwing et al., 2007) .....	16
Figure 5: Detailed overview of household interaction with networks and energy company.....	17
Figure 6: Operating minutes Stirling engine during a winter and summer day (outcome of model, see paragraph 4.2.1).....	22
Figure 7: Operating minutes SOFC during a winter and summer day (outcome of model, see paragraph 4.2.1)...	22
Figure 8: Typical electrical demand profile of individual Dutch household (Oosterkamp and Van der Laag, 2003) .....	24
Figure 9: Voltage profile without DG, adapted from BP Power (2007).....	26
Figure 10: Voltage profile with DG, adapted from (PB power, 2007).....	26
Figure 11: Islanding in a distribution network .....	27
Figure 12: The $\mu$ CHP heat output given the operating mode vs. the household heat demand .....	33
Figure 13: The $\mu$ CHP electrical output given the operating mode vs. the household electricity demand.....	33
Figure 14: Short run marginal costs vs. electricity price (Lindboe et al., 2007, p.) .....	35
Figure 15: APX prices in per hour per year.....	37
Figure 16: $\mu$ CHP model input, outputs and constraints .....	39
Figure 17: Monte Carlo simulation NPV outputs Stirling VPP.....	43
Figure 18: Monte Carlo simulation NPV outputs SOFC VPP.....	43
Figure 19: Tornado diagram Stirling VPP.....	44
Figure 20: Tornado diagram SOFC VPP.....	45
Figure 21: Framework based on the four layer model by Koppenjan and Groenewegen (2005).....	50
Figure 22: Energy tax $\mu$ CHP VPP vs. energy tax large CHP and district heating system .....	56
Figure 23: Two bus system with DG, adapted from (Vovos et al., 2007).....	78
Figure 24: Hours where APX price is above SRMC of a Stirling engine .....	86
Figure 25: Hours where APX price is above SRMC of a SOFC.....	86

## Executive summary

Dutch households are responsible for a significant part of the total Dutch energy consumption and CO<sub>2</sub> emissions. One possibility for decreasing household energy consumption and CO<sub>2</sub> emissions is to deploy micro-combined-heat-power ( $\mu$ CHP) units.  $\mu$ CHP units are small scale (1-5kW<sub>e</sub>) residential distributed generation (DG) units that can *simultaneously* produce useful heat and electricity and thereby can reduce primary energy use and CO<sub>2</sub> emissions compared to separate production of electricity and heat. When a cluster of  $\mu$ CHP units is controlled and monitored on an aggregate level, the  $\mu$ CHP units can be used for trade in energy markets and can be deployed for technical network management objectives. This principle is called a virtual power plant (VPP).

A micro-CHP VPP was defined as: *a cluster of grid connected  $\mu$ CHP units that is monitored and controlled on an aggregate level by a VPP operator for commercial or technical objectives.* Only Stirling engine and solid oxide fuel cell (SOFC)  $\mu$ CHP units were included in the research because the Stirling engine will be the first  $\mu$ CHP to enter the Dutch market and the SOFC can achieve the highest energy savings. The main research question that was answered in this research was:

*Is it technically feasible, economically viable, and beneficial to implement and operate a micro-CHP virtual power plant in the Netherlands and what is the impact of the institutional environment on those aspects?*

### **Technical feasibility**

An extensive literature research was performed and interviews with experts were conducted to identify the major problems concerning the main components needed for  $\mu$ CHP VPP operation:

- $\mu$ CHP units
- Control system: ICT infrastructure, local controllers and software
- Electricity networks

In general it can be concluded that it is technically feasible to implement and operate a  $\mu$ CHP VPP in the Netherlands if the  $\mu$ CHP VPP is combined with heat storage.

$\mu$ CHP units can not respond instantly to energy demand changes and their overall efficiencies are low during start-up and shut-down. The biggest issue with a Stirling VPP is that it can only be operated for a couple of hours per day during summer without dumping heat, and that therefore either very expensive seasonal storage is needed, or central power capacity that will almost not be used during winter. The biggest problem for the SOFC is that it can not be operated dynamically and that therefore the number of start-stop cycles should be almost limited to zero. Energy storage and supplementary heating can solve most of the  $\mu$ CHP limitations and provide the VPP operator with more flexibility.

Not much literature on the control system components is yet available because most of them are under development. Based on interviews with ICT and software experts, no major problems for the control system were identified. The only possible problem might be that the local control system needs to be adjusted when a next generation wire-less communication network emerges.

For network impacts it can be concluded that large amounts of  $\mu$ CHP units (up to 50-75% penetration) can be accommodated within existing electricity networks without causing major problems and without having to make adjustments to the networks or equipment. Almost all identified problems can be solved by technical solutions at a certain cost. So the connection of large amount of  $\mu$ CHP units is not a technical problem but an economic one. The conclusions should however be confirmed by large scale field tests.

### **Economic viability**

Based on costs calculations, modeling, and calculating economic viability indicators, the economic viability of a  $\mu$ CHP VPP was determined. The main conclusion is that under current institutional conditions and economic assumptions, it is not economically viable to implement and operate a  $\mu$ CHP VPP in the Netherlands. Also it is not an economically viable option to use the  $\mu$ CHP VPP as an electricity only plant.

The economic viability was evaluated on the basis of two scenarios:

1. The  $\mu$ CHP is purchased/leased by the household and placed behind the customer meter and the VPP operator only invests in control systems and heat storage and has indirect control;

2. The  $\mu$ CHP VPP is considered to be an alternative for a centralised CHP with district heating system and the VPP operator finances and places the  $\mu$ CHP system before the customer meter. The VPP operator has direct control over the  $\mu$ CHP units.

Scenario 1 is not economically viable because for both the Stirling and SOFC VPP, the short and the long run costs of electricity production are higher than the wholesale electricity prices. In scenario 2, the capital costs of the VPP can not be recovered with electricity sales and trade because the levelized costs of electricity production are much higher than the electricity retail and wholesale price.

A Stirling engine is not suitable for base and intermediate operation because this would lead to large heat dump for most households. The SOFC can be operated as a base load and intermediate load plant but not as a peak load plant because of performance degradation due to dynamic operation.

The most common indicators used to determine the economic viability of a system by investors are the net present value (NPV)<sup>1</sup>, the internal rate of return (IRR)<sup>2</sup> and the discounted payback time<sup>3</sup>. Monte Carlo simulations were performed to determine the certainty levels of positive values for those indicators for scenario 2. The certainty that the NPV is positive, the IRR is higher than 8% and the discounted payback period shorter than the lifetime of the system (under these conditions the system is in principle economically viable), was 2% for a Stirling VPP and 0% for a SOFC VPP under current economic and institutional conditions.

The factors that influence these indicators the most are:

- the capital costs the of the  $\mu$ CHP unit
- the lifetime of the  $\mu$ CHP
- the wholesale gas price
- the consumer heat price

The Stirling VPP can break even with significant changes of those critical factors while for the SOFC even bigger changes in these factors are needed to break even.

### ***Institutional impact***

The impact of the institutional environment on the technical feasibility and economical viability was determined by first describing and evaluating the institutional context with the four layer model of Koppenjan and Groenewegen (2005), and then combining this evaluation with the feasibility and viability analysis from the previous chapters.

The general conclusion is that institutional change is needed to make the  $\mu$ CHP VPP economically viable and to accommodate the system into the existing power system without problems. The institutional environment has a very large impact on the economic viability.

### ***Impacts institutional environment on the technical feasibility of the $\mu$ CHP VPP***

The  $\mu$ CHP units should comply with the requirements in the Grid Code to prevent damage to the  $\mu$ CHP units and problems for the network. No provisions are made for the outputs of  $\mu$ CHP units connected to the grid with power electronic converters, which implicates that also converters can be connected that produce harmonics.

Currently, the protection thresholds and disconnection times for power electronic devices do not guarantee the proper functioning of the LV network. Also no provisions have been made for voltage rises due to electricity production by  $\mu$ CHP units.

The provisions for planning and production in the Grid Code do not apply for a  $\mu$ CHP VPP. This leads to unfair competition with large power plants that have obligation like reactive power provision.

### ***Impacts institutional environment on the economic viability the $\mu$ CHP VPP***

---

<sup>1</sup> The present value<sup>1</sup> of expected future net cash flows minus the initial investment costs during a certain period (Mayes, 2009). The NPV calculates the economic profit of an investment.

<sup>2</sup> “the discount rate that makes the net present value of the investment's income stream total to zero”

<sup>3</sup> The discounted payback period is the time required to earn back the investment with discounted future cash flows.



The arrangements between the VPP operator and the household can impact the economic viability, especially in scenario 1 if the maintenance costs of the SOFC are underestimated.

The formal institutions can have a very large impact on the economic viability. The regulations with the largest impact are:

- Purchasing subsidies for  $\mu$ CHP
- Heat law: heat prices have a large impact on the economic viability, so stricter price regulation can severely impact the viability
- Energy tax: if the energy tax exemption would include units smaller than 60 kW, the economic viability of the SOFC VPP would improve significantly. If the tax exemption would also be given for units with an electrical efficiency lower than 30%, the Stirling VPP could become economically viable.
- Emission trading scheme:  $\mu$ CHP units do not fall under this regime and thus if the emission rights for the power sector will be fully auctioned in 2013, a  $\mu$ CHP VPP can save costs compared to a conventional power plant.

From the values and norms of the government it can be concluded that it is likely that they are willing to change some institutions to stimulate  $\mu$ CHP. It is however not likely that the 30% efficiency threshold for the energy tax exemption will be lowered.

### ***Beneficiality of a $\mu$ CHP VPP***

To determine whether it would be justified to change institutions to make the VPP feasible and viable, the system was compared to other systems for the supply of heat to households (district heating and boiler + grid electricity). Criteria to compare the systems were derived from the informal institutions identified in the previous chapter. Based on the same model that was used for the economic viability calculations, the scores on the criteria were calculated.

The  $\mu$ CHP systems were compared with existing systems for household heating on criteria based on the values/norms/goals of the actors identified in 5.2. Both the Stirling as the SOFC VPP can save energy and reduce CO<sub>2</sub> emissions compared to a reference system consisting of a condensing boiler and grid electricity. The Stirling VPP scores worse on almost all criteria and the SOFC VPP produces heat at the highest costs. District heating is currently a more costs effective (in terms of capital costs/GJ energy saving) option to reduce primary energy consumption and CO<sub>2</sub> emissions but its application is limited to new houses and densely populated areas.

### ***Recommendations***

Based on the conclusions the following recommendations are given:

- To safeguard the power quality of the grid, also output requirements for power electronic devices connected to the LV grid should be included in the grid code;
- Implement the proposal that has been made by the DSOs to align the Grid Code with European  $\mu$ CHP standard CENELEC EN 50438;
- Include provisions for voltage rises due to production by  $\mu$ CHP units in the Grid Code;
- Make or change regulation based on the total power capacity of the  $\mu$ CHP VPP and not based on individual  $\mu$ CHP capacity to prevent unfair competition for:
  - Large power plants: for large plants much more provisions are made in the Grid Code than for small units. A  $\mu$ CHP VPP would have the benefits of large power plants but not the obligations;
  - $\mu$ CHP VPP: currently there is no energy tax exemption for electricity producing installations smaller than 60kW. Such an exemption would greatly improve the economic viability of a  $\mu$ CHP VPP;
- Don't support or invest in Stirling VPPs. A large capacity of conventional power plants, that will almost not be operated during winter, would be needed for supplying electricity during summer because then the Stirling can almost not be operated without dumping heat (without seasonal storage). This is economically not efficient from the total power system point of view. Also the Stirling VPP scores worst on almost all the criteria compared to the SOFC VPP and district heating systems;
- Support or invest in district heating instead of  $\mu$ CHP VPP on the short term. The district heating system is currently more costs effective than a  $\mu$ CHP VPP in terms of costs per energy saving and costs of heat production.

- On the longer term, support a SOFC VPP because it is the best alternative of the researched options to reduce energy consumption and CO<sub>2</sub> emissions in the domestic sector in less densely populated areas and existing housing.

***Further research is recommended on the following topics:***

- Research on the effect of seasonal and electricity storage on the feasibility of a  $\mu$ CHP VPP;
- Research on the energy savings and revenues achieved by the  $\mu$ CHP VPP with more sophisticated simulation models;
- A social costs benefit analysis to determine if the  $\mu$ CHP VPP is beneficial for society as a whole;
- Further research into profitable arrangements between VPP operator and households;
- Research on other commercial purposes that were not included in this research;
- Comparison on relevant criteria between  $\mu$ CHP systems, solar boilers and heat pumps to determine which technology should be supported to reduce energy consumption and CO<sub>2</sub> emissions.

# 1 Introduction

The research subject and motivation for the research will be introduced in 1.1. In 1.2, research possibilities are identified which are used to formulate the research objective in 1.3. Then, the research framework will be presented and described in 1.4. Next, the research questions and methods will be presented in 1.5. Finally, the thesis outline is given in 1.6.

## 1.1 Background and motivation for research

Environmental concerns, decreasing fossil fuel reserves, and an increasing dependency on politically unstable regions for fossil primary energy supply have increased the importance for a more efficient use of fossil primary energy. The Dutch government has therefore formulated a number of ambitious goals for reducing CO<sub>2</sub> emissions and energy consumption: in 2020, 30% less CO<sub>2</sub> should be emitted compared to 1990 and a 2% energy saving per year should be realized. However, the total primary energy consumption and CO<sub>2</sub> emissions in the Netherlands are expected to keep steadily increasing (Van Dril en Elzenga, 2005).

Dutch households are responsible for a significant part of the total Dutch energy consumption and CO<sub>2</sub> emissions (see table 1). There is thus a large potential for energy savings in the domestic sector and to a lesser extend for CO<sub>2</sub> emission reductions.

**Table 1: 2007 household energy consumption and CO<sub>2</sub> emissions in comparison to total Dutch energy consumption and emissions (CBS, 2008; EnergieNed, 2008)**

	Household	Total	Percentage of total
Gas	287 PJ	1376 PJ	21%
Electricity	91 PJ	408 PJ	22%
CO <sub>2</sub> emissions	16 Mtonne	172 Mtonne	9.4%

One option for decreasing domestic energy consumption and CO<sub>2</sub> emissions is to deploy micro-combined-heat-power (μCHP) units. μCHP units are small scale (1-5kW<sub>e</sub>) residential distributed generation (DG) units<sup>4</sup> that can *simultaneously* produce useful heat and electricity (called cogeneration). Those units can achieve a higher overall energy conversion efficiency (85-95%) for producing electricity and heat than with separate production, which leads to less primary energy use and a reduction of CO<sub>2</sub> emissions. This is illustrated in figure 1 where it is shown that it costs more primary energy to separately produce a certain amount of electricity (including 8% grid loss<sup>5</sup>) with a central power plant and heat with a condensing boiler (with a seasonal efficiency of 90%<sup>6</sup>) than with simultaneous production by a μCHP.

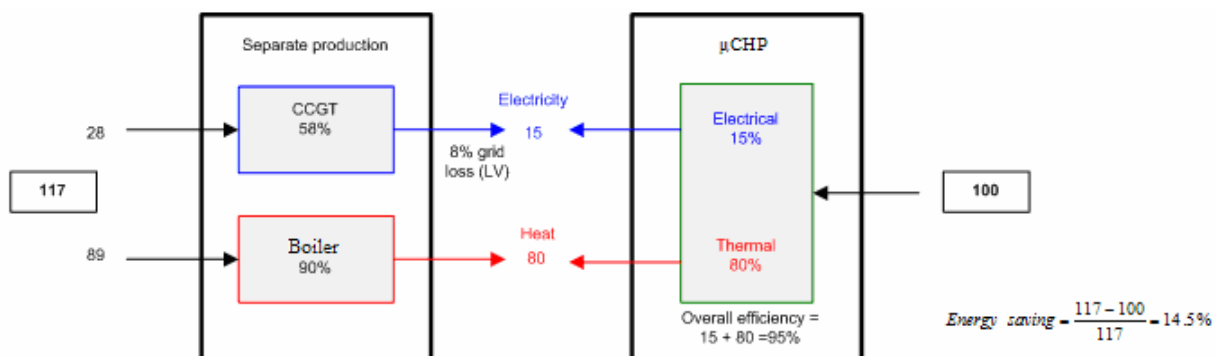

**Figure 1: micro-CHP vs. separate production of heat and electricity (all efficiencies based on LHV)<sup>7</sup>**

<sup>4</sup> “an electric power generation source connected directly to the distribution network or on the customer side of the meter” (Ackerman, T et al., 2001)

<sup>5</sup> When transporting and distributing electricity from a central power plant to the low voltage grid, a loss of 8% of the electrical power occurs (EnergieNed, 1996).

<sup>6</sup> In theory, the efficiency of a condensing boiler can have an efficiencies higher than 90%, but in practice these efficiencies are only achieved for a small part of the year, because only during very cold days the boiler is operated at full output and achieves its highest efficiency. See Carbon Trust (2007) and <http://www.sedbuk.com/> for seasonal efficiency ratings.

<sup>7</sup> The actual energy savings will be lower, because during start/stop operation the μCHP efficiencies are low and a supplementary boiler is needed to provide the peak heat demand.

The Netherlands is one of the key European markets for  $\mu$ CHP because (Dentice d'Accadia et al., 2003; Harrison, 2003; Pehnt et al., 2006):

- There is a substantial heat demand throughout the year: 22 – 53 GJ/yr, 35 GJ/yr average (EnergieNed, 2004, 2008);
- A high percentage of households is connected to the gas network: 96% (EnergieNed, 2008);
- A significant price difference between gas and electricity exists (see table 2).

**Table 2: Overview of price difference between average consumer electricity and gas price (incl. energy and VAT) (EnergieNed, 2007b, 2008)**

<i>Year</i>	<i>Electricity (€/kWh)</i>	<i>Gas (€/kWh)*</i>
2008	23	8.3
2007	22	8.2
2006	19	7.0

\*Calculated with a LHV of 31.65 MJ/m<sup>3</sup>

The  $\mu$ CHP unit is currently being marketed as the replacement for the heating boiler and the first  $\mu$ CHP units are expected to enter the consumer market by 2010 (Remeha, 2008). An estimation about the market penetration of  $\mu$ CHP in the Netherlands has been made by De Jong et al. (2008). They predict that in 2020, 0.9 - 1.4 million Dutch households will have a  $\mu$ CHP unit and in 2030 2 – 3.8 million households. However these estimations are based on a scenario that was made by  $\mu$ CHP producers (Smart Power Foundation, 2006) and thus tend to be over optimistic. In reality these numbers will therefore probably be lower<sup>8</sup>.

A cluster of  $\mu$ CHP units can be controlled and monitored on an aggregate level and then be treated as a single power plant. This principle is called a virtual power plant (VPP) (see 2.1 for detailed definition and description). The main advantage of a VPP over stand-alone operated  $\mu$ CHP units is that when aggregated into a VPP, the  $\mu$ CHP units can be used for trade in energy markets and can be deployed for technical distribution network management purposes.

## 1.2 VPP literature overview and research possibilities

Houwing and Ilic (2008) provide conceptual insight in aggregated control of  $\mu$ CHP units and hypothesize that through intelligent<sup>9</sup>, centralized control, operational (energy) cost savings can be achieved. Schulz et al. (2005) made a simulation tool for a  $\mu$ CHP VPP and illustrated the economic potential of the VPP in Germany with a business model for control power. Smaardijk et al. (2005) performed a mainly qualitative analysis about the potential for dispersed generation in the Netherlands, and the possibilities to integrate dispersed generation into a VPP. A VPP feasibility study was performed by MacDonald et al. (2006) in which the technical, economical and regulatory aspects of a VPP in the province of Ontario were researched. Braun (2007) researched the technical and economic potential of  $\mu$ CHP VPPs for the provision of active power reserve. Setiawan (2007) used simulation to analyze different control systems for a VPP. He also studied the possibilities for voltage regulation with a VPP. Werner and Remberg (2008) present a detailed overview of the IT and software requirements for a VPP, provide an overview of possible economic purposes of a VPP and give an overview of the regulatory problems in Germany. Pudjianto et al. (2007) describe the concept and functionality of a commercial and technical VPP and state that integrating DER (distributed energy resources) in to a VPP leads to economic and technical benefits.

### *Research possibilities*

While economical, technical and institutional aspects of a ( $\mu$ CHP) VPP have been researched, none or little of this research has been done specifically for the Dutch situation, which can significantly differ in terms of economic and technical regulations, energy prices, and household energy demand. Also most research focussed on one specific technical or economical aspect and often not on the interrelation between the technical, economical and institutional aspects. In the next paragraph the research objective based on the research possibilities will be formulated.

<sup>8</sup> The regulatory regime and the  $\mu$ CHP unit costs however have a big influence on this figure. If the government decides to provide a large amount of subsidies and the unit price goes down significantly, indeed a large amount of  $\mu$ CHP could be installed in 2020. This is however difficult to predict.

<sup>9</sup> Taking into account future information in setting control actions.

### **1.3 Problem statement, research objective and perspective**

#### *Problem statement*

$\mu$ CHP units are expected to contribute to energy savings, CO<sub>2</sub> emission reductions, and security of supply and reduction of network losses. When combined into a virtual power plant (VPP) additional benefits are expected: the  $\mu$ CHP units can then be deployed for commercial or technical purposes by a VPP operator (energy companies, distribution system operators, housing cooperation).

It can be concluded from the overview in 1.2 that it is still uncertain whether it is technically feasible and economically viable to operate and implement a virtual power plant in the Netherlands and how these aspects are interrelated with the institutional environment. Also it is not quantified whether the implementation of a VPP is beneficial compared to existing technologies.

#### *Research objective*

The goal of this research is to analyze and evaluate the technical feasibility, the economic viability, and beneficiality of implementing and operating a  $\mu$ CHP virtual power plant in the Netherlands and what the impact of the institutional environment on these aspects is.

#### *Perspective*

The thesis will be written from the perspective of Nuon Energy Sourcing (a potential VPP operator) that is responsible for energy trade, electricity and heat generation and for developing new energy projects.

### **1.4 Research framework**

The research framework is presented in figure 2. First a definition and description of a  $\mu$ CHP VPP will be given which will serve as basis for the technical and institutional analysis. The technical feasibility of the system will be evaluated on the basis of the main technical components that can be identified from the VPP definition and description. If the VPP is not technically feasible, it can not be implemented or operated.

Then the economic viability of the VPP system will be evaluated by comparing the costs of electricity production of a  $\mu$ CHP VPP with electricity prices and by calculating economic viability indicators. If the system is not economically viable under current economical and institutional conditions, the VPP could still be implemented with government support.

Next, the institutional environment will be described and evaluated with the four layer model by Koppenjan and Groenewegen (2005) on the basis of which the impact on the technical feasibility and economic viability will be analyzed. The VPP definition and description will be used to identify the most important actors in the first layer of the model.

Whether or not the government should support the implementation of a VPP will be researched by comparing the  $\mu$ CHP VPP with existing technologies on relevant criteria. Based on the values/goals/norms of the relevant actors as identified in the institutional analysis, relevant criteria will be derived to compare the  $\mu$ CHP VPP with existing technologies. From that comparison it can be concluded whether the system would be beneficial and thus whether it would be justified to change institutions or give support to the system if needed.

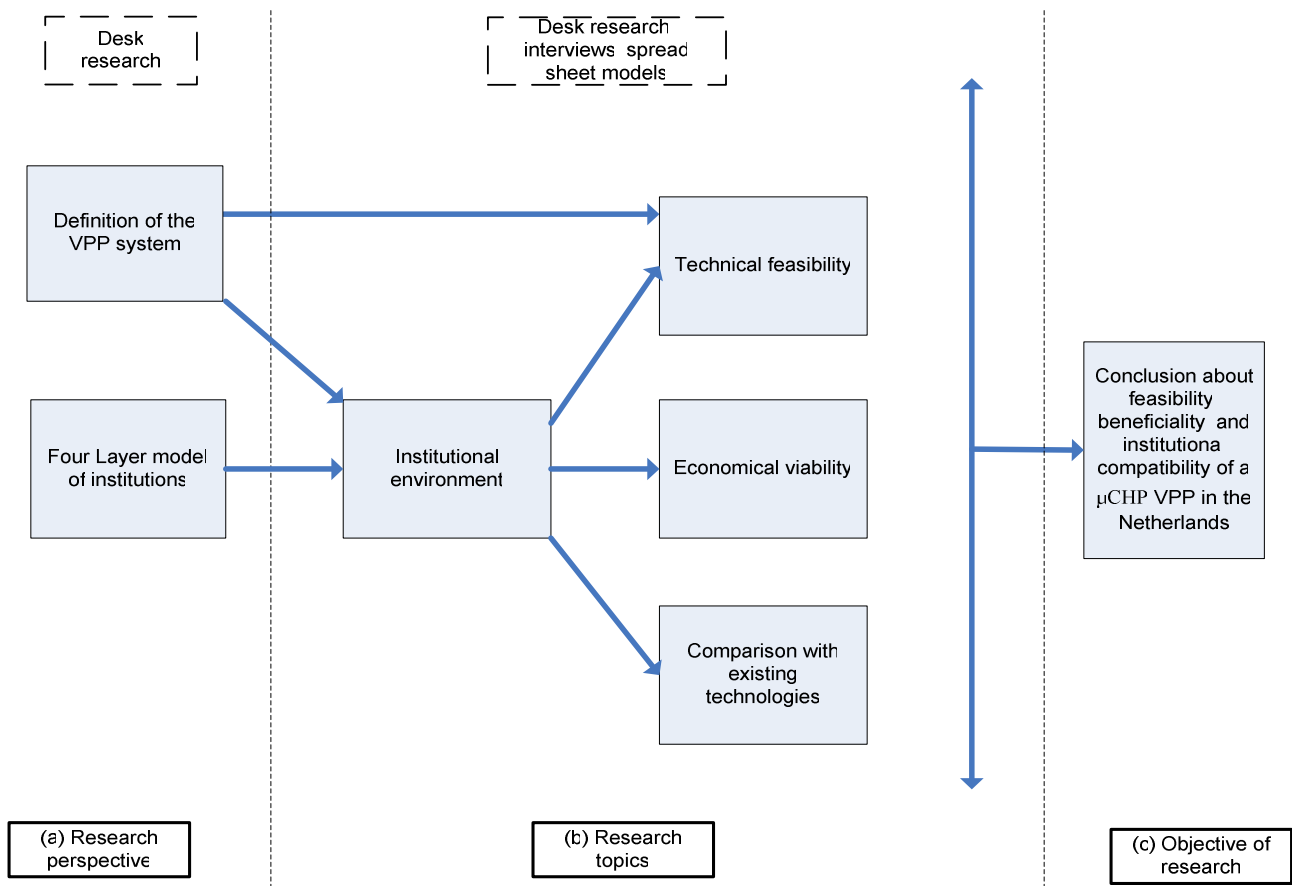

Figure 2: Research framework

## 1.5 Research questions and methods

Based on the research objective and the research framework, the research questions will be formulated. In the boxes, the methods to answer these questions are discussed. The main research question is:

***1 Is it technically feasible, economically viable, and beneficial to implement and operate a micro-CHP virtual power plant in the Netherlands and what is the impact of the institutional environment on those aspects?***

***1.1 What is the definition of  $\mu$ CHP VPP, what are the benefits of such a system, and what  $\mu$ CHP types are available?***

- *What is a ( $\mu$ CHP) virtual power plant?*
- *What are the advantages and disadvantages of such a system compared to central power plants and stand-alone  $\mu$ CHP units?*
- *What  $\mu$ CHP types are available for the VPP?*

These questions will be answered with desk research and evaluation.

***1.2 Is it technically feasible to implement and operate a micro-CHP power plant in the Netherlands?***

- *What technical problems for implementing and operating a VPP can be identified?*
- *What are the possibilities to cope with those problems?*

Answers to these questions can be largely found in literature about DG/ $\mu$ CHP/VPP. ICT and software for VPPs are under development and not much literature is yet available on these topics. Therefore experts will be interviewed to determine the technical problems for ICT and VPP software. Conclusions on the technical feasibility will be verified with experts from Nuon and Liandon.

*1.3 Under which conditions can a micro-CHP virtual power plant be implemented and operated in economically viable way?*

- *Can a  $\mu$ CHP VPP be operated as a conventional power plant in an economically viable way?*
  - *What are the costs of electricity production of a  $\mu$ CHP VPP?*
  - *How do these costs compare with the wholesale and retail electricity prices?*
- *Under which conditions can the implementation of a  $\mu$ CHP VPP be economically viable?*
  - *Which indicators can be used to determine the economic viability of a system?*
  - *How does a  $\mu$ CHP VPP system score on these indicators?*
  - *What factors influence these indicators the most?*
  - *How much need these factors to be changed to break even with the investment costs?*

These questions will be answered by analyzing and calculating with data from literature, Nuon Retail and Nuon Risk Management (forecasted energy prices). A spreadsheet model of a VPP will be developed in Excel to generate inputs for the economical calculations. Also a sensitivity and break-even analysis will be performed.

*1.4 What is the impact of the institutional environment on the technical feasibility and economic viability of the  $\mu$ CHP VPP?*

- *What is the current institutional environment that impacts  $\mu$ CHP/VPP?*
- *What changes are expected in this environment?*
- *How does this environment impact the technical feasibility of a  $\mu$ CHP VPP?*
- *How does this environment impact the economic viability of a  $\mu$ CHP VPP?*

The questions will be answered by evaluating and interpreting relevant laws, amendments and policy documents. The four layer model by Koppenjan and Groenewegen (2005) will be used as a basis for the institutional analysis. This analysis will be combined with the analyses from chapters 3 and 4 to answer the last two sub questions. Conclusions will be verified in discussion with the legal experts.

*1.5 Is it beneficial to implement and operate a  $\mu$ CHP VPP?*

- *How does the  $\mu$ CHP VPP compare to existing technologies for the supply of heat to households?*
  - *What criteria can be derived from the values/norms of the actors identified in 5.2?*
  - *What are currently the most used existing technologies?*
  - *What are the scores on the criteria of the identified technologies and the  $\mu$ CHP VPPs?*

The existing technologies will be identified by desk research. The criteria will be derived from values/norms/goals of the most relevant actors that are identified in chapter 5. The scores on the criteria will be calculated with data from literature and Nuon Asset Valuation.

## **1.6 Thesis outline**

First, the  $\mu$ CHP VPP system will be defined and described in chapter 2. Based on this definition the technical feasibility of the system is evaluated in chapter 3. Then, the economic viability of the system will be evaluated and quantified in chapter 4. In chapter 5 the institutional environment will be described and evaluated based on institutional theory. Then, this institutional evaluation will be combined with the technical and economical analysis from chapters 3 and 4 to determine the impact of the institutional environment on the technical feasibility and the economic viability. In chapter 6 it will be determined whether it would be beneficial to implement the system by comparing the  $\mu$ CHP VPP with existing household heating system on relevant criteria derived from the values and goals of the most important actors. This is how it can be evaluated if it would be justified to change institutions or give government support. Then, conclusions and recommendations are given in chapter 7. Finally, the research will be reflected upon and recommendations for further research are given in chapter 8.

## 2 Virtual power plant definition and $\mu$ CHP review

As a basis for the rest of the research the  $\mu$ CHP VPP will be defined in 2.1. To indicate the relevance of a  $\mu$ CHP VPP, the main advantages and disadvantages will be presented in 2.2. Finally the  $\mu$ CHP types that can be used for the VPP will be shortly reviewed and a choice will be made about which types will be included in the research in 2.3. The following questions will be answered in this chapter:

*What is the definition of  $\mu$ CHP VPP, what are the benefits of such a system, and what  $\mu$ CHP types are available?*

- *What is a ( $\mu$ CHP) virtual power plant?*
- *What are the advantages and disadvantages of such a system compared to central power plants and stand-alone  $\mu$ CHP units?*
- *What  $\mu$ CHP types are available for the VPP?*

### 2.1 VPP definition and description

A virtual power plant can be defined as a cluster of grid connected micro-CHP units that is monitored and controlled on an aggregate level by a VPP operator for commercial or technical objectives. The  $\mu$ CHP cluster can then be treated as a single power plant. A commercial VPP can be used to participate in trade on energy markets (APX, forward) and a technical VPP can be used to contribute to distribution network management like providing regulating and reserve power (Pudjianto et al., 2007).

Some VPP definitions have a broader scope and also include renewable energy sources and controllable loads (Werner and Remberg, 2008) and some define a VPP as a trade option (Willems, 2005). Also a distinction between centralized and decentralized<sup>10</sup> VPPs is made by Setiawan (2007).

Given the perspective, in this research the focus will be on a centralized commercial VPP consisting of only  $\mu$ CHP units that is operated by an energy company. In figure 3 the concept of a commercial VPP system is shown.

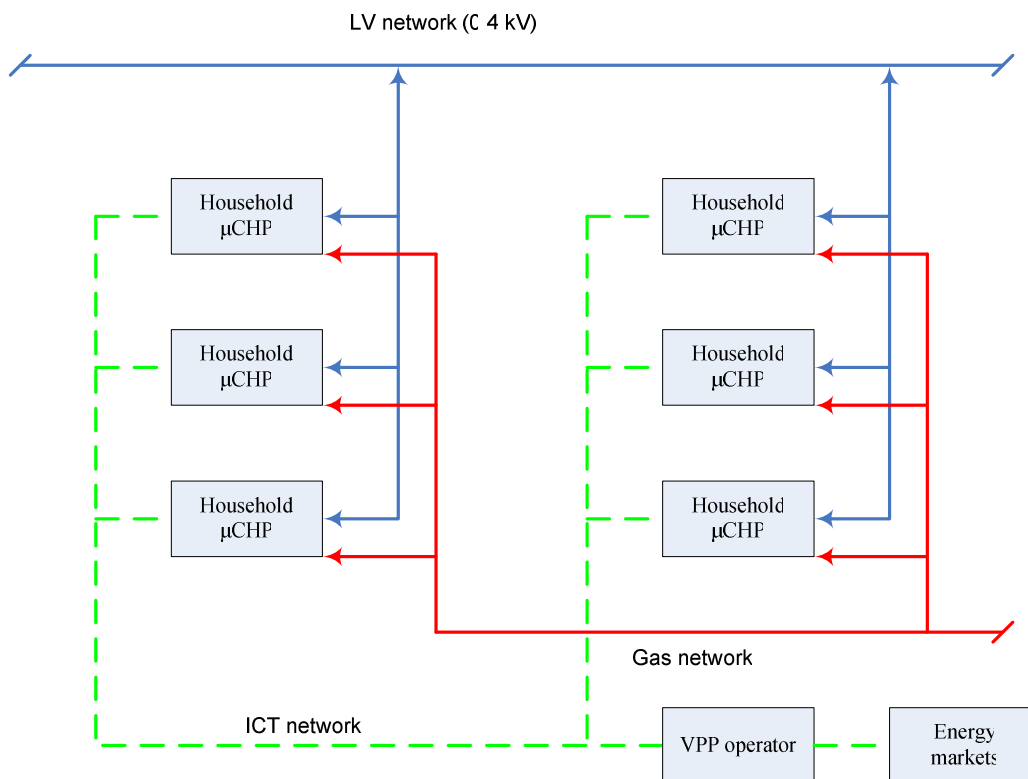

**Figure 3: Commercial virtual power plant concept**

<sup>10</sup> With centralized control the control intelligence is located in a central system that send signals to individual  $\mu$ CHP units. With a decentralized VPP the control intelligence is located in local control units that are interconnected to form an integrated system.



### Control options for $\mu$ CHP

There are several ways in which  $\mu$ CHP units can be controlled. The control can be centralized, distributed and decentralized (see figure 4) (Houwing et al., 2007). With decentralized control, the households themselves decide how to operate the  $\mu$ CHP independently from other households or a VPP operator. It is also possible that households interact with each other in making control decisions for example via a market platform that is operated by an aggregator. This is called distributed control. The last possibility is centralized control in which a VPP operator controls the  $\mu$ CHP units.

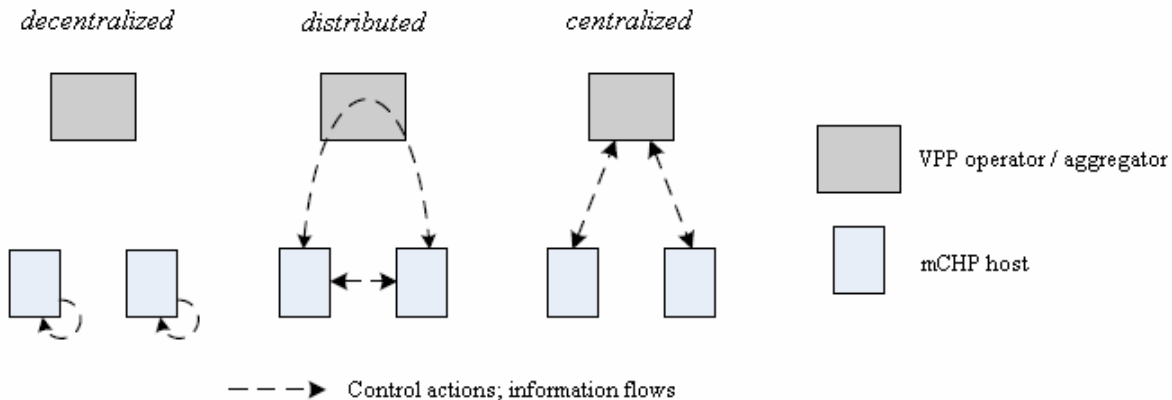

Figure 4:  $\mu$ CHP control possibilities, adapted from (Houwing et al., 2007)

In this research the focus will be on the centralized control option. For centralized control, there are two control options: direct or indirect control (Houwing and Ilic, 2008).

#### Direct control

With direct control the VPP operator has full control over the  $\mu$ CHP output and sends dispatch signals/programs to the  $\mu$ CHP controllers of available  $\mu$ CHP units via a central control unit. A  $\mu$ CHP unit is available for dispatch when there is no conflict of the  $\mu$ CHP output with household heat demand or heat storage capacity.

With this type of control the VPP will be placed in the merit order of power plant dispatch. From field tests (ECN and Gasunie, 2006) it was concluded that initial worries from the households about losing control over the  $\mu$ CHP disappeared after no changes in heat comfort were noticed.

#### Indirect control

It is also possible that the  $\mu$ CHP units will be controlled indirectly through price signals that are sent to the households. A local control unit decides whether and to what extent to respond to the price signal based on household price preferences and heat demand limitations.

Some intelligence in the local controller will be needed to automatically process the price signals and dispatch the  $\mu$ CHP when it meets/exceeds household predefined prices. The exact dispatch parameters can be agreed on in contracts with the households so that the VPP operator can forecast how the households will respond and thereby how big the VPP capacity is at a certain time.

#### Local control

Always some local control is needed to respond to thermostat and heat storage settings to meet the household heat demand. VPP control is an alternative control mode of the  $\mu$ CHP units and not the dominant control mode. The dominant operating mode is determined by local heat demand and other household setting/preferences in the local control system.

#### VPP operator - household interaction

In figure 5 the interaction between the VPP operator and household is shown in more detail. The energy company is the VPP operator and uses the VPP for commercial purposes. The households are connected to the electricity

and gas grid and via an ICT infrastructure to the energy company. The energy company controls and monitors the  $\mu$ CHP units that are hosted by the households with a central control unit (CCU) (see figure 5). The central control system uses a logic control algorithm that is developed for one or multiple control objectives. This algorithm uses information needed for the commercial purpose (for example energy prices) and information about the households' (forecasted) energy demand, energy storage and  $\mu$ CHP status, to determine how the individual  $\mu$ CHP units should be dispatched and configured to produce the required output of the VPP and fulfill the households' requirements.

The household information is gathered and transmitted to the CCU by an in-house local control unit (LCU) that also translates the control signals from the CCU into  $\mu$ CHP settings and dispatch actions. This LCU will also respond to signals from the thermostat set by the  $\mu$ CHP host or when the temperature of the heat storage becomes too low.

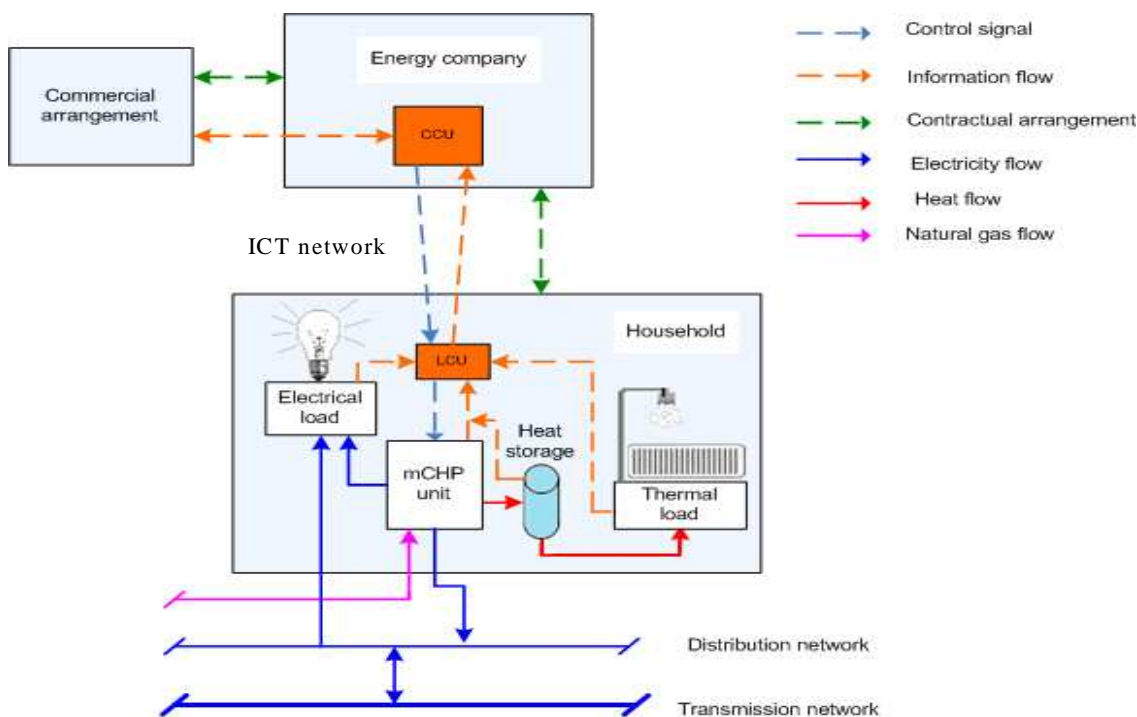

**Figure 5: Detailed overview of household interaction with networks and energy company**

Now that the  $\mu$ CHP VPP system is defined and described, the potential advantages and disadvantages of such a system will be discussed in the next paragraph.

## 2.2 Advantages and disadvantages of a VPP

A  $\mu$ CHP VPP can have several advantages over stand-alone operated  $\mu$ CHP units and large scale power plants. When combined in a VPP,  $\mu$ CHP units can be used for commercial or technical purposes. When  $\mu$ CHP/DG units are operated stand-alone, they don't have enough capacity, flexibility or controllability to make such activities cost effective or technically feasible (Pudjianto et al., 2007). Other possible advantages are summarized in table 3.

**Table 3: Advantages of a  $\mu$ CHP VPP over stand-alone  $\mu$ CHP units and central power plants**

<i>Advantages over stand-alone <math>\mu</math>CHP</i>	<i>Advantages over central power plants</i>
It is expected that intelligent central control of a cluster of $\mu$ CHP units will lead to operational costs savings for the cluster (Houwing, M. and M.Ilic, 2008)	Reduction of energy consumption and associated greenhouse gas emissions is possible because of a higher overall energy conversion efficiency compared to electricity only power plants.
Aggregation of many DG units into a VPP can improve the economics of DG because of the possibility to	The $\mu$ CHP VPP has a larger application scope than a CHP coupled to a district heating system.

capture system benefits and more favorable financing terms (MacDonald et al., 2006).	Limited financial risk compared with a central power plant because the power capacity and the investments for that capacity can be incrementally increased (Smaardijk et al., 2005).
The peak load reductions are higher with centralized (VPP) control of the $\mu$ CHP units than with local heat-led control of $\mu$ CHP units (ECN and Gasunie, 2007).	A VPP has higher operational flexibility than large power plants. In principle a VPP can be operated between 0-100% of the maximum capacity, while large power plants can not.
When combined into a VPP, the $\mu$ CHP capacity will become more visible to the system operator. This can prevent over-capacity problems, underutilisations of assets, and an increase of the electricity cost (Pudjianto et al., 2007).	Higher security of electricity supply: <ul style="list-style-type: none"> <li>• Failure of one of the <math>\mu</math>CHP units is less disruptive than failure of a central power station;</li> <li>• More regulating and reserve power is available from central power plants when <math>\mu</math>CHP units (partly) replace power production.</li> </ul>
Improved voltage regulation is possible by coordination of distribution elements (Setiawan, 2007).	Limited strategic risk: planning and building a central power station can take many years, while disperse generation could be deployed rather quickly and can therefore better react to changes in the market (Smaardijk et al., 2005).
	Deployment of $\mu$ CHP can lead to a decrease of power distribution and transmission losses (IEA, 2002; Mott MacDonald, 2004).
	$\mu$ CHP units and thus a $\mu$ CHP VPP does not fall under the EU emission trading scheme and can thus save costs.
	Less heat losses than a large CHP with district heating system.

Next to the benefits of a  $\mu$ CHP VPP, also some disadvantages of the system can be mentioned (see table 4).

**Table 4: Disadvantages of a  $\mu$ CHP VPP over stand-alone  $\mu$ CHP units and central power plants**

<i>Disadvantages over stand-alone <math>\mu</math>CHP</i>	<i>Disadvantages over central power plants</i>
Extra capital costs are needed for control systems and software.	A $\mu$ CHP VPP has higher costs per kW <sub>e</sub> installed.
The household partially loses control over the $\mu$ CHP.	Most $\mu$ CHP types have a lower electrical efficiency.
More complex contractual arrangements are needed with households.	The operation is limited by heat demand of <i>individual</i> households (see 3.1.3)
	$\mu$ CHP units are usually not equipped with voltage/frequency control <sup>11</sup> .
	Regulation might need to be changed to accommodate $\mu$ CHP in the power system.

<sup>11</sup> Voltage and frequency control is however possible when the  $\mu$ CHP is connected to the grid with a power electronic device.

## 2.3 $\mu$ CHP review

To determine which  $\mu$ CHP units can be used in the research a short overview of the currently available technologies is given and a choice is made on what types to include in the research.

The main CHP technologies that are being developed or marketed for residential application are: reciprocating engines, Stirling engines, fuel cells, and micro (gas)turbines (Onovwiona and Ugursal, 2006; Pehnt et al., 2006). Reciprocating engines are already commercially available and Stirling engines are expected to be commercially available in 2010/11 in the Netherlands. Residential fuel cell systems are claimed to be commercially available within 4/5 years. It is unknown when micro-turbine will be available for residential applications. Each type will be shortly discussed below.

- Reciprocating engines are internal combustion engine that have high  $\text{NO}_x$  emissions and noise levels compared with the other  $\mu$ CHP technologies. Since most  $\mu$ CHP units in the Netherlands will be placed inside homes, this type of  $\mu$ CHP is therefore not considered to be a suitable option and will not be included in the present research (Onovwiona and Ugursal, 2006; Pehnt et al., 2006).
- Most micro turbines are small scale gas turbines that are not yet suitable for residential applications because of their high power capacity (20 - 500 kW) and will therefore not be included in the research (Moore, 2002).
- The Stirling engine is a external combustion engines and will be the first  $\mu$ CHP technology that will enter the Dutch market (Remeha, 2008). This  $\mu$ CHP type will therefore be included in the analysis.
- $\mu$ CHP fuel cell systems are expected to achieve the highest energy savings and emission reductions of all  $\mu$ CHP systems, and will therefore be included in the research (Kreijl, 2007; Van der Laag, and Ruijg, 2002, 2003; Peacock and Newborough, 2005). There are currently two types of fuel cells that are developed for residential application: (1) the polymer electrolyte fuel cell (PEFC), and (2), the solid oxide fuel cell (SOFC). A PEFC is a low temperature (60-80 °C) fuel cell that needs pure hydrogen as input. A SOFC is a high temperature (650 - 1000°C) fuel cell that can use a variety of fuels as input because of its internal reforming capabilities. In this research the focus will be on the SOFC system because it has several advantages over the PEFC:
  - It does not need extensive fuel processing and can internally reform natural gas which reduces costs, energy use and space (Oosterkamp and Van der Laag, 2003);
  - It has a higher electrical efficiency which will lead to higher energy savings and emission reductions (Kreijl, 2007; Van der Laag and Ruijg, 2002, 2003; Peacock and Newborough, 2005).

So in this research only a Stirling engine VPP and a SOFC VPP will be analyzed. See table 5 for the specifications that will be assumed in this research and paragraph 3.1.1 for a more detailed evaluation of the units.

**Table 5: Assumptions on the Stirling engine and SOFC (CFCL, 2008; De Sanctis, 2007)**

	<i>Stirling engine</i>	<i>SOFC</i>
Electrical power output	1 kW <sub>e</sub>	1 kW <sub>e</sub>
Heat power output	5.3 kW <sub>th</sub>	0.7 kW <sub>th</sub>
Electrical efficiency (LHV)	15%	50%
Thermal efficiency (LHV)	80%	35%
Supplementary boiler	20kW <sub>th</sub>	25kW <sub>th</sub>

## 2.4 Concluding

The VPP system was defined and described and the advantages and disadvantages of such a system were discussed. Also a short overview of available  $\mu$ CHP units was given and only the Stirling engine (because it is the first on the market) and SOFC (because it can achieve the highest energy savings) will be included in the current research.

*Next...*

Based on the definition and description of the  $\mu$ CHP VPP in this chapter, it will be evaluated if the system is technically feasibility in chapter 3.

### 3 Technical feasibility of a $\mu$ CHP VPP

The technical analysis is based on the main technical components needed for VPP operation. The main technical components needed for operation of the  $\mu$ CHP VPP that can be identified from the previous chapter are:

- $\mu$ CHP units
- Control system: ICT infrastructure, local controllers and software
- Electricity networks

The technical problems related to those components will be identified and described, and also possible solutions will be given if available. The following research questions will be answered in this chapter:

*Is it technically feasible to implement and operate a micro-CHP power plant in the Netherlands?*

- *What technical problems for implementing and operating a VPP can be identified?*
- *What are the possibilities to cope with those problems?*

First the technical problems associated with  $\mu$ CHP units will be discussed as well as solutions to cope with the problems in paragraph 3.1. Then the technical problems related to the control system will be shortly discussed in 3.2. The potential impacts of connecting  $\mu$ CHP units to the electricity distribution grid will be analysed in 3.3. Conclusions based on the feasibility evaluation are drawn in 3.4.

#### 3.1 Technical problems related to micro-CHP units

The main technical problems related to  $\mu$ CHP units will be discussed and then possible solutions are presented.

##### 3.1.1 Technical limitations of the $\mu$ CHP units

###### *Stirling engine*

A Stirling engine is an externally gas fired combustion engine. Kinematic Stirling engine designs have durability and reliability problems and also have complicated power modulation (EPRI, 2002). Free-piston Stirling engines don't have these problems according to (Tsoutsos et al., 2003). For this research, specifications of a free-piston Stirling engine will be used. The efficiency during part-load is lower than during full-load operation. Current pre-commercial versions of Stirling engines can not modulate their output and need a grid connection for proper functioning. However potentially these systems can modulate between 50-100% of their rated output and can be operated off-grid after minor changes in the system design (Bozelie, 2009).

###### *SOFC*

A solid oxide fuel cell is a device that electrochemically converts natural gas directly into electricity. The most often mentioned technical problem related to SOFCs is that the performance (cell voltage) degrades over time and that this degradation is enhanced by dynamic operation of the SOFC system (DeBruyn, 2006; Oosterkamp and Van der Laag, 2003). Also during start-up and shut-down of  $\mu$ CHP units the efficiency of these systems are very low and frequent start-stop operation will decrease lifetime. Also the system efficiency is lower during part-load operation. Therefore the number of start-stop cycles should be very limited. Some fuel cell suppliers (Ceres Power, Topsoe Fuel Cell) claim to have solved these problems but no scientific evidence is yet available to confirm this.

Since households will always be connected to the electricity grid and because a supplementary boiler is integrated in the  $\mu$ CHP system, there is always full back up of energy supply in case the  $\mu$ CHP fails.

Based on personal communication with experts and suppliers the operational limitations of and assumptions about the  $\mu$ CHP Stirling engine and the SOFC are given in table 6. These assumptions and characteristics will be used throughout the research.

**Table 6: Operational limitations of  $\mu$ CHP Stirling engine and SOFC (Bozelie, 2009; Topsoe fuel cell, 2008)**

	<i>Stirling engine</i>	<i>SOFC</i>
Start up time	3 - 6 min.	120 min.
Shut-down time	3 min.	30 min.
Modulation	50-100% of max power	30-100% of max. power
Modulation rate	50 W/min	60 W/min
Max start/stop cycles per day	20	-
Technology specific limitations	- Currently needs grid to function properly; - High heat-to-power ratio, which implicates low operating flexibility for VPP operator outside winter season.	- Needs to be heated with burner for full start-up; - Limited heat output, so supplementary boiler often needed, which reduces energy savings of cogeneration.

### 3.1.2 Seasonal operating limitations of the $\mu$ CHP units

$\mu$ CHP units are only partially controllable because they must run to cover heat demand and not more than that to prevent heat dump. Since heat demand is strongly interrelated with seasonal temperature variation, the  $\mu$ CHP units also have seasonal operating limitations.

Since Stirling engines have a high heat output, a Stirling VPP can almost not be operated during summer (just 1-2 hours on a summer day, see fig. 6) unless you can store the heat in a seasonal storage facility like an aquifer or with phase change materials. This implicates that, unless seasonal storage is possible, next to the Stirling VPP capacity, a large central power plant capacity is needed to supply the demanded power during summer, which will almost not be used during winter because the Stirling VPP is then operated.

Because of the low heat output the SOFC will run almost continuously at full output (24 hours on a winter day, see fig. 7) during winter to partly fulfill the heat demand. This means that then there is no operational flexibility for the VPP. For a Stirling VPP this limitation is less severe because of the higher heat output of the Stirling engine.

So during fall/spring the operational flexibility will be greatest for the VPP operator. To what extent depends on the  $\mu$ CHP types and the specific heat demand profile of the households.

In principle VPP control could override the heat-led operating mode of the  $\mu$ CHP units, and let a supplementary boiler provide a larger part of the heat demand. However this would decrease the potential energy savings of cogeneration<sup>12</sup>.

<sup>12</sup> This is because then electricity and heat are separately produced instead of simultaneously which diminishes the energy savings of cogeneration. In principle the more operating hours the  $\mu$ CHP makes, the more energy savings.

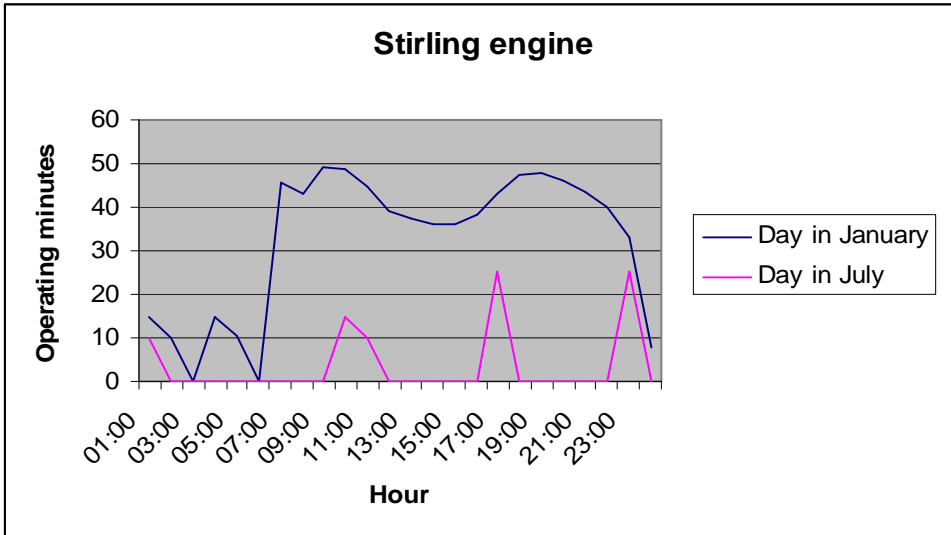

**Figure 6: Operating minutes Stirling engine during a winter and summer day (outcome of model, see paragraph 4.2.1)**

### 3.1.3 Solutions to overcome $\mu$ CHP limitations: energy storage and supplementary heating

As became clear from the previous paragraphs, the  $\mu$ CHP VPP operation is limited by technical and seasonal constraints. Energy storage and supplementary heating can (partly) overcome these constraints. Also, since the heat and electricity demand of an individual household is highly variable, a  $\mu$ CHP can not match this without the help of grid electricity, supplementary heating, and energy storage (Newborough, 2004).

#### Heat storage

Heat storage is needed to cope with the operational limitations of the  $\mu$ CHP units for the following reasons. First,  $\mu$ CHP units can not instantly follow changes in heat or electrical demand (low modulation rates) and the  $\mu$ CHP units can not cover peak heat demand. Heat storage can solve this by supplying instant heat from the storage.

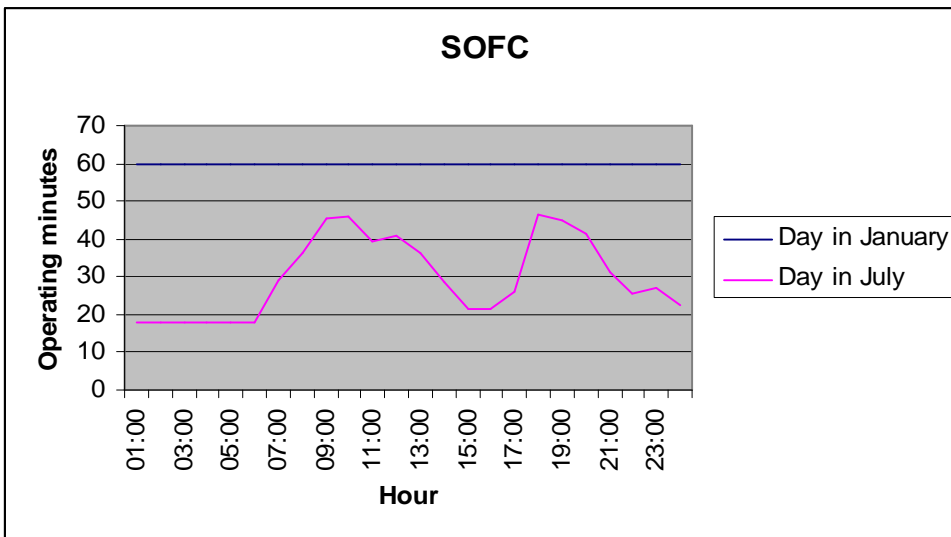

**Figure 7: Operating minutes SOFC during a winter and summer day (outcome of model, see paragraph 4.2.1)**

In addition, heat storage can prevent too much start-stop operation of  $\mu$ CHP units which decreases the lifetime and in the case of a SOFC also the performance. Frequent start-stop also decreases the system efficiency because:

- The overall efficiency is very low during start-up because the gas flow is high and the useful heat output very low and the electrical output close to zero (Paddock trial, 2008);
- The SOFC system has to be heated before to start-up and the cell voltage will degrade with dynamic operation.

Simulations show that the number of start-stops of a Stirling engine can be reduced significantly with a heat storage which increases the thermal efficiency of the  $\mu$ CHP system. This is because with frequent start-stop a large part of the combustion heat is absorbed and dissipated by the engine block instead of reaching the coolant (Beyer and Kelly, 2008). Another simulation study (Streicher et al., 2008) showed that with heat storage, the number of start-stop cycles of a boiler significantly decreased and the annual boiler efficiency increased. The same conclusions apply for  $\mu$ CHP units.

Also, heat storage increases the operational flexibility of the VPP system. Heat storage is needed if the VPP operator wants the  $\mu$ CHP units to produce electricity when there is no heat demand and vice versa<sup>13</sup>. Research shows that the use of heat storage increases the electricity production by  $\mu$ CHP units (Ruijg and Ribberink, 2004b). This implicates the  $\mu$ CHP unit can achieve more operating hours which leads to a higher operational flexibility of a VPP.

During summer heat demand is so low, that a Stirling engine VPP will almost not be able to operate without the use of large scale (seasonal) storage.

For short term (daily/weekly) storage a cylindrical hot water tank is the best option from a production, cost, operational and storage efficiency point of view (Wit, 2007). These systems are already on the market and are typically in the range of 100 – 200 liters and would add about €1000 - €2000 per household to the total VPP system cost. A problem is that a large part of the Dutch households does not have enough space for large systems. For long term (monthly/seasonal) storage the two most often mentioned options are storage in an aquifer and storage with phase change materials (PCM). For an individual household however these types of systems are too costly.

#### *Electricity storage*

Electricity storage can also increase the operational flexibility of a VPP since electricity can be stored during high heat demand when the electricity demand is lower than the electrical output of the  $\mu$ CHP. The stored electricity can then be dispatched at a time that is commercially attractive for the VPP operator.

For a household itself electrical storage can also be attractive. Because of the significant difference between the electricity price and the gas price (see table 1) it is cheaper for the household to produce its own electricity with the  $\mu$ CHP than to buy it from the energy retailer. However the electrical demand can be highly variable (see figure 8) and because of the operating limitations mentioned in the previous paragraph the  $\mu$ CHP can not instantly follow electrical demand. An electricity storage system could overcome these problems.

The most suitable electrical storage systems for households in terms of costs and size are lead-acid and Li-ion batteries according to Blom (2008). The capital costs of such a battery system are however extremely high for an individual household and such systems will not be further included in this research.

---

<sup>13</sup> Sometimes the VPP operator will want to shut down a  $\mu$ CHP unit when electricity prices are low.



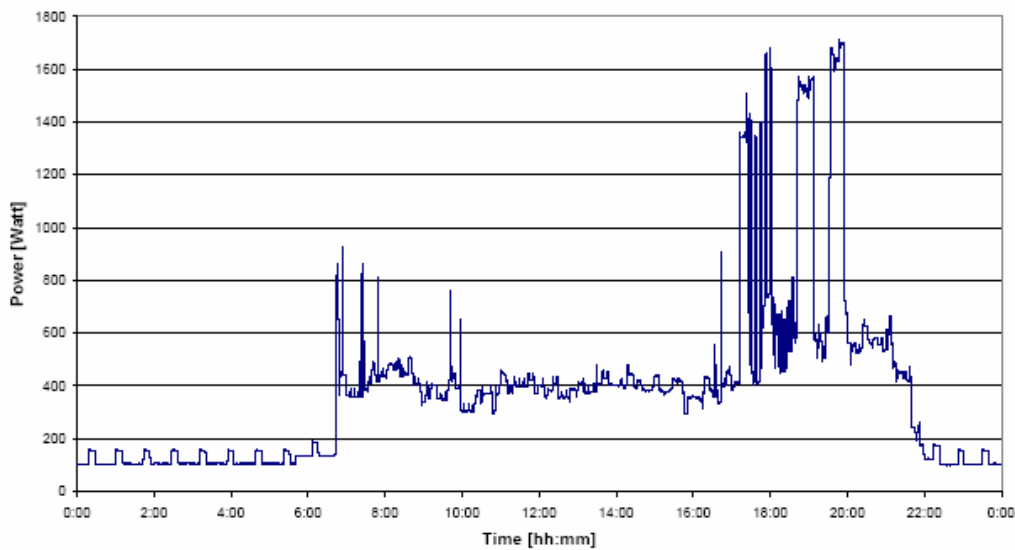

**Figure 8: Typical electrical demand profile of individual Dutch household (Oosterkamp and Van der Laag, 2003)**

### *Supplementary heating*

Also supplementary heating can overcome some of the technical limitations of  $\mu$ CHP units. A supplementary boiler is needed for the following reasons:

1. Because a  $\mu$ CHP can not instantaneously follow a change in hot tap water demand, the boiler is needed to provide this heat instantly;
2. The heat demand in a Dutch household can be as high as 28 kW (Laag and Ruijg, 2002). Since the  $\mu$ CHP units used in this research have a maximum of 5.3 kW<sub>th</sub> output, a supplementary boiler is needed;
3. The boiler can also provide the VPP operator with more flexibility, since it can shut down the  $\mu$ CHP even when there is a heat demand;
4. A boiler is also needed as a back-up in case the  $\mu$ CHP fails.

So concluding, energy storage and supplementary heating can overcome the operating limitations of the  $\mu$ CHP for a large part and improves the operational flexibility of the VPP (more operating hours  $\mu$ CHP).

## **3.2 Technical problems related to the VPP control system**

No specific literature about most components of the VPP control system was found because they still need to be developed or are under development. So only a small amount of information and problems were found in literature and by personal communication with software/ICT experts.

The  $\mu$ CHP units are controlled via data communication networks. The households will be connected to a central VPP server via wireless communication networks (GPRS/UMTS) or Internet (Akkermans, 2006; ECN and Gasunie, 2007). There are two problems associated with wireless communication networks:

- Communication network life cycles change regularly<sup>14</sup>. This is a problem if the VPP system has a longer lifetime than the communication network system;
- Wireless networks have limited bandwidth, so it should be researched if the communication system could handle data traffic of large amounts of  $\mu$ CHP units. The data traffic between the household and the VPP operator is however only a couple of kB per 15 min (Van der Velde, 2008) so it is not likely to be a problem.

Internet has these problems to a lesser extend, but because of the Internet protocol the response time could be too slow for near real time control of  $\mu$ CHP units. For the commercial purposes in this research such a fast response is however not needed, so no problems are expected.

<sup>14</sup> Wireless communication started with 1G and is now moving towards 4G networks. The problem is that networks and appliances using these network need to change along with these network generation changes.

For local control systems no specific problems were found in literature or were mentioned by ICT experts. These systems are currently being developed by several commercial parties (Salland Electronics, Sagem).

Software is needed for the central server to translate the household and energy markets information into dispatch signals for the  $\mu$ CHP units. The central software is based on an algorithm made for a specific VPP objective. It is possible to achieve multiple objectives with the algorithm (Doorn, 2008; Van der Velde, 2008). Van Doorn (2008) indicated that the main challenge for developing the software is to translate central control objectives into individual  $\mu$ CHP settings.

### **3.3 Possible network problems when connecting $\mu$ CHP/DG to electricity distribution networks**

For VPP operation, a large base of  $\mu$ CHP units is needed. An often mentioned potential problem is the impact on the low voltage (LV) electricity network when connecting DG and  $\mu$ CHP to it. The impacts of connecting  $\mu$ CHP/DG to LV distribution networks were identified with literature research and with interviews with network experts. Also solutions to cope with the identified problems are given where needed and when available.

High penetrations of distributed generation (DG) can lead to network problems because most distribution networks are designed to distribute power from the transmission system to consumers with power flowing from a higher to a lower voltage level. With increasing penetration of DG, these power flows could reverse and the power flows and voltage will be determined by loads as well as generation and the network becomes active.

First the impact on network voltage is discussed in 3.3.1. Then potential fault level problems are discussed in 3.3.2. Network protection problems are discussed in 3.3.3. In paragraph 3.3.4 power quality problems are presented that might arise when DG is connected to the grid. The possible impacts on network stability are presented in 3.3.5. In appendix B, a more detailed discussion of the network impacts is presented.

#### *3.3.1 Voltage*

The voltage topics discussed in this paragraph are longer (>1 sec) timeframe problems and deal with relatively large voltage deviations. Short timeframe (<1 sec) problems with smaller voltage deviations (harmonics, fluctuations/flicker, transients) are related to power quality and will be discussed in paragraph 3.3.4. Voltage stability is also a longer timeframe issue but will be separately discussed in 3.3.5.

The voltage in distribution networks should stay within specified limits to prevent damage on or malfunctioning of electrical equipment and customer appliances (in the Netherlands: 230V +/-5% during normal operation). The impact of an individual micro-generator on the distribution network is negligible but when a large number of micro-generators are connected or when the capacity of individual generators is high, voltage problems might arise.

Connecting DG to can also have a positive impact on the network voltage, but this not of relevance for evaluating the technical feasibility. The focus will thus be on the negative voltage impacts that connecting DG might cause. The positive voltage impacts are described in appendix B.

#### *Negative voltage impacts*

When a DG unit is connected to the distribution network, the electricity flows in the circuit change and thus also the voltage profile. The networks and transformers are designed to provide the most remote customer, which experiences the highest voltage drop, with an acceptable voltage level<sup>15</sup> during maximum load (when network voltage is lowest). During minimum load (at night), the voltage in the network is just below the maximum statutory voltage limit (see fig. 9). So when then power is fed in the grid by  $\mu$ CHP units, the voltage level can exceed the upper voltage limit, especially at the end of the distribution line (see fig. 10) (Dondi et al., 2002; PB Power, 2003b; PV Upscale, 2007b). See appendix B for a more elaborate discussion of the impact of DG on the network voltage.

---

<sup>15</sup> The bigger the distance between de load and the generator/feeder, the bigger the voltage drop over the electricity line. The voltage is highest at the generator point and lowest at the most remote load point.

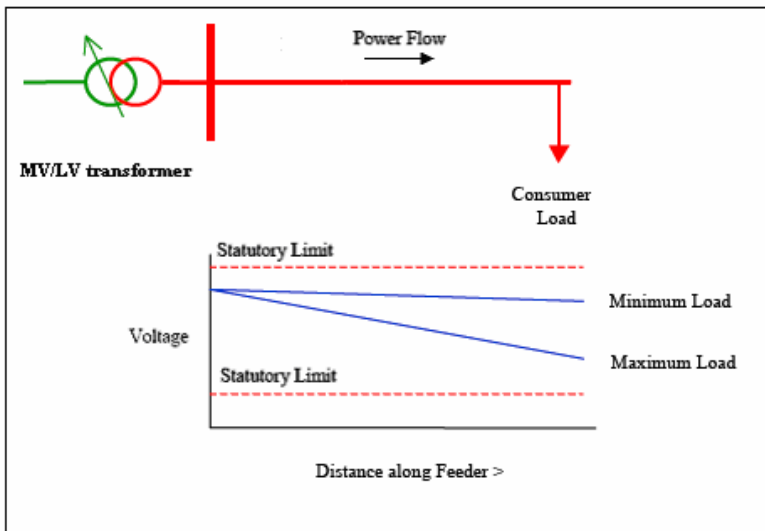

Figure 9: Voltage profile without DG, adapted from BP Power (2007)

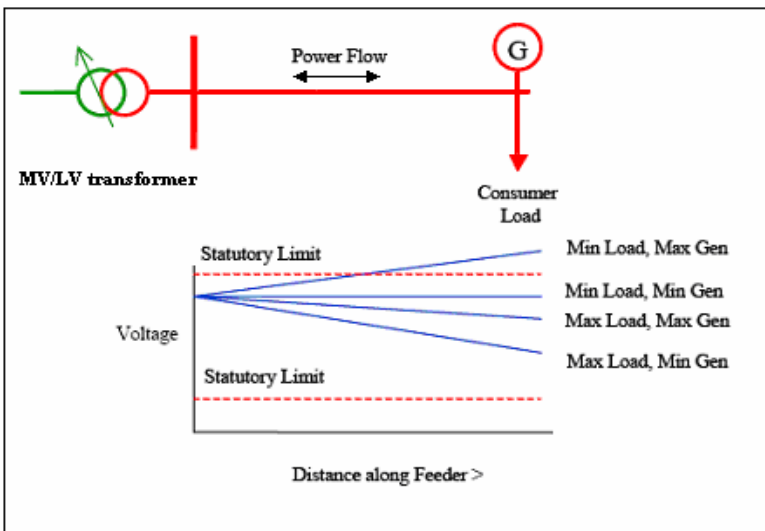

Figure 10: Voltage profile with DG, adapted from (PB power, 2007)

Several authors have researched the impacts on networks when connecting 1-1.2 kW micro-(co)generators to UK<sup>16</sup> and Dutch LV networks. The general conclusion is that large amounts of micro-(co)generators can be accommodated in existing LV networks without adjustments to equipment or networks (Boxum et al., 2000; Cipcigan et al., 2007; Kelly et al., 2008; KEMA 2001, 2002, 2003, 2005; Mott MacDonald, 2004; PV Upscale, 2007a; Thomson and Infield, 2007b, Tran-Quoc, 2003).

Simulation studies and field tests have been performed on the basis of which penetration level thresholds for DG in the LV network have been determined. In table 7 these allowable penetration levels are summarised.

**Table 7: Allowable penetration levels of DG in existing LV networks without causing voltage limits to be exceeded**

Source	Penetration level without voltage problems
PV Upscale (2007a)	75% of the transformer capacity
PB Power (2003a)	48% of number of households
Thomson and Infield (2007a)	50% of number of households
IEA (1998)	80% of number of households

#### Voltage impact with VPP operation of $\mu$ CHP units

<sup>16</sup> UK networks are to a large extent similar to Dutch networks, see (KEMA, 2005)

The biggest problems arise when a DG unit feeds back electricity to the grid during minimum load since this can cause the voltage to rise above the upper voltage limit. During minimum load the heat demand is usually also low so stand-alone heat-led  $\mu$ CHP units are not likely to cause problems.

When the VPP is used to trade on electricity markets, also no problems will arise because the electricity prices are normally low during minimum load and thus electricity feed-in will be avoided by the VPP operator.

### 3.3.2 Fault level

A fault is an unintentional short circuit between two conductors or between a conductor and ground. The fault level of a network is the maximum fault current that flows to the short circuit point. The fault current should not be too high to prevent that the switchgear<sup>17</sup> gets damaged/destroyed and is not able to break the current. This could lead to explosions and fire.

The total fault level of a network is determined by the fault contribution from the upstream network and fault level contributions from DG units. Thus when connecting DG units to the grid, the total fault level will change.

Increased fault currents can be caused by directly connected rotating synchronous and induction generators (see appendix A ) and to a much lesser extend or not at all (depending on the converter type) by power electronic interfaced DG units like fuel cells (Emhemed et al., 2007; Jenkins et al., 2000; KEMA, 2005; PB Power, 2007; PSERC, 2006; Wall, 2001). However the fault level contribution of direct connected  $\mu$ CHP Stirling engines is very low compared to the fault level of the grid (Bozelie, 2009).

KEMA performed several studies (KEMA 2001, 2002, 2003, 2005; Boxum et al., 2000) for Dutch and UK DSOs and concludes that impact of  $\mu$ CHP on the network fault levels is very small. Also other reports conclude that a high penetration of small scale DG to the LV network does not lead to significant increases in fault levels and that that the fault level contribution from the upstream network is always higher than that from small scale DG units (Emhemed et al., 2007; Halcrow Group, 2003; PV Upscale, 2007b; Tran-Quoc et al., 2003).

### 3.3.3 Anti-islanding / loss of main (LOM) protection

The most often mentioned problem concerning network protection is the islanding phenomenon. In case of a network fault, the faulted part of the network is selectively disconnected from the rest of the network through relays and fuses. Islanding is defined as “any situation where a section of electricity Network containing generation becomes physically disconnected from the DNO’s or user’s distribution network, and one or more generators maintains a supply of electrical energy to that isolated network.” (PV Upscale, 2007b, p. 39). In figure 11 this is illustrated.

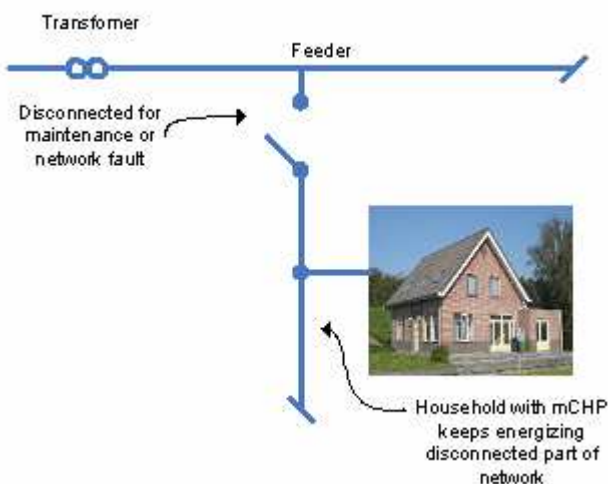

**Figure 11: Islanding in a distribution network**

Two types of islanding are possible:

<sup>17</sup> Network protective devices like electrical disconnects, fuses and circuit breakers

- *Intentional/operational islanding*: DG units are used to supply power within acceptable voltage and frequency limits to the customers in case of pre-planned (maintenance) disconnection from the network power supply. Islanded operation is usually however only allowed when the unit is disconnected from the grid by most grid codes (Jenkins et al., 2000). Potentially all  $\mu$ CHP units can be operated in islanded mode with small modifications (Bozelie, 2009);
- *Unintentional/unwanted islanding*: the DG units continue operating when they are supposed to disconnect in case of a network fault. This is considered to be a problem. The chance of unintentional islanding is not negligible according to Arsenal research and Econnect Ltd (2005) and Brundlinger and Bletterie (2005).

The main problems with unintentional islanding are electric shock hazard, power quality problems because  $\mu$ CHP units are usually not equipped with voltage and frequency control, and reconnection problems (see appendix B for more detailed description) (Kumpulainen and Kauhaniemi, 2004; Kumpulainen et al., 2007; Resource Dynamics Corporation, 2006).

To prevent unintentional islanding the DG unit must detect the loss of mains and then disconnect from the grid. There are three types of anti-islanding/LOM protection methods available of which telecommunication based methods are considered to be the most effective but are also the most expensive (Horgan et al., 2002; Jarrett et al., 2004; Kumpulainen et al., 2007). How effective an anti-islanding method is however also strongly depends on the grounding method of the network which can differ even within one country (Geschiere, 2009).

When the  $\mu$ CHP units of the VPP are disconnected from the grid, export to the grid is no longer possible and therefore no electricity trade. All  $\mu$ CHP units can however potentially operate off-grid with minor changes (Bozelie, 2009) and have a supplementary boiler, so heat supply can always be guaranteed.

#### 3.3.4 Power quality

Power quality problems can cause electrical devices to fail or malfunction and therefore power quality parameters must stay within specified limits. Power quality refers to the quality of voltage and/or the quality of current and is defined by Sankaran (2002, p.1) as: "Power quality is a set of electrical boundaries that allows a piece of equipment to function in its intended manner without significant loss of performance or life expectancy". The main power quality problems related to connecting small scale DG are:

- Harmonics (Barker and De Mello, 2000; El-Samahy and El-Saadany, 2005 Fuchs and Masoum, 2008; Jenkins et al., 2000; Tran-Quoc et al., 2003)
- Voltage unbalance (Jenkins et al., 2000; PB Power, 2007 ; Trichakis et al., 2006)
- Voltage dips (Renders and Vandeveld, 2006; Renders, 2008)
- Voltage flicker (Jenkins et al., 2000; Knazkins, 2004; NREL, 2003)

In appendix B a more elaborate discussion of potential power quality issues is given. Below, the main findings are discussed.

The biggest power quality concern is the production of harmonics by DG units connected to the grid with power electronic converters. Harmonics can increase losses in and cause maloperation of electronic devices and cables. Harmonics are defined as "sinusoidal voltages or currents with frequencies that are integer multiples of the power system fundamental frequency" (Fuchs and Masoum, 2008, p. 8). Mainly problems are expected when connecting DG with older thyristor convertors (Kauhaniemi, 2003). However small scale DG units are usually connected to the grid with newer converter types<sup>18</sup> (Bozelie, 2009), which cause much less problems (El-Samahy and El-Saadany, 2005; Jenkins et al., 2000; Kauhaniemi, 2003).

The three biggest distribution network companies in the Netherlands reported that harmonic problems only occurred in special cases (resonance) with inverter connected PV-panels (PV-Upscale, 2007a). In a study by PV Upscale (2008) measurements on four sites with different network and load characteristics and high PV penetration (up to 80%) confirmed that the power quality limits were in general not violated. See appendix B for a more detailed discussion of harmonics.

---

<sup>18</sup> Insulated gate bipolar transistors (IGBT).

Voltage unbalance<sup>19</sup> problems are expected when large numbers of  $\mu$ CHP units are connected to one phase of a three phase system (Econnect Ventures Ltd., 2007). However most Dutch households have a one phase connection, so it is not likely to be a problem.

Voltage dips can be exacerbated by DG units if they are disconnected by the voltage drop by anti-islanding protection. However converter connected units (like SOFC) as well as Stirling engines have voltage dip ride through capabilities and thus no major problems are expected (Bozelie, 2009; Renders and Vandeveld, 2006).

Voltage flicker<sup>20</sup> can occur with frequent start-stop operation of DG units and by sudden and large variation of DG output (Jenkins et al., 2000). DG units equipped with voltage regulation can however prevent voltage flicker (NREL, 2003).

### 3.3.5 Network stability

The stability of the power system depends on how well it can respond (return to steady state operation) to changing power demand and to disturbances, which are the two main sources of power system dynamics (Machowski, 1997). Large disturbances like faults can cause stability problems and may even lead to collapse of parts of the network. Problems with stability will only occur if very large amounts of  $\mu$ CHP will be connected and will replace a large part of the central power supply (Geschiere, 2009).

There are three kinds of stability: (1) rotor angle stability<sup>21</sup>, (2) voltage stability<sup>22</sup> and (3) frequency stability<sup>23</sup>. Each will be shortly discussed below. See appendix B for more details.

#### *Rotor angle stability*

Simulation results from Azmy and Erlich (2005) show that high utilization of power electronic interfaced DG units (fuel cells, micro-turbines) connected to the LV grid can improve the small signal stability. Directly connected synchronous DG can cause local or inter-area instabilities depending on system's topology, operating point, and control parameters (Genc and Usta, 2005). Net export of power by  $\mu$ CHPs is possible up to 60% of the transformer capacity without causing voltage small signal instability problems (Bozelie, 2009).

DG units connected to the grid with power electronics can improve the transient stability by decreasing the magnitude of the maximum power angle deviation between synchronous generators. Voltage and frequency control of DG is an important factor for maintaining or improving transient stability (Thong, Vandenbrande et al., 2004; Reza, 2006).  $\mu$ CHP systems are however usually not equipped with voltage and frequency control so when they will (partly) replace the power supply by central generators, the transient stability might worsen. Also the power system inertia and the reactive power support are important factors for transient stability.  $\mu$ CHP units contribute very little to the power system inertia, so high penetrations of  $\mu$ CHP might negatively impact the transient stability Reza (2006). However Reza found that up to 50% penetration level no stability problems occurred. A reduction in power flows will improve the transient stability and  $\mu$ CHP can reduce power flows in networks and thereby increase the transient stability (Reza et al., 2004). So only at very high penetration levels,  $\mu$ CHP could worsen the transient stability but it can also improve it by decreasing the power flows.

#### *Voltage stability*

To maintain the voltage stable, reactive power demand and supply must stay balanced. Both converter based units with reactive power control and directly connected synchronous generators can improve the voltage stability by providing reactive power (Azmy and Erlich, 2005; Chen et al., 2006; Thong, Dommelen et al., 2004). Induction generators that draw reactive power can worsen the voltage stability (Thong, Dommelen et al., 2004). However newly installed induction generators are usually connected to the grid with modern power converters (DFIG<sup>24</sup>)

---

<sup>19</sup> "...a condition in which the three-phase voltages differ in amplitude or are displaced from their normal 120 degree phase relationship or both" (Trichakis et al., 2006, p.183).

<sup>20</sup> Dynamic variation of the network voltage that causes the brightness of lamps to fluctuate.

<sup>21</sup> The power system is stable when the generators are able to remain in synchronism after being subjected to a disturbance. There two types of rotor angle stability: small signal and transient stability.

<sup>22</sup> "the ability of the power system to maintain steady voltages at all buses in the system after being subjected to a disturbance from a given initial operating condition" (Kundur et al., 2004, p.1390)

<sup>23</sup> "...the ability of a power system to maintain steady frequency following a severe system upset resulting in a significant imbalance between generation and load." (Kundur et al., 2004, p.1392)

<sup>24</sup> Doubly-fed induction generator

that do not draw reactive power and therefore do not have a negative impact on the voltage stability (Knazkins, 2004). So in general no problems are expected.

#### *Frequency stability*

With increasing levels of power electronic interfaced DG, the rated output of (central) synchronous generators decreases which means a decrease in absolute reserve power from the synchronous machines. This can cause higher maximum frequency deviations (Azmy and Erlich, 2005).

### **3.4 Conclusions technical feasibility of a $\mu$ CHP VPP**

#### ***Conclusions technical problems $\mu$ CHP units***

A general problem is that  $\mu$ CHP units have slow modulation rates and can therefore not instantly respond to energy demand changes. Also the overall efficiency of the Stirling and SOFC is very low during start-up and shut-down and the units have a lower efficiency during part-load.

#### *Stirling engine*

The biggest problem of the Stirling engines is its high thermal output. Because of this, the Stirling can only be operated for a couple of hours per day during summer (without dumping heat). This implicates that either seasonal storage or a significant amount of back-up central power generating capacity is needed to guarantee power supply during that period. Since seasonal storage is very expensive for individual households and the back-up central power capacity will almost not be used during winter, this is a major problem for the Stirling VPP.

#### *SOFC*

The main problem of the SOFC is that it is not suitable for dynamic operation without performance degradation and decrease in lifetime. There are suppliers that claim to have solved this problem, but no publicly available evidence for this claim yet exists. Their low heat output increases the VPP operational flexibility during summer (12 hours per day possible) but decreases this flexibility during winter, since the units will then be operated constantly at full maximum output to fulfil household demand.

#### *Energy storage and supplementary heating*

Energy storage and supplementary heating can overcome most the above mentioned problems to a large extent. They also provide the VPP operator with more operational flexibility by decoupling  $\mu$ CHP production and household energy demand and increasing the operating hours of the  $\mu$ CHP units.

Assuming heat dump is not desirable and there is no heat network, the VPP operation is limited by the heat demand (lower limit) and the heat storage capacity (upper limit) of *individual* households. In principle the heat demand can also be provided by a supplementary boiler when it is not economically attractive for the VPP operator to operate the  $\mu$ CHP, but this would decrease the energy saving potential of the  $\mu$ CHP VPP system and is therefore only allowed for small periods of time.

#### ***Conclusions technical problems VPP control system***

No major problems were identified for the control system from the scarce information that was available about this topic in literature and experts. The only problem might be that the wireless communication network life cycles change regularly which would mean the local controller would need to be adjusted when this happens.

#### ***Conclusions network impacts***

Large penetration of  $\mu$ CHP is possible (sometimes up to 75%) without causing voltage limits to be violated. Unintentional islanding could occur which can lead to power quality and safety problems. Several anti-islanding methods have been proposed of which telecommunication based methods are considered the most effective but also the most expensive. The fault level contribution of  $\mu$ CHP units is insignificant compared to the fault level contribution of the upstream network and no major power quality problems are expected to arise.

Only if very large amounts of  $\mu$ CHP will be connected to the LV grid and will displace a very large part of the central power supply, network stability problems might occur. No small signal instability problems are expected with net export of power by a  $\mu$ CHPs up to 60% of the transformer capacity. High penetration levels (>50%)  $\mu$ CHP can worsen the transient stability but can also can improve this stability by decreasing power

flows. No problems are expected with voltage instability. Higher maximum frequency deviations can be caused by connecting large amounts of power electronic interfaced to the grid.

It should be noted that the largest part of the reviewed literature used simulation models and not actual measurements to determine the effects of large-scale implementation of  $\mu$ CHP/DG. So conclusions should be confirmed by large scale field tests. Also the impacts of connecting DG/ $\mu$ CHP depend highly on the specific network configuration and therefore the DSO should always investigate for that specific network whether limits will be violated.

Almost all identified problems can be solved by technical solutions at a certain cost. So the connection of large amount of  $\mu$ CHP units is not a technical problem but an economic one. Also the introduction of  $\mu$ CHP will probably evolve gradually and thus the distribution system operators (DSOs) will have sufficient time to investigate the impacts of  $\mu$ CHP connection to their networks and adjust their equipment where necessary.

In general it can be concluded that large amounts of  $\mu$ CHP units can be accommodated within existing networks without causing major network problems and without having to make adjustments to the networks or equipment. In some particular cases (high  $\mu$ CHP concentration) network equipment might need to be adjusted, reconfigured or updated.

*Next...*

The main technical problems have been identified and possible solutions have been discussed. It can be concluded that a VPP system is technically viable at a certain cost. Commercial parties shall however only invest in such a system if the economic prospects are also positive. Therefore, in the next chapter it will be evaluated if the system is economically viable or that some form of government support is needed to make the system viable.



## 4 Economic viability of a $\mu$ CHP VPP

Economic viability can be defined as the ability of a system to be profitable in an open, competitive market without the need for external subsidies or protection (Lin, 2002). The economic viability determines whether or not commercial parties like energy companies would invest in such a system without any government support. This is important to know for making recommendations for possible government support. The following research questions will be answered in this chapter:

*Under which conditions can a micro-CHP virtual power plant be implemented and operated in economically viable way?*

- *Can a  $\mu$ CHP VPP be operated as a conventional power plant in an economically viable way?*
  - *What are the costs of electricity production of a  $\mu$ CHP VPP?*
  - *How do these costs compare with the wholesale and retail electricity prices?*
- *Under which conditions can the implementation of a  $\mu$ CHP VPP be economically viable?*
  - *Which indicators can be used to determine the economic viability of a system?*
  - *How does a  $\mu$ CHP VPP system score on these indicators?*
  - *What factors influence these indicators the most?*
  - *How much need these factors be changed to break even with the investment costs?*

Since the VPP system can be seen as a (partial) replacement of conventional power plants, the analysis will be based on the commercial purposes that are common for these power plants. Conventional power plants are either operated in base-load, intermediate-load, or peak load depending on their marginal costs<sup>25</sup>. In paragraph 4.1 the possibilities for operating a  $\mu$ CHP VPP as a base, intermediate or peak plant are analysed based on energy output and costs of electricity production. The most common indicators used to determine the economic viability of a system by investors are the net present value (NPV), the internal rate of return (IRR) and the discounted payback time (Hendriks, 2009). In 4.2 these economic viability indicators will be calculated for the  $\mu$ CHP VPP. Not all costs and benefits are included in these calculations and therefore in 4.3 other potential costs and benefits are identified for the most important actors.

Two main scenarios will be used as a basis for the economic analysis in this chapter:

- **Scenario 1:  $\mu$ CHP as a replacement of the condensing boiler:** in this scenario,  $\mu$ CHP units (including supplementary boiler) are already installed on a large scale and bought/leased from an energy company by the households. The energy company only invests in the control system and the heat storage<sup>26</sup> to make the VPP operational. The  $\mu$ CHP units are indirectly controlled by the VPP operator by price signals. Gas at consumer gas price is used as an input for the  $\mu$ CHP and exported electricity is sold by the household to the VPP operator for the feedback tariff (see 5.2.3). The exported electricity is traded by the VPP operator.
- **Scenario 2:  $\mu$ CHP as alternative for district heating system:** in this scenario, the VPP operator decides to invest in a  $\mu$ CHP VPP system ( $\mu$ CHP<sup>27</sup>, storage, control system) instead of a centralised CHP coupled to district heating system to provide households with heat. The VPP operator has direct control over the  $\mu$ CHP units. The  $\mu$ CHP units will be placed before the consumer meter so that gas at the wholesale gas price is used as an input. Electricity and heat produced by the  $\mu$ CHP is sold to the household and excess electricity is traded on energy markets by the VPP operator.

This might be an interesting option for an energy company because the application of a district heating system is economically limited to newly built houses and densely populated areas. A  $\mu$ CHP VPP can also be applied in existing housing and rural area without additional costs.

### 4.1 Base, intermediate, and peak load operation of a $\mu$ CHP VPP

One of the conclusions of the previous chapter was that VPP operation is limited by individual household energy demand. Therefore in paragraph 4.1.1 the feasibility for a  $\mu$ CHP VPP to be operated in specific mode is analysed

<sup>25</sup> The higher the marginal costs the higher a power plant will be in the dispatch merit order and the lower the number of operating hours per year.

<sup>26</sup> Assuming this is not yet installed and that there is sufficient space.

<sup>27</sup>  $\mu$ CHP systems will have an integrated supplementary boiler, see Remeha, 2008 for example.

by comparing the energy output of the  $\mu$ CHP units with the energy demand of the households. In 4.1.2 the costs of electricity production of the  $\mu$ CHP VPP are compared with wholesale and retail prices per operating mode to determine the economic viability.

Base load plants are operated for 6000 – 8000 hours per year, intermediate load plants between 700 - 6000 hours, and peak load plants for 700 hours or less per year (Bolt et al., 2006; Smaardijk et al., 2005; Steinkohleportal, 2002). For the calculations in this research it is assumed that a base load plant will operate for 7500 hours, an intermediate load plant for 4500 hours, and a peak load plant for 500 hours per year.

#### 4.1.1 Heat and electrical output of the $\mu$ CHP VPP vs. the energy demand of a household

In figure 12 and figure 13 the heat and electricity outputs of a Stirling engine and SOFC (based on the assumptions from table 5) when operated in the three operating modes are compared with three average yearly household energy demands<sup>28</sup> retrieved from Nuon Retail (see table 32 in appendix D).

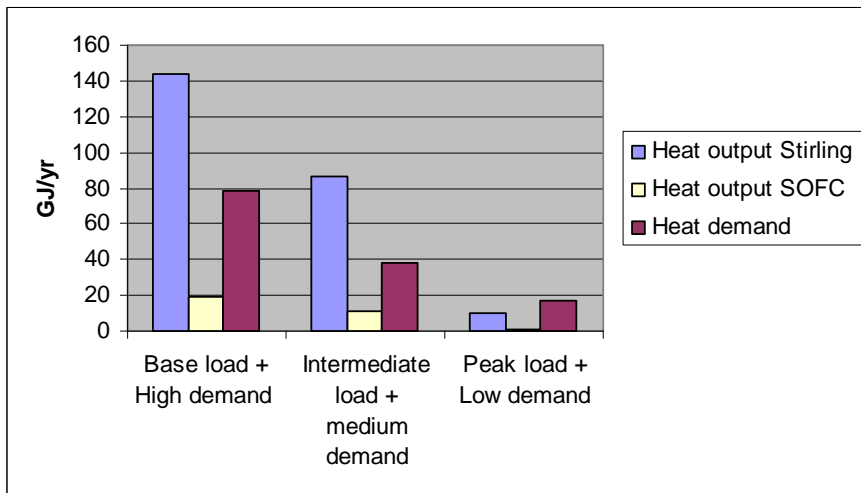

Figure 12: The  $\mu$ CHP heat output given the operating mode vs. the household heat demand

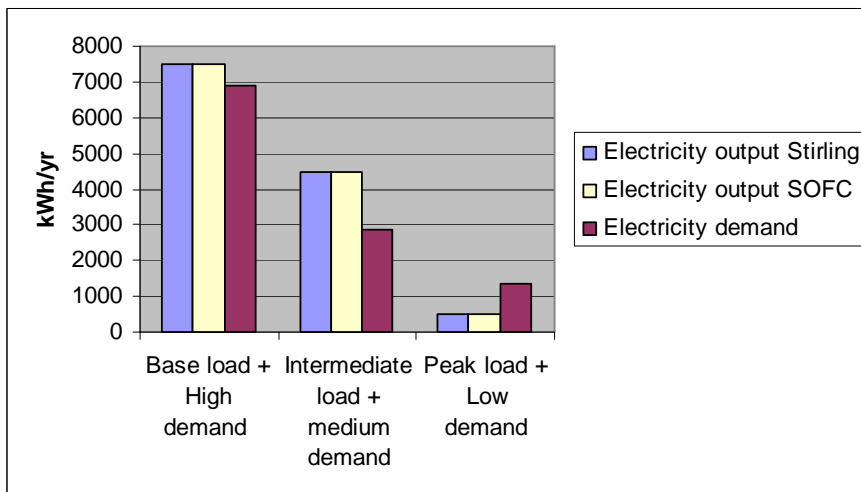

Figure 13: The  $\mu$ CHP electrical output given the operating mode vs. the household electricity demand

### Stirling

<sup>28</sup> Average energy demand from households with a low electricity and gas demand, with a medium electricity and gas demand, and with a high gas and electricity demand. The gas demand data were converted into heat demand by multiplying the gas demand by 0.97 to subtract gas that is used for cooking and times 0.8 to take into account an average conversion loss of boilers (LHV gas: 31.65 MJ/m<sup>3</sup>).

From figure 12 it can be concluded that base and intermediate load operation of Stirling engine would lead to a heat dump even at households with the highest heat demand and is therefore not desirable. A peak load operation would be possible for all household demands without dumping heat.

### **SOFC**

A SOFC can be operated at any mode without dumping heat. For households with a high or medium heat demand the heat output of a SOFC would however be not sufficient to meet heat demand even if it would be operated in base load. This means the supplementary boiler would have to produce a large part of the heat which would decrease the energy savings of cogeneration. With a base load operation, the heat demand of households with a low heat demand could be covered. From figure 13 it can be concluded that when operated as a base load plant, a lot of electricity will be exported when the household has a low or medium electricity demand. This can be used for trade by the VPP operator.

### **VPP**

As explained in paragraph 3.1 the VPP operation -and thus the operating mode- is limited by individual household heat demand and storage capacity. A VPP base and intermediate load operation is therefore only possible with a SOFC only VPP (preferably installed at households with low heat demand). Peak load operation is feasible for both types of  $\mu$ CHP although the household heat demand would have to be covered almost completely by a supplementary boiler in case of a SOFC VPP. When the  $\mu$ CHP VPP is operated as a base load or intermediate load plant in a household with a low or intermediate electricity demand, a large part of the electricity will be exported and can be traded by the VPP operator on an electricity market (see figure 13).

In the above analysis it is assumed that the heat or electricity produced by the  $\mu$ CHP will be fully used by the household. Because of the operational limitations of the  $\mu$ CHP units (like low modulation rates), heat storage, a supplementary boiler and grid electricity will be needed to follow household heat and electrical demand even if the  $\mu$ CHP output is higher or equal to the household demand.

The feasibility of operating a  $\mu$ CHP VPP as a conventional power plant based on energy outputs has been discussed. In the next paragraph the feasibility of the three operating modes based on the marginal and levelized costs of electricity is analysed.

#### *4.1.2 Costs of electricity production of a $\mu$ CHP VPP vs. wholesale and retail electricity prices*

Next to the match between VPP energy outputs and household energy demand, the costs of electricity production are an important factor in power plant dispatch.

A power plant will only be *operated* if it can at least cover its short run marginal costs<sup>29</sup> (SRMC) by the electricity price. In a perfectly competitive market, electricity from power plants is sold at a price equal to the short run marginal costs. A power plant will be *invested in* only if also the investment and fixed costs can be recovered by the electricity price (ECN, 2003). The levelized (averaged) costs of electricity (LCOE) generation will be calculated to take into account these fixed costs. To cover the fixed costs, the electricity price should therefore be higher than the SRMC for long enough periods. This is illustrated in figure 14. Both types of costs will be calculated and compared to historical wholesale spot market (APX) and retail electricity prices.

For sake of simplification<sup>30</sup>, it is assumed that the lifetime is independent of the operating mode and that the maintenance costs are proportional to the operating time.

---

<sup>29</sup> The short run marginal costs are the costs needed to produce one extra unit of electricity with existing capacity. Short run marginal costs only consists of variable costs. If these costs are not covered by the electricity price, the plant will not be operated because a loss would be made.

<sup>30</sup> No literature was found on the relation between operating hours and lifetime/maintenance costs.

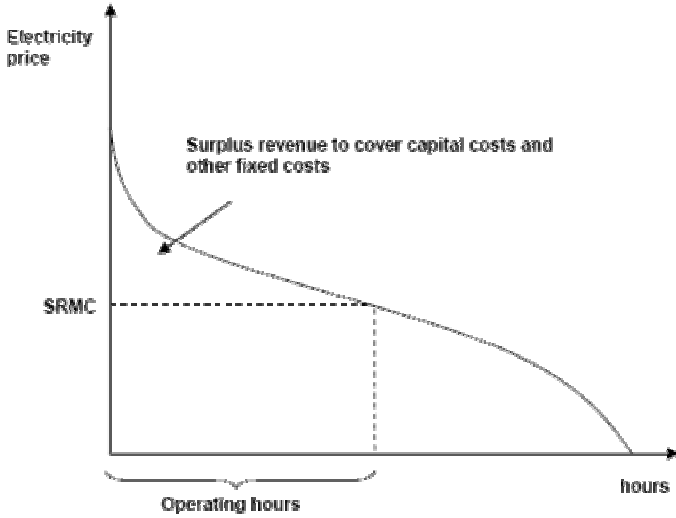

Figure 14: Short run marginal costs vs. electricity price (Lindboe et al., 2007)

### Short run marginal costs (SRMC)

The short run marginal costs only consists of variable costs like the fuel costs, the price of CO<sub>2</sub> emissions rights and variable maintenance costs. Since  $\mu$ CHP does not fall under the CO<sub>2</sub> emission trade scheme, (see paragraph 5.2.3), the short run marginal costs therefore consists of the fuel and variable maintenance costs. Since the maintenance costs are assumed to be proportional to the operating time, the marginal costs are the same for all operating modes. The marginal fuel costs of electricity production can be calculated by determining the gas costs per kWh<sub>el</sub> and then subtracting the part of the costs that is used for producing heat. This way only the marginal costs for producing electricity are obtained. The following formula is used (see table 8 and 9 for inputs):

$$SRMC_{el} = \frac{P_{el}}{H + P_{el}} \cdot \frac{P_{gas} \cdot P_{el}}{\eta_{el}} + \frac{C_{main}}{E_{prod}} \quad (1)$$

where  $p_{gas}$ , is the gas price in €/kWh,  $P_{el}$  the electrical power output in kW,  $\eta_{el}$  is the electrical efficiency,  $H$  is the heat output in kW,  $C_{main}$  are the yearly variable maintenance costs in €/yr, and  $E_{prod}$  is the yearly electricity production in kWh/yr.

### Levelized cost of electricity (LCOE)

The LCOE also includes all fixed and investment costs during the lifetime of the system. Since some of these costs will occur in the future, the time value of money<sup>31</sup> will be taken into account by including an interest/discount rate of 8%. Only the investment costs, maintenance costs, and fuel costs are considered in the calculations (see table 8). No salary, insurance, or decommissioning costs are taken into account. The LCOE are calculated with the following formulas (adapted from Verkooijen, 2008):

$$LCOE = \frac{K_0}{P_{el} \cdot PF} \cdot \frac{i \cdot (1+i)^n}{(1+i)^n - 1} \quad (2)$$

$$K_0 = I_0 + g \cdot \frac{(1+i)^n - 1}{i \cdot (1+i)^n} \quad (3)$$

$$g = (g_m + g_F) \cdot P_{el} \quad (4)$$

<sup>31</sup> Money is worth more today than in the future because today's money can be increased with a yearly interest rate when put on a bank.

where,  $n$  is the lifetime of the system,  $K_0$  is the present value of the costs in €,  $P_{el}$  is the power output in kW<sub>el</sub>,  $i$  is the interest rate in %/yr, PF are number of operating hours per year,  $I_0$  are the investment costs in €/kW/yr,  $g$  are the variable cost in €/kW/yr,  $g_m$  the maintenance costs in €/kW/yr,  $g_f$  the electricity fuel costs in €/kW/yr.

**Table 8: Assumptions for economic calculations (based on sellers information and EPRI (2002))**

	<i>Stirling engine</i>	<i>SOFC (stack)</i>	<i>Control system</i>	<i>Heat storage</i> <sup>32</sup>
Capital costs (€/household)	3000	5000 (1000)	200	1000
Average maintenance costs (€/yr)	60	170 <sup>33</sup> (-)	-	-
Lifetime system (yrs)	15	10 (5)	15	15

**Table 9: Consumer and wholesale gas prices (APX data services, 2009; EnergieNed, 2007, 2008)**

	2007	2008
Consumer gas price	0.082	0.083
Wholesale gas price (TTF)	0.015	0.025

In table 10 and 11 the outcomes of the cost calculations are presented. The two scenarios will be analyzed separately for each VPP type because the costs and revenues are different:

- **Scenario 1:** the produced electricity is either consumed by the household or exported to the grid. For the exported electricity the VPP operator will have to pay the household the consumer electricity tariff (including energy tax and VAT) (see paragraph 5.2.3). Thus the marginal costs for the VPP operator are equal to that tariff. The VPP can only trade the expected<sup>34</sup> exported electricity and can do nothing with the rest of the produced electricity.
- **Scenario 2:** the produced electricity is either sold directly to the household or if the household demand is expected to be lower than the production, the excess electricity is traded on an electricity market. For the direct sales to the household the retail price without energy tax and VAT is used to compare the costs with, since this is what the VPP operator will actually earn.

Below, the costs of electricity production of a Stirling and SOFC VPP are compared with the wholesale and retail electricity price for each operating mode to determine the viability for operating the VPP like a conventional power plant.

### *Stirling engine VPP*

From the previous paragraph it was concluded that base and intermediate load operation for a Stirling VPP is not possible without dumping large amounts of heat. Therefore only peak load operation was analyzed for a Stirling VPP.

#### *Scenario 1*

From table 10 and figure 15 it can be concluded that with scenario 1 the SRMC are much higher than the average wholesale APX price and that the SRMC are not covered by the APX price for a large part of the year. So the operational costs can not be covered. The same can be concluded for the LCOE which means the capital costs can not be recovered with electricity trade.

#### *Scenario 2*

<sup>32</sup> See <http://www.omnia-online.nl/index1.html> for price indications

<sup>33</sup> Includes stack replacement after five years. Is based on suppliers estimations.

<sup>34</sup> No real time trade is possible. All power capacity has to be offered in advance in trade transactions. So the VPP operator has to anticipate how much and when electricity will be exported.

The SRMC are much lower than in scenario 1 because the electricity can be produced with gas at the wholesale price and because no feedback tariff has to be paid. The LCOE are higher than in scenario 1 because of the higher capital costs. The SRMC are covered for the largest part by the APX prices during the year (see figure 15) and the average APX and retail price are higher. So the operational costs can be largely covered. The LCOE are however much higher than both the average APX price and the retail price and the APX price are never higher during the year, so the capital costs can not be recovered with electricity trade and sales.

**Table 10: Costs of electricity production of a Stirling engine vs. historical APX and retail electricity prices (APX Data Services, 2008; Energiekamer, 2009; EnergieNed, 2008)**

	2007			2008		
	Base	Intermed.	Peak	Base	Intermed.	Peak
<i>Scenario 1</i>						
SRMC (€/kWh)*			0.22			0.23
LCOE (i =8%) (€/kWh)			0.489			0.485
<i>Scenario 2</i>						
SRMC (€/kWh)			0.024			0.034
LCOE (i =8%) (€/kWh)			1.117			1.128
<b>Retail electricity price</b> (€/kWh)†			<b>0.097</b>			<b>0.10</b>
<b>Average APX price</b> (€/kWh)			<b>0.062</b>			<b>0.093</b>

\* The SRMC for scenario 1 are equal to the feedback tariff, which will be equal to (up to 5000 kWh export) the consumer electricity price including energy tax and VAT

† The consumer price without energy tax and VAT.

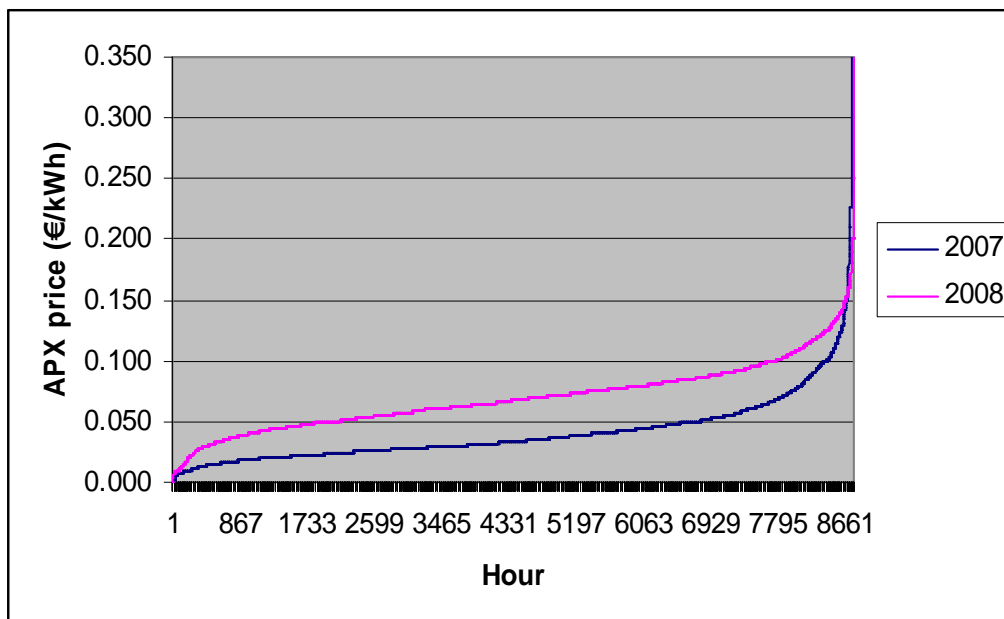

**Figure 15: APX prices in per hour per year**

### SOFC VPP

The SRMC are higher than for the Stirling VPP because of the higher maintenance costs. The LCOE are higher because of the higher capital costs. In chapter 3 it was discussed that dynamic operation of a SOFC will lead to performance degradation and decrease of lifetime. Therefore peak-load operation is not included in the analysis.

### Scenario 1

Both the SRMC and the LCOE are higher than the average APX price (see table 11). Only a few hours per year the APX prices are higher. So both the operational and capital costs can not be recovered by electricity trade in this scenario.

## Scenario 2

The SRMC can be covered for a large part of the year by APX prices and also the retail prices are much higher. The LCOE are higher than the average APX price and retail price and only a few hours per year the APX price is higher. So the operational costs can be covered by electricity trade and sales but the capital costs can not. A peak-load operation would lead to large economical losses when the VPP is used for electricity only purposes.

**Table 11: Costs of electricity production of a SOFC vs. historical APX and retail electricity prices (APX Data Services, 2008; Energiekamer, 2009; EnergieNed, 2008)**

	2007			2008		
	Base	Intermed.	Peak	Base	Intermed.	Peak
<i>Scenario 1</i>						
SRMC (€/kWh)*	0.22	0.23		0.22	0.23	
LCOE (i =8%) (€/kWh)	0.146	0.177		0.141	0.172	
<i>Scenario 2</i>						
SRMC (€/kWh)	0.040	0.040		0.052	0.052	
LCOE (i =8%) (€/kWh)	0.155	0.247		0.167	0.259	
<b>Retail electricity price</b>						
(€/kWh) †	<b>0.097</b>	<b>0.097</b>		<b>0.10</b>	<b>0.10</b>	
<b>Average APX price</b> (€/kWh)	<b>0.042</b>	<b>0.051</b>		<b>0.070</b>	<b>0.081</b>	

\* The SRMC for scenario 1 are equal to the feedback tariff, which will be equal to (up to 5000 kWh export) the consumer electricity price including energy tax and VAT

† The consumer price without energy tax and VAT.

## Conclusion economic operating modes $\mu$ CHP VPP

Scenario 1, in which the  $\mu$ CHP units are installed behind the customer meter, is not an economically viable option for a VPP operator because the short run operational costs as well as the capital costs can not be recovered with electricity trade for both a Stirling and SOFC VPP. In the second scenario where the  $\mu$ CHP units are placed before the customer meter, the operational costs can be covered with electricity trade and/or sales but the capital costs can not be recovered for both VPP types. *So a  $\mu$ CHP VPP is not economically viable as an electricity only plant.*

## 4.2 Calculation of economic viability indicators

Since it was concluded that scenario 1 is not an economically viable option for a VPP operator, the economic viability indicators will only be calculated for scenario 2. The most common indicators used to determine the economic viability of a system by investors are the net present value (NPV), the internal rate of return (IRR) and the discounted payback time (Hendriks, 2009). The net present value (NPV) is the present value<sup>35</sup> of expected future net cash flows minus the initial investment costs during a certain period (Mayes, 2009). The NPV calculates the economic profit of an investment. The internal rate of return is defined as “the discount rate that makes the net present value of the investment’s income stream total to zero” (Mayes, 2009). If the NPV is larger than zero and the IRR is higher than the discount rate, the investment should be made (Mayes, 2009). The IRR is considered a measure of quality of the investment while the NPV is measure of quantity. The discounted payback period is the time required to earn back the investment with discounted future cash flows. See appendix C for the formulas and assumptions used for the calculations.

To calculate these indicators all expected costs and revenues during the lifetime of the system should be estimated. One of the revenues is trade of the expected exported electricity on electricity markets. These revenues are determined in 4.2.1 with a spreadsheet model. Then the indicators are calculated in 4.2.2. To determine the input parameters that are most critical for the values of indicators, a single factor sensitivity analysis was performed in 4.2.3. How much these parameters should change to break even is calculated in 4.2.4.

<sup>35</sup> The present value is today’s value of future cash flows and is calculated with a certain discount rate.

#### 4.2.1 Possible trade revenues on Dutch electricity markets

First, a short description is given of trade options in the Dutch market. Next, the most favourable times to sell electricity are analysed. Then, the model to calculate these revenues is described and validated. Last, the possible revenues are presented.

##### *Electricity trade options in the Dutch market*

The Dutch electricity trade consists of day ahead and intraday trade on the Amsterdam Power Exchange (APX) spot market and trade in forward and future contracts on the European Energy Derivatives Exchange (ENDEX) (Energiekamer, 2008a). The largest part of the electricity trade consists of bilateral forward (over the counter) contracts traded via ENDEX or brokers (60% in 2007). The rest of the electricity volume is traded in the form of futures on the ENDEX (24% in 2007) and day-ahead and intraday contracts on the APX (16% in 2007) (Energiekamer, 2008a). The intraday trade volume is negligible compared to the total APX trade volume (<1%) (APX, 2009).

The price agreed upon in bilateral contracts is based on the APX prices (Anderson et al, 2007) and the prices of futures traded on ENDEX are also comparable with the APX prices (see Endex and APX site). So with calculations based on APX prices, the possible revenues of electricity trade with a VPP are largely covered.

##### *APX price analysis*

To determine at which times the  $\mu$ CHP VPP export should be maximized to maximize the APX profits, it was analysed at which times during the year the APX prices are higher than the average SRMC of a Stirling (0.029 €/kWh) and a SOFC (0.046 €/kWh) from scenario 2 (see appendix D). From the analysis it was concluded that a Stirling VPP needs to export between 6:00 and 1:00 and a SOFC VPP between 7:00 and 21:00 to maximize profits<sup>36</sup>.

##### *VPP model description, assumptions, and validation*

A spreadsheet model based on heuristics was developed to calculate the possible trade gains. The outputs of individual  $\mu$ CHP models were aggregated to calculate the total VPP output. The assumptions from table 5 and the operating limitations from table 6 are used in the model. See figure 16 for the inputs, constraints, outputs of the model. The outputs of the model will also be used for calculating other revenues and costs in paragraph 4.2.2 and for comparing the VPP with other systems in chapter 6.

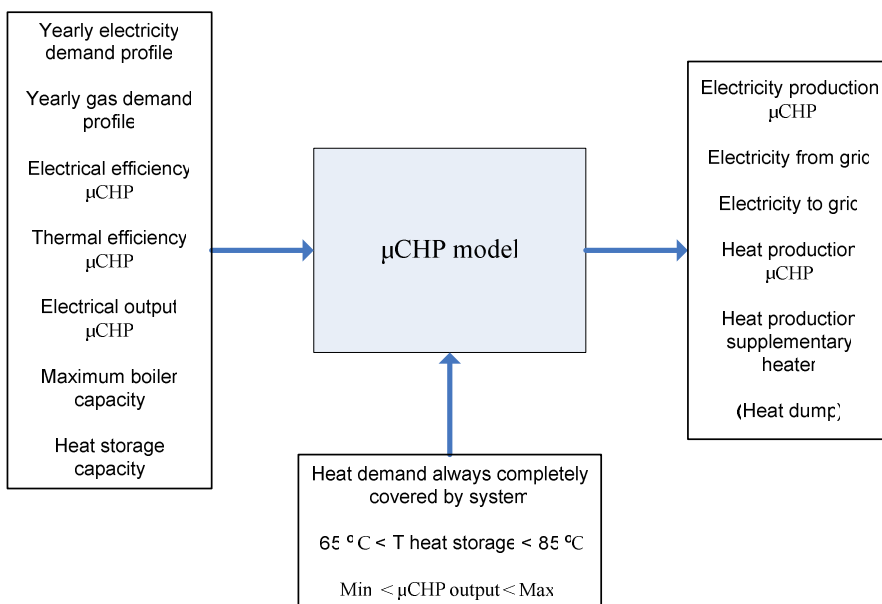

**Figure 16:  $\mu$ CHP model input, outputs and constraints**

<sup>36</sup> Taking into account that offered capacity has to be dispatched the whole hour before the hour the bid is made and APX price is determined.



Assuming the VPP operator wants to maximize its profits and also wants to prevent heat dump as much as possible, the following VPP operating strategies were modelled.

#### *Stirling VPP control strategy*

The VPP control is an alternative operating mode next to the normal heat-led operating strategy of the  $\mu$ CHP. So first the normal (heat-led) operating strategy is described and then the specific VPP control strategy.

All household heat demand is subtracted directly from the heat storage (water tank). The temperature of the water tank should be between 65°C and 85°C to meet tap water and high temperature space heating demand (Van der Laag and Ruijg, 2002). A water tank of 200 l is used in the model. If the temperature of the vessel goes below 65°C, the Stirling will turn on and will add heat to the storage until the water has reached a temperature of 85°C. Electricity produced in excess of the electricity demand is fed into the grid and can be used to trade on the APX. The supplementary boiler turns on if the heat demand exceeds the available heat (> 65°C) in the storage.

With VPP control the  $\mu$ CHP produces at maximum power output during the hours identified in 4.2.2 if the temperature in the water tank goes below 65°C (until 85°C) and no operation outside those hours to prevent that exported electricity is traded at a price lower than the SRMC.

#### *SOFC VPP control strategy*

For the SOFC a different operating strategy is chosen to prevent start-stop operation which degrades performance and lifetime severely as explained in paragraph 3.1.1. The SOFC is therefore operated as a base/intermediate load plant between 30-100% of its maximum thermal and electrical power output. If more heat is produced than is demanded, the excess heat will be stored the water tank (200 l). If the storage capacity limit is reached (85 °C), the excess heat will be dumped. If the SOFC does not produce enough heat to cover demand, heat will be subtracted from the heat storage, and if the temperature in the heat storage goes below 65°C, heat will be provided by the supplementary boiler.

The same VPP control strategy as with the Stirling would lead to a large heat dump (436 kWh for a household with average energy demand). So a slightly different VPP control strategy is used. Maximum possible  $\mu$ CHP power output given the heat demand and heat storage capacity during the hours identified in 4.2.1, and minimum output in the other hours.

#### *Other model assumptions (see reflection for critical discussion):*

- All heat produced by the  $\mu$ CHP can be fully used by the household;
- No gas consumption of  $\mu$ CHP units during start-up;
- Negligible heat losses from hot water tank;
- No parasitic load of  $\mu$ CHP system;
- Thermal and electrical efficiencies are assumed to be linearly interrelated<sup>37</sup>;
- Efficiencies are assumed to be same as with rated output during start-up/shut-down of the  $\mu$ CHP and during part-load operation.

#### *Model validation*

To validate the model, the outcomes of the model are compared with the outcomes of other models. The assumptions of the other models/field tests were used as much as possible as input for the developed model to make a good comparison possible. In tables 12 and 13 the percentage deviations of the outcomes of the model from the outcomes of the other models are presented (see appendix E for exact figures). The model outputs of Houwing (2009) and Ruijg and Ribberink (2004b) were chosen as reference to compare the model with, because exactly the same demand profiles were used as input and also largely the same control strategy is used.

#### *Validation Stirling model*

In table 12 the deviations of the outcomes of the model with the outcomes of the model of Houwing are presented. It can be seen that the model produces less electricity and exports significantly less. That the model produces less electricity than Houwing's model can be almost completely explained by the fact that the supplementary boiler is

---

<sup>37</sup> If power output is at 30% of the maximum power output, the thermal output is at 30% of the maximum thermal output

used more in the model<sup>38</sup>. This implicates (given the heat-led operating mode) that the Stirling is operated less and thus also produces less electricity. This can also partly explain why there is less export. The supplementary boiler in the model is used more because the boiler in Houwing's model is operated within a smaller heat storage temperature range<sup>39</sup>. That the model exports much less could be because the Stirling is operated at different times than in Houwing's model and the  $\mu$ CHP production times therefore matches more with electricity demand times. However there is no insight into operating times of the  $\mu$ CHP in the model of Houwing so this explanation could not be verified. For the economic viability calculations less production implicate less electricity sales, and less export implicates fewer revenues from electricity trade.

**Table 12: Deviation of outcomes Stirling engine model with outcomes of Houwing's model (see also appendix E)**

	<i>Deviation from Houwing model</i>
Produced electricity $\mu$ CHP (%)	-7
Imported electricity (%)	-9
Exported electricity (%)	-30
Produced heat $\mu$ CHP (%)	-7

#### *Validation SOFC model*

In table 13 the deviations from the output of the model with the outputs of the model of Ruijg and Ribberink (2004b) are presented. The same deviations as with the Stirling model can be seen. Again the supplementary boiler is operated slightly more in the model which leads to less electricity production by the  $\mu$ CHP in a heat-led operating mode. This can be explained by the fact that Ruijg and Ribberink assume a higher thermal efficiency which means a larger part of the heat demand can be fulfilled by the  $\mu$ CHP without the use of a boiler. Less export could be explained by different operating times of the  $\mu$ CHP. However the author has no insight into the exact operating times of the SOFC from the model of Ruijg and Ribberink so this could not be verified.

**Table 13: Deviation of outcomes SOFC model with outcomes of Ruijg and Ribberink (see also appendix E)**

	<i>Deviation from Ruijg and Ribberink's model</i>
Produced electricity $\mu$ CHP (%)	-7
Imported electricity (%)	-11
Exported electricity (%)	-17
Produced heat $\mu$ CHP (%)	-7

#### ***Possible VPP revenues from trade on APX***

The above described model was used to calculate the outputs of individual  $\mu$ CHP units which were then aggregated to create the output of a VPP consisting of 100,000 units. The model outputs are based on 9 different household electricity and heat demand profiles (see table 14). Based on Nuon Retail data per segment a proportion of the total households is assumed (indicated as percentage). Six of the segments are based on measured 10 min. electricity and gas demand profiles (the so called EBA-patterns) which were obtained from ECN<sup>40</sup> and University of Amsterdam. For the other three segments (for which no measured data were available) demand profiles were created with the profile methodology combined with the retail data<sup>41</sup> (see appendix D for more details and explanation of methodology).

The VPP operator will bid the expected exported electricity into the APX at zero price to ensure that all the exported electricity is sold. The revenues were calculated by multiplying the weighed average<sup>42</sup> export per time

<sup>38</sup> Exactly 7% of Houwings  $\mu$ CHP heat production is produced by the supplementary boiler in the model. See Appendix E

<sup>39</sup> In the model the boiler provides heat to the storage from 65-85°C. In Houwing's model this range is 53-58 °C.

<sup>40</sup> A Dutch energy research institute.

<sup>41</sup> The profile methodology is used to forecast energy demand of non-measured customers. For each year, 15 minute fractions of the total yearly electricity and gas demand are determined by Ecofys based on measured energy demand of multiple households which are then aggregated and averaged.

<sup>42</sup> The export per time unit per household segment multiplied by the percentages assumed in table 16

unit with the (forecasted) electricity price per time unit and with the number of households. Forecasted electricity wholesale prices by Nuon Risk Management were used for the calculations. The outcomes of the calculations are presented in tables 15 and 16 (see appendix D for more details).

**Table 14: Yearly electricity and heat demand per household segment and assumed proportion of total households under VPP control (yellow marked segments are created with profile methodology)**

		H (kWh)		
		Low	Interm.	High
E (kWh)	Low	1339	1770	1586
		4615	12592	17447
		20%	10%	5%
	Interm.	2148	3262	2278
		6146	12794	15010
		10%	15%	10%
	High	5223	4638	4855
		5586	18020	22556
		5%	10%	15%

**Table 15: Possible APX revenues Stirling VPP 100,000 units (in million €)**

2010	2011	2012	2013	2014	2015	2016	2017	2018	2019	2020	2021	2022	2023	2024
7.0	7.2	8.3	8.9	8.6	10.4	10.9	10.3	11.7	11.8	11.2	12.8	12.9	12.5	14.2

**Table 16: Possible APX revenues SOFC VPP 100,000 units (in million €)**

2013	2014	2015	2016	2017	2018	2019	2020	2021	2022
18.1	17.8	20.4	22.0	21.3	22.9	24.0	23.2	25.1	26.2

#### 4.2.2 NPV, IRR and discounted payback period

To calculate the NPV, IRR and discounted payback period (at 8% discount rate) all cost and revenues should be estimated as well as the total investments costs. Only the cash flows that can be directly linked to the system were taken into account. The following cash flows were used to calculate the economic indicators:

- Incoming cash flows: revenues from electricity trade and electricity and heat sales
- Outgoing cash flows: fuel costs, maintenance costs, and APX trading costs, gas and electricity distribution costs, energy tax<sup>43</sup>, and VAT<sup>44</sup>

Because the VPP operator is a company, a corporate tax of 25.5% has to be paid over the positive<sup>45</sup> earnings before interest and tax (EBIT) (see appendix C for further details). The outputs of the model from the previous paragraph was used to calculate most revenues and costs based on the same household energy demand profiles. See appendix C for all assumptions on inputs and cash flows. In table 17 the values of the economic viability indicators based on the expected values are presented.

**Table 17: NPV, IRR and discounted payback period based on expected values**

	Stirling VPP	SOFC VPP
NPV (mil €)	-76	-227
IRR	5.3%	-0.92%
Discounted payback period (years)	>15	>10

<sup>43</sup> Only energy tax on electricity supplied to the household and gas used as an input for the  $\mu$ CHP is calculated. Electricity sold on the APX is not considered a supply in the Law on environmental taxes. See paragraph 5.2.3 for explanation.

<sup>44</sup> Value added tax: a tax levied on sold products.

<sup>45</sup> If the focus is only on the specific investment and not on the company as a whole, no corporate tax has to be paid for a negative EBIT.

Based on these figures a commercial party would never invest in such a system without some form of government support. The figures however only give a point estimate and do not take into account the uncertainty of the input variables. Therefore Monte Carlo simulations were performed with Crystal Ball (an Excel add-in) to determine the likelihood of a positive NPV, an IRR higher than 8% and a discounted payback period of less than the lifetime of the system. A Monte Carlo simulation selects random numbers of input variables (within a specified range with a specified probability distribution) to calculate the NPV, IRR and discounted payback period. For all model input variables an expected value (base case), a minimum value and a maximum value were assumed based on analysis of historical data as far as available and otherwise have been estimated (see appendix F for all assumptions and historical data analysis). Based on these values a triangular probability distribution was assumed for all variables and 100,000 runs with the model were performed to calculate the certainty levels of the output indicators. Below, the results are presented and discussed.

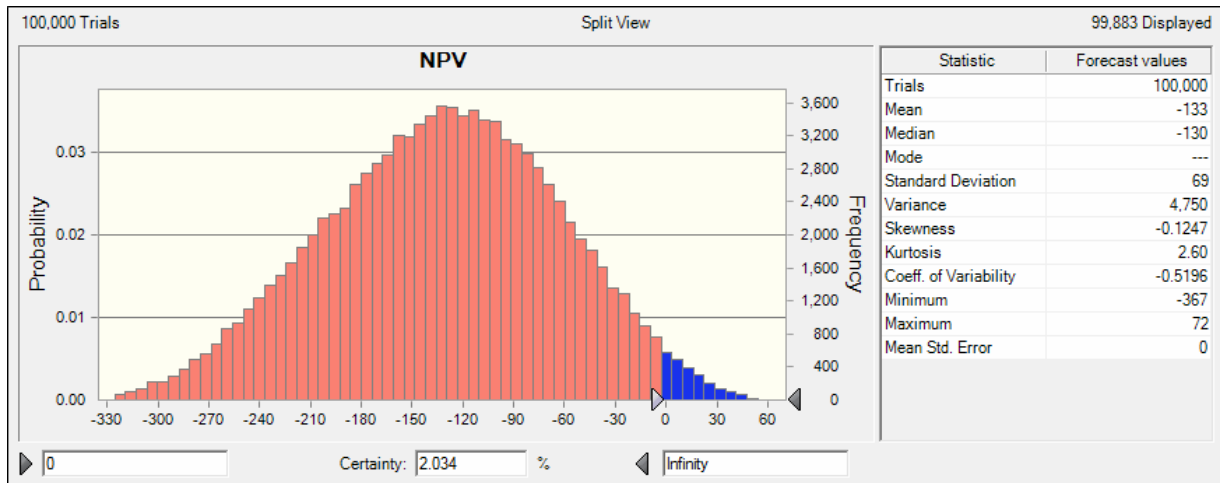

Figure 17: Monte Carlo simulation NPV outputs Stirling VPP

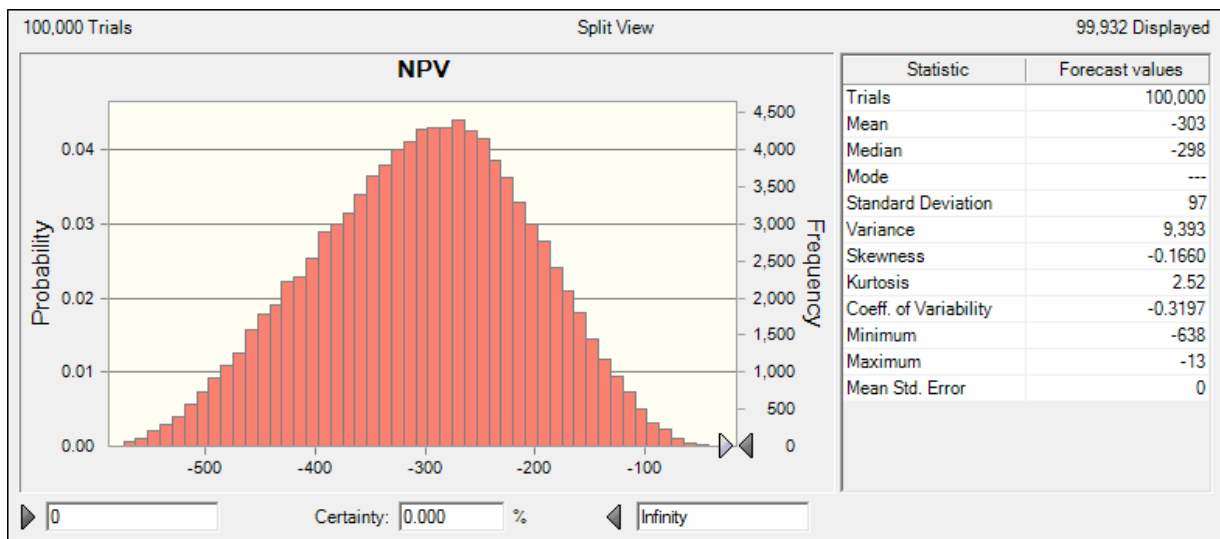

Figure 18: Monte Carlo simulation NPV outputs SOFC VPP

Similar probability distributions were made for the IRR and the discounted payback period. The results presented in table 18.

**Table 18: Certainty levels and mean values of IRR and discounted payback period**

	<i>Stirling VPP</i>	<i>SOFC VPP</i>
Certainty level IRR > 8%	2.1%	0.0%
Mean value (stand. dev.)	3.8% (1.8)	-3.2% (2.3)
Certainty level discounted payback period < lifetime	2.0%	0%
Mean value (stand. dev.)	>15 yr	>10 yr

From table 18 and figures 17 and 18 it can be read that it is for 2% or 0% certain that the NPV is positive, the IRR is higher than 8% and that the discounted payback period is lower than the lifetime of the systems. It can therefore be concluded that both a Stirling VPP and SOFC VPP are not economically viable under current institutional conditions and economic assumptions.

#### 4.2.3 Sensitivity analysis to determine critical parameters

From the previous paragraph it was concluded that both the Stirling and the SOFC VPP are not economically viable. It is therefore important to understand which parameters are most critical for the economic viability, so the best opportunities to improve the economic viability of the VPP system can be identified. A single factor sensitivity analysis was therefore performed. Based on realistic minimum and maximum values (same as for Monte Carlo simulations) a tornado diagram was constructed in which the influence of a single variable on the NPV compared to the base case assumptions is shown (see appendix F). The IRR and discounted payback period are determined completely by the cash flows, the investment costs, and discount rate (the parameters on which the NPV is determined), so the outcomes of the NPV sensitivity analysis are also valid for these indicators. In figures 19 and 20 the results are presented.

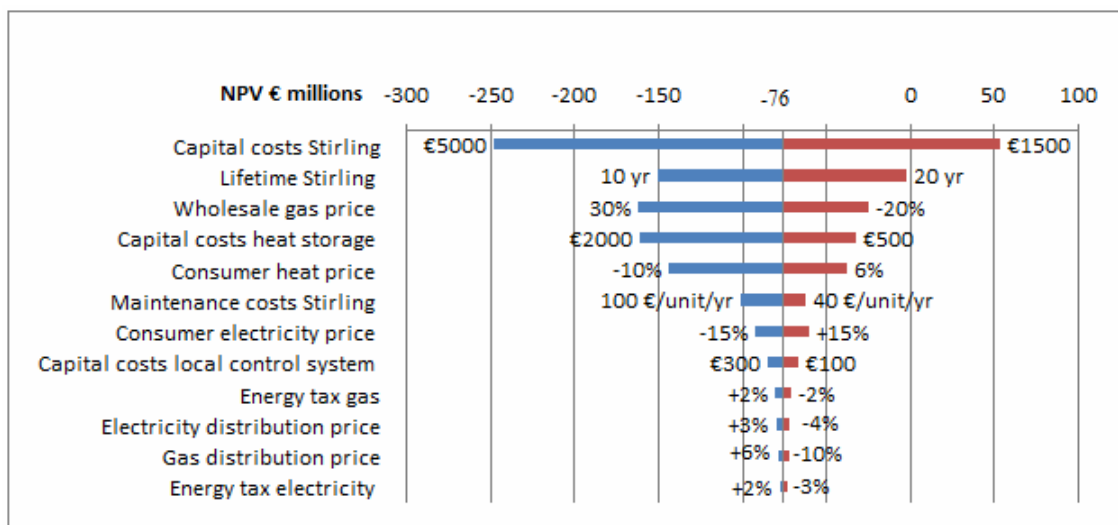

**Figure 19: Tornado diagram Stirling VPP**

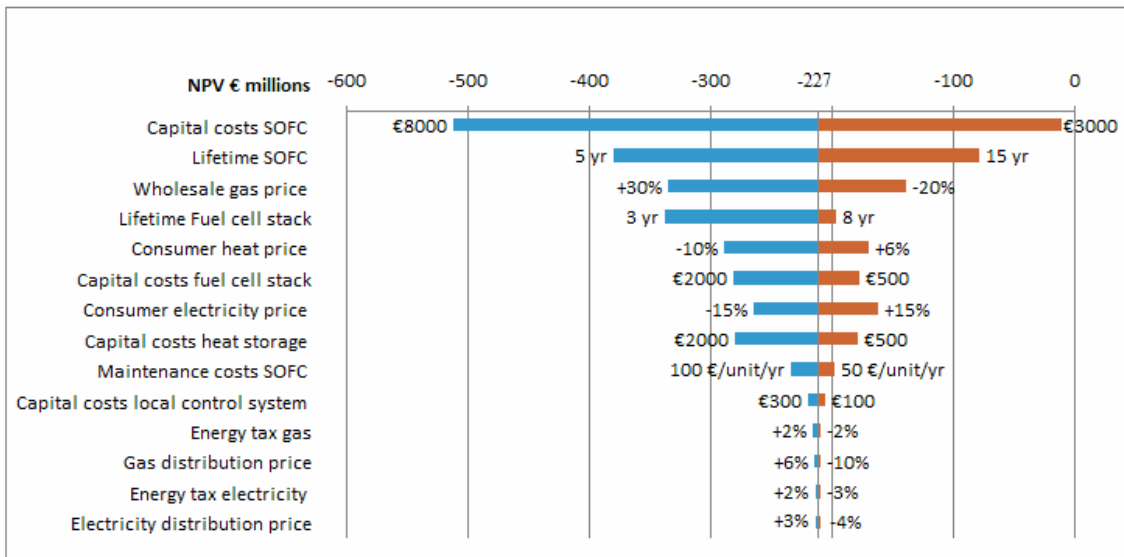

**Figure 20: Tornado diagram SOFC VPP**

The diagrams can be read as follows. If the capital costs of the Stirling engines would be €5000, the NPV would be, ceteris paribus, €-247 million instead of €-76 million in the base case where the capital cost is assumed to be €3000.

The most critical parameters for both VPP types are the capital costs of the  $\mu$ CHP, the lifetime of the  $\mu$ CHP, the wholesale gas price and the consumer heat price. The capital costs of the  $\mu$ CHP constitute the largest part of the total capital costs and have the highest uncertainty so that why it has by far the biggest influence on the NPV and the other indicators. If the lifetime of the system increases, there are more years to recover the capital costs. Since most cash flows are positive this explains why it has such a large influence. The wholesale gas price has such a large influence because of the high uncertainty and because it is the biggest cost. The consumer heat price has such a large influence, despite the relatively small uncertainty bandwidth, because the heat sales are the biggest revenue.

For the Stirling VPP also the capital costs of the heat storage system has a large influence since it has a relative high contribution to the total capital costs. The lifetime of the fuel cell stack can have a large influence when it is shorter than 5 years because then more than once during the lifetime of the system a maintenance expense of €100 million is added to the cash flow calculations. The increase of the stack lifetime has a lot less influence because the number of times the stack has to be replaced stays the same with a stack lifetime between 5 and 10 years. If the lifetime of the stack would be 10 years like the rest of the system this would greatly improve the NPV.

#### 4.2.4 NPV break even values of most critical parameters

Based on the most critical parameters identified above, the break even values of these parameters have been calculated assuming all the other variables constant, to see under which conditions a NPV equal to zero can be expected. This gives an indication of how much the most critical parameters must change compared to the expected values for the sum of the cash flows to be equal to the investment costs. The IRR and discounted payback period are calculated based on the same input variables and will therefore have similar break even values. The break even values and/or percentage are presented in tables 19 and 20.

**Table 19: Change of value of single parameters needed to break-even with the investment cost for a Stirling VPP**

	NPV break even value	NPV break even percentage
Capital costs Stirling	€2171	-27.6
Lifetime Stirling	20 yrs	+33%
Wholesale gas price	-	-26.5% (in all years)
Capital costs heat storage	€170	-83%
Consumer heat price	-	+10.2% (in all years)

**Table 20: Change of value of single parameters needed to break-even with the investment cost for a SOFC VPP**

	<i>NPV break even value</i>	<i>Percentage change</i>
Capital costs SOFC	€2455	-51%
Lifetime SOFC	17 yr	+70%
Wholesale gas price	-	-75% (in all years)
Lifetime fuel cell stack	-	-
Consumer heat price	-	+36.5% (in all years)

From tables 19 and 20 it can be concluded that significant changes are needed in the critical parameters for the Stirling VPP to break even. For the SOFC even larger changes are needed to break even. No break even values for the fuel cell stack lifetime could be calculated because the costs can only be deducted during the lifetime of the system (10 yr). So if the lifetime of stack would be higher than ten years, it does not have any effect on the NPV any more. With a stack lifetime of ten years or higher the NPV is €-159 mil.

### 4.3 Other potential costs and benefits

In the above calculations not all costs and benefits of the system were taken into account. A detailed quantitative valuation of these costs and benefits falls outside the scope of this research but should be further researched to determine whether it would be socially beneficial to implement a  $\mu$ CHP VPP. In the table below, a qualitative description of these costs and benefits is given for the most important actors.

**Table 21: Other potential costs and benefits of a  $\mu$ CHP VPP system**

	<i>Society/government</i>	<i>VPP operator/energy company</i>	<i>Network operators</i>	<i>Households</i>
<b>Potential other benefits</b>	Reduction of CO <sub>2</sub> emissions (see chapter 6, Van der Laag and Ruijg, 2002)	Avoided expenditures on CO <sub>2</sub> emission rights (see chapter 5)	Reduction of network (peak) load (ECN and Gasunie, 2006; Peacock and Newborough, 2007)	Share in trade profits
	Reduction of primary energy use (see chapter 6, Van der Laag and Ruijg, 2002)	Income from lease and maintenance contracts with households and capture of clients ( <i>in scenario 1</i> ) (Smaardijk et al., 2005)	Reduction of network losses (IEA, 2002; Mott MacDonald, 2004)	Reduction of energy costs ( <i>in scenario 1</i> ) (Van der Laag and Ruijg, 2003)
	Higher security of electricity supply (Abu-Sharkh et al., 2006).	Avoided investments in peak power plants	Avoided investments in network capacity (Mott MacDonald, 2004; Papaefthymiou et al., 2008)	
		Higher gas sales		
<b>Potential other costs</b>	(extra) Tax expenditures to support $\mu$ CHP and VPP system	No or part-load operation of existing central power plants during $\mu$ CHP export	Less income from electricity distribution	Higher gas bill ( <i>in scenario 1</i> )
		Less revenues from electricity sales ( <i>in scenario 1</i> )	Possible network adjustments to accommodate $\mu$ CHP	Expenditures for purchasing or leasing the $\mu$ CHP system ( <i>in scenario 1</i> )
				Partial loss of control over $\mu$ CHP output

				Loss of space
--	--	--	--	---------------

#### 4.4 Conclusions economic viability $\mu$ CHP VPP

An economic viability analysis of the  $\mu$ CHP VPP was performed on the basis of two scenarios:

1. The  $\mu$ CHP is purchased/leased by the household and placed behind the customer meter and the VPP operator only invests in control systems and heat storage;
2. The  $\mu$ CHP VPP is considered to be an alternative for a centralised CHP with district heating system and the VPP operator finances and places the  $\mu$ CHP system before the customer meter. This could be an interesting option because a  $\mu$ CHP VPP can also be applied in existing houses and rural area without additional costs in contrast to a district heating system.

It can be concluded that scenario 1 is not an economically viable option for the VPP operator because for both the Stirling and SOFC VPP, the short run marginal costs (SRMC) and the levelized costs of electricity (LCOE) are higher than the wholesale electricity price for the largest part of the year. This means that the operational and capital costs can not be recovered with electricity trade. The SRMC in this scenario is equal to the consumer electricity price (including energy tax and VAT) because this is what the VPP operator will need to pay for the exported electricity that can be traded.

In scenario 2 the operational costs of both VPP types can be covered by both the retail price and the wholesale price, but because the LCOE are higher than both prices most of the year, the capital costs can not be recovered. So it can be concluded that a  $\mu$ CHP VPP as electricity only power plant is not economically viable in the long run.

As a basis for the analysis the commercial activities for which conventional centralised power plants are commonly used were taken as a starting point. These power plants are operated either as base load, intermediate load, or peak load plants. A Stirling VPP is not suitable for base and intermediate load operation because this would lead to a large heat dump for most households. With a peak load operation the capital costs of the system can not be recovered with electricity sales and trade.

A SOFC can in principle be operated in any operating mode without dumping heat. However the LCOE are higher than the retail and wholesale electricity price most of the year and therefore the capital costs can not be recovered with electricity sales and trade.

The most common indicators used to determine the economic viability of a system by investors are the net present value (NPV), the internal rate of return (IRR) and the discounted payback time. Since it was concluded that scenario 1 is not a viable option, these indicators were only calculated for scenario 2. Based on the expected values of all the input variables the NPV was negative, the IRR smaller than the discount rate (8%) and the discounted payback period was higher than the lifetime of the system. So the systems are not economically viable based on the expected values of the input variables.

To include uncertainty of the input variables in the calculations, Monte Carlo simulations were performed. The outcomes show that for the Stirling VPP it can be said with 2% certainty that the NPV is larger than zero, the IRR is higher than 8%, and the discounted payback period is less than 15 years. For the same indicators the certainty level was 0% for a SOFC VPP.

The factors that influence the economic viability indicators the most are:

- the capital costs the of the  $\mu$ CHP unit
- the lifetime of the  $\mu$ CHP
- the wholesale gas price
- the consumer heat price

With a significant change of these parameters, the Stirling VPP can break even. Because the NPV of the SOFC VPP is very negative, these parameters need even bigger changes for the system to break even.

Not all the potential costs and benefits were included in the calculations because of time limitations. These other potential cost and benefits were identified based on literature and own research (see table 21) It could be that the



overall cost-benefit balance is positive for society and this should be further researched with a social cost-benefit analysis.

In general it can thus be concluded that a  $\mu$ CHP VPP as an electricity only plant is not an economically viable option in the long run and that under current institutional conditions and economic assumptions an investment in a  $\mu$ CHP VPP is not economically viable.

*Next...*

The system is technically feasible, but economically not viable under current economic and institutional conditions. Therefore, in the next chapter the impact of institutional environment on the economic viability and technical feasibility will be evaluated.

## 5 The institutional environment and the impact on the feasibility and viability of a $\mu$ CHP-VPP

The institutional environment can put constraints on the VPP system but it can also enhance the implementation of the system. It is therefore important to understand the institutional context and how it influences the technical feasibility and economic viability of the  $\mu$ CHP VPP. The following research questions will be answered in this chapter:

*What is the impact of the institutional environment on the technical feasibility and economic viability of the  $\mu$ CHP VPP?*

- *What is the current institutional environment of the  $\mu$ CHP/VPP?*
- *What changes are expected in this environment?*
- *How does this environment impact the technical feasibility of a  $\mu$ CHP VPP?*
- *How does this environment impact the economic viability of a  $\mu$ CHP VPP?*

First, a framework as a basis for the institutional analysis will be described in 5.1. The current institutional environment and expected changes in that environment are discussed in 5.2. Then, the impact on the feasibility and viability of the  $\mu$ CHP VPP is analyzed in 5.3 and 5.4. Last, conclusions about the impact of the institutional environment on the  $\mu$ CHP VPP will be drawn in 5.5. In appendix G, a more detailed discussion of the institutional environment can be found.

### 5.1 Introduction and framework as basis for analysis

Institutions are needed to coordinate behavior of the parties involved in a complex system like the VPP. Institutions are defined by Koppenjan and Groenewegen (2005, p. 245) as: “*Durable sets of agreements between parties that are part of a complex (technological) system, which have the form of formal and informal rules and organizational arrangements.*”. The framework that will be used as a basis for the institutional analysis is presented in figure 21. Institutions can be categorized in four layers (Koppenjan and Groenewegen, 2005) on the basis of which the current and expected institutional environment will be described and evaluated in relation to  $\mu$ CHP/VPP. This evaluation will then be combined with the analyses from chapters 3 and 4 to determine the impact on the technical feasibility and economic viability. Only layers 2 - 4 will be used for this analysis, because the actors themselves do not have a direct impact on the feasibility and viability but only indirectly via the institutions in the layers above they can create or influence. In chapter 6 the informal institutions will also be used to derive criteria for comparing the  $\mu$ CHP VPP with existing systems.

### 5.2 Institutional environment of the $\mu$ CHP/VPP

On the basis of the four layers, the current institutional environment and expected changes in this environment will be discussed and evaluated and will be used as a basis for the analysis of the impact on the feasibility and viability of the  $\mu$ CHP VPP.

#### 5.2.1 Layer 1: Actors

Based on the definition and description of the  $\mu$ CHP VPP system in chapter 2, the main involved parties can be identified. This will be used to describe the institutional arrangements in layer 2 and the informal institutions in layer 4. The main actors are: (1) households that will host  $\mu$ CHP units, (2) energy companies that will operate the VPP and will lease, rent or sell  $\mu$ CHP to households, and (3) DSOs that will possibly need to take measures to accommodate  $\mu$ CHP into their grids and need to place meters that can register import and export of electricity. Also the government will be involved in case regulations need to be changed and/or other support is needed.

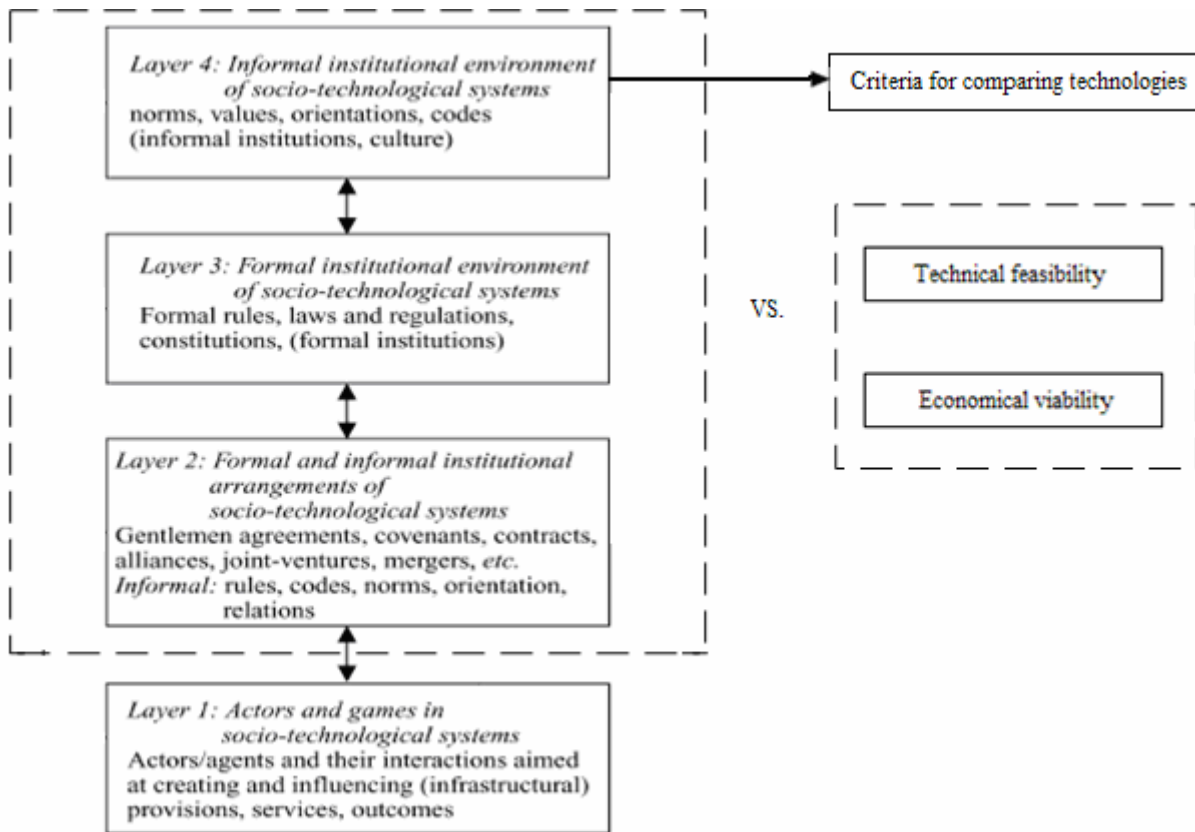

**Figure 21: Framework based on the four layer model by Koppenjan and Groenewegen (2005)**

### 5.2.2 Layer 2: Institutional arrangements between the actors

The above discussed actors have arrangements with each other, which will be shortly described below.

Households have bilateral contractual arrangements with electricity and gas retailers (not necessarily from the same energy company) for the supply of electricity and gas. They are free to choose their retailers and can switch from retailer within 30 days as is arranged in article 95m (7) of the Dutch Electricity law 1998 (Staatsblad, 1998).

Households are not free to choose their DSO, but are bound to the DSO that manages the network in the area they live. Because the DSOs have a monopoly position, the tariffs they charge for their services are regulated by the Energy chamber of Dutch competition authority NMa as arranged in paragraphs 5 and 6 of the Electricity law. The households have to pay the DSO for connection, transport and system services as is arranged in the Tariff Code electricity (Energiekamer (2008b)).

Since the  $\mu$ CHP is considered to be an alternative for the boiler, it is expected that the finance and maintenance arrangements shall be the same as with traditional boilers. Currently the three main finance and service arrangements that are used for boilers in the Netherlands are (Smaardijk et al., 2005):

1. Purchase from and installation by a boiler supplier and possibly also a maintenance contract with the same supplier
2. Purchase from a supplier and the installation and maintenance is performed by the household itself or by an installation company.
3. Lease and maintenance contract with an energy company.

Given the high initial investment costs of  $\mu$ CHP units, it is very likely that most households would prefer the last option.

### 5.2.3 Layer 3: Formal institutions

Next to specific arrangements between the actors, higher level formal institutions exist that apply to all actors. For VPP no regulation yet exists. In the Grid Code (DTe, 2007) some provisions are made for generators connected to

the low voltage grid and there is a proposal to change the Grid Code by the Dutch DSOs (Enbin, 2008). An amendment of the Electricity law (Ministry of EZ, 1998) has been proposed to include  $\mu$ CHP in the feedback tariff scheme (First Chamber, 2008). Furthermore a subsidy scheme for  $\mu$ CHP is currently available and a proposal for a heat law has been approved by the First Chamber of the Dutch parliament. Regulation that can have an impact on  $\mu$ CHP and VPP are the Law on environmental taxes and the CO<sub>2</sub> emission trading scheme. All these regulations and possible changes will be discussed and evaluated

#### ***Regulation related to technical aspects of micro-CHP/VPP***

Small consumers have to notify the DSO before feeding back electricity to the grid (art. 2.1.5.1, Grid Code). If an installation feeds electricity back to grid it has to comply with the requirements in paragraph 2.4 of the Grid Code. These requirements mainly relate to protection, reconnection, behavior, grounding and power factor of small generators. For  $\mu$ CHP units connected to the grid with power electronics only a limited amount of provisions are. See appendix G for detailed overview of the requirements.

A proposal has been made by Enbin (association of Dutch DSOs) to align the Grid Code with the European norm CENELEC EN 50438: “Requirements for the connection of micro-generators in parallel with public low-voltage distribution networks” that lists requirements for micro-CHP connecting to low voltage networks. This proposal simplifies the regulation and connection of  $\mu$ CHP on Dutch LV grids. The most important proposed changes are that the DSO does not need to be notified beforehand on feeding back electricity by small consumers, the protection requirements of power electronics converters will be equal to those of synchronous generators, and the thresholds and disconnection times of the units will be changed. See appendix G for details on all proposed changes. This proposal has not yet been implemented or decided on by the Dutch energy regulator.

#### ***Regulation related to economic aspects of micro-CHP/VPP***

There are a number of regulations or proposed regulations that could impact the economic viability of the  $\mu$ CHP VPP. These will be discussed below.

#### ***Subsidy***

As of September 2008 a subsidy scheme for sustainable heat in existing housing for the period 2008 - 2011 has been implemented (SenterNovem, 2008). The systems for which a subsidy can be received by private home owners or housing associations are heat pumps, solar boiler and  $\mu$ CHP units. A subsidy of €4000 will be available for 10.000  $\mu$ CHP units. The subsidy will be revised on a yearly basis depending on market developments. The first  $\mu$ CHP units (Stirling) are expected to enter the Dutch market in 2010 (Remeha, 2008) and the first possibility to apply for a subsidy in 2010 will be on September 1<sup>st</sup>.

#### ***Feedback tariff***

The feedback tariff for sustainably produced electricity (up to 3000 kWh) by small consumers is arranged in article 31c of the Electricity Law 1998. A proposal to amend the Electricity Law has been made to also include electricity that is produced with non-sustainable generation (like  $\mu$ CHP) in the feedback tariff scheme and to increase the feedback tariff threshold from 3000 kWh to 5000 kWh as amended by Samson and Hessels (2008) (First Chamber, 2008). The First Chamber still has to approve this proposal before it will become effective, but it is expected that the amendment will be approved in the next voting round<sup>46</sup>.

When the amendment becomes effective this means a household will only have to pay for the net imported electricity (so in principle it will get the same tariff (including taxes) for the exported electricity as it pays to the retailer up to 5000 kWh export). If more than 5000 kWh is fed back, a reasonable tariff will be paid for every kWh above the 5000 kWh. The reasonable tariff is defined as 70% of the retail tariff (excluding taxes) or 70% of the average APX price of the past 12 months (NMa, 2006). If the household exports more electricity than it imports, it will receive a reasonable tariff for every kWh that is exported more than is imported and the rest of the fed back electricity is settled for the normal feedback tariff (NMa, 2006).

---

<sup>46</sup> See <http://www.eerstekamer.nl/nieuws> for the latest developments.

### *Heat law*

The First Chamber has approved the proposal for a heat law by Ten Hoopen and Samsom (First Chamber, 2009). This means the law will become effective as soon as it is published in the public journal. The proposed heat law entails that heat suppliers should have license and that the heat tariffs shall be regulated by the Dutch competition authority NMa (Ten Hoopen and Samsom, 2008). The tariffs shall be based on the total costs a consumer would incur if the heat would have been supplied with gas. Currently the heat price is calculated by a formula set by EnergieNed, the Dutch organisation of energy suppliers, brokers and producers. It is likely that the regulator will have stricter price calculations and that the heat price will become lower.

### *Energy tax<sup>47</sup>*

In a non- $\mu$ CHP situation an energy tax is levied<sup>48</sup> for the supply of gas and electricity through a distribution network and the energy supplier has to pay this tax (Law on environmental taxes, article 50 (1)) (Staatsblad 1994, 925). This tax is settled with the household via the electricity and gas price.

When a household produces heat and electricity with a  $\mu$ CHP, in principle an energy tax has to be paid for the gas (to the supplier which is taxable party) that is used for the electricity production. An exemption for this tax is possible on the basis of articles 64(1) and 64(2) (Law on environmental taxes) that state that no energy tax has to be paid if the supplied gas is used in an electricity production installation with an electrical efficiency of at least 30%. In article 22(2) of the 'Implementation decision environmental taxes' an additional provision for a minimum electrical power output of the installation of 60 kW is stated (Secretary of State of Finance, 1994a). So a  $\mu$ CHP will never fall under this exemption since the power output will be in the range of 1-5kW.

If a household consumes the electricity produced by a  $\mu$ CHP, this is considered to be a fictive supply according to article 50(4) for which in principle an energy tax has to be paid by the household (which then becomes taxable) unless the electricity is produced with a CHP (article 50(5)d). An installation is considered to be a CHP if the total energetic efficiency<sup>49</sup> is at least 60% based on the lower heating values of the gas (art. 47(1)g). Both the Stirling and the SOFC fulfill this requirement, so no taxes have to be paid for the consumed electricity from the  $\mu$ CHP.

If a small consumer feeds back electricity, taxes are levied on the positive margin of the supplied electricity minus the fed back electricity (art. 50 (2)). So if the electricity export is less than the electricity import, no energy tax has to be paid for the exported electricity, just for the net electricity supplied to the household (energy supplier is taxable). When the Electricity Law amendment (First Chamber, 2008) will become effective, the tariff paid for electricity exported to the grid till 5000 kWh (if the export is less than the import) will include energy taxes and VAT. So no double taxation problem exists unless the export is larger than the import or if the export is higher than 5000 kWh (see also feedback tariff description).

However, since the exported electricity will usually be supplied by the household to an energy company, a party that is an electricity supplier itself and thus resells the electricity, no energy tax has to be paid by the household according to art. 50(3). This exemption applies only if the household gets a declaration from the energy company in which it is stated that it supplies the bought electricity via a connection to users (art. 16(1) of the Implementation regulation environmental taxes, (Secretary of State of Finance, 1994b)). So even if the export is larger than the import and the export is higher than 5000 kWh no energy tax has to be paid by the household for the exported electricity with a declaration from the energy company.

No energy tax has to be paid for electricity sold via an electricity trade platform like APX, because this is not considered to be a supply. However, an energy tax has to be paid for gas or electricity bought via a trade platform by the buyer according to article 50(4)b because this is considered fictive supply.

The specific implications of the energy tax for a  $\mu$ CHP VPP operator will be discussed in paragraph 5.4.

---

<sup>47</sup> Much of the detailed interpretations of the Law on Environmental taxes is based on personal communication with Ecolegis (2009).

<sup>48</sup> For electricity supply up to 10.000 kWh the energy tax is 0.1085/kWh and for natural gas supply with a higher heating value of 35.167 MJ/m<sup>3</sup> up to 5000 m<sup>3</sup> 0.1580/m<sup>3</sup> (Law on Environmental taxes, article 59 (1a, c)). A tax reduction of €318,62 for the supplied electricity is given per 12 months per connection. All taxes are levied on the supplier which is passed on to the consumer.

<sup>49</sup> The sum of the electrical efficiency and two thirds of the thermal efficiency.

### *CO<sub>2</sub> Emission trading scheme (ETS)*

As a part to attain the Kyoto protocol goals, the EU introduced the European CO<sub>2</sub> emission trading scheme (ETS) based on Directive 2003/87/EC (European Parliament and Council, 2003). It is a cap and trade scheme in which all Member States set a cap to the total allowable emissions for the installations mentioned in Annex I from the Directive. For the energy sector all combustion installations with a rated heat output higher than 20 MW fall under this scheme and they need to have a permit to emit CO<sub>2</sub>. This means all large power plants and CHP plants fall under the ETS and  $\mu$ CHP units do not. Currently 90% of the emission allowances are given free of charge to the operators of the installations (grandfathering principle) (art. 10 of the Directive).

However a proposal has been made to amend the Directive in which the emission allowances for the power sector will be fully auctioned (European Commission, 2008b). The proposal has not yet been adopted by the Council and the Parliament, but the Council has indicated that they welcome the direction of the proposed changes, in particular the auctioning of emission allowances (Europa press releases, 2008). The Dutch government has advocated for these changes and therefore fully supports them (Ministry of VROM, 2007).

See appendix G for a more detailed description of the scheme and proposal. In paragraph 5.4 the implications for a  $\mu$ CHP VPP will be discussed.

### *5.2.4 Layer 4: Informal institutions*

The above described institutions and arrangements are created by the actors from layer 1. These actors use their values and norms as a basis for making these institutions and arrangements and it is thus relevant to have insight in them.

#### *Values, goals and norms of the Dutch government*

The Dutch government is very focussed on sustainability and energy savings and strongly believes in reducing the effects on climate change and sees efficient energy use as one of the means to do that. This is reflected by the ambitious goals they have formulated in the policy documents “Clean and Efficient (“Schoon en Zuinig”): New energy for the environment” (Ministry of VROM, 2007) and “Innovation Agenda Energy” (Ministry of EZ, 2008). The main goals that are relevant for  $\mu$ CHP/VPP are:

- A reduction of greenhouse gasses (mostly CO<sub>2</sub>) by 30% compared to the emissions in 1990 (preferably also on a European level);
- A doubling of the current energy savings to 2% per year;
- 10% of the cold and heat demand in the built environment<sup>50</sup> should be fulfilled with sustainable and innovative technologies like PV,  $\mu$ CHP, and solar boilers.

The minister of economic affairs has indicated that she sees the  $\mu$ CHP as a potential replacement of the condensing boiler and not as a mini-power plant (Minister of Economic affairs, 2007). The government currently has no opinion about VPP, but from the minister’s opinion about  $\mu$ CHP it could be inferred that a VPP is not considered to be option for which support will be given at the moment. For the energy sector the government sees (central) CHP as an important means for more efficiently energy use and they are investigating the possibilities for micro-CHP in the built environment.

#### *Values of households*

Awareness on energy saving is increasing in the Netherlands as well as the concerns about climate change and the number of people that take measures to contribute to reducing climate change (Duurzaam-ondernemen.nl, 2008). A recent survey among 800 participants by TNS-NIPO has indicated that the 75% of the Dutch are willing to save more energy than they already do and that 72% are already take some measures and 21% take a lot of measures to save energy (Duurzameenergiethuis.nl, 2008). A more general trend of increasing environmental awareness, of actual measures taken to reduce environmental impact, and of the willingness to pay for measures to prevent climate change by European citizens can be seen (TNS-NIPO 2005, 2007a, 2008).

Around 80% of the Dutch households indicate that they believe their energy bill is too high and this that is an incentive to save energy (TNS NIPO, 2007b). ECN research confirms that financial considerations are the main reason for energy savings, followed by environmental concerns (ECN, 2003).

---

<sup>50</sup> This sector consists of all buildings including non-residential buildings like hospitals, sport complexes, etc.

From a survey among households the following requirements/values for their home energy supply were indicated to be important (Pehnt et al., 2006):

- Reliability
- Energy efficiency
- Low operating costs
- Low pollution
- Climate protection
- User-friendly
- Low maintenance
- Good room climate
- Low capital costs
- Low noise
- Needs little space

It is assumed that  $\mu$ CHP suppliers will make units that will fulfill these requirements; otherwise they can not compete with existing systems.

#### *Values of energy companies/VPP operator*

Most Dutch energy companies encourage energy savings as part of their corporate social responsible policies or as a company strategy (see sites of Nuon, Essent, Eneco, Delta, etc.). Some of these companies see  $\mu$ CHP as a means to increase energy savings. Furthermore the energy companies anticipate the market introduction of the  $\mu$ CHP as in 2007 the largest Dutch energy companies have signed the “Covenant Gas transition” in which they indicated to install 10.000  $\mu$ CHP test units (EnergieNed, 2007a). A more general value of commercial parties is to make profits.

#### *Values of distributed system operators*

The main values of the DSOs are to distribute electricity and gas in a safe, reliable and environmentally friendly way (see sites of Alliander, Enexis, Stedin, etc.). They also anticipate the market introduction of the  $\mu$ CHP by testing the effects of these units on their networks (see for example Alliander, 2009). From the proposal to change the Grid Code (see Regulation related to technical aspects of micro-CHP/VPP) to make connection of  $\mu$ CHP to the grid easier it could be concluded that the DSOs are not unwilling to accommodate  $\mu$ CHP units in their networks.

### **5.3 Impact of institutional environment on technical feasibility**

By combining the institutional evaluation from the previous paragraph with the analysis from chapter 3, the impact of institutions on the technical feasibility of the  $\mu$ CHP VPP will be analyzed (see figure 21).

#### *Impact of institutional arrangements between the actors*

Since households can change of supplier within 30 days, the maximum capacity of the VPP can in principle change every month. However with VPP aggregator software you can see which units are online and working (and thus how big the capacity is) before engaging in economic activities so this is not expected to be a problem.

#### *Impact of formal institutions*

$\mu$ CHP units and their protection systems should be designed to comply with the requirements of paragraph 2.4 of the Grid Code and NEN 1010 to prevent damage to the units, unsafe situations or unwanted impacts on the networks. Whether  $\mu$ CHP units comply with these requirements should be tested with (pre-) commercial units. No information about such tests is currently publicly available, however such tests were recently performed by Alliander<sup>51</sup> (‘meadow tests’).

In case  $\mu$ CHP units will be disconnected from the grid in case of under/over voltage and frequency deviations of the grid, a part of the VPP will be out of operation. However this can be detected with VPP

---

<sup>51</sup> A Dutch distribution network operator.

aggregator software and it is likely that households with  $\mu$ CHP will be dispersed over different parts of the grid, thus it is not likely this will be a big problem.

While for  $\mu$ CHP units with small synchronous generators requirements for their behaviour and output to the network are arranged in 2.4.4 of the Grid Code, almost no such requirements for  $\mu$ CHP units connected to the grid with electronic power converters are included. This means that also converter systems could be connected to the grid that produce harmonics.

According to Bozelie (2009) a number of provisions in the current Grid Code need improvement or are unclear. The unit protection requirements as laid down in article 2.4.2.3 (protection requirements for small power electronics) of the Grid Code can not guarantee the proper functioning of the low voltage network. The disconnection times and the thresholds are too low to be selective compared to the medium voltage network. The DSOs have proposed to change these disconnection times and thresholds. Also no provisions have been made for voltage rises due to electricity production by  $\mu$ CHP units.

The provisions for planning and production in the Grid Code do not apply for the total  $\mu$ CHP unit capacity in a VPP. This leads to unfair competition with central power plants because a  $\mu$ CHP VPP would have the benefits of central power plants but not the same obligations with respect to reactive power, voltage regulation, etc.

### ***Impact of informal institutions***

To match the expectations and values of the households a  $\mu$ CHP system should be reliable, reduce the energy bill, save energy, have low costs (operational + capital), be user-friendly, be compact, have low noise levels and should provide the same comfort level as a traditional boiler. Fulfilling these requirements is a precondition before a household would agree to install such system and thus is precondition for the implementation of a  $\mu$ CHP VPP.

## **5.4 Impact of institutional environment on economic viability**

From the previous chapter it was concluded that a  $\mu$ CHP VPP is not economically viable for a commercial party without government intervention. Therefore, the impact of the institutional environment on the viability shall be analyzed below.

### ***Impact of institutional arrangements between the actors***

For the  $\mu$ CHP VPP the arrangements between the VPP operator/energy company and households are the most important. Based on the arrangements discussed in 5.2.2 and the scenarios from chapter 4, an analysis was made.

#### Scenario 1

In scenario 1 the sale or lease and/or maintenance contract with the household and the feedback price can impact the economic viability of the VPP operator.

If maintenance costs are higher than anticipated and arranged in the maintenance contract with the household, it would negatively impact the economic viability. For the Stirling VPP, the maintenance costs are a relatively small contributor to the total costs of a VPP operator. For the SOFC VPP however, the fuel cell stack lifetime has a very large influence on the total costs of the system. So for the SOFC VPP, the maintenance arrangements can have a large impact on the viability.

The feedback tariff determines the SRMC of the VPP operator in this scenario and therefore has a large impact on the profitability of the VPP. It was shown in 4.1.2 that under the expected regulatory regime, the SRMC are much higher than the wholesale electricity prices.

#### Scenario 2:

In this scenario the only arrangements between household and VPP operator are electricity and heat supply contracts.

In principle the electricity retail price should be set so that it covers the long run levelized costs of electricity. However because the VPP operator operates in a competitive market this would lead to loss of market share because the LCOE of the VPP are much higher than the normal retail prices (see tables 10 and 11).

The heat price is now calculated by a formula set by EnergieNed and is based on the principle the costs for the household can not be higher than it would be when the heat would have been produced with natural gas



(“not-more-than-normally” principle). The heat price is not set higher than that, and thus limits the profitability for the VPP operator.

**Impact of formal institutions**

The possible impact of all the described formal institutions in 5.2.2 will be analyzed.

*Subsidy*

A purchasing subsidy would have no effect on the VPP operator economics in scenario 1 because the household purchases or leases the  $\mu$ CHP. For scenario 2, the subsidy would lower the capital costs for the VPP operator. Since from the sensitivity analysis it was concluded that the capital costs of the  $\mu$ CHP have the largest impact on the economic viability, it can be stated that a purchasing subsidy improves the economic viability significantly.

*Feedback tariff*

The feedback tariff only has a consequence for the VPP operator in scenario 1. A higher feedback tariff would increase the SRMC for the VPP operator and vice versa. Higher SRMC would lead to less operation hours of the VPP and thus for less revenues.

*Heat law*

The new heat law that has been approved by both chambers of the Dutch parliament will make the heat price regulated. It is likely that the regulator will have a more strict interpretation of the not-more-than-normally principle and that therefore the heat price will become lower than it was. From the sensitivity analysis it became clear that the consumer heat price is a critical factor for the economic viability so a lower heat price will have a significant impact on the viability.

*Energy tax<sup>52</sup>*

For scenario 1, two different situations can be discerned. In the first situation, where the household exports less than 5000 kWh and less than it imports, the VPP operator has to pay the retail tariff including energy tax for the exported electricity<sup>53</sup>. In the second situation, where the household exports more than 5000 kWh or more than it imports, the VPP operator has to pay a reasonable tariff without energy tax for the electricity exported in excess of 5000 kWh or the import. For the rest of the exported electricity, the normal feedback tariff including energy tax applies.

With a Stirling engine it is likely that more than 5000 kWh will be exported., but with the SOFC it is well possible and that thus no energy tax has to be paid for a part of the export.

In scenario 2, the VPP operator has to pay energy tax for the gas that is used by  $\mu$ CHP VPP and also for the electricity that is supplied to the households by the  $\mu$ CHP VPP (see figure 22). The energy tax of the electricity will be passed on to the customer via the retail electricity price. A large CHP (with an electrical efficiency > 30%) however gets a tax exemption on the gas it uses to produce electricity and heat (see figure 22).

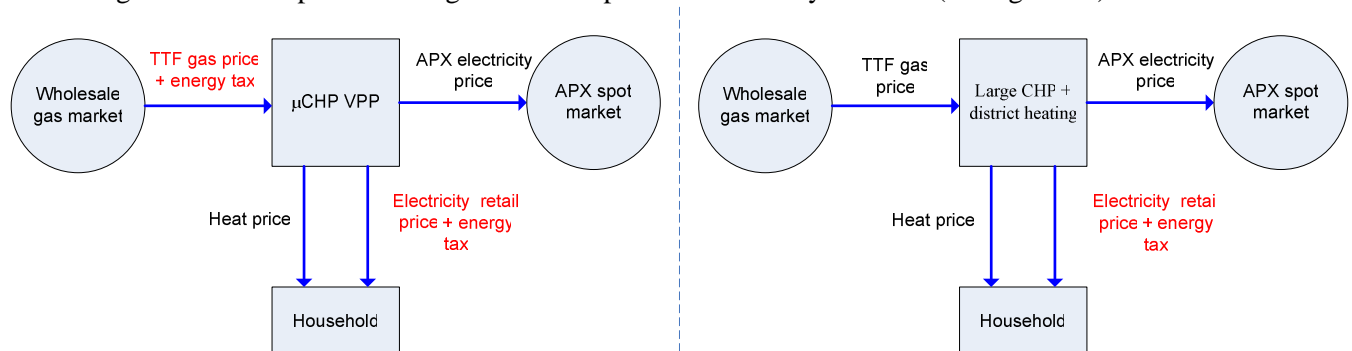

**Figure 22: Energy tax  $\mu$ CHP VPP vs. energy tax large CHP and district heating system**

<sup>52</sup> It is assumed in for this analysis that the VPP operator is also the gas and electricity supplier of the household.

<sup>53</sup> The VPP operator does not actually has to pay this, but the household does not have to pay for the exported electricity. It only has to pay for net import. Because it is assumed that the VPP operator is also the electricity supplier, this means that indirectly the VPP operator has to pay the retail tariff including the energy tax and VAT.

If the threshold of a minimum power output of 60 kW to get a gas tax exemption would not exist, the SOFC VPP would have the same gas tax exemption as large power plants. Monte Carlo simulations were run to show the impact on the economic viability. In table 22 the outcomes of the simulations are presented (100,000 runs). It is shown that the mean value of the NPV of the SOFC would become significantly less negative and that it would become more certain that the NPV is positive. This certainty level and mean value of the NPV however indicate that the SOFC would still not be economically viable if only the tax exemption would apply.

If the tax exemption would be combined with a €2000 purchasing subsidy, the certainty level of a positive NPV would go to 59% and the mean value of the NPV would be €16 million.

**Table 22: NPV SOFC base case vs. no energy tax gas**

	<i>Base case</i>	<i>No energy tax gas</i>
Certainty level NPV > 0	0%	5.9%
Mean value (stand. dev.) in million €	-303 (97)	-147 (97)

A Stirling VPP would still not fall under this exemption because it has an electrical efficiency smaller than 30%. In Germany however a gas tax exemption is given for all  $\mu$ CHP units. Monte Carlo simulations were run to show the impact on the economic viability of a Stirling VPP if such a gas tax exemption would be implemented and the results are presented in table 23. From table 23 it can be read that the impact is enormous. The certainty that the NPV will be larger than zero is significantly increased and the mean value of the NPV will become positive. Thus, the Stirling VPP has a much bigger chance of being economically viable.

If combined with a subsidy of €1000, the certainty level would become 97% and the mean value €109 million.

**Table 23: NPV Stirling base case vs. no energy tax gas**

	<i>Base case</i>	<i>No energy tax gas</i>
Certainty level NPV > 0	2%	74.6%
Mean value (stand. dev.) in million €	-133 (68)	47 (68)

#### *CO<sub>2</sub> Emission trading scheme (ETS)*

$\mu$ CHP units do not fall under the ETS while conventional power plants do. It is expected that the emission rights for the power sector will be fully auctioned as from 2013. This would mean that investing in a  $\mu$ CHP VPP would lead to costs savings compared to conventional power plants.

With the model from 4.2.1, it was calculated that per year 0.07 Mtonne CO<sub>2</sub> per can be saved with a 100,000 unit Stirling VPP and 0.12 Mtonne with a SOFC VPP of equal size. If the CO<sub>2</sub>-emission allowance price would go up to €50/tonne CO<sub>2</sub> this would lead thus to a cost saving of €3.3 million for a 100,000 units Stirling VPP and to a saving of €6.1 million for SOFC VPP of the same size per year compared to a conventional power plant.

#### ***Impact of informal institutions***

Given the ambitious goals of the government on energy savings, CO<sub>2</sub> emission reductions and the use of innovative technologies to provide heat in buildings, it is likely that they are willing to change some of the institutions to stimulate  $\mu$ CHP (providing subsidy, removing the 60 kW minimum threshold from energy tax exemption). However since the minister indicated she sees the first generation  $\mu$ CHP units (Stirling) not as mini power plants it not very likely that the also the 30% efficiency threshold would be lowered, so that the Stirling VPP would also fall under the energy tax exemption.

## 5.5 Conclusions on the impact of the institutional environment on the technical feasibility and economic viability

The institutional environment of the  $\mu$ CHP VPP was described and evaluated based on the four layer model by Koppenjan and Groenewegen (2005). The impacts of the institutional environment on the technical feasibility and economic viability were analysed by combining the institutional evaluation with the analyses from chapter 3 and 4.

### *Impacts institutional environment on the technical feasibility of the $\mu$ CHP VPP*

To prevent damage to  $\mu$ CHP units and unwanted grid impacts, the  $\mu$ CHP units should comply with requirements for the generators connected to the low voltage (LV) grid as laid down in the Grid Code. In the grid code no provisions for the outputs of power electronic interfaced  $\mu$ CHP units are specified which means that also converters could be connected that produce harmonics.

The protection thresholds and disconnection times for power electronic devices as currently in the Grid Code (at. 2.4.2.3) are too low to be selective and do not guarantee the proper functioning of the LV network. No provisions have been made for voltage rises due to electricity production by  $\mu$ CHP units.

The provisions for planning and production should be applied for the size equal to the total  $\mu$ CHP capacity of the VPP to prevent unfair competition towards central power plants.

### *Impacts institutional environment on the economic viability the $\mu$ CHP VPP*

The arrangements between the VPP operator and the household can have impact on the economic viability. In scenario 1, the actual maintenance costs of a SOFC could be much higher than anticipated in the maintenance contract if the life time of the fuel cell stack is shorter than estimated. This has a large impact on the viability. In scenario 2 the viability of the VPP is limited by electricity prices set by the market and heat prices that will be set by the regulator.

The formal institutions can have a very large impact on the economic viability. The regulations with the largest impact are:

- Purchasing subsidies for  $\mu$ CHP: capital costs are the most critical factor for the economic viability in scenario 2 and a subsidy would reduce the capital costs
- Heat law: heat prices are also a big factor for the economic viability, so stricter price regulation can severely impact the viability
- Energy tax: with Monte Carlo simulations it was shown that if the energy tax exemption would include units smaller than 60 kW, the economic viability of the SOFC VPP would improve significantly (although no positive NPV). If the tax exemption would also be given for  $\mu$ CHP units with an electrical efficiency lower than 30%, the Stirling VPP could become economically viable.
- Emission trading scheme:  $\mu$ CHP units do not fall under this regime and thus if the emission rights for the power sector will be fully auctioned in 2013, a  $\mu$ CHP VPP can save a significant amount of costs per year compared to a conventional power plant.

From the values and norms of the government it can be concluded that it is likely that they are willing to change some formal institutions to stimulate  $\mu$ CHP. It is however not likely that the 30% efficiency threshold for the energy tax exemption will be lowered.

*Next...*

It was concluded that institutional change is needed to accommodate a  $\mu$ CHP VPP in the existing power system without problems and to improve the economic viability of the system. Whether it would be justified to change institutions or give financial support to a  $\mu$ CHP VPP will be researched in the next chapter by comparing the  $\mu$ CHP VPP with existing systems for the supply of heat to households.

## 6 Comparison of a $\mu$ CHP VPP with existing technologies for the supply of heat to households

From the previous chapters it was concluded that institutional change and government support is needed to make the system economically viable and to accommodate the VPP system in the existing system without problems. It was also concluded that an electricity only  $\mu$ CHP VPP is not an attractive option.

To determine whether it is justified to change institutions or give support, the  $\mu$ CHP VPP is compared with existing technologies for the supply of heat to Dutch households. Institutional changes should only be made and support should only be given, if the  $\mu$ CHP VPP system is better than existing technologies, since the government should only support systems that are beneficial for society as a whole. The following research questions will be answered in this chapter:

*Is it beneficial to implement and operate a  $\mu$ CHP VPP?*

- *How does the  $\mu$ CHP VPP compare to existing technologies for supply of heat to households?*
  - *What criteria can be derived from the values/norms of the actors identified in 5.2?*
  - *What are currently the most used existing technologies?*
  - *What are the scores on the criteria of the identified technologies and the  $\mu$ CHP VPPs?*

First the existing technologies will be identified and shortly described in paragraph 6.1. Then a number of relevant criteria to compare these technologies are derived from the values of the actors as described in paragraph 5.2.4. In 6.3 the scores on the criteria per system are presented. Finally conclusions are drawn in 6.4.

### 6.1 Existing technologies for the supply of heat to households in the Netherlands

There are basically five options to (partially) supply households with heat: (1) heating boiler, (2) district heating, (3) heat pumps, (4) solar-boilers and (5) micro-CHP. Since the boiler and district heating are by far the most commonly used heating systems in the Netherlands (EnergieNed, 2008), the  $\mu$ CHP VPP will be compared with these options.

In 2007 96% of the households in the Netherlands were connected to the gas grid and 4% to a district heating grid (EnergieNed, 2008). A district heating system only makes economic sense in densely populated areas and in new buildings. Boilers and  $\mu$ CHP units have a much larger application area and can in principle be placed in any building. Since new buildings usually have better insulation than existing buildings, a Stirling engine would be more useful - in terms of operating hours and energy savings - in existing buildings and a SOFC in newer buildings.

### 6.2 Criteria derived from actor's values for comparing the $\mu$ CHP VPP with other technologies

To compare the  $\mu$ CHP VPP with other technologies relevant criteria are needed. These criteria are derived from the values of the main actors in paragraph 5.2. A number of common themes among the actors were identified and on the basis of those, more specific criteria were derived.

*Common themes that can be derived from the actor's values:*

- Energy savings
  - The government wants to save energy for environmental reasons and to become less dependent on foreign fossil fuel supply;
  - Households want to save energy to reduce the energy bill and also for environmental reasons;
  - Energy companies want to save energy as part of their social responsibility goals;
  - DSOs don't explicitly state anything about energy savings, but some of them state that they want distribute gas and electricity in an environmentally friendly manner;
- CO<sub>2</sub> emission reduction
  - The government wants reduce CO<sub>2</sub> for environmental reasons and because of European obligations;
  - Energy companies want to reduce CO<sub>2</sub> emissions because of the emission trading scheme and social responsibility goals;
  - Households want a reduction of environmental impact;

- Sustainability
  - Almost all actors have sustainability goals or awareness;
- Capital and operational costs of the system
  - The government has limited resources and therefore wants to support the most cost effective method for energy savings;
  - Energy companies want to earn back their investments and want the lowest capital costs for a system to deliver a certain amount of energy to the customer;
  - Households want a low energy bill, and thus a system with low operational costs.

From these themes more specific criteria were defined:

- *Energy savings*: fossil fuel savings compared with heat from a condensing boiler and grid electricity (this is the reference system);
- *CO<sub>2</sub> emission reduction*: emission reduction for the production of heat and electricity compared to reference system;
- *Exergetic efficiency*: one indicator that can be used as an indicator for sustainability for energy conversion systems is the **exergetic efficiency** of a system. Exergy is defined as the maximum amount of work (like electricity) that can be obtained from a system. The exergy of a system can be seen as:  $exergy = energy\ quantity \times energy\ quality$  (Canadianarchitect, 2009). High temperature heat is more useful than low temperature heat and therefore has a higher quality. Electricity can be converted in almost any other energy form and therefore has a very high quality. A system is exergetically efficient when energy is used in a better way thus if the quality of the energy input is matched with the quality of energy that is needed. In this way it is prevented that high quality energy is used for low quality tasks, which prevents waste of energy. *A system with higher exergetic efficiency can therefore be said to be more sustainable than a system with low exergetic efficiency.* The advantage of an exergetic comparison is that systems can be compared independently from a reference system;
- *Total costs/GJ of produced heat*: the total discounted costs of the systems during 15 years<sup>54</sup> divided by the total heat production during 15 years. With this criterion the capital and operational costs of the system can be compared based on their main task: supplying the households with heat;
- *Capital costs/GJ energy saving*: the capital costs over 15 years per unit of energy saving. With this criterion the costs effectiveness of an option can be determined.

### 6.3 The scores of the options on the criteria

The scores on the criteria that were determined and defined in the previous paragraph are presented in table 24. The worst scores are marked red and the best scores are marked green. A condensing boiler (90% thermal efficiency) and grid electricity were used as reference system to determine the energy savings and emission reductions. The energy savings and CO<sub>2</sub> emission reductions are calculated by comparing the energy needed by the reference system to produce same amount of heat and electricity as with the other systems (see appendix G). The Stirling VPP will mainly export electricity during peak hours and will then push power plants out of the dispatch merit order that are no longer economic to operate<sup>55</sup>. So the Stirling VPP should be compared with those plants, which are older gas fired power plants with an electrical efficiency of 50% (Van der Bor, 2008). A SOFC VPP and larger CPHs are operated more as base/intermediate load units<sup>56</sup> between their minimum and maximum values and will therefore be compared with the average grid efficiency (43% incl. grid loss, see SenterNovem, 2006) and the average emission factor for electricity *supply* of 416 g /kWh<sup>57</sup> (WISE, 2008).

<sup>54</sup> This is the assumed lifetime of the Stirling engine, the local controller and the heat storage. So all costs (including capital costs) of the systems are levelized over 15 years.

<sup>55</sup> Power demand is provided by power plants in order of their marginal costs. When electricity is exported to the grid because there is a heat demand (so the  $\mu$ CHP VPP must run), other plants will not operate or operate in part-load to maintain the balance between electricity supply and demand in the power system. So during this export power plants at the end of the merit order (with high marginal costs) will be the first not to be operated (pushed out of the merit order).

<sup>56</sup> The large CHP is operated as base/intermediate load plant because a cluster of households will always have a base heat demand. This in contrast to a Stirling engine which has to fulfil the individual heat demand of a household and will therefore be mainly operated during peak hours because the more capricious heat demand profile.

<sup>57</sup> In most literature the average emission factor of electricity production is taken as reference emission factor. However not all produced electricity is supplied to retail customers (see Groot and van de Vreede, 2007)

The VPP energy use and CO<sub>2</sub> emissions were calculated on the basis of the same VPP model outputs as with which the economic viability indicators were calculated. See appendix H for the used assumptions, formulas and exact figures.

**Table 24: Comparison of systems to supply 100,000 households with heat**

	<i>Stirling VPP</i>	<i>SOFC VPP</i>	<i>CHP + district heating</i>
Energy savings (%)	13	22	28
CO <sub>2</sub> emission reduction (%)	13	23	21
Overall exergetic efficiency <sup>58</sup> (%)	25	53	51
Total costs €/GJ heat	13	24	11
Capital costs € / GJ energy saving	563	409	75

## 6.4 Conclusions

The main technologies that are currently used for household heat supply are heating boilers and district heating systems. Criteria were derived from the values/norms/goals of the main actors of the μCHP VPP system. It can be concluded that all the systems will provide energy savings and CO<sub>2</sub> emission reductions compared to the reference system of a boiler and grid electricity. The Stirling VPP scores worst on almost all criteria compared to the SOFC VPP and district heating systems. The SOFC VPP scores the best on the CO<sub>2</sub> emission reduction and on exergetic efficiency (because of the high heat loss of the district heating system), but is by far the most expensive option to produce heat. The district heating system produces the heat the cheapest and can achieve the highest energy savings and is therefore the most cost-effective option.

*Next...*

Last, the overall conclusions will be given on the basis of which recommendations shall be formulated. Also a reflection on the research and suggestions for further research will be given.

<sup>58</sup> The exergetic efficiency of electricity + the exergetic efficiency of heat.

## 7 Conclusions, recommendations, reflection and further research

Based on the above analyses and evaluations the general conclusions and recommendations will be presented. Also the research will be reflected upon and based on this, further research suggestions are given. See the last paragraphs of each chapter for more detailed conclusions.

### 7.1 Conclusions

$\mu$ CHP can potentially contribute to energy savings, CO<sub>2</sub> emission reductions, less grid losses and higher security of electricity supply. When aggregated into a VPP they can be deployed for technical and commercial purposes. The main research question of this research was:

*Is it technically feasible, economically viable, and beneficial to implement and operate a micro-CHP virtual power plant in the Netherlands and what is the impact of the institutional environment on those aspects?*

First a general conclusion will be given and then a more elaborate one.

#### General conclusions

It can be concluded that it is technically feasible to implement and operate a  $\mu$ CHP VPP in the Netherlands if the VPP system is combined with heat storage.

Under current institutional conditions and economic assumptions, it is not economically viable to implement and operate a  $\mu$ CHP VPP in the Netherlands. Also it is not an economically viable option to use the  $\mu$ CHP VPP as an electricity only plant.

Institutional change is needed to make the  $\mu$ CHP VPP economically viable and to accommodate the system into the existing power system without problems. The institutional environment has a very large impact on the economic viability.

It is beneficial to implement a  $\mu$ CHP VPP compared to supplying heat with a boiler and electricity. Energy savings and CO<sub>2</sub> emission reductions can be achieved by implementing a  $\mu$ CHP VPP. However the cost effectiveness in terms of energy savings is rather low for both the Stirling and SOFC VPP compared to a district heating system.

#### Detailed conclusions

##### ***Technical feasibility***

The technical feasibility evaluation was based on the main technical components needed for operation:  $\mu$ CHP units, control system, and electricity networks.

$\mu$ CHP units can not respond instantly to energy demand changes and their overall efficiencies are low during start-up and shut-down. The biggest issue with a Stirling VPP is that it can only be operated for a couple of hours per day during summer without dumping heat, and that therefore either very expensive seasonal storage is needed, or central power capacity that will almost not be used during winter. The biggest problem for the SOFC is that it can not be operated dynamically and that therefore the number of start-stop cycles should be almost limited to zero. Energy storage and supplementary heating can solve most of the  $\mu$ CHP limitations and provide the VPP operator with more flexibility.

Not much literature on the control system components is yet available because most of them are under development. Based on interviews with ICT and software experts, no major problems for the control system were identified. The only possible problem might be that the local control system needs to be adjusted when a next generation wire-less communication network emerges.

For network impacts it can be concluded that large amounts of  $\mu$ CHP units (up to 50-75% penetration) can be accommodated within existing electricity networks without causing major problems and without having to make adjustments to the networks or equipment. Almost all identified problems can be solved by technical solutions at a certain cost. So the connection of large amount of  $\mu$ CHP units is not a technical problem but an economic one. The conclusions should however be confirmed by large scale field tests.

##### ***Economic viability***

The economic viability was evaluated on the basis of two scenarios:

1. The  $\mu$ CHP is purchased/leased by the household and placed behind the customer meter and the VPP operator only invests in control systems and heat storage and has indirect control;
2. The  $\mu$ CHP VPP is considered to be an alternative for a centralised CHP with district heating system and the VPP operator finances and places the  $\mu$ CHP system before the customer meter. The VPP operator has direct control over the  $\mu$ CHP units.

Scenario 1 is not economically viable because for both the Stirling and SOFC VPP, the short and the long run costs of electricity production are higher than the wholesale electricity prices. In scenario 2, the capital costs of the VPP can not be recovered with electricity sales and trade because the levelized costs of electricity production are much higher than the electricity retail and wholesale price.

A Stirling engine is not suitable for base and intermediate operation because this would lead to large heat dump for most households. The SOFC can be operated as a base load and intermediate load plant but not as a peak load plant because of performance degradation due to dynamic operation.

The most common indicators used to determine the economic viability of a system by investors are the net present value (NPV)<sup>59</sup>, the internal rate of return (IRR)<sup>60</sup> and the discounted payback time<sup>61</sup>. Monte Carlo simulations were performed to determine the certainty levels of positive values for those indicators for scenario 2. The certainty that the NPV is positive, the IRR is higher than 8% and the discounted payback period shorter than the lifetime of the system (under these conditions the system is in principle economically viable), was 2% for a Stirling VPP and 0% for a SOFC VPP.

The factors that influence these indicators the most are:

- the capital costs the of the  $\mu$ CHP unit
- the lifetime of the  $\mu$ CHP
- the wholesale gas price
- the consumer heat price

The Stirling VPP can break even with significant changes of those critical factors while for the SOFC even bigger changes in these factors are needed to break even.

### ***Institutional impact***

The institutional environment of the  $\mu$ CHP VPP was described and evaluated based on the four layer model by Koppenjan and Groenewegen (2005). The impacts of the institutional environment on the technical feasibility and economic viability were analysed by combining the institutional evaluation with the analyses from chapter 3 and 4.

#### ***Impacts institutional environment on the technical feasibility of the $\mu$ CHP VPP***

The  $\mu$ CHP units should comply with the requirements in the Grid Code to prevent damage to the  $\mu$ CHP units and problems for the network. No provisions are made for the outputs of  $\mu$ CHP units connected to the grid with power electronic converters, which implicates that also converters can be connected that produce harmonics.

Currently, the protection thresholds and disconnection times for power electronic devices do not guarantee the proper functioning of the LV network. Also no provisions have been made for voltage rises due to electricity production by  $\mu$ CHP units.

The provisions for planning and production in the Grid Code do not apply for a  $\mu$ CHP VPP. This leads to unfair competition with large power plants that have obligation like reactive power provision.

#### ***Impacts institutional environment on the economic viability the $\mu$ CHP VPP***

The arrangements between the VPP operator and the household can impact the economic viability, especially in scenario 1 if the maintenance costs of the SOFC are underestimated.

<sup>59</sup> The present value<sup>59</sup> of expected future net cash flows minus the initial investment costs during a certain period (Mayes, 2009). The NPV calculates the economic profit of an investment.

<sup>60</sup> “the discount rate that makes the net present value of the investment's income stream total to zero”

<sup>61</sup> The discounted payback period is the time required to earn back the investment with discounted future cash flows.



The formal institutions can have a very large impact on the economic viability. The regulations with the largest impact are:

- Purchasing subsidies for  $\mu$ CHP
- Heat law: heat prices have a large impact on the economic viability, so stricter price regulation can severely impact the viability
- Energy tax: if the energy tax exemption would include units smaller than 60 kW, the economic viability of the SOFC VPP would improve significantly. If the tax exemption would also be given for units with an electrical efficiency lower than 30%, the Stirling VPP could become economically viable.
- Emission trading scheme:  $\mu$ CHP units do not fall under this regime and thus if the emission rights for the power sector will be fully auctioned in 2013, a  $\mu$ CHP VPP can save costs compared to a conventional power plant.

From the values and norms of the government it can be concluded that it is likely that they are willing to change some institutions to stimulate  $\mu$ CHP. It is however not likely that the 30% efficiency threshold for the energy tax exemption will be lowered.

### ***Beneficiality of a $\mu$ CHP VPP***

The  $\mu$ CHP systems were compared with existing systems for household heating on criteria based on the values/norms/goals of the actors identified in 5.2. Both the Stirling as the SOFC VPP can save energy and reduce CO<sub>2</sub> emissions compared to a reference system consisting of a condensing boiler and grid electricity. The Stirling VPP scores worse on almost all criteria and the SOFC VPP produces heat at the highest costs. District heating is currently a more costs effective (in terms of capital costs/GJ energy saving) option to reduce primary energy consumption and CO<sub>2</sub> emissions but its application is limited to new houses and densely populated areas.

## **7.2 Recommendations**

Based on the conclusions the following recommendations are given:

- To safeguard the power quality of the grid, also output requirements for power electronic devices connected to the LV grid should be included in the grid code;
- Implement the proposal that has been made by the DSOs to align the Grid Code with European  $\mu$ CHP standard CENELEC EN 50438;
- Include provisions for voltage rises due to production by  $\mu$ CHP units in the Grid Code;
- Make or change regulation based on the total power capacity of the  $\mu$ CHP VPP and not based on individual  $\mu$ CHP capacity to prevent unfair competition for:
  - Large power plants: for large plants much more provisions are made in the Grid Code than for small units. A  $\mu$ CHP VPP would have the benefits of large power plants but not the obligations;
  - $\mu$ CHP VPP: currently there is no energy tax exemption for electricity producing installations smaller than 60kW. Such an exemption would greatly improve the economic viability of a  $\mu$ CHP VPP;
- Don't support or invest in Stirling VPPs. A large capacity of conventional power plants, that will almost not be operated during winter, would be needed for supplying electricity during summer because then the Stirling can almost not be operated without dumping heat (without seasonal storage). This is economically not efficient from the total power system point of view. Also the Stirling VPP scores worst on almost all the criteria compared to the SOFC VPP and district heating systems;
- Support or invest in district heating instead of  $\mu$ CHP VPP on the short term. The district heating system is currently more costs effective than a  $\mu$ CHP VPP in terms of costs per energy saving and costs of heat production.
- On the longer term, support a SOFC VPP because it is the best alternative of the researched options to reduce energy consumption and CO<sub>2</sub> emissions in the domestic sector in less densely populated areas and existing housing.

## **7.3 Reflection and further research**

A reflection on the research and the research methods is given and further research recommendations are given based on this reflection.

### ***Energy storage***

Both seasonal storage and electricity storage were not included in the research because these systems are currently way too costly for individual households. Seasonal storage could however make the Stirling VPP a more attractive option because one of the arguments not to invest in such a system would no longer apply: large back-up capacity of central power plants needed during summer. Electricity storage could enhance the operational flexibility for the VPP operator and thereby can increase the trade profits. It is therefore recommended that further research is conducted on this system in relation to VPPs.

### ***VPP spreadsheet model***

The model described in 4.2.1 used to calculate the VPP outputs that were used for the economic and scores on criteria calculations has a number of limitations which will be discussed below.

The first limitation of the model is that the energy demand profiles used as an input have a resolution of 10/15 minutes. In reality the electricity and heat demand can have high fluctuations within minutes. This means the energy savings and CO<sub>2</sub> emission reductions can be overestimated because the boiler will be operated less than in reality. It also implicates that the electricity export and thus the trade revenues might be underestimated because with more capricious demand profiles it harder for the  $\mu$ CHP to follow these demand changes given its operational limitations and will thus export more to the grid and the boiler will operated more. Ruijg and Ribberink (2004b, p.20) showed that the use of a 10 minute energy demand profile instead of a 1 minute profile would lead only to a deviation in outcomes or around 4-6%.

Second, the efficiencies are assumed constant during part-load and start-stop to keep the simple. In reality the efficiencies of  $\mu$ CHP is very low during start-up because the gas input flows are high and the output low. Also the efficiencies are lower during part-load operation of  $\mu$ CHP systems. So the model overestimates the energy savings and CO<sub>2</sub> emission reductions.

Third, another simplification was that the thermal and electrical efficiencies are assumed linear. In practice when the electrical power is modulated the heat output is not per se modulated with the same magnitude. So in reality the heat to power ratio can differ per time units which has an influence on the model outputs.

The model output however in general compared rather well with the outcomes of model from other sources and most differences could be explained.

Further research with more sophisticated models and lower resolution energy demand profiles (measured with smart-meters) is recommended to calculate more precisely what the energy savings, CO<sub>2</sub> emission reductions and revenues could be.

### ***Economic calculations***

Also the economic calculations have limitations mainly because the limited time and resources of the author.

In the economic calculations not all possible benefits and costs were included in the calculation because of time limitations and because the thesis was written from perspective of Nuon Energy Sourcing, a potential VPP operator. To determine the benefits and costs of such a system for society as a whole, a social costs benefits analysis should be performed and factors like emission reductions and higher security of supply should be valued.

Further, not all possible commercial purposes were included in the research (again because of time limitations and perspective). Only the most common costs and revenues you would have with conventional power plants were included in the calculations. There are however other possibly profitable purposes for a  $\mu$ CHP VPP, like combining it with intermittent renewable energy sources and thereby reducing imbalance costs. This should be further researched. See the research of Houwing (2009) for other possible commercial purposes of (clusters of)  $\mu$ CHP units.

Also not all possible arrangements between VPP operator and household were researched in detail. Only two possible scenarios were used as basis of analysis to limit the scope of the research and because research about these arrangements or more interesting from a retail point of view.

There are however also other arrangements possible that might be more profitable for the VPP operator. This should be further researched.

High oil prices fluctuations can cause a very high deviation from forecasted wholesale and consumer heat prices. Both factors have significant impact on the economic viability calculations. Some variation was however built in the model with the Monte Carlo simulations based on historical changes of the price parameters.

The assumed proportions of household demand segments to calculate the output of the VPP was based on the Nuon retail data which might not be representative for the whole of Netherlands. However no other accurate enough data were found in literature about this average energy demand distribution to verify.

### ***Comparison with existing technologies***

The VPP is only compared with the currently most widely used heating systems for households. To determine whether solar boiler and heat pump systems could better be supported than a  $\mu$ CHP VPP in the future, also the score on the criteria of those systems should be researched.

## References

- Abu-Sharkh, S., Arnold, R. J., Kohler, J., Li, R., Markvart, T., Ross, J. N., Steemers, K., Wilson, P. and Yao, R. (2006), Can microgrids make a major contribution to UK energy supply?, In: *Renewable & Sustainable Energy Reviews*, 10: 78-127.
- Ackerman, T., G. Andersson, L.Sodder (2001), Distributed Generation: A definition, In: *Electric Power. Systems Research*, 57: 195–204
- Ackermann, T. and V. Knyazkin (2002), Interaction between distributed generation and the distribution network: Operation aspects, In *Proceedings Second International. Symposium Distributed Generation: Power System Market Aspects*
- Akkermans, H (2006), *CRISP (Critical Infrastructures for Sustainable Power)*, Malmö: EnerSearch AB
- Alliander (2009), *Grootschalige praktijkproef in Gelderland met HRe-ketel (Large scale field test in Gelderland with HRe-boiler)*, [in Dutch],  
[http://www.alliander.com/pers/20090206\\_Grootschalige\\_praktijkproef\\_in\\_Gelderland\\_met\\_HRe-ketel.jsp](http://www.alliander.com/pers/20090206_Grootschalige_praktijkproef_in_Gelderland_met_HRe-ketel.jsp)
- Anderson, E.J., X. Hua, D. Winchester (2007), Forward contracts in electricity markets: The Australian experience, In: *Energy Policy*, 35: 3089–3103
- Andrieu C., Tran, T, (2003), The connection of decentralised energy producers to the low voltage grid (Le raccordement en basse tension des producteurs décentralisés d'énergie), INPG/IDEA
- APX Group (2009a), Day ahead market, <http://www.apxgroup.com/index.php?id=193> , last accessed on 9 April 2009
- APX (2009), *Press release February 04, 2009*,  
[http://www.apxgroup.com/index.php?id=24&tx\\_ttnews\[tt\\_news\]=279&tx\\_ttnews\[backPid\]=94&cHash=a34e7cc8cc](http://www.apxgroup.com/index.php?id=24&tx_ttnews[tt_news]=279&tx_ttnews[backPid]=94&cHash=a34e7cc8cc) , accessed on Feb. 23, 2009
- Arsenal research and Econnect Ltd (2005), *Unintentional Islanding in Distribution Systems with DG*, Dispower info 28
- Azmy, A.M. and Erlich, I. (2005), Impact of distributed generation on the stability of electrical power system, In : *IEEE Power Engineering Society General Meeting, 2005. 2*: 1056 – 1063
- Bakker, V., A. Molderink, J. L. Hurink, and G. J. M. Smit (2008), Domestic Heat Demand Prediction Using Neural Networks, In: *Systems Engineering, 2008. ICSENG '08. 19th International Conference on*, p. 189-194.
- Barker, P.P. and R.W. De Mello (2000), Determining the impact of distributed generation on power systems: Part 1 Radial distribution systems, In: *Power Engineering Society Summer Meeting*, 3: 1645 – 1656
- Beyer, D. and N.J. Kelly (2008), Modelling the Behaviour of Domestic Micro-Co-Generation under Different Operating Regimes and with Variable Thermal Buffering, In: *Proceedings Microgen 2008, Ottawa*
- Blom, J.H. (2008), *“The virtual power storage - Opslaan elektrische energie bij huishoudens” Master thesis*, unpublished, Top Tech, Delft University of Technology
- Boljevic, S., Michael F. Conlon, Barry, N. (2008), Impact of High Penetration of CHP Generation on Urban Distribution Networks, In: *UPEC 2008. 43rd International Universities Power Engineering Conference, 2008*, pp. 1-5
- Borges, C.L.T. and Falcao, D.M. (2003), *Impact of distributed generation allocation and sizing on reliability, losses and voltage profile*, paper presented at 2003 IEEE Bologna PowerTech Conference, June 23-26, Bologna, Italy
- Bolt, N, F.M. Combrink, P.T.M. Vaessen, (2006), *State of the art studie techniekontwikkeling voor de elektriciteitsvoorziening (State of the art study technology development for electricity supply)*, KEMA T&D Consulting, 10 February 2006, p. 12
- Bor, Jan van der<sup>62</sup> (2008), personal communication
- Boxum, E et al. (2000), Methodiek bepaling maximaal inpasbaar decentraal vermogen, In: *Energietechniek*, 78 (9): 416-419, 2000 [in Dutch]
- Bozelie, J.<sup>63</sup> (2009), personal communication

---

<sup>62</sup> Jan van der Bor is head asset management at Nuon Energy Trade and Wholesale

<sup>63</sup> Jan Bozelie is a network expert which was involved in  $\mu$ CHP Stirling engines tests. He works for Liandon as a techno consultant.

- Braun, M. (2007), “*Virtual power plants consisting of micro CHP plants for the provision of active power reserve - Analysis of the technical and economical potential*”, Master thesis, Munich University of applied sciences [in German]
- Brundlinger, R., Bletterie, B. (2005), Unintentional islanding in distribution grids with a high penetration of inverter-based DG: Probability for islanding and protection methods, In: *IEEE Russia Power Tech, 2005*, pp. 1-7
- Canadianarchitect (2009), *Measures of Sustainability -Exergy*, [http://www.canadianarchitect.com/asf/perspectives\\_sustainability/measures\\_of\\_sustainability/measures\\_of\\_sustainability\\_exergy.htm](http://www.canadianarchitect.com/asf/perspectives_sustainability/measures_of_sustainability/measures_of_sustainability_exergy.htm), last accessed on 14 April 2009
- Canova, A., Giaccone, L., Spertino, F., Tartaglia, M. (2007), Electrical Impact Of Photovoltaic Plant in Distributed Network, In: *42nd IAS Annual Meeting. Conference Record of the 2007 IEEE Industry Applications Conference, 2007*.
- Carbon Trust (2007), *Micro-CHP Accelerator – Interim report*, p.64, retrieved on 6 Amy 2009 from [www.carbontrust.co.uk/publications](http://www.carbontrust.co.uk/publications)
- CBS (2008), *Emissies van broeikasgassen, berekend volgens IPCC-voorschriften (Emissions of greenhouse gasses, calculated according to IPCC rules)*, <http://statline.cbs.nl>
- Cetinkaya, E. and Lemmens, J. (2008), “*Dimensionering van micro-wkk voor residentiele gebouwen (Dimensioning of micro-CHP for residential buildings)*” Master thesis, Katholieke Hogeschool Limburg
- CFCL (2008), [http://www.cfcl.com.au/Assets/Files/Gennex\\_Brochure\\_\(ENG\)\\_09-07.pdf](http://www.cfcl.com.au/Assets/Files/Gennex_Brochure_(ENG)_09-07.pdf), accessed on March 1 2009
- Chen, H., Chen, J., Shi, D., Duan, X. (2006), Power flow study and voltage stability analysis for distribution systems with distributed generation, In: *IEEE Power Engineering Society General Meeting, 2006*
- Chiradeja, P. and R. Ramakumar (2004), An Approach to Quantify the Technical Benefits of Distributed Generation, In: *IEEE Transaction on Energy Conversion*, 19 (4): 764 – 773
- Cipcigan, L.M., Taylor, P.C., Trichakis, P. (2007), The Impact of Small Scale Wind Generators on LV Distribution System Voltage, In: *ICCEP apos;07. International Conference on Clean Electrical Power, 2007*, pp. 9-13
- Cobben, S., Gaiddon, B., Laukamp, H. (2008), WP4 – Deliverable 4.3 IMPACT OF PHOTOVOLTAIC GENERATION ON POWER QUALITY IN URBAN AREAS WITH HIGH PV POPULATION, EIE/05/171/SI2.420208
- Consumentenbond.nl (2008), *Consumentenbond forum – micro-WKK*, <http://www.consumentenbond.nl/forum/showthread.php?t=5087>, [in Dutch], accessed on March 14 2009
- Dauensteiner, A. (2005), *European Virtual Fuel Cell Power Plant - System Development, Build, Field Installation and European Demonstration of a Virtual Fuel Cell Power Plant Consisting of Residential Micro-CHPs*, Management summary, EUVPP, NNE5-2000-208
- DeBruyn, A.B. (2006), “*Integration of Combined Heat and Power Generators into Small Buildings - A Transient Analysis Approach*” Master thesis, Waterloo, Canada: University of Waterloo
- Dentice d'Accadia, M., M. Sasso, S. Sibilio, and L. Vanoli (2003), Micro-combined heat and power in residential and light commercial applications, In: *Applied Thermal Engineering*, 23: 1247-1259
- Dondi, P., Bayoumib, D., Haederlic, C., Julianb, D., Suter, M. (2002), Network integration of distributed power generation, In: *Journal of Power Sources*, 106: 1–9
- Doorn, Ferry van <sup>64</sup> (2008), personal communication
- Dril, A.W.N. van and Elzenga, H.E. (2005), *Referentieramingen energie en emissies 2005-2020 (Reference estimates energy and emissions 2005 -2020)*, Petten: ECN, revised version May 2005, ECN-C--05-018
- DTe (2007), Grid Code, The Hague: DTe, 4 September 2007
- DTI/OFGEM (2000), *Future Network Design, Management and Business Environment*, DTI/OFGEM Embedded Generation Working Group Rapporteur Contribution
- Duurzameenergiethuis.nl (2008), *Nederlanders willen graag meer energie besparen (Dutch are willing to save more energy)*, [http://www.duurzaam-ondernemen.nl/detail\\_press.phtml?act\\_id=8073](http://www.duurzaam-ondernemen.nl/detail_press.phtml?act_id=8073), [in Dutch], accessed on March 16

---

<sup>64</sup> Ferry van Doorn studied Computer Science at University of Twente and is head software developer at Homa Software, a company that develops software for controlling and diagnosing  $\mu$ CHP units

- Duurzaam-ondernemen.nl (2008), *Kennis Nederlanders over energiebesparing in half jaar 10% gestegen (Knowledge of Dutch about energy saving has increased with 10% in half a year)*, [in Dutch], [http://www.duurzaam-ondernemen.nl/detail\\_press.phtml?act\\_id=8073](http://www.duurzaam-ondernemen.nl/detail_press.phtml?act_id=8073)
- EA Technology Ltd (2001), *Likely changes to network design as a result of significant embedded generation*, DTI Pub URN/01/782
- ECN (2003), *Te weinig investeren in nieuwe elektriciteitscentrales vergroot risico's stroomuitval (Not enough investment in new power plants increases the risk of power outages)*, Petten: ECN, retrieved on 29 April from <http://www.energie.nl/dossier/voorzieningszekerheid.pdf>
- ECN and Gasunie (2007), *Aggregatie van micro-wkk's in een virtuele centrale - First trial smart power system*, Petten: ECN-E--07-055
- Ecolegis (2009)<sup>65</sup>, personal communication with Hans Spaermon and Patrick Donders which both have a background in tax law
- Econnect Ventures Ltd. (2007), *Embedded controller for LV networks with distributed generation*, DTI URN NUMBER: 07/921
- Edwards, F.V., Dudgeon, G.J.W., McDonald, J.R., Leithead, W.E. (2000), *Dynamics of Distribution Networks with Distributed Generation*, In: *IEEE Power Engineering Society Summer Meeting, 2000*, 2: 1032 – 1037
- EG&G Technical Services, Inc. (2004), *Fuel Cell Handbook (Seventh Edition)*, U.S. Department of Energy, Office of Fossil Energy
- El-Samahy, I. and El-Saadany, E. (2005), *The effect of DG on power quality in a deregulated environment*, In: *IEEE Power Engineering Society General Meeting, 2005*
- El-Shark, M.Y., A. Rahman, M. S. Alam, A. A. Sakla, P. C. Byrne, T. Thomas (2004), *Analysis of Active and Reactive Power Control of a Stand-Alone PEM Fuel Cell Power Plant*, In: *IEEE Transactions on Power Systems*, 19 (4): 2022 – 2028
- Emhemed, A.S., Burt, G., Anaya-Lara, O. (2007), *Impact of high penetration of single-phase distributed energy resources on the protection of LV distribution networks*, In: *UPEC 2007 42nd International Universities Power Engineering Conference, 2007.*, pp. 223-227
- Enbin (2008), *Codewijzigingsvoorstel inzake laagspanningsproductie-eenheden met een aansluitwaarde van maximaal 3x16 A (Proposal to revise the Nedtcode with regards to low voltage production units with connection of maximum 3 x16 A)*, [in Dutch], Arnhem: Enbin
- Energiekamer (2008a), *Monitor energiemarkten 2007 - Analyse van ontwikkelingen in de Nederlandse groothandelsmarkten voor gas en elektriciteit (Monitor energy markets – Analysis of developments in the Dutch wholesale markets for electricity and gas)*, [in Dutch], Nma-Energiekamer: project number 102872 [in Dutch]
- Energiekamer (2008b), *TarievenCode Elektriciteit (Tariff code electricity)*, The Hague: NMa, Energiekamer
- Energiekamer (2009), *Tariff decisions for gas and electricity*, <http://www.energiekamer.nl>
- EnergieNed (1996), *Elektriciteitsdistributienetwerken (Electricity distribution networks)*, [in Dutch], Deventer: Kluwer BedrijfsInformatie b.v.
- EnergieNed (1999), *Basisonderzoek Aardgasverbruik Kleinverbruikers BAK 1998*, Arnhem: Energiened
- EnergieNed (2004), *Basisonderzoek Warmte Kleinverbruik BWK (Basic research heat of small consumers)*, [in Dutch], Arnhem: June 2004
- EnergieNed (2007a), *Eneco Energie, Essent, Nuon en GasTerra geven extra impuls aan duurzame energievoorziening (Eneco Energy, Essent, Nuon and GasTerra give extra impuls to sustainable energy supply)*, [in Dutch], <http://www.energiened.nl/Content/News/Current.aspx?NewsItemID=19487>
- EnergieNed (2007b), *Energie in Nederland 2007 (Energy in the Netherlands 2007)*, [in Dutch], Arnhem
- EnergieNed (2008), *Energie in Nederland 2008 (Energy in the Netherlands 2008)*, [in Dutch], Arnhem
- EPRI (2002), *Stirling Engine Assessment*, 1007317, Final Report, October 2002, retrieved from <http://mydocs.epri.com/docs/public/000000000001007317.pdf>
- European Commission (2008a), *Proposal for a Decision Directive of the European Parliament and of the Council on the effort of Member States to reduce their greenhouse gas emissions to meet the Community's greenhouse gas emission reduction commitments up to 2020*, COM(2008) 17 final, 23 January 2008

---

<sup>65</sup> An company specialised in giving advice on the Law on Environmental taxes

- European Commission (2008b), *Proposal for a Directive of the European Parliament and of the Council amending Directive 2003/87/EC so as to improve and extend the greenhouse gas emission allowance trading system of the Community*, Brussel: COM(2008) 16 final, 23 January 2008
- European Parliament and Council (2003), *DIRECTIVE 2003/87/EC establishing a scheme for greenhouse gas emission allowance trading within the Community and amending Council Directive 96/61/EC*, Luxembourg, 13 October 2003
- Europa press releases (2008), *2856th Council meeting Environment*, Brussels: 3 March 2008  
<http://europa.eu/rapid/pressReleasesAction.do?reference=PRES/08/50&format=HTML&aged=0&lg=en&guiLanguage=en>, accessed on 15 March 2009
- First Chamber (2008), *Wijziging van de Elektriciteitswet 1998 en de Gaswet ter verbetering van de werking van de elektriciteits- en gasmarkt, GEWIJZIGD VOORSTEL VAN WET 3 juli 2008*, Chamber piece: KST121101, First Chamber
- First Chamber (2009), *Press release: Warmtewet aanvaard in Eerste Kamer*, The Hague, [http://www.eerstekamer.nl/nieuws/20090211/warmtewet\\_aanvaard\\_in\\_eerste\\_kamer](http://www.eerstekamer.nl/nieuws/20090211/warmtewet_aanvaard_in_eerste_kamer)
- Fuchs, E.F. and Masoum, M.A.S. (2008), *Power quality in power systems and electrical machines*, Amsterdam: Elsevier, 2008
- Gandomkar, M, Vakilian, M, Ehsan, M (2005a), A Genetic-Based Tabu Search Algorithm for Optimal DG Allocation in Distribution Networks, In: *Electric Power Components and Systems*, 33 (12):1351-1362
- Gandomkar, M., Vakilian, M. Ehsan, M. (2005b), *A combination of genetic algorithm and simulated annealing for optimal DG allocation in distribution networks*, paper presented at Canadian Conference on Electrical and Computer Engineering 1-4 May 2005
- Gas transport services (2009), Trade related gas prices, [http://www.gastransportservices.nl/shippers/tariefinformatie/beurs\\_gasrijzen/](http://www.gastransportservices.nl/shippers/tariefinformatie/beurs_gasrijzen/), last accessed on 20 May 2009
- Geidl, M. (2005), *Protection of Power Systems with Distributed Generation: State of the Art*, Power Systems Laboratory, Swiss Federal Institute of Technology (ETH) Zurich
- Genc, I. and Usta, O. (2005), Impacts of Distributed Generators on the Oscillatory Stability of Interconnected Power Systems, In: *Turk J Elec Engin*, 13 (1).
- Geschiere, A. (2009)<sup>66</sup>, personal communication
- Groot, M. and G.J. van de Vreede (2007), *Achtergrondgegevens Stroometikettering 2006* [in Dutch], Delft: CE
- Halcrow Group Ltd (2003), *Micro-generation network connection (renewables)*, K/EL/00281/00/00, DTI: <http://www.dti.gov.uk/publications>
- Halcrow Group Ltd (2004), *Distribution system constraints and their impact on distributed generation*, DTI URN 04/1114
- Harrison, J. (2003), *Micro CHP (Combined Heat & Power) and its relevance to the gas industry*, Paper presented at 22nd World Gas Conference, Tokyo, 2003.
- Harrison, G.P. and Wallace, A.R. (2004), Network integration of CHP: how to maximize access, In: *Cogeneration and On-Site Power Production*, 5 (4): 69-76
- Heidweiller, D.J. (2008), *Mogelijkheden voor restwarmte afzet rond the centrale Velsen* [unpublished], The Hague: Tebodin
- Hemdan, N.G.A. and Kurrat, M. (2008), Distributed Generation Location and Capacity Effect on Voltage Stability of Distribution Networks, In: *2008 Annual IEEE Conference Student Paper*, pp. 1-5
- Hendriks, R.<sup>67</sup> (2009), personal communication
- Heptonstall, P (2007), *A REVIEW OF ELECTRICITY UNIT COST ESTIMATES*, UK Energy Research Centre, retrieved on 2 June 2009 from [http://data.ukedc.rl.ac.uk/browse/edc/Electricity/ProductionCostEstimates/Heptonstall2007\\_WorkingPaper.pdf](http://data.ukedc.rl.ac.uk/browse/edc/Electricity/ProductionCostEstimates/Heptonstall2007_WorkingPaper.pdf)
- Hoopen, J. ten, and D. M. Samsom, (2008), *Voorstel van wet van de leden Ten Hoopen en Samsom tot het stellen van regels omtrent de levering van warmte aan verbruikers (Warmtewet)*, The Hague: chamber piece KST120879
- Horgan, S., Iannucci, J., Whitaker, C., Cibulka, L., Erdman, W. (2002): *Assessment of the Nevada Test Site as a Site for Distributed Resource Testing and Project Plan*. NREL/SR-560-

<sup>66</sup> Alex Geschiere is a network expert which works for Liandon as a techno consultant.

<sup>67</sup> Ruud Hendriks is a business analyst for the asset valuation team at Nuon BD&P

31931

- Houwing, M., P.W. Heijnen, , I. Bouwmans (2007), *Coordination regimes for applying residential energy sources*, presented at 9th IAEE European Energy Conference "Energy Markets and Sustainability in a Larger Europe"
- Houwing<sup>68</sup>, M. (2008), personal communication
- Houwing, M. and M.Ilic (2008), The Value of IT for Virtual Power Plants with Micro Cogeneration Systems, In: *Proceedings of the IEEE International Conference on Systems, Man and Cybernetics*, 12-15 Oct. (2008), Beijing, China, pp.1-6
- Houwing, M. (2009), "*Smart Power Systems; Exploring Options to Enhance the Value of Micro Cogeneration through Intelligent Coordination Schemes*" (forthcoming). *Ph.D. Dissertation*. Faculty of Technology, Policy and Management. Delft University Press, Delft University of Technology, 2009
- IEA (1998), *Utility aspects of grid connected photovoltaic power systems*, Task V Report IEA PVPS T5-01:1998
- IEA (2002), *Distributed Generation in Liberalised Electricity Markets*, Paris, p. 128.
- Jaganathan, R.K. and Saha, T.K. (2004), *VOLTAGE STABILITY ANALYSIS OF GRID CONNECTED EMBEDDED*, presented at Australasian Universities Power Engineering Conference (AUPEC 2004) 26-29 September 2004, Brisbane, Australia
- Jarrett, K., Hedgecock, J., Gregory, R., Warham, T. (2004): *Technical guide to the connection of generation to the distribution network*. K/EL/00318/REP, DTI/UK
- Ijumba, N.M., Jimoh, A.A., Nkabinde, M. (1999), Influence of distribution generation on distribution network performance, In: *IEEE AFRICON, 1999*, 2: 961 – 964
- Jong, A. de., E.-J. Bakker, J. Dam, and H. v. Wolferen (2008), *Technisch energie- en CO2-besparingspotentieel van micro-wkk in Nederland (2010-2030) – Update 2008*, Utrecht: SenterNovem, Working group Decentraal, Platform Nieuw Gas [in Dutch]
- Jenkins, N, R. Allen, P. Crossley, D. Kirschen, G. Strbac (2000), *Embedded Generation*, Stevenage: The Institution of Electrical Engineers
- Kamalinia, S., Afsharnia, S., Khodayar, M.E., Rahimikian, A., Sharbafi, M.A. (2007), *A combination of MADM and genetic algorithm for optimal DG allocation in power systems*, paper presented at UPEC 2007. 42nd International Universities Power Engineering Conference, 2007.
- Kauhaniemi, K. (2003), *CODGUNet WP4 - Technical analysis of network connection of different types of generation units*, University of Vaasa
- Kelly, N., S. Galloway, I. Elders, R. Tumilty and G. Burt (2008), Modelling the impact of micro generation on the electrical distribution system, In: *Proceedings Microgen 2008, Ottawa Apr 29-May 1, 2008*
- KEMA (2001), *Concrectiserende hybride (AC +DC) middenspanningsnetten met decentrale opwekking en opslag (Hybrid (AC + DC) MV networks with DG and storage – system studies)*, report 40050080-TDP 01-20686A [in Dutch]
- KEMA (2002), *Grootschalige inpassing van kleine opwekkers in laagspanningsnetten, elektrotechnische gevolgen voor het laagspanningsnet van de inpassing van micro en mini warmtekracht (Large scale integration of micro and mini CHP in LV networks, technical consequences for the network)*, report 098462526-TDC 99-04489B [in Dutch]
- KEMA (2003), *Van berekening naar beoordeling – inpassing van decentrale opwekking (From calculation to assessment – network integration of DG)*, report 40230030-TDC 03-36739A [in Dutch]
- KEMA (2005), *The Contribution to Distribution Network Fault Levels from the connection of Distributed Generation*, DTI report DG/CG/00027/00/00
- Kets, A., W.G. van Arkel, and H. Jeeninga (2003), *Energiebesparing en huishoudens - Een onderzoek naar energiebesparing, typen huishoudens, geprefereerde doelstellingen en motivatie (Energy savings and households – A research into energy savings, households types, preferred goals and motivation)*, [in Dutch], Petten: ECN-C--03-118
- Kinectrics Inc. (2006), Impact of large-scale distributed generation penetration on power system stability, Report – CETC 2006-089
- Kreijl, N. v. (2007), "*Micro warmtekracht in 2030 – Nieuwe standaard in residentiële energievoorziening? - Studie naar mogelijkheden van micro warmtekracht in Nederland (Micro CHP in 2030 - New standard in residential energy supply? - Study of the possibilities of micro CHP in the Netherlands)*" Master thesis, Universiteit Utrecht

---

<sup>68</sup> Michiel Houwing is a Ph.D. candidate at TU Delft that researches  $\mu$ CHP and VPP



- Knazkins, V. (2004), “*Stability of Power Systems with Large Amounts of Distributed Generation*” Ph.D. Thesis, KTH Institution f'or Elektrotekniska System, Stockholm
- Koppenjan, J. and Groenewegen (2005), J., Institutional design for complex technological systems, In: *Int. J. Technology, Policy and Management*, 5 (3): 240-257
- Kroes, P. A., Franssen, M. P. M., Poel, I. v. d., and Ottens, M. M. (2004). Engineering systems as hybrid, socio-technical systems. *Presented at Engineering Systems Symposium 2004*, Cambridge Marriott.
- Kumpulainen, L. and Kauhaniemi, K. (2004), DISTRIBUTED GENERATION AND RECLOSING COORDINATION, [http://powersystems.tkk.fi/nordac2004/papers/nordac2004\\_kumpulainen\\_et\\_kauhaniemi\\_slides.pdf](http://powersystems.tkk.fi/nordac2004/papers/nordac2004_kumpulainen_et_kauhaniemi_slides.pdf)
- Kumpulainen, L., Ristolainen, I., Kauhaniemi, K. (2007), LOSS-OF-MAINS PROTECTION – STILL AN ISSUE WITH DISTRIBUTED GENERATION, In: *Proceeding 19th International Conference on Electricity Distribution, Vienna, 21-24 May 2007*
- Kundur, P., Paserba, J., Ajjarapu, V., Andersson, G., Bose, A., Canizares, C., Hatziargyriou, N., Hill, D., Stankovic, A., Taylor, C., Van Cutsem, T., Vittal, V. (2004), Definition and Classification of Power System Stability, In: *IEEE transactions on Power Systems*, 19 (2): 1387-1401
- Laag, P. C. v. d. and G. J. Ruijg (2002), *Micro-warmtekrachtsystemen voor de energievoorziening van Nederlandse huishoudens*, Petten: ECN-C--02-006 [ in Dutch]
- Laag, P. C. v. d. and G. J. Ruijg (2003), *Rentabiliteit micro warmtekracht systemen; Beschouwingen vanuit een particulier (eindgebruikers-) perspectief*, Petten: ECN [in Dutch]
- Lakshmi Devi, A. and B. Subramanyam (2007), Optimal DG unit placement for loss reduction in radial distribution system – A case study, In: *ARPN Journal of Engineering and Applied Sciences*, 2 (6), December 2007
- Lin, J.Y. (2002), *Viability, Economic Transition and Reflections on Neo-classical Economics*, Peking University
- Lindboe, H.H., Werling, J., Kofoed-Wiuff, A. (2007), *Impact of CO2 quota allocation to new entrants in the electricity market*, Danish Environmental Protection Agency, retrieved on 28 April 2009 from <http://www2.mst.dk/>
- MacDonald, A, Navigant Consulting Inc., McMillan Binch Mendelsohn LLP, Sustainable Edge Ltd., Budd Energy Law, E4 Inc., Natural Resources Canada CANMET Energy Technology Centre (2006), *Virtual power plant feasibility study*, Toronto: Final Report March 31<sup>st</sup>
- Machowski, J., J.W. Bialek, J.R. Bumby (1997), *Power system dynamics and stability*, Chichester: John Wiley and Sons Ltd.
- Mansouri, I., M. Newborough, D. Probert (1996), Energy consumption in UK households: Impact of domestic electrical appliances, In: *Applied Energy*, 54(3), July 1996, Pages 211-285
- Mayes, T.R. (2009), *Time Value of Money Calculations*, <http://www.tvmcals.com/terminology> , last accessed on 15 April 2009
- Menkveld, M. (2007), *Beoordeling werkprogramma Schoon en Zuinig - Effecten op Energiebesparing, hernieuwbare energie en uitstoot van broeikasgassen (Review working program Clean and Efficient - Effects on energy savings, renewable energie and emissions of greenhouse gasses)*, Petten: ECN and MNP, ECN-E--07-067
- Merwe, J. van der (2008), *The impact of co-generators on network fault levels and switchgear rating*, presented at ICUE conference 2008
- Micro Power (2005), *Microgen sets new standards in Micro-CHP Performance*, <http://www.micropower.co.uk/news/microgen01.html>, accessed on Feb. 24, 2009
- Ministry of EZ (Economic Affairs) (1998), *WET van 2 juli 1998, houdende regels met betrekking tot de productie, het transport en de levering van elektriciteit (Electriciteitswet 1998) (Law of July 2 1998, rules for production, transport, and supply of electricity (Electricity Law 1998))*, The Hague, July 2 1998
- Minister of EZ (Economic affairs) (2007), *answers to questions from parliament*, Chamber piece KVR29542
- Ministry of EZ (Economic Affairs) (2008), *Innovatieagenda Energie (Innovation agenda Energy)*, The Hague
- Ministry of VROM (Housing, Spatial Planning and Environment) (2007), *Werkprogramma Schoon en Zuinig: Nieuwe energie voor het klimaat (Working program Clean and Efficient: New energy for the environment)*, The Hague
- MNP (2006), *Micro-warmtekracht en de virtuele centrale - Evaluatie van transitie op basis van systeemopties*, Bilthoven: MNP Rapport 500083003/2006
- Moore, M.J. (2002), *Micro-turbine generators*, Hoboken: John Wiley & Sons

- Morsche, Remôn te<sup>69</sup> (2009), personal communication
- Mott MacDonald (2004), System Integration of Additional Microgeneration (SIAM), DTI, DG/CG/00028/00/00, accessible at [www.berr.gov.uk](http://www.berr.gov.uk)
- Nara, K., Hayashi, Y., Deng, B., Ikeda, K., Ashizawa, T. (2001), Optimal allocation of dispersed generators for loss minimization, In: *Electrical Engineering in Japan*, 136 (2): 1-8
- Newborough, M. (2004), Assessing the benefits of implementing micro-CHP systems in the UK, In: *Proc. Instn Mech. Engrs Vol. 218 Part A: J. Power and Energy*, pp. 203 - 218
- NMa (2006), *Besluit Beleidsregel Redelijke Terugleververgoedingen Vergunninghouders Elektriciteit (Decision on policy measure reasonable feed back tariff permit holder electricity)*, The Hague: 102252-1
- NREL (2003), DG Power Quality, Protection and Reliability, Golden: National Renewable Energy Laboratory, NREL/SR-560-34635
- Onovwiona, H. I. and V. I. Ugursal (2006), Residential cogeneration systems: review of the current technology, In: *Renewable and Sustainable Energy Reviews*, 10: 389-431
- Oosterkamp, P.F. van den, Laag, P.C. van der (2003), *Operational Experience with Micro-CHP Residential Fuel Cell Systems*, Petten: ECN
- Paddock trial (2008),  $\mu$ CHP Measurement overview. Unpublished.
- Papaefthymiou, G., M. Houwing, M.P.C. Weijnen and L. van der Sluis (2008), Distributed Generation vs Bulk Power Transmission, In: *Proceedings of the NGInfra-IEEE International Scientific Conference "Building Networks for a Brighter Future"*, 10-12 November (2008), Rotterdam, The Netherlands
- PB Power (2003a), *The impact of small scale embedded generation on the operating parameters of distribution networks*, DTI K/EL/00303/04/01
- PB Power (2003b), *Micro generation network connection*, DTI sustainable energy programme, URN 03/537
- PB Power (2007), *Future Network Architectures*, BERR URN NUMBER: 08/641
- Peacock, A. D. and M. Newborough (2005), Impact of micro-CHP systems on domestic sector CO2 emissions," *Applied Thermal Engineering*, 25: 2653-2676
- Peacock, A.D. and M. Newborough (2007), Controlling micro-CHP systems to modulate electrical load profiles, In: *Energy*, 32: 1093–1103
- Pehnt, M., M. Cames, C. Fischer, B. Praetorius, L. Schneider, K. Schumacher, and J.-P. Vos (2006), *Micro Cogeneration - Towards decentralised energy systems*, Berlin: Springer
- Power Engineering (2008), *First virtual power plant operated by Siemens and RWE Energy on line*, [http://pepei.pennnet.com/display\\_article/344295/6/ARTCL/none/PRODJ/1/First-virtual-power-plant-operated-by-Siemens-and-RWE-Energy-on-line/](http://pepei.pennnet.com/display_article/344295/6/ARTCL/none/PRODJ/1/First-virtual-power-plant-operated-by-Siemens-and-RWE-Energy-on-line/), accessed on March 1 2009
- PSERC (2006), *Consequences of Fault Currents Contributed by Distributed Generation*, Power Systems Engineering Research Center Publication 06-21
- Pudjianto, D., C. Ramsay, and G. Strbac (2007), Virtual power plant and system integration of distributed energy resources, In: *Renewable Power Generation, IET*, 1: 10-16
- PVE (2004), *Profielenmethodiek aardgas Versie 2.10*, Utrecht: Platform Versnelling Energieliberalsing, februari 2004
- PV-Upscale (2007a), WP4 – Deliverable 4.2: UTILITIES EXPERIENCE AND PERCEPTION OF PV DISTRIBUTED GENERATION – ANNEXES, EIE/05/171/SI2.420208, <http://www.pvupscale.org/spip.php?rubrique7>
- PV Upscale (2007b) WP4 – Deliverable 4.1: STATE-OF-THE-ART ON DISPERSED PV POWER GENERATION: Publications review on the impacts of PV Distributed Generation and Electricity networks ANNEXES, EIE/05/171/SI2.420208, <http://www.pvupscale.org/spip.php?rubrique7>
- PV Upscale (2008), WP4 – Deliverable 4.3: *Impact of photovoltaic generation on power quality in urban areas with high PV population*, <http://www.pvupscale.org/spip.php?rubrique7>
- Remeha (2008), *HRe@-ketel: warmte, warm water en elektriciteit*, <http://remeha.buyways.nl/hre/>
- Renders, B. and L. Vandeveld (2006), Interaction of Converter-Connected Distributed Generation Units with Grid Voltage Dips, presented at 7th FirW PhD Symposium, 29 Nov 2006, Ghent
- Renders, B., De Gussemé, K., Ryckaert, W.R., Stockman, K., Vandeveld, L., Bollen, M.H.J. (2008), Distributed Generation for Mitigating Voltage Dips in Low-Voltage Distribution Grids, In: *IEEE Transactions on Power Delivery*

<sup>69</sup> Remôn te Morsche is a business analyst for the asset valuation team at Nuon BD&P

- Resource Dynamics Corporation (2006), *Application Guide for Distributed generation interconnection - The NRECA Guide to IEEE 1547*, Arlington: National Rural Electric Cooperative Association
- Reza, M., Schavemaker, P.H., Slootweg, J.G., Kling, W.L., van der Sluis, L. (2004), Impacts of distributed generation penetration levels on power systems transient stability, In: *IEEE Power Engineering Society General Meeting, 2004*.
- Reza, M. (2006), *Stability analysis of transmission systems with high penetration of DG – Ph.D. thesis*, Delft University of Technology
- Ruijg, G. J. and J. S. Ribberink (2004a), *OPTIMALE INZET VAN MICRO-WK - SPANNINGSVELD TUSSEN ECONOMIE EN ECOLOGIE*, Petten: ECN-C--04-118
- Ruijg, G.J., and Ribberink, J.S. (2004b), Rentabiliteitsanalyse van micro-warmtekrachtsystemen: invloed van opslag en regeling, Petten: ECN-C-04-023
- Samson and Hessels (2008), Wijziging van de Elektriciteitswet 1998 en de Gaswet ter verbetering van de werking van de elektriciteits- en gasmarkt (Revision of the Electricity Law 1998 and the Gas Law to improve the functioning of the electricity and gas market) 31374 nr. 9, Amendment, Chamber piece: KST118663
- Sanctis, G de, (2007), Micro-cogenerative units for domestic appliances: state of the art and perspectives, presented at: *A winter school on state of the art & future of “Hydrogen & Fuel Cell Technologies” Bardonecchia, 21-26 January 2007*
- Sankaran, C. (2002), *Power Quality*, Boca Raton, Florida: CRC Press LLC
- Secretary of State of Finance (1994a), Uitvoeringsbesluit belastingen op milieugrondslag (Implementation decision environmental taxes), The Hague, BWBR0007178
- Secretary of State of Finance (1994b), Uitvoeringsregeling belastingen op milieugrondslag (Implementation regulation environmental taxes), The Hague, BWBR0007159
- SenterNovem (2006), *Protocol Monitoring Duurzame Energie - Update 2006*, 2DEN0611
- SenterNovem (2008), *Duurzame warmte voor bestaande woningen (Sustainable heat for existing housing)*, <http://www.senternovem.nl/duurzamewarmte/index.asp>
- Schulz, C., G. Röder, and M. Kurrat (2005), Virtual Power Plants with combined heat and power micro-units, In: *Proceedings of the International Conference on Future Power Systems*
- Schwaegerl, C., M.H.J. Bollen, K. Karoui, A. Yagmur (2005), *Voltage control in distribution systems as a limitation of the hosting capacity for distributed energy resources*, 18th International Conference on Electricity Distribution
- Setiawan, E. A. (2007), *“Concept and Controllability of Virtual Power Plant” PhD thesis*, University of Kassel
- Sjödin, J. and D. Henning (2004), Calculating the marginal costs of a district-heating utility, In: *Applied Energy*, 78: 1-18
- Smaardijk, E. J., E. M. v. d. Fliert, A. Ledebor, and M. J. G. Jak (2005), *Disperse energie - Liberale markt: Disperse nergieproductie in een liberale markt*, SenterNovem: 5005-03-20-01-055
- Smart Power Foundation (2006), *Marktontwikkeling Micro – en mini- warmtekracht in Nederland tot 2020*
- Staatsblad (1994), *Wet belastingen op milieugrondslag (Law on Environmental taxes)*, The Hague: Staatsblad 1994, 925, 23 December 1994
- Staatsblad (1998), *Elektriciteitswet 1998 (Electricity law 1998)*, The Hague: Staatsblad 1998, 427, 2 July 1998
- Steinkohleportal (2002), *A power-station mix for changing consumption patterns*, [http://www.steinkohleportal.de/en\\_content.php?id=648](http://www.steinkohleportal.de/en_content.php?id=648)
- Strbac, G., Jenkins, N., Green, T., Pudjianto, D. (2006), *Review of Innovative Network Concepts*, DG-Grid WP2, <http://www.ecn.nl/en/ps/research-programme/energy-supply/dg-grid/results/wp2/>
- Streicher, W., A.Heinz, J. Bony, S. Citherlet, L. Cabeza, J. M. Schultz, S. Furbo (2008), *Final report of Subtask C “Phase Change Materials”*, Institute of Thermal Engineering, Graz University of Technology Austria
- Svalova, I., Sauhats, A., Svalovs, A. (2007), Estimation of the Distributed Generation Impacts on the Angle Stability of the Two-Machine Scheme, In: *IEEE Lausanne Power Tech, 2007*, pp. 1975 – 1980
- TenneT (2003), *Handleiding bieden regel- en reservevermogen (Handbook bidding regulating and reserve power)*[in Dutch] BS 2000-167, Version 1.2, May 12th 2003
- TenneT (2005), *De onbalansprijssystematiek per 01-01-2001, herzien per 26-10-2005 (Imbalance method per 01-01-2001, revised on 26-10-2005)* [in Dutch] SB-MO 2005, Version 1.3, August 1st 2005
- TNS-NIPP (2005), *Europeanen maken zich grote zorgen over milieu (Europeans very worried about environment)*, [in Dutch], [http://www.tns-nipo.com/pages/nieuws-pers-vnipo.asp?file=persvannipo/zorgen\\_milieu05.htm](http://www.tns-nipo.com/pages/nieuws-pers-vnipo.asp?file=persvannipo/zorgen_milieu05.htm)

- TNS-NIPPO (2007a), *Europese burger bereid te betalen voor klimaatbeleid (European citizen willing to pay for climate policy)*, [in Dutch], <http://www.tns-nipo.com/pages/nieuws-pers-vnipo.asp?file=persvannipo\klimaatbeleid07.htm>
- TNS NIPO (2007b), *Acht op de tien Nederlanders vinden energierekening nu al hoog (Eight out of ten Dutch think energy bill is laready to high)*, [in Dutch], [http://www.tns-nipo.com/pages/nieuws-pers-rtl.asp?file=persvannipo%5Crtl\\_stijging\\_energiekosten07.htm](http://www.tns-nipo.com/pages/nieuws-pers-rtl.asp?file=persvannipo%5Crtl_stijging_energiekosten07.htm)
- TNS-NIPPO (2008), *Negen op de tien Europeanen milieubewust (Nine out of ten Europeans aware of environmental impacts)*, [in Dutch] [http://www.tns-nipo.com/pages/nieuws-pers-vnipo.asp?file=persvannipo\eurobarometer\\_milieu08.htm](http://www.tns-nipo.com/pages/nieuws-pers-vnipo.asp?file=persvannipo\eurobarometer_milieu08.htm)
- Topsoe Fuel Cell (2008), personal communication
- Tsoutsos, T., V. Gekas, K. Marketaki (2003), Technical and economical evaluation of solar thermal power generation, In: *Renewable Energy*, 28(6): 873-886
- Thomson, M and D.G. Infield (2007a), Impact of widespread photovoltaics generation on distribution systems, In: *IET Renewable Power Generation*, 1 (1): 33-40
- Thomson, M and D.G. Infield (2007b), Network Power-Flow Analysis for a High Penetration of Distributed Generation, In: *IEEE Transactions on Power Systems*, 22 (3): 1157-1163
- Thong, V. van, Dommelen, D. van, Driesen, J., Belmans, R. (2004), *Impact of large scale distributed and unpredictable generation on voltage and angle stability of transmission system*, Paris: CIGRE
- Thong, V van., Vandenbrande, E., Soens, J., Van Dommelen, D., Driesen, J., Belmans, R. (2004), Influences of large penetration of distributed generation on N-1 safety operation, In: *IEEE Power Engineering Society General Meeting, 2004*
- Tran-Quoc, T. Andrieu, C., Hadjsaid, N. (2003), Technical impacts of small distributed generation units on LV networks, In: *IEEE Power Engineering Society General Meeting, 2003*, 4: 2459-2464
- Trichakis, P., Taylor, P.C., Cipcigan, L.M., Lyons, P.F., Hair, R., Ma, T. (2006), An Investigation of Voltage Unbalance in LV distribution networks with high levels of SSEG, In: *UPEC apos06. Proceedings of the 41st International Universities Power Engineering Conference, 2006*
- Velde, Jörgen van der <sup>70</sup> (2008), personal communication
- Verkooijen, A.H.M. (2008), *Lecture sheets of the course "Technology and Sustainability"*, Delft, 2008
- Vovos, P.N., Kiprakis, A.E., Wallace, A.R., Harrison, G.P. (2007), Centralised and Distributed Voltage Control Impact on Distributed Generation Penetration, In: *IEEE Transactions on Power Systems*, 22 (1): 476-483
- Wall, S.R. (2001), Performance of inverter interfaced distributed generation, In: *2001 IEEE/PES Transmission and Distribution Conference and Exposition*
- Werner, T. G. and R. Remberg (2008), Technical, economical and regulatory aspects of Virtual Power Plants, In: *Proceedings of Third International Conference on of the Electric Utility Deregulation and Restructuring and Power Technologies 2008. DRPT 2008*
- Willems, B. (2005), *Physical and Financial Virtual Power Plants*, Leuven: Center for Economic Studies
- WISE (2008), *Stroometiketten*, <http://www.groenestroomjagraag.nl/Stroometiket>, last accessed on 1 June 2009
- Wit, J. de, (2007), *Heat Storages for CHP Optimisation*, PowerGen Europe 2007 paper (ID-94)
- Woudstra, N. (2008), Lecture sheets "Thermodynamic Aspects of Energy Conversion", Delft, Mechanical Engineering
- Wu, X., Mutale, J., Jenkins, N., Strbac, G. (2003), *An investigation of Network Splitting for Fault level reduction*, Tyndall Centre for Climate Change Research
- Ye, Z., Finney, D., Zhou, R., Dame, M., Premerlani, B, Kroposki, B., Engleretson, S. (2003): *Testing of GE Universal Interconnection Device*. NREL/TP-560-34676

---

<sup>70</sup> Jörgen van der Velde is a software architect at ICT Embedded BV and was involved in VPP tests.

## Appendix A Generator types

The impact of connecting DG to the network differs per generator type. Therefore several generator types and their impacts on networks are shortly discussed.

### *Rotating synchronous and asynchronous/induction generators*

Synchronous generators produce a 50 Hz alternating current (AC) output and are synchronized with the electricity power system. Asynchronous generators, also called induction generators, need the grid to produce a voltage and follow the voltage and frequency of the power system.  $\mu$ CHP reciprocating engines and some Stirling engines types (Microgen) are connected to the grid through synchronous generators (Double Fed Induction Generator (DFIG)). Wind turbines usually use asynchronous generators and some  $\mu$ CHP Stirling engine designs (Whispergen) as well.

A big difference between the two generator types is that synchronous generators can keep producing power when disconnected from the grid and asynchronous generators can not unless the lack of reactive power is compensated by capacitor banks. Another important difference is that asynchronous generators can only provide real power to the network and will draw reactive power and synchronous generators can both provide active and reactive power, but can also draw reactive power from the grid. This has implications for the voltage profile of the electricity networks they are connected to as explained in chapter 3.

### *Power electronic interfaced systems*

Fuel cells, PV cells and batteries produce direct current (DC) power and need a DC/AC inverter to connect to the grid. Micro turbines have very high rotating speeds and therefore produce high frequencies and need a power converter to connect to the grid. The main task of the power electronic interface system is to convert the DC or non-50 Hz AC output of the distributed generator/battery into 50 Hz AC network input. These converter/inverter based technologies have different impacts on the network compared to the directly connected generators. The converter/inverter based generators can cause harmonic disturbances in the network but have a low impact on network fault levels and network instability. Active as well as reactive power can be provided with a function the power electronic control (Ackermann and Knyazkin, 2002).

### *Differences between large DG units and $\mu$ CHP units*

A large part of the literature dealing with network impacts are based on larger DG units (<10MW). The main difference between larger DGs and  $\mu$ CHP are summarised in table 25

**Table 25: Differences between large and micro (co)generators**

<i>Aspect</i>	<i>Large DG (&gt;250 kW &lt; 10MW)</i>	<i><math>\mu</math>CHP (&lt;5kW)</i>
Network connection	To 10/20/36 kV network (MV)	To 0.4 kV network (LV)
Voltage/frequency control	Usually equipped with this control, but often not used (Bozelie, 2009)	Not equipped with control, but converters connected units could be equipped with control for that function
Phases	3 phase generators	1 phase generators
Fault level contribution	Can be significant	Insignificant compared to network contribution
Network protection	Less of an problem (Bozelie, 2009)	Can be problem
Power quality	Generally produce smooth sinuses (Bozelie, 2009)	Could produce harmonics / non-sinusoidal currents

## Appendix B Detailed description of network impacts

In this appendix some more details about the network impacts are given

### B.1 Voltage impacts of DG

The impact on the network voltage depends on the size and location of the DG unit, the active and reactive power output of the DG unit, the load in the network, the voltage regulator settings and the network impedance (Barker and De Mello, 2000; Tran-Quoc et al., 2003).

Connecting DG also have a positive impact on the network voltage. The voltage profile<sup>71</sup> of the system can be improved by connecting DG because DG units can provide reactive and real power to the load which decreases the current in a section of the distribution network and increases the voltage magnitude at the customer side. This improvement increases with decreasing power factor<sup>72</sup>, increasing power rating, and increasing load at busses (Chiradeja and Ramakumar, 2004). The improvement also depends on the location of the DG. Locating DG units near the load centres can achieve improvements in the voltage profiles if they supply part of the customer load (Azmy and Erlich, 2005; Ijumba et al., 1999). This positive impact will mainly occur in highly loaded or weak networks (Geidl, 2005).

A number of factors can increase the chance of voltage problems to arise:

- A high concentration of DG units in a particular network causes bigger voltage problems than more evenly distributed DG units (Cobben et al., 2008; Jenkins et al., 2000; Geschiere, 2008; Tran-Quoc, 2003).
- A DG connection further away from the MV/LV transformer leads to bigger changes in the voltage profile than DG connections near the MV/LV transformer (Tran-Quoc, 2003).
- Rural distribution networks are more sensitive for voltage rises than urban networks because they have a higher impedance, lower capacity and low loads (Andrieu and Tran, 2003; Canova et al, 2007; PB Power, 2007; Strbac et al., 2006; Tran-Quoc, 2003). But they are easier to control because the network reactance is bigger than resistance (Bozelie, 2009).

There are also some factors that decrease the chance of voltage problems:

- If the aggregated power generation by DG units is smaller than the power consumption in a distribution grid, the voltage profile changes stays within the limits (Dondi et al., 2002).
- Variations between maximum and minimum voltage level compared to a situation without CHP are reduced when a CHP unit follows the local electrical load and vice versa compared to when a CHP unit does not follow the electrical load (Boljevic et al., 2008).
- Urban networks are usually more suitable for connection of DG because of their low section impedance (thus low voltage rise), short cable, high load, and big MV/LV power transformer (Andrieu and Tran, 2003; Canova et al, 2007; PB Power, 2007; Strbac et al., 2006; Tran-Quoc, 2003).

A voltage change in a distribution network can be caused by active/reactive power produced by a DG unit ( $P_G$ ,  $Q_G$ ) or drawn by a load ( $P_L$ ,  $Q_L$ ) and can be approximated by:

$$V1 - V2 = (PR + XQ)/V$$

where  $P$  = active power output of the generator  
 $Q$  = reactive power output of the generator  
 $R$  = resistance of the circuit  
 $X$  = inductive reactance of the circuit  
 $V$  = nominal voltage of the circuit  
 $Z = R + jX$  = impedance of the circuit

---

<sup>71</sup> The magnitude of the voltage during the day.

<sup>72</sup> Ratio between real power and apparent power (reactive + real power).

In figure 23 this is illustrated for a simple two bus system. In distribution networks the active power output of a DG unit has a bigger impact on the voltage profile than reactive power output because radial networks (which are often used for distribution) have a higher resistance than reactance (Hemdan, and Kurrat 2008; Tran-Quoc et al., 2003).

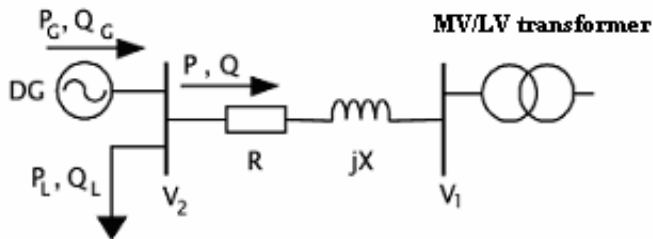

Figure 23: Two bus system with DG, adapted from (Vovos et al., 2007)

### B.2 Anti-islanding

An island can occur if there is a match between load and generation when the loss of mains occur and when the LOM protection fails to detect the LOM.

Unintentional islanding can lead to the following problems (Arsenal research and Econnect Ltd 2005; Bozelie, 2009; EA Technology Ltd, 2001; Kauhaniemi, 2003; Kumpulainen and Kauhaniemi, 2004; Kumpulainen et al., 2007; Resource Dynamics Corporation, 2006):

- Electric shock hazard for maintenance personnel;
- Voltage and frequency control can no longer be provided by the utility and need to be provided by the DG units.  $\mu$ CHP units are usually not equipped with voltage and frequency control. If active and reactive power is not balanced between load and generation, voltage and frequency limits may be exceeded;
- The DG units may continue operation during autoreclose open time and thereby sustain voltage and feed fault current. This will lead to unsuccessful reclosure and the fault becomes permanent;
- The islanded part of the network may not fulfil the grounding requirements, and therefore unearthed operation may occur;
- Uncleared earth or phase faults due to low short circuit capacity;
- Reconnection of the islanded part of the network becomes more complicated in case of automatic reclosing. Out of phase reclosing of the DG units can occur which can cause damage to network components, the DG unit and customer loads.
- Tripping and clearing of fault can become not selective

There are several anti-islanding/LOM protection methods available (Kumpulainen et al., 2007):

- *Passive methods:* these are the most commonly used methods (ROCOF and voltage vector shift relays) for LOM protection. Passive methods monitor voltage and frequency locally and relays are tripped when significant changes are detected. All passive methods have a non-detection zone and can cause unnecessary tripping of DG units (nuisance tripping).
- *Active methods:* these methods actively de-stabilize the island by monitoring the system response to self-created network disturbances. These methods are not considered to be reliable or effective when multiple DG units are connected to the network (Ye et al., 2003).
- *Telecommunication based methods:* these methods (Transfer trip/intertripping, power line signalling) don't have a non-detection zone and do not cause nuisance tripping (Kumpulainen et al., 2007). Both (Jarrett et al., 2004) and (Horgan et al., 2002) state that transfer trip is the most effective LOM protection method. These type of methods are however expensive.

### B.3 Power quality

#### Harmonics

“Harmonics are sinusoidal voltages or currents with frequencies that are integer multiples of the power system fundamental frequency” (Fuchs and Masoum, 2008, p. 8) (50Hz in the Netherlands). Any deviation from the pure

sine form of the voltage and/or current creates harmonics. Harmonics are caused by equipment or loads with non-linear characteristics like power converters/inverters, Harmonics can increase losses in and cause maloperation of electronic devices, cables, transformers, and communication systems. Like with the problems discussed in the previous paragraphs, a few  $\mu$ CHP units are not likely to cause severe problems but the cumulative effect of a large amount of  $\mu$ CHP units could cause harmonic distortion.

DG units like PV-panels, fuel cells, and micro-turbines are always connected to the grid by power electronics. Concerns exist that power converters will produce harmonic currents. The use of low loss converters like line commutated (thyristor) converters, can cause harmonics. Newer types of converters (self-commutated, Insulated gate bipolar transistor (IGBT)) that use PWM (pulse width modulation) are capable to significantly reduce harmonics but are far more expensive (El-Samahy and El-Saadany, 2005; Jenkins et al., 2000; Resource Dynamics Corporation, 2006). Kauhaniemi (2003) performed simulations to research the impact of a thyristor and a PWM converter on harmonics. The higher harmonics produced by a PWM converter during a high power situation are 0,8% of the fundamental line current and 1% of the fundamental line voltage. Harmonic filters could be used to further reduce harmonics. Under the same conditions, the thyristor converter produced 5th harmonics that are 20% of the fundamental line current and 2% of the fundamental line voltage. Also resonance between thyristor converter and the network could occur. So Insulated gate bipolar transistor (IGBT) converters produce less severe and higher harmonics than thyristor converters and higher harmonics are more quickly reduced than lower harmonics (PV Upscale, 2007b). So IGBT converters are preferred over the older thyristor converters to reduce harmonics problems. For  $\mu$ CHP units no thyristor converters are used, so no big problems are expected.

The three biggest distribution network companies in the Netherlands reported that harmonic problems only occurred in special cases (resonance) with inverter connected PV-panels (PV-Upscale, 2007a). In one study (PV Upscale, 2008) measurements on four sites with different network and load characteristics and high PV penetration (up to 80%) confirmed that the power quality limits were in general not violated. However, in cases of high PV production some voltage harmonics were found. The harmonic limits were exceeded in one case because of a resonance effect between network harmonics, cable impedance and high inverter input capacitance.

Directly connected rotating generators can have a positive as well as a negative impact on harmonics. They can produce significant harmonics depending on the generator windings, grounding and other factors (Barker and De Mello, 2000; El-Samahy and El-Saadany, 2005). On the other hand they lower the harmonic impedance of the networks which reduces the harmonic voltage and they can absorb harmonics (Jenkins et al., 2000; Tran-Quoc et al., 2003).

#### *Voltage unbalance*

Voltage unbalance in a three-phase distribution system is defined by (Trichakis et al., 2006) as: "...a condition in which the three-phase voltages differ in amplitude or are displaced from their normal 120 degree phase relationship or both". Voltage unbalance can occur when the exported power of single phase micro-(co)generators is distributed unevenly across the phases or where single phase loads are unbalanced. Low impedance networks can better cope with unbalanced loads and generation than high impedance networks. (PB Power, 2007). Voltage unbalance can have detrimental effects on rotating generators (counter rotating torque, motor overheating) and also on power electronic converters which can produce more non-sinusoidal harmonics (Jenkins et al., 2000; PB Power, 2007).

(Trichakis et al, 2006) performed simulations to study the impact on the voltage unbalance for a typical UK LV network after connecting 1.1 kWe  $\mu$ CHP units. They conclude that the voltage unbalance exceeds the limit of 1.3% with a 150% penetration<sup>73</sup> of  $\mu$ CHP units. Problems are expected when large numbers of small scale embedded generation (SSEG) units are connected to one phase of a three phase system (Econnect Ventures Ltd., 2007).

#### *Voltage dips*

---

<sup>73</sup> 100% penetration is defined as all customers having a 1.1 kW SSEG installed. So 150% means that the power output of the  $\mu$ CHP units is 1.5 times higher (bigger units).



Voltage dips are usually caused by network faults, by start/stop operation of many or large distributed generators, and switching of large loads. Voltage dips cause power frequency disturbances which can be harmful to electrical equipment and rotating DG units. DG units can exacerbate a voltage dip if they are tripped because of anti-islanding protection and will no longer contribute to maintaining the voltage profile. Converter connected units have voltage-dip ride-through capability and can therefore prevent this problem (Renders and Vandeveld, 2006). Test units of Stirling engines have proven to have voltage ride through capabilities as well. Converter connected DG units can also help mitigate a voltage dip by injecting active power (Renders et al, 2008).

#### *Voltage flicker*

Voltage flicker is the dynamic variation of the network voltage that can be caused by loads or generators. This flicker needs to stay within limits laid down by national and international standards to prevent annoyance to customers (with voltage flicker the brightness of lamps fluctuates). DG can contribute to voltage flicker because the DG unit may start and stop frequently (Jenkins et al., 2000). Also sudden and large variation of DG output may cause voltage flicker. With converter connected DG the starting current can be reduced and thereby also voltage flicker (Knazkins, 2004). Converter based systems will only be able to reduce voltage flicker if they are equipped with voltage regulation or when they are operated as controlled voltage sources (NREL, 2003).

### **B.4 Network stability**

#### *Rotor angle stability*

The ability of synchronous machines in an interconnected power system to remain in synchronism after being subjected to disturbances is referred to as the rotor angle stability. After a disturbance, the equilibrium between electromagnetic torque and mechanical torque for each synchronous machine in the system has to be restored/maintained. If this is not realised, instability may occur in the form of increasing angular swings of some generators which leads to loss of synchronism (Kinectrics Inc., 2006). Rotor angle stability can be divided in two categories:

- Small disturbance/signal stability: how the system responds to small disturbances;
- Transient stability: how the system responds to large signal disturbances.

The angle stability might become more difficult to maintain when a large number of DG units is connected to the grid. When they are tripped during a network disturbance, the central power plants are put on a lot of stress to retain the system synchronism (Thong, Dommelen et al., 2004). However when loads are served over large distances and when there are sufficient generating reserves and thermal transmission capacity, angular stability is unlikely to constrain DG penetration (Kinectrics Inc., 2006).

#### *Small-disturbance (or small-signal) rotor angle stability*

The power system is stable when the generators are able to remain in synchronism after being subjected to a small disturbance (Kundur et al., 2004). If the disturbance does not cause significant deviations of the system parameters from the steady-state equilibrium, it is called a small disturbance (switching a capacitor/load).

Small signal instability can occur if the system lacks sufficient oscillation damping capability which can lead to rotor oscillations of increasing amplitude (Kundur et al., 2004). Simulation results from (Azmy and Erlich, 2005), show that high utilization of power electronic interfaced DG units (fuel cells, micro-turbines) connected to the LV grid can improve the damping of electromechanical modes. Another research (Genc, I. and Usta, O., 2005) focussed on the effects of DG synchronous generators on the oscillatory instability. They conclude that synchronous DG can cause local or inter-area instabilities depending on system's topology, operating point, and control parameters. According to Bozelie (2009) the following rule of thumb can be used to prevent voltage stability problems: net export of power is possible up to 60% of the transformer capacity without causing voltage instability problems (small signal instability).

#### *Transient stability or large-disturbance rotor angle stability*

The power system is transient stable if it can reach an acceptable steady-state operating point following a large disturbance like a short circuit fault and loss of large loads/generators (Machowski, 1997). In case of a large disturbance, rotating machines could start swinging with respect to each other and that is why the transient

stability is also referred to as the first swing stability. The transient stability depends on the following factors (Harrison and Wallace, 2004; Kundur et al., 2004):

- Network topology
- Severity, nature, and location of the disturbance
- Initial operating state of the system
- DG characteristics and penetration level

#### *Power electronic interfaced DG units*

Azmy and Erlich (2005) show with simulations that an increase in penetration level of power electronic interfaced based DG units (fuel cells, micro-turbines) connected to the LV grid can improve the transient stability after a fault by decreasing the magnitude of the maximum power angle deviation between two central synchronous generators connected to the HV grid. They also state that larger disturbances can be handled with increasing penetration levels and that damping is somewhat increased.

(Svalova et al., 2007) calculated the critical fault clearing time (CCT) for different DG penetration scenarios. CCT is defined as: “the maximum duration of the fault which will not lead to the loss of synchronism of one or more generators”. So higher values of CCT indicate higher transient stability. For increasing penetration (up to 40%) of converter based DG units, no change in the CCT values were observed compared to the 0% converter penetration situation.

#### *Directly connected synchronous and induction generators*

Thong, Vandenbrande et al. (2004) simulated the Belgian transmission system and researched the transient stability when subjected to two different large disturbances: generator outage and 380kV line outage. They studied the stability with and without large synchronous and induction DG units connected to the 70kV network. It is assumed that the load remains the same and therefore that power produced by DG units will reduce the power output of the central generators. They conclude that for both disturbances the transient stability is worse with DG connected cases compared with the base case without DG and that induction generators have a larger negative impact on the transient stability. This is because less central generators were online (because they can't operate below a certain threshold) with stronger voltage and frequency control.

Reza et al. (Reza et al., 2004) simulated faults in all branches of a power system consisting of 10 central generators and different penetration levels<sup>74</sup> of five different types of DG units<sup>75</sup>. They quantified the effects on maximum rotor speed deviation and oscillation duration. The results show that the maximum motor speed deviation of most central generators decreases with increasing DG penetration levels. They show that large power flows have a detrimental effect on the damping of oscillations and that implementing DG limits the active power flows when used to supply local loads. They therefore conclude that implementing DG improves the transient stability. In his Ph.D. thesis Reza (Reza, 2006) in which he used the same simulation scenarios he further concludes that there is no significant stability problem up to 30% penetration level regardless the DG technology when the centralized production is remained the same while increasing load is covered by DG. Furthermore he concludes that DG equipped with voltage and frequency control improves the power system transient stability by reducing oscillations. He also simulated the case in which an increase DG units is followed by a reduction of centralized generators in service which reduces power system inertia (rotating masses) and reactive power support which are important factors to maintain transient stability. In this case power system instabilities can occur at very high penetration levels (>50%).

#### *Voltage stability*

Voltage stability is “the ability of the power system to maintain steady voltages at all buses in the system after being subjected to a disturbance from a given initial operating condition” (Kundur et al., 2004, p.1390). To maintain the voltage stable, reactive power demand and supply must stay balanced. An instability often occurs as a progressive and uncontrollable voltage drop. Voltage instability can lead to loss of load, and tripping of

---

<sup>74</sup> Defined as the ratio of the DG power output and the total power output.

<sup>75</sup> Asynchronous machine (Squirrel cage induction generator), Synchronous machine (generator) without grid voltage and frequency control, Synchronous machine (generator) with grid voltage and frequency control, Power electronic interface of distributed generation without grid voltage and frequency control, power electronic interface of distributed generation with grid voltage and frequency control.

transmission lines and equipment leading to cascading outages. Some situations can increase the chance of voltage instability:

- radial distribution system have a high resistance to reactance ratio, so they are more prone to voltage instability (Hemdan and Kurrat, 2008);
- if generation resources are located far away from the load centres, reactive power support is more difficult because of high reactance losses in distribution networks, and this can have a negative impact on the voltage stability (Kinectrics Inc., 2006);
- a high concentration of DG is worse for the voltage stability than more distributed DG (Hemdan and Kurrat, 2008).

#### *Power electronic interfaced DG units*

Chen et al. (2006) performed simulations with three different large scale (3MW) DG units to study the impact on voltage stability of a 90 bus power system. For fuel cells they conclude that they can improve the voltage stability especially when they are located near the weakest branches of the system. Electronic power interfaced DG units (FC, micro-turbine) equipped with reactive power controllers can improve the voltage stability at the loads (Azmy and Erlich, 2005).

#### *Directly connected synchronous and induction generators*

(Thong, Dommelen et al., 2004) simulated the Belgian transmission system and conclude that a 10% penetration of synchronous DG units connected to the 70kV grid increases the voltage stability limit and that a 10% penetration level of induction generators decreases the voltage stability limit. This is because induction generators draw reactive power from the grid. (Chen et al., 2006) confirm this finding with a simulation of connecting 3MW synchronous and induction generators. Knazkins (2004) however states that newly installed induction generators (Double fed induction generator (DFIG)) use modern converters (self-commutated) which do not draw reactive power and that in general it can be expected that DG units will not adversely impact the voltage stability. (Jaganathan and Saha, 2004) conclude that DG units can significantly improve the voltage collapse margin depending on the connection location. Especially units operating at lagging power factor improved this margin because they provide reactive power to the network.

#### *Frequency stability*

Frequency stability is defined as: "...the ability of a power system to maintain steady frequency following a severe system upset resulting in a significant imbalance between generation and load." (Kundur et al., 2004, p.1392). Instability occurs as sustained frequency swings which can lead to tripping of generators and/or loads and overloading of lines. To maintain frequency stability, sufficient generation reserve is needed.

With increasing levels of power electronic interfaced DG, the rated output of (central) synchronous generators decreases which means a decrease in absolute reserve power from the synchronous machines. This can cause higher maximum frequency deviations (Azmy and Erlich, 2005).

## Appendix C Economical viability: formulas, assumptions and cash flows

In this appendix the formulas used for the NPV, IRR and discounted payback period are given. Also the assumptions on the basis of which these calculations are made and the resulting cash flows are presented.

The formula used for the net present value (NPV) calculations:

$$NPV = \sum_{t=1}^T \frac{C_t}{(1+r)^t} - C_0$$

where NPV is the net present value, T is the period for which cash flows are expected,  $C_t$  is de cash flow in year t, r is the discount rate, and  $C_0$  are the investment costs.

The internal rate of return (IRR) is calculated with the same formula by calculating at which discount rate the NPV would be equal to zero. This illustrated with an example:

$$10,000 = \frac{2000}{(1+IRR)^1} + \frac{2500}{(1+IRR)^2} + \frac{3000}{(1+IRR)^3} + \frac{3500}{(1+IRR)^4} + \frac{4000}{(1+IRR)^5}$$

The discounted payback period is determined by calculating the years it takes to payback the investment with the discounted cash flows.

To calculate the net cash flow the following steps need to be taken (Te Morsche, 2009):

- (1) First the EBITDA<sup>76</sup> has to be calculated by: revenues – costs
- (2) Then the EBIT<sup>77</sup> has to be calculated by: EBITDA – depreciation
- (3) The net profit is calculated by subtracting 25.5% corporate tax from the EBIT
- (4) The net cash flow is calculated by: net profit + depreciation – investments

For depreciation the following formula can be used:

$$\text{Annual Depreciation Expense} = \frac{\text{Cost of fixed asset} - \text{Scrap Value}}{\text{Life span}(\text{years})}$$

It is assumed that the scrap values of the VPPs are zero.

The consumer heat price is calculated with (based on “Tariefadvies voor de levering van warmte aan Kleinverbruikers 2008”, Energiened)

$$1 \text{ GJ} = \frac{(1.330 \text{ m}^3 \times \text{gasprijs}) + (4.136 \text{ kWh} \times \text{elek.prijs}) - (4.117 \text{ kWh} \times \text{elek.prijs})}{34,87 \text{ GJ}}$$

The Nuon consumer gas and electricity prices were used as an input.

**Table 26: Base case assumptions for the NPV, IRR and discounted payback period calculations**

	<i>Value</i>	<i>Remarks</i>
Discount rate	8%	Value used by Nuon Asset Valuation team. Is based on weighed average cost of capital (WACC).
Inflation	2%	Assumed inflation by Nuon Asset Valuation
Year of introduction Stirling in Dutch matte	2010	Based on suppliers expectations

<sup>76</sup> Earnings Before Interest, Tax, Depreciation and Amortisation

<sup>77</sup> Earnings Before Interest and Taxes

Lifetime Stirling engine (years)	15	Based on suppliers expectation
Investment costs Stirling (€/unit)	3000	Based on target costs of suppliers
Maintenance costs Stirling (€/unit/yr)	60	Based on estimations of suppliers
Year of introduction SOFC in Dutch matte	2013	Based on suppliers expectations
Lifetime SOFC system (years)	10	Assumption based on larger SOFC systems
Lifetime Fuel cell stack	5	Based on supplier targets
Investment costs SOFC (€/unit)	5000	Based on target costs of suppliers
Fuel cell stack costs (€)	1000	Based on prices indicated by suppliers. Since the lifetime of the system is 10 years the stack will be replaced once in 2017.
Maintenance costs SOFC (€/unit/yr)	70	Based on estimations of suppliers
Investment costs 200l storage (€/unit)	1000	Based on supplier sites
Investment costs local control system (€/unit)	200	Based on target costs of SAGEM that will produce an residential energy gateway
Investment cost aggregator software (€)	100000	Based on estimation by Van der Velde (2008)
Consumer E price (€/kWh)	Varies per year (0.19 - 038)	The 2009 Nuon retail prices are used as a basis. Corrected for inflation and corrected with the ratio of forecasted wholesale electricity prices and the 2009 wholesale price to take into account price fluctuations.
Consumer heat price (€/kWh)	Varies per year (0.078- 0.124)	The 2009 Nuon retail prices are used as a basis. Corrected for inflation and with forecasted wholesale electricity and gas prices during the lifetime of the system
Wholesale gas price (€/kWh)	Varies per year, <b>confidential</b>	Forecasted wholes gas prices by Nuon Risk Management
APX fee (€/kWh)	0.00008	From APX site
Annual APX fee	30000	From APX site
VAT	19%	
Energy tax electricity (€/kWh) 2008	0.108	From Law on environmental taxes
Energy tax heat (€/kWh)	0.022	Calculated with same formula as heat price with electricity and gas energy tax from Law on environmental taxes as input. Recalculated to value per kWh
Electricity distribution price (E/kWh) 2008	Varies per year (0.034 – 0.045)	2009 prices from the tariff decision of ‘Energiekamer’ were used as basis. The price for other years was calculated by correcting the price for inflation.
Gas distribution price (E/kWh) 2008	Varies per year (0.011 – 0.0016)	2009 prices from the tariff decision of ‘Energiekamer’ were used as basis. The price for other years was calculated by correcting the price for inflation.

**Table 27: Stirling VPP cash flows**

Cash flows (mil E)	2009	2010	2011	2012	2013	2014	2015	2016	2017	2018	2019	2020	2021	2022	2023	2024
<b>Revenues</b>																
Revenues APX	0	7	7.2	8.3	8.9	8.6	10.4	10.9	10.3	11.7	11.8	11.2	12.8	12.9	12.5	14.2
Revenues electricity prod. - electricity export	0	17	19	19	21	22	24	26	26	27	28	28	29	30	31	32
Revenues heat mCHP + heater	0	98	111	117	123	129	134	140	142	144	145	146	148	151	153	156
<b>Costs</b>																
<i>Taxes</i>																
VAT APX + electricity + heat	0	23	26	28	29	30	32	34	34	35	35	35	36	37	38	39
Energy tax supplied electricity	0	8.2	8.2	8.2	8.2	8.2	8.2	8.2	8.2	8.2	8.2	8.2	8.2	8.2	8.2	8.2
Energy tax used gas	0	27	27	27	27	27	27	27	27	27	27	27	27	27	27	27
<i>Expenses</i>																
Fuel costs mCHP + heater	0	31	35	37	38	40	42	44	44	45	45	46	46	47	48	49
Distribution costs electricity	0	3.8	3.9	4.0	4.1	4.2	4.2	4.3	4.4	4.5	4.6	4.7	4.8	4.9	5.0	5.1
Distribution costs gas	0	1.8	1.9	1.9	1.9	2.0	2.0	2.1	2.1	2.1	2.2	2.2	2.3	2.3	2.4	2.4
Maintenance costs	0	6	6	6	6	6	6	6	6	6	6	6	6	6	6	6
APX transaction fee	0	0.009	0.009	0.009	0.009	0.009	0.009	0.009	0.009	0.009	0.009	0.009	0.009	0.009	0.009	0.009
Annual APX costs	0	0.03	0.03	0.03	0.03	0.03	0.03	0.03	0.03	0.03	0.03	0.03	0.03	0.03	0.03	0.03
Investments	420	0	0	0	0	0	0	0	0	0	0	0	0	0	0	0
Depreciation	0	28	28	28	28	28	28	28	28	28	28	28	28	28	28	28
EBITDA	0	21	29	33	38	41	47	51	52	54	56	56	59	61	63	66
EBIT	0	-6.8	1.0	5.2	9.9	13.1	18.7	23.1	24.0	26.4	27.7	28.1	30.9	32.9	35.0	38.2
Net profit	0	-5.1	0.8	3.9	7.4	9.8	14.0	17.3	18.0	19.8	20.7	21.1	23.2	24.7	26.2	28.6
<b>Net cash flow</b>	<b>-420</b>	<b>22.9</b>	<b>28.8</b>	<b>31.9</b>	<b>35.4</b>	<b>37.8</b>	<b>42.0</b>	<b>45.3</b>	<b>46.0</b>	<b>47.8</b>	<b>48.7</b>	<b>49.1</b>	<b>51.2</b>	<b>52.7</b>	<b>54.2</b>	<b>56.6</b>
<b>Discounted cashflow (8% discount rate)</b>	<b>-420</b>	<b>21.2</b>	<b>24.7</b>	<b>25.3</b>	<b>26.0</b>	<b>25.8</b>	<b>26.5</b>	<b>26.4</b>	<b>24.9</b>	<b>23.9</b>	<b>22.6</b>	<b>21.1</b>	<b>20.3</b>	<b>19.4</b>	<b>18.5</b>	<b>17.9</b>

**Table 28: SOFC VPP cash flows\***

Cash flows (mil E)	2012	2013	2014	2015	2016	2017	2018	2019	2020	2021	2022
<b>Revenues</b>											
Revenues APX	0	18.1	17.8	20.4	22	21.3	22.9	24	23.2	25.1	26.2
Revenues electricity prod. - electricity export	0	61	64	69	73	75	77	79	82	83	86
Revenues heat mCHP + heater	0	124	130	136	141	143	145	146	147	150	156
<b>Costs</b>											
<i>Taxes</i>											
VAT APX + electricity + heat	0	39	40	43	45	46	46	47	48	49	51
Energy tax supplied electricity	0	23	23	23	23	23	23	23	23	23	23
Energy tax used gas	0	28	28	28	28	28	28	28	28	28	28
<i>Expenses</i>											
Fuel costs mCHP + heater	0	49	51	53	56	56	57	58	58	59	62
Distribution costs electricity	0	8.4	8.6	8.8	9.0	9.1	9.3	9.5	9.7	9.9	10.1
Distribution costs gas	0	2.5	2.5	2.6	2.6	2.7	2.7	2.8	2.8	2.9	2.9
Maintenance costs	0	7	7	7	7	107	7	7	7	7	7
APX transaction fee	0	0.019	0.019	0.019	0.019	0.019	0.019	0.019	0.019	0.019	0.019
Annual APX costs	0	0.03	0.03	0.03	0.03	0.03	0.03	0.03	0.03	0.03	0.03
Investments	580	0	0	0	0	0	0	0	0	0	0
Depreciation	0	58	58	58	58	58	58	58	58	58	58
EBITDA	0	47	51	59	66	-32	71	74	75	79	85
EBIT	0	-11	-7	1	8	-90	13	16	17	21	27
Net profit	0	-11	-7	1	6	-90	9	12	13	16	20
<b>Net cash flow</b>	<b>-580</b>	<b>46.6</b>	<b>50.7</b>	<b>58.8</b>	<b>64.0</b>	<b>-32.3</b>	<b>67.5</b>	<b>70.0</b>	<b>71.0</b>	<b>73.9</b>	<b>78.1</b>
<b>Discounted cashflow (8% discount rate)</b>	<b>-580</b>	<b>43.1</b>	<b>43.5</b>	<b>46.6</b>	<b>47.1</b>	<b>-22.0</b>	<b>42.5</b>	<b>40.9</b>	<b>38.3</b>	<b>36.9</b>	<b>36.2</b>

\*In 2017 the fuel cell stacks need to be replaced. That explains the negative cash flow and higher maintenance costs.

## Appendix D Trade revenues analysis

### D.1 APX price analysis

In the figures below, the number of times the electricity price is above the SRMC during 2006, 2007, and 2008 is shown. Since in 2008 the electricity price were very high and in 2007 very low compared to others years, a good range is shown.

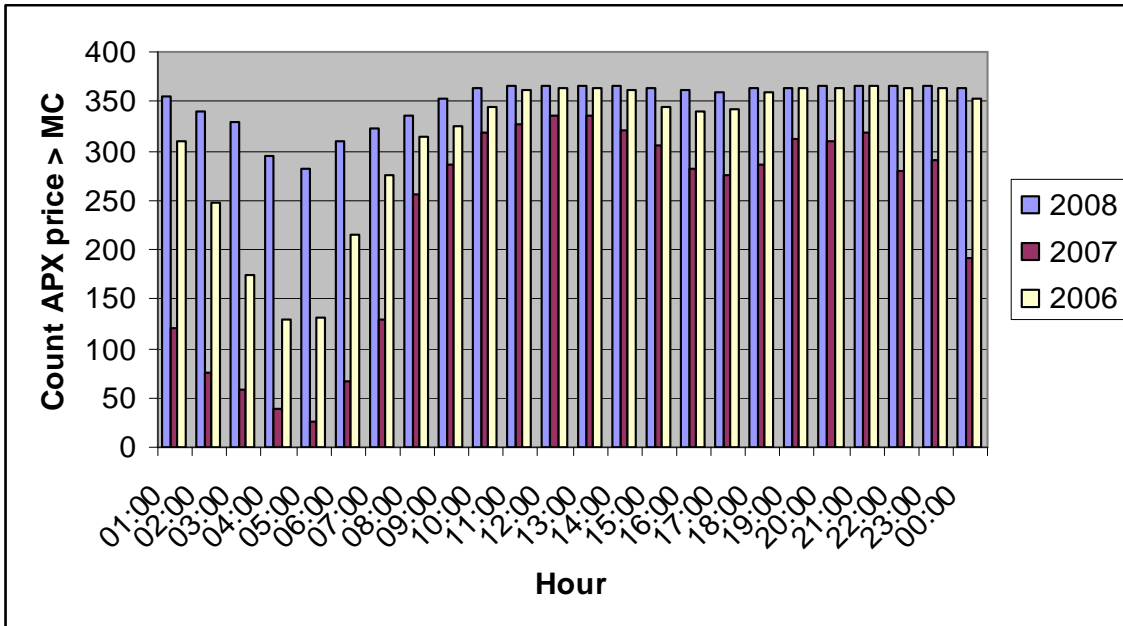

Figure 24: Hours where APX price is above SRMC of a Stirling engine

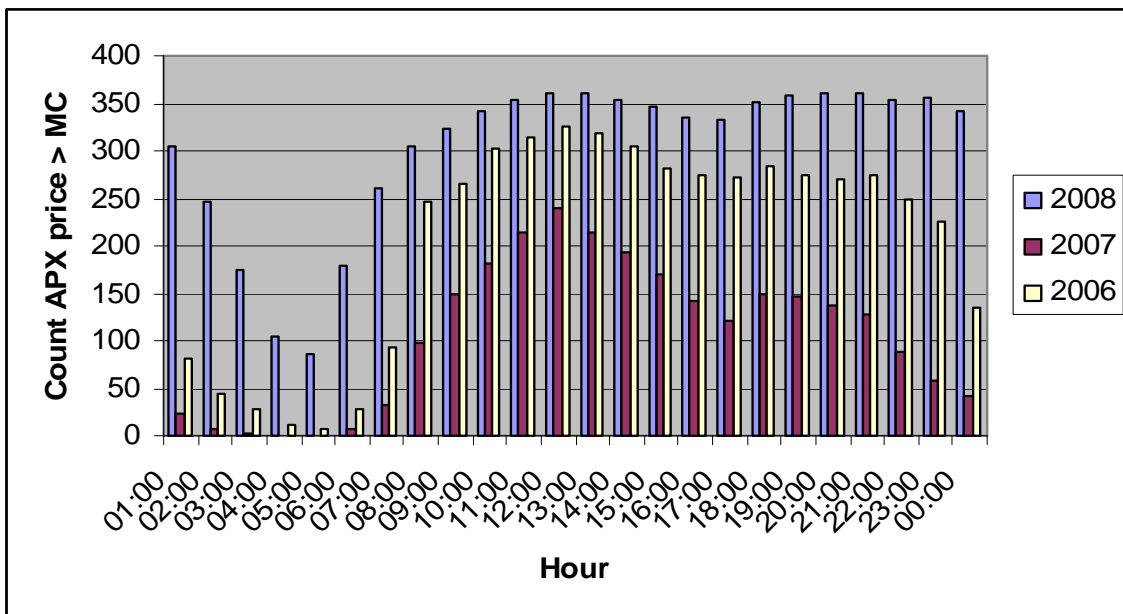

Figure 25: Hours where APX price is above SRMC of a SOFC

### D.2 Detailed assumptions trade revenue calculations

Six of the nine energy demand profiles from table 16 are measured electricity and gas demand data with a resolution of 10 minutes (the so called EBA patterns). These data were measured by IVAM<sup>78</sup> and the Amsterdam energy company in 1994. Although the household demand patterns will be different in magnitude in 2009 and in

<sup>78</sup> Department of the University of Amsterdam.

the future because of the use of different and more electric appliances and because of better insulation of houses, the yearly heat and electricity demand compare very well with data from the Nuon Retail division of the average electricity and gas demand per segment (see tables 29 and 30). So the author believes that these patterns are still very useful to produce realistic outcomes of the model.

**Table 29: Yearly household energy demand measured**

		H (kWh)		
		Low	Interm.	High
E (kWh)	Low	1339	1770	1586
		4615	12592	17447
		20	10	5
	Interm.	2148	3262	2278
		6146	12794	15010
		10	15	10
	High	5223	4638	4855
		5586	18020	22556
		5	10	15

**Table 30: : Yearly household energy demand retail**

		H (kWh)		
		Low	Interm.	High
E (kWh)	Low	1339	1530	1586
		4615	10417	17447
		2795	2884	2956
	Interm.	5351	10658	17770
		5223	5179	6903
		5586	10877	21888

Since the measured data only covered 6 of the nine possible segments, the other three demand profiles (per 15 minutes) were created with the profile methodology based on the average yearly energy demand of the household segments from the Nuon retail data (as in [Appendix..](#)). Since the profile methodology only provides hourly gas demand estimates, these were divided by four to create an average 15 min. heat demand profile. The heat demand for all profiles has been calculated by multiplying the gas demand with the LVH of gas (31.65 MJ/m<sup>3</sup>), and by multiplying with 97% to subtract the gas that is used for cooking and by 80% which is the average boiler efficiency in the Netherlands (EnergieNed, 1999).

For future electricity prices and calculation of fuel costs the yearly power price and TTF gas price estimations corrected for inflation (2%/yr) from Nuon Risk Management were used. These forecasted yearly power prices were divided by the average yearly electricity price of 2006, 2007, or 2008 and multiplied with the hourly price curves of these years repetitively till the end of the lifetime of the unit to estimate the future hourly prices. These three different price curves were used to create some variation in the future estimations.



## Appendix E Comparison of outcomes of the model with other sources

In the tables below, the figures with which the percentage deviations of the model with the outcomes of other models are presented.

<b>SOFC</b>	<i>Ruijg and Ribberink (2004b)</i>		
<i>Inputs</i>	Source	Model	Diff. (%)
Energy demand profile	EBA pattern	Idem	
Electricity demand (kWh)	438	Idem	
Heat demand (kWh)	3262	Idem	
Electrical efficiency (%)	16487	Idem	
Thermal efficiency (%)	40	Idem	
Thermal output (kW)	45	Idem	
Heat storage size (l)	1.13	Idem	
$\Delta T$ heat storage	86	Idem	
	20	Idem	
<i>Outputs</i>			
Electricity prod. kWh	5271	4884	-7
Electricity imp. (kWh)	753	667	-11
Electricity exp. (kWh)	2762	2288	-17
Heat prod. $\mu$ CHP (kWh)	5930	5494	-7
Heat prod. Boiler (kWh)	10557	11188	+6

<b>Stirling engine</b>	<i>Houwing (2009)</i>		
<i>Inputs</i>	Source	Model	Diff.(%)
Energy demand profile	Based on profile methodology	Idem	
Electricity demand (kWh)	3400	Idem	
Heat demand (kWh)	12500	Idem	
Electrical efficiency (%)	15	Idem	
Thermal efficiency (%)	85	Idem	
Thermal output (kW)	6	Idem	
Heat storage size (l)	150	Idem	
$\Delta T$ heat storage	25	Idem	
<i>Outputs</i>	Source	Model	Diff.(%)
Electricity prod. kWh	2203	2043	-7
Electricity imp. (kWh)	2431	2216	-9
Electricity exp. (kWh)	1235	860	-30
Heat prod. $\mu$ CHP (kWh)	12483	11580	-7
Heat prod. Boiler (kWh)	2	918	-
Surplus boiler heat production as percentage of source heat production			+7

## Appendix F Monte Carlo input parameters and data analysis

Below, the assumptions for the Monte Carlo simulations and the data analysis are presented. The data ranges are determined based on historical data as far as available (see table 31) For data ranges with no available historical data the range was determined on best guesses based on knowledge gained throughout the research. For all parameters a triangular probability was assumed as input for the Monte Carlo simulations.

**Table 31: Data analysis of Monte Carlo input parameters (all prices corrected for 2% inflation) (Energiekamer, 2009; EnergieNed, Energie in Nederland 2004 -2008; Gas transport services, 2009)**

	2004	2005	2006	2007	2008	Average	Deviation from value	Deviation from min. value	Deviation from max. value
Cons. electricity price (€/kWh)	0.195	0.212	0.218	0.255	0.260	0.228	14.6%	14%	
Heat price (€/GJ)	29.2	31.7	33.7	33.0	34.2	32.3	10%	6%	
Wholesale gas price (€/MWh) <sup>79</sup>			21.6	15.4	25.4	19.1	19%		33%
Energy tax electricity (€/kWh)	0.072	0.076	0.076	0.074	0.075	0.074	3.4%	1.4%	
Energy heat gas (€/kWh)	0.158	0.162	0.162	0.159	0.159	0.160	1.3%	1.4%	
Electricity distribution price (€/kWh) <sup>80</sup>		0.0353	0.0343	0.0341	0.0329	0.034	3.7%	3.4%	
Gas distribution price (€/m <sup>3</sup> )		0.0132	0.0128	0.0124	0.0112	0.012	10%	6.4%	

**Table 32: Inputs for the sensitivity and Monte Carlo analysis (based on historical data analysis and estimations)**

	<i>Expected</i>	<i>Min</i>	<i>Max</i>
Capital costs Stirling (€/unit)	3000	1500	5000
Lifetime Stirling (years)	15	10	20
Maintenance costs Stirling (€/unit/yr)	60	40	100
Capital costs SOFC (€/unit)	5000		3000 8000
Capital costs fuel cell stack	1000	500	2000
Lifetime SOFC (years)	10	5	15
Lifetime Fuel cell stack	5	3	8
Maintenance costs SOFC (€/unit/yr)	70	50	100
Capital costs heat storage (€/unit)	1000	500	2000
Capital costs local control system (€/unit)	200	100	300
Consumer electricity price (€/kWh)	As in model	-15%	+15
Consumer heat price (€/kWh)	As in model	-10%	+6%
Wholesale gas price (€/kWh)	As in model	-20%	+30%

<sup>79</sup> No data available before 2006

<sup>80</sup> Before 2005 another tariff calculation method was used by the regulator.

Energy tax electricity (€/kWh)	0.1080	-3%	2%
Energy tax gas (€/kWh)	0.022	-2%	2%
Electricity distribution price	As in model	-4%	+3%
Gas distribution price	As in model	-10%	+6%

## Appendix G Detailed description of current institutional environment

In this appendix the a more detailed description of the institutional environment is given.

In table 33 the low voltage connection requirements that are relevant to  $\mu$ CHP are summarized. For installation of production units to the low voltage network also the Dutch standard NEN 1010 for low voltage installations applies.

**Table 33: Requirements for  $\mu$ CHP units connected to the low voltage grid**

Topic	Provision	Grid Code article
Synchronisation production units	Automatic synchronization with the grid required	2.4.1.1
Power factor of production units	Can be between 0.9 capacitive and 0.9 inductive	2.4.1.2
Protection of production units	Must be selective compared to network protection systems	2.4.2.1
Protection of power electronic devices smaller than 5 kVA	Units need to be disconnected in case limits for over and under voltage, frequency deviations are violated.	2.4.2.3
Protection of synchronous generators smaller than 5 kVA	Units should be disconnected from the grid in 0.2 seconds if the network voltage drops below 70% in one of the three phases.	2.4.2.4
Protection of asynchronous generators smaller than 5 kVA	<b>No requirements</b> , however these type of generators are proven to be grid tolerant (Bozelie, 2009)	-
Grounding of generators	Units that can be operated in islanded or parallel mode must be properly grounded at the neutral point.	2.4.3.1
Requirements for rotating directly connected generators	<ul style="list-style-type: none"> <li>• Equipment to disconnect unit from grid during loss of mains required. After the grid voltage has been recovered, units smaller than 5 kVA are allowed to be immediately reconnected</li> <li>• Units must fulfil requirement of harmonic production as laid down in NEN3173:1991</li> <li>• maximum voltage drop during grid connection</li> <li>• possible measures to minimize fault level contribution</li> <li>• stable and calm behaviour required (no swinging)</li> </ul>	2.4.4
Requirements for units with a power electronic grid connection	Units with a peak power of less than 5 kVA can be reconnected directly after the voltage distortions as mentioned in 2.4.2 has been resolved have been resolved.	2.4.5.2

The changes that are proposed by Enbin to align the Grid Code with the European norm CENELEC EN 50438 are:

- $\mu$ CHP with a connection of less than 3 x 16 A can be connected to the grid without notifying the DSO beforehand unless it is planned on a project base to install several of  $\mu$ CHP units to the same part of the grid. The household has to inform the DSO within a month after the  $\mu$ CHP has been connected.
- The protection requirements for power electronic converters and generators with a connection smaller than 3 x 16 A (was <5kVA) are now equal.
- The thresholds and disconnection times in 2.4.2.3 have been changed (increased times and thresholds)
- Rotating generators should comply with a new standard for harmonic: NEN-EN 60034-1:1999
- Requirements for units with a power electronic grid connection have been adjusted: now units smaller than 11 kVA are allowed to reconnect to the grid directly after the voltage has been restored.

#### *CO<sub>2</sub> Emission trading scheme (ETS)*

The total allowable emissions are based on the Kyoto protocol obligations for each member state<sup>81</sup>. Each member state then allocates the emission allowances (emission rights) to all the existing installations based on historical emissions of the installation (Directive 2003/87/EC, article 6e). If an installation emits more than was allocated, the operator of that installation has to buy emission rights from a legal person in the European Community that has emitted less than was allocated (Directive 2003/87/EC, article 12). From 1 January 2008 to 1 January 2013, 90% of the emission permits are given free of charge to the operators of the installation (Directive 2003/87/EC, article 10). This is called the grandfathering principle.

A proposal for amending Directive 2003/87/EC to improve and extend the ETS system from 2013 (post-Kyoto) has been made by the European Commission (2008b). The following changes to the current ETS are proposed:

- EU level cap on greenhouse gas emissions instead of national caps;
- Reducing the EU cap of emission allowances for the sectors covered by the system with 1.74% per year until at least 2028 so that in 2020 the emission allowances will 21% below the 2005 emission levels;
  - If a global agreement will be reached the EU cap will be adjusted accordingly (to reach the 30% target);
- Broader scope: other big industrial emitters (chemicals, aluminum) and other greenhouse gasses besides CO<sub>2</sub> will also be included;
- Progressive replacement of the free allocation of emission allowances by auctioning the allowances;
  - Full auctioning of allowances for the power sector and carbon capture in 2013;
  - Full auctioning for all sectors in 2020;
- 20% of the revenues from the auctions should be used to combat climate change by contributing to energy efficiency, CCS etc.;
- Free allowances could be given to electricity generators for heat delivered to a district heating system or industrial installations.

---

<sup>81</sup> For the Netherlands a 6% greenhouse gas emission reduction compared to the emissions in 1990 is required.

## Appendix H Scores on criteria calculations

### Energy saving and CO<sub>2</sub> emission reduction calculations

Heat losses of a district heating system are estimated on 25% by Heidweiller (2008). The grid losses from a central power plant to the low voltage grid are 7-8% (Energiened (1996)).

Assumptions									
	El. efficiency	Th. efficiency	Grid loss (%)	Heat loss (%)	emission factor (kg/kWh)				
Stirling	0.15	0.8							
SOFC	0.5	0.35							
CHP	0.54	0.35	8%	25%					
Grid (av)	0.43		8%		0.416				
Grid (peak)	0.5		8%		0.409				
Boiler		0.9			0.23				
Gas (kg/GJ)					56.8				
<b>Stirling VPP output (kWh)</b>									
Electricity mCHP	1.87E+08					<b>SOFC VPP output (kWh)</b>			
Import electricity	2.15E+08					Electricity mCHP	4.49E+08		
Heat mCHP	9.99E+08					Import electricity	7.40E+07		
Heat boiler	2.56E+08					Heat mCHP	3.14E+08		
						Heat boiler	9.50E+08		
						Heat dump	9.54E+06		
<b>Stirling</b>									
	Energy input	CO2 output	Heat	Electricity		<b>Grid</b>			
mCHP	1.25E+09	0.255	9.99E+08	1.87E+08		Energy input	8.76E+08	0.179	Electricity (incl.loss)
Boiler	2.84E+08	0.058	2.56E+08		Grid El.	1.39E+09	0.285	1.26E+09	4.38E+08
Grid electricity	4.31E+08	0.088		2.15E+08	Boiler				
<b>Total</b>	<b>1.96E+09</b>	<b>4.02E-01</b>	<b>1.26E+09</b>	<b>4.03E+08</b>	<b>Total</b>	<b>2.27E+09</b>	<b>0.464</b>	<b>1.26E+09</b>	<b>4.38E+08</b>
					<i>Difference (%)</i>	<i>0.13</i>	<i>0.13</i>		
<b>SOFC</b>									
	Energy input	CO2 output	Heat	Electricity		<b>Grid</b>			
mCHP	8.98E+08	0.184	3.05E+08	4.49E+08		Energy input	1.32E+09	0.236	Electricity (incl.loss)
Boiler	1.06E+09	0.216	9.50E+08		Grid El.	1.39E+09	0.285	1.25E+09	5.68E+08
Grid electricity	1.72E+08			7.40E+07	Boiler				
<b>Total</b>	<b>2.13E+09</b>	<b>3.99E-01</b>	<b>1.25E+09</b>	<b>5.23E+08</b>	<b>Total</b>	<b>2.72E+09</b>	<b>0.522</b>	<b>1.25E+09</b>	<b>5.68E+08</b>
					<i>Difference (%)</i>	<i>0.22</i>	<i>0.23</i>		
<b>CHP</b>									
	Energy input	CO2 output	Heat (incl.loss)	Electricity		<b>Grid</b>			
Prod. needed with 25% loss			1.67E+09			Energy input	3.66E+09	0.655	Electricity
CHP (61%)	2.92E+09	0.596	1.02E+09	1.58E+09	Grid El.	1.39E+09	0.285	1.26E+09	1.58E+09
Boiler (39%)	7.25E+08	0.148	6.53E+08		Boiler				
Grid electricity					<b>total</b>	<b>5.06E+09</b>	<b>0.940</b>	<b>1.26E+09</b>	<b>1.58E+09</b>
<b>Total</b>	<b>3.64E+09</b>	<b>0.745</b>	<b>1.67E+09</b>	<b>1.58E+09</b>	<i>Difference (%)</i>	<i>0.28</i>	<i>0.21</i>		

### Formulas and assumptions used to calculate exergetic efficiency (Woudstra, 2008)

It is assumed that the temperature of the delivered heat is the same for all systems (65 °C) to make a fair comparison possible.

Average T requested heat	338 K	(65°C)
T environment	293 K	(20°C)
1-(T <sub>o</sub> /T <sub>Q</sub> )	0.13	
Emission factor NG	56.8	kg/GJ
f <sub>ex</sub> (Groningen Gas)	1.04	
	El. eff.	Th. eff.
Boiler	0.0	0.9
CHP (including heat and grid loss)	0.49	0.29
Stirling	0.15	0.8
SOFC	0.5	0.35

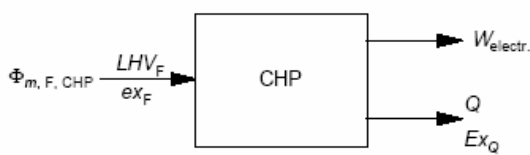

electrical efficiency: 
$$\eta_{ex,el} = \frac{W_{el}}{\Phi_{m,F} \cdot ex_F} = \frac{1}{f_{ex,F}} \cdot \frac{W_{el}}{\Phi_{m,F} \cdot LHV_F} = \frac{1}{f_{ex,F}} \cdot \eta_{th,el}$$

heat efficiency: 
$$\eta_{ex,Q} = \frac{EX_Q}{\Phi_{m,F} \cdot ex_F} \quad \text{with:} \quad EX_Q = Q \cdot \left(1 - \frac{T_0}{T_Q}\right)$$

this becomes:

$$\eta_{ex,Q} = \frac{Q}{\Phi_{m,F} \cdot LHV_F} \cdot \frac{1}{f_{ex,F}} \cdot \left(1 - \frac{T_0}{T_Q}\right) \quad \text{or:} \quad \eta_{ex,Q} = \eta_{th,Q} \cdot \frac{1}{f_{ex,F}} \cdot \left(1 - \frac{T_0}{T_Q}\right)$$

overall efficiency: 
$$\eta_{ex,overall} = \eta_{ex,el} + \eta_{ex,Q} = \frac{1}{f_{ex,F}} \cdot \left[ \eta_{th,el} + \eta_{th,Q} \cdot \left(1 - \frac{T_0}{T_Q}\right) \right]$$

### Cost calculations

Assumed capacity factor district heating system: 0.30 (based on CHP district heating system data from Nuon Energy trade and Wholesale). All costs for the CHP + district heating system are from Heidweiller (2008) and Hendriks (2009).

#### Assumptions CHP + district heating

<b>CCGT CHP</b>	
Electrical efficiency	0.54
Thermal efficiency	0.35
Current capex <sup>82</sup> CCGT (€/kWe)	750
Maintenance costs (% of Capex)	3
P <sub>el</sub>	450 MW
P <sub>th</sub>	292 MW
Capacity factor	0.30
Lifetime	30 yr
<b>Pipeline data</b>	
Capex primary grid (€/household equivalent)	3000
Capex secondary grid (€/woning equivalent)	3800
Capex substations (€/woning equivalent)	350
Maintenance costs primary grid (% capex)	2
Maintenance costs secondary grid (% capex)	2.5
Maintenance costs substations (% capex)	3
Lifetime	50 yr

	<b>Stirling</b>	<b>SOFC</b>	<b>CHP +DH</b>
Capex (15 yr) € mil.	6.20E+08	8.70E+08	3.83E+08
Energy saving GJ	1.10E+06	2.13E+06	5.10E+06
Capex €/GJ	563	409	75

<sup>82</sup> Capital expenditures