

## Techno-economic and ex-ante environmental assessment of C6 sugars production from spruce and corn. Comparison of organosolv and wet milling technologies

Moncada, Jonathan; Vural Gursel, Iris; Huijgen, Wouter J.J.; Dijkstra, Jan Wilco; Ramirez Ramirez, C.A.

**DOI**

[10.1016/j.jclepro.2017.09.195](https://doi.org/10.1016/j.jclepro.2017.09.195)

**Publication date**

2018

**Document Version**

Final published version

**Published in**

Journal of Cleaner Production

**Citation (APA)**

Moncada, J., Vural Gursel, I., Huijgen, W. J. J., Dijkstra, J. W., & Ramirez Ramirez, C. A. (2018). Techno-economic and ex-ante environmental assessment of C6 sugars production from spruce and corn. Comparison of organosolv and wet milling technologies. *Journal of Cleaner Production*, 170, 610-624. <https://doi.org/10.1016/j.jclepro.2017.09.195>

**Important note**

To cite this publication, please use the final published version (if applicable). Please check the document version above.

**Copyright**

Other than for strictly personal use, it is not permitted to download, forward or distribute the text or part of it, without the consent of the author(s) and/or copyright holder(s), unless the work is under an open content license such as Creative Commons.

**Takedown policy**

Please contact us and provide details if you believe this document breaches copyrights. We will remove access to the work immediately and investigate your claim.

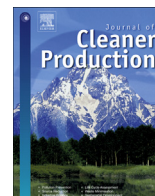

# Techno-economic and ex-ante environmental assessment of C6 sugars production from spruce and corn. Comparison of organosolv and wet milling technologies



Jonathan Moncada<sup>a,\*</sup>, Iris Vural Gursel<sup>a</sup>, Wouter J.J. Huijgen<sup>b</sup>, Jan Wilco Dijkstra<sup>b</sup>,  
Andrea Ramírez<sup>a,c</sup>

<sup>a</sup> Energy & Resources, Copernicus Institute of Sustainable Development, Utrecht University, The Netherlands

<sup>b</sup> Biomass & Energy Efficiency, Energy Research Centre of the Netherlands (ECN), Petten, The Netherlands

<sup>c</sup> Energy & Industry, Faculty of Technology, Policy and Management, Delft University of Technology, The Netherlands

## ARTICLE INFO

### Article history:

Received 17 April 2017

Received in revised form

17 September 2017

Accepted 20 September 2017

Available online 21 September 2017

### Keywords:

Organosolv

Corn wet milling

C6 sugar

Lignin

Techno-economic assessment

Environmental assessment

## ABSTRACT

This study assesses the techno-economic and environmental performance of C6 sugars production from softwood (spruce) and corn. Two technologies were considered in the assessment: organosolv of spruce woodchips (2nd generation) and corn wet milling (1st generation). Process models were developed to generate relevant data to assess the technical performance and derive inputs for the economic and environmental assessments. The economic assessment was carried out using Net Present Value (NPV) as indicator, while the environmental assessment followed a prospective cradle-to-gate life cycle assessment (LCA) for 5 impact categories. The results indicate that when organosolv is integrated with an anaerobic digestion unit, the net energy requirements are lower than those of the wet milling process to produce an equivalent flowrate of C6 sugars. Assuming equivalent C6 sugar prices for the two technologies (300 €/t), the corn based technology shows positive NPV (178 M€) and lowest fixed capital investment requirements (55 M€). The organosolv technology (coupled to anaerobic digestion) also shows positive NPV (238 M€) at base case lignin prices (630 €/t), but higher fixed capital investment needs (236 M€). The economics of the organosolv process were found to be highly sensitive to sugar and lignin yields and prices as well as biomass feedstock costs. From an environmental perspective, the organosolv based routes show relatively better performance than corn wet milling, with 3 categories including climate change and non-renewable energy use showing lower impacts and 2 showing potentially higher impacts. Overall, the organosolv process (2nd generation) shows better performance from an environmental point of view in addition to a positive NPV. However, the inherent risks of new technologies and high investments associated with the 2nd generation technologies assessed in this work, mean that significant additional development, coupled with appropriate government support, are likely necessary before full-scale implementation.

© 2017 Elsevier Ltd. All rights reserved.

## 1. Introduction

Biomass is a plentiful renewable raw material that can contribute to reach global warming targets by decarbonizing products that are conventionally produced from fossil sources. The biorefinery concept has been widely defined as an analogy to oil

refineries where a large portfolio of products can be obtained (Cherubini, 2010). Biorefineries are classified according to feedstocks, processes, platforms and products (Cherubini et al., 2009). Similar to the oil industry, the platforms link the feedstocks with final products by a number of processing steps (Cherubini et al., 2009; de Jong et al., 2012).

In biorefineries, the most common platform chemicals are syngas, biogas, vegetable oils, organic solutions (nutrient rich juice extracted from fresh wet biomass such as grass), lignin, pyrolysis oil and carbohydrates (Cherubini et al., 2009; de Jong et al., 2012). The carbohydrates platform offers a wide variety of options to produce

\* Corresponding author. Energy & Resources, Copernicus Institute of Sustainable Development, Utrecht University, Heidelberglaan 2, 3584 CS, Utrecht, The Netherlands.

E-mail address: [J.MoncadaBotero@uu.nl](mailto:J.MoncadaBotero@uu.nl) (J. Moncada).

valuable products such as alcohols, organic acids, polyols among other (Bozell and Petersen, 2010; Maity, 2015).

The carbohydrates platform can be obtained from crops such as corn, sugarcane and sugar beets, and from lignocellulosic biomass such as wood and wood residues, grasses and agricultural residues. There are many technologies to convert biomass into the carbohydrates platform (*i.e.*, disaccharides, C5 and C6 sugars) either from food crops or lignocellulosic feedstocks. In the case of food crops feedstocks, the most common are corn wet milling (Ramirez et al., 2008), sugarcane milling (Luo et al., 2009) and sugar beets milling (Renouf et al., 2008). In the case of lignocellulosic biomass, biomass pretreatment is generally applied first to enable effective enzymatic saccharification. Among the most common pretreatment methods are dilute acid, soda pulping, steam explosion and organosolv (Kudakasseril Kurian et al., 2013; Menon and Rao, 2012). In the pretreatment stage, the lignocellulosic biomass is may be simultaneously refined into its main components and three main streams are obtained, namely: lignin, hemicellulose hydrolysate (hemicellulose fraction) and cellulose pulp. Lignin can be considered a by-product which can be marketed (Zakzeski et al., 2010). The hemicellulose hydrolysate can be used for fermentation (*e.g.*, to produce ethanol) (Menon and Rao, 2012), to obtain other products such as furfural (Bhaumik and Dhepe, 2013), or as feed for anaerobic digestion (Nitzsche et al., 2016). The pulp stream (rich in cellulose) is generally used as substrate for its further enzymatic hydrolysis into C6 sugars (Menon and Rao, 2012).

Currently, there is a debate on the use of food related feedstocks for biorefinery systems (*e.g.*, crops for 1st generation (1G) technologies) due to sustainability concerns such as environmental impacts related to land use change and food security (Karlsson et al., 2014; Wiloso et al., 2012). Consequently, increasing attention has been paid on producing energy carriers and materials from lignocellulosic biomass (as feedstock for 2nd generation (2G) technologies) due to its abundancy, potential lower costs than crops, potential reductions on land use change and non-competition with food (Eerhart et al., 2015; Karlsson et al., 2014; Wiloso et al., 2012). In this context, techno-economic and environmental assessments of biorefinery systems based on lignocellulosic feedstocks are needed in order to be able to early identify potential bottlenecks and adopt lessons learned from the processing of crop related feedstocks. Many of the studies carrying out techno-economic and/or environmental assessments comparing food related and lignocellulosic feedstocks, generally focus on a final product such as bioethanol (Bernardi et al., 2013; Miret et al., 2016; Watanabe et al., 2015) and little attention has been paid to the comparison of C6 sugars production which can be used for fuels production (*e.g.*, ethanol, butanol) and/or chemicals production (*e.g.*, lactic acid, succinic acid).

In this study, techno-economic and ex-ante environmental assessments of C6 sugars production are carried out for one 2G technology for lignocellulosic biomass conversion and one 1G technology for food crops processing. Corn is used as representative food crop feedstock for the production of C6 sugar. The wet milling technology was selected due to the relatively high maturity of this technology in the USA (Ramirez et al., 2008), and the role that corn may play as a source of C6 sugars in Europe (Tsiropoulos et al., 2013). In the case of lignocellulosic biomass, various biomass sources were considered as candidates for the production of C6 sugars such as agricultural residues (*e.g.*, wheat straw, cane bagasse, rice straw, corn stover) and, wood and wood residues (*e.g.*, softwood, hardwood). Although agricultural residues have large potential due to their availability, their supply at large scale is complicated by issues in collection, handling, and transport as well as the relatively fragmented supply chain in some countries (Bakker et al., 2013). Instead, as representative of lignocellulosic

biomass, softwood (spruce in this case) was selected as feedstock relying on the advantage and maturity related to logistics, large biomass supply and general infrastructure of the existing pulp and paper industry (Palgan and McCormick, 2016). Organosolv technology was selected as pretreatment technology as it allows obtaining good pulp quality for further conversion into C6 sugars, as well as a lignin by-product, which can be used for further conversion into high value-added chemicals (Ennaert et al., 2016; Nitzsche et al., 2016; Wildschut et al., 2013).

In summary, three main questions will be addressed in the article: i) What is the technical performance of the organosolv process for producing C6 sugars<sup>1</sup> from spruce in comparison to the wet milling process for producing C6 sugar from corn?; ii) What is the economic performance of the organosolv process to produce C6 sugars from spruce in comparison to the wet milling process for producing C6 sugars from corn?; and iii) What is the ex-ante environmental performance (in key impact categories) of the organosolv process for producing C6 sugars from spruce in comparison to the wet milling of corn for producing C6 sugars?

## 2. Methodology

This study has three levels of analysis. The first level compares the production of C6 sugars from lignocellulosic biomass and corn from a technical perspective on the processing level (*e.g.*, mass flows, energy consumption, processing yields). The second level focuses on the economic analysis (*e.g.*, production costs, net present value). The third level focuses on the Life Cycle Assessment of the production of C6 sugars for each option. The three levels of analysis are linked to each other (see Fig. 1). In the first step, the pretreatment technology, feedstock (*i.e.*, lignocellulosic biomass), plant capacity and location were defined. Simultaneously, a benchmark technology, feedstock (*i.e.*, corn) and plant capacity were also selected. In the second step, data such as feedstock composition, conversion steps, product distribution and energy consumption of each technology option were collected and used as input for the process modeling, economic and environmental assessments. The third step is the development of process models for both technologies (*i.e.*, second generation and first generation) aiming to generate mass and energy balances. The fourth step is the economic and environmental assessments. Final results have been obtained after feedback and fine-tuning of the data after several runs.

### 2.1. Plant capacities

A plant capacity of 1000 kt of dry wood (feedstock) per year was defined, considering that large scale of biomass processing is needed to economically compete with conventional fossil refineries (Thornley et al., 2014). Organosolv processes also showed benefits from economies of scale as reported in previous studies (Viell et al., 2013). The plant capacity of corn processing was set to match the capacity of C6 sugars produced with the organosolv technology. To be able to compare both feedstocks and technologies under the same basis, the port of Rotterdam was assumed as location for both lignocellulosic and corn based C6 sugars production.

### 2.2. Process modeling

Process models were developed in Aspen Plus v8.4 (Aspen

<sup>1</sup> In this work, C6 sugars refer to hexoses (mainly glucose) derived from the cellulose fraction of spruce. In the case of corn, C6 sugars refer to hexoses (mainly glucose and fructose).

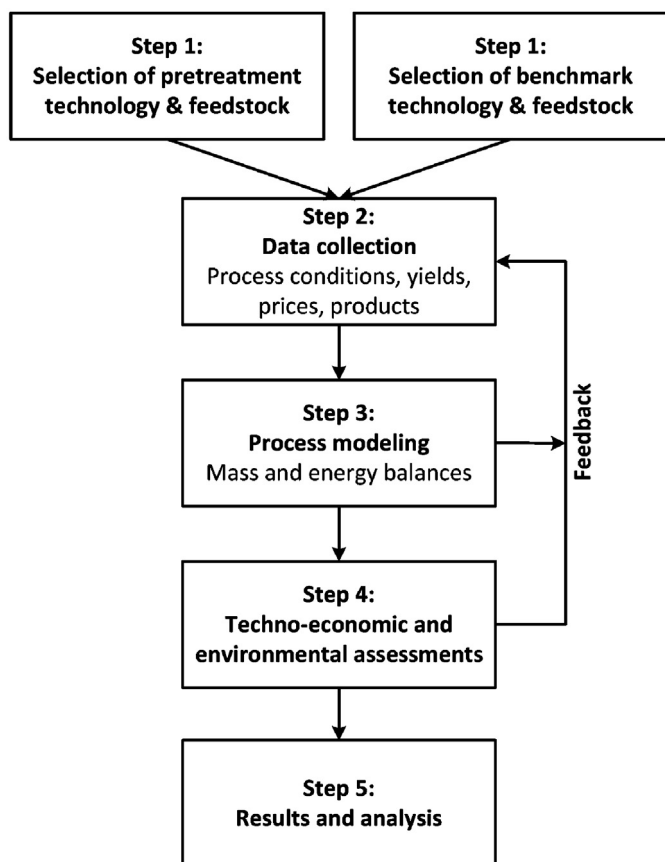

Fig. 1. General description of the methodological approach for the comparative assessment of C6 sugars production from lignocellulosic biomass and corn.

Technology, Inc., USA). As several of the compounds involved in the modeling were not available in the databases of Aspen Properties, a property database of the National Renewable Energy Laboratory was used, which is based on the work of Wooley and Putsche (1996). Furthermore, the nonrandom two-liquid (NRTL) thermodynamic model was used to calculate the activity coefficients of the liquid phase and the Hayden O'Connell equation of state was used to describe the vapor phase. All processes are assumed in continuous mode and whole year operation (*i.e.*, 8000 h/y). In all cases energy integration was considered by using excess heat of available streams, nevertheless, optimization using pinch analysis was not considered. Integration of water stream and water recycling was not considered in the scope of this study.

### 2.3. Process description

This section provides a brief description of the processes and main assumptions used for model them.

#### 2.3.1. Organosolv process

The organosolv processes (see Fig. 2) is composed of four main sections: i) spruce wood chips conditioning and organosolv fractionation; ii) lignin precipitation and recovery; iii) solvent recovery and recycling, and iv) pulp stripping and enzymatic hydrolysis. The main outputs of this process are the C6 sugar stream (crystallized), organosolv lignin (dried), furfural (concentrated, 97 wt%), non-converted solids (from enzymatic hydrolysis, diluted stream) and hemicellulose derived sugars (including extractives, diluted stream). It should be mentioned

that since organosolv fractionation is a technology under development, not all unit operations as depicted in Fig. 2 have been technically proven (for example, lignin precipitator (column 12) and pulp stripper (column 5)).

The main data inputs are the composition of spruce wood, process conditions and set of reactions describing the organosolv fractionation. The chemical composition of spruce wood was gathered from the work of (Constant et al., 2016), and assuming a water content of 10 wt%. The organosolv reactor operates at 190 °C and 15 bar, using sulfuric acid as catalyst (dosage 10 mM), and a solid to liquid ratio of 5 L per kg of dry biomass using ethanol as solvent at 60 wt% in water. Conditions used for the organosolv fractionation were taken from (Constant et al., 2016). Delignification and hemicellulose hydrolysis reactions during the organosolv fractionation step were proposed based on lignin and pulp recovering yields reported by (Constant et al., 2016). The chemical composition of spruce, organosolv description and set of reactions can be found in the supplementary information section (Section S1.1), as well as the assumptions on process parameters used in solvent recovery steps and enzymatic hydrolysis of pulp.

#### 2.3.2. Anaerobic digestion

The hemicellulose sugar stream from the organosolv process and non-converted solid stream from the enzymatic hydrolysis contain significant amounts of organics such as C6 sugars, C5 sugars, humins, furans, extractives, lignin and hemicellulose.<sup>2</sup> An option for utilizing these streams is to develop by-product recovery and separation systems and extract *e.g.* the useful sugars as additional products. However, since these are complex streams which are diluted in water, product separation is probably energy-intensive and costly (Michels, 2014; Nitzsche et al., 2016). Therefore, this study considers the use hemicellulosic sugars and non-converted solids streams, as feedstock to produce biogas and later heat and power to fully (or partially) cover the demand of the organosolv process. The biogas unit was modeled using biogas yields according to the description provided by (Nitzsche et al., 2016), and the combined cycle system for producing steam and electricity was modeled according to descriptions provided in (Moncada et al., 2013; Rincón et al., 2014).

Fig. 3 shows the simplified flowsheet diagram of the biogas plant coupled to a combined heat and power unit. The detailed explanation of input data and assumptions used to model the anaerobic digestion process can be found in the supplementary information (Section S1.2).

#### 2.3.3. Corn wet milling

This system (see Fig. 4) is comprised of four main sections: i) handling and steeping; ii) germ and fiber separation; iii) gluten separation, and iv) starch separation and hydrolysis. Input data (*e.g.*, process yields, utilities consumption, consumables) to calculate the mass and energy balances for was gathered from (Ramirez et al., 2008). Additional steps on the hydrolysis stage (conversion of starch into glucose) were incorporated using calculations in Aspen Plus. The main outputs of this technology are the C6 sugars stream, corn germ, corn gluten meal and corn gluten feed. Detailed information on input data and assumptions used to model the corn wet milling process is provided in the supplementary information (Section S1.3).

<sup>2</sup> C6 sugars, furans and humins are the major compounds in the hemicellulose rich stream derived from the organosolv process. Lignin and hemicellulose are the major compounds of the non-converted solids resulted from the enzymatic hydrolysis step.

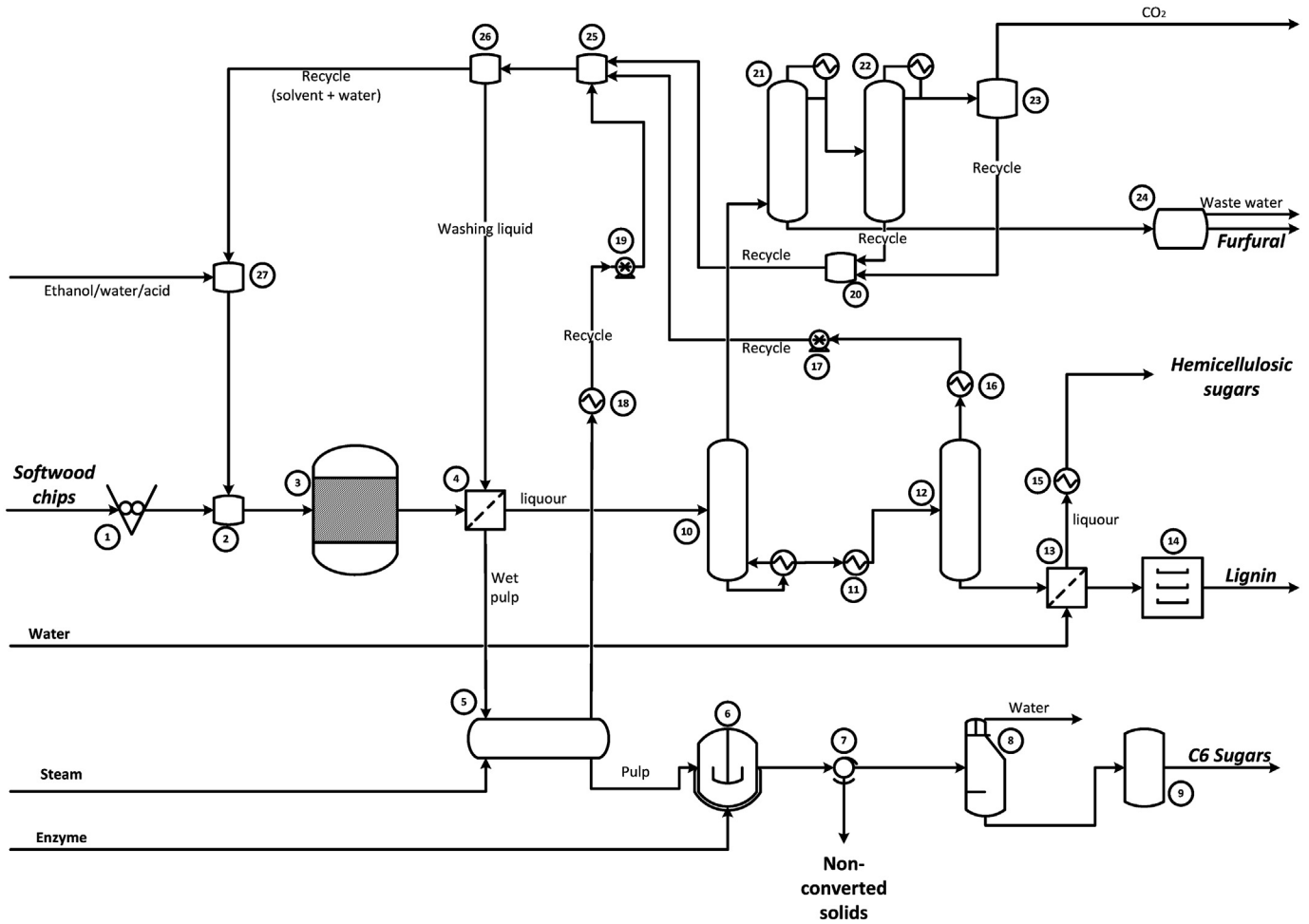

**Fig. 2.** Simplified flowsheet diagram of organosolv fractionation of spruce wood chips to produce C6 sugars and lignin. Equipment list: 1. Milling, 2. Mixer, 3. Organosolv reactor, 4. Filter/Washer, 5. Pulp stripping, 6. Enzymatic hydrolysis reactor, 7. Filter/Washer, 8. Evaporation train, 9. Crystallizer, 10. Column 1, 11. Heat Exchanger, 12. Column 2 (Precipitator), 13. Filter, 14. Dryer, 15. Heat Exchanger, 16. Heat Exchanger, 17. Pump, 20. Mixer, 21. Column 4, 22. Column 5, 23. Knockout drum, 24. Decanter, 25. Mixer, 26. Mixer, 27. Mixer. Process modeled based on descriptions from (Nitzsche et al., 2016; van der Linden et al., 2012).

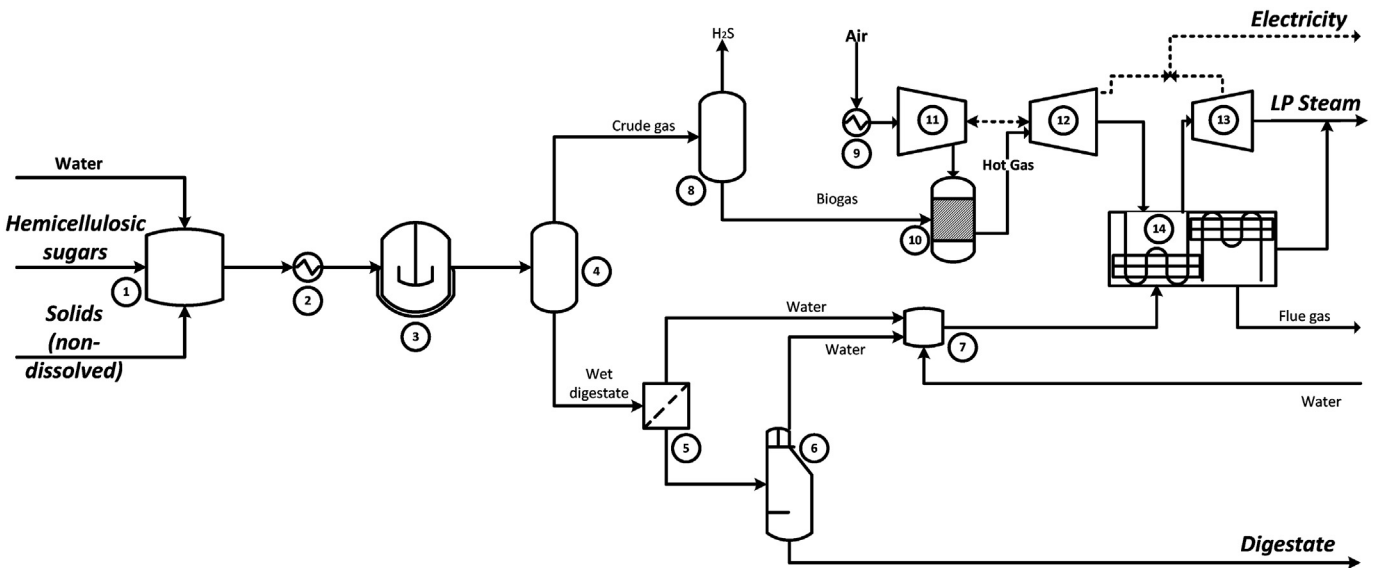

**Fig. 3.** Simplified flowsheet diagram of anaerobic digestion integrated to a combined heat and power unit. Equipment list: 1. Mixer tank, 2. Heat exchanger, 3. Digester, 4. Gas separation, 5. Dewatering, 6. Evaporation and drying, 7. Mixer, 8. Gas Cleaning, 9. Heat Exchanger, 10. Combustion Chamber, 11. Compressor, 12. Gas Turbine, 13. Steam Turbine, 14. Heat Recovery Steam Generator (HRSG).

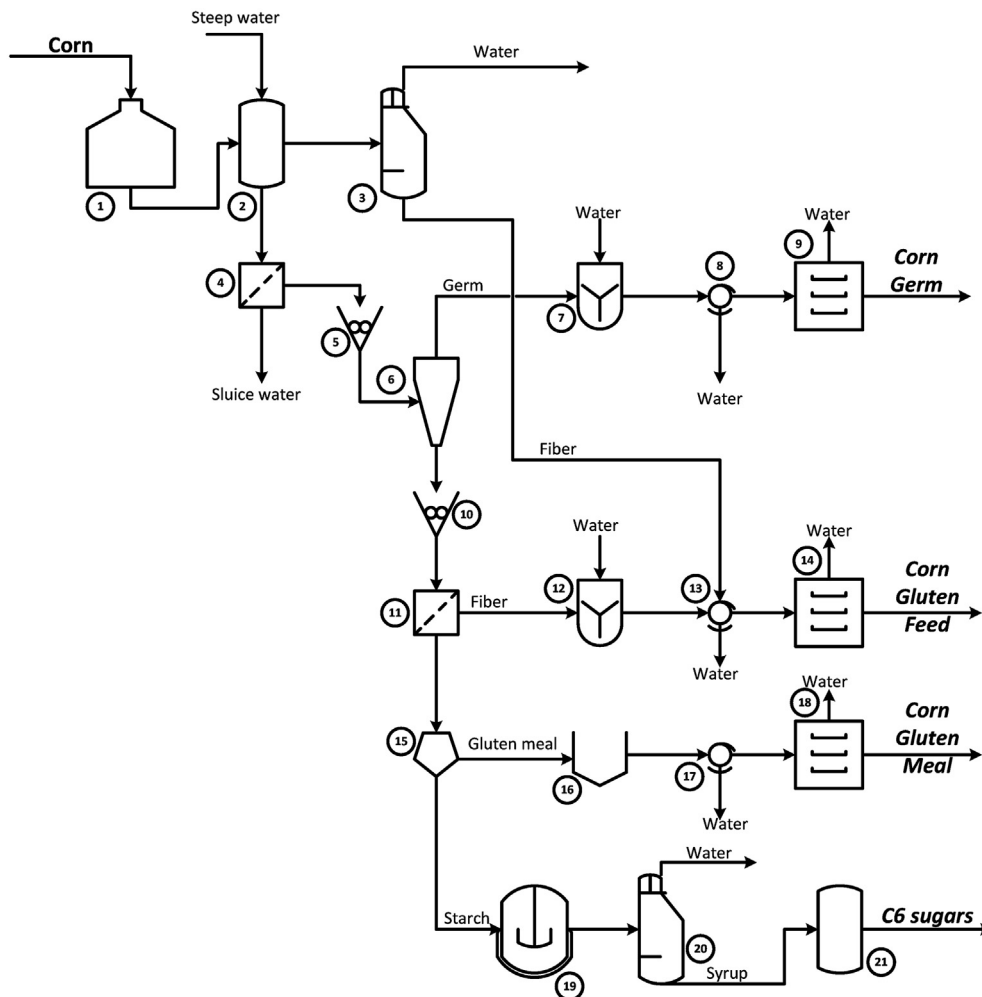

**Fig. 4.** Simplified flow diagram of the corn wet milling process. Equipment list: 1. Corn Storage, 2. Corn Steeping, 3. Steep water evaporator, 4. Screen, 5. Mill, 6. Germ Separator, 7. Washer, 8. Dewatering, 9. Dryer, 10. Mill, 11. Screen, 12. Washer, 13. Dewatering, 14. Dryer, 15. Centrifuge, 16. Thickener, 17. Dewatering, 18. Dryer, 19. Starch Hydrolysis, 20. Evaporator, 21. Crystallizer.

#### 2.4. Process systems

Three systems were considered for the technical, economic and environmental assessments. These systems allow us to compare organosolv with and without anaerobic digestion with corn wet milling, and assess the effect of the integration of anaerobic digestion to the organosolv system. System I consists of standalone organosolv (including hydrolysis) to produce C6 sugars, lignin and furfural. The hemicellulose sugar stream and the non-converted solid from the enzymatic hydrolysis are assumed as waste streams (see Section 2.3.1), implying that the hemicellulose fraction is not valorized. System II consist of organosolv plus anaerobic digestion to account for the use of the hemicellulose hydrolysate stream and non-converted solids. The system will assess whether their further processing improves the overall performance of the organosolv system (see Section 2.3.2). In this system, the products are C6 sugars, lignin furfural, digestate (can be considered as bio-fertilizer) and electricity. System III is the corn wet milling process (benchmark).

#### 2.5. Economic assessment

The economic assessment provides an overview of the capital and operating costs, which were estimated using information

(equipment list, mass and energy flows) generated in the process modeling. In the case of the organosolv and anaerobic digestion processes, the capital investment is based on adding up equipment costs (estimated using Aspen Economic Analyzer v8.4) and using typical factors for capital investment according to (Peters et al., 2003). The factors used in this study can be found in the supplementary information Section S2. In the case of the wet milling process, the capital investment was estimated using the capital costs data reported by (Ramirez et al., 2008). Since the capital costs only covers until the starch recovery step, the equipment costs of the hydrolysis step were estimated using Aspen Economic Analyzer v8.4. All costs were updated to 2014 prices using the Chemical Engineering Plant Cost Index (CEPCI) and are expressed in Euros. When necessary an average 2014 exchange rate of 0.784 €/USD was applied.

Annualized costs include raw materials, utilities, maintenance, labor, fixed & general, overheads and capital depreciation. Raw materials costs were based on the mass balances, and prices. Utilities costs were estimated using energy balances and prices calculated as additional process modules based on the equations reported by (Ulrich and Vasudevan, 2006) and updated to 2014 prices (using 2014 CEPCI). Labor costs consisted of operating labor cost (3 shifts of 8 h each, 10 operators per shift for organosolv and 5 for wet milling), operating supervision cost and laboratory charges

cost (Peters et al., 2003). The yearly wage was assumed at 50,000 € per person. Additional cost categories such as maintenance, fixed & general, and plant overhead were included in the analysis. Estimation of these categories was carried out using typical factors (Peters et al., 2003) as shown in supplementary information (Section S2). Green premiums, CO<sub>2</sub> credits and subsidies were not taken into account in the analysis. Capital depreciation was estimated using the straight line method for a depreciation time of 10 years based on suggestions by (Peters et al., 2003).

To assess the profitability of each system, the Net Present Value (NPV) was used as indicator. The NPV was estimated for 20 years using information on capital investment, operating costs and revenues from products by calculating discounted cash flows. The discount rate was set to 10% and income tax of 25% for the Netherlands (NPV calculations after taxes). Each step considered in NPV calculations were based on those reported by (Peters et al., 2003). Details on NPV calculations are provided in the supplementary information Section S5. Prices and main economic input parameters used in the assessment are displayed in Table 1.

Sensitivity analyses were considered at two different levels. The first one corresponds to changes in NPV results when conversions from lignin and glucan in the organosolv fractionation step were increased or decreased, and also when pulp digestibility is increased or decreased in the enzymatic hydrolysis step (in the organosolv process). The set of conversions considered in the sensitivity analysis are listed in Section S2 in the supplementary material. The second level, corresponds to changes in NPV results when input prices change up to 50% above and below the reference values shown in Table 1. These sensitivity analyses allow identifying key parameters affecting the economic analysis accounting for both uncertainties in the performance of the technology and uncertainty in economic parameters such as volatility in prices.

## 2.6. Life cycle assessment

The life cycle assessment was carried out following the steps suggested by the International Standardization Organization (ISO) in their ISO 14040 series (ISO, 2006).

**Table 1**  
Price inputs used in economic assessment of organosolv, anaerobic digestion and corn wet milling processes.

| Feature   | Value | Unit             | Reference   |
|---|-------|------------------|---|
| Spruce woodchips                                      | 100   | €/t (dry)        | Based on (Skogsstyrelsen, 2014)   |
| Sulfuric Acid <sup>a</sup>                            | 220   | €/t              | Average from (Alibaba, 2015)  |
| Cellulase Enzyme cocktail <sup>a</sup>                | 2000  | €/t              | (Nitzsche et al., 2016)   |
| Ethanol <sup>a</sup>                                  | 620   | €/t              | (Platts, 2016), Price assumed to be applicable for 2014                                 |
| Lignin <sup>a,b</sup>                                 | 630   | €/t              | (Nitzsche et al., 2016)   |
| C6 sugars <sup>a</sup>                                | 300   | €/t              | Price assumed based on ranges reported by (Torres et al., 2010) and by (Michels, 2014). |
| Furfural <sup>a</sup>                                 | 900   | €/t              | Average from (Alibaba, 2015)  |
| Natural Gas Price <sup>a</sup>                        | 11    | €/GJ             | (IEA, 2015), Price assumed to be applicable for 2014                                    |
| Electricity <sup>a</sup>                              | 0.10  | €/kWh            | (IEA, 2015), Price assumed to be applicable for 2014                                    |
| Digestate   | 10    | €/t              | Price assumed based on (Gebrezgabher et al., 2010) and updated to 2014                  |
| Corn <sup>a</sup>                                     | 160   | €/t              | Price based on (Indexmundi, 2015)   |
| Sulfur <sup>a</sup>                                   | 10    | €/t              | Average from (Alibaba, 2015)  |
| Gluten feed <sup>a</sup>                              | 158   | €/t              | Price based on (U.S.Grains, 2015)   |
| Germ <sup>a</sup>                                     | 270   | €/t              | Price based on (U.S.Grains, 2015)   |
| Gluten meal <sup>a</sup>                              | 632   | €/t              | Price based on (U.S.Grains, 2015)   |
| α-Amylase, gluco-amylase enzyme cocktail <sup>a</sup> | 700   | €/t              | Average from (Alibaba, 2015)  |
| Cooling Water <sup>c</sup>                            | 0.12  | €/m <sup>3</sup> | Based on (Ulrich and Vasudevan, 2006) and updated to 2014 price                         |
| Low-pressure Steam <sup>c</sup>                       | 40    | €/t              | Based on (Ulrich and Vasudevan, 2006) and updated to 2014 price                         |
| Mid-pressure Steam <sup>c</sup>                       | 46    | €/t              | Based on (Ulrich and Vasudevan, 2006) and updated to 2014 price                         |
| Wastewater treatment <sup>c</sup>                     | 0.08  | €/m <sup>3</sup> | Based on (Ulrich and Vasudevan, 2006) and updated to 2014 price                         |
| Process water <sup>c</sup>                            | 0.10  | €/m <sup>3</sup> | Based on (Ulrich and Vasudevan, 2006) and updated to 2014 price                         |
| Demineralized water <sup>c</sup>                      | 6.53  | €/m <sup>3</sup> | Based on (Ulrich and Vasudevan, 2006) and updated to 2014 price                         |
| Solid disposal <sup>c</sup>                           | 23    | €/t              | Based on (Ulrich and Vasudevan, 2006) and updated to 2014 price                         |

<sup>a</sup> Prices assumed to be representative for 2014.

<sup>b</sup> Price of lignin considered for high value added applications. Assumed as market price for organosolv lignin.

<sup>c</sup> Prices calculated using the equations proposed by (Ulrich and Vasudevan, 2006), updated to 2014 prices using the CE PCI, and using natural gas as fuel source in the Netherlands (11 €/GJ, (IEA, 2015)).

### 2.6.1. Goal definition and system boundaries

The analyses use three systems considered in the techno-economic assessment (see Section 2.4). Each system is divided into three main process modules (stages of the life cycle): feedstock production (i.e., spruce woodchips and corn), feedstock transportation (i.e., transportation to the processing facility) and bio-refinery (i.e., feedstock processing). Utilities production, auxiliary raw materials production (e.g., enzymes, solvents, sulfuric acid) and waste treatment/disposal are considered within the LCA. The system boundaries correspond to the aggregation of all process modules, and is a cradle-to-gate analysis. System boundaries are depicted in Figs. S1–S3 in the supplementary information.

The functional unit is 1 kg of C6 (dry) sugars since the objective of the analysis is to compare the environmental performance of C6 sugars from lignocellulosic biomass and corn. The three systems are multiproduct biorefineries, which implies multi-functionality. As a consequence, the environmental impacts need to be allocated among the different products.

In this study, two main approaches were considered:

- 1) All environmental impacts were allocated to the C6 sugars stream, leaving all co-products burden free. From the point of view of C6 sugars production, this is the most conservative case.
- 2) Distributing the impacts between the main product and co-products using mass allocation. For all systems allocation factors were calculated using equation (1).

$$AF_i = \frac{m_i}{\sum_{j=1}^n m_j} \quad (1)$$

where  $AF$  are the allocation factors,  $m$  the product flowrates, and  $i, j$  counters for the products.

In the case of the electricity produced in system II, mass allocation is not possible to be applied. However, a fraction of the biogas produced can be associated to the production of electricity. This mass was then used to calculate the electricity mass allocation factor. Justification of the allocation approaches and detailed justification of the approach for calculating the allocation factor for

electricity can be found in the supplementary information (S3).

The LCA was carried out for 4 impact categories using the ReCiPe impact characterization method (Goedkoop et al., 2009): Climate change potential (CCP), water depletion potential (WDP), agricultural land depletion potential (ALOP), and human toxicity potential (HTP). Non-renewable energy use (NREU) was considered as additional impact category, using the non-renewable section of the cumulative energy demand characterization method (Hischier et al., 2010).

### 2.6.2. Life cycle inventory and data

Detailed explanation of the assumptions and data inputs of the feedstock production and transportation steps can be found in the supplementary information (Section S4). Data related to impacts of corn and woodchips was gathered from the Ecoinvent v2.2 databases (Ecoinvent, 2010). Data related to drying efficiency of woodchips and transport efficiencies (rail and maritime) was gathered from (Giuntoli et al., 2014). Additional data on rail transport efficiencies was collected from (UIC and IEA, 2014). Sea distances were retrieved from (Sea-distances, 2015). Additional data related to fuel inputs such as diesel and heavy fuel oil was gathered from the Ecoinvent v2.2 database (Ecoinvent, 2010).

## 3. Results and discussion

This section focuses on results and discussion of process modeling (*i.e.*, mass and energy balances), economic analysis and environmental assessment.

### 3.1. Process modeling

Table 2 shows the mass balances of organosolv (System I), organosolv with anaerobic digestion (System II) and corn wet milling (System III). All mass balances are expressed on wet basis and provide an indication on the consumption of raw materials and the efficiency of the technologies. As shown in Table 2, the mass balances of Systems I and II, the input streams are identical (since the organosolv section is equal in both systems) with exception of the air stream in System II, which is used for combusting biogas. The flowrates of furfural and lignin are also identical, however, additional products such as digestate, steam (although used internally) and recovered water are obtained in System II. In terms of waste streams, System I shows 17% higher flowrates than System II. This highlights the importance of anaerobic digestion for recovering the carbon fraction of the non-converted solids and crude sugars stream and obtain additional products, which can be integrated within the organosolv process (*i.e.*, steam and electricity). Material inputs significantly differ among the systems. In terms of feedstock (*i.e.*, woodchips and corn), the corn wet milling (System III) requires 52% less than organosolv (on a dry basis) for producing the same amount of C6 sugars. The latter is due differences in polysaccharide content of each raw material to produce the C6 sugar stream, and the efficiency of each technology to recover the sugars. In the case of corn, starch represents 67% of the corn mass (dry basis), while in the case of spruce only the cellulose fraction was used for producing the C6 sugar stream, which represents approx. 42% of the biomass. It should be noted that if C6 sugars can be recovered from the hemicellulose stream (not considered in this study), higher C6 sugars yields from spruce could be expected. When translating this into processing yields (total feed to C6 sugars basis), values of 0.36 kg C6 sugars per kg of woodchips (Systems I and II), and 0.74 kg C6 sugars per kg of corn (System III) are obtained on a dry basis. The C6 sugars yield based on corn is 107% higher than that from woodchips. In terms of waste streams, System I and II produce 3.0 and 2.5 times higher flowrates than those

of System III, respectively. The higher contribution to waste streams is wastewater with 62%, 73% and 100% for Systems I, II and III, respectively. These high flowrates are a consequence of high water input requirements for dilution, in steps such as organosolv fractionation in Systems I and II, steeping in System III and hydrolysis steps in the three systems. It should be noted that integration of water stream was not considered in the scope of this study and thus further improvement is possible if the reader would extend the current analysis. The only integration of water considered in this study, was using part of the clean water after anaerobic digestion as feed for producing LP and MP steam. This is why water inputs are not increased in System II in comparison to System I. Table 2 also shows that the recovery of the organic solvent is high. However, it should be taken into account that possible ethoxylation reactions of lignin and carbohydrates were not considered. In consequence, it may be possible that a higher ethanol make-up is required after recycling.

The yield of hemicellulosic sugars plus non-converted solids (dry basis) is 0.52 kg per kg of woodchips, which reflects that 52% of the initial mass of dry biomass is contained within these two streams. In System II, the conversion of hemicellulosic sugars and non-converted solids leads to a biogas flowrate of 148 kt per year, which is equivalent to 0.15 kg per kg of woodchips (dry). The yields of corn wet milling are in agreement with results reported in literature (Ramirez et al., 2008; Tsiropoulos et al., 2013).

Table 3 displays the energy inputs, outputs and net requirements for the three systems. In System I, heating utilities (*i.e.*, LP and MP steam) contribute to 58% of the net energy requirements, followed by cooling water (42%) and electricity (1%). When comparing the total energy requirement with literature (including all utilities types) (Nitzsche et al., 2016), reported a consumption of 2.5 MJ per kg of dry biomass processed (value calculated only using the pretreatment and hydrolysis sections in (Nitzsche et al., 2016)), while this study reports a consumption of 2.4 MJ per kg of dry biomass processed (approx. 13% of the LHV of dry woodchips). In System II, the energy inputs are equal to those of System I, however, electricity and steam are produced. In the case of LP and MP steam, the cogeneration system is able to cover 96 and 100%, respectively. The latter implies a reduction of net requirements on heating utilities of about 97% in System II (in comparison to system I). In the case of electricity, the requirements are 100% covered by the cogeneration unit with a surplus electricity (*i.e.*, electricity for revenues) of 99% of the total produced (1% of total electricity produced used for biorefinery consumption). This shows the importance of valorizing the hemicellulose and non-converted solids streams, which in this case were used for energy production. Based on the lower heating value of biogas, the efficiency of the cogeneration system corresponds to 49% to heat, 41% to electricity and 10% energy losses. Although heating utilities are not 100% covered by the cogeneration unit, the requirement of outsourced steam significantly decreased and its contribution to net requirements decreased from 58% in System I to 4% in System II. The remaining fraction of net energy requirements of System II is satisfied with cooling water (96% contribution). Net energy requirements of System II are 56% lower than net requirements of System I when electricity surplus is not accounted for, and 100% when electricity surplus is accounted for. In the case of System III, the contribution of heating utilities to net requirements is 82% (*i.e.*, LP steam and natural gas) and contribution by electricity is 18%. System III consumes less energy than Systems I by 60%, however, System II consumes 100% less energy than System III. Thus, it is expected higher costs in utilities in Systems I in comparison to System III, and higher utilities costs in System III in comparison to System II. The energy consumption levels are in alignment with the data reported by (Ramirez et al., 2008). The economic performance of each system is



**Table 2**

Mass balances accounting for key material inputs and outputs of each system, expressed in kt/y.

| Systems                               | Organosolv, No valorization of hemicellulose fraction (System I) |             | Organosolv & Anaerobic Digestion, Valorization of hemicellulose fraction (System II) |             | Corn wet milling (System III) |             |
|---------------------------------------|--|-------------|--|-------------|-------------------------------|-------------|
|                                       | Inputs   | Outputs     | Inputs   | Outputs     | Inputs                        | Outputs     |
| <b>Raw materials</b>                  |  |             |  |             |                               |             |
| Woodchips <sup>a</sup>                | 1111   | –           | 1111   | –           | –                             | –           |
| Corn <sup>b</sup>                     | –  | –           | –  | –           | 563                           | –           |
| Sulfuric Acid                         | 6  | –           | 6  | –           | –                             | –           |
| Sulfur                                | –  | –           | –  | –           | 1                             | –           |
| Solvent <sup>c</sup>                  | 0.01   | –           | 0.01   | –           | –                             | –           |
| Water                                 | 4231   | –           | 4321   | –           | 1581                          | –           |
| Enzyme                                | 10   | –           | 10   | –           | 3                             | –           |
| Air                                   | –  | –           | 937  | –           | –                             | –           |
| <b>Products</b>                       |  |             |  |             |                               |             |
| C6 sugars <sup>d</sup>                | –  | 359         | –  | 359         | –                             | 359         |
| Furfural <sup>e</sup>                 | –  | 12          | –  | 12          | –                             | –           |
| Lignin <sup>f</sup>                   | –  | 191         | –  | 191         | –                             | –           |
| Digestate                             | –  | –           | –  | 352         | –                             | –           |
| MP steam <sup>g</sup>                 | –  | –           | –  | 195         | –                             | –           |
| LP Steam <sup>g</sup>                 | –  | –           | –  | 462         | –                             | –           |
| Treated water <sup>h</sup>            | –  | –           | –  | 655         | –                             | –           |
| Gluten Feed <sup>i</sup>              | –  | –           | –  | –           | –                             | 104         |
| Germ <sup>i</sup>                     | –  | –           | –  | –           | –                             | 38          |
| Gluten Meal <sup>i</sup>              | –  | –           | –  | –           | –                             | 33          |
| <b>Waste streams</b>                  |  |             |  |             |                               |             |
| CO <sub>2</sub> <sup>j</sup>          | –  | 1           | –  | 1           | –                             | –           |
| Hemicellulosic sugars <sup>k, l</sup> | –  | 950         | –  | –           | –                             | –           |
| Non-converted solids <sup>k, l</sup>  | –  | 857         | –  | –           | –                             | –           |
| Waste water                           | –  | 2989        | –  | 2989        | –                             | 1613        |
| H <sub>2</sub> S                      | –  | –           | –  | 2           | –                             | –           |
| Flue gas <sup>m</sup>                 | –  | –           | –  | 1077        | –                             | –           |
| <b>Total</b>                          | <b>5358</b>  | <b>5358</b> | <b>6295</b>  | <b>6295</b> | <b>2148</b>                   | <b>2148</b> |

<sup>a</sup> Woodchips water content 10 wt%.<sup>b</sup> Corn water content 14 wt%.<sup>c</sup> Fresh ethanol required at 96 wt%. The required solvent is recycled within the battery limits.<sup>d</sup> Stream free of water, C6 sugars purity 100%.<sup>e</sup> Furfural purity 98 wt%.<sup>f</sup> Lignin water content 10 wt%.<sup>g</sup> LP steam pressure: 3 bar, MP steam pressure: 10 bar. Products integrated within the organosolv process in the energy balance.<sup>h</sup> Water recovered after anaerobic digestion.<sup>i</sup> Water content: gluten feed 10 wt%, germ 3 wt%, gluten meal 10 wt%.<sup>j</sup> CO<sub>2</sub> produced during organosolv fractionation.<sup>k</sup> Water content: hemicellulosic sugars 70 wt%, non-converted solids 74 wt%.<sup>l</sup> Residues composition (dry basis): hemicellulosic sugars: sugars 53 wt%, furans 14 wt%, humins 1 wt%, others 33 wt%. Non-converted solids: Cellulose and hemicellulose 15 wt%, lignin 50 wt%, other 35 wt%.<sup>m</sup> Flue gas composition: water 11 wt%, CO<sub>2</sub> 21 wt%, O<sub>2</sub> 1 wt%, N<sub>2</sub> 67 wt%.

explained in more detailed in Section 3.2.

### 3.2. Economic assessment

The economic analysis focuses on the net present value (NPV), which include aspects such as annualized operating costs and capital investment. Table 4 shows the summary of capital

investment for each system. For System I, capital costs are split among organosolv and hydrolysis sections with a contribution of 82% and 18%, respectively. In the case of System II, the contributions of organosolv, hydrolysis and anaerobic digestion (including cogeneration unit) are 75%, 17% and 8%, respectively. Total investment costs (Fixed capital investment + working capital) in System II are 12% higher than those of System I as anaerobic digestion was

**Table 3**

Energy requirements and energy produced in each system, expressed by utility type in TJ/y.

| Systems                    | Organosolv, No valorization of hemicellulose fraction (System I) |          |                  | Organosolv & Anaerobic Digestion, Valorization of hemicellulose fraction (System II) |             |                  | Corn wet milling (System III) |          |                  |
|----------------------------|--|----------|------------------|--|-------------|------------------|-------------------------------|----------|------------------|
|                            | Input  | Output   | Net <sup>a</sup> | Input  | Output      | Net <sup>a</sup> | Input                         | Output   | Net <sup>a</sup> |
| Cooling water <sup>b</sup> | 998  | 0        | 998              | 998  | 0           | 998              | 0                             | 0        | 0                |
| LP Steam <sup>c</sup>      | 1025   | 0        | 1025             | 1025   | 980         | 45               | 219                           | 0        | 219              |
| MP Steam <sup>c</sup>      | 350  | 0        | 350              | 350  | 350         | 0                | 0                             | 0        | 0                |
| Natural gas <sup>d</sup>   | 0  | 0        | 0                | 0  | 0           | 0                | 556                           | 0        | 556              |
| Electricity                | 13   | 0        | 13               | 13   | 1059        | –1046            | 175                           | 0        | 175              |
| <b>Total</b>               | <b>2386</b>  | <b>0</b> | <b>2386</b>      | <b>2386</b>  | <b>2389</b> | <b>–3</b>        | <b>950</b>                    | <b>0</b> | <b>950</b>       |

<sup>a</sup> Negative values indicate surplus for sales.<sup>b</sup> Cooling water heat capacity: 50 kJ/kg.<sup>c</sup> Latent heat steam: LP steam 2120 kJ/kg, MP steam 1899 kJ/kg.<sup>d</sup> Natural gas lower heating value (LHV): 47.1 MJ/kg.

included as an additional process. It can be predicted higher operating costs in System II, that depend on fixed capital investment (e.g., maintenance, depreciation), in comparison to System I. In the case of corn wet milling (System III), the contribution of starch production (including germ, gluten meal and gluten feed production) and starch hydrolysis to total capital investment is 85% and 15% respectively.

The capital costs of the corn wet milling are relatively known due to its maturity for producing corn derived products and ethanol (Michael et al., 2007; Ramirez et al., 2008). However, this is not the case for the organosolv technology which is still at early development stages, thus bringing uncertainties on capital costs at large scales. From literature, it becomes difficult to make a direct comparison of capital investment of the organosolv section since many of the studies focuses on C6 sugars derived products such as ethanol. Consequently, data for certain process sections are difficult to split due to differences in scope (e.g., battery limits, production capacities). Nevertheless, there are few studies which provide a more detailed breakdown of capital costs of the organosolv section (excluding hydrolysis section). Table 5 shows the fixed capital investment of the organosolv section to obtain pulp, in comparison to other studies available in literature (The comparison excludes the enzymatic hydrolysis and C6 sugars recovery sections due to differences in scope among the referenced literature). All studies were at different biomass processing capacities (see Table 5), thus, the six-tenth rule of thumb was used to scale up the fixed capital investment of each study to the feedstock capacity of this work. At 1 Mt/y capacity, the low end is for the work reported by (Nitzsche et al., 2016), while the high end for the work reported by (Michels, 2014). Table 5 shows a range of 126 M€, which reflects the uncertainty on capital cost estimation for the organosolv technology and the importance to include it as part of the sensitivity analysis.

Table 6 shows the annualized operating costs (year zero), capital investment and revenues for each system (inputs used for calculating NPV). In the three systems, the aspects that contribute the most to operating costs are raw materials and utilities. Due to savings on external energy use after the integration of anaerobic digestion with organosolv, System II shows a reduction of utilities costs by approx. 90%, in comparison to System I. System I shows the highest operating costs, being 16% and 66% higher than those for Systems II and III, respectively. System III shows the best performance for producing C6 sugars in terms of operating costs. In Systems I and II, C6 sugars has the highest contribution to revenues, followed by lignin. This shows the high correlation between the valorization of lignin with the feasibility of the system. In the case of corn wet milling, revenues are highly dominated by C6 sugars income. In terms of product revenues, System II shows the highest income being 16% and 63% higher than Systems I and III, respectively. This highlights the importance of the valorization of the hemicellulosic sugar stream for producing biogas and subsequently, electricity and steam.

The NPV results (see Table 6) show a negative value for System I, which implies economic unfeasibility. To reach break-even (assuming all other parameters fixed, such as C6 sugars and furfural prices), the price of lignin needs to be increased from 630 €/t (base case lignin price in Table 1) to 751 €/t. Similarly, in case that lignin price is to remain fixed at 630 €/t, to reach break-even

(assuming all other parameters fixed), the price of C6 sugars needs to be increased from 300 €/t to 354 €/t. The NPV for System II is above break-even indicating economic feasibility of the organosolv system when anaerobic digestion is included (valorization of hemicellulosic sugars). The NPV of this system is also above break even due to the fact that lignin price was set to 630 €/t. On one hand, the minimum lignin price to keep system II working above break-even (leaving all other parameters fixed) corresponds to 388 €/t. When comparing the price of lignin reported in literature (for organosolv systems) with the value used in this study (630 €/t), our findings fall within the ranges reported (van der Linden et al., 2012): reports a lignin price of 750 €/t, while (Michels, 2014) reports a base lignin price of 622 €/t, and low and high ends of 400–800 €/t, respectively. However, it is important to highlight that the base capacities (dry biomass processing) of the cited studies are lower than that of this study, implying that for small scale systems higher product prices (e.g., lignin price) will be required. The common aspect of this study and literature on organosolv fractionation systems is the high price dependency of lignin to allow the system to work above break-even. System's III NPV is positive indicating the economic feasibility of corn wet milling. Fig. 5 shows the cumulative NPV for each System. System I shows that the payback period is outside the project's lifetime, while System II shows a payback period of 8 years. In the case System III, the investment is recovered in year 4 (payback period). However, in economic terms, System II shows higher NPV value at the end of projects lifetime. This behavior can be explained by the fact that although higher capital investment is required for System II in comparison to System III, higher revenues guarantee higher NPV at the end of projects lifetime. It is also important to highlight that system II shows positive economic outcome if markets of organosolv lignin can be developed. Nevertheless, this study shows that in the case that lignin price drops (up to 388 €/t), when anaerobic digestion is included, organosolv can still be feasible.

### 3.2.1. Sensitivity analysis

The results of sensitivity analysis focus on the NPV. Fig. 6 shows the results in sensitivity analysis when main prices are varied. The reader should note that all prices discussed in this section were considered independent of each other (i.e., varying one price at a time and leaving all other parameters fixed). The results for System I (see Fig. 6a) suggest that the parameters that influence NPV the most are C6 sugars price, lignin price, biomass price and capital investment. In the case of lignin price an increase of 20% will lead the system to reach break-even. However, price decreases will lead to more unfeasible scenarios. Similarly, the price of C6 sugars needs to be 18% higher than the reference value shown in Table 1 to reach break-even, while a decrease of its price leads to a very unfeasible case. One of the options to decrease the dependency on lignin revenues is to increase the price of C6 sugars. However, this aspect depends on market prices and uncertainties on C6 sugars prices would have an impact on lignin minimum selling price. The base case price of C6 sugars (300 €/t in Table 1) seems low in comparison to 400 €/t reported by (Michels, 2014). If the price of C6 sugars is increased to 400 €/t, the minimum selling price of lignin (to reach NPV = 0, leaving all other parameters fixed) in System I is reduced by 17% (from 630 €/t to 526 €/t), while in System II it

**Table 4**  
Summary of capital investment costs for each system.

| Capital investment            | Organosolv (System I) | Organosolv & A. Digestion (System II) | Corn wet milling (System III) |
|-------------------------------|-----------------------|---------------------------------------|-------------------------------|
| Fixed Capital Investment – M€ | 210                   | 236                                   | 55                            |
| Working capital – M€          | 48                    | 52                                    | 10                            |

**Table 5**

Fixed capital investment of organosolv pretreatment section. Investment cost comparison only considers the organosolv pretreatment section for obtaining pulp.

| Parameters  | Source          |                               |                         |            |
|---|-----------------|-------------------------------|-------------------------|------------|
|   | (Michels, 2014) | (van der Linden et al., 2012) | (Nitzsche et al., 2016) | This Study |
| Base Capacity - kt/y dry biomass                                    | 150             | 150                           | 400                     | 1000       |
| Fixed Capital Investment (at base capacity) - M€                    | 80              | 75                            | 71                      | 172        |
| Fixed Capital Investment at 1 Mt/y dry biomass - M€ <sup>a, b</sup> | 250             | 234                           | 124                     | 172        |

<sup>a</sup> Capital investment scaled to 1000 kt/y of biomass supply (capacity used in this study).

<sup>b</sup> The comparison excludes the enzymatic hydrolysis and C6 sugars recovery sections due to differences in scope among all studies compared. Cogeneration investment costs are also excluded.

decreases from 630 €/t to 163 €/t. Nevertheless, on one hand, a lower C6 sugar price is more attractive for downstream processes such as the conversion of C6 sugars into fuels and chemicals. On the other hand, low prices in lignin are also attractive for downstream processes using organosolv lignin as feedstock. This clearly shows, that a good balance need to be found and/or that both markets (cellulose and lignin) need to be well-developed to allow taking-off

of both products at sufficient prices. It should also be taken into account that both lignin and C6 sugar yields are dependent on the fractionation degree. Finally, changes in feedstock can imply different composition and fractionation degree and therefore different techno-economic performances.

Biomass price should also be considered as a key aspect on the performance of the systems, slight price fluctuations of biomass significantly affect the performances. For instance, decreases above 20% allows System I to reach break-even, while increases on woodchips prices will make the system even more unfeasible. This highlights the importance on developing a biomass supply

**Table 6**

Annualized production costs, revenues and Net Present Value of all Systems.

| Feature  | Organosolv (System I) |             | Organosolv & A. Digestion (System II) |             | Corn wet milling (System III) |             |
|--|-----------------------|-------------|---------------------------------------|-------------|-------------------------------|-------------|
|  | M€/y                  | Share (%)   | M€/y                                  | Share (%)   | M€/y                          | Share (%)   |
| <b>Operating costs</b>                           |                       |             |                                       |             |                               |             |
| Raw materials                                    | 121.7                 | 62%         | 121.7                                 | 72%         | 92.6                          | 78%         |
| Utilities  | 36.0                  | 18%         | 3.5                                   | 2%          | 15.3                          | 13%         |
| Maintenance                                      | 14.5                  | 7%          | 16.5                                  | 10%         | 3.5                           | 3%          |
| Labor  | 2.0                   | 1%          | 2.0                                   | 1%          | 1.0                           | 1%          |
| Fixed & general                                  | 13.4                  | 7%          | 15.2                                  | 9%          | 3.3                           | 3%          |
| Overhead   | 8.6                   | 4%          | 9.6                                   | 6%          | 2.3                           | 2%          |
| <b>Total</b>                                     | <b>196.1</b>          | <b>100%</b> | <b>168.4</b>                          | <b>100%</b> | <b>118.0</b>                  | <b>100%</b> |
| <b>Revenues</b>                                  |                       |             |                                       |             |                               |             |
| C6 sugars  | 107.6                 | 49%         | 107.6                                 | 42%         | 107.6                         | 69%         |
| Lignin   | 100.5                 | 46%         | 100.5                                 | 39%         | —                             | —           |
| Furfural   | 10.6                  | 5%          | 10.6                                  | 4%          | —                             | —           |
| Digestate  | —                     | —           | 3.7                                   | 1%          | —                             | —           |
| Electricity                                      | —                     | —           | 32.3                                  | 13%         | —                             | —           |
| Gluten feed                                      | —                     | —           | —                                     | —           | 16.5                          | 11%         |
| Germ   | —                     | —           | —                                     | —           | 10.4                          | 7%          |
| Gluten meal                                      | —                     | —           | —                                     | —           | 21.1                          | 14%         |
| <b>Total</b>                                     | <b>235.8</b>          | <b>100%</b> | <b>261.1</b>                          | <b>100%</b> | <b>181.9</b>                  | <b>100%</b> |
| <b>Fixed capital investment</b>                  |                       |             |                                       |             |                               |             |
| M€   | 210                   |             | 236                                   |             | 55                            |             |
| <b>Net present value after taxes<sup>a</sup></b> |                       |             |                                       |             |                               |             |
| M€   | -119                  |             | 238                                   |             | 168                           |             |

<sup>a</sup> NPV at the end of project lifetime.

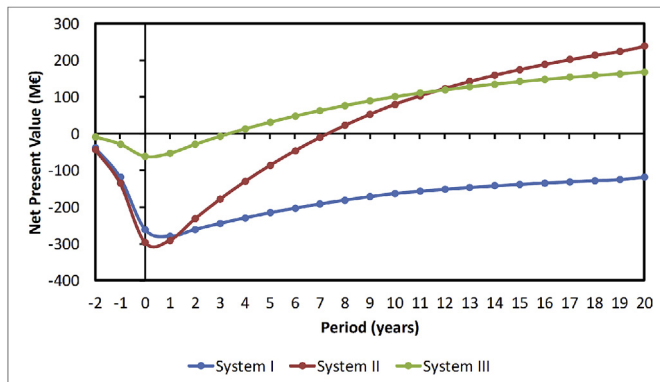

**Fig. 5.** Cumulative Net Present Value of all Systems for a project life-time of 20 years. Lignin price of 630 €/t for Systems I and II.

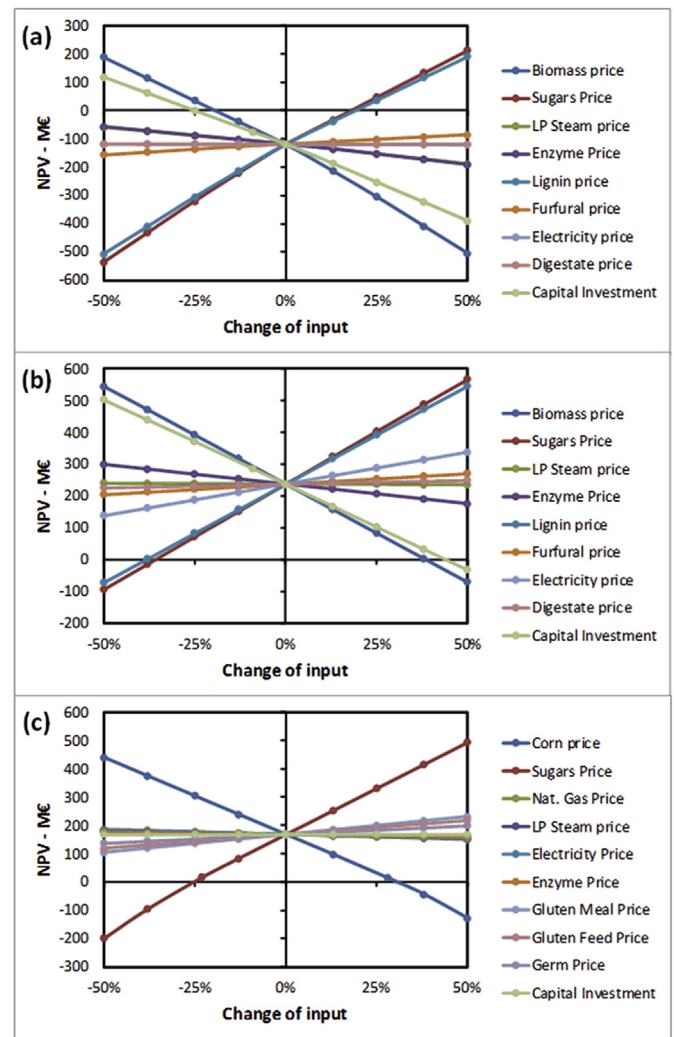

**Fig. 6.** Results of sensitivity analysis on economic parameters of all Systems: a) System I, b) System II, c) System III.

structure that guarantees low fluctuations on feedstock prices. The influence of capital investment is also important since decreases above 25% of the capital costs may lead System I to work in NPV values above its break-even point ( $NPV > 0$ ). In contrast, increases on capital investment negatively affect the overall performance of the system. The effect of LP steam and enzyme price on the NPV is similar, though significant, it is not at the level of the previously mentioned parameters. In the case of enzyme consumption, this is relevant to mention that we assumed the highest enzyme dosage reported in literature among techno-economic studies for biomass conversion (see [Supplementary information Section S1](#)). In consequence, if enzymes dosages and prices can be decreased it is expected to have a positive contribution on the overall economic performance of organosolv fractionation systems. The effect of furfural and electricity price is low in comparison to the previously mentioned parameters.

The parameters that affect the NPV of System II the most are C6 sugars, lignin price, biomass price and capital investment. Small fluctuations of the four parameters (*i.e.*, lignin price, C6 sugar price, biomass price and capital investment) may drastically impact the economic performance of the system. However, the threshold to keep the system working above break-even is larger in comparison to that of System I. If biomass price is increased above 40% of the reference price, the system starts to be unfeasible. The effect of capital investment is similar and increases above 44% lead the system to be unfeasible. In terms of C6 sugars price, decreases above 36% lead the system to be unfeasible. Similarly, in the case that lignin price drops by 39% of the reference price, the system starts to be unfeasible. The effect of the remaining parameters is not that strong, and even by varying those (independently) up to  $\pm 50\%$ , the system is still able to operate under feasible conditions. All in all, System II seems robust given the possibility to remain in the feasibility zone if parameters such as lignin and C6 sugars price vary. Overall, System I is very sensitive to changes in most economic parameters, thus, suggesting higher risks to implementing this technology. Although system II seems more robust, fluctuations in some parameters highly affect positively and negatively the NPV. Thus, this analysis allows identifying hotspots for further developing the technology, which in this case is to ensure a stable biomass supply system to avoid high fluctuations on prices and reach a proper balance between the markets of sugars and lignin. The latter can be overcome for instance by increasing C6 sugars prices which include premiums for favoring 2G technologies.

The results of sensitivity analysis for System III (see [Fig. 6c](#)) show strong influence of the prices of biomass and C6 sugars on NPV. An increase of corn prices above 30%, leads the system to work under unfeasible conditions. The effect of varying C6 sugar prices is similar, though with opposite direction than that of corn price. A decrease of C6 sugars price of approx. 25% will lead the system to work under unfeasible conditions. The strong influence of corn and C6 sugars prices is not surprising since both raw materials costs and revenues of C6 sugars are the features with the highest contribution to annualized production costs and product revenues, respectively. The effect of co-product prices (*i.e.*, corn germ, gluten meal and gluten feed) follow the previous parameters that affect the NPV the most. As expected, the recovery and sales of gluten meal, gluten feed and germ have a significant effect on the NPV. However, at the considered range these do not lead to unfeasible scenarios. Finally, parameters such as natural gas, electricity and enzyme prices and capital investment can negatively affect the system if those are increased. Nevertheless, due to the maturity of the technology, it is unlikely to have high fluctuation on those costs. Overall, the corn wet milling (System III) seems to show lower risks than System I. However, System II seems to have less risk in comparison to System III since only changes in corn and C6 sugars

prices can lead the system to work under unfeasible conditions. In the case of System II, it is important to highlight the high dependency of lignin valorization, and the sensitiveness to capital investment changes. In general, it should be taken into account that 2G technologies are in principle more expensive than 1G technologies and that a transition to 2G should be accompanied by incentives for its development.

[Fig. 7](#), shows the effect of varying conversions (see [Tables S2 and S3](#) in supplementary information) on lignin, glucan and pulp. In the case of System I ([Fig. 7a](#)), lignin and pulp conversions show to have an important influence on the techno-economic performance. By increasing lignin conversion by 20% (conversion from 57.8% to 69.4%, see [Table S6](#)), and therefore increasing the lignin yield to 0.17 kg/kg of woodchips (dry), the NPV of the system becomes positive (7 M€). In the case that C6 sugars yield increases (up to 0.40 kg/kg woodchips dry), by the action of increasing pulp conversion during enzymatic hydrolysis, the NPV is still negative (−44 M€), but closer to breakeven. Additionally, in the case where glucan solubilization could be decreased during organosolv fractionation, higher C6 sugar yields could be obtained (0.39 kg/kg woodchips dry, leaving all other parameters fixed). This yields a higher NPV, though still negative for System I (−62 M€). These results suggest that both by increasing C6 sugars and lignin yields, the system can perform economically better. In the case of System II (see [Fig. 7b](#)), although changes in the three conversion can significantly affect the system those do not lead to unfeasible scenarios. However, the NPV of the system is clearly benefited by increases in lignin yield.

### 3.3. Life cycle assessment

Technical data obtained from process modeling regarding mass and energy balances (see [Tables 2 and 3](#)) were used to complete the life cycle inventory of the biorefinery section (see [Figs. S1–S3](#) in supplementary information). [Figs. 8 and 9](#) show the results of the

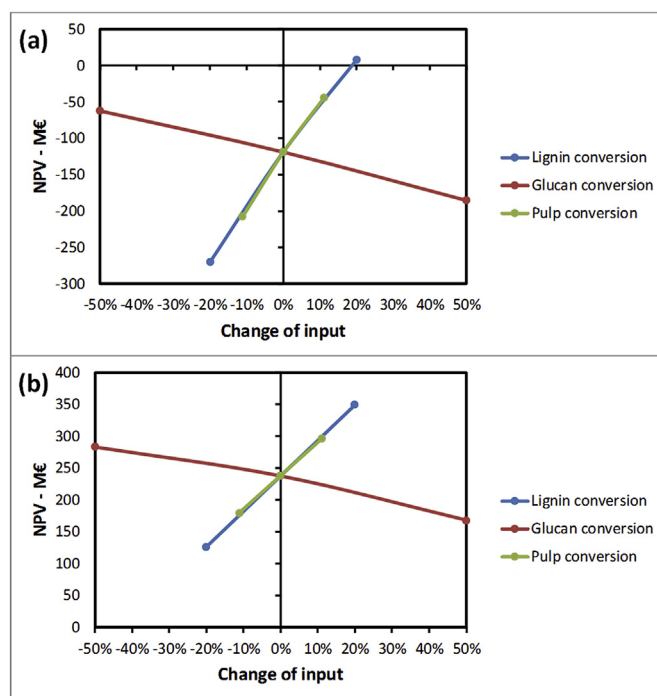

**Fig. 7.** Results of sensitivity analysis on lignin, glucan and pulp conversions: a) System I, b) System II.

life cycle environmental impacts, including the two allocation approaches (i.e., no allocation, mass allocation) of the three systems relative to the reference case (corn wet milling, System III). The results also present the process contribution analysis for each system split into features such as feedstock, transportation, other raw material inputs, utilities (e.g., steam, cooling water, electricity) and waste treatment/disposal. The absolute values of the life cycle environmental impacts expressed per functional unit (kg of C6 sugars) are shown in Section S6 of the supplementary material.

Fig. 8 shows the results for the categories CCP, NREU and HTP. When no allocation among co-products is used (Allocation approach 1, see Fig. 8a), NREU is 21 and 54% lower in Systems I and II than for System III (reference system). When comparing Systems I and II, the NREU is 42% lower for System II than for System I. The reduction on NREU in System II is due to energy savings from the production of steam and electricity from biogas. This emphasizes the importance of valorizing the hemicellulosic sugar stream and

non-converted solid stream to improve the overall performance of the organosolv process. In the case of CCP using allocation approach 1, the potential environmental impact of Systems I and II are 14 and 60% lower than that of System III. Analogous to NREU, System II shows lower CCP by 54% in comparison to System I. Overall, the main difference in NREU and CCP for organosolv (Systems I and II) and corn wet milling (System III) processes, is on the feedstock production step with higher impacts for corn (See Fig. 8a). In the case HTP, when using allocation approach 1, the impacts for System I are higher than that of System III (25%), while the impact for System II are lower than that of System III (2%). The difference between System I and II is due to reduction of impacts related to waste disposal/treatment and utilities due to the use of electricity and steam produced after the anaerobic digestion of the hemicellulosic sugars stream. For the three impact categories discussed so far, System II shows to be highly benefitted by the valorization of the hemicellulose sugar stream in comparison to System I.

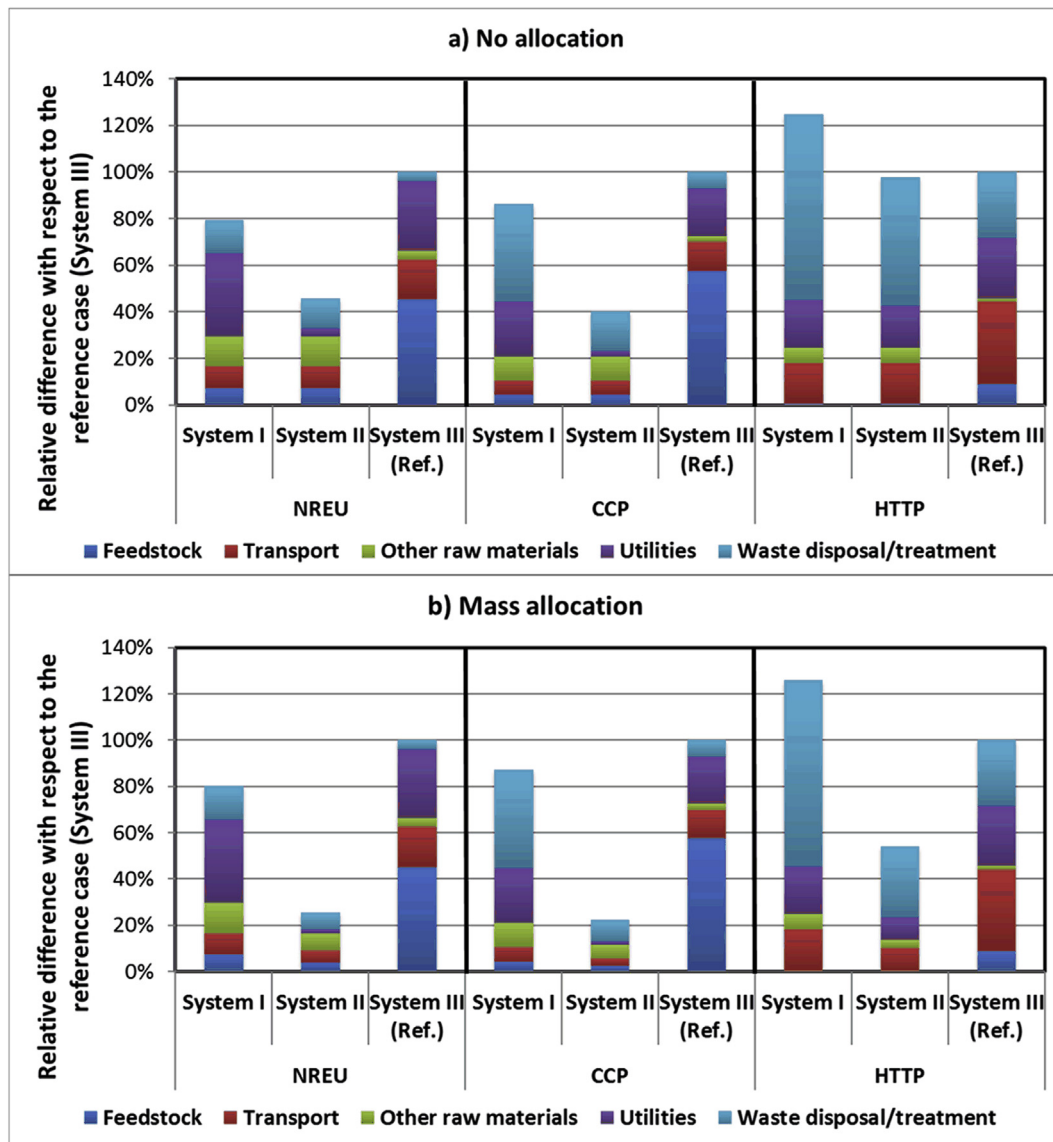
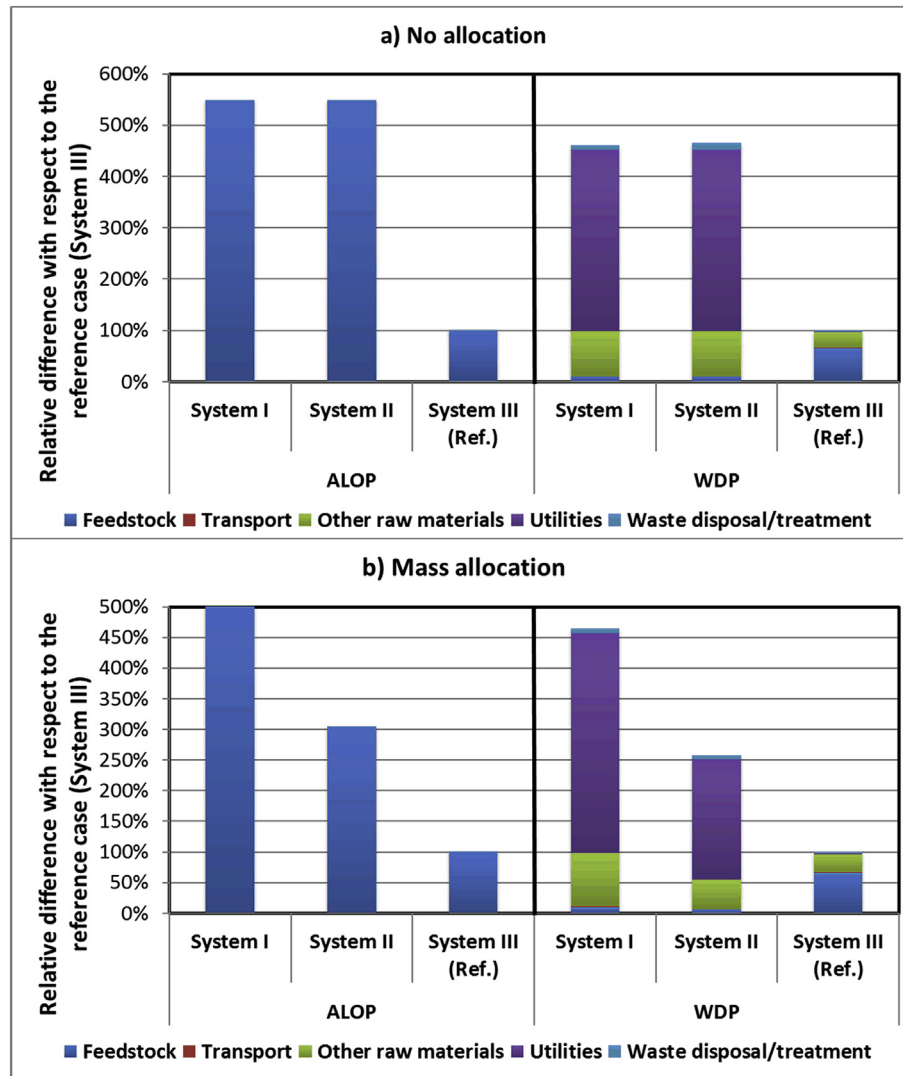

Fig. 8. Environmental impacts for non-renewable energy use (NREU) climate change potential (CCP) and human toxicity potential (HTP) relative to the reference system (System III, corn wet milling). Each system is divided into contributions from feedstock production, feedstock transportation, consumption of auxiliary raw materials, utilities and waste treatment/disposal. a) Results when no allocation is applied (100% of environmental impacts allocated to C6 sugars), b) mass allocation applied to C6 sugars streams and co-products.



**Fig. 9.** Environmental impacts for agricultural land occupation potential (ALOP) and water depletion potential (WDP) categories relative to the reference system (System III, corn wet milling). Each system is divided into contributions from feedstock production, feedstock transportation, consumption of auxiliary raw materials, utilities and waste treatment/disposal. a) Results when no allocation is applied (100% of environmental impacts allocated to C6 sugars), b) mass allocation applied to C6 sugars streams and co-products.

When using mass allocation among the C6 sugar stream and co-products (Allocation approach 2, see Fig. 8b), for NREU and CCP categories, the direction of the impacts is not affected (e.g., lower values for Systems I and II in comparison to System III, and lower impacts of System II in comparison to System I), however, the relative difference to the reference system is affected by decreasing further the NREU and CCP of the woodchips based processes (Systems II mainly) in comparison to the corn wet milling (Reference system). In the case of HTP, the direction of results does not change (i.e., higher for System I and lower for System II compared to System III), however, the relative difference in comparison to the reference system is increased (see Fig. 8b). By comparing System II with System I when using allocation approach 2, the difference of NREU, CCP and HTP is larger in favor of System II (lower by 68%, 75% and 57% respectively). This is due to the difference in allocation factors (based on mass, see Methodology section, equation (1)) among the processes (Allocation factors shown in Table S14 in supplementary information). The use of allocation is controversial since it is affected by the products that are included in the distribution of environmental impacts. For instance, in System II, 39% of the total impacts are allocated to dry digestate from anaerobic

digestion, however, this stream only contributes to less than 1% of total revenues. Instead, if economic allocation is used (assumed as % of total revenues in Table 6), the allocation factor for C6 sugars would be 49% for Systems I, which would bring lower impacts to those using mass allocation (allocation factor based on mass, 68%, see Supplementary Information Table S14). In contrast, in the case of System II, mass allocation and economic allocation factors (37 and 42%, respectively) seem relatively close. In System III, if economic allocation is used, the allocation factor to C6 sugars for corn wet milling would be 69%, which is relatively robust when compared to the allocation factor based on mass (67%). Due to the multiple possible approaches for distributing the environmental impacts among the multiple products and the possible deviations that this may bring to the objectivity of the comparison of the systems, the approach of allocating all impacts to the C6 sugars stream (allocation approach 1, see methodology section) allows a better understanding of the total performance of each system.

To further understand the results, a comparison is made with results published in literature. NREU and CCP are the most reported impact categories for bio-based systems. Nevertheless, in the case of production of C6 sugars from lignocellulosic biomass using the

organosolv technology, little is reported and direct comparison was not possible (due to differences in scope). In the case of C6 sugars production from corn (Tsiropoulos et al., 2013), reported the cradle-to-gate NREU and CCP discussing the differences when using different allocation approaches. Our findings show a NREU of 9.01 MJ/kg of C6 sugars (using mass allocation, see Table S13 in supplementary information), which falls within the range of 6.8–9.3 MJ/kg of C6sugars reported by (Tsiropoulos et al., 2013). In the case of CCP, our findings show a value of 0.79 kg CO<sub>2eq</sub>/kg of C6sugars which also falls within the range of 0.7–1.1 kg CO<sub>2eq</sub>/kg of C6sugars reported by (Tsiropoulos et al., 2013).

Fig. 9 shows the results of ALOP and WDP categories, where Systems I and II have higher values than the reference System (System III). When using allocation approach 1 (See Fig. 9a), the results for ALOP show that the impact of both Systems I and II are a factor 4.5 higher than those of System III. ALOP impacts are driven by the feedstock production step (>99.5%), thus suggesting an advantage of corn over woodchips in agricultural land occupation. This is due to difference in feedstock flowrates for producing the same volume of C6 sugars, with woodchips (dry basis) requiring 2.1 times more than corn for producing 1 kg of sugars (see Table 2). It should be taken into account that the current analysis highly rely on the characterization factors of the ReCiPe method, which may be questionable when comparing forestry feedstocks (woodchips in this case) to agricultural feedstocks such as corn. In the case of WDP, the impact of both Systems I and II are approx. factor 3.6 higher than that of System III. The main difference can be attributed to higher cooling water consumption in the organosolv process in comparison to the corn wet milling (utilities consumption calculated based on data reported in Table 3). The inclusion of anaerobic digestion does not improve the performance of System II compared to System I, since their relative difference (compared to System III) is almost identical in the two impact categories. It is important to highlight that in the case of the organosolv systems, optimization on the use of cooling utilities (integrated with water effluents from the system) was not considered. In consequence, there is room for improvement in WDP of the organosolv systems in case that cooling utilities can be decreased by further integration of streams. It is also important to note that in the case of corn wet milling (System III), no cooling utilities were reported (see Table 3). When using allocation approach 2 (i.e., mass allocation, See Fig. 9b), the direction of the impacts of ALOP, WDP do not change (i.e., impacts higher than reference system, System III) when comparing with allocation approach 1. Nevertheless, the relative difference of the impacts of both System I and II compared to those of System III decreases in the two categories. Additionally, when comparing System I and II, System II seems to have lower impacts than those of System I. This can be explained by the difference in allocation factors to C6 sugars in all three Systems as discussed previously for NREU, CCP and HTP.

Independent of the allocation approach used, 2 (NREU and CCP) out of the 5 categories assessed, showed lower impacts for the organosolv based Systems (Systems I and II) compared to the corn wet milling System (reference, System III). However, 2 (ALOP and WDP) out of the 5 impact categories showed higher impacts for the organosolv (with and without anaerobic digestion) compared to corn wet milling. Finally, 1 (HTP) out of the 5 impact categories showed to have higher values for System I and lower for System II in comparison to System III. When comparing Systems I and II, 3 (NREU, CCP and HTP) out of the 5 impact categories showed lower impacts for System II, suggesting clear benefits for including anaerobic digestion to the organosolv process as an option for valorizing the hemicellulosic sugar stream. Finally, 2 (ALOP and WDP) out of the 5 impact categories showed little difference in System II in comparison to System I.

#### 4. Conclusions

The results presented in this study provide insights into the technical, economic and environmental performance of organosolv (2G) and corn wet milling technologies (1G) for producing C6 sugars. When integrated with anaerobic digestion of organic residues (in this case essential for valorizing the hemicellulose sugar stream), the organosolv technology (System II) shows lower net energy consumption than corn wet milling (System III). However, in terms of processing yields to C6 sugars (total feed to C6 sugars basis), the corn wet milling technology shows higher values due to higher polysaccharide availability for producing the C6 sugar stream. From an economic point of view, organosolv coupled to anaerobic digestion (System II) shows the highest NPV (feasible scenario at base case lignin price of 630 €/t), but it also requires the highest fixed capital investment. The corn wet milling (System III) also showed positive NPV (feasible scenario) with the lowest fixed capital investment costs. The economic performance of the wet milling technology (System III) is sensitive to variation of C6 sugars and corn prices. However, the organosolv technology (Systems I and II) is very sensitive to changes in lignin, C6 sugars and woodchips prices, as well as changes in capital investment. The latter suggests higher robustness of the corn based technology relative to changes in economic input parameters (e.g., prices). The feasibility of the organosolv technology (System I and II) highly relies on whether lignin and C6 sugars can be sold at good prices. The latter, highlights that 2G technologies can perform well for producing C6 sugars in the long term if markets for lignin have been developed. Nevertheless, 2G technologies also require large initial investments compared to 1G technologies. In the case of organosolv, integration of an anaerobic digestion unit as an option for valorizing the hemicellulosic sugars, has an important effect on improving the performance of the technology by decreasing energy requirements (i.e., steam and electricity) and consequently utilities costs. Extra revenues by surplus power generated also have a positive effect on the economic performance of the organosolv technology.

From an environmental point of view, 3 out of the 5 assessed impact categories showed lower impacts for the organosolv based systems in comparison to the corn wet milling route (i.e., climate change, non-renewable energy use and human toxicity). This is mainly due to the high contribution of corn production in the total aggregation of the impacts in the corn wet milling process, in comparison to the low contribution of woodchips production in the organosolv based processes. In 2 of the 5 assessed categories (agricultural land occupation and water depletion), the organosolv based systems showed higher impacts than corn wet milling. Overall, the results indicate that the organosolv technology shows a better environmental performance than corn wet milling. The latter also highlights the possible environmental benefits of using 2G technologies over 1G technologies. However, special attention needs to be paid to prioritize impact categories with a higher long term impact on policy making for implementing 2G technologies. For instance, care needs to be taken into account when assessing agricultural land occupation for feedstocks such as spruce. The environmental assessment also showed the large influence that allocation brings into the results.

Summarizing, the 2G systems described herein have better environmental performance on most impact categories than the baseline (1G) case. However, both 2G scenarios (Systems I and II) have far higher capital costs than the 1G case (System III). The non-energy-recovery 2G process (System I) was not able to achieve positive NPV for this reason, but the addition of anaerobic digestion to System II revealed that a 2G case could ultimately outperform the 1G case on an NPV basis (at a lignin price of 630 €/t). However,

the inherent risks of new technologies and high investments associated with the 2nd generation technologies assessed in this work, mean that significant additional development, coupled with appropriate government support, are likely necessary before full-scale implementation of 2G systems.

## Acknowledgements

This research has been performed within the framework of the CatchBio program. The authors gratefully acknowledge the support of the Smart Mix Program of the Netherlands Ministry of Economic Affairs and the Netherlands Ministry of Education, Culture and Science. Project number 053.70.381.

## Appendix A. Supplementary data

Supplementary data related to this article can be found at <https://doi.org/10.1016/j.jclepro.2017.09.195>.

## References

- Alibaba, 2015. Average Prices of Chemicals. Available at: [https://www.alibaba.com/Chemicals\\_p8](https://www.alibaba.com/Chemicals_p8). Accessed: July 2015.
- Bakker, R.R.C., Elbersen, H.W., Poppens, R.P., Lesschen, J.P., 2013. Rice Straw and Wheat Straw - Potential Feedstocks for the Biobased Economy. NL Agency, Utrecht.
- Bernardi, A., Giarola, S., Bezzo, F., 2013. Spatially explicit multiobjective optimization for the strategic design of first and second generation biorefineries including carbon and water footprints. *Ind. Eng. Chem. Res.* 52, 7170–7180.
- Bhaumik, P., Dhepe, P.L., 2013. Efficient, stable, and reusable silicoaluminophosphate for the one-pot production of furfural from hemicellulose. *ACS Catal.* 3, 2299–2303.
- Bozell, J.J., Petersen, G.R., 2010. Technology development for the production of biobased products from biorefinery carbohydrates—the US Department of Energy's "Top 10" revisited. *Green Chem.* 12, 539–554.
- Cherubini, F., 2010. The biorefinery concept: using biomass instead of oil for producing energy and chemicals. *Energy Convers. Manag.* 51, 1412–1421.
- Cherubini, F., Jungmeier, G., Wellisch, M., Willke, T., Skiadas, I., Van Ree, R., de Jong, E., 2009. Toward a common classification approach for biorefinery systems. *Biofuels, Bioprod. Biorefining* 3, 534–546.
- Constant, S., Wienk, H.L., Frissen, A.E., de Peinder, P., Boelens, R., van Es, D.S., Grisel, R.J.H., Weckhuysen, B.M., Huijgen, W.J.J., Gosselink, R.J.A., Bruijninx, P.C.A., 2016. New insights into the structure and composition of technical lignins: a comparative characterisation study. *Green Chem.* 18, 2651–2665.
- de Jong, E., Higson, A., Walsh, P., Wellisch, M., 2012. Bio-based Chemicals Value Added Products from Biorefineries. IEA Bioenergy, Task42 Biorefinery.
- Ecoinvent, 2010. Ecoinvent Database v2.2. [www.ecoinvent.ch](http://www.ecoinvent.ch).
- Eerhart, A.J.J.E., Patel, M.K., Faaij, A.P.C., 2015. Fuels and plastics from lignocellulosic biomass via the furan pathway: an economic analysis. *Biofuels, Bioprod. Biorefining* 9, 307–325.
- Ennaert, T., Op de Beeck, B., Vanneste, J., Smit, A.T., Huijgen, W.J.J., Vanhulsel, A., Jacobs, P.A., Sels, B.F., 2016. The importance of pretreatment and feedstock purity in the reductive splitting of (ligno)cellulose by metal supported USY zeolite. *Green Chem.* 18, 2095–2105.
- Gebrezgabher, S.A., Meuwissen, M.P.M., Prins, B.A.M., Lansink, A.G.J.M.O., 2010. Economic analysis of anaerobic digestion—a case of Green power biogas plant in The Netherlands. *NJAS Wagening. J. Life Sci.* 57, 109–115.
- Giuntoli, J., Agostini, A., Edwards, R., Marelli, L., 2014. Solid and Gaseous Bioenergy Pathways: Input Values and GHG Emissions. Report EUR 26696.
- Goedkoop, M.J., Heijungs, R., Huijbregts, M., De Schryver, A., Struijs, J., Van Zelm, R., 2009. ReCiPe 2008, a Life Cycle Impact Assessment Method Which Comprises Harmonised Category Indicators at the Midpoint and the Endpoint Level, first ed. Report I: Characterisation Available at: <http://www.lcia-recipe.net>.
- Hischier, R., Weidema, B., Althaus, H.-J., Bauer, C., Doka, G., Dones, R., Frischknecht, R., Hellweg, S., Humbert, S., Jungbluth, N., Köllner, T., Loerincik, Y., Margni, M., Nemecek, T., 2010. Implementation of Life Cycle Impact Assessment Methods. Ecoinvent report No. 3, v2.2. Swiss Centre for Life Cycle Inventories Dübendorf, Switzerland.
- IEA, 2015. Key World Energy Statistics. International Energy Agency.
- Indexmundi, 2015. Commodity Price Indices. Available at: <http://www.indexmundi.com/>. Accessed: July 2015.
- ISO, 2006. ISO 14044:2006. Environmental Management – Life Cycle Assessment – Requirements and Guideline.
- Karlsson, H., Börjesson, P., Hansson, P.-A., Ahlgren, S., 2014. Ethanol production in biorefineries using lignocellulosic feedstock – GHG performance, energy balance and implications of life cycle calculation methodology. *J. Clean. Prod.* 83, 420–427.
- Kudakasseril Kurian, J., Raveendran Nair, G., Hussain, A., Vijaya Raghavan, G.S., 2013. Feedstocks, logistics and pre-treatment processes for sustainable lignocellulosic biorefineries: A comprehensive review. *Renew. Sustain. Energy Rev.* 25, 205–219.
- Luo, L., van der Voet, E., Huppes, G., 2009. Life cycle assessment and life cycle costing of bioethanol from sugarcane in Brazil. *Renew. Sustain. Energy Rev.* 13, 1613–1619.
- Maity, S.K., 2015. Opportunities, recent trends and challenges of integrated biorefinery: Part I. *Renew. Sustain. Energy Rev.* 43, 1427–1445.
- Menon, V., Rao, M., 2012. Trends in bioconversion of lignocellulose: Biofuels, platform chemicals & biorefinery concept. *Prog. Energy Combust. Sci.* 38, 522–550.
- Michael, W., May, W., Hong, H., 2007. Life-cycle energy and greenhouse gas emission impacts of different corn ethanol plant types. *Environ. Res. Lett.* 2, 024001.
- Michels, J., 2014. "Lignocellulose Biorefinery – Phase 2" – Final Scientific and Technical Report of All Project Partners. DECHEMA Gesellschaft für Chemische Technik und Biotechnologie. Available online: <http://edok01.tib.uni-hannover.de/edoks/e01fb15/837304261.pdf>. Accessed: May 2016.
- Miret, C., Chazara, P., Montastruc, L., Negny, S., Domenech, S., 2016. Design of bio-ethanol green supply chain: comparison between first and second generation biomass concerning economic, environmental and social criteria. *Comput. Chem. Eng.* 85, 16–35.
- Moncada, J., El-Halwagi, M.M., Cardona, C.A., 2013. Techno-economic analysis for a sugarcane biorefinery: Colombian case. *Bioresour. Technol.* 135, 533–543.
- Nitzsche, R., Budzinski, M., Gröngroft, A., 2016. Techno-economic assessment of a wood-based biorefinery concept for the production of polymer-grade ethylene, organosolv lignin and fuel. *Bioresour. Technol.* 200, 928–939.
- Palgan, Y.V., McCormick, K., 2016. Biorefineries in Sweden: perspectives on the opportunities, challenges and future. *Biofuels, Bioprod. Biorefining* 10, 523–533.
- Peters, M., Timmerhaus, K., West, R., 2003. *Plant Design and Economics for Chemical Engineers*. McGraw Hill, New York.
- Platts, 2016. Petrochemicals - Price Index. McGraw Hill Financial. Available at: <http://www.platts.com/news-feature/2015/petrochemicals/pgpi/propylene>. Accessed: July 2016.
- Ramirez, E.C., Johnston, D.B., McAloon, A.J., Yee, W., Singh, V., 2008. Engineering process and cost model for a conventional corn wet milling facility. *Ind. Crops Prod.* 27, 91–97.
- Renouf, M.A., Wegener, M.K., Nielsen, L.K., 2008. An environmental life cycle assessment comparing Australian sugarcane with US corn and UK sugar beet as producers of sugars for fermentation. *Biomass Bioenergy* 32, 1144–1155.
- Rincón, L.E., Becerra, L.A., Moncada, J., Cardona, C.A., 2014. Techno-economic analysis of the use of fired cogeneration systems based on sugar cane bagasse in south eastern and mid-western regions of Mexico. *Waste Biomass Valorization* 5, 189–198.
- Sea-distances, 2015. Port-to-port Sea Distances. Available at: <http://www.sea-distances.org/>. Accessed: July 2015.
- Skogsstyrelsen, 2014. Prices. Swedish Forest Agency. Available at: [http://pxweb.skogsstyrelsen.se/pxweb/en/Skogsstyrelsen%20statistikdatabas/Skogsstyrelsen%20statistikdatabas\\_Rundvirkespriser/J00303\\_1\\_20160128.px/?rxid=0762e9f1-f8c9-46e3-9135-97ca4631f207](http://pxweb.skogsstyrelsen.se/pxweb/en/Skogsstyrelsen%20statistikdatabas/Skogsstyrelsen%20statistikdatabas_Rundvirkespriser/J00303_1_20160128.px/?rxid=0762e9f1-f8c9-46e3-9135-97ca4631f207).
- Thornley, P., Chong, K., Bridgwater, T., 2014. European biorefineries: implications for land, trade and employment. *Environ. Sci. Policy* 37, 255–265.
- Torres, A.I., Daoutidis, P., Tsapatsis, M., 2010. Continuous production of 5-hydroxymethylfurfural from fructose: a design case study. *Energy & Environ. Sci.* 3, 1560–1572.
- Tsiropoulos, I., Cok, B., Patel, M.K., 2013. Energy and greenhouse gas assessment of European glucose production from corn—a multiple allocation approach for a key ingredient of the bio-based economy. *J. Clean. Prod.* 43, 182–190.
- U.S.Grains, 2015. FOB Price Charts. U.S. Grains Council. Available at: <http://www.grains.org/market-data/charts-tables>. Accessed: July 2015.
- UIC, IEA, 2014. Railway Handbook. Energy Consumption and CO2 Emissions. Focus on Infrastructure.
- Ulrich, G.D., Vasudevan, P.T., 2006. How to estimate utility costs. *Chem. Eng.* 113, 66.
- van der Linden, R., Huijgen, W.J.J., Reith, J.H., 2012. Ethanol-based organosolv biorefineries: feedstock-flexibility & economic evaluation. In: Niemelä, K. (Ed.), NWBC 2012, the 4th Nordic Wood Biorefinery Conference. VTT Technical Research Centre of Finland, Helsinki, Finland, pp. 199–204.
- Viell, J., Harwardt, A., Seiler, J., Marquardt, W., 2013. Is biomass fractionation by Organosolv-like processes economically viable? A conceptual design study. *Bioresour. Technol.* 150, 89–97.
- Watanabe, M.D., Chagas, M.F., Cavalett, O., Guilhoto, J.J., Griffin, W.M., Cunha, M.P., Bonomi, A., 2015. Hybrid input-output life cycle assessment of first- and second-generation ethanol production technologies in Brazil. *J. Ind. Ecol.* 20, 764–774.
- Wildschut, J., Smit, A.T., Reith, J.H., Huijgen, W.J.J., 2013. Ethanol-based organosolv fractionation of wheat straw for the production of lignin and enzymatically digestible cellulose. *Bioresour. Technol.* 135, 58–66.
- Wiloso, A.I., Heijungs, R., de Snoo, G.R., 2012. LCA of second generation bioethanol: a review and some issues to be resolved for good LCA practice. *Renew. Sustain. Energy Rev.* 16, 5295–5308.
- Wooley, R.J., Putsche, V., 1996. Development of an ASPEN PLUS Physical Property Database for Biofuels Components. National Renewable Energy Laboratory (NREL), Golden, Colorado, pp. 1–32.
- Zakzeski, J., Bruijninx, P.C., Jongerijs, A.L., Weckhuysen, B.M., 2010. The catalytic valorization of lignin for the production of renewable chemicals. *Chem. Rev.* 110, 3552–3599.