

STUDIO PUBLIC REALM- UTOPIA ANKARA

INNER CITY LOOP- STUDENT CENTER P5 PRESENTATION- JUNE 29

WENLI PAN

CONTENT

-Urban Situation

-Position

-Urban Strategy

Inner city loop

-Site

Site condition

Site reconfiguration

Site Plan

-Architectural Design

Concept

Composition

Program Distribution

-Structure and Materialization

-Building Performance

-Urban Situation

-Position

-Urban Strategy

Inner city loop

-Site

Site condition

Site reconfiguration

Site Plan

-Architectural Design

Concept

Composition

Program Distribution

-Structure and Materialization

-Building Performance

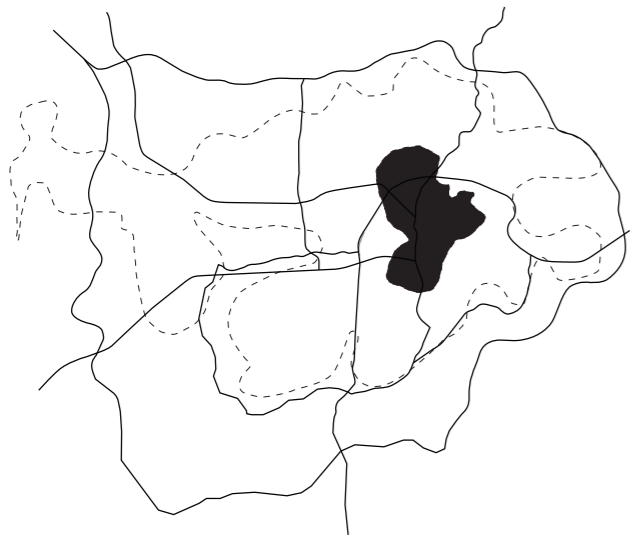

Lörcher Plan (1924)

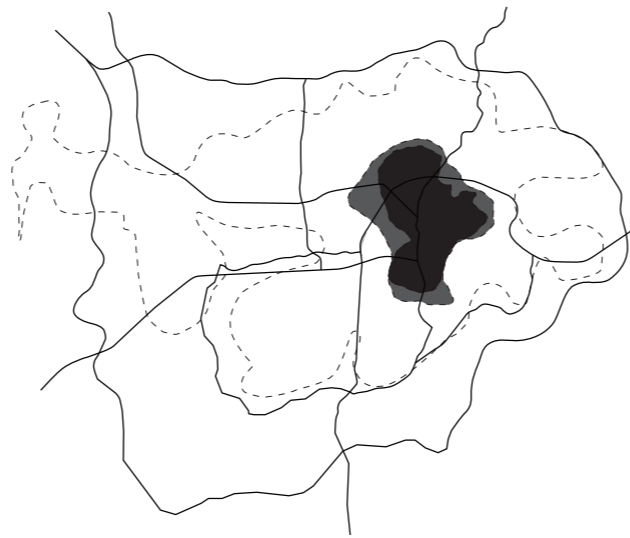

Jansen plan (1932)

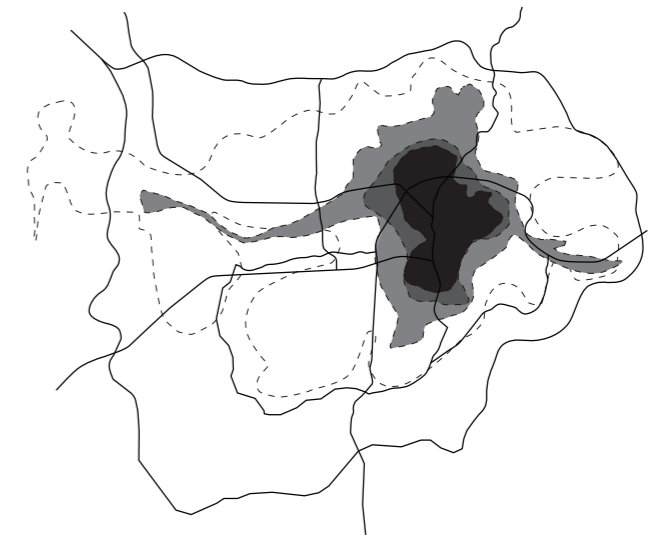

Ankara Master 1990 Master Plan(1975)

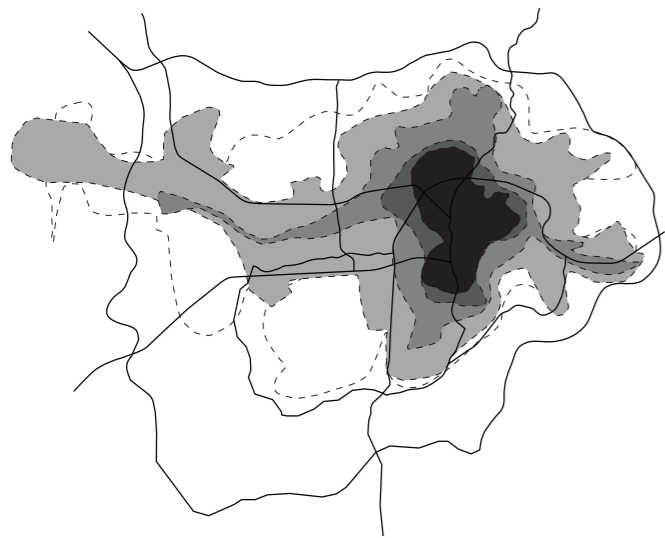

Ankara 2015 Structure Plan(1986)

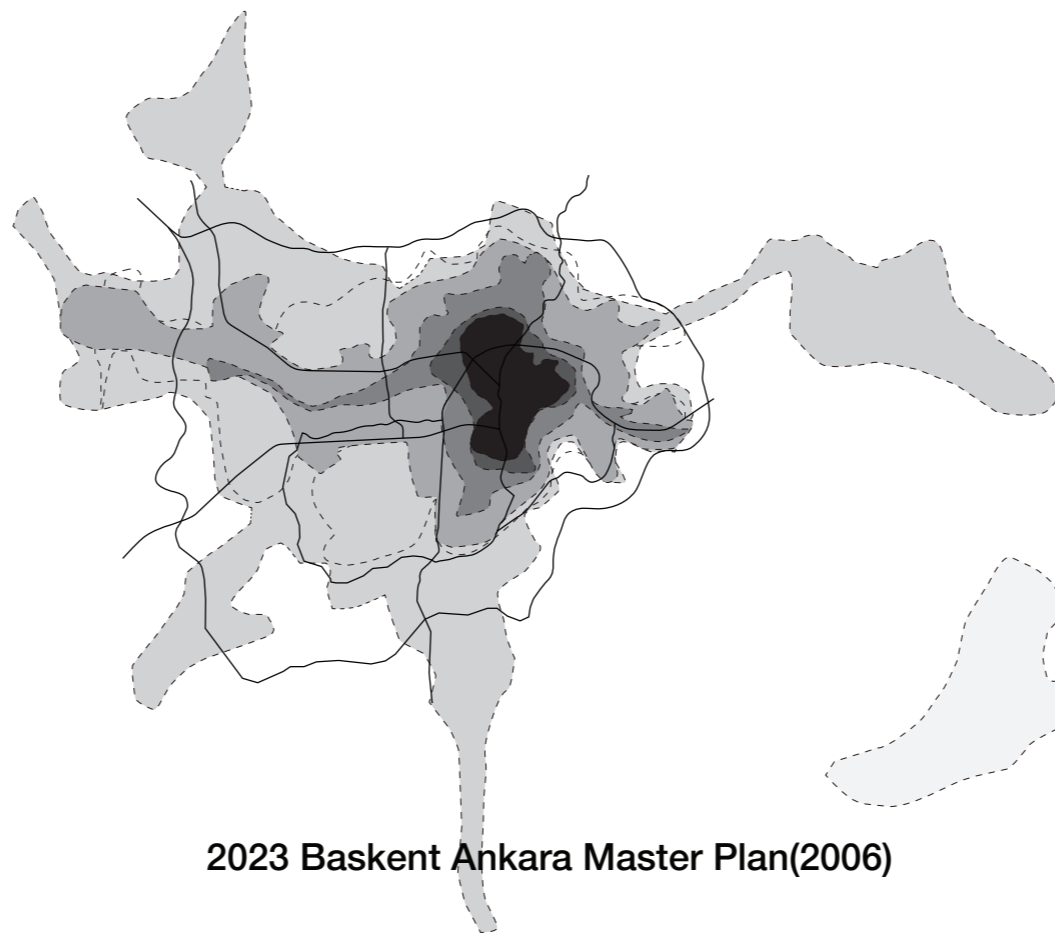

2023 Baskent Ankara Master Plan(2006)

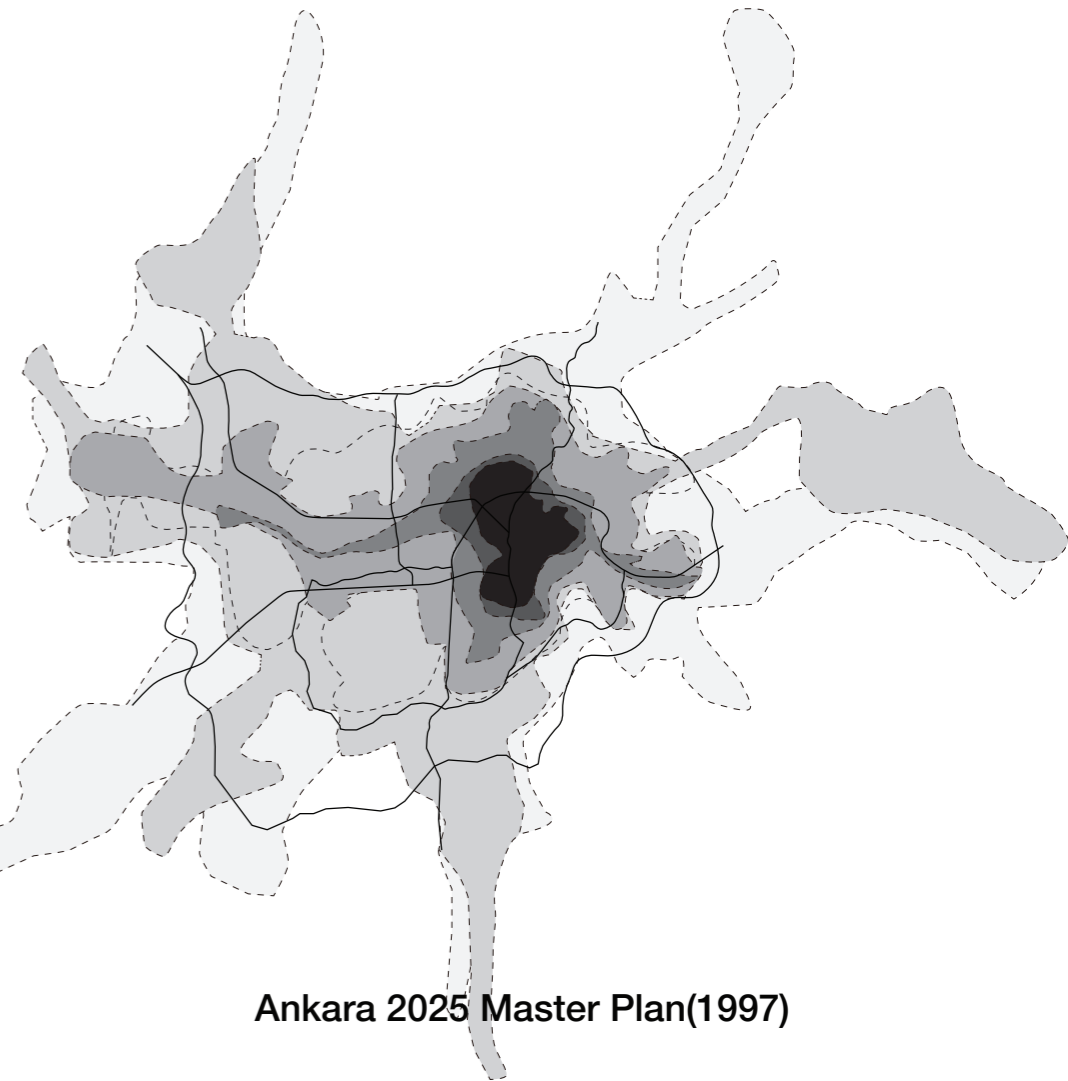

Ankara 2025 Master Plan(1997)



0 1000m 2000m

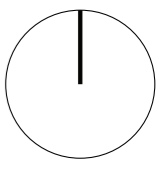

-Urban Situation

-Position

-Urban Strategy

Inner city loop

-Site

Site condition

Site reconfiguration

Site Plan

-Architectural Design

Concept

Composition

Program Distribution

-Structure and Materialization

-Building Performance

UTOPIA GOAL

CONTROL THE URBAN SPRAWL

PROVIDE EASY ACCESS TO THE FRAGMENTED CITY

-Urban Situation

-Position

-Urban Strategy

Inner city loop

-Site

Site condition

Site reconfiguration

Site Plan

-Architectural Design

Concept

Composition

Program Distribution

-Structure and Materialization

-Building Performance

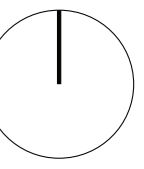
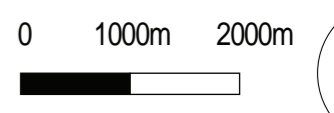

0 1000m 2000m

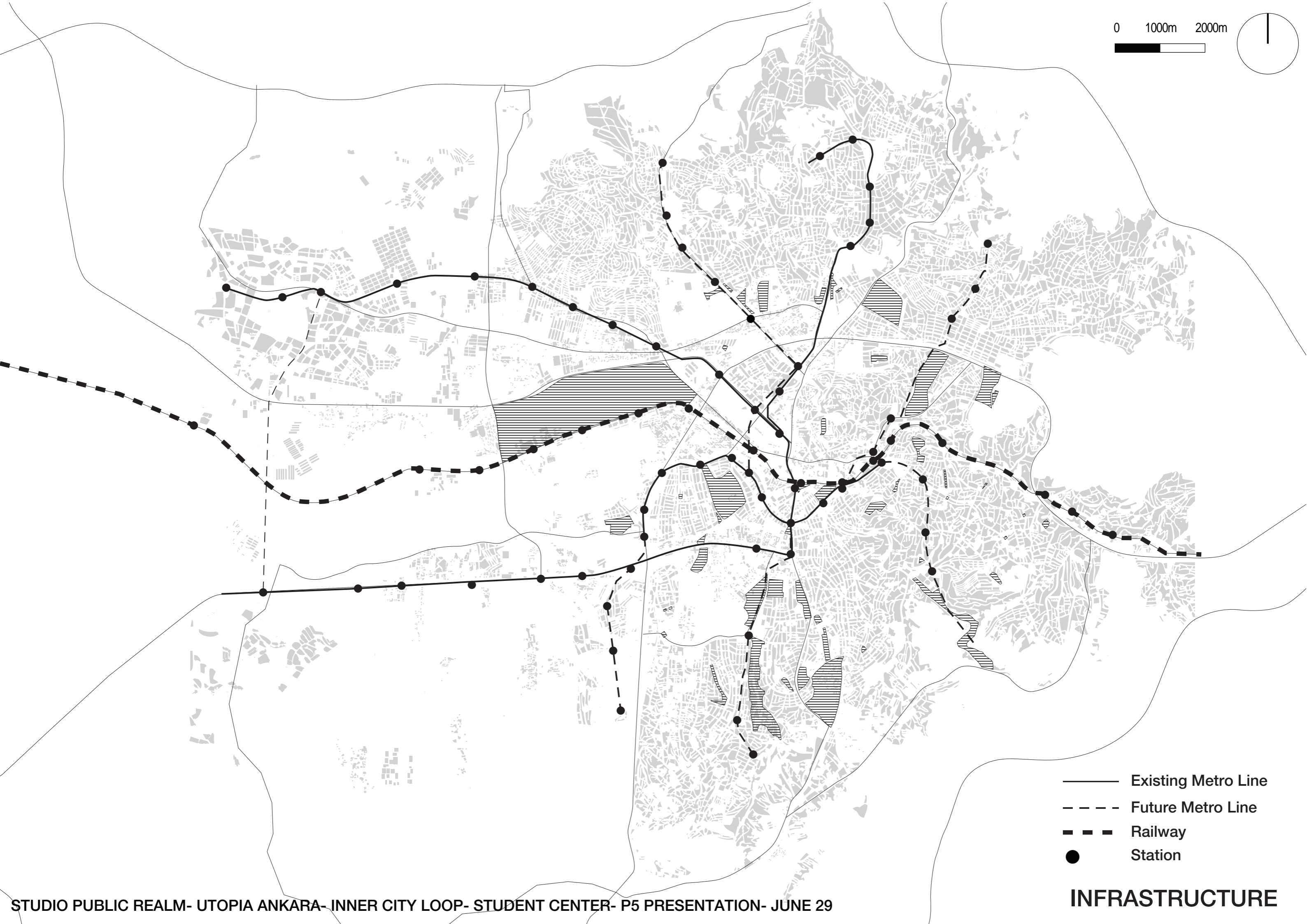
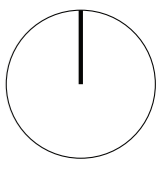

- Existing Metro Line
- - - Future Metro Line
- - - Railway
- Station

INFRASTRUCTURE

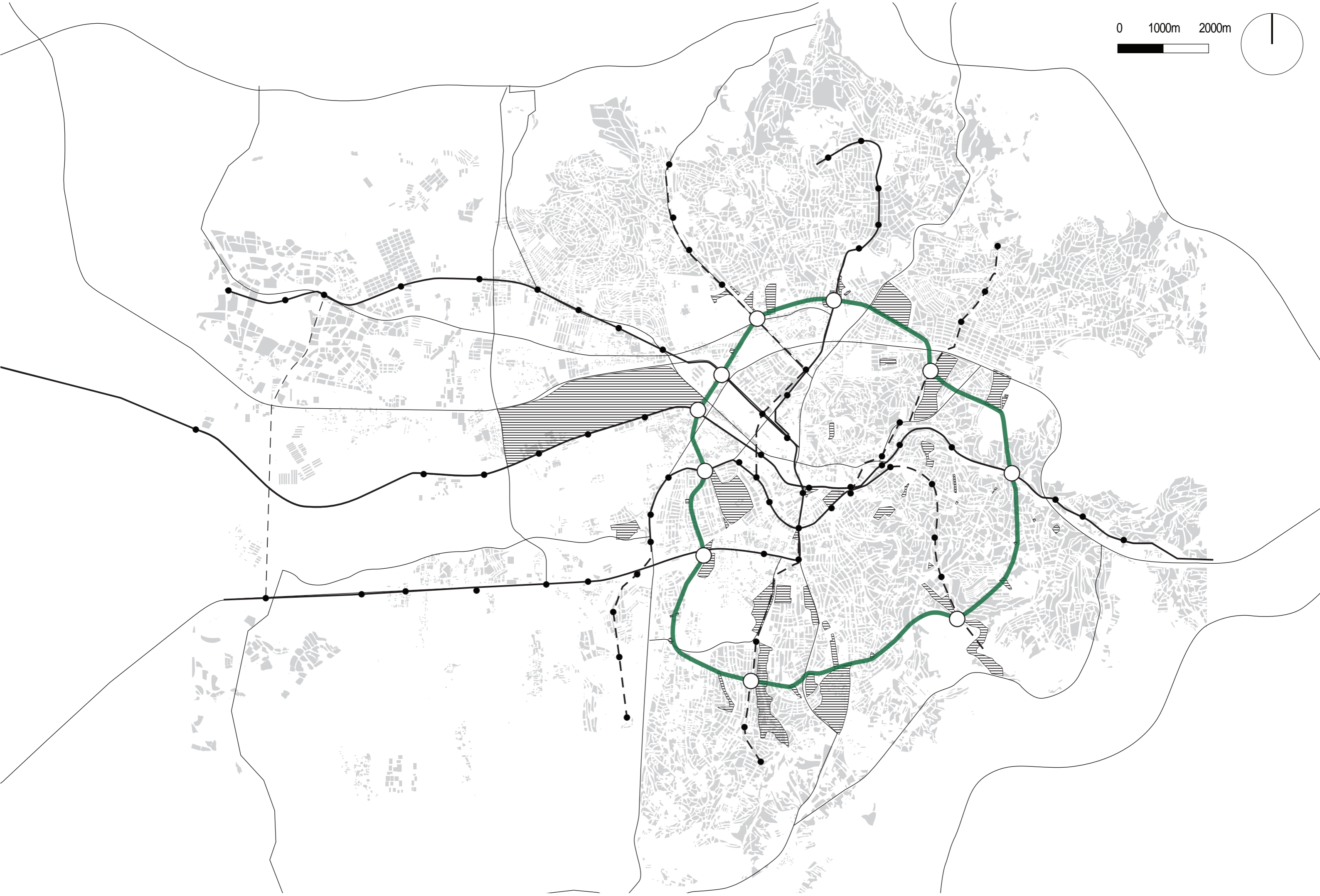
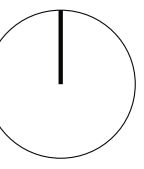
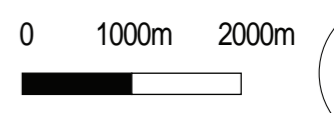

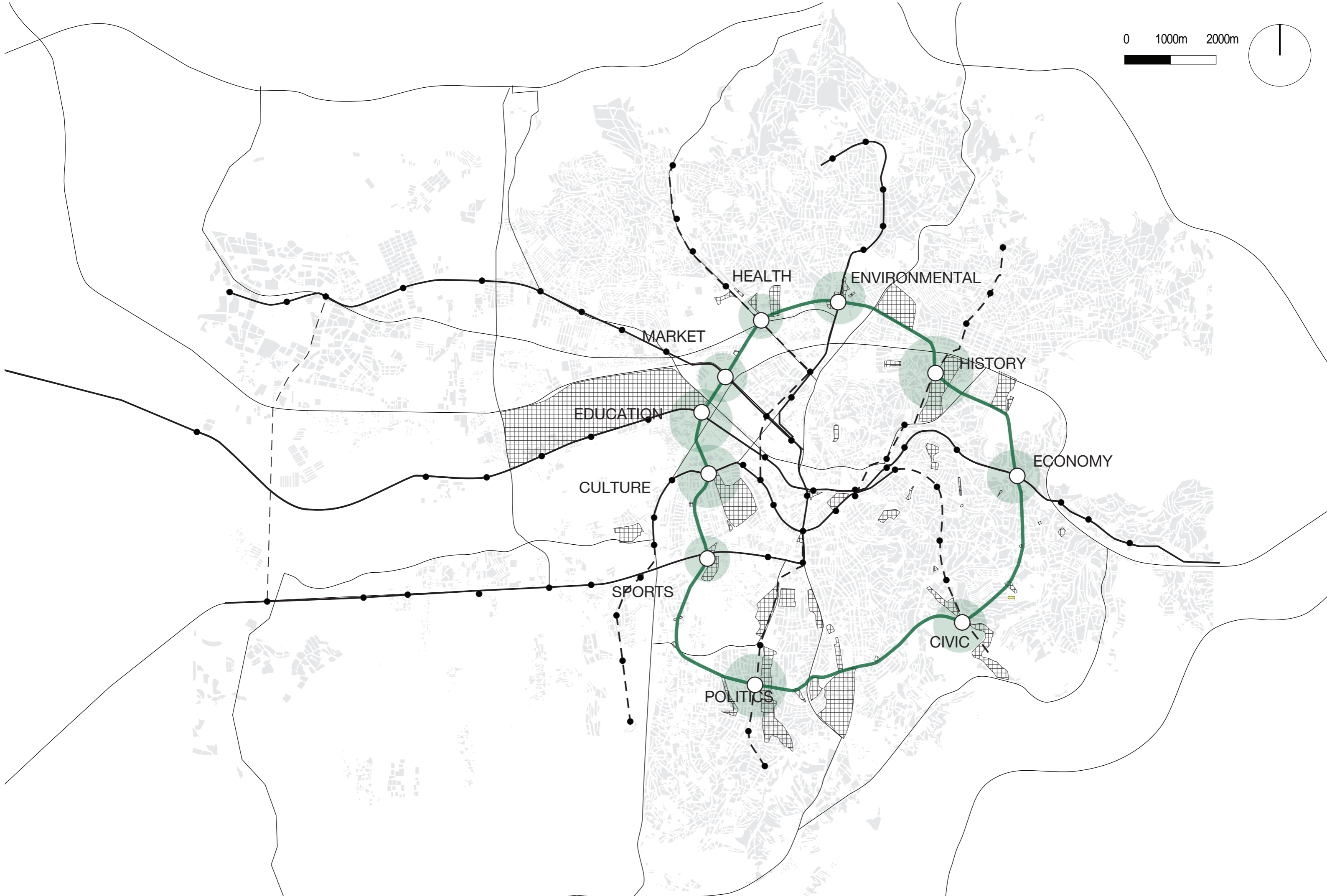
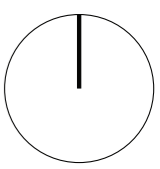

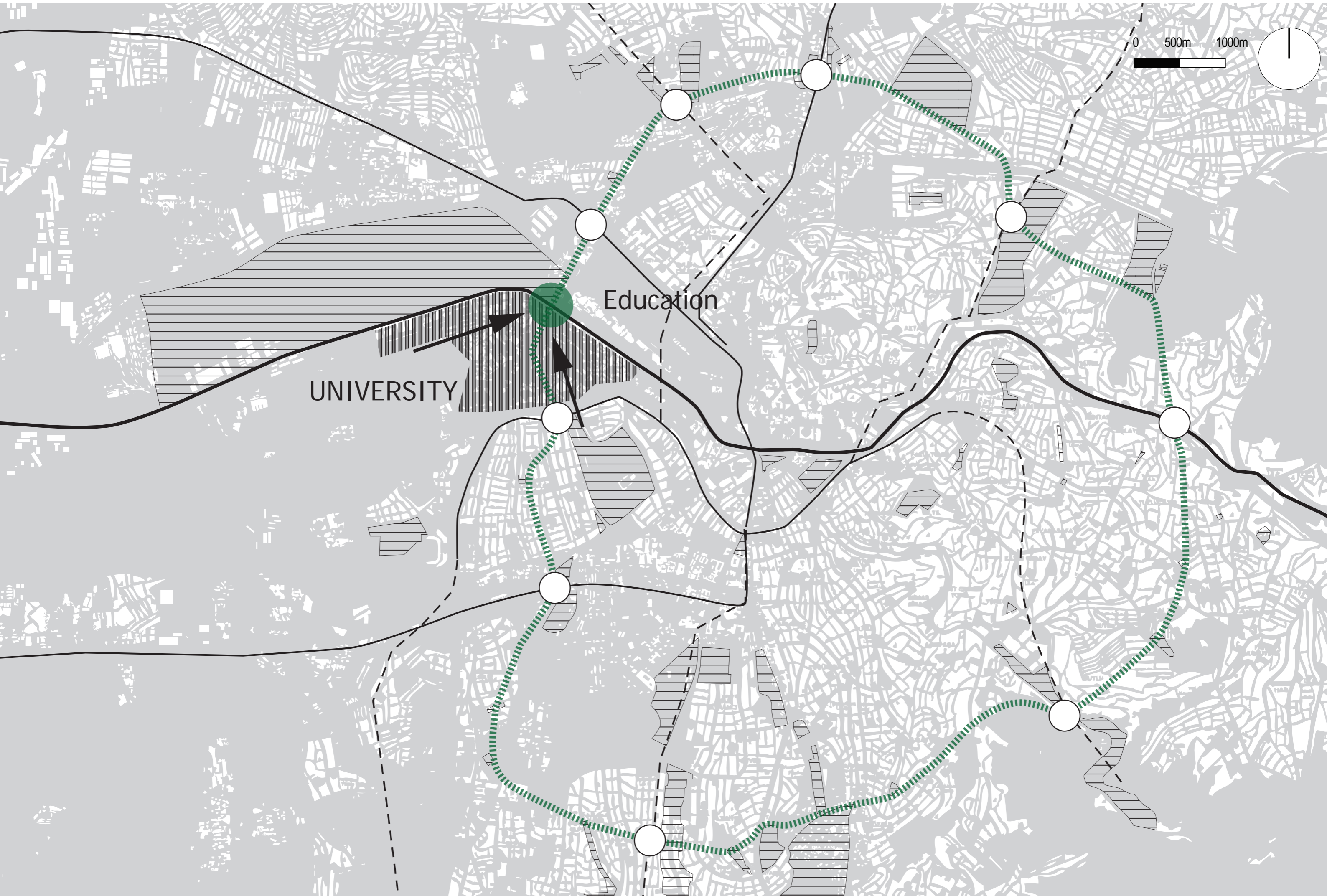

-Urban Situation

-Position

-Urban Strategy

Inner city loop

-Site

Site condition

Site reconfiguration

Building Position

-Architectural Design

Programmatic

Concept

Composition

-Structure and Materialization

-Building Performance



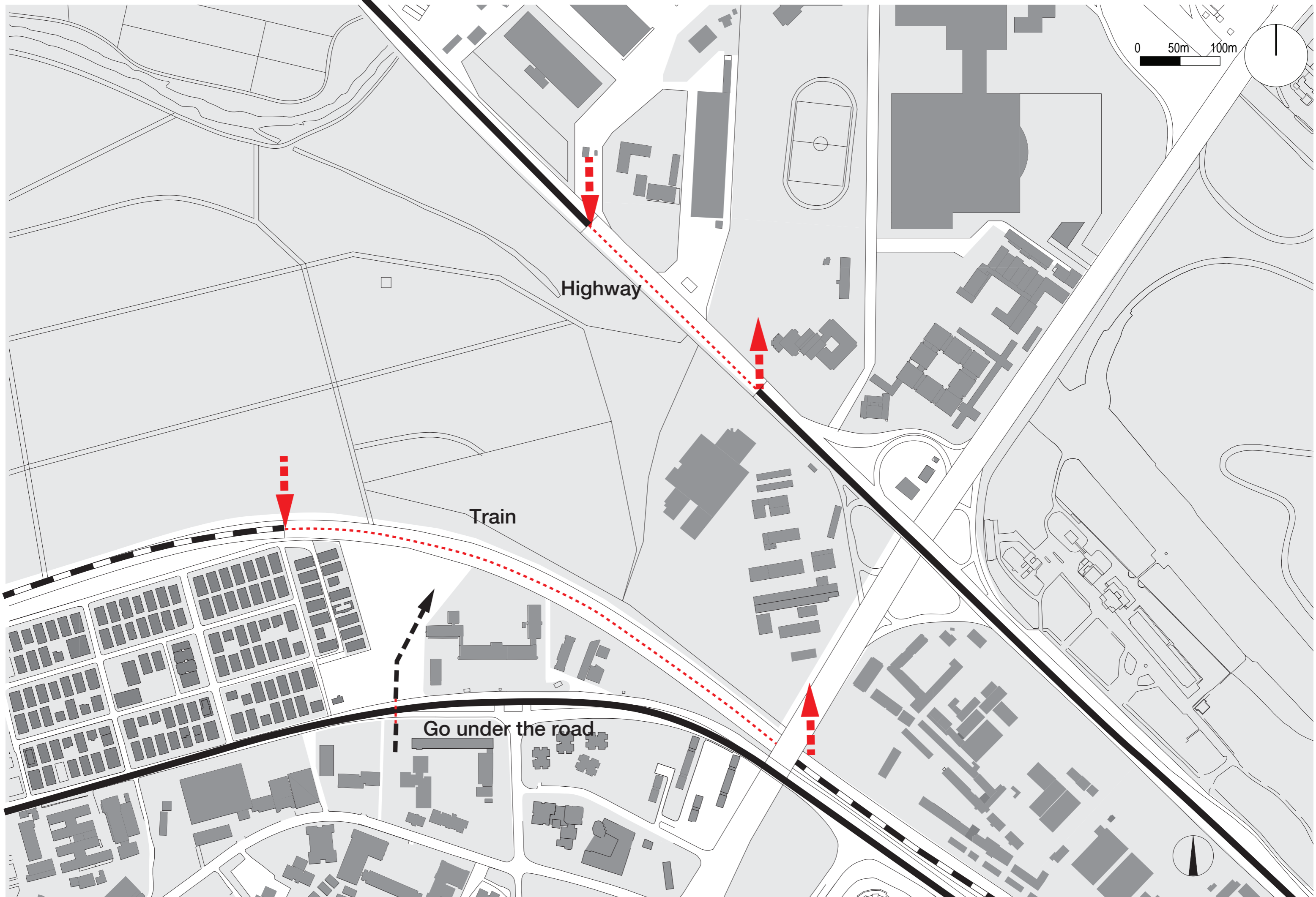

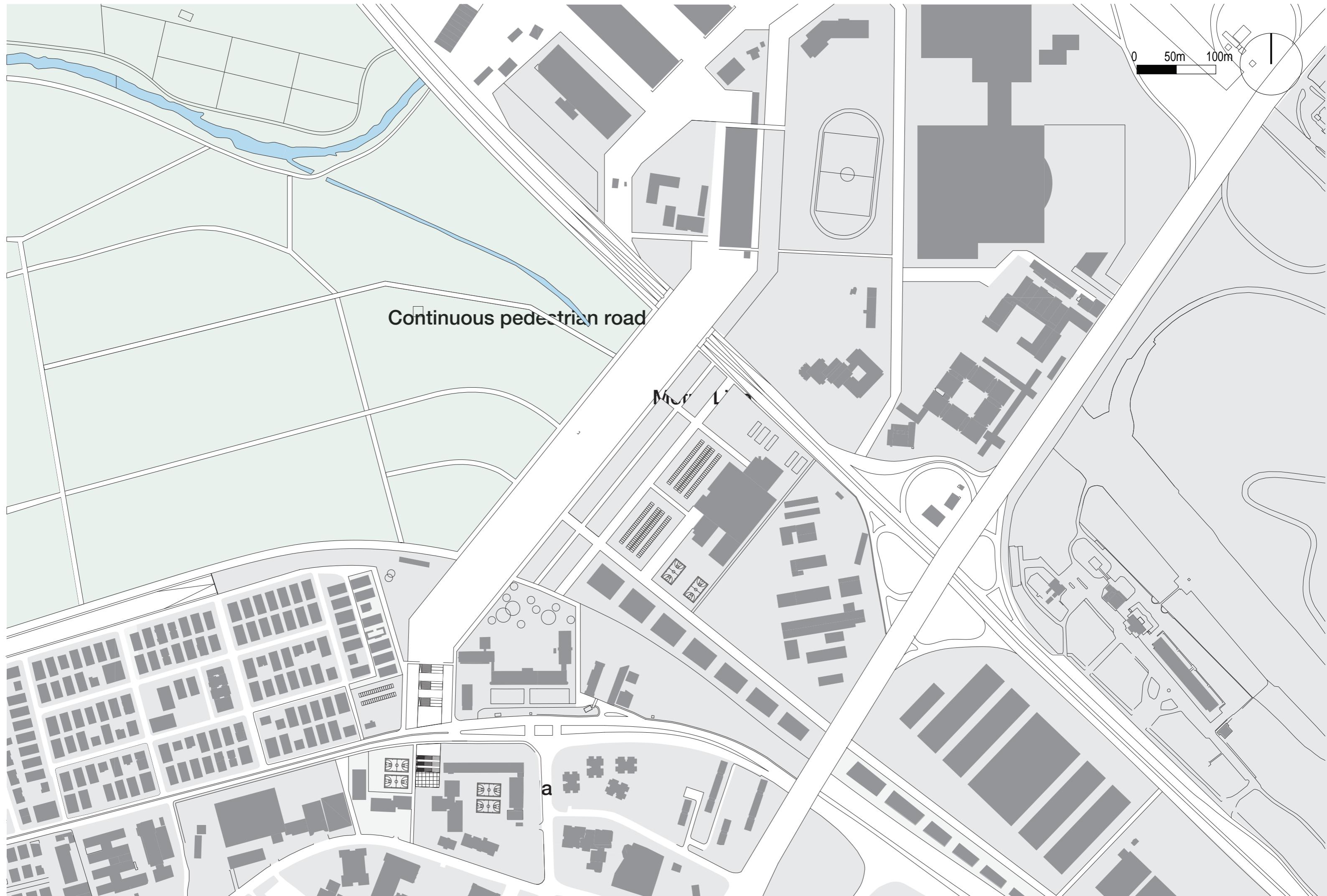

Continuous pedestrian road

Metrolin

a

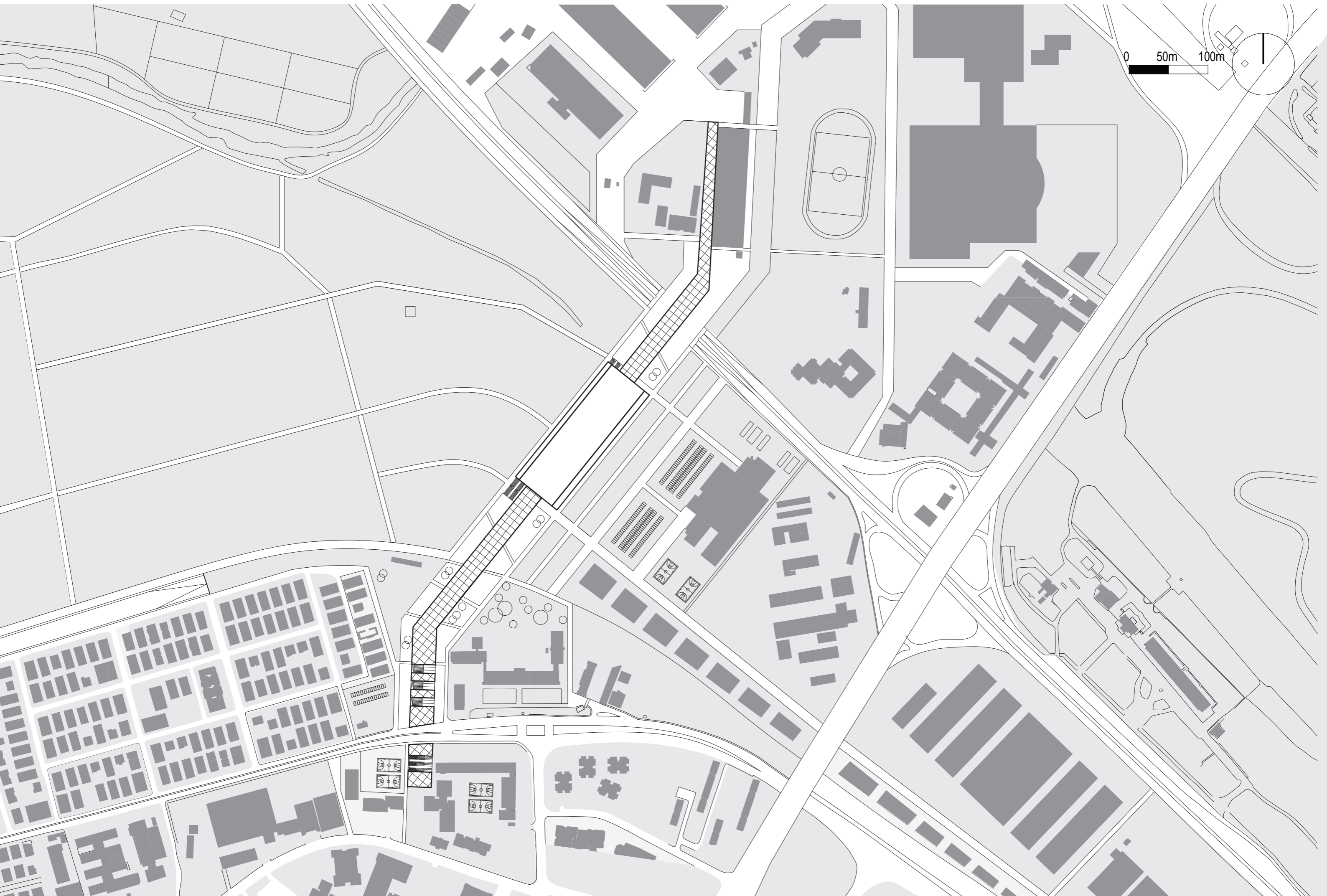

0 50m 100m



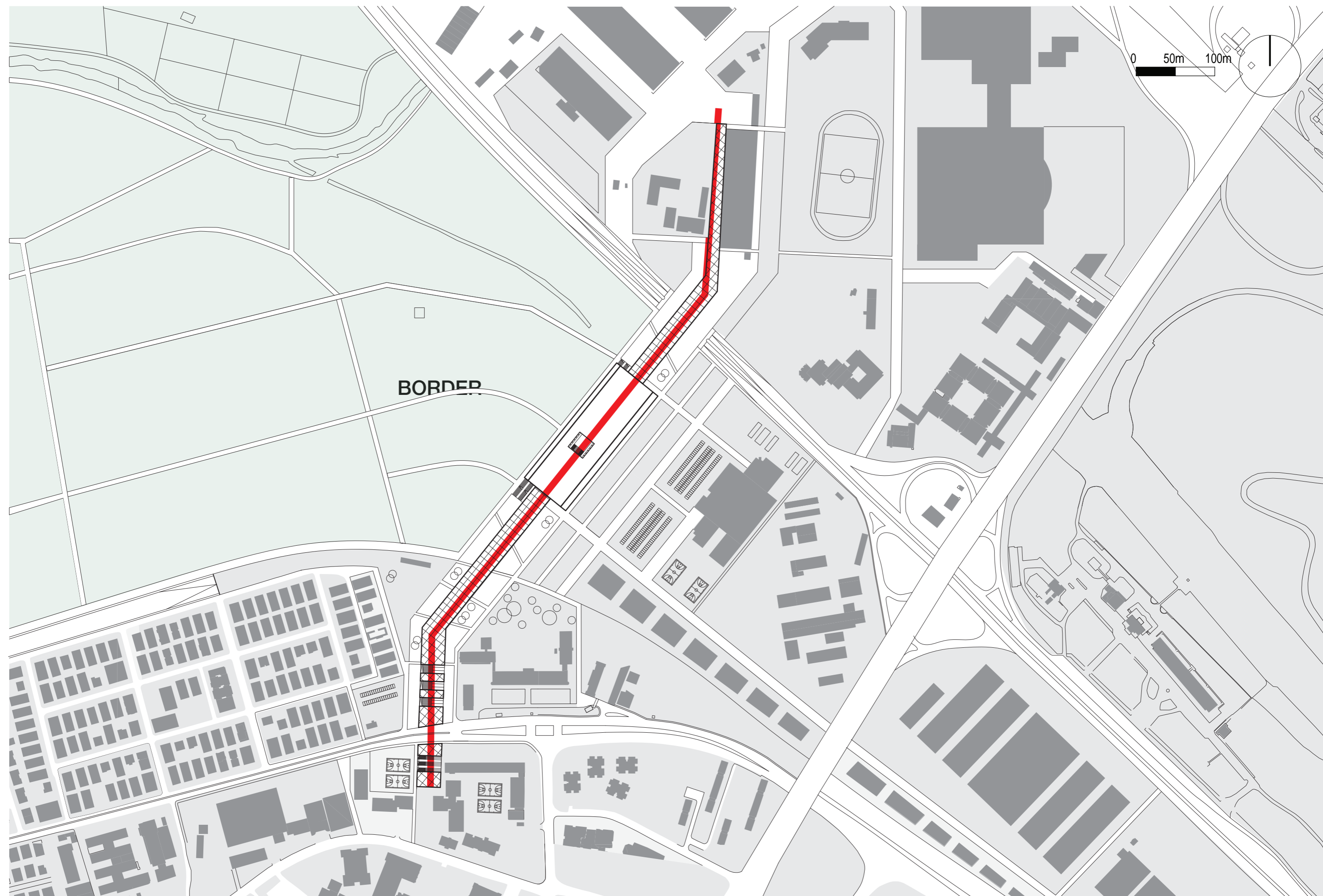



0 50m 100m



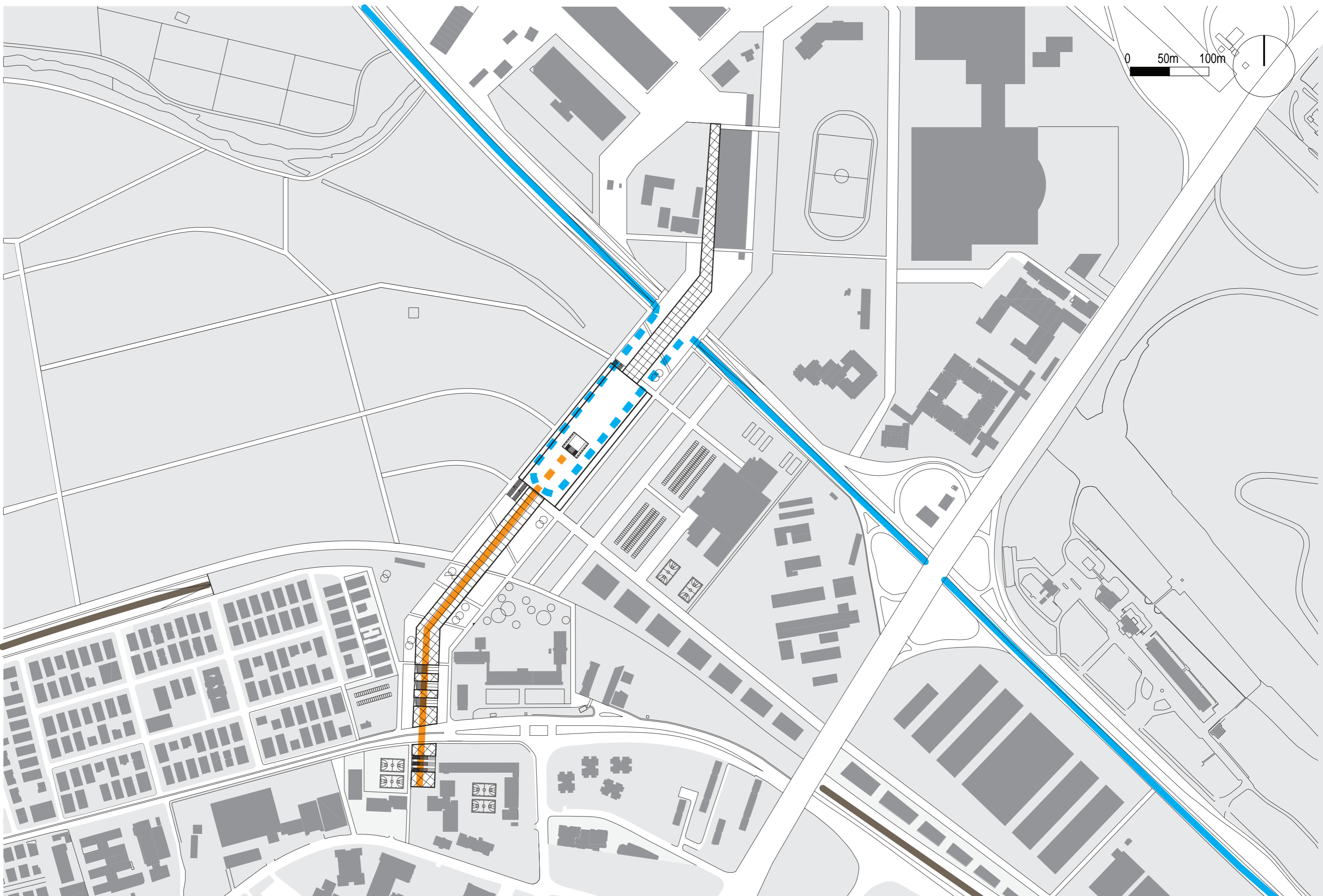

0 50m 100m

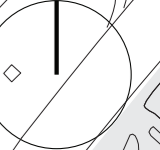

-Urban Situation

-Position

-Urban Strategy

Inner city loop

-Site

Site condition

Site reconfiguration

Building Position

-Architectural Design

Programmatic

Concept

Composition

-Structure and Materialization

-Building Performance

STUDENT LIFE

WORKING AND LIVING



Group work Lecture Student Organization Reading Seminar Individual study

RELAXATION AND MEETING



Sports Culture Hangout Eating Shopping Meeting and Event

STUDENT LIFE

WORKING AND LIVING

RELAXATION AND MEETING

Largest space

Smaller space

Smallest space

Largest space

Smaller space

Smallest space

Lecture Hall

Different
Lounging area

Seminar room
Student Organization
Group working
Personal studio
Hotel

Basketball court
Swimming Pool

Cheap Market
Bookstore
Foodcourt
Gamerom

Different cultural studio
Meeting room
Salon

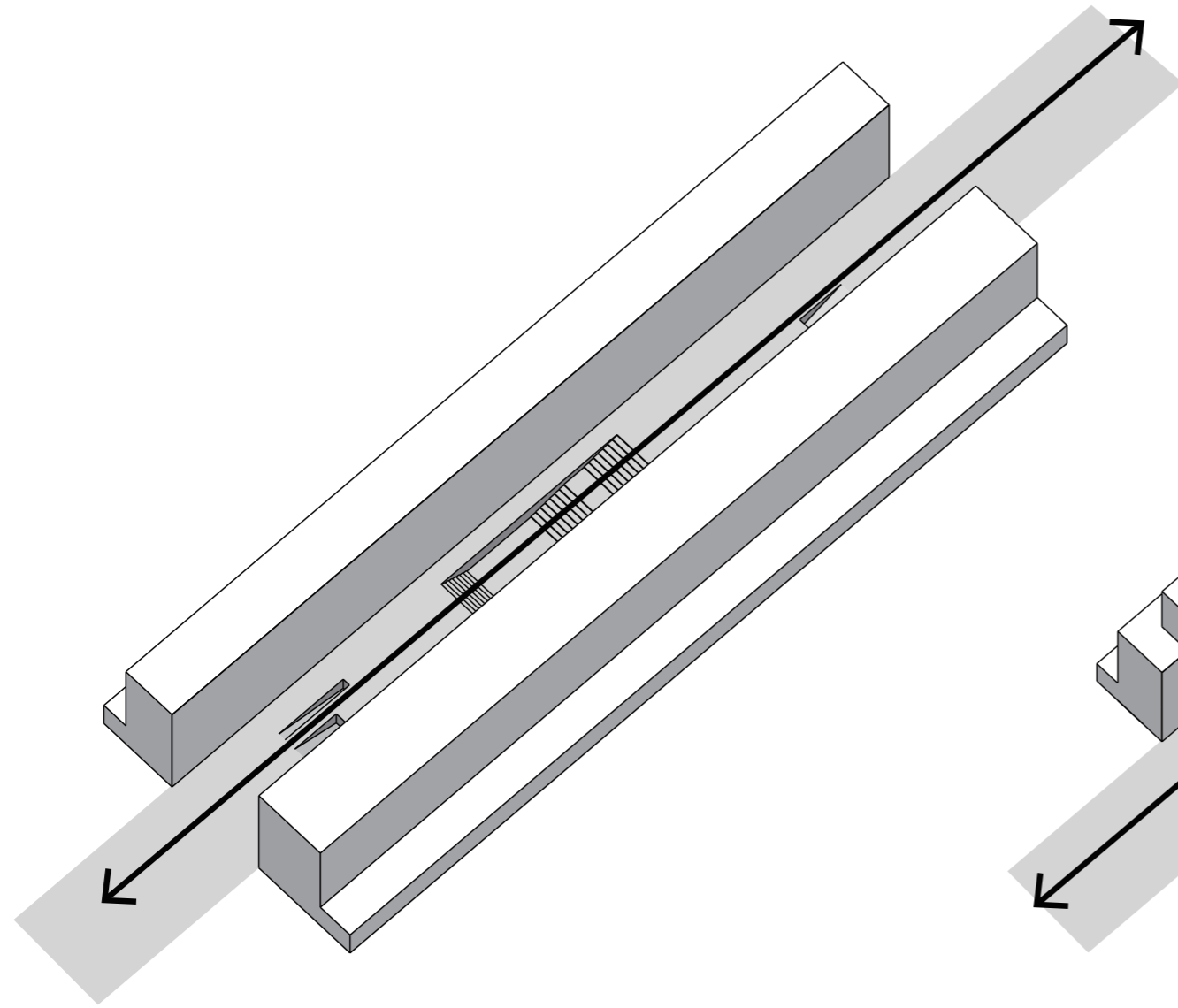

Continuation

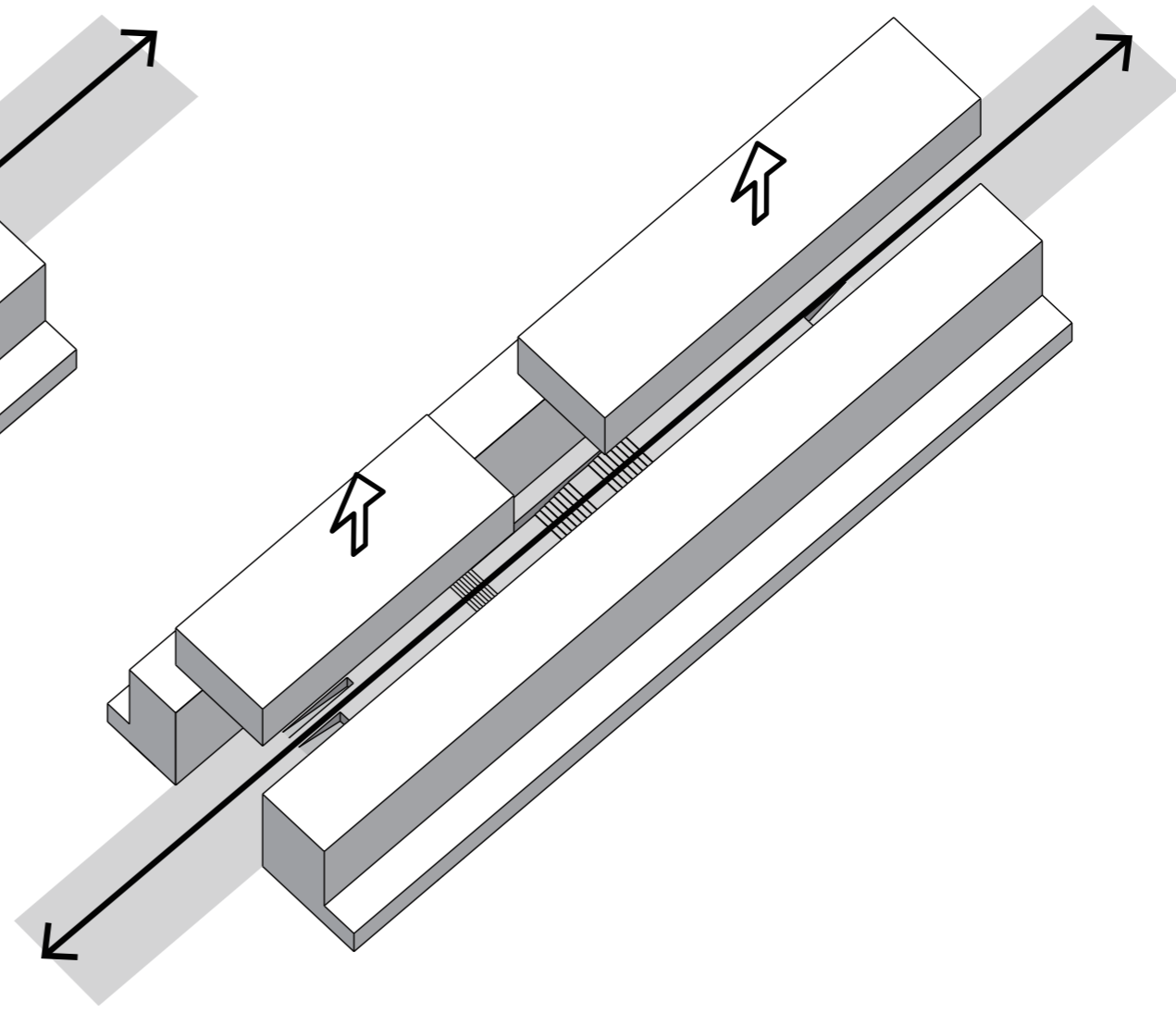

Lift up

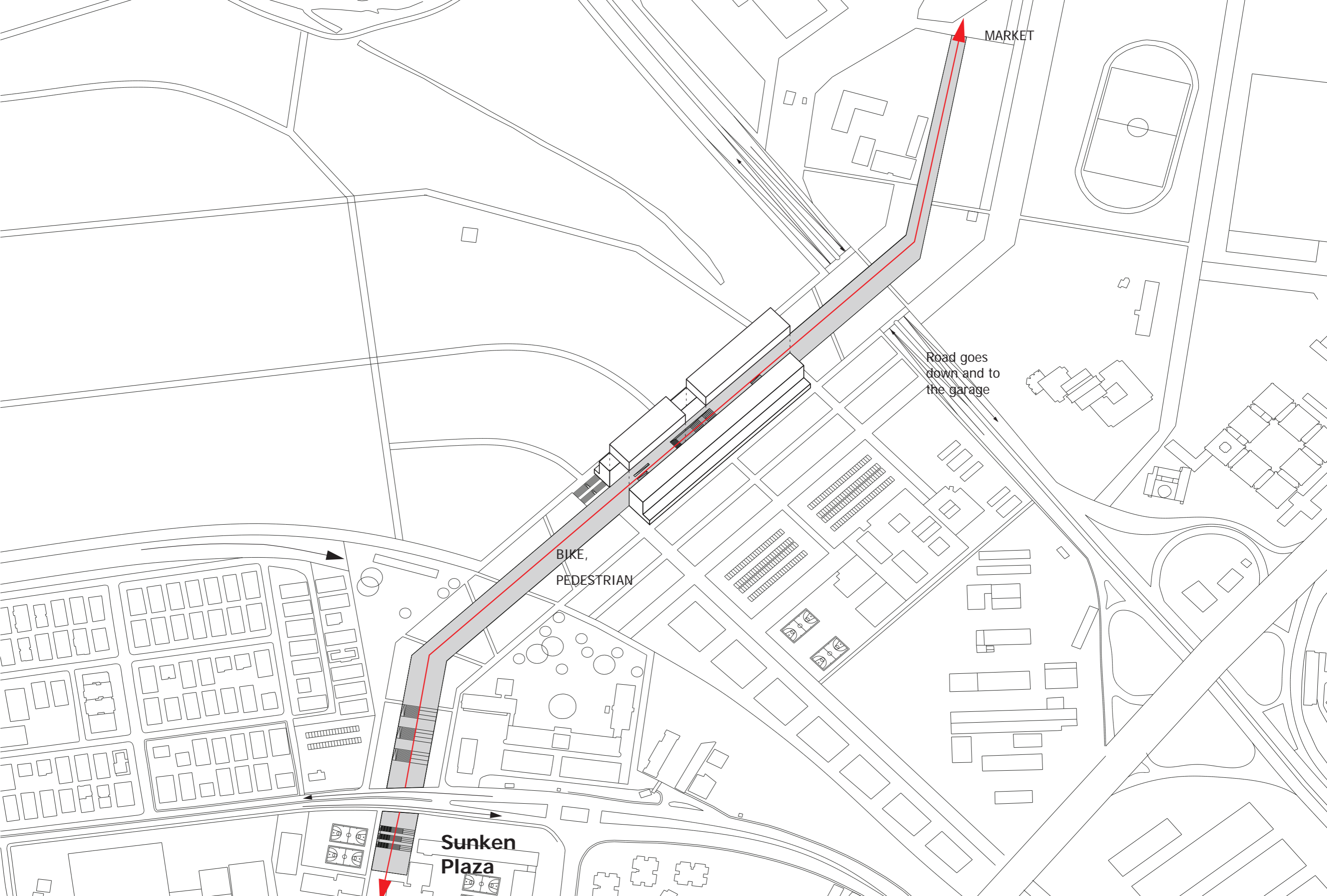

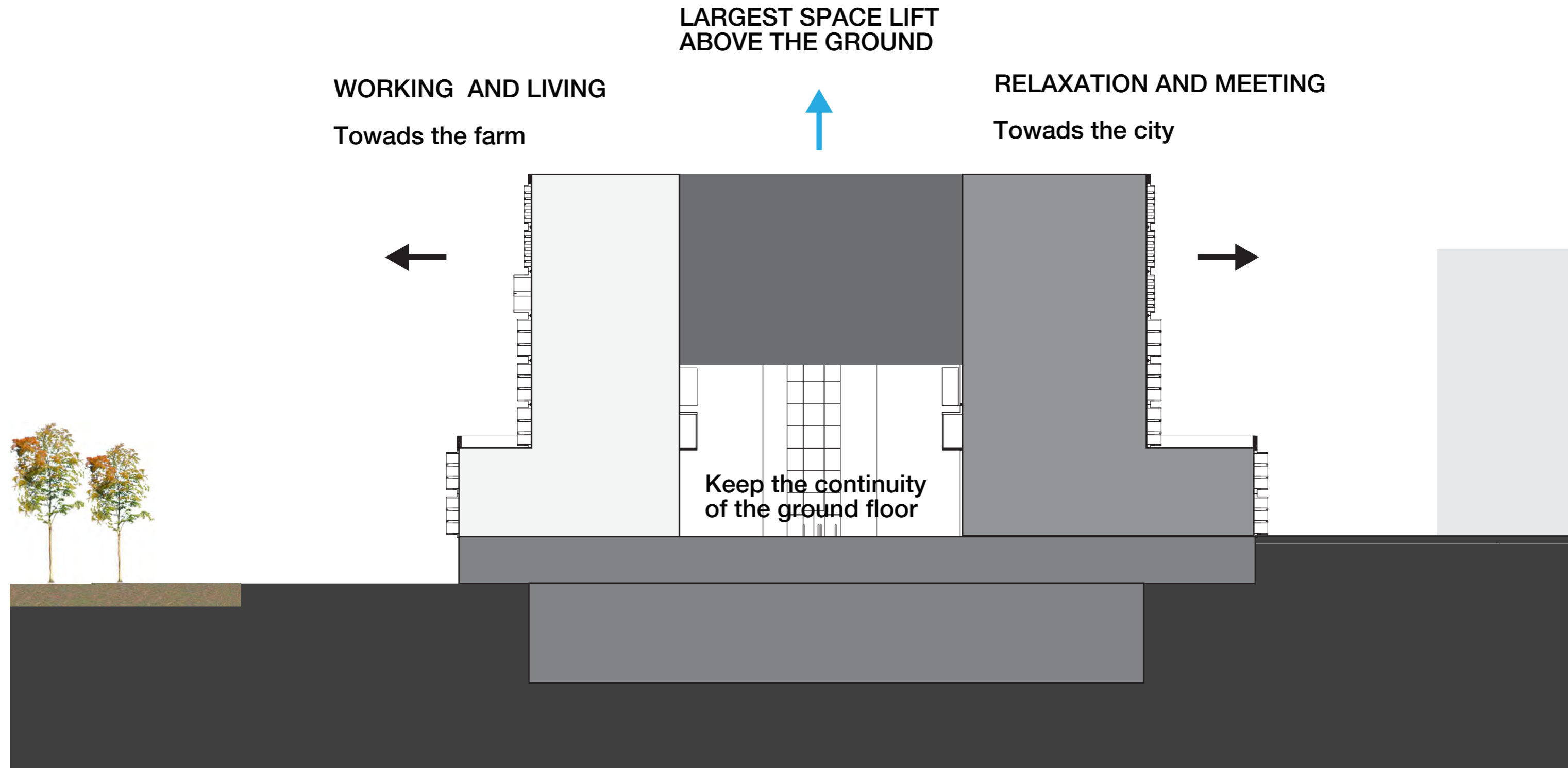

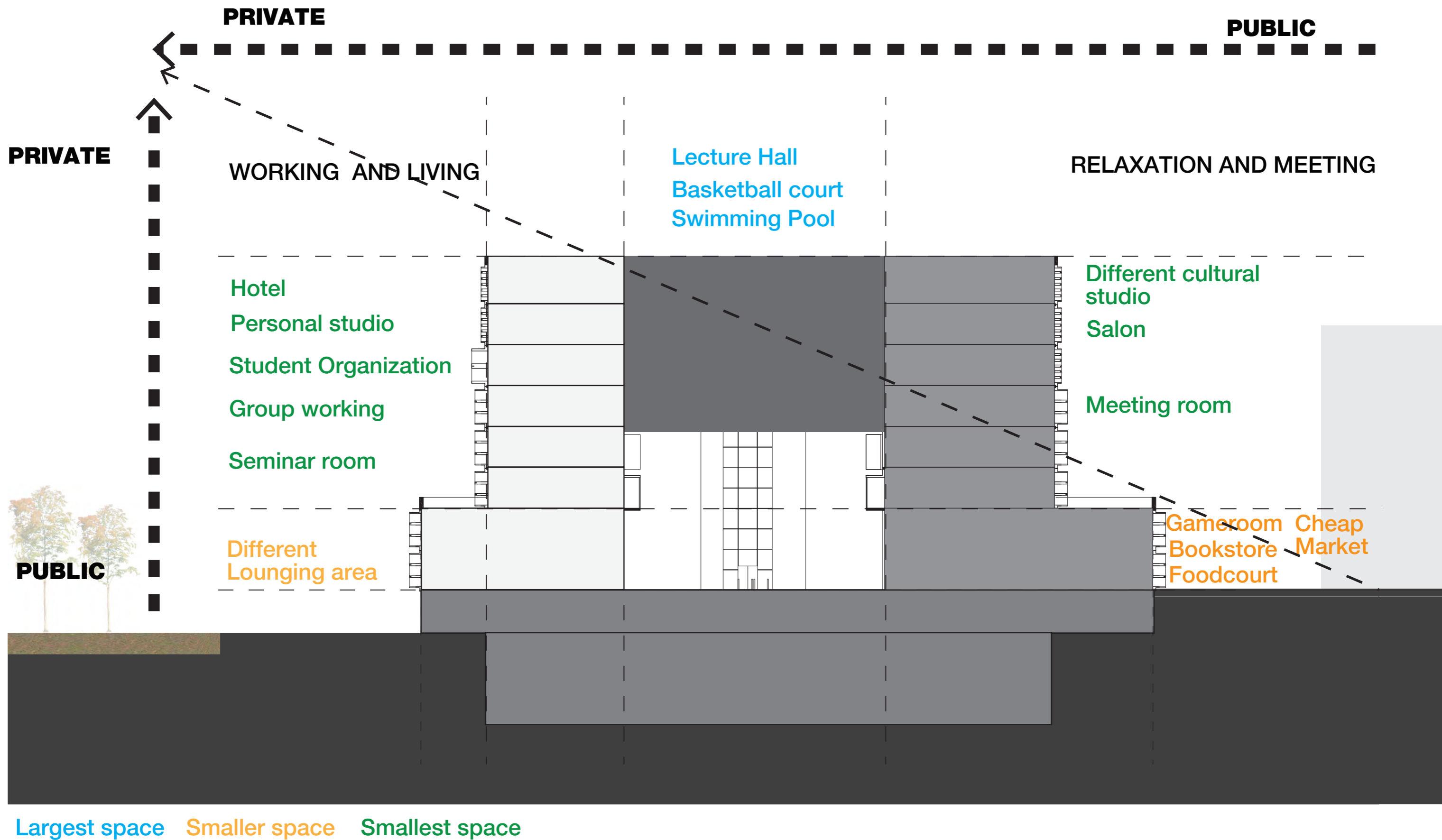

COVERED URBAN SPACE

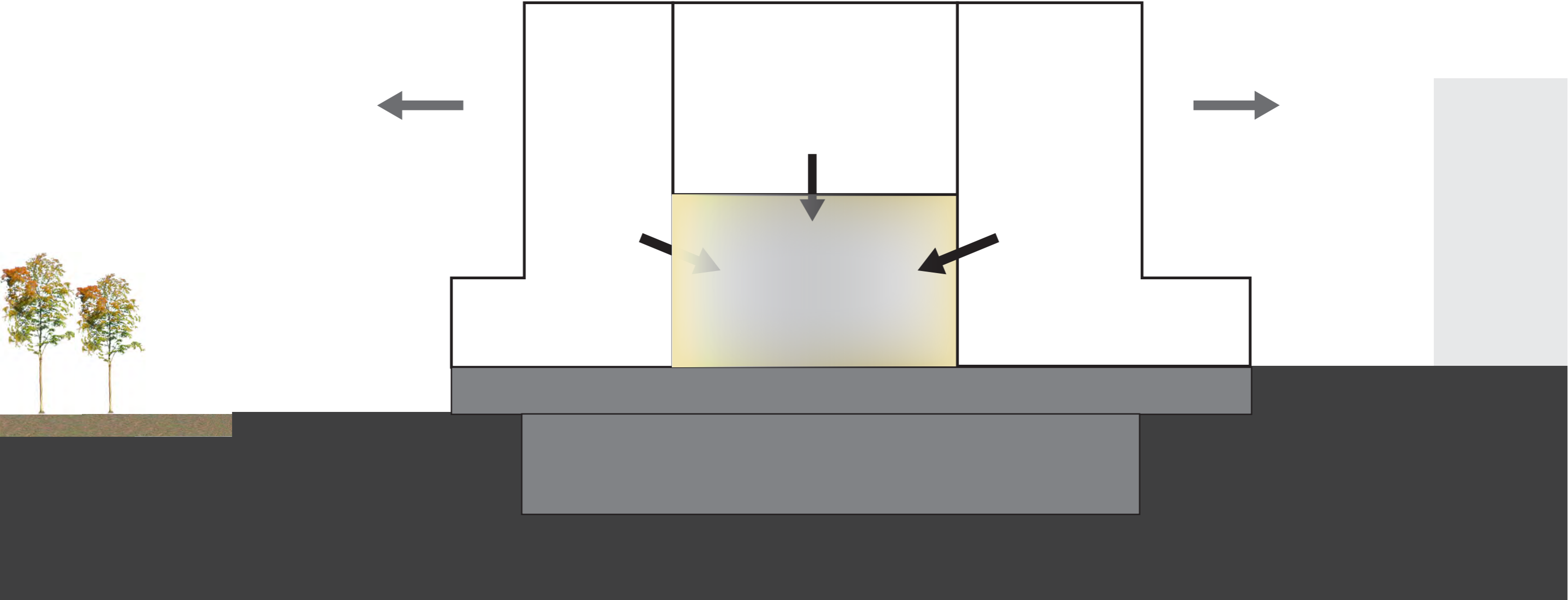

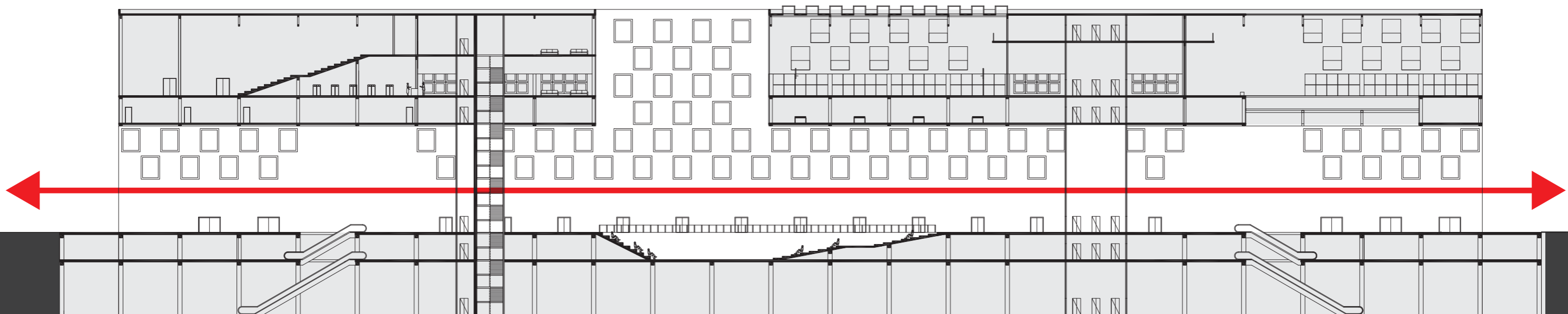

- - - **BIKE**
- - - **CAR**
- - - **METRO**

Bike entrance
Metro entrance

Outdoor performance area

Garage entrance
Metro entrance

UNIVERSITY
BIKE

ROAD
CAR

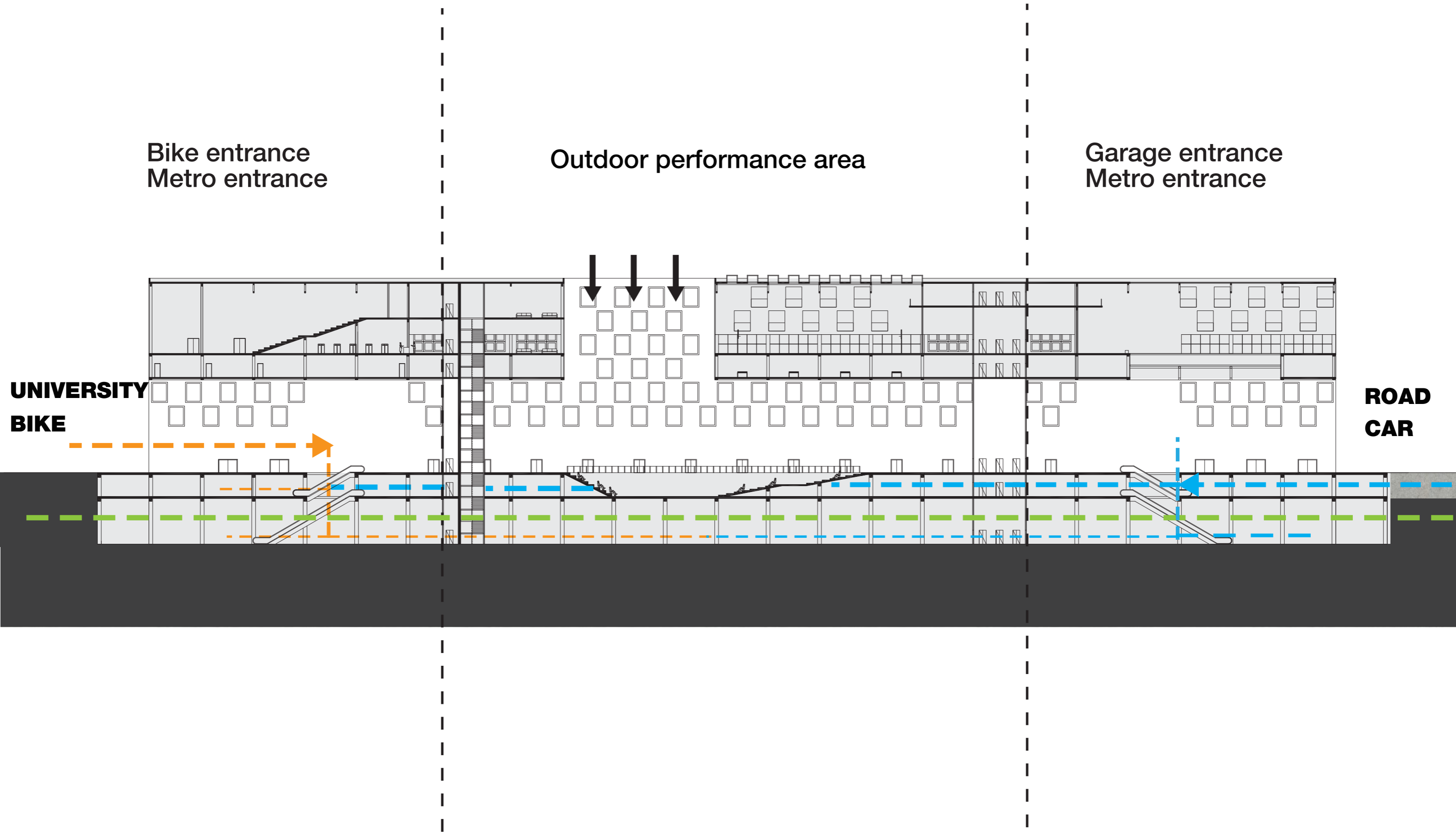

Bike entrance
Metro entrance

Outdoor performance area

Garage entrance
Metro entrance

ROAD
CAR
ENTRY

BIKE
UNIVERSITY

ROAD
CAR
EXIT

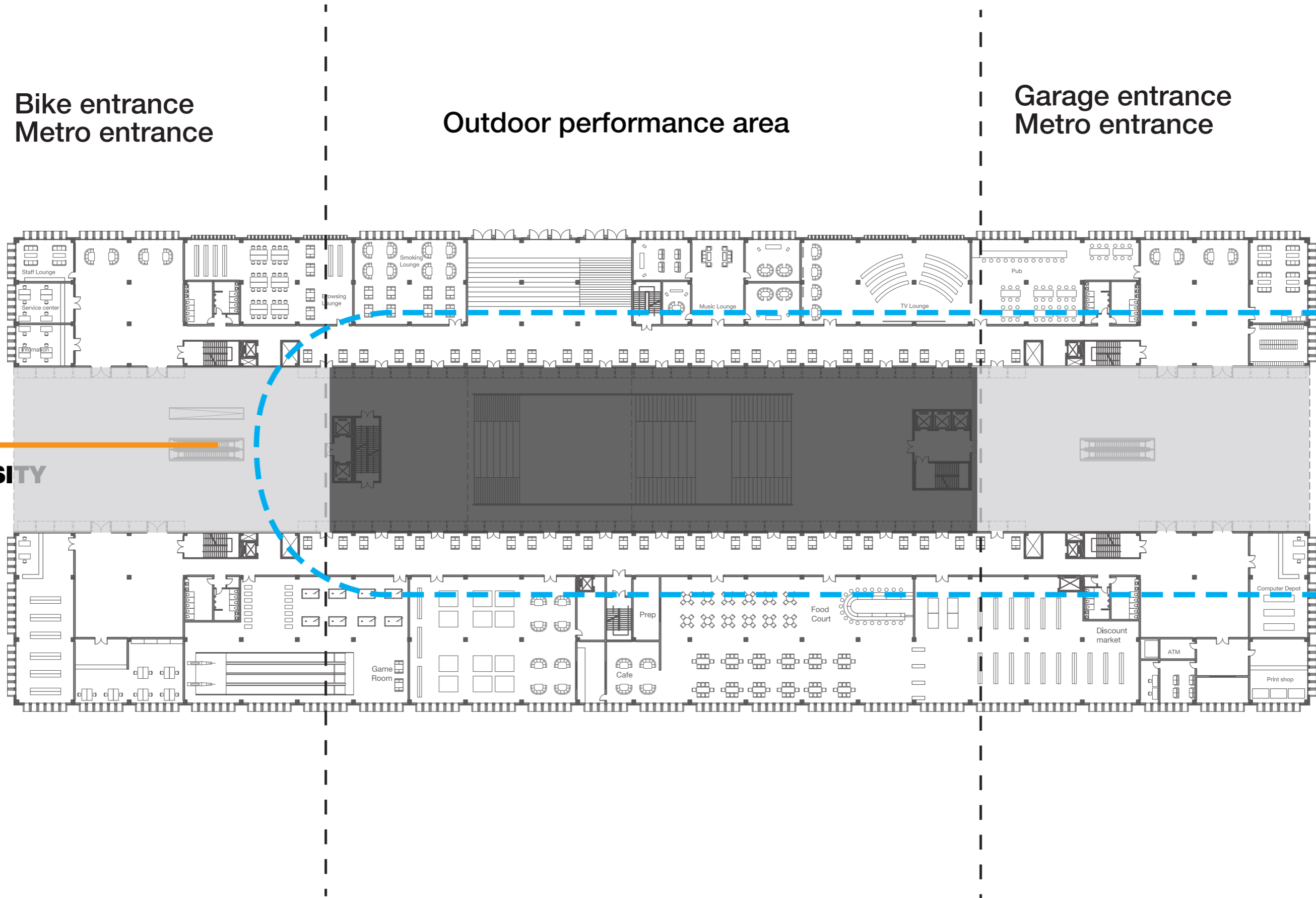

STUDENT ORIENTED

Lecture Hall

PUBLIC ORIENTED

Basketball court

Swimming Pool

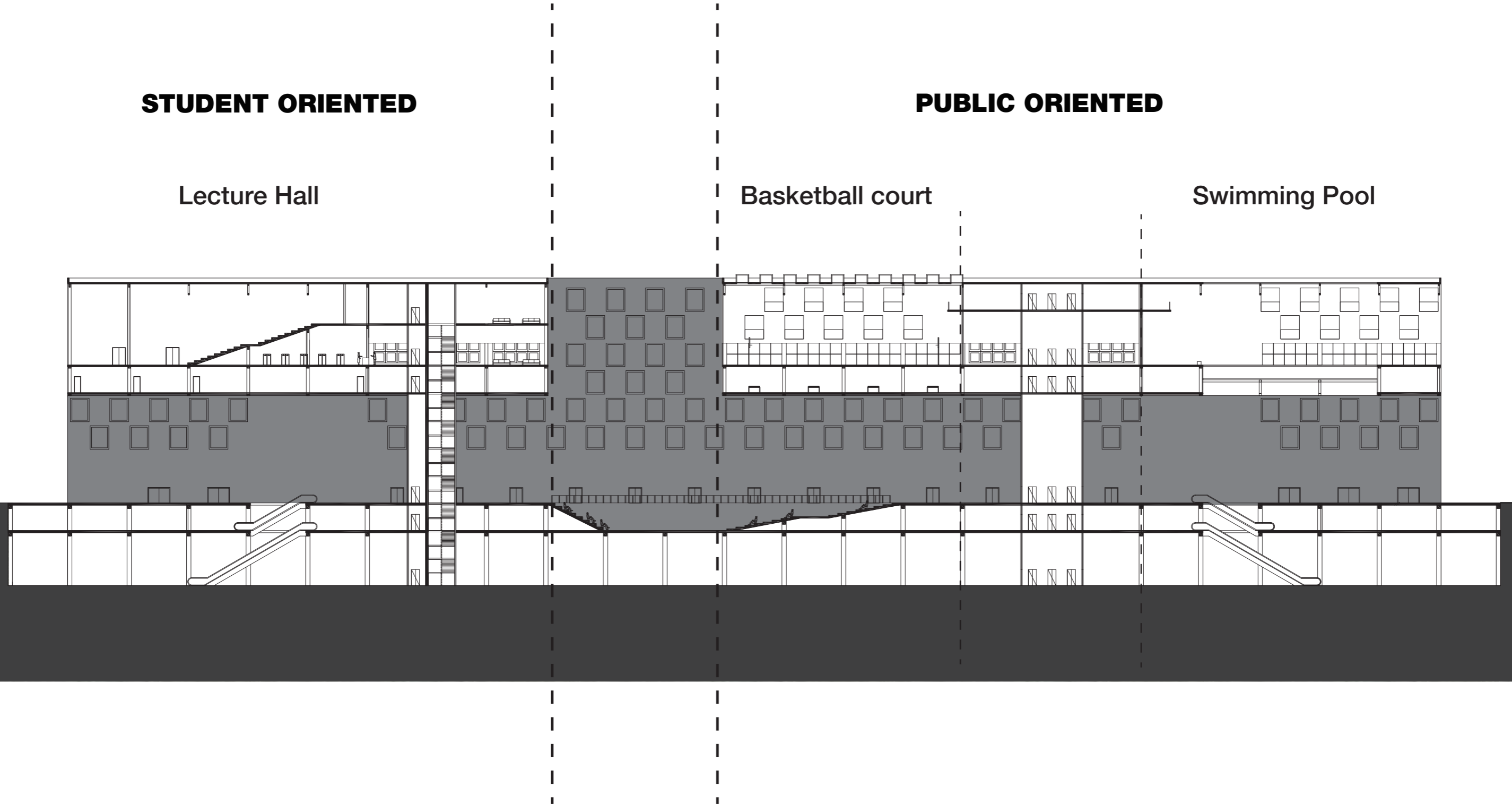

STUDENT ORIENTED

PUBLIC ORIENTED

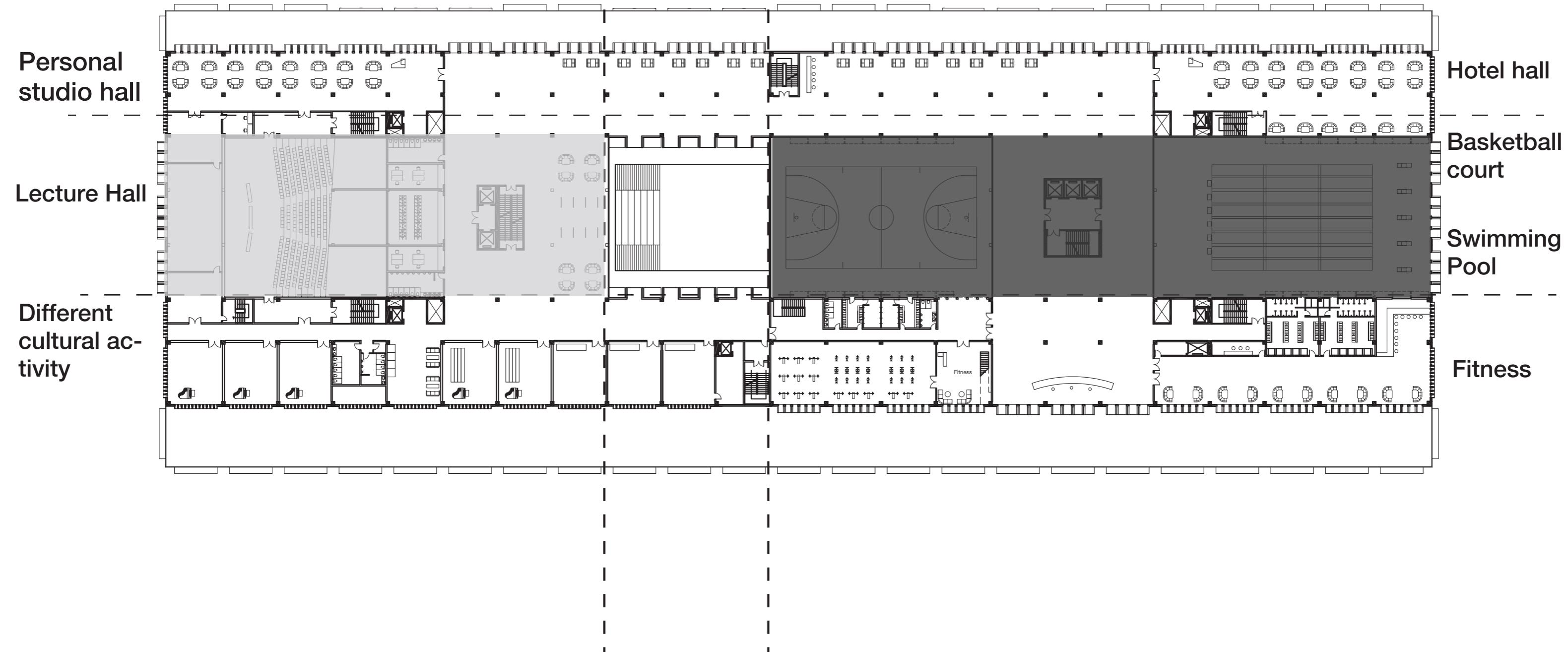

Personal studio hall

Hotel hall

Lecture Hall

Basketball court

Different cultural activity

Swimming Pool

Fitness

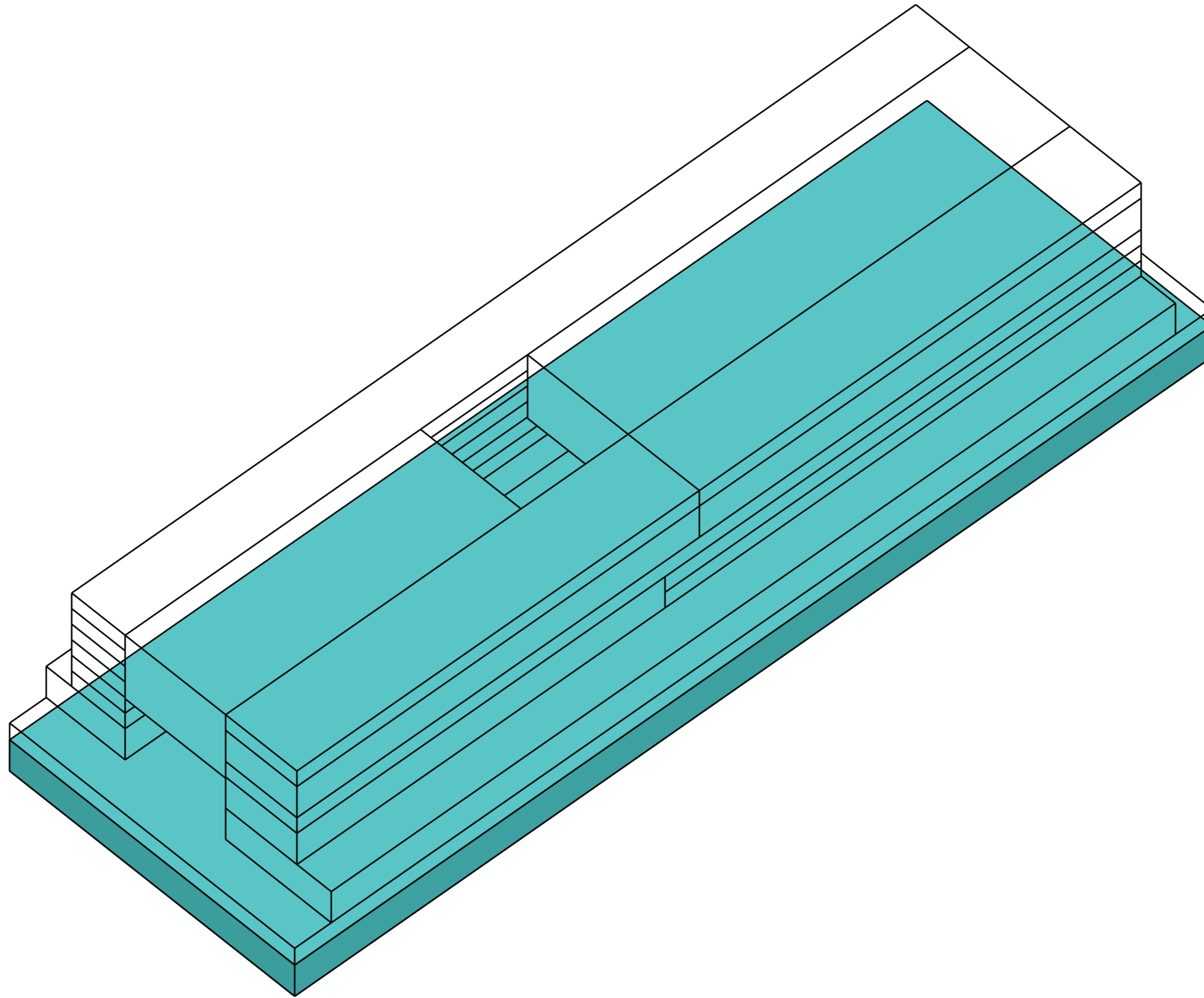

METRO STATION

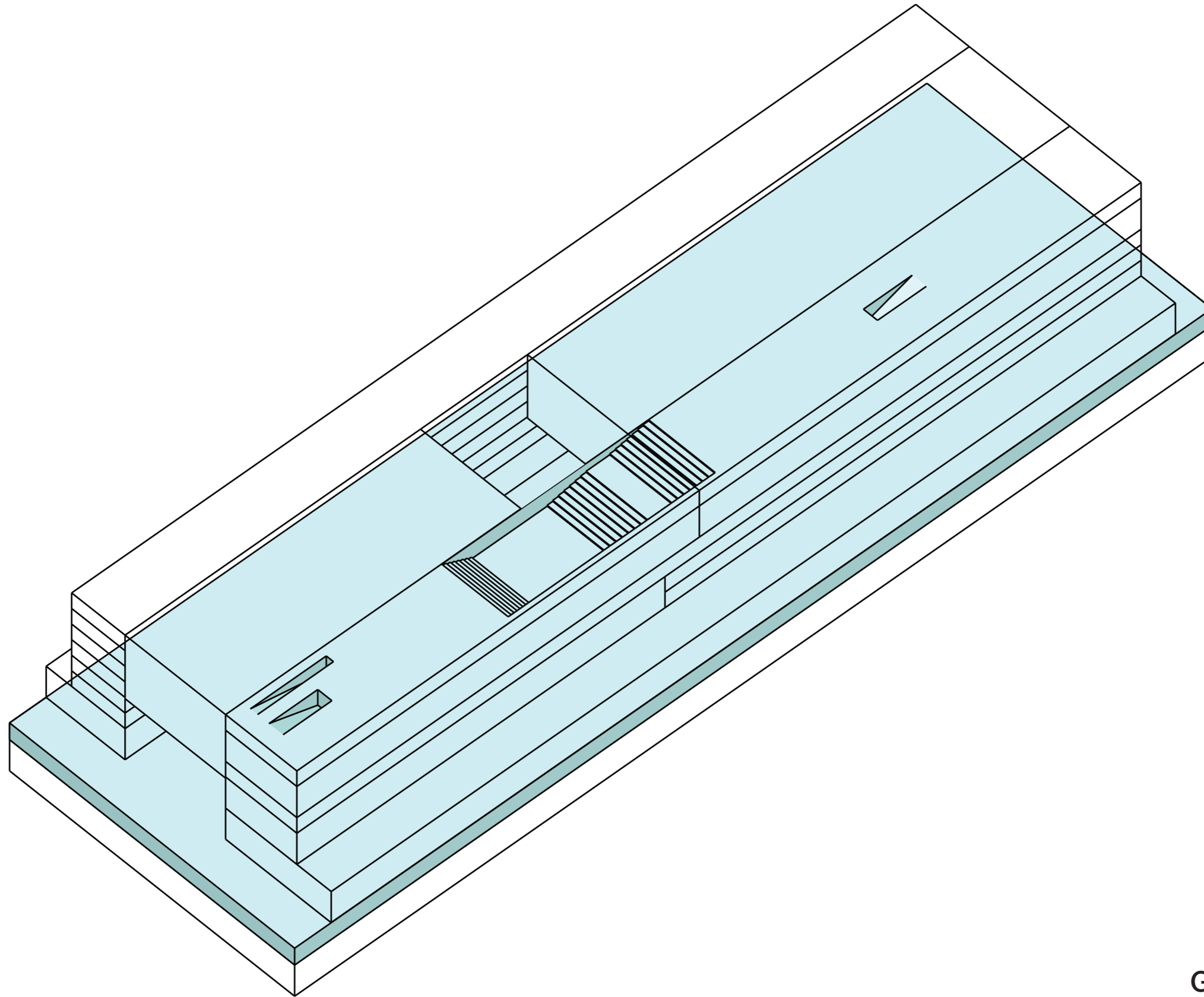

GARAGE (CAR,BIKE)

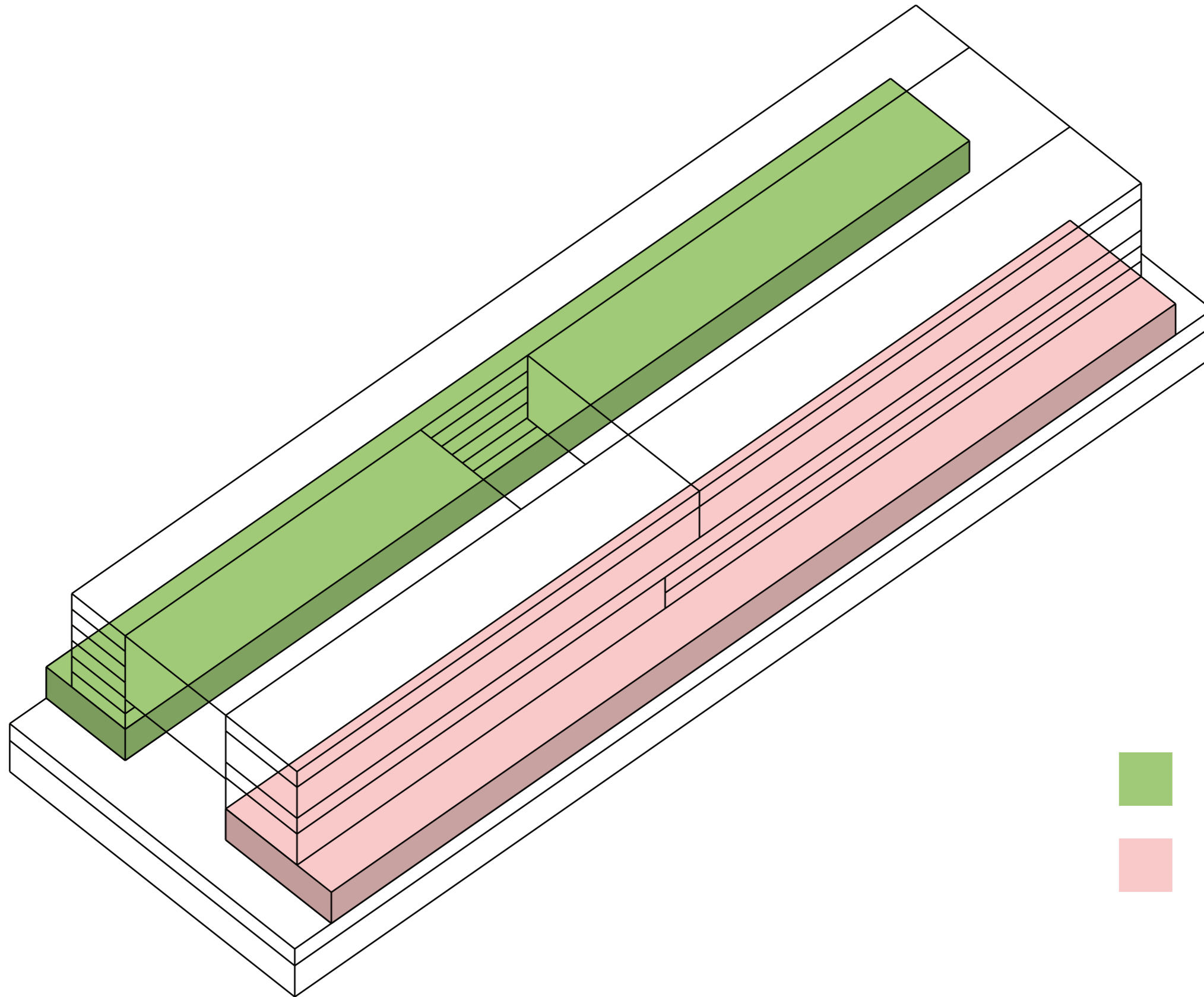

LOUNGES



GAMEROOM
BOOKSHOP
FOODCOURT
CHEAP MARKET
COMPUTER DEPOT
PRINT SHOP

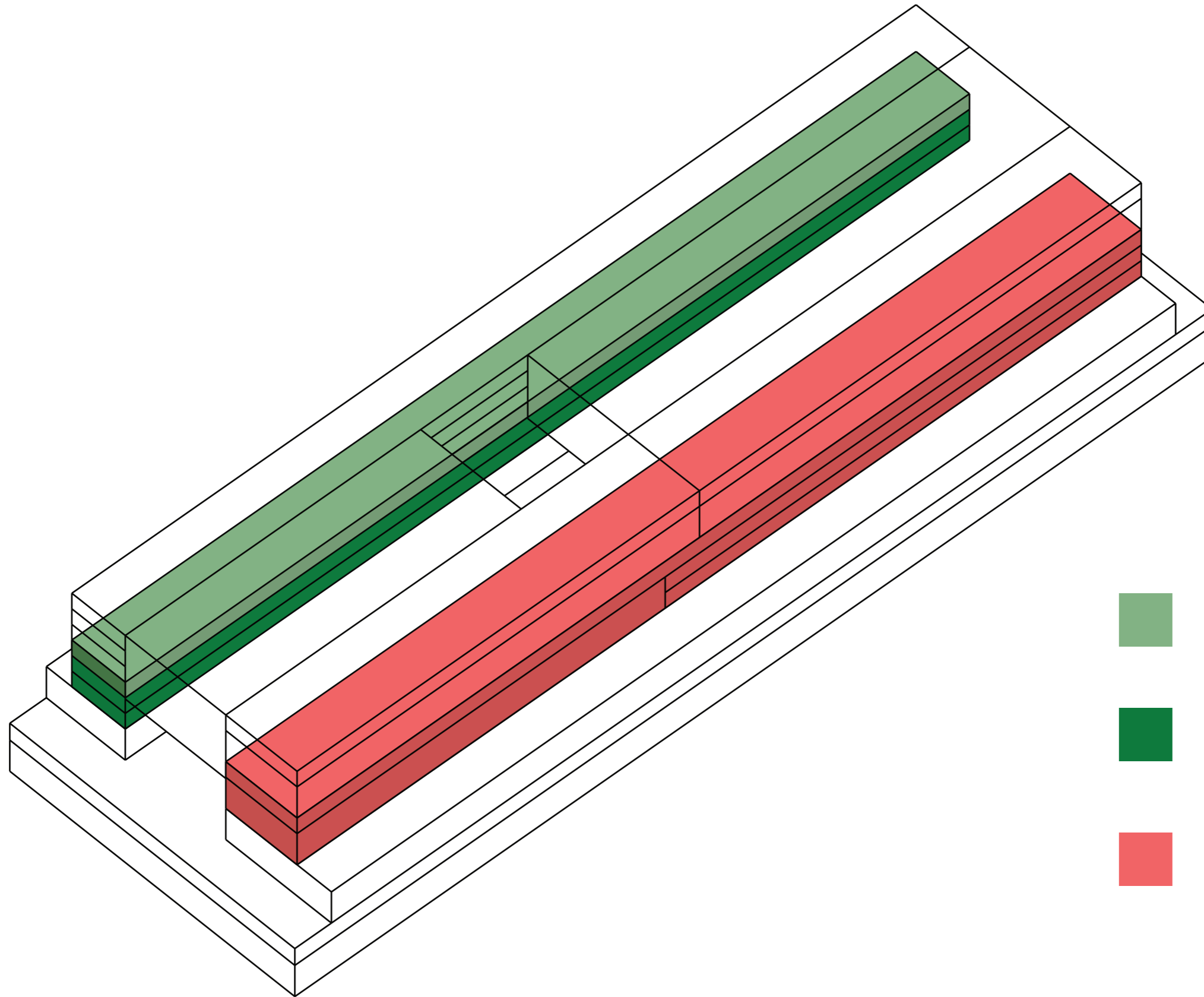

- STUDENT ORGANIZATION, ADMINISTRATION
- SEMINAR GROUP STUDY
- MEETING ROOM EVENT ROOM

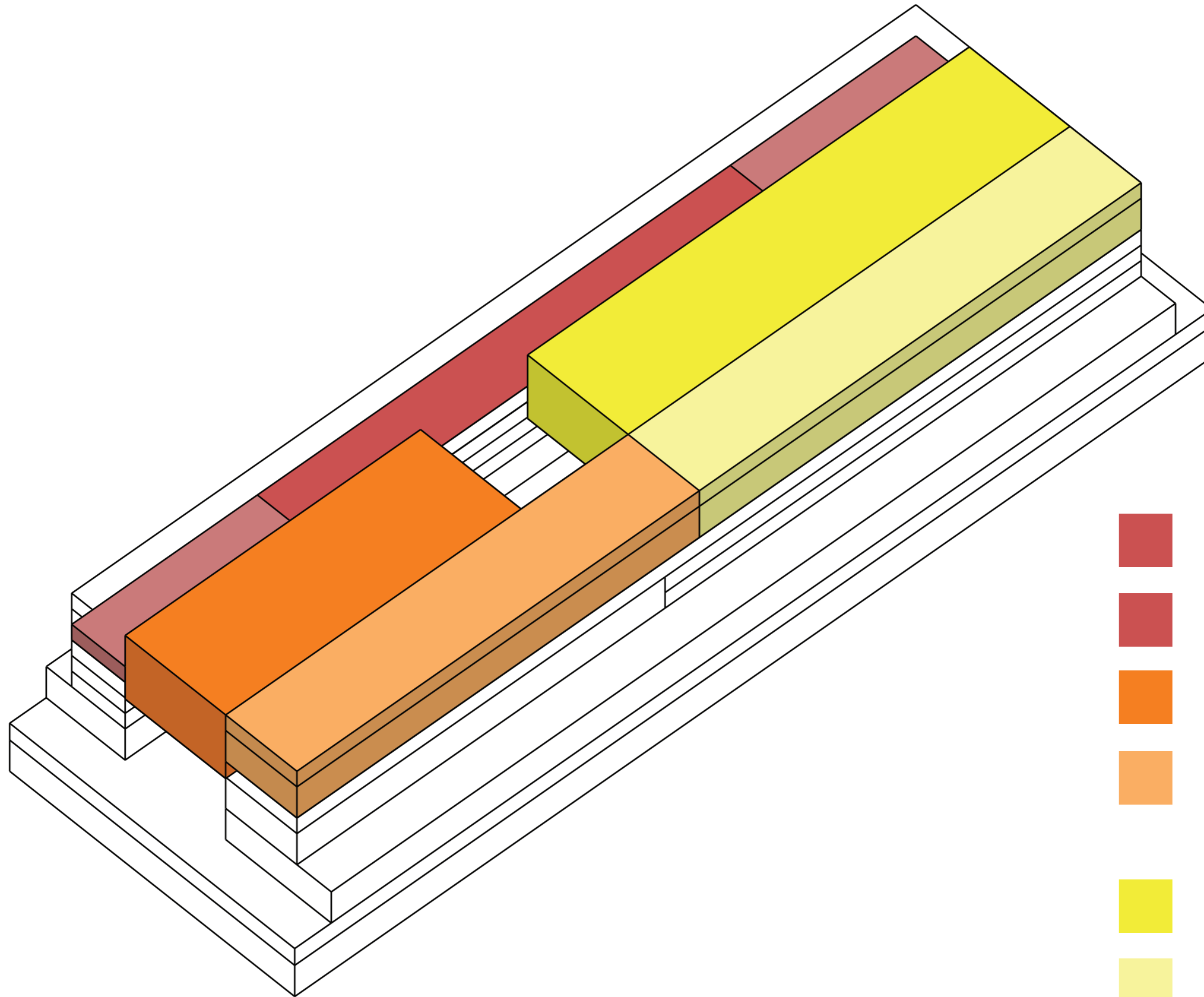

- FOYER AND LOUNGE
- HALL OF THE PERSONAL
SRUDIO AND HOTEL HALL
- LECTURE
- DANCING ROOM
MUSIC ROOM
CHOIR
- DIFFRENT STUDIO
WORKSHOP
- SPORTS HALL
SWIMMING POOL
- FITNESS
MEDITATION ROOM
SALON

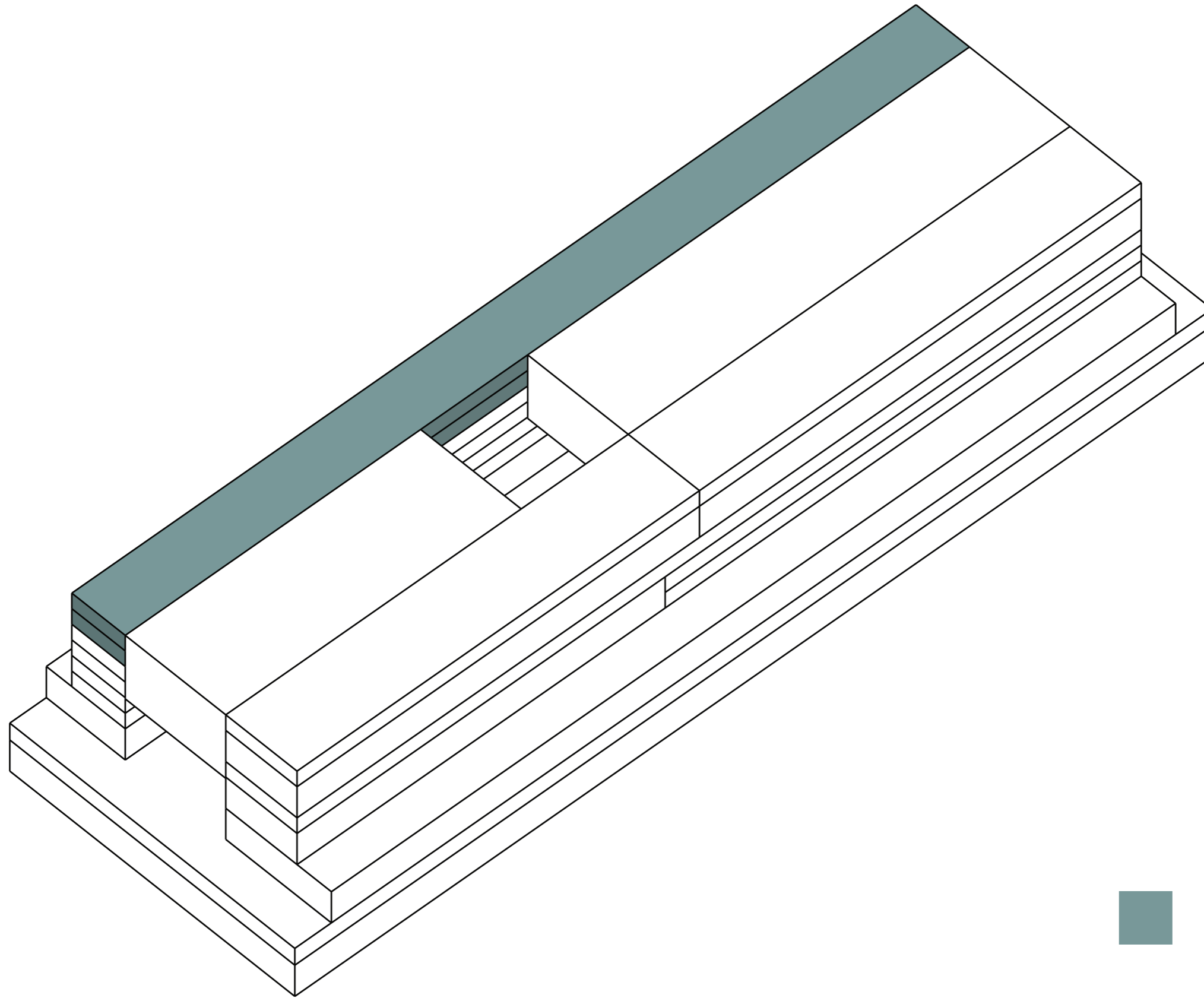

PERSONAL SRUDIO
HOTEL

-Urban Situation

-Position

-Urban Strategy

Inner city loop

-Site

Site condition

Site reconfiguration

Building Position

-Architectural Design

Programmatic

Concept

Composition

-Structure and Materialization

-Building Performance

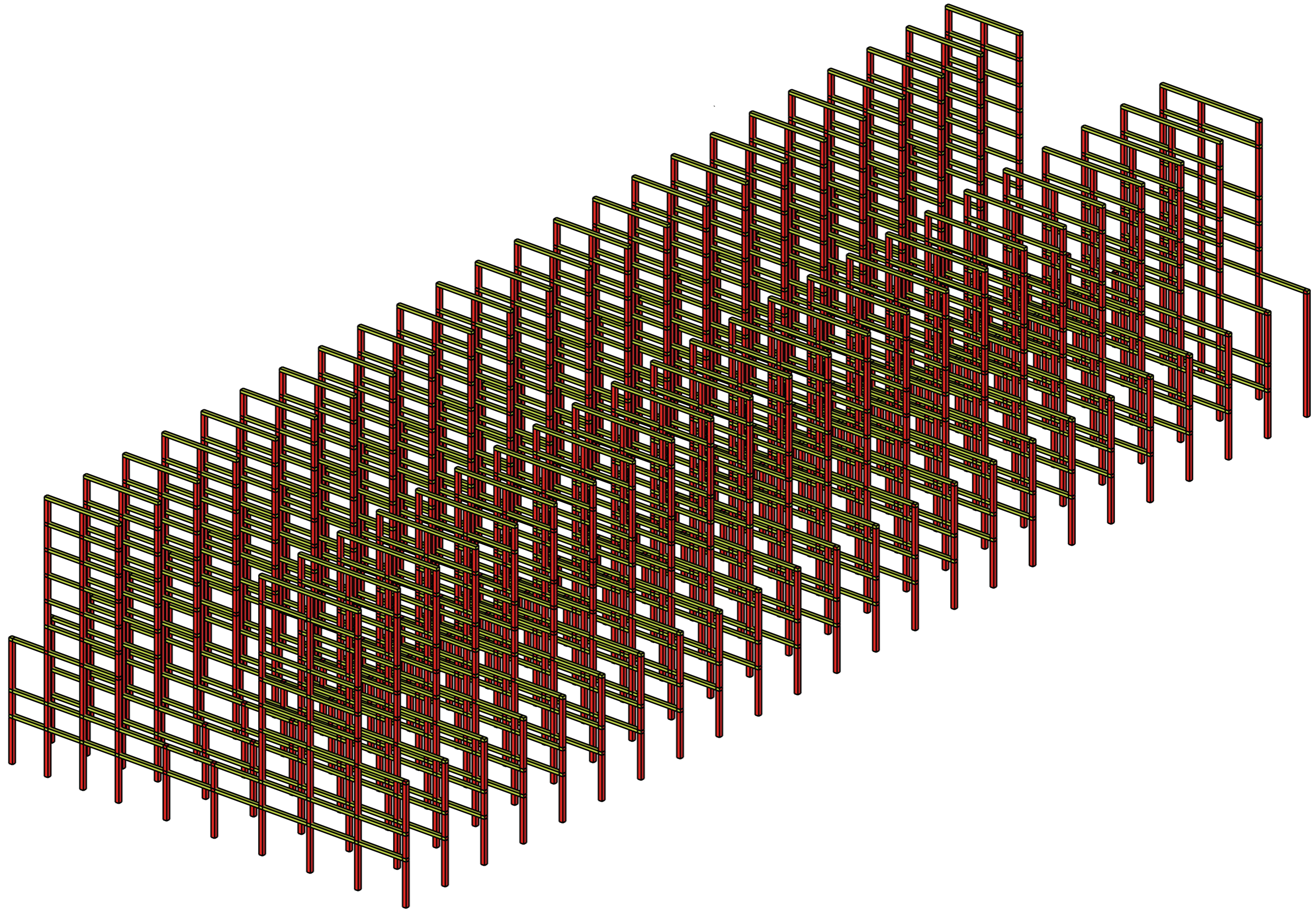

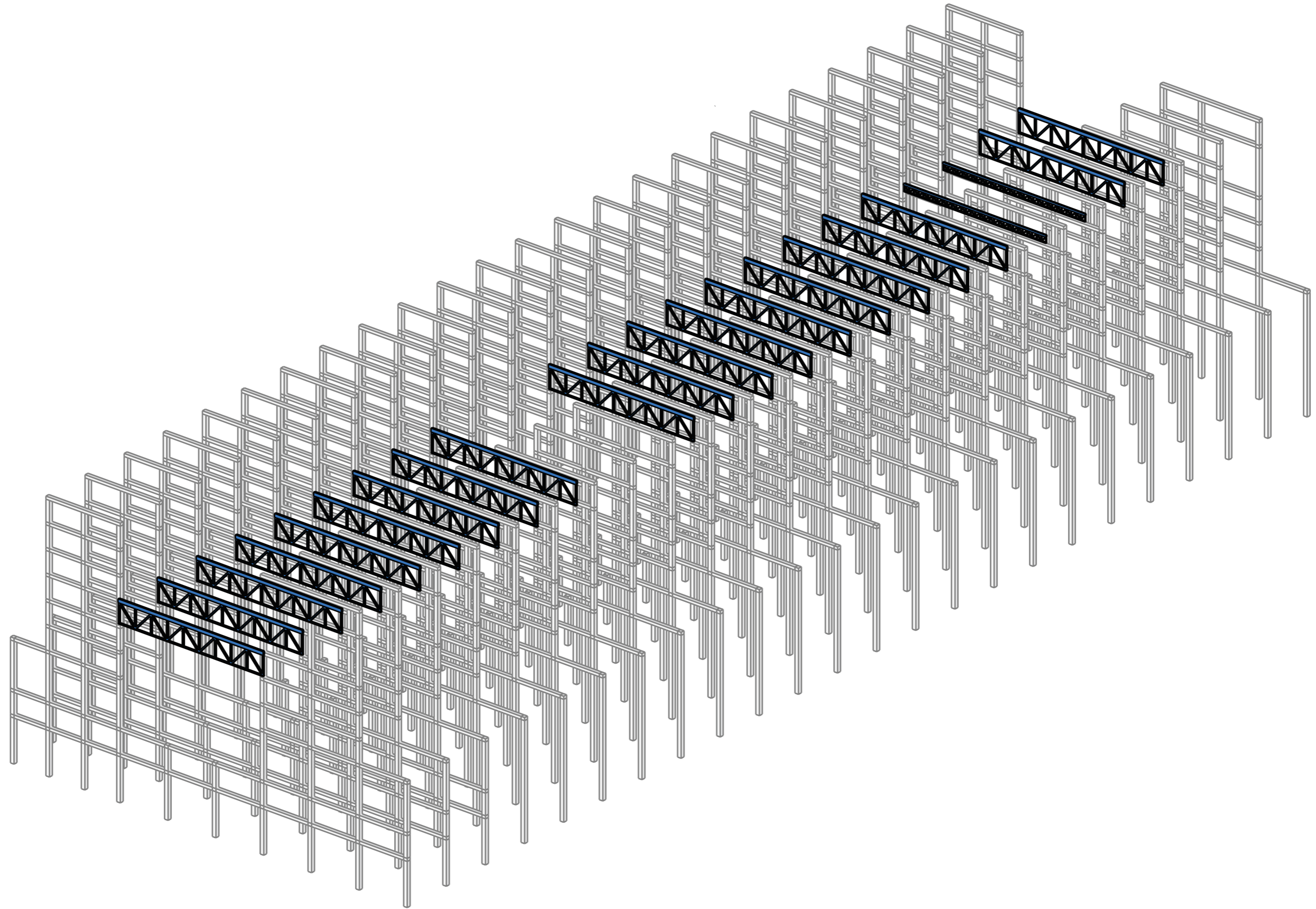

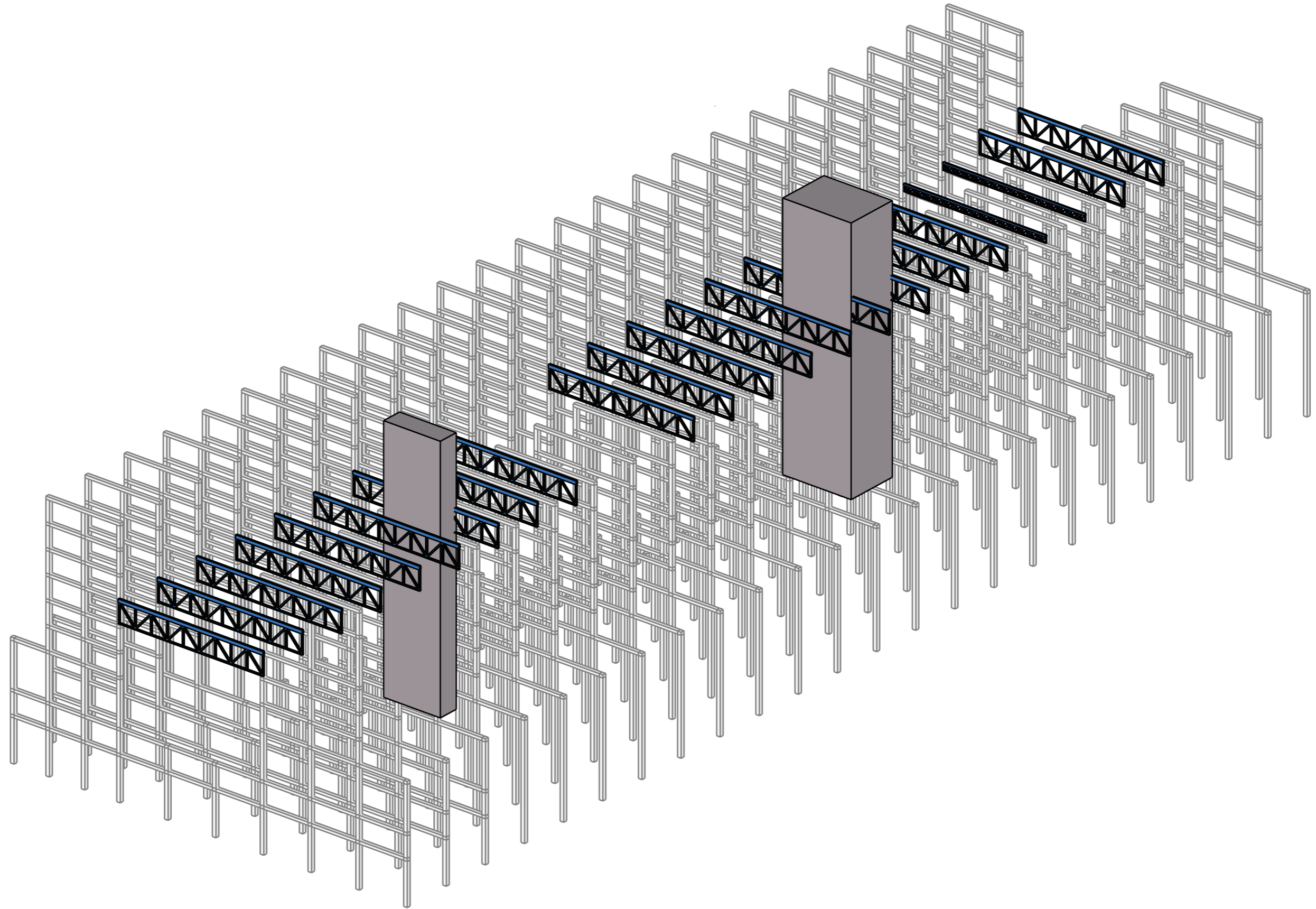

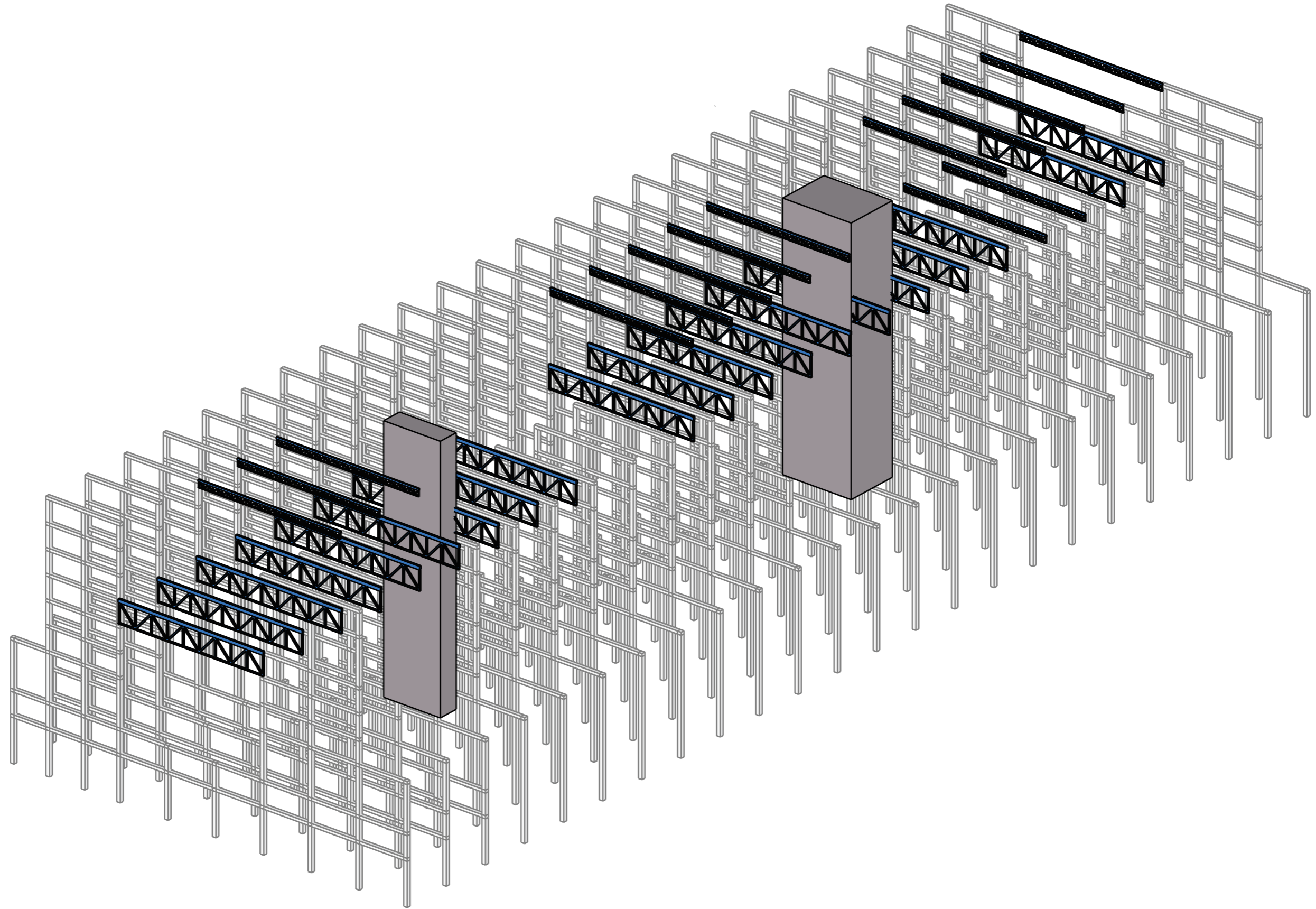

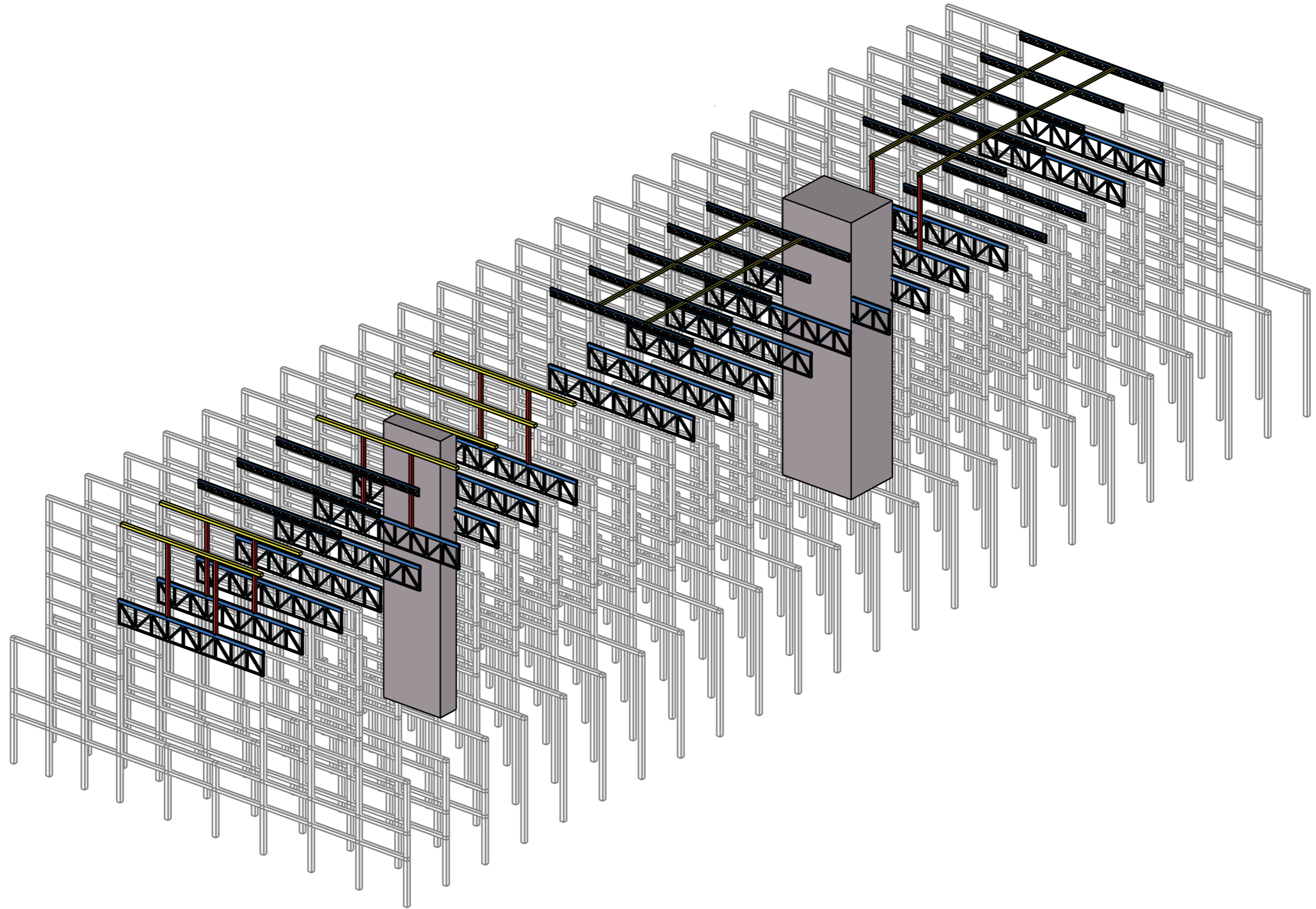

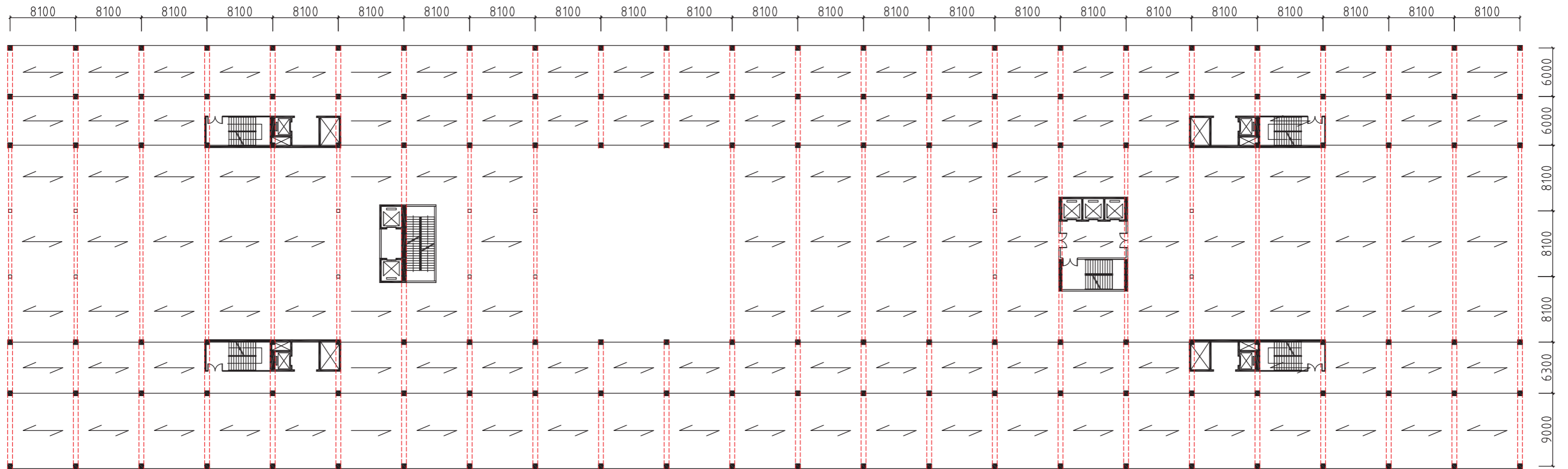

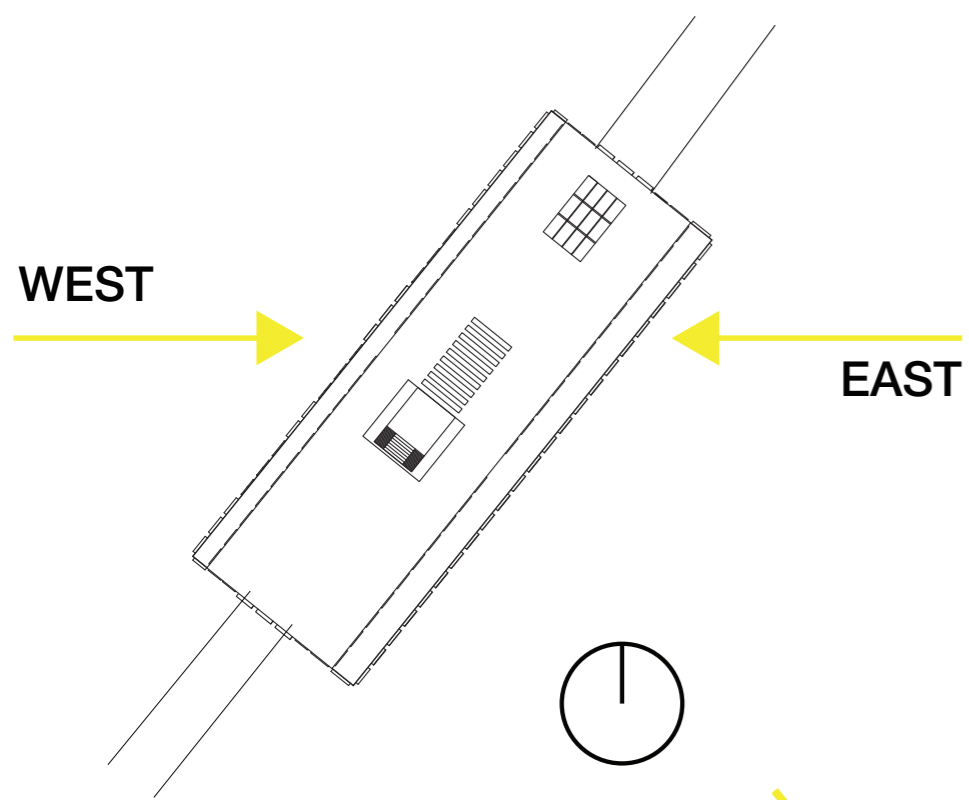

WORKING AND LIVING

RELAXATION AND MEETING

NORTHWEST

SOUTHEAST

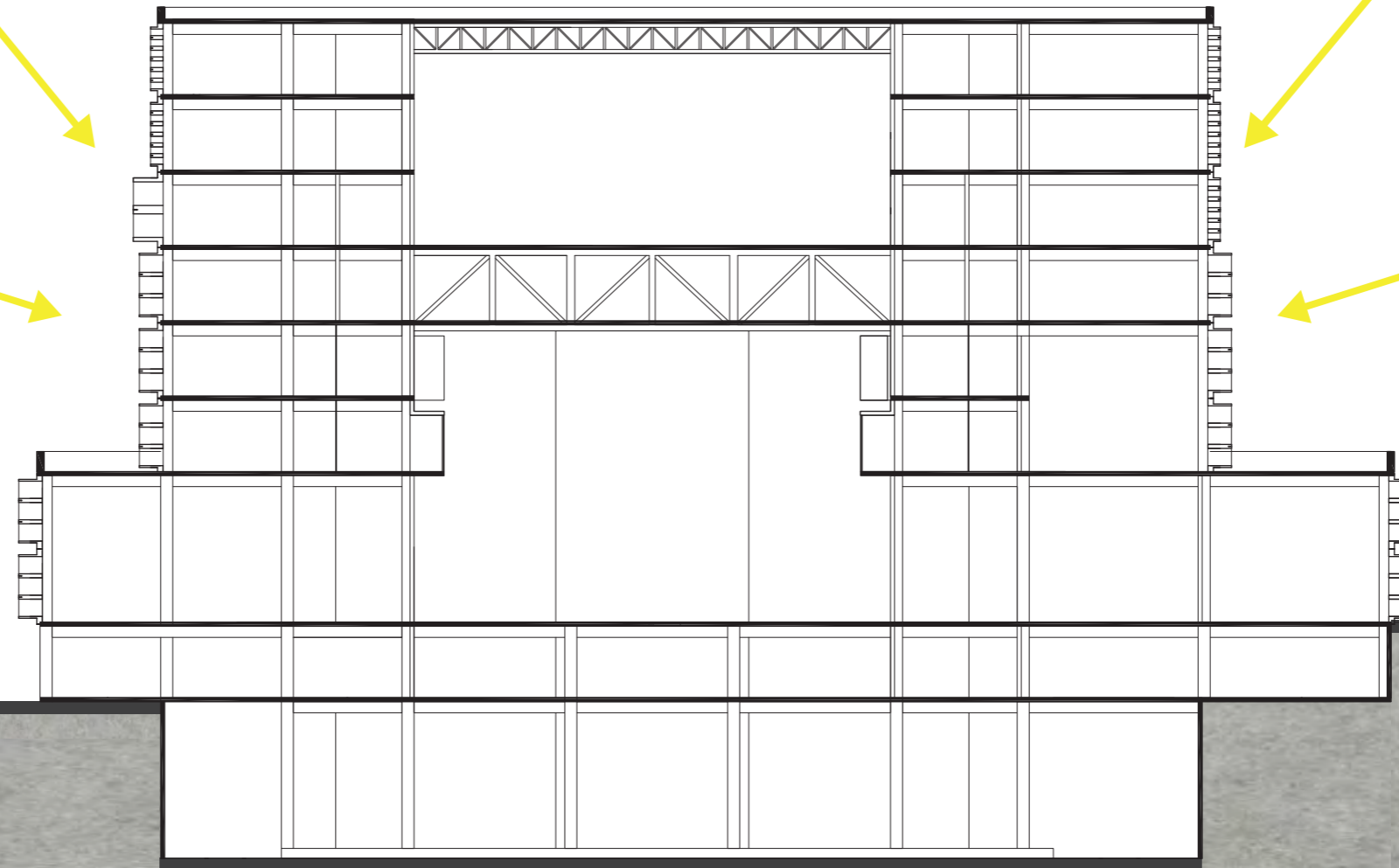

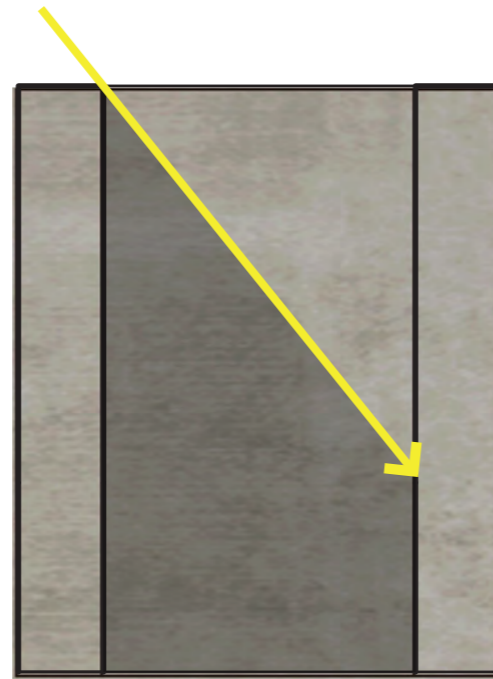

Extruding window
Block the sunlight
Keep the view

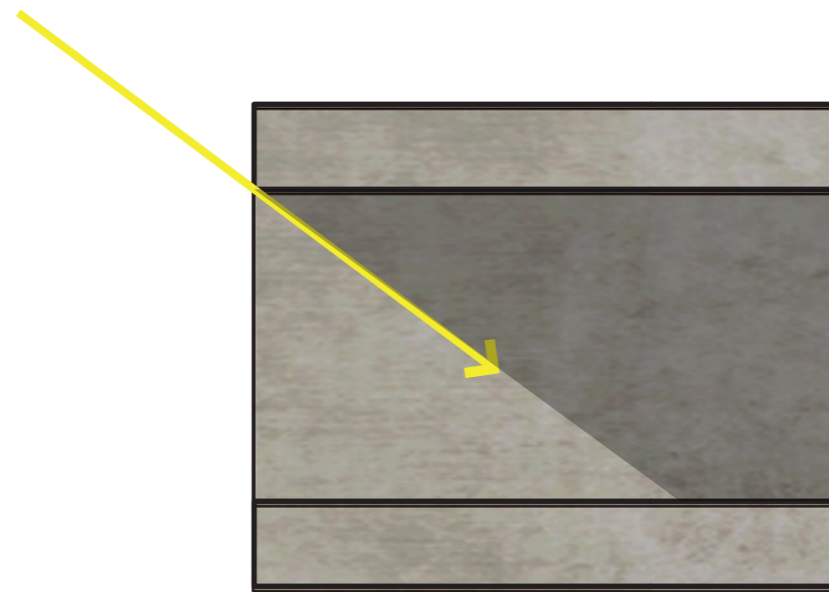
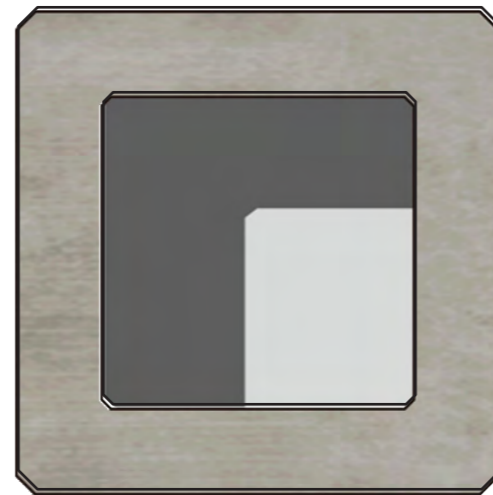

ONE FACADE UNIT

INPUTS

fin depth
fin thickness
fin spacing
fin tilt degrees

latitude °
show values
orientation

calculate

	MORNING									AFTERNOON								
	4:00	5:00	6:00	7:00	8:00	9:00	10:00	11:00	12:00	1:00	2:00	3:00	4:00	5:00	6:00	7:00	8:00	
Jan												100%	100%					Jan
Feb												100%	100%	100%				Feb
Mar										100%	100%	100%	100%					Mar
Apr										100%	100%	100%	100%	100%				Apr
May										100%	100%	100%	100%	100%	100%	91%		May
Jun										100%	100%	100%	100%	100%	100%	79%		Jun
Jul										100%	100%	100%	100%	100%	100%	84%		Jul
Aug										100%	100%	100%	100%	100%	100%			Aug
Sep										100%	100%	100%	100%	100%	100%			Sep
Oct												100%	100%	100%				Oct
Nov												100%	100%					Nov
Dec												100%	100%					Dec
	4:00	5:00	6:00	7:00	8:00	9:00	10:00	11:00	12:00	1:00	2:00	3:00	4:00	5:00	6:00	7:00	8:00	
	MORNING									AFTERNOON								

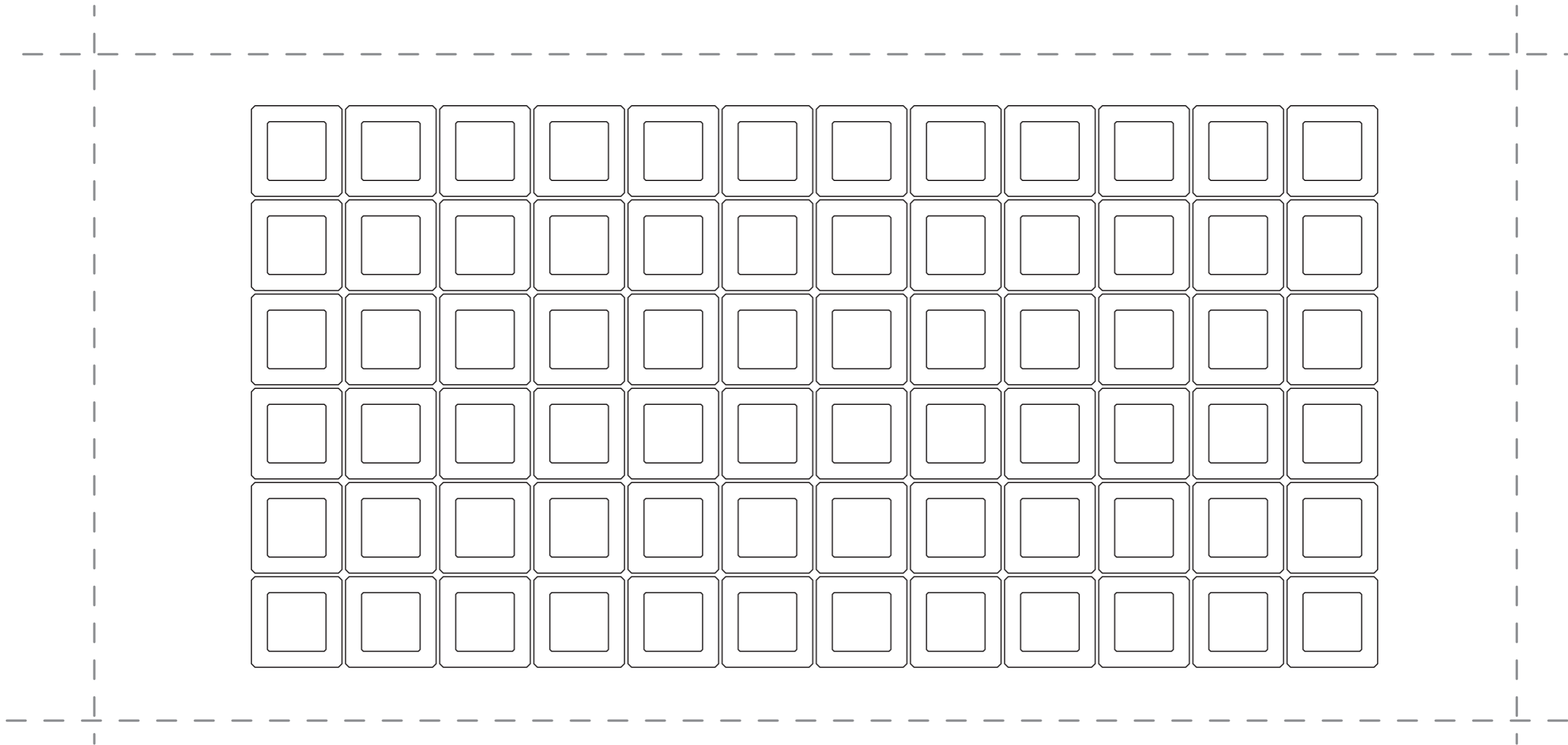
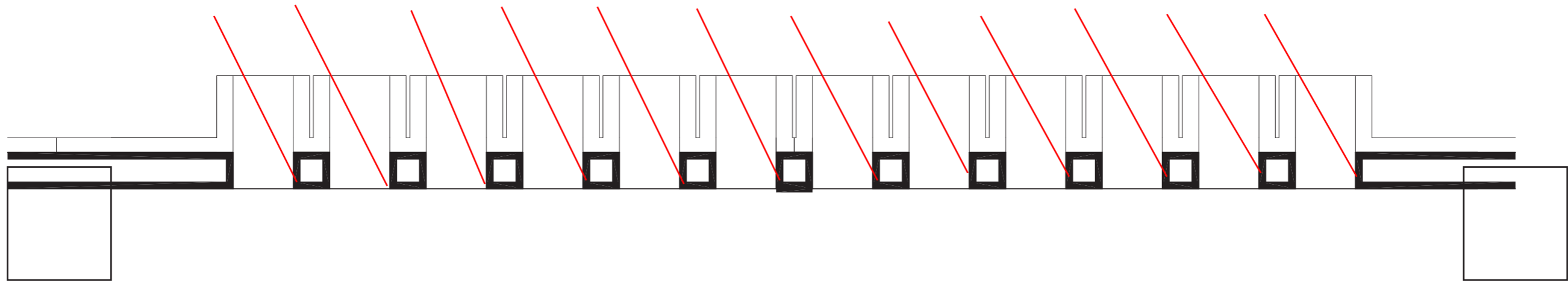

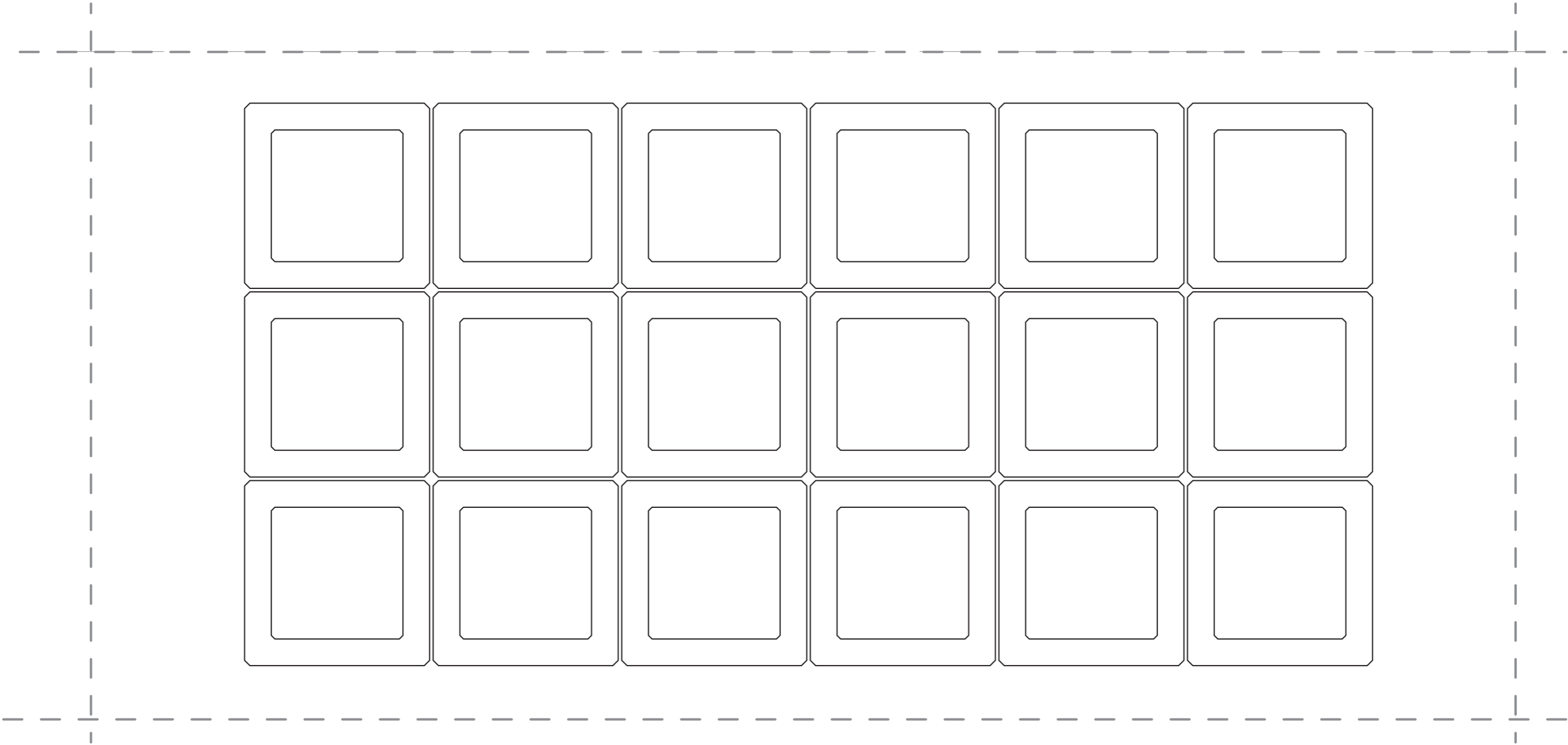
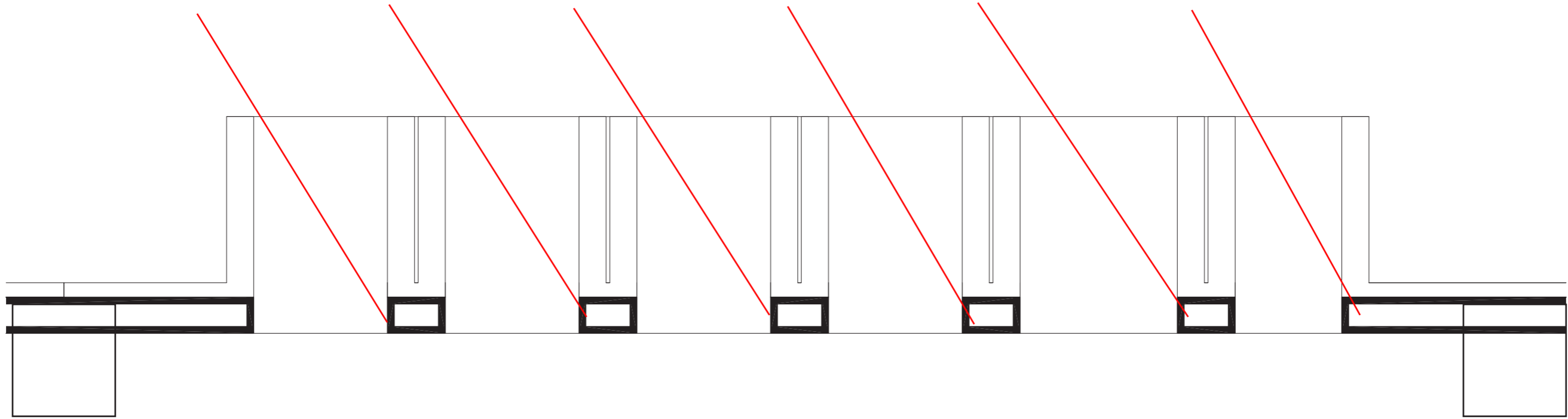

INPUTS

fin depth

 latitude °

fin thickness

 show values

fin spacing

 orientation

fin tilt degrees

calculate

	MORNING										AFTERNOON								
	4:00	5:00	6:00	7:00	8:00	9:00	10:00	11:00	12:00	1:00	2:00	3:00	4:00	5:00	6:00	7:00	8:00		
Jan												100%	100%					Jan	
Feb												100%	100%	100%				Feb	
Mar											100%	100%	100%	100%				Mar	
Apr											100%	100%	100%	100%	95%			Apr	
May											100%	100%	100%	100%	75%	52%		May	
Jun										100%	100%	100%	100%	89%	66%	45%		Jun	
Jul											100%	100%	100%	94%	70%	48%		Jul	
Aug											100%	100%	100%	100%	86%			Aug	
Sep											100%	100%	100%	100%	100%			Sep	
Oct												100%	100%	100%				Oct	
Nov												100%	100%					Nov	
Dec												100%	100%					Dec	
	4:00	5:00	6:00	7:00	8:00	9:00	10:00	11:00	12:00	1:00	2:00	3:00	4:00	5:00	6:00	7:00	8:00		
	MORNING										AFTERNOON								

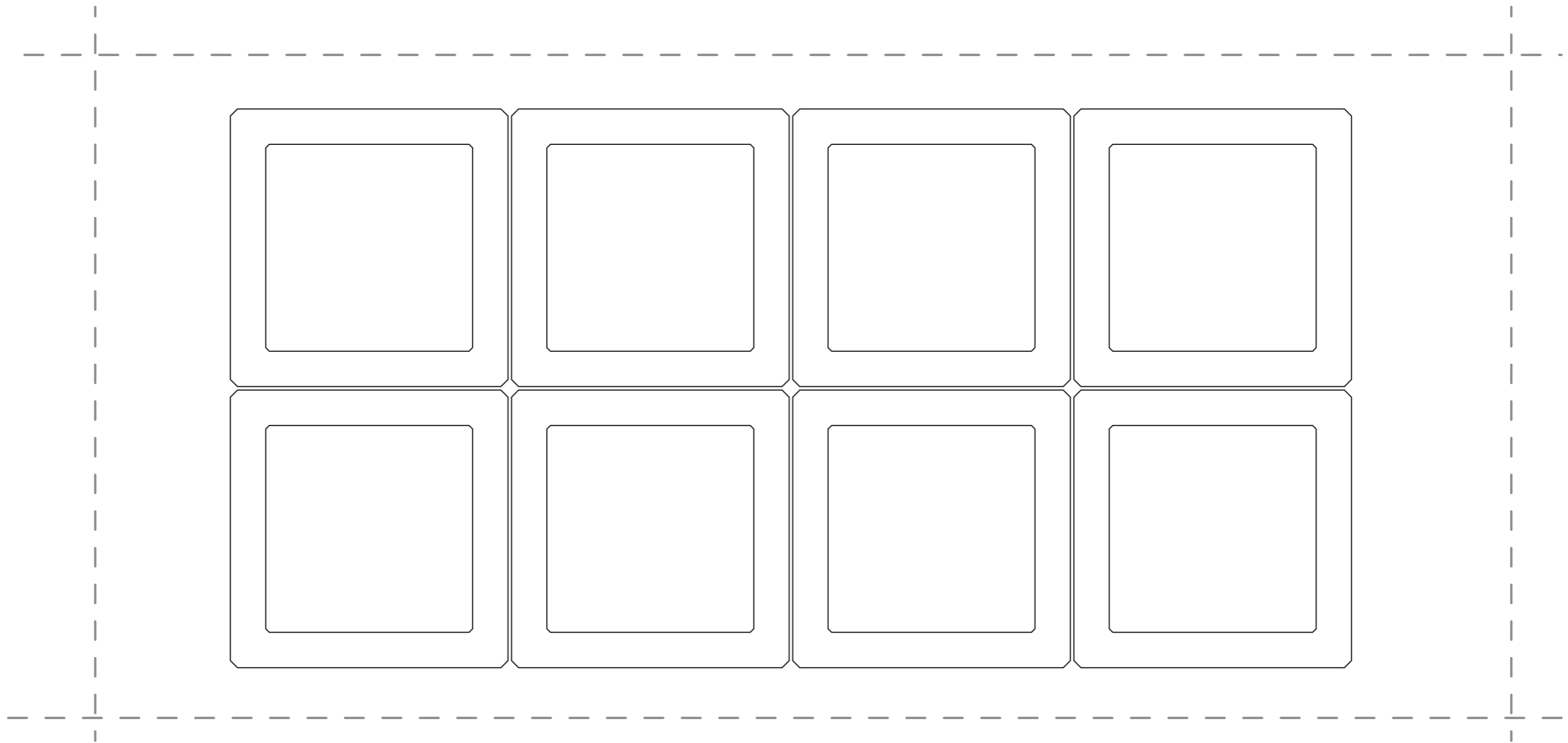
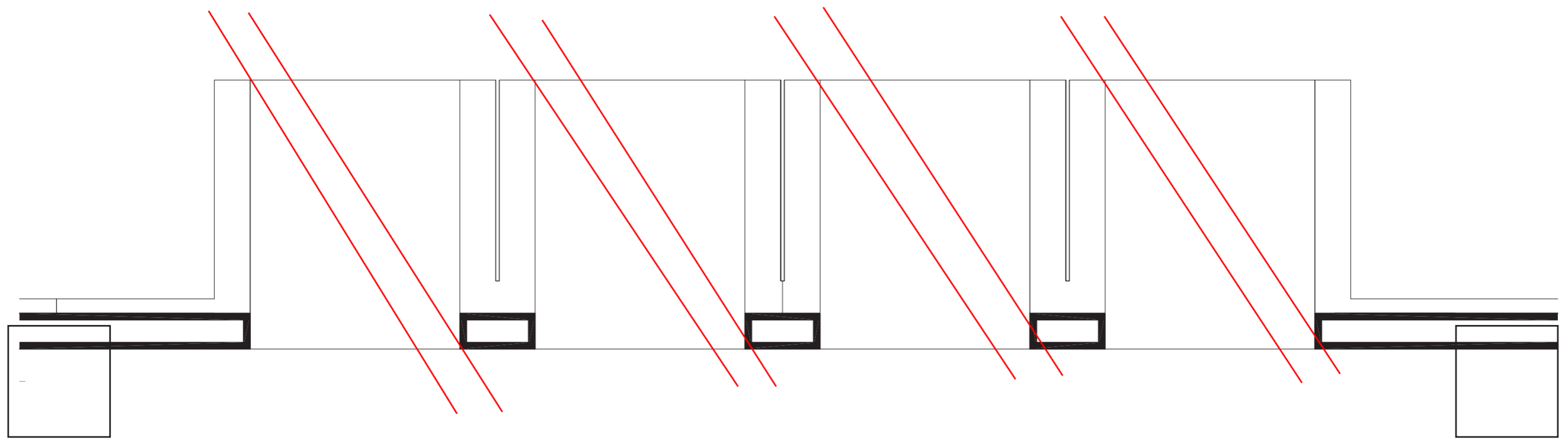

INPUTS

fin depth

 latitude °

fin thickness

 show values

fin spacing

 orientation

fin tilt degrees

calculate

	MORNING									AFTERNOON								
	4:00	5:00	6:00	7:00	8:00	9:00	10:00	11:00	12:00	1:00	2:00	3:00	4:00	5:00	6:00	7:00	8:00	
Jan												100%	100%					Jan
Feb												100%	100%	100%				Feb
Mar											100%	100%	100%	100%				Mar
Apr											100%	100%	100%	100%	80%			Apr
May											100%	100%	100%	84%	63%	44%		May
Jun										100%	100%	100%	98%	74%	55%	38%		Jun
Jul											100%	100%	100%	78%	58%	40%		Jul
Aug											100%	100%	100%	96%	72%			Aug
Sep											100%	100%	100%	100%	94%			Sep
Oct												100%	100%	100%				Oct
Nov												100%	100%					Nov
Dec												100%	100%					Dec
	4:00	5:00	6:00	7:00	8:00	9:00	10:00	11:00	12:00	1:00	2:00	3:00	4:00	5:00	6:00	7:00	8:00	
	MORNING									AFTERNOON								

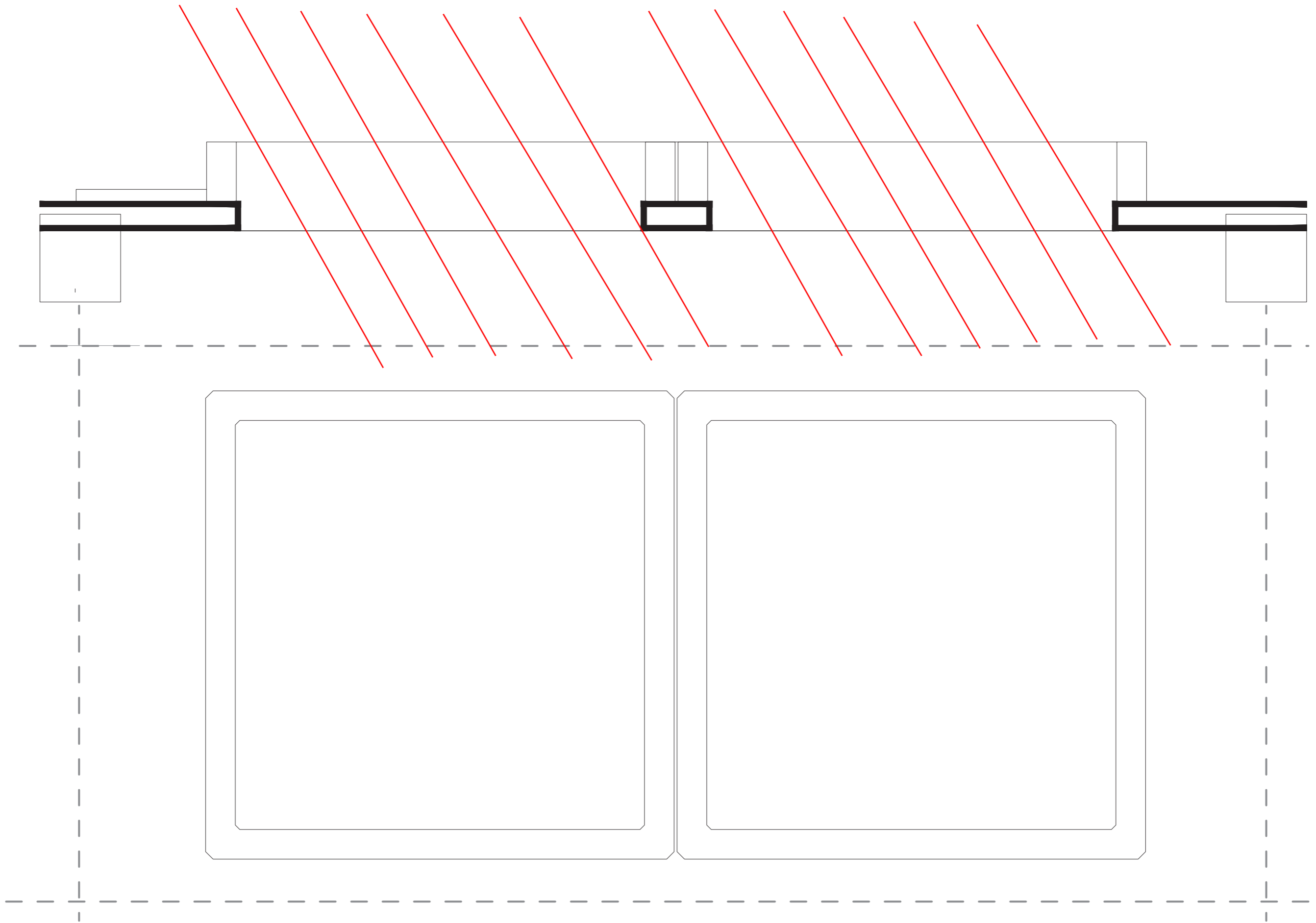

INPUTS

fin depth
fin thickness
fin spacing
fin tilt degrees

latitude ° ▾
show values ▾
orientation ▾

calculate

	MORNING									AFTERNOON								
	4:00	5:00	6:00	7:00	8:00	9:00	10:00	11:00	12:00	1:00	2:00	3:00	4:00	5:00	6:00	7:00	8:00	
Jan												100%	85%					Jan
Feb												100%	61%	41%				Feb
Mar											100%	79%	45%	32%				Mar
Apr											100%	49%	33%	25%	20%			Apr
May											64%	36%	26%	21%	16%	13%		May
Jun										100%	49%	31%	23%	19%	15%	11%		Jun
Jul											54%	33%	25%	19%	15%	12%		Jul
Aug											88%	42%	30%	23%	18%			Aug
Sep											100%	63%	39%	29%	22%			Sep
Oct												100%	54%	37%				Oct
Nov												100%	76%					Nov
Dec												100%	94%					Dec
	4:00	5:00	6:00	7:00	8:00	9:00	10:00	11:00	12:00	1:00	2:00	3:00	4:00	5:00	6:00	7:00	8:00	
	MORNING									AFTERNOON								

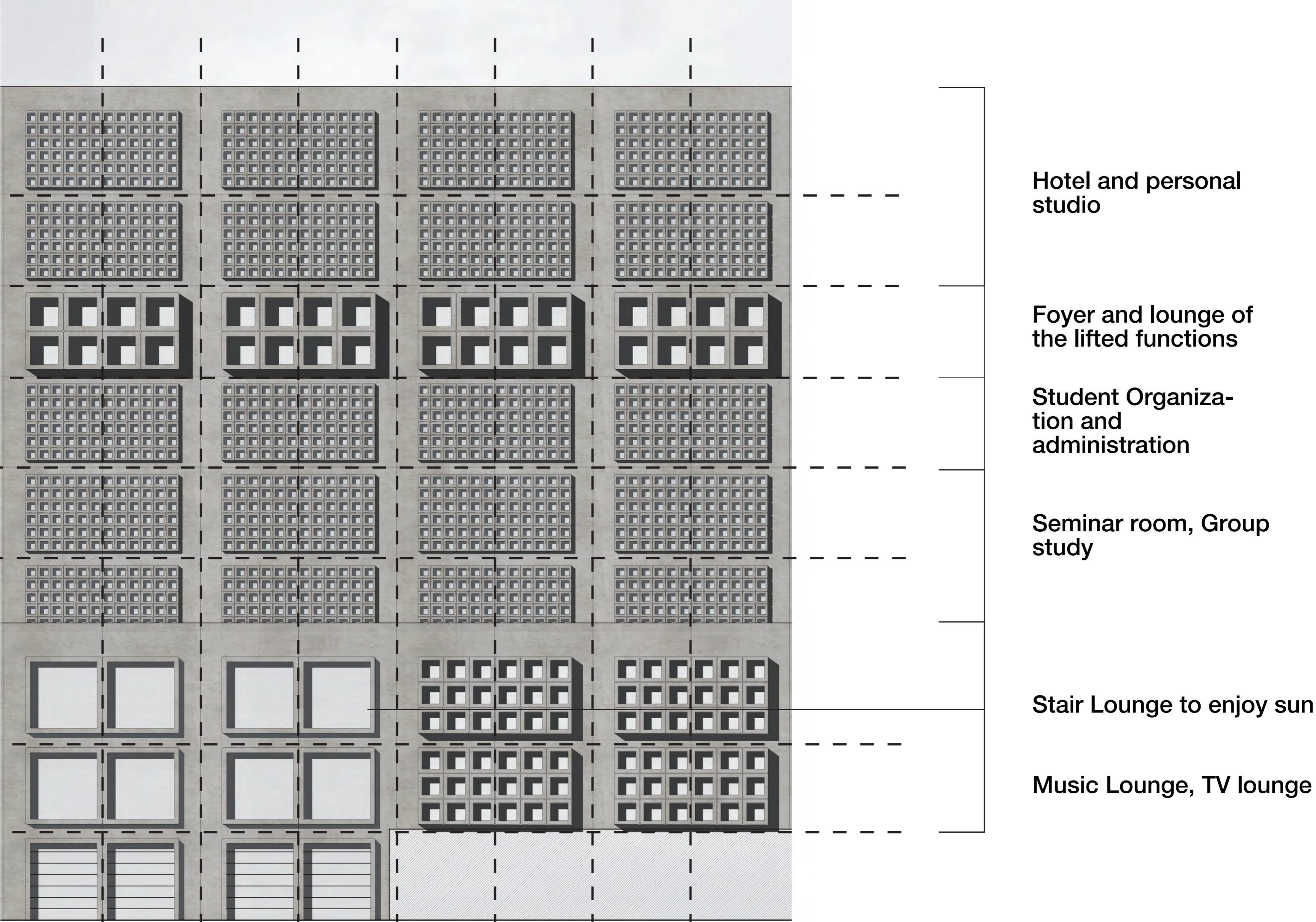

Hotel and personal studio

Foyer and lounge of the lifted functions

Student Organization and administration

Seminar room, Group study

Stair Lounge to enjoy sun

Music Lounge, TV lounge

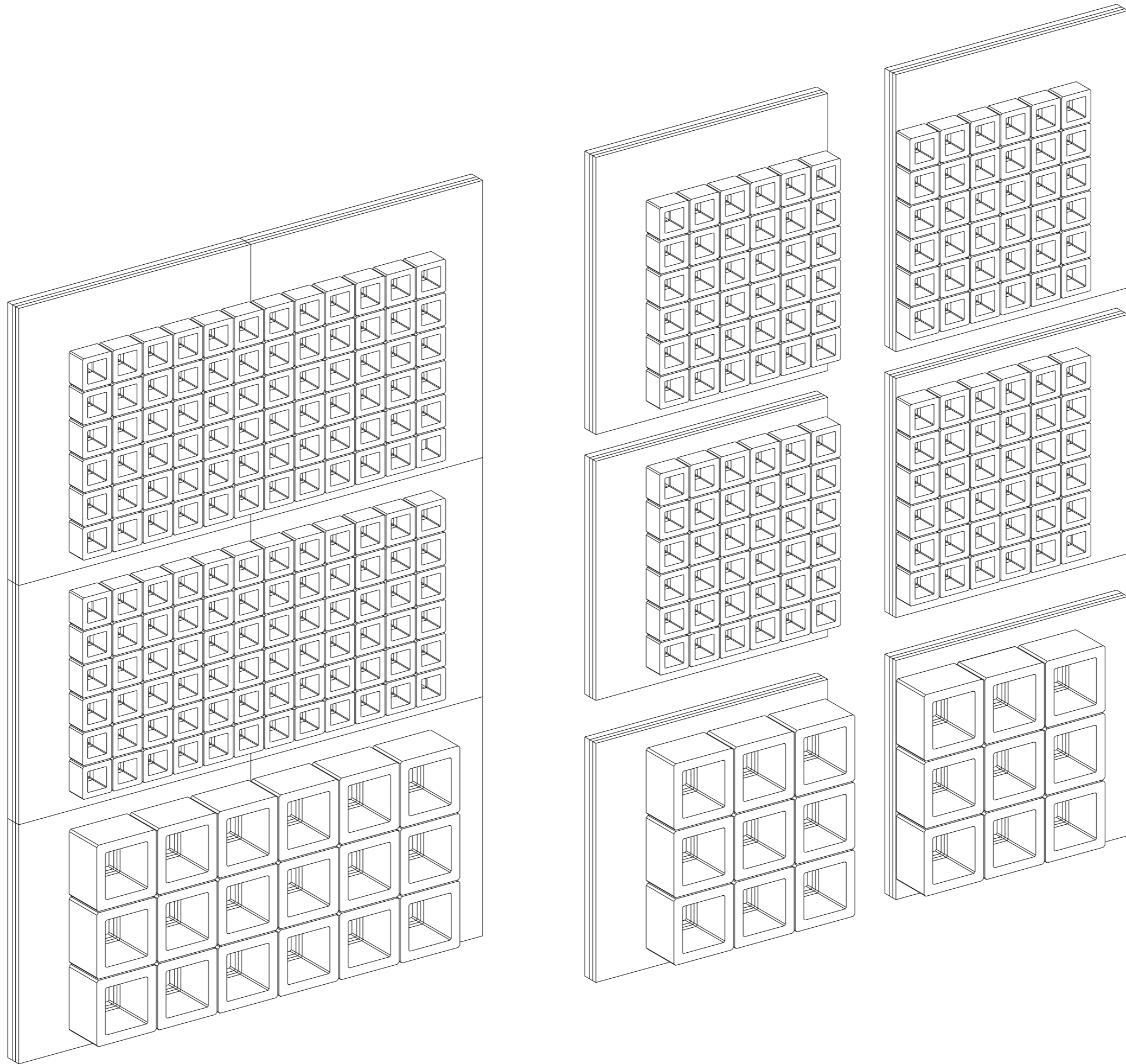

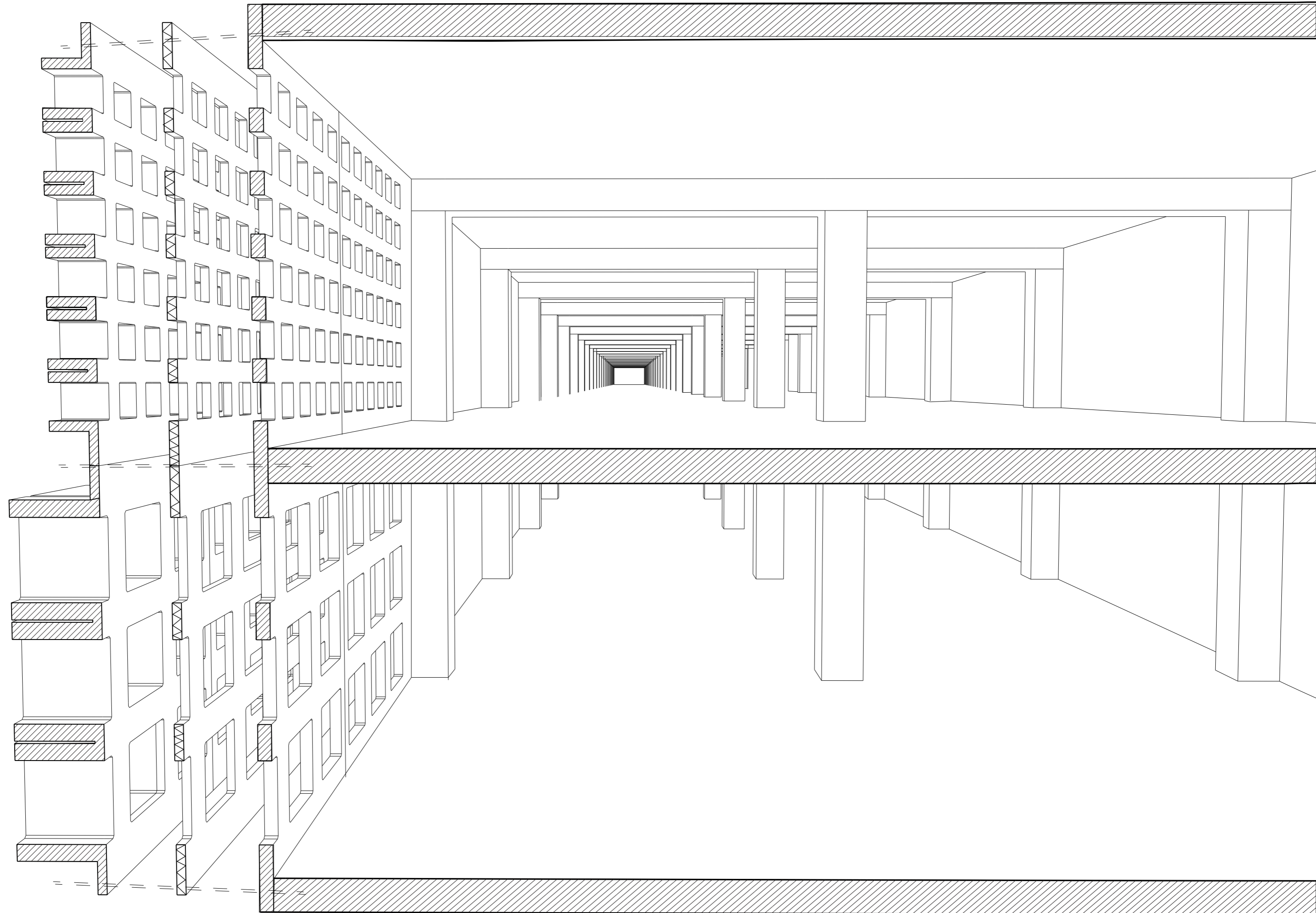

ELEVATION

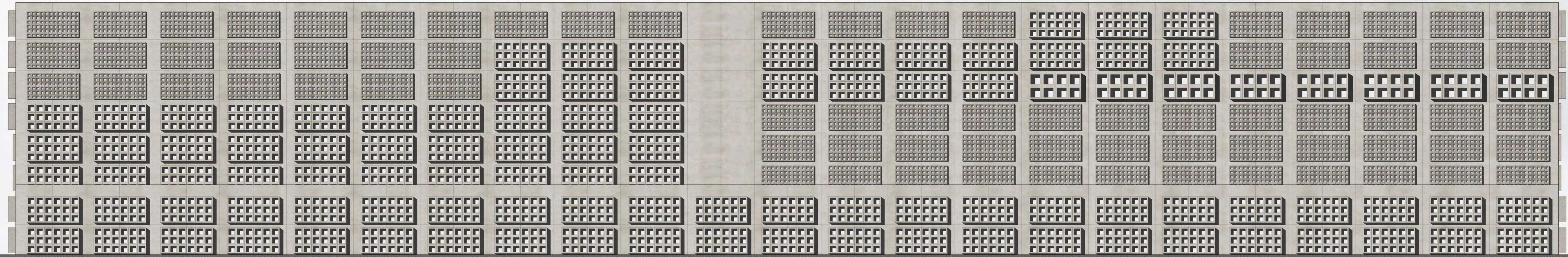

SOUTHEAST ELEVATION 1:200

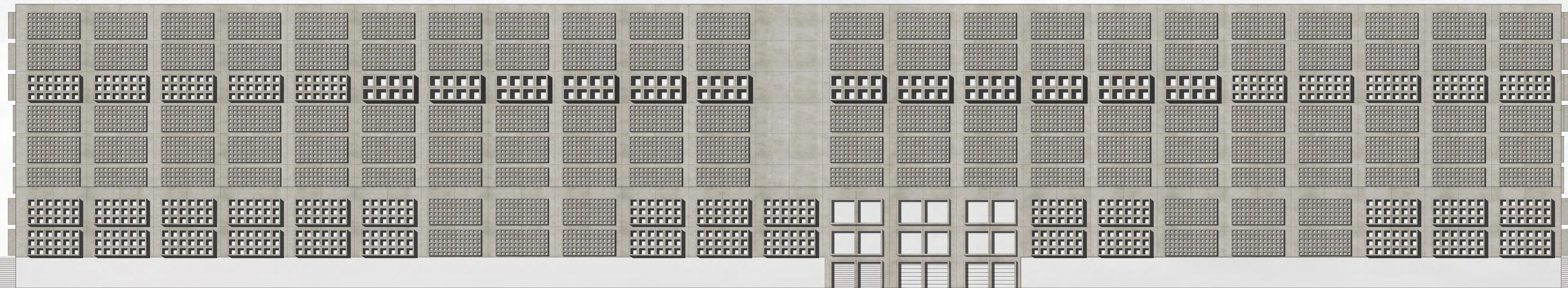

NORTHWEST ELEVATION 1:200



SOUTHWEST ELEVATION 1:200

NORTHEAST ELEVATION 1:200

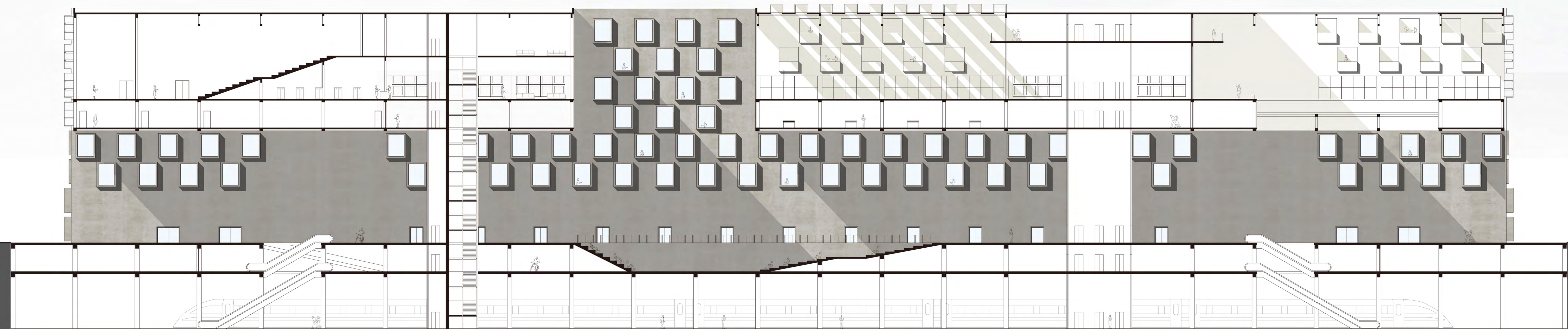
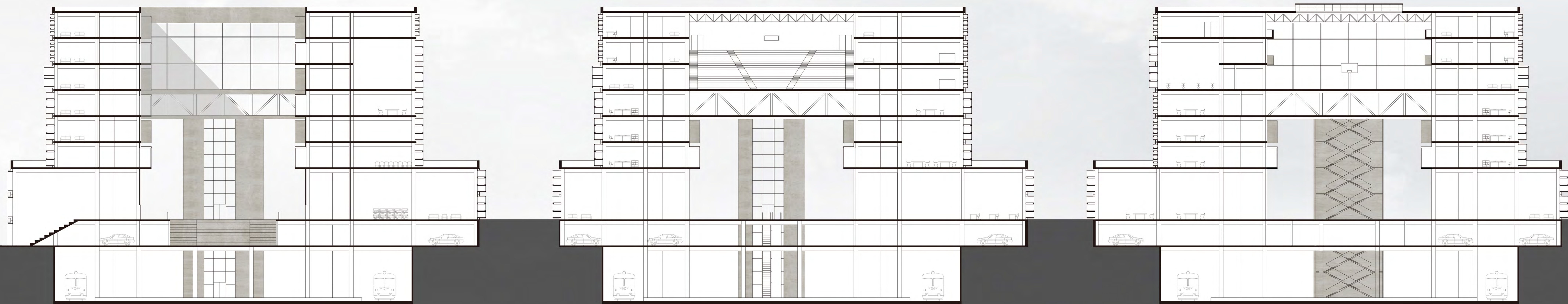

-Urban Situation

-Position

-Urban Strategy

Inner city loop

-Site

Site condition

Site reconfiguration

Building Position

-Architectural Design

Programmatic

Concept

Composition

-Structure and Materialization

-Building Performance

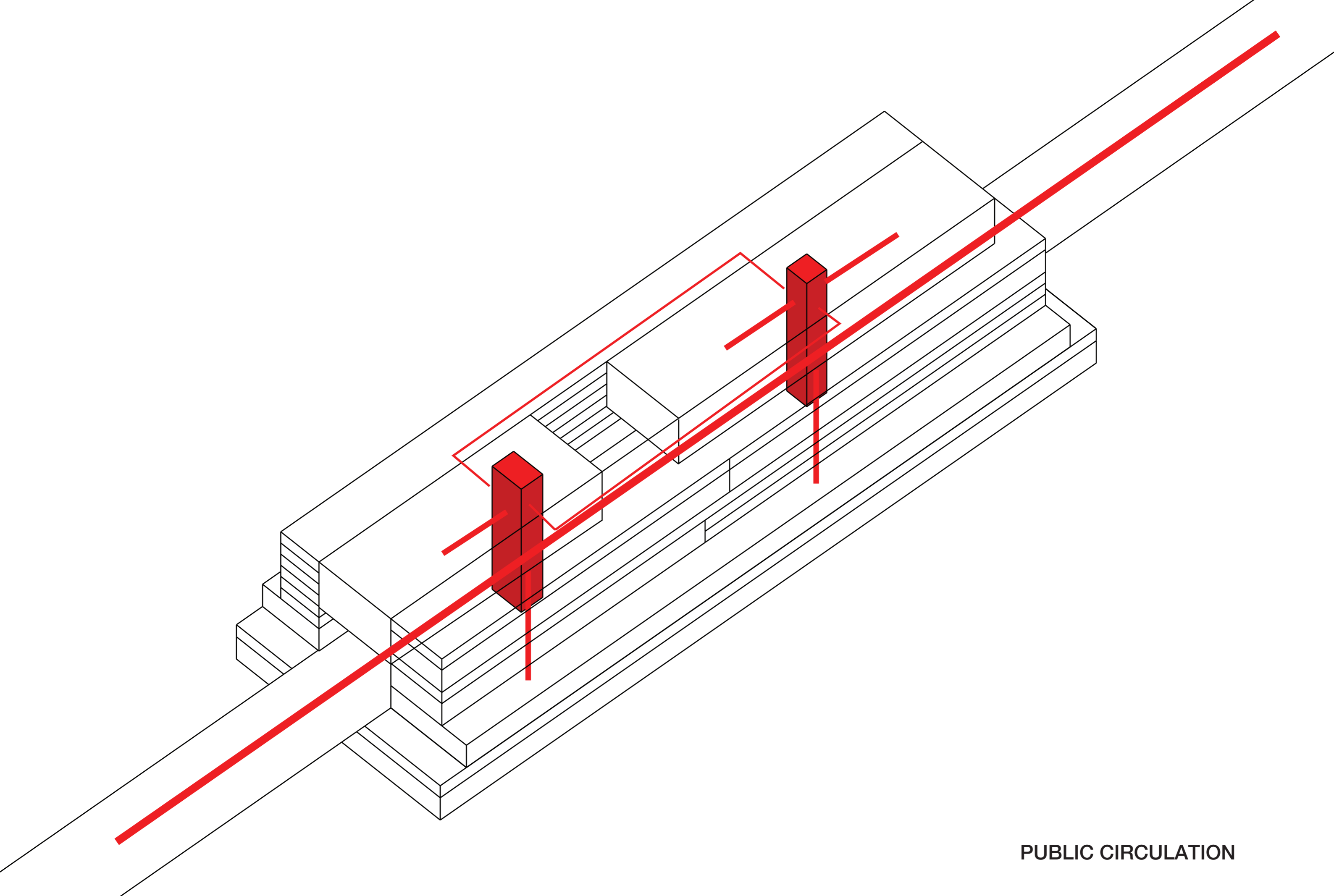

PUBLIC CIRCULATION

CIRCULATION

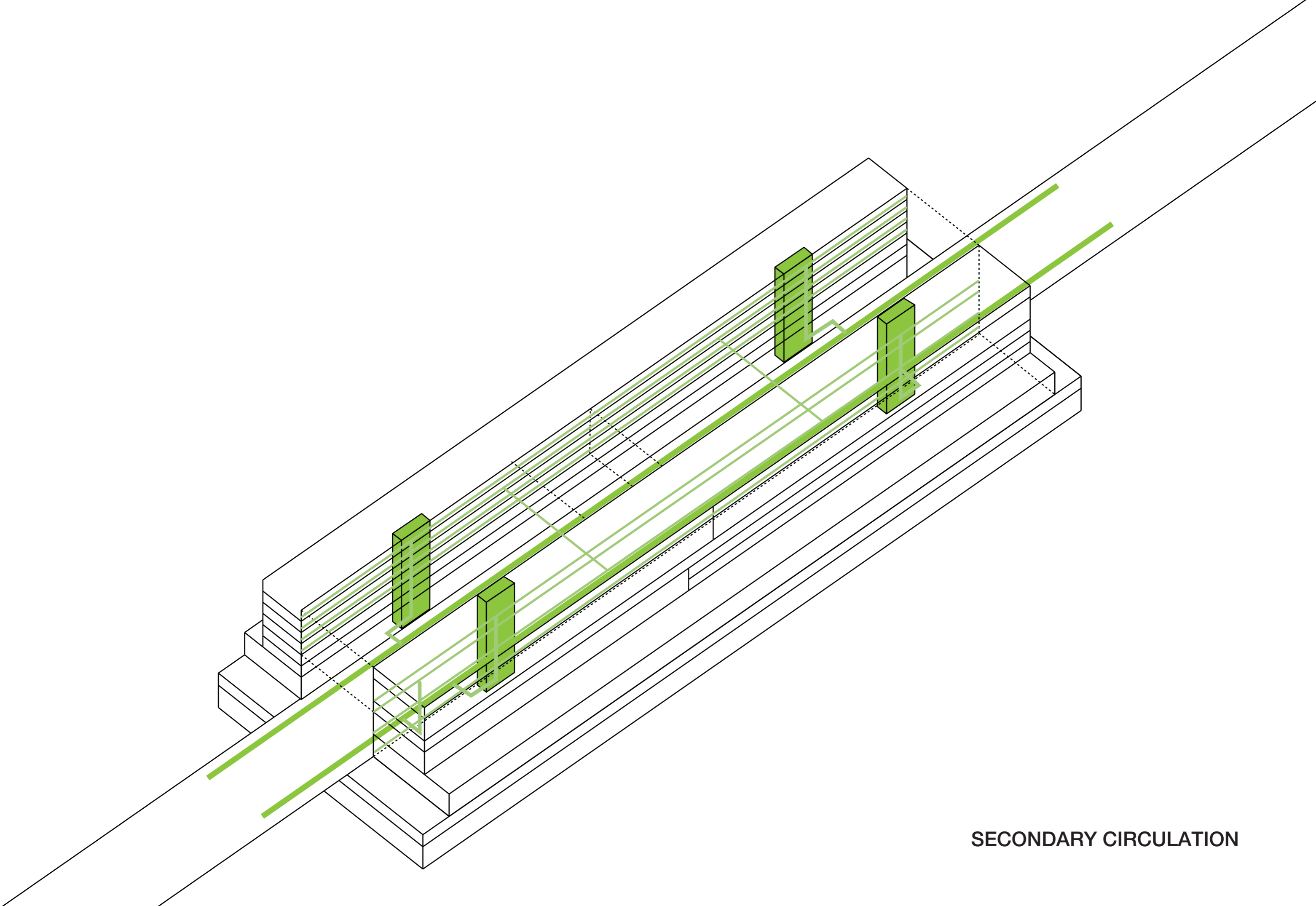

SECONDARY CIRCULATION

CIRCULATION

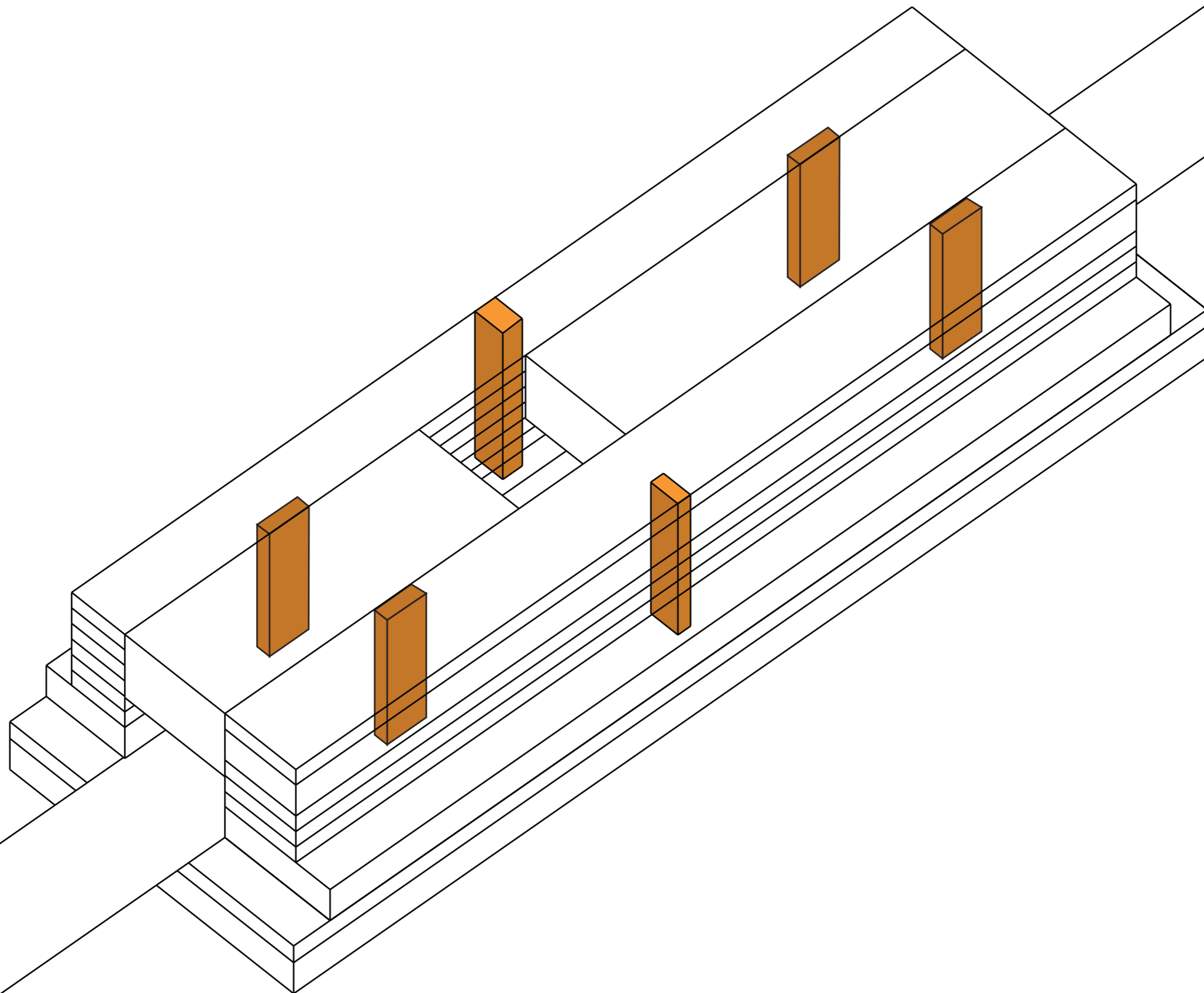

ESCAPE ROUTE

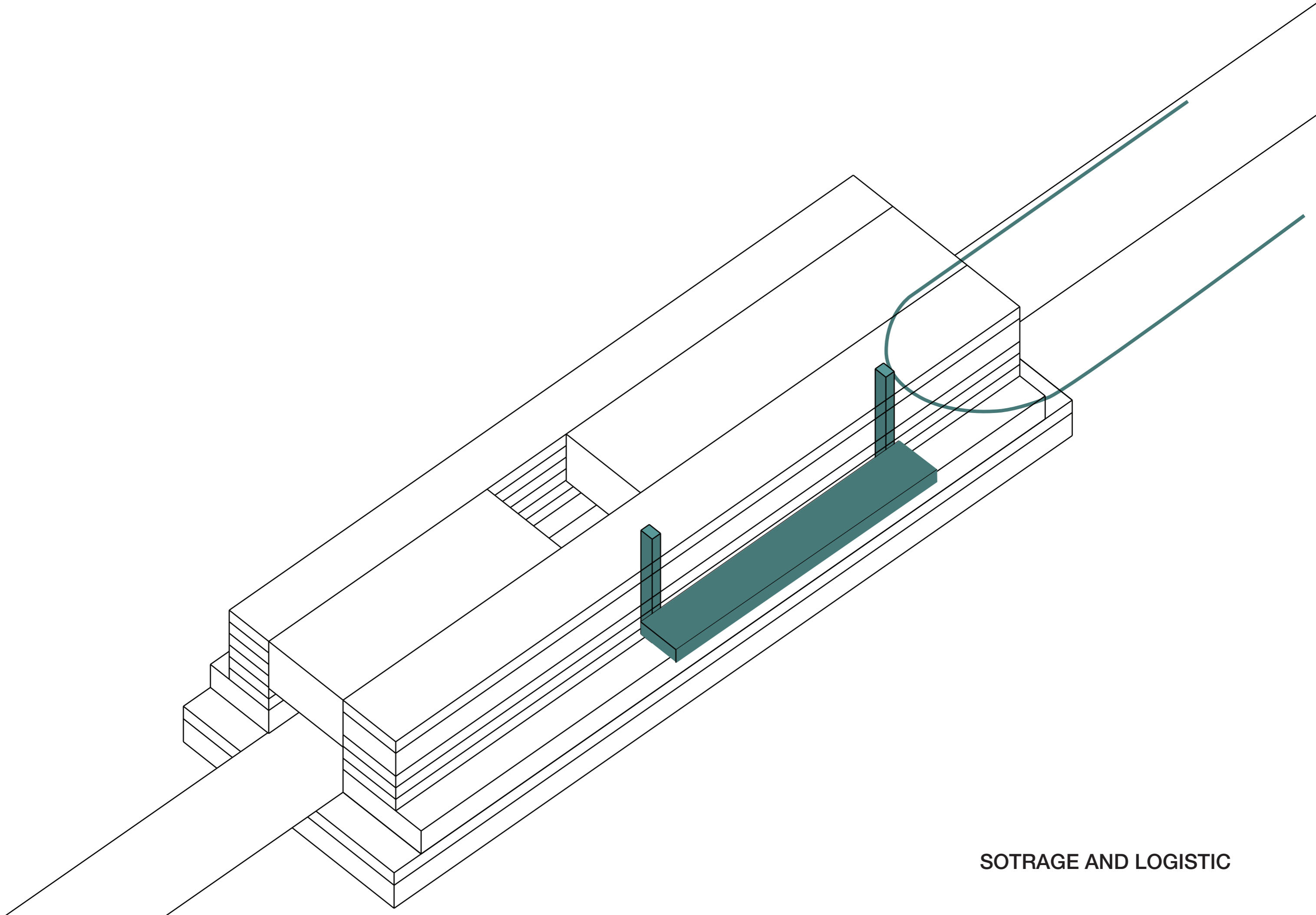

SOTRAGE AND LOGISTIC

CIRCULATION

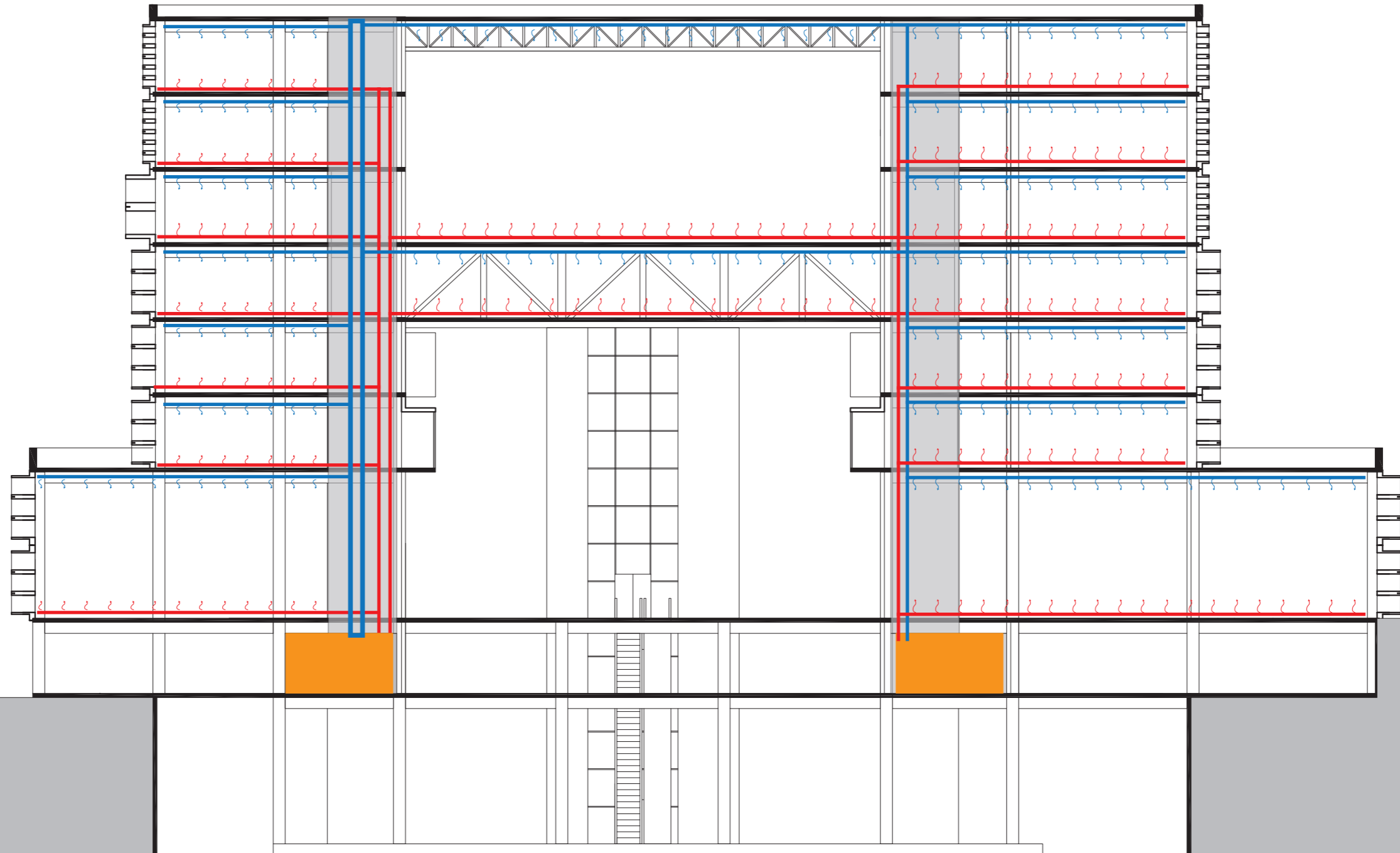

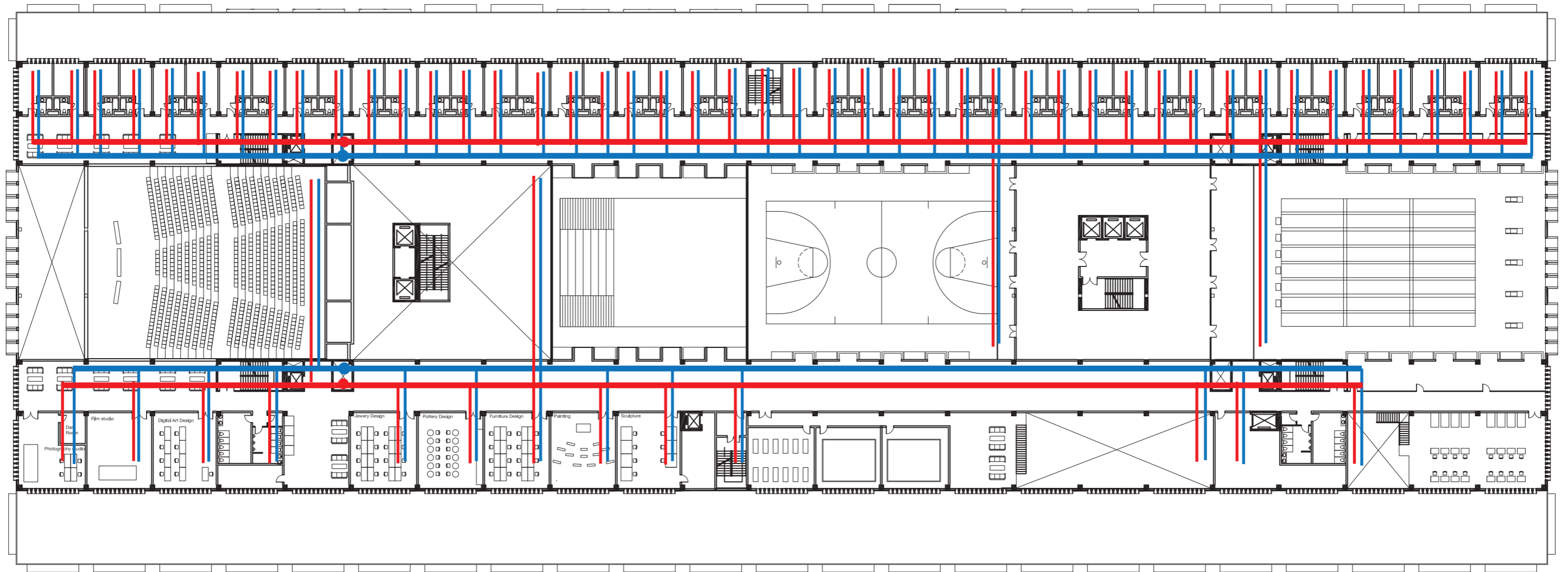

Lecture Hall

Basketball court

Glass bottom Swimming Pool

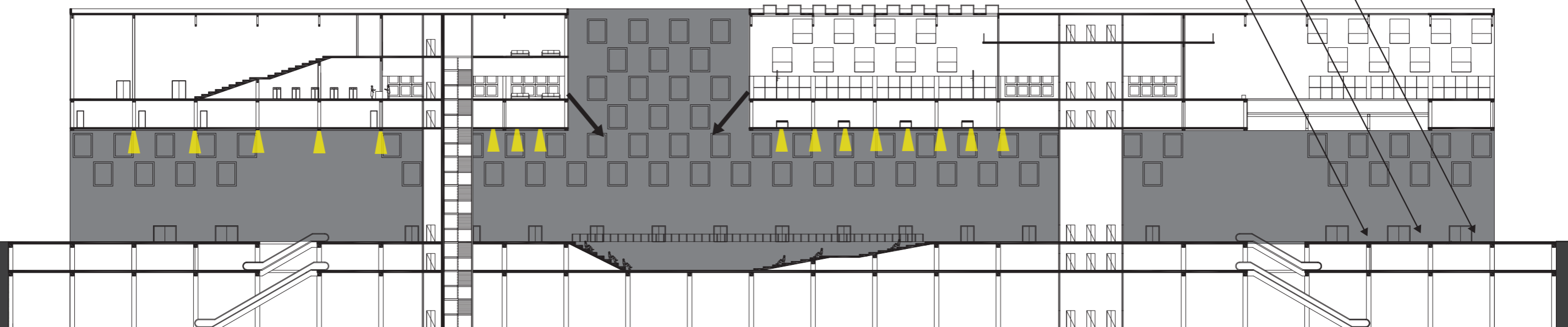

Lecture Hall

Basketball court

Glass bottom Swimming Pool

