



HAS Toolbox

Nick den Hoed 5583306

AR4AH120

Lidy Meijers

Thijs Bennebroek

Table of contents

| | | |
|-----------------------------|------|------|
| Content | p.2 | |
| Foreword | p.3 | |
| Why | p.5 | |
| Method | p.7 | |
| Airbases | p.9 | |
| HAS | p.13 | |
| Soesterberg airbase | p.17 | |
| Value assessment | p.21 | |
| Criteria | p.25 | |
| Evaluation | p.27 | |
| Strategies | p.31 | |
| Existing scenarios | p.33 | |
| Scenarios ensemble | p.35 | |
| <i>Ruins Park</i> | p.36 | |
| <i>Military reuse</i> | p.37 | |
| <i>Cemetery</i> | | p.38 |
| <i>residential district</i> | p.39 | |
| <i>Cultural area</i> | p.40 | |
| <i>olympic village</i> | p.41 | |
| Scenarios shelter | p.43 | |
| <i>Memorial</i> | p.44 | |
| <i>Military</i> | p.45 | |
| <i>Animal shelter</i> | p.46 | |
| <i>Shroom farm</i> | p.47 | |
| <i>Chapel</i> | p.48 | |
| <i>Columbarium</i> | p.49 | |
| <i>Food hall</i> | p.50 | |
| <i>Swimming pool</i> | p.51 | |
| <i>School</i> | p.52 | |
| <i>Housing</i> | p.53 | |
| <i>Event ruin</i> | p.54 | |
| <i>Restaurant</i> | p.55 | |
| Developed design | p.57 | |
| Comparison | p.61 | |
| Conclusion | p.63 | |

Foreword

During the Cold War, military infrastructure and buildings rapidly emerged across Europe. In a short period of time, driven by the fear of total annihilation, these structures were developed quickly. The focus was not on aesthetics or sustainability, but on speed, secrecy, and strength. This led to a high degree of standardization, and because the allied nations worked closely together, similar buildings were constructed throughout Europe.

One example of this is the spread of USAF airbases across the UK, Germany, Italy, Norway, the Netherlands, and Belgium. Most of these airbases also featured hardened aircraft shelters along their perimeters. However, after the Cold War ended, many countries downsized their militaries, and there was no longer a need for all of this military infrastructure. As a result, many of these sites were abandoned. Today, many have been demolished, are deteriorating, have been rapidly transformed, or remain in use.

At the same time, several interesting developments are taking place. First, there is growing interest in the Cold War era, and countries are deciding which buildings should be preserved as heritage sites or monuments. Furthermore, many of these sites have proven to possess unique ecological value. Due to the controlled and predictable nature of military activities, as well as restricted public access, natural environments were able to develop relatively undisturbed. Finally, there is increasing interest in the sustainable reuse of existing buildings.

This raises several important questions. Should these buildings be reused or preserved, and what strategies should be applied? How can ecological values be balanced with cultural heritage and societal interests? And how can this be achieved in practice?

This toolbox provides a solution to the problems and questions outlined earlier. Through a case study of Soesterberg Air Base, multiple scenarios will be explored. These scenarios will be evaluated using a set of criteria derived from the site's specific values. Furthermore, the toolbox can be used by stakeholders and architects as a source of inspiration and as a starting point for discussion. Policymakers can also use it as a framework for evaluating potential scenarios.

The lessons learned will be divided into site-specific findings and insights that can be more broadly applied to other airbases. Furthermore, the structure of the toolbox can be adapted to similar typologies where information is limited or lacking.

Why?

Why is a toolbox necessary? What makes shelters different or special? Here the main reasons for the design are stated and some specific numbers as well as personal motivation.

Why?

The need for this toolbox emerges from societal challenge and the increasing recognition of Cold War heritage. Interest in this period of military architecture has grown significantly in recent years, while the RCE is currently identifying Cold War structures that may qualify for a monument status.

At the same time, governments are trying to reduce carbon emissions and promote more sustainable forms of construction. This has created an interest in the adaptive reuse of existing buildings and the reuse of materials. Next to that, Europe faces urgent challenges related to housing shortages, refugee accommodation, climate adaptation, and food production.

Within this context, Utrechts Landschap owns a large part of Soesterberg Air Base, including a flourishing natural landscape and seventeen large HAS structures. Their current strategy combines conservation through abstinence with selective reuse through rental functions.

This situation raises a the question: should these shelters be transformed to address societal problems, or should society reconsider the assumption that every square meter must put to economical use? The shelter offer a large potential. A single shelter has a ground surface of approximately 800 m², and the insertion of an additional floor could create around 600 m² of extra usable space. At Soesterberg alone, this could result in approximately 288 houses of 85 m². Throughout the whole of Europe this would be 16 times the architectural faculty of the TU Delft or 67 soccer fields.

This toolbox will explore different scenarios and try to generate information, a way to compare different scenarios, test strategies and inspire. The toolbox therefore serves as a research instrument to explore and compare different transformation scenarios. Rather than proposing a single solution, it aims to create knowledge, test strategies, possibilities, and inspire future approaches to the adaptive reuse of Cold War heritage.



One shelter has 800m² of usable area and with the addition of one floor this would be 1400m²



Combining all the shelters at the Soesterberg airbase this would be 23.800m²

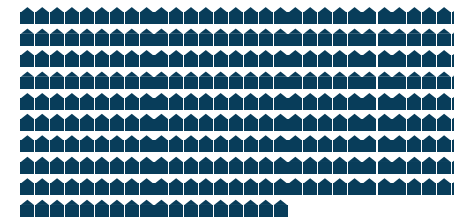

Which totals to 288 houses of 85m² at the soesterberg airbase alone

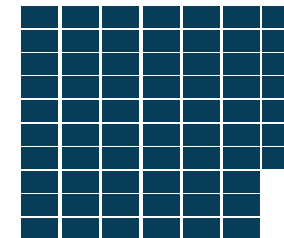

420 shelters combined result in a surface area of approximately 67 soccer fields (8701)

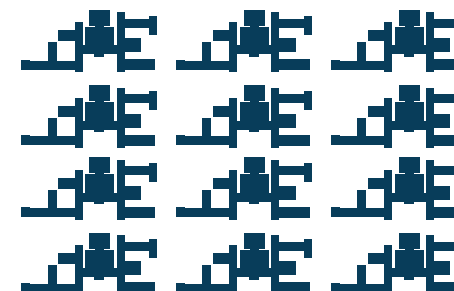

And when repurposing 420 shelters throughout europe (588000m²), the faculty of architecture at the TU Delft (3600m²) can be created 16 times

Method

How will the toolbox be set up, what will be done and through what research? What are the starting principles?

Airbases

Where are the airbases, how do they function? What is generic and what is alternating?

Airbases

Inventarisation

Its needed look at different scales to multiple airbases so that common characteristics and differences can be defined. Which are needed for the toolbox to generate scenarios and find perimeters. These results will be shown in the following chapter

Throughout Europe there are 21 USAFE airbases containing Hardened Aircraft Shelters. Most of them are located in the UK and Germany. Nine of these airbases are analyzed and shown on the following pages.

The diagrams are in relative scale and they show how the HAS are oriented towards the airstrip and the connection with nature. Soesterberg has an average size and amount of shelters, being larger then Erding but smaller then Ramstein. Its unique that the shelters of Soesterberg are also located in between the runways whereas most of the times they are located on the sides of the runway. Furthermore not all airbases use trees to camouflage the shelters like at the soesterberg airbase.

4 out of the 9 airbases are still in use by the military. The others are under development, in commercial use or vacant. However, often its not used to its full potential and in connection with its context and only used as storage space.

Furthermore the airbases are located next to a large city or a smaller city developed next to the airbase as an effect of the sudden growth of activity. Soesterberg airbase has a combination of both laying in between Amersfoort, Soest and Zeist.

Together the 21 airbases used to contain more than 420 shelters of which approximately 50 are already destroyed.



Soesterberg
Country: Netherlands
Status: Nature reserve

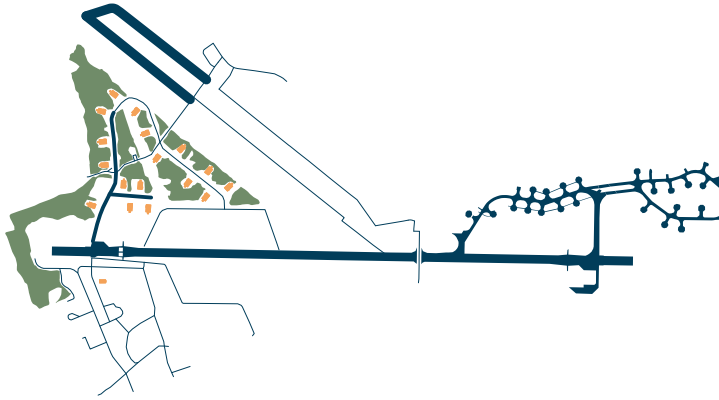

Aviano
Country: Italy
Status: Operational

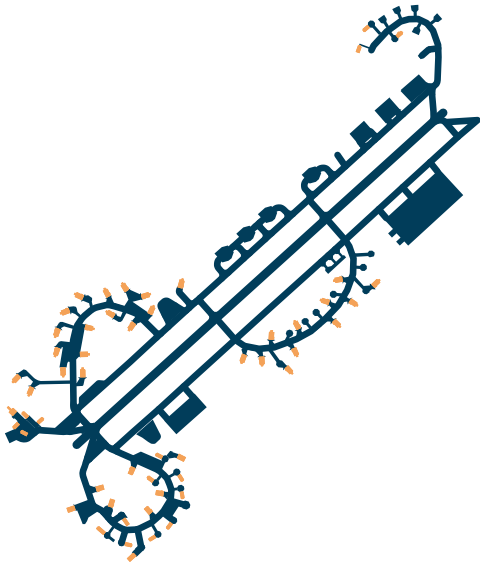

Bitburg
Country: Germany
Status: Commercial airport

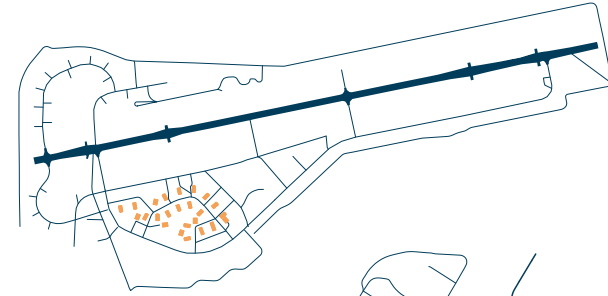
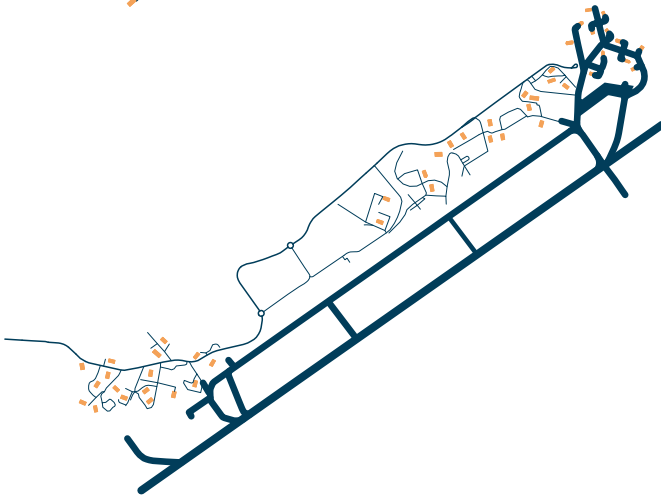

Erding
Country: Germany
Status: Under development



Hahn
Country: Germany
Status: Commercial airfield



Ramstein
Country: Germany
Status: Active USAF

Sembach
 Country: Germany
 Status: Active US Army

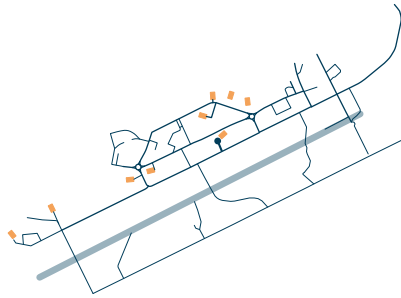

Spangdahlen
 Country: Germany
 Status: Active USAF

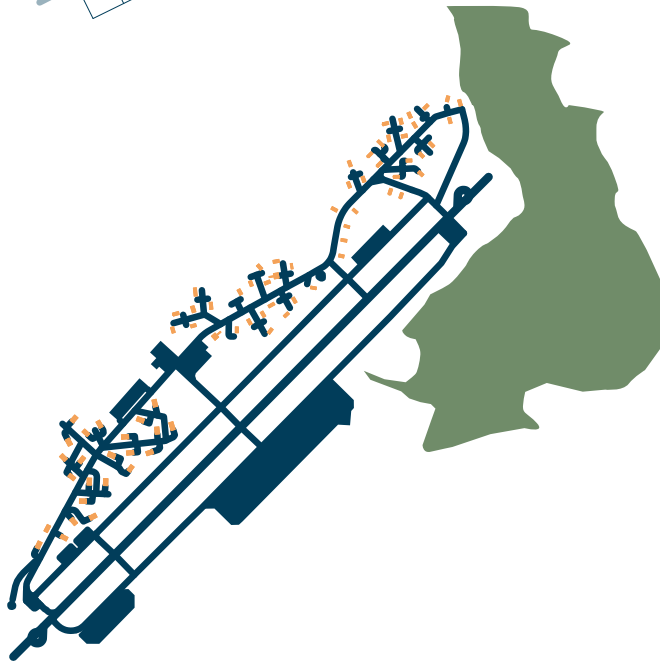

Zweibrücken
 Country: Germany
 Status: Commercial and Civil use



Ensemble

The analysis shows multiple ways of connecting the shelters to the runway. First of all it can be divided in two main setups. The tree, which is structured and branching off from the runway or organic, which is less structured and more free flowing. The tree layout results in small groups of shelters enabling the buildings to closely work together whereas the organic layout is less defined and tends towards a more complete use of the shelters where they all work together.

It also differs how the shelters are orientated, this can be divided into 4 ways. The street, perpendicular, branch and court. This could influence the functions where a street can exist of multiple different ones and a court of one function divided over multiple shelters

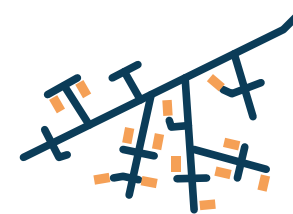

Tree

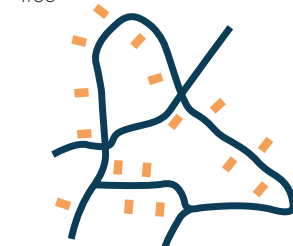

Organic

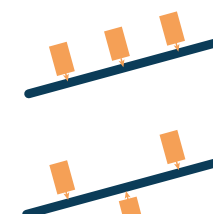

Street

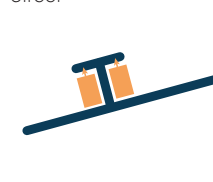

Branch

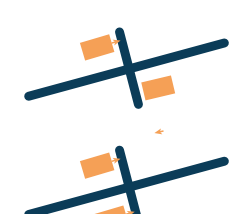

Perpendicular

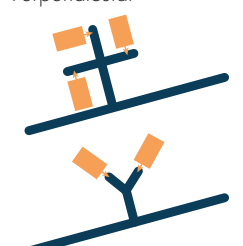

Court

HAS

What defines a HAS? What spatial qualities does it have? What are the technicalities. What is generic and what is unique for the site?

Shelters

Development

The development of HAS skyrocketed after the destruction of the Egyptian air force in 1967 by the Israeli. The NATO had to quickly come up with a solution. This was eventually solved by the USAF.

They used wonder building system to quickly build shelters and then they would cover these shelters with concrete resulting in the HAS.

Throughout the cold war this design has been altered a few times resulting in four generations of shelters. The following chapter defines the spatial qualities of the shelters and breaks down its components.

**slash building costs, construction time
right down the middle!**



DOUBLE CORRUGATION!

Each Wonder Building panel is Cor-ripped in a series of small corrugations. Assembled panels form 2-foot corrugations. The combination results in the amazing DOUBLE CORRUGATION design — strongest in the building industry!

You can put up a Wonder Building structure and start using it in just half the time it takes to construct other buildings! And you can figure on saving 50% in labor and construction costs in the bargain! The reason? Simple, uncomplicated building plans. You can even do it yourself! Patented Wonder Building panels are heavy-gauge, zinc-coated steel — double-curved and corrugated to form rigid, self-supporting arches. Bolted construction assures fast, low-cost erection. No costly framework... no posts, pillars, braces or trusses. The only foundation needed is a concrete slab. The Wonder Building system makes conventional construction obsolete — you pocket the difference in time and labor savings!

- 1. START WITH A SLAB**
Low-cost foundation... a simple "floating" concrete slab with channel for sides of the structure.
- 2. FAST ASSEMBLY**
Precision-made panels bolt together quickly to form self-supporting arches. Caulking assures a weather-tight seal.
- 3. SIMPLE SCAFFOLDING**
A rough support to hold half-arches in position speeds erection.
- 4. ARCH CONSTRUCTION**
Half-arches are set on scaffolding, lapped and bolted together to complete the full arch.
- 5. BUILDING IS COMPLETED**
Arches are progressively joined together until structure is completed. Arch bases are sealed with concrete in foundation channel.
- 6. ACCESSORIES**
All-steel end walls are available in a wide variety of designs. Choice of doors and windows — ventilators. Translucent fiberglass panels in stock for natural lighting. Easily insulated.

SYMBOL OF SIMPLICITY
No other type of structure can be erected so simply and economically. Arch panels assemble with one site bolt. Only toolman required! Weather sealed with neoprene washers. 50% of construction labor is done on the ground — save time, cut cost.

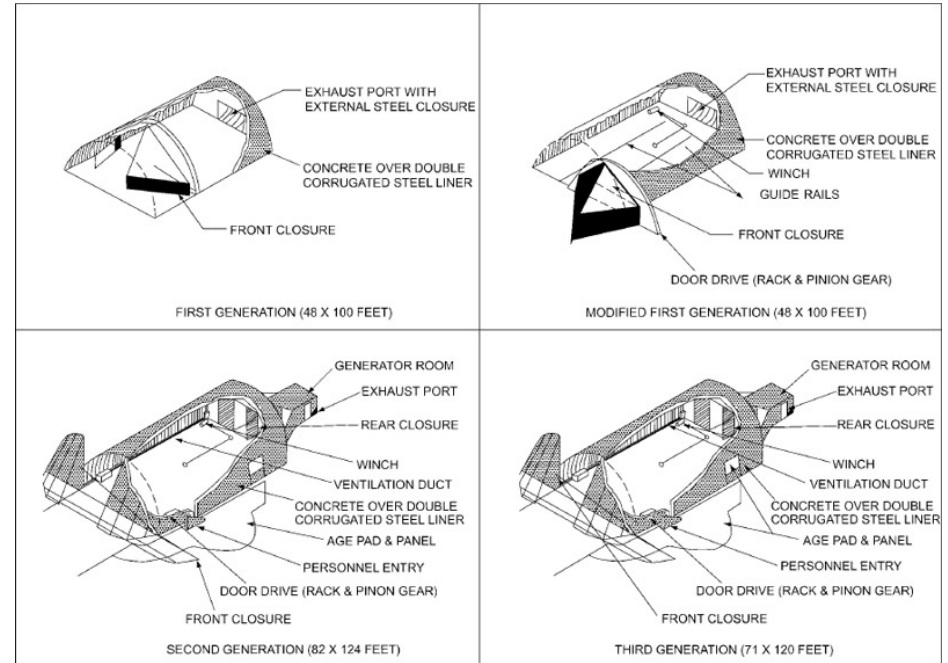

Spatial qualities

The building

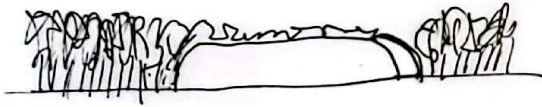

Hidden

- Camouflaged with trees and plants

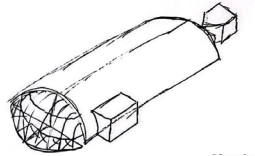

Half pipe

- Long tubular half pipe shape



Hierarchy of volumes

- Large main volume, small side volume, stepped backside and sloped front

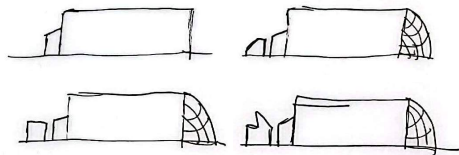

Anomalies

- Local adaptations and differences

The space

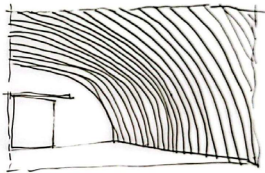

Ribbed dome

- Large tubular open volume covered by a ribbed dome structure

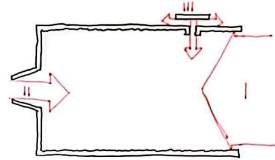

Entrances

- Hierarchy of three entrances, front, back and side



Curved walls

- Two straight walls and one large curved roof

Elements

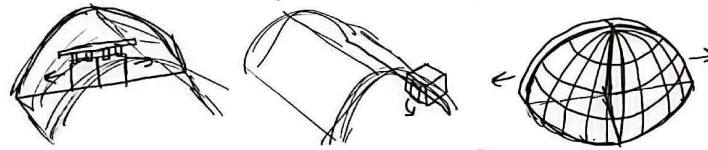

Doors

- Sliding and pivoting doors
- Different constructions

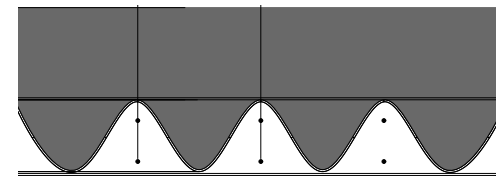

Walls

- Double corrugated steel panel, poured over with concrete, overgrown with moss

Components



Wonder building steel

- Double corrugated
- Galvanized steel

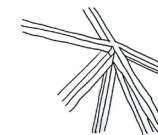

Steel door structure

- HE 180 B

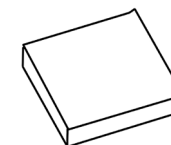

Concrete floor

- Concrete floor slab
28mm thick

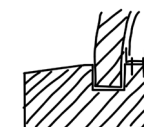

Foundation beam

- Beam running around the edge ~
200x100mm

Soesterberg airbase

Define the focus, analyze its characteristics. Where is it? Who are the stakeholders? What are the dimensions?

Soesterberg airbase

Site

The Soesterberg airbase has a long history as military camp and flight activities. It is located in between Zeist and Amersfoort and lies next to the A28, N237 and N238.

The airbase itself can be divided into 8 areas as shown in the image on the right. The focus for this toolbox will be sector F, Shelters North. This part is located within the two runways and the former runway used to run through it.

Furthermore its ecology is thriving and there are some pioneer species on the airbase. At the moment most of the site is owned by Utrechts landschap. And a residential project is being realized on site. The shelters are partially rented out for events and working space while the other shelters are used for storage or they are closed and given back to nature.

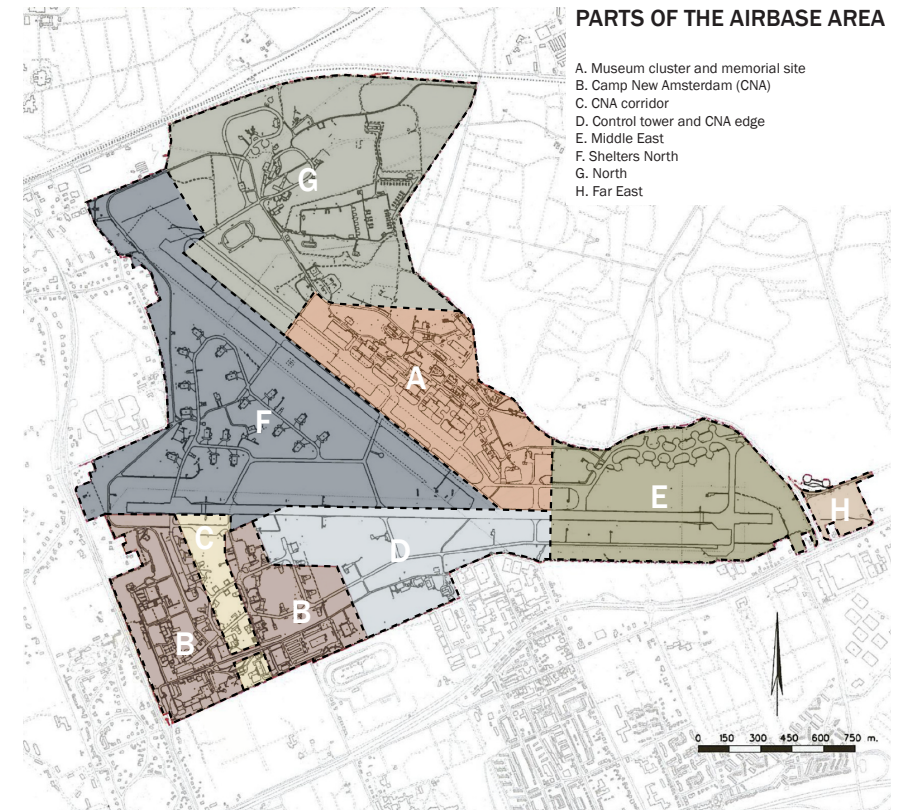

Stakeholders

There are four main stakeholders for the airbase. Utrechts landschap and the local residents are the most important for the shelter area

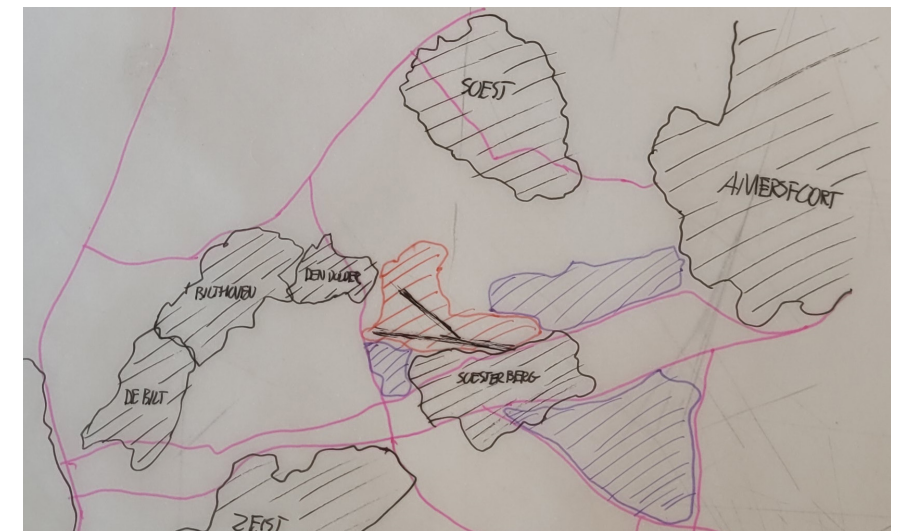

Sun path diagram

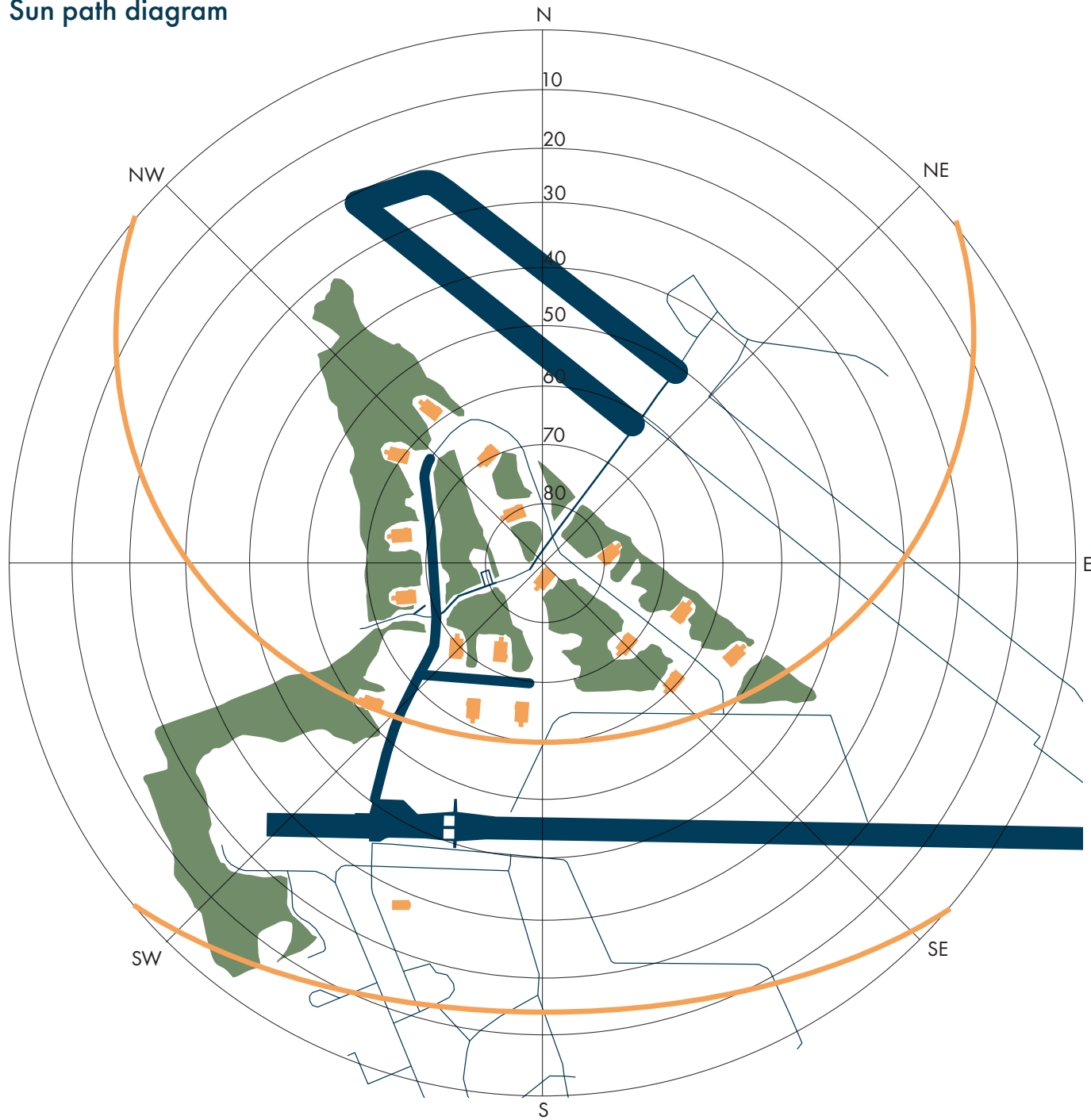

Sun path analysis

For the toolbox and its scenarios it is also needed to understand the sun path and the orientation of the site. The diagram below illustrated the sun path during the summer and winter solstice. The orientation of the shelters might influence the placement of windows and also functions within the shelter.

For example, a large glass facade would better be orientated north than south. Some functions need sunlight in the morning and others in the evening. And due to all the trees at the site the sun path also becomes important regarding their shadows.

Orientation of shelters



Value Assessment

What are the values, what should be kept and what is less important?
What is unique and are there conflicts?

Value assessment

Site

The purpose of this value assessment is to define the criteria and parameters for the toolbox. The value assessment is performed in two methods. First through the method proposed by ERM, here floor plans and sections are colored to distinct the value of different parts and to easily see what should be kept and what can change. The second method is proposed by Kuipers & de Jonge.

The value assessment shows that the shell, front door and front door structure is high valued. However the shelters themselves are quite monotonous. This raises the question how much can be altered or how much should be preserved to maintain this value.

Main takeaways are the high ecological value, the rarity of the ensemble, the spatial values of the shelters and the way these shelters are situated in the nature. There are also some high valued intangible values. The sense of the past through the weathering of the shelters and also the stories and mysteries surrounding the site.

When comparing the values with the values of Utrechts Landschap three main values are defined: Nature, Society and Heritage.

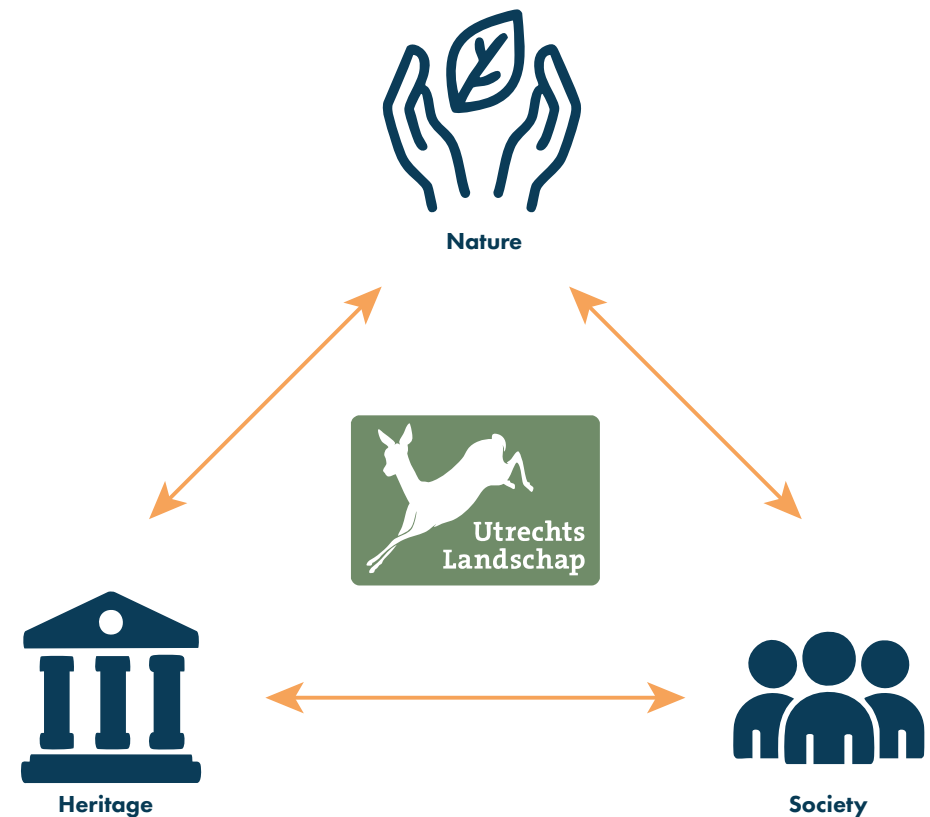

Value assessment

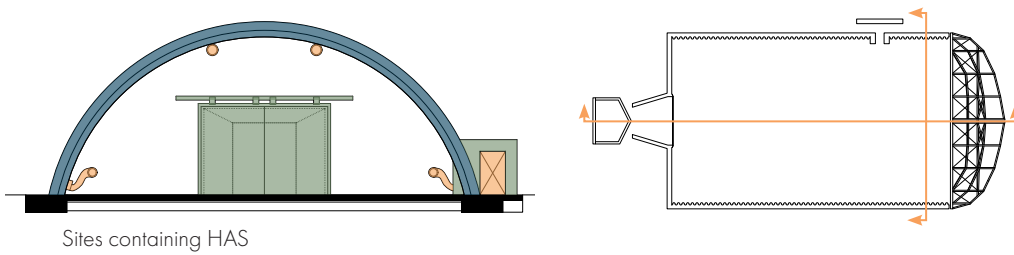
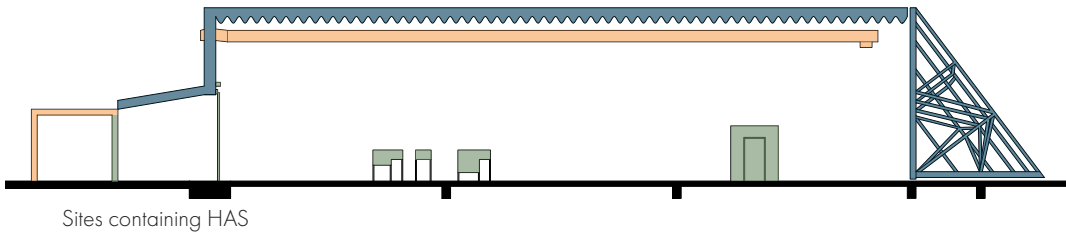
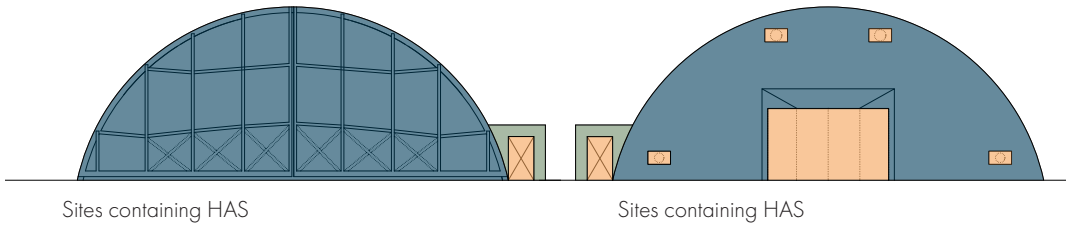
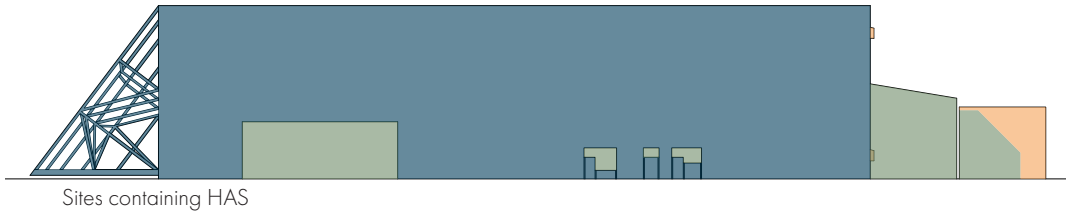

Value matrix

Value assesment Airshelter area Soesterberg Airbase

What are the possibilities with the heritage?

| | Age | Historical | Artistic | Commemorative | Rarity | Nostalgic | Use | Conflict /Dilemma |
|--------------------------|---|---|--|---|---|--|--|---|
| Surroundings | Layers of Moir sine and plain landscapes, traces of war and Human intervention | Layered history from Neolithic to VEGEHEID | Paintable nature due to depth and perspectives. | Intended commemorative value through the museum and memorials. | Its the first military aviation site in the Netherlands and NATO airbase | Public airshows and the first MCHive for american soldiers | Schema From disas-off military airbase to public nature park | What is the harchy between the different time periods/layers? |
| Site | Mature trees, remains of airfield infrastructure and old tracks visible in the vegetation | | | | | American influence and soldiers, restricted access to the airbase. | High diversity of ecology, well maintained infrastructure. Unmechanistic | What is the harchy between the ecology and cultural heritage? |
| Sub-cluster | | Randomness in orientation of shelters. | | | Use of planted trees to camouflage the shelters and general ensemble. | | Clusters of buildings, easy accessibility | |
| Structure | Aging of the steel structure, water damage | Use of the Wond building steel structure | | | | | Self-supporting dome structure. | The idea is valuable but it is not rare in the world. |
| Space plan | Directional paint stripes | Third generation TAD VEE shelter | | | | Sense of past function and usage through the old directional paint stripes | Open floorplan and three different sized entrances | Do you preserve or restore the spaceplan? |
| Skin | Weathering of the concrete skin and overgrown moss | | | | | | Overdimensioned structure, thick skin | How much can you alter the skin so the appearance of the whole doesn't change? |
| Service | Original machinery and systems | Implementation of exhaust opening and old doors | | | | Sense of past function through service systems | Old services are still mostly usable | |
| Stuff | | | | | | | | Most stuff is in the museum or taken away by the previous users. So the original stuff is not present at the site |
| Spirit of place | The combination of nature, materials, buildings, stories and spatial qualities create a feeling of the past | | | | USAP under direct command of the Dutch military | For the military feelings of orderliness, teamwork, respect and discipline. For the community feelings of secrecy, safety, danger and mystery | Opportunity for story telling, using the mystery and revealing the secrecy | What story do you tell and how do you tell it? How can you tell a story of secrecy? |
| Conflict /Dilemma | Is the age value lost when you restore materials? And if so, how do you preserve it? | | Airshelters are not meant to be artistic, but looking at it now people could see it as art | Airshelters is uncommemorative- it was meant to be functional and quick built | Airshelters are not rare in the world but in the context of the Netherlands, Soesterberg and landscape it is. | Personal and conflicting memories, everything together creates sense of past, how much can you take away? | Value difficult to determine Do you look at the past present or future? | |

- High Value
- Positive Value
- Indifferent Value

Criteria

What are the criteria derived from the analysis and value assessment?
What do they entail?

Criteria

To make a complete and equal evaluation of the scenarios, its needed to define the criteria through which it will be evaluated. These criteria are derived from the value assessment and are explained below. There are six in total, being the following:

- A) Level & method of intervention
- B) Public or private
- C) Occupancy
- D) Heritage & values
- E) Utrechts landschap
- F) Sustainability

How these criteria are evaluated will be explained in the following chapter.



C) Occupancy

The third criteria is occupancy. This is specifically important due to the fact that the site is a nature reserve. Furthermore its important for it will differ when people will be coming.



D) Heritage & values

The fourth criteria will be about how the various heritage values are changed. This is based on the 8 values proposed by Pereira Roders



E) Utrechts landschap

The fifth criteria is based on the three main pillars of Utrecht Landschap; Nature, Heritage and Society. The scenario will be evaluated on how much it aligns with those values.



F) Sustainability

The sixth criteria is sustainability. This reverts to the broad definition of sustainability; environmental, social and economic.



A) Level & method of intervention

The first criteria is about the level and method of intervention. This can be important to understand the scale of the scenario, the impact on the building and how much will be changed.



B) Public or private

The second criteria is about if the site and its program is public, semi-public, semi-private or private. This is interesting for the Soesterberg started with a public function, turned into private and now public again.

Evaluation

How are the criteria evaluated? Is there a difference between the different scales? How will the evaluation look like?

Evaluation

To evaluate the criteria defined in the previous chapter different methods are used. The ensemble scenarios are approximately evaluated and the evaluation of the shelters is better defined.

The level of intervention is evaluated in two ways, first of all how much of the shelter is removed and how much is added. Secondly which method of intervention is used. These methods are derived from The Vlaams Bouwmeesters and consist of the following:

- I Open up (openen)
- II Divide (opdelen)
- III Isolate (afzonderen)
- IV Add (toevoegen)
- V Remove (wegnemen)
- VI Integrate (integreren)
- VII Facilitate (faciliteren)
- VIII Acces (ontsluiten)
- IX Activate (activeren)
- X Connect (verbinden)

For the public or private criteria the scenarios are evaluated and can be public, semi-public, semi-private or private.

The Occupancy is also evaluated in two ways. When is used? Is it used weekly, once a month or only during the summer? And furthermore during which hours of the day is the scenario used.

The heritage values and the other main values of Utrechts landschap are evaluated through a rubric shown on the following pages. The results of this rubric is put into a radar graph.

Sustainability will be evaluated according to the wilderness-based checklist by Malcolm Wells from Daylighting for Sustainable Design by a worked out design for its depends a lot on specific design choices

Evaluation ensemble

Intervention



Public/Private



Occupation



Heritage & Utrechts Landschap

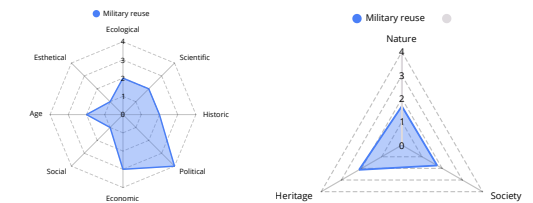

Evaluation shelter

Intervention:

- 70% Removed & 0% Added
- Method V

Public/Private

- Semi public, paid entree

Occupation:

- Summertime
- 14:00-23:00

Heritage & Utrechts Landschap

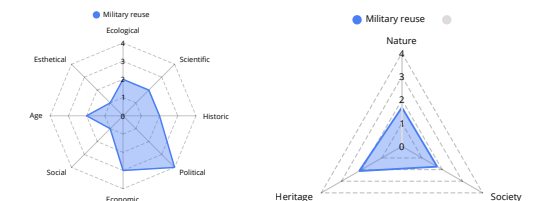

Values:

Nature:

- | | |
|----|---|
| 1. | Animals (1 = decrease; 2 = no change; 3 = small increase; 4 = large increase) |
| 2. | Plants (1 = decrease; 2 = no change; 3 = small increase; 4 = large increase) |
| 3. | Attention (1 = decrease; 2 = no change; 3 = small increase; 4 = large increase) |

Society:

- | | |
|----|--|
| 1. | Quality of life (1 = decrease; 2 = no change; 3 = small increase; 4 = large increase) |
| 2. | Densification (1 = decrease; 2 = no change; 3 = small increase; 4 = large increase) |
| 3. | Social and active (1 = decrease; 2 = no change; 3 = small increase; 4 = large increase) |
| 4. | Climate & energy (1 = decrease; 2 = no change; 3 = small increase; 4 = large increase) |

Heritage:

- | | |
|----|---|
| 1. | Average of Heritage (1 = decrease; 2 = no change; 3 = small increase; 4 = large increase) |
| 2. | Scientific (1 = decrease; 2 = no change; 3 = small increase; 4 = large increase) |
| 3. | Historic (1 = decrease; 2 = no change; 3 = small increase; 4 = large increase) |
| 4. | Political (1 = decrease; 2 = no change; 3 = small increase; 4 = large increase) |
| 5. | Economic (1 = decrease; 2 = no change; 3 = small increase; 4 = large increase) |
| 6. | Social (1 = decrease; 2 = no change; 3 = small increase; 4 = large increase) |
| 7. | Age (1 = decrease; 2 = no change; 3 = small increase; 4 = large increase) |
| 8. | Aesthetical (1 = decrease; 2 = no change; 3 = small increase; 4 = large increase) |

● Military reuse ●

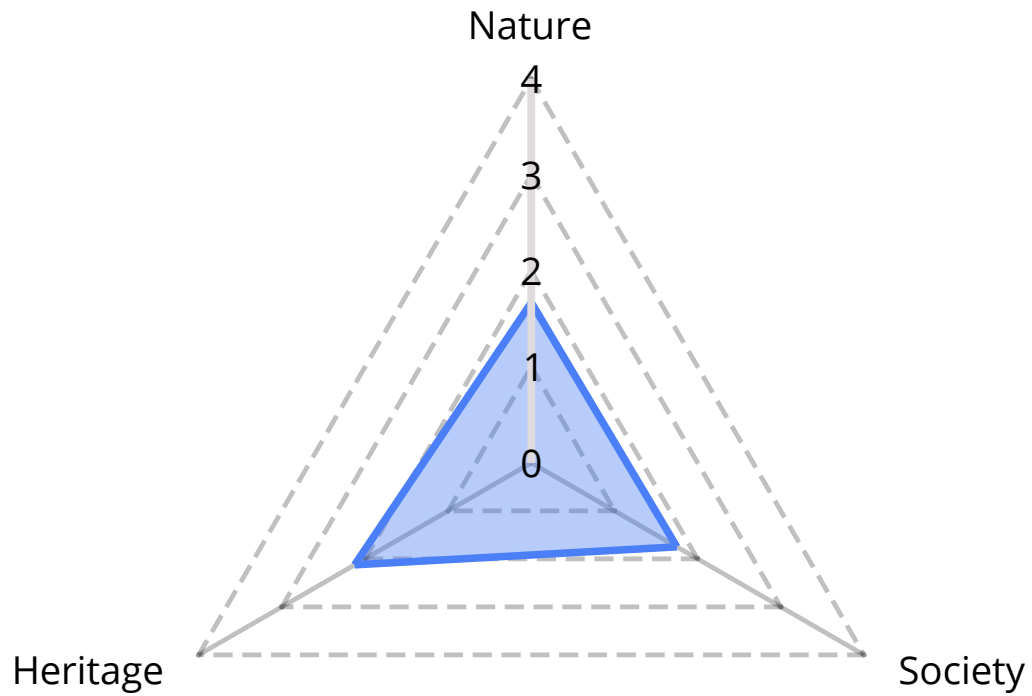

● Military reuse

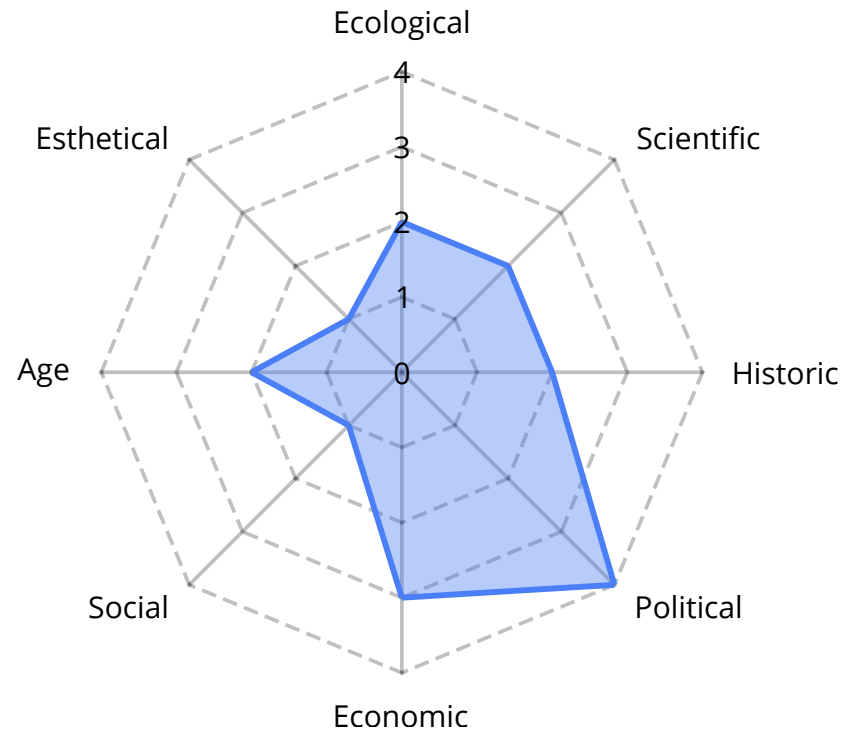

Strategies

Through which perspectives will be looked at the scenarios? What strategies will be used to create the scenarios?

Strategies

RRR and conservation through abstinence

There are a wide variety of strategies and methods on how to approach the adaptive reuse of existing buildings. Utrechts landschap applies two main strategies, conservation through abstinence and conservation through development. To better define these approaches and to generate a wider variety of scenarios other literature is used. Being the 10 strategies proposed by Petzet, in the publication Reduce, Reuse, Recycle, architecture as resource. These strategies are listed on the right.

Utrechts Landschap's conservation through abstinence approach would fall under the Reduce section and primarily the change of perception and behavior.

The designed scenarios don't necessarily align with only one strategy. It can be possible that multiple strategies are implemented into one scenario. For example curated decay, this would fall under change of perception and behavior but could also be subtraction if there is active demolition.

Reduce

Perception: perceive, recognize, represent, document, analyze, explore, compare, collect, discuss, inform, publish, sensitive, reevaluate

Maintenance: clean, care, improve, patch, seal, cure, prepare, repair

Behavior: challenge, standards, alter conduct, adapt for comfort, flexible use, zone creation

Reuse

Renovation: renew, replace, exchange, restore, rebuild

Conversion: reprogram, convert, reorganize, rededicate, adapt, transform, remodel

Infill: fill, insert, fit, embed, install, connect, close, implant

Redesign: reformulate, reshape, rewrite, interpret, tune, tweak

Subtraction: reduce, downsize, dismantle, remove, differentiate, lower, shear, demolish

Additions: raise, lengthen, complement, attach, expand, continue, enlarge, append

Recycle

Material recycling: transform, use of spolia, recycle, reprocess, transplant, reassemble

Gestalt Recycling: Adapt, cast, imitate, reproduce/copy, emulate, adopt, reuse vocabulary, carry over / transfer, reproduce, reconstruct

Existing scenarios

What kind of scenarios are already existing? What can be learned from this?

Existing scenarios

From solar park to sheepfold

As stated earlier there used to be more than 420 HAS in Europe. Before developing the scenarios a few of these 420 HAS were analyzed to see in what way they are used or altered. In Germany some airbases are still used by the military while others are repurposed for industrial functions like storage or car dealers. Two interesting examples are the Ahlhorn airbase which is turned into a solar park and the Erding airbase. At the Erding airbase the shelters had been adapted to create temporary housing for asylum seekers.

In the UK a few airbases have been destroyed or are turned into housing projects. An example of the destruction of the shelters can be seen on the right.

At the Soesterberg airbase ten of the shelters are closed off and given back to nature while the other seven are rented out or used as storage. This is mostly done by applying the box-in-box principle like with the ateliers on the right. In the past they even used to have a sheepfold in one of the shelters.



Scenarios ensemble

What scenarios can be applied to the ensemble? How would they work?
What is the evaluation?



RUINS PARK

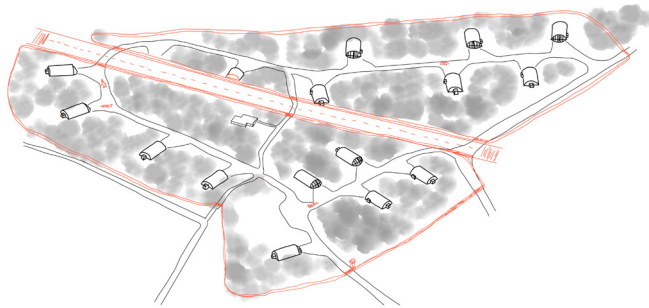

MILITARY REUSE

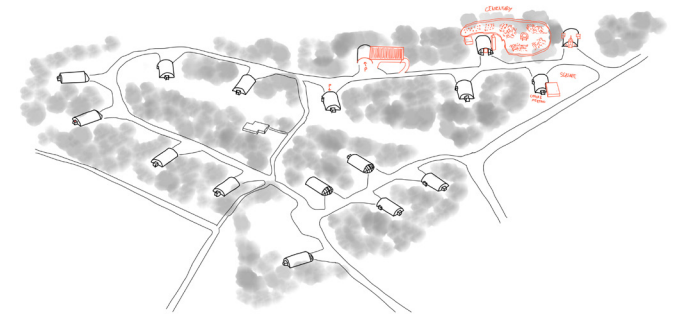

NATURAL CEMETERY

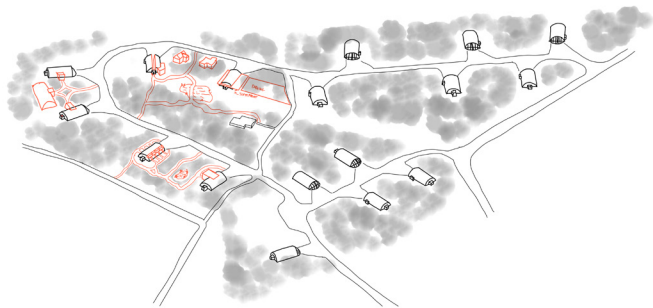

RESIDENTIAL DISTRICT

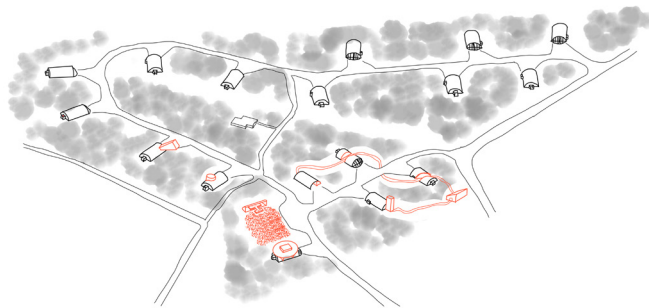

CULTURAL AREA



OLYMPIC VILLAGE

1) Ruins park

Perception & behavior

The first scenario applies the perception & behavior strategy. By giving the shelters back to nature, they slowly turn into ruins. Creating an interesting scenery of broken down concrete buildings in the middle of nature. This can be achieved in different ways; curated decay, a hands off approach or active demolition. There are quite a few locations where they apply these approaches for example in the United kingdom with former cold war site Greenham common. Or St Dunstan in the East Church Garden. The scenario could be combined with the implementation of urban agriculture or a petting zoo.



Ruined church scene in 'The Revenant'



St Dunstan in the East Church Garden

Evaluation ensemble

Intervention



Public/Private



Occupation



Heritage & Utrechts Landschap

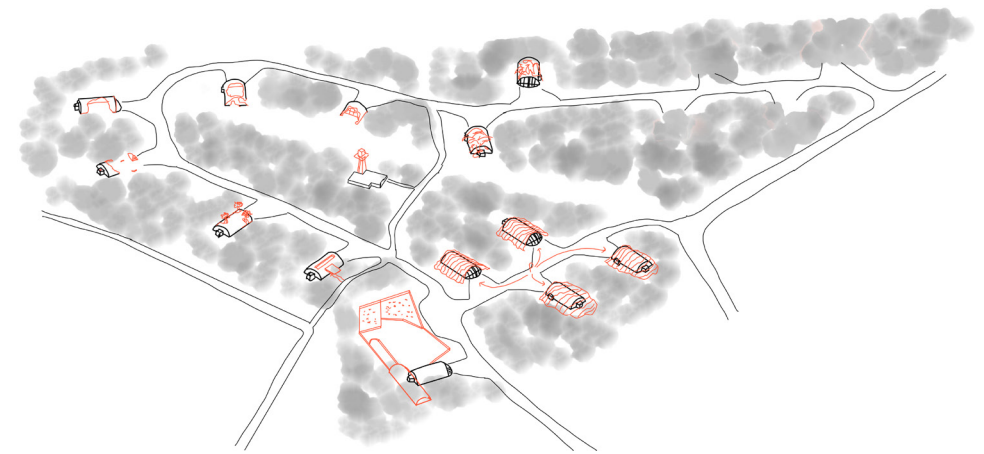
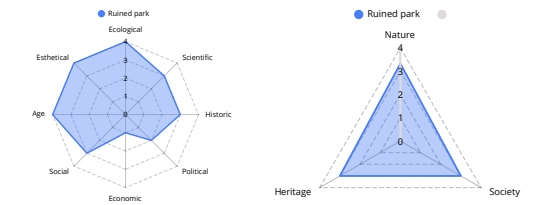

Site plan curated decay

II) Military Reuse

Maintenance & renovation

This scenario uses the fact that the shelters are still intact and almost ready for use. This enables the reuse for military purposes. Some small reparations are needed and there is the possibility to remake the landing strip. An other option could be to make a shooting range or obstacle track on the landing strip. This scenario is primarily focused on the most simple reuse but as said it can also be combined with housing and training.

Through Europe other shelters are also still used in this way. As well as the fact that there is an increasing tension in the world and an increase in military infrastructure.



Site plan military reuse



Shelter in use at Spangdahlen airbase

Evaluation ensemble

Intervention



Public/Private



Occupation



Heritage & Utrechts Landschap

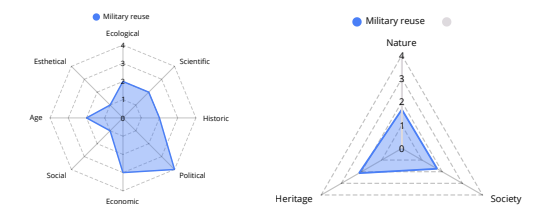

III) Cemetery

Perception & infill

The peacefulness, nature and also harsh concrete structures align well with a natural cemetery and creates a space for contemplation. Some shelters are already given back to nature, combining this with a secondary function will generate an income to maintain the nature reserve as well as protect the future of the park for it will stay public.

If designed well, a transcendental atmosphere can be created. Where the deterioration of the shelters represent the transiency of life.

This scenario will be further developed and tested in the following chapters.

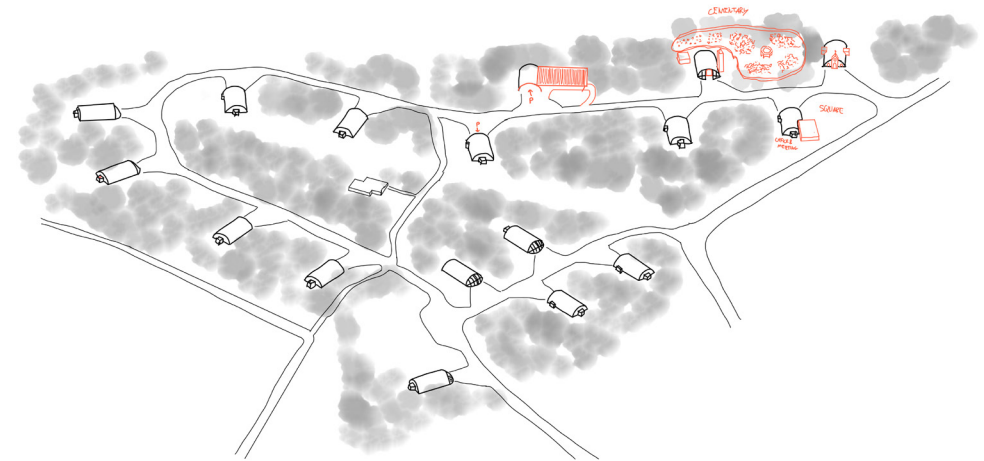

Ceremonial room Koningsakker

Evaluation ensemble

Intervention



Public/Private



Occupation



Heritage & Utrechts Landschap

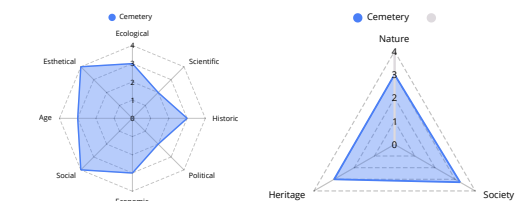

IV) Residential district

Conversion

This scenario transforms the shelters into residential buildings. This can be done in different ways each depending on the future usage. 8 houses of 120m² can fit into one shelter. An other possibility is to turn them into studios or urban villa's. It is important to think about what group you want to place there. The site lends itself for some form of ecological living where each shelter supports itself through the use of helophyte filters and small allotments for food production. The shape also resembles a quonset house giving inspiration on how to repurpose them.

Furthermore a connection can be made with the existing housing project at the airbase. Public functions can be combined improving the overall connection on the airbase.



Proposed housing project 'Wonen op de Vliegbasis'

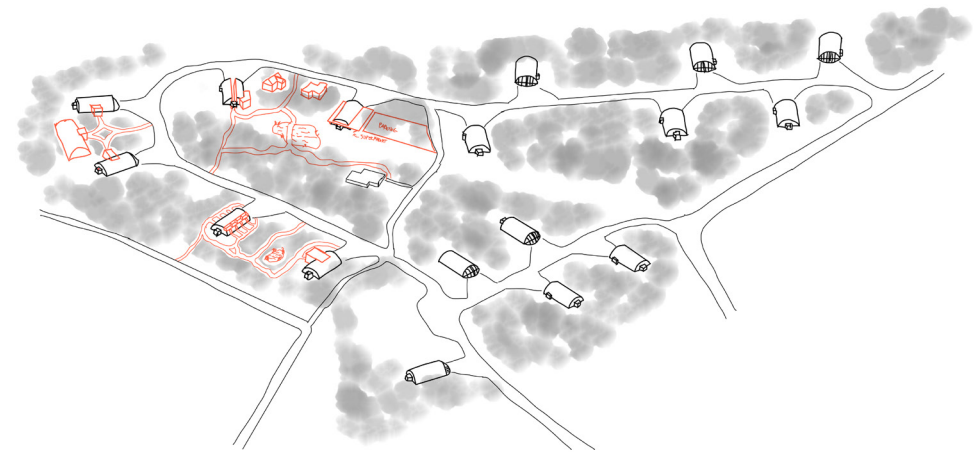

Site plan residential district

Evaluation ensemble

Intervention



Public/Private



Occupation



Heritage & Utrechts Landschap

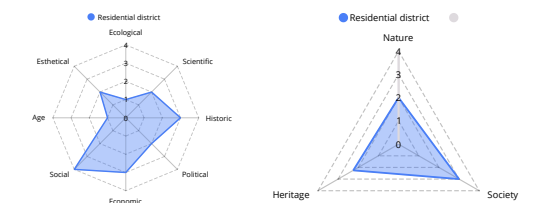

V) Cultural area

Conversion & Addition

At the moment, the National Military Museum is located at the airbase, furthermore there are also quite a lot of events taking place on the landing strips. Within the shelter area there are some artist residences, kermis op de basis as well, dinners and temporary art exhibitions.

This scenario enhances these functions and events and creates a cultural hub. Containing a festival area, art residences, exhibition spaces and museums. This would align with the heritage and cultural values of the side. Although such hubs often also have statement pieces or attractions which conflicts with the camouflaged secret identity of the site.



Event in a shelter

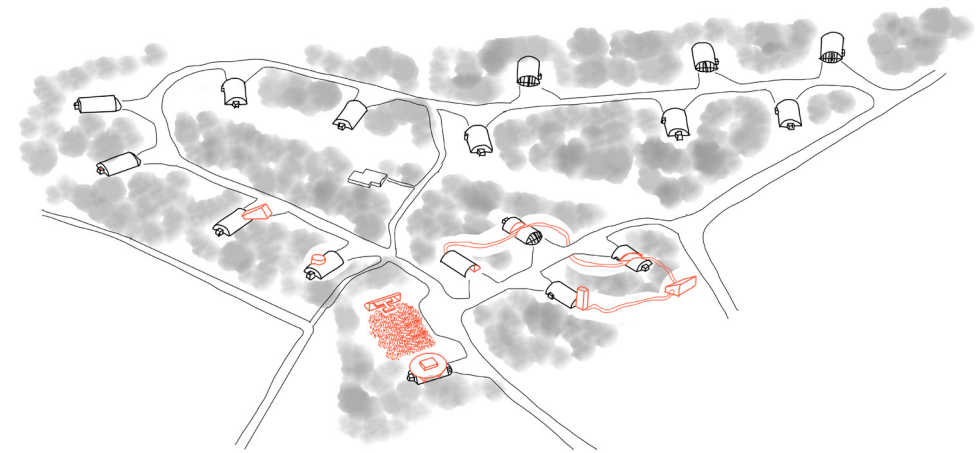

Site plan cultural area

Evaluation ensemble

Intervention



Public/Private



Occupation

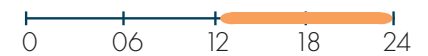

Heritage & Utrechts Landschap

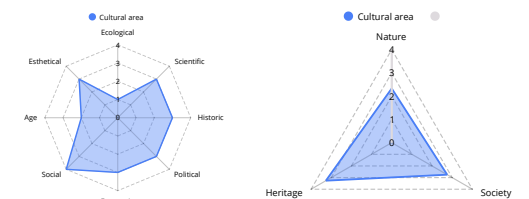

VI) Olympic village

Conversion & Redesign

An olympic village would align with the nature and societal values of the site. In the past, Utrechts Landschap has already hosted multiple sport events. Furthermore the scale of the site as well as the location, being semi secluded fits well with an olympic village.

This scenario can be developed in two different ways, the first being temporary and the second being permanent. When made permanent the surrounding residents would also benefit and the site can be turned into a sport hub. There could also be a connection with the KNVB Campus located in zeist.

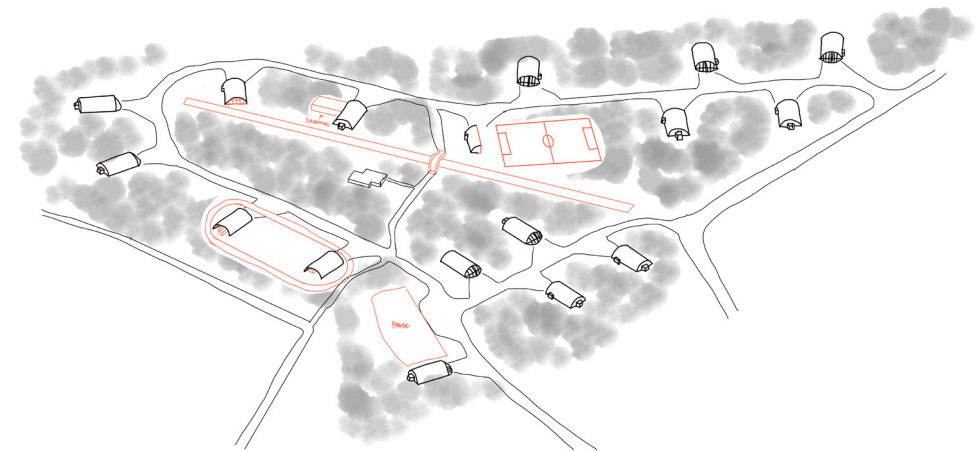

Site plan olympic village



Olympic village 2004 athens

Evaluation ensemble

Intervention



Public/Private



Occupation



Heritage & Utrechts Landschap

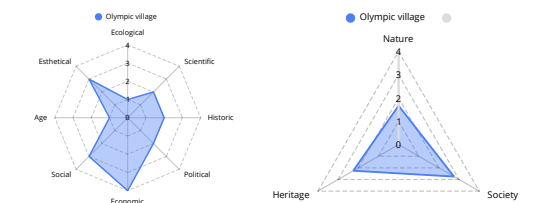

Scenarios Shelter

Possibilities for specific shelters

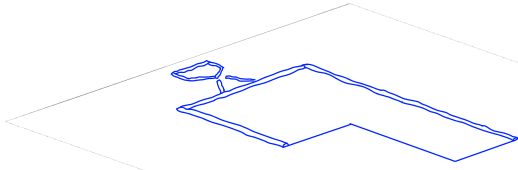

MEMORIAL

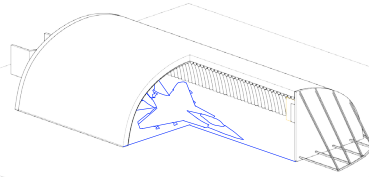

MILITARY

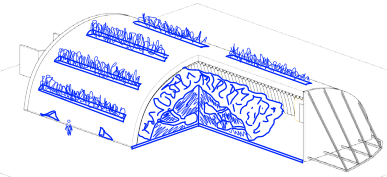

ANIMAL SHELTER

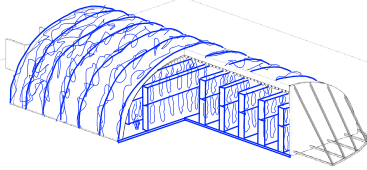

SHROOM FARM

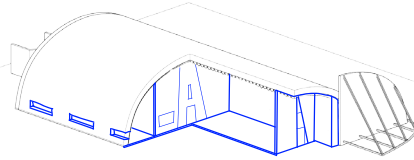

CHAPEL

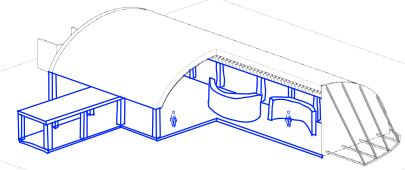

COLUMBARIUM

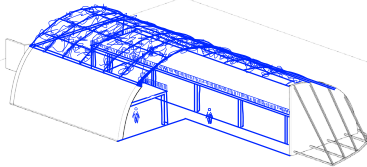

FOOD HALL

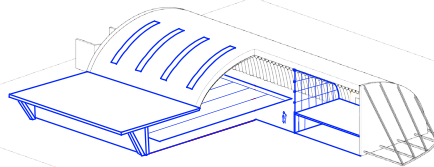

SWIMMING POOL

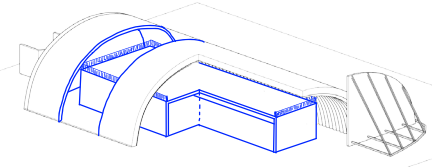

SCHOOL

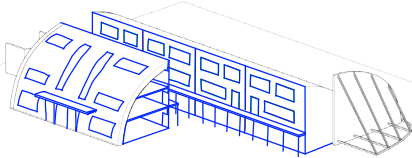

HOUSING

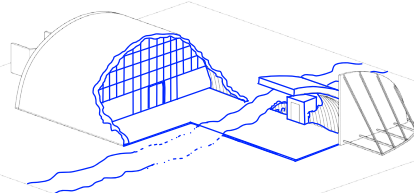

EVENT RUIN

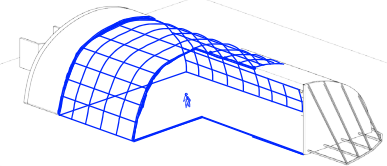

RESTAURANT

1) Memorial

Perception & Subtraction

This scenario creates a memorial by removing the whole shelter and only keeping its footprint. Resulting in an open space for gathering and memorials.

Evaluation shelter

Intervention:

- 95% Removed & 0% Added
- Method V

Public/Private

- Public

Occupation:

- Once a year a large ceremony
- 09:00-22:00

Heritage & Utrechts Landschap

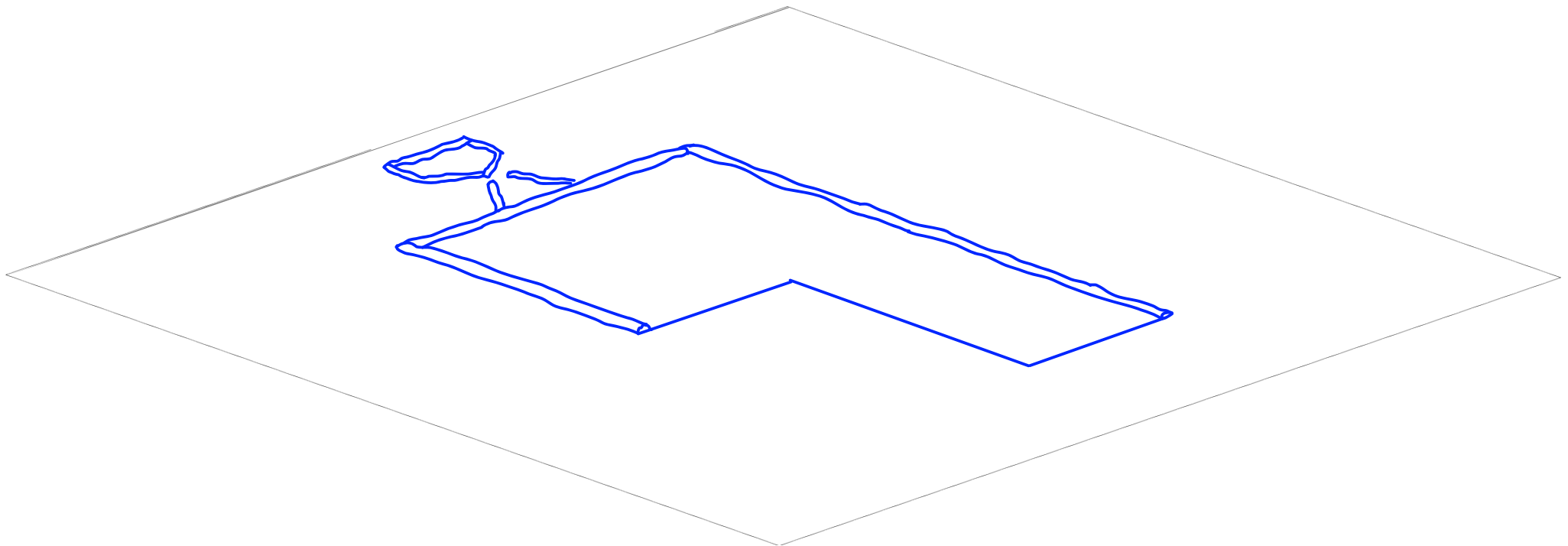
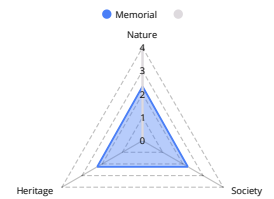
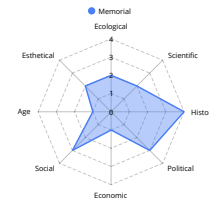

II) Military

Maintenance & Renovation

This scenario reuses the shelters in its original function by sheltering airplanes.

Evaluation shelter

Intervention:

- 0% Removed & 0% Added
- Method IX

Public/Private

- Private

Occupation:

- Whole year round
- 00:00-24:00

Heritage & Utrechts Landschap

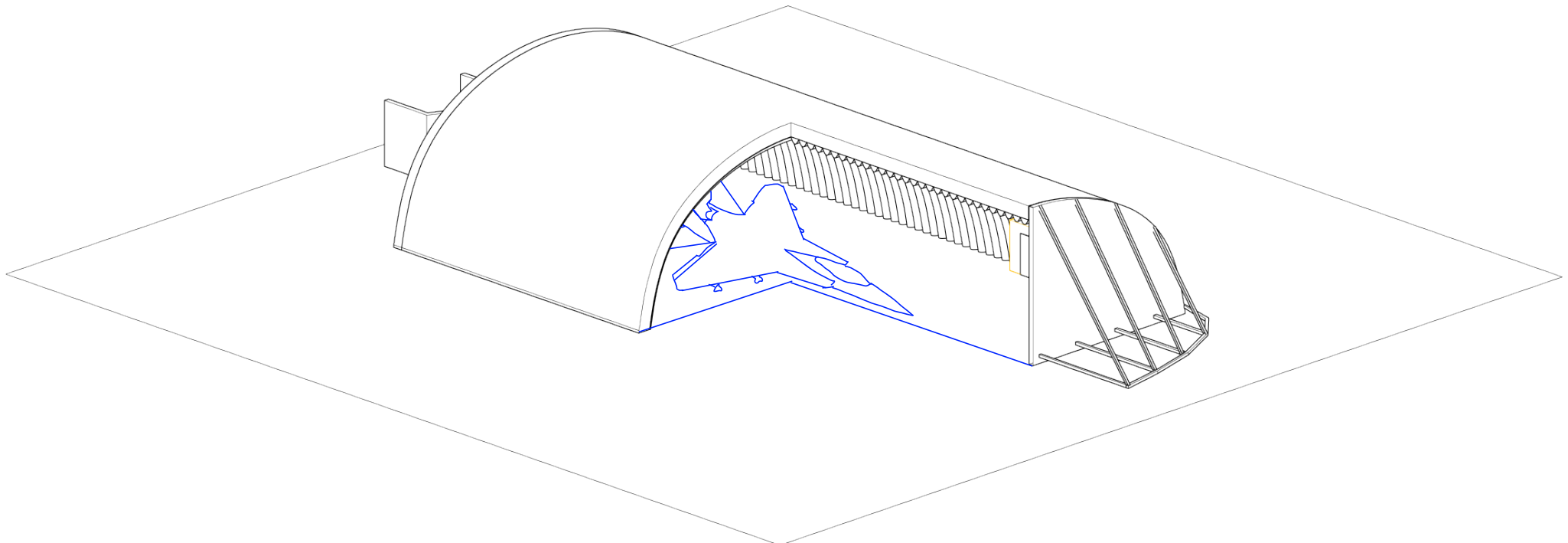
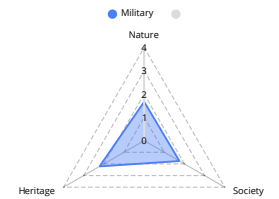
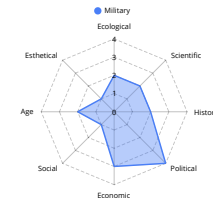

III) Animal Shelter

Behavior & subtraction

This scenario is aimed at the animals of the site. By closing the shelters and creating smaller openings on the side, animals can take shelter. Furthermore the shell is adjusted so that plants can grow there

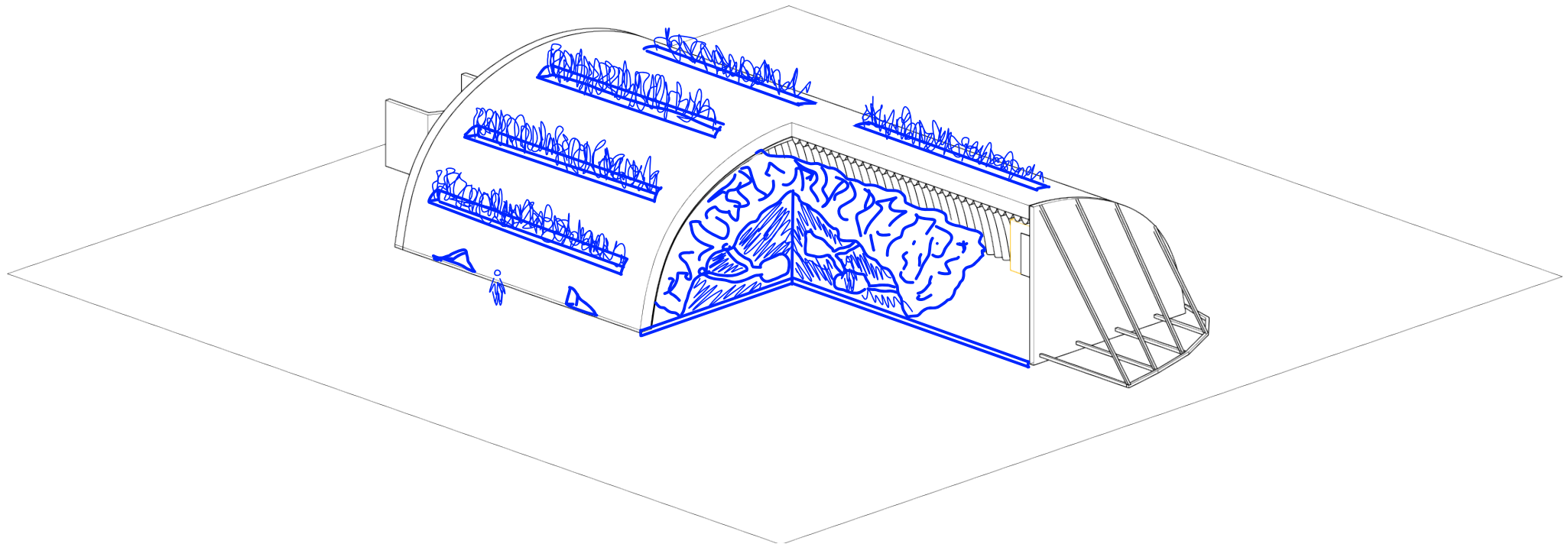

Evaluation shelter

Intervention:

- 15% Removed & 0% Added
- Method I

Public/Private

- Private

Occupation:

- closed all year
- closed

Heritage & Utrechts Landschap

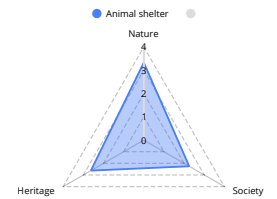
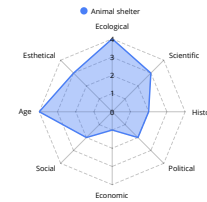

IV) Shroom farm

Behavior & conversion

For this scenario the shelter has been converted into a mushroom farm. The darkness and inside atmosphere of the shelter is ideal for mushroom agriculture.

Evaluation shelter

Intervention:

- 0% Removed & 20% Added
- Method III

Public/Private

- Private

Occupation:

- Mon-Sat
- 09:00-17:00

Heritage & Utrechts Landschap

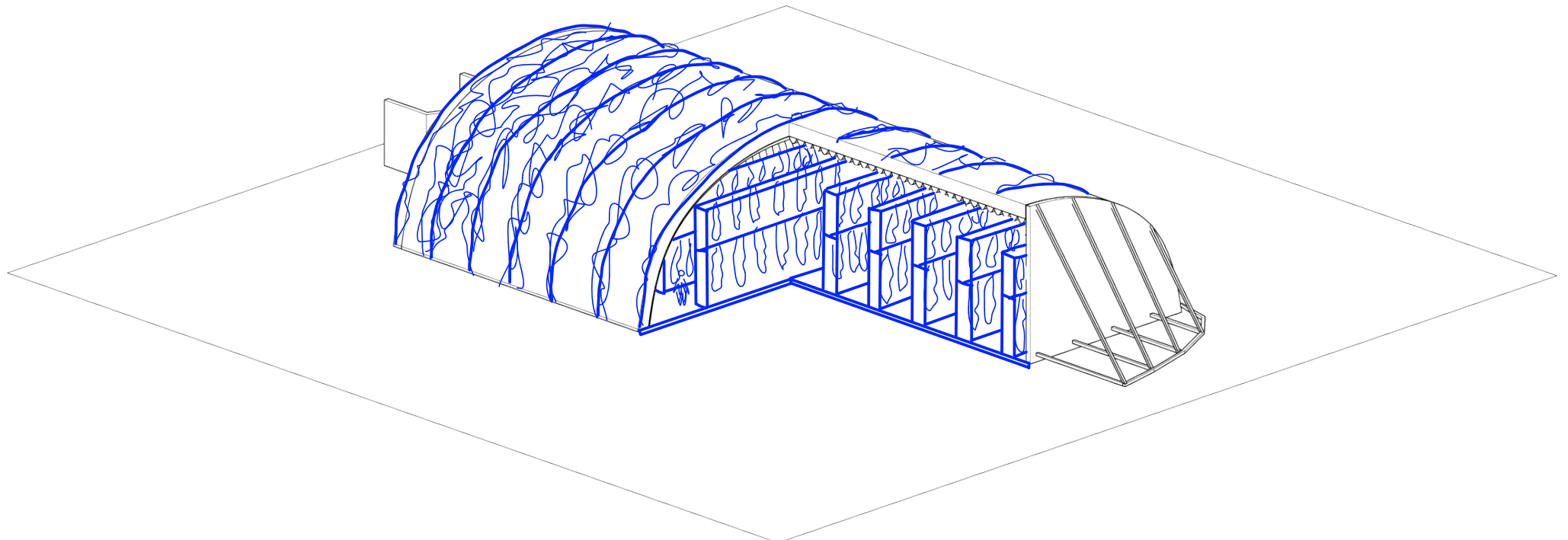
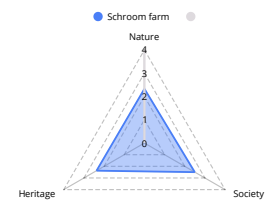
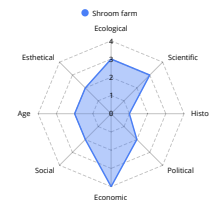

V) Chapel

Behavior & conversion

This scenario started from the special spatial qualities inside of the shelter. When seen from a different perspective these qualities seem alike to a church. Raising the question how could a place of contemplation and ceremony be created in such a shelter.

Evaluation shelter

Intervention:

- 10% Removed & 50% Added
- Method I, II, IX & X

Public/Private

- Semi Public

Occupation:

- Few times a week
- 09:00-14:00 & 17:00-22:00

Heritage & Utrechts Landschap

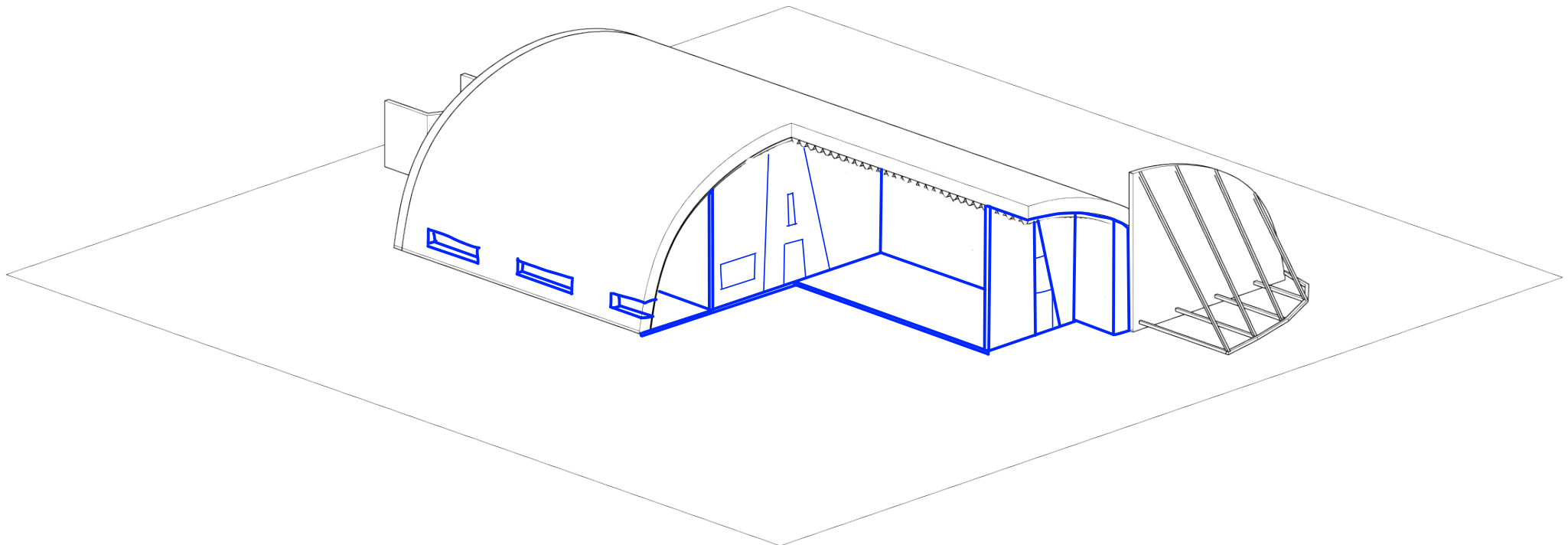
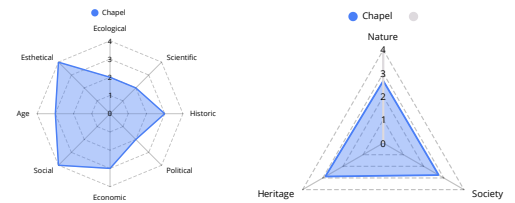

VI) Columbarium

Conversion & Subtraction

This scenario opens the sides of the shelter and turns it into a canopy. Creating a covered area connected to the nature around it ideal for a columbarium

Evaluation shelter

Intervention:

- 50% Removed & 30% Added
- Method IV, V & IX

Public/Private

- Public

Occupation:

- Whole year round
- 08:00-22:00

Heritage & Utrechts Landschap

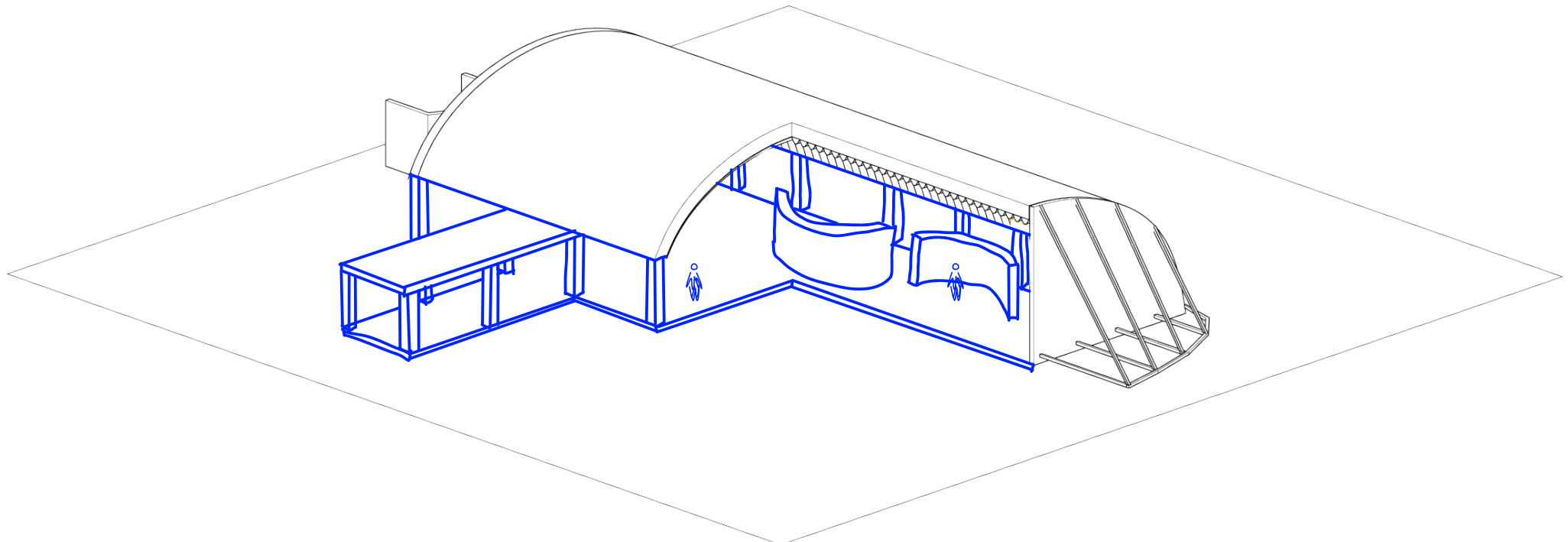
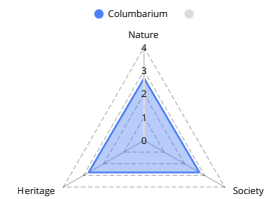
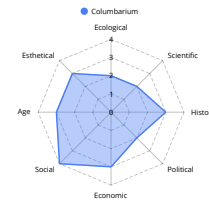

VII) Food hall

Conversion & Subtraction

By opening the roof and placing street like food stalls a food hall can be created in the shelter. This scenario could create attention to biological food production and urban agriculture by eating biological food in the middle of nature.

Evaluation shelter

Intervention:

- 45% Removed & 50% Added
- Method II, V & VII

Public/Private

- Semi-Public

Occupation:

- From spring till autumn
- 11:00-01:00

Heritage & Utrechts Landschap

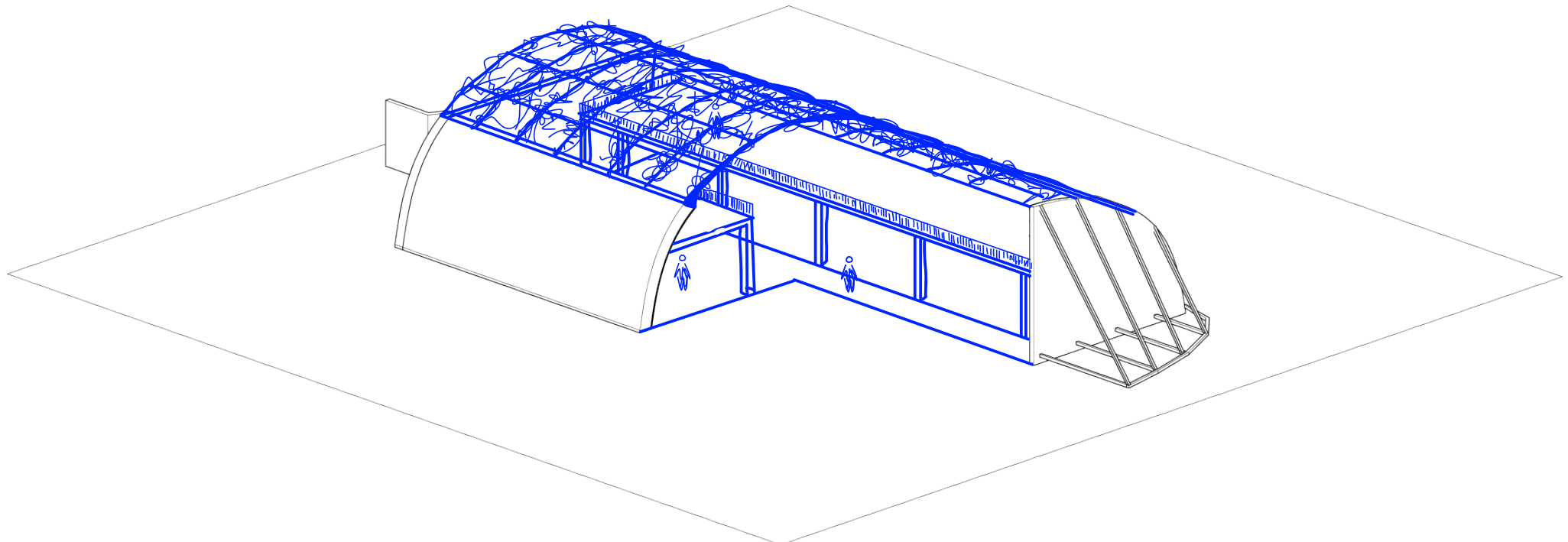
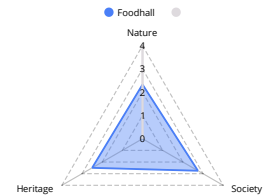
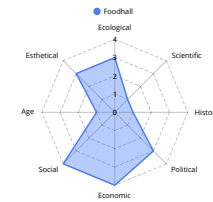

VIII) Swimming pool

Conversion & Addition

The original Wonder Building structure was often used for swimming halls. This scenario converts the shelter into an olympic swimming pool.

Evaluation shelter

Intervention:

- 30% Removed & 60% Added
- Method I,II,IV,V

Public/Private

- Semi-Public

Occupation:

- Whole year round
- 07:00-21:00

Heritage & Utrechts Landschap

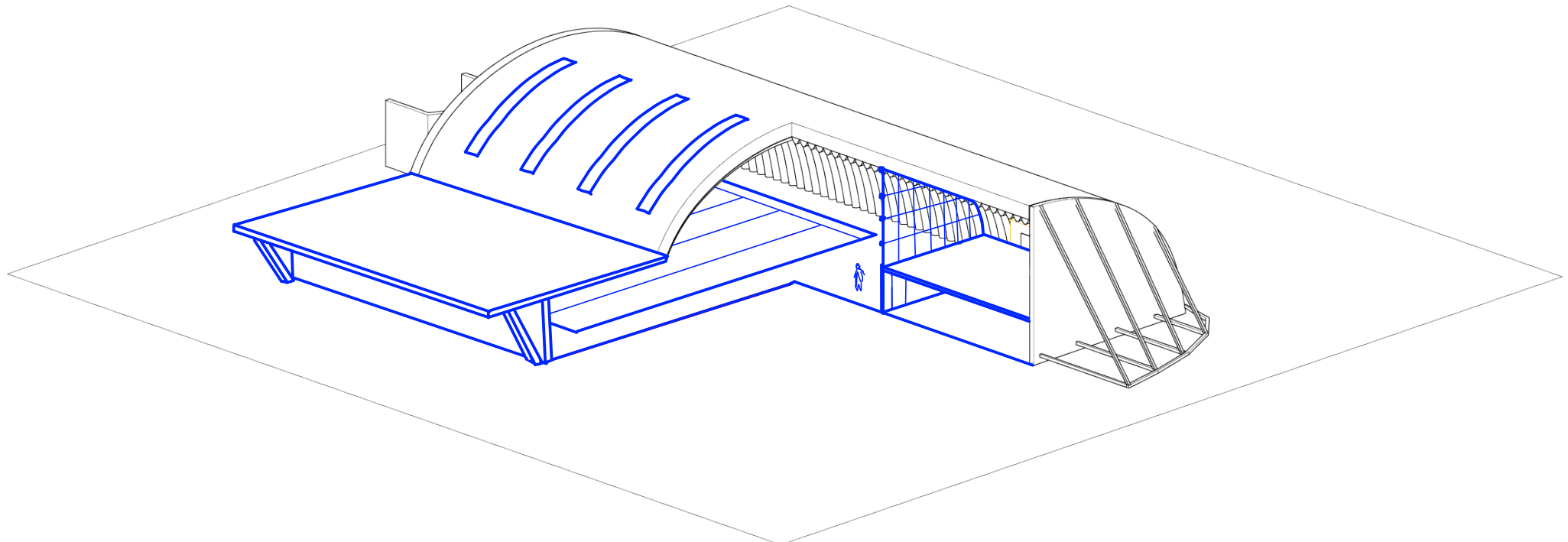
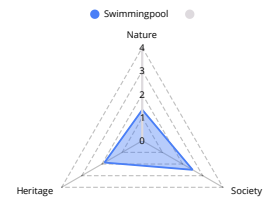
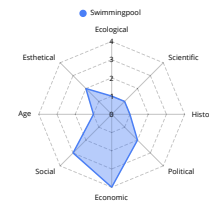

IX) School

Redesign & subtraction

By removing slices of the shelter and placing a separate structure inside a unique building is created. This scenario puts a school within this shelter having a good connection with the nature as well as some flexible covered outside space.

Evaluation shelter

Intervention:

- 35% Removed & 60% Added
- Method III & V

Public/Private

- Semi Public

Occupation:

- Mon-Fri
- 08:00-16:00

Heritage & Utrechts Landschap

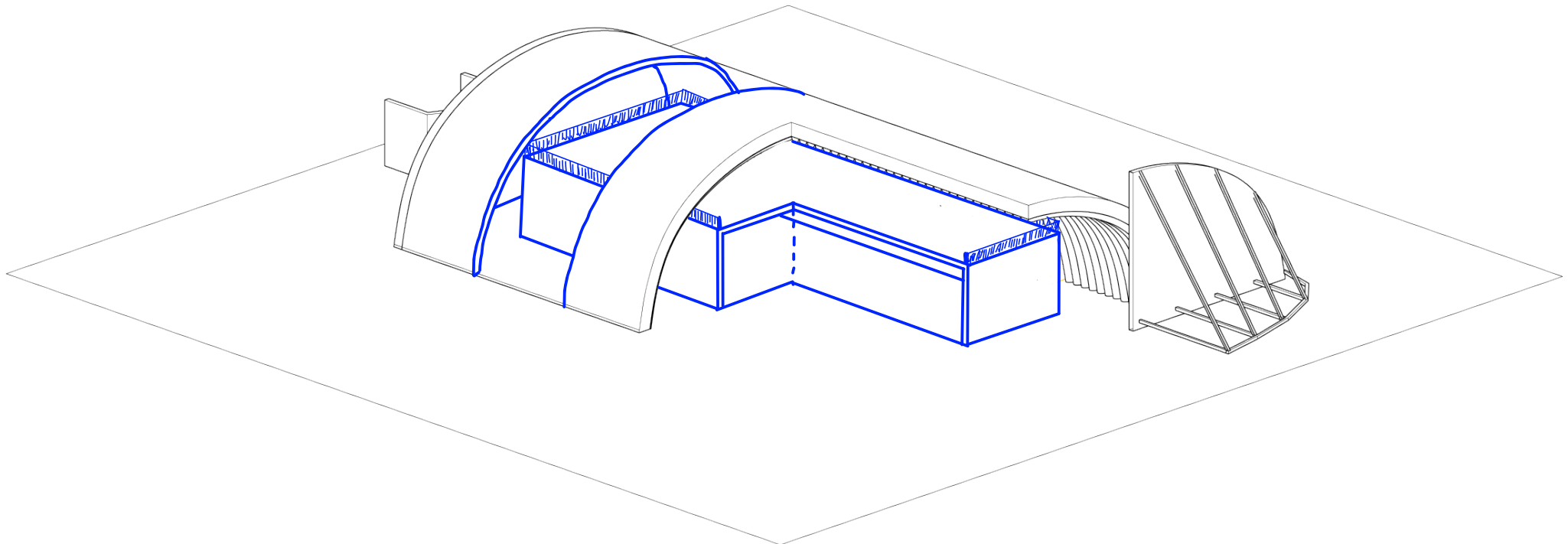
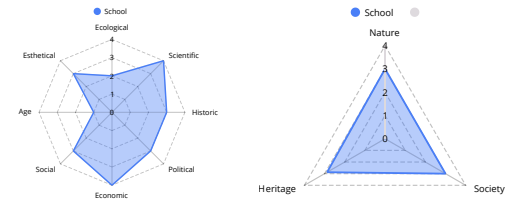

X) Housing

Redesign & subtraction

This scenario creates 8 houses with a floor area of 120m². Due to the sloped roof enough light and air can get into the homes.

Evaluation shelter

Intervention:

- 35% Removed & 60% Added
- Method III & V

Public/Private

- Semi Public

Occupation:

- Mon-Fri
- 08:00-16:00

Heritage & Utrechts Landschap

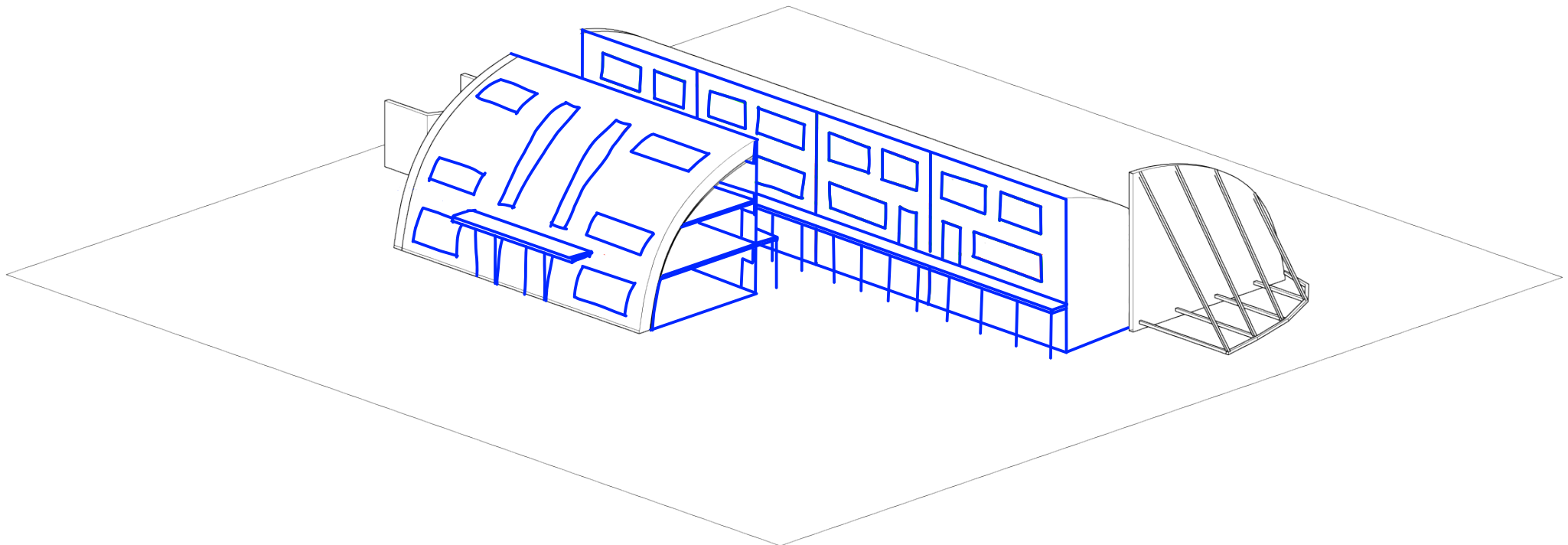
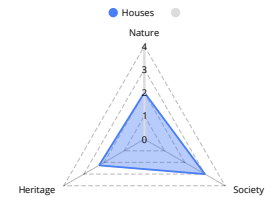
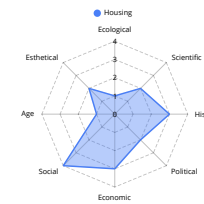

XI) Event ruin

Infill & subtraction

This scenario begins with the creation of a ruin after which the remaining ruin will be filled in with a separate structure. This way a large outdoor area is created which can be used for events and at the same time there is a smaller indoor area also open for events and to support the activities on the square in front.

Evaluation shelter

Intervention:

- 75% Removed & 40% Added
- Method IV,V, IX & X

Public/Private

- Semi Public

Occupation:

- Wed-Sun
- 12:00-02:00

Heritage & Utrechts Landschap

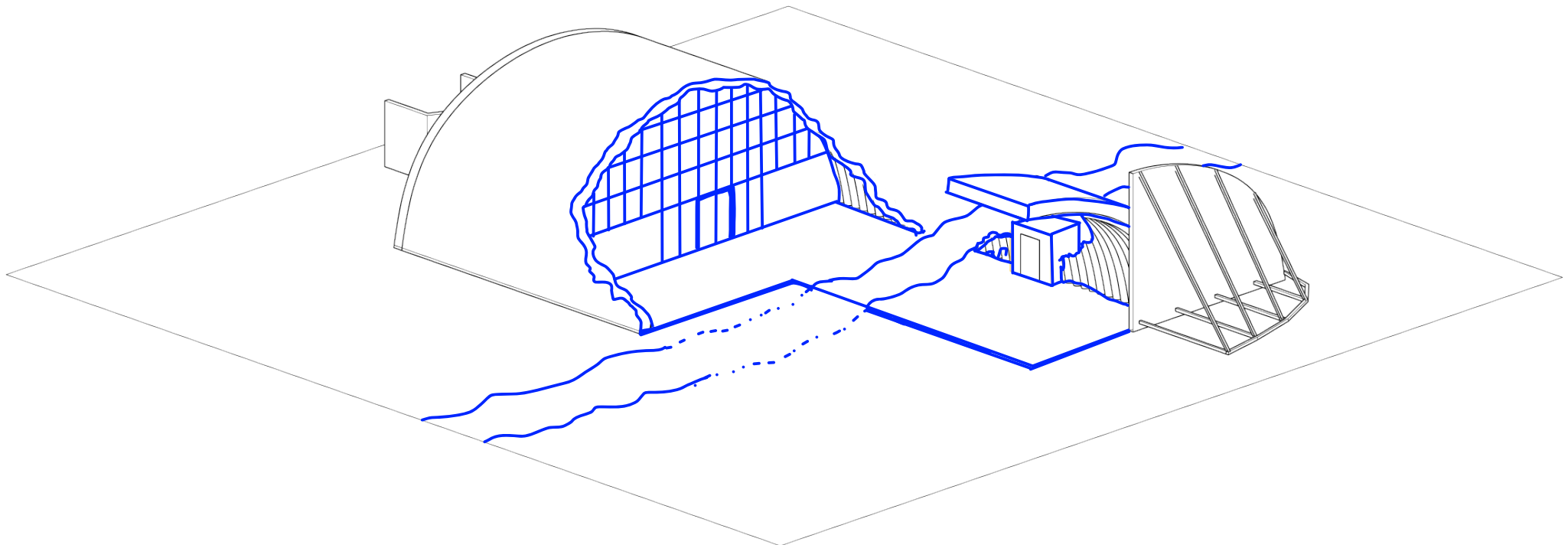

XII) Restaurant

Gestalt recycling

In this scenario a large part of the shelter is removed and replaced with a contemporary redesign in glass. Creating an ideal space for a restaurant with a beautiful connection to the outside

Evaluation shelter

Intervention:

- 80% Removed & 80% Added
- Method IV,V

Public/Private

- Semi-Public

Occupation:

- Wed-Sun
- 14:00-24:00

Heritage & Utrechts Landschap

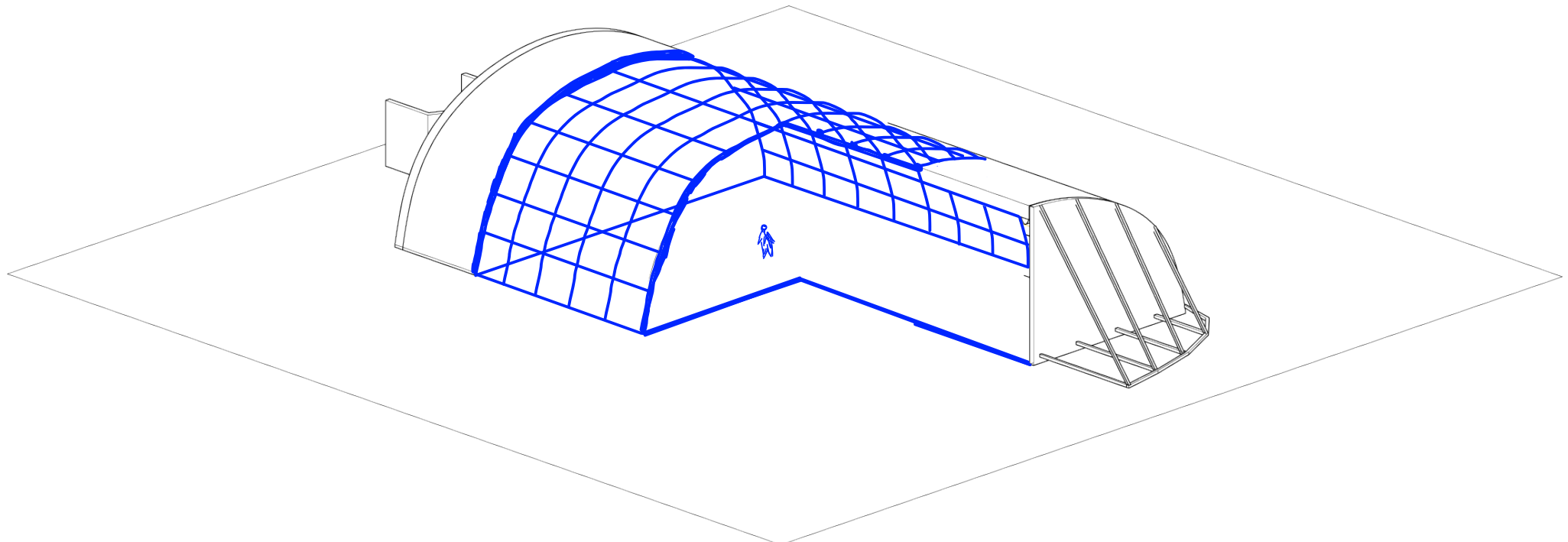
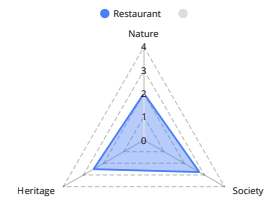
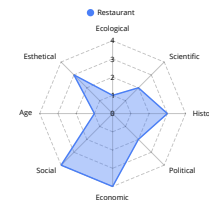

Developed design

How does a further developed scenario look like? How will certain interventions be realized? What kind of sustainability methods will be applied?

Naturbegraafplaats 'de Schuilplaats'

Perception & Conversion

The developed design is a natural burial cemetery called 'de schuilplaats'. It evolves the shelters that are now given back to nature by Utrechts landschap and it applies multiple strategies. Scenario's V, VI and XI are incorporated and XI is further developed.

The shelter is reinterpreted as a sacral space and split up into a large ceremonial space, two thematic hallways and a cafe. An important theme is lighting and the connection with the nature outside. The construction is of CLT and the climate strategy is box-in-box.



Evaluation

The developed design is evaluated on sustainability through the wilderness-based checklist

Wilderness-based checklist:

- 1. Create pur air
- 2. Creates pure water
- 3. Stores rainwater
- 4. Produces its own food
- 5. Creates rich soil
- 6. Uses solar energy
- 7. Stores solar energy
- 8. Creates silence
- 9. Consumes its own wastes
- 10. Maintains itself
- 11. Matches nature's pace
- 12. Provides wildlife habitat
- 13. Provides human habitat
- 14. Moderates climate and weather
- 15. ... And is beautifull

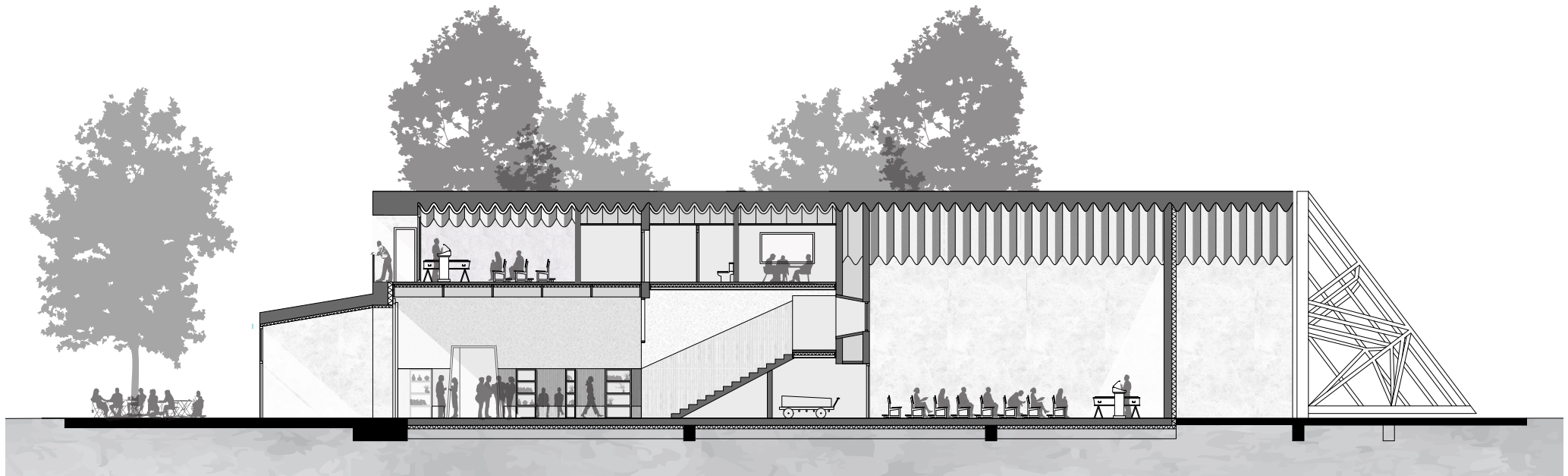

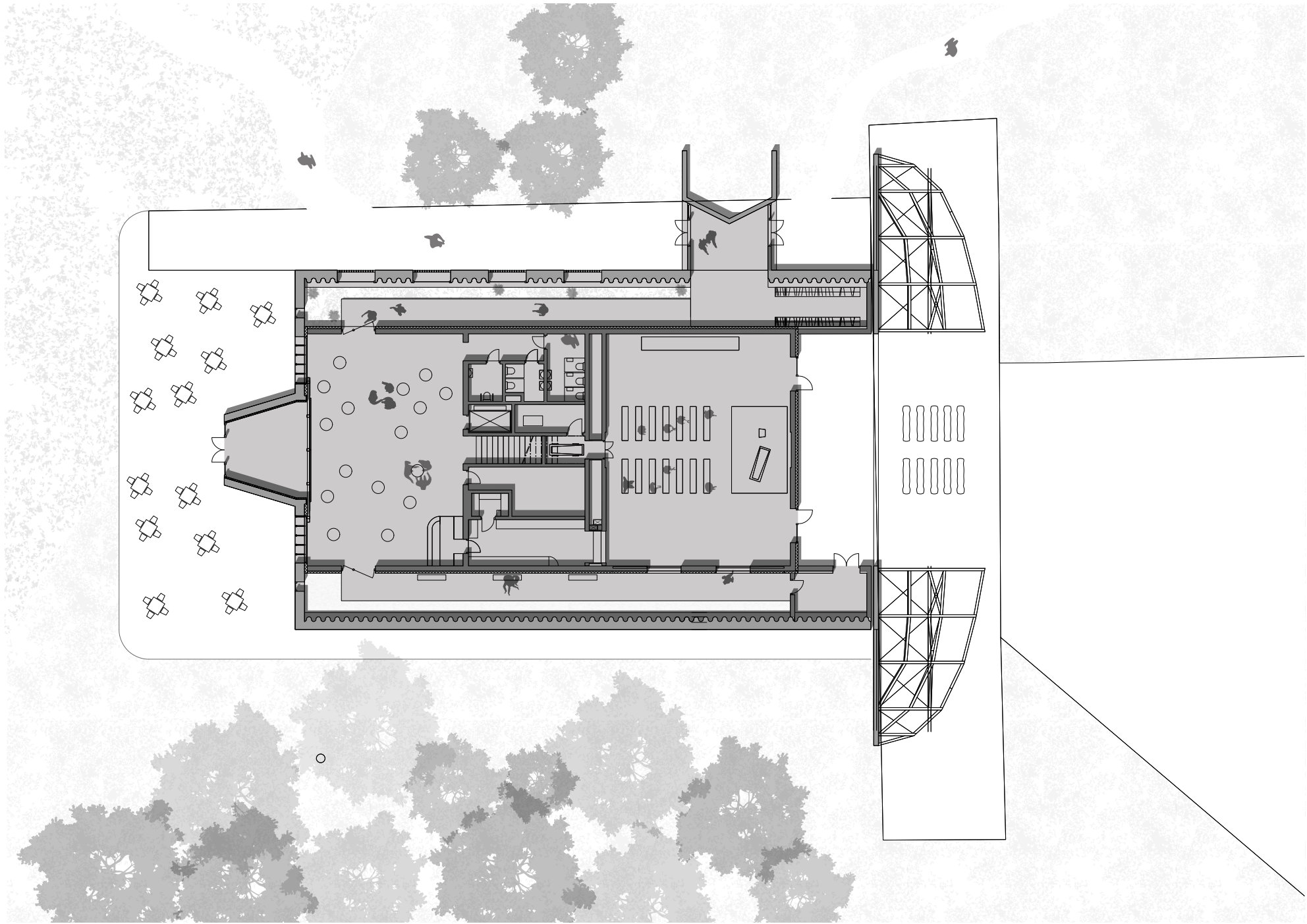

Comparison

What are the similarities and differences between the scenarios?
Are there any remarkable results?

Comparison

Heritage values

The evaluation of the scenarios show how certain functions and interventions impact the heritage values. Two examples are the shroom farm and the ruined park. The shroom farm is purely economic and a bit scientific but it denies the history, age and social values. The ruined park on the other hand strengthens the age, historic, aesthetical and ecological values but it decreases the economic value.

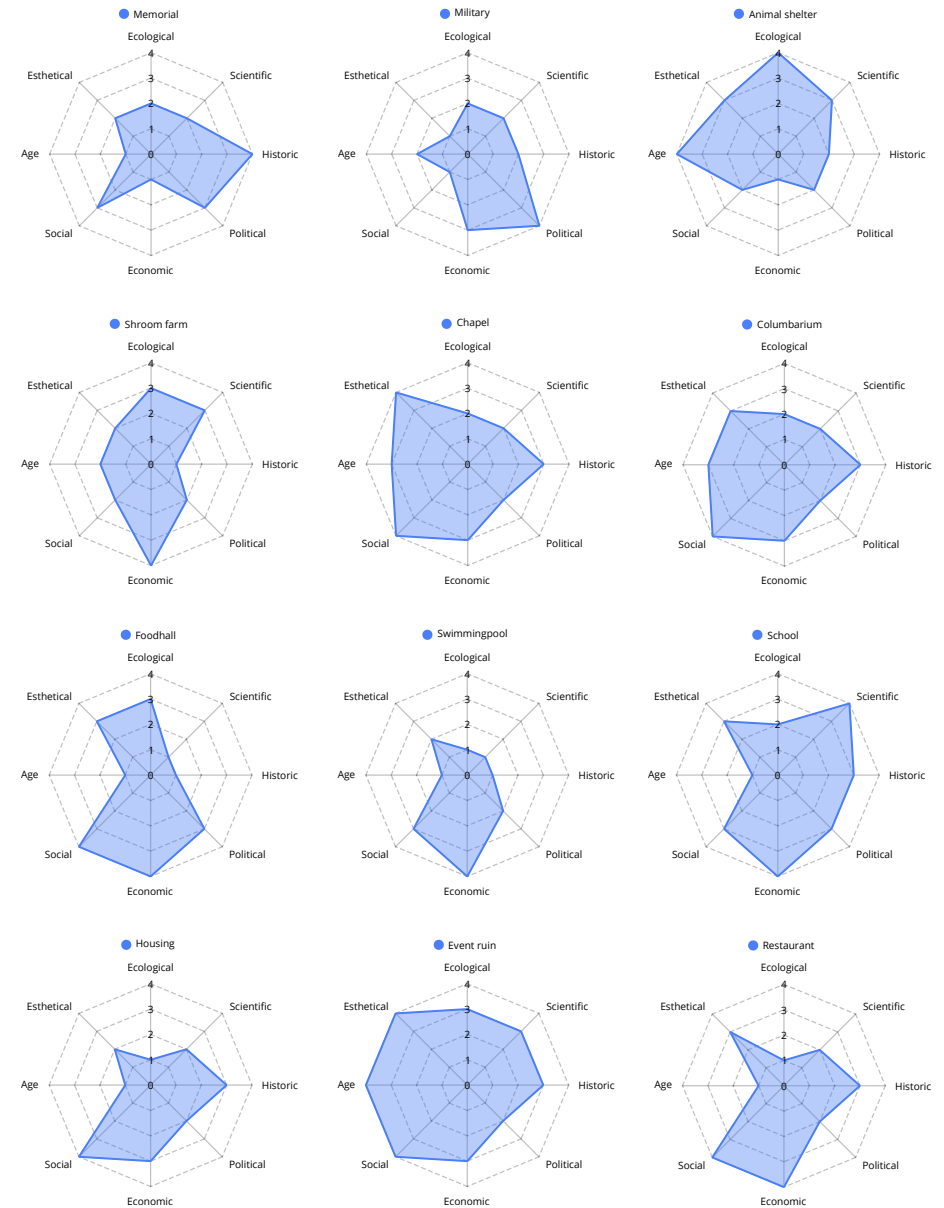

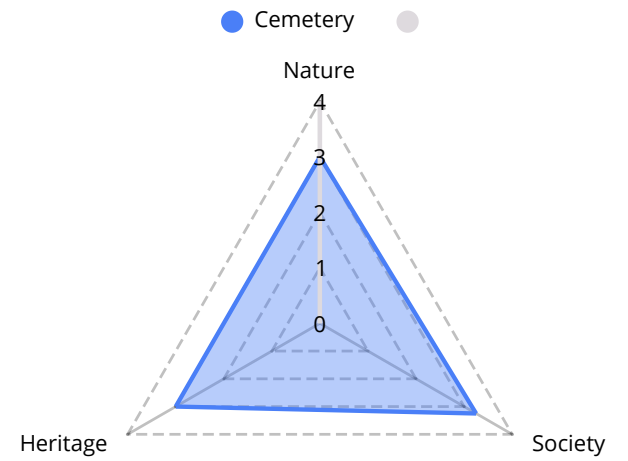
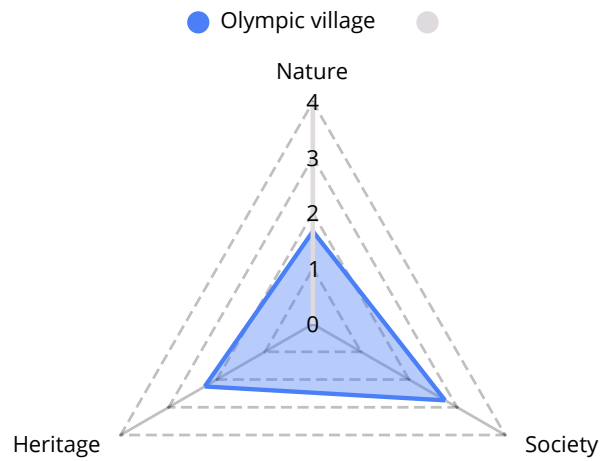
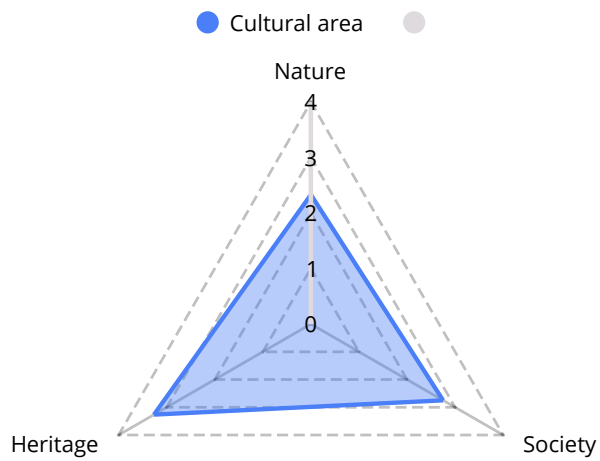
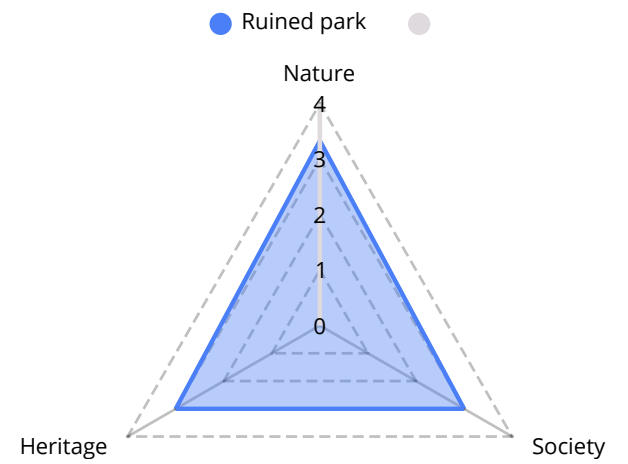
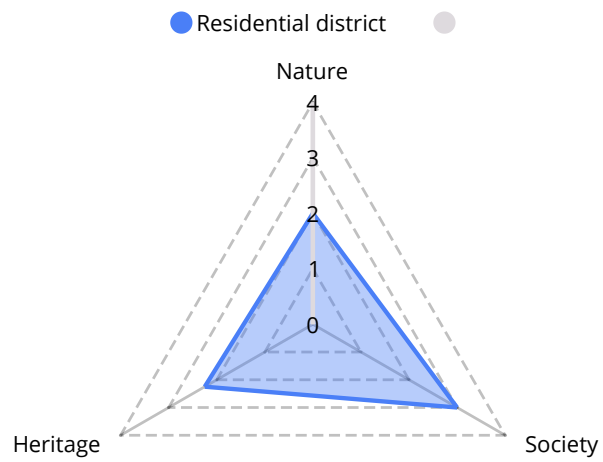
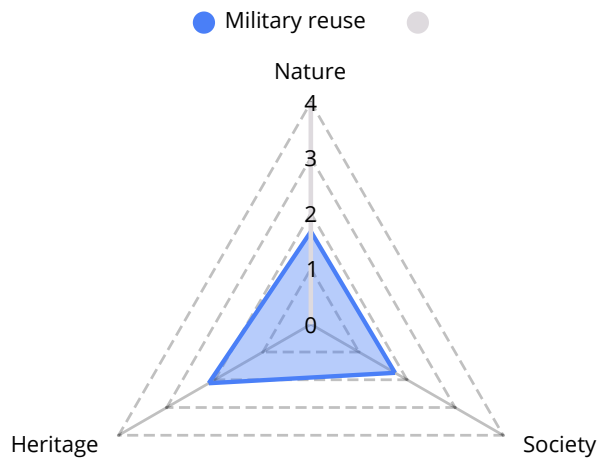

Utrechts Landschap's values

These graphs show how much it aligns with the values of Utrechts landschap. The swimming pool for example is primarily focused on society and doesn't align with the heritage and nature value.

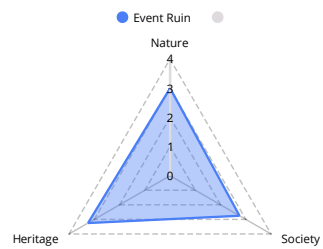
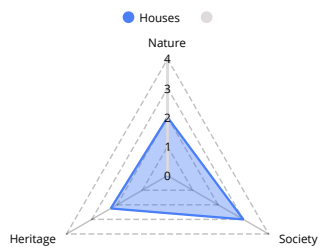
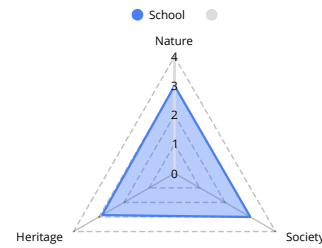
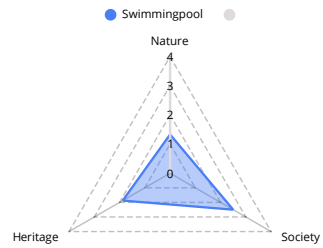
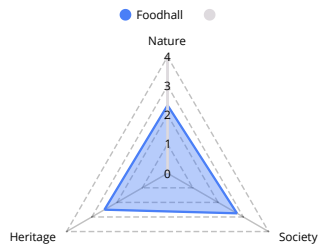
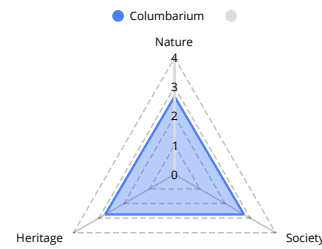
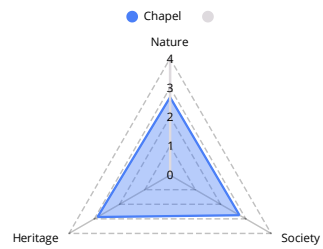
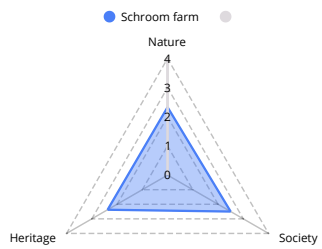
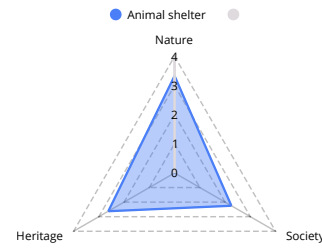
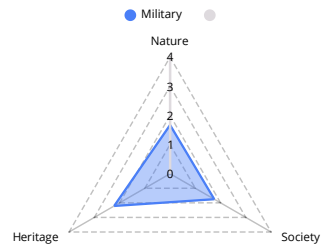
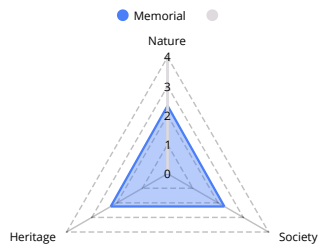

Conclusion

Which scenario fits best? What are the main takeaways? Which lessons can be applied to different locations?

Conclusion

Heritage values

For the Shelter area at soesterberg the best scenarios would be a ruin park, event ruin or a natural burial cemetery. These scenarios fit the demands best and overall improve the most values. However this is also because the nature value is strongly taken into account, if there would be more room for different functions then the cultural area or the school would be a good option. These two scenarios can strongly link back to the historic and cultural past and at the same time work together with the existing nature.

The results can not be randomly applied to other shelters at different airbases for its important to first define the values and criteria of that specific site. Still some lessons can be learned from this toolbox for other locations.

First of all the terminology and strategies. Secondly there are multiple ways of adapting the structure while maintaining the overall shape and appearance. The challenge however is to truly incorporate the shelter in the design and connecting it with its identity. Thirdly there are different strategies that can lead to the same result so try not to limit yourself to one strategy. For example the memorial and the school both improve the social and historical value in completely different ways.

Hopefully this toolbox helps to ignite the discussion on how we should deal with these shelters. As well as inspire stakeholders, architects and the government of all the possibilities.

