



ITEMS THAT

MARK

THE URBAN ROOM

KLAAS MELLE
BROUWER

NINA
AALBERS

DWELLING
11.01.'12

PREFACE

In each city, one will find a series of urban places in which the distinction between private and public is defined in different ways. For example, one will find that a sidewalk in the Netherlands usually belongs to the passer-by, whereas in Japan it is often used as a front garden for the dweller. The rules for occupation of urban spaces are made explicit by the objects that are present: fences, greenery, walls, and etcetera.

When we visited the location of our graduation project, Varallo in Sesia Valley, we noticed the differences in this subject in comparison to the urban places we know very well in the Netherlands. We got fascinated by these differences and the difficulties in the way users understand the language of a city.

This report provides insight into our research on the 'items that mark the urban room'. The aim of this research is to gain different means for architects, which can be used for communication about what a place is meant for, while designing the urban environment. The research is part of our graduation project 'Living in Sesia Valley' within the department of Dwellings at the Faculty of Architecture, TU Delft.

The report consists of 3 different parts: the introduction of the theme and method, the analysis in two categories and the conclusion and reflection.

Since we had a different starting point for this research, we described our individual problem statement before writing the common theme. The social relevance, aim and research question are distilled from this theme, which all are underpinned by definitions. In the method we described the different steps we took during the research process, followed by the study cases we chose.

The research report itself consists of the different case studies. We chose medieval and urban projects and made an analysis of their context and of two photos, taken in different urban places that were the result of these projects. The items we found are categorized by their impact on the character of the places. We brought them together in schemes to divide them by the subjects symmetrical/asymmetrical, formal/informal, borders/transition zones and movement/place, to draw conclusions about their influence on the character.

As the first designers to use this set of tools, we already have some suggestions for improvement of the method we used, as can be read in the reflection. Though, we are convinced that we found a lot of interesting tools to use while designing the urban environment.

Nina Aalbers

Klaas-Melle Brouwer

Master Graduation Studio Dwellings Living in sesia valley 11-2011

Faculty of Architecture, TU Delft.

TABLE OF CONTENTS

PREFACE.....	2
TABLE OF CONTENTS.....	3
RESEARCH QUESTION KLAAS-MELLE BROUWER.....	4
RESEARCH QUESTION NINA AALBERS.....	6
COMMON GROUND.....	8
THEME.....	8
RELEVANCE.....	9
RESEARCH QUESTION.....	9
AIM.....	9
DEFINITIONS.....	10
METHOD.....	12
LEGENDA ITEMS.....	14
PARAMETERS.....	16
MEDIEVAL URBAN ROOMS.....	18
VIA ALBERGANTI VARALLO.....	20
BORNHOFZUTPHEN.....	26
SHINBASI DORI KYOTO.....	32
COMPARISON MEDIEVAL ROOMS.....	38
CONCLUSION MEDIEVAL ROOMS.....	40
MODERN URBAN ROOMS.....	42
GUIDECAVENICE.....	44
SCHUTTERSVELDDELFT.....	50
SEIJO TOWNHOUSES TOKYO.....	56
COMPARISON MODERN ROOMS.....	62
CONCLUSION MODERN ROOMS.....	64
FINAL CONCLUSION.....	66
REFLECTION.....	67
REFERENCES.....	68
JUSTIFICATION OF IMAGES.....	69

KLAAS-MELLE BROUWER

QUESTIONS

INTRODUCTIE

For our final thesis project we went for 10 days to Varallo. An old medieval city in Nord Italy, situated in a valley called as the river that runs through it, Sesia.

Walking through these streets you get surprised each corner you cross, each bend you take.

New even more decorated balcony's, small streets and alley's have been waiting there for you.

There is so much happening in these streets just in the urban interior, it even attracts a lot of tourists to these old town centre's in Italy.

Back in Holland starting the research I visited the recently build town of Ypenburg just East of The Hague. I was shocked in how plane we make our newly build streets here in Holland.

They are sometimes so amazingly boring or desolate places and that is just what we build a few years ago.

The Danish sociologist Jan Gehl wrote about this in his book "life between houses"

"Het is fijner zich te bevinden in een kromme straat, waar alle gebeurtenissen zich afspelen tegen een wisselende decor, dan in een kaarsrechte straat. Zo is het ook gemakkelijker zich te bewegen in een 'gemeubileerde' ruimte dan in een lege..."

When looking better to what is happening between the houses in several contexts and cultures you find a lot of differences (ofcourse!). I wonder, if you look to the several elements that or combined in these space, you will find rules for quality or the lack of it.

FASCINATION

Before starting the research we looked to a lot of different spaces that could be part of our research.

What amazed me is that the better decorated (the way things are put to place) a urban interior space is the better it seems.

Many of these spaces are really well made for their public purpose that we like them.

*"De middeleeuwse stad bestaat niet primair uit gebouwen maar veeleer uit straten en pleinen, omdat de gebeurtenissen zich in ruimten afspelen, de gevels vormen het decor."*²

The space gives the rules for the people using it and when these rules are clear people unconsciously seem to like this.

*"it must be remembered that equally as important as buildings is the space between them and the use to which it is designated"*³

But looking further I think it is very important how the transitions between the several elements work.

How strong are the borders between a street and a sidewalk for instance. Or between a lawn and the entrance step of a house. Looking from the public toward the front door of a house.

Next to that I like to count the several transitions but looking better to that I wonder if the size of these zones is not important as well.

The last is hard to say and really dependant on the kind, how this element is made and used. A combination of several elements can enstrengthen a transition zone, but maybe does what a single element could have done as well.

1. J. Gehl, 'Het leven tussen huizen' p. 36

2. J. Gehl, 'Het leven tussen huizen' p. 27

3. P. Smith, 'The dynamics of Urbanism' p. 9

4. <http://www.comuni-italiani.it>

TARGET

There is much to say about the decoration of urban interiors and how they work. This makes it hard to focus on the essence or only a few questions.

In my target I only try to focus on the several elements that I will find in casestudies and how they are designed.

The target of the research should than be:

To understand how the transitions between public and private spaces are designed in the urban interior.

PROBLEM STATEMENT:

With a project in Italy we have to understand that this land is going towards years with economical cutbacks. Next to that is the region, Sesia Valley, a region that is already partly shrinking in population numbers. Next to that the average age is 47 and young people leave for cities like Novarra, Vercelli, Turin and Milano. ⁴

Looking to Varallo and our project-location we see that the qualitative 'urban-rooms' abruptly come to an hold next to this project location. An old existing hospital building that can't be entered publicly, the above facts are a good basis for this location.

I think this side should attract inhabitants but visitors to Varallo as well in stead of being an empty building. Making this site publicly accesible and connect it to the city and its public live.

QUESTIONS

Like you read before there are a lot of questions to ask about the transition zones in the urban interior. But in the end I only focused on some of them. Since I focus on the transition zones in the urban interior I think the main question for me should be:

What are the transitions in the urban interior between the public and private space?

- o What kind of transitions are there and how strong are the borders between these transitions?

LIST OF REFERENCES

J. Gehl, 'Het leven tussen huizen, Köln, Taschen, 2004

P. Smith, ' The dynamics of Urbanism' London, The Anchor Press Ltd. ,1974

<http://www.comuni-italiani.it>

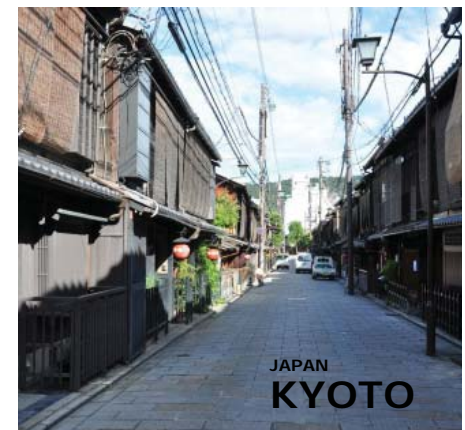

NINA AALBERS

INDIVIDUAL RESEARCH QUESTION

Valsesia is a valley with a range of qualities. It lies in between the mountains, which are full of nature. It holds culture and history, especially displayed on the Sacro Monte, and it is arranged by the river Sesia that brought the valley into being. But the number of inhabitants in Valsesia is shrinking. The main question for our design studio is, how can we get the best out of this development? Should we put up a fight against it or should we guide the process of shrinking, to take care of a positive outcome?

Krimplab, a Dutch design lab specialized in shrinking areas, provided a range of recommendations for this design issue. Some of these are that we should expose remarkable spatial qualities and interweave buildings and landscape. That would strengthen the image of the area, to attract and retain inhabitants. The process of shrinking is also articulated as a chance to leave space for new types of dwelling, and to create a suitable mix of care, dwelling and economy.

Besides the negative consequences of the inhabitants moving away from the valley, shrinkage also leaves space for new opportunities. We can take advantage of the vacant space, to focus on the quality of living. We should design for a smaller amount of people, but we have to do it better. My challenge in this project for the city of Varallo, lies in the search for the quality of the Varallo-house. To uncover its qualities I intent to examine the play of private and public, of front and back. My special interest lays in the position the particular house in this play, which is always present in Varallo.

BODY METAPHOR

Bloomer and Moore describe two ways to experience the built environment. One of them is by using the Cartesian system, "in which the spatial relationship of things can seem much more precise, even as the quality of location is safely ignored. This system can locate precisely any point along x, y and z axes even as it renders all the possible points somehow the same" (1977: 1). This system is implemented in our way of seeing three-dimensional objects, as we recognize in the way we measure and model architectural projects at our faculty. Before building a house, we first make a ground floor plan and a section to tell the builders what material to use and what the demanded measurements are in width, length and height (x-y-z).

When we only look at a place as a builder would do, by using this Cartesian system, the way we experience a place is easily neglected. To make the distinction between the way we measure and build the environment and the way we see it in relation to our own being, Bloomer and Moore describe the meaning of the free-standing, single-family house to the way we understand our surroundings. It is their sign of "[...] a world based not on a Cartesian abstraction, but on our sense of ourselves extended beyond the boundaries of our bodies to the world around: that is the single-family house, free-standing like ourselves, with a face and a back, a hearth (like a heart) and a chimney, an attic full of recollections of up, and a basement harboring implications of down." (1977: 1). When we look at it that way, our houses can be seen as the position we take in the world.



The image of a face



Common boundary

A single-body metaphor for one or more persons.



The comfort zone

The boundary of the parcel



Body in control

The home of King Louis XIV

The relation between the words face and façade is no coincidence. With the front façade we show a face towards the rest of the world. This is very directly shown by the image of a house in children's drawings, which most of the times look like the image of a face in itself. And less explicitly, by choosing the amount of openings we determine the relation between our private places and the rest of the world. The façade gives a glimpse of what could be going on inside the private place of our houses, just as our faces show what we feel inside.

We find another example of the relation between the free standing house and the way we position ourselves in the world, when we compare the way the house is positioned on its parcel to the comfort zone of people. In traditional houses the small front garden shows that the front façade is closely related to the outside world whereas the back garden, which is often used for private activities, creates more distance between house and outside world.

In the case of the traditional free-standing family house, we can conclude that we relate architecture to our own bodies and the relation with the outside world. "Its power, surely, comes from its being the one piece of the world around us which still speaks directly of our bodies as the center and the measure of that world" (Bloomer and Moore, 1977:4). Though, the relation between human and built bodies recurs in many examples in architecture: churches with the proportions of the human body; the sky-scrapers on the cover of Koolhaas' *Delirious New York*, lying in bed; the palace of king Louis XIV, centralized in the town of Versailles to show his control towards the surroundings.

LEGIBILITY OF THE CITY

As concluded before, the way we give form to our houses illustrates how we position ourselves in the world. The language we use to communicate our relation with the outside world is different in each city, so one could say each city has its own language. The more clear this language is for the passers-by, the more easily the places between houses can be understood. In relation to this subject, Kevin Lynch describes the idea of a legible city: "... a legible city would be one whose districts or landmarks or pathways are easily identifiable and are easily grouped into an over-all pattern" (Lynch, 1960:3). He sees this legibility as an important factor of the well-being of the inhabitants of the city: "A good environmental image gives its possessor an important sense of emotional security. He can establish an harmonious relationship between himself and the outside world. This is the obverse of the fear that comes with disorientation; it means that the sweet sense of home is strongest when home is not only familiar but distinctive as well." (Lynch, 1960:4-5).

PROBLEM STATEMENT

As stated before we relate our own bodies to the body of the house, and the position of our house to our position in the world. The distinction between front and back takes an important part in this issue. As Bloomer and Moore state it: "Front is the orientation toward mobility and is imagined perhaps too moralistically, to signify strength and virtue, while back has private and earthy (spatially lower) implications. This psychological debasement of the back illustrates again the distinction between the body image and the physical body. It seems to derive from the fact that most of the sensory apparatus is forward and high up on the face, while the regions of the back have fewer defences and possess more private and lower functions." (Bloomer and Moore, 1977:41). Within urban places seem to be general agreements about what is front and what is back, and hereby which are the private and the representative side of a building. Architecture can be a tool for communication to make this distinction clear. My interest lies in the different ways this communication works, how people would 'read' the language of a city and how architects can create a legible city.

QUESTIONS

- When do we generally read the frontside as a front and the backside as a back, when looking at a dwelling?
- Is there any common pattern to be found in the difference between front and back?
- Does every dwelling have a front and a back or can it be all-round (turned towards all sides)?
And leads this to a better dwelling or not?

And related to architectural design:

- Is differentiation of front and back within a dwelling desirable?
- How to create a front- and backside that are legible as such?

REFERENCES

Bloomer, Kent C., Moore, Charles W. (1977) *Body, Memory, and Architecture*; Yale University Press, pp. 1-4, 41
Lynch, Kevin (1960) *The image of the city*; Massachusetts: The MIT Press, pp. 3-5
Krimplab: coop. BNA, Stagg, Staro, Stawon, Aedes, KEI (2009) *Ruimte maken voor krimp - Ontwerpen voor minder mensen*; BNA.

THEME

"WHAT IS THIS PLACE?"

FORMAL OR INFORMAL? A PLACE FOR MOVEMENT OR TO REPOSE?

As we walk through cities we pass through a series of urban places. Each place is defined by a set of items: facades, windows, entrances, greenery, vehicles, garbage cans, and so forth. The collage of present items tells us, consciously or unconsciously, in what kind of place we are. The places seem to have rules for usage, given by the present items and elements from which the places are built up. We distill the rules for behavior in an urban place also from the way these items are organized. In the case of the surroundings of the Palazzo della Civiltà Romana the windows follow up each other in a rhythmical sequence, their sizes and the distances between them are equal. By this strict order the architect showed that he was extremely in control; there is no freedom for the users to disregard this order. Hereby he translated the political statement of his client. To go into this subject of rules for usage of public places, we draw the distinction between formal and informal places. In formal places we find ourselves controlled by a set of rules, written or unwritten. Compared to that, we can do anything we want to do in informal places.

In this research we go into the set of items that are present in different urban places. We look at these places as if they are an interior room with façades as walls, the ground as the floor and sky as the ceiling. In these rooms there are transitions made between other 'rooms' and different zones within the room. There is furniture, such as balconies and seats, the walls and floor can be clad and there is facilitation of water and electricity.

The surrounding buildings tell us something about the character of a place. Symmetry is a sign of control; irregularity shows that changes are an option. Also important for what we think we are allowed to do in a place, is the occupation by others. Another aspect of urban places is that most of them have to deal with a lot of passing traffic. People, cyclists, cars, busses and trains take a part of urban space. The urban places give direction to their movement, or tell them that the place is occupied for something else.

All these means together form a vocabulary for the language of the city. And each city has its own. As Lynch puts it: *"a legible city would be one whose districts or landmarks or pathways are easily identifiable and are easily grouped into an over-all pattern"* (Lynch, 1960: 3). In this research we dive into different languages of cities, to understand the differences and enlarge our vocabulary of means for designing urban places.

"Borders can be thrillingly abrupt when they strike the edges of grand differences; the city and the sea, the protected and the wild, the sacred and the profane. But when they reflect territorial claims that are ultimately negotiable, when they take their place in the midst of human transactions, they should generally be layered and interwoven, thick with opportunities for reconsideration."

(Moore, 1994, p. 96)



Formal? Why?



Formal? Why?

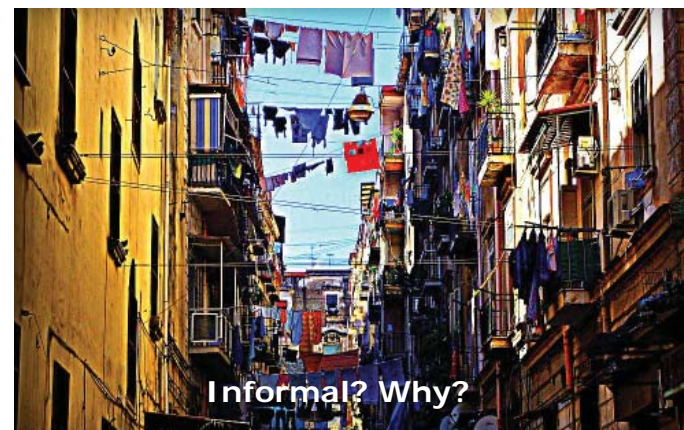

Informal? Why?



Informal? Why?

SOCIAL RELEVANCE

When looking at the public space in Ypenburg, we were wondering what this row of garbage cans is doing in front of the houses. To us it is a place without clear communication about to who it belongs and if we are allowed to use it. There is no clear public path since the sidewalk is full with the garbage cans. There is a lot of green in the middle, which could be someone's front garden, but to who it belongs is not articulated. The architect could have thought of it as a place where the whole town can go picnicking, or as a collective barrier between the different houses. Either way, we don't know what the purpose of this place is and we see this dis- or miscommunication as a missed opportunity.

As architects, we should be conscious about what we communicate with the design of urban places. With this research we bring attention to the added value of well-designed communication in urban places, and create a catalogue of means to achieve a place that communicates in a clear way about its character.

*"Can architects meet society's plural demand?
... If society has no form—how can architects
build the counterform?"*

(Van Eyck, 1962, p. 56)

AIM OF THE RESEARCH

We are interested in these aspects of urban places. How do we know where we can sit down or drive through with 120 km/h? How do we know if we are in someone's back garden or a public park? And especially, what does architecture contribute to that? The goal of this research is to find out how we understand the language of the city.

By interpreting the contra-space between dwellings as an urban room, we want to understand the differences in the **marking of places** and to draw conclusions about their character.

RESEARCH QUESTION

What are architectural and non-architectural items that mark the urban room?

- What different items do we find in the (sub) urban room?
- Where does architecture mark the urban room and where does architecture leave space for non-architectural items to mark the urban room?
- Does the presence of the different items influence the (in)formality of the urban room? Do they create rules for occupation?
- To what extent do the items indicate a place for movement or repose? And how is this division between these places arranged?



DEFINITIONS

To answer our research question - What are architectural and non-architectural items that mark the urban room? - the first step would be to define what the words 'urban' and 'room' mean to us. Besides that we categorized a lot of items and used several terms for that like, formal/informal, symmetry and asymmetry. In this way the several categories will be clearer and better to understand. We used the Oxford and Dikke van Dale dictionary and sometimes some literature to come to these definitions.

ROOM

According to the Oxford Dictionary the definition of the word room is a "Space that is or might be occupied by something, capaciousness or ability to accommodate contents" or a "Part of house enclosed by walls or partitions, floor, & ceiling; (pl.) set of these occupied by person or family, apartments or lodgings" (Fowling, 1969, p. 1085). This definition brings us the main elements of a room: walls, floor and ceiling. Another characteristic of the room is that it is occupied. The word 'room' is strongly connected to the German word 'Raum' and the Dutch word 'ruimte'. Ruimte is explained by the Van Dale dictionary as a place to be in, or to move through, and as a place defined by borders in three dimensions.

We consider 'room' as an occupied place, enclosed by walls, floor and ceiling. It is a place to be in or to move through, or both.

URBAN

The Oxford Dictionary defines the word urban as "living or situated in, a city or town, as urban districts, population" (Fowling, 1969, p. 1431). The Dutch Van Dale dictionary describes the word 'urbaan' as something similar: related to or part of city life, city culture. It is derived from either the French or Latin language, in which 'urbanus' means: of the city.

CITY

In the Dutch language a city (stad) is defined as a (walled) place that forms its own administrative unity, by the privilege it is granted. It is separated by the countryside. Another definition is a coherence of buildings, ordered by streets; an economical-geographical center.

Where urban speaks more about the usage of space, city is the administrative and physical space wherein this happens.

SPACE

A place to stay or to move through made by borders that create a three dimensional defined place.

ROOM

Space that is or might be occupied by something, capaciousness or ability to accommodate contents. An interior space within a building enclosed by walls or separated from other similar spaces by walls or partitions. It is always made by walls or partitions, floor, & ceiling. Even in the photo-analysis research we kept that closely in mind to use pictures of clear 'urban rooms'.

PLACE

A point where someone, of something is located and a space intended for something or suitable for something that is looked for.

SYMMETRY

A correct mutually proportion between form and dimensions of the different part of a unity.

ASYMMETRY

Assymetric is the opposite of symmetric: A incorrect mutually proportion between form and dimension of the different part of a unity.

FORMAL

Formal in spatial sense means that something only happens because of the form, or according to the rules belonging to the space. According to the spatial aspect, a formal space is a place where the form belongs to the essential.

INFORMAL

Informal is the opposite of formal. It is something free of obligations. Something out of everyday life.

TRANSITION ZONE

A change between two areas. A zone purely for transitions, quick linear movements ('Leven tussen huizen' Jan Gehl 1978 p.83).

ZONE

An area between certain borders.

EDGE

An edge is that what determines, either or the point where the one area stops and the other begins.

MOVEMENT

Movement is going from one point to the other, different said a relocation. Different than transition can this be movement to all direction.

STAY

To be at one place for a longer time. It is the opposite of movement.

LITERATURE

- Abrams, C.; The language of cities - A glossary of terms; The Viking Press, New York, 1972
- Fowler, H. W., Fowler F. G., The Concise Oxford Dictionary of current English, Oxford University Press, 1969

RESOURCES

- Van Dale Woordenboek; Online professioneel Nederlands en Van Dale Online professioneel Engels, Frans en Duits; Van Dale Uitgevers, Antwerpen, 2010
- Abrams, C.; The language of cities - A glossary of terms; The Viking Press, New York, 1972

INTRODUCTION OF METHOD

DEFINITIONS

At first we started with define all the terms we stumbled over. Even during the proces we found new terms that should be defined. You can think about terms like *place*, *formal*, *space*, *room* and *urban*. But we had to come up with our own terms as well and define these. Such terms like urban room.

It is not only for ourselves that we understand these terms but for the reader of this research as well.

PLAN REDUCTIONS

To give a brief introduction of the projects we chose we decided to make some plan reductions as well. This is either to show where the two sides of our research are taken but as well to give some short information about the context. A Nolli map to show the private/public relations of the space. With the DeBois method we showed 3 cognitive step, this tells you something about the routing surround the location and the anchoring with the urban fabric. Of each chosen project we we took two different sides. Besides these we showed a map with the entrances to the houses behind the walls of the urban rooms.

PHOTO ANALYSIS 2 SIDES OF PROJECT

Of each project we took 2 sides that we wanted to analyse. We did this using pictures of both sides made in the middle of what we called the 'urban room'.

By analysing all the objects that mark these 'urban rooms' we tried to distil the several elements to see them one by one and how they form ensembles with each other. By categorising all this individual elements we want to compare them to each other and notice the influence they have in these 'urban rooms'. The other reason for the categorising is that we easily can compare the elements of different case-studies with each other. We end this analysis with a conclusion of the important elements for each case-studie.

CLASSIFICATIONS

After the photo-analysis of the cases, we made a distinction between important and less important items within the different urban rooms. The analysis helped us to see the separate types of items and their value for the character of the room. Looking at the items separately also helped us to see how they worked together. Certain elements strengthen or weaken each other. We looked several times at each case-study and discussed our opinions with each other. Besides that we used literature about the urban environment, to draw conclusions about the items we analyzed.

By doing this we found more and less important items by discussing them and the effects of the combination of items on the character of the urban room. Our earlier photo-analysis stated our opinions or made us change our point of view. For

place formal
 space
 room

DEFINITIONS



PLAN REDUCTIONS

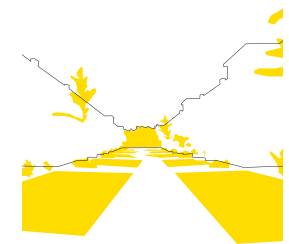
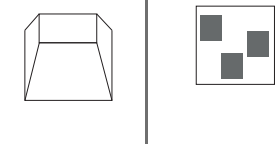

PHOTO ANALYSIS

FORMAL INFORMAL



CLASSIFICATIONS

1991																				
1992																				
1993																				
1994																				
1995																				
1996																				
1997																				
1998																				
1999																				
2000																				
2001																				
2002																				
2003																				
2004																				
2005																				
2006																				
2007																				

CLASSIFICATIONS

instance you can see in our conclusion that the walls are always important (definition of room: walls and floor).

“De middeleeuwse stad bestaat niet primair uit gebouwen, maar veeleer uit straten en pleinen, omdat de gebeurtenissen zich in ruimten afspelen: de gevels vormen het decor”

J.Gehl live between houses p.27

Afterwards we made a distinction between important and less important elements. For instance, some items have a formal character and others informal. We chose 8 different characters that are dealing for instance with informal/formal sides, borders/transition zones and symmetry and asymmetry. We chose these characters because they are related to our research questions.

COMPARISON

After making the conclusions we put all these case-studies together in one big matrix. This gives an overview of all the different case-studies and conclusions focused on the urban-rooms together in one image.

Subjects as (as)symmetric, movement and place are strong related to the former characters and help us to classify the case-studies. The classifications conclude the characters of each (important) element. For each chapter of 3 comparable case-studies we made a conclusion as well.

THE FRAME OF THE METHOD

We were bounded to pictures from other sources, except for some projects of which we were able to make the pictures ourselves.

When making the plan reductions we used 6 methods to show them, considering that a certain method fits the one project better than the other.

This also goes for the icons that we made for the different categories. Not all character types could be named considering each single project. We tried to pick character types in which all the projects could be defined.

For each project we took 2 pictures of 2 sides of the project, this is not always a relevant image, even though we tried to get as much relevant images as possible.

LEGENDA ITEMS

When going through our case studies we tried to categorize all the items that we found in the urban rooms. For this we made small icons to give an abstract view of the different items. Next to the photo-analysis we looked for a more abstract way to quickly show an item out of the analysis and put them in typologies together. We made icons that say something about the typology, for example randomly placed windows.

This made it easier to focus on the several different elements and it gave a quick view on which elements are found. Next to that you can see in the conclusion scheme which elements are found in each category. For instance, in a single glance one could see that windows most of the time make the urban rooms formal, since the icons are found under this category.

WALLS



Each room has a floor and walls as we explained in our definition of the urban room. With these icons we want to show the proportion between floor and walls, in relation to each other.

CONTOUR



Sometimes the contour of the wall is important as well for the character of a room, since this is so related to the walls we used this as an addition.

OPENINGS



This classification is more about the typology of openings than their appearance. For instance they can be doors, windows or loggia's. It is about the way all these openings are combined in a composition.

CLADDING WALL



These are the different types of plinths this can be either be a painted plinth but it can be a very structural plinth as well by materialization or even a building part.

CLADDING FLOOR



In this classification we find all the items that are linked to the floor. This differs from an 'urban carpet' to piece of floor that is raised (sidewalks).

IN-OUT OBJECTS



These are all the elements added or cut into the main building form. Terraces, balcony's or dormers are examples.

HOVERING ITEMS



These are the items that are added on or part of the walls of the urban room. This can be cantilevers, eaves or porches. These elements always hover above a part of the urban room and create a space under it.

GREEN



These are all the natural elements either placed by people or by nature itself, from flower box to big trees.

FENCES



These are bordering objects in space, this can be either a point (pole), plains or a line (fences).

WATER & ELECTRICITY



Items for water- and electrical equipment, most of the times publicly used like street lanterns or power lines.

WALLS

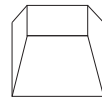

HORIZONTAL ROOM



VERTICAL ROOM



CUBICAL ROOM

CONTOUR



CONTINUOUS ROW



ROW OF FREE STANDING BLOCKS



ROW OF IRREGULAR BLOCKS



ROW OF SADDLE ROOF BLOCKS

OPENINGS



SEQUENCE



CLASSICAL



RANDOM

CLADDING WALL



NO PLINTH



REGULAR PLINTH



IRREGULAR PLINTH



OBJECT AS PLINTH

CLADDING FLOOR



CONTINUOUS



SIDEWALK



PATH IN FLOOR



ACCENTS IN FLOOR



STAIRS ON FLOOR



THRESHOLD

IN-OUT OBJECTS



BALCONY



LOGGIA



DORMER



ROOFTERRACE

HOVERING ITEMS



EAVES



CANTILEVER



PORCH



STAGGERED WALLS

GREEN



HEDGE



GREEN ON WALL



BUSHES ON FLOOR



GREEN FLOOR



TREES

FENCES



POINT IN SPACE



LINE IN SPACE



OBJECTS IN SPACE

WATER & ELECTRICITY



NO ELEMENTS

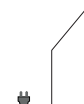

ELECTRIC ELEMENTS



DRAINAGE ELEMENTS



CABLE SALAD

PARAMETERS

CASE STUDIES

CRITERIA CASE-STUDIES

For our case-studies we took 2 categories:

1. Medieval Urban rooms
A traditional way of building that fits the way of building of the cultural context.
2. Modern Urban rooms
Modern projects situated in a modern context.

We found 3 projects for each category, in 3 different countries:

- Italy
- Japan
- Netherlands

For choosing these case-studies we used the following parameters.

- the urban rooms should be surrounded by dwelling blocks
- it should be a well-defined room (see our definition of 'room')
- we wanted to take the two most different sides of one project
- we needed a clear picture with walls (facades), floor (ground) and ceiling (sky) of the room, relevant for the project.

The first case-study was a street in Varallo it is a typical street near our project location. A modern equivalent was the Junghans project in Guidecca, Venice by Cino Zucchi.

Next to the old city of Varallo we wanted to place a very Dutch context, with about the same age. Finally we took the entrance to the courtyard of Zutphen and a surrounding street. This was comparable to the collective spaces in Varallo, which made it different than other case locations we could have chosen in the Netherlands.

In Japan, a whole other context, we took the traditional medieval Machiya dwellings. A side street of a main Machiya street the Shinbasi Dori was for us the second side we chose that had some collectiveness in it.

Both in Holland and Japan we looked for a modern building implementation in an older city.

We found the Schuttersveld project in Delft and the Seijo townhouses in Tokyo.

Comparing different potential case-studies we tried to pick projects that were almost built in the same time.

URBAN ROOMS
MEDIAVAL

URBAN ROOMS
MODERN



BORNHOF ZUTPHEN 1600



SCHUTTERSVELD DELFT 2005



VARALLO 1200



GUIDECCA VENICE 2002



MACHYA KYOTO 600



SEIJO TOKYO 2007



FOTO ANALYSIS

MEDIEVAL URBAN ROOMS

VIA ALBERGANTI, VARALLO

IT 1200

Varallo is a small city in the north of Italy situated in the Sesia Valley on a 2 hours' drive of Milano.

Since our final project will be in this city we chose to investigate a typical street in Varallo. Ofcourse it was interesting as well because a lot of people are fascinated by these kind of streets.

In this small city we chose for the street called Via Alberganti.

As second side to investigate we took a courtyard that is accessible by an archway situated adjacent to the Via Alberganti. A typical typological situation for Varallo. In this courtyard a public function and the entrances to the surrounding dwelling blocks are situated.





BORDERS

Defining the borders of the outdoor space.



NOLLI

Defining the borders of the public space.



DEBOIS

Showing the connection with the urban fabric, taking 3 cognitive steps from the location.

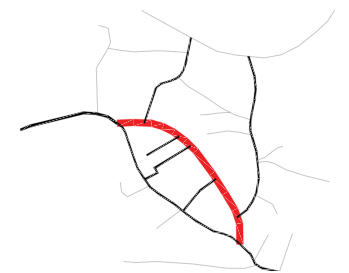

CONTRASPACE

An image of the in between space. The darker the image the opener the spaces between the buildings.



ENTRANCES

Showing the entrances of the research area.



PROFILE

A section off the street we researched.





=

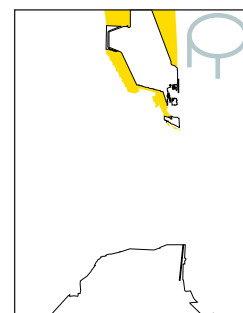
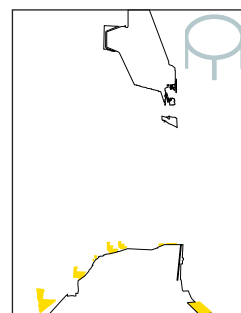
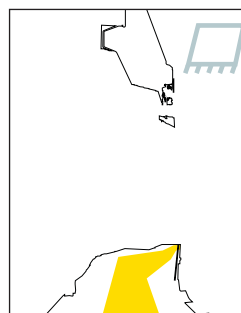
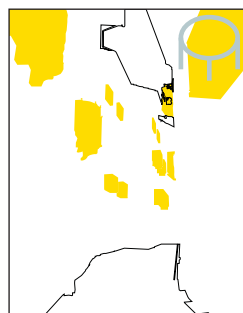
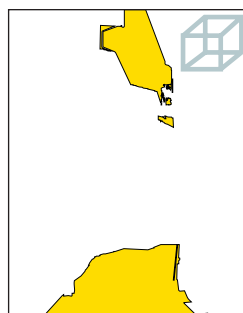

ROOM A

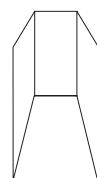

+

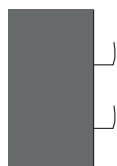

+

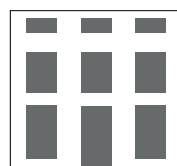

Most important items: vertical cube; balcony's; classical windows.



+

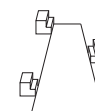

+



Less important items: floor covering; small stairs; eaves.



=

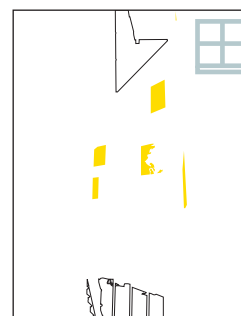
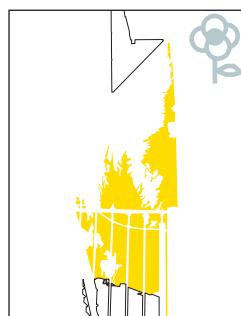
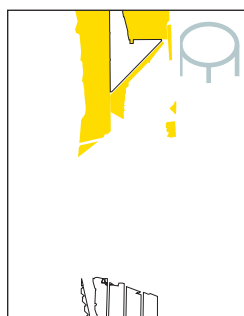
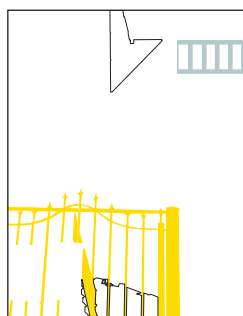
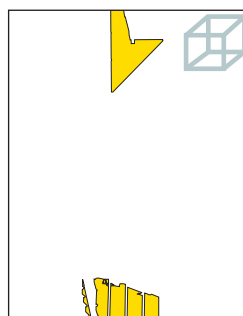

ROOM B

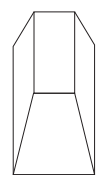

+

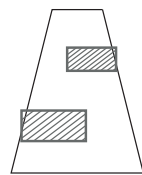

+

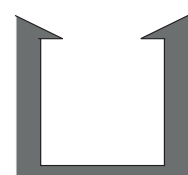

Most important items: narrow room; enclosed by fence; eaves.



+



Less important items: green in front of the walls; irregular pattern in wall openings

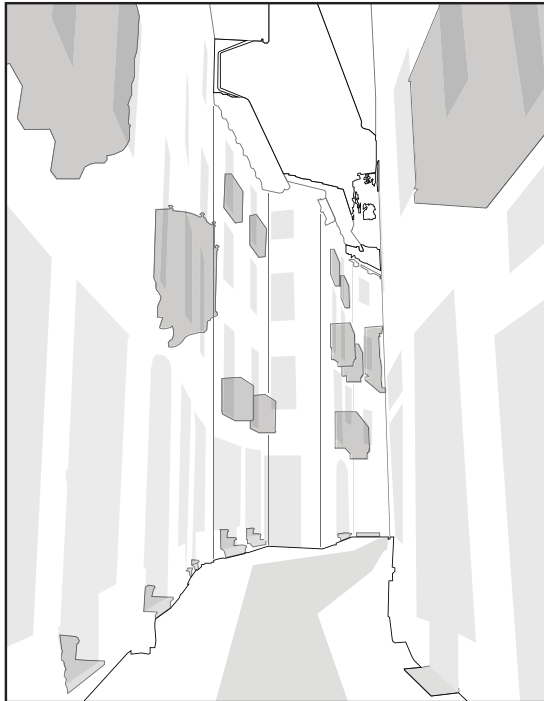

In the medieval city of Varallo a lot is going on. Near the plinth the paving of the floor is different than the pavement in the middle of the room, emphasizing a path. Towards the wall small stairs are placed these are the transitional zones to the dwellings behind the wall. Window sizes differ but in the overall their typology is classic. Decorated balcony's seem to be hung randomly on the wall, but together they form a sequence of the room. The same goes for the windows. The eaves of the houses seem like ceiling ornaments.



This urban room is a collective enclosed room. Being closed by a big fence, a strict border although it is transparent. The windows give some transparency to the walls in this small space. The eaves function here as ornaments on the ceiling. The green bushes create some distance between path and dwelling. This makes the borders softer.

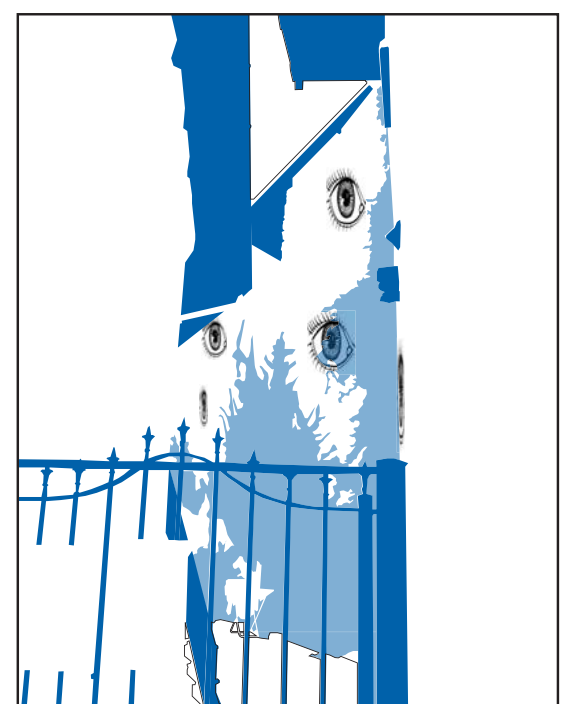

CONCLUSION

SYMMETRY – ASYMMETRY

In room A the elements are not symmetrically placed. Even the path in the middle varies in width and doesn't follow the walls of the room exactly. Though, the two sides of the room are quite similar. For instance, the walls have a similar height and the amount of windows is comparable on all walls. It is a place with an over-all system of randomness. Compared to that, in room B there is no system to find at all. It is a very asymmetrical place looking to the walls, openings and the eaves. The windows seem placed randomly in the walls; their situation is only depending on the rooms of the dwelling behind them. All elements together make an asymmetrical ensemble.

FORMAL – INFORMAL

In room A the floor covering in the middle defines the path for movement. The stairs create an extra obstacle between in- and outside. The wall openings are emphasized by large embrasures, ornaments and wall paintings. This makes the floor in an easily readable place, the rules are quite clear. We can say this makes the room more formal compared to the other room, which is not organized by such items. What contributes to the informality of the place, are the objects of daily use such as the paintings hanging outside an antiquary. The balconies seem hung randomly on the walls of this urban room, only depending on the rooms of the dwelling behind them.

BORDERS – TRANSITIONS

Room A in Varallo is built up from different zones. In the middle of the room a clear path is defined. On both sides of that we found zones with a different pavement, which make the transition between the path and the private houses softer. The next transition elements are the small stairs that lead to the private houses. The eaves of the buildings hover above this transition zone and separate this space even more from the rest of the street. Besides these zoning items, the space is clearly bordered by its walls. In room B some green is placed against the walls, which makes the borders of the room less hard. They make the users of the urban room keep distance from the houses. A hard border in this space is the fence, even though you can see through it you can't go behind it. The space is enclosed by the walls and together with the fence this creates separate place.

MOVEMENT - STAY

The path in the middle of room A emphasizes the possible movement through the space and the walls follow the bend of the path in this ensemble. One is attracted to follow the road since it is visibly continuing around the corner, although we cannot see what is there. The sequence of windows continues as well as the eaves.

Although all these items follow the form of the path, the place is at all points enclosed by the high walls. Besides enhance the stairs in front of the houses the connection between in- and outside. In room B, there is no path visible and the road is blocked by a fence. This makes the room a place to be in, it is a private, dead-end place, just as room B in the machiya-case.

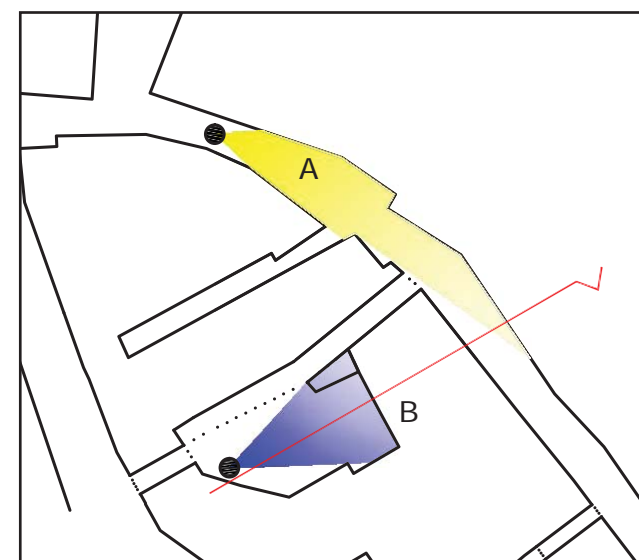

Room A

SYMMETRY

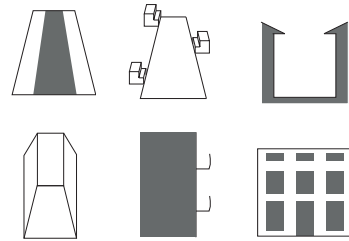

ASYMMETRY

FORMAL

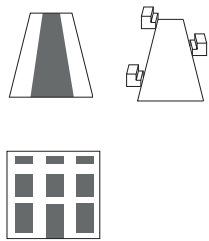

INFORMAL

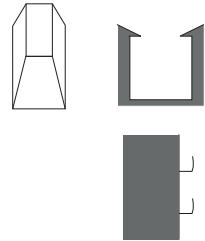

HARD BORDERS

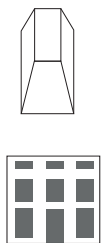

TRANSITION ZONES

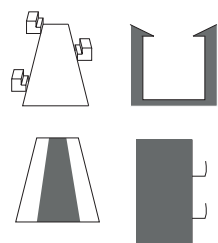

MOVEMENT

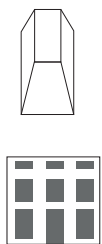

PLACE

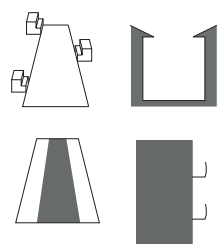

Room B

SYMMETRY

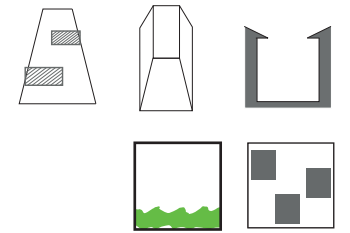

ASYMMETRY

FORMAL

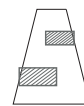

INFORMAL

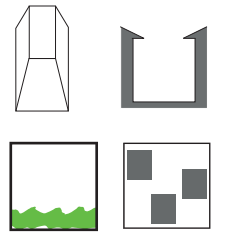

HARD BORDERS



TRANSITION ZONES

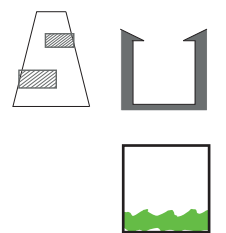

MOVEMENT



PLACE

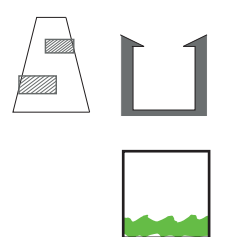

BORNHOF, ZUTPHEN

NL 1600

The Bornhof a courtyard situated in the old city centre of Zutphen. We took a small street that is leading to this courtyard and a street just outside the courtyard. The Bornhof was founded in the same medieval period that Varallo was founded. The street leading to the courtyard is different of character than the streets outside the courtyard.

The other side of the project is a street parallel to this courtyard, the 'Bornhovestraat'. Being a street with on-going traffic with old buildings defining the in between space. The profile of the street is typical for the old streets we find in the old city centres in Holland.





BORDERS

Defining the borders of the outdoor space.

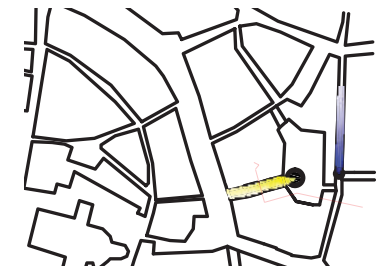

NOLLI

Defining the borders of the public space.



DEBOIS

Showing the connection with the urban fabric, taking 3 cognitive steps from the location.

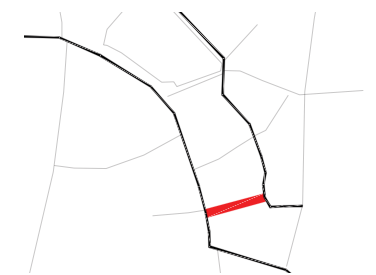

CONTRASPACE

An image of the in between space. The darker the image the opener the spaces between the buildings.

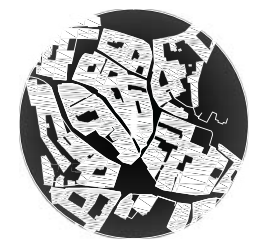

ENTRANCES

Showing the entrances of the research area.

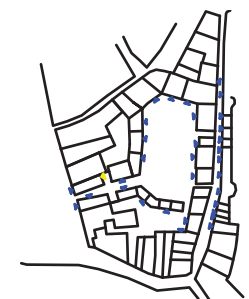

PROFILE

A section off the street we researched.





=

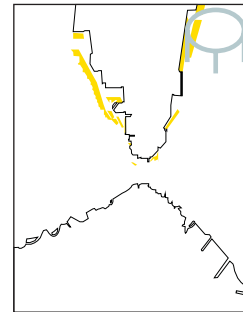
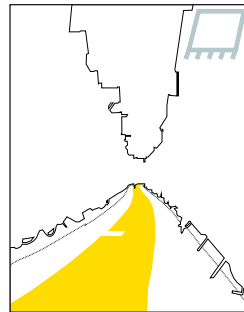
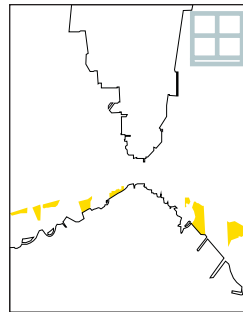
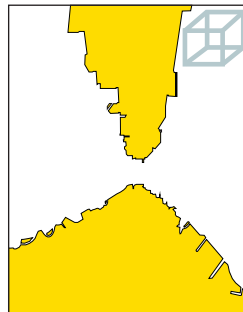

ROOM A

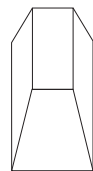

+



+

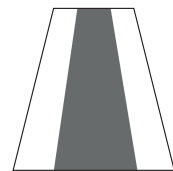

+



Most important items: vertical cube; continuous plinth; continuous floor covering.

Less important items: classical ordered window openings; eaves.



=

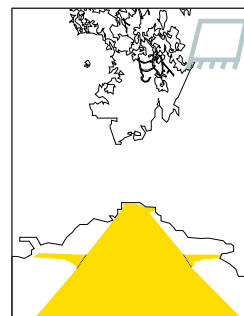
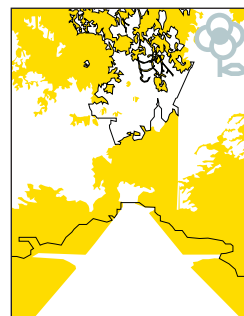
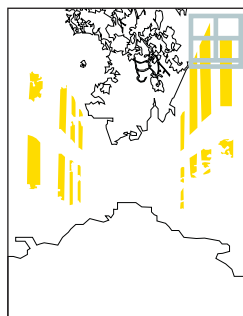
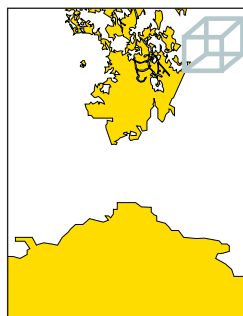

ROOM B

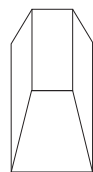

+

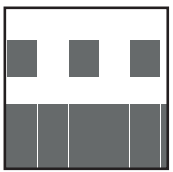

+

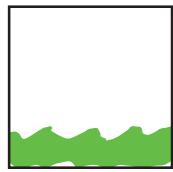

Most important items: vertical cube; random windows; irregular plinth.

Less important items: accents in floor covering



This street in Zutphen is clearly defined by its wall that by their white colour enstrengthen this idea. Due of the plinth the white wall doesn't reach to the floor, it blurs the border between wall and floor.

The white wall is emphasizing a direction towards the end of the street.

By using different paving material in the floor of this urban room, a clear path is made. Together with the eaves, the walls and the path become a harmony giving a clear orientation to this room.

The windows openings give the idea that this room is not only focused on its direction.

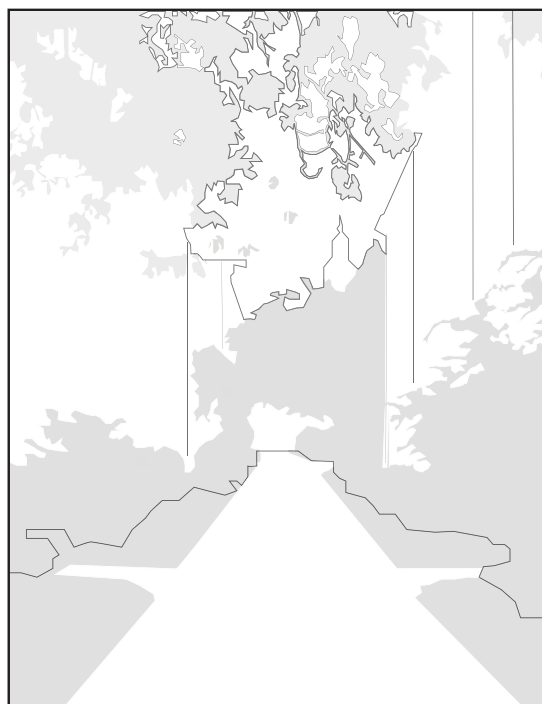
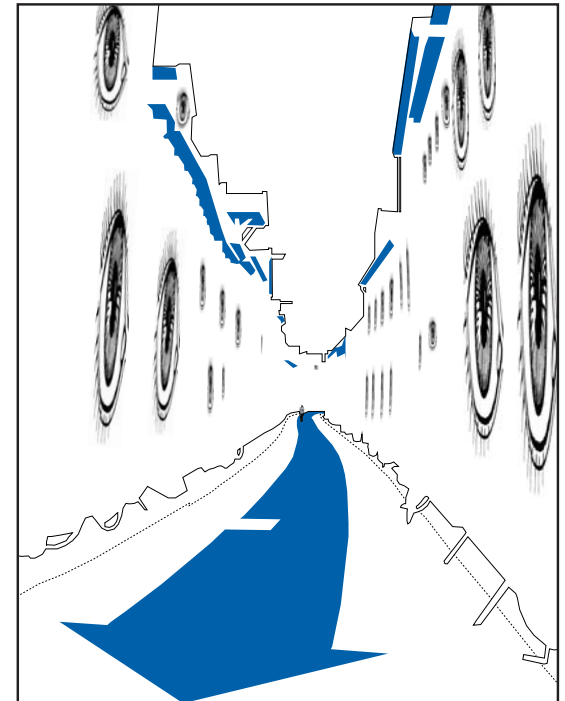

The street leading to the Bornhof is defined by the surrounding green flowerbeds. Being a natural green zone between the public street and dwellings.

But emphasizing the direction of this street very clearly towards the green field of the courtyard.

Towards the top of the urban-room the green leaves of the trees become like a natural ceiling of this room.

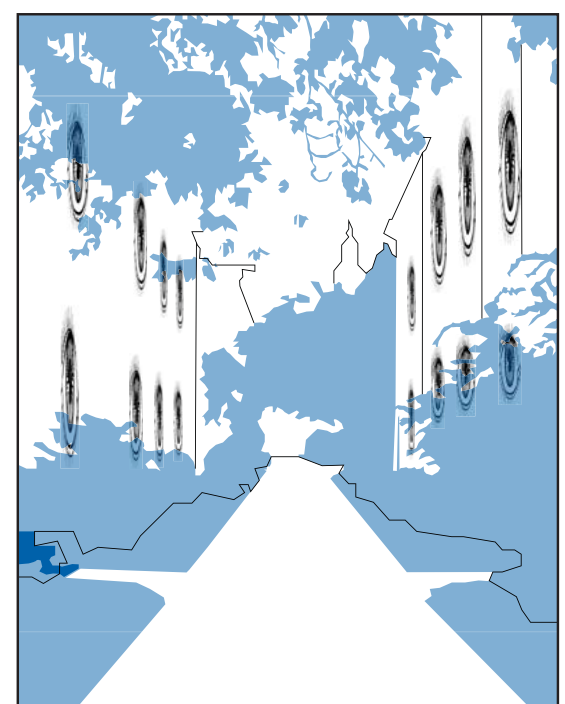

CONCLUSION

SYMMETRY – ASYMMETRY

Room A is very organized. The sidewalks, plinths and white painted walls appear on both sides of the floor in almost the same way. Both sides are quite similar, so this room reaches a high extend of symmetry. The objects that disrupt the symmetry in this room are the objects of use and the eaves. Room B has a similar amount of symmetry in its objects, although it is done with different means. The symmetrically organized greenery alongside the path takes a big part in this.

FORMAL – INFORMAL

In the Bornhof the green bordered path with parallel to this the facades as a second layer make the room look very formal. Through these elements the borders of the room and the path are clear for the users of this space. A sequence of the window openings and the side path leading to the houses are giving some kind of order for the usage of this space, so these have a formal appearance. The green alongside the path and in front of the walls makes the room look more informal and less strict. In the Bornhovestraat, the path and the white walls above the grey plint are giving clear direction to the room. These elements are giving the rules for the route to follow. The eaves of the roof and window sequence are making the room more informal because they vary all along the room.

TRANSITIONS - BORDERS

In room A the floor covering besides the path and the sidewalk are transition zones between the central public path to the walls where the private houses begin.

It is this green that is a transitions zone between the public path on the one side and the private houses on the other.

The floorcovering defines a clear path through the room and the white coloured facades seem to run parallel to tis as a border of the path. The plinth of the walls has influence to this because it seem to raise the walls and strengthen the effect of the white walls above it.

MOVEMENT – STAY

In room A the path is defined by the differences in floor covering. This is done to an even greater extent than in room A of Varallo. The sidewalks, plinths, white painted walls and eaves all emphasize the direction that the path goes. In room B the path displays a lot more choices along the way. Since the direction is not emphasized as it is in room A, this room is more a place to stay in than to move through. The extend of enclosure contributes to that.

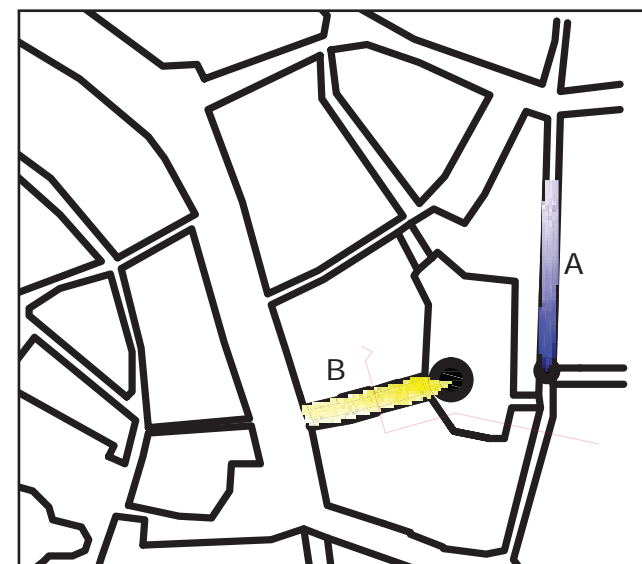

Room A

SYMMETRY

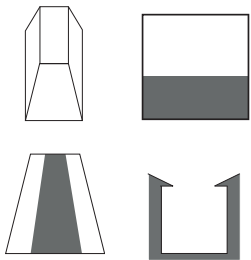

ASYMMETRY



FORMAL

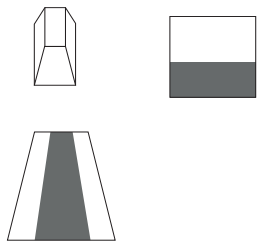

INFORMAL



HARD BORDERS

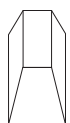

TRANSITION ZONES

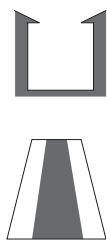

MOVEMENT

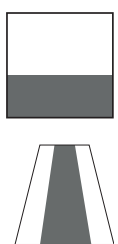

PLACE

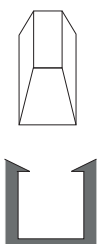

Room B

SYMMETRY

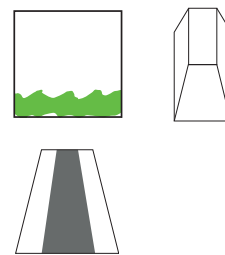

ASYMMETRY

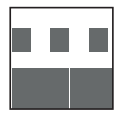

FORMAL



INFORMAL



HARD BORDERS



TRANSITION ZONES

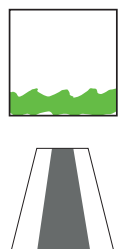

MOVEMENT

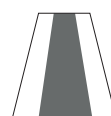

PLACE

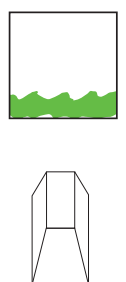

MACHIYA, KYOTO

JP 600

A Machiya house is a traditional wooden townhouse found throughout Japan. This typology is found as early as the Heian period, ca. 700 A.D.

This typology most of the times had a public function on the street side most of the times a small shop or workplace. Behind that was a inner courtyard after which came all the private functions of the house.

A bigger Machiya had more rooms and with that more courtyards.

Nowadays a lot of Machiya houses are destroyed and only some are preserved. In the centre of the Japanese city of Kyoto some streets are still surrounded with this type of houses.

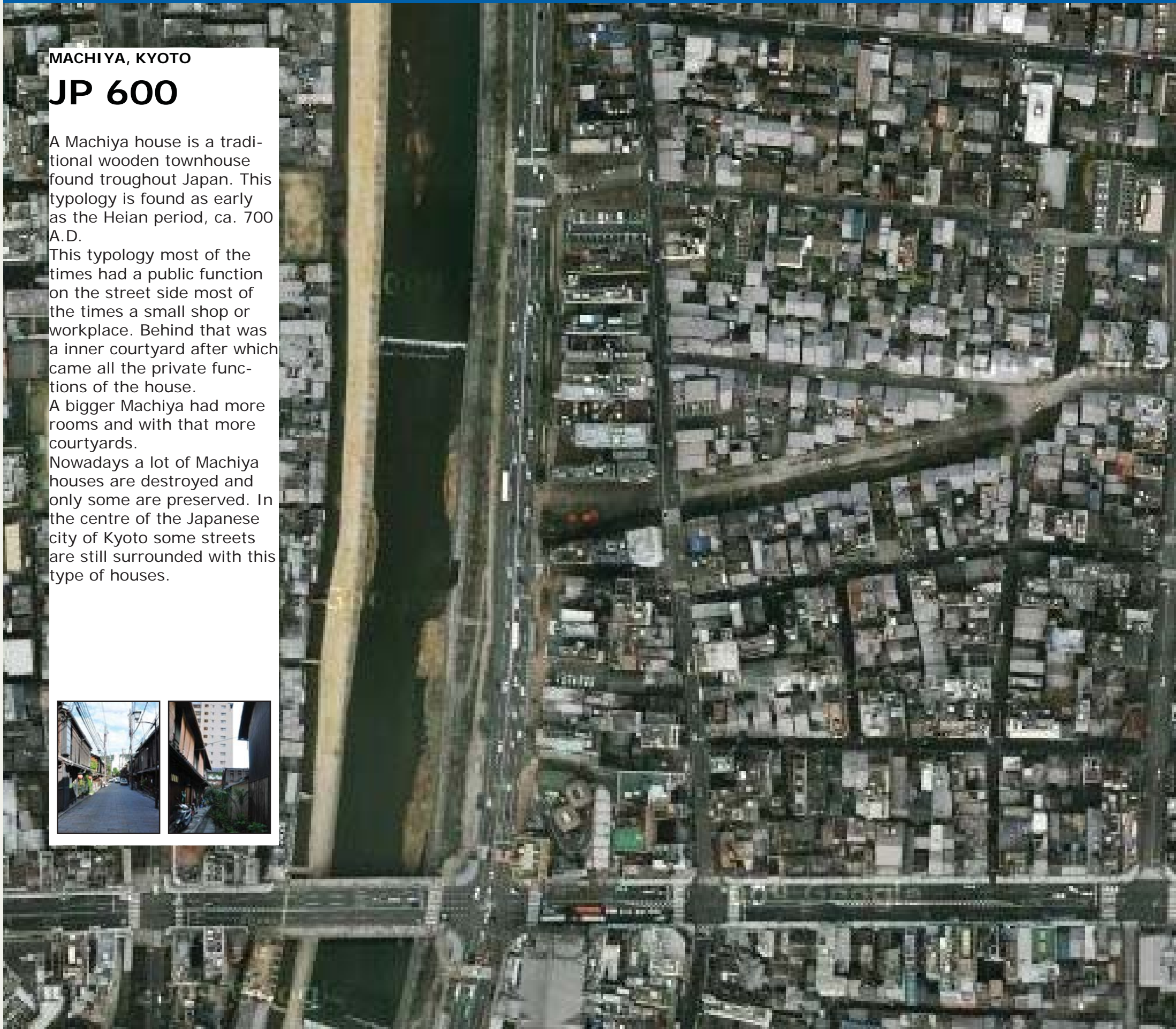

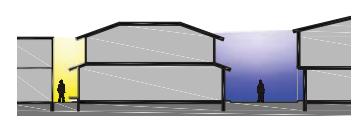
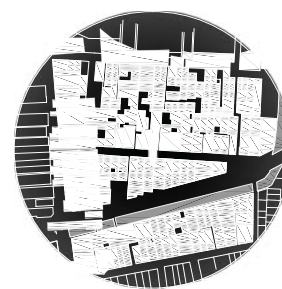
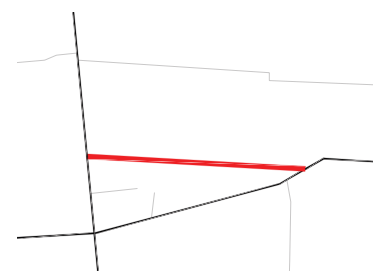
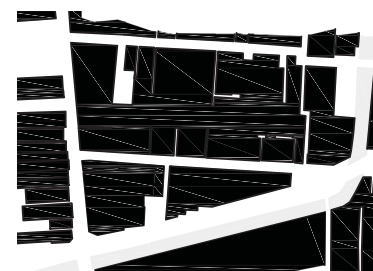
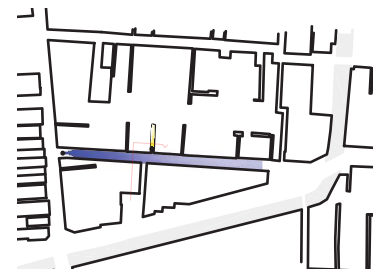



=

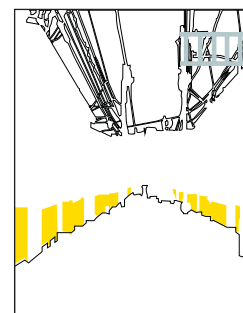
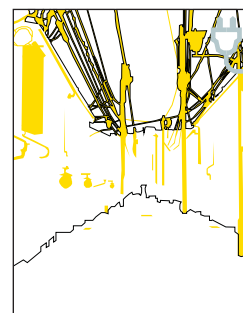
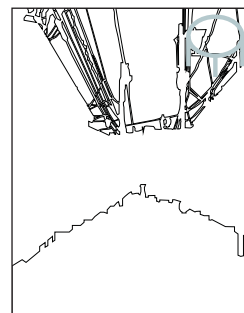
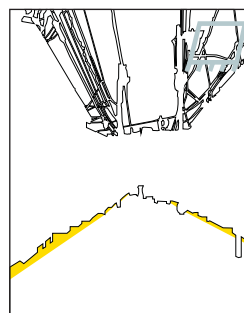
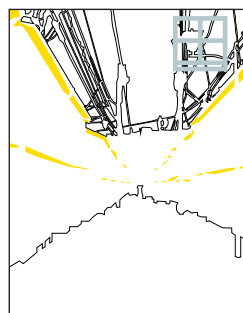

ROOM A

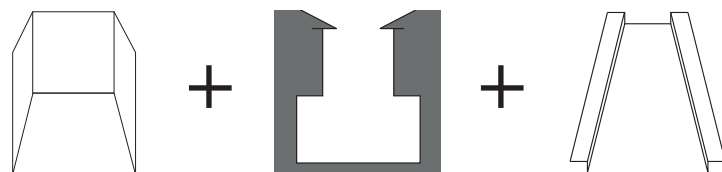

Most important items: vertical cube-formed room; random windows; emphasized path in floor covering



Less important items: sidewalk; overhanging slab above entrance; green on floor.



=

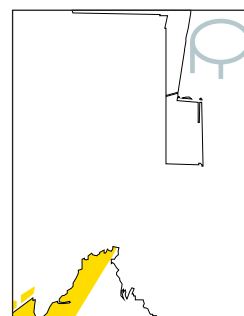
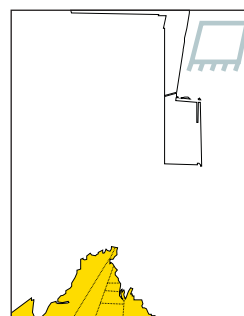
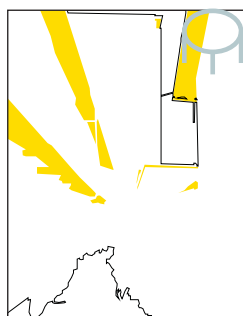
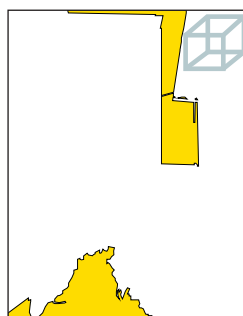

ROOM B

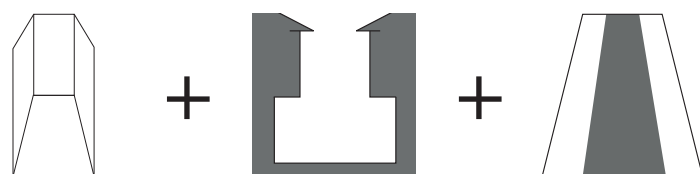

Most important items: cube-formed room; random windows; emphasized path in floor covering



Less important items: sidewalk; green on streetlevel

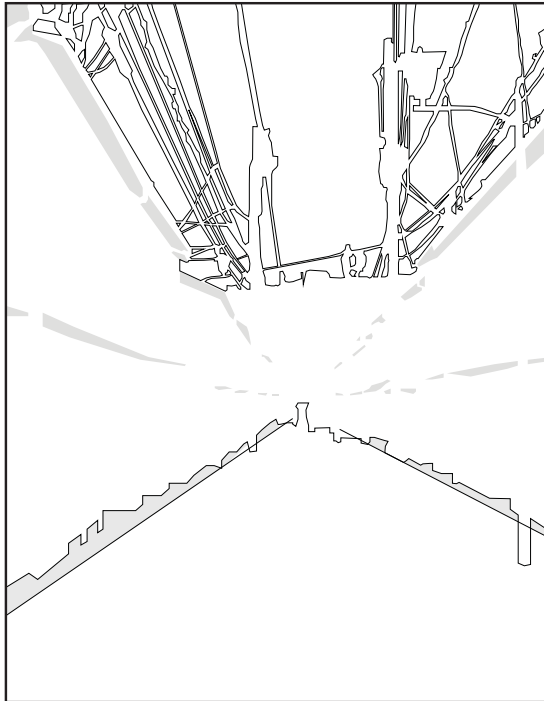

This urban room is made by its walls which are layered by fences and tatami sunscreens. The floor is bordered with a straight sidewalk, both a transition zone in front of the houses and a element that emphasizes the direction of the street. It is in such a way a first step into the public room of the Machiya house and a semi-public border in front of the house. You can't see the walls of this room clear because of all the fences that are placed on the sidewalk. The eaves of the houses are most of the times aligned with the street emphasizing the direction. Due to the many earthquakes Japan is facing all the electric lines are situated above ground,

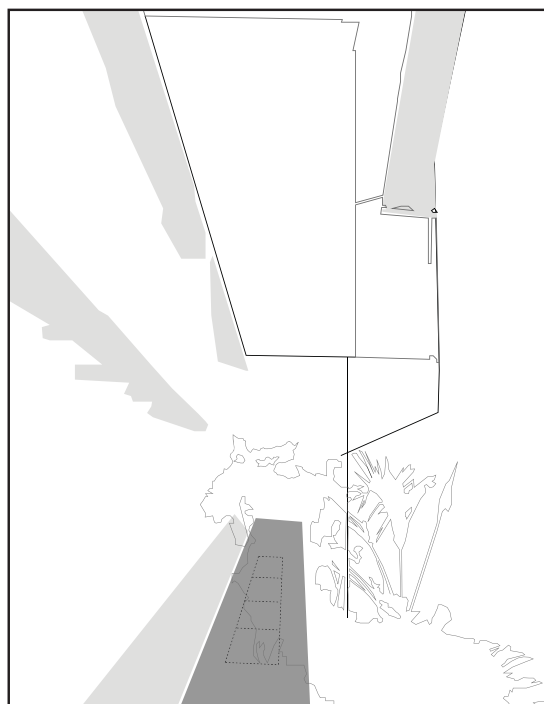
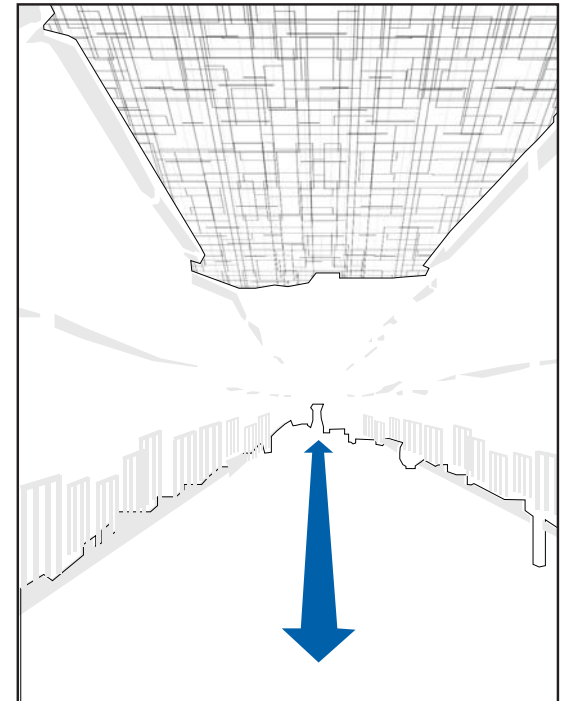

An alley in the part of Kyoto where there are still some Machiya filled districts. Here the path is emphasized by colour and material. The sidewalk is also a doorstep which alligns the direction of the path. This direction is more emphasized by the eaves of the surrounding Machiya houses. Green plants hide the right wall of this urban-room. But where is this path leading to? most of the times towards a dead end.

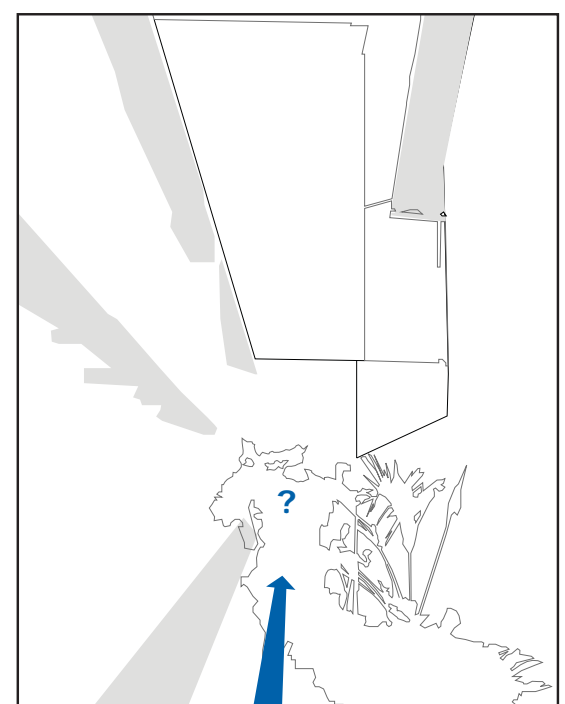

CONCLUSION

SYMMETRY – ASYMMETRY

The urban room in Shinbasi Dori, Kyoto, is generally symmetrical. The walls, the sidewalk and the plinth of the buildings appear the same on both sides. Though when looking at the details, each house is different. Compared to that room B is asymmetrical, we only find elements on one side of the room. Only the floor covering (path of tiles) seems to be symmetrical and defines a path in the middle of the room. Overall we can say the rooms are asymmetrical in detail, but symmetrical in the general system.

FORMAL – INFORMAL

What makes both rooms typical is that one is not able to look into the windows, the “eyes”, of the buildings. The private places are hidden from the urban space. This makes the street a rather formal place, public and private are clearly divided. The many borders between house and street in room A contribute to this division and give rules for where to enter the houses. This is the sidewalk, which acts as a collective doorstep, the fences and the porches in front of the houses. The small green on the wall is randomly placed decoration on the wall. Together with the electric wiring and the eaves that vary in height, this shows the presence of daily life objects and adds to the informality of the place. Room B is more enclosed than room A, and the path in the middle has a dead end. The green and objects of use make the place more informal than room B, it is clearly more a room to live in. It seems to be a more collective space, occupied by the dwellers, since no-one is passing this street. The difference between private and public/collective is made clear by using the same items: the path and the sidewalk give rules for where to walk and where to enter the ‘private terrace’ of the house.

TRANSITIONS – BORDERS

In room A the earlier described plinth, sidewalk and fences altogether form the transition zone from public to the private house. It is a clear area dividing the private inside and the public outside. The sidewalk in room B is more of a private terrace where dwellers of these houses leave their possessions. It is this sidewalk that works like a transition zone between the semi-collective path and private house. On the left side of the path we find a layered house façade with a transition zone, but on the other side we find fences as a hard border. Some informal green tries to decorate that wall and plain borders of this urban room. The sidewalk and path give clear direction, emphasized by the tiles in the path.

MOVEMENT – STAY

All items in room A point out a clear direction, aligned with the street. This room is definitely about moving through, instead of staying in. The end of the path is not visible from the place where the picture is taken. This is because the street is long and straight, there is no exit visible. In the other direction, the movement from street to house is slowed down by signs of privacy: the walls, fences, sidewalk and shelter. The street light in the middle of the street creates a place. During night it defines a light area in the dark. In room B the exits of the path are not visible, because they are not there. The room is an enclosed place to stay in. Since no-one will pass it one could call it a collective place, a front garden of the adjacent houses.

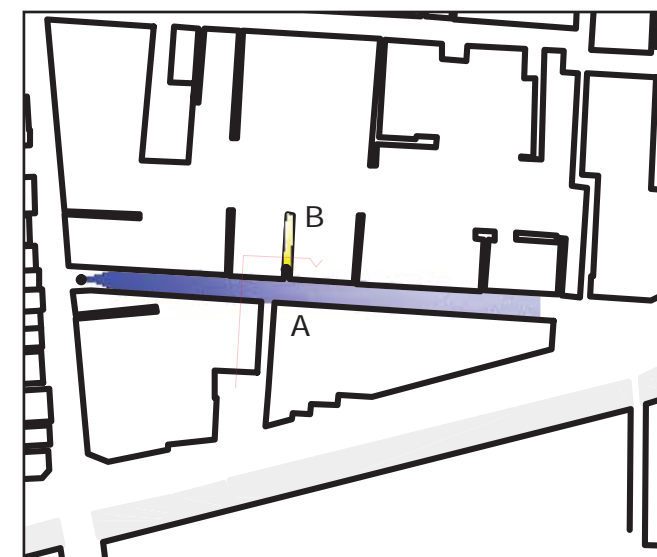

Room A

SYMMETRY

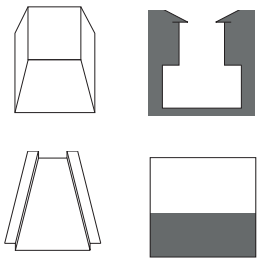

ASYMMETRY

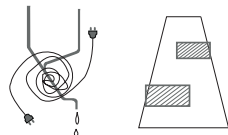

FORMAL

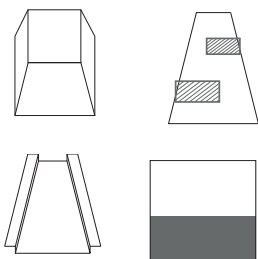

INFORMAL

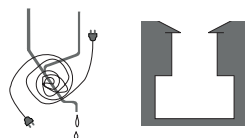

HARD BORDERS

TRANSITION ZONES

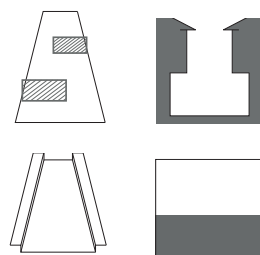

MOVEMENT



PLACE

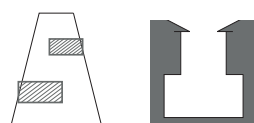

Room B

SYMMETRY

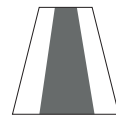

ASYMMETRY

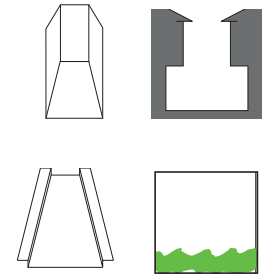

FORMAL

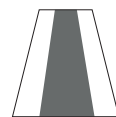

INFORMAL

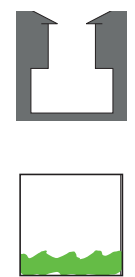

HARD BORDERS

TRANSITION ZONES

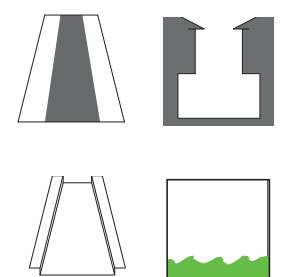

MOVEMENT

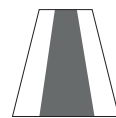

PLACE

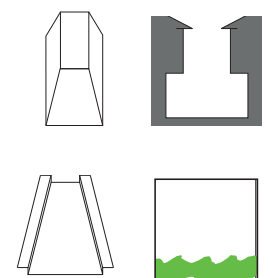

MARK

the urban interior catalogue

ALL







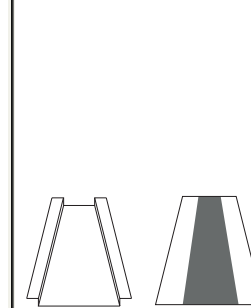
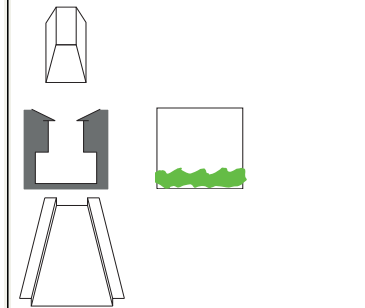
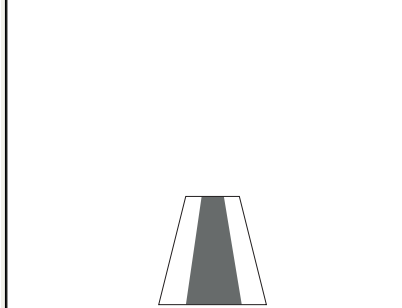
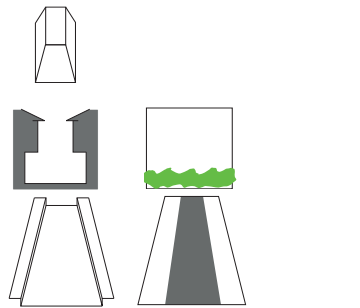
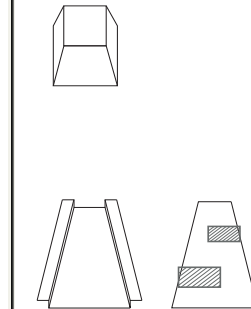
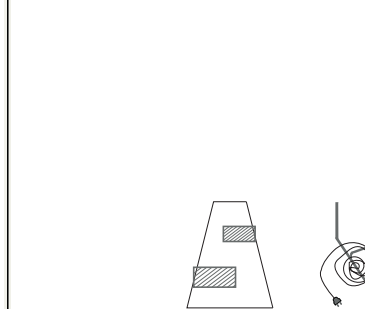
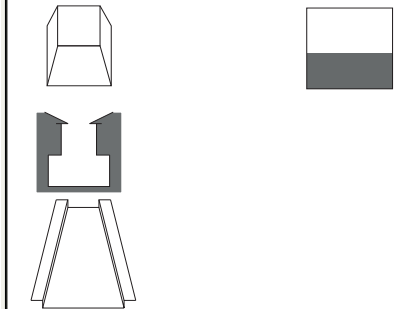
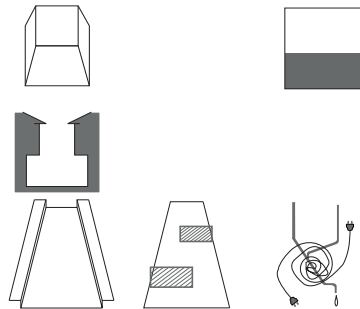
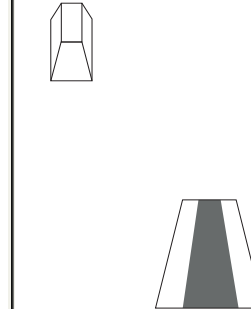
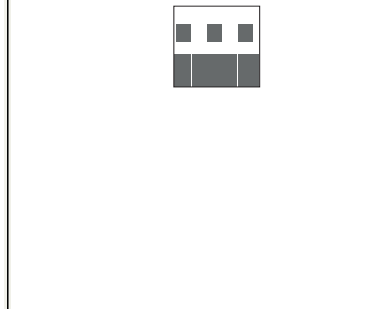
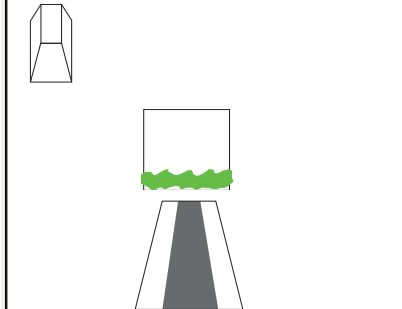
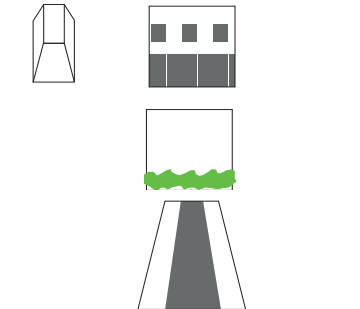
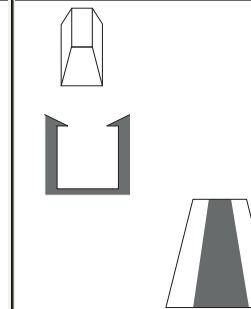
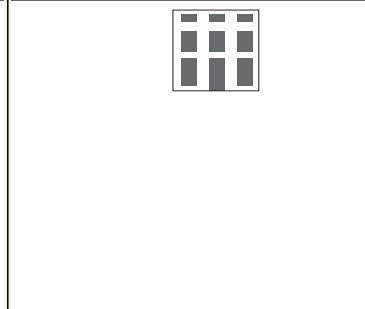
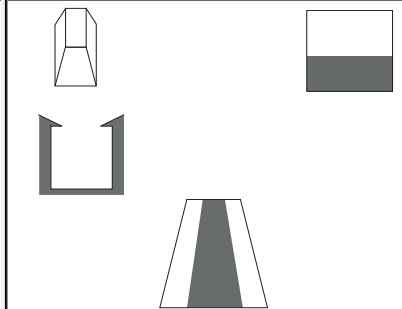
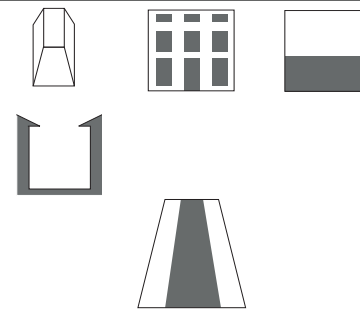
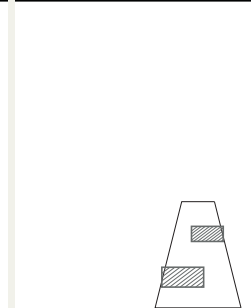
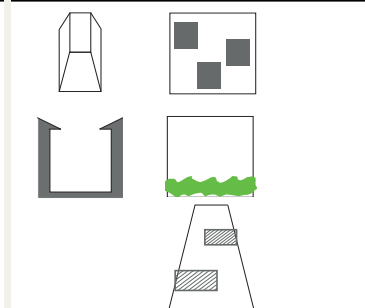
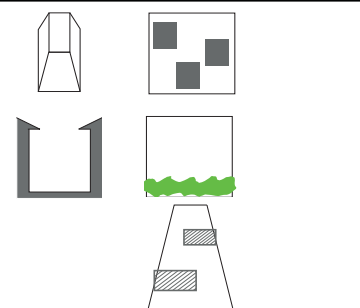
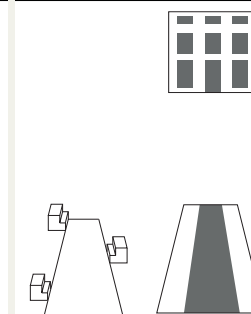
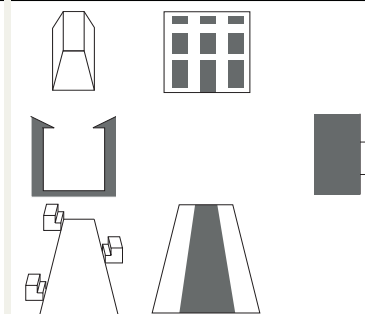
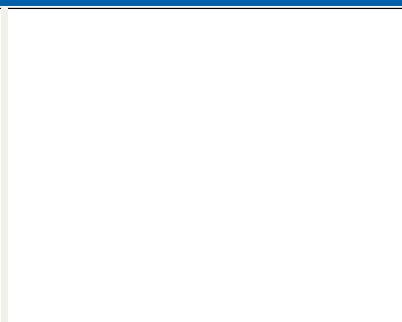
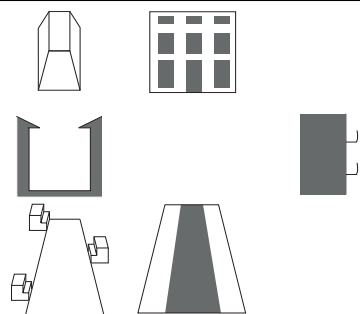



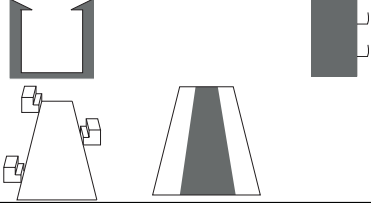

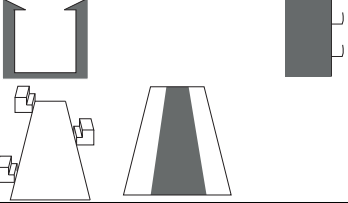
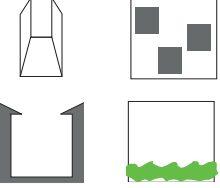
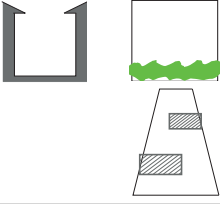

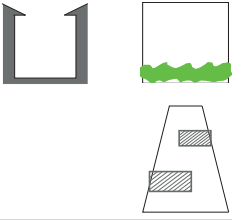

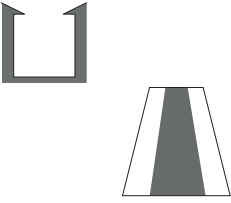
SYMMETRIC

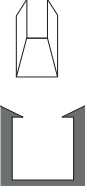
ASYMMETRIC

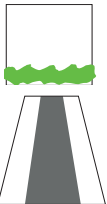
FORMAL

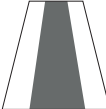
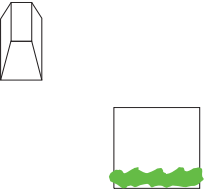

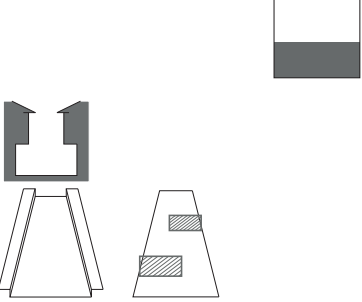
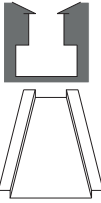
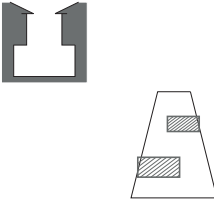
INFORMAL**TRANSITION ZONE****HARD BORDER****MOVEMENT****PLACE**

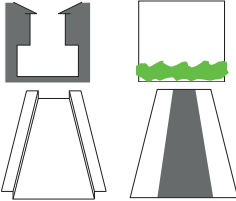
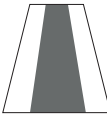
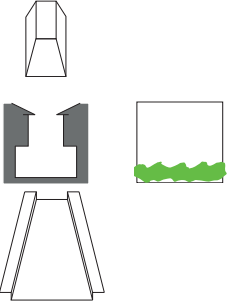
MEDIEVAL ROOMS

CONCLUSION

ALL

In the overall of the medieval casestudies somethings are notable. The routes are always clear defined and emphasized, most of the times by a sidewalk or floor covering of combination of these two. Walls of the rooms are always essential, this fits the definition of a room, you always need bordering walls to make a clear defined room. And by the form of the room you can tell something about the climate. In Varallo there is less space between the blocks but in Holland and Japan they leave more space for sunlight entering the in-between space and the houses.

SYMMETRIC – ASSYMETRIC

In most of the case studies symmetry is emphasized by both the walls and the floor. All of the times the window openings are asymmetrical, they are different between different houses and on both sides of the streets. This is because each house is identical build, not like the repetitive dwelling blocks we build nowadays.

FORMAL – INFORMAL

The formal appearance is most of the times dependent on elements on the floor. In Holland and Japan they designed with more rules and according to symmetry. But in Varallo we see nothing symmetrical at all and the room is not like Holland and Japan where you have sight axes, but you go from urban-room to urban room instead. A street in Varallo is rather a collection of rooms than being only one big room.

Greenery is always informal in the medieval cases, even though sometimes it strengthen formal elements (path at Bornhof, Zutphen), it always have an informal appearance. The appearance is always different (natural) in the cases we investigated.

TRANSITION ZONE – HARD BORDER

We find the transition zones most of the times embedded in the floorcovering or in element connected to the floor of the urban rooms. But in Varallo and Japan a lot of elements are put unto or in the wall. But most of the times the walls are the hard borders of the room. Except in the casestudie of Japan there is a clear layering of a sidewalk and division with fences. In Varallo we see these transition zones, transitions layers more on the floor of the urban rooms.

MOVEMENT – PLACE

The movements in the urban-rooms is most of the times emphasized by the walls and the floor of the room. Only the collective courtyard in Varallo is different (in typology), this is a place more focused to stay and not so much to move through.

Looking to the elements that make a place you see that these elements can be either formal and informal. It is not important which of these they are, both can add to the character of a place. But mostly all of these elements are asymmetric. Out of these medieval cases we investigated you can conclude that a place is most of the times defined by asymmetric elements. The reason for this can be that asymmetrical elements give us the idea for interference into these rooms (there is less order).



FOTO ANALYSIS

MODERN URBAN ROOMS

GIUDECCA, VENICE

IT 2002

A dwelling project near the centre of Venice on the island Guidecca. The Italian architect Zucchi designed several buildings in the existing fabric of this old part of Venice.

This new residential building stands in the place of an existing building at the junction between two canals. A smokestack is preserved as a document of the industrial past of this area.

By its form and eye-catching windows the building has a clear face to the surrounding waterways.

On the inside a white-stuccoed court is made as an intimate space that leads to the main entrance of the building where the elevator of the block is placed.





BORDERS

Defining the borders of the outdoor space.

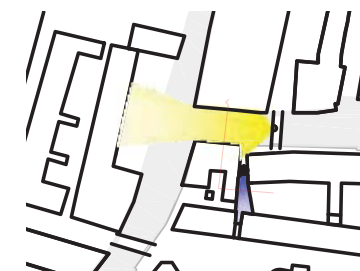

NOLLI

Defining the borders of the public space.



DEBOIS

Shows the connection within the city, in 3 cognitive steps from the location. Dotted lines show watertraffic

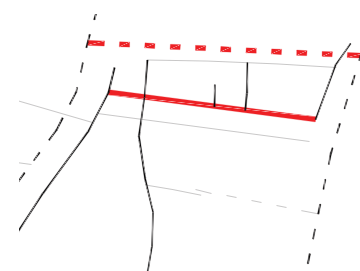

CONTRASPACE

An image of the in between space. The darker the image the opener the spaces between the buildings.



ENTRANCES

Showing the entrances in the research area.

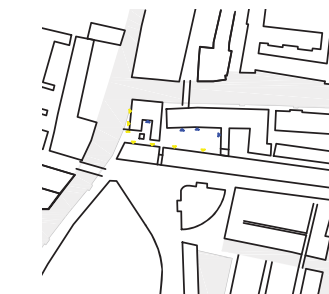

PROFILE

A section off the street we researched showing the 2 rooms we researched.

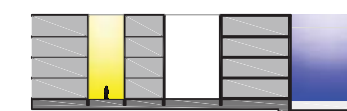

MARK

the urban interior catalogue

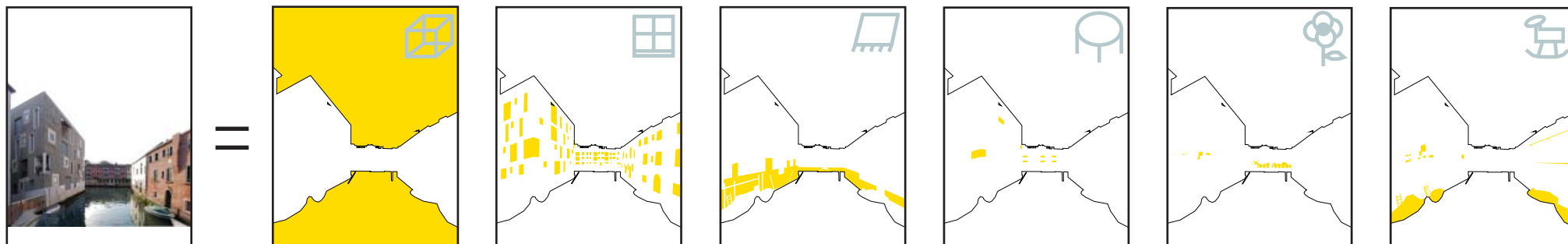

ROOM A

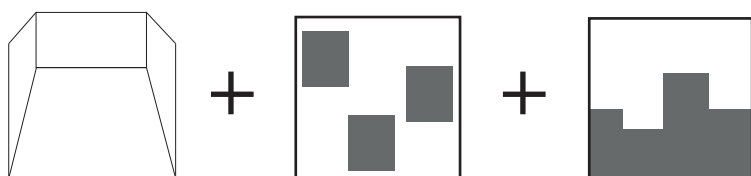

Most important items:
horizontal cube; random windows; irregular plinth.



Less important items:
loggias; green on the walls; objects of use on the floor.

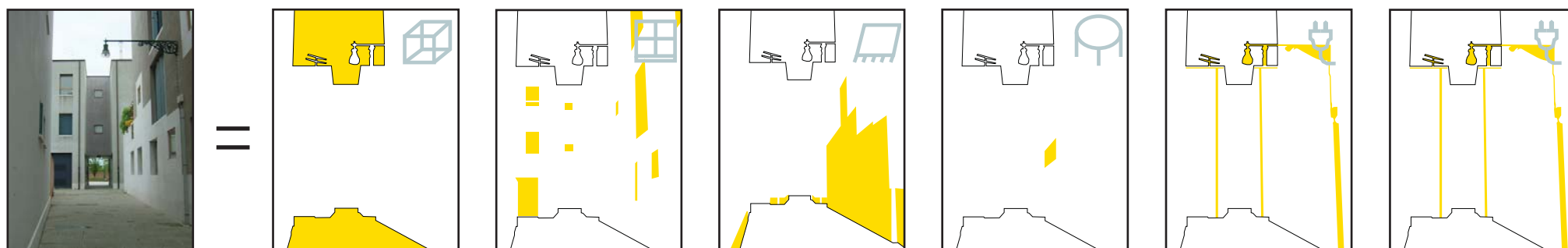

ROOM B

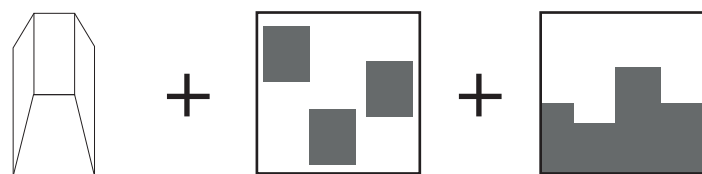

Most important items:
horizontal cube; random windows; irregular plinth.

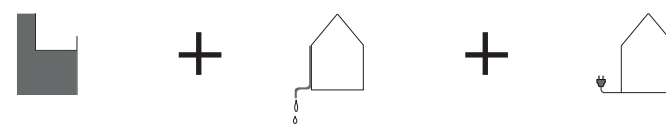

Less important items:
continuous floor covering with plane fences; roof terraces;
water and electricity elements.

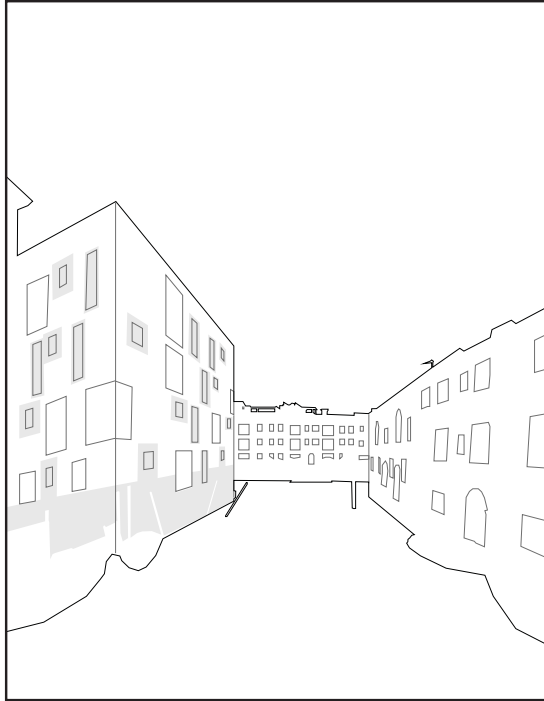

A room with a floor of water in the context of typical Venice houses. The block of Zucchi tries to come along with the dynamic of the surrounding blocks starting with a irregular plinth. The different opening types are the variations on the wall, they decorate this urban-room that has a continuous water floor that is the main traffic route.

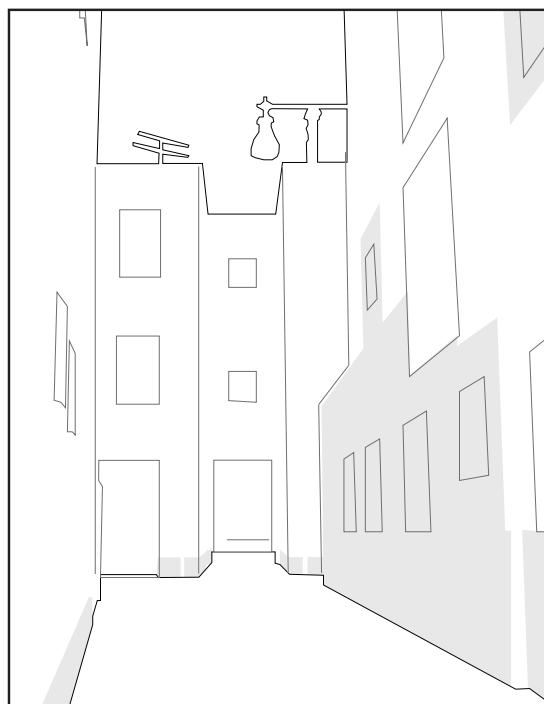
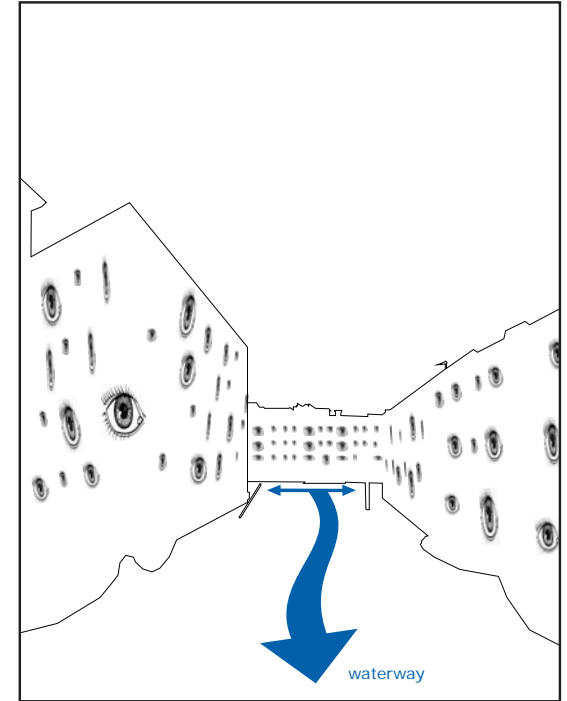

In between the dwelling blocks the space is bordered, with only a small gate that functions as an entrance that connects this small street with the surrounding area. The openings in the wall seem to look into this room, being some kind of variation on the walls (paintings). Together with the white irregular plinth it helps to distinguish the different housing blocks. With only some other small elements as an chandelier these items decorate this urban room.

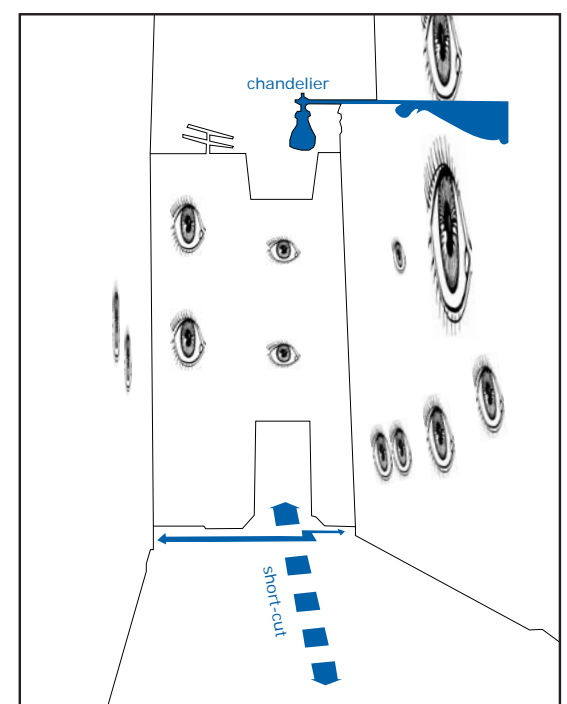

CONCLUSION

SYMMETRY - ASYMMETRY

In this project of Cino Zucchi we see at the waterside that only the floor (surface) is symmetrical, next to that all the other elements are asymmetrical and dynamic in form. The boats are asymmetrically placed objects on the edges of the floor. This whole image fits the context of traffic canals and buildings of the island Guidecca. Between the building blocks we find a more symmetrical room. The emphasis of this symmetry is situated near the opening (gate) into this room. This opening is emphasized with symmetrical windows, drainpipes and the concave backdrop of this part of the façade. The plain floor is going along with these elements. The window opening on the sides of the room are asymmetrical along with the plinth on the one side of the square block. This asymmetrical elements strengthen the contrast with the opening, this gives an extra emphasis to the opening of in this room.

FORMAL – INFORMAL

As one could conclude from the amount of ceiling (sky) and floor (ground/water) that we see in these images the rooms are different from each other. Room A has a wide, horizontal form and room B is relatively narrow and vertical. The wideness and amount of windows contribute to what extend the rooms are orderly arranged, and therefore formal. Furthermore, the amount of wall openings in the room A is larger than the amount of wall openings of room B. There are more windows that look out to the room, and it is therefore more controlled. We consider room A as the formal side, in comparison to the more room B.

In room B we find more items that are signs of daily life: drainpipes, some green and street lightning. The street lamp in the middle of the urban room is more of a chandelier, which contributes to the domesticity of the room by emphasizing the central point of the place. Because of these items, which we do not find in room A, we consider room B as the informal side. On the other hand we do find some vehicles, boats, in room A. The irregular pattern of the windows that we find in room B, we also find in room A. So the rules of the 'formal' side A are not really strict, there is also some informality to find.

TRANSITION ZONES – HARD BORDERS

The passageway is both the exit and entrance of room B and it is the only transition zone we find in this room. It emphasizes the division between room B and the space behind. In room A the vehicles can be seen as a transition between the path and the walls. Besides these elements we could not point out any items that make a subdivision within the rooms. There is no variation in floor coverings, both are continuous through the whole room and the walls manifest themselves as hard borders: transition zones are hard to find.

MOVEMENT – PLACE

In both rooms there is no subdivision in the floor coverings and furniture on the floors is absent. Since no clear path is defined, we consider the whole floors as the paths of these rooms. The whole of the rooms are meant for movement. The entrances/exits of the rooms manifest themselves by the way the walls and paths are composed. In room B the exit is more clear, the passageway marks the end of the room and the transition into another one. The path of room B is therefore considered as a short-cut, compared to the waterway of room A.

The ground floor image, showing the borders of the area, validates the findings of the photo analysis. Since in Venice the main transport is by boat, Room A is well connected to this main network of waterways. Room B is a hidden place, in between building blocks, with a pedestrian short-cut.

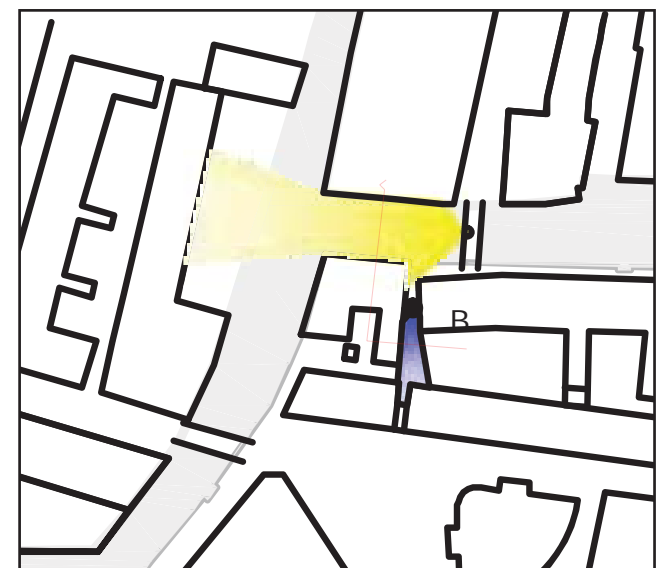

Room A

SYMMETRY



ASYMMETRY

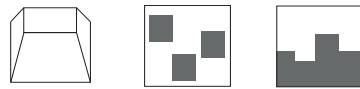

FORMAL

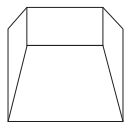

INFORMAL



TRANSITION ZONES

HARD BORDERS

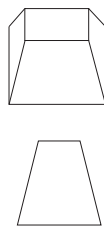

MOVEMENT

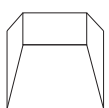

PLACE



Room B

SYMMETRY

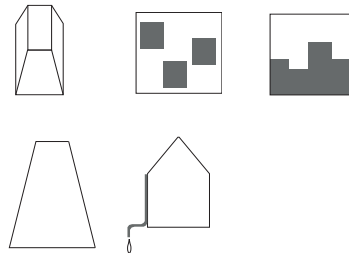

ASYMMETRY

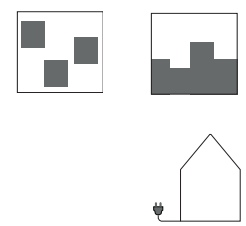

FORMAL



INFORMAL

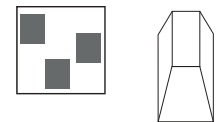

TRANSITION ZONES



HARD BORDERS



MOVEMENT



PLACE



SCHUTTERSVELD, DELFT

NL 2005

A dwelling project near the centre of the old Dutch city of Delft. Including to rows of houses and 8 separated housing blocks.

Surrounding the court there are 8 detached houses. According to the old town centre dwelling typology, these houses have a study and kitchen downstairs. There livingroom is on the first floor. The gardens are only bordered with a small row of beech hedges. In this way the open character of the court is kept.

Due to its setting, scale and the obvious relations with its surrounding it became a well integrated city project.

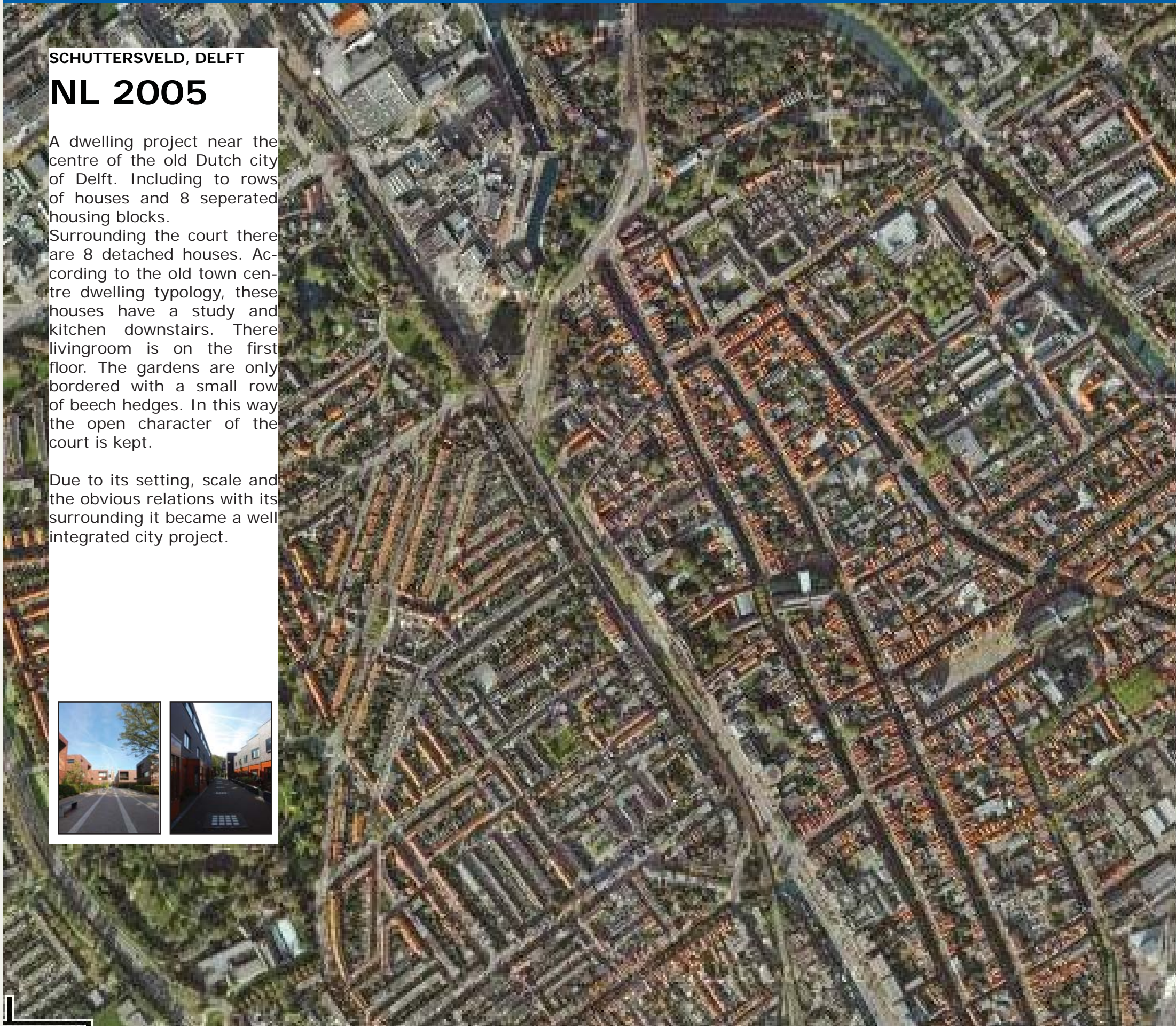



BORDERS

Defining the borders of the outdoor space.

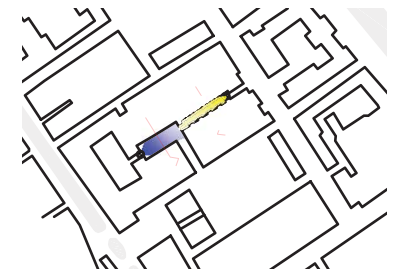

NOLLI

Defining the borders of the public space.

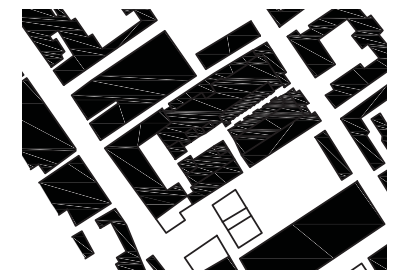

DEBOIS

Showing the connection with the urban fabric, taking 3 cognitive steps from the location.

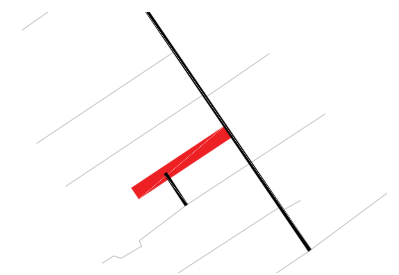

CONTRASPACE

An image of the in between space.
The darker the image the opener the spaces between the buildings.

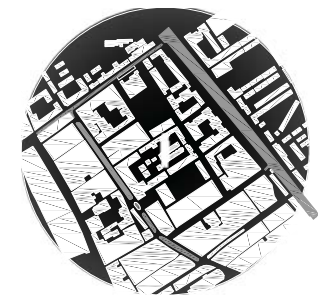

ENTRANCES

Showing the entrances of the research area.

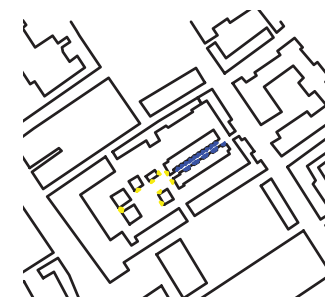

PROFILE

A section off the street we researched.

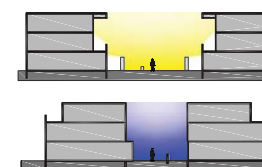



=

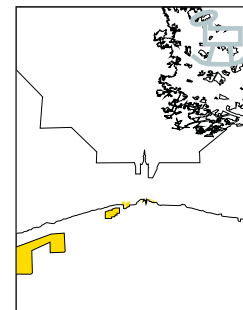
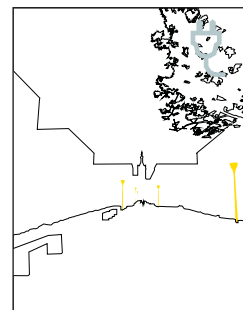
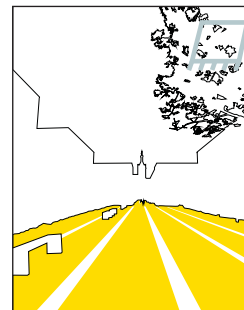
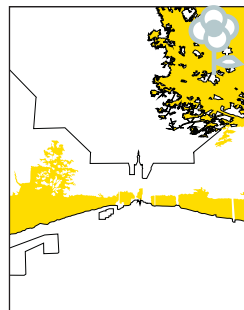
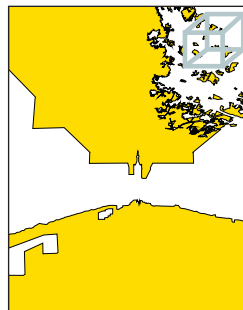

ROOM A

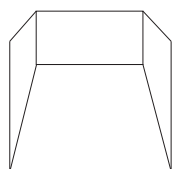

+

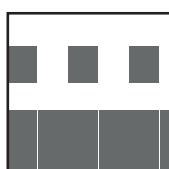

+

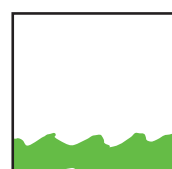

+



+



Most important items: horizontal cube; random windows; irregular plinth

Less important items: continuous floor covering; loggias; green on the walls; objects of use on the floor.



=

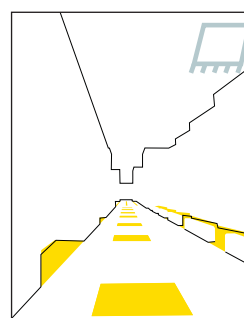
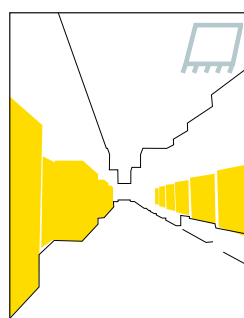
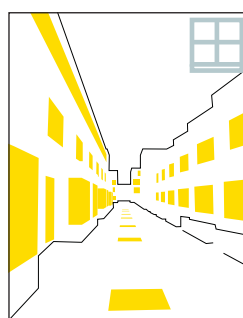
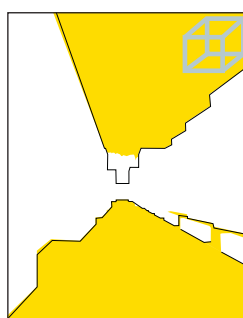

ROOM B

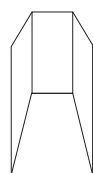

+

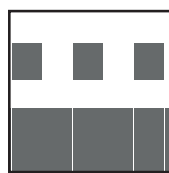

+

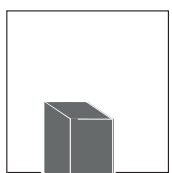

+



Most important items: vertical cube; random windows; irregular plinth.

Less important items: accents in floor covering; objects of use on the floor;

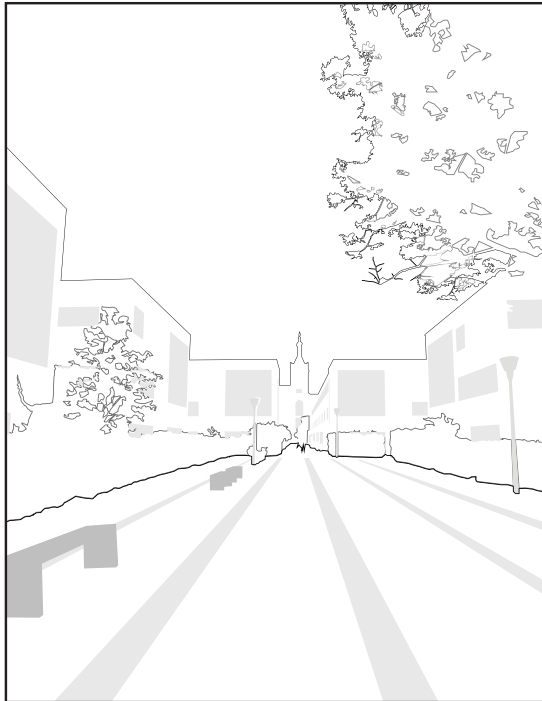

An urban room, enclosed by 8 different blocks. Big openings in the blocks bring some layering in the wall as a big niche. On ground scale accents on the floor emphasize the connection with the neighbouring street with on the end the old tower of a former university building. Green beech hedges are bordering this floor, being a border between the blocks as a big natural plinth.

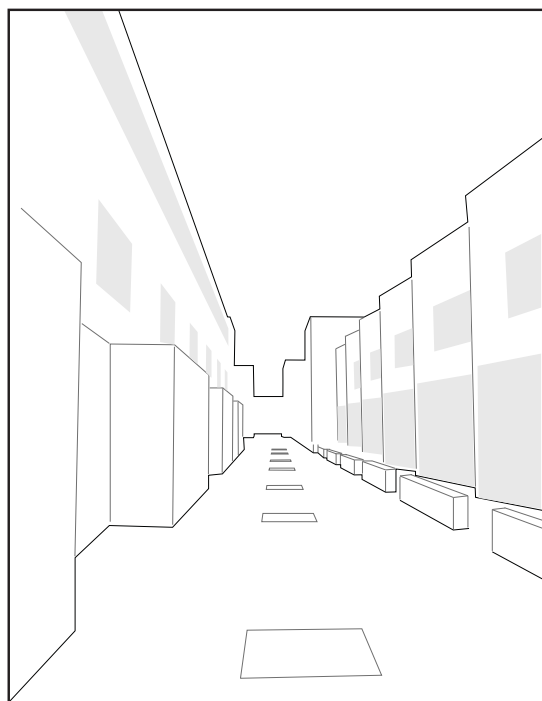
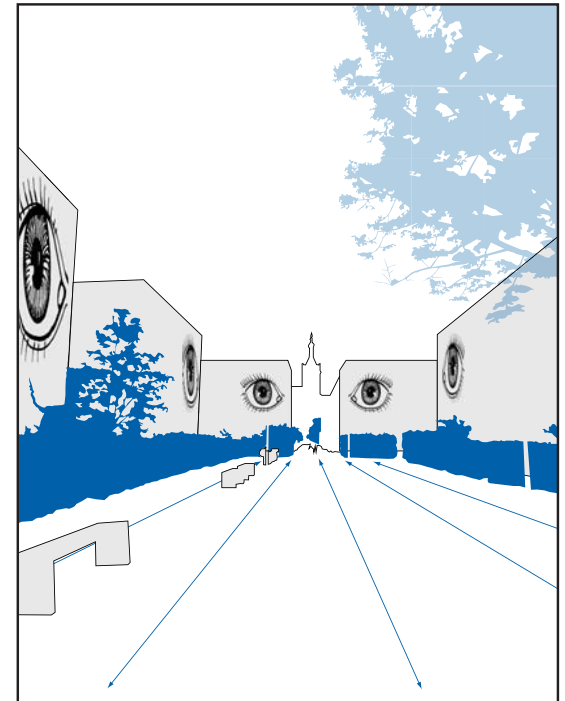

In this urban-room you immediately see the paneled extensions of the houses. As small blocks put against the wall a sequence of additions is forming the plinth. In the middle of the street are different tiles emphasizing the direction of the street to the small square of the Schuttersveld. Small brick walls are a border from the streetfloor to the wall and the dwelling laying behind it.

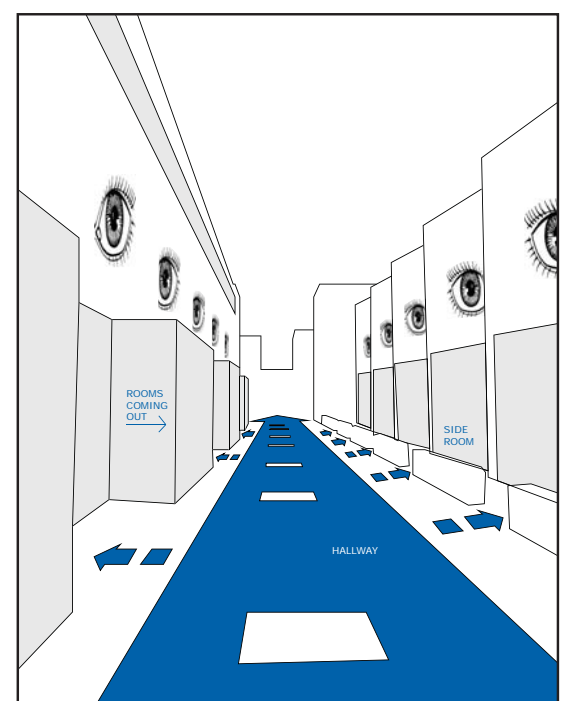

CONCLUSION

SYMMETRY – ASYMMETRY

As one could see in the analysis drawings, in both rooms a lot of items contribute to the symmetry of the place. The symmetrical items in room A are the walls, openings, loggia's, accents in the floor covering and the hedge. The only asymmetrical items are the benches on only one side of the room and a street light.

In room B also the wall openings and accents in floor covering are symmetrical. When looking at mirror symmetry in room B, the walls and plinth are asymmetrical. Though, they have the same rhythm and seem to react on each other: where the plinth on the left side is pushed out of the building, the plinth of the right wall is pushed inwards a little. Both facades have a similar rhythm, which results in a harmonious composition.

FORMAL – INFORMAL

The symmetry makes us conclude the rooms have a high extend of formality. Room A is a lot wider than room B and contains a square within the hedge. The square is completely empty, except for the benches that allow for some informal activities to take place.

We found that room B is built up from a series of smaller rooms, which form an enfilade. The openings, walls and floor covering all join in this sequence. The brickwork benches contribute to this rhythm, as small walls. The symmetry in room A and the sequence of the enfilade in room B create a certain order, which contributes to the formality of the space. But then both rooms also allow for some activities behind the green hedge and the brickwork benches and in between the out-coming plinth in room B.

TRANSITION ZONES – HARD BORDERS

The item that adresses a transition is in room A clearly the green hedge. It makes the border between private life and the square. This border is visually hard since the view from one side to the other is blocked, but physically soft since the sound and smells can pass this border, it is not comparable to a brick wall.

The brick benches in room B make a border between the path and a place in front of the houses on the right side of the room. This space becomes a transition zone between the house and the path.

The only hard borders in room A are the walls, which are hidden behind the green hedge. In room B the plinth is coming out, which makes a visually soft but physically hard border.

MOVEMENT – PLACE

The lines in the floor covering of room A give a direction to the room, which makes it likely to be a space for movement. The street furniture and walls make this room more into a place to stay.

In room B the rhythm of all the items together adds up to the continuity of the room, and gives a direction towards the other side. Although the room consists of several small rooms which are linked up together, they form one room as well: an enfilade. In room B several places to stay can be found, they are divided by the brickwork benches.

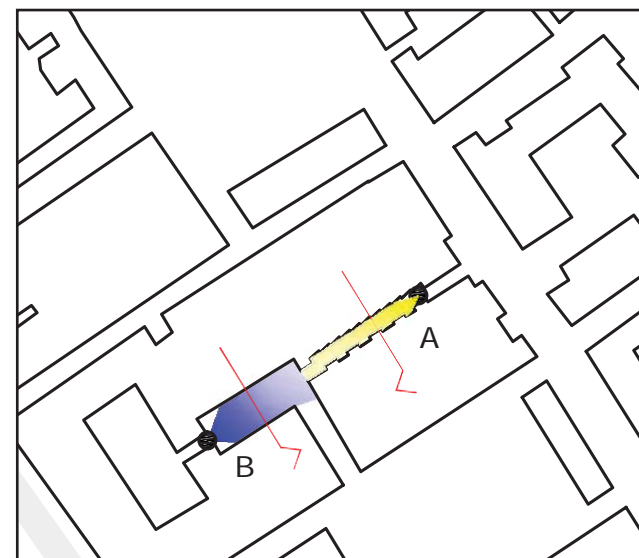

Room A

SYMMETRY



ASYMMETRY

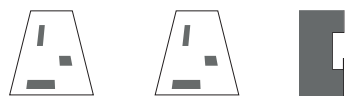

FORMAL



INFORMAL

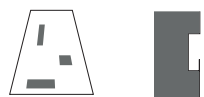

TRANSITION ZONES



HARD BORDERS



MOVEMENT



PLACE

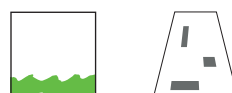

Room B

SYMMETRY



ASYMMETRY



FORMAL



INFORMAL



HARD BORDERS



TRANSITION ZONES



MOVEMENT

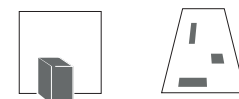

PLACE

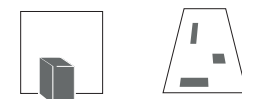

SEIJO, TOKYO

JP 2007

In a urban district of Tokyo this dwelling project of 20 houses is build on only 1.400 m². The volumes only leave a littebit space in between where lanes, perspectives and internal spaces have been created.

It is the cluster of apartments that makes the different identities in the in between spaces.

Every apartment is composed of a sequence of living spaces which are only connected at narrow points. In this way you get loose rooms that are linked carefully with treshold form flowing sequences.

It gives a transition that sets two rooms diagonally in relation to each other. So that the spcae is not closed but rather opens up to the next room.



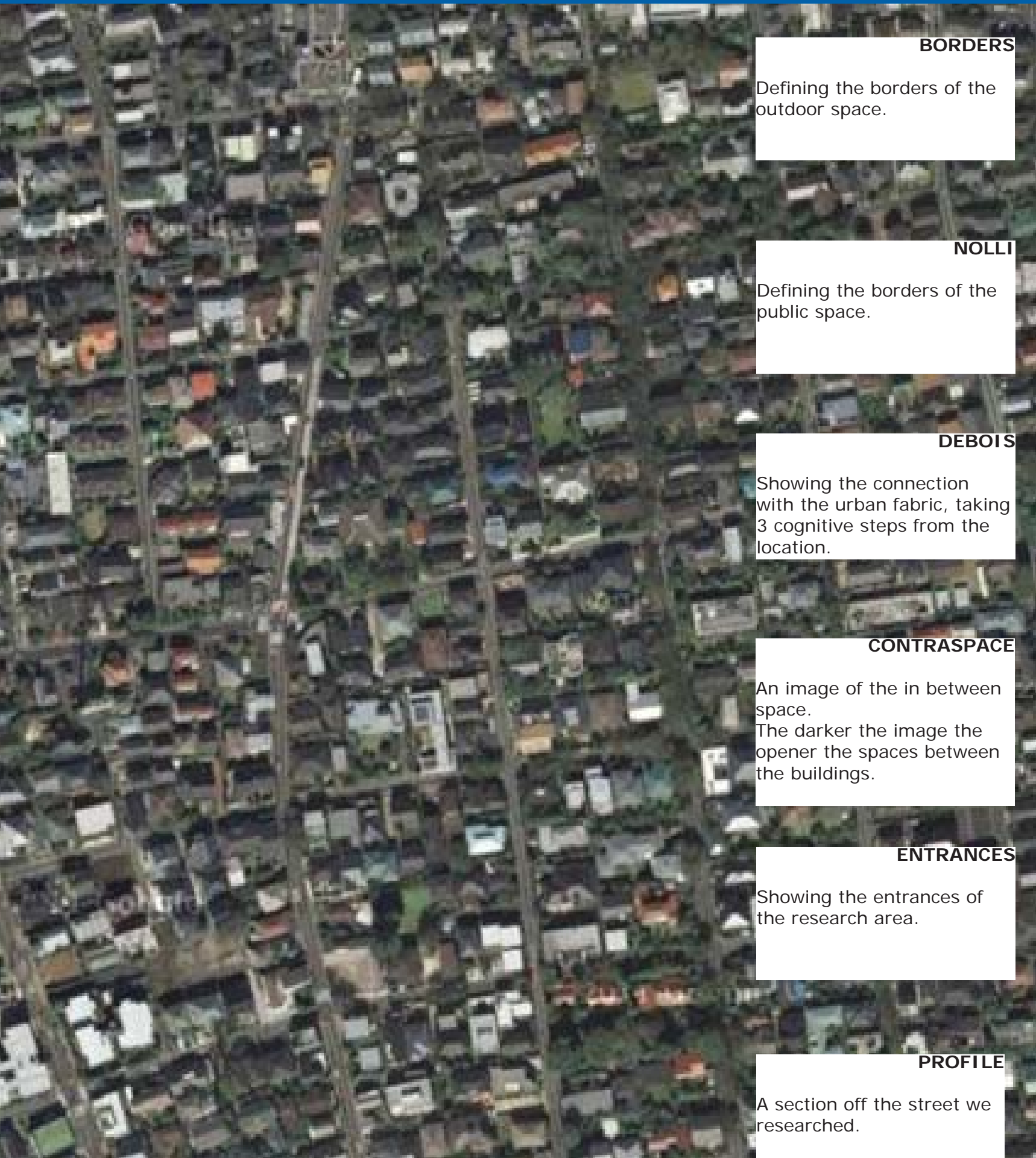

BORDERS

Defining the borders of the outdoor space.

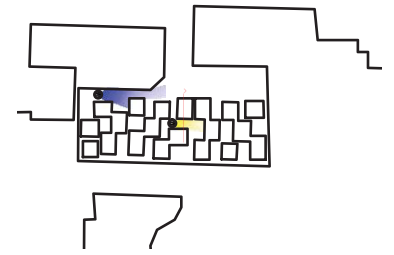

NOLLI

Defining the borders of the public space.

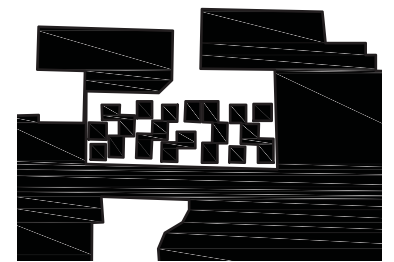

DEBOIS

Showing the connection with the urban fabric, taking 3 cognitive steps from the location.

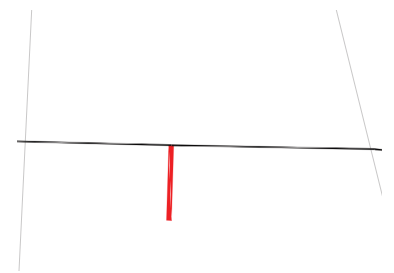

CONTRASPACE

An image of the in between space. The darker the image the opener the spaces between the buildings.

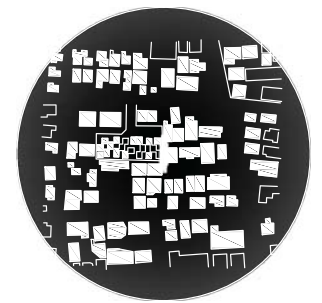

ENTRANCES

Showing the entrances of the research area.



PROFILE

A section off the street we researched.

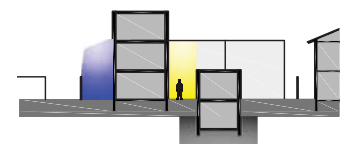

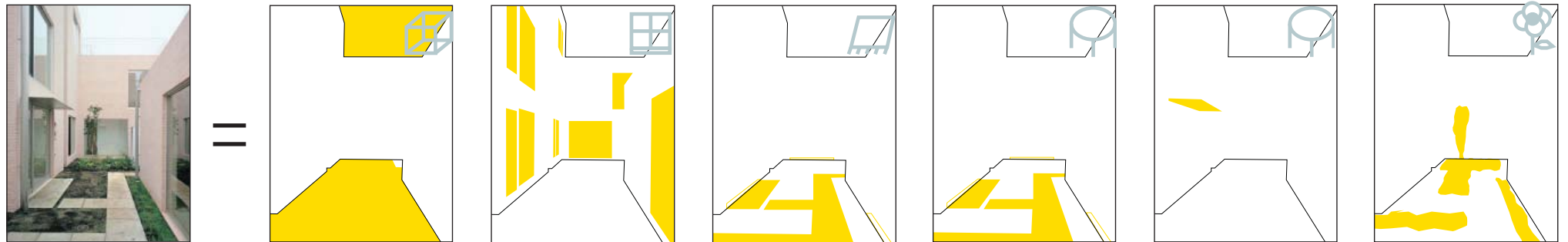

ROOM A

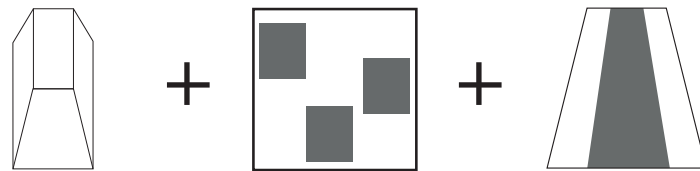

Most important items: vertical cube-formed room; random windows; emphasized path in floor covering



Less important items: sidewalk; overhanging slab above entrance; green on floor.

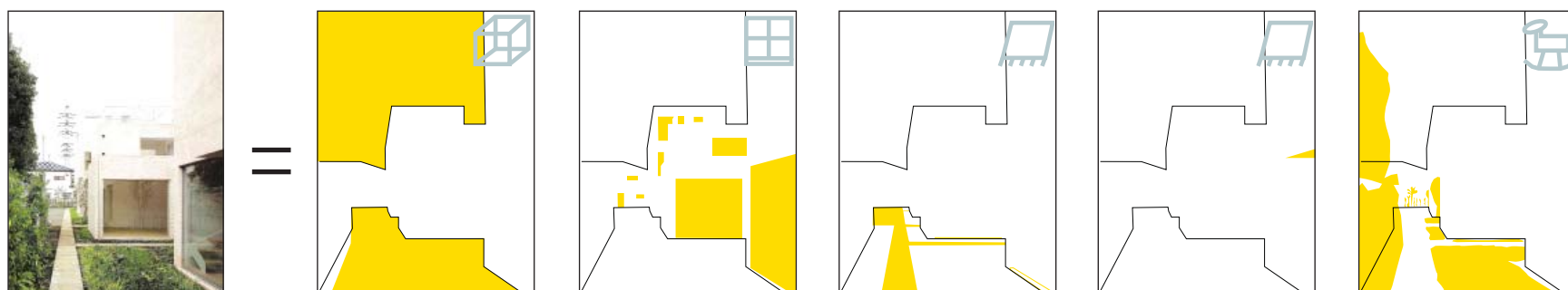

ROOM B

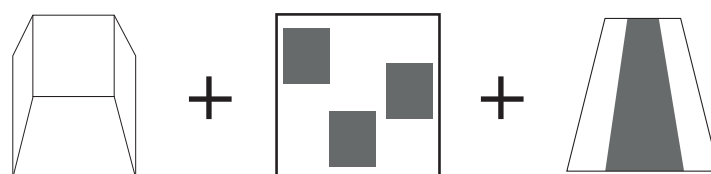

Most important items: cube-formed room; random windows; emphasized path in floor covering



Less important items: overhanging slab above entrance; green on floor.

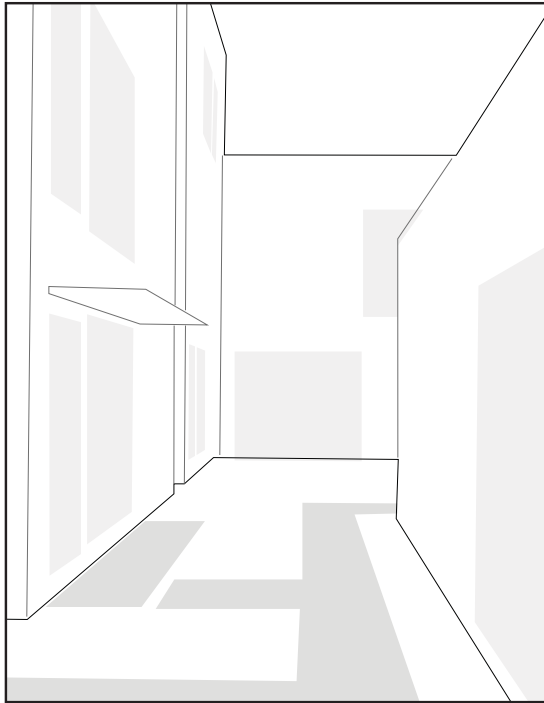

By different surrounding volumes different urban-rooms exist in this project. This room is quite narrow and supposed to walk through. The path is clearly emphasized by the white material that contrast with the green of the floor of the room. The porch is emphasized with a small sliced steel plate hovering above the door. The big windows are holes in the wall.

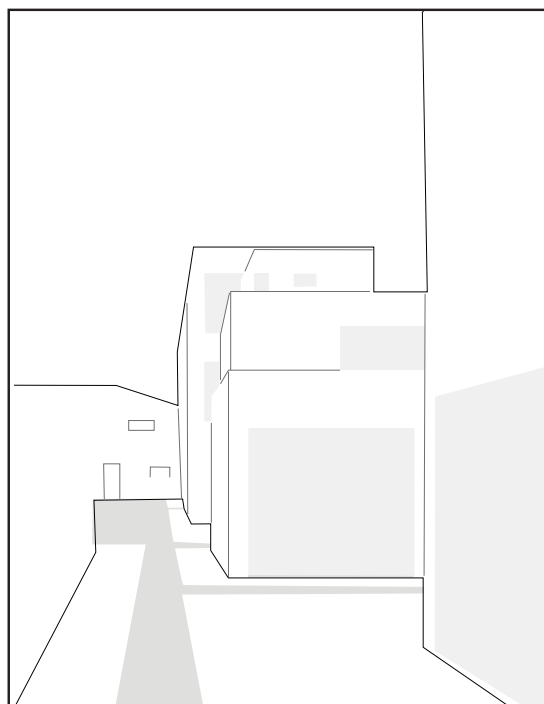
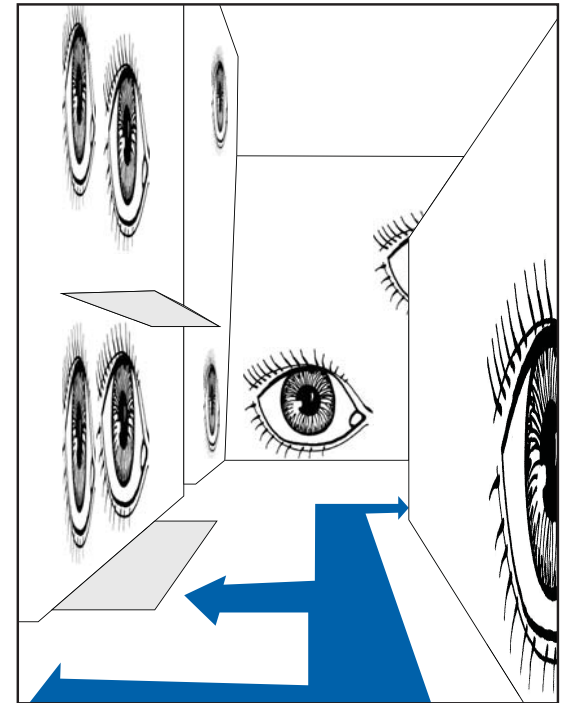

In this part of the project the space is less defined because one of the walls is covered with a natural layer. The wall of the volumes is irregular giving the straight blocks a dynamic look. By the contrast of materials the white stone walking path is emphasized.

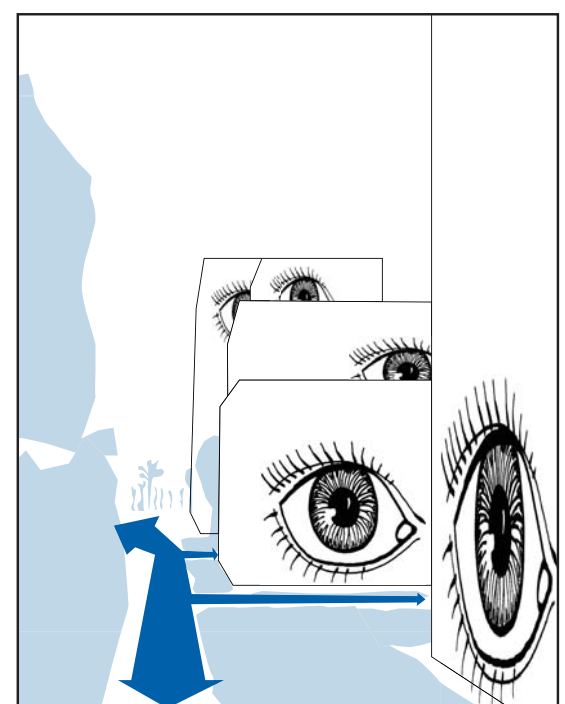

CONCLUSION

SYMMETRY - ASYMMETRY

None of the items we found, contribute to the mirror symmetry of both images. Although the path, green, wall openings, entrances and green all follow an irregular pattern, there is a certain harmony in these images. By their asymmetry all items contribute to a system of irregularity. In both rooms we found that the windows have similar sizes, the walls have similar materials and the path is clearly defined.

FORMAL - INFORMAL

We consider both rooms quite informal. This has a lot to do with the asymmetry we found in both rooms. Some formality derives from the clarity between path and green and from the way the entrance is emphasized by the hovering slab and doorstep.

There is no difference between the items we found in both rooms, except for the entrance in room A and the corresponding hovering slab and doorstep, which is missing in room B. Because of the similarity of items we consider the project for Seijo Townhouses as an all-round project, there is no clear hierarchy between the rooms on the in- and outside of the project.

HARD BORDERS - TRANSITION ZONES

The paths cut across the green pavement of both the urban rooms. There is a clear division between the green- and the path-zone; the green maintains the distance between the path and the house. In room A the combination of the hovering slab and the doorstep creates a transition zone between the house and the urban room. In all other parts, the walls are a hard border between dwelling and urban room.

MOVEMENT - PLACE

In both rooms the composition of the walls defines which way one could move in the rooms. Room B is on one side enclosed by bushes. In between these walls the floor covering gives direction, it forms a path. Since there is no sign of occupation of the rooms, we consider both rooms as places to move through instead of to be in.

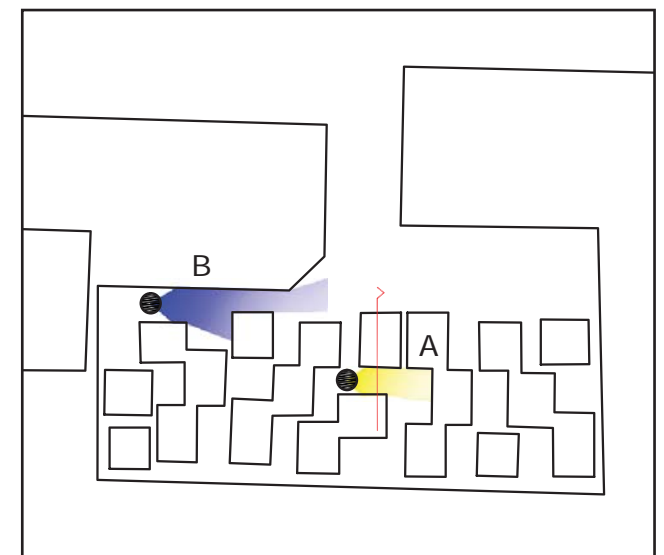

Room A

SYMMETRY

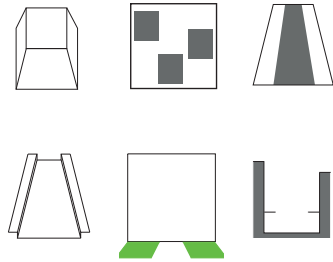

FORMAL

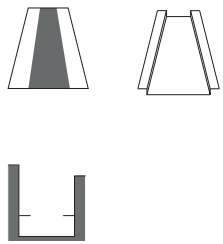

INFORMAL

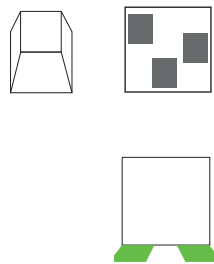

HARD BORDERS



TRANSITION ZONES

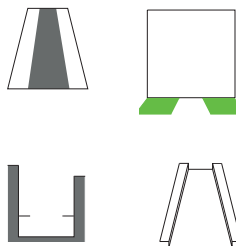

MOVEMENT



PLACE

Room B

SYMMETRY

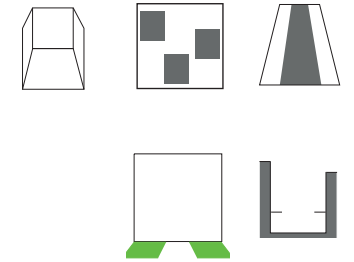

FORMAL

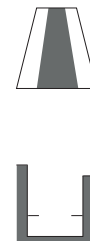

INFORMAL

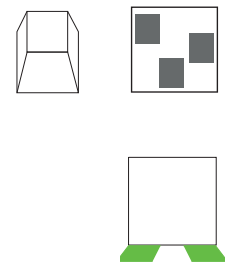

HARD BORDERS



TRANSITION ZONES

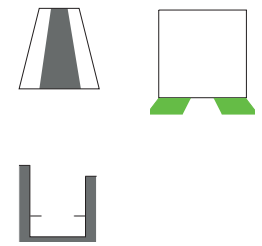

MOVEMENT



PLACE

MARK

the urban interior catalogue

		ALL	SYMMETRIC	ASYMMETRIC	FORMAL
GUIDECCA					 amount of, sequence of windows ornaments
	2002				 setback of the wall amount of, sequence of windows emphasizing the 'entrance' of the room
DELFT					 big openings
	2005			 a-symmetry of walls	 enfilade rhythm of facade
TOKYO					
	2007				

INFORMAL

TRANSITION ZONE

HARD BORDER

MOVEMENT

PLACE



pattern



objects in space: boats



water



water



pattern

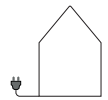

street furniture



accents in floor

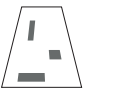

street furniture



street light



a-symmetry of walls



objects in space



accents in floor

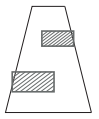

objects in space

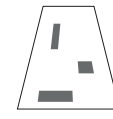

enfilade

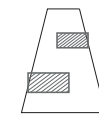

enfilade

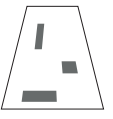

carpet in room

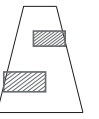

objects in room

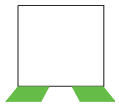

stoop

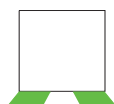
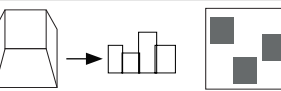

MODERN ROOMS

CONCLUSION

ALL

In all the modern urban-rooms we see just like the medieval rooms that the borders, the walls, are important. The window openings are important in all of these rooms and important for the character of these rooms.

SYMMETRIC – ASSYMETRIC

At the Junghans project at Guidecca we see a lot of symmetrical elements at the B-side of the project. These elements are located surround the entrance (gate) of the room. This puts the emphasis to this point in the space, the asymmetrical elements further in the room are strengthening this idea. It seems to strengthen the idea of movement. In Delft the Schuttersveld has the same difference, where the square is more symmetric the adjacent street has a more asymmetric character. The asymmetric appearance of the Seijo Townhouses fits the all-round project appearance.

FORMAL – INFORMAL

The informality of the projects is most of the times emphasized by elements related to the wall. Only small elements (elements of secondary importance for the character of the place) on the floor are informal. The room form (floor, wall, ceiling) at Seijo is the only one informal of the modern case-studies. The height of the volumes seem differs so much that it has an informal character. Even though the volumes emphasize the movement of the path through the projects (give unconsciously rules about routing). The formality is at the Guidecca and Delft projects found in the elements related to the walls where at Seijo the formal elements are related to the floor.

TRANSITION ZONE – HARD BORDER

The most of the transition zones are designed in the floor. Only added elements (extensions on façade and porches) connected to the wall give some appearance of transitions. But primarily we find transitions in the floors of the rooms that are making the transitions. At Guidecca the floor is made out of one material (water, grey stone). So there are no transitions to find, even though you could say that the object in space (boats) form a cluster that can be perceived as a transition between the wall and the water.

The hard borders are made by the walls. In almost all the rooms, except at the Junghans project in Venice where the water is a hard border. It is just the fact that people can't go over water on foot, that makes this space a hard border. The hard borders are in each project made by the walls. Only in Delft where we find the extended boxes to the wall that are directly facing the street. The border between private and public here is only a window.

MOVEMENT – PLACE

Movement is emphasized by the floors and walls, only at the square of Schuttersveld there we only see the movement on the floor. At Guidecca the movement at the one side is focused on this gate and everything that emphasis this doorway to this room. But the fact that this space is so enclosed makes it as well a space, the chandelier seems to strengthen this character. On the otherside of the project we find water, this water is the main route for the people living here. Even though possible it is not the place to repose, you stop with your car in the middle of the road to stay there.

Only at Schuttersveld, Delft we find this square where the place is really made by the street furniture and greenery surrounding the square.

At Seijo all the space are made only suitable for movement (there is only a small path to stay/move upon). The big glass openings in the walls can be opened so people can enjoy the green in between place in there house and make these spaces a part of their place.



FINAL CONCLUSION

MEDIEVAL ROOM:

At first looking to the different 'medieval urban rooms' the first thing to notice is that they differ in size. In the Netherlands the spaces between the walls are quite wide, to let sunlight in the 'urban room' as well as in the houses behind the walls. In Varallo the urban rooms are narrow, which makes them dark and the contrast with the 'enlightened' squares is bigger. In this way one can walk in the shaded streets during the hot summer. Besides the climatological difference, there is also a cultural difference in the preferred amount of direct sunlight. We discovered that the Japanese find more comfort in shaded places and for that reason we found so many tatami-screens on the walls of the Japanese 'urban rooms', to keep the sunshine outside.

In the medieval rooms we the walls seem to be naturally grown with a variety in height and form. There are some similar sequences to find between the individual houses, for instance in materials or the use of the same elements like small stairs, balcony's, eaves or fences. The openings in the wall strengthen this naturally-grown-atmosphere, since they differ in shape and are irregular placed in the walls of the medieval room. In general one could say that there is a clear cohesion, although there is a great variety within the set of items. In all 3 different medieval contexts we found the use of eaves. The big eaves were important for rain-water drainage, it poured down in front of the façade on such a distance that the walls of the house did not get wet or dirty from the rain.

Where in the modern rooms we sometimes doubted about the importance of certain items, in the medieval rooms every item has a clear purpose, the one being more important than the other. Even in the floors of these rooms we found that the difference in material communicates the transitions between different spaces.

MODERN URBAN ROOMS

In the modern rooms cases we found more rationality in comparison to the medieval rooms. The modern rooms are very geometrical with straight lines placed on a Euclidian grid, only some accents in Delft deviate from that.

In the 3 different case-studies we found the cohesion of the same heights, openings and additions on the wall. Where we found difference in the repeating items in the 'medieval rooms', we found a lot of the same repeating items in the modern 'urban rooms'. Mostly all walls of the rooms have one equal height. Only in the Seijo town houses project we found a variation of wall heights. In each case-study the walls are straight and cantilevers or eaves are absent, which is due of the lack of sloping roofs in the 'modern urban room' case-studies. All the modern rooms are abstract with a minimal number of items placed on the floor or against the wall. This idea is strengthened by the openings in the wall of the urban-room. They are most of the times bigger than the medieval ones.

Since we have the ability to make glass panels a lot bigger nowadays in comparison to the medieval era, we do not see any other supporting items in the windows which adds to the minimal utterance.

In the Zutphen case we found only one building height and in Italy the height differs a little in the urban-rooms surrounding the project. On the contrary the building blocks in the 'urban rooms' of the Seijo town house project show a great variety in height. The architect used several block heights, creating different 'urban rooms' in and around the project. The small shifts of blocks in the rooms enhance the route passing through the different rooms of the project.

REFLECTION

Looking back on past 10 weeks in which we went through the process of making this research we learned a lot.

From this research we learned to look better to other 'urban rooms' and it gave us the ability to distinguish certain things. It is as well a tool that can help us in our design project to make till example an informal urban room. We found a way to look carefully at the character of a space and what it is that makes this space having this character.

The method to research wasn't always as easy to work with, for instance you have to find pictures that are taken from the right angle. This is not a problem for a project nearby but harder when this project is on the other side of the globe. Next time we probably would have chosen Dutch projects because that would give us the ability to go there and visit the project, something that is very vital for analysis and research.

The method as well shows only 2 sides of the same project and that is quite subjective which makes it hard to give a total image of the project and 'urban rooms' that we investigated.

In this method a lot can be adjusted but it learned us a lot as well.

Nina Aalbers
Klaas-Melle Brouwer

REFERENCES

- Abrams, C
1972 The language of cities – A glossary of terms; New York: The Viking Press.
- Bloomer, Kent C.; Moore, Charles W.
1977 Body, Memory, and Architecture; Yale University Press, pp. 1-4, 41, 96.
- Dorst, M. van
2005 Een duurzaam leefbare woonomgeving; Zutphen: Eburon Academic Publishers.
- Ford, Larry R.
2000 The spaces between buildings; Baltimore: Johns Hopkins University Press.
- Fowler, H. W.; Fowler, F. G.
1969 The Concise Oxford Dictionary of current English; Oxford University Press, pp. 1085, 1431.
- Gehl, J.
2004 Het leven tussen huizen; Köln, Taschen, pp. 83.
- Eyck, Aldo van
1962 Team 10 Primer 1953-62, in Architectural Design, ed. Alison Smithson; London:
 publishers Academy Editions, p. 564.
- Koolhaas, R.
2004 Content; Köln: Taschen.
- Lynch, Kevin
1960 The image of the City; Massachusetts: MIT Press, pp.3-5.
- Smith, P.
1974 The dynamics of urbanism; London, The Anchor Press ldt.
- Van Dale Woordenboek
2010 Online professioneel Nederlands en Van Dale Online professioneel Engels, Frans en
 Duits; Van Dale Uitgevers.

JUSTIFICATION OF IMAGES

Cover:	collage by Klaas-Melle Brouwer	
p. 5	Italy Varallo: Netherlands Ypenburg: Japan Kyoto:	photo by Klaas-Melle Brouwer photo by Klaas-Melle Brouwer photo by Birgit Jürgehake
p. 6	The image of a face: Common boundary: The comfort zone: Body in control:	drawing by Nina Aalbers drawing by Nina Aalbers drawing by Nina Aalbers drawing by Nina Aalbers
p. 8	Palace of King Louis XIV, Versailles: E.U.R., near Rome: Street in Napels: Street in the Mathare slums:	photo by Kaipullah, 21-11-2009 www.flickr.com photo by Christos Constantinou 21-08-2010, www.flickr.com photo by Karsten, 27-10-2011, www.flickr.com photo by Von Glitschka, 07-05- 2010, http://artbackwash.blog spot.com/2010/05/slum-life
p. 9	Street in Varallo: Dwellings in Ypenburg:	photo by Klaas-Melle Brouwer photo by Klaas-Melle Brouwer
p. 12-13	Diagrams	by editors
p. 15	Zutphen 1 & 2 Delft 1 & 2 Varallo 1 Varallo 2 Venice 1 Venice 2 Machiya 1 & 2 Seijo Townhouses 1 Seijo Townhouses 2	photo by Nina Aalbers photo by Nina Aalbers photo by Nina Aalbers photo by Klaas-Melle Brouwer photo by julian_pierre, 03-11-2006, www.flickr.com photos by Birgit Jürgehake El Croquis 139: SANAA Madrid, 2008, p 252-256
The images on page 15 are placed on several other pages in the report.		
p. 18-61	aerial photographs diagrams	google maps by editors