

TWIGA



High precision positioning system for Ghana

Master thesis of Peter Verweij

Student: P.J. Verweij
Client: Prof. dr. ir. N.C. van de Giesen & A. Krietemeyer, MSc.
Chair: Dr. ir. J.C. Diehl
Mentor: ir. S.M. Persaud

1. Summary

In this report, the design process of a high precision positioning system for Ghana is described. The system consists of two devices, a base station and a user operated rover (figure 1.1). These devices provide precision positioning, using dual frequency receivers and the principle of differential positioning. The high precision positioning system can be utilized for multiple purposes. The system can open up business opportunities in surveying, can be used to make height maps for flood prediction and to gather meteorological data. The gathering of weather data is the main purpose of TWIGA, under which flag this project runs.

During this project, the main focus is to create a working product, which can be tested in Ghana as soon as possible. Therefore, the highest priority is to make a functional device in terms of accurate positioning, data connection and power supply. This device should be suitable for the local environmental conditions, such as tropical rain and a high humidity.

After clarification of the working principles and purpose of the system in chapter 2, an overview of the different phases of the project is shown in chapter 3. Next, the highest prioritized requirements for both products are noted down in chapter 4. Before elaborating on all the design challenges, the product overview of the rover and base station device is presented in the concept overview of chapter 5. Now that the reader has seen the final products, and knows its purpose, the design challenges are elaborated in chapter 6. The challenges consist of choosing a system hardware structure, defining the physical shape and appearance of the product, coping with rain and condensation water, setting up a reliable data connection, providing power to the system and making the products robust. For each challenge, first the applying requirements and inspiration is shown. After this, it is described how the intuitive model of a rover and base lead to learnings which were used to iterate to the final design. To clarify the business opportunities which the devices bring, the option of local production is elaborated in chapter 7. Also, the price of the two devices is calculated in this chapter. The rover costs 489 euro and the base 647 euro, including a 20% profit margin. This price is about 1/3 of the cheapest commercial competitor product. The product was evaluated in chapter 8, with a performance test in the Netherlands and with a usability focused test in Ghana. Both tests had a rather successful outcome, as is described in the overall conclusion of chapter 9. The system works in Ghana and the performance of the system is up to spec. However, there is place for improvement in the software and the user feedback which the devices provide. Finally, recommendations for the product are made in chapter 10. These recommendations describe what the software should be like, how the electronics could be improved, which improvements can be made for producibility and whether new features that were requested in the evaluation should be added or not.



1.1. Left, final design of base station final design - Right, final design of rover on tripod.

Contents



Contents

1.	Summary	6
2.	Introduction	7
	2.1. Where	8
	2.2. What	9
	2.3. Why	10
	2.4. Who	11
	2.5. Summarized problem statement	12
3.	Assignment and process	14
4.	Requirements	16
5.	Concept overview	20
	5.1. Setting up the base station	21
	5.2. Base station user journey	22
	5.3. Base station internal components	24
	5.4. Ways to use the base station	28
	5.5. Setting up the rover	29
	5.6. Rover user journey	30
	5.7. Rover internal components	32
6.	Main design challenges	34
	6.1. System structure	38
	6.2. Physical shape and appearance	42
	6.3. Condensation water	44
	6.4. Coping with rain	48
	6.5. Data connection	50
	6.6. Power supply	54
	6.7. Robustness	58
7.	Business perspective	59
	7.1. Local production	59
	7.2. Cost price	60

8.	Evaluation	62	
	8.1. Performance test in The Netherlands	63	
	8.2. Test in Ghana	65	
	8.3. Comparison to plan of requirements	69	
9.	Conclusion	70	
10.	Recommendations	72	
11.	References	74	
12.	Appendices	76	
	Appendix A.	Full list of requirements	78
	Appendix B.	Part list BASE2	80
	Appendix C.	Part list ROVER2	82
	Appendix D.	Estimation of production labor costs	84
	Appendix E.	Estimation of product machining costs	85
	Appendix F.	Interview with Stylish	86
	Appendix G.	Competitor products, main features and prices	88
	Appendix H.	Research on design for condensation water	89
	Appendix I.	Examining the Stego drain element	91
	Appendix J.	Condensation water test	92
	Appendix K.	Research on waterproof design	94
	Appendix L.	Base station solar system calculation	96
	Appendix M.	Rover power consumption calculation	97
	Appendix N.	Solar panel test	98
	Appendix O.	Solar converter selection process	100
	Appendix P.	Connectivity options	103
	Appendix Q.	ROVER1 Design and build process	106
	Appendix R.	BASE1 Design and build process	112
	Appendix S.	ROVER2 Build process	117
	Appendix T.	BASE2 Build process	121
	Appendix U.	Original project brief	126

Abbreviation list

APN	Access Point Name
GNSS	Global Navigation Satellite System
GPRS	General Packet Radio Service
GSM	Global System for Mobile communications
MPPT	Maximum power point tracking
NTRIP	Networked Transport of RTCM via Internet Protocol
PCB	Printed Circuit Board
PDA	Personal Digital Assistant
RF	Radio Frequency
RTCM	Radio Technical Commission for Maritime Services
RTK	Real Time Kinematics
SIM	Subscriber Identity Module
SMA	SubMiniature version A (Coaxial RF connector)



The work leading to these results has received funding from the European Community's Horizon 2020 Programme (2014-2020) under grant agreement n° 776691. The opinions expressed in the document are of the authors only and no way reflect the European Commission's opinions. The European Union is not liable for any use that may be made of the information.



TWIGA

Preface

Writing this thesis has been quite a journey. Up front I was planning to work at the campus all day. The occurrence of a pandemic was not something I had ever even considered an option. The first week of my research seemed normal, only not shaking hands while meeting so many new people was a little confusing. However, soon more would be different. During the second week, everyone had to stay at home and now, six months later, the way of working and living has changed for people around the world.

Working and prototyping at home was a whole new added challenge, which triggered a lot of creativity. Who would have known that the refrigerator would be used as climate chamber, the shower would simulate the rainy season, 3D printer sounds could be heard in the house for days on end and solar systems can be tested in your living room window (figure 1.2).

Despite this setting, it does not feel like the end result has been compromised. The situation of prototyping at home might even have helped getting more insight in the low resource setting in which my final product has to be built. Also traveling to Ghana was impossible. Luckily, I had traveled to multiple African countries before so that I was able to clearly understand the described circumstances. A lot of hours have been spend talking and testing the device over a video connection. Seeing someone smile while using the device you have designed is well worth the effort.

Acknowledgment

At first, I like to thank Stefan Persaud and Jan Carel Diehl for their coaching and good remarks during the process. I like to thank Nick van de Giesen as a flexible client with a clear vision. Furthermore, I like to thank Andreas Krietemeyer for all the hours he spend to explain and solve software problems with me. A working product would surely not have been here without Andreas. The civil engineering students Ruben Smits and Ivo van Balen should be thanked for testing the performance aspect of the system during my design process. Of course, I like to thank Stylish for his clear comments and great testing in Ghana. His effort really made the difference between designing in a vacuum or designing with Ghana in mind. Finally, I like to thank all my house mates for the infinite patience when all kind of project related objects were kept showing up around the house. Besides their patience, I also like to thank them for the support and diversion from the project, while working at home often has no end.

For the same reason, I like to thank my family and all other friends for making this study time bearable, memorable and fun.

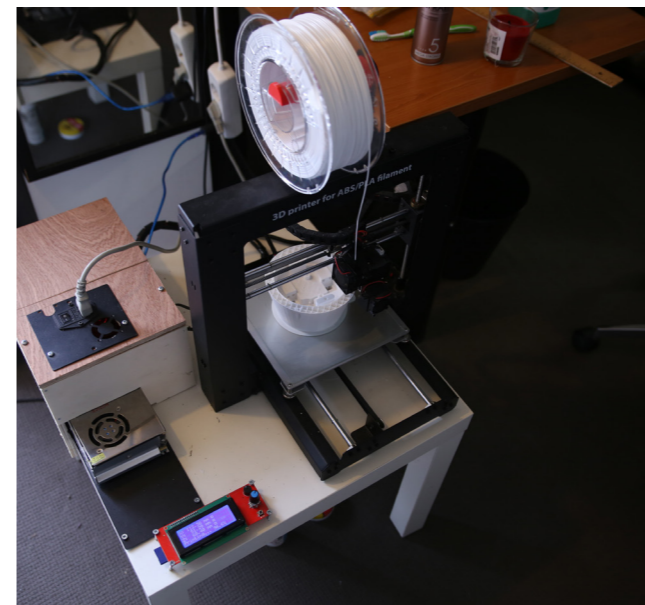

1.2. ↵ Repaired 3D printer has been printing continuously for 30 - → Rain testing in the shower
↵ Refrigerator as climate chamber - → Testing a solar system out of the living room window.

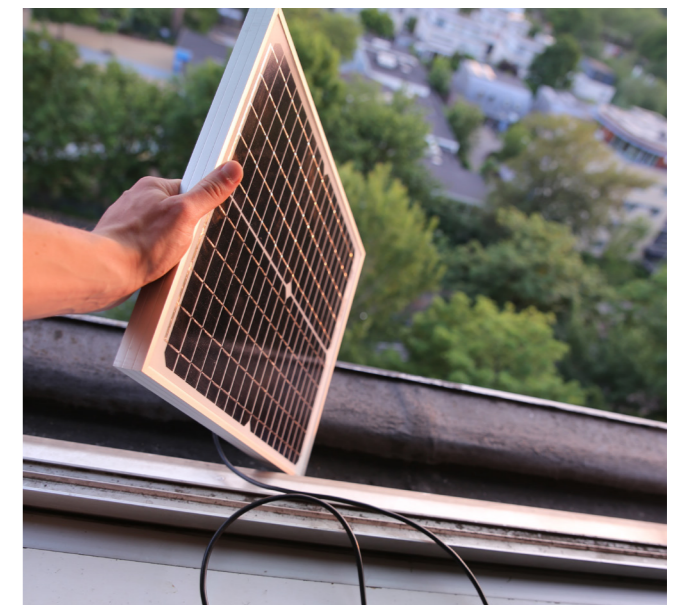

2. Introduction



This project is part of TWIGA:

“The TWIGA project (Trans African Water Information for Geo-Applications) is a 4-year project funded by the EU. The aim of TWIGA is to provide African countries with more accurate satellite-based weather data and positioning equipment.”
(Twiga, 2020)



Therefore this project will serve the following goals:

- 1. Providing weather data to improve the weather forecast.**
- 2. Providing cost efficient precise positioning equipment.**

Several students and researchers have already worked on low cost precision positioning equipment before the start of this project. They have proven that, by using the latest relatively inexpensive dual frequency GNSS receivers, it is possible to acquire weather data by analyzing the tropospheric delay. (Krietemeyer, van der Marel, van de Giesen, & ten Veldhuis, 2020) During this project, students have shown that low cost GNSS receivers can potentially deliver usable positioning results, compared to professional GNSS positioning devices. (van Balen, 2020), (Smits, 2020).

This chapter will further elaborate on the question why Ghana would need precise positioning equipment, how it works and who are participating in the project.

2.1. Where

The project is focused on the city Kumasi in Ghana. This city is positioned 200km north west of the main city Accra. Kumasi is the second biggest city of Ghana with an estimated 3 million inhabitants. (United Nations, 2019)

The main industries of Kumasi are the production of timber, cultivation of cocoa and mining of gold. Despite these activities, the GDP per capita in Ghana is about 23 times lower than in the Netherlands. This economic situation and the fast growth of Kumasi make people live in rather poor conditions. (Worldbank, 2019)

Infrastructure wise more than 95% of the Ghanaian population has access to a GSM and 2G network. (GSM Association, 2020) 82% of the population has access to electricity in Ghana. This is relatively good considering that in whole Sub-Saharan Africa only 35% of the population has electricity access. However, having electricity access is not everything, due to fuel supply issues and revenue loss by lack of payment the Ghanaian electricity network is often plagued by load shedding. (Center for Global Development & Kumi, 2017)

Kumasi is positioned close to the equator. Therefore the climate is tropical. This climate is characterized by an extensive amount of precipitation and high average temperatures. Due to this combination, the humidity is often above 80%. The wet season lasts from February to November. While the dry season, December and January, is very short. (WMO, 2017)

2.2. What

GNSS is a global positioning system based on the principle of lateration. Satellites from multiple global positioning networks are used among which: Europe's Galileo, GPS of USA and BeiDou from China. At least 4 satellites are needed. Three to define the position in three dimensions and a fourth to define a fixed time offset from the often less accurate user-device clock.

Several factors cause errors in the final positioning result. The origin of these errors is explained in 2.1. (de Bakker, 2017)

Due to these errors a normal receiver in your mobile phone can have an accuracy of +/- 15m. For our application, we are looking for a centimeter accuracy.

Satellite error

Satellite orbit (Ephemeris)

Ground-stations track the orbits of the satellite. Here, a small deviation can occur in-between the hourly updates.

Satellite clock

Each satellite clock has to be corrected for drift.

Environmental errors

Ionospheric error

The ionosphere is the upper part of the earth's atmosphere. The ionosphere is ionized by solar radiation. Waves can travel at a different speed in the ionosphere. This is often the biggest factor in the positioning error. The error caused by the

The proposed system for centimeter accuracy positioning (figure 2.2) is a differential GPS system. It uses dual frequency receivers which can largely eliminate the ionospheric error by comparing the travel speed of two waves with a different wavelength through the ionosphere. A reference base station is used to correct for other positioning errors. This base station is situated at a known location. By measuring its own known location, the base station can define the current present error. The defined positioning error can be sent to a rover nearby, using the standardized NTRIP protocol. This data is used to refine the position of the rover. The real time refinement process is called RTK (Real Time Kinematics). It has to be noted that this refinement does not account for multi-path errors, as rover and base experience different surroundings.

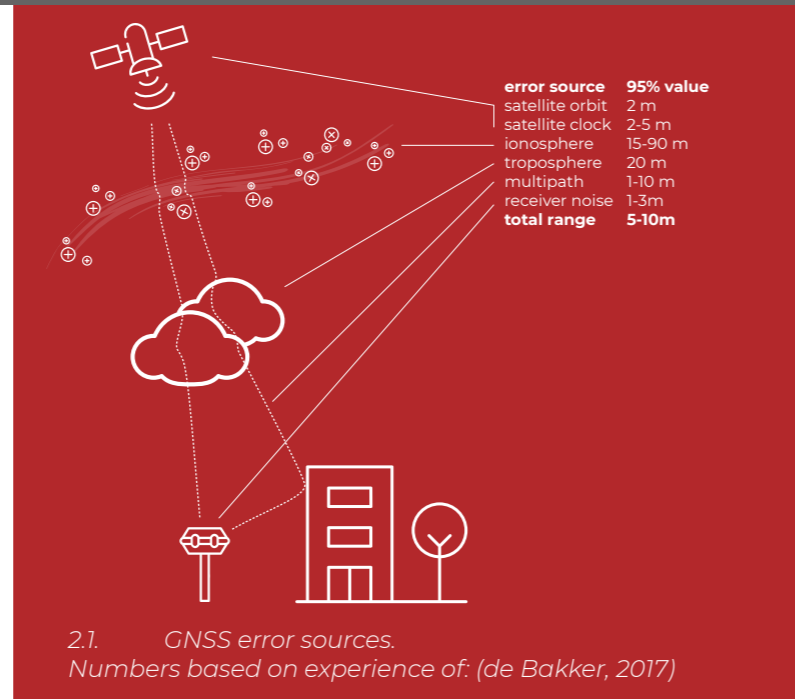

2.1. GNSS error sources. Numbers based on experience of: (de Bakker, 2017)

ionosphere becomes larger at higher sun intensity. (Guo et al, 2015)

Tropospheric error

Moisture and other weather conditions can cause the waves to travel slower.

Multi path error

Waves can reach the receiver with a longer route by bouncing along an object such as a building.

Receiver noise

To measure the distance to the satellite, the Receiver has to compare of the received wave chip to the current wave code in the receiver. Noise on the received wave can create errors in this comparison. (de Bakker, 2017)

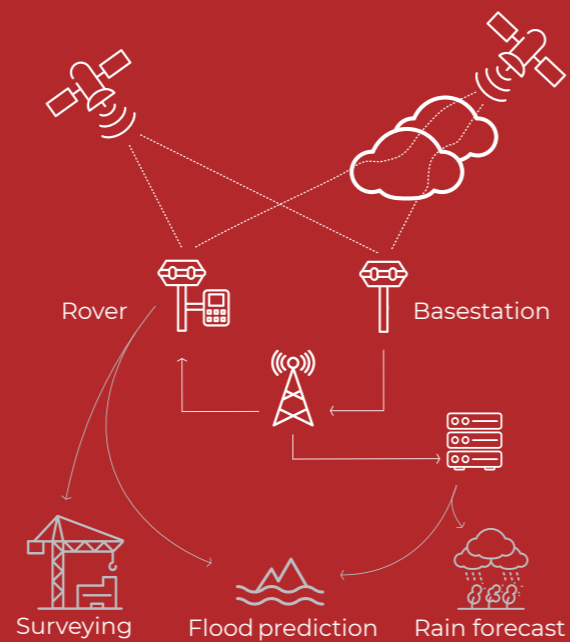

2.2. System and use case overview

2.3. Why

Floods

Due to the fast growth of inhabitants, people in Kumasi tend to build their houses on floodplains. Due to the extensive amounts of precipitation, these areas can be flooded. This flooding can have disastrous consequences. (See figure 2.3) Dependent on the rainfall, several cases like this occur each year, as can be seen in (figure 2.4, P. Amoateng et al., 2017)

Using precise positioning, height maps can be made to predict which areas will flood. In this way people could be warned before the flooding occurs.

Surveying

Besides the purpose of making height maps, positioning equipment can also open up business opportunities. Meanwhile, the service could also be used for other purposes such as positioning and observation of constructions, survey services, vehicle positioning, etcetera.

Rain forecast

52% of the people in Ghana are working in the agricultural sector (Food and agriculture organization of the UN, 2020). They rely largely on the prediction of rainfall.

The data of base-stations can be used to measure water vapor in the atmosphere (the tropospheric error). In figure 2.5 it can be seen that base-station data is widely available in Europe and America. However in west Africa this data is not gathered at all.

When water vapor data is available it can be used to improve the weather forecast. Thus, helping the Ghanaian people to achieve a better harvest.



2.3. Flood in Kumasi, 7 people drowned after a heavy downpour of rain in 2018 (GhanaWeb, 2018)

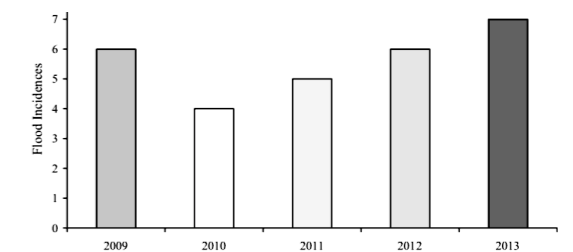

2.4. Flood in Incidences in Kumasi from 2009 to 2013 (P. Amoateng et al., 2017)

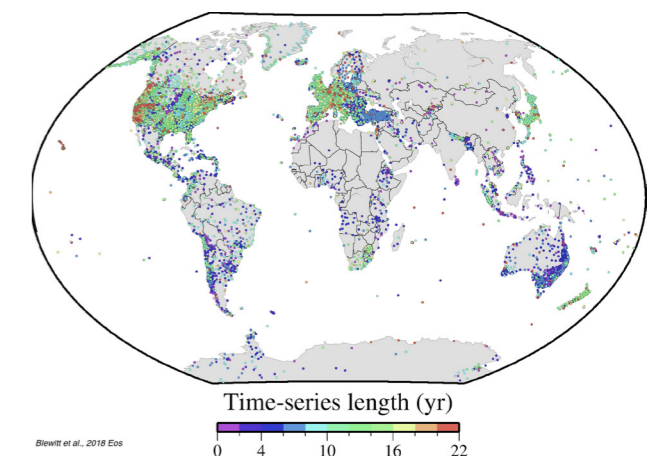

2.5. Length of base-station datasets world wide (Blewitt et al., 2018 Eos)

2.4. Who

In this paragraph all stakeholders of the project, and groups of people affected by the project are mentioned. The relation between the stakeholders is visualized in figure 2.6

TWIGA aims to transform water, weather and climate information through in situ observations for geo-services in africa. (TWIGA, 2020) (1)

The weather data could in this case add value for inhabitants of flooding areas and for farmers in Ghana. (2) The project is funded by the European union (3), while been executed by several institutions, among which: the TU Delft and KNUST university (4). Within the TU Delft Prof. dr. ir. Nick van de Giesen and Andreas Krietemeijer MSc are developing a precise positioning system for the TWIGA project. Functional prototypes of a rover and base station have already been developed. However, there is no neath product which suits the local conditions. Therefore, the goal of this graduation project is to design a rover and base station which can be used in the west African context. The products which will be the result of this design

process (5) have to comply to the Ghanaian law (6). The products could be of interest for several commercial parties. Among these commercial parties could be providers which are interested in running a NTRIP service (7), or survey companies who are interested in using the NTRIP data (8). Finally, there are the employees of these companies who have to use the products themselves. This includes technicians for installation or repair (9) and survey employees to use the rover device in the field on a daily basis (10).

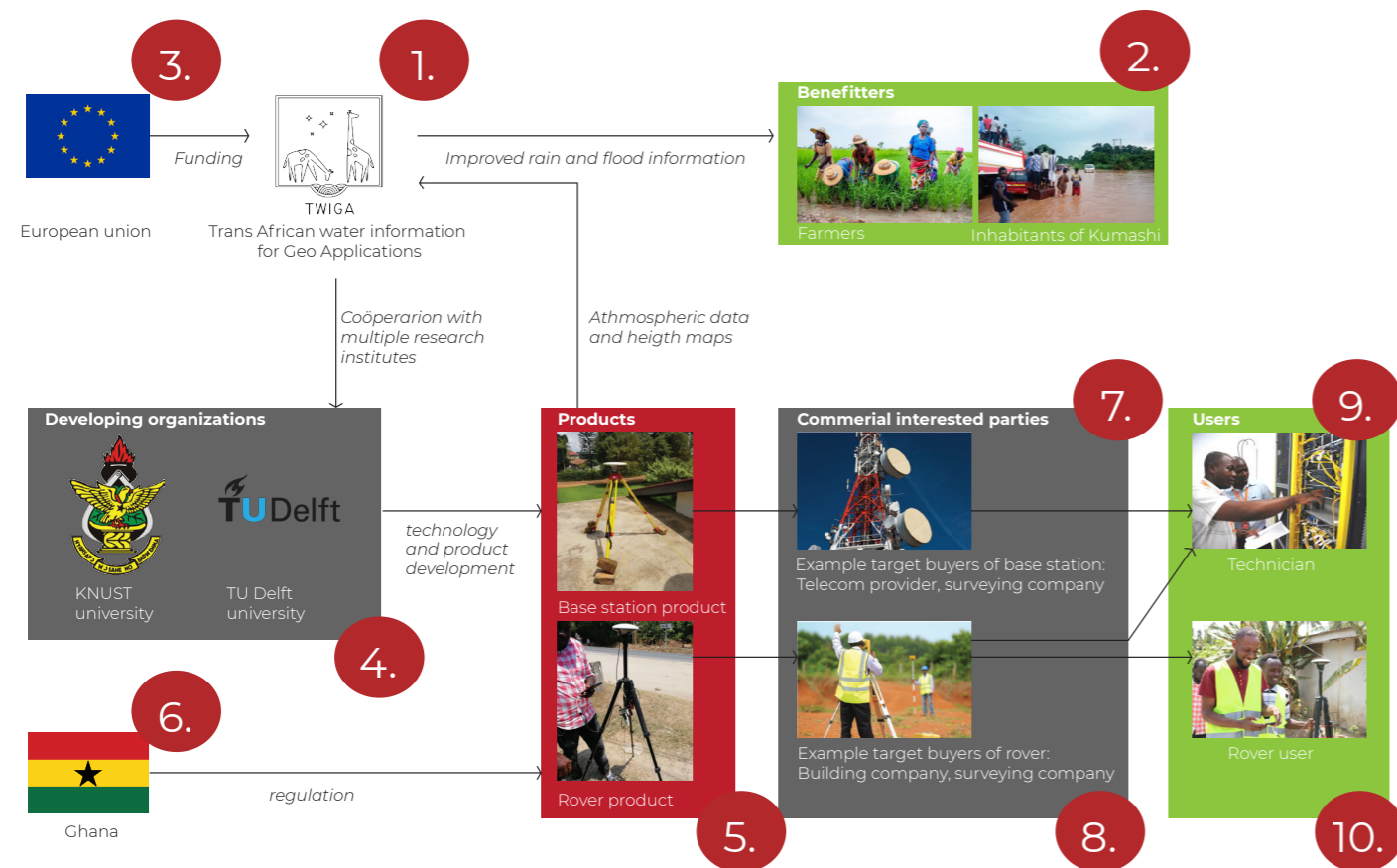

2.6. Stakeholdermap

Introducing stylish

Stylish (figure 2.9) lives in Kumasi. He got his BSc in Geomatic Engineering from KNUST university. After his study Stylish started doing survey work. Because he was very interested in GIS, he teamed up with his co founder and started making all kinds of GIS software solutions under the company name Maptech. Stylish and his partner consider the viability of using GIS for other sectors like land survey, agriculture, health and environmental purposes.

High precision positioning equipment would be of good use to gather data for these systems. Stylish described his first thoughts about high precision positioning in an interview which can be read in Appendix F. During the process, Stylish commented on the intuitive ROVER1 and BASE1 designs and tested the final ROVER2 and BASE2 design. Therefore Stylish himself and his feedback can be found throughout the report.



2.9. Stylish

2.5. Summarized problem statement

Currently there is no cost-efficient precise position equipment for Ghana. At the same time the weather forecast for Ghana is very inaccurate due to lack of weather data.

The current rover and base station prototypes (figure 2.7 and 2.8) are functionally working, however they are not intuitive, not suitable for series production, inadequately protected against tropical weather conditions and neither suitable for operation during power cuts.



2.7. Initial state of rover



2.8. Initial state of base station

3. Assignment and process



Assignment:

Design a high precision positioning system, based on a dual-frequency receiver, which can be produced in small batches. This system should suit the Sub-Saharan African context in terms of usage, weather resistance, communication, producibility and power supply.

The assignment was changed slightly. The mass production was changed to small batches, while 100 pieces can not be considered mass production. Also Sub-Saharan was found to match the defined area better than west Africa. The initial assignment can be read below.

Initial assignment: *Design a mass producible high precision positioning system, based on a dual-frequency receiver. This system should suit the west African context in terms of usage, weather resistance, communication, producibility and power supply.*

Process



Previous tests, with dual frequency receivers, have proven the concept of cheap high precision positioning to be viable. (Krietemeyer, van der Marel, van de Giesen, & ten Veldhuis, 2020)



Literature research and comparison with competitor products lead to the envisioned product mockups; Rover and base could be seen as one universal device with a solar panel or screen attached depending on their use as either base or rover.



An intuitive version of ROVER1 and BASE1 were built to find out if the made assumptions were correct. It seemed that the use of existing hardware components prohibited the build of one universal device.

Performance and usability was tested during several tests of the whole system and tests of the subsystems. Ghanaian contact persons also gave their feedback on the design by a video call.

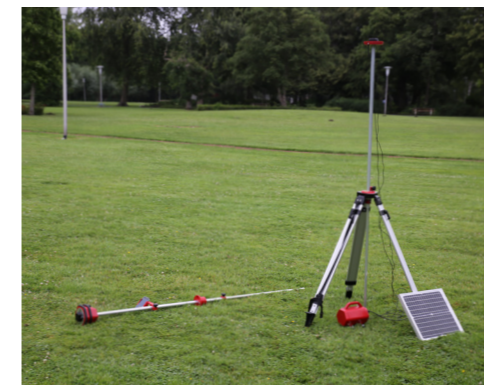

The findings and feedback were used to create the final prototypes ROVER2 and BASE2. The impossibility to create one unified device was converted in a chance to make two completely different optimized setups. Together with the client it was decided to focus mainly on robustness.

Finally, the devices were send off to Ghana for evaluation and exploration of business possibilities by the survey company Maptech.



4. Requirements

This chapter describes the requirements which are the selected top priorities for this project. The requirements have been defined in discussion with the clients, Prof. dr. ir. N.C. van de Giesen and A. Krietemeyer, MSc. Also Stylish was consulted when setting up the plan of requirements. The requirements have been prioritized based on the preference to obtain a functional product which is suitable for the target environment.

Of course there are requirements which are taken into account, yet require more focus in the future. The full list of requirements can be found in Appendix A.



Basestation

Can transmit NTRIP data for RTK

Provides RTK correction data for the rover.

Can transmit raw data for weatherforecast

Can log and upload data to a webserver for rainforecast.

Product is easy to use

Mounting process can be learned by Ghanaian technician of target company within a half day.

Can be powered without the use of the power grid

Power 24 hours at every day of the year.

Requirements for both devices

Can withstand tropical humidity	85% Humidity
Can withstand tropical rain	IPx4
No dust should harm the product	IP6x
Can withstand rough winds	Sudden gusts of wind
Aesthetics suitable for local context	The Ghanaian employees should approve the appearance of the product.
Costprice of product	€250-€500 (rover & basestation no more than 1000 euro)
The device should be positioned straight up when measuring	Component which shows/makes sure that device is positioned upwards when measuring.



Rover

Device can measure an accurate position.

Accuracy matches the tollerances given by the manufacturer Ublox.

Can receive NTRIP data from base station for RTK

Data connection available around Kumasi

Product is easy to use.

University graduate or even Senior High School leavers are able to use the device within 30 minutes of training

Can withstand Impact damage.

Product should be undamaged after fall from 1,5m to a hard surface

Fixed distance to the ground.

Mechanism which ensures the distance from the antenna to the ground is the same at each measurement

5. Concept overview

Before being immersed in all the design challenges and considerations of the project in chapter 5, it is good to know what the final products actually look like and how they work.

In this chapter, the final design of the rover and base station are presented. The code name of these devices is ROVER2 and BASE2, however in this chapter they will be referred to as ROVER and BASE.

For both devices, first an product summary is shown, followed by a through description of how the product should be used. Finally, an exploded view can be found in which all components of the product are defined. Furthermore, we show how the base station can be used either mobile or stationary.



BASE

The base station measures its location and calculates the current present error from its known location. This current present error can be used as “refinement data” to refine the positioning of a nearby positioning device (rover).

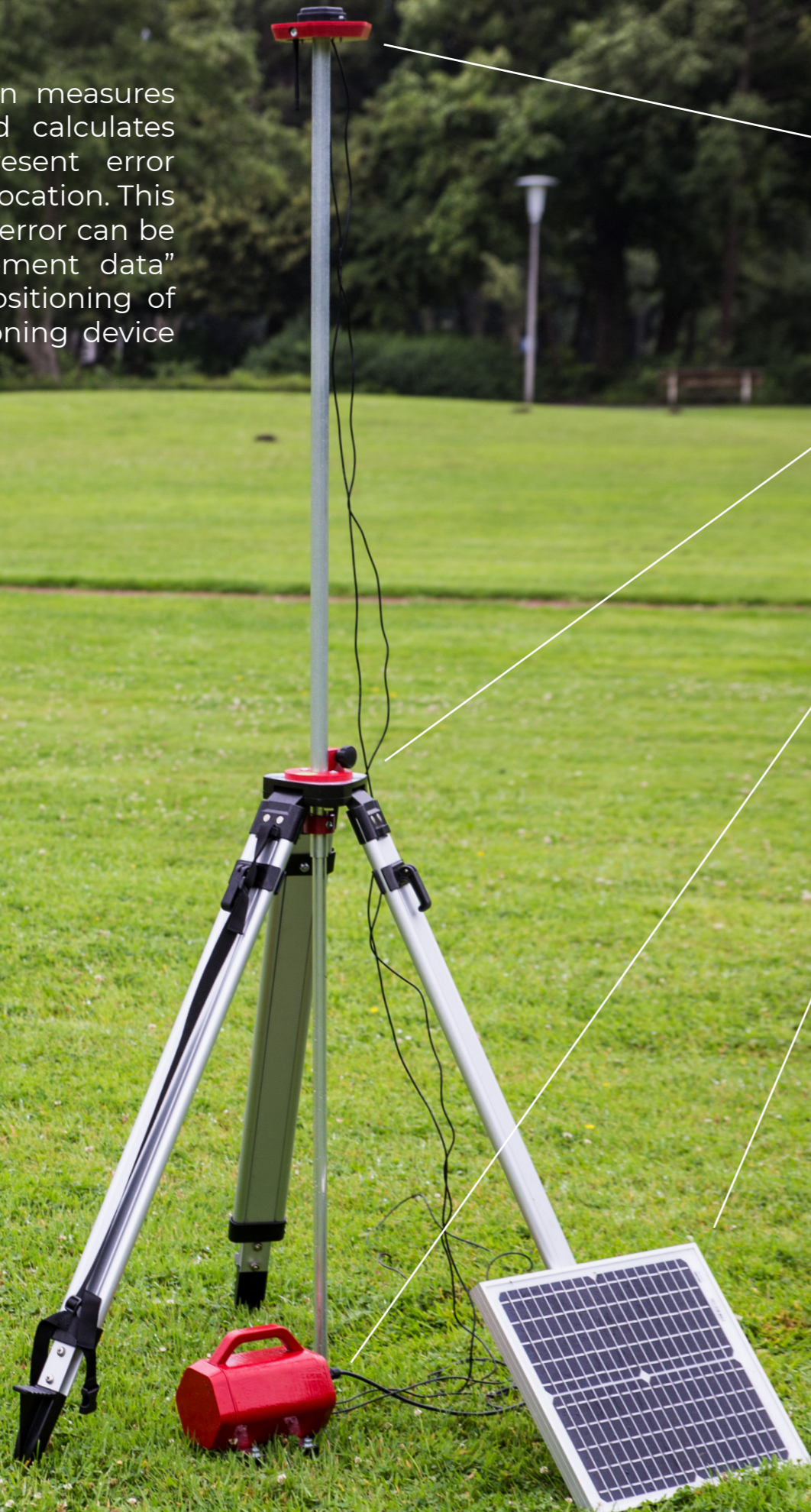

Part functions

Antenna platform:

This platform contains the GNSS antenna for positioning and GPRS antenna for sending data to the server.

Tripod clamp:

A standard tripod for survey equipment can be used to position the base station antenna firmly. In a clear sky location.

Main unit:

This unit acts as the brain of the setup. It contains the batteries, GNSS receiver, cellular modem and microcontroller.

Solar panel:

20Watt solar panel can be attached to the device to be able to use the base infinitely.



Technical specifications



Weight main unit: 1,3kg
Weight antenna and pole: 0,9kg
Weight tripod: 3kg



Main unit antenna and pole: €418
Solar panel: €46
Tripod: €75



Battery capacity: 65Wh
Uptime on battery: 50h
Time to fully load battery: 5,8h (Bright sun)



Data usage: 1,5mb/h for RTK streaming
Max possible data transfer: 20,2mb/h (45kbps)

5.1. Setting up the base station

Before the first use of the base station, some configuration steps have to be executed.

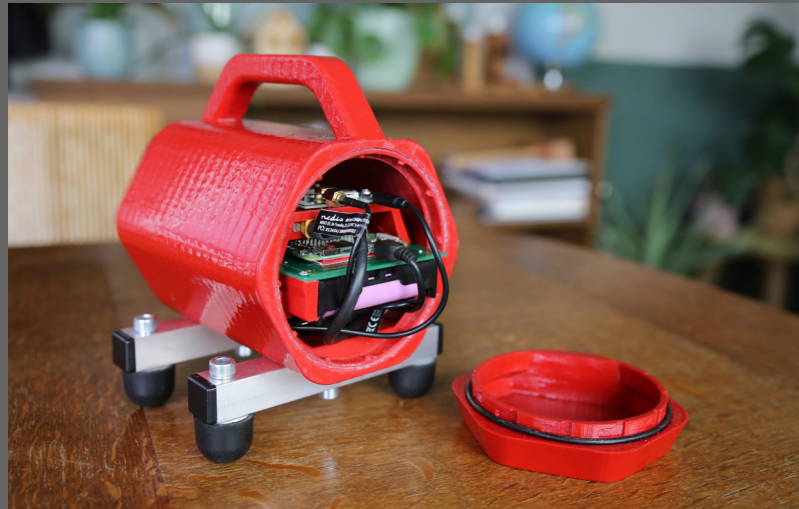

1. The system is still in ongoing development. The exact use cases, hardware and software wise, will be examined by Maptech in Ghana. For this reason, this working prototype is of great importance. To speed up the progress of coming to a working product, the used electronics are existing parts combined on a custom PCB. In this stage, the electronic parts often have to be reached for programming or physical adjustment. Therefore, all electronics are placed on a sled behind a removable cap. The cap can be removed turning the cap counter clockwise.

2. The user can insert a micro SIM-card, for connection with the preferred network provider. After inserting the SIM card some settings have to be adjusted in the Raspberry PI (Access Point Name, password, PIN etc.)

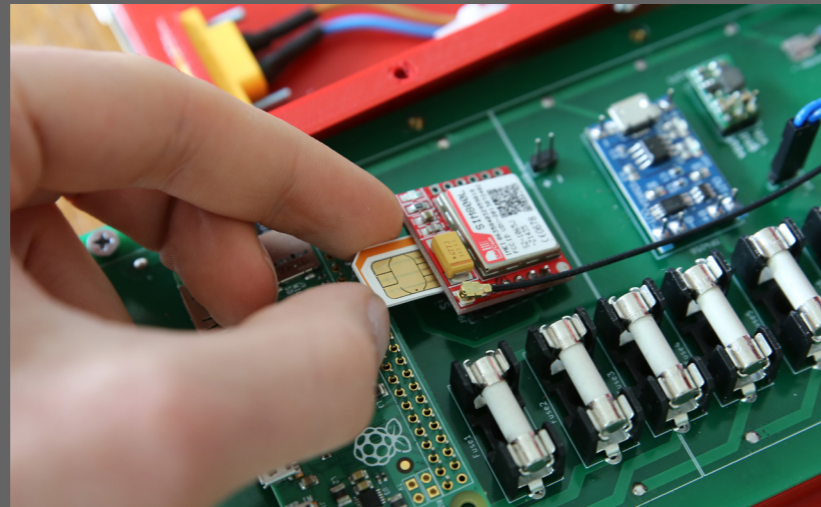

3. All input/output ports are reachable behind the front cap. In this way a monitor and keyboard can be attached to program the Raspberry PI microcontroller. Also, the GNSS receiver can be reached to be programmed using a laptop or desktop.

Future software development could make it possible to configure the device in a more convenient way by means of remote access. More about this can be read in chapter "10. Recommendations" on page 72

5.2. Base station user journey

After finishing the configuration, it is time to use the base station in the field.



1

The base station components are brought to a clear sky location.



2

The tripod is setup at first



3

One can put the pole into the stative and mount the antenna platform using an Allen wrench.



4

The pole can be leveled using the level in the tripod plate. Afterwards, the pole can be tightened with the knob.



5

The SMA connectors of the GNSS antenna and GPRS antenna can be connected to the main unit.



6

Cable glands can be screwed over the SMA connectors in the housing, to assure the watertightness.



7

Optionally, a solar panel can be attached as wished to use the device for an extended period of time.



8

The initialization process starts after the base station has been turned on.



9

In a few hours¹ the user will be able to use the RTK corrections from his base station

¹Currently this process still involves some computer tasks which can be automated in the future.

5.3. Base station internal components

This paragraph shows the internals of the most comprehensive parts of the base station product, the antenna platform and main unit respectively. At each number a description of the specific component can be read.

Antenna platform

1. Ublox GNSS antenna.
2. 120mm circular aluminum ground plane, to cover antenna from signals which are not directly received from the sky. (Tallysman, 2018)
3. Cellular antenna.
4. Plastic antenna top bracket.

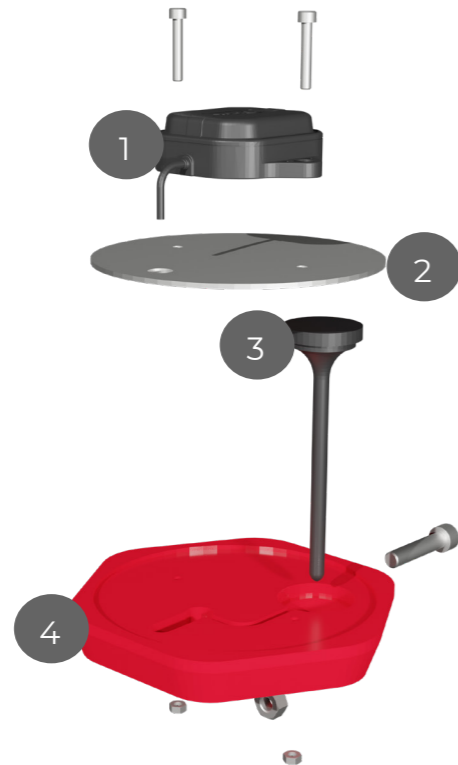

Base station main unit

1. Maximum power point tracking (MPPT). Solar power converter and lithium battery charger in one.
2. Arduimple GNSS receiver.
3. Plastic electronics bracket.
4. XT60 connector to attach internal solar power plug.
5. Plastic housing with hand-grip, coated in epoxy.
6. Step up voltage converter, delivers 5v to Raspberry PI and GNSS receiver.
7. External power solar panel power plug, with cap to ensure watertightness when solar panel is not in use.
8. On/Off switch.
9. T4056 charge circuit which protects lithium batteries from under voltage.
10. SIM800 cellular modem.
11. Raspberry PI Zero micro controller.
12. Fuse for each battery cell to protect them against short circuits.
13. Cable glands which can be screwed over the SMA antenna connectors to ensure watertightness.
14. Condensation water drain element.
15. Custom PCB to connect all the electronic components.
16. SMA bulkhead connectors to connect the GNSS and cellular antenna.
17. Rails to slide the electronics in the main housing.
18. Battery holders.
19. O-ring to seal housing.
20. Housing cap, coated in epoxy.
21. 8x 18650 lithium cell for energy storage.
22. Rubber feet.

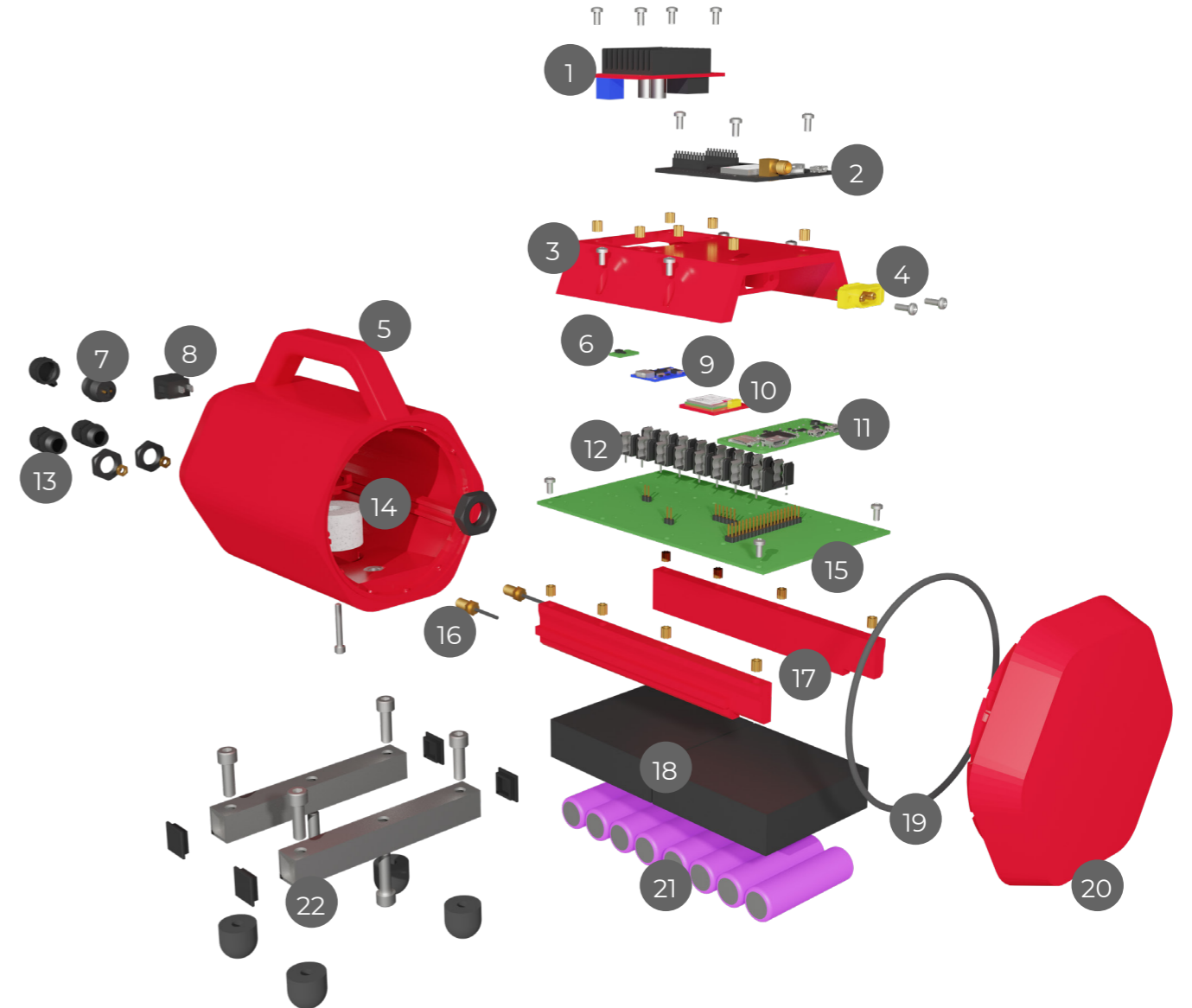

5.4. Ways to use the base station

Mobile BASE

A mobile base can be used when there is no NTRIP service locally available. All parts fit in a car easily. Once installed, the known position should be entered. The position can also be determined by averaging the measured location over a period of time. This is useful when the base station position is not known in advance.



Stationary BASE

For stationary use, the base can be mounted to a wall. The option exists to place the base main unit inside the building, while the solar panel and antenna are outside. This reduces the wear caused by the environment.

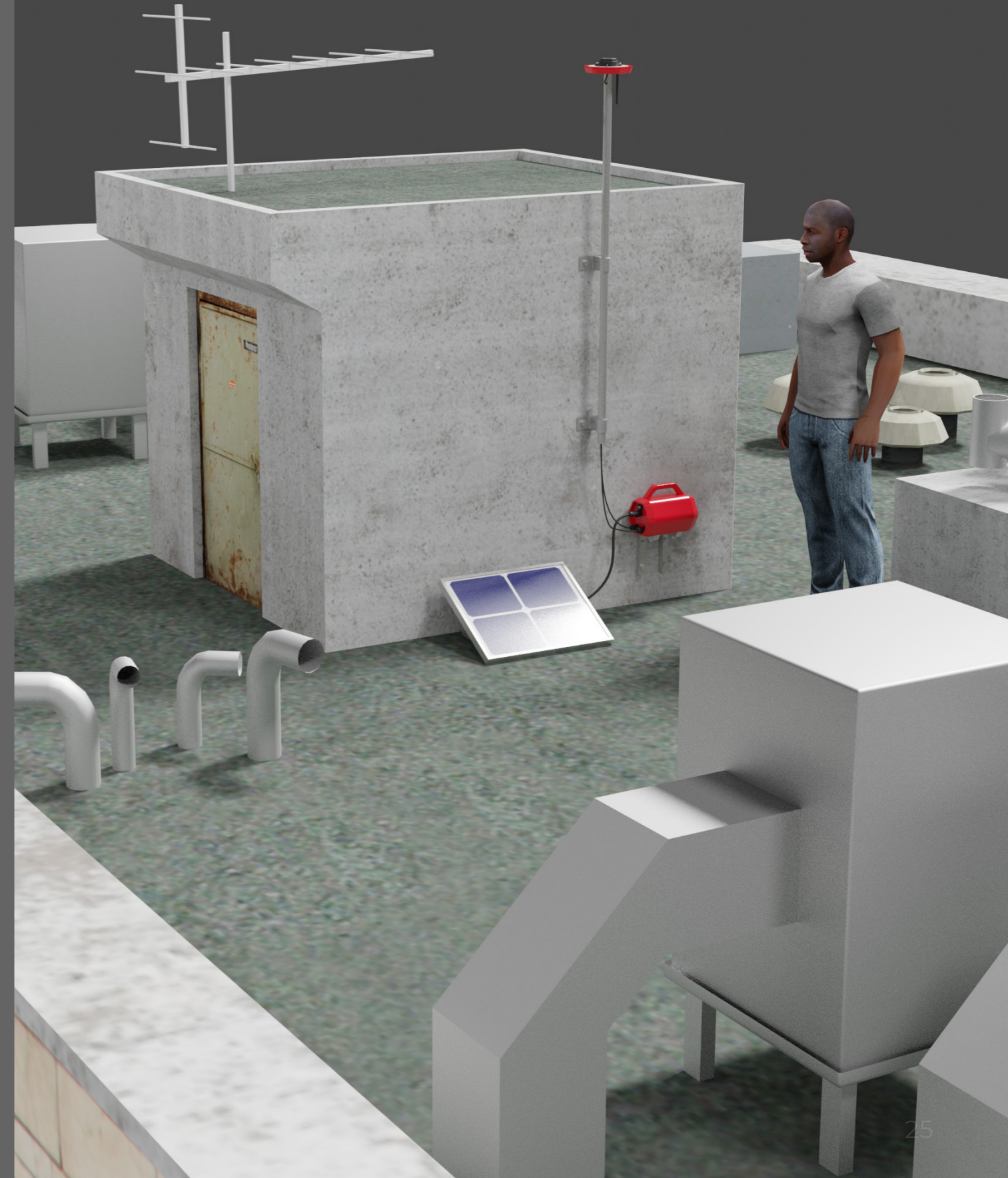

ROVER

The rover can measure its location with centimeter accuracy. This is achieved by using the “refinement data” measured by a nearby base station.

Part functions

Rover unit:

This unit contains the GNSS antenna and receiver for positioning. This receiver has Bluetooth for communication with a smartphone. Also, the unit holds the batteries to run these electronics, or charge the smartphone.

Phone holder

The phone holder can be changed in height according to the users preferences. In the phone holder a level is integrated to help the user to keep the device straight up. All interaction with the Rover is performed using an app on the smartphone.



Technical specifications



Weight main unit: 0,7kg
Weight with pole attached: 1,5kg



Rover with phoneholder and pole: €312
Tripod: €76



Battery capacity: 16Wh per accupack
Uptime on battery, rover only: 24h
Uptime on battery, phone powered by rover: 3h



Data usage of phone: 1,5mb/h for RTK streaming

5.5. Setting up the rover

Before taking the rover outside for survey work, some steps have to be executed.

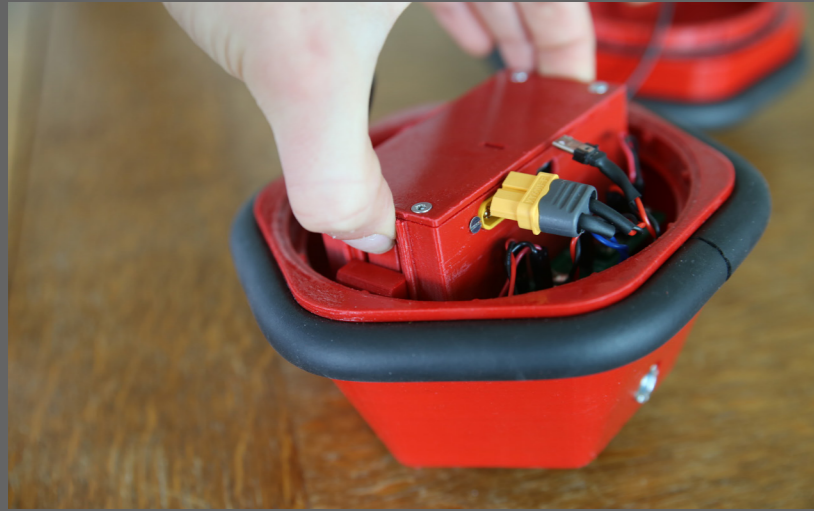

1. The rover can be opened by moving the top counter clockwise. After disconnecting the USB cable and the power cable, the battery can be pulled out by squeezing the two click-fingers on the side of the battery packs.

The installed battery can be charged, using the USB port at the bottom of the device. This means, changing batteries physically is not needed if there is enough time to charge.

2. When outside the device, the battery packs can also be charged using USB.

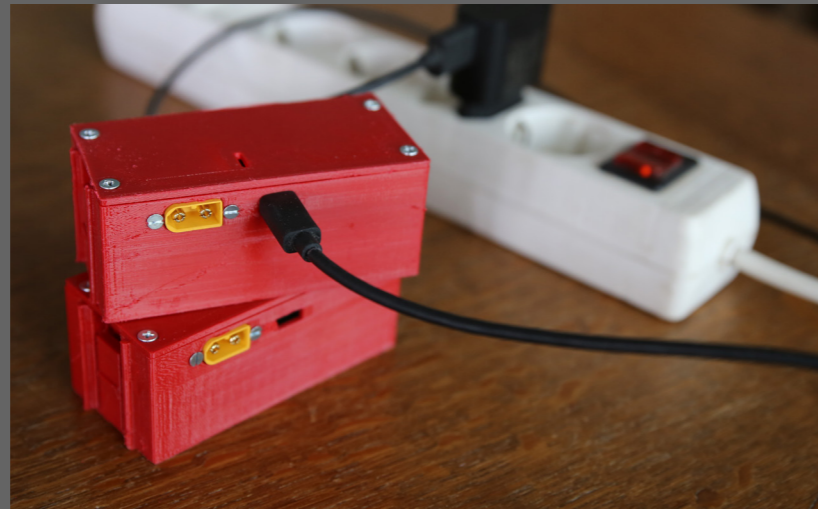

5.6. Rover user journey

It is time to start surveying.



1 The rover components are brought to the site where measurements have to be taken.



2 The parted pole can be connected using the knob and the rover main unit can be attached using an allen wrench.



3 The phone can be inserted in the phoneholder.



4 The user can now connect to the rover by Bluetooth and store measurements on the phone.



5 When the phone battery runs out of juice, the rover can be charged using the port under the screw plug.



6 At one end the USB type B charge cable is connected



7 On the phone side, the micro USB or USB-C connector is inserted to start charging.



8 The user can run the rover and phone combined for about 3 additional hours on one full rover battery.



9 When needed, the rover can be placed on a tripod to measure in one location for a longer time.

5.7. Rover internal components

This paragraph shows the internals of the most comprehensive parts of the rover product: the main unit, battery pack and phone holder. At each number a description of the specific component can be read.

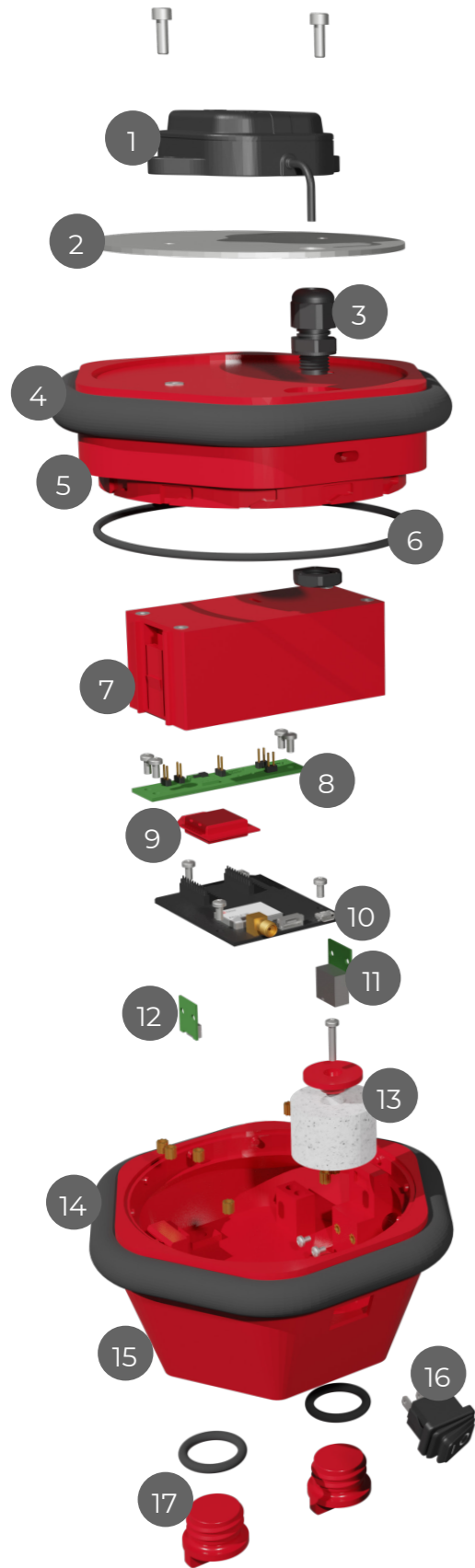

Rover main unit

1. Ublox GNSS antenna.
2. 120mm circular aluminum ground plane, to cover antenna from signals which are not directly received from the sky. (Tallysman, 2018)
3. Cable gland, seals the throughput of the GNSS antenna cable.
4. Foam rubber ring, to dampen impact on fall.
5. Plastic upper rover housing, coated in epoxy.
6. O-ring to seal rover housing.
7. Rover battery pack.
8. Rover power PCB with step up voltage converter, which delivers 5v to GNSS receiver.
9. Arduisimple GNSS receiver.
10. USB type A for charging smartphone.
11. USB type micro for charging Rover.
12. Condensation water drain element.
13. Foam rubber ring to dampen impact on fall.
14. Plastic lower rover housing, coated in epoxy.
15. On/off switch.
16. Plugs with O-rings to close off USB ports.

Battery

1. Battery housing lid
2. XT60 connector, can be used to connect the battery to the rover
3. TP4056 charging circuit, protects lithium cells from over and under voltage.
4. Fuse for each cell to protect against short circuits.
5. Custom PCB to connect all battery components.
6. Battery holder.
7. 2x 18650 lithium cell for energy storage.
8. Battery housing with clips to click the battery in the rover housing

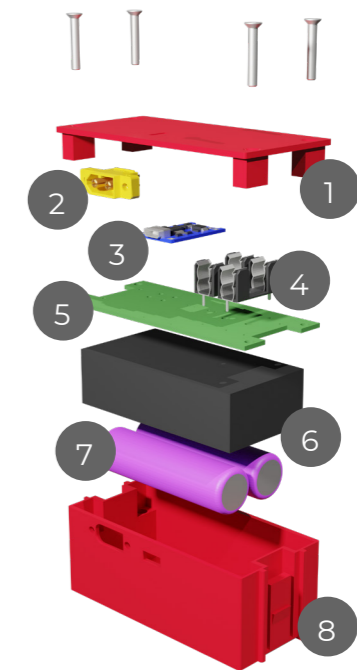

Phoneholder

1. Level to be able to hold the rover straight up.
2. Fixed side of phone clamp.
3. Movable part of phone clamp.
4. Knob, can be used to tighten phoneholder to pole.
5. Plastic phoneholder base, connects the phoneholder to the pole.
6. Spring, clamps phone between the fixed and movable part of the phoneholder.

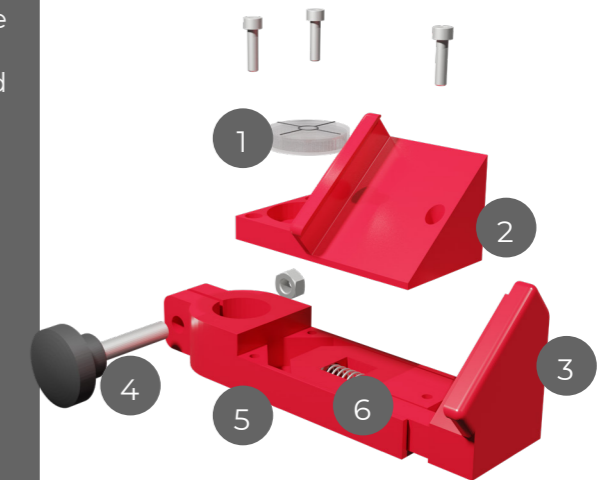

6. Main design challenges

This chapter describes the design process which has led to the final result as described in the previous chapter, “5. Concept overview”. All learnings and considerations are presented topic wise:

- “6.1. System structure” on page 34
- “6.2. Physical shape and appearance” on page 38
- “6.3. Condensation water” on page 42
- “6.4. Coping with rain” on page 44
- “6.5. Data connection” on page 48
- “6.6. Power supply” on page 50
- “6.7. Robustness” on page 54

For each topic, it is first described what the challenge is. Then, the most relevant requirements on the topic are listed. Next, an outline is given of the main inspiration sources which solve the same challenge. Subsequently, if this particular challenge was already addressed in the first intuitive design of ROVER1 or BASE1, this approach is shown. Hereafter, the learnings from the intuitive design or other relevant test are stated. Finally, the final design solution to the challenge used in ROVER2 and BASE2 is shown.

While it is preferred to quickly come to testable products, we choose to 3D print all prototypes. Due to the available printer, the FDM (Fused Deposition Modeling) process is used. For 3D printing PETG (Poly-Ethylene Terephthalate Glycol) was used instead of the often used PLA (Polylactic acid) as PETG has a higher heat resistance, higher impact resistance and is more suitable for outdoor conditions (3D hubs, 2020). Whether 3D printing is suitable for future production is discussed in chapter “10. Recommendations”.

For detailed assembly steps of the products one could look at:

- “Appendix Q. ROVER1 Design and build process”
- “Appendix R. BASE1 Design and build process”
- “Appendix S. ROVER2 Build process”
- “Appendix T. BASE2 Build process”

Of course also the 3D model of ROVER2 and BASE2 can be explored in the technical data package.



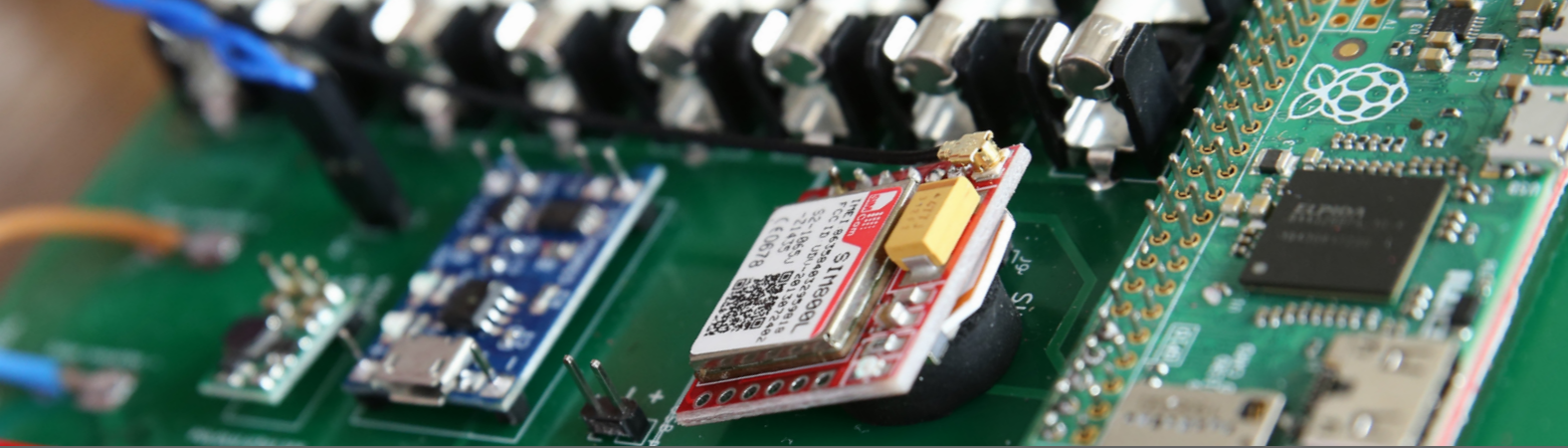

6.1. System structure

Challenge

Combine the (mostly) predefined hardware parts in a robust, usable manner, without extensive hardware and software development.

Most relevant requirements - Rover

- Device can measure a position which accuracy matches the tolerances given by the manufacturer U-blox.
- Can receive NTRIP data from base station for RTK

Most relevant requirements - Base

- Can transmit NTRIP data for RTK.
- Can transmit raw data for weather forecast
- Can be powered without the use of the power grid

Inspiration

Inspiration for developing the new system structure was taken from the hardware setup used by previous researchers. This hardware structure can be seen in figure 6.1. The functions of each component are noted briefly. Also, the idea of an device which can be both a base station or rover, such as the Trimble R8 (figure 6.11) was of great inspiration.

The U-blox ZED F9P receiver in combination with a ANN-MB-00 antenna was proven to be a good solution for low cost high precision positioning (Krietemeyer, van der Marel, van de Giesen, & ten Veldhuis, 2020) Therefore this hardware will be used. The SWmaps app is proposed by Krietemeyer, A. to use for surveys on Android. For base station use, Krietemeyer, A. provided python scripts which can be run on a Raspberry PI with Raspberry PI OS.

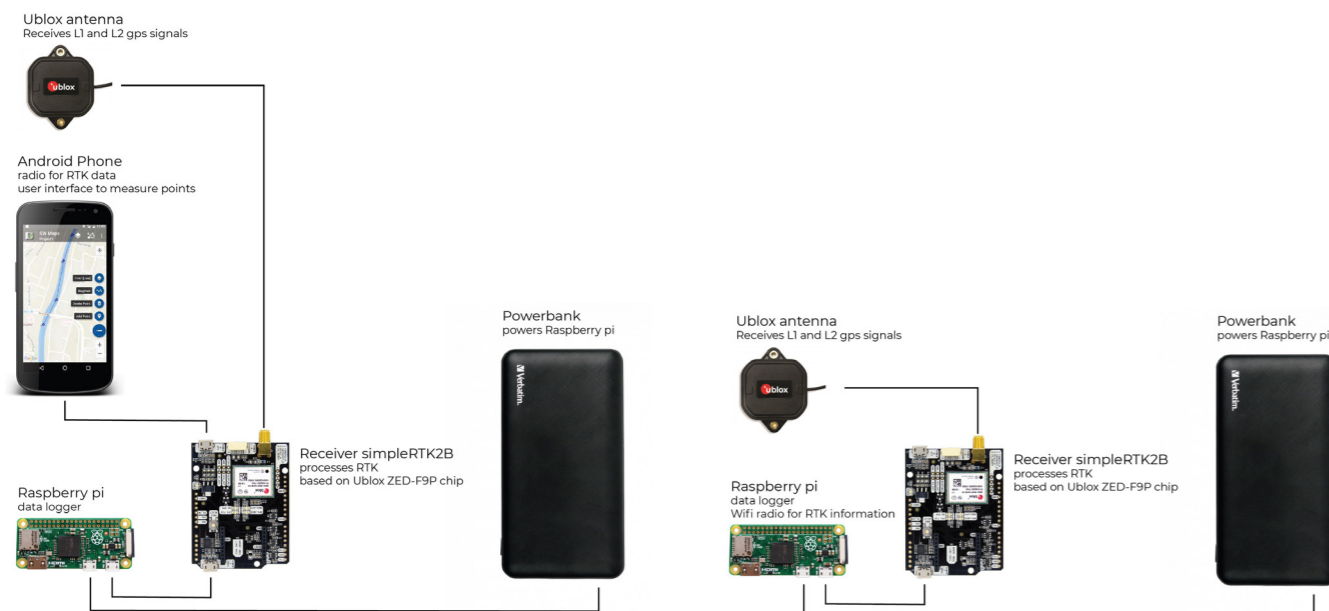

6.1. Initial hardware setup used by previous researchers.
Left: Rover, Right: Base Station

Hardware structure concepts

Two potentially interesting hardware concepts were tested; Concept1 (Figure 6.2) is based on the initial idea from the previous researchers, the base is extended with a cellular connection to send NTRIP data for RTK to a server. The rover is extended with Bluetooth to connect to the smart phone. Concept2 (Figure 6.3) is focused on building one hardware platform which can be used as both a base or a rover.

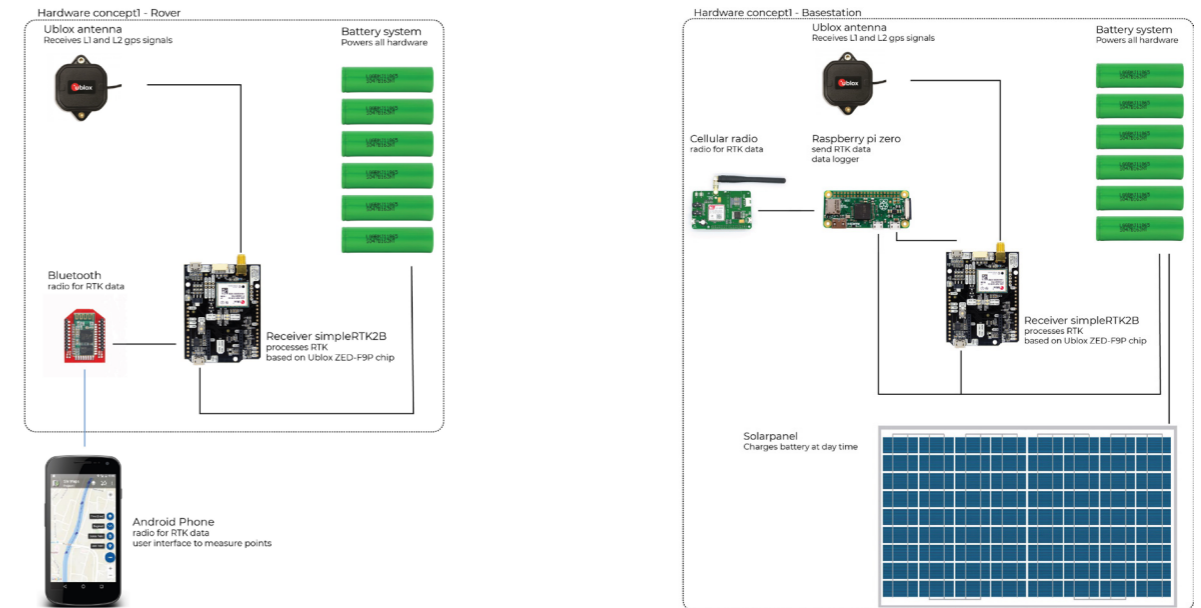

6.2. Hardware concept1. Extending the existing hardware
Left: The initial rover hardware extended with a Bluetooth connection to the phone.
Right: The initial base hardware extended with a cellular modem and solar-panel.

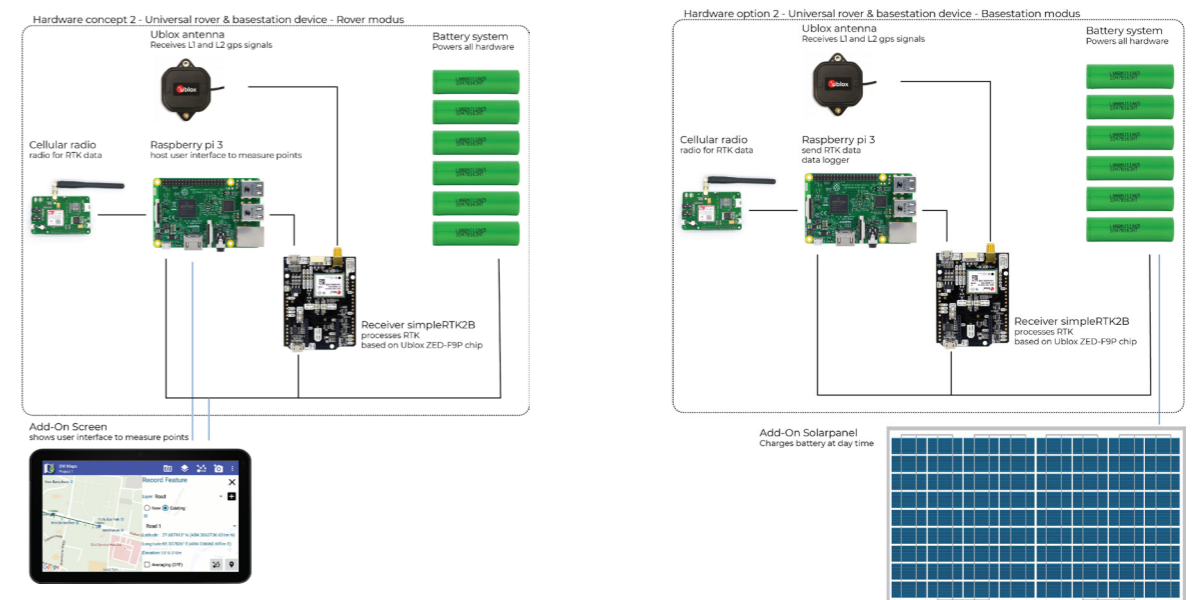

6.3. Hardware concept2. One universal device
Left: Universal device used as rover with an add-on screen
Right: Universal device used as base with a solar panel.

The two concepts were examined in practice. Figure 6.4 shows how the Raspberry PI 3 can be used to run the SWmaps app on top of Google's 'Android Things', while it normally would run the base station scripts. However, the app seems to respond very slow. On the other hand, improving the existing hardware of the previous researchers, by adding a Bluetooth transmitter for example, worked very smoothly. (figure 6.5).



6.4. Raspberry PI 3 running SWmaps on Android



6.5. Android phone running SWmaps, connected to ArduSimple GNSS receiver using Bluetooth

The power consumption of the universal device is calculated to be higher, in both rover (figure 6.6) and base station (figure 6.7) mode. This is due to the fact that the Raspberry PI 3, would be required to run the SWmaps app on Android things. This device runs an Android app less efficient than a Phone. Besides, it has more processing power than needed when running the base station tasks on Linux without a graphical interface.

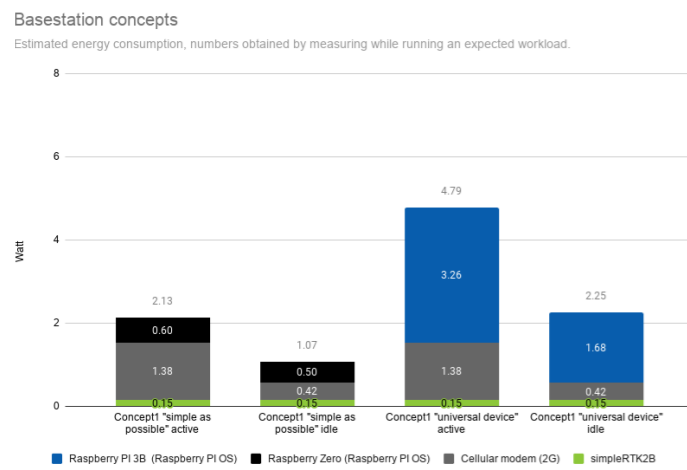

6.6. Power consumption of the concept1 and concept2 base stations in active and idle mode.

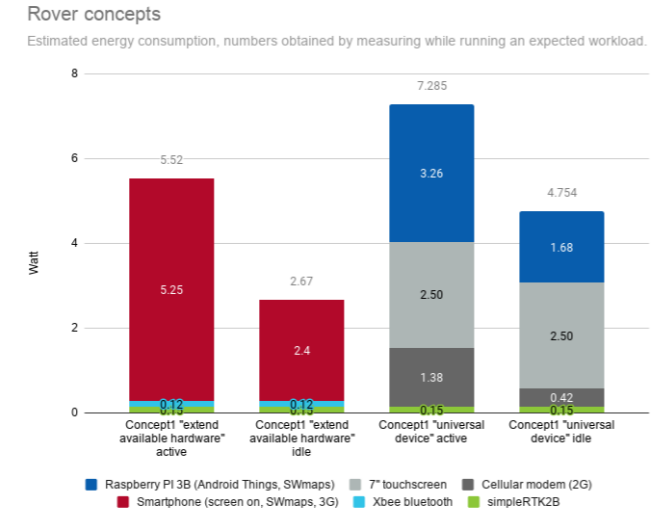

6.7. Power consumption of the concept1 and concept2 rovers in active and idle mode.

Learnings

- Without extensive software development it is not possible to run the available rover and base station software smoothly on one hardware platform.
- Running the rover software on a less optimized platform leads to an energy inefficient system.

Final hardware structure

For the sake of energy efficiency and smooth running available software, It was decided to further develop the hardware structure of concept1. This means that the existing hardware will be extended with some needed features, such as cellular data communication for remote locations. Designing an universal device would certainly be beneficial, but is not possible without extensive soft- and/or hardware development.

Final ROVER2 hardware structure

The final rover hardware structure can be seen in figure 6.8. The existing rover hardware structure is extended with a Bluetooth module so that the phone can be coupled to the rover without a cable, which is preferable when using the device in the rain. This adjustment also makes that the GNSS receiver is not powered on the internal phone battery.

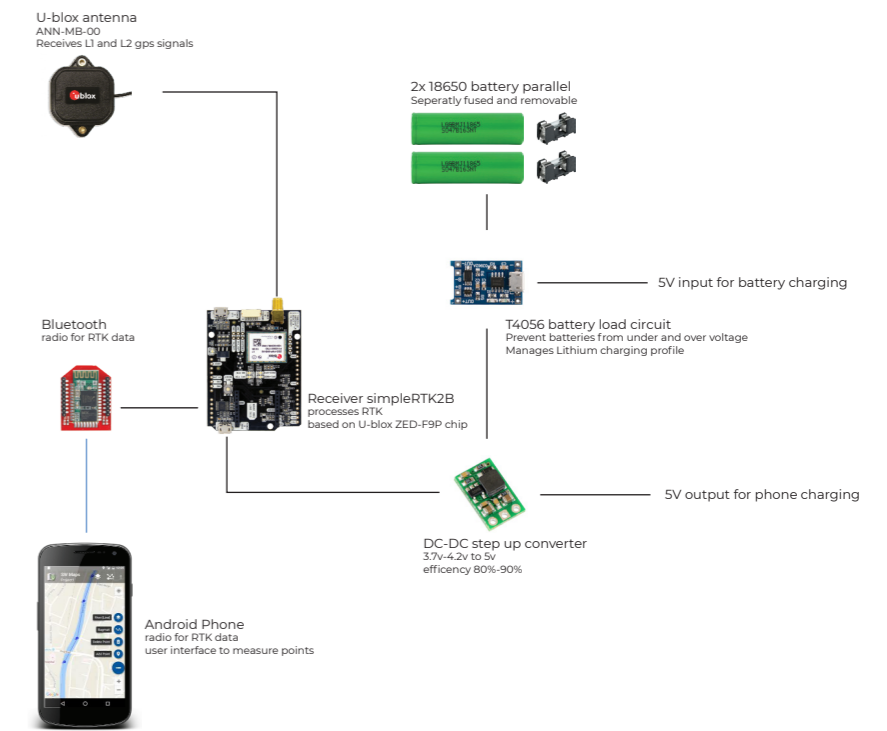

6.8. Hardware structure of final rover design

Final BASE2 hardware structure

The final base station hardware structure can be seen in figure 6.9. Along the initial GNSS receiver and Raspberry PI, a cellular modem has been added for remote data communication. More information about this topic can be found in the paragraph "6.5. Data connection". Also, a solar panel is added as an off-grid power supply. More information on this topic can be found in "6.6. Power supply" on page 50

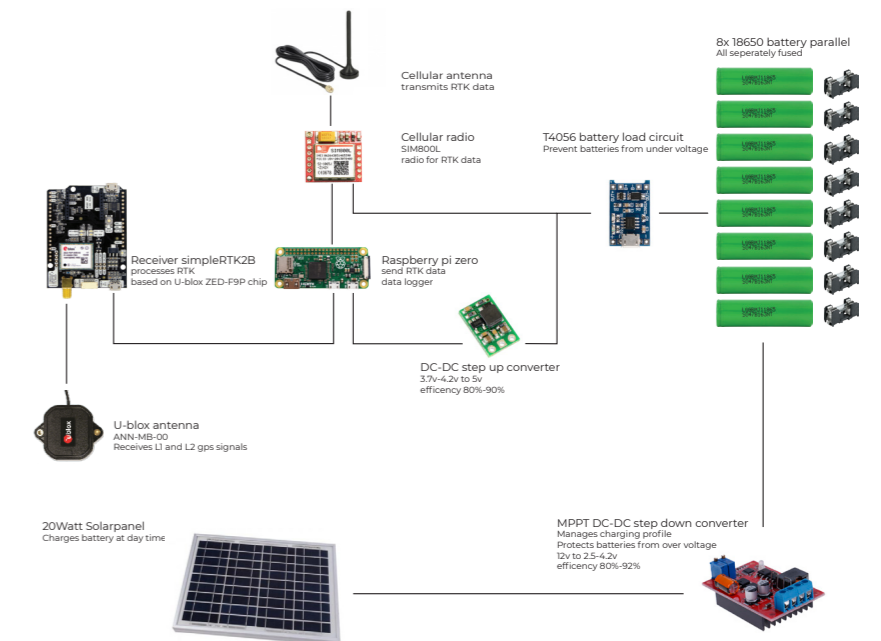

6.9. Hardware structure of final base station design

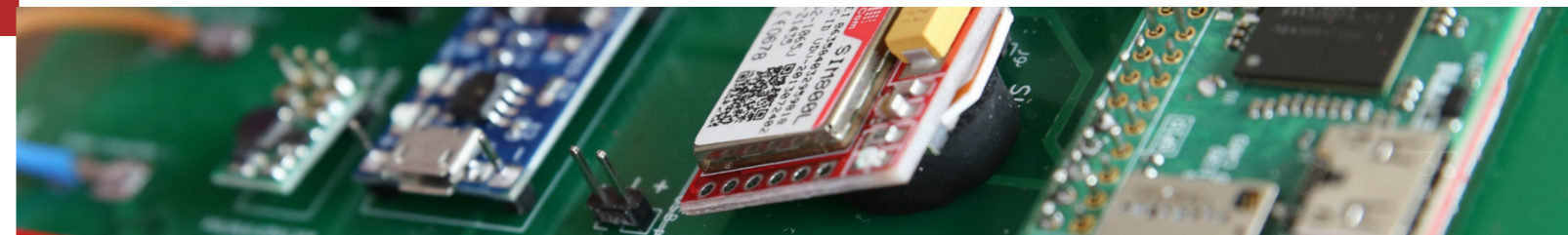



6.2. Physical shape and appearance

Challenge

Create a device which suits the chosen hardware, while the setup is practical to work with for the Ghanaian user group. It would be even better if the appearance is not only practical but also appreciated by the Ghanaian users.

Most important requirements - Base

- Weight can be transported by one person.
- Size is suitable for transport by one person.
- Mounting process can be learned by Ghanaian technician of target company within a half day.
- The device should be positioned straight up when measuring.
- Each component should be removable within 10 minutes.

Most important requirements - Rover

- Size is suitable for hand held use.
- Size is suitable for transport by one person.
- University graduate or even Senior High School leavers are able to use the device within 30 minutes of training.
- The device should have a fixed distance to the ground when measuring.
- The device should be positioned straight up when measuring.
- Each component should be removable within 10 minutes.

Inspiration

The first shapes of both the rover and base were designed intuitively. Choices in this design were based on the assumption that a base station would be used statically such as the base stations which previously have been built for the TWIGA projects (figure 6.10). The rover was assumed to be a mobile device which is used by someone walking around.

Inspiration was found in currently available setups which provide an universal device which can be both a base station or rover, such as the Trimble R8 (figure 6.11).

These assumptions and inspiration sources, together with the size constraints of the already chosen components, lead to the first intuitive rover and base prototype, which is described in detail on the right page.



6.10. Left: TWIGA base station (TWIGA, 2019)

6.11. Right: Trimble R8



Intuitive design - shape and appearance

1. Both main units have a cylinder shape which is tapered on the lower side. Their height differs as the base station contains more batteries and an additional microcontroller. This difference in electronics size can be seen in figure 6.34 in the paragraph "6.6. Power supply"

2. The GNSS antenna is placed on a round ground plane on top of the device. This antenna is outside the unit for the reason that this antenna is developed for outside use and would have to be re-calibrated when used inside a housing.

3. On the pole of the rover a phone holder can be found. This in height adjustable phone holder is much like the PDA found on the Trimble R8 (Figure 6.11)

4. Both devices have a two piece aluminum pole. This is a sturdy and cost effective alternative to the treaded carbon fiber rods used on the Trimble devices.

5. A very simple photography tripod is used to keep the base-station in its position.

6. The solar panel is placed next to the tripod. The cable from the panel to the base is fixed.

BASE1

ROVER1



Learnings on shape and appearance

Learnings on the shape and appearance of the device were done during multiple events:

Conversation

- “There can be sudden strong winds in Ghana. I’m afraid that the devices will tip over. A tripod which can be anchored in the ground would be very useful”
- “Until there is complete base station coverage of Ghana, I still like to take the base station with me to setup one at site.”
- “A white housing will get dirty, I would like to have a color which is easy to find back in the bush.”

Building process

- During the building stage the rover was placed to lean against the wall. Due to its cylindrical shape it was able to roll sideways and dropped down scattering in pieces.

Field test

- During the field test it became apparent that currently internal electronics have to be accessed a few times during the setup of the base station.
- While testing, the rover appeared to be much easier to handle as rover weights about half as much as the professional Trimble device.

Color

The color of the devices has been chosen by the target group using rendered examples (figure 6.12). The bright red color ensures visibility in the bush while it will not get dirty like the white plastic.



6.12. Several renders against a bush background to discuss the best color for the device. (inbetween rover model)

ROVER2 design - shape and appearance

The placement of components in the second rover iteration is alike to the first design, however:

1. The main unit shape is now six sided so that it can be placed against a wall without rolling over. Also, a rubber band has been placed around the rover which gives the device a more robust appearance. The practical side of this ring will be explained in paragraph 6.7.

2. The phone holder got minor changes to the first one, more rounded corners and the padding for the phone has been integrated in the clamp.

3. An extra ring has been added which can be used to place the rover on a tripod.

BASE2 design - shape and appearance

The base station has changed significantly in appearance and component placement.

4. Along with the GNSS antenna, the GPRS antenna is now also outside the housing to maintain good signal strength.

5. A much stronger laser tripod with feet which can be put in the ground is chosen to be able to withstand strong winds.

6. All electronics are now placed in a bigger housing on the ground. This makes sure this heavy and fragile part of the base station can not fall. The bigger device also allows for better access of the electronics, more space for detachable connectors and more room for heat dissipation of the solar power system. Finally a handle has been added for portability.





6.3. Condensation water

Challenge

Ghana has a very hot and humid climate. During evening time when the temperature drops, water could condensate within the device and harm the electronics. (Appendix H)

Most important requirements

- The product should be able to withstand tropical temperatures within a range of 0-40 ° C
- The product should be able to withstand a tropical humidity of 85% in the temperature range of 0-40 ° C

Inspiration

Inspiration was taken from the Disdro rain meter (figure 6.13) This rain meter was not specially designed with condensation water in mind, but it seems to perform well in humid environments.

There are probably multiple reasons why the rain meter can cope this well with condensation water. First, there is a very limited amount of air in the device, which minimizes the amount of water which can be released from that air.

Secondly, the housing and bracket will first cool down when the ambient temperature drops. This will cause water to condensate on the bracket or housing walls. On the lower side of the device there is (unintentionally) a cable hole which could release any buildup moisture.

Inspiration was also taken from power electronics which have to cope with condensation due to their large heat dissipation and active cooling. The complete research on condensation solutions in power electronics can be found in appendix (Appendix H). The idea to use a drain element (figure 6.14), to let water out and prevent dust coming in, was taken from this research.



6.13. Disdro rain meter



6.14. Stego condensation water drain element

Learnings

- Using a drain which releases water in fluid form will prohibit a device from being completely water tight. See test results in "Appendix I. Examining the Stego drain element".
- The amount of moisture which can be released from the small contained amount of air is so small that it would take dozens of day-night cycles with changed air before the buildup of water can even be noticed. See test results in "Appendix J. Condensation water test"

ROVER2 and BASE2 design - condensation

In both the final rover and final base station design water will condensate on the walls as these walls cool down when the ambient temperature drops in the evening. The devices have a wall shape which will lead water down to a drain without touching the electronics, as can be seen in figure 6.15. This is accomplished by using curved roof surfaces. Drops of water will always roll down along the curve of the wall as long as there are no sharp corners. This is showcased in figure 6.16.

The drain is the internal part of a Stego drain element. This is in fact a block of foam which prevents dust from entering the device while water can get out.

It is of importance to note that both devices have to be kept with their right side up for the drain system to work properly.



6.16. Drops of water roll down following the curved roof surface of the ROVER2 housing.

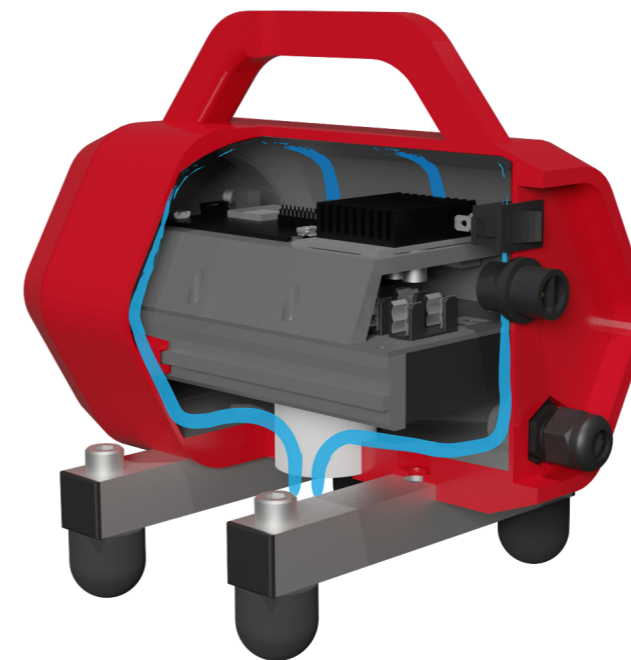

6.15. Left: visualization of condensation water drain in BASE2. Down: visualization of condensation water drain in ROVER2.

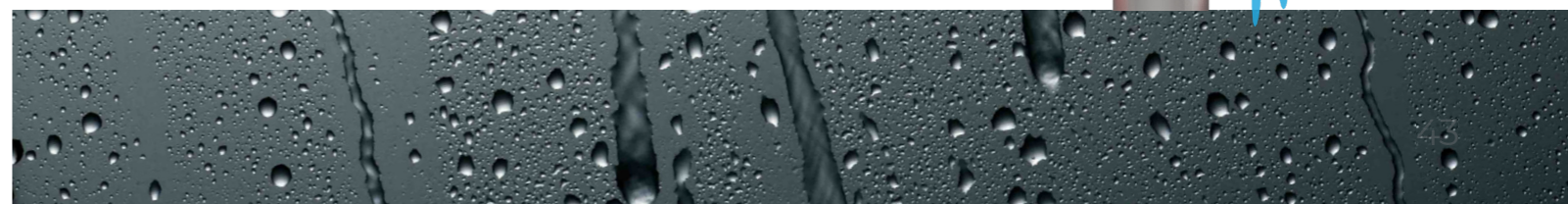
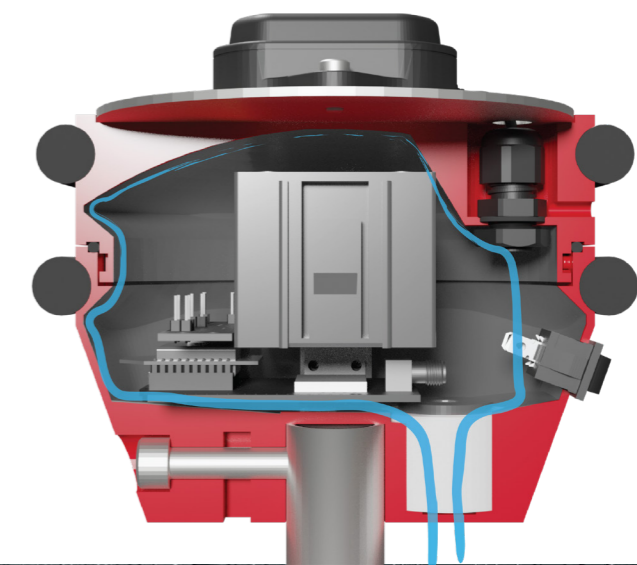



6.4. Coping with rain

Challenge

Ghana has a rainy season in which there can be rainfall at a tropical rate. Users should be able to use the base and rover in these conditions.

Most important requirements

- IP6x (IP64) Totally protected against dust.
- IPx4 (IP64) Protected against water splashed from all directions, limited water ingress permitted.

Inspiration

Inspiration was taken from multiple waterproof devices which can be found around the house. An example of such a device is the JBL charge 4 speaker. Which has a IPx7 rating and is thus submersible for at least 30 minutes. This design uses a plug integrated in the housing plastic to close off all input ports (figure 6.17). The housing of the of the device is entirely closed. The active speaker itself is sealed using a gasket (figure 6.18). The movable part with the JBL logo on the side of the product is needed because the speaker would otherwise not be able to move.

Several general advices on waterproof design were combined in “Appendix K. Research on waterproof design” In this appendix also an analysis of multiple waterproof connectors can be found.



6.17. Connectors of JBL charge 4 can be closed off using a plug.



6.18. Connection between speaker and housing is closed off using a gasket.

ROVER1 and BASE1 design - coping with rain

In the first Intuitive design, the round housing parts are sealed with an O-ring in a groove (figure 6.20). This O-ring was squeezed using 4 bolts. This method was used for both the rover and base station. The USB-ports were closed off with screw plugs which squeeze a smaller O-ring (figure 6.19).



6.19. ROVER1, plugs to close off usb ports



6.20. ROVER1, O-ring in a groove which can be tightened with 4 bolts

Learnings

- Using a drain which releases water in fluid form will prohibit a device from being completely watertight. See “Appendix I. Examining the Stego drain element”
- During rain tests, using a shower, it became apparent that uncoated 3D prints tend to leak at small features such as bolt holes. Reaching consistent levels of watertightness in 3D printing is hard to ensure, while different machines and different environmental conditions will deliver slightly different results.
- Squeezing an O-ring evenly seemed to be hard using bolts.

Iterating

The 4-bolt sealing mechanism needed to be improved. Therefore, a mechanism was designed which divides pressure more equally. It consists of 12 notches, each fitting in a slot on the opposite side. Turning the mechanism clockwise pushes the notches along a small taper, after which the slot gets wider again and the ring will be locked in this position. The mechanism is based on the mechanism which can be found on a toothpaste cap (figure 6.21)

The 12 notches ensure an equal divided pressure on the O-ring. This pressure will always be exactly the same, in contrast to a screw or bolt connection which can be under or over tightened. The six sided shape of the housing parts make it very obvious when the device is not closed properly.

After a lot of tests (figure 6.21), a squeeze of 0.2mm seemed to be enough to squeeze the O-ring to seal. While bolts are no longer required at the outside of the housing, the whole outer housing can be coated in epoxy without a big risk of filling tiny bolt holes.



6.21. Tooth paste cap, of the brand Prodent



6.22. Test models of the 12-notches seal mechanism

After coating the parts in epoxy, it was time to put the new design principles to the test. A rain test of 15 minutes in the shower (figure 6.23) showed that the internals of the rover will stay dry (figure 6.24), which means that the designed sealing mechanism works properly. This test was carried out for both devices.



6.23. ROVER2 in the 15-minute rain test using the shower.



6.24. Tissues within the device are dry after 15 minutes of rain.

Final design - coping with rain

Both the base station and rover consist of two (internally) round parts which have been sealed with an O-ring. The 12-notch mechanism is applied to both devices. All the 3D printed housing parts have been coated in epoxy on the outside, to ensure their watertightness.

ROVER2

The main sealing of the rover is the 12 notch mechanism (figure 6.27). At the lower side it has two screw caps to close off its usb ports (figure 6.28). Furthermore the on/off switch is rated at IP65 and the antenna cable is lead through a cable gland. The internal battery can be replaced, but has no separate opening. This keeps the total amount of sealing parts in the design at a minimum.



6.27. ROVER2 opened up



6.28. Screw plug on ROVER2

BASE2

The base stations main sealing is also a 12 notch mechanism (figure 6.26). The connectors are all on the other side of the device. On this side (figure 6.25) you can find the solar power connector, which can be closed off with a screw cap. Here you also find the SMA connectors, over which cable glands can be screwed to ensure their watertightness. Finally, the same IP65 on/off switch is used as on the rover.

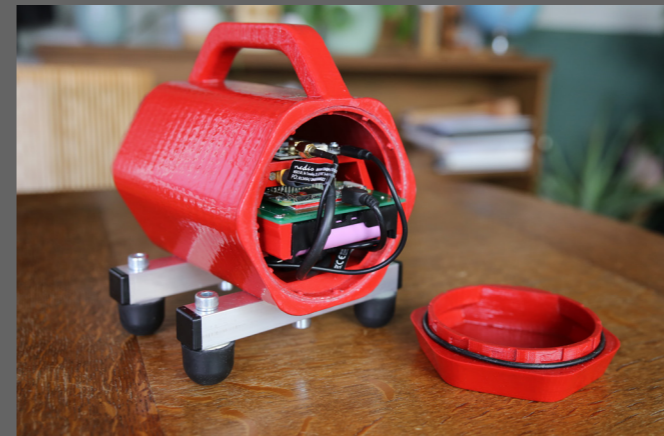

6.26. BASE2 opened up



6.25. View at the external connectors of BASE2



6.5. Data connection

Challenge

The RTK data should be streamed to the rover and raw positioning data should be uploaded for meteorological analysis. A reliable data connection is needed to get the data to the server.

Most important requirements

- Can transmit NTRIP data for RTK
- Can transmit raw data for weather forecast.

Inspiration

Previously, researchers used a Wifi connection for the data transmission to the Internet. They noticed that this will cause the system to stop working when there is a power cut. The Disdro rain meter (figure 6.13) uses a low power data connection which is called LoRa. The Trimble R8 uses a cellular data connection. In “Appendix P. Connectivity options” these methods of data connection have been compared to choose the most robust connectivity method.

Intuitive BASE1 data connection design

The rover uses the data connection of the smartphone, which will probably be a cellular connection.

For the base station, we choose to use a 2G (GPRS) modem. 2G is chosen as this is publicly available. 2G is the most wide available network in Ghana compared to 3G, 4G and 5G. The SIM800 cellular modem can transfer 20,5mb each hour. For RTK purposes, only 1,5mb/h is needed. Almost all cell towers in Ghana have a power backup system (GSM Association, n.d.) and can therefore work during powercuts.

After testing the data connection with a SIM800 board for the Raspberry PI, a smaller edition of the chip, the SIM800L, is used in the intuitive base station design. A small antenna is placed on the side of the electronics rack within the base station. This antenna is directly connected to the modem.

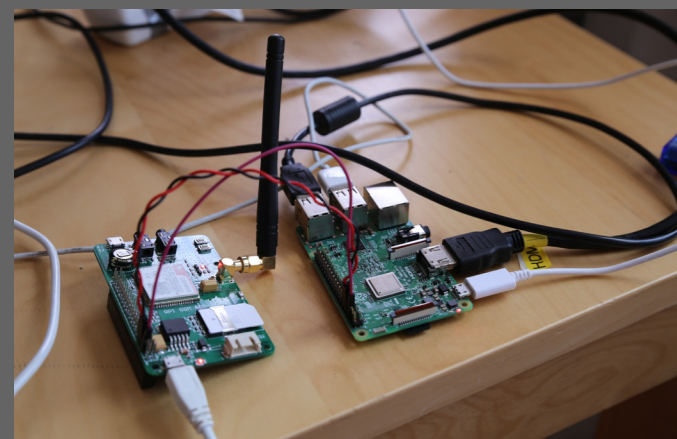

6.29. Testing cellular connection with SIM800



6.30. Sim800L and antenna on BASE1 electronics rack.

Learnings

- The cellular connection can be really weak in Ghana, especially in remote locations
- Having the base station hardware on the ground in the BASE2 design would negatively affect the use of an internal cellular antenna.

Iterating

It turned out that in the same location an external antenna provides much better signal strength than the internal one. As can be seen in figure 6.31. It has to be noted that the signal strength in the test location (close to a cellular tower) was so good that even without antenna a data connection could be setup.

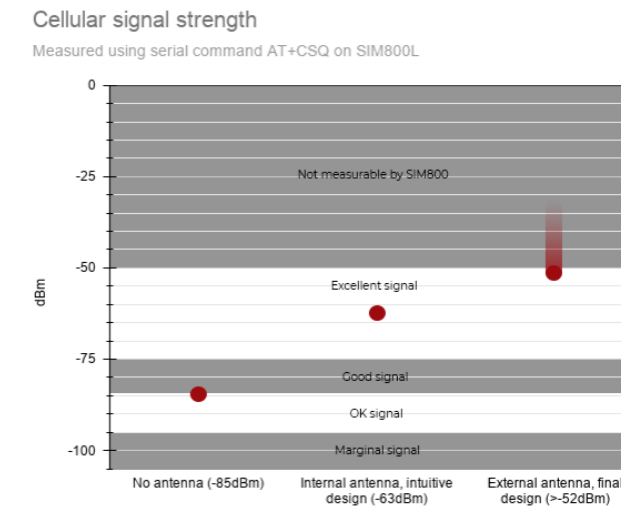

6.31. Signal strengths measured with different cellular antenna's

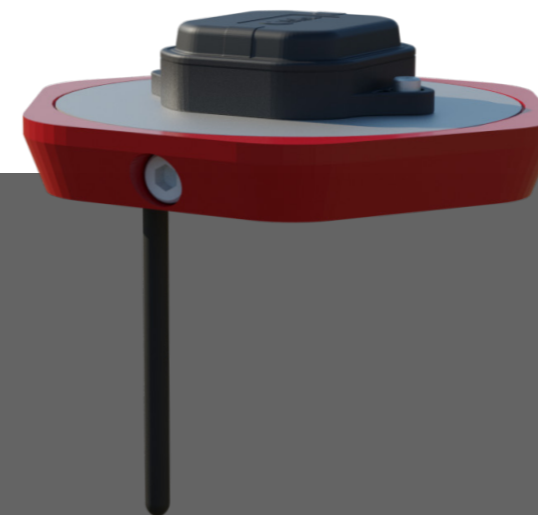

6.32. Antenna top of BASE2

Final design BASE2 data connection

Finally the SIM800L is combined with a DELOCK 89618 outdoor antenna. This antenna is placed on the lower side of the antenna top (figure 6.32). This system provides a 45kbps 2G connection.

In the future a 3G chip set could be used if 2G would be phased out.

Scripts and a manual, to get the SIM800L working with the Raspberry PI can be found in the technical data package.

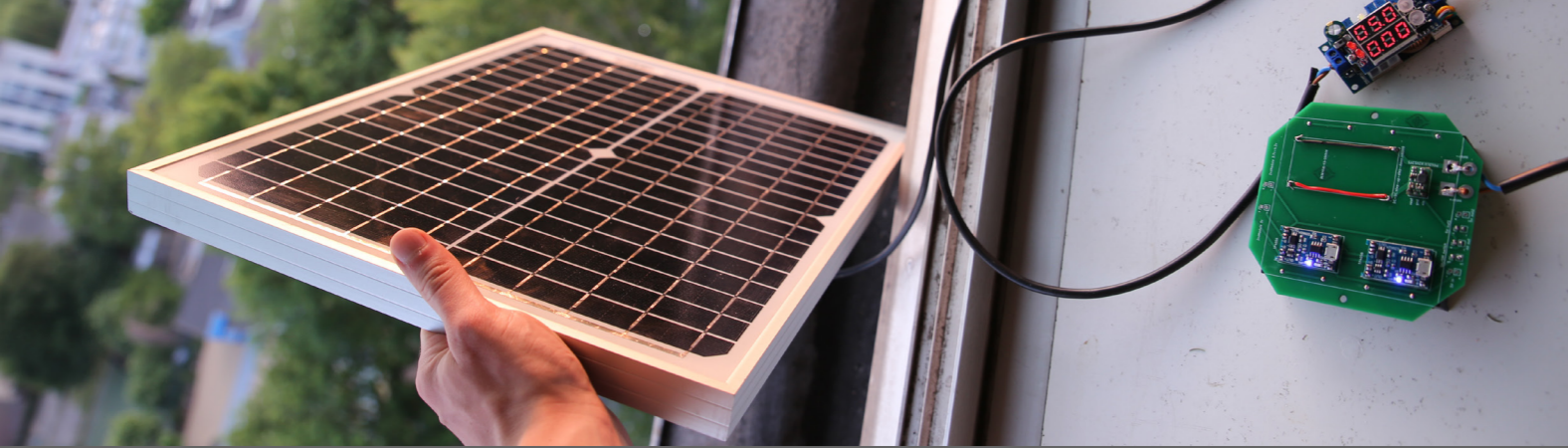

6.6. Power supply

Challenge

Ghana has an instable electricity network. Also, in some places the electricity network is not available. Therefore it would be good to make the base station an off-grid appliance.

Most important requirements - Base

- Can be powered without the use of the power grid, 24 hours a day, at all times.

Most important requirements - Rover

- Can be powered for one working day (8 hours).

Inspiration

Inspiration on off-grid appliances was taken from the Distro rain meter (figure 6.13) All the electronics of this rain meter have been designed to consume as less power as possible. This is done by building completely dedicated hardware with a low level micro controller and a LoRa radio to transmit the data. In this way only a very tiny solar panel is needed. It is so small, that it can be integrated in the mounting bracket of the device.

Of course, also the current TWIGA base stations were used as an inspiration source for the power supply (Figure 6.33). These systems are continuously powered by a solar panel in combination with a lead-acid battery. The systems are robust and very accessible due to the use of an electronics cabinet. However, the devices are by no means transportable, which would be a requirement for the first stage of commercial use as can be read in the learnings of paragraph “6.2. Physical shape and appearance”



6.33. Twiga GNSS stations in Uganda (TWIGA, 2020)

Intuitive power supply design - ROVER1

In the first intuitive rover design a fixed battery was used, consisting of four lithium 18650 cells. These cells were chosen for their wide availability and great capacity to weight ratio. The rover can be charged before and after its use, it does not always have to be on. Therefore, it is acceptable to charge the rover using the power grid.

Intuitive power supply design - BASE1

The base should run at all times without being depended on the power grid. Solar energy is the most straight forward option to supply power for the base station. Powering the appliance on solar energy is viable, for the appliance does not require a lot of power, and Ghana is positioned close to the equator and thus has many sun hours during the entire year. The first intuitive base station design used the same battery cells, on the same battery board, as the rover. However, the base station was equipped with two battery boards, to increase the total battery capacity (Figure 6.34). In this stage, the solar converter was still outside the base station, due to the research which had to be done to find the correct solar converter. One can read about the selection of the solar converter in “Appendix O. Solar converter selection process”

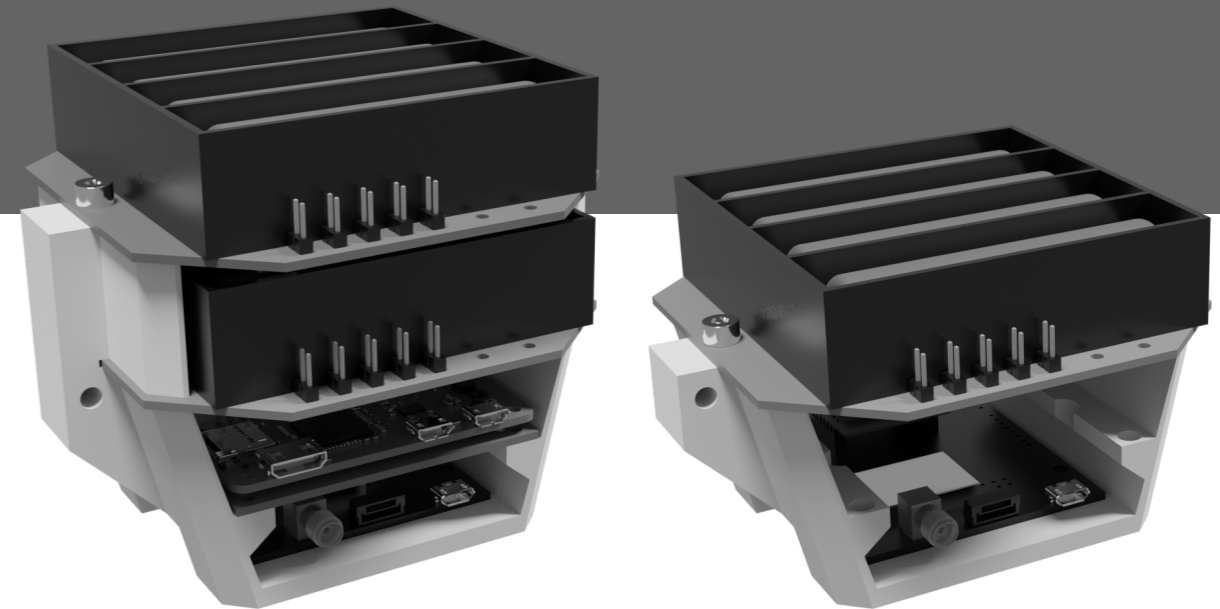

6.34. Electronics assembly of the first intuitive design. Left: BASE1. Right: ROVER1.

Learnings

- Solar panels need a solar converter. This converter should regulate both the output voltage and current, to keep the solar panel at its maximum power point.
- The required batteries are a big part of the devices total weight.
- Lithium batteries cut down the weight but need extensive over and under voltage protection as well as short circuit protection. Because their high output current can be a fire hazard.
- Non dedicated hardware such as the Raspberry PI gives high flexibility in usage, but comes with the price of high power consumption.
- Multiple battery boards with in between wiring and connectors are less reliable than having all batteries placed on one PCB.
- A 20 watt solar panel and four lithium cells can keep the base station hardware running continuously on relatively sunny days in the Netherlands (See “Appendix N. Solar panel test”)

Final power supply structure ROVER2

The final rover power supply can be seen in figure 6.35.

It was decided to give the rover less battery capacity to reduce weight. Instead, the battery was made replaceable. More about this design choice can be read in paragraph "6.7. Robustness". The batteries are secured with a charging/protection circuit and both batteries are fused. The voltage regulator is part of the rover itself to lower the battery costs. Each battery will power the rover for 32 hours and power the rover with an attached phone for 3,8 hours as calculated in Appendix M.

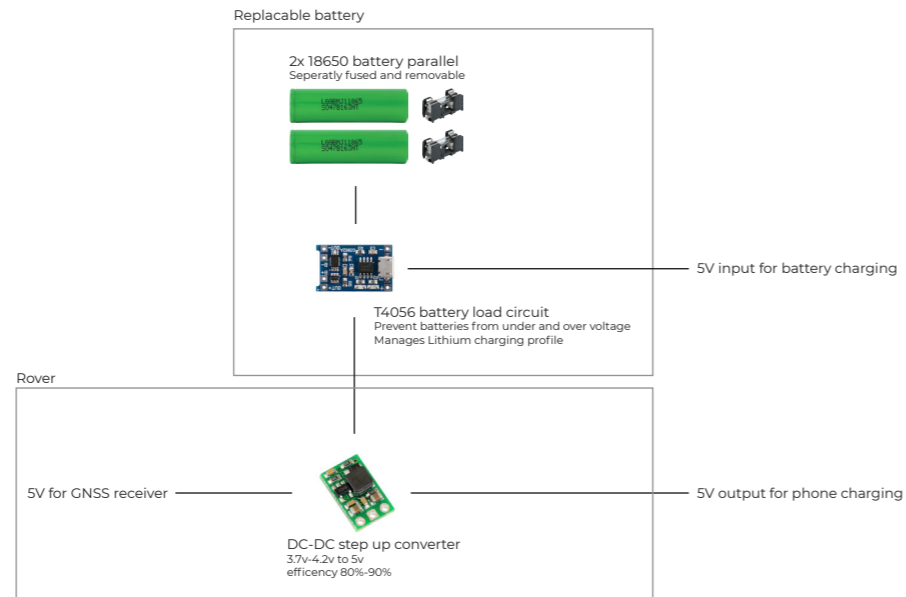

6.35. Final structure of the ROVER2 powersupply →

Final power supply structure BASE2

The final base power supply can be seen in figure 6.36.

The device contains eight lithium batteries in parallel. While the batteries are placed in parallel, they act as one big cell so that no cell balancing electronics are needed. All batteries are again fused and protected for under voltage with an T4056 circuit. The modem runs directly on the batteries to reach maximum efficiency, while the voltage for the receiver and Raspberry PI are stepped up to a constant 5V. The large cell of batteries is charged by the MPPT solar converter. The CN3772 chip in the charge controller keeps the solar panel at its maximum power point, while the lithium batteries are charged with a suitable charge profile. The solar converter has been modified to stop charging at the correct voltage. One can read about this modification in "Appendix O. Solar converter selection process". On their own, the eight batteries will power the base station on their own for 50 hours as is calculated in Appendix L.

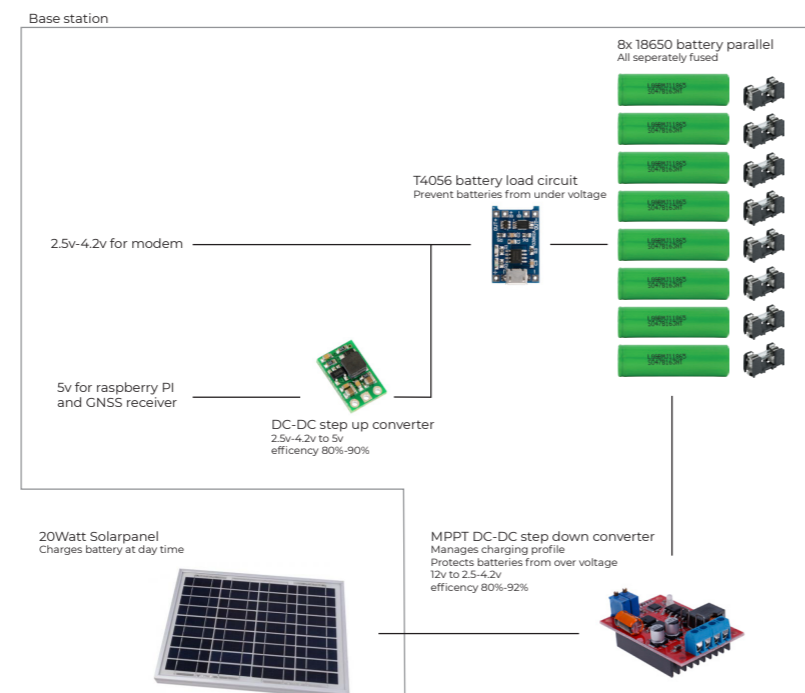

6.36. Final structure of the BASE2 power supply →

Final physical form power supply ROVER2

The rover batteries contain two 18650 lithium-ion cells on the lower side (figure 6.41). On top of the batteries, the fuses and charging circuit are placed (figure 6.40). The batteries can be charged within the rover or outside the rover with a 5V phone charger.

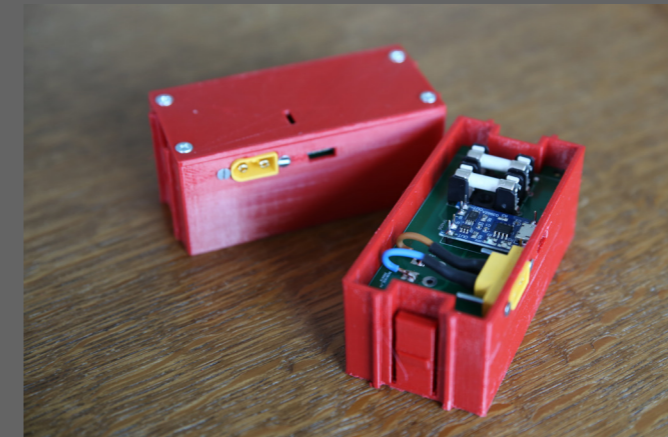

6.40. Custom battery PCB with charge/protection circuit and a fuse for each lithium cell.



6.41. Rover battery lithium-ion cells.

Final physical form power supply BASE2

All base batteries are placed on the lower side of the electronics sled (figure 6.37). On top of the PCB, the TP4056 circuit can be found to protect the cells from under voltage. Over the length of the PCB all battery fuses are placed (figure 6.39). On the top side of the electronics sled the solar converter is placed (figure 6.38). The solar converter has to dissipate its heat into the housing with a heatsink.

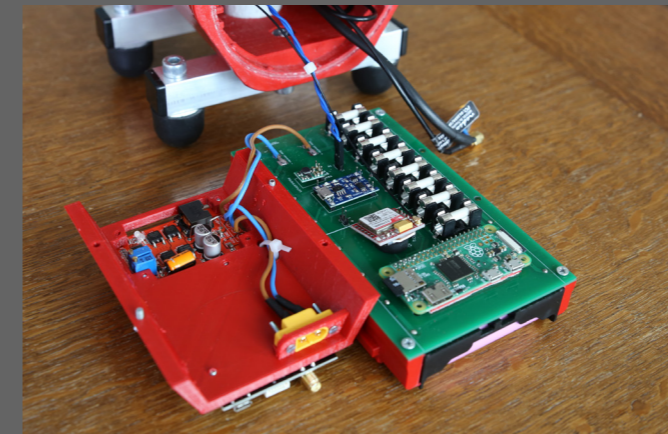

6.37. → BASE2 lithium-ion 18650 cells.

6.39. ← Custom BASE2 PCB with charge/protection circuits and a fuse for each lithium-ion battery cell.

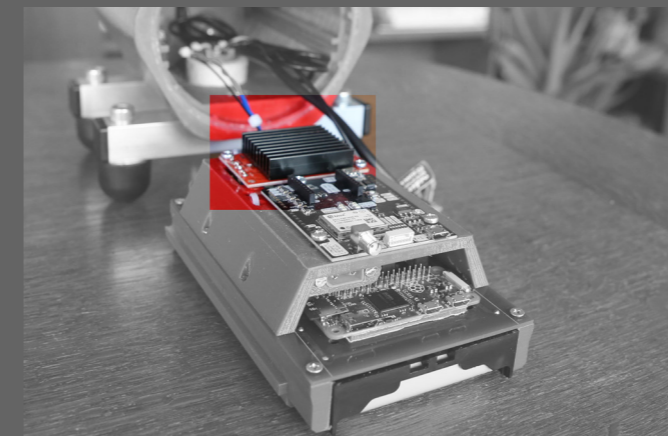

6.38. ← MPPT solar converter on the back of the BASE2 electronics sled.

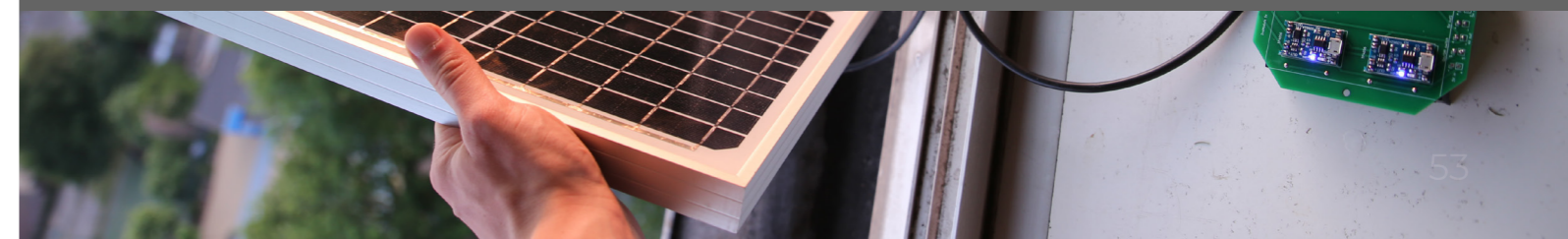



6.7. Robustness

Challenge

The devices will be taken into the field, providing a substantial possibility that conditions will be rough, especially for the rover which will hold the whole dau during use.

Most important requirements - general

- Can withstand sudden gusts of wind

Most important requirements - Rover

- Product should be undamaged after fall from 2m to a hard surface.

Intuitive design - ROVER1

The first intuitive rover design was not especially focused on robustness. The device weighed 790gram and was entirely unprotected for bumping and dropping.



Intuitive design - BASE1

The first intuitive base station had a weight of about 1200gram. The entire device was located at antenna height, to be as much like the rover design as possible.

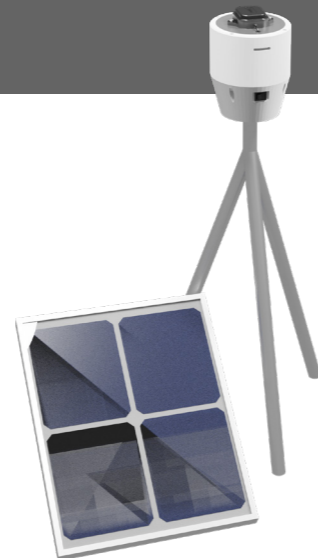

Learnings on robustness

Conversation

- *“There can be sudden strong winds in Ghana. I’m afraid that the devices will tip over. A tripod which can be anchored in the ground would be very useful.”*

Field test

- *During the building stage the rover was placed leaning against the wall. Due to its cylindrical shape it was able to roll sideways and dropped down scattering in pieces.*

Building stage

- *Having the very heavy base station hardware on top of a two meter high pole makes it very easy to let it tip over.*

Iterating

Both the initial design of the base station and rover needed to be adjusted to be able to withstand rough conditions such as bumping and dropping. In general there are four aspects which can be addressed to make the devices less likely to be damaged by a fall:

- Reducing the weight which falls down.
- Reducing the speed at which the product hits the ground (related to the height from which the object falls).
- Increasing the distance over which the device is slowed down to a full stop.
- Increasing the contact surface on impact, to divide the force over the impacted surface.

The easiest way to protect a device against drop damage is to place it in a location where it can not be dropped. Therefore it was chosen to place the heavy part of the base station equipment on the ground instead of on the top of the antenna pole.

Placing the rover flat on the ground is no option. The weight could be placed lower on the rover pole. However, this would result in wires running down from the antenna across the pole. It was chosen to make the rover six sided to make the occurrence of a drop less likely when it is placed against the wall. The remaining protection should be created by reducing the total weight, increasing the distance over which the device is slowed down and increasing the contact surface on impact. The weight was reduced by removing lithium cells from the rover and making the battery pack replaceable. Furthermore, the plastic housing was reduced in height. An in-between rover model was built to check if a hollow rubber tube could prevent the rover from breaking at a drop.



6.42. In between rover model has slight internal damage after fall on sand.



6.43. In between rover model collapsing after fall on asphalt

The hollow rubber ring was not able to prevent the rover from being damaged on a fall (figure 6.42 & 6.43). The video of this test "Droptest_ROVER1.5" can be found attached to the digital version of this report.

As a result of the measures not having the desirable effect, a new version of the design was made. Multiple rubber like materials in different shapes were examined in a drop test with a weight, equivalent to that of the rover, on a pole (figure 6.47). The high speed footage of each fall was analyzed to select the profile which took longest to slow the weight down to a full stop (most video frames). The video of this test "Droptest_RubbercComparison" can be found attached to the digital version of this report.

A foam rubber cord showed the best dampening effect on this object.

The new foam rubber cord was used to make two rings around the final rover design. The two rings will increase the surface at which the impact force acts. Also, the impact force does now act on the upper and lower rover housing. This will prevent the connection mechanism from shearing apart as happened in the last drop test (figure 6.46).



6.47. Testing the dampening effect of several rubber profiles with high speed footage.



6.44. ROVER2 model undamaged after fall on sand



6.45. ROVER2 model seemingly undamaged after fall on asphalt.

In a final drop test, the rover stayed in one part after a fall on asphalt (figure 6.44 & 6.45). However, the lower housing still cracked between the point of impact and the pole (figure 6.46). The video of this test "Droptest_ROVER2" can be found attached to the digital version of this report.

It seems that the iterations have reduced the drop damage, however the device will not be undamaged when the rover drops sideways from a height of two meters on a hard surface.

The 3D printed plastic is very brittle. It is possible to increase the wall thicknesses of the material, however, this will also significantly increase the print time and weight of the device.



6.46. ROVER2 lower rover housing cracked after fall on asphalt.

One can conclude that more research is needed to make a damage free fall possible. However, it has to be noted that it is already an achievement that the hardware in the device stays undamaged. Furthermore, it is unknown if GNSS rovers of other brands would be resistant to a drop like this.

Final design for robustness - BASE2

The final base station has a main unit of 1300gram. The unit has two aluminum legs with rubber feet which are wider than the device itself, which will cause people to hit the legs instead of the housing. For the same reason, switches and connectors have been placed into a cavity. The main unit can be placed in a low position to prevent it from falling. The antenna platform, which has a low weight, is placed on a pole, on a very sturdy tripod. The legs of this tripod can be pushed into the ground.

Final design for robustness - ROVER2

The final rover has a main unit of 765 gram, this unit is covered in two rubber rings to protect it when it falls down. Despite these measures, the rover does not stay undamaged when falling to a very hard surface, as has been elaborated in this chapter.

The main unit of the rover has six sides to not roll down when placed against a wall. Also, a sturdy tripod can be used to leave the rover safe in one position.



7. Business perspective

A big part of the motive for building a low costs GNSS solution for Ghana is to open up new business perspectives. Competitor high precision GNSS positioning solutions do exist and are available in Ghana. These competitor products could just as well be used for surveying, making height maps and might as well be modified to log raw data for rain forecast improvement.

For this reason, the new product should beat the existing solutions in function or price to make the production of the product a viable business. The only clear functional distinction with competitor products is the option to attach a solar panel to the base. To give insight in the price difference the price difference a cost price calculation can be found in paragraph 7.2.

An additional factor for success could be the pride and product customization which can be realized by producing or assembling the product locally. The possibilities for local production are elaborated on in paragraph 7.1.

7.1. Local production

Local production brings employment opportunities, can increase the pride/adaptation of the product and makes it easier to deliver custom solutions. For example by delivering the product in a custom color, or by producing a special bracket to mount an antenna to a certain roof.

Difference in labor cost and production method viability

It is important to realize that the location of production also greatly influences the price of labor. For example the average wage of an Ghanaian mechanic is on average 13 times lower than in the Netherlands (“Salaries by positions in Mechanical Engineering -... - Paylab.com,” 2020). Subsequently, this lower price of labor can make a certain production method in Ghana much more viable than using the same production method in the Netherlands.

For this reason printing and coating a housing part would be very cost ineffective in the Netherlands but is not out of question in Ghana.

The housing parts can all be 3D printed, In this way there is no investment needed in molds. When increasing produced quantities significantly from 100 to >1000 it would probably start to pay off to make moldable parts.

Method of local production

The relatively low amount of devices which have to be build, could be produced in a local makerspace. A good option could be the KI-Hub Makers space which will be started in Kumasi within some time.

In the case of local production, the logic chips will still be produced by the manufacturers of these components in other countries. This would also be the case when production would take place in the Netherlands. Etching the PCB and soldering can already be done locally, dependent on the sophistication of future PCB’s. Printing the housing parts, coating these housing parts and assembly of all the components can be done within the KI-Hub Makers space.

For 3D printing a reliable electricity source is required. The power grid in Ghana is not stable, therefore, there is a solution needed such as a power buffer or an off grid power solution.

By coating the housing parts in epoxy, slight imperfections can be handled while still guaranteeing watertightness. This is important when environment conditions change while printing or when using low cost printers.

The complete production and assembly process can be seen in “Appendix T. BASE2 Build process” and “Appendix S. ROVER2 Build process”. The fact that the first four prototypes have been made within a Dutch student home without any advanced equipment, proves that the production can be done with little equipment. Table 7.1 shows which equipment would be needed in the makerspace to allow for local production of the designs.

Equipment	Use	Demand
3D printer	Print housing parts	Very high
Protective clothing and ventilated space	Sanding, degreasing and coating housing parts in epoxy.	High
General assembly tools, screwdrivers and allenwrench	Assembly of components	High
Solder equipment	Soldering power plugs.	Average
Drill press	Drill poles and aluminium feet	Low
Lathe	Turn optional 5/8-11 screw thread adapters	Optional

Table 7.1. Equipment needed in makerspace for local production

7.2. Cost price

The cost price of ROVER2 can be calculated using the rover material costs (Appendix C), the estimated machining costs (Appendix E) and the estimated labor costs, when producing the device in Ghana (Appendix D). The complete rover cost calculation has been summarized in Table 7.2.

	Rover part	Material	Machining	Labor	Sum
	Main unit	€254,6	€5,4	€26,2	€286,2
	Battery	€14,8	€1,1	€4,1	€20,0
	Phone holder	€5,8	€1,7	€4,1	€11,6
	Pole	€10,9	-	€2,8	€13,7
	Tripod and clamp	€71,4	€1,7	€2,8	€75,8
				Total:	-----+ €407
				20% profit:	€489

Table 7.2. ROVER2 cost price calculation

The cost price of BASE2 can be calculated using the base station material costs (Appendix B), the estimated machining costs (Appendix E) and the estimated labor costs, when producing the device in Ghana (Appendix D). The complete base station cost calculation has been summarized in Table 7.3.

	Rover part	Material	Machining	Labor	Sum
	Main unit	€287,8	€8,2	€31,7	€327,7
	Antenna platform	€71,3	€1,5	€4,1	€77,0
	Solar panel	€42,7	-	€2,8	€45,5
	Pole	€10,9	-	€2,8	€13,70
	Tripod and clamp	€71,4	€1,2	€2,8	€75,3
				total	-----+ €539
				20% profit	€647

Table 7.3. BASE2 cost price calculation

The base station is the most expensive device in the complete setup. At a 20% profit margin, the base station still costs €647, which is one third of the cheapest competitor device. This cheapest competitor device is the Emlid RS2 which comes in at \$1899 (Appendix G). However, had the devices been developed in a commercial environment, the added development costs would have made the price gap much smaller.

8. Evaluation

In this chapter the final product will be evaluated. First, a look is taken at the test in the Netherlands concerning performance of the device. Secondly, to find out how the device is received in Ghana in terms of user friendliness, aesthetics and future potential, Stylish has evaluated both devices in Ghana. Finally, we come back the requirements stated in chapter 4 of this report and evaluate to what extend the final product complies with these requirement.



8.1. Performance test in The Netherlands

Using the first rover prototype, Ruben Smits and Ivo van Balen measured positions in the Broomwaard and Delft. All points were measured twice. One time using the ROVER1 prototype and one time using the Trimble R8 for comparison. The ROVER1 was connected to an improvised base station which contains the same hardware as the final product (Figure 8.2).

Conclusions of the BEP students

Ruben Smits researched the ability to make a height map using the positioning devices to measure reference markers (figure 8.1) for a drone.

Ruben Smits concludes:

“An elevation model retrieved by a low-cost positioning device and a dense network of GCPs (Ground Control Points) to correct the UAV (Unmanned Aerial Vehicle) images resulted in a mean absolute error and root mean squared error of approximately 1.77 and 2.39 centimeters, respectively. The errors were measured relative to a DEM (Digital Elevation Model) generated by a professional GNSS receiver using a dense network of GCPs, which was set to be the reference DEM.” (Bsc, Smits 2020)

(These errors are well within range, considering that the U-blox ZED-F9P receiver and Trimble R8 device in the vertical plane both have an error margin of 2cm + 1mm for each kilometer moved away from the base station.)

Ivo van Balen directly compared the coordinate output of the Trimble R8 with that of the ROVER1.

Ivo van Balen concludes:

“In terms of accuracy in the horizontal and vertical plane, the low-cost positioning device in form of the ROVER1 and BASE1 with the u-blox inside, can definitely compete with the high-end equipment.” (Bsc. Van Balen, 2020)



8.1. Ivo van Balen putting down a reference marker for a drone.



8.2. Temporary base station setup at the Broomwaard.

User friendliness

Of course also relevant observations were made on the non-performance part of the ROVER1.

What stood out directly was that the weight of the ROVER1 was about half that of the Trimble R8.

Furthermore, it was clear that mobile computer technology has made a big leap forward since 2009, when the Trimble R8 was introduced. A modern smart-phone is much more responsive and user friendly than the PDA which is included with the Trimble device (figure 8.3). Knowledge of the smart-phone app turned out to be really important for the accuracy of the results. For example, when the app measures the average position for a few seconds, the results are much more accurate than just picking one coordinate. In a worst case scenario, someone could measure positions using the internal phone location service, while thinking to be connected to the rover. Therefore, giving the user a clear instruction on how to use the app is crucial to get accurate results.

During the setup of the base station in the Broomwaard (figure 8.2 and 8.4), it became clear that setting up the base station on a known location is already quite a hassle. The receiver needs to be programmed using a laptop and specialized software.

Finally, the lack of audio or visual feedback on the ROVER1 can make it hard to use. Especially information about the Bluetooth connection and battery is needed.



8.3. Using a smartphone by hand versus the PDA with stylus.

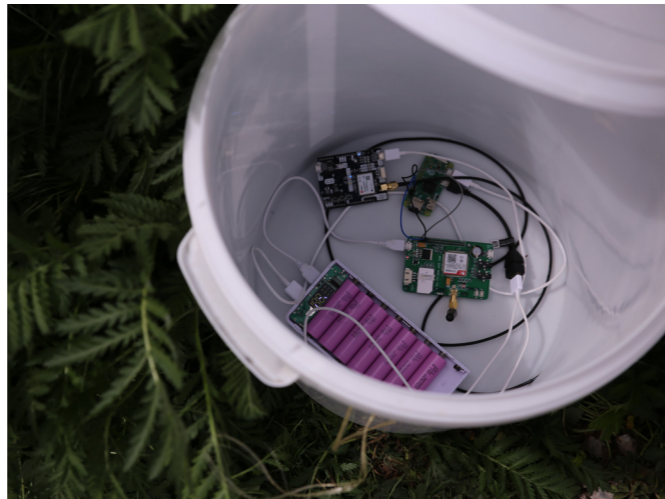

8.4. Base station hardware in a bucket.

8.2. Test in Ghana

Initial setup

The rover and base were initialized by Stylish in Ghana, while Peter provided support over a video connection.

The mount point for the RTK connections was already defined. Also, the SIM card could be inserted without further configuration as telecom providers in Ghana do not use an APN user name and password.



8.5. Stylish and Peter preparing the rover and base for the first use in Ghana. Using video conference.

Fitting the devices with stylish equipment

Only the ROVER2 and BASE2 devices themselves had been sent over to Ghana. Not the poles and the tripod, to reduce the size and weight of the package.

It was found that Stylish was already in possession of tripods a survey pole and a tribrach. Therefore an adapter was designed to fit the rover and base antenna to a 5/8"-11 thread (figure 8.6). Stylish had the adapter made locally (figure 8.7). Now the rover and base could be tested using the existing equipment of Stylish (figure 8.8).

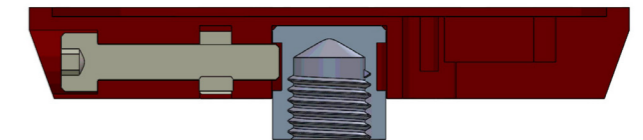

8.6. UNC 5/8-11 adapter to use the rover and base with existing survey tripods and poles.

It was a good test to obtain a part of the setup locally. Stylish was able to get the part within two working days, which is a good first step if later on the complete devices have to be made in a makerspace.



8.8. ROVER2 with thread adapter.



8.7. Stylish had the thread adapter made locally

Stylish testing the high precision positioning system



1

1. Stylish is setting up the base station antenna on top of the tribrach. He uses the newly made 5/8"-11 thread adapter screw.



2

2. Stylish connects the solar panel. He thinks it would be good to have a stand to be able to put the solar panel down towards the sun.



3

3. The base station has been setup, on a safe roof. Now, Stylish is ready to go off to survey.



4

4. Stylish mounts the rover to his extendable survey pole with the newly made 5/8"-11 thread adapter.



5

5. Stylish explains that the phone holder does not fit his survey pole because it has an other diameter than the original aluminum pole. He would like it if there was a clamp which suits to each size of pole.

Setting up the Bluetooth connection between the rover and the phone is done within a minute by Stylish, while he has done this at the office before.



6

6. Stylish can now measure points with the rover. He is still able to hold the rover straight up while his survey pole also has a level.

7. Stylish is surprised that the rover is still able to give a fixed RTK position 20km from the base or under the canopy. He is used to other devices losing connection over this distance normally.

It does stand out to Stylish that the base station is restarting sometimes. He doubts if this is due to the software or due to his cellular connection.



7

The video of this test "Test_Ghana_BASE2andROVER2" can be found attached to the digital version of this report.

Overall test impression

This test can be seen as quite a success. Stylish was able to smoothly assemble the base station by inserting the batteries and his own SIM card.

Furthermore, Stylish was able to perform a test all on his own, he was able to setup the base station and rover entirely correct and thereafter he could survey around Kumasi. During the survey process, he did not experience severe connection losses, neither is the rover or base battery drained despite of keeping everything on during the whole test. The most obvious downfall was the incompatibility of the Phone holder with Stylish survey pole.

It was evaluated with Stylish after the test that the ability to get a RTK fix over long distance is due to the use of the cellular network, whereas the devices he previously used relied on their own radio connection. The accuracy of the fixed position which Stylish obtains will still be negatively affected by increasing the distance from the base or the amount of high objects around the rover. However, the test shows that the overall system, based on cellular connectivity is usable around Kumasi.

Of course there are things to be desired:

User friendliness

Stylish thinks the SW maps app is easy to use. He also has no doubt whether a technician is able to setup the base. However, he would like to have a better monitoring system for the base. One should be able to configure the base over the web without attaching a monitor or cable. For now it's a shame that it is so hard to put a fixed coordinate in the base or to have it define its own location. When the base restarts it is not clear to Stylish, nor to someone else, if it is because of a connection error, a software issue or that the batteries are low.

Stylish would like the base station main unit to be mountable to his tripod (With a strap for example). He thinks that this location is safer for water and dust not to get into the base station, besides it would look better.

Stylish is missing the feedback on the rover device. He would like the button on the rover to show: The battery level (green when full - red when low), the state of the Bluetooth connection and the signal status (float or Fix).

Finally, Stylish is afraid that opening up the Rover to change the battery will eventually damage the Rover. He would like to have a separate door for the battery pack.



8.9. Trimble R10 featuring a swappable battery with door.



8.10. Unistrong G970II featuring status lights

Aesthetics

Stylish and his colleagues approve the red color of the device. They say that the rubber adds to the feeling of overall robustness, however the fact that the ring is not one continuous piece is perceived to be looking bad. Concerning the base, they would rather have it with a flexible handle, such as can be found on outdoor speakers.



8.11. Unbranded outdoor speaker featuring a carrying strap.

Practicality

Stylish pointed out that the Ghanaian government requires survey companies to deliver the raw data of their base and rover so that their results can be examined. Therefore, the RTK solutions are interesting, but only usable when not surveying for the government.

8.3. Comparison to plan of requirements

In this paragraph the main focus requirements from chapter 4 are examined. The full list of requirements can be found in "Appendix A. Full list of requirements"

Requirements for both devices				
Requirement for Rover & Base station	Value	Prove for accomplishment of requirement	Result	Achieved
Can withstand tropical humidity	85% humidity	No prove	Measures have been taken, should be monitored over a longer time	Unkown
Can withstand tropical rain	IPx4 (IP64) Protected against water splashed from all directions, limited ingress permitted.	Rating of components & rain test	After 15 minutes under the shower no water inside device	Yes
No dust should harm the product	IP6x (IP64) Totally protected against dust.	Rating of components & rain test	When no water enters the device, no dust will enter either. The foam water drain is rated against dust.	Yes
Can withstand rough winds	Sudden gusts of wind	No prove	Measures have been taken, should be monitored over a longer time	Unkown
Aesthetics suitable for local context	The Ghanaian employees should approve the appearance of the product.	Questioned by Stylish	Yes the employees like the appearance, however there are points to improve.	Yes
Costprice of product	Costprice between €250 and €500 (rover & basestation no more than €1000)	Cost calculation	Rover €407 Base station €539. Combined €946.	Yes

The most important requirements concerning both devices have been accomplished, or need testing over a longer period in the right conditions.

Basestation				
Requirement for Base station	Value	Prove for accomplishment of requirement	Result	Achieved
Can transmit NTRIP data for RTK	Provides RTK correction data for the rover.	Test by BEP students Ruben and Ivo	Possible (1,5mb/hour)	Yes
Can transmit raw data for weather forecast	Can log data and upload to a web server for rain forecast.	Bandwith left beside RTK data.	Possible (max 20mb/hour alongside RTK data)	Yes
Product is easy to use	Mounting process can be learned by Ghanaian technician of target company within a half day.	Estimation during test by Stylish	"When the software would be easy to handle the system installation can be learned to technicians within half a day"	No
Can be powered without the use of the power grid	Energy source which provides power 24hours at every day of the year.	Solar panel test	Possible	Yes

Of the most important base station requirements, only the easy base station installation training is currently not within reach. This is due to the complicated software steps which have to be taken by the technicians. The off grid power works but can be tested more thoroughly.

Rover				
Requirement for Rover	Value	Prove for accomplishment of requirement	Result	Achieved
Can measure accurate position.	Matches the tolerances given by the manufacturer Ublox.	Test by BEP students Ruben and Ivo	Matches tolerances	Yes
Can receive NTRIP data from basestation for RTK	Data connection available around Kumasi	Test by Stylish	GSM network is available near Kumasi	Yes
Product is easy to use	University graduate or even Senior High School leavers are able to use the device within 30 minutes of training	Estimation during test by Stylish	"If the teacher knows how the app works, it can be taught within half an hour"	Yes
Can withstand Impact damage	Product should be undamaged after fall from 1,5m to a hard surface	Drop test	Housing of rover cracks	No
Fixed distance to the ground	Mechanism which ensures the distance from the antenna to the ground is the same at each measurement.	Physical inspection	2m pole maintains constant distance from ground	Yes

The requirements applying to the rover have all been accomplished, except for the resistance against impact damage. The availability of the cellular network can be tested on more locations.

9. Conclusion

A high precision positioning system can be used to make height maps to predict flooding, to improve the rain forecast and to generate business opportunities in surveying. Currently high precision positioning systems are very expensive. Therefore, the assignment was:

Design a high precision positioning system, based on a dual-frequency receiver, which can be produced in small batches. This system should suit the west African context in terms of usage, weather resistance, communication, producibility and power supply.

Two products have been designed during the writing of this thesis. The first product is a rover, which can be used to measure an accurate position. The second product is a base station which can be used to provide correction data to refine rover position measurements.

The resulting products performed up to spec at performance tests in the Netherlands and are received well by the Ghanaian target group. During the evaluation stage in Ghana, it became apparent that there is a good prospect on using the device in the future as the used technologies are fully working on location. Also the users were able to successfully perform tests on their own within a few days after receiving the package. It seems they are able to handle the system with quite some ease, as long as the base station software does not have to be touched. The choice of using the cellular network for data communication turned out well. The assumption that the cellular network is ahead of other infrastructure in Sub-Saharan Africa seems to be correct as it caused little to no problems during the test stage. Of course, there are suggestions for improvement of the designs, but there are no big flaws to be considered which would prevent the system from executing its main functions.

During the design process, it turned out to be the most feasible route to make a separate rover and base station device. Concerning the electronics, the two devices had to be diverted while the available software for rover and base did not run on the same hardware platforms. Also the requirements for the rover and base were too far apart to allow for one physical product shape. For this reason, the rover is designed as a light and portable device. While the base is a modular system, with more battery capacity, focused on easy hardware access.

Measures have been taken to cope with environmental effects such as rain and condensation. Furthermore, the base station can be completely used off-grid, using the solar panel. These design features were examined in the Netherlands. However, the features could only be proven to work partially. A longer period of time in the correct environment should give a better view on the effectiveness of the choices.

A lot of effort was put into making the device robust, especially to make the rover drop proof. Unfortunately a drop proof design could not be realized using of 3D printed parts. The parts are too brittle for the impact of a drop, even when a rubber rugging is used.

3D printing was mainly considered while it allows for quick prototyping and as the process can be easily started Ghana. The inability to make a drop resistant design shows the downside of the technique.

The price point of the rover product (€489 incl. 20% profit) and base station product (€647 incl. 20% profit) is considered to be good by the local users. This price point is about 1/3th of the cheapest competitor product, while providing some interesting extra features such as the off-grid power system. The price is not only low due to the availability of new cheaper GNSS receivers, but also due to the fact that labor prices are relatively low when assembling the product in Ghana. Finally, the development hours at the university are not added to the product price, which makes a considerable difference in the price point of both devices.



10. Recommendations

In this chapter recommendations are made on how to proceed with the project. It can be hard to define at which point a product is good enough for the intended purpose. All recommendations in this chapter will improve the product, but it is good to define at which point the implementation should start.

Business perspective

It is important to implement this product at the right time if the business model of this project is to succeed. Competitor products which provide about the same functionality do exist at a higher price. The designed product can be cheaper, partly because development hours at the university are not added to the product price. In time, the mass produced competitor products will surpass this series product price wise. For this reason the development stage should not take too long.

Software development

Much of the shortcomings of the current system are caused by the absence of dedicated software. This software is really needed to sell the product.

A rough outline of what the software could comprise:

The company or organization which exploits base stations will need to have its own server. To this server, all RTK and raw data can be streamed by the base stations. In this way, all data is in possession of the system owner. The server could at the same time be used to monitor each base station on its own web page. This page should, in a clear way, show the current state of the base station and allow to change the most important base station settings. Entering a fixed coordinate, or letting the base refine its own position should be possible by pushing a single button. An example of what this web page could look like is shown in figure 10.1.

When the software system is available, physically connecting with keyboard, mouse and monitor is no longer needed. Also, people with less informatics knowledge will be able to use the system. Because the proposed system is quite complex it should surely be designed by a software specialist.

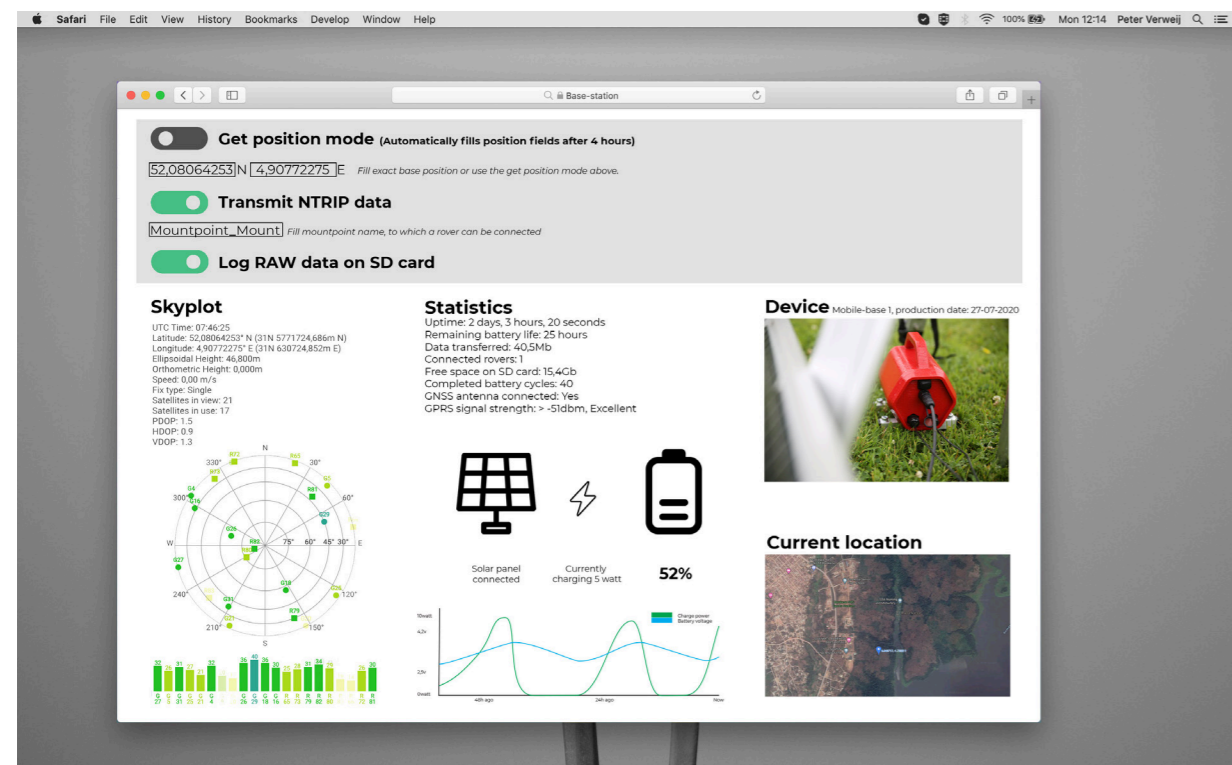

10.1. Example base station monitoring web page.

Electronics development

The current products are build out of PCB's which can be bought ready to use. This allowed for fast tests. However, the down side of this approach is that all the separate components contain a lot of unused features, are connected by wires and have their indicator lights and connectors in very clumsy locations. Improving these electronics would greatly improve the product, however this step is not obligatory for having a working product.

A rough outline of what a complete custom PCB could bring:

The function of the currently separate PCBs could be combined in to one circuit. The GNSS receiver, cellular modem, micro controller and power electronics can all be integrated into one circuit board.

While designing the PCB, the capabilities of the used chips can be reconsidered together with the software specialist. For example, the base station probably does not need a micro controller running a full blown Linux distribution. Finally, the option to add indicator lights in logical positions would be a much appreciated feature. When the hardware is integrated in one PCB, the device will consume less power, will be more reliable and will be smaller. Knowledge of delicate RF electronics is essential to build this PCB. Therefore this task should be fulfilled by an electronics specialist.

Hardware development

3D printing is a very fast way to get to a prototype product. During this thesis we used this speed to our advantage, four prototype products have each been build in only a few weeks time. However, the downsides of this technique is that the printing process itself is slow. For good waterproofing, a coating is needed and the printed products are too fragile to survive a drop even when the product is rugged in rubber. Of course it is still possible to make a series of products using 3D printing.

Injection molding the parts would really improve the quality of the rover housing, but the molds come at such a high cost that this is not financially feasible when building less than 1000 products. New techniques which are rising could change this. For example, a mold could be 3d printed an then be used to mold a low amount of parts at much lower costs. (Redwood, 2020) It should be researched if this method could also be used in Ghana. When heading over to a production method which requires molds, the total amount of molds should be kept low. This could for example be done by sharing housing parts between rover and base station. Sharing housing parts might be possible after having developed one integrated PCB.

Features

Several features have been implemented in the product. However not each feature could be confirmed to work correctly. For example, there was almost no water to drain in the condensation test. If there is little moisture to drain when testing in Ghana as well, the drain might be reconsidered and changed into a ventilation element. In the full list of requirements, Appendix A. It can be seen which aspects require further testing.

In the user evaluation (chapter 8) new features are requested. Adding these features should be considered wisely, while new features often add parts and costs.

The request for raw data files was already made by Stylish at the beginning of the project. Only during the last test, it was understood that the raw files are required for government survey work in Ghana. Therefore this feature is much more essential than was thought. From this example it can be learned that it is very important to thoroughly ask for the underlying reason of a requests. Getting insight in another work field and simultaneously in another culture is harder than one would think up front.

11. References

3D hubs. (2020). FDM 3D printing materials compared | 3D Hubs. Retrieved August 13, 2020, from 3D Hubs website: <https://www.3dhubs.com/knowledge-base/fdm-3d-printing-materials-compared/#methodology>

3D hubs, & Redwood, B. (n.d.). 3D printing low-run injection molds. Retrieved from 3D Hubs website: <https://www.3dhubs.com/knowledge-base/3d-printing-low-run-injection-molds/#configurations>

Amoateng, P., Finlayson, C. M., Howard, J., & Wilson, B. (2018). A multi-faceted analysis of annual flood incidences in Kumasi, Ghana. *International Journal of Disaster Risk Reduction*, 27, 105–117. <https://doi.org/10.1016/j.ijdr.2017.09.044>

Blewitt, G., Hammond, W., & Kreemer, C. (2018). Harnessing the GPS Data Explosion for Interdisciplinary Science. *Eos*, 99. <https://doi.org/10.1029/2018eo104623>

Center for Global Development, & Kumi, E. (2017). The Electricity Situation in Ghana: Challenges and Opportunities. Retrieved from <https://www.cgdev.org/sites/default/files/electricity-situation-ghana-challenges-and-opportunities.pdf>

de Bakker, P. (2017, January). Reader on GPS positioning. Retrieved August 12, 2020, from TU Delft website: <https://www.tudelft.nl/en/ceg/about-faculty/departments/geoscience-remote-sensing/education/bsc-education/reader-on-gps-positioning/>

Food and agriculture organisation of the UN. (2020). Ghana at a glance | FAO in Ghana | Food and Agriculture Organization of the United Nations. Retrieved from Fao.org website: <http://www.fao.org/ghana/fao-in-ghana/ghana-at-a-glance/en/>

GhanaWeb. (2018, June 30). Floods kill 7 in Kumasi. Retrieved August 12, 2020, from www.ghanaweb.com website: <https://www.ghanaweb.com/GhanaHomePage/NewsArchive/Floods-kill-7-in-Kumasi-664672>

GSM association. (n.d.). Mobile Coverage Maps. Retrieved August 12, 2020, from www.mobilecoveragemaps.com website: https://www.mobilecoveragemaps.com/map_gh#7/9.056/-2.762

GSM Association. (n.d.). Powering Telecoms: West Africa Market Analysis. Retrieved from <https://www.gsma.com/mobilefordevelopment/wp-content/uploads/2013/03/GPM-Market-Analysis-West-Africa-.pdf>

Guo, J., Li, W., Liu, X., Kong, Q., Zhao, C., & Guo, B. (2015). Temporal-Spatial Variation of Global GPS-Derived Total Electron Content, 1999–2013. *PLOS ONE*, 10(7), e0133378. <https://doi.org/10.1371/journal.pone.0133378>

Krietemeyer, A., van der Marel, H., van de Giesen, N., & ten Veldhuis, M.-C. (2020). High Quality Zenith Tropospheric Delay Estimation Using a Low-Cost Dual-Frequency Receiver and Relative Antenna Calibration. *Remote Sensing*, 12(9), 1393. <https://doi.org/10.3390/rs12091393>

Paylab. (n.d.). Salaries by positions in Mechanical Engineering - Ghana - Paylab.com. Retrieved August 12, 2020, from www.paylab.com website: <https://www.paylab.com/gh/salaryinfo/mechanical-engineering>

Smits, R. (2020). Retrieval of an Elevation Map using UAV Imagery and Ground Control Points collected with a Low-Cost Positioning Device. TU Delft.

Tallysman. (2018). Embedded Antennas -Reference Guide. Retrieved from <https://www.tallysman.com/app/uploads/2019/10/Embedded-Antennas-Reference-Guide-v4.pdf>

TWIGA. (2020). twiga-h2020.eu. Retrieved August 12, 2020, from twiga-h2020.eu website: <https://twiga-h2020.eu/index.html>

United Nations. (2017). World Population Prospects - Population Division - United Nations. Retrieved from Un.org website: <https://population.un.org/wpp/>

van Balen, I. (2020). Accuracy of low-cost positioning device. TU Delft.

WMO. (2017). World Weather Information Service. Retrieved August 12, 2020, from World Weather Information Service website: <http://worldweather.wmo.int/en/city.html?cityId=922>

Worldbank. (2019). GDP per capita (current US\$) | Data. Retrieved August 12, 2020, from data.worldbank.org website: https://data.worldbank.org/indicator/NY.GDP.PCAP.CD?name_desc=true

12. Appendices

Appendix A. Full list of requirements

Stakeholder/interested party	Requirement for Rover	Type	Value		Source of requirement specification	Prove for accomplishment of requirement	Result	Achieved
Target company	Can measure accurate position.	Performance	Matches the tolerances given by the manufacturer Ublox.		Nick & Andreas	Test by BEP students Ruben and Ivo	Matches tolerances	Yes
Target company	Can receive NTRIP data from basestation for RTK	Functional	Data connection available around Kumasi		Nick & Andreas	Test by Stylish	GSM network is available everywhere near Kumasi	Yes
Enduser (Rover user)	Product is easy to use	Ergonomics	University graduate or even Senior High School leavers are able to use the device within 30 minutes of training		Stylish	Estimation during test by Stylish	"If the teacher knows how the app works, it can be taught within half an hour"	Yes
Enduser (Rover user)	Can withstand Impact damage	Functional	Product should be undamaged after fall from 1,5m to a hard surface		Peter	Drop test	Housing of rover cracks	No
Target company	Fixed distance to the ground	Functional	Mechanism which ensures the distance from the antenna to the ground is the same at each measurement.		Nick & Andreas	Physical inspection	2m pole maintains constant distance from ground	Yes
Enduser (Rover user)	Can be powered for one working day	Electronics	battery lasts at least 8 hours		Stylish	Battery life test	Rover only, battery lifetime of 22 hours	Yes
Enduser (Rover user)	Can be charged on powergrid within night	Electronics	battery can be reloaded within 10 hours		Stylish	Charge test	charging in 2 to 3 hours	Yes
Enduser (Rover user)	Weigh comfortable for long term handheld use	Ergonomics	optimal below 1.4kg (max 2.3kg)		MIL-HDBK-759C P.257 department of defence, human engineering guidelines - handheld tester.	Weighted using scale	1,5kg, much lighter than comparable trimble R8	Yes
Enduser (Rover user)	Size is suitable for handheld use	Ergonomics	Footprint not bigger than extended position of Trimble R8 (2000x190x190)		Stylish	Measured with measuring tape	2000mmx140mmx140mm extended without tripod.	Yes
Enduser (Rover user)	Device gives feedback on action	Ergonomics	Gives visual or audio feedback when measuring.		Peter	Physical inspection	No audio or visual feedback on device itself.	No
Stakeholder/interested party	Requirement for Base station	Type	Value		Source	Prove for accomplishment of requirement	Result	Achieved
Target company	Can transmit NTRIP data for RTK	Performance	Provides RTK correction data for the rover.		Nick & Andreas	Test by BEP students Ruben and Ivo	Possible (1,5mb/hour)	Yes
TWIGA	Can transmit raw data for weather forecast	Performance	Can log data and upload to a web server for rain forecast.		Nick & Andreas	Bandwith left beside RTK data.	Possible (max 20mb/hour alongside RTK data)	Yes
Enduser	Product is easy to use	Ergonomics	Mounting process can be learned by Ghanaian technician of target company within a half day.		Stylish	Estimation during test by Stylish	"When the software would be easy to handle the system installation can be learned to technicians within half a day"	No
Target company	Can be powered without the use of the power grid	Electronics	Energy source which provides power 24hours at every day of the year.		Nick & Andreas	Solar panel test	Possible	Yes
Enduser (Technician)	Weight can be transported by one person	Ergonomics	below 11.3kg		MIL-HDBK-759C P.257 department of defence, human engineering guidelines - handheld tester.	Weighted using scale	2,3 kg without tripod, 6,3 kg with tripod.	Yes
Enduser (Technician)	Product is easy to mount	Ergonomics	Device is mountable by Ghanaian technician of target company within 60 minutes.		Stylish	Estimation during test by Stylish	When the software would be easy to use one can	Yes
Stakeholder/interested party	Requirement for Rover & Base station	Type	Value		Source	Prove for accomplishment of requirement	Result	Achieved
Target company	Can withstand tropical humidity	Environment	85% humidity		https://en.wikipedia.org/wiki/Climate_of_Ghana	No prove	Measures have been taken, should be monitored over a longer time	Unkown
Target company	Can withstand tropical rain	Environment	IPx4 (IP64) Protected against water splashed from all directions, limited ingress permitted.		https://en.wikipedia.org/wiki/IP_Code	Rating of components & rain test	After 15 minutes under the shower no water inside device	Yes
Target company	No dust should harm the product	Environment	IP6x (IP64) Totally protected against dust.		https://en.wikipedia.org/wiki/IP_Code	Rating of components & rain test	When no water enters the device, no dust will enter either. The foam water drain is rated against dust.	Yes
Target company	Can withstand rough winds	Environment	Sudden gusts of wind (strength unknown)		Stylish	No prove	Measures have been taken, should be monitored over a longer time	Unkown
Enduser (Rover user or Technician)	Aesthetics suitable for local context	Aesthetics	The Ghanaian employees should approve the appearance of the product.		Peter	Questioned by Stylish	Yes the employees like the appearance, however there are points to improve.	Yes
Target company	Costprice of product	Price	Costprice between €250 and €500 (rover & basestation no more than €1000)		Nick & Andreas	Cost calculation	Rover €407 Base station €539. Combined €946.	Yes
Government	Electronics are safe to use	Safety	Meets CE standards		DIRECTIVE 2014/53/EU (electromagnetic compatibility) and DIRECTIVE 2014/30/EU (Radio equipment)	Product compared to CE guidelines	No inconsistency's found at quick readthrough.	Yes
Enduser (Rover user or Technician)	Size of both devices is suitable for transport by one person	Ergonomics	Can be transported in a normal family car		Stylish	Measured with measuring tape	1000mmx140mmx140mm folded in, without tripod.	Yes
Target company	Operation cost of device	Price	max. €0,25 a day.		Stylish	Calculated	€0,15 euro a day on a MNT daily plan. (cheaper with longterm subscription)	Yes
Target company	Required amount of rovers	Quantity	10 rovers should be build for the city Kumashi. Future quantities will be around 100 to 1000		Nick & Andreas	Discussed with stylish	Making 10+ would be possible in the future using the KI-Hub Makers space	Yes
Target company	Design minimizes multipath error	Performance	Plate which prohibits waves entering side of antenna. Atleast 10cm diameter		Andreas	Physical inspection	120mm diameter 2mm thick aluminium groundplane	Yes
Target company	The device should be positioned straight up when measuring	Functional	Component which shows/makes sure that device is positioned upwards when measuring		Andreas	Physical inspection	Level with bubble	Yes
Target company	Can withstand tropical temperatures	Environment	0-40 degrees celcius		https://en.wikipedia.org/wiki/Climate_of_Ghana	Test by Stylish, should be monitored over longer time	Measures have been taken, should be monitored over a longer time	Unkown
Inhabitants of Kumasi	Local assembly of product	Producion	Product and can be assembled locally.		Peter	Discussed with stylish	KI-Hub Makers space will have the right equipment	Yes
Inhabitants of Kumasi/ Government	Disposal of product	Disposal	Materials disposable in country of use, without harm to environment		Peter	No prove	Unkown if materials can be removed safely	Unkown
Target company	The product should be locally repairable	Life in service	Local technician should be able to replace each product component.		Nick & Andreas	Discussed with stylish	Each component can be removed with normal tools	Yes
Target company	The product should be modular	Life in service	Each component should be removable within 10 minutes.		Peter	Tested by Peter	Every component is reachable in seconds.	Yes
Target company	The product should last	Life in service	Products should be suitable for 5 years of everyday use		Nick & Andreas	No prove	Long term testing has to be done, wear on the housing and batteries should be monitored.	Unkown

Appendix B. Part list BASE2

	Part description	Official part name/measurements	Part price NL	Amount (pieces or weight)	Total price		Link
Base	GNSS receiver	simpleRTK2B	€161.00	1	€161.00		https://www.ardusimple.com/product/simplertk2b-basic-starter-kit-ip65/
	Base station PCB board	BASEPCB (technical documentation)	€1.39	1	€1.39		https://jlcPCB.com/
	PCB battery holder 4x 18650	-	€4.50	2	€9.00		https://www.tinytronics.nl/shop/en/batteries/battery-holders/4x-18650-battery-holder-for-PCB
	Samsung 18650 Battery 2600Mah	Samsung ICR18650-26J	€3.45	8	€27.60		https://www.nkon.nl/samsung-icr18650-26j.html
	5v step-up voltage regulator	U3V12F5 Pololu 2115	€3.95	1	€3.95		https://www.vanalleenmeer.nl/5V-Step-Up-Voltage-Regulator-U3V12F5-Pololu-2115
	Battery protection circuit	TP4056	€2.00	1	€2.00		https://www.tinytronics.nl/shop/en/batteries/chargers/tp4056-micro-usb-li-ion-charger-1a-with-li-ion-protection-circuit
	Raspberry PI zero	Raspberry Pi Zero v. 1.3, 1 GHz, 512 MB RAM	€14.01	1	€14.01		https://www.reichelt.nl/Raspberry-pi-zero-v-1-3-1-ghz-512-mb-ram-rasp-pi-zero-p256439.html?&trstct=pos_5&nc=1
	Sim800l modem	SIM800L	€6.50	1	€6.50		https://www.tinytronics.nl/shop/en/communication/telecom/sim800l-gsm-gprs-module-with-antenna
	MPPT CN3722 solar power regulator	CN3722	€10.07	1	€10.07		https://www.banggood.com/MPPT-5A-Solar-Panel-Regulator-Controller-Battery-Charging-9V-12V-24V-Automatic-Switch-p-1307801.html
	Rockerswitch IP65	R1366A802	€0.39	1	€0.39		https://www.tme.eu/nl/details/r1366a802/rocker-schakelaars/sci/r13-66a8-02/
	Dupont connector	-	€0.05	2	€0.10		https://www.tinytronics.nl/shop/en/connectors/dupont/dupont-plastic-connector-housing-2p
	Dupont headers	-	€0.01	5	€0.05		https://www.tinytronics.nl/shop/en/connectors/pin-header/2x40-pins-header-male-double
	Dupont pins	-	€0.05	4	€0.20		https://www.tinytronics.nl/shop/en/connectors/dupont/dupont-shrink-connector-female-10-pieces
	Drain element	STEGO 08410.0-00	€9.22	1	€9.22		https://www.tme.eu/nl/details/08410.0-00/cabinets-accessories/stego/
	Cable gland PG9	PG9/BK AKS ZIELONKA	€0.30	2	€0.60		https://www.tme.eu/nl/details/pg9_bk/wartels/aks-zielonka/220215/
	Power connector bolts	m2.5x10 countersunk bolt	€0.04	2	€0.08		https://nl.rs-online.com/web/p/machine-screws/9087475/
	Electronics attachment bolts	M3x6mm bolt	€0.03	15	€0.45		https://nl.rs-online.com/web/p/machine-screws/0560580/
	3D print insert	M3 brass insert 4.2x6mm	€0.02	15	€0.30		https://nl.aliexpress.com/item/32958273559.html
	Nuts	M8 nut	€0.06	3	€0.18		https://www.indi.nl/nl-nl/p/Zeskantmoer-M8-DIN934-9348A
	Feet to aluminium bar bolts	M8x25 bolt	€0.19	4	€0.76		https://www.indi.nl/nl-nl/p/Cilindrische-inbusbout-M8x25-8.8-verzinkt-DIN912-912825
	Feet to housing bolt	M8x30 bolt	€0.21	2	€0.42		https://www.indi.nl/nl-nl/p/Cilindrische-inbusbout-M8x30-8.8-verzinkt-DIN912-912830
	3mmx118mm EPDM O-ring	1250E0009373 TECHNIRUB	€4.71	1	€4.71		https://www.technirub.nl/O-ringe-und-O-ring-rundschnure/epdm-O-ringe-70-shore-a/O-ring-118x3-mm-epdm-70-shore-a.html
	PETG electronics rack parts	-	€18.00	0.084	€1.51		-
	PETG housing	-	€18.00	0.327	€5.89		-
	PETG cap	-	€18.00	0.061	€1.10		-
	Aluminium feet bars	150x20x20 Square aluminium profile with caps	€1.68	2	€3.36		https://www.aluminiumopmaat.nl/aluminium-buizen/aluminium-buis-vierkant.html
	Rubber feet 30x28mm M8	1500ER0000002 TECHNIRUB	€1.44	4	€5.76		https://www.technirub.nl/schwingungsdampfer-gummipuffer-anschlagpuffer-anschlagdampfer/anschlagpuffer-typ-e-halbrund/aanslagbuffer-type-e-30x26-m8x8.html
	Generic fuse 2A 5x20mm	0001.1007 SCHURTER	€0.25	8	€2.00		https://www.tme.eu/nl/details/0001.1007/zekeringen-5x20mm-snele/schurter/
	Fuse holders	0031.8201 SCHURTER	€0.33	8	€2.64		https://www.tme.eu/nl/details/0031.8201/zekeringcontacten-op-PCB/schurter/
	SMA bulkhead to modem SMA cable	DELOCK 88417	€3.80	1	€3.80		https://www.reichelt.nl/sma-bus-inbouw-mhf-u-fl-stekker-350-mm-delock-88417-p133376.html?&trstct=pos_0&nc=1
	SMA bulkhead to SMA male - cable	NEDIS CSGP02010BK10	€2.49	1	€2.49		https://www.kabelshop.nl/Nedis-SMA-verlengkabel-Nedis-1-meter-100-koper-Verguld-CSGP02010BK10-i15324-t24885.html
	M16 IP67 two pole connector Male (solar panel)	CN-M16-CHS-ML-2P	€4.89	1	€4.89		https://www.applamp.nl/m16-2-polige-ip67-waterdichte-chassis-connector-m.html
	Power male connector	XT60E-M	€0.71	1	€0.71	sum:	https://www.tme.eu/nl/details/xt60e-m/dc-connectoren/amass/
Power female connector	XT60-F	€0.67	1	€0.67	€287.80	https://www.tme.eu/nl/details/xt60f-f/dc-connectoren/amass/	
Antenna platform	GNSS antenna	UBLOX ANN-MB-00	€50.00	1	€50.00		https://www.ardusimple.com/product/ann-mb-00-ip67/
	PETG antenna platform	-	€18.00	0.105	€1.89		-
	Cellular antenna	DELOCK 89618	€7.21	1	€7.21		https://www.reichelt.nl/antenne-lte-omnidirectioneel-outdoor-delock-89618-p259573.html
	groundplane	120x2mm aluminium disk	€11.90	1	€11.90	sum:	https://www.metalpoint.nl/vlak-plaatwerk/schijf.html
	Antenna platform clamp bolt	M8x60 bolt	€0.34	1	€0.34	€71.34	https://www.indi.nl/nl-nl/p/Cilindrische-inbusbout-M8x60-8.8-verzinkt-DIN912-912860
Solar panel	20 Watt Solar panel	SPP040201200 VICTRON	€37.82	1	€37.82	sum:	https://www.druppellader.com/victron-bluesolar-20wp-poly.html
	M16 IP67 two pole connector Female (solar panel)	CN-M16-FM-2P	€4.89	1	€4.89	€42.71	https://www.applamp.nl/m16-tweepolige-ip67-waterdichte-connector-female.html
Pole	Aluminium upper pole	1200mmx25mmx2mm Aluminium tube	€5.99	1	€5.99	sum:	https://www.aluminiumopmaat.nl/aluminium-buizen/aluminium-buis-rond.html
	Aluminium lower pole	1200mmx20mmx2mm Aluminium tube	€4.91	1	€4.91	€10.90	https://www.aluminiumopmaat.nl/aluminium-buizen/aluminium-buis-rond.html
Tripod	Tripod	Universal tripod 160cm	€66.5	1	€66.50		https://www.top-bouwlaser.nl/universeel-160cm-statief-standaard-alu.html
	knob screw	M8x38mm	€2.13	1	€2.13		https://www.hornbach.nl/shop/DREssELHAUS-Stergreepschroef-55-mm-M8x38-mm-kunststof-zwart-20-stuks/8823309/artikel.html
	PETG tripod clamp	-	€18.00	0.073	€1.31	sum:	
	Level	32mm round	€0.81	1	€0.81	€69.94	https://www.aliexpress.com/i/32824755879.html
				total:	€481.38		

Appendix C. Part list ROVER2

	Part description	Official part name/measurements	Part price NL	Amount (pieces or weight)	Total price		Link
Main unit	GNSS receiver	simpleRTK2B	€161.00	1	€161.00		https://www.ardusimple.com/product/simplertk2b-basic-starter-kit-ip65/
	GNSS antenna	UBLOX ANN-MB-00	€50	1	€50		https://www.ardusimple.com/product/ann-mb-00-ip67/
	Mini USB breakout	-	€0.95	1	€0.95		https://opencircuit.nl/Product/Micro-USB-naar-dip-adapter-5pin
	USB breakout	-	€1.05	1	€1.05		https://opencircuit.nl/Product/Female-USB-naar-dip-adapter-4pin
	PCB board rover	ROVERPCB (technical documentation)	€0.68	1	€0.68		https://jlcPCB.com/
	4mmx22mm NBR O-ring		€0.73	2	€1.46		
	3mmx118mm EPDM O-ring	1250E0009373 TECHNIRUB	€4.71	1	€4.71		https://www.technirub.nl/O-ringe-und-O-ring-rundschnure/epdm-O-ringe-70-shore-a/O-ring-118x3-mm-epdm-70-shore-a.html
	Cable gland PG7	PG7/BK AKS ZIELONKA	€0.49	1	€0.49		https://www.tme.eu/nl/details/pg7_bk/wartels/aks-zielonka/220214/
	groundplane	120x2mm aluminium disk	€11.90	1	€11.90		https://www.metalpoint.nl/vlak-plaatwerk/schijf.html
	5v step-up voltage regulator	U3V12F5 Pololu 2115	€3.95	1	€3.95		https://www.vanallesmeer.nl/5V-Step-Up-Voltage-Regulator-U3V12F5-Pololu-2115
	Rockerswitch IP65	R1366A802	€0.39	1	€0.39		https://www.tme.eu/nl/details/r1366a802/rocker-schakelaars/sci/r13-66a8-02/
	Drain element	STEGO 08410.0-00	€9.22	1	€9.22		https://www.tme.eu/nl/details/08410.0-00/cabinets-accessories/stego/
	Solderable SMA male connector	-	€1.99	1	€1.99		https://www.allekabels.nl/searchresult.php?keyword=1019640
	Electronics attachment bolts	M3x6mm bolt	€0.03	7	€0.21		https://nl.rs-online.com/web/p/machine-screws/0560580/
	Clamp bolt	M8x60 bolt	€0.34	1	€0.34		https://www.indi.nl/nl-nl/p/Cilindrische-inbusbout-M8x60-8.8-verzinkt-DIN912-912860
	Nuts	nut	€0.06	1	€0.06		https://www.indi.nl/nl-nl/p/Zeskantmoer-M8-DIN934-9348A
	3D print insert	M3 brass insert 4.2x6mm	€0.02	4	€0.08		https://nl.aliexpress.com/item/32958273559.html
PETG upper housing		€18.00	0.142	€2.56		-	
PETG lower housing		€18.00	0.181	€3.26		sum: -	
PETG plugs		€18.00	0.014	€0.25		€254.55 -	
Pole	Aluminium upper pole	1200mmx25mmx2mm Aluminium tube	€5.99	1	€5.99	sum:	https://www.aluminiumopmaat.nl/aluminium-buizen/aluminium-buis-rond.html
	Aluminium lower pole	1200mmx20mmx2mm Aluminium tube	€4.91	1	€4.91	€10.90	https://www.aluminiumopmaat.nl/aluminium-buizen/aluminium-buis-rond.html
Battery	Samsung 18650 Battery 2600Mah	Samsung ICR18650-26J	€3.45	2	€6.90		https://www.nkon.nl/samsung-icr18650-26j.html
	PCB board accu	ACCUPCB (technical documentation)	€0.28	1	€0.28		https://jlcPCB.com/
	PCB battery holder 2x 18650	-	€2.50	1	€2.50		https://www.tinytronics.nl/shop/en/batteries/battery-holders/2x-18650-battery-holder-for-PCB
	Battery protection circuit	TP4056	€2.00	1	€2.00		https://www.tinytronics.nl/shop/en/batteries/chargers/tp4056-micro-usb-li-ion-charger-1a-with-li-ion-protection-circuit
	housing bolts	M3x20 countersunk bolt	€0.05	4	€0.20		https://www.indi.nl/nl-nl/p/Verzonken-schroef-met-kruisgleuf-M3x20-verzinkt-DIN965-965320P100
	Power connector bolts	m2.5x10 countersunk bolt	€0.04	2	€0.08		https://nl.rs-online.com/web/p/machine-screws/9087475/
	3D print insert	M3 brass insert 4.2x6mm	€0.02	4	€0.08		https://nl.aliexpress.com/item/32958273559.html
	Power female connector	XT60-F	€0.67	1	€0.67		https://www.tme.eu/nl/details/xt60h-f/dc-connectoren/amass/
	Generic fuse 2A 5x20mm	0001.1007 SCHURTER	€0.25	2	€0.50		https://www.tme.eu/nl/details/0001.1007/zekeringen-5x20mm-snele/schurter/
	Fuse holders	0031.8201 SCHURTER	€0.33	2	€0.66	sum:	https://www.tme.eu/nl/details/0031.8201/zekeringcontacten-op-PCB/schurter/
	Accu housing	-	€18.00	0.051	€0.92	€14.79	-
Phone holder	Spring	Hornbach spring	€0.68	1	€0.68		-
	housing bolts	M4x20	€0.15	3	€0.45		https://www.indi.nl/nl-nl/p/Cilindrische-inbusbout-M4x20-8.8-verzinkt-DIN912-912420
	nuts	M4	€0.02	3	€0.06		https://www.indi.nl/nl-nl/p/Zeskantmoer-M4-DIN934-9344A
	knob screw	M8x38mm	€2.13	1	€2.13		https://www.hornbach.nl/shop/DREssELHAUS-Stergreepschroef-55-mm-M8x38-mm-kunststof-zwart-20-stuks/8823309/artikel.html
	Level	32mm round	€0.81	1	€0.81	sum:	https://www.aliexpress.com/i/32824755879.html
	PETG housing parts		€18.00	0.093	€1.67	€5.81	-
Tripod	Tripod	Universal tripod 160cm	66.5	1	€66.50		https://www.top-bouwlaser.nl/universeel-160cm-statief-standaard-alu.html
	knob screw	M8x38mm	€2.13	1	€2.13		https://www.hornbach.nl/shop/DREssELHAUS-Stergreepschroef-55-mm-M8x38-mm-kunststof-zwart-20-stuks/8823309/artikel.html
	Level	32mm round	€0.81	1	€0.81	sum:	https://www.aliexpress.com/i/32824755879.html
	PETG tripod clamp		€18.00	0.107	€1.93	€71.37	-
				total:	357.41		

Appendix D. Estimation of production labor costs

To estimate the amount of labor needed to build a rover or base, all tasks have been split up and have been given an estimated duration in Table D.1. This estimation is made by experience from building the prototypes. To give a value to these hours, the upper bound average salary of a Ghanaian mechanic is used. This salary is converted to a hourly salary in euro in Table D.2.

	Ghanian mechanic, salary average lower bound	Ghanian mechanic, salary average upper bound
Ghs/Month	1071 ¹	3139 ¹
€/Month	€158	€463
€/Hour	€0.94	€2.76

Table D.1. Salary of a Ghanaian mechanic

Assembly	Task	Labor hours	Labor price	Labor price for each assembly
Base main unit:	print housing base	1	€2.76	
	print cap base	1	€2.76	
	Epoxy coating	2	€5.51	
	Soldering PCB and cables	3	€8.27	
	print electronics rack	0.5	€1.38	
	assembly main unit	4	€11.02	€31.69
Base Antenna platform:	print antenna platform	0.5	€1.38	
	assembly antenna platform	1	€2.76	€4.13
Solar panel	mounting solar-plug	1	€2.76	€2.76
Base pole:	Cutting and drilling pole parts	1	€2.76	€2.76
Base tripod clamp:	print tripod clamp base	0.5	€1.38	
	Assembly clamp	0.5	€1.38	€2.76
Rover main unit:	Lower housing rover	1	€2.76	
	Upper housing	1	€2.76	
	Epoxy coating	2	€5.51	
	printing plugs	0.5	€1.38	
	Soldering PCB and cables	2	€5.51	
	Assembly rover	3	€8.27	€26.18
Rover battery:	print battery housing	0.5	€1.38	
	soldering battery PCB	1	€2.76	
	Assembly battery	1	€2.76	€4.13
Rover phone holder:	print phone holder	0.5	€1.38	
	assembly phone holder	1	€2.76	€4.13
Rover pole:	Cutting and drilling pole parts	1	€2.76	€2.76
Rover tripod clamp:	print tripod clamp rover	0.5	€1.38	
	assembly clamp	0.5	€1.38	€2.76

Table D.2. Labor time estimated for each assembly and converted to euros

1. Salaries by positions in Mechanical Engineering - Ghana - Paylab.com. (2020). Retrieved August 7, 2020, from Paylab.com website: <https://www.paylab.com/gh/salaryinfo/mechanical-engineering#:~:text=The%20salary%20range%20for%20people,total%20monthly%20salary%20including%20bonuses>.

Appendix E. Estimation of product machining costs

To estimate the machining price of the mostly 3D printed parts, the depreciation of the printer and energy costs are taken into account.

A Prusa i3 printer is depreciated in 3650 hours and will use about 0.2kwh of energy each hour. This leads to an hourly cost of €0,22. as can be seen in Table E.1.

It has to be noted that the prototypes in this report have been printed on an even lower cost machine.

In Table E.2, the print times for each assembly have been multiplied by the hourly cost of the printer. The price of the printed material itself is counted in the material costs.

	Price (€)	Assumed minimum lifespan in hours (h)	Price/hour
Prusa i3 original	€769 ¹	3650	€0.21
	Price of electricity in Ghana (€/KWH)	Assumed energy consumption 3D printer per hour (KWH)	Price/hour
KWH energy	€0.05 ²	0.2	€0.01
		Print price/h:	€0.22

Table E.1. Printer price/hour estimation

Assembly	Part	Print hours	Machining price	Machining price for each assembly
Base main unit:	Housing base	25.5	€5.63	
	Cap base	5.1	€1.13	
	Electronics rack parts	6.75	€1.49	€8.24
Base Antenna platform:	Antenna platform	7	€1.54	€1.54
Base tripod clamp:	Tripod clamp base	5.5	€1.21	€1.21
Rover main unit:	Lower housing rover	13.1	€2.89	
	Upper housing	10.5	€2.32	
	Plugs	1	€0.22	€5.43
Rover battery:	Battery housing parts	4.75	€1.05	€1.05
Rover phone holder:	Phone holder parts	7.5	€1.66	€1.66
Rover tripod clamp:	Tripod clamp rover	7.75	€1.71	€1.71

Table E.2. Print time for each assembly, converted to euros

1. Original Prusa i3 MK3S kit. (2020, July 25). Retrieved August 7, 2020, from Prusa Research website: https://shop.prusa3d.com/en/3d-printers/180-original-prusa-i3-mk3s-kit.html?gclid=CjwKCAjw97P5BRBQeIwAGfIV6YIwGbio798pUnXKnG6m-xE4oTC8O8Mhz8sSf6rxhE-WQYCGHCalMBoCZWQAvD_BwE

2. Ghana electricity prices, December 2019 | GlobalPetrolPrices.com. (2019). Retrieved August 7, 2020, from GlobalPetrolPrices.com website: https://www.globalpetrolprices.com/Ghana/electricity_prices/

Appendix F. Interview with Stylish

Mail:

1. Can you introduce yourself a bit more so that I can better understand your current situation?

I'm Stylish. I have a Bsc in Geomatic Engineering. It was during my study I was exposed to land survey, remote sensing, GIS and computer programming etc.

After school I practiced land surveying but I stopped because I had passion for GIS and software development. I teamed up with my co-founder and started Maptech Logistics. At the time we didn't know much about business, however, through Kumasi Business Incubator (KBI) we learnt the basics.

At the time we started, our vision was to use GIS to solve problems related to supply chain management. This included Customer relationship management, Revenue collection etc.

We built customized applications for some of our clients and used third party apps to solve their needs.

When we started, GIS and data gathering was expensive due to the high cost of hand held GPS, internet connection and human labor.

We decided to keep learning and understand the market need while we waited for the ecosystem to be more responsive. Now we feel that Africa is more than ready for Location Intelligence to be integrated in the way business is done.

2. Nick told that you're thinking/planning to start a company in GIS (Geo informatics service). Is that correct? What kind of company would you like to start?

Last year, we also decided to consider the viability of using GIS for other sectors like land survey, agriculture, health and environmental purposes. This year, while still deliberating on this, I got a call from Frank and Nick and they informed me about this project.

3. Nick also told that the business plan is not very clear yet. What are things you're still thinking of?

We are still considering the areas that this could be applied, what is the market looking for? At what price would they want to pay? Currently we taught of Rapid

Mapping, but we are considering if there are other uses that will benefit the local community and

bring in more revenue.

4. Why would you like to start this company? Is there no GIS in the area or do you have another motivation?

Currently there are many GIS companies in Ghana, however, to my best of knowledge there is only one company in Accra that provides Continuous Operating Reference Stations. We see that there is not a lot of competition in this area.

5. Will your company be located in Kumasi? Yes

6. Will you start just by yourself or are there others involved as-well? There are others involved. Once the project starts, we will include more people if the need be.

Nick probably explained the high precision positioning principle with use of reference stations:

The next questions are about the future rover positioning device:

1. If you have a device which is capable of positioning with an accuracy of 30mm would it be of use and what applications would you use it for?

Yes it will be useful for, precision agriculture, engineering survey, drone survey, research, mapping and data collection.

2. If high precision positioning surveys have to be done with this device, would you go yourself? Or hire someone to do it? What would be the education level of the one using the equipment?

It will depend on the complexity of the work. But the idea is to train people and make it simple for people to learn how to use with little technical knowledge.

University graduate or even Senior High School leavers should be able to use it. While working as a surveyor we had people with no formal education who could use the rover due to the training provided for them.

3. What are challenges you suspect to encounter in the Ghana/Kumasi when you have to do high precision positioning surveys?

Setting up the base stations where they will not be tempered with. There are many development projects and it's difficult at times to predict that a site will not be used for any project that will not disturb the base stations.

4. Have you got examples of other equipment/products which you think are very well suitable for use in Ghana?

Normally many people use Trimble, Garmin, Sokkia and Leica products. There are also other who use other GPS from China.

5. Are there things you can think of Ghanaian people value high in choosing their equipment? Both in functional and aesthetical aspect?

Functionally they consider:

- * robustness (withstand bad weather, withstand rough handling, not easily damaged when it falls to the ground etc)

- * battery life span (prefer one with very good batteries),

- * weight (light weight rover)

- * low cost of maintenance (less costly and easy to repair)

- * Durable (can be used for many years without the need to replace it after few years)

- * High level of accuracy

- * Easily transfer data via Bluetooth, wireless and internet.

- * Good data storage capabilities

- * Portable (easy to move with and easy to hold)

Aesthetically for now I may not be able to say much but I know it influences people a lot.

6. I'm designing the devices so that they can resist high temperature, a lot of dust, high moisture/rain and keep working within power cuts. Would there be more circumstances which I have to take into account?

I think this is good. In addition it should be able to communicate remotely with poor telecommunication network. Also it should be able to resist violent winds.

Mail2:

1. In what way can you practically use GIS for supply chain management? Do you for example track vehicles and keep up statistics for them? Or does it work different?

In a lot of cases you might also gather other data than positioning data?

We use GIS for locating customers assets and track vehicles and keep up statistics. We also use GIS to conduct location intelligence. Eg Client can view the distribution of their retail shops, customers and make necessary decisions. We also use it for Customer Relationship Management.

Some more questions:

2. The Trimble, Sokkia and Leica products which you mentioned are quite expensive (for what I have seen thousands of dollars per device) Are these devices too expensive for use within Maptech logistics, or would it be feasible?

Maptech would like to consider more cost effective options so that our products will not be expensive.

3. What would be the maximum price at which a high precision positioning device would be feasible for map-tech logistics? (I know this is hard to say. Maybe a rough estimation like \$200, \$500, \$1000, \$2000?)

\$200 Currently mainly because we are a start-up. As we grow bigger we will not mind considering more expensive options if they satisfy our goals and policies.

Appendix G. Competitor products, main features and prices

Name: Trimble R2
 Price: \$4,700.00
 Leveling: Mechanical bubble
 Accuracy vertical RTK: 20mm + 0.5ppm
 Accuracy horizontal RTK: 10mm + 0.5ppm
 Time usable on battery: 5 h



Name: Trimble R1
 Price: \$1,995.00
 Leveling: Not possible
 Accuracy vertical RTK: 500mm
 Accuracy horizontal RTK: 500mm
 Time usable on battery: 10+ h



Name: UNI-GRI
 Price: €2,995.00
 Leveling: Visualization with led ring
 Accuracy vertical RTK: 15mm +1ppm
 Accuracy horizontal RTK: 10mm +1ppm
 Time usable on battery: 12 h



Name: Leica iCON gps 60
 Price: \$7,450.00
 Leveling: on screen visualized
 Accuracy vertical RTK: 15mm +1ppm
 Accuracy horizontal RTK: 8mm +1ppm
 Time usable on battery: 4h 40min



Name: Leica GS18 T
 Price: \$20,120.00
 Leveling: Automatic
 Accuracy vertical RTK: 15mm +0.5ppm
 Accuracy horizontal RTK: 8mm +0.5ppm
 Time usable on battery: 5 h



Name: Stonex S10
 Price: €7,995.00
 Leveling: Mechanical bubble
 Accuracy vertical RTK: 15mm +1ppm
 Accuracy horizontal RTK: 8mm +0.8ppm
 Time usable on battery: 7 h



Name: Reach RS2
 Price: \$1,899.00
 Leveling: Phone application
 Accuracy vertical RTK: 14mm +1ppm
 Accuracy horizontal RTK: 7mm +1ppm
 Time usable on battery: 22 h

Appendix H. Research on design for condensation water

Relative humidity (RH) is “The ratio of the water vapor density (mass per unit volume) to the water vapor density at the saturation vapor pressure, typically expressed as a percentage [%]” (Drexhage, 2016)

As can be seen in figure H.2 the amount of water which can be contained within air changes with the temperature and pressure of the air. Increasing the pressure of a certain amount of air with a given humidity, raises the relative humidity. Increasing the temperature of this same amount of air, lowers the relative humidity.

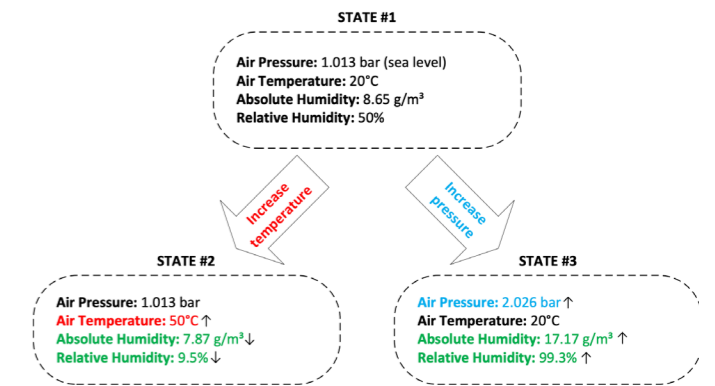

H.2. Relationships in a closed system of water vapor/air (variable volume) (Drexhage, 2016)

The example of figure H.1 shows that in a room at 20°C with a relative humidity of 60% water will condensate at a bottle which has a temperature below 12°C. The temperature of the air in the direct surrounding of the bottle is decreased in temperature. Therefore, the relative humidity of this air will increase and finally the water will leave the air in liquid form.

When the day temperature in Ghana is 30°C and the relative humidity is above 80%, condensation can already be present on materials with a temperature of 26 °C. This situation will surely occur at the transition from day to night time.

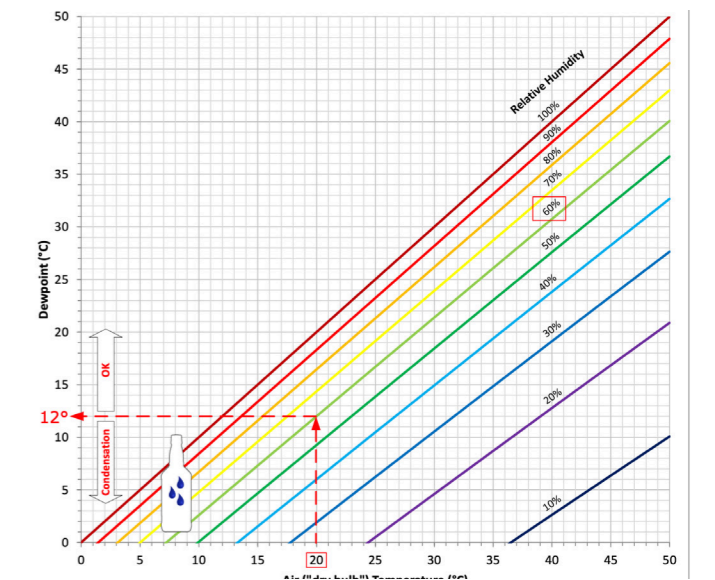

H.1. Chart to determine the dew point based on the Magnus equation (altitude = 0m) (Drexhage, 2016)

There are different solutions which are used to prohibit condensation within an electronics housing:

Coating of electronics:

PCB's can be sprayed or dipped in a coating. Normally silicone or polyurethane are used against moisture. (Coating.nl, 2019) However, air can often propagate through the gel layer. Therefore moisture is still able to get in. Once inside, the water molecules can corrode the PCB. (Drexhage, 2016)

Heating:

Use a heater to keep relative humidity low. The disadvantage is that water can still condensate on the walls inside the housing when the external ambient temperature gets lower. (Drexhage, 2016)

Ventilation:

Use vents (Figure H.3) to keep the pressure in and outside the housing the same. (Drexhage, 2016)

Drain:

Use a membrane (figure H.4) to drain water on the lower part of the housing. (Drexhage, 2016)

Desiccants:

Material which can absorb water. The disadvantage is that when the material is saturated with water, it has to be replaced. (Drexhage, 2016)

Dehumidifier:

Cool air so that water vapor will condensate. Dry air will now enter the electronics housing. The disadvantage is the high power consumption. (Drexhage, 2016)

References

Coating.nl. (2019, December 19). Conformal Coating | PCB Coating | Kopen - Coating.nl. Retrieved April 7, 2020, from Coating.nl website: <https://coating.nl/conformal-coating/>

Drexhage, P. (2016). *Effect of Humidity and Condensation on Power Electronics Systems* (J. Lamp, Ed.).



H.3. Ventilation element with a non water permeable membrane (seller: Wiska)



H.4. Drainage element which should be mounted at the bottom of a case. The element prevents splashing water and dust from getting in. (seller: Gunneman Group)

Appendix I. Examining the Stego drain element

To remove condensed water a drain is needed. STEGO sells one (figure I.1) which is used in electrical appliances. It should be able to drain 200ml/hr with a water column of 5mm and is rated at IP66 / IP67 / IP69K. (STEGO, 2020) This is quite interesting while IP69K is the highest rating available. This means that the drain element should be able to keep water out at high pressures, submerged and even at temperatures of 80°C+. This is quite a claim for an element which should also be able to let water leave.



I.1. Datasheet image of STEGO drain element

When disassembled (figure I.2) the device seems to contain a foam block. The foam is hard and not compressible.

When water is put on top of it it gets through the block by gravity. This works in both directions. This means the device is not water tight.



I.2. Drain element disassembled

When the element is mounted in a container and tap water is directly sprayed it (approximately 1 bar), clearly water gets into the container after 5 minutes. (see figure I.3)

When the element is sprayed with a showerhead (lower pressure) water is not getting in after 5 minutes. (figure I.4).



I.3. Drain element sprayed directly with tap water



I.4. Drain element sprayed with showerhead

This element clearly does not reach the by STEGO stated IP69K rating. However it probably does reach the requirements of IP64/IP65 (water jets of 0.3 bar from all directions) as long as the element is pointed downwards.

References

STEGO. (2020). DD 084 | Drainage Device | STEGO UK Ltd. Retrieved April 23, 2020, from Stego.co.uk website: <https://www.stego.co.uk/products/accessories/miscellaneous/dd-084-drainage-device/>

Appendix J. Condensation water test

A test was conducted to check the implemented measures against condensation water. The implemented measures are smooth walls which guide water drops to a drain on the lower side of the housing. The housing walls will cool down at night and therefore water will condensate on these walls.

Setup

A round top (figure I.5) was used while this was expected to be the best housing shape to integrate the antenna into the housing. A round roof surface is needed to let water drops flow down instead of dripping down.

Dummy electronics were inserted with resistors to emit exactly 1 watt of heat, to imitate the base electronics. (figure I.6)

An old fridge (figure I.7) is used as climate chamber. First, this chamber is heated to 35 degrees with 95% humidity. Then, the chamber is cooled down to below 20 degrees. In the meanwhile cameras are used to check the state within the chamber. In figure I.8 all the components for this setup can be seen.

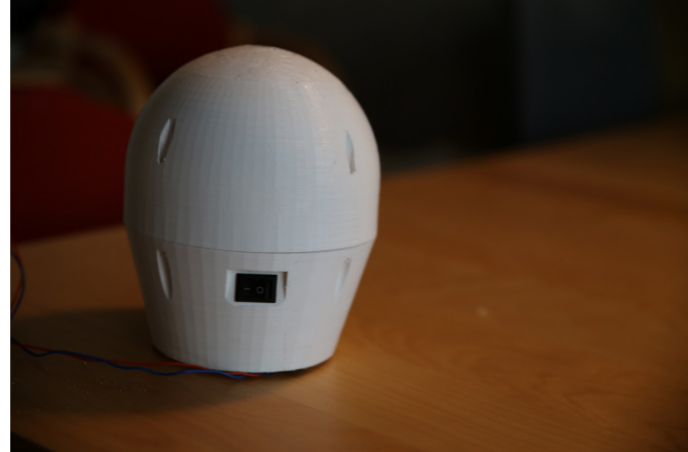

I.5. Model for condensation testing with round top

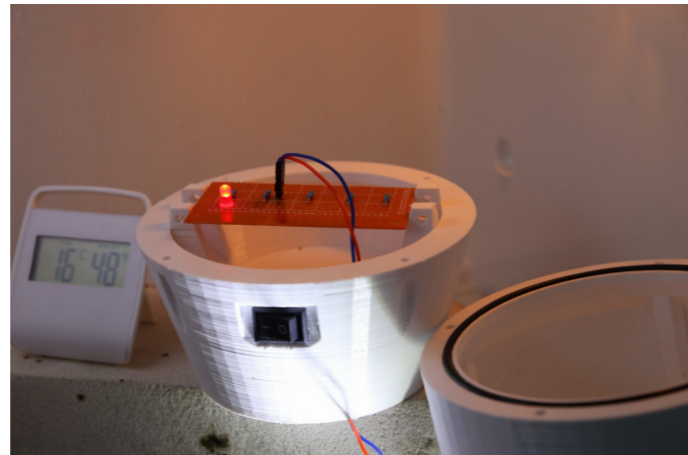

I.6. "Dummy" electronics emitting 1 watt of heat



I.7. Old fridge as climate chamber

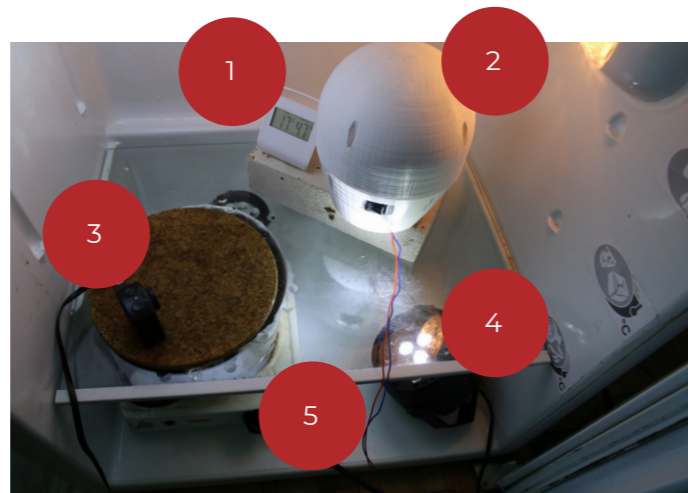

I.8. Test setup attempt2
 1. Temperature and humidity meter
 2. BASE with dummy electronics
 3. Camera for observation
 4. Light source for camera
 5. Pan with water on heating element

Results

After several attempts of a cycle between 35 degrees with 95% humidity (figure J.1) and about 20 degrees Celsius it seems to be impossible to see drops of water on the walls, by eye or with the internal camera (figure J.2). However, some moisture can be seen on the O-ring (figure J.3) and some moisture can be felt by hand on the inner walls. The electronics are absolutely dry. (figure J.4)

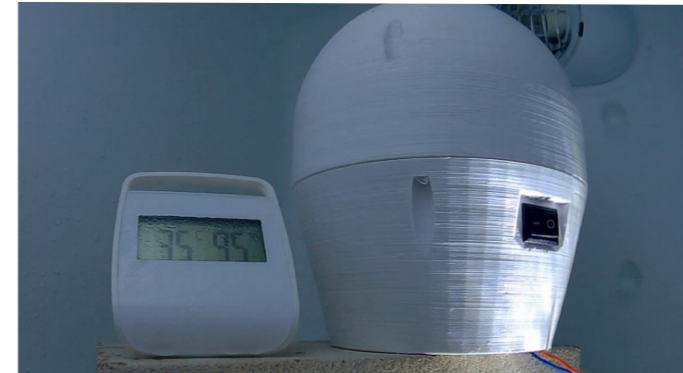

J.1. 35 degree Celcius and 95% humidity

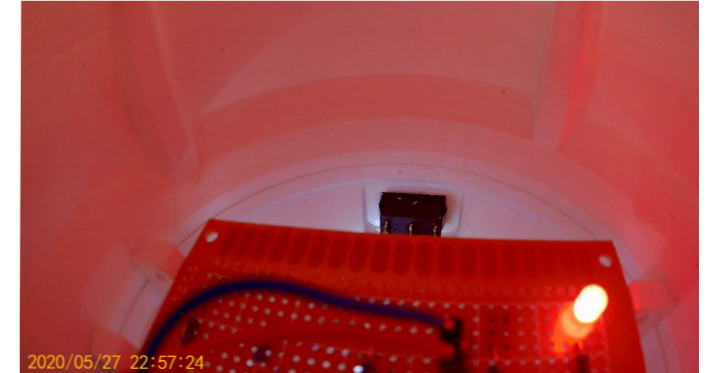

J.2. Internal camera view



J.3. Visible moisture on O-ring

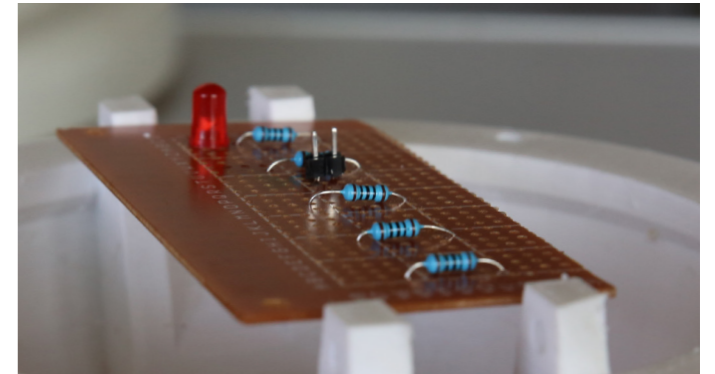

J.4. No moisture on electronics

Conclusion

Considering that air can contain these amounts of water:

37,56g/m³ at 35 °C 95% humidity
 13.82g/m³ at 20 °C 80% humidity
 (Rotronic, 2020)

23,74 gram of water per cubic meter will be released during the cycle. The internals of the tested object however are so small that only about 0,08 gram will be released there. Not seeing this amount of water is logical. The wall being moist and the electronics being dry shows at least that the measures could work.

Recommendations

- Repeat this test a multiple times in a climate chamber or in a real environment to confirm the results.
- One could consider that with this little moisture, air ventilation might be a better solution than a drain. Besides, this would improve the water tightness of the device, as water tight ventilation elements do exist and water tight drain elements do not.

References

Rotronic. (2020). Relative Humidity Calculator - Free Online Tool - ROTRONIC Measurement Solutions. Retrieved May 28, 2020, from Rotronic.com website: https://www.rotronic.com/en/humidity_measurement-feuchtemessung-mesure_de_l_humidite/humidity-calculator-feuchterechner-mr

Appendix K. Research on waterproof design

An IP64 rating is required to cope with the tropical rainfall and dust in the area. Practically this means that no dust may enter. Also, the housing should be protected against water splashed from all directions (Table K.1).

Gaskets, O-rings and a cable gland can be used to make a water tight housing.

There are several guidelines to provide a proper sealing:

- Start designs from circular shapes to be able to use O-rings and let them provide uniform sealing. (DesignWorld, 2012)
- Avoid sealing between multiple part interfaces. (DesignWorld, 2012)
- Gaskets need to be supported evenly to prevent them from “squirting” out. (DesignWorld, 2012)
- Stiffer parts are easier to seal. Plastic will deflect when a gasket is pressured. (DesignWorld, 2012)



K.1. O-ring used as sealing for a non circular case.

First Digit	Intrusion Protection	Second Digit	Moisture Protection
0	No protection.	0	No protection.
1	Protected against solid objects over 50mm, e.g. accidental touch by hands.	1	Protected against vertically falling drops of water, e.g. condensation.
2	Protected against solid objects over 12mm, e.g. fingers.	2	Protected against direct sprays of water up to 150 from the vertical.
3	Protected against solid objects over 2.5mm, e.g. tools & wires.	3	Protected against direct sprays of water up to 600 from the vertical.
4	Protected against solid objects over 1mm, e.g. wires & nails.	4	Protected against water splashed from all directions, limited ingress permitted.
5	Protected against dust limited ingress, no harmful deposits.	5	Protected against low pressure jets of water from all directions, limited ingress permitted.
6	Totally protected against dust.	6	Protected against strong jets of water, e.g. on ships deck, limited ingress permitted.
7	Submersible up to 1 meter		

Table K.1. IP rating system (Rainford Solutions Ltd, 2020)

Waterproof connectors

In figure K.2 examples of waterproof usb connectors can be found. Below the advantages and disadvantages of each method are listed.

1. closed micro USB connector

These connectors are widely used on waterproof phones. The contacts are not protected and will still corrode or trap dust.

2. Closed panel connector made by DataPro

For panel montage, The contacts are not protected and will still corrode or trap dust.

3. Dust plug for closed panel connector made by DataPro

Using a plug, dust can be kept out of a panel connector. Water will still be able to corrode the contacts.

4. USB connector with screw cap made by ES&S

A screw cap prevents water and dust from

entering the connector. However, this screw cap has to be closed manually.

5. USB connector with hinged door

A hinged door prevents water and dust from entering and will close automatically when a cable is removed.

6. Male cable with waterproof screw cap

A screw cap on the male cable side can provide a waterproof connection while the cable is inserted.

7. Housing material as closing plug made by JBL

A flexible housing material can be used as plug to prevent water and dust from entering. In this way the plug will not be lost.



K.2. Ways to make a waterproof USB connector

References

designworld. (2012, October 5). Tips on waterproofing components in harsh environments. Retrieved April 7, 2020, from Design World website: <https://www.designworldonline.com/tips-on-waterproofing-components-in-harsh-environments/>

Rainford Solutions Ltd. (2020, April 15). IP Enclosure Ratings & Standards, IP66, IP65, IP55, IP54. Retrieved April 20, 2020, from Rainford Solutions Ltd website: <https://www.rainfordsolutions.com/ip-enclosure-ratings-and-standards>

Appendix L. Base station solar system calculation

The Base Station can be powered on its battery for 2,1 days. On average there is 43,9Wh of solar power available each day of which only 31,2Wh is actually needed. (Table L.1)

Calculation of the solar PV energy output of a photovoltaic system

Orange cell = enter your own data
Green cell = result (do not change the value)
White cell = calculated value (do not change the value)

Global formula: $E = A * r * H * PR$

E = Energy (kWh)	21	kWh/an
A = Total solar panel Area (m ²)	0,154	m ²
r = solar panel yield (%)	13%	
H = Annual average irradiation on tilted panels (shadings not included)*	1500	kWh/m ² .an
PR = Performance ratio, coefficient for losses (range between 0.9 and 0.5, default value = 0.75)	0,71	

Total power of the system 0,02 kWp

Losses details (depend of site, technology, and sizing of the system)

- Temperature losses (5% to 15%)	15%
- DC cables losses (1 to 3 %)	2%
- Shadings 0 % to 40% (depends of site)	10%
- Losses weak irradiation 3% yo 7%	3%
- Losses due to dust, snow... (2%)	2%
- Other Losses	0%

DC-DC converter efficiency CN3722	85%		
Annual energy which could be stored	18,2 kWh/an	equals	49,8 Wh/day
Battery to 5v converter efficiency S7V7F5	88%		
Annual energy available for usage	16,0 kWh/an	equals	43,9 Wh/day
Actual power need (1,3watt continuously)	11,4 kwh/an	equals	31,2 Wh/day
battery capacity (8x2200mah 3,7v)			65,1 Wh
uptime on battery			2,1 days

*You can find this value on the map below or here: [solar radiation data](#)
 You have to find the global annual irradiation incident on your PV panels with your specific inclination (slope, tilt) and orientation (azimut).

More info
 Source: www.photovoltaic-software.com

Table L.1. Base station solar system calculation

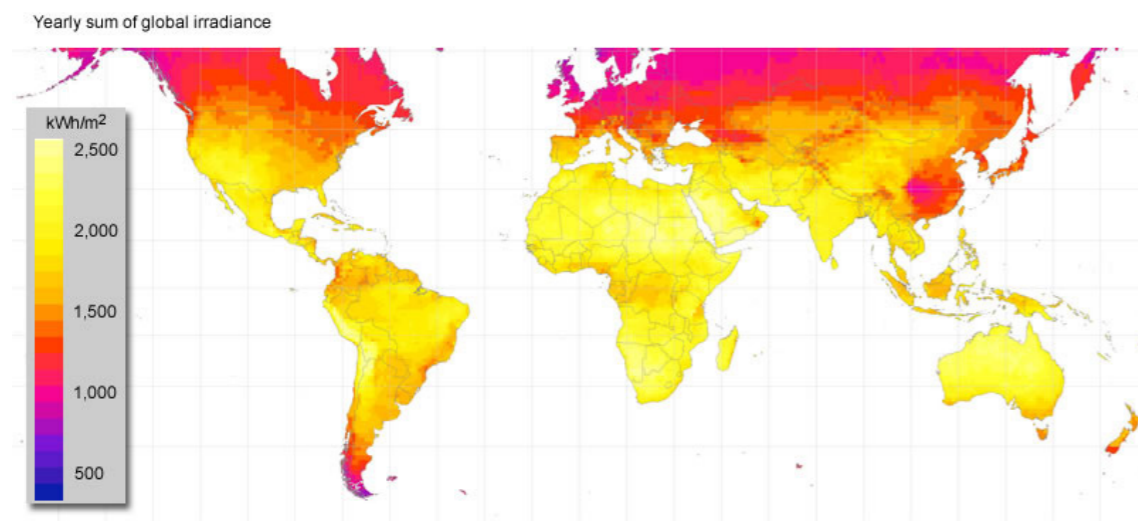

References

Photovoltaic-software.com. (2020). How to calculate output energy of PV solar systems? Retrieved August 14, 2020, from Photovoltaic-software.com website: <https://photovoltaic-software.com/principle-ressources/how-calculate-solar-energy-power-pv-systems>

Appendix M. Rover power consumption calculation

The rover can be powered for 32 hours on one battery. When also running the smartphone from the internal battery, this time is about 3,8 hours. (Table M.1)

Rover final design				
Component (active)	Current (mA)	Voltage	Power (Watt)	Source
simpleRTK2B + Bluetooth	90	5.0	0.45	measurement
Smartphone (screen on, scrolling SWmaps 3G)	1050	5.0	5.25	measurement (Samsung Galaxy S5 NEO)
			Total power consumption:	
			5.70	
Component (inactive)	Current (mA)	Voltage	Power (Watt)	Source
simpleRTK2B + Bluetooth	90	5.0	0.45	measurement
Smartphone (screen on, idle SWmaps, 3G)	480	5.0	2.40	measurement (Samsung Galaxy S5 NEO)
			Total power consumption:	
			2.85	
	Capacity (Mah)	Average voltage (V)	Capacity (Wh)	90% voltage regulator efficiency (Wh)
One battery (18650)	2200	3.7		
Total battery capacity (2x 18650)	4400	3.7	16.28	14.65
Use case	Uptime (Hr)			
simpleRTK2B + Bluetooth only	32.56			
Smartphone (1/3 of time active, 2/3 of time idle) + simpleRTK2B + Bluetooth	3.86			

Table M.1. Rover energy consumption calculation

Appendix N. Solar panel test

A test was conducted to confirm the capacity of the designed battery system and the solar panel.

Setup

The Ublox antenna and solar panel are put on the south east side of a building. (figure N.2) The hardware attached to these devices is put inside the building. (figure N.1) A time-lapse camera is used to observe the battery voltage and charge power.

Remarks

During the test, the dc-dc solar regulator did not power on itself when the sun is rose. To start, the output voltage has to be put down shortly. In the results, it is visible that this intervention was executed at 9.00.

The dc-dc solar regulator does not have an automatic MPPT (Maximum power point tracking) feature. This means that the regulator is working sub-optimal at certain points in time.

For practical reasons only one battery module with four batteries was used in this test, instead of the final eight batteries which will be in the base station. The battery protection circuits can at maximum charge with 1 ampere. This means that the two battery circuits can handle a maximum of 10 watt. (two times 1A at 5V)



N.2. Solar panel and U-blox antenna at South-east side of building

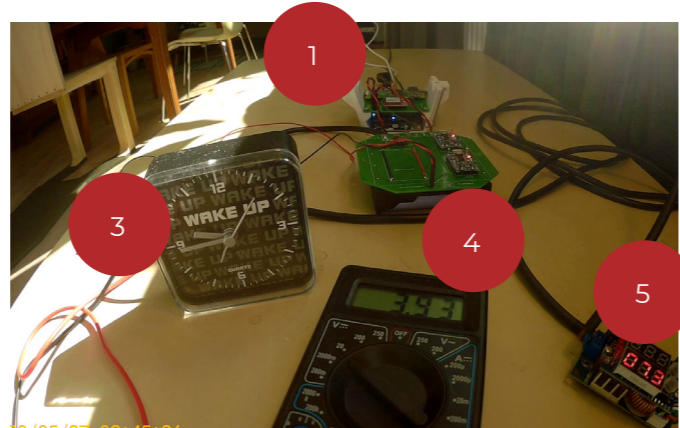

N.1. View from the observing camera:
1. Modem receiver and Raspberry
2. Battery system in the middle
3. Clock for time reference
4. Battery voltage
5. Power meter on the solar dc-dc converter.

Charge power and battery voltage

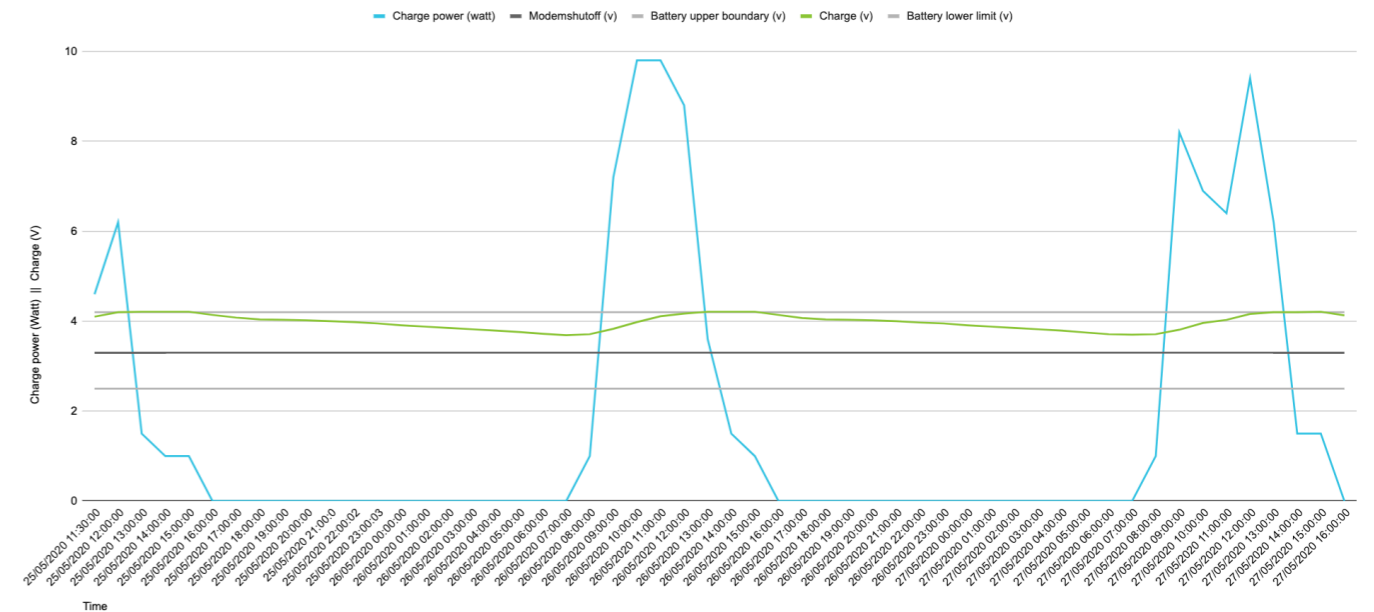

N.3. Charge power and battery voltage graph 25-27may

Solar irradiation (KNMI)

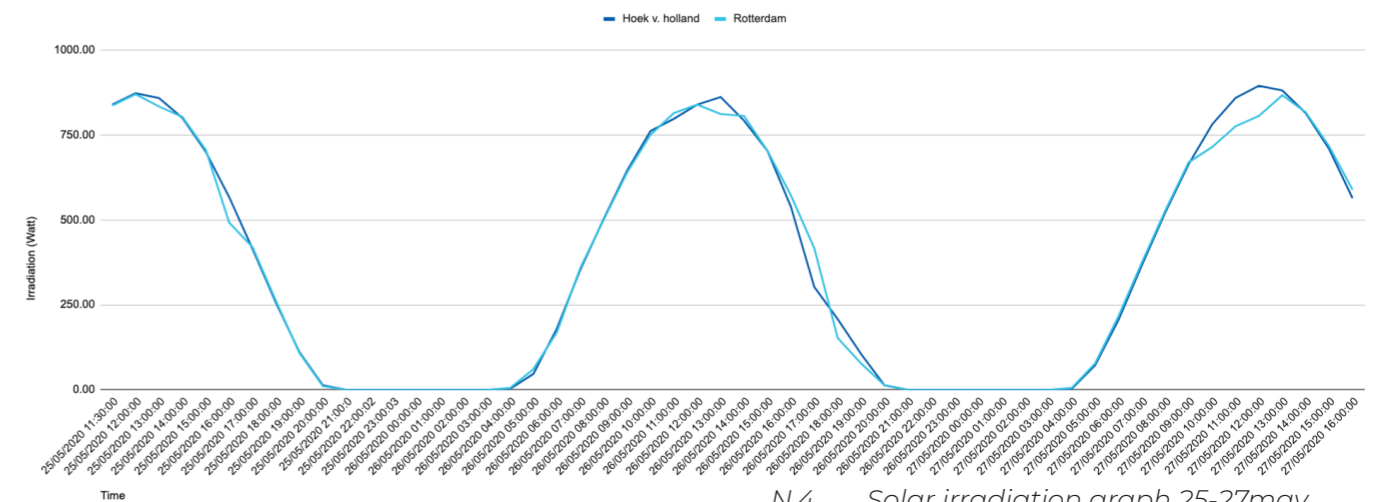

N.4. Solar irradiation graph 25-27may

Results

In graph N.3 the charge power and battery voltage can be seen over a timespan of 52 hours. In graph N.4 the solar irradiation of the same timespan can be seen of the two nearest KNMI measurements sites. ("KNMI - Daggegevens van het weer in Nederland," 2020)

After 16.00 the solar panel is in the shade of the building. At this point the charge power is zero.

Conclusion

Despite the use of half the battery capacity and a non optimal dc-dc solar regulator:

- The batteries are charged within 3-4 hours.
- The batteries are able to power the hardware for 14 hours on their own, without coming close to the modem shut-off voltage.

Recommendations

- Find a dc-dc solar regulator which features MPPT and turns on automatically, or control this regulator with a micro-controller.
- Repeat this test with the full battery capacity.

References

KNMI - Daggegevens van het weer in Nederland. (2020). Retrieved August 8, 2020, from Knmi.nl website: <https://www.knmi.nl/nederland-nu/klimatologie/daggegevens>

Appendix O. Solar converter selection process

While the solar panel does not provide a continuous voltage, a dc-dc buck/boost converter is needed to provide a constant voltage to the battery charging circuit. At first an XL6009 buck/boost converter (figure O.1) was chosen.



O.1. XL6009 buck/boost converter

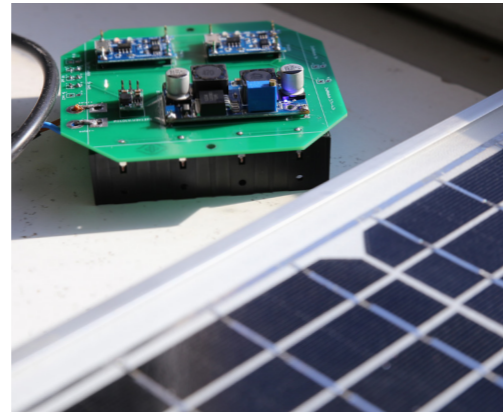

O.3. XL6009 buck/boost converter on PCB

After connecting the XL6009 buck/boost converter to the solar panel (figure O.3), the voltage of the solar panel dropped to about 3 volts. At this point, the panel does not deliver any power. It seems that a solar panel does not only need a voltage converter, but the current should also be limited. In this way the panel can be kept at an optimal voltage to deliver power. The solar panel power curve can be seen in figure O.4. Here, V_{MP} is the maximum power point.

O.5. Graph of a typical solar panel voltage/current curve (PVEDUCATION, 2019)

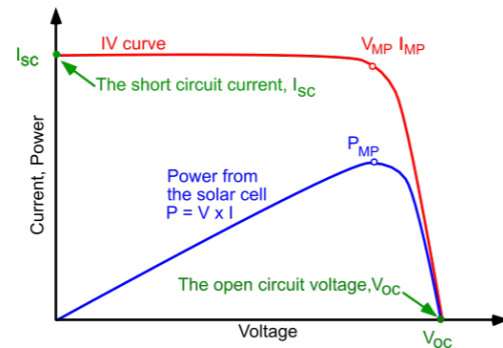

In the second attempt, we replaced the XL6009 buck/boost converter by a MPPT (Maximum power point tracking) Solar Panel Controller. (figure O.2). When connected (figure O.4), the potentiometers on this regulator can change the input voltage, output voltage and limit the maximum output current. Despite the name, this regulator does not track the maximum power point, only a fixed voltage and current combination can be dialed in using the potentiometers. A real maximum power point tracking regulator would be needed to use all the power of the solar panel.

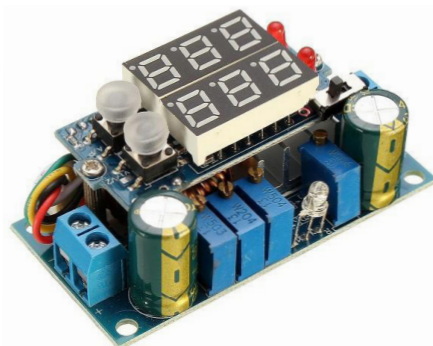

O.2. "MPPT" Solar Panel Controller

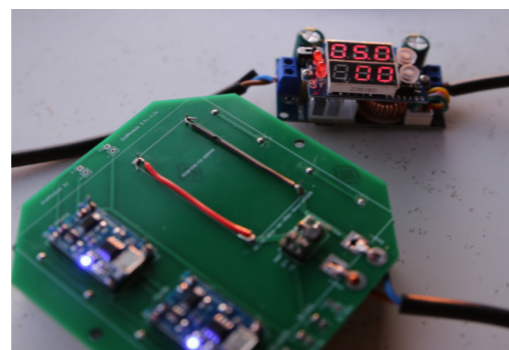

O.4. "MPPT" Solar Panel Controller between the solar panel and PCB

In the final iteration, the solar converter has been replaced by a real MPPT device. This board is based on the CN3722 chip (figure O.6). The CN3722 chip tracks the maximum power point by adjusting the current throughput, so that the solar panel stays at a constant voltage. This optimum voltage can be tuned in by using the potentiometer indicated with number 1 in image O.6. In this specific case, the optimum solar panel voltage for the Victron 20watt solar panel is 18.4V (Victron energy, 2020). The CN3722 chip also provides a charge profile for lithium batteries. The voltage to which the cells will be charged is dialed in with the potentiometer indicated at number 2 in image O.6.

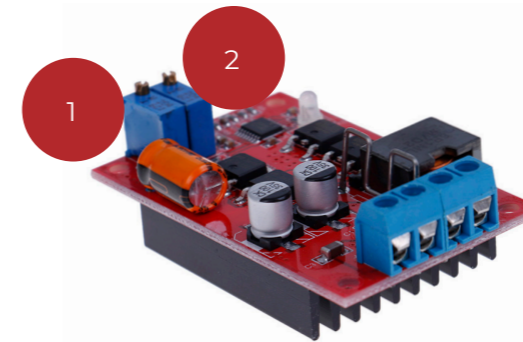

O.6. CN3722 MPPT solar charge controller

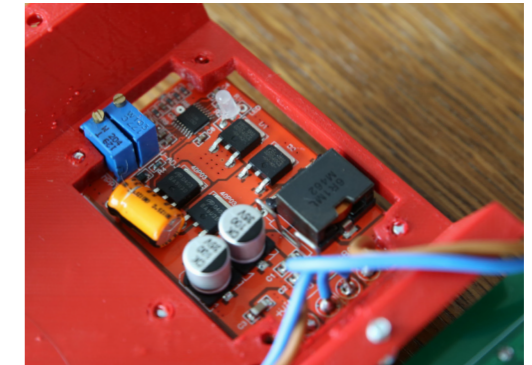

O.7. CN3722 MPPT solar charger mounted in

The bought CN3722 device, which is integrated in the final base design, was adjustable to a maximum charge voltage of 5v. However, the required maximum charging voltage of the 18650 lithium cells is 4.2v. Therefore the potentiometer and a resistor on the board have been altered. The output voltage V_{BAT} can be calculated using the formula given by manufacturer Consonance (Consonance electronics, 2019):

$$V_{BAT} = 2.416 \times (1 + R7/R6) + I_B \times R7$$

$$R6 = 22 \times 10^3 \Omega \text{ Inspection of board}$$

$$I_B = 50 \times 10^{-6} \text{ A Typical value, according to data sheet (Consonance electronics, 2019)}$$

Solve:

$$4.2 = 2.416 \times (1 + R7 / 22 \times 10^3) + 50 \times 10^{-6} \times R7$$

$$R7 = 11.16 \text{ K}\Omega$$

This means, a 11.16K Ω should be put in the place of resistor R7 to get a maximum charging voltage of 4.2V.

To keep the same layout, and still able to change the output voltage slightly, R7 is build by combining a fixed resistance of 10KΩ and a potentiometer which can regulate between 0Ω-10KΩ (figure O.8 and O.9). This gives a total adjustable range of 10KΩ to 20KΩ. After this adjustment, a maximum charging voltage of exactly 4.2V can be set using the new adjustable resistor (Resistor has to be turned about 20 full rounds inwards starting at its most extended position).

On a future custom PCB, all resistors could be fixed to match the exact desired output and solar panel voltage.

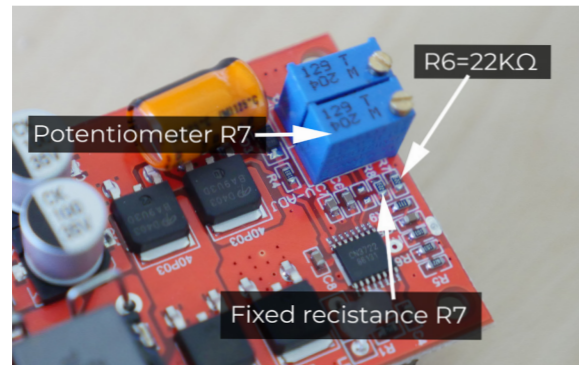

O.8. CN3722 MPPT solar charge controller before adjustment. The named resistor on this PCB is unfortunately not in line with the Consonance datasheet.

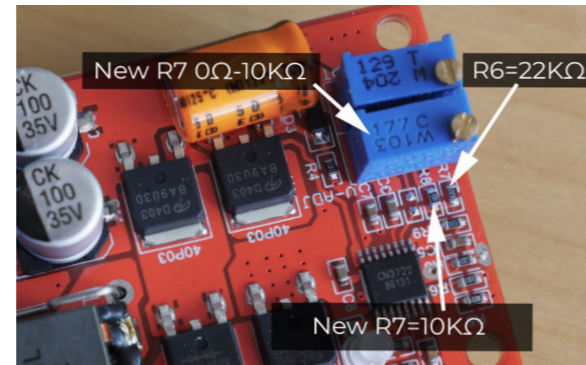

O.9. CN3722 MPPT solar charge controller after adjustment.

References

PVeducation. (2019). IV Curve | PVeducation. Retrieved May 28, 2020, from Pveducation.org website: <https://www.pveducation.org/pvcdrom/solar-cell-operation/iv-curve>

Consonance electronics. (2019). CN3722 5A, Multi-Chemistry Battery Charger IC With Photovoltaic Cell MPPT Function. Retrieved August 10, 2020, from Consonance-elec.com website: <http://www.consonance-elec.com/seriesCN3722-E.html>

Victron Energy. (2020). BlueSolar Polycrystalline Panel. Retrieved August 10, 2020, from Victron Energy website: <https://www.victronenergy.nl/upload/documents/Datasheet-BlueSolar-Monocrystalline-Panels-NL.pdf>

Appendix P. Connectivity options

There are multiple possible technologies to transmit data between the base-station, rover and servers. In figure O.10 it can be seen that long range options with low power consumption often compromise on the rate of data transfer. For some technologies a public network does exist. For other technologies, there would be the need to setup an access point when the data finally needs to be transferred to a web server.

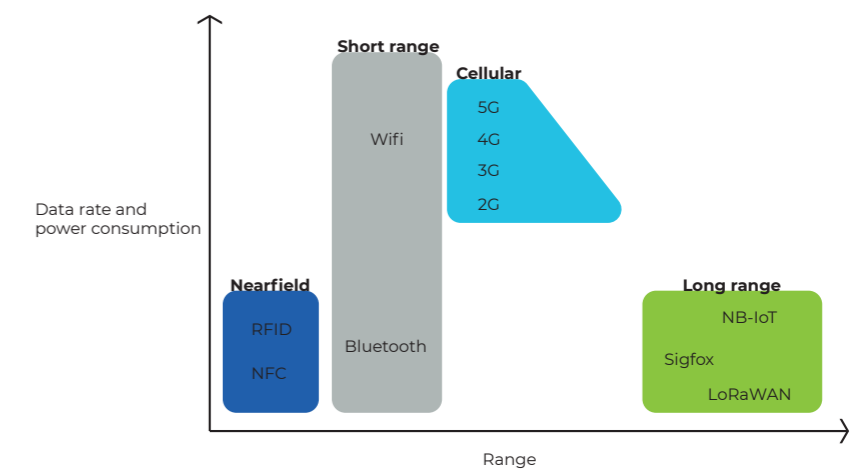

O.10. Range versus data rate of several technologies. Based on (Mekki, Bajic, Chaxel, & Meyer, 2019)

The needed data rate for RTK streaming is 1,5mb/h. The amount of raw data for meteorological purposes can be compressed to about 5mb/day (estimation by A. Krietemeyer) which results in a minimum continuous capacity of 3,8kbps. Options which provide this bandwidth are elaborated below:

Cellular technologies



SIM7600G

Principle: cellular
 Initial hardware price: €32
 Operation costs: €0,003/mb (MTN, 2019)
 Range: everywhere on cellular network
 Data rate: 2G, 85,6kbps
 3G 5.76Mbps
 4G 50mbps
 Power need: 2G 1,38watt (SIMCom, 2019)
 3g 1,6watt (SIMCom, 2019)
 4G 2 watt (SIMCom, 2019)

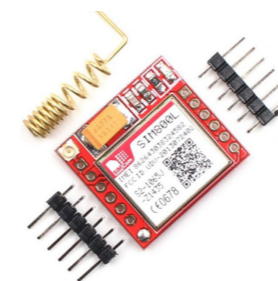

SIM800

Principle: cellular
 Initial hardware price: €6
 Operation costs: €0,003/mb (MTN, 2019)
 range: everywhere on cellular network
 Data rate: 2G, 45kbps (limited by baudrate of SIM800)
 Power need: 2G 1,38watt (SIMCom, 2014)

Cellular communication is available publicly in Ghana. The network is maintained by commercial operators. In figure P.1 it can be seen that the 2G network covers the greatest part of the country followed by 3G and 4G subsequently. Almost all cell towers in Ghana have a power backup system (GSM Association, n.d.) and therefore can work during power cuts. Most modern cellular modems can switch between 2G, 3G and 4G. The power consumption of the cellular chip is higher for the faster networks, however, this might be compensated by the fact that the modem sooner returns to a lower power state when sending the same amount of data over a faster connection.

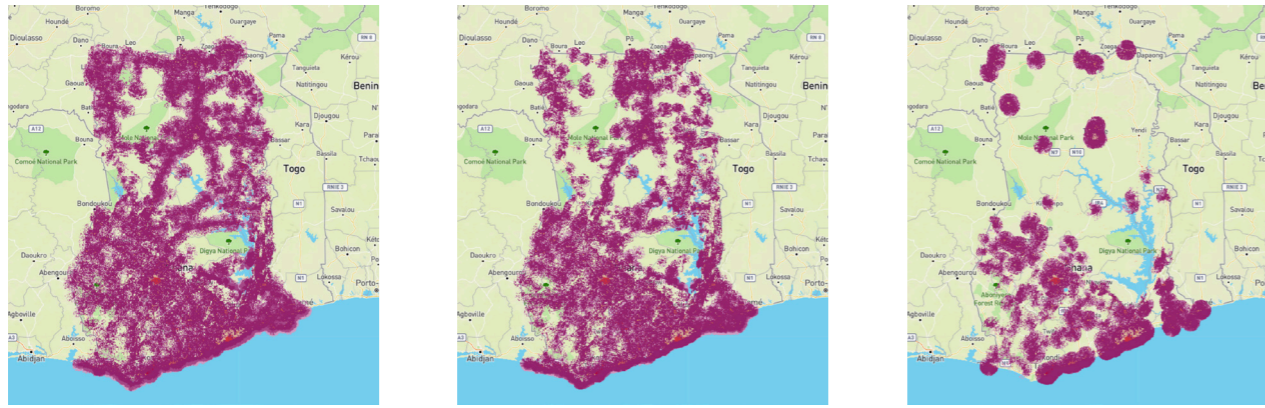

P.1. Coverage area of cellular networks in Ghana. left: 2G, middle 3G and right 4G. (GSM association, n.d.)

Long range technologies



Digi XBee SX

Principle: 900mhz radio
 Initial hardware price: €30
 Operation costs: €0/day
 range 10-14km
 Data rate: 10 kbps
 Power need: 0,18watt

The Digi XBee SX provides a point to point radio connection. This means that when an internet connection is needed, an access point needs to be setup which connects the radio to the internet. This access point needs to be protected against power cuts.



LoRa

Principle: regional open band radio (900mhz)
 Initial hardware price: €25
 Operation costs: €1,1/3000 uplinks (OIDUTS, 2017)
 range: everywhere the network exists, also used by Disdrometrics
 Data rate: 0.3-50kilobits/second
 (max 30sec a day dependent on rovider)
 Power need: 0,3 watt

The LoRa system is another long range radio, but for the LoRa a public radio networks exist. In Ghana there is a developer network available. Not all devices on the LoRaWan network can use the full on air time in their band as it decreases the bandwidth too much. (Adelantado et al., 2017). Therefore, LoRaWan networks often have an maximum amount of uplinks a day and are not intended for continuous streaming.

Conclusion

Because continuous streaming is a must and the availability of a public network is preferred, the cellular network is the best choice. 2G is fast enough to operate the system and is the most widely available in Ghana. Newer chips which support 3G, 4G and 5G could make the device more future proof but add costs as well.

References

GSM association. (n.d.). Mobile Coverage Maps. Retrieved August 12, 2020, from www.mobilecoveragemaps.com website: https://www.mobilecoveragemaps.com/map_gh#7/9.056/-2.762

GSM Association. (n.d.). Powering Telecoms: West Africa Market Analysis. Retrieved from <https://www.gsma.com/mobilefordevelopment/wp-content/uploads/2013/03/GPM-Market-Analysis-West-Africa-.pdf>

Lora Alliance. (2020). Coverage & Operator Maps. Retrieved August 14, 2020, from Lora-alliance.org website: <https://lora-alliance.org/>

Mekki, K., Bajic, E., Chaxel, F., & Meyer, F. (2019). A comparative study of LPWAN technologies for large-scale IoT deployment. *ICT Express*, 5(1), 1–7. <https://doi.org/10.1016/j.icte.2017.12.005>

MTN. (2019). Tariffs - MTN Ghana. Retrieved August 14, 2020, from MTN Ghana website: <https://mtn.com.gh/insight/tariffs/>

OIDUTS. (2017, March 6). LoRa. Retrieved August 14, 2020, from SIMPoint website: <https://www.simpoint.com/en/lora/#rates>

SIMCom. (2014). SIM800 Hardware Design V1.07. Retrieved from http://www.vis-plus.ee/pdf/SIM800_Hardware%20Design_V1.07.pdf

SIMCom. (2019). SIM7600 series hardware design v1.03. Retrieved from https://simcom.ee/documents/SIM7600E/SIM7600%20Series%20Hardware%20Design_V1.03.pdf

Appendix Q. ROVER1 Design and build process

This appendix contains the design and build process of ROVER1 as presented in intermediate report 'Rover 1 - prototyping'

The design of the first rover was made intuitively and inspired on the information gathered from the analysis. First, the design considerations and the build process will be shown. Next, the considerations and build process of the phone holder will be shown.

ROVER1 main-unit design

Hardware

The main rover unit (figure Q.1) contains a simpleRTK2B GNSS receiver which can communicate to a phone with Bluetooth. This hardware combination is powered by four 2200Mah batteries. Theoretically this is enough to power the receiver with Bluetooth for 65 hours. The smart-phone will be exhausted within 3 hours during heavy work with screen, Bluetooth and mobile data turned on. The internal battery can therefore also be used to extend the battery life of the phone by 7 hours. For this reason there is not only a port to charge the ROVER1 but also an output to charge a smart-phone.

The Antenna is placed on top of a 2mm thick aluminum plate with a diameter of 120mm. The material and size have been proven to be optimal by Tallysman (Tallysman, 2018). When a plastic housing part is placed over the antenna, the received frequency will have an offset, this would require the antenna to be re-calibrated (Tallysman, 2018). For this reason

the antenna is placed outside the housing in this first prototype.

The total material costs of this main unit are €290,07

Water and dust resistance

The round shape is not only optimal to place the antenna ground-plane but is also ideal to seal the two housing parts with one O-ring. Both USB ports are protected for water and dust with a plug with O-ring. Cable glands and switches are at least rated for IP65. The current 3D printed PETG housing parts are for prototyping purposes. They are practically watertight due to over-extrusion and slow printing speed. 100% watertightness can be assured by priming the main rover unit.

Condensation water

It is best to assume that air with moisture will get into the housing. During evening time the walls of the housing will cool down first. This will cause drops of water to be formed on these walls. Water-droplets can roll down to the bottom without touching the electronics, as all electronic parts are standing on pillars and do not touch the walls. A future rounded top of the housing can help to prevent the droplets from falling down. On the lowest point of the housing the droplets can leave through the drainage element. This drainage element is now temporary represented by a cable gland. (10. in figure Q.2) Tests have been done with a drainage element from STEGO. This element lets water out while low pressure splashing water will not get in as long as the device is with its right side up. Unfortunately, water tight drainage elements do not exist.

Coating the PCB's in the housing can still be done, but to prevent corrosion it is better to prevent water from reaching these elements.



Q.1. Render of outside - ROVER1 main-unit

Hardware

1. U-blox GNSS antenna.
2. 120mmx2mm Aluminum ground-plane to prohibit signals to reach the antenna via the ground.
3. 4x 18650 2200Mah battery.
4. O-ring to seal housing.
5. Rocker switch to turn device on.
6. Arduimple RTK GNSS receiver with Bluetooth module to connect to smart-phone.
7. USB type micro input to charge the device.
8. USB type A output to charge phone while working.
9. Plugs with O-ring to keep moisture and dust out of USB ports.
10. Moisture drain for condensed water. Temporarily represented by cable gland.

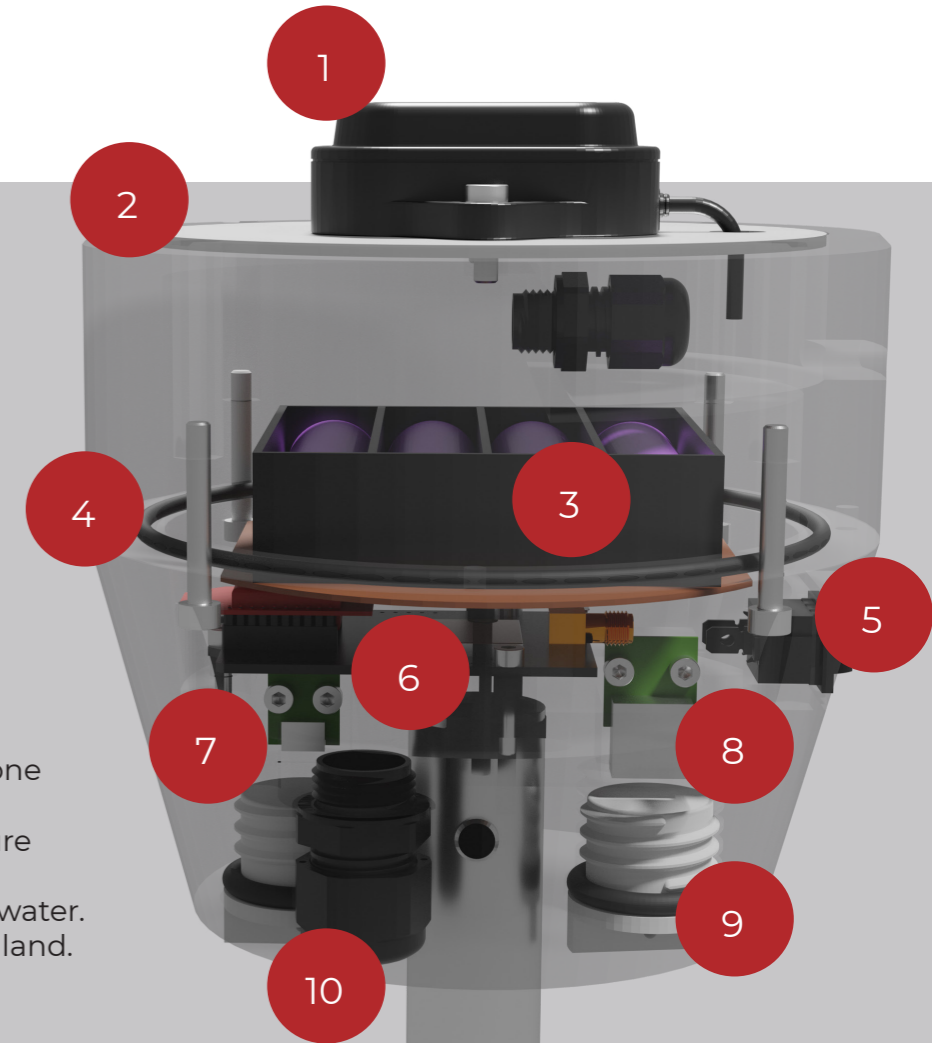

Q.2. Look through render of ROVER1

ROVER1 main unit Assembly

Step1

M3 inserts are placed in the holes for the M3 bolts. Cables are soldered to the USB breakout boards and rocker switch, after which these parts can be mounted in the lower housing.

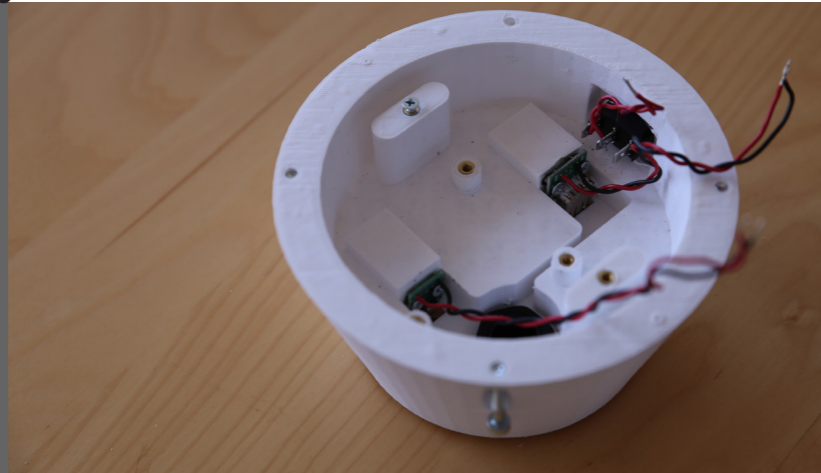

Step2

The receiver with bluetooth module is screwed on it's mounting pillars.

Normally, at this point the SMA antenna connector should be connected.

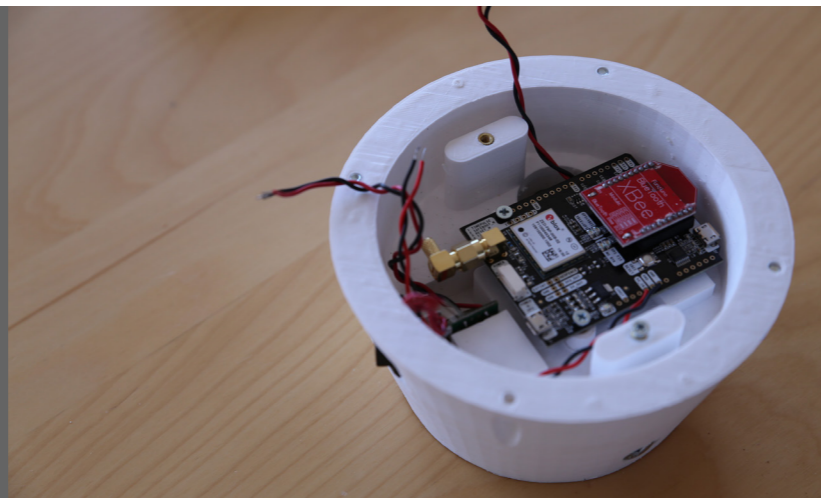

Step3

The battery protection circuit, voltage-regulator, battery-holder and terminals are soldered to the prototype PCB.

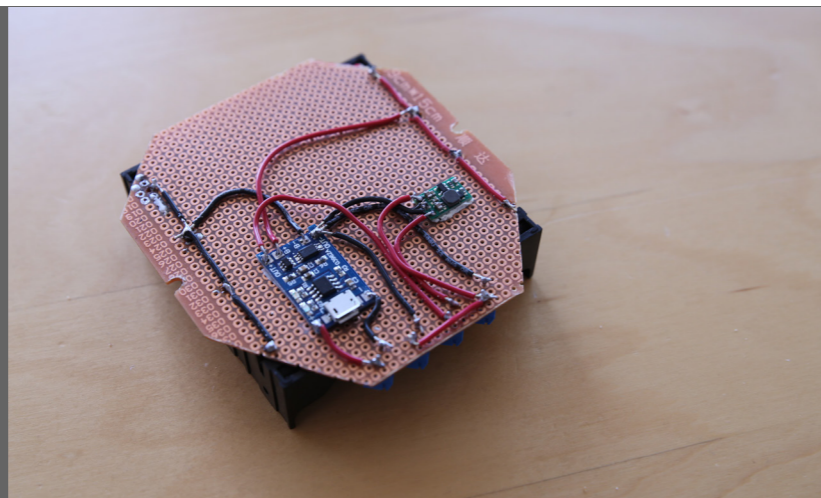

Step4

The battery module is mounted on it's pillars and all the wires can be connected to the correct terminals.

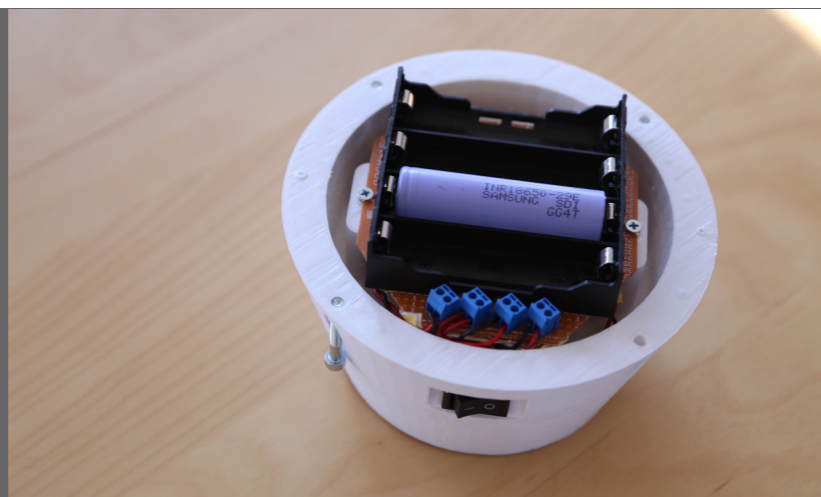

Step5

The antenna is mounted to the top part of the housing, its cable is lead through the cable gland. Here, the ground plate still has to be added

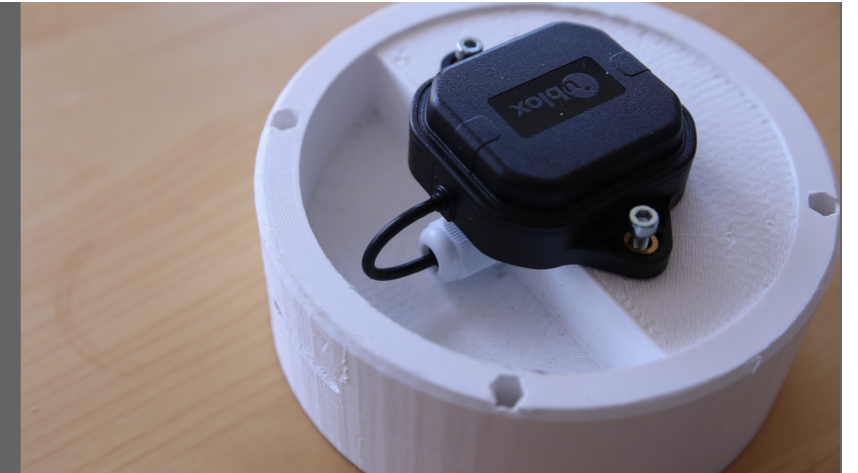

Step6

The 119mmx3mm O-ring is inserted.



Step7

The housing can now be closed by tightening the M4 socket head bolts evenly.



Step8

Plugs can be used to close-off the USB connectors.



ROVER1 Smart-phone holder design

Because the users will have to use SWmaps to control the ROVER1 a smart-phone holder (figure Q.3) is needed to keep one hand free while walking with the device. A compression spring is used to make a clamp. The clamp can hold a phone between 58mm and 85mm. This range suits the currently most used smart-phones.

The holder can be moved up and down for use by longer and shorter people. The knob should be unscrewed in this case and can be screwed again at the desired level.

A simple level of 32mm diameter is mounted next to the phone to be able to position the ROVER1 straight up.

The total material cost of this smart-phone holder with level is €6,54.

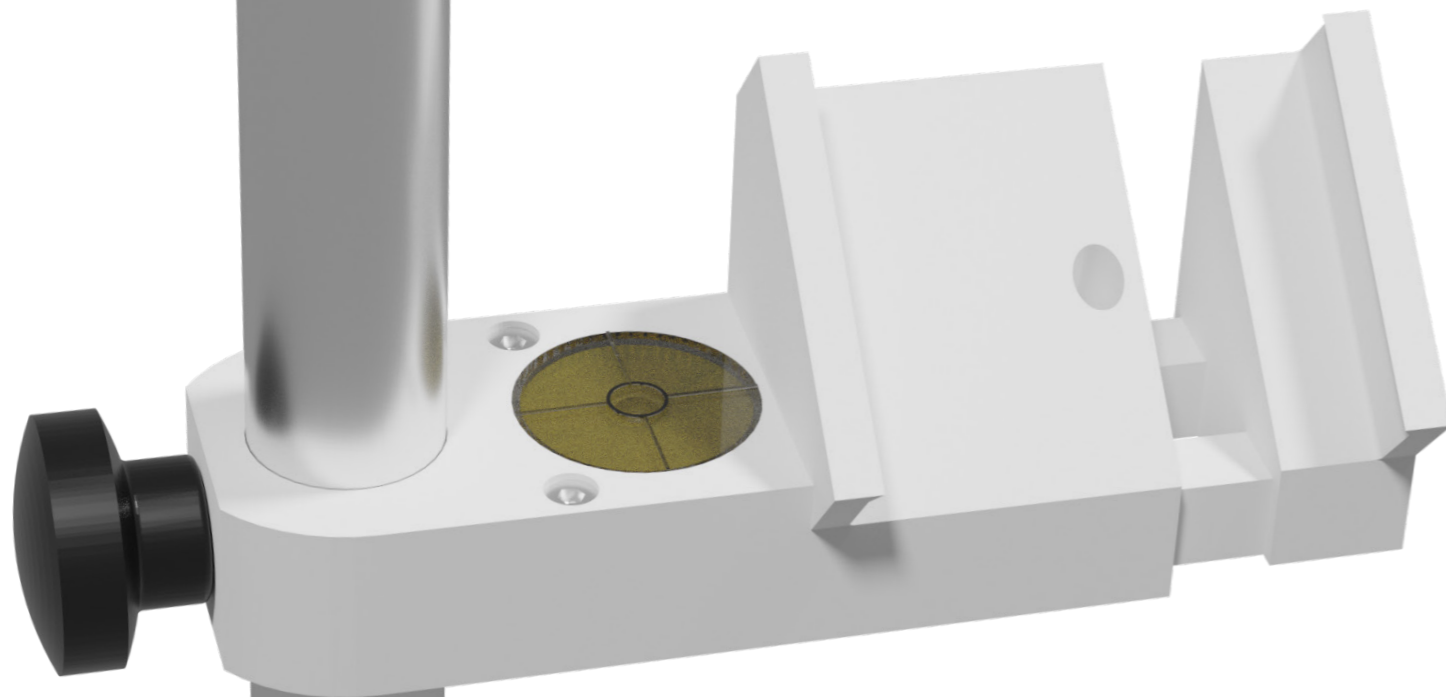

Q.3. Render of ROVER1 smart-phone holder

ROVER1 Smart-phone holder assembly

Step1

Insert the movable part with spring in the base.

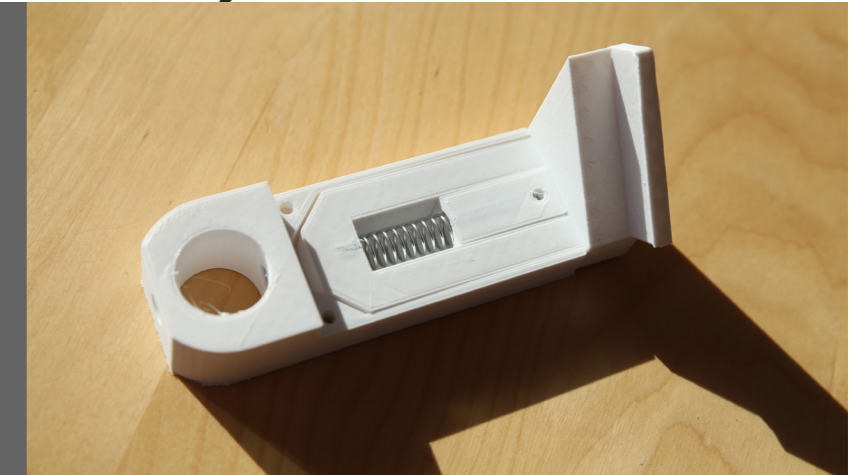

Step2

Screw in the top part with three M4 bolts.

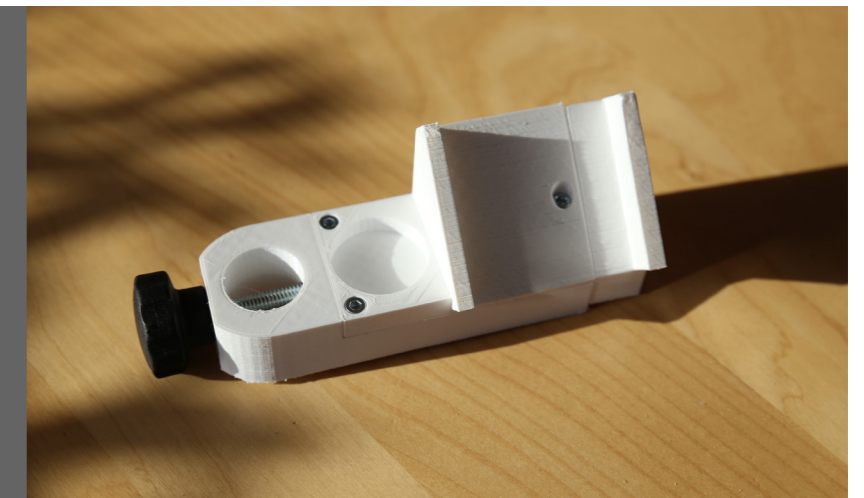

Step3

Any phone can be held by the smart-phone holder.



References

Tallysman. (2018). Embedded Antennas -Reference Guide. Retrieved from <https://www.tallysman.com/app/uploads/2019/10/Embedded-Antennas-Reference-Guide-v4.pdf>

Appendix R. BASE1 Design and build process

This appendix contains the design and build process of BASE1 as presented in intermediate report 'Base 1 - prototyping'

The design of the first base was made based on the information gathered from the analysis in combination with the learnings from the build process of the first rover. In the following paragraphs the design considerations of BASE1 are shown, design choices which stay the same are only noted shortly.

BASE1 main-unit design

Components

All electronics are now mounted in a rack for easy access (figure R.1) This rack can be used in the rover as well as in the base.

The Antenna is placed on top of a 2mm thick aluminum plate with a diameter of 120mm. According to the report of Tallysman (Tallysman, 2018). The antenna is placed outside the housing in this first base prototype so that there is no need for antenna re-calibration.

The total material costs of the base1 are €380

Water and dust resistance

The round shape is chosen to suit the antenna ground plane and to seal the housing with one O-ring. Cable glands and switches are at least rated for IP65. The current 3D printed PETG housing parts are for prototyping purposes. They are practically watertight due to over-extrusion and slow printing speed. 100% watertightness can be assured by priming the main rover unit.

Condensation water

In a climate with high humidity, drops of water will be formed on the inside walls of the housing when they cool down in the evening. The as all water droplets can roll down to the bottom of the housing without touching the electronics, as all electronics are mounted in a rack which does not touch the wall. A future rounded top of the housing is needed to prevent droplets from falling down. On the lowest point of the housing the droplets can leave through the drainage element. This foam block is the internal part of a STEGO drainage element. This element will let water out whereas at the same time splashing water will not get in, as long as the device is held upright. Unfortunately, watertight drainage elements are not available.

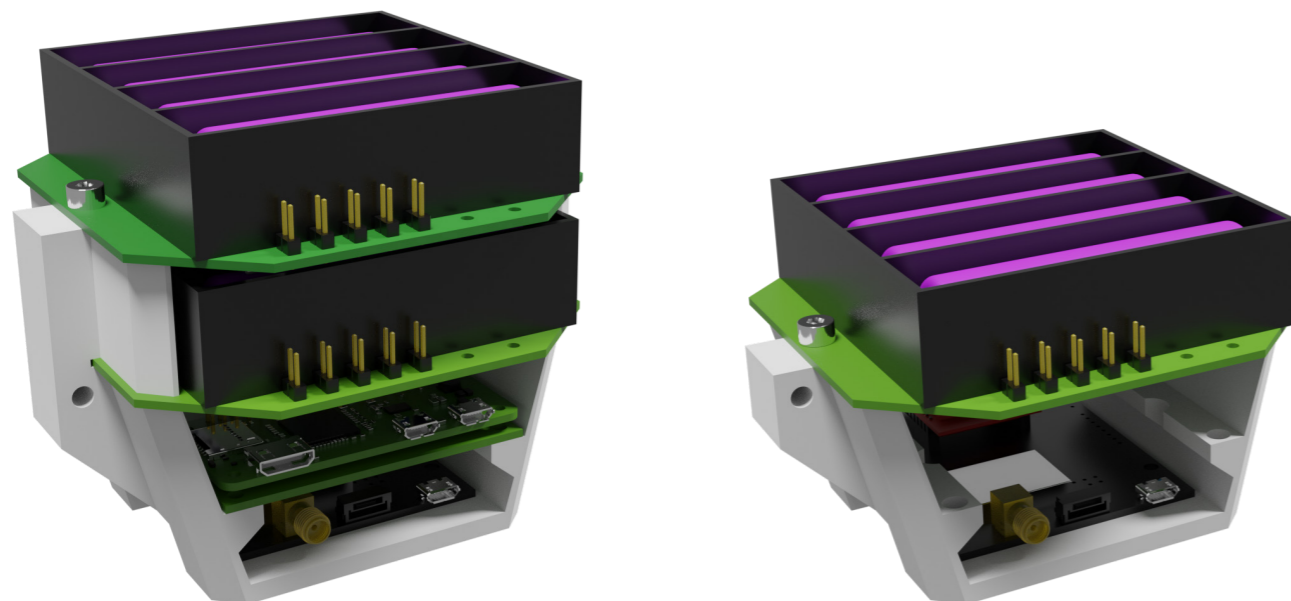

R.1. left: Render of electronics rack configured for the base, right: render of electronics rack configured for the rover.

Hardware

1. U-blox GNSS antenna.
2. 120mmx2mm Aluminum ground-plane to prohibit signals to reach the antenna via the ground.
3. 8x 18650 2200Mah battery and electronics to regulate solar power.
4. O-ring to seal housing.
5. Rocker switch to turn device on.
6. Arduimple RTK GNSS receiver
7. Raspberry PI and modem for data transfer.
8. Moisture drain for condensed water.

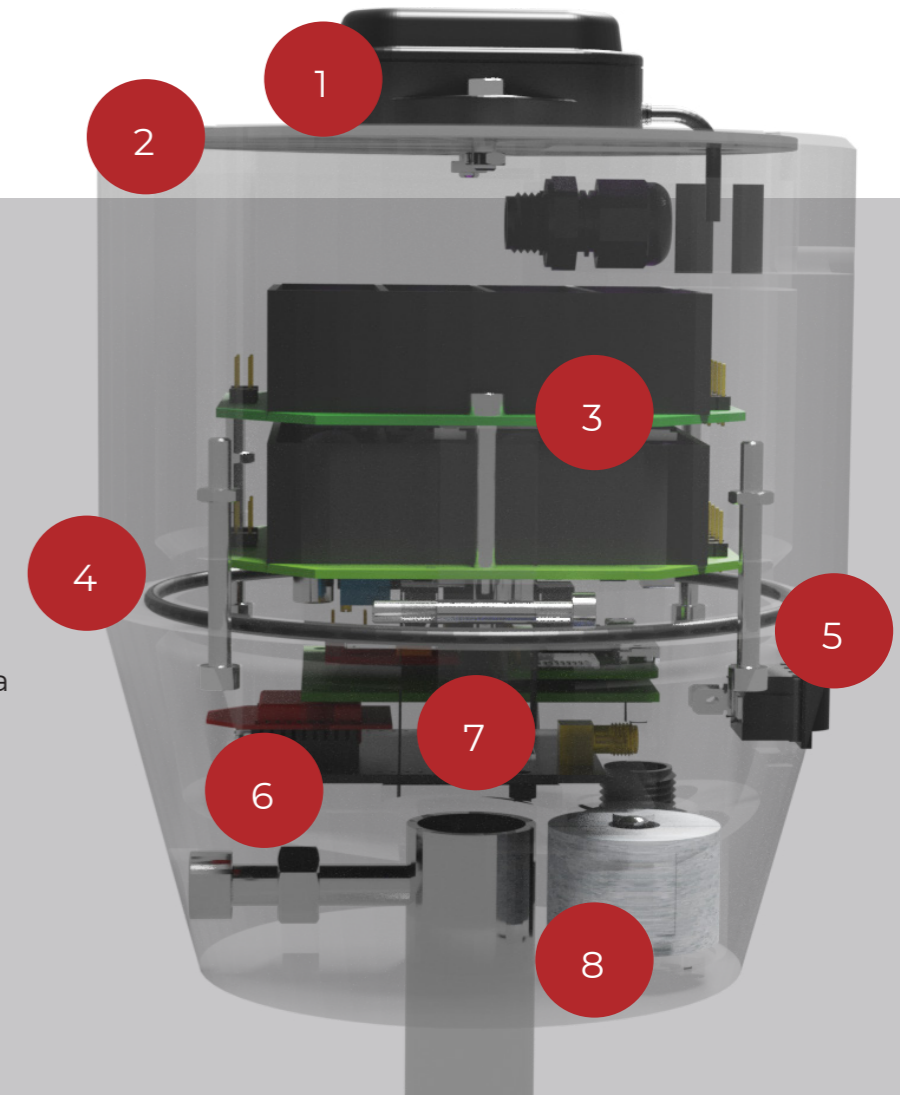

R.2. Look through render of BASE 1

BASE1 main unit Assembly

Step1

The logic PCB has power connections for the modem and raspberry PI. It contains the leads for the serial connection as well.

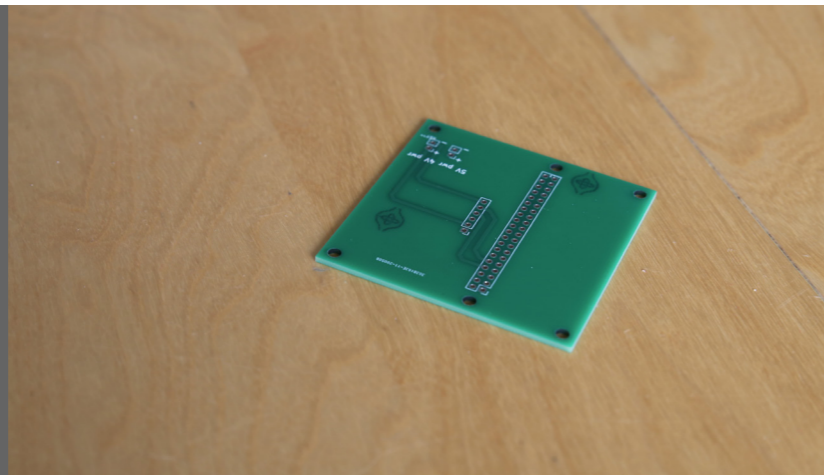

Step2

Solder the modem and Raspberry PI zero to the logic PCB.

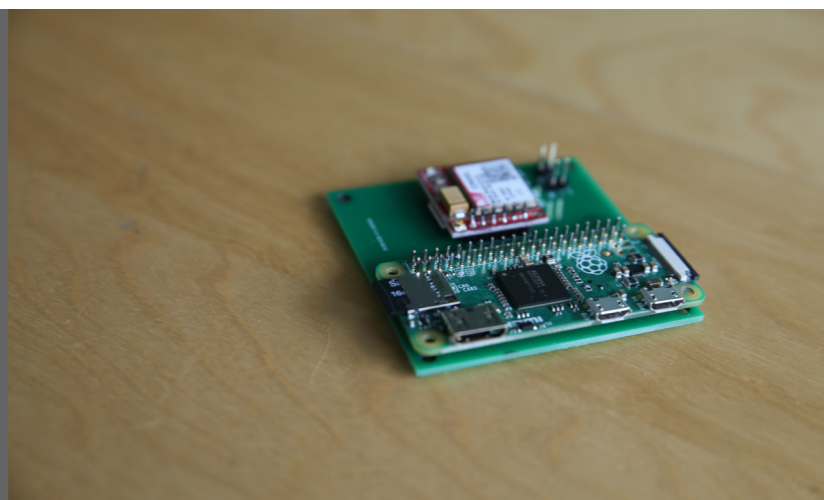

Step3

The battery protection circuit, voltage-regulator, solar power regulator and battery holder will be connected through the battery PCB.

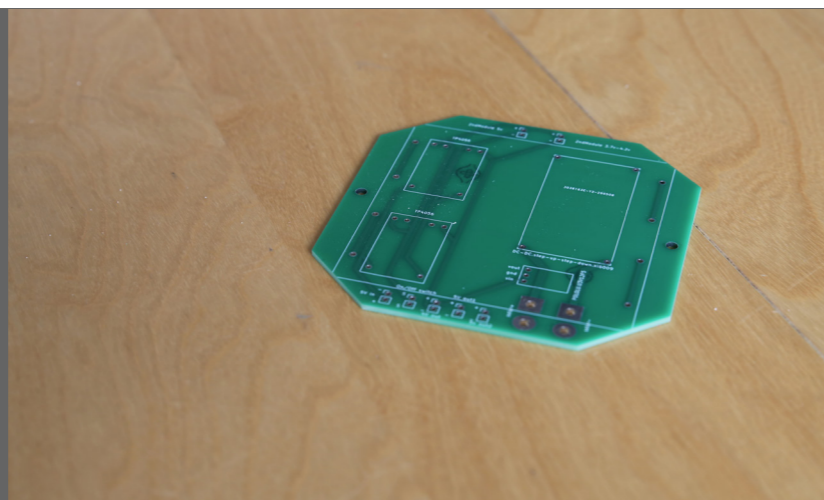

Step4

The battery holder, voltage-regulator and battery protection circuits are mounted to the battery PCB. The solar power regulator had to be replaced and is for this reason not on the PCB itself.

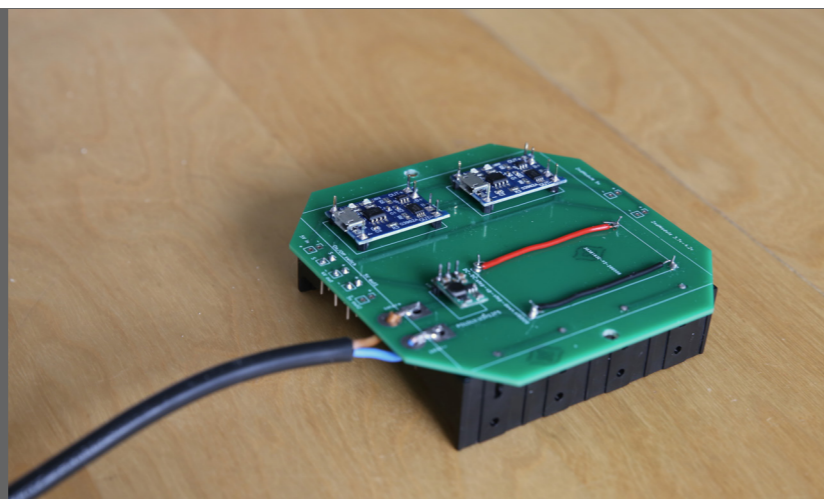

Step5

The GPRS antenna is mounted to the electronics rack.

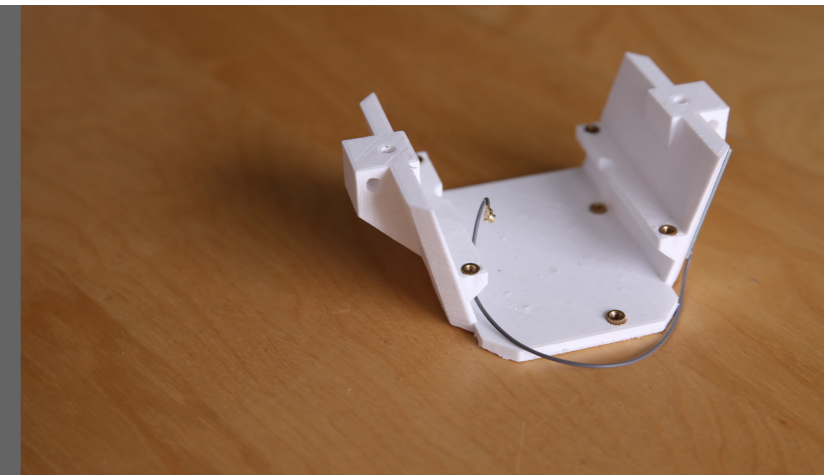

Step6

The ArduSimple RTK GNSS receiver can be mounted on the electronics rack with three M3 screws.

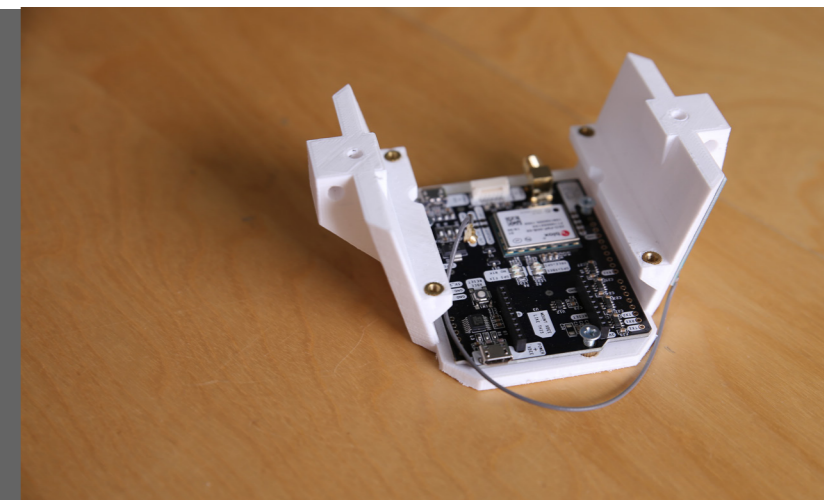

Step7

the logic PCB can be mounted on the electronics rack with four M3 screws.

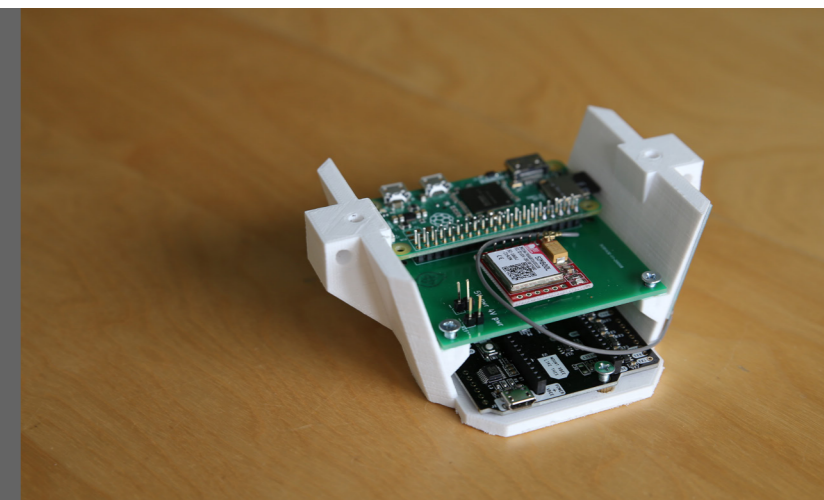

Step8

The battery PCB's and power cables can be mounted on top of the electronics rack with two M4 socket head bolts.

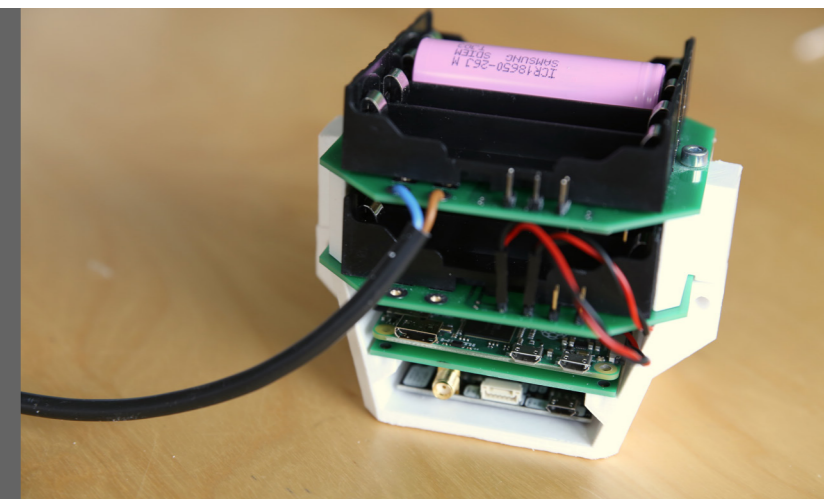

Step5

The rocker switch, drain element and cable gland can be inserted in the lower housing.

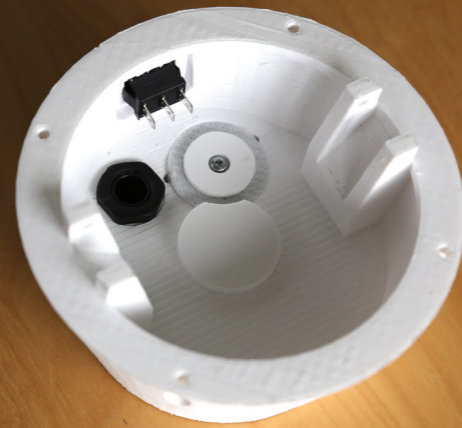

Step6

The electronics rack can be inserted in the lower housing. At this point, the connector of the GNSS antenna and the switch can be attached. The solar power cable should be fed through the cable gland.

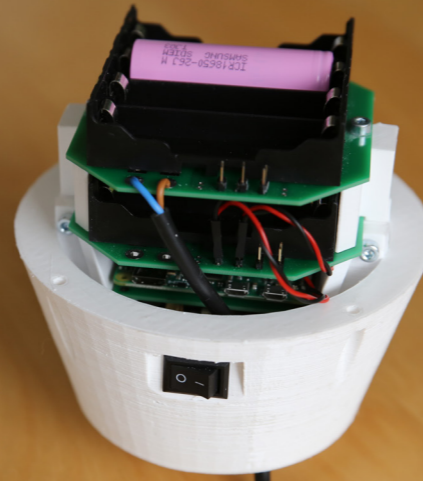

Step7

The 119mmx3mm O-ring is inserted in the top of the housing. The housing can now be closed by tightening the M4 socket head bolts evenly.



References

Tallysman. (2018). Embedded Antennas -Reference Guide. Retrieved from <https://www.tallysman.com/app/uploads/2019/10/Embedded-Antennas-Reference-Guide-v4.pdf>

Appendix S. ROVER2 Build process

This appendix gives an overview of how ROVER2 is assembled. The process of the main unit is shown, as it is the most complicated unit to assemble.

ROVER2 main unit Assembly

Step1

Sand and degrease the outside of the housing parts.
(The inside of the upper housing of the rover also needs sanding to make sure that the surface is smooth enough so that water will run down.)

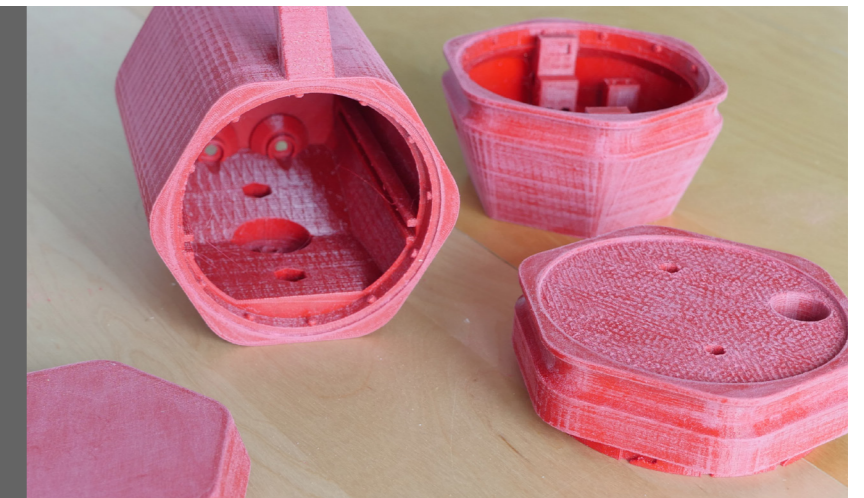

Step2

Coat the outside parts of the rover housing in epoxy.



Step3

Glue the foam rubber cord around the housing parts.



Step4

Glue two M4 nuts in the rover upper housing. Put the antenna wire (has been cut) through the ground plane, cable gland and upper housing part. Tighten the cable gland as well.



Step5

Push the cable gland in its position and screw the GNSS antenna in place with 2 M4x12mm bolts.



Step6

Melt M3 inserts into the holes in the lower rover housing.

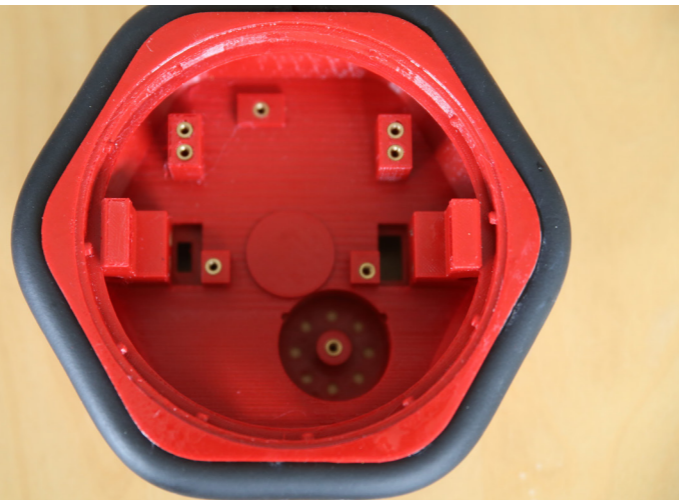

Step7

Solder wires with Dupont connectors to the USB breakout boards and power switch. Screw in the USB breakout boards using M3 bolts. Screw in the STEGO foam block and push in the power switch.

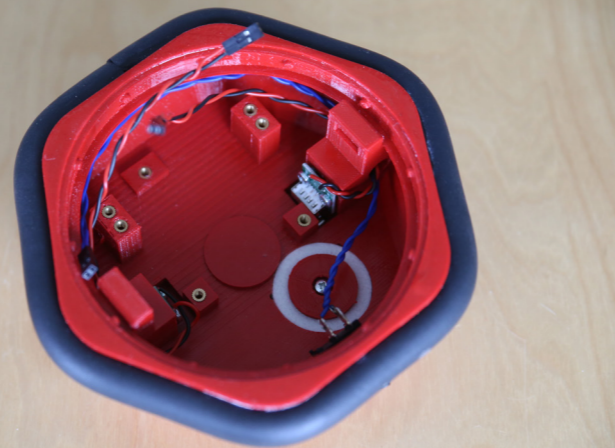

Step8

Screw the Adusimple GNSS receiver in place, using 3 M3x8 bolts.

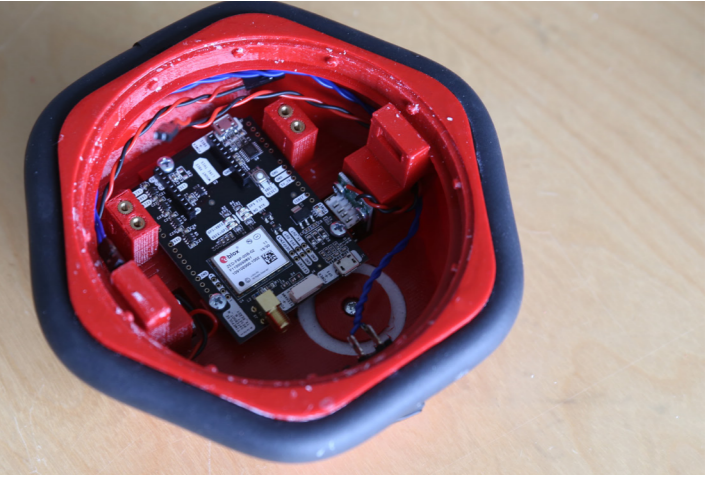

Step9

Solder headers, XT60 plug and the step up converter to the rover power PCB.

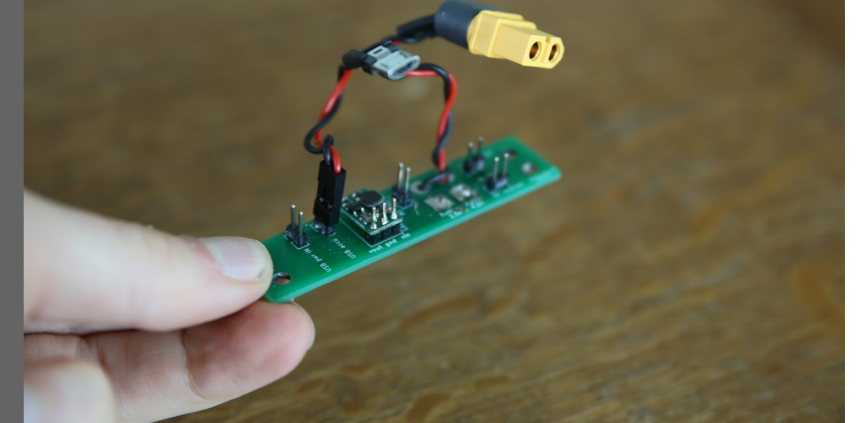

Step10

Add the O-ring to the rover upper housing. Push the Xbee-Bluetooth module in the Ardusimple receiver and screw the rover power PCB in the lower rover housing. Using 4 M3x8 screws. Solder a new SMA male connector to the GNSS antenna.

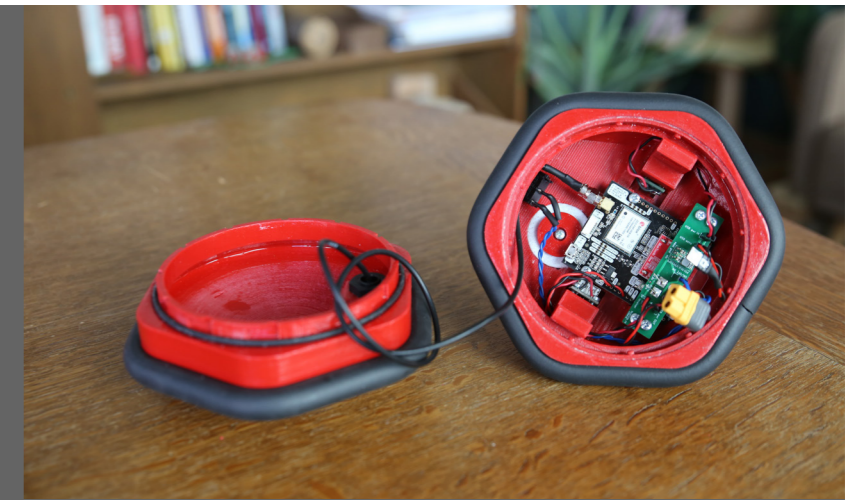

Step11

Solder the XT60 plug, TP4056, fuse holders and battery holder to the rover battery PCB.

Then add in the fuses (2A) and 18650 lithium cells.

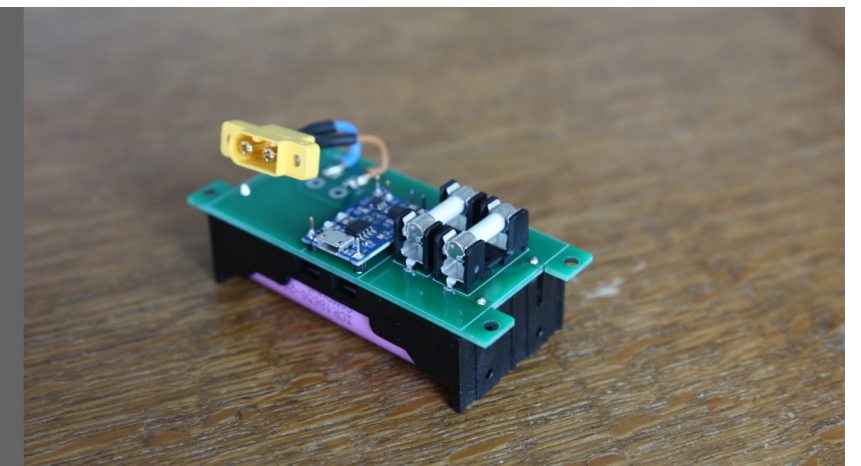

Step12

Put the battery PCB in its housing. The housing can be closed with 4 M3 bolts (which screw in inserts at the lower part of the battery housing)

The XT60 plug is attached using two m2.5 bolts

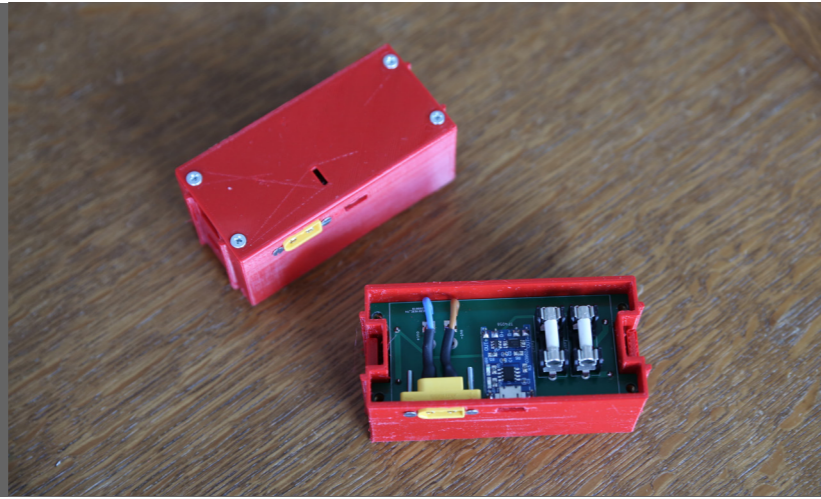

Step13

Click in the rover battery and connect the XT60 and USB plug.



Step14

Add O-rings to the USB plugs and screw them in.



Step15

The rover can be closed by turning the lid on. When the first time this requires a lot of force, it can be advised to put a bit of candle wax on the closing mechanism.



Appendix T. BASE2 Build process

This appendix gives an overview of how BASE2 is assembled. The process of the main unit and antenna top are shown, as these are the most complicated units to assemble.

BASE2 main unit Assembly

Step1

Sand and degrease the outside of the housing parts. (The inside of the upper housing of the rover also needs sanding to make sure that the surface is smooth enough so that water will run down.)

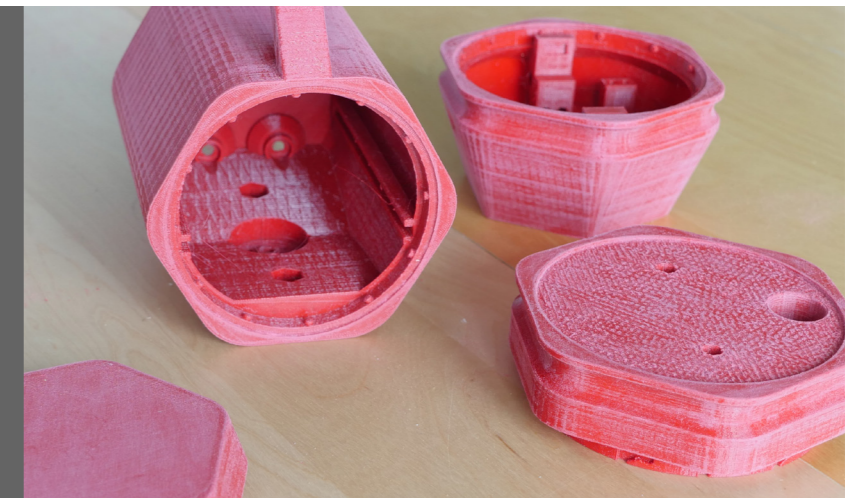

Step2

Coat the outside parts of the base housing in epoxy.



Step3

Solder the Raspberry Pi, SIM800L, TP4056, step up converter and 8 fuse holders to the base PCB.

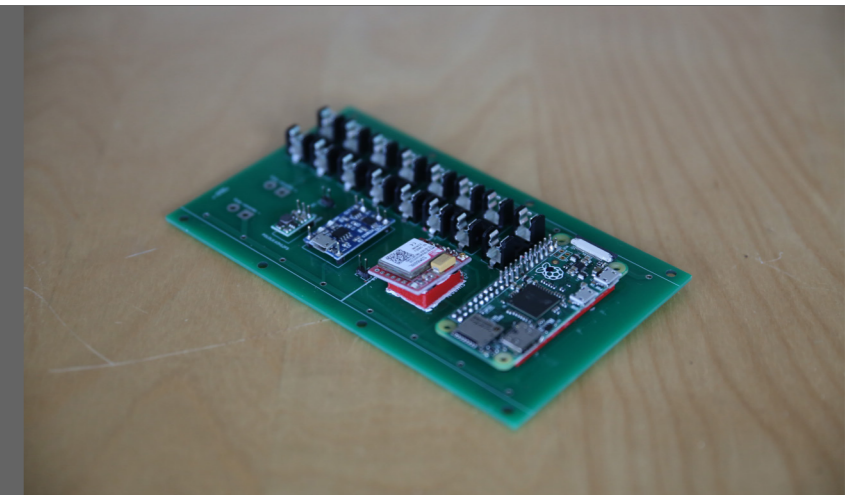

Step4

Solder the battery holders to the lower side of the PCB.

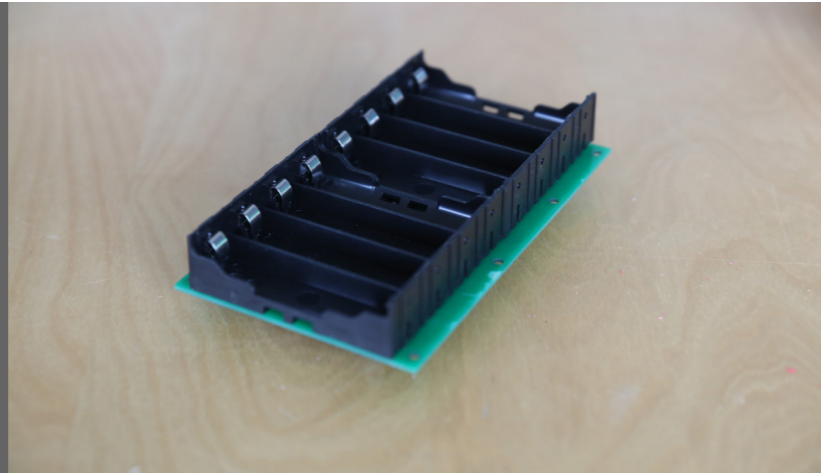

Step5

Screw the printed rails to the PCB using 4 M3x8 bolts. (The bolts screw into M3 inserts in the rails)

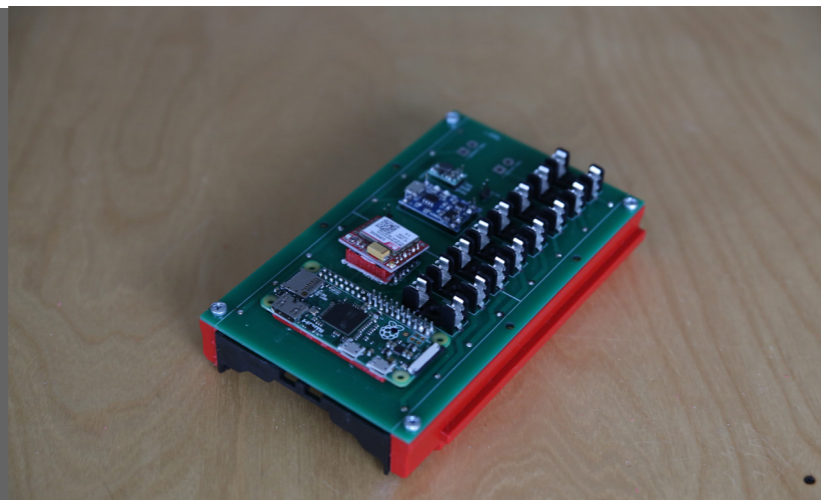

Step6

Solder wires to the MPPT solar converter and mount it in the upper electronics sled with 4 M3x8 bolts.

(MPPT solar regulator has been adjusted as can be read in Appendix O)

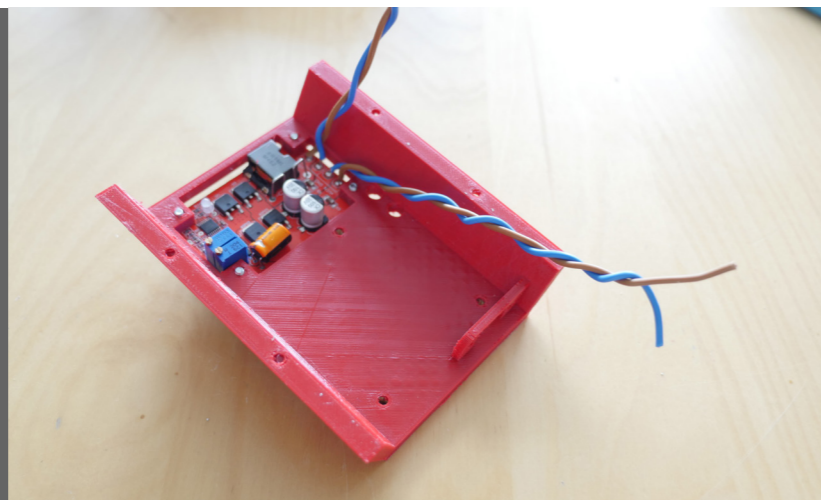

Step7

Solder the wires of the MPPT solar converter to the base PCB and mount the upper electronics sled to lower electronics sled using M3x8 bolts.

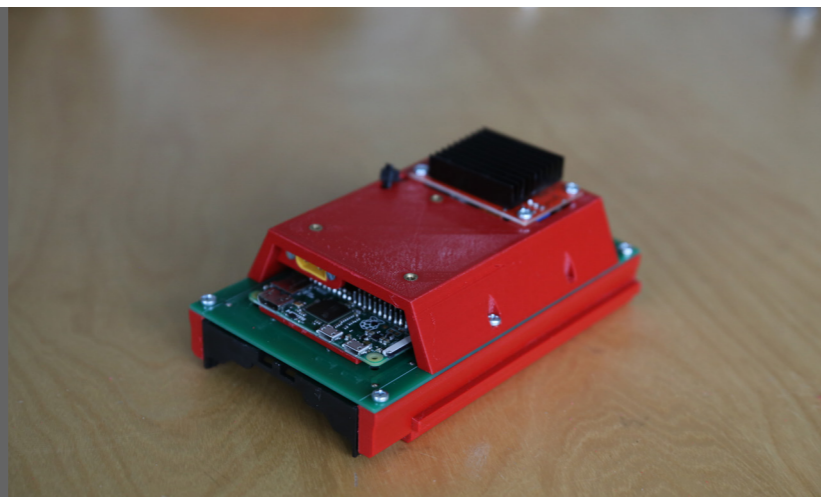

Step8

Solder the solar plug to a wire with a XT60 plug and add these to the base housing.



Step9

Screw the two antenna bulkhead connectors into the back of the base housing.

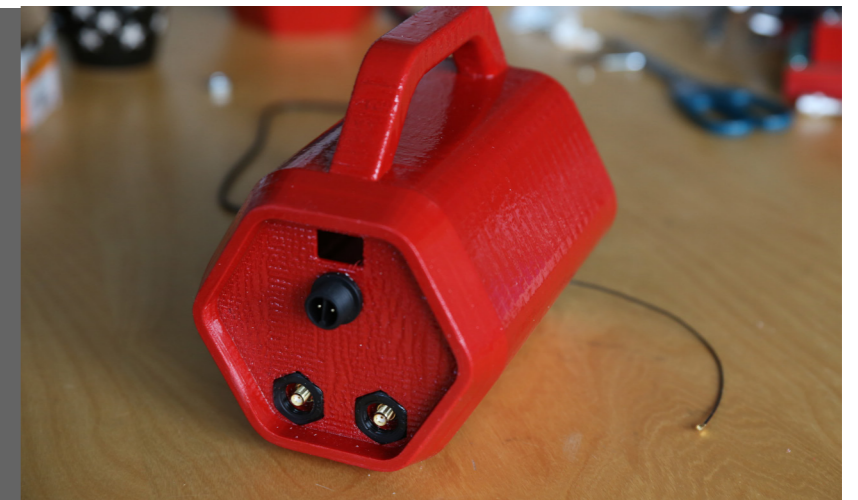

Step10

Insert the STEGO foam block. The part which holds the foam block can also be used to tie-wrap cables to.

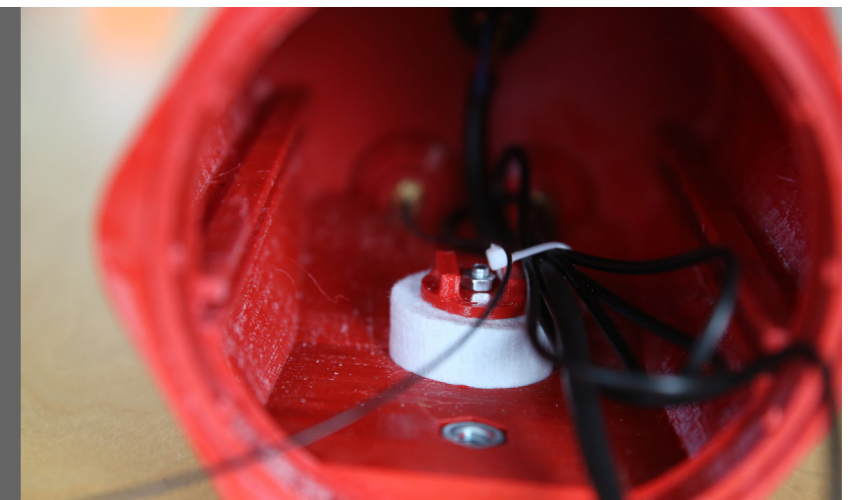

Step11

Assemble the feet for the base station and mount them to the base housing using M8x30 bolts.



Step12

Attach the cables from the base housing to the electronics sled.

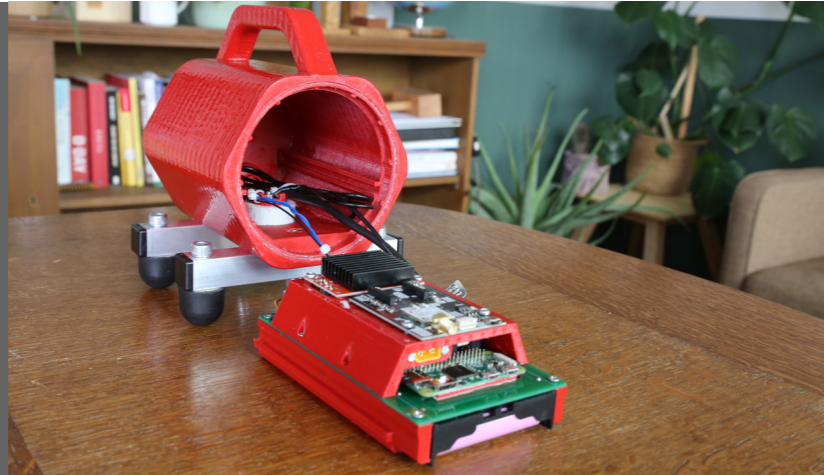

Step13

Push the electronics sled into the housing. Add an O-ring to the cap of the base housing. The base can be closed by turning the lid on. When the first time this requires a lot of force, it can be advised to put a bit of candle wax on the closing mechanism.

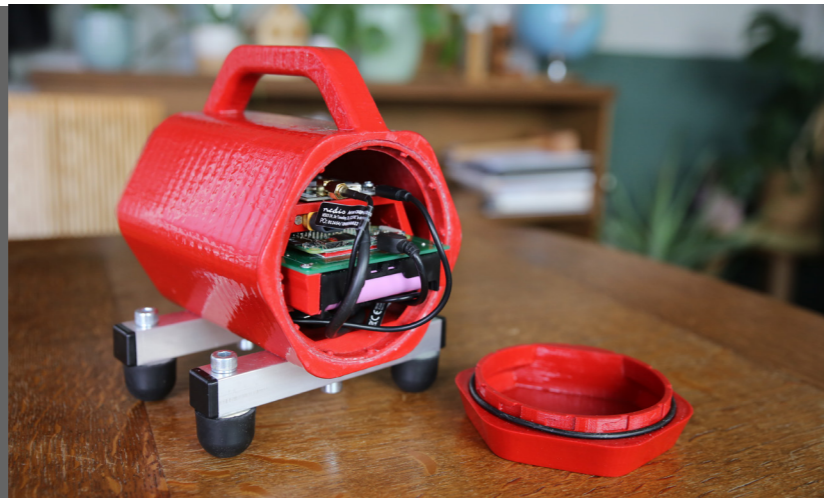

Step14

Because the two bulkheads look much alike, it is advised to mark which antenna should attach to which SMA bulkhead connector.



BASE2 antenna top assembly

Step1

Put the cellular antenna in the antenna top.



Step2

Put the GNSS antenna cable through the ground plane and antenna top.

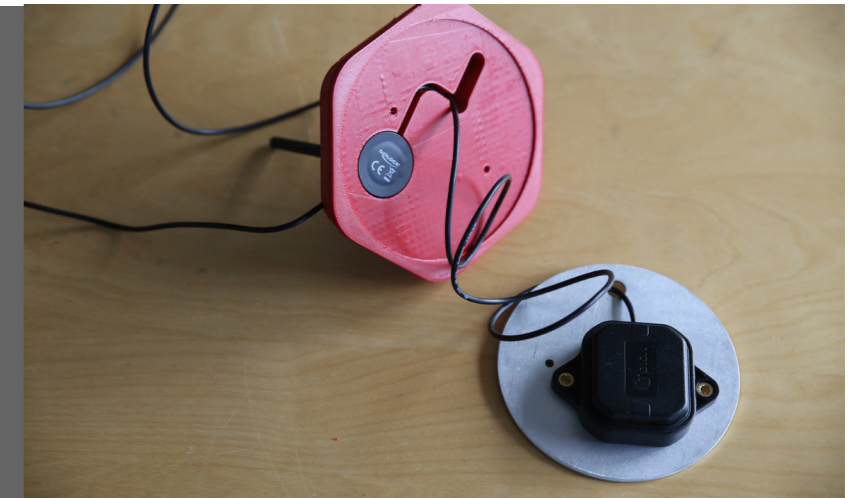

Step3

Screw the GNSS antenna in place using two M4x25 bolts. These bolts screw into M4 nuts on the other side.





Personal Project Brief - IDE Master Graduation

High precision positioning system for Ghana project title

Please state the title of your graduation project (above) and the start date and end date (below). Keep the title compact and simple. Do not use abbreviations. The remainder of this document allows you to define and clarify your graduation project.

start date 09 - 03 - 2020 24 - 07 - 2020 end date

INTRODUCTION **

Please describe, the context of your project, and address the main stakeholders (interests) within this context in a concise yet complete manner. Who are involved, what do they value and how do they currently operate within the given context? What are the main opportunities and limitations you are currently aware of (cultural- and social norms, resources (time, money,...), technology, ...).

The TWIGA project (Trans African Water Information for Geo-Applications) is a 4-year project funded by the EU. The aim of the project is to provide African countries with more accurate satellite-based weather data and positioning equipment.

Recent advances in technology: the latest generation of mass-market low-cost dual-frequency receivers, have the potential of precise positioning with cost-efficient equipment, while at the same time weather data could be gathered.

Prof. dr. ir. Nick van de Giesen and Andreas Krietemeijer MSc are developing this precise positioning system for the TWIGA project. Functional prototypes of a rover and base station have already been developed. However there is no neat mass producible product which suits the local conditions. Therefore, the goal of my graduation project is to design a rover and base station which can be used in the west African context. The product will be tested in Ghana together with local partner organisation Kwame Nkrumah University of Science & Technology (KNUST).

The system consists of a base station which corrects the error of GNSS (Global Navigation Satellite System) by using a dual-frequency receiver in a base station at a known location. Users of the system can make precise measurements using a portable rover, which applies the correction of a nearby base station. (<5km) When there are enough base stations installed, the atmospheric data gathered by the dual-frequency receiver can be used to increase weather forecast reliability.

The project is based on two challenges:

The first challenge is precise positioning. At this moment, high precision positioning in Africa (in the order of a few cm accuracy and precision) is only available to a limited extent and usually only performed by specialised survey companies. Even if services are available, the use of products from existing geodetic networks is often very expensive and not sustainable. As a result, positioning information for applications such as land registry, monitoring of critical infrastructure and traffic planning remains unavailable in many regions. The services are simply not affordable for local entrepreneurs.

The second challenge is improving weather data. Few places on Earth are served worse with geo-information than Africa. At the same time, the potential value of geo-information services in Africa is extremely large. For example to predict flooding and make better estimations of the best moment to plant a crop.

space available for images / figures on next page

Personal Project Brief - IDE Master Graduation

introduction (continued): space for images



image / figure 1: Users using the current portable rover prototype



image / figure 2: Current state of the base station; left: the electronics, right: its fixed location antenna

PROBLEM DEFINITION **

Limit and define the scope and solution space of your project to one that is manageable within one Master Graduation Project of 30 EC (= 20 full time weeks or 100 working days) and clearly indicate what issue(s) should be addressed in this project.

Problem definition:

Currently there is no cost-efficient precise position equipment for Ghana. At the same time the weather forecast for Ghana is very inaccurate due to lack of weather data.

The current rover and base station prototypes are functionally working, however they are not intuitive, not suitable for mass production, inadequate protected against tropical weather conditions and neither suitable for operation during power cuts. Finally all current prototypes have been made outside of africa.

Scope:

In scope is making a rover and base station design and prototype which is suitable for the local conditions and employees. Also researching local production and repairability is in scope.

Out of scope is:

Out of scope is changing the currently used GNSS hardware and (extensive) software development. Making the rover work with more than one base station is also out of scope.

ASSIGNMENT **

State in 2 or 3 sentences what you are going to research, design, create and / or generate, that will solve (part of) the issue(s) pointed out in "problem definition". Then illustrate this assignment by indicating what kind of solution you expect and / or aim to deliver, for instance: a product, a product-service combination, a strategy illustrated through product or product-service combination ideas, In case of a Specialisation and/or Annotation, make sure the assignment reflects this/these.

Design a mass producible high precision positioning system based on a dual-frequency receiver which suits the west African context in terms of usage, weather resistance, communication, producibility and power supply.

I aim to deliver an in Ghana tested base station and rover which are suitable for the west African context.

These devices should be:

- Cost efficient.
- Producible in larger amounts.
- Usable by local employees.
- Repairable by local technicians.
- Preferably locally producible.
- Resistant for tropical weather conditions.
- Continue working during power cuts.
- Communicate using local available network.
- Made of materials which don't harm the local environment.

PLANNING AND APPROACH **

Include a Gantt Chart (replace the example below - more examples can be found in Manual 2) that shows the different phases of your project, deliverables you have in mind, meetings, and how you plan to spend your time. Please note that all activities should fit within the given net time of 30 EC = 20 full time weeks or 100 working days, and your planning should include a kick-off meeting, mid-term meeting, green light meeting and graduation ceremony. Illustrate your Gantt Chart by, for instance, explaining your approach, and please indicate periods of part-time activities and/or periods of not spending time on your graduation project, if any, for instance because of holidays or parallel activities.

start date 9 - 3 - 2020 end date 24 - 7 - 2020

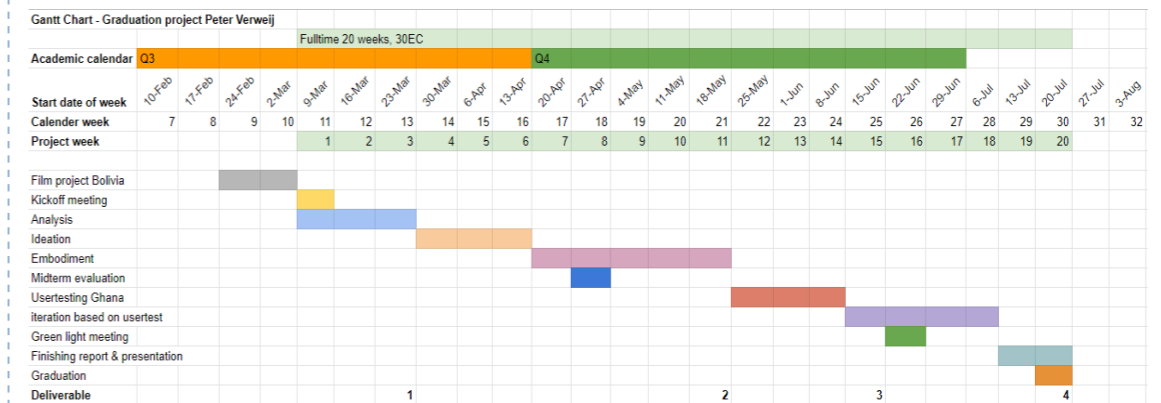

Deliverables:

- 1 Analysis report
- 2 Embodiment report + CAD model + Prototype
- 3 Field research report
- 4 Graduation report + presentation

MOTIVATION AND PERSONAL AMBITIONS

Explain why you set up this project, what competences you want to prove and learn. For example: acquired competences from your MSc programme, the elective semester, extra-curricular activities (etc.) and point out the competences you have yet developed. Optionally, describe which personal learning ambitions you explicitly want to address in this project, on top of the learning objectives of the Graduation Project, such as: in depth knowledge a on specific subject, broadening your competences or experimenting with a specific tool and/or methodology, Stick to no more than five ambitions.

My main source of motivation to set up this project is the fact that I want to design for developing countries. This motivation originates from previous visits to subsahara africa and asia for development aid.

I have chosen this specific project because performing the embodiment phase of a products is what I want to do after graduating as well. I would like to show that the combination of my bachelor in mechanical engineering, interest for electronics, and IPD master which focussed more on user interaction, is a good set of experience to make this project a success.

Some of the yet acquired competences I want to prove are: Translating user needs in a product, detailing a product, prototyping techniques, CAD modelling and simulation.
Competences I want to learn are: Designing for a different culture.

My ambitions for this project are:

1. Getting in depth knowledge about making off-grid electrical appliances.
2. Getting in depth knowledge about sustainable production and material choices for a non-western country.
3. Getting in depth knowledge about design for tropical weather conditions.
4. Experiencing the gains as well as the difficulties during designing for a different culture.

FINAL COMMENTS

In case your project brief needs final comments, please add any information you think is relevant.