

A Monograph on Rubble Mound Breakwaters

O. Juul Jensen



Danish Hydraulic Institute

A Monograph on Rubble Mound Breakwaters

by
Ole Juul Jensen
Danish Hydraulic Institute

Published by Danish Hydraulic Institute, November 1984

Cover: Skagen Harbour, Denmark. Southern breakwater during a storm, October 1983.

Published by
Danish Hydraulic Institute
Agern Allé 5
DK-2970 Hørsholm
Denmark
Telephone: +45-2-86 80 33
Telex: 37 402 dhicph dk

© O. Juul Jensen

All rights reserved.

No part of this publication may be reproduced in any form, by print, photoprint, microfilm or any other means without prior written permission of the publisher.

LIST OF CONTENTS

PAGE NO.

PREFACE	7
1. INTRODUCTION	9
2. ENVIRONMENTAL LOADS TO BE CONSIDERED IN BREAKWATER DESIGN	12
2.1 General	12
2.2 Wave Conditions	13
2.2.1 Wind, Waves and Swells	13
2.2.2 Wave Statistics	14
2.2.3 Maximum Waves at the Breakwater	16
2.2.4 Hurricane Waves	17
2.2.5 Seismic Sea Waves (Tsunamis)	17
2.3 Water Level	17
3. CONSTRUCTION AND GENERAL DESIGN	21
3.1 Typical Cross-Sections	21
3.2 Selection of Type of Structure	23
3.2.1 Available Resources	23
3.2.2 Operational Claims to be Considered	23
3.2.3 Technology Level	24
3.2.4 Economy versus Safety	24
3.3 Rubble Mound Breakwater Construction Methods	25
3.3.1 Construction Methods	26
3.3.2 Construction from Firmly Standing Equipment	26
3.3.3 Construction from Floating Equipment	28
3.3.4 Construction of Various Components of a Rubble Mound Breakwater	29

LIST OF CONTENTS

PAGE NO.

4. WAVE LOADS ON RUBBLE MOUND	35
BREAKWATERS	
4.1 Wave Breaking	35
4.2 Velocity in Run-Down	41
4.3 Forces on Armour Units	42
5. DETAILED EVALUATION OF THE VARIOUS COMPONENTS OF A RUBBLE MOUND BREAK- WATER	49
5.1 Construction Material	49
5.1.1 Stone Classes	49
5.1.2 Core Material	52
5.1.3 Artificial Armour Units	53
5.2 Modes of Damage of Rubble Mound Breakwaters	55
5.3 Filter on Sea Bed and Toe Protection	56
5.4 Core	58
5.5 Filter Layers	59
5.5.1 Stone Gradations	59
5.5.2 Layer Thickness	62
5.5.3 Examples of Stone Gradations for Rubble Mound Breakwaters	63
5.5.4 Filter Layers for Precast Concrete Armour Units	66
5.5.5 Conclusion on Filter Layers	67
5.6 Berm	67
5.6.1 Purpose and Configuration of the Berm	67
5.6.2 Width of the Berm	68
5.6.3 Stone Size for the Berm	69
5.6.4 Berms on Breakwaters in Shallow Water	72
5.7 Main Armour Layer on Seaward Face	72
5.7.1 Introduction	72

LIST OF CONTENTS

PAGE NO.

5.7.2	Armour Layer Thickness and Number of Armour Units	74
5.7.3	Parameters to be Used for Description of Armour Sta- bility and Discussion of Damage	75
5.7.4	Breakwater Damage Development and Examples of Failures	83
5.7.5	Design of Breakwater Armour Layers	89
5.7.6	Damage to an Armour Layer as Function of Time	93
5.7.7	Stability of Quarry Stone Armour Layer	98
5.7.8	Design of Deep Water Breakwater Armoured with Rectangular Blocks, Example	100
5.7.9	Tetrapod Breakwater in Shallow Water, Example	107
5.7.10	Wave Incidence Angle	115
5.8	Breakwater Crest	117
5.9	Superstructure	117
5.9.1	Introduction	117
5.9.2	Width of Superstructure	117
5.9.3	Reasons for Superstructures	118
5.9.4	Problems Relating to Wave Forces	118
5.9.5	Physics of Wave Forces on Super- structures	120
5.9.6	Model Laws	127
5.9.7	Parameters Influencing Wave Forces	128
5.9.8	Results of Measurements	129
5.9.9	Superstructure Configurations	139
5.10	Overtopping	140

LIST OF CONTENTSPAGE NO.

5.10.1	Introduction	140
5.10.2	Presentation of Results	141
5.10.3	Test Equipment and Procedure	142
5.10.4	Test Results	143
5.10.5	Horizontal Distribution	145
5.10.6	Problems Caused by Overtopping	146
5.11	Rear Side	162
5.11.1	Rear Side Armour Layer on Pure Rubble Structures	162
5.11.2	Rear Side Armour Layer on Break- water with Superstructures	163
5.12	Bends and Corners	167
5.13	Roundheads	168
5.14	Special Types of Sloping Breakwaters	176
5.14.1	Heavy Seaward Face Armouring	176
5.14.2	Profile with a Stock Pile of Armour Stones	177
5.14.3	Asphalt Breakwaters	178
5.15	Selection of Construction Profiles and Strategy	179
5.15.1	Introduction	179
5.15.2	Characteristics of Construction Profiles	180
5.15.3	Construction Strategy	180
6.	HYDRAULIC MODEL TESTS ON BREAKWATERS	186
6.1	Models	186
6.2	Selection of Strategy for Model Tests	188
6.2.1	Introduction	188
6.2.2	On Selection of Wave and Water Level Conditions	189
6.2.3	Test Procedures	189
	LIST OF REFERENCES	197

PREFACE

The background for this Monograph on Rubble Mound Breakwaters has been a constantly growing need at the Danish Hydraulic Institute (DHI) for a general presentation of the experience and the methods of the Institute within the field.

The Monograph should not be read as an attempt to give a complete review of the present state of knowledge in this field of civil engineering. Neither has it been the purpose to take into account the historical developments of the design of rubble mound breakwaters. The readers will also notice that many findings from recent years have not been dealt with in the book.

Rather is it my hope that the presentation will form the basis of fruitful discussions among engineers working in the field, be useful for consulting engineers working on breakwater design, for contractors constructing breakwaters, and for laboratory engineers working both scientifically and practically within the field.

Since the general understanding of the basic mechanisms governing the stability of rubble mound structures is still in its childhood, it has been the aim to avoid mathematical and academical sophistications. Therefore, the presentation is based mainly upon rather simple engineering "methods".

The book is not intended to be a manual for design of rubble mound breakwaters, but rather a presentation of the various aspects to be considered in the design process and a presentation of relevant case stories from which general experience can be extracted.

The report is generally based upon DHI's and the author's experience from model studies and consulting works for clients in connection with a large number of breakwater projects. Besides, research works carried out in cooperation with the Institute of Hydrodynamics and Hydraulic Engineering (ISVA) at the Technical University of Denmark has been of great importance.

Many engineers at DHI have given valuable comments on the manuscript. Special thanks are due to Mr. Torben Sørensen, Director of DHI, and Mr. Jens Kirkegaard, DHI, for discussions, comments, and suggestions for improvements. Special thanks also to Mr. Helge Gravesen for many years of co-operation on breakwater studies. I am especially grateful to Mr. Hans Agerschou for reviewing the manuscript.

Finally, I wish to direct my thanks to the Knud Højgaard Foundation *) which has graciously financed the publication of the manuscript.

November, 1984
Hørsholm, Denmark
Ole Juul Jensen

*) The Knud Højgaard Foundation obtains its funds as major shareholder in the large Danish engineering and contracting company Højgaard & Schultz A/S. Among several fields Højgaard & Schultz A/S has a wide experience within marine works from port projects in many parts of the world.

1. INTRODUCTION

Rubble mound breakwaters are used for protection of harbours, structures and various facilities against wave action, but they are also used for protection of navigation channels and as groins in an attempt to diminish sediment transport.

Rubble mound breakwaters have been built since ancient time, but taking a brief historical look at rubble mound breakwaters it seems evident that many structures have been under-designed in the past and have consequently been destroyed. The reason for the many failures has primarily been the poor understanding of the physics of rubble mound breakwaters and, as a result, lack of applicable and safe engineering methods to be used in the design. Therefore, rubble mound breakwaters were usually designed on the basis of experience gained from neighbouring breakwaters or breakwaters which, on the part of the designers, were judged to be equally exposed.

Early designers and contractors of rubble mound breakwaters were normally bound by the necessity of using quarry rock for the armour layers. However, there are also many examples of concrete cubes used as armour. The capacity (reach and moment) of the cranes available for breakwater construction used to be limited compared with contemporary equipment, and it was often necessary, at that time, to dump the stones in the armour layer instead of placing them and thereby increasing the slope steepness and reducing the total stability.

During recent years, the demand for larger vessels has resulted in many breakwaters being built in much greater water depths than before. In greater depths, the wave

impact on breakwaters is often more severe than in shallow water. In spite of this change, it seems as if the methods used for the design of smaller breakwaters in shallow water have also been applied for breakwaters with complicated profiles and artificial concrete armour units in deep water. In deep water, the risk of disastrous damage is bigger because of the breakwaters often being built with rather steep slopes to minimize the volume of construction material. The deep water also prevents the wave height and hence the impact from being limited by wave breaking.

There has been a considerable number of breakwater failures during recent years. Many of these breakwaters had just been completed or had been in place for a few years only. The economic consequences of the failures are substantial. Not only because of the costs related to repairs, but also because of the economic losses due to stopping or hampering of the port operations.

It therefore seems well justified to conclude that there is a strong need for safer and more reasonable engineering methods in connection with the breakwater design.

A considerable number of researchers all over the world are conducting studies within this field of engineering these years. The great interest is no doubt caused by the many and costly applications of rubble mound breakwaters and by the many failures. In spite of the research, though, there seems to be a long way to go to obtain a more complete understanding of the physics of the rubble mound breakwater because of the complexity of the problem. The physics of a breakwater under wave attack involves both wave hydraulics and sciences, such as soil mechanics, structural engineering, classical hydraulics and material science.

At the moment, the most important obstacle to progress in the development of the theoretical understanding is perhaps the lack of a physical and mathematical description of breaking waves, i.e. the non-stationary velocities and accelerations in a breaking wave and its up- and down-rush against and inside a rubble mound breakwater. Even if a suitable theory describing the kinematics of breaking waves were available the uncertainty of the characteristics of waves arriving at a breakwater would normally not allow great accuracy in prediction of the long-term behaviour of a particular structure.

Still, because of the lack of a sufficient theory for description of the velocities and accelerations in wave up- and down-rush, the main effort in rubble mound breakwater research has not been directed towards the micro-process, i.e. the hydrodynamic conditions for the individual units in the armour layer. Instead, much attention has been paid to the macrofeatures of the problem by observations in scale models and by prototype observations in an attempt to evaluate relationship between the many parameters of importance. The present publication follows this tradition.

2. ENVIRONMENTAL LOADS TO BE CONSIDERED IN BREAKWATER DESIGN

2.1 General

The environmental conditions to be considered in the design of a rubble mound breakwater may be summarized as follows:

a. Wave Conditions

- i. Wind waves and swells
- ii. Hurricane waves
- iii. Seismic sea waves (tsunamis)

b. Water Level Variations

- i. Astronomical tides
- ii. Wind set-up
- iii. Water level variations due to changes in the barometric pressure

c. Soil and Foundation Conditions

- i. Soil conditions
- ii. Possible morphological changes (possible changes in the bathymetry due to erosion or sedimentation)

d. Other Environmental Loads

- i. Drifting ice and ice packing
- ii. Possible collisions of floating structures
- iii. Salt water and pollutional effects on the durability of materials.

Of the above-mentioned environmental loads, waves are the most important single factor to be evaluated during the

design process. It is of paramount importance for the economy of a breakwater project to have a thorough knowledge of the waves to be expected during the lifetime of the structure. It is therefore strongly recommended that wave measurements are being performed in connection with any significant project. More information can be achieved by measurements than by any other available method.

2.2 Wave Conditions

Many clients and consulting engineers neglect the execution of wave measurements during the first phase of a project, and therefore wave measurements may not be carried out at all or perhaps initiated only at a late stage. Wave measurements should be carried out with instruments which allow a direct reproduction of the wave records in hydraulic scale models. This may be achieved by an accelerometer buoy by which the waves are also recorded on magnetic tape.

2.2.1 Wind, Waves and Swells

For a breakwater project it is necessary to analyse all available information on wave conditions. The information may come from wave records or hindcast based on wind data. The analyses include determination of wave statistics for a specific point near the breakwater site. If, for instance, wave records are available from a far-away position from the breakwater location (i.e. in deep water) it is necessary to make further studies including the possible refraction, diffraction and energy loss of the waves propagating from the measurement position to the breakwater site. It is often very difficult to make such evaluations with the required accuracy due to the

complexity of the physical phenomena involved. However, such an analysis is necessary because the dimensions of the breakwater structures and armour units are dependent upon the wave conditions in a highly non-linear way.

For these reasons, it is often preferable to take wave measurements very close to the breakwater site. As mentioned above, wave conditions at a breakwater site may, however, be related to the deep water wave conditions in a very non-linear way (both wave height, wave period and wave direction dependent). Therefore it is often extremely difficult and uncertain to estimate extreme design wave conditions from, for example, one year of measurements at a site, since the measurements may be atypical and thereby not representative for long-term conditions. Thus, wave measurements are often supplemented with wave hindcast on computer by use of a mathematical model. The hindcast study may typically include calculations of historical storms in order to obtain as much information as possible on the extreme waves occurring at the site.

2.2.2 Wave Statistics

In Fig. 2.2.a is shown a traditional wave height statistics for a harbour in the Mediterranean Sea. The data comes partly from measurements and partly from hindcast of synoptic weather maps using DHI's computer hindcast model, Ref. 7.

Here the significant wave height, H_s , is used in agreement with the tradition in coastal engineering. H_s is defined as the average of the highest one third of the waves in a wave record. For measurements in shallow water, the maximum wave height in the wave record should also be considered in the analysis.

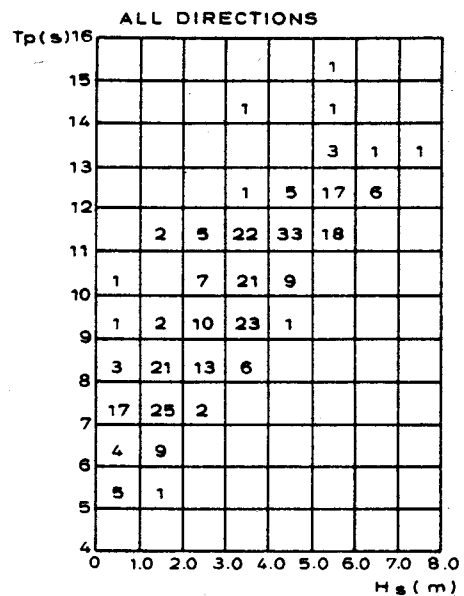
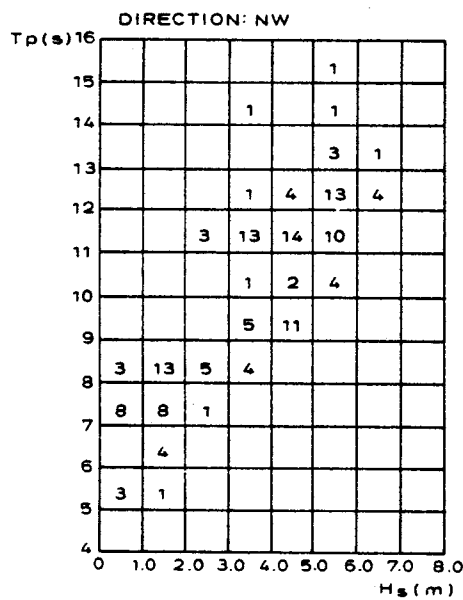
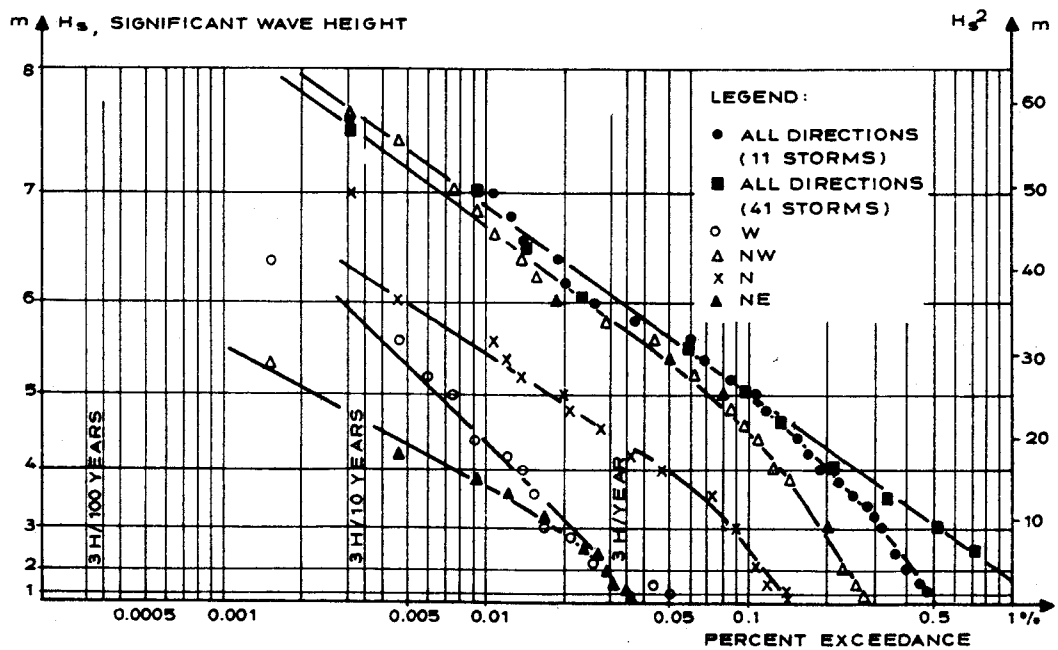

Fig. 2.2.a Example of wave statistics and wave height/wave period relation.

Besides knowledge of the wave heights, it is just as important to know the corresponding wave periods. The wave period is, as will be shown in Section 5.7, almost as important for the stability of a rubble mound breakwater (Fig. 2.2.a) as the wave heights.

2.2.3 Maximum Waves at the Breakwater

When the wave climate at the site is defined, including the extreme wave conditions to be expected during the lifetime of the project, it is necessary to evaluate whether the waves impinging on the structure are limited due to wave breaking in front of the structure. If this is the case, it is possible, as it will be shown in Chapter 5, to design the breakwater structure in such a way that the maximum possible damage is limited. This makes the structure very safe compared with structures in deep water. In the Shore Protection Manual, Ref. 74, the figures presented may be used for a preliminary evaluation of the maximum waves that are likely to impinge on the breakwater. However, the results of the Shore Protection Manual are based upon tests with regular waves, and therefore the maximum wave heights evaluated are not necessarily conservative. It has for instance been experienced in connection with a specific breakwater study, where the breakwater was located on a rather steep bottom sloping from 1:20 to 1:7, that the maximum impact on the structure was caused by a rare combination of two waves succeeding each other. In order to get the maximum impact, it was necessary that a relatively small wave piled up against the breakwater to allow for a large wave following shortly after to reach the structure and break directly on the armour layer. This type of phenomenon does not occur in regular waves, and emphasizes the necessity of using irregular waves based on measurements for model testing.

2.2.4 Hurricane Waves

Hurricanes occur in some areas of the world. The waves caused by hurricanes may be determinant for the stability of a rubble mound breakwater. It is not only the areas directly struck by hurricanes that are affected, but also adjacent areas to which the hurricane waves may reach. Special attention should be paid to projects in such areas where two regimes of waves occur. Hurricanes may be so rare that they are not covered within, for example, one year of measurements at a site. For the evaluation of hurricane waves, literature is referred to (Ref. 74).

2.2.5 Seismic Sea Waves (Tsunamis)

Sea waves can also be generated by seismic activity of the sea bottom. Such waves are called tsunamis. They are especially occurring along the coast lines of the Pacific Ocean. They may, although very limited in height in deep water, be very damaging to coastal structures and other structures near the coast line due to their very low steepness causing large up-rush. In Ref. 87 is a brief presentation on the subject.

2.3 Water Level

Since the maximum waves depend on the water depth, it is necessary to establish a correlation between wave conditions and water level.

An evaluation of the probability of simultaneous occurrence of waves and water level is possible for sites where the astronomical tide is dominant, since there is no correlation between the astronomical tides and storms. For other areas, such as the inner Danish waters, the evaluation of the design water level is extremely diffi-

cult. This is because both the wind set-up and the water level variations, due to changes in the barometric pressure, in a very complex way are related to the low pressure system and its wind field.

If shallows are present in front of a breakwater the actual water depth over the shallow may be determinant for the maximum waves that can reach the breakwater. As an example may be mentioned the Zwara Port in Libya having a ridge-formed reef with a water depth of approximately 13 m about 2 km in front of the coast line. In this case only waves of approximately $0.8 h$ (h being the depth) were able to reach the structure. Fig. 2.2.b shows wave spectra of wave records measured in a model in front of and behind the reef respectively. The transformation of the waves is clearly distinguished for this extreme wave situation.

In Fig. 2.2.c a typical analysis of the wave record used for generation of irregular natural waves in the model is presented, including scatter diagram, wave height distribution, and wave spectrum.

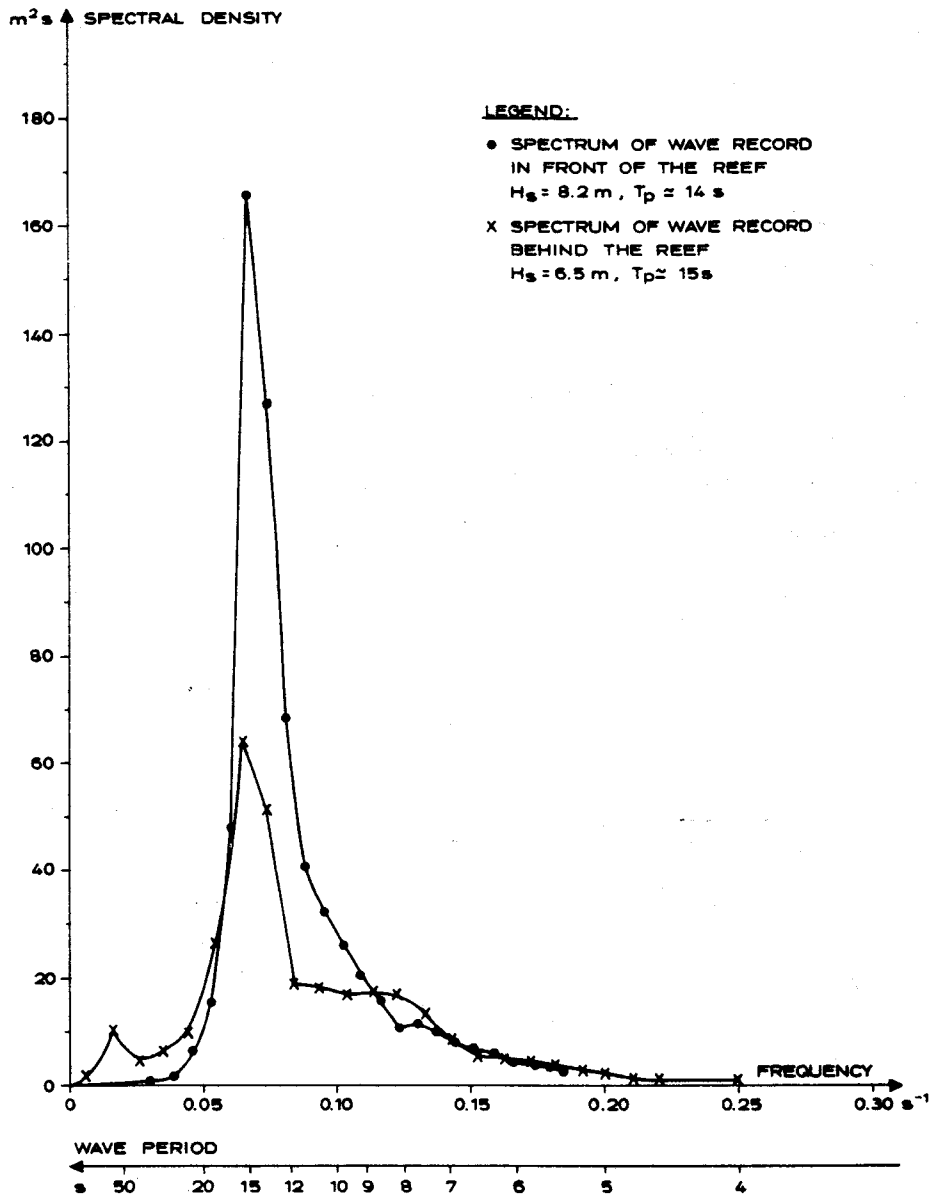

Fig. 2.2.b Wave spectra from physical model as measured in front of and behind a reef with water depth 13 m.

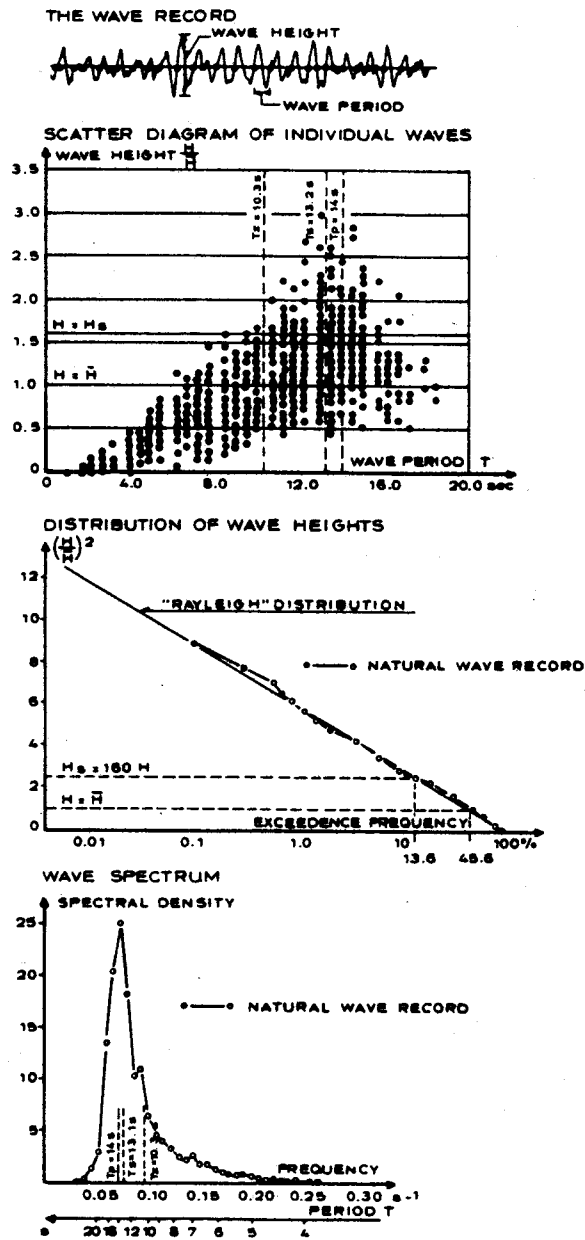

Fig. 2.2.c Analysis of wave record.

3. CONSTRUCTION AND GENERAL DESIGN

Before describing the various types of rubble mound breakwaters it seems worthwhile to define what a rubble mound breakwater is. In a discussion among engineers at DHI, one engineer concluded: "A rubble mound breakwater is a heap of stones thrown into the sea in the most economical manner to withstand the environmental loads at the site".

Breakwater design is often considered more as an art based upon previous knowledge than as a field to which commonly accepted engineering rules may be applied.

3.1 Typical Cross-Sections

The rubble mound breakwaters normally constructed may be divided into four types as shown in Table 3.1.a.

Crest	Crest Elevation	
	"Low"	"High"
Pure rubble mound structure	Breakwater where excessive overtopping is acceptable. "Large" armour units are necessary to make crest and rear side stable.	Breakwater where only limited overtopping is acceptable.
Rubble mound structure with super-structure	Excessive overtopping is acceptable. The super-structure is introduced to stabilize the crest or to make access to the breakwater at low tide and during limited wave action.	Only limited overtopping is acceptable. The superstructure is introduced for one of the following reasons. 1. As roadway to make access to the breakwater. 2. To carry structures for example pipelines.

Table 3.1.a. Types of rubble mound structures.

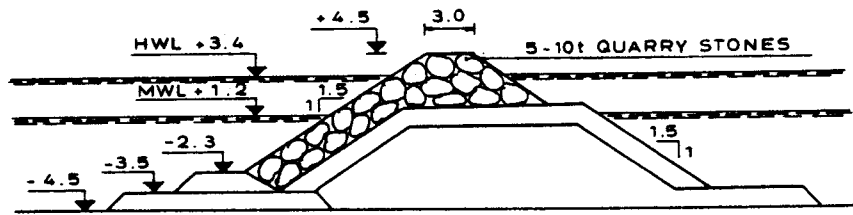

Fig. 3.1.a Pure Rubble Mound Structure, "Low".

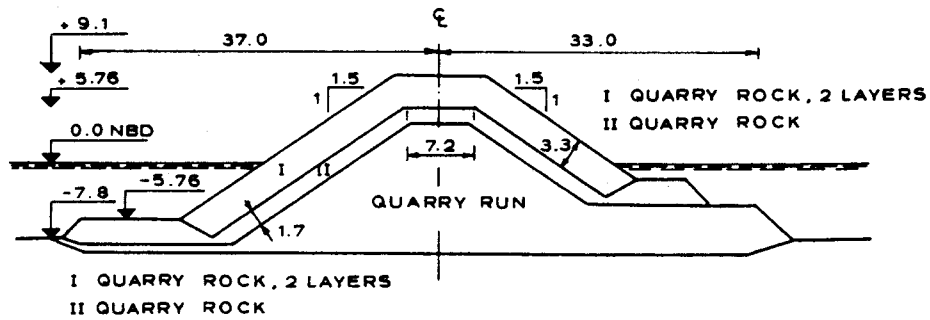

Fig. 3.1.b Pure Rubble Mound Structure, "High".

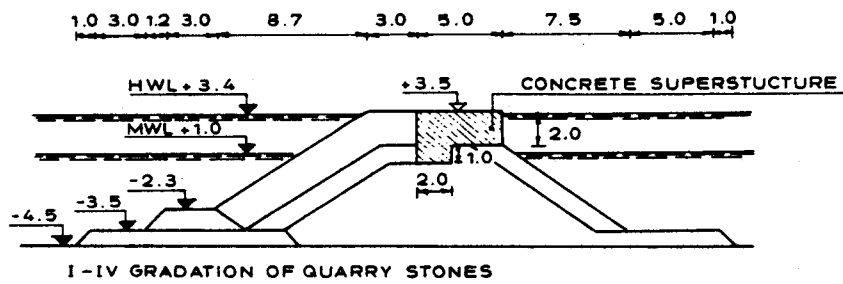

Fig. 3.1.c Rubble Mound Structure with Superstructure, "Low".

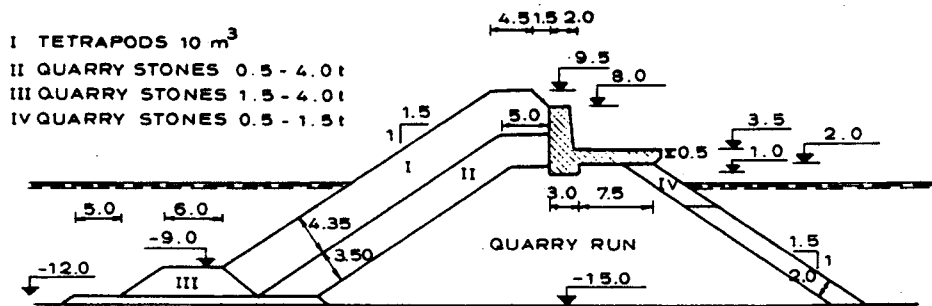

Fig. 3.1.d Rubble Mound Structure with Superstructure, "High".

Examples of the four types are shown in Figs. 3.1.a-3.1.d. All these examples, except the pure low rubble mound structure, have been developed through model testing.

3.2 Selection of Type of Structure

The selection of the type of breakwater structure for a specific harbour project is often made by the consulting engineer. The hydraulic laboratory is then carrying out hydraulic tests under the supervision of the consulting engineer. In other cases, the laboratory is directly involved from the very beginning of a project to outline possible types of structures. The task of the consulting engineer is then, on the basis of economy, material and construction considerations, to select one or maybe two alternative breakwater profiles to be used for the subsequent design phase and model testing.

The selection of the profile should be made considering the following aspects.

3.2.1 Available Resources

Available resources, like natural stones and gravel, possible locations for a quarry at or in the neighbourhood of the site, should be analysed.

3.2.2 Operational Claims to be Considered

- a. Access conditions during daily operations and in relation to the possibility for carrying out repair work in case of damage.

- b. Strategy of maintenance. Is the breakwater to be almost maintenance-free during the expected lifetime or is maintenance/repair work acceptable?
- c. Demands with regard to overtopping. Are operations sensitive to overtopping to take place closely behind the breakwater or are roads, structures or buildings to be placed in the immediate vicinity of the breakwater, or must the breakwater itself carry structures sensitive to overtopping, such as pipelines?
- d. Is a breakwater superstructure or crown wall necessary? This depends on all three points a, b, and c mentioned above.

3.2.3 Technology Level

Whether or not a high technology level is rational for example with artificial armour units and reinforced concrete for a superstructure and parapet wall. Such a structure demands more from the contractor than a pure rubble mound structure with maybe a larger volume of material, but with less specialized construction operations.

3.2.4 Economy versus Safety

It is often seen that a consulting engineer for a specific project is selecting a size of armour unit, that is just sufficient from a hydraulic point of view, while it may have no significant influence on the economy to use larger units. This is because the total cost for construction of one m^2 of armour layer surface is composed

of two factors: The cost of manufacturing the armour units and the cost of placing them on the breakwater.

The volume of stones or concrete is proportional to the layer thickness, r , which again is proportional to $V^{1/3}$ (V is the volume of the units) (see Section 5.7.2). The price for placing of the units depends on two factors: Firstly, the price for the necessary crane to do the job, which is often determined by the weight of the units and the required reach of the crane. It should not be forgotten, that if larger units and/or a flatter slope are required on the breakwater head, this may be decisive for the necessary crane size. It may be assumed that the necessary time to place one armour unit is independent of the size of the units within the range of sizes considered. Thereby the price for placing the blocks will be proportional to the number of units. Secondly, the number of units per unit area is proportional to $V^{-2/3}$ (see Section 5.7.2). This means for example that a 50% increase in armour weight (volume) only increases the volume of stone or concrete by 14%, while the number of units to be placed decreases by 24%. Further, it should not be forgotten that a reduced number of units reduces the number of operations during casting and transport and thereby the construction time.

3.3 Rubble Mound Breakwater Construction Methods

Engineers working on the design of rubble mound breakwaters are usually facing the problems of not knowing how an actual breakwater is going to be constructed. This is because the various contractors tendering for the breakwater construction are free to choose the methods of construction within certain limitations. This means that although there is a close influence of the design and

construction methods on the cost of construction, the choice of construction methods is normally handed over to the contractor. However, it is always necessary in the design process to consider how the breakwater is to be constructed. Designs that are difficult to construct may be the source of endless quarrels between the contractor and the engineer(s) responsible for construction supervision.

3.3.1 Construction Methods

There is in principle three different construction methods:

1. To construct the breakwater in the dry behind a cofferdams or at low tide.
2. To place or dump the material from equipment standing either on the breakwater or on a self-elevating platform.
3. To place or dump the material from floating equipment.

The first method is hardly never used except in cases where cofferdams are constructed for other purposes. However, dry construction may sometimes be accomplished during low tide on sites with extreme tidal variations. Dry construction is preferable (but usually not recommended) because it makes construction work more accurate.

3.3.2 Construction from Firmly Standing Equipment

The traditional method of breakwater construction is to

tip the core material in the breakwater alignment either from dump trucks or dump waggons. When the core has reached the required size, the filter and armour stones are placed or dumped on the sides of the core material. After having reached the final length, the crest is constructed on the way back by placing more stones on the crest. The disadvantage with this method is that the side slopes of the breakwater become very steep and close to the natural angle of repose of the material, especially under water. This causes poor stability compared with a breakwater made of the same stone materials, but with a somewhat flatter slope.

The method by which the core of the breakwater serves as a roadway during construction makes demands on the width of the roadway. The roadway may have to be wider than dictated from hydraulic reasons. It should be made so wide as to make it safe and easily manoeuvrable for the equipment on the crest.

It is necessary that the roadway is at such a high level that the safety of equipment is not endangered by wave up-rush during normal operations. It is normally feasible to accept a certain probability of damage to equipment during construction. This may be carefully examined by the contractor prior to construction. The available wave and water level data may be studied to evaluate the risk of damage to equipment for different roadway levels and construction methods and in this way select the most appropriate method for the specific case.

If the breakwater is long it may be advantageous to make the roadway with two lanes so that two vehicles can pass each other on the breakwater. This may also be achieved by introducing spots either permanently or temporarily

where two vehicles can pass each other. If it is necessary to have two or more cranes working on the breakwater it may also be necessary that the roadway is wide enough to allow vehicles to pass a crane.

Many breakwaters constructed have crown walls which may serve as roadway during construction. If the crown wall is constructed before placing of the armour units, the crown wall may form an excellent foundation for crane rails. This is especially important for large, exposed breakwaters for which a huge crane is necessary.

3.3.3 Construction from Floating Equipment

Nowadays large breakwaters are normally constructed by a combination of floating and land-based equipment. It is often most economical to place the large volumes of material needed in the core and lower parts of a breakwater from floating equipment. The core material may be placed by various types of barges, such as: dump barges (split barges) and side unloading barges. A dump barge tends to deposit its load of material in a heap, while it is possible with a side unloading barge to place the material in a more even layer. Barges are restricted by their draft so they can only be used to place material up to a certain level. For split barges it is necessary to avoid that it is grounded by the heap of material, while unloading.

Sometimes barges are equipped with a crane to make it possible to place material at a higher level or to place armour stones. Waves and current are of inconvenience for the use of floating equipment, especially for specialized operations such as placing of berms and armour stones. For this, jack-up barges or other types of platforms may be used.

A disadvantage of floating equipment is the requirements to the positioning system to make it easy to position a barge before unloading its cargo. As mentioned earlier a combination of floating and breakwater-based equipment will normally be the most economical and efficient way to construct a rubble mound breakwater. If filter and armour stones are delivered to the site on barges it is often most economical to have equipment that can place the material directly from the barge.

3.3.4 Construction of Various Components of a Rubble Mound Breakwater

a. Toe Protection and Filter Layers between Bottom and Core

Filter layers of gravel or similar are normally constructed from barges. In this case, side dumping barges are preferable because they can more accurately place the material in layers of the required thickness.

b. Core Material

As mentioned earlier core material may be placed by barges or by dumping material from the free end of the breakwater. The greatest problem of placing the material is to achieve the required slope under water. There is a tendency for gravel and especially quarry run to stand with rather steep slopes under water such as 1 on 1 to 1 on 1.2. This means that it is often necessary to use other equipment to complete core construction.

c. Berms

The berm(s) for armour layer foundation is a very essential component of a rubble mound breakwater. A berm may

be constructed either from floating equipment or from a crane on the breakwater. The use of a crane from the breakwater is preferable because it is more likely that sufficient accuracy is achieved. This is normally possible if the reach of the crane is large enough because the primary armour units to be placed next to the berm will determine the maximum bending moment to be resisted by the crane. If floating equipment is used, it is recommended that special precaution is taken to assure accurate positioning and that the stones are lowered into position and not dropped from above water level. If the latter, less accurate method is used it should be compensated for in the design by making the berm so wide that it still provides a safe foundation for the main armour layer. (See also the detailed description of berm design in Section 5.6).

d. Filter Layers between Core and Armour Layer

The filter layer(s) between core and principal armour is of major importance for the stability of the entire structure.

A filter layer should, as shown in Section 5.5, be sufficiently thick to make construction reasonably easy. Construction of filters may as for the berms and primary armour be carried out both from floating equipment and from the breakwater itself. Unless allowed for in the design, the filter layer should be constructed from the breakwater or other fixed structure in order to obtain satisfactory accuracy.

e. Armour Layers

The primary armour layer on a rubble mound breakwater is nearly always placed by a crane, usually from the break-

water, but sometimes also from floating equipment or a fixed structure. Many of the large breakwaters built in recent years, have very heavy armour units, and the horizontal extent of the armour layer is large. Thus it is necessary for the crane to resist a very large bending moment. In some cases it may be necessary to build cranes with a moving counterweight. For some breakwaters, such as those at Sines and Bilbao, other methods have been used. In Sines 42 t dolos units were placed from floating equipment and in Bilbao the lower part of the armour layer, consisting of 65 or 85 t rectangular blocks, was constructed from a barge dropping a number of blocks in one operation. These methods seem rather crude since the two breakwaters were designed with a very limited berm and no protruding berm respectively. It seems that the construction methods were rather risky. There has been found no proof for any of the two structures, which were very severely damaged, that the construction methods were determining for the damage.

Many types of armour units, such as quarry stones, cubes and dolos, are normally specified to be placed at random.

In order to assure uniform distribution of the units, it is necessary to be able to place the required number of units per unit surface area. This may be achieved by using a grid system indicating the position of each unit. The application of such a system requires, however, a fast and accurate method for positioning established on the site. For tetrapods and especially for tribars the placing of the individual units are normally being guided by the use of a grid system indicating the position of each specific unit. This is in particular important for tribars because these blocks are often placed in a single layer.

Tetrapods, invented and patented by Neyrpic Inc., France, are often placed according to the "Système Sotramer" developed by Sotramer, France. An example of such a system for a large breakwater with 20 m³ tetrapods is shown in Fig. 3.3.a. For this project the tetrapods were placed after construction of a heavy crown wall. A crane working from the crown wall made the exact positioning of each individual tetrapod possible.

In order to assure uniform distribution of the armour units under water, it is advisable that such systems be considered for all significant projects, no matter which type of armour units. Whether or not a grid system is used, the structure should always be inspected by divers before, during and after construction. However, it is essential to design a breakwater in such a way that it is not too difficult to construct, as too much surveying of profiles and diving inspection may interrupt and hamper the execution of the work.

PLAN FOR PLACEMENT OF 48 t TETRAPODS

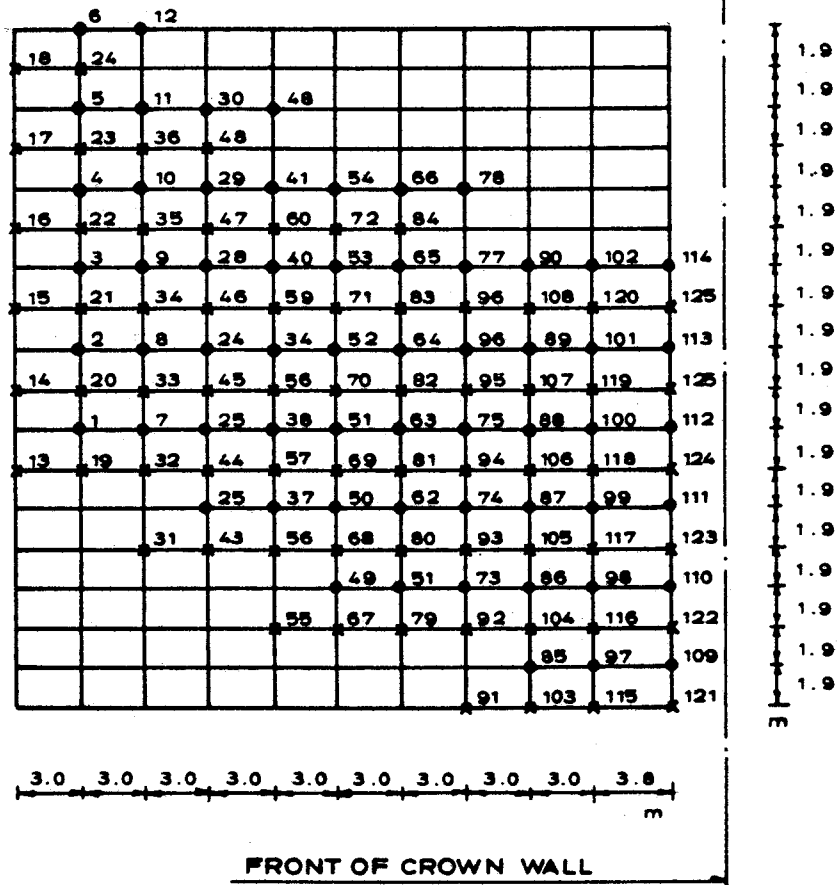

Fig. 3.3.a Plan for placing of 48 t tetrapods.

f. Breakwater Crest

If the crest is to be armoured in the same manner as the seaward face, it may be constructed as described under e. above. The crest should from a constructional point of view be made wide enough to accommodate the necessary traffic of trucks and cranes during construction.

Crown walls and superstructures should be designed not only to resist the expected wave forces, but also with

due consideration to practical construction. As described in Section 5.9, it is of major importance that the superstructure is somehow protected from wave action during construction. This means that it should be placed at such a high level that it is normally not affected by the uprush of waves occurring frequently during construction. If, for other reasons, it is at a lower level, even below still water level, a rather wide shoulder of the armour and filter layer in front of the superstructure may provide the necessary protection. Superstructures are normally cast in elements of for example 10 m length. This is practical because one element or at least its base may be cast in one operation.

g. Construction Strategy

Construction strategy is described separately in Section 5.15.

4. WAVE LOADS ON RUBBLE MOUND BREAKWATERS

Waves are the most important environmental load to be considered for design of rubble mound breakwaters. Wave loads are therefore considered separately in this chapter. The detailed examination of the various components of a rubble mound breakwater is described in Chapter 5.

4.1 Wave Breaking

The critical situation for a rubble mound breakwater occurs when large waves cause extensive up-rush and down-rush water velocities and accelerations that may cause displacements of armour units. The way the waves break on the structure or in front of it depends upon four factors:

1. Geometry and slope of the sea bottom in front of the breakwater.
2. Geometry and slope of the breakwater itself.
3. Water depth.
4. Wave conditions - height, period and shape of individual waves but also on the succession of individual waves in the wave train.

In order to describe the various types of wave breaking on a rubble mound breakwater a so-called similarity parameter, ξ_0 , was used by Iribarren, Battjes (Ref. 5) and others to describe wave breaking:

$$\xi_0 = \frac{\tan \alpha}{\sqrt{\frac{H_0}{L_0}}} \quad \{4.1.a\}$$

ρ is the slope angle, H_0 is the wave height and L_0 is the wave length.

H_0 and L_0 refer to deepwater wave height and length. The various types of wave breaking corresponds approximately to the following ranges of ξ_0 :

<u>Type of Breaking</u>	<u>Criteria</u>
Surging or collapsing	$3.3 < \xi_0$
Plunging	$0.5 < \xi_0 < 3.3$
Spilling	$\xi_0 < 0.5$

Instead the wave height, H_b , at the breaking point (at the initiation of breaking) may be used in Eq. {4.1.a}. Ref. 5 shows the following ranges:

<u>Type of Breaking</u>	<u>Criteria</u>
Surging or collapsing	$2.0 < \xi_b$
Plunging	$0.4 < \xi_b < 2.0$
Spilling	$\xi_b < 0.4$

This means that the different types of wave breaking occurring on the slope of the structure may be evaluated from the criteria above. It is further important to analyse whether the waves will break in front of the structure due to limited water depth or wave steepness. In other words it is essential to analyse whether the structure is exposed to non-breaking, breaking or broken waves.

Before evaluating the maximum wave, which may exist on a given depth and slope of bottom, it is necessary to examine the transformation of the waves from deep water to breaking.

The ratio of H_b to H_o is to some extent dependent upon the ξ_o -factor, where α should be taken as the slope of the bottom. In the Shore Protection Manual (Ref. 74) the results of Goda are presented as function of wave steepness and slope of the bottom. The diagram from Ref. 74 is shown in Fig. 4.1.a.

After having determined the ratio of H_b/H_o , the maximum breaker height may be determined by using the results from the Shore Protection Manual shown in Fig. 4.1.b. The depth at breaking is defined as shown in Fig. 4.1.a.

It should be noted that all results used for the above evaluation come from tests with regular waves, and that substantial scatter exists in this type of testing. Besides, tests with irregular waves may in some cases result in somewhat larger waves than those found in tests with regular waves. As mentioned earlier, it has for steep bottom slopes been experienced that a rare combination of two waves may give rise to the most severe impact on a structure, because if two waves follow each other within a specific period of time the second wave may ride on the down-rush of the first one and reach the structure with a greater height than would be possible for regular waves. On this basis it is recommended that the above figures are used only for a rough preliminary evaluation, and that model tests are carried out in cases where the maximum breaker height is governing for the design.

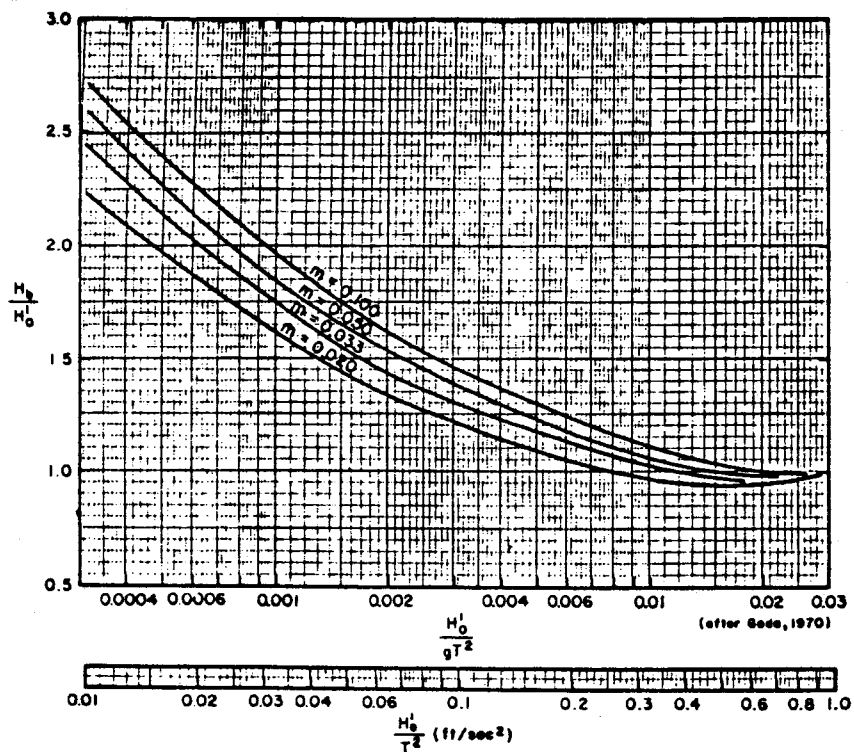
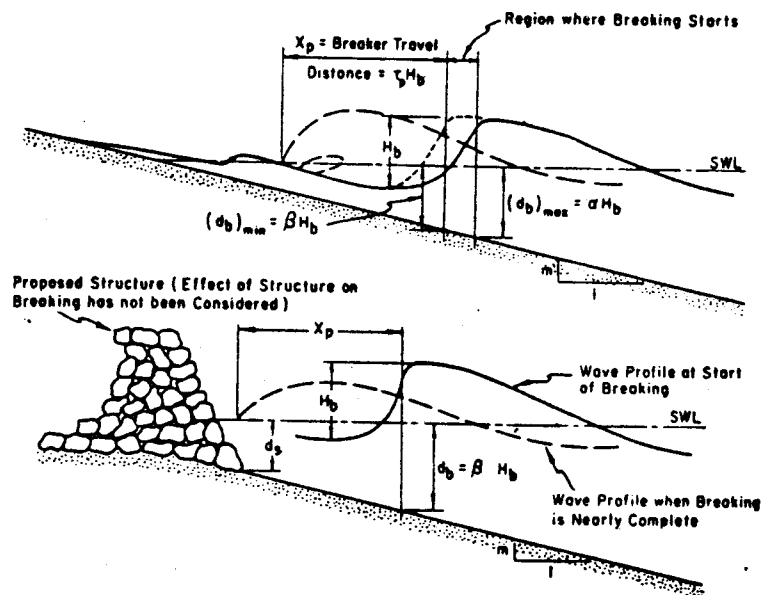

Fig. 4.1.a Breaker height index, H_b/H_0' , versus deep water. Wave steepness, H_0'/gT^2 .
 (From Shore Protection Manual, Ref. 74).

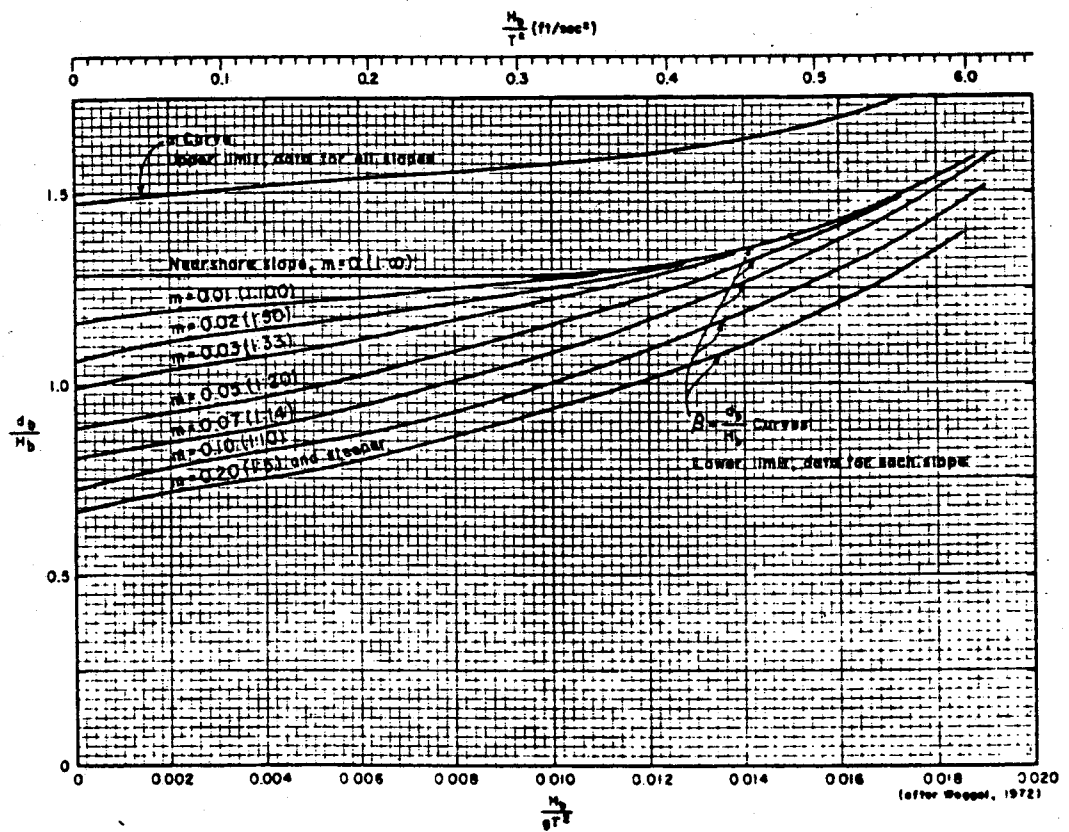

Fig. 4.1.b α and β versus H_b/gT^2 .

(From Shore Protection Manual, Ref. 74).

For irregular natural waves, the maximum waves on different slopes have been measured in wave flumes. As examples for comparison with the results in Figs. 4.1.a and 4.1.b the results in Table 4.1 are presented.

Slope of Bottom	Depth at Gauge	H_s Deep Water	T_p	H_s Local	H_{max} Local	$\frac{H_s}{h}$	$\frac{H_{max}}{h}$	$\frac{H_{max}}{h}$
	(m)	(m)	(s)	(m)	(m)			(from Fig. 4.1.b)
1:50	9.3	8.40	16	5.60	9.10	0.60	0.98	0.89
1:50	5.1	8.40	16	3.65	6.00	0.71	1.18	0.90
1:70	10.45	6.10	14	5.70	9.50	0.55	0.91	0.86
1:70	10.45	6.70	16	5.90	9.90	0.56	0.95	0.88
1:100	13.0	9.50	12-15	7.70	9.65	0.59	0.74	0.83
Plane	10.2	6.0	12	4.90	8.00	0.48	0.78	0.78

Table 4.1.a Wave measurements for irregular waves and comparison with Fig. 4.1.b from Ref. 74.

By comparison of the examples in Table 4.1.a it is seen, as mentioned earlier, that on steeper slopes the irregular waves can generally obtain larger values than regular waves as presented in Ref. 74.

4.2 Velocity in Run-Down

When a wave is breaking on the slope of a rubble mound breakwater it is the combination of drag, lift and inertia forces, caused by the un-steady flow of water in the up- or down-rush compared to the stabilizing gravity, friction and maybe interlocking forces, that determine whether a specific unit in the armour layer remains stable or not. The drag- and lift forces are normally considered to be the major forces endangering the stability, and it may therefore be of importance to evaluate the order of magnitude of the velocities in the wave run-up and run-down on a breakwater.

For a smooth slope the up-rush, R_u , divided by the wave height H was found to be: (Ref. 11).

$$\frac{R_u}{H} = \xi_0, \quad \xi_0 < 2.3 \quad \{4.2.a\}$$

This means that in order to reach the level R_u above SWL, a water particle of mass m must have a kinetic energy in the order of $E_{kin} = \frac{1}{2}mu^2$ when passing the SWL. In the top position it has a potential energy of $E_{pot} = mgR_u$. The E_{kin} and E_{pot} are equal thus:

$$\frac{1}{2}mU^2 = mgR_u \Rightarrow$$

$$\frac{1}{2}U^2 = gH\xi_0 \Rightarrow$$

$$U = \xi^{\frac{1}{2}}\sqrt{2gH}, \quad \xi_0 < 2.3 \quad \{4.2.b\}$$

Note $\sqrt{2gH}$ is the velocity of a body falling freely a distance H under the action of gravity. In Ref. 11 it was shown that the up-rush on various rough slopes are slightly increasing with ξ . A value of $\frac{R}{H}$ of 1.0 to 1.2 was found for ξ of 2 to 4. Thus the velocity at SWL in the down-rush will be in the order of, $U_{max} = \sqrt{2gH}$.

In general it may be concluded that as an approximation the maximum velocity on a rough slope may be written

$$U \approx \alpha \sqrt{2gH} \quad \{4.2.c\}$$

This result will be used in the following.

4.3 Forces on Armour Units

The forces acting on an armour unit for down-rush is shown in Fig. 4.3.a. Down-rush is the most important case for normal rubble mound breakwater with slopes of 1 on 1.5 and 1 on 2.0. Only for slopes less steep than approximately 1 on 3.5, the up-rush may be governing for the stability.

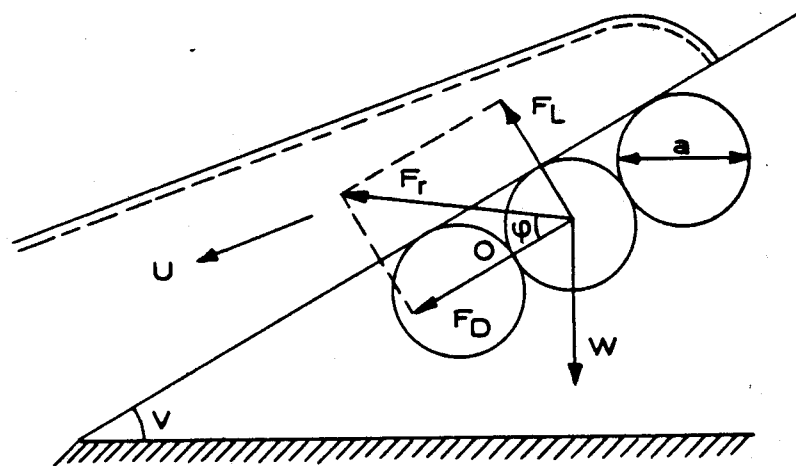

Fig. 4.3.a Forces on armour units during down-rush.

For evaluation of stability criteria for the case of down-rush, it is possible to establish equations governing the stability by considering the 2-dimensional case

shown in the figure. The units are considered to be squares with diameter, d , and density, ρ_s . It is assumed for simplicity that two units are in contact in two points in a plane parallel to the slope and that no friction forces prevent the blocks from being lifted out. The hydrodynamic forces acting on the units are the lift force, F_L , and the drag force, F_D , respectively. The drag force may, according to elementary theory, be written as:

$$F_D = C_D (R) \frac{1}{2} \rho_w U^2 A \quad \{4.3.a\}$$

F_D is caused by the skin friction acting on the surface of the unit and the form drag on the unit due to the difference in pressure on the up- and downstream side of the unit. The form drag is considered to be many times larger than the skin friction for the case of a rubble mound breakwater armour unit.

The lift force is caused by the difference in pressure on the upper- and lower side of the unit due to a difference in velocity. The pressure is lowest on the upper side with the highest velocity (reference to classical hydraulics - Bernoulli's equation). Also the lift force may be written in basically the same form as the drag form, Ref. 22. This means that the resultant hydrodynamic force, F_R , may be written:

$$F_R \sim C_L \frac{1}{2} \rho_w U^2 A = C_L \frac{1}{2} \rho_w U^2 d^2 \cdot \frac{\pi}{4} \quad \{4.3.b\}$$

By inserting that the velocity according to Eq. 4.2.c may be written as $U = \alpha \sqrt{2gH}$, the following formula is obtained:

$$F_R = C_L \frac{1}{2} \rho_w \alpha^2 2gH d^2 \frac{\pi}{4} = \frac{\pi}{4} C_L \alpha^2 \cdot \rho_w g d^2 H \quad \{4.3.c\}$$

A criteria for stability is obtained by taking moment around O. (Cf. Fig. 4.3.a).

$$F_R \cdot \sin\phi \cdot \frac{d}{2} \leq W_S \cos v \cdot \frac{d}{2} \Rightarrow$$

$$F_R \cdot \sin\phi \leq W_S \cos v. \quad (3.4.d)$$

By inserting the relations for F_R and W_S the eq. 4.3.d is transformed:

$$W_S = \frac{\pi}{6} d^3 (\rho_s - \rho_w) g \text{ (note submerged weight).}$$

$$\frac{\pi}{4} C\alpha^2 \rho_w g d^2 H \cdot \sin\phi < \frac{\pi}{6} d^3 (\rho_s - \rho_w) g \cos v \Rightarrow$$

$$\frac{H}{\left(\frac{\rho_s - \rho_w}{\rho_w}\right)} \leq \frac{2 d \cos v}{3 C\alpha^2 \sin\phi} \quad (4.3.e)$$

By taking the third power on each side, and inserting the armour unit weight in air, $W = \frac{\pi}{6} d^3 \rho_s g$. Eq. 4.3.f is obtained:

$$\frac{H^3}{\left(\frac{\rho_s}{\rho_w} - 1\right)^3} \leq \frac{2^4}{3^2} \frac{W \cos^3 v}{\pi (C\alpha^2)^3 g \rho_s \sin^3 \phi} \Rightarrow$$

$$\frac{g \rho_s H^3}{W \left(\frac{\rho_s}{\rho_w} - 1\right)^3 \cdot \cos^3 v} \leq \frac{2^4}{3^2 \pi (C\alpha^2)^3 \sin^3 \phi} = K_1 \quad (4.3.f)$$

or by introducing $\gamma_s = \rho_s g$, and using the point where the sign of equation is valid, this equation may be written:

$$\frac{\gamma_s H^3}{W \left(\frac{\rho_s}{\rho_w} - 1\right)^3 \cos^3 v} = K_1 \quad (4.3.g)$$

This formula is identical to the one found by Svee in Ref. 76 for the case of down-rush. If instead, as done by Iribarren, the friction force is considered to be the governing force in keeping an armour unit in its original position the situation shown in Fig. 4.3.6 is valid for down-rush.

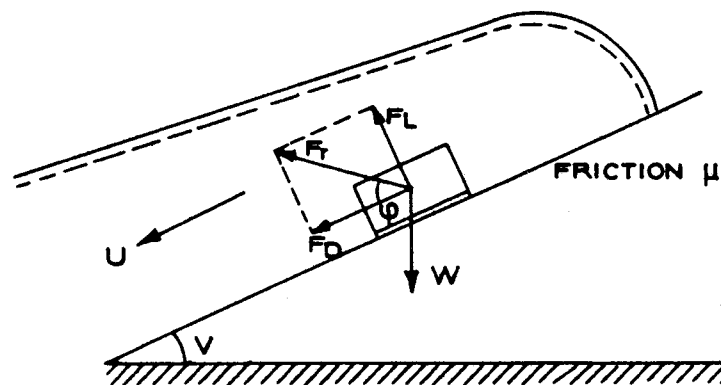

Fig. 4.3.b Down-rush forces when friction is considered governing.

The hydrodynamic force may as previously be written:

$$F_R \sim a \rho_w g d^2 H \quad \{4.3.h\}$$

a is a constant dependent upon the form of the armour units: The gravity force may be written

$$W_S \sim b d^3 (\rho_s - \rho_w) g. \quad \{4.3.i\}$$

The friction coefficient between the armour unit and the armour layer is equal to μ . Now, the force components are calculated:

Force component parallel to slope: $P = F_R \cos \phi + W_S \sin v$
 Force component vertical to slope: $V = W_S \cos v - F_R \sin \phi$

The criteria for stability may be expressed:

$$P < \mu V \quad \{4.3.j\}$$

or by inserting P and V and expressions for F_R and W_S :

$$bd^3(\rho_s - \rho_w)g(\mu \cos v - \sin v) > a\rho_w g d^2 H(\cos \phi + \mu \sin \phi) \quad \{4.3.k\}$$

Rearranging, cubing and inserting $W = \rho_a g b d^3$, Eq. 4.3.k yields:

$$\frac{H^3 \gamma_s}{W \frac{\rho_s}{\rho_w} - 1} (\mu \cos v - \sin v)^3 < \frac{b^2 (\cos \phi + \mu \sin \phi)^3}{a^3} = K_2 \quad \{4.3.l\}$$

This formula is basically the same as derived by Iribarren for the case of down-rush. By comparison with the formulae derived earlier, Eq. 4.3.g, it may be seen that they are identical except with respect to the influence of the slope. The commonly used Hudson's stability formula may be written in the same way:

$$\frac{H^3 \gamma_s}{W \frac{\rho_s}{\rho_w} \cot^3 \alpha} = K \quad \{4.3.m\}$$

The above evaluations have demonstrated that we arrive at the same type of stability formula, whether we consider the stability criteria for the units to be a pull-out and rotation, or to be a pure displacement.

It is the influence of the slope of the armour layer that comes out in different terms for the two stability criteria. The real case is very complicated because both friction, lifting, and rotation of the units together with

possible interlocking play a role. Therefore the influence of slope steepness on stability is generally very complex. Formula 4.3.1 is in one respect very sound because it indicates zero-stability when the slopes become equal to the natural angle of repose. This is not the case for Eq. 4.3.g or for Hudson's Formula Eq. 4.3.m which both predict stability for slopes steeper than the critical angle of repose.

Besides it should be mentioned that by considering formulae more complex than the one used for the velocity in the down-rush, the influence of the wave period can possibly also be included in the stability formula in a semi-theoretical manner.

In order to demonstrate the difference of the three formulae Eq. 4.3.g, Eq. 4.3.1, and Eq. 4.3.m, Fig. 4.3.c has been prepared. This figure shows the relative variation in stability predicted by the three formulae for a change in slope around a value of $\cot v = 2$ ($v = 26.56^\circ$). For $\cot \alpha = 2$, the slope of all formulae is put equal to 1. Further, the friction coefficient, μ , is for this comparison considered to be 1.0.

The figure clearly demonstrates the variance in prediction by the three formulae, a matter which is also revealed from model testing. Compared with the influence of the other parameters involved, the slope influence on stability of a breakwater is generally the most unpredictable.

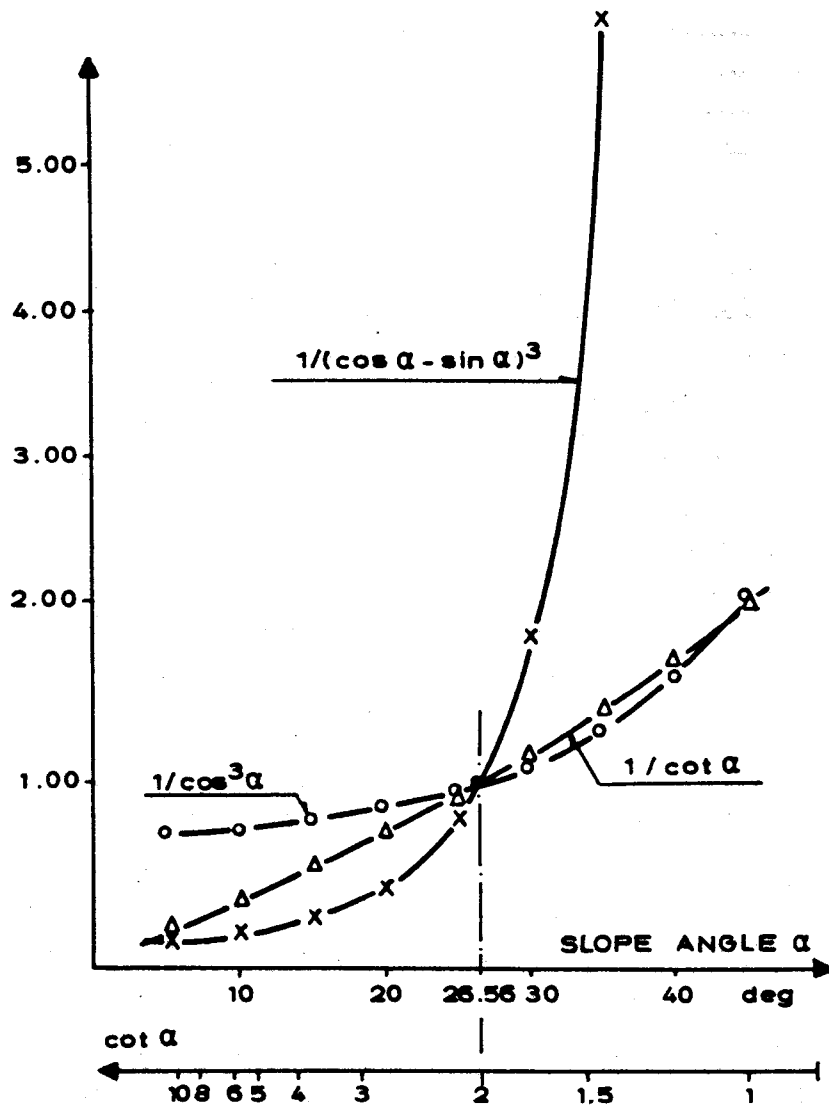

Fig. 4.3.c Influence of slope angle for Eq. 4.3.g, Eq. 4.3.1 and Eq. 4.3.m.

5. DETAILED EVALUATION OF THE VARIOUS COMPONENTS OF A RUBBLE MOUND BREAKWATER

5.1 Construction Material

The materials used for construction of rubble mound breakwaters shall fulfil certain requirements, such as stability against wave attack, durability, and easy construction with the available equipment.

The construction material mostly used is rock of various kinds.

In a country like Denmark where glacier deposits are common, gravel and glacier stones from these resources are often used for breakwater construction. In other countries glacier deposits are normally not available for construction material and it is therefore necessary to produce the material from solid rock in a quarry. Sometimes, when the rock in the available quarry is of poor quality or when the wave conditions are too severe, artificial armour units made of concrete must be used.

5.1.1 Stone Classes

In order to facilitate the construction work and the quarry operations, the number of stone classes should be minimized. Within this field many unreasonable decisions are made whereby a lot of problems are created, both for the people in the quarry and for engineers responsible for the supervision of the construction work.

The range of stone sizes within each gradation should be so wide that the different gradations are easily distinguishable.

Further, gradations should normally not overlap. In case they do so it will, if there is a shortage of one gradation, affect the average stone weight in the adjacent gradation. All stones in the weight range of the overlapping will automatically be placed only in the gradation where there is a shortage of stones.

In many projects, in which DHI has been involved in recent years, the lack of knowledge of available stone sizes in the quarry has turned out to be decisive for the breakwater profile at a very late stage, namely after initiation of the construction work. In some cases it has been necessary to modify the profile to fit the actual stone classes available. Such an example is presented in Fig. 5.1.a.

The alternative to a change of the profile is to blast enough material until the necessary amount of large stones is available. This means an increase in the costs if the remainder material cannot be used for other parts of the entire project, such as for instance concrete aggregate or road construction. It is for the above reasons extremely important for a breakwater project that information on the specific quarry is available at an early stage. It may therefore be necessary that test blastings are carried out at a very early stage to ensure that the stone classes that can actually be obtained from the quarry are used in the project design.

To make it easy to distinguish between the different gradations it is essential that the relative stone sizes differ 25-30% or more. A difference of 30% means a ratio of weights or volumes of approximately 2.2 from the largest stone to the smallest stone within the gradation. Therefore, for primary armour stones, DHI normally recommends,

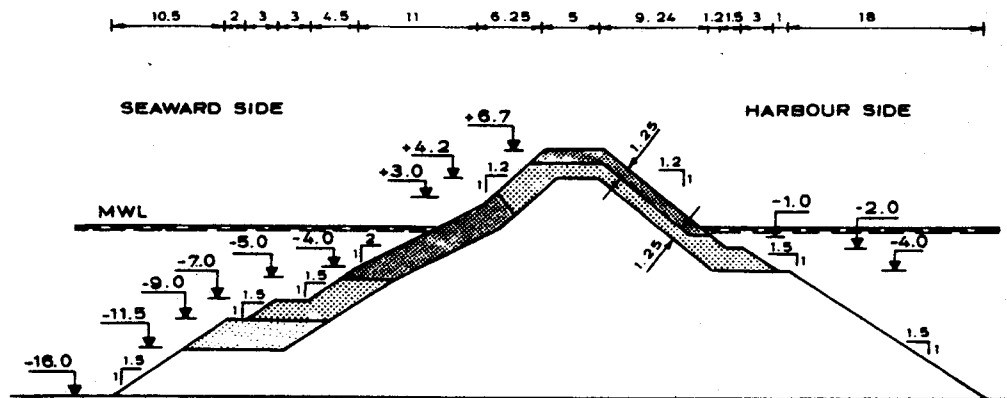

LEGEND:

I:  $3.3 < w < 8.6 t, \bar{w} = 5.8 t$

II:  $1.2 < w < 4.2 t, \bar{w} = 2.1 t$

 $> 0.3 t$

 CORE MATERIAL: QUARRY RUN

NOTE: ALL DIMENSIONS IN METERS

$$W_{\min} \leq \bar{W} \leq W_{\max}, \text{ where} \quad \{5.1.a\}$$

$$W_{\min} \approx \frac{\bar{W}}{1.5} \text{ and } W_{\max} \approx 1.5 \bar{W} \quad \{5.2.b\}$$

Examples of practical stone gradations for rubble mound breakwaters are presented in the various examples enclosed in this section.

5.1.2 Core Material

The core of rubble mound breakwaters are primarily constructed of natural gravel or of quarry run. However, sometimes sand is also used as core material. Sand as core material imposes very strict claims on the design of the filter layers between the core and the main armour.

The quarry run used as core material may be screened to remove the finer material. This is done in order to reduce the risk of settlements due to wash out of the finest fraction. The screening means an extra operation in the quarry, and thereby extra costs, especially if the fine material which is screened out cannot be used for other construction work. It will normally be cheaper either to avoid this screening or to remove only the very fine grains. In an important project for a very large breakwater, the tender documents included that all material below 25 kg should be removed. According to the contractor, this resulted in a tremendous increase in the construction costs. Further, the breakwater core is now so permeable that the stability of the reclamation behind the breakwater is endangered due to wave action through the core of the breakwater.

In a number of breakwater projects in the Faroe Islands in the North Atlantic where DHI was involved, the core materials were not screened before placing. This made the operations in the quarry easy. For the Midvaag Breakwater (Fig. 5.1.a) there has been some sedimentation of fine material around the breakwater and in the harbour area. This fine material was washed out from the core during construction and also during wave action. In Midvaag the moderate sedimentation was acceptable.

In general it may be concluded that there exists no precise rules to be applied in the selection of the lower limits of core material to be accepted in a rubble mound breakwater. The above-mentioned aspects point out that it is very essential for each breakwater project to analyse which requirements are actually needed for the core material.

5.1.3 Artificial Armour Units

When quarry stones of the required size are not available for a project, it is indispensable to introduce artificial armour units made of concrete. Simple concrete cubes have been used for rubble mound breakwaters for decades. In the last 30 years many engineers and researchers have tried to invent specially formed blocks in order to increase the stability conditions of the units and thereby reduce the volume of concrete necessary for construction. About fifty different types have been developed. The first one was the tetrapod, invented and patented by Neyrpic Inc., France, in 1950. The tetrapod, used for about 1,000 projects, is still being used. It is seen in Fig. 5.1.b together with a few other units.



Fig. 5.1.b Tetrapod, akmon, cube, and dolos.

It should be mentioned that, in principle, there exist two very different types of units: Units which have to be placed in a certain pattern with each block interlocked in the adjacent blocks to obtain high stability conditions and units which are placed at random with the stability depending on random interlocking of the individual units. Due to the uncertainty of breakwater construction under water, the first type is to be questioned. The stability of the armour layer is dependent upon all units being in due position, because if only one is displaced the stability of the rest of the armour layer is endangered.

For the second type (e.g. all units shown in Fig. 5.1.b) the stability of the whole armour layer is not endangered by displacement of a few units from the armour layer.

Until recently it was the general opinion that the dolos armour unit had the best stability characteristics, and dolos have therefore been used for many breakwaters. However, extensive breakage of dolos, especially the serious damage to the Sines breakwater in Portugal and the San Ciprian breakwater in Spain, has questioned the dolos as a safe and reliable armour unit. However, although it seems reasonable to conclude that the very high stability coefficients that have previously been used for the design of dolos breakwaters are exaggerated, it seems not justified, on the present basis, completely to abandon dolos as armouring for breakwaters. There exist successful applications of dolos in relative shallow water depth with dolos weights in the order of 5 to 10 t (cf. Fig. 5.14.a).

As a laboratory engineer engaged in many harbour projects, one is often asked: "What is the best armour

unit?" Obviously, it is not possible to give any definite answer to this question because besides being dependent upon the stability coefficient to be used for the various types of armour unit, the choice of armour type is also dependent upon various features related to the specific project.

With the increased capacity of construction cranes available nowadays there seems to be a trend back to simple, robust and durable armour units, as for example cubes or rectangular blocks in the form of "cubes rainurés" or "Antifer Blocks" cubes. Also rectangular blocks have got a renaissance. Antifer blocks are cubes with grooves on four sides. Ref. 58 is describing the use of such blocks for the Port of Le Havre, Antifer, in France. The blocks have also been selected for provisional repair of the damaged breakwaters in Sines, Portugal and Arzew-El-Djedid, Algeria.

5.2 Modes of Damage of Rubble Mound Breakwaters

A rubble mound breakwater can be damaged in several ways depending on its configuration, the wave conditions, and the relative water level during the storm. The following main modes of damage can be identified:

- a) Sliding of the seaward face due to scouring of the sea bed and/or the toe of the breakwater.
- b) Sliding of the seaward armour layer due to an unstable berm.
- c) Damage due to geotechnical instability of the sub-soil.

- d) Damage to the armour layer by displacement of armour units due to excessive wave forces mainly during wave run-down. Wave run-up is only critical for damage to the armour layer for flat slopes ($\cot \nu > 3.5$). Ref. 32.
- e) In special cases on steep slopes excessive wave forces may cause a sliding of the whole armour layer for a single wave run-down. (See section 5.7.5).
- f) Damage to the crown wall or superstructure due to excessive wave forces. Damage to a breakwater superstructure is often an integrated problem occurring simultaneously with damage to an armour layer in the front and erosion under the base of the superstructure.
- g) Damage to the crest and rear side armour layer due to excessive overtopping. Damage to the rear side armour layer may also be a problem for breakwaters with a superstructure in the case where the configuration of the superstructure is not protecting the rear side armour layer from being hit by voluminous wave overtopping. (See Section 5.11.2).
- h) Damage to the armour layer due to insufficient strength of armour units.

5.3 Filter on Sea Bed and Toe Protection

Rubble mound breakwaters on a sandy bottom are traditionally constructed with a toe, for instance as shown in Fig. 3.1.d to protect the breakwater from undermining due to the possible formation of a scour hole.

The toe protection is normally constructed from material which is relatively coarse compared to the underlying sand. The material is therefore not fulfilling the traditional filter criteria for the sand bottom.

For the above reasons, it is often used in breakwater construction to introduce a bottom protection of fine material or a filter sheet between the sand and the core material in an attempt to reduce the settlement of the mound.

The procedure mentioned above is normally applied and does not seem to cause any problems. At present there exists no generally accepted practice that can be applied for the design of the toe protection and the filter between the core and the bottom, so the above practice can be maintained and should for any project of significance be checked by model tests.

When a rubble mound breakwater is constructed on sand the core material and the bottom protection material will penetrate the sand to a certain degree. After a while the boundary between the two materials will stabilize and the settlements stop.

If, for one reason or another, a strong hydraulic gradient is present across such a layer transition it is recommended to investigate whether or not a filter between the two types of material is necessary.

Very thin and geometrically complicated multi-layer filters for toe protection, as is sometimes seen, should be deprecated. Although it is possible to verify, at the desk, that such a profile fulfils the filter criteria, the many thin layers may be impossible to construct.

It is possible by hydraulic model tests to study the behaviour of toe protection under wave attack and the possible scour of the sea bottom. But due to the inevitable errors when reproducing natural sand by sand of almost the same grain size such tests will only give a qualitative evaluation of the effect of the toe protection. However, such tests are at present the only available tool in the design of a toe protection.

In recent years, also artificial filter sheets made of plastic fibres and similar materials have been introduced in breakwater construction.

5.4 Core

The core of rubble mound breakwaters are generally constructed from quarry run. In Denmark where glacial deposits are easily available gravel (pebbles) is frequently used.

It is of importance that the core is not constructed of too coarse a material which would make the breakwater permeable for wave transmission and might cause excessive agitation behind the breakwater.

When the core is built of quarry run, it is general practice to stipulate a lower limit for stone sizes. This is done in order to avoid that the smallest fractions of the quarry run are washed out which might cause settlements of the mound and accumulation of material in the project area. The demand for removal of the fines from the quarry run makes the construction costs rise because of the extra operation.

In Midvaag in the Faroe Islands, the rubble mound breakwater shown in Fig. 5.1.a was built without removal of the fines. This caused limited accumulation of fines around the breakwater which was acceptable in this case. The breakwater settlement was in the order of 2% of its total height.

In special cases the breakwater core or part of it may be constructed from sand. This was done for an extension of Arhus Harbour in Denmark. For this project three alternative schemes, shown in Fig. 5.4.a, were considered. Actually the third profile was constructed. For other projects some of the breakwater core was constructed of sand being held in position in the core by banks of gravel or similar material. The banks of gravel are placed and sand pumped in between. This operation is repeated, and the core is successively completed.

5.5 Filter Layers

5.5.1 Stone Gradations

Rubble mound breakwaters are normally constructed with one or more filter layers between the core material and the main armour layer. The purpose of the filter layer (or layers) is to prevent the core material from being washed out through the main armour layer. Lundgren and Brinch Hansen, Ref. 50, give the following criteria for stability of filters. Index f refers to the filter and b to the base material:

$$\frac{d_{15,f}}{d_{85,b}} < 4-5 \quad \{5.5.a\}$$

and

$$\frac{d_{15,f}}{d_{15,b}} < 20-25$$

{5.5.b}

These criteria are called Terzaghi's filter criteria and are known from geotechnical engineering.

In Shore Protection Manual, Ref. 74 it is recommended that stone sizes in the filter layer have a weight ranging from 1/10 to 1/15 of the main armour stones weight.

This corresponds to stone dimensions of approximately 40 to 45% of the stones in the main armour layer. For the core, the Shore Protection Manual recommends stone weights of 1/200 to 1/6000 of the stone sizes in the main armour layer. This means a ratio of 4-8 between the stone sizes in the filter layer and the core. In general the criteria recommended in Ref. 74 are very strict compared with other criteria, and with materials actually used in many breakwaters. These criteria will often lead to a need for two filter layers.

The geotechnical criteria in Ref. 50 are somewhat hazardous to use for breakwater filter layers, because the flow situation in a breakwater is different from a well and other geotechnical problems for which the criteria of Ref. 50 are intended. Inside the breakwater mound the flow situation is changing continuously, both in direction and velocity, and the flow is in general not perpendicular to the boundaries between the different layers.

Due to the changing flow direction, it is reasonable to adopt more strict criteria for design of rubble mound filters than those used for geotechnical filters.

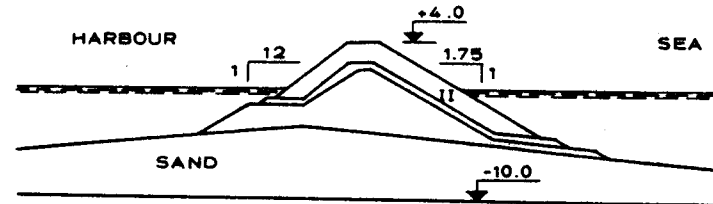
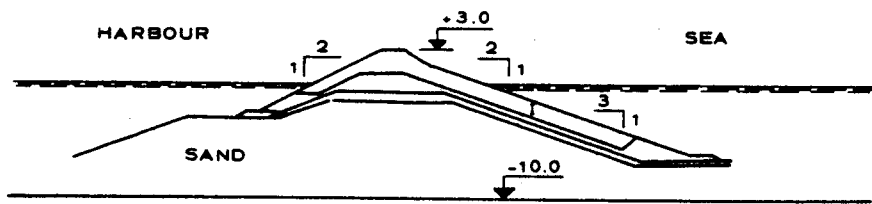
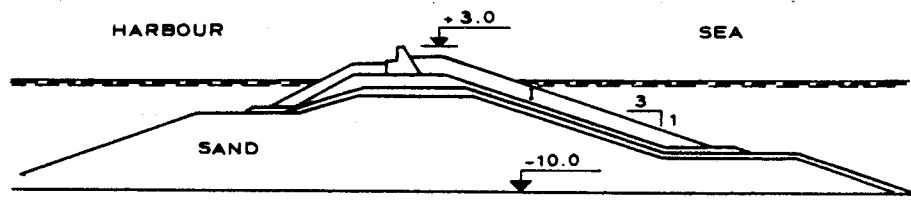

LEGEND:
 I SEA STONES 1 2t
 II QUARRY STONES 1.5 - 4t

Fig. 5.4.a Alternative profiles for a breakwater at Aarhus Harbour, Denmark.

Thompson and Shuttler, Ref. 79, also give filter criteria for design of rubble mound breakwaters. These criteria are less strict than the ones in the Shore Protection Manual but more severe than the ones in Ref. 50.

For comparison of filter criteria for armour and filter, Table 5.5.a has been prepared.

Reference.	$\frac{d_{15,a}}{d_{85,f}}$	$\frac{d_{50,a}}{d_{50,f}}$	$\frac{d_{15,a}}{d_{15,f}}$
Terzaghi	≤ 4 to 5	-----	≤ 20 to 25
U.S. Army Coastal Engineering Research Center (1975)	~ 2.2	~ 2.3	~ 2.5
Thompson and Shuttler (1976)	≤ 4	≤ 7	≤ 7

Table 5.5.a Filter criteria for armour and filter stones.

5.5.2 Layer Thickness

Many rubble mound breakwaters have been designed with very thin filter layers in order to minimize the amount of filter material. Such thin filter layers are very difficult or impossible to construct under water. It is important that the filter layer is designed in such a way that it is easy to construct, i.e. a relatively thick filter layer. The thickness should be equal to several stone dimensions and not necessarily only to two stone dimensions as recommended in for example Ref. 74. A thickness of two stone dimensions should be regarded as an absolute minimum. The stone dimension, d , may be related to the volume, V , of the stone by the following formula from Ref. 75.

$$V = 0.75 d^3$$

In addition to the above criteria, it is important that the filter layer is so thick that after construction one can be fairly sure that an intact filter is present over the entire surface. This means that due consideration should be given to inevitable construction inaccuracies. The magnitude of inaccuracies, especially under water, depends mainly upon the construction method (see Section 3.3). Further, the filter layer is often directly exposed to moderate wave action during construction, which may displace some of the stones. In Ref. 74, a minimum filter layer thickness of 0.5 times the size of the overlying stones is recommended to ensure that the filter is not damaged during placing of armour stones. A minimum corresponding to the approximate size of the armour units seems more safe considering all the above aspects.

The use of relatively thick filter layers has beneficial effects on the stability of the main armour layer. Model tests carried out at DHI, Ref. 31, have shown that the stability of the main armour layer increases with the filter layer thickness. This may be explained by the fact that increased thickness of the relatively permeable filter layer decreases the water velocities in the down-rush on the outer side of the armour layer because more of the flow discharge takes place in the filter layer.

5.5.3 Examples of Stone Gradations for Rubble Mound

Breakwaters

The breakwater in Midvaag in the Faroe Islands was built with the profile shown in Fig. 5.1.a. The breakwater has no filter layer between the core and the armour layer.

This breakwater is designed for wave heights up to $H_s = 3.9$ m with a peak wave period, $T_p = 20$ s. Since the completion of the project in 1977, H_s in the range of 2-2.5 m has occurred several times and once the design situation is believed to have occurred although no measurements were made. There have been no stability problems. Fig. 5.5.a shows the gradation curves of the armour layer and core material respectively. The curves were determined by the weight of individual stones. These materials only partly fulfil the geotechnical filter criteria in Ref. 50 (see Table 5.5.a).

Breakwaters in the Danish inner waters are according to tradition constructed with a core of gravel (pebbles), a filter layer of larger stones, and an armour layer of even larger stones usually found on the sea bottom. A typical profile of this type of breakwater is shown in Fig. 5.9.a (Ref. 56). This type of breakwater, of which many successful applications are present in Denmark, does not fulfil the requirements in Ref. 74. These two examples indicate that the recommendations in Ref. 74 are too strict.

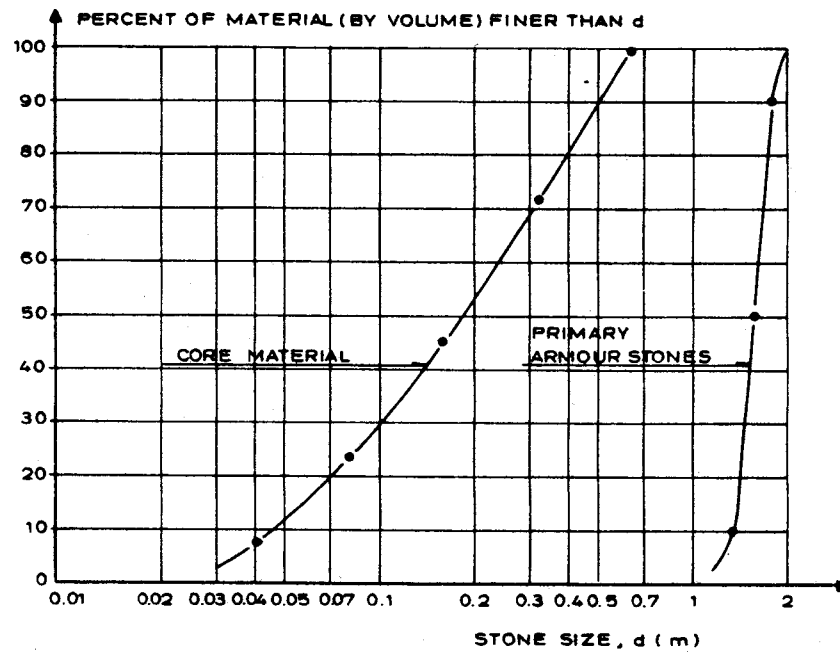

Notes:

$$\frac{d_{15,a}}{d_{85,f}} = \frac{1.4}{0.45} = 3.1$$

$$\frac{d_{50,a}}{d_{50,f}} = \frac{1.55}{0.18} = 8.6$$

$$\frac{d_{15,a}}{d_{15,f}} = \frac{1.4}{0.058} = 24$$

Fig. 5.5.a Gradation curves for the Midvaag Breakwater shown in Fig. 5.1.a.

5.5.4 Filter Layers for Precast Concrete Armour Units

Where large precast concrete armour units are used quarry stones are used as filter layer or secondary armour as it may be called. Ref. 74 recommends that the stones in this layer have a weight approximately equal to 10% of the weight of the main armour units. This applies for armour units having a K_D -factor (see Ref. 74) of 12 or less. For $K_D \leq 20$, stones of 20% weight are recommended. The experience of DHI is that the above criteria do not necessarily have to be fulfilled. The main thing is to design the breakwater with a secondary armour layer that is easy to construct and which provides a good and rough basis for placing of the main armour layer. Further, it is important for some projects that the secondary layer is composed of relatively large stones for protection of the breakwater during construction until the main concrete armour units are placed. Fig. 3.1.d shows a tetrapod breakwater for Zwara Port in Libya developed on the basis of model tests at DHI in 1979. Only one very thick filter layer was used under the 10 m³ tetrapod armour layer. The filter layer has a thickness of 3.5 m and consists of 0.5-4.0 t quarry stones in the range of 1/48 to 1/6 of the tetrapod weight. Tests on the sensitivity of the stone gradations of the filter layer were carried out. This was done in order to define a reasonable range of stone sizes to be used. The study also comprised tests with 6-16 t stones and 0.1-0.5 t stones as filter layer. The tests with $H_s = 7.0$ m and $T_p = 14.5$ s on the coarse gradation showed that the core material was washed into the filter layer, but the core material went neither through the filter layer nor the tetrapod layer. The tests on the fine gradation showed that some of the filter stones were washed into the tetrapod armour layer, but none of them penetrated it.

It was concluded that design with 0.5-4.0 t stones is adequate, but that minor deviations in filter stone sizes much smaller than those tested, would be acceptable.

Many other tetrapod breakwaters have been tested at DHI. For one project stone sizes for the secondary layer ranged from 1/10 to 1/75 of the tetrapod weight without any erosion of the filter layer.

5.5.5 Conclusion on Filter Layers

The previous discussion and examples demonstrate that there is a need for more practical criteria for filter layer design than those in Ref. 74, which will often lead to multi-layer thin filters. Such criteria make construction and supervision more difficult than necessary. Thick filter layers with a relative wide range of stone sizes are in many cases a realistic alternative. Model testing with natural irregular waves is recommended to check the design. Tests on the sensitivity to the stone gradation of filter layers should be used more often in order to define a reasonable range of gradation.

5.6 Berm

5.6.1 Purpose and Configuration of the Berm

The berm on the seaward side of a breakwater has three principal functions:

- a. The berm acts as the foundation for the main armour layer.
- b. The berm may catch armour units extracted from the

armour layer, whereby the slope of the armour layer becomes more gentle and the breakwater stability may improve.

- c. From a construction point of view the berm is essential because it makes the transition between the berm stones and the armour units well-defined for the contractor.

It is normally recommended to construct the berm with a trough on the inner side, as shown on Fig. 3.1.b. This trough will make the foundation for the primary armour layer safer. It has, however, not been possible by model tests to show any beneficial effects of this trough on the stability of the armour layer. The philosophy is that if the berm is not constructed in this way, but horizontal instead, stones from the filter layer falling down during construction may give the surface of the berm and its transition to the filter layer a convex shape. This will make placement of the first armour units difficult, whereby the stability of the whole armour layer may be endangered, especially for breakwaters with very steep faces. The trough will collect stones displaced from the filter layer during construction, before placing of the primary armour units.

5.6.2 Width of the Berm

The berm should be sufficiently wide to fulfil the above requirements. This means that besides the hydraulic and geotechnical requirements of providing a safe foundation for the armour layer, the berm should have a width large enough to compensate for inevitable inaccuracies during construction and to allow for some damage during extreme wave action.

For berms constructed from a breakwater or from a fixed structure with special attention to positioning, the width may be in the order of 3 to 4 typical berm stones, provided the berm is designed to be stable during extreme wave action.

If less accurate construction methods are used, such as dumping of stones from floating equipment, a berm width of 5 to 10 stone dimensions is needed depending upon the actual profile, depth of the berm, etc.

5.6.3 Stone Size for the Berm

Berm stone sizes should be determined from model tests.

The critical situation for a berm occurs if large waves reach the structure during low water. This means that the analysis should include determination of probabilities of occurrence for combinations of wave conditions and low water levels to be used for design and model testing.

The necessary stone size for the berm depends upon the following factors:

- a. Type of breakwater - armour layer type, slope and extension of armour layer both above and below the SWL (a high breakwater results in larger wave down-rush than a low one and thereby a more exposed berm).
- b. Wave conditions - wave height/period combinations and the down-rush velocities caused by these waves on the breakwater.
- c. Water level - the water level is important, because

the lower the water level, the larger the velocities caused by the down-rush at the berm level.

For large breakwaters with heavy artificial armour units the largest available quarry stones are normally used for berm construction. This means the designers have to determine the highest possible level at which a berm made of available stones is stable.

In other projects, the class of the largest stones is used for the primary armour layer, the next smaller stone category is used as berm.

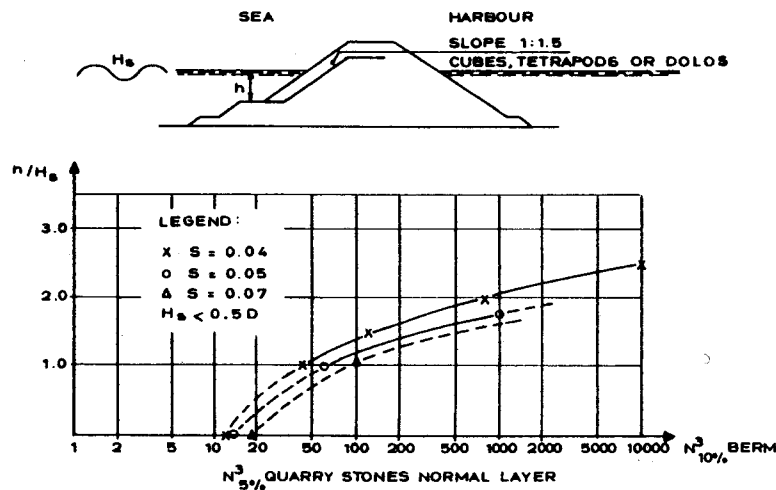

Fig. 5.6.a Results for the stability of the berm on a rubble mound structure (from Ref. 30)

Fig. 5.6.a shows results from Gravesen & Sørensen, Ref. 30, obtained from model tests on various breakwater profiles. These results may be used for preliminary evaluation of the necessary stone size for berms at various levels and for different steepness of the incoming waves.

The wave steepness is defined in Section 5.7.3. It should be noted that the results presented correspond to approximately 10% damage (percentage of stones displaced) to the berm during approximately 1,000 waves, so the design situation (wave height, H_s , and water level) should be selected carefully.

It may be seen that the lower the wave steepness, the lower placement of the berm. This is in accordance with results for primary armour layers in Section 5.7, and with the results of Ref. 11, showing that the smaller the wave steepness (longer periods), the larger the down-rush on a breakwater slope.

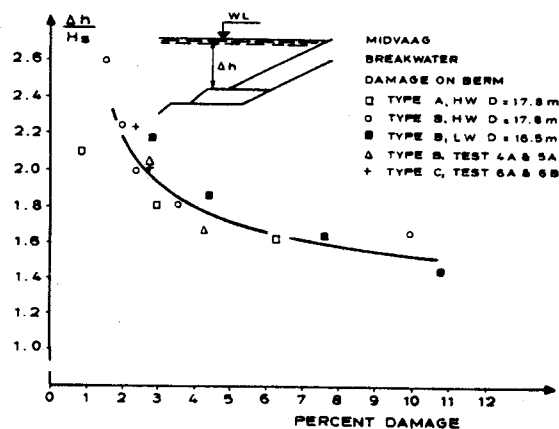

Fig. 5.6.b Model tests results for the Midvaag Breakwater (the profile is shown on Fig. 5.1.a).

As an example of berm design Fig. 5.6.b shows the results from the model test on the Midvaag Breakwater. The profile of this breakwater is shown in Fig. 5.1.a. It is seen how the percentage of stones displaced from the berm depends upon the parameter h/H_s . The damage percentage is here defined as the number of stones displaced relative

to the total number of stones in the berm. A certain damage can be accepted as long as the berm fulfils its tasks as defined in the beginning of this section.

5.6.4 Berms on Breakwaters in Shallow Water

For breakwaters in shallow water exposed to maximum breaking waves it is often not possible to make the berm stable, and it is therefore necessary to extend the primary armour layer all the way down to the toe protection. In special cases, when the bottom is steep, it is extremely difficult to make the lower part of the armour layer stable.

Fig. 5.6.c shows some alternative solutions for a breakwater constructed on a rocky slope of approximately 1 to 7. A special "toe hold" was shown by model tests to be necessary to prevent the whole armour layer from sliding down. All the proposed solutions are very difficult to construct. It should be mentioned that for the specific project another alternative proposal was to place loose 40 t cubes on the bottom as toe hold. They were not stable, which demonstrates the very large wave forces at the bottom under such conditions.

5.7 Main Armour Layer on Seaward Face

5.7.1 Introduction

The main armour layer on the seaward face is the component to which most attention has been paid for many years.

Many researchers have tried to develop formulae for the

PROFILE C2T8C1

TEST SERIES 28 AND 29

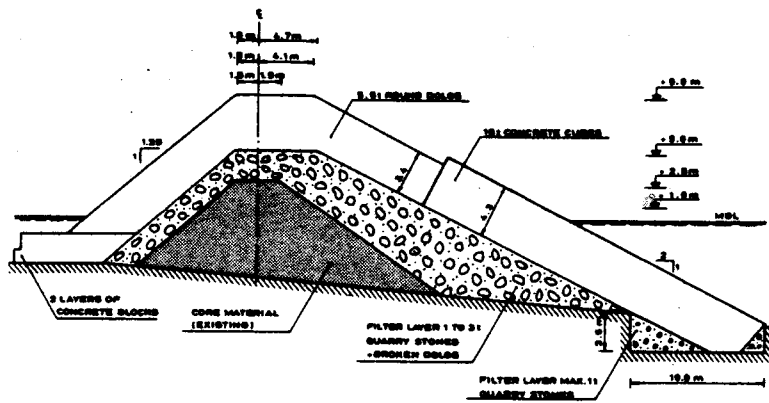

PROFILE C2T7

TEST SERIES 31

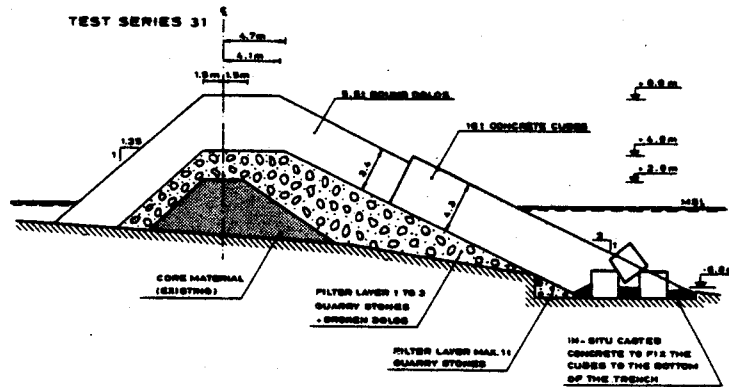

PROFILE C2T5

TESTS SERIES 15

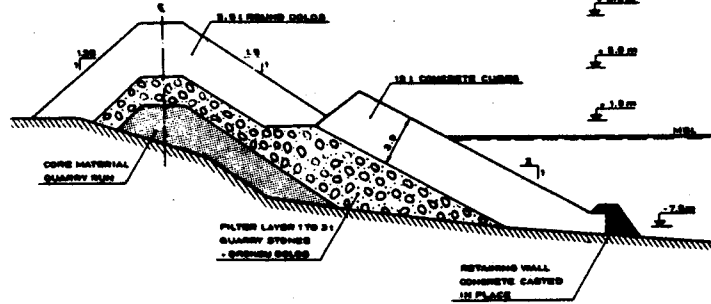

Fig. 5.6.c Alternative toe holds for a breakwater on a sloping rocky bottom.

necessary armour unit size. This seems justified, since the armour layer is normally the single most expensive component of a breakwater, especially if precast concrete units are used.

In this chapter the general basis for design and considerations for use in the design process are presented. The ideas and suggestions will be documented by examples, model test results and case stories.

5.7.2 Armour Layer Thickness and Number of Armour Units

The thickness, r , of an armour layer may be calculated by the following formula:

$$r = nc v^{1/3} \quad (5.7.a)$$

n	= number of layers	cubes	$c = 1.1$
c	= shape factor	tetrapods	$c = 1.0$
V	= block volume = $\frac{W}{\gamma_c}$	quarry stones	$c = 1.0$
W	= block weight	dolos	$c = 1.3$

γ_c = density of the block

The number of blocks N per unit area is calculated by the formula:

$$N = n c \left(1 - \frac{P}{100}\right) v^{-2/3}$$

P = porosity of the layer:

cubes	$P = 47$
tetrapods	$P = 53$
dolos	$P = 60$
quarry stones	$P = 40$

The values of c and P are chosen according to Ref. 62.

For quarry stones it is normal practice to use the average stone weight (or volume) in the calculation. The average weight \bar{W} of a stone gradation is defined as:

$$\bar{W} = \frac{1}{N} \sum_{i=1}^N W_i \quad \{5.7.b\}$$

The number of layers n is normally equal to 2 except for tribars for which only one layer is used. However, more than two layers are sometimes used on exposed spots, or if the breakwater is constructed in such a way that big inaccuracies, i.e. by dumping of stones, are foreseen.

5.7.3 Parameters to be Used for Description of Armour Stability and Discussion of Damage

In Section 4 an evaluation of stability formulae was presented. It turned out that all the formulae may be written in the form:

$$N^3 = \frac{H^3 \gamma_s}{W \left(\frac{\rho_s}{\rho_w} - 1 \right)^3} = K \cdot f(\alpha) \quad \{5.7.c\}$$

The coefficient K is regarded as a constant and $f(\alpha)$ a function of the armour layer slope, α .

Here N may be interpreted as a dimensionless wave height.

Since the wave heights occurring in natural wave trains are a stocastic phenomenon, to which statistical analysis in the form of wave height distributions are applied, it is difficult to choose which representative wave height should be applied when using this type of formula. Tradi-

tionally the significant wave height, H_s , has been used for deep water conditions. Deep water means that the wave height distribution in front of the structure, normally being a Rayleigh distribution, is not significantly transformed due to wave breaking. The significant wave height is also commonly used in all aspects of coastal engineering.

The only way of making reliable model tests on coastal structures is to reproduce the waves so that they resemble the natural waves as much as possible. In this way, which is the easiest model procedure to understand, the analysis of the test results can be concentrated on the behaviour of the breakwater. The analysis has not to go through dubious comparisons of the effect of regular waves versus natural irregular waves. From such tests representative stability coefficients to be used in the design process may be determined.

This may be done by evaluation of the damage observed during model tests as function of N^3 , defined from Eq. 4.3.m by using the significant wave height, H_s .

$$N^3 = \frac{\gamma_a H_s^3}{W (S_r - 1)^3} \quad \{5.7.d\}$$

Because the stability coefficient $N^3 = K_D \cdot \cot \alpha$ is depending upon a number of parameters both relating to the wave conditions in front of the structure and to the actual geometry of the breakwater profile etc., a K_D value determined for one profile should only be used with great precaution for other profiles, and only as a rough guideline.

As shown in many recent publications, i.e. Refs. 11, 15

and 30, also the wave period is playing an important role for the stability of a rubble mound structure.

The K_D values to be used with Hudson's formula Eq. {4.3.m} as a first approximation in the design process should be selected with great caution. The K_D value is a function of various factors of which the most important are:

- (i) type of armour unit
- (ii) type of structure
- (iii) slope and extent of armour layer
- (iv) wave impact characteristics, i.e. wave height and period (length) and wave height to water depth ratio
- (v) degree of acceptable damage to the armour layer.

For the above reasons it is not possible to give definite values of K_D , but the following list gives an order of magnitude for slopes of 1:1.5 and 1:2.0.

Quarry stones	1.0 - 4.0
Cubes	2.0 - 7.0
Tetrapods	3.0 - 8.0
Dolos	6.0 - 15

The lower values correspond to initiation of damage and very long waves (low wave steepness), while the higher values correspond to high steepness and acceptable damage in the order of 5% after exposure to the given wave conditions (H_s , T_p) for durations from 3 to 5 hours.

The Shore Protection Manual, Ref. 68, presents the following K_D -coefficients for different types of units and

for "limited" damage to the armour layer:

Quarry Stones	$K_D = 2.4-4$
Cubic Blocks	$K_D = 7$
Tetrapods	$K_D = 7-8$
Dolos	$K_D = 22-25.$

These coefficients should, as previously mentioned, be considered with great precaution and therefore not be used directly for design purposes, but only for preliminary evaluations of various alternative solutions. The K_D -factors are generally very high compared with the previous given range. Further, the K_D -factor for dolos and, to some degree, tetrapods should for most breakwaters (especially large structures in deep water with big units) be selected significantly smaller for preliminary evaluations, since for dolos armour layers (especially larger units) neither displacements nor serious rocking should be allowed for in the design.

Design Wave Parameters for Breakwaters in Shallow Water

For breakwaters in shallow water the impact wave heights are limited due to wave breakings in front of the structure. For such structures the significant wave height, H_s , in front of the structure is not directly representative for design purposes and is more difficult to evaluate by analytical means than the design wave in deep water, where the Rayleigh distribution normally applies.

However, there exists no sharp limit between non-breaking and breaking wave conditions (is it breaking conditions, if for example 0.5% (1 out of 200) of the waves breaks?). It is, therefore, convenient to use $H_{13,6\%}$ as a measure for the wave height both for deep

water and shallow wave conditions, where a certain percentage of the waves is breaking. In deep water $H_{13,6\%}$ is equal to the significant wave height, if the cumulative wave height distribution is equal to the Rayleigh distribution. In shallow water $H_{13,6\%}$ is close to H_s and still a reasonable estimate of this parameter.

In shallow water, where wave breaking occurs it is also relevant to consider the maximum wave heights occurring in front of the structure.

For specific projects it is often convenient to relate the damage and stability conditions of a breakwater to the deep water conditions which are often known or estimated. For such projects in shallow water, where the sea bottom in front of the structure is reproduced in a physical model, the description of stability can be based on the deep water conditions.

Wave Period, Wave Steepness

Besides the wave height the wave period also has also great influence on the stability of rubble mound breakwaters, both in deep and shallow water. It is usually found from model tests that the stability decreases with increasing wave period for a fixed wave height (decreasing wave steepness). For this reason it is necessary to define parameters for description of the wave steepness.

The peak wave period, T_p , is generally close to the wave periods of the highest waves in a wave train, and because this period is easy to identify in the computer analyses used nowadays, it may be used as representative wave period for a wave train. For deep water conditions we may,

by using the significant wave height, H_s , as a representative wave height, write the characteristic wave steepness as:

$$S_p = \frac{H_s}{L_{po}} = \frac{2\pi H_s}{gT_p^2} \quad \{5.7.e\}$$

Note, $L_{po} = \frac{g}{2\pi} T_p^2$

Many researchers, as mentioned in Section 4, have been using the surf similarity parameter, ξ_0 , for the description of wave steepness.

By using H_s and L_{po} , ξ_0 , may be written:

$$\xi_0 = \frac{\tan \alpha}{\sqrt{\frac{H_s}{L_{po}}}} \quad \{5.7.f\}$$

This means by combining Eq. 5.7.e and 5.7.f,

$$\xi_0 = \tan \alpha S_p^{-\frac{1}{2}}$$

In shallow water, where the wave celerity is equal to $c = \sqrt{gD}$, a characteristic wave steepness may be defined as in Ref. 30.

$$S = \frac{H_s}{T_p \sqrt{gD}} \quad \{5.7.g\}$$

Density of Armour Units

The density of the armour units plays an important role in the stability of the units. Considering all the stability formulae presented in Section 4, the same term is

$$\frac{\gamma_s}{\left(\frac{\gamma_s}{\gamma_w} - 1\right)^3}$$

present in all formulae. If the relation $W_s = V \cdot \rho_s$, with V being the volume of the units, is included the stability formula may be written:

$$\frac{N^3}{H_s^3} = \frac{1}{V(\rho_s/\rho_w - 1)^3} \quad (5.7.h)$$

For a certain slope and wave conditions N^3 and H_s^3 is constant. The term $1/V(\rho_s/\rho_w - 1)^3$ is therefore also constant. This means for example that an increase in density can be counterbalanced by a decrease in the volume of the units without decreasing the stability. Due to the third power of the density term, this decrease in volume is very pronounced. An increase of concrete density from 2.3 to 2.65 t/m³ results, for instance, in the volume being reduced to half the value. This aspect has been used in different projects to improve stability conditions. Some types of iron core can be used as concrete aggregate and a durable concrete can be obtained.

In some projects the same unit sizes (volume) have been used for both the trunk of a breakwater and for the head, but on the head the density has been increased to obtain increased stability. In this way the same concrete forms can be used for the two "types" of units.

Damage Definition and Discussion of Acceptable Damage

All stability coefficients presented in the literature correspond to a certain degree of damage to the armour layer, often without any precise definition. The damage

percentage is often defined as the number of units displaced in proportion to the total number of units.

Another aspect, which plays an important role in the selection of a proper stability coefficient to be used in the design is the degree of acceptable damage to the armour layer. The question is often put like this: "What is the acceptable percentage of damage to a rubble mound structure?" It is not possible to establish general rules to be used, since the acceptable damage is depends on a number of factors. There is, for instance, a great difference between a breakwater in shallow water armoured with natural rock, which can absorb some displacements and settlements, and one in deeper water armoured with artificial units such as for example tetrapods.

Further, there is a great difference between the possibilities of carrying out repairs on a structure with a concrete superstructure which may be used as repair roadway and a structure with a rubble mound crest.

In the case of sophisticated concrete units, such as dolos, the acceptable degree of displacements is zero. Even rocking of such units may endanger the stability of the armour layer if it causes failure of individual units.

Besides, the acceptable damage degree depends on the reserve stability capacity of the damaged structure and how fast and at which costs material and equipment for the repair work can be brought in.

Generally it can be said that the acceptable degree of damage should be defined on the basis of an analysis of the overall economy of the structure, including capital costs and expected maintenance costs for various break-

water solutions. In such evaluations the economic consequences, including the interruption of operations and the possibility of breakwater-protected structures being damaged, should also be included. Such structures are often of much greater value than the breakwater itself.

5.7.4 Breakwater Damage Development and Examples of Failures

Damage Development

In stability formulae for design of armour layers the duration of wave conditions is not included. It is obvious that this parameter is of major importance for the stability.

Earlier, when model tests on rubble mound breakwaters were made using regular waves, this aspect did not seem to be as important as it has turned out to be during testing with irregular waves. When testing a breakwater with regular waves of a certain height there are three possibilities:

- a) No damage at all.
- b) A limited damage occurring in the beginning of the test. After a certain number of waves the increase in damage stops which means a stable situation for the specific wave height. Since all waves are almost identical the damage does not develop further.
- c) The wave height applied is great enough to cause a complete destruction of the structure. For regular

waves, in case of this situation, the destruction will normally occur very quickly after a small number of waves.

In nature and during model tests with regular natural waves the situation is quite different from the situation described above, although 'no damage', 'limited damage', 'complete destruction' may still be observed. Due to the random occurrence of big, damaging waves in a wave train it is not possible after a short test duration to identify whether or not the conditions applied correspond to 'no damage' at all (category a). For test conditions causing moderate or partial damage (category b) this generally occurs more slowly than with regular waves. Further for a certain significant wave height a completely stable situation is very difficult to identify, since there is always a probability of occurrence of large waves of unusual shape or successions of waves causing further damage. For breakwaters in deep water a complete stable situation is hardly ever reached for the category b) situation as documented in the following. For category c) damage tests may show rapid destruction of the armour layer and then suddenly during the attack of one big wave a slide of the armour layer as a whole and/or complete destruction due to sliding or overturning of the superstructure.

Examples of Destroyed Breakwaters

The profile which develops when a breakwater in deep water is seriously damaged is shown in Fig. 5.7.a (profiles of damaged sections of the Sines Breakwater in Portugal, Ref. 88). Fig. 5.7.b shows the damaged breakwater in Port d'Arzew-El-Djedid, Algeria, Ref. 1. Sines had an armour layer of 42 t dolos with a 1 on 1.5 slope and

Arzew-El-Djedid 48 t tetrapods with a 1 on 1.33 slope. In both cases a very high percentage of the armour units broke during the storms.

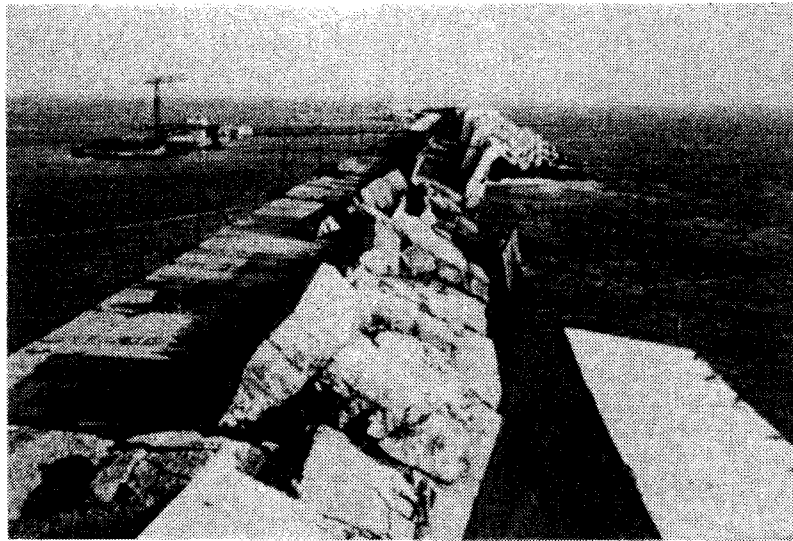

a) MAIN DAMAGE AREA BETWEEN BERTH NO's 2 AND 1, 12/6/78

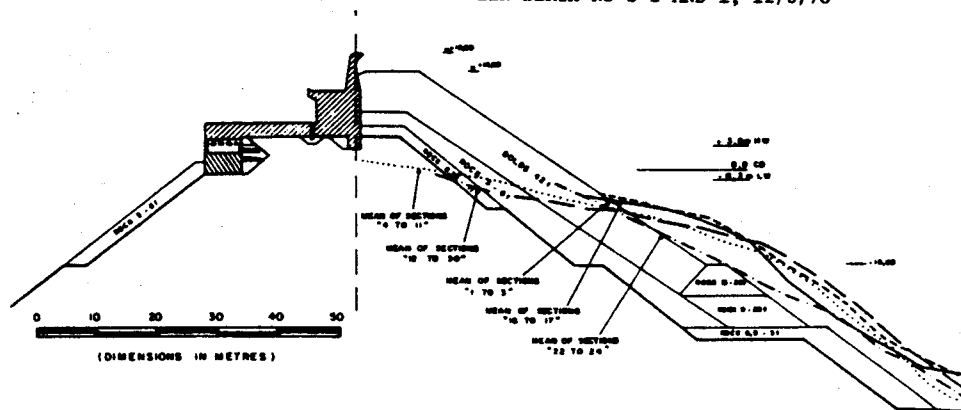

MEAN PROFILES AFTER FEBRUARY 1978 STORM

Fig. 5.7.a Photo and damaged profile of the breakwater in Sines (Ref. 88).

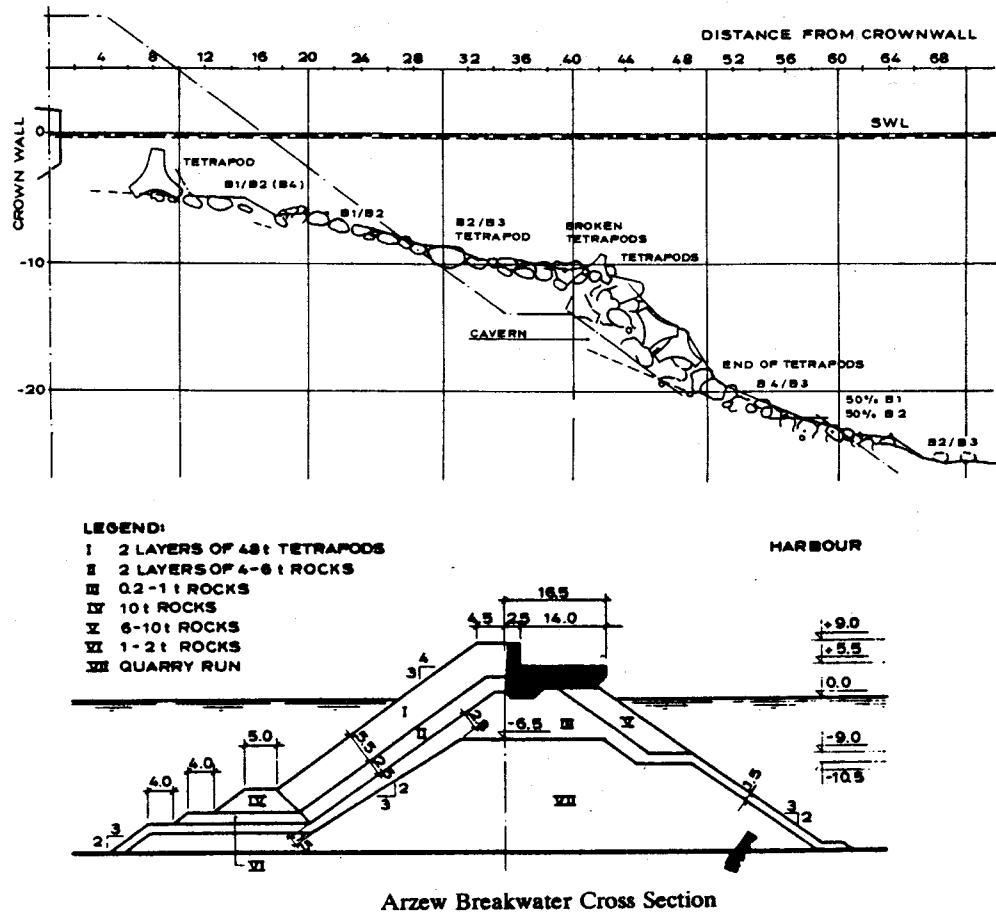
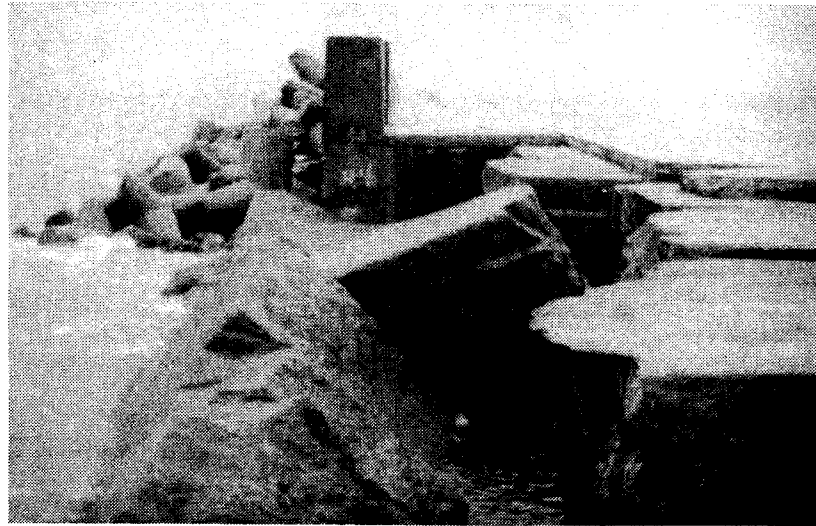

Fig. 5.7.b Photo and damaged profile of the breakwater in Port d'Arzew-El-Djedid (Ref. 1).

It is interesting to notice that both profiles were very similar after destruction. The superstructure and crown wall had become directly exposed when all the material slid down after failure of the armour layer. The slope is very flat at a depth of about 3 to 10-12 m below SWL. Below this level the material, being a mixture of armour units (broken and unbroken) and quarry stones from the core and filter layers, stands very steep with almost its natural angle of repose. Due to the large run-down/ backwash of the waves from the wave scene erosion of the material under the superstructure happened, and the wall consequently tilted forward. In Arzew-El-Djedid a backward displacement of the entire superstructure occurred due to wave action. It is clear from these examples that once the armour layer of a structure with a steep slope in deep water fails it means a complete breakdown of the seaward face simply due to the "limited" amount of available material compared to the depth. In other words, the material tends to settle at so flat a slope under exposure to the severe wave attack that the superstructure becomes directly exposed to wave forces and critical erosion under the structure. This erosion is causing differential settlements which further increase the destruction because the weight of the superstructure elements damage each other due to high contact pressures (observed in Port d'Arzew-El-Djedid).

Surveying of Breakwater Profiles

Both during and after construction of breakwaters it is necessary to survey the breakwater profiles which is also the case with damaged breakwaters.

In order to demonstrate the difficulties in planning and interpretation of such surveys, Fig. 5.7.c shows the re-

sults of three surveys of a model of the Arzew Breakwater built according to the project drawings. In the model the survey was made in the same way as in nature by using a 30 cm device suspended in a string. The soundings show the depth, when the device touches the tetrapods (20 m^3 , height 4.15 m) or quarry stones on the slope. A very great scatter of the measured surface appears and the average surface measured is about 2,0 m below the design surface.

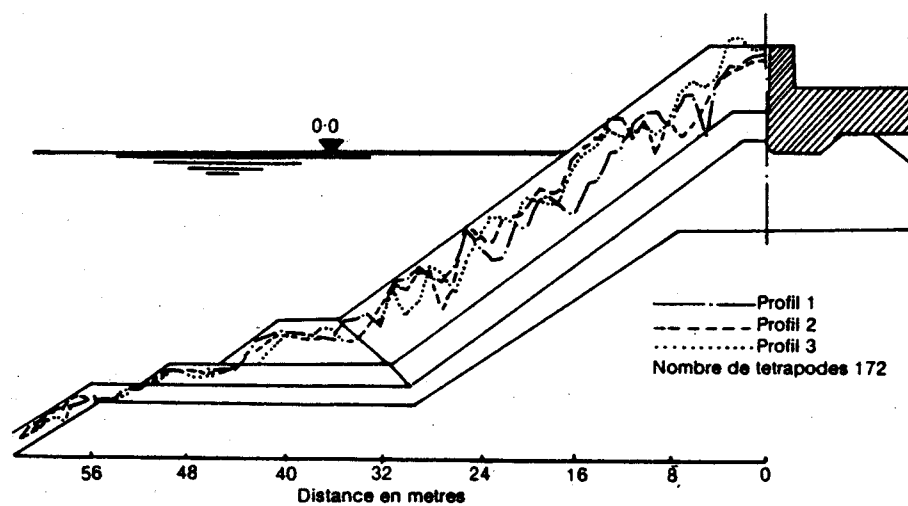

Fig. 5.7.c Surveys of the model of the breakwater in Port d'Arzew-El-Djedid.

The example demonstrates that the method of soundings in each case should be tuned to the "roughness" of the surface. Further it seems a good idea to survey profiles in a scale model under ideal conditions for comparison with prototype as built surfaces.

Damage to Shallow Water Structures

Breakwaters in shallow water behave differently when exposed to waves able to displace armour units. A breakwater in shallow water with a slope of for example 1 on 2.0, and crest elevation adequate to avoid serious damage to its crest and rear side will normally have an S-shaped damaged profile. Due to the limited depth such structures (if not severely under-designed) do normally not experience complete destruction because they contain enough material in relation to the water depth. The seaward slope adjusts, and thereby stabilizes, itself against the wave impact. If such structures are built with a too low crest elevation, there is a risk of serious damage to the rear side due to excessive overtopping, which may lead to complete structural failure.

5.7.5 Design of Breakwater Armour Layers

The following aspects have to be taken into consideration:

- a) The distribution of damage occurring along the length of a breakwater is of a random statistical nature. If a breakwater is designed on the basis of average values established from model tests, stretches of the breakwater will suffer much greater damage. Therefore, hydraulic model tests should emphasize determination of the scatter of the damage so as to make a prediction of average and maximum damage.
- b) The wave statistics used for the design are based on the information available, which is often limited though. This means that there is a certain probability that the waves which will occur during

the life of the structure will show a wave height distribution somewhat higher than the one used for the design, maybe because the wave statistics are based on information that is not representative for long-term conditions. Even if the wave information is representative there is a risk of higher waves during the lifetime of the structure, simply due to the statistical nature of storm occurrence. Assuming as an example that the desired life of a structure is 50 years, and that a storm, which on the average occurs once every 50 years, is used for the design there is a 63% probability that the design storm occurs during the 50 years' lifetime. Even if a 500 year situation is used, the probability of occurrence is 10%. This means that rather than designing a structure for conditions which on average are expected to occur once in the life of the structure, one should choose a certain acceptable probability for failure of the structure and then design the structure in accordance with the wave conditions derived from this probability, as shown in Table 5.7.a.

- c) The fact that the strength of concrete armour units is not properly reproduced in a hydraulic model is especially important for artificial blocks. A unit displaced from its original position in the model will fall down the front slope and normally settle on the lower part of the armour layer or on the berm. If a unit settles on the lower part of the armour layer it still has a beneficial effect on the stability of the total armour layer.

In reality this is to some extent different. A unit displaced from its original position may break when

Desired life L of structure (years)	Recurrence interval for design conditions T_d					
	10	20	50	100	200	500
1	10	5	2	1	0.5	0.2
5	41	23	10	5	2	1
10	65	40	18	10	5	2
25	93	72	40	22	12	5
50	99.5	92	64	39	22	10
75	-	98	78	53	31	14
100	-	99.4	87	63	39	18
200	-	-	98	87	63	33

Formula:

$$R = 1 - \left(1 - \frac{1}{T_d} \right)^L = 1 - \left(\frac{T_d - 1}{T_d} \right)^L$$

Example:

Desired lifetime : 50 years
 Design conditions : 200 years
 Risk for excess of design conditions within lifetime : 22%

Table 5.7.a Calculated risk (R) in % for exposure to design conditions within desired life.

it tumbles down the front slope of the breakwater and may also break other units. It is not possible on the basis of present knowledge to estimate the probability that units may break when displaced from their original position, as it depends upon the structural strength of the concrete. It is, however, evident from projects where dolos and tetrapods were used that a number of units were broken without being displaced from their original

positions. In some cases this probably happened during placing, and in other cases due to wave action. The fact that artificial units may break indicates that armour layers, consisting of such units shall be designed for very small damage percentages based on model test results in order to allow for some residual stability of the armour layer. It is also necessary to consider the possible damaging effect of rocking of armour units and settlements of the entire armour layer.

Principle of Accumulated Damage

The armour layer shall, besides being able to resist the effect of extreme storms, also in general have sufficient stability to resist the accumulated effect of many more moderate storms occurring in its life.

For breakwaters located in relatively shallow water the wave conditions may be depth-limited due to wave breaking. This means that the rate of damage inflicted on the breakwater does not increase above a certain level with the significant wave heights in deep water.

A number of recent model tests performed by DHI have shown that average damage to a breakwater in deep water develops linearly with time for a fixed significant wave height and "peak" wave period (stationary wave conditions). For moderate storms which are able to cause only limited damage to the structure there is a tendency for the breakwater to become more stable, and thereby the rate of damage decreases with the storm duration. If this is ignored it is possible to calculate the expected damage after a certain number of years. This will, for the above reason, be a conservative estimate. This is called

accumulated damage because it is the result of the effect of many storms, each of which is only able to displace a very limited number of units.





Applying the concept presented above yields that a specific storm will cause approximately the same damage, no matter which wave conditions the breakwater has been exposed to earlier. This means that the armour layer is treated as having no "memory".

5.7.6 Damage to an Armour Layer as Function of Time

Hudson's formula, Eq. 4.3.m, and other stability formulae do not include any term related to duration of wave conditions. This aspect is, however, of major importance. Fig. 5.7.d shows results from many series of model tests on the deep-water breakwater at Bilbao, Spain, which was seriously damaged in 1976 and -77. DHI made tests to verify the damage and to investigate alternative profiles to be used for its final repair. Reproductions of irregular natural waves were used. The breakwater was built with rectangular block armour. Fig. 5.7.e shows for different fixed stationary significant wave heights, H_s , the number of blocks displaced completely from the armour layer as function of time. For this breakwater with a slope of 1 to 1.5 the following is seen:

- a) The damage develops almost linearly with the storm duration for constant significant wave height, until approximately 50% of the blocks (weight 82 t) are displaced.

LEGEND:

-  CONCRETE WAVE WALL
-  ARMOUR LAYER, CUBES 82t
-  QUARRY STONES, 6-9t
-  QUARRY STONES, 2t

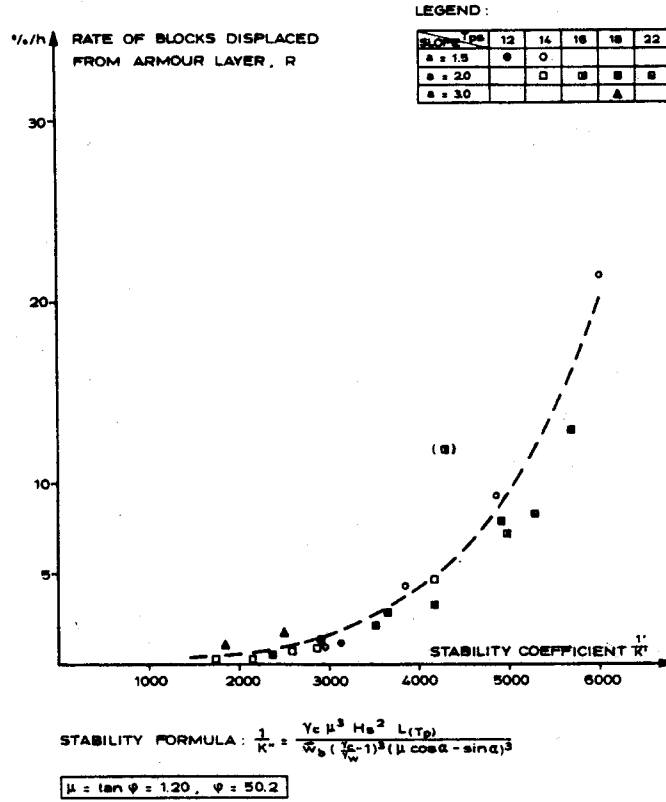
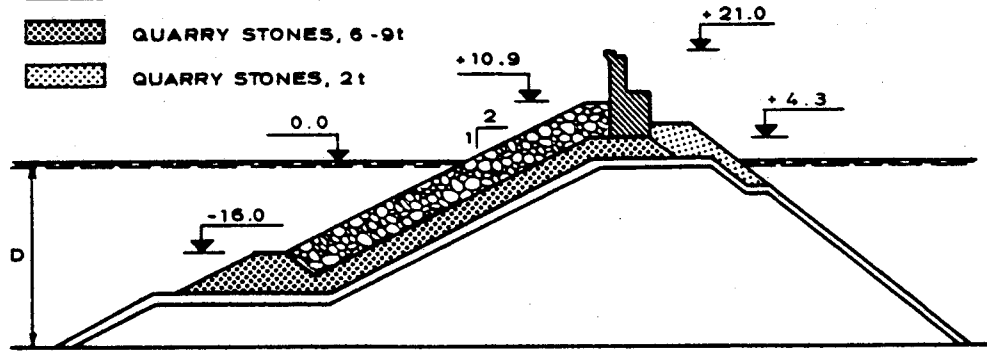

Fig. 5.7.d Combined effect of wave period and armour layer slope. Bilbao Breakwater (from H. Gravesen et al., Ref. 29).

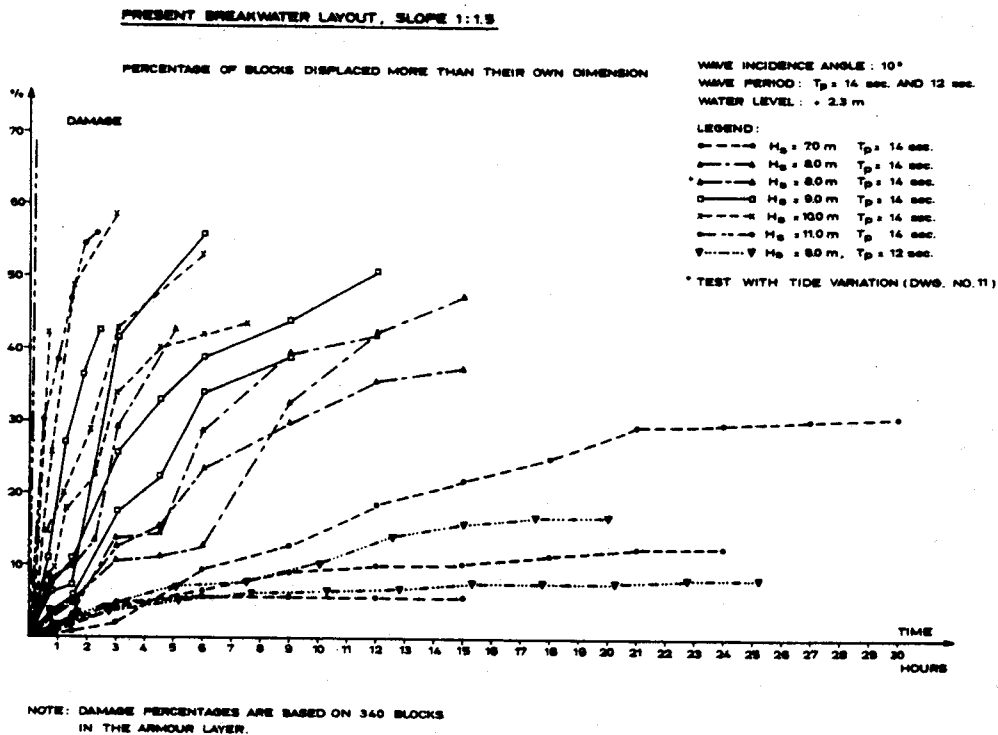
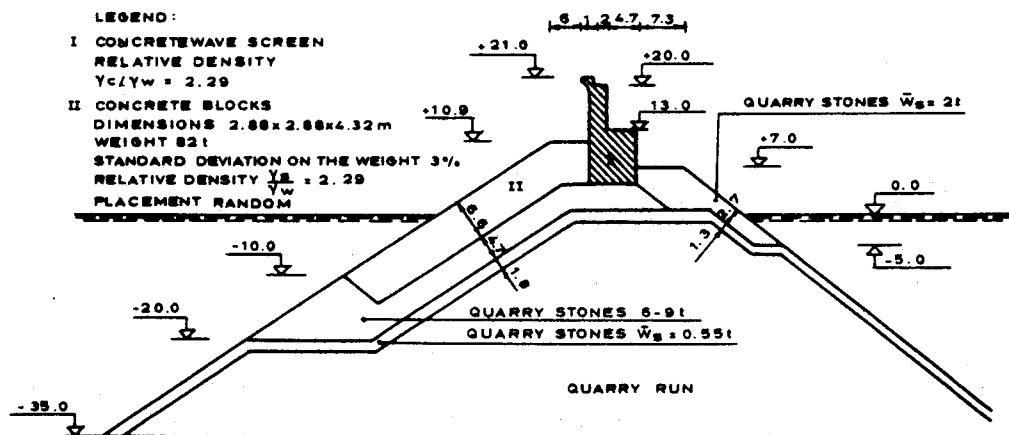

Fig. 5.7.e Model test results for Bilbao Breakwater (Original profile).

- b) There is a very significant scatter in the test results when repeated for the same significant wave height and peak period.
- c) For very large waves, $H_s = 11$ m, the armour layer failed once during the down-rush of a single wave. The complete armour layer slid down the front slope.

These observations document the need for considering also the duration of storms. It is also necessary to consider the scatter of stability conditions in the design. In case an evaluation based on average stability conditions is used there will be a large probability that limited sections suffer much greater damage. This is dangerous in case local severe damage develops and spreads to cause complete failure of part of the structure.

In the case of Bilbao the breakwater was severely damaged in three sections, two of which can be seen from the harbour side on the photo in Fig. 5.7.f. Note also the broken oil pipelines on the breakwater.

Scatter in Test Results

The scatter of stability conditions in scale model tests is caused by random placing of the armour units, which is obviously not identical from test to test. Similar or larger scatter must therefore also be expected for a long breakwater which may be regarded as consisting of a number of sections with a length equal to the model section.

It is difficult to prove that in some cases even a larger scatter should be expected in reality than in models. However, the author believes that real breakwater con-

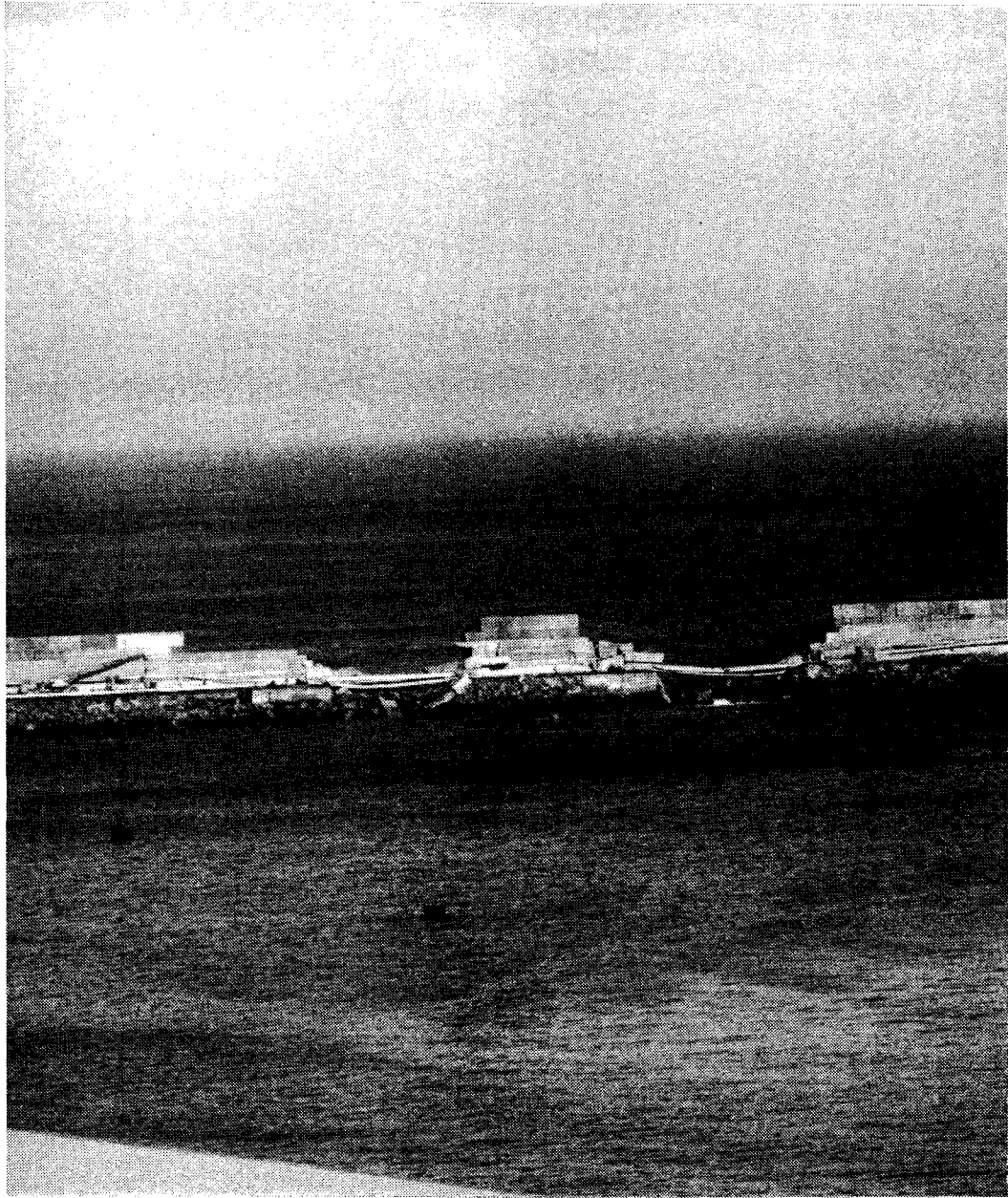

Fig. 5.7.f The damaged Bilbao Breakwater seen from the harbour side.

struction is generally made with less accuracy than model construction. This is simply a matter of cost and of the fact that it is almost impossible to observe the construction of the major portion of actual breakwater construction work which takes place below the water level, while model construction does not.

5.7.7 Stability of Quarry Stone Armour Layer

The damage is difficult to identify and describe. Traditionally, it has been reported as the number of stones moved more than their own dimension, divided by the total number of stones in the armour layer, or sometimes by the number of stones present within the section of the armour layer between $+H_s$ and $-H_s$ measured from still water level. This damage definition will also be used in the following.

Fig. 5.7.g shows results from stability tests on a breakwater for Korsør Ferry Port in Denmark.

The armour stones are rounded sea stones. The damage percentage inflicted on the armour layer (the number of stones displaced from the seaward armour layer divided by the total number of stones in this armour layer) is presented as function of the stability coefficient K_D , which may be considered a dimensionless wave height in the third power.

Fig. 5.7.h presents results from model tests carried out by DHI on a traditional rubble mound breakwater with quarry stone armour. The results are for tests runs with 5h prototype duration. The damage percentage is seen as function of the stability coefficient; here N and H_s are used.

ARMOUR: $W_{min} = 0.80t$
 $\bar{W} = 1.28t$ I
 $W_{max} = 1.90t$
 BERM: $W_{min} = 0.08t$
 $\bar{W} = 0.21t$ II
 $W_{max} = 0.48t$
 FILTER: $W_{min} = 0.008t$
 $\bar{W} = 0.056t$ III
 $W_{max} = 0.160t$

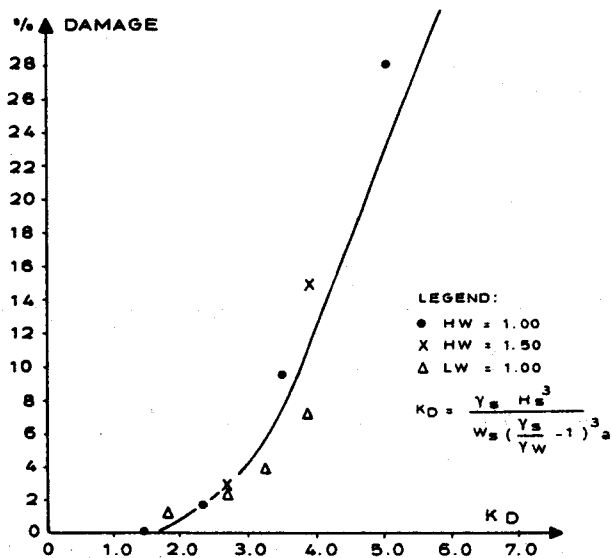
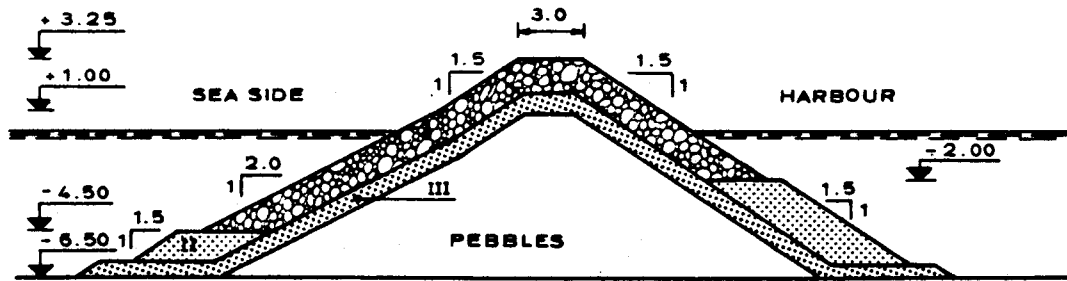

Fig. 5.7.g Results for Korsør Breakwater armoured with "rounded" sea stones (boulders).

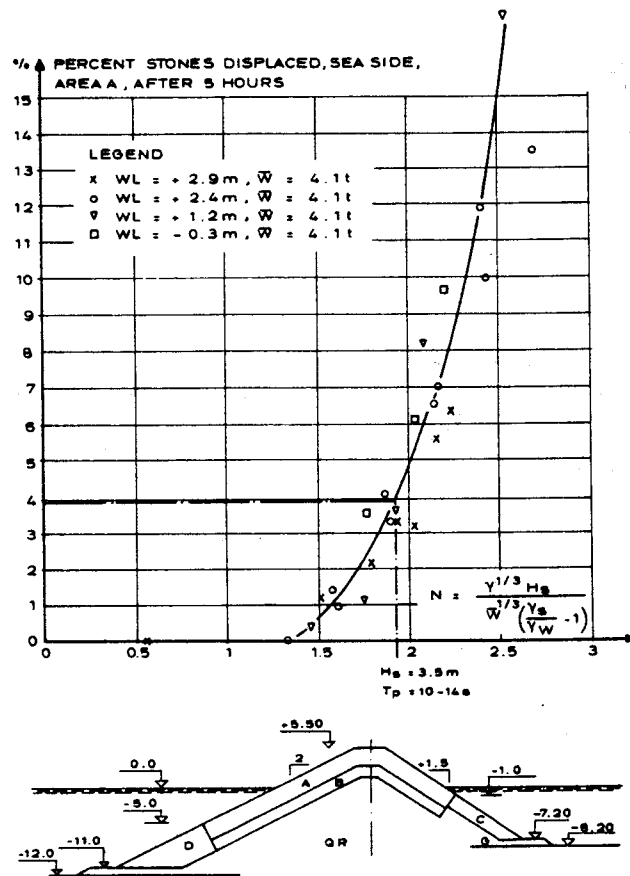

Fig. 5.7.h Test results for quarry stone armour layer.

5.7.8 Design of Deep Water Breakwater Armoured with Rectangular Blocks, Example

This section will as a practical example demonstrate the design of a breakwater armoured with rectangular blocks for a wave climate described by the wave height distribution shown in Fig. 5.7.i. The statistics show that a wave height of approximately $H_s = 7.1$ m is on average exceeded in one hour per 100 years. The corresponding peak period is approximately $T_p = 14$ s (mean wave period $T_z = 10$ s). Two alternative solutions called I and II were con-

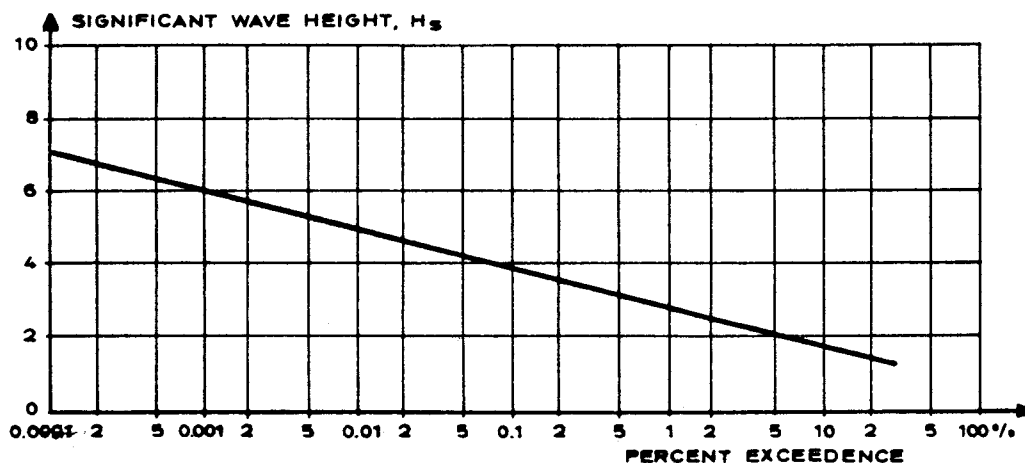

Fig. 5.7.i Wave height distribution used in Table 5.7.c.

sidered both with an armour layer extending from about -15 m to +10 m, but with a slope of 1 to 1.75 for Profile I and 1 on 2.0 for Profile II. The block weights were 60 t for Profile I and 58 t for Profile II, both with a concrete density of $\gamma_s = 2.3 \text{ t/m}^3$. The design evaluation is based on the Bilbao Breakwater model tests, the results of which are shown in Fig. 5.7.d. In Fig. 5.7.j a special analysis is made showing the percentage of blocks displaced per hour as function of wave conditions, block weight and density of the blocks. The use of the parameter

$$W^{1/3} \left(\frac{\rho_s}{\rho_w} - 1 \right) / (H_s^2 L_p \gamma_s)^{1/3} \quad \{5.7.i\}$$

is based on the presentation of all test results in Fig. 5.7.d. The wave period influence is taken into consideration by using $H_s^2 L_p$ in the stability formula instead of H_s^3 in accordance with Ref. 31. The stability formula is otherwise identical to Iribarrens formula, Refs. 35 and 36.

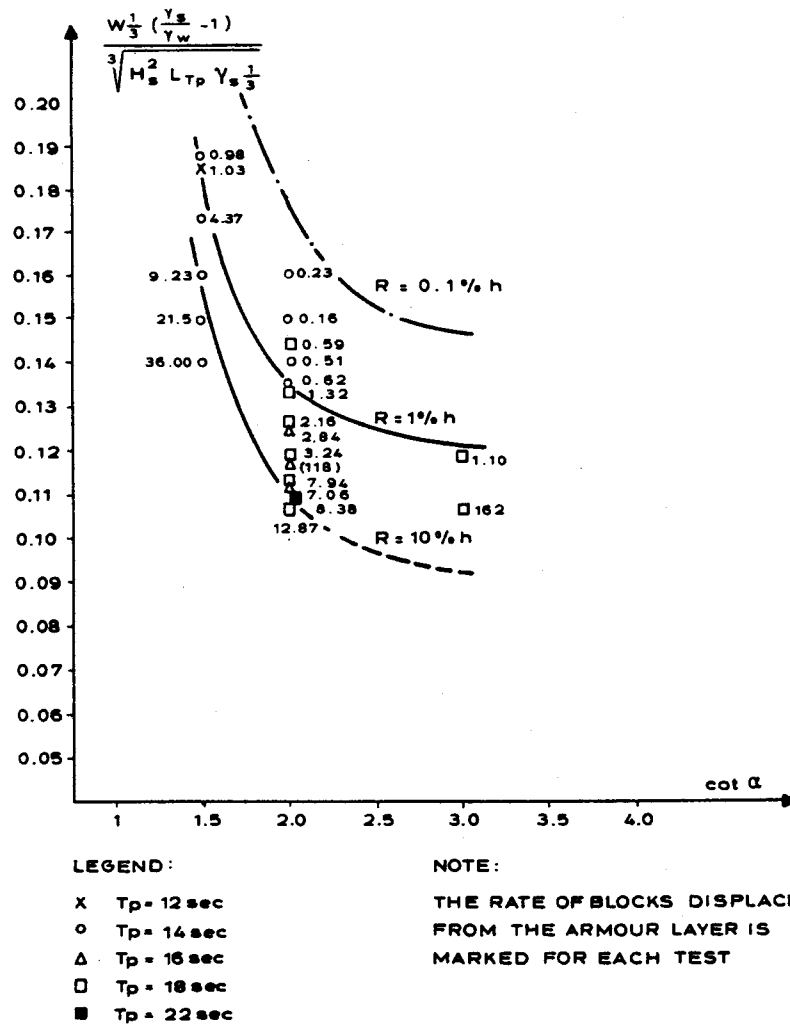

Fig. 5.7.j Test results for Bilbao Breakwater, special analysis.

From the results of Fig. 5.7.e it may be assumed that the damage development on average is linear with time for stationary wave conditions. On this basis it is possible to estimate the expected average accumulated number of blocks displaced after, for example, 100 years by making a simple integration of expected damage for each wave height interval multiplied by the expected number of hours in each wave height interval in the period in ques-

tion. The calculations are shown in Table 5.7.b.

Wave Height Level H_s (m)	Probability $p(\%)$	Hours in 100 years	$\frac{W^{1/3} \left(\frac{\gamma_s}{\gamma_w} - 1 \right)}{\sqrt[3]{H_s^2 L_p \gamma_s}}$		Profile I Slope 1:1,75 $W_s = 60 \text{ t}$		Profile II Slope 1:2,0 $W_s = 58 \text{ t}$		
			Pro-file I	Pro-file II	Dam-age/h	Total %	Dam-age/h	Total %	
> 7.0	$1.2 \cdot 10^{-4}$	1.1	0.164	0.163	0.5	0.559	0.20	0.20	
6.5-7.0	$(3.5-1.2) \cdot 10^{-4}$	2.0	0.168	0.167	0.33	0.65	0.15	0.30	
6.0-6.5	$(9.5-3.5) \cdot 10^{-4}$	5.3	0.177	0.175	0.25	1.35	0.10	0.55	
5.5-6.0	$(28-9.5) \cdot 10^{-4}$	16	0.187	0.185	0.18	2.90	0.07	1.10	
5.0-5.5	$(75-28) \cdot 10^{-4}$	41	0.199	0.197	0.10	4.10	0.03	1.25	
4.5-5.0	$(200-75) \cdot 10^{-4}$	110	0.213	0.210	0.03	3.3	0.015	1.65	
			Total estimate of average damage				12.9%		5.1%

Table 5.7.b Calculation of total average expected percentage of blocks displaced from the armour layer in level -10 to +10 m.

Damage Distribution

From the Bilbao Breakwater tests and from other tests it is known that the number of blocks displaced in a number of individual similar sections of a breakwater for an important level of damage follows approximately the normal distribution. See also Section 5.7.9, where it is shown that the damage distribution is close to a binomial distribution, which is close to a normal distribution for larger values of the mean value of the parameter. The Bilbao tests were made with a model section representing 80 m in reality. As an example a breakwater consisting of 10 such sections is considered. The Bilbao tests showed

a relative standard deviation (ratio of standard deviation of damage to average damage) of approximately 0.50. With 10 sections equally exposed, the most damaged section is expected to suffer damage equal to the average value plus 1.3 times the standard deviation according to the normal distribution, equal to 1.65 times the average damage. For profiles I and II this means that after 100 years it is expected that about 20% and 8%, respectively, of the blocks are displaced in the most seriously damaged 80 m section. Over a 20 year period the expected damage will be approximately 20% of the 100 year damage.

Comparison Tests in Regular and Irregular Waves for a Breakwater Armoured with Rectangular Blocks

In order to compare test results for irregular natural waves and regular waves a test series on the Bilbao Breakwater was also carried out with regular waves with $T = 14$ s and wave heights, H , in the range 6-13.5 m. The test runs for each wave height were continued until no further damage occurred. The results of these tests are shown in Fig. 5.7.k. It is to be noticed that for a wave height below $H = 10.5$ m only limited damage occurred with less than 5% of the blocks being displaced. For a wave height of approximately $H = 11$ m a rapid increase in the damage is observed with up to 50-60% of the blocks being completely displaced from the armour layer. As mentioned earlier a direct comparison of the results with the results of the tests with irregular waves is not relevant, since with regular waves the damage is limited for each wave height. For irregular waves as shown in Fig. 5.7.e the damage develops continuously with increasing duration of the wave conditions applied.

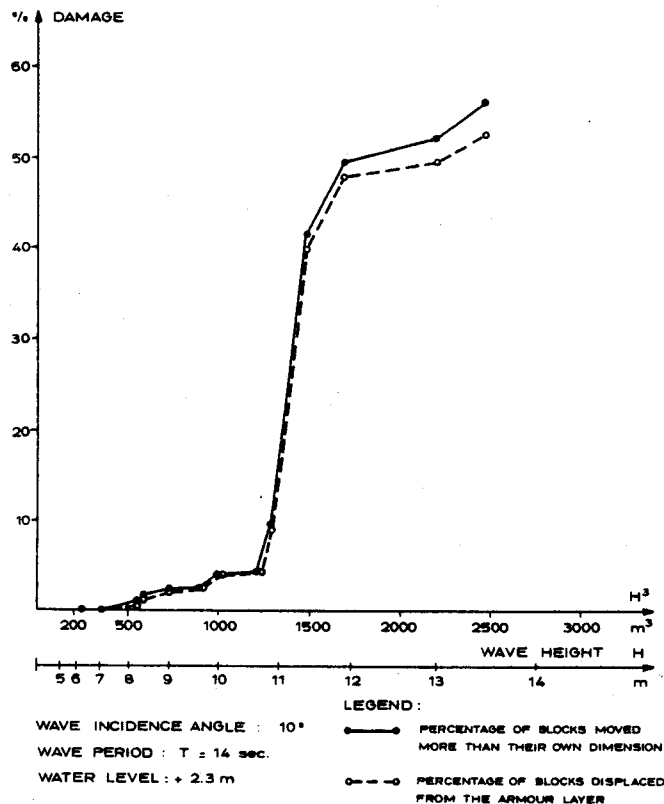

Fig. 5.7.k Test on Bilbao Breakwater (Fig. 5.7.e) for regular waves.

In order to see whether the tendency for damaged produced by waves larger than approximately $H = 11$ m could also be recognized in the tests with irregular waves. The results for irregular waves and $T_p = 14$ s is presented in Fig. 5.7.1. Both the average number of blocks displaced and the standard deviation is shown. The number of waves exceeding the wave height $H_{do} = 11$ m was calculated. For $H_s = 6.0$ m to $H_s = 11$ m this percentage is in the range 0.12% to 13.4%.

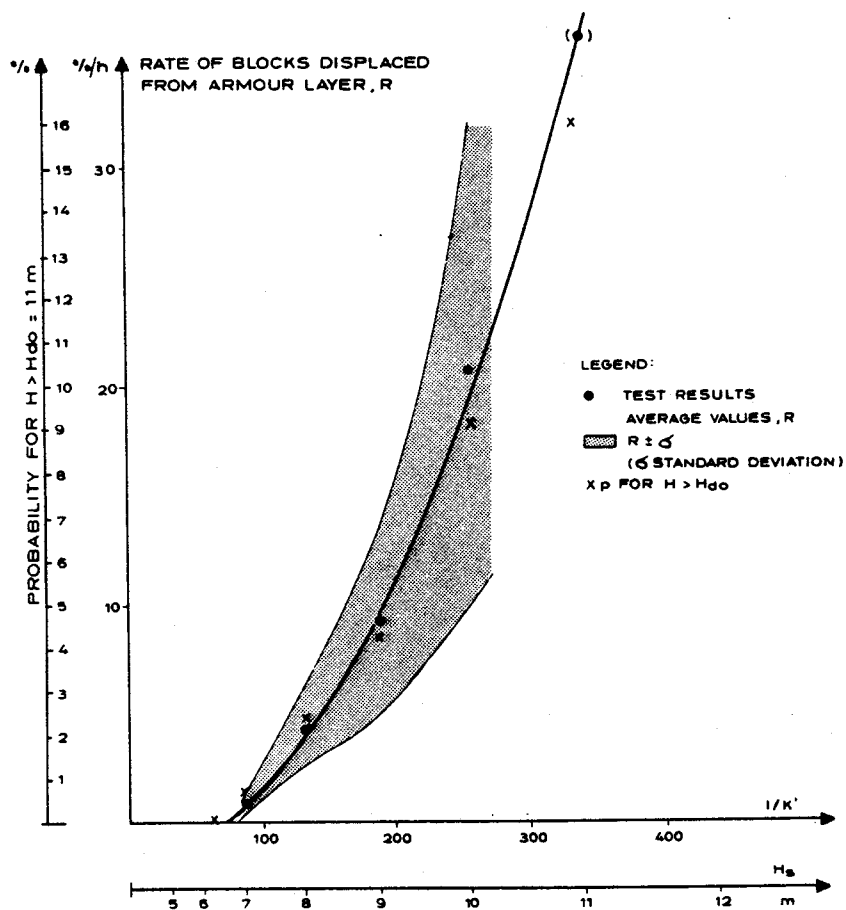

Fig. 5.7.1 Test with irregular waves, rate of blocks displaced as function of H_s compared with probability for $H > 11 \text{ m}$.

For all the significant wave heights the percentage is plotted in Fig. 5.7.1 on an ordinate axis making the best fit to the actual average test results.

The results show that the number of blocks displaced from the armour layer is proportional to the number of waves exceeding $H_{do} = 11 \text{ m}$ in the irregular wave tests for each significant wave height applied.

This kind of relationship has also been used in the example of a tetrapod breakwater presented in Section 5.7.9.

5.7.9 Tetrapod Breakwater in Shallow Water, Example

On the tetrapod breakwater shown in Fig. 3.1.d long series of tests were carried out. Due to the depth of approximately 12 m in front of the structure and extreme waves in the range $H_s = 7$ to 9 m, the maximum waves are limited by breaking.

As basis for calculation of accumulated damage the test results are presented in Fig. 5.7.m in the form of histograms showing the distribution of damage after 4 hours for each wave height applied. The results are for the middle third part of the armour layer, where nearly all damage took place.

It may be noted that the average number of blocks displaced from the armour layer does not show a consistent increasing tendency for significant wave heights greater than approximately 6.8 m. This is due to wave breaking, which occurs in front of the structure for the greater wave heights.

The total distribution of damage after 4 hours in all the tests for H_s greater than 6.8 m is shown in Fig. 5.7.n. In order to estimate the damage after a certain number of years a distribution may be used. For an estimate of the stability condition for lower waves, where the number of test results is smaller, another approach must be adopted. Based upon the general experience gained in the laboratory it may be concluded that damage occurring to a rubble mound breakwater is proportional to the number of

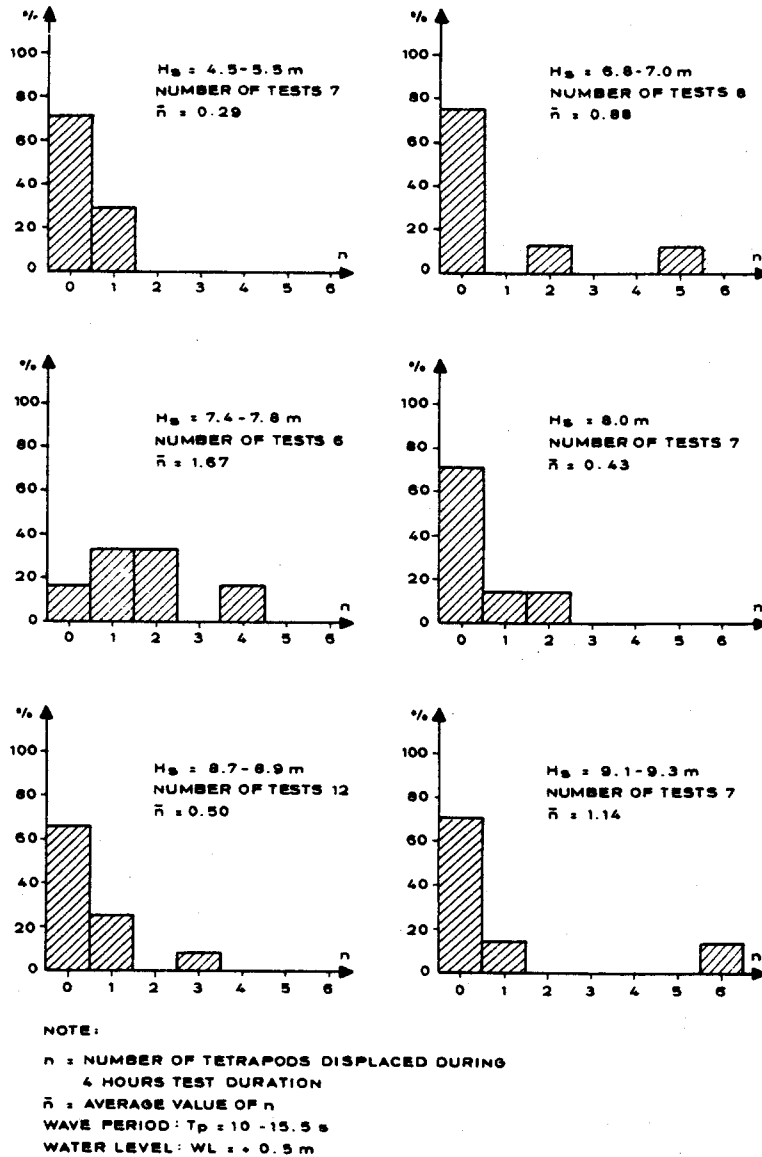
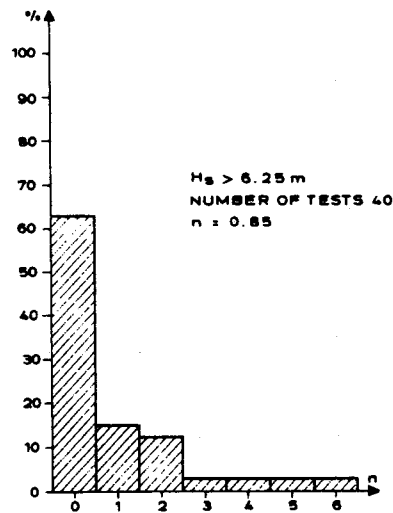

Fig. 5.7.m Distribution of damage for profile in Fig. 3.1.d.

"big" waves in the wave train causing the damage. For simplicity, the number of big waves in the wave train may be taken as the number of waves greater than a specific



NOTES:
 n = NUMBER OF TETRAPODS DISPLACED
 DURING 4 HOURS TEST DURATION.
 \bar{n} = AVERAGE VALUE OF n
 WAVE PERIOD: $T_p = 12-15.5$ s.
 WATER LEVEL: WL = +0.5m.

Fig. 5.7.n Test results for $H_s > 6.25$ m.

wave height, H_{do} , taken as the lowest wave height, which is able to really cause damage. In the present case this wave height was evaluated to be about 8.0 m. The assumption that damage is a function of the number of big waves in the wave train means that for wave conditions only containing a very limited number of big waves, the number of armour units displaced in the armour layer will be very small. In other words, the probability that a specific armour unit is displaced during a storm is very low. However, the total number of hours with moderate waves is rather high, and therefore has to be taken into consideration.

The tests have shown that significant wave heights greater than 6.8 m caused more or less the same rate of damage

to the armour layer and that wave heights between 5.5 and 6.8 m caused significantly lower damage. For the following calculation $H_s = 6.25$ m in between the two wave heights above has been used as the limiting significant wave height above which the average rate of damage may be regarded constant.

The expected rate of damage for more moderate wave conditions may be estimated from the number of waves greater than $H_{do} = 8.0$ m. In this way, the cumulative effect of all wave conditions in a certain number of years may be regarded as inflicted on the armour layer not by the "real" wave conditions, but by equivalent wave conditions, such as a certain number of hours with $H_s = 6.25$ m. This assumption facilitates the calculations. For the deep water wave condition the Rayleigh distribution will be applied as representative for the wave height distribution of individual waves in the wave record.

The results of the calculation is shown in Table 5.7.c.

This means that in the present case the complete effect of 100 years of storms is equivalent to approximately 40 hours storm with $H_s = 6.25$ m. This makes it possible to estimate the damage to the breakwater for any chosen number of years by using the assumption that damage develops linearly with time. Further, this analysis will evaluate the statistical distribution of damage in individual sections along the breakwater which is very important for safe design of the complete breakwater.

For one test section with a length corresponding to 0.6 m width of the flume which corresponds to 28.4 m in nature, damage distribution after approximately 10 years in a number of test sections each with a length of 28.4 m will

be in accordance with the distribution shown in Fig. 5.7.n.

Significant wave height, H_s (m)	Mean wave height \bar{H} (m)	$(H_{do}/\bar{H})^2$	P_1 =probability for $H>H_{do}=8,0$ m (%)	P_2 =probability for H_s acc. to wave statistics	h = number of hours in 100 years	Equivalent number of hours in 100 years with $H_s = 6.25$ m $h \cdot \frac{P_1(H_s)}{P_1(H_s=6.25)}$
6.25	3.91	4.19	3.72	$0.08 \cdot 10^{-4}$	7.0	7.00
6.00	3.75	4.55	2.80	$0.08 \cdot 10^{-4}$	7.0	5.27
5.50	3.44	5.41	1.42	$0.24 \cdot 10^{-4}$	21	8.02
5.00	3.13	6.53	0.59	$0.60 \cdot 10^{-4}$	53	8.41
4.50	2.81	8.11	0.17	$2.0 \cdot 10^{-4}$	175	8.00
4.00	2.50	10.24	0.032	$3.5 \cdot 10^{-4}$	307	2.64

Total: \approx 39.34 h.

Table 5.7.c Calculation of equivalent wave conditions in 100 years.

This means that in the first 10 years after construction of the breakwater on average 0.85 tetrapod will be displaced in each section of 28.4 m length, which corresponds to an average value of 0.75 tetrapod for 25 m sections. Further, the histogram shows that in 2.5% of the 25 m sections, or in one section per kilometer breakwater, 6 tetrapods will be displaced in the first 10 years.

The random nature of damage development means that the maximum rate of damage will not develop linearly with time, but will tend to decrease. This aspect will be treated in the following.

Evaluation of Damage Distribution along the Breakwater

It is not possible to estimate the probability that a specific block in the armour is displaced for a wave height exceeding $H_{do} = 8.0$ m, and thus the distribution of damage in sections along the breakwater for any specific number of years.

One specific block has two possibilities, when a wave greater than H_{do} arrives. It may be displaced or remain in place. This means there is a certain probability, p , that the block will be displaced for wave heights exceeding H_{do} . With the probability, p , that a specific block is displaced, the probability that the block is not displaced is $1-p$. The probability, Pr , that n blocks are displaced from the armour layer may be determined from the binomial distribution.

$$Pr (X = n) = \binom{N}{n} p^n (1-p)^{N-n} \quad \{5.7.j\}$$

From test results and the wave height distribution, p may be estimated in the following way. From the test results presented in Fig. 5.7.n the average rate of tetrapods displaced from each test section during 4 hours storm duration is equal to 0.85, (0.75 for a 25 m section).

Table 5.7.m indicates that for $H_s = 6.25$ m the probability that a specific wave exceeds $H_{do} = 8.0$ m is equal to 3.72%. In 4 hours the total number of waves will be equal to 1470 for a representative wave period, $T_p = 14$ s, and a ratio of 0.7 between T_z and T_p and thereby $T_z = 9.8$ s. The number of individual waves exceeding $H_{do} = 8.0$ m in 4 hours is therefore $0.0372 \times 1470 = 55$.

The probability that one wave exceeding $H_{do} = 8.0$ m will displace one tetrapod in the 25 m section will therefore

be equal to:

$$n = \frac{0.75}{55} = \underline{0.0136} \quad \{5.7.k\}$$

In "i" years the number of waves, N, exceeding $H_{do} = 8.0$ m is equal to:

$$N = \frac{i}{100} \cdot \frac{39.34 \text{ hours per 100 years}}{4} \cdot 55 = 5.41 i,$$

where N has to be an integer. Now the probability that X blocks are displaced from a 25 m section after "i" years may be determined from the binomial distribution:

$$\text{Pr } (x = n) = \binom{5.41 i}{x} 0.0136^x (1-0.0136)^{5.41 i-x} \quad \{5.7.l\}$$

For 5, 10, 25, and 50 years Eq. 5.7.l gives the results shown in Fig. 5.7.o. No more than 3 to 4 tetrapods should be displaced in the most damaged section after 10 years, whereas the distribution in Fig. 5.7.n yields approx. 6 tetrapods. It is expected that the damage distribution in various sections along the breakwater is binomially distributed, so the results of Fig. 5.7.o may be used for design of the armour layer.

In Fig. 5.7.o the distribution of damage in 25 m sections along the breakwater is also shown for other numbers of years. As mentioned earlier, it is to be expected that damage of the worst section does not develop lineally with time. As an example, after 5 years it is to be expected that 3 tetrapods are displaced from the most damaged 25 m section, while after 50 years 9 tetrapods are displaced.

Because nearly all tetrapods are displaced from the middle third part of the armour layer located around the still water level, the damage is shown both in relation to the total number of blocks in the armour layer and in relation to the number of tetrapods in the middle third section.

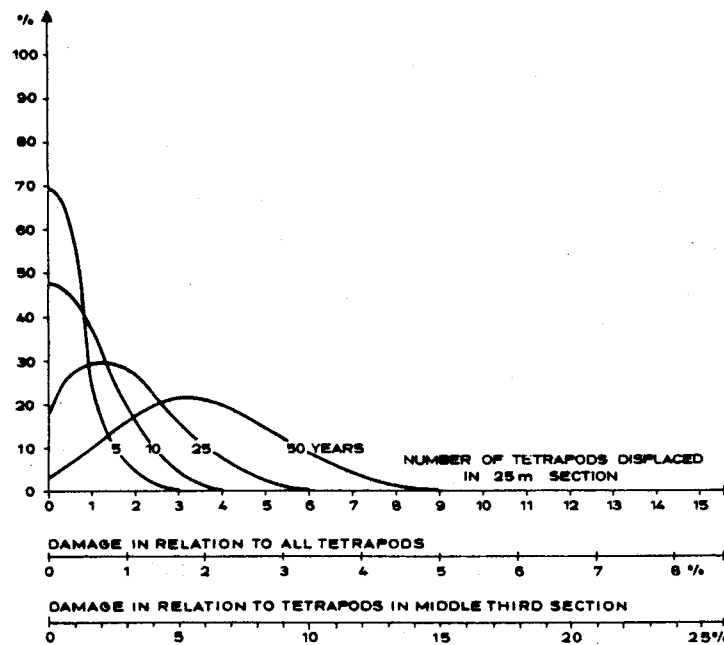

Fig. 5.7.o Evaluation of damage distribution for the breakwater shown in Fig. 3.1.d.

Stability as Function of Tetrapod Size

The model tests were performed with tetrapods with a size corresponding to 10 m^3 and a density of 2.32 t/m^3 . For final design it is also necessary to evaluate the stability for other tetrapod sizes. It is assumed that Hudson's formula describes the influence of the wave height and the weight of the armour units. Hudson's formula may be written as follows:

$$\frac{H_s^3}{V} = N^3 \left(\frac{\rho_s}{\rho_w} - 1 \right)^3 = \text{constant} \quad \{5.7.m\}$$

This implies that for a constant value of H_s^3/V the damage may be regarded as constant. With a change in the tetrapod volume from 10 to 8 m³, the damage will be the same for the two tetrapod sizes, if the wave heights causing the damage are reduced by $(8/10)^{1/3} = 0.93$. Thus the same calculation as presented in Table 5.7.c may be carried out for other tetrapod sizes. The results are shown in Fig. 5.7.p. By changing the tetrapod volume from 10 to 8 m³ the average number of blocks displaced from the armour layer per year is increased by a factor of approximately 2.

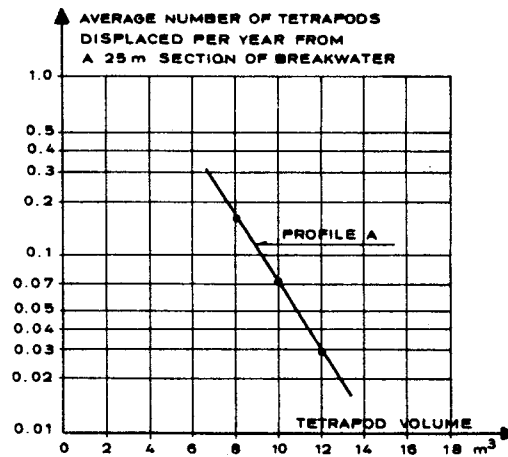

Fig. 5.7.p Number of tetrapods displaced as function of tetrapod size.

5.7.10 Wave Incidence Angle

The stability coefficients for armour units are normally given for perpendicular wave attack (wave fronts parallel to breakwater alignment). Intuitively it is expected that oblique wave attacks will result in less damage. This is

not always the case, for example for dolos. Fig. 5.7.q shows results of DHI model tests. For a wave incidence angle from 0° up to 45° no increase in stability is observed, for dolos even a decrease. For dolos it is seen that even for 75° incidence angle no stability increase is observed. For quarry stones the stone weight may be reduced by a factor 1.5 for the same angle of incidence.

It should be noted that the incidence angle has more influence on other factors, such as for example wave overtopping and forces on crown walls. Ref. 86 and Ref. 26 deal with oblique wave attack for dolos and tetrapods respectively.

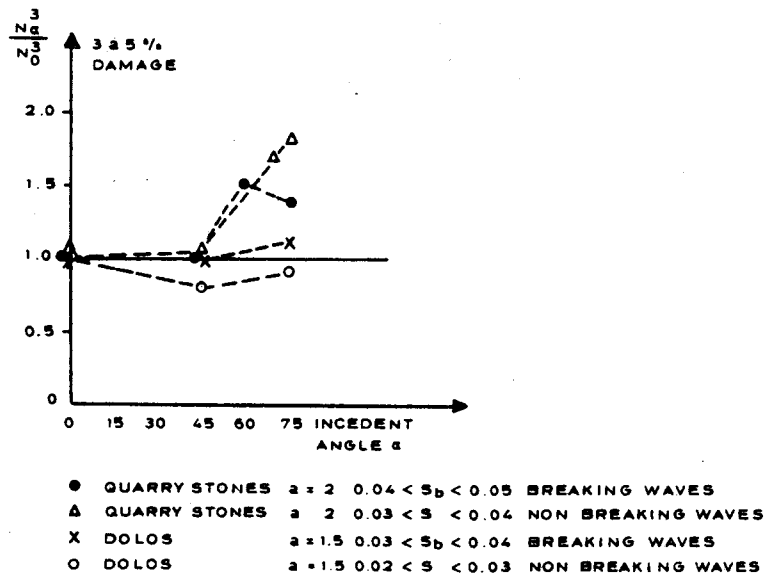

Fig. 5.7.q DHI results for oblique wave attack on quarry stones and dolos-breakwaters (from Gravesen et al, Ref. 30).

5.8 Breakwater Crest

A breakwater crest should always be so wide and high that it ensures the rear side against damage due to wave overtopping. It should further be made so wide that it is well-defined for the contractor, which means equal to the size of a certain number of armour units. In practice a minimum width equal to three or four times the armour unit size (stone or artificial unit) has been sufficient. Other factors than stability and constructability also play a role for the width of a breakwater, for example the wish to have a certain minimum width during construction.

5.9 Superstructure

5.9.1 Introduction

No guidelines exist for design of concrete superstructures and for determination of wave forces on superstructures. It is therefore necessary to perform model tests to determine design forces.

This section presents the results and considerations from a number of model investigations carried out at DHI. The model tests were all performed with irregular waves reproduced directly from natural wave records. The influence of the various geometrical and hydrographic parameters on the wave forces are illustrated.

5.9.2 Width of Superstructure

For breakwaters with a crown wall and superstructure the considerations of Section 5.8 are also relevant. In this case the wish for a certain minimum width of the roadway

during or after construction will often be determinant for the width of a superstructure.

With respect to the rubble mound in front of a crown wall it is important to have a "shoulder" (Horizontal layers). This makes construction more easy, because there will be less wave up-rush where the superstructure is cast. Further, in case of serious damage to the structure the risk of complete displacement of material in front of the wall will be reduced. Consequently, the risk of erosion under the crown wall and failure are reduced.

5.9.3 Reasons for Superstructures

Crown walls and concrete superstructures are normally used either in order to reduce the crest elevation or to reduce wave overtopping, or as a roadway for traffic or pipelines etc. They give easy access to the breakwater when in service, which may be of importance to repair work. Superstructures and parapets are usually constructed of concrete, but also steel and wood may be used. There is for example in Denmark a tradition to use a wave screen made of wood on small breakwaters in shallow water. An example of this type of structure is shown in Fig. 5.9.a. When a superstructure or parapet wall is introduced to reduce wave overtopping, it will normally be exposed to large wave forces.

5.9.4 Problems Relating to Wave Forces

The wave forces on a superstructure are a function of the volume of water hitting the structure and its velocity. The forces are therefore related to the magnitude and velocity in the wave up-rush which is a function of wave

conditions in front of the structure, the water level, the geometry of the breakwater slope and its hydraulic roughness and porosity characteristics.

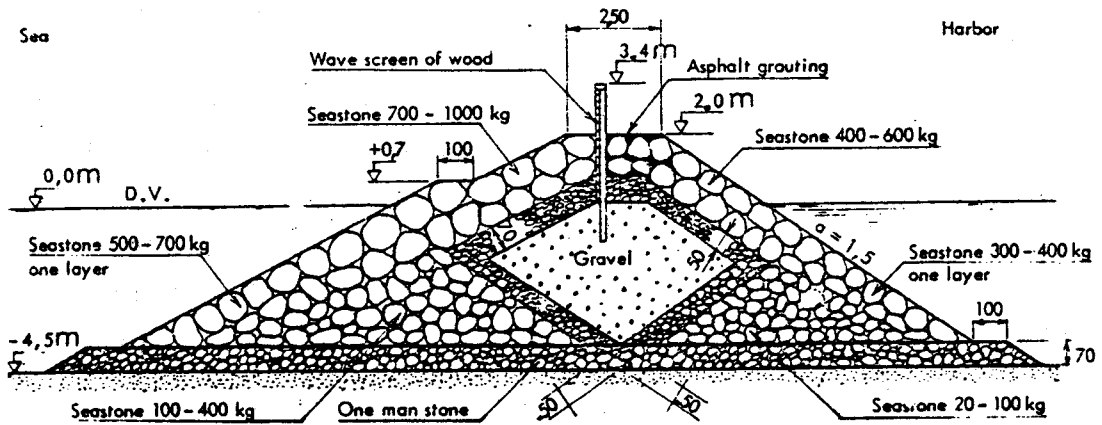

Fig. 5.9.a Typical Danish rock breakwater built of "seastones" (rock from the bottom of the sea of glacial origin) (Ref. 56).

The physics of wave forces on superstructures are for the above mentioned reasons very complicated. It should also be noted that the design of a breakwater superstructure is a combined hydraulic, geotechnical and construction material problem, because also the material in which the superstructure is founded plays an important role for the wave forces and the overall stability. When the foundation material is very permeable, as is the case for quarry stones, wave pressure penetrates to the base of the superstructure. In this case the combined wave pressures on all parts of the structure is important, because the structure is exposed to varying horizontal and vertical lift forces, which do not peak at the same moment.

It should also be realized that the material in front of the structure (armour layer and filter layer etc.) is

flexible and may be displaced. During extreme wave conditions damage may be inflicted on the armour in front, which may cause greater wave loads on the more exposed superstructure.

For the above reasons a rational and optimum design of a rubble mound structure with a superstructure requires that the combined and complex relations between damage to the flexible protection and forces to the superstructure be considered. The only tool to analyse this problem is model tests, and only tests with reproduction of the natural sea state can provide the necessary information pertaining to this problem. For the design of a superstructure it is thus also important to obtain a profound knowledge of the hydrographic conditions at the site. For the magnitude of wave forces on a superstructure not only the wave conditions are important, but the simultaneous expected water level during the storm conditions as well.

5.9.5 Physics of Wave Forces on Superstructures

In order to discuss the physics of wave forces on superstructures some principles of wave forces on vertical face breakwaters presented by Lundgren in Ref. 52 may be repeated:

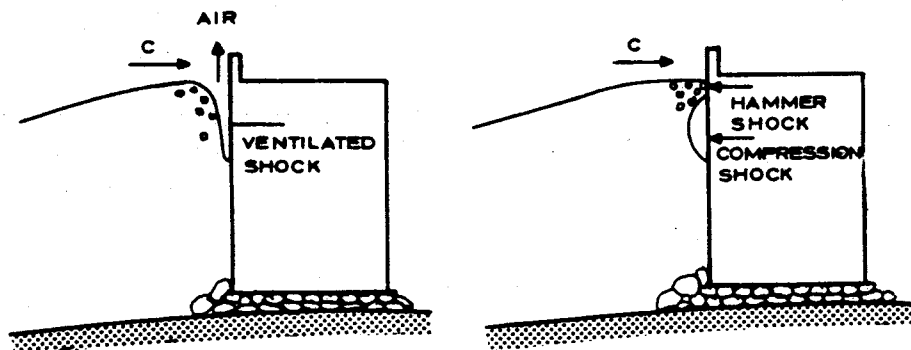

Fig. 5.9.b Types of shock forces on a vertical face breakwater.

The three types of shock forces are:

- 1) Ventilated shocks.
- 2) Compression shocks.
- 3) Hammer shocks.

For a typical breakwater superstructure the forces occurring on the front side are a combination of all three types of shock.

The air entrapped in the mass of water is bubbles and "pockets" of different sizes, generally very small compared to the size of the superstructure.

Forces on the Front Face

The forces on the front face of the superstructure are impulse forces due to the water in the run-up hitting the structure. Figs. 5.9.c and 5.9.d show that the water is forced up into the air or flowing over the crest of the structure. In case the forces on the superstructure become excessive it may fail by being displaced backwards and at the same time lifted due to the pressure under its base.

Time series of typical forces for perpendicular wave incidence are shown in Fig. 5.9.e. The positions of the eight pressure gauges, five on the front side and three under the base plate are also shown.

Generally the duration of the peak of the total wave force on superstructures is long compared to shock forces on vertical breakwater. For the case shown in Fig. 5.9.e about 1 to 2 s, which is in the order of 10% of the wave period.



Fig. 5.9.c Wave up-rush on tetrapod armour layer.

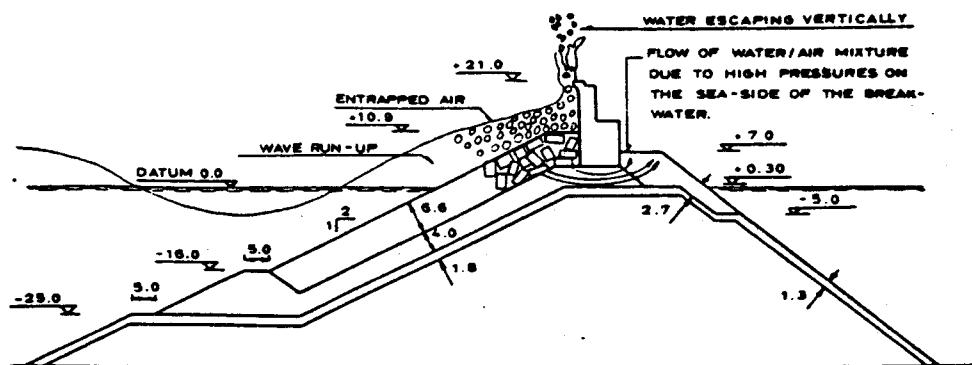

Fig. 5.9.d Principle of wave up-rush on breakwater with crown wall.

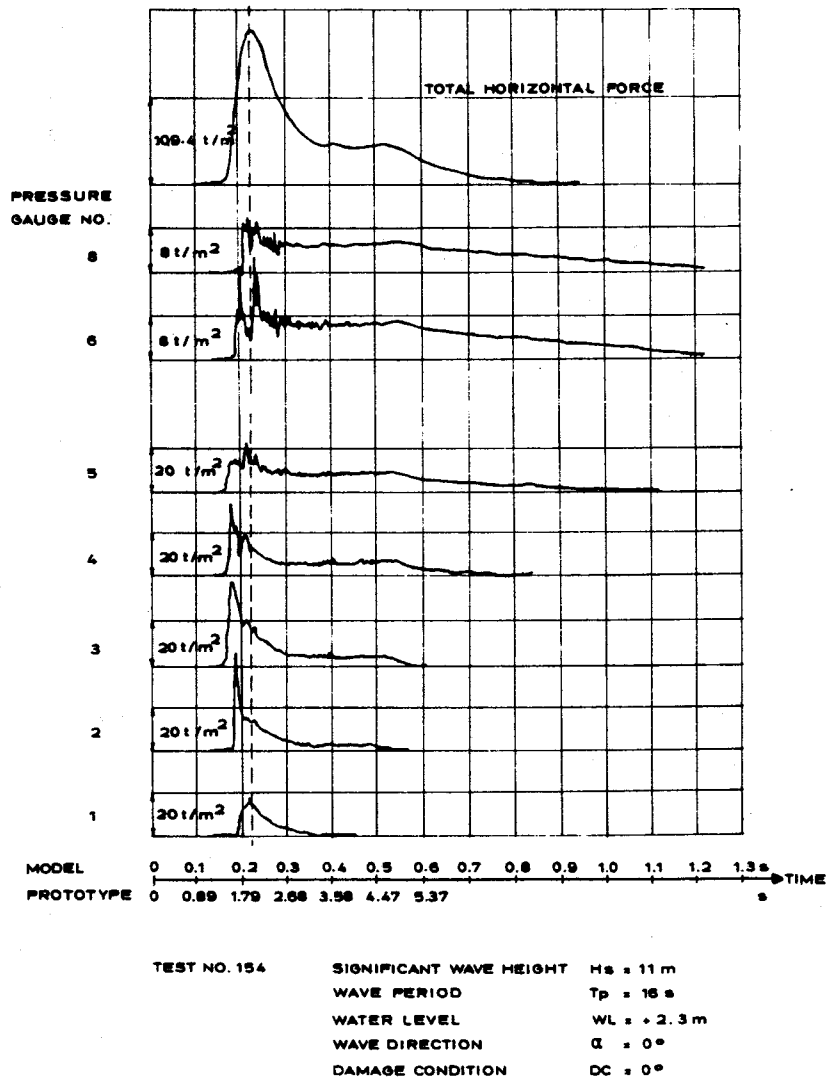
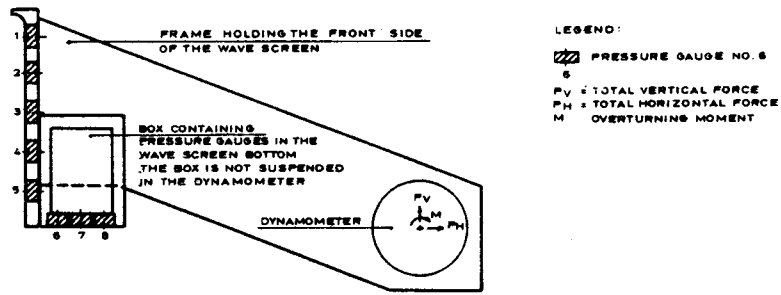

Fig. 5.9.e Records of maximum wave pressure on breakwater crown wall for perpendicular wave attack. Profile is shown in Fig. 5.9.b.

On the front side sharp peak pressures are recorded. However, they are a very local phenomena occurring due to compression on air bubbles/pockets. These forces are not reproduced in scale in the model and should be interpreted using the compression model law described in Ref. 51. The total horizontal force measurement shows a continuous smooth curve without sharp peaks and is therefore be a true representation of the wave forces in scale. For oblique wave attack the pressures are more smooth and the duration of the horizontal force longer, as it can be seen from the pressure and force records in Fig. 5.9.f.

Forces under the Base

If the superstructure is founded in porous media, such as quarry stones special attention should be paid to the conditions under the base. The forces occurring here are due to pressure in compressible media, a mixture of water and air. If the base is above SWL the physics are especially complex. In this case the pores between the stones under the superstructure are normally filled with air. During the fast up-rush of waves on and in the armour layer a large volume of air may be trapped. Due to the high pressure, when the up-rush reaches the front wall of the superstructure, the air pocket will be squeezed out under the base towards the rear side (Fig. 5.9.d). This phenomenon of squeezing out the air under the superstructure appears to cause oscillating pressures in the air trapped here. Such oscillations normally only occur in the beginning of pressure exerted by a single wave, when the maximum pressure occurs. Later the pressure becomes more quasistatic with less rapid changes.

The oscillations do not occur for all wave conditions. They are most predominant for normal incident waves and

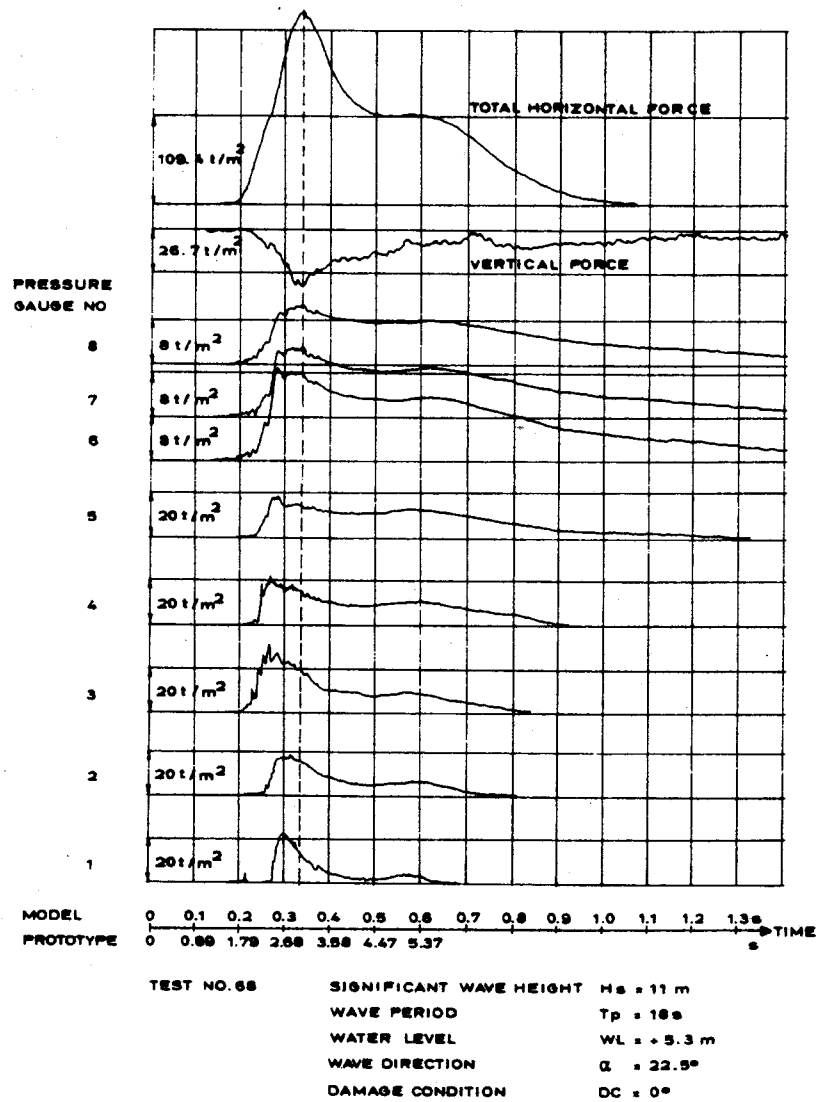

Fig. 5.9.f Records of maximum wave pressure on breakwater crown wall for oblique wave attack ($\alpha = 22.5^\circ$). Profile is shown in Fig. 5.9.h.

for situations, where the still water level is below the superstructure. The described phenomenon is shown by the maximum pressure records in Fig. 5.9.g for the breakwater

shown in Fig. 5.9.h. The pressures presented are from measurements under the base plate for 1,000 waves impinging on the structure. Note the differences in time series dependent upon water level and wave incidence angle, α . For oblique waves the rising time of the pressure is much longer than for perpendicular incidence where the wave up-rush suddenly hits the superstructure, whereas for oblique waves the pressure also escapes laterally.

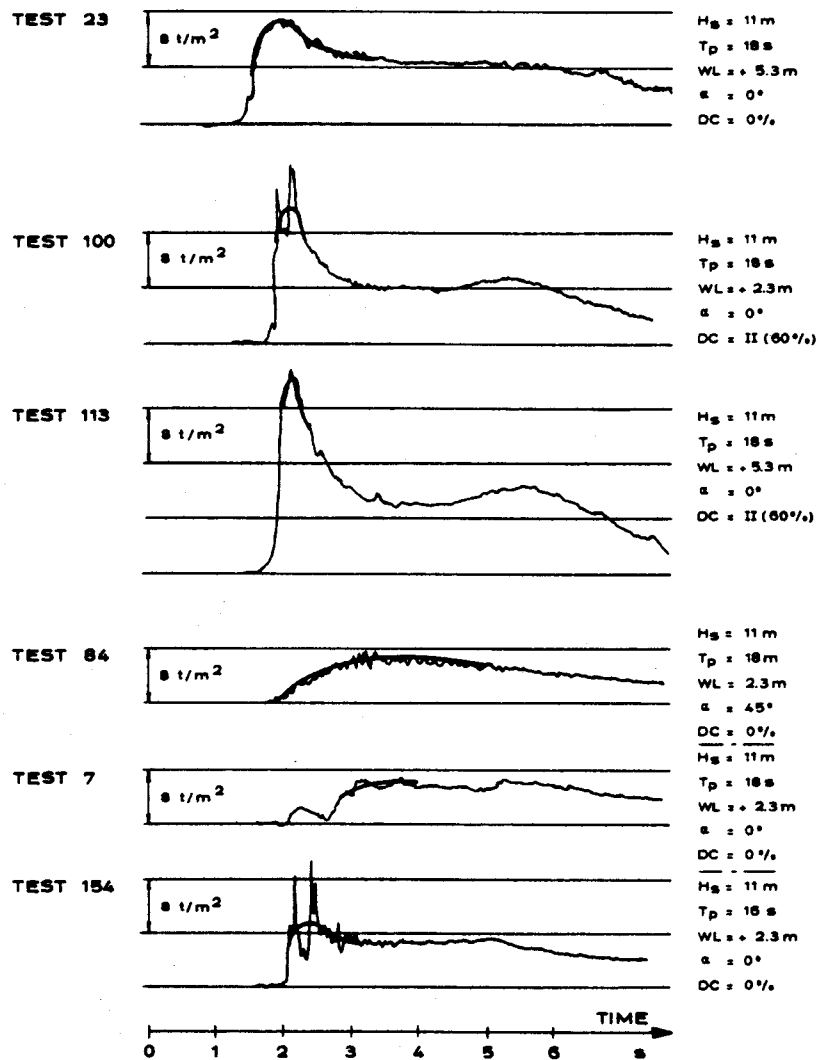

Fig. 5.9.g Pressure records from pressure gauge No. 6 under the base plate. Profile is shown in Dwg. No. 5.9.h.

5.9.6 Model Laws

Since model tests are indispensable to determine wave forces on superstructures it is necessary to establish laws of similitude for models.

Froude's Law is described in Section 6.1, and the Compression Model Law in Ref. 51.

- (1) Model impulses, $\int p \cdot dt$ can be converted directly according to Froude's Law.
- (2) Froude's Law also applies to the maximum pressure from a well ventilated shock, but will yield conservative values, if the bubble content in the prototype is high, and the pressure rise is very rapid.
- (3) The Compression Model Law (see Ref. 51) applies approximately to the maximum pressure from a compression shock.
- (4) Froude's Law is valid for a normal hammer shock, but in many cases a composite effect, also involving compressibility, may occur due to entrapped air pockets.

For analysis of the pressure records shown in Fig. 5.9.g the procedure is as follows:

- 1) The "Froude" part of the pressure record is assumed to be the non-oscillating part (see heavy lines in Fig. 5.9.g).
- 2) The peaks occur because of oscillations of pressure in the air pockets/bubbles. As estimates of the

mean pressure on the bottom of the wave screen these peaks are converted according to the Compression Model Law.

This procedure will give prototype pressures which may normally be considered slightly conservative. The model water hitting the front face of the wall has a larger relative density due to the smaller content of air. These considerations have shown how complex the nature of forces on superstructures is, and it is therefore at present not possible to present a profound hydrodynamic description of the problem. A simple evaluation of the important parameters is presented in the following.

5.9.7 Parameters Influencing Waves Forces

The wave forces are caused by wave up-rush. It is therefore the same parameters that influence the magnitude and extent of the up-rush that govern the magnitude of wave forces together with the position and configuration of the superstructure.

a) Slope angle

Since the up-rush is generally decreasing with decreasing slope angle the wave forces are smaller on flatter slopes than on steep slopes. However, for steep slopes such as 1 on 1.5 to 1 on 2.0 the difference is only marginal due to nearly the same up-rush characteristics as shown in Ref. 74.

b) Slope roughness and permeability

The wave forces strongly depend upon the slope roughness and permeability. As an example the up-rush, and thereby wave forces are much larger on

cube armour than on tetrapods (Ref. 4).

c) Wave height, wave period

Wave forces generally increase with increasing wave height and also with the wave period, since an increase in both parameters increases the up-rush. As shown in Section 4.2, the velocities in the wave up-rush are proportional to \sqrt{gH} . Since the forces on the superstructure are impulse forces they are proportional to mv^2 , m being the mass of water hitting the structure and v its velocity.

However, since the superstructure is normally at a certain level above SWL, a certain minimum wave height, H_{SO} , is required to cause up-rush which reaches the superstructure. The maximum pressure on a wall or superstructure may therefore be written:

$$p = C_p \cdot \gamma_w \cdot f(T, \alpha, \dots) (H_s - H_{SO}) \quad \{5.9.a\}$$

where:

p = pressure on wave wall (N/m^2)
 C_p = dimensionless coefficient
 $\gamma_w = \rho_w \cdot g$ = specific weight of water (N/m^3)
 $f(T, \alpha, \dots)$ = dimensionless function of wave period T , slope angle α , type of armour units, permeability of sublayers, etc.

5.9.8 Results of Measurements

Horizontal Forces

In the following the parameter F_H represents the maximum

horizontal force per meter of wall for 1000 waves. For a given structure F_H (kN/m) will be made dimensionless by division by $\gamma_w hbL_p$, where

- γ_w = specific weight of water (N/m^3)
- h = height of wall (m)
- b = width of wall (m)
- L_p = wave length corresponding to the peak wave period (m).

The significant wave height is made dimensionless by division by the vertical distance from still-water to the crest of the armour layer.

All results presented come from model tests, using reproductions of irregular natural wave records, Ref. 29. All results are for perpendicular waves. All tests lasted 1000 or more waves. The total horizontal wave force was measured by use of a dynamometer. The wall model was suspended in a dynamometer to allow for measurements of total forces and moments. The measurements of moments made it possible to determine the moment arm for the total horizontal forces.

The results for three different types of breakwaters are shown in Figs. 5.9.h, 5.9.i and 5.9.j.

The results show that generally the wave forces increase almost linearly with the significant wave height, H_s , as expected from Eq. 5.9.a. Further almost no wave forces on the wave walls occurred for $H_s/\Delta h$ values of less than approximately 0.5. With the maximum waves equal to about $1.85 H_s$, it means that wave forces occur for $H_{max} > 0.9 \Delta h$, which is in agreement with measurements showing that the up-rush is about equal to the wave height.

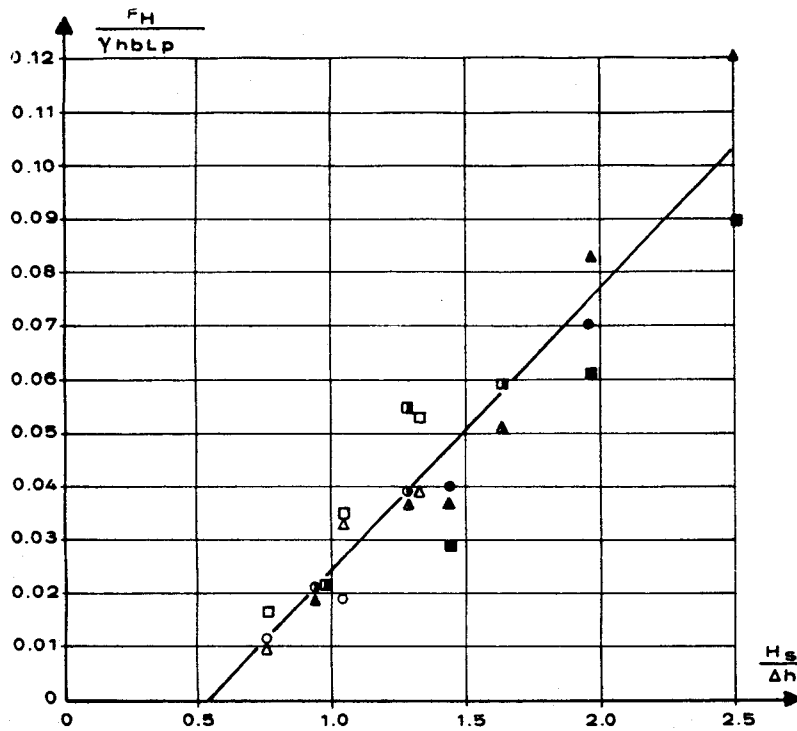

LEGEND:

WATER LEVEL (m)	PEAK WAVE PERIOD T_p (s)		
	14	16	18
+ 5.3	●	▲	■
+ 2.3	○	△	□
+ 0.3	○	△	□

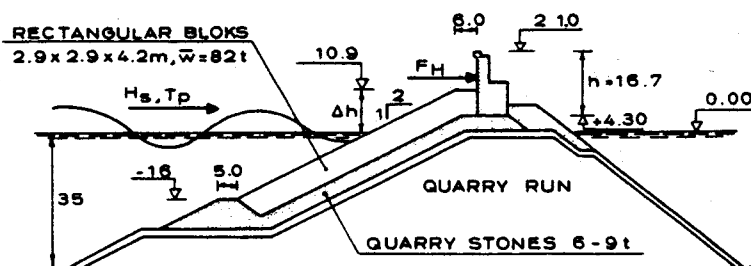
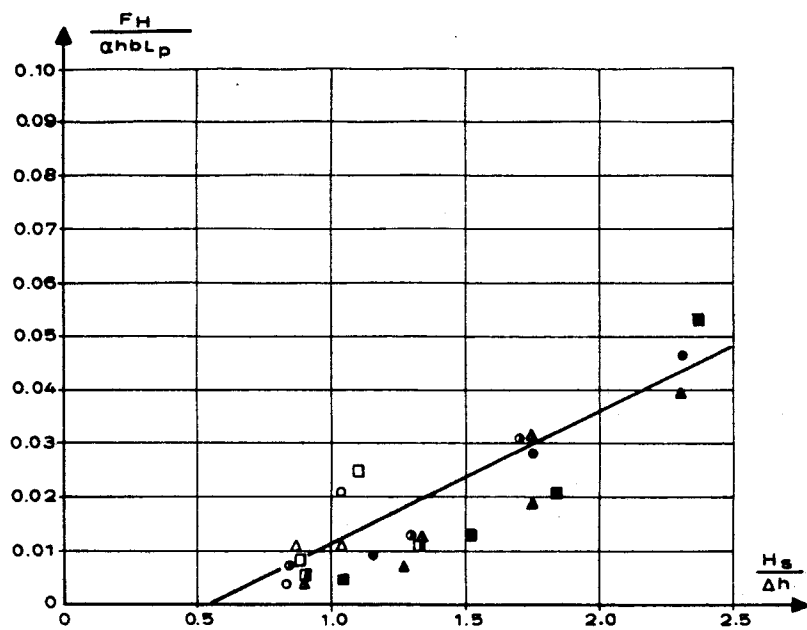

Fig. 5.9.h Results from tests, I.



LEGEND:

WATER LEVEL (m)	PEAK WAVE PERIOD Tp (s)		
	14	16	18
+1.5	●	▲	■
+1.0	○	△	□
0.0	○	△	□

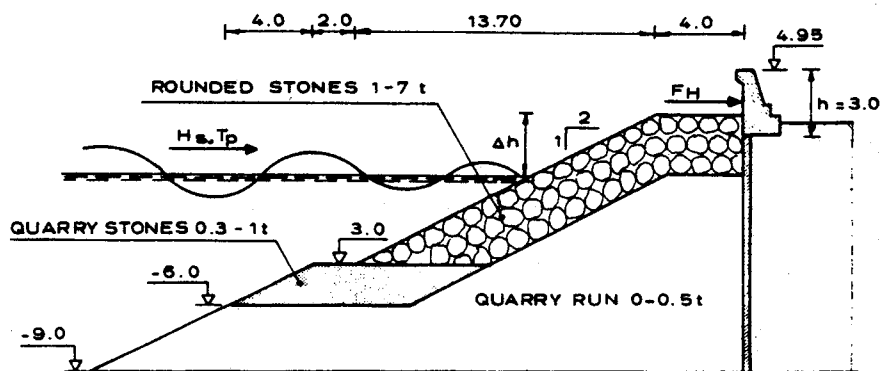
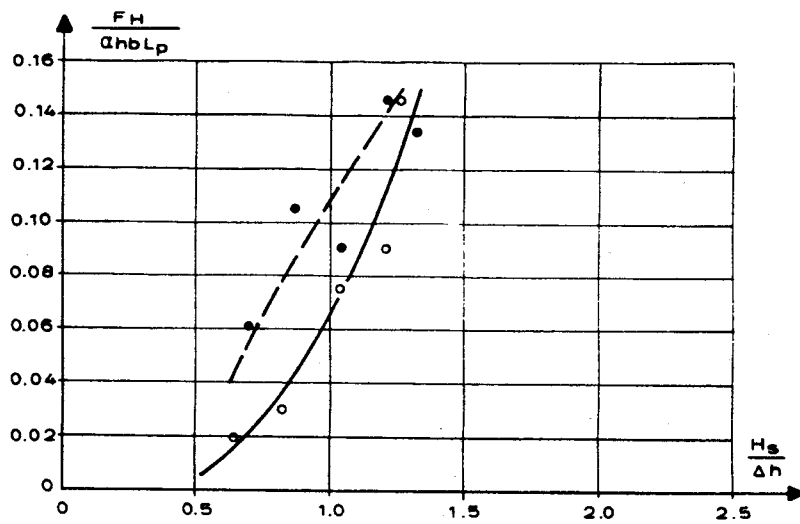

Fig. 5.9.i Results from tests, II.



LEGEND:

PROFILE	SIGNAT.
B	o
C	•

NOTE:

H_s IS MEASURED IN DEEP WATER
 WAVE PERIOD, $T_p = 10 - 14$ s

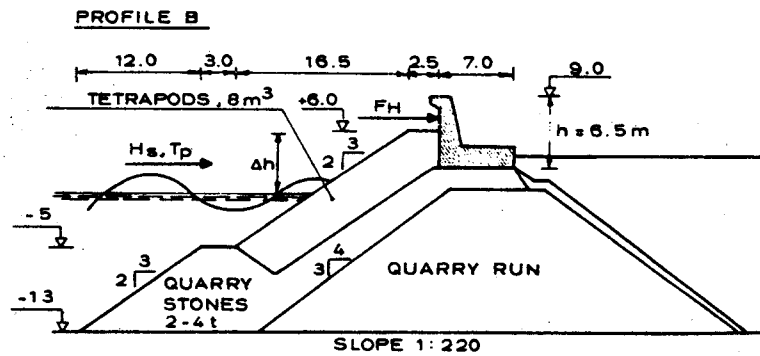

PROFILE C

(PROFILE IDENTICAL TO B EXCEPT THE DEPTH)

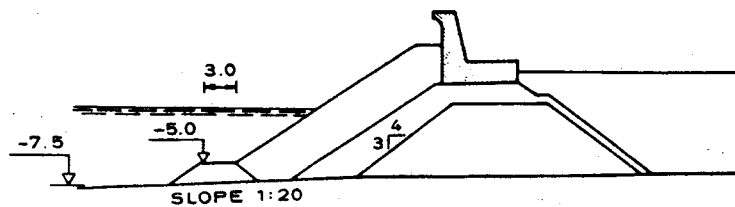
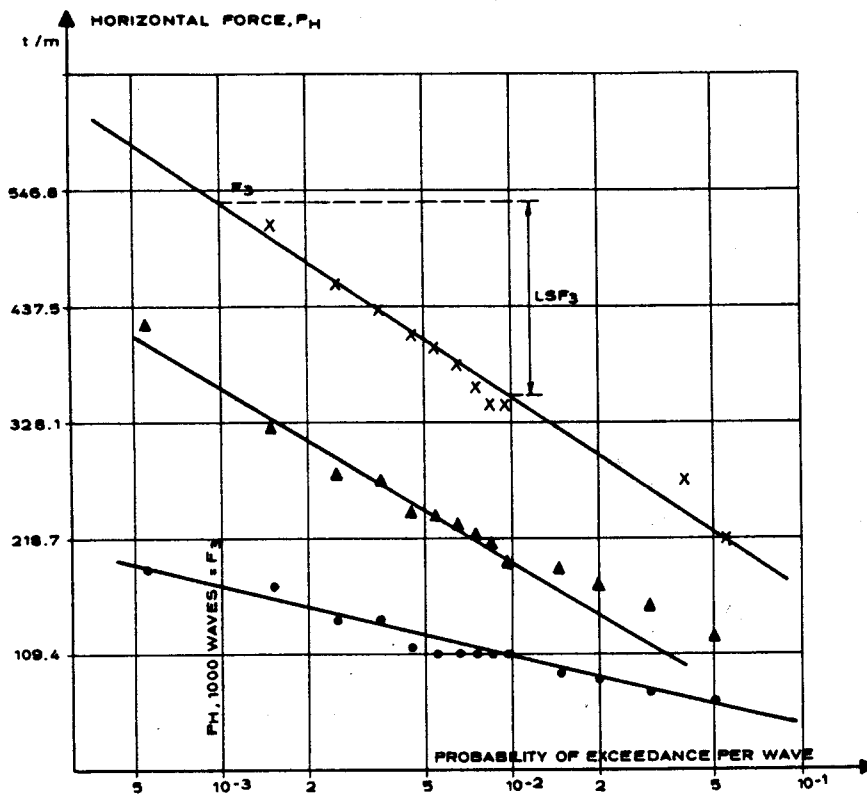

Fig. 5.9.j Results from tests, III.

Distribution of Waves Forces

Fig. 5.9.k shows the distribution of wave forces measured on the breakwater in Fig. 5.9.h. The results are for perpendicular wave incidence, wave period $T_p = 18$ s, a water level of +5.3 m and a significant wave height of 8, 11 and 14 m respectively. The results show that an exponential distribution fits the wave forces. The drawing also shows how the maximum force for 1000 waves are determined from the distribution.



NOTE :	LEGEND:
ANGLE OF WAVE INCIDENCE : 0°	● H _s = 8m
WAVE PERIOD: T _p = 18s	▲ H _s = 11m
WATER LEVEL: + 5.3m	X H _s = 14m
DAMAGE CONDITION: 0%	

Fig. 5.9.k Example of distribution of total horizontal wave force on breakwater crown wall.

Influence of Water Level

The results presented as a function of H_s/h show that this parameter is able to take the influence of the water level into consideration. This means that wave forces increase almost linearly with increasing water levels in the same manner as with the wave heights. Fig. 5.9.1 shows results for the breakwater in Fig. 5.9.h.

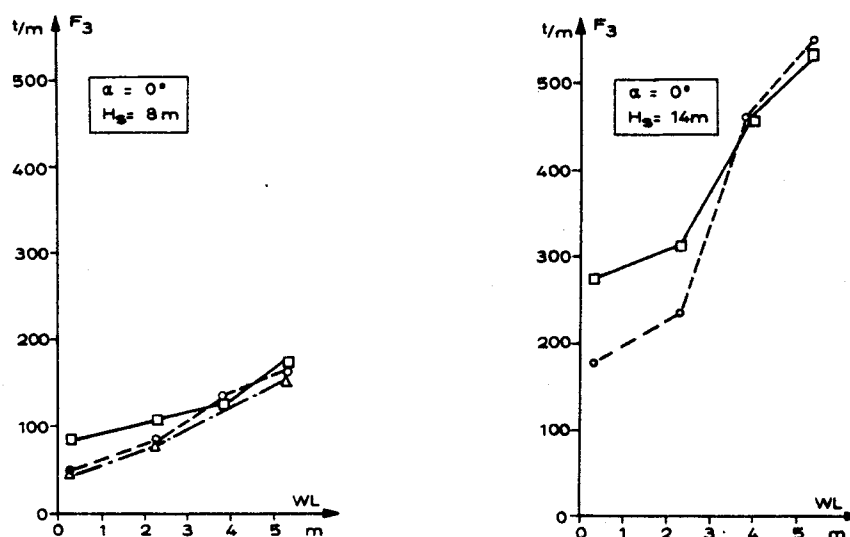

Note: Signatures as in Fig. 5.9.h.

Fig. 5.9.1 Influence of water level on the total horizontal wave force on a breakwater crown wall.

Influence of Wave Period

The results show that wave forces increase with the wave period. Due to lack of more precise methods the wave length seems to be a reasonable substitute parameter for the wave period.

Influence of Angle of Incidence

Fig. 5.9.m shows the influence of different angles of incidence for the breakwater in Fig. 5.9.h. Results are only presented for high water at +5.3 m, but for three different wave heights. F_3 clearly decreases with increasing incidence angle. For the test results available this decrease seems to be almost linear. It is interesting that the decrease does not occur with the same relative rate for the three significant wave heights considered. On average this relative decrease is most pronounced for the largest wave heights.

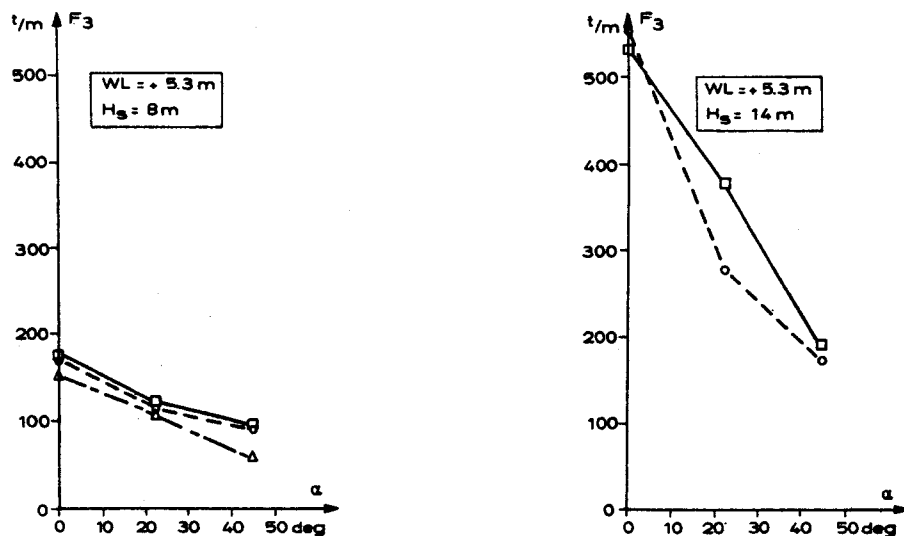

Note: Signatures as in Fig. 5.9.h.

Fig. 5.9.m Influence of wave incidence angle on the total horizontal wave force on a breakwater crown wall.

These measurements were carried out on a model representing a 48 m test section of the wall. This aspect has to be taken into consideration in the design, since the

measured values are average values over the length of model structure.

Influence of Damage Conditions

The breakwater shown in Fig. 5.9.h was also tested with different damage degrees of the armour layer. The tests clearly demonstrate that the forces on the wave wall increase when a significant part of the armour units disappear. For the situation with all units removed from the front of the wave wall, the total horizontal force increase by about 50% for perpendicular wave attack, while for oblique attack (22.5° and 45°) the forces are almost independent of the damage conditions.

Pressure Distributions and Uplift Forces under the Base

The pressure distribution on a superstructure is normally very complex, since the pressure at different points of the structure have their maxima at different times. There is for example often a time lag between the maximum forces on the front side and under the base. However, the most dangerous situation for the superstructure generally arises when the horizontal force on the front side has its maximum. Pressure distributions are shown in Fig. 5.9.n for the breakwater in Fig. 5.9.h. The distributions are valid for the moment when the total horizontal force is maximum. It is clear that the pressure distributions are complex, but also that the pressure distribution on the front side tends to be almost even, and that the pressure under the superstructure decreases about linearly towards the rear.

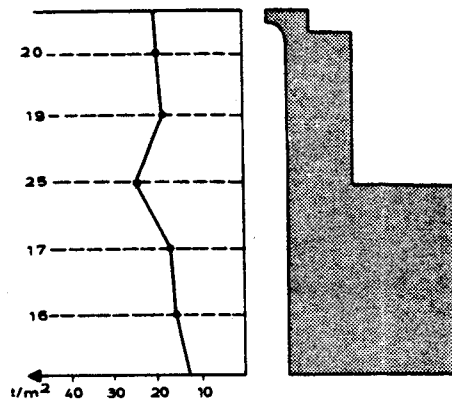

TEST NO: 153

$H_s = 11\text{ m}$
 $T_p = 18\text{ s}$
 $WL = +2.3\text{ m}$
 $\alpha = 0^\circ$
 $DC = 0\%$

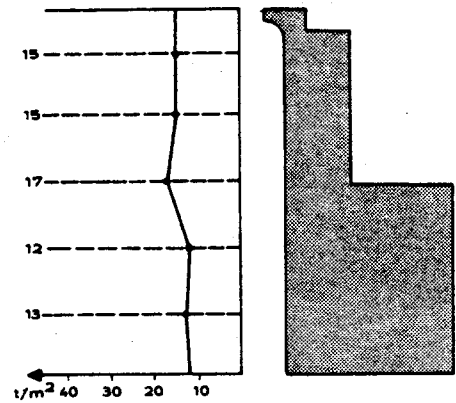
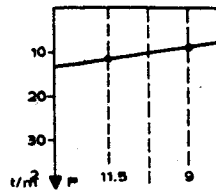

TEST NO: 154

$H_s = 11\text{ m}$
 $T_p = 16\text{ s}$
 $WL = +2.3\text{ m}$
 $\alpha = 0^\circ$
 $DC = 0\%$

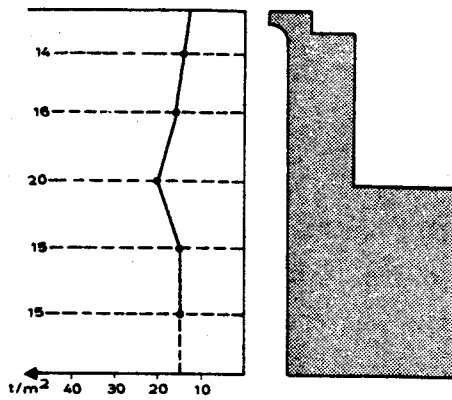
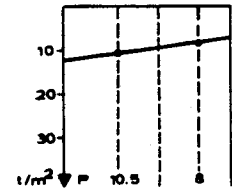

TEST NO: 68

$H_s = 11\text{ m}$
 $T_p = 18\text{ s}$
 $WL = +5.3\text{ m}$
 $\alpha = 22.5^\circ$
 $DC = 0\%$

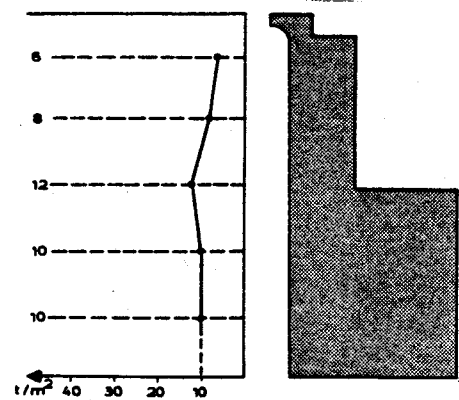
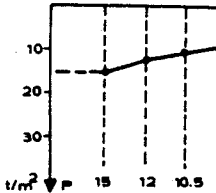

TEST NO: 71

$H_s = 11\text{ m}$
 $T_p = 18\text{ s}$
 $WL = +5.3\text{ m}$
 $\alpha = 45^\circ$
 $DC = 0\%$

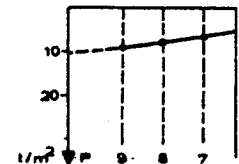

NOTE:

H_s = SIGNIFICANT WAVE HEIGHT
 T_p = PEAK WAVE PERIOD
 WL = WATER LEVEL
 α = ANGLE OF WAVE INCIDENCE

Fig. 5.9.n Examples of the distribution of maximum wave pressure on the crown wall shown in Fig. 5.9.h.

5.9.9 Superstructure Configurations

A concrete superstructure should be placed at such a high level that it is easily constructed without being hampered by wave action.

The configuration of the harbour side edge of a superstructure is discussed in Section 5.11. It is shown that it is essential to have a cantilevered edge towards the harbour in case of large overtopping.

With respect to the front face of the superstructure many different designs have been used. In general it is not a good idea to have a high wall extending above the crest of the armour layer, such as the ones in Figs. 5.9.h and 5.9.j, because such a structure will be exposed to very large wave forces. For many projects, superstructures with a parapet wall, shaped to reverse the flow of water in the up-rush, have been constructed (see Figs. 5.9.h, 5.9.i and 5.9.j). This type of structure functions for a certain limited range of wave heights. However, for large waves the up-rush is so voluminous that the water is either thrown high up into the air or simply passes the crest of the structure as if the extension on top of its front side was not present at all. Therefore such structural elements should be considered very carefully and their function and the forces on them always evaluated by model testing.

Another important aspect is the configuration of the underside of the superstructure. A smooth concrete surface resting on a quarry stone surface has only a friction coefficient of 0.5-0.55. The resistance and stability of a superstructure can be tremendously increased by introduction of a heel preferably as far seaward as possible. Tests on alternative designs of the superstructure

(Fig. 3.1.d) showed that the one proposed by DHI has a very good stability compared to its weight. This is due to the heel with a vertical inner side, which results in a large passive soil pressure in the rock foundation, when the superstructure is exposed to large wave forces. In this case the apparent friction coefficient, μ , was above 1.0.

$$\mu = \frac{\Sigma F_H}{W - \Sigma F_V} \quad \{5.9.b\}$$

μ = apparent friction coefficient
 ΣF_H = sum of all horizontal wave forces
 W = mg, weight of superstructure in air
 ΣF_V = sum of all vertical wave forces.

5.10 Overtopping

Overtopping of rubble mound breakwaters is the topic for Ref. 43. In the following its main content is presented together with further information and evaluations.

5.10.1 Introduction

In a number of projects, in which DHI has been involved in recent years, overtopping has been important. Especially when reclaimed areas or structures are situated behind breakwaters, but also for harbour basins behind a breakwater. For reclaimed areas, it has been experienced that even when no mass-overtopping occurs, the wind-carried spray may inconvenience the use of the area close to the breakwater or the access on a roadway located close to it. In other cases damage has been experienced to structures located closely behind low breakwaters.

The present experience comes partly from basic research by DHI, but mainly from studies performed by DHI on actual projects. Also other references as mentioned in the following have contributed.

5.10.2 Presentation of Results

The parameter Q represents the average amount of water (m^3) overtopping the crest of a breakwater per second per meter length of the breakwater.

The amount of overtopping water is very irregularly distributed over time. When the maximum waves in the wave train impinge on the structure, the overtopping intensity is many times greater than the average value. In other words, the overtopping is an extremely non-linearly function of the wave height.

For a given structure the parameter Q will depend upon:

- (1) significant wave height, H_g (as well as wave height distribution and wave shapes);
- (2) wave period; mean zero crossing period, T_z , has been used here;
- (3) water level, WL; and
- (4) angle of wave incidence.

The parameter Q is made dimensionless by use of T_z and B^* , where B^* is a representative dimension of the breakwater, namely the horizontal distance from the point, where the armour layer intersects with the SWL to the limit of the reclamation or to the rear side of the crown

wall (Cf. Fig. 5.10.a). In this way the parameter $Q \cdot T_z / (B^*)^2$ is derived. Note that $Q \cdot T_z$ is the overtopping per wave. The parameter $Q \cdot T_z / (B^*)^2$ is plotted against a dimensionless significant wave height, $H_s / \Delta h$, where Δh is the vertical distance from still-water level to the crest of the breakwater. Thus the water level is also taken into account.

The wind speed, U , is made dimensionless by use of the acceleration of gravity, g and B^* , and the parameter $U / \sqrt{gB^*}$ is derived.

In some cases wave periods are made dimensionless by division with $\sqrt{B^*/g}$, thus the parameter $T_z / \sqrt{B^*/g}$ is derived.

Fig. 5.10.a shows the different parameters on an idealized breakwater profile.

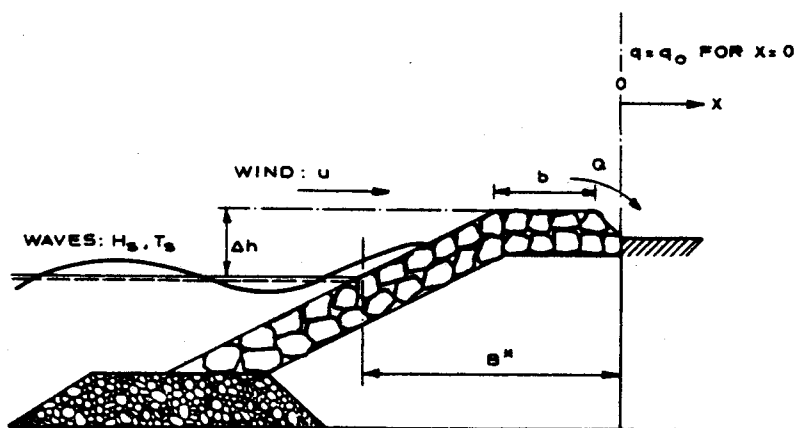

Fig. 5.10.a Breakwater profile (definition of parameters).

5.10.3 Test Equipment and Procedure

In models and prototype measurements the parameter Q was

determined by collecting the amount of overtopping water in separate trays placed at different distances behind the breakwater. In this way not only the total overtopping quantities were determined, but also the intensity of water falling as function of the distance from the breakwater.

All the tests were performed with wave trains recorded by accelerometer buoys. The DHI method of direct reproduction of natural wave records was used. This method was published by Gravesen et al., Ref. 29. All tests were performed in a flume of 0.6 m wide and about 22 m long. When reflection occurred, the wave conditions in the flume were controlled by the procedure presented by Gravesen et al., Ref. 29. All tests has a prototype duration of 0.5-1 hour. The significant wave height, H_s , was measured at a limited distance in front of the breakwater.

In all cases the waves were not limited by depth, and the wave height distribution was close to a Rayleigh distribution.

Table 5.10.a presents for the various breakwaters tested, the range of depth, D , and significant wave heights, H_s , relative to the wave length, L_{po} or L_p , where p refers to the "peak" wave period. L_{po} is the deep-water peak wave length.

5.10.4 Test Results

The general test results for seven different breakwater structures (profiles A-G) are presented in Figs. 5.10.f to 5.10.1. The results show that the overtopping varies

Profile	D/L_{po}	D/L_p	H_s/L_{po}	H_s/L_p
A, B and C	0.038-0.075	0.074-0.128	0.007-0.027	0.013-0.041
D	0.037-0.069	0.076-0.113	0.010-0.034	0.020-0.057
E and F	0.059-0.142	0.103-0.177	0.018-0.071	0.032-0.088
G	0.043-0.083	0.087-0.126	0.024-0.026	0.036-0.050

Table 5.10.a Relative depth and wave steepness for the tests.

from structure to structure, but some general conclusions may be derived:

- (1) The amount of overtopping increases rapidly with the parameter $H_s/\Delta h$. The logarithm of $Q \cdot T_z / (B^*)^2$ is normally a linearly function of $H_s/\Delta h$.
- (2) The influence of the wave period is very different from structure to structure. However, there is a tendency that longer periods cause greater overtopping. This was pronounced during the tests with profiles E and F.
- (3) No sharp limit exists between wind-carried spray and mass-overtopping where solid masses of water are passing the crest of the breakwater ("green water").
- (4) The wind effect is most pronounced for small values of $H_s/\Delta h$, while for high sea states and/or high water levels (large values of $H_s/\Delta h$) where mass-overtopping occurs the wind has no influence on the amount of overtopping (Cf. Fig. 5.10.f).

- (5) Prototype measurements are only available for one site. They were generally in agreement with model tests (Cf. Fig. 5.10.f).

5.10.5 Horizontal Distribution

The intensity of overtopping behind a breakwater decreases very rapidly with the distance from the breakwater. In all the tests performed and in the prototype measurements it has been experienced that on average the intensity of overspill decreases exponentially with the distance, x , from the breakwater. This means:

$$q(x) = q_0 10^{-(x/\beta)} \quad \{5.10.a\}$$

where q is the intensity at a distance x , and q_0 is the intensity for $x = 0$. The parameter β is a constant and equal to the distance for which the overspill intensity decreases by a factor 10.

Now the total amount of overtopping, Q , may be calculated by integration:

$$Q = \int_0^{\infty} q_0 10^{-(x/\beta)} dx \quad \{5.10.b\}$$

resulting in the following formula:

$$Q = q_0 \beta / \ln 10 \quad \{5.10.c\}$$

knowing Q and β , the intensity, q_0 , for $x = 0$ may be calculated, and thus the intensity $q(x)$ for any distance x is known.

In all the tests performed β has been nearly constant,

independent of both wave and wind conditions. The only exception to this is the overspill behind breakwaters with a high parapet wall (profiles C and G), where the intensity close to the wall is constant before the exponential decrease of the intensity starts. Table 5.10.b presents approximate values of β obtained during model tests with profiles A, B and D. β is made dimensionless by division with B^* .

Structure (Profile)	β/B^*
A	0.40-0.55
B	0.55-0.70
D	0.50-0.60

Table 5.10.b Values of β/B^* evaluated from model measurement.

Fig. 5.10.b shows the exponential distribution from tests on breakwater profile A. During these tests the amount of water falling behind the breakwater was collected in three different trays representing distances of 0-7.33 m, 7.33-14.67 m, and 14.67-22.0 m from the breakwater. 22 m is equal to the width of the roadway behind the breakwater. For these tests the following values apply: $\Delta h = 3.2$ m, $B^* = 13.1$ m and $U = 20$ m/s. Note that the overtopping here is presented as intensity $\{m^3\}$ per second per square metre for each of the three trays.

5.10.6 Problems Caused by Overtopping

With reclaimed areas, buildings, structures, berths, etc. behind the breakwater, the overtopping may be of great inconvenience for the following reasons, which should be

taken into consideration:

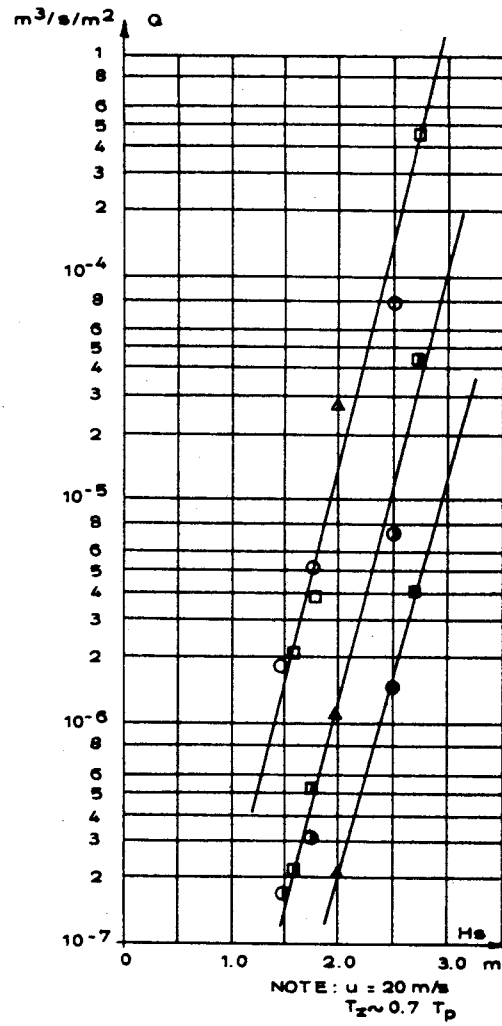

LEGEND:

Tp (s)	DISTANCE FROM BREAKWATER [m]		
	0-7.33	7.33-14.67	14.67-22.0
8	○	○	●
10	□	□	■
12	△	△	▲

Fig. 5.10.b Results from Tests on Profile A.

- (1) The water must be drained away. For design of the drainage system the expected intensity of water must be known.

- (2) If buildings, structures, berths etc. are located behind a breakwater, the effects of the overtopping water must be taken into consideration in the design in order to avoid damage or unacceptable down-time of operations.
- (3) In a harbour basin behind a breakwater waves caused by overtopping may inconvenience its use or damage moored vessels and structures etc.

Fig. 5.10.d shows two breakwaters where overtopping inconveniences use of the roadway behind the structure. Wave disturbance caused by overtopping is normally only a problem for very low breakwaters where solid masses of water pass over the crest. Fig. 5.10.c shows wave records from model tests on a breakwater with a permeable core, allowing wave transmission through the breakwater. At the same time overtopping occurs. Both the waves in front of and behind the structure are shown. It may be noted that the overtopping creates waves with much shorter periods than the incoming waves or the transmitted waves.

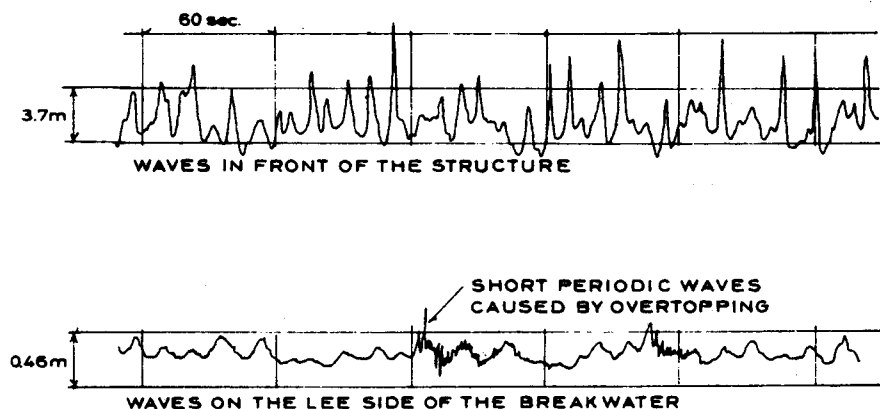
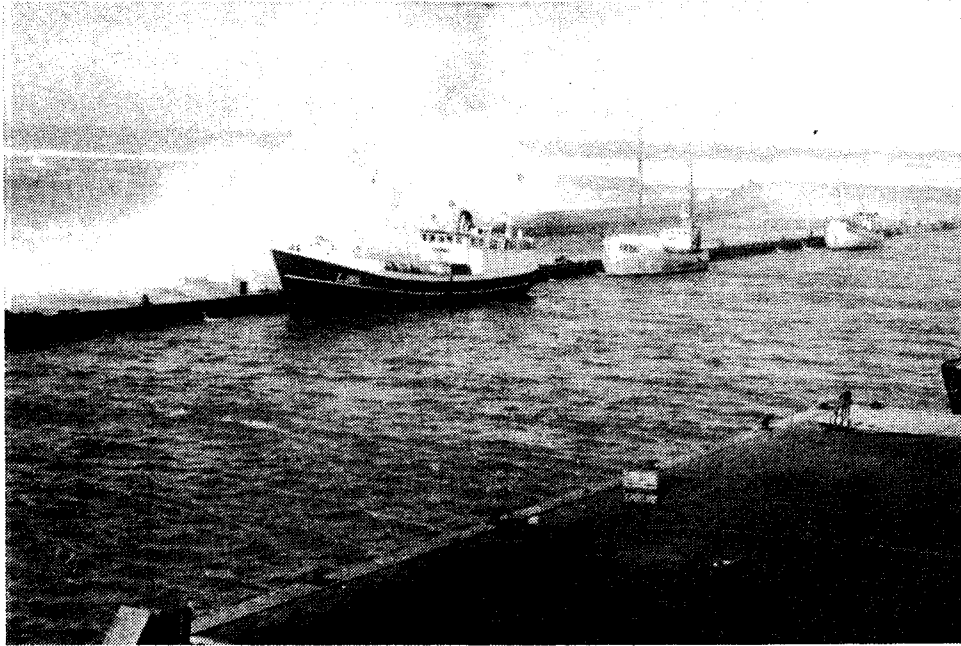

Fig. 5.10.c Record of waves caused by overtopping and transmission.



Secondary Breakwater in Hanstholm Harbour, Denmark.



Outer Breakwater, Tripoli Harbour, Lybia.

Fig. 5.10.d Wave overtopping.

It should, however, be emphasized that in case of extreme overtopping large waves may be generated in a basin behind the breakwater. This was the case for the harbour of Oran in Algeria, where an extreme storm in December 1980 caused so large waves due to overtopping that five ships were damaged and sunk. The photo on Fig. 5.10.e shows a ship that was severely damaged by beam sea. The ship rolled so much that it both damaged itself and the concrete quay front. The crest elevation of this breakwater is approximately +6.0 m and the waves during the storm attained a significant height of approximately $H_s = 7.0$ m, which means a maximum height of 12-13 m.

Fukuda et al. (1974), Ref. 25, present an evaluation of the effect of different intensities of wave overtopping based on prototype measurements and observations. As a result of their study, they present figures for acceptable overtopping. They distinguished between the effect of the overtopping on different objects such as 1) a walking person 2) a car 3) a building. Although Fukuda et al. arrived at figures showing the order of magnitude of acceptable wave overtopping, which to date is the most detailed study that the author is aware of, there exist no internationally approved guidelines to be used in breakwater design. To establish such guidelines, it is the author's opinion that further prototype measurements are necessary. Such measurements should be made simultaneously with reporting of any inconvenience due to overtopping and with measurements of wave and wind conditions. However, on the basis of the results of Fukuda et al. and the experience of DHI, it seems worthwhile to recapitulate the available information on overtopping quantities. For this purpose the following information is useful.

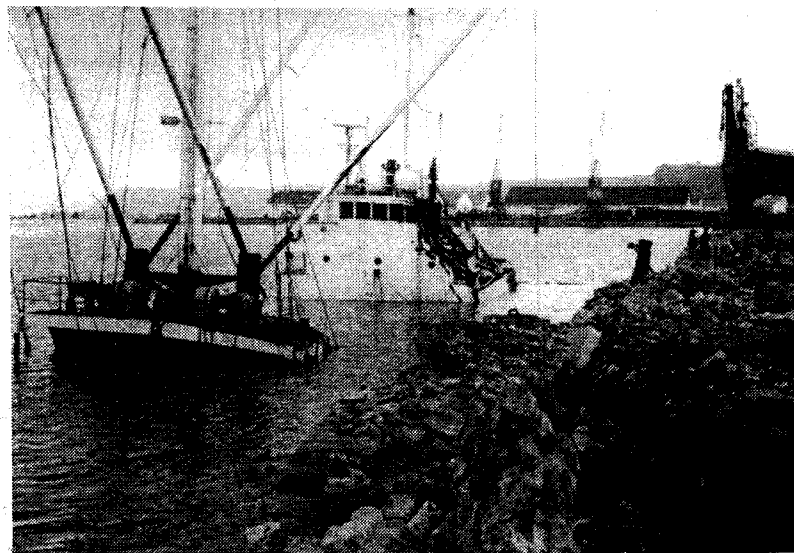
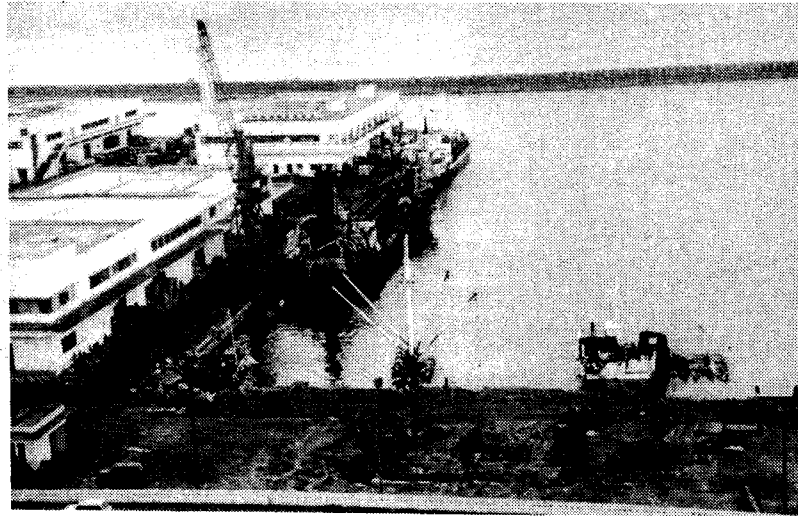

Fig. 5.10.e Photos of a vessel damaged due to waves caused by overtopping in the harbour of Oran, Algeria.

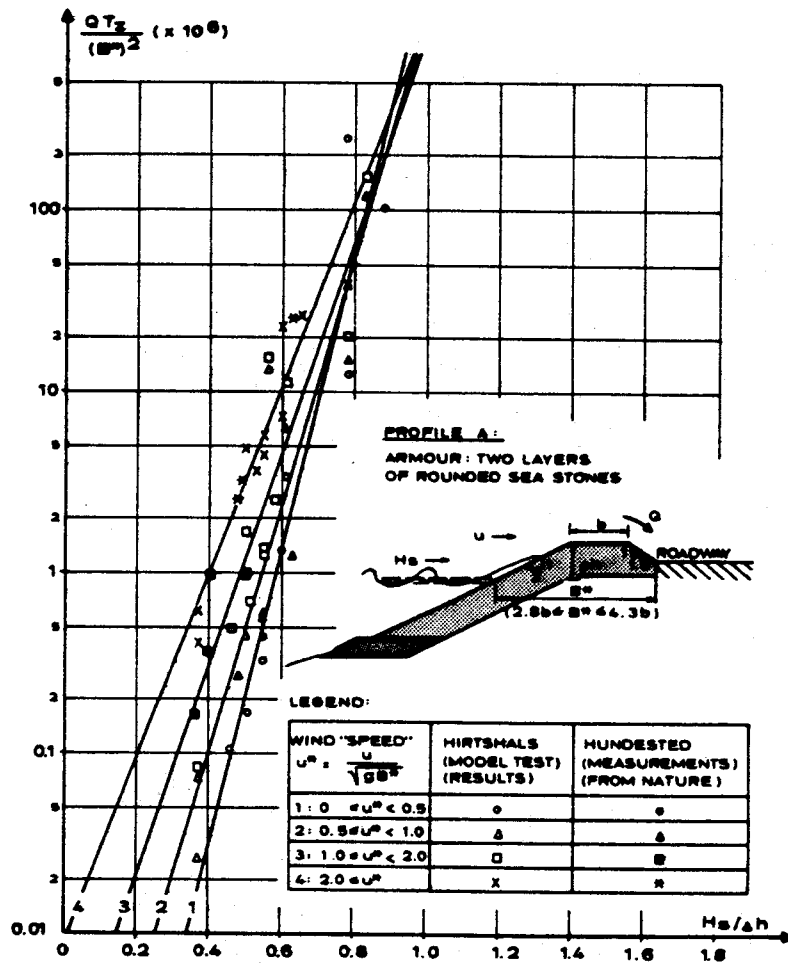

Fig. 5.10.f Test results for Profile A.

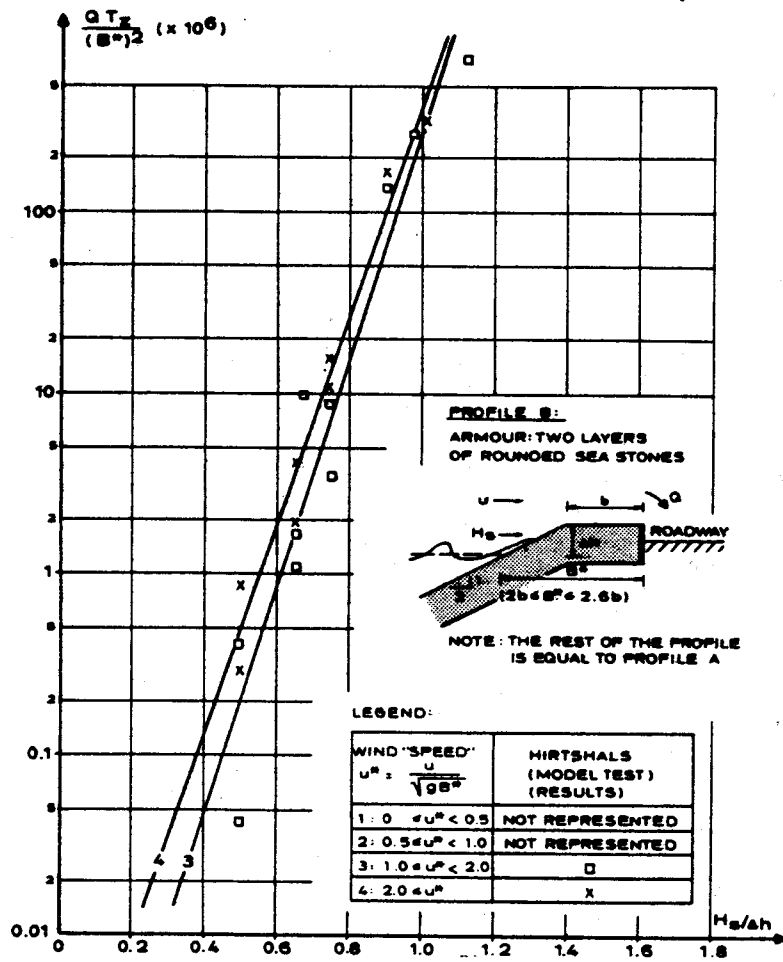

Fig. 5.10.g Test results for Profile B.

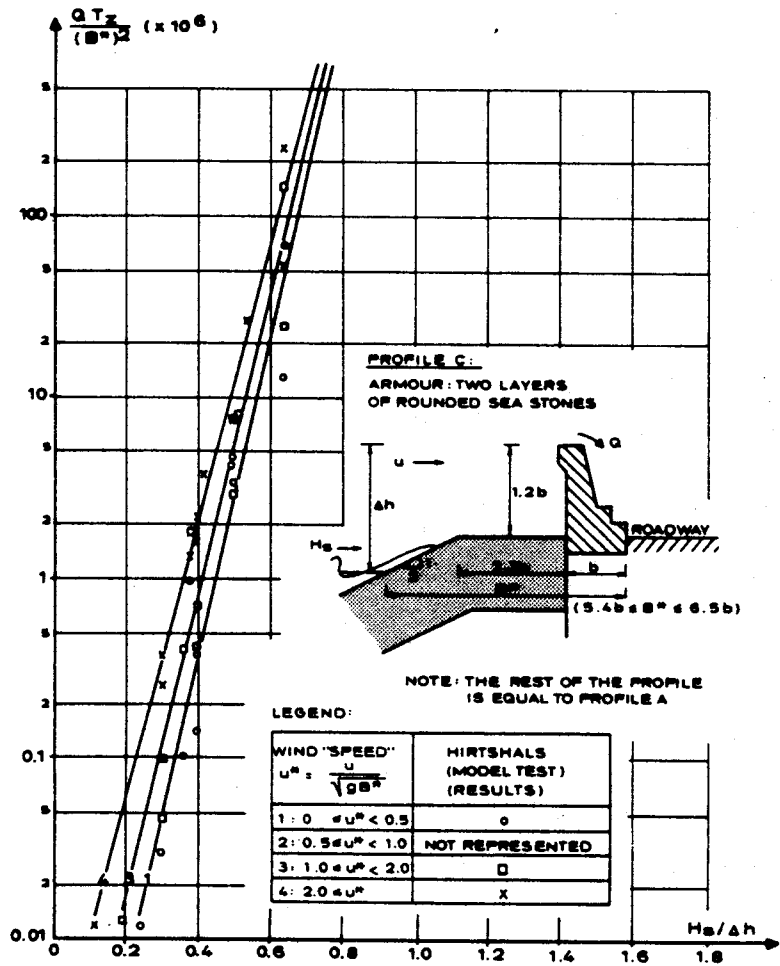

Fig. 5.10.h Test results for Profile C.

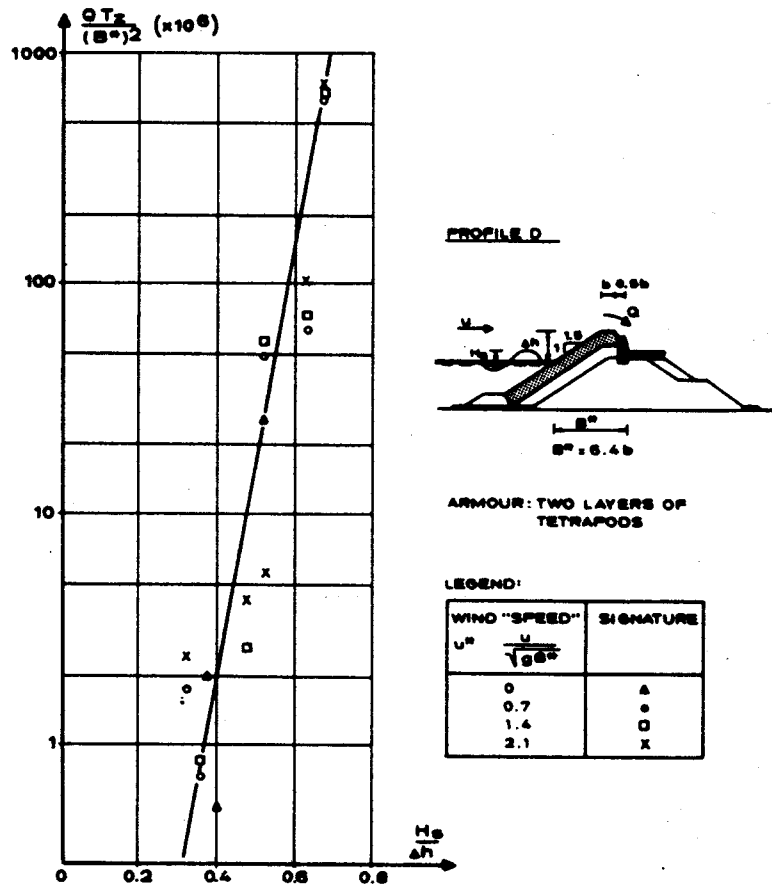

Fig. 5.10.i Tests results for Profile D.

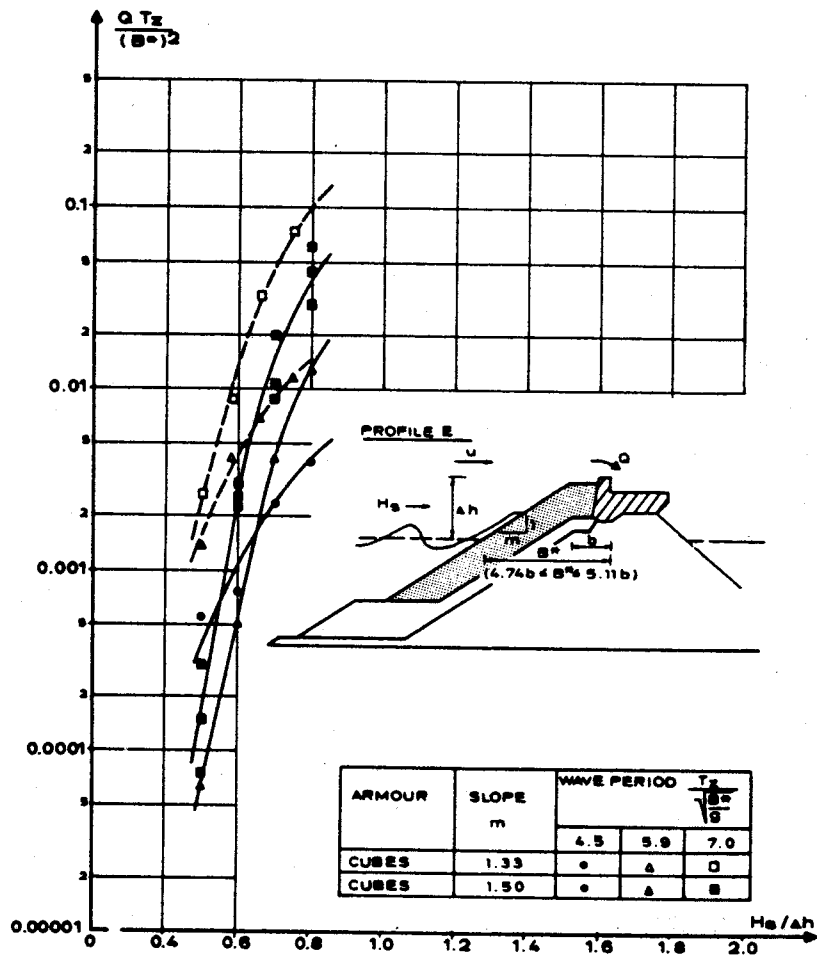

Fig. 5.10.j Tests results for Profile E.

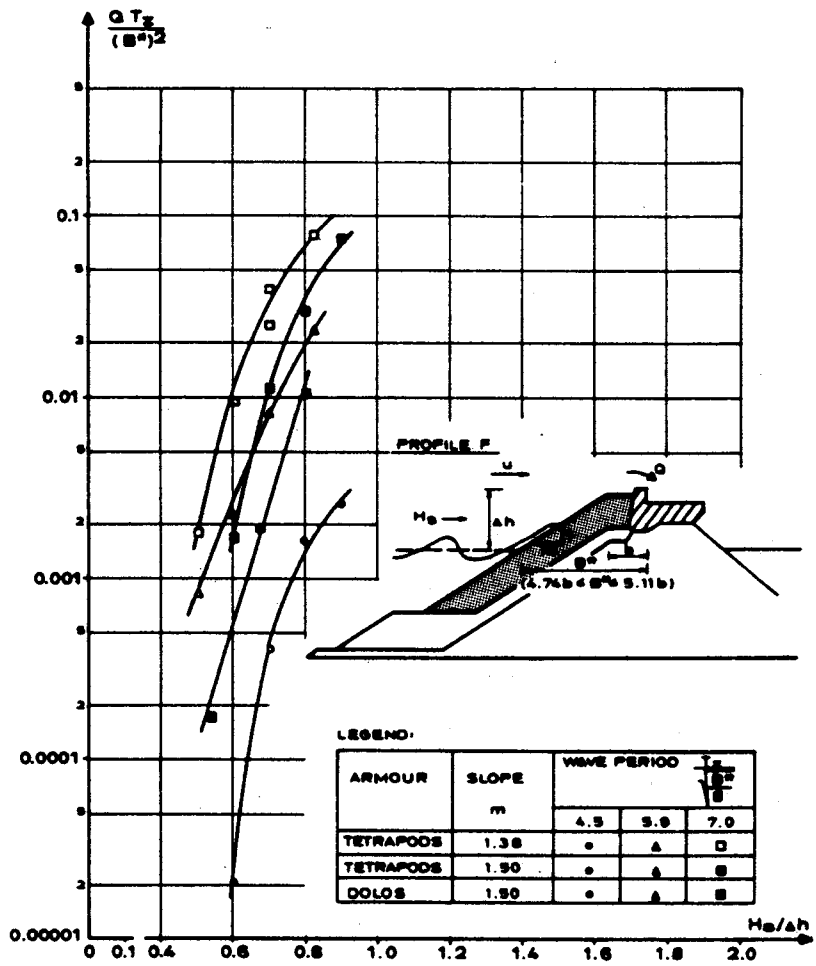

Fig. 5.10.k Test results for Profile F.

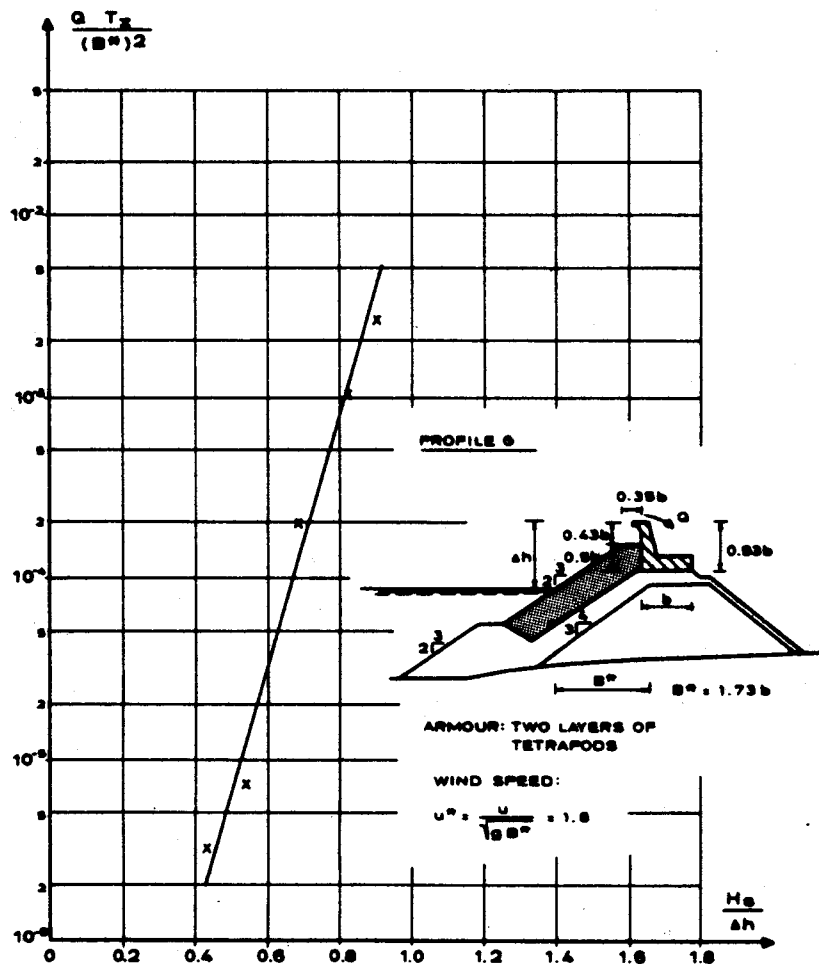

Fig. 5.10.1 Test results for profile G.

1. The intensity of extreme rainfall differs considerably from place to place with the largest intensities occurring in the tropics. In Denmark extreme rainfalls have an intensity in the order of $2 \cdot 10^{-5} \text{ m}^3/\text{m}^2/\text{s}$ while the largest reported intensity in the world in one minute is $5 \cdot 10^{-4} \text{ m}^3/\text{m}^2/\text{s}$. (Ref. 81).

In order to compare such intensities with the intensity of wave overtopping, it should be recognized, as mentioned earlier, that the intensity of

water falling behind a breakwater is highly irregular over time due to the irregularity of the wave impact. This means that the maximum short-term intensity is many times larger than the average intensity. The ratio between the two is probably in the order of 100.

2. Fukuda et al., Ref. 25, present results of a field investigation of wave overtopping carried out in Japan. To evaluate the effect of overtopping a film was made simultaneously with measurements of the average intensity. The film was later shown to eight experienced harbour engineers. The engineers were asked to evaluate the effect of the overtopping on different subjects placed for example 3 m behind the breakwater. Three different subjects were considered: a walking person, a car and a building. The effect of the overtopping was divided into three classes "awful, a little", "awful", and "dangerous".

The intensities shown in Table 5.10.c were by 10% of the observing engineers classified as one degree worse than indicated (safety standard 90%).

Degree of Inconvenience	Overtopping Intensity, Q ($m^3/m/s$, Ref. 24)
1. "awful, a little"	$< 4 \cdot 10^{-6}$
2. "awful"	$4 \cdot 10^{-6} - 3 \cdot 10^{-5}$
3. "dangerous"	$> 3 \cdot 10^{-5}$

Table 5.10.c Effect of wave overtopping on walking person 3 m behind the breakwater. Safety standard 90%, Ref. 25.

For a car 3 metres behind the breakwater the intensities of Table 5.10.d were found.

Degree of Inconvenience Overtopping Intensity, Q (m ³ /m/s, Ref. 24)	
"passable in high speed"	< 10 ⁻⁶
"passable in slowing down"	10 ⁻⁶ - 2 · 10 ⁻⁵
"impassable in normal order"	> 2 · 10 ⁻⁵

Table 5.10.d Effect of wave overtopping on a car 3 m behind the breakwater. Safety standard 90%, Ref. 25.

3. In 1978 DHI made model tests with the new breakwater for Tripoli Harbour in Libya. The breakwater, which has not earlier been investigated at DHI, was nearly finished in 1978. Wave overtopping on a roadway placed a few metres behind the breakwater gave rise to problems and for this reason DHI was asked to study various means to reduce the overtopping. The profile of the breakwater is shown in Fig. 5.10.1.

Based on visual observations by the consulting engineer, simultaneous wave measurements and measurements in the hydraulic model, it has been possible to estimate the intensities related to different degrees of wave overtopping.

From the model tests, it is estimated that notable overtopping corresponds to an average intensity of approximately $5 \cdot 10^{-7}$ m³/m²/s, and that inconveni-

ences for the traffic is experienced for an average intensity of approximately $1.5 \cdot 10^{-6} \text{ m}^3/\text{m}^2/\text{s}$ of a distance of 1 to 15 m from the parapet wall. This means a discharge of approximately $2 \cdot 10^{-5} \text{ m}^3/\text{m} / \text{s}$. For this situation it is reported that the spray is carried more than 20 m from the parapet wall. There seems to be a high degree of agreement between these figures and the results of Fukuda et al., Ref. 24.

The following are rough, preliminary guidelines for overtopping quantities.

Inconvenience for Persons

Inconveniences for persons behind a breakwater seem to occur for overtopping discharges of approximately $4 \cdot 10^{-6} \text{ m}^3/\text{m}^2/\text{s}$, corresponding to intensities of approximately $10^{-6} \text{ m}^3/\text{m} / \text{s}$ a few meters behind the breakwater. This intensity is only 2.5% and 0.1% respectively of the intensity of a heavy rainfall in Denmark and the world largest rainfall intensity. The reason for such low intensities being of inconvenience is the highly irregular maximum intensity being in the order of 100 times its average value.

Inconvenience for Vehicles

Inconvenience for vehicle traffic on a roadway just behind a breakwater occurs for an overtopping discharge of approximately $10^{-6} \text{ m}^3/\text{m} / \text{s}$, corresponding to an intensity of approximately $3 \cdot 10^{-7} \text{ m}^3/\text{m}^2/\text{s}$ a few metres behind the breakwater.

Danger for Persons

An overtopping discharge of approximately $3 \cdot 10^{-5}$ $\text{m}^3/\text{m}/\text{s}$, corresponding to approximately 10^{-5} $\text{m}^3/\text{m}^2/\text{s}$ a few metres behind the breakwater, is estimated as dangerous for persons. This is approximately 10 times the intensity which causes inconvenience.

Impassable for Vehicles

From Ref. 24 it is estimated to be impossible to pass with a vehicle at a distance of 3 m from a breakwater when the average discharge of overtopping exceeds approximately $2 \cdot 10^{-5}$ $\text{m}^3/\text{m}/\text{s}$. Of course, this figure depends upon the type of vehicle.

5.11 Rear Side

The stability of the armour layer on the rear side depends on the overtopping discharge and the way it falls on the rear side. This is the case both for pure rubble structures and for structures with a concrete superstructure. The wave overtopping velocity and discharge are functions of the up-rush on the front slope which, as previously mentioned, depend on the geometry, on other properties of the structure, on wave conditions in front of the structure, and on the water level. For these reasons overtopping is complex and difficult to predict accurately. Model tests are therefore the safest tool to evaluate also the rear side stability.

5.11.1 Rear Side Armour Layer on Pure Rubble Structures

Fig. 5.11.a shows the results from model studies of breakwaters in Midvaag, Faroe Islands (Fig. 5.1.a) and

Korsør Ferry Port, Denmark (Fig. 5.7.g) which are pure rubble structures. The relation between the damage percentages for the armour layers on the harbour and sea sides is shown as function of the ratio between the vertical distance from the crest to the still water level and the incoming significant wave height, H_s . The stone weight is the same for both armour layers. Results for three different wave periods, T_p (different steepness), are shown. It is seen that the shorter the wave period is, the lower is the crest level requirement. This is related to lower up-rush and overtopping, see Ref. 74. The crest elevations or interpolations between them cannot be used directly for design of similar structures, because the results are very project dependent. However, they may be used for a preliminary estimate. Based on other DHI tests, in Ref. 30, it is possible to reduce the crest elevation by using larger stones in the crest and on harbour side. However, the reduction in crest level was only about 25% for 4 times larger stones.

5.11.2 Rear Side Armour Layer on Breakwater with Superstructures

For a breakwater with a superstructure with overtopping, the geometry of the edge of the superstructure towards the harbour is of major importance. This may be illustrated by the two figures from Ref. 30 in Fig. 5.11.b, showing the progression of overtopping for two alternative configurations of the crown wall for a breakwater project in the Mediterranean. The breakwater is also shown in Fig. 5.10.k. For alternative A the overtopping water hit directly onto the rear side armour slope and caused severe damage.

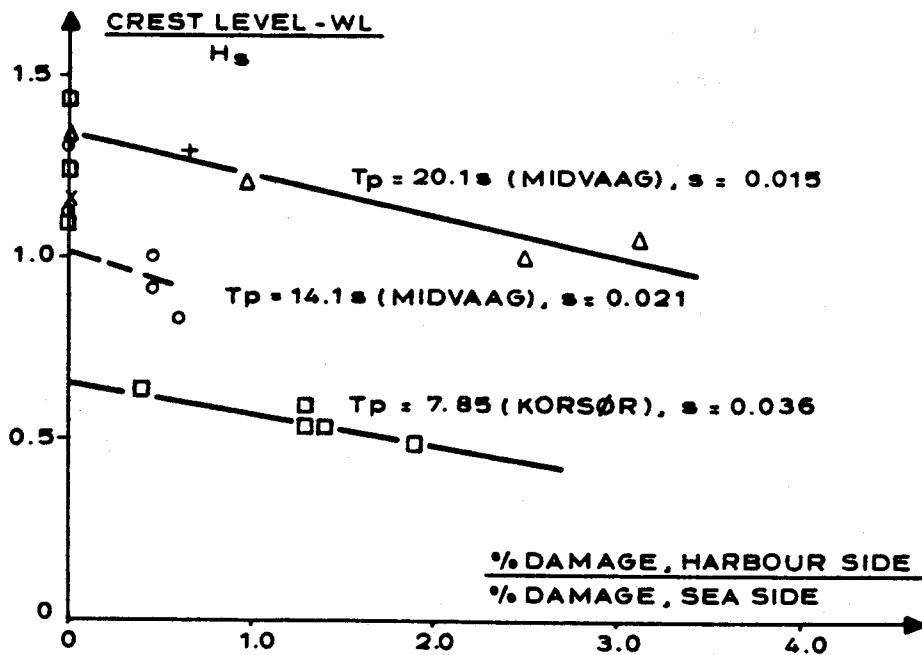

Fig. 5.11.a Rear side damage.

This was not the case for alternative B, where the overtopping hit the water surface behind the breakwater due to the cantilevered configuration. However, for very large overtopping also this type of structures may suffer damage to its rear side. This may be documented by the model test results for a tetrapod breakwater as shown in Fig. 5.11.c.

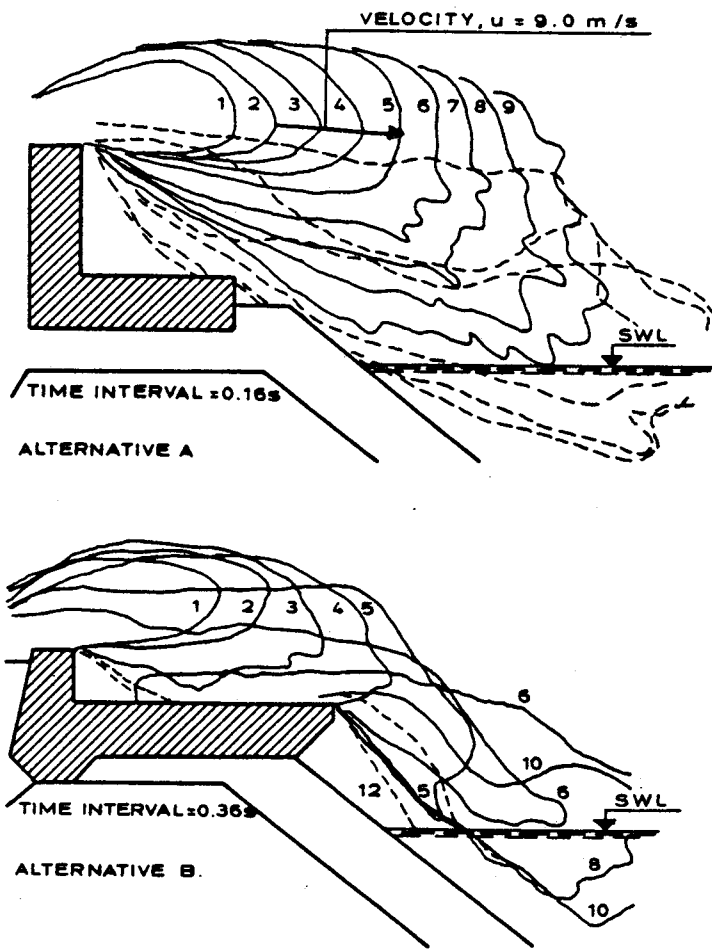

Fig. 5.11.b Development of overtopping.

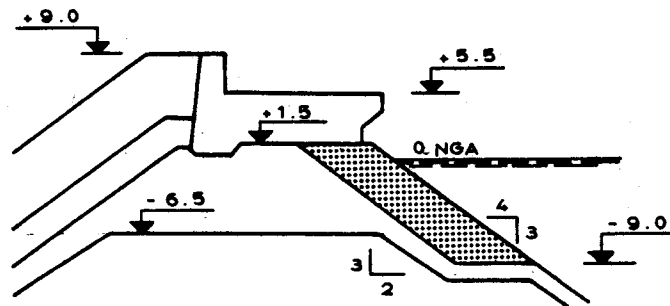
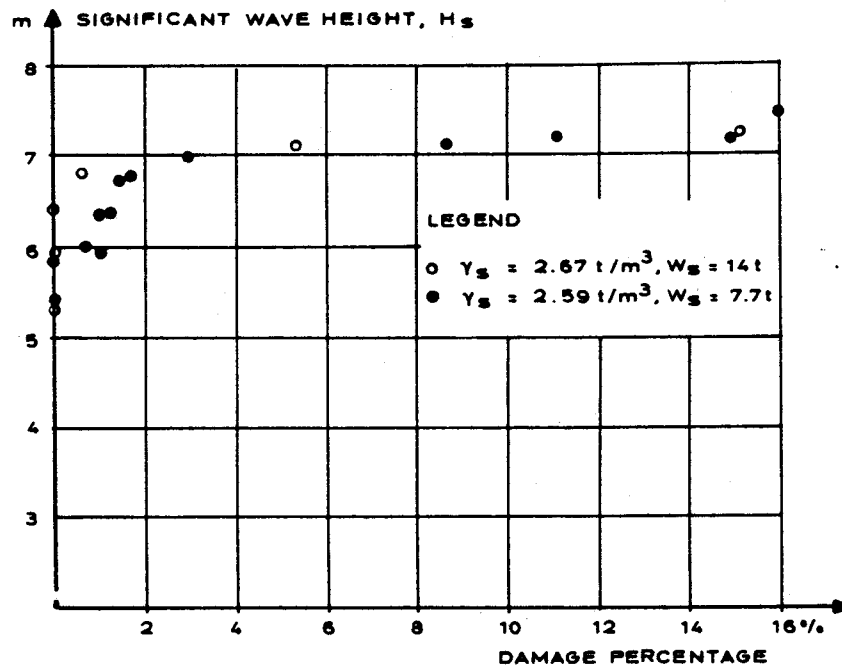

Fig. 5.11.c Damage to rear side of tetrapod breakwater (rear side armour is quarry stones).

Up to a certain significant wave height no damage at all occurs to the rear side. Above this limit a small increase in wave height causes large increase of damage.

It is interesting to notice that when the waves become so large that they cause severe damage to the rear side, a very significant increase in stone size only marginally

increases the stability of the rear side.

The rear side is much more sensitive to an increase in wave height than the front side. This means that in case a breakwater is designed for the same degree of damage to both sides for certain wave conditions, the risk of serious damage to the rear side will be much larger than to the front side. Instead a probability approach considering the frequency of occurrence for different wave heights and the damage inflicted on the two sides should be made to obtain the same risk for failure of the two elements of the breakwater. This is often extremely difficult, since the water level also influences damage to the two sides of a breakwater in a highly non-linear way.

5.12 Bends and Corners

Breakwater bends and corners are generally more exposed than a straight stretch. Therefore heavier armour protection is necessary. The necessary increase in armour weight depends on breakwater profile, block type, radius of curvatures of bends, angles of corners, and wave direction and should be determined from model tests. A very sharp corner may be as exposed as a breakwater head.

In special cases it may be necessary to increase the crest elevation of a corner. Especially if the wave direction corresponds to the mean angle between the perpendiculars to the two alignments, because the up-rush and overtopping may thus be amplified at the corner.

5.13 Roundheads

Roundheads represent a special stability problem. When a wave is forced to break over a cone-shaped roundhead it leads to large velocities. For a specific wave direction and water level only a limited area of the roundhead is highly exposed. It is an area around the still water level where the wave orthogonal is tangent to the surface and on the lee side of this point. It is therefore general procedure in design of roundheads to increase the weight of the armour units to obtain the same stability conditions as for the breakwater trunk. Alternatively, the slope of the roundhead can be made less steep or a caisson structure be introduced. For both solutions, however, it will generally be necessary to increase the armour unit weight too, e.g. by increasing the concrete density by using heavy aggregate, such as iron ore, as explained in Section 5.7.3.

Model tests have shown that by using a specific test procedure and by accepting the same percentage of units displaced for the trunk and the roundhead, it is necessary to increase the weight of the roundhead units by a factor of 1.5 to 4. The factor depends on the configuration of the roundhead and on the type of units. There is a tendency for the most complicated units, such as dolos or tetrapods, to require the largest weight increase. For these units the stability depends more on interlocking than on gravity. In general the values shown in Ref. 74 are on the unsafe side. As an example, for dolos on a slope of 1 on 2 a factor of 1.5 is recommended, whereas in some examples a factor of 3 to 4 was found from model tests with irregular waves.

There is an aspect with regards to the stability of roundheads, which to the author's knowledge has never

been discussed. That is the relation between wave height and displaced units on trunk and roundhead respectively. From tests at DHI, as it will be shown in the following, it is known that for a certain increase in wave height the increase in damage is much higher for a roundhead than for a trunk. This means in general that if both breakwater trunk and roundhead are designed for e.g. 2% allowable damage for a certain design wave, an increase in this wave will increase the damage to the roundhead much more than on the trunk. In other words, a roundhead has a more limited reserve stability than a trunk. This means that, in principle, it is not possible to present general weight factors to be applied for the design of roundheads, as done in Ref. 74.

Stability tests on a tetrapod breakwater head with slope 1 to 1.33 are shown in Fig. 5.13.a.

For interpretation and evaluation of the damage, the roundhead was divided into 6 sectors as shown in the same figure.

This tetrapod roundhead was tested with different wave angles relative to the alignment of the roundhead. All results for 2% allowable damage are shown in Fig. 5.13.b. It is seen that in the most exposed sector of the roundhead one must increase the tetrapod weight by a factor of approximately 2.3. The most exposed sector depends on the relative wave direction and is located where the wave orthogonal is tangent to the cone and extends somewhat to the lee side of this point. As mentioned earlier, however, an increase in the design wave height will result in larger damage to the roundhead than to the trunk. Depending on the probability for exceeding the design wave height it could thus be feasible to use even larger roundhead units.

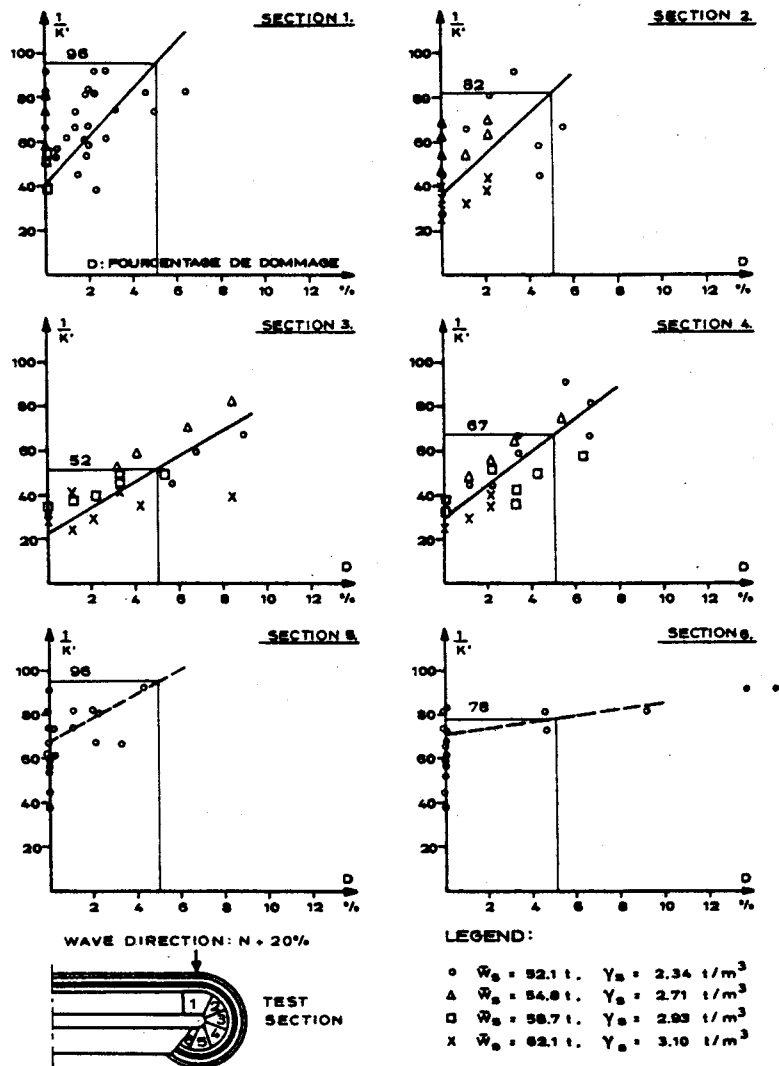

Note: D = Damage, $1/K = K_2$, Stability Coefficient (Eq. 4.3.1).

Fig. 5.13.a Tests results for tetrapod roundhead.

The tests showed that better stability could also be obtained by increasing the density of the units. The test results were in accordance with the predictions of the stability formulae in Section 4. This means that a density increase of approximately 18% is as effective as a 130% volume increase.

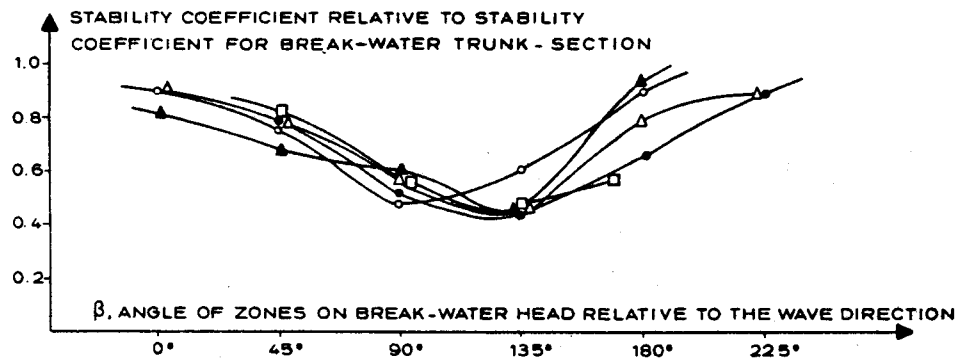

LEGEND:

WAVE DIRECTION α

● — 50°

△ — 70°

○ — 90°

▲ — 110°

□ — 130°

NOTE:

SLOPE: 1:1.33

WAVE STEPNESS: $\frac{H_s}{L_{Tp}} \approx 0.035$

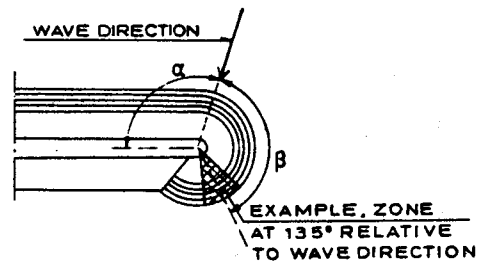

Fig. 5.13.b Stability coefficients for tetrapod round-head as function of wave direction and location on the roundhead.

The stability of armour units on a cone roundhead also depends on the size of the units relative to the size of the cone (radius of curvature at the position of the unit considered) where the wave orthogonal is tangent to the cone. By considering the armour units as spheres on a cone, as shown in Fig. 5.13.c, an evaluation of the stability in the tangent point has been made.

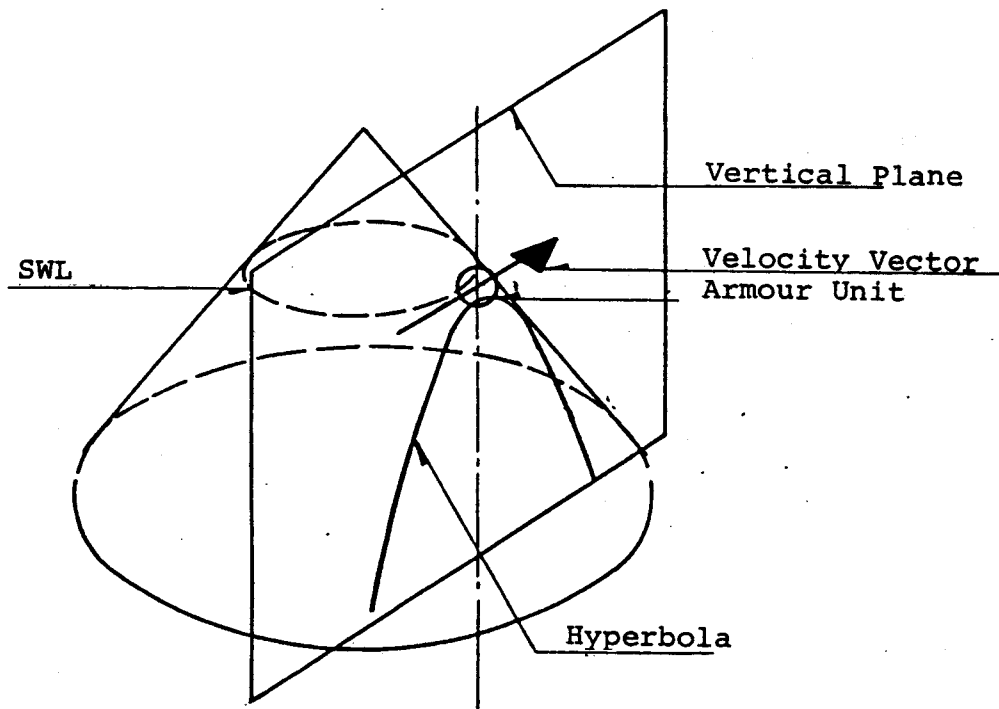

Fig. 5.13.c Cone model of roundhead.

Fig. 5.13.d shows the vertical plane in Fig. 5.13.c. The curve of intersection between the plane and the cone is a hyperbola with a radius of curvature of ρ .

The hydrodynamic forces on the most exposed armour unit (sphere with radius, r) are shown and also the stabilizing gravity force. The effective gravity force is $G_{\text{eff}} = V \cdot (\rho_s - \rho_w) \cdot g$. The hydrodynamic force is the sum of two forces, the lift force F_L and the drag force F_D (see also Chapter 4). From the geometry is obtained:

$$\sin \frac{v}{2} = \frac{r}{\rho} \quad \{5.13.a\}$$

and

$$\cos \frac{v}{2} = \sqrt{1 - \left(\frac{r}{\rho}\right)^2} \quad \{5.13.b\}$$

By moment around O the criterion for stability is established:

$$G \cdot r \cos \frac{v}{2} \geq P \cos \beta (b + r \sin \frac{v}{2}) + P \sin \beta \cdot r \cos \frac{v}{2} \quad \{5.13.c\}$$

or

$$G \leq P \left\{ \cos \beta \left(\frac{b}{r \cos \frac{v}{2}} + \operatorname{tg} \left(\frac{v}{2} \right) + \sin \beta \right) \right\} \quad \{5.13.d\}$$

by inserting Eq. 5.13.a and 5.13.b Eq. 5.13.d is transformed:

$$G \leq P \left\{ \cos \beta \left(\frac{\rho b + r^2}{\rho r \sqrt{1 - \left(\frac{r}{\rho}\right)^2}} + \sin \beta \right) \right\} \quad \{5.13.e\}$$

for small values of $\frac{r}{\rho}$ which is generally the case Eq. 5.13.e is transformed to:

$$G \leq P \left\{ \left(\frac{b}{r} + \frac{r}{\rho} \right) \cos \beta + \sin \beta \right\} \quad \{5.13.f\}$$

b and $\sin \beta$ are not known, so it is not possible to evaluate the influence of r/ρ with any accuracy. However, it is evident from Eq. 5.13.f that the larger the value of r/ρ , the larger the weight requirement for the units.

A cone is mathematically described by the formula:

$$x^2 + y^2 = a^2 z^2 \quad \{5.13.g\}$$

where (x,y,z) are coordinates. a is equal $\cot \alpha$, α being the slope angle of the cone. From calculations it has

been determined that at the vortex of the hyperbole the radius of curvature is equal to:

$$\rho = -a^2 z_0 \quad (5.13.h)$$

z_0 is the z coordinate of the vortex.

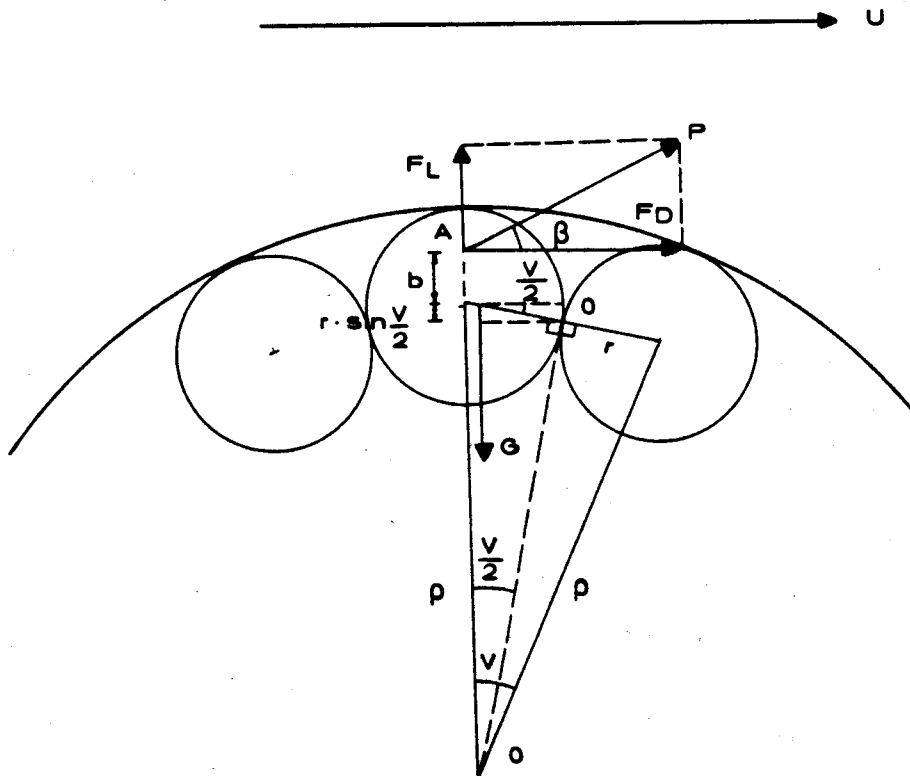

Fig. 5.13.d Vertical plane of Fig. 5.13.c.

Example

For the Korsør Harbour in Denmark DHI made stability tests with a rubble mound breakwater head (Fig. 5.7.e). The tests were made with three different water levels.

On Fig. 5.13.g the damage percentage is shown as function of the K_D -factor (dimensionless wave height in the third power). The damage refers to the most exposed 45° sector

$\pm 22.5^\circ$ on each side of the tangent point of a wave orthogonal. It is clearly seen that the stability of the roundhead decreases with increasing water level.

For the breakwater roundhead the following parameters apply: the vortex of the cone is of a level of +3.55 m. $\cot\alpha$ is equal to 2. From this the radius of curvature at SWL is equal to $2^2(3.55-WL)$. The radius of the armour stones has been determined, considering these as spheres.

With $\bar{W}_s = 1.56 \text{ t}$, $\alpha_s = 2.70 \text{ t/m}^3$, $r = \sqrt[3]{\frac{3\bar{W}}{4\pi\gamma_s}} = 0.52 \text{ m}$.

For simplicity b and β of Fig. 5.13.d are considered zero and it is seen from Eq. 5.13.f that the damage percentage is independent of the water level, if plotted as function of the parameter $K_D \cdot \frac{r}{\rho}$.

Fig. 5.13.f shows the corrected results. The results now show significantly less scatter. Due to the limited number of test results it is not possible to make general conclusions. However, the model seems to provide a tool, which can be used in planning and analysis of similar future tests.

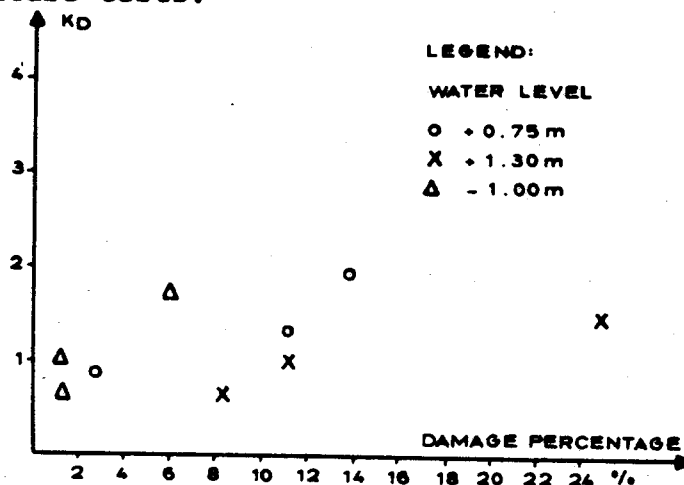

Fig. 5.13.e Test results for Korsør Breakwater Round-head.

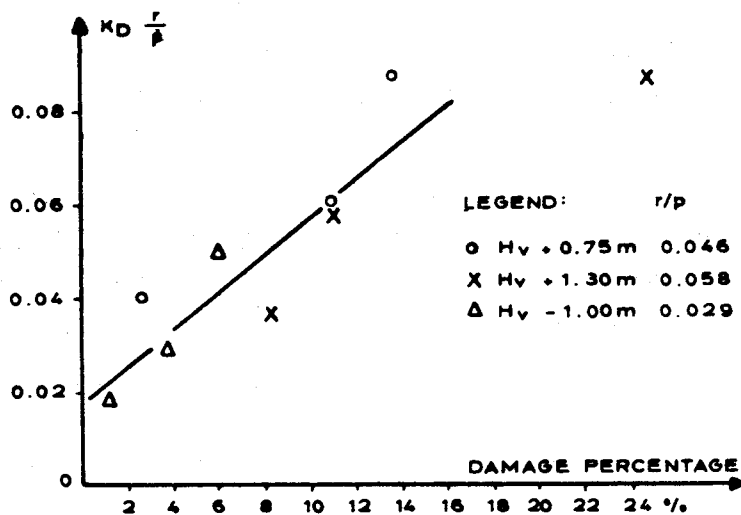

Fig. 5.13.f Corrected results from Fig. 5.13.e.

5.14 Special Types of Sloping Breakwaters

5.14.1 Heavy Seaward Face Armouring

On a sloping breakwater with an adequate crest elevation the wave forces are largest on the seaward slope around and somewhat below SWL. Due to this fact it is possible to obtain a saving by using only very heavy armouring in this very exposed zone. Such a profile is shown in Fig. 5.14.a. This type of dolos breakwater was built at Thorlafshöfn in Iceland. A similar breakwater has been built at Hirtshals Harbour on the Danish North Sea coast (Fig. 5.14.a). The same principle has been used for the breakwater at Midvaag Harbour (the Faroe Islands) by using different categories of quarry stones (Fig. 5.1.a).

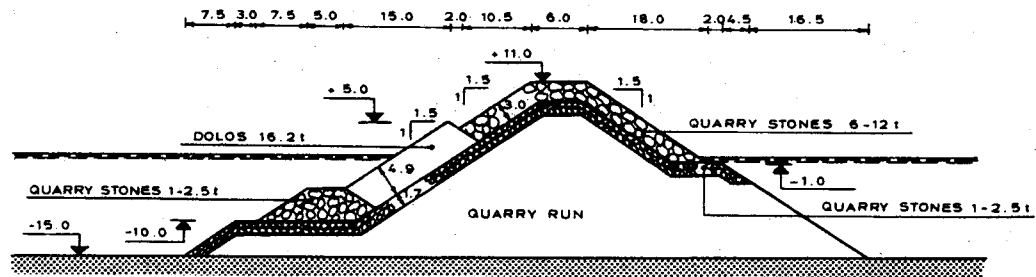

Fig. 5.14.a Profile of breakwater at Hirtshals Harbour, Denmark.

5.14.2 Profile with a Stock Pile of Armour Stones

At certain sites, where quarry stones are not available in adequate sizes, but where it is difficult to use artificial concrete armour units, a special type of profile with a stock pile of stones can be feasible.

That was the case with Skopun Harbour (the Faroe Islands) with design wave heights of up to about $H_s = 6$ m. For this harbour it would be very difficult and costly to make concrete armour units, and no area is available for storing such units.

In connection with a planned harbour extension different types of breakwaters were considered, and among these alternatives the one shown in Fig. 5.14.b, which is a pure quarry stone structure. To make the large quarry stones stable under extreme conditions would require a slope of approximately 1 to 4. This slope would require a very large crane. Instead the stones are placed in a stock pile on the seaward side with nearly their natural

angle of repose of about 1 on 1. During severe wave action the stones are rearranged until the shown flat profile develops. This type of structure is thereby self-stabilizing. The profile was studied by model tests, but was never constructed because of a selection of a harbour layout, for which this new breakwater was not necessary.

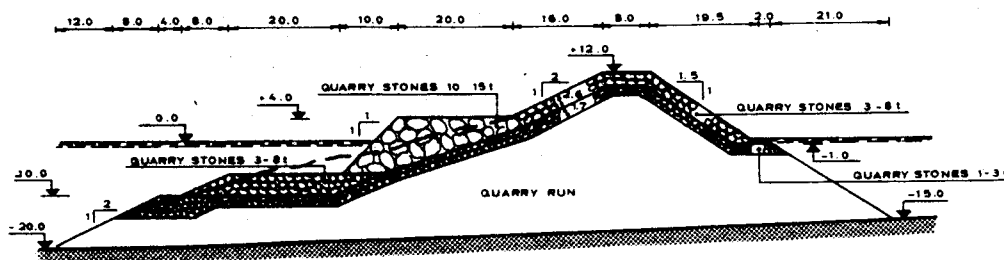

Note: - - - Profile after extreme wave exposure.

Fig. 5.14.b Proposed profile for breakwater at Skopun in Faroe Islands.

5.14.3 Asphalt Breakwaters

At sites where adequate quarry stone or other stones are scarce another possibility is to use asphalt/bitumen to tie smaller stones/gravel together to make stable slopes. This technique has been used with success, especially in The Netherlands, both for breakwaters and dikes. Recently an asphalt breakwater was also built in Esbjerg, Denmark, with the profile shown in Fig. 5.14.c. Basically this type of structure consists of two banks of sand asphalt

with a bitumen content in the order of 3-4% to keep the core of sand in place. The front side is protected with a layer of larger stones grouted with an asphalt mix. On the upper part of the structure the sand core is protected by two layers, first a sand asphalt and, as final cover-layer, a mixture of gravel and bitumen, plus filler. Both cover-layers are permeable.

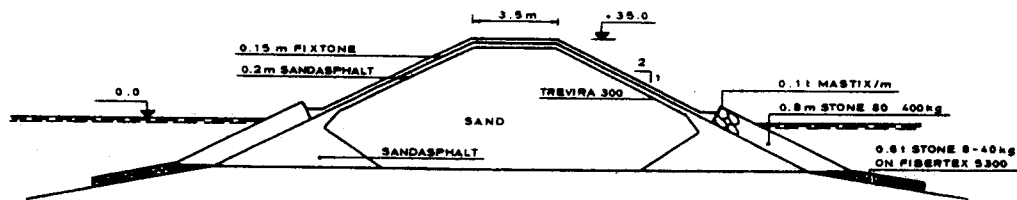

Fig. 5.14.c Profile of asphalt breakwater in Esbjerg, Denmark.

5.15 Selection of Construction Profiles and Strategy

5.15.1 Introduction

Besides evaluation of the final profile of a breakwater to ensure its stability during extreme conditions it is also necessary during the design process to consider the different construction stages.

Rubble mound breakwaters are in general very vulnerable during construction. The aim of evaluation of construction procedures is thus to reduce the vulnerability to a minimum without excessively reducing the construction practicability.

5.15.2 Characteristics of Construction Profiles

A breakwater composed of a number of layers of gradually increasing stone (or element) size will be vulnerable for the following reasons:

- a. The seaside is highly vulnerable before the filter layer and the final armour layer are placed. Especially the core is easily eroded if brought up to a high level (penetrating still-water).
- b. A rubble mound breakwater is often constructed from the core. Therefore, construction crest levels are lower than the final crest level. For this reason the crest and especially the rear side is vulnerable during construction due to overtopping.
- c. The free end of a breakwater under construction is a special problem, because here the core material is directly exposed to wave action.

5.15.3 Construction Strategy

It is not possible to present general rules for selection of construction profiles which depend upon many factors as for example the configuration and material of the breakwater, the construction equipment and the risk for occurrence of waves that can cause damage. But considering the points a, b, and c above, the following general comments can be made:

- a. The construction strategy should aim at completion of the seaward armour layer at the earliest possible stage and should aim at keeping at a minimum the length of breakwater with core and/or filter

layer directly exposed.

- b. The construction roadway should be at such a high level that the unavoidable risk of damage to the structure and the equipment is acceptable, in particular if casting operations for a superstructure take place on the crest. This should also be considered in the design phase, aiming at the base of the superstructure being so high that it can be constructed in a practical manner.
- c. The free end of a breakwater under construction always represents a special problem, and damage has occurred in many cases. In order to decrease the vulnerability only one thing can be done: to reduce the length of exposed core to a minimum.

For larger projects where the major part of the core material is placed by split barges or other types of barges, it is possible to reduce the vulnerability of the core only by bringing it up to a level where normal waves cannot erode it. Thus the core may be built as a submerged structure far ahead of the rest of the structure. The construction strategy should then be aimed at placing the filter and armour layers immediately after placing of the last portion of core material around and above SWL.

Fig. 5.15.a shows the construction profiles of a large breakwater for which the outermost end of the core was constructed by barges up to a level of -5.0 m. The rear side of the core was not filled to its final shape before placing of filter stones on the seaward side. In this way it is avoided that erosion of the core brings material outside the final core limit.

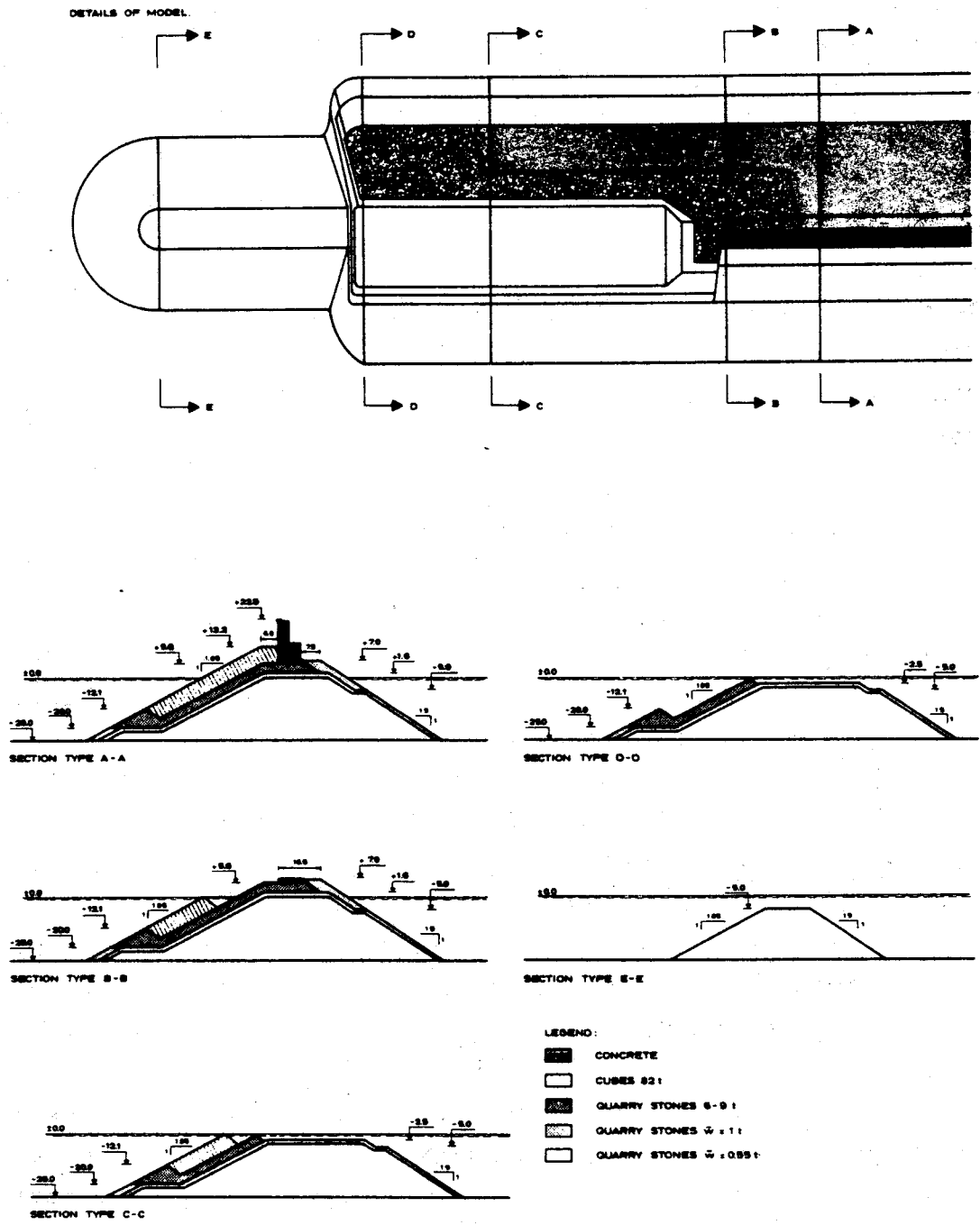

Fig. 5.15.a Example of breakwater construction profiles.

5.15.4 Stability of a Submerged Core

A proper core level for a given wave situation can be found from testing, or estimated roughly by calculations. Such calculations can be made by using the results in Refs. 23, 77, 78 as shown in the following example.

Example

Water depth : 25 m

Depth over submerged breakwater core: 9 m

Wave conditions: $H_s = 4.5$ m, $T_p = 15$ s

The horizontal particle velocity in -9.0 m is found from Ref. 78.

$$\frac{D}{L_0} = \frac{9}{1.56 \cdot 15^2} = 0.026 \rightarrow \frac{D}{L} = 0.067 \rightarrow$$

$$L = \frac{9}{0.067} = 134 \text{ m} \quad \{5.15.a\}$$

$$\eta' = \frac{2\pi\eta}{L} = 0 \quad \{5.15.b\}$$

$$D' = \frac{2\pi D}{L} = \frac{2\pi \cdot 9}{134} = 0.422 \quad \{5.15.c\}$$

The velocity is found as:

$$U_{\max} = \frac{\pi \cdot H}{T} \frac{\cosh \eta'}{\sinh D'} = \frac{\pi \cdot 4.5}{15} \cdot \frac{\cosh 0}{\sinh 0.422} = 2.2 \text{ m/s} \quad \{5.15.d\}$$

The particle amplitude is found as:

$$a_{\max} = \frac{H}{2} \cdot \frac{\cosh \eta'}{\sinh D'} = \frac{4.5}{2} \cdot \frac{\cosh 0}{\sinh 0.422} = 5.2 \text{ m} \quad \{5.15.e\}$$

The shear stress, τ_o , over the top of the core is found as:

$$\tau_o = f_w \cdot \frac{1}{2} \rho U_{\max}^2 \quad \{5.15.f\}$$

The friction factor, f_w , is found from Ref. 78.

$$\ln (f_w) = -5.98 + 5.21 \left(\frac{a_{\max}}{k_N} \right)^{-0.194} \quad \{5.15.g\}$$

k_N is the equivalent sand roughness.

The necessary stone size is guessed,

$$d = 0.20 \text{ m,}$$

$$f_w = e^{-5.98} + 5.21 (5.2 / (2.5 \cdot 0.20))^{-0.194} = 0.069 \quad \{5.15.h\}$$

The shear stress is equal to:

$$\tau_o = 0.069 \cdot 0.5 \cdot 10^3 \cdot 2.2^2 = 167 \text{ N/m}^2 \quad \{5.15.i\}$$

The necessary stone size is found from Engelund et al., Ref. 23.

$$\tau_c = \theta_c (\gamma_s - \gamma_w) d \quad \{5.15.j\}$$

$$d = \frac{\tau_c}{\theta_c (\gamma_s - \gamma_w)} \quad \{5.15.k\}$$

From Ref. 77 the critical dimensionless bed shear stress θ_c is equal to $\theta_c = 0.05$.

Tests at DHI on a submerged rubble mound breakwater core have shown that $\theta_c = 0.05$ if d is interpreted as d_{85} and H_s is used to calculate the representative velocity, U_{max} .

In DHI's tests $d_{85}/d_{15} = 2.5$.

For $H_s = 4.5$ m and $T_p = 15$ s, d_{85} is obtained as:

$$d_{85} = \frac{\tau_o}{\theta_c (\gamma_s - \gamma_w)} = \frac{167}{0.05 \cdot 1.7 \cdot 10^3 \cdot 9.81} = 0.20 \text{ m.} \quad \{5.15.1\}$$

6. HYDRAULIC MODEL TESTS ON BREAKWATERS

6.1 Models

As mentioned in Section 5 hydraulic model testing is the most efficient and accurate tool for determining dimensions of rubble mound breakwaters and for stability evaluation of their various components.

Breakwater model tests are as all hydraulic models based on model laws. Since all physical parameters (forces) cannot be properly scaled in a hydraulic model, it is necessary only to consider the most important forces, gravity and inertia or other forces scaled with the same factor, such as turbulent drag forces.

In order to properly scale these forces breakwater models are carried out in accordance with Froude's model law. In Froude's model law, the Froude number $F = \frac{V}{\sqrt{gD}}$ should be the same in the model and in nature. V is a characteristic velocity, g the gravitational acceleration, and D a characteristic length.

From this requirement, the scales for different physical parameters may be derived. The most important ones are the following:

Length scale:	1: λ
Time scale:	1: $\sqrt{\lambda}$
Force scale:	1: λ^3
Volume scale:	1: λ^3
Acceleration scale:	1:1

The acceleration scale is obviously 1:1, since the gravitational acceleration is the same in the model and in nature.

The scale of any physical parameter is most easily found from an analysis of its dimension. For example, the scale of stresses is (force/length scale squared) = $\lambda^3/\lambda^2 = \lambda$.

When making a hydraulic model also other forces than gravity and inertia play a role, especially for very small models. In such models both the water surface tension and the non-turbulent flow in porous media with low flow velocities (laminar or partly laminar flow) are important, especially the latter, as demonstrated in Ref. 42. This effect can be compensated for by using larger stones than calculated by Froude's model law, in certain areas of the model.

However, if models are large enough and waves are of considerable height, the model can be an accurate representation of natural conditions. This requires also as advocated in Chapter 5 that all tests are made by using reproductions of records of irregular natural waves.

It should be mentioned that breakwater models can never be distorted models (different vertical and horizontal length scales) such as for example river models in certain cases.

In the case of large concrete armour units model tests have a limitation in correct scaling of the structural strength of the concrete elements. The concrete strength has the dimension of (force/length unit squared). This means that the structural strength of the units used in a model with a length scale of 1:40 should also have a structural strength scale of 1:40.

Nearly the same concrete is used for armour units in nature, no matter which size is used. This means that, if

we take a 1 ton unit as a reference, a unit of the double size with a weight of 8 tons should have double structural strength and a 64 tons unit should have triple strength.

The required concrete technology is not available for this. Even if it is possible to make concrete with very high compression strength, it will be nearly as fragile as concrete with lower strength. One important factor in determining the structural strength for dynamic loads is the modulus of elasticity, E .

Burcharth showed in Ref. 16 from dynamic load tests on different sizes of dolos made of concrete with different characteristics that an increase in structural strength is followed by an increase in the modulus of elasticity, which increases the fragility, i.e. reduces the resistance against dynamic loads relative to static loads.

This means that the interpretation of hydraulic model tests without correct scaling of structural strength, should be made somewhat on the conservative side in the case of concrete armour units. One should always try to imagine how the units would actually behave.

However, numerous model tests on various breakwaters prove that this aspect is only very important for the most fragile types and for large artificial units.

6.2 Selection of Strategy for Model Tests

6.2.1 Introduction

In various laboratories all over the world different

testing procedures are used. Also among the most developed laboratories that have the capability of making tests with reproduction of irregular waves different procedures are often applied. It seems therefore quite clear that it is necessary to try to systematize present knowledge concerning methods and procedures. This may make planning of future tests more rational.

In the following, selection of wave and water level conditions and test procedures will be examined.

6.2.2 On Selection of Wave and Water Level Conditions

Traditionally stability tests on rubble mound breakwaters have been carried out in series which include a number of individual test runs, in which the wave height and sometimes also the wave period is increased step by step. Without reconstruction of the breakwater, damage is recorded after each test runs. In this way a relation between damage and wave height (wave period) is determined.

The shortcoming of this method is that it is difficult afterwards to relate the test wave conditions to the expected actual wave conditions. This simple, traditional method of testing is often used with the concept of a design wave height, a method which does not consider storm duration and wave period influence, and which does not take effects of less extreme storms into account.

6.2.3 Test Procedures

The following test procedures should be considered in each case:

- I : Tests with increasing wave impact.
- II : Tests with design situation.
- III : Tests reproducing individual storms.
- IV : Tests with stationary wave conditions of long duration.
- V : Tests reproducing the accumulated effect of wave action over a span of years. (For example the expected life of the structure).
- VI : Tests to determine residual stability.
- VII : Investigation of breakwaters under construction.

Assuming that the statistical occurrence of wave and water level conditions during the life of the project are known the following ought to be considered before test procedures, and a test programme is selected:

- a. Is the structure of concern a "deep water" structure? This means, are the wave conditions to be expected within the life of the structure not limited by wave breaking? As explained in Section 4 a breaker height index may be used for this analysis.
- b. Are the wave conditions limited by water depths.

It is very important to know whether a structure belongs to a. or b. In deep water there is always a certain probability for occurrence of wave conditions more severe than assumed for the design.

For shallow water structures, the maximum possible wave impact is limited and known with much greater accuracy.

I. Tests with Increasing Wave Impact

The traditional testing method increases wave conditions step by step from test run to test run, and damage is reported for each run. The test duration for each step is typically 3 to 10 prototype hours. Such tests are suited for a first evaluation of stability. For a deep water structure they give a reasonable picture of the behaviour of the structure for increasing significant wave heights and show approximately at which wave height complete failure occurs.

However, it is necessary to point out that the damage to the structure depends upon test duration, and the same damage may normally also result in a lower wave height over a longer duration (see Section 5.7.7).

Such test runs may also be used to determine the maximum wave height that can reach the structure and thereby the upper limit for wave impact. Depending upon the test duration they can also show the upper limit of damage if such a limit exists. The wave periods (T_p or T_s or other representative wave period) are of major importance for the maximum waves that actually reach the structure. This means that tests should be carried out with all representative wave periods. Wave breaking and maximum wave height in front of the structure is also influenced by water levels, so the selection of representative water levels should be made with great caution. In case conditions are just at the transition between type a. and b., wave action on the structure will not be completely depth limited. However, there will normally be a slow increase in damage for the greatest wave heights, because the highest waves in the wave train are breaking or broken due to the depth at the structure.

II. Tests with "Design Situation"

In certain cases it is relevant to carry out tests with a design situation instead of Procedure I. Such tests are suitable, if it is only a single construction element that is to be tested, while the rest of the profile has sufficient stability. This may typically be the case for design of a superstructure or for the crest determined from stability requirements for the rear side.

III. Tests Reproducing Individual Storms

In some cases it may be advantageous to test the stability of a rubble mound breakwater for individual storms. This may be of interest for one who is fortunate enough to have a record or a reliable hindcast estimate of an extreme storm from the site.

Such tests can also turn out to be suitable in cases where only a few storms are likely to occur during the life of the project. This may be the case for breakwaters under construction or for breakwaters exposed to rare hurricanes where the wave conditions of a design hurricane can be evaluated. These tests are a bit complicated to perform, if the water level is also a governing factor, since water level variations during the storm also have to be represented correctly in the model.

IV. Tests with Stationary Wave Conditions of Long Duration

Tests with stationary wave conditions (fixed H_s , T_p and WL) may serve the same purpose as Procedure I, namely a description of damage as a function of wave conditions and should be of such long duration that it is possible

to determine whether or not the damage occurring to the breakwater stabilizes or continues until complete collapse. The first situation is, of course, preferable for all projects, but is normally not economical for case a. (deep water) because very much larger waves than expected during the project life would have to be considered in the design. As previously pointed out for armour layers as steep as 1 to 1.5 the damage development in deep water will be nearly linear with time (for fixed wave conditions) whereas for less steep slopes there will be a stabilizing tendency for damage development.

V. Tests Reproducing the Accumulated Effect of Many Storms

Both at DHI and elsewhere calculations of the accumulated damage over the life of rubble mound breakwaters have been carried out. The basis for such calculations are Procedure I or IV tests to determine relationships between wave conditions and damage. The results from such tests have been used together with knowledge of wave statistics to calculate long-term damage. However, such calculations are somewhat uncertain as they are necessarily based upon certain assumptions and linearisations.

Instead, long-term damage, the accumulated effect of many storms, may be determined by tests, usually of very long duration carried out in the following way (cf. Fig. 6.2.a):

- a. The lower limit for wave conditions able to cause damage is determined (significant wave height H_{sdo}). This may be done by type I or IV tests.

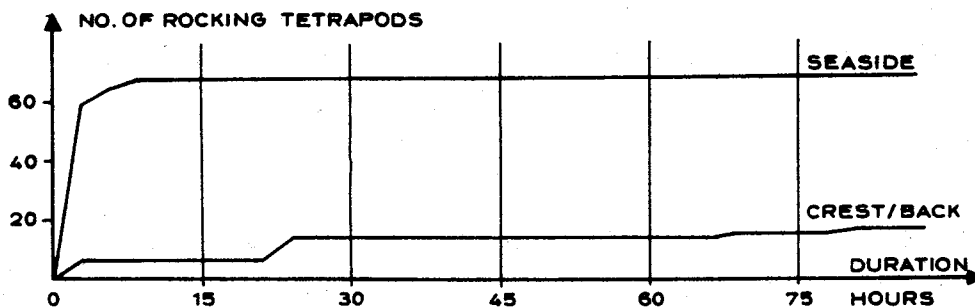
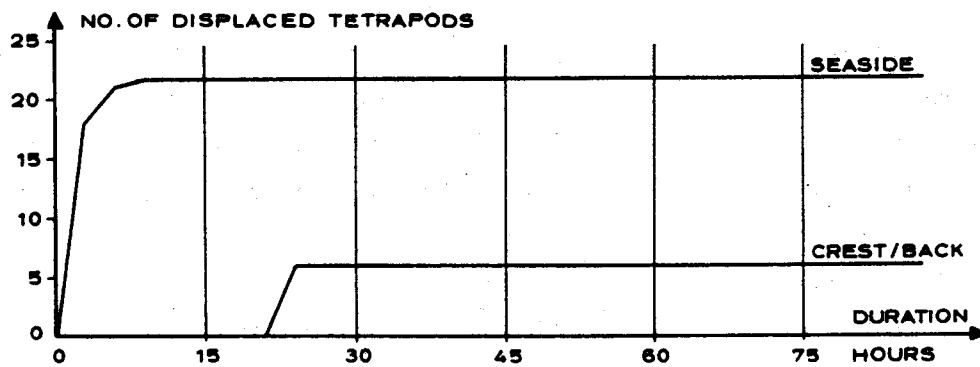
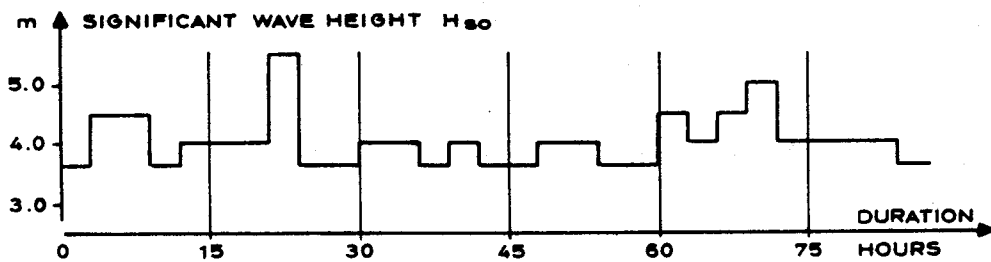
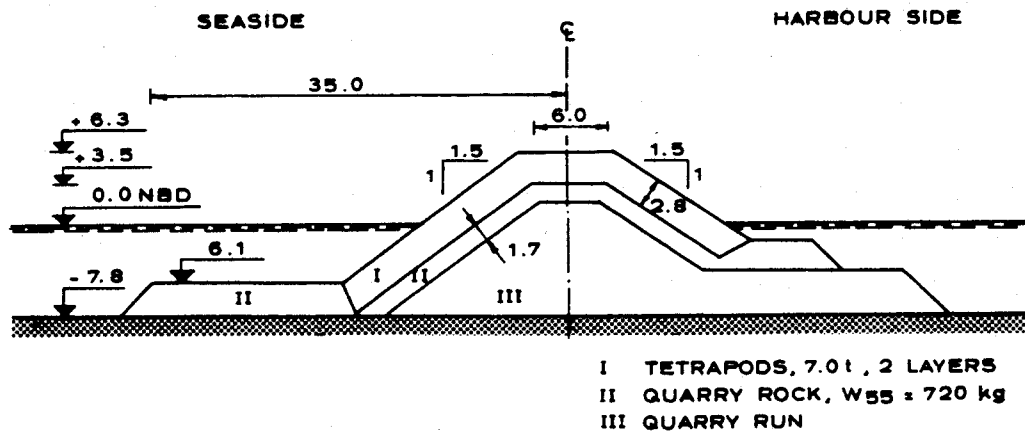

Fig. 6.2.a Damage development in long duration stability test.

- b. From wave statistics for the site is calculated the number of hours of storm of different intensities generating waves greater than H_{sdo} during the considered period (H_s is divided into a number of intervals).
- c. A duration for individual test runs is selected. For example a 3-hour prototype time, as used in the following example.
- d. It is calculated how many 3-hour periods each individual interval with $H_s > H_{sdo}$ corresponds to during the considered period of years. The method may be refined by division into (H_s, T_p, WL) intervals, if judged necessary.
- e. To be representative, it is necessary that the 3-hour tests are run in random order to imitate the stochastic occurrence of the storms.

VI. Tests to Determine Residual Stability

Regardless of which methods are used a model test programme, especially for a deep water structure, should be completed by determination of the residual stability. This is especially important for total risk-analysis, as the structure may not be economically feasible if a small increase in design conditions should result in complete collapse. This is especially important for the following structures and structural elements, for which a single or a few large waves may cause collapse!

1. Breakwaters in deep water with steep slope, where the armour layer in its entirety may slide down. (Ref. Bilbao Breakwater, see Section 5.7.5).

2. Breakwater superstructures.

3. Rear side armour layer for which a limited increase in wave height may change the situation from being acceptable to complete collapse (see Section 5.11).

VII. Investigation of Breakwaters under Construction

Such tests should be planned very carefully, because the structure is very vulnerable and is damaged by a wide range of wave conditions. Consequently, the tests should normally be of long duration.

LIST OF REFERENCES

- /1/ Abdelbaki, A. & Jensen, O. Juul. Study of Provisional Repair of the Breakwater in Port d'Arzew El Djedid, 1983. Conference on Coastal and Port Engineering in Developing Countries, Colombo, Sri Lanka, March 1983.
- /2/ Ahrens, I., 1977. Prediction of Irregular Wave Overtopping. U.S. Army Corps. Eng. Coastal Eng. Center. CETA-77-7.
- /3/ Ahrens, P. and McCartney, B.L. Wave Period Effect on the Stability of Riprap. Civil Engineering in the Oceans 1975, pp 1019-1034.
- /4/ Battjes, J.A., 1974. Wave Run-up and Overtopping. Technical Advisory Committee on Protection against Inundation, Haag.
- /5/ Battjes, J.A., 1974. Surf Similarity. Proc. Conf. on Coastal Eng. 14th Copenhagen, pp 446-480.
- /6/ Battjes, J.A. and Roos, A. Characteristics of Flow in Run-up of Periodic Waves. Report No. 75-3. Communications on Hydraulics Department of Civil Engineering, Delft University of Technology.
- /7/ Brink-Kjær, O.C., Dietrich, J. & Mangor, K. Wave and Current Study for the Danish North Sea Gas Pipeline. Preprint for Symp. on "Directional Wave Spectra Applications" (81). ASCE 1982.

LIST OF REFERENCES contd.

- /8/ Brorson, M., Burcharth, H.F. & Larsen, T. Stability of Dolos Slopes. Coastal Eng. Conf. 1974 Copenhagen. Chapter 99.
- /9/ Bruun, P. Practical Views on the Design of Mound Breakwaters. Report No. 7, 1979. Div. of Port and Ocean Eng. University of Trondheim, Norway.
- /10/ Bruun, P. Common Reasons for Damage or Breakdown of Mound Breakwaters. Coastal Engineering, 2 (1979) 261-273. Elsevier Scientific Publishing Company, Amsterdam.
- /11/ Bruun, P. and Günbak, A.R., 1977. Stability of Sloping Structures in Relation to $\xi = \tan \alpha \sqrt{H/L_0}$ Risk Criteria in Design. Coastal Eng. 1:287-322.
- /12/ Bruun, P. & Günbak, A.R. Hydraulic and Friction Parameters Affecting the Stability of Rubble Mounds. PIANCH, Bulletin No. 24, 1976.
- /13/ Bruun, P. and Johannesson, P. 1974. A Critical Review of Hydraulics of Rubble Mound Structures. Dir. Port Ocean Eng., Univ. Trondheim, Norway Publ. Inst. Rep. R 3.
- /14/ Bruun, P. and Johannesson, P., 1977. Parameters Affecting Stability of Rubble Mounds. Journal Waterw. Harbours Coastal Eng. Div. ASCA 103 (WW2): 141-164.

LIST OF REFERENCES contd.

- /15/ Burcharth, H.F. Effect of Waves on On-Shore Structures. Hydraulic Research Station Wallingford. Summary No. 40.
- /16/ Burcharth, H.F. Full Scale Trials of Dolosse to Destruction. Bulletin No. 17, May 1980. Laboratoriet for Hydraulik og Havnebygning, Alborg Universitetscenter, Denmark.
- /17/ Coastal Engineering, Vol. III. Breakwater Design. Edited by W.W. Massie, Delft University of Technology, Coastal Eng. Group, 1976.
- /18/ Collins, J.I. Wave Statistics and Rubble Mound Breakwaters. Conf. on "Waves" 1974.
- /19/ Dai, Y.B. and Kamel, A.M. Scale Effect Tests for Rubble Mound Breakwaters. U.S. Army Eng. Waterways Experiment Station, Vicksburg, Mississippi, Research Report H-69-2, 1969.
- /20/ Danel, P. & Greslou, L. The Tetrapod. Coast. Eng. 1962, Chapter 27.
- /21/ Edge, B.L. & Magoon, O.T. A Review of Recent Damages to Coastal Structures. Conf. on Coastal Structures 79, Virginia, U.S.A.
- /22/ Engelund, F. On the Laminar and Turbulent Flows of Ground Water through Homogeneous Sand. Transactions of the Danish Academy of Technical Sciences, Vol. 3, No. 4, 1953.

LIST OF REFERENCES contd.

- /23/ Englund, F. & Hansen, E. A Monograph on Sediment Transport in Alluvial Streams. Teknisk Forlag, Copenhagen 1972.
- /24/ Ergin, A. & Pora, S. Irregular Wave Action on Rubble-Mound Breakwaters. Journal of the Waterways, Harbours and Coastal Engineering Division WW2, May 1971.
- /25/ Fukuda, N., Uno, T. and Irie, I., 1974. Field Observations of Wave Overtopping of Wave Absorbing Revetment. Coastal Eng. in Japan, 17: 117-128.
- /26/ Gamot, J.P. Stabilité des Carapaces en Tétrapodes de Brise-Lames à Talus. La Houille Blanche no. 2 1969.
- /27/ Ge, Wu & Jensen, O. Juul, 1983. Stability of Rubble Foundation for Composite Breakwaters. Conference on Coastal and Port Engineering in Developing Countries, Colombo, Sri Lanka, March 1983.
- /28/ Goda, Y., 1971. Expected Rate of Irregular Wave Overtopping of Seawalls. Coastal Eng. in Japan, 14: 43-51.
- /29/ Gravesen, H., Frederiksen, E.W. and Kirkegaard, J., 1974. Model Tests with Directly Reproduced Natural Wave Trains. Proc. Conf. on Coastal Eng., 14th, 1974, pp. 372-385.

LIST OF REFERENCES contd.

- /30/ Gravesen, H. & Sørensen, T. Stability of Rubble Mound Breakwaters. PIANCH, 24th International Navigation Congress, Leningrad 1977.
- /31/ Gravesen, H., Jensen, O.J. & Sørensen, T. Stability of Rubble Mound Breakwaters II. Presented at the Conf. on Coastal Structures 1979, Virginia, U.S.A.
- /32/ Hedar, P.A. 1960. Stability of Rock-fill Breakwaters. Doktorsavhandling vid Chalmers Tekniska Högskola, No. 26 (Göteborg, Sweden).
- /33/ Hudson, R.Y. 1959. Laboratory Investigation of Rubble Mound Breakwaters. Proc. Am. Soc. Civ. Eng., J. Waterw. harbours Div., Vol. 85, WW3.
- /34/ Hunt, Ira A. Design of Seawalls and Breakwaters. Journ. of the Waterways and Harbours Division, September, 1959.
- /35/ Iribarren, R. & Nogales, C. New Confirmation of the Formula for the Calculation of Rock Fill Dikes. Proceedings, Chapter 14, page 185-189. 3th Conf. on Coastal Engineering, Berkeley, 1953.
- /36/ Iribarren, R. & Nogales, C. Other Verifications of the Formula for the Calculation of Breakwater Embankment. PIANC, Bulletin No. 39, pp 119-139. Brussels 1954.
- /37/ Iversen, H.W., 1952. Laboratory Study of Breakers. National Bureau of Standards, Washington, D.C. Circular 521.

LIST OF REFERENCES contd.

- /38/ Jackson, P. & Jensen, O. Juul, 1983. Development of a Fishing Harbour at Azefoun, Algeria. Conf. on Coastal and Port Engineering in Developing Countries, Colombo, Sri Lanka, March 1983.
- /39/ Jensen, Ole Juul. Stenkastningsmoler (in Danish). Vandbygningsteknisk Selskab. Oktober 1980.
- /40/ Jensen, O. Juul. Breakwater Superstructures. Conf. on "Coastal Structures 83", Washington, U.S.A., March 1983.
- /41/ Jensen, O. Juul, Gravesen, H. & Kirkegaard, J. Breakwater Optimization for Small Craft Harbours. Conf. on Coastal and Port Engineering in Developing Countries, Colombo, Sri Lanka, March 1983.
- /42/ Jensen, O. Juul & Klinting, P. Evaluation of Scale Effects in Hydraulic Models by Analysis of Laminar and Turbulent Flow. "Coastal Engineering", 7 (1983) 319-329. Elsevier Publishers B.V., Amsterdam.
- /43/ Jensen, O. Juul & Sørensen, T. Overspilling/Over-topping of Rubble-Mound Breakwaters. Results of Studies, useful in Design Procedures. Coastal Engineering, 3 (1979) 51-65. Elsevier Scientific Publishing Company, Amsterdam.

LIST OF REFERENCES contd.

- /44/ Johnson, R.R., Mansard, E.P.D. & Ploeg, J. Effects of Wave Grouping on Breakwater Stability. Preprint of paper for the 16th Coastal Eng. Conference, Hamburg 1978. Hydraulics Laboratory, National Research Council of Canada.
- /45/ Kreeke, J. van de & Paape, A. On Optimum Breakwater Design. Coastal Eng. Conf. 1964, Chapter 34, pp 532-552.
- /46/ Lee, Theodore T. Design of Filter System for Rubble-Mound Structures. Coastal Engineering Conf. 1972, Chapter 109.
- /47/ Lillevang, O.J. & Wayne, E.N. Experimental Studies of Stresses within the Breakwater Armour Piece "Dolos". Coast. Eng. Conf. 1976, Chapter 145.
- /48/ Longuet-Higgins, M.S., 1975. On the Joint Distribution of the Periods and Amplitudes of Sea Waves. J. Geophy. Res. Vo. 80, No. 18: 2688-2694.
- /49/ Losado, M.A. and Giménez-Curlo, L.A. Mound Breakwaters under Wave Attack. Univ. of Santander, June 1980. Dep. of Oceanographical and Ports Eng., Report No. SR.-1-80.
- /50/ Lundgren, H. & Brinch Hansen, J. Geoteknik, Teknisk Forlag, Copenhagen 1965.

LIST OF REFERENCES contd.

- /51/ Lundgren, H. Wave Shock Forces: An Analysis of Deformations and Forces in the Wave and in the Foundation. Proc. Symp. Research on Wave Action, Delft 1969, Vol. 2, Paper 4.
- /52/ Lundgren, H. & Gravesen, H. Vertical Face Breakwaters. Proceedings 6th Int. Harbour Conference, Antwerp 1974, Paper 2.11.
- /53/ Madsen, O. Secher. Wave Transmission through Porous Structures. Journal of the Waterways, Harbours and Coastal Eng. Div., August 1974.
- /54/ Magoon, T., Sloan, R.L. & Foote, G.L. Damages to Coastal Structures. Proc. Coast. Eng. Conf. 1974, Copenhagen, Chapter 97.
- /55/ Magoon, O. & Baird, W.F. Breakage of Breakwater Armour Units. Symp. on Design of Rubble Mound Breakwaters. British Hovercraft Corporation, 1977.
- /56/ Mandrup Andersen, V. & H.F. Burcharth. Vandbygning III (in Danish). Den Private Ingeniørfond, Danmarks Tekniske Højskole, 1968.
- /57/ Mansard, E.P.D. & Ploeg, J. Model Tests on Sines Breakwater. National Research Council of Canada, Hydraulics Laboratory, Laboratory Technical Report, October 1978.

LIST OF REFERENCES contd.

- /58/ Maquet, J.F. & Lemasson, P. Les Ouvrages de Protection (Les Travaux du Fermal Pétrolier du Havre-Antifer). Extrait de la Revue Travaux no. 488. Novembre 1975.
- /59/ McCartney, B., & Ahrens, J. Wave Period Effect on the Stability of Riprap. Abstract for Civil Eng. in the Ocean III, ASCE 1975.
- /60/ Le Méhauté, B. Wave Absorbers in Harbours. National Engineering Science Company. Pasadena, CA 1965.
- /61/ Le Méhauté, B. Similitude in Coastal Engineering. Journal of the Waterways, Harbours and Coastal Engineering Division, ASCE, August 1976.
- /62/ Merrifield, E.M. and Zwamborn, J.A. The Economic Value of a new Breakwater Armour Unit Dolos. Coastal Eng. Conf. Tokyo, 1966.
- /63/ Oorschot, J.H. & Wevers, A. Sea Bed Configuration in Relation to Breakwater Stability. Paper presented at the 13th Int. Conf. on Coast. Eng., Vancouver 1972. Delft Hydraulics Laboratory, Publ. No. 159.
- /64/ Oullet, Y. Effects of Irregular Wave Trains on Rubble-Mound Structures. Journal of the Waterways, Harbours and Coastal Engineering Division WW1, Feb. 1972.

LIST OF REFERENCES contd.

- 65/ Paape, A. & Ligteringen, H. Model Investigations as Part of the Design of Rubble-Mound Breakwaters. International Seminar on Criteria for Design and Construction of Breakwaters. Santander, Spain, July 1980. (Delft Hydraulics Laboratory, Publ. No. 246).
- /66/ Paape, A. & Walther, A.W. Akmon Armour Units for Cover Layers of Rubble Mound Breakwaters. Coast. Eng. Conf. 1962, Chapter 25.
- /67/ Paul, M.W. & Baird, W.F. Discussion of Breakwater Armour Units. Port and Ocean Eng. under Arctic Cond. Techn. Univ. of Norway, 1971.
- /68/ Price, W.A., 1979. Static Stability of Rubble Mound Breakwaters. The Dock & Harbour Authority, Vol. LX, No. 702, May 1979.
- /69/ Ramkema, C. A Model Law for Wave Impacts on Coastal Structures. Paper presented at the 16th Int. Conf. on Coast. Eng., Hamburg 1978. Delft Hydraulics Laboratory, Publication No. 207, October 1978.
- /70/ Sandström, Ake, 1974. Wave Forces on Blocks of Rubble Mound Breakwaters. Hydraul. Lab., Royal Inst. of Tech., Stockholm, Bull. 83.
- /71/ Savage, Rudolph P. Wave Run-Up on Roughened and Permeable Slopes. Journ. of the Waterways and Harbours Division, Paper 1640, May 1958.

LIST OF REFERENCES contd.

- /72/ Seelig, W.N. Effect of Breakwaters on Waves: Laboratory Tests of Wave Transmission by Overtopping. Conf. on Coastal Structures 79, Virginia, U.S.A.
- /73/ Shiraishi, N., Numata, A. and Endo, T., 1968. On the Effect of Armour Block Facing on the Quantity of Wave Overtopping. Proc. Conf. on Coastal Eng., 11th, 1968, pp. 853-869.
- /74/ Shore Protection Manual, Volume II, 1975. U.S. Army Coastal Engineering Research Center, Fort Belvoir, Virginia, U.S.A.
- /75/ Stephensen, D. Rockfill in Hydraulic Engineering. Developments in Geotechnical Engineering, Vol. 27. Scientific Publishing Company. Elsevier, Amsterdam, 1978.
- /76/ Svee, R. Formulas for Design of Rubble-Mound Breakwaters. Journal of the Waterways and Harbours Division, WW2, May 1962.
- /77/ Svendsen, Ib A. Sedimenttransport på kyster, maj 1979. Institutet for Strømningsmekanik og Vandbygning (ISVA), DTH, Lyngby, DK.
- /78/ Svendsen, I.A. & Jonsson, I.G. Hydrodynamics of Coastal Regions. Den Private Ingeniørfond, Technical University of Denmark, DK-2800 Lyngby.

LIST OF REFERENCES contd.

- /79/ Thomsen, A.L., Wohlt, P.E. and Harrison, A.S. Riprap Stability on Earth Embankments Tested in Large and Small Scale Wave Tanks. Techn. Memorandum No. 37, June 1972. U.S. Army Corps of Eng. Coast. Eng. Research Center.
- /80/ Thompson, D.M. and Shuttler, R.M. Design of Riprap Slope Protection against Wind Waves. CIRIA Report 61, December 1976.
- /81/ Todd, David Keith. The Water Encyclopedia. Water Information Center, Manhasset Isle, Port Washington, N.Y.
- /82/ Tsuruta, S. and Goda, Y., 1968. Expected Discharge of Irregular Wave Overtopping. Proc. Conf. on Coastal Eng., 11th, 1968, pp. 833-852.
- /83/ Tørum, A., Mathiesen, Bj. & Escutia, R. Reliability of Breakwater Model Tests. Conf. on Coastal Structures 1979, Virginia, U.S.A.
- /84/ Visser, W. Coast Protection with Bitumen. Shell Bitumen Reprint 20, 1969.
- /85/ Whillock, A.F. & Price, W.A. Armour Blocks as Slope Protection. proc. Coast. Eng. Conf. 1976, Chapter 147.
- /86/ Whillock, A.F., 1977. Stability of Dolos Blocks under Oblique Wave Attack. Hydraulics Research Station, Wallingford, Rept. IT 159.

LIST OF REFERENCES contd.

- /87/ Wiegel, R.L. Oceanographical Engineering. Englewood Cliffs, N.J. Prentice-Hall, 1964.
- /88/ Zwambourn, J.A. Analysis of Causes of Damage to Sines Breakwater. Conf. on Coastal Structures 1979, Virginia, U.S.A.