

Using Vmcg-Limited V1, Controllability Issues on Contaminated Runways and in Crosswind

Huijbrechts, Erik-Jan; Koolstra, Herman; Mulder, Bob

DOI

[10.2514/1.C035222](https://doi.org/10.2514/1.C035222)

Publication date

2019

Document Version

Final published version

Published in

Journal of Aircraft: devoted to aeronautical science and technology

Citation (APA)

Huijbrechts, E.-J., Koolstra, H., & Mulder, B. (2019). Using Vmcg-Limited V1, Controllability Issues on Contaminated Runways and in Crosswind. *Journal of Aircraft: devoted to aeronautical science and technology*, 56(4), 1342-1352. <https://doi.org/10.2514/1.C035222>

Important note

To cite this publication, please use the final published version (if applicable). Please check the document version above.

Copyright

Other than for strictly personal use, it is not permitted to download, forward or distribute the text or part of it, without the consent of the author(s) and/or copyright holder(s), unless the work is under an open content license such as Creative Commons.

Takedown policy

Please contact us and provide details if you believe this document breaches copyrights. We will remove access to the work immediately and investigate your claim.



Using V_{mcg} -Limited V_1 , Controllability Issues on Contaminated Runways and in Crosswind

Erik-Jan A. M. Huijbrechts,* Herman J. Koolstra,† and J. A. Mulder‡
Delft University of Technology, 2600 GB Delft, The Netherlands

DOI: 10.2514/1.C035222

V_{mcg} , or ground minimum control speed, is established by aircraft manufacturers during the aircraft certification process. V_{mcg} is used as a limiting speed for V_1 (decision speed) when performing takeoff performance calculations. Performance calculations on contaminated and slippery runways will result in a V_1 speed equal to V_{mcg} -limited V_1 for a wide range of takeoff weights when using aircraft manufacturer procedures in a flight crew operations manual or computer calculations based on the V_{1-min} policy. In this paper, it will be shown that V_{mcg} will not be a safe speed to continue a takeoff after an engine failure in strong crosswind or reduced runway surface friction conditions. A model is used to determine the effect of these environmental conditions on lateral deviation. Apart from the continued takeoff, the lateral deviation in the rejected takeoff after an engine failure was also calculated under different environmental conditions. This resulted in advice for the use of a differential braking technique to prevent a runway excursion if a runway is not dry. A method to mitigate the risk of runway excursion on contaminated and slippery runways is presented. An evaluation, conclusions, and subjects for further research are also presented.

Nomenclature

er	=	right engine
F	=	force, N
gl	=	(main) left gear
gr	=	(main) right gear
H_{dg}	=	heading, deg
M	=	moment, N/m
ng	=	nose gear
q	=	dynamic air pressure, N/m ²
r	=	yaw rate, deg/s
Trk	=	track
V	=	speed, kt/(m/s)
V_{ef}	=	engine fail speed, kt
V_g	=	ground speed, kt
V_{mcg}	=	minimum control speed ground, kt
V_R	=	rotation speed, kt
V_1	=	decision speed, kt
$V_{1(MCG)}$	=	V_{mcg} -limited V_1 , kt
V_2	=	one-engine-inoperative climb speed, kt
V_{30ft}	=	engine failure speed that will result in a 30 ft deviation from runway centerline, kt
W	=	weight, ton
β	=	aerodynamic sideslip angle, deg
β_g	=	ground sideslip angle, deg
β_t	=	tire sideslip angle, deg
μ	=	friction coefficient
μ_s	=	side force friction coefficient
ρ	=	air density, kg/m ³
ω	=	rotational speed of tire, deg/s

I. Introduction

FLYING in winter, a pilot will encounter situations with reduced runway friction. Not all airfields clear their runways or, if they do, freshly fallen precipitation will result in a contaminated runway.

On a contaminated (in particular, slippery) runway, performance calculations using flight crew operations manual (FCOM) procedures or computer performance based on the V_{1min} policy (an understandable choice for an operator regarding the recommendations from the industry) will result in a V_1 equal to V_{mcg} -limited V_1 for the greater part of the takeoff weight. Computer performance output will result in a V_1 even below the V_{mcg} -limited V_1 speed in the FCOM and shows that, in most cases, there is excess performance available.

The question arises as to whether a V_1 equal or close to the V_{mcg} -limited V_1 is safe to continue a takeoff on a contaminated runway. V_{mcg} is established with favorable environmental conditions (dry runway, and no crosswind) with an uncoupled nosewheel steering during the certification process of an aircraft.

A pilot will reject his takeoff after V_1 if a runway excursion is imminent by continuing the takeoff. In these cases, a higher V_1 would have been a better choice. Accident investigators are reluctant to blame procedures. If a rejected takeoff initiated after V_1 leads to a runway excursion, most probably, the crew will get the blame for not complying with procedures. The causal procedure fault may remain hidden.

Environmental conditions do affect V_{mcg} , as demonstrated by simulated certification tests using a model developed in Ref. [1]. The present procedures using V_{mcg} -limited V_1 as V_1 contain a part of the takeoff roll in which an unacceptable lateral deviation or runway excursion will occur after an engine failure. Also, the simulations of rejected takeoff resulted in some interesting discoveries. The simulation findings are summarized in the Evaluation section (Sec. VI). Some recommendations to improve safety for takeoff on contaminated runways are also presented.

II. Takeoff

A. Takeoff Performance and Speeds

Takeoff performance calculations must assure the aircraft will reach a certain screen height at the end of the runway and clear obstacles lying ahead of the runway when an engine failure is experienced. They must also assure the aircraft can be stopped on the runway in case the takeoff is rejected because of an engine or other failure.

Received 21 August 2018; revision received 28 November 2018; accepted for publication 2 December 2018; published online Open Access 24 January 2019. Copyright © 2018 by Delft University of Technology. Published by the American Institute of Aeronautics and Astronautics, Inc., with permission. All requests for copying and permission to reprint should be submitted to CCC at www.copyright.com; employ the ISSN 0021-8669 (print) or 1533-3868 (online) to initiate your request. See also AIAA Rights and Permissions www.aiaa.org/randp.

*Captain Boeing 737, KLM Royal Dutch Airlines, P.O. Box 7700, 1117 ZL Schiphol; erik.huijbrechts@klm4u.com.

†Experimental Test Pilot/Researcher, Faculty of Aerospace Engineering, Control and Simulation Division, P.O. Box 5058; H.J.Koolstra@TUDelft.nl.

‡Professor, Faculty of Aerospace Engineering, Control and Simulation Division, P.O. Box 5058; J.A.Mulder@tudelft.nl.

The procedures used by flight crew are incorporated in the flight crew operations manual. Calculation methods are based on runway surface condition. Different methods are used for dry, wet, and contaminated runways. For dry or wet runways, a reduced thrust setting can be selected. For contaminated runways, rated (or fixed derated) thrust must be used. Factors that are considered are weather, aircraft, and runway related: e.g., air pressure, anti-ice systems used, and accelerate–stop distance available. The head wind or tailwind is accounted for; the crosswind, however, is not considered for performance or takeoff speeds [2].

Performance calculations result in a performance-limited takeoff weight (PLTOW), an assumed temperature (if reduced thrust is allowed), and takeoff speeds at the selected takeoff weight (TOW).

The takeoff speeds are 1) V_1 (decision speed), 2) V_R (rotation speed), and 3) V_2 (initial climb speed with one engine inoperative).

In the past, “paper” calculations were made using takeoff weight limitations: tables for the runway concerned, and tables to calculate the speeds. Nowadays, most performance calculations are performed by onboard (electronic flight bag) or home-based (accessible via an aircraft communications addressing and reporting system or satellite communications) computer programs.

Performance on dry runways is based on certified performance data delivered by the manufacturer in the airplane flight manual (AFM). Wet runway performance can be found in the performance engineers manual (PEM) or, for newer aircraft, as certified performance in the AFM or the AFM’s digital performance information (AFM-DPI). Performance for aircraft on contaminated runways is based on advisory information in the PEM or AFM. The research and calculation methods for this information date back to the 1960s.

In 2006, European regulations had a major revision in the acceptable means of compliance (AMC) with guidance material on the calculation method for contaminated runway performance including hydroplaning [3].

B. V_1 (Decision Speed)

Before every takeoff, a single value for V_1 is established. Below V_1 , the takeoff can be rejected. At speeds higher than V_1 , takeoff must be continued. A pilot will lift his hand from the thrust levers to the yoke at V_1 to continue the takeoff. Elaborate discussions about the go/no-go decision can be found ([4] Par. 2.2).

Decision speed is too short a description of V_1 . The Federal Aviation Administration (FAA) definition of V_1 is as follows:

The maximum speed in the takeoff at which the pilot must take the first action (e.g., apply brakes, reduce thrust, deploy speed brakes) to stop the airplane within the accelerate–stop distance. V_1 also means the minimum speed in the takeoff, following a failure of the critical engine at V_{ef} , at which the pilot can continue the takeoff and achieve the required height above the takeoff surface within the takeoff distance [5].

On the low side, V_1 speed is limited by the ground minimum control speed V_{mcg} [6] CS25.107, [7] FAR25.107. On the high side, V_1 is limited by V_R (at TOW). Performance calculations for continued and rejected takeoff limit V_1 as a function of TOW.

For dry and wet runways, V_1 is mostly calculated to match accelerate–stop and accelerate–go distances. This is called the balanced field principle ([2] Par. 3.1.5, [4] Par. 2.3.1.3). If excess performance is available, reduced thrust can be used to save on engine life. Dry runway calculations typically result in a V_1 equal, or close, to V_R . Wet runway calculations typically result in a lower V_1 with a speed gap to V_R .

Speed calculations on contaminated and slippery runways based on manufacturer FCOM procedures will result in a V_1 speed equal to V_{mcg} -limited V_1 for a wide range of takeoff weights, even if this is not required to meet accelerate–stop performance. Standardized computerized aircraft performance (SCAP) software offers the option to calculate the minimum V_1 and maximum V_1 . Some

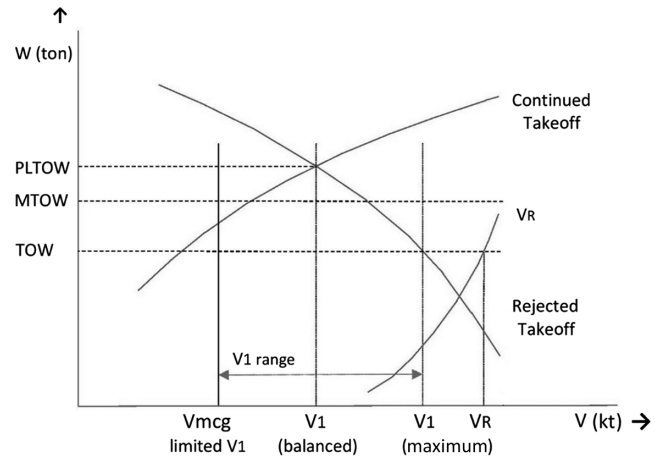

Fig. 1 Typical V_1 envelope for a contaminated runway.

operators choose to use the $V_{1-\min}$ option for their operation, assuming these speeds are safe.

Figure 1 shows a typical diagram for a contaminated runway. At the lower side, V_1 is limited by V_{mcg} ; at the high side, it is limited by accelerate–stop performance. The V_1 in which both curves intersect is called the balanced V_1 . A V_1 within the range complies with AFM performance requirements.

C. Runway Surface Condition and Braking Action

The relation between the runway surface condition used for performance calculations and the reported or measured braking action (runway surface friction coefficient) of a runway is not clear.

Following a runway excursion after landing in 2005, the Federal Aviation Administration instated the Takeoff and Landing Performance Assessment Aviation Rulemaking Committee. This committee released Safety Alert for Operators 06012 [8] and, later, the paved runway condition assessment table (Table A1 in the Appendix) [9]. These publications give better guidance for operators and pilots to assess what performance calculations to use in specific runway contamination situations. Some operators have incorporated this guidance in the FCOM. The FAA and the European Aviation Safety Agency (EASA) have devoted a lot of effort to harmonize runway surface condition reporting and the methods to establish and report measured braking actions [10].

D. Takeoff Safety

In the 1990s, the FAA, together with the aviation industry, published the Take-Off Safety Training Aid [4]. A continued takeoff was considered safer than a rejected takeoff (RTO). Research showed that, in 58% of RTO accidents, the takeoff was rejected at a speed above V_1 . In 24% of the accidents, engine problems played a role and, in at least one-third of the accidents, the runway was wet or contaminated ([4] Par. 2.2.4). The Training Aid aimed at emphasizing to pilots not to reject a takeoff after V_1 . To reduce the number of RTOs, V_1 should be reduced as much as possible.

In preparation for the revision of AMC 25-1591 [3], the British Civil Aviation Authorities (U.K. CAA) have questioned the use of V_{mcg} for contaminated runways and in crosswind conditions. The Joint Airworthiness Authorities Flight Study Group expected some effect of crosswind and little effect of runway surface conditions but recommended to seek an improvement in the knowledge necessary to account for V_{mcg} and crosswind effects on controllability when operating on contaminated surfaces [11]. The dissenting opinion of the U.K. CAA has led to the following statement: “The provision of performance information for contaminated runways should not be taken as implying that ground handling characteristics on these surfaces will be as good as can be achieved on dry or wet runways, in particular following engine failure, in crosswinds or when using reverse thrust” ([3] Par. 8.1.3). However, V_{mcg} as established under test conditions (dry runway, no crosswind, and free castering nosewheel) was preserved as the minimum speed for V_1 .

III. Dynamics of an Engine Failure

Apart from aerodynamic forces, ground forces play a role in the dynamics of the takeoff roll. Lateral forces on a rolling tire are, for given conditions, a function of the vertical force and the slip angle of the tire [12]. The slip angle of an individual tire is the vector sum of the slip angle of the aircraft related to the ground, the yaw rate induced slip angle, and (if applicable) the steering angle of the tire. The maximum side force coefficient ($\mu_s = F_Y/F_Z$) is dependent on the runway surface condition and the velocity of the tire (see Fig. 2).

A. Before Engine Failure

Before an engine failure occurs, an aircraft tracks the centerline of the runway. If crosswind is present, a certain rudder deflection will be applied to counteract the weathervane and side force effect. An equilibrium of moments and lateral forces acting on the gears and aerodynamic surfaces will exist.

B. Initial Reaction

The initial reaction of the aircraft after a left engine failure will be a heading change toward the failed engine causing a slip angle β_g to the right (see Fig. 3). This slip angle causes the main gear to generate a side force for a track change toward the failed engine. The yaw rate r will cause an additional slip angle on the nose gear to the left. The aerodynamic slip angle β will be dependent on crosswind but, as compared to the previous situation, will counteract the moment generated by the asymmetric thrust, as will the yaw rate induced aerodynamic sideslip angle at the tail. The moments generated by the gears will also counteract the asymmetric thrust moment.

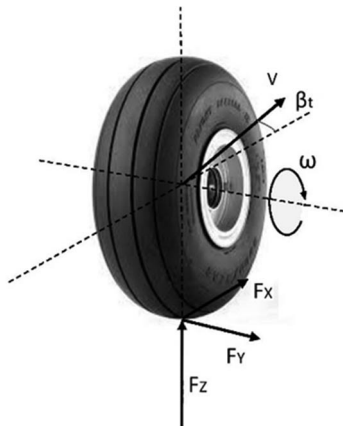

Fig. 2 Forces on a rolling tire. Adapted from Ref. ([12] p. 91, fig. 3.2).

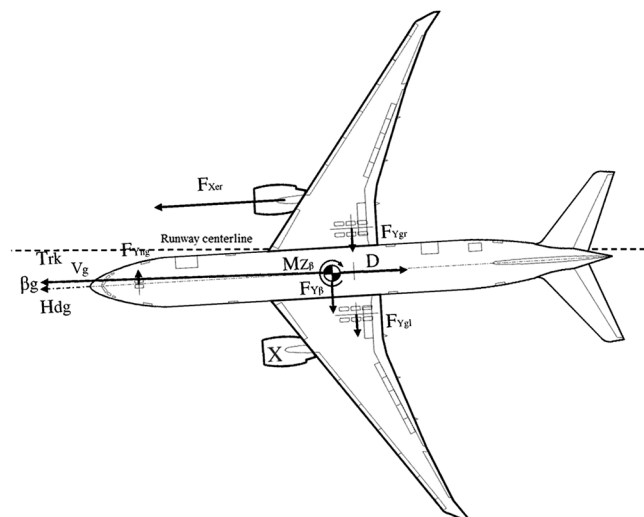

Fig. 3 Initial reaction of aircraft after engine failure.

C. Rudder Application

The pilot will react on the heading change of the aircraft and apply the rudder to steer back to the centerline (see Fig. 4). The moment generated by the rudder will counteract that due to the asymmetric thrust. If nosewheel steering is coupled, it will support this counteracting moment. If these moments are strong enough, the yaw rate will be reversed. This will cause the slip angle β_g to shift to the left. Forces on the main gear will be reversed, and the aircraft will return to the centerline. The aerodynamic moment and the moment of the main gear forces are in the opposite direction of the rudder moment. As the main gears are close to the center of gravity, the contribution to the total moment about the center of gravity is relatively small.

Aerodynamic forces are proportional to the dynamic pressure ($q = (1/2)\rho V^2$) and are the dominant forces at high speeds. At low speeds, the gear forces are dominant in the dynamics during the takeoff roll.

IV. Minimum Control Speed on the Ground V_{mcg}

To certify an aircraft, the manufacturer has to run ground tests to establish a value for V_{mcg} .

The following is the definition of V_{mcg} [6] CS25.149:

V_{mcg} , the minimum control speed on the ground, is the calibrated airspeed during the take-off run at which, when the critical engine is suddenly made inoperative, it is possible to maintain control of the aeroplane using the rudder control alone (without the use of nosewheel steering), as limited by 667 N of force (150 lbf), and the lateral control to the extent of keeping the wings level to enable the take-off to be safely continued using normal piloting skill. In the determination of V_{mcg} , assuming that the path of the aeroplane accelerating with all engines operating is along the centreline of the runway, its path from the point at which the critical engine is made inoperative to the point at which recovery to a direction parallel to the centreline is completed, may not deviate more than 9.1 m (30 ft) laterally from the centreline at any point (see Fig. 5). V_{mcg} must be established, with 1) The aeroplane in each take-off configuration or, at the option of the applicant, in the most critical take-off configuration; 2) Maximum available take-off power or thrust on the operating engines; 3) The most unfavourable centre of gravity; 4) The aeroplane trimmed for take-off; and 5) The most unfavourable weight in the range of take-off weights.

The same certification basis can be derived from Ref. [7] FAR25.149 in combination with the flight test guidance [13].

As there is no requirement on the runway surface condition or wind conditions, the V_{mcg} certification test is conducted on a dry runway in calm wind conditions. The flight test guidance suggests that not using the nosewheel steering compensates for the effect of a wet runway surface [13]. Major aircraft manufacturers have summarized their experience with V_{mcg} certification tests [14].

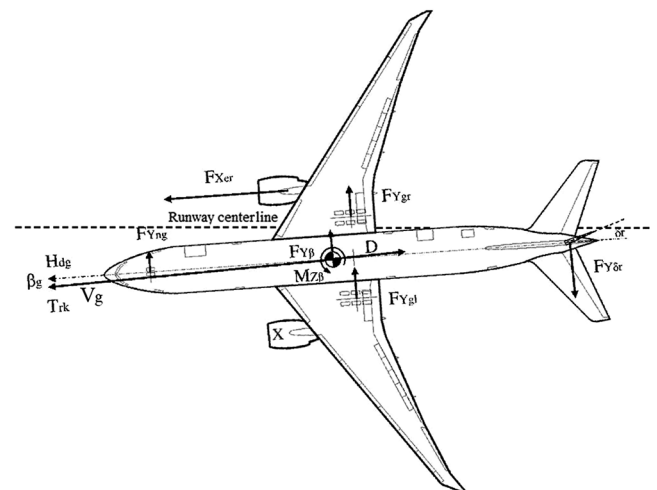

Fig. 4 Situation after rudder application.

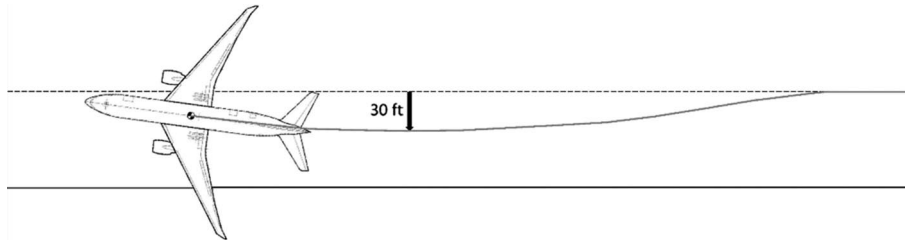

Fig. 5 Maximum permitted lateral deviation during V_{mcg} certification test.

V_{mcg} is called an aerodynamic speed. This means that it is expressed in indicated air speed. It does not imply that it is fully determined by aerodynamic forces alone.

The lateral deviation of the aircraft from the centerline is largely affected by the side forces between the main-wheel tires and the runway. In fact, major manufacturers say the test is highly influenced by the ground-to-tire reaction, and they advise using new tires to perform these tests ([14] p. 3, 7).

Crosswind is another factor with a high influence on the V_{mcg} certification tests ([14] p. 16).

Aircraft manufacturers use the V_{mcg} value, obtained by this test, to calculate the V_{mcg} -limited V_1 [$V_{1(MCG)}$] by applying the engine failure recognition time (1 s). $V_{1(MCG)}$ is presented in the PEM, the AFM [15], or the AFM-DPI for performance calculations and the FCOM [16] for use by crews.

V. Modeling Results

A model of a Boeing 737-300 with 20 klb rated engines is used to evaluate the influence of the pilot reaction time, nosewheel steering, and environmental factors, such as runway surface condition and crosswind, on V_{30ft} [1]. This model was validated by reproducing the certified V_{mcg} value by simulating the certification test.

The following definition was made up for the present research: V_{30ft} is the engine failure speed that will result in a 30 ft deviation from the runway centerline.

Most figures show lateral deviation as a function of the engine failure speed V_{ef} .

The width of most runways is 45 m (150 ft). As a rule of thumb, a lateral deviation of 30 ft or less can be considered safe. A lateral deviation of 60 ft or more, with regard to the position of the main wheels, can be considered a runway excursion.

The V_{mcg} -limited V_1 value for the Boeing 737 – 300/20 k (standard conditions) is 111 kt [15,16]. The corresponding V_{mcg} value is 107 kt. This can be used as a reference value for V_{ef} .

NWS on refers to nosewheel steering (NWS) coupled to the rudder pedals. NWS off refers to an uncoupled nosewheel steering modeled as the absence of lateral forces on the nose gear.

Continued takeoff (CTO) was evaluated first. To make sure a rejected takeoff (RTO) would not result in a larger lateral deviation than a continued takeoff, the RTO was also evaluated.

A. Continued Takeoff

1. Reaction Time

Figure 6a shows V_{30ft} values of 97 kt at 0.2 s, 103 kt at 0.4 s, 111 kt at 0.6 s, and 124 kt at 0.8 s (NWS off). With NWS on (Fig. 6b), these values are, respectively, 82, 88, 98, and 117 kt.

The model confirms that the reaction time is of great influence on V_{30ft} .

For evaluation of the effect of environmental conditions, the effective reaction time in the model was set to 0.5 s ([1] Par. II.H). The V_{30ft} value at 0.5 s. in Fig. 6a is 107 kt, which is the certified V_{mcg} value for the Boeing 737 – 300/20 k.

2. Runway Surface Condition

Based on NASA Technical Paper 1080 [17], three runway friction models were developed from measurements on dry, damp, and flooded concrete runway surfaces. These models are called NASA dry, NASA damp, and NASA flooded. These models can be linked to, respectively, dry, wet, and contaminated runway surface conditions ([1] Par. II.F).

Figure 7 shows that V_{30ft} is 107 kt on a dry surface, 113 kt on surface damp (wet) runway surface, and 114 kt on a flooded (contaminated) surface (NWS off). With NWS-on, these figures are, respectively, 93, 109, and 113 kt.

The effect of nosewheel steering is considerable (14 kt) on a dry surface and negligible on a flooded (low friction) surface. Runway surface friction has a considerable influence on V_{30ft} . The simulations show that the adverse effect of a wet runway or slippery runway is worse than the adverse effect of an uncoupled nosewheel steering.

3. Crosswind

All crosswind-related figures are calculated with a crosswind from the right and a right engine failure (critical engine). (This may not be correct for a B737-300, see Sec. VI.J for an explanation.)

Figure 8 shows that V_{30ft} increases from 107 to 113 kt with a 10 kt crosswind component, to 118 kt with a 20 kt crosswind component, and to 125 kt with a 30 kt crosswind component (NWS off). With NWS-on, the numbers are, respectively, 93, 100, 108, and 116 kt. The effect of crosswind turns out to be considerable. The model shows NWS may compensate for the adverse effect of almost 20 kt of the crosswind component on a dry runway.

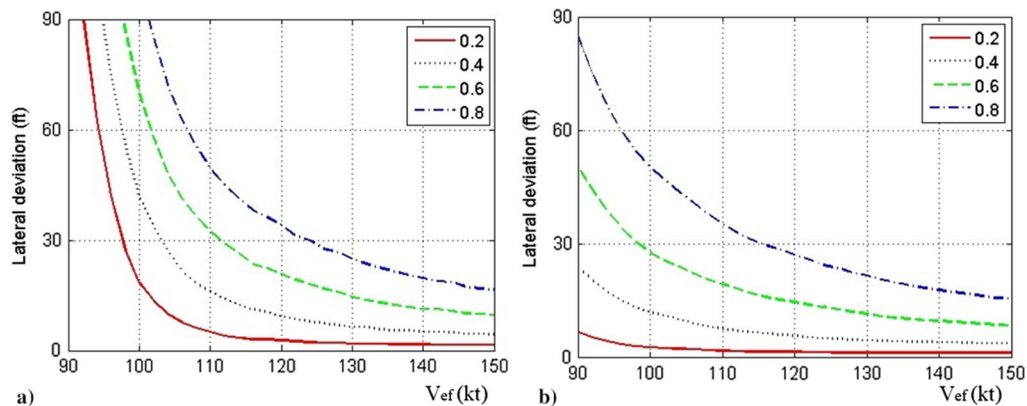

Fig. 6 Lateral deviation as function of V_{ef} . CTO with different reaction times (in seconds): a) NWS off, and b) NWS on. (Runway friction model: NASA dry.)

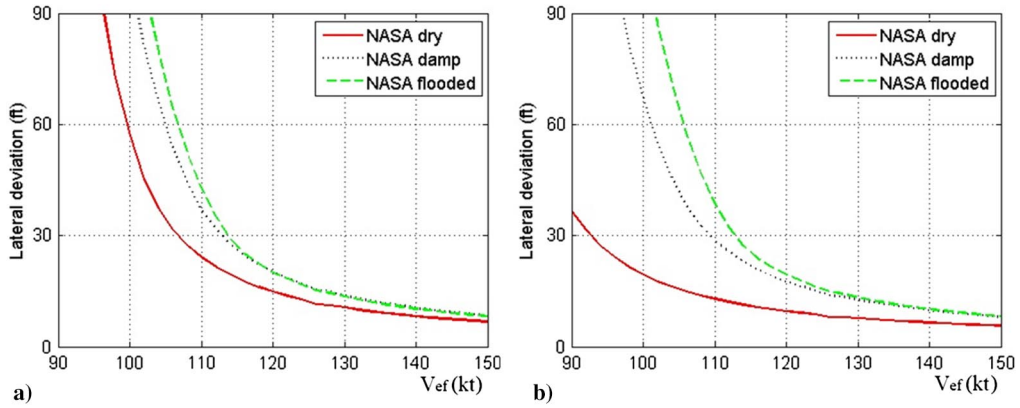

Fig. 7 Lateral deviation as function of V_{ef} . CTO with different runway friction models: a) NWS off, and b) NWS on.

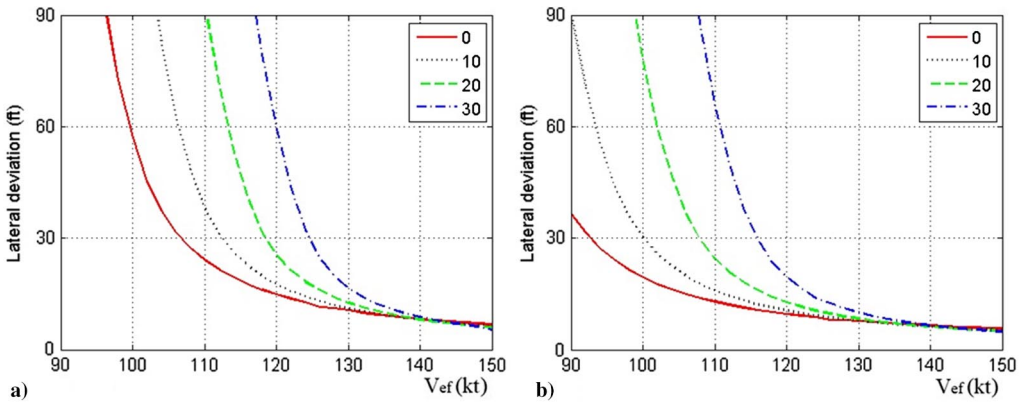

Fig. 8 Lateral deviation as function of V_{ef} . CTO for different crosswind components: a) NWS off, and b) NWS on. (Runway friction model: NASA dry.)

4. Crosswind and Runway Surface Condition

For the next figures, friction coefficients μ_s were assumed to be independent of speed ([1] Par. II.F). At a 100 kt ground speed, a μ_s value of about 0.5 can be linked to a dry runway surface, of about 0.1 to a damp/wet surface, and 0.05 to a flooded/contaminated surface ([17] table I, [18] table II).

Figure 9 shows, surprisingly, that the crosswind has more influence at high μ_s values. This is caused by the larger gear moments requiring more rudder input to correct for crosswind. Based on the model, a margin of 10 kt on V_{mcg} (and thus on $V_{1(MCG)}$) would be sufficient to remain below V_{30ft} for crosswinds up to 25 kt for all μ_s values (NWS on).

B. Rejected Takeoff

The model was also used to see if lateral deviation is acceptable when rejecting takeoff after an engine failure. For a reaction time, a rudder input of 0.5 s was used. The reaction time before closing the

operating engine was 1 s ([4] Par. 2.3.1.2), and a 1 s linear decay to idle thrust for the operating engine was assumed. The deployment of lift dumpers and three braking modes (no braking, symmetrical braking, and differential braking 0.2 s after full rudder deflection) were modeled. The differential braking mode changed into symmetrical braking when rudder deflection was reduced. No data were available for combined braking and lateral forces on dry surfaces [17]. So, lateral deviation is only calculated for damp and flooded surfaces with braking. The use of reverse thrust was not modeled.

Figure 10a clearly shows that NWS is required to prevent a runway excursion after engine failure at low speed. With NWS on (Fig. 10b), the lateral deviation will still result in a runway excursion when the runway is not dry at low speeds. Figure 10c shows that symmetrical braking will not prevent a runway excursion at lower speeds; it may even aggravate the situation. Differential braking can keep the aircraft on the runway when the runway is not dry (Fig. 10d).

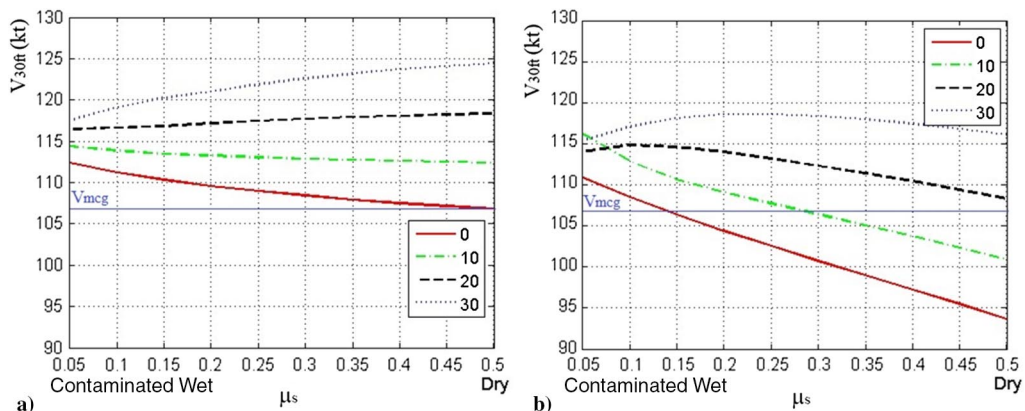

Fig. 9 V_{30ft} as function of μ_s . CTO with different crosswind values: a) NWS off, and b) NWS on.

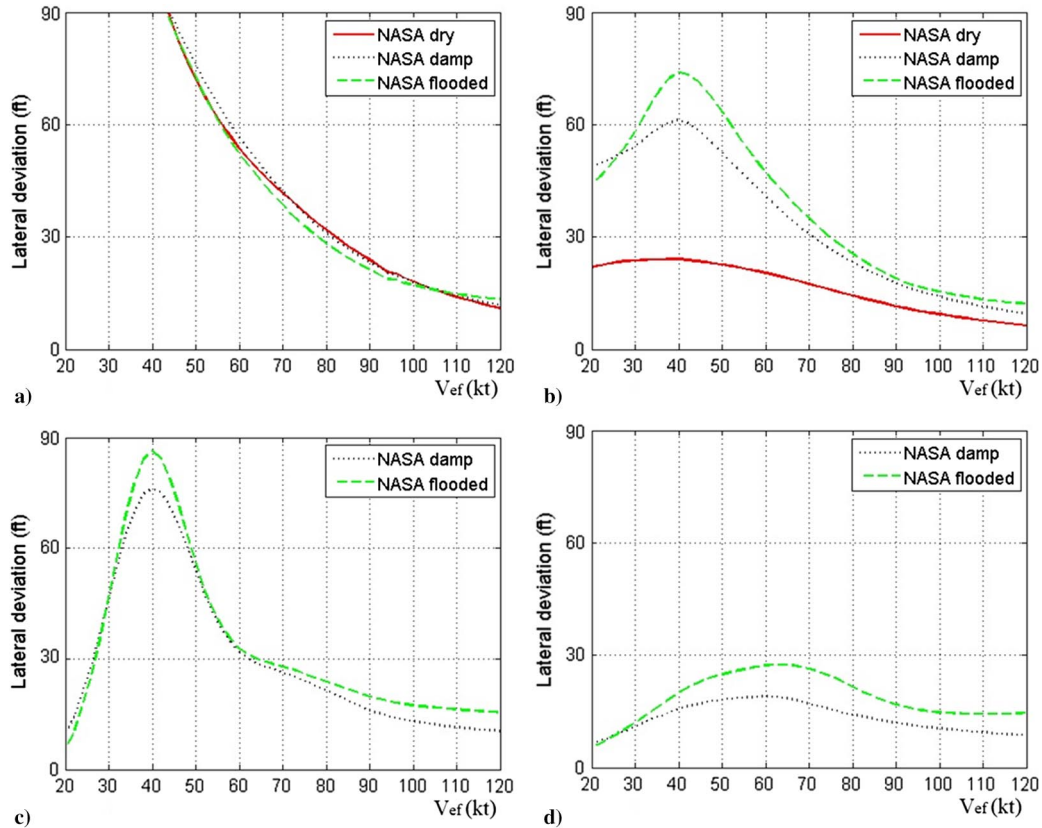

Fig. 10 Lateral deviation as function of V_{ef} . RTO with different runway friction models: a) NWS off with no braking; b) NWS on with no braking; c) NWS on with symmetrical braking; and d) NWS on with differential braking.

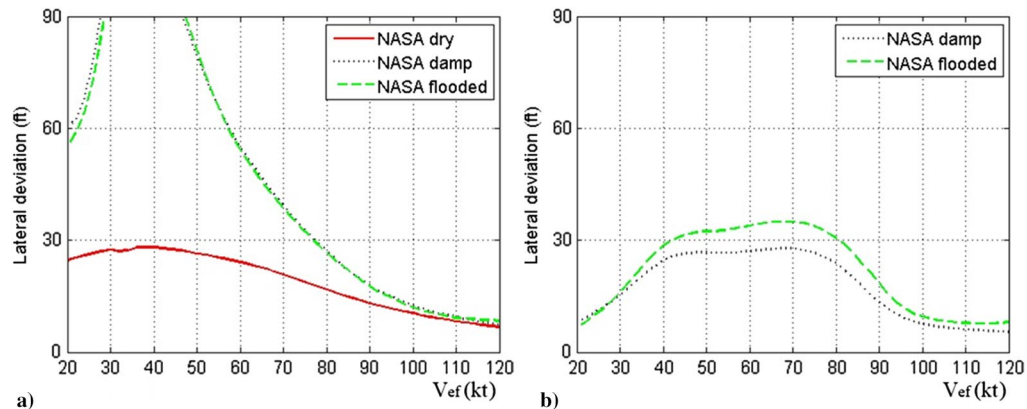

Fig. 11 Lateral deviation as function of V_{ef} . RTO, NWS on, and 10 kt crosswind with different runway friction models: a) no braking, and b) differential braking.

The lateral deviation at speeds around V_{mcg} is smaller in the RTO than in continued takeoff (see Fig. 7).

Figure 11 shows that, in crosswind conditions, the lateral deviation at speeds around V_{mcg} is still smaller than in continued takeoff. Figure 11a also shows that, in crosswind conditions, a runway excursion is likely to happen at low speeds when the runway is not dry. Differential braking, however, can still keep the aircraft on the runway (Fig. 11b).

Figure 12 shows that, in stronger crosswind conditions, the lateral deviation at speeds around V_{mcg} is still lower than in continued takeoff. Figure 12b shows that, in stronger crosswind conditions, differential braking may not prevent a runway excursion on a contaminated runway. Operators use constraints on the maximum crosswind allowed in case of reduced runway friction coefficients [19].

VI. Evaluation

In this section, findings from the research are discussed. Some findings have resulted in conclusions; other findings have raised

questions that require further investigation. We have added the findings we want to share with the aviation community as food for thought.

A. V_1 Policy in FCOM Procedures for Contaminated Runways

Reviewing FCOM performance calculation procedures on contaminated runways for different (Boeing) aircraft reveals that V_1 is reduced to V_{mcg} -limited V_1 [$V_{1(MCG)}$] for a wide range of takeoff weights [for some types/variants up to maximum takeoff weight (MTOW)], even if this is not required for accelerate-stop performance. Apparently, a V_{1-min} policy is applied in the FCOM procedures.

B. Transition from Paper Performance Calculations to Computer Performance Calculations

Pilots trust their performance calculations and the procedures they use from the FCOM. Whereas, in paper calculations, numbers are always conservative due to the simplified presentation; computers

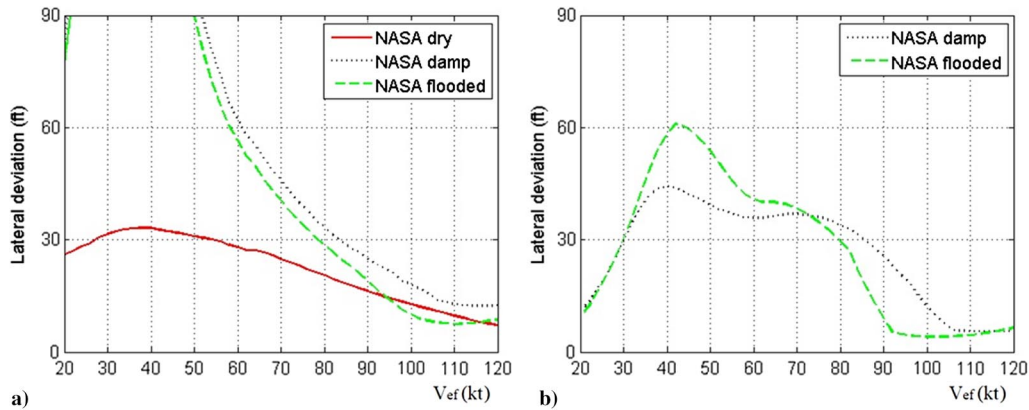

Fig. 12 Lateral deviation as function of V_{ef} . RTO, NWS on, and 20 kt crosswind with different runway friction models: a) no braking, and b) differential braking.

can calculate numbers accurately to legal or certification limits. Computer V_{mcg} -limited V_1 values will be lower than paper values because weight corrections can be accurately applied with the AFM-DPI performance data. PLTOW values have increased with computer calculations.

When calculation methods get to be more accurate, it is important that the underlying legislation and calculation methods are correct. An accurate calculation of an unsafe value does not improve safety.

The transition from paper performance calculations to computer performance calculations has reduced safety margins in operation.

This requires an evaluation of established procedures to assess if the safety standards are still acceptable.

C. Training Simulators and Pilot Expectations

Observations by the authors in training simulators (KDC-10, B737, and B777) showed less (only a few feet) lateral deviation and better controllability after an engine failure around V_{mcg} than can be expected from the certification test. A training simulator is not suitable to evaluate the influence of environmental conditions on the resulting lateral deviation after an engine failure. The aircraft behavior after an engine failure around V_{mcg} has no priority when accepting a simulator from a simulator manufacturer because it is not a part of the qualification process of a training simulator.

An engine failure just after V_1 is an often a trained event in training simulators. It serves as an examination topic for aircrew proficiency checks. The handling qualities of the simulator provide confidence to pilots that they can handle the engine failure in the aircraft. Within airline companies, simulator instructors are often considered to be experts in aircraft handling; and sometimes the training simulators are used to solve handling questions. Pilots are not used to experience a lateral deviation of about 30 ft. They will be surprised by the aircraft behavior when a real engine failure occurs, even if there are no adverse environmental conditions. The benign reaction of training simulators has probably masked the controllability problems at speeds around V_{mcg} after an engine failure to pilots and instructors.

The quality of the ground model in training simulators should be investigated in order to establish if the lateral deviations and controllability on dry, wet, and contaminated runway surfaces are realistic, also under crosswind conditions.

D. Runway Friction Coefficients and Ground Speed

The runway friction coefficients given in the paved runway condition assessment table (Table A1; Appendix) are fixed values. These values can be linked to friction measuring equipment. Pilots use the paved runway assessment table to find a calculation method for the takeoff ahead.

NASA reports [17,18,20] show a significant speed influence on runway friction coefficients (braking actions) on damp and flooded

runway surfaces. The reports show that runway friction coefficients drop from around 0.6 at low speed to around 0.2 at 100 kt on damp runway surfaces and 0.1 on flooded runway surfaces. Also, AMC 1591 ([3] Par. 7.3.1) gives a speed-dependent runway friction coefficient on wet runway surfaces to be used for performance calculations. Braking actions on snow and ice do not show a high-speed dependency, but they have a low value through the whole speed range [20].

Measured lateral friction coefficients show the same speed dependency on damp and flooded surfaces; they drop to around and below 0.05 on flooded runway surfaces around 100 kt ([17] table I, [18] table II). No data can be found for lateral friction coefficients on snow- and ice-covered runway surfaces.

The conditions described in these NASA reports as damp are linked to a wet runway surface and flooded to a contaminated runway surface in the model.

E. Aircraft Tire Characteristics

Aircraft tires cannot be compared to car tires. Bias-ply tires are still common, and the tire pressure is much higher than in car tires. Car tires are mostly radial-ply tires, which are designed to cope with lateral forces. Little information can be found on the lateral force characteristics of aircraft tires at high speeds.

Additional research is required on the lateral force characteristics of aircraft tires on dry, wet, and contaminated runway surface conditions at operational speeds of aircraft in the takeoff roll.

F. Reaction Time

There are constraints on the reaction time that is used in certification tests [13]. The reaction time is of great influence on V_{30ft} . Major manufacturers have already pointed this out ([14] p. 15), and it is confirmed by the modeling (Fig. 6). The reaction time for rudder input was set to 0.5 s in the model. This is the average target reaction time (0.4–0.6) as used in certification tests ([14] p. 15). Line pilots will be surprised by an engine failure. A longer reaction time as compared to that of a well-prepared test pilot can be expected. V_{30ft} will increase due to the longer reaction time.

Manufacturers sometimes install systems to improve reaction time with an automatic rudder input after sensing an engine failure [21]. These systems will have a positive effect on handling an engine failure.

The rudder input to keep an aircraft near the centerline is skill-based behavior. Rejected takeoff should be considered to be a rule-based procedure with corresponding larger reaction times for closing the operating engine [22]. Especially at low speeds, a short reaction time is important to keep the aircraft on the runway in a RTO.

G. Nosewheel Steering

V_{mcg} certification tests are conducted with a free castering nosewheel or with the nosewheel lifted from the runway surface [13].

If nosewheel steering is coupled to the rudder, this will help to limit the deviation from the centerline of the runway. The modeling shows nosewheel steering is required at low speeds to keep the aircraft on the runway after an engine failure. This is important, especially in a rejected takeoff.

Some sources, including the FAA Flight Test Guidance [13], suggest that uncoupling the nosewheel steering simulates the runway surface condition of a wet runway. The simulations show that the adverse effect of a wet runway or slippery runway is worse than the adverse effect of an uncoupled nosewheel steering (Fig. 7).

Experience from a V_{mcg} certification test with uncoupled nosewheel steering shows considerable wear on nosewheel tires.[§] This shows that lateral forces on the nosewheels will still have an influence on the V_{mcg} certification test.

H. Runway Surface Condition

Observing V_{mcg} certification tests shows a high amount of strain on the main wheels when dealing with the engine failure. When a runway is not dry, the decreased lateral friction coefficient will affect the amount of sideslip on the tires and the maximum achievable side force. This maximum achievable side force is also reduced as speed increases. Nosewheel steering will be less effective with lower lateral friction coefficients.

The modeling confirms a considerable influence of runway surface condition on V_{30ft} (Fig. 7b).

V_{mcg} , as certified by the manufacturer, is not a safe speed to continue the takeoff after an engine failure on runways with reduced runway friction coefficients (contaminated runways).

I. Crosswind

Major manufacturers confirm crosswind to have a high impact on the V_{mcg} certification test. The effect of crosswind depends on the design of the aircraft and is influenced by ground effect. An accurate quantitative assessment of the influence of crosswind can only be made if wind-tunnel data are available for the type concerned.

When operating in crosswind conditions, a certain rudder input is required to counteract the crosswind during the takeoff roll. In strong crosswinds, large rudder inputs may be required. Any amount of rudder input will decrease the remaining rudder deflection available to counteract an engine failure. Crosswind will increase V_{30ft} .

Aircraft are neither designed nor tested to cope with crosswind, and an engine failure at the same time [6] CS25.149, [7] FAR25.149 does not require accounting for the effect of crosswind and [6] CS25.237, [7] FAR25.237 does not require accounting for an inoperative engine. The part of the takeoff roll after V_1 is a gray area with respect to controllability in these crosswind conditions.

The modeling confirms crosswind is of considerable influence on V_{30ft} . With the model, NWS compensates for the effect of crosswind to almost 20 kt of crosswind on a dry runway (Fig. 8). A decrease in the runway surface friction coefficient will decrease the influence of crosswind on V_{30ft} (Fig. 9). This is caused by a higher ground slip angle when the runway surface friction coefficient is lower, requiring less rudder input to counteract crosswind.

V_{mcg} , as certified by the manufacturer, is not a safe speed to continue the takeoff after an engine failure in strong crosswind conditions.

J. Ground Effect

According to major manufacturers, a failure of the downwind engine results in a higher lateral deviation in crosswind conditions ([14] p. 16). In the model, the upwind engine is critical. Large wing-mounted high-bypass engines close to the ground

have a more effective side area. This results in a higher side force effect and a reduced weathervaning effect because the pressure point shifts forward. The model parameters, derived from DATCOM ([1] Par. II.C), do not account for this ground effect. Observations showed training simulators have not incorporated this ground effect either.

Through variation of relevant parameters, it is possible to decrease the weathervaning effect of the model and make the side force effect dominant. The downwind engine becomes critical, and the impact of crosswind on lateral deviation at high μ_s values (dry runway) (Figs. 8 and 9) decreases somewhat in the resulting model. The qualitative effect of the reaction time and the runway surface condition (Figs. 6 and 7) was checked to be similar in the resulting model.

K. Is it Possible to Quantify the Effect of Environmental Conditions on V_{30ft} ?

The modeling showed a 6 kt margin on V_{mcg} (and thus on $V_{1(MCG)}$) would compensate for a slippery runway (Fig. 7). A 10 kt margin would compensate for a crosswind component up to 25 kt, even with a reduced runway friction coefficient (Fig. 9). The ground model for the simulations is, however, based on very limited data [17]; and the effect of crosswind on V_{30ft} depends on type-specific aerodynamic properties. A margin on V_{mcg} , as established by the manufacturer, will improve safety; but it is not possible to quantify this margin.

L. Rejected Takeoff

The lateral deviation in the simulations is lower in the RTO than in continued takeoff at speeds around V_{mcg} .

The simulations of rejected takeoff showed a quite violent reaction of the aircraft after an engine failure at low speeds. This behavior is confirmed to be similar on real aircraft by test pilots and can be demonstrated in training simulators. Pilot response is critical in a low-speed rejected takeoff. The reaction time for closing the operating engine is of great influence on the resulting lateral deviation. The modeling shows differential braking is necessary to keep the aircraft on the runway if an engine failure is experienced at low speed and the runway is not dry. The use of reverse thrust on the operating engine may also help. More emphasis should be given to this in pilot training.

The simulations showed that veeroffs in a rejected takeoff after engine failure at low speed are likely to happen, especially in crosswind and low runway friction conditions. The simulations also showed that application of symmetrical braking at low speeds before control toward the centerline is regained may aggravate the situation. This is important to keep in mind when designing autobrake systems.

This behavior may explain the runway excursion of the Iran Air Airbus after an engine failure in Stockholm in 2010 [23]. This incident also confirmed that a runway excursion at low speed does not necessarily lead to a catastrophic or critical accident.

The low-speed RTO is recommended as a subject for further research.

M. Incident/Accident Reports

Incident/accident reports sometimes lead to procedure changes. After the Turkish Airlines crash [24] the stall recovery procedure was changed. Accident investigators are, however, reluctant to blame procedures. If a RTO, initiated after V_1 , leads to a runway excursion, most probably the crew will get the blame for not complying with procedures. In 58% of RTO accidents, the RTO was initiated after V_1 ([4] Par. 2.2.4). A pilot will reject his takeoff after V_1 if a runway excursion is imminent by continuing the takeoff. In these cases, a higher V_1 would have been a better choice. Pilots may perceive a lateral deviation of less than 30 ft as a loss of control already. It is recommended to review the circumstances in accident reports to establish if takeoffs were rejected after V_1 due to controllability problems. Pilots may have saved their aircraft by

[§]Personal reference and fotos from Duke Ham, retired Performance Engineer Fokker Aircraft, September 2017.

rejecting a takeoff after V_1 . In these cases, no evidence will be left to feed statistics.

N. Overrun or Veeroff

A lot of effort is put in accelerate–stop performance to prevent an overrun of the runway. Little effort is put in controllability issues to prevent a veeroff. It is important to prevent runway excursions at all sides.

O. Hydroplaning

The hydroplaning speed of modern aircraft tires [25] may be lower than V_{mcg} for modern aircraft. When hydroplaning occurs, the maximum achievable side force on the tires will drop to a value at which we expect it is difficult to keep the aircraft on the runway if an engine failure occurs and takeoff is either rejected or continued.

It is recommended to investigate this with models of current aircraft types.

P. What Can Aircraft Manufacturers Do to Improve Safety on Contaminated Runways?

Aircraft manufacturers have access to more accurate aerodynamic and inertial data of their aircraft. They can make an accurate prediction of the V_{mcg} value before the test ([14] p. 7). Using the manufacturer models to predict the V_{mcg} value, it is not difficult to predict the V_{30ft} value at $\mu_s = 0$. We can call this the aerodynamic V_{30ft} . Aircraft manufacturers can calculate these values for their types and make them available to the operators. An operator can then choose if they want to stick to using V_{mcg} -limited V_1 as a minimum speed for V_1 or use the aerodynamic V_{30ft} (corrected for engine failure recognition time) in their SCAP modules to calculate takeoff performance. Aircraft manufacturers can also make a better estimate of the impact of crosswind on V_{30ft} on their types if wind-tunnel data are available.

Q. What Can Regulatory Authorities Do to Improve Safety on Contaminated Runways?

We share the concerns that were raised by the U.K. CAA in preparation of the revision of AMC 25-1591 [11]. The modeling provides scientific evidence to support this concern. We do not aim to change the procedure to establish V_{mcg} during certification of an aircraft. Any change in Certification Specifications [6]/Federal Airworthiness Regulations [7] would not affect the operation for earlier certified aircraft anyway. Rather, we want to change the way V_{mcg} is used in operation.

The FAA and EASA can raise the issue in their safety committees. If these committees agree with our point of view, a Safety Advice for Operators can be issued to advise operators to replace their V_{1-min} policy by a policy that provides some margin on V_{mcg} . Regulatory authorities can ask aircraft manufacturers to provide additional data (e.g., an aerodynamic V_{30ft}) to operators to improve safety. Regulatory authorities can discuss the need for a margin on V_{mcg} for operation in crosswind.

VII. Risk Assessment

Modeling showed that V_{mcg} is not a safe speed to continue a takeoff after an engine failure on either a runway with reduced friction coefficients (contaminated runway) or in strong crosswind conditions. The combination of either reduced runway friction coefficients or strong crosswind conditions with a V_1 equal, or close to, $V_{1(MCG)}$ will lead to a situation with part of the takeoff roll in which an engine failure, recognized after V_1 , will lead to an unacceptable lateral deviation or runway excursion if takeoff is continued.

Crosswind policies [19] prevent operation in strong crosswind conditions on contaminated runways. The balanced takeoff procedures on wet and dry runways usually result in a V_1 with a considerable margin to $V_{1(MCG)}$. The combination of strong

crosswind conditions with a V_1 equal, or close to, $V_{1(MCG)}$ is remote.

On a contaminated (in particular, slippery) runway, however, (Boeing) FCOM procedures will result in a V_1 equal, or close to, $V_{1(MCG)}$ for a wide range of takeoff weights. There is a (small) margin in the $V_{1(MCG)}$ tables in the FCOM that is discarded when using computer programs to calculate $V_{1(MCG)}$. Using this lower value for $V_{1(MCG)}$ as V_1 will increase the risk significantly because there is a near-hyperbolic correlation between the engine failure speed and the resulting lateral deviation (Figs. 6–8).

Operators are encouraged to choose for the V_{1-min} policy by the recommendations of the FAA's Take-Off Safety Training Aid ([4] Par. 4.3.6.8).

VIII. Present Methods to Mitigate the Risk in Contaminated and Slippery Runway Operations

Takeoffs on contaminated and slippery runways are conducted with full rated (or fixed derated) power. Excess performance can be used to increase the V_1 value if it is equal or close to $V_{1(MCG)}$. This way, a margin is created to compensate for the increase of V_{30ft} due to the runway surface condition.

A. Method for Pilots

A pilot can find the V_1 value for the PLTOW, as provided by computer performance output, in the FCOM for the runway surface conditions/braking actions concerned.

This is an authorized value to use as long as it remains below V_R . As the actual TOW is lower, there will even remain a margin on the accelerate–stop performance. In fact, a pilot can pick a single value for V_1 from the range between the V_1 value on the computer output and the V_1 value at the PLTOW (or V_R if lower). All V_1 speeds in this range will comply with AFM performance requirements.

B. Method for Operators

SCAP modules of the present computer performance programs offer operators a choice of one of the following options to use for their contaminated runway operation:

1. V_1 Range

Both minimum and maximum values for V_1 are presented. A pilot can choose a value from this range to use as V_1 . This requires an explication of risks and benefits of low and high V_1 s to pilots. It will leave the responsibility of choice to the pilot.

2. V_1 Mean

A single value for V_1 is presented, which is calculated as the average of the minimum and maximum values for V_1 .

3. V_1 at Performance-Limited Takeoff Weight

A single value for V_1 is presented, which is calculated as the value for V_1 at the PLTOW (or V_R if lower).

IX. Additional Research

Additional research is required on the lateral force characteristics of aircraft tires on dry, wet, and contaminated runway surface conditions at operational speeds of aircraft in the takeoff roll.

The quality of the ground model in training simulators should be investigated in order to establish if the lateral deviations and controllability on dry, wet, and contaminated runway surfaces are realistic, also when including crosswind conditions.

It is recommended to review the circumstances in incident and accident reports to establish if takeoffs were rejected after V_1 due to controllability problems.

It would be interesting to analyze the controllability issues involved with the Iran Air incident in Stockholm [23] and other controllability-related runway excursions.

Through modeling, we may increase our knowledge of aircraft behavior in a low-speed RTO.

Modeling can be used to assess the safety of operation of modern aircraft ($V_{mcg} \approx 130$ kt) in the takeoff roll when hydroplaning occurs.

X. Conclusions

V_{mcg} , as certified by the manufacturer, is not a safe speed to continue the takeoff after an engine failure on runways with reduced runway friction coefficients (contaminated runways).

V_{mcg} , as certified by the manufacturer, is not a safe speed to continue the takeoff after an engine failure in strong crosswind conditions.

The transition from paper performance calculations to computer performance calculations has reduced safety margins in operation.

Pilot reaction time is of great influence on V_{30ft} .

Runway surface friction is of considerable influence on V_{30ft} .

Crosswind is of considerable influence on V_{30ft} . The effect of crosswind on V_{30ft} depends on the type-specific aerodynamic properties and ground effect.

At low speeds, a coupled nosewheel steering is required to keep the aircraft on the runway after an engine failure. This is important, especially in a rejected takeoff. With the model, nosewheel steering can compensate for the adverse effect of crosswind on a dry runway up to a considerable amount of crosswind. The effect of nosewheel steering is negligible at low runway friction coefficients at high speeds.

Excess performance can be used to create a margin on top of V_{mcg} to mitigate the risks in contaminated runway operation. A method for pilots and for operators is presented in this paper.

The lateral deviation after engine failure is lower in the rejected takeoff than in continued takeoff at speeds around V_{mcg} .

The modeling shows differential braking is necessary to keep the aircraft on the runway if an engine failure is experienced at low speed and the runway is not dry.

Appendix: Paved Runway Condition Assessment Table

Table A1 Paved runway condition assessment table [9]

Airport estimated runway condition assessment				
Runway condition assessment: reported		Downgrade assessment criteria		
Code	Runway description	Mu, μ	Deceleration and directional control observation	Pilot reports (PIREPs) provided to ATC and flight dispatch
6	Any temperature: 1) Dry	— —	— —	Dry
5	Any temperature: 1) Wet (smooth, grooved, or porous friction course) 2) Frost Any temperature with 1/8 in. or less of the following: 1) water, 2) slush, 3) dry snow, or 4) wet snow	40 μ or higher	Braking deceleration is normal for the wheel braking effort applied. Directional control is normal.	Good
4	At or colder than -13°C at any depth: 1) Compacted snow	39 – 36 μ	Braking deceleration and controllability is between good and medium	Good to medium
3	Any temperature: 1) Wet (slippery) At or colder than -3°C and greater than 1/8 in. of the following: 1) Dry or wet snow Warmer than -13°C and at or colder than -3°C at any depth: 1) Compacted snow	35 – 30 μ	Braking deceleration is noticeably reduced for the wheel braking effort applied. Directional control may be slightly reduced.	Medium
2	Any temperature and greater than 1/8 in. of the following: 1) Water 2) Slush Warmer than -3°C and greater than 1/8 in. of the following: 1) Dry or wet snow Warmer than -3°C at any depth: 1) Compacted snow	29 – 26 μ	Braking deceleration and controllability is between medium and poor. Potential for hydroplaning exists.	Medium to poor
1	At or colder than -3°C at any depth of ice	35 – 21 μ	Braking deceleration is significantly reduced for the wheel braking effort applied. Directional control may be significantly reduced.	Poor
0	Any temperature and any depth of the following: 1) Wet ice 2) Water on top of compacted snow 3) Dry or wet snow over ice Temperature warmer than -3°C at any depth: 1) Ice	20 μ or lower	Braking deceleration is minimal to nonexistent for the wheel braking effort applied. Directional control may be uncertain.	Nil

Acknowledgments

The Faculty of Aerospace Engineering of the Delft University of Technology (the Control and Simulation section) facilitated this research. There is no funding involved. We thank Duke Ham (retired Performance Engineer, Fokker Aircraft B.V.), Wim Huson (retired Certification Test Pilot, Fokker Aircraft B.V.), and Gerard Temme (Certification Test Pilot, European Aviation Safety Agency) for critical reading, hints, and tips.

References

- [1] Koolstra, H. J., Huijbrechts, E. J. A. M., and Mulder, J. A., "Analysing Aircraft Controllability After Engine Failure During Take-Off in Adverse Weather Conditions," *Journal of Aircraft* (to be published). doi:10.2514/1.C035219
- [2] "Takeoff," *Getting to Grips with Aircraft Performance*, Airbus Industries, Blagnac Cedex, France, 2002.
- [3] "CS-25 Book 2," *Certification Specifications, and Acceptable Means of Compliance for Large Aeroplanes*, European Aviation Safety Agency, Amendment 2 or Higher, AMC 25.1591.
- [4] *Take-Off Safety Training Aid*: Federal Aviation Administration, 1993 (See. FAA AC No: 120-062).
- [5] Electronic Code of Federal Regulations "Title 14, Subchap. A, Part. 1, §1.2, <https://www.gpo.gov/fdsys/pkg/CFR-2012-title14-vol1/pdf/CFR-2012-title14-vol1-sec1-2.pdf> [cited 9 June 2016].
- [6] Certification Specifications and Acceptable Means of Compliance for Large Aeroplanes European Aviation Safety Agency, CS-25 Book 1, Subpart B.
- [7] *Federal Aviation Regulations Part 25 Airworthiness standards: Transport category Airplanes*, Federal Aviation Administration,
- [8] *Landing Performance Assessment at Time of Arrival, Safety Alert For Operators 06012*, Federal Aviation Administration, 2006
- [9] *Takeoff and Landing Performance Assessment Validation Effort of the Runway Condition Assessment Matrix*, Federal Aviation Administration, DOT/FAA/TC-TN13/22, 2013, Page 5: Paved Runway Condition Assessment Table.
- [10] *RuFAB—Runway friction characteristics measurement and aircraft braking Research Project EASA 2008/4*, European Aviation Safety Agency, 2008.
- [11] *Notice of Proposed Amendment (NPA) NO 14/2004 Draft Decision of the Executive Director of the Agency, on Certification Specifications for Large Aeroplanes (CS-25) Operation on Contaminated Runways*, European Aviation Safety Agency, JAA NPA 25G-334 Comment-Response Document: Par. 7.7.1 Comment NR 6,12,15,16,55,62,65,66, 2004, Sec. D.
- [12] Pacejka, H., *Tire and Vehicle Dynamics*, 3rd ed., Elsevier Ltd., 2012.
- [13] *Flight Test Guidance (US FAA AC 25-7C)*, Federal Aviation Administration, Minimum Control Speed § 25.149(e).
- [14] Bolds-Moorehead, P. J., Chaney, V. G., Lutz, T. L., and Vaux, S., "Ground Minimum Control Speed Testing of Transport Aircraft," *AIAA Flight Testing Conference*, Dallas, TX, June 2015. doi:10.2514/6.2015-3226
- [15] *Airplane Flight Manual B737-300*, Minimum V1 for control on the ground V1(MCG) The Boeing Company, Seattle WA, Doc. Nr. D6-8730, p. 15, Sec. 4.7.
- [16] "Performance Inflight V1(MCG)," *Tire and Vehicle Dynamics*, The Boeing Company, Seattle WA.
- [17] Yager, T. J., and McCarty, J. L., "Friction Characteristics of Tires 30 × 11.5–14.5, Type VIII, Aircraft Tires With Various Tread Groove Patterns and Rubber Compounds," NASA TP 1080, Dec. 1977.
- [18] Dreher, R. C., and Tanner, J. A., "Experimental Investigation of the Braking and Cornering Characteristics of 30 × 11.5–14.5, Type VIII, Aircraft Tires With Different Tread Patterns," NASA TN D-7743, Oct. 1974.
- [19] van Es, G. W. H., van der Geest, P. J., and Nieuwpoort, M. H., "Use of Crosswind Limitations by Operators," *Safety Aspects of Aircraft Operations in Crosswind*, National Aerospace Lab./NLR TP 2001-217, Amsterdam, 2001, Sec. 4.3.
- [20] Yager, T. J., Vogler, W. A., and Baldasare, P., "Evaluation of Two Transport Aircraft and Several Ground Test Vehicle Friction Measurements Obtained for Various Runway Surface Types and Conditions," NASA Technical Paper 2917, 1990.
- [21] Latimer, K., and Ross, J., *C-17 Engine-Out Compensation System Testing*, Edwards AFB, CA, 1998, Paper 93524.
- [22] van Es, G. W. H., "Rejecting a Take-Off After V₁ Why Does it (Still) Happen," National Aerospace Lab./NLR TP 2010-177, Amsterdam, 2010.
- [23] "Serious Incident on 16 of January 2010 to Aircraft EP-IBB at Stockholm/Arlanda Airport, Stockholm County, Sweden," Swedish Accident Investigation Authority Final Rept. RL 2012 21e, Stockholm, 2012.
- [24] Crashed During Approach, Boeing 737-800, Near Amsterdam Schiphol Airport, Feb. 2009, The Dutch Safety Board, The Hague, The Netherlands, May 2010.
- [25] van Es, G. W. H., "Hydroplaning of Modern Aircraft Tires," National Aerospace Lab./NLR TP 2001-242, Amsterdam, 2001.