

A DYNAMIC MODULAR SLEEP SYSTEM

MODULE

The sleep system consists of multiple rows of modules. Pressurized bellows control the positioning of the modules.

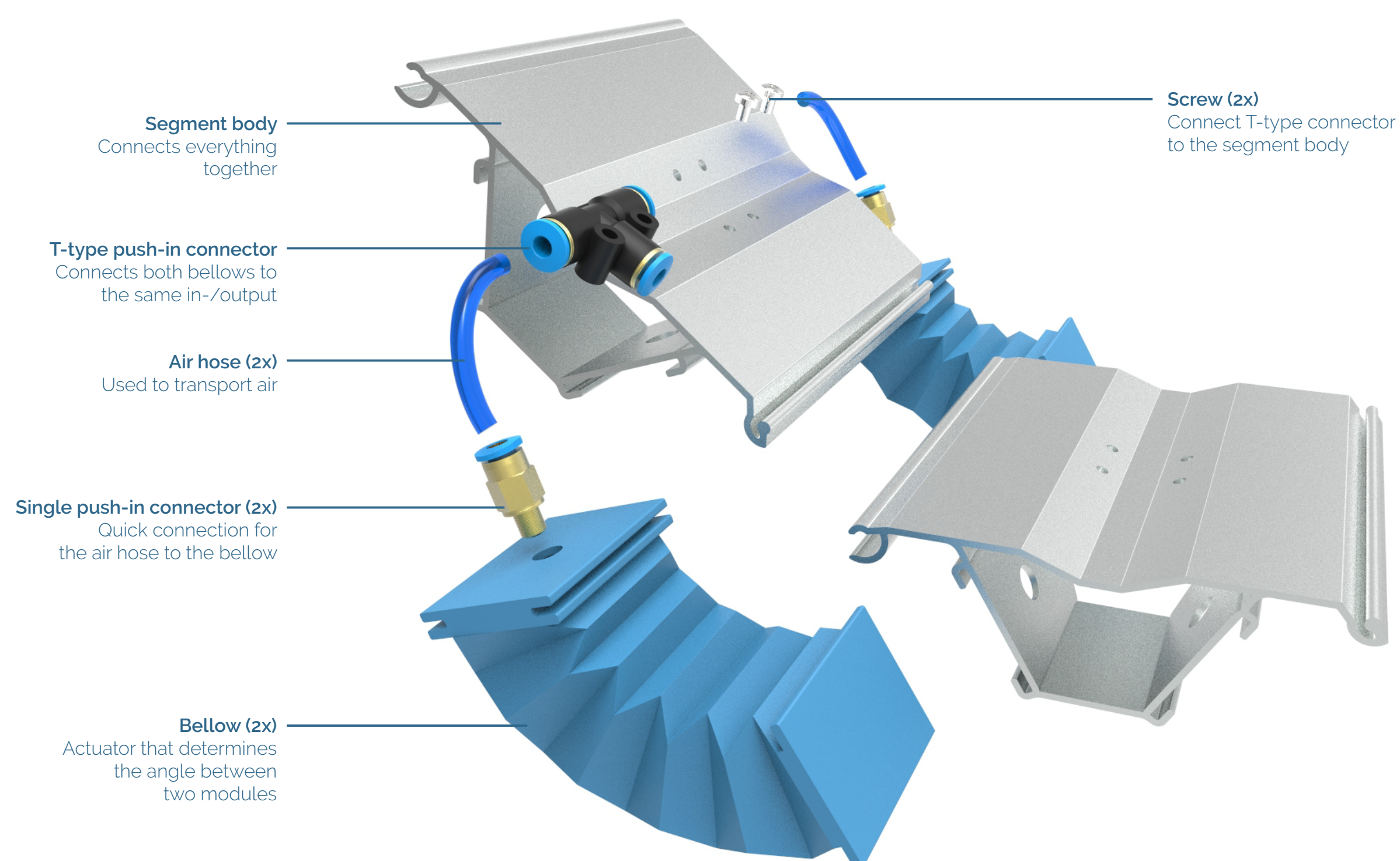

DYNAMIC

People change position many times during the night. The dynamic bed measures the spinal alignment and adjusts the shape of the bed to the ideal position.

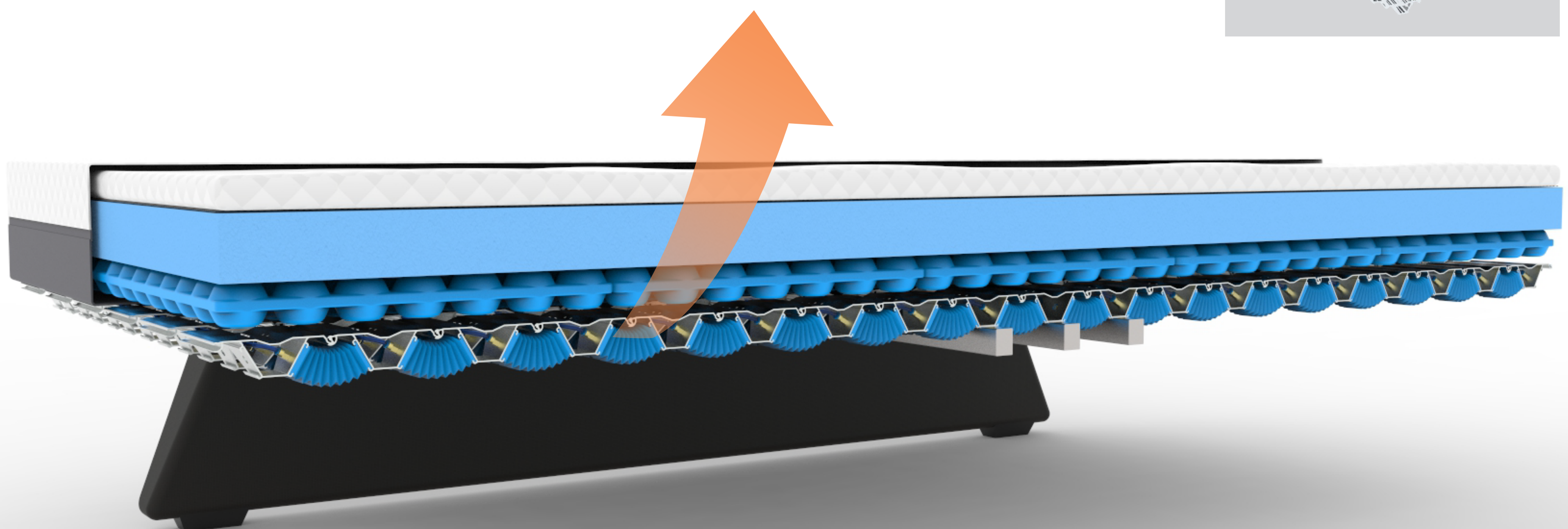
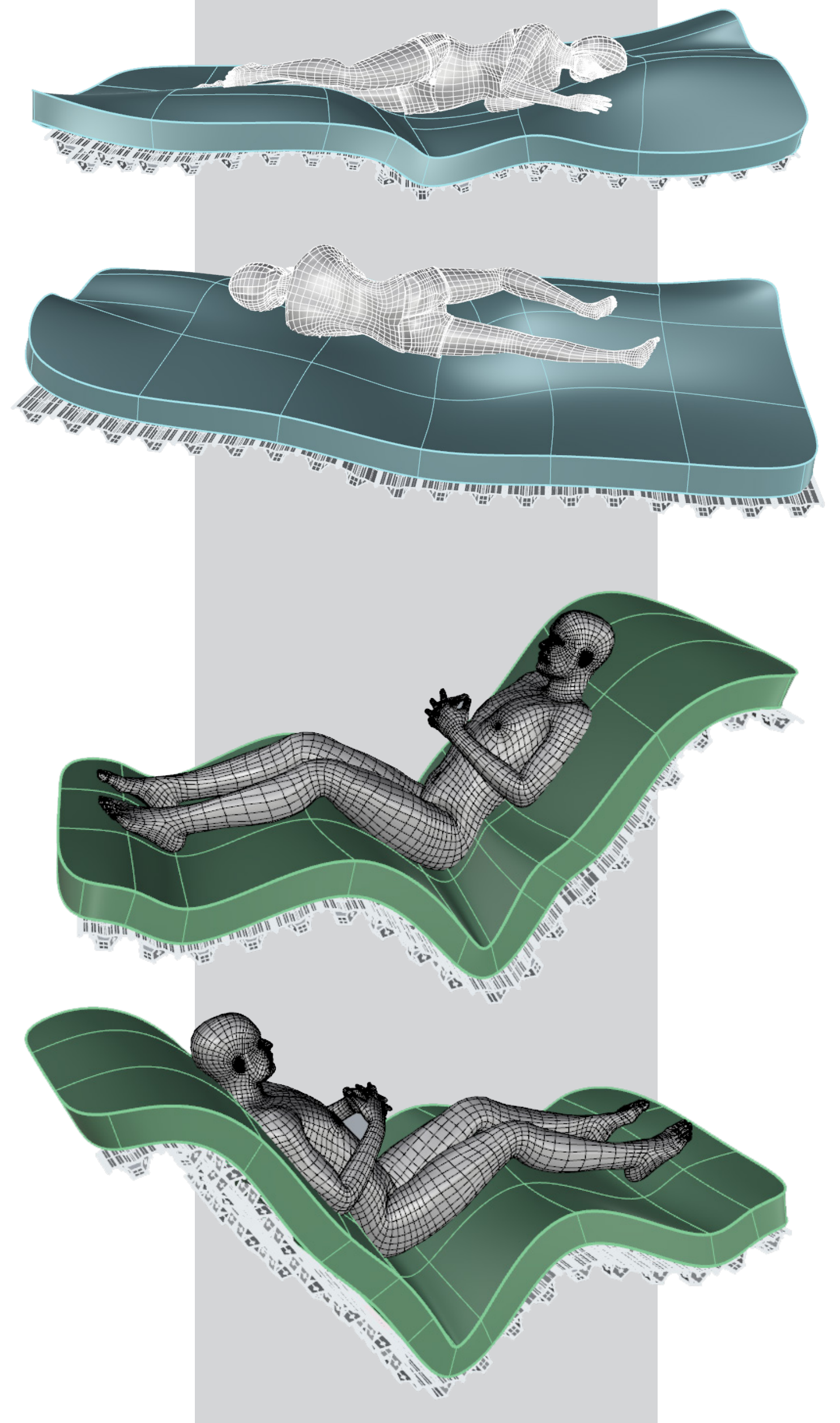

SLEEP SYSTEM

The bed contains an integrated multi-layered sleep system which can change shape, firmness and temperature to allow optimal comfort and the best sleep quality.

Paul Bosch
A Dynamic Modular Sleep System
July 18, 2018
Integrated Product Design

Committee Prof. dr. Vink, P.
Prof. dr. ir. Poelman, W.A.

 TU Delft