

The Relevance of the Introverted at
the Binnengasthuis area Amsterdam

Quirijn Petersen
Research Report Heritage & Architecture 2016

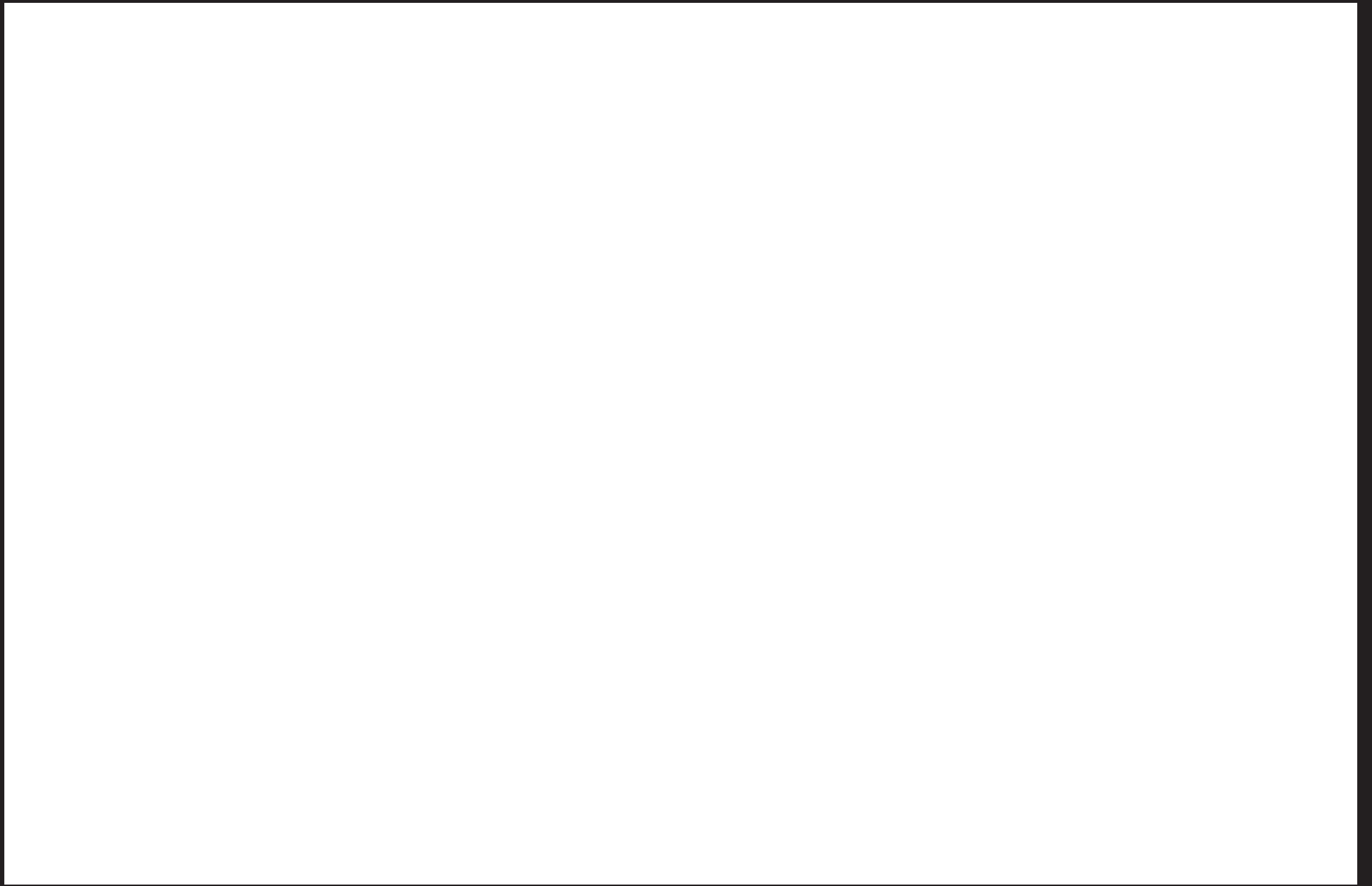
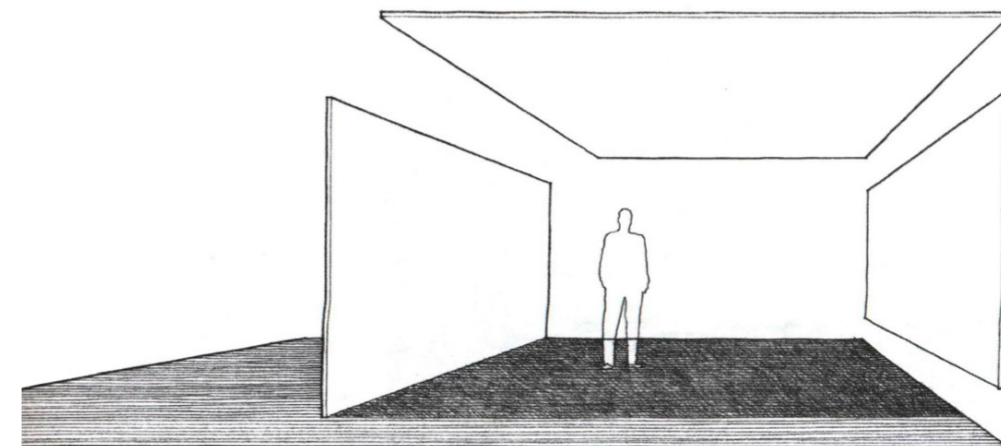

Table of contents

Introduction	p.8
Space, Structure & Enclosure	p.12
Analysis & Research	p.54
Evaluation	p.70
Movement in Space-Time	p.71
Analysis & Research	p.96
Evaluation	p.122
Conclusions	p.124
Table of references	p.126

“Zeg eens (omdat je zo gevoelig bent voor de werking van architectuur), heb je bij je wandelingen door deze stad niet gemerkt dat sommige van de gebouwen die haar bevolken *stom* zijn; dat andere *spreken*; en dat nog andere, en die zijn uiterst zeldzaam, *zingen*?”

- Valéry (Heynen - p.113)



Introduction

This research report is written for the graduation project of the Heritage & Architecture department of the faculty of Architecture at the Technical University in Delft. The core of this studio is the manner how cultural historic and technological information are to be translated into a design. The main theme is exploring the tolerance for change (Graduation Studio Manual). This report will constitute thematic research concerning the posed research question.

Location

This design-project focuses on the city centre of Amsterdam, both the UNESCO canal ring area as well as the Binnengasthuis area. Both sites are related due to the allocation of the UNESCO nomination of making the canal ring world heritage: the Binnengasthuis area lays in the so called buffer-zone, which has a great influence on the world heritage. For this research the decision is made to concentrate on the Binnengasthuis site.

In the nomination document for UNESCO the

area of the Binnengasthuis is described as an enclosed and, for the most part, inward-looking group of buildings and gardens. It has little connection with the surrounding urban area (Nomination Document UNESCO - p.191).

Design objective

The University of Amsterdam has quite some buildings in the centre of Amsterdam scattered at different locations. The plan of the University is to combine functions more on the same locations. The Binnengasthuis area is such a site. Here the UvA already possesses the most of the buildings, although some of these are not in use right now. The plan is to also move the University library to this area and to create a so called 'open city-campus' for local residents and students alike.

The posed problem

"The initial phase of any design process is the recognition of a problematic condition and the decision to find a solution to it." (Ching - p.IX)

- Local residents are afraid of losing the quite and introverted character of the site by the creation of an open city-campus.
- The public space is poor defined. The site knows quite some corners, directions and different forms. There is no clear function for this space apart from passage through this terrain and as a parking lot for bikes and mopeds.
- The buildings have none or little connection with their surroundings. Part of this is to blame to the poor defined public space, but the buildings themselves know also an introverted character. The ground floors are raised or lowered or defined as less important than higher levels. Moreover the entrances are not accentuated in a obvious way or connected in a logical way to its surroundings.
- The introverted site gets a packet of functions to create an open city-campus, which shows as an extroverted position. Unclear is what this will do with the area.

Research question

“Art is solving problems that cannot be formulated before they have been solved. The shaping of the question is part of the answer.” - Piet Hein (Danish poet and scientist. Ching - p.IX)

The site is a lot about the tension between ‘inside’ and ‘outside’, and ‘introvert’ and ‘extrovert’. The wish for creating an ‘open’ city-campus seems to be extroverted in essence. How will this go along with the character of the site?

What is the value of the introverted at the Binnengasthuis area?

Definitions

When talking of introvert or extravert, we all have our own sense of what the exact meaning is. There is the need for a common understanding of these terms though if the subject and the underlying question of every chapter is about the introverted or the extraverted. What is it what

we are talking about? My hypothesis is that the Binnengasthuis-area is introverted and inevitably this means that there are values attached to this. My research focuses on the question what these values are and if it has indeed to do with the area and it’s buildings being ‘introverted’.

Psychology

Being an introvert or an extravert has to do with a description of the character of a human. These terms originally are coined by Carl Jung. The Myers-Briggs Type Indicator is a questionnaire created to measure psychological preferences based on the theories proposed by Jung. Here an extraverted person is described as someone who gets energy from being actively involved in events and who gets excited when being around other people. This person likes to energize other people and likes moving into action and making things happen. This person is seen as ‘outgoing’. An introverted person on the other hand is described as someone who gets energy from doing things alone and who takes time to reflect before acting. This person is seen as ‘reflective’ or ‘reserved’. It is a misconception though that one is introvert *or* extravert. Most people have an introverted side *and* an extraverted side, with one being more dominant than the other. What is more is that introversion is not to be confused with being shy or reclusive; these are not related.

Architecture

In architecture the introverted and the extraverted involves the separation of the public and the private or the inside and the outside. In this respect you can compare the terms with the use of the terms in psychology: an extraverted space opens itself up to the outside world and wants to create a relationship with it surroundings. An introverted space acts more reserved and reflective and is more focused inwards. It is important to note that being introverted or extraverted is not negative or positive. It is not black or white. This implies that the qualification of the Binnengasthuis-area being ‘introverted’ is not a negative thing.

Nor is it a positive thing. Both introversion and extraversion can have their strong and weak points. What is more is that like the character of a person, the character of the space shall not entirely be introverted or extraverted. One can be more dominant than the other though (see figure Xa).

Method of research

“Hoe leren wij een gebouw kennen? We kunnen daar heen gaan: een keer, drie keer, twaalf keer. Maar als het gebouw niet in de buurt ligt, wat dan? We kunnen het gebouw ontmoeten, interpreteren en doorgronden als we het gebouw tekenen. We tekenen om beter te kunnen zien, om dieper te kunnen beleven, om sterker in het wezen van het gebouw in te leven.” - Jaap Dawson (Voorwoord Kleine Openbare gebouwen - p.5)

As we have noted above the introverted and the extraverted is about the separation of space. Public or private, inside or outside. This research focuses on the values of the introverted and is thus about the separation of space. Because of this it is necessary to look into the transition and continuity of space and the perception of it. Therefore two subtopics can be distinguished that have to be investigated:

1. Space, structure and enclosure

- Organizational pattern, relationships, hierarchy
- Formal image and spatial definition
- Qualities of shape, color, texture, scale, proportion
- Qualities of surfaces, edges, and openings

2. Movement in Space-Time

- Approach and entry
- Path configuration and access
- Sequence of space
- Light, view, touch, hearing and smell

Space, structure & enclosure will describe the space, as *Movement in Space-Time* will tell about the transition and sequence of space. This subdivision derives from the theory of F.D.K Ching in his book *Form, Space & Order*. With these subtopics the hypothesis is that the values of the introverted can be extracted. Knowing these will enable me to see what the weak and the strong points are of the area. Literature about the two subtopics can help to interpret these values and supplement to obtain opportunities and threats about the subject. All together will hopefully result in a solid SWOT analysis, with which I can put a strong design.

Outside of the Binnengasthuis area

The Binnengasthuis is surrounded with a continuous volume of buildings. Two openings are present: at the Grimburgwal and at the Kloveniersburgwal. Other entries to the site are through gates. By moving along the Grimburgwal a glimpse of what is happening inside is available. The water forms a barrier though for direct access.

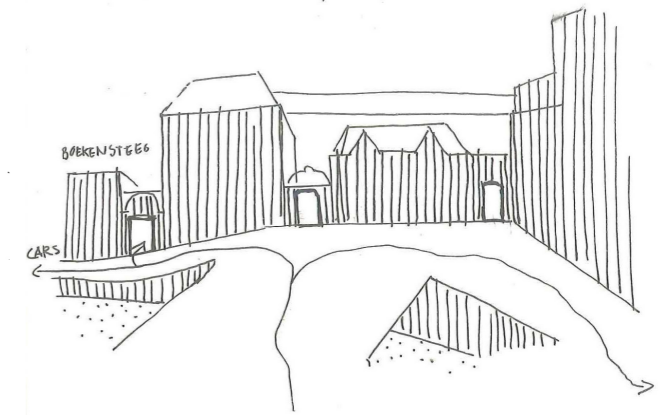
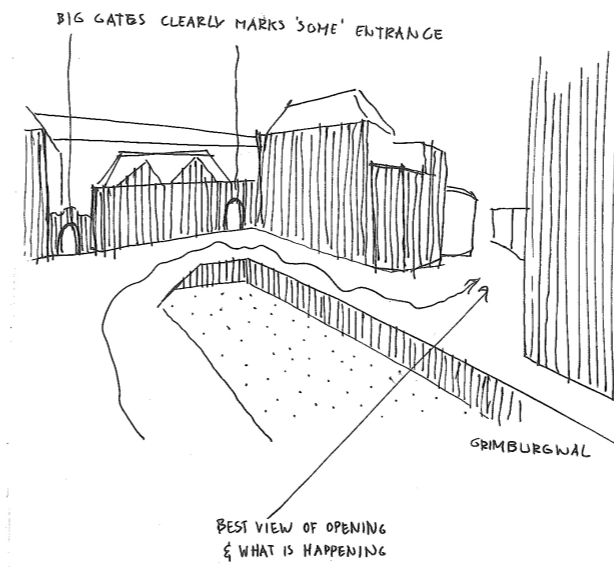
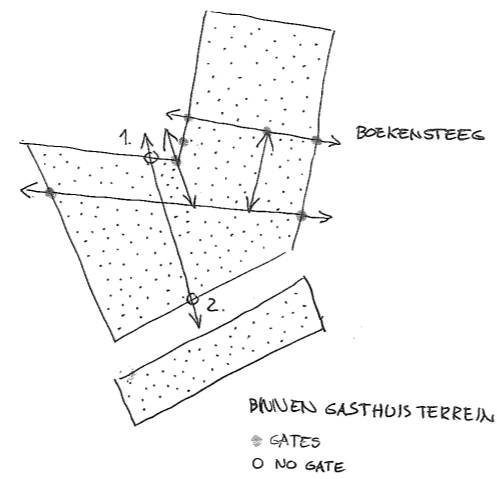

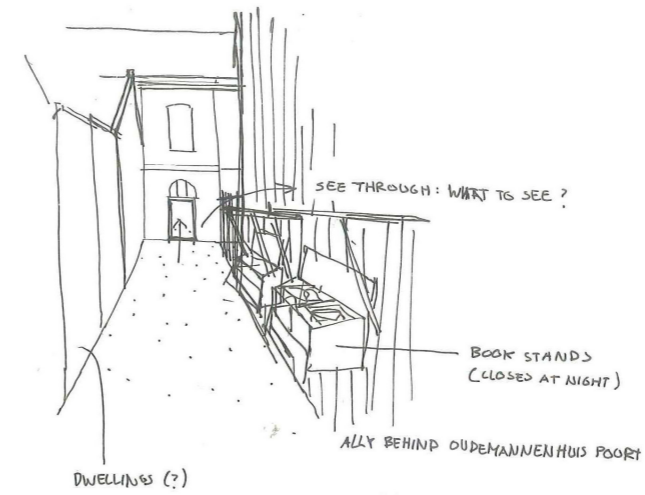
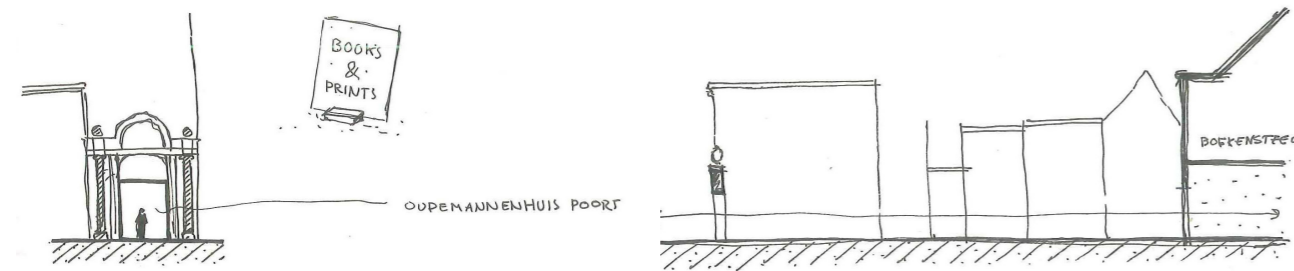

Behind the gates from the Grimburgwal and the Kloveniersburgwal there is first an open space before entering the covered passage used as a book market. This conceals function and space even more.

At the side of the Kloveniersburgwal the space is relatively open and wide. Going towards the Binnengasthuis area through the Nieuwe Doelenstraat, the city sight is transitioned to closed and narrow.

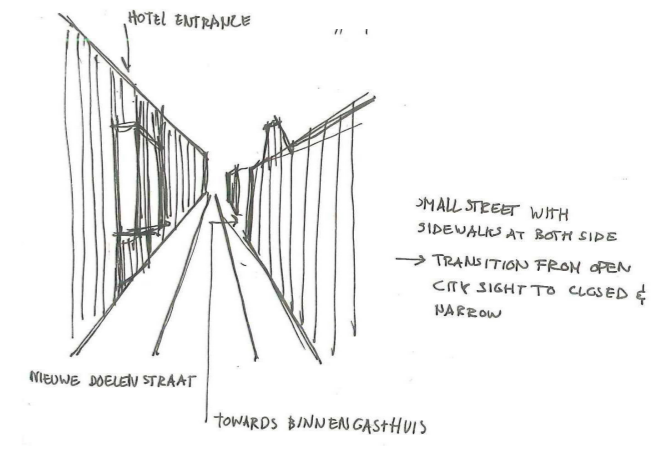
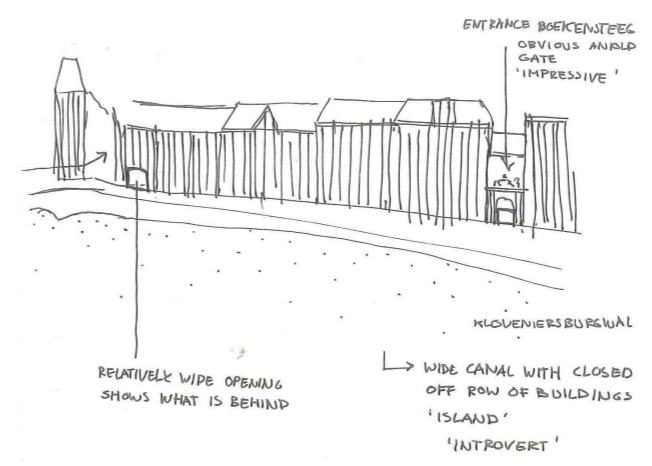
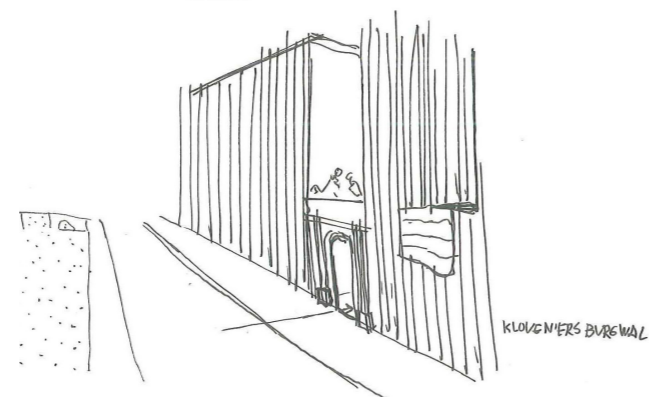

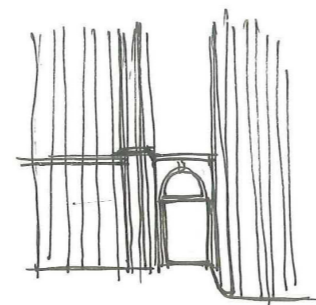
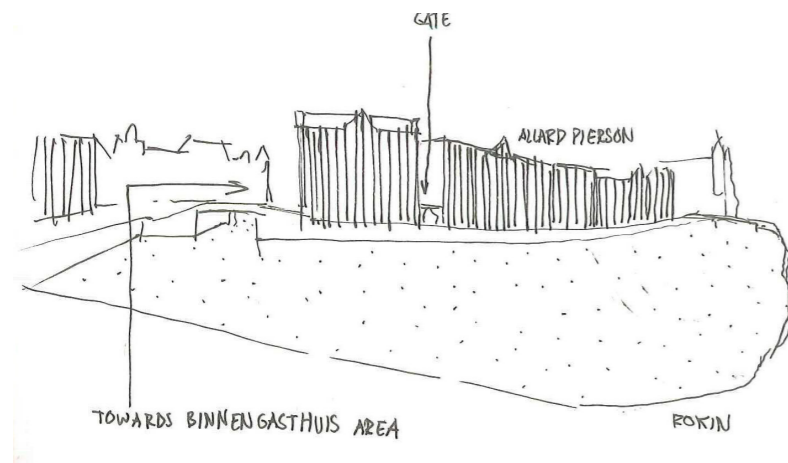

From the Rokin the city is showing itself again in a relatively wide and open space. No notion is there that the Binnengasthuis area is behind it. The faculty building facing the Rokin doesn't have its entrance at that side anymore. A gate is putted away.

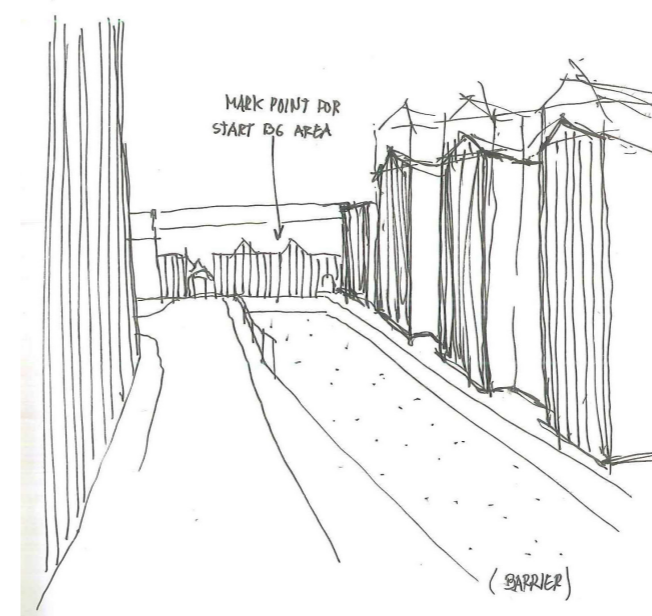
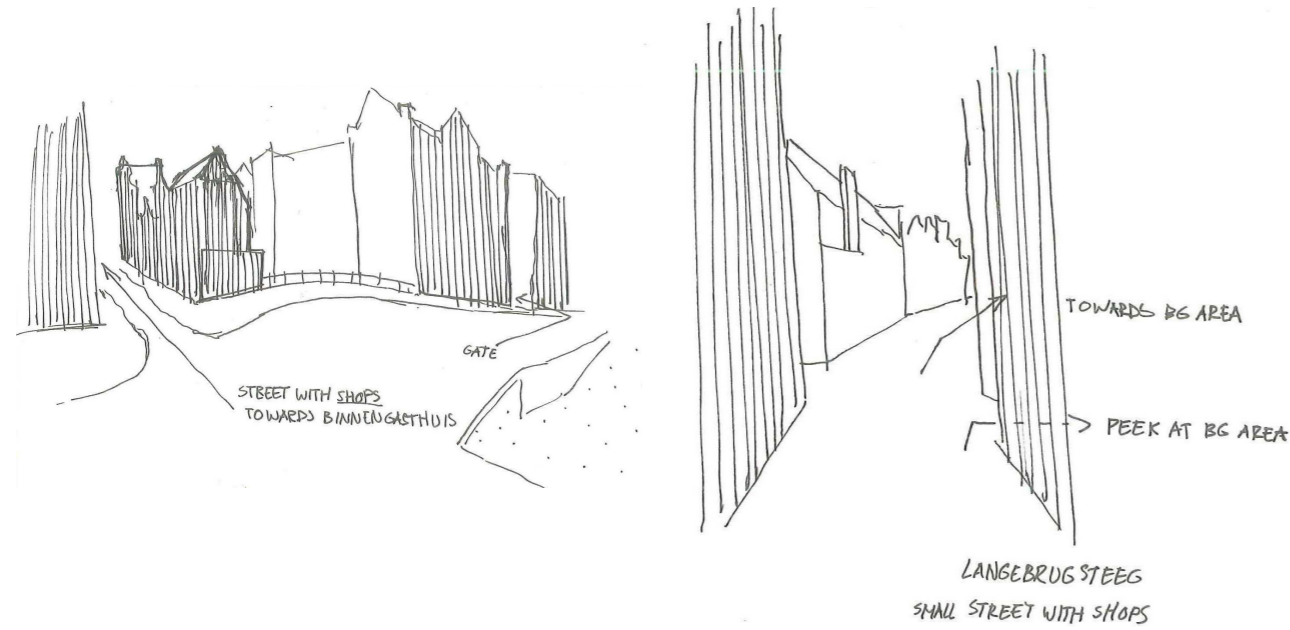

Moving from the Rokin towards the Grimburgwal there is still no showing of the Binnengasthuis area. The main functions in the narrow street are shops and restaurants. At the end of the street some buildings reveal themselves, although situated behind water.

Moving from the Rokin towards the Grimburgwal there is still no showing of the Binnengasthuis area. The main functions in the narrow street are shops and restaurants. At the end of the street some buildings reveal themselves, although situated behind water.

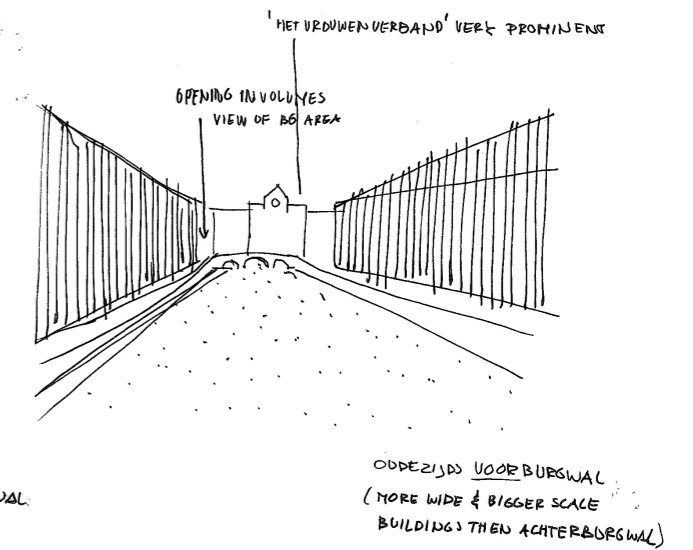
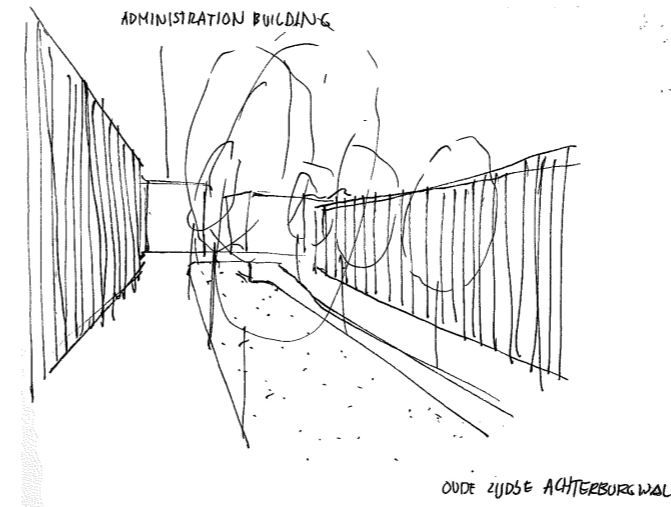
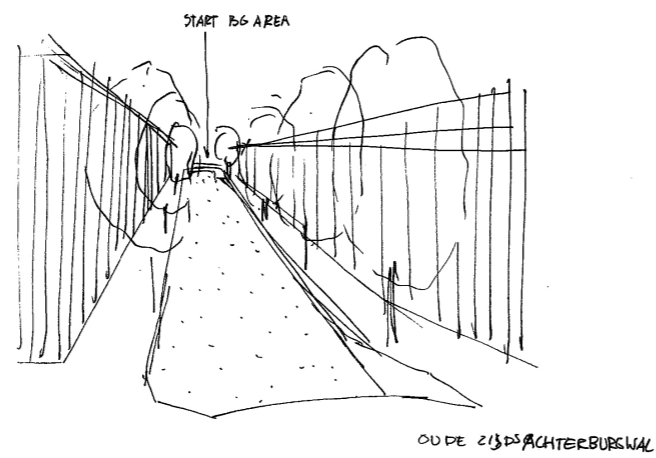

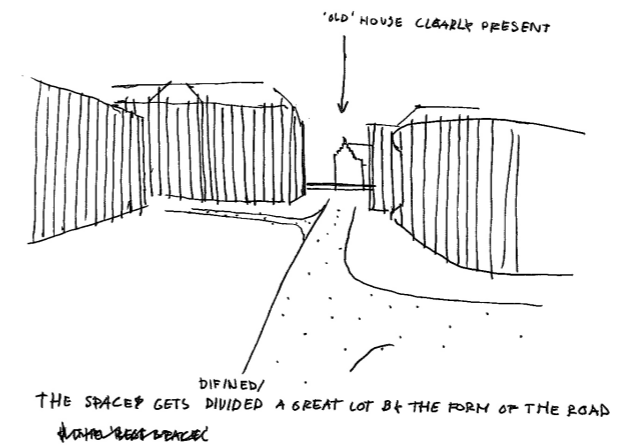
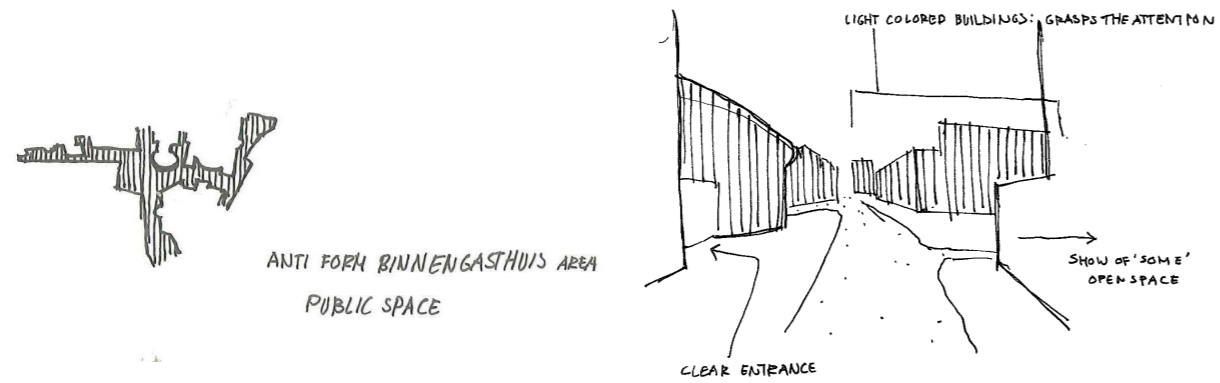

Inside the binnengasthuis area

The space gets defined and divided a great lot by the coarse of the road. The Binnengasthuis area knows a lot of forms, directions and corners. Space is not well defined.

The space is formed by a lot of corners, directions and different forms. Some clue of direction in this mess is the course of the road. The volumes at the sides of the area really form a border between 'inside' and 'outside'.

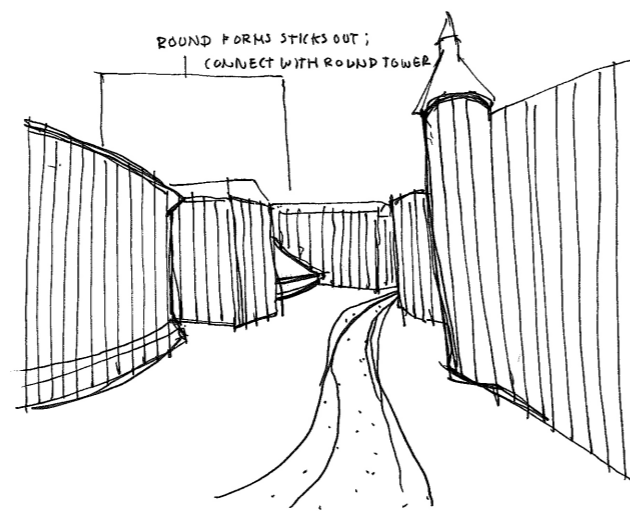

A LOT OF CORNERS, DIRECTIONS
& DIFFERENT FORMS
↳ DIRECTION IS GIVEN BY THE ROAD
WHICH DEFINES THE SPACE

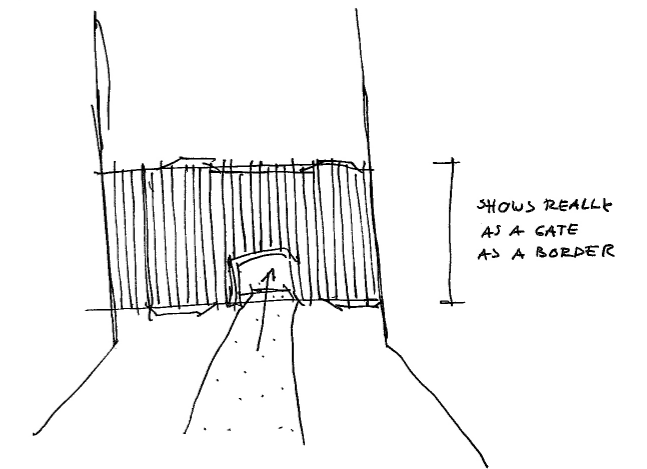
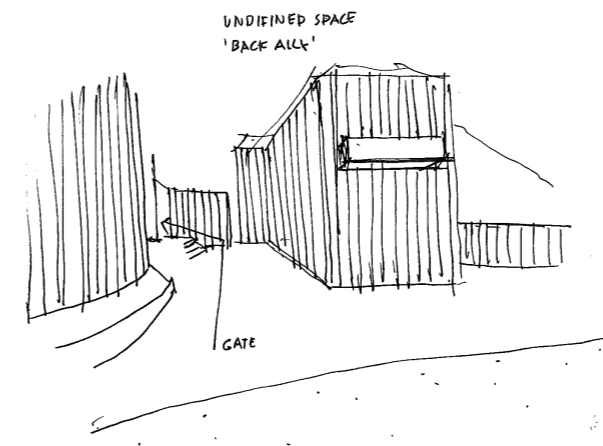

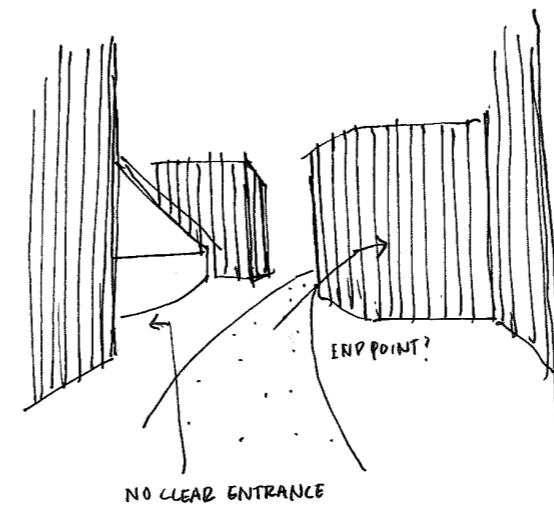
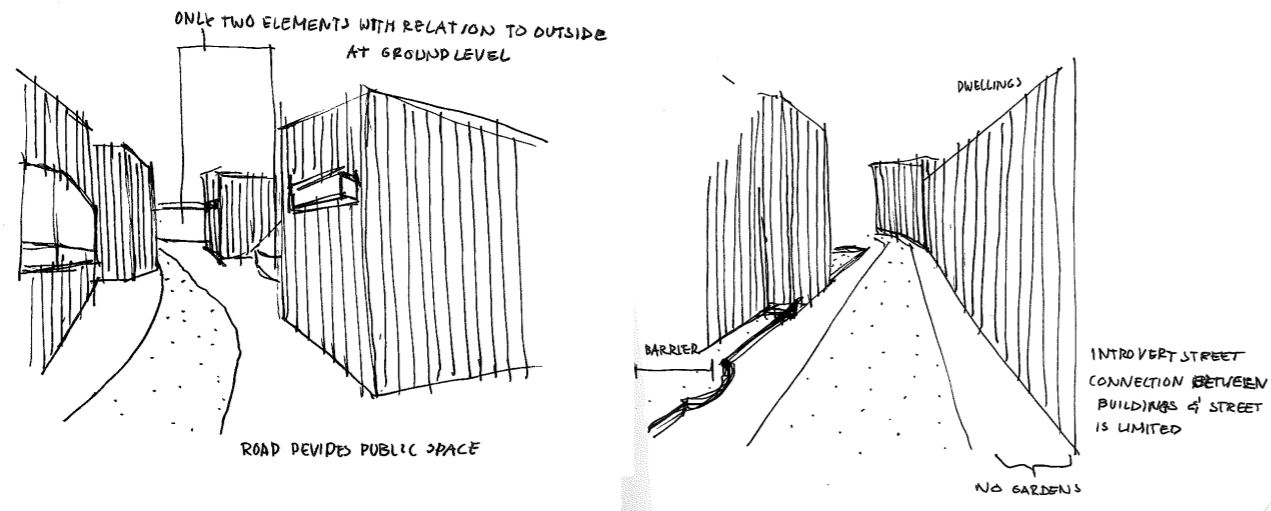

Elements that create possible interactions between inside and outside are positioned on higher level (some balconies) or are laying behind barriers like some stairs or a lowered ground plane. Noteworthy is the fact that there are no or a minimum of transition spaces present. Gardens for instance can fulfill this roll.

Gardens that are present though are laying hidden behind some fences or around the corner in a courtyard.

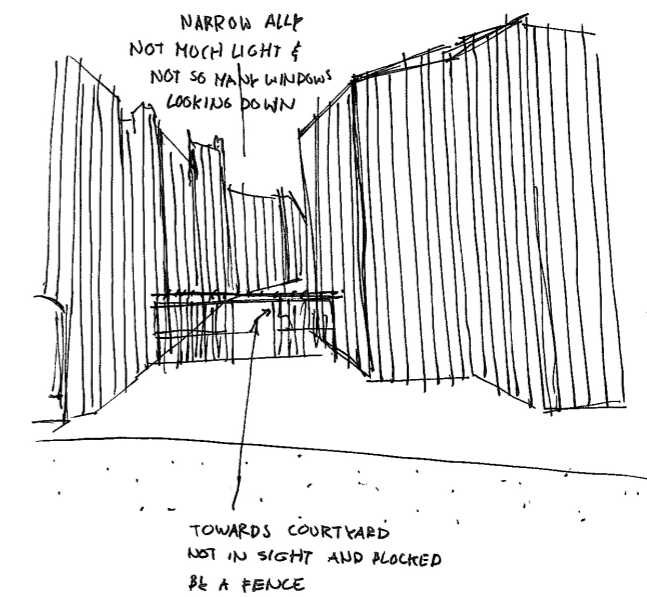
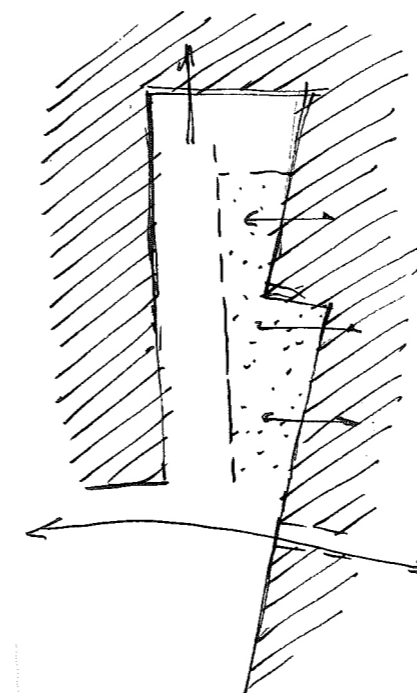
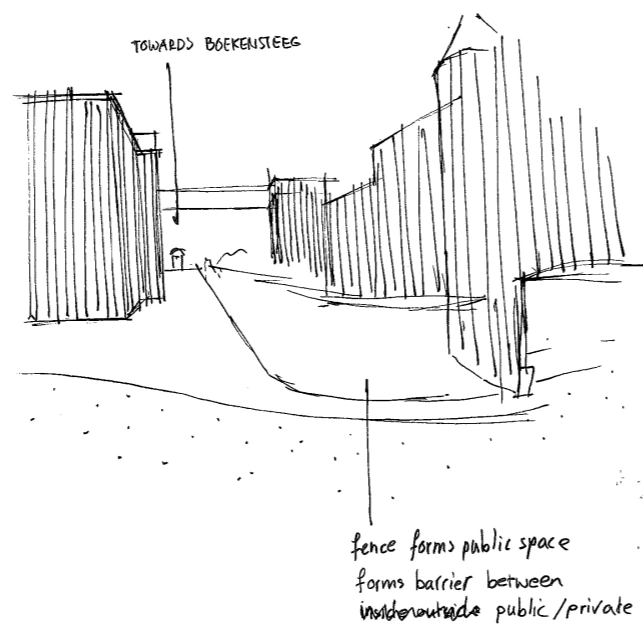

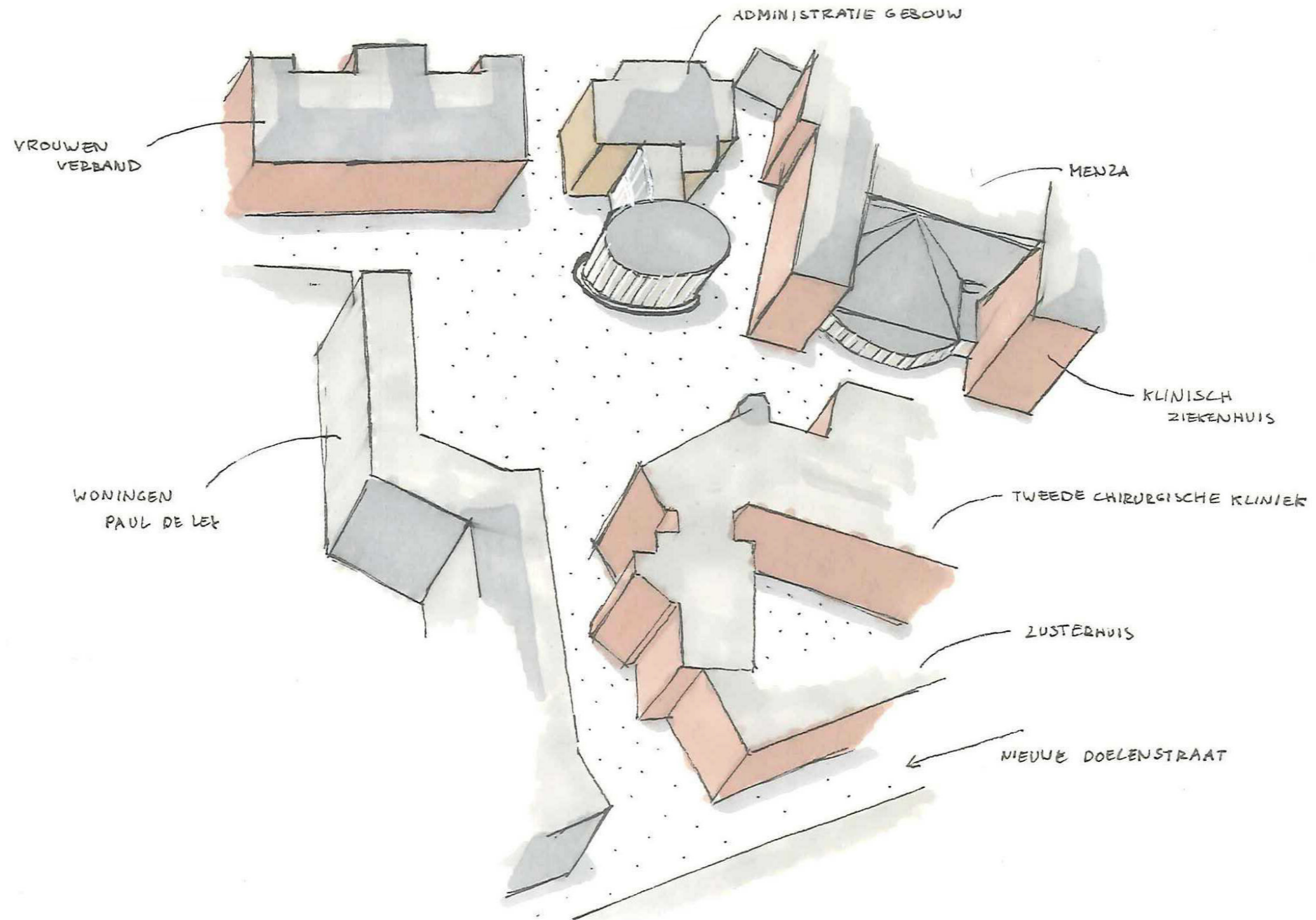

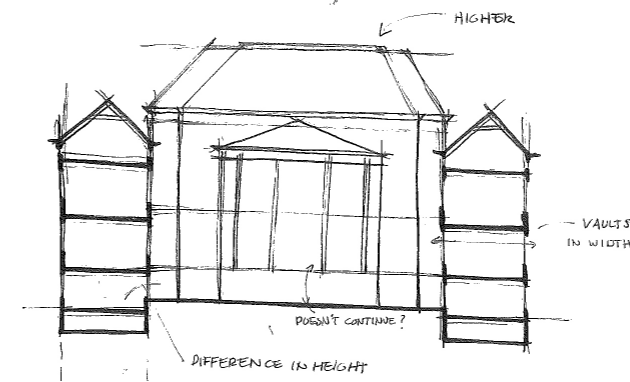
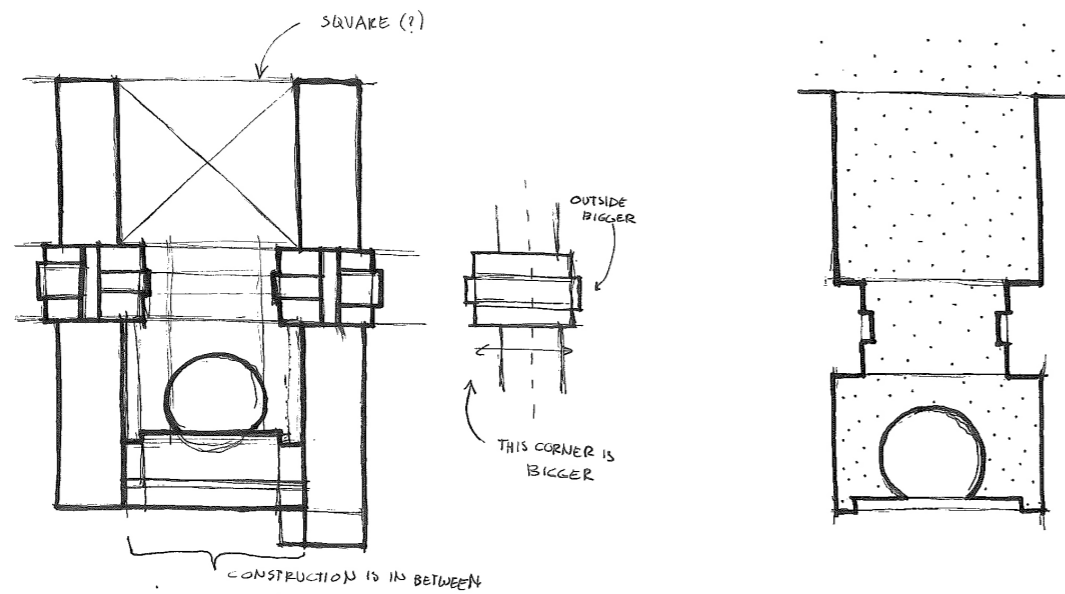

The klinisch ziekenhuis

The Klinische ziekenhuis originates from 1881. Its setup is symmetrical with two large wings at either side of a higher structure that knows a protrusion of a round structure. Seen from above, the plan creates three different open spaces, with the biggest one almost a square. In the middle of the two wings the construction widens, thus making space for the two main entrances and the vertical circulation.

The round structure takes the same height as the two wings. The amount of floors differentiates however, due to the upper floor being higher than others. The windows are only for letting light in and not for any outside look as they are situated high in the room. This changes later.

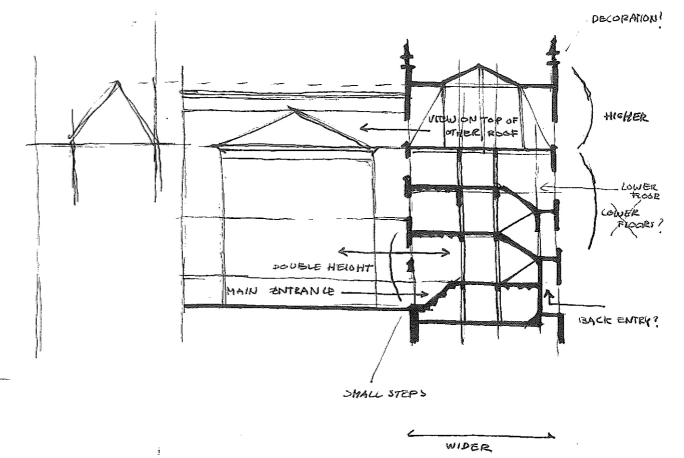
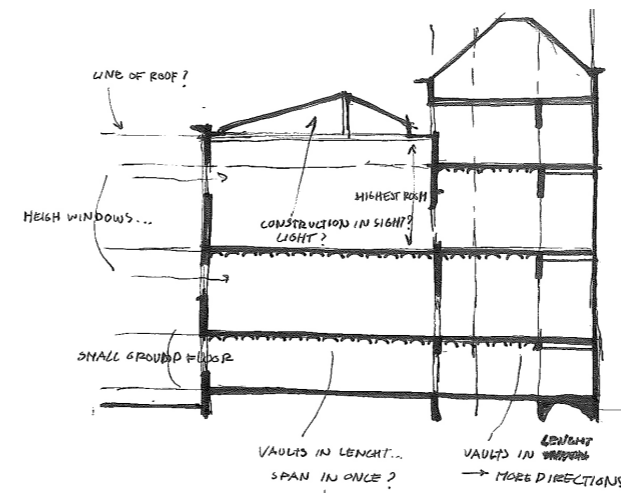
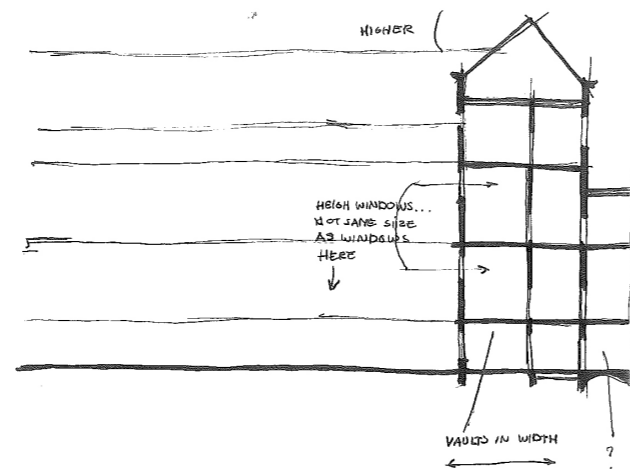

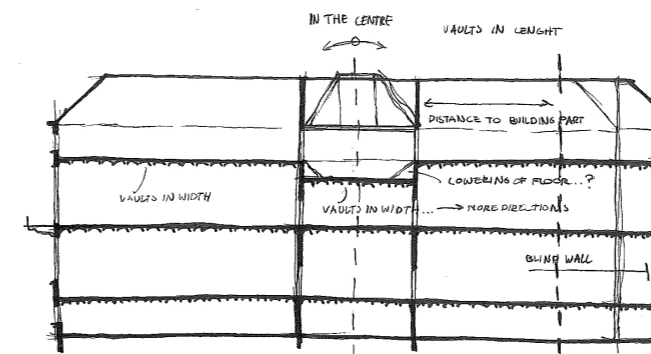
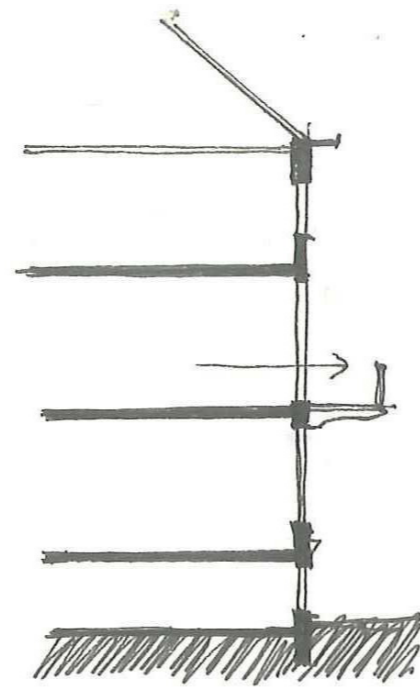
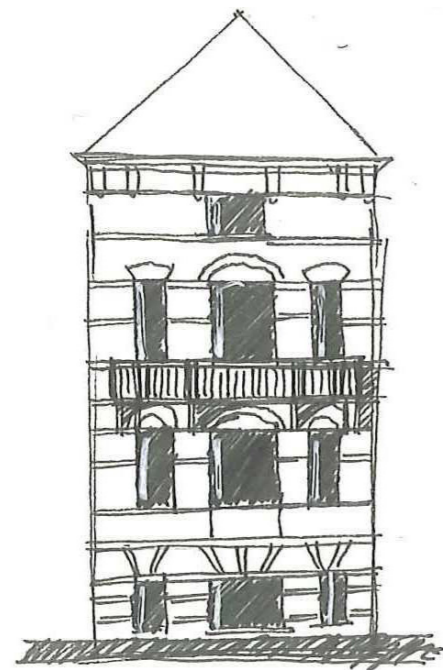

The whole building has a so-called 'bel-etage'. The ground floor is less high, making the first floor more important. This is most clearly expressed in the presence of bigger windows at the higher levels.

On the end face of both wings a balcony is been constructed. These are the only signs of any outward flow from the inside.

The middle parts of the two wings had two clearly different faces. At the courtyard side the main entrance was situated, taking two floors in height in the center of a symmetric grid. At the other side only a small door was present. Due to the placement of the door a bit to the right, this side is not entirely symmetrical.

Later the situation changed, as the main entrance is now at the outside of the building plot. The small door and window are joined. The original main entrance lost its function.

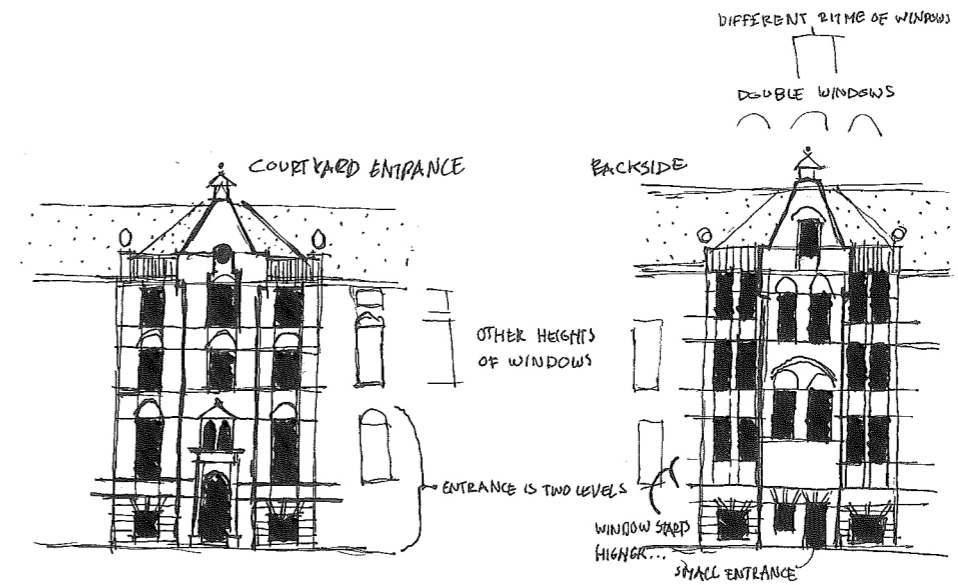
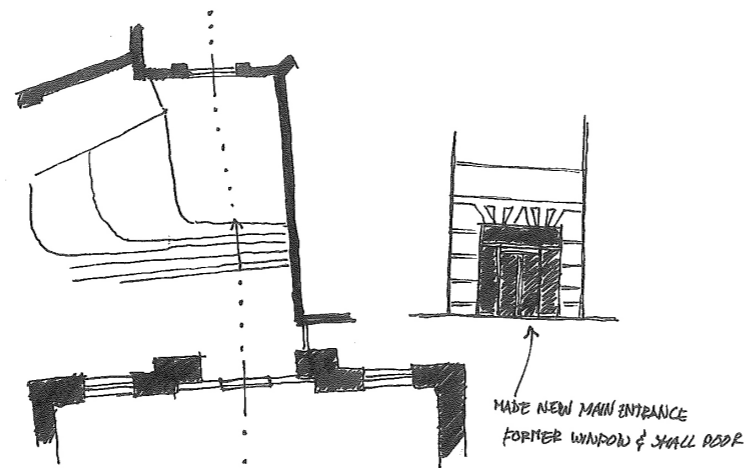

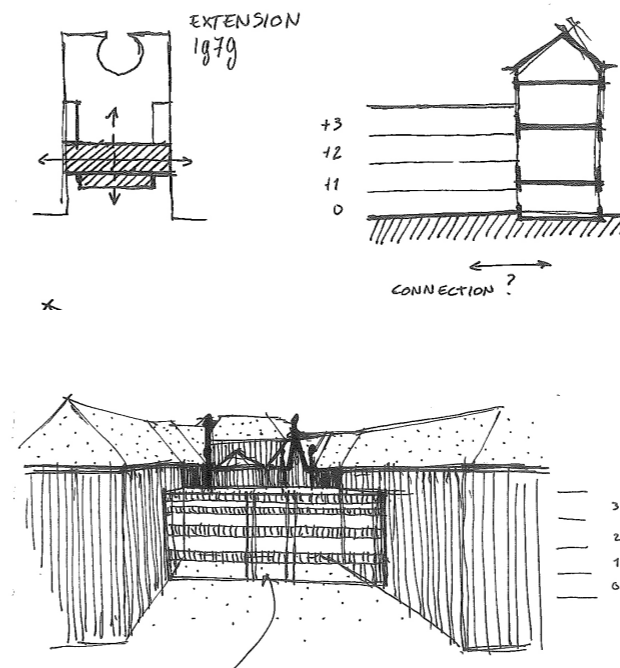
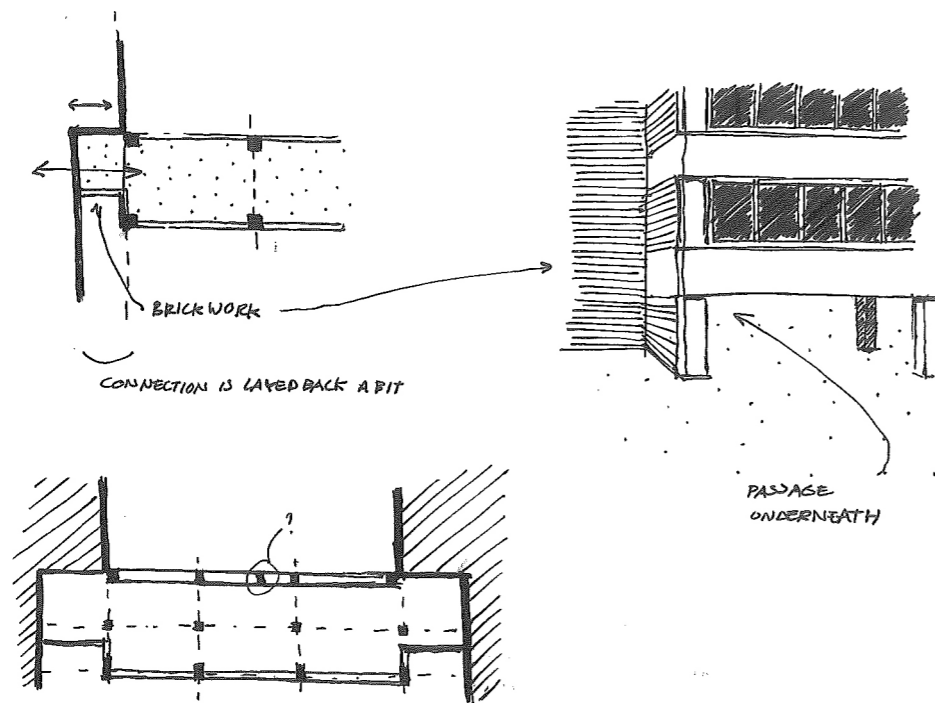

In 1979 the first extension is being built. The two wings are being connected by a four-floor construction. The open view of the courtyard is being partly blocked by this, although at the ground level an open connection is retained.

In 1991 a further extension of the building is being realized. This time the courtyard is almost completely covered, blocking the open view at the round structure entirely. The whole courtyard is lowered to the level of the souterrain. A pyramid-like structure is being placed in the front of the previous extension. Light and space were the intended goals.

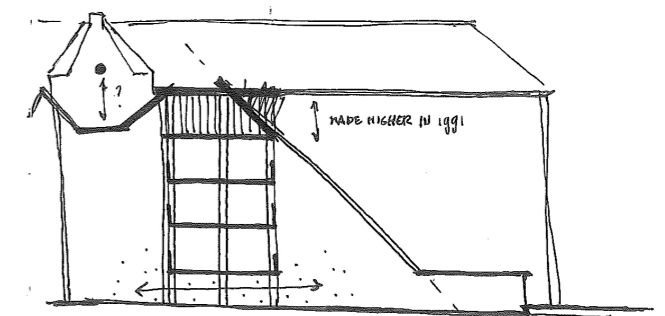
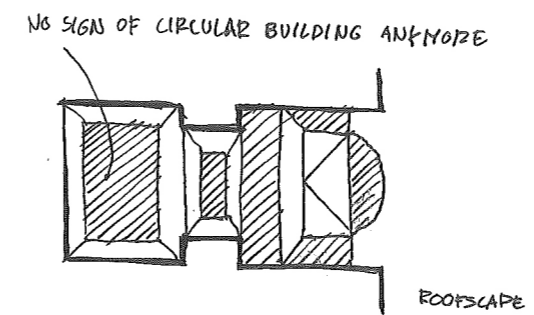
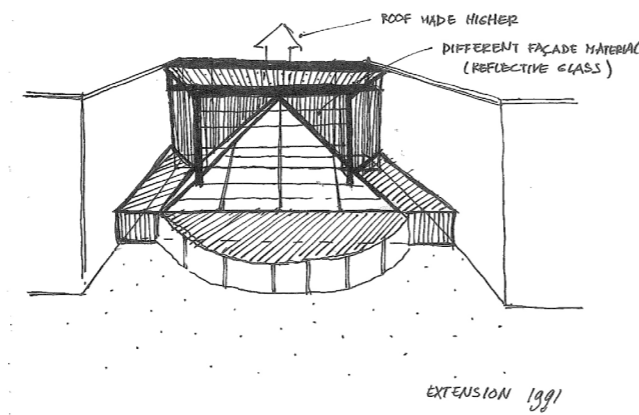

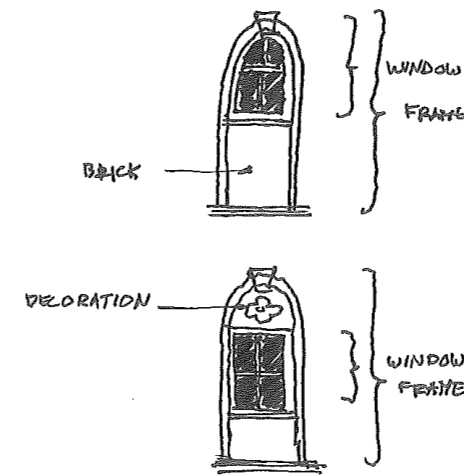
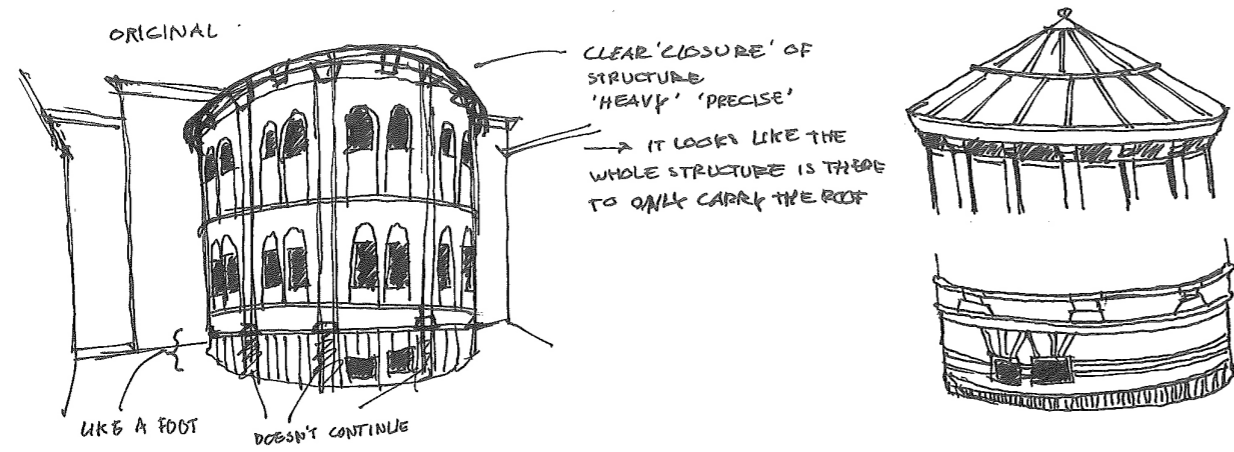

The round structure, used as lecture theatre, functioned as the focal point of the entire complex. It lays in the centre of the symmetric axis, differentiates in form and shows self-contained. The heavy foot, the clear rhythm of the middle part and the well-accentuated roof, shows comparisons with the division of the classical column.

With the alteration of the building in 1991, this structure is also being changed. The foot is made more open and is covered by a new floor. From now on visitors have direct access to the structure from the 'outside'. The windows are made bigger, giving the possibility for an outside look as wasn't possible before from the inside. The roof is being replaced with the covering of the courtyard. The whole structure shows imprisoned.

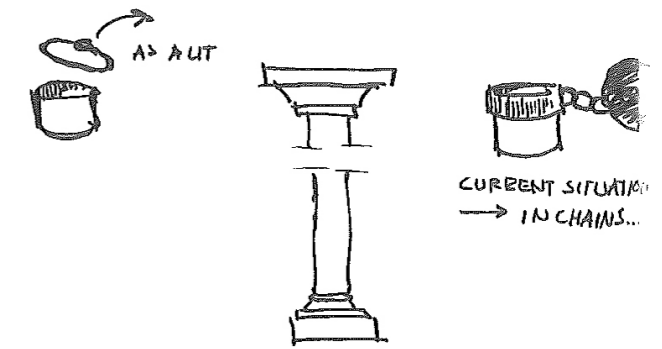
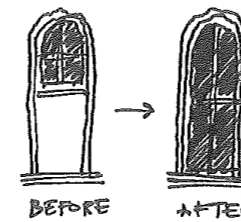
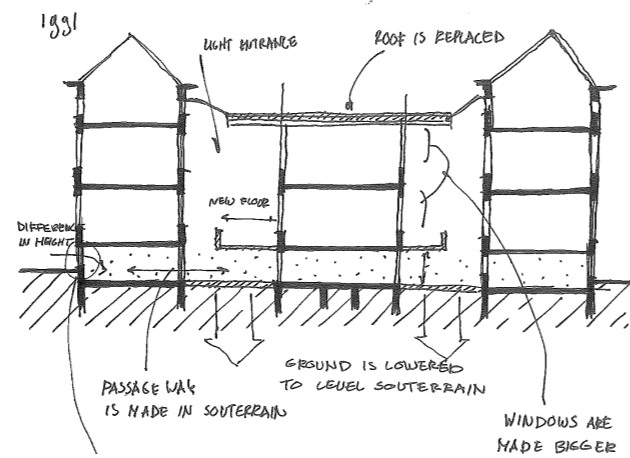

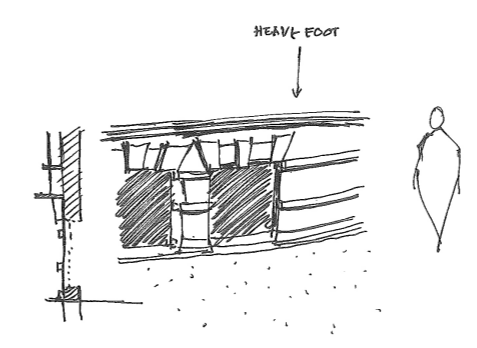

With the lowering of the level of the courtyard, the small windows from the souterrain are occasionally made bigger to form doorways.

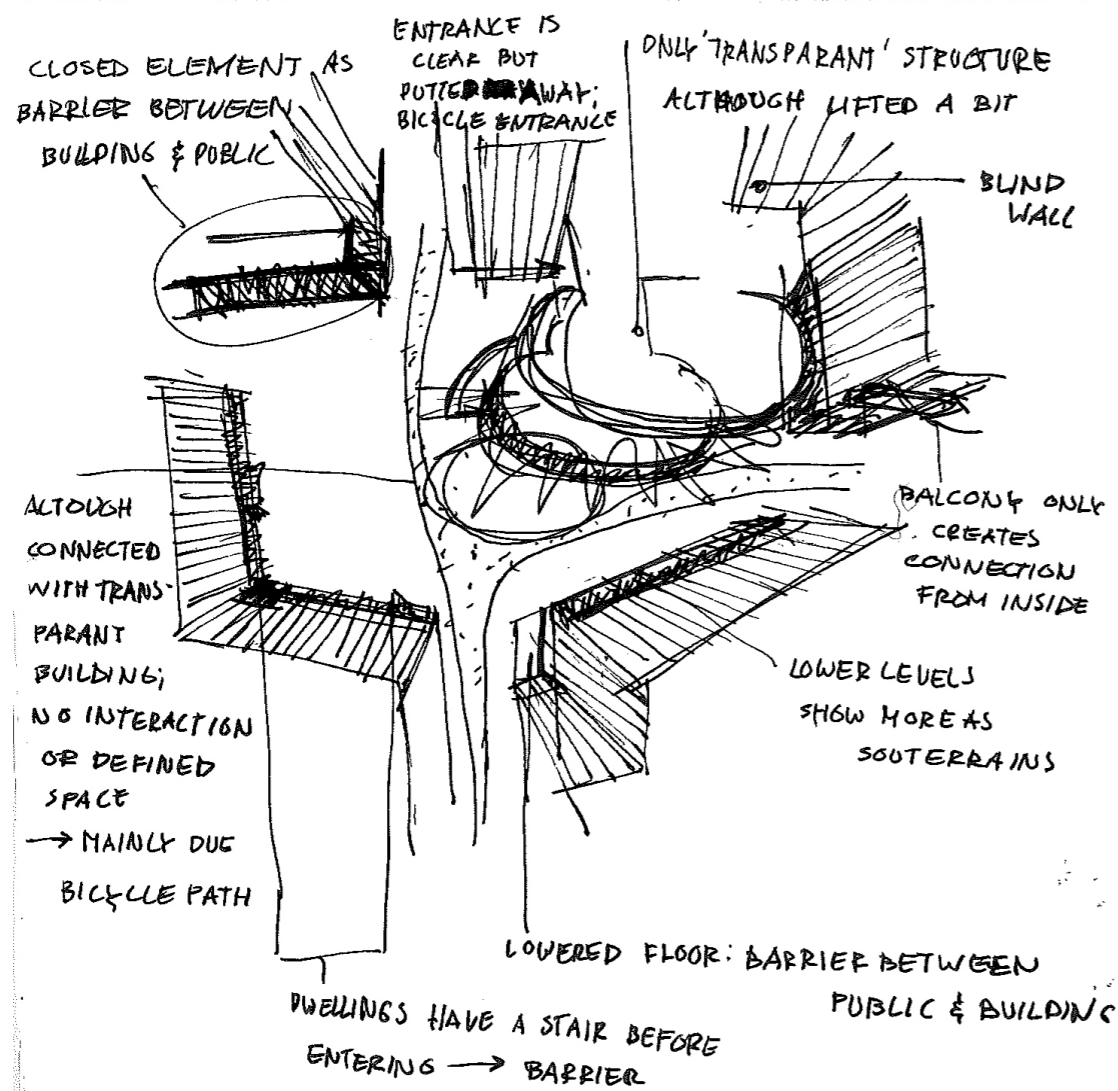

Findings

The hypothesis was that the site showed an introverted character foremost to the surrounding urban area. Although the Binnengasthuis area has quite some entry points, there are only two openings in the line of volumes. At those locations barriers of water or an increase of building density are present, making a great contrast with the more wide and open surrounding cityscape. Moreover are all the buildings inward-looking with their entrances facing inside the area. This can give the idea that, once 'inside', the site shows itself. This assumption is not totally correct. The space inside the Binnengasthuis area proved to be poor defined. A lot of forms, corners and directions are present. The coarse of the road through the site divides the space for a great lot. The most determined for the character of the site though is the minimum of interaction between the public space and the adjacent buildings. Different elements are having an effect on this creating the introverted character the site is known for.

Elements influencing the introverted:

- + Poor defined public space.
- + No clear relation between different building volumes.
- + No clear relation between the public space and the building volumes.
- + A minimum of direction is given.
- + Ground levels show as less important than higher floors.
- + Entrances are not clearly stated.
- + Lowering of the ground plane in between inside and outside.
- + Raise of entrances above ground plane.

Analysis & research

Literature

What does literature say about the obtained findings extracted from the description of the space, structure and enclosure?

Defining space

One of the elements of the description was that the public space is currently poor defined. Reasons put forward were the great lot of different forms, directions and corners present within the public space. These, of course, are the result of the different buildings that have been put together (see figure 2). When those buildings form a group, the space between the buildings is seen to have a life of its own as Gordon Cullen states. You can say 'I am inside it' or 'I am entering it'. (Cullen - p.7) The public space at the Binnengasthuis area however does not create this feeling. In an enclosed site like this you may expect otherwise. The separation between inside and outside seems clear with the presence of some impressive gates. The area shows introvert to the outside. You

are not inside yet though, due to the fact that the buildings within the area are introverted as well. In other words: the buildings don't form a group. This results in a public space that has no relationship with the adjacent buildings and loses its character of being introverted as it had so strongly before entering. Buildings putted together in a group have the potential to collectively give visual pleasure which none can give separately. (Cullen - p.7) It proves not to be a guarantee. However, it doesn't explain why the space actually is been experienced as poor defined.

Cullen calls enclosure the artefact of possession; one can only identify with a place when there is the possibility of postulate a sense of *hereness*. We need enclosure. It is the separation between the outside, where the noise and speed of impersonal communication is not of any place, and the inside, where there is quietness and human scale. Enclosure is the destination of traffic. (Cullen - p.25) As we don't experience being inside it within

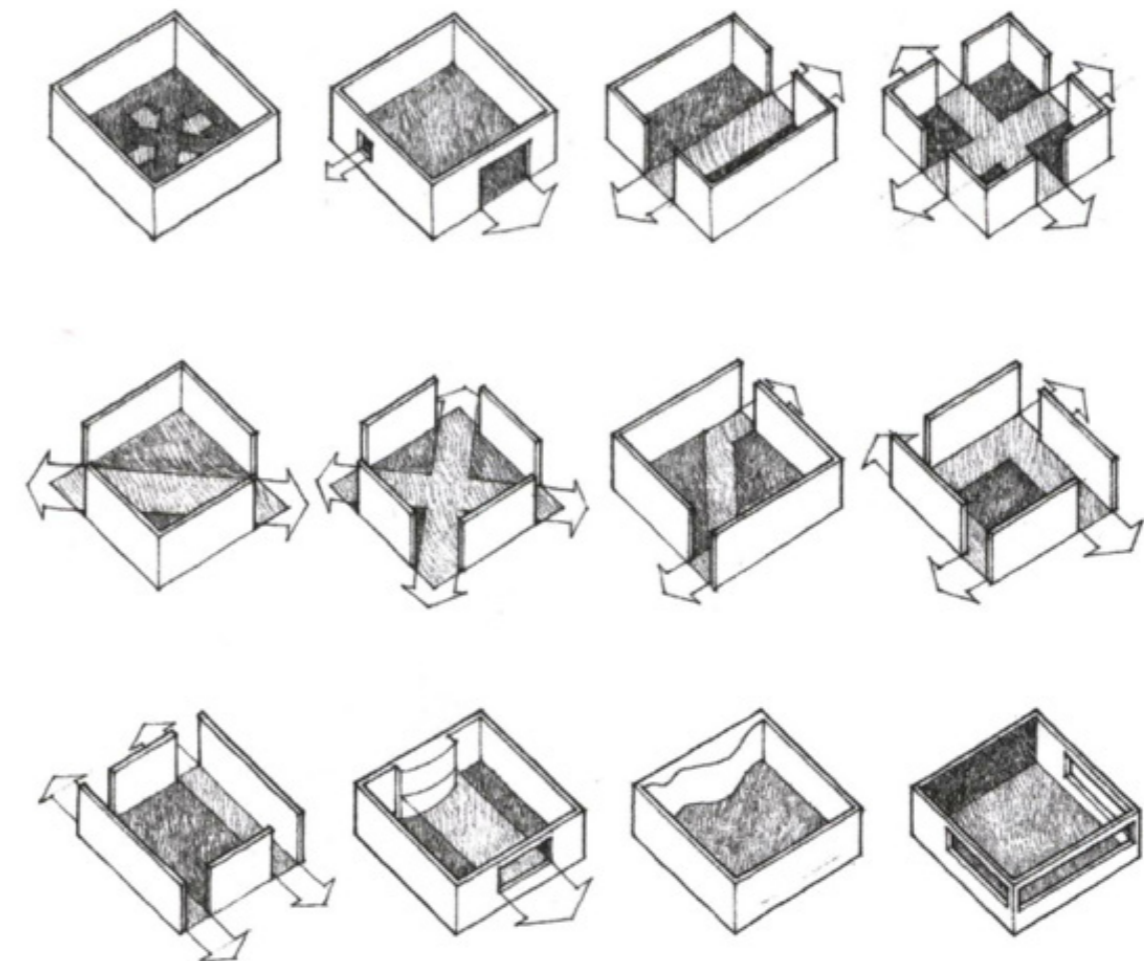

Fig.2 - Enclosure and defining space. Ching p.158

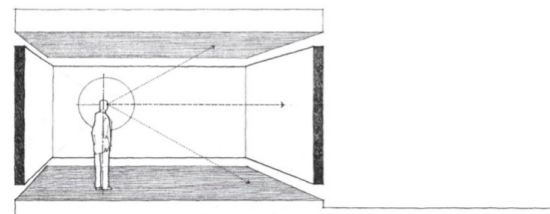

Fig.3 - The wall plane is active in our normal field of vision. Ching p.120

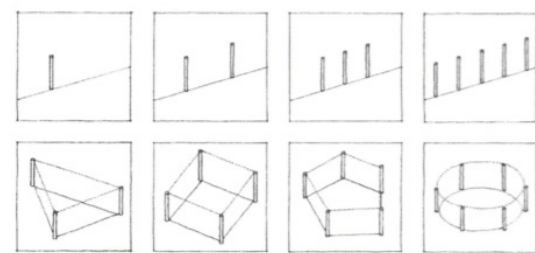

Fig.4 - Different forms of enclosing space. Ching p.123

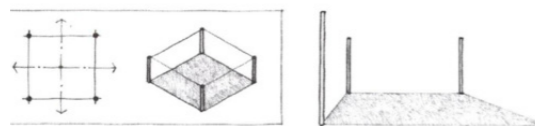

Fig.5 - Enclosed and extrovert. Ching p.121

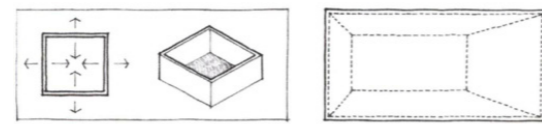

Fig.6 - Enclosed and introvert. Ching p.121

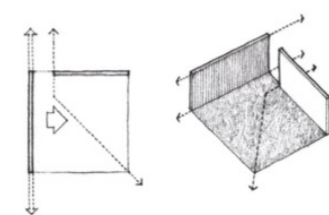

Fig.7 - One wall plane dominates the other. Ching p.134

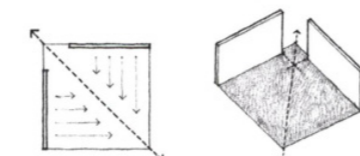

Fig.8 - No extension of either plane to the corner. Ching p.134

the Binnengasthuis area, we can conclude that we are not able to identify ourselves properly with our environment and thus that the space is not well enclosed. Francis Ching states that the degree of enclosure is one of the elements that influence the quality of space. (Ching - p.167) For him the wall plane is vital to the shaping and enclosure of space as it is active in our normal field of vision (see figure 3). This may not be surprising as vertical forms have a greater presence in our visual field than horizontal planes. Ching therefore names these instrumental in defining a discrete volume of space which provides a sense of enclosure and privacy for those within it. Furthermore he puts forward that the vertical forms serve to separate spaces from each other and by this establish a common boundary between the interior and the exterior. (Ching - p.120) It is important to note that space is for a great lot enclosed as well as defined by these vertical elements. The way the space is enclosed determines how the space will be defined. A well-defined and enclosed space can for example also be articulated by the use of only three trees (see figure 4). Cullen was astonished by how

fragile establishing an enclosure can be. (Cullen - p.32) A space enclosed by trees can be described as extrovert; it embraces the site without concealing what is beyond (see figure 5). Enclosure created out of four vertical planes, however, establishes a typical and certainly the strongest sense of introversion as the separation between inside and outside cannot be better emphasized (see figure 6).

Present voids are no direct threat as we have seen, but depending on their size, number and location they can begin to weaken the enclosure of the space. This is most likely the case of the Binnengasthuis site. Ching states that the definition of a field will be weakened when a void is introduced to one side of the configuration (see figure 7). If this occurs the two planes will be isolated from each other and it will appear as one slides by and dominates the other visually. (Ching - p.134) Exactly this happens at the area of the Binnengasthuis. A closed corner or no extension of either plane to the corner could solve this, creating a strongly defined and enclosed field (see figure 8). (Ching - p.134) Right now we cannot speak



Fig.9 - Closure does not block our sense of progression. Cullen p.47

of enclosure but of a space which is under the influence of what Cullen describes as 'closure': a temporarily break in the street (see figure 9). The volumes do contain the eye but does not block our sense of progression beyond. (Cullen - p.47)

Enabling a clear enclosure will make it possible to identify oneself with the surroundings and give the idea of being inside *it*, automatically creating an outside and by this giving a stronger sense of introversion to the area.

Architecture

The feeling of introversion is also created by the strict separation of public and private between the inside and outside of the adjacent buildings. Because of this the buildings show as standing alone. The only building that does allow a look inside is the central positioned Administration building. This is the most distinctive building volume at the Binnengasthuis area and consists for the biggest part out of glass, creating a very transparent building. It seems the most extroverted

volume. Ching states however that a circle is an introverted figure. The form is self-centering in its environment whereby it reinforces its centrality (see figure 10). This way the volume gets a lot of attention but none is giving to its surroundings. (Ching - p.39) Moreover, most of the blinds have to be closed to block the sun entrance during summer (see figure 11 & 12). Due to the use of all the glass in the facade the building needs to be almost completely closed to its surroundings, making interaction with the public space more impossible than other buildings at the area.

Apart from the question of the defined space, such an introverted structure can function well inside an enclosure. Cullen calls this the focal point, the 'vertical symbol of congregation'. According to him such a focal point can crystallize the situation; it confirms that you have arrived. 'Stop looking, it is here'. (Cullen - p.26) However, we cannot ignore the undefined space the building sits in as it now functions more as one of the many disturbing elements present at the site. The human mind reacts to a contrast.

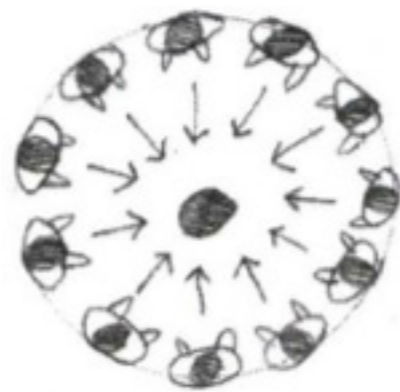

Fig.10 - All the attention, but none giving. Ching p.39

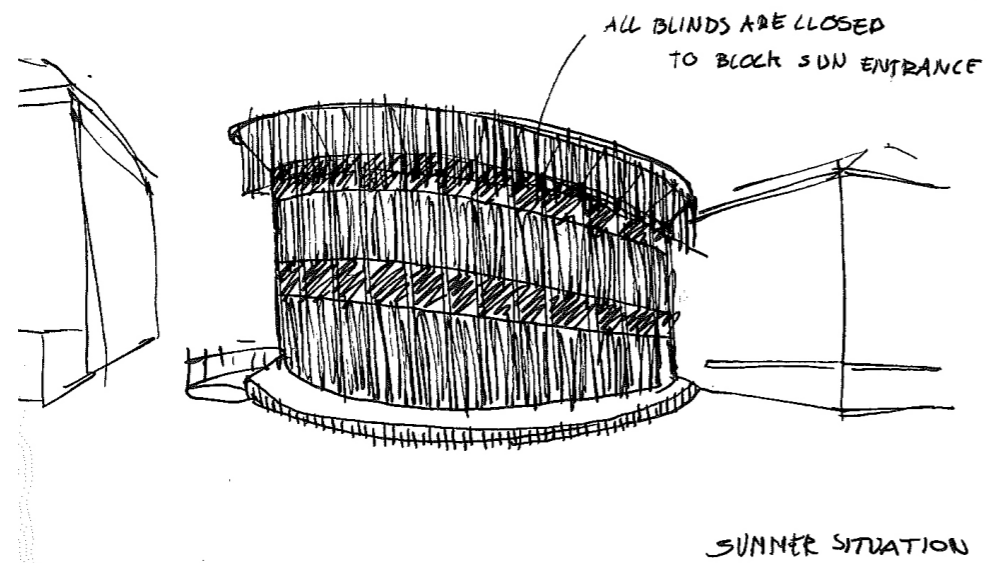

Fig 11 - Administration building Own image

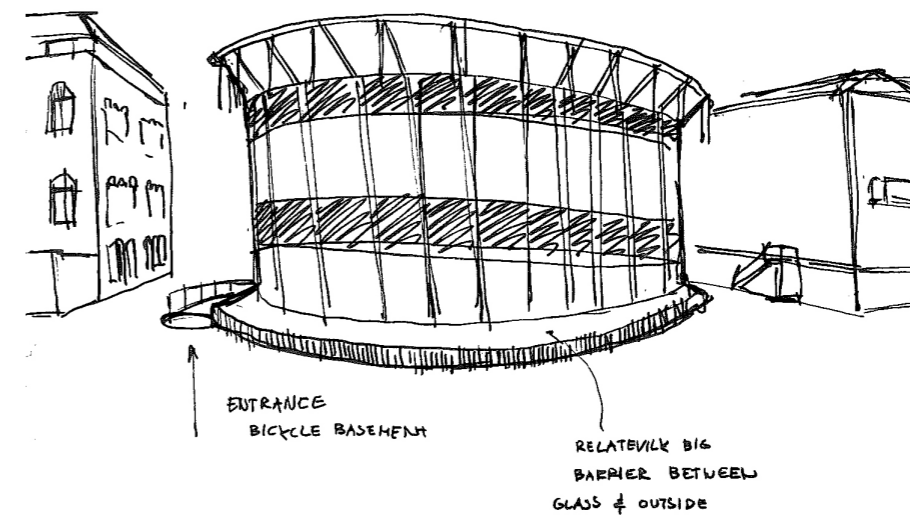

Fig 12 - Summer situation Administration building Own image



Fig.13 - Salk Institute, California by Louis Kahn. Archdaily.com

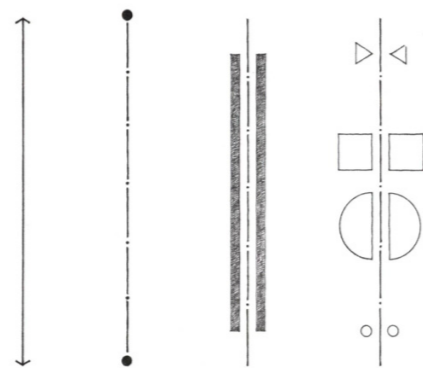

Fig.14 - Different ways of creating an axis. Ching p.322

It stimulates our senses. (Cullen - p.9) Currently the human mind finds so many contrasts that it starts to be confused. Kengo Kuma states that people become too occupied in western plaza. He appeals to a design-less empty space as it makes people more sensitive towards their surroundings. Emptiness has the great influence of changing people's sensitivity drastically. According to him this enables people to feel the smells of the wind and feel the softness of materials. If the architecture is not overemphasizing itself, the empty space gets a chance to exist. (Avermaete - p.161) A similar appeal can be seen from the correspondence between Luis Barragán and Louis Kahn about the creation of the Salk Institute in La Jolla, California (see figure 13). Barragán advises to leave the space between the buildings open, with no garden in between, as was the original idea of Kahn. This way the space would better reflect the spirit of the location. (Curtis - p.523) The original setup of the Klinisch ziekenhuis was quite strong in this respect. The building, laid out in a U-form, created and contained space within its arms, as it was protective to what it enclosed. Although still

being outside, this location was clearly defined in contrast to the space around the building. Like we have seen the rhythm of the façade and the openings in it do not differentiate at either side; the building shows closed, heavy and introvert with the small windows and lower spaces at the ground floor and the bigger windows and higher spaces above it, out of reach. Still, the space within the U-form gave the sense of greater importance. This had to do with the presence of a strong axis that is established by two points in space (see figure 14). (Ching - p.322) The central positioned circular structure at the end and the end faces of the two wings, which get extra empowered by the only sign of outward flow in the entire building, namely a balcony, making these like an important gate. The emptiness of the space in combination with the strong enclosure of high vertical and closed planes, made the space having an introvert character where one could be sensitive again.

The strong separation between inside and outside, emphasized by the placement of imposing entrances at this side, is lost however, due to the

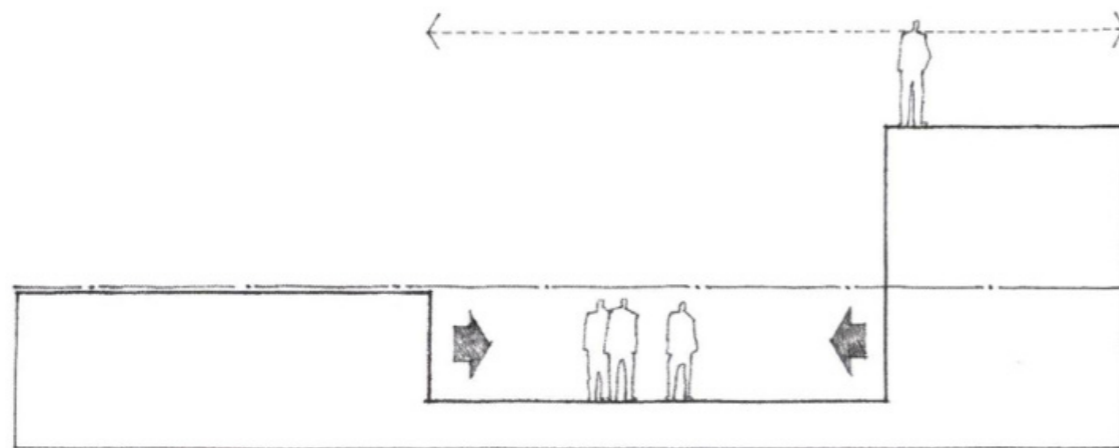

Fig.15 - Elevated or lowered space. Ching p.109

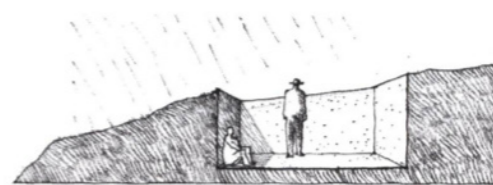
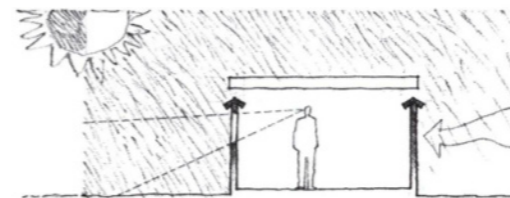

Fig.16 - Shelter and protection. Ching p.120



several reconstructions that have taken place since. The situation nowadays is that the strong axis does not exist anymore. With the addition of a multi-story structure in between the two wings, the view at the circular protrusion has been made impossible. A situation is created where this circular structure has lost its strength of being a focal point with a strong introvert character. Its roof, which fitted like a lid on a pod, has been removed and replaced by an overlapping horizontal plane that cannot establish the same importance. The heavy pedestal is made invisible by yet another horizontal plane covering the foot of the structure. A space is emerged with so many disturbing elements that the mind can't have any moment of reflection. Even the imposing entrances have been removed from their duties, now only present like old memories of better times. The bel-etage, in turn, has lost importance to the placement of the main function (canteen) outside of the original building and on the ground level, which needed to be deepened to make it possible. The lowering of space can however, in a different situation, also prove to enhance the

introvert character of space ^(see figure 15). Ching states that in contrast with elevated space that might express the extroverted nature of the space, space below it surroundings allude to its sheltering and protective qualities ^(see figure 16). (Ching – p.109)

Human scale

Till now we talked about spaces that are created outside and bring a certain character to the site but are not of human scale. The question remains what the value is of the introverted at a human scale. The human scale is how we relate to space on the dimensions and proportions of the human body. Although mentioned as not to be used as an absolute measuring device, Ching describes the way we gauge the width of a room or judge its height by the proportions of ourselves. The presence of a doorway, the steps to a second floor, a table or a chair in a room. If the space is monumental in scale it will make us feel small, but a room that is intimate in scale will describe an environment in which we feel comfortable, in control, or important. (Ching – p.316) The biggest effect on the scale of a space has its

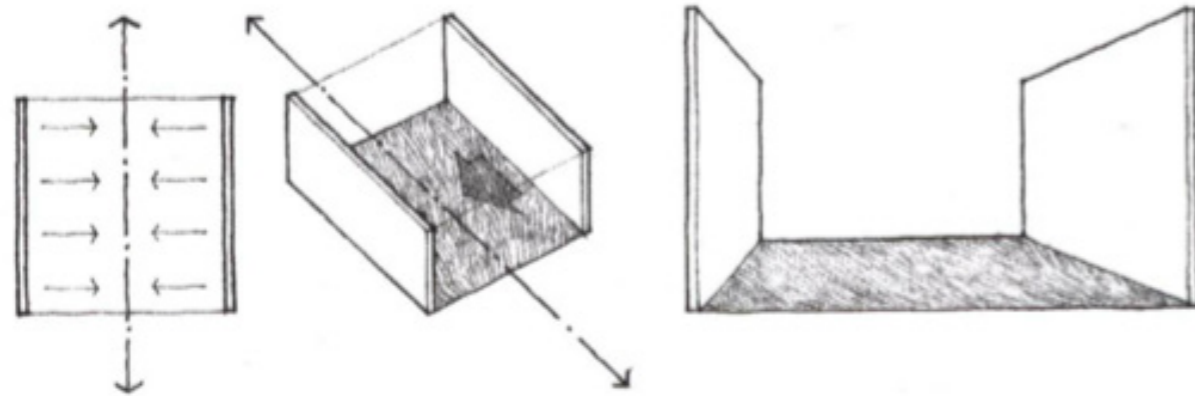

Fig.17 - Open ends at either side create a strong directional quality. Ching p.140

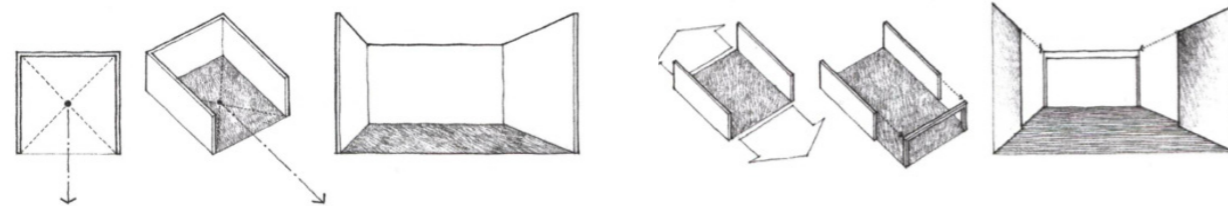

Fig.18 - Stimulation of movement. Ching p.140

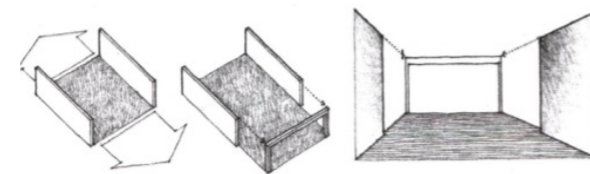

Fig.19 - Movement and arrival. Ching p.140

height. The enclosure of a room is provided with the placement of the walls, but the quality of shelter and intimacy is determined by the height of the ceiling plane overhead. (Ching – p.317) Yet this does not explain when a space will be characterized as introverted or extravert, as a high enclosed space can make us feel small but will not necessarily be entitled as being introverted or visa-versa. Some explanation is given when we look at how *extroversion* is explained. According to Ching a typical example of extroversion are two parallel planes that do not meet to form any corners (see figure 17). Due to the vertical edges of the plane and the open ends at either side of the field, a strong directional quality is established. (Ching – p.140) In other words: extroversion stimulates movement, an outward flow (see figure 18). As the opposite of extroversion, we can conclude

that introversion brings movement to a stop, as an inward flow. The introverted gives the sense of arrival, which brings peace to the human mind (see figure 19).

A great example is this study place created at Villa Savoye by Le Corbusier. Suited only for one person a space is created around a corner. A blind wall with a small desk awaits. The window to its left gives light and an occasional outward look, but the person studying here will not be seen from the outside. Here one can settle down and concentrate on what needs to be done (see figure 20).

You employ stone, wood, and concrete, and with these materials you build house and palaces. That is construction. Ingenuity is at work. But suddenly, you touch my heart, you do me good. I am happy and I say: 'This is beautiful.' That is architecture. Art enters in.

- Le Corbusier (Ching – p.375)



Fig.20 - Study place Villa Savoye. Own images.

Strengths

- The separation between inside and outside seems clear with the presence of some impressive gates. The area shows introvert to the outside.
- The original setup of the Klinisch ziekenhuis created and contained space within its arms, as it was protective to what it enclosed. This space was clearly defined.
- The Klinisch ziekenhuis shows closed, heavy and introvert with the small windows and lower spaces at the ground floor and the bigger windows and higher spaces above it, out of reach.
- The space within the U-form gave the sense of greater importance. This had to do with the presence of a strong axis that was established by two points in space.
- The emptiness of the space in combination with the strong enclosure of high vertical and closed planes, made the space having an introvert character where one could be sensitive again.

Weaknesses

- The buildings don't form a group. This results in a public space that has no relationship with the adjacent buildings and loses its character of being introverted.
- As we don't experience being inside it within the Binnengasthuis area, we can conclude that we are not able to identify ourselves properly with our environment and thus that the space is not well enclosed.
- The public space is under the influence of 'closure': a temporarily break in the street. The volumes do contain the eye but does not block our sense of progression beyond.
- Currently the human mind finds so many contrasts in all the disturbing elements, that it starts to be confused.
- The strong axis of the Klinisch ziekenhuis does not exist anymore.
- The view at the circular protrusion has been made impossible; the circular structure has lost its strength of being a focal point with a strong introvert character.
- The roof of the circular structure, which fitted like a lid on a pod, has been removed and replaced by an overlapping horizontal plane that cannot establish the same importance. The heavy pedestal is made invisible by yet another horizontal plane covering the foot of the structure.
- The imposing entrances have been removed from their duties
- The bel-etage has lost importance to the placement of the main function (canteen) outside of the original building and on the ground level.

Opportunities

- Buildings put together in a group have the potential to collectively give visual pleasure which none can give separately.
- Enclosure created out of four vertical planes establishes a typical and certainly the strongest sense of introversion as the separation between inside and outside cannot be better emphasized.
- Enabling a clear enclosure will make it possible to identify oneself with the surroundings and give the idea of being inside it, automatically creating an outside and by this giving a stronger sense of introversion to the area.
- The Administration building can function well inside an enclosure as the focal point, the 'vertical symbol of congregation'. Such a focal point can crystallize the situation; it confirms that you have arrived. 'Stop looking, it is here'.
- A design-less empty space makes people more sensitive towards their surroundings. Emptiness has the great influence of changing people's sensitivity drastically.
- The lowering of space can prove to enhance the introvert character of space. It alludes to its sheltering and protective qualities.
- The introverted gives the sense of arrival, which brings peace to the human mind.

Threats

- The definition of a field will be weakened when a void is introduced to one side of the configuration. If this occurs the two planes will be isolated from each other and it will appear as one slides by and dominates the other visually.
- It may be possible that there will be too much activity to establishing real introvert space(s).
- A space can be created that will be too closed off for inhabitants of Amsterdam to find their way to it.
- A space that has its main goal of being introverted, may be unsuitable to work in.
- Too much 'silence of the introverted' can be intimidating and perhaps work on people's nerves.

Moving towards the Klinischziekenhuis from the Grimburgwal. Remarkable is the front facade of the Administration building at the Grimburgwal that has, in contrast to other buildings at the Binnengasthuis are, no differentiation in window heights at the different levels. Moreover there is some connection through the use of the same eyelevel between inside and outside. It can be said that this part is less introvert, although there is no sign of an entrance to the building. A gate to the left of the building is present though.

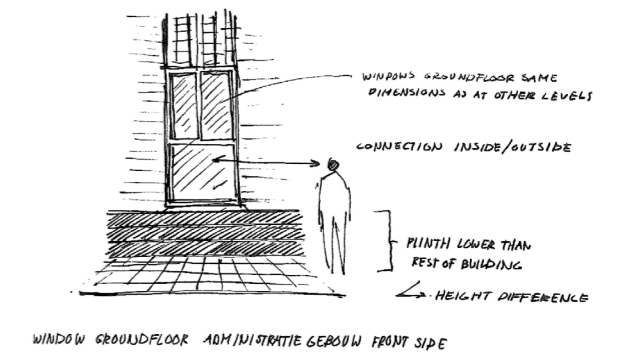
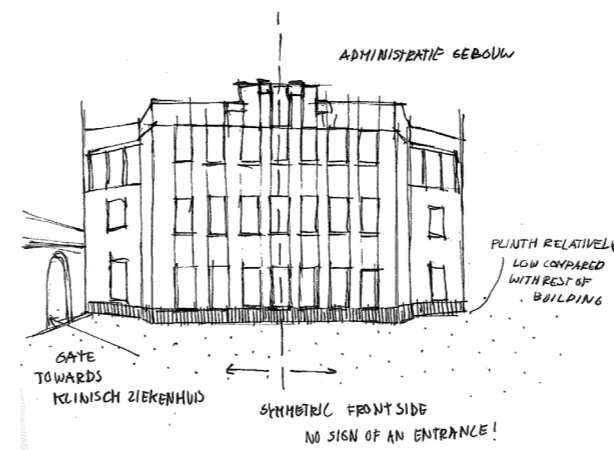
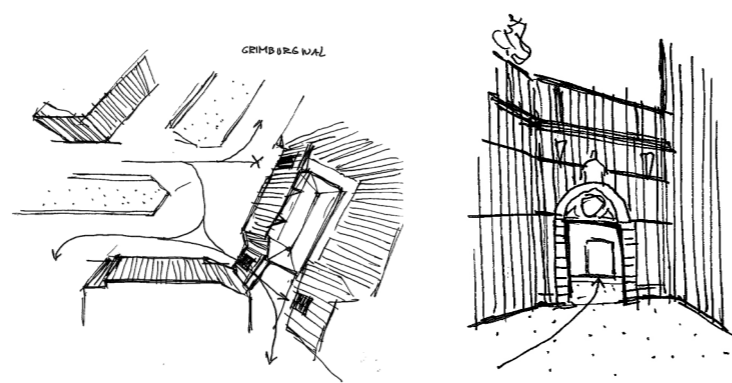

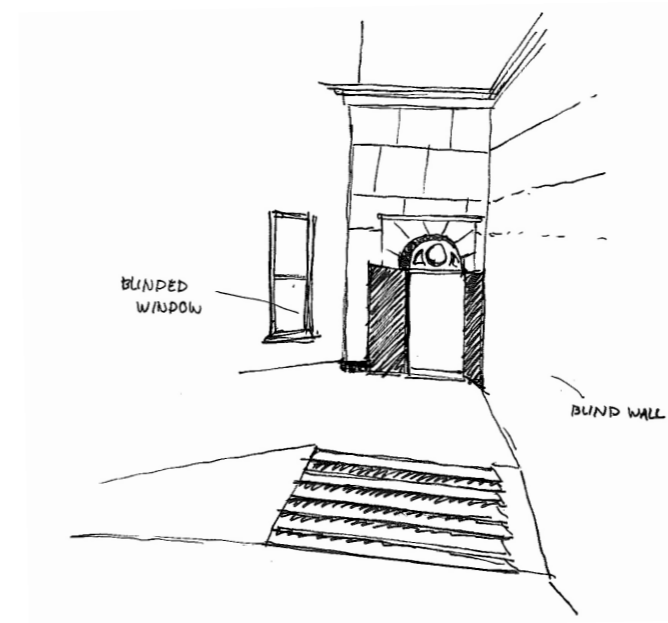
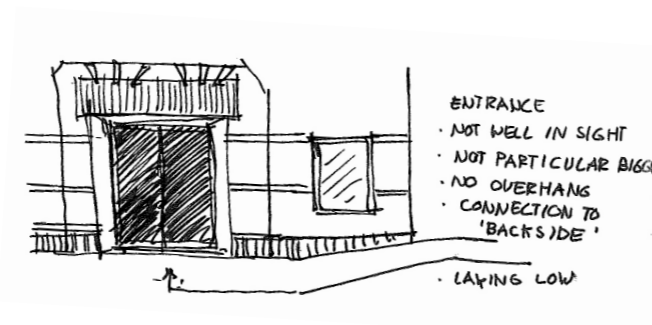
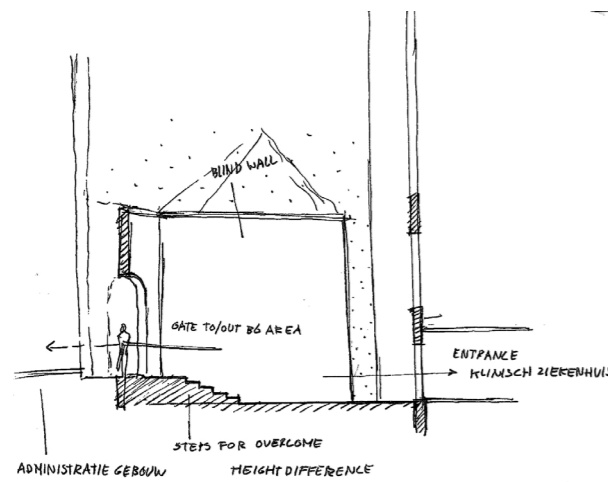

Going through the gate next to the Administration building, a narrow open space becomes present. By some steps a lower lying entrance can be reached. The entrance is one of the main entrances of the building, but doesn't show like it:

- It lays not well in sight.
- It is not noticeable in size compared with the rest of the building.
- The entrance has no overhang or other articulation.
- The entrance is laying low.

Due to the gradient in the area, a base underneath the Administration building is becoming more obvious. This creates some kind of a threshold as the building develops in space. Other entry points at this side are present but are deliberately trying not to stand out. This time it is understandable due to the fact that the main entrance is at the other side. It does however create an even more atmosphere of a 'backside area'.

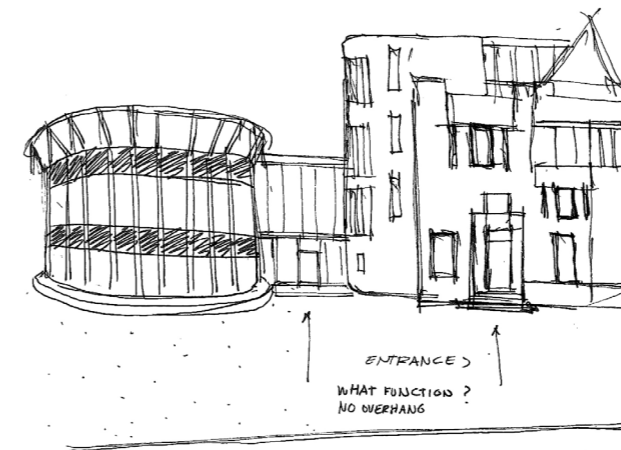
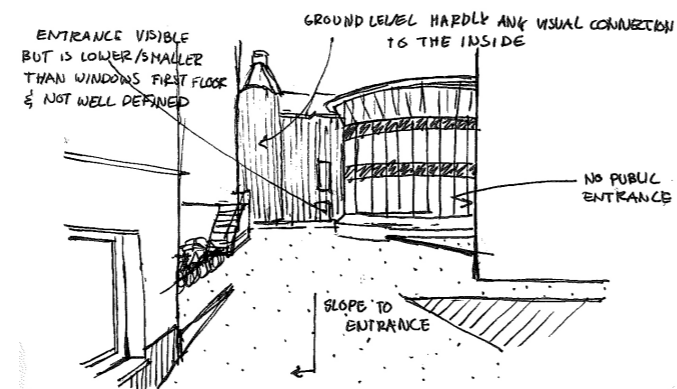

GRADIENT OF SLOPE

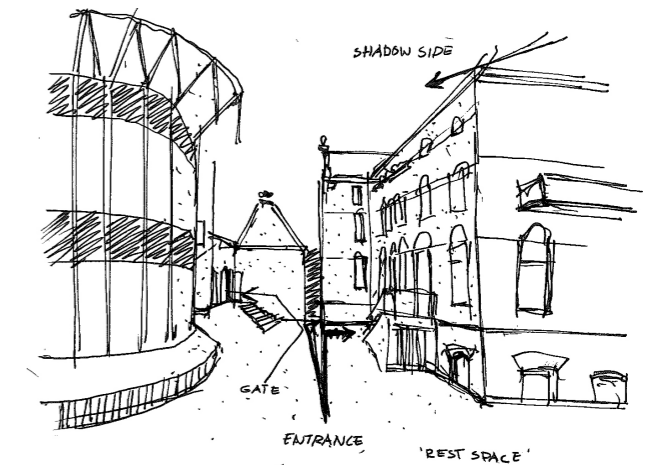

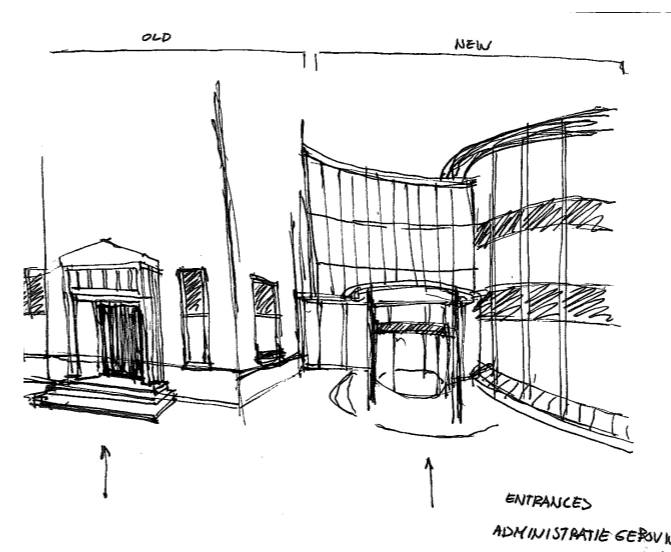
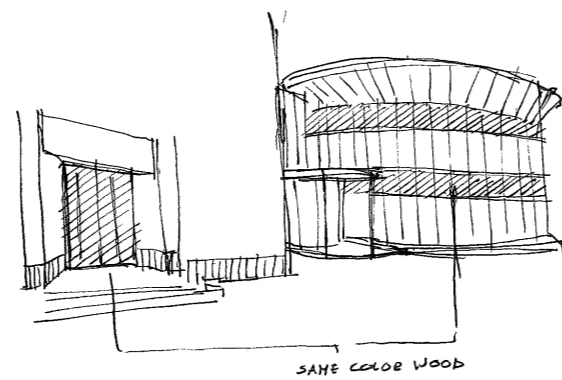
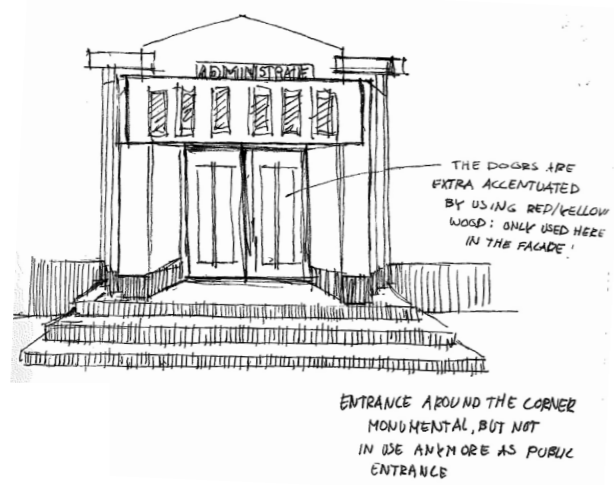

The Administration building knows some quite distinctive entrances at the other side of the volume.

The former main entrance stands out by having more relief in the facade around it, laying on a higher level with some steps to it and the doors are constructed out of wood that isn't (or: wasn't in the time it was build) present in the rest of the building.

The new main entrance lays in between two contrasting volumes. This part of the volume is less high. The entrance is furthermore articulated by the use of an overhang and two columns at either side. On the floor the circular form is reflected in dark stone, which accentuates the entrance even more. Last but not least: on top of the entrance a sign is present, making clear the function and importance of this part of the building.

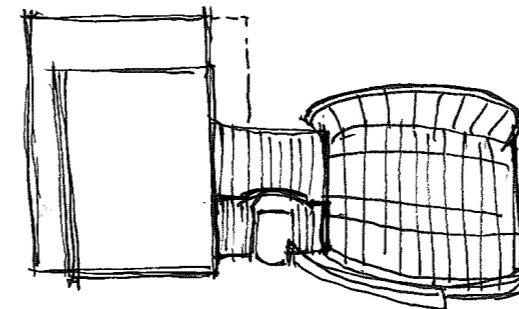
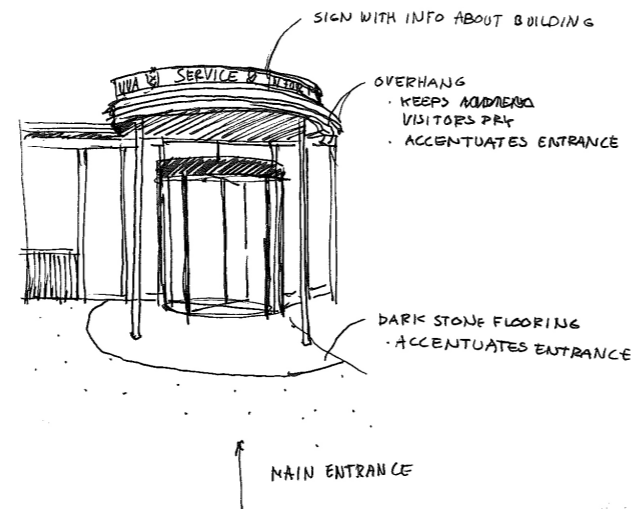

BRICK	CONNECTOR	GLASS
SOLID	ENTRANCE	STEEL
CLOSED		TRANSPARENT
STRAIGHT		ORGANIC
YELLOW		FRAGILE
STRONG		CONCRETE BASE
HEAVY		REFLECTIVE

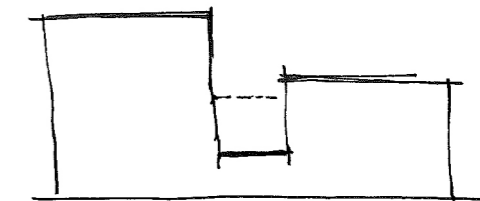
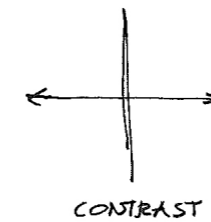

ENTRANCE
IN LOWEST PART
'INVITING'?

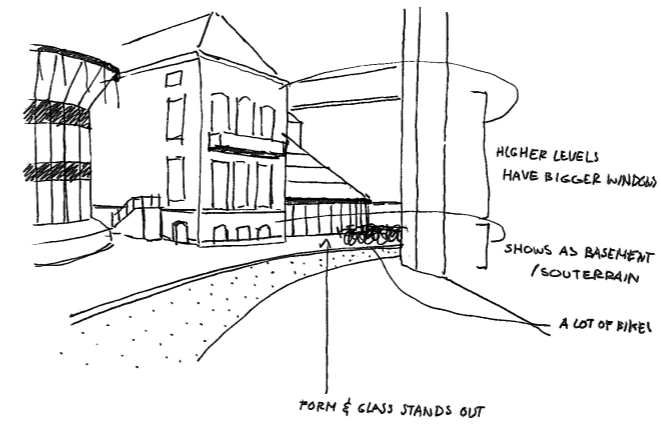
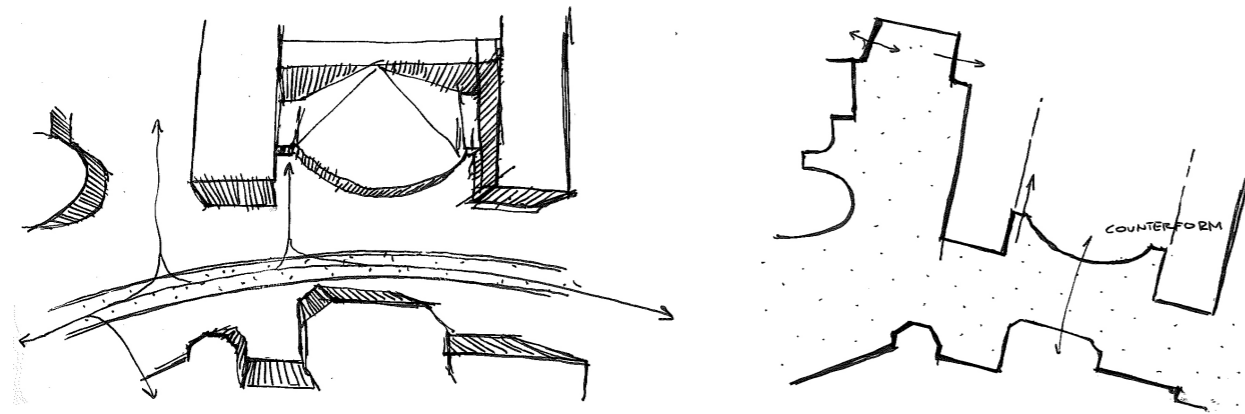

Coming from the 'backside' of the Administration building the view of the pyramid-like structure shows a like a part of the building that isn't afraid of showing itself. The plinth is constructed in mostly glass and is by this transparent. A clear view to the inside stays out though. The triangle form on top of it is not transparent and shows 'heavy' by its form. By this dominating form, the transparent part underneath it shows only minimum and almost being crushed. There is no sign of the presence of any kind of entrance, although there is an entrance here.

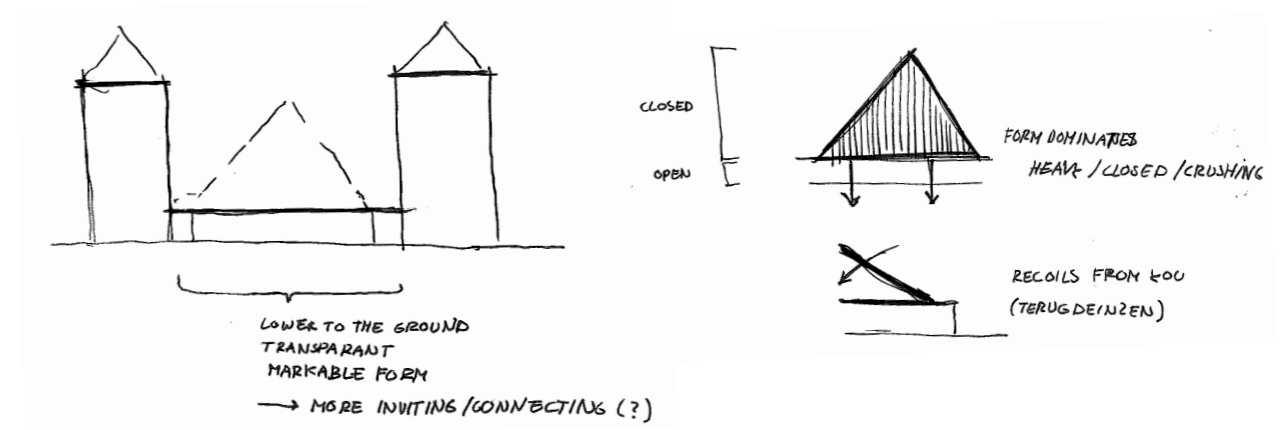
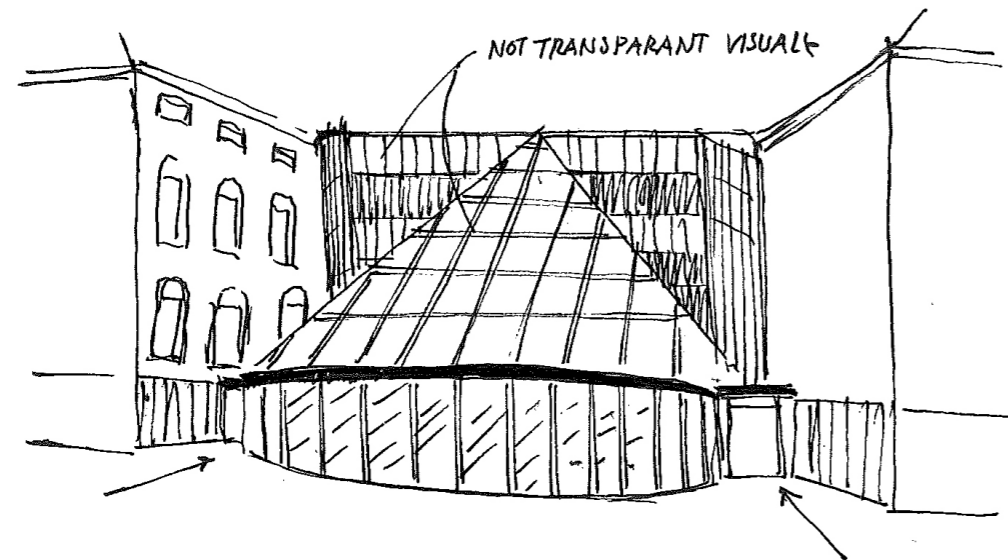

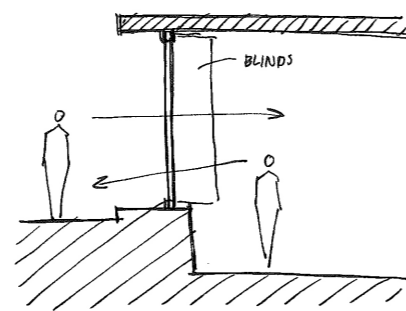
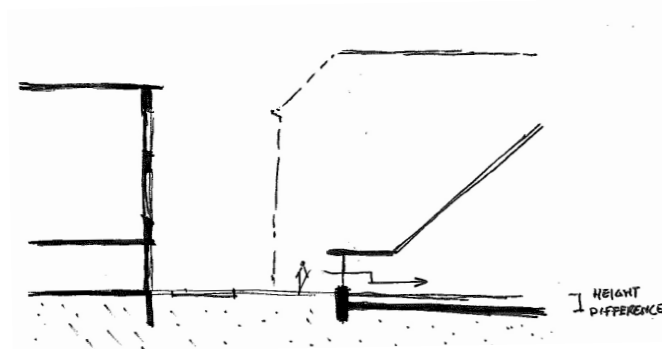

VISUAL CONTACT
POSSIBLE, BUT NOT
ON EYE LEVEL...
LOOKING AT PASSING FEET

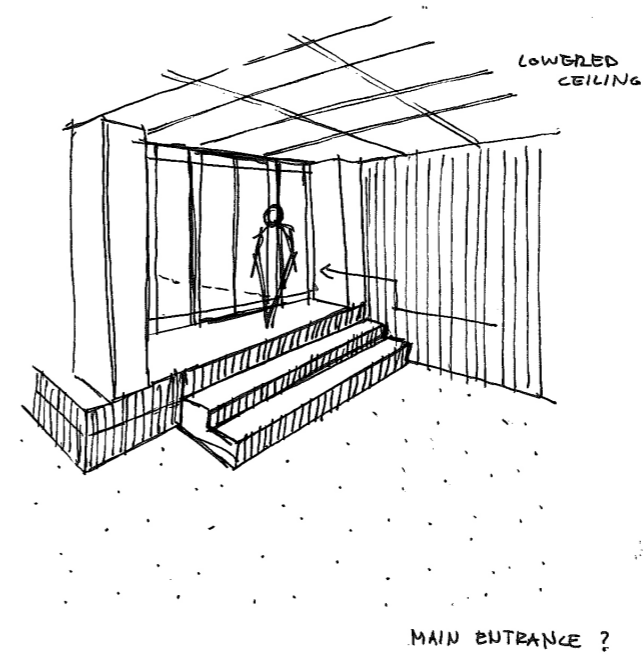

The inside ground plane lays lower than the outside space. This gets noticed immediately by entering the building by the small stairway inside. Looking outside (or inside) creates less of an interaction because of this lowering. The lowered ceiling in this part makes that the space is still small and closed, which strengthens the character of the introverted.

The space opens up really rapidly though. The 'heavy' pyramid from outside presents itself here as a beacon of light. Noticeable is the presence of quite some construction elements and directions in the roof.

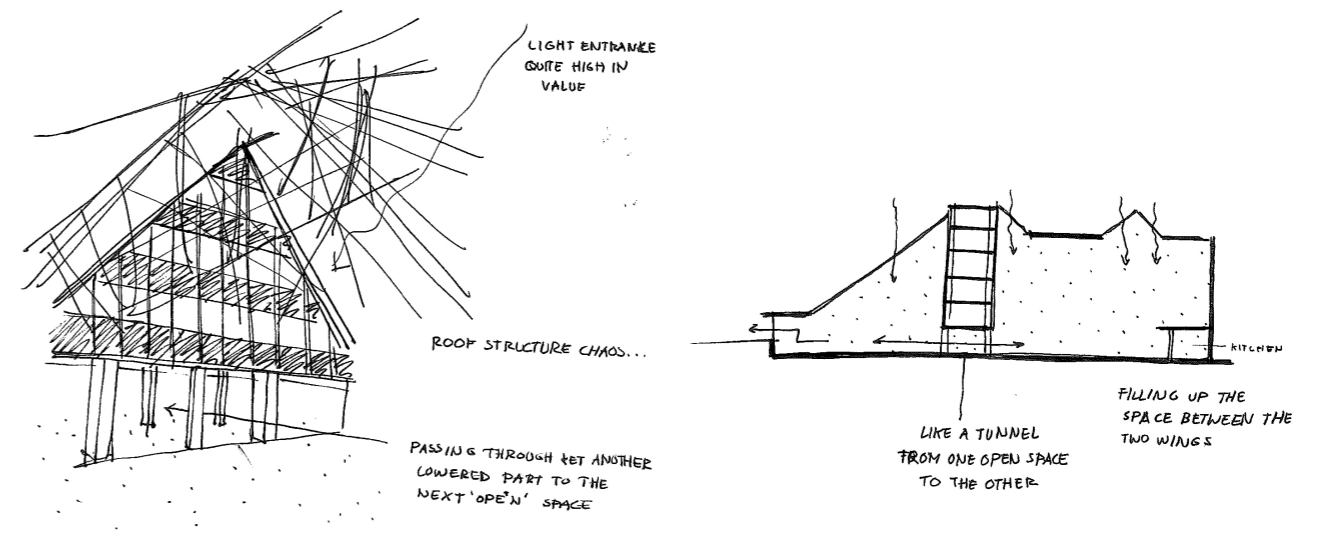
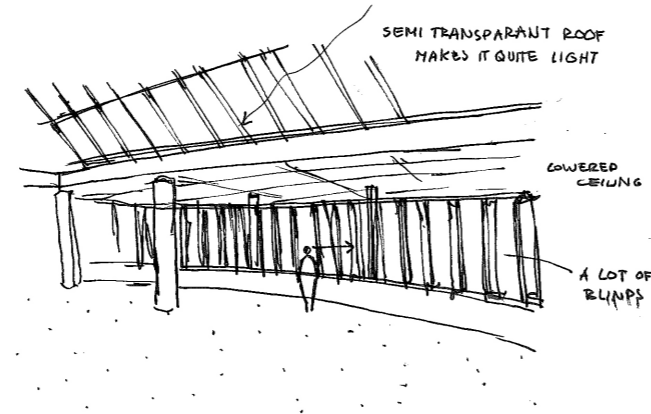

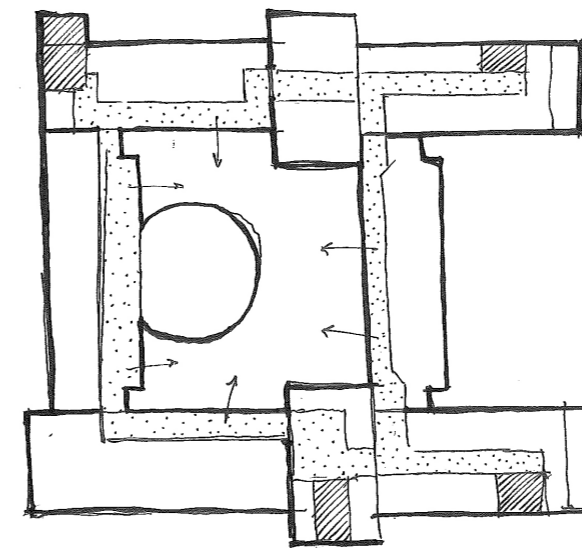
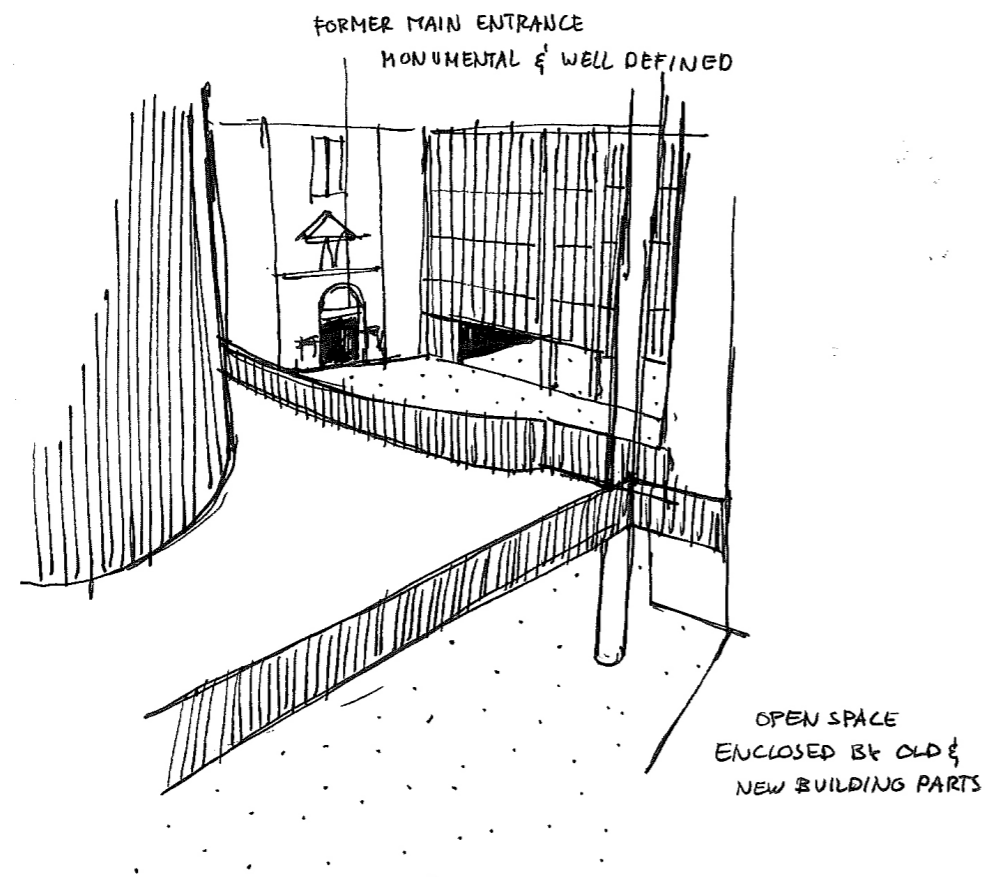

The space opens up again after passing underneath a relatively new added building volume in between of the original Klinischziekenhuis. Although the horizontal view-lines were present the whole time, the height and the abundance of light really opens the space up again. What's more is the presence of high window frames in the former outside facade of the Klinischziekenhuis. These were part of the reason of the introverted character at the outside, but remarkable opening up the space at the inside. A lot of possible interactions are made possible. A well defined and accentuated 'entrance' is present here as well: the former main entrance(s) of the building are not afraid of showing.

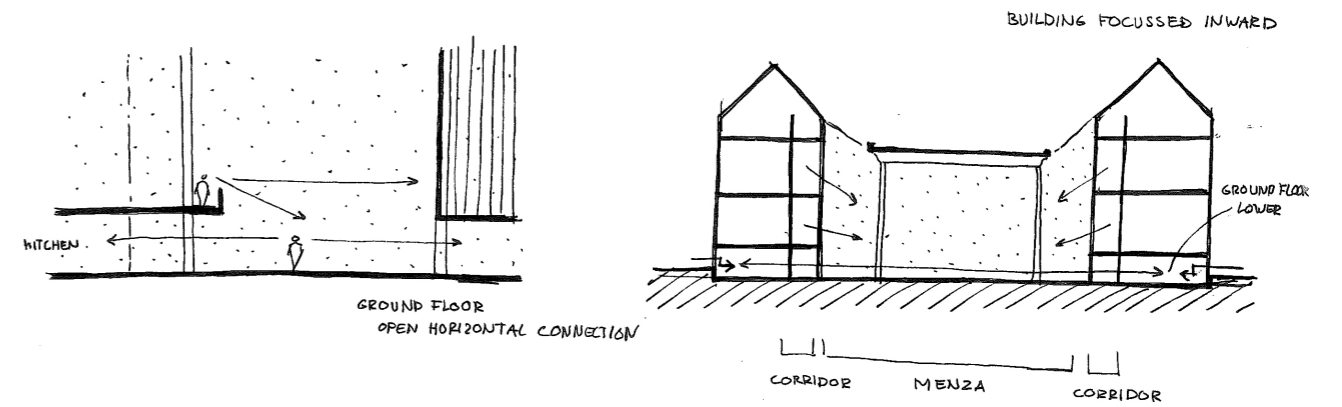
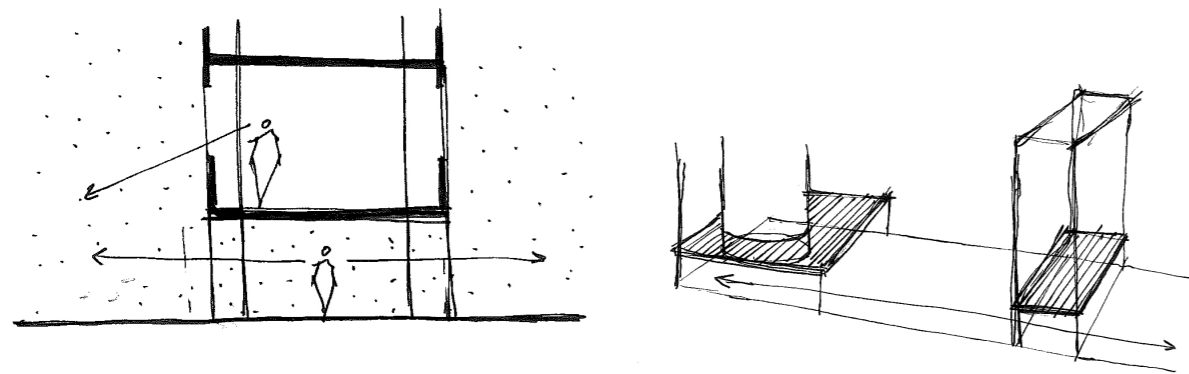

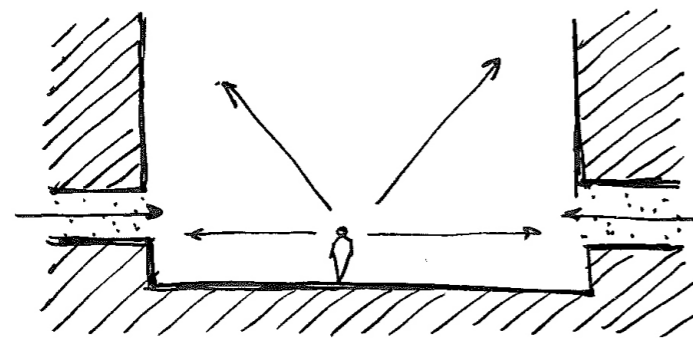
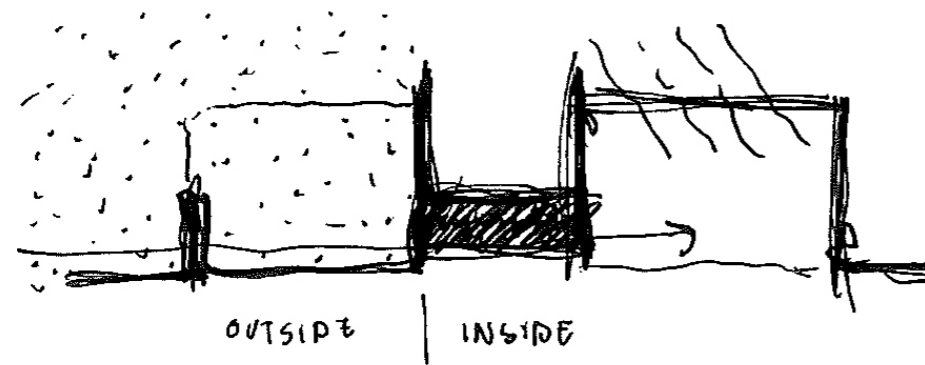

ENCLOSED OPEN/LIGHT SPACE
ALMOST LIKE A SECRET

Findings

Coming from the open cityscape around the Binnengasthuis area, the presence of a gate is the first notice of this 'exclusive' site. Do you belong here? Do you have any business here? Going through the gate at the Grimburgwal doesn't feel rewarding though. The space feels like a backside with no clear defined entrance that has been lowered quite a lot compared with the gate. Entering here also doesn't feel really special: dark, small and unclear of a direction of continuation.

Passing along the facade of the Klinischziekenhuis the pyramid-like structure comes in sight, which is not afraid of showing itself so it seems. The plinth is constructed in mostly glass and is by this transparent. A clear view to the inside stays out though. The triangle form on top of it is not transparent and shows 'heavy' by its form. By this dominating form, the transparent part underneath it shows only minimum and almost being crushed. There is no sign of the presence

of any kind of entrance, although there is an entrance here.

Entering at this side is as unrewarding as at the other side. A lowered floor-plane, a lowered ceiling: here the space is still introverted, afraid of showing itself. The reward is the abundance of light and open space that follows all this. A lot of possible interactions are made possible here.

The building is really facing inward and isn't afraid of opening up here, though to itself and not to its surroundings.

The extroverted character of the introverted shows as a secret, passing a lot of thresholds. The contrast is building up this tension, having a clear climax at the end. This all is ignoring the disturbing elements at this 'climax' though. A lot can be said about materialisation, acoustics and construction.

Analysis & research

Literature

What does literature say about the obtained findings extracted from the description of the movement in space-time?

Sequence of spaces

If we would call the analysis and research of *space, structure and enclosure* an investigation of the third dimension, than the analysis and research of *movement in space-time* will definitely be the elucidation of the fourth dimension. It is by moving through space that one experiences the arrangement of the architecture. (Samuel – p.41) Juhani Pallasmaa sees the role of the body moving through space as the locus of our perception. He states that an architectural work is not just a series of isolated pictures, but an experience of the essence of the integrated whole of material, embodiment and spirit. It creates physical and mental structures that help us to strengthen coherence and giving significance to our existential experience. (Pallasmaa – p.12) It is questionable if Pallasmaa is right about the physical and mental structures that architecture creates, as we have seen that the public space at the Binnengasthuis area currently is poorly defined, however, it is

true of course that an architectural work does not exist of just a series of isolated pictures. Sigfried Giedion describes this as one large and indivisible space that is dominated by interaction and penetration, not by demarcation. (Heynen - p.258) We are dealing with a sequence of spaces, which stimulates our sense of position as we are moving through it. (Cullen – p.46) Cullen states that our experience of space is a journey through pressures and vacuums, a sequence of exposures and enclosures, of constraint and relief (see figure 21). (Cullen – p.10) Therefore, the way we move or are moved through the sequence of spaces becomes an important factor in the design of the environment.

Transitions

"Sometimes there is a door: one opens it - enters - one is in another realm, the realm of gods, the room which holds the key to the great systems. These doors are the doors of the miracles. Having gone through one, man is no longer the operative force, but rather is his contact with the universe."

- T. Schumacher (Samuel - p.89)

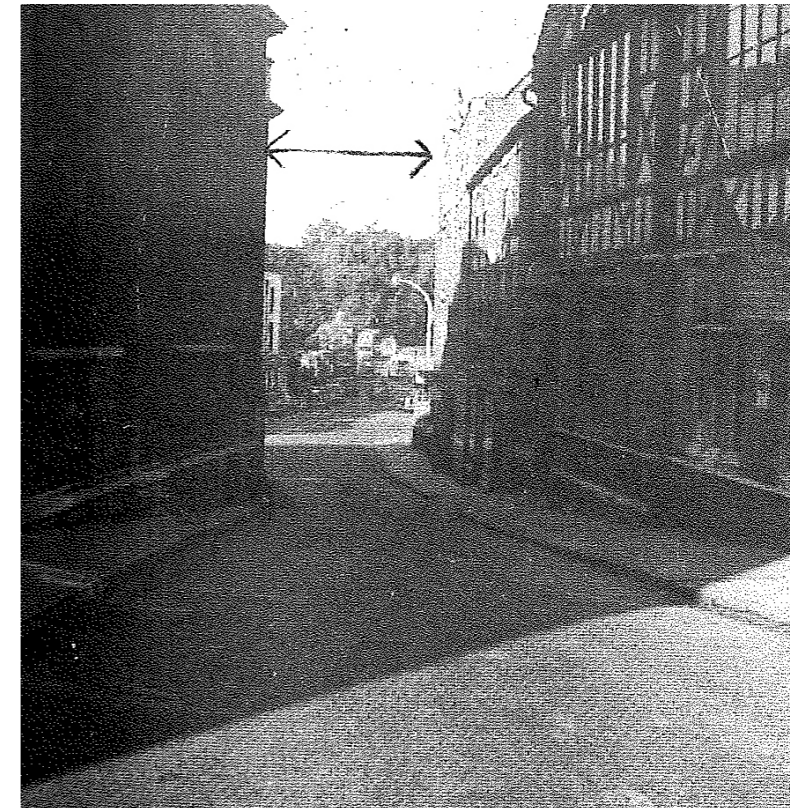

Fig 21 - A sequence of exposures and enclosures. Cullen - p.45



Fig.22 - The entrance dissolving: The surrounding landscape flows through the building and becomes an integrated part of the interior. It lets you wonder where to enter... College Eireen Schreurs - TU Delft Interiors



Fig.23 - The entrance celebrated: Making one particular moment where the difference between the inside and outside is being maximized. College Eireen Schreurs - TU Delft Interiors

It was described what the findings were about the movement through the sequence of spaces of the Binnengasthuis area. The experience was indeed one like Cullen described as a sequence of exposures and enclosures, of constraint and relief. (Cullen – p.10) Concentrated on these areas as separate spaces, and isolated pictures, like we previously did in the analysis and research of *space, structure and enclosure*, we could already conclude that the introvert and extrovert is about the flow of movement. Extroversion being the outward flow, the continuation of movement, and the introversion being the inward flow, the arrival. Translated to the movement through time-space: the way the transitions between spaces are taken form is of a great importance to this subject (see figure 22).

The notion of an introvert area makes sense when we approach the Binnengasthuis site. Although portals and gateways are traditionally means of welcoming our entry, they also create a threshold towards the path beyond (see figure 23). The gates make

you suddenly aware of a separation between *here* and *there*. (Ching - p.238) They tend to stop the continuation of movement unless you do belong there. Furthermore, the presence of the water that lies in between and the almost always-continuing volume at the border of the area will create an even bigger separation between *inside* and *outside*. Ching states that the approach is preparing us to see, experience and use the spaces that will follow. (Ching - p.230) The majority of the gates are well decorated and show impressive. It arouses our curiosity of what scene will meet our eyes, as the here is known, but the there is unknown, infinite and mysterious (see figure 24 & 25). (Cullen - p.49) In this case though, we enter an undefined dark space, which feels unrewarding. There is no mystery here, just an ordinary backside. As there is no clear sign of continuation of one's path, we might tend to describe this as introvert space. We have however already concluded that this is not the case due to the fact that the space is poorly enclosed and give no sense of being inside *it*. The space leaves us in uncertainty of what character

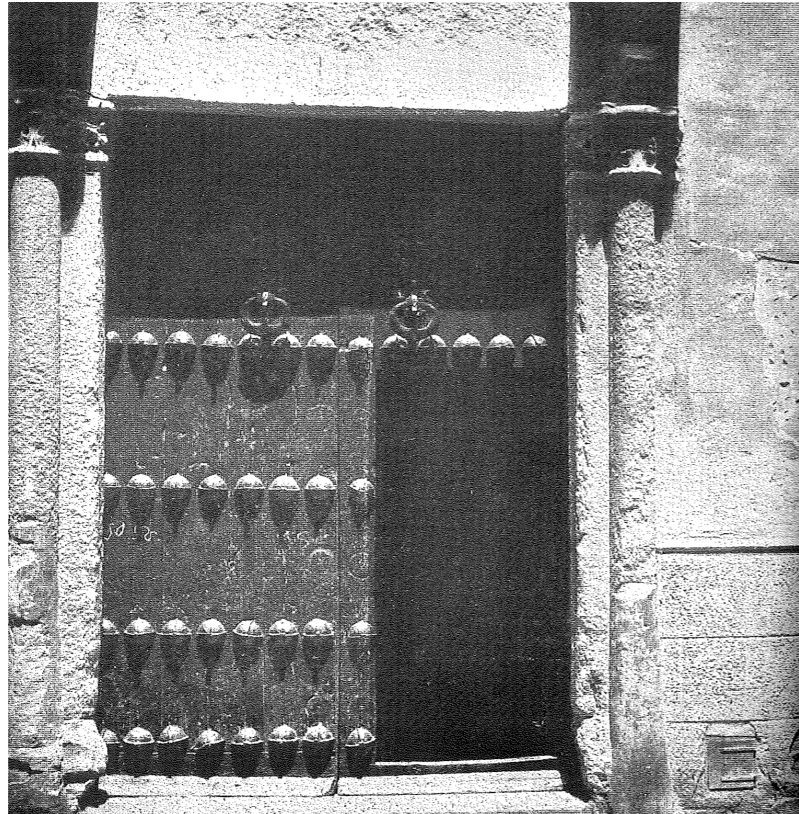

Fig 24 - The mystery of the maw. Cullen - p.52

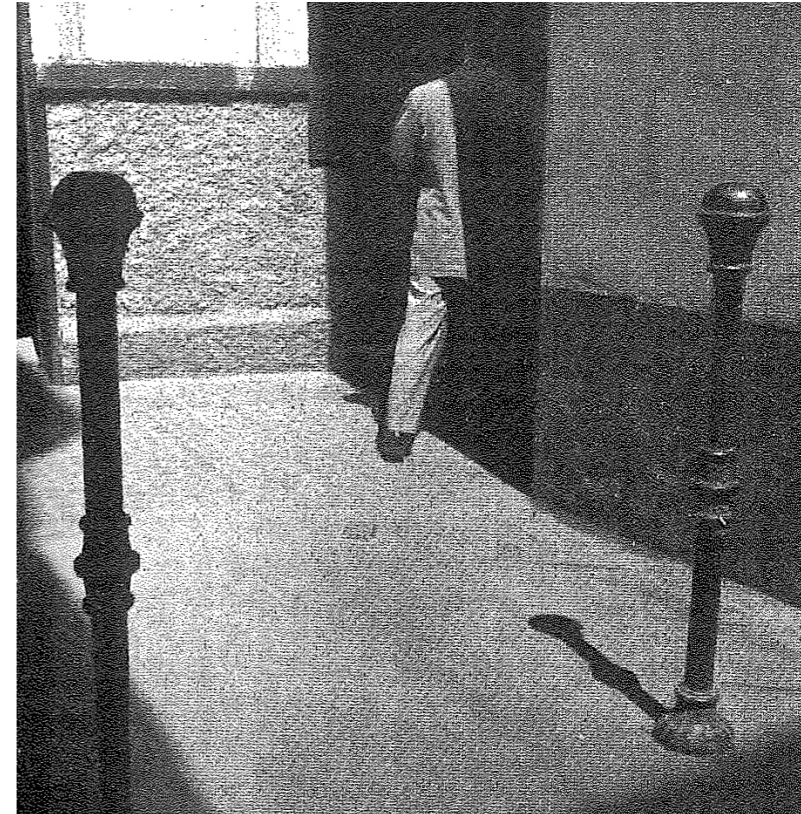

Fig 25 - Curiosity. Cullen - p.51

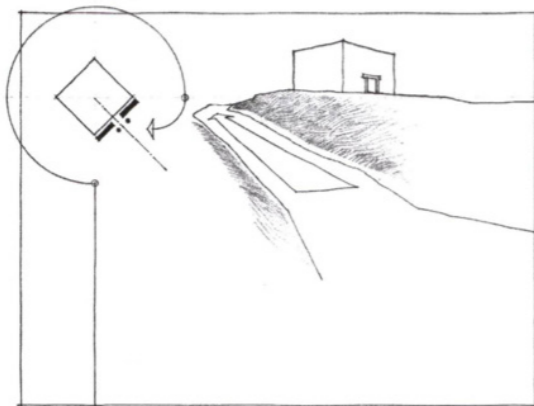

Fig.26 - Elements that can help to articulate an entrance.
Ching - p.247

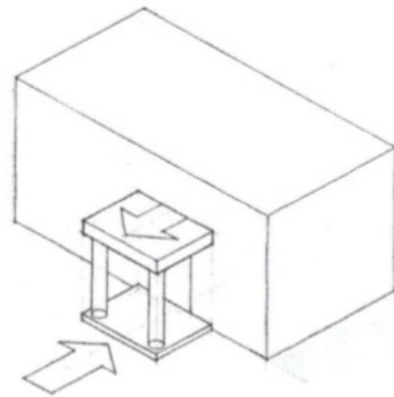

Fig.29 - A spiral path towards the entrance. Ching - p.231

it has. Nevertheless, an entrance is present here, although it feels almost hidden. It is not of significantly size, there is nothing to articulate its importance and moreover it is literally laying low because the need to descend before entering. This entry being the main entrance will not be anyone's guess. According to Ching the potential of the form and scale of entrances and paths is that they can help us distinguish major routes from secondary paths ^(see figure 26). (Ching - p.252) It therefore may not be surprising that this entry-point was never supposed to be the main entrance. With the alteration of the Klinisch ziekenhuis this changed, as a small passage and a window were combined. Knowing this, the sequence of space behind this entrance feels naturally of no importance or any significance and is not burdened with any sign of direction or continuation.

Yet again we do not enter but are still approaching. In the distance a road is visible that seems to give some clue of direction but in the end is only leading through and out of the area. Cullen puts

it optimistically when he says that the path we continue is an unfolding drama of solid geometry ^(see figure 27). He calls it the unfolding of a mystery where more is revealed as you press on. (Ching - p. 19) It is quite a revelation to find a pyramid-structure, constructed of materials that contrast with its surroundings, around the corner. Glass, from which it is erected, tends to have an extrovert image. It has the idea of dissolving boundaries, causing a blurring between interior and exterior. (Samuel - p.90) Its form catches our eye as the human mind reacts to contrasts ^(see figure 28). (Cullen - p.9) We are drawn towards it. We are disappointed however. Nor is the facade extrovert as the glass is reflecting due to its position at the south side, and neither does the structure guide us any further, as an entrance is hard to find. The space refuses again to give us a clear definition of its character. The distinctive shape remains in our minds as an exception in the whole, expecting to see it again later, once we have entered the building elsewhere. It reminds of a spiral approach ^(see figure 29), where we have caught a glimpse of what is coming later.

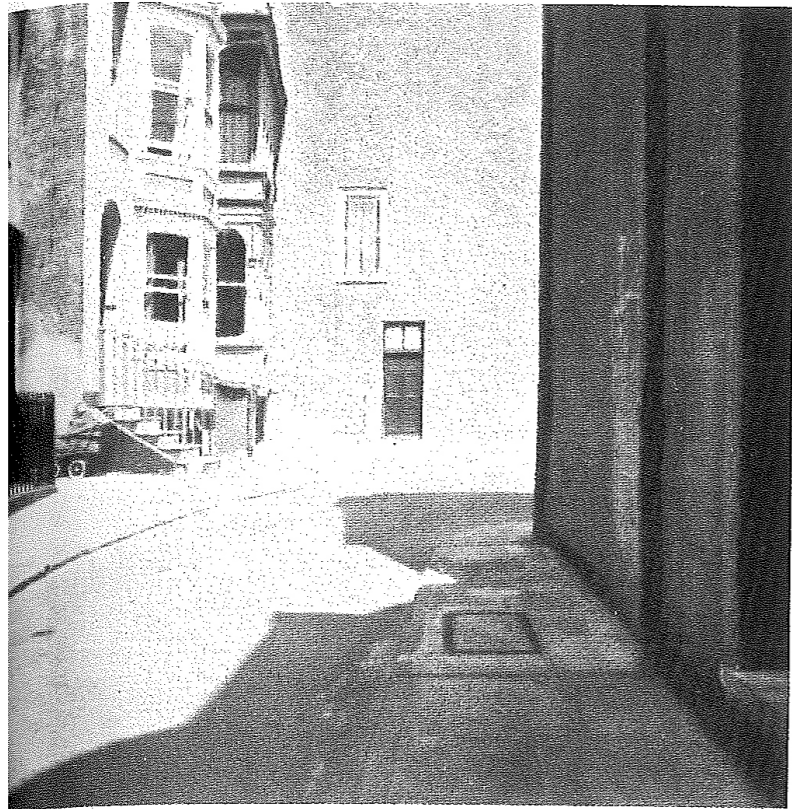

Fig 27 - The geometry forms an unfolding drama. Cullen - p.49

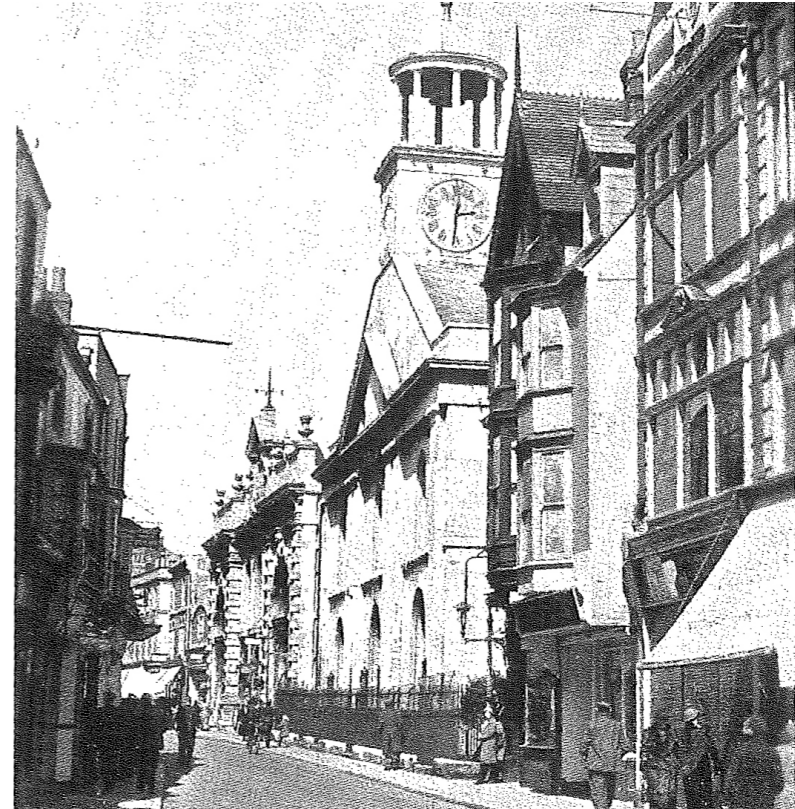

Fig 28 - An incident attracts the eye. Cullen - p.44



Fig.30 - The round structure in the middle of the courtyard seems imprisoned. Own image

(Ching - p.231) Thus an expectation is built and broken down almost instantly as we realize that a better distinct point of entry will not follow. Here we enter through a nondescript entrance.

Many thresholds did one overcome to finally arrive at the heart of the building. Like an introvert person it may be a struggle to be allowed in, but once there the reward is unexpected: an abundance of light in a high and well-enclosed space. Due to the contrast with the conditions of the path before does this space feels like a discovery of a secret. It is the covering of the courtyard that makes it possible to enjoy this space no matter what the weather does.

However, the rest of the additions do not improve the space but are indeed disturbing elements as we have concluded before. The circular structure acted as a protagonist to the narrative of the building. It aroused one's expectations and gave physical and mental structure. Now it feels chained and oppressed, laying in the shadow of a

meaningless thick horizontal plane *(see figure 30)*.

To progress our way is not easy, as yet again the continuation is not articulated very well. This is even more surprising as the former main entrances to the building are still present and as an exception are very well defined and off a significant size. They show important and will hold your steps before entering, giving the structure an even bigger sense of introversion. Here you enter! As we have seen however, they are removed from their duties and replaced by an anonymous passage. One will end up in the same meaningless dark and narrow space as we have seen before which does not give any sign of direction. It is only when we stride up and find our way through a maze of corners and equivalent scaled directions, that we find a clear structured straight hallway. Here we are able to orientate ourselves. To our left multiple doors that will lead us to rooms equal in size. To our right a view of the courtyard and the circular structure standing there and waiting for us. The entering daylight



Fig.31 - Pinpointing with light. Cullen - p.37

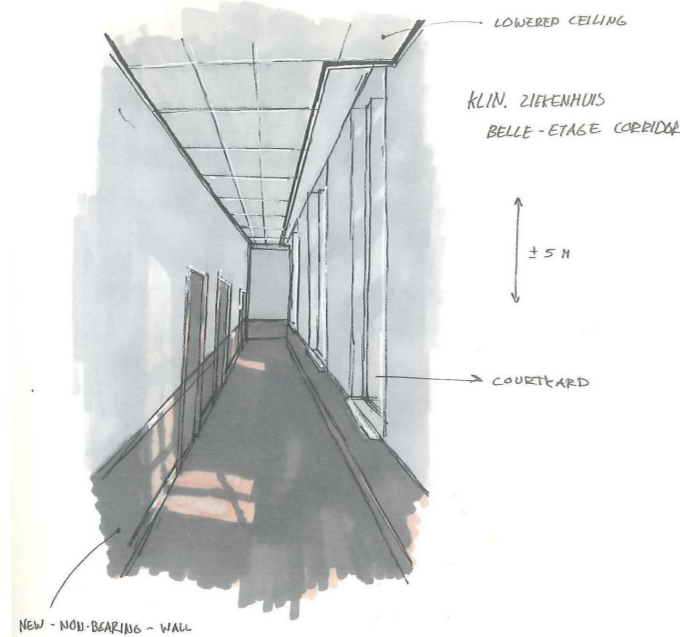

that falls on the wall makes us aware of the courtyard and, as we are drawn by light, prepares us to our path towards the round pavilion (see figure 31). Cullen describes this principle as *pinpointing*, where through the use of light a *sense of otherness* is aroused (see figure 32). According to him it is not so much the thing pointed out but the evocative act of pointing that arouses our emotions. (Cullen - p.37)

The arriving, in the end, is an anti-climax. The transition passed unnoticed and the rooms of the circular structure are almost entirely stripped of anything that made it remarkable. From here we could have a clear overview of the entire courtyard and the route we progressed, was it not that all the disturbing elements and obstacles are still in place. Instead of the finale, the arrival is a summary of let-downs.

Promenade

It is important to note that no matter how the sequence of spaces was realized it always has

a certain effect on us when walking through it. Passing extrovert or introvert spaces will influence our thoughts and behaviour. Le Corbusier saw this promenade therefore as a chance to re-sensitise people to their surroundings in his designs. (Samuel - p.9) We will be able to get beyond the cruder sensations if a building succeeds in *moving us*. Only then would we be capable to fully employ our gifts of memory, analysis, reasoning and of creation. (Samuel - p.12) Flora Samuel states that Le Corbusier used a fixed order of experiences along the route. From a threshold towards a culmination.

The *threshold* or *introduction* is a build-up towards the point of entry. Le Corbusier recognised the importance of this space as a link between disparate realms, calling it a gateway of reverie. Like Cullen he saw the entrance as the point of transition between two realities. Muted in light, here one is provided a point of focus after the *mental silence* of the street. (Samuel - p.85) The shadow and the well-defined entrance give time to

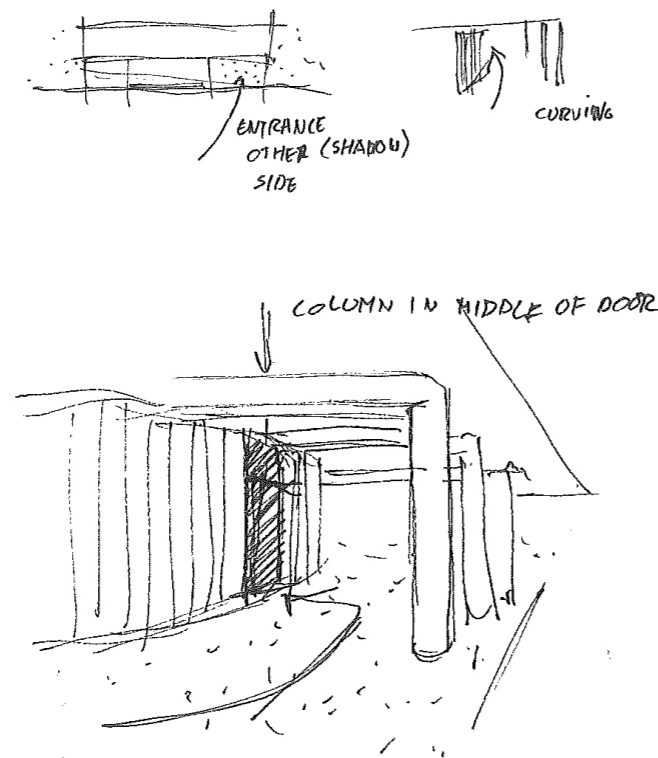

Fig.34 - The entrance of Villa Savoye positioned on the spot where a load-bearing column should have been.

reflect and thereby create a sense of introversion. At Villa Savoye a comparable situation is indeed established, as we see the openness of the first floor but first are lead into the shadow underneath ^(see figure 33). Only here do we notice the entrance, which marks its significance by being positioned on the spot where a load-bearing column should have been ^(see figure 34).

According to Le Corbusier the corollary would be the *vestibule* space. Here the scene should be set for what is to come. Through the absence of details, the use of homogenous materials and the creation of *geometric echoes* by mirror and glass, the visitor is forced to engage, focus and participate. (Samuel - p.90) It is exactly that what happens at entering the vestibule space at Villa Savoye. More precisely the falling of the light over the central positioned ramp is what arouses our senses and gives us an idea of progression. Although this space might seem extrovert, the contrary is true. The shadowed room gives a strong feeling of enclosure and security and moreover, even the continuing up the ramp make us turn inwards as

the light and the warmth on our skin appeals to our emotions ^(see figure 35). Remarkably a space can have an extrovert appearance, but stimulates our introverted selves. This may not be a surprise for Le Corbusier as he stated that light is the key as it illuminates the shapes, which have an emotional power. (Samuel - p.32)

What follows is the *questioning* stage of the promenade. Here we have the opportunity to examine multiple options of sub-routes and sub-destinations. Questions may be asked about direction and destinations. (Samuel - p.92) The second floor of Villa Savoye reigns in the spirit of this phase. Doors, directions and corners appear. What way to go? We have access to the bedrooms, bath, kitchen and living room. Once entered the living room through the glass door, we meet the overwhelming light again. As much as we wandered, the light brings us back, as if Ariadne's golden thread, to the point of reorientation and culmination. (Samuel - p.92) Here we know how to progress ^(see figure 36).



Fig.35 - The beginning of the ramo at Villa Savoye. Own image

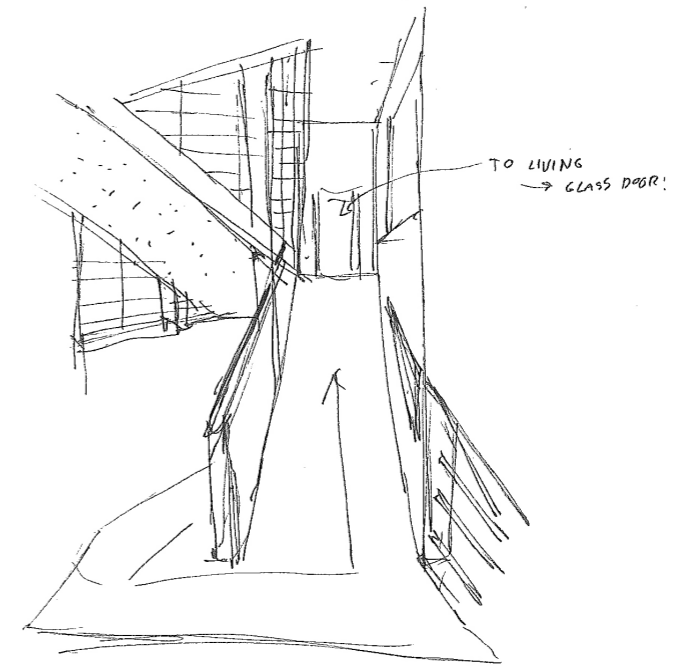

Fig.36 - The questioning stage. Own image

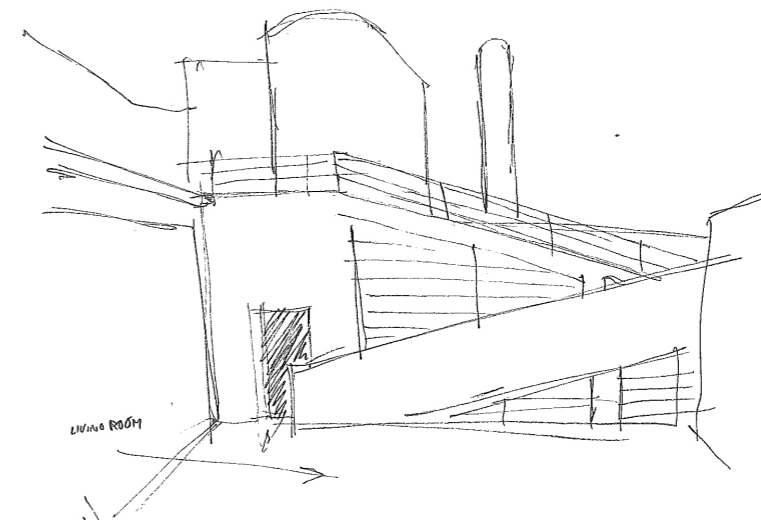

Fig.37 - The roof terrace at Villa Savoye next to the living room. Own image

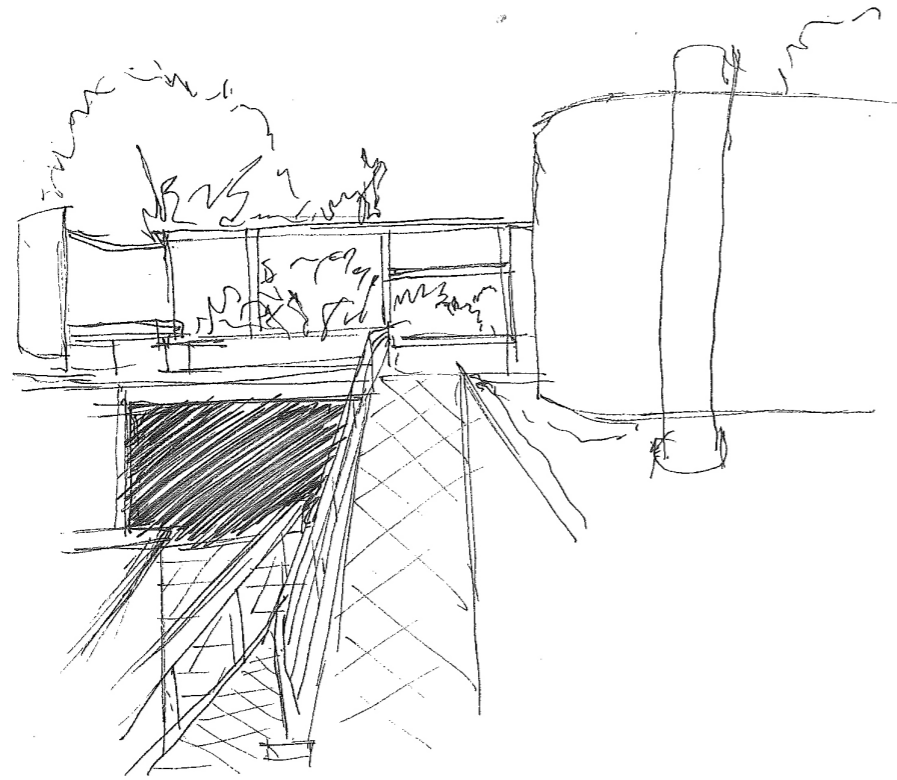

Fig.38 - Culmination. The last stage of the 'promenade architectural' at Villa Savoye. Own image

We progress up. Samuel states that the *reorientation* is about the spirit and the route to the sky. The preceding section of the route has built up momentum, tension and excitement. (Samuel - p.92) At Villa Savoye it is the reunion of the ramp ^(see figure 37). He guides and orientates us, like many stairs do in the designs of Le Corbusier. (Samuel - p.93) According to Samuel it is within the reorientation space that Le Corbusier deploys all persuasive techniques. To inspire curiosity there is a built-up of light. To simulate the sense of touch there are contrasts in materials. To heighten tension there are unnerving gaps. To inspire sensual appreciation the surrounding consists out of curved and bodily forms. (Samuel - p.100) The flow of the ramp at Villa Savoye takes you up in the middle of a well enclosed outside space towards the light. The curved railing is nice to hold and the ramp creates a growing distant to the ground. It may lead to culmination and awareness of oneself, but at least feels as an opportunity of escape and thus creates the feeling of extroversion. Here one is looking for

continuation although there is none. The space may be introvert, but the feeling of extroversion does not leave the body ^(see figure 38).

Alley of books

The question is if we recognize any of the elements that Le Corbusier described, at the Binnengasthuis site? If we look at the route from the Grimburgwal to the atrium of the Klinisch ziekenhuis - the same as described above - we notice some similarities. For one the route is a series of unfolding views, clearly separated from each other. Another is that all the different steps of the setup of the promenade can be detected. The gate as the introduction and gateway to reverie. The space behind with its blind wall as the vestibule, where there is a lack of detail to encourage the visitor to focus and participate. The dark narrow space that follows as the questioning phase, where people wander and multiple directions and possible destinations are given. And finally the atrium as the space of reorientation and culmination, where we connect



Fig.39 - The alley of books located at the Oudemanspoort. Own image

to the heavens by the use of all the height and light. Unfortunately all the similarities stop here, as we already know due to the analysis of the exact same route before. We thus have to conclude that the use of the different steps of the promenade are no guarantee whatsoever ^(see figure 39).

The alley of books is, however, a whole different experience. Here too are transitions between contrasts of light, scale and view, but in this situation it does work quite well. It seems like all the elements that we have missed during the path to and through the Klinisch ziekenhuis are present here ^(see figure 40). Laying just a bit to the left, this route too starts with a gate at the Grimburgwal. What follows is a sequence of well-enclosed spaces with proper articulated transitions and with the bookshops as the most notable piece. Here little shops with crates stuffed with books are situated at your right as you pass high windows at your left. The rhythm of the shops and the windows and the cadence of the light from the fixtures give peace to the mind. The well-lit white ceiling

forms a contrast with the dark materials of the rest of the corridor that is muted in light. Even the windows, situated at the north, do not provide too much light. The view of the courtyard gives us a glimpse of the near future and thereby we know how to progress and what to expect. Time, space and atmosphere is created where we can be introverted.

Light

Samuel states that the promenade is a series of unfolding views that begins in darkness and ends in light. (Samuel - p.85) Having researched the built-up of the promenade, we can now conclude that indeed light is playing a very important role. Moreover, it helped us realize that the formulation of space as introvert or extrovert can differentiate from the effect such a space has on its visitor. Maybe it is the mysterious beauty of the shadow, that we try to eliminate with light and brightness, that deforms and fills the objects with its magic. (Heynen - p.235)

We have seen that the contrast between light and

Fig 40 - The elements of the 'promenade architecturale' at the route through the Binnengasthuis area. Own image

ARCHITECTURAL PROMENADE: ROUTE OF THE INTROVERTED

Water: the act of cleansing is a universal symbol of new beginnings.

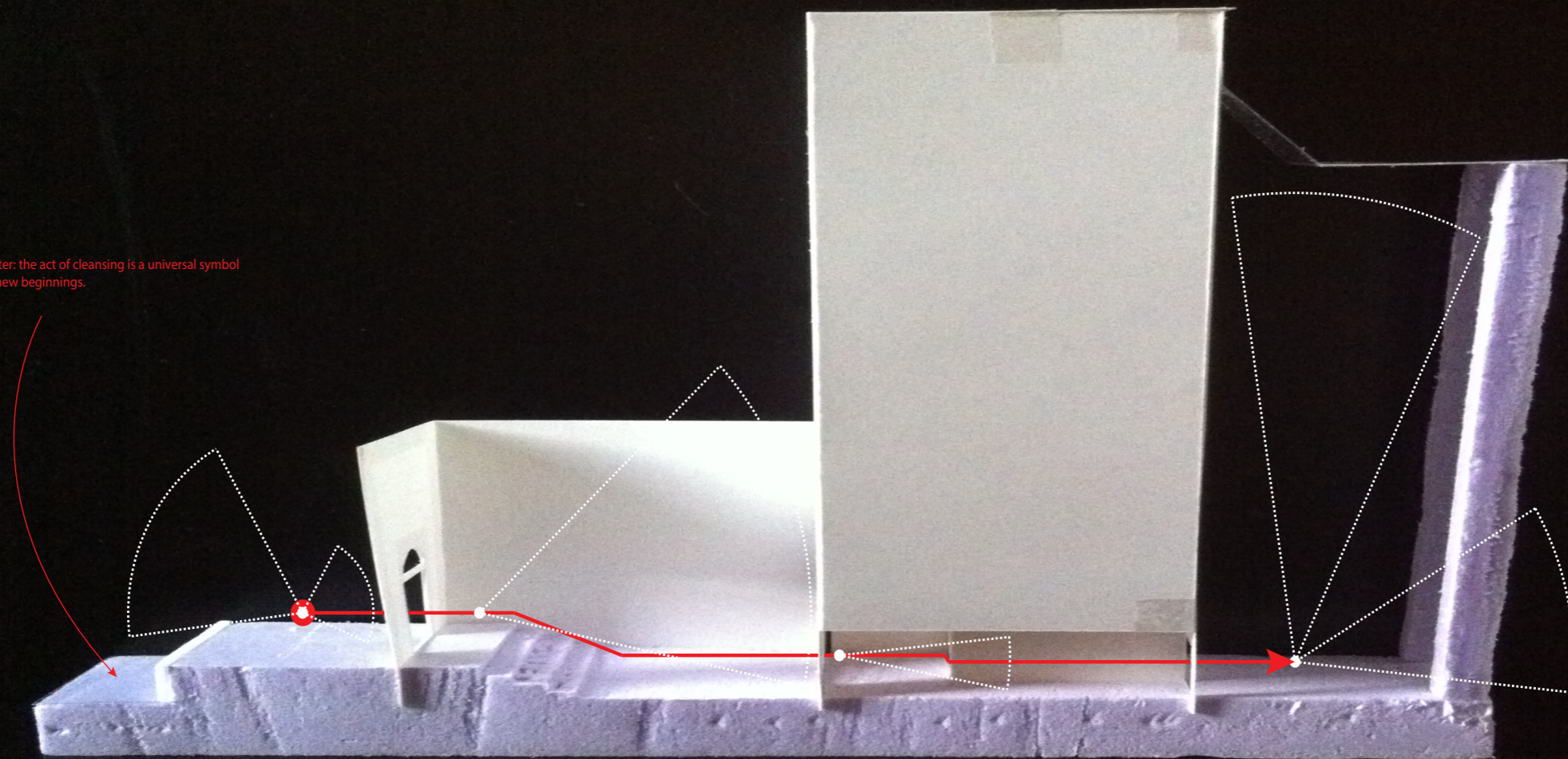

THRESHOLD OR INTRODUCTION

Linking disparate realms:
"Gateway of reverie"

Doors and eyes are almost interchangeable.
The building is a protagonist in the drama,
entering into a tense and passionate relationship with the reader.

SENSITISING VESTIBULE

It sets the scene for what is to come, it forces the reader to engage, to focus and to participate.

...causing a blurring between interior and exterior space, adding to its limbo like a sense of mystery.

QUESTIONING - SAVOIR HABITER

The next stage [...] is the point at which various options are examined and questions are asked.

...the body gives access to the spiritual realm. If this is the case this questioning stage of Le Corbusier's narrative is very much about engagement with the body.

REORIENTATION AND CULMINATION

If the questioning phase of Le Corbusier's narrative path is about the body, this phase is about the spirit, the route to the sky.

It is within the space of reorientation that Le Corbusier marshals his full panoply of persuasive techniques. A built-up of light inspires

curiosity. Contrasts in materials stimulate the sense of touch. Unnerving gaps and spatial trickery heighten tension. The surrounding curved and bodily forms inspire sensual appreciation, while jagged treads and rough metal inspire a fear of abression and downfall.



Fig 41 - Church of Light by Tadao Ando. Naoya Fijii.

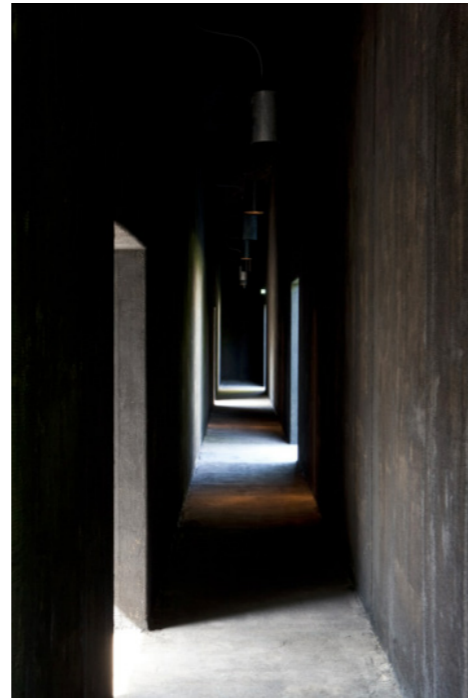

Fig 42 - Serpentine Gallery 2010 by Peter Zumthor Serpentine Gallery.



Fig 43 - Swimmingpool by Álvaro Siza. Porto.

dark appeals to our emotions and to our introvert side. This could as well be the reason a cloister seldom is bathing in light as it is supposed to be a space for contemplation and reflection. The importance of light is of course nothing new. Louis Kahn even referred to architecture as 'spent light'. (Curtis - p.525) Tadao Ando creates vertical planes to catch the light as a reflection of time ^(see figure 41). (Van Dam - p.243) Peter Zumthor recognizes the effect of light to the sensory and spiritual aspects of the architectural experience ^(see figure 42). (Serpentine) For Siza the contrasts of light creates a certain tension that acts on the sensory experience ^(see figure 43). (Van Dam - p.215)

They have in common that they all use strong directional light to create shadow and to give necessary emphasis to the rhythm of the structure. The light will show the architecture, as the shade will give it the chance to be introvert.

Strengths

- The gates make you suddenly aware of a separation between here and there. They tend to stop the continuation of movement unless you do belong there.
- The presence of the water that lies in between and the almost always-continuing volume at the border of the area will create an even bigger separation between inside and outside.
- The majority of the gates are well decorated and show impressive. It arouses our curiosity of what scene will meet our eyes, as the here is known, but the there is unknown, infinite and mysterious.
- Like an introvert person it may be a struggle to be allowed in, but once inside the covered courtyard the reward is unexpected: an abundance of light in a high and well-enclosed space.
- The circular structure acted as a protagonist to the narrative of the building. It aroused one's expectations and gave physical and mental structure.
- Due to the contrast with the conditions of the path before does the covered courtyard feels like a discovery of a secret. It is the covering of the courtyard that makes it possible to enjoy this space no matter what the weather does.
- The former main entrances of the Klinisch ziekenhuis show important and will hold your steps before entering, giving the structure an even bigger sense of introversion. Here you enter!
- At the bel-etage a clear structured straight hallway is present. Here we are able to orientate ourselves.
- The entering daylight that falls on the wall makes us aware of the courtyard and, as we are drawn by light, prepares us to our path towards the round pavilion.

Weaknesses

- Through the gate we enter an undefined dark space, which feels unrewarding. There is no mystery here, just an ordinary backside.
- The public space leaves us in uncertainty of what character it has.
- The main entrance of the Klinisch ziekenhuis is not of significantly size. There is nothing to articulate its importance and moreover it is literally laying low because the need to descend before entering.
- The sequence of space behind this entrance feels naturally of no importance or any significance and is not burdened with any sign of direction or continuation.
- The bicycle-path seems to give some clue of direction but in the end is only leading through and out of the area.
- The pyramid-like structure shows extrovert but due to its position at the south side all the glass is reflecting. Neither does the structure guide us any further, as an entrance is hard to find.
- An expectation is built and broken down almost instantly as we realize that a better distinct point of entry will not follow. Here we enter through a nondescript entrance.
- The circular structure now feels chained and oppressed, laying in the shadow of a meaningless thick horizontal plane.
- To progress our way from the courtyard is not easy, as yet again the continuation is not articulated very well. One will end up in the same meaningless dark and narrow space as we have seen before which does not give any sign of direction.
- The arriving at the circular structure is an anti-climax. The transition towards it passed unnoticed and the rooms are almost entirely stripped of anything that made it remarkable. Instead of the finale, the arrival is a summary of let-downs.

Opportunities

- The way the transitions between spaces are taken form is of a great importance to the character of both spaces.
- The form and scale of entrances and paths can help us distinguish major routes from secondary paths.
- A spiral approach; where we have caught a glimpse of what is coming later. Preparing us to what is to come.
- Pinpointing; through the use of light a sense of otherness is aroused. The evocative act of pointing arouses our emotions.
- From the circular structure we could have a clear overview of the entire courtyard and the route we progressed.
- Passing extrovert or introvert spaces will influence our thoughts and behaviour. Therefor the promenade is a chance to re-sensitise people to their surroundings.
- Shadow and a well-defined entrance give time to reflect and thereby create a sense of introversion.
- A shadowed room gives a strong feeling of enclosure and security.
- A space can have an extrovert appearance, but stimulates our introverted selves due to the effect of light and shade.
- A geometrical rhythm and a cadence of light can give peace to the mind. The same goes for a view that allows us a glimpse of the near future. Thereby we know how to progress and what to expect.
- Strong directional light creates shadow and gives the necessary emphasis to the rhythm of a structure.
- The light will show the architecture, as the shade

Threats

- The space(s) may be introvert, but with the wrong use of light the feeling of extroversion will not leave the body.
- The community may not appreciate closing of circulation for passing through the Binnengasthuis area.
- Too strong contrast in light can result in confusion and maybe dangerous situations.

Conclusion

The main question of this Research Report is what the value of the introverted at the Binnengasthuis area is. This value is not something that can be answered in one sentence, but is a list of strengths, weaknesses and possibilities and threats. The research has been divided in two, which both resulted in a table of values. Of course the underlying idea of this research has been always to look for, and hopefully find, ways to improve the Binnengasthuis area. The obtained values can help with this. The strengths can be further strengthen with the possibilities that are established out of the research. The weaknesses also form possibilities for the designer to turn them into strengths. Last but no least are the threats that we should be aware of during the design.

The first thing that we can conclude is that the area is not as well enclosed as we might have

thought. The present gates of course form an important barrier and enhance the introvert character the site is known for, but within the space does not establish the feeling of 'inside'. We cannot identify ourselves with the area as it is not well-enclosed. This results in neither an introvert nor an extrovert character of the space, but rather feels un-defined. To be able to change this, the site needs to be enclosed more in a proper way. The road that is currently passing through the area, divides the public space with only gives a false sense of direction. Furthermore, the positioning of the buildings towards each other are in a constant battle of domination. We have seen that closing of corners, or create equal planes that both don't cross the corner will define space in a better way. This way the space becomes more enclosed and better defined, which will result in establishing a more introverted space in which we can identify ourselves. The Administration

building in the middle of the public space won't be a problem anymore, as it then marks the site as a landmark.

A better enclosed and defined space helps a lot with the improvements that can be made at the Binnengasthuis area. Signs of direction and continuation will be easier to create. Transitions, that are of great importance as we have concluded, can be now be deliberately be deployed in the design to strengthen the introverted. Shade will then be a positive thing that will stimulate our senses.

This all will enable us to open up the now covered courtyard of the Klinisch ziekenhuis. It no longer has to compete with other forms and directions. It can be itself, which, as we have seen, was a quite strong enclosed space with a great sense of introversion to it. This way the chance comes up to bring back the former glory of the circular protrusion and the imposing entrances. Furthermore, an axis will reappear that will connect the Klinisch ziekenhuis with the Tweede Chirurgische kliniek. The lowered ground plane

of the courtyard can be turned into a strength as it can enhance the introvert character of the space even more. Placing the most important function back into the building will also give the building its relevance back.

The opportunity exists to create a sequence of well-enclosed spaces with clear defined transitions that will revive the introverted of the site. We have seen that the use of strong directional light can help us with this. A shadowed room gives a strong feeling of enclosure and security, but also the light can stimulate our introverted selves as it appeals to our emotions. A geometrical rhythm and a strong cadence of light can give peace to the mind. It is the sense of arrival that the introverted can establish, even if we are progressing. A dead-end, a vertical plane, but also a view that allows us a glimpse of the near future. Thereby we know how to progress and what to expect. We can now conclude that the sense of introversion starts with ourselves. The enclosed space, the defined transitions, the clear lines and directions and the use of light and shadow can create time, space and atmosphere where we can experience the introvert side.

Table of references

Avermaete, T. (2009). *Architectural Positions*. SUN Publishers, Amsterdam.

Ching, F.D.K. (1996). *Form, Space & Order*. John Wiley & Sons, New York.

Cullen, G. (1971). *The Concise Townscape*. Routledge, London.

Curtis, W.J.R. (2009). *Modern Architecture*. Phaidon Press, New York.

Heynen, H. (2009). *Dat is Architectuur*. Uitgeverij 010, Rotterdam

Pallasmaa, J. (2007). *The Eyes of the Skin: Architecture and the Senses*. Wiley-Academy, Chichester.

Samuel, F. (2010). *Le Corbusier and the Architectural Promenade*. Birkhauser, Basel.

Van Dam, S. (2007). *Kleine Openbare Gebouwen*. SUN Publishers, Amsterdam.

