

The transformation of Cable Factory no.2

Delft, NL



Studio: RMIT, the old line

Location: the Netherlands, Delft

Building of interest: NKF, Cable factory no.2 - Schieoevers Noord

Teachers: A.W. Hermkens
F. Koopman

Examinator: P. de Jong

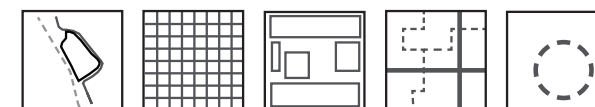



Introduction

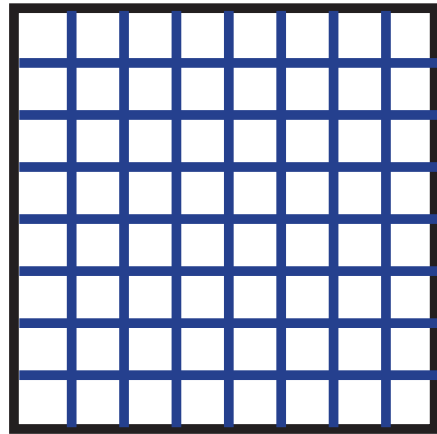

Transformation

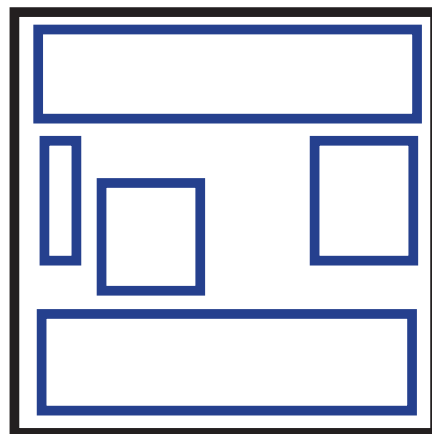

Design

Urban design, building design and representational fragment.
Based on existing and related to the overall tructure.

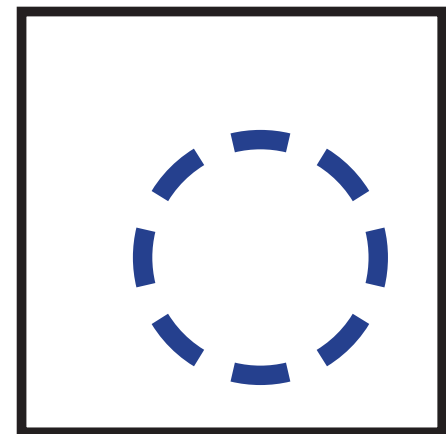
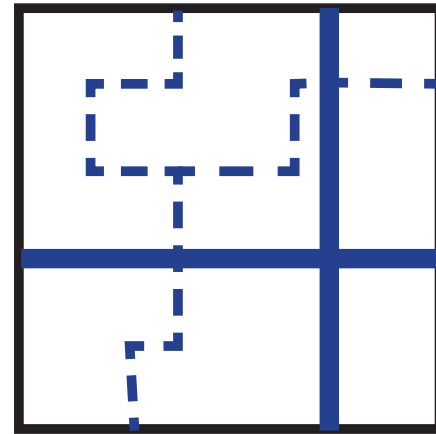

Introduction

The old line, NL

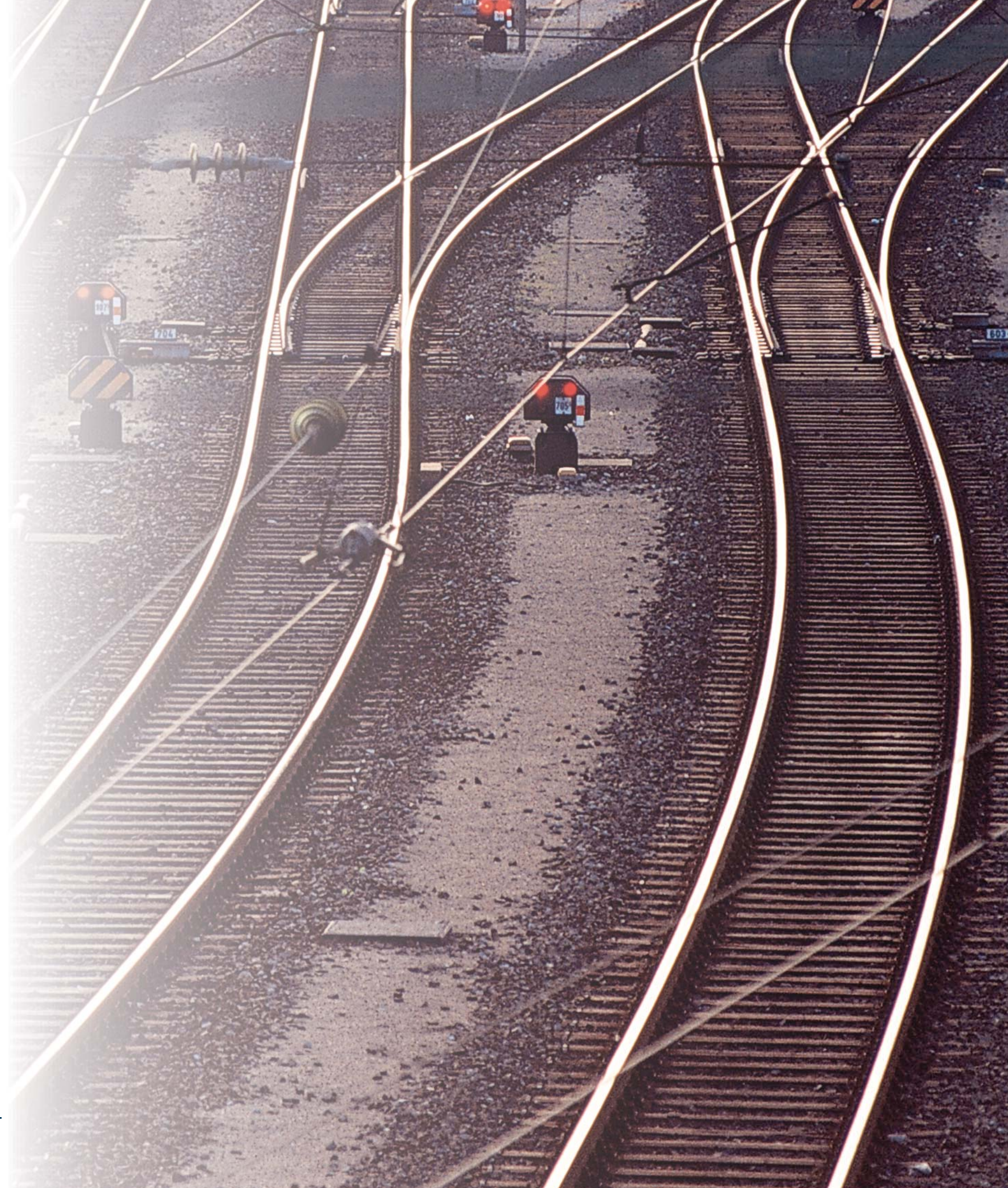

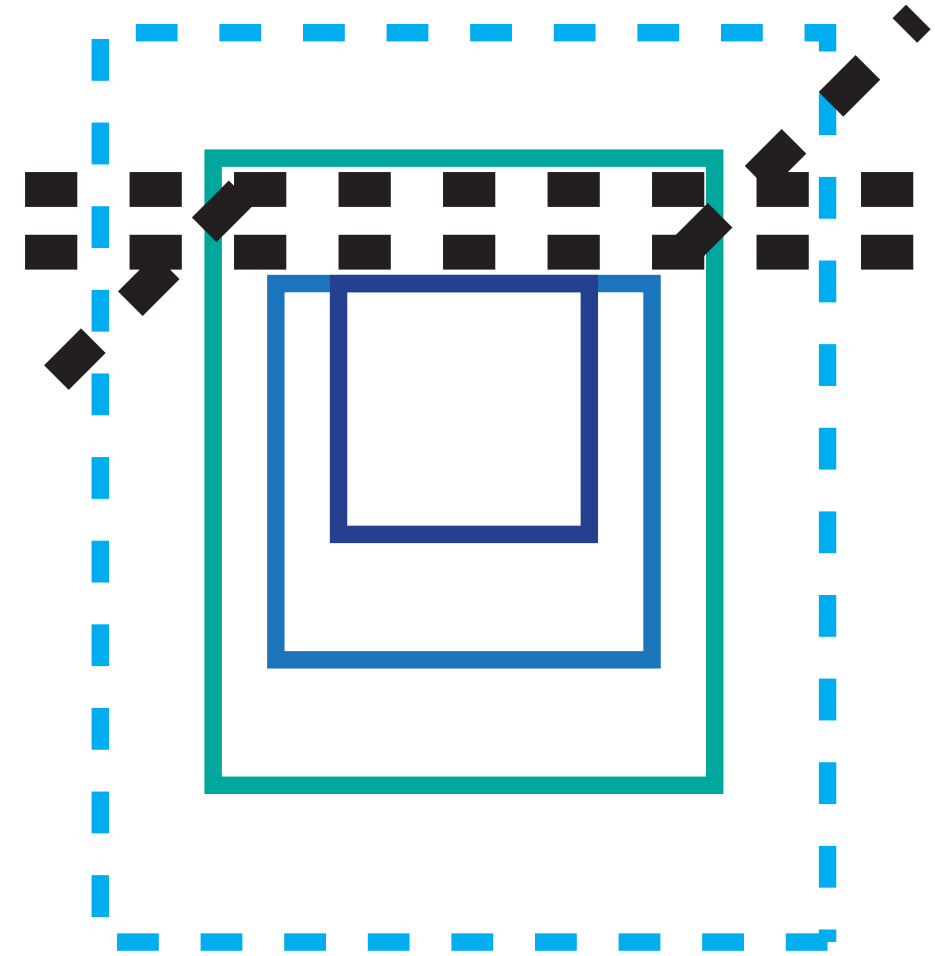
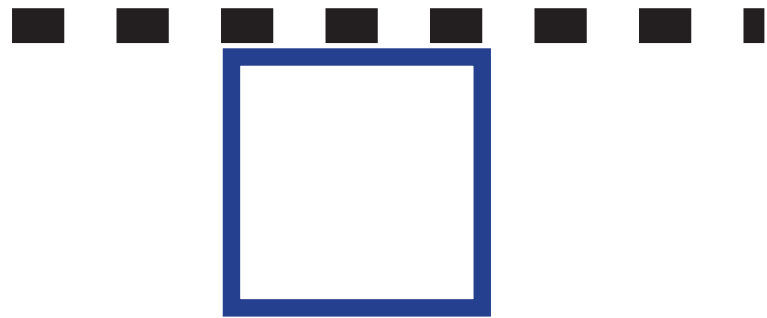



Influence of the traintrack

Delft, NL





The transformation of Cable Factory no. 2
TU Delft | RMIT
Pelle Alons

Delft, NL

2011/06/27

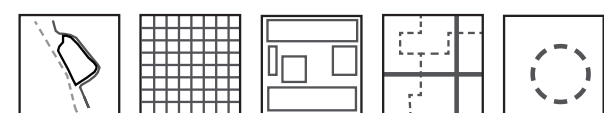

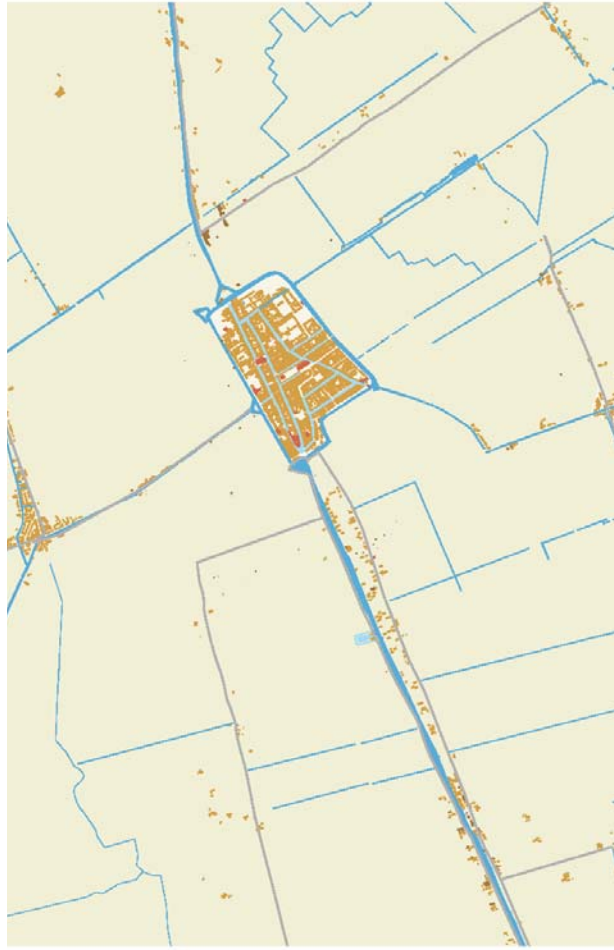

1800

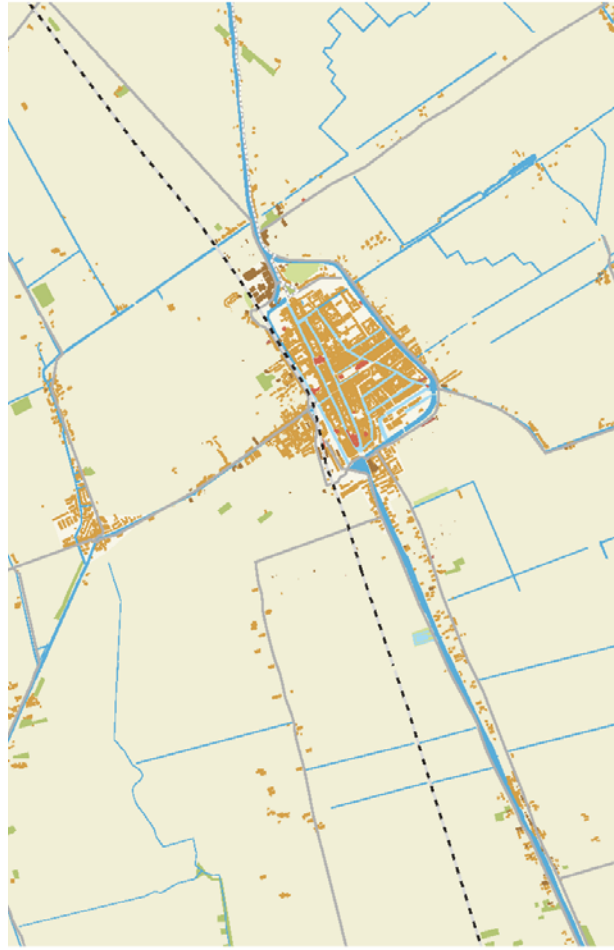

1900

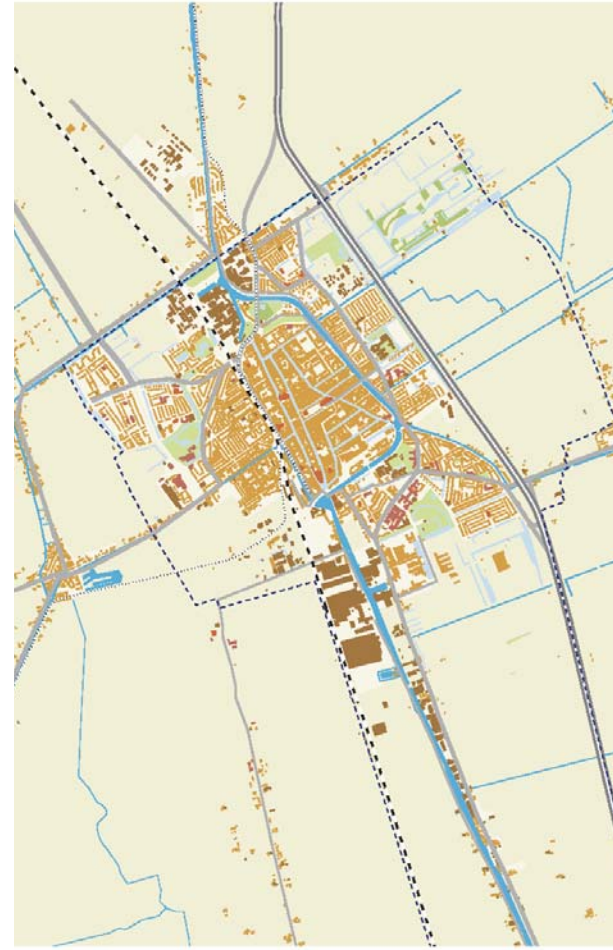

1960

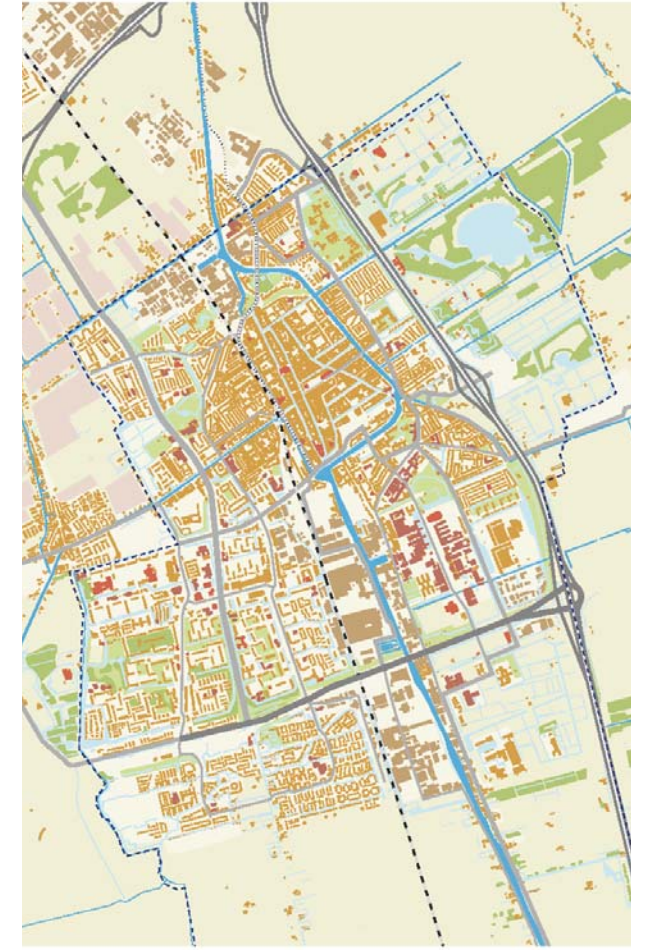

1990





1990

The transformation of Cable Factory no. 2

TU Delft | RMIT
Pelle Alons

Delft. NL

2011/06/27

10



Schieoevers Noord

Delft, NL



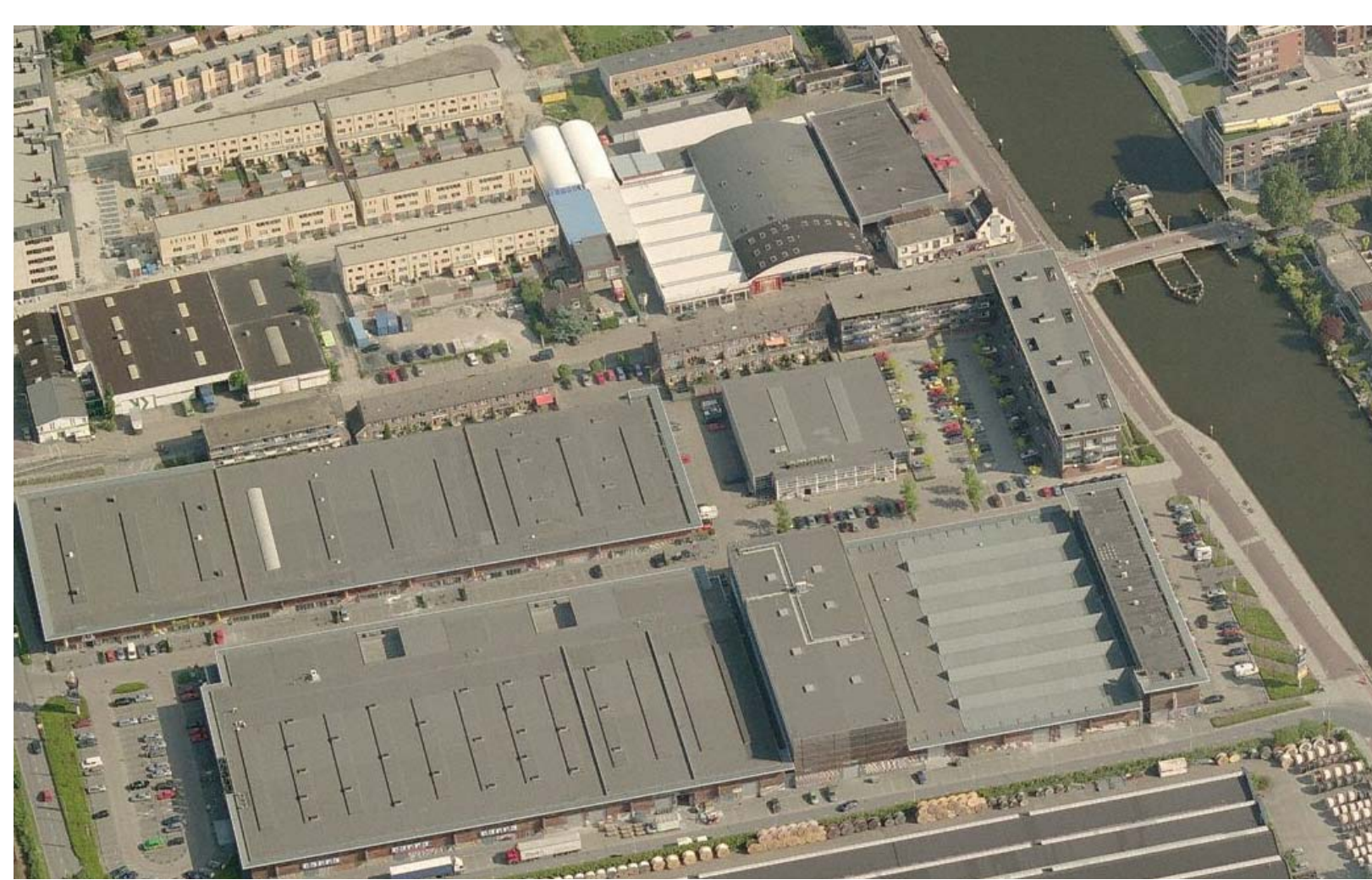
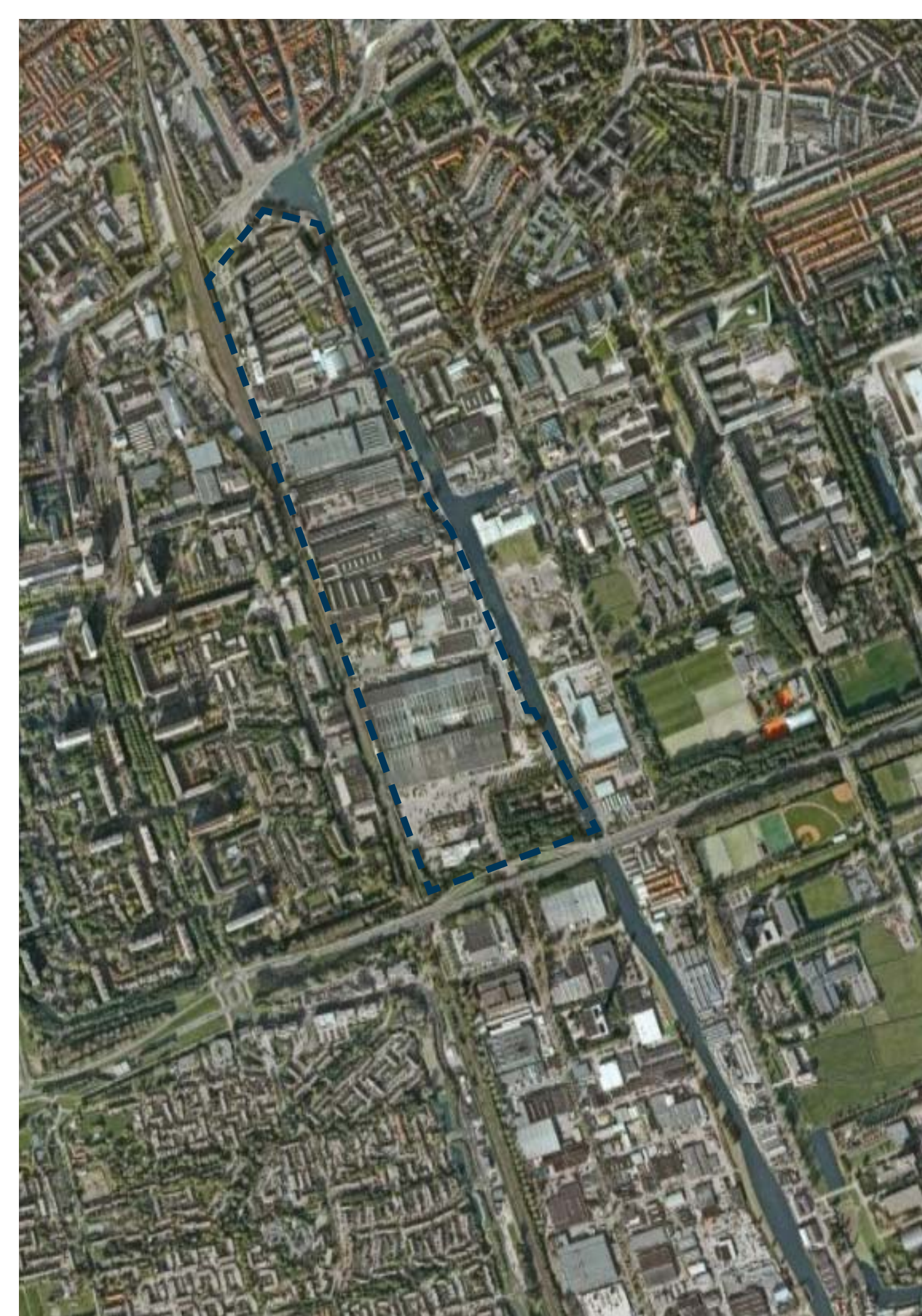

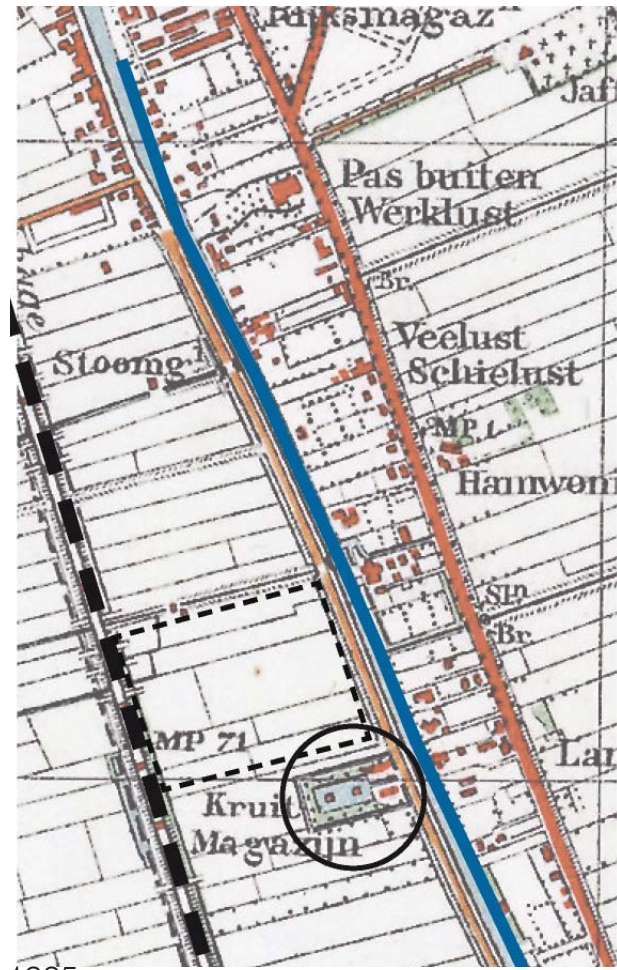

1925

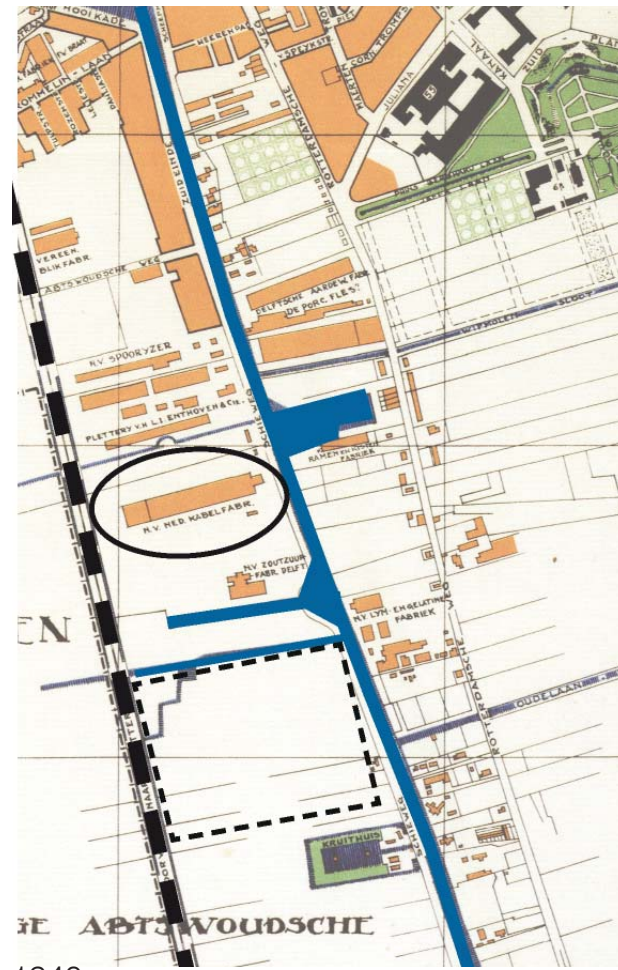

1940



1958

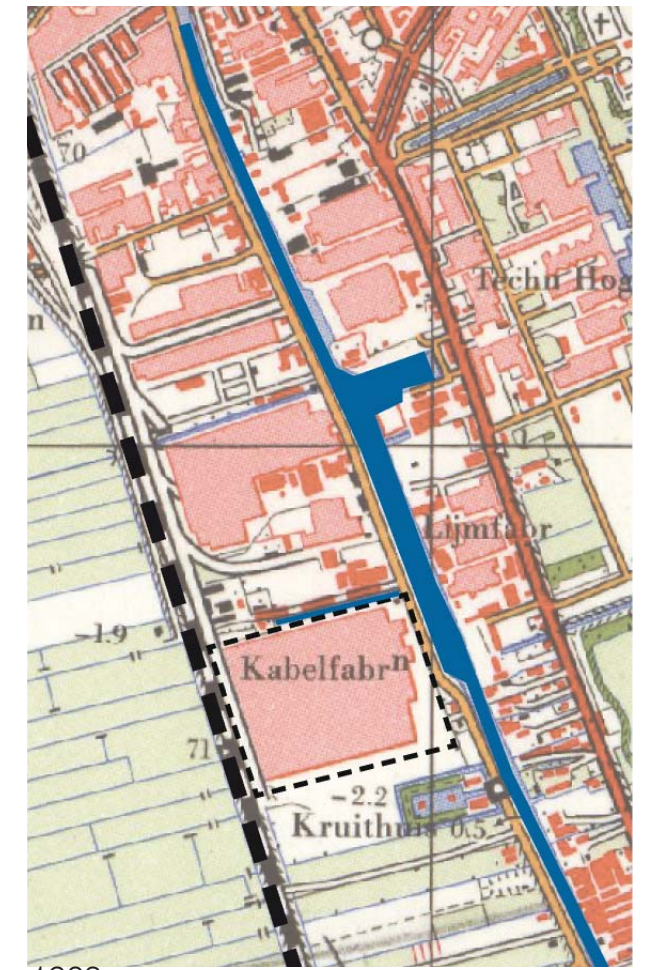

1963











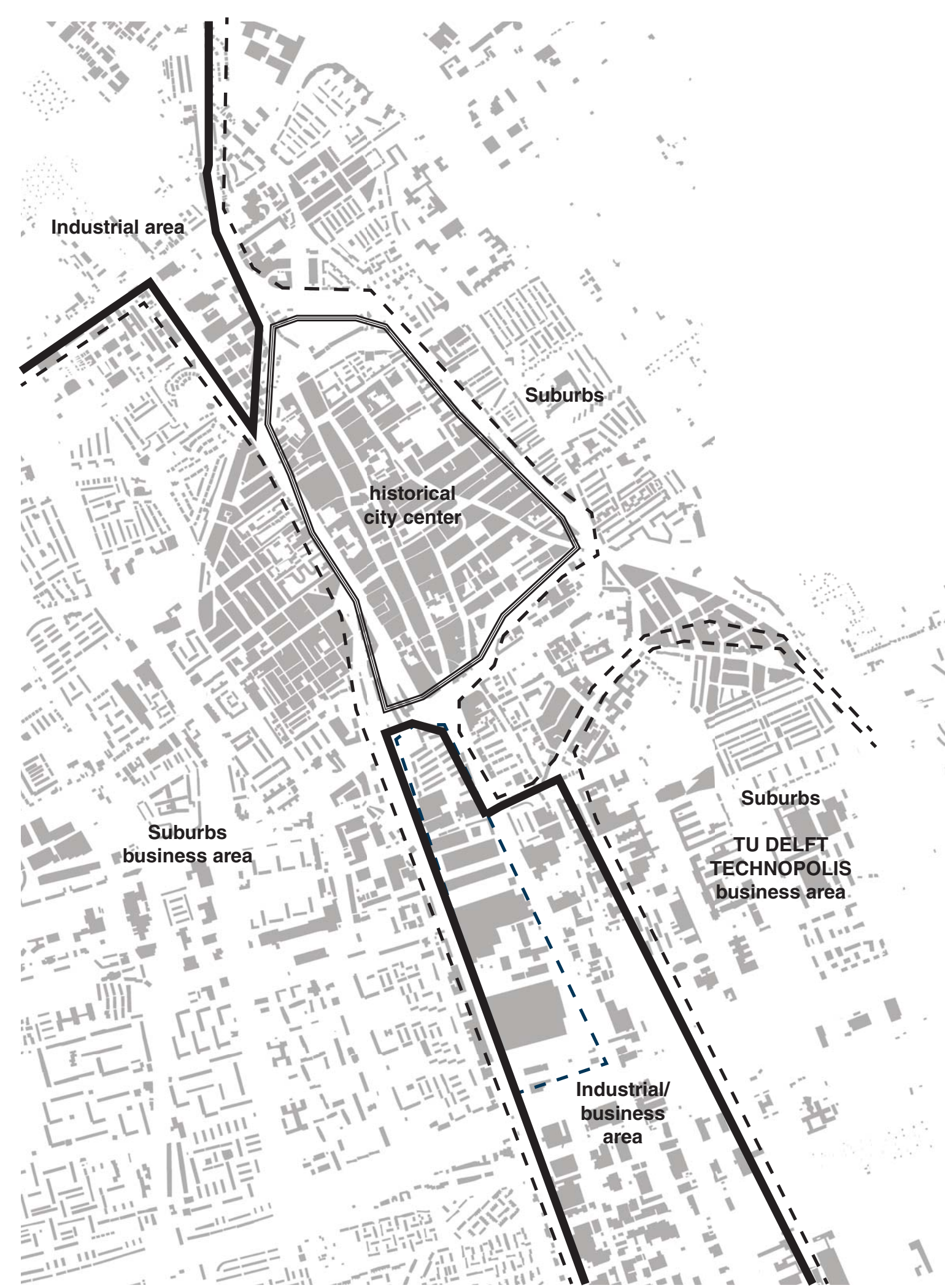

Industrial area

Suburbs

historical
city center

Suburbs
business area

Suburbs
TU DELFT
TECHNOPOLIS
business area

Industrial/
business
area



Urban Strategy

cohesion of industrial area and city centre



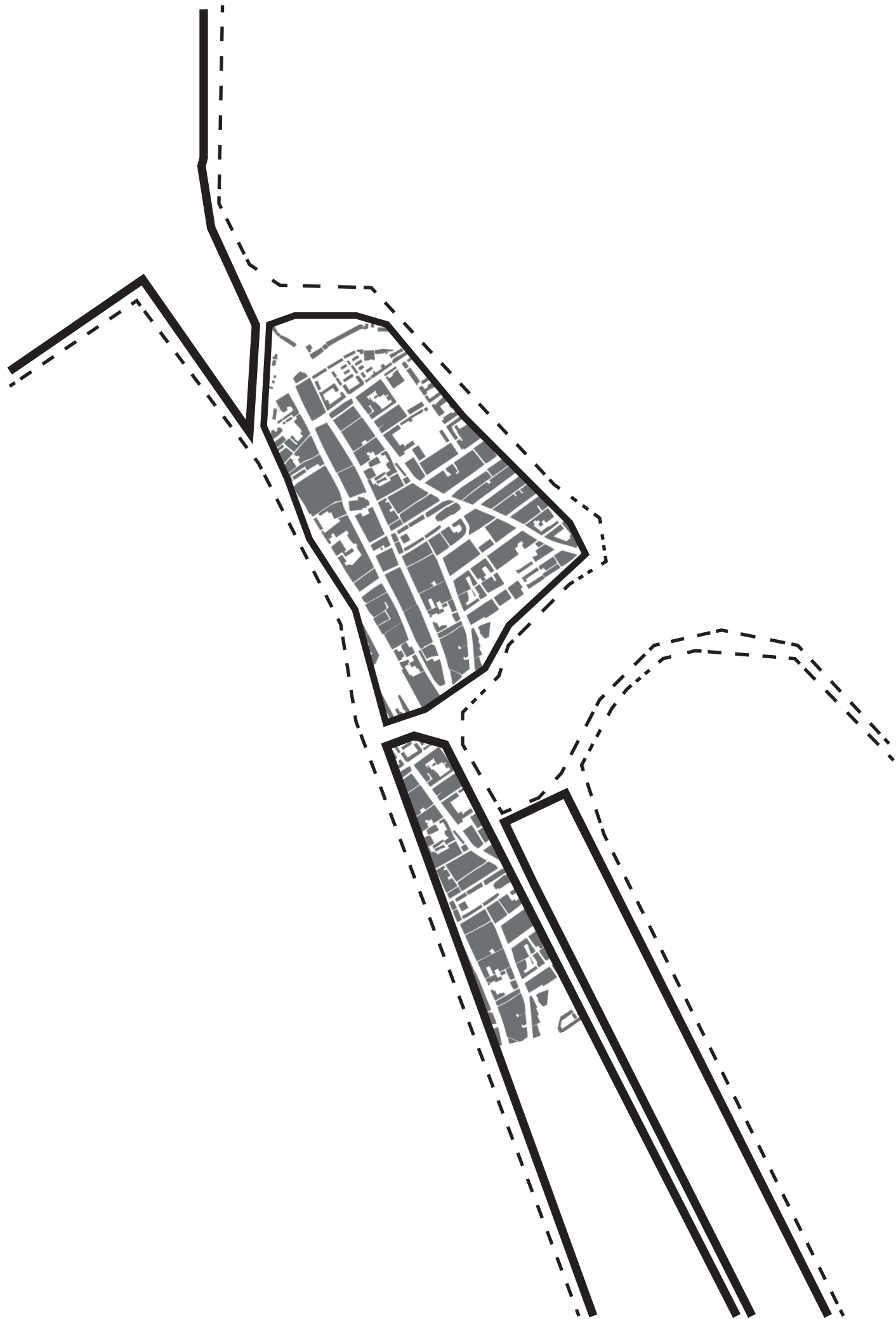

> **Intricacy**

> **Active and vivid atmosphere**

> **Accessible**



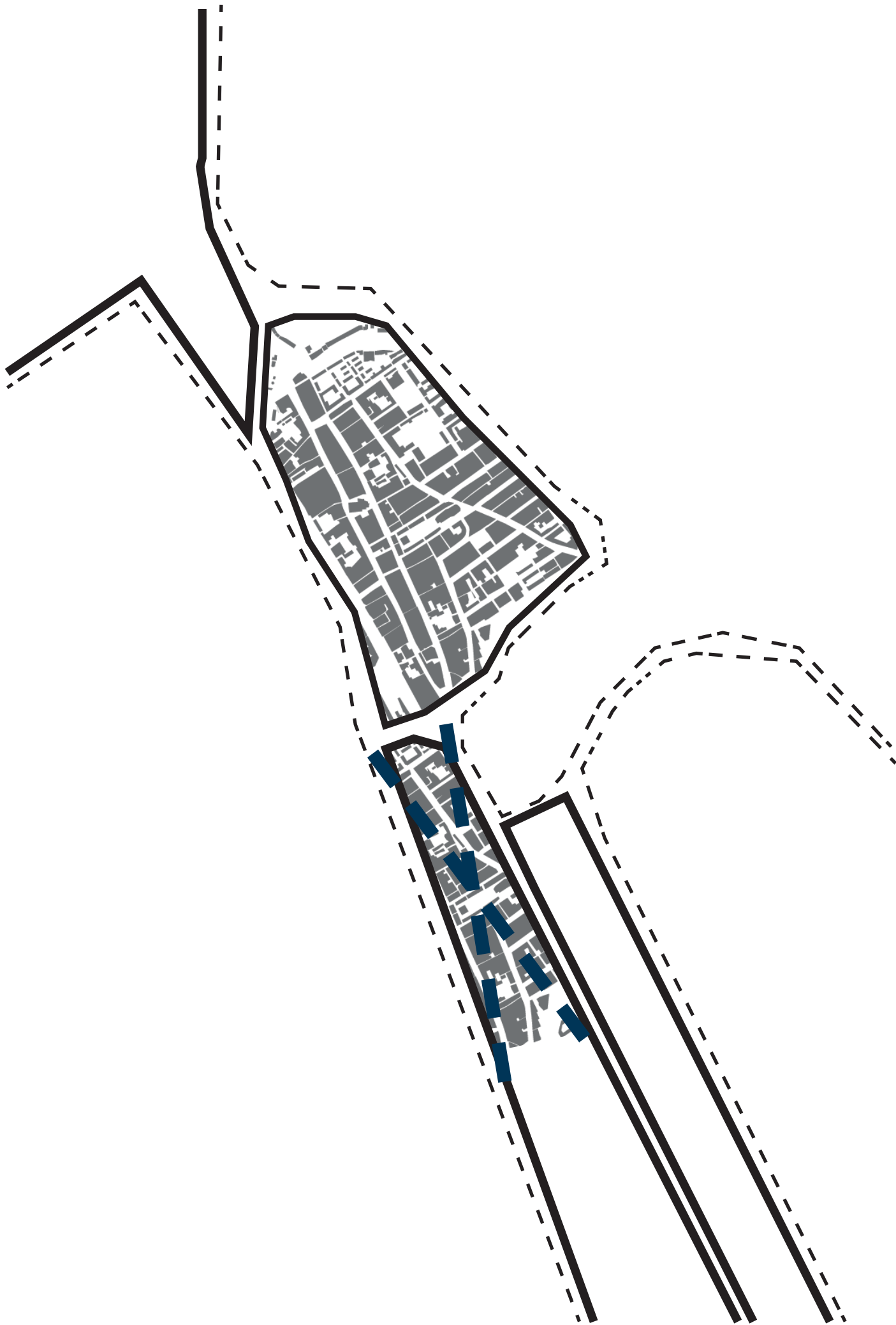

+ Industrial atmosphere

+ Water / green relation





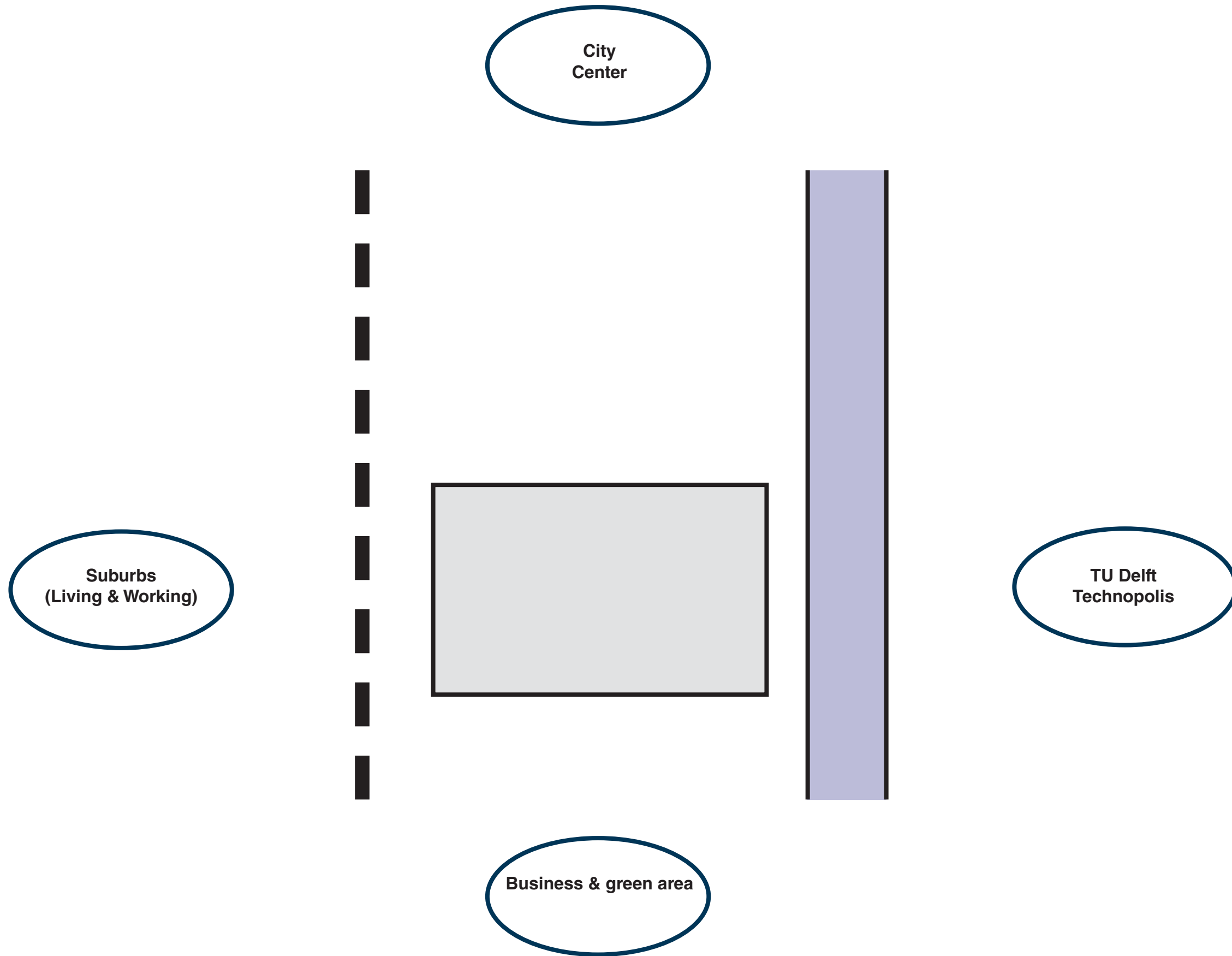

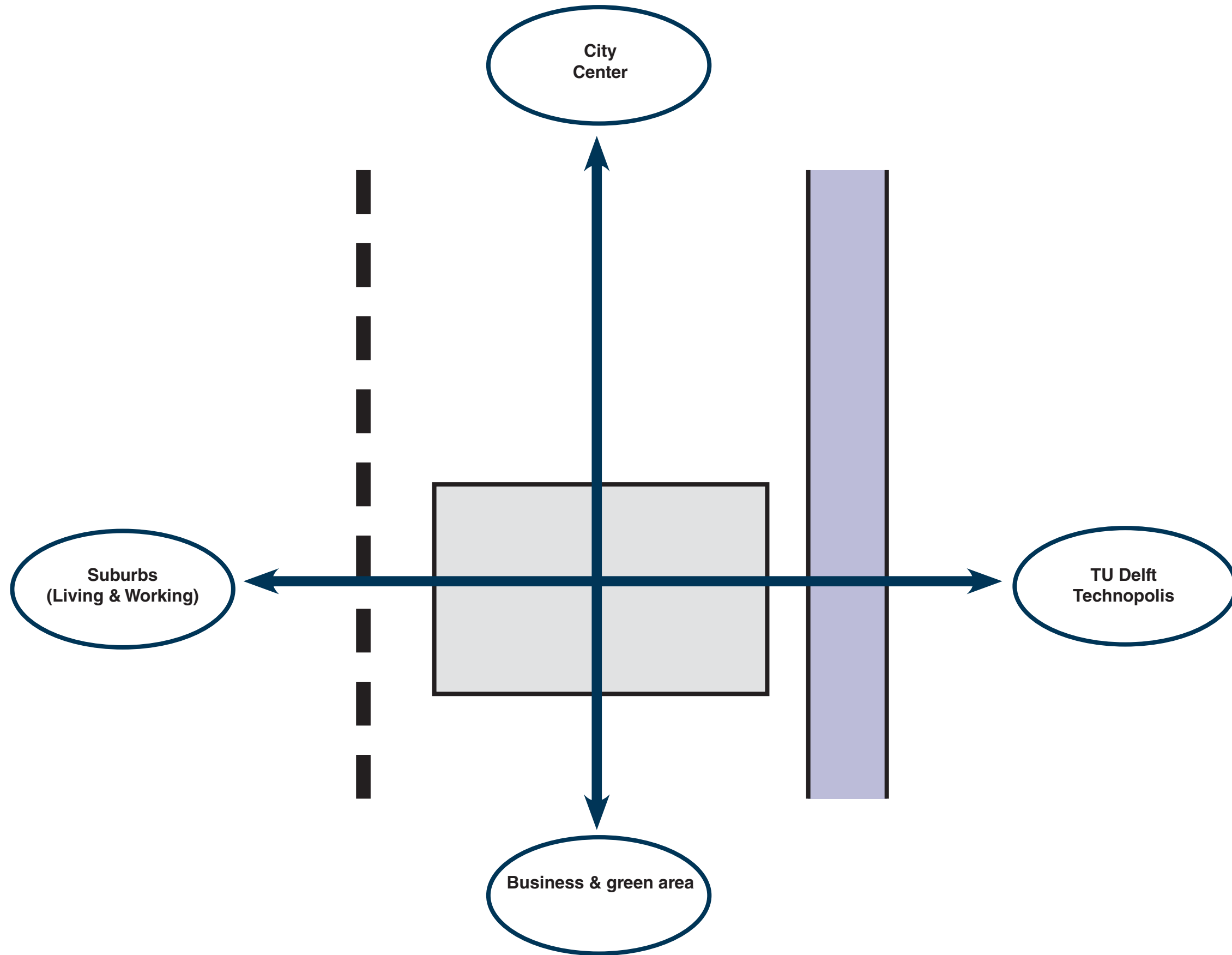

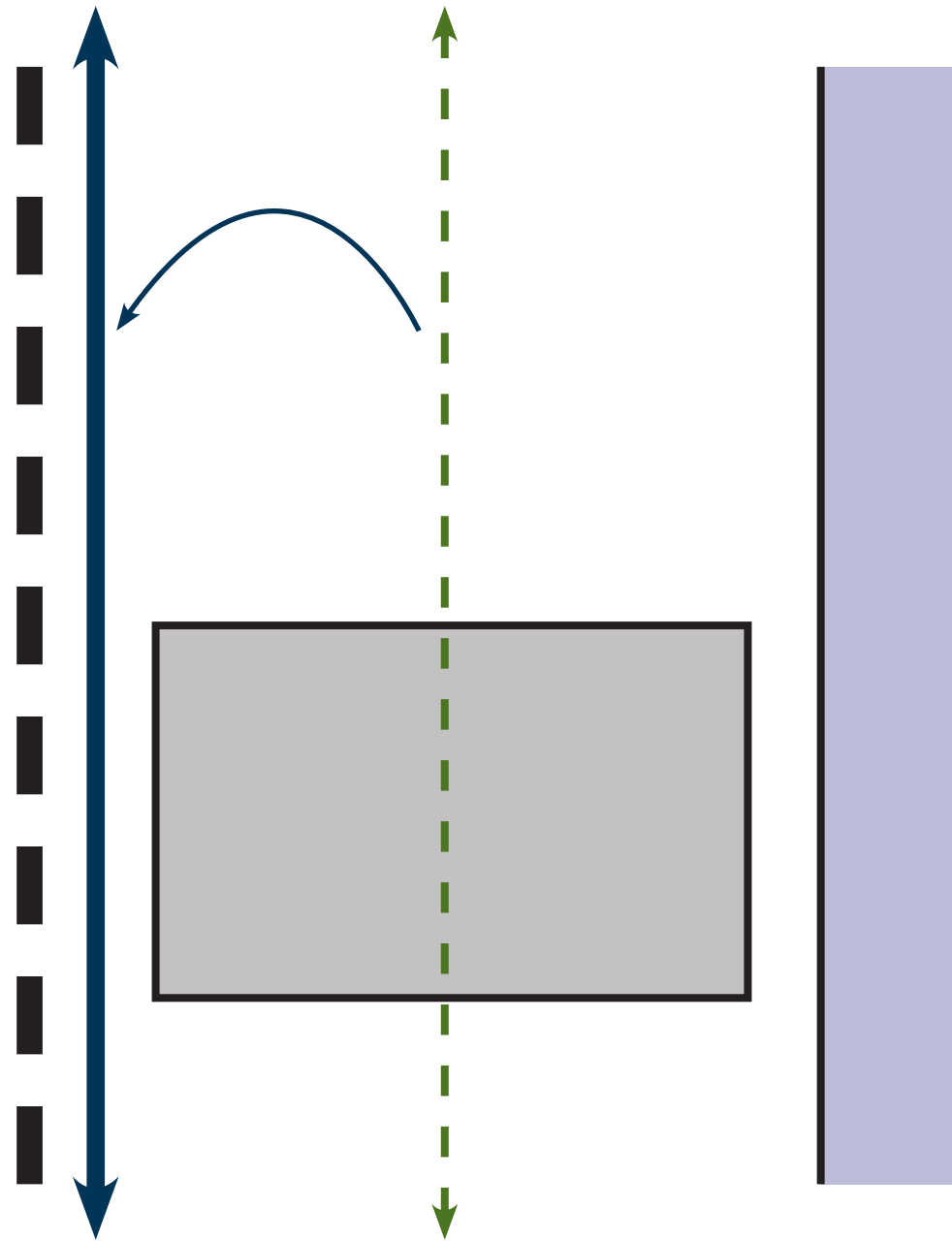

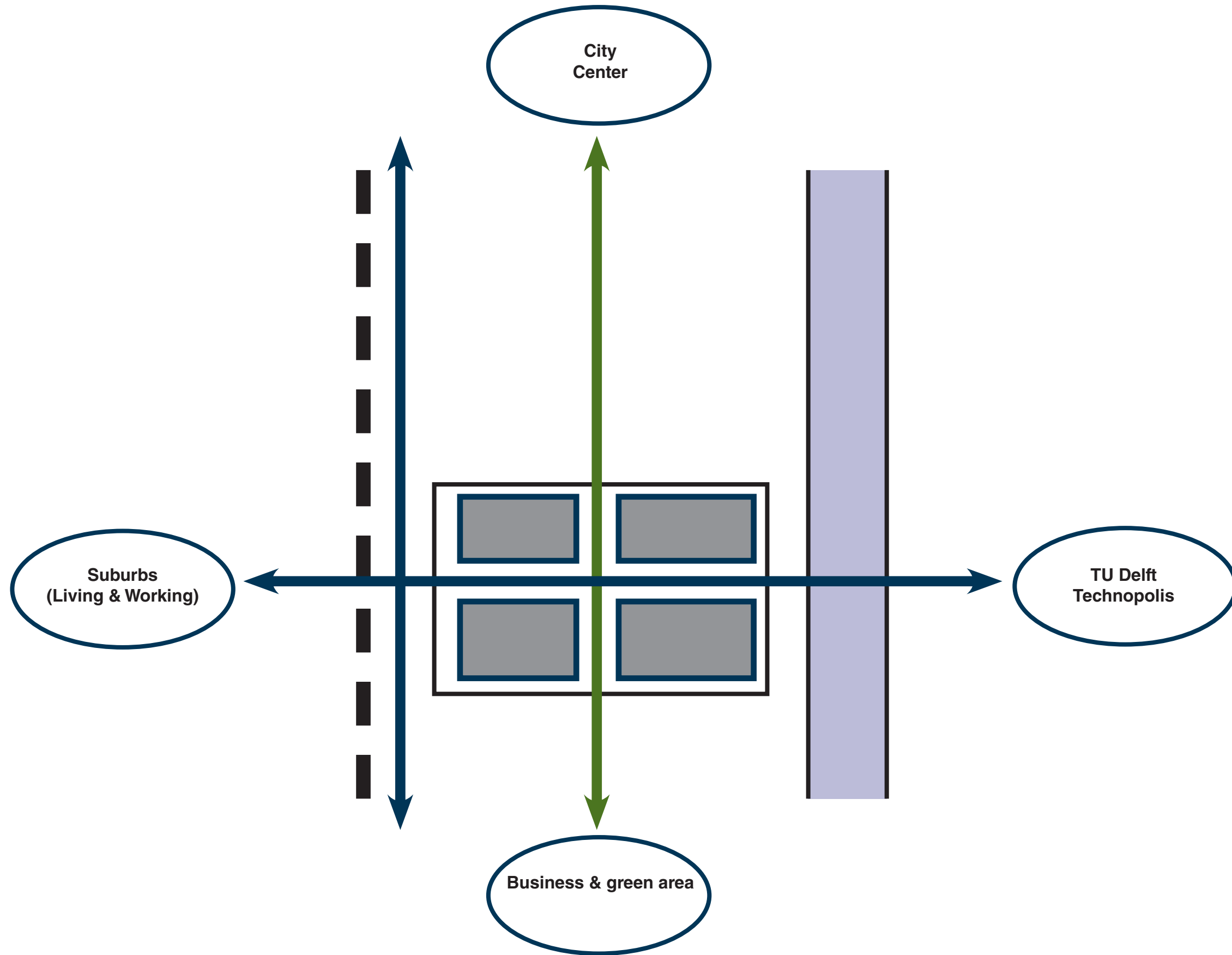

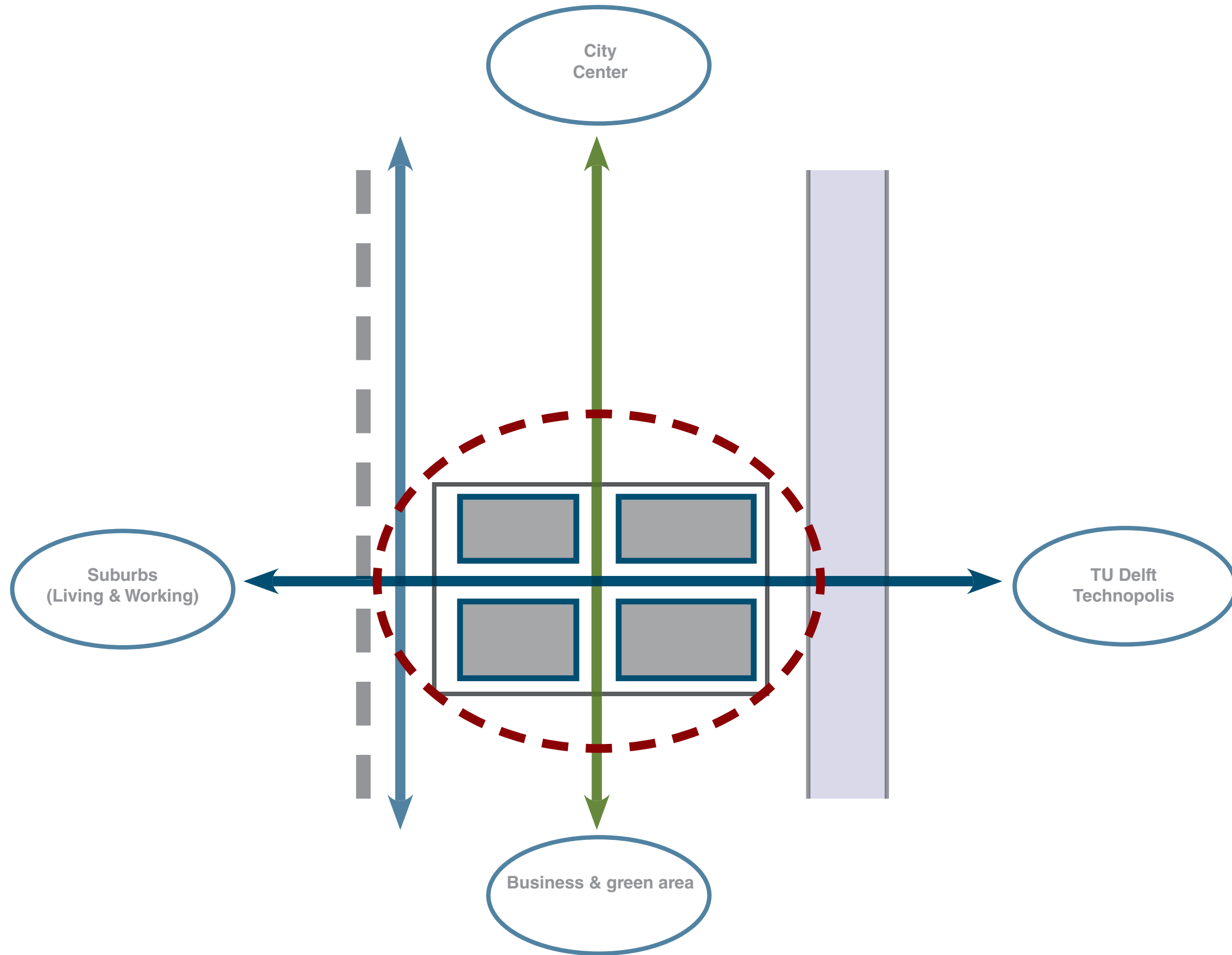

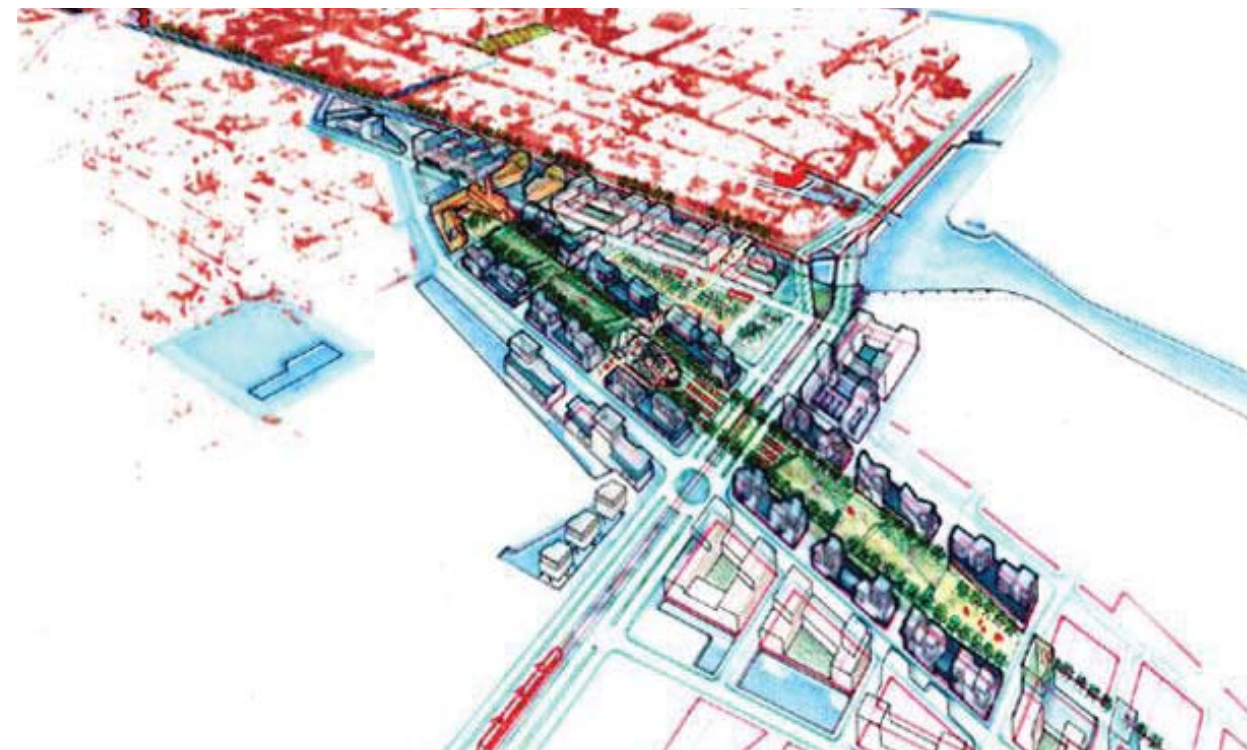
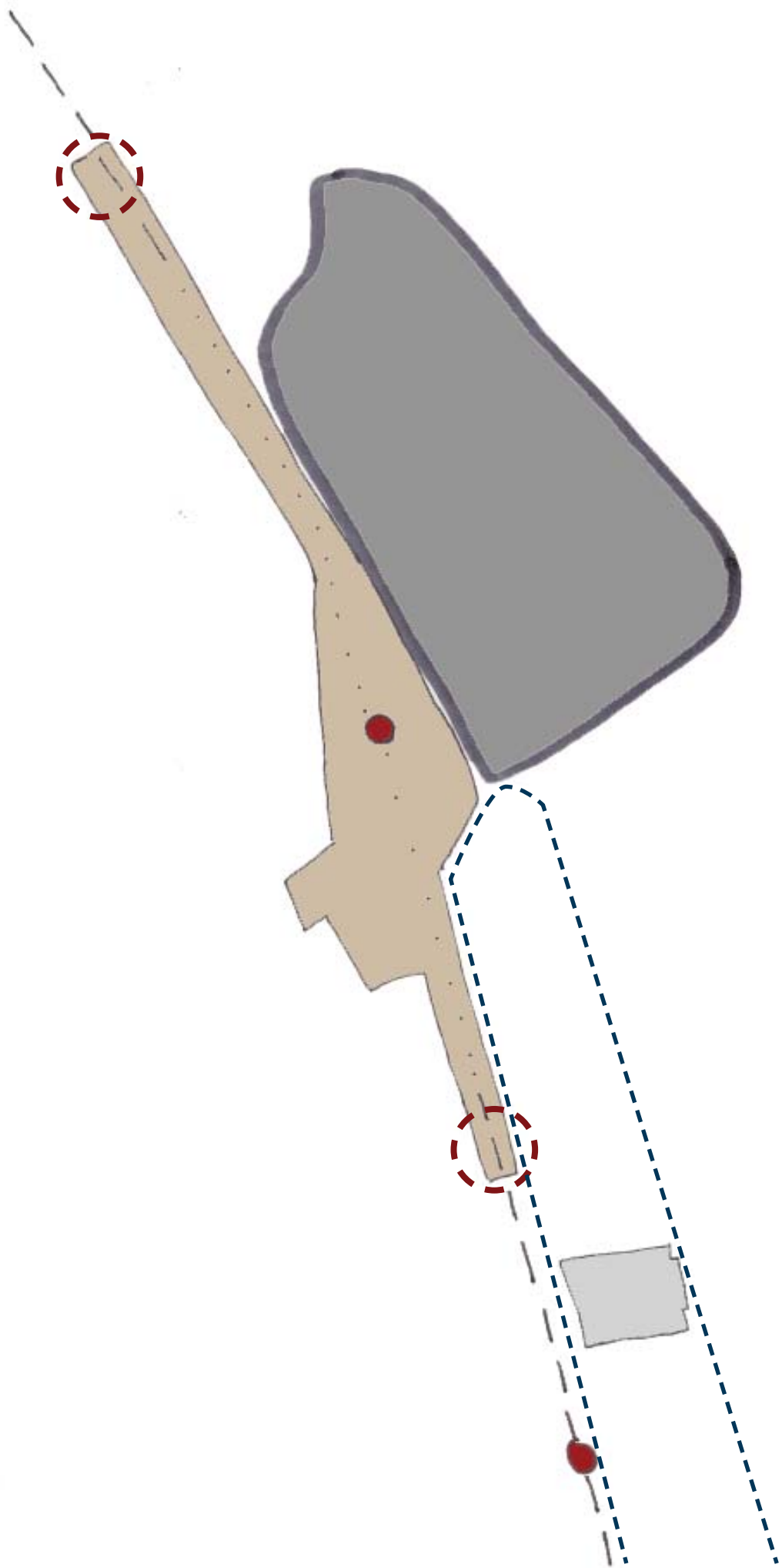



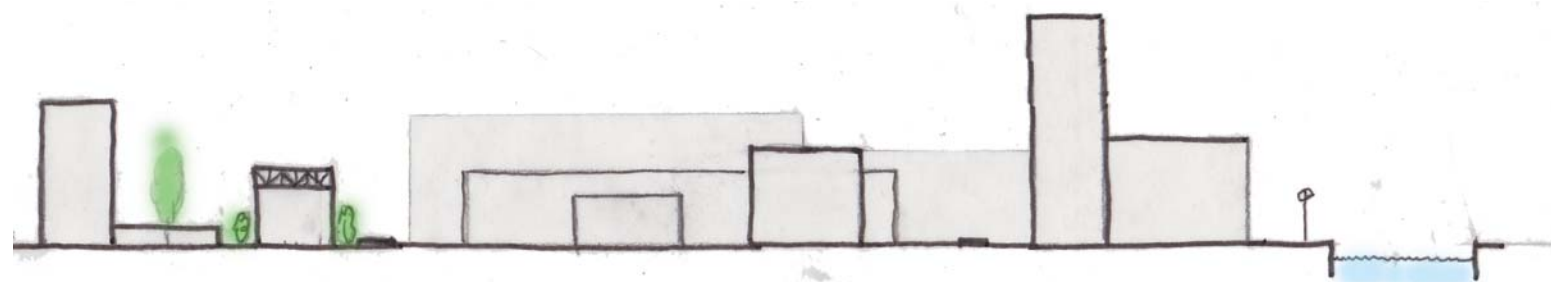
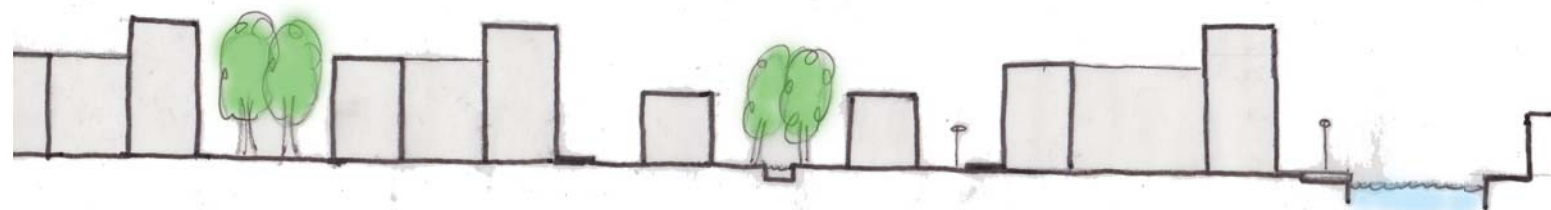
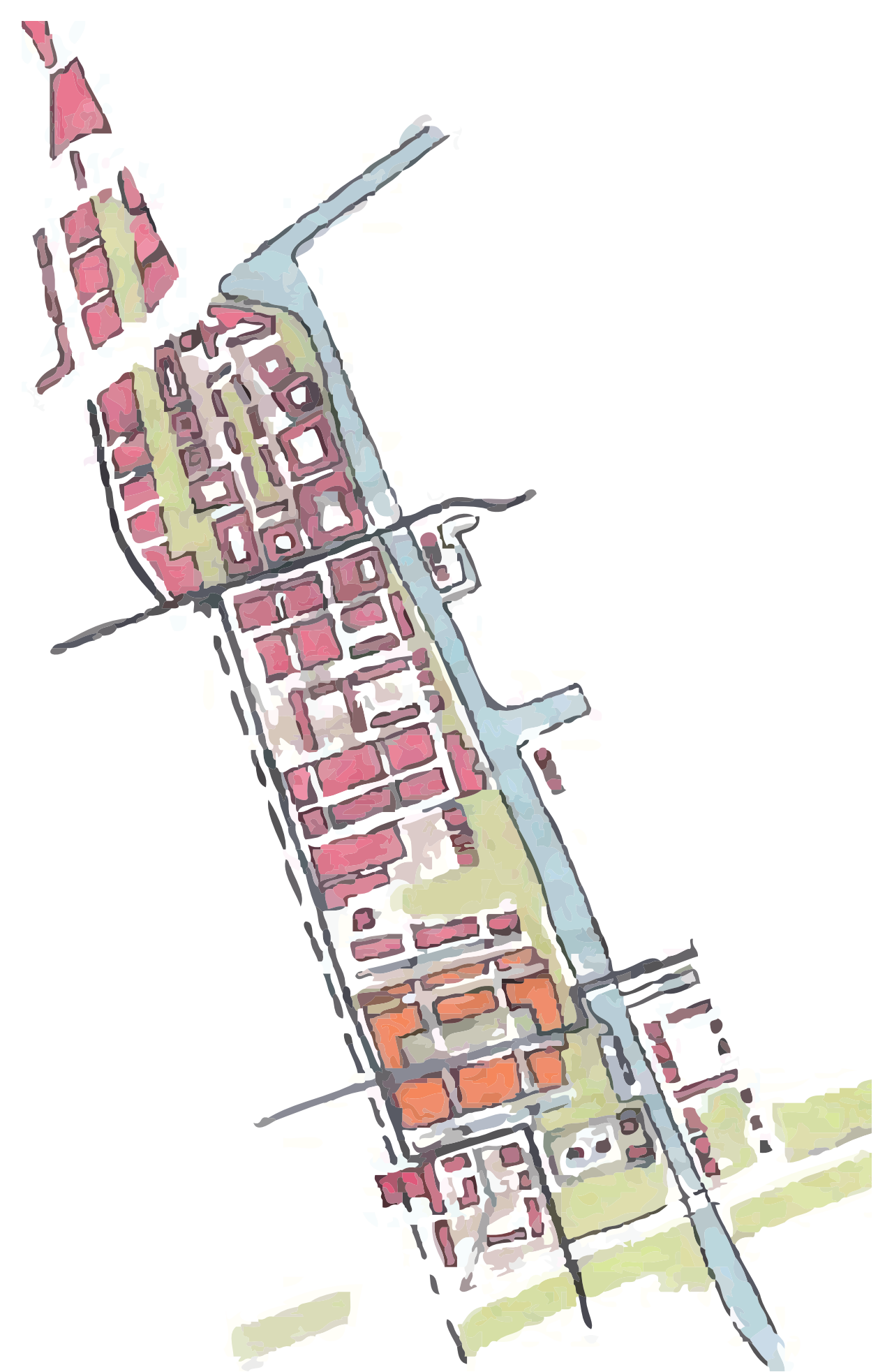

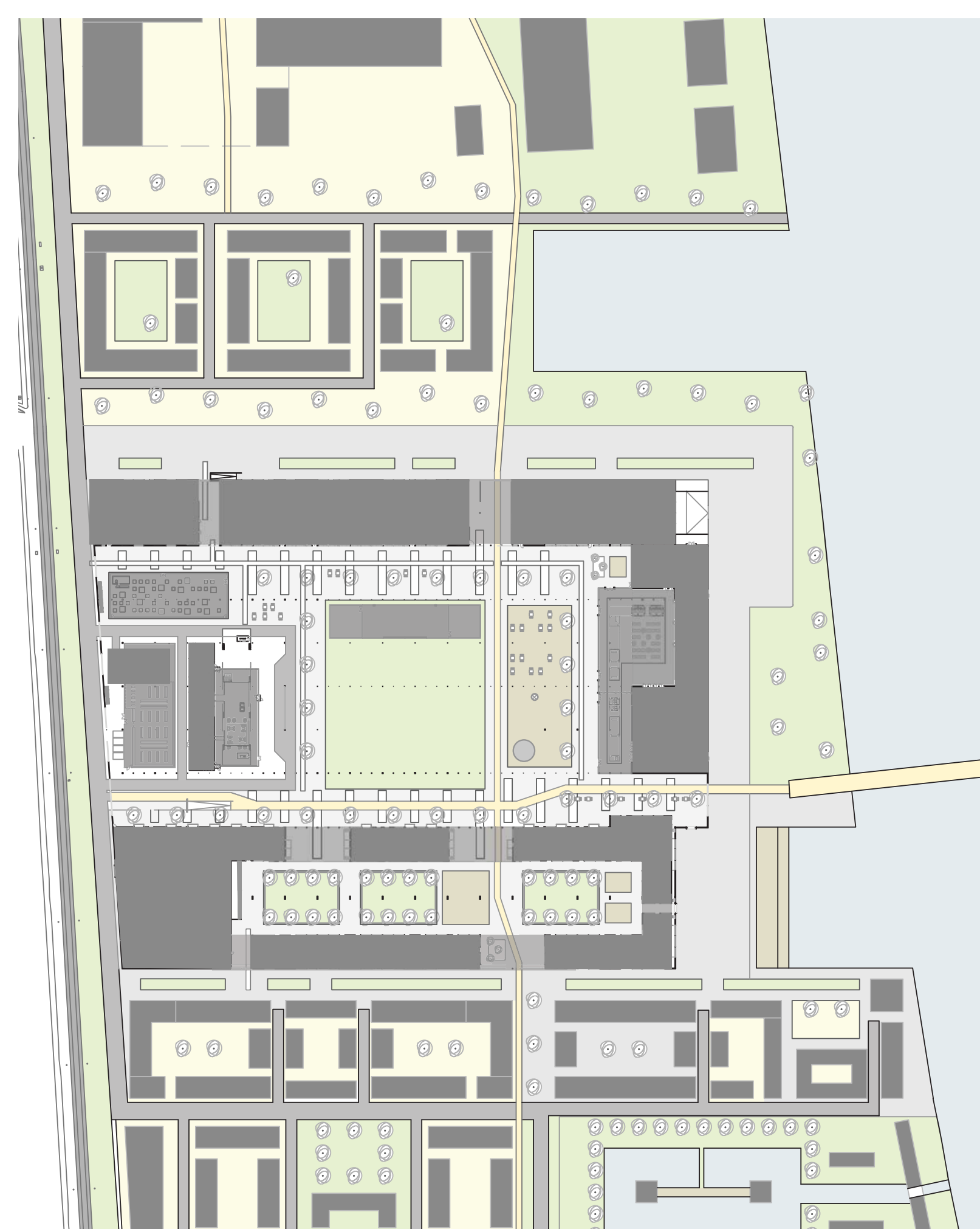

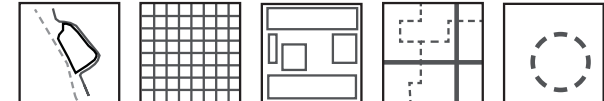
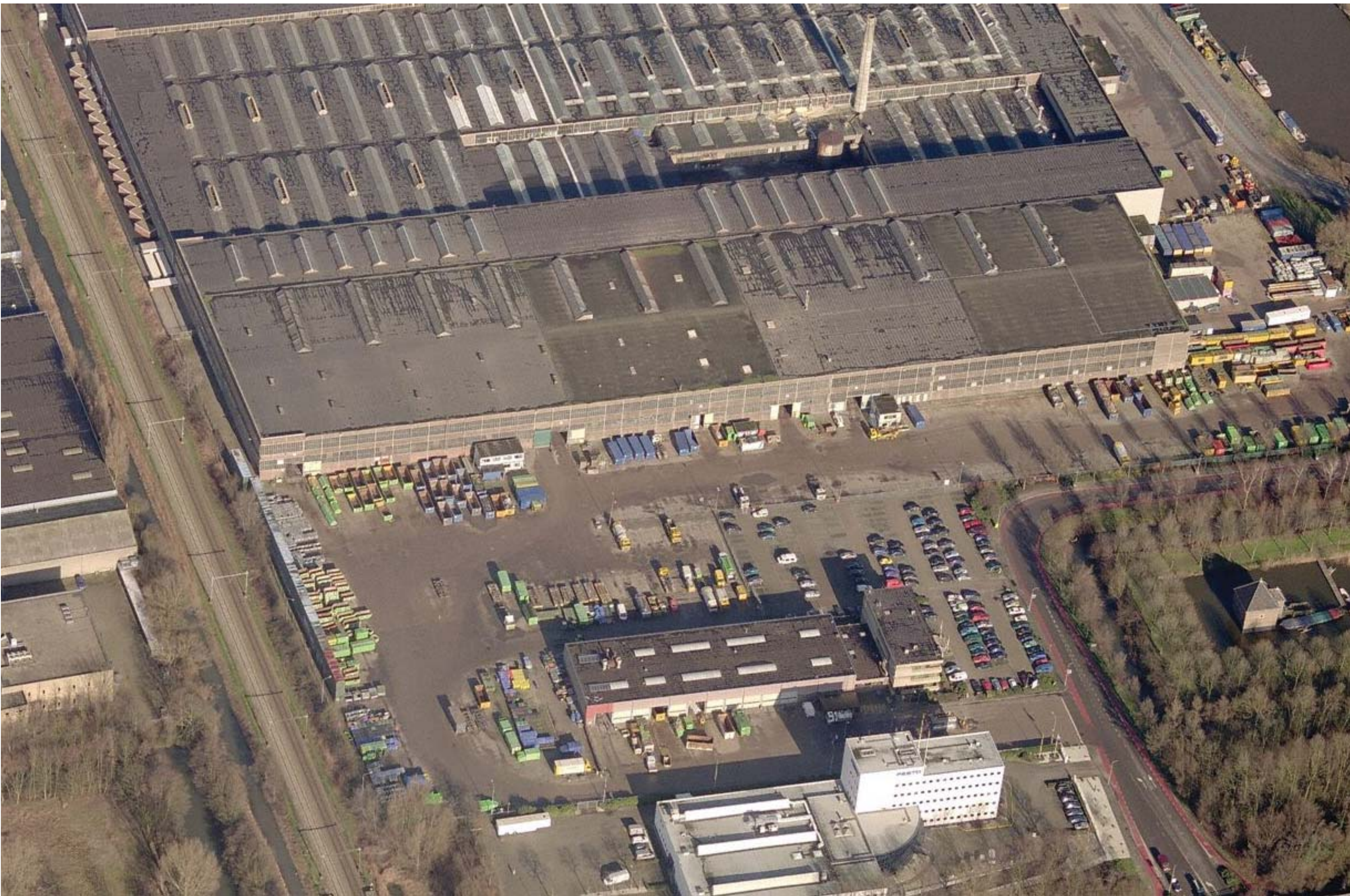

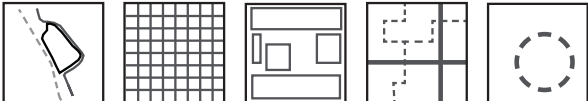
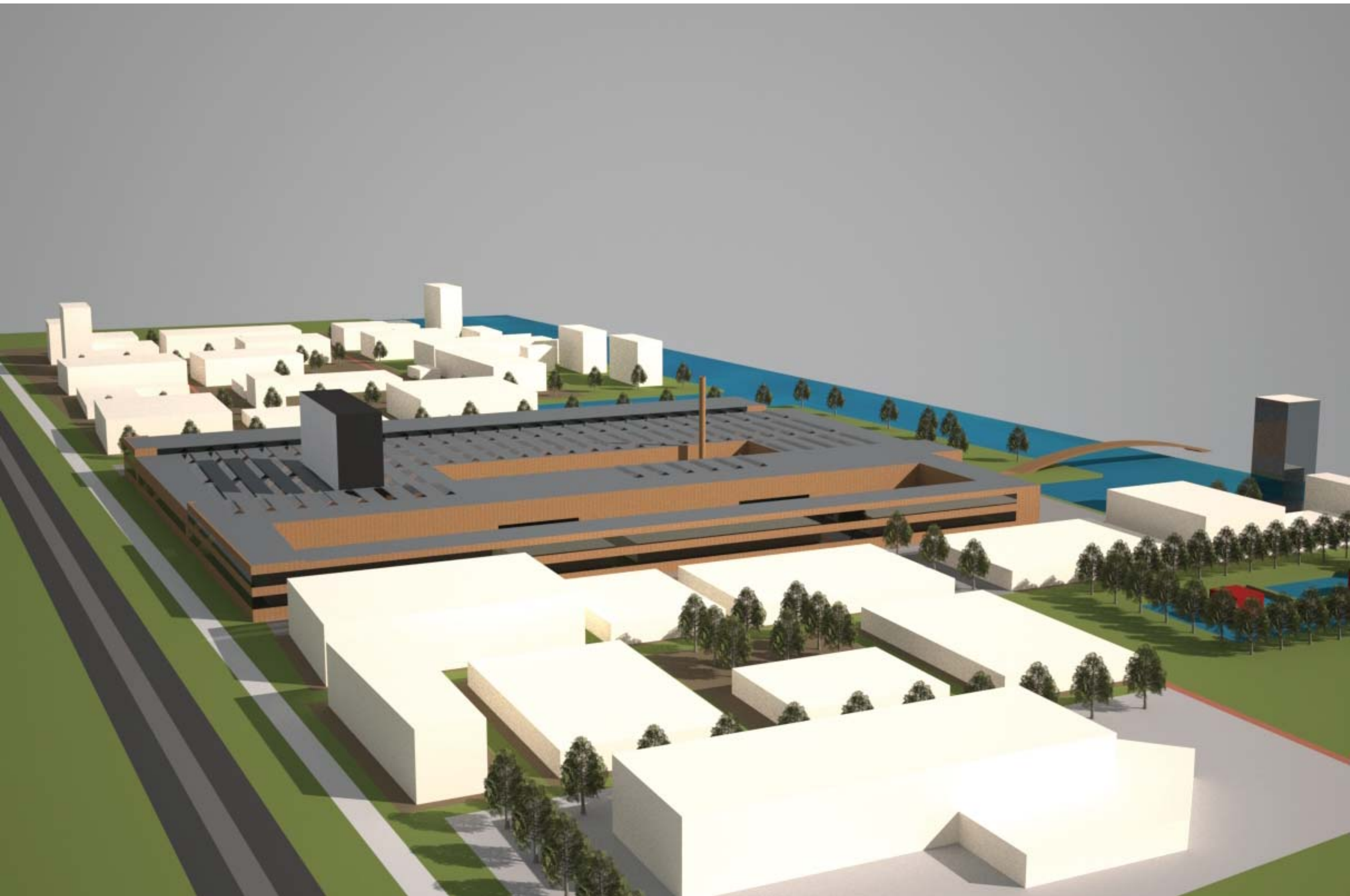

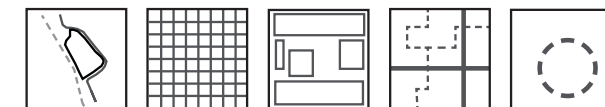

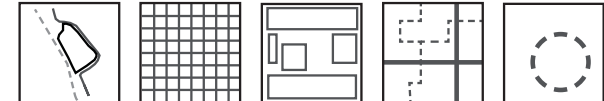

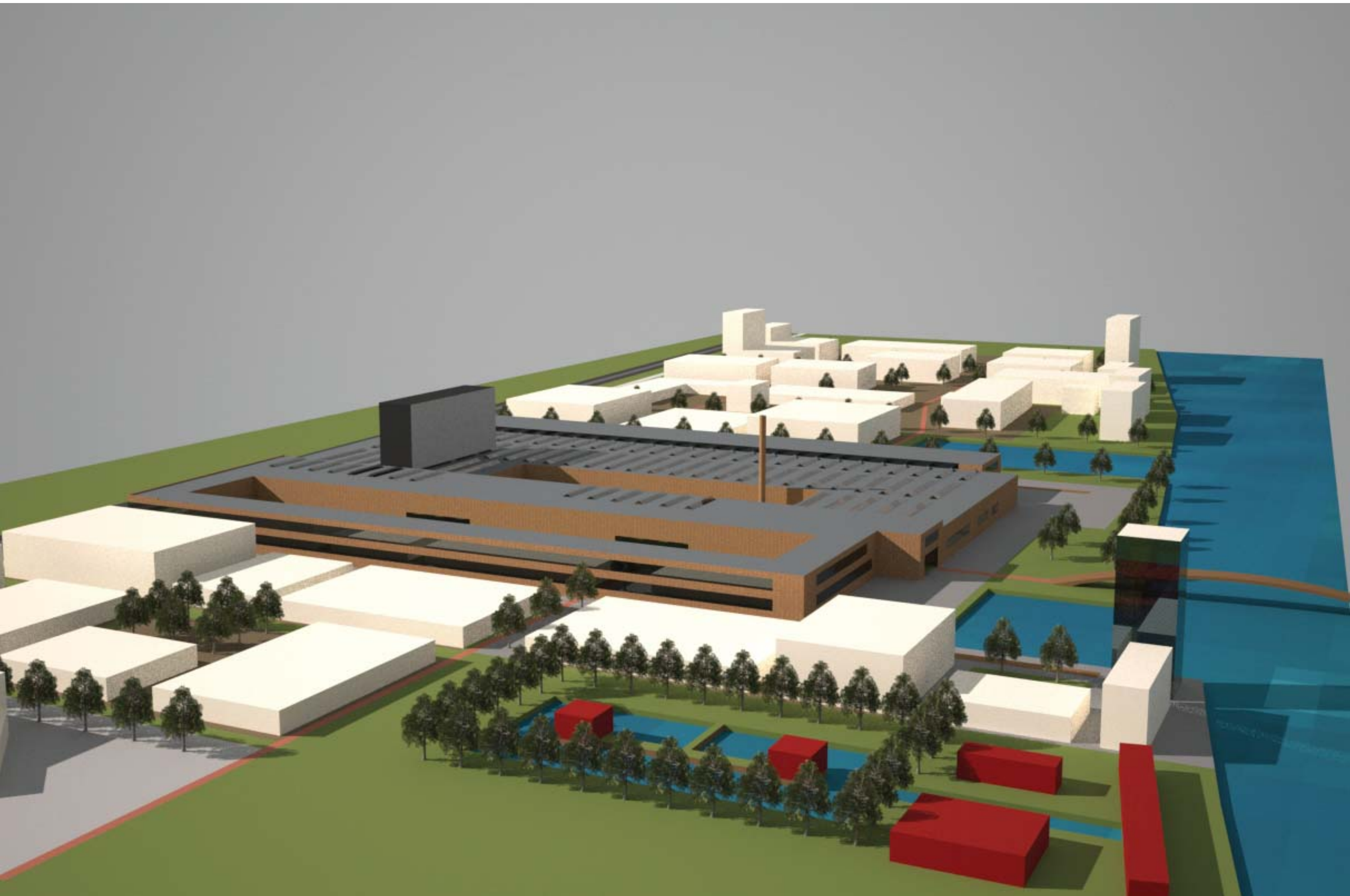

Dutch Cable Factory (NKF)

Strategy for an intervention

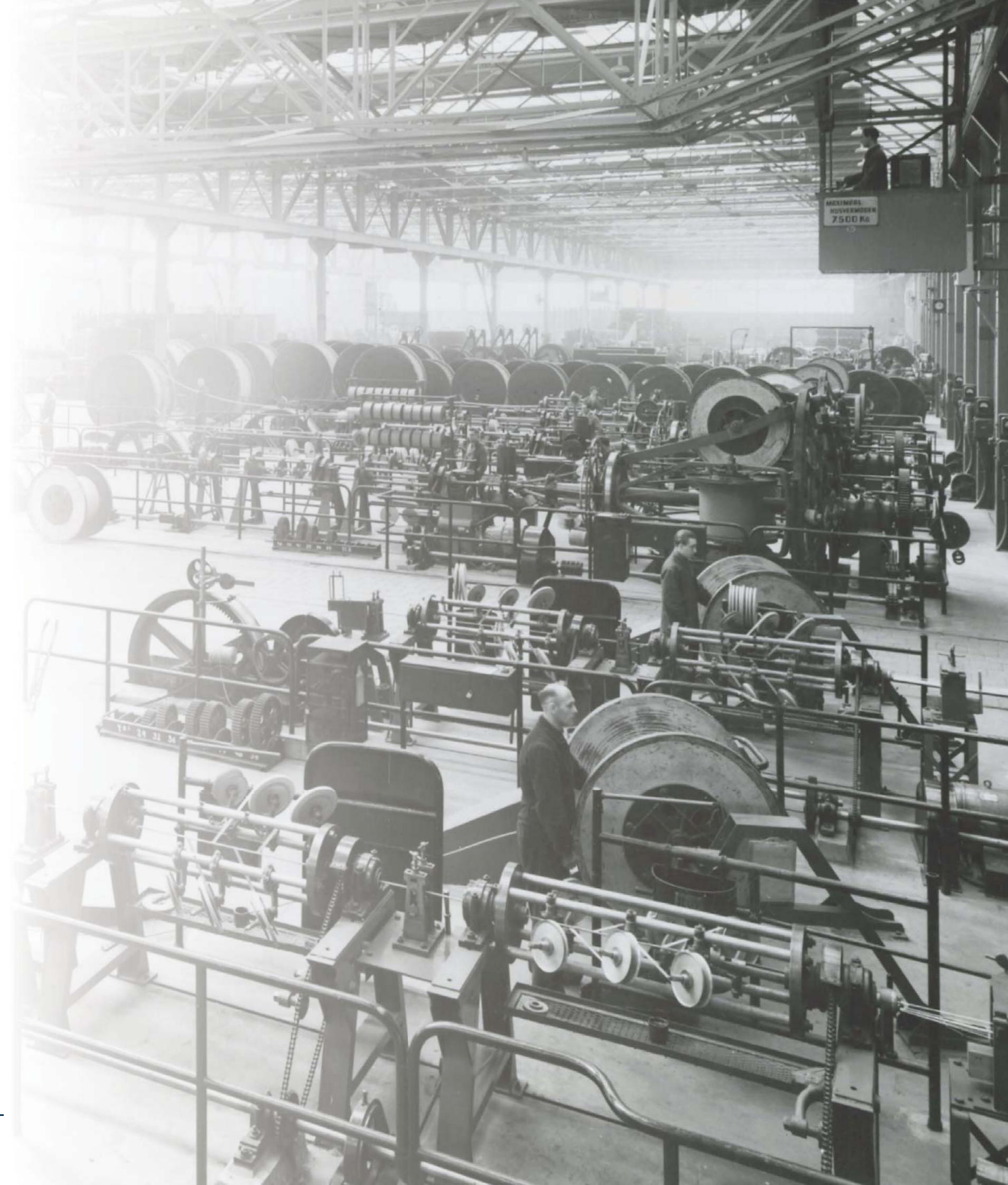



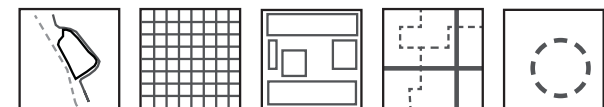
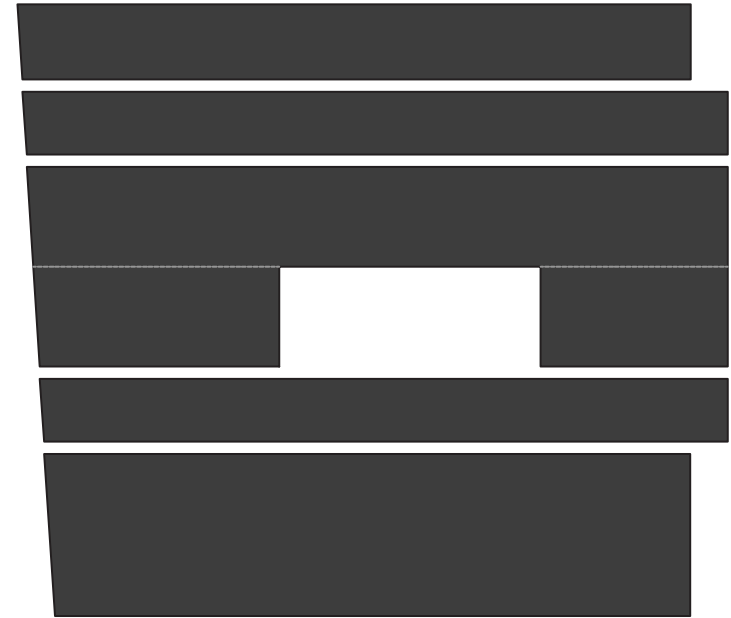



> Indoor < > Outdoor

> Preservation
Industrial identity & perception quality



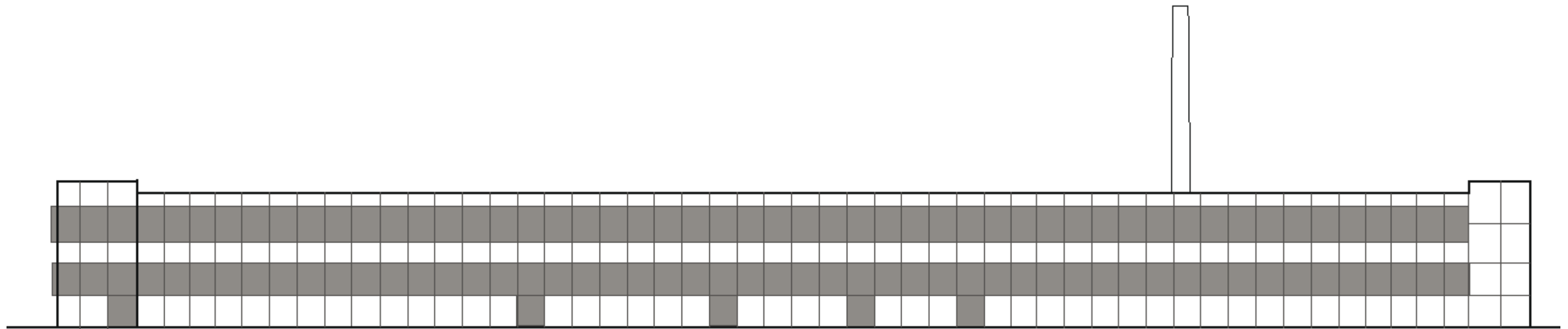
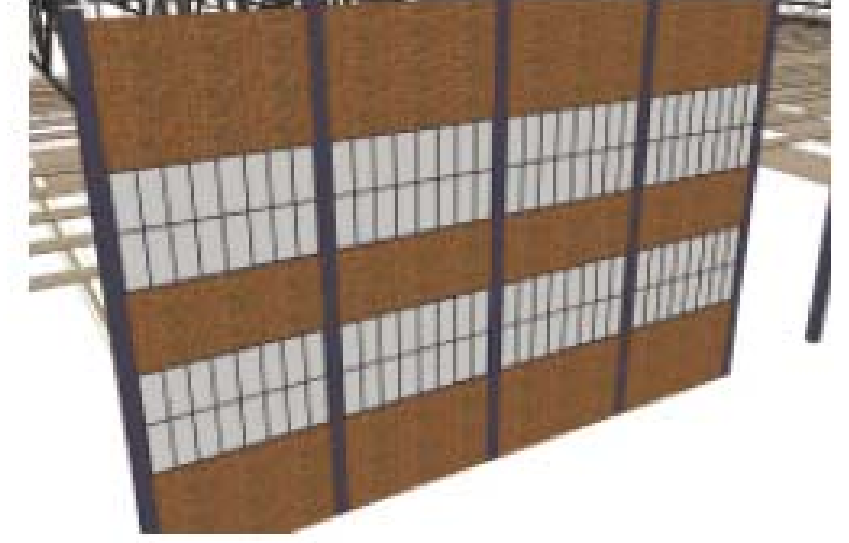
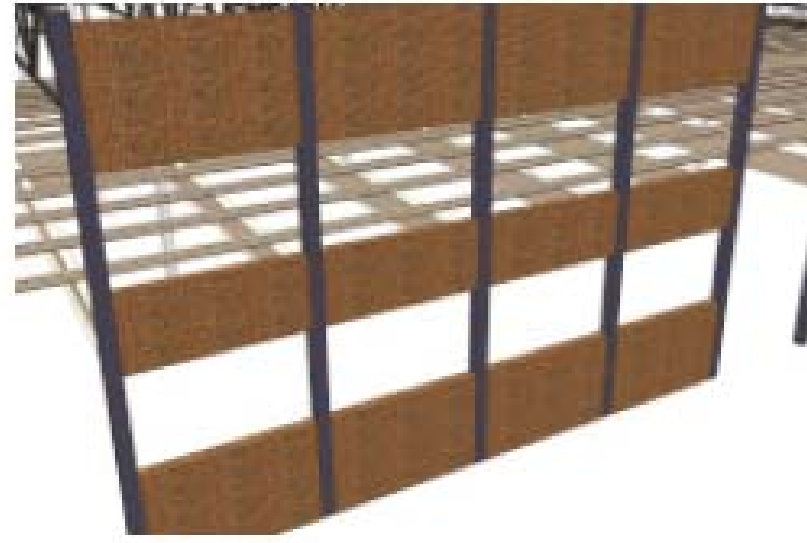
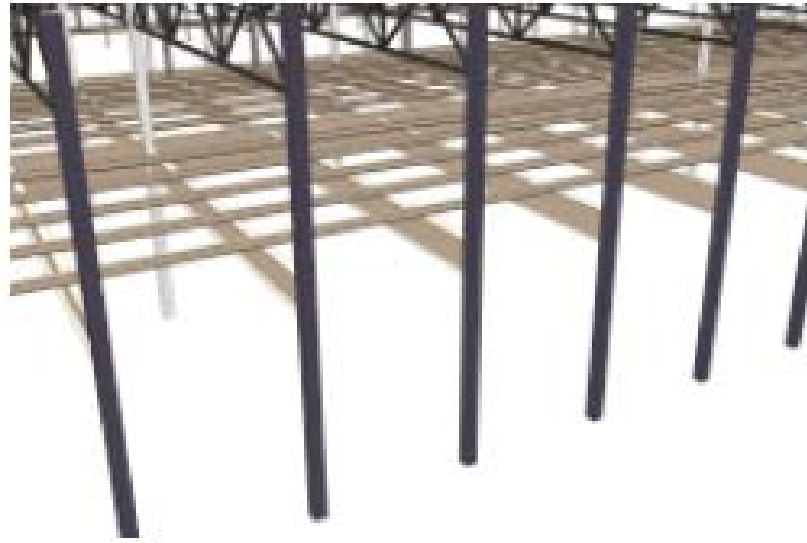

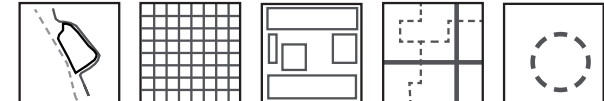
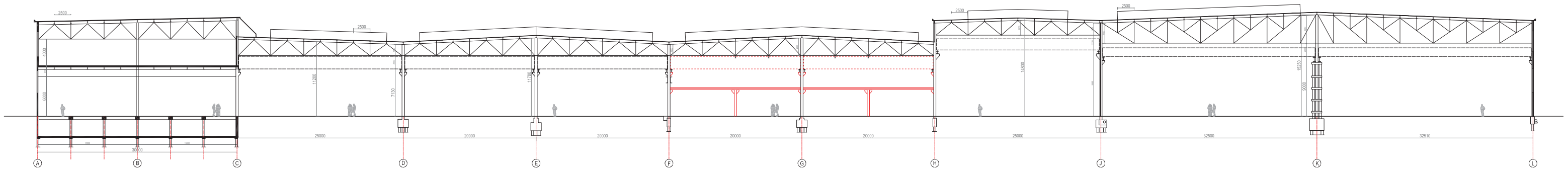
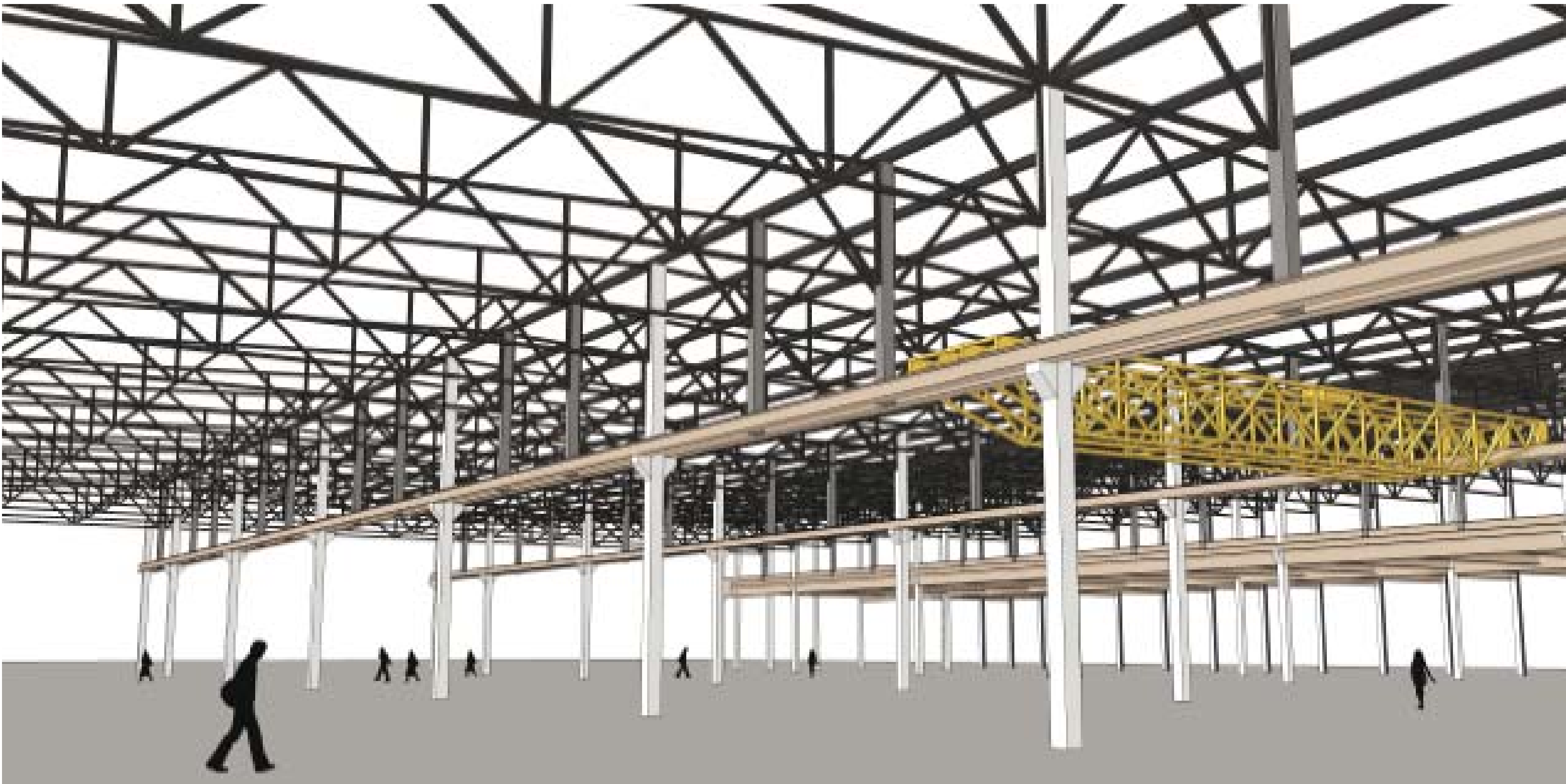

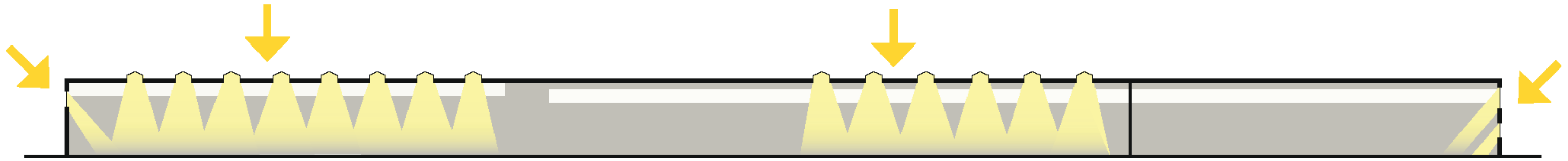



> **Facades**

> **Construction**

> **Light**



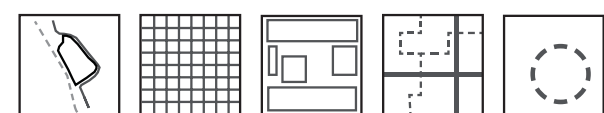
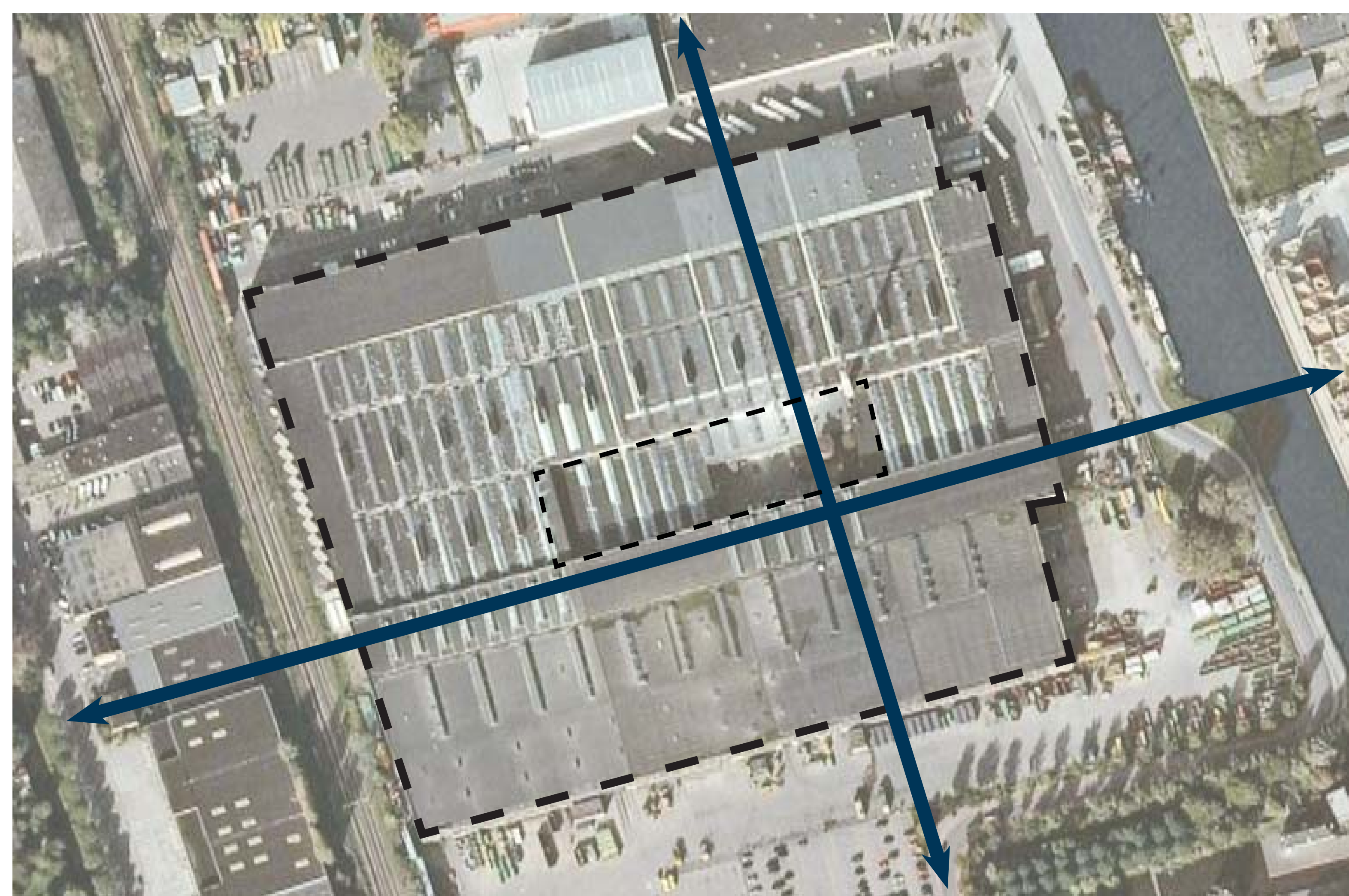

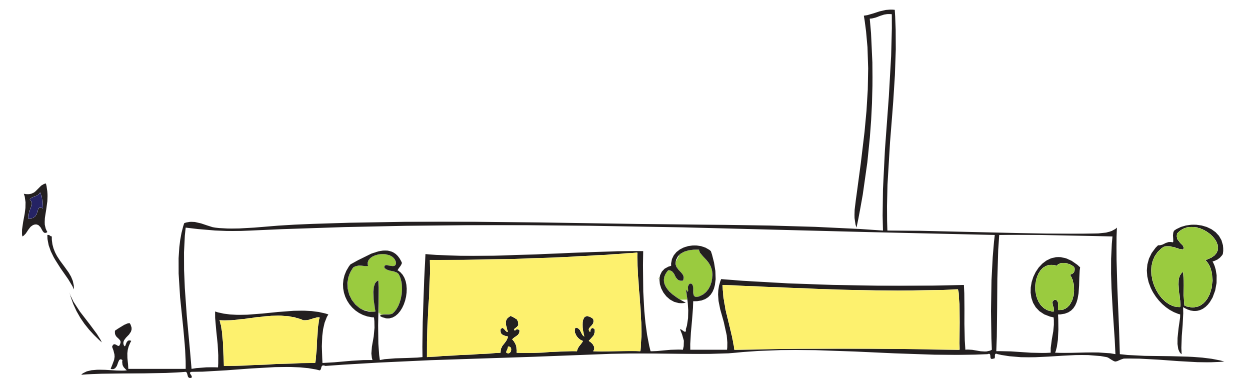
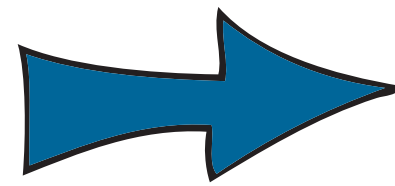
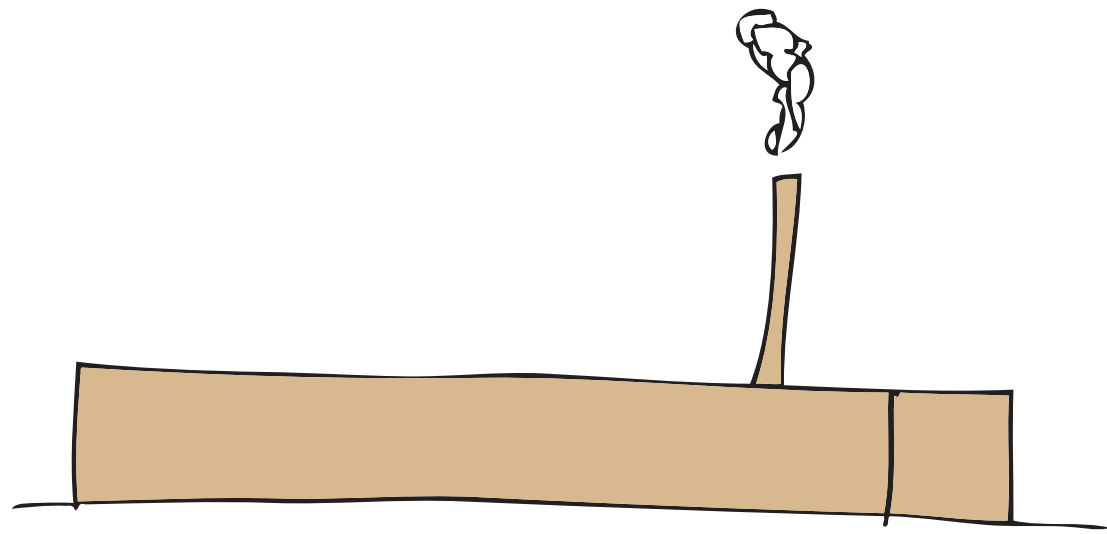



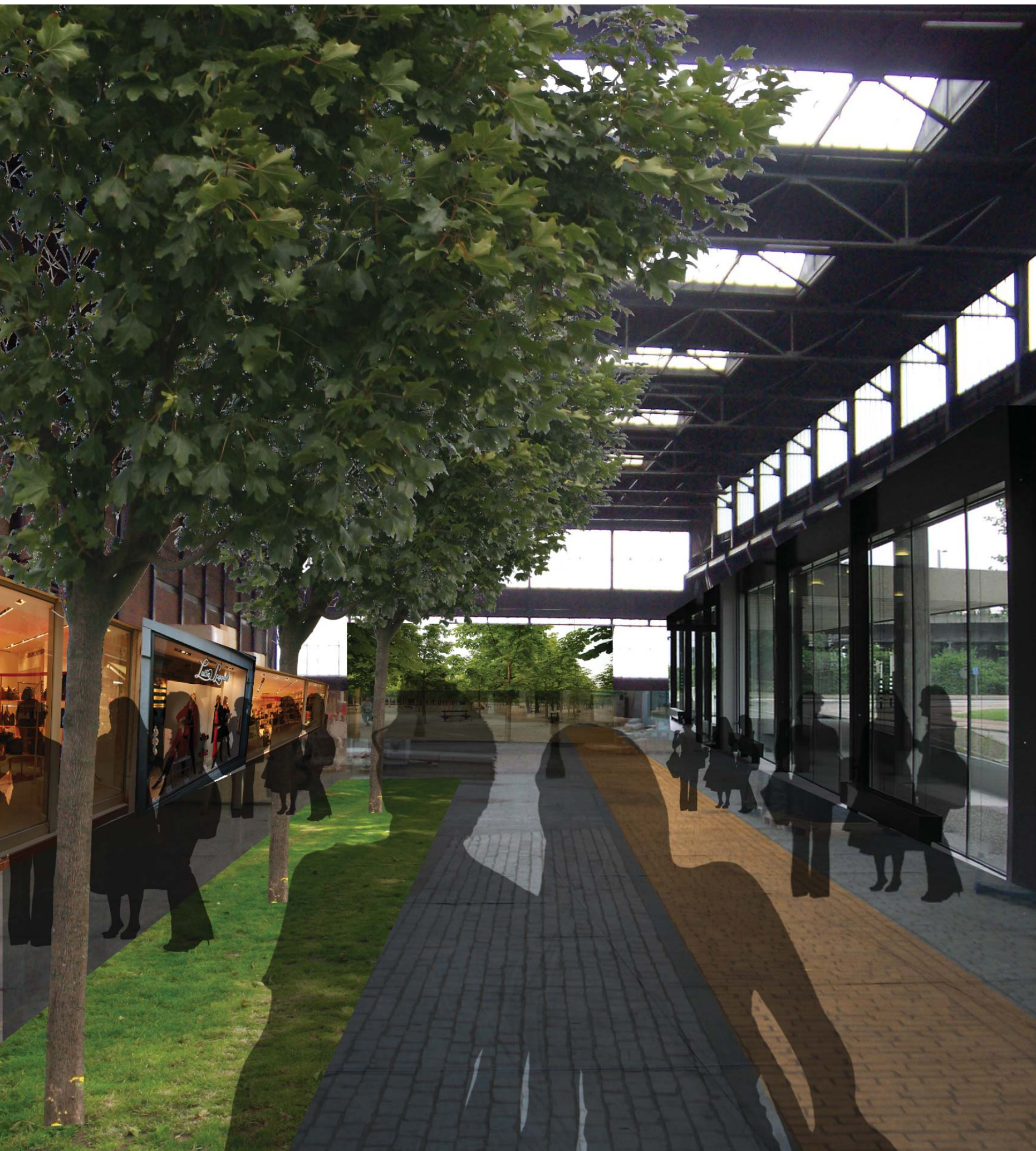

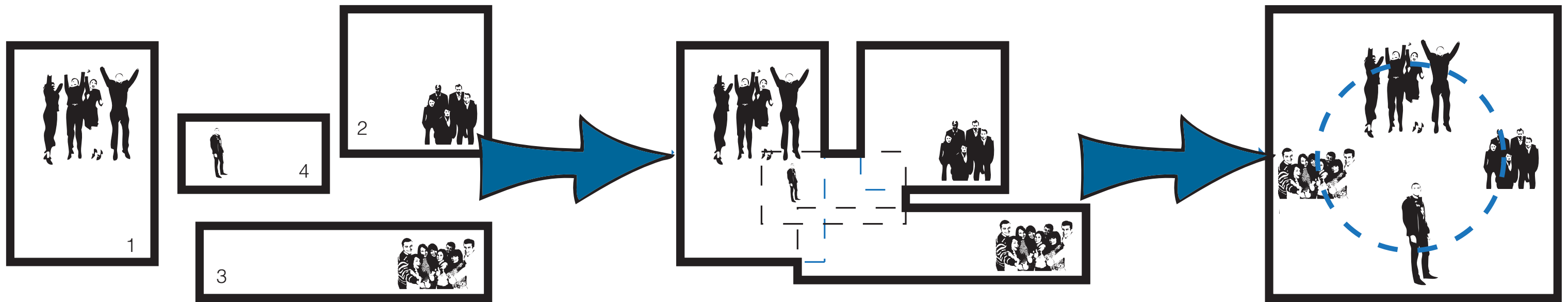

1. (Young) professionals

2. DiNk-ies (starters with double income)

3. Students

4. Artists



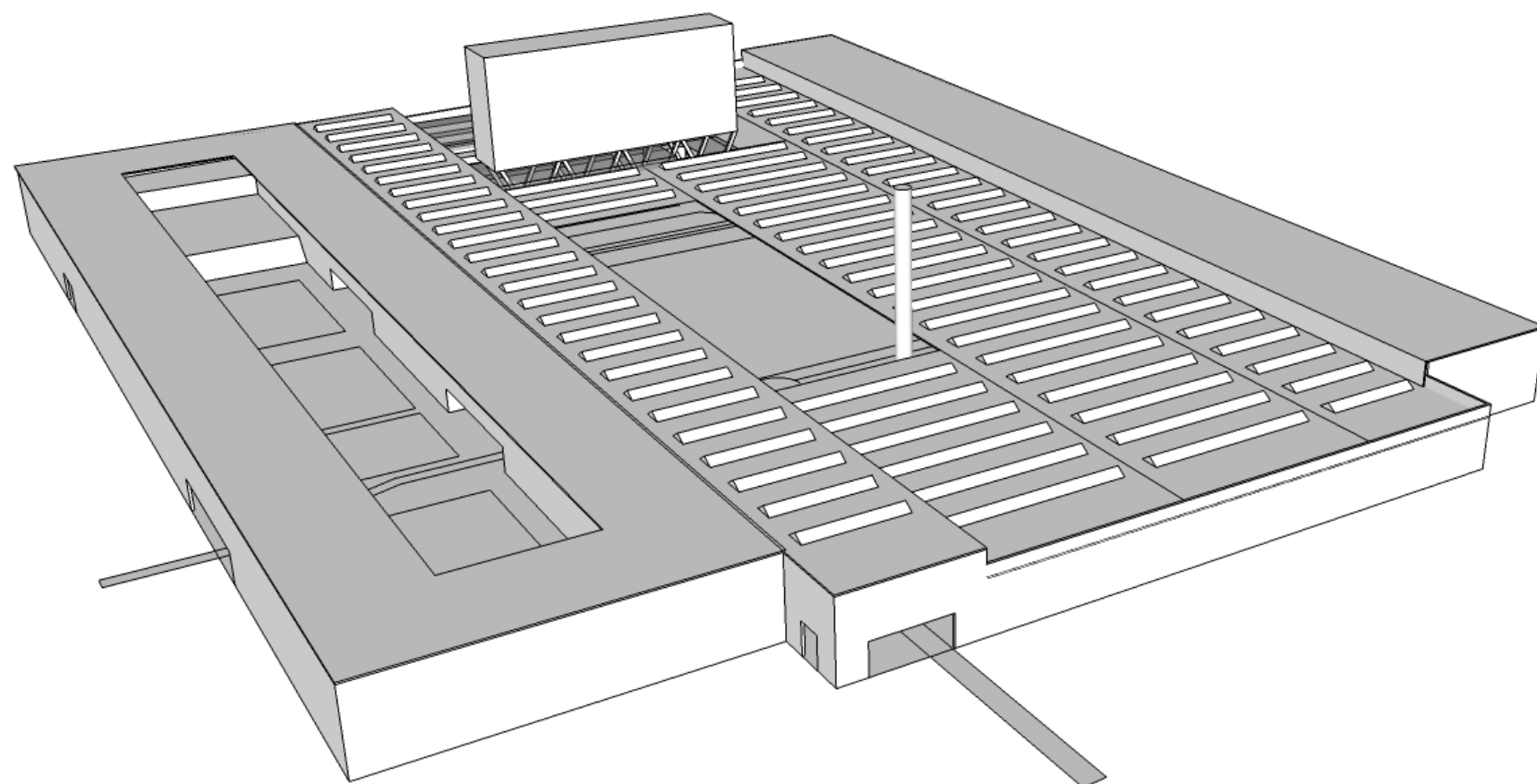

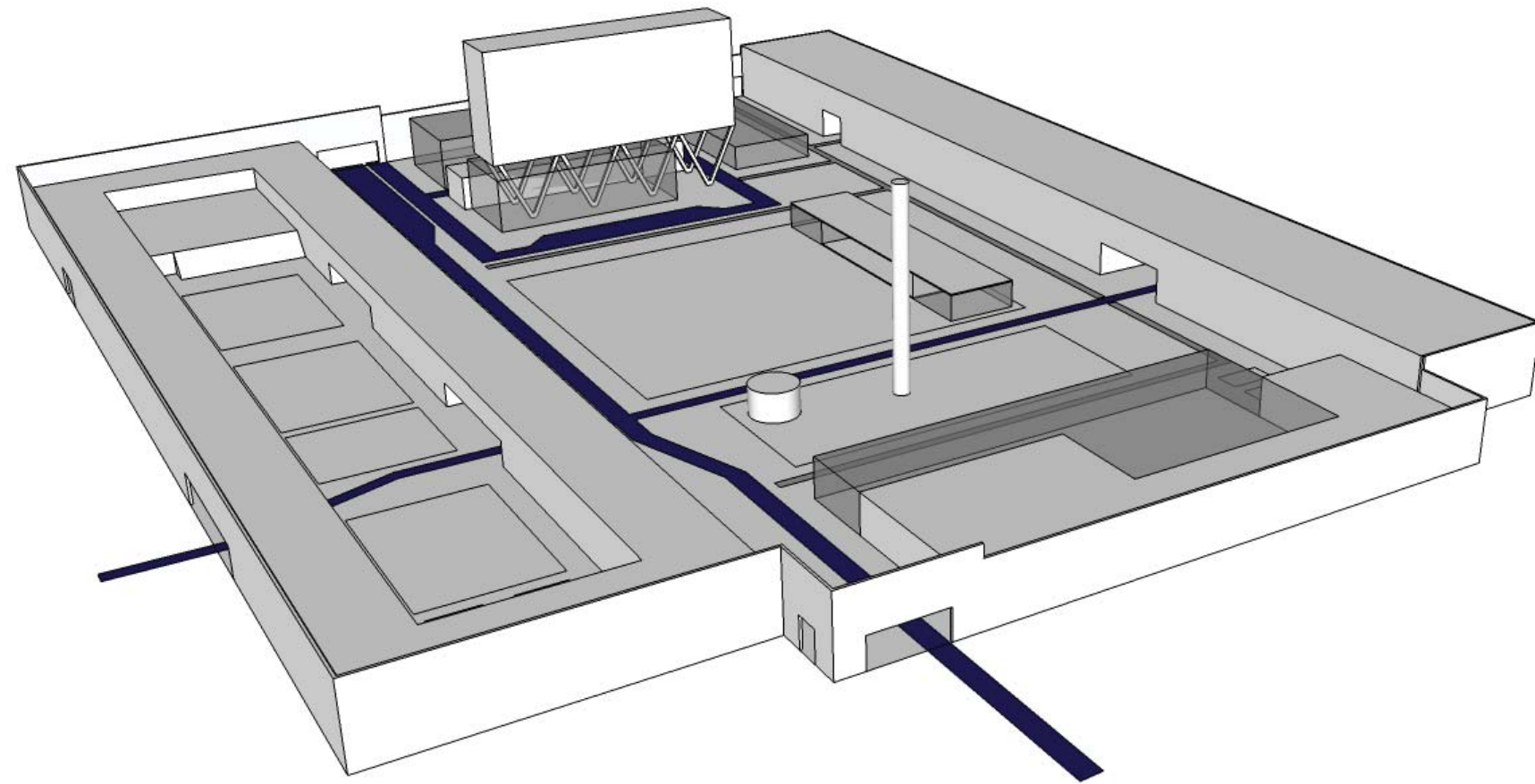





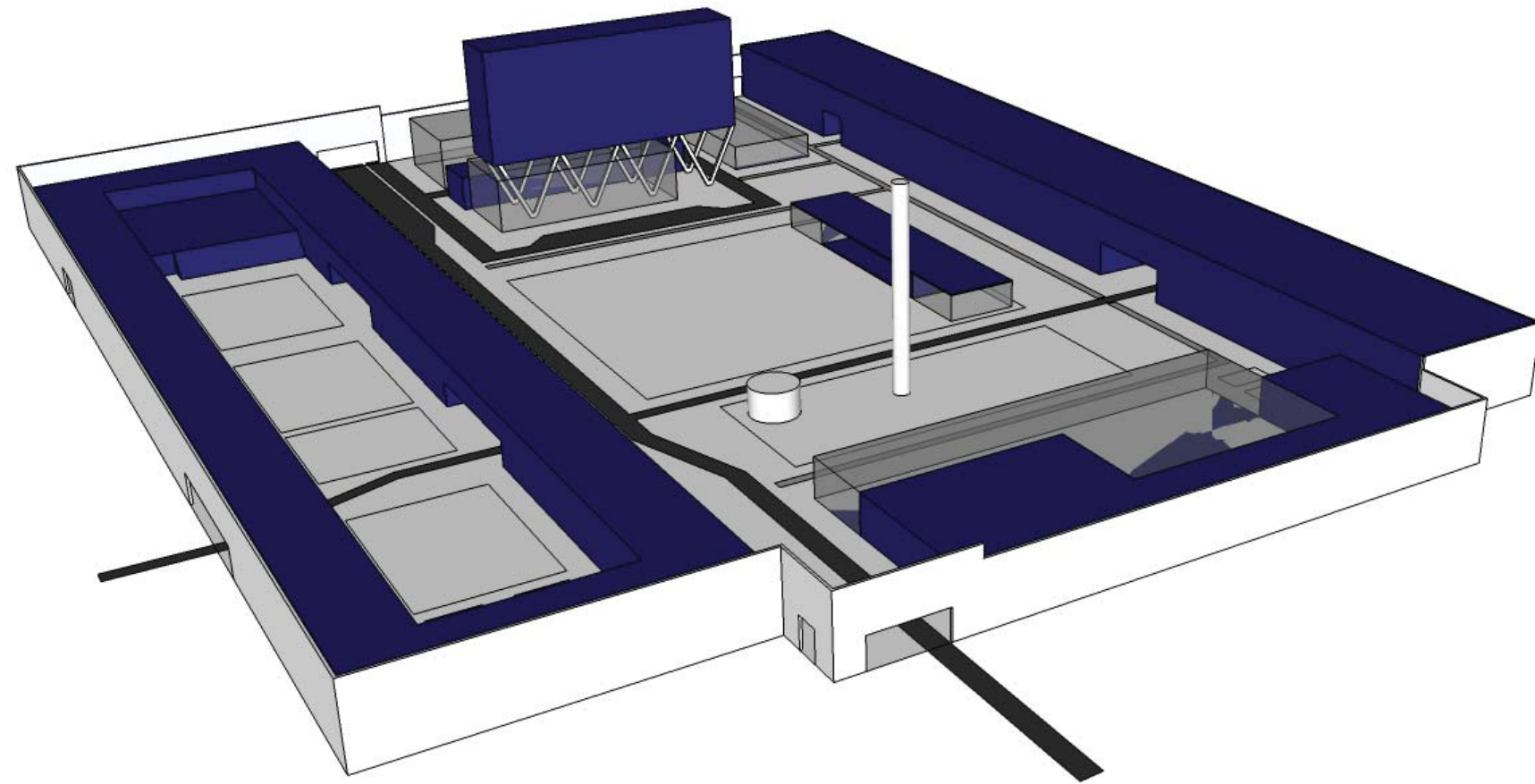

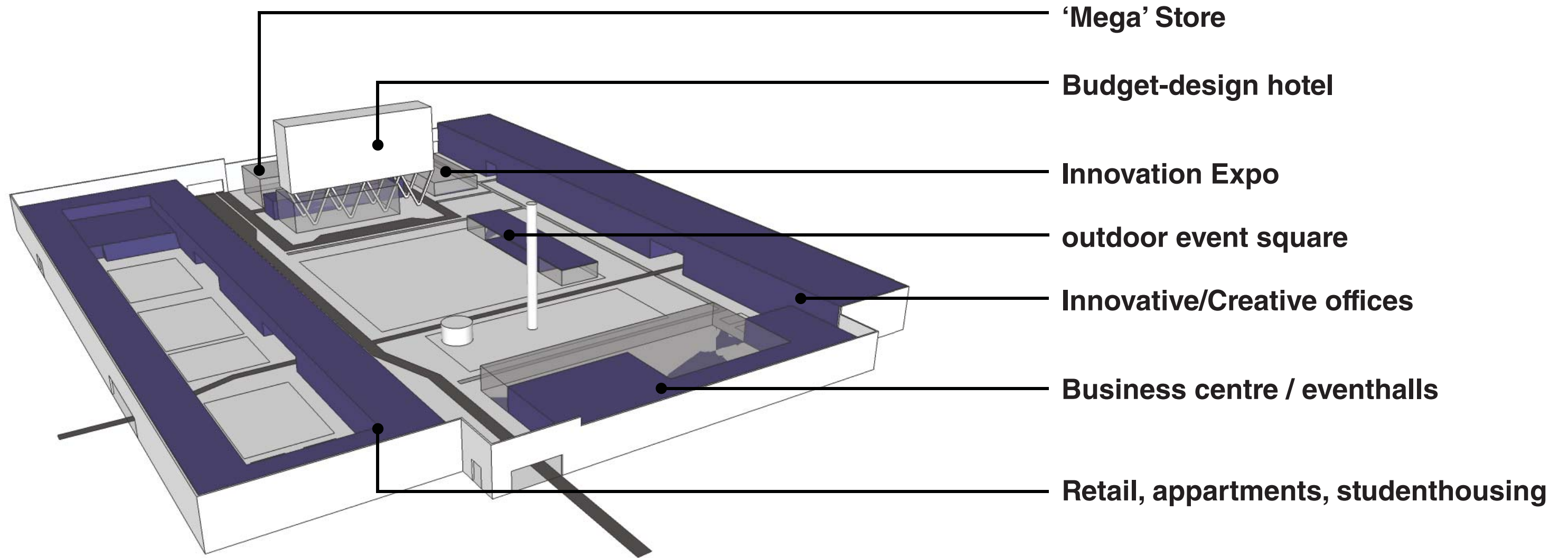



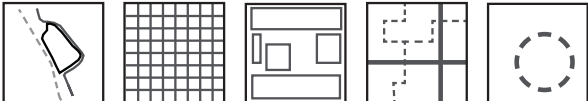

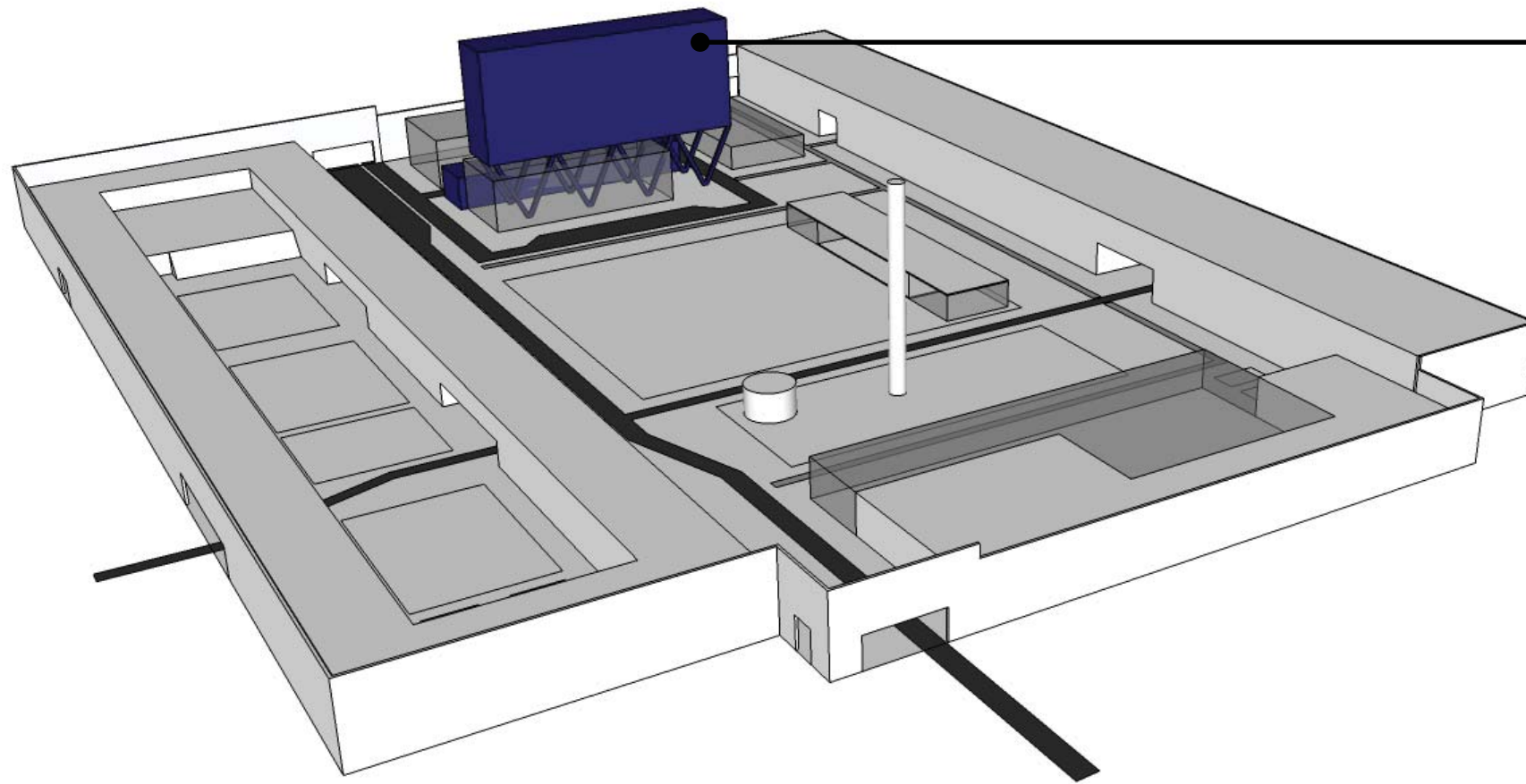

Budget-design hotel

exposition space
relax/fitness centre
restaurant
hotelrooms



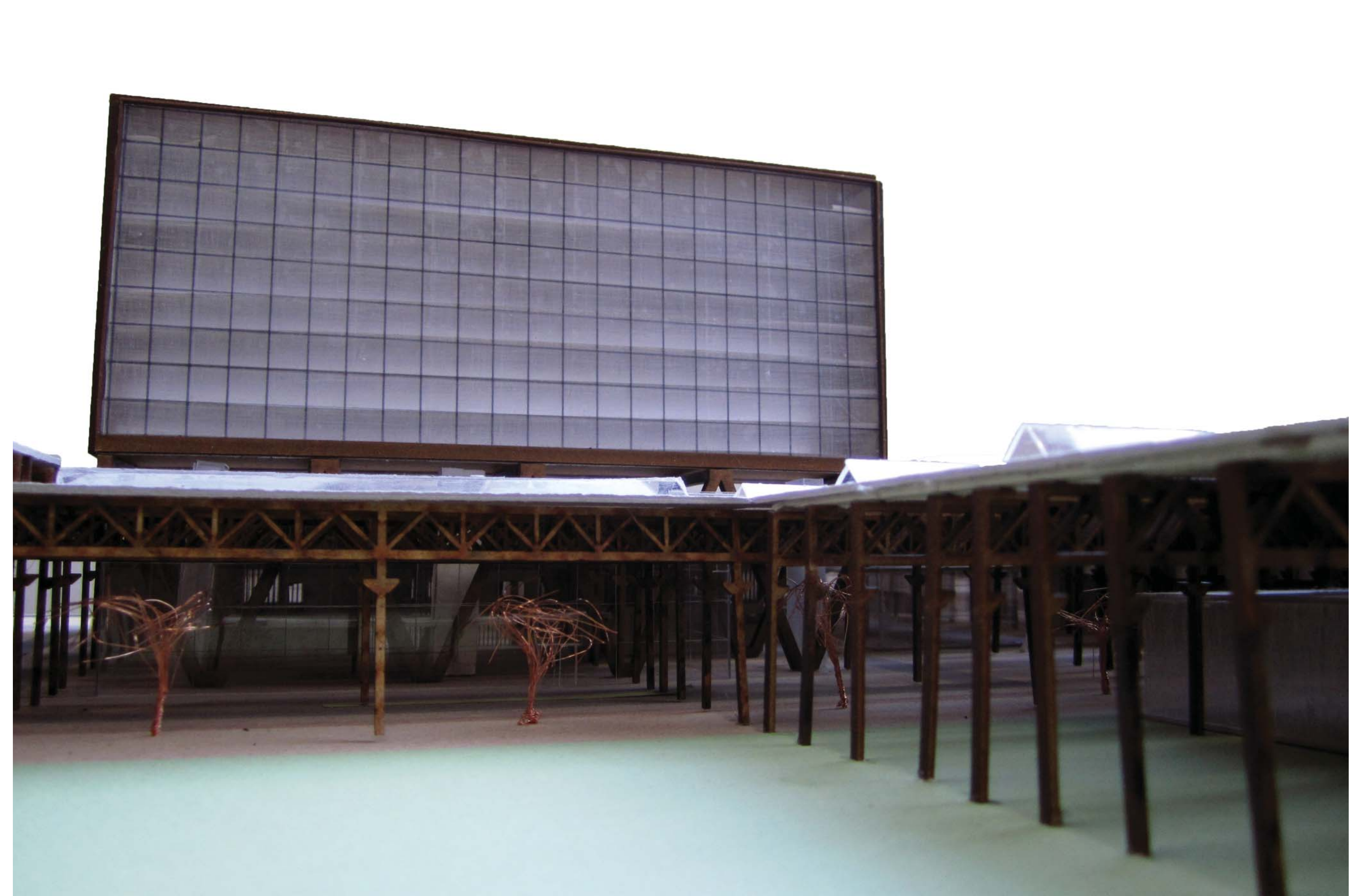

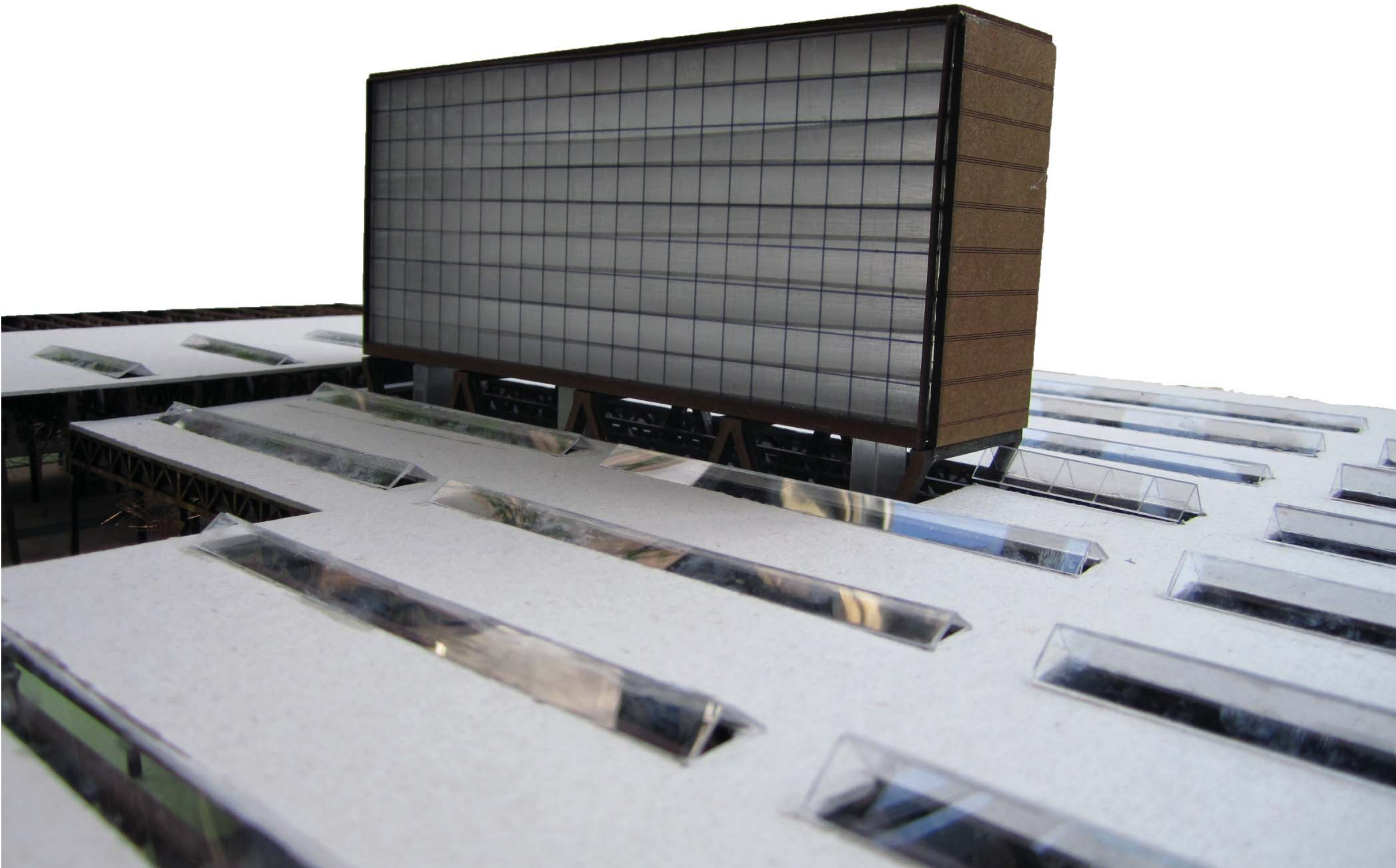

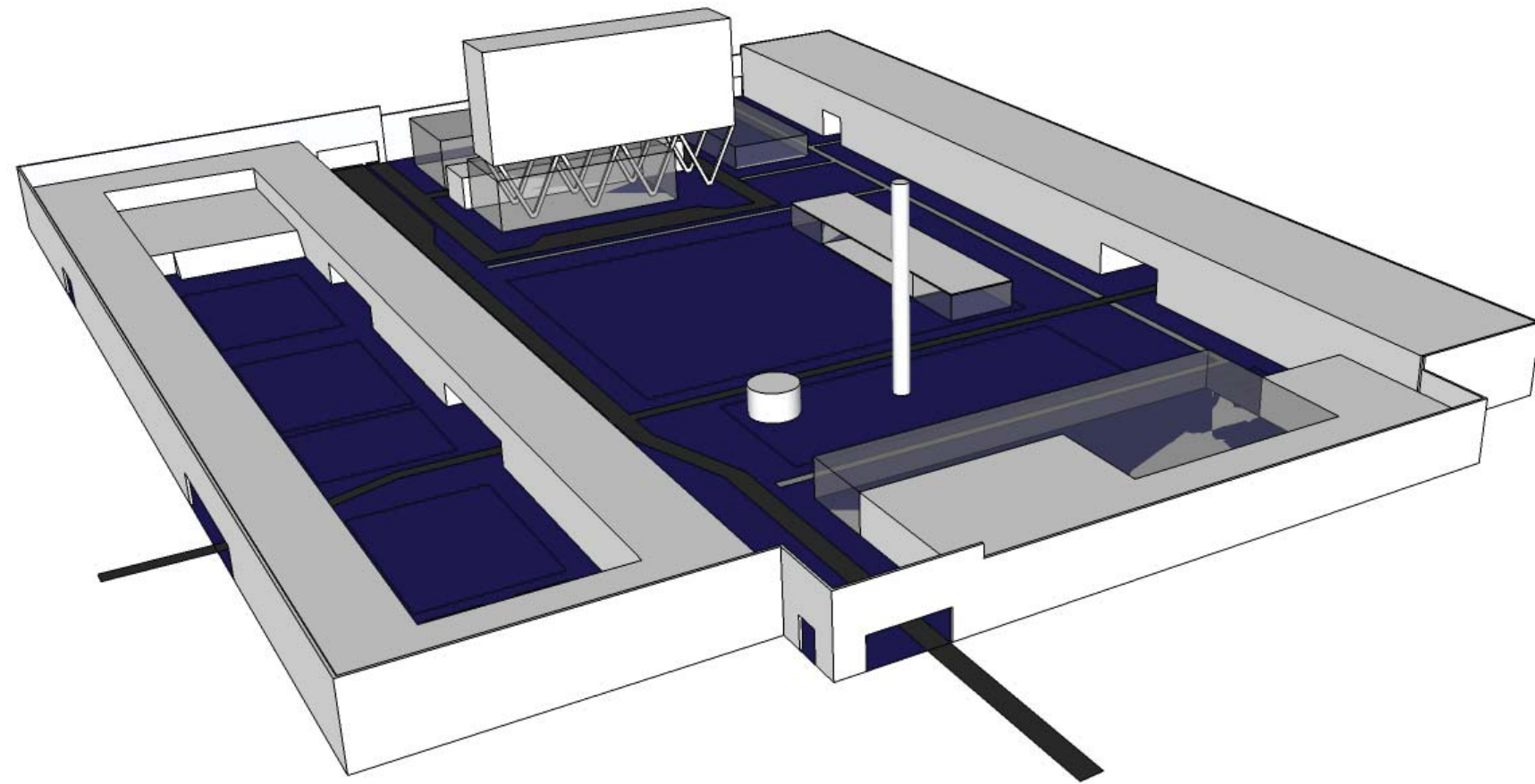

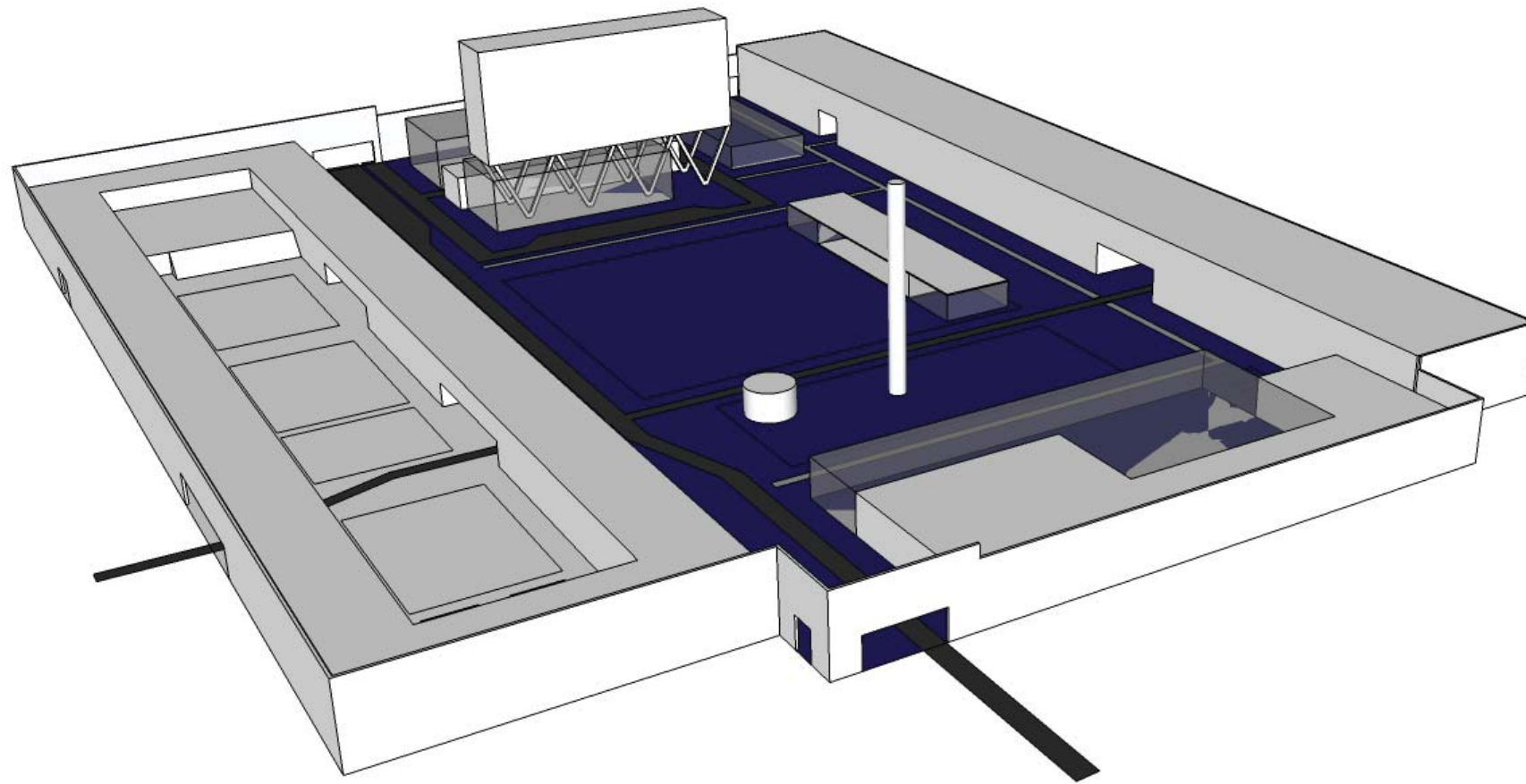

Grote markt, Delft NL



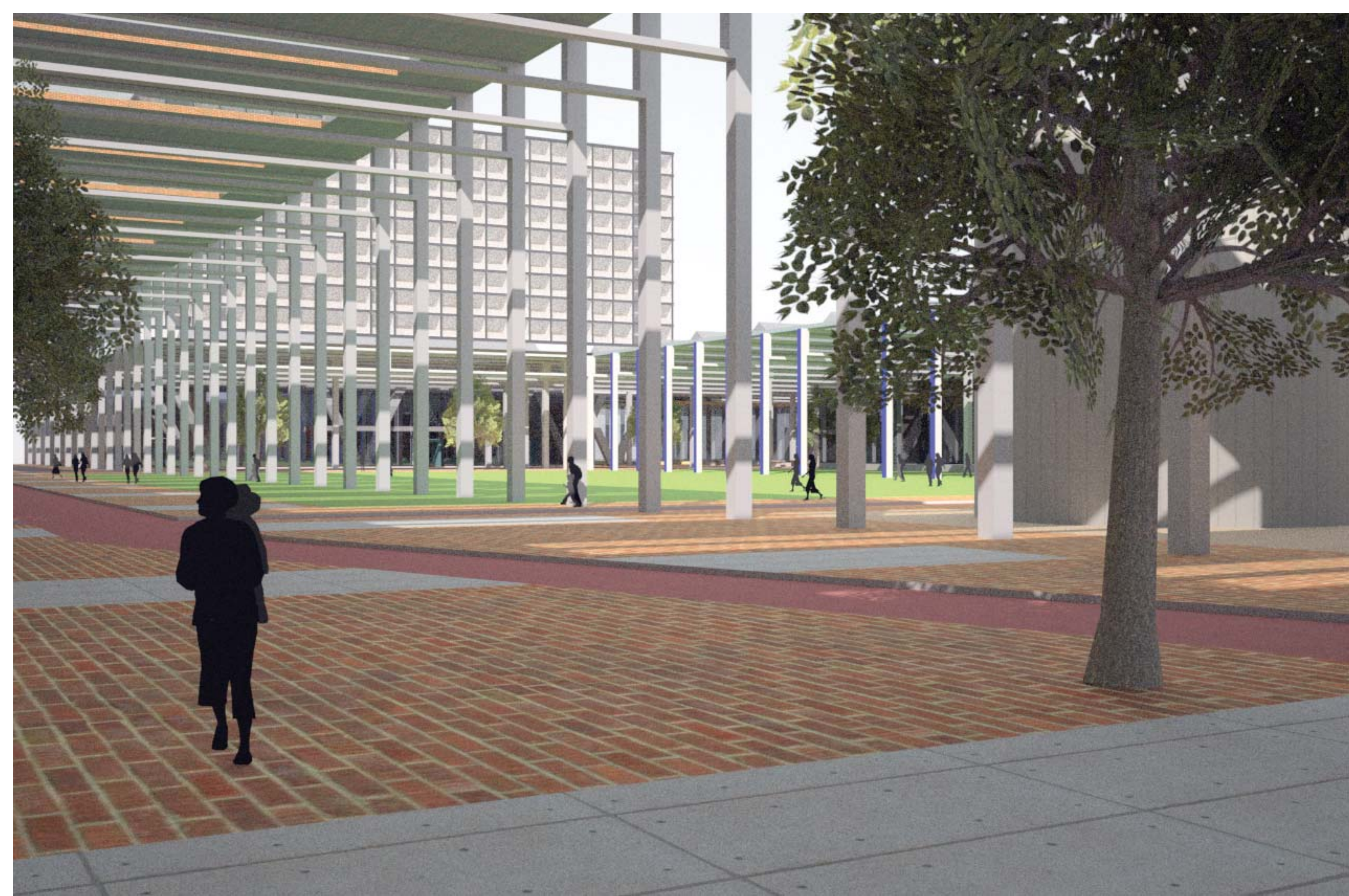

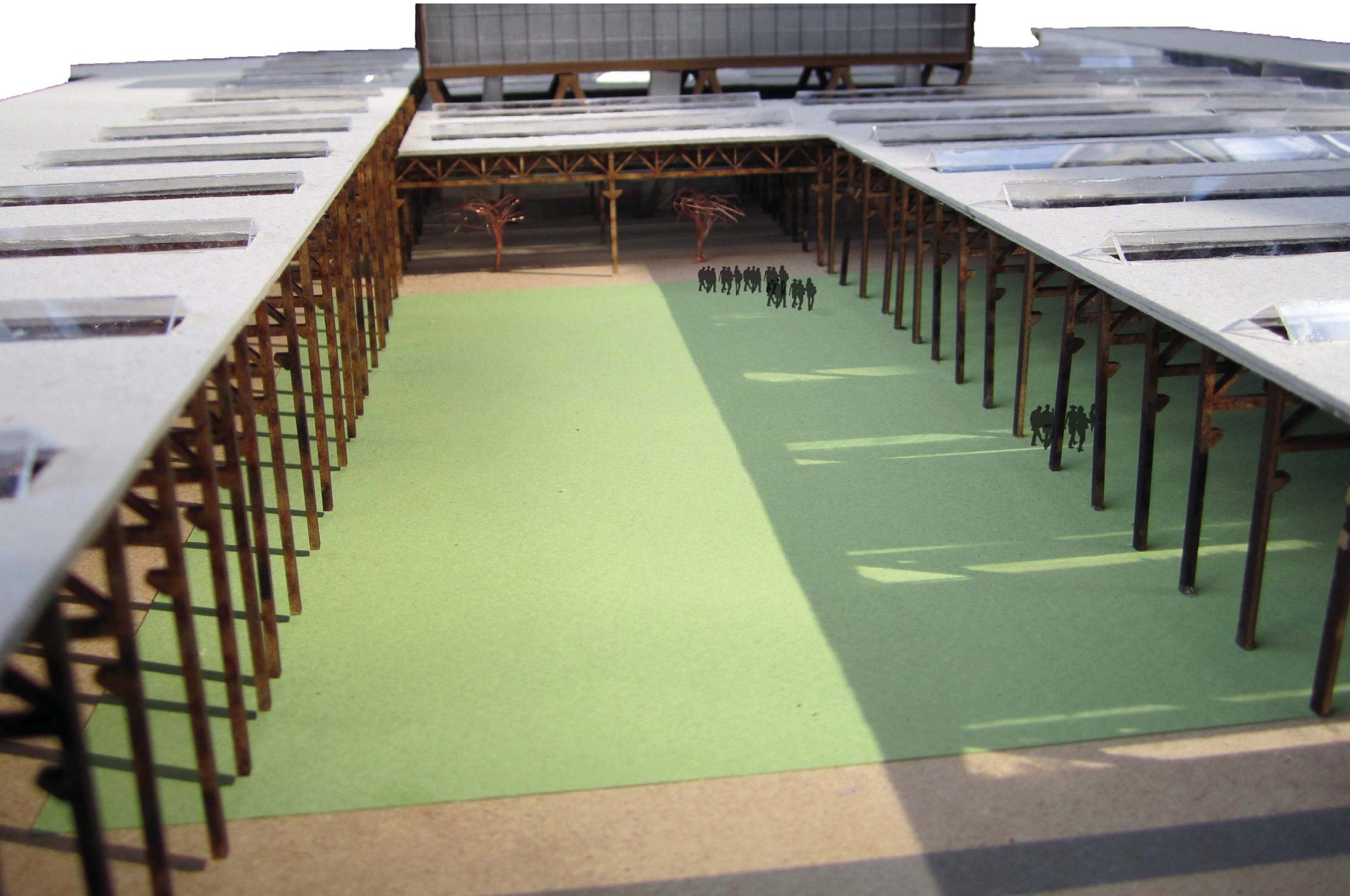

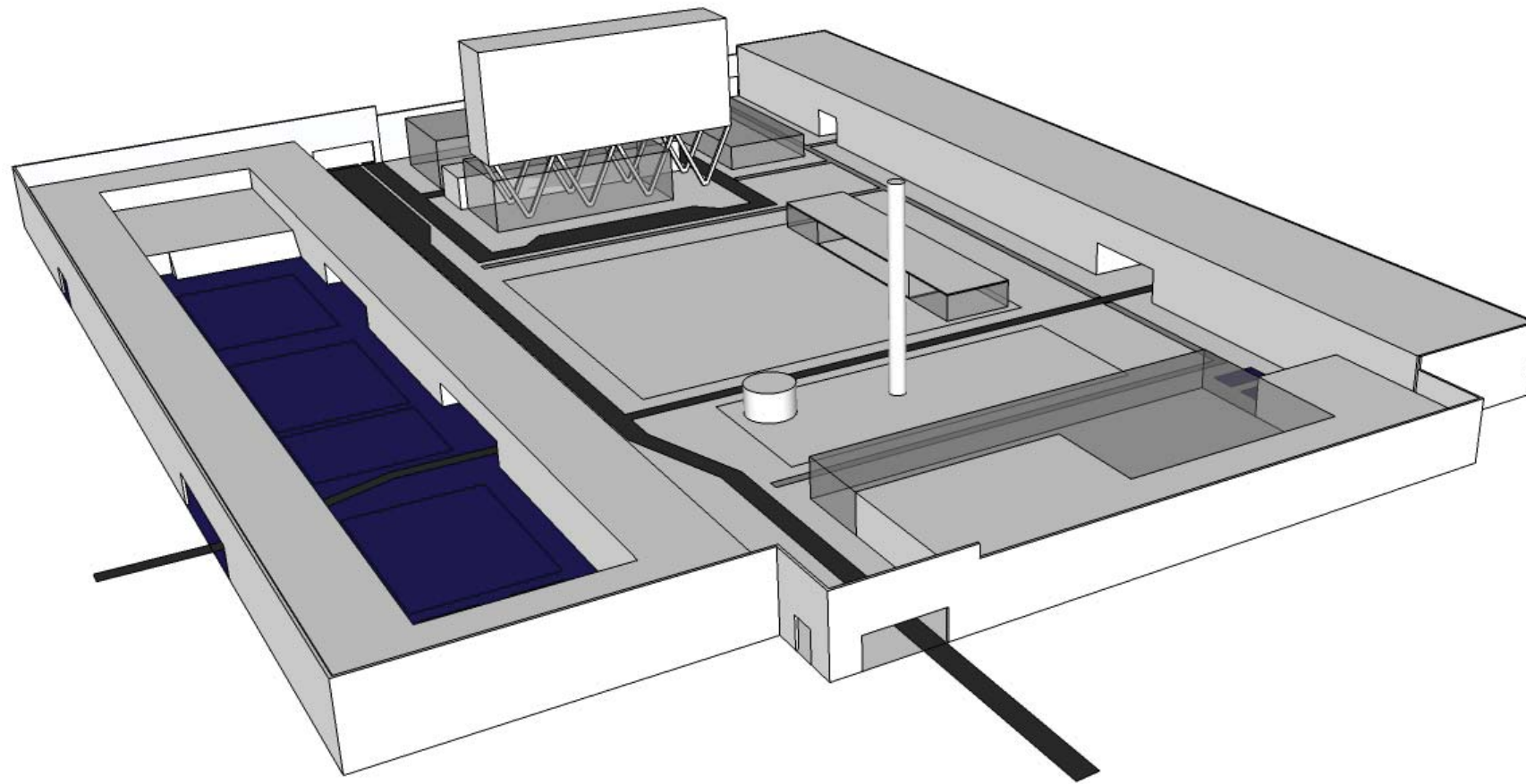

Doelenplein, Delft NL







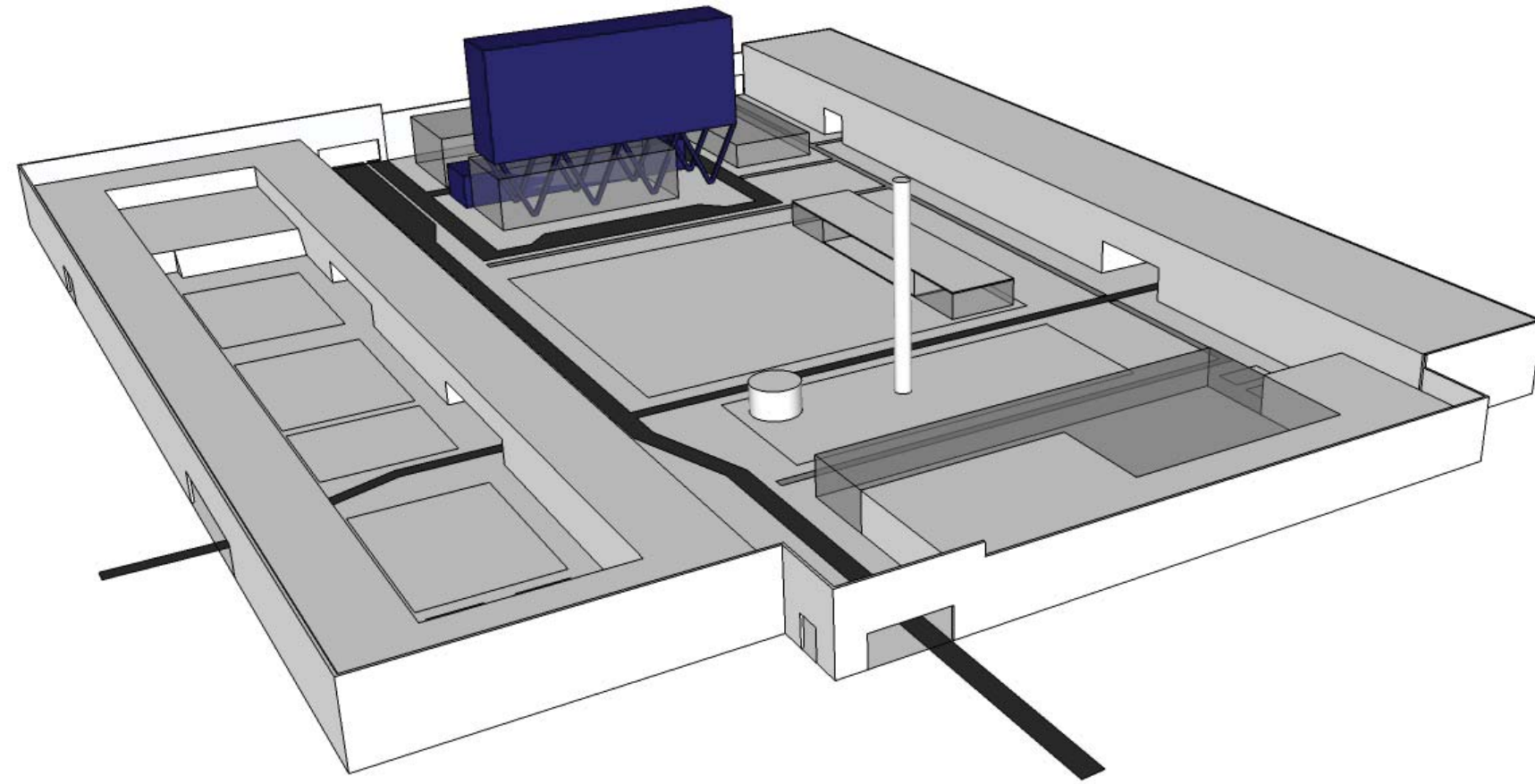

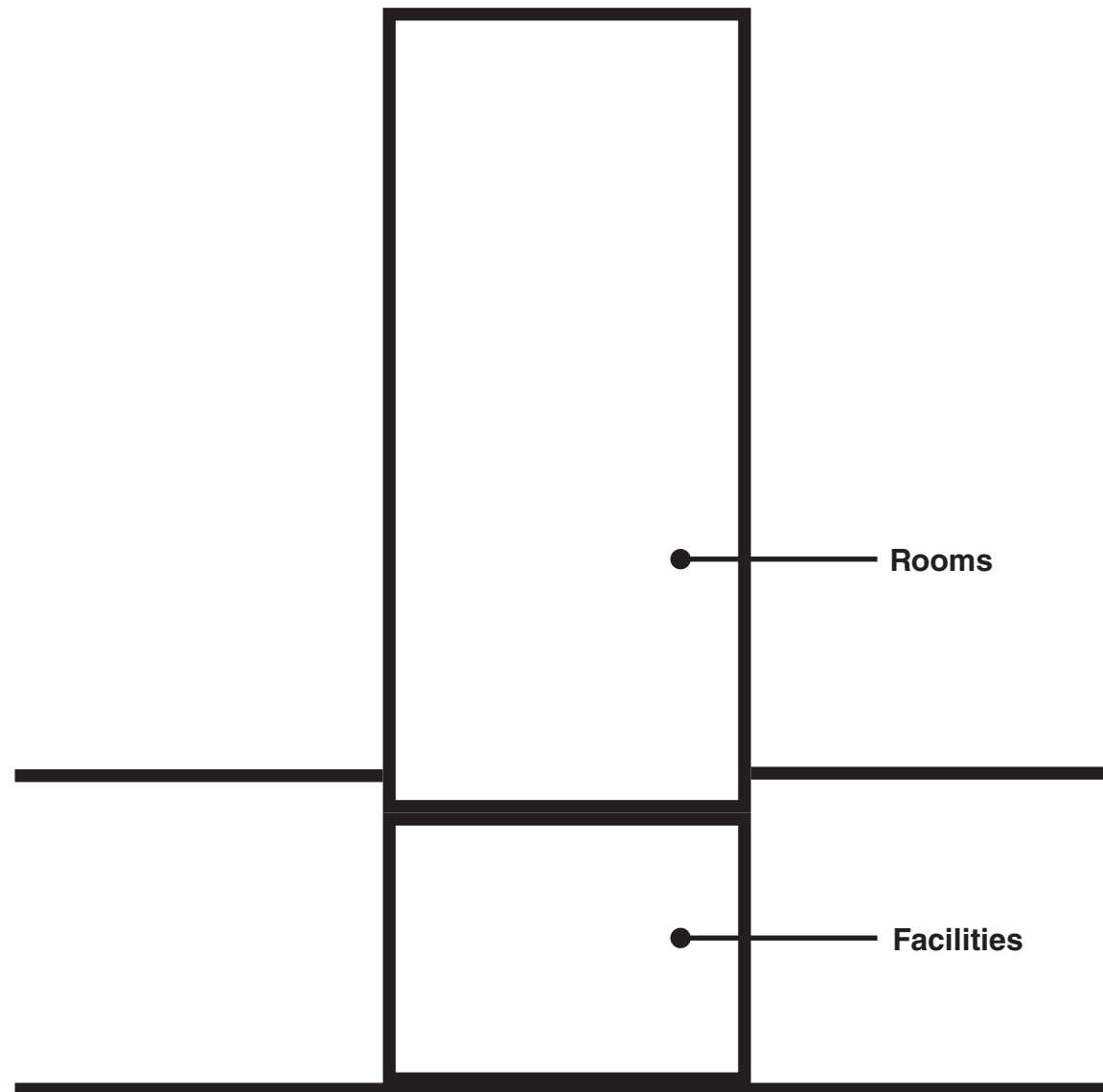

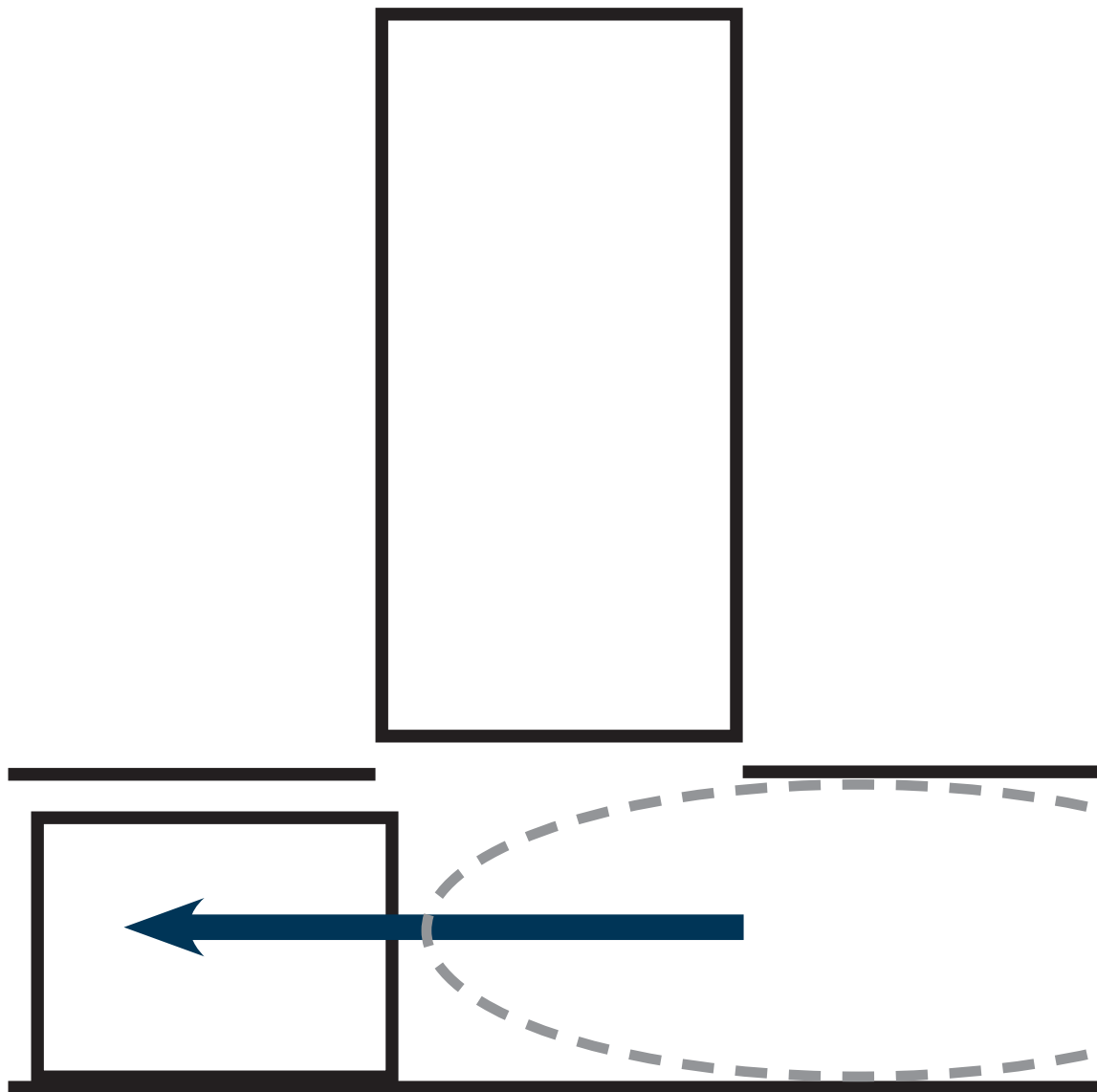

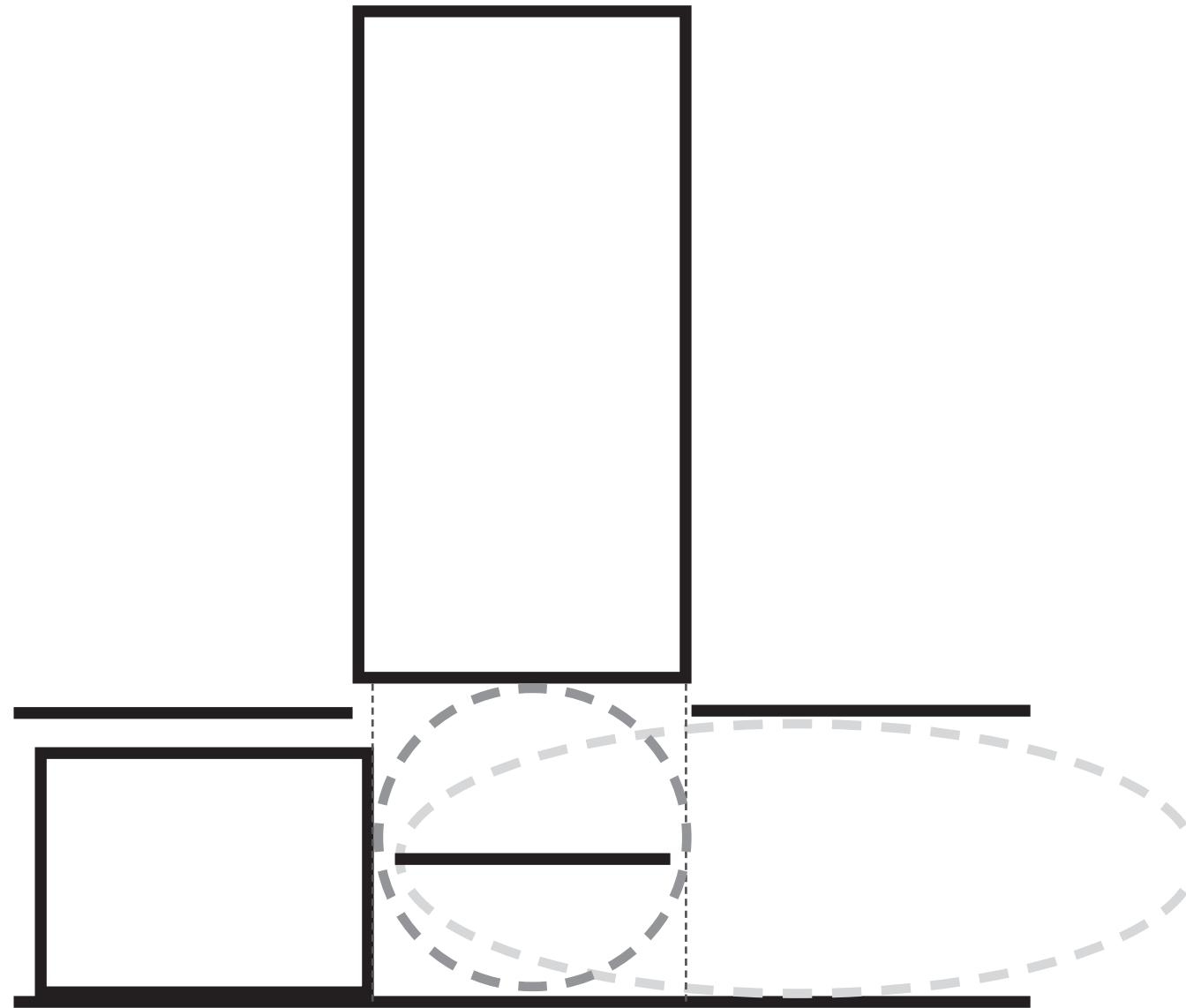

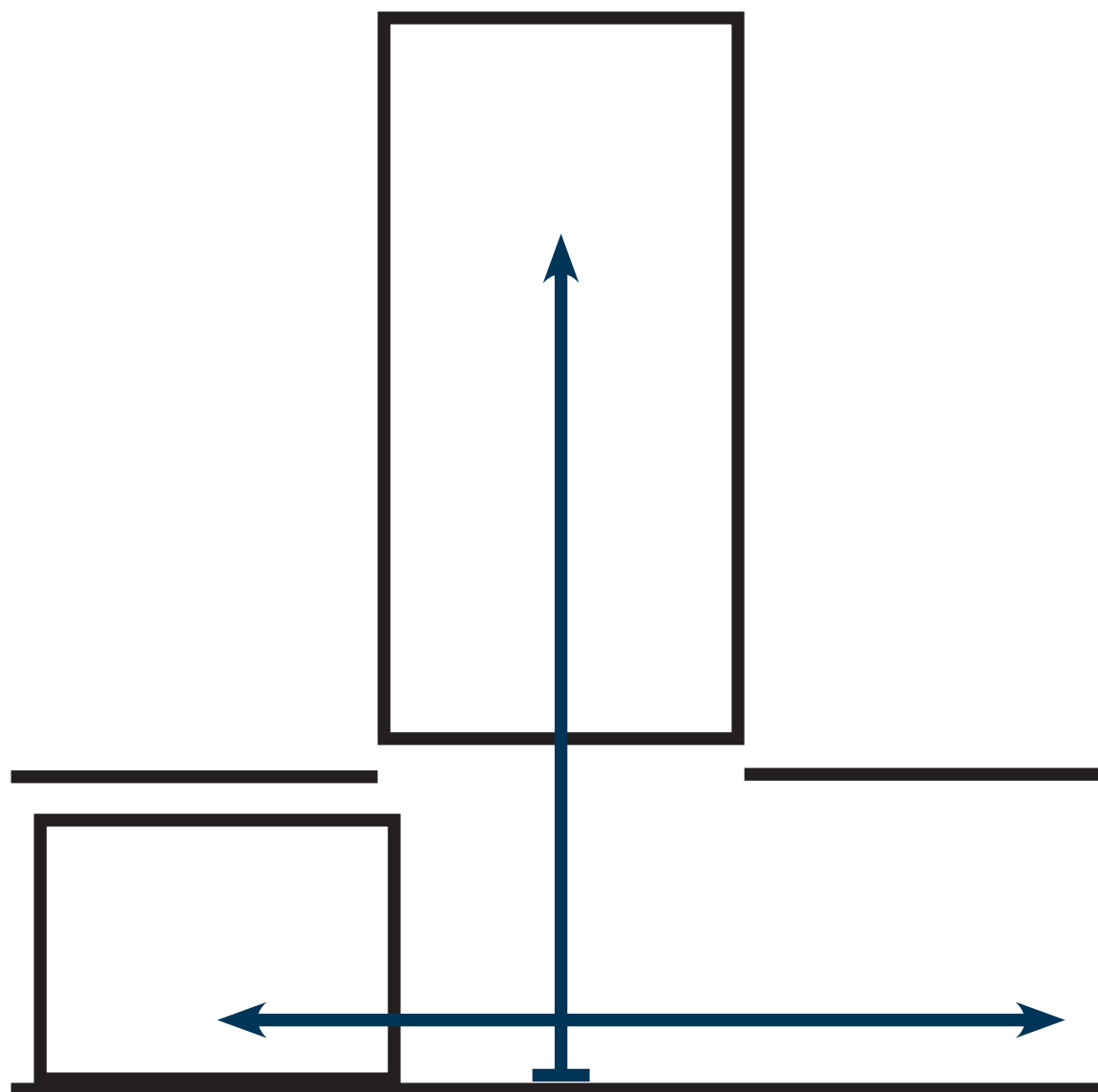

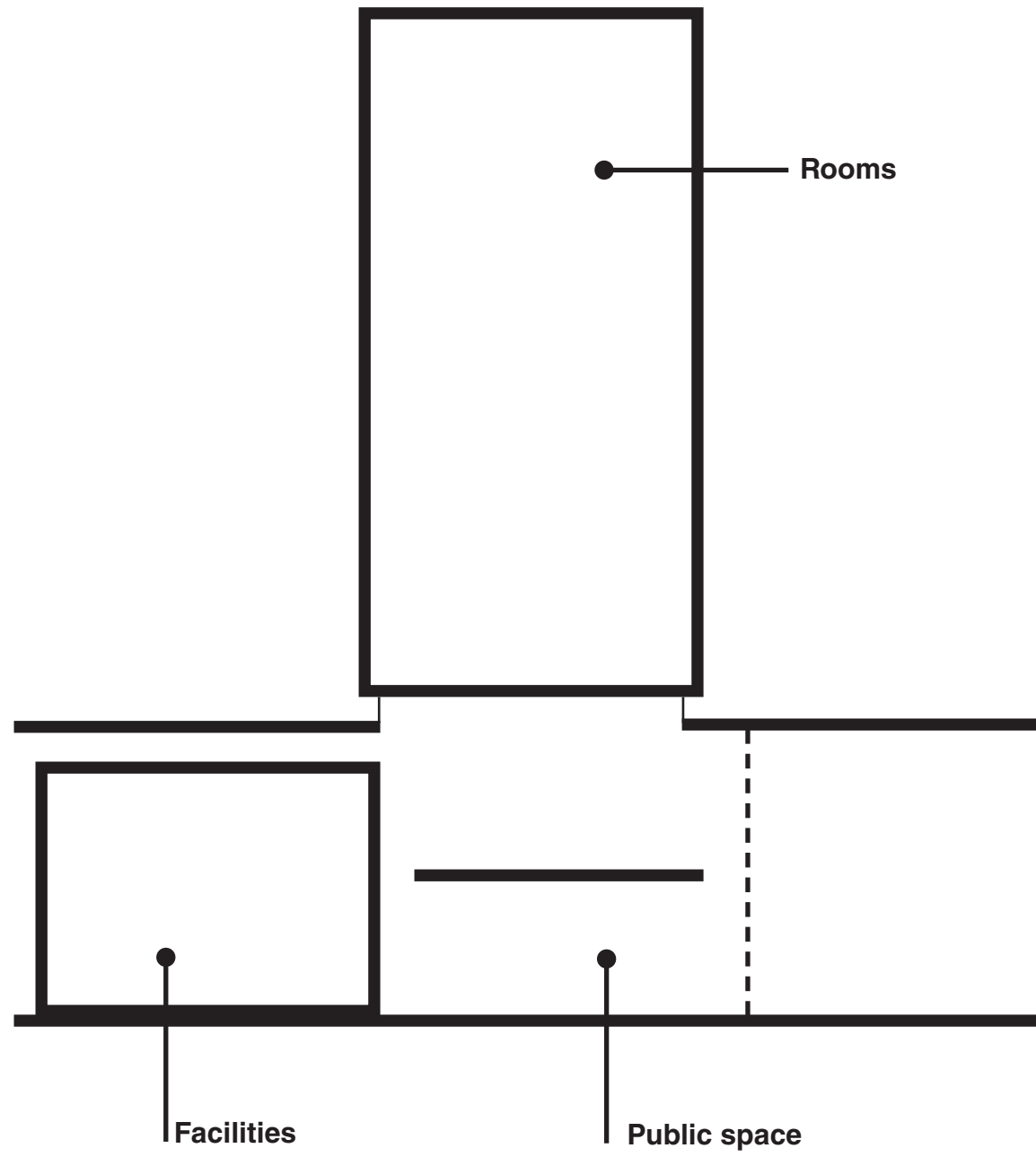

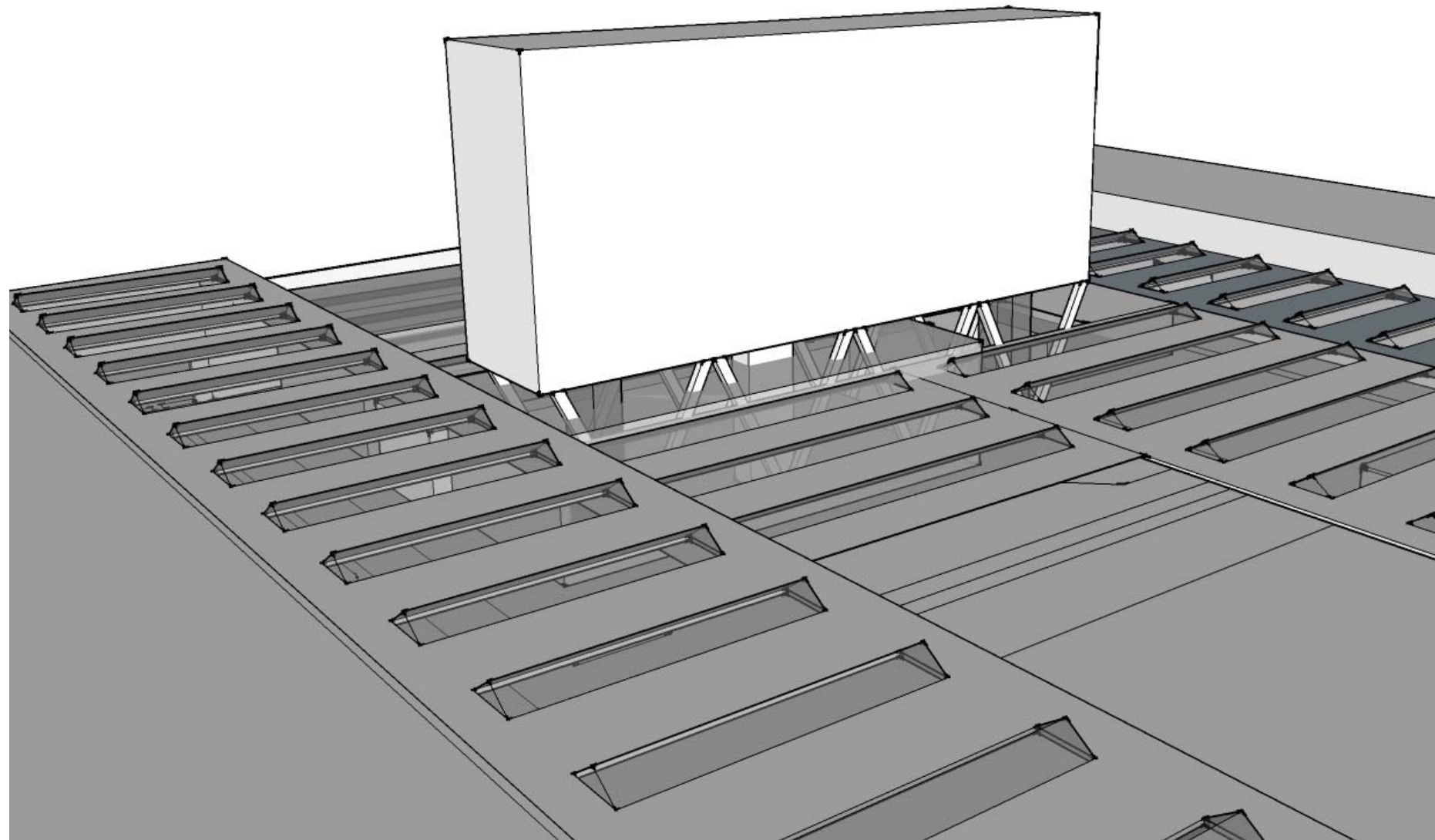

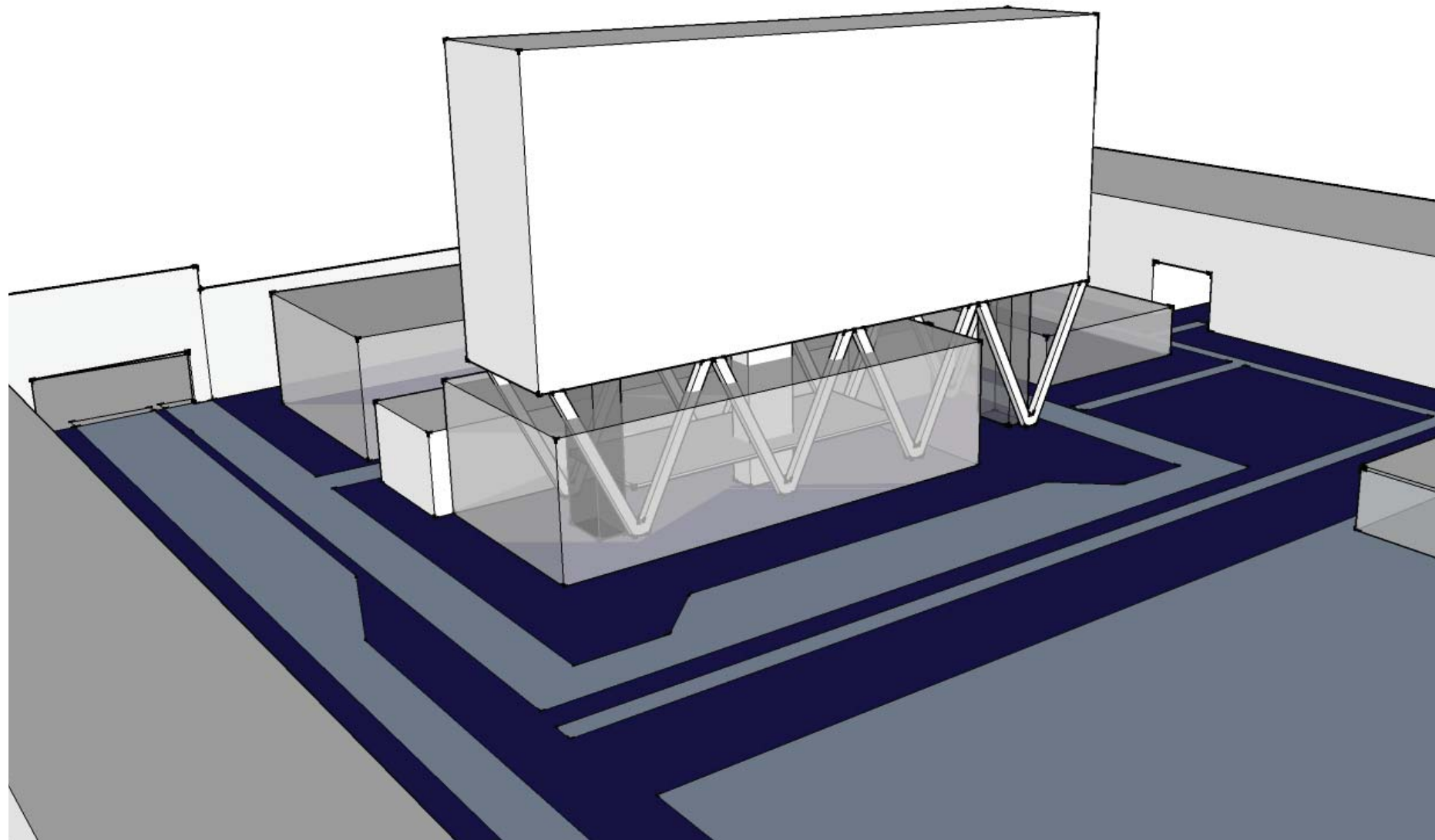

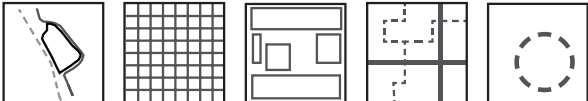
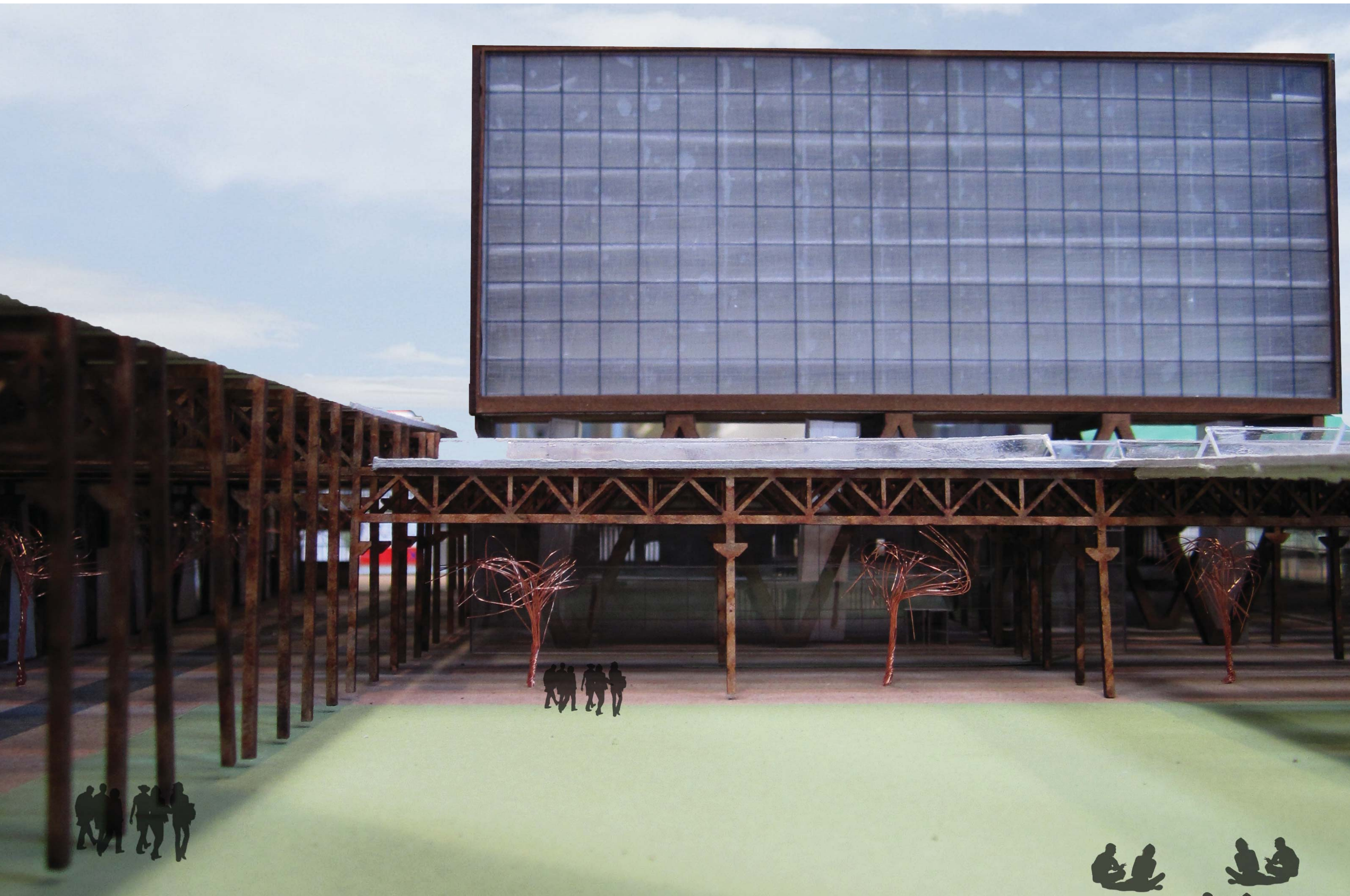

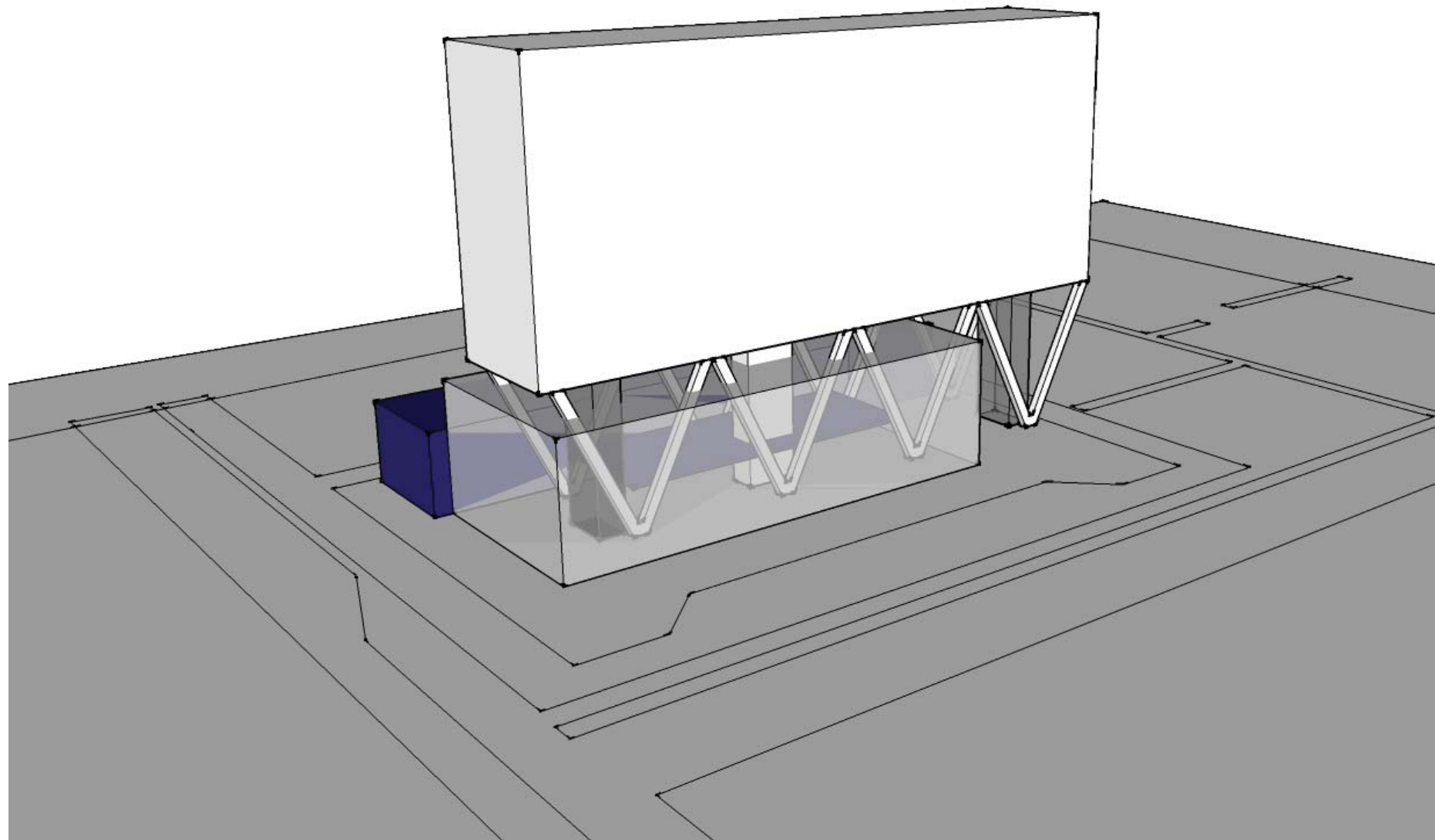

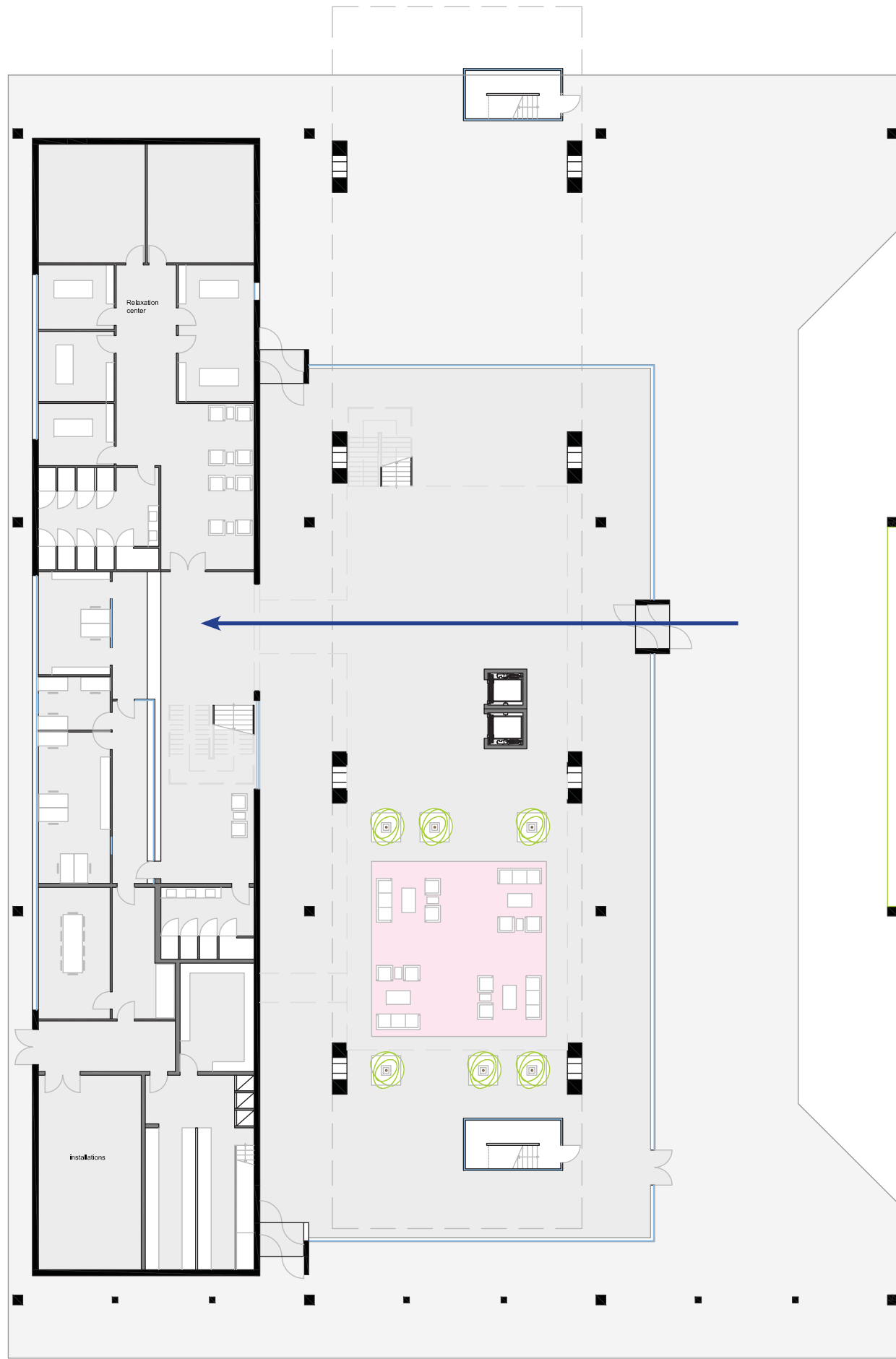

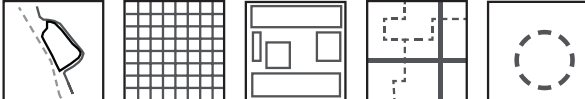

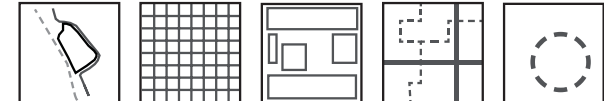

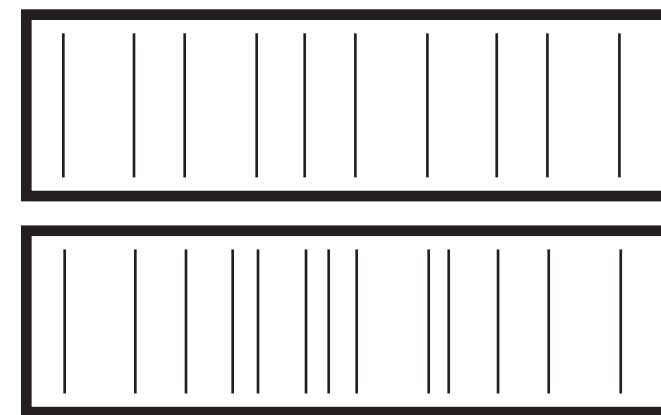
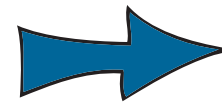
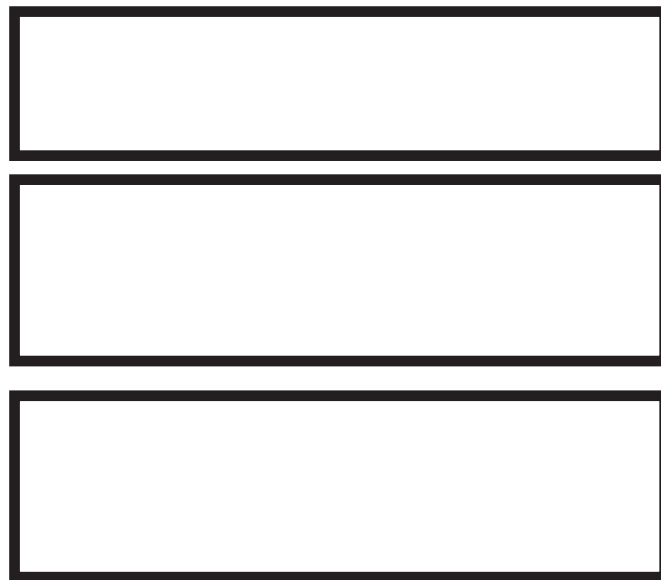
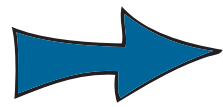
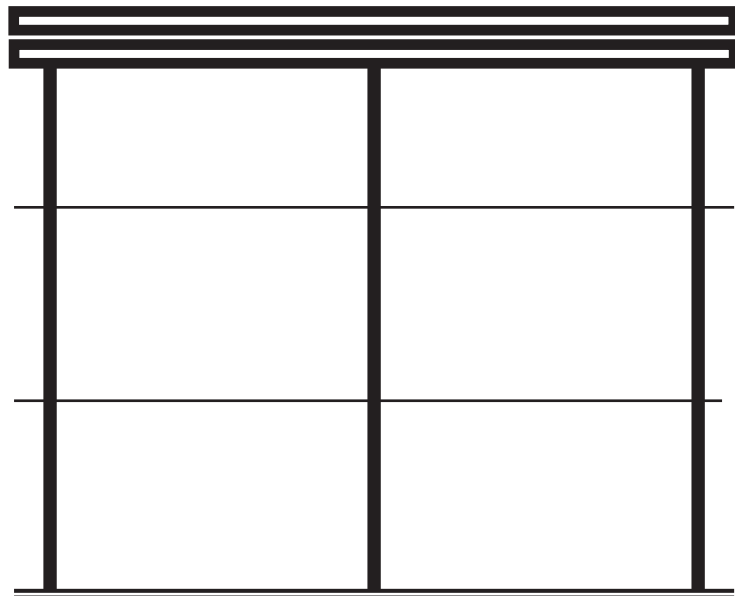

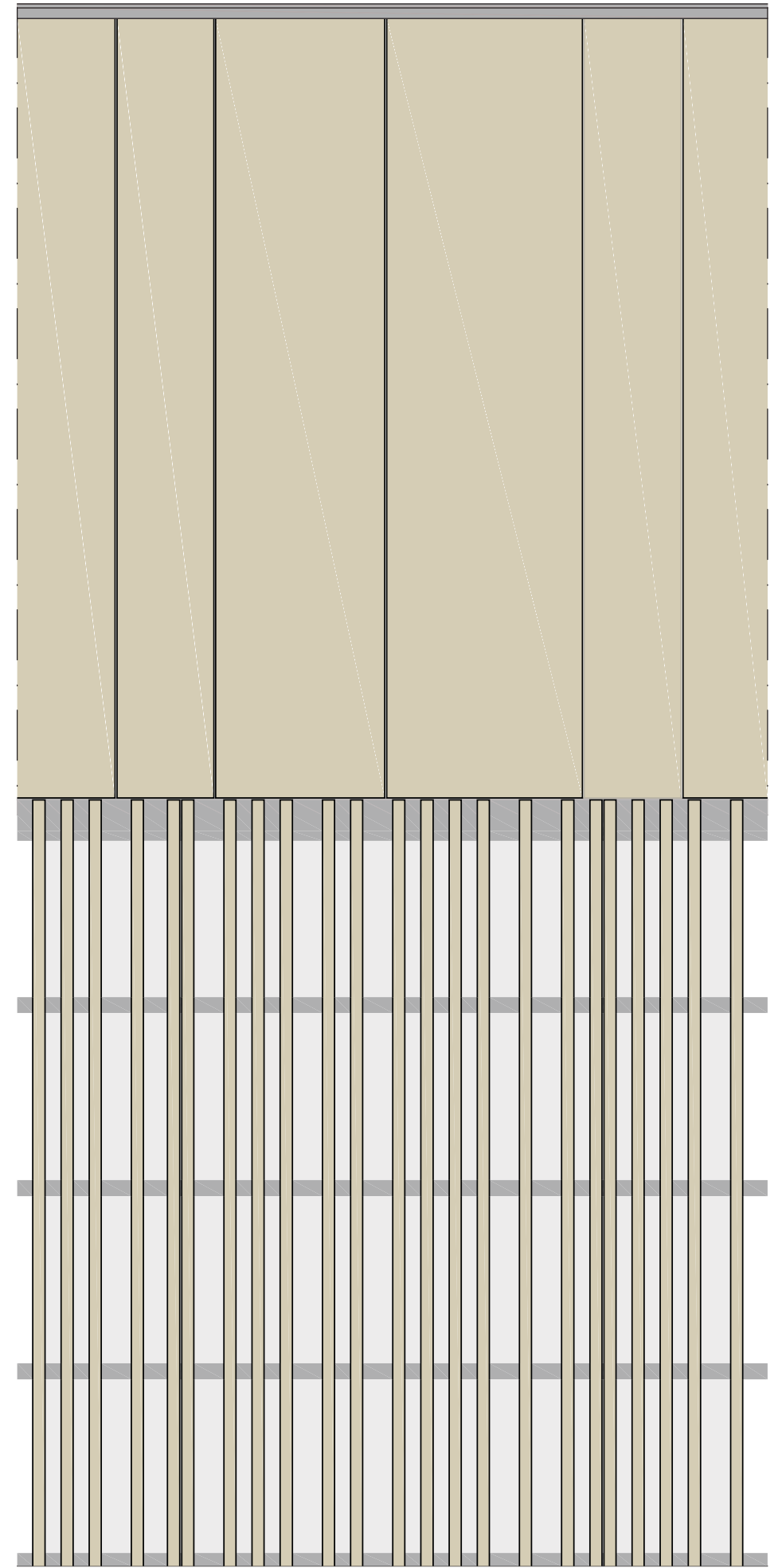
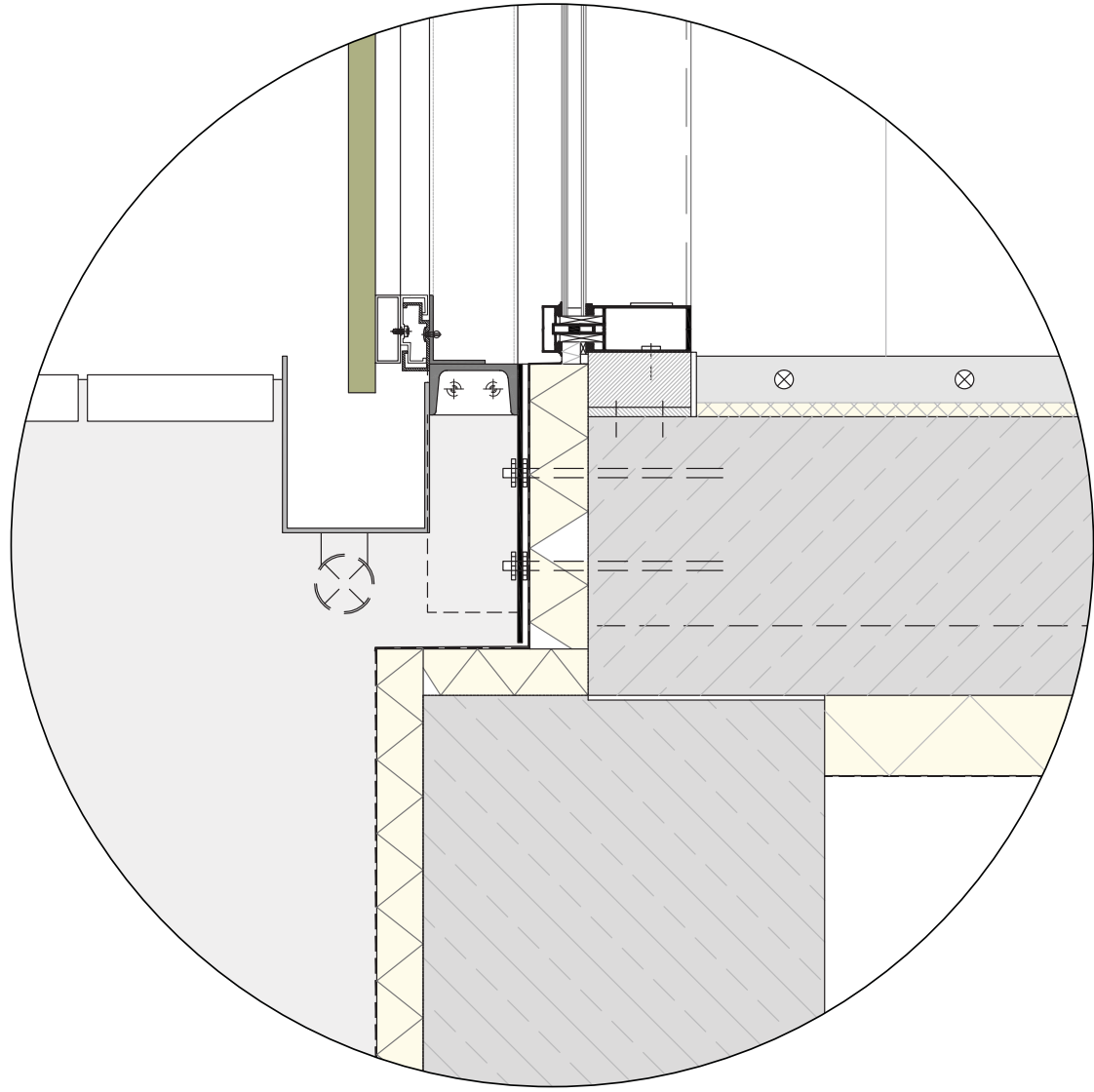

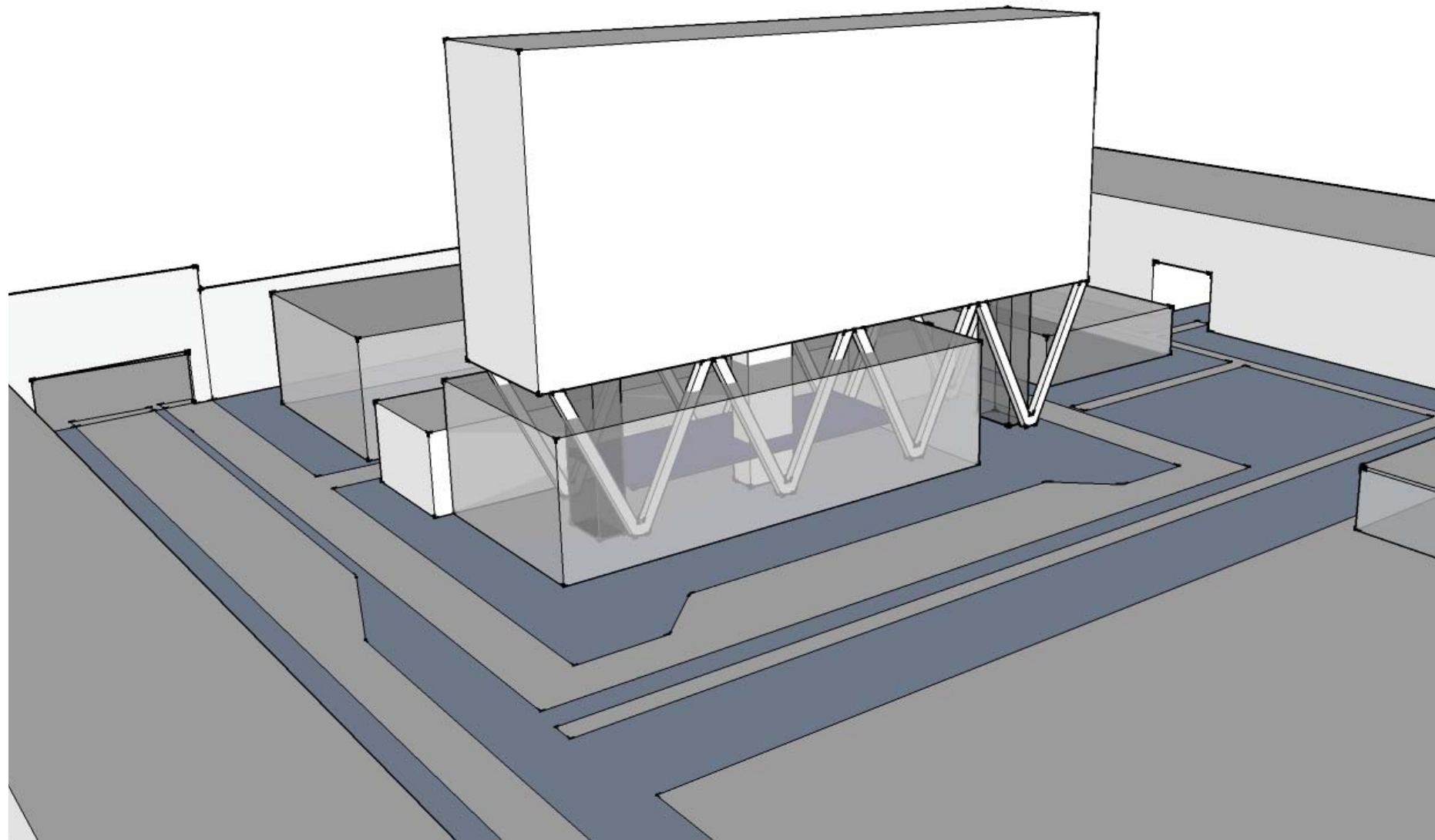

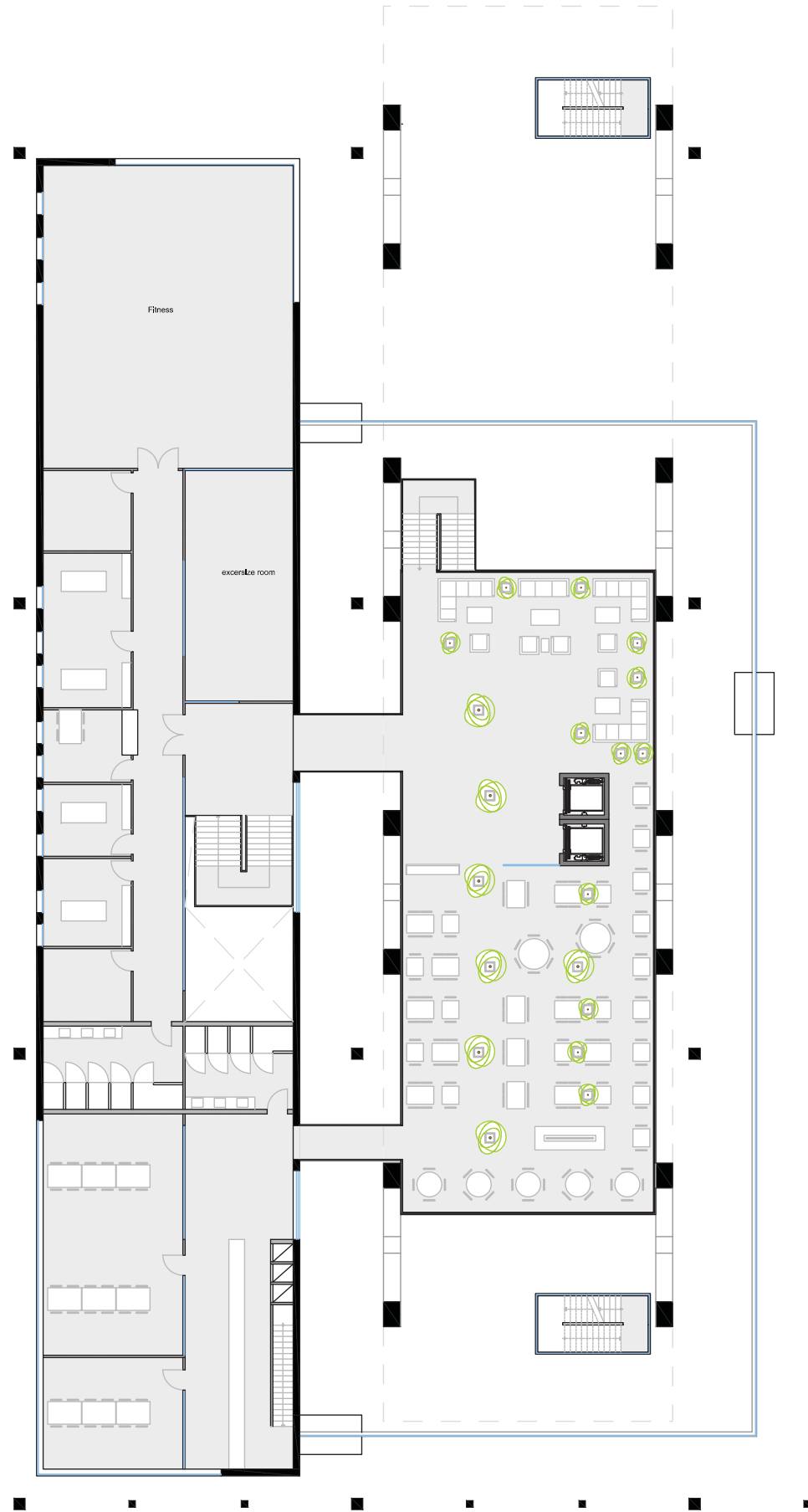

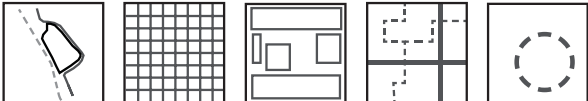
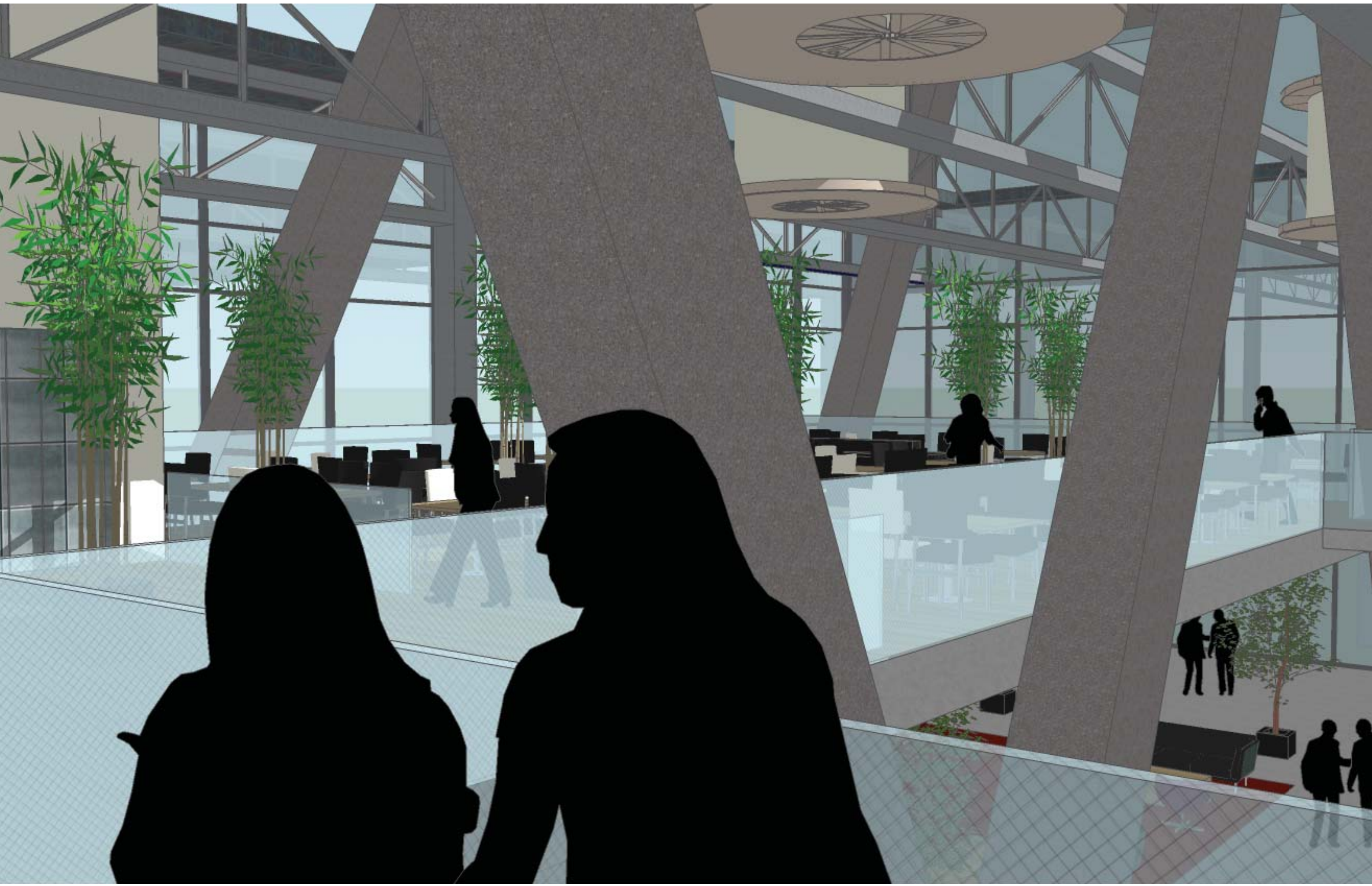

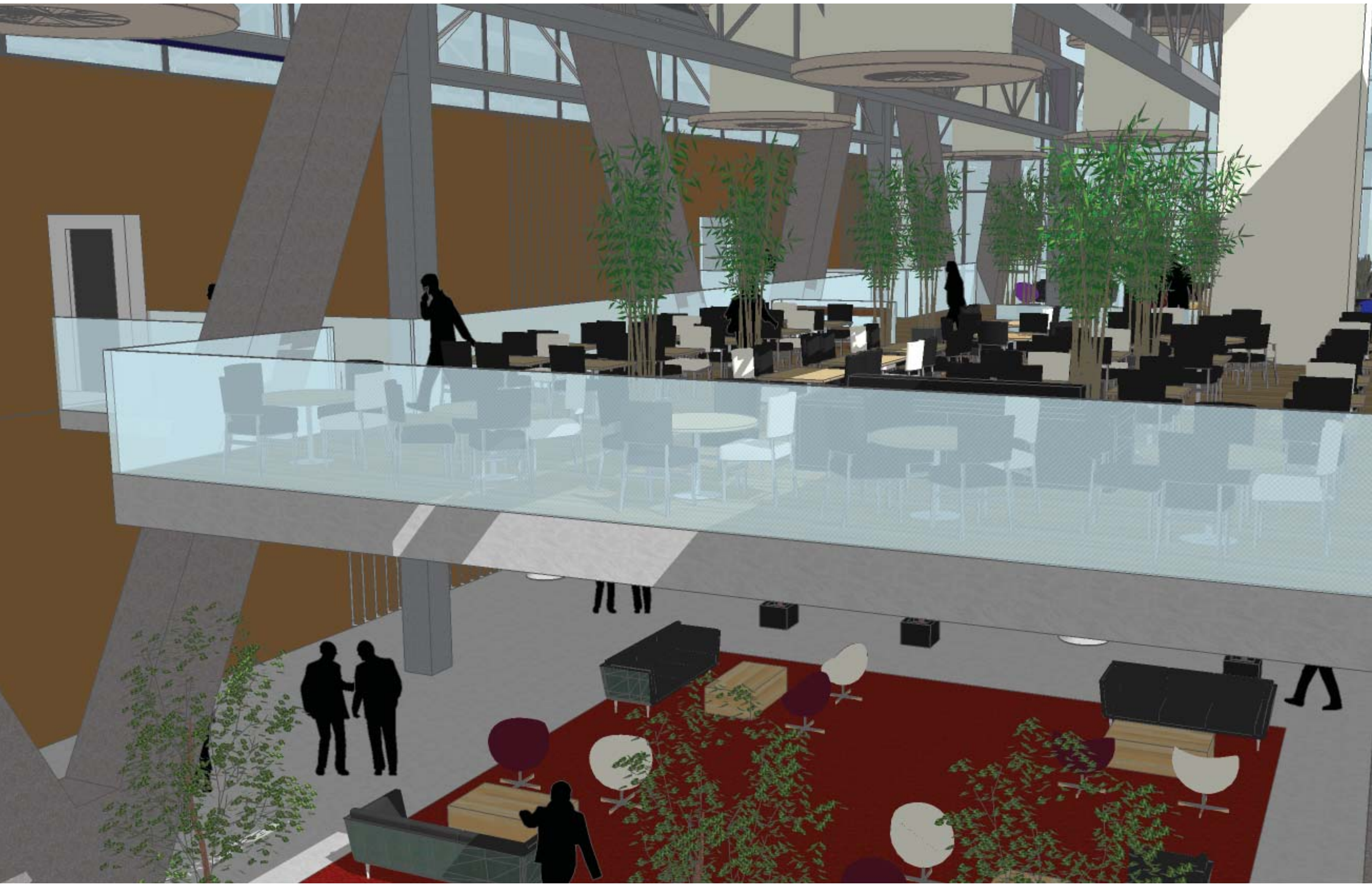

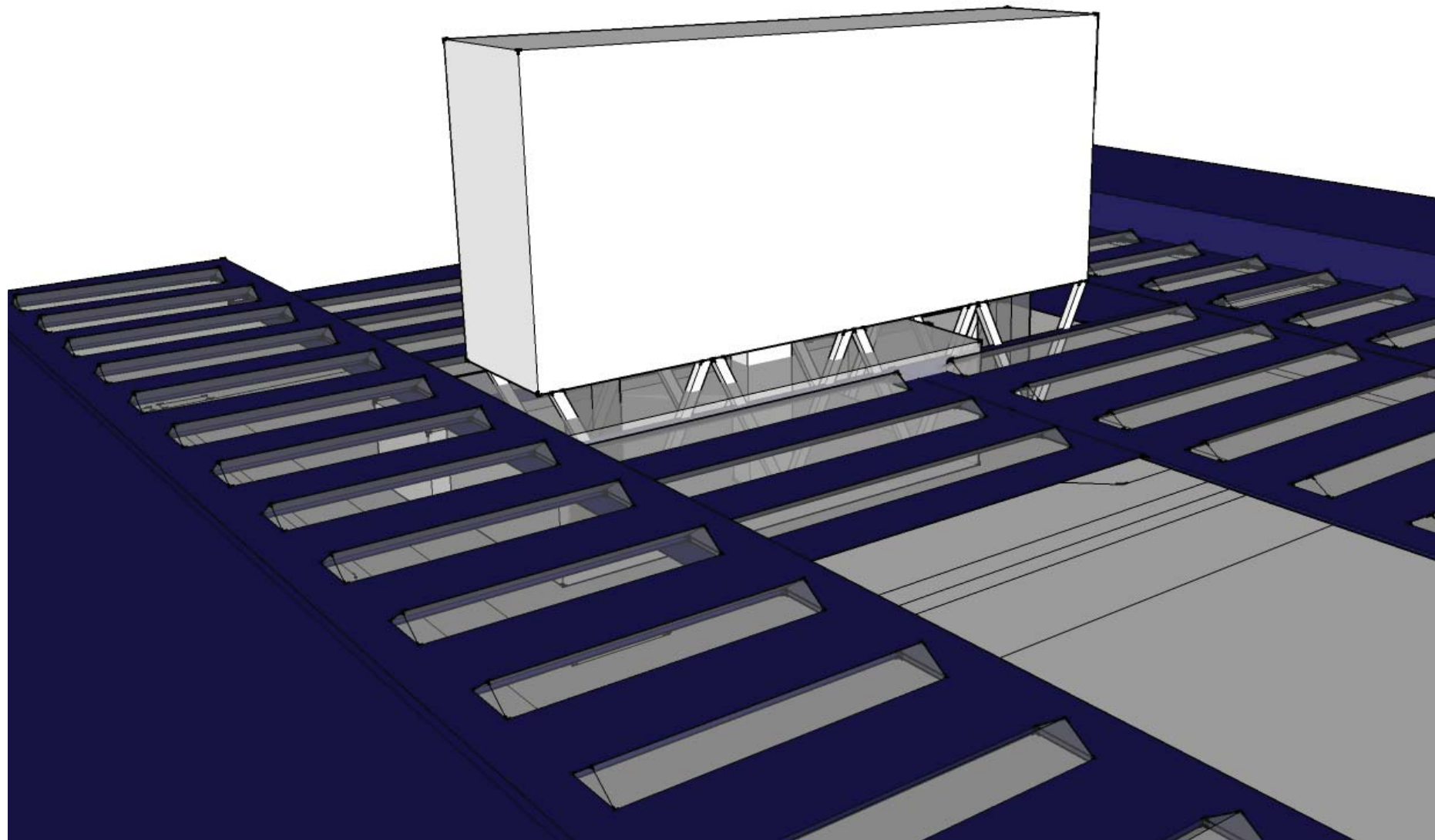

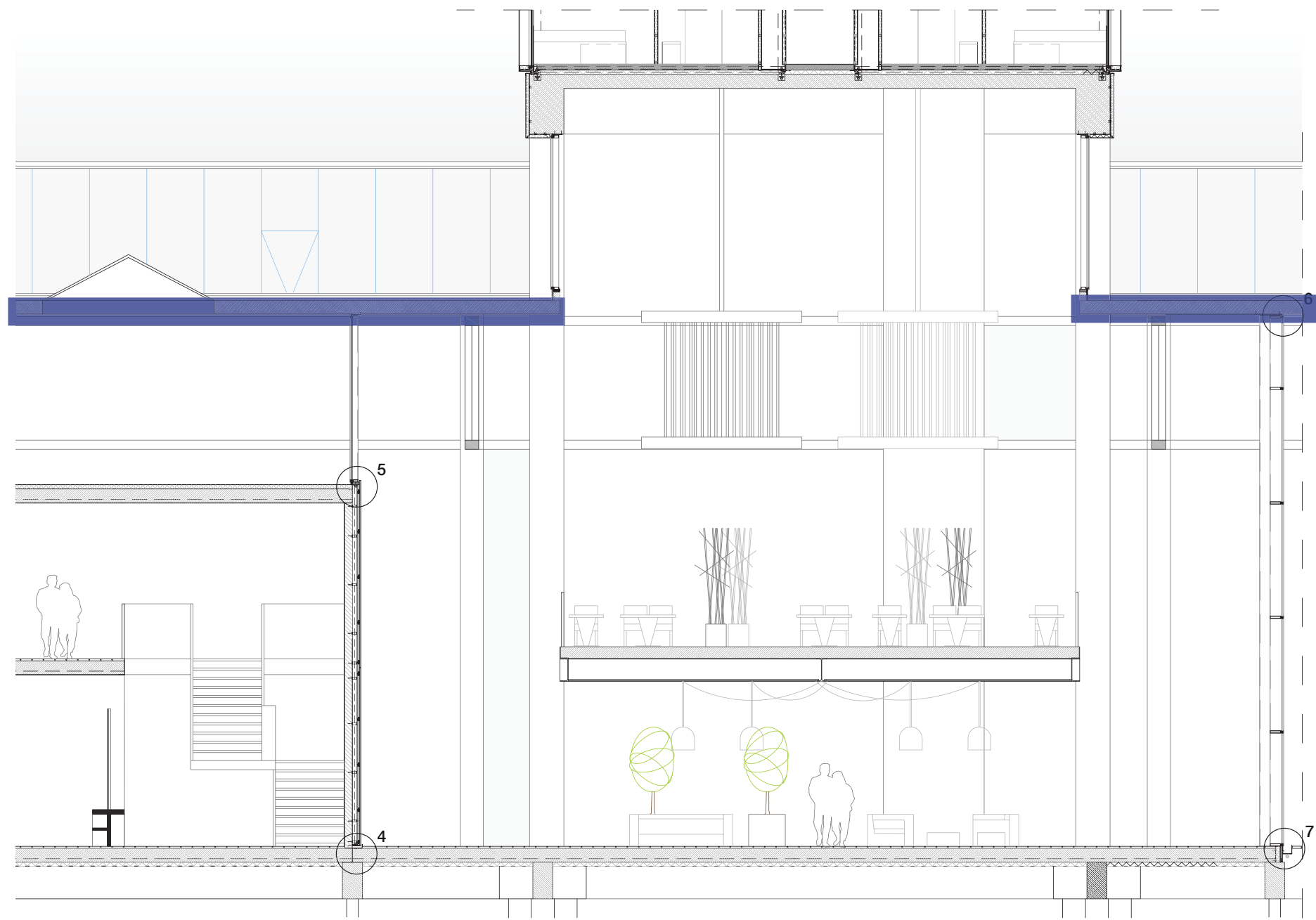

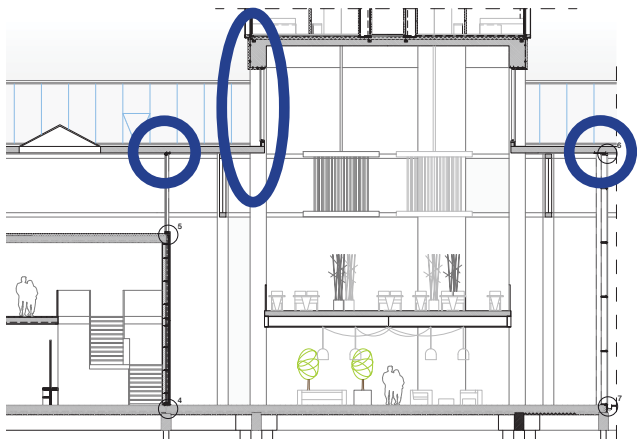
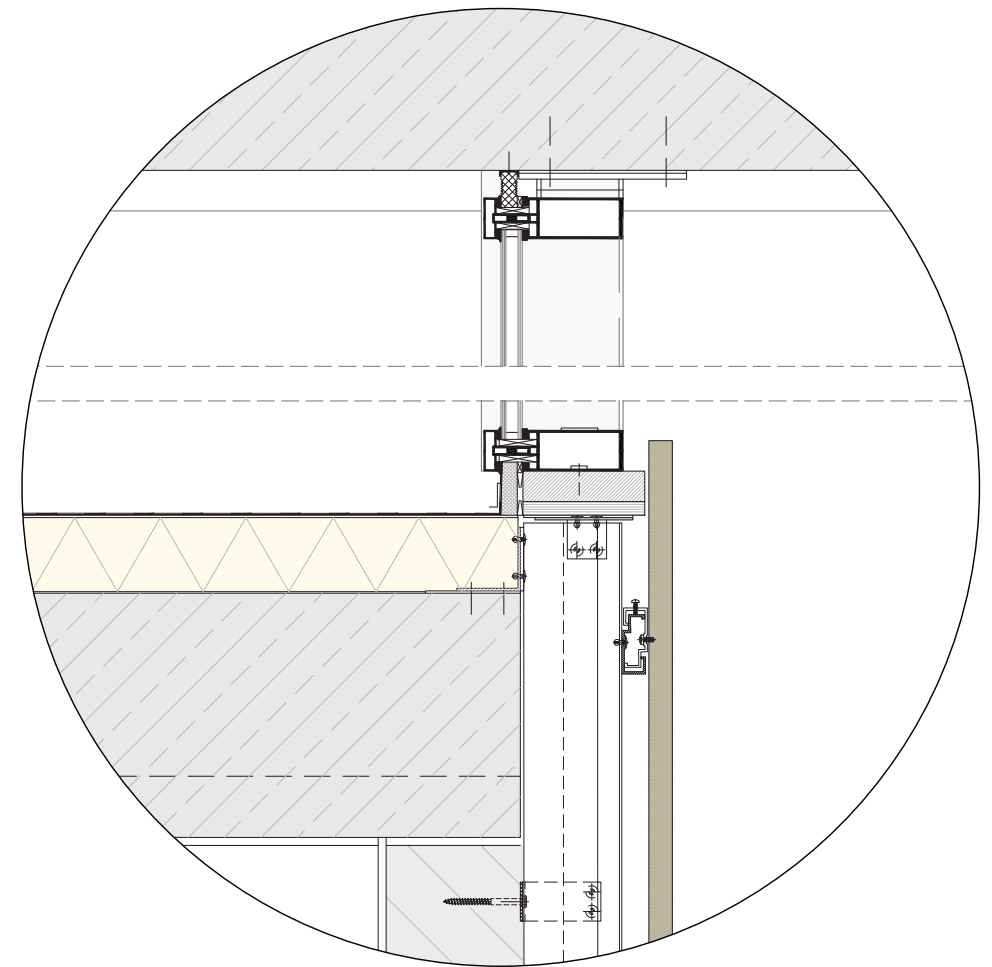
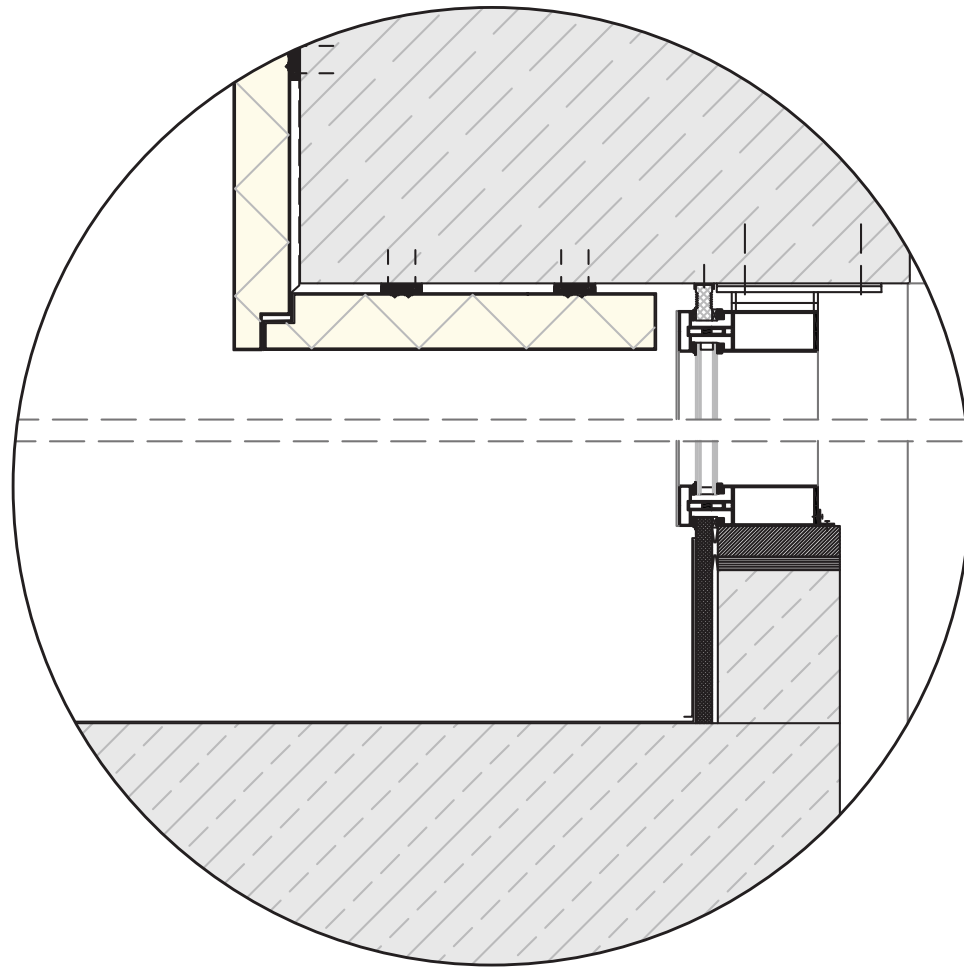
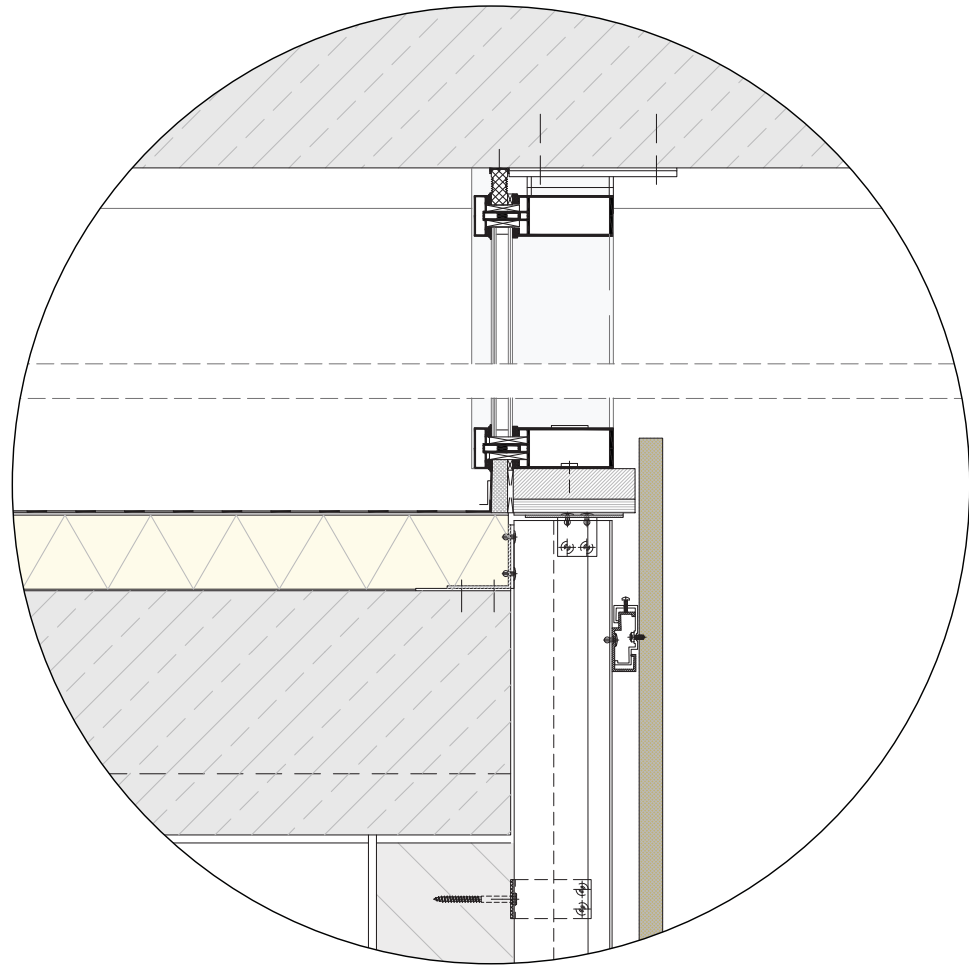

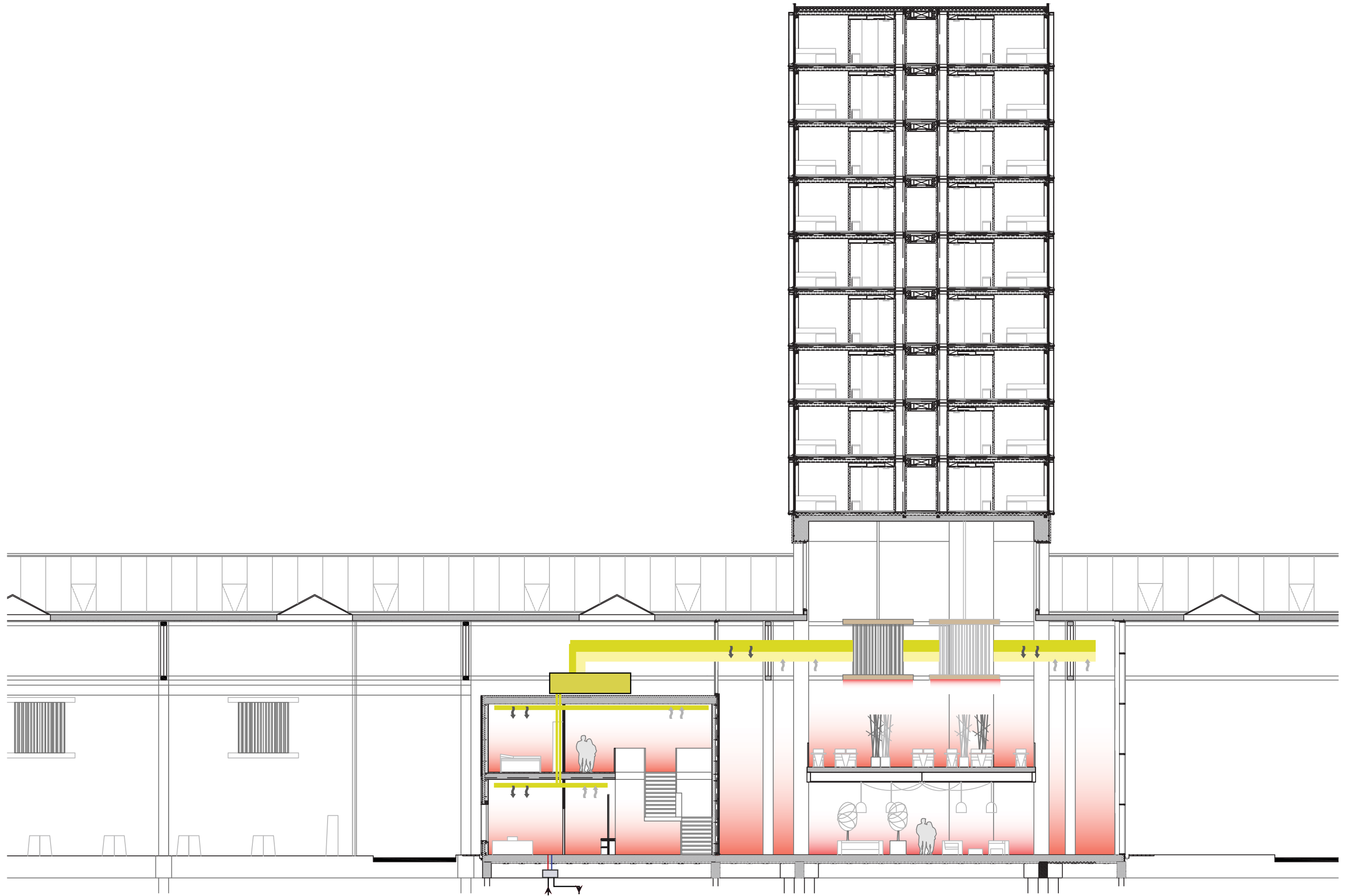

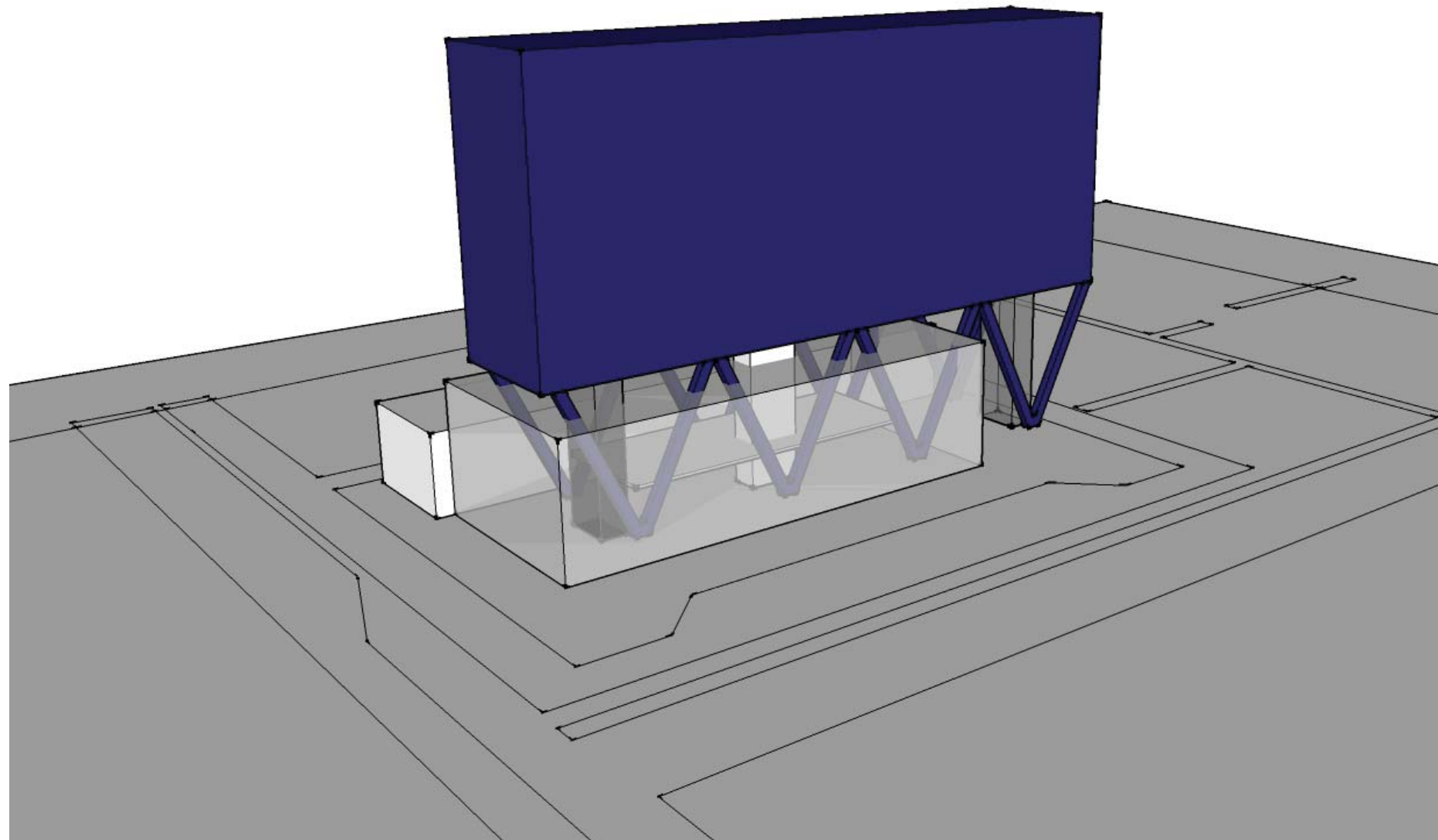



■



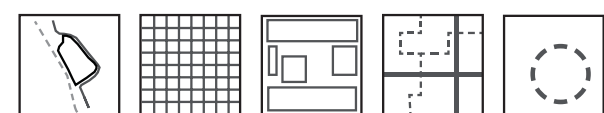

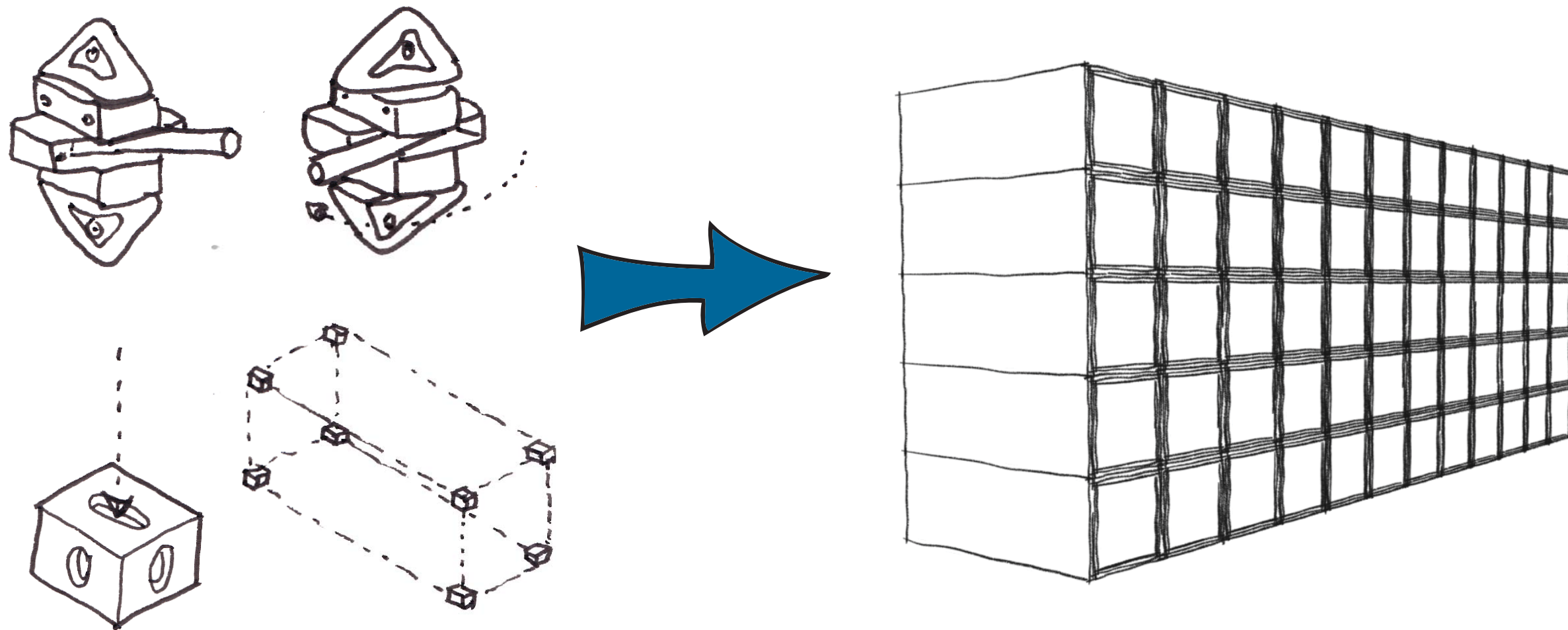

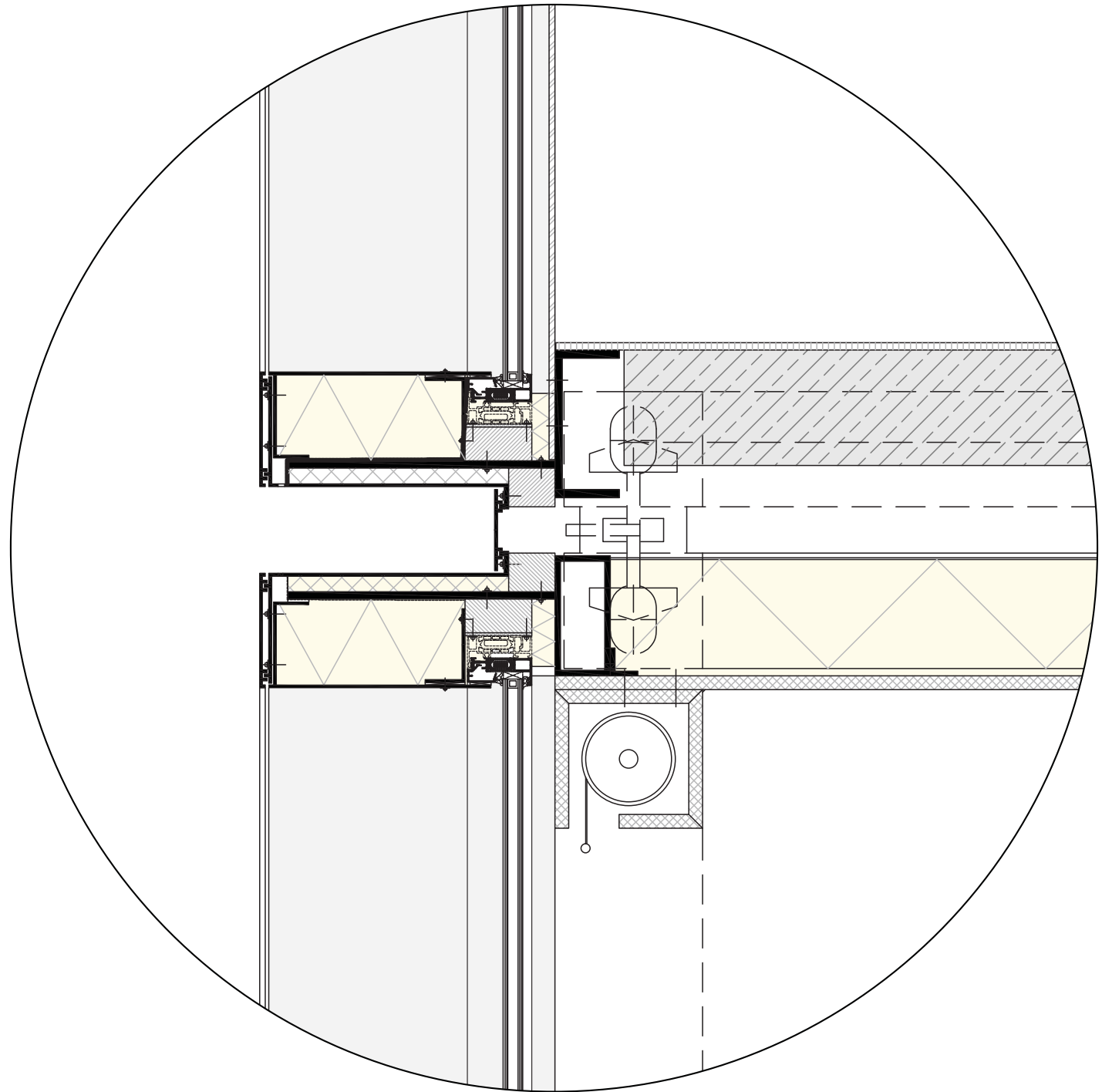

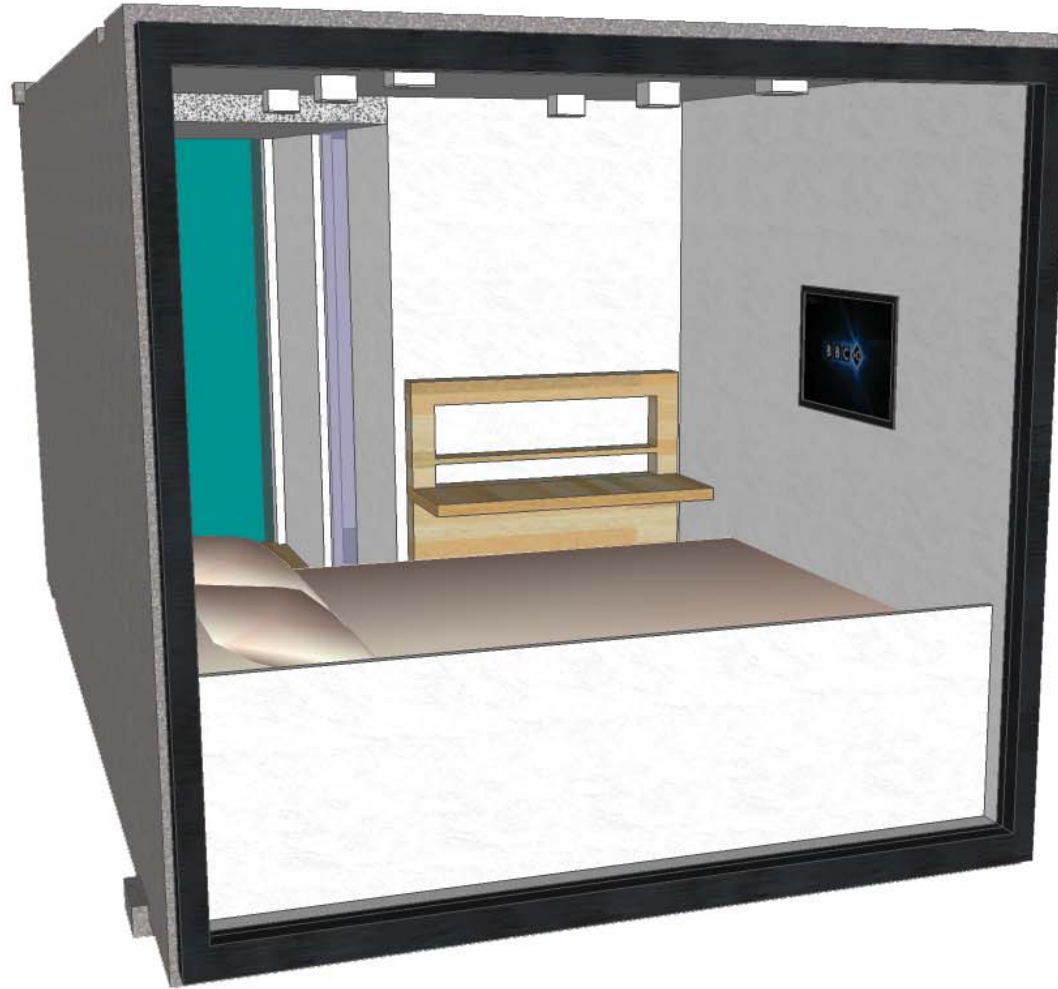

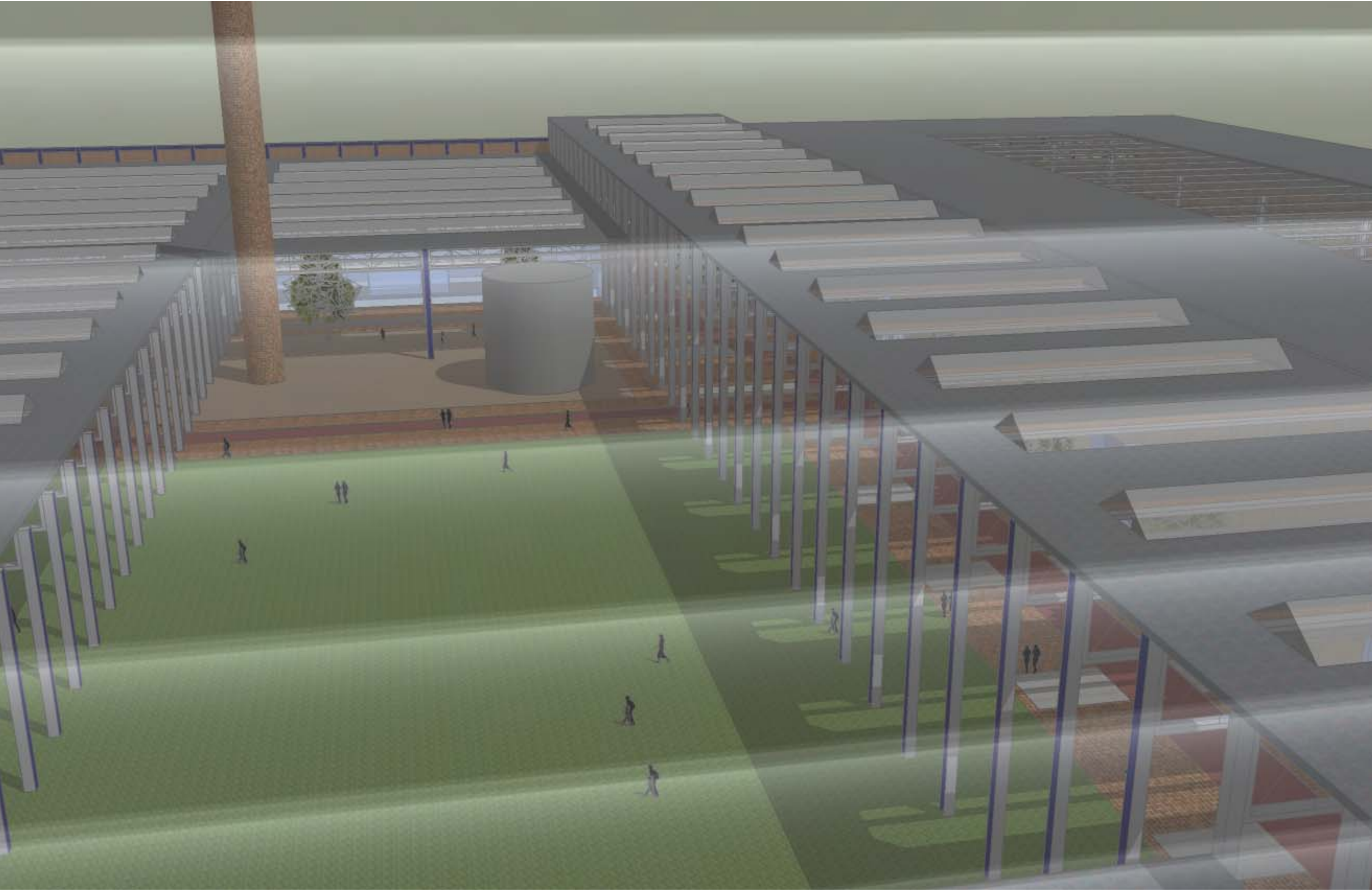

Reflection

From urban strategy to detail

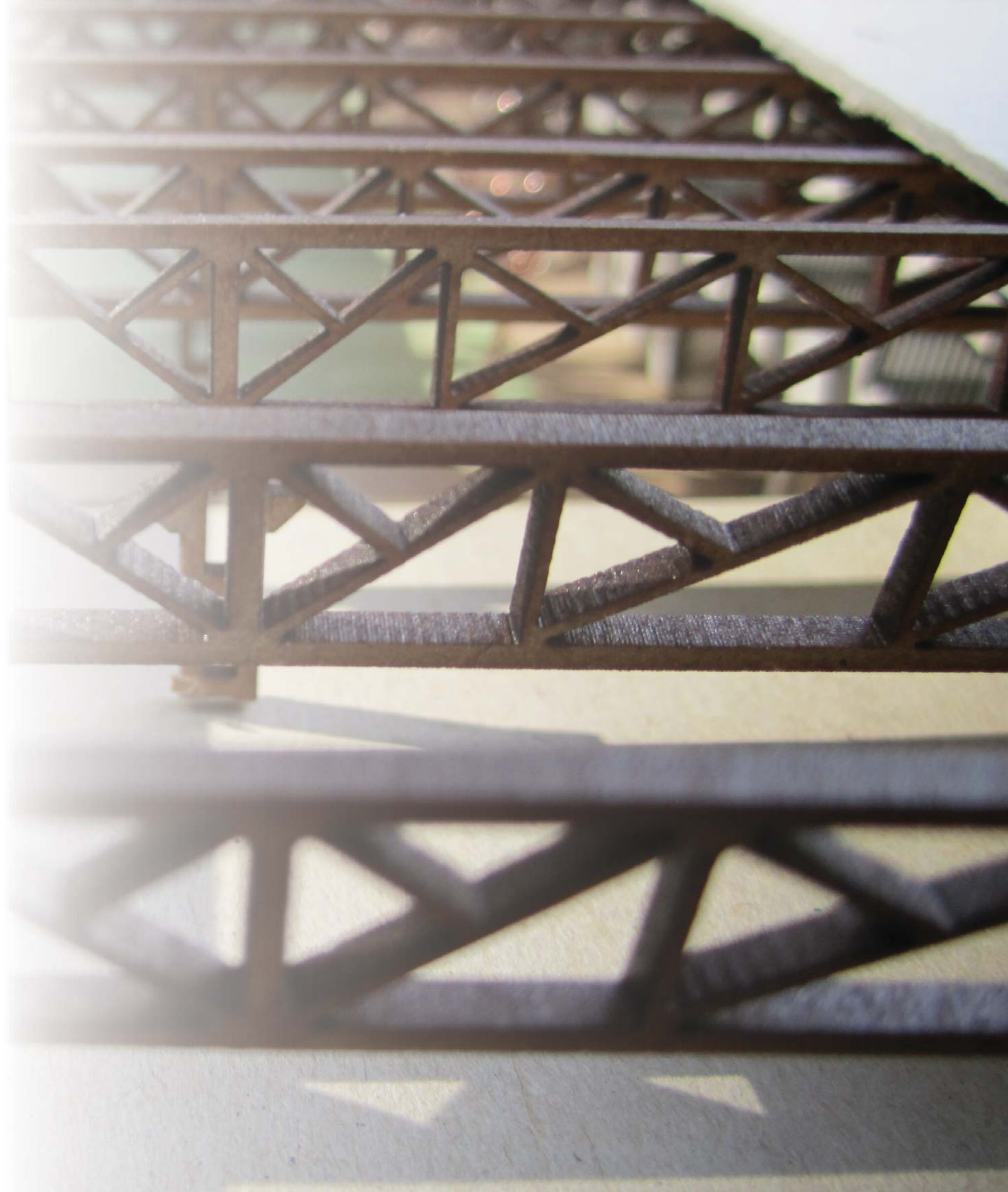

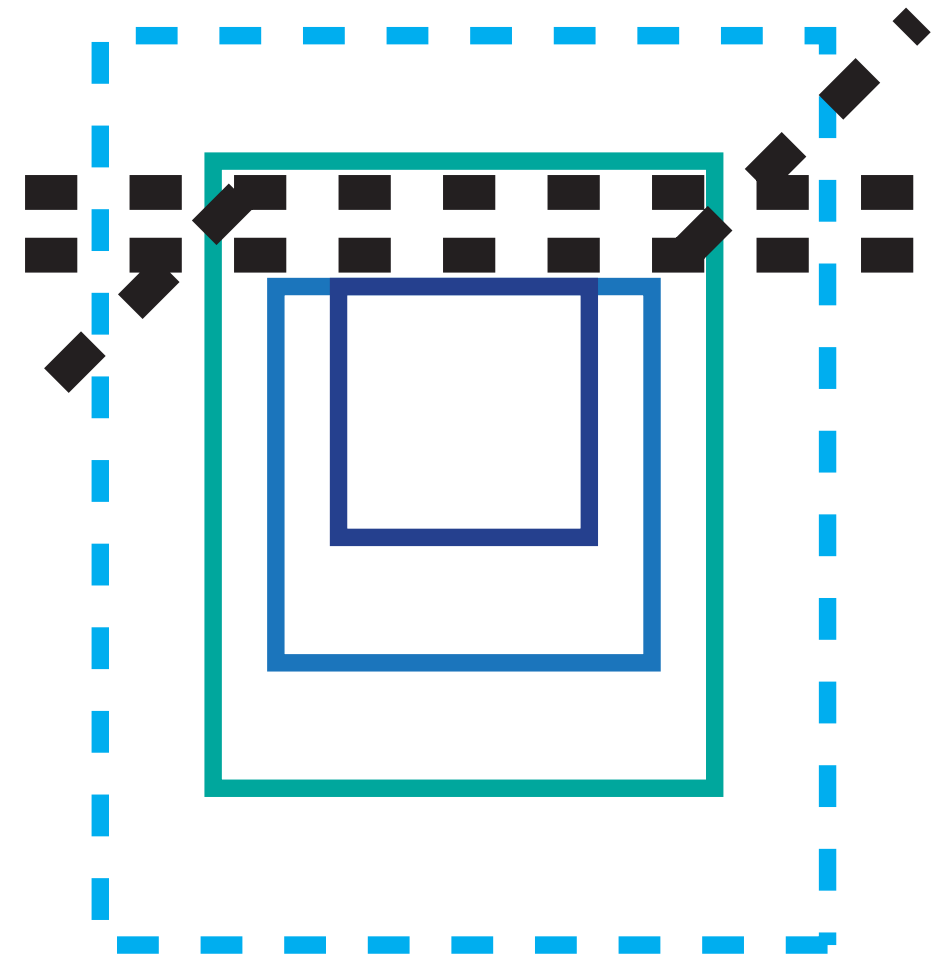
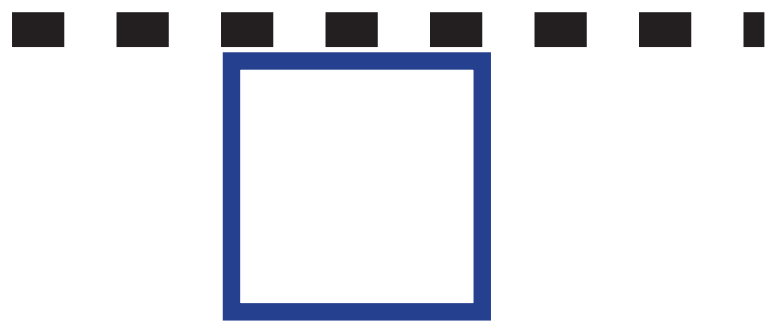

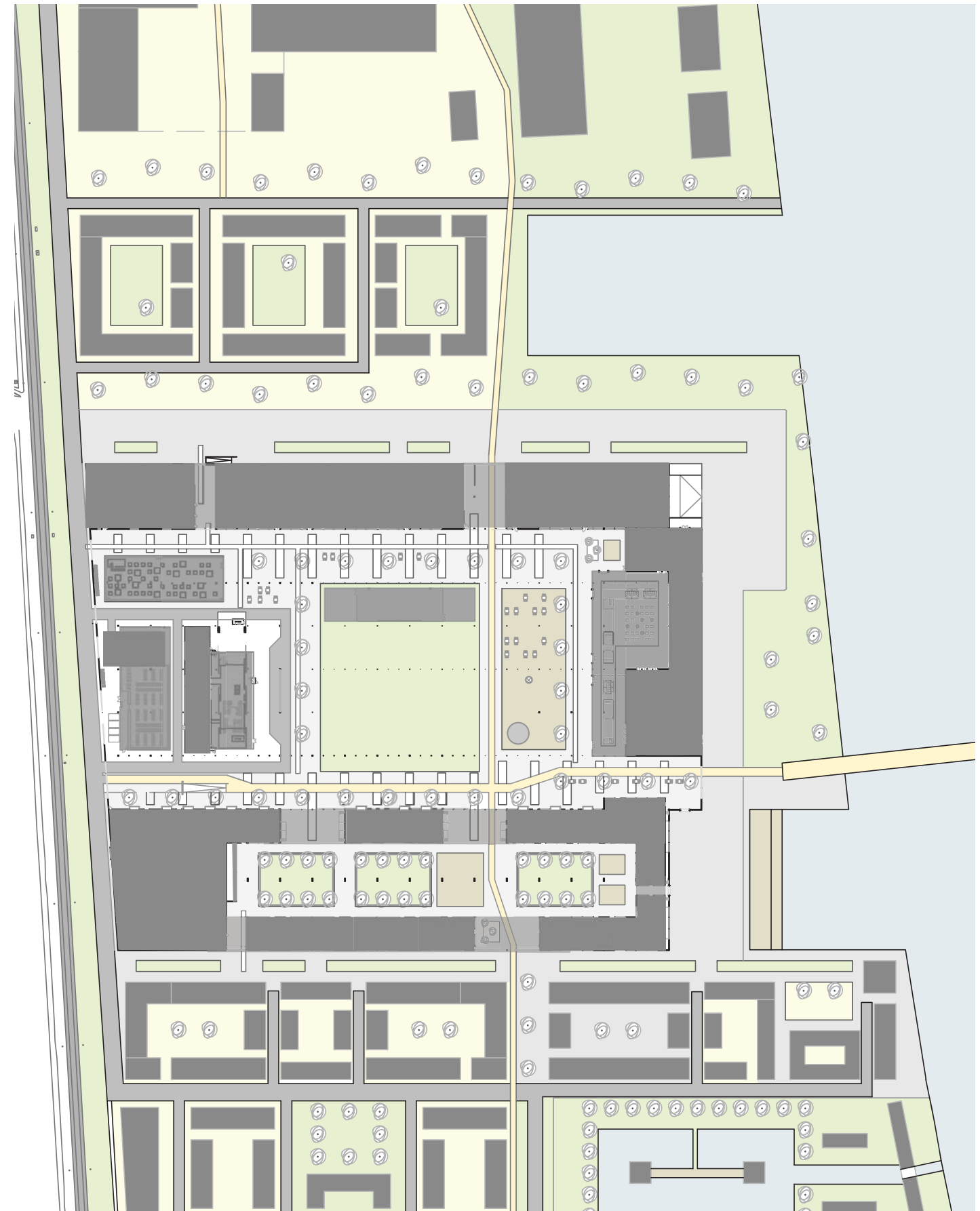
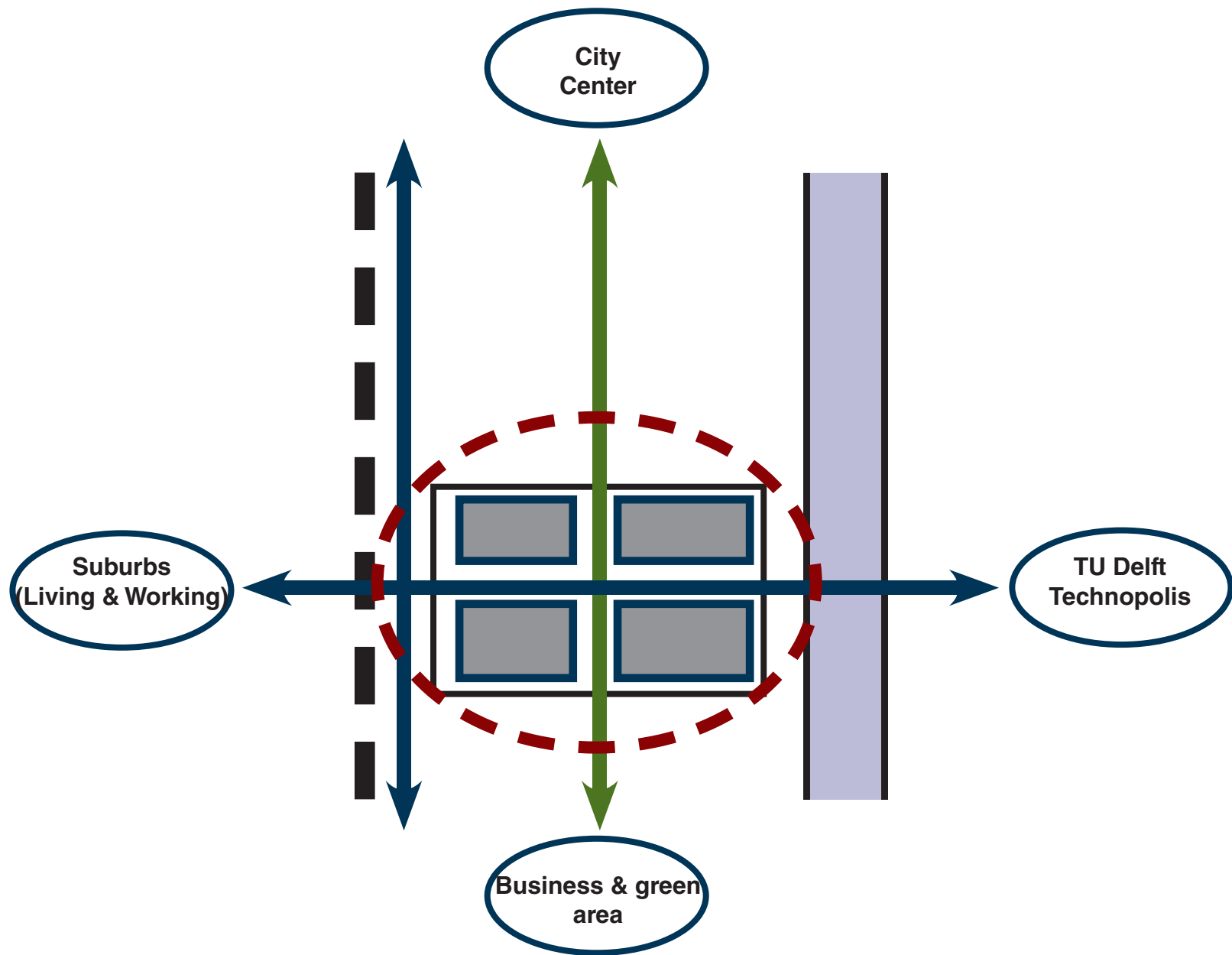

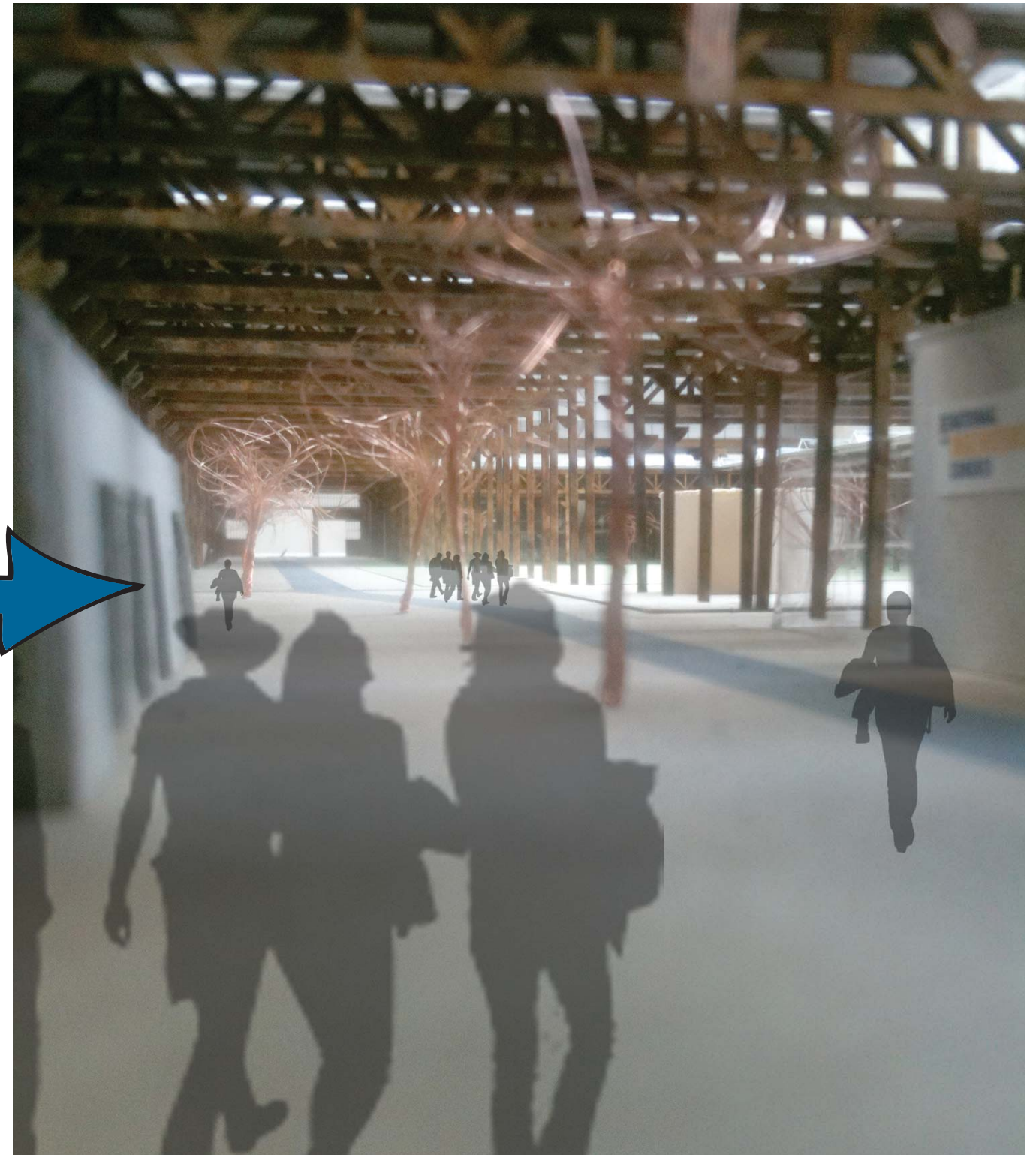

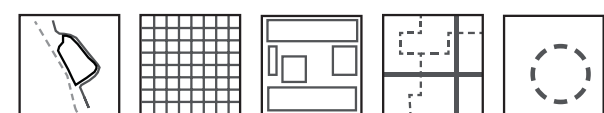
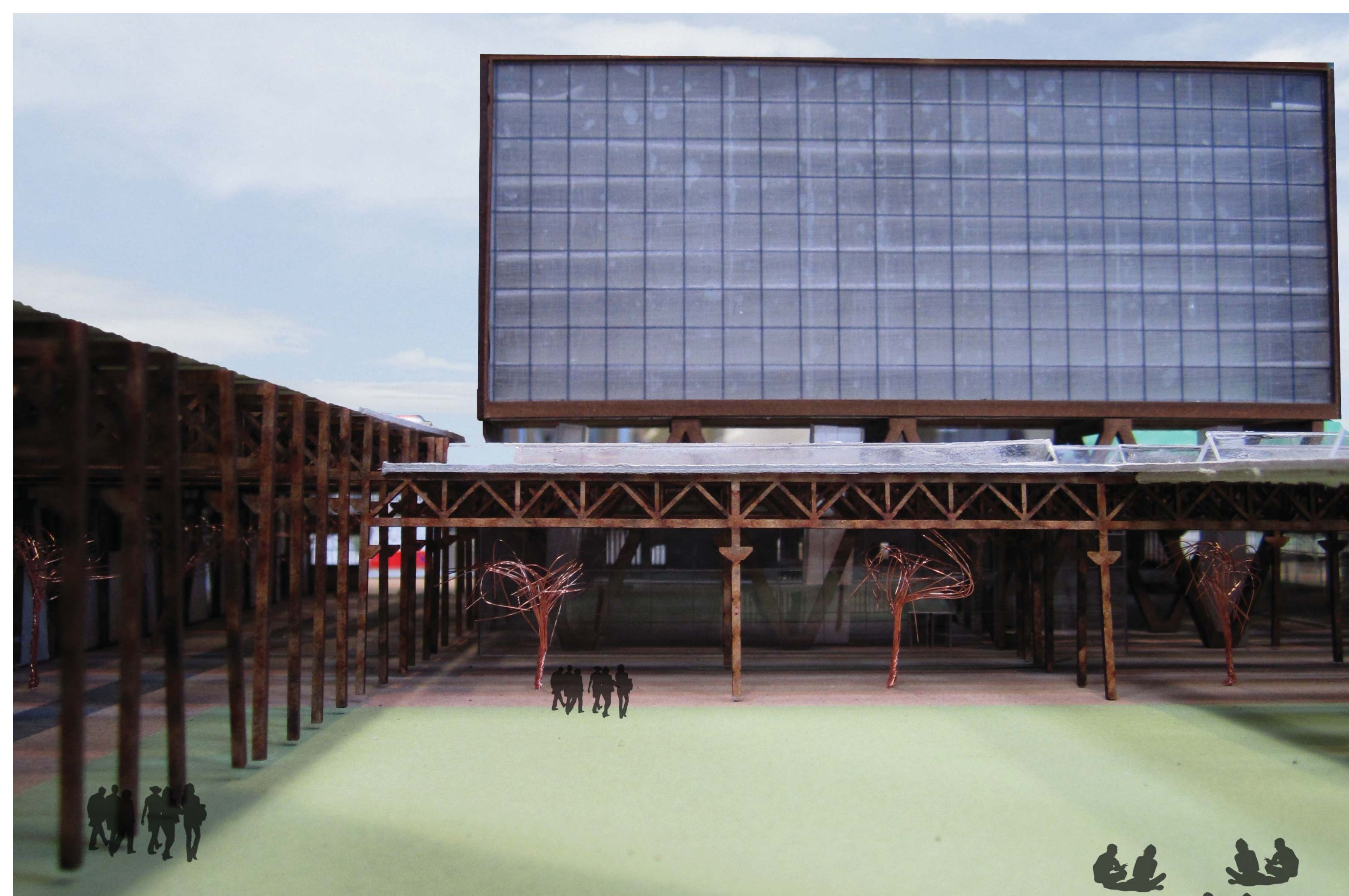

‘The transformation from an industrial area into a vibrant living and working environment’

Thank you for your attention

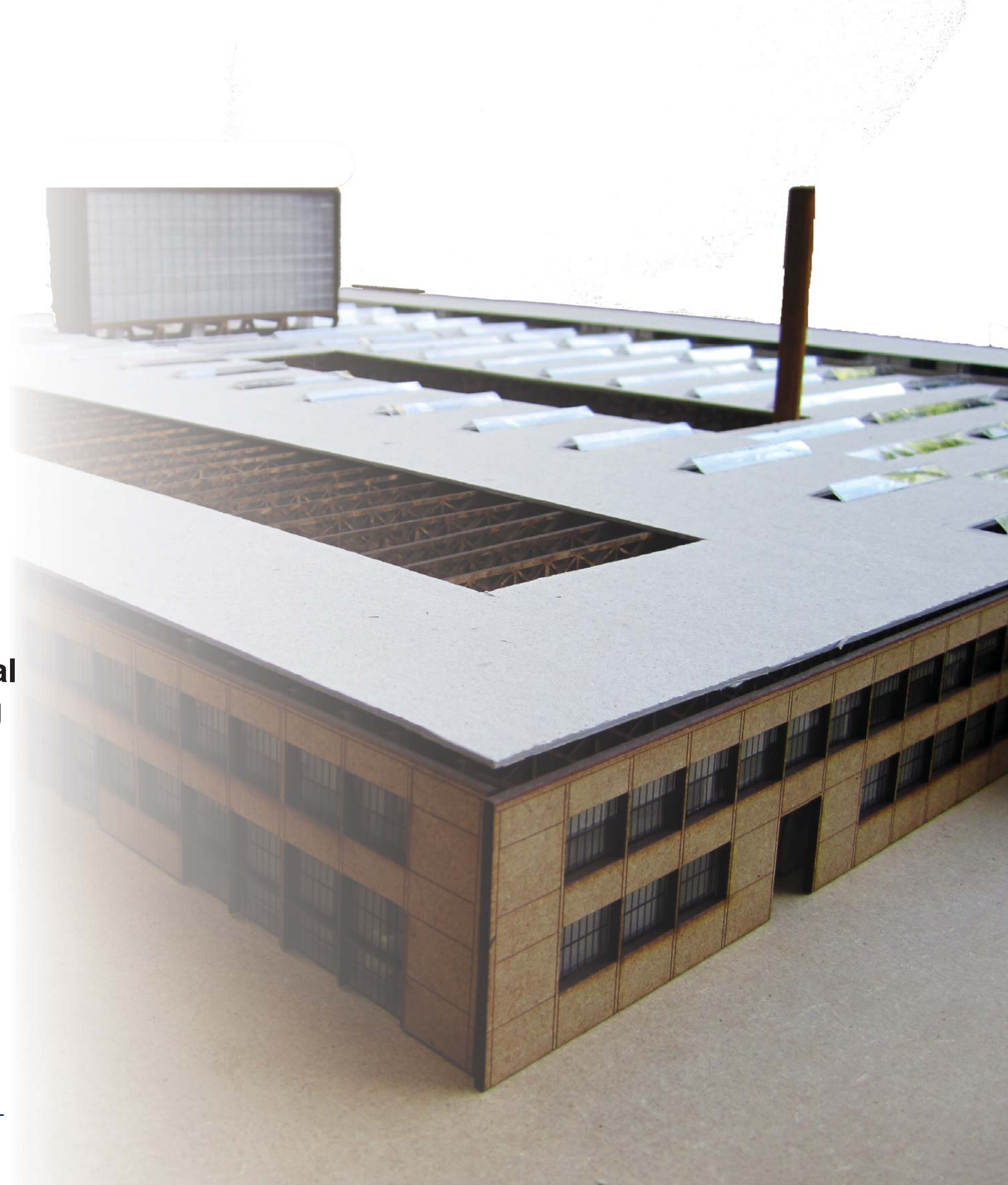

Special thanks to:

Vera, Joep, Margit, Ingeborg, Kim, Romain
and all others that have helped and supported me.

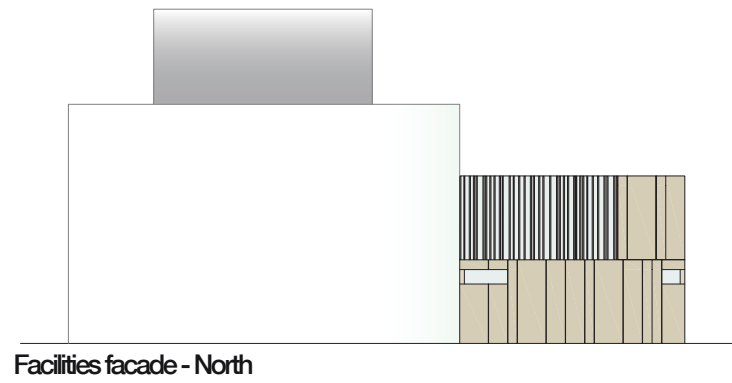

Facilities facade - North



Facilities facade - West

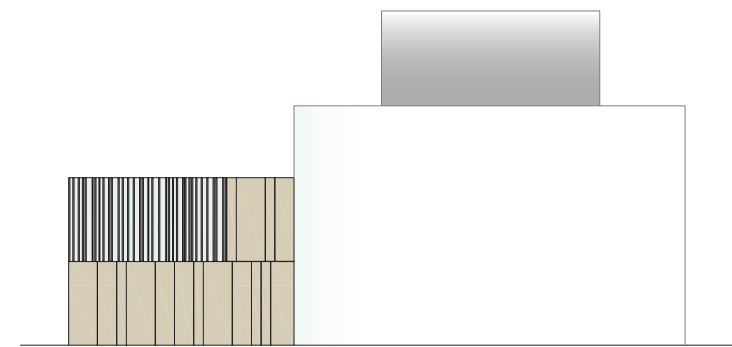

Facilities facade - South



Facilities facade - East





Facilities facade - North



Facilities facade - West

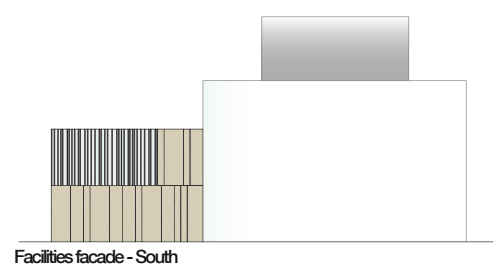

Facilities facade - South

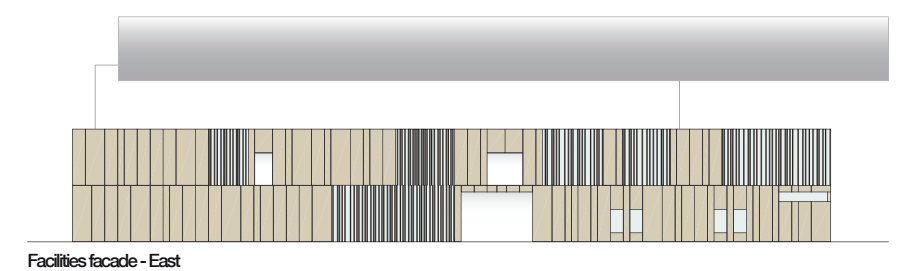

Facilities facade - East

