

Introduction A-Z Encyclopedia

Our body of social research has developed organically by visiting Nijmegen and talking to locals about their stories, lives, and connections to the city. From our visits we have selected a sample of 26 in depth interviews in which we explored Nijmegen's scenes, subcultures, turfs and territories by engaging with the residents.

Our investigation into the social scenes of Nijmegen explored a methodology of impromptu qualitative research as we spontaneously approached people in different areas of the city and engaged in conversations with them. These conversations built up an image of the city for us from different perspectives as we focused on their personal experiences and traces within the city. A variety of people from different age groups, genders, nationalities, and socio-economic backgrounds was selected to provide a balanced view of Nijmegen.

These 26 personal profiles collectively make up an A-Z encyclopaedia of 'Nijmegenaars'. From this body of research, we were then inspired to follow 9 people's stories in depth in our film which represents their personal landmarks in a theatre stage as a collage of Nijmegen, letting us experience the city through their eyes.

A

Annemieke



Age: 45 years old

Occupation: Sex Education Teacher

What's missing in Nijmegen: Support for the elderly and low income families

Annemieke

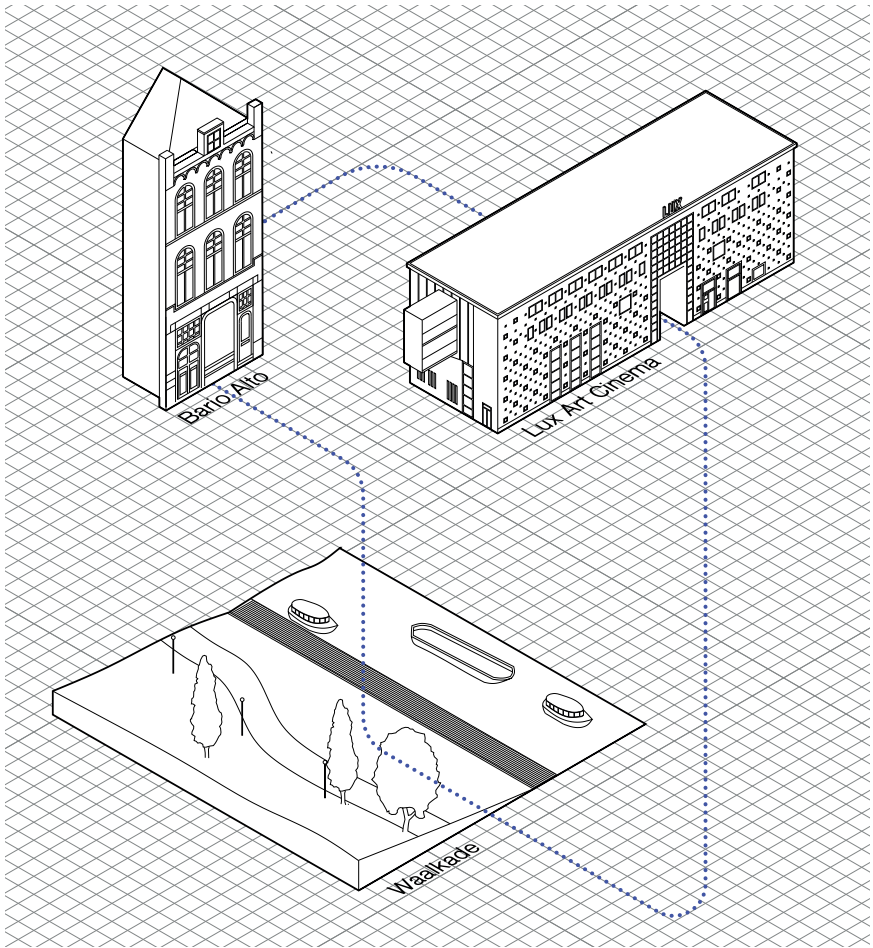

personal landmarks

Annemieke

T: What are the places you like in the city?

A: **Barrio Alto to drink some coffee**, that's nice with a view. And I like to go to the cinema, **Lux an independent cinema with art movies**. For museums you have **De Bastei along the river**, by building the museum they found some old walls from the medieval age and they reconstructed it so you can walk underground along the ancient city walls. Tonight I am going to dinner with a friend at **café buur**, a little bit out of the centre. It is an initiative by some younger people for local products, vegetarian food.

L: What would you add to the city that's not here?

A: **Lots of green in the city. More support for elderly people and those on lower incomes**. We still have a lot of poverty and this has become more clear during the Covid-19 pandemic. When children stayed home and got lessons online, **lots of families didn't have a computer or ipad to work on**, they didn't have the facilities needed to get online lessons. **I think we need to pay more attention to this discrimination**.

A: And **more facilities for young children to play outside**. When I was young we had fields with mud and rocks to climb and bike on. Now everything is built on with houses. **There is no escape here**. It is important for children to climb in trees, build sandcastles, play with dirt and little animals. Now they all have computers but they don't know little creatures.

L: Do you work in the city centre?

A: I worked in several cities Arnhem, Doetinchem, Nijmegen. **I teach children about their own bodies, sexuality, gender problems**. I think love never can be wrong...essentially the love isn't wrong.

conversation transcript

Annemieke



traces of everyday life

Annemieke



Nijmegen Highlight
Lux Art Cinema

B

Bart

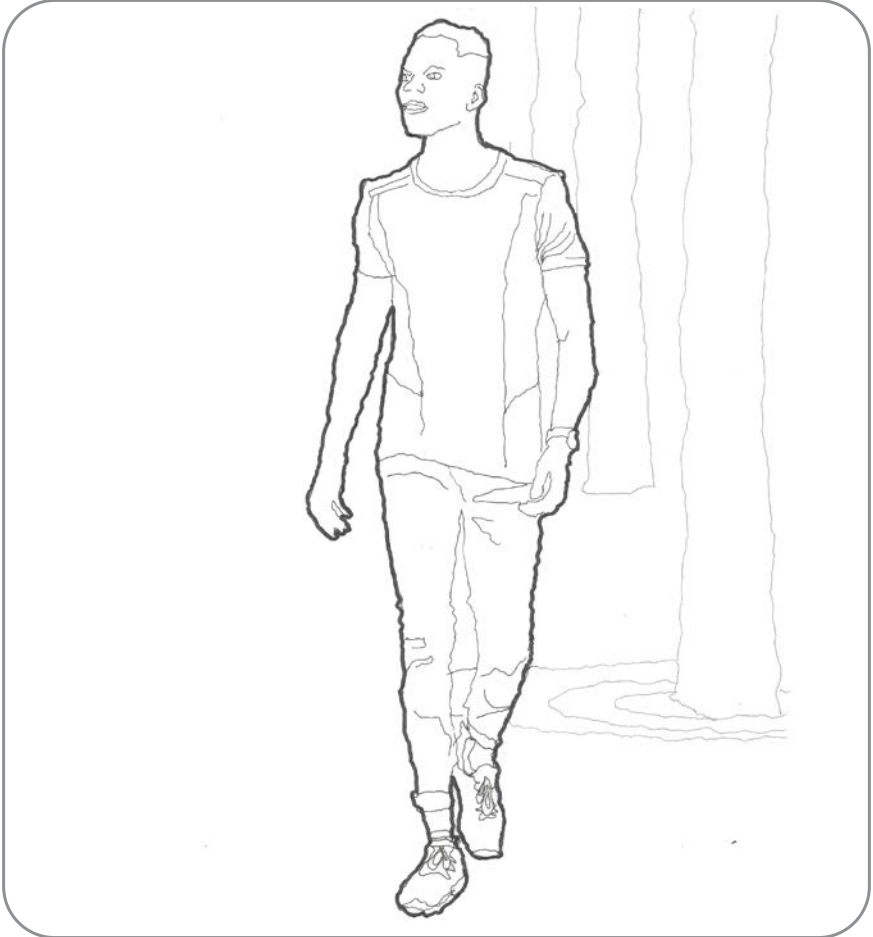

Age: 25 years old

Occupation: Personal trainer

What's missing in Nijmegen: Bring back old architecture

Bart

B: I think **Nijmegen is very open**. There are a lot of students from other countries. It is a **very open city also with immigrants and refugees**. In 2015 there was a refugees' crisis, it was quite big. In the campus, in the south, **a lot of refugees were hosted in a military base** that was converted into a refugee's base.

B: Nijmegen organized a lot of events and activities for them. In this sense, Nijmegen is a very open city.

[...]

A: Can you describe places of your routine or places that you consider interesting in Nijmegen?

B: There are a lot of **industrial complexes** in the riverside that were **converted into public spaces for citizens**. For example, the Honig complex was a cookie factory. They turned into a bar/club.

B: Another example is Waahalla. It was an industrial complex that now is a skate centre/club. These are the most famous ones. I really like this kind of vibe!

conversation transcript



traces of everyday life



Nijmegen Highlight
Syrian migration – openness and inclusiveness of Nijmegen

C

Cecilia



Age: 26 years old
Occupation: HR management
What's missing in Nijmegen: Diverse communities

Cecilia

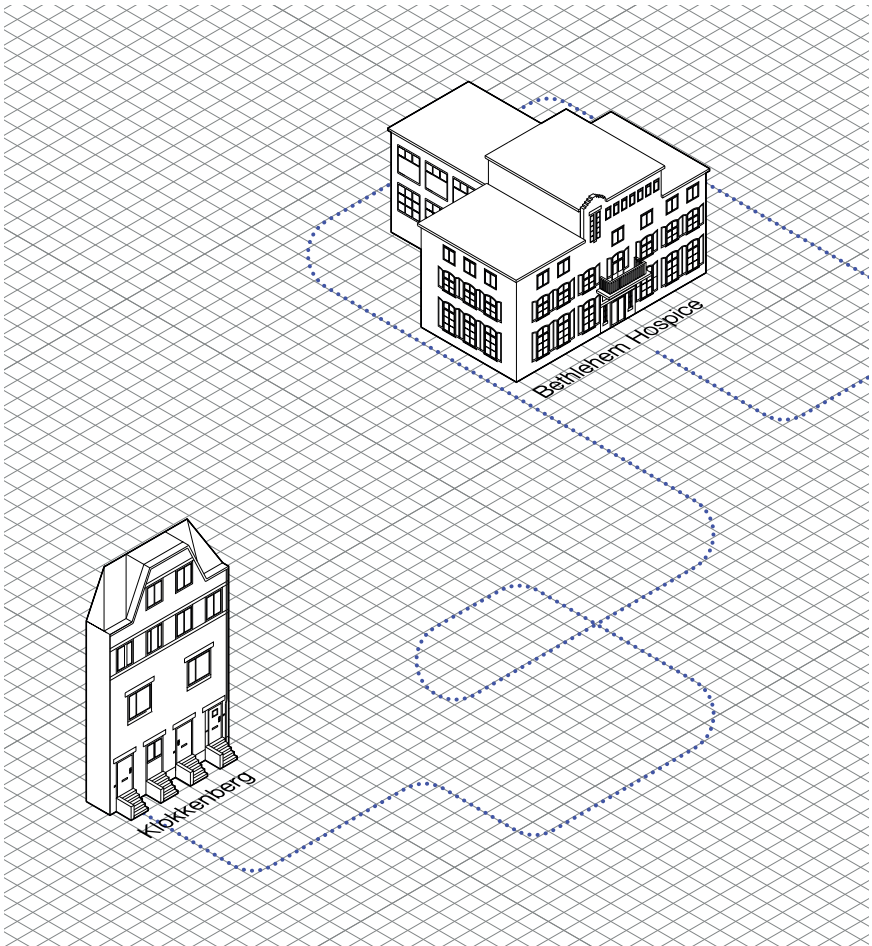

personal landmarks

Cecilia

A: How would you describe Nijmegen in comparison with other Dutch cities?

C: I am very happy of my years spent in Nijmegen. I think Nijmegen lives in a perfect condition. In comparison with other chaotic cities such Amsterdam or Rotterdam, it is a quite city where you can create a pleasant routine. It is less touristic than other Dutch cities and it was a positive aspect for me. I really liked the position of Nijmegen on the border of the country: there were many people working or visiting the city from Germany. It was an interesting node between different cultures.

A: How local people welcomed international students and foreign communities?

C: International students were really integrated in the local community. There was equality between international and local students. The campus offered every kind service and introduced me to the life in Nijmegen. They have an open attitude. I was included and integrated in the city. I had the impression to be part of the local community. It does not happen in every country. There is social inclusion, but I did not see communities from other countries, most of the foreigners were students or citizens from Dutch colonies. I met some Italian people who moved there to open restaurants, but I did not meet real foreigners' communities. On the other hand, in other big cities I saw many foreigners' communities.

conversation transcript

Cecilia



traces of everyday life



D

Danielle



Age: 55 years old
Occupation: Social worker in elderly home
What's missing in Nijmegen: Apartments for students

Danielle

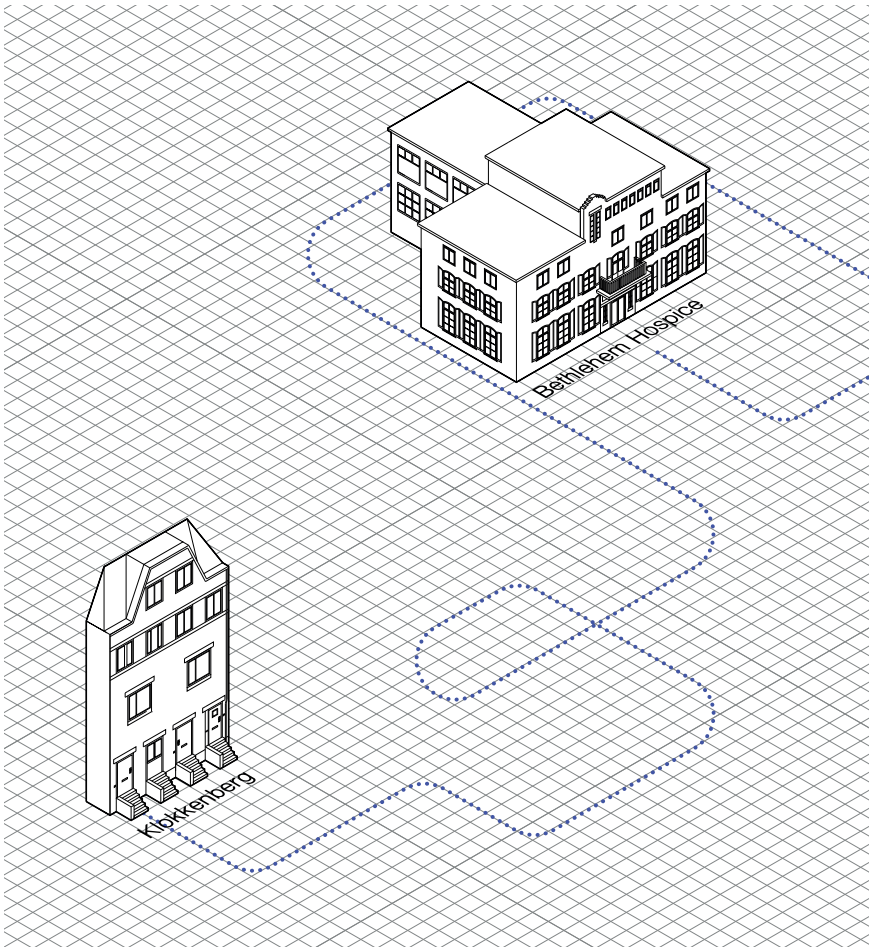

personal landmarks

Danielle

D: We live here in a little paradise. **The municipality allowed us to take pavements away and grow plants.** Every year we take a little bit more from the street. We love to stay in our neighbourhood, especially on the weekend because we meet quite many people during the week when we work.

D: I never go shopping in Nijmegen because I live here. **If I need something I just go to a local shop to pick it.** We do our shopping once a week and we eat it the whole week.

S: Would you like to change something in the city?

D: I think it is a very nice city because of what I have told you. Lots of young people. I like to have the vibe of young people. **I like to live with young people and students because they can dream and change things.** Here, in Nijmegen, it is a **very socialist city and they also support to make the city greener.**

K: What is your profession?

D: I used to be a manager but half a year ago I stopped working there. Now I work in an elderly home (hospice), supporting people in the last days of their lives. When I was a manager I was always very busy earning money. Now I don't get paid but I can finally be satisfied in my life.

conversation transcript

Danielle



traces of everyday life

Danielle



Nijmegen Highlight
Klokkenberg, her residential street

E

Eric



Age: 25 years old
Occupation: Music therapy student
What's missing in Nijmegen: More places to sit and talk

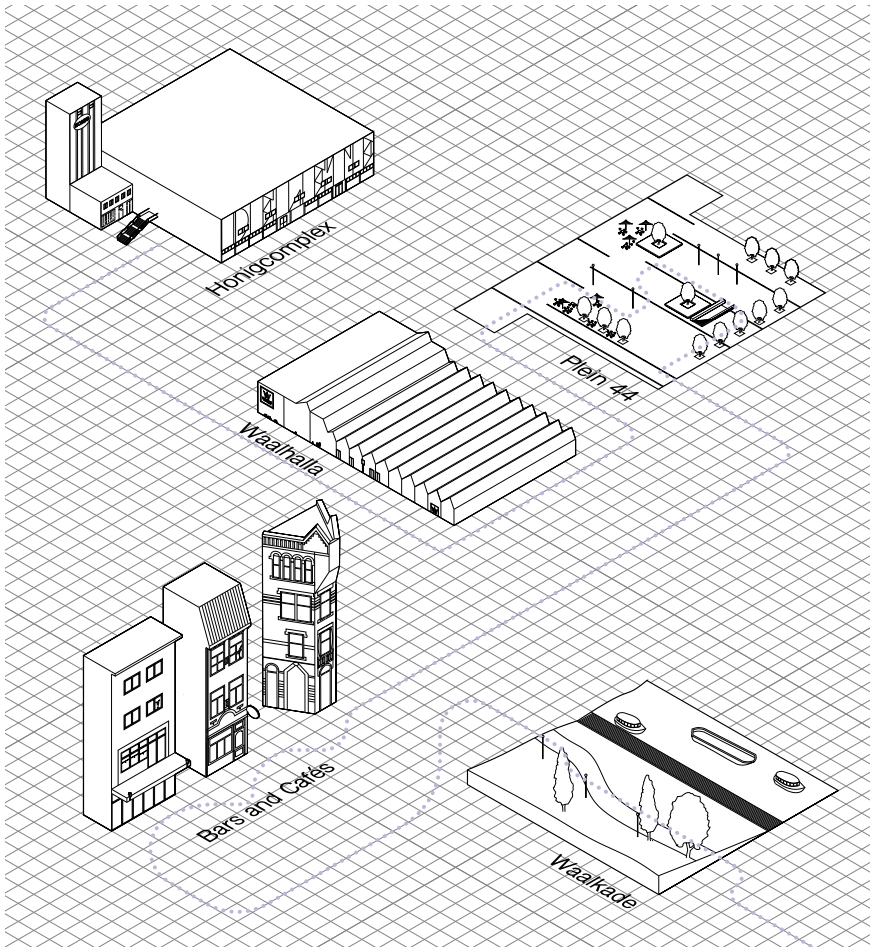

personal landmarks

Eric

J: What defines the people of Nijmegen?

E: It is a **politically left oriented city**, which is unusual for bigger towns in the Netherlands. The people are nice, not judging. But it is also **monotonous in terms of population due to the student life** – what happens in the city is student-based, so, focused on students. I hear people usually stay here after their graduation because they really like the city.

R: Do you think that the city has changes over the last years?

E: It depends on the neighbourhood. It became a bigger city due to student life and University. Building wise, **more buildings, more city**. On the other hand, **there are more different places for culture, for party, to have a show**, in different kinds locations of the city. I don't know if you have heard about Honigcomplex, Vasim, De Kaaij...There are more places around the city that give it more culture, it became busier.

J: What are the landmarks in Nijmegen?

E: Umm, some may change, but there is always like a **free jam session at cafés**, to make music, drink and have fun. There is always something here in Nijmegen, it fades away

conversation transcript

Eric

and comes back. I think since 15 years it's like that. It is not a specific place, but it is the attitude of people that want to listen to music and play music.

E: I have told you already about the nature. **Waalstrand**, for example, when it is good weather I always go there. For a walk or to swim. It is also near De Kaaij, so you can have a beer there and hang out at the pier.

E: Also the neighbourhood where I live, **Nijmegen Oost**. I really like old buildings and this neighbourhood has a lot. I like walking around.

J: What do you think is missing/should be add to the city?

E: I am not sure, because people already created a lot of places around the city this last 5 years when a lot of stuff was happening.

E: If Nijmegen needs something, it would be a **bridge over Keizer Karelplein. It is the worst thing about Nijmegen**. When you stand there for few minutes, you hear honking, cars almost crashing. It is pure chaos.

E: **Plein 1944 used to be a nice open area, for people just to hang out, skate**. There was even grass. And now it's all bricks and buildings. I think it was nicer when It was just one space in the middle, with grass and some chill, maybe some terrace...**it would be nice to have an open space**.

conversation transcript

Eric

E: There are **a lot of refugees** in Nijmegen. They work here, live here. They already speak Dutch, since the Syrian war started. I also did my internship in a welcome centre, so I worked with them a few hours a week for a year. One guy works here and speaks Dutch in full sentences now in just three years. So it's going pretty well I think.

E: People soon won't be able to afford housing anymore in Nijmegen, inside the city. The city is expanding, and developers are building and building houses, but expensive houses – so not social housing. So, **only the rich people can afford to live in the city centre and that's why it's starting to look empty again.**

E: "Not many people come to Nijmegen when they come to the Netherlands. If you want the picture-perfect Dutch experience you don't come here. It's far away from the centre (Delft, Den Haag, Amsterdam, Rotterdam)... even though Rotterdam is not so beautiful. Here, one wants to see the water, the old buildings. Also they come here because of the bombing.

Eric

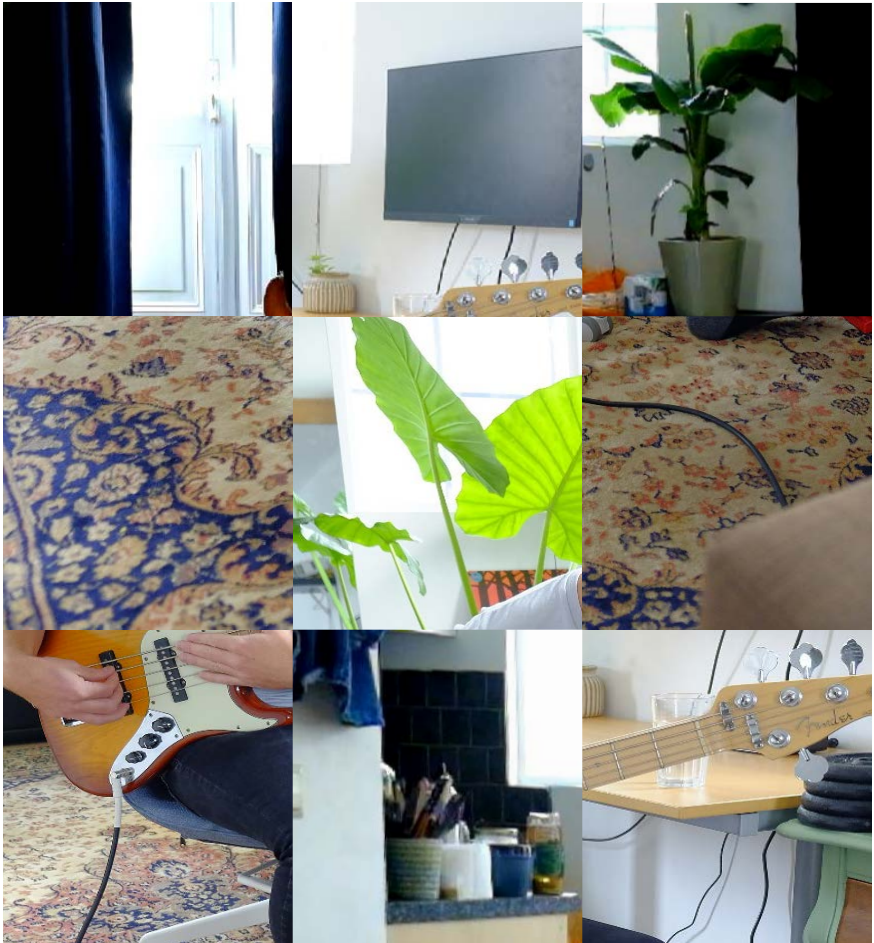

traces of everyday life

Eric



Nijmegen Highlight
De Kaaij, Waalbrug at the background

F

Fred



Age: 52 years old
Occupation: Record Store Owner
What's missing in Nijmegen: Nothing

Fred

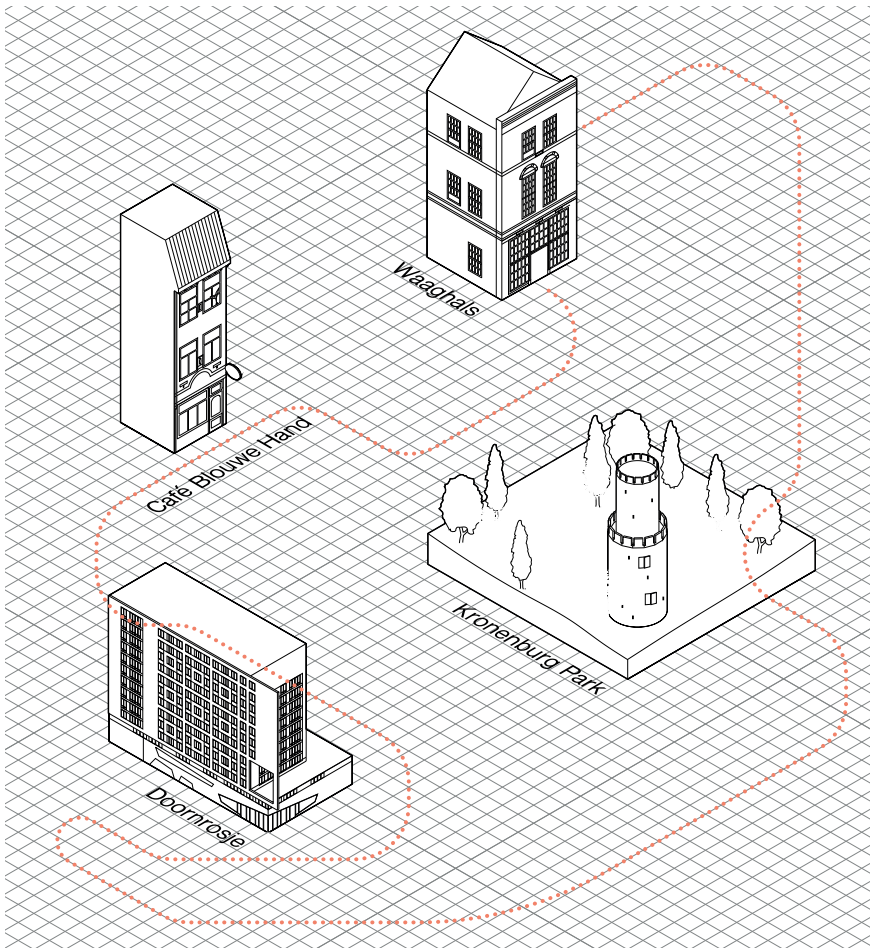

personal landmarks

Fred

T: What made you think that Nijmegen needed a record shop?

F: I use to work in **Doornroosje**, it's a club, lots of gigs, lots of shows. I use to work there as a non-paying job, you know, I was volunteering. So I was working there and then another record shop in town as a paid job. So I went to work there and after a couple years I thought I wanted to do something for myself. So I started the shop here.

[...]

L: What would you add to the city that's not here at the moment?

F: Vaccine?

[HAHAHA]

L: Do you think the city needs more event space or cultural facilities?

F: No, **Nijmegen maybe together with Groningen are culturally very sound. There is a good theatre, clubs for alternative film house.**

Nijmegen is a student town so there is a lot of alternatives and lots of people thinking of initiatives to start something. And also **the city is very supportive** of that so when there is like an empty building, somebody goes hey there is an empty building would you like to organise this or that everyone gets involved, so that's good for Nijmegen. **I'm really happy in this town, really really happy.**

T: Do you live locally? Do you commute into the city?

F: I live the other side of the river, **just across the river**. Well, it's new so it's not as expensive as the inner city.

conversation transcript

Fred



traces of everyday life

Fred



Nijmegen Highlight
Doornroosje club - popular music venue

G

Geertje

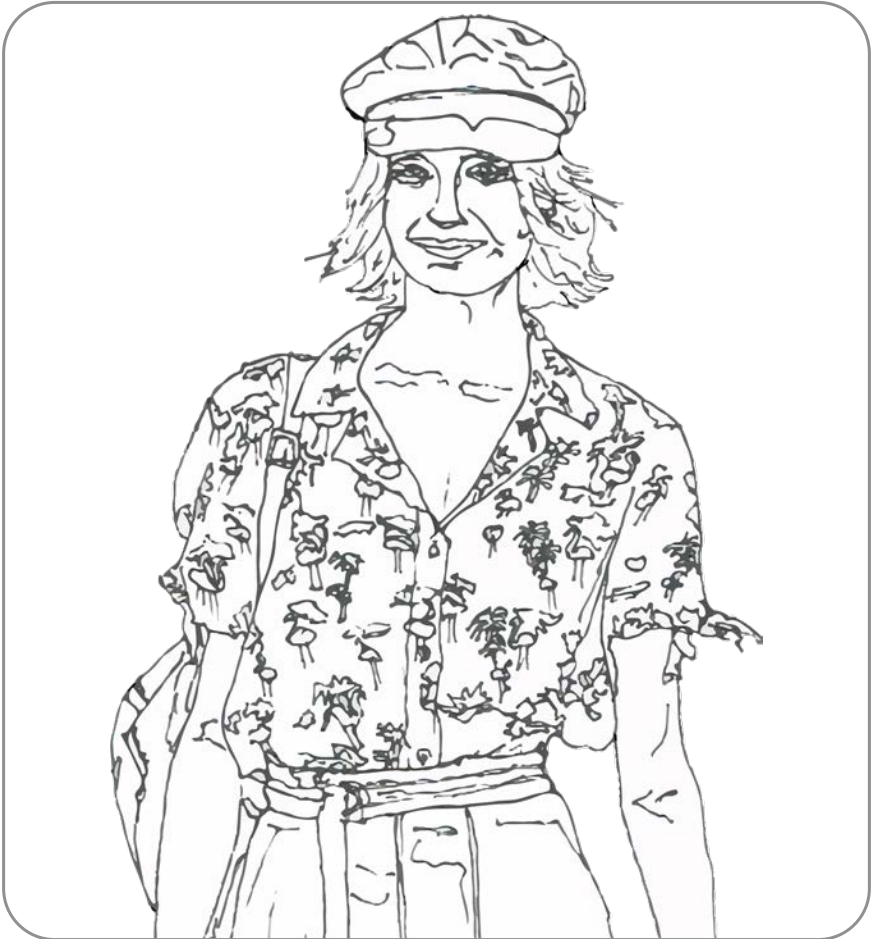

Age: 47 years old
Occupation: In Nijmegen for a Pilgrimage
What's missing in Nijmegen: Nothing

Geertje

J: We saw that you were looking around, and you had a map...

G: Yes! **I was on a seven days wisdom march.**

R: Oh Ok, Is that a premade route or something?

J: Is it like a pilgrimage?

G: Yes! It **starts at Stevenskerk** and then it has **136 Kilometres**, I walked everyday for the past 7 days.

R: Are you from Nijmegen?

G: Nono, I am from the North of the Netherlands. I was born in the south and moved to the north.

J: Are you religious?

G: No, **I did it for the spiritual experience** but I am **not religious**. It is a lot of walking and you are by yourself with your mind.

R: Did you find your wisdom?

[HAHAHA]

G: Well, next time I would not bring such a heavy bag

J: Are you walking by yourself?

G: Yes I was on the way by myself. It was a nice route. Halfway there is a **small Maria chapel** and on **every station you get a new bead** (showing a bracelet with several coloured beads) Now today I finished and I got my certificate with stamp and everything haha.

R: So you came to Nijmegen for this Pilgrimage?

G: Exactly, I am number... (looks at the bracelet) **6534 who finished this journey**. It is kind of the training to do the Santiago Pilgrimage later.

J: In which direction are you going now that you are finished ?

G: Well my car is in Lent across the river but firstly I will treat myself something before going home.

conversation transcript

Geertje



traces from the conversation

H

Henry



Age: 24 years old
Occupation: Studying Hotel Management in Eindhoven
What's missing in Nijmegen: Water park and more bins in public space

Henry

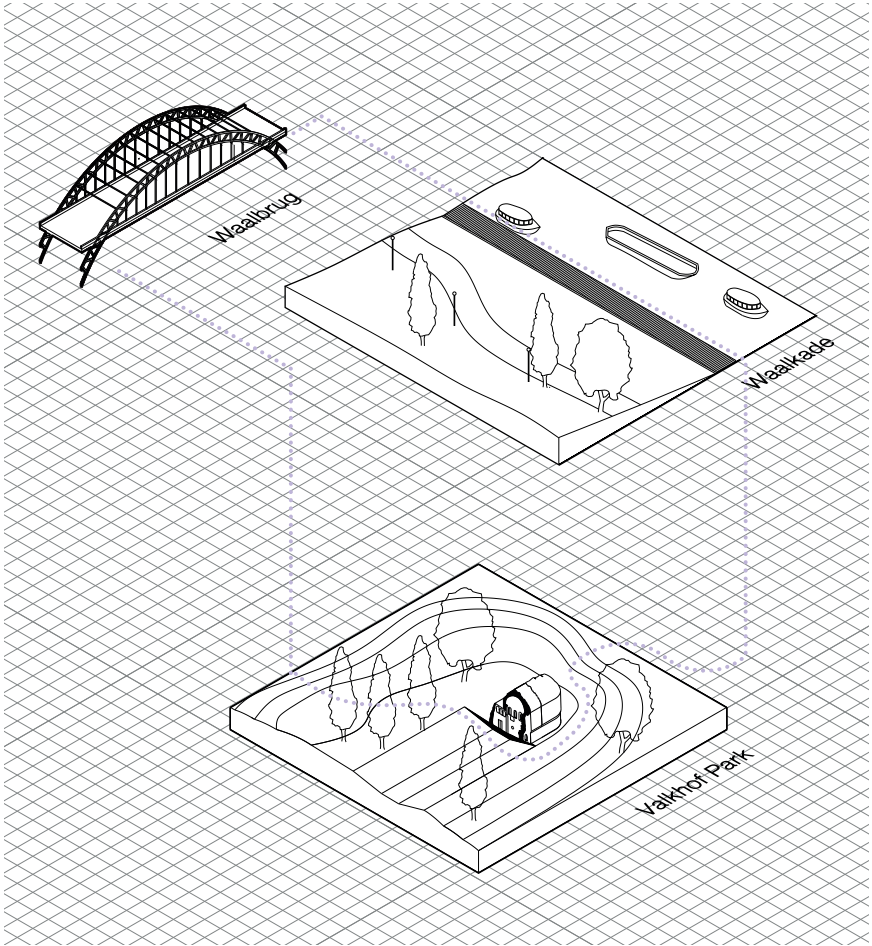

personal landmarks

Henry

J: What define the people of Nijmegen?

H: I think the **easygoingness**. It is just a **very relaxed city**. For example, in bigger cities I think people are very stressed in the work atmosphere, always rushing around, looking at phone etc...In Nijmegen people are more laid back in general – just walking around, chilling, no rush.

R: What makes Nijmegen unique (If it is)?

H: It is a combination of everything. In **15-minutes-walk you can find everything that is present in the country**. You have the historic centre, nature reserve, water and beaches, restaurants and shopping street. It's the only beautiful city in the Netherlands. I always told myself that I'll never live in a city in the Netherlands, but then I moved to Nijmegen...

H: Look at it, for example, this is the **oldest shopping street** in the Netherlands. I do not shop a lot, but it's just cool – it's from Roman history, and Roman history is my thing – I love it.

J: Which are you 3 personal landmarks?

H: The **beaches**, just across the city – it is the most beautiful beach and you have the best view ever. The **Valkhof park**, with the Roman city walls, the medieval chapel and the view, you can see Arnhem. The third one, **Goffert park** – a huge park, where also the stadium is, very calming, it has a food garden, theatre...

J: What do you think that should be add?

H: Yeah, a **swimming pool** would be so cool. I really like the tropical pools, like Central park, with rapid water. We miss a swimming pool where you can just get a milkshake and hang out with your friends. In

conversation transcript

Henry

the summer months, people can swim in the Waal. In winter, a hot tub maybe on the roof. Other than that, I don't know what you could add, programme wise, as this city has everything.

H: But, we have this **round-bound** (Keizer Karelplein) and it sucks, everyone is just breaking in the last moment, honking. I think it is **one of the shittiest road networks in the city**, so maybe I would change this.

J: What do you think about the motto "Old city, Young vibe"

H: Nijmegen used to be on the border of the Roman empire, so it is definitely an old city. But also around 40-50% of people here are students. You just see that on the streets, so the vibe is young. It is a short, but fitting motto of the city. Most of student housing is also in the centre, students walk through the centre and you see them.

R: Do you think that the city has changed over the last years?

H: Since I live here, 4 years now, I think only one building was demolished. One of the buddies said that the city changed a lot since the '80s – he lives in a region that is now like a family area, but used to be more like a gangster area, a bit more industrial. Wolfskuil, it is a bit to the west, south-west of the centre.

conversation transcript

Henry



traces from the conversation

Henry



Nijmegen Highlight
Waalstrand



Ivan

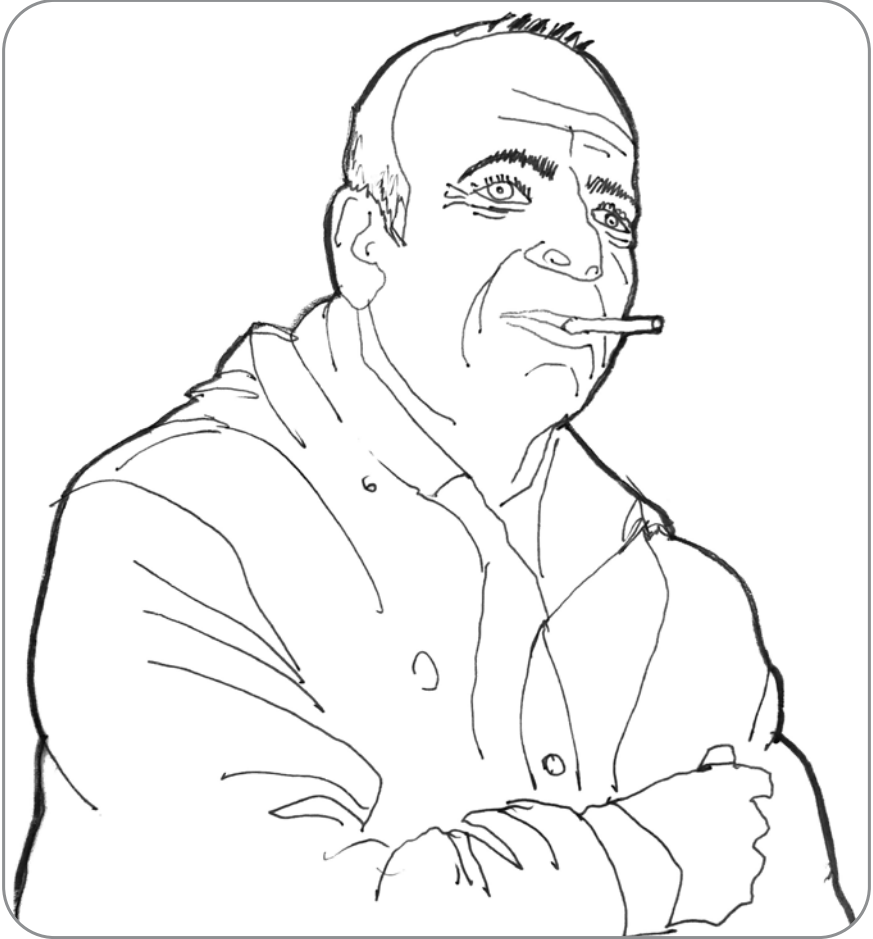

Age: 57 years old
Occupation: Bulgarian street musician
What's missing in Nijmegen: Affordable housing

Ivan

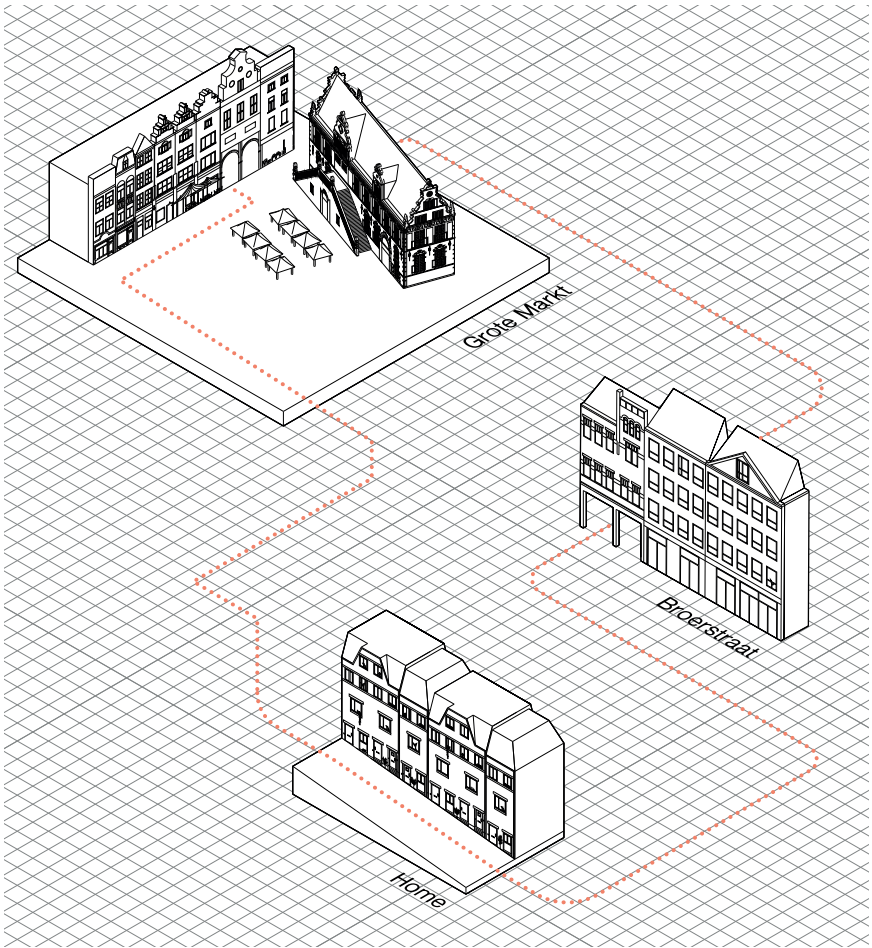

personal landmarks

Ivan

K: Where do you live in Nijmegen?

I: I **live illegally close to the main station in Nijmegen**, together with other Bulgarians. They work in the construction industry. But **I have an allowance to be a street musician**. Do you want to see the document?

K: When did you learn to play the accordion?

I: I learnt how to play during music lessons at school in Kotel (small city in Bulgaria) and since then I am working like a musician on the street, on weddings, restaurants...

K: Can you make a living as a street musician?

I: Yes, I **usually earn around 40 - 80 Euro per day**.

K: Do you like Nijmegen?

I: I find **the city friendly and people are very open. There is a respect**. But now because of Corona people are scared. They are scared to get closer and to leave me money.

I: I would like to learn Dutch language, but I cannot afford not to work during the day and go to the courses. I need to work.

conversation transcript

Ivan



traces of everyday life

Ivan



Nijmegen Highlight
Broerstraat, the street where he plays usually

J

Jolene

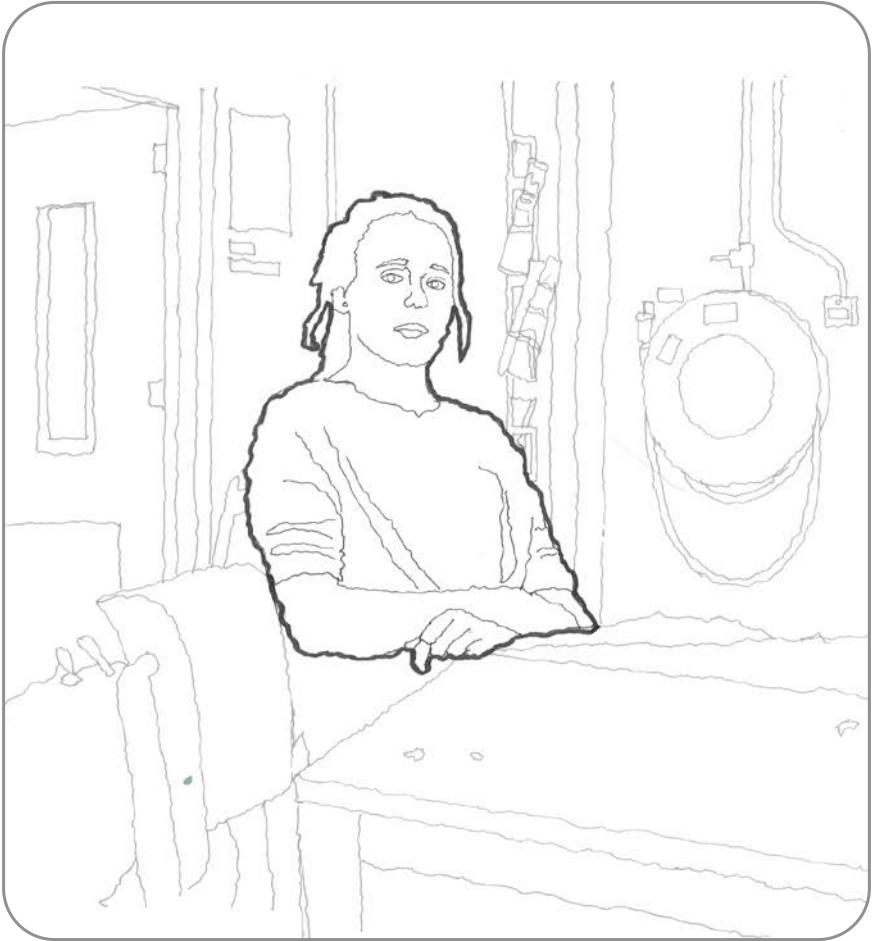

Age: 35 years old
Occupation: Phd Student
What's missing in Nijmegen: Green areas and public space

Jolene

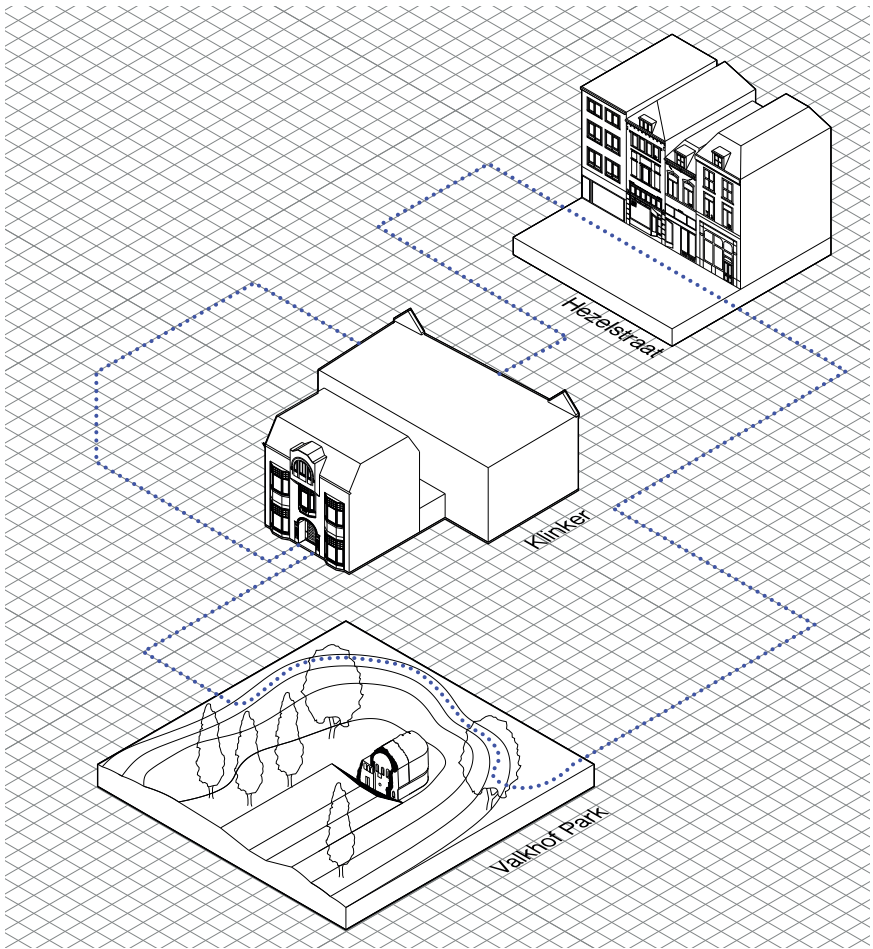

personal landmarks

Jolene

R: So when did you move here? *[the Klinker]*

J: urrm in 2009. I currently **live 10 minutes away by bike on the other side of the train station**

R: What defines the people of Nijmegen?

J: There is definitely a **left wing vibe as it's a student city**. This means that there is always something going on as **everyone is socially minded so they create organisations and volunteering** programs

R: What makes Nijmegen unique if it is?

J: Definitely the **river front** with its long promenades and the green spaces running alongside it.

R: Is there something you do not like about Nijmegen?

J: Not really, there are new neighbourhoods that I do not like that much but its fine

R: Do you think the city has changed over the last years?

J: I don't think it's changed that much, **the only thing that has changed in the housing prices!**

[HAHAHA]

R: What do you think should be added to the city?

J: Probably **more green space, squares and more outdoor spaces for people to meet and hang out in**

R: Are there other places in the city that are squatted?

J: Yes, there's a few near my house but now it is not legal

R: Are there many people from different nationalities in Nijmegen?

J: Yes! **Migrants, international students** but there is not a big black community

conversation transcript

Jolene

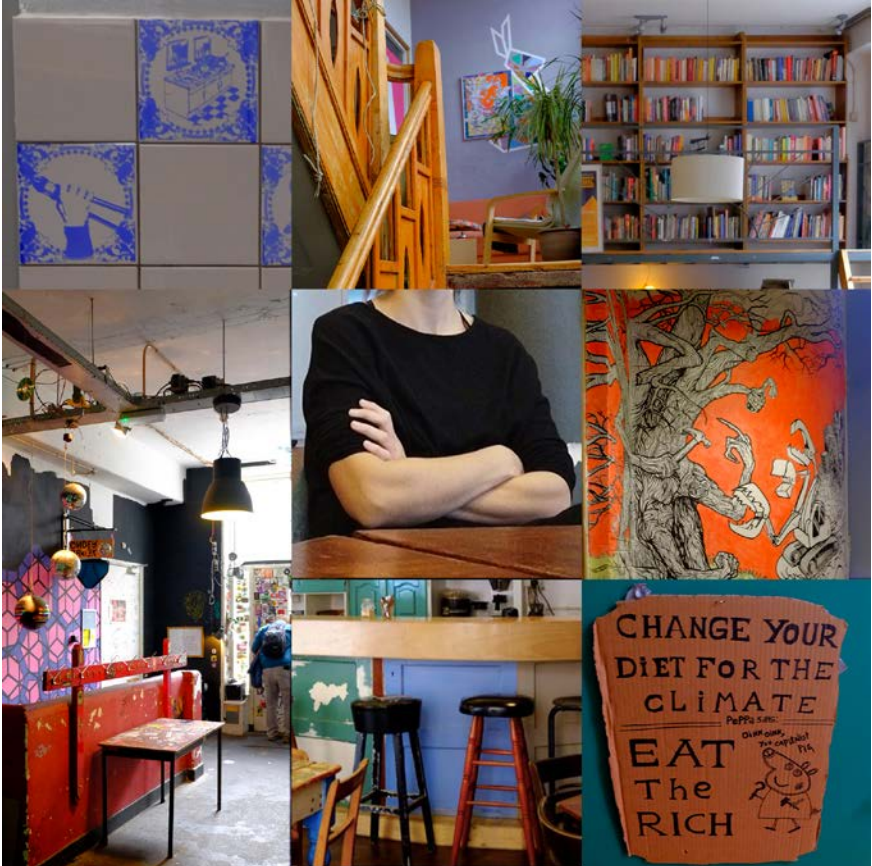

traces from the conversation

Jolene



Nijmegen Highlight
De Klinker, Political Cafe / De Onderbroek (Concert Space)

K

Kas

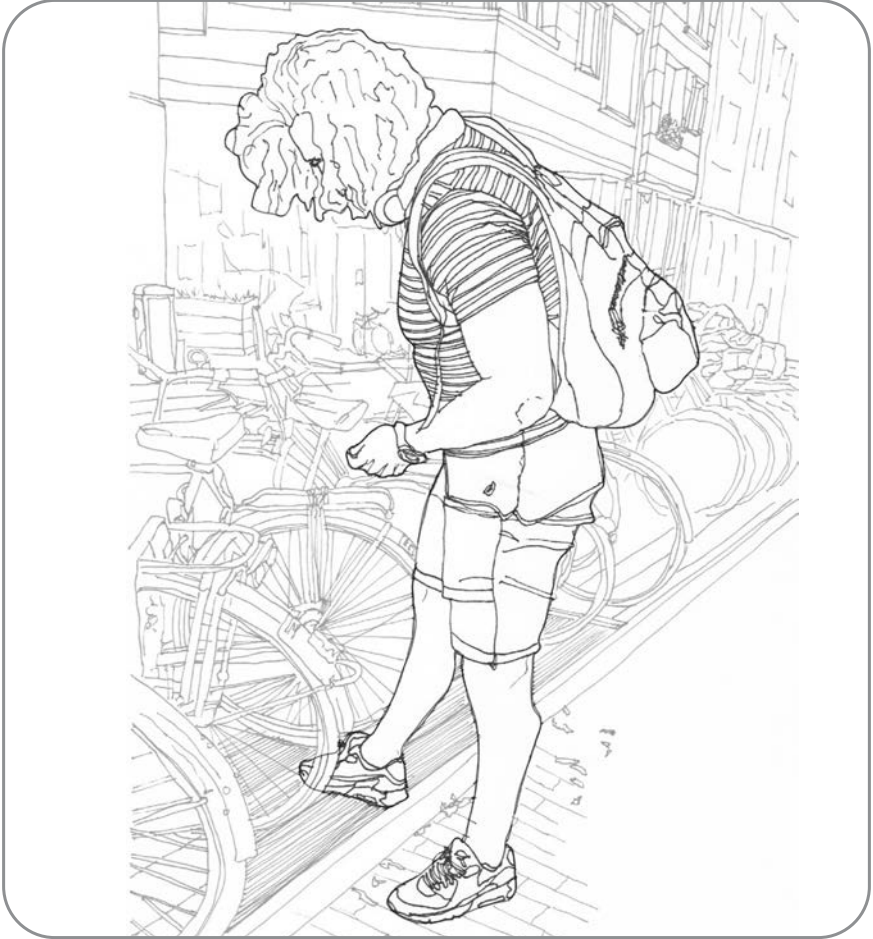

Age: 31 years old
Occupation: Data analyst
What's missing in Nijmegen: Affordable housing

Kas

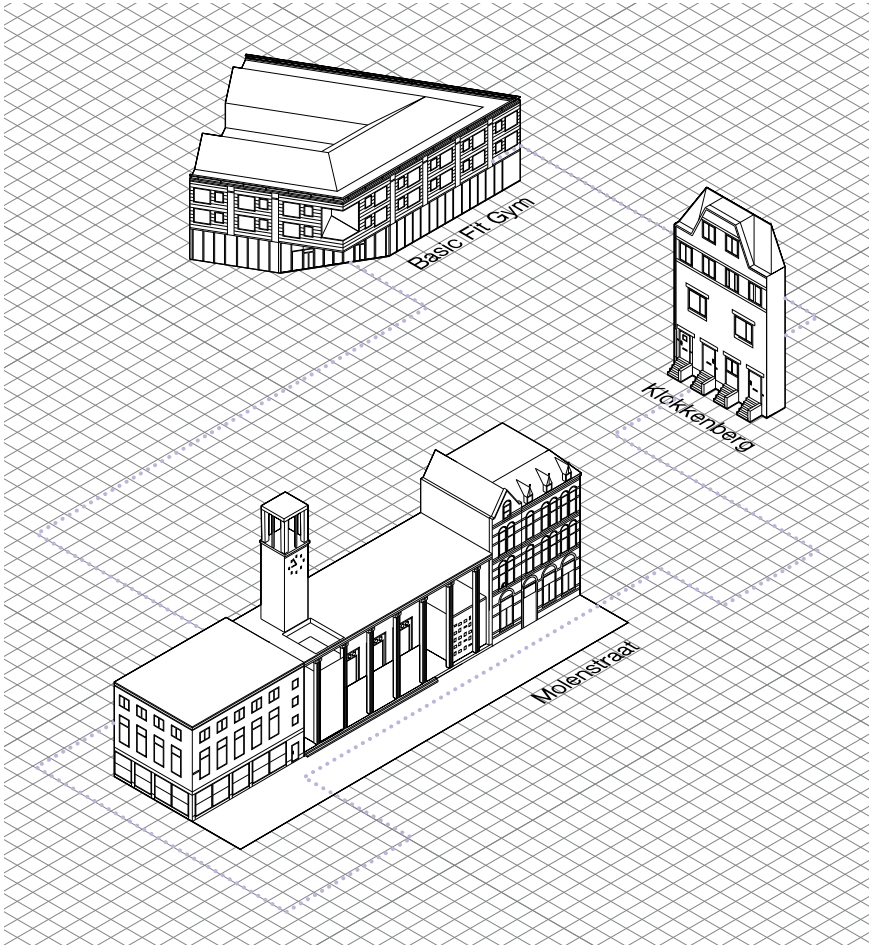

personal landmarks

Kas

L: Why did you come to Nijmegen

K: Oh err, originally, I'm from the South, Limburg. It's kind of a village, err but I decided to study here. At first I lived just outside of Nijmegen in Diervoort.

T: Is that where most students live?

K: No no no, my mum lives over there. Then I decided to live in the city and then I decided to stay here err I guess because **I just found the city pretty welcoming**. I know this might not be the safest street...

[HAHHAA]

K:..but everywhere else is pretty chilled. **Most of my friends live here aswell** so that's also a big factor

L: Would you say you came into the centre to like socialise or shop?

K: I'm not really sure, **I'm not really much of a shopper kind of guy**. So err, friends usually visit more often if you're living more centrally

L: oh so you live in the centre then?

K: yep yep. **I live just over there**

[Kas points at one of the houses on the street]

K: I know like a lot of students decide they want to live in Nijmegen after they leave college. But there aren't like...especially in the centre... there aren't a lot of affordable houses. Especially with renting, it's hard to get into because there are not a lot of apartments for that in the centre.

T: ...so like what's the attraction?

K: I don't know errr I think **I just like the city, the atmosphere**

conversation transcript

Kas

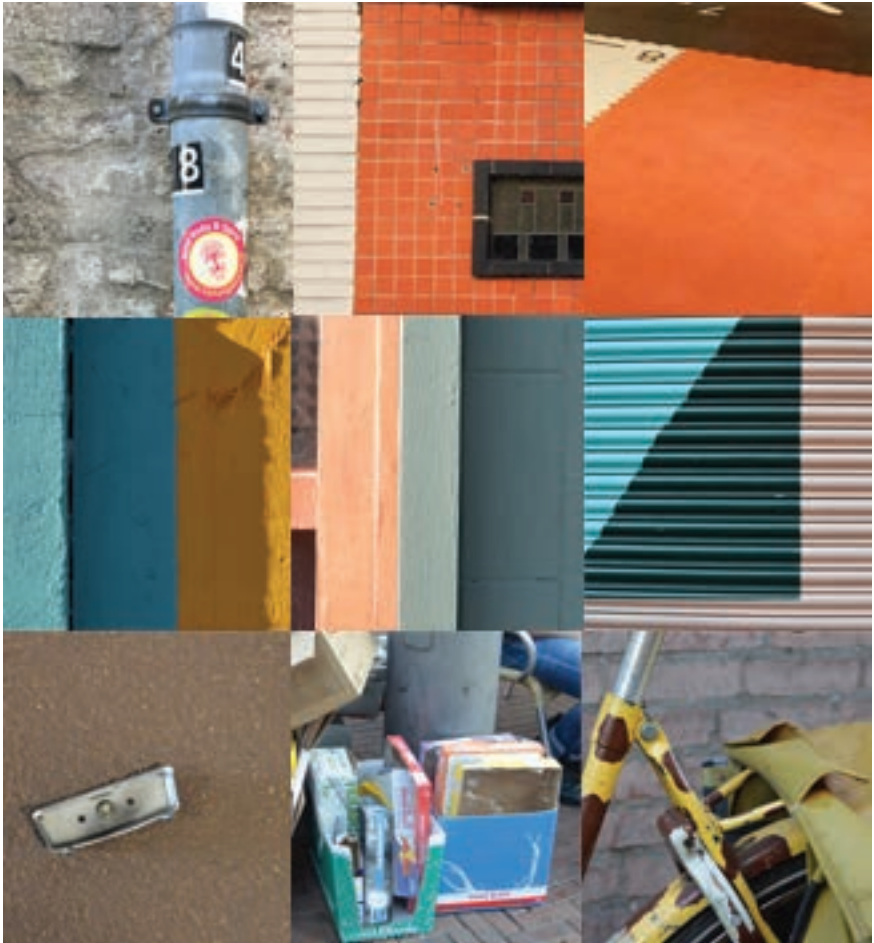

traces of everyday life

Kas



Nijmegen Highlight
Basic Fit

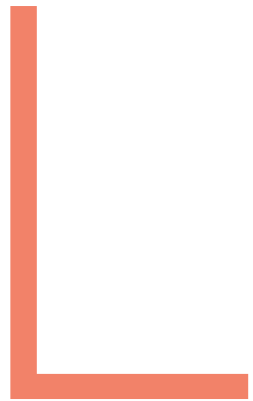

Ledewina



Age: 74 years old
Occupation: Book shop assistant
What's missing in Nijmegen: Cosy shops

Ledewina

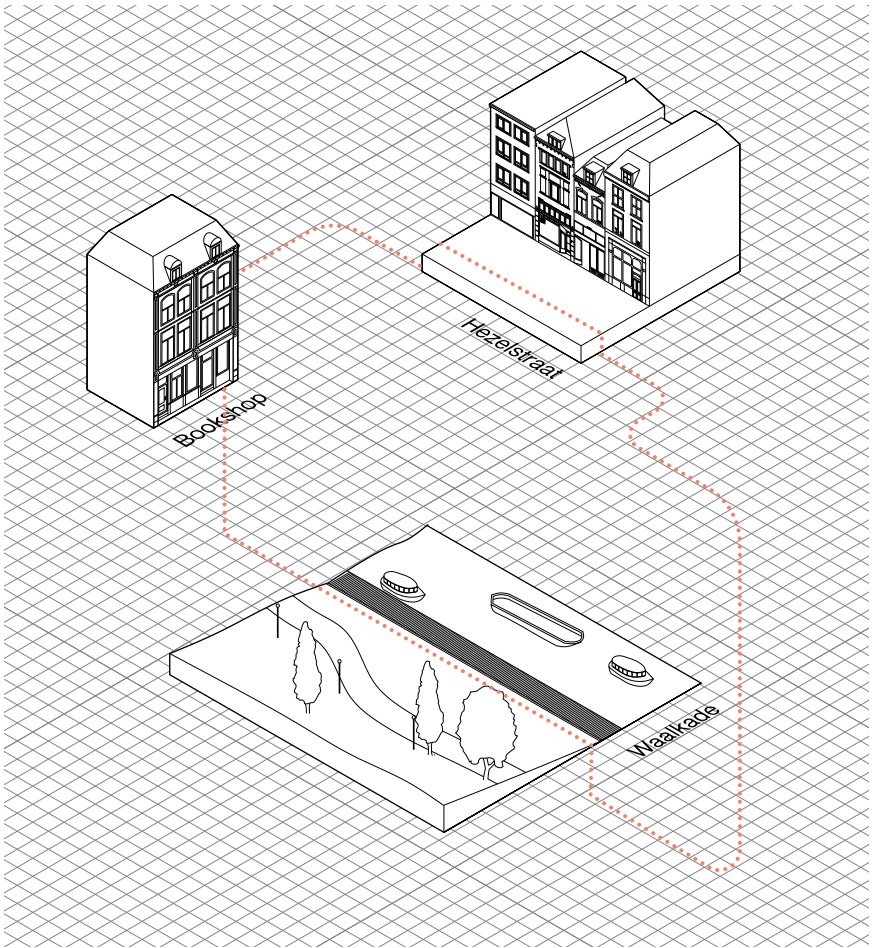

personal landmarks

Ledewina

Lo: Were you born in Nijmegen?

Le: Yes, I was born in Nijmegen

Lo: How has the city changed over your lifetime?

[church bells]

Le: Oh, the town down- all gone. **From my early years when I was ten, all gone.** The old streets, the old houses they're all gone. To see some old things you have to go to Doesburg or Eindhoven.

Lo: Do you like the way they've designed the city since or are you not a massive fan of it?

Le: **No, no I don't like it.** It was bombed in the war but after the war they took away some more just like Arnhem.

[...]

V: Ah okay, and you lived your whole life here in Nijmegen?

Le: Mmm well **I live near the river Waal in an old ferry house,** not exactly Nijmegen in doinburg. You can go by bike.

Lo: Do you only come into the city centre to work or do you come here for leisure? What do you like in the city centre?

Le: What I like in the city centre is this area, the hezelstraat

Lo: Yes it's very nice, very pretty

Le: Yes that's the only thing that remains. But **I think all the cities are changing, like Arnhem. It's not like it was, no cosy shops just a few.**

V: Do people just come here to shop and then just go back home?

Le: Well they go to the terraces outside just like that, over there. Sit outside and have some coffee and beer.

conversation transcript

Ledewina



traces of everyday life

Ledewina



Nijmegen Highlight
Book shop – Roelants

M

Mattie

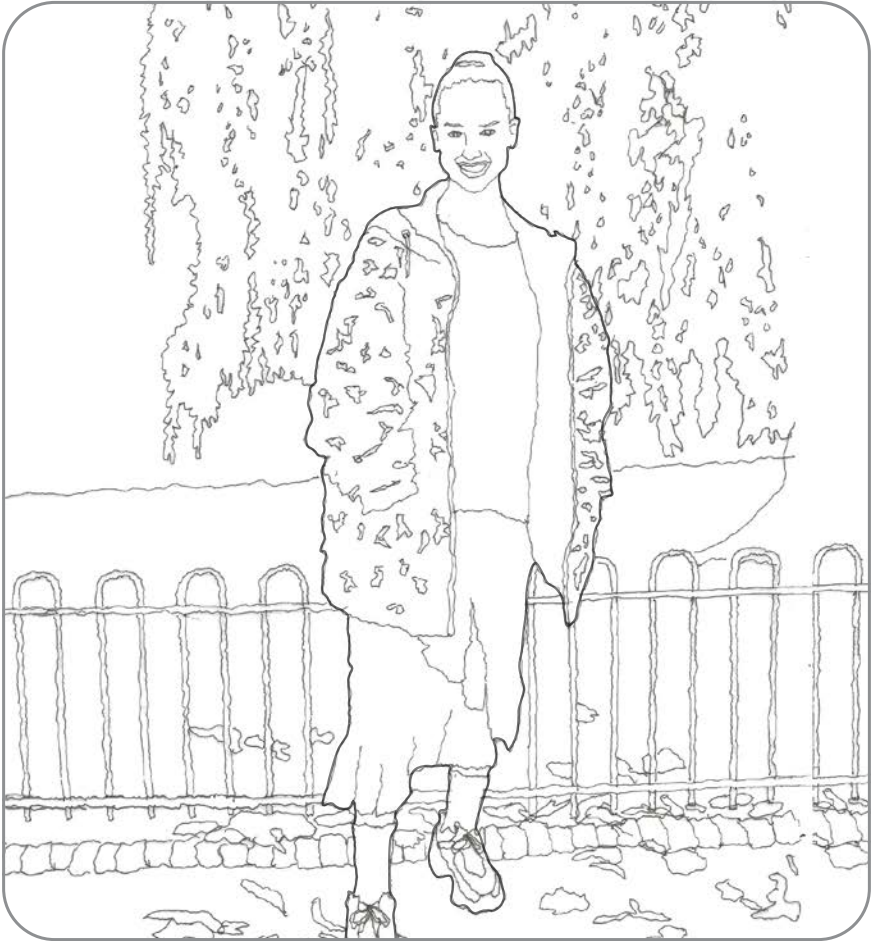

Age: 21 years old
Occupation: Sales assistant
What's missing in Nijmegen: Clubs and nightlife

Mattie

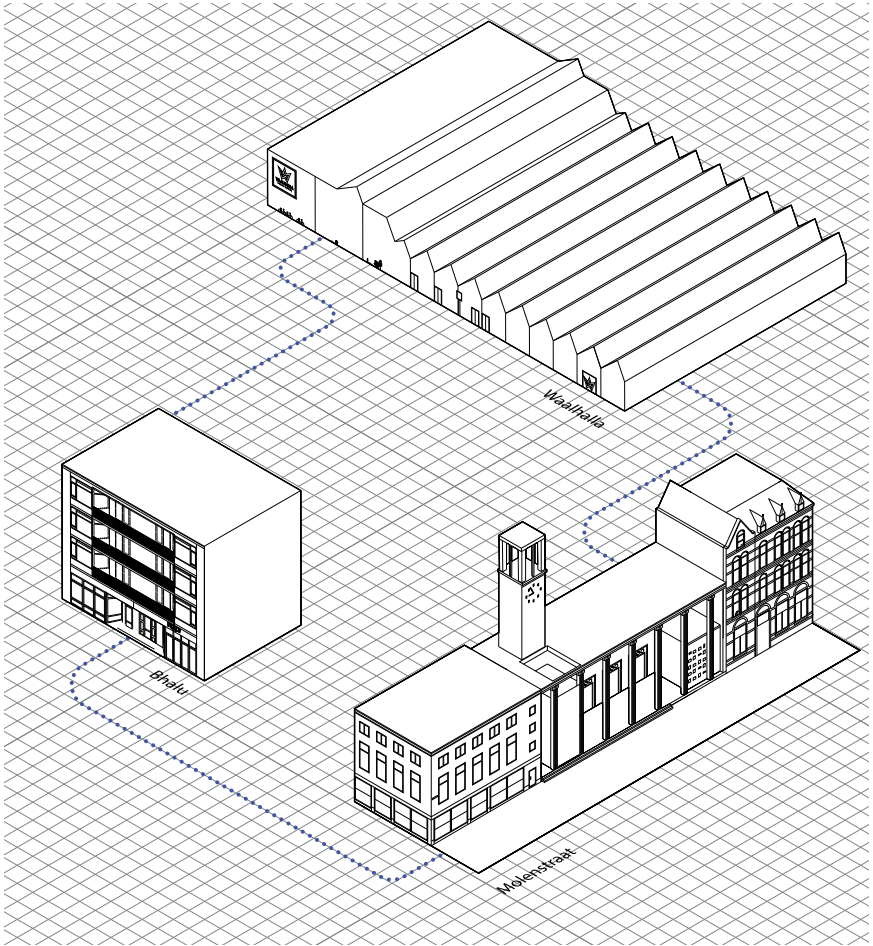

personal landmarks

Mattie

M: I live just outside of Nijmegen, I come here often, all my family and friends live here

L: What do you think defines the people of Nijmegen?

M: The first thing that comes to my mind is just **really left, really liberal, really accepting of all people**. We have a **huge community of LGBT**, if you look outside all the rainbow flags are out and all the gay bars.

L: What makes Nijmegen unique?

M: I think how **green it is**, because it is a city but its nothing like Eindhoven or Rotterdam, there is a lot of green areas

L: What would you like to add to Nijmegen that is not here already?

M: **Clubs**, there is not a lot of opportunity to go out. We have bars but **we love to dance and there's not a lot of places to go dancing**.

T: Where do the student community go out in the city?

M: So there's this one main street, **molenstraat** that has loads of cafés on the right side. **During the day people drink on the terrace** but during the **evening young people go clubbing**. Also **Waalhalla**, just outside the city, an old factory that has been turned into a skatepark.

T: What attracted you to Nijmegen since you don't live in the city?

M: I live in quite a small town and the nearest city is Nijmegen so it's not like i specifically chose to come here because this is where all the cool stuff is, and I **definitely do not have the desire to live here when I'm older**.

T: How would you describe Nijmegen?

M: I think **Havana on the Waal** says it all, it's such a warm and comforting place and it's **evolving with it's time**. **They're adapting to the new generation** and that's great.

conversation transcript

Mattie



traces of everyday life

Mattie



Nijmegen Highlight
Kattencafé Balthazar Cat Cafe

N

Norbert



Age: 49 years old
Occupation: Social worker in organization for homeless
What's missing in Nijmegen: Streets with cafes

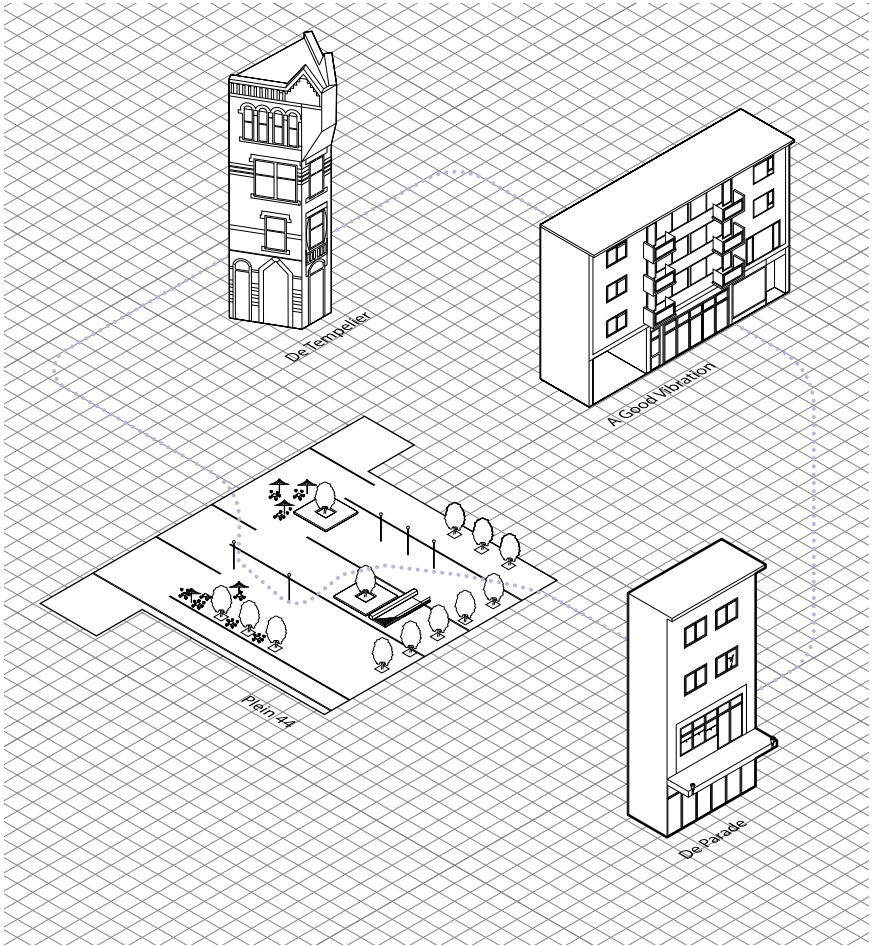

personal landmarks

Norbert

J: What defines the people of Nijmegen?

N: They are **nice people**.

H: More **friendly** than other Dutch cities. And I can illustrate that. 5 years ago, other cities accepted 500 Syrian immigrants, whereas in Nijmegen we welcomed 3000 and collected clothes for them.

J: What makes Nijmegen unique?

N: I think it is a city with the mentality of a village people. People know each other here, friendly, warm welcome.

H: The mentality in this city is **strangers are friends, who we never met**.

K: What do you think should be added? Nothing, instead of Molenpoort?

N: I don't know, I am missing nothing. I think it is great here, I like it the way it is. I came here 15 years ago.

H: Molenport – tear it down! I don't go there – before it was a hospital for elderly, a police station. Only good store is the leather shop owned by a Turkish guy.

N: Streets with cafes. The plans are to have nice small streets to walk, with shops. Old London style. Oh, **I would like that kind of neighbourhood image of the city**. Not like this mall.

conversation transcript

Norbert

J: Do you think that the city has changes over the last years?

H: It didn't. It is still the same.

N: I have changed.

H: **When he came, homeless he was.** Without home, without job, without any future. Now, **he is working with homeless, he is now managing the shelter.**

J: Where, which one?

N: For RIVM, hospice in Groesbeeksedwarsweg.. **We help youngsters between 17 and 25.** I am working there now for 13 years.

K: How did you find help, find help when you came to Nijmegen?

N: I made good friends here. Noble family, outside of the homeless world – they took me in. Started from there on, looking for job and work. Because of my own experience as homeless, they want to hire me. Because I approach the youngsters from different point. I can talk to them in a different way. “Oh I didn't use today... N: Ohh, I can see it in your eyes, why you try to fool me”.

N: So, **it is a project for 2 to 4 years** and we try to learn them what it needs to live by your own. **After 2 years we give them a house.** 1 year it is on our name, so we can control it still a little bit. And after 1 year we give them the

Norbert

house and, yeah, they go on.

N: Yes, we have housing shortage. They have to give us like 7 houses each year. We made an agreement with the city, the municipality.

H: I have a house. I was on a waiting list, you have to rent for 15 years before you can buy a house.

N: I rent, for something like 650 Euro/month. 3 Bedrooms.

H: He has a family residence by himself.

K: Why you are not at De Tempelier today?

H: Sometimes we meet there, sometimes we come here in De parade.

N: I don't work Friday and Saturday, so we usually drink beers on Friday, around that time.

[...]

K: Have you been to De Klinker? We are just coming from there.

H: No. But, the biggest post-war military operation here in Nijmegen, with tanks and so on, was the displacement of squatters. In 1981, from the houses on Piersonstraat.

Norbert



traces of everyday life

Norbert



Nijmegen Highlight
De Tempelier

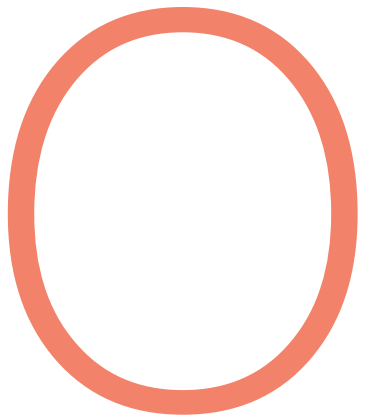

Olof

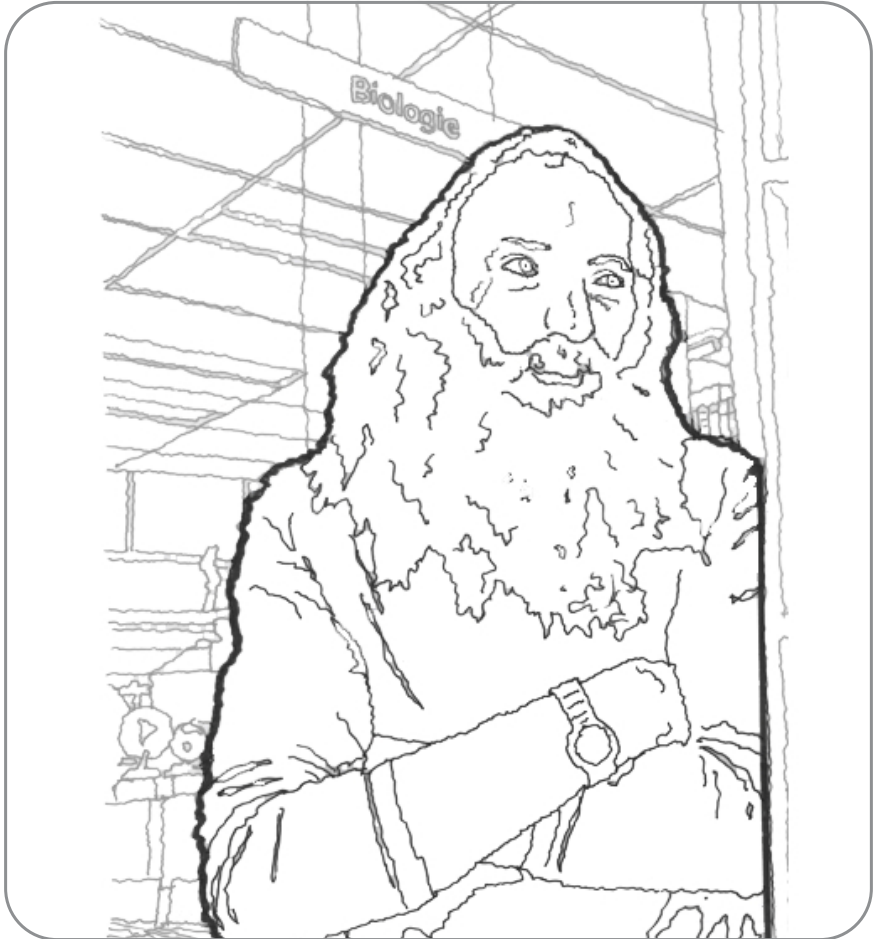

Age: 82 years old
Occupation: Book shop owner
What's missing in Nijmegen: The old town

Olof

L: Were you born in Nijmegen?

O: Yah I was born in Nijmegen

L: Do you like it?

O: Urr I'm not going away

T: We're trying to get to know whose here, what they think about the city etc. I was wondering if you could tell us anything interesting, what you like about the city, what you don't like?

O: **Some things I like, some things I don't like.** WW2 gave us bombardments, **the inner city was destroyed.** The down city most of it was saved but in the beginning of the 70s the town council decided to demolish most of the buildings, not all of the buildings. And **now it looks so modern, bleugh...**

[HAHHAA]

O: **It's not my fashion of Nijmegen,** certainly not that part of Nijmegen. **I miss the old situation,** it was not restored in the 70s but it could have been restored. They sold out to companies

L: We've heard its quite a left wing open city

O: The town council is indeed except the major who is right wing

T: And what's your favourite part of the city?

O: **My favourite part of the city? I don't have that...**

L: Do you live in the city centre?

O: No, no I live in Dikkeboomweg

conversation transcript

Olof



traces of everyday life



Nijmegen Highlight
Book shop – Boekhandel Antiquariaat O.M. van Hoorn

P

Peter



Age: 38 years old
Occupation: Sales man
What's missing in Nijmegen: -

Peter

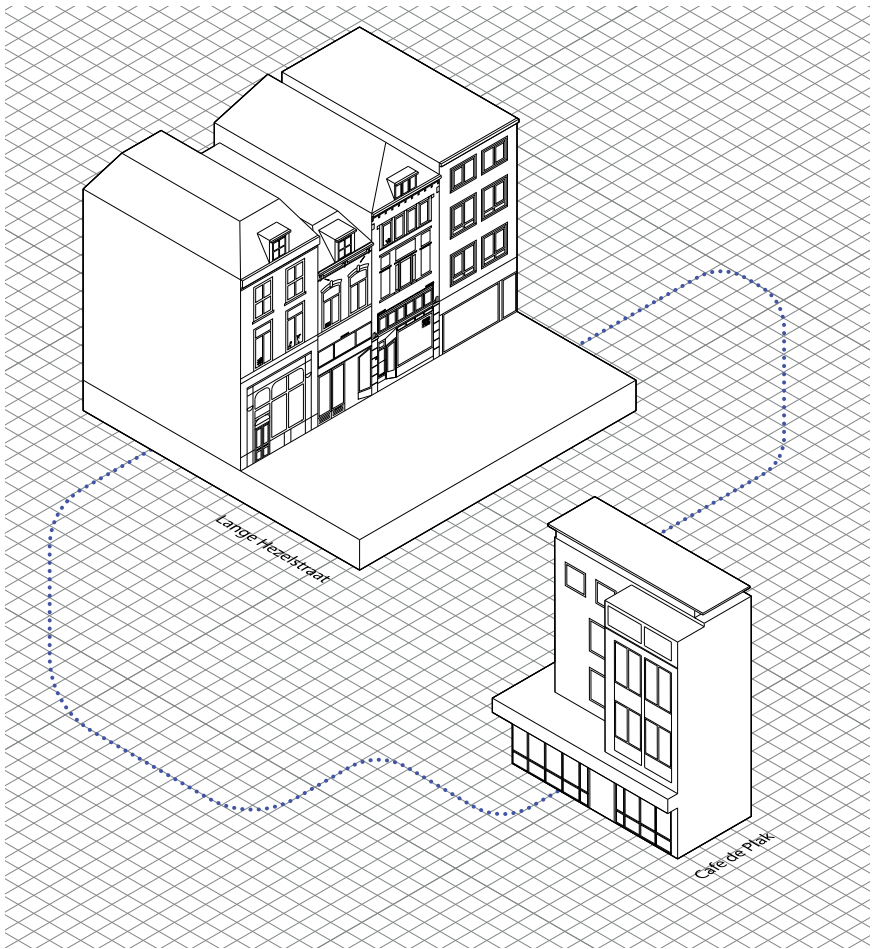

personal landmarks

Peter

L: We're trying to get a feeling of the city, what you like, what you don't like?

P: **What I don't like? Not much.** I'm really from here, I have moved around a little but I guess this is really my city because it's on the border with Brabant which is all about coming together, going to cafes and meeting each other

P: I guess this is the most beautiful part of Nijmegen because it is not bombed. They say **Hezelstraat is the oldest shopping street in Holland.** They also say Nijmegen is the oldest city in Holland because it was built by the romans more than 2000 years ago. What I really like is all the little cafes and dining places, I guess that is because there is a lot of students here.

P: I guess also the **diversity of people** I also like. It's really left of the political scale

P: When you're in Nijmegen you have to eat at **Café de Plak**, I live there around the corner, it's a go to place, everyone is there. The people who work there **give away all the profit they earn to refugees, feed the homeless.** One you have to order the kaas burger, its their speciality!

P: You can book a really good guided tour, Gileda Nijmegen. I recommend the second world war tour about the bombing which is really interesting. Before three years ago they thought it was accidental bombing but actually the bombs made the airplanes too heavy so the captain decided to bomb the train station because it was a really good point for the **Germans but he pressed 1.2 seconds too early and that is why the whole city is bombed.** Sorry about the spoiler alert...

conversation transcript



traces of everyday life



Nijmegen Highlight
Cafe de Plak

Q

Quincey

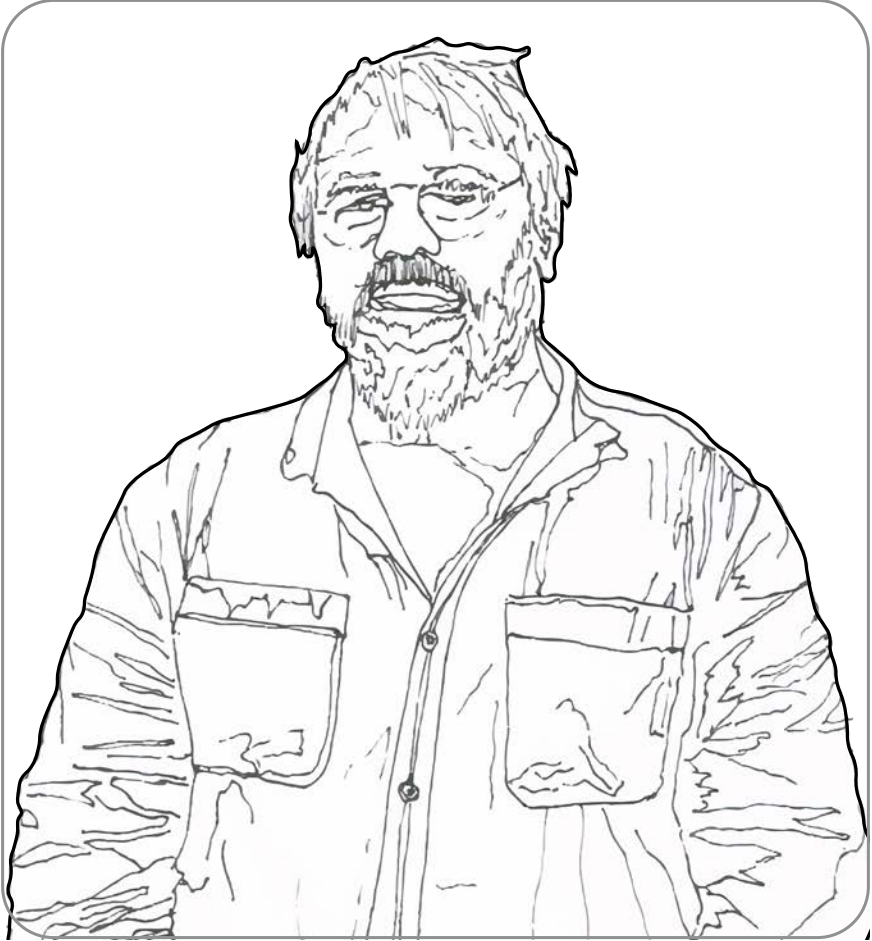

Age: 72 years old
Occupation: Archeologist and second hand shop owner
What's missing in Nijmegen: -

Quincey

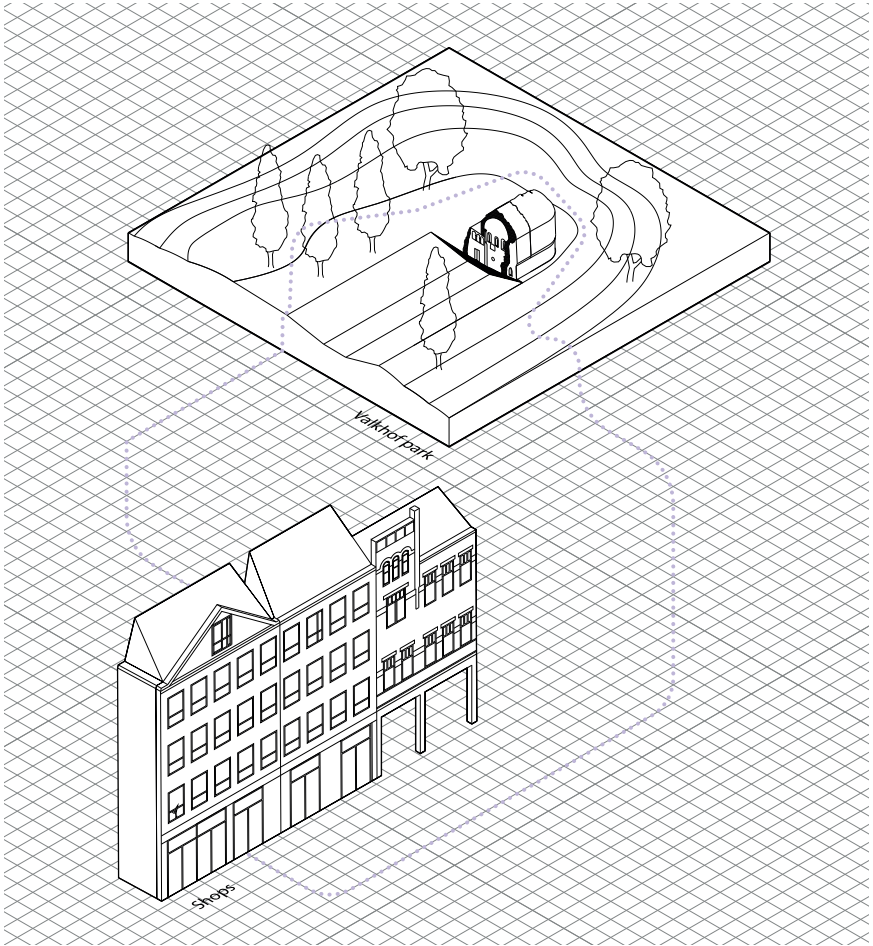

personal landmarks

Quincey

J: Do you have a favourite spot in Nijmegen, where do you go, what do you do in the city?

Q: **I think it is a very special place**, as long as it lasts, because they were talking about building something there. This is the Valkhof park

J: Ah, yeah ok the one where the museum is?

Q: Yeah, but if you cross you go to the park and **the city is really busy**. And if you go to the park, **the birds can sing and sit on a bench and view over the river**. This is I think always a kind of special place. Not that I go there often, but still, I think it would be a shame if they ah, build ah ... they are planning to build the castle that used to be there, build it up again.

Q: Ja, that is all important, that's my first reason why I started my second hand store, because it is important to re use your stuff.

J: Is this your main job?

Q: No I also work in Archeology.

J: Alright! so you are full in heritage! Impressive

Q: Yes! That is also why I think it is important that they don't build the castle! Of course, It would mean a lot of work for me, that's a good thing... but well we have done **some digging in the park** and you have so many stuff there to find... Roman coins. When they were building the museum, we had days where we find maybe **400 - 500 Roman coins**. Just just on the surface... and when you go down ...

conversation transcript

Quincey



traces of everyday life

Quincey



Nijmegen Highlight
Roman ruins in Nijmegen

R

Roman



Age: 35 years old
Occupation: Barber
What's missing in Nijmegen: Clubs, parties

Roman

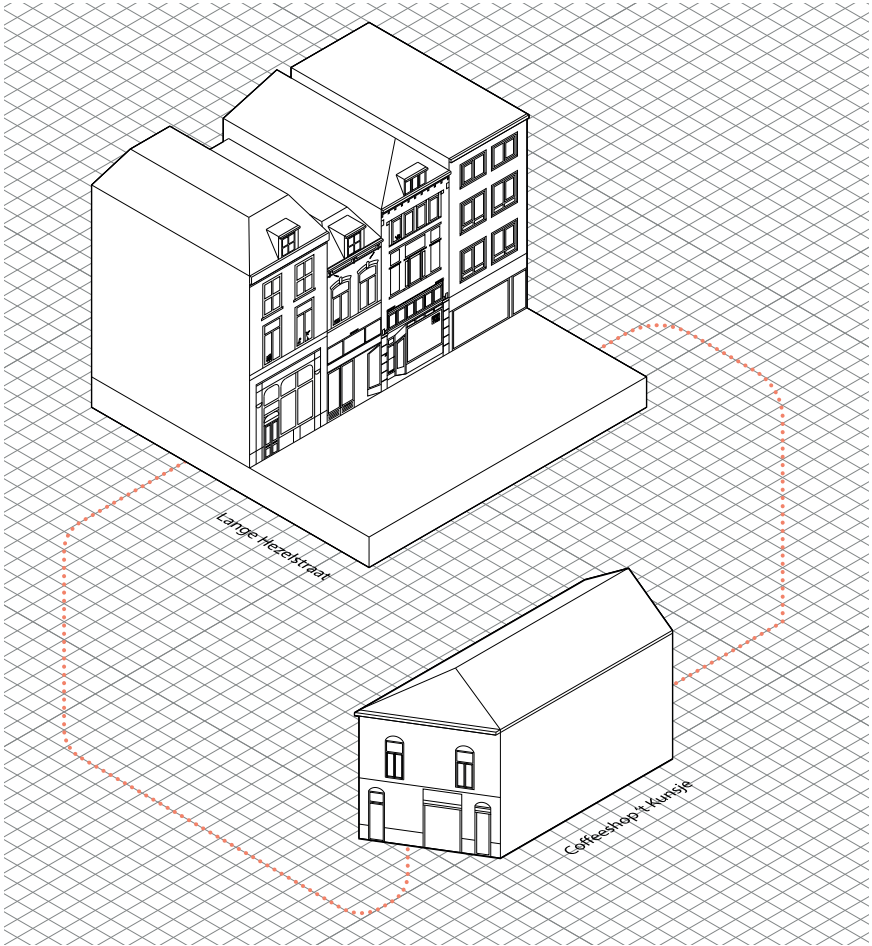

personal landmarks

Roman

R: What do you want to know about Nijmegen? Party, eating or culture?

L: The highlights, you guys think of. The highlights spot

R: Highlights, highlights, hot spot, hot spot spot... **Coffee shop** in Nijmegen!

[HAHAHA]

R: Thinking about...

N: **We have enough bars...** so... and normally there are also clubs, but now with the 1,5 metres... so... **You have a lot of old stuff**

V: And, you like Nijmegen?

R: I like Nijmegen, because it's old and a student city. But I prefer Arnhem, there are more things to do.

L: Oh, do you think in Arnhem, there is more happening? Kinda like Delft and Rotterdam.

R: Yeah, **more clubs next to each other, more parties.** Here, in Nijmegen, they are all scattered around the city.

L: Oh, thank you

V: Thank you, very much.

L: Bye, bye...

V: Bye

conversation transcript

Roman



traces of everyday life

Roman



Nijmegen Highlight
Coffee shop in Nijmegen

S

Saskia



Age: 23 years old
Occupation: Waitress at Bhalu
What's missing in Nijmegen: Windsurfing on the river Waal

Saskia

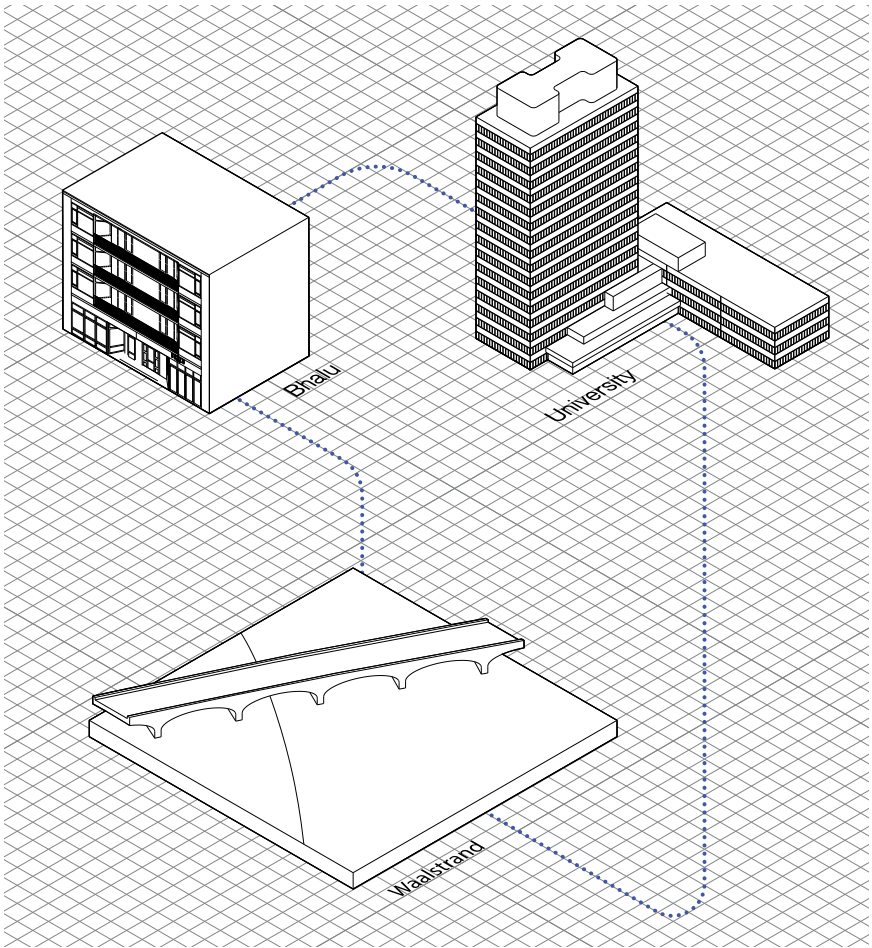

personal landmarks

Saskia

T: Did you grow up here?

S: Yes but I am going to live in Utrecht to do a masters there for one year

T: Did you do your bachelors here?

S: Yes, yes

T: So you're like proper born and bread

[HAHAHA]

S: Yeah, but I want to see something else now

R: What do you think makes the city special?

S: This city? **You are in the centre in one minute and the beach in five minutes so I think that's special.**

S: Also the people here vote socially left, **everyone is welcoming** to each other, doesn't matter what status you have or where you're from, I think that's special here in this place, the people from Netherlands say that about Nijmegen.

[...]

L: If you had a chance to improve Nijmegen what would you improve it with?

S: Windsurfing. I would like to windsurf more on the Waal

L: I like the city a lot

S: Yes me too, there are a lot of students here

conversation transcript

Saskia

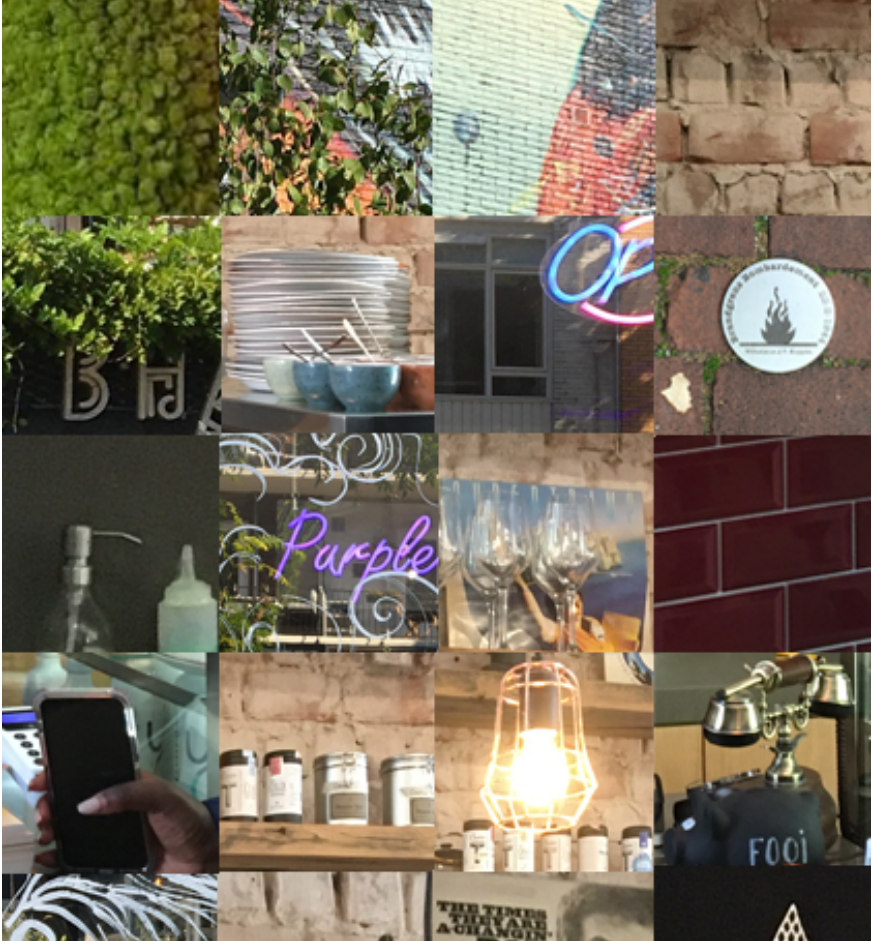

traces of everyday life

Saskia



Nijmegen Highlight
Bahu – vegan restaurant and yoga studio

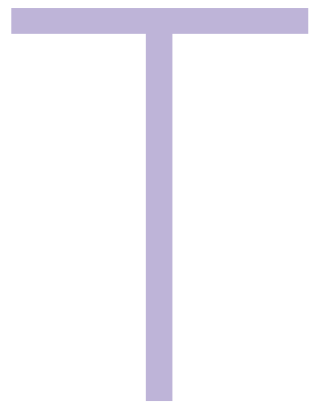

Thomas



Age: 66 years old
Occupation: Retired

What's missing in Nijmegen: More places to sit and talk

Thomas

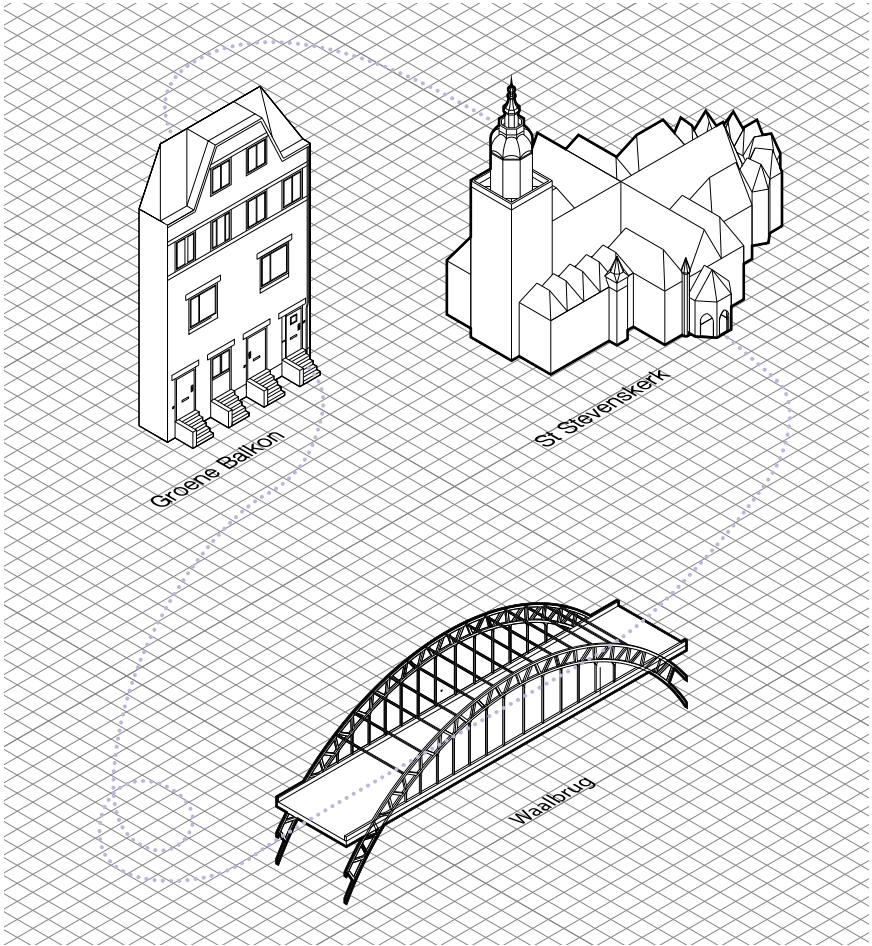

personal landmarks

Thomas

S: Hello! We are students coming from Delft. What would you tell us about Nijmegen?

T: Nijmegen is famous for being **the oldest city in the Netherlands**. In Maastricht they say the same, but they are lying. You should also go to **Lange Hezelstraat**, it is the oldest street in the city. We have a **very beautiful old bridge (Waalbrug)** opened by the previous queen – Wilhelmina in 1936.

K: Has the city changed during the years?

T: The city has changed, many people from all around, many students came. **There weren't so many shops before**, but **Nijmegen was very hard hit by the war**, Merkel had bombed, they thought it was Emmerich, but it was Nijmegen. On 20th of February 1944. It was a really nice city, and it is still a nice city, **but so many churches...**(were bombed), **it was so catholic...**

S: Is there something you miss in the city?

T: I think **we live with too few communication, there should be more communication - more places to sit and talk**. Too many people live in their world, I feel like 20 years ago was more social.

T: We sing in Stevenskerk on Sunday in the choir, organized by Stichting Ontcommers. There is a very famous organist in the church also.

conversation transcript

Thomas



traces of everyday life

Thomas



Nijmegen Highlight
Groene Balkon, residential area

U

Ursula



Age: 22 years old

Occupation: Just graduated art school from Utrecht

What's missing in Nijmegen: Events to learn about the history of the city

Ursula

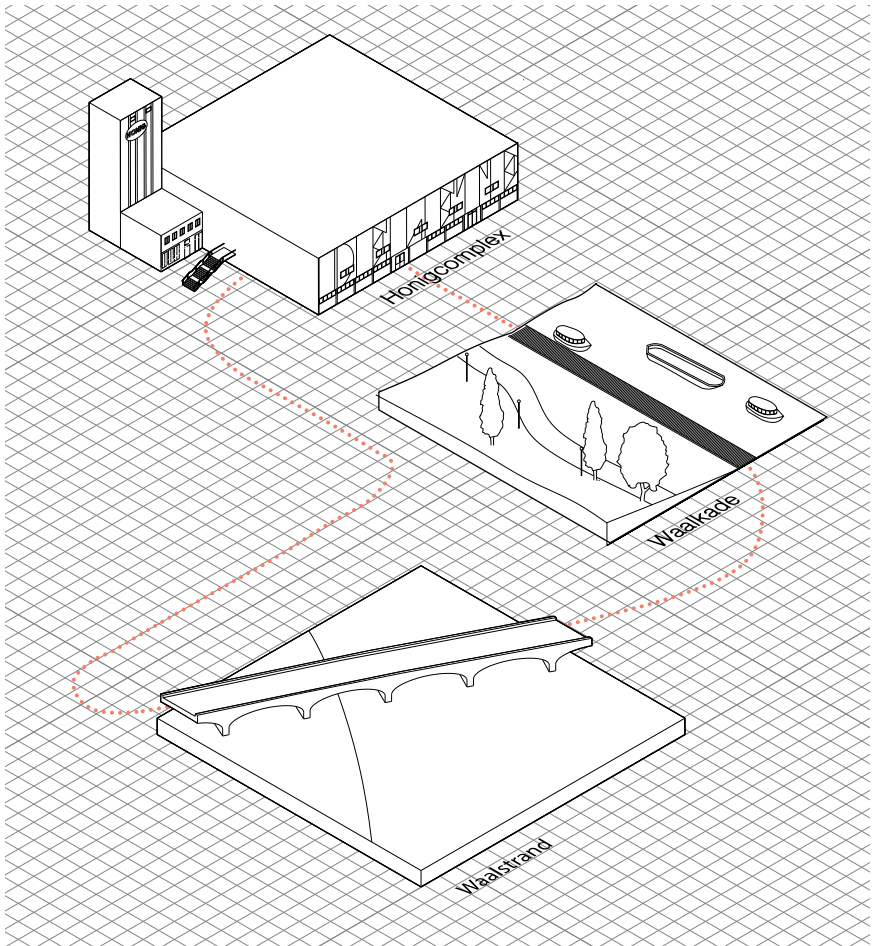

personal landmarks

Ursula

J: What is your favorite spot in Nijmegen?

U: I just love to get coffee at new places, just try new coffee places. But have you visited the **Ooyse**? I like nature, if you go that way along the Wall, and then it's like a **nature reserve**, it's also very quiet. It's only nature. you don't have the feeling like you're in the city, you know, like it's so beautiful. It's around **five minute bike ride**. I think very special that we have that in Nijmegen. **Because you don't have the feeling that you're in the city.**

U: Also the locations at the river front like the **Honigcomplex** are like the main spot for all the cultural things like the more freer people

J: Like for young people?

U: also older. It's very nice. And yeah actually I only go out there, not in the city, **we go to the Honig and we have to like the cool parties, the locals, the undergrounds.** The stuff not everybody knows about.

R: Our project is at the Molenpoort shopping malls. so if we can find something better for it?

U: Yeah. Yeah. **I don't really like the molenpoort** because it's like a bit of an old feeling. you know, **it's not very cozy inside.** I never really visit

J: Is there something that maybe you're missing in the city?

U: There's a lot of culture and art and stuff, but I think like when you're in Amsterdam or another big city, there's always something to do. You know, you can approach that exhibition or you go to that party. But in Nijmegen, it's not there's not always something to do besides party. **I think there should be more events in the city centre**

R: To meet people?

U: And to **know more about our history** maybe.

conversation transcript

Ursula

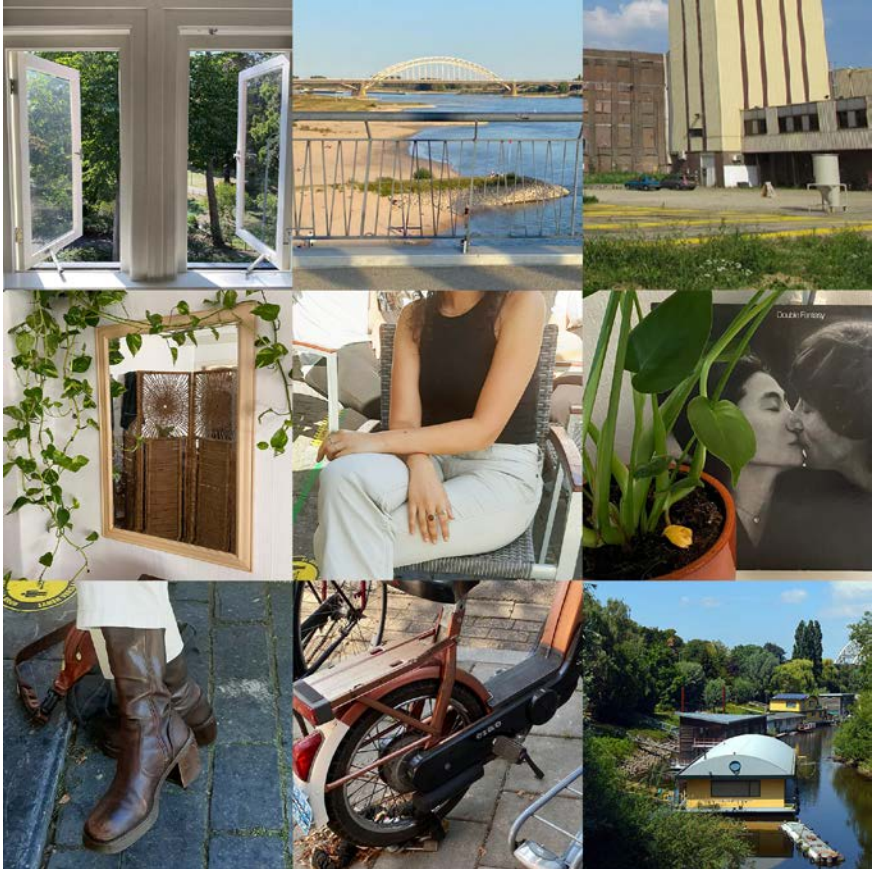

traces of everyday life

Ursula



Nijmegen Highlight
Honigcomplex

V

Vittorio



Age: 26 years old
Occupation: Maths student
What's missing in Nijmegen: Professional opportunities

Vittorio

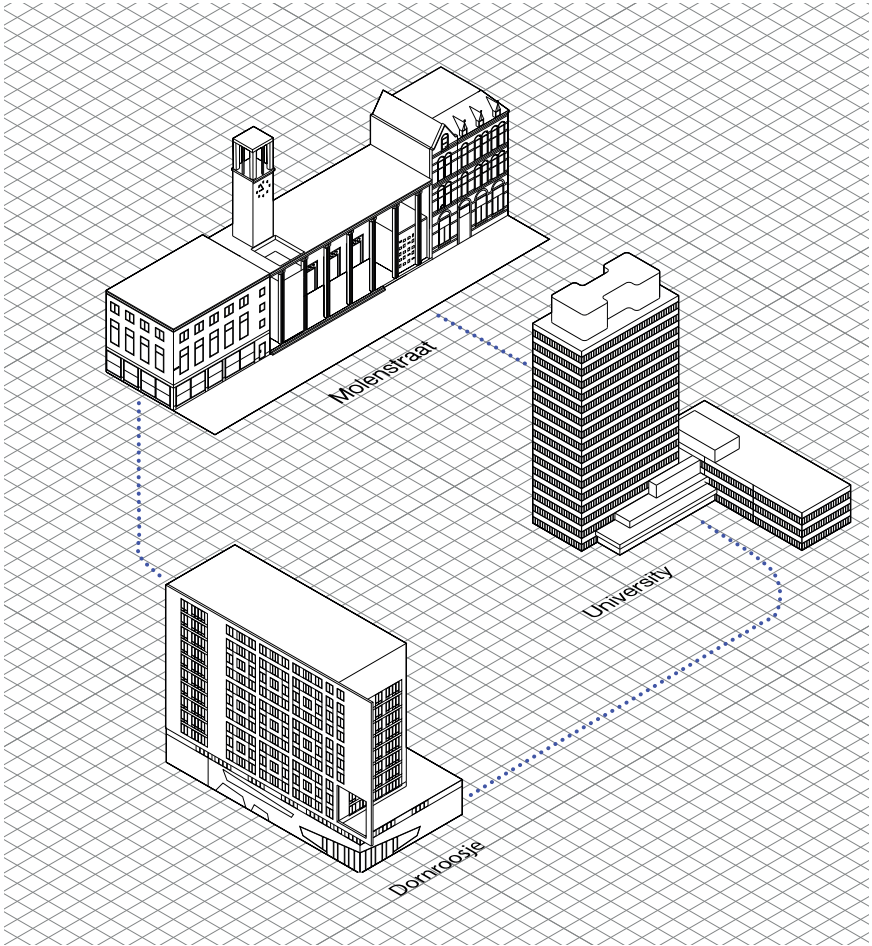

personal landmarks

Vittorio

V: I know many people that found it difficult to feel integrated into the Dutch community. My experience is different. **I had a very positive experience.** In my course, another girl and me were the only international students. For this reason, I had the chance to get in touch with local people. In general, **I found Nijmegen to be an open and dynamic city.** There is a **very young vibe.** They are **very open to diversity** which is considered as an added value. Of course, there is a minority of politically right people, but it is just a minority. In general, The Netherlands is much more open than other countries such as Italy.

A: Is there any event that you consider important in your experience in Nijmegen?

V: Yes, I would like to talk about LGBT+ community. **For the first time in my life I felt completely free and comfortable with my sexuality.** I had a boyfriend in Nijmegen, and **I did not feel any kind of social discrimination** like in other countries where I have lived. For example, in Italy I did not feel free to express my sexuality in public. These themes of respect and harmony are fundamental. For this reason, I would really like to come back to live in The Netherlands. Maybe not in Nijmegen, but in The Netherlands.

A: Where would you like to go? Why?

V: Maybe Utrecht or Amsterdam. **I would like more social and professional opportunities.**

conversation transcript

Vittorio



traces of everyday life

Vittorio



Nijmegen Highlight
LGBT+ community

W

Wido

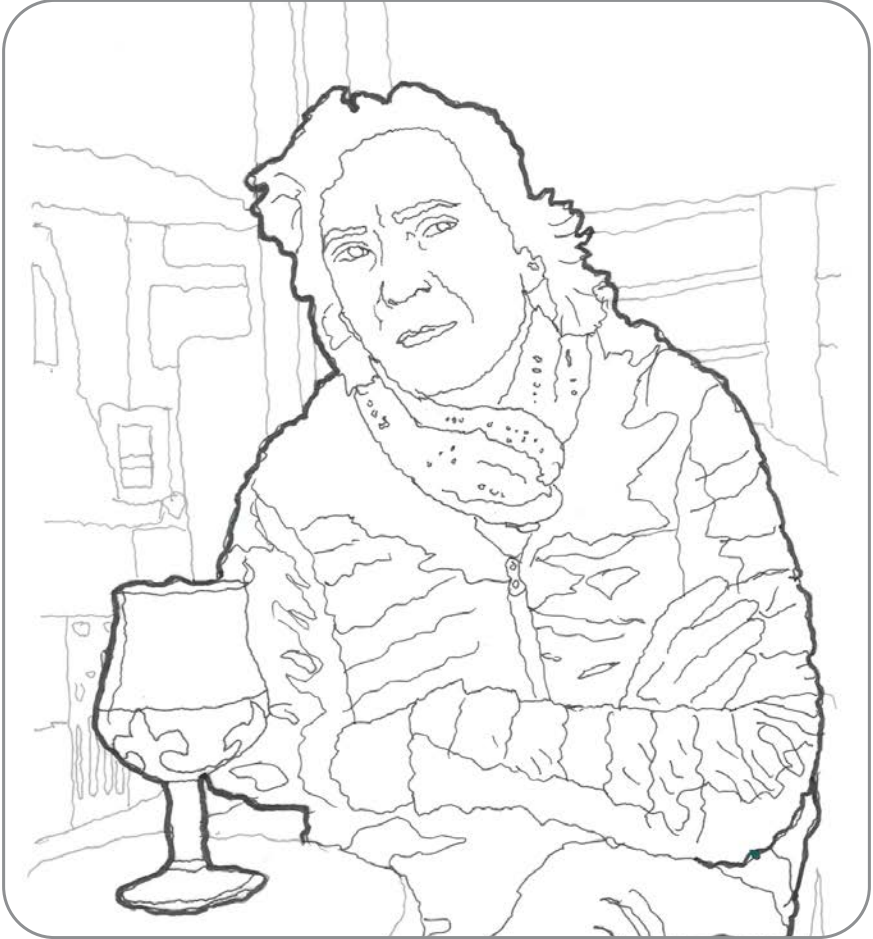

Age: 47 years old
Occupation: Support worker
What's missing in Nijmegen: -

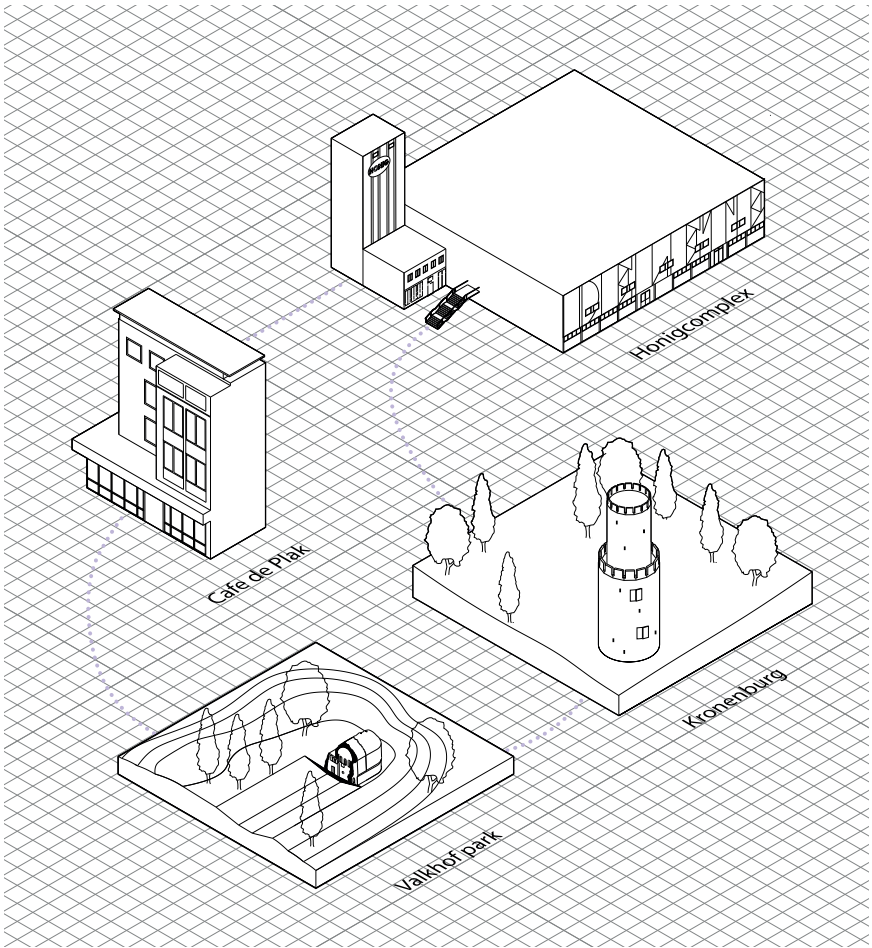

personal landmarks

Wido

W: Molenpoort. People do not go there, in Molenpoort. I have been there for my eyes. I used to go there, more than now. I don't know, it depends on what kind of shops they have, and I don't shop that much anyway. But I think, if they **take it down and put homes**, perfect. I think I would like **small streets and public spaces**. I always hear that, I like it myself. If I go to Maastricht, that's what I like there. Not New York (screams), oh my God, New York...I mean, I like it, but it is a shame it is in America. I love Brooklyn. it has the same vibe as the street we lived on, Burghardt van den Berghstraat - with cafes, people say hey, wow, hello.

W: Have you been around the main church yet?: If you go around, there is also the oldest café - **Blaauwe hand**. Why it is called the blue hand - because next to it there was a shop for bedsheets, they were washed there and painted in blue. That's how you got blue hands and people that worked there went to the café. It is also a very nice corner to go, it is part that was not bombed. I am still curious how it would look like if the bombing hasn't been? Maybe Maastricht, Den Haag type you would have seen here. **Ugliest architecture is this...** why do you like? **It is so plastic and metal, it's ugly. It is a fucking casino...**

W: Nijmegen has been known as a leftist city, Small Cuba, Havana they call it. The government has always been so

conversation transcript

Wido

cial, green party. **But if you have seen how many new houses have been built for people that don't have money...I think they could be more...** The local government also needs money...and because the ground it is expensive, it is very easy to sell the ground to companies that will build expensive houses there. Are the principles number one. or the balance of the municipality...

R: Is there anything particular about Nijmegen?

W: Nijmegen is in the middle, in terms of attitude. The way you would be approached in Arnhem is different and I prefer how it is here. It is not too cold, everyone says hi, me too. **I am feeling welcomed here...**That it is a bit left oriented, I like that very much. **Nijmegen is good in making things possible for new generations.** For me, it is a city of cafés, not city of big discotheques.

J: Is there anything you feel is missing in the city?

W: To be honest, I think Nijmegen could do something on **new energies**, make more effort about it. The only thing I hear is that there are 2 areas appointed to be first areas without gas. But nobody knows how to do it as these are old houses. Something more about the environment, that's what I miss, but maybe I don't know everything.

conversation transcript

Wido



traces of everyday life

Wido



Nijmegen Highlight
Burghardt van den Berghstraat, small streets



Xavier

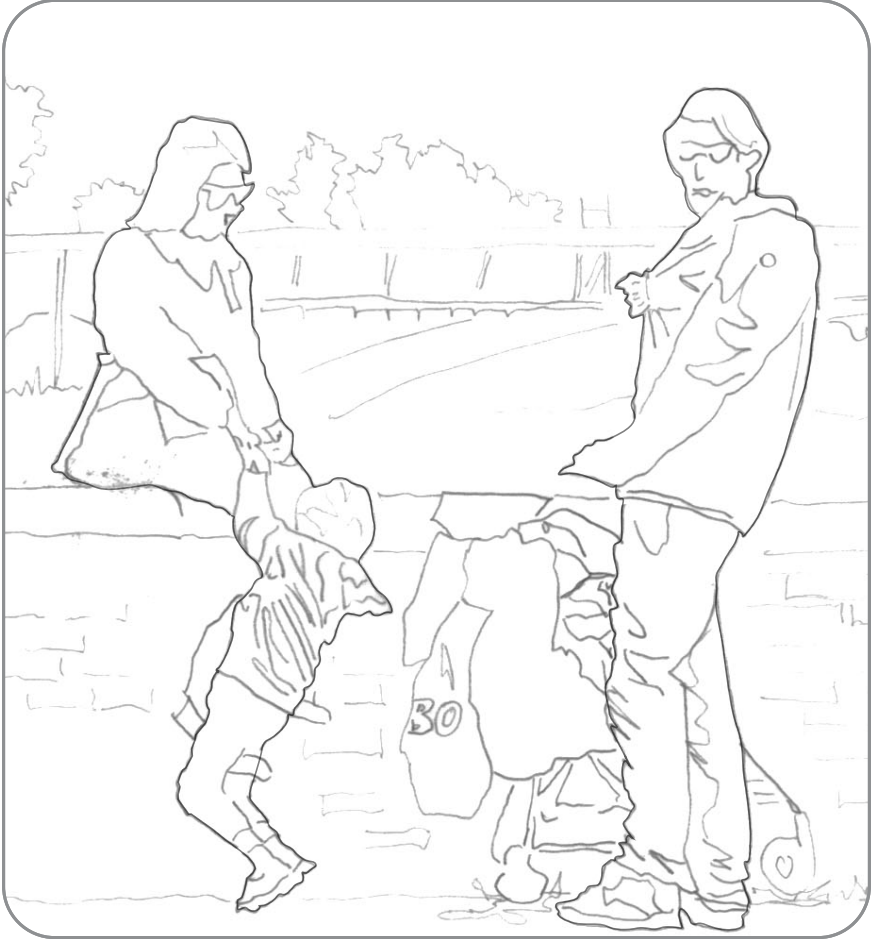

Age: 37 and 40 years old
Occupation: -
What's missing in Nijmegen: -

Xavier

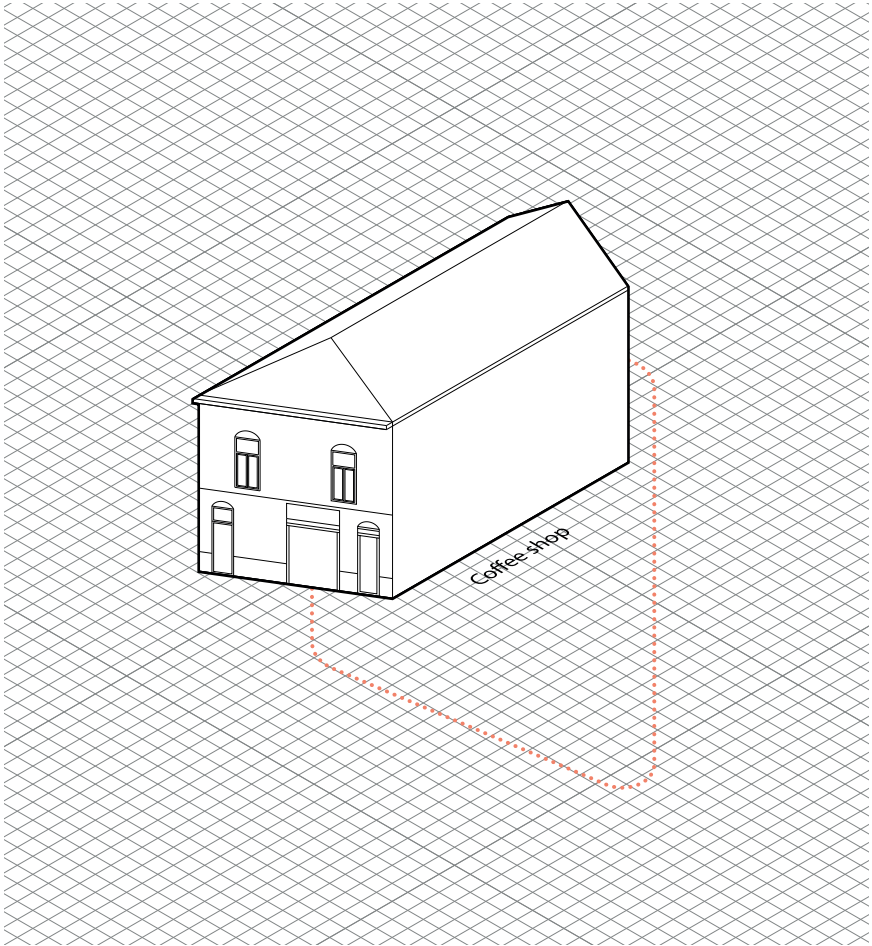

personal landmarks

Xavier

V: Et vous êtes ici...?

And you are here...?

F: Moi je suis ici pour... (laugh) **visiter et acheter** ... (laugh)
Mais, Bruxelles, c'est pas près de la frontière... On est à 2h
30! (I'm here to...(laugh) **visit and to buy**...(laugh). But, Brus-
sels is not close... No! We're at 2h 30!)

V: Mais pourquoi Nijmegen et pas une autre?

(But why Nijmegen and not another one?)

F: Parce que **c'est beau ici...** et **c'est moins cher. C'est aussi
des bons Coffee...** (Because **it's beautiful here...and it's
cheaper. They also have good Coffee shops...**)

F: Ca dépend aussi des Coffee. Il y a certains Coffee qui
ne sont pas terribles et il y en a d'autre qui sont mieux.
(It also depends on the Coffee shops. There are some Cof-
fee shops that are not so good and there are others that
are better.)

V: Ah okay! Du coup ils sont moins cher et ils sont...

(Ah okay! So they are cheaper and they are...)

F: Et ils sont bons. A Bruxelles tu payes le même pris
pour... Rien! (And they are good! In Brussels you pay the
same price for... Nothing!)
comme ca on peut s'appeler

conversation transcript

Xavier



traces of everyday life

Xavier



Nijmegen Highlight
Coffee shop street

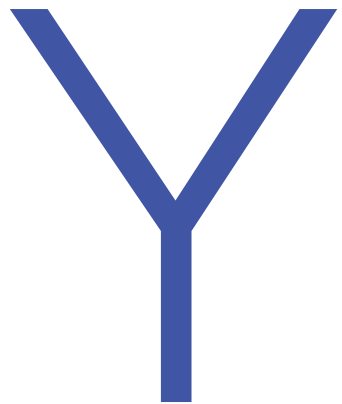

Yolanda



Age: 75 years old
Occupation: Cleaner
What's missing in Nijmegen: -

Yolanda

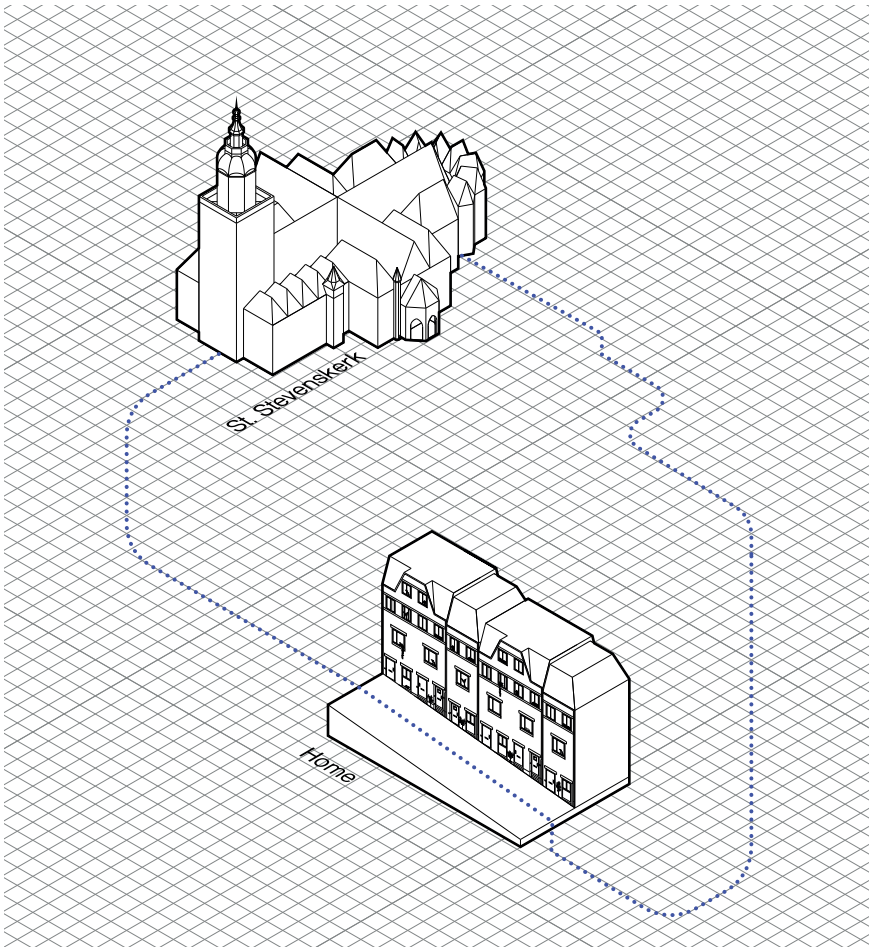

personal landmarks

Yolanda

J: Which is your favourite part of the city?

Y: This building was a school. Over there, there is a Lutheran church. Which is also a special building.

J: Do you go to that church?

Y: Yes! Nearby there is a beautiful neo-gothic church

[...]

J: How about the people in Nijmegen, is there a lot of neighbourhood community?

Y: Yes, **I have the Nijmegen feeling**. That's the feeling that **Nijmegen is my town. It's not my hometown, but it has become my town and I feel happy in Nijmegen.**

J: How long have you been here for?

Y: I've been here since 1988.

[...]

J: Do you live in this neighbourhood?

Y: Around the corner, on the left. Near the Lutheran church.

J: Do you often go to the centre of the town?

Y: Yes, I am coming back from the **laundry**. I have cleaned my sheets, and clothes, and towels and I have to go home to put them in the closet.

J: Enjoy!

conversation transcript

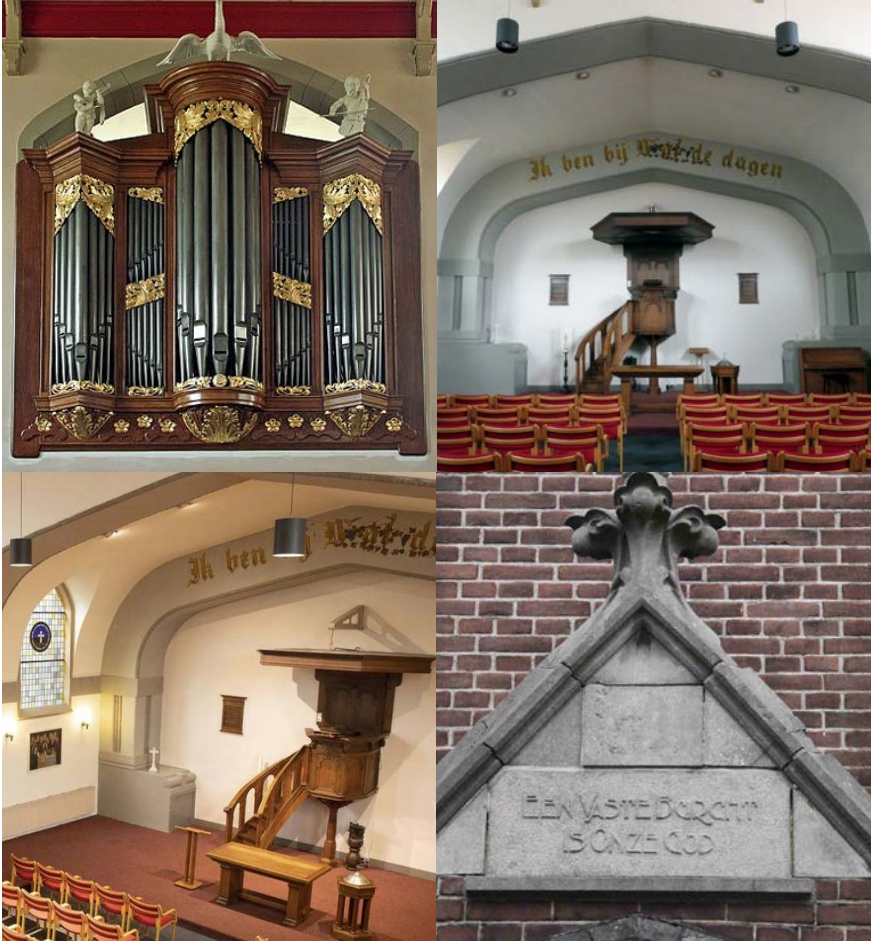

traces of everyday life

Yolanda



Nijmegen Highlight
Lutheran church

Z

Zain

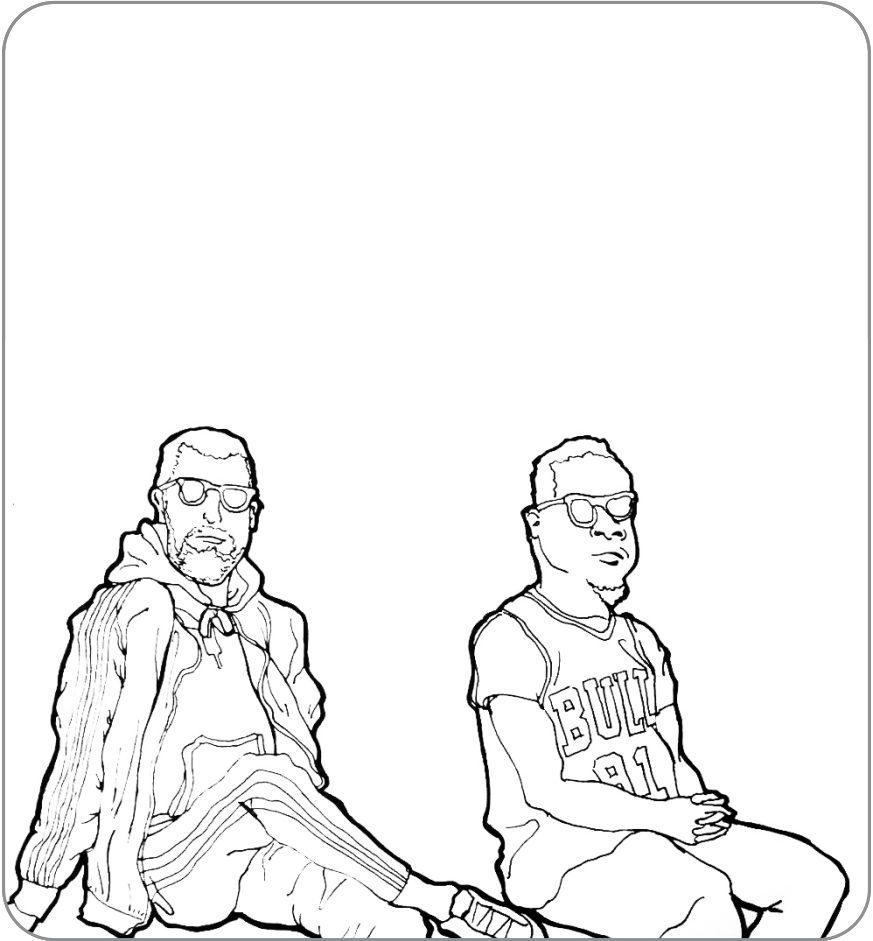

Age: 30 years old
Occupation: Footballer
What's missing in Nijmegen: Night life variety

Zain

J: Where do you go out in Nijmegen?

Z: I like this place called the **Honigcomplex**, sometimes there is a **food market** there like a food court. It's good to go there in the evening **if you don't want to go to a terrace and you just wanna eat and chill and listen to music.**

[...]

J: What do you think of Molenpoort?

Z: Right now **I think it's horrible** and it's been that way for years, it's never been a nice shopping centre.

J: I guess people use it if they wanna go to a specific hair dresser, there's a carpet store in there but it's never been busy

Z: No, no no body goes there. I think there's a restaurant in the middle the only old people go there.

[...]

J: When you do architecture it's quite unusual to just talk to people, you normally focus on buildings and more the urban context but actually getting the stories of people have been really interesting because then you understand what they want and what they like

Z: Yeah yeah, it's a cool project because then you understand **the people in the city, there are the city**

conversation transcript

Zain



traces of everyday life

Zain



Nijmegen Highlight
NEC Football Club, Goffert Stadium

Social Experiment

During one of our fieldwork visits to Nijmegen, we distributed some disposable cameras to Nijmegenaars for them to document their daily lives for 24hrs. Through this study, we wanted to experience the city 'through their eyes'.

The photographs reveal two vibrant weekends from Eric and Henry. We follow Eric through his trip round the city centre and Nijmegen-Oost and then onto an open air concert in the evening at Openluchttheater de Goffert. The next morning, we observe him enjoying the sun on the beach alongside some horses and cows. Meanwhile, Henry was strolling the markets in the city centre and Valkhof park, then he ventured onto the nature reserve to the east called Ooyse Schependom.

Although these two Nijmegenaars do not know each other, they both took a very similar photo of the view Het Meertje river from the Wandelbrug Ooypoort. From this, we can therefore gather that this view is an important landmark for Nijmegenaars to identify their city and admire its beauty.

Nijmegen through their eyes

Social Experiment



Eric documented a day through his eyes in Nijmegen. He met Jasmine and Robert in Grote Markt where he was having lunch with his girlfriend around 1pm. He then proceeded to head home, taking pictures of his daily routine through the city. In the evening he attended a socially distanced outdoor music concert at the Openluchttheater de Goffert.

The next morning he woke up early to enjoy the last of the summer weather on the Waalstrand. He cycled so far out that he came across horses and cows basking in the sun on the beach. He looked over at the view of the Waalbrugge and admired his city, feeling proud to

A day in the life of Eric

Social Experiment



Henry also crossed paths with Jasmine and Robert at Grote Markt whilst picking up some kipling for lunch. He then walked home through town, admiring the street art and murals as he passed through the familiar back alleyways.

In the afternoon he took a stroll round the corner to Valkhof park, purusing the markets and relaxing on the grass by the St Nicholas Chapel ruins. He then cycled to the east of Nijmegen to the nature reserve Ooijpolder, one of his favourite spots to spend his weekend surrounded by nature. He appreciates the varietiy of landscapes in Nijmegen which are within such close contact to the city centre.

A day of the life of Henry

Social Organisations

Our process also entailed further research into the subcultures and social organisations of the city, introduced to us by our interviews. The prevalence of these organisations in the city highlights the open and caring attitude of the philanthropic Nijmegenars. These organisations span a wide range of assistance – from rehousing the homeless, providing company for the lonely and welcoming refugees into their community. We have documented these organisations in the following pages, describing their purpose, location and their connections to the city.

The politically left attitude of Nijmegen earned it the Nickname “Havanna an der Waal”. Squatters (Dutch: Kraakers) following more radically left ideals shaped the city persistently. Lots of creative or social hot spots like De Klinker (Political Café) are located in formerly squatted buildings that got legalized. The following pages examine places where this form of illegal occupation can be considered successful. The term success in this circumstance means that the formerly occupied space provides at least one of the following:

Affordable Housing

Affordable Workspaces for young/social businesses

Publicly accessible social/creative meeting areas

In Nijmegen squatting is not a relic of the past. In 2019 for example, an old fort in Lent was squatted. Even though the Occupants were evicted the squat can still be considered successful. Due to the occupation, Staatsbosbeheer – the manager of the fort – was pressured to open it to the public and found Stichting Fort Beneden Lent, which is a garden that can be visited by anyone.

Guidance at home Nijmegen



About us

Guidance at home in Nijmegen

Address

Wheat Road 20
6534 AM
NIJMEGEN

IRISZORG

Iris Zorg – a social organization that helps people with addiction problems, supports recovery and provides a shelter
source: iriszorg.nl/home

Cafe de Plak



Café de Plak – the collective gives away all the profit they earn to refugees, feeding the homeless, fighting against discrimination and racism, supporting environmental movement. Place of activism, solidarity, former squatting block
source: cafedeplak.nl

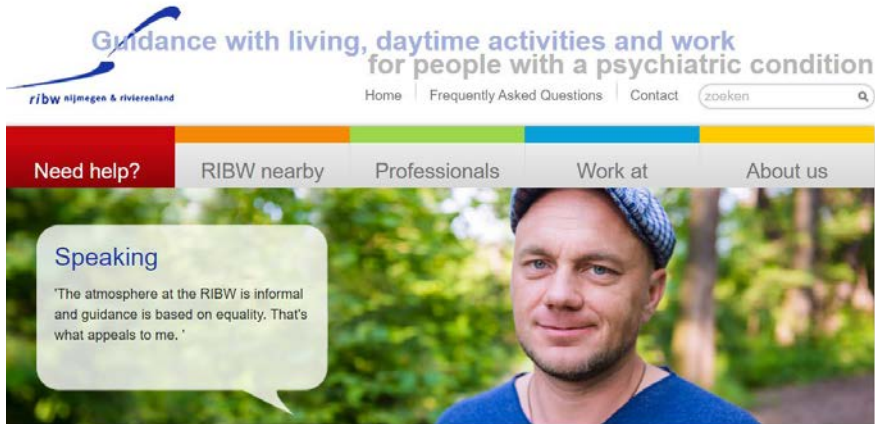

Need help?

Guidance in recovery

Guidance in recovery >

Individual (ambulatory) support

To do together

At RIBW Nijmegen and Rivierenland you work step by step on your recovery. That doesn't always mean getting better. It is about accepting your vulnerabilities and learning to deal with them as best you can. We will work with you to determine what you need to be able to participate in society. In doing so, we start from your capabilities and talents.

RIBW – helps homeless youngsters, 17–25 years old, find home and learn hoe to live on their own

source: ribw-nijmegenrivierenland.nl/Hulp-nodig-/Begeleiding-bij-herstel

Stad Van Compassie



Organizations

| | | | | | | |
|-----------------|----------------|------------------------------------|------------------------|----------------------|--------------------------|------------------------------------|
| Everything | Volunteer work | Neighborhood and neighborhood work | Debate, Dialogue | Health and Nutrition | Hobby and leisure | |
| Art and culture | Informal care | Human Rights | Nature and environment | Undertake | Education | Reception of undocumented refugees |
| | Organization | Sport | Peace | Wellbeing | Meaning and spirituality | |



Amnesty Nijmegen

Amnesty International Nijmegen contributes by means of its own actions to raising awareness and compliance with human rights in Nijmegen. Amnesty Nijmegen is a volunteer organization with several dozen active ...

[read more...](#)



Astarte Rituals & Ceremonies

There are important moments in life that require extra attention: a birth, naming, relationship or breakup, goodbye to a loved one, from work or health, gender reassignment, a silver or golden marriage. I offer ...

[read more...](#)



BASTA

BASTA is an ideal thrift store in the center of Nijmegen. Our address is Begijnenstraat 34 (side street of the Lange Hezelstraat). In our shop you can find household goods, curiosities, paintings, clothing, toys, books and CDs. ...

[read more...](#)



Consciously Nijmegen

Bewust Nijmegen is a lively network, a platform to promote awareness in the Nijmegen region. Are you a



Gelderland South Library

The Gelderland Zuid Library is a vibrant place where you can find inspiration in the field of written and



At Bosshardt - Living room of the neighborhood

Bosshardt is the living room of the Salvation Army neighborhood. During

Nijmegen, stad van compassie – initiative that aims at making visible and connecting various social organizations
source: nijmegenstadvancompassie.nl

Squatting



to squat: unlawfully occupy an uninhabited building or settle on a piece of land. (Oxford dictionary)

- Political mean of action since the 60's
- Protest against unoccupied sites, against unoccupation for speculation
- Means of making a place accessible
- Squatters are often in contact with the owner, take care of the house and are peaceful

Squatting



Map of legalized Squats in the Area of Nijmegen

De grote Broek



1_De grote Broek (Van Broeckhuysenstraat 46, Tweede Waalstraat 18tm 21)

year squatted: 1984; year legalized: 2004

History:

-built in 1901, as Headquarter of Provinciale geldersche en Nijmegense Courant
-later furniture store, after vacancy in 1984 squatted

-After the owner's death the Municipality acquired the house in 2004 and sold it to Standvast Wonen (Social housing agency)
-renovation until 2009, funded by Standvast Wonen + VB1895 for 1.2mio Euro

Functions:

- 15 Inhabitants in the upper floors
- De Underbroek (Concerts)
- De Klinker (Political Café)
- Anarchists: Black Cross Nijmegen; Group Nijmegen; Library (the black owl)
- Extrapool (Production company for independent artists, music, art, print)
- Guerilla Kitchen (anti food waste dinners)
- Just People (Refugee support)
- Stichting Gast (Refugee support)
- Straatmensen (Support for Homeless people)

De Paraplufabriek



2_De Paraplufabriek (Van Oldenbarneveltstraat 63a)
year squatted: 1982; year legalized: 1984 (squatters become tenants); year owned: 1995 (tenants become owners)

History:

- Built in 1889
- former royal umbrella factory in Nijmegen
- the building was unmaintained for years and was taken care of by the squatters
- early legal status enhanced the stability and diversity

Functions:

- living and working place
- workshops for artists, small businesses
- communal living room
- Plupub with dance parties and concerts

Businesses at PLU:

Browsy (Search engine that "plants" trees); Atelier Arte Nova (art & music); Kami Kami (Hairdresser); Liquid Sky Tattoos; Ralph Schmitz (photography); Expoplu (art & culture); Dark Roast (Graphic- and Webdesign); Studio Marienaade Kunst (conceptual art); El Yasmine (Dance, Yoga)...

Pontanus



3_Pontanus (Pontanusstraat 18-22)

year squatted: 1980; year legalized: 1986
(Sold to Gelderland Housing Association,
which rented it to the squatters)

History:

- Former Umbrella factory
- later furniture store
- during legalisation number 18 was purchased additionally (was not squatted)
- Became a stronghold for political activism, Radio Rataplan
- today three residential groups

Functions:

- three residential groups
- architecture office (? still up to date?)
- Radio Rataplan
- Iken printing house
- women's right shop
- massage practice

(check for "up to dateness")

NuNN



4_NuNN

In de Betouwstraat 19

year squatted: 1996

year legalized: -/-

(The squat was not legalized but due to the pressure from the squatting the Self- Management Activities for the Roof and Homeless foundation was relocated here)

Functions:

-ZDT (Zelfbeheeractiviteiten Dak- en Thuislozen)

-NuNN (Nachtopvang uit Nood Nijmegen): open emergency night service for the homeless

-23 beds available

-offers assisted living projects for former homeless people

-sports and other activities for residents and users

The Beguines



5_The Beguines (Begijnenstraat 34–36)
year squatted: 1986; year legalized: 1992,
bought by the residents

History

-maintained and preserved due to the
squat

Functions:

- Residential group of six people
- mixed housing and working
- social thrift store, Basta
- archive of the Anti Militaristies Bureau
- Eigenreid foundation
- Raamwerk (Bookkeepers)
- one freelance journalist



6_Women's school (Dominicanenstraat 6)
 year squatted: 1979 (Squatting former school building at Gerard Noodstraat)
 year legalized: 1997, different house firstly rented and then bought by the residents of the Squat)

History:

- Former Dominican nun monastery
- Women's School stems from the feminist movement
- Hosts women in the chapel (Women hotel) during the Nijmegense Vierdaagse
- tied to the LGBTW+, feminist community

Functions:

- Houses 19 living spaces and 10 work areas
- Women's bicycle workshop
- Women's screen printing
- accordion studio
- acrobatics
- various workshops

De Dobbelmann



7_De Dobbelmann (Dobbelmannweg 1)
year squatted: 1976
year legalized: 1990,

History:

- monastery garden had to be given over to project developer as compromise for legalisation
- largest former squat without workspaces

Functions:

- Residential
- 35 resident units
- 8 resident groups

De Refter



8_De Refter (Rijksstraatweg 37, Ubbergen)
year squatted: 1970's (detailed year?)
year legalized: 1983, bought by the residents' own housing association

History:

- Former functions: Vila, Nunnery, Ski alpine center
- Deteriorated in the 1970's after the Ski alpine center did not take off
- partially rented out to students, partially squatted. Long debate between residents, project developer, debtor bank

Functions:

- Residential and working units with hospitality
- 70 residential units, divided in living groups
- residential units for the elderly
- group accommodation: elegant
- all residents work in the building for six hours a week (maintenance, managing the forest)v

De Koopvaart



9_De Koopvaart (Koopvaardijweg 3)

year squatted: 1982

year legalized: 1986, legalized by the council, permitting housing on the industrial site, even granting a renovation credit

History:

- former leather goods factory
- located in the industrial area of Nijmegen

Functions:

- Residential and working
- Resident group for six inhabitants
- Several workshops and cheap space for small companies to start out.
- Companies that started there and made it bigger / moved to other spaces later on: bosjuweel (producing authentic tents + tipis), Stichting Gast (Supporting refugees, now housed at 1_De grote Broek in the city centre)

KB school



10_KB school (Koolmans Beynenstraat 16)

year squatted: 1982

year legalized: 1991, due to the squats the municipality converts it into 12 official residential units, Managed by the Gelderland Housing Association, which buys it in 1997

Functions:

-Residential with 12 units

History:

-former Catholic girls school

Fort Beneden Lent



13_Fort Beneden Lent (Zaligestraat 6)
year squatted: 2019 (the building was squatted several times, the last squat was very recent)

year legalized: -/- (the squat was evicted, yet due to the pressure of the squat the staatsbosbeheer was forced to find a function for the vacant building / site

History:

-built in 1862 to defend the city of Nijmegen and protect the railway bridge
-bombproof lodging building, surrounded

by an earthen moat
-managed by Staatsbosbeheer since 1983
-firstly squatted in the 1970's

Functions:

-Became a "city garden" which is accessible to the public
-Hosts cultural events

Squatting

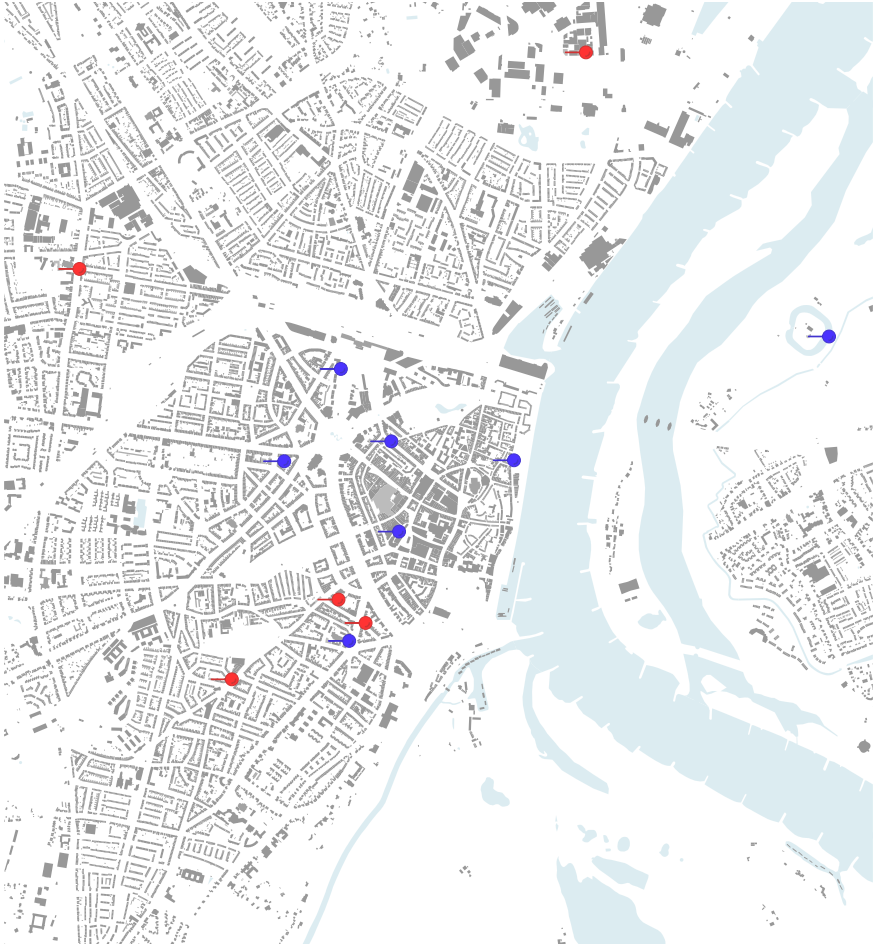

Former Squats, which enrich city life, socially, culturally or by granting access

D

Demographic Research

Demographic Research

We have extracted the quantitative data from our personal profiles to compare our sample of 26 Nijmegenars on the basis of age range, ethnicity, and gender distribution. Our methodology entailed mapping each person as a triangle which is formed by plotting three points on the map, each representing where they live, work, and spend leisure time. By connecting these three dots a triangle is created which illustrates each person's 'sphere of influence' in Nijmegen. From this information, we have created three maps which categorise our sample in terms of age range, ethnicity, and gender. As a comparison, we also extracted general demographic data of Nijmegen in the same neighbourhoods as our research to compare the raw data to our findings across the same categories.

It is worth noting that our research cannot comprehensively represent the entire population of the city as we are only representing the information of 26 individuals that we encountered on the streets around the city centre. Our data would have therefore been different if we ventured further out into the more residential, industrial or rural areas of Nijmegen as we would have encountered different people with different 'spheres of influence'. However, this data is relevant in forming an image of the city based on the inhabitants we studied in our encyclopaedia and film.

Our analysis of age range appears to reflect a similar balance to the figures in the raw data, as we can see that there is a higher concentration of elderly people in the city centre and towards the waterfront than compared to those neighbourhoods in the south east of the city, towards Radboud University where the student population generally resides. Our sample also consists of a higher percentage of middle-aged people (50%) which may reflect an unintentional bias in our fieldwork. However, this proportion of age range is reflected in the raw data as there is a higher rate of older people across the city in general.

Demographic Research

The maps reveal that different communities in the city tend to dwell in different areas, with more immigrants living in the south of the city, whilst more natives tend to live around the city centre. This is also reflected in the raw data which illustrates how more immigrants live in the south west of the city, especially in neighbourhoods such as Hatert. When comparing the ethnicity maps, it is evident that our sample is more diverse than the average population in the city which may reveal a bias of opinion in our personal profiles.

In terms of gender balance, the raw data illustrates that there is a fair balance between men and women in all the neighbourhoods across the city, with slightly higher rates of women in neighbourhoods such as Galgenveld and Altrade. In comparison, our data reflects a slight imbalance with a 62% representation of men. Therefore, our 'spheres of experience' triangles may be slightly skewed towards a masculine perspective of Nijmegen than that of the general population.

From this comparison, we can conclude that whilst different ethnicities, age groups and genders may dwell in different areas, they largely intersect in the city centre and on the waterfront. These locations can therefore be deemed the 'cultural hotspots' of Nijmegen where the different social groups and organisations interact in close contact with each other in the compact urban area. Together, their individual experiences and collective memories build a patchwork image of the city and its identity.

Profile Research

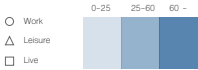

Age and population distribution
Nijmegen map 1:20000

Demographic Research

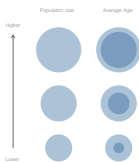
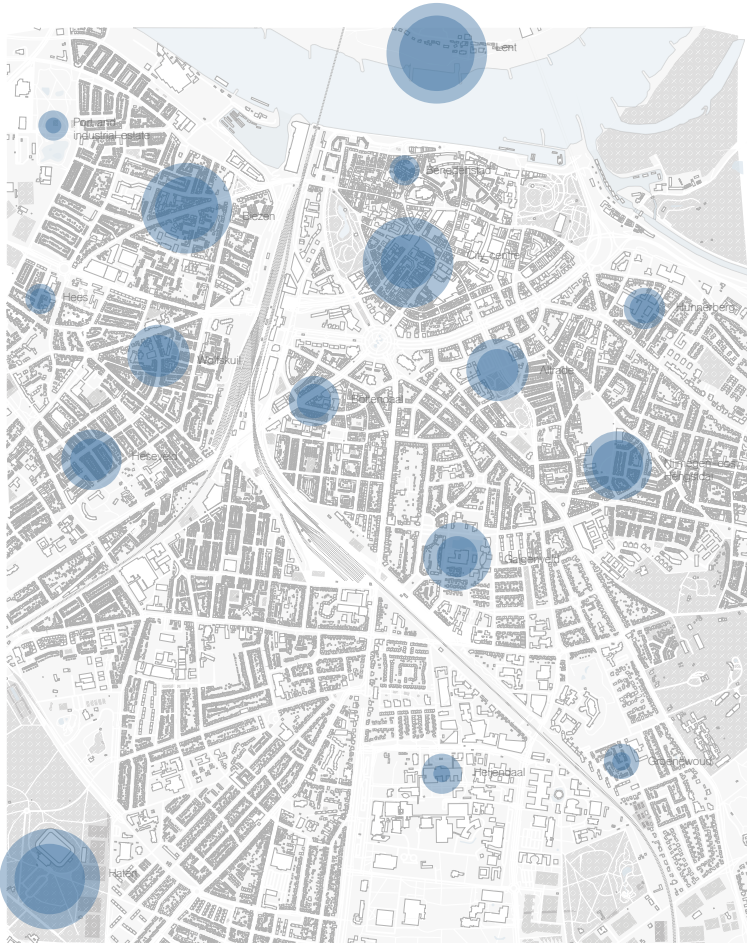

Age and population distribution
Nijmegen map 1:20000
source: public.tableau.com/king

Profile Research

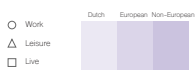

Ethnicity
Nijmegen map 1:20000

Profile Research

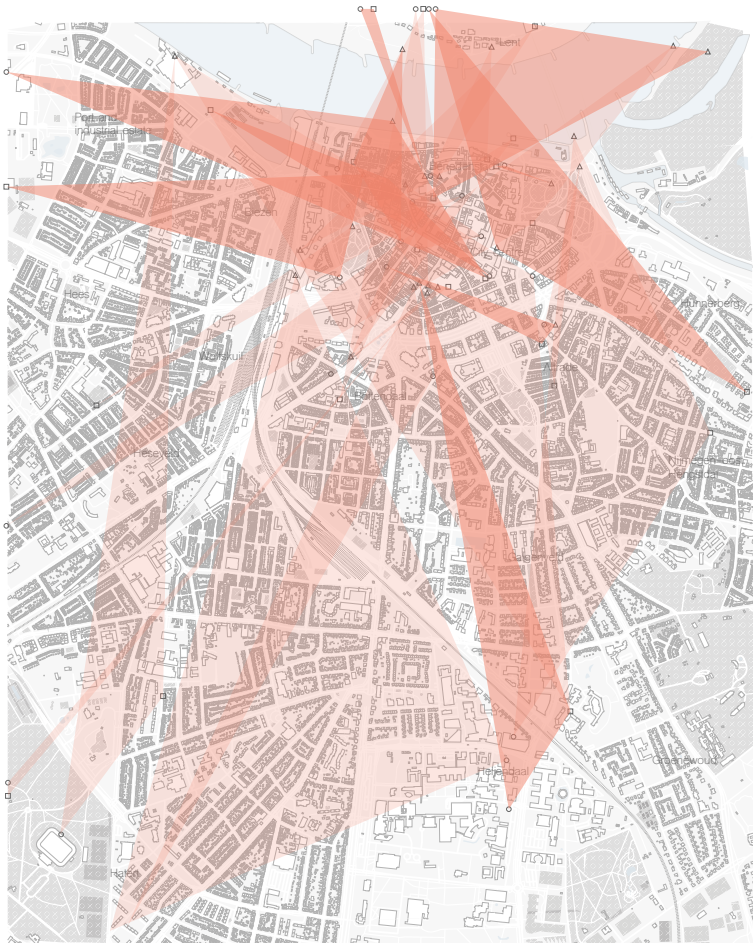

Gender distribution
Nijmegen map 1:20000

Demographic Research

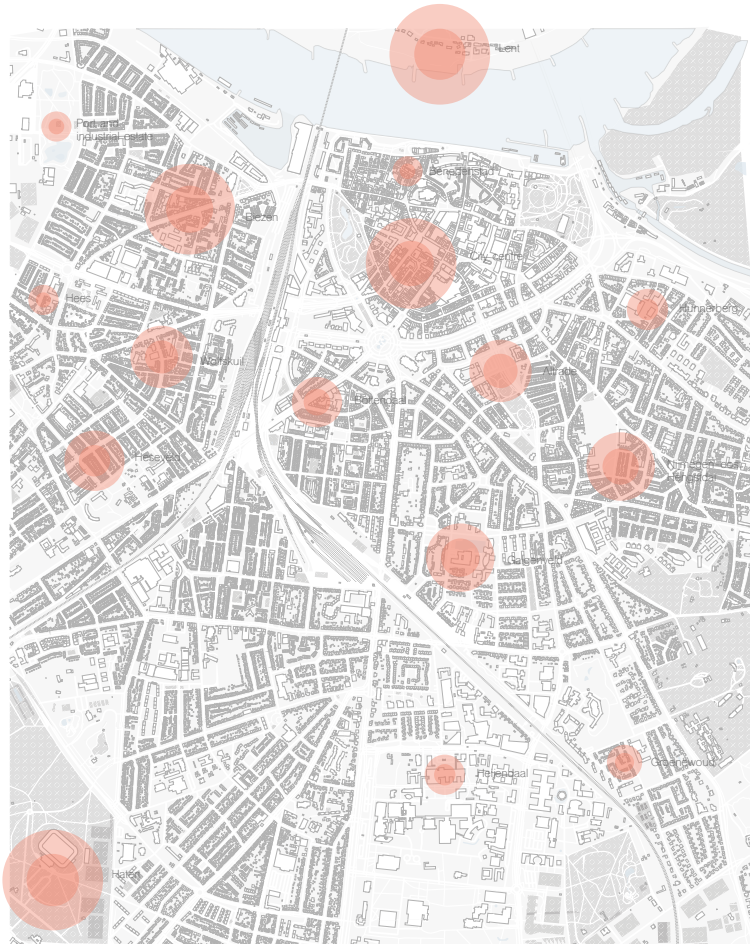

Gender distribution
Nijmegen map 1:20000
source: public.tableau.com/king

