

## Approaches in the design of softwood sheet pile-vegetation system as an alternative to twin-wood sheet pile

Kamath, Abhijith Chandrakaran; Gard, Wolfgang; van de Kuilen, Jan Willem

**Publication date**

2021

**Document Version**

Accepted author manuscript

**Citation (APA)**

Kamath, A. C., Gard, W., & van de Kuilen, J. W. (2021). *Approaches in the design of softwood sheet pile-vegetation system as an alternative to twin-wood sheet pile*. Paper presented at World Conference on Timber Engineering 2021, WCTE 2021, Santiago, Chile.

**Important note**

To cite this publication, please use the final published version (if applicable).  
Please check the document version above.

**Copyright**

Other than for strictly personal use, it is not permitted to download, forward or distribute the text or part of it, without the consent of the author(s) and/or copyright holder(s), unless the work is under an open content license such as Creative Commons.

**Takedown policy**

Please contact us and provide details if you believe this document breaches copyrights.  
We will remove access to the work immediately and investigate your claim.

# APPROACHES IN THE DESIGN OF SOFTWOOD SHEET PILE-VEGETATION SYSTEM AS AN ALTERNATIVE TO TWIN-WOOD SHEET PILE

Abhijith Chandrakaran Kamath<sup>1</sup>, Wolfgang Gard<sup>1</sup>, Jan-Willem Van de Kuilen<sup>1,2</sup>

**ABSTRACT:** Tropical hardwood or treated wooden sheet piles have been used historically to protect stream banks in countries like the Netherlands. However, there is an imminent need for alternative as exploitable tropical hardwood forests available in the country is limited. Locally available softwoods are less resistant to decay and in extreme conditions like in a stream bank with high moisture content, softwoods show minimal durability. The section of the sheet pile at air-water-soil interface is the most prone to decay. Hence twin-wood sheet piles have been developed in industrial scale, which is a combination of hardwood and softwood. Hardwoods which have high resistance to decay is used above the water table while softwood is used in the section which is always below water. An alternative stream bank protection system using vegetation and softwood sheet pile was proposed recently. In such a system the effect of vegetation can be included as an increase in cohesion of the soil or an increase in internal friction angle. In this article two different approaches (System approach (SA) and Discrete approach (DA)) for the design of wooden sheet pile-vegetation system are examined. The SA shows that the presence of vegetation increased the time for complete damage of the wooden sheet pile-vegetation system to occur. In DA approach a change in slope of the face of the stream bank is required if the effect of vegetation is considered as an increase in friction angle of the soil.

**KEYWORDS:** Hardwood, Twin-wood sheet pile, vegetation reinforcement

## 1 INTRODUCTION

Historically, the Netherlands has a pedigree of using wood in the in-ground conditions. Millions of wooden piles were used to support structures from the 15th to 20th century [1]. Wooden sheet piles are still used to protect thousands of kilometres of canals and stream banks that are part of the remarkable water management system in the country. While Pine and Spruce were commonly used for the foundations, azobé (*Lophira alata*) and treated pine (*Pinus sylvestris*) are used for the sheet pile walls [2].

Vegetation roots reinforce the soil mechanically by increasing the apparent cohesion of the soil and by anchoring the unstable layers to the stable layers [3]. As a part of evapo transpiration the vegetation draws water from the soil and there by inducing a negative pore water pressure in the soil and there by further reinforcing the soil [3].

Tropical hardwoods were traditionally used in stream bank protection structures owing to their high resistance to decay and attack by fungi and marine organisms [4]. However, if locally available softwood is used for the wood-sheet pile systems, it will undergo high rate of

decay. This high rate of decay will not be uniform throughout the timber sheet pile. The air-water-soil interface provides an ideal environment for the decay causing organisms to thrive. This results in non-uniform decay with high concentration of decay at the part which is at and above the water table. The part of the sheet pile below this water table is less prone to attack and shows high durability. To tackle this issue twin-sheet pile walls which are a combination of tropical hardwoods and softwoods were introduced. The part of the sheet pile which is more prone to decay is made of tropical hardwoods and the part which is less prone to decay is made of less resistant softwoods.

The riparian vegetation, for instance Willow (*Salix fragilis* L.) grow roots as deep as the permanent water table. These roots could reinforce the top layers of the soil till the water table which is prone to wood decay. In this paper two different approaches for the design of wooden sheet pile-vegetation system are examined for a typical stream bank section found in the Netherlands. In the SA the vegetation is seen as a structural element reducing the load acting on the wooden sheet pile with its growth. In DA, the vegetation and wooden sheet pile are considered

<sup>1</sup> Abhijith Chandrakaran Kamath, Delft University of Technology, The Netherlands, A.C.Kamath@tudelft.nl  
Wolfgang Gard, Delft University of Technology, The Netherlands, [W.F.Gard@tudelft.nl](mailto:W.F.Gard@tudelft.nl)

<sup>2</sup> Jan-Willem van de Kuilen, Technische Universität München, Germany, [vandekuilen@hfm.tum.de](mailto:vandekuilen@hfm.tum.de)

as separate elements each contributing to the stability of the stream bank.



**Figure 1:** Twin-wood sheet pile, (Taken from FORECO houtproducten., <https://www.foreco.nl/nl/producten/twinwood>).

Top layers of the stream embankment which is protected by the hardwood section (Figure 1) in a twin sheet pile, is protected by vegetation reinforcement in DA. This reinforcement will be minimal in the beginning and with time it will increase. Thus, using a softwood-vegetation system could be used in locations where hardwoods are scarce.

## 2 METHODS

### 2.1 Mechanical reinforcement due to vegetation

Large scale shear boxes (500mm \* 500mm) were used to grow Willow (*Salix fragilis* L.) and Hop (*Humulus lupulus* L.) for a period of 12-24 months. Mechanical reinforcement was estimated using saturated direct shear tests at low confining pressure (< 10 kPa) to simulate stream bank conditions. A shearing speed of 0.2 mm/minute was used. The bare soil had a friction angle of  $36^\circ$  and no cohesion. The results of rooted samples were analysed for an increase in internal friction angle due to presence of vegetation roots as previously reported by [5]. Contrasting to this, majority of the researchers have observed the vegetation roots to increase the apparent cohesion of the soil [6,7]. Thus, it was decided to include the effect of vegetation as both an increase in cohesion as reported in literature (5 kPa) and increase in friction angle of soil ( $54^\circ$ ) obtained in shear tests in the laboratory in both the design approaches used in this study (Table 1).

### 2.2 Discrete approach

Considering vegetation and softwood timber sheet pile as separate elements, it is hypothesized that vegetation is able to support the stream bank in the parts where the softwood timber sheet pile has undergone complete decay. The reinforcement provided by the roots is analysed in two different ways: in the first analysis, the reinforcement is seen as an increase in cohesion ( $C_R$ ); and in the second analyses, the contribution is an increase of the frictional component of the soil strength as obtained in shear tests.

The minimum water level was assumed to be 1.25 m below the top of embankment, which implies that

the top 1.25 m of the sheet pile is less resistant to decay. The water level in the canals/streams in the Netherlands are generally regulated, hence assuming a stable water level is valid. In cases where the effect of vegetation is considered as an increase in frictional component of the soil, stream bank with the slope angle of the face greater than the friction angle of soil will be unstable. Hence, an additional case was considered by designing stream bank with a slope angle of  $45^\circ$  of the face of the bank. The summary of all the cases is presented in Table 1 and Figure 2 and Figure 3.

The stream bank considered in this study was 5.5 meters wide and retaining height of 3 meters. The vegetated zone considered behind the sheet pile wall was 3 meters length, 5.5 meters in width and 1.25 meters deep. Safety factor analysis were conducted in Plaxis 3D using strength reduction analysis.

**Table 1:** Summary of all the cases analysed in the discrete approach. Abbreviations used: Slope angle-SA, Timber sheet pile-TS, Vegetated stream bank-VSB

Case	Stream bank protection	TS decay length (m)	SA ( $^\circ$ )	RH (m)	Effect of vegetation
1	TS	0	90	3	-
2	TS and VSB	0	90	3	$C_R=5$ kPa
3	TS and VSB	1.25	90	3	$C_R=5$ kPa
4	TS and VSB	0	90	3	$\phi_R=54^\circ$
5	TS	1.25	90	3	$\phi_R=54^\circ$
6	TS	1.25	45	3	-
7	TS and VSB	0	45	3	$\phi_R=54^\circ$
8	TS and VSB	1.25	45	3	$\phi_R=54^\circ$

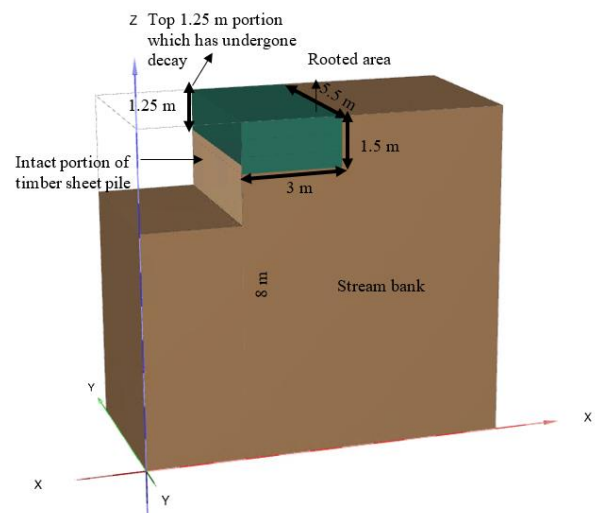

**Figure 2:** Illustration of case 3 in DA

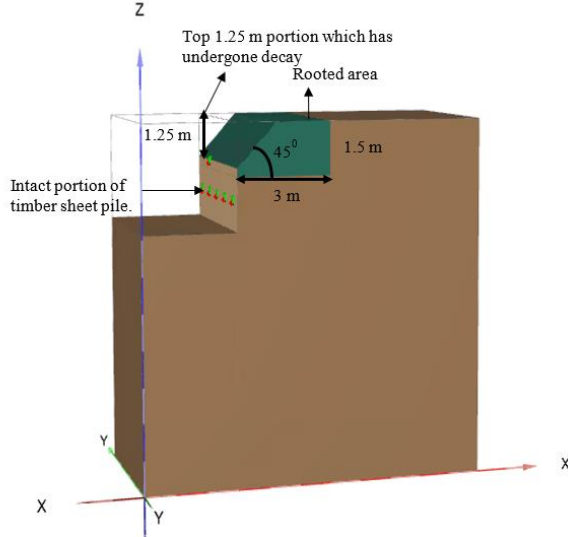

Figure 3: Illustration Case 8 in DA

### 2.3 System approach

Timber service life modelling is generally conducted as a time-dependent structural safety evaluation. The prediction of the rate of decay of wooden members, and hence their structural strength, is key to any bio-engineered structure design. For an ideal bio-engineered structure, herein timber sheet pile-vegetation combination, the load transfer and the load sharing design depend on the ability to accurately predict the contribution of sheet pile to the system over time. Effects due to variation of load and resistance determine the time-dependent behaviour of the sheet piles. Timber service life models are also referred to as damage accumulation models and a number of approaches can be found in literature [8-10]. These models describe the development of the timber strength over time under the influence of a long-term load. In these models, the elements' cross sections do not change over time, for instance by assuming that the wood material properties are not influenced by decay and the cross section is constant. A modification of the straightforward exponential damage model provided by [10], for changing material properties and cross sections, can be found in [11] and [12] for deteriorating timber piles and cracked timber beams respectively. To include the time dependent reduction in load carrying capacity of the timber when physical and biological deterioration takes place, as given in equation (1).

$$\frac{d\alpha}{dt} = \exp \left[ -a + \frac{b\sigma(t)}{f_s(t)} \right] \quad (1)$$

Where  $\frac{d\alpha}{dt}$  is the rate of damage, in which  $\alpha$  can be any value from 0 to 1 (0 representing no damage and 1 representing structural failure),  $\sigma(t)$  represents the history of load variation (N or Nmm),  $f_s(t)$  represents the variation of the load carrying capacity with time (N or Nmm). Often, instead of plotting the development of  $\alpha$ ,  $1-\alpha$  is plotted, indicating the residual load carrying capacity. The moment carrying capacity varies with time due to the

reduction of cross-section, and also because the strength of the outer layers may be reduced because of biological decay. Thus, the total rate of change of the effective sectional moment of area ( $\epsilon_I$ ) and change in effective cross-sectional area ( $\epsilon_A$ ) resisting shear can be written as:

$$\epsilon_I(t) = \left(1 - \frac{2\delta}{b}\right) \left(1 - \frac{2\delta}{t}\right)^2 \quad (2)$$

$$\epsilon_A(t) = \left(1 - \frac{2\delta}{b}\right) \left(1 - \frac{2\delta}{h}\right) \quad (3)$$

Where  $\delta$  is the rate of decay per year,  $b$  is the width, and  $h$  is the thickness of the sheet pile.

Thus, the time dependent area ( $A_t$ ) and the moment of area ( $W_t$ ) could be written in terms of original area ( $A_0$ ) and original moment of inertia ( $W_0$ ) as:

$$W_t = W_0 \epsilon_I \quad (4)$$

$$A_t = A_0 \epsilon_A \quad (5)$$

The damage accumulation approach for wood can be considered to be on the conservative side [8]. It is to be noted that the cross-sectional decay is considered here. For more details on the approach refer to [13]. For estimating the increase in service life due to the presence of vegetation the following two cases are analysed:

Case -1: Stream bank with a retaining height of 3 m protected by a timber sheet pile.

Case -2: Stream bank of retaining height 3 m protected by timber sheet pile and mature vegetation combination. Two different analysis were conducted each with a different mechanical reinforcement due to vegetation as discussed earlier. Firstly, the effect of vegetation is considered as increase in cohesion ( $C_R$ ) due to the presence of roots. In the second analysis, the effect of vegetation is assumed to be an increase in the frictional component of the soil, determined from shear tests. Summary of all cases is given in Table 2.

Table 2: Summary of all the cases analysed in the system approach

Case	Effect of vegetation
Case -1	Nil
Case-2	$C_R=5$ kPa
Case-3	$\phi_R = 54^\circ$

### 2.4 Assumptions

The following assumption were made in both approaches:

- The maximum rooting depth is 1.5 meters.
- A maximum cohesion increase due to presence of roots  $C_R$ , is assumed to be 5 kPa. Though very high value of  $C_R$  has been reported in literature ( $C_R > 50$  kPa) [14], a conservative  $C_R$  value is chosen in this study.

- (iii) The variation of the reinforcement effect of roots with depth are not included, instead a uniform value for strength parameters ( $C_R$ , internal friction angle, soil unit weight) are used throughout the rooting depth.
- (iv) A time lag of two years is taken for the decay of the sheet pile to start which is reasonable for locally available wood. This assumption implies that the roots have reached a certain depth to reinforce mechanically the soil.
- (v) A width of 3 meters behind the timber sheet pile is considered as vegetated. In practical terms, this would correspond to two matured plants of *Humulus lupulus* L. for every 1.0-1.5 m in width.
- (vi) The water level is at 1 m below the top of the embankment and the suction above the water table is ignored.

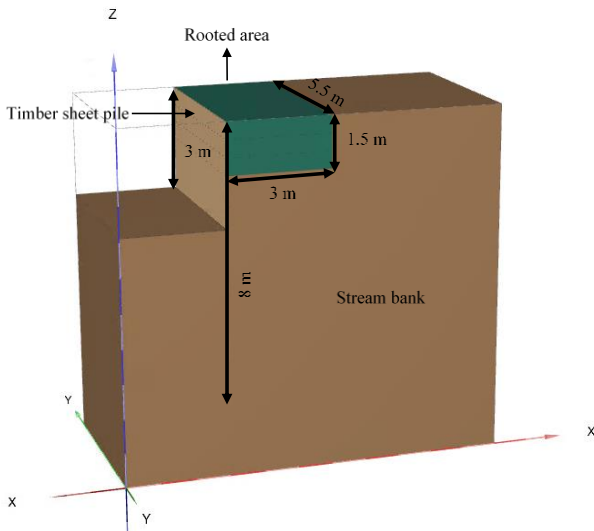

**Figure 4:** Illustration of Case 2 and Case 3 in SA

### 3 RESULTS

#### 3.1 Discrete approach

The input parameters used for the study are shown in Table 3. The estimated factor of safety obtained from Plaxis 3D for all cases is presented in Table 4.

The presence of vegetation in combination with the timber sheet pile increased the factor of safety of the stream bank (Case-2, Case-4) when compared to the non-vegetated timber sheet pile only case. When the vegetation effects were included as an increase in cohesion, the stream bank was observed to be stable (Factor of safety > 1) even after the decay of top 1.25 meters of the sheet pile had occurred (Case-3). The stream bank was not stable when the vegetation was responsible for an enhancement of the friction angle and the sheet pile had decayed in the top 1.25 m. When the face of the stream bank had a slope gradient of  $45^\circ$ , the stream bank was stable when the vegetation effect is included as an

increase in friction angle even after the decay of the top 1.25 m portion of the timber sheet pile (Case-8). However, the stream bank with a  $45^\circ$  gradient was unstable in the absence of vegetation, even when the timber sheet pile decay did not occur. This was primarily due to localized failures. Nevertheless, on inclusion of vegetation the stream bank was found to be stable (Case -7).

**Table 3:** Soil and sheet pile properties used for safety analysis

Parameter	Value
Soil unsaturated unit weight	15 kN/m <sup>3</sup>
Soil saturated unit weight	17 kN/m <sup>3</sup>
Soil stiffness	2000 kPa
Soil friction angle	$36^\circ$
Soil cohesion	$0^\circ$
$C_R$ , additional cohesion due to roots	5 kPa
Friction angle due to presence of roots	$54^\circ$
Stiffness of sheet pile	20,000,000 kN/m <sup>2</sup>
Thickness of sheet pile	100 mm
Unit weight of sheet pile	12.2 kN/m <sup>2</sup>
Depth of sheet pile	8 m

**Table 4:** Safety factors obtained for various cases analysed according to discrete approach

Case	Factor of safety
1	1.28
2	1.6
3	1.31
4	1.58
5	<1
6	<1
7	1.60
8	1.60

#### 3.2 System approach

The input parameters of the soil and timber sheet pile are summarized in Table 5. The maximum bending moment and shear stress obtained from PLAXIS 3D are reported in Table 6.

The maximum bending moment (M) acting on the sheet pile in case 1 was obtained from the outputs of the analysis on PLAXIS 3D, corresponding to the initial bending moment ( $M_0=21.82\text{kNm}$ ) experienced by the sheet pile before the growth of vegetation. Sheet piles are often made of wood species azobé (*Lophiara alata*) which is assigned to the strength class D70 of European standard EN 338 (Van de Kuilen and Blass, 2006). This corresponds to a characteristic bending strength of  $f_m = 49.5\text{MPa}$ , after taking into account the safety factors of the material properties ( $\gamma_M = 1.3$  EC5,  $k_{ls}=1.15$ ) modification factor and a shear strength of  $15\text{N/mm}^2$ , but excluding the influence of long-term loading, as this is now incorporated in the damage model. The decay rate of

the entire timber sheet pile was assumed to be  $-0.001$  m/year ( $1$  mm/year). The parameters of the timber damage accumulation model,  $a=21$ ,  $b=24.63$  were adopted for the estimation of the time to failure for timber beams [10].

**Table 5:** Input parameters to PLAXIS 3D for system approach

Parameter	Value
Soil unsaturated unit weight	$15 \text{ kN/m}^3$
Soil saturated unit weight	$17 \text{ kN/m}^3$
Soil stiffness	$2000 \text{ kPa}$
Soil friction angle	$36^\circ$
Soil cohesion	$0^0$
Stiffness of sheet pile	$20,000,000 \text{ kN/m}^2$
Thickness of sheet pile	$84 \text{ mm}$
Unit weight of sheet pile	$12.2 \text{ kN/m}^2$

**Table 6:** Maximum bending moment and shear force acting on the timber sheet pile obtained from PLAXIS 3D

Case	Effect of vegetation	Max bending moment (kNm-m)	Max shear force kN-m
Case -1	Nil	21.82	49.26
Case-2	$C_R=5 \text{ kPa}$	17.74	26.47
Case-3	$\phi_R = 54^\circ$	20.47	27.89

The variation of damage accumulation ( $\alpha$ ) with time for all the cases in both bending and shear are shown in Figure 5. The presence of vegetation increased the time for complete damage of the sheet pile-vegetation system to occur. In Case -1, with no vegetation, the complete damage ( $\alpha$ ) occurs after 26 years. When the vegetation effects are included the service life of the timber sheet pile-vegetation system increases to 29 years (Case-2) and 33 years (Case-3). Thus, the effect of vegetation can be seen as an increase in service life of 3 years if the effects of vegetation are included as an increase in friction angle of the rooted zone and 7 years if effects of vegetation are included as an increase in cohesion in the rooted zone.

When the vegetation effects can be effectively considered as an increase in friction angle of the rooted area. Thus, it can be concluded that, a well-maintained vegetated stream bank with a retaining height of 3 meters would increase the service of the stream bank protection system (timber sheet pile-vegetation) at least by 3 years and maximum of 6 years for the parameters used.

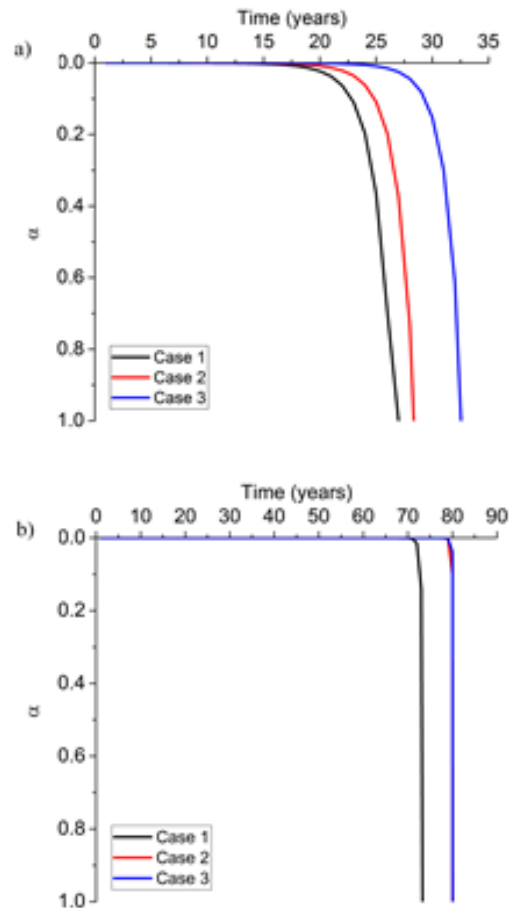

**Figure 5:** Damage accumulation a) in bending b) in shear

## 4 DISCUSSION & CONCLUSIONS

Bio-engineered earth retaining structures like the wooden sheet pile-vegetation system discussed in this article, involves combining materials which evolve with time and hence have varying contribution to support the load acting on it. [8] suggested that a methodology which takes into account the deterioration of materials involved and subsequent variation in load supporting capacity would be a useful tool for eco-engineers. This study demonstrates the use of a timber sheet pile-vegetation bio engineered earth retaining structure to be used for stream bank protection. Two approaches, both conservative, taking into account the deterioration of timber sheet piles from a practical perspective and the increase in strength of the stream bank due to the presence of vegetation are proposed.

In SA an increase in service life was observed in both the cases where vegetation effect was included. The stream bank did not require any change in slope. An increase in stability of the stream bank is observed in DA approach when a timber sheet pile is used in conjunction with vegetation. When the reinforcing effects of vegetation are included as an increase in frictional angle of the rooted zone, the system seems to collapse when the decay of sheet pile occurs. However, when the slope of the face of the bank was reduced to  $45^\circ$ , the vegetation was found to be able to support the stream bank even after the decay of the sheet pile. When the effect of vegetation is considered

as an increase in cohesion, the stream bank was stable even after the decay of the sheet pile.

The SA is based on the superposition of the vegetation benefits onto the conventional timber sheet pile design principles. The SA approach would hamper the need for interim stability checks because the benefits of presence of vegetation is considered as an increase in service life. In other bio-engineered earth retaining structures the design methodology involved ensuring sufficient growth of vegetation to support the slope before the complete decay of wood occurred [8-9]. Considering shear data as used in this study, unlike other bio-engineered earth retaining structure (eg. cribwall-vegetation retaining structure) the design of timber sheet pile-vegetation system could be considered operational at a very early stage (< 1 year; provided sufficient growth of vegetation occurs). The time lag required for decay to start depends on the timber used, for instance [8] used a time period of less than one year while [10] used a delay time of 5 years in their calculations. The assumed delay time used in this study depends on the biophysical circumstances where air-water-soil exposure represents the worst possible case for wood decay.

The data required for both approaches can be obtained through field or laboratory testing of rooted specimens. The proposed approaches can be easily translated into conventional geotechnical analysis and included in sheet pile analysis software's like D-sheet piling which is widely used in the Netherlands.

[11] suggested that the autochthonous developed vegetation have to ensure the stability of a bio-engineered earth retaining structure after the decay of the sheet pile occurs. However, in the system approach adopted here vegetation is included as a structural element and the vegetation and sheet pile are considered to be in symbiosis throughout the service period. Thus, SA approach does not truly fit into the concept of an eco-engineering work where natural ecological succession is expected [8]. In contrast, DA approach will depend on a natural restoration of the stream bank. The SA approach leads to the possibility of designing timber sheet pile walls with smaller dimensions, or with less durable material. The structural safety of the 'combined' system of sheet pile and vegetation can be estimated using the proposed procedure. Thus, the SA approach is more of a conventional engineering approach while DA approach is more friendly to the flora and fauna usually found around the stream banks. It is to be noted again, that the real scenario would be a combination of both the approaches. More research is necessary for successful merging of both the approaches.

## 5 REFERENCES

- [1] Klaassen, R. K., & Creemers, J. G. (2012). Wooden foundation piles and its underestimated relevance for cultural heritage. *Journal of cultural heritage*, 13(3), S123-S128.
- [2] Van de Kuilen, J. W. G., & Van Der Linden, M. L. R. (1999). Reliability based design of timber sheet pile walls. *NZ Timber Des J*, 11(1), 11-16.
- [3] Dias, A. S. R. A. (2019). *The effect of vegetation on slope stability of shallow pyroclastic soil covers* (Doctoral dissertation, Université Montpellier; Università degli studi di Napoli Federico II. Istituto di fisica).
- [4] Van de Kuilen, J. W. G., & Blaß, H. J. (2005). Mechanical properties of azobé (*Lophira alata*). *Holz als Roh-und Werkstoff*, 63(1), 1-10.
- [5] Graf, F., Frei, M., & Böll, A. (2009). Effects of vegetation on the angle of internal friction of a moraine. *Forest Snow and Landscape Research*, 82(1), 61-77.
- [6] Operstein, V., & Frydman, S. (2000). The influence of vegetation on soil strength. *Proceedings of the Institution of Civil Engineers-Ground Improvement*, 4(2), 81-89.
- [7] Ali, F. H., & Osman, N. (2008). Shear strength of a soil containing vegetation roots. *Soils and Foundations*, 48(4), 587-596.
- [8] Van der Put, T. A. C. M. (1986). A model of deformation and damage processes based on the reaction kinetics of bond exchange. In *CIBW18 timber structures, proceedings of the 19th meeting, Paper* (pp. 19-9).
- [9] Foschi, R. O., & Yao, Z. C. (1986). Another look at three duration of load models. In *Proceedings of IUFRO wood engineering group meeting, Florence, Italy, paper* (pp. 19-9).
- [10] Gerhards, C. C., & Link, C. L. (1987). A cumulative damage model to predict load duration characteristics of lumber. *Wood and Fiber Science*, 19(2), 147-164.
- [11] Van de Kuilen, J. W. (2007). Service life modelling of timber structures. *Materials and Structures*, 40(1), 151-161.
- [12] Van de Kuilen, J. W. G., & Gard, W. F. (2012). Residual service life estimation using damage accumulation models. In *World conference on timber engineering, Auckland, New Zealand, 15-19 juli 2012*.
- [13] Kamath, A., Gard, W., & Van de Kuilen, J. W. (2020). Biodynamic timber sheet pile walls: vegetation retaining structure. *European Journal of Wood and Wood Products*, 78(5), 1045-1055.
- [14] Zhang, D., Cheng, J., Liu, Y., Zhang, H., Ma, L., Mei, X., & Sun, Y. (2018). Spatio-temporal dynamic architecture of living brush mattress: root system and soil shear strength in riverbanks. *Forests*, 9(8), 493.
- [15] Tardío, G., & Mickovski, S. B. (2016). Implementation of eco-engineering design into existing slope stability design practices. *Ecological Engineering*, 92, 138-147.
- [16] Acharya, M. S. (2018). Analytical approach to design vegetative crib walls. *Geotechnical and Geological Engineering*, 36(1), 483-496.
- [17] Jones, D., & Brischke, C. (2017). *Performance of bio-based building materials*. Woodhead Publishing.
- [18] Fernandes, J. P., & Guiomar, N. (2016). Simulating the stabilization effect of soil bioengineering interventions in Mediterranean environments using limit equilibrium stability models and combinations of plant species. *Ecological Engineering*, 88, 122-142.