

LECTURE NOTES FOR
INTRODUCTION TO COASTAL ENGINEERING
and
BREAKWATERS

Compiled and Edited

by

THE STAFF OF COASTAL ENGINEERING

for

lectures given by

PROF.DR.IR. E.W. BIJKER.

Delft University of Technology
Delft, The Netherlands.

August, 1972.

Contents

INTRODUCTION TO COASTAL ENGINEERING

	Page nr.
Short waves	1
Refraction	8
Wave Height Characterization	10
Coastal Formation	12
Sediment transport by waves	14
Groins	16
Delta Coasts	20
Muddy Coasts	25
Tidal Rivers	28
Measurement of Waterlevel on Tidal Rivers	30
Density Currents	34
 BREAKWATER DESIGN	 43

Introduction

This set of lecture notes is intended to supplement the lectures of Prof. Bijker covering Introduction to Coastal Engineering and Brakwaters.

In many cases, the information in these notes will be amplified in the lectures.

These notes are written in American rather than English. The reader will see some words spelled differently.

a.

List of Symbols

<u>Symbol</u>	<u>Definition</u>	<u>Dimensions</u>
\bar{A}	Cross-section river outlet	L^2
a	Wave amplitude ($\frac{H}{2}$)	L
b	Distance between wave orthogonals	L
C	Chézy friction coefficient	$L^{\frac{1}{2}} T^{-1}$
C	Coefficient dependent on density and type of stone	-
c	Wave velocity (phase velocity)	LT^{-1}
c	Elasticity constant of subsoil	MT^{-2}
c_g	Wave group velocity	LT^{-1}
E	Wave energy per unit surface area	MT^{-2}
E	Encounter probability	-
E_T	Energy contained in an entire wave per unit crest length	MLT^{-2}
Fl	Cost in guilders	f
f	Friction coefficient	-
g	Acceleration due to gravity	LT^{-2}
H	Wave height ($2*a$)	L
H_s	Significant wave height	L
H_{so}	Significant design wave height	L
h	Water depth	L
I	Initial construction costs	f
K	Coefficient dependent on shape armour unit	-
K	Force	MLT^{-2}
K_r	Wave refraction coefficient	-
K_s	Shoaling coefficient	-
K'_s	Shoaling coefficient including refraction effects	-

b.

<u>Symbol</u>	<u>Definition</u>	<u>Dimensions</u>
k	Wave number ($2\frac{\pi}{L}$)	L^{-1}
L	Wave length	L
m	Mass (kg)	M
m	Slope of the shoreline	-
N	Coefficient based on type stone	-
N	Newton	MLT^{-2}
N	Number of waves	-
n	Percentage damage	-
n	Ratio of group velocity to phase velocity	-
o	Subscript denoting that the parameter was evaluated in deep water conditions	-
P	Dynamic pressure force (N/m^2)	$ML^{-1}T^{-2}$
P	Tidal prism in cuft	L^3
p(...)	Probability of exceedence in short term distribution	-
Q	Runoff in $m^3/sec.$	L^3T^{-1}
q(...)	Probability of exceedence in long term distribution	-
S	Total longshore sediment transport	L^3T^{-1}
S	Total capitalized expected damage	f
s	Wave steepness ($\frac{H}{L}$)	-
s	Actual damage in given year	f
T	Tidal period	T
T	Wave period	T
t	Time	T
u	Instantaneous horizontal water particle velocity	LT^{-1}
v	Current velocity	LT^{-1}

c.

<u>Symbol</u>	<u>Definition</u>	<u>Dimensions</u>
w	Instantaneous vertical water particle velocity	LT^{-1}
W	Mass armour unit	M
z	Vertical coordinate	L
z	Vertical movement of breakwater	L
z	Financial factor used in construction	-
α	Angle of face of breakwater with horizontal	-
Δ	Relative density of stone in water $(\frac{\rho_s - \rho_w}{\rho_w})$	-
ρ	Density	ML^{-3}
ρ_s	Density of stone	ML^{-3}
ρ_w	Density of water	ML^{-3}
ξ	Amplitude of horizontal motion of water particle	L
ζ	Amplitude of vertical motion of water particle	L
w	Wave frequency $(\frac{2\pi}{T})$	T^{-1}
ϕ_b	Angle of wave incidence in breakerzone	-

Short Waves

The purpose of this course is to explain the physical phenomena occurring along a coast. A short section is presented first containing the necessary linear short wave theory necessary for a working knowledge. More information on wave theory can be obtained from courses on short waves and from the literature. The book by Kinsman is especially good.

Water Particle Motion

The water motion in a progressive wave may be described by water particles moving, in general, in elliptical paths. The major axes of these ellipses are horizontal; they describe the so-called orbital motion. The orbital motion is greatest at the water surface and decreases exponentially below the surface. The amplitude of the horizontal and vertical motion components can be expressed by:

$$\xi = \frac{H}{2} \frac{\cosh k(z+h)}{\sinh kh} \quad (1)$$

$$\zeta = \frac{H}{2} \frac{\sinh k(z+h)}{\sinh kh} \quad (2)$$

where:

ξ is the maximum horizontal amplitude

ζ is the maximum vertical amplitude

H is the wave height

k is the wave number = $\frac{2\pi}{L}$

h is the water depth

z is the vertical coordinate measured from an origin at the still water surface (+ up).

L is the wave length

The instantaneous water particle velocity components are:

$$\dot{u} = \frac{\omega H}{2} \frac{\cosh k(z+h)}{\sinh kh} \cos(kx - \omega t) \quad (3)$$

$$\dot{w} = \frac{\omega H}{2} \frac{\sinh k(z+h)}{\sinh kh} \sin(kx - \omega t) \quad (4)$$

where:

\dot{u} is the instantaneous horizontal velocity

\dot{w} is the instantaneous vertical velocity

x is the horizontal coordinate

ω is the circular wave frequency = $\frac{2\pi}{T}$

t is time

T is the wave period.

Wave Energy

The energy of waves is usually expressed in terms of energy per unit of water surface area:

$$E = \frac{1}{8} \rho g H^2 \quad (5)$$

where ρ is the water density.

The total energy on an entire wave of unit width (crest length) is, then:

$$E_T = \frac{1}{8} \rho g H^2 L \quad (6)$$

Wave Speed

If we observe a float on the surface of waves, we see that its position oscillates about a fixed position, while the wave profiles move forward with a definite velocity. Obviously, there is a difference between the water particle velocities and the wave velocity.

Indeed, the velocity with which a wave crest moves (often called the phase speed or wave celerity) is given by:

$$c = \frac{L}{T} = \frac{\omega}{k} = \sqrt{\frac{g}{k} \tanh kh} \quad (7)$$

When a finite number of waves are left to propagate in otherwise still water, we observe that waves seem to originate at the rear of the group, move through the group with speed c , and die out near the front of the group. This implies that the energy of the group of waves moves forward with a speed which is less than the individual wave speed. The speed with which the energy is propagated (often called the group velocity) is given by:

$$c_g = \frac{c}{2} \left(1 + \frac{2kh}{\sinh 2kh} \right) \quad (8)$$

$$\text{yielding } \frac{c_g}{c} = \frac{1}{2} \left(1 + \frac{2kh}{\sinh 2kh} \right) \quad (9)$$

This ratio is often denoted by the symbol n .

Behavior of Hyperbolic Functions

Various hyperbolic functions have been used in the proceeding equations. Figure 1 shows graphs of these functions. Using the approximate properties of these functions, it is often possible to simplify equations 1 through 9.

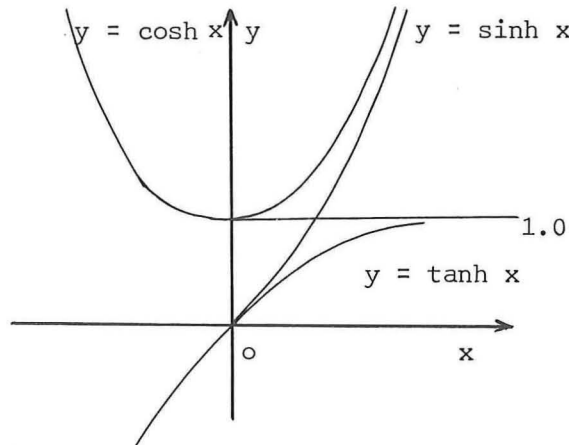

Hyperbolic functions

Fif. 1

Approximations for Deep Water.

For deep water ($h > \frac{L}{2}$), kh is large. Therefore, approximately:

$$\sinh kh \quad \cosh kh \gg kh$$

$$\tanh kh \quad 1.$$

Thus, with a bit of algebra the following changes take place:

$$\xi_o = \frac{H_o}{2} e^{kz} \tag{1a}$$

$$\zeta_o = \frac{H_o}{2} e^{kz} \tag{2a}$$

$$\ddot{u}_o = \frac{\omega H_o}{2} e^{kz} \cos(kx - \omega t) \tag{3a}$$

$$w_o = \frac{\omega H_o}{2} e^{kz} \sin(kx - \omega t) \tag{4a}$$

$$E_o = \frac{1}{8} \rho g H_o^2 \tag{5a}$$

$$E_{\text{TP}o} = \frac{1}{8} \rho g H_o^2 L_o \tag{6a}$$

$$c_o = \frac{L_o}{T} = \frac{\omega}{k_o} = \frac{g}{2\pi} T \quad \text{or in metric units } c_o = 1.56 T \tag{7a}$$

$$c_{g_o} = \frac{c}{2} \tag{8a}$$

$$n_o = \frac{1}{2} \tag{9a}$$

The subscript o has been added to denote deep water conditions. This has not been done with T since this parameter remains constant. From (7a) it follows that

$$L_o = 1.56 T^2 \tag{10}$$

in metric units. We note from (1a) and (2a) that $\xi_o = \zeta_o$. Hence the water particles move in circles, the radii of which decrease exponentially with depth. At a depth $z = -\frac{L}{2}$, the motion amplitudes have decreased to $\frac{1}{500}$ x their values at the surface. Motion, here, is essentially zero; the wave does not feel the bottom.

Figure 2 shows flow patterns within a deep water wave.

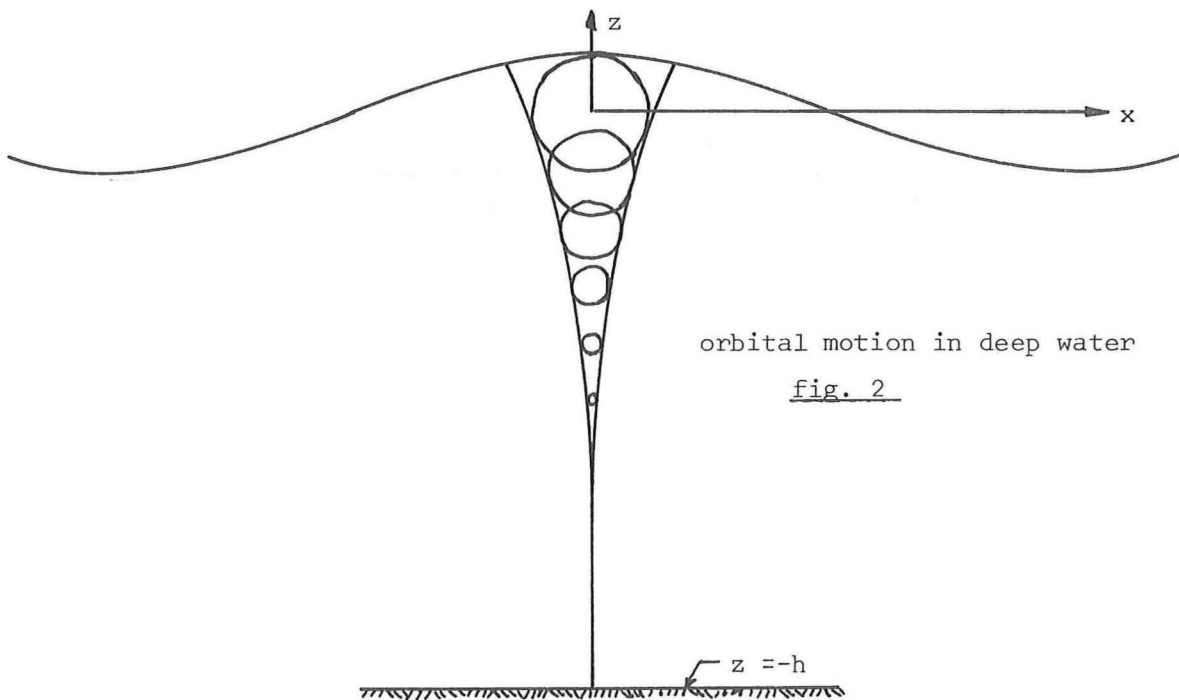

Approximations for Shallow Water.

Another set of approximations can be substituted when the water is shallow ($h < \frac{L}{25}$). In this case, kh is small as is also kz . This yields:

$\sinh kh$	kh
$\cosh kh$	1
$\tanh kh$	kh

Again using a bit of algebra we get:

$$\xi = \frac{H}{2kh} \tag{1b}$$

$$\zeta = \frac{H}{2} \left(1 + \frac{z}{h}\right) \tag{2b}$$

$$\bar{u} = \frac{\omega H}{2kh} \cos(kx - \omega t) \tag{3b}$$

$$w = \frac{\omega H}{2} \left(1 + \frac{z}{h}\right) \sin(kx - \omega t) \tag{4b}$$

$$E = \frac{1}{8} \rho g H^2 \tag{5b}$$

$$E_T = \frac{1}{8} \rho g H^2 L \tag{6b}$$

$$c = \frac{L}{T} = \sqrt{gh} \tag{7b}$$

$$c_g = \frac{c}{2} (1 + 1) = c \tag{8b}$$

$$n = 1$$

We see from (8b) that in shallow water the group velocity is equal to the wave celerity. Further, at $z = -h$, $w = 0$ according to equation 4b; this seems logical. Also, \bar{u} is now independent of the water depth (3b). Indeed these equations are the same as we find for long waves.

Figure 3 shows flow patterns within a shallow water wave.

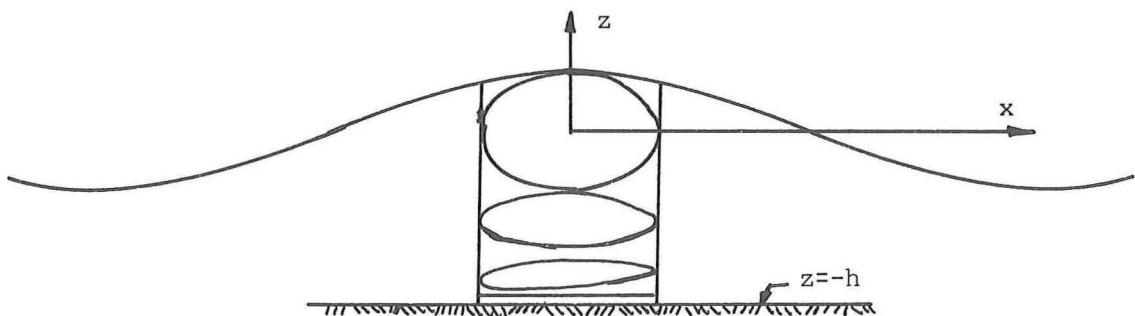

Figure 3. Orbital motion in shallow water

Intermediate Water Depths

For water of all intermediate depths ($\frac{L}{25} < h < \frac{L}{2}$), we are forced to use the complete equations as given earlier in 1 through 9. Water particles move along elliptical paths. These ellipses degenerate to horizontal lines as we approach the bottom and are nearly perfect circles at the surface.

Effects of Shoaling Water

What happens as a wave moves from deep water into shallower water? As long as h is greater than $\frac{L_0}{2}$, nothing happens. As the depth continues to decrease the wave speed slowly decreases. (There is an initial, insignificant speed increase which we ignore for most practical work). Since the wave period remains constant, the wave length must also decrease. If we neglect bottom friction effects which are small until the wave breaks, then we may apply the principle of conservation of energy. Using equation 6 we are forced to conclude that the wave height increases. Ultimately, of course, the wave becomes so high and so short that it breaks.

Before considering the extreme case of breaking, let us consider some intermediate conditions. Applying conservation of energy to the transport of energy (energy flux) we get:

$$E_o c_{g_o} = E_1 c_{g_1} \tag{11}$$

The subscript 1 refers to the condition other than deep water. Using (9)

$$E_o n_o c_o = E_1 n_1 c_1 \tag{12}$$

With (9a) and (5) substituted in (12) we get:

$$\frac{H_1}{H_o} = \sqrt{\frac{c_o}{c_1} \frac{1}{2n_1}} = K_s$$

where K_s is often called the shoaling coefficient.

Wave Breaking Criteria

Either of two criteria can be used to predict when or where a wave will break. ^{Deep water} Waves will break if their steepness, defined as the ratio $\frac{H}{L}$, becomes greater than about $\frac{1}{7}$. Also, waves will break if the ratio of wave height to water depth becomes too large. Solitary wave theory gives a value of 0.78 for this ratio; a more practical value of $\frac{H}{h}$ is 0.5 to 0.6.

There are several types of breaking waves. These are shown in the diagrams of figure 4.

Figure 5 quantifies their classification.

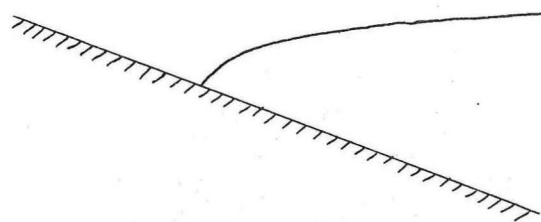

"surging breaker"
extremely steep slope

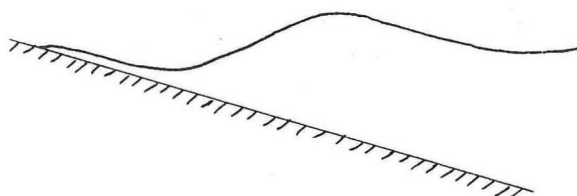

"collapsing breaker"
very steep slope

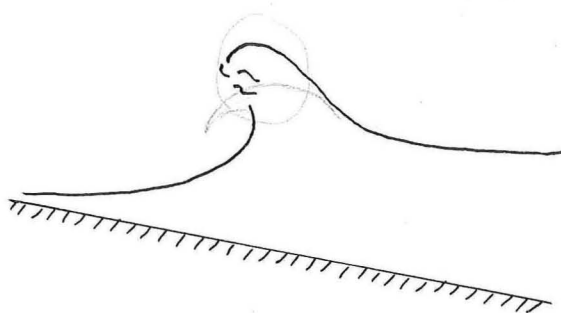

"plunging breaker"
steep slope of the beach

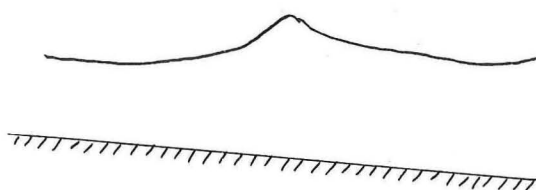

"spilling breaker",
gentle slope , may cause
the most severe beach
erosion

Figure 4 Types of breakers

Galvin (C.E.R.C.) has developed several empirical criteria for the classification of the breakers.

(C.J. Galvin: Breaker Type Classification on Three Laboratory Beaches. Journal Geophysical Research, Vol.73,nr.12, June 15, 1968, pp. 3651-3659) The various criteria as given by Galvin can be summarized as follows shown in the following figure.

Figure 5 Wave breaking classifications *

a) ~~Outside the refraction zone:~~

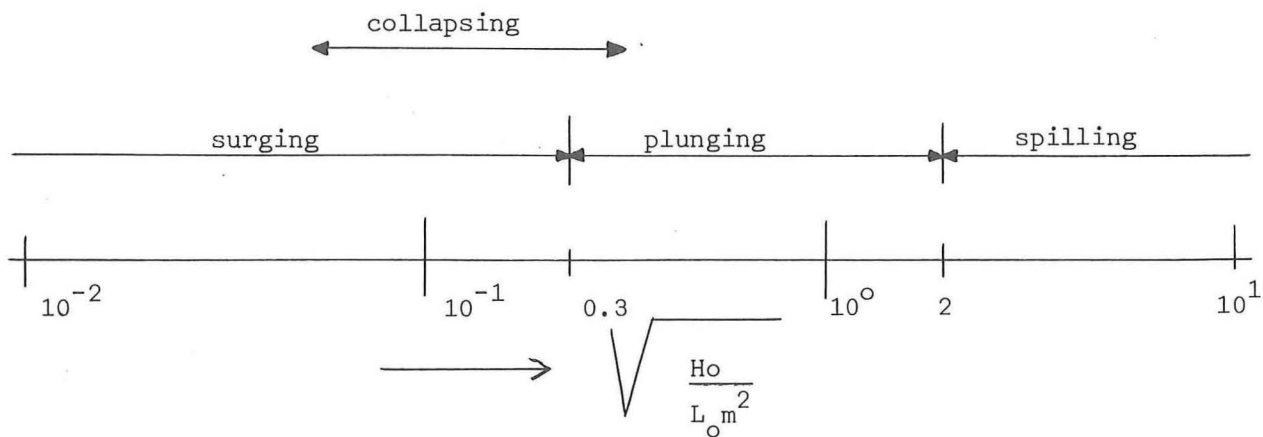

H_o = wave height in deep water

L_o = wave length in deep water

m = slope of the beach

b) ~~Inside the refraction zone:~~

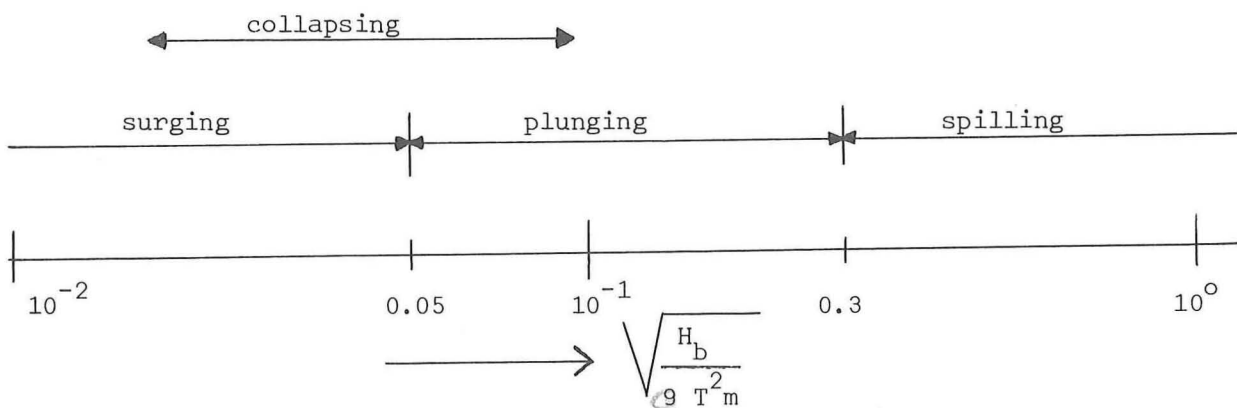

H_o = wave height in deep water

L_o = wave length in deep water

m = slope of the beach

T = wave period

*H_b = breaker height
g = accel. of grav.*

* Refraction is discussed on the following pages.

Three Dimensional Effects

Until now, we have considered waves only in two dimensions (the xz plane). Waves moving into shallower water were assumed to be moving with their crests parallel to the depth contours. Further, until now, no partial obstacles have been allowed to interrupt the path of the waves. These restrictions will now be relaxed.

Refraction

When waves enter water of changing depth with their crests not parallel to the depth contours, then the phenomena of refraction occurs. The term refraction has already appeared on the previous page. We have seen that as a wave enters shallow water its celerity decreases. Thus, a wave crest oblique to the depth contours moves forward more slowly in the shallower water. This causes the crest to bend as shown in figure 6. This phenomena is exactly parallel to that studied in geometrical optics.

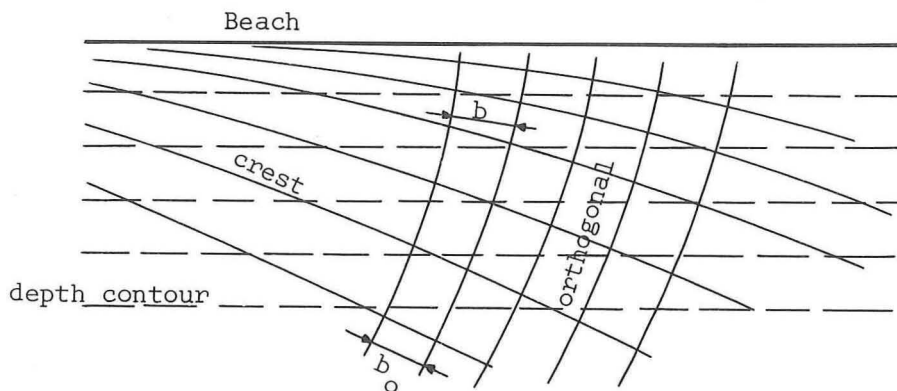

Figure 6 Wave refraction

The wave crests, obviously, do not remain parallel; the distance between successive crests varies. This is also true of the wave rays (or orthogonals), lines which are always perpendicular to the wave crests. A bit of geometry will reveal that the distance between orthogonals increases as we approach shallow water. *with // depth contours*

Earlier we made an assumption, implicit in our energy conservation scheme, that wave energy does not cross wave orthogonals. We may modify our equations involving shoaling, 11 through 13, to include refraction effects. Using the notation shown in figure 6, (11) becomes:

$$E_o c_{g_o} b_o = E_1 c_{g_1} b_1 \quad (14)$$

Carrying this through:

$$E_o n_o c_o b_o = E_1 n_1 c_1 b_1 \quad (15)$$

and

$$\frac{H_1}{H_o} = \sqrt{\frac{1}{2n_1} \frac{c_o}{c_1} \frac{b_o}{b_1}} = K'_s \quad (16)$$

It is left to the reader to apply these principles to waves travelling from shallow to deep water.

Diffraction

Diffraction is another three-dimensional effect arising as a result of a "shadow" being formed by an obstacle. Diffraction refers to the spreading of the waves into this shadow zone. Since it is impossible to discuss this problem simply and quickly, one is referred to courses or literature on short waves.

Wave Height Characterizations

In the proceeding section we worked with sinusoidal waves of uniform height H . This is an extreme idealization as anyone who has watched the sea will understand. Indeed, the sea surface is uniformly chaotic.

A record of wave heights made at a particular location seems to satisfy many laws of probability, or statistics.

Often, we wish to have a simpler description of wave conditions. Instead of specifying all of the statistical parameters, we choose a single parameter, usually a wave height. This height is some sort of average of the heights of the individual waves passing a location over a time interval. Some common averages are:

H_s = average of the highest 1/3 of the waves.

H = average of all waves.

$H_{13\%}$ = wave height exceeded by 13% of the waves observed.

H_{rms} = square root of average of squares of all wave heights.

In practice we find that $H_s = H_{13\%}$. Also, when an experienced observer is asked to estimate the wave height in a particular seaway, his estimate corresponds closely to the significant wave height.

Wave heights measured over a relatively short time (tens of minutes to a few hours) during which the meteorological conditions remain constant may be statistically described by a Rayleigh Distribution. Such a distribution is called a micro distribution, and is shown in figure 7.

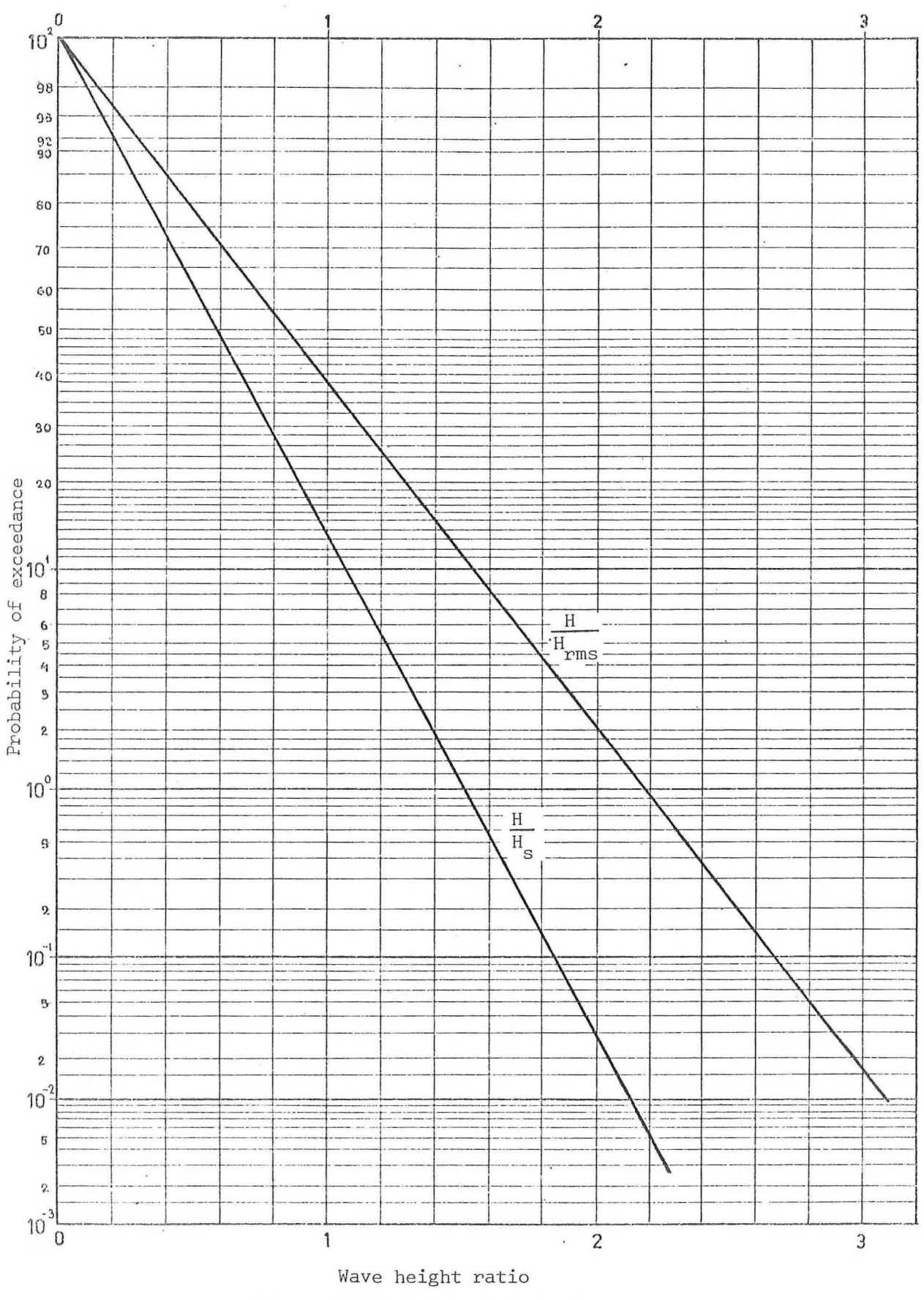

Figure 7 Rayleigh Distribution

For this distribution, the probability, $P\left(\frac{H_P}{H_S}\right)_e$ that the ratio $\frac{H_P}{H_S}$ exceeds a given value is:

$$P\left(\frac{H_P}{H_S}\right)_e = \exp\left\{-\frac{\pi}{4}\left(\frac{H_P}{H_S}\right)^2\right\} \quad (17)$$

where \exp denotes the exponential function.

Conversely, the probability that $\frac{H_P}{\bar{H}}$ does not exceed a given value is:

$$P\left(\frac{H_P}{H_S}\right) = 1 - P\left(\frac{H_P}{H_S}\right)_e \quad (18)$$

Equations 17 or 18 may be used to describe the line in figure 7 depending upon upon the direction of the probability scale.

From this micro distribution, we can extract the following handy ratios:

$$\frac{H_S}{\bar{H}} = 1.59$$

$$\frac{H_{\max}}{\bar{H}} = 1.65 \text{ if we take } H_{\max} \text{ as the wave height exceeded by 0.5\% of}$$

the waves. Of course, the theoretical absolute maximum wave height is infinite.

So far we have considered short-term wave height distributions. If, on the other hand, we were to characterize each of hundreds of micro distributions at a point each by its significant wave height, then we would find that these values would also form a distribution. This macro distribution would extend over perhaps several years. From this distribution we might predict the significant wave height which would be exceeded, on the average, once every so many years. This sort of information will be very useful when designing coastal structures.

One must be careful to note that both of these distributions are based upon an assumption that the waves do not break. As we can conclude from the section on wave theory, the highest waves are first to break in shoaling water. When these waves are removed by breaking, then, of course the top of our wave height distribution has been chopped off.

Svasek and Koele have found that for conditions such as exist along the Dutch coast, the significant wave height at the breaking point is approximately one-half of the water depth at that point. When a wave breaks, it dissipates its energy in sound, turbulence and by the generation of smaller waves.

what is that

Coastal Formations

In the previous sections we have discussed how waves behave as they approach a coast. In this section, we shall examine an opposite case: the effect of waves on coasts or beaches. Figure 8 gives some nomenclature associated with a shore.

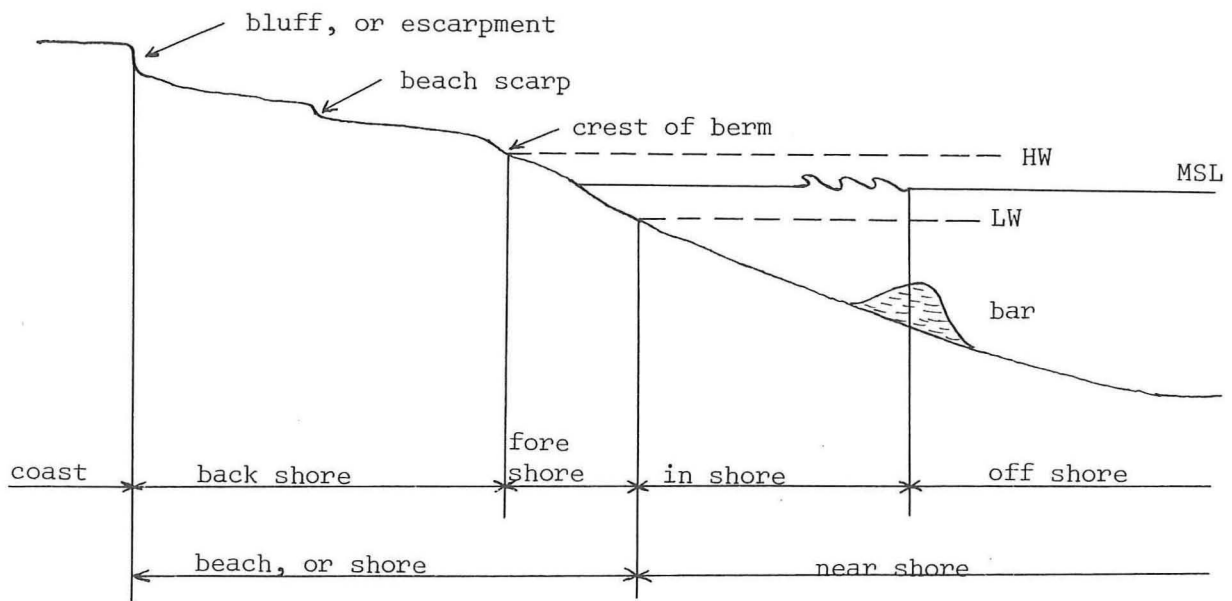

Figure 8 Nomenclature of a beach profile

Flat coasts usually consist of fine materials such as mud, clay, or sand. Sling mud forms an extremely flat coast. Coarser materials such as rounded flat stone (often called shingle), and gravel form steeper coasts.

Some typical coastal formations are described and sketched below in figure 9. All of these forms extend at least above the low tide level. Usually they extend above the high tide level as well. Formations which always remain under water are more properly called shoals. Beaches are attached to the more permanent shore along their entire length. Spits are connected to shore at one end and extend more or less perpendicular to a coast. Tombolos form between islands and the mainland connecting the two. Barriers are low structures more or less separating the sea from a usually shallow coastal area.

These barriers may or may not connect to the mainland. They may have numerous breaks, making them appear more like a string of islands.

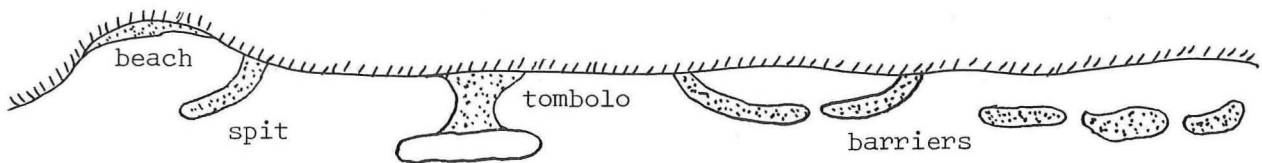

Figure 9 Coastal Formations

Generally, fine materials are moved more easily by the action of waves. For this reason, shores consisting of fine material must have a large supply of sediment to maintain their equilibrium. This supply may come from the sea itself, from another portion of the coast, or from a river. The wind can, in some cases, contribute to this supply of material.

Necessary conditions for appreciable transport and dune formation by winds are:

- The wind must blow from one prevailing direction;
- The sediment material must become dry;
- The sediment may not contain much cohesive material;
- Evaporation may not be so great that a caliche formation develops.

In this section we have concluded that the transport of sediment is (usually) necessary for the development of various coastal formations. In the following section, we shall discuss how this transport is caused by waves.

Sediment Transport Caused by Waves

Waves generally move sediment (sand) both along the shore and off the beach. We consider the second of these first, the movement of sand and water along a beach profile.

When a wave breaks, it results in a considerable mass transport of water toward the coast and a considerable turbulence at the place of breaking. This turbulence tends to stir bottom material loose so that it may be transported toward the coast with the water. The water escapes from the zone between the breakers and beach (the inshore) by flowing back along the bottom and by percolating into the beach. This back flow continues to the breaker line where it rises to flow toward the beach again. Since the return flow over the inshore is both smaller and less turbulent, less sediment can be transported from the beach. Beach accretion with increasing inshore slope results. The slope increases until a state of dynamic equilibrium is reached.

Outside the breaker zone, offshore, the waves move material toward the bar. Thus, the bar is fed with material from both sides while material is removed by the breaking waves. These transports and bar are shown in figure 10. Ultimately, a state of dynamic equilibrium is reached. This equilibrium can be upset by a large change in wave height or water level.

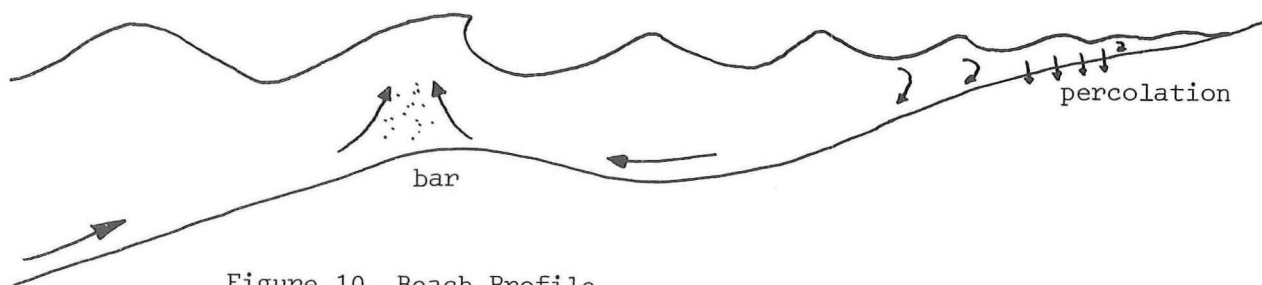

At this same time, sediment is usually being transported along the coast as well. This is also moved by water currents. These currents can be caused by waves, tides, or even by rivers. The longshore current parallel to the coast caused by waves is often the dominant current component causing the longshore transport of sediment (sand). The derivation of how this current is caused by waves and how this current transports the material is covered in another set of lecture notes.

The transport of sediment along a coast is sometimes called littoral drift; a more specific term, longshore sediment transport is usually preferred. This longshore sand transport is carried by a longshore current after the sand has been stirred loose from the bottom by the breaking waves, just as with transport along the profile. Since the longshore current is also caused by the breaking waves, we must conclude that the sand transport takes place in the inshore zone.

Using available data, the Coastal Engineering Research Center derived the following empirical formula for the total sediment transport along a coast caused by waves:

$$S = 0.114 H_o^2 c_o K_r^2 \sin \phi_b \cos \phi_b \quad (19)$$

where:

S = total longshore sediment transport

K_r = refraction coefficient = $\sqrt{\frac{b_o}{b_1}}$

ϕ_b = angle of wave incidence in the breaker zone.

This formula does not include the effects of additional current components such as tides. Also, no mention is made of the sediment particle characteristics. Bijker and Bakker have overcome many of the limitations of this formula. Some of their results are included in another set of notes.

It should be pointed out that the longshore sand transport is nearly always much more important than the transport to and from the inshore along the profile. The longshore transport is primarily responsible for such phenomena as the migration of islands. Transport perpendicular to the shore usually only causes seasonal variations.

With this insight into how waves affect a natural shore, we can, in the next section, investigate the effects of artificial structures on the beach processes.

Groins

Groins are often used as defense system. If, for any reason, the sediment transport capacity of the longshore current increases on its way along the sandy coast, beach erosion will take place. One way to stop this is to build groins.

A study of the littoral drift along the Dutch coast has shown that 200 m from the beach the littoral drift per m' is three times as high as at a distance of 600 m from the beach. This means that a considerable portion of the littoral drift is fairly close to the beach. If we are able to decrease the sandtransport in this area we can stop the beach erosion.

According to Bakker, applying Bijkers transportformula, and Bowens longshore current approach S_s is directly proportional to S_b and S_b is directly proportional to v .

- S_s = transport of material in suspension
- S_b = bottom transport
- v = current velocity

In fig.11 we can distinguish between two zones A B in which practically all the littoral drift is taking place from left to right.

S^I and S^{II} are total transports at crosssection I and II respectively

Subscriptst A and B refer to the different zones parallel to the coast.

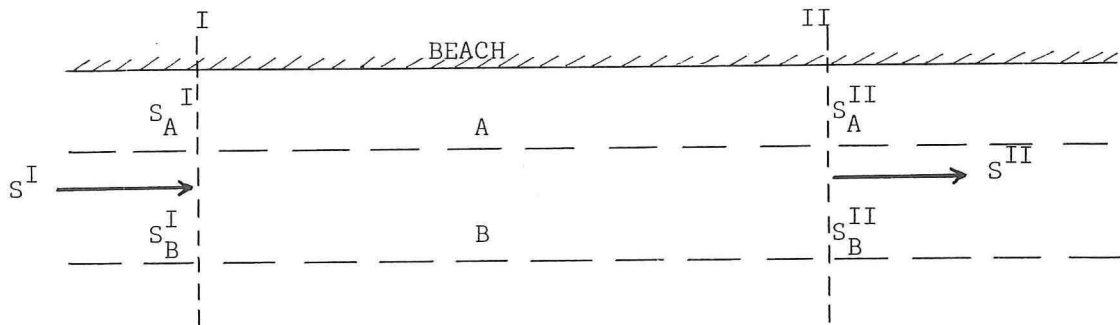

Fig 11 Zones of littoral drift (longshore transport)

$S^{II} > S^I$ so between I en II the beach will erode. Now let us say that $S^{II} = 1.2 S^I$ and $S_A : S_B = 2 : 3$ then

$$S_B^{II} = 0.6 S^{II} \approx 0.7 S^I$$

$$S_A^{II} = 0.4 S^{II} \approx 0.5 S^I$$

In order to stop beach erosion we have the decrease S_A^{II} from $0.5 S_A^I$ to $0.3 S_A^I$. This can be achieved by decreasing the \bar{v} in this area by 40%. This could be done by building permeable groins made out of piles or unpermeable groins in the form of miniature breakwaters or a combination of both.

At first sand will start to accrete at the first number of groins, but because the bottom in S_B stays at the same level the slope of the beach will become so steep than an equilibrium position will be reached and the "excess" sand goes from A to B.

The student has to be aware of the fact that this is a simple presentation of a complex problem. In the first place it is hard to determine total net sandtransport and secondly, to divide this transport according to different zones to a certain degree of accuracy is, up till this moment, practically impossible. Groins have been built up to this day, with varying degrees of success, and this is one more factor to make research in sand transport worthwhile.

One thing has to be kept in mind and that is that building groins is not solving a problem, but moving a problem. This can be explained with the help of fig. 12. If, for example, because of building of a harbour, area I is threatened by erosion it can be defended by building

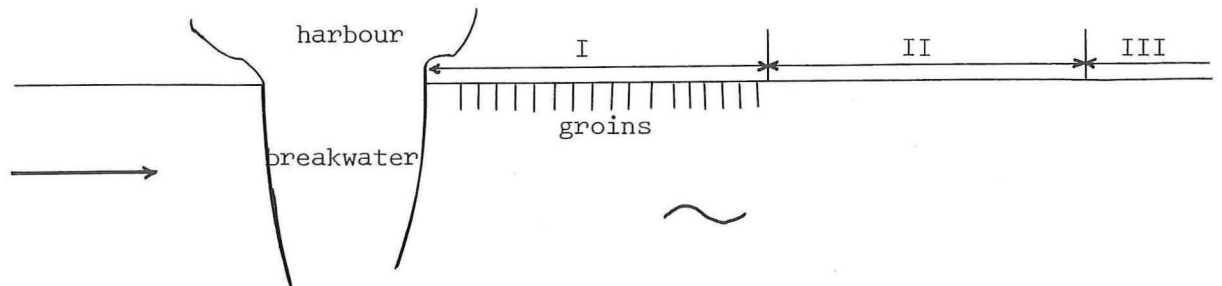

fig. 12

location of groins

groins. Now the sandtransport after an equilibrium condition is reached is larger in area II than in area I, so the beach will start to erode in II. If erosion in II is just as undesirable in II as it is in I we will have to build groins in area II also. Now area III will start to erode, so if conditions stay the same along the coast we will have to keep on building groins.

It is evident that in a case like this it is far more economical to transfer sand by mechanical means from the accreting to the eroding zone. A set up of this nature is called a sand by-pass.

Types of groins

Groins can either be permeable or non-permeable; depending on whether one wants to stop completely the longshore transport along the entire width of the groin system or not. Most often this is a matter of economics, as permeable groins are cheaper than non-permeable groins; about by a factor five.

Non-permeable groins are usually made in the form of a rubble mound, possibly impregnated and/or clad with asphalt. At the Dutch coast the crest is only 0.75 m above the LW line to prevent the occurrence of large eddies during high tide. They are extended in the direction of the dunes up to the point where the intersection will be between the crest and the future equilibrium profile of the beach. The profile at the time they are built is steeper, as is mostly the case of beach erosion in the Netherlands. The crest can have a low gradient, but never more than the equilibrium profile of the beach because of the flood-eddies. See fig.12^a.

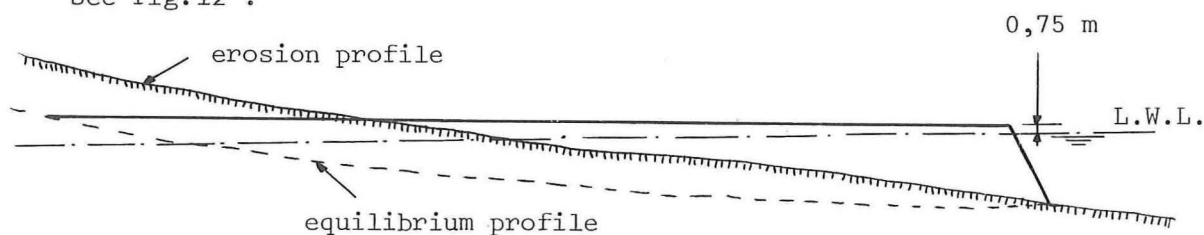

fig.12^a
groin profile

An example of the permeable groin is the pile-row. At the Dutch coast the distance between the piles is about equal to the diameter of the piles. From the low water level towards the dunes the groins consist of a single row and extending from the L.W.L. into the fore-shore of a double row of piles.

The distance between the pile-groins can be larger than the distance between the stone groins because the waterline between them is straighter as is shown in figure 12^b.

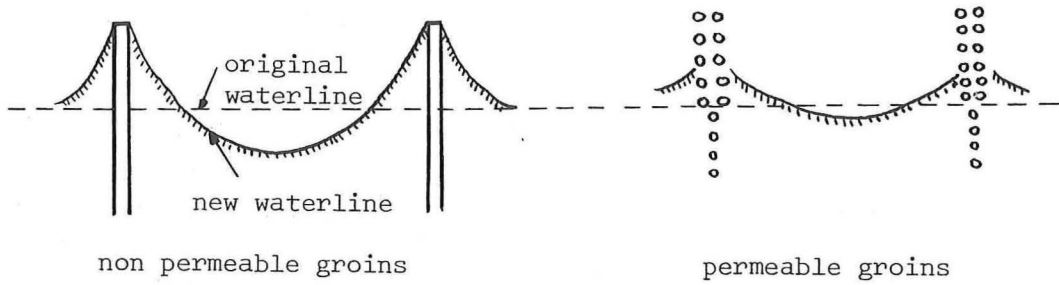

fig. 12^b

waterline due to groins

The bottom in front of the groins has to be defended in some cases as erosion tends to be considerable in that area.

A new development in the field of groins are giant sausages made out of synthetic fiber filled hydraulically with gravel or sand, supported by a mat because otherwise they run the risk of sinking in the sand.

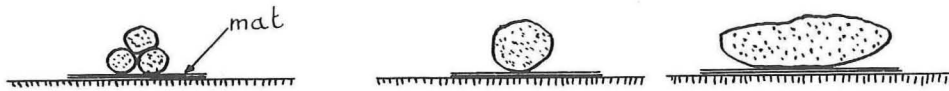

fig. 12^b

cross section groins made out of synthetic fiber.

The experts are still divided on the issue of the usefulness of this type of groin as it is susceptible to damage by people and freezing, and influence of ultraviolet light.

Delta Coasts

The delta coast is a relatively local coastal accretion where the material is supplied mainly by a river. Let us first consider the simple case in which we have no tidal or longshore current so the wave front is at all times parallel to the coast. The river will deposit material in the immediate vicinity of the river outlet because the water velocity and its inherent transport capacity are reduced to zero practically. If we would not have waves a delta would be formed as shown in figure 13 consisting of sand, silt and clay.

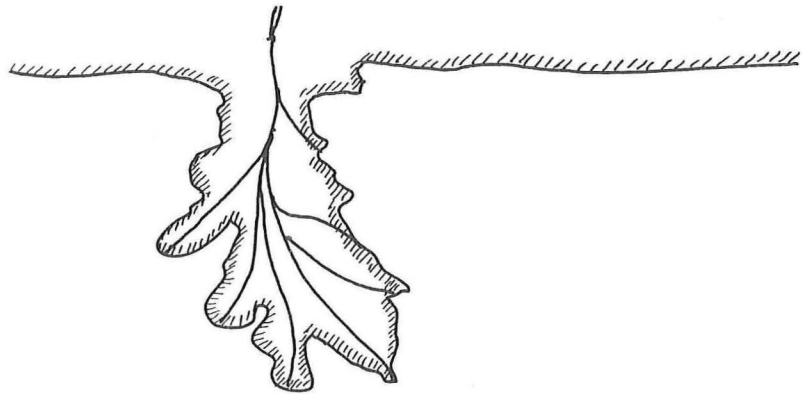

fig. 13
delta in case of no waves

If at the same time we do have waves, refraction will occur and along both sides of the delta a longshore current comes into being. This current combined with the stirring action of the waves will transport material in the direction of the original shore. Along the way the refraction will first increase and later decrease. So will the velocity of the longshore current and the material will settle out at both extremities of the delta. The coarser fractions first and finally the silty material. The final result is the, often called bird-foot delta.

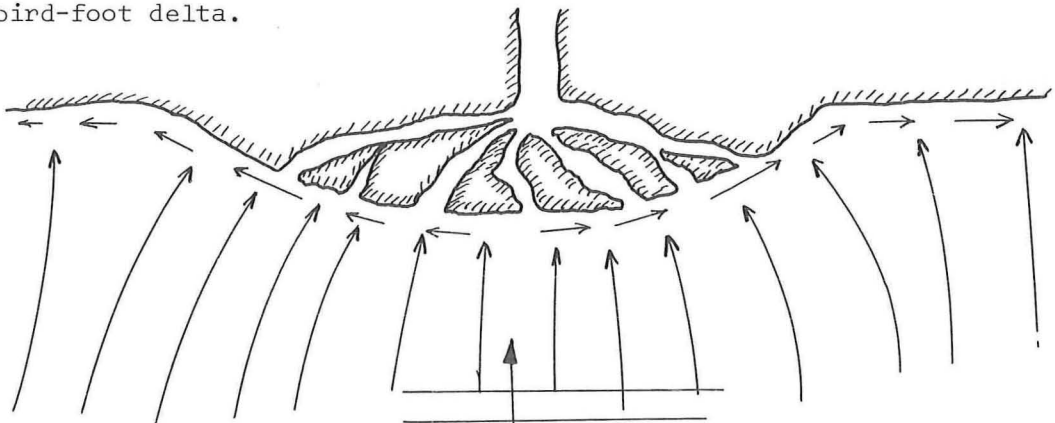

fig. 14 | bird-foot delta

Generally we will have tides and the waves will approach the coast under such angles that a longshore-current will develop. The tidal current will tend to maintain openings in the coast, whereas the sediment transport at sea by waves and currents will try to restore a closed coastline. The type of river or estuary outlet that will be established finally, depends on many factors. The most important factors are:

- a. currents in the outlet (caused by tides and run-off)
- b. current and waves in the coastal area
- c. littoral drift
- d. sediment load of the river

Variation of one of these factors allow a great number of possible combinations, each of which will produce its own type of outlet. Most characteristic appears to be the ratio between the supply of sediments and the distributive forces of the water acting on it. This conception should be taken in two ways, viz., sediments of the river versus water of the sea and sediments of the coastal area versus water of the river.

First, there is the variation of the sediment supply by the river.

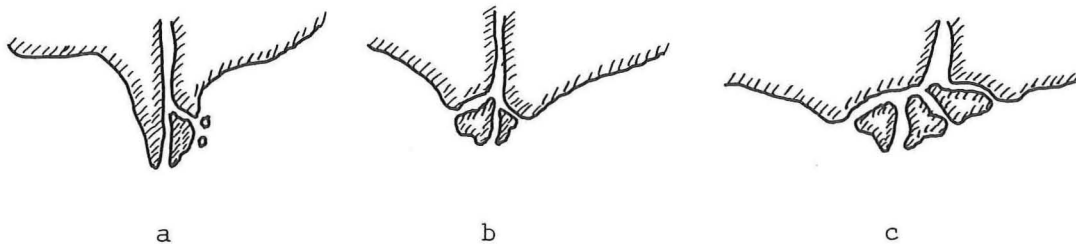

Influence of sediment supply

fig. 15

Fig. 15-a shows the case of an overwhelming supply while the effect of the other factors is relatively negligible; there is little opportunity for spreading of the sediment. If the sediments consists of fine silts only, a bird's-foot delta will develop.

In fig. 15-b the case is shown of a considerable supply and a relatively less important effect of the other factors; whereas fig. 15-c represents the case where a fair supply is balanced by fairly good distributive forces. From the examples given, it may be clear that a variation of the sediment supply by the river relative to the magnitude of the other factors effects not only the type of outlet, but also very much the type of delta as a whole.

Secondly there is the variation of the tidal currents. Fig. 16-a shows the case of very strong ebb currents disposing of a fair supply of river sediment. On both sides of the outlet spits are built out and the deep bar is far offshore. Fig. 16-b represents the average case of a less pronounced jet current balanced by distributive forces in the coastal area; whereas in fig. 16-c relatively strong distributive forces spread the sediment load of the river before it is carried well into the sea.

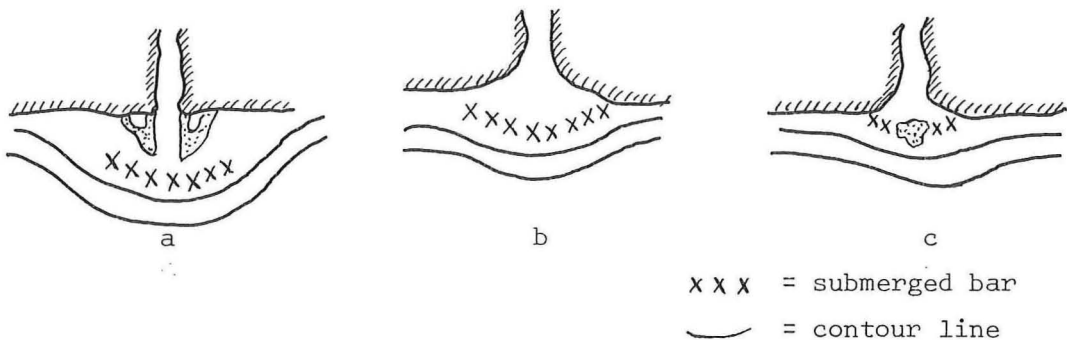

Influence of tidal currents

fig. 16

Fig. 17 shows the case where the distributive forces caused by waves and currents, are strong, fair and moderate respectively relative to the magnitude of the other factors.

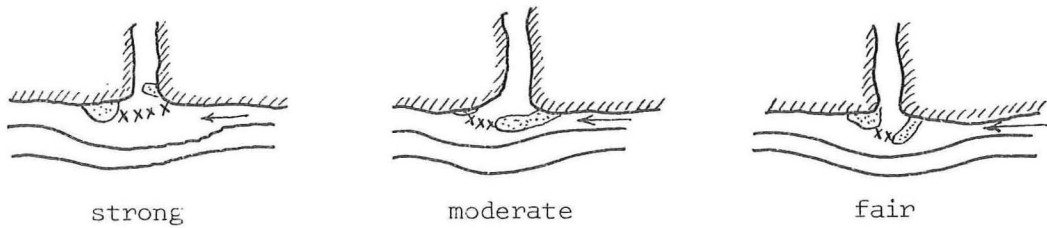

Influence of distributive forces.

fig. 17

Lastly, there is the variation of the longshore transport. Fig. 18 shows the cases where the longshore transport is large, fair and small respectively relative to the magnitude of the other factors.

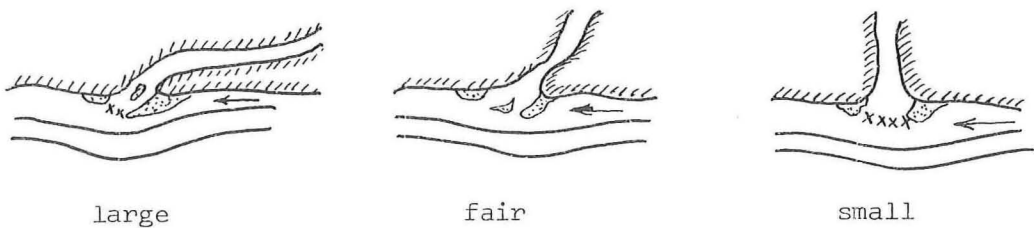

Influence of the longshore transport

fig. 18

As far as the more detailed configuration of the outlet area is concerned, the number of possibilities is almost infinite. In general the flood currents are relatively stronger on the banks of the outlet contrary to the concentrated ebb currents which predominate in the center.

This is due to the fact that the average water-depth is less during low tide than during high tide.

Often the configuration of the outlet area is not stable but follows a certain pattern of changes. Long-period cyclic movement takes place sometimes, with a succession of scouring and shoaling, generally in shifting channels. The stability of the outlet seems largely dependent on the ratio of average littoral sediment transport to average maximum tidal flow. Low ratios generally enhance the stability of the outlet.

Muddy coasts

Large rivers like the Amazon transport such vast quantities of clay material in the form of wash load, that the adjacent coastline consists almost entirely of sling mud. This wash load material, mainly finer than 0.002 mm is transported in suspension. The concentration can be very high. When the concentration exceeds 200,000 ppm, the mixture does not behave like a fluid any longer.

When this washload comes into contact with the salt water a process of flocculation will occur because salt water has a relatively high concentration of positively charged metal-ions (Na, K. etc.) and these ions neutralize the neg. charge of the clay particles so flocculation becomes possible.

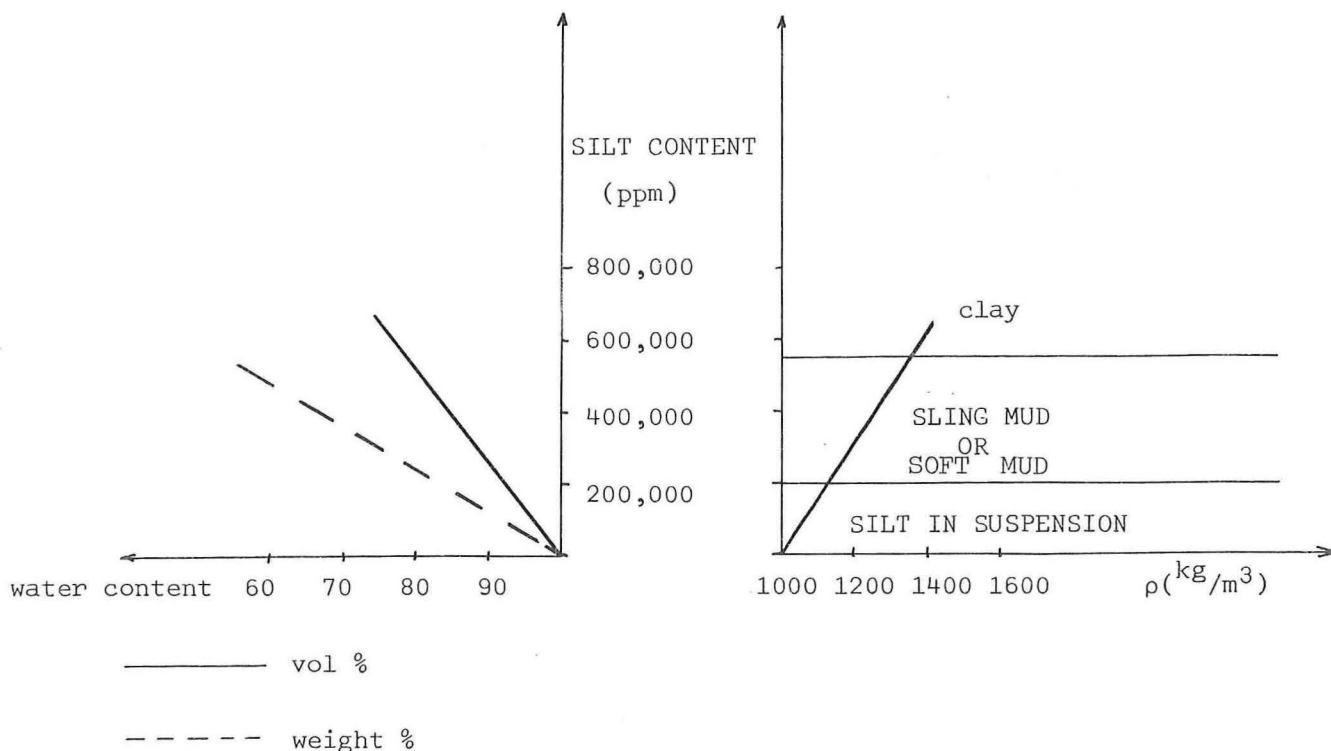

nomenclature according to SILT concentration

fig. 19

The resulting clay sediment is sling mud and still consists of 85% of water by volume. It has no stability to speak of, and it tends to move with the ocean current along the coast in long waves with a wave length of 40 km and a celerity of 1.3 km per year.

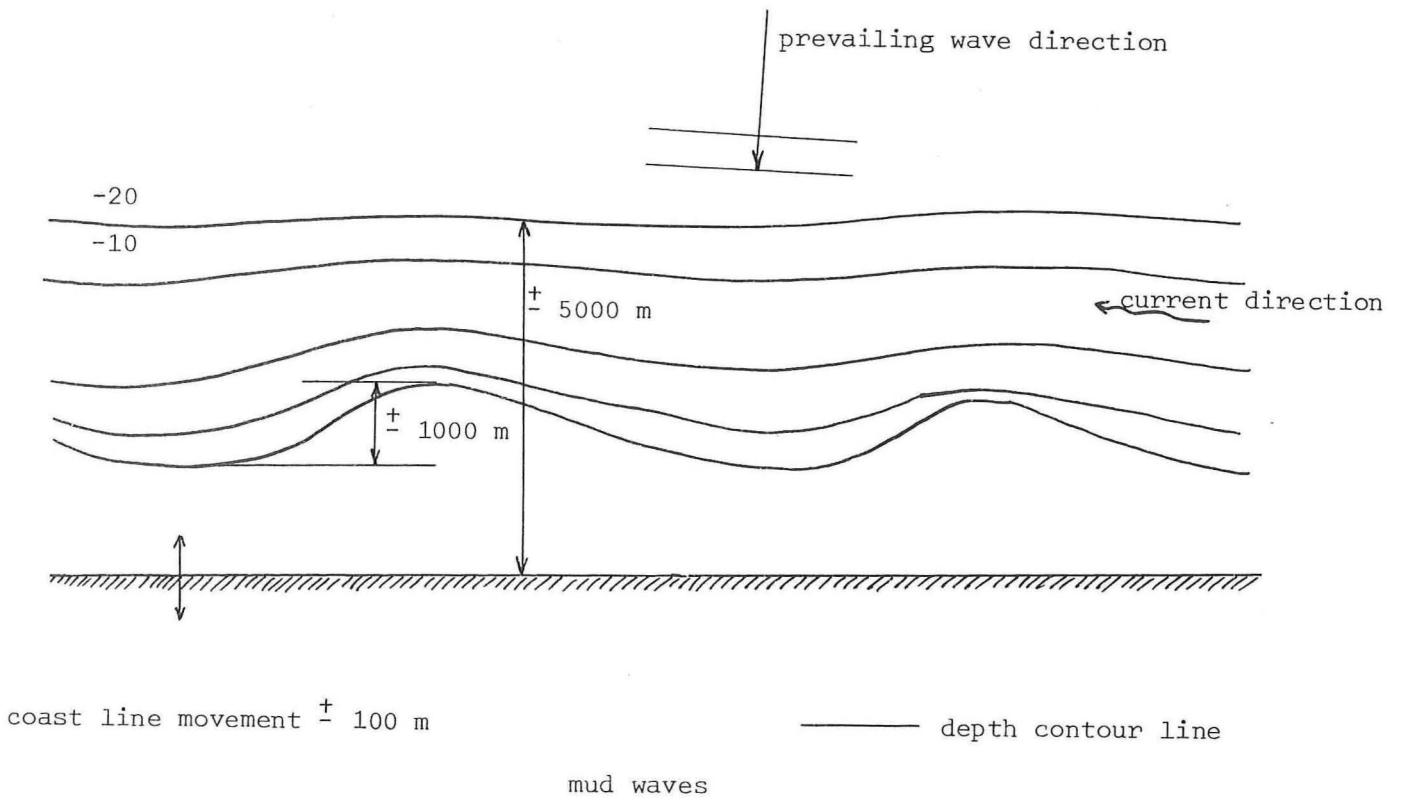
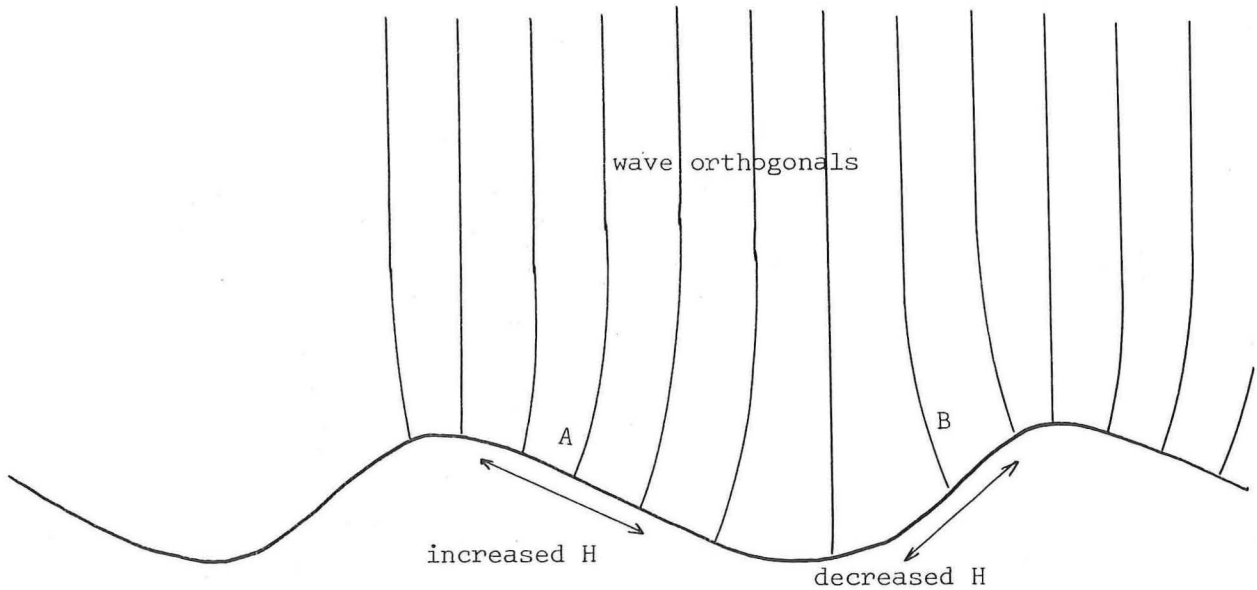

fig. 20

The transport mechanism is shown in fig. 21.



transport mechanism of mud waves

fig. 21

Streamlines tend to be perpendicular to contour lines. When the prevailing wind direction is as shown in the figure then in point A refraction will cause an increase in energy per unit area, so H will increase, resulting in stirring up more material. This material is transported by the current to B where the refraction will cause divergence of the waves so H will decrease. This gives the material stirred up at A a chance to settle at B.

The coastline tends to move with the mud waves. As this movement can amount to hundreds of meters it is desirable to check it, but this is very difficult because the mud cannot support heavy structures. Sometimes there include ridges consisting of fine sand on which defense systems can be built, but these ridges are not continuous. Other possibilities are encouraging vegetation or construction of structures that float on the mud.

The increase of the size of ships poses difficult problems for the harbors on muddy coasts. The faint slopes of these coasts (1 : 1000) necessitate extensive dredging which is relatively expensive because clay does not settle out in the hoppers of the suction hopper dredgers. Agitation dredging is only possible when there is sufficient current velocity to disperse the material. One advantage is that keel clearance can be very small.

The slingmud allows a negative keel clearance of ± 50 cm. This has, however, an abrasive effect on the ship's hull and results in an increase of friction. Heavy shipping will have the effect of continuous agitation dredging and can cut the cost of maintenance dredging considerably. It remains questionable whether this is an economic solution to the problem when compared with dredging.

Tidal rivers.

River outlets in flat coasts handle not only the runoff of the river basin, but also a tidal prism. According to O'Brien in ASCE WW1 Febr. '69

$$A = 2 \times 10^{-5} P$$

A = cross-section river outlet in ft^2

P = tidal prism in cuft (volume of water flowing in and out due the tide)

Usually different natural channels develop for the flows during high- and low tide.

As explained in the courses in river engineering the deeper channel in a river bend will develop at the outside of the bend and will be shifted somewhat downstream when compared with the geometric curve.

In case of a current of alternating direction in a rather wide channel, a double channel system can develop as shown in fig. 22.

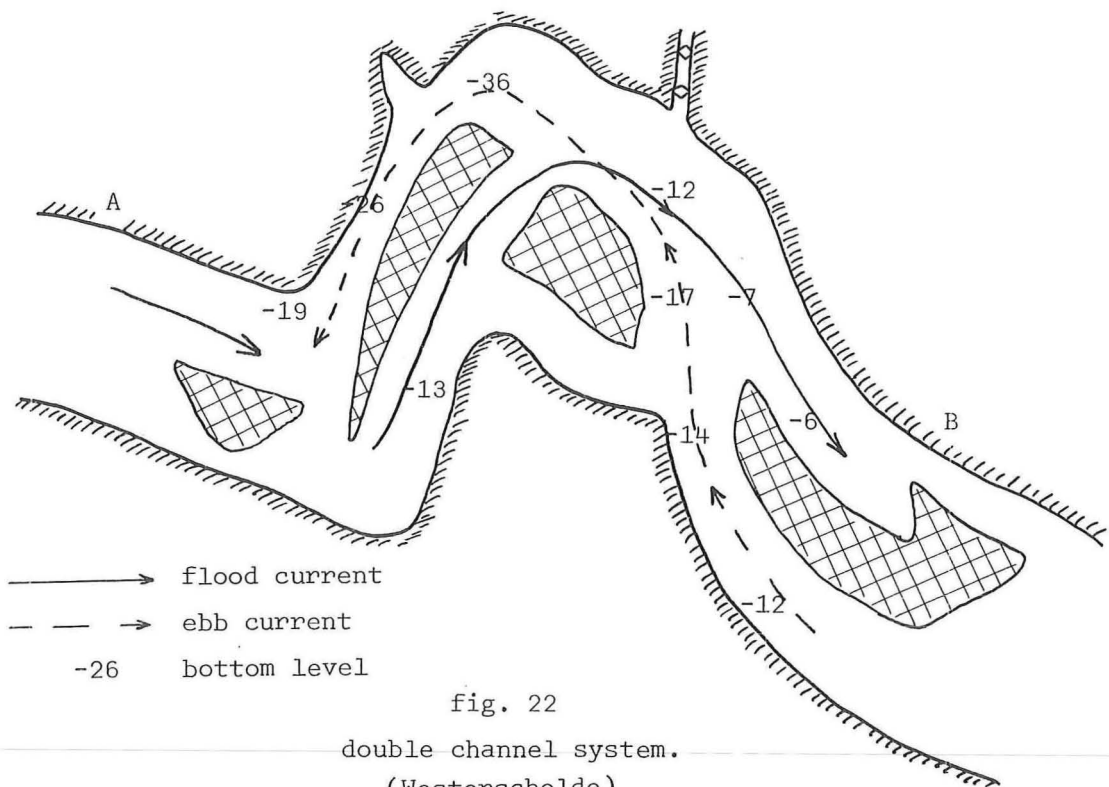

Due to the fact that the waterlevel during flood tide is normally rising the flood channels have, moreover, the tendency to "die out" into flats or shoals. At a certain moment the waterlevel is so high that, at any rate, the end of this flood channel (after the actual curve), the water will not be confined anymore to a channel and will flow out over the flats to the next bend.

Just the contrary will occur during ebb. In that case the water level will go down and the ebb current will be even more restricted to a narrow channel. Also $Q_{\text{flood}} < Q_{\text{ebb}}$ because Q_{ebb} contains, besides the tidal prism, the river run-off too. For these reasons, the ebb channels are normally deeper and have a smaller tendency to be choked at the downstream (seaward) end.

In tidal rivers the normal discharge of the river runoff is hampered by the tidal motion. Due to this tidal action the current at the outlet and more upstream even reverses its direction. At all places on the river where the vertical tidal motion is still noticeable, the magnitude of the current varies with the tide.

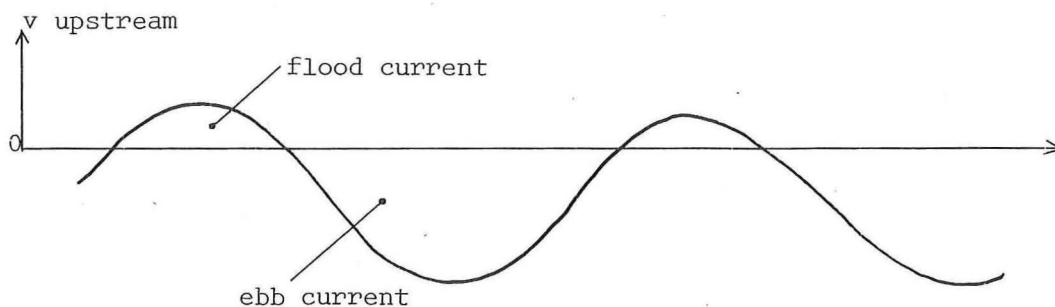

Current variation at the outlet

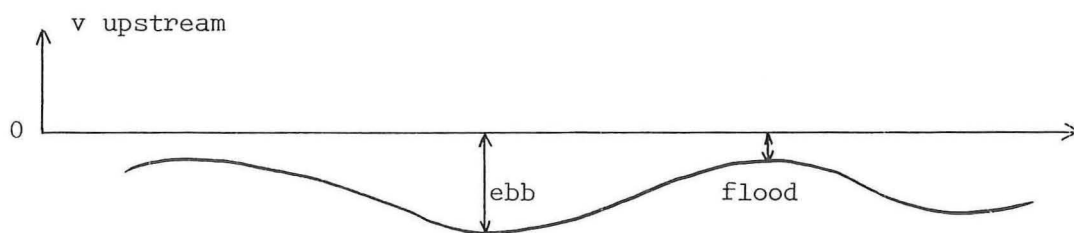
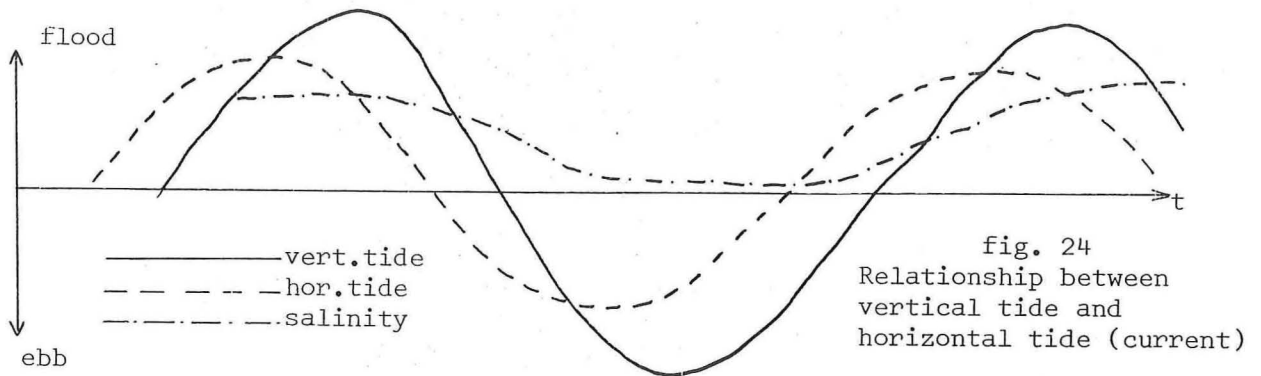

fig. 23

Current variation farther upstream from outlet.

From the theory of long (tidal) waves the relationship between the vertical tide and the horizontal tide (current) can be estimated.

The relationship is indicated in fig. 24 (neglecting the river runoff).



Due to the change in velocity and direction of the current, the normal sediment transport toward the sea is hampered. It depends on the magnitude of the tide and the influence of differences in salinity (density) of the water, have the transport of material (bed load as well as suspended load) will take place. Normally the tidal stretches of the river are wider and deeper than the stretches more upstream, due to the fact that the total capacity is increased as a result of the tidal motion.

An analysis of the equation of motion of the tidal wave shows, that in shallow water the resistance term is relatively large in comparison with the inertia term. Therefore in shallow water, slack water (changing of direction of the current) does occur earlier than in deep water.

Measurement of Water Level on Tidal Rivers

On a tidal river the vertical tide at the river outlet is fully known. Not only the shape as a function of the time, but also the level itself. This level can be related to m.s.l. (determined out of a series of measurements stretching out over one whole month) or to a benchmark that is tied in with the local vertical control system by means of a gage.

Upstream we may want tidegages. Often it is difficult to tie these in with a benchmark as these are often few and far between.

As long as we have not calibrated these gages we can determine the shape of the tidal curve, but we do not know the absolute waterlevel as yet. The purpose of this chapter is to show a way to calibrate these gages with the help of observations done during slack tide.

The principle applied is the following. If it were not for the inertia the watervelocity between two gages would be zero if the Δh were zero. So before slack tide can occur the water has to build up a gradient to counter these inertia forces. The necessary gradient depends on the watervelocity at the moment Δh is equal to zero. The time lag between the moment $\Delta h = 0$ and the slack tide depends on the shape of the tidal curve.

The equation of motion of the tidal wave is

$$\frac{\partial v}{\partial t} + v \frac{\partial v}{\partial x} + g \frac{\partial h}{\partial x} + \frac{g v/v/}{C^2 h} = 0.$$

Close to slack tide the term $v \frac{\partial v}{\partial x}$ can be neglected with respect to the term $\frac{\partial v}{\partial t}$. (v is very small)

When Δh between the points a en b = 0 $\rightarrow \frac{\partial h}{\partial h} = 0$. (see fig. 25)

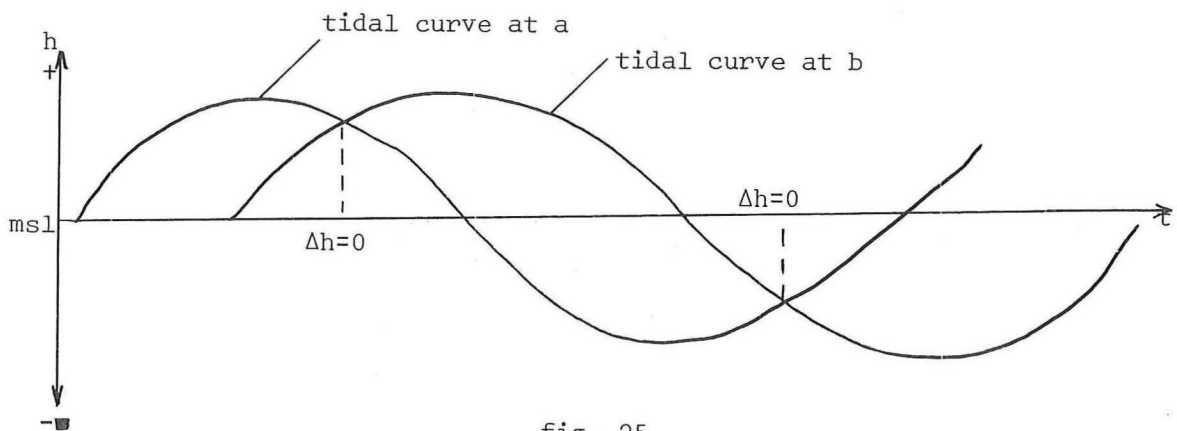

fig. 25

tidal curves at different points

then $\frac{\partial v}{\partial t} + \frac{g v/v/}{C^2 h} = 0$

$$\text{so } \frac{\partial v}{\partial t} = - \frac{g v/v/}{C^2 h}$$

as $v = f(x, t)$ and $\frac{\partial v}{\partial x} = 0$ we can write

$$\frac{dv}{dt} = - \frac{g v/v/}{C^2 h} \quad \frac{dv}{v/v/} = - \frac{g dt}{C^2 h}$$

$$\frac{1}{v} = \pm \frac{gt}{C^2 h} \quad (+ \text{ constant})$$

$\pm vt = \frac{C^2 h}{g}$. This equation gives us the relationship between velocity

and time as a function of $\frac{C^2 h}{g}$ when $\frac{\partial h}{\partial x} = 0$, so when the waterlevel at a is the same as the level at b. When t is expressed in hours the equation transforms into

$$\pm vt = \frac{C^2 h}{3600 g}$$

In the $v - t$ diagram we can draw, for several waterdepths, the functions of $\pm vt = \frac{C^2 h}{3600 g}$. The point where one of these constructed curves is tangential to the original $v - t$ curve, is the moment Δh between a and b is equal to zero.

Suppose we want to calibrate the gage at b and gage at a is calibrated already. We mark the moment we found on the $v - t$ curve on the $h - t$ curve of a. This gives us the moment and the water level when Δh between a and b is zero. In other words this is the point where the tidal curves of a and b have to intersect. We do know the shape of the tidal curve in b but not its line of reference. By moving the tidal curve of b in a vertical fashion we can make it intersect the other curve in the given point. Now we have the line of reference for the gage at b and the gage at b is calibrated.

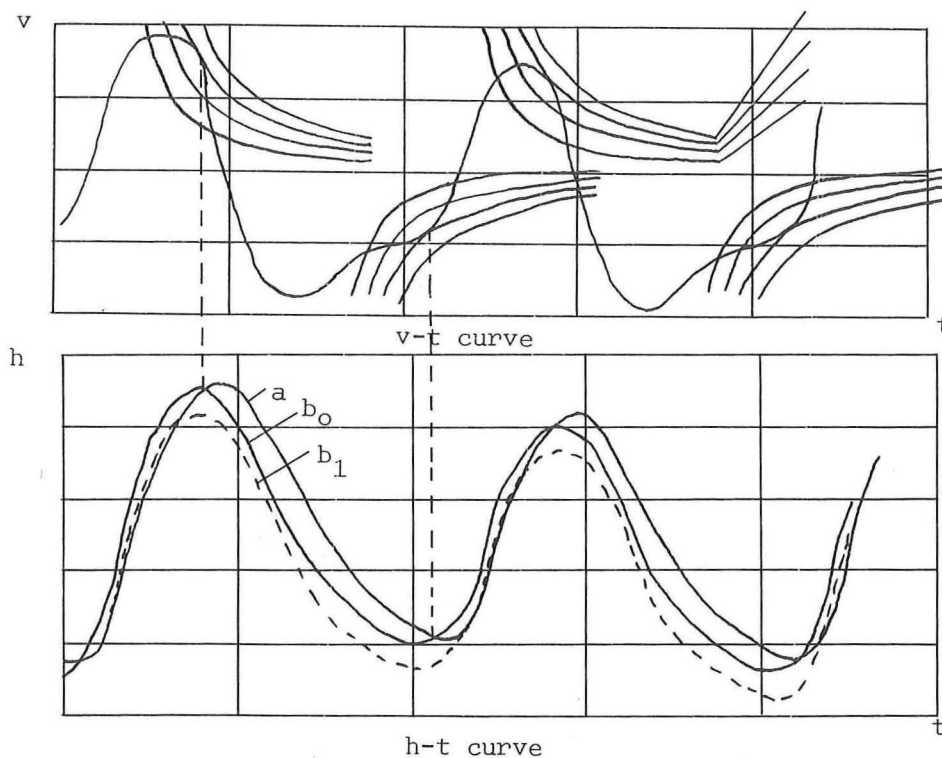

fig. 26
tidal curves

As a first approximation it can be said, moreover, that the time lapse between the moment $\Delta h = 0$ and the moment $v = 0$ (slack tide) has to be the same for high- and low tide. This holds exactly when the shape of the current curve near slack water high tide is the same as the shape near slack water low tide. This condition can be met by moving the b-curve vertically also. This method of approximation does not require the need for a v - t diagram.

In principle the v - t curve necessary for the first method described has to be determined at a point halfway between the two stream gages. If this cannot be done for any reason the velocity curve can tentatively be moved until the timelapses are equal again. If this is not succesful it can be attempted to move curve b with respect to the t-axis to make the timelapses equal.

Density Currents

Density currents arise from differences in salinity (or density) between two interconnected or periodically separated bodies of water.

Suppose we have two bodies of water; one with fresh water and the other with salt water, as shown in the figure.

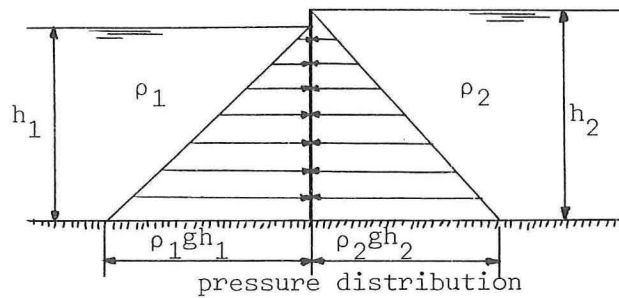

fig. 27

The pressure forces acting on the separation are in equilibrium when

$$\frac{1}{2} \rho_1 gh_1^2 = \frac{1}{2} \rho_2 gh_2^2$$

$$\rho_1 > \rho_2 \quad h_1 < h_2$$

The net pressure distribution at the separation looks like:

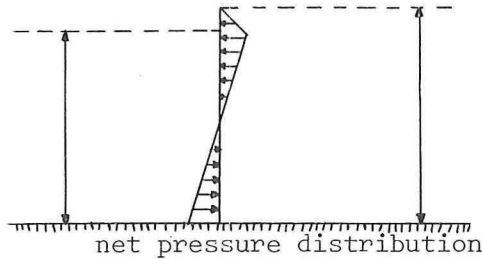

fig. 28

When the separation is removed these pressure differences will result in a flow of salt water near the bed into the section with fresh water and a flow of fresh water near the surface into the section with salt water. After some time the interface between the two fluids of different density will have the following appearance (often called the dry-bed curve):

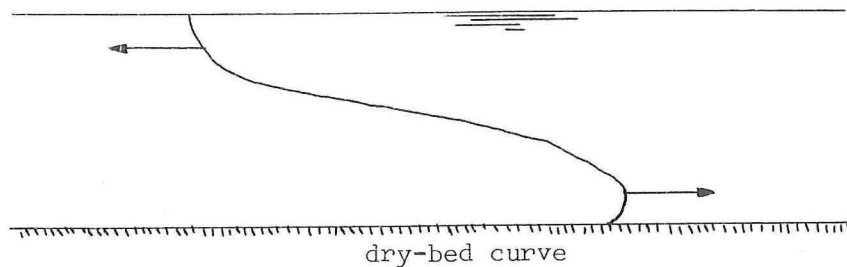

fig. 29

The velocity v of the dry-bed curve is equal to:

$$v = 0.45 \sqrt{\frac{\Delta\rho}{\rho} gh}$$

The distortion near the bed is caused by the bed resistance. The shape of this curve is roughly the same as the shape of the water surface in case of collapse of a reservoir dam. In case of the locks of IJmuiden this velocity will be

$$v = 0.45 \sqrt{0.012 \times 10 \times 10^7} = 0.50 \text{ m/sec}$$

When the salt water wedge reaches the end of a basin it acts like a proper translation wave, thus removing all the fresh water out of the area.

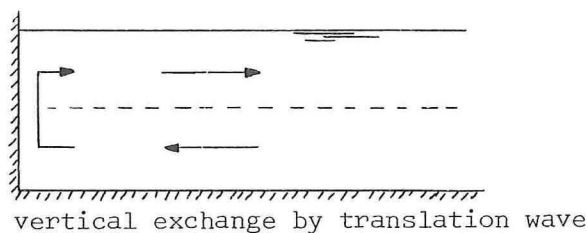
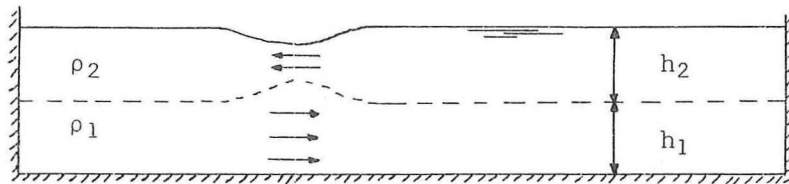

fig. 30

When salt water is injected (slowly) near the bottom of a closed basin filled partly with fresh water we will have, after some time has passed, two layers of water, the top one consisting of fresh- and the bottom one consisting of salt water. When a translation wave is generated in the salt water, the wave will travel with a velocity

$$c = \sqrt{\frac{h_1 h_2 \Delta\rho g}{\rho_2 h_1 + \rho_1 h_2}} \approx \sqrt{\frac{h_1 h_2 \Delta\rho g}{\rho h}}$$



effect of translation wave in bottom layer

fig. 31

From the basic equation of the water motion for the upper layer it becomes clear that a positive wave at the interface should correspond with a negative wave at the surface.

Problems connected with density currents

These problems can be divided into three groups:

- a. Navigation
- b. Siltation
- c. Salt intrusion

ad.a Navigation problems arise when the current experienced by a ship changes direction rather abruptly. Figure 32 shows a situation in which a harbor basin has an open connection with a tidal river or estuary.

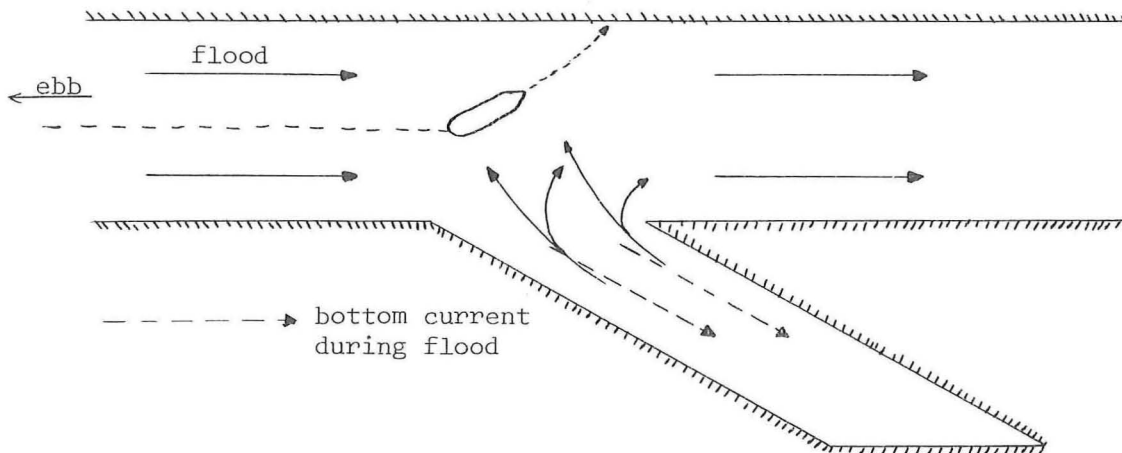

navigation problems due to density currents

fig. 32

When a ship with a relatively small draught is steaming upriver during high tidal it will suddenly experience a cross current created by the relatively fresh water being pushed out of the harbor basin by the inflow of salt water. The effects of this phenomena can be disastrous as the mariners expect a current going into the basin. This can be avoided by briefing the local pilot service on the situation as was done during the construction of Europoort.

ad. b Siltation and for sedimentation occurs in harbor basins adjoining to the river and upstream. Upstream, the salt water wedge shown in fig.

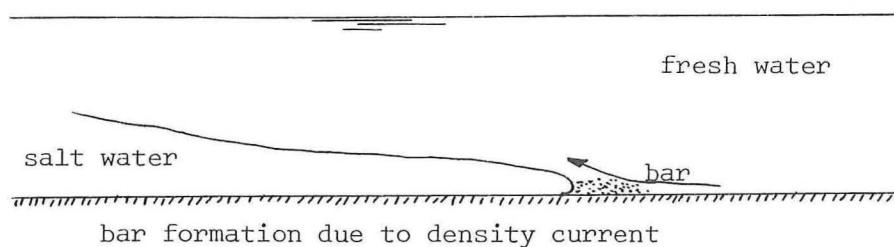

fig. 33

will slow down the water velocity at the bottom to such an extent that the bedload will settle out and form bars in the river. In the harbor basin the heavily silt-charged salt water is carried into the relatively tranquil basin during the flood, and deposition of the suspended material will occur. During the ebb the velocities will not be high enough to bring this settled material into suspension again. Because the fresh water (which has filled the basin during the ebb) is forced out by the salt water, the quantity of silt-laden bed-water entering the basin is much larger than is required to fill the tidal prism. When the basin is very long the salt water wedge will not be able to travel the whole length of the basin and back, so a complete exchange of water will not occur. This depends also on the length of time salt water is present at the entrance of the basin. Short basins, however can experience several complete exchanges depending on the variations in salinity during one tide, with each exchange resulting in a new deposition of material.

The volume of silt entering the basin depends on its concentration. When we have a harbor with a width of 300 m, a length of 3000 m, a h_{\max} of 10 m, the silt water having a silt concentration of 0.4 kg/m^3 flowing in and a concentration of 0.1 kg/m^3 flowing out and one full exchange per tide, then the quantity of dry material being deposited per day is

$$\frac{2 \times 300 \times 3000 \times 10 \times (0.4-0.1)}{1000} = 0.6 \times 10^3 \text{ tons/day}$$

This siltation caused by the so called vertical exchange of the water accounts for practically all the siltation in the basin. Some additional siltation occurs because of two other phenomena. First, an eddy is likely to come into being at the entrance of the basin (see fig. 34), throwing water into the (tranquil) basin, out of which silt can settle out before the water flows out again.

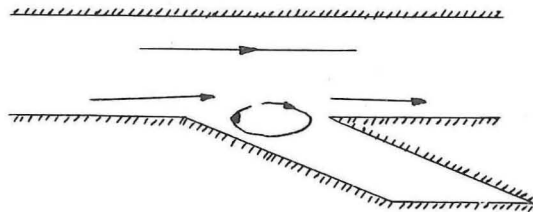

eddy formation at basin entrance
fig. 34

Second, we have flocculation of suspended material present in the fresh water while this is being pushed out of the basin. Clay particles in fresh water tend to shed positive ions after which the water molecules show their dipole character, thus bonding a layer of water around each clay particle. At the outer boundaries of this layer of fixed water system the potential is still negative and therefore the clay particles are prevented to come together and to settle out.

The salt water entering the basin (the same will happen on the river) has a relatively high concentration of positively charged ions (N_a^+ etc.). This will neutralize the negative charge of the suspended material to some extent after which flocculation of the clay particles will occur.

So far we have neglected the mixing of the fresh- and the salt water. Of course there will be mixing; the rate of it depending on the ratio river runoff to tidal prism. Complete mixing occurs when:

$$\frac{QT}{V} < \frac{1}{10}$$

QT = runoff during one tidal period

V = tidal prism in m³

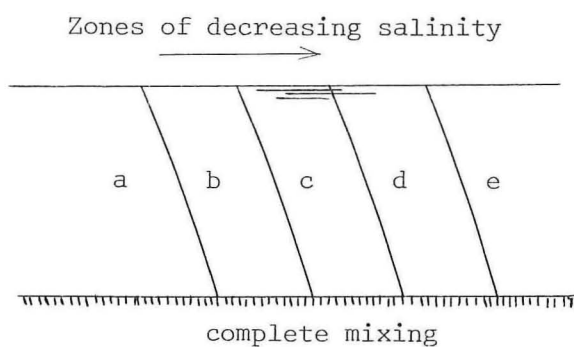

fig. 35

Partial mixing when:

$$0.1 < \frac{QT}{V} < 1$$

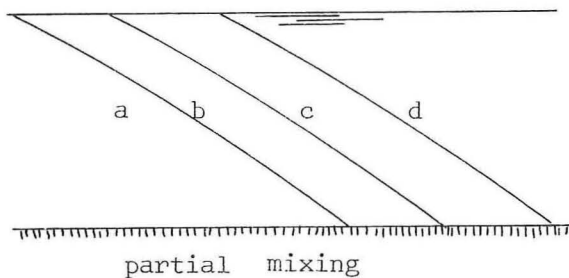
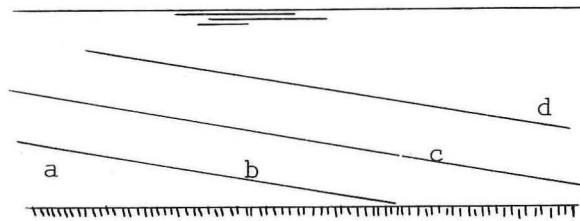

fig. 36

Little mixing when:

$$\frac{QT}{V} > 1$$



Little mixing

fig. 36

almost horizontal layers of different salinity.

Remedies against siltation.

1. Small (short) harbor basins experience a lot of siltation caused by the eddy formation at the entrance. Reshaping the entrance from a to b, shown in fig. , will often result in a reduction of the eddy and in the accompanying siltation.

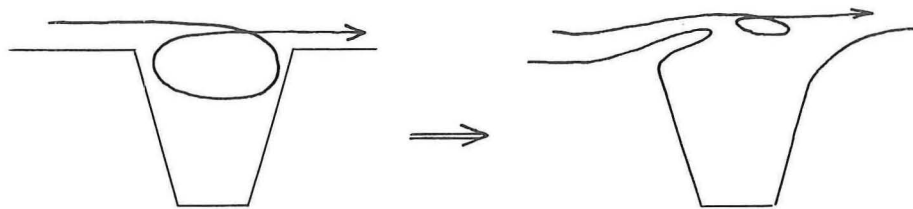

reduction of eddy formation

fig. 37

2. Long harbor basins experience less siltation when the entrance to the basin is made narrower. The velocity of a density current only depends on the pressure difference caused by the difference in salinity, so now the amount of salt, silt-laden, water entering the basin per unit of time has been decreased. When the basin is so long that originally not (or just barely) a full exchange of water was reached, the ratio of siltation in the new situation compared with the original one will be the same as the ratio b_1/b_0 .

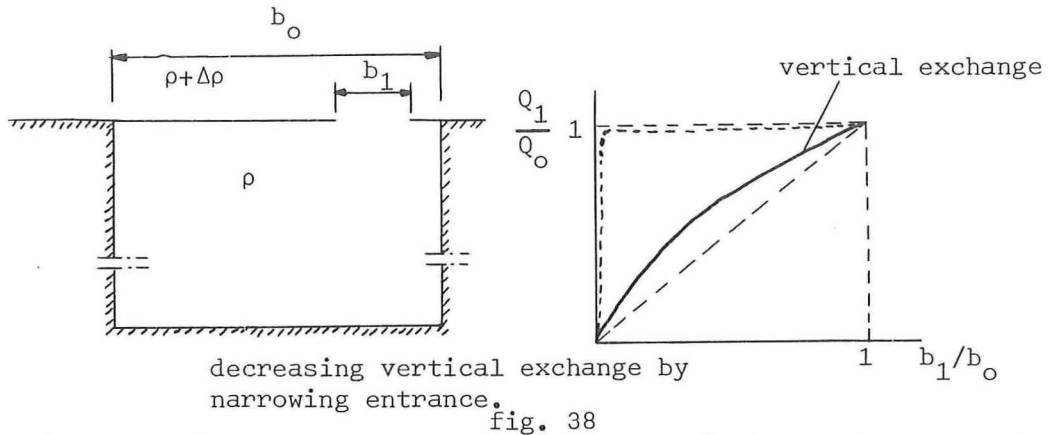

A second siltation deterrent for a long basin is a bubble curtain. The air will induce a water current shown in fig. 39. When this new current has a velocity at least as large as the velocity of the salt water wedge approaching the basin, the only salt water entering will

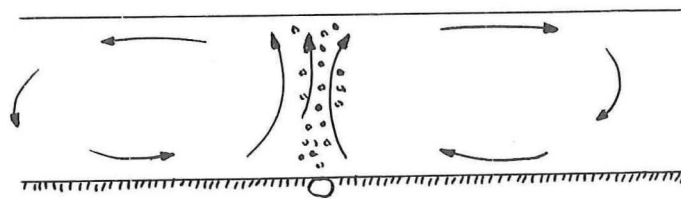

bubble curtain
fig. 39

the amount necessary to raise the water level plus the effect of the mixing in the rising current.

ad c. Salt water intrusion is always a problem in case of locks connecting bodies with fresh and salt water. When we take IJmuiden again we have locks with the dimensions $400 \times 50 \times 10$ m and a difference in salinity between both bodies of water of 20 p.p.m. = $0,02 \text{ kg/m}^3$. With each locking operation the amount of salt entering the North Sea Canal will be $50 \times 400 \times 10 \times 0,020 = 4 \times 10^3 \text{ kg}$ or 4 tons.

This intrusion problem can be solved in different ways:

1. Dredging a deep hole behind the lock in the canal that can hold the volume of salt water in the lock. After each locking operation the salt water can be pumped out of the hole and back into the sea.

2. Opening and closing of the doors as fast and as soon as possible as it takes some time to realize a complete exchange of water.
In IJmuiden the velocity of the wedge is $\pm 0,50$ m/sec, so it will take $\frac{2 \times 400}{0,5} = 1600$ sec to get a complete exchange.
3. Bubble curtain (Volkeraksluizen)
4. Each time removing the salt water out of the lock and replacing it with fresh water (Terneuzen).

A numerical example regarding a bubble curtain is given in the section on breakwaters. It should be noted that the necessary velocity of the induced current in case of prevention of salt water intrusion is considerably less than the in case of the bubble curtain serves as a pneumatic breakwater.

Additional information on this subject can be found in the following references:

1. Abraham E. v.d. Burgt
"Reduction of salt water intrusion in locks".
2. R.W.S.
"Luchtschermen in schutsluizen".

f 5 A

BREAKWATER DESIGN

Contents

Chapter I

Some aspects of breakwater or Harbor Moles

1. Functions, requirements and shapes
2. Advantages and disadvantages of the three types of fixed constructions
3. Method of optimal design
4. Probability (frequency) of exceedance of a certain waveheight

Chapter II

Mound breakwaters

1. Construction of a mound breakwater
2. Building of breakwaters
3. Calculation of the weight of armour units according to the method of optimal design
4. Numerical example

Chapter III

Vertical breakwaters

1. Introduction
2. Wave impact and resulting vibrations
3. Construction of vertical breakwaters

Chapter IV

Some special types of breakwaters

1. Pneumatic breakwater
2. Floating breakwater

Chapter I

Some aspects of Breakwaters or Harbor Moles

1. Functions, requirements and shapes.

The functions of breakwaters and harbor moles can be

- A. Protection against waves (IJmuiden)
- B. Guiding of current (Abidjan)
- C. Protection against shoaling (IJmuiden, Abidjan and Maracaibo)
- D. Provision of a dock or quay (Assab, Takoradi)

The requirements that depend upon its function are determined by the following characteristics:

- A. Permeability, crest level and energy absorbing capacity
- B. " " " " roughness
- C. " " " "
- D. Nature of its construction at lee-side.

Depending on its function the breakwater or harbor mole can be of one or more of the following types:

- a. Pneumatic breakwater; an air bubble curtain that forces the waves to break

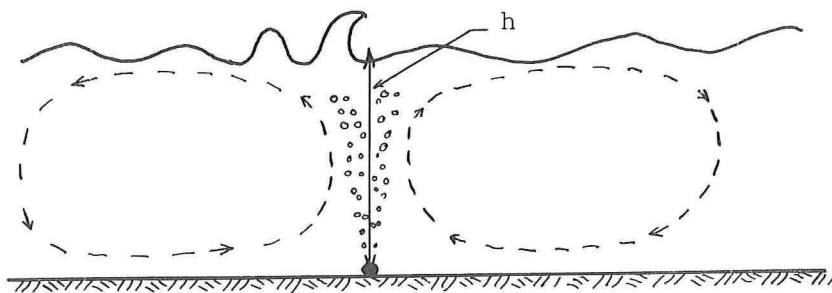

pneumatic breakwater

fig. 40

- b. Resonant breakwater; in the harbor entrance basins acting as resonators decrease the height of the waves penetrating into the harbor (Dunkirk, in front of its lock system).

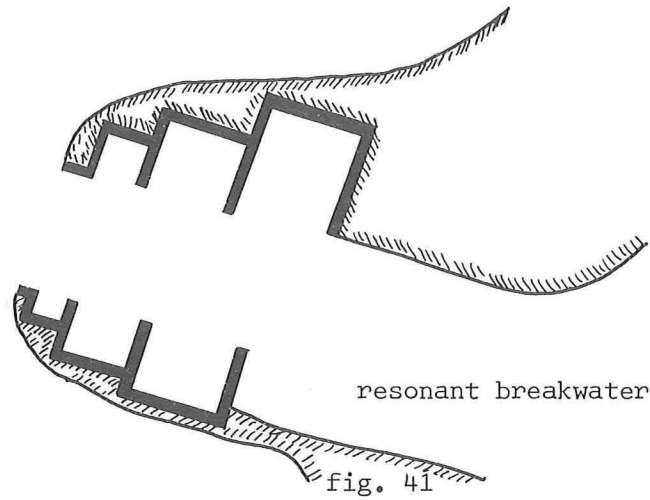

c. Hydraulic breakwater; a waterjet at some distance under the water surface forcing the waves to break.

d. Rigid floating breakwater; which consists of some floating and anchored construction.

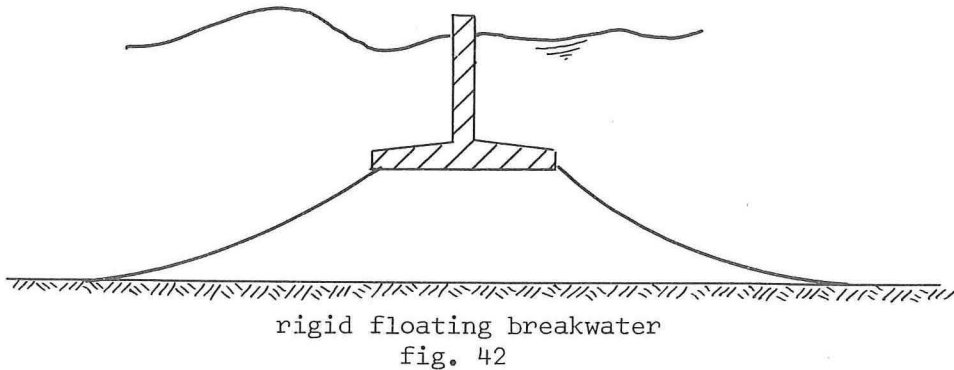

e. Flexible floating breakwater; which consists of a flexible construction of sufficient size to dampen the wave height by dissipating part of its energy.

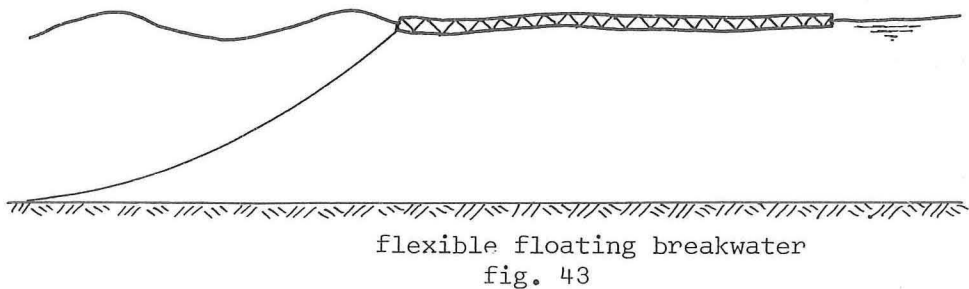

f. Mound breakwater; consisting of a body of sand, gravel, quarry run and rock, covered with one or more layers of armor units consisting of heavy rock (boulders) or concrete blocks of various shapes.

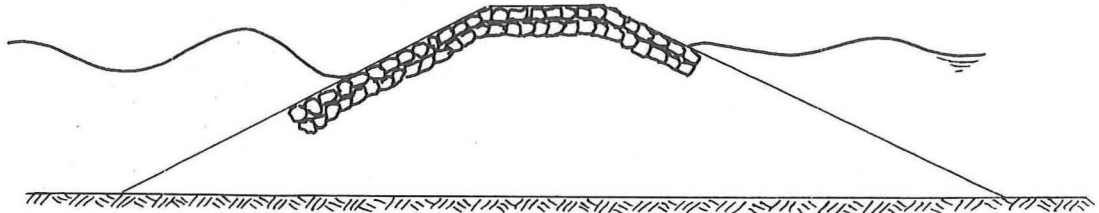

mound breakwater

fig. 44

g. Vertical breakwaters; formed by concrete blocks or caissons.

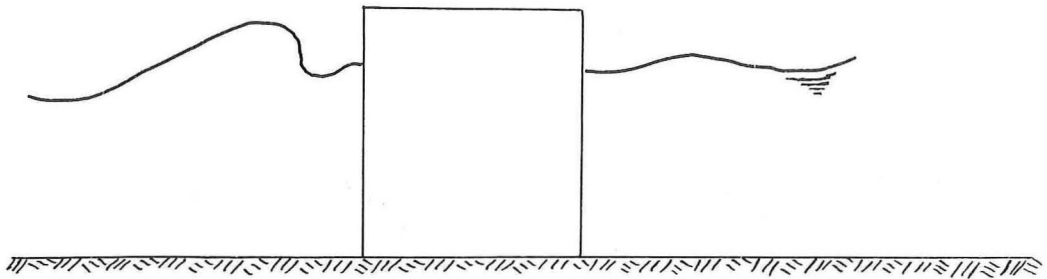

Vertical breakwater

fig. 45

h. Composite breakwaters; consisting of a mound breakwater topped with a vertical one.

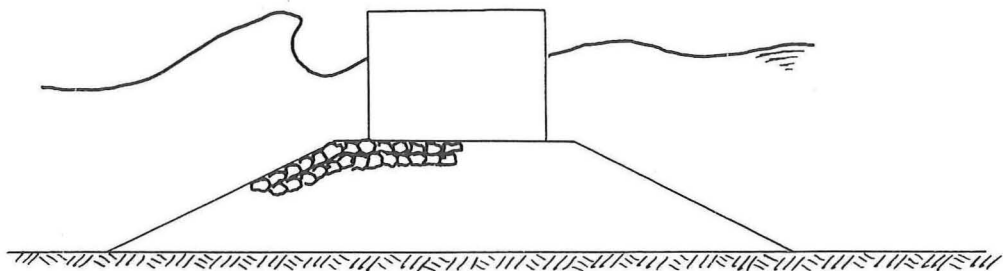

composite breakwater

fig. 46

Breakwater types a, c, d and e are more or less temporary constructions. Types b, f, g and h are mostly permanent constructions. Types f, g and h are the only ones that can be used for current guidances and against shoaling. These types will be discussed more completely.

2. Advantages and disadvantages of the three types of permanent constructions.

- * In deep water the mound breakwater requires vast quantities of material.
- * The vertical breakwater is, because of its monolithic character, sensitive to subsidence of the subsoil while the mound can follow this movement to a large extent without causing problems.
- * The damage caused by wave heights exceeding the design waveheight (H_{SO}) is more extensive in case of a vertical than in case of a mound breakwater. When with a vertical breakwater, only one wave exceeds the H_{SO} , it will probably not have a disastrous effect, but it will cause extensive damage. To resist this, the vertical breakwater can be reinforced with vertical bars such as rails.
- * A mound breakwater can stand a lot of damage before the construction has to be considered a total-loss and ceases to function.
- * The shape of the construction has a lot to do with the forces the waves can exert on it. A wave breaking on the slope of the mound breakwater will lose much of its energy in breaking and, moreover, the wave will have the possibility of run-up on the slope, thus losing its kinetic energy. A vertical impervious wall can cause standing waves, thus doubling the original H . This will make the wave steeper and more susceptible to breaking, thus causing large volumes of water to crash against the wall. (A non-breaking standing wave will have its anti-node at the wall thus horizontal water velocities at this point are zero). Breaking will cause very high forces of short duration (wave impact) in the order of magnitude as high as $100 \times 10^4 \text{ N/m}^2$ in case of a vertical wall. Mound breakwaters are not likely to induce forces larger than $40 \times 10^4 \text{ N/m}^2$. If, depending on the seasons, the periods of workable weather are relatively short, a breakwater made out of caissons can have a construction speed advantage.
- * The diffraction pattern at a harbour entrance protected by two vertical breakwaters can become so unfavorable due to reflection, that the objective of lowering the H will not be met.
- * The composite breakwater has both the advantages and disadvantages of the mound and vertical type. An extra disadvantage of the composite breakwater is that waves can be forced to break on the slope of the mound and so exert very high forces (impact) on the vertical wall of

the superstructure. For this reason few of this type are being build now; it is considered "asking for trouble".

3. Method of optimal breakwater design

A breakwater design is optimal when the design results in a construction which meets the demands while having the lowest total costs.

These total costs are composed of the initial building costs, the capitalized damage costs, and economic losses due to damage of the construction. A breakwater will, sooner or later, experience damage because off-shore conditions are determined and described on the basis of statistics. If no damage would ever occur, it would mean that the construction is over designed.

Economic losses could be defined as damage to harbor equipment and losses caused by disruption of normal harbor operations because of damage to, or failure of the breakwater.

The design of the breakwater includes the following points:

- a. Selection of type of construction
- b. Determination of its dimensions

The design criteria depend on:

- a. Function of the breakwater
- b. Maximum allowable (one-time) damage.

For every design we can determine a maximum wave impact or wave-height at which it will suffer no damage. Because off-shore conditions can best be described as a stochastic process, we will always have the probability that this design load or H_{SO} will be exceeded. The fact that the construction will suffer damage has to be accepted. When the design load or design wave is small, the initial construction costs will be low, but the damage to be expected will be considerable. Increasing the design wave or design load will reduce the future damage because the probability of exceedance of the H_{SO} (and so the damage) will become less.

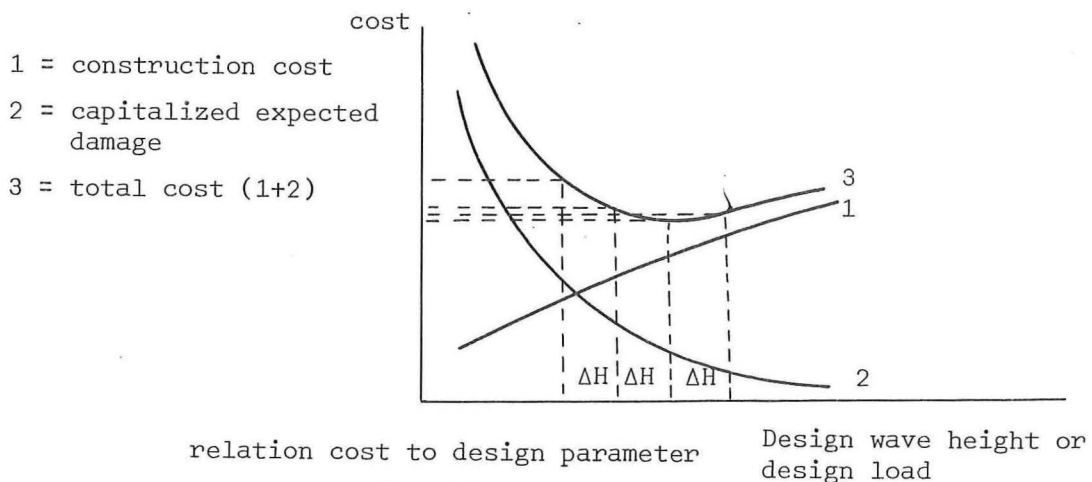

fig. 47

Sometimes it is possible to determine the minimum of the total cost function analytically, but, in general, it is easier to do this graphically. The advantage of this last approach is that we get a good idea of the function in the neighborhood of its minimum. This is of the utmost importance because this gives us an idea of the amount of money that will be "wasted" when we select the wrong H_{SO} or design load. This amount of money may be called the "regret". The main reason for a wrong selection can be that the available data are not entirely correct, which causes the curve 2, above to be incorrect.

The shape of curves 1, 2 and 3 is usually about the same. The construction costs increase when the H_{SO} or design load is increased. At the same time, however, the capitalized damage decreases progressively, especially since the probability of exceedance of the H_{SO} or design load decreases in a progressive manner.

The total cost curve always has a relatively steep slope to the left of its minimum as compared to the part on the right. The consequence of this is that the "regret" is more when the H_{SO} is ΔH too small than when it is ΔH too large. Therefore, it is always advisable to be on the safe side when the H_{SO} is determined.

The determination of the total cost of the breakwater according to the method described above is called the optimisation problem.

The following four factors play an important part:

1. The frequency of occurrence of different offshore conditions.
2. The relationship between offshore conditions (especially wave conditions) and the behavior of the structure.
3. The relationship between design wave or design load and construction costs.
4. The relationship between offshore conditions, design wave of design load and expected damage.

In the chapters II and III we will discuss the design of breakwaters more deeply, starting with the rubble mound breakwater, followed by the vertical one.

4. The frequency of exceedance of a certain waveheight

With the help of the short term (micro) and long term (macro) distributions of waveheights the resulting probability of the exceedance of a certain waveheight can be determined according to the following procedure (see also: "Some aspects of the design procedure of maritime structures" SII-5, Int. Nav. Congress, Paris, 1969 by A. Paape).

In a period of N successive waves let the frequency (probability) of exceedance of a wave height, H_p , be $p(H)$ (the short term distribution). The probability that during a series of N waves the height H_p is exceeded one or more times is the encounter probability E_1 .

$$E_1 = 1 - | 1 - p(H_p) |^N$$

If the series of N successive waves and duration D is characterized by the significant wave height H_s with a probability of $q(H_s)$ times per year (long-term distribution) and the structure has an assumed lifetime of L years. The encounter probability of occurrence of H_s during this lifetime is:

$$E_2 = 1 - | 1 - q(H_s) |^L$$

The encounter probability of a wave height H_p as a result of the wave condition H_s during the lifetime L is

$$E = E_1 \cdot E_2$$

In this procedure the history of the storm has not been considered. Paape discusses an example in which this history has been taken into account. The difference in the final encounter probability is not significant.

The computation of this encounter probability is important for structures such as light towers, oil rigs and probably vertical breakwaters; where a single wave can cause serious damage.

Chapter II

Mound Breakwater

1. Function of a mound breakwater

A typical cross-section of a mound breakwater is the following:

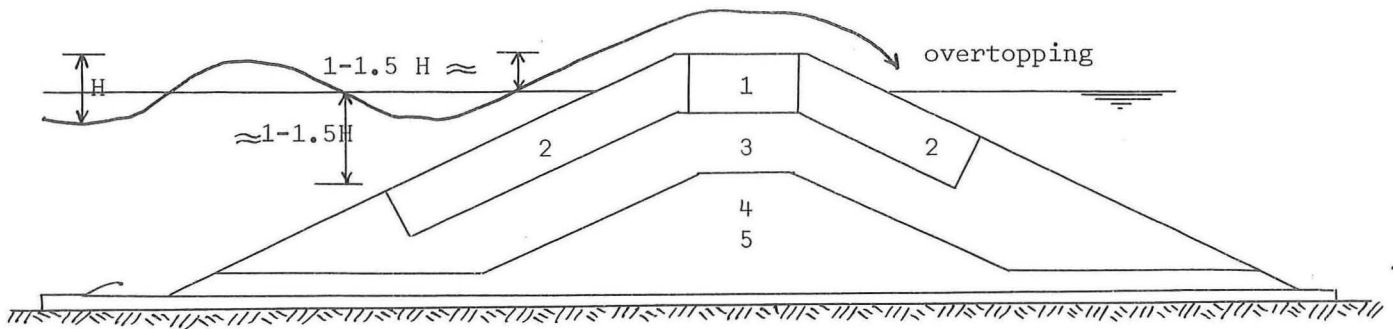

cross-section mound breakwater

fig. 48

1. (Possible) cap construction
2. Armor units
3. Second-class stones
4. Small stones or quarry-run
5. Filter layer

Parts 1 and 2 form the protection against wave attack. The cap construction can be omitted; the crest can be made of armor units also. A cap construction is made when the crest has to be able to carry traffic such as maintenance equipment or when a support is necessary for the outside armor units when these are artificial concrete blocks with a high K-value (see below). The armor units (boulders or concrete blocks) should be sufficiently heavy to be able to withstand the wave forces. When the breakwater is relatively low, overtopping will occur and the inside will also be attacked. Above the water level this attack will be just as heavy, or even heavier than the attack on the outside. The reason for this is that the armor of the inner slope is attacked more heavily than the armor on the outside because on the outside the wave attack is directed more perpendicular to the slope.

Therefore, it is advisable to test each breakwater design in the laboratory. When the crest is high enough to prevent serious over-topping the cover stones on the inside can be lighter.

The cover layer is usually composed of two (sometimes three) layers of armor units. Under the cover layer of heavy stones, smaller and lighter stones can be applied, with a weight of 1/10 to 1/20 of that of the armor units. The only requirements of these second-class stones are that they cannot be drawn through the cover layers by the water motion, and secondly, that they are sufficiently stable during construction.

If this last condition can't be met, special construction methods have to be applied as will be discussed later. The core of the breakwater usually exists of quarry run. This material has the advantage that it is almost impermeable for sand, which is important when the breakwater has to stop the longshore transport also.

When the breakwater is build on a sandbed, special precautions have to be taken to prevent the sand from being eroded out from under the breakwater by the water motion inside the breakwater. The wave action is responsible for pressure fluctuations inside the breakwater. This results in a water motion and the accompanying erosion causing undesirable settlement of the breakwater. To counteract this, a filter construction is necessary which will retard the water velocity to such an extent that the sand will remain in place. The necessary filter construction can be designed with the help of model tests. This is not an easy matter as it is difficult to translater the results of model tests properly to the prototype. In these tests the pressure fluctuations at the boundary between stones and sand are determined first. Precautions should be taken that the proper scale laws for the permeability of the stones are applied. With these pressure gradients and the permeability of the stones, the filter velocities are calculated or determined from tests. Especially in this last case, and when the tests are executed on full scale, reliable results can be obtained. Normally the maximum pressure gradient is used when computing velocities within the filter.

The filter can exist of gravel or fascine mattresses. It is possible, also, to use a woven cloth of synthetic material as long as it is sand-tight but not water-tight. When it is water-tight, the pressure fluctuations can result in a quick-sand condition which will still cause instability of the breakwater.

On the cloth we will first have to put a layer of gravel or reed to prevent the larger stones from puncturing. The filter layer is normally extended beyond the toe of the breakwater to avoid scouring. In order to prevent the filter layer itself (beyond the toe acting as a bottom protection layer or revetment) from being attacked too much by the wave action in shallow water, a layer of heavier stones should be placed on this filter layer outside the toe of the breakwater.

2. Construction phases of the breakwater

Often it is impractical to construct a breakwater in the dry using cofferdams and pumps. As a result of the continuous wave action and current it is possible (dependent on the waterdepth) that the finer material of the breakwater (mass varying from 10 to 200 kg) will scour if not protected. In this case the breakwater cannot simply be built layer by layer, starting with the core. One way to do this is shown in the following figure. The material is put in place in the numbered sequence.

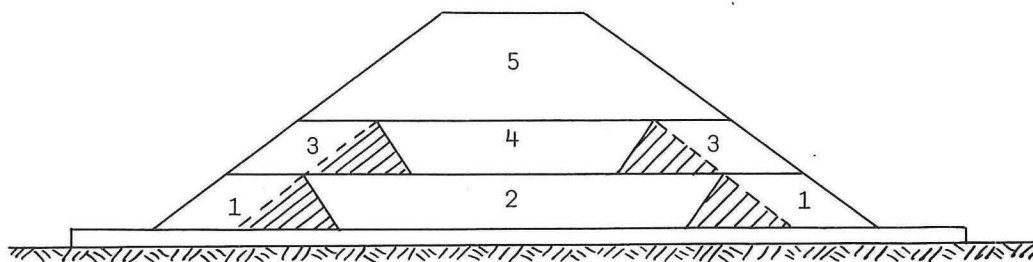

possible construction sequence of mound breakwater

fig. 49

The disadvantage of this system is that the cross hatched areas contain the heavier stone which is more expensive. However, this is acceptable when the cost difference is not too great.

Another possibility, saving on the heavier stones but not on labor is as follows:

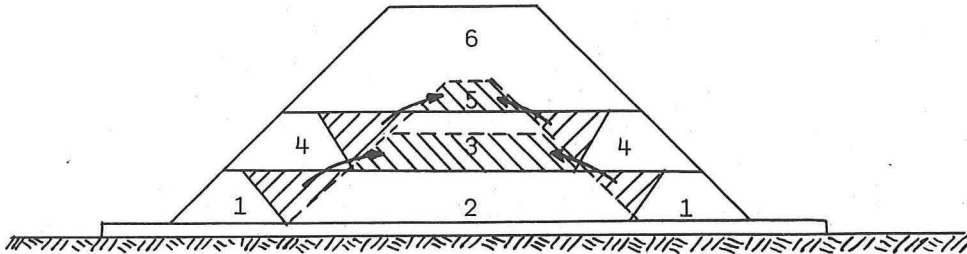

possible construction sequence of mound breakwater

fig. 50

First the dams (1) are constructed. Between these two the finer material such as quarry run is dumped. Then the cross-hatched sections are dug out and backfilled with heavier material as in (1) after which dams (4) are constructed consisting of the same, or heavier, units than in (1). The material that has been dug out is used for the core in section (3) etc. The excavation has to be done during calm weather with a crane which can be situated on a platform on legs (IJmuiden) which enables the crane operator to determine the exact position of the bucket.

The recently built breakwaters for the harbor entrance of Hook of Holland consist of:

- a. Noorderdam, which is basically an extension of the existing Noorderhoofd.
- b. Zuiderdam, which is connected with the closure dam of the Brielse gat.
- c. Separation dam between the Rotterdamse Waterweg and the new Caland Canal which is the entrance to Europoort.

To meet the demands of the shipping industry regarding guidance of current, reduction of wave height, and marking of entrance channels, it was necessary to build the Zuider- and Noorderdam up to a level of MSL + 2 m. The southern part of the Zuiderdam could be made out of sand, because the small slope of the sea bottom forces the higher waves to break before they reach the breakwater.

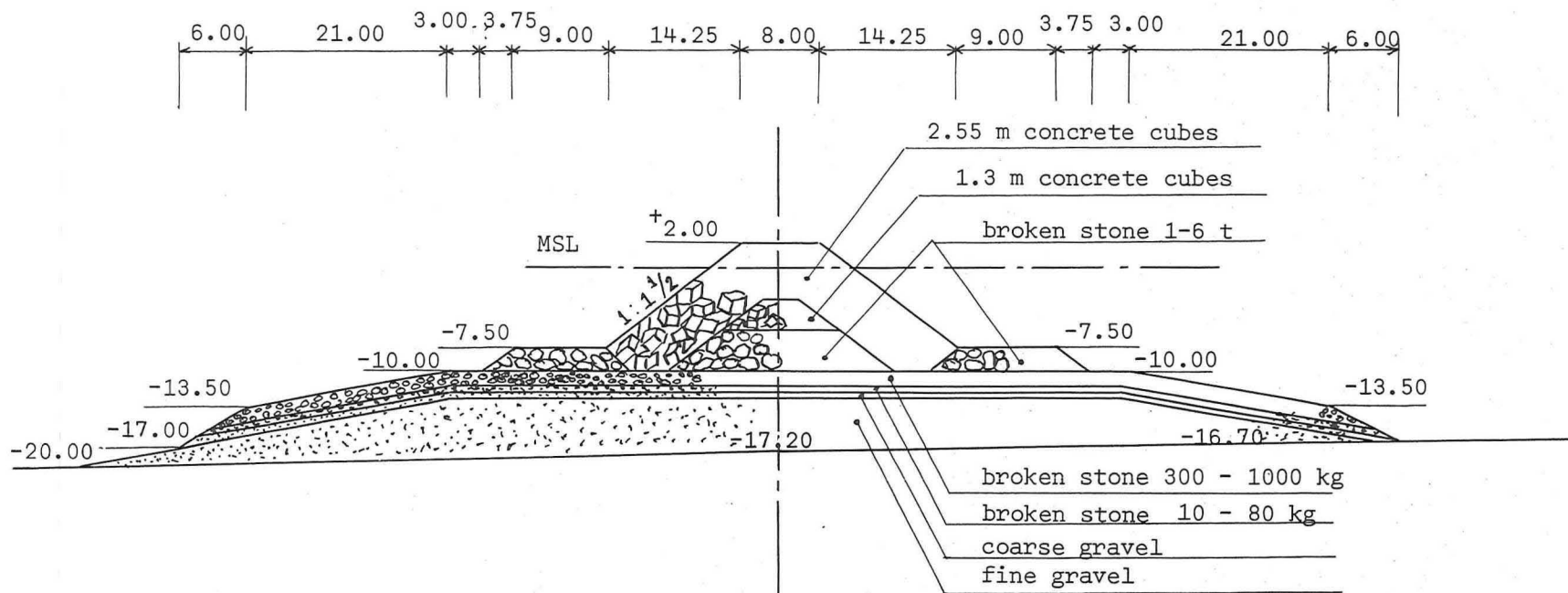

fig. 51

CROSS SECTION NOORDERDAM

HOOK OF HOLLAND

schaal 1:600

The northern part of the dam is built in deeper water and the harbor complex behind it is protected by a second defense system between the breakwater and the complex.

This implies that mass overtopping will occur and that, consequently, the crest and the inner side of the breakwater will be subject to severe wave attack. To reduce the overtopping substantially the crest would have had to have been raised to a level of at least MSL + 7 meters. This appeared to be an uneconomical solution in view of the increase in cross-sectional area and the relatively expensive core material. Therefore the crest height was kept at a level of MSL + 2 m. Offshore conditions and economical reasons dictated the adoption of the steepest possible slope which turned out to be 1.5 : 1. To reduce the resulting high rate of wave reflection it was recommended to make use of aprons and a cover layer with a high degree of porosity.

The following types of breakwaters have been considered and tested in the laboratory:

- I. Caissondam (vertical breakwater)
- II. Composite breakwater
- III. Mound breakwater with a cover layer of pell-mell placed concrete blocks.

Type III was finally selected because this type required the least complicated construction method. This method would also suffer the least amount of down-time because of weather conditions.

The construction phases of the northern part of the Zuiderhavendam in Hook of Holland was executed as shown in the next figure:

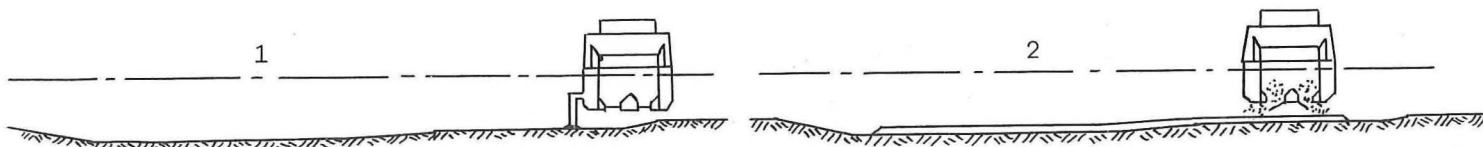

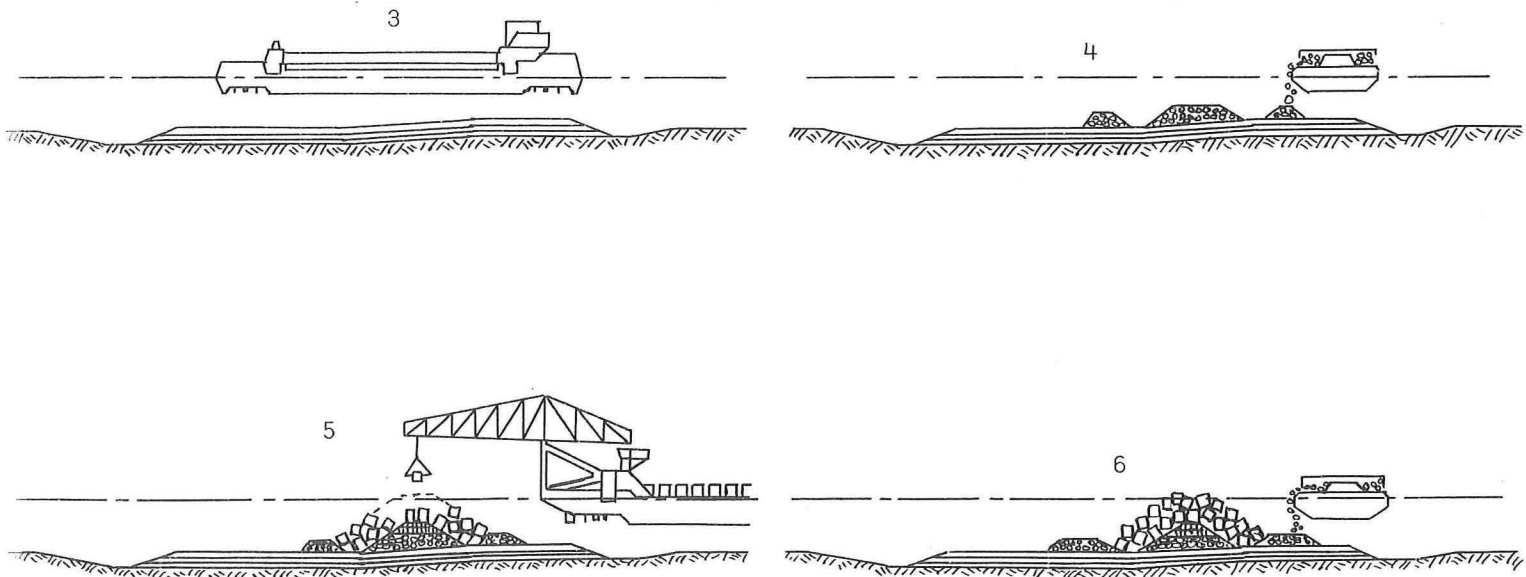

3. Dredging to remove silty material
4. Construction of 1st filter layer
(sea gravel)
5. Construction of 2nd filter layer
(alluvial gravel)
and small rock
6. Placing boulders 1 - 6 tons
7. Placing armor units
8. Placing apron consisting of boulders
1 - 6 tons

construction phases
Zuiderdam

fig. 52

As another example the development - and history - of the design of the breakwater of IJmuiden will be described. The various cross sections are given on figures ① through ⑨.

- ① The original cross section. Failure occurs due to damage on the harbor side of the crest (inner slope).
- ② In order to avoid this, these armor units have been removed. In order to protect the much lighter rock blocks of one to five tons under the first cover layer, these rock blocks have been penetrated with asphalt.

Due to the typical lay-out of the moles, waves will reach the inner slope of the mole with crests almost perpendicular on the breakwater ("strijkgolven" in Dutch), with the result that the armor units on the inner slope just below the water surface are attacked.

- ③. In order to avoid the necessity of penetration, the cap construction of rock asphalt has been extended below water level. When the armor units on the inner slope move (due to the oblique waves) the stability is endangered.
- ④. In order to overcome these difficulties, the entire inner slope is made from rock asphalt. The disadvantage of this solution is however, that the layer can be lifted due to pressure differences across this layer. This layer, therefore, has to be of sufficient thickness and weight.
- ⑤. For this reason the inner slope is not covered completely with rock asphalt, but only in spots. These spots increase the stability sufficiently without the danger of uplifting.
- ⑥. In order to avoid or to decrease the uplift forces the cover of rock asphalt has been extended to the inner and outer slope of the breakwater.
- ⑦. Since this breakwater does not suffer from overtopping it can be lowered also.
- ⑧. In a later stage of this design development, the crest has again been made higher in order to enable the transport of construction materials over this crest to the cranes standing at the construction area at both sides of the breakwater.
- ⑨. This figure shows the savings in material (by the double hatching).

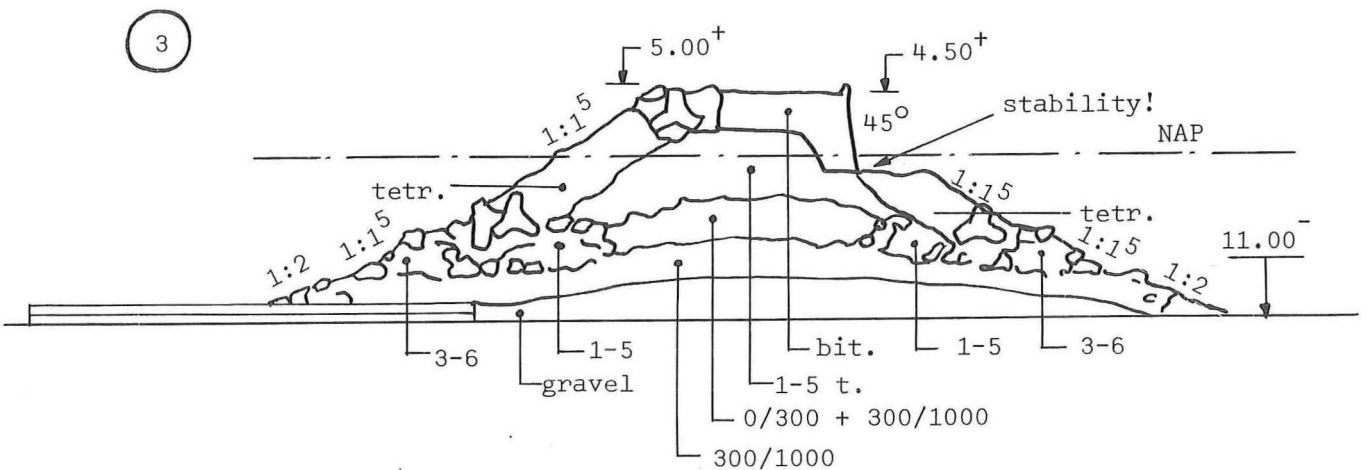
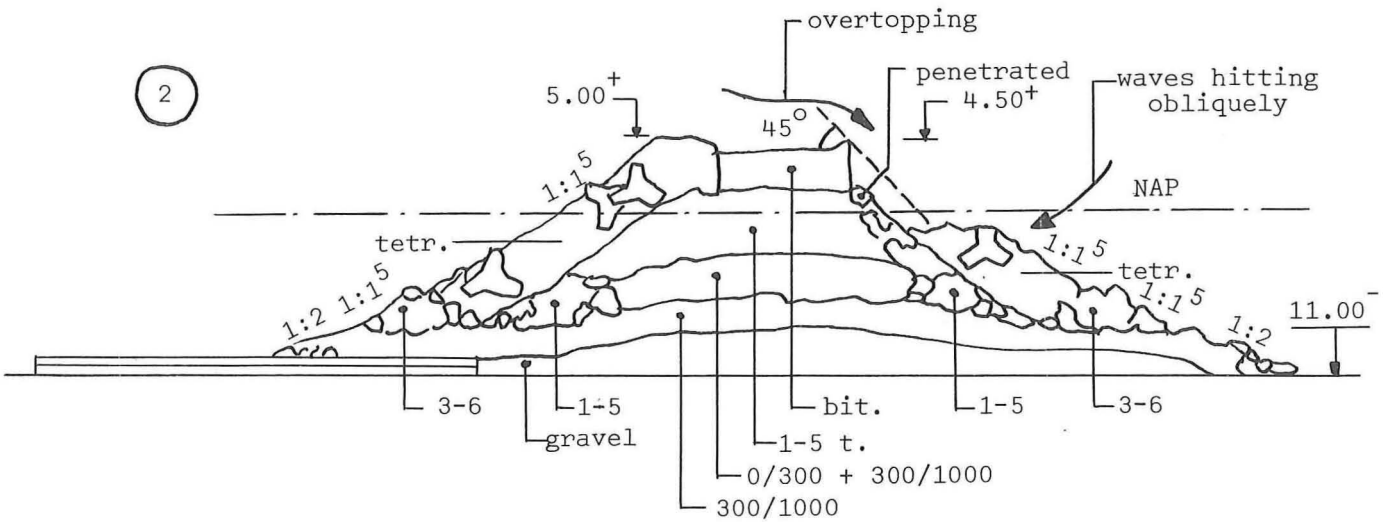
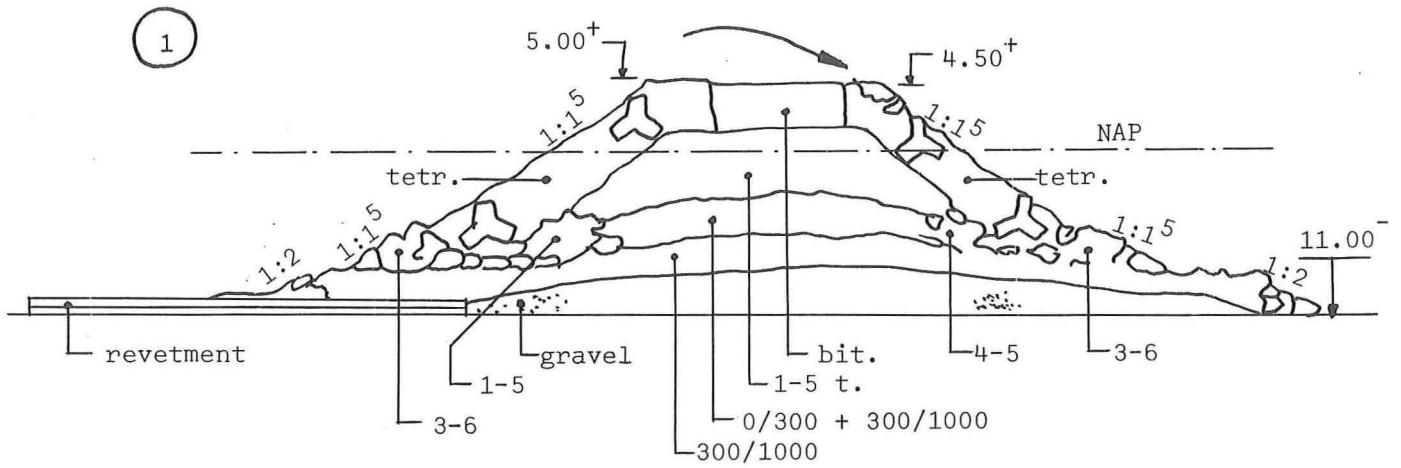

4

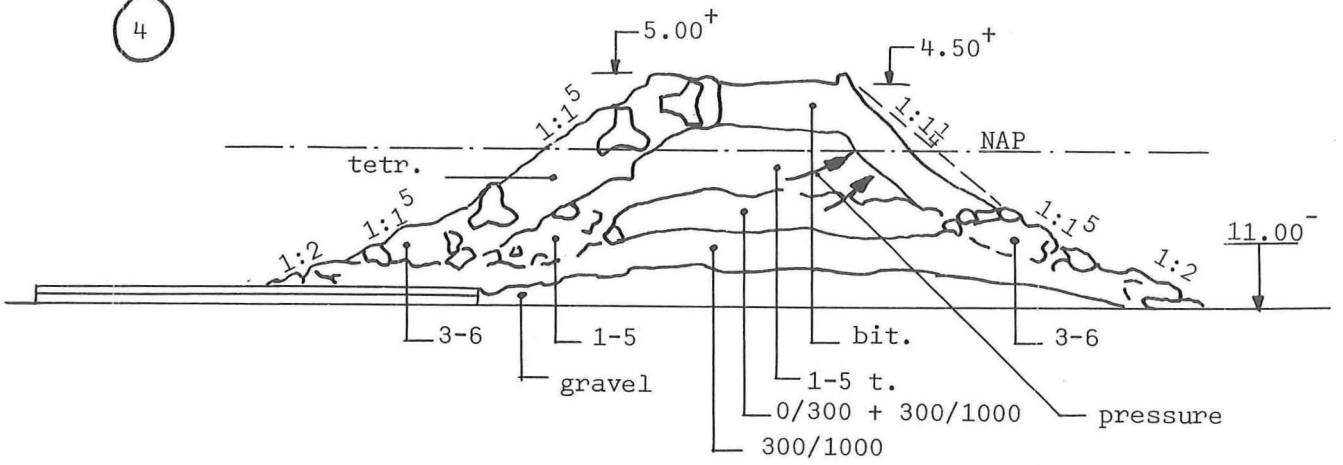

5

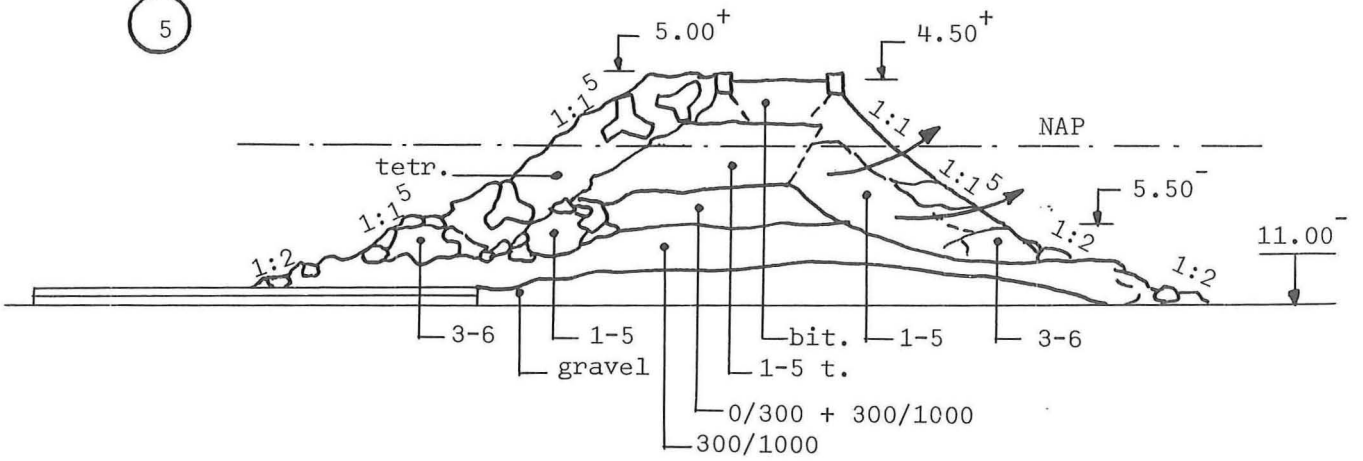

6

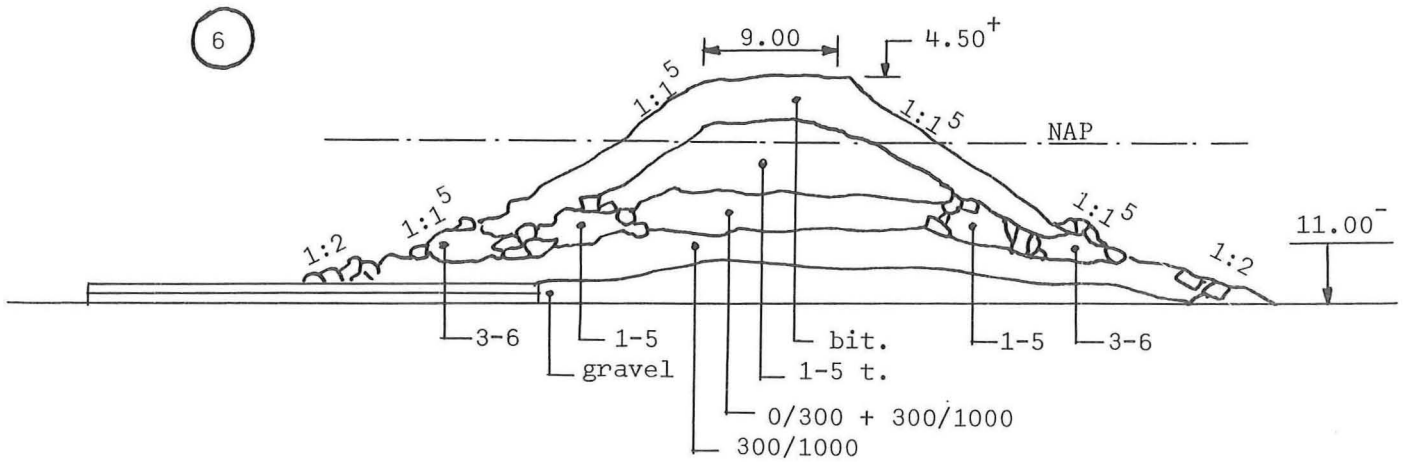

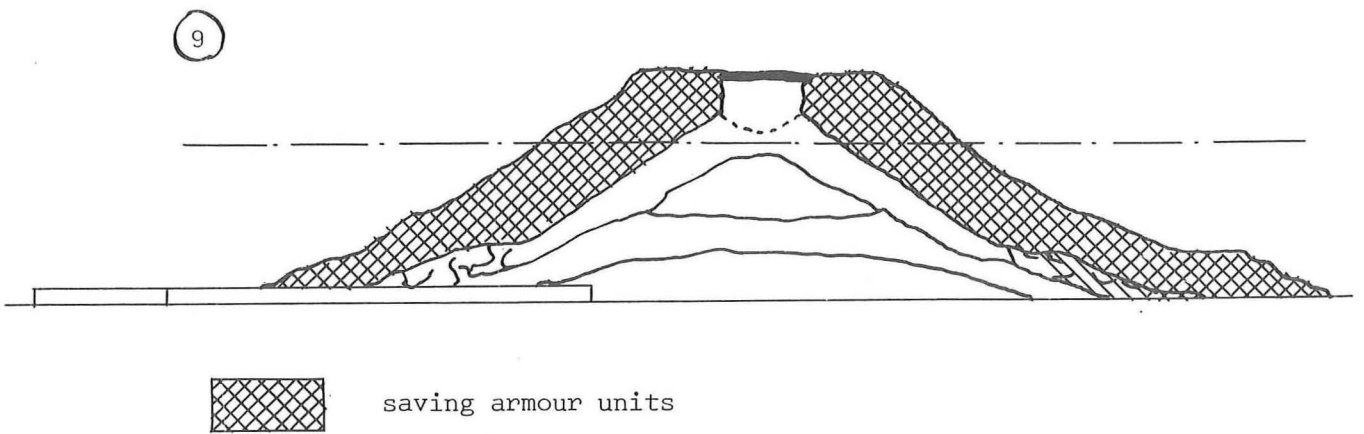
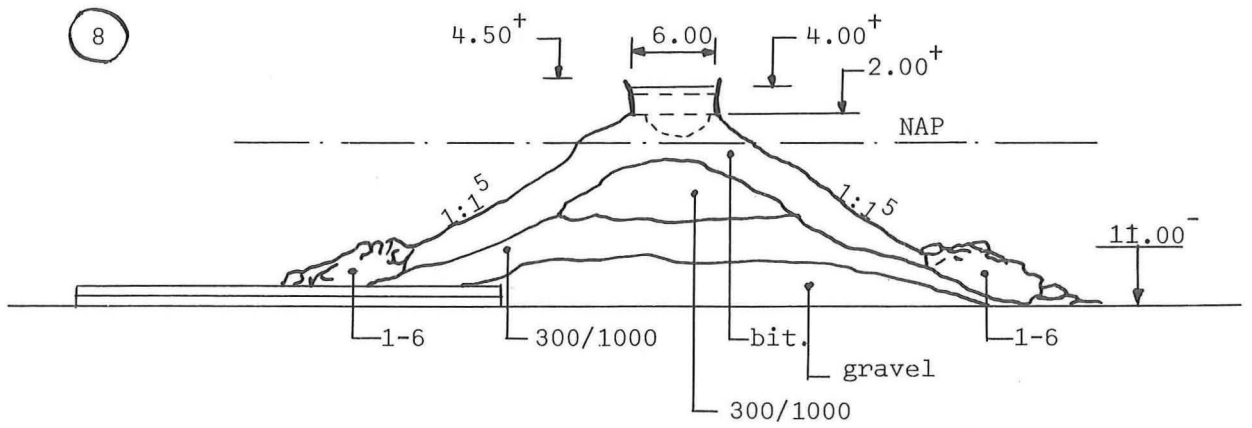
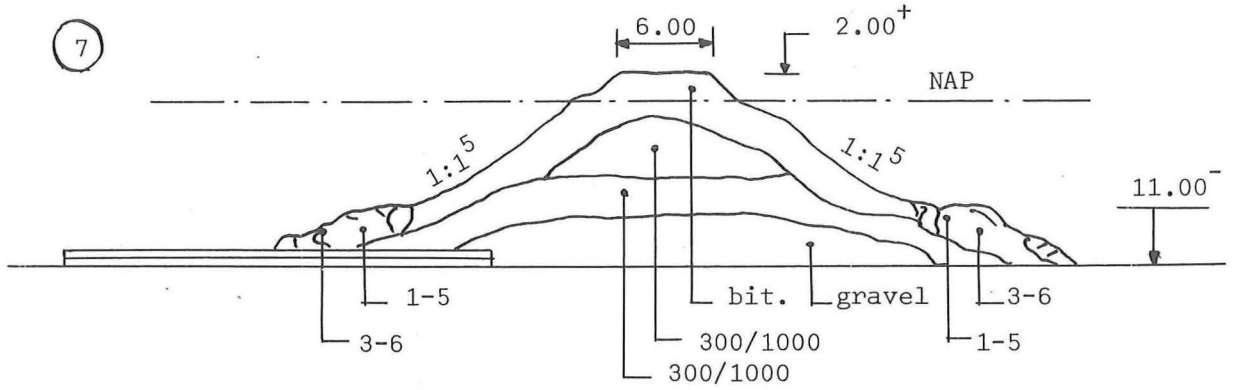

3. Computation of armor unit size

Several formulas have been developed for computing the size of breakwater armor units. Although many have a quasi-theoretical background, most are based upon model experience. Most of these formulas have the following basic form:

$$W = \frac{C H^3}{F(\alpha)}$$

where:

W = desired armor unit mass

H = wave height

α = slope of breakwater face

C is a coefficient dependent upon the mass density of the units and its shape.

Irribarren, who developed one of the earlier formulas, used a reasonably theoretical approach. Starting with equilibrium of forces acting on a stone (see figure below) he derived:

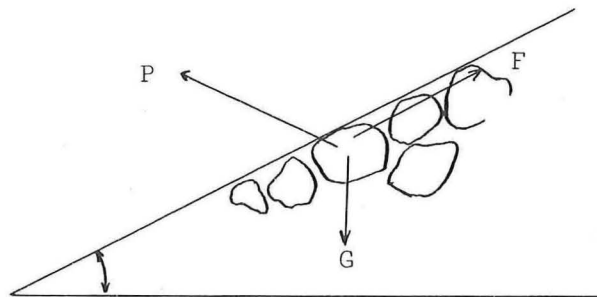

fig. 53 forces acting on a stone

P = wave force; F = friction force; G = weight of unit.

$$W = \frac{N \rho H^3}{\Delta^3 | f \cos \alpha - \sin \alpha |^3}$$

where:

N is a coefficient based upon stone type

ρ_s is the mass density of stone

Δ is the relative density of stone

$$\frac{\rho_s - \rho_w}{\rho_w}$$

ρ_w is the mass density of water

f is a friction coefficient.

The factor, f , makes this formula hard to use. f varies with the shape and method of placement of armor units. Still, however, nearly every model test resulted in a new f value. Another limitation of this formula is that it may only be used for small values of α with an associated f value near 1.0. At a slope near $\alpha = 45^\circ$, the equation gives ridiculously high values.

Hudson modified the Irribarren Formula and arrived at a more practical but less theoretically correct result:

$$W = \frac{\rho_s H^3}{K \Delta^3 \cot \alpha}$$

where K is a coefficient depending upon the armor unit shape $K = 3$ for rough, broken stone, and $K = 15$ for special artificial concrete units.

More details of these formulas can be found in the CERC Technical Report No. 4 and in R.L. Wiegel's book "Oceanographical Engineering".

The Hudson formula gives a good approximate answer in practice. These computations must be refined via model tests if optimum values are needed. These model tests can, at the same time, yield other valuable construction information.

Hudson based his formula a no-damage criterium. No-damage is defined as the situation in which not more than 1 % to 2 % of the armor units is removed by the waves. In this formula we have only one value of K for a given armor block. This means that the amount of damage caused by a storm having a wave height H_s greater than the design wave H_{so} is not taken into account. The duration of this storm is also neglected. In reality, the rate of increase as wave heights increase varies with the block type. This is discussed in the follow model test example.

Two breakwater models were tested in a wave flume. Both had the same general shape and dimensions. One had a cover layer of type A armor units; the other used type B. The masses of the units A and B were the same. The test results were as shown in the following graph:

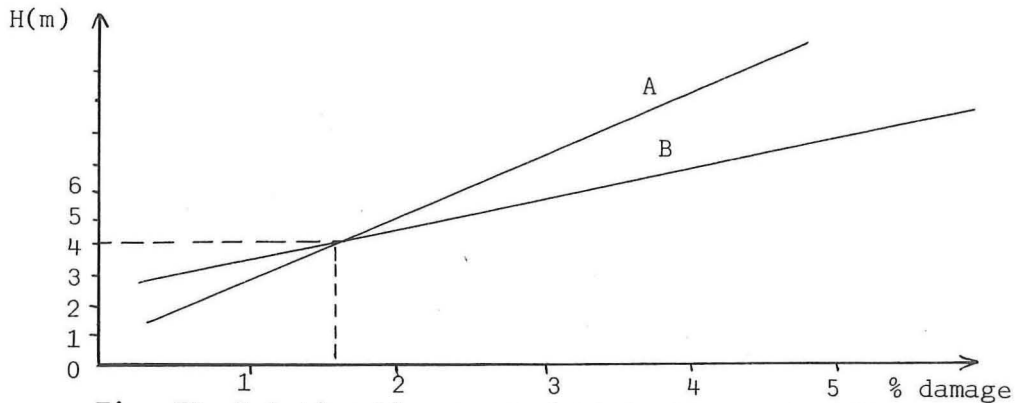

Fig. 54. Relationship wave height to damage for different block shapes.

At a wave height of 4 m. both types suffered the same damage. With waves higher than 4 m, the damage to blocks B was more extensive, while smaller waves caused more damage to type A.

This example shows that a K value based upon a no-damage criterium alone does not result in optimum design. Damage caused by possible waves higher than the H_{SO} must also be considered.

The method of optimum design has been discussed in a previous section. The four most important factors for determining the minimum total breakwater cost will now be discussed and illustrated.

A. The frequency of occurrence of different off-shore conditions.

To describe the wave attack, use is made of a probability curve giving significant wave heights to be expected. This curve can be constructed after a program of wave measurements have been carried out. As an alternative, it can be constructed from meteorological data using known wave forecasting techniques.

B. The relationship between offshore condition and structure performance.

Because wave forces are difficult to determine, the significant wave height, H_s , is taken as a characteristic wave attacking the structure. This implies, still, that the known distributions of wave heights and periods are applied. This enables us to define a H_{SO} for the structure. H_{SO} is the maximum wave height which can satisfy the no-damage criterium. When the design wave height H_{SO} is exceeded, a number of armor units will be moved from their placed positions. The point of this work is to establish the relationship between the percentage of armor units moved (percent damage), the design wave height (H_{SO}), and the actual incident wave (H_s). One complication to this, is that time is also an important factor, however. Until recently model tests could only be carried out with regular waves which made it difficult to relate the model to the prototype.

Several investigations indicated that the H_s of a series of irregular waves is well represented by a H_r of the same height of a series of regular waves.

For some years now the Hydraulic Laboratory in Delft has at its disposal a so-called wind wave flume with a programmed wave generator which produces irregular waves.

The relationship between the damage caused by a certain H_s can, via the tests, be related to the design wave H_{so} . H_{so} is obviously, directly related to the shape and dimensions of the breakwater.

C. Relationship between construction cost and H_{so} .

The initial costs will, to a large extent, depend upon the quantities of the different kinds of rock, and also on the size of the used material, especially the armor units. As a simplification the influence of size is neglected for the moment; we can say for the construction cost I:
 $I = f(H_{so})$.

D. The relationship between expected damage, off-shore conditions and H_{so} .

A breakwater designed for a given H_{so} is damaged whenever the H_s is exceeded. The damage to be expected depends upon the probability of occurrence of waves higher than the waves of the storm characterized by the H_{so} .

To determine the damage to be expected it is assumed that an insurance company is willing to insure the structure against damage. When the company covers a large amount of constant risks, which are unrelated, then the premium is s , where s is the probability of damage multiplied by the repair costs.

In this case constant risk means that all damage is repaired immediately. This premium s that would have to be paid for a single structure that would function indefinitely is equal to the average amount that would have to be paid each year to repair the damage.

When the H_{so} is exceeded by the amount $\Delta H_{s(i)}$ this is accompanied by an amount of damage $\Delta W_{(i)}$. The probability of this happening each year is $\Delta p_{(i)}$. Then the average yearly total damage is $s = \sum_{i=1}^n \Delta p_{(i)} \cdot \Delta W_{(i)}$ when other factors such as inflation are neglected. $\Delta W_{(i)}$ also contains economic losses. The amount $s_{o(b)}$ which has to be reserved now, to pay the damages, b years from now can be calculated with the method of compounded interest.

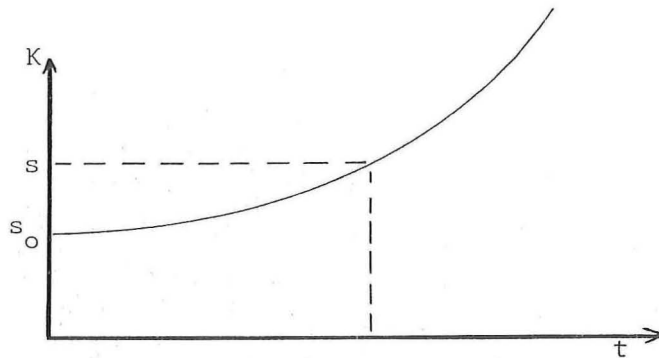

fig. 55. Growth of capital with compounded interest.

$$\frac{dK}{dt} = \frac{\delta}{100} K \rightarrow \frac{dK}{K} = \frac{\delta}{100} dt$$

$$\int_{s_0(b)}^s \frac{dK}{K} = \int_0^b \frac{\delta}{100} dt$$

$$\ln K \Big|_{s_0(b)}^s = \frac{\delta}{100} t \Big|_0^b \rightarrow \ln s - \ln s_0(b) = \frac{\delta}{100} * b$$

$$\frac{s}{s_0(b)} = e^{\frac{\delta}{100} * b}$$

$$s_0(b) = s e^{-\frac{\delta}{100} * b}$$

The amount $s_{0(20)}$ (the amount we have to reserve now to pay the amount s twenty years from now) is of course less than the amount $s_{0(10)}$. The total amount S we have to reserve now to pay the damage during the lifetime, T , of the construction is

$$S = s_{0(1)} + s_{0(2)} + s_{0(3)} + \dots + s_{0(t)} + \dots + s_{0(T)}$$

$$= \int_0^T s_{0(t)} dt = s \int_0^T e^{-\frac{\delta}{100} * t} dt.$$

$$= s \frac{100}{\delta} (1 - e^{-\frac{\delta T}{100}}).$$

$$T = 100 \text{ years: } S = s \frac{100}{\delta} (1 - e^{-\delta}) \quad s \frac{100}{\delta}$$

$$T = 10 \text{ years: } S = s \frac{100}{\delta} (1 - e^{-\frac{\delta}{10}}) \quad 0.35 \frac{100}{\delta} * s$$

$\delta = 3.5\%$

So the total cost F_1 of the breakwater is the initial construction cost I + the capitalized value of the total damage over the years S

$$\begin{aligned} F_1 &= I + S \\ &= f(H_{SO}) + \frac{100}{\delta} \Sigma \Delta p * \Delta W \end{aligned}$$

if the expected lifetime of the structure is 100 years or more. This computation has to be executed for all crosssections (based on varying design waves). In principle, all crosssections are exposed to the same wave program, i.e. the waves occurring in the prototype. However, for every crosssection waves lower than the design wave are of no importance, and for waves higher than about $1,5 H_{SO}$ the breakwater is completely destroyed. So the various breakwater crosssections to be tested are exposed to a certain, and to the design wave related, part of the total probability spectrum of the wave climate.

The method described is suitable only to draw a comparison between different breakwaters as far as the economical consequences are concerned. It should be noted that governmental agencies do not reserve money to repair future damage to their projects: these raise the money necessary at a certain time in a different way.

It is not realistic to suppose that all damage is repaired immediately. To a certain extent the breakwater shows a degree of flexibility depending upon the shape of the armor units. When one armor unit has moved away, the surrounding units tend to move in order to fill the created gap. It is up to the engineer to determine the moment repair becomes necessary. It is better not to repair too often, as mobilization for maintenance work can be more costly than the repair job itself.

4. Numerical examples

Neglected in this example are the following factors:

- a. Whether there is enough natural rock of the desired size available or whether it is desirable to use some kind of artificial concrete block (cube, Akmon or Tetrapod). The principle of optimal design is not changed this way even if it has an influence on the construction cost.
- b. Whether overtopping is allowed if harbor activities permit no overtopping then the crest will have to be at a high level. In this case the inside berm is defended against wave attack. When a high waterlevel (wind set up + high tide) coincides with high waves damage can be extensive to the inside berm.

Low crest level will result in a coverlayer almost as strong on the inside as it will be on the outside berm so high water levels will not be that important.

c. Construction methods. Developments in this field are so many nowadays that including this cost in these examples will not be realistic.

This example discusses a possible breakwater construction for use in Europoort. The next figure shows a crosssection of a breakwater-design that was tested in the laboratory:

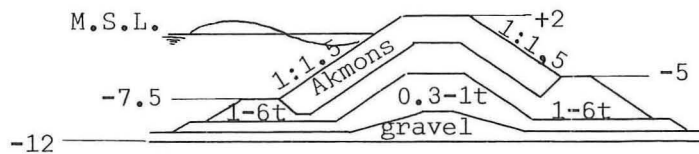

structure with cover layer of concrete blocks

fig. 56

The principles involved in the design of this crosssection have been discussed in previously. The coverlayer exists of a concrete Akmons having a mass density of 2800 kg/m^3 .

The data of the offshore conditions in the planned area of the prototype were obtained from wave recording stations in the North Sea. A probability distribution curve of H_s was derived from data that described wave conditions in terms of "the number of storms in which a certain H_s was exceeded" (see below).

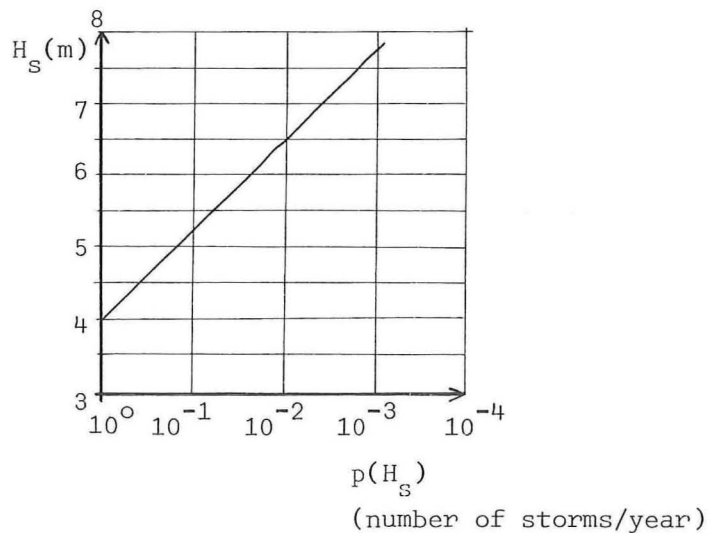

Fig. 57. Probability of excess of H_s

Relationship between off-shore conditions and behaviour of the structure.

According to the theory explained earlier, the amount of damage to the breakwater occurs as shown in the figure below in case H_s exceeds H_{so} . This relationship was established in the laboratory. Here, the

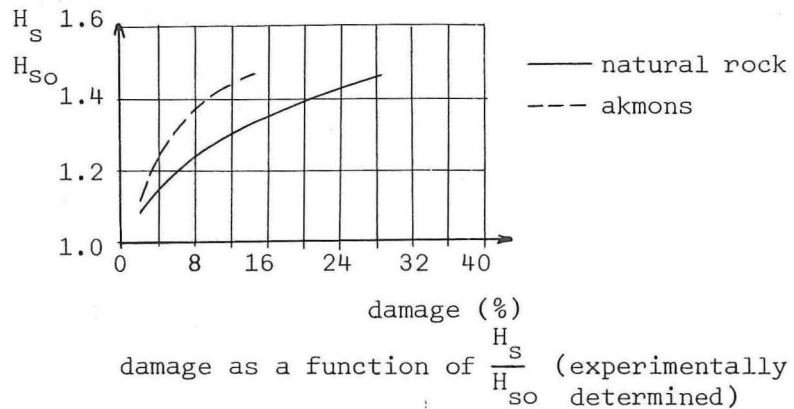

fig. 58

percentage of damage refers to the whole concrete cover layer. Arbitrarily, it was assumed that the structure will collapse when the Akmons suffered 10 % damage hence, from the figure above, when $H_s/H_{so} = 1.45$. In earlier tests, it was established that when the slope of the face is 1.5 : 1 with Akmons of $\rho = 2800 \text{ kg/m}^3$, the required mass of the units was:

$$W = \frac{2,8 (H_{so})^3}{50}$$

Relation between cost of construction and H_{so} ($F1 = f(H_{so})$)

The cost of construction can be divided between the cost of the cover layer and the cost of the secondary layer and core. The latter two are independent, to a large extent, of the design wave height. These latter two were estimated to cost f 8620,-- per m.

The cost of the cover layer was estimated to be equal to $1320 \times H_{so}$. (For a detailed report on this see publication 31 of the Delft Hydraulic Laboratory by v.d. Kreeke and Paape)

Consequently the construction cost of the structure per meter is:

$$F1 = 1320 H_{so} + 8620$$

Relationship between anticipated damage, off-shore conditions and design wave.

$$S = \frac{100}{\delta} \Sigma \Delta p \Delta W$$

In this particular case three intervals of $\frac{H_s}{H_{so}}$ were tested in the laboratory, namely:

$$1 < H_s/H_{so} < 1.3, 1.3 < H_s/H_{so} < 1.45 \text{ and } \frac{H_s}{H_{so}} > 1.45.$$

The corresponding damage percentages and the probability of occurrence of these damage have been discussed in above. The amount of damage ΔW is assumed to be: percentage of damage * cost of construction of coverlayer * z. The factor z has been adopted arbitrarily in view of the fact that the placing of a limited number of blocks is more expensive. In case of collapse ($H_s/H_{so} \geq 1.45$) ΔW is assumed to be equal to the total initial cost of the construction.

The following table shows the relationship between the various parameters for four breakwaters with different H_{so} 's.

Table 1.

H_{so} (m)	I	I_{cl}	$1 < H_s/H_{so} < 1.3, n=4\%$			$1.3 < H_s/H_{so} < 1.45$ $n=8\%$			$H_s/H_{so} > 1.45; \text{collapse}$		
			Δp	ΔW	$\Delta p \Delta W$	Δp	ΔW	$\Delta p \Delta W$	Δp	ΔW	$\Delta p \Delta W$
4	13900	5280	1.01	420	430	$5.2 \cdot 10^{-2}$	860	40	$3.8 \cdot 10^{-2}$	13900	530
5	15220	6600	$1.6 \cdot 10^{-1}$	530	80	$4.7 \cdot 10^{-3}$	1060	5	$2.8 \cdot 10^{-}$	15220	40
5.5	15900	7280	$6.3 \cdot 10^{-2}$	580	40	$1.6 \cdot 10^{-3}$	1160	-	7.10^{-4}	15900	10
6	16540	7920	$2.5 \cdot 10^{-2}$	630	15	$5.2 \cdot 10^{-4}$	1260	-	$1.8 \cdot 10^{-4}$	16540	3

As it is not always advantageous to repair all partial damage immediately, two cases will be considered:

- the total amount of damage when all partial damage is repaired
- the total amount of damage when all partial damage is not repaired

For $\frac{100}{\delta} = 30$ values of s and S are given in table 2.

Table 2.

H _{so} (m)	With repairing partial damage		Without repairing partial damage	
	s=ΣΔp.ΔW	S = $\frac{100}{\delta}$ s	s	S
4	1000	30000	530	15900
5	125	3750	40	1200
5.5	50	1500	10	300
6	18	540	3	90

The total cost of the structure Fl = I + S

The total cost of the structure for various values of H_{so} is given in table 3 and plotted in the following graph.

Table 3.

H _{so} (m)	With repairing partial damage			Without repairing partial damage	
	I	S	Fl	S	Fl
4	13900	30000	43900	15900	29800
5	15220	3750	18970	1200	16420
5.5	15900	1500	17400	300	16200
6	16540	540	17080	90	16630
6.5	17200	100	17300	20	17220

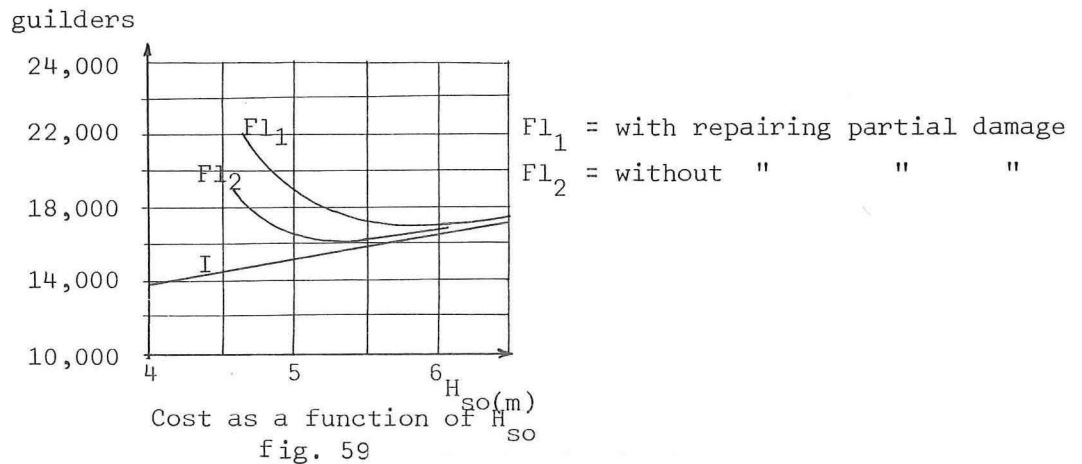

The design and required block weight

According to the minimum cost criterium the optimal design wave is:

$H_{so} = 6$ m when partial damage is repaired

$H_{so} = 5.5$ m when partial damage is not repaired

H_{so}	probability of damage		W
	$\rho(1 < \frac{H_s}{H_{so}} < 1.45)$	$\rho(\frac{H_s}{H_{so}} \geq 1.45)$	
6 m	$2.6 * 10^{-2}$	$1.8 * 10^{-4}$	12 tons
5.5 m	$6.5 * 10^{-2}$	$7.4 * 10^{-4}$	9 tons

Besides this example, other examples can be found in the report No. 31 of Delft Hydraulics Laboratory mentioned before. Among others, an example is included of a rubble mound breakwater of which the crest level is dependent upon the wave height. In the case the inner slope is not protected by armor units, overtopping of any importance is not acceptable. In the case this overtopping nevertheless occurs, the breakwater will suffer severe damage, comparable with severe damage of the outer slope. In this case the most economic crest level is that level at which the outside- and inside faces are destroyed at the same time. The former by the direct wave attack; the latter, by serious overtopping. According to Hudson, for a first approach to determine the wave run-up, R, the formula $R = \frac{1.35 H_s}{\sqrt{\cotg \alpha}}$ can be used. R is the vertical component of the run-up, and is measured relative to S.W.L. This formula does not take into account the importance of the ratio $\frac{H}{L}$ (wave steepness). The importance of the wavesteepness is shown in the next figure.

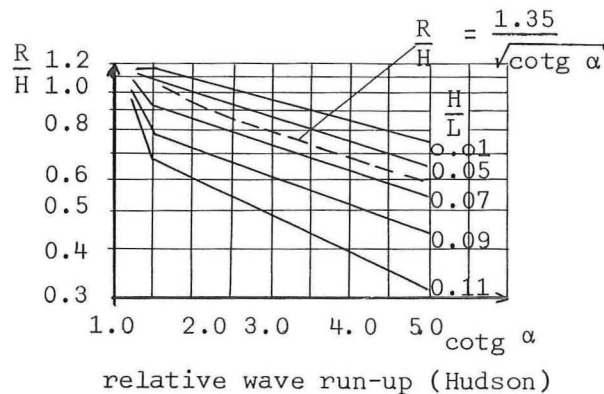

fig. 60

When it is assumed that the armor-layer is being destroyed when $\frac{H_s}{H_{so}} = 1.45$ (this ratio has to be determined in each case by laboratory tests!) then the design wave height to cause collapse in case of overtopping has to be

$$H'_{so} = \frac{R \sqrt{\cot \alpha}}{1.35}$$

$$H'_{so} = 1.45 H_{so}$$

$$R = \frac{1.95 H_{so}}{\sqrt{\cot \alpha}}$$

To describe the relationship between the slope of the outside berm and the design wave height, H_{so} , in case of an armor unit of natural rock having mass W and relative density $\Delta = \frac{(\rho_{st} - \rho_w)}{\rho_w}$, the following expression can be used:

$$\cot \alpha = \sqrt{\frac{\rho_s H_{so}^3}{1.25 \Delta^3 W}}$$

this is shown in the following graph.

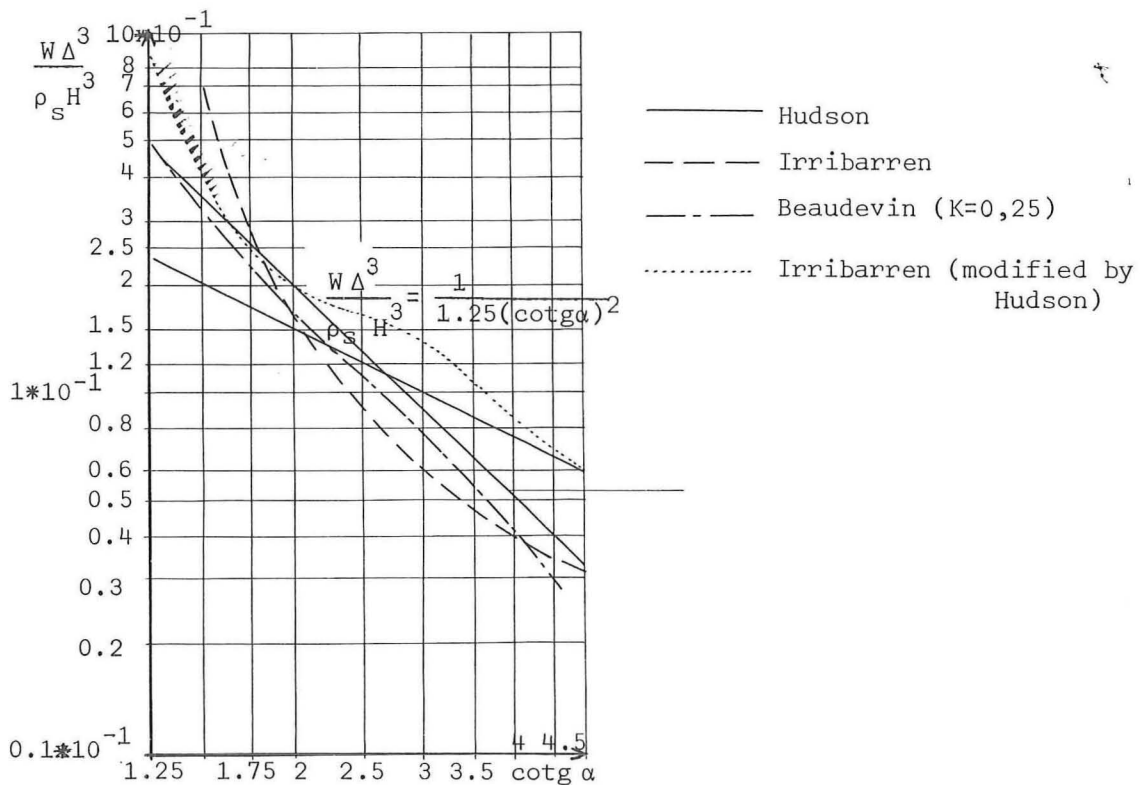

Stability of natural rock

fig.60

Chapter IV

Vertical Breakwaters

1. Introduction

To get to an economical design for a vertical breakwater the same method of optimal design has to be applied as was done for the mound breakwater. The applied principles are the same as the ones discussed in the previous chapter. Still, there are some basic differences. For example, when the design wave (in case of a vertical breakwater translated into the design load) is exceeded, the structure is considered damaged to such an extent that it is a total loss. In case the breakwater is made up of caissons this failure could be caused by tipping or by lateral movement of one or more caisson units. Here again we have to work with probability of exceedence of the H_{50} , the accompanying damage, the expected yearly damage, capitalized damage costs, and initial construction costs, to get an economical design. Contrary to the experience with the mound breakwater, it is possible to make a more or less accurate estimate of the wave forces and the resulting vibrations in case of a vertical breakwater.

2. Wave forces and vibrations

The forces exerted on a vertical wall by a standing wave (french: clapotis) show a sinusoidal fluctuation with the same period as the wave. The following pressure diagram assumes no wave action at the lee side of the breakwater. The amplitude of the standing wave is H_0 , the wave-height of the oncoming wave at some distance from the breakwater. It should be noted that the increase in pressure caused by the wave decreases exponentially below the S.W.L.

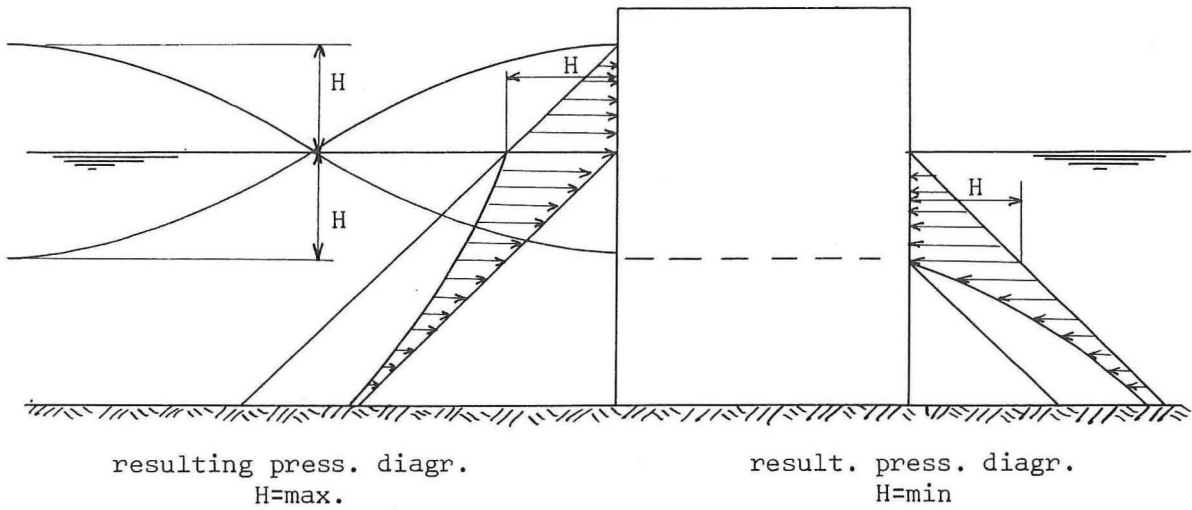

pressure diagram standing wave

fig.61

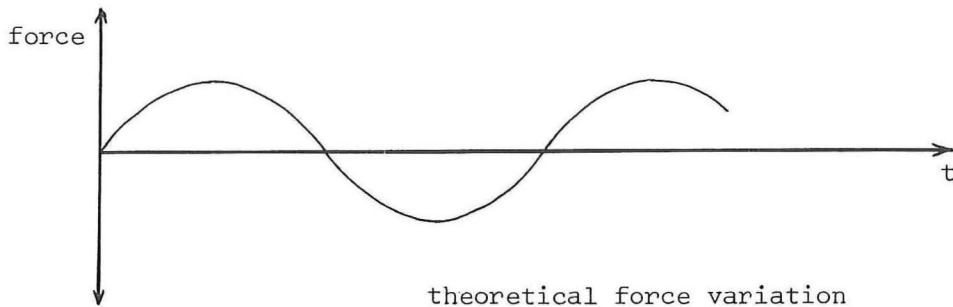

theoretical force variation

fig.62

The preceding figure shows the theoretical force. In reality, the breakwater will experience wave impact forces. Tests carried out during design of the Haringvliet Sluices of the Delta Plan showed the following relationship between time and wave forces.

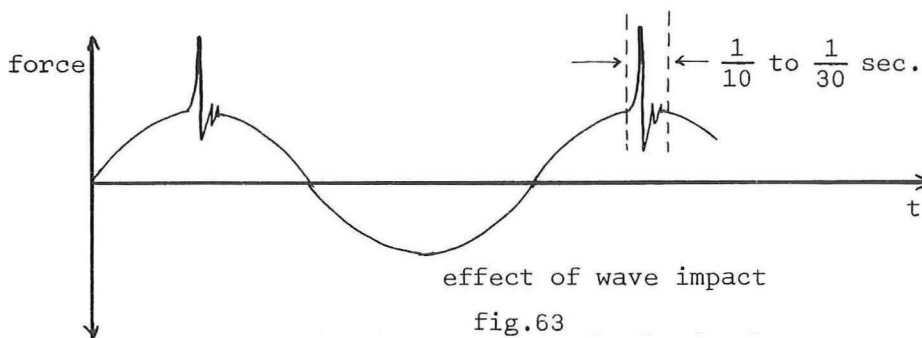

effect of wave impact

fig.63

These sudden peaks in the load are caused by wave impact; a phenomena caused by breaking of the wave. The gradient of the bed will cause an increase of steepness of the wave and as the wave progresses towards the breakwater it will be distorted as shown in the following figure:

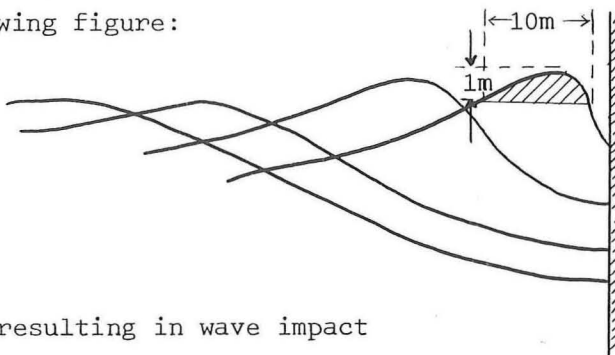

distortion of wave resulting in wave impact

fig. 64

The peak is caused by the force of the mass of water, indicated by the cross-hatching, crashing into the wall with a speed equal to the wave celerity. This mass depends to a large extent on the characteristics of the wave, but this case is fairly representative. For a wave with $H = 4$, $L = 80$ m, $T = 10$ sec. and $h = 10$:

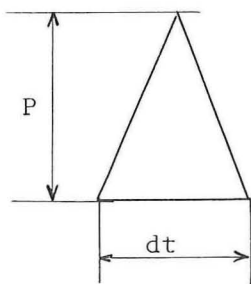

$$c = \sqrt{gh} = 10 \text{ m/sec.}$$

$$dt = 1/10 \text{ sec}$$

$$Kdt = d(mv) = \frac{1}{2} Pdt$$

$$mv = \rho_w \times 10 \times 1 \times 10 = 10^5 \text{ kgm/sec } (\rho_w = 1000)$$

$$P = \frac{d(mv) \times 2}{dt} = 2 * 10^6 \text{ N/m}^2$$

This high value of P would not act along the whole breakwater at the same moment, but would be limited to some tens of meters, during one particular time interval. This is caused by the fact that the crest is never completely straight. In practice the area of impact is limited.

These high values have never been measured, This is probably due to the fact that water escapes in all directions and the value of the mass that actually contributes to the impact is only about one-third of the value assumed in this example.

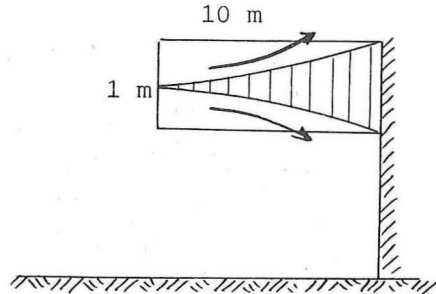

reduction of wave impact
because part of water can escape

fig. 65

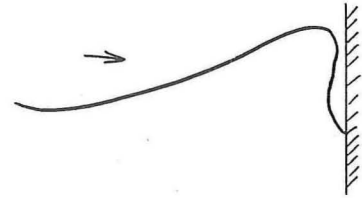

cushioning effect by
trapped air

fig. 66

When air is trapped between the water mass and the wall this will have a cushioning effect, causing a slower deceleration, thus increasing the value of z at which will result in a lower value of P .

To compute the effect of the wave impact forces, the total breakwater and bottom has to be regarded as a mass-spring system. Only the value of the dynamic pressure P will be taken into account. The principle of this computation will be demonstrated for the vertical load and movement. The load will be schematized as a block function.

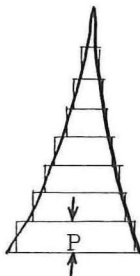

For the various blocks with value P the movement of the mass-spring system will be analyzed. P is the vertical component of the actual load on the construction.

Due to this load the vertical movement of the breakwater is z . When c is the elasticity constant of the soil the pressure which is exerted by the soil on the construction is $z \cdot c$. In reality the soil does not behave as an elastic medium. The force displacement diagram is as shown in the sketch.

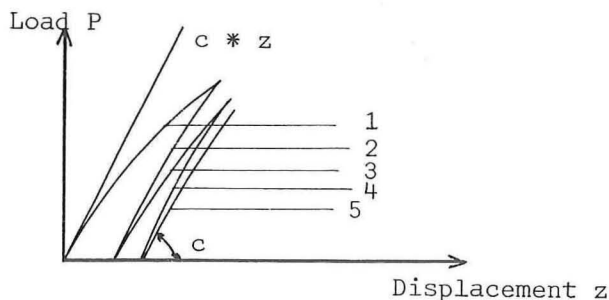

force displacement diagram of the soil

fig. 67

It is possible that after some time the curves for loading and unloading will be almost identical.

For a static load the equation of motion of the breakwater in a vertical direction is

$$P + (m_{br} - \rho_w b \cdot h)g - c \cdot z = 0.$$

in which m_{br} = mass of breakwater, ρ_w = density of the water, b = width of breakwater, h = depth of water, z = vertical displacement of breakwater, c = elasticity constant of soil.

For a dynamic load the mass-acceleration of the breakwater and the soil moving with the breakwater (m_s) have to be taken into account. The movement of the soil decreases as its distance from the foundation of the breakwater increases. For m_s an equivalent mass is introduced which moves as one rigid volume with the displacement of the breakwater. The energy in this virtual equivalent mass should be equal to the energy of the real mass of the soil.

When only the forces due to the dynamic load are taken into consideration, the equation of motion of the breakwater becomes:

$$P - (m_{br} + m_s) \ddot{z} - c z = 0$$

The solution of this equation is

$$z = \frac{P}{c} (1 - \cos \omega t), \text{ in which}$$

$$\omega = \sqrt{c / (m_{br} + m_s)}.$$

In this solution the forces in the ground vary from positive to negative. Of course, in normal soil this is not possible, due to the static load and the slowly varying wave forces and the mass of the breakwater. Due to this load there is a pre-pressure on the subsoil. The force which is exerted by the breakwater on the subsoil is:

$$K = P - m_{br} \ddot{z} = P \left| 1 - \frac{m_{br}}{m_{br} + m_s} \cos \omega t \right|$$

The maximum force which is exerted by the breakwater on the bottom is:

$$P \left(1 + \frac{m_{br}}{m_{br} + m_s} \right)$$

The value $1 + \frac{m_{br}}{m_{br} + m_s} = \chi =$ enlargement factor.

If it is assumed that the duration of the block function P is infinitely long, the following extreme values of χ are possible.

$\chi = 2$, for a great mass of the breakwater as compared with the virtual mass of soil. This will be the case for rock bottoms.

$\chi = 1$, for a light breakwater, on soft soil, so with a great equivalent mass of the soil as compared with the mass of the breakwater.

The variation in values of ω will be as follows.

large ω for hard soil; great value of c and small value of m_s .

small ω for soft soil, small value of c and rather great value of m_s .

For a breakwater the following values for $T = \frac{2\pi}{\omega}$ have been estimated:

hard soil $T = 0,04$ sec.

soft soil $T = 0,4$ sec.

The force K exerted by the breakwater on the subsoil can be

determined graphically (assuming $\frac{m_{br}}{m_{br} + m_s} = 1/2$ resulting in $K = P$

$(1 - \frac{1}{2} \cos \omega t)$). The enlargement factor $X = 1.5$)

1. Assume P acts continuously:

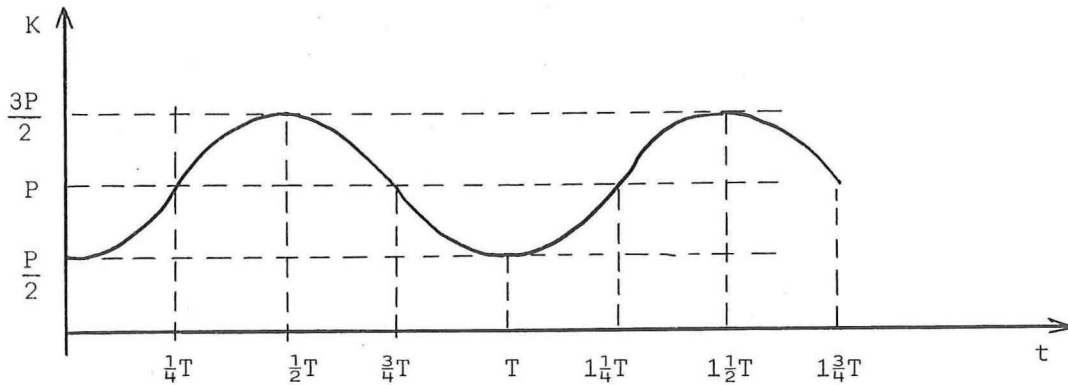

force K exerted by the breakwater of the subsoil fig.68
K varies sinusoidally with amplitude $\frac{P}{2}$.

2. Assume P is discontinued at $t = \frac{T}{2}$: The result of this can be shown by superimposing a negative block function on the graph above.

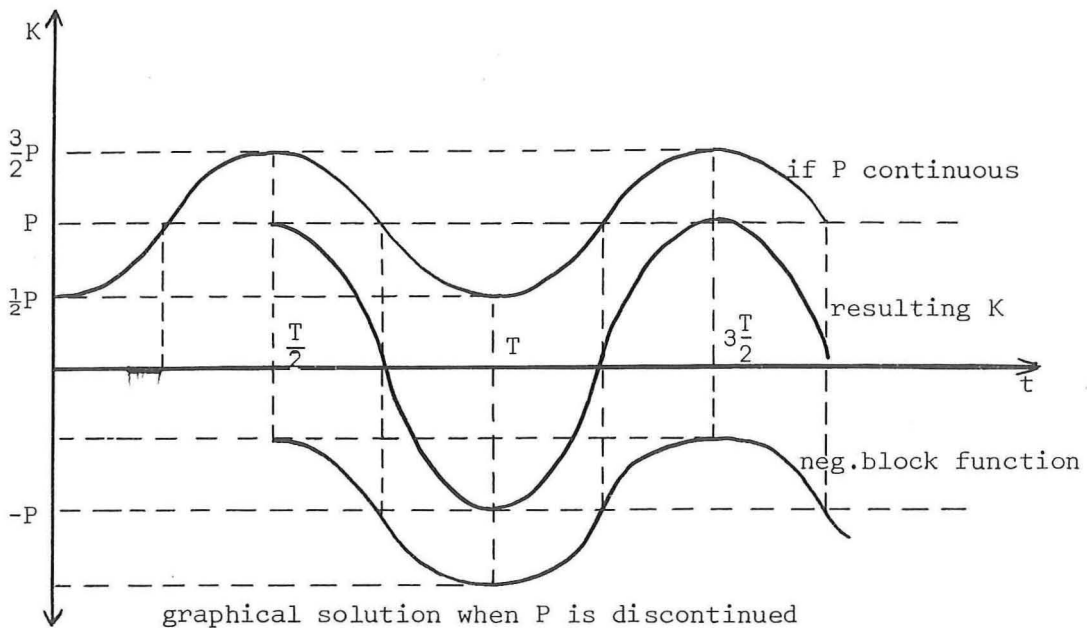

graphical solution when P is discontinued
fig. 69

This approach causes a discontinuity for K at $t = \frac{T}{2}$. This results from applying the entire force P at $t = 0$.

The variation of K as a result of a force P applied to the construction in a infinitesimally short time can be determined by applying this force as a series of block functions of increasing value and very short duration.

The following procedure can be applied to determine the effect of wave impact:

1. Assume the registered wave-impact load to consist of several block functions.

2. Determine the effect of each of these block functions separately.

3. Addition will provide us with the effect of the wave-impact as a function of time. The different steps are shown in the following figure.

Increase in the number of block functions will make the discontinuities in the summation curve smaller. This is a typical job for a computer.

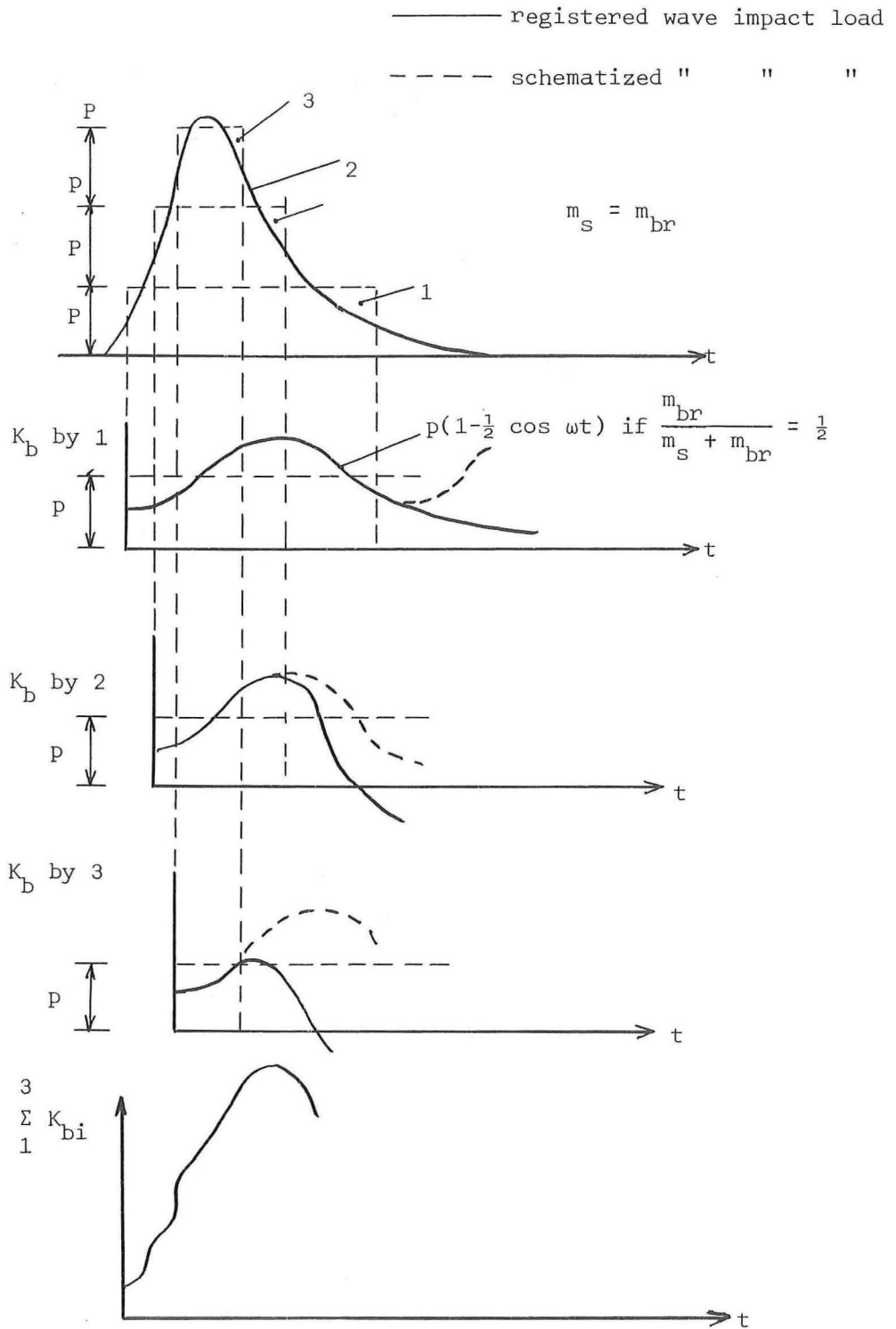

determination of wave impact
 by graphically adding the effect of each of the block
 functions

fig. 70

3. Design and construction of a vertical breakwater

Vertical breakwaters can be made up out of blocks or out of caissons. When blocks are used care has to be taken that the joints are sealed well, otherwise there is the chance that scouring will occur (especially since they tend to loosen a bit because of the vibration) and that the pressure of the wave impact will act on a larger area of the block causing eventual destruction of the breakwater. The blocks can be put together in the following fashions:

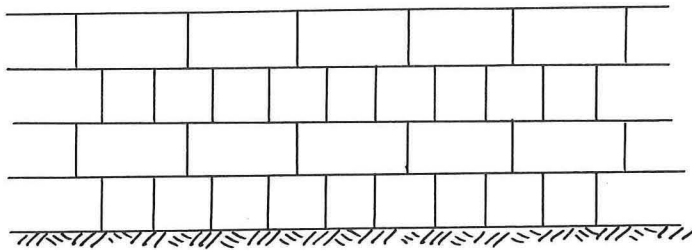
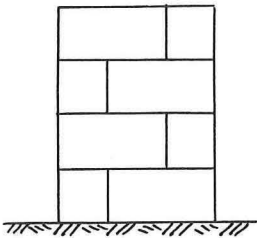

block construction
fig. 71

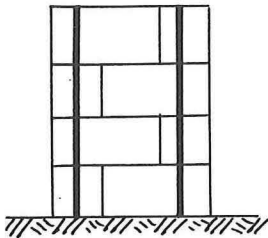

reinforcing
fig. 72

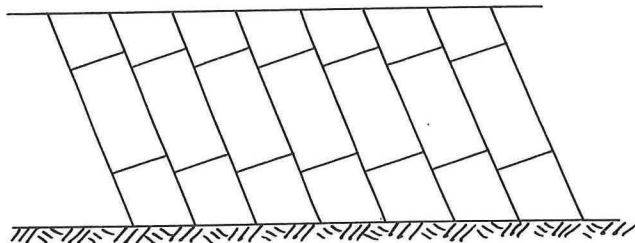

minimizing the effect of local settlement
fig.73

To make the blocks act more as one unit reinforcing can be included using vertical rails etc.

To reduce wave-impact, the top of the front of the breakwater can have a slope as shown in the figure.

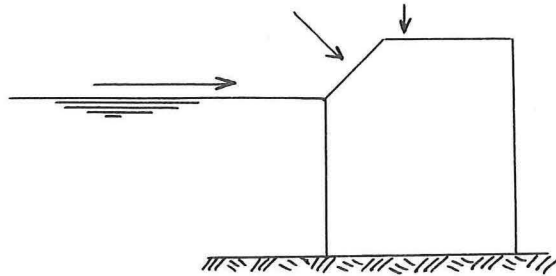

reduction of wave impact by sloping front
fig.74

Another way to reduce impact is to build the breakwater from a single line of piles of large diameter.

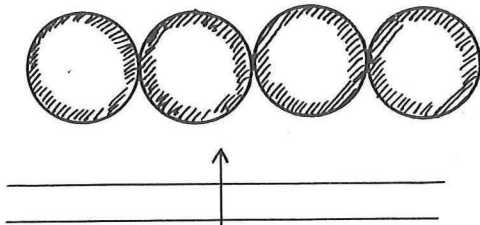

vertical breakwater consisting of piles fig. 75

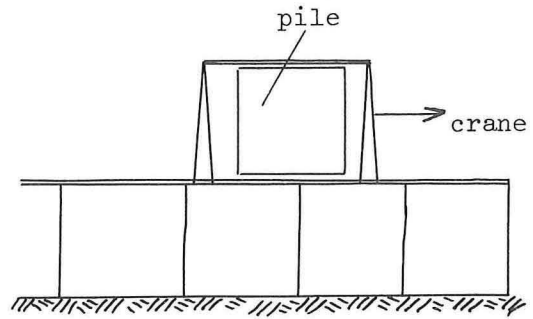

construction method with crane fig. 76

The units can be built by filling circular cofferdams with concrete or sand. Sometimes circular concrete caissons are built and towed to the construction site.

It is also possible that the caissons are transported over that part of the breakwater which is completed and that they are placed with the aid of a heavy crane.

When caissons are used it is sometimes necessary to build a filter layer to act as an underdrain thus avoiding liquifaction of the subsoil. This can be caused by wave-impact forces propagating through the caisson and by the accompanying vibrations. Another advantage of a filter layer is that the forces are distributed more evenly over the subsoil.

Chapter V

Some special types of breakwaters

1. Pneumatic breakwater

The principle of the pneumatic and hydraulic breakwater is the generation of a current against the direction of wave propagation. Through this current the waves are forced to break and therefore, lose their energy. When they are not forced to break, the wave height will become greater in the region with counter current, but this height will again decrease in the region with a current in the direction of propagation of the waves.

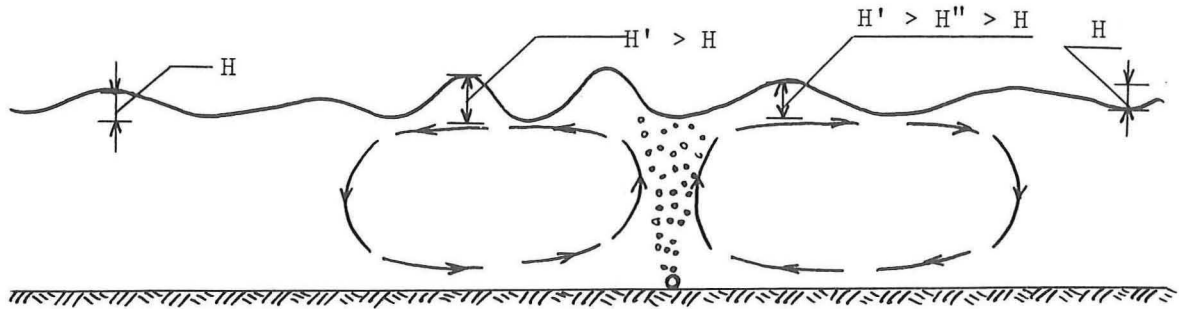

pneumatic breakwater

fig. 77

In order to calculate this phenomenon, a wave travelling from an area with no current into an area with a current against the direction of wave propagation, will be followed.

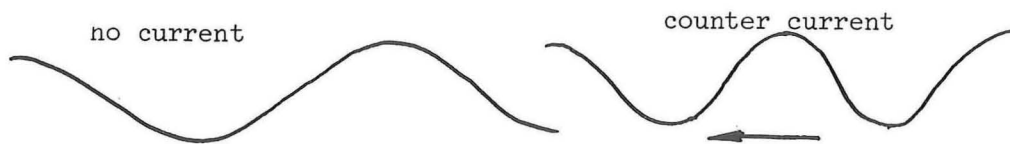

effect of current in direction opposite to direction of wave propagation

fig.78

$$\omega = ck$$

$$c^2 = \frac{g}{k} \tanh kh$$

no current

$$\omega' = ck'$$

$$\left(\frac{\omega'}{k'}\right)^2 = c'^2 = \frac{g}{k'} \tanh k'h$$

with counter current

It is necessary for both systems that the wave periods related to a fixed coordinate system be equal.

The relationship between ω , c , k and h are physical and related to the medium.

In the case of counter current v , this relationship holds for a coordinate system moving with v . For transformation to a coordinate system which is identical to that of the approaching waves, the relationship $x' = x+vt$ holds.

When this is introduced in the cosine function which holds for the various parameters, X_1 , of the waves such as height, pressure, and orbital velocity at any depth,

$\chi \cos (k'x' - \omega't)$ this function will become

$$\chi \cos \{k'(x+vt) - \omega't\} = \chi \cos k'x - (\omega' - k'v)t$$

The new ω , with respect to the coordinate system fixed to that of the approaching waves, is $\omega' - k'v$ and must be equal to ω .

We can now write:

$$\omega'^2 = (\omega + k'v)^2 = g k' \tanh k'h$$

For deep water, $\tanh k'h = 1$:

$$(\omega + k'v)^2 = gk', \text{ from which follows:}$$

$$k' = \frac{-2\omega v + g \pm \sqrt{(2\omega v - g)^2 - 4v^2\omega^2}}{2v^2}$$

The value of k' can only exist if

$$(2\omega v - g)^2 > 4v^2\omega^2,$$

or if:

$v < g/4\omega = c_0/4$, with c_0 = wave celerity in undisturbed deep water.

Therefore, when the current is equal or greater than $c_0/4$ the waves cannot exist, that is, they will be forced to break. In that case, a considerable energy dissipation will take place and the pneumatic breakwater will be effective. In the case $v < c_0/4$, the waves will not break and no energy dissipation and consequently no wave attenuation will occur. This will also occur in the case the waves are longer than expected.

In the case of shallow water the relationship between ω and k' is not so simple and has to be solved by iteration. The relationship in this case is

$$\omega' = (\omega + k'v)^2 = gk' \tanh k'h = g'k'.$$

In order to be able to follow the same procedure as for deep water waves $g \tanh k'h$ is written as g' . So in this case the requirement for the current velocity v , with respect to ω is

$$v \leq g'/4 \omega = (g \tanh k'h)/4\omega$$

From this equation, v cannot be solved in a simple way since k' is also a function of v .

This relationship is

$$(\omega + k'v)^2 = gk' \tanh k'h.$$

For very shallow water, that is for values of $\tanh k'h = k'h$ the equations become:

$$v \leq gk'h/4\omega \quad \text{and}$$

$$(\omega + k'v)^2 = gk'^2h$$

This can be written as:

$$(gh - 4v^2)^2 = 0.$$

The equations cannot be solved when $v > \frac{1}{2} \sqrt{gh} = \frac{1}{2} c_0$, where c_0 is, in this case, the celerity of wave propagation in shallow water without counter current.

When the equations cannot be solved, the wave in the area with counter current is non-existent. The physical meaning of this is that the wave is forced to break.

For circumstances between deep and very shallow water the two equations

$$(\omega + k'v)^2 = g k' \tanh k'h$$

$$v = (g \tanh k'h)/4\omega$$

have to be solved by iteration.

This iteration will now be executed for a specific example.

(1)	(2)	(3)	(4)	(5)	(6)	(7)	(8)
L'	$\frac{h}{L'}$	$k'h$	$\tanh k'h$	$gk'\tanh k'h$	v	$k'v$	$(\omega + k'v)^2$
70	.143	.90	.72	.65	2.2	.20	.98
60	.67	1.05	.78	.82	2.4	.25	1.08
50	.20	1.26	.85	.99	2.6	.33	1.25
40	.25	1.57	.92	1.44	2.8	.44	1.52
30	.33	2.07	.97	2.03	3.0	.62	1.98

L' is estimated; via a rough computation for deep water $L_0 = 1.56 T^2$, and this computed wave length is then considerably shortened (by estimate), since the water is shallow and there is a counter current. From L' , the values of h/L' , $k'h$, $\tanh k'h$ and $gk'\tanh k'h$ are calculated. These values are also tabulated in T.R. No. 4. With the second of the two equations, v is now computed, and from this value $(\omega + k'v)^2$ is determined.

According to the first equation this should be equal to $gk'\tanh k'h$. From comparison between the columns (5) and (8) it follows that $v = 2.92$ m/s satisfies both equations.

In the foregoing the wave height is not taken into consideration. When this is done, there may occur a situation in which the incoming wave is already so steep that some shortening of the waves (due to the counter current) will increase the steepness beyond the limit of stability and break the waves. For this computation, the transport of the energy has to be regarded, since the wave height is also changing when the wave comes into the area with a counter current.

The energy transport equation is

$$c_{gr} E = c'_{gr} E' - v E'$$

where c'_{gr} , and E' are the values for the group velocity and the energy per unit of surface in the area with counter current.

For deep water the equation becomes:

$$\frac{1}{2} c_o E_o = (\frac{1}{2} c' - v) E', \text{ where the index } o \text{ indicates the undisturbed wave.}$$

Thus:

$$E'/E_o = \frac{1}{2} c_o / (\frac{1}{2} c' - v)$$

$$\text{Since } E = 1/8 \rho g h^2,$$

$$E'/E_o = H^2/H_o^2.$$

From this follows:

$$H'/H_o = \sqrt{1/(c'/c_o - 2v/c_o)}$$

$c/c_o = \sqrt{k_o/k'}$, as can be found from the basic formulas for the celerity. From the relationship between ω and k' the following equation can be derived, using the relationship for deep water: $c = g/\omega$.

$$\frac{k'}{k_o} = \frac{g}{\omega^2} * \frac{-2\omega v + g \pm \sqrt{(2\omega v - g)^2 - 4v^2\omega^2}}{2v^2}$$

$$k'/k_o = -c_o/v + (c_o/v)^2 \left[\frac{1}{2} \pm \frac{1}{2} \sqrt{1 - 4v/c_o} \right]$$

From this, we get the increase in wave steepness:

$s'/s_o = (H'/H_o)(L_o/L') = (H'/H_o)(k'/k_o)$ can be computed as a function of v/c_o .

This is a rather lengthy computation which yields a useful decrease in the required velocity, v , only for rather high initial steepnesses.

For normal use, it is, therefore, sufficient to use the first described procedure which is based on the possible existence of a wave when it is met by the counter current.

In order to design a pneumatic breakwater, it is necessary to determine the air discharge required to generate the required horizontal current. In an empirical way, the following formula is obtained:

$$v = 1.46 (gq_0)^{1/3} (1 + h/h_a)^{-1/3}, \text{ in which}$$

v = horizontal velocity of the water at the surface in m/s, h = depth under the surface of the air discharge pipe, h_a = atmospheric pressure in meters water column, q_0 = air discharge in $m^3/m/s$ at atmospheric pressure, and g = acceleration of earth gravity = 9.81 m/s^2 .

In this case the current generated by the air bubbles can flow out in two directions.

This velocity cannot be determined easily from models, since the air bubbles need two meters to reach their equilibrium speed. This is the reason that the original models, in which the air discharge was scaled down according the Froude scale, gave pessimistic results. The above mentioned formula can be simplified to:

$$q_0 = (v/2.6)^3 \text{ for double flow}$$

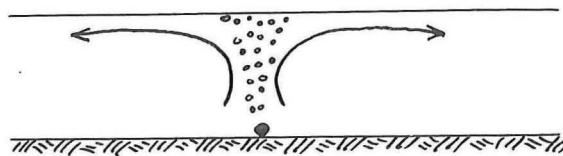

double flow pneumatic breakwater

fig. 79

and $q_o = (v/3.2)^3$ for single flow

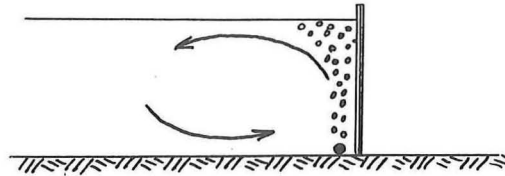

single flow pneumatic breakwater
fig. 80

In order to compute the required power for the air plant, the following procedure has to be followed:

For the supply of the air at a depth of h m the air has to be compressed from h_a to h meters water column. When the temperature of the air is assumed to remain constant (which is certainly allowed due to the surrounding water) the product of volume and pressure of the air remains constant.

So: $q_o h_a = q_i (h_a + h_i)$, in which q_o is the air discharge at atmospheric pressure h_a and q_i = the discharge at a depth of h_i below the surface.

$$q_i = \frac{q_o h_a}{h_a + h_i}$$

The required power is

$$P = \rho g \int_{h_a}^h q_i dh_i = \rho g \int_0^h \frac{q_o h_a}{h_a + h_i} dh_i$$

$$P = \rho g h_a q_o \ln (h_a + h_i) \Big|_{h_a}^h$$

When $h_a = \approx 10$ m,

$$P = \rho g 10 q_o 2,3 \{ \log (10 + h) - \log 10 \}$$

$$P = 23 \rho g q_o \{ \log (10 + h) - 1 \} \text{ watt}$$

Example

A wave of 8 sec ($c = 12,5$ m/s in deep water) has to be stopped by a pneumatic breakwater which has an air discharge pipe at a depth of ten meters below the water surface. The required horizontal velocity is $v = 3.1$ m/s.

For an out flow in two directions the required air discharge is

$$q = (v/2,6)^3 = 1,7 \text{ m}^3/\text{m s}.$$

When the pneumatic breakwater has a length of 500 m,

$$Q = 500 \times 1,7 = 850 \text{ m}^3/\text{s}.$$

The required power is $P = 850.23 \cdot 10^4 (\log 20-1) = 59000$ kw. When this breakwater has to work during 400 hours per year and the price of the electricity is f. 0,07/kwh, the exploitation costs of this breakwater will be with a plant efficiency coefficient of 0,7:

$$59000 \cdot 400 \cdot 0,07/0,7 = \text{f. } 2380,000/\text{year}.$$

This sum is so high that for normal use these breakwaters are not a feasible proposition.

A solid breakwater of this length will cost about $500 \times 40.000 =$
f. 20,000,000.

With an interest and depreciation percentage of ten percent, the yearly cost of this breakwater will be f. 2,000,000, which is in the same order of magnitude.

More information can be found in D.H.L. publ. 42, "Increase of effective working time during operations at sea by means of movable structures", by J.J. Vinjé. In this publication more references are given.

2. Floating Breakwaters

Other temporary means to decrease wave heights are floating breakwaters. A possible solution is the following construction.

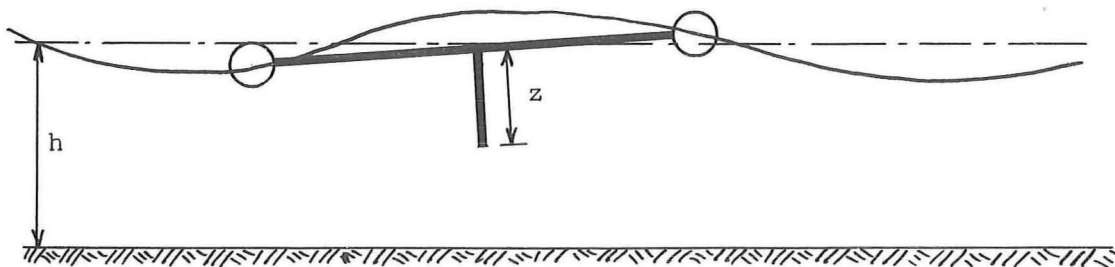

fig. 81 floating breakwater

Two floats (cylinders) are connected by a construction which supports a vertical screen or bulkhead. When the distance of the cylinders is rather great there will hardly be any movement of the vertical bulkhead and the construction will have its greatest obtainable effect. It is, however, also possible to decrease the distance of the floats to such an extent that, although the screen is moving, it has a sufficient wave damping effect. To this end, the natural frequency (period of oscillation) of the structure must be appreciably greater than that of the wave..

The decrease of the waves can be described for a non-moving screen by

$$H_t/H_i = \sqrt{\frac{2k(h-z) + \sinh 2k(h-z)}{2kh + \sinh 2kh}}$$

in which H_t = transmitted wave height and H_i = incident wave height.

This sort of floating construction is named "small width platform".

The damping effect results from the depth of the construction.

Other possibilities are "large width" platforms. In that case the damping effect results from the length of the construction.

There are three different types of this construction:

a) completely flexible: for instance a synthetic foil, pack ice(!), or thin oil layer. For these the attenuation of the wave height is most probably the result of friction between the moving water and the foil.

b) partly flexible, such as a fascine mattress. In this case the damping effect results from a combination of friction and vertical pressure.

For a completely fixed plate the following relationship holds

$H_t/H_i = \lambda/(\lambda^2 + \pi^2 w^2)^{\frac{1}{2}}$, in which λ = wave length and w = width of the construction.

c) rigid: for instance a caisson. Also in this case the own oscillation period of the caisson determines the damping effect of the construction.

The following two formulas give the wave height attenuation for bulkheads emerging from the bed or from the surface.

For a bottom screen:

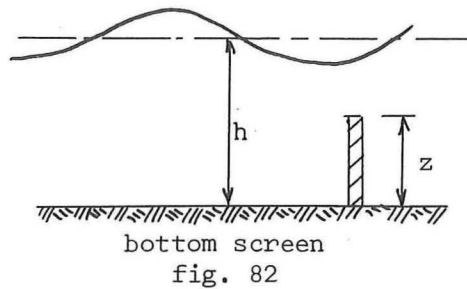

$$\frac{H_t}{H_i} = \sqrt{\frac{1 - \frac{2k(h-z)}{\sinh 2k(h-z)} + \frac{\sinh 2k(h-z)}{\sinh 2kh}}{1 + 2 \frac{kh}{\sinh 2kh}}}$$

For a surface screen:

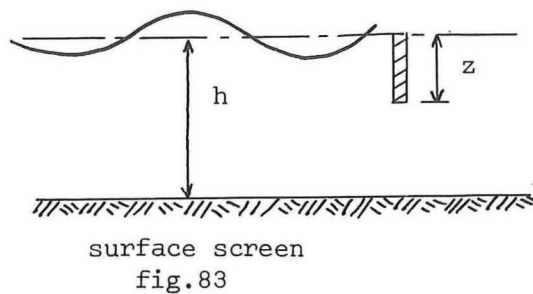

$$\frac{H_t}{H_i} = \sqrt{\frac{2k(h-z) + \sinh 2k(h-z)}{2kh + \sinh 2kh}}$$

From a specific example the following results are obtained:

$k = 0.08 \text{ m}^{-1}$	$2 k h = 1,6$
$L = 80 \text{ m}$	$\sinh 0.08 = 0.08$
$h = 10 \text{ m}$	$\sinh 1.6 = 2.4$

For a bottom screen this gives $H_t/H_i = 0.6$; so, forty percent damping.

For a surface screen this gives $H_t/H_i = 0.2$; so, eighty percent damping.

In model tests, carried out by Wiegel and Friend with floating sheets of plastic material, it was discovered that the sheets will have a wave-damping effect if the length λ is equal to several times the wave length.

Some results:

$\frac{\text{length slab } \lambda}{\text{wave length } L}$	$\frac{\text{transmitted wave height } H_t}{\text{incoming wave height } H_i}$
5	0.8
10	0.4 - 0.5
20	0.2

Another type of a flexible floating breakwater is bags filled with water. The damping effect is probably caused by a wave which is generated inside the bags and which is not in phase with the incoming surface wave.

In the Delft Hydraulics Lab., tests have been executed in order to determine the wave-damping effects of fascine mattresses. With the fascine mattress reinforced with scaffolding-poles, the following results are obtained in the model.

$\frac{\lambda}{L}$	$\frac{H_t}{H_i}$
0.5	0.9
0.75	0.6
1	0.4
1.25	0.3

Fixed constructions, other than normal breakwaters, are arrays or rows of piles, and movable, partly submerged constructions. Pile rows are not very effective since the energy that is transmitted is proportional to the relative opening between the piles. When the distances between the piles is equal to their diameter the transmitted energy is fifty percent. Since the wave energy is proportional with H^2 , the wave attenuation is only 0.7.

See for more results Publication no. 42 of the Delft Hydraulics Laboratory, written by J.J. Vinjé.

References:

1. A.T. Ippen
"Estuary and Coastline Hydrodynamics"
Mc. Graw-Hill.
2. R.L. Wiegel.
"Oceanographical Engineering"
Prentice Hall
3. Technical Report No. 4
"Shore Protection, Planning and Design"
U.S. Army Coastal Engineering Research Center.
4. Proceedings on several conferences on "Coastal Engineering"
American Society of Civil Engineers.
5. R.J. Hudson
"Laboratory Investigations of Rubble-Mound Breakwater"
U.S. Army Engineers, Waterways Experiment Station, Vicksburg 1959.
6. A.J. Rogan
"Destruction criteria for rubble-mound breakwaters"
Proc. Coastal Eng. Conference 1968.
7. "On Optimum Breakwater Design"
Delft Hydraulics Laboratory, Publication no. 31
8. A. Paape
"Some Aspects of the Design Procedure of Maritime Structures"
Int. Navigation Congress, Paris, 1969.
9. J.J. Vinjé
"Increase of effective working time during operations at sea by means
of moveable structures".
Delft Hydraulics Laboratory, Publication no.42.