

P5 | June 2025

# TRASH INTO TREASURE

Designing a **Circular Public Condenser** in Bispebjerg, Copenhagen

Marit Smit

Graduation studio 'Public Condenser in Copenhagen'

Architecture and Public Building | TU Delft

Paul Kuitenbrouwer, Stefano Corbo, Elina Karanastasi



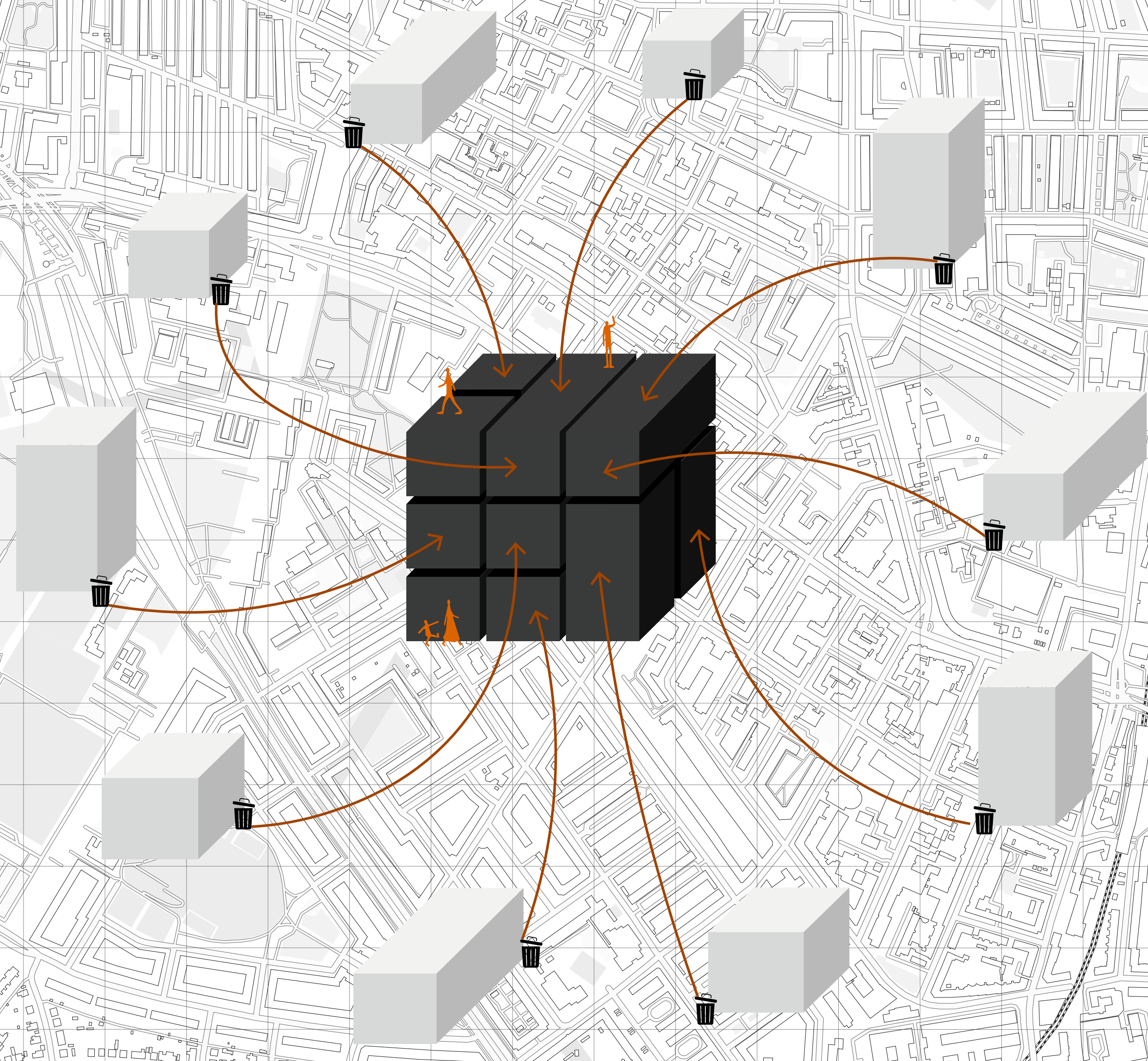

## A Public Condenser that:

**Transforms waste into resources**

built using locally sourced and reused materials

**Encourages circularity**

through shared spaces, hands-on activities, and workshops

**Strengthens connections**

by bringing together local residents and students

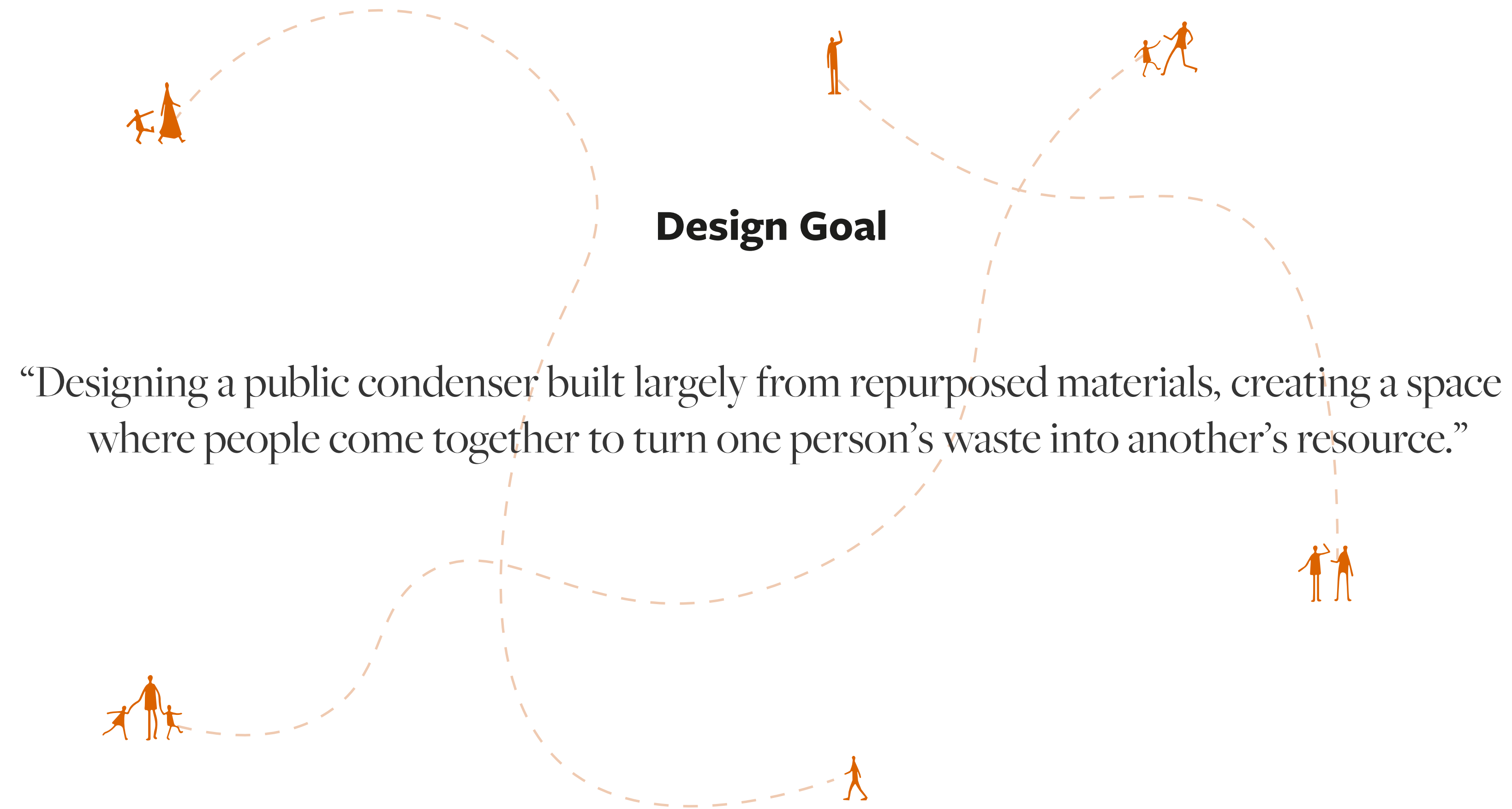

# ‘How can circularity be implemented in a public condenser to contribute to and inspire a more circular neighbourhood in Bispebjerg, Copenhagen?’

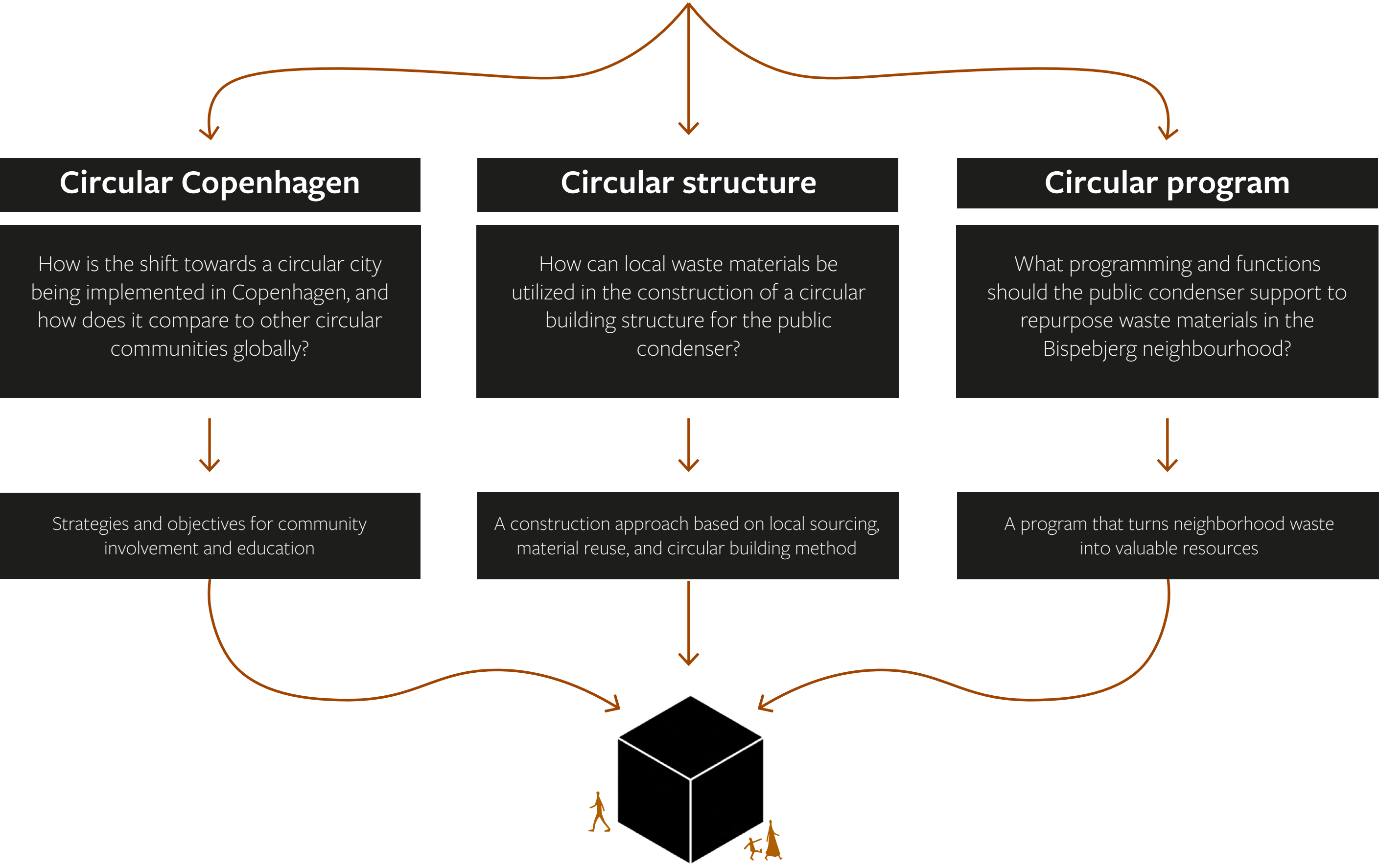

## **Contents**

Problem statement

Site Context

Circular Design Strategy

From Strategy to System

From System to Space

The Public Condenser in the City

From Design to Impact

# Problem statement

**Cities are at the forefront the natural resource crisis, consuming 80 %  
of global resources and generating 50% of the world's waste.**



Denmark's economy is only 4% circular. This is considerably lower than the global average, measured at 7.2% in 2023.

*The Circularity Gap Report, 2023*





### **EU Circular Economy Action Plan**

A carbon-neutral, environmentally sustainable, toxic-free and fully circular economy by 2050.

*The European Commission, 2023*



### **Denmark National Plan for Circular Economy**

Bending the waste curve: less waste, more resource efficiency and more reuse. A climate-neutral waste sector by 2030.

*Ministry of Environment of Denmark, 2020*



## 2019 - Resource & Waste Management Plan

- 70 % of household and light industrial and commercial waste to be sorted and collected for recycling
- Tripling reuse

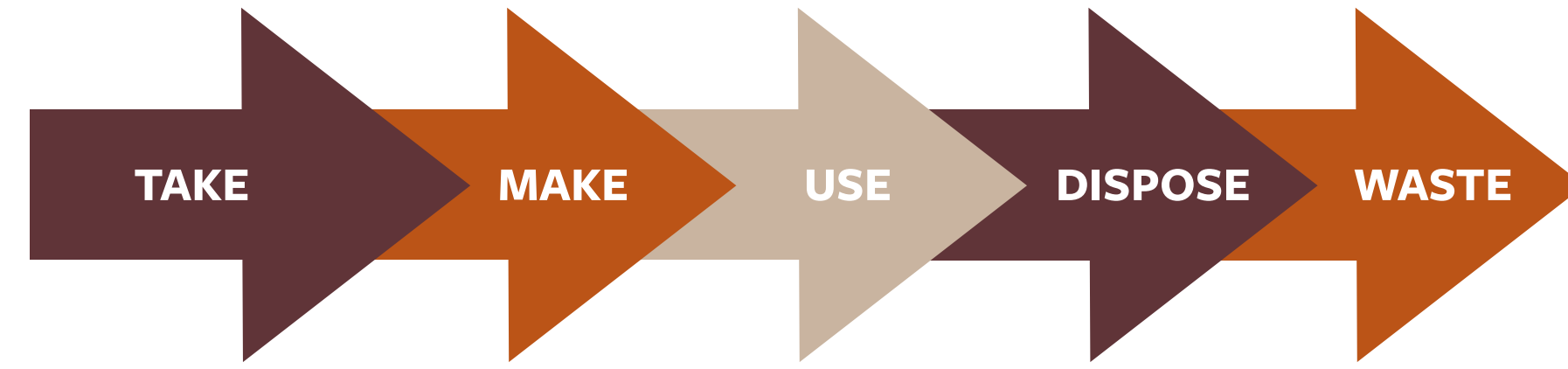

Linear Economy

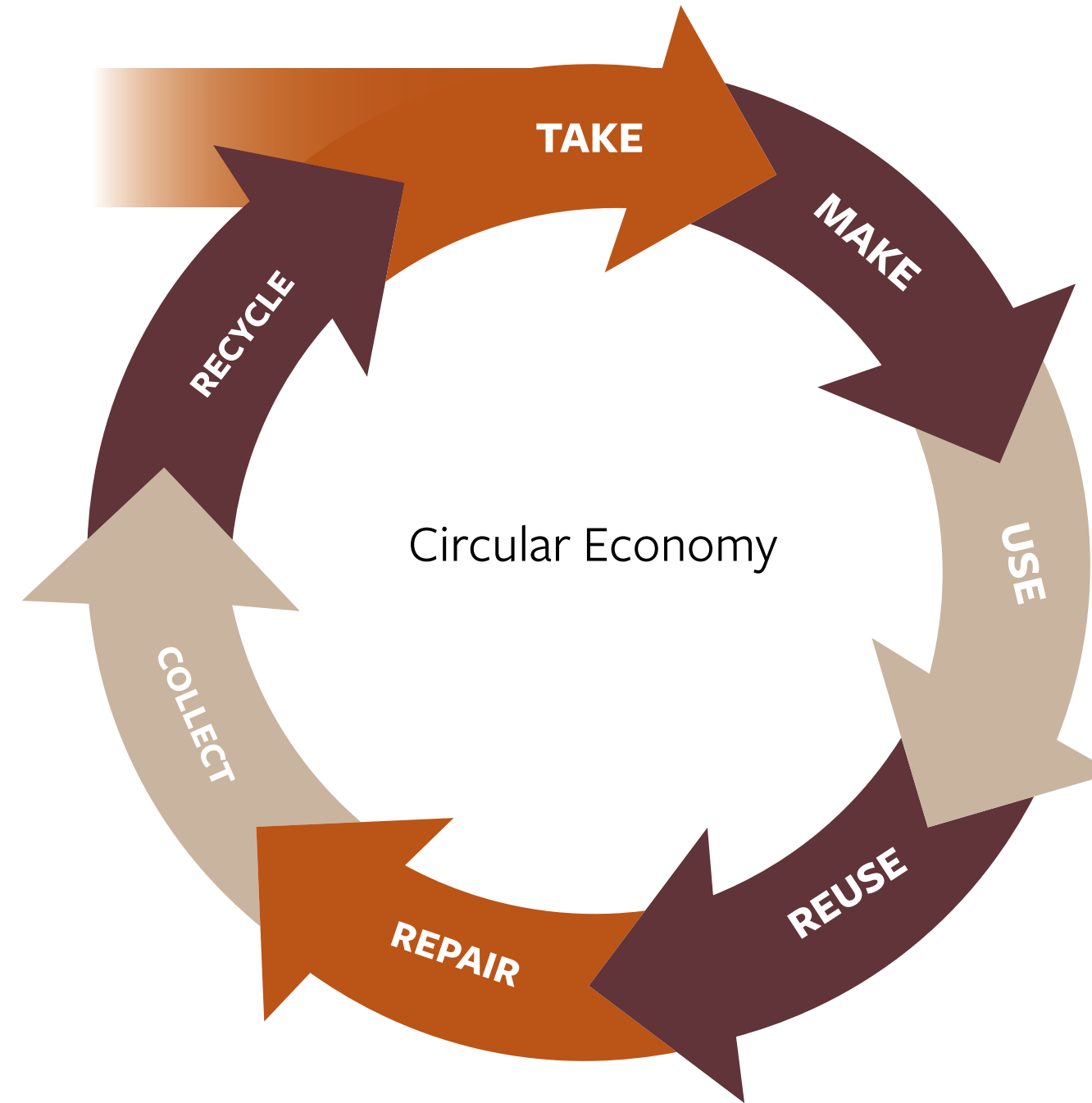

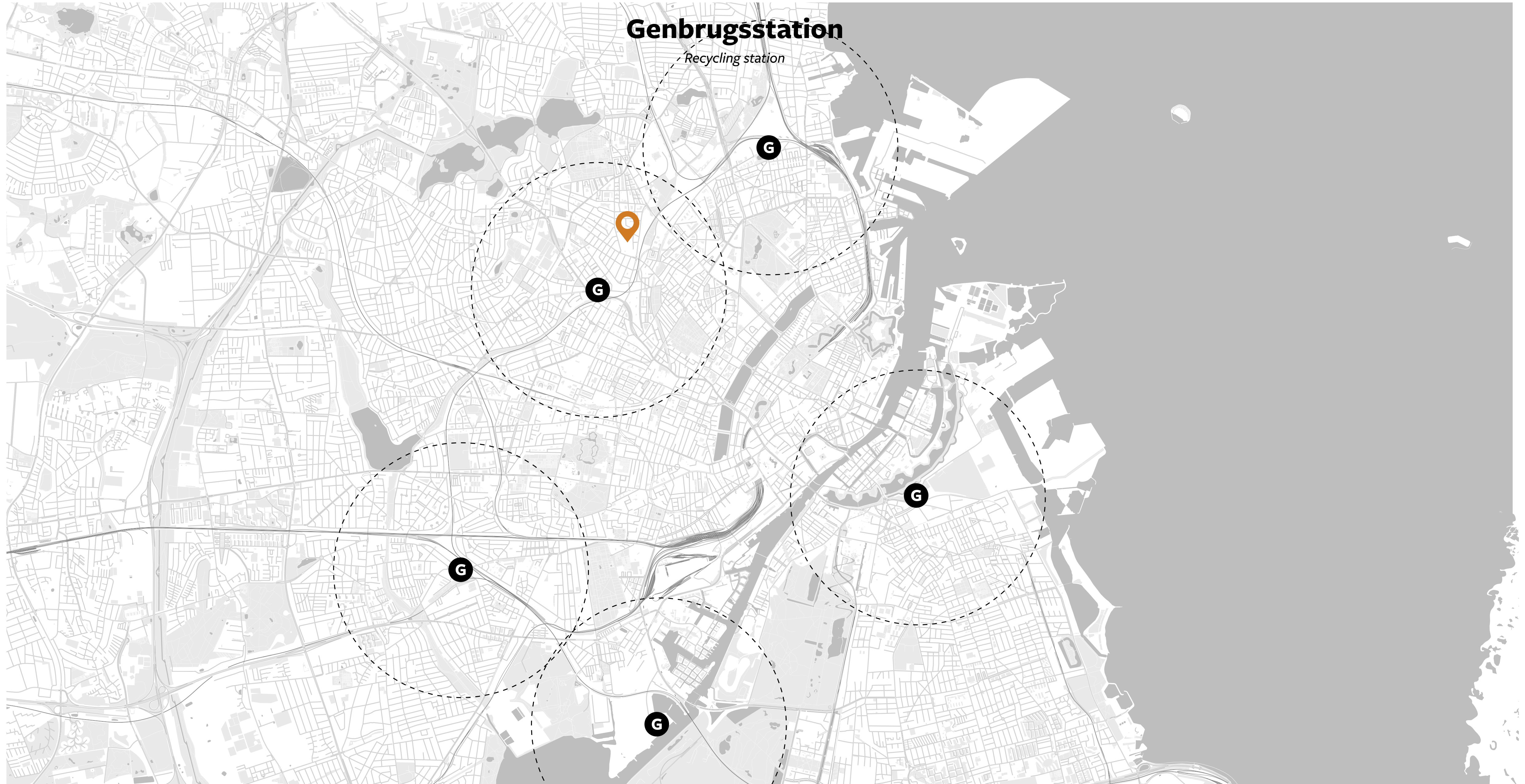

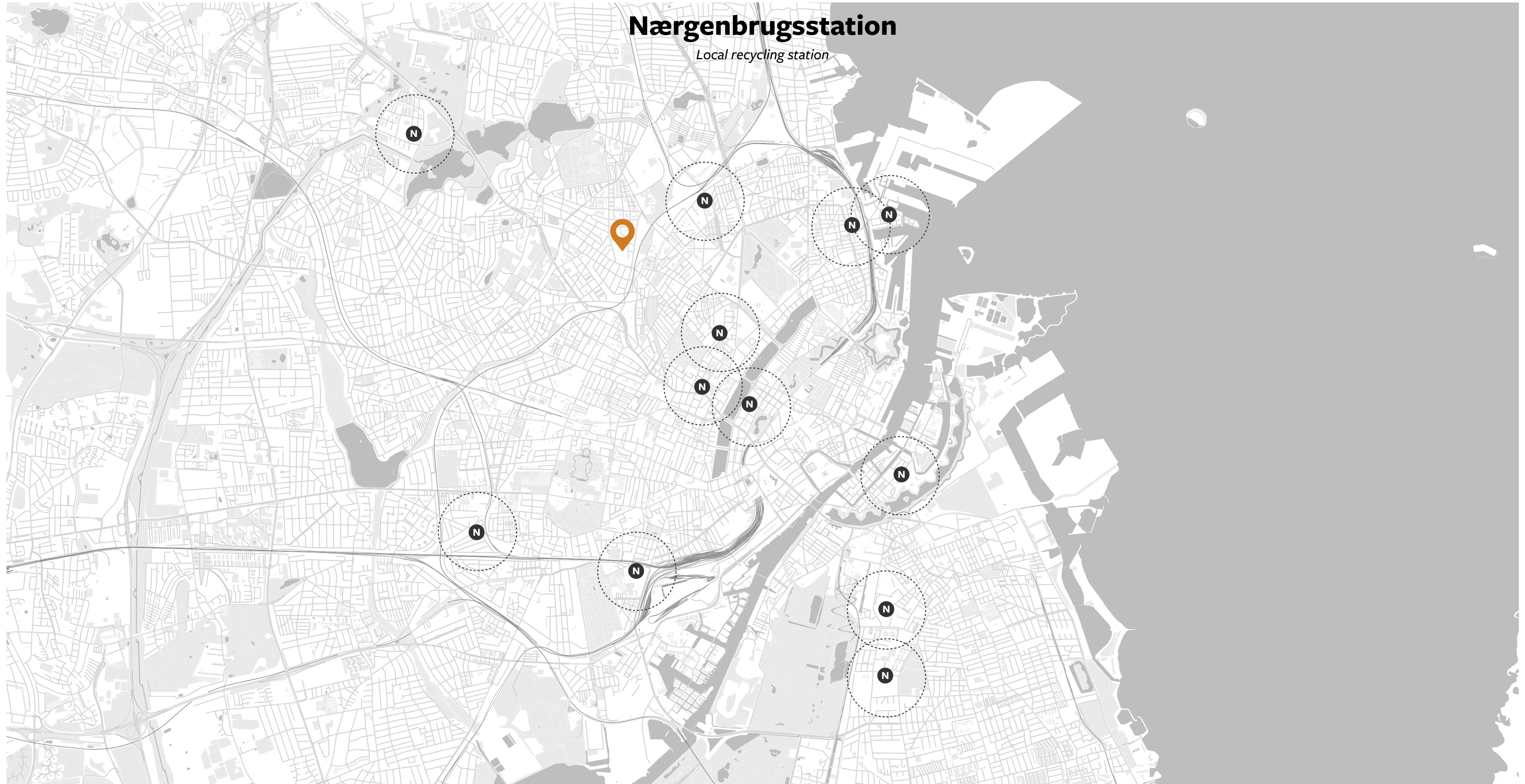

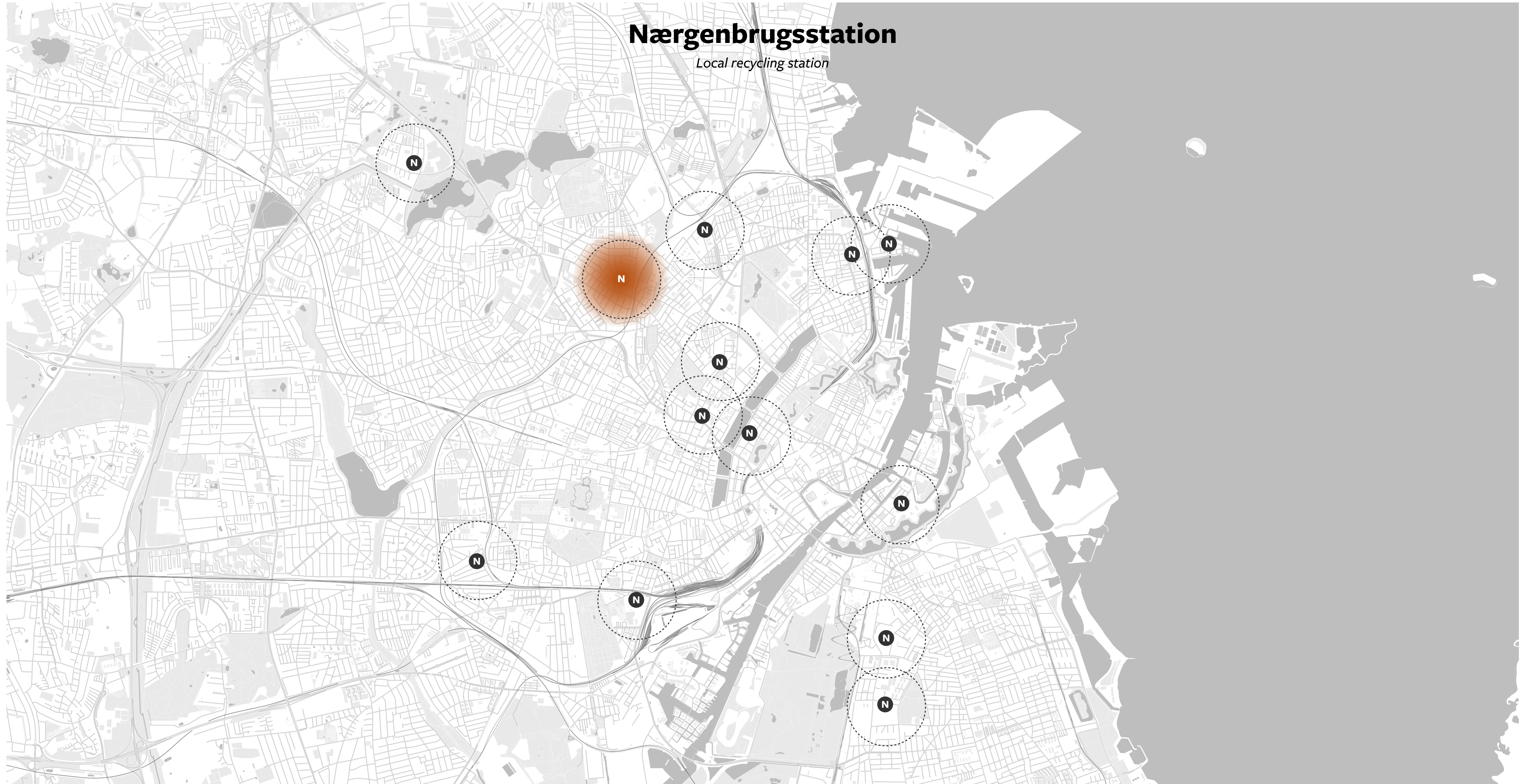

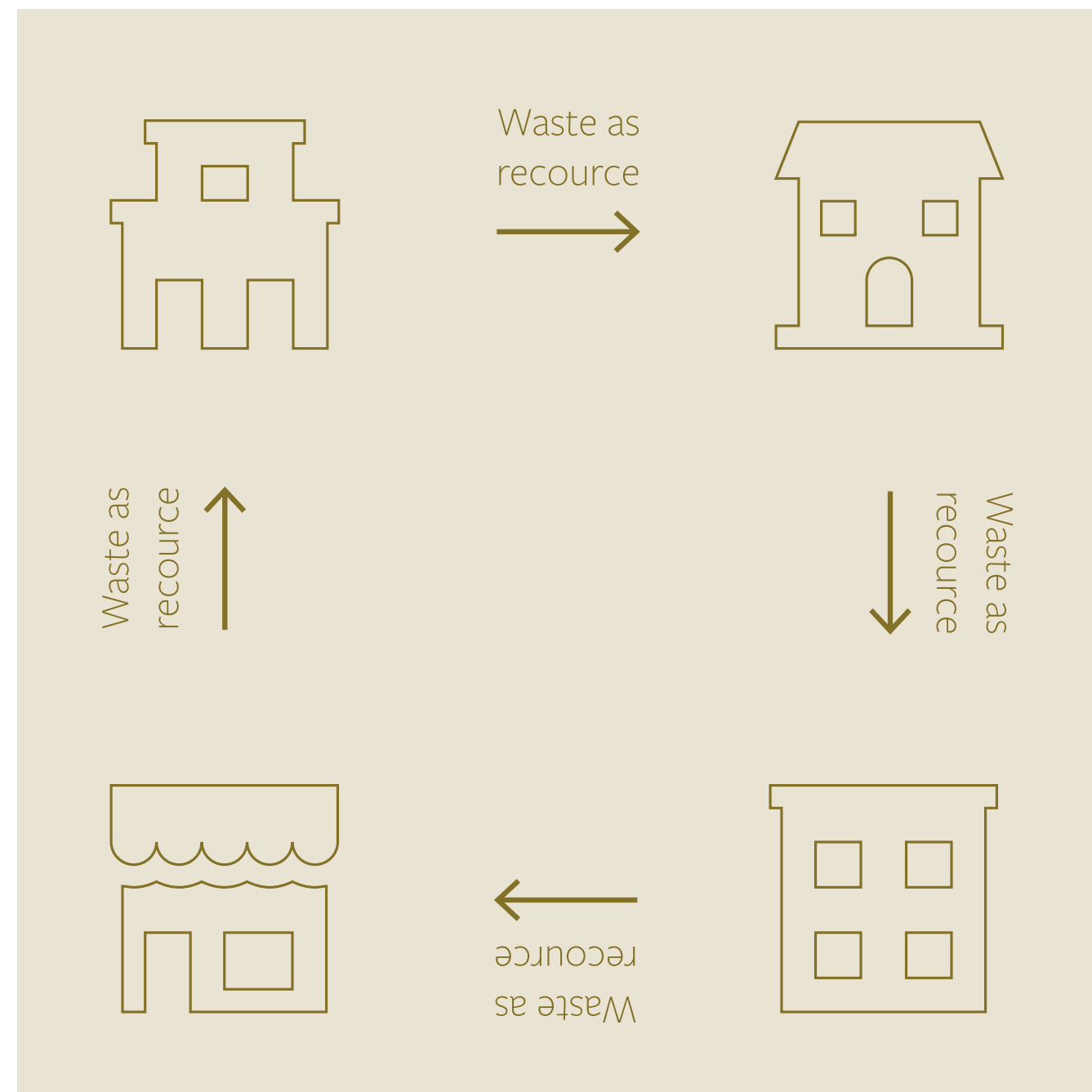
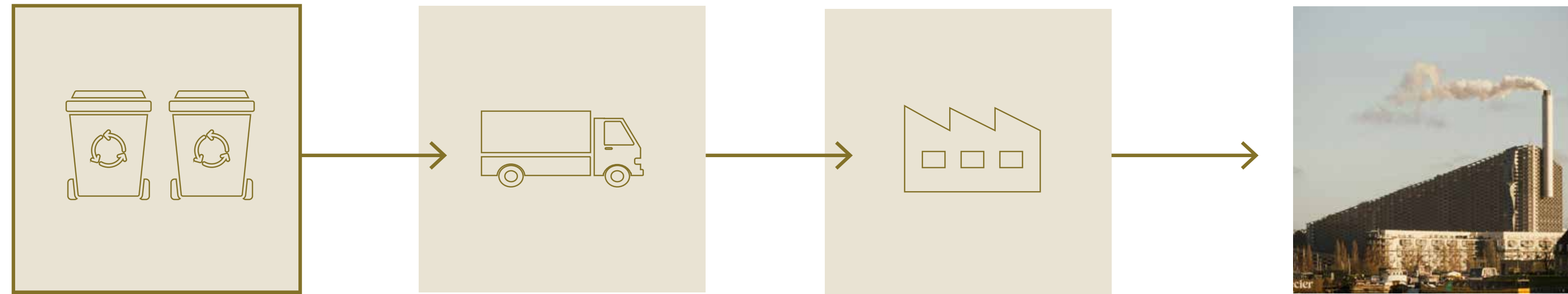

### Urban Symbiosis

- 'One's waste product, becomes another's resource.'
- Focus on local production for local consumption.

# Site Context

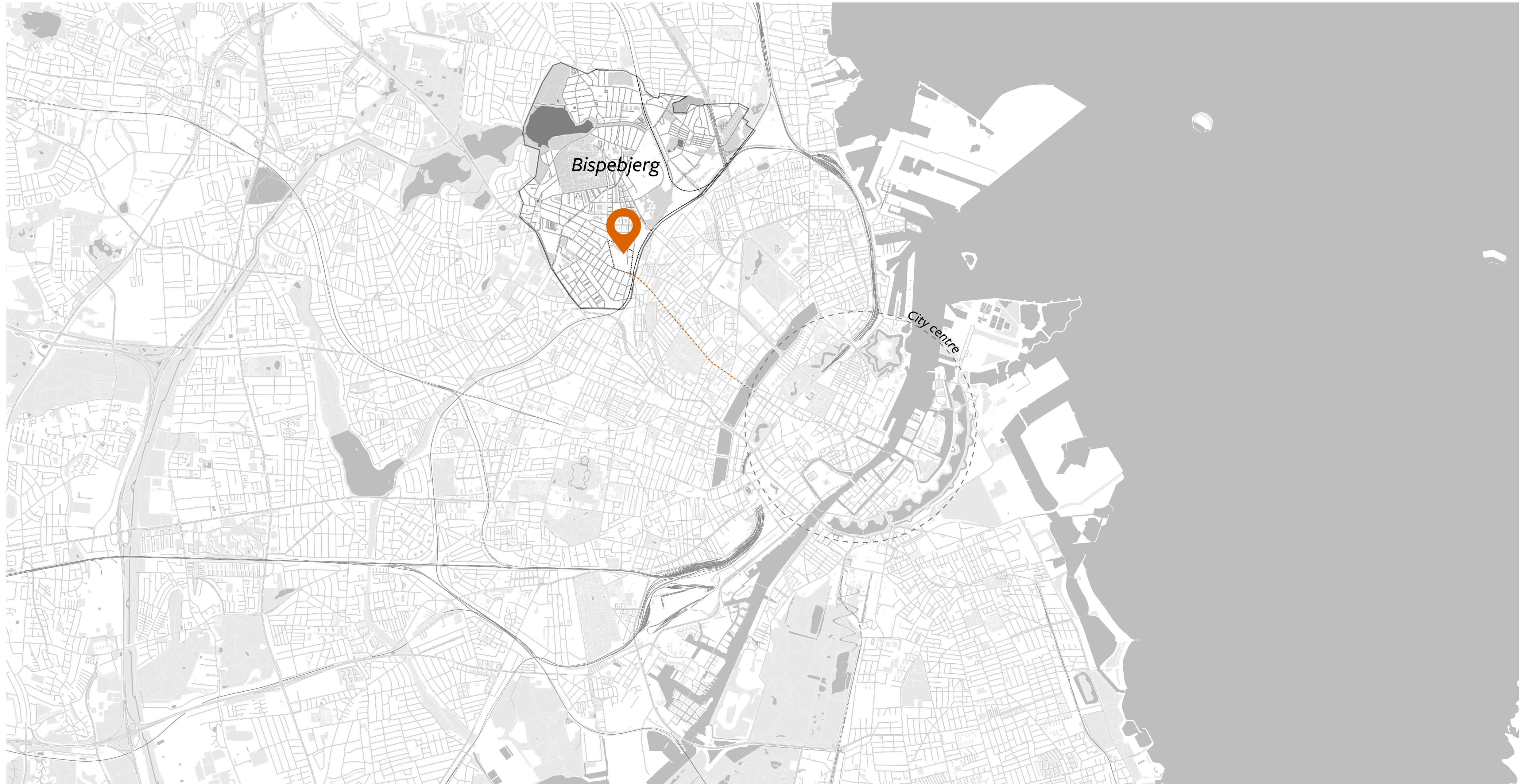



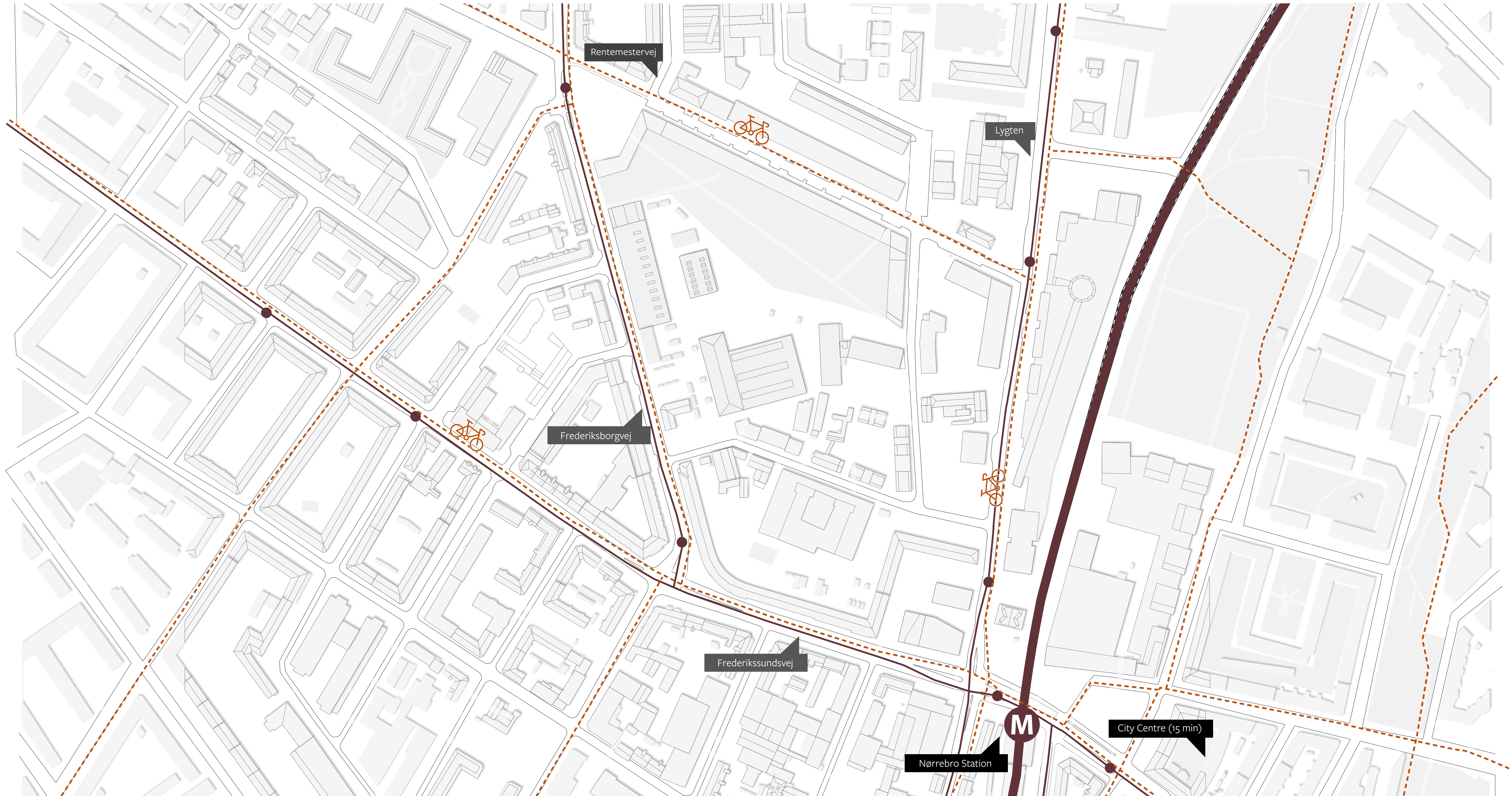



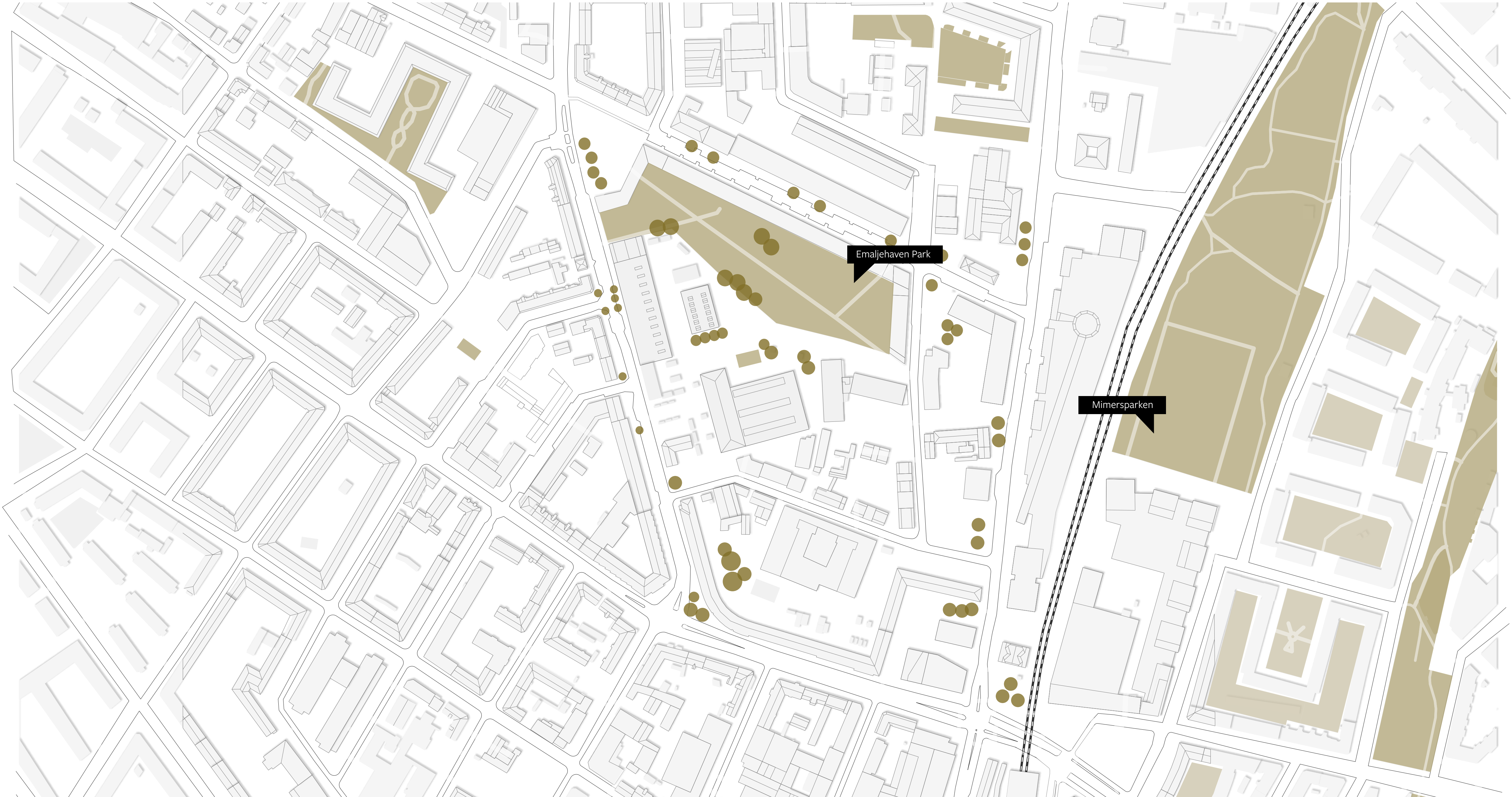

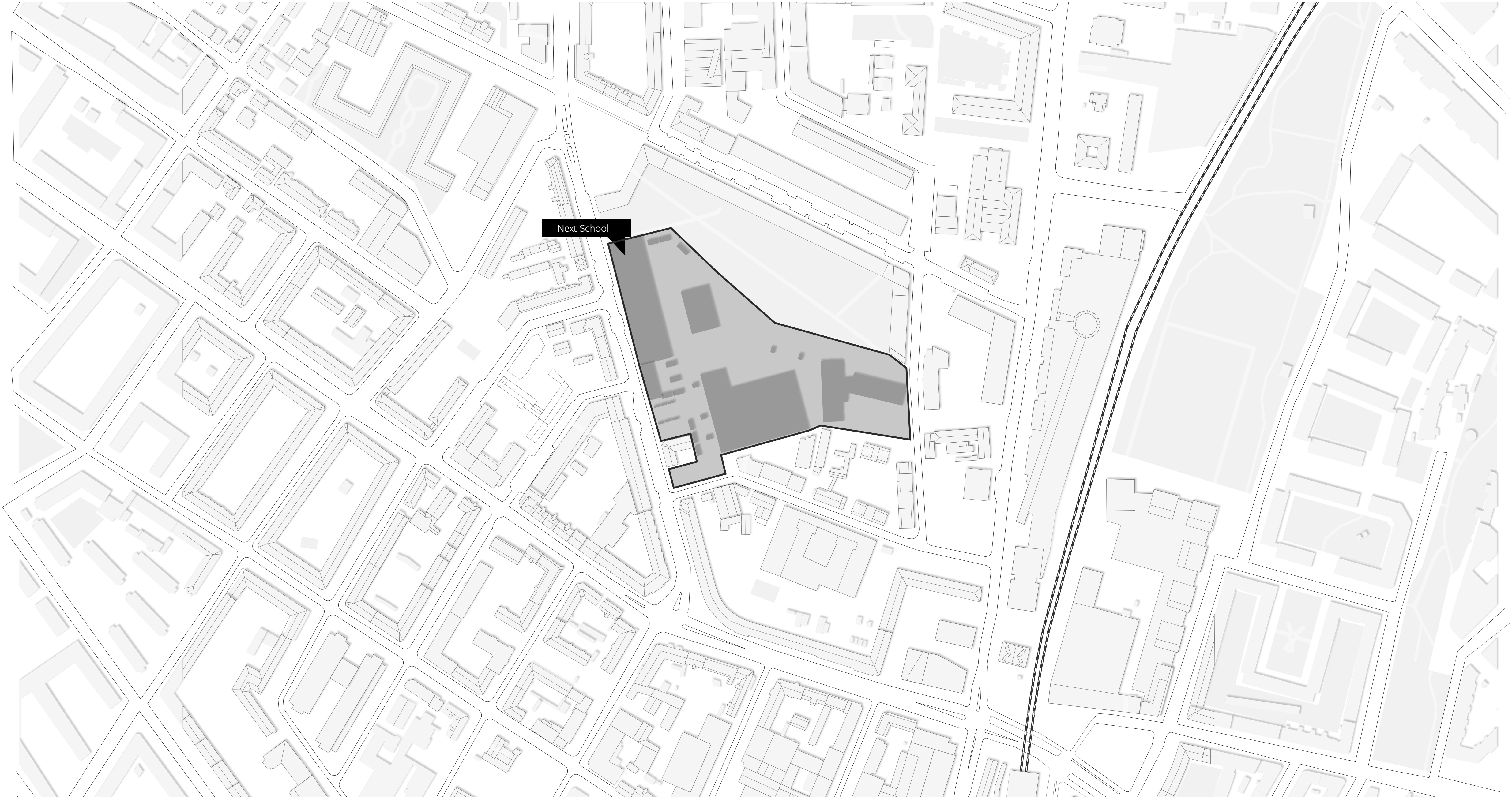



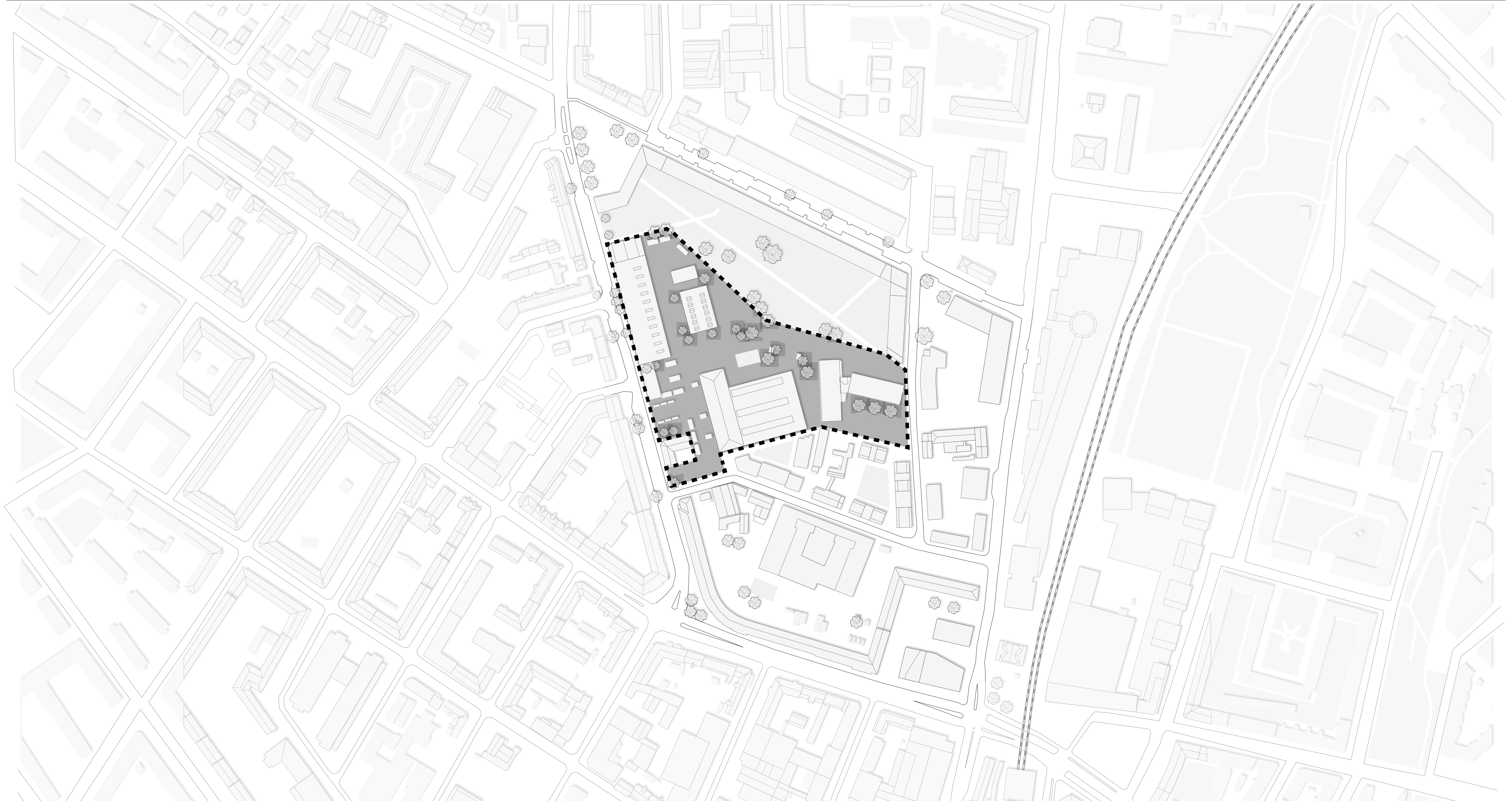

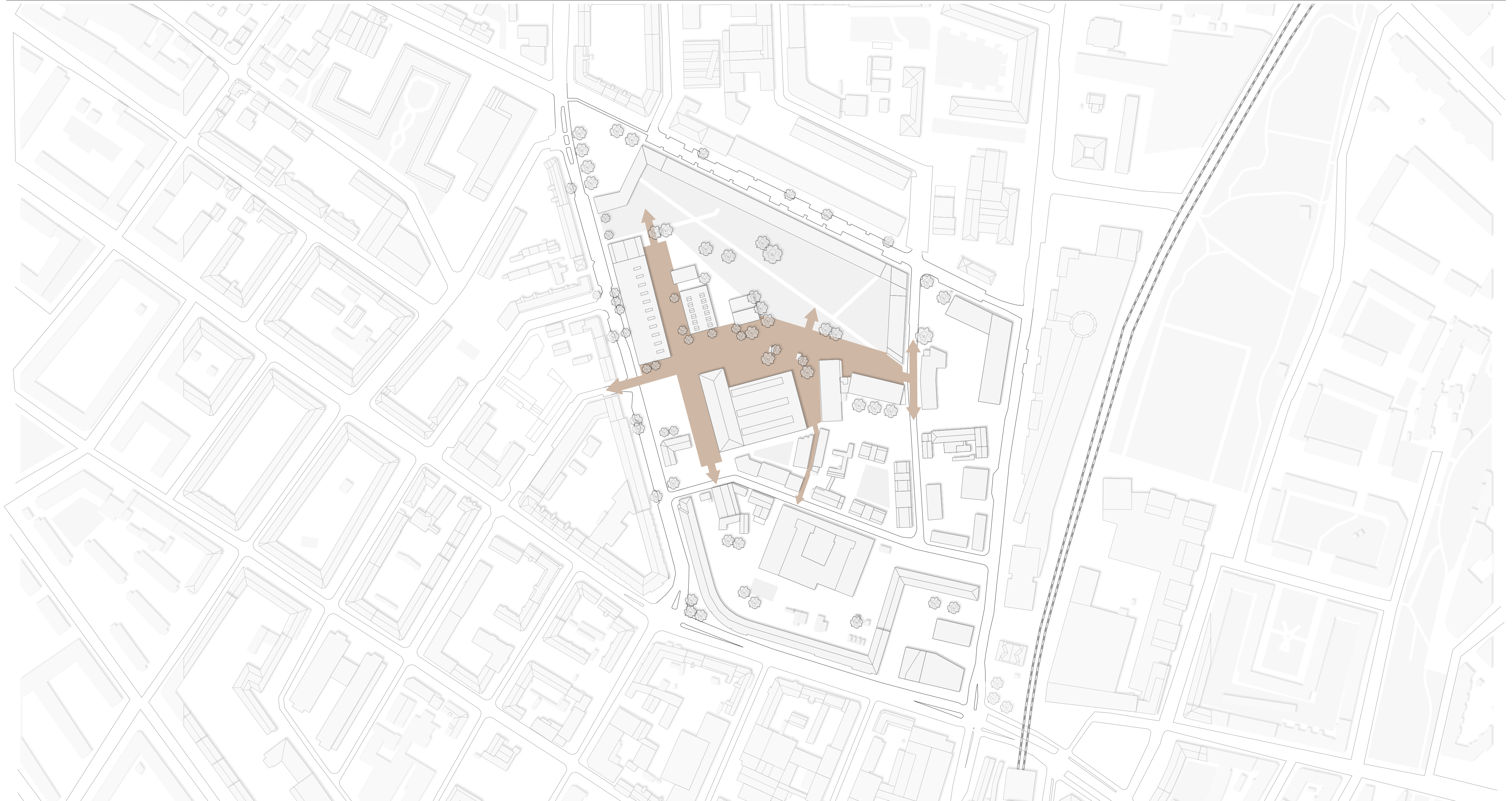

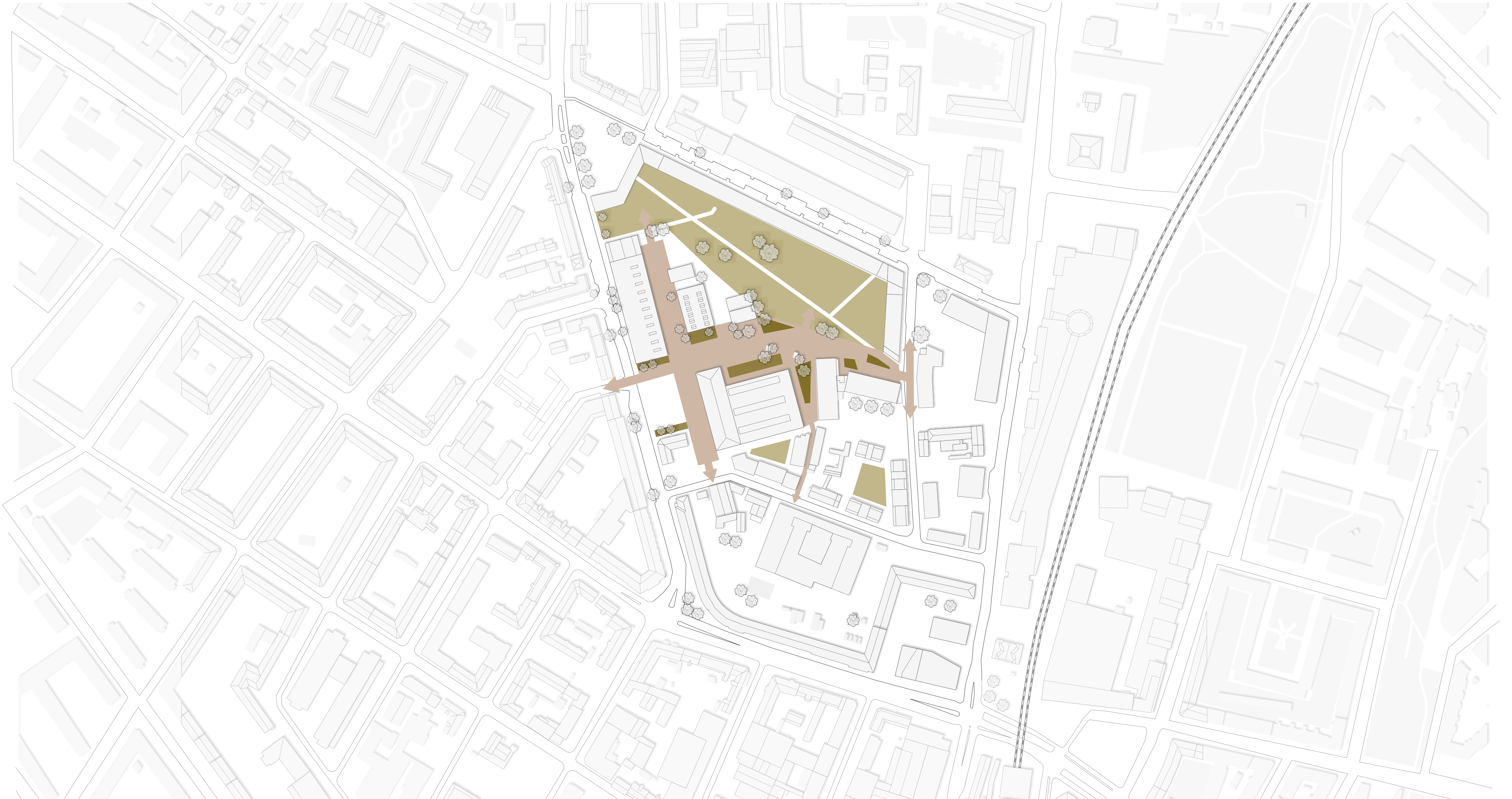

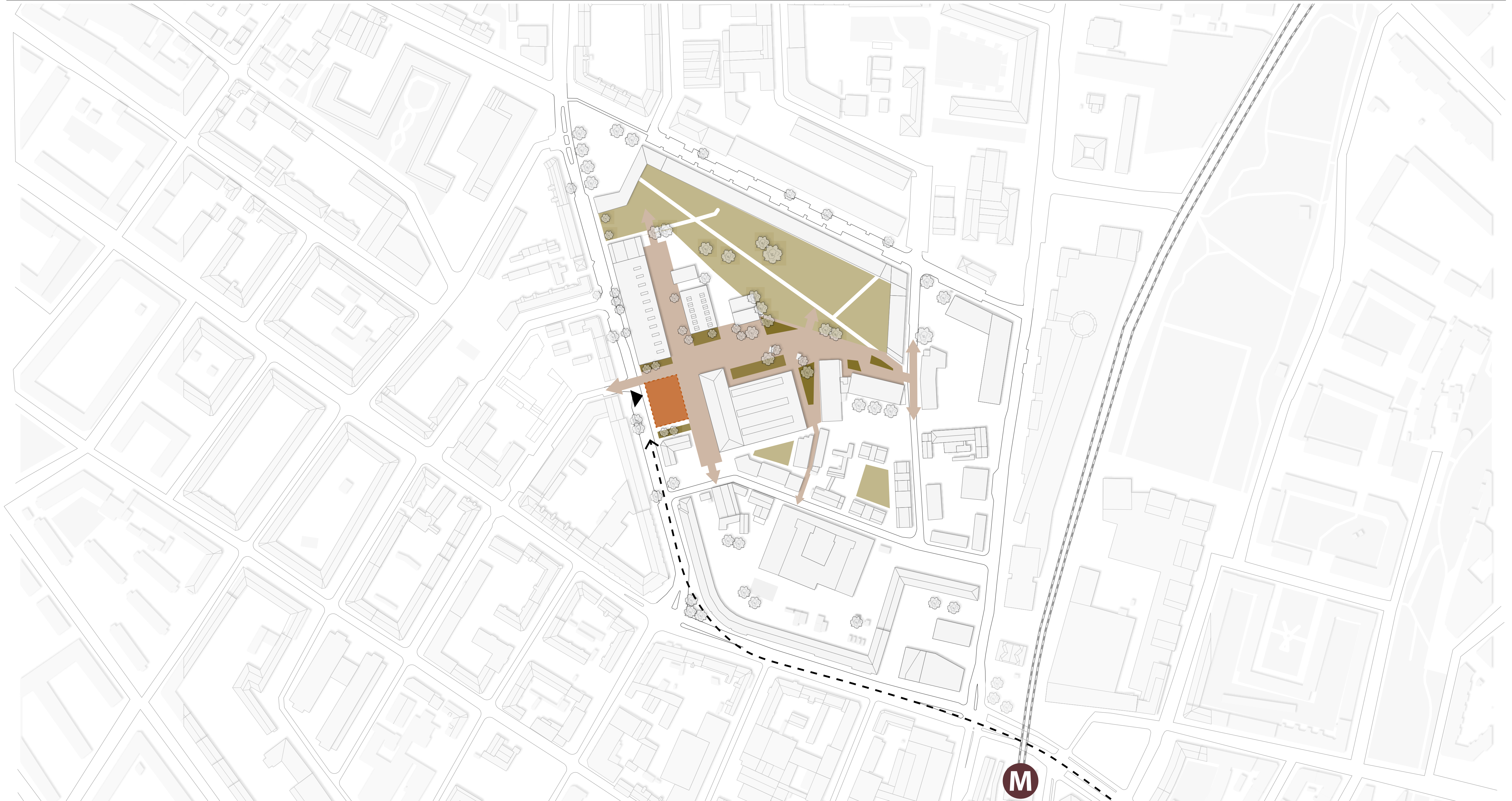

# Circular Design Strategy

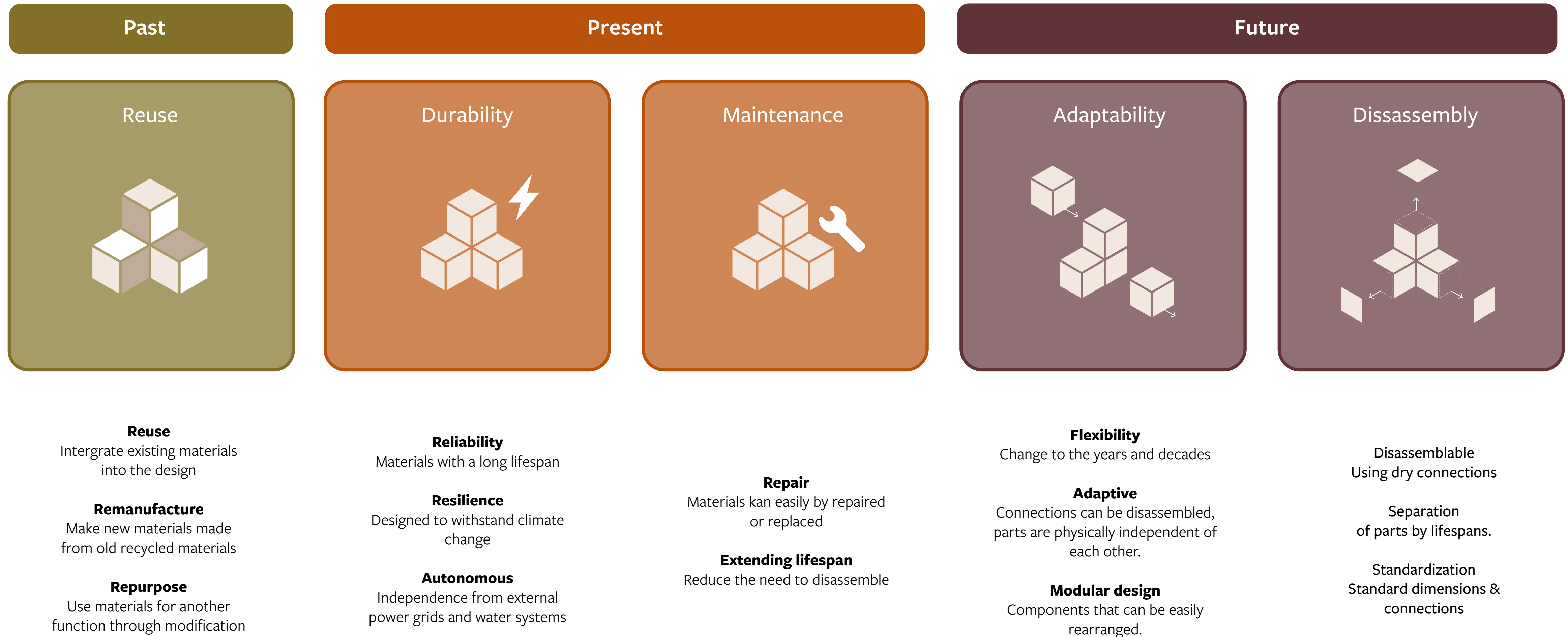

### Circular Materials: Decision Tree

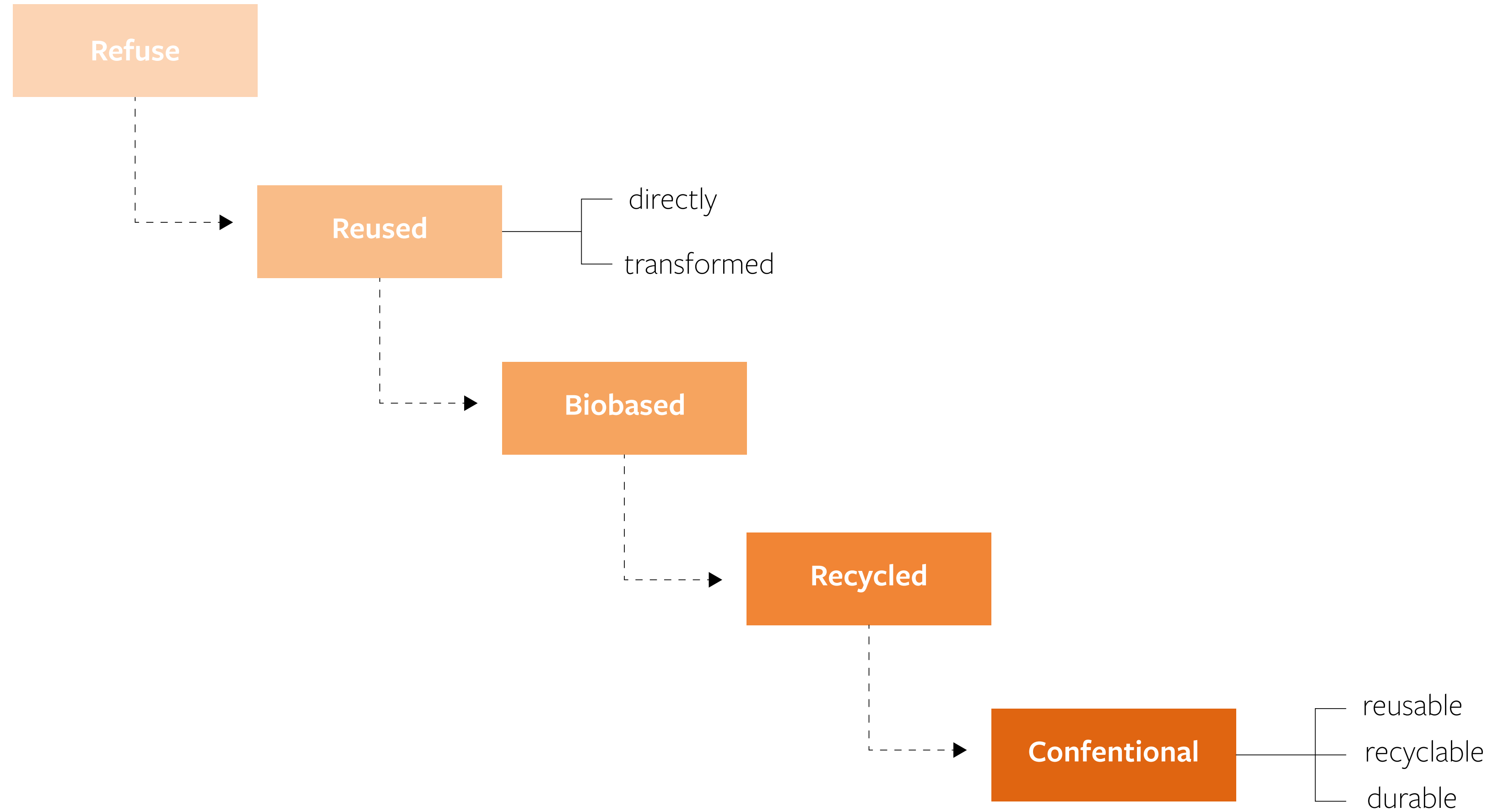

## Urban Mining : The city as a material stock



*Lendager, Resource rows*

# From Strategy to System

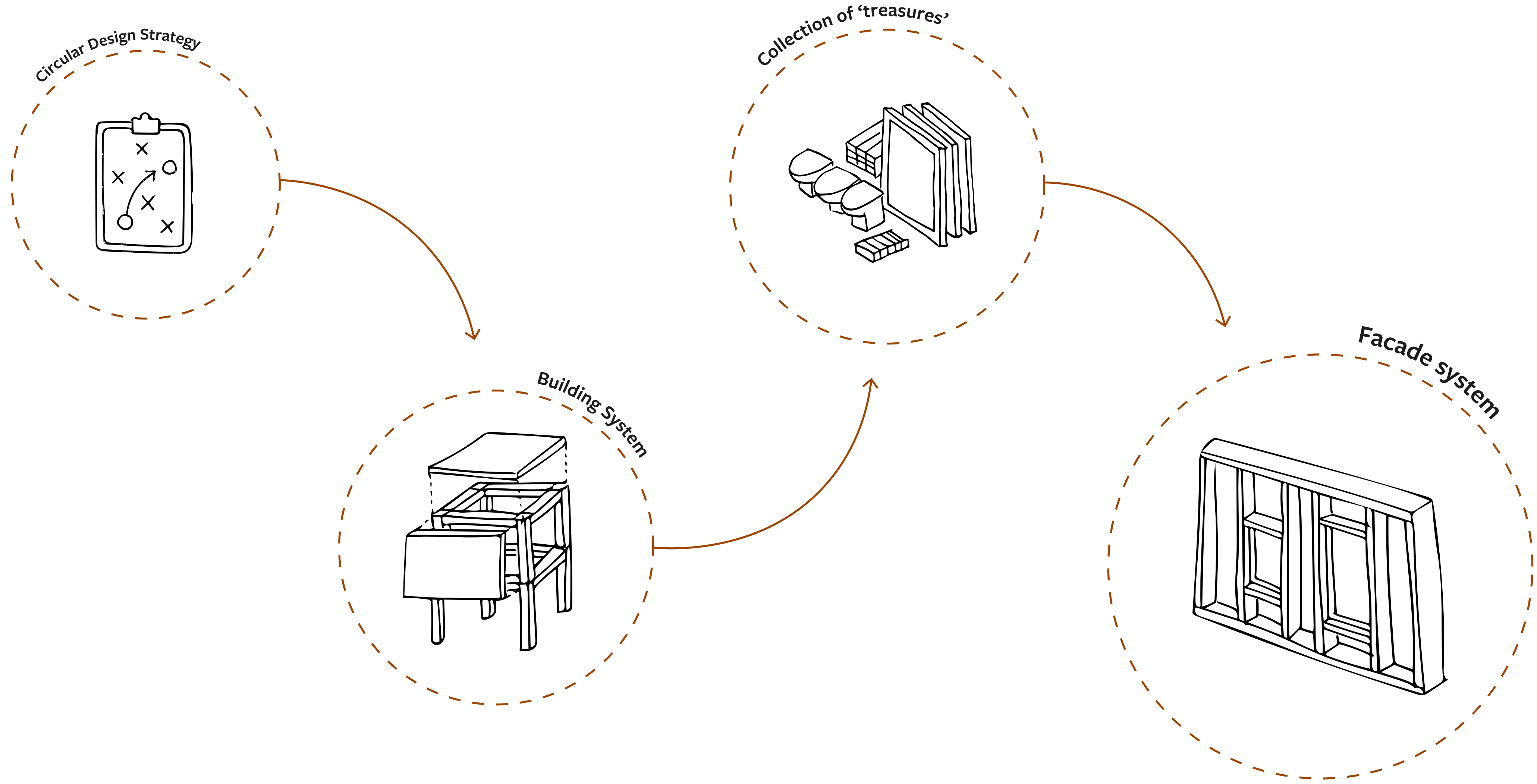

Greendozer, Aarhus

JK genbrugscenter, Odense

Genbyg, Kastrup

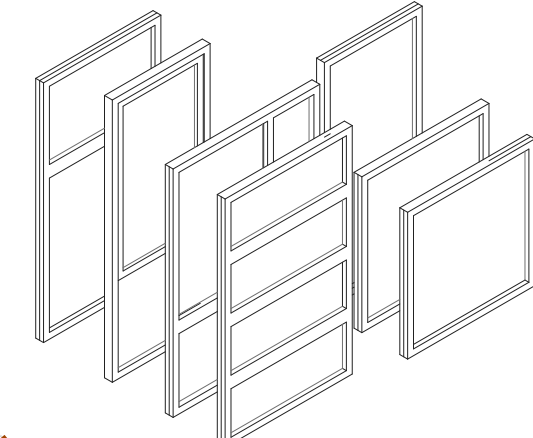
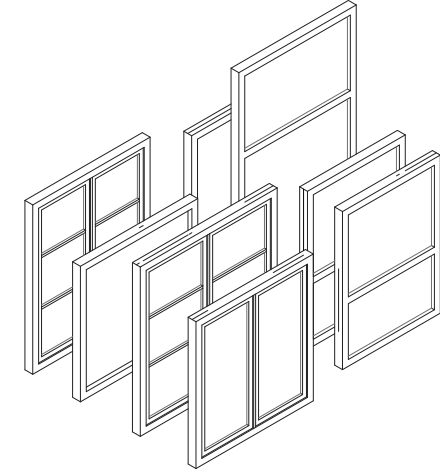
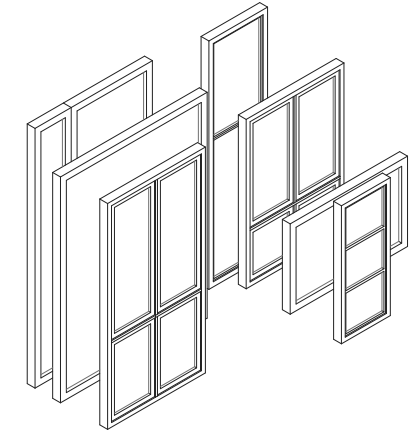

180 km



45 km

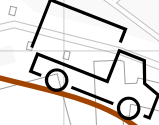

190 km



Taasinge Elementer, Svendborg

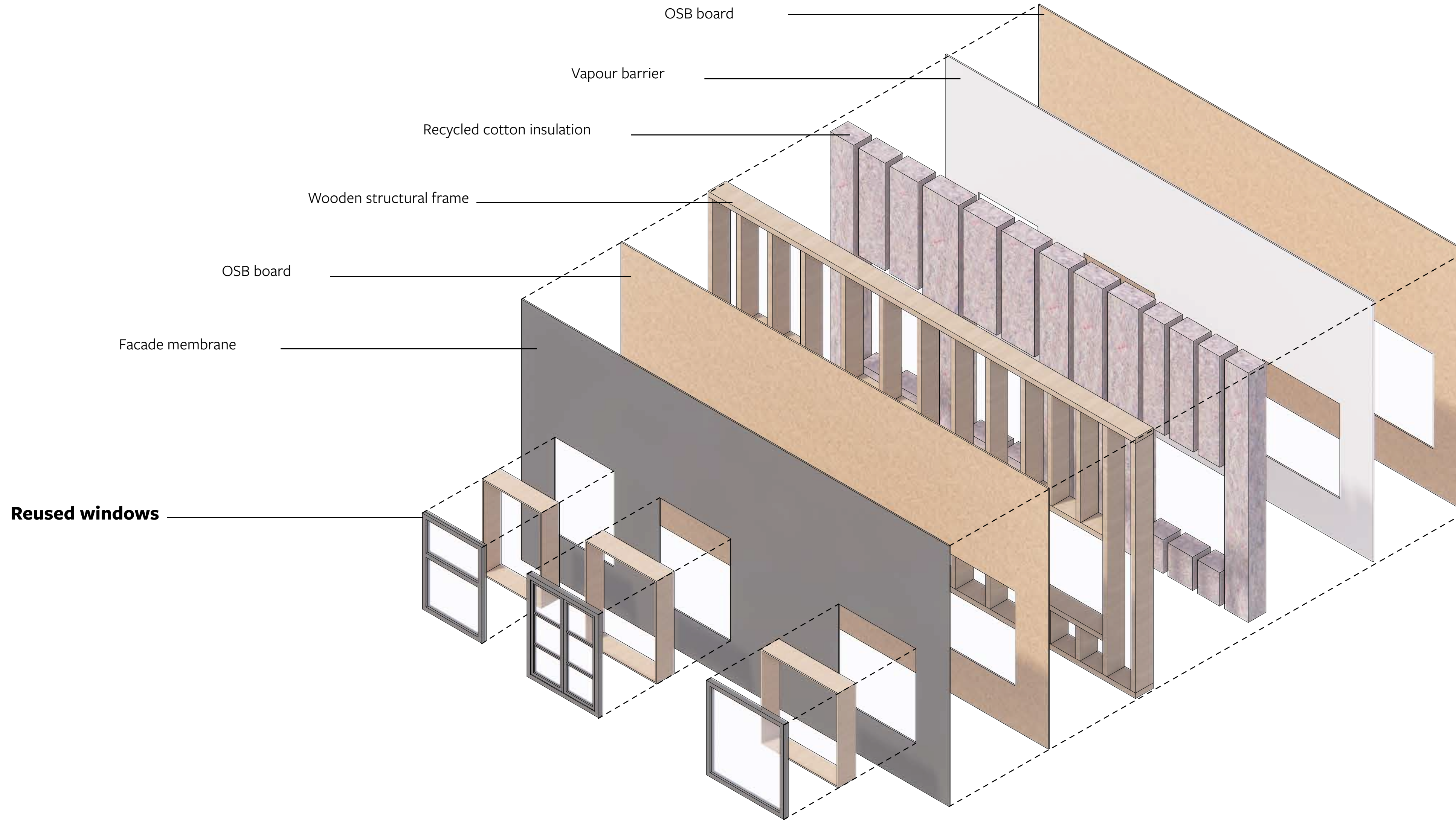

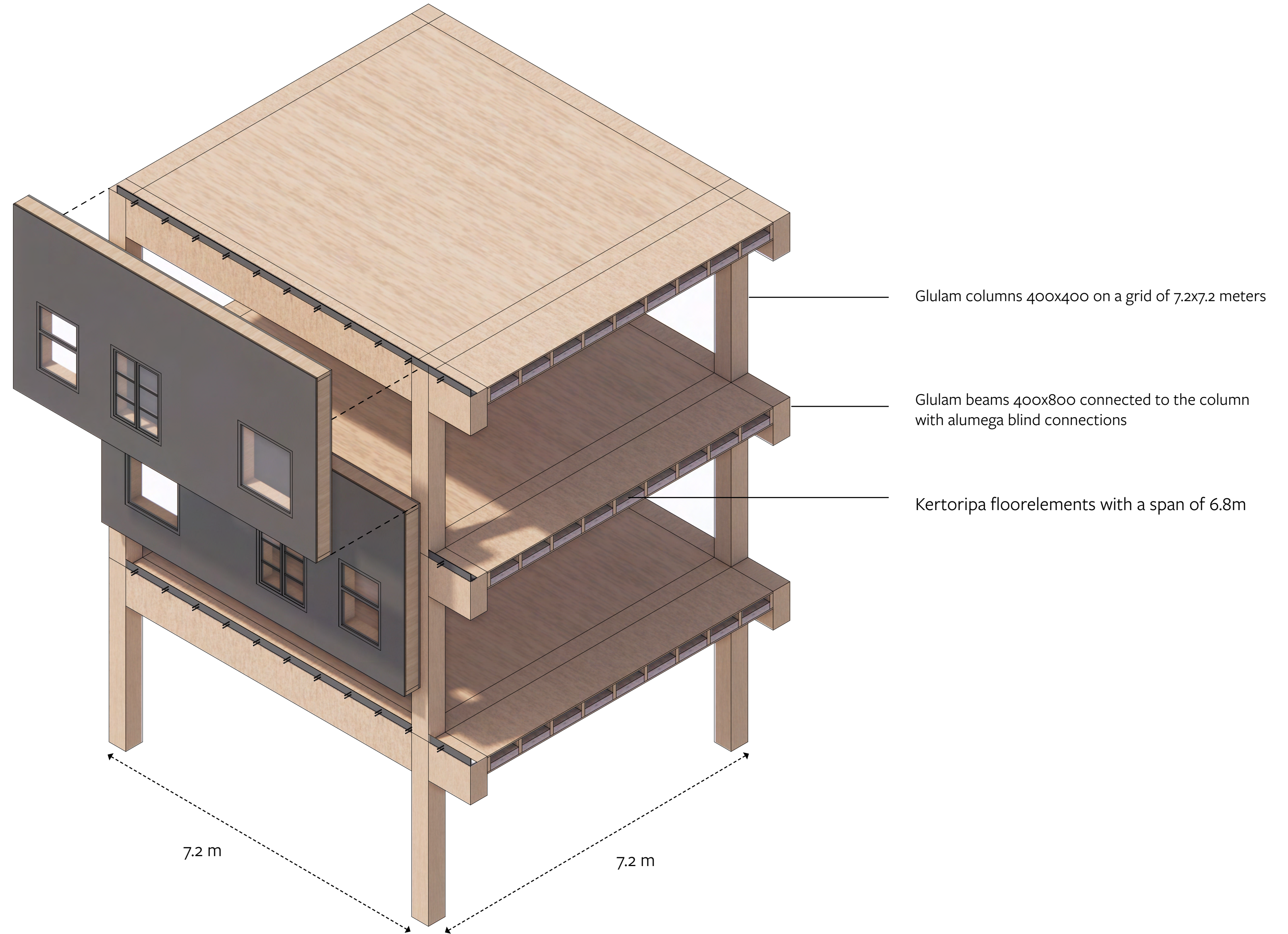

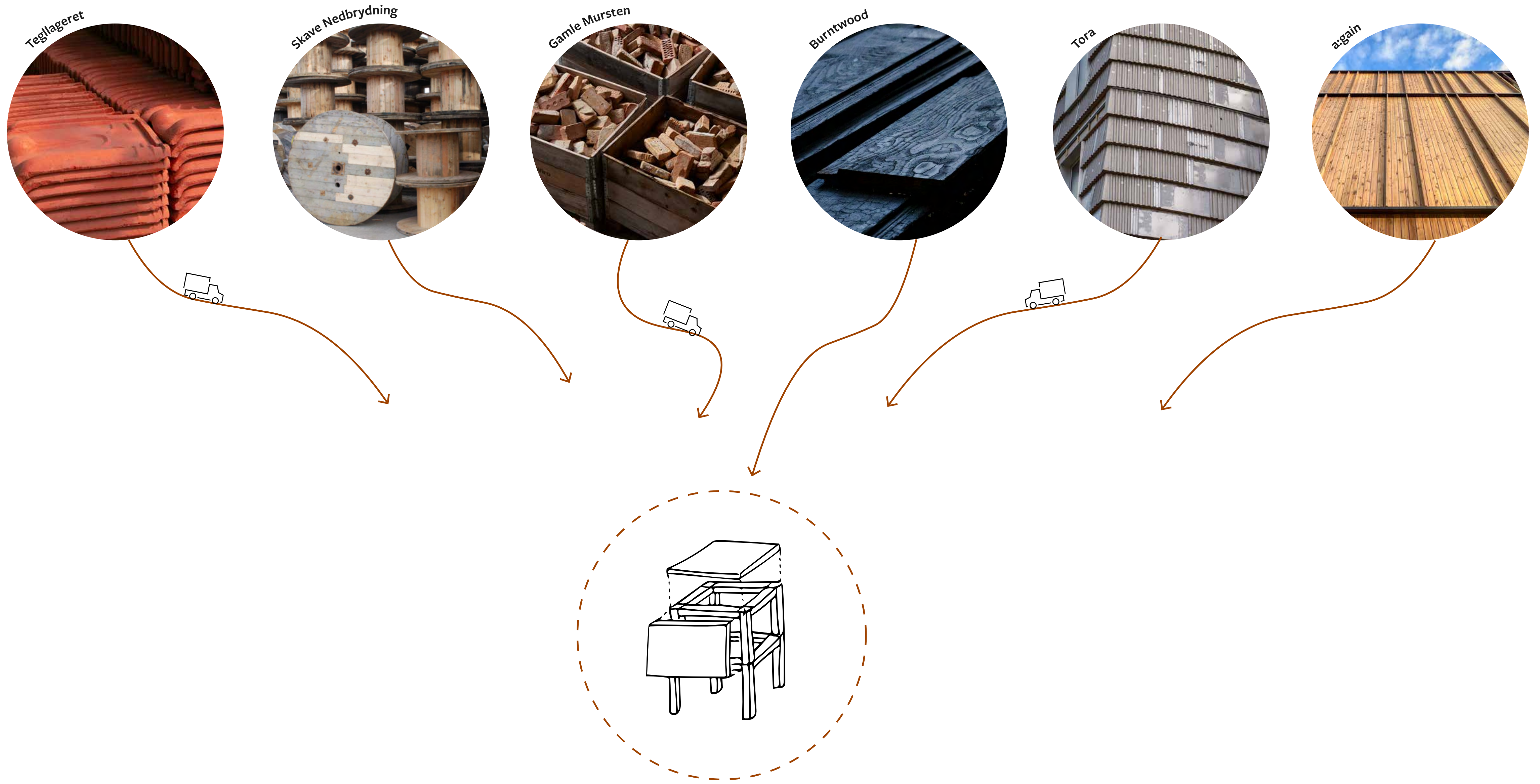

20 mm OSB board

PE-HD vapour barrier

recycled cotton insulation

wooden structural frame with reused windows

OSB panel with bio-EPDM facade membrane

Timber facade slats

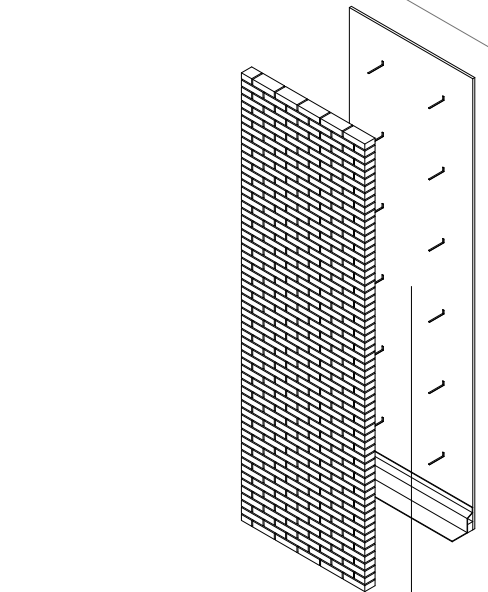

Reused brick cladding

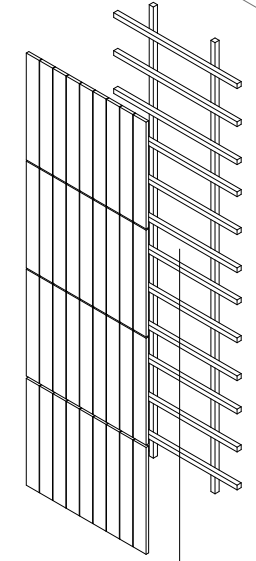

Reclaimed wood cladding

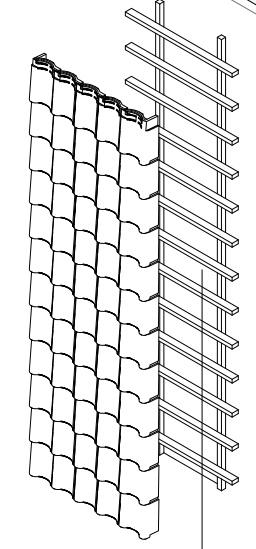

Reused roof tiles cladding

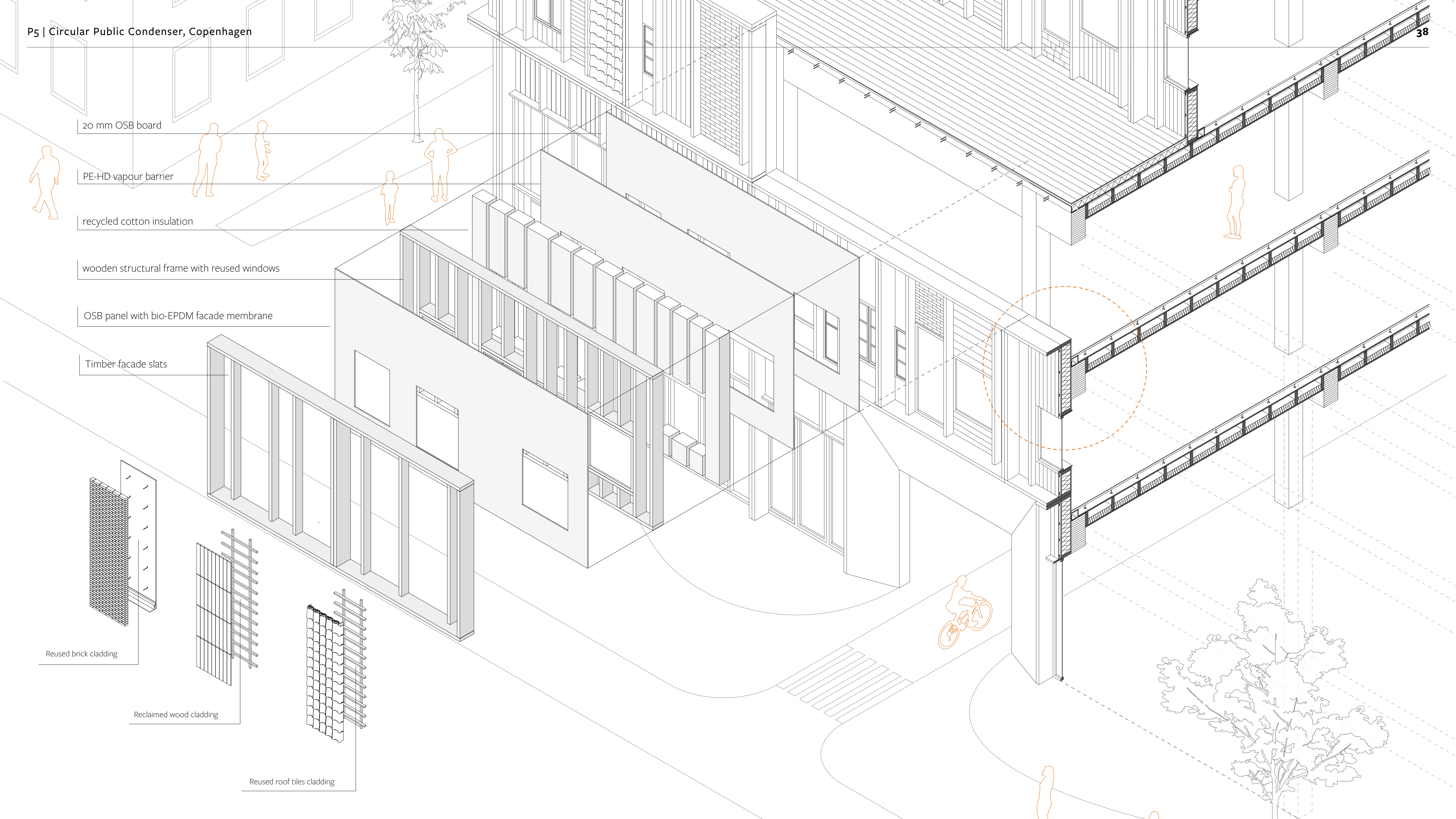

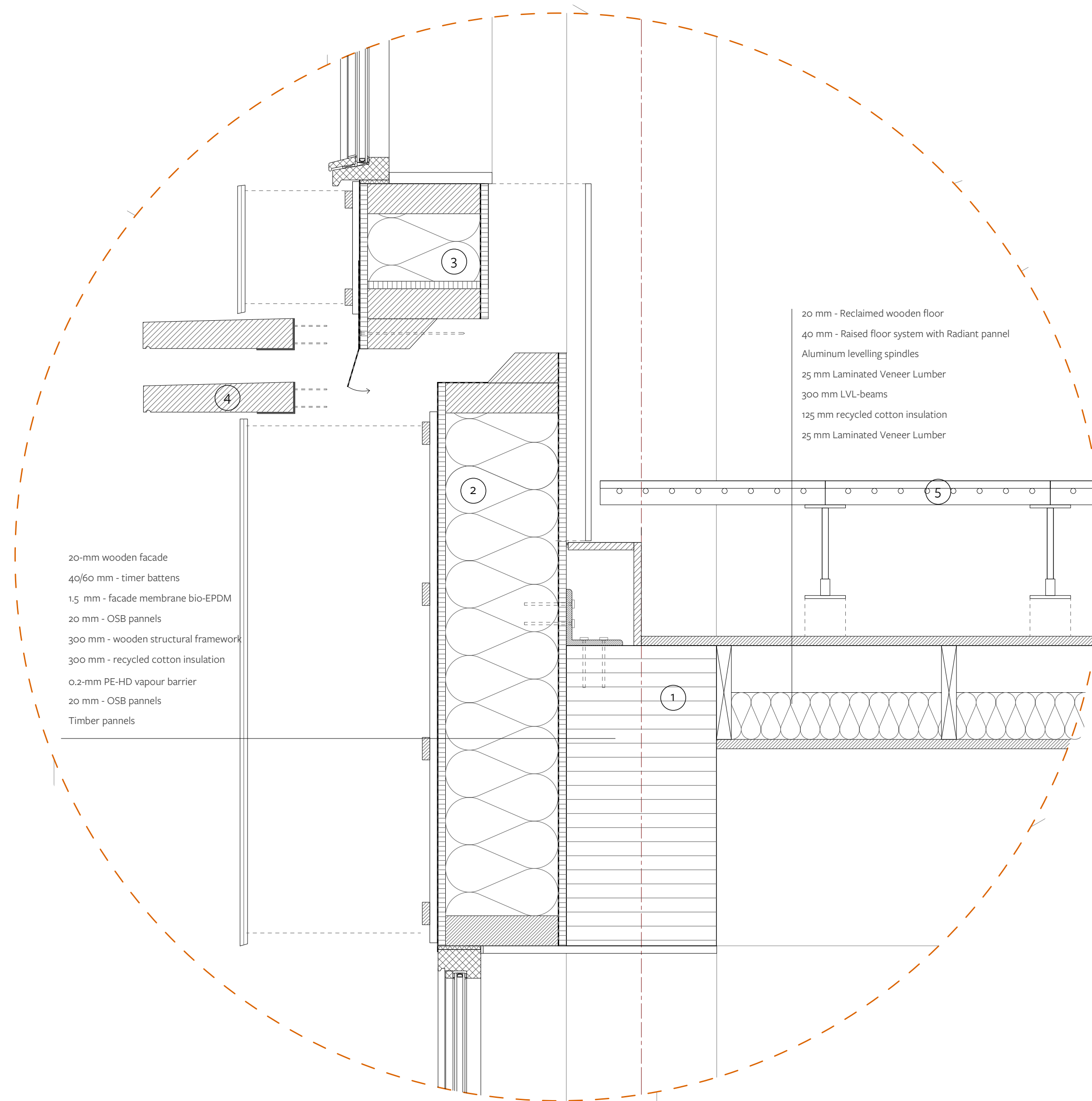

20-mm wooden facade  
 40/60 mm - timer battens  
 1,5 mm - facade membrane bio-EPDM  
 20 mm - OSB pannels  
 300 mm - wooden structural framework  
 300 mm - recycled cotton insulation  
 0,2-mm PE-HD vapour barrier  
 20 mm - OSB pannels  
 Timber pannels

20 mm - Reclaimed wooden floor  
 40 mm - Raised floor system with Radiant pannel  
 Aluminum levelling spindles  
 25 mm Laminated Veneer Lumber  
 300 mm LVL-beams  
 125 mm recycled cotton insulation  
 25 mm Laminated Veneer Lumber



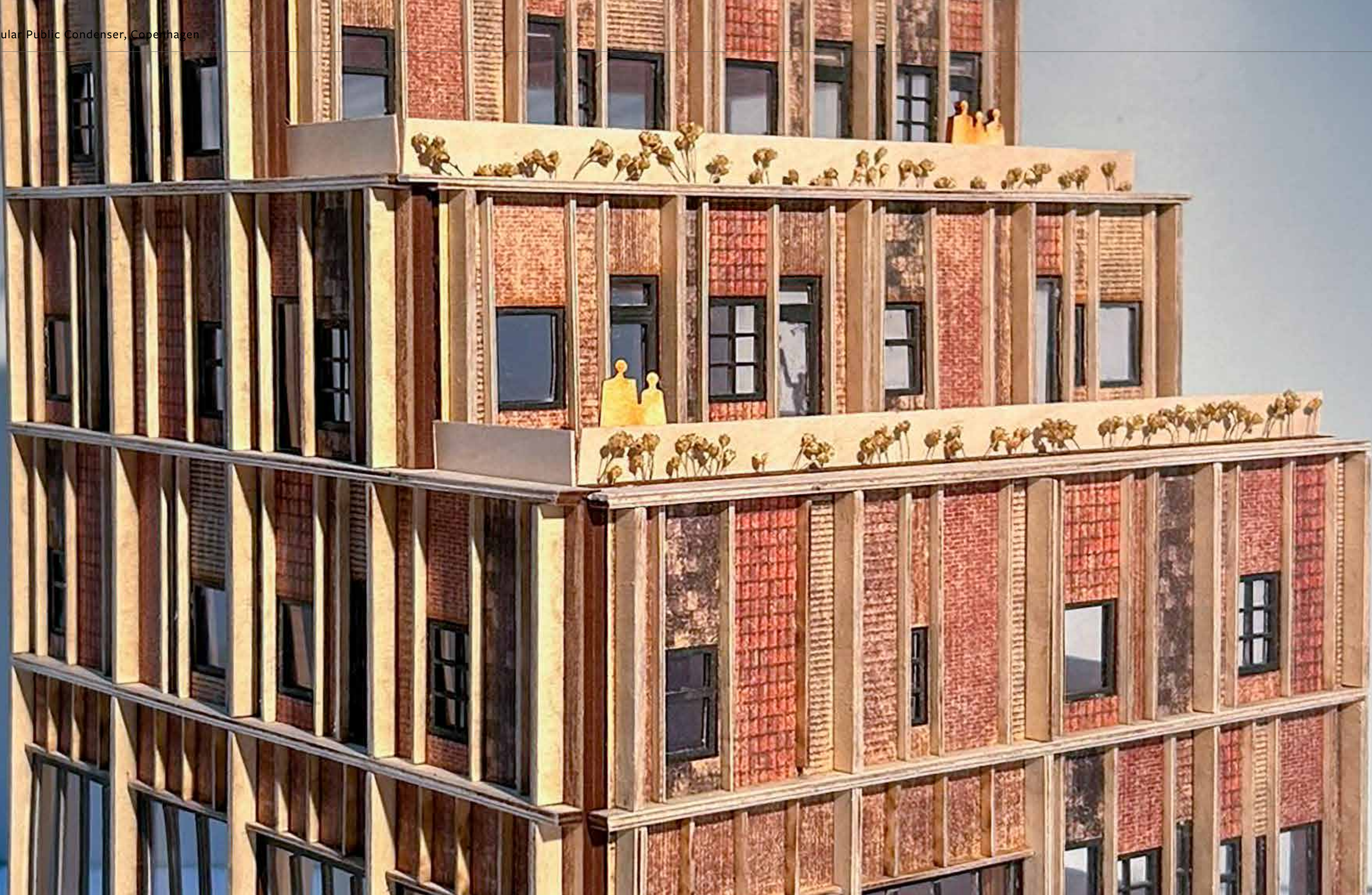

# From System to Space: The Public Condenser

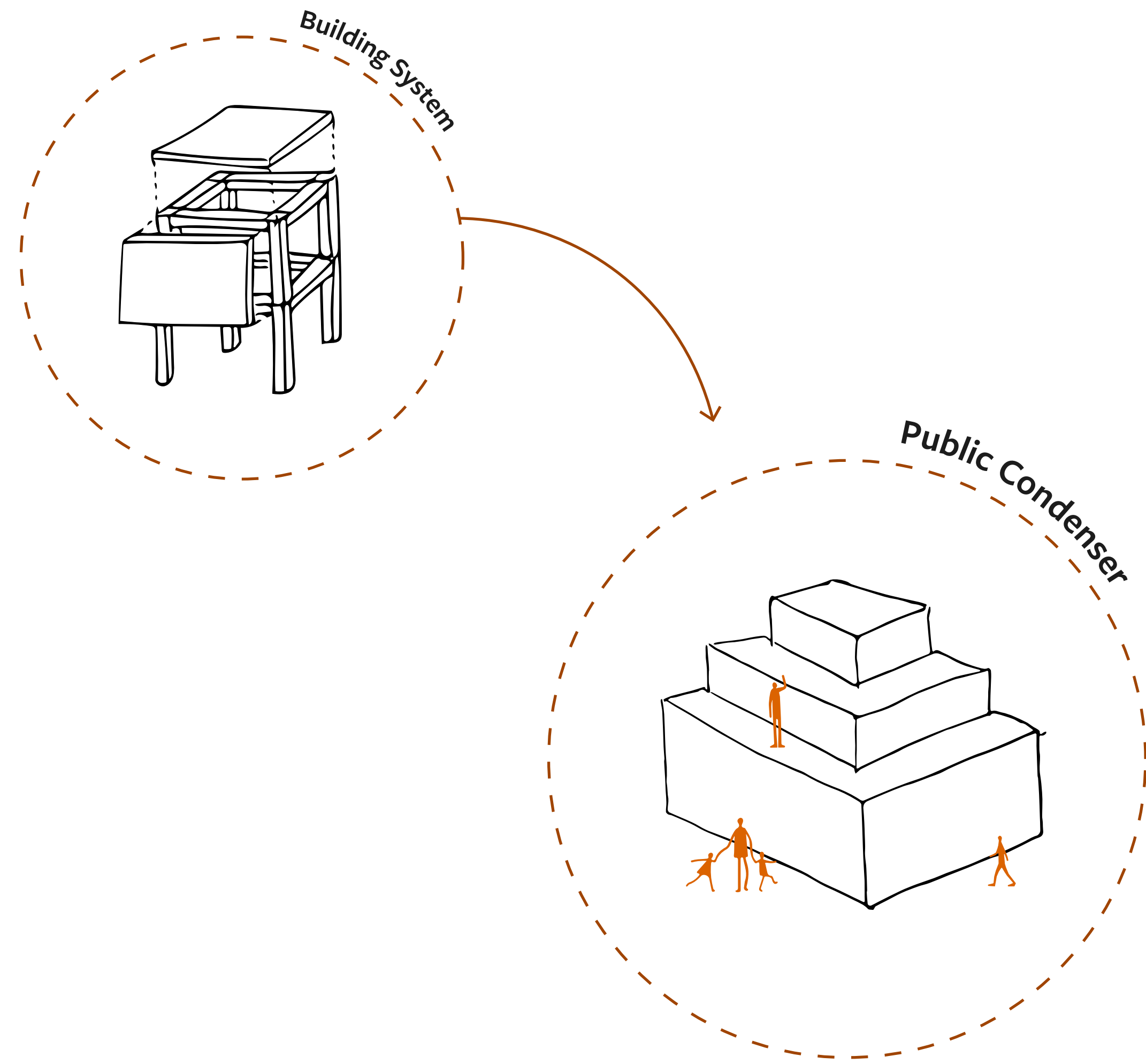

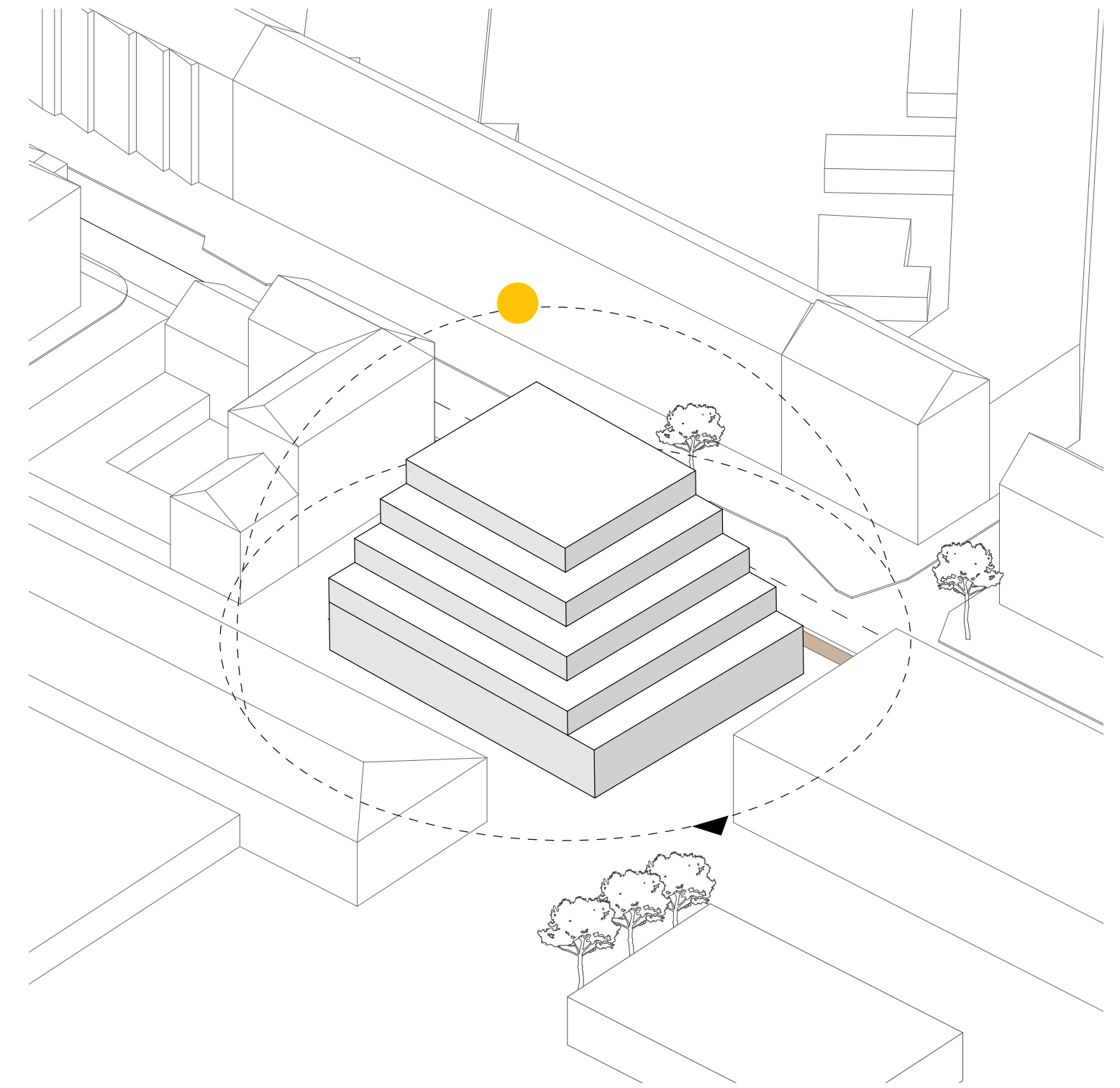
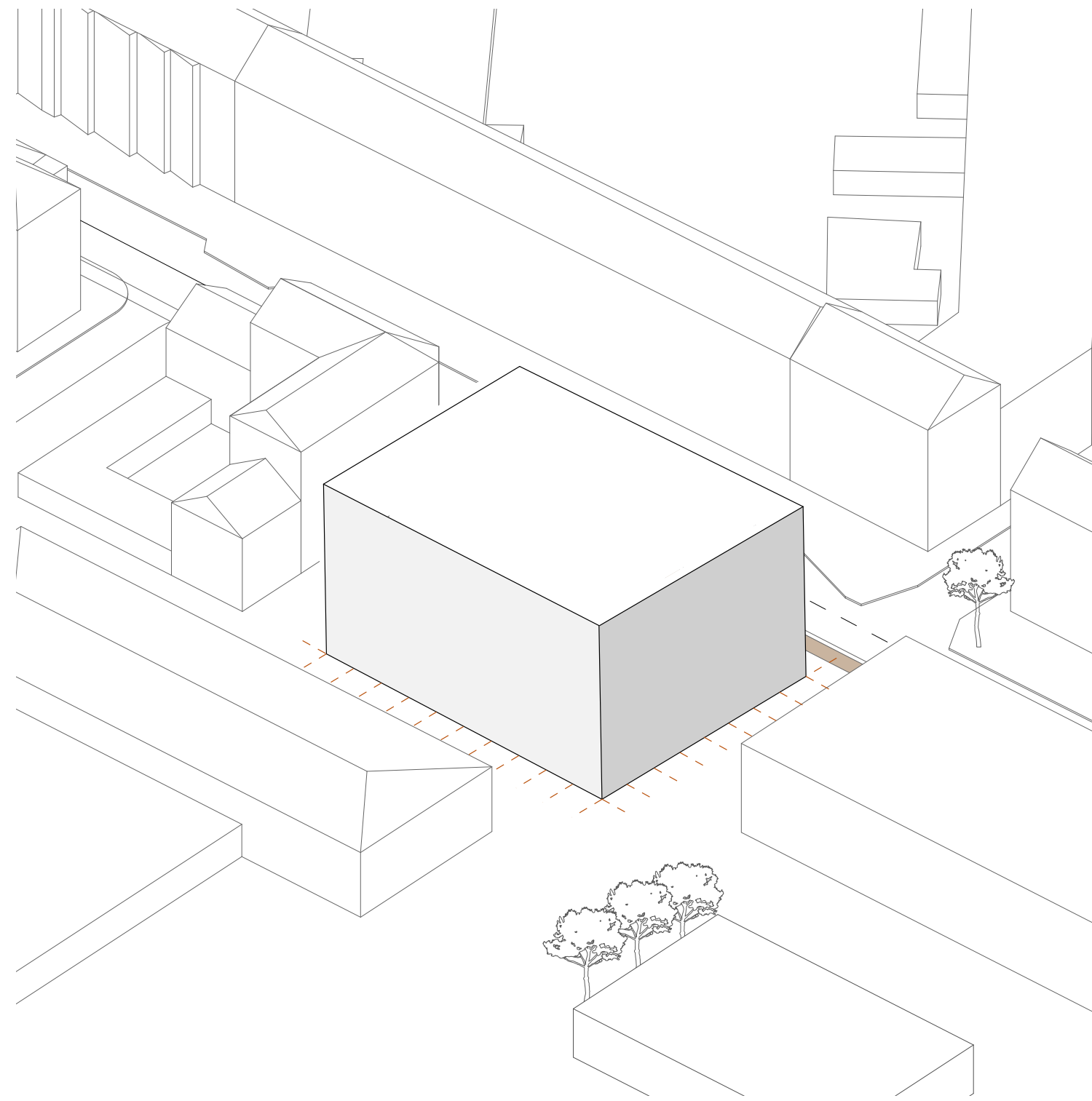
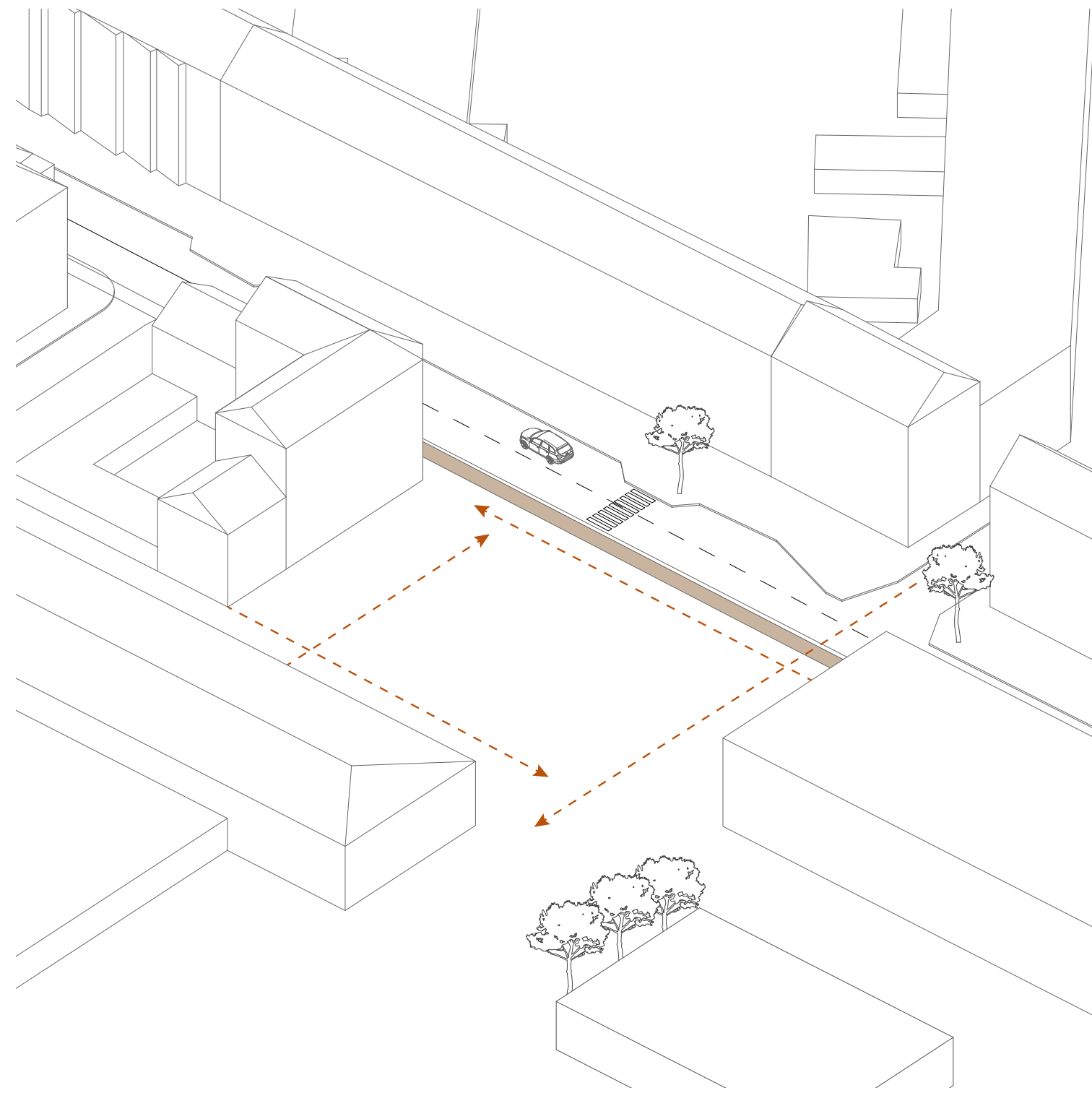

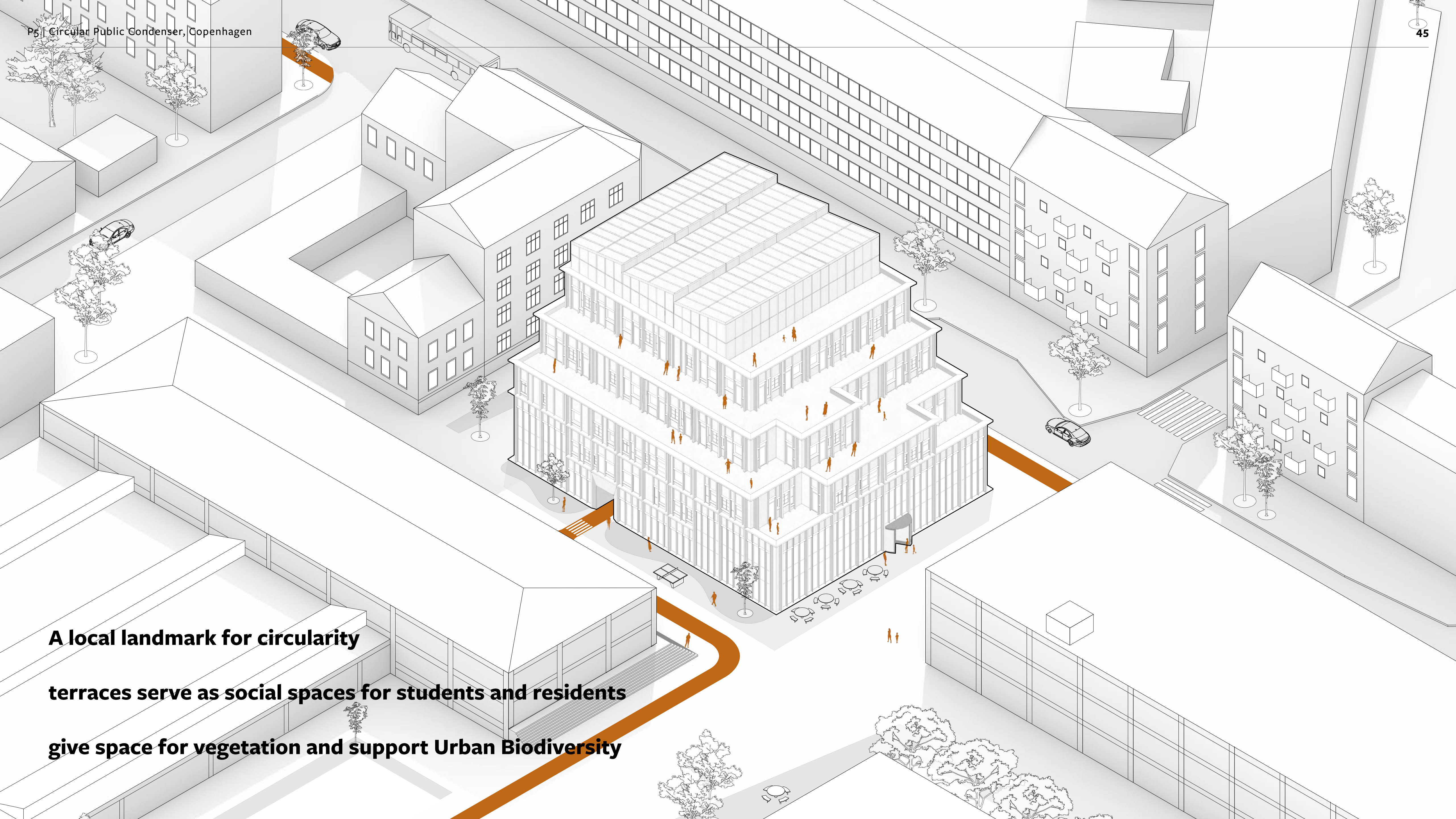

**A local landmark for circularity**  
**terraces serve as social spaces for students and residents**  
**give space for vegetation and support Urban Biodiversity**





# a **space** to

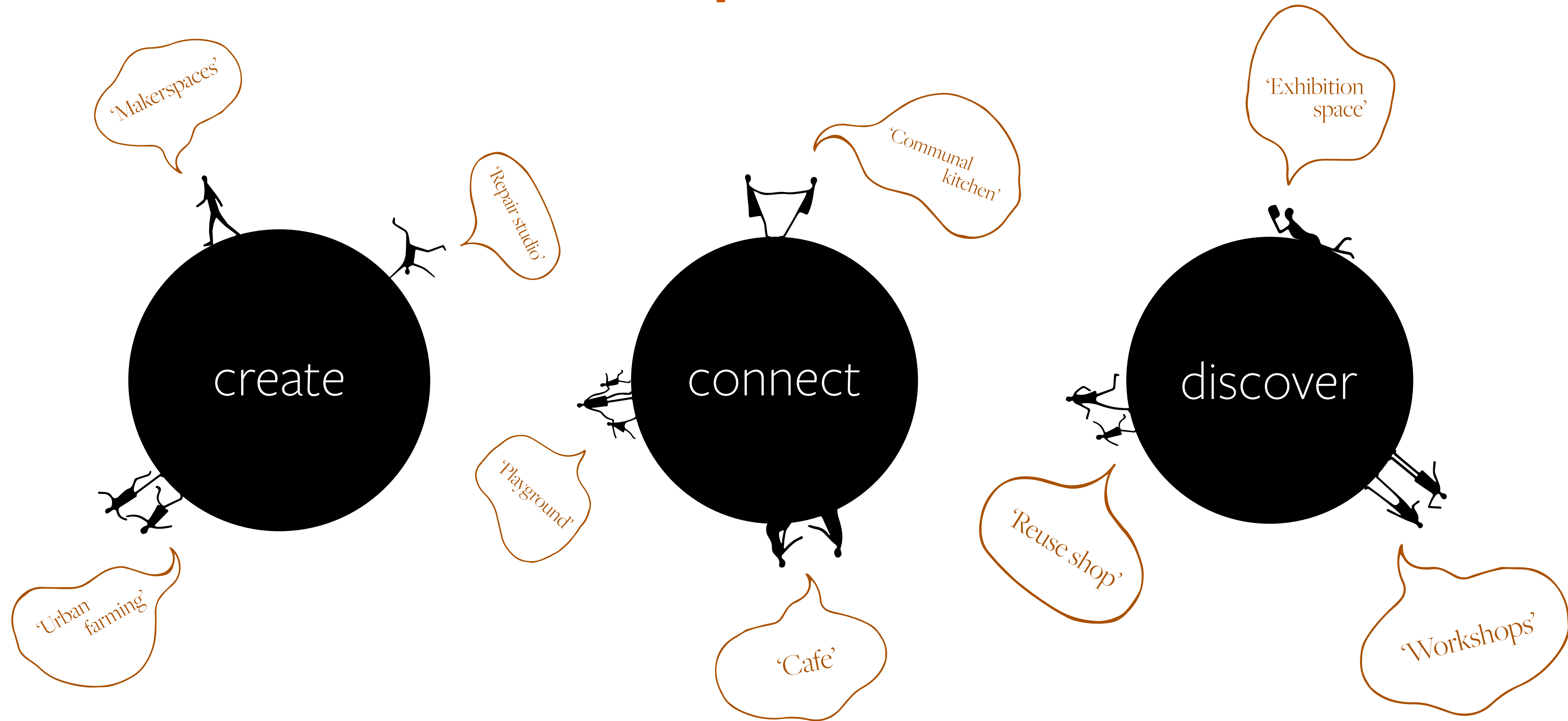

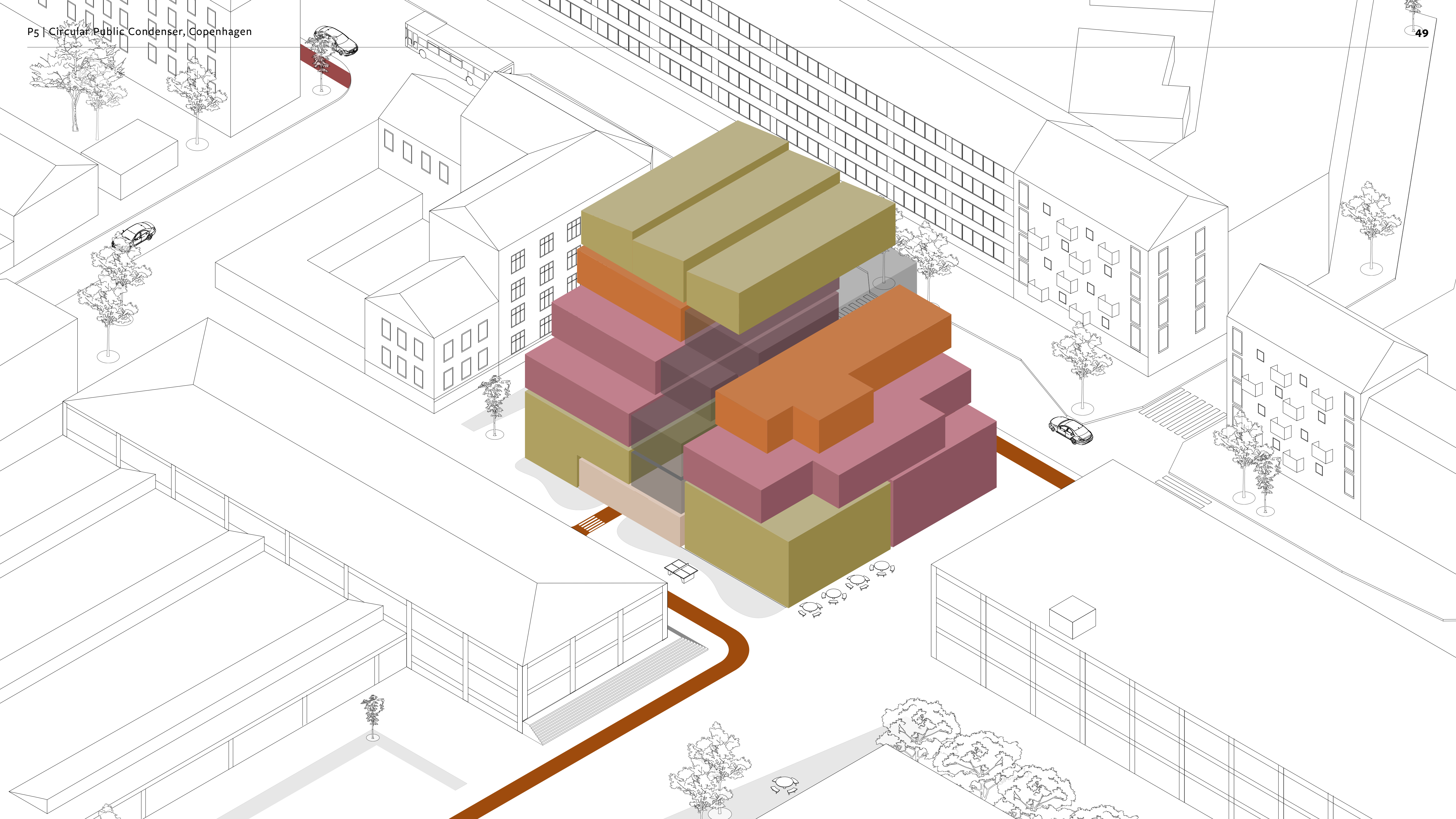

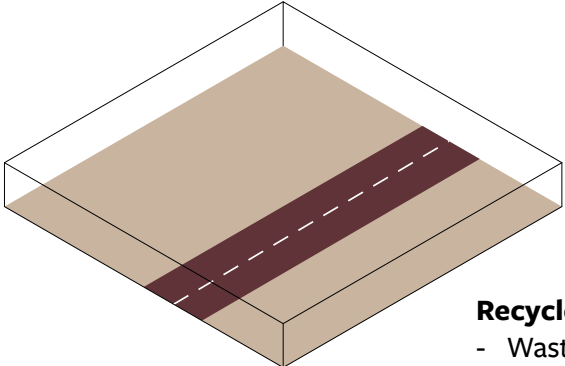
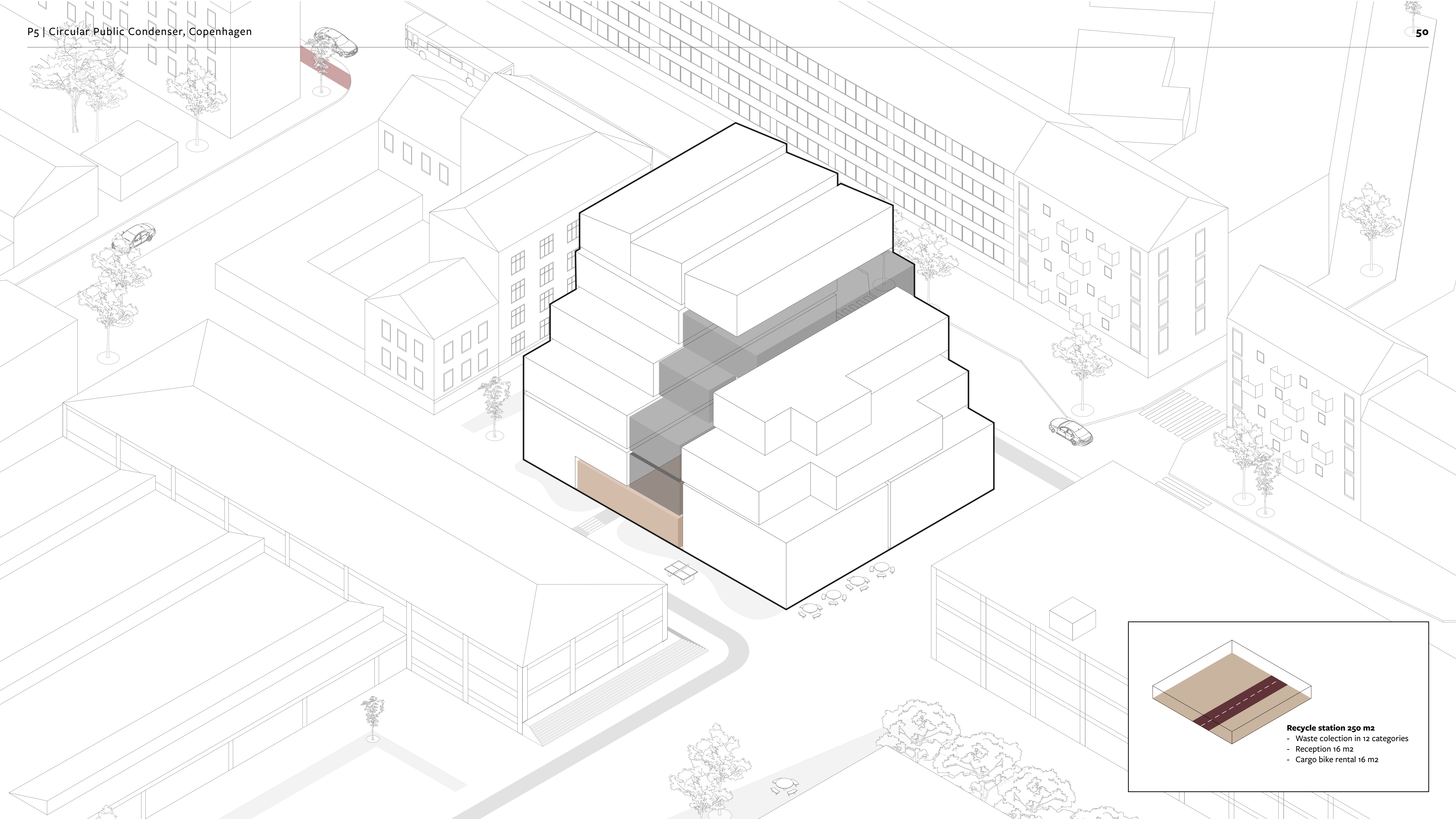

**Recycle station 250 m<sup>2</sup>**

- Waste collection in 12 categories
- Reception 16 m<sup>2</sup>
- Cargo bike rental 16 m<sup>2</sup>

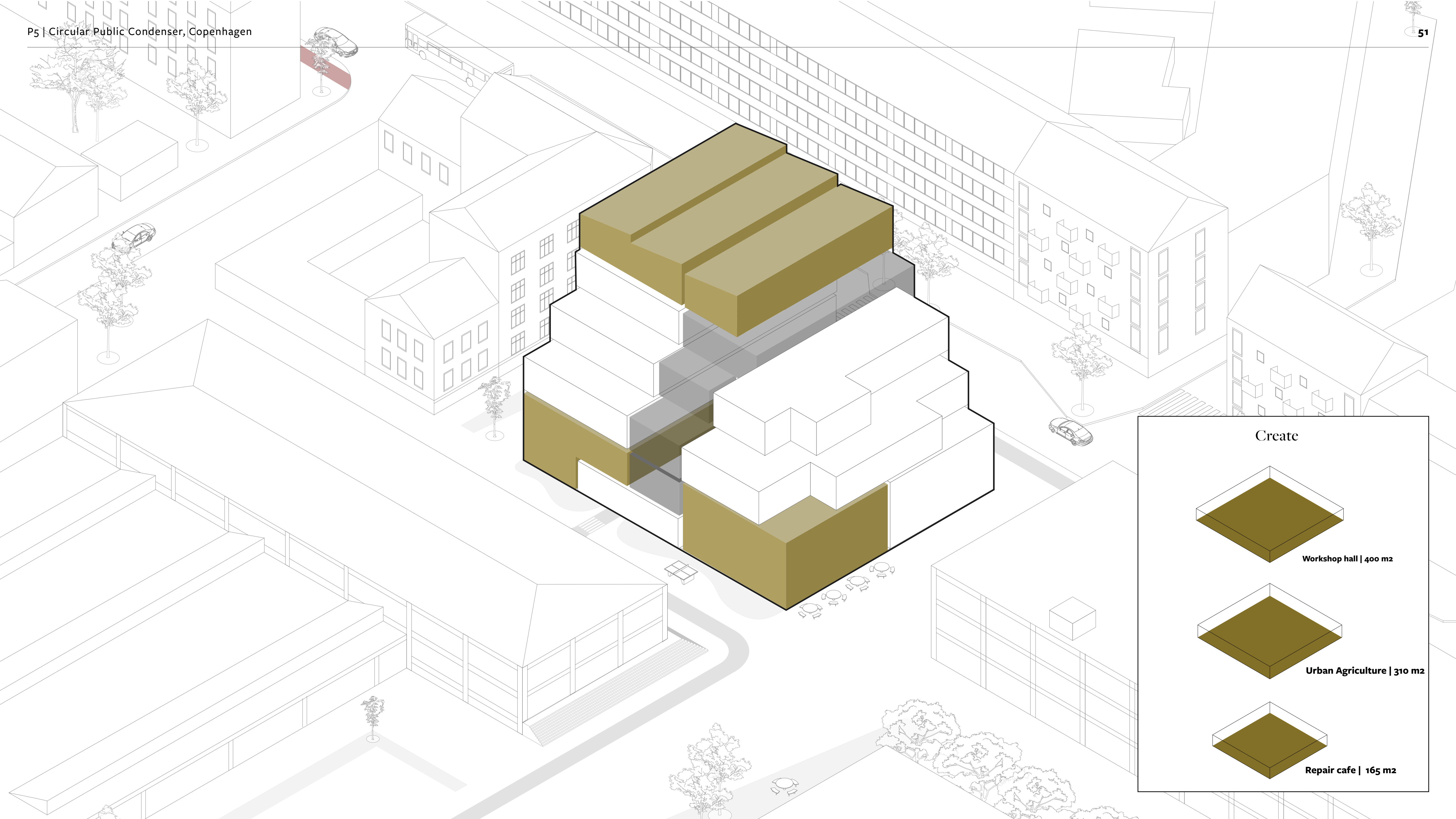

**Create**

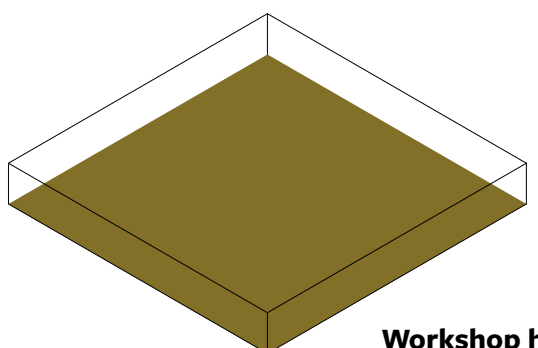

**Workshop hall | 400 m<sup>2</sup>**

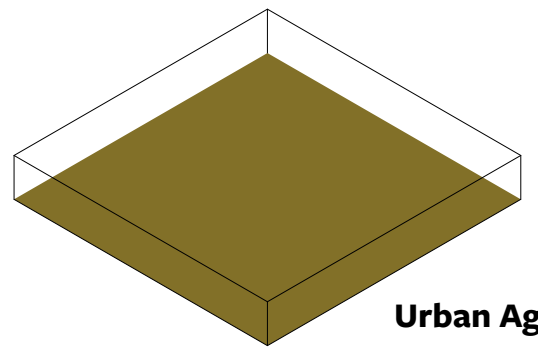

**Urban Agriculture | 310 m<sup>2</sup>**

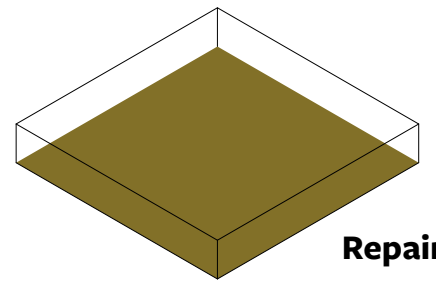

**Repair cafe | 165 m<sup>2</sup>**

A rectangular inset box containing three isometric diagrams of square floor plates. Each diagram is a dark olive green block. To the right of each diagram is a text label indicating the space's name and area. The labels are: 'Workshop hall | 400 m<sup>2</sup>', 'Urban Agriculture | 310 m<sup>2</sup>', and 'Repair cafe | 165 m<sup>2</sup>'. The word 'Create' is centered at the top of the inset.

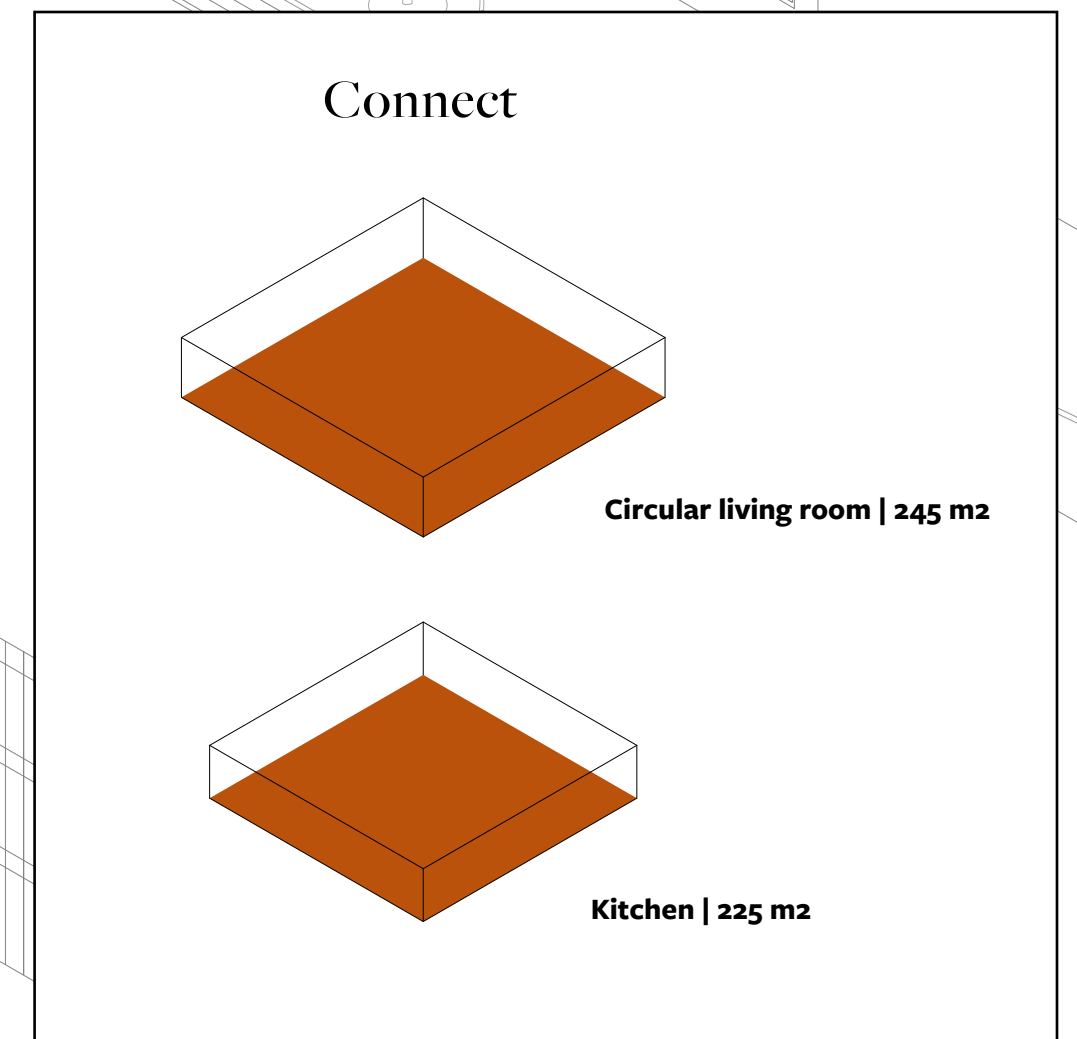
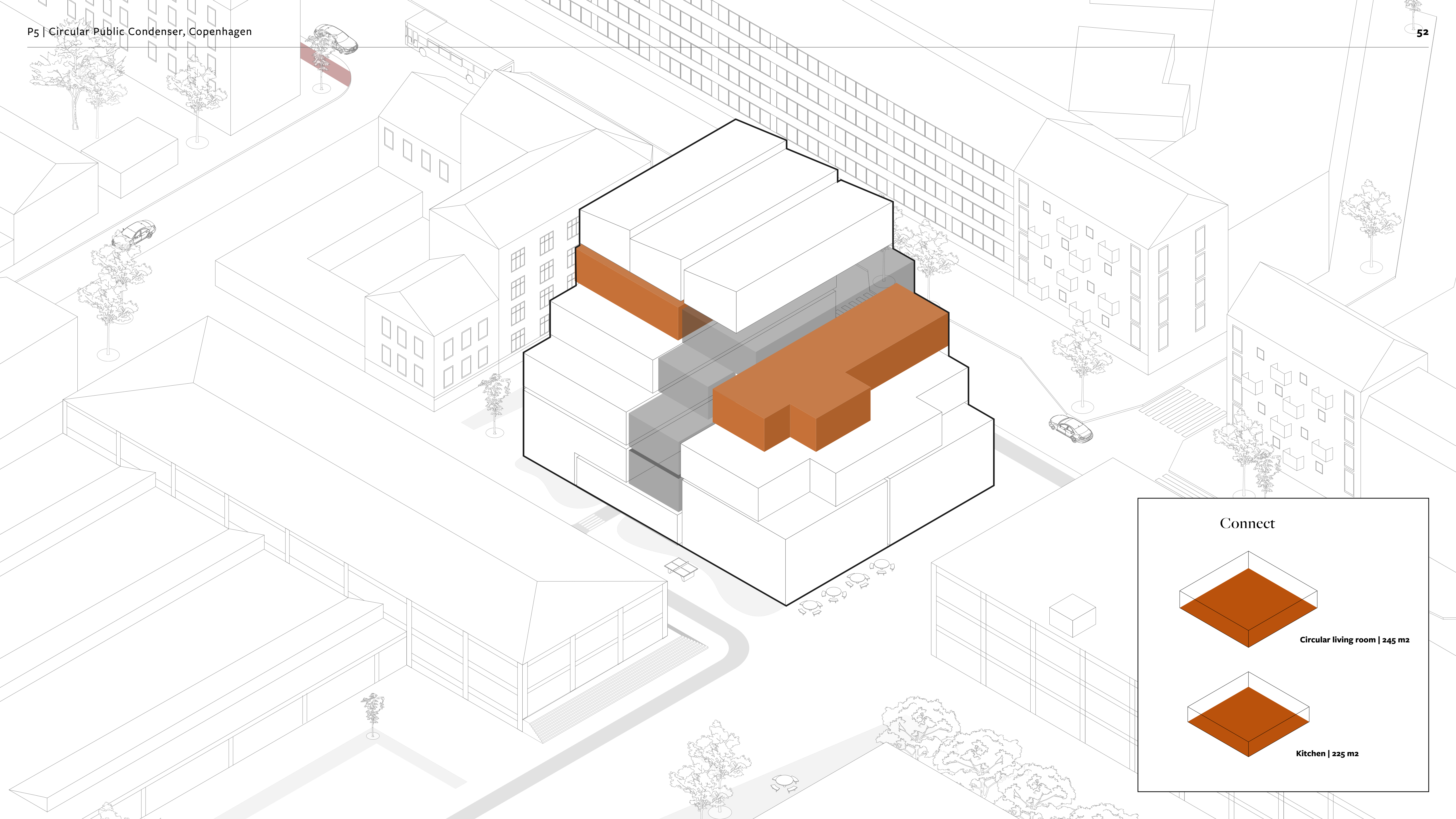

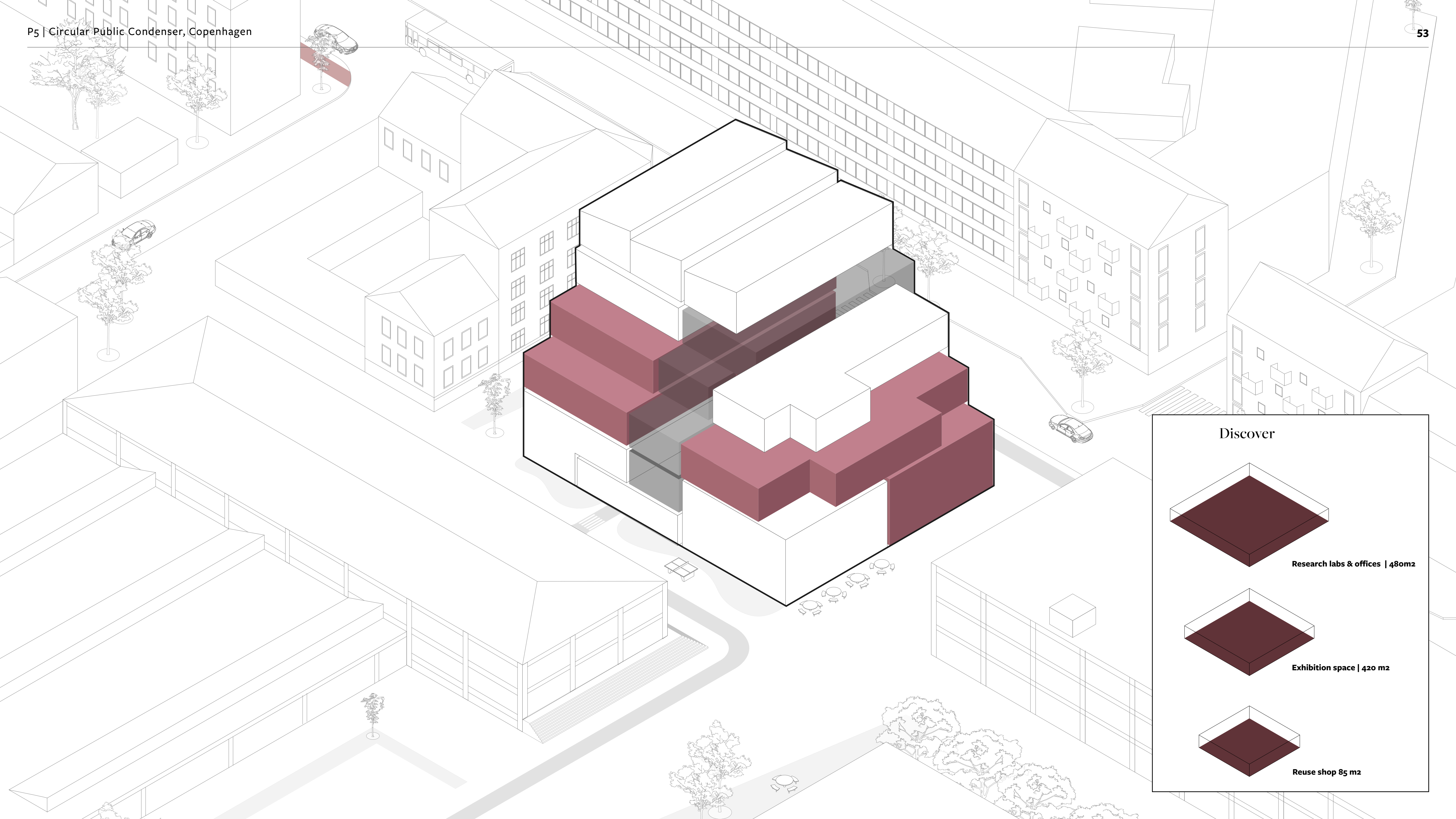

**Discover**

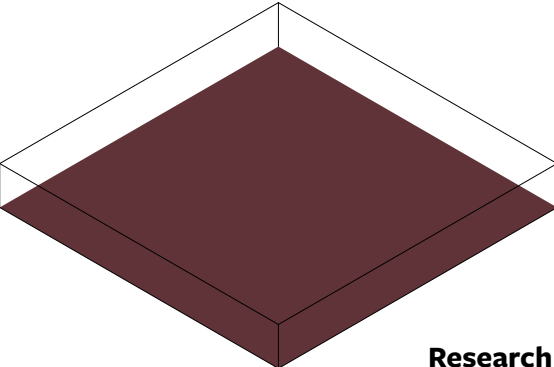

**Research labs & offices | 480m<sup>2</sup>**

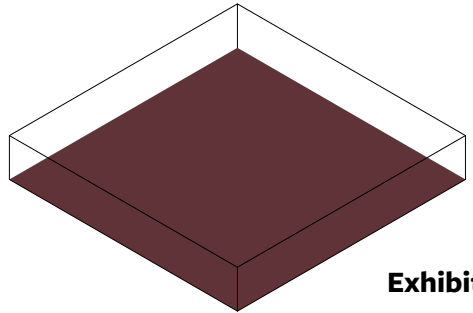

**Exhibition space | 420 m<sup>2</sup>**

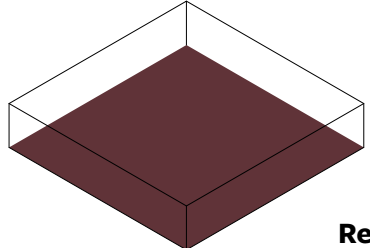

**Reuse shop 85 m<sup>2</sup>**

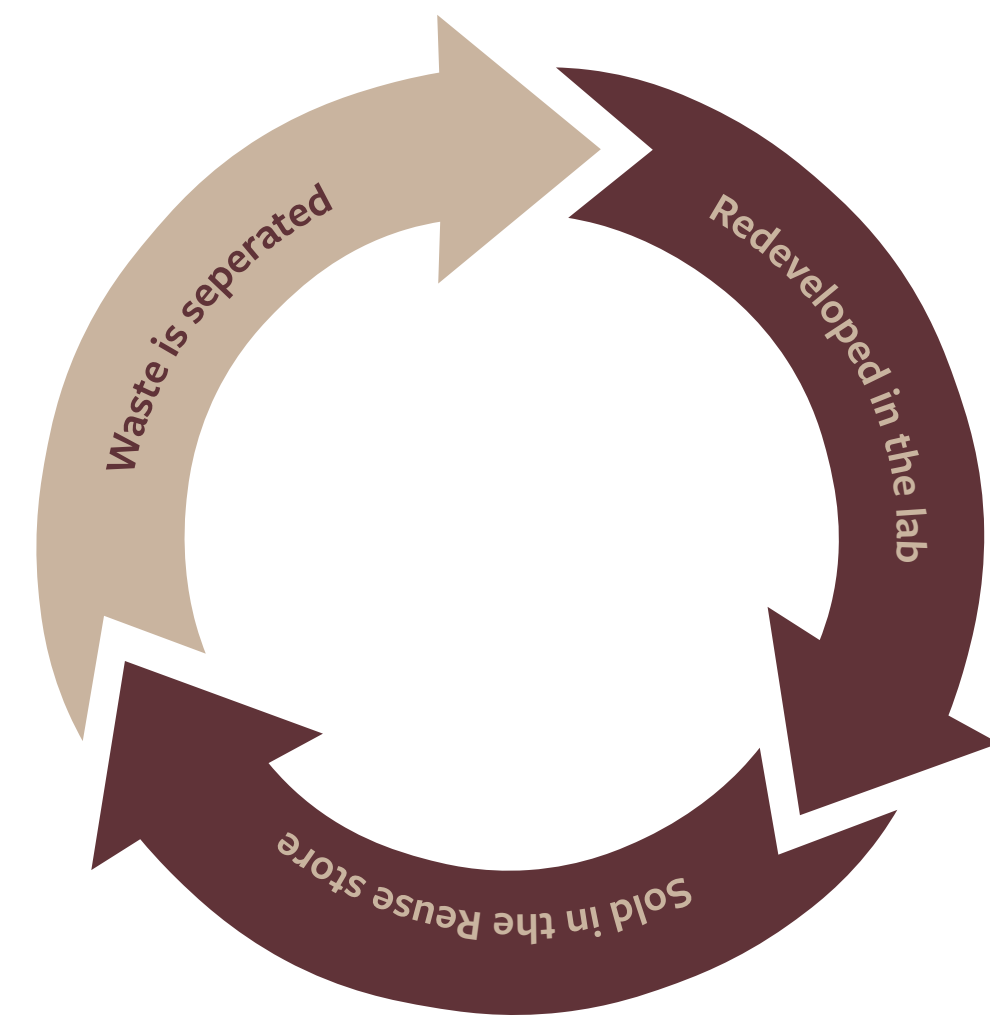
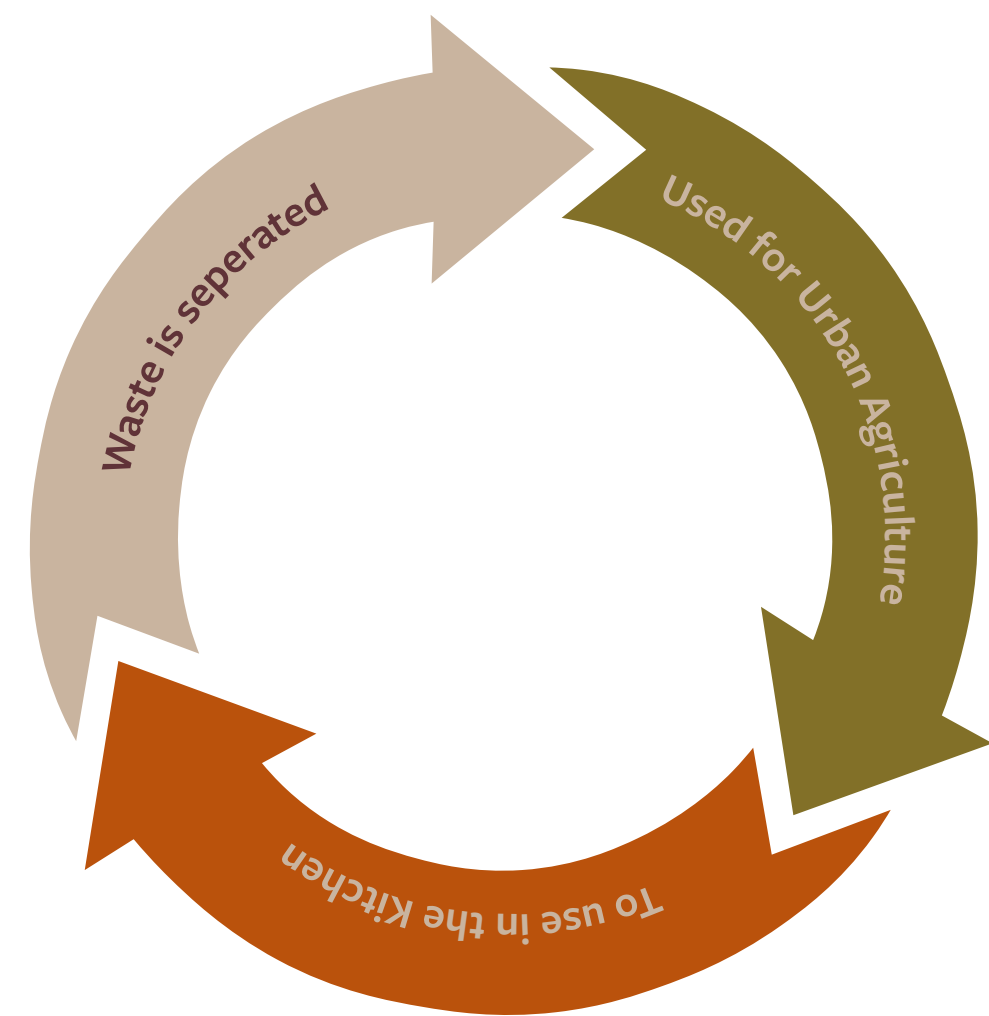
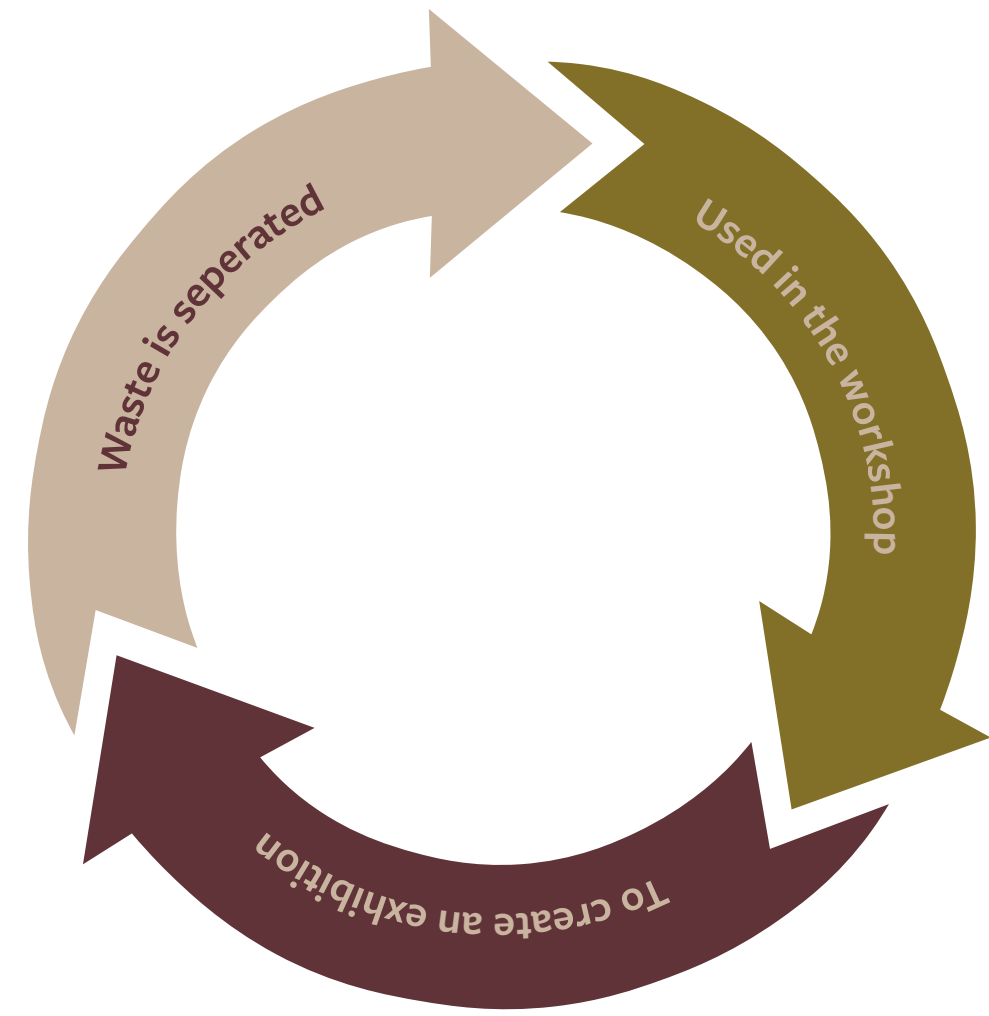

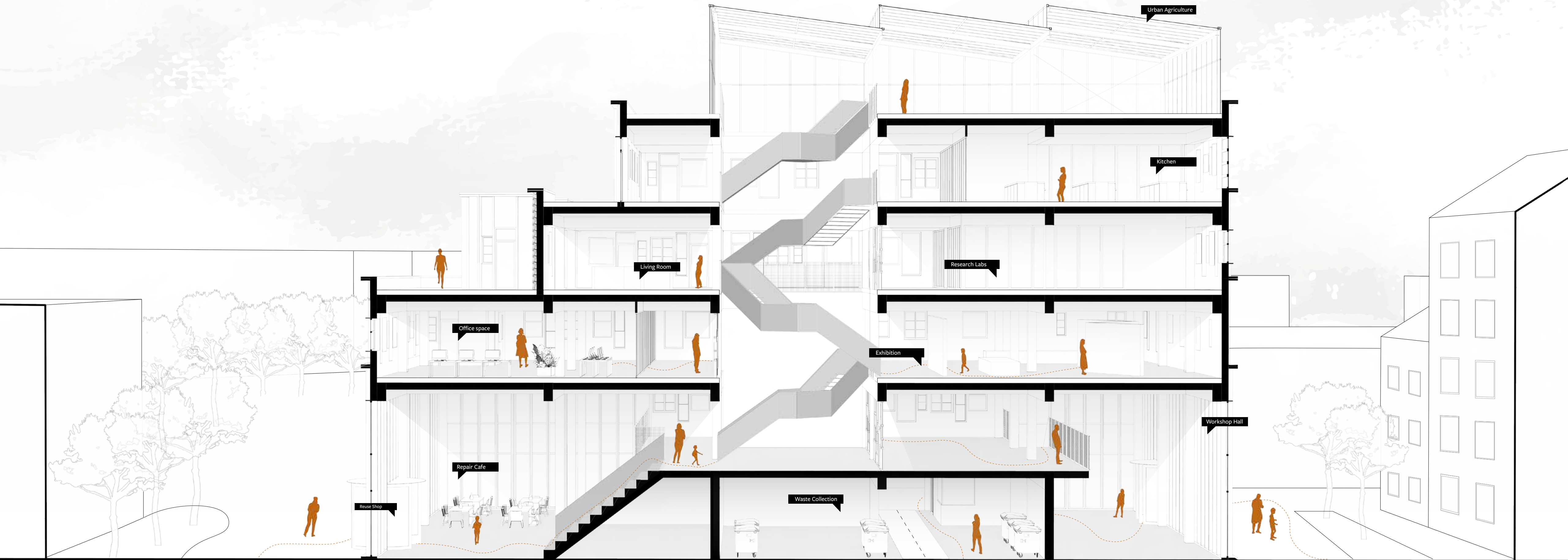



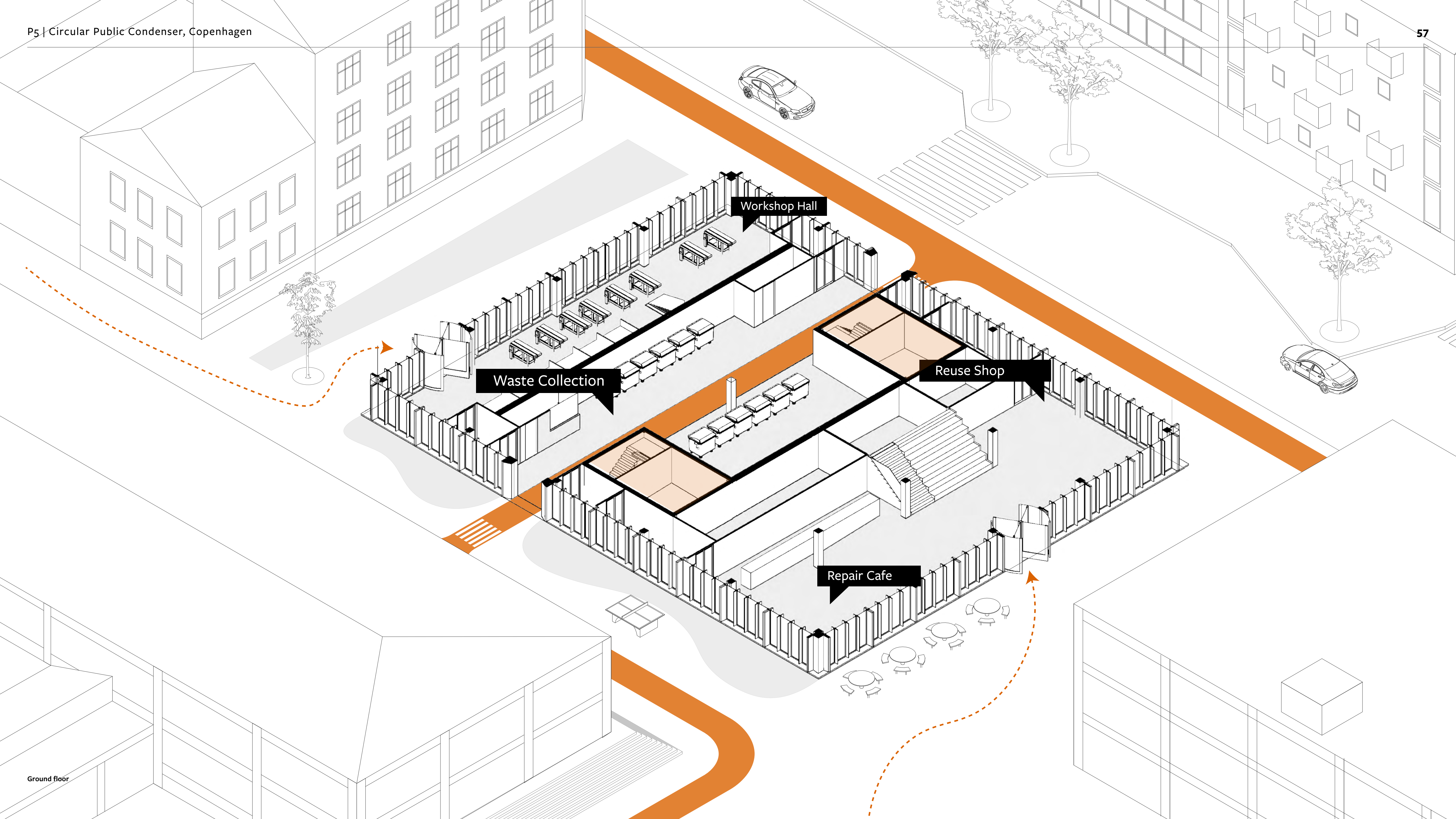

Workshop Hall

Waste Collection

Reuse Shop

Repair Cafe

Ground floor



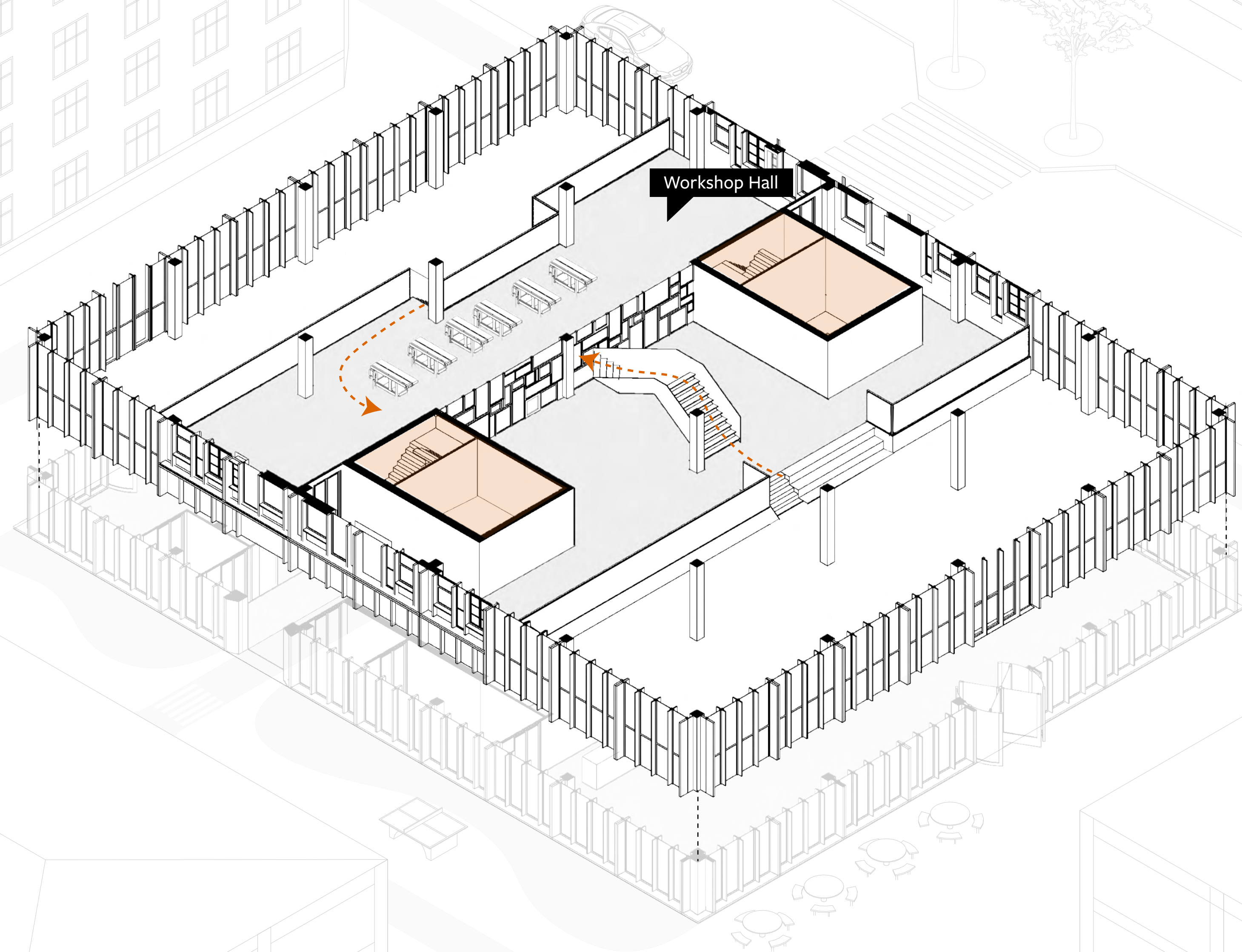

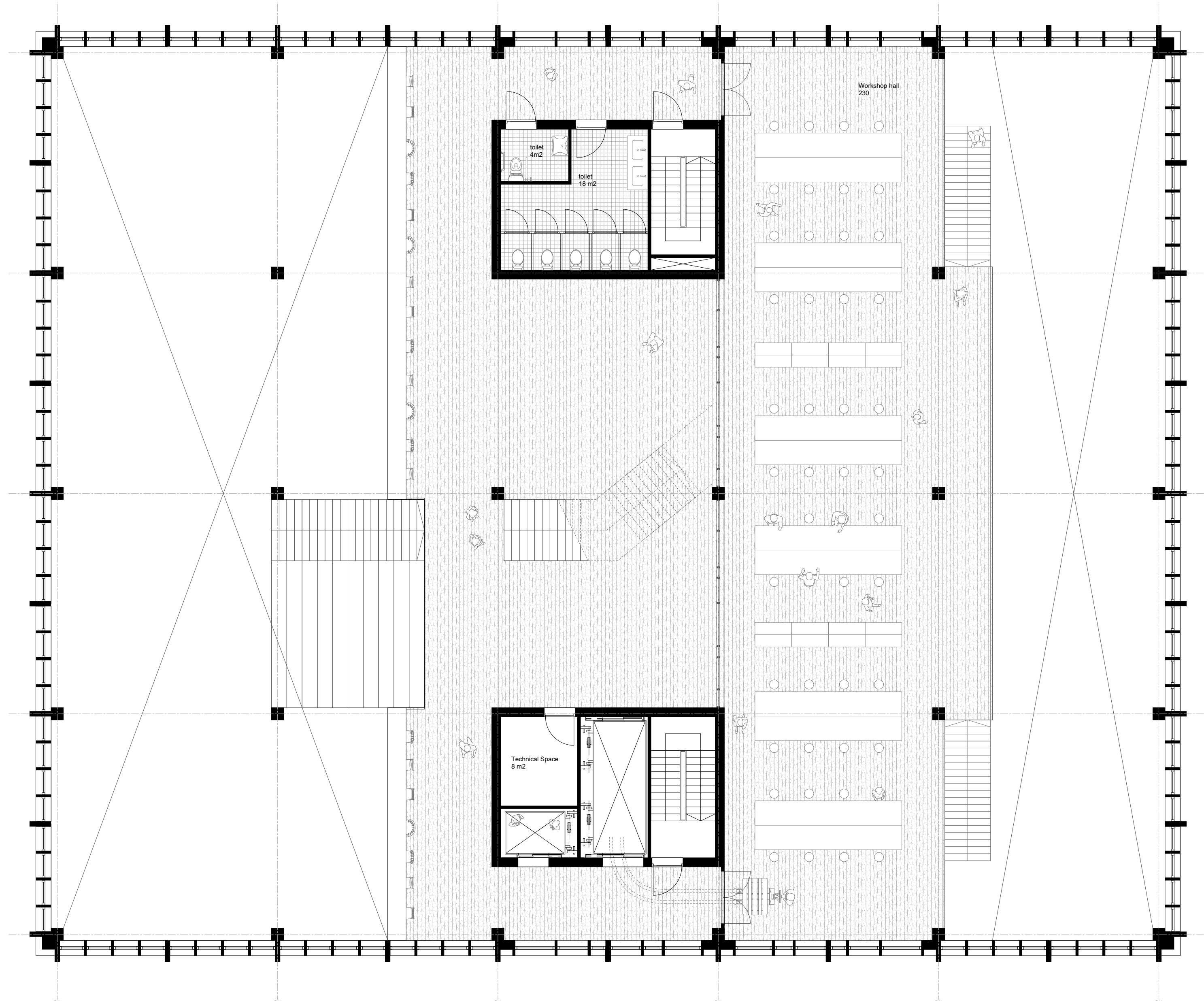

2nd floor

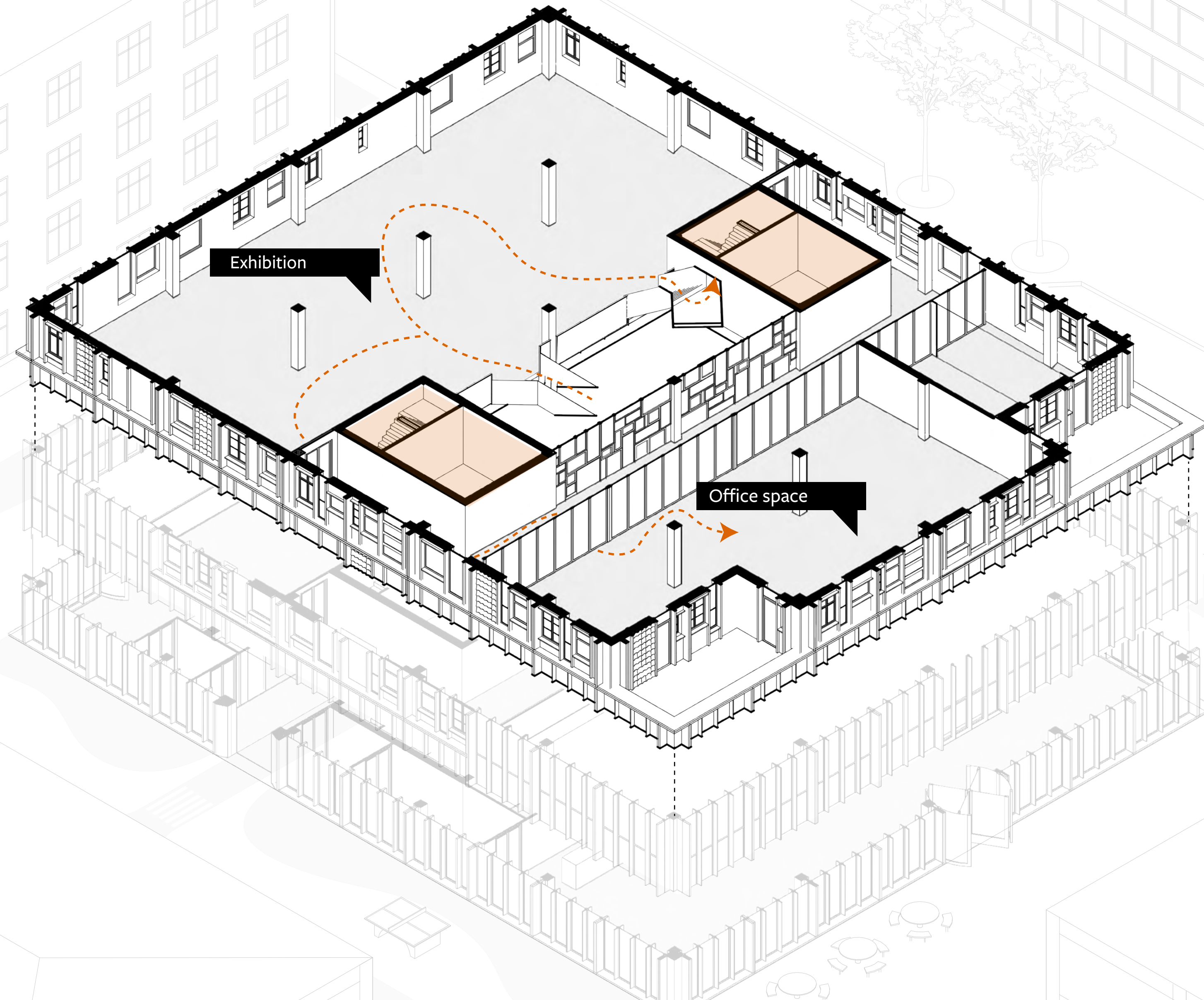

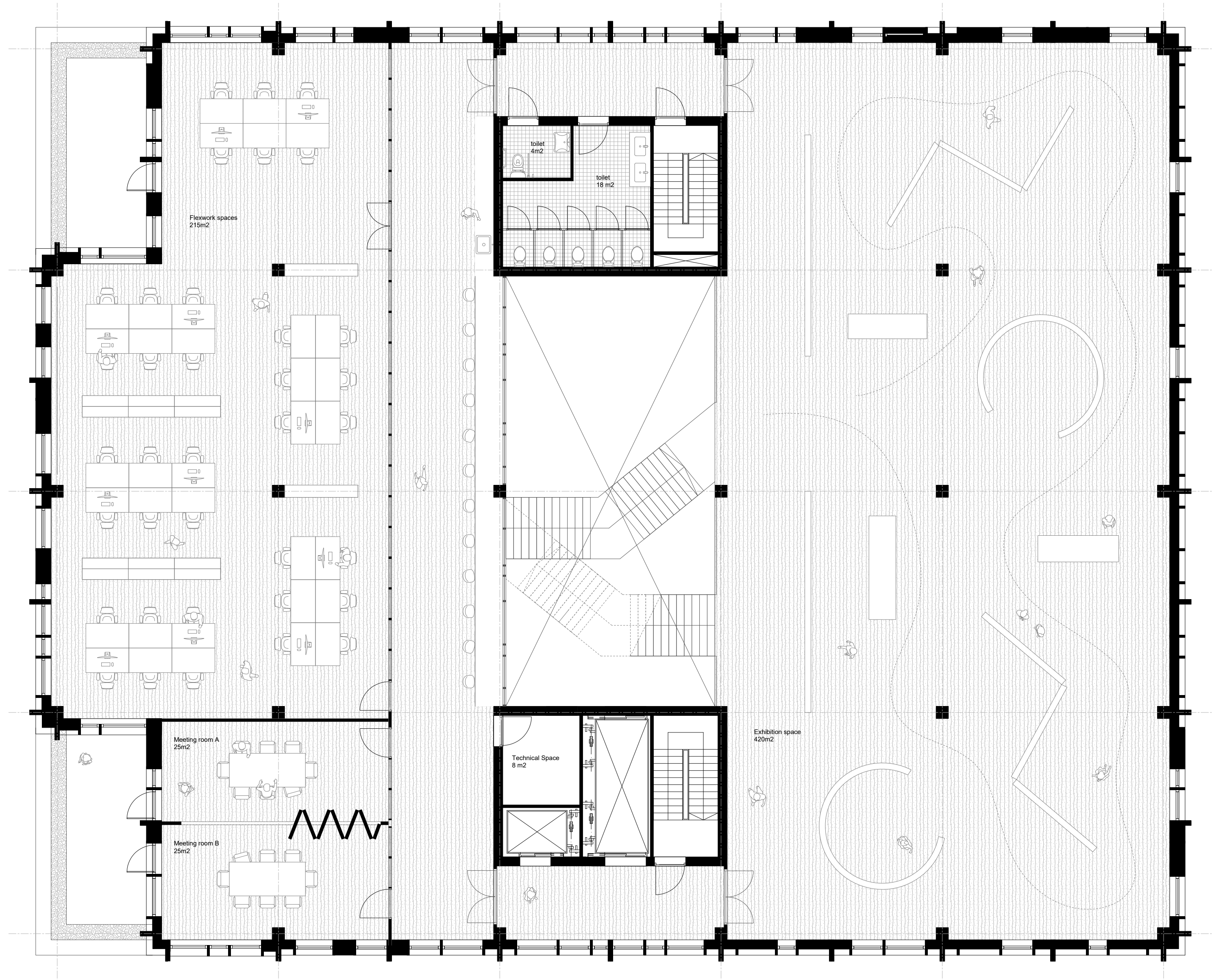

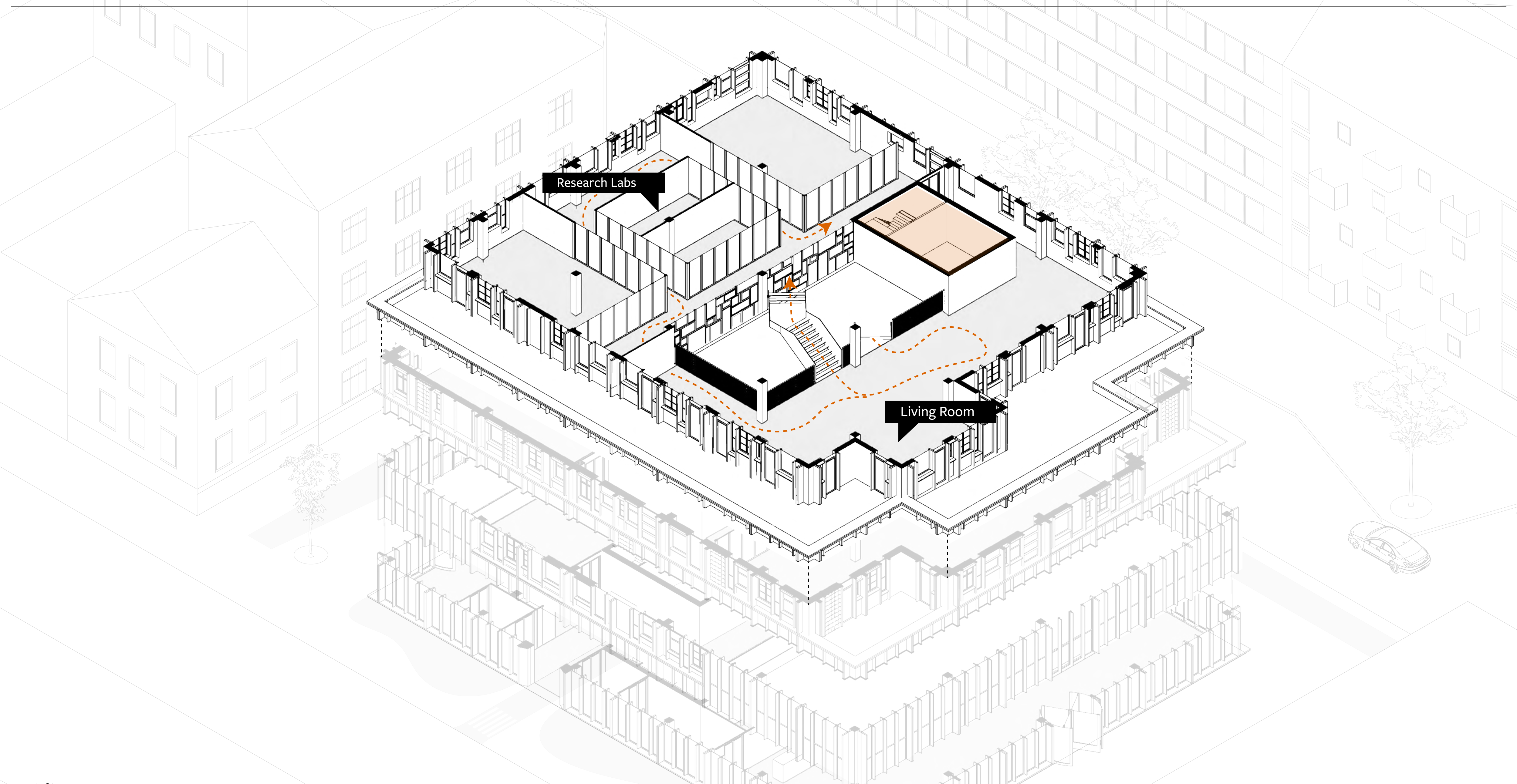

Research Labs

Living Room

3rd floor

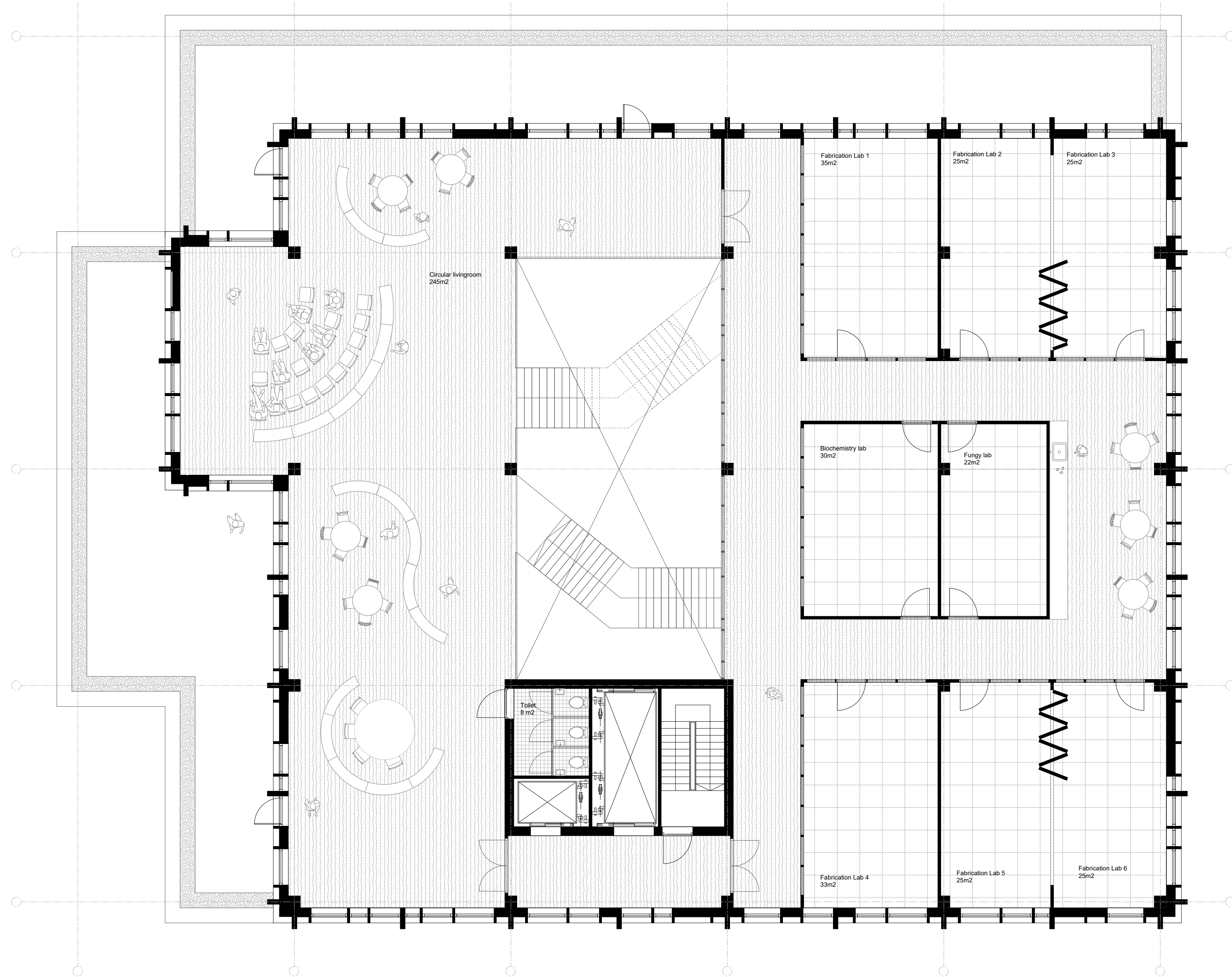

4th floor

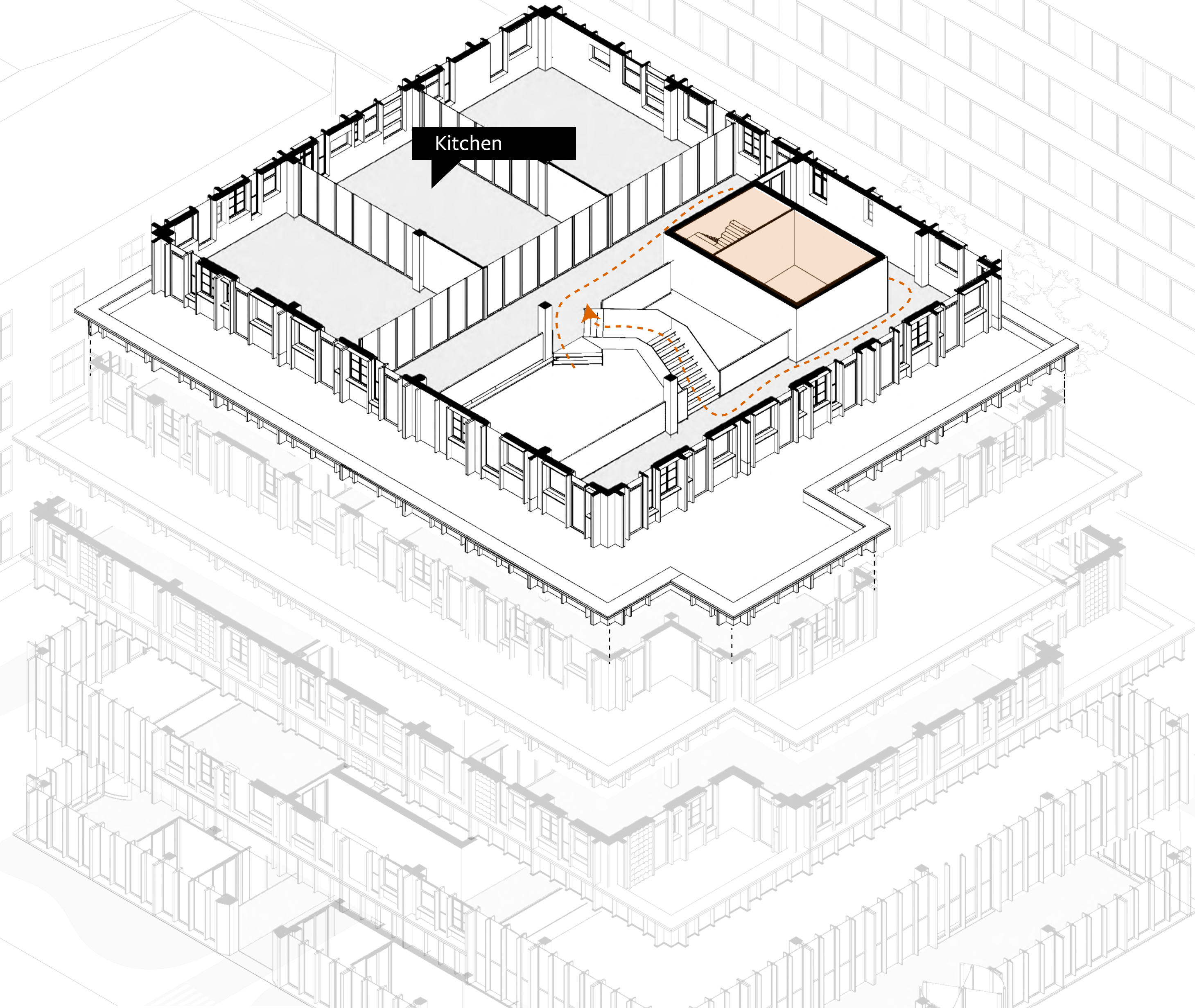

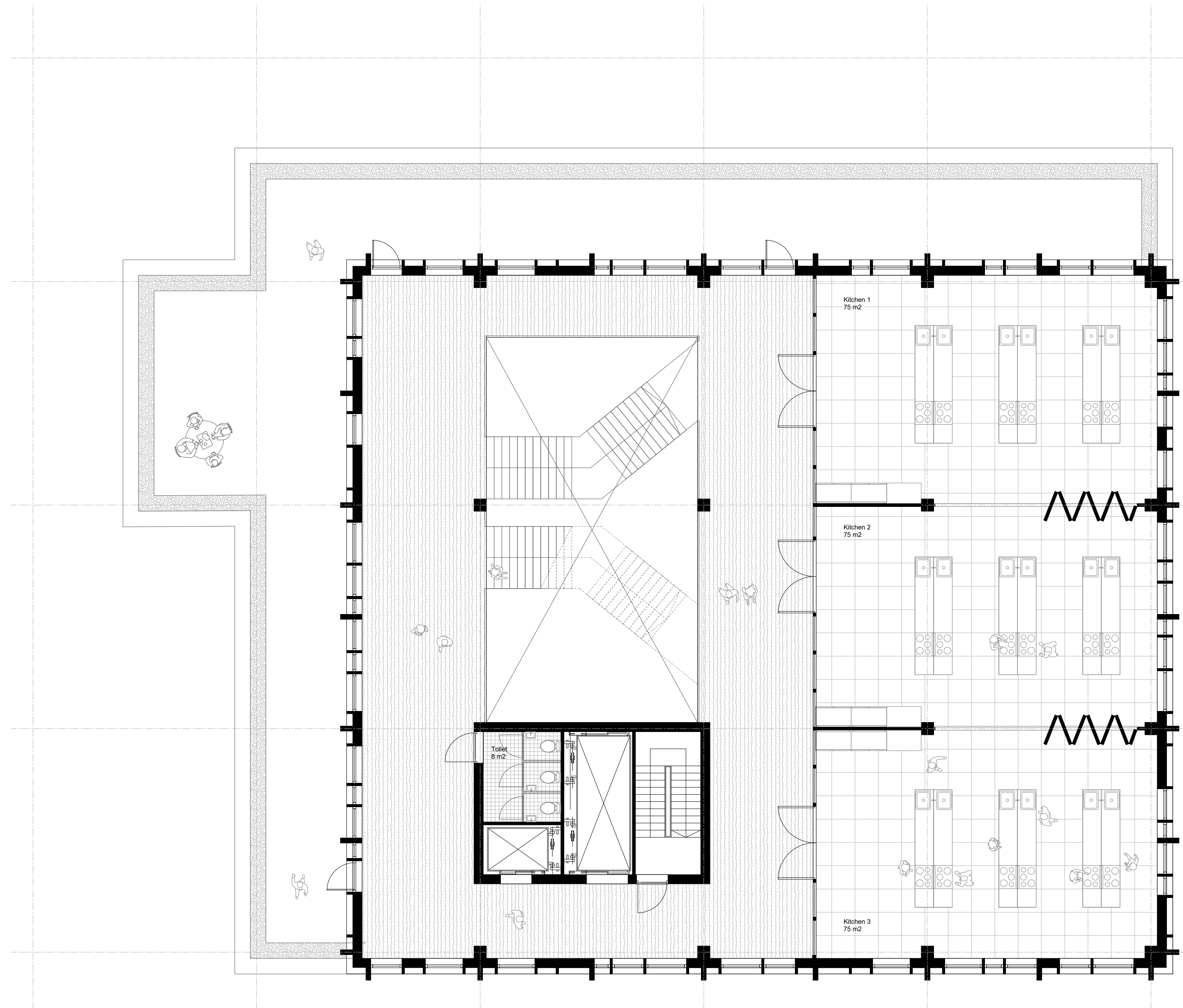

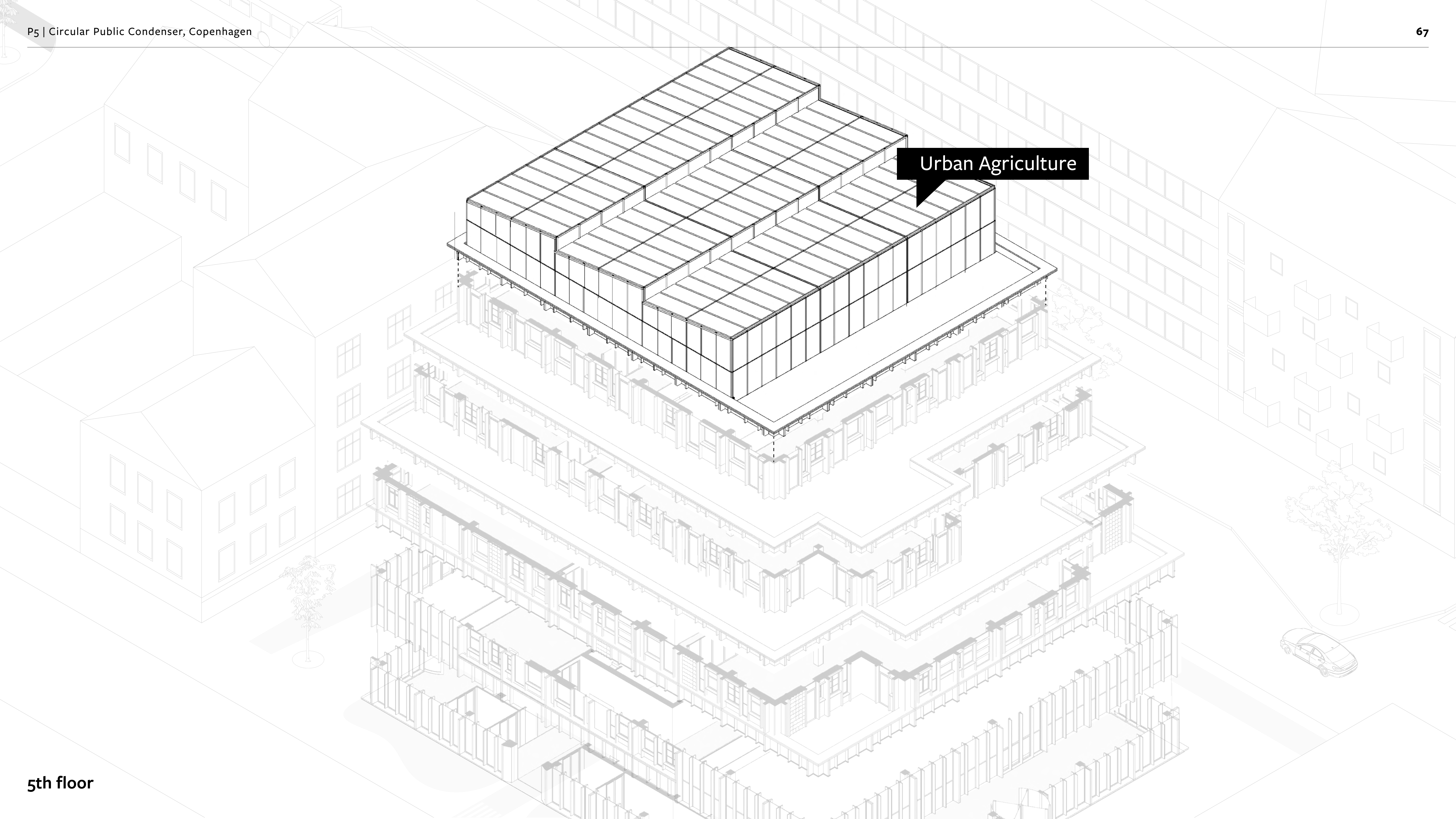

Urban Agriculture

5th floor

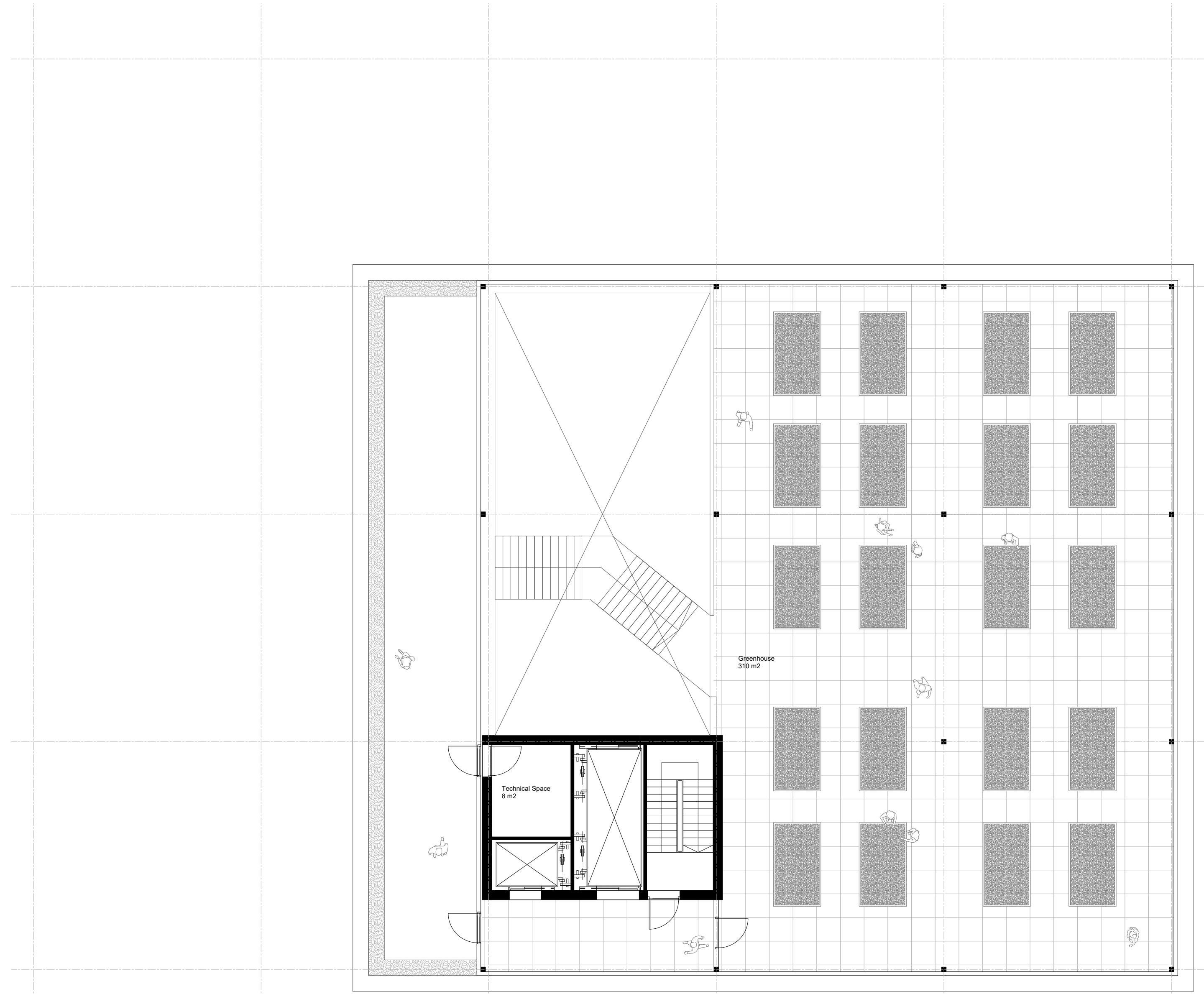









# The Public Condenser in the City





**The building as an infrastructure**

- Managing and transforming neighborhood waste

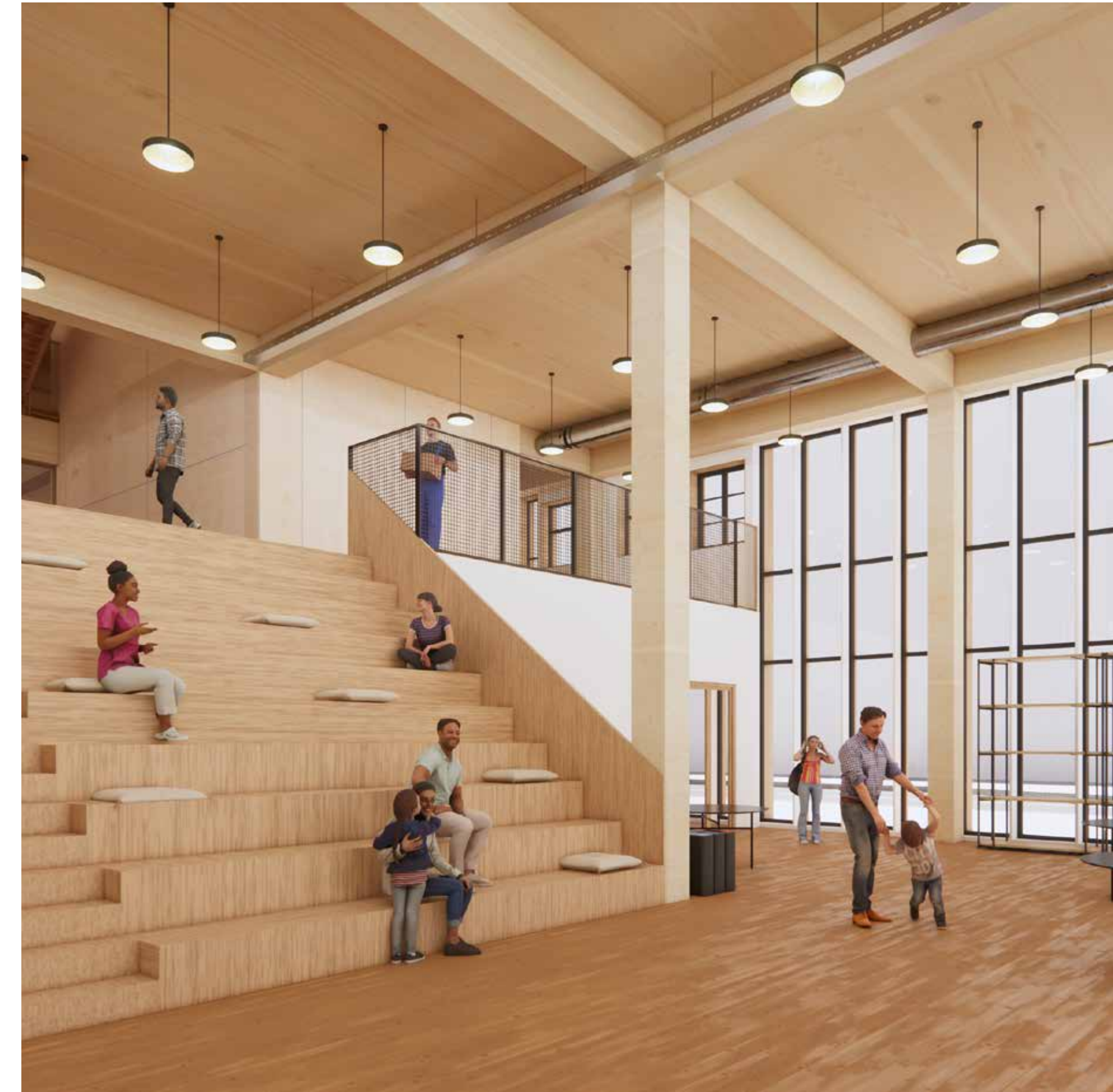

**The building as a social condenser**

- Bringing together residents, students, makers, and entrepreneurs

# From Building to Impact

## The Impact of the Public Condenser



### Environmental Impact

- Transforming local waste into valuable resources
- Reducing the need for raw material extraction
- Promoting circular construction and sustainable lifestyles

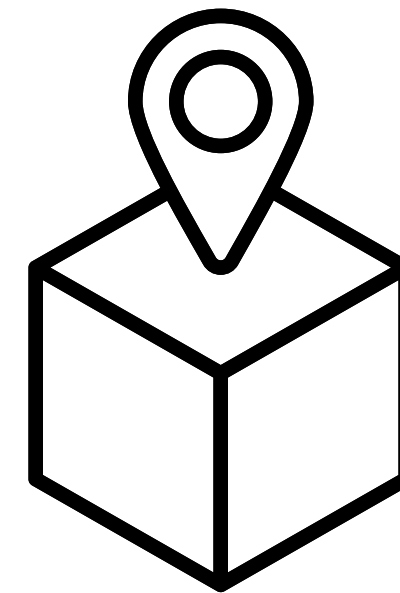

### Spatial Impact

- Brings together diverse functions centered on creating, connecting and discovering
- A building as a flexible systems, designed to adapt to change

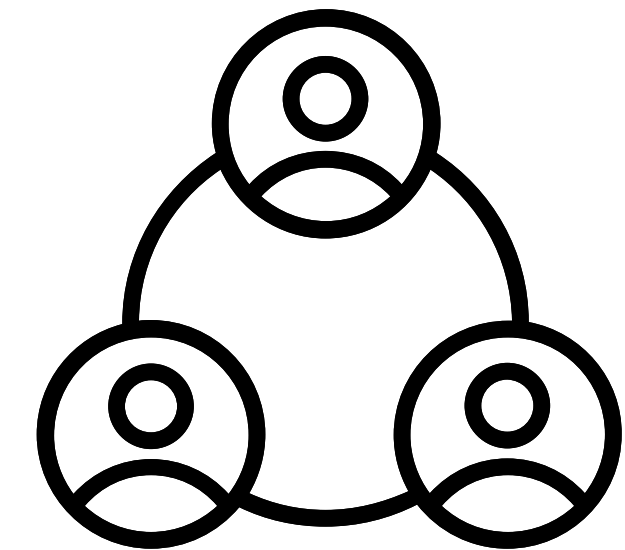

### Social Impact

- More than a reuse facility — a civic platform for circularity
- Encourages active participation: people donate, build, and share skills
- Strengthens community

### Roof

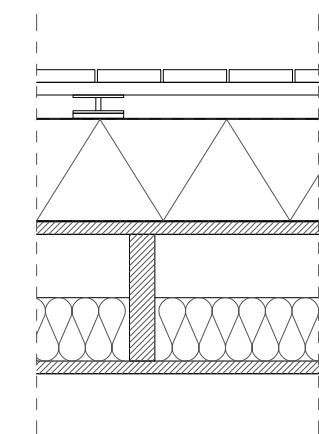

	[kg/m2]
30 mm - Hardwood terrace decking	25,3
25 mm - timber battens	1,05
Aluminum levelling spindles	0,45
1.5 mm roof sealing bio-EPDM	1,9
200 mm Recycled foam glass insulation	33
0.2-mm PE-HD vapour barrier	0,2
25 mm Laminated Veneer Lumber	15
300 mm LVL-beams	13,5
125 mm recycled cotton insulation	4,4
25 mm Laminated Veneer Lumber	15
<b>Total</b>	<b>109,8</b>

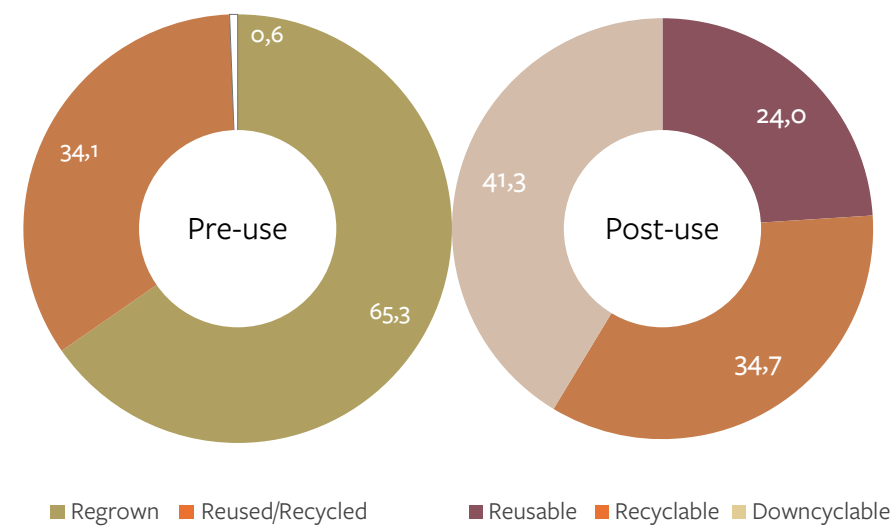

### Exterior wall

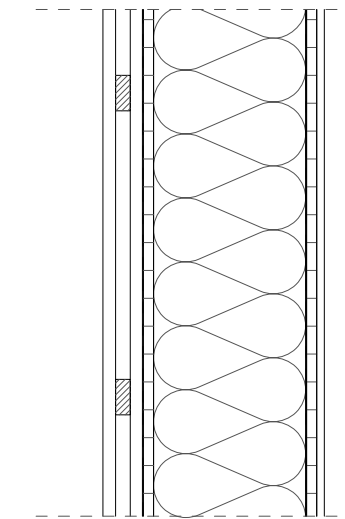

	[kg/m2]
20-mm wooden facade	14
40/60 mm - timer battens	5
1.5 mm - facade membrane bio-EPDM	1,9
20 mm - OSB pannels	13
300 mm - wooden structural framework	11,3
300 mm - recycled cotton insulation	7,5
20 mm - OSB pannels	13
0.2-mm PE-HD vapour barrier	0,2
Timber pannels	11
<b>Total</b>	<b>76,9</b>

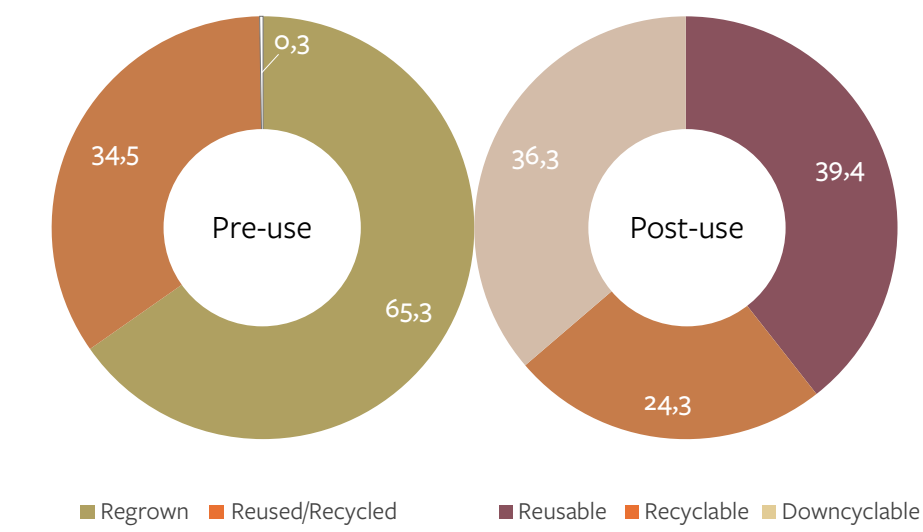

### Floor

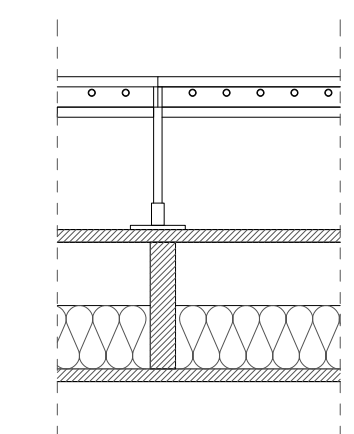

	[kg/m2]
20 mm - Reclaimed wooden floor	14
40 mm - Raised floor system with Radiant pannel	32
Aluminum levelling spindles	0,45
25 mm Laminated Veneer Lumber	15
300 mm LVL-beams	13,5
125 mm recycled cotton insulation	4,4
25 mm Laminated Veneer Lumber	15
<b>Total</b>	<b>94,35</b>

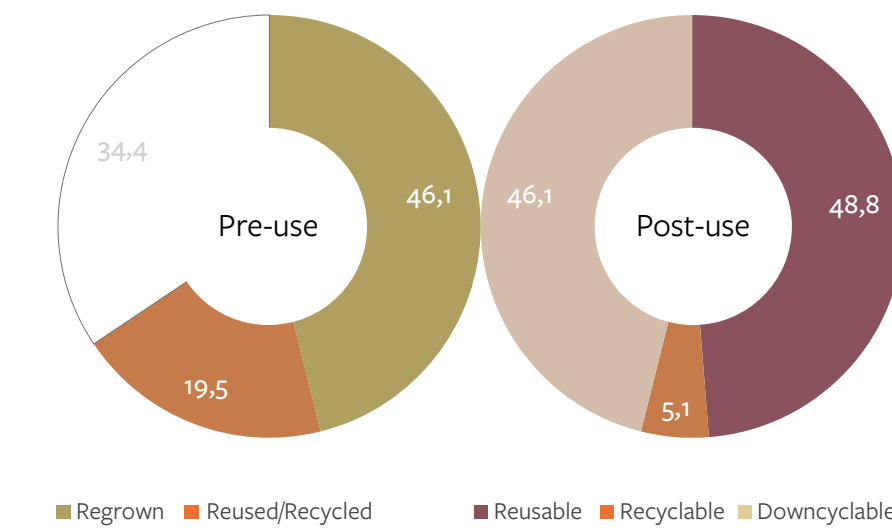

### Foundation

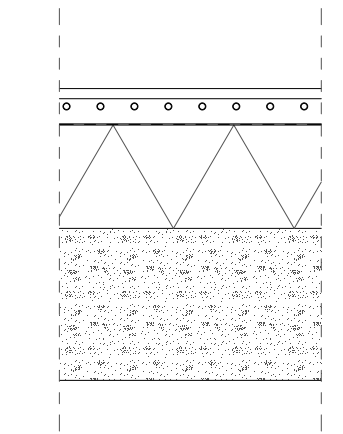

	[kg/m2]
20 mm - Reclaimed wooden floor	14
50 mm - Dry Screed with underfloor heating	60
0.2-mm PE-HD vapour barrier	0,2
200 mm Recycled foam glass insulation	33
Foundation slab of UNI-Green Concrete	480
<b>Total</b>	<b>587,2</b>

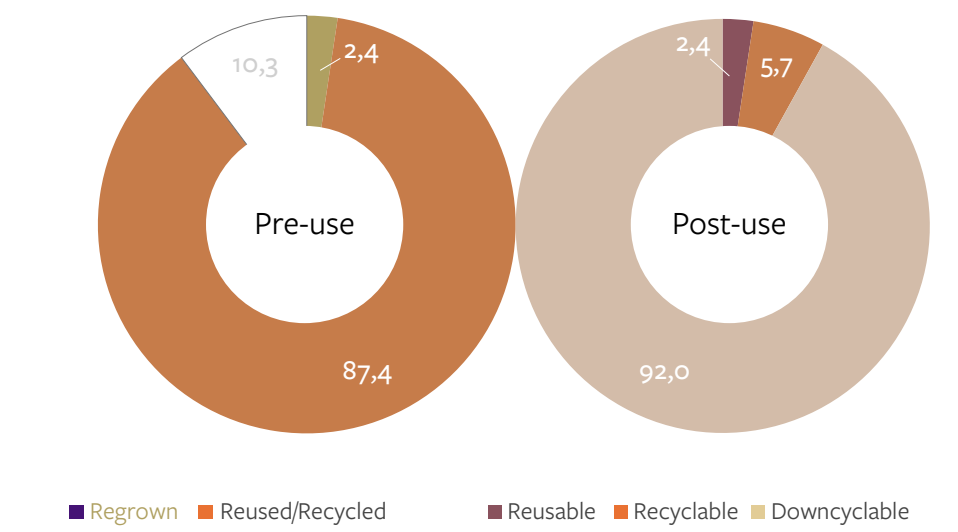



CLT Construction, Woodconstruction Denmark 195 km



Windows, GreenDozer 195 km



Prefab Facade & Floor, Taasinge Elementer 170 km



Windows, Genbyg 14 km



Windows, JK Genbrugscenter 160 km



Brick, Gamle Mursten 165 km



Roof tiles, teglageret 220 km



Wood, Burntwood 195 km



Cable drums, reclaimed wood, Skave Nedbrydning 340 km



Wood facade, flooring a:gain 10 km



Concrete foundation Unicon København 10 km



Underside floor heating system Heatcom Corporation A/S 210 km



facade membranes AAG 315 km



Metal Facade Tora 230 km

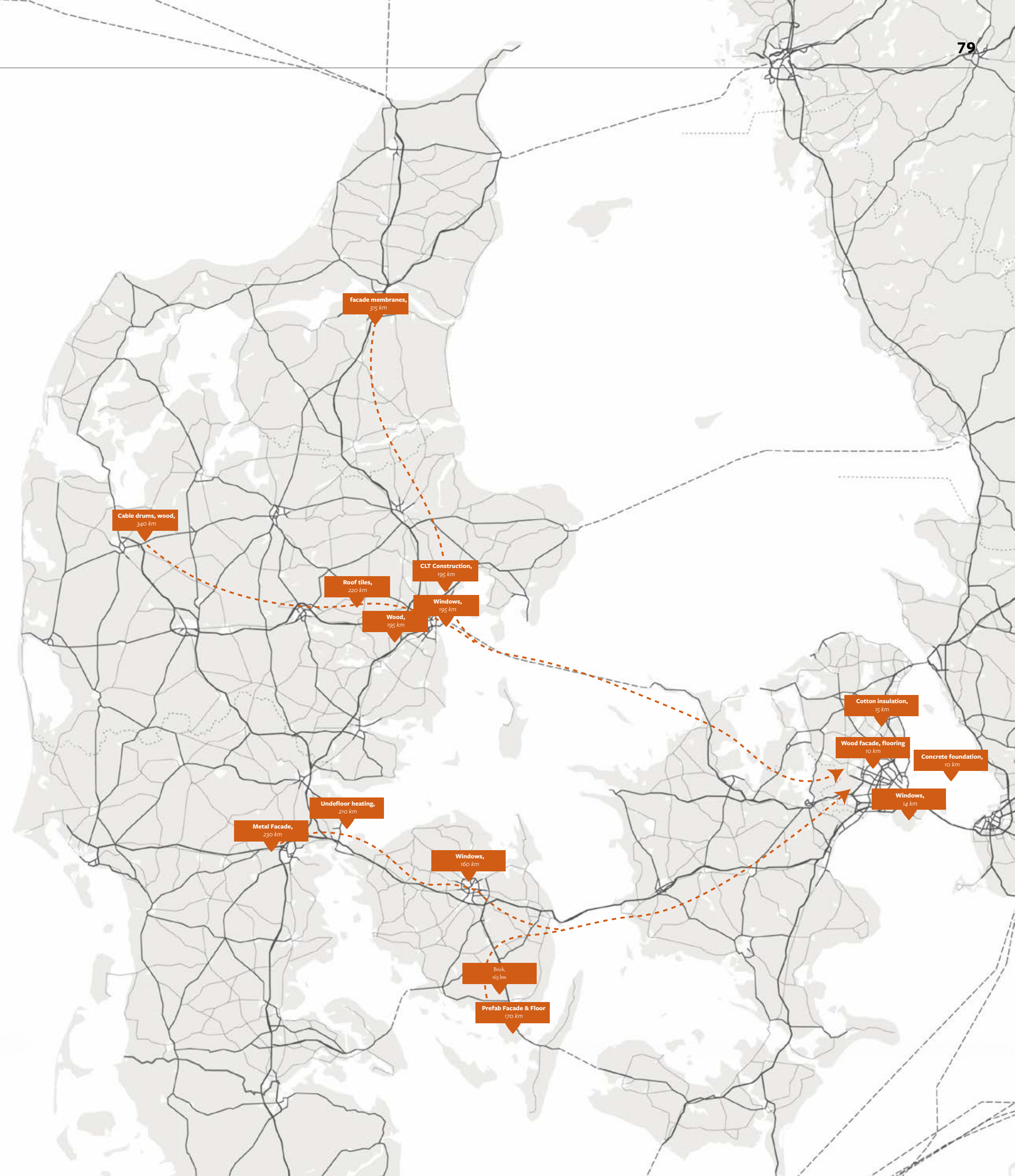

The public condenser as more than a building: Creating a new mindset about how we relate to waste, materials, and one another



Thank you!

