

Therme Biomass

Biomass power plant integrated recreation program

Yixin Lyu | 4617487

AE Graduation studio | P5 presentation

Design Tutor | Anne Snijders

Building Technology tutor | Engbert van der Zaag

Research Tutor | Jan Jongert

Content

Background Introduction

Overview

Context

Research

Research questions

Data analysis

Design

Site and surrounding

Concept design and strategy

Typology study and test

Spacial quality

Construction detail

Materiality & structure

Climate system

Conclusion

Introduction



Introduction-Overview

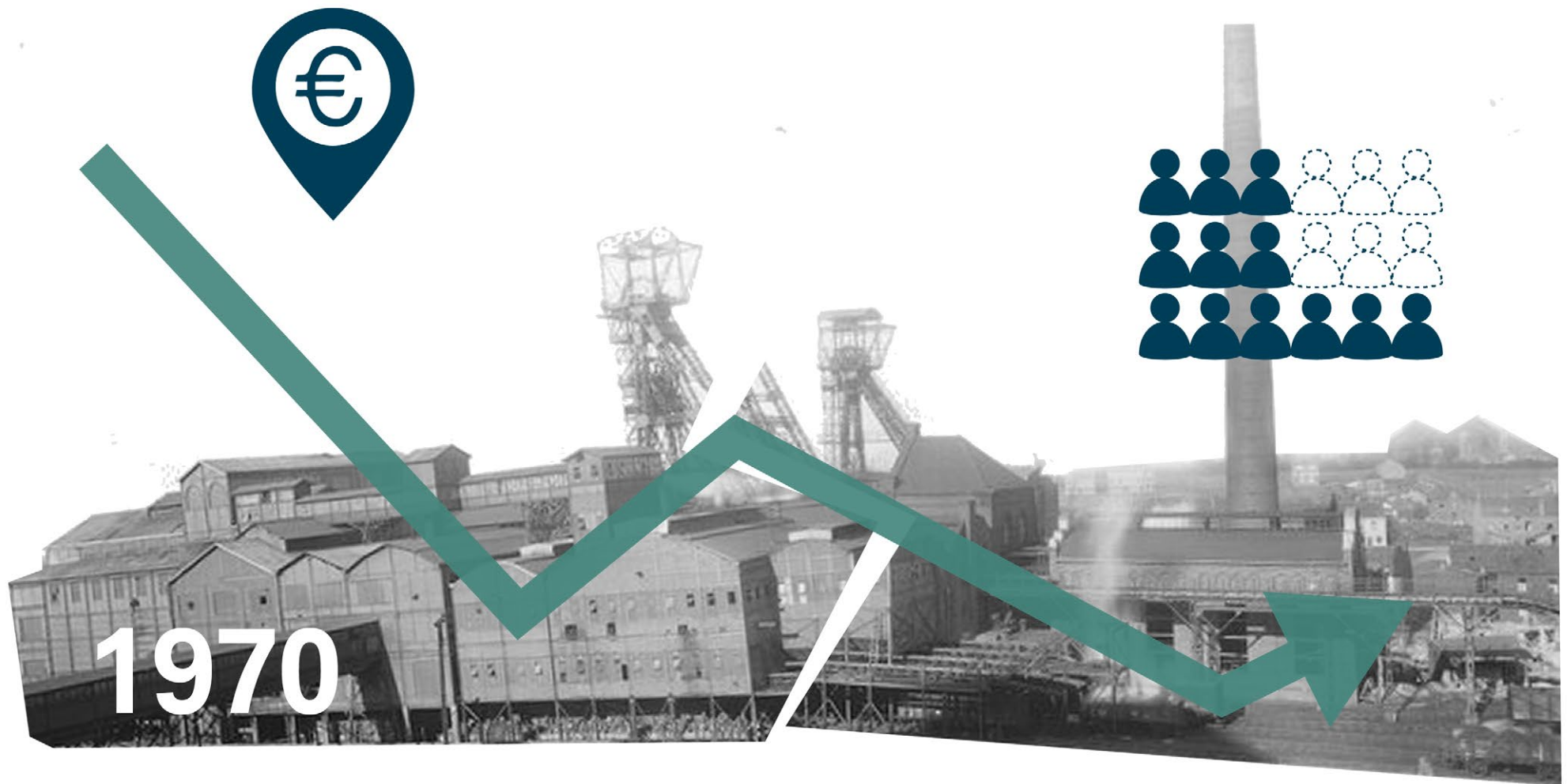

Introduction-Research



Government developping stratagies in Parkstad

Research

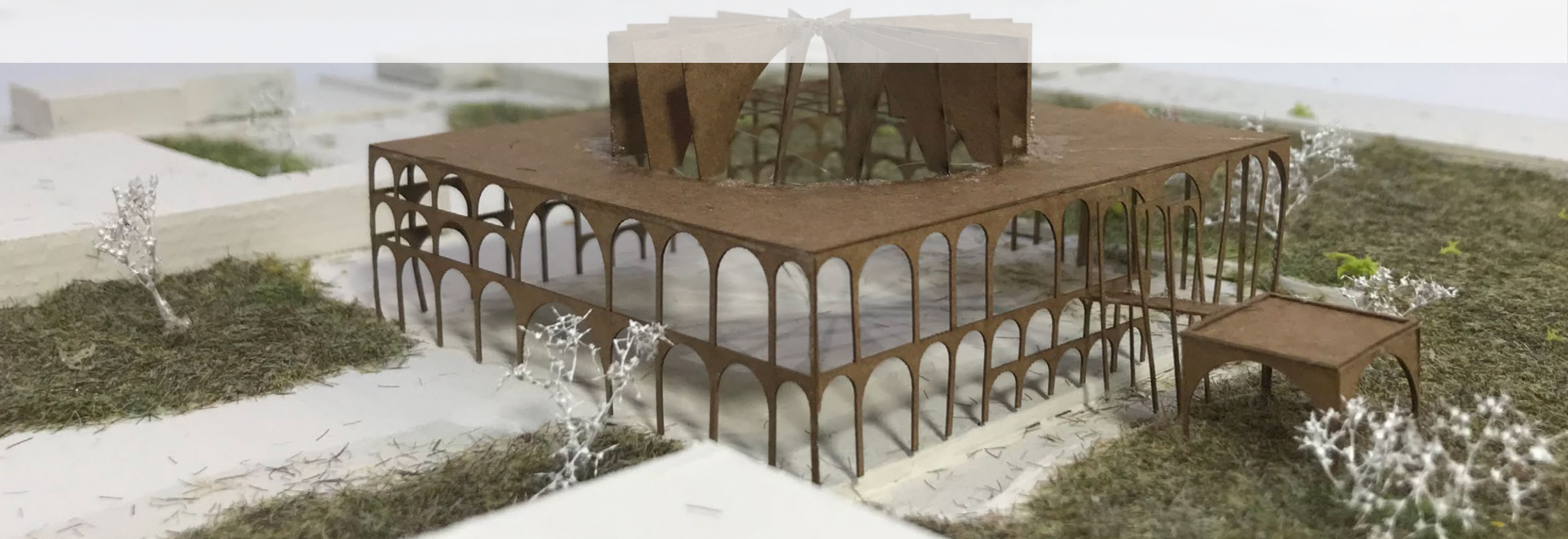

Research question

Objective

To have recreation programs with energy plant to relive the region and serve for both locals and tourists

Design question

How to integrate biomass energy plant cohesively into a recreation project (a bath center) in Parkstad?

How social connection could be built between proposal spots and existing urban fabric?

Thematic question

Whether a satellite plant system will have a potential to exist in the region of Parkstad?

How could a biomass conversion flow permeate in a design of a bath center?

Research- Renewable energy strategies in Parkstad



Wind



Hydropower

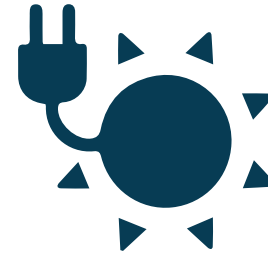

Solar

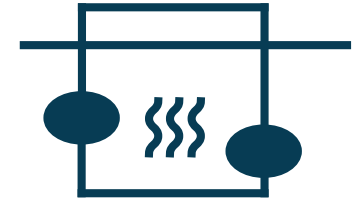

Heat-cold storage



Biomass



60%



23%







20%



17%

A **30%** contribution of biobased raw materials and fuels

Research - Waste in Parkstad for biomass

	 <p>Wood waste</p>	 <p>Household waste</p>	 <p>Agricultural crops</p>	 <p>Livestock and manure</p>	 <p>Energy Crops</p>
Waste	17.80 km ²	68,129.64t (organic waste: 22,950t)	74.96 km ²	7,960,000m ² Grassland	137,176,8t
Energy from clearance kWh/year	7,712,740	35,966,876	2,517,621	32,134,032	617,295,600

Research - Waste in Parkstad for biomass



	Household	Commercial service	Public service	Total
Energy consumption million kWh	500	216	172	888
Energy Supply from waste million kWh	/			675
Ratio	/			76%

Research- Logistics cost for waste source

Heavy duty vehicles (HDV)

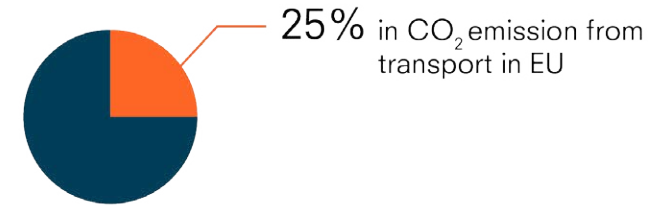

 A typical 18-tonne HDV

 0.2-0.35L/km

 100-300 gCO₂/t-km

Railway

 Gasoil and energy mix

 1 kWh/t-km

 45 gCO₂/t-km

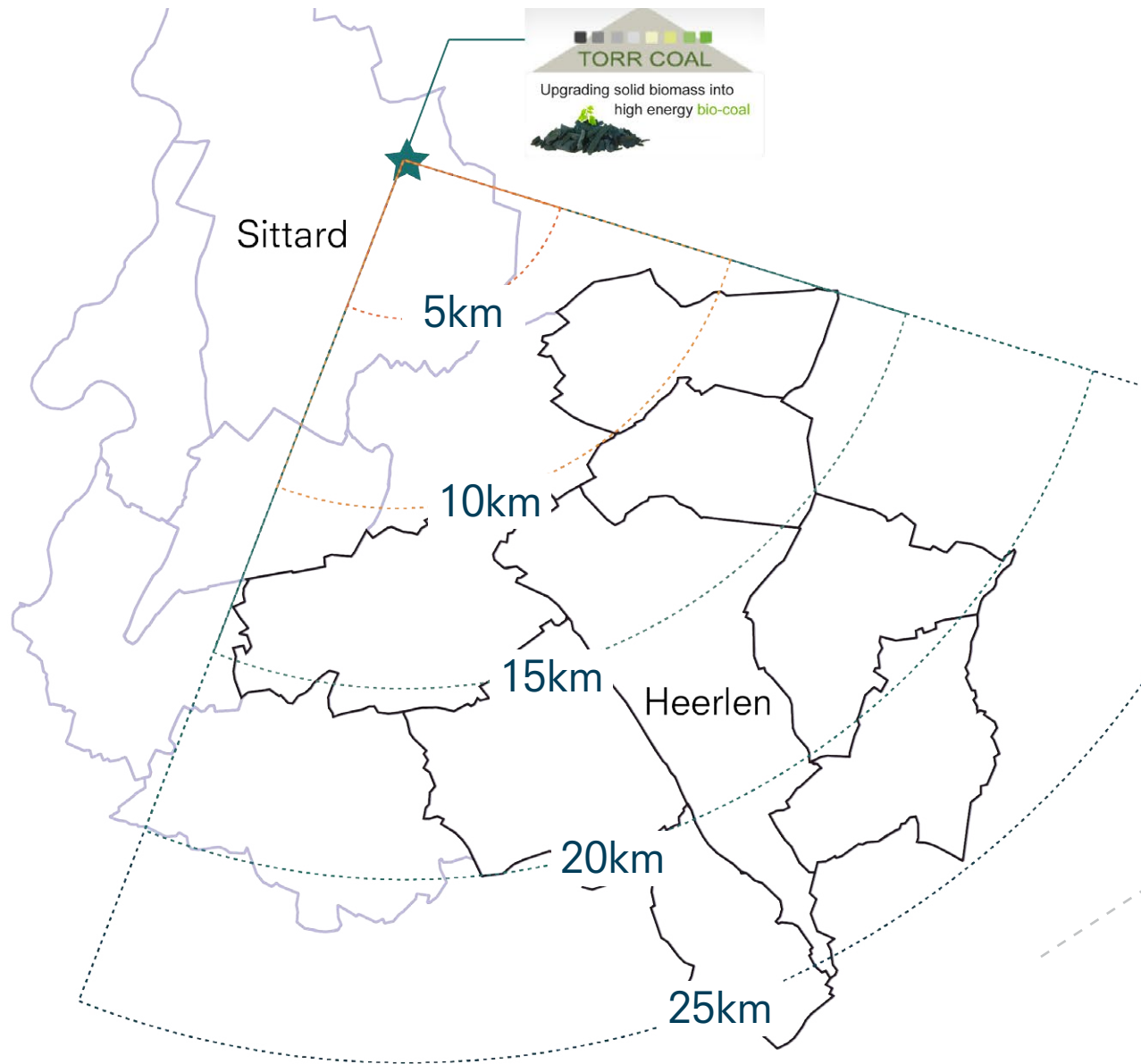

Research- Biomass network comparison

Type

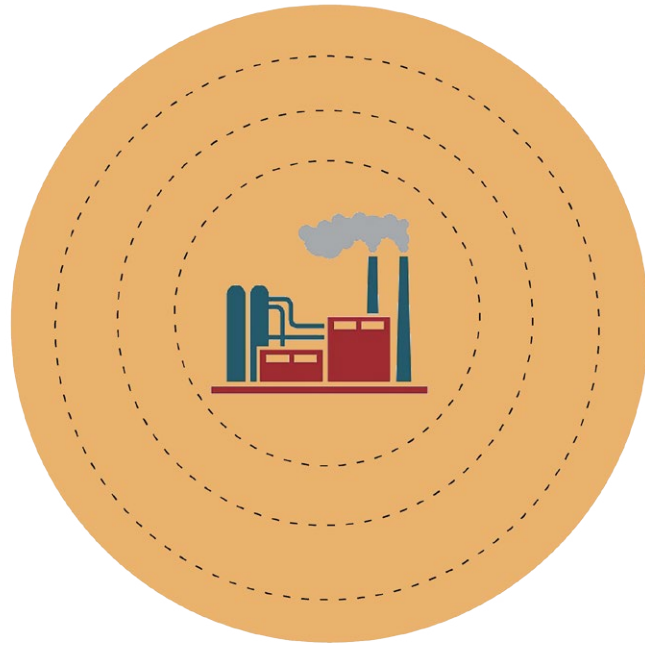

One large scale power plant

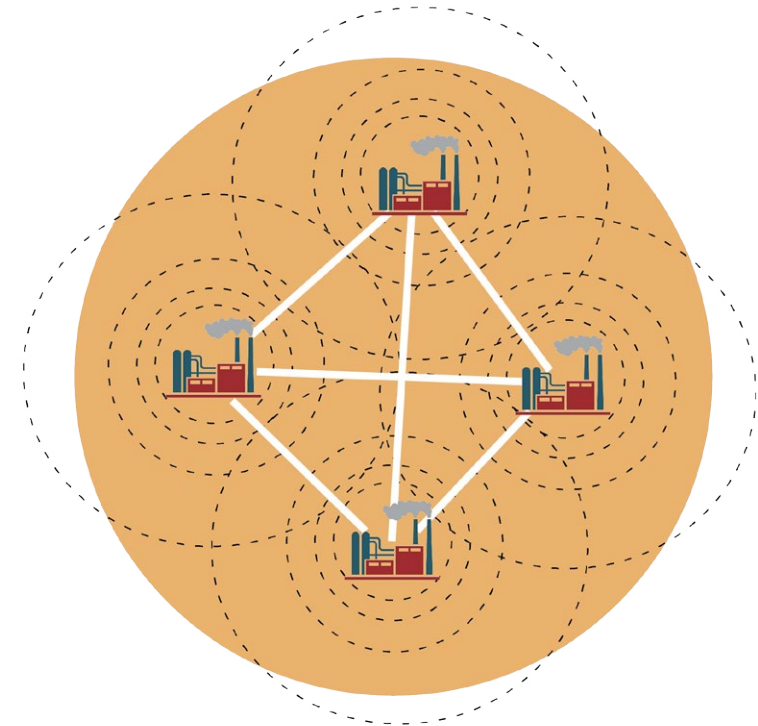

Multiple small scale plants in a system

Pros

- Higher efficiency
- Cheaper costs for a unit of power output
- Less effect on environment

- Closer delivery distance
- Reduce cost and gas emission
- More jobs offered

Cons

- High cost for transporting, handling and delivery
- Loose material has difficulty to handle

- Less thermally efficient
- Higher labour cost

Research- Biomass conversion

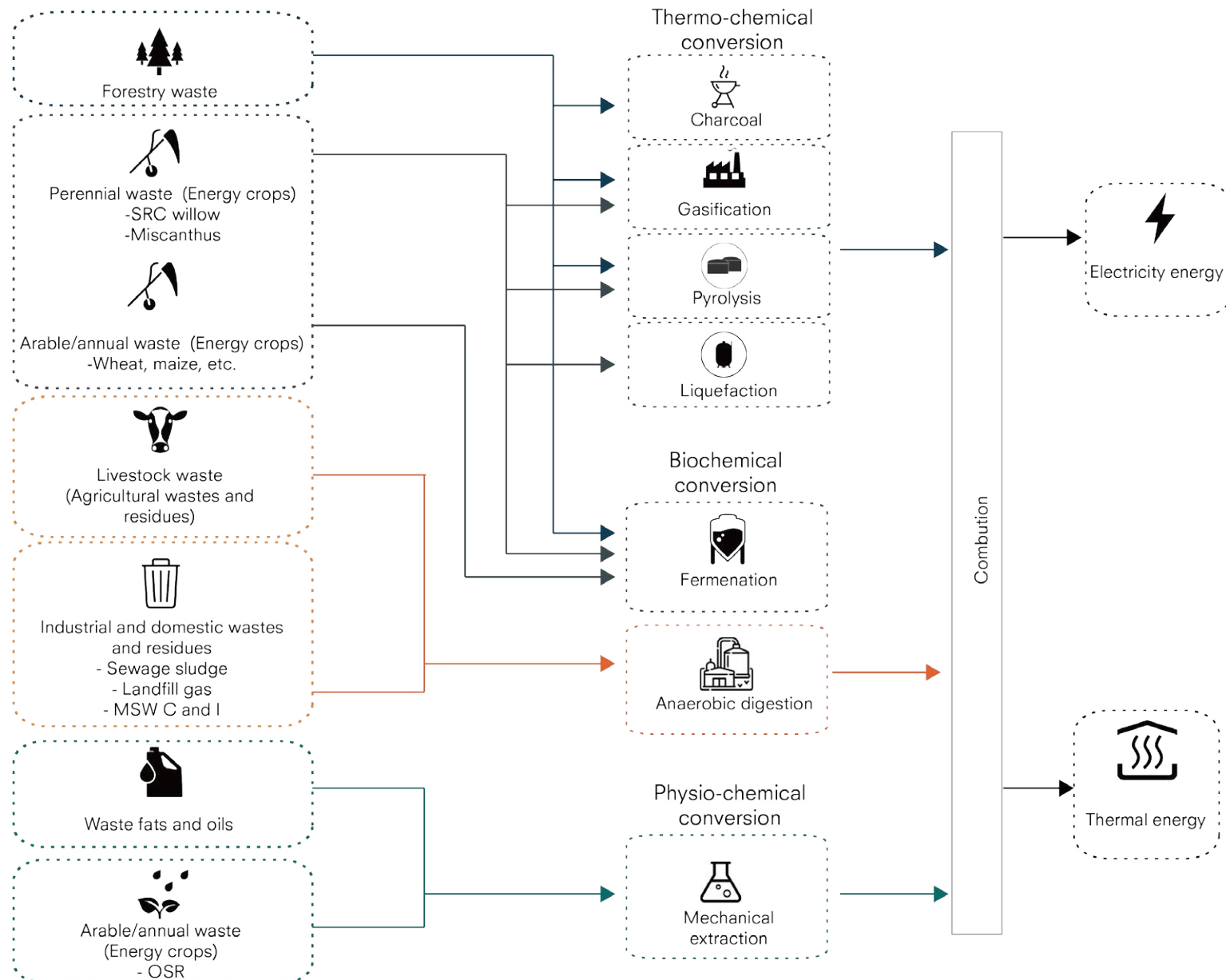

Research- Landuse in Parkstad

- Red space
 - Houses
 - Building land
 - Other built-up area
- Green space
 - Recreation
 - Agriculture
 - Woodland
 - Nature
- Blue space
 - Water

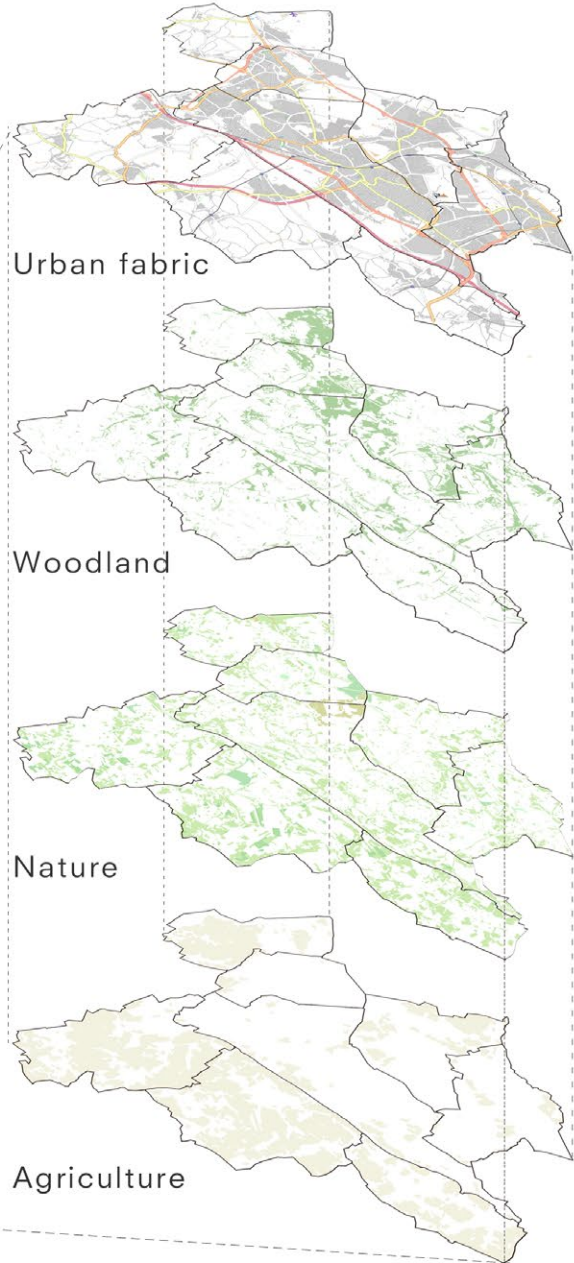

Research- Proposed network

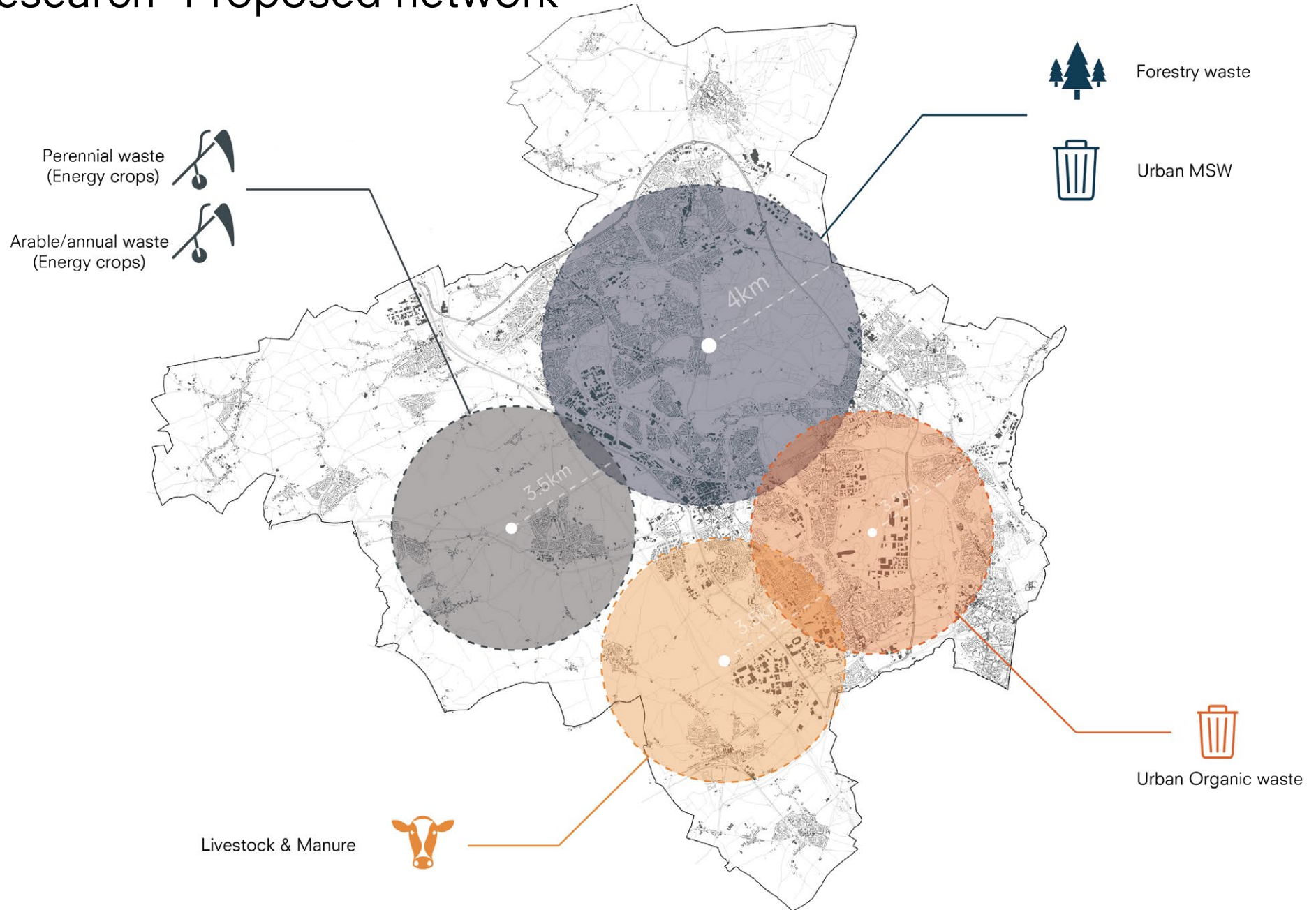

Research- Case study 1

Waste-to-Energy plant by BIG in Copenhagen



Architect: BIG
Area: 41,000m² (210m x 210m = 25,200m²)
Height: 80m
Location: Copenhagen, Denmark
Time: 2017



Building: 95,000m²
Landscape: 90,000m²
Roof + ski slope: 32,000m²
Facade area: 74,000m²
Administrative + visitor center floor area: 6,500m²

Research- Case study 1

Waste-to-Energy plant by BIG in Copenhagen

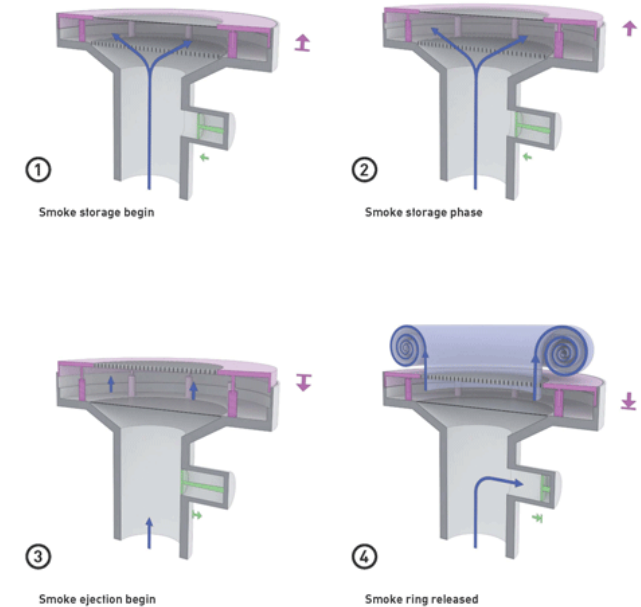
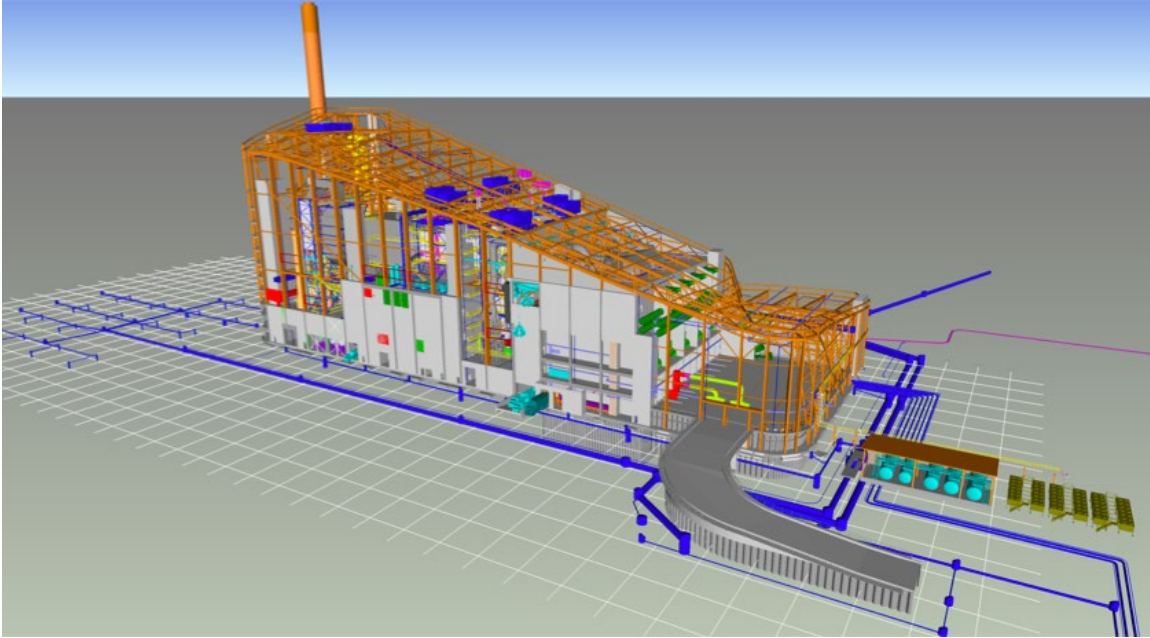

- Treat around 400,000 tonnes of waste annually produced by 500,000 – 700,000 inhabitants and at least 46,000 companies.
- 400,000 tons of waste a year result in:
 - 99% energy efficiency.
 - District heating for 160,000 households.
 - Electricity for 62,500 households.
 - 100 million litres of spare water recovered through flue gas condensation.
 - 90% reuse of metals from waste amounting to 10,000 tonnes of metal a year.
 - reduce sulphur emissions by 99.5%
 - minimize NOx emissions to a tenth
- Have steam data at 440 degrees and 70 bars which doubles the electrical efficiency compared to the former plant.
- Flue gas system: climate/ environmental damage

Research- Case study 2

EcoTricity Anaerobic Digestion Plant







Area: 4.5 ha
Location: Fiddington, TEWKESBURY, England
Time:2017

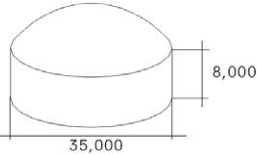
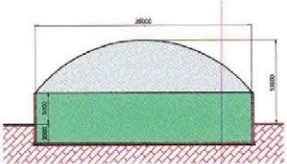
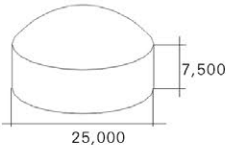
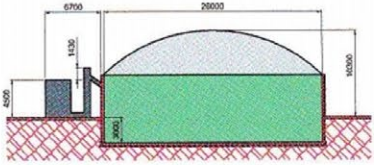
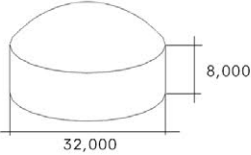
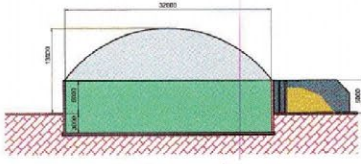
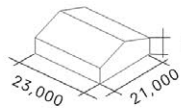
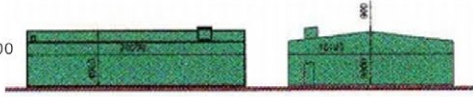
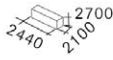

- provide enough green gas to power nearly 3,500 typical UK homes
- save over 2,500 tonnes of carbon dioxide each year

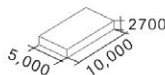
Research- Case study 2

Program	Size requirements	TECH. Requirements	Basic volume	Reference
Pre-treatment tank		Shred and mix the waste		
Anaerobic Digester Tanks		Two main temperature ranges: -Mesophilic conditions, 20-45°C -Thermophilic conditions, 50-65°C		
Digestate Storage		- 1000 kg MSFW = 370 kg natural fertilizer		
Biogas storage Upgrading unit		- 1000 kg MSFW = 160 Nm ³ biogas		
CHP engine room		- 160 Nm ³ biogas = 390 kWh _{el} 333 kWh _{th}		
Office and security		Temp: 18-21°C		

Research- Energy from waste

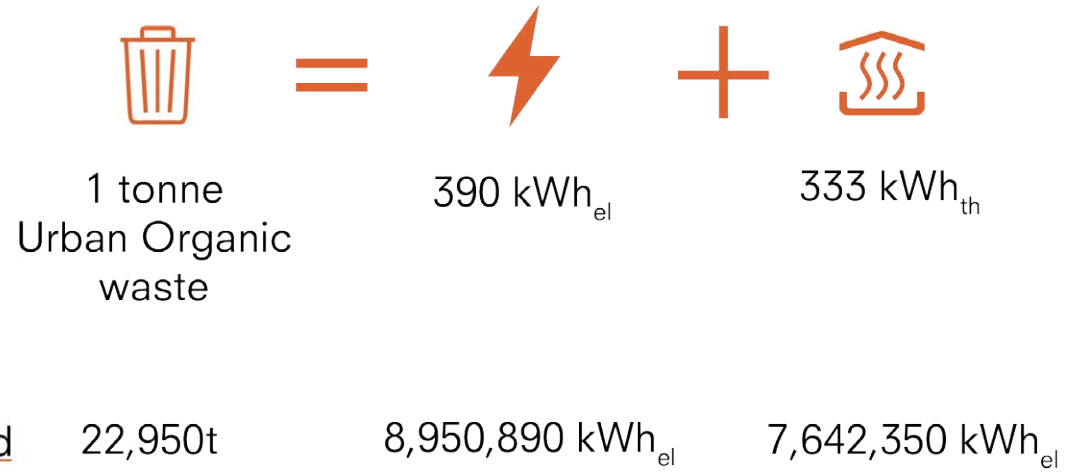
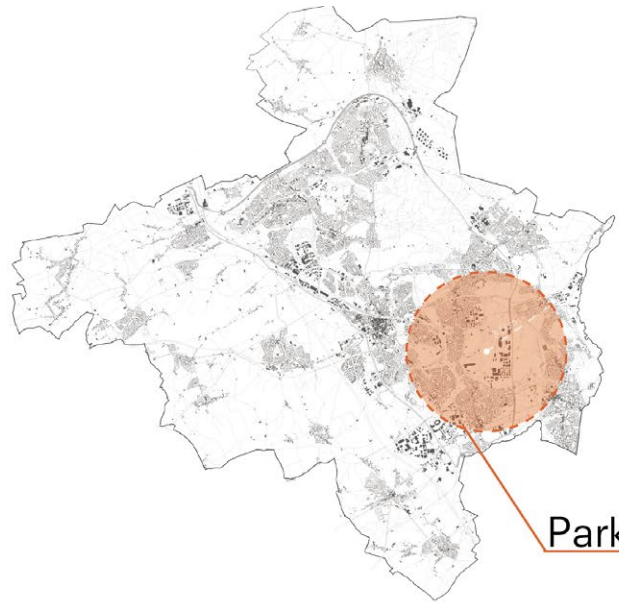

Biomass energy conversion - Anaerobic digestion

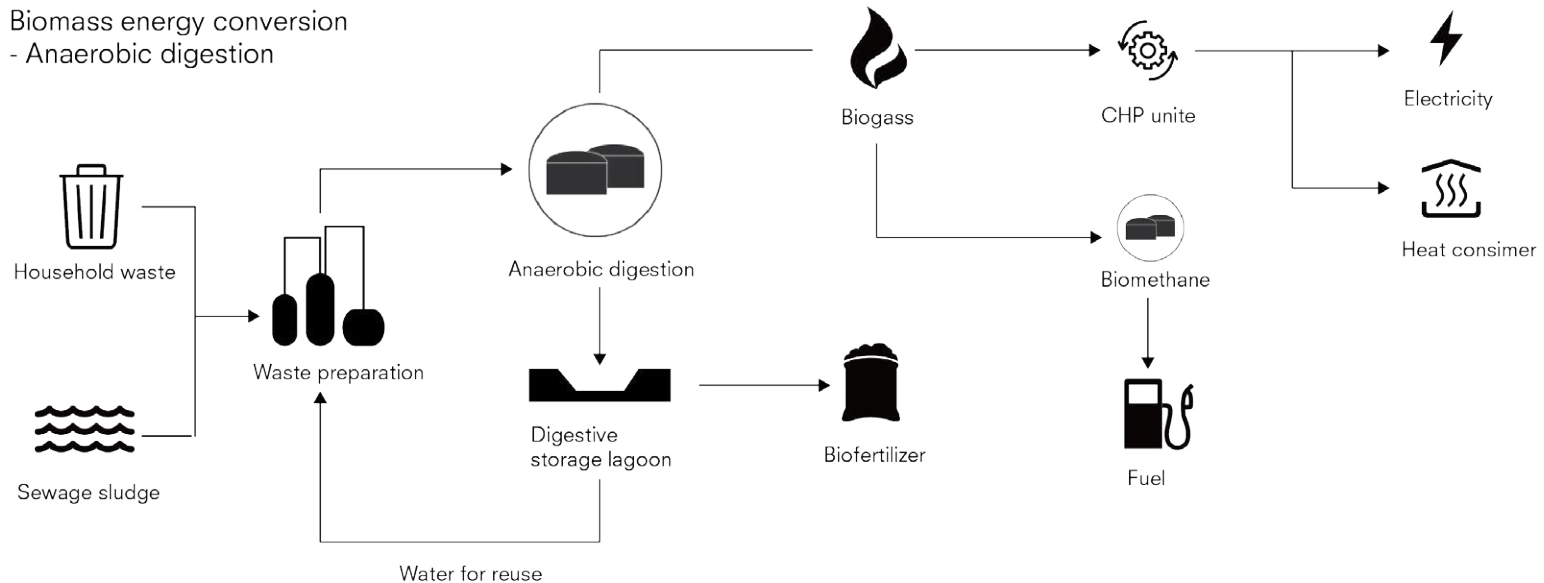

Research- Density of recreation

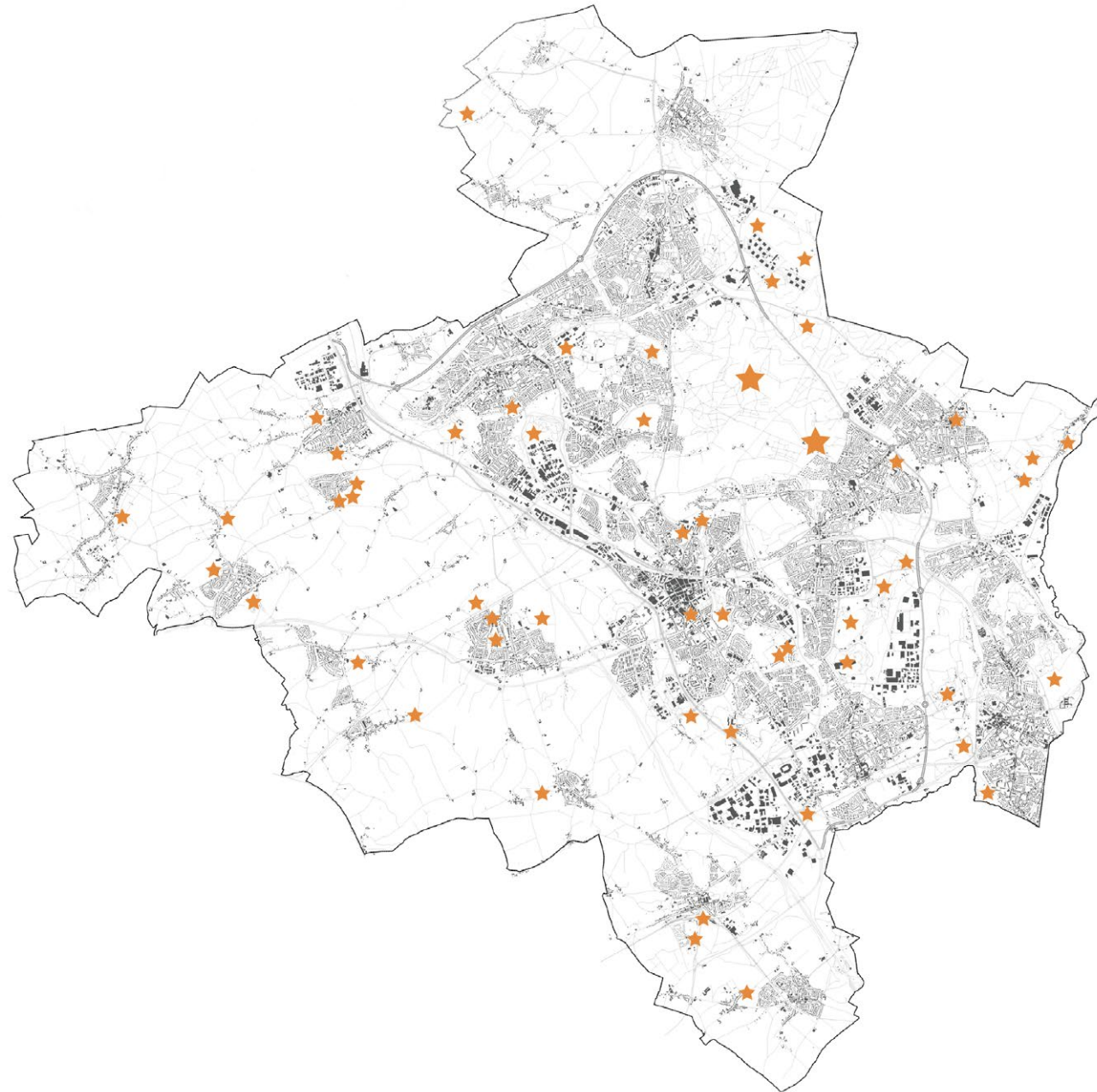

 Fishing

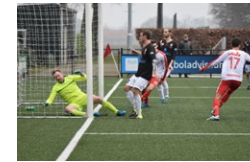

 Sports



 Golf



 Park



 Camping

Research- Proposed Gathering Area

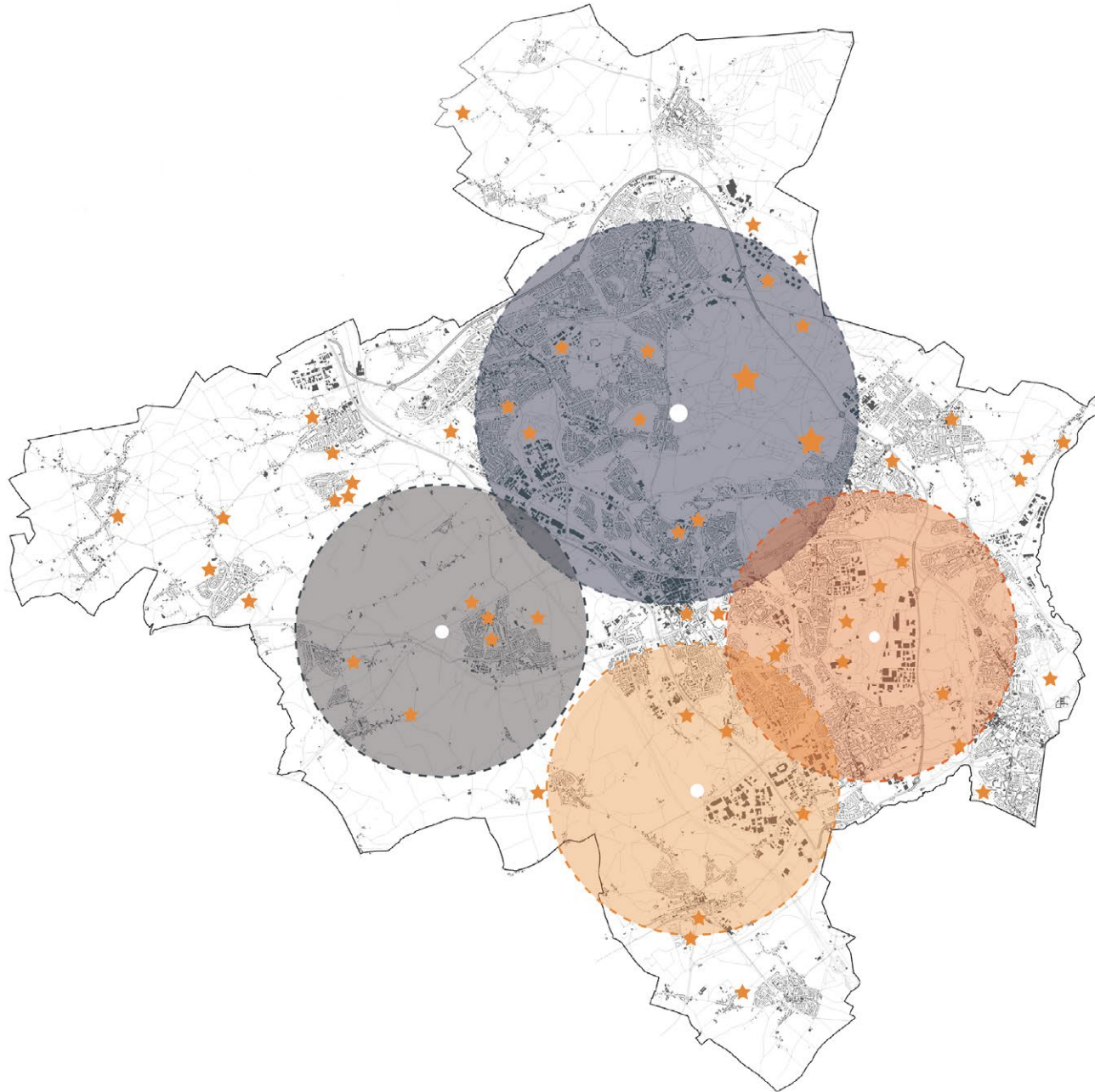

Fishing



Sports



Golf



Park



Camping



Bath



Water-based facilities



Concert



Food plaza



Culture center

Research- Proposed Gathering Area



Objective and Design strategy

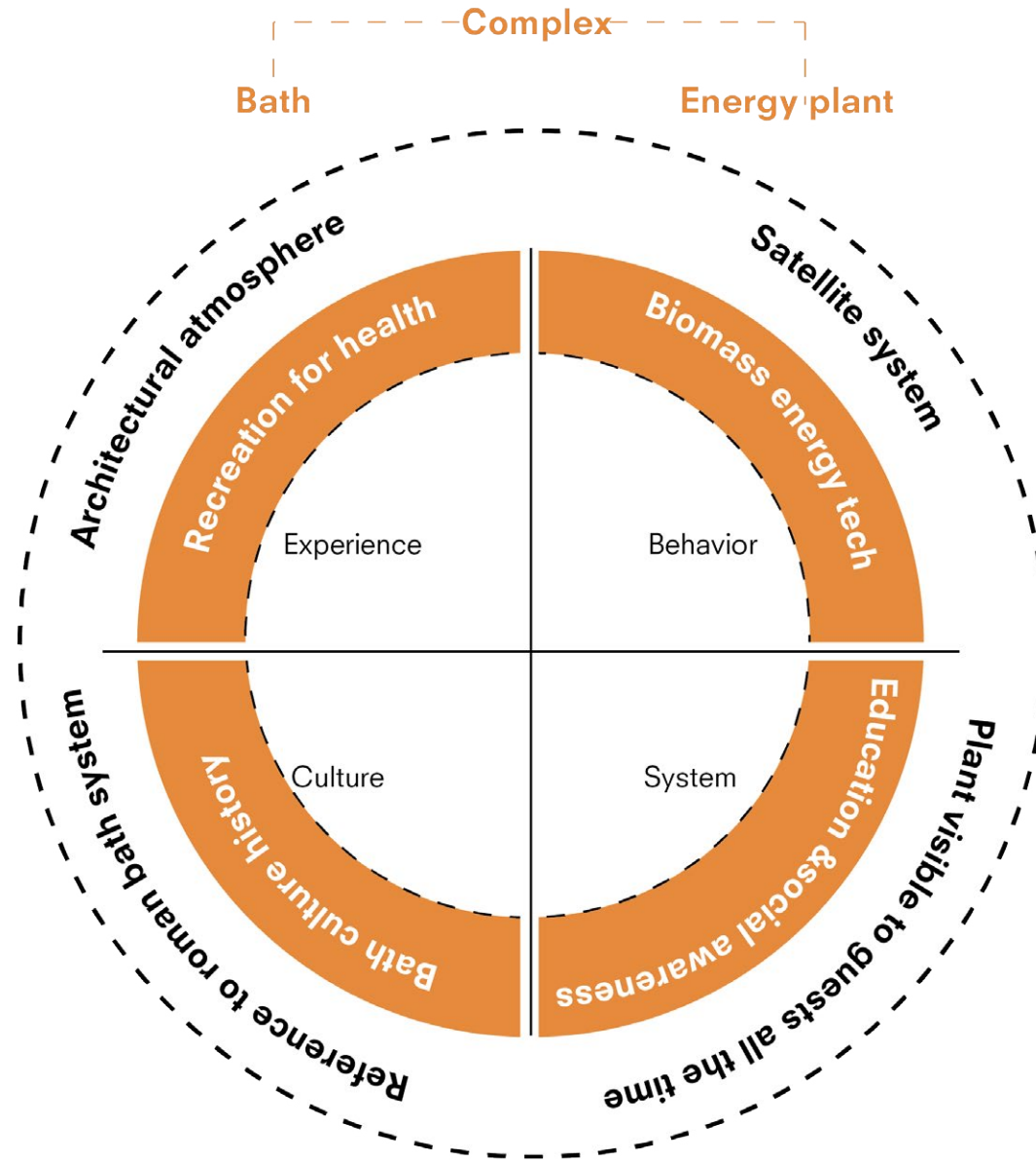

Objective and Design strategy

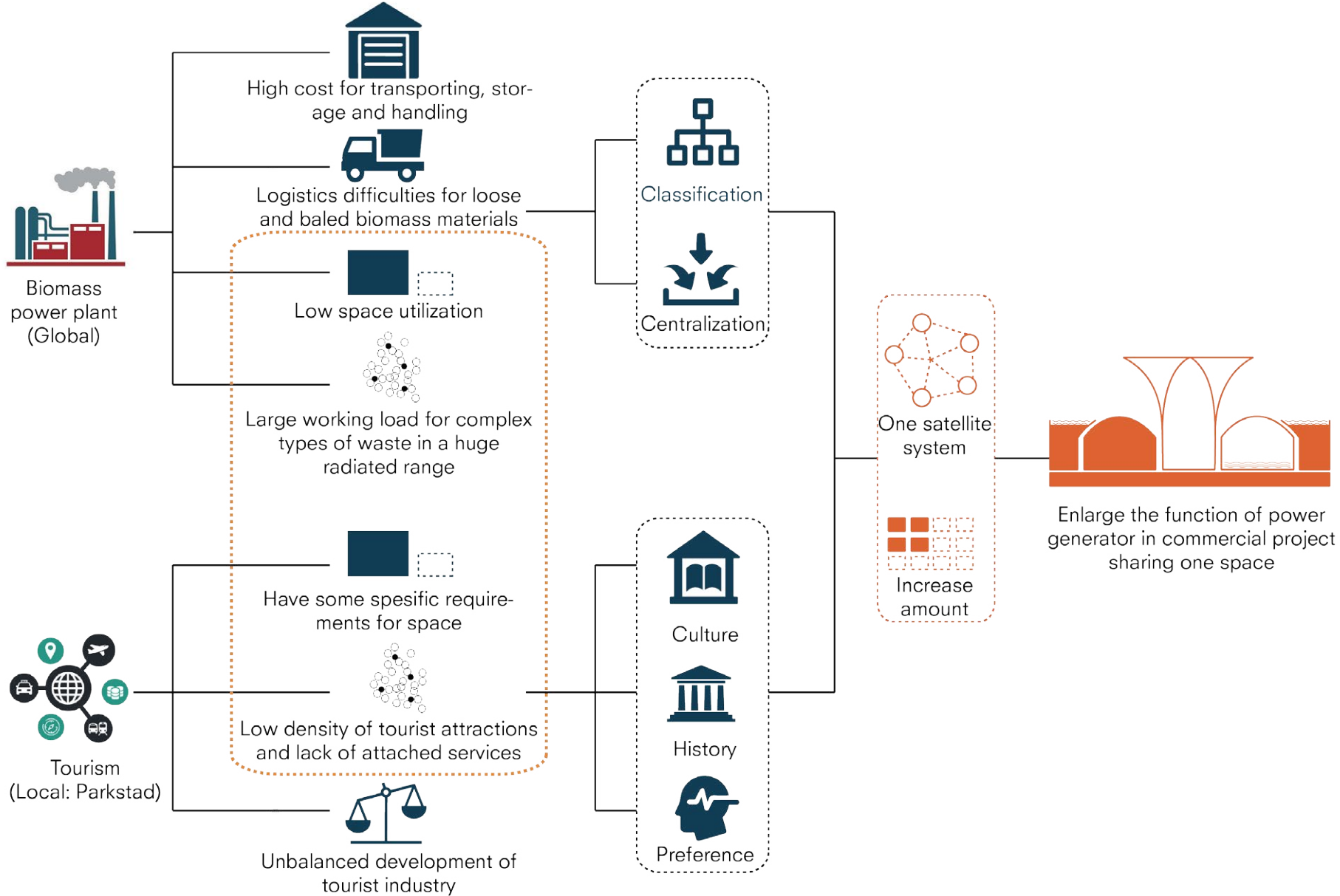

Research- Case study 3

Hallenbad Bambados



Architect:
Area: 13,500 m²
Water surface: 1,800 m²
GV: 93.500 m³
Guests: 1,100 pers./d
Location: Bamberg, Germany
Time: 2011

Research- Case study 3

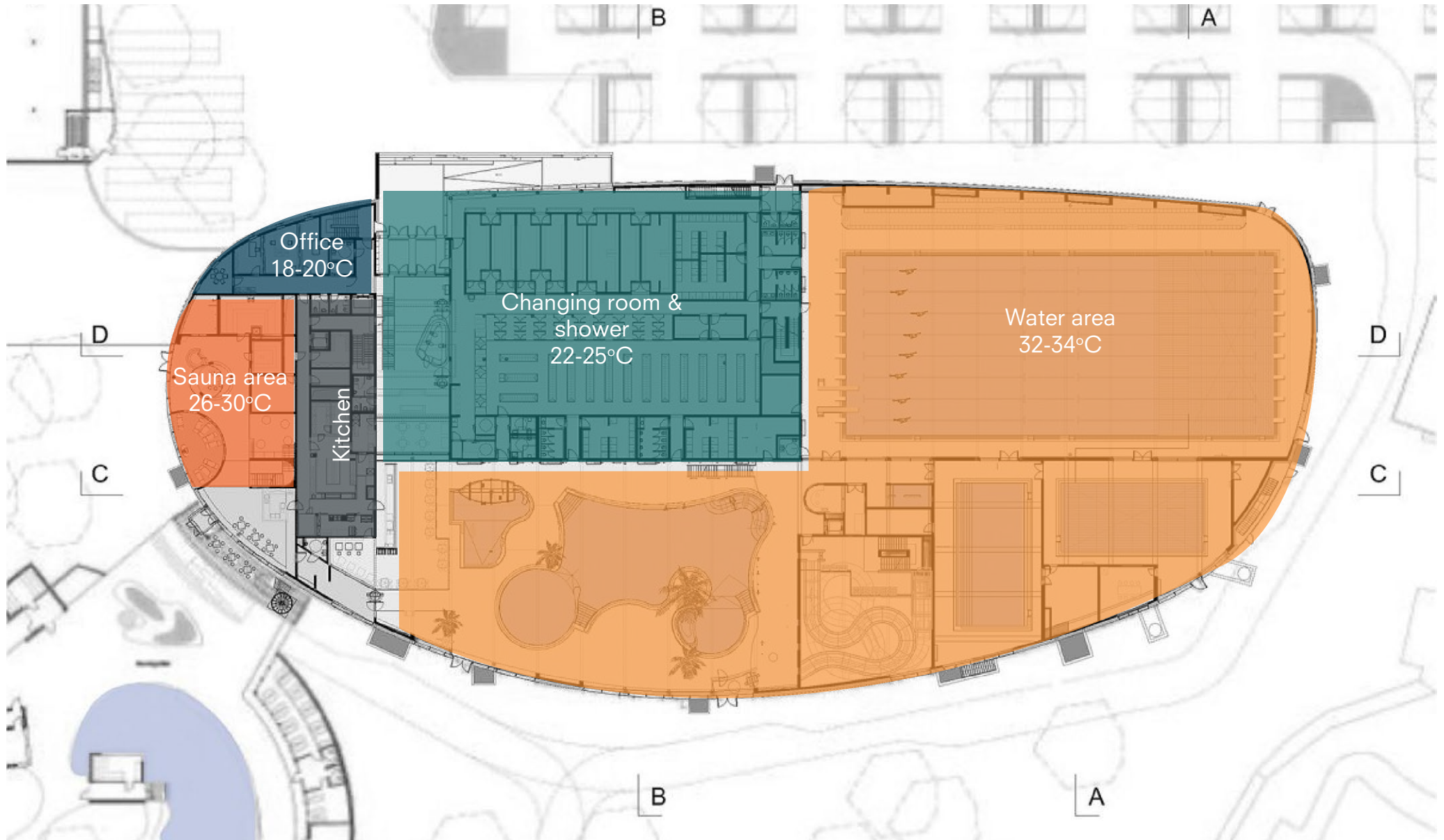

Research- Case study 3

Energy consumption



156 kWh/m²/year

Electricity



Heat

258 kWh/m²/year

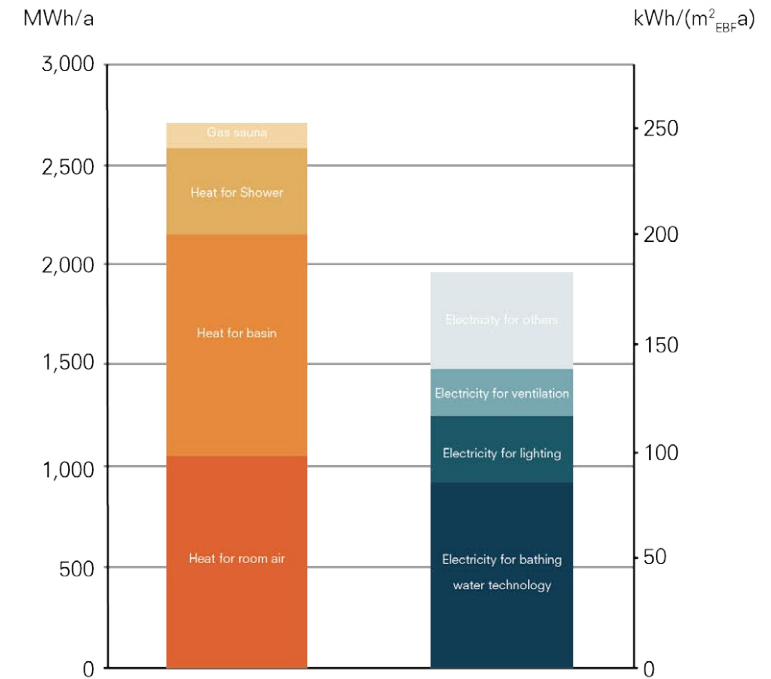

Water flow

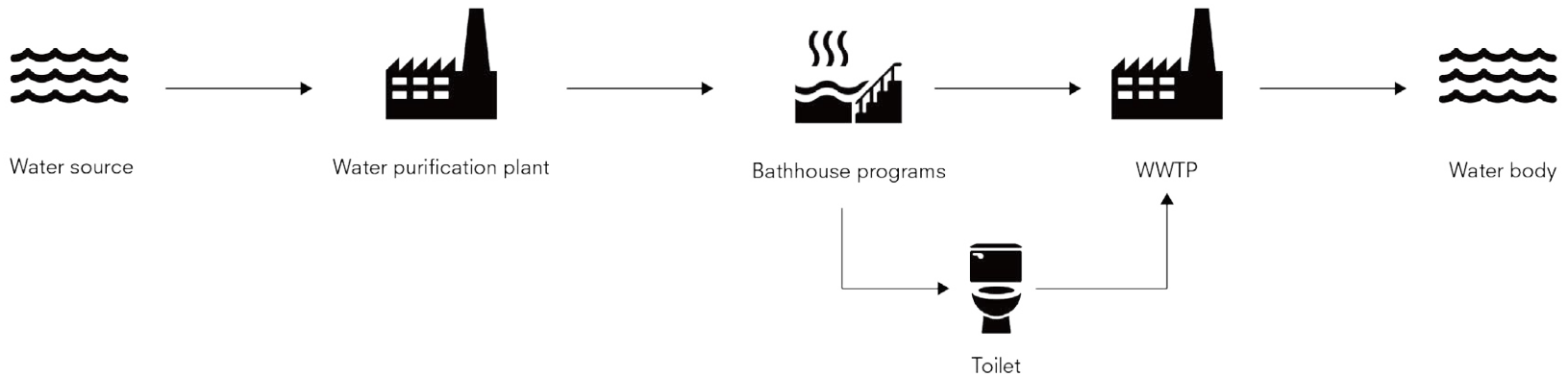

Research- Proposed flow system

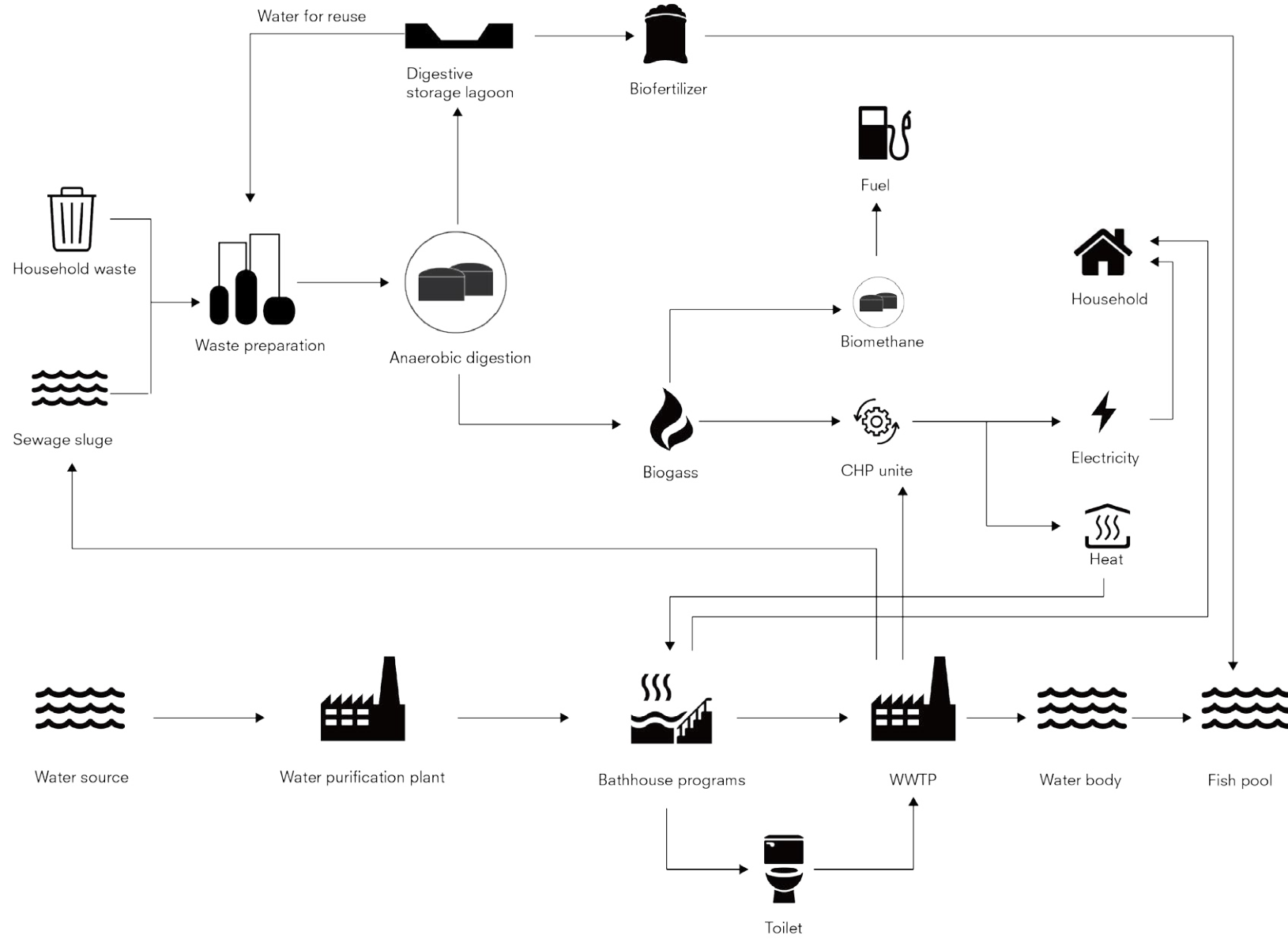

Design



Objective and Design strategy

Urban

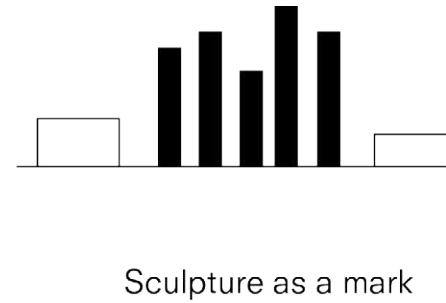
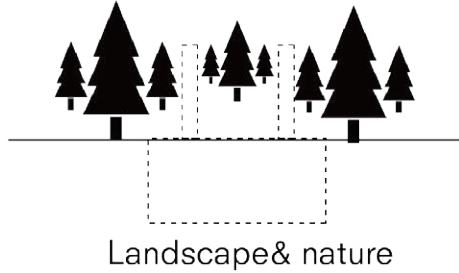

Building

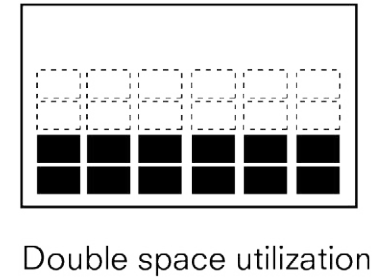

Introduction- site choice

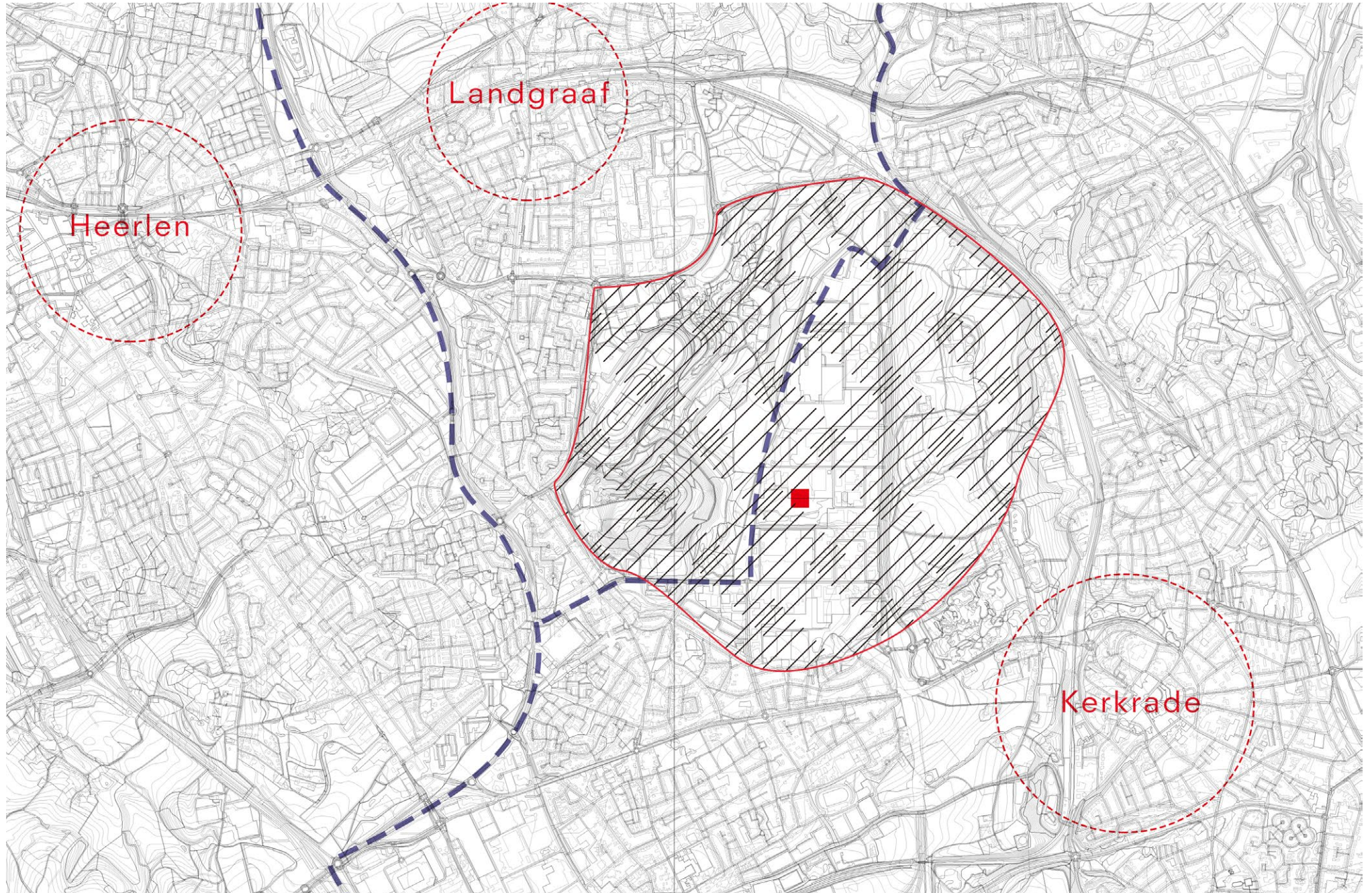

Introduction- site choice

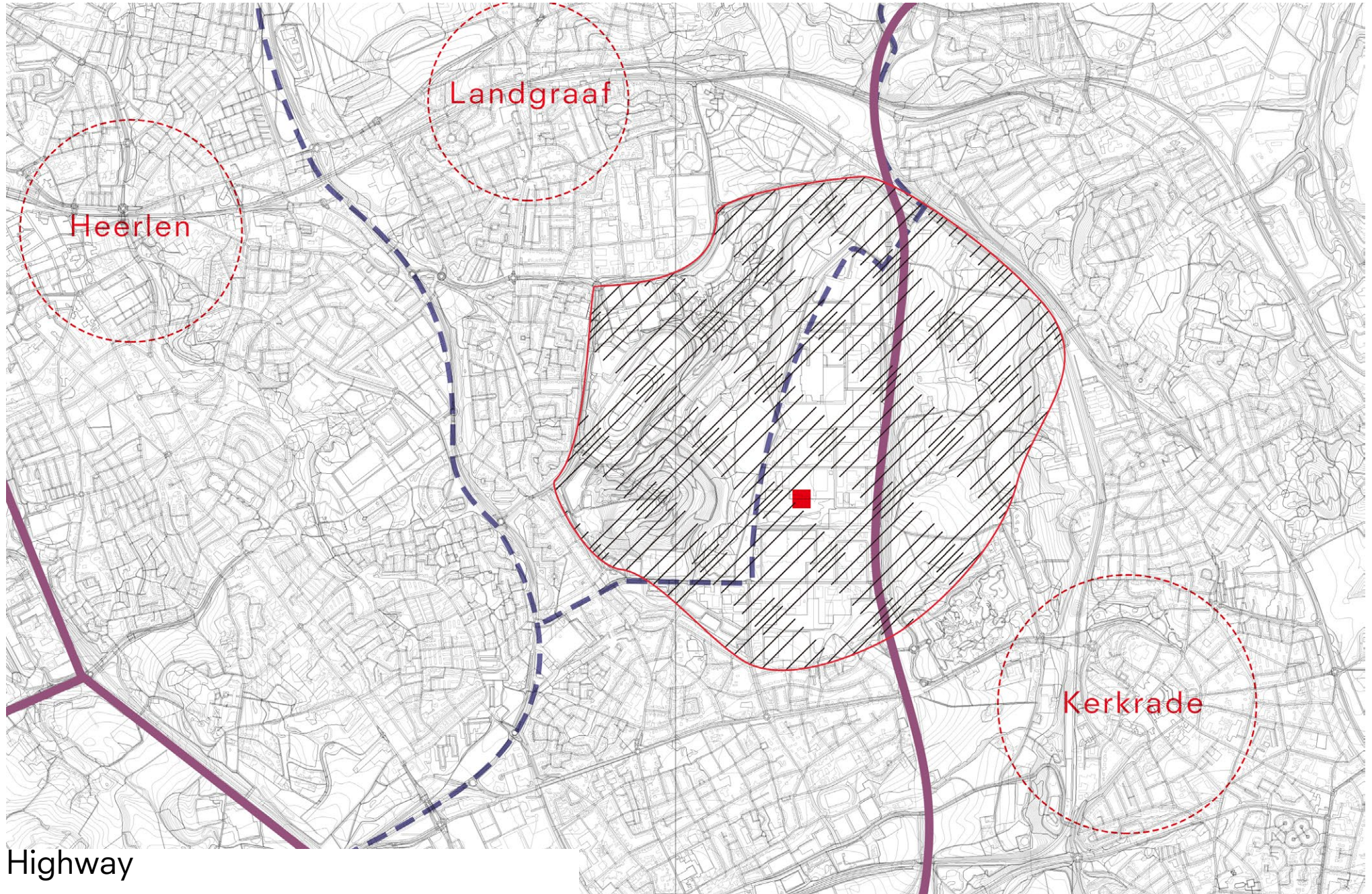

Introduction- site choice

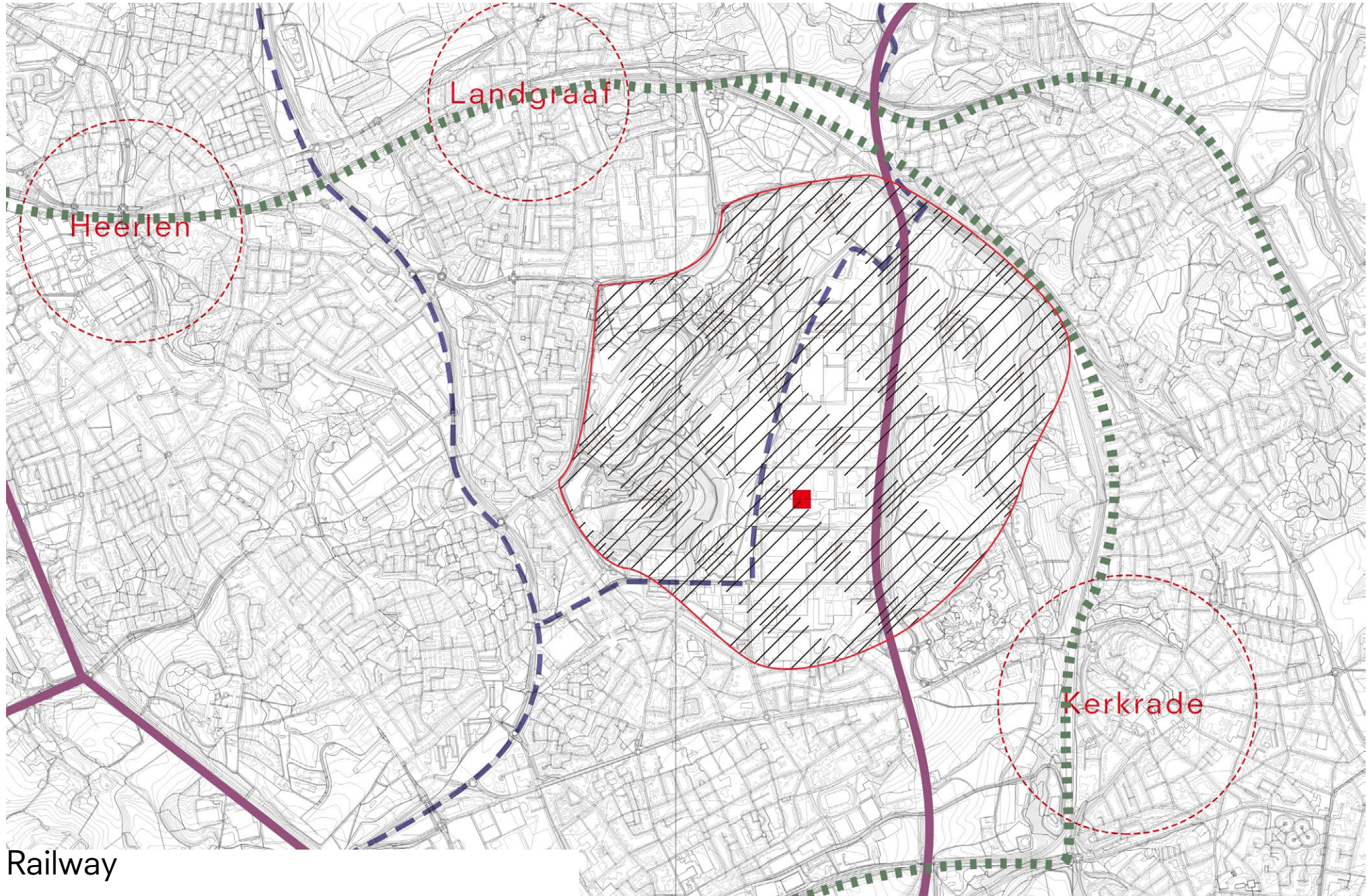

Site and surrounding - residence



Site and surrounding- green land



Site and surrounding - water body

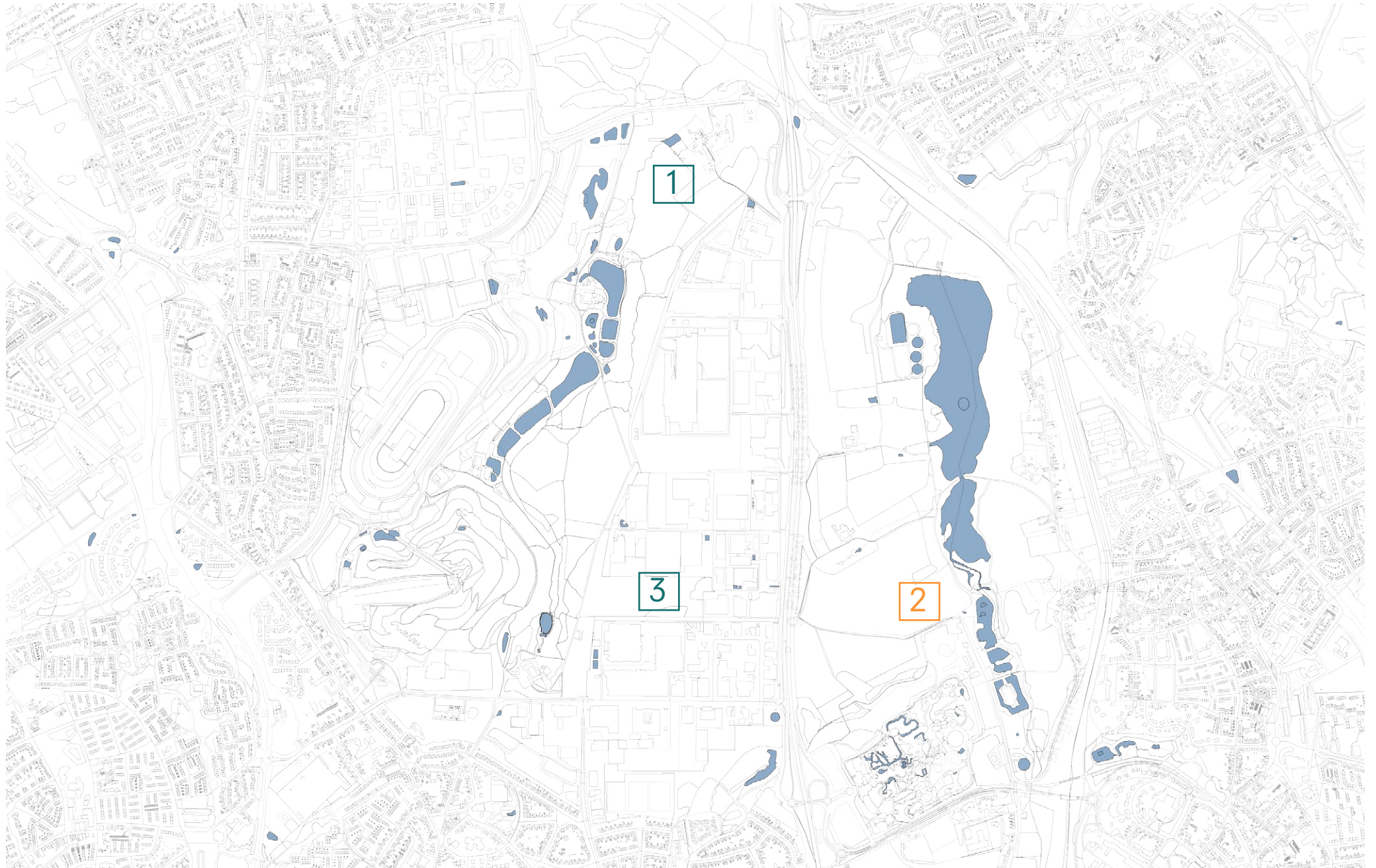

Site and surrounding - traffic

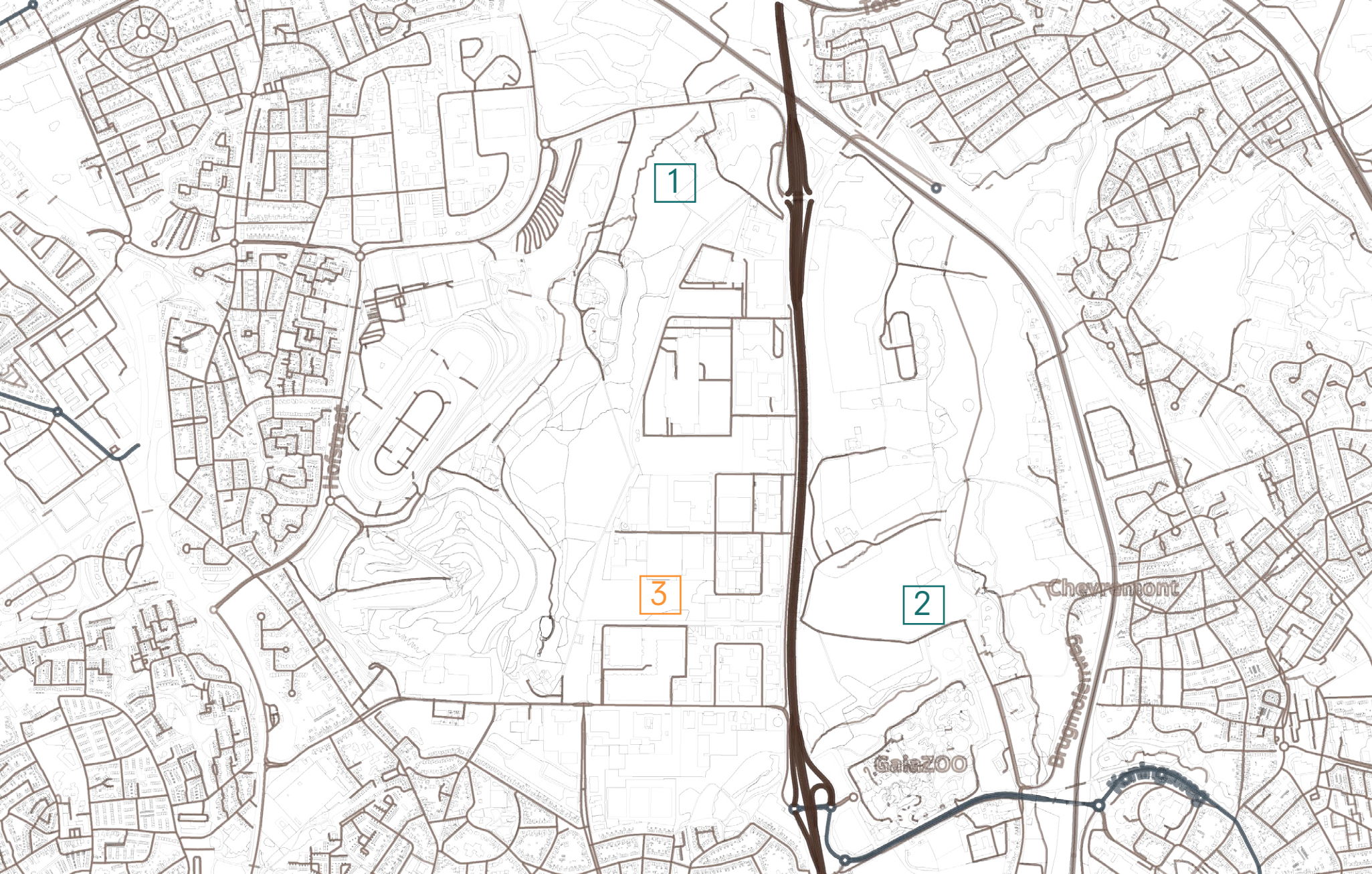

Site and surrounding - Industrial background

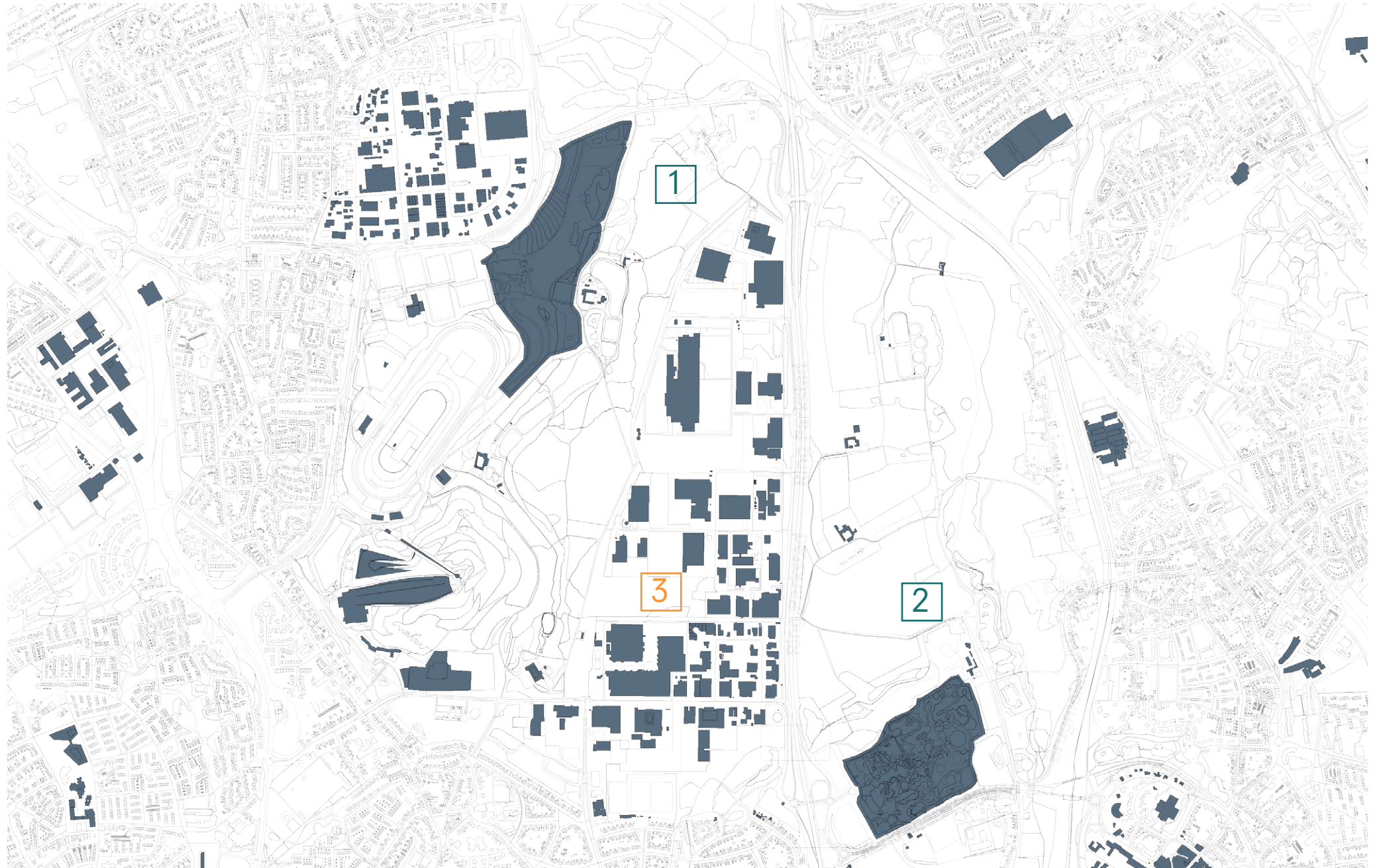

Site and surrounding - topography in east-west

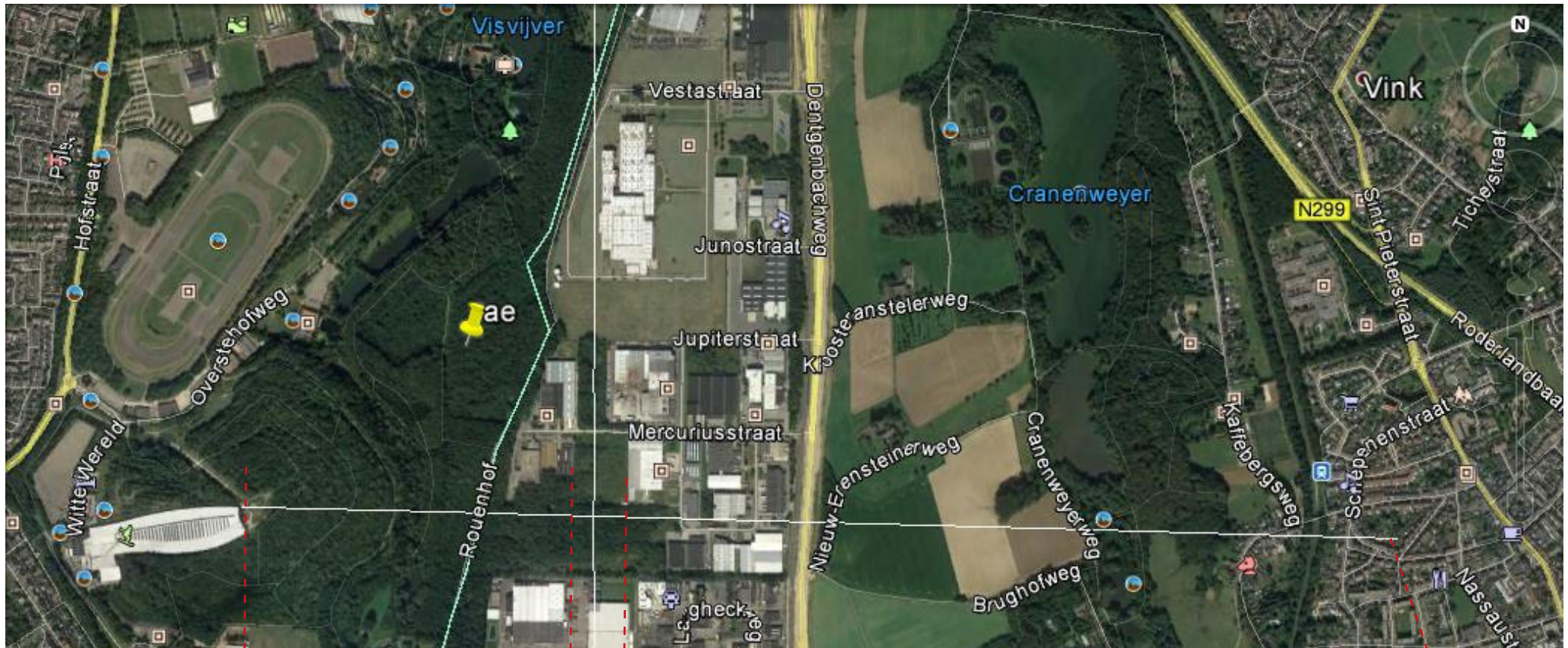

Site and surrounding - topography in North-south

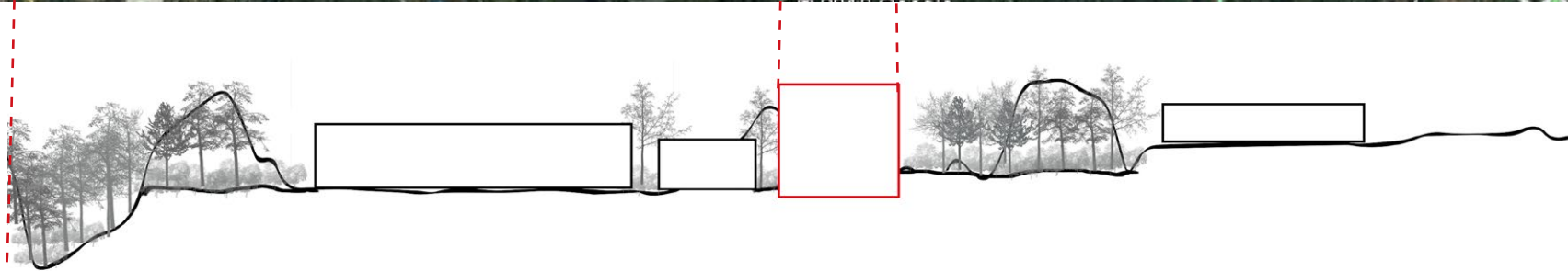
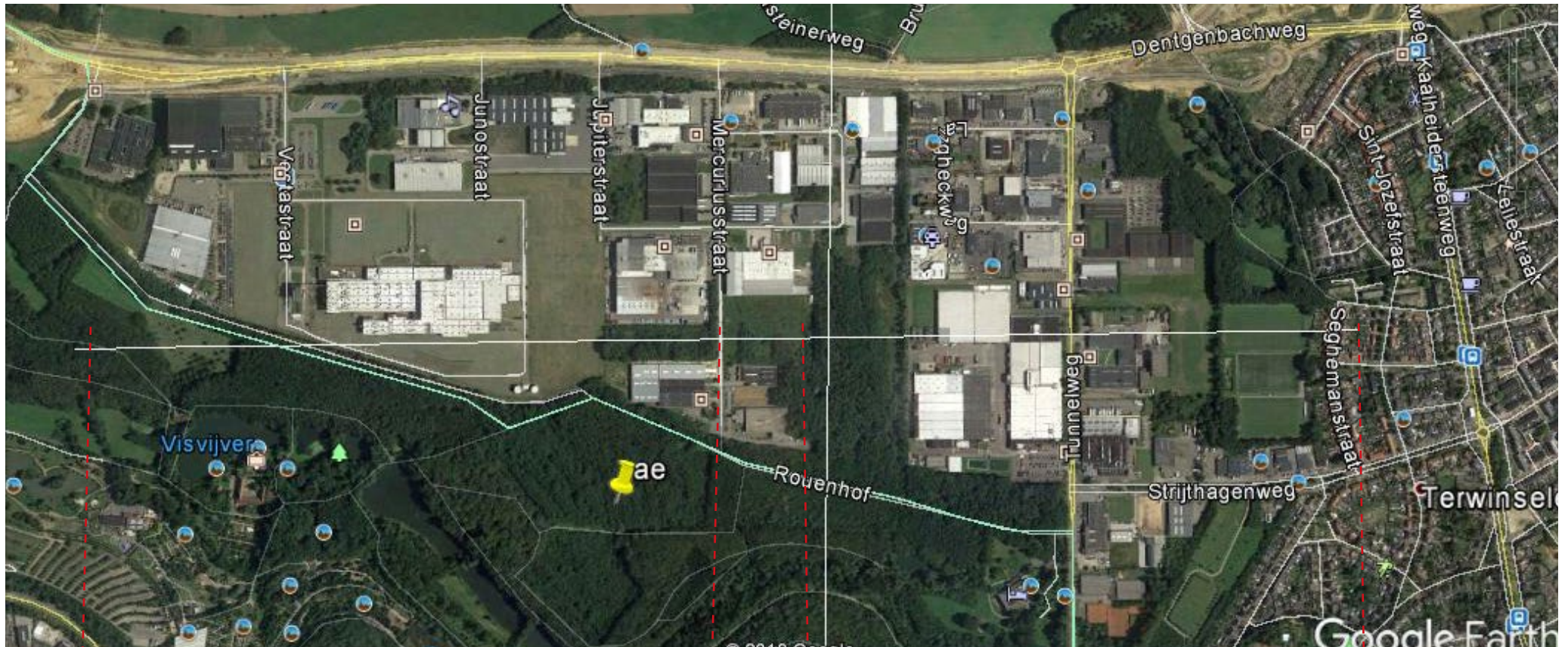

Site and surrounding - woods in the site



Site and surrounding - woods in the site



Site and surrounding - woods in the site



Site and surrounding - master plan

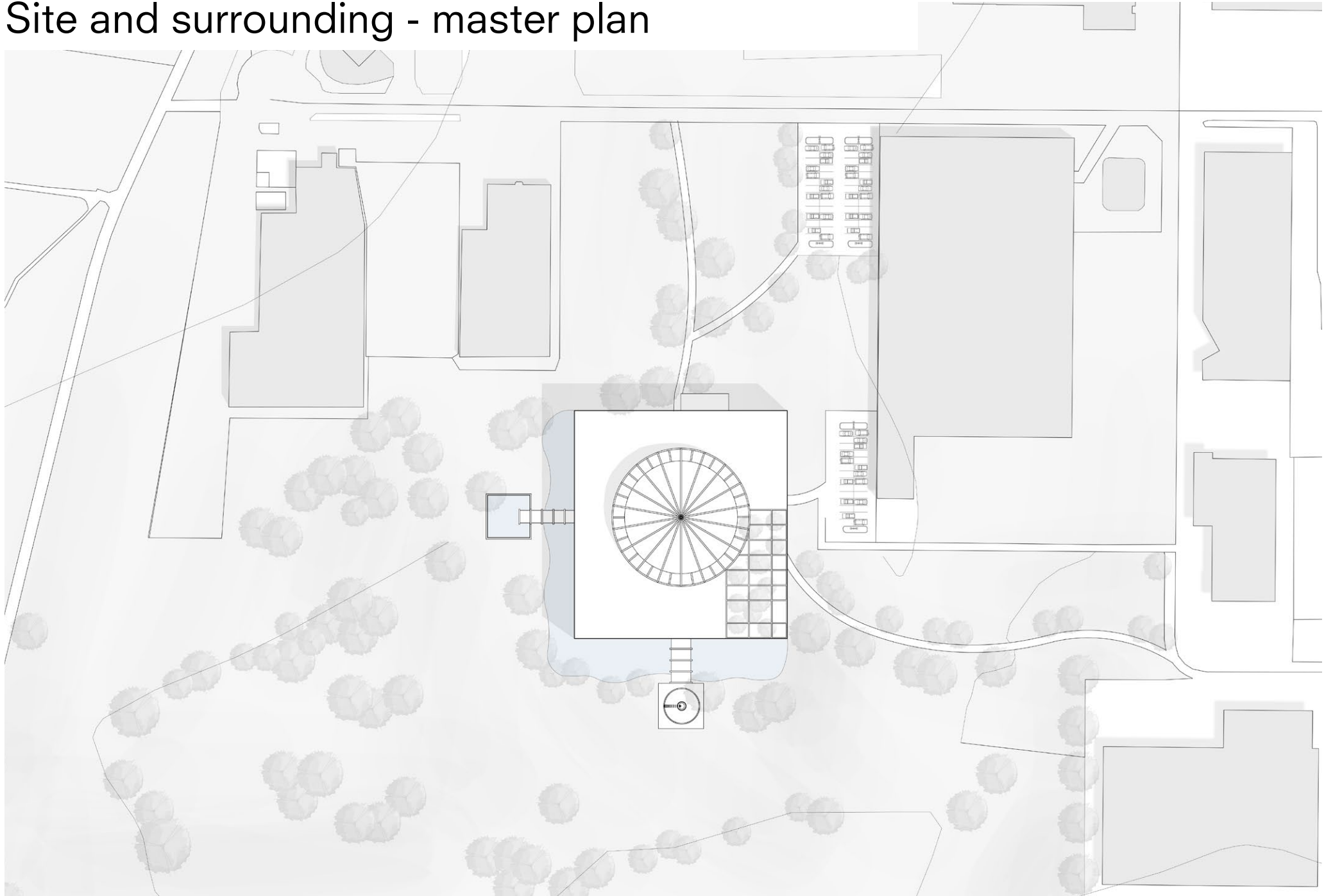

Site and surrounding

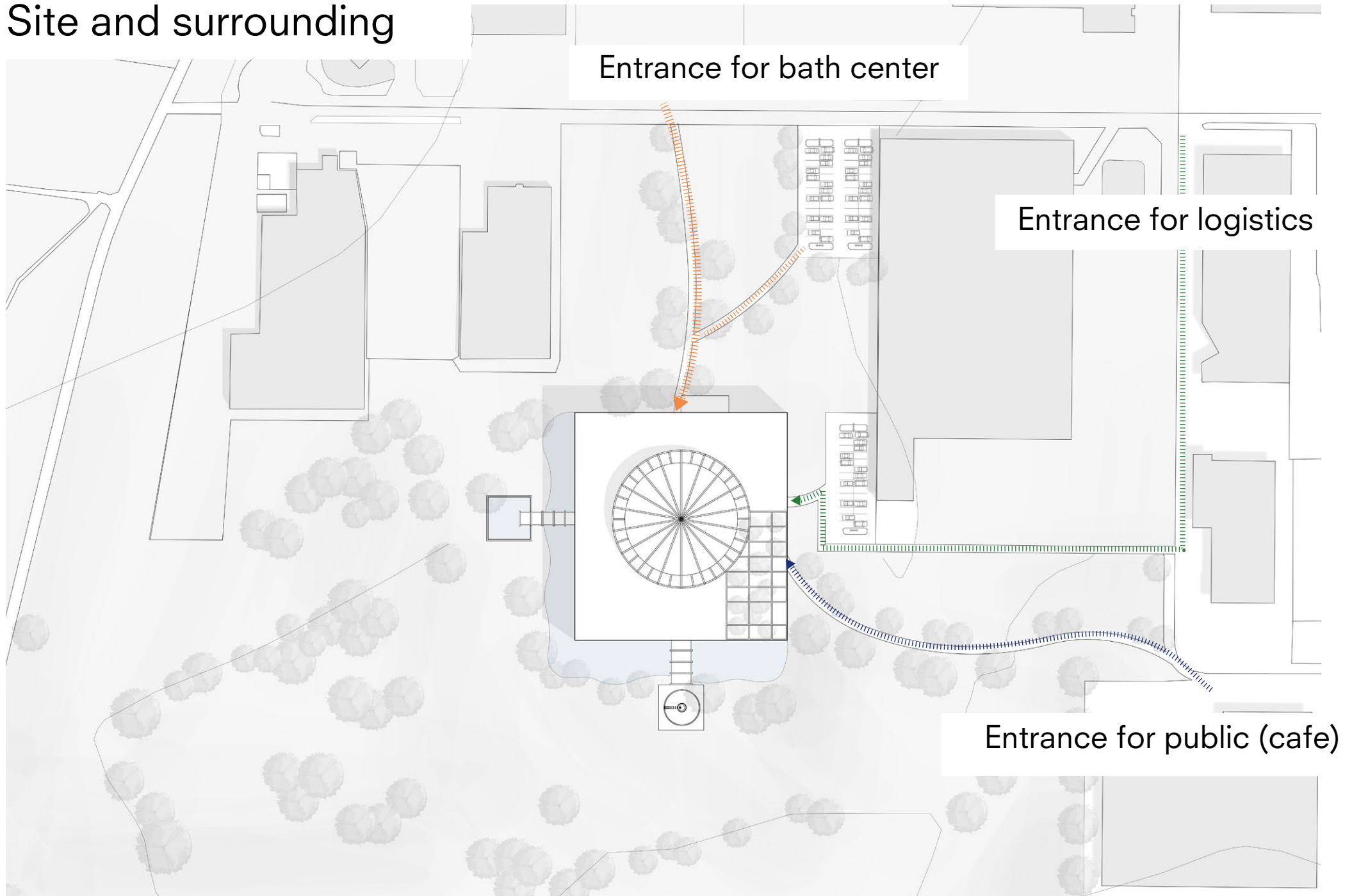

Site and surrounding

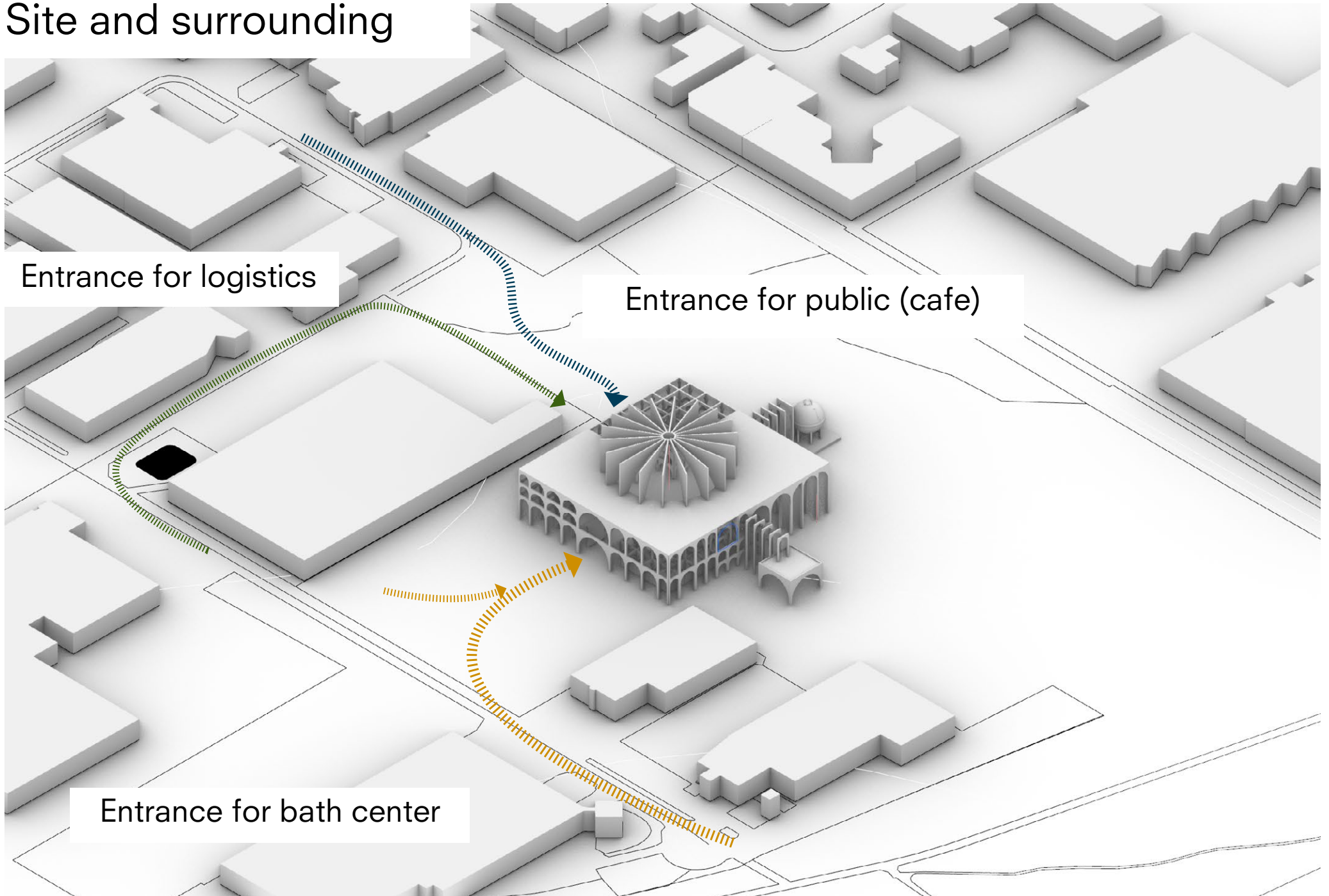

Entrance for logistics

Entrance for public (cafe)

Entrance for bath center

Site and surrounding

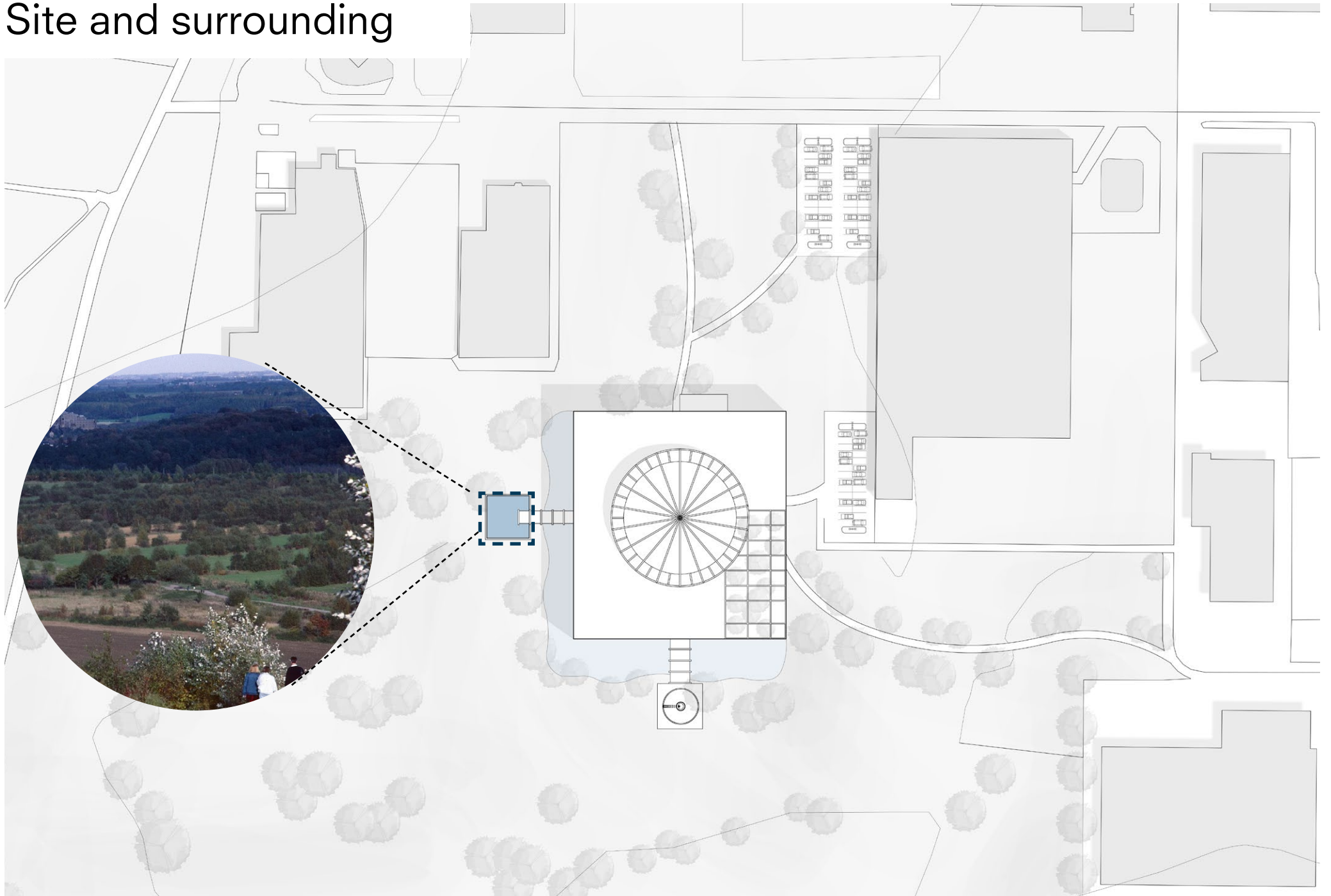

Site and surrounding

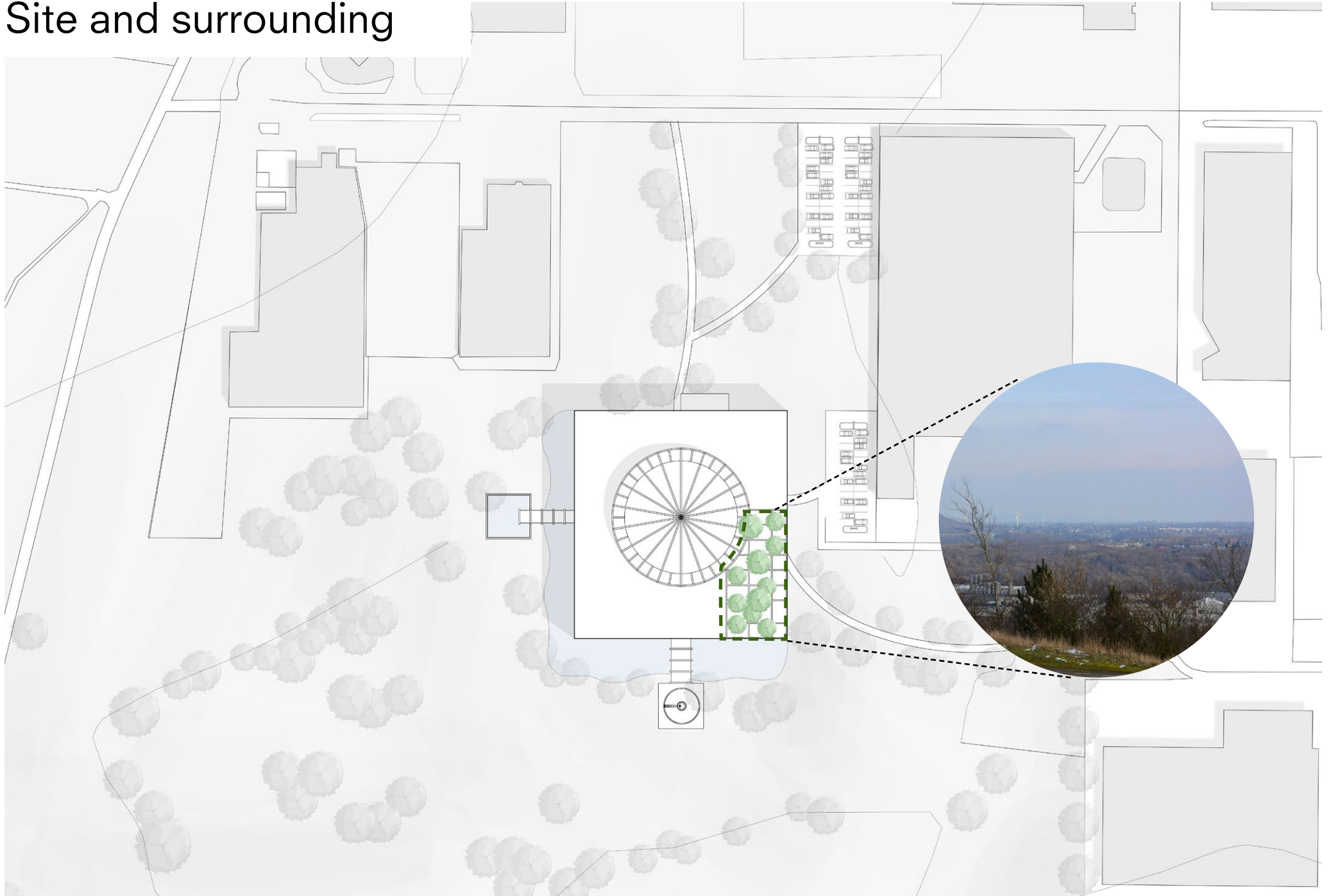

Site and surrounding - master plan



Site and surrounding



Concept design and strategy

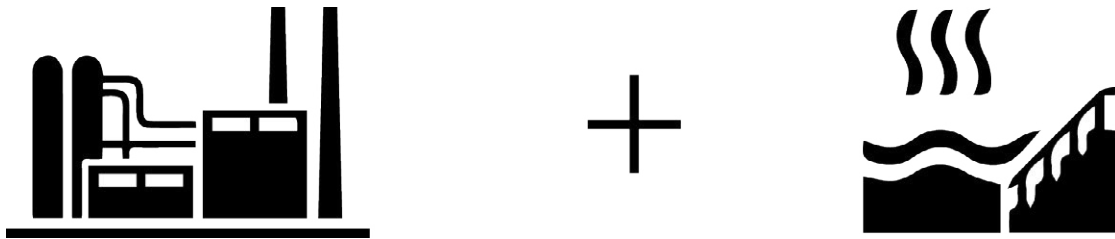

Design- Case study 4

The Therme Vals / Peter Zumthor



Architects: Peter Zumthor, with Marc Loeliger, Thomas Durisch and Rainer Weitschies
Location: Graubünden, Switzerland Project
Year: 1996



Design- Case study 4

The Therme Vals / Peter Zumthor

Precedent Study: Therme Vals, Peter Zumthor

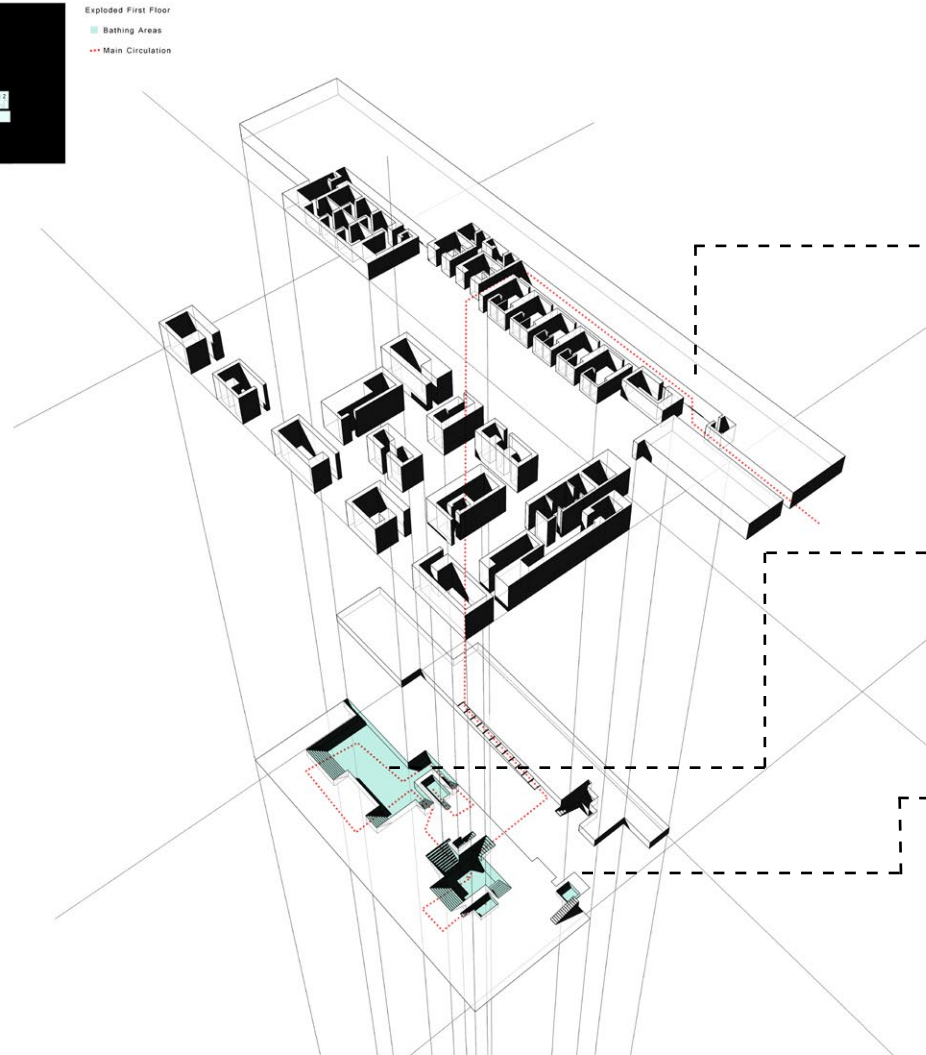
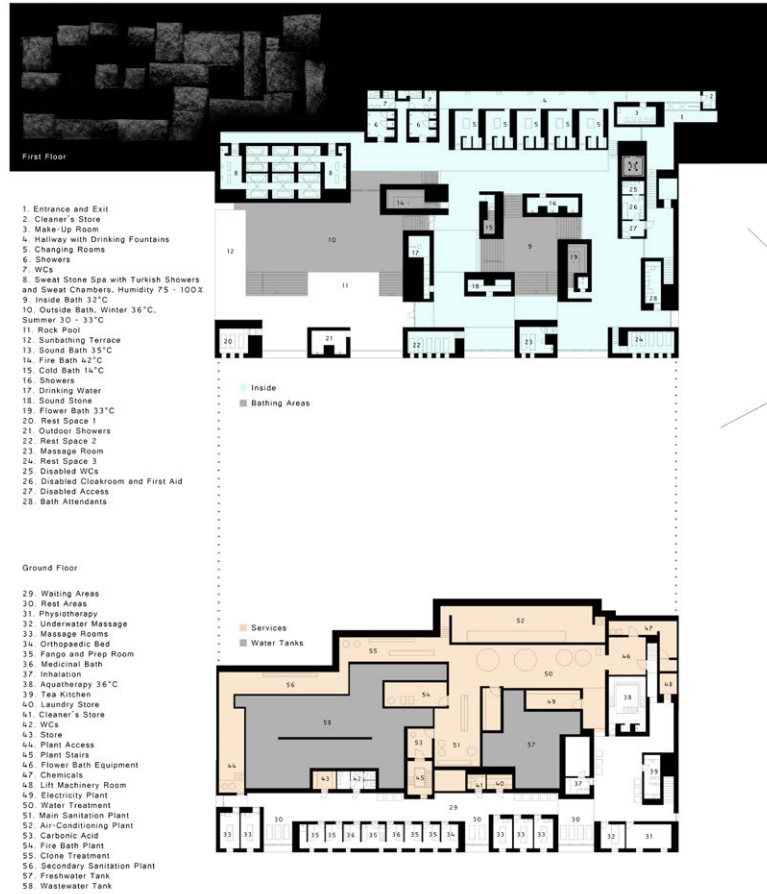

Bath area:
6347m²

Water tank:
1975m²

Service area:
4560m²



Source: Sigrid Heuser, Peter Zumthor, 2007; Peter Zumthor, Therme Vals, Zürich, Scheidegger & Spiess

Design- Case study 1

Waste-to-Energy plant by BIG in Copenhagen

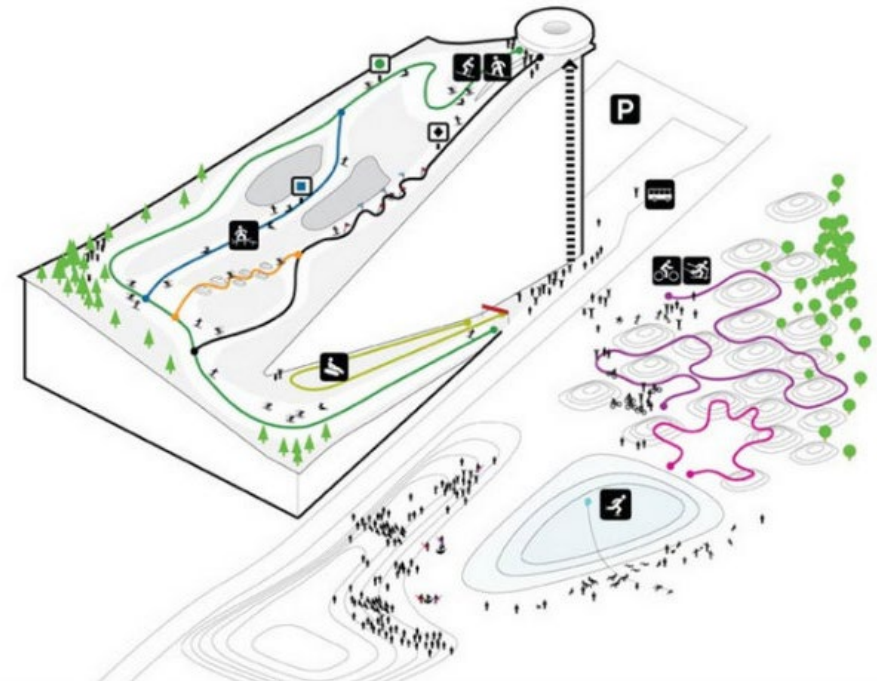
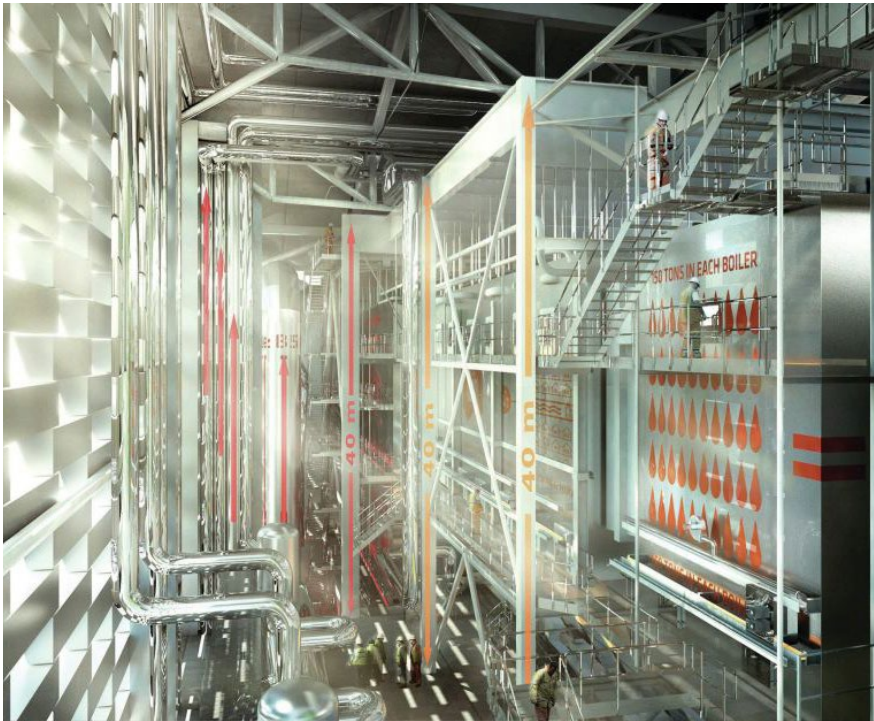





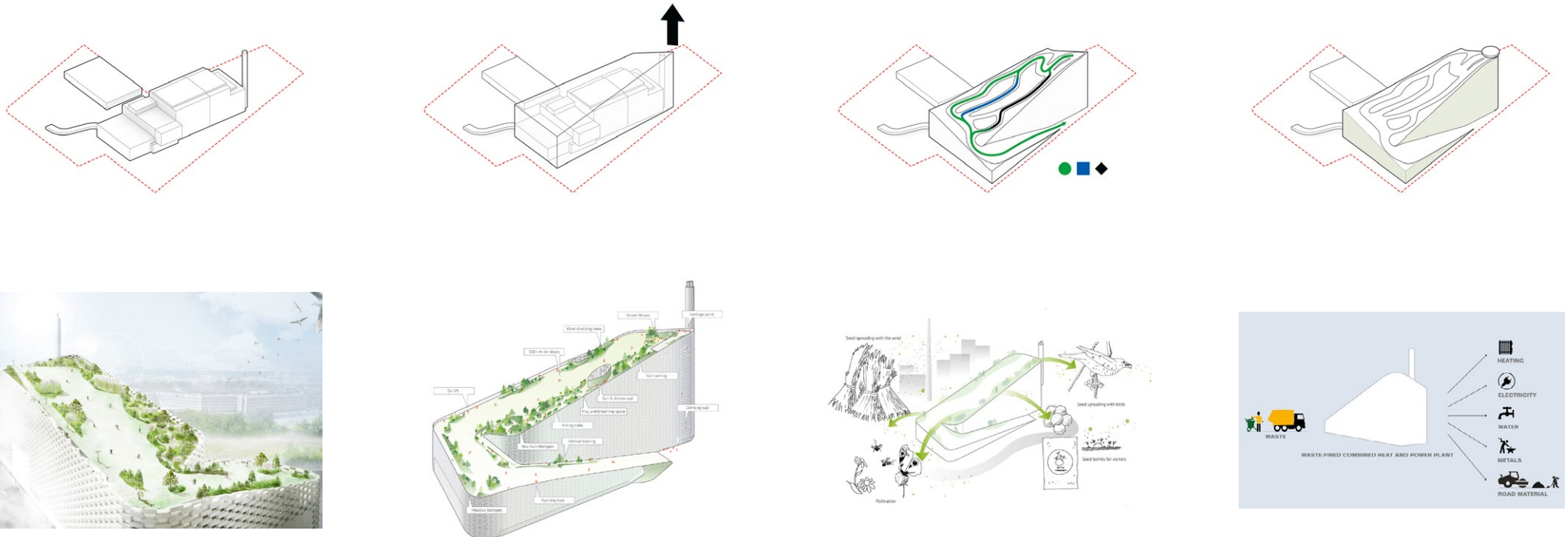

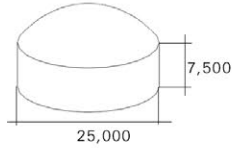

Design- Case study 1

Waste-to-Energy plant by BIG in Copenhagen

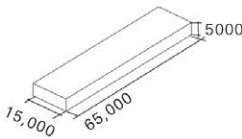

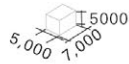
- Plant is designed as a core in a public project rather than design as a factory.
- Power plant should not be treated as a place far away from daily life, and try to get closer to life.

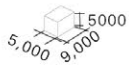
Design- Bath area

Program	Size requirements	TECH. Requirements	Basic volume	Reference
Main pool	500m ²	Air Temp.: 33°C Water Temp.: 32°C		
Outside pool		Winter Temp.: 36°C Summer Temp.: 30-33°C		
Multipal bath area	1000m ²	Different bath requirements different Temp.		
Main Sauna room	35m ²	Temp.: 85°C		
Steam toom	45m ²	Temp.: 45-47°C Humidity 100%		

Design- Service area

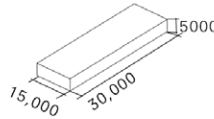
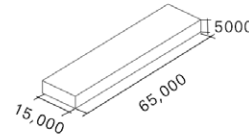
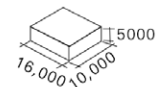
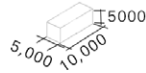
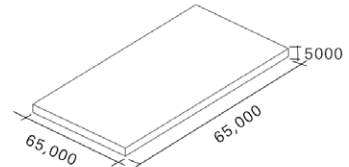
Program	Size requirements	TECH. Requirements	Basic volume	Reference
Changing room & shower	450m ²	Temp.: 25°C		
Lobby & waiting area	1000m ²	Temp.: 18-21°C		
Cafe and kitchen	160m ²	Temp.: 18-21°C		
Office	50m ²	Temp.: 18-21°C		
Equipement and service	10,000m ²	Temp.: 18°C Same area with baths and pools		

Concept design and strategy

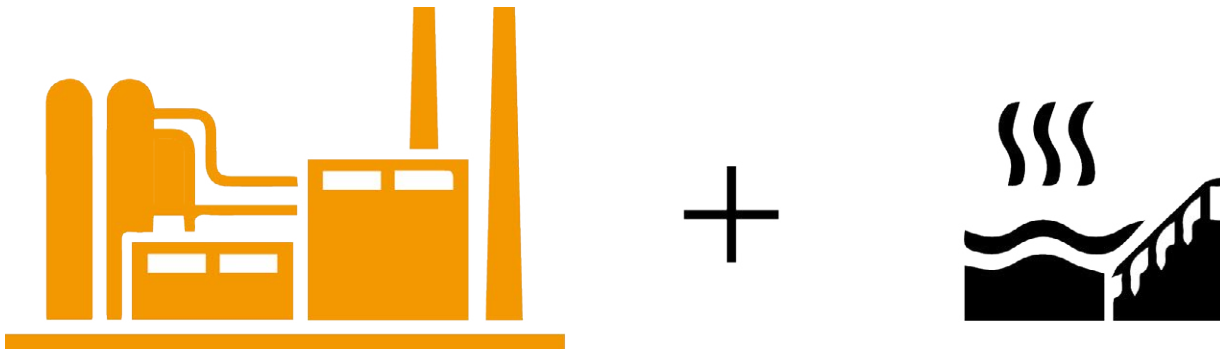

Typology study and test

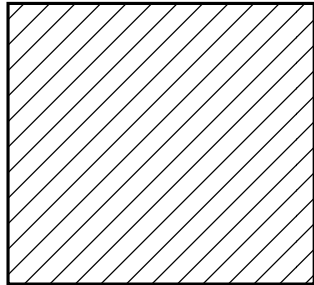

Gathering layout

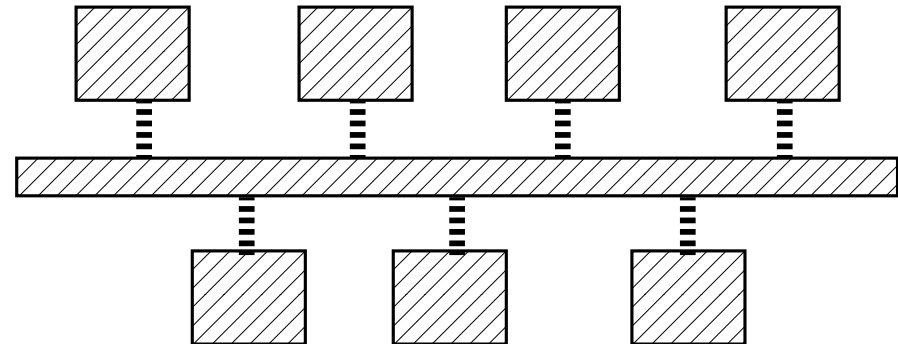

Linear layout

Typology study and test

Gathering layout

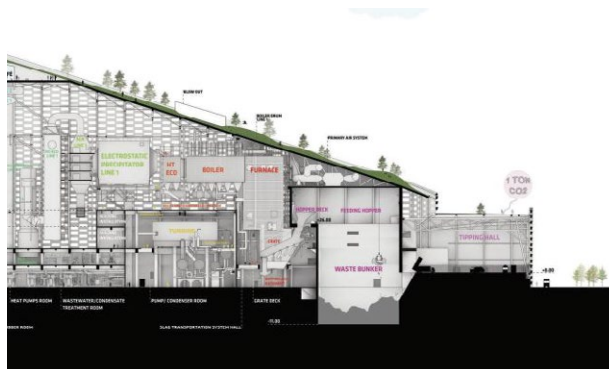
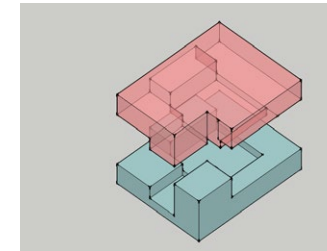
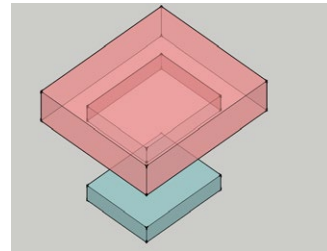
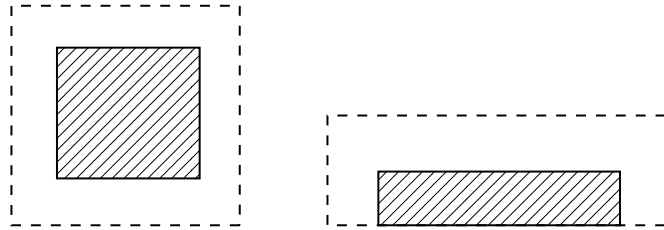

Typology study and test

Linear layout

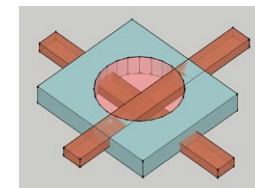
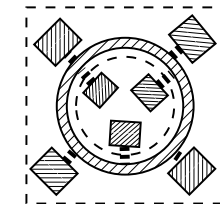
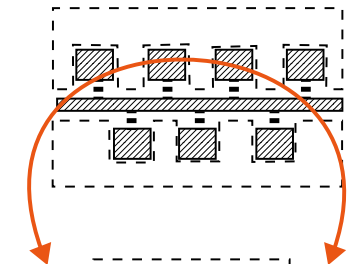
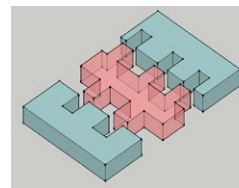
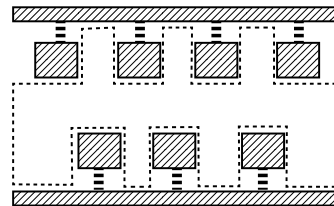
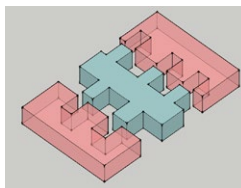
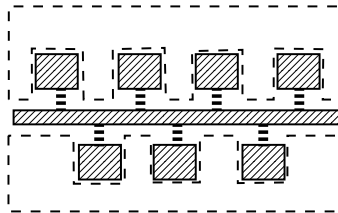
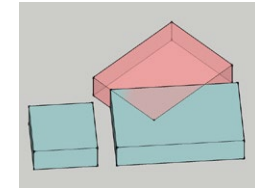
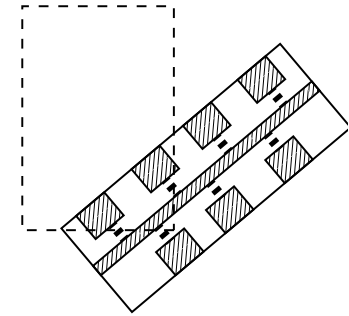
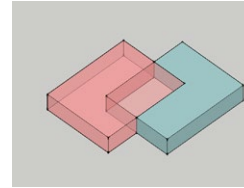
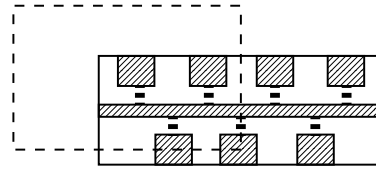
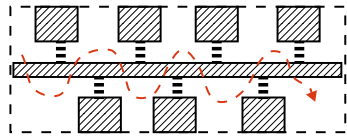

Typology study and test

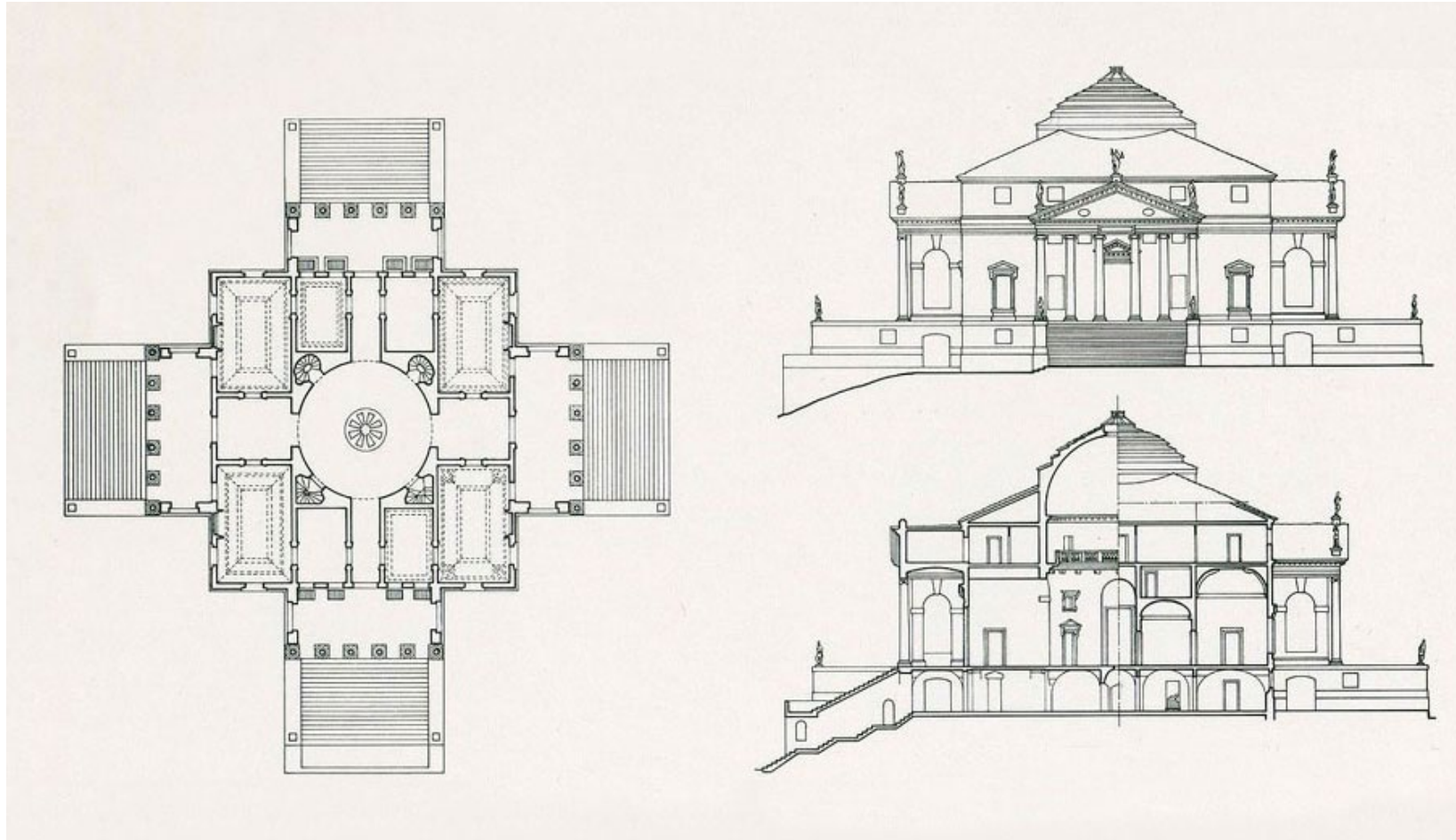

Palladio's Drawings (Villa Rotonda) (Palladio 1965 p42 plate 13) PALLADIO, A., 1965

Typology study and test

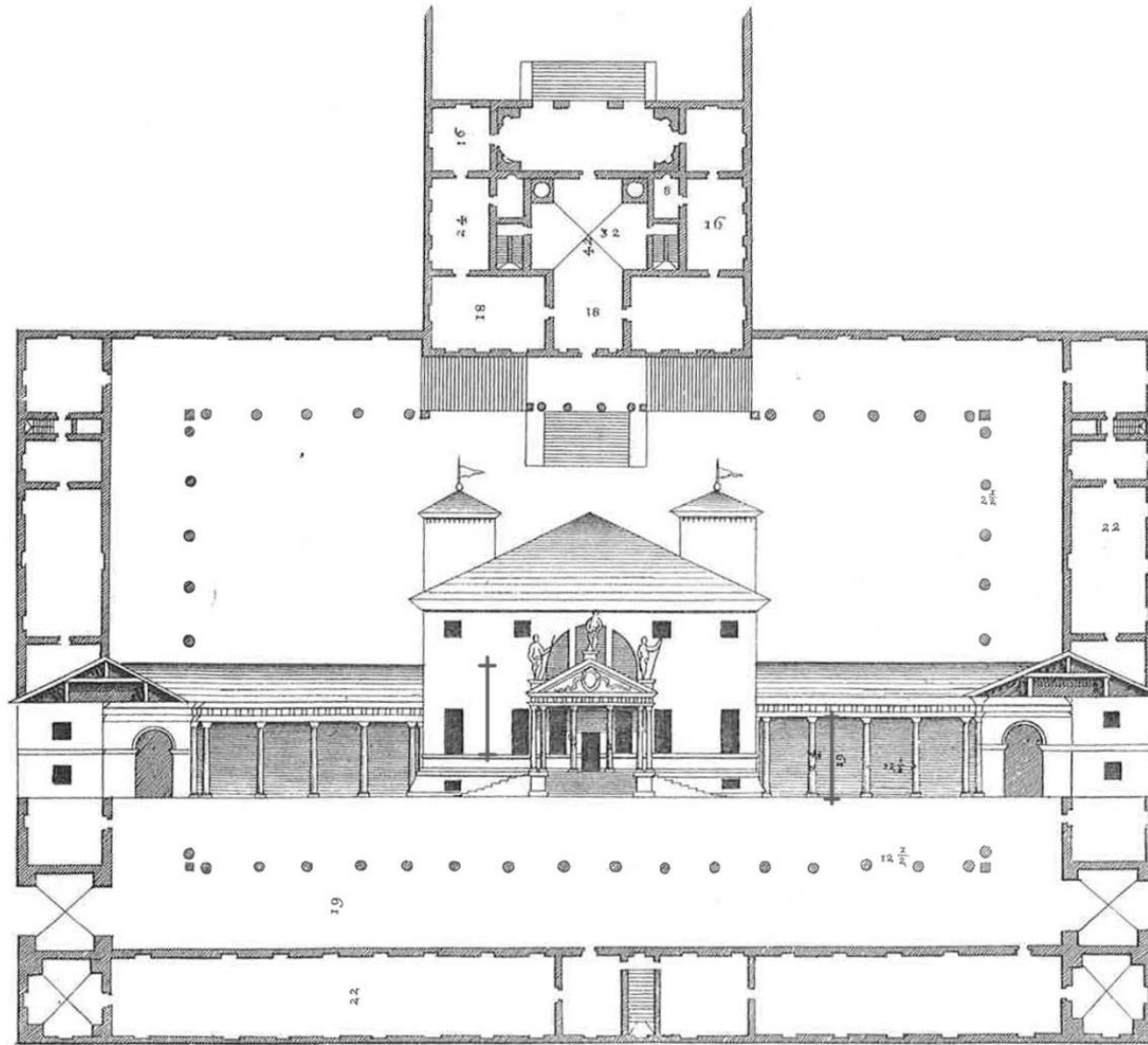

Palladio's Drawings (Villa Rotonda) (Palladio 1965 p42 plate 13) PALLADIO, A., 1965

Ground floor plan

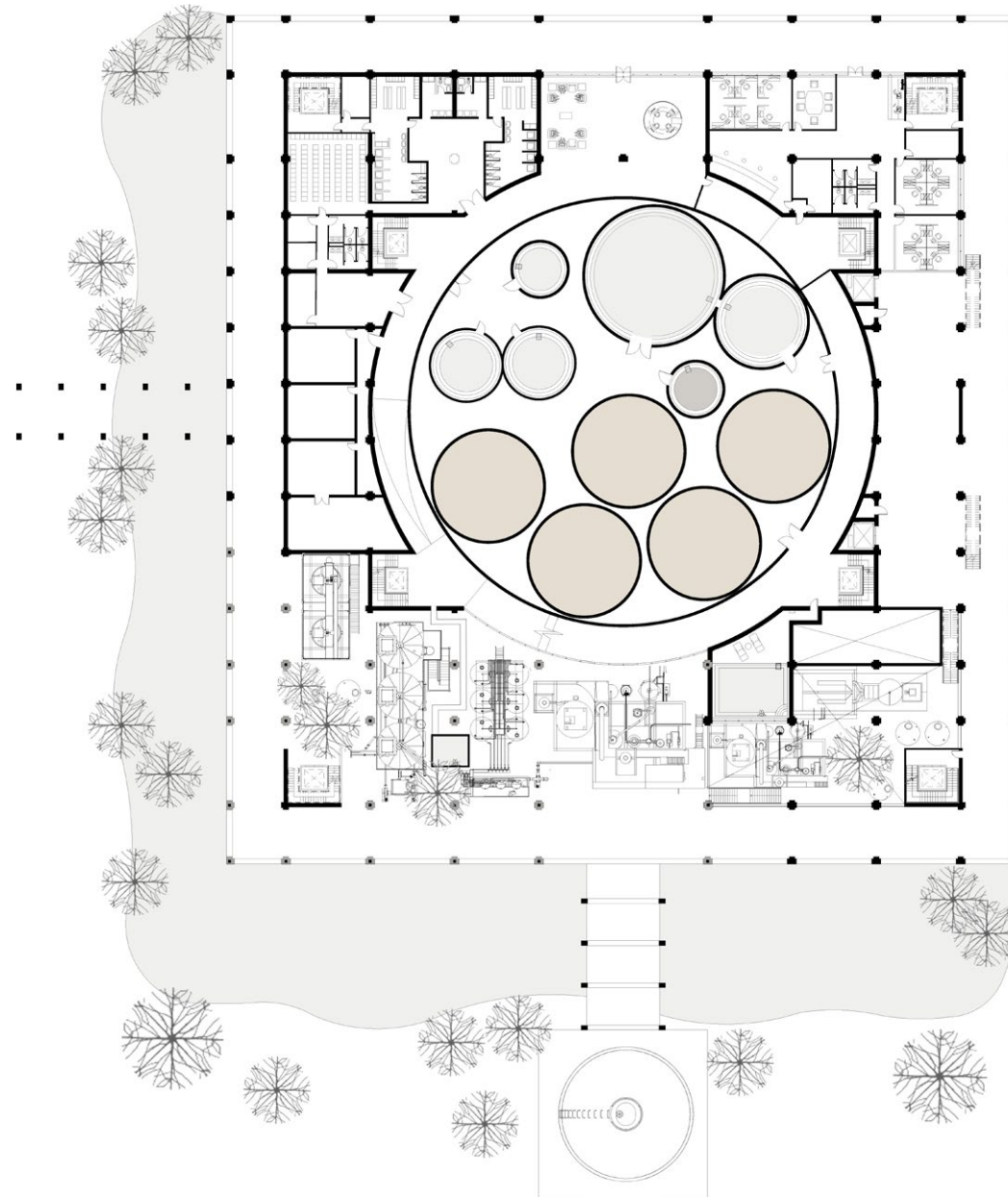

Power plant

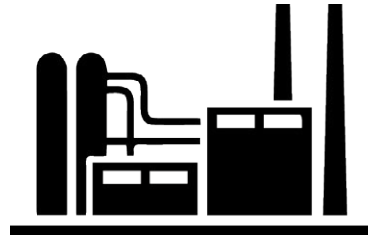

Factory area

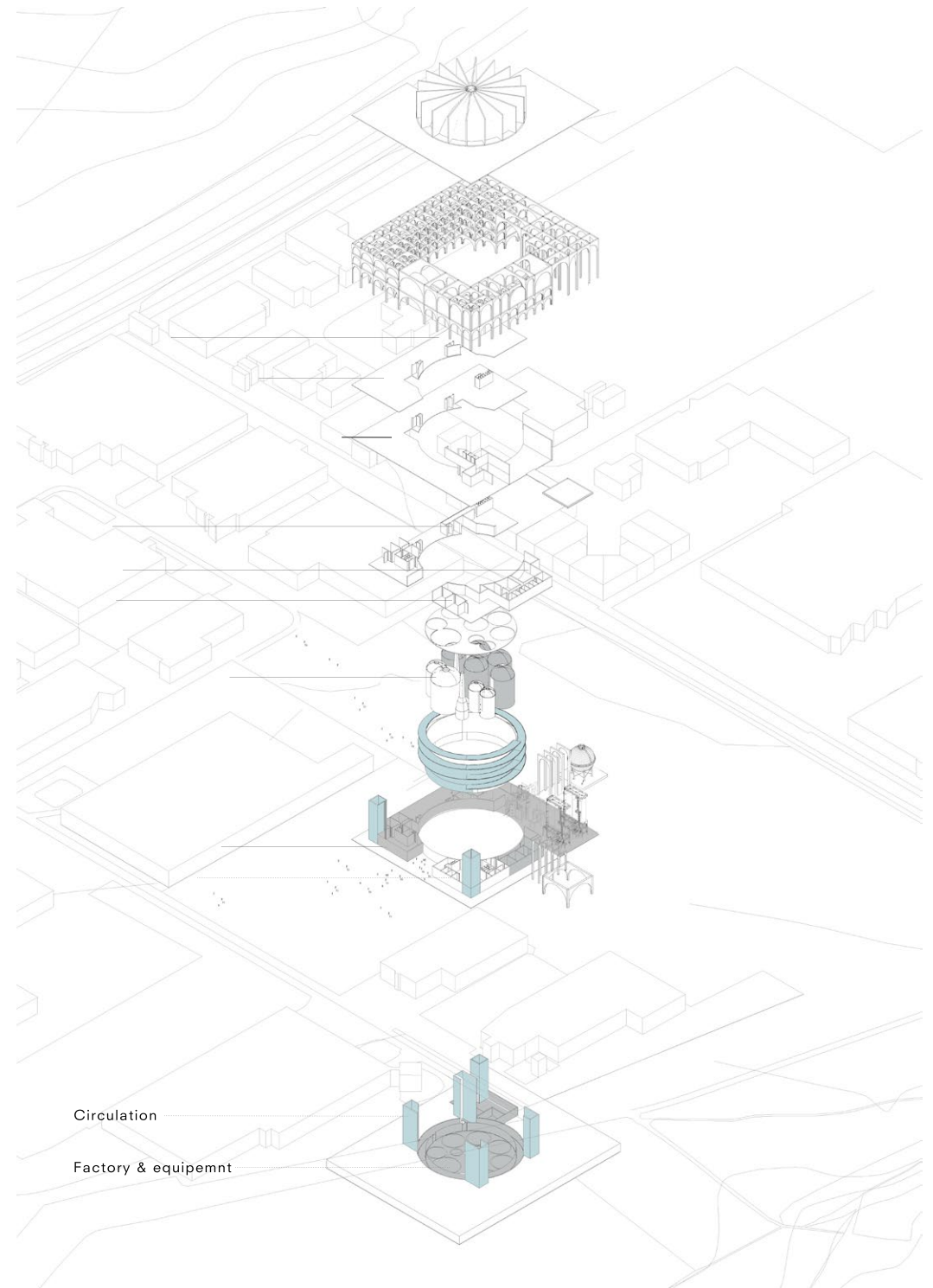

Power plant- plan

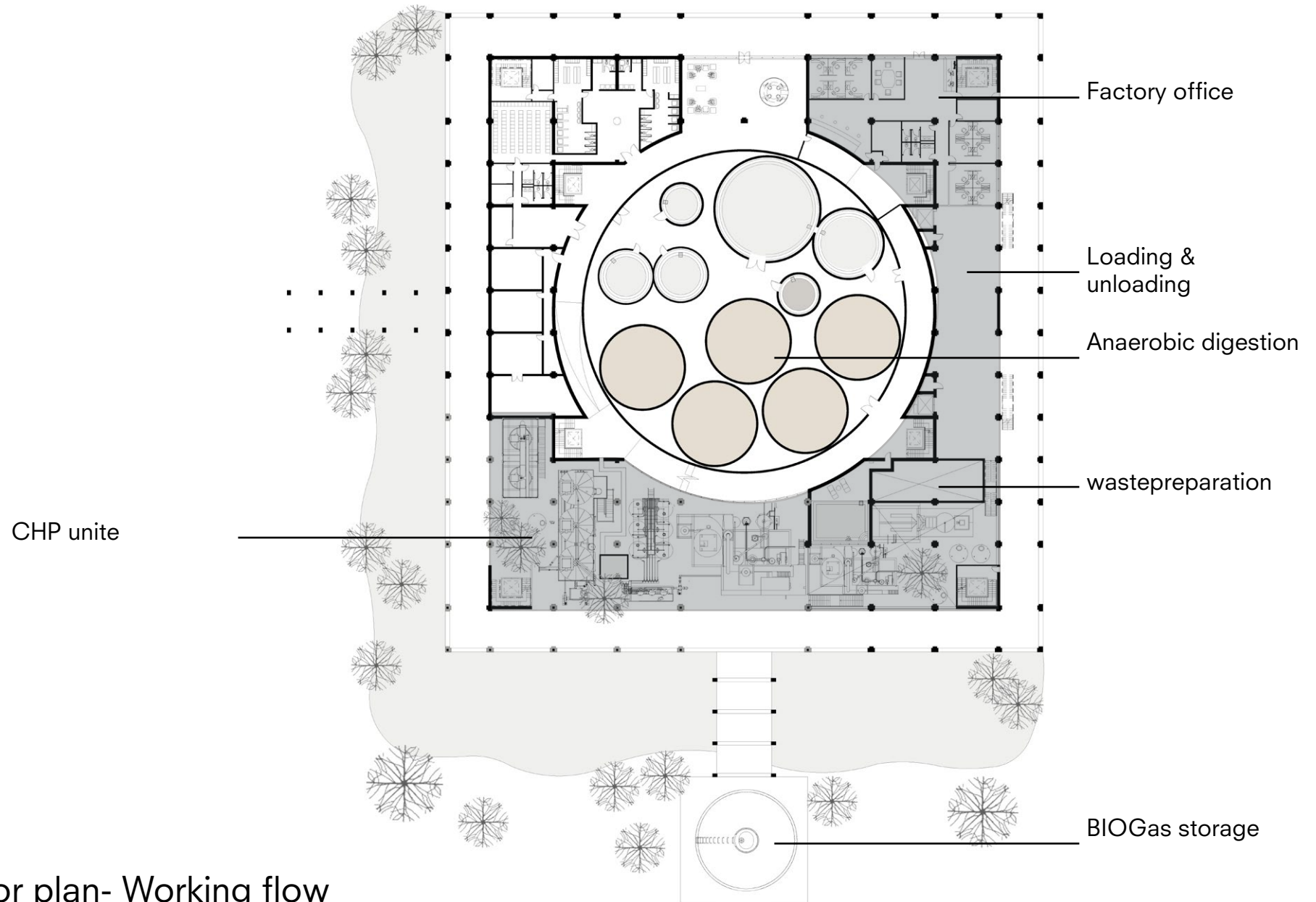

Ground floor plan- Working flow

Power plant- plan

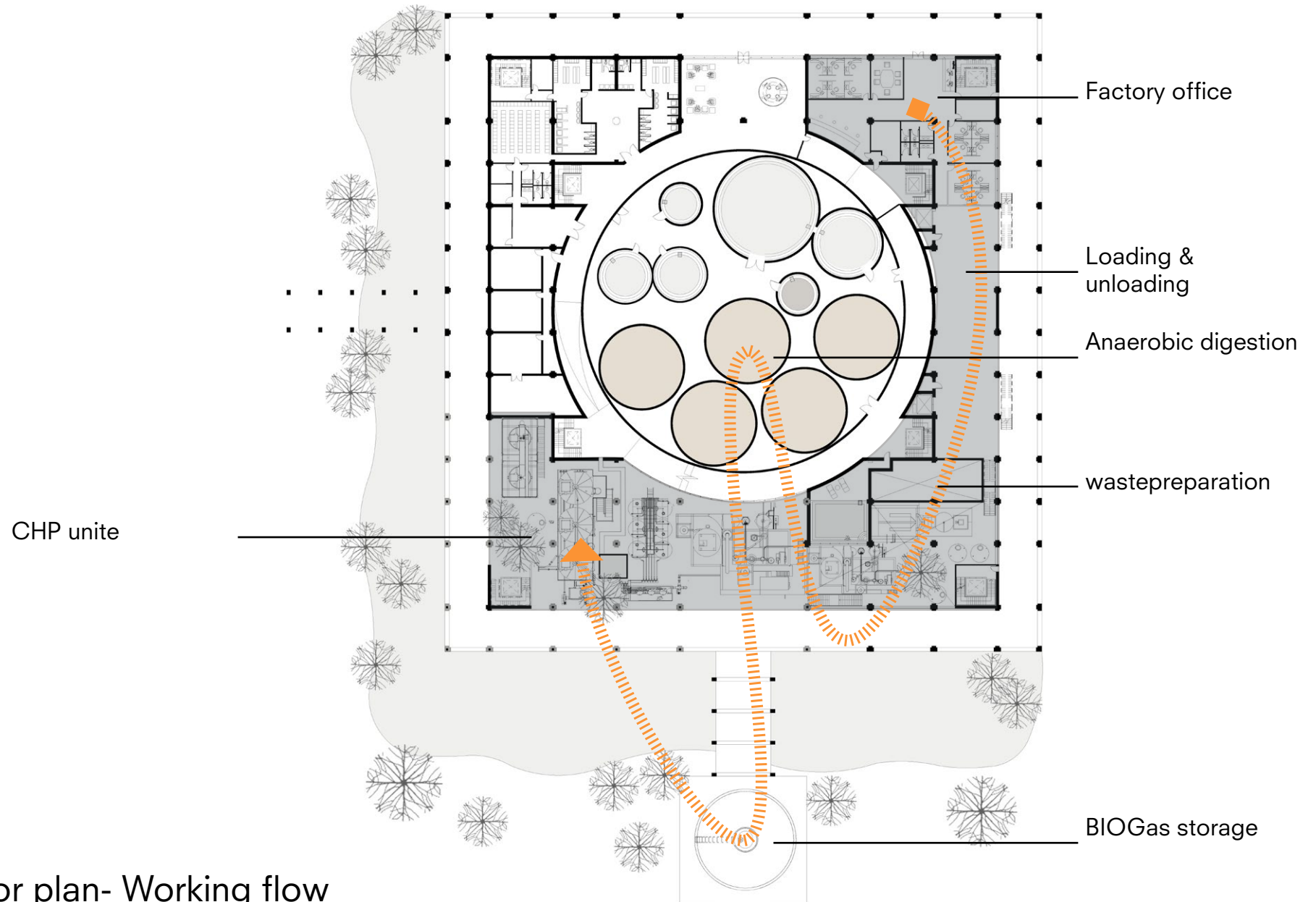

Ground floor plan- Working flow

Typology study and test

The area of factory as a base



The space of bath overlaying above

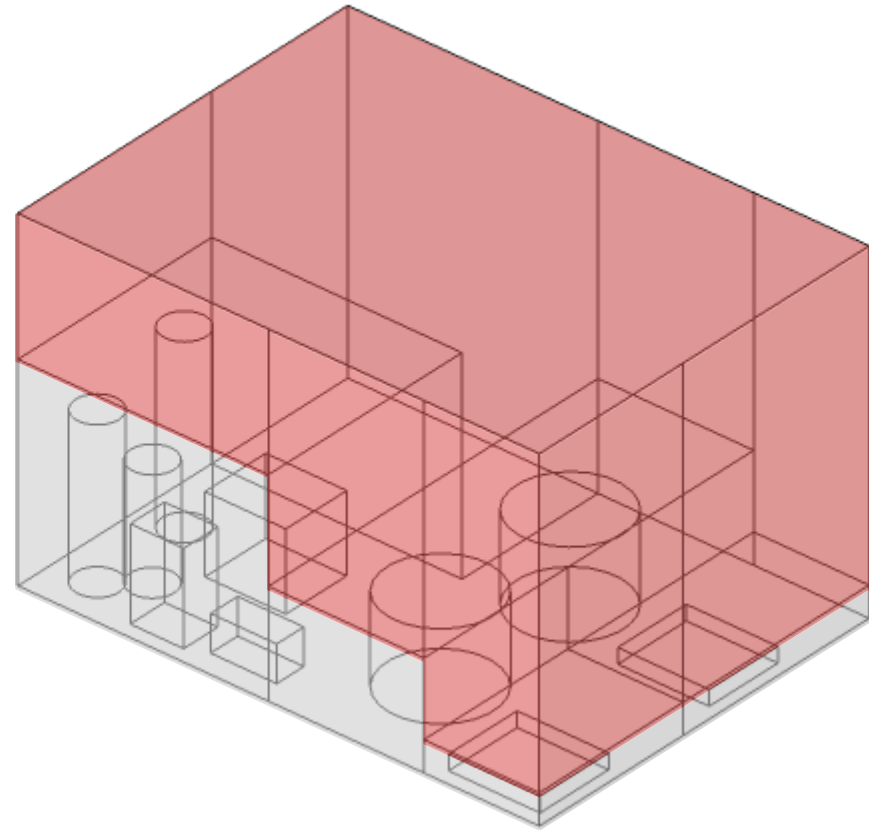

Spatial quality - bath area

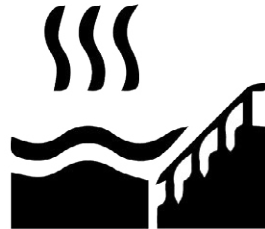
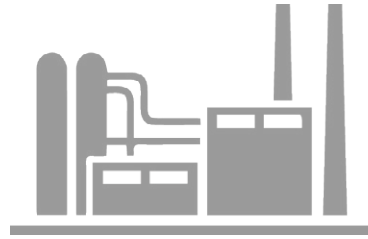

Typology study and test - Bath and Sauna

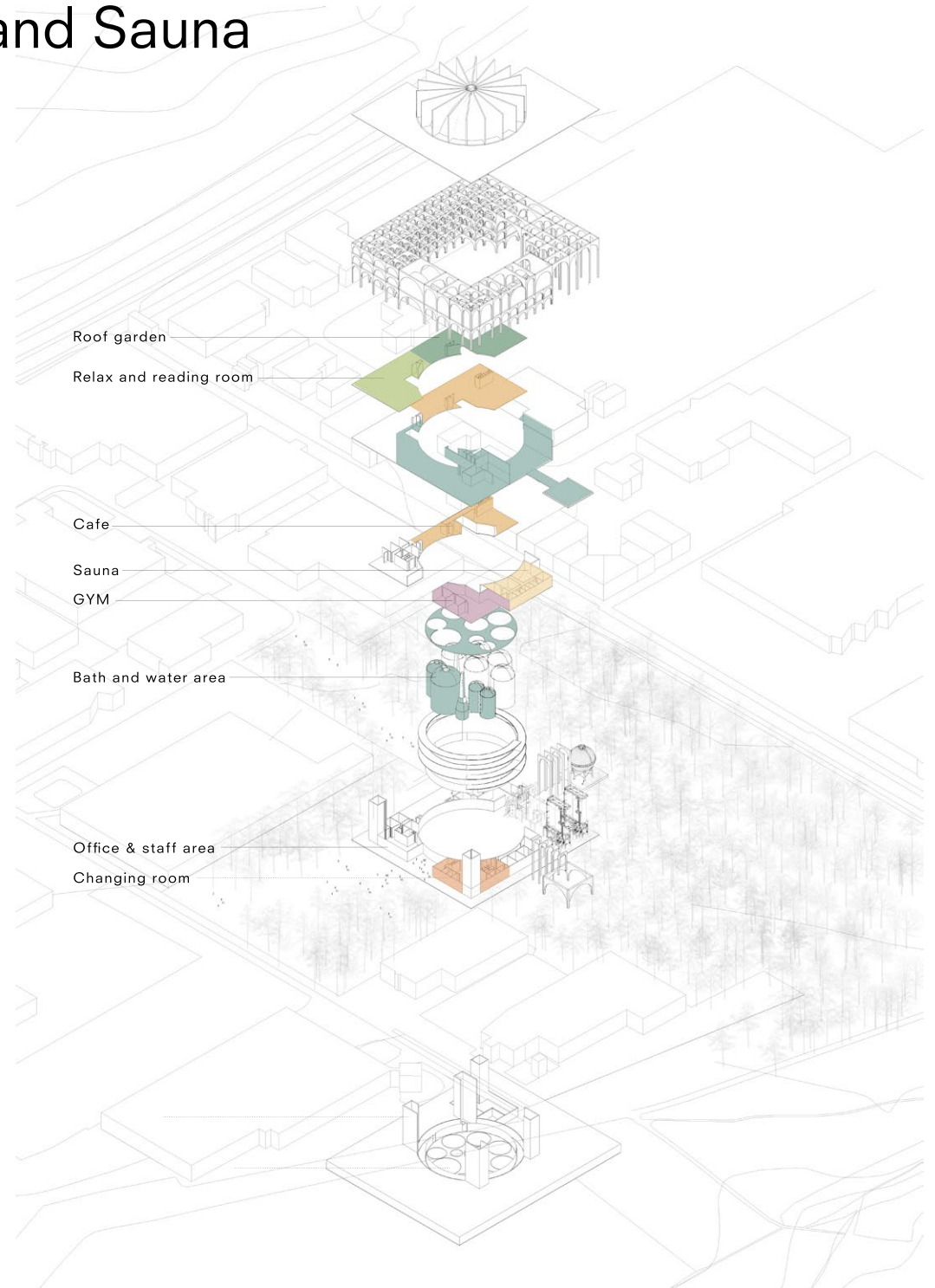

Spacial quality - bath area

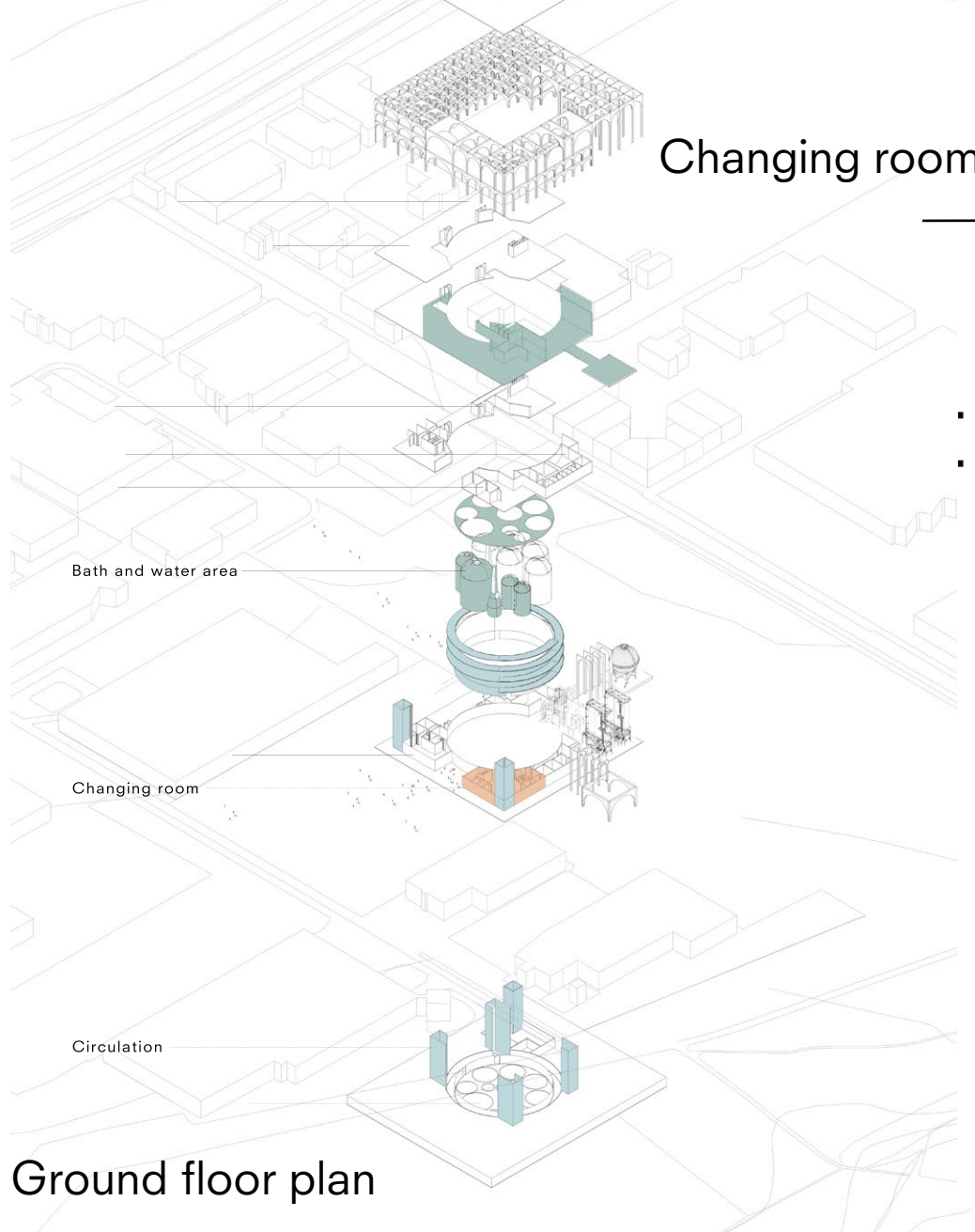

Ground floor plan

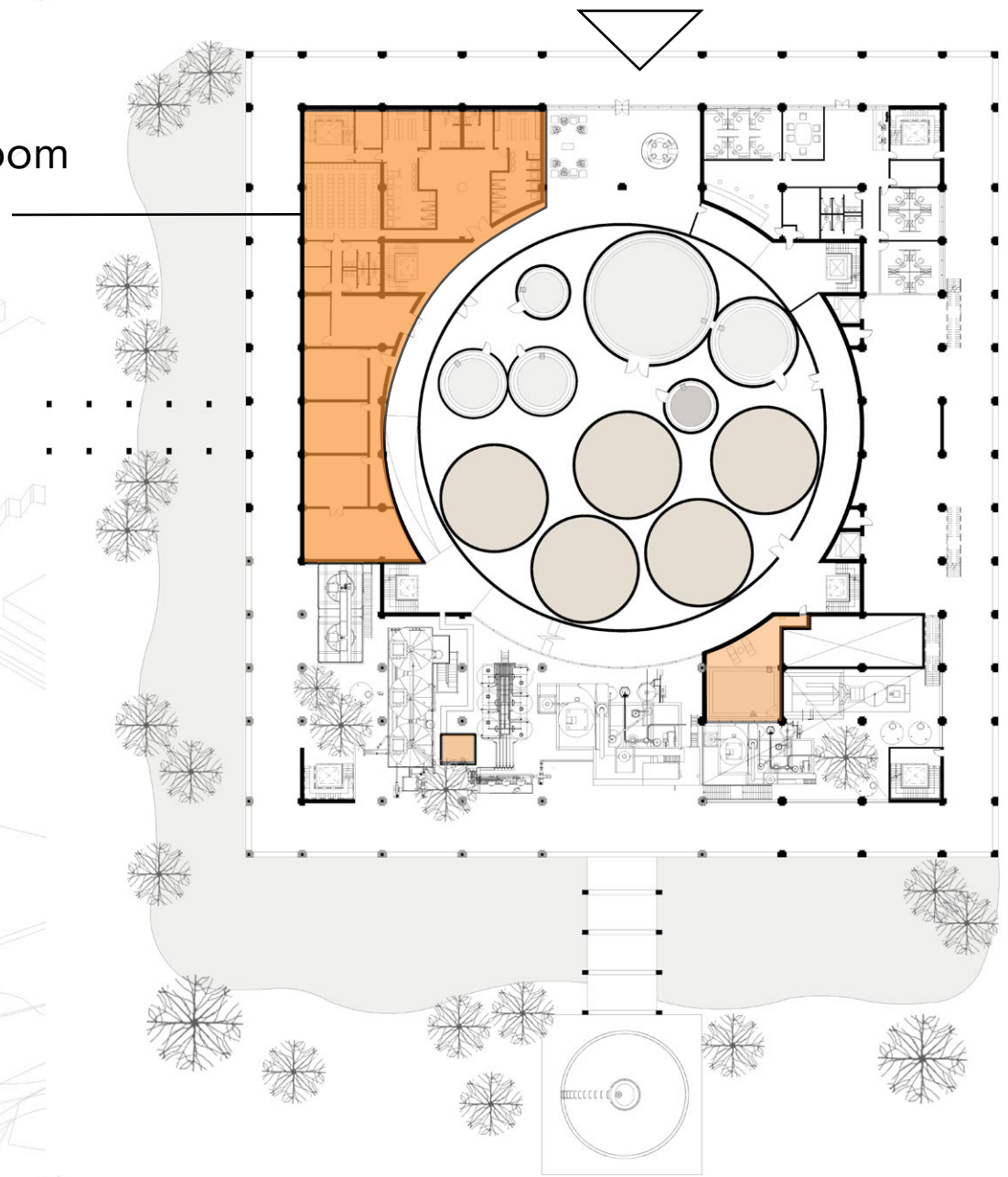

Spacial quality - bath area

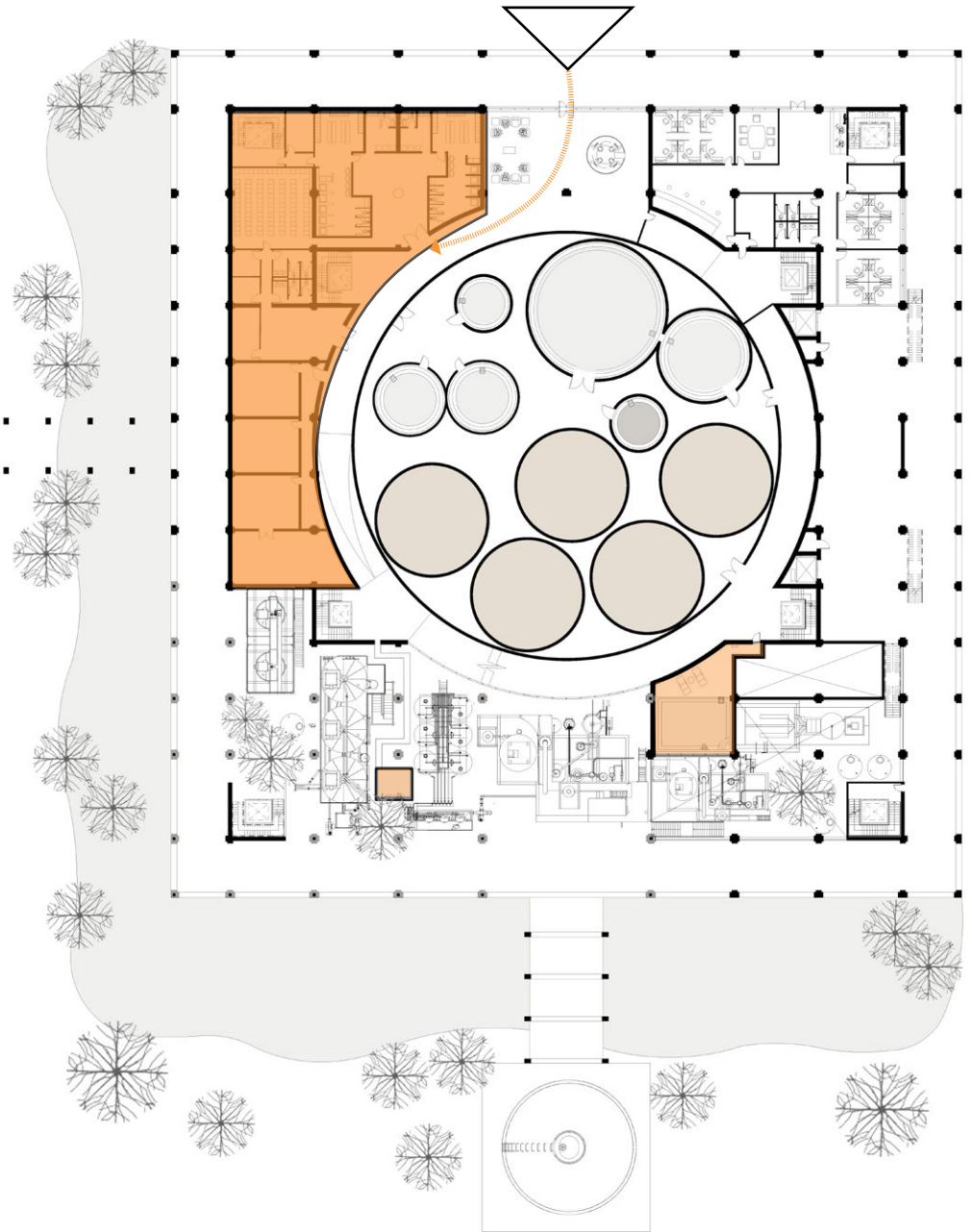
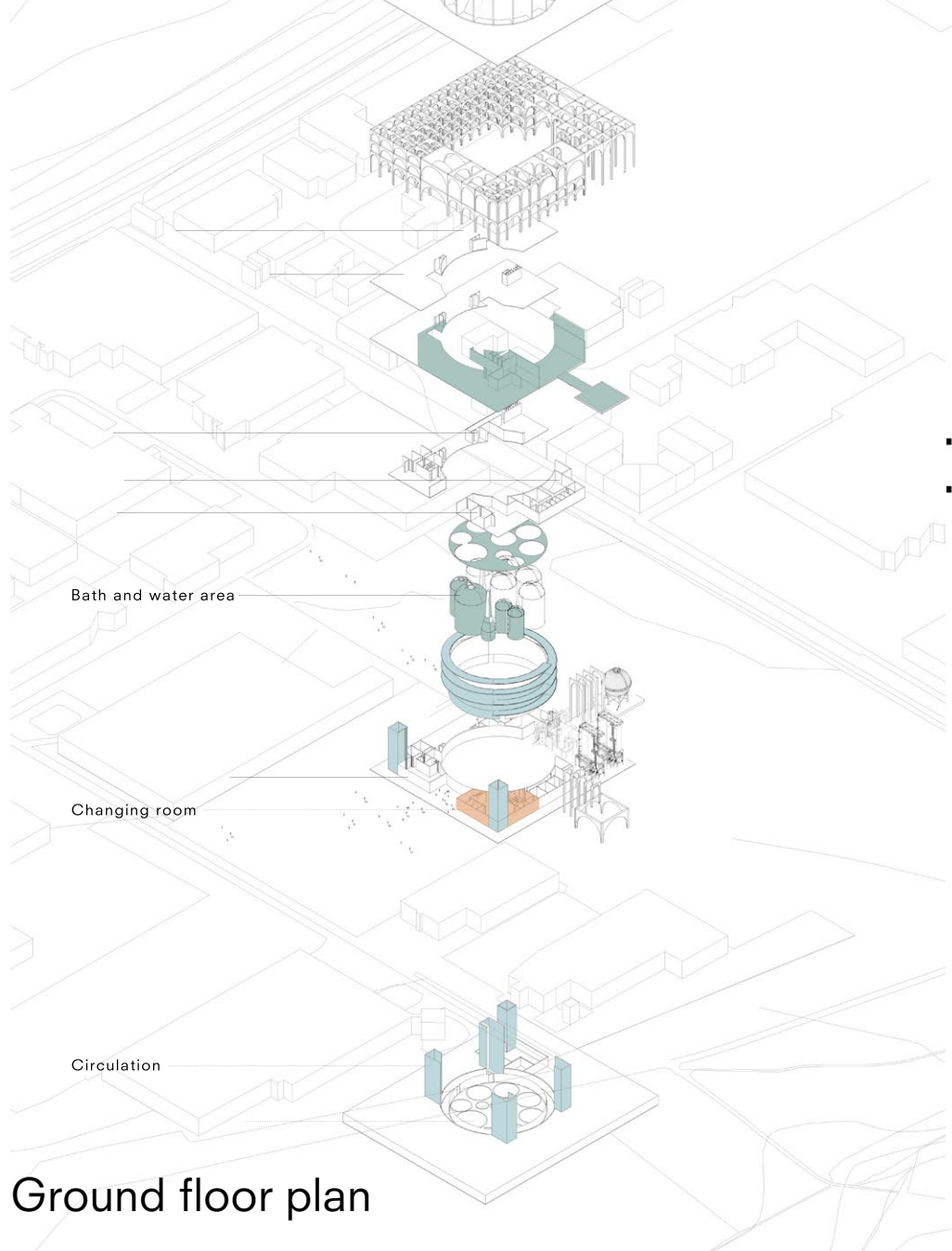

Spacial quality - bath area

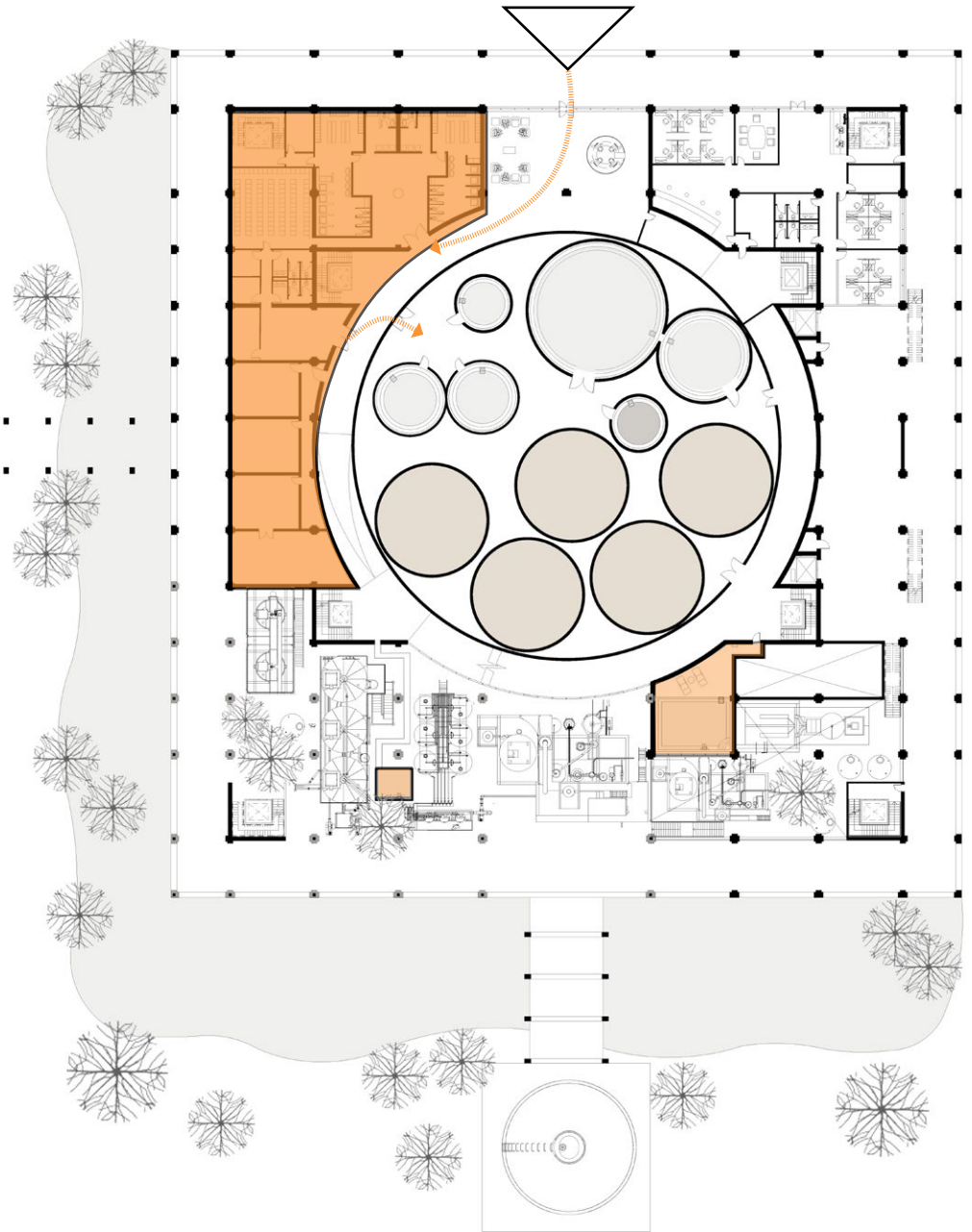
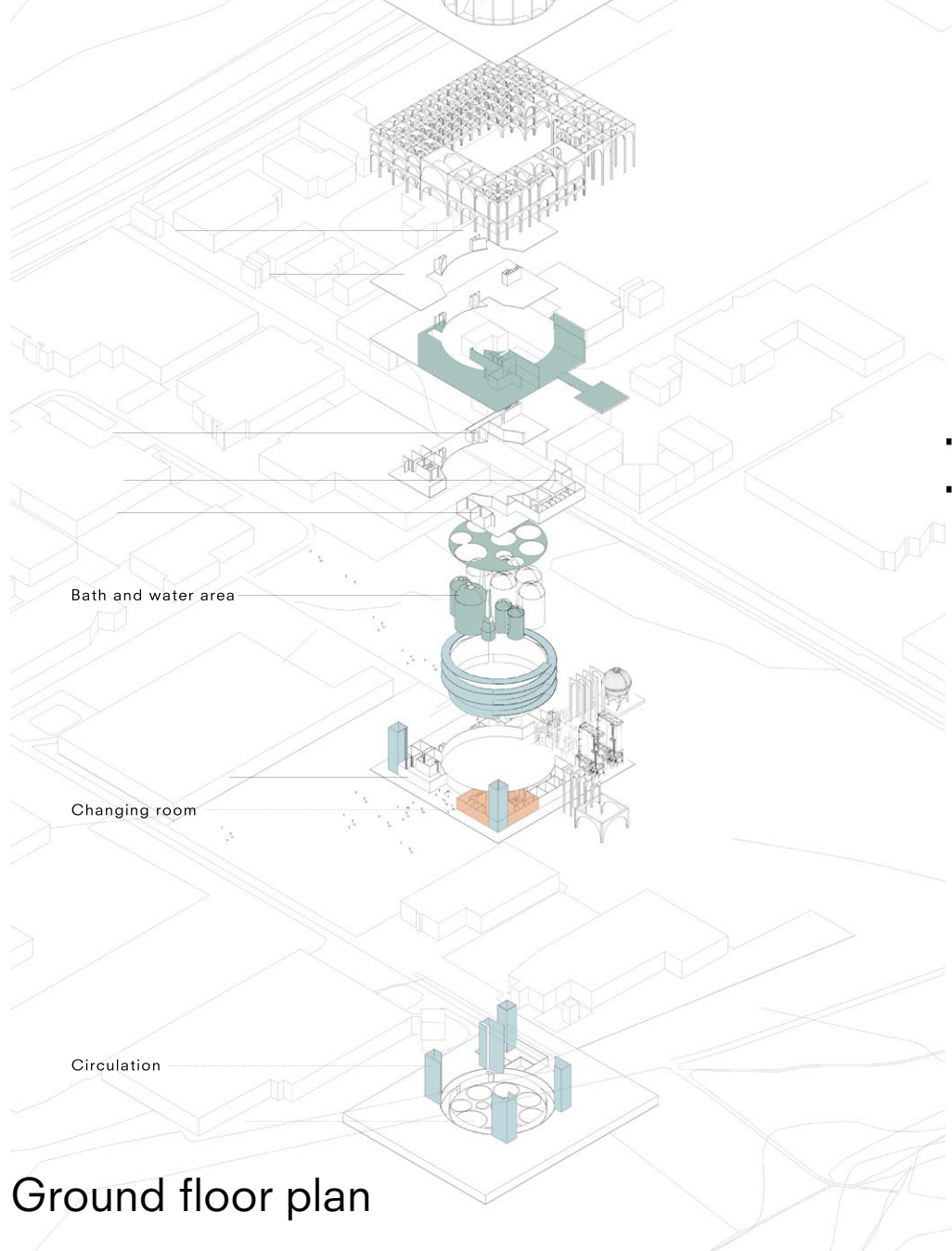

Spacial quality - bath area

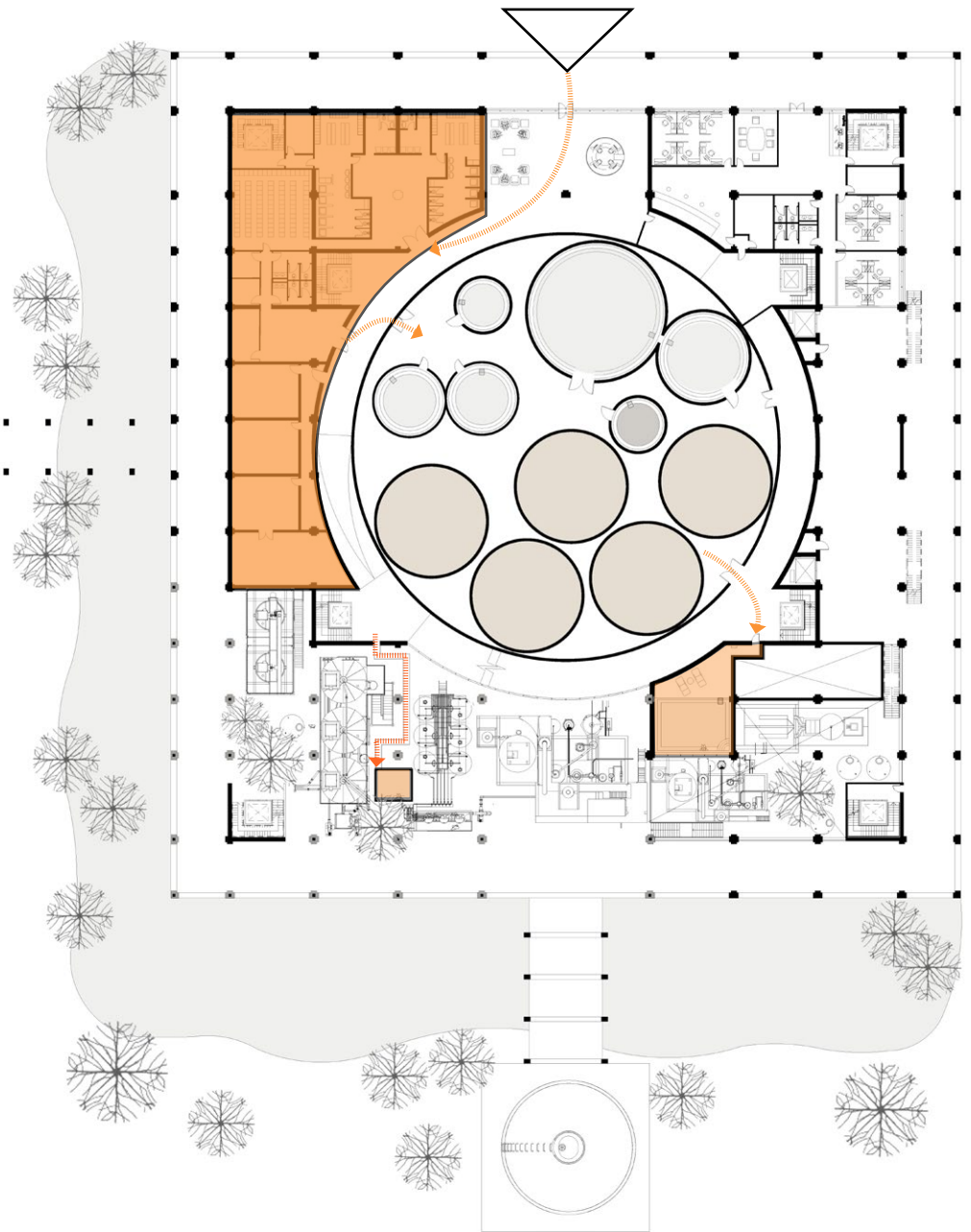
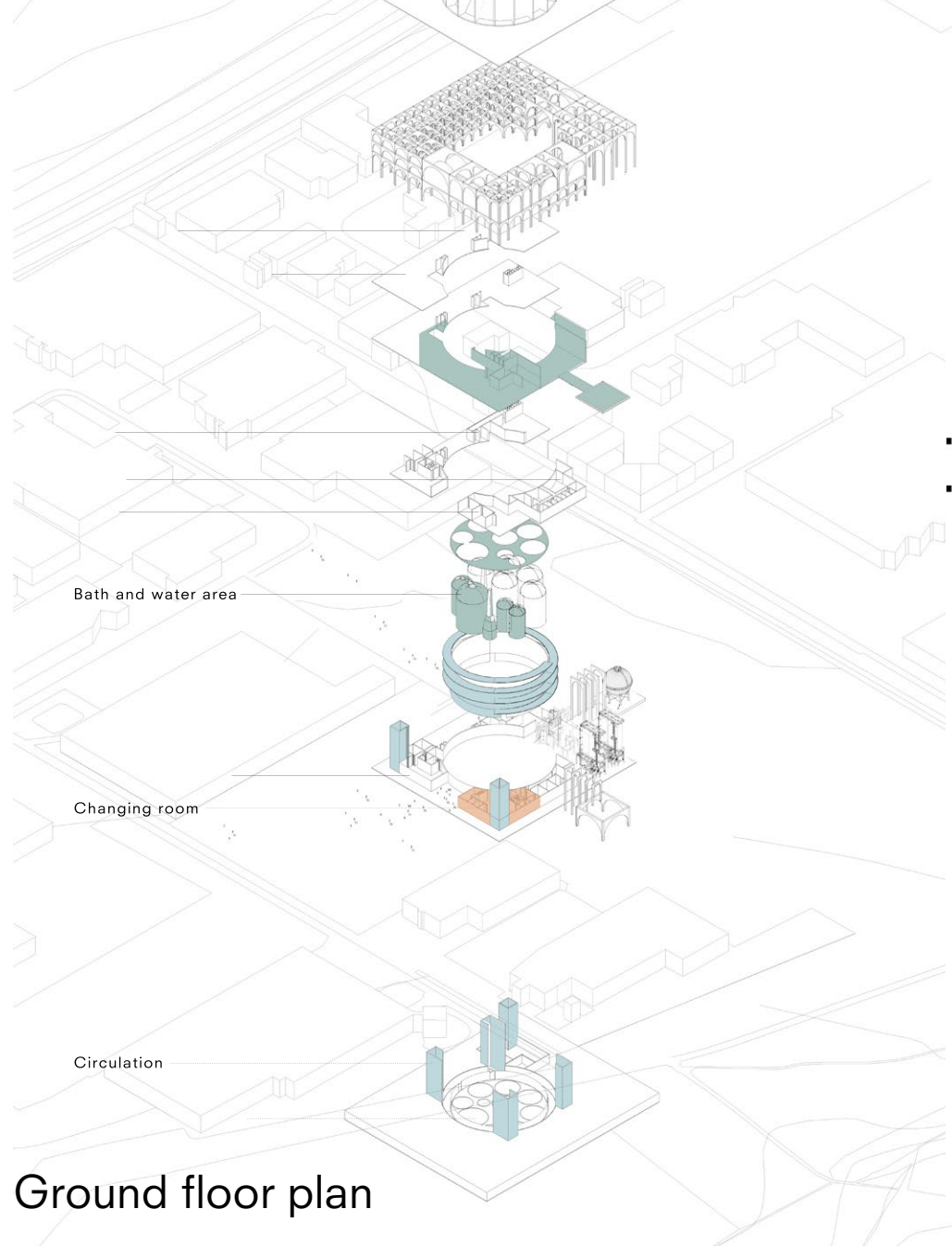

Spacial quality - Bath area

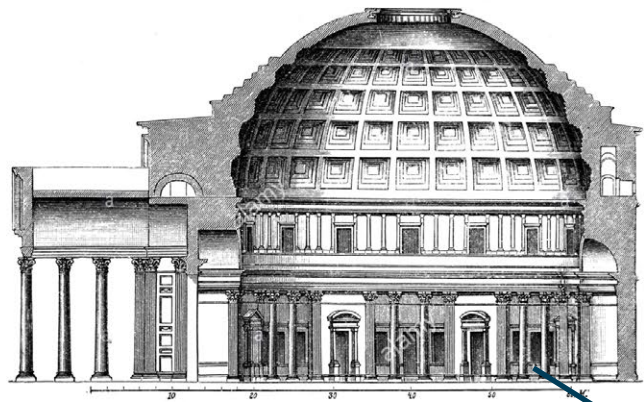

Pantheon Rome Dome



Anaerobic digester

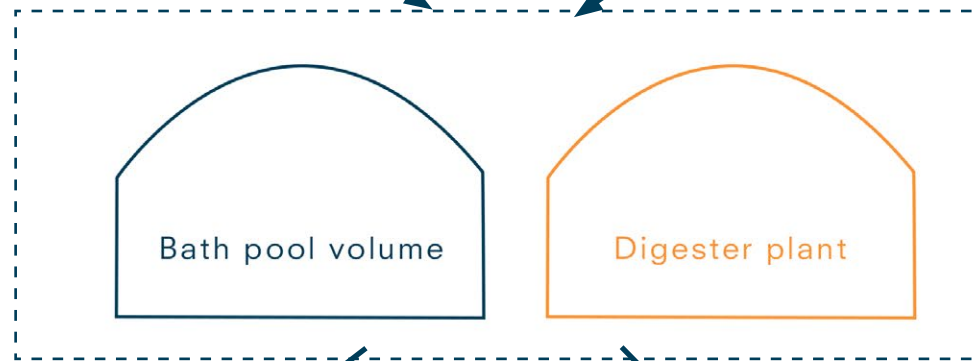

Natural lighting

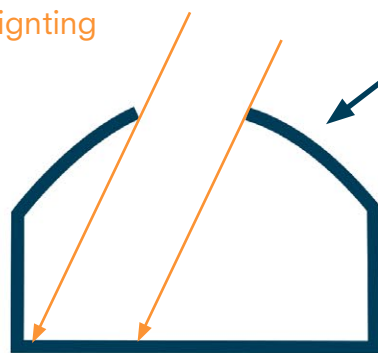
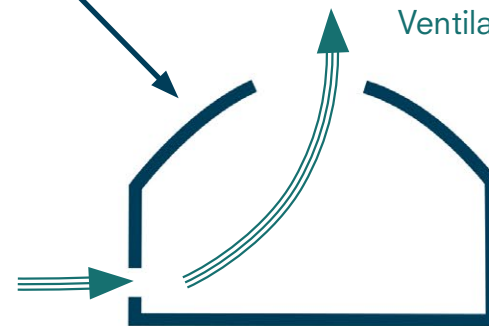
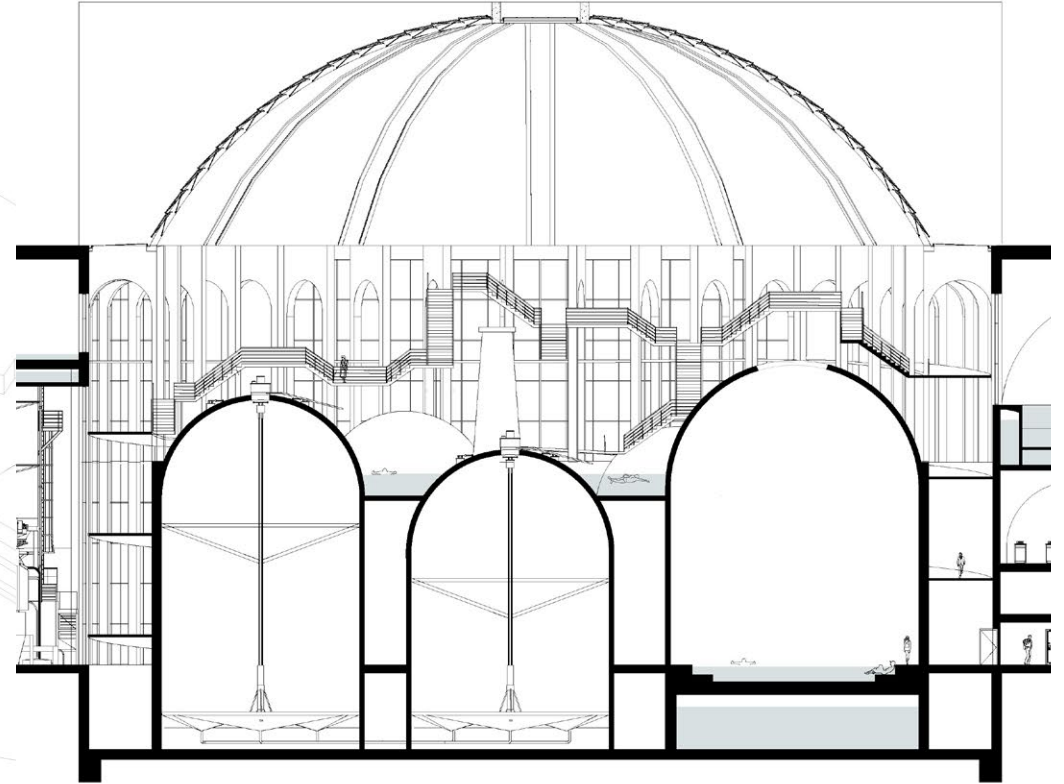
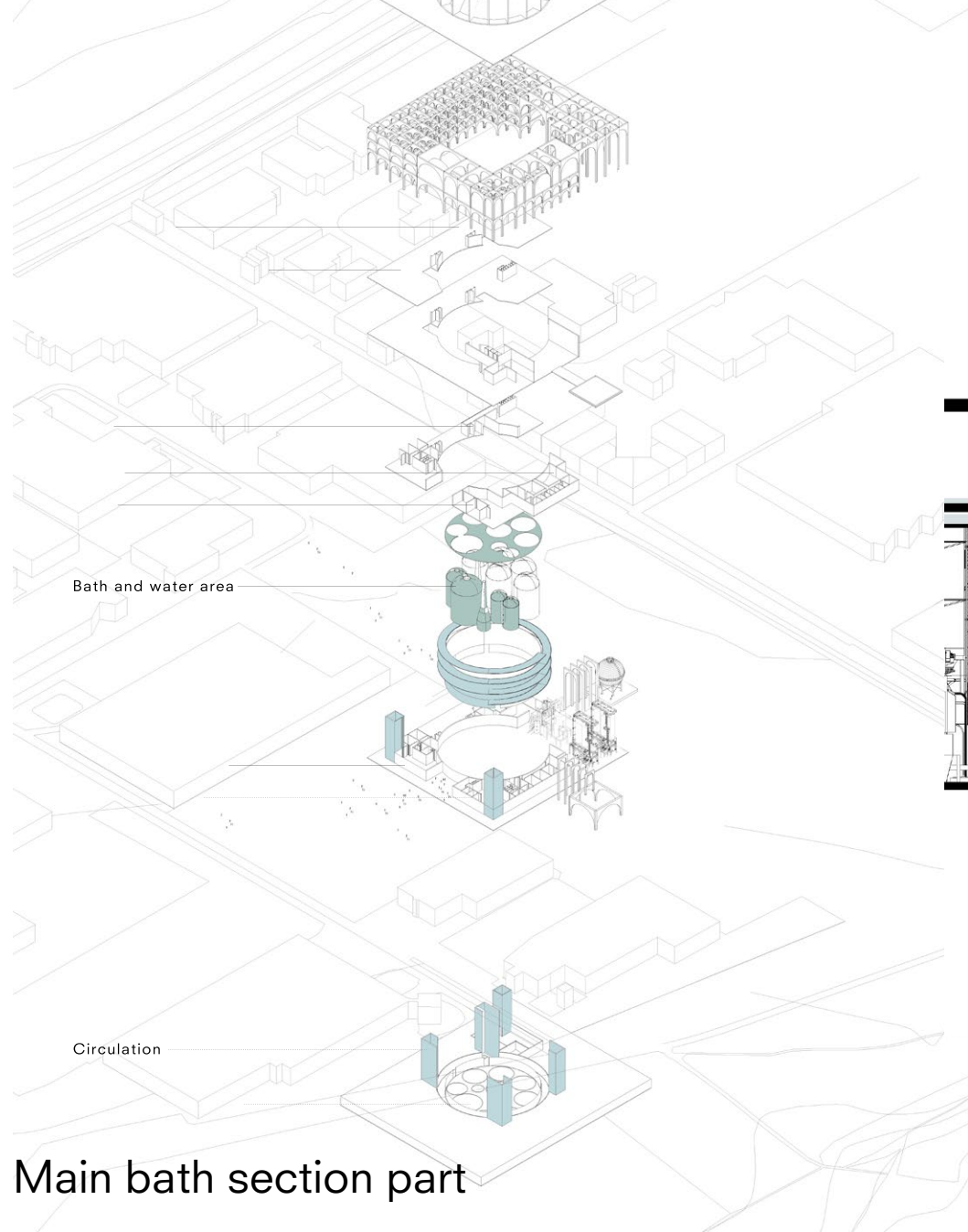

Diagram of bath 'tank' shape

Ventilation



Spatial quality - Bath area



Spacial quality - Bath area

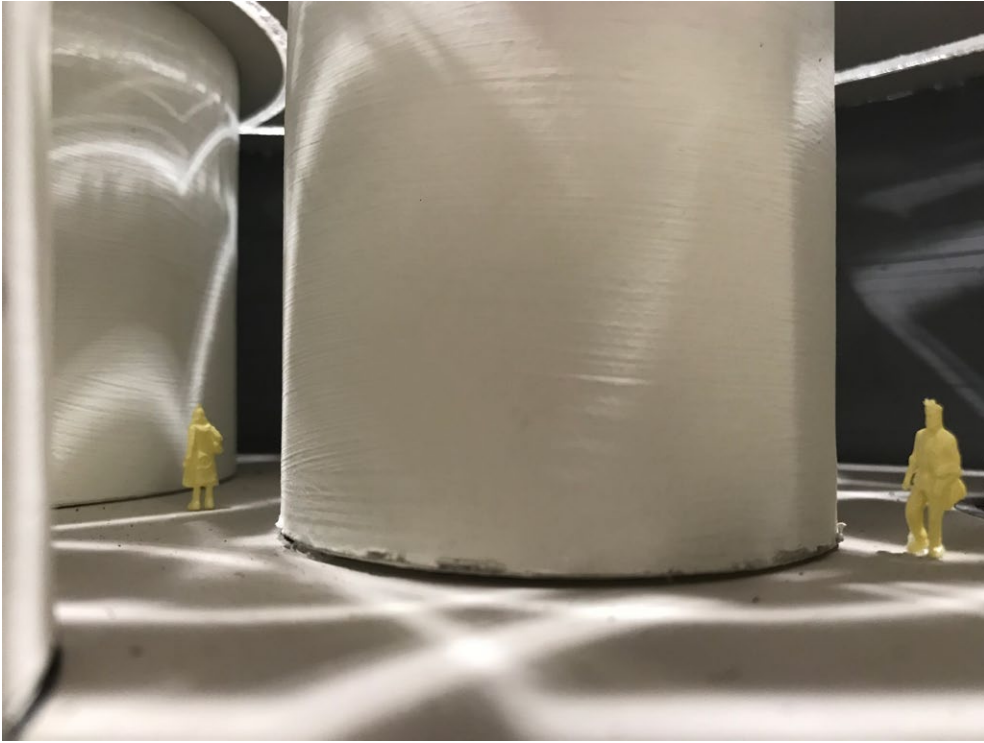

Model photo- Main bath

Spatial quality - Bath area

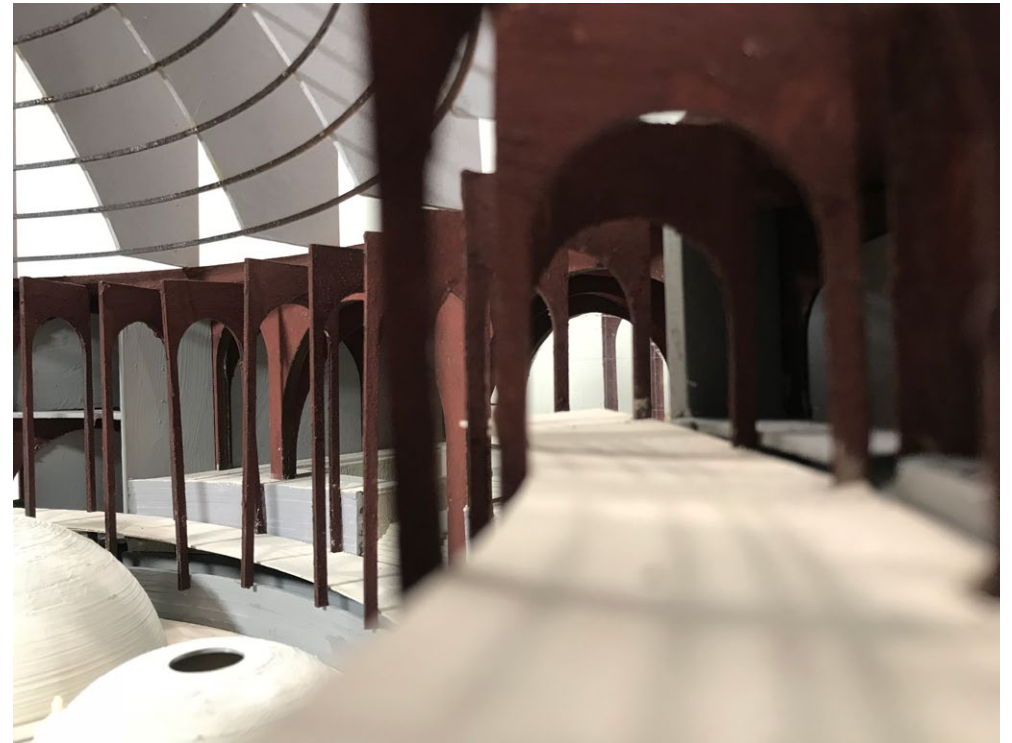

Model photo- play pool

Spatial quality-bath area

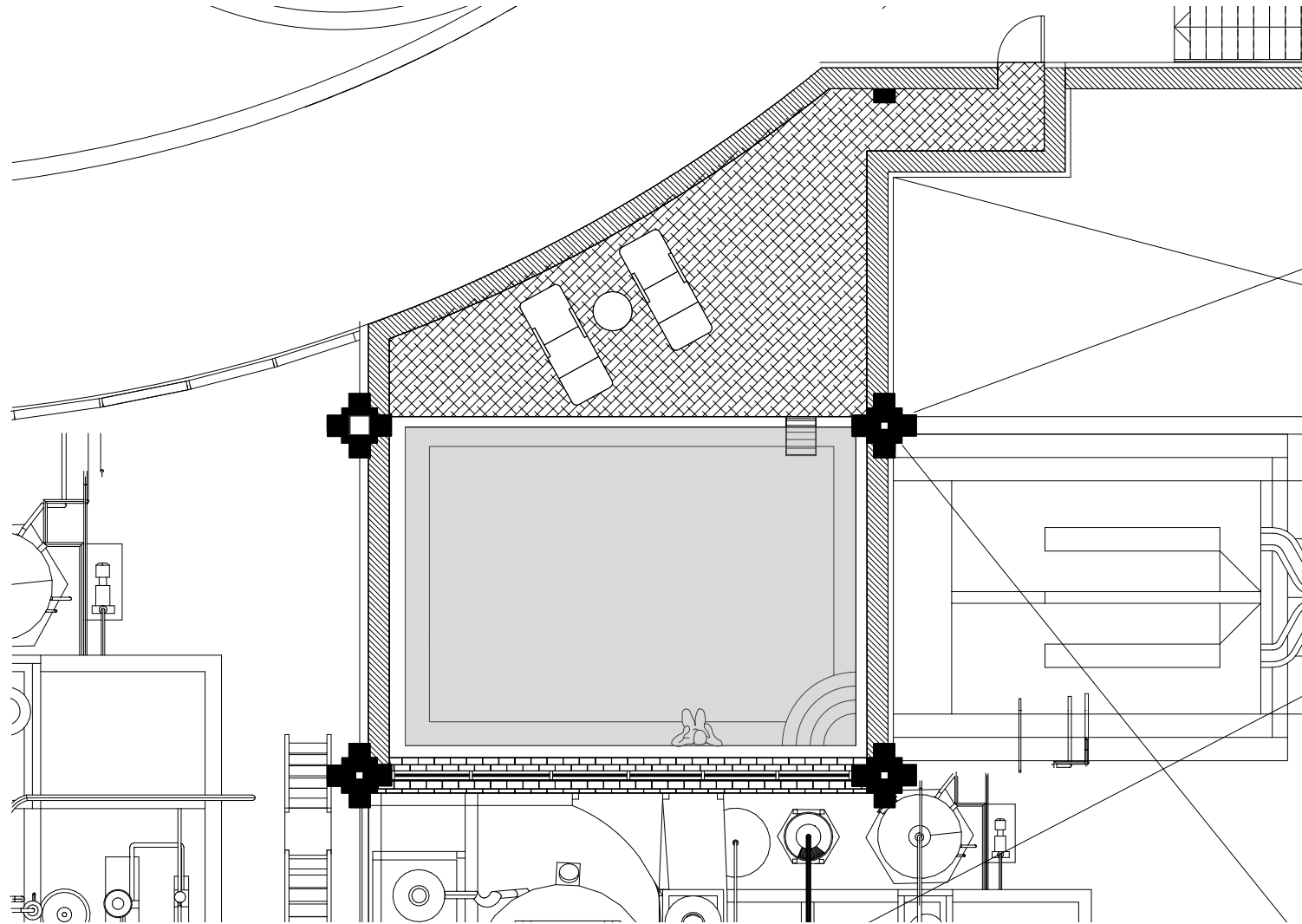

Spacial quality-Bath area



Spacial quality - Bath area

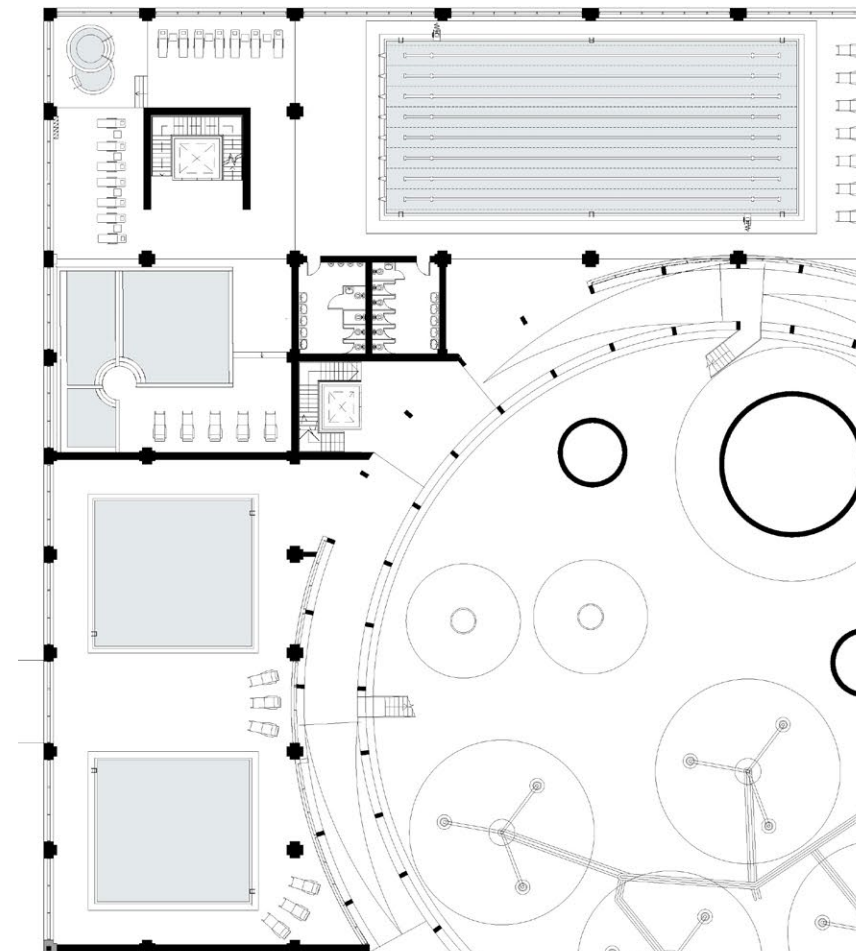
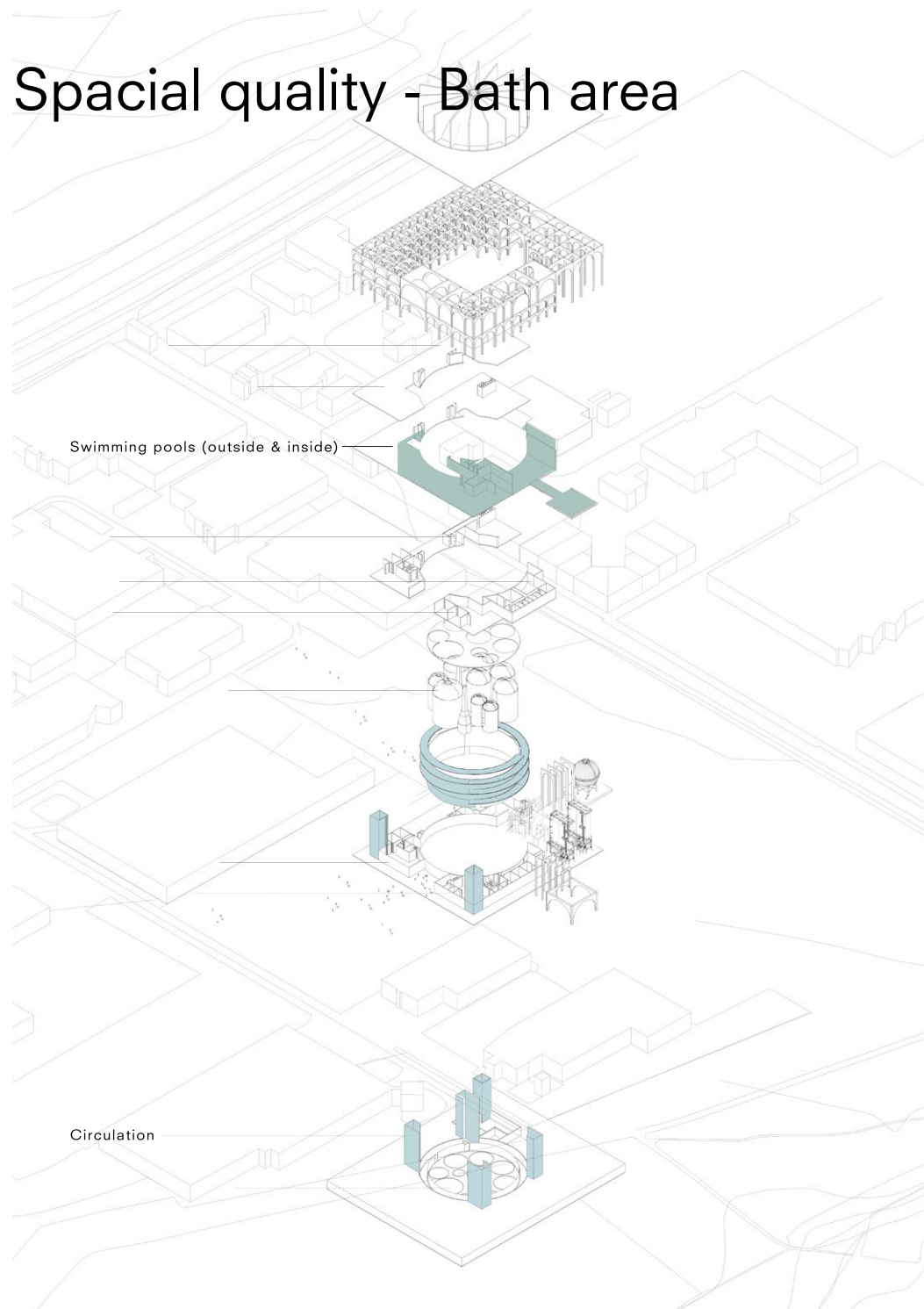

Second floor plan - swimming pool

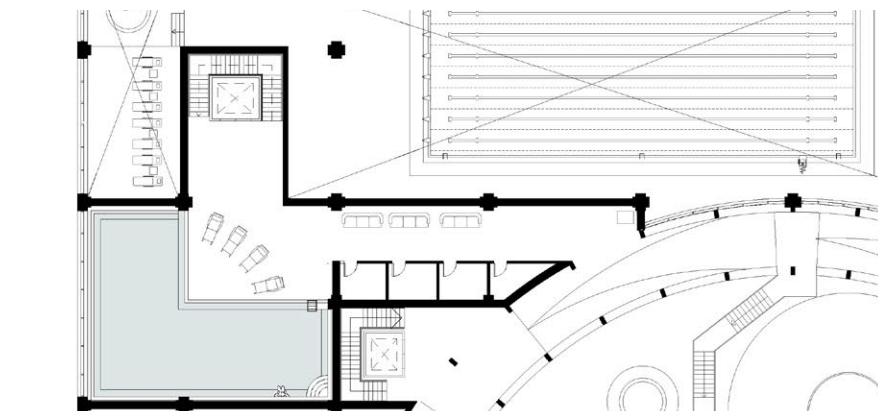

Third floor plan part - functional pool

Spatial quality - Bath area



Model photo - swimming pool

Spacial quality - GYM & Relax

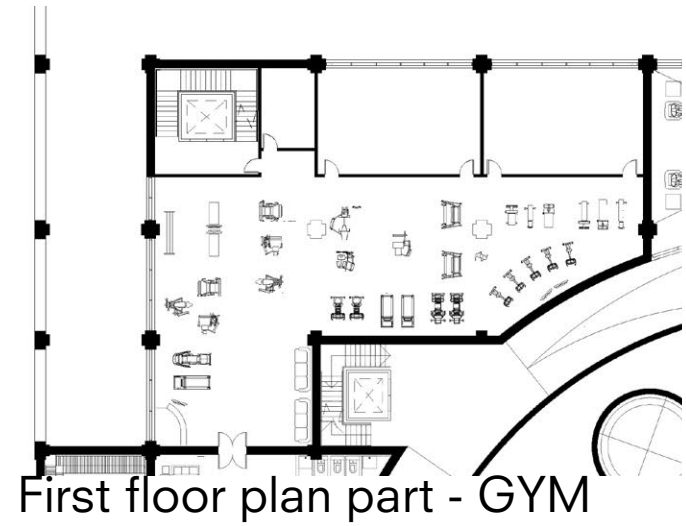
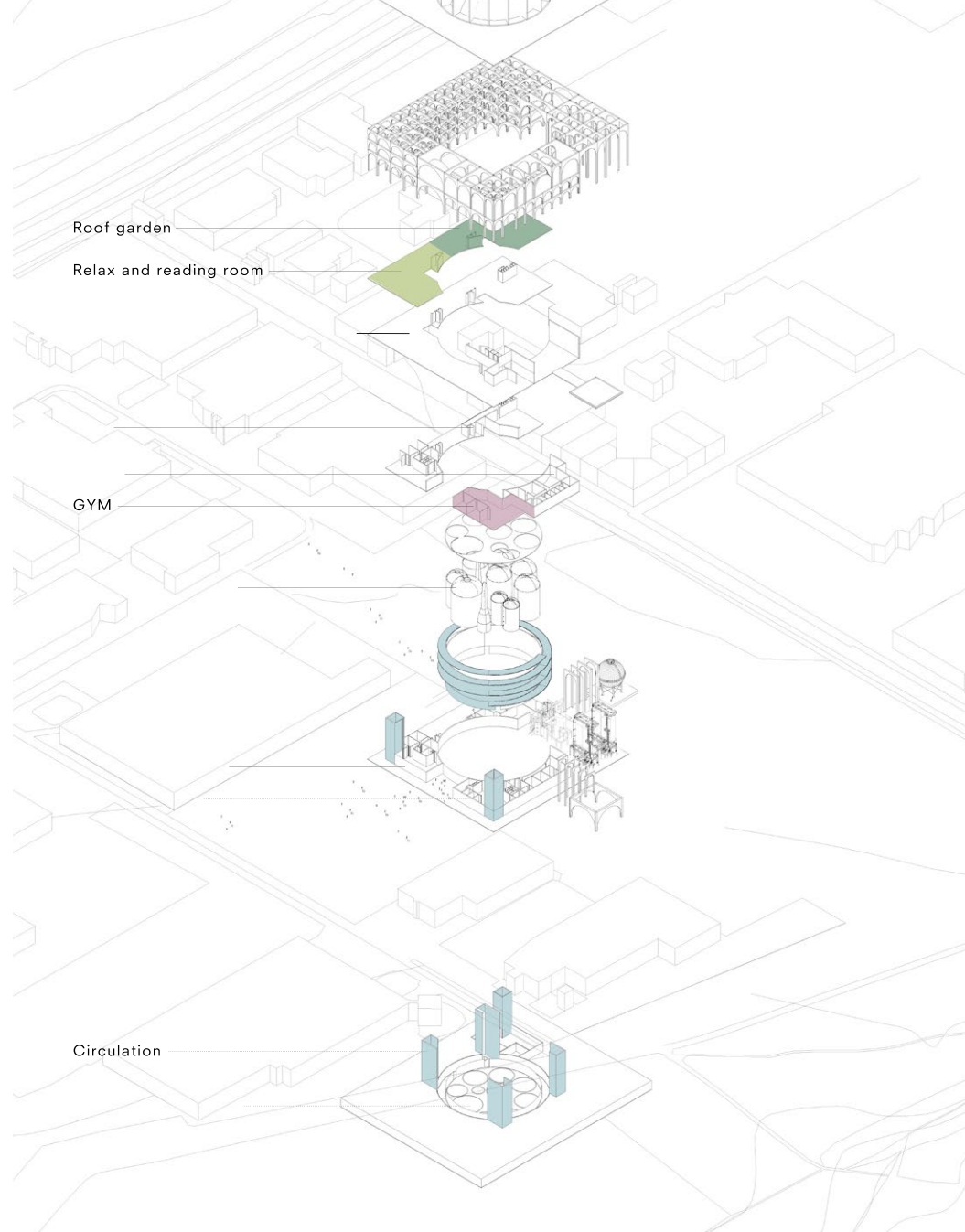

Spacial quality - Cafe for public

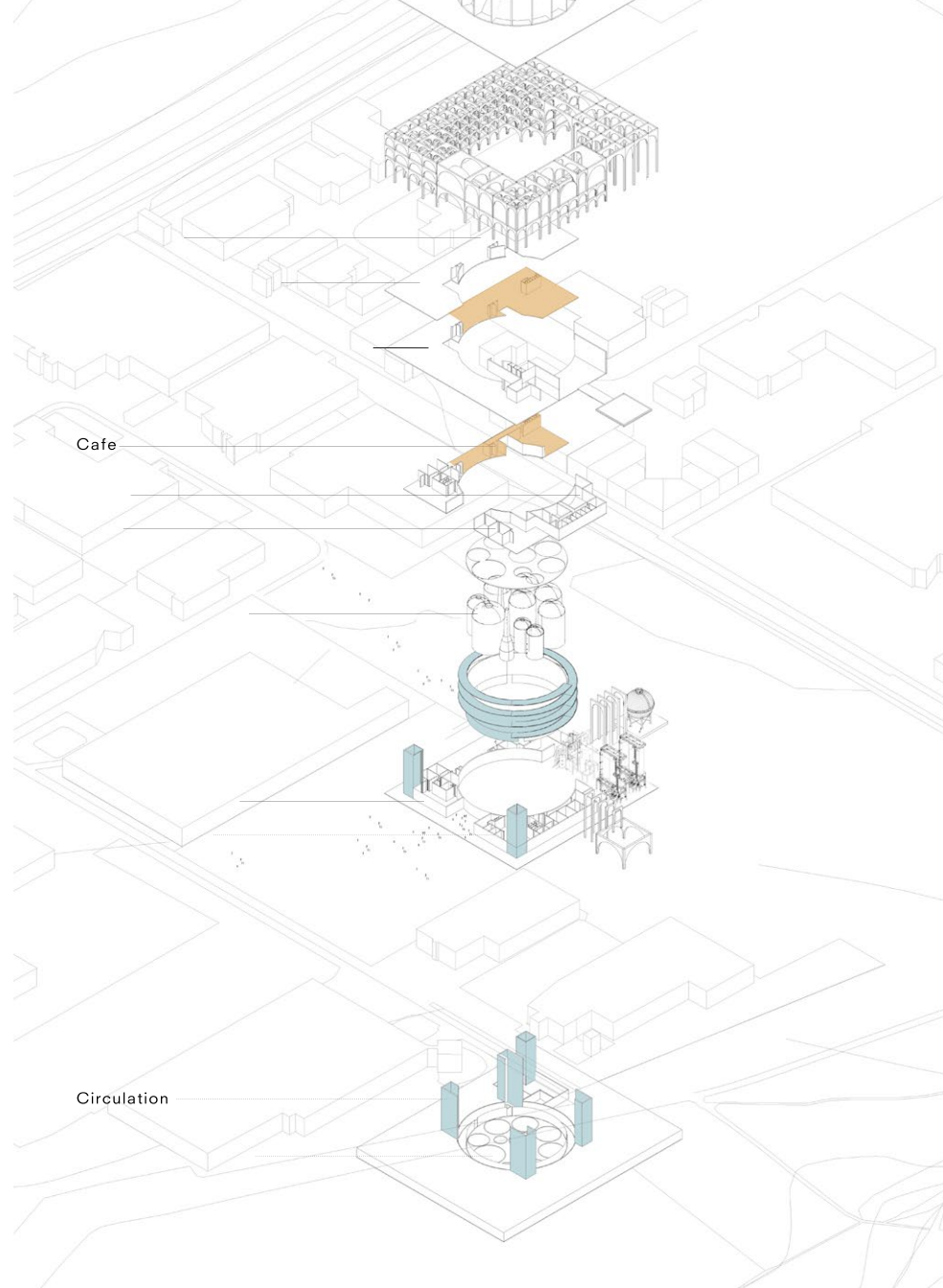

First floor plan

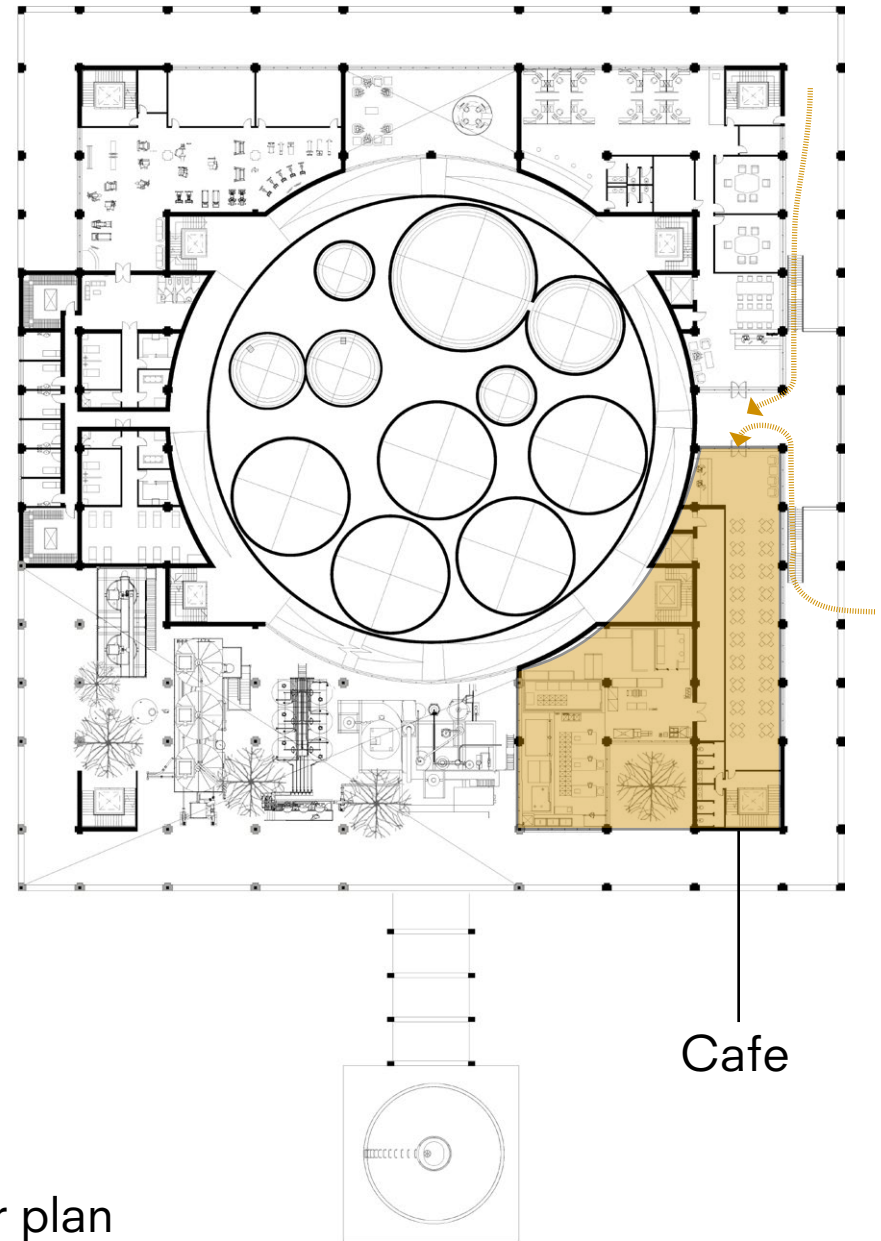

Spacial quality - Cafe for public

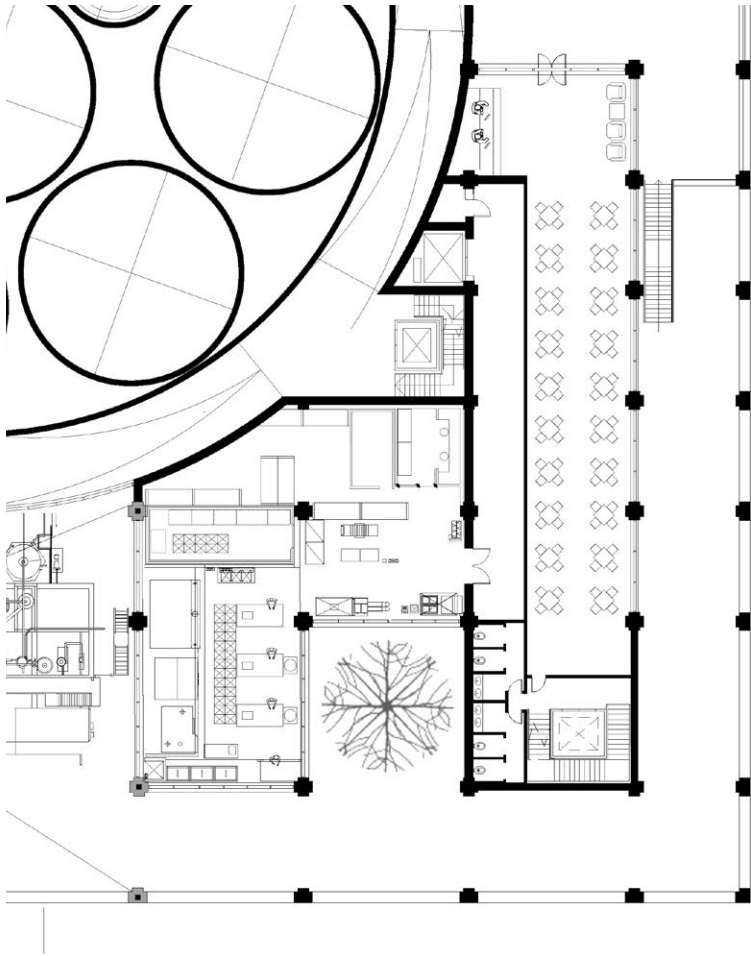

First floor plan part

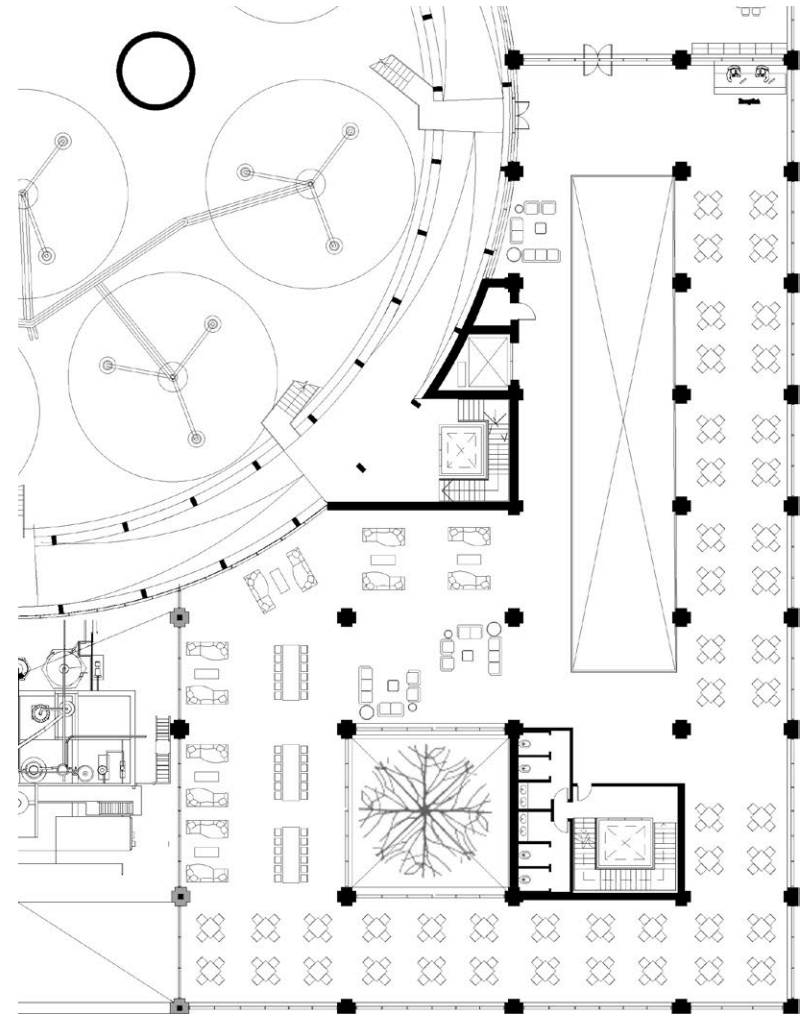

Second floor plan part

Section

Section 1

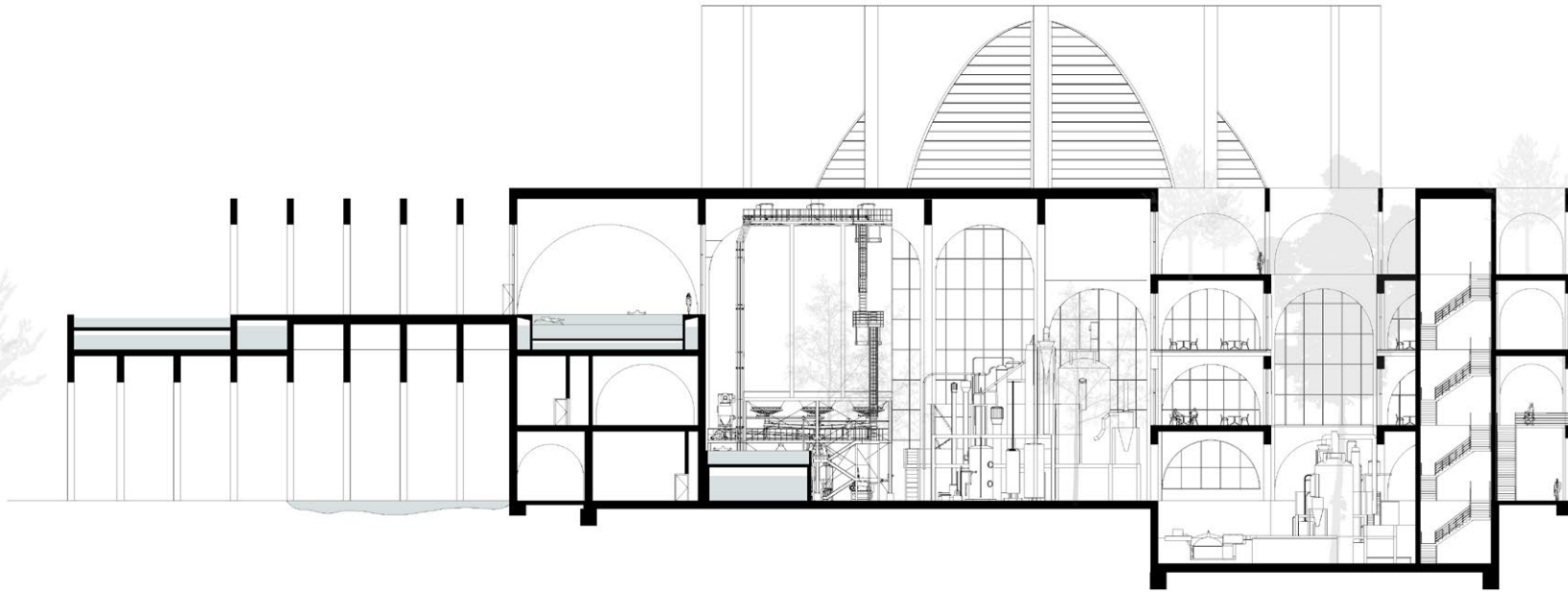

Section 2

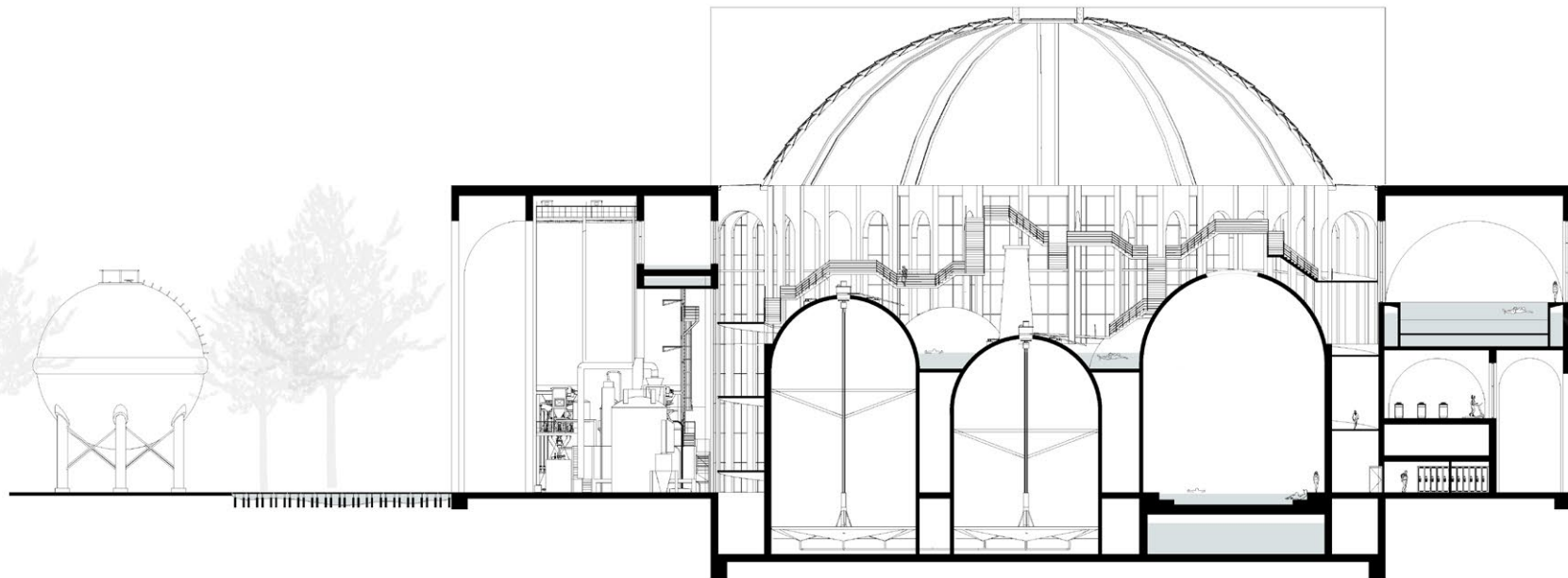

Typology study and test

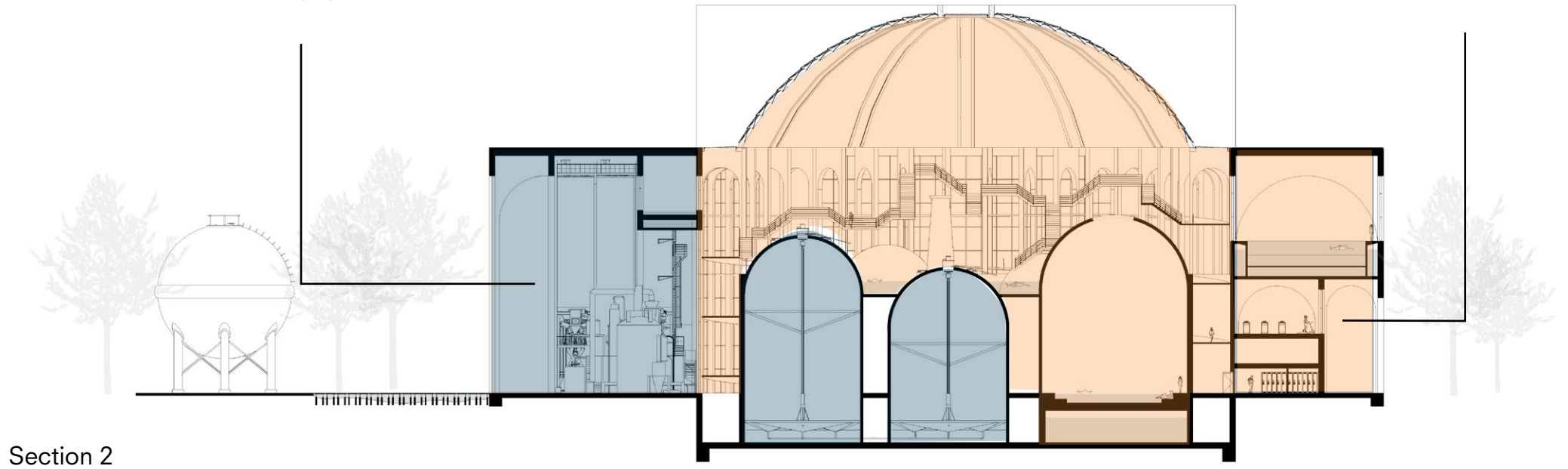
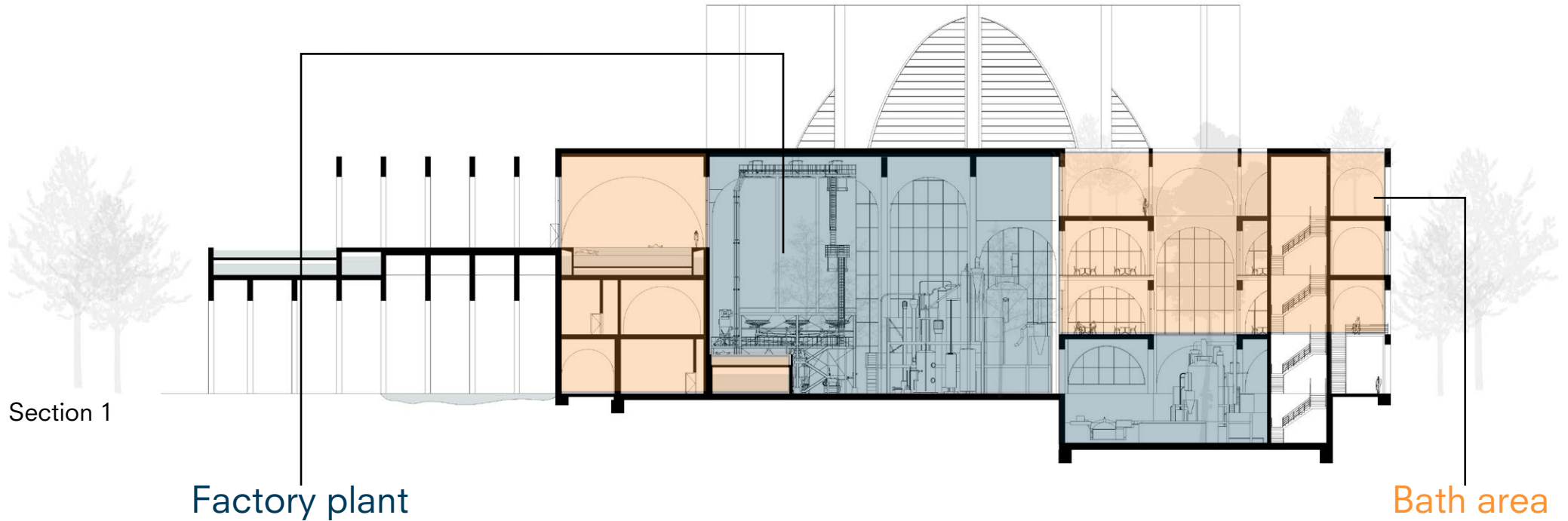

Typology study and test - Section



Model photo- section

Spatial quality - Public



outside pool

Spatial quality - Public



next to engines

Spatial quality - bath area

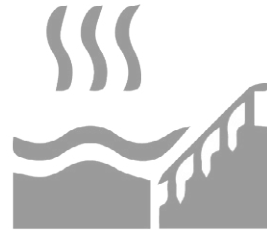
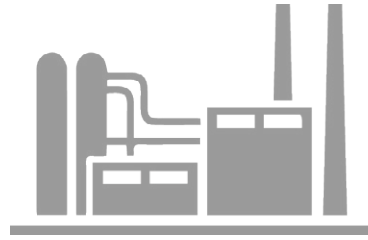

Spacial quality - office for staff

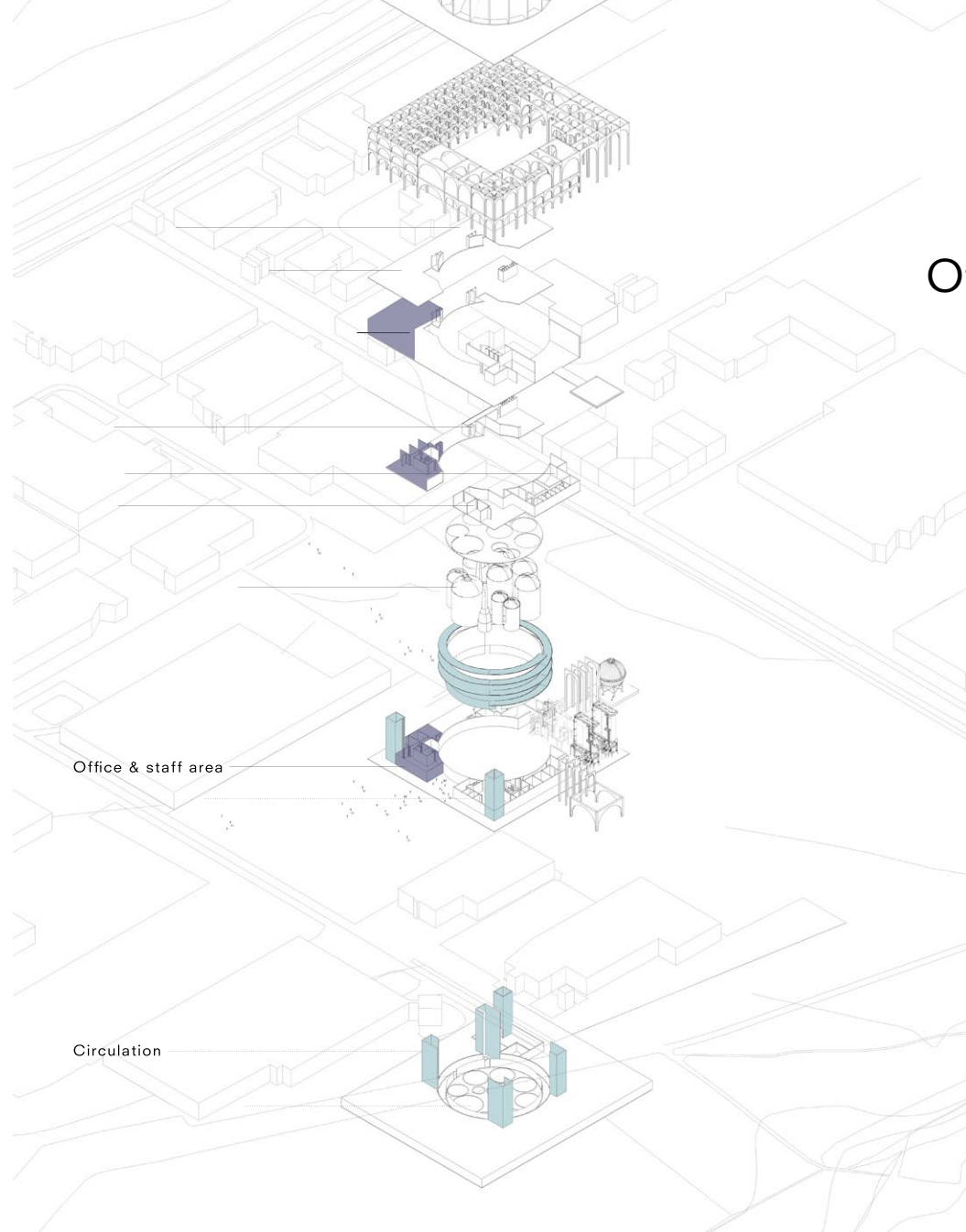

Office

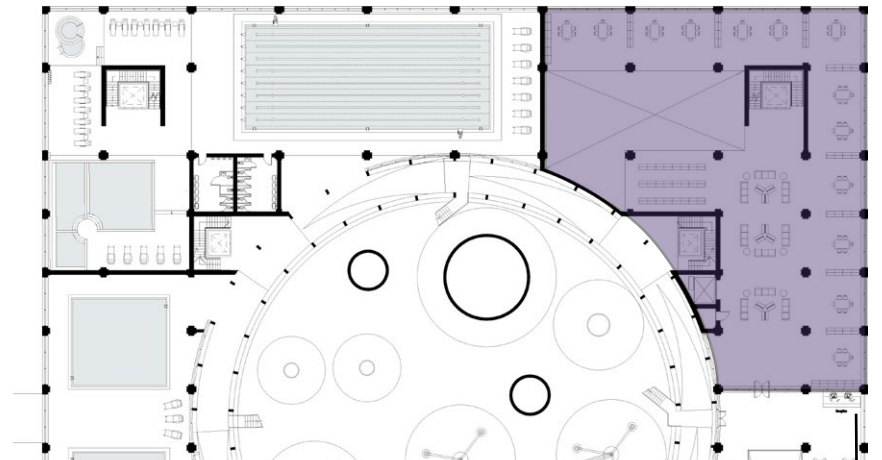
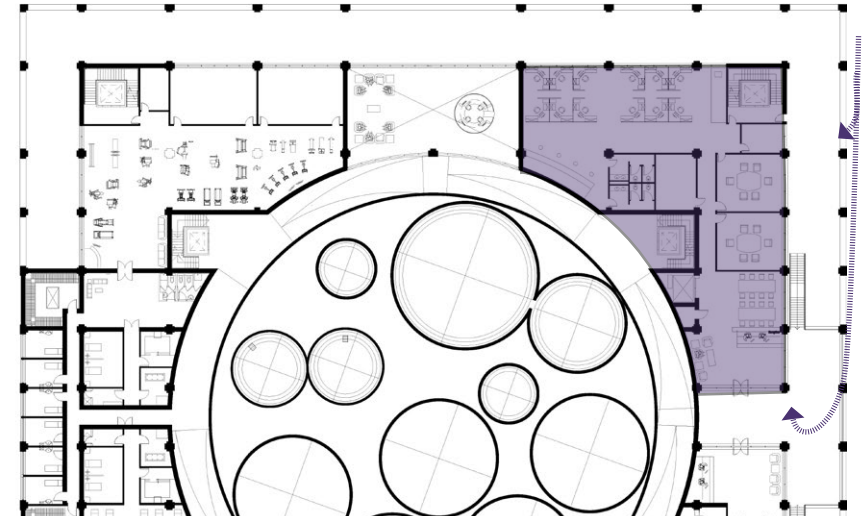

Construction- Detail

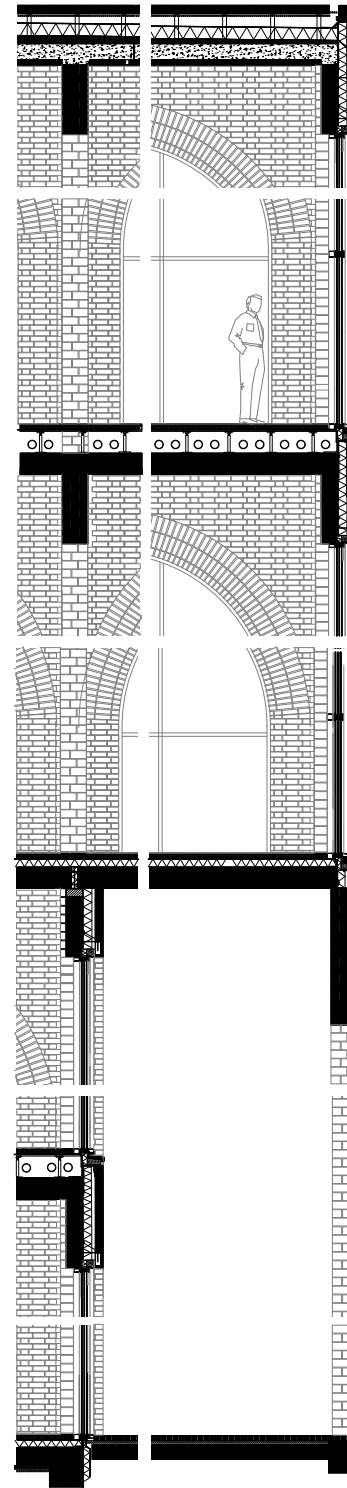

Construction -Detail

Roof detail section 1:20

1. Precast concrete with brick layer
2. 50mm grave fill
bituminous seal
polystyrene insulation to falls
vapour barrier
primer
3. Metal supported product
4. lintel: precast concrete unit
5. sunshading rolling

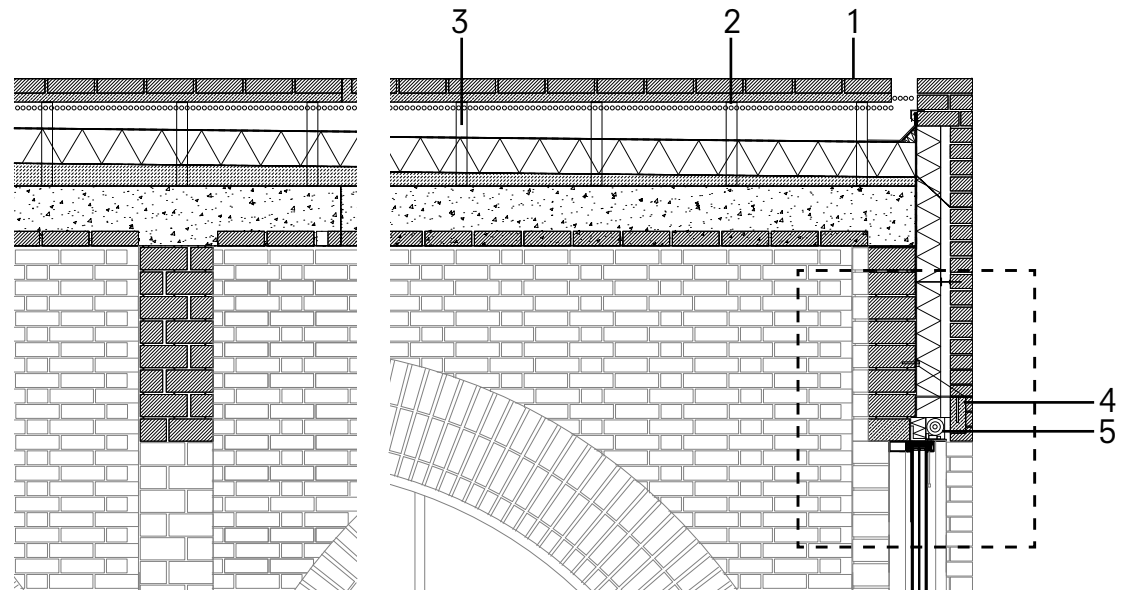

Construction -Detail

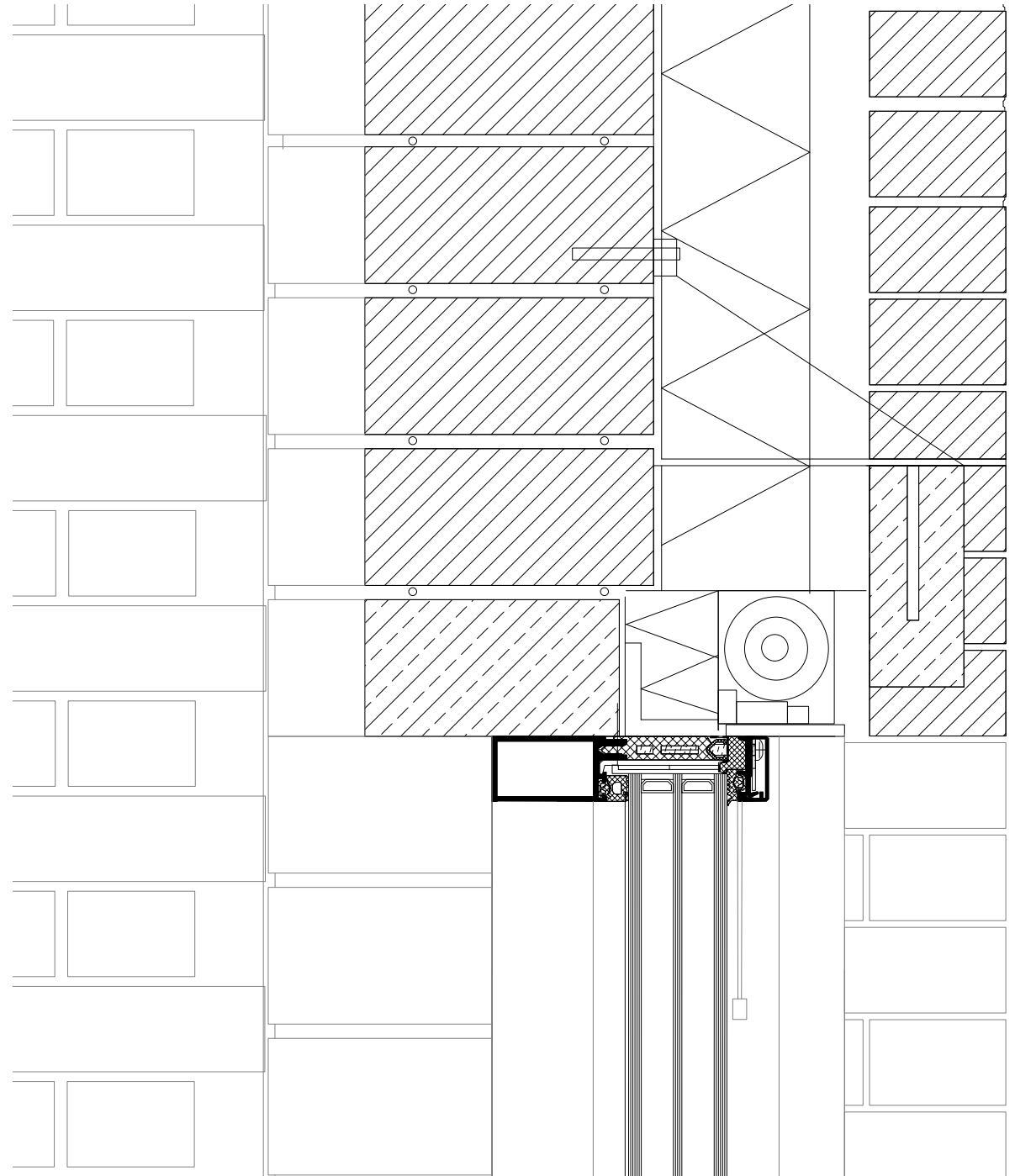

Detail section 1:5

Construction- Detail

Detail section 1:20

- 7. 80mm cement underfloor heating screed, sanded, oiled polythene membrane, 18mm gypsum fibreboard, raised floor, 300mm precast reinforced concrete with brick layer
- 8. 240/115/71 mm brick, irregular bond, in dry premix mortar, ventilated cavity, 140mm mineral wool thermal insulation, 360mm reinforced brick wall

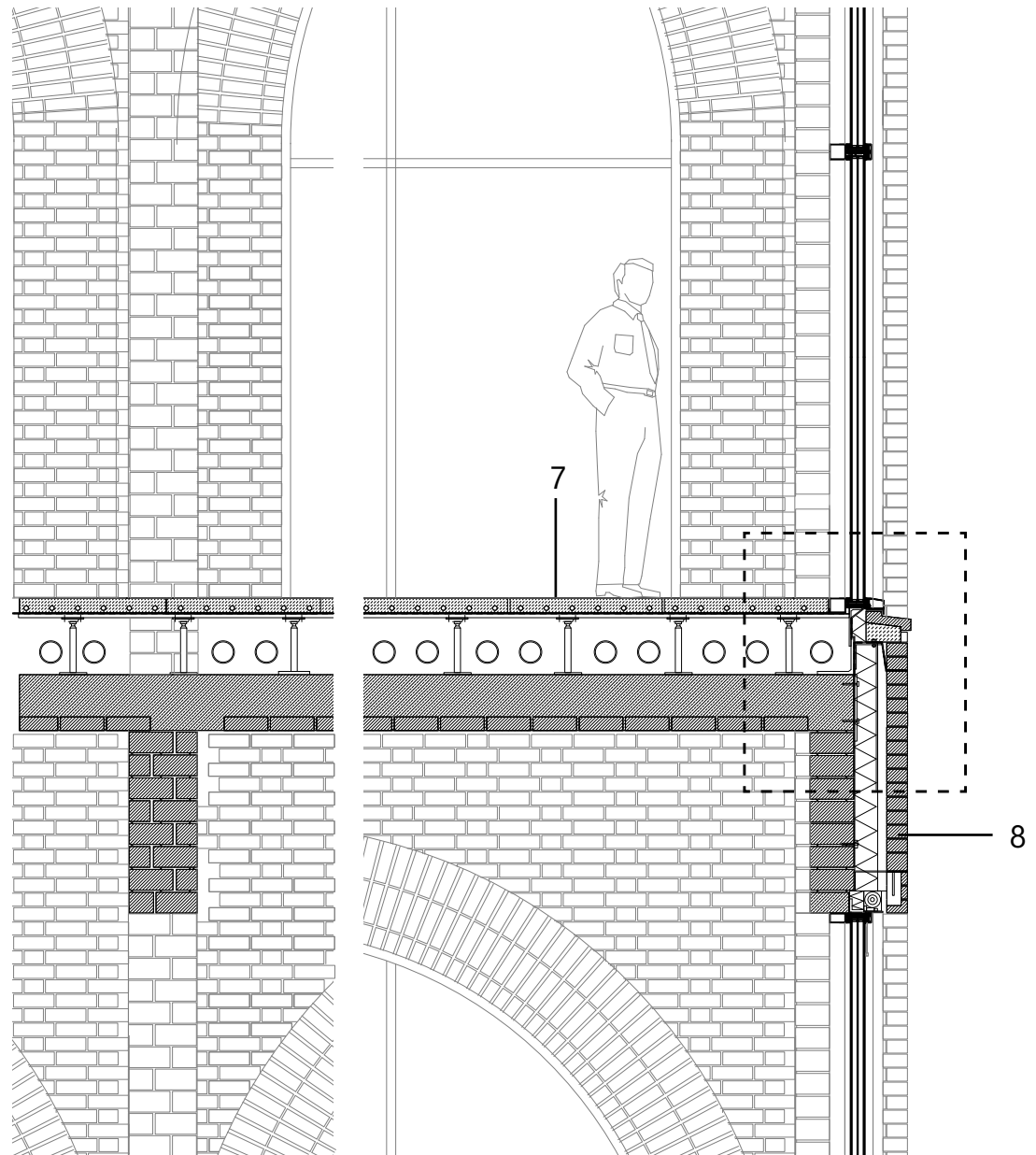

Construction -Detail

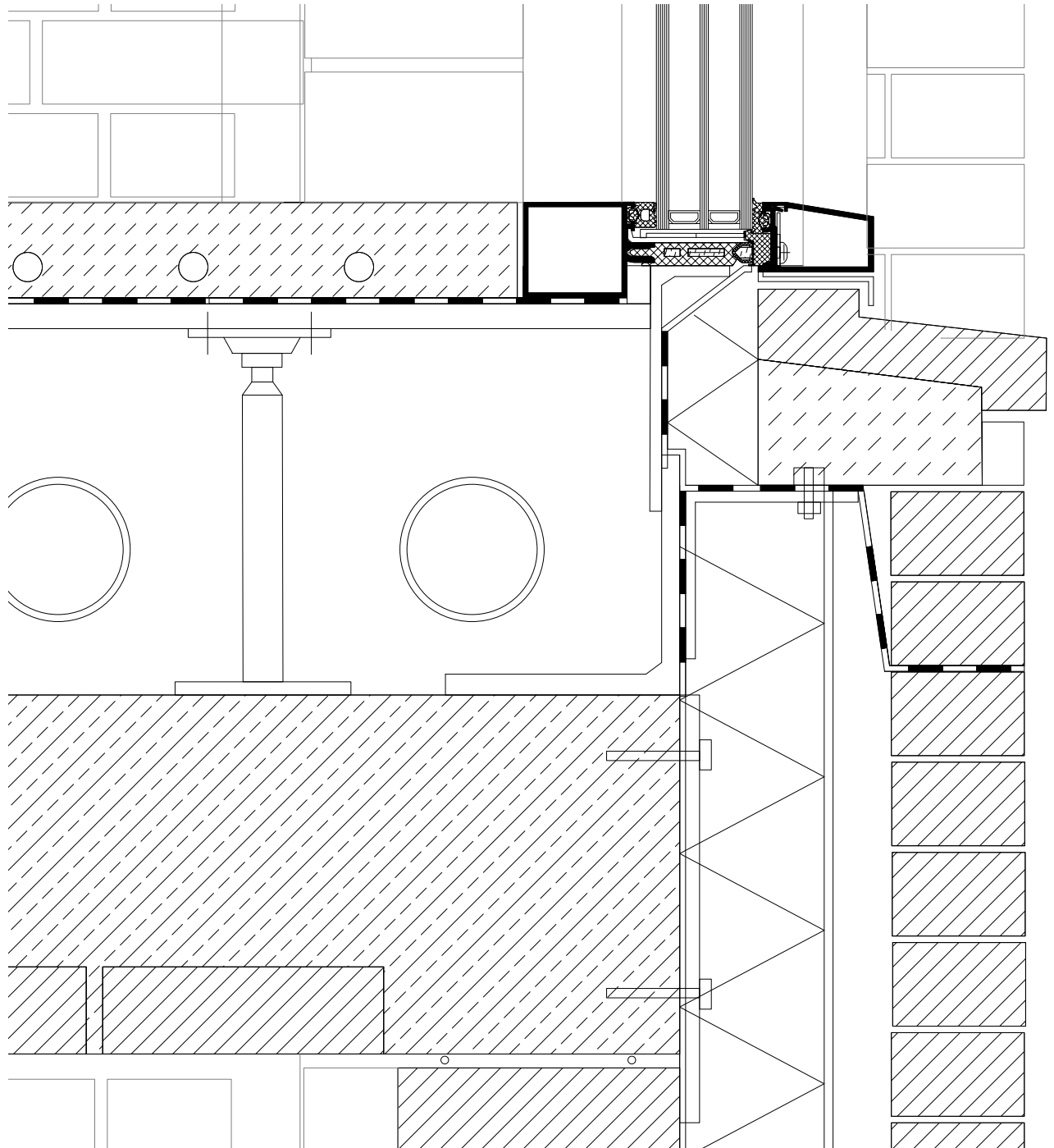

Detail section 1:5

Construction-Detail

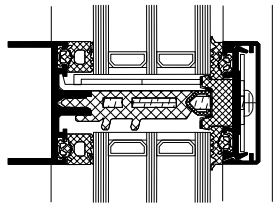

Triple glazing in aluminum frame
1:5w

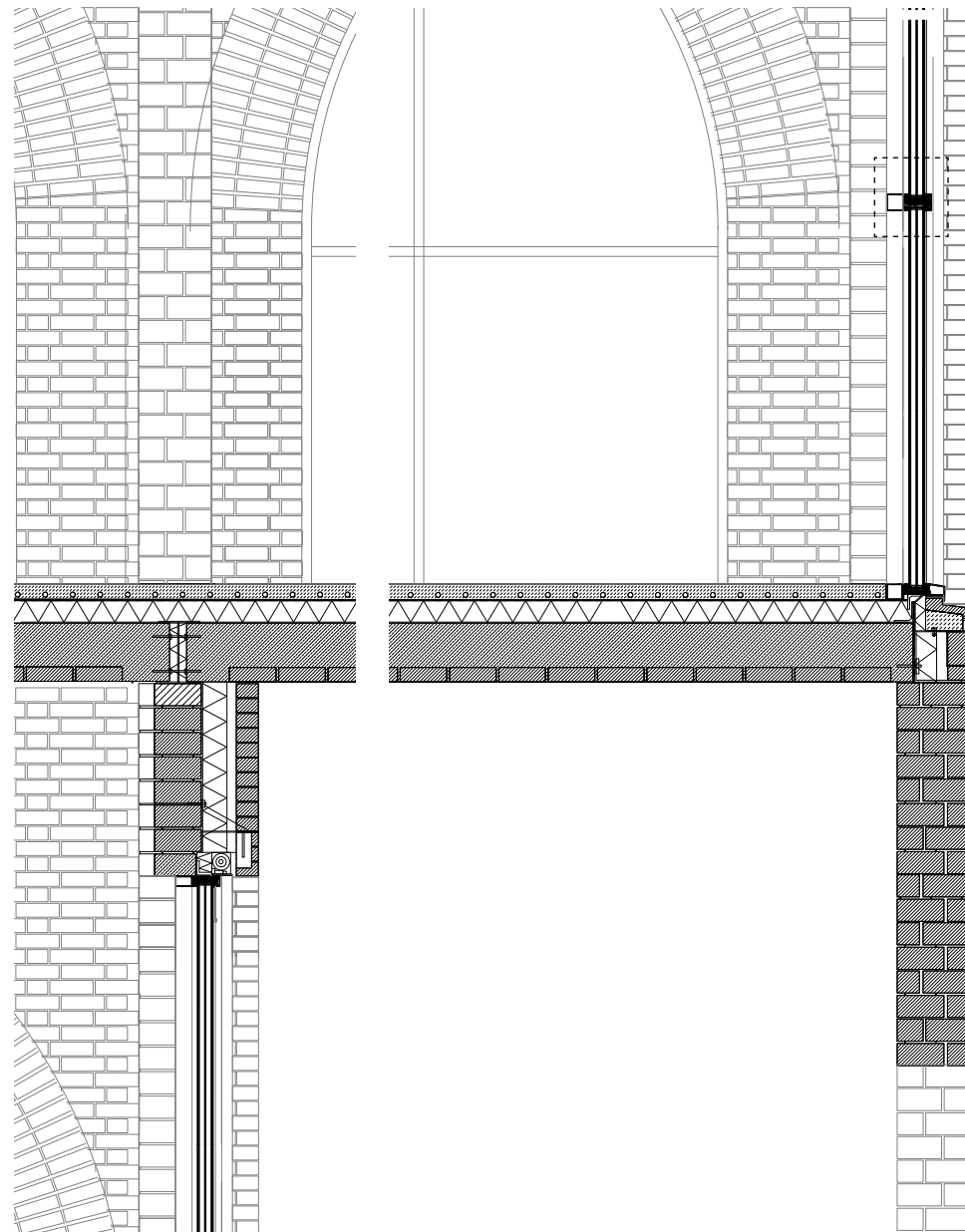

Construction -Detail

Floor detail section 1:20

- 9. 80mm cement underfloor
- heated screed
- polythene membrane
- 110mm rigid foam board insulation seal
- 250mm reinforced concrete
- polythene membrane
- 150mm gravel fill

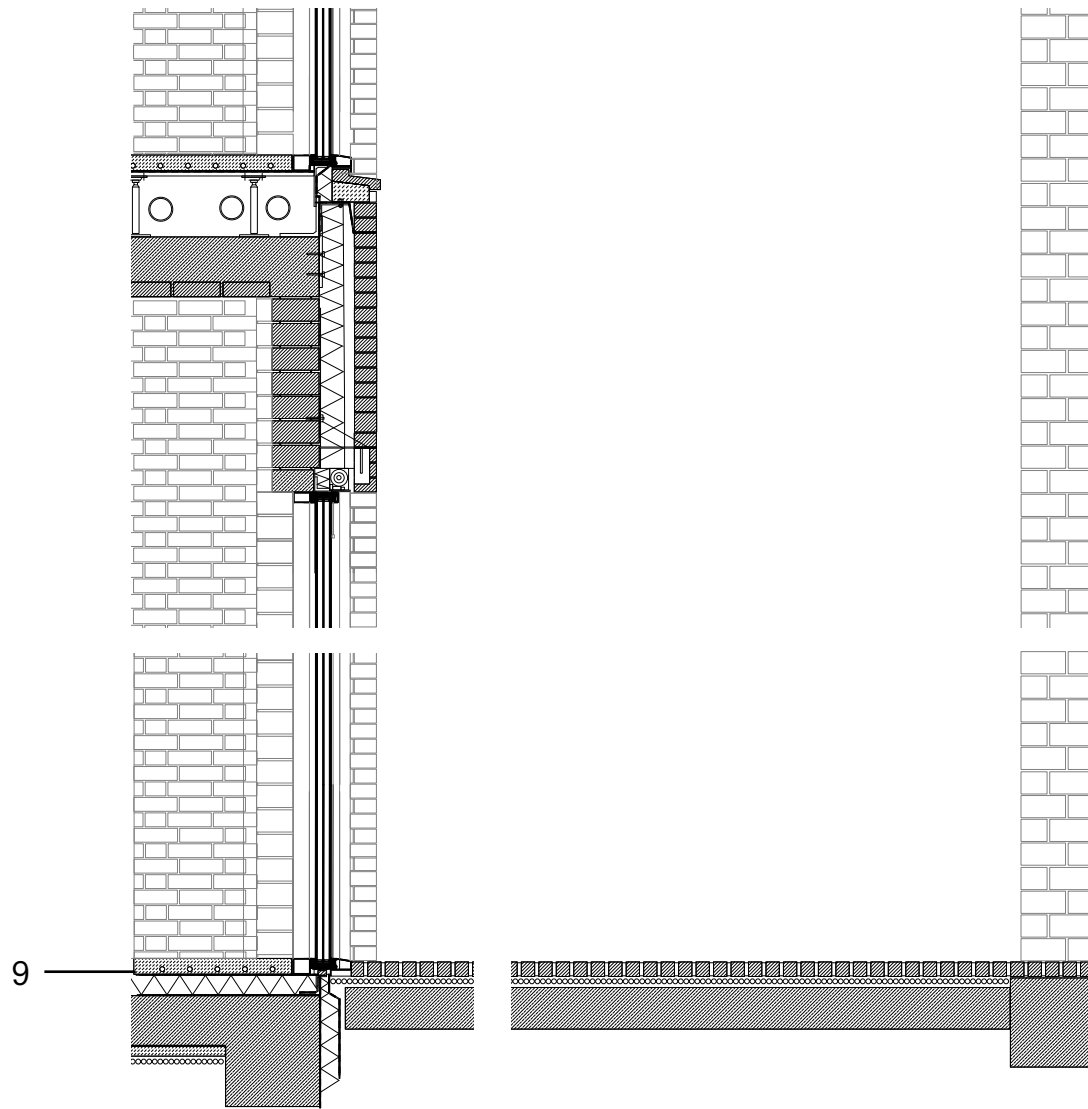

Construction -Detail

Horizontal detail section 1:20

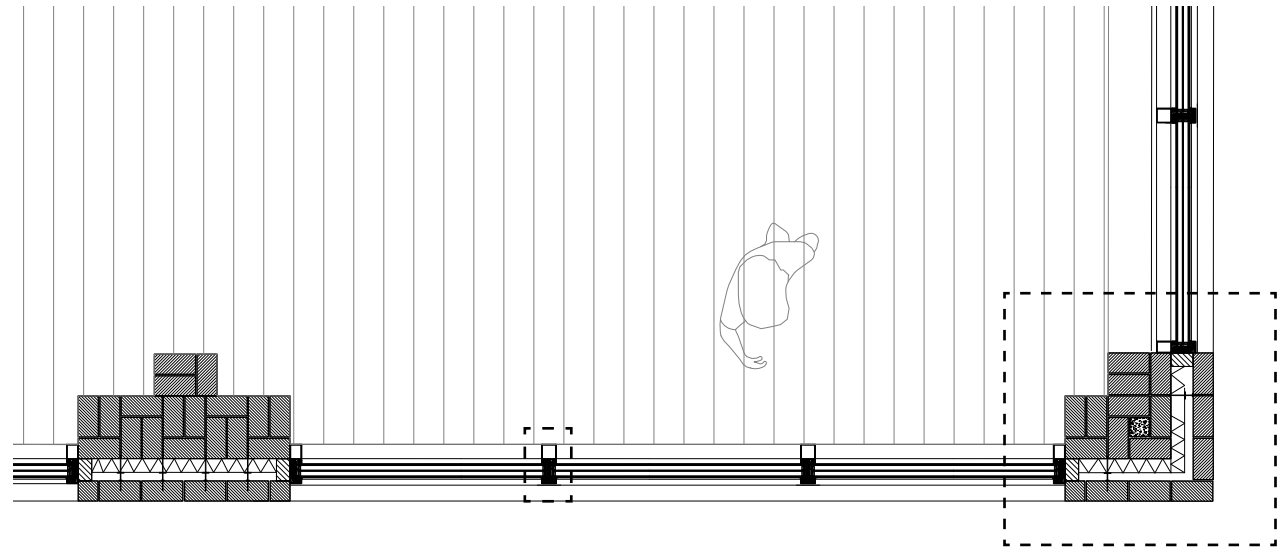

Horizontal detail section 1:5

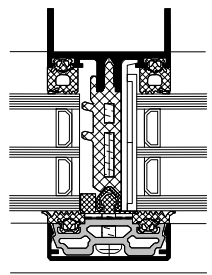
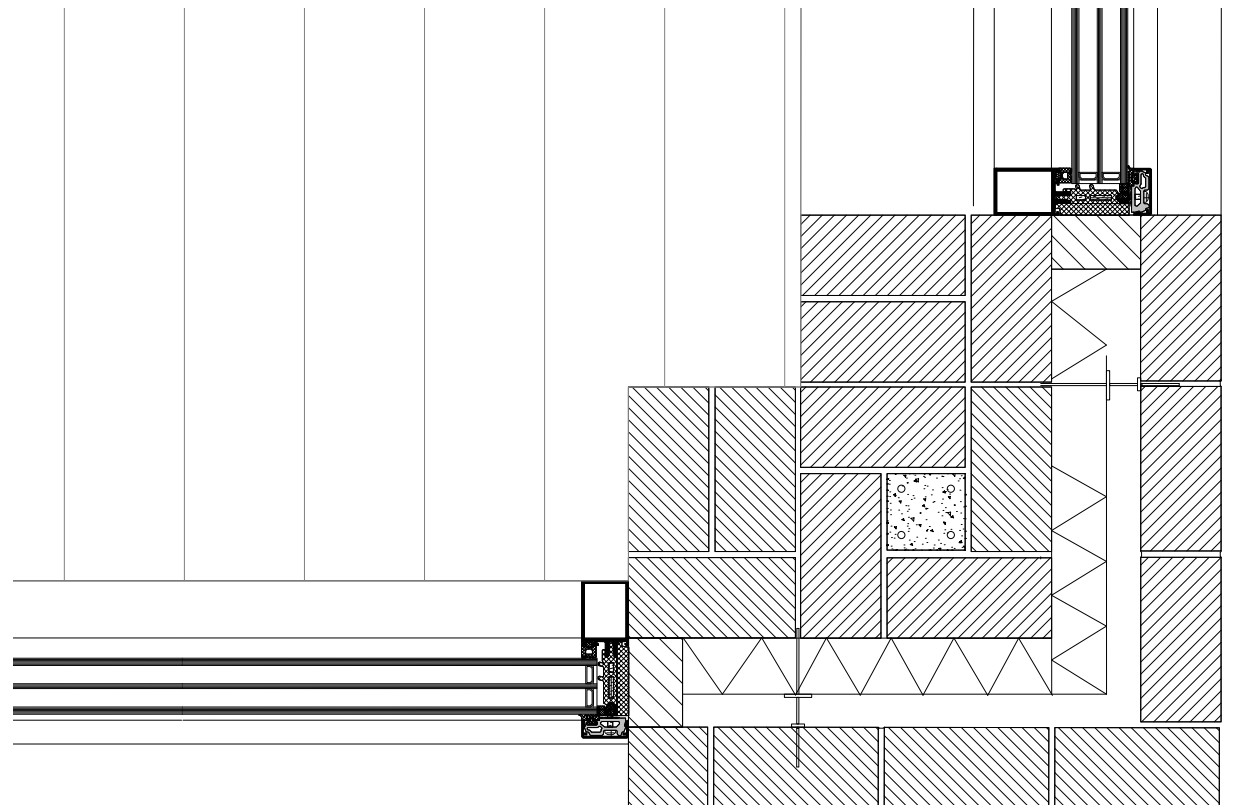

Triple glazing in aluminum frame 1:5

Materiality

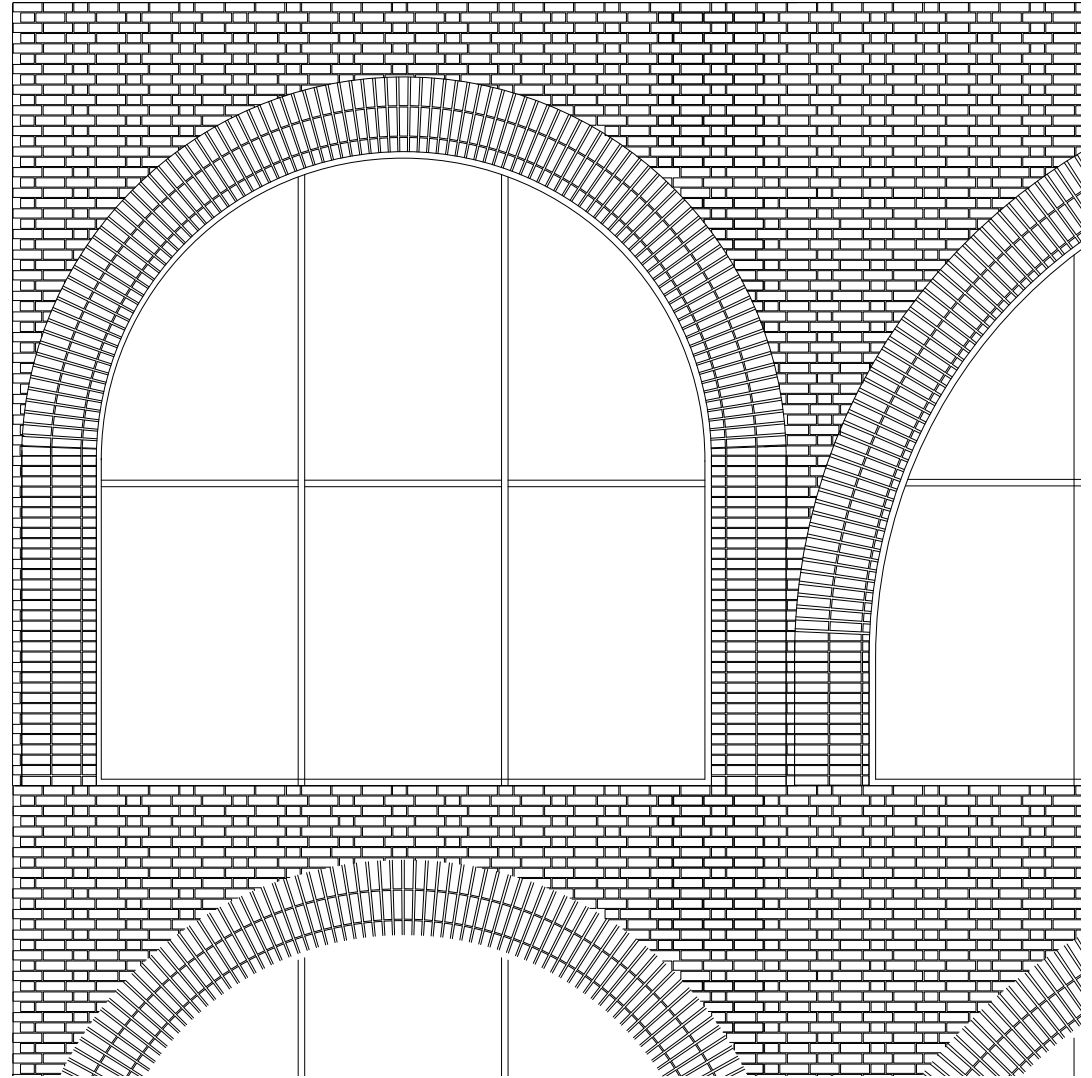

Elevation 1:20

Materiality

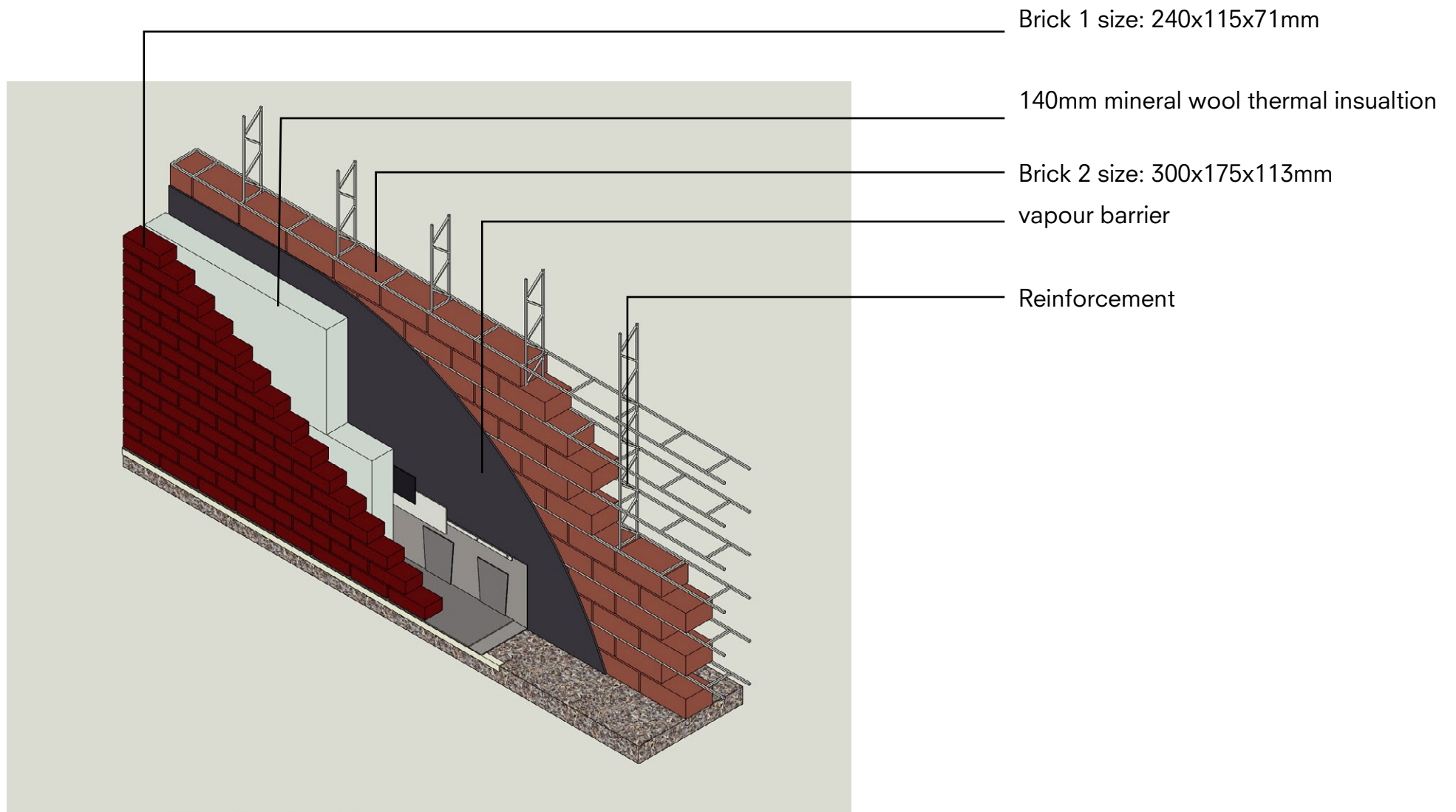

Materiality

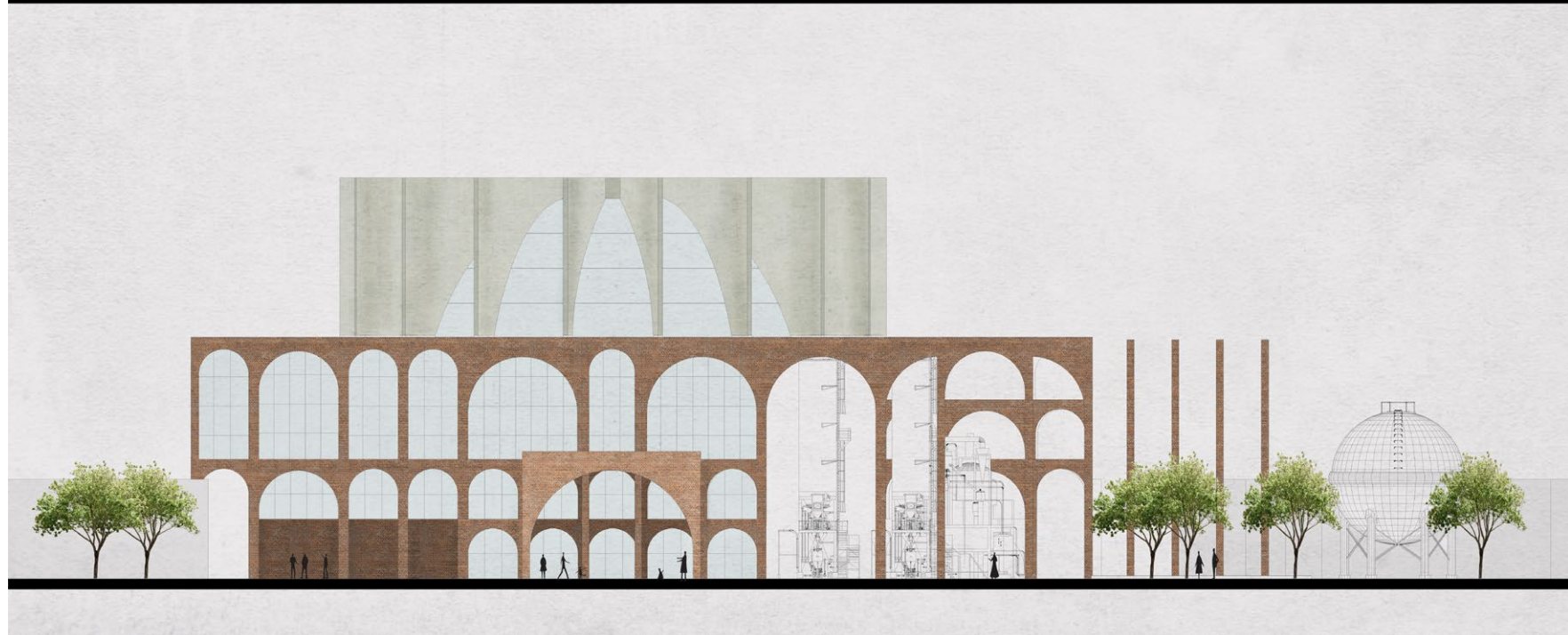
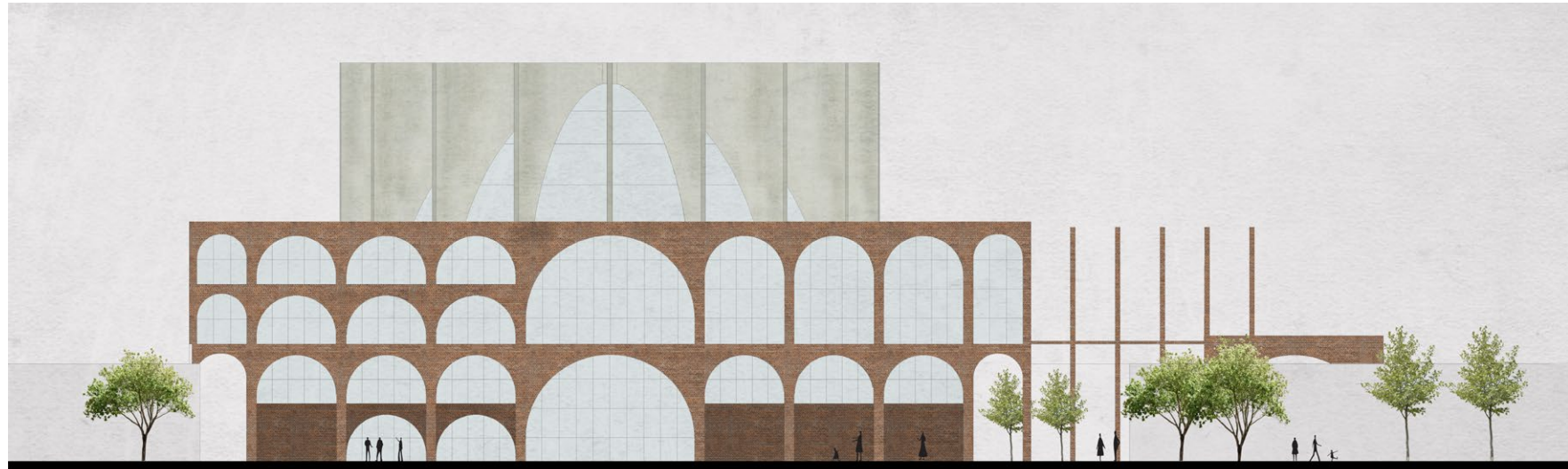

Elevation

Construction -Roof

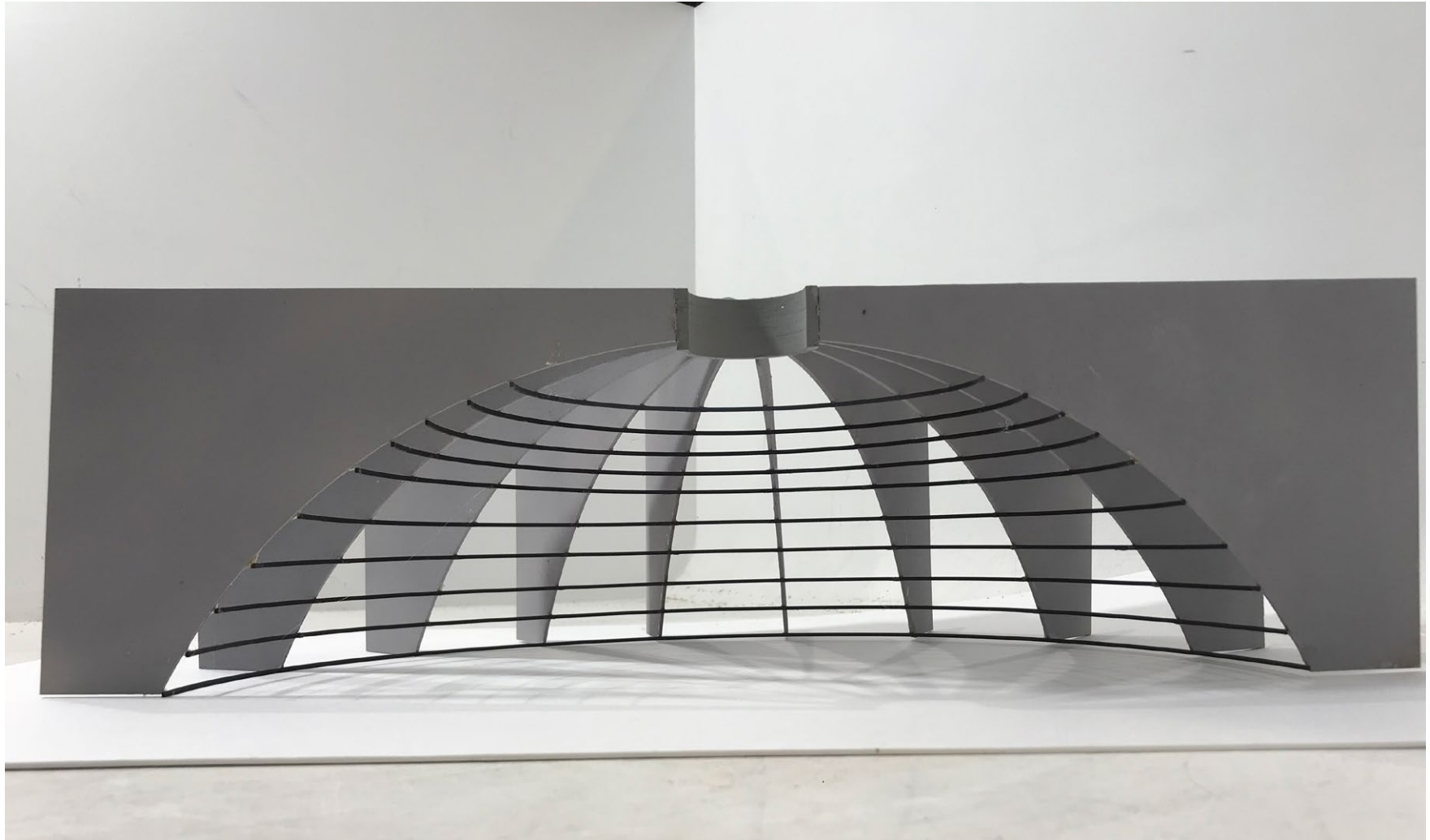

Construction -Roof

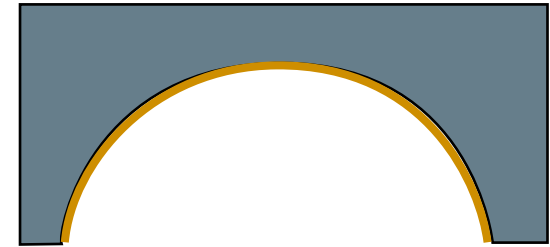
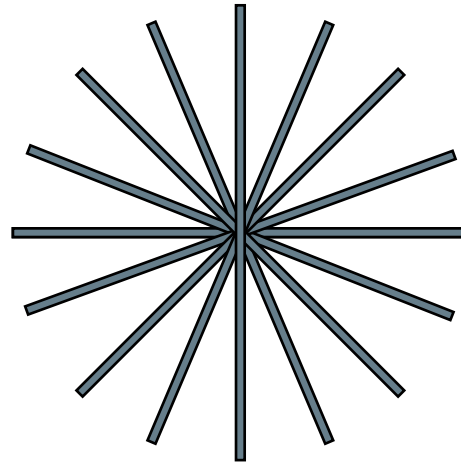
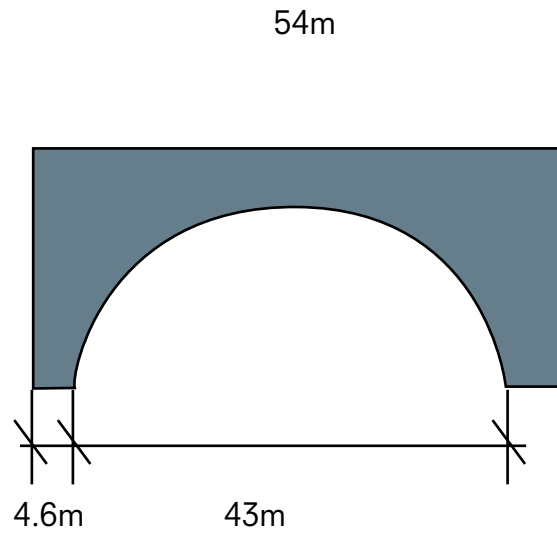

Construction -Roof

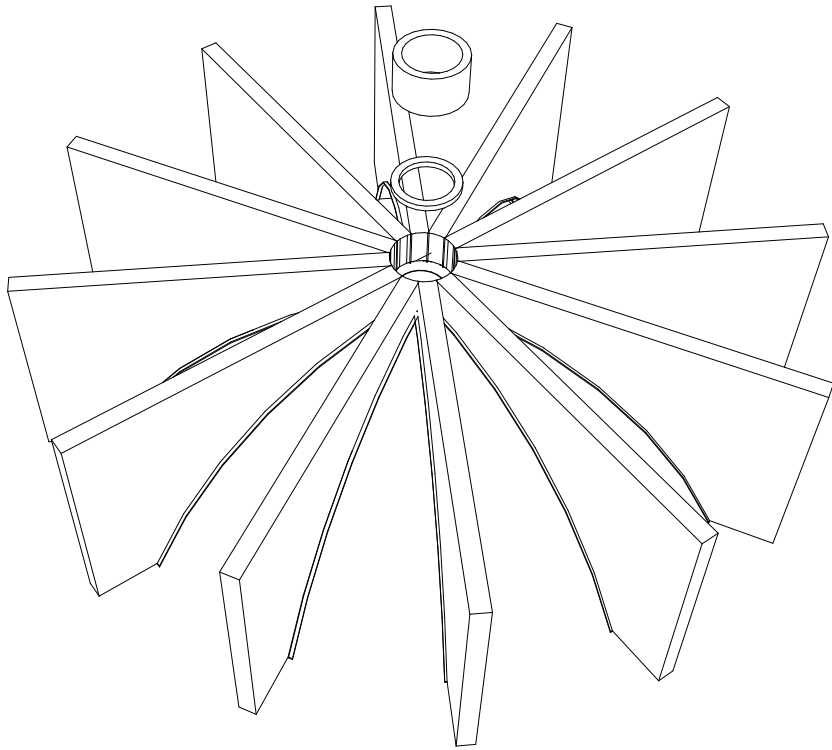

Construction -Roof

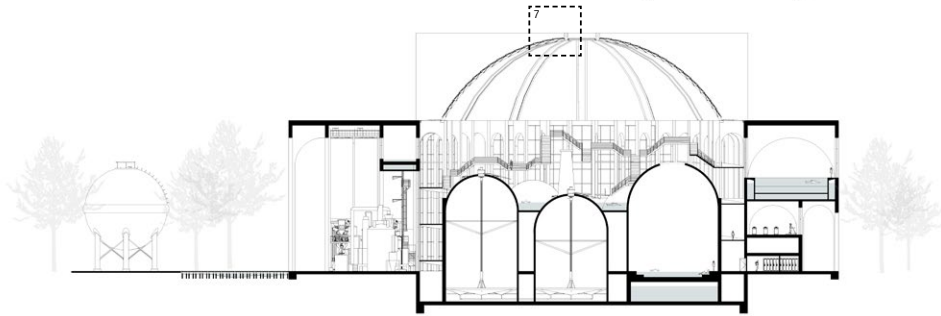

Roof

- A. Supporting frame:
Hanging underneath concrete sheet, steel flat tension or pressure band
- B. Glass assembly:
laminated safety glass of float-glass panes
- C. aluminium sliding frame

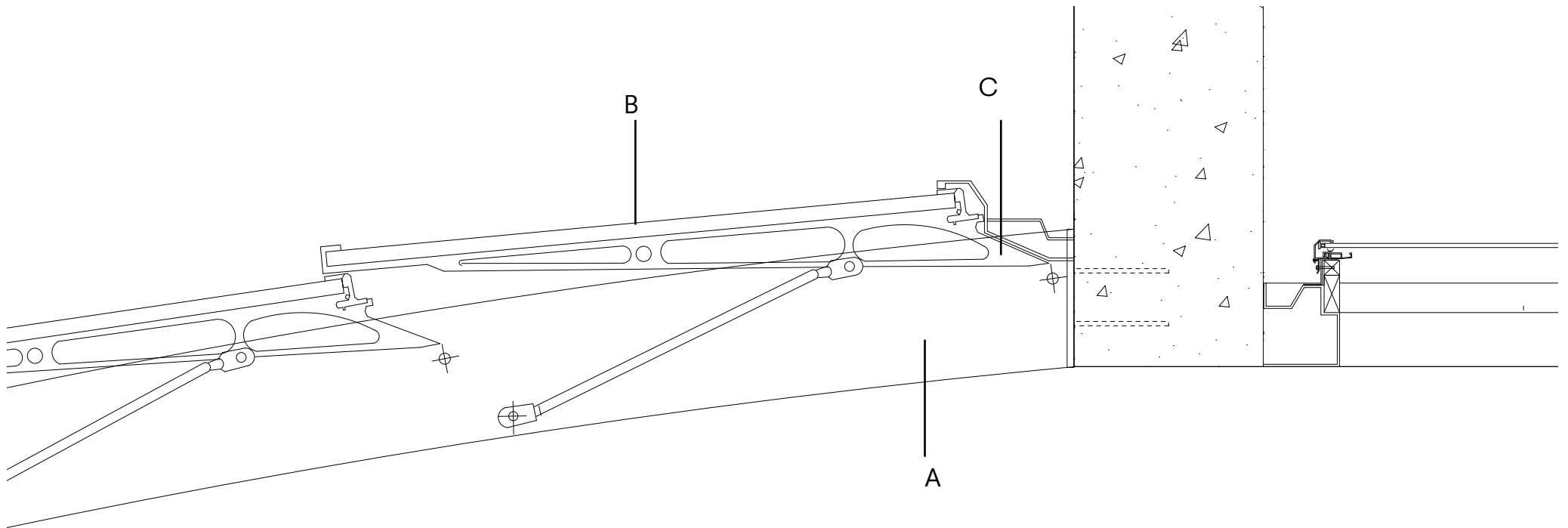

Climate

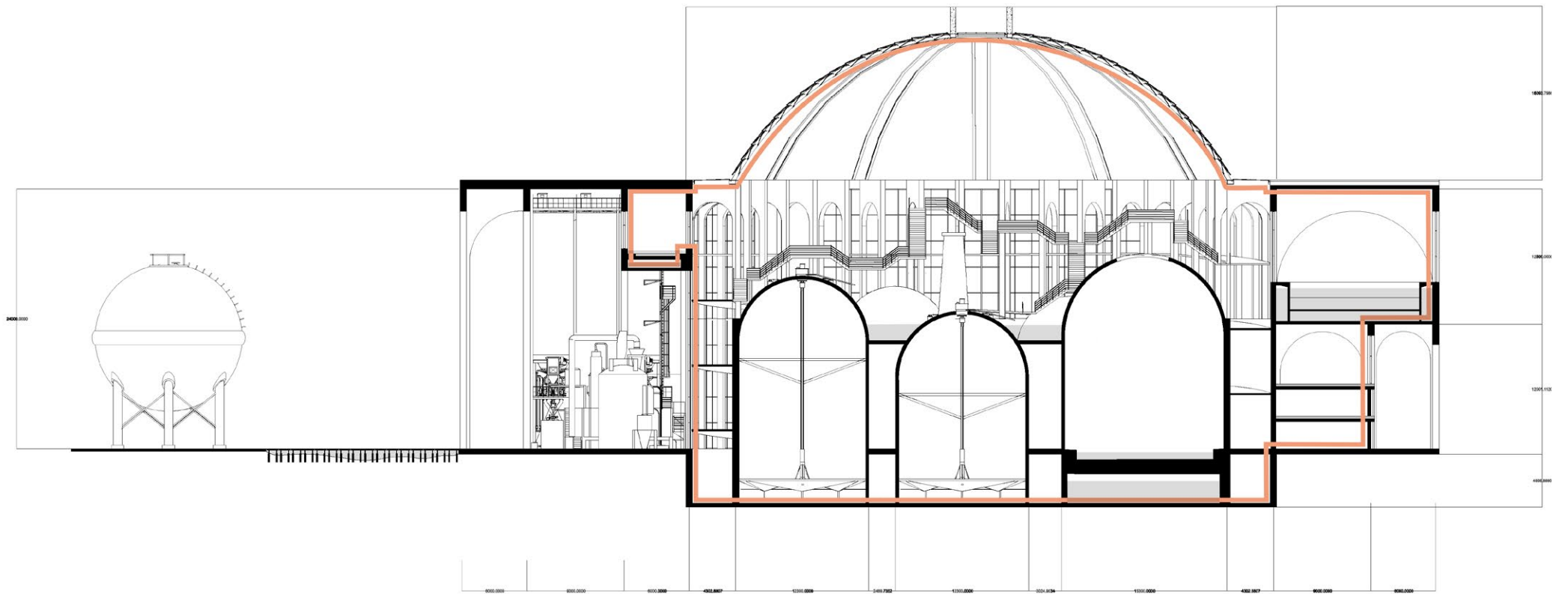

Climate

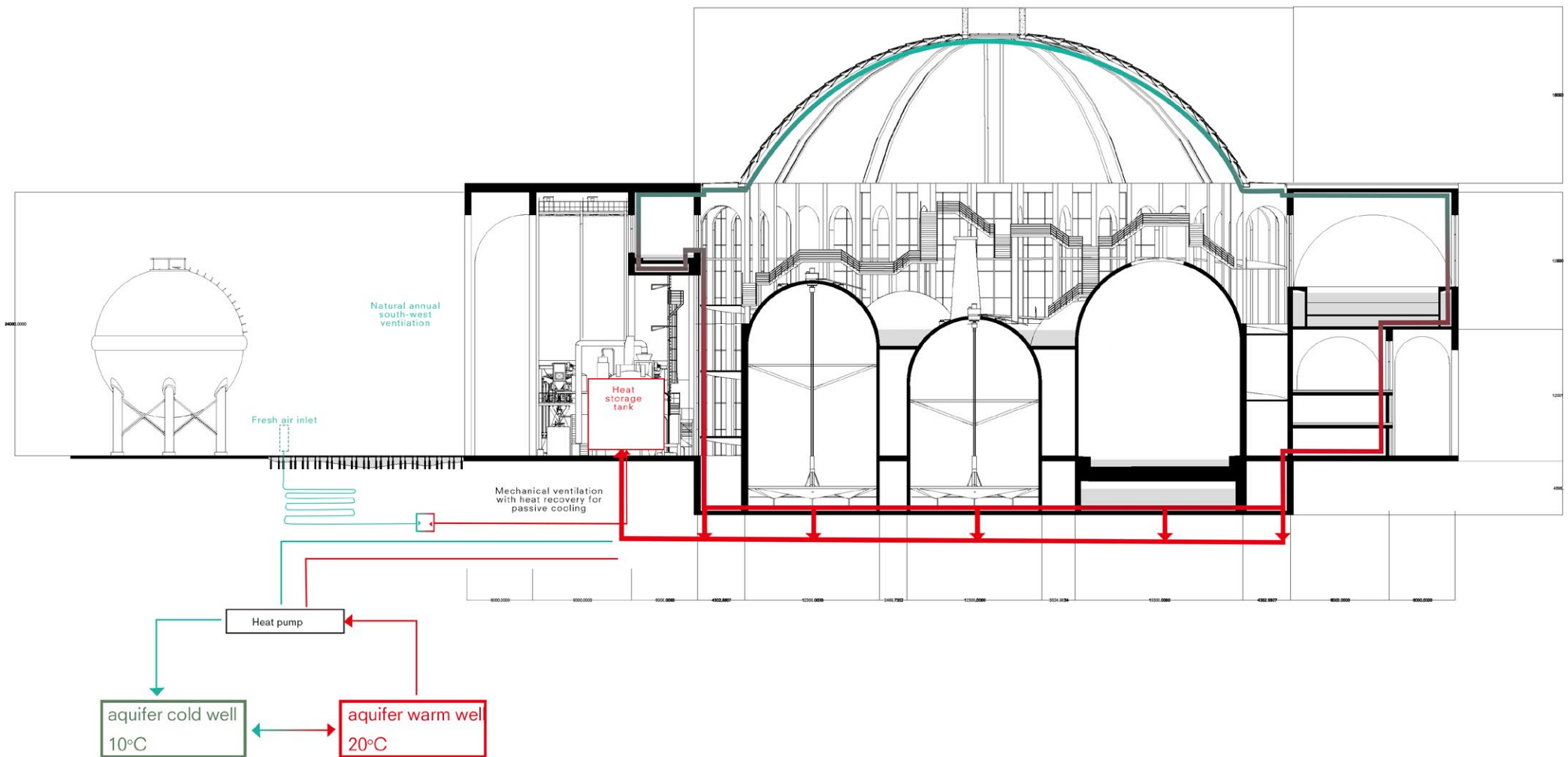

Climate

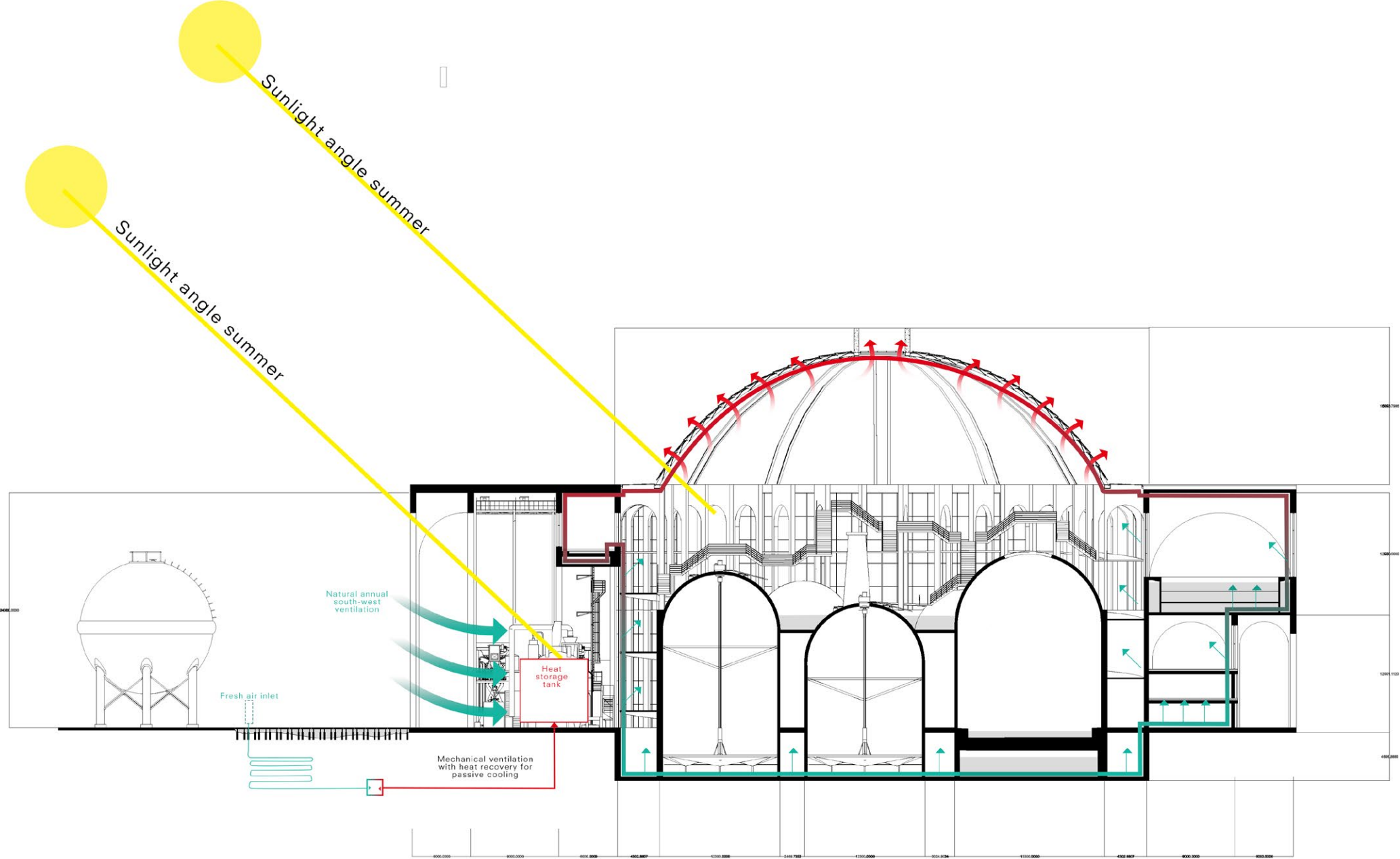

Climate

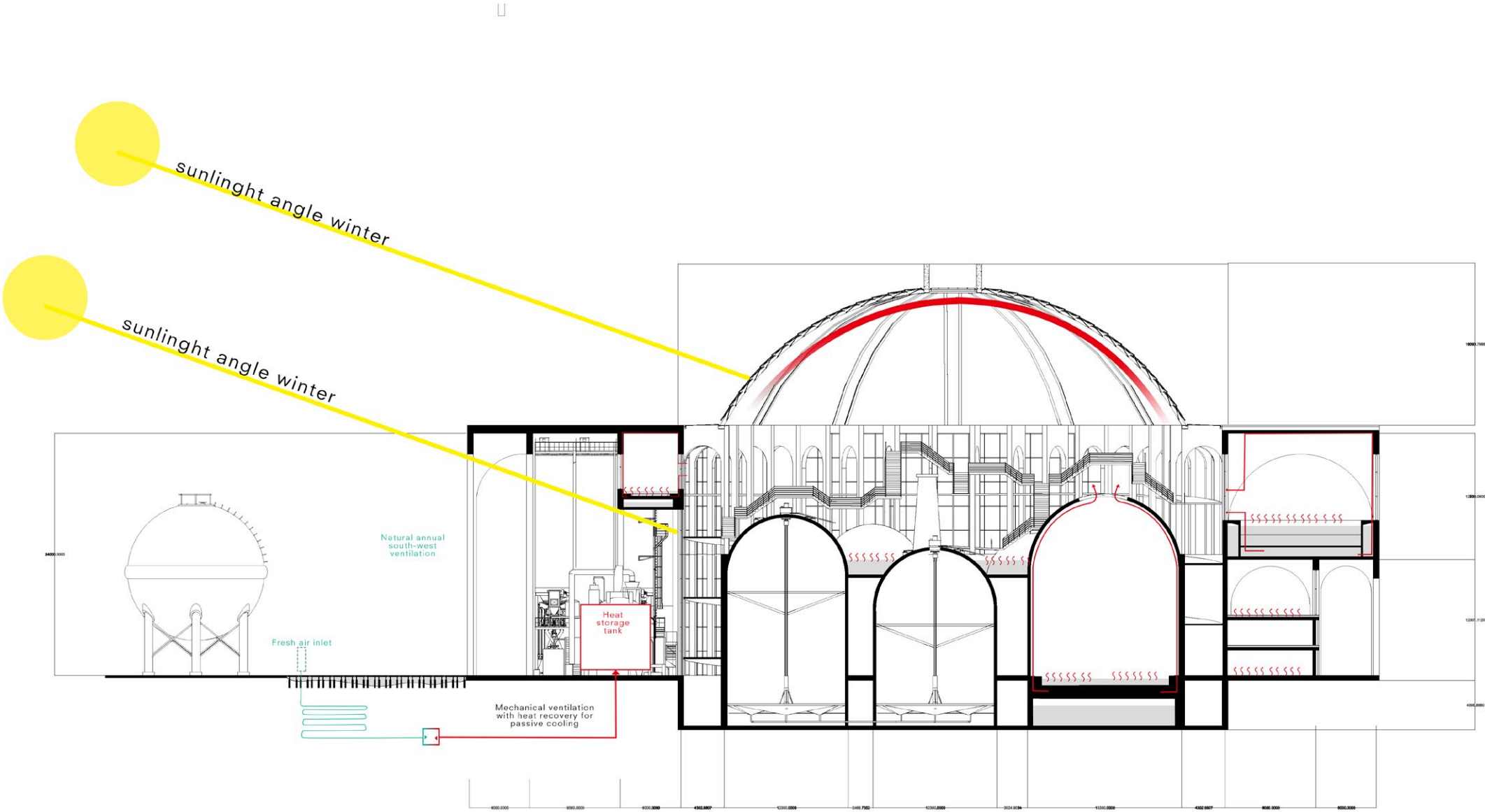

Climate

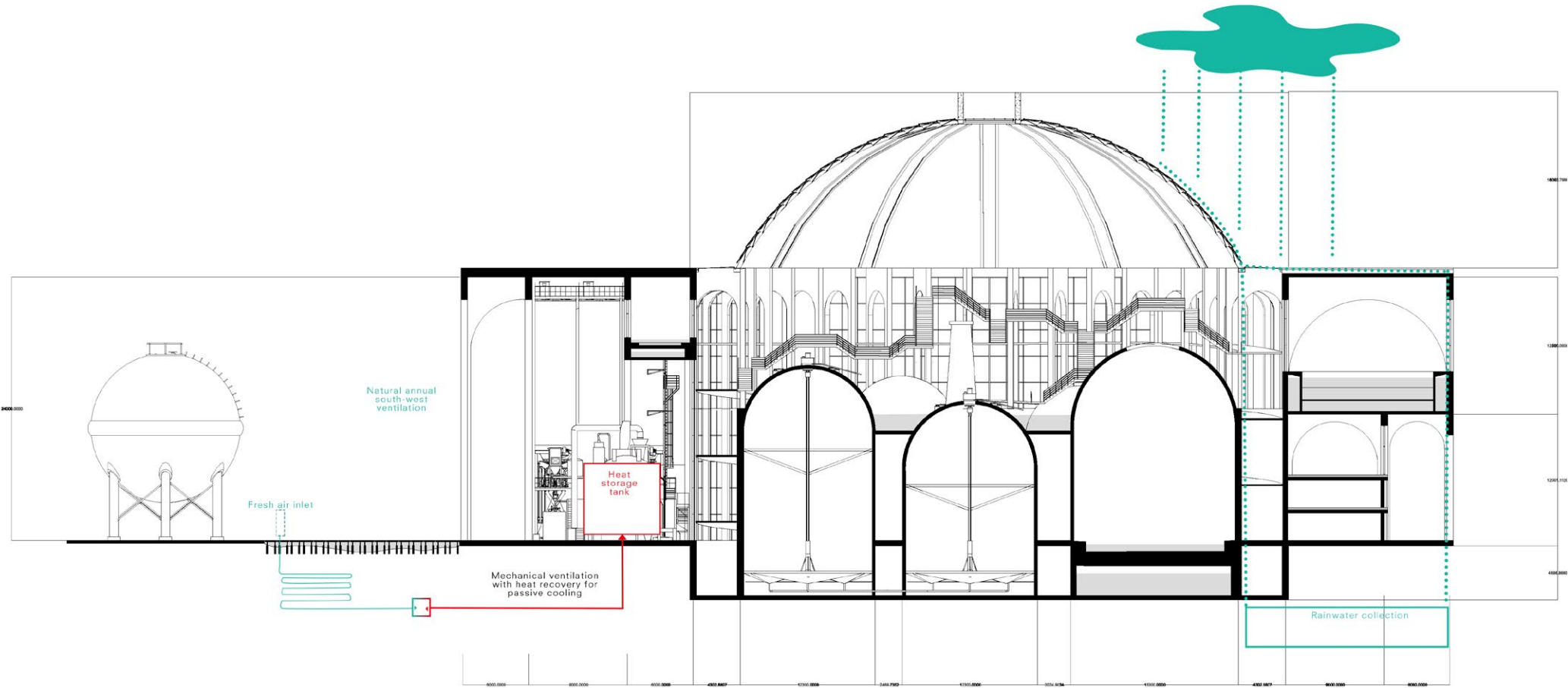

Thank you!

