



TECHNISCHE HOGESCHOOL DELFT
VLIEGTUIGBOUWKUNDE

Report VTH-122

ATTITUDE STABILIZATION AND CONTROL
OF EARTH SATELLITES

by

DR. IR. O. H. GERLACH

Delft - Nederland

March 1965



TECHNISCHE HOGESCHOOL DELFT
VLIEGTUIGBOUWKUNDE

Report VTH-122

ATTITUDE STABILIZATION AND CONTROL
OF EARTH SATELLITES

by

DR. IR. O. H. GERLACH

Delft - Nederland

March 1965

Attitude stabilization and control of earth satellites.

dr.ir. O.H.Gerlach.

Abstract.

In this paper a survey is made of some aspects of satellite attitude stabilization and control. After a brief discussion of the equations of motion governing the satellite's behaviour, the various disturbing torques acting on a satellite in a space environment are considered. Quantitative values for a hypothetical satellite are discussed. Next, attention is given to several methods of attitude stabilization and control. The analysis is based on the various means to exert torques on the satellite for control purposes. Passive methods, such as spin-stabilization and gravity-gradient stabilization, are discussed in some detail. Not only are the basic principles involved indicated, but also some quantitative values of the variables concerned are mentioned where possible.

<u>Contents</u>	page
1. Introduction	1
2. Some mathematical aspects of a satellite's angular motions	2
3. Torques acting on a satellite	5
3.1. Aerodynamic effects	6
3.2. Electromagnetic induction	7
3.3. Solar radiation pressure	9
3.4. Gravity-gradient	10
3.5. Micrometeorites	15
3.6. A comparison of the various torques	15
4. Some methods to stabilize and control a satellite's attitude	16
4.1. Spin-stabilization	18
4.2. Gravity-gradient stabilization	24
4.3. The use of electromagnetic induction for attitude control	30
4.4. Reaction-jets	32
4.5. Flywheels	34
4.6. The yo-yo de-spin device	37
5. Concluding remarks	38
6. Appendix	38
7. References	41

1. Introduction.

For many applications earth satellites are required to maintain a certain prescribed attitude in space during their useful life. For an astronomical satellite for example, this attitude may be invariant with respect to some distant body, such as the sun or a certain star. A satellite intended for weather observation or communication purposes usually will be of the earth-pointing type, one of its axes being constantly directed along the local vertical.

In the first case the required attitude may be considered constant in inertial space, in the second case this certainly does not hold. This difference has a direct bearing on the method of attitude control to be selected.

The accuracy with which the required attitude must be maintained depends on the purpose the satellite has to serve. This accuracy also largely dictates the choice of the method of attitude control.

Some insight in the required levels of accuracy may be gained from the following, see also ref. 4. For investigations concerning the space environment and for weather observations, attitude is to be maintained with an accuracy of approximately $\pm 1^\circ$. The antennae of a communications satellite may require an attitude maintained within $\pm 0,5^\circ$. For astronomical observations a much higher accuracy may be needed, up to 0,1 sec of arc. This actually is the requirement set for the American O.A.O. (Orbiting Astronomical Observatory), the most stringent requirement that has been mentioned thus far.

This report mainly consists of three parts. In the first, some general remarks are made concerning the mathematical foundations upon which the theory of attitude control of satellites is based. The second part deals with the various torques acting on a satellite in space, which may be considered as disturbances or may be utilized to aid in the stabilization of the satellite. In the third part some methods for stabilization and control of the satellite's attitude are discussed.

The developments presented in this report are based largely on the extensive literature covering the field. A few summary papers dealing with the subject are refs. 1 to 7.

2. Some mathematical aspects of a satellite's angular motions.

The attitude of a satellite with respect to inertial space changes only due to rotations of the satellite. It is a permissible approximation to assume that these rotations have no direct influence on the motion of the centre of mass in its orbit around the earth. As a consequence the angular motions of a satellite may for a given orbital motion be studied quite separately from its translatory motions.

The angular motions of a body in space are described by Euler's equations, ref. 8. Assuming the satellite to be a rigid body containing no moving parts, and using the principal axes OXYZ of the satellite, these equations are:

$$\begin{aligned}M_x &= I_x \dot{p} + (I_z - I_y)qr \\M_y &= I_y \dot{q} + (I_x - I_z)rp \\M_z &= I_z \dot{r} + (I_y - I_x)pq\end{aligned}\tag{2-1}$$

where M_x , M_y and M_z are components of the external moment acting on the satellite, Figure 1. I_x , I_y and I_z are the principal moments of inertia

$$\begin{aligned}I_x &= (y^2 + z^2)dm \\I_y &= (z^2 + x^2)dm \\I_z &= (x^2 + y^2)dm\end{aligned}$$

and p, q and r are the components of the angular velocity relative to inertial space, about the X-, Y- and Z-axes respectively.

The satellite's attitude may be described in several ways. In this paper the attitude will be indicated by the angle of yaw ψ , the angle of pitch θ and the angle of roll ϕ , between the satellite's OXYZ-axes and a set of reference axes. These three angles are obtained

by rotating the satellite axes from an attitude coinciding with the reference axes to the desired attitude in the following way, Figure 2.

1. allow a rotation ψ about the Z-axis,
2. about the newly displaced Y-axis, rotate through θ ,
3. finally allow a rotation ϕ about the final position of the X-axis.

The magnitudes of the three angles obtained in this manner, depend for large angles on the particular sequence of rotations chosen. For small angles, however, this sequence is of no importance.

The angles ψ , θ and ϕ are the same as used in stability studies of aircraft. Although they often are referred to as Euler angles, they differ from the classical Euler angles in that only one rotation takes place about each axis, whereas in the classical Euler angular coordinates, two rotations are made about the Z-axis.

In the following sections two right-handed sets of reference axes will be used both having their origin in the centre of mass of the satellite.

1. Inertial or space-fixed axes,
2. Orbit-plane axes, with a fixed orientation relative to the motion of the satellite's centre of mass in a circular orbit, Figure 3. The X_o -axis coincides with the velocity vector of the centre of mass, the Y_o -axis is perpendicular to the orbit-plane, the Z_o -axis is directed towards the centre of the earth.

It may be seen that the orbit-plane axes rotate in space with a fixed angular velocity ω_o about the Y_o -axis.

The relations between the angular velocities p , q , r of the satellite about its own principal axes and the rates of change of ψ , θ and ϕ are somewhat different for the two sets of reference axes. It is shown in the Appendix that these relations are as follows.

1. Inertial reference axes.

$$\dot{\phi} = p + (q \sin \varphi + r \cos \varphi) \operatorname{tg} \theta$$

$$\dot{\theta} = q \cos \varphi - r \sin \varphi$$

$$\dot{\psi} = (q \cos \varphi + r \sin \varphi) \cdot \frac{1}{\cos \theta}$$

or

$$p = \dot{\phi} - \dot{\psi} \sin \theta$$

$$q = \dot{\theta} \cos \varphi + \dot{\psi} \cos \theta \sin \varphi$$

$$r = -\dot{\theta} \sin \varphi + \dot{\psi} \cos \theta \cos \varphi$$

For small angles θ and φ , these formulae are reduced to:

$$\dot{\phi} = p + r\theta \qquad p = \dot{\phi} - \dot{\psi}\theta$$

$$\dot{\theta} = q - r\varphi \qquad \text{or} \qquad q = \dot{\theta} + \dot{\psi}\varphi$$

$$\dot{\psi} = q\varphi + r \qquad r = -\dot{\theta}\varphi + \dot{\psi}$$

2. Orbit-plane reference axes.

$$\dot{\phi} = p + (q \sin \varphi + r \cos \varphi) \operatorname{tg} \theta + \omega_0 \frac{\sin \psi}{\cos \theta}$$

$$\dot{\theta} = q \cos \varphi - r \sin \varphi + \omega_0 \cos \psi$$

$$\dot{\psi} = (q \sin \varphi + r \cos \varphi) \cdot \frac{1}{\cos \theta} + \omega_0 \sin \psi \operatorname{tg} \theta$$

or

$$p = \dot{\phi} - \dot{\psi} \sin \theta - \omega_0 \sin \psi \cos \theta$$

$$q = \dot{\theta} \cos \varphi + \dot{\psi} \cos \theta \sin \varphi - \omega_0 (\cos \psi \cos \varphi + \sin \psi \sin \theta \sin \varphi)$$

$$r = -\dot{\theta} \sin \varphi + \dot{\psi} \cos \theta \cos \varphi - \omega_0 (-\cos \psi \sin \varphi + \sin \psi \sin \theta \cos \varphi)$$

For small angles ψ , θ and ϕ these formulae are reduced to:

$$\begin{aligned}
 \dot{\phi} &= p + r\theta + \omega_0 \psi & p &= \dot{\phi} - \dot{\psi}\theta - \omega_0 \psi \\
 \dot{\theta} &= q - r\phi + \omega_0 & q &= \dot{\theta} + \dot{\psi}\phi - \omega_0 \\
 \dot{\psi} &= q\phi + r & r &= -\dot{\theta}\phi + \dot{\psi} + \omega_0\phi
 \end{aligned}
 \tag{2-2}$$

Considering the angular motions as described by Euler's equations (2-1), it will be clear that the attitude of the satellite at a certain time t entirely depends on:

1. The attitude (ψ , θ , ϕ) and angular velocities (p , q , r) at some earlier time $t_0 = 0$, for instance at the moment of injection into orbit,
2. the magnitude of the torques (M_x , M_y , M_z) during the time interval between t_0 and t .

These torques are the subject of the following section.

3. Torques acting on a satellite.

If no torques were acting on the satellite, the pattern of rotations existing initially would be maintained indefinitely. Experience has shown, however, that in space several different types of torques may be present. They can alter the satellite's rotations considerably. The principal causes for these torques are:

1. aerodynamic effects,
2. electromagnetic induction,
3. solar radiation pressure,
4. gravity gradient,
5. micrometeorities.

The torques caused by these effects will be discussed in the following paragraphs.

3.1. Aerodynamic effects.

The aerodynamic force acting on a body can be expressed by the formula:

$$F_a = C_D \cdot \frac{1}{2} \rho V^2 \cdot A$$

where C_D is a dimensionless dragcoefficient, having a magnitude of approximately 2 or slightly larger for a flat plate, $\frac{1}{2} \rho V^2$ is the dynamic pressure and A is the frontal area.

In a circular orbit the dynamic pressure has a value depending only on altitude, as shown in Table 1, based on data from ref. 8.

Table 1

Dynamic pressure in a circular orbit as a function of altitude.

Altitude km	Dynamic pressure dyne/cm ²	
	day	night
0	3,82.10 ¹¹	3,82.10 ¹¹
100	4,09.10 ²	4,09.10 ²
200	2,57.10 ⁻¹	2,47.10 ⁻¹
500	2,89.10 ⁻³	6,23.10 ⁻⁴
1000	2,39.10 ⁻⁵	4,00.10 ⁻⁷

A relatively simple calculation of C_D is possible if:

- a. the mean free path of the air molecules is much greater than the size of the satellite,
- b. the mean free stream molecular speed is much smaller than the satellite's speed.

Using free-molecule flow theory, refs. 6, 8, C_D can be calculated with an accuracy sufficient for many purposes.

Once the magnitude of the aerodynamic force and its centre of pressure are known, the resulting moment about the satellite's centre of mass can easily be found.

From the above table it will be clear that the aerodynamic torque rapidly decreases as the altitude above the earth's surface increases. Roughly speaking, aerodynamic torques are of importance for altitudes up to about 800 km, whereas they may be used for stabilization purposes at altitudes up to about 500 km.

The aerodynamic torque depends only on the attitude of the satellite relative to the direction of motion, and not on its angular velocities. It provides, therefore, no damping of the angular motions. If the aerodynamic torque is to be used for stabilization of the satellite, the required damping has to be obtained from a different source.

In ref. 10 several torques acting on a hypothetical satellite, pictured in Figure 4, have been calculated. In the determination of the aerodynamic torque, use was made of the free-molecule flow theory mentioned above. Furthermore the assumption was made that the centre of mass of the satellite is situated at a distance of 30,5 cm from the geometric centre, which is also the centre of pressure. In the present paper the range of altitudes considered was slightly extended. Figure 5 presents the results. As the size of the satellite is relatively large, the aerodynamic torque also is somewhat larger than the aerodynamic torque acting on many other satellites at the same altitudes.

3.2. Electromagnetic induction.

The magnetic field of the earth can induce torques on the satellite, if there is a magnetic field present in the satellite itself. The latter field may have different origins:

- a. permanent magnetism in the satellite,
- b. eddy currents, induced in a rotating satellite or in rotating parts of the satellite,
- c. a current flowing through a coil in the satellite, often with the sole purpose of producing a controllable torque on the satellite.

At altitudes of practical interest, i.e. greater than about 150 km, the earth's magnetic field can be approximated with sufficient accuracy by the field of a dipole at the earth's center. The axis of the dipole makes an angle of 18° with the earth's spin axis, Figure 6.

The earth's magnetic field intensity \vec{H} can be expressed in oersted by the formulae:

$$H_{\text{axial}} = 0,308 \cdot \frac{1-3 \cos^2 \delta}{(r/r_e)^3}$$

$$H_{\text{normal}} = 0,461 \cdot \frac{\sin 2 \delta}{(r/r_e)^3}$$

where H_{axial} and H_{normal} are the components of field intensity parallel and normal to the axis of the dipole. The meaning of δ , r and r_e follows from Figure 6.

The three possibilities to induce a magnetic torque, will not all be discussed here, only the case of a current-carrying coil in the satellite will be considered, ref. 5. The other two have been dealt with in ref. 11.

Suppose a coil is given with n windings, carrying a current of i ampères. The area enclosed by the windings is $S \text{ cm}^2$. The coil is placed in a magnetic field, the flux density of which is \vec{B} gauss. The flux density is related to the field intensity by:

$$\vec{B} = \mu \cdot \vec{H}$$

In vacuum $\mu = 1$ gauss/oersted.

If the plane of the windings is parallel to \vec{B} , the torque acting on the coil is:

$$M = \frac{S}{10} \cdot i \cdot n \cdot B \text{ dynecm}$$

As a numerical example, the satellite shown in Figure 4 is

considered, see ref. 10. The magnetic torque, produced by a current of 1 ampère in a coil consisting of only one winding around the largest cross-section of the satellite has been computed. Figure 5 presents the result as a function of altitude. The maximum torque at the magnetic poles is twice as large as it is at the magnetic equator. If the diameter of the wire used in the coil is 0,68 mm, the required electrical power is just 1 watt, while the mass of the wire is 72 grams.

Torques at the levels referred to in the above computation - up to about 10^4 dynecm - can be very useful in controlling the attitude of the satellite. They can of course be increased with relative ease, using a larger number of ampère-turns in the coil.

The usefulness of the earth's magnetic field is somewhat limited by the fact that no torque can be generated about an axis parallel to the local magnetic field. Moreover the torques that can be produced at great altitudes, for instance in a synchronous satellite at approximately 36000 km, are small. It follows from the formulae for the magnetic field intensity that the torque is proportional to $\frac{1}{r^3}$. At 36000 km altitude, the torque has only $1/300$ th of its value near the earth's surface.

Inducing magnetic torques by means of eddy currents, as mentioned above, offers a very attractive possibility to damp the angular motions of the satellite, refs. 11, 12. On the other hand for spin-stabilized earth satellites it may be desirable to compensate the torque produced by eddy currents, in order to eliminate the decay of the satellite's spin rate, ref. 13.

3.3. Solar radiation pressure.

In the vicinity of the earth, the radiation emitted by the sun amounts to $1,94 \text{ cal/cm}^2/\text{min}$ on a surface perpendicular to the direction of the radiation. This radiation exerts a small force F_r on the surface, expressed by:

$$F_r = p_o (1 + R).A \quad \text{dynes}$$

where A is the area in cm^2 and the constant p_o equals $4,3 \times 10^{-5} \text{ dynes/cm}^2$.

R is a coefficient of reflection. A surface providing complete absorption has a value $R = 0$, while for a perfect reflector R equals 1. A transparent surface has a value of R between 0 and -1. If the radiation strikes the surface at an angle α with the normal to the surface, the force - in the case of perfect reflection - is proportional to $\cos^2 \alpha$. The moment of F_r about the centre of mass follows at once when the centre of pressure has been found, refs. 6, 14 to 18.

For earth satellites the torque due to solar radiation may be relatively small if compared to other torques. But the radiation torque is very nearly independent of the satellite's altitude, in contrast to the other torques. At great altitudes - for instance at synchronous altitude - radiation pressure may provide the dominating contribution to the total torque acting on the satellite. By proper design, solar radiation pressure may be used for attitude stabilization, even at the relatively low altitude of 500 km, as has been shown in ref. 14. For extraterrestrial missions of long duration, solar radiation pressure promises to be a highly useful source of control torques, ref. 18. On the other hand, by giving the satellite a symmetrical shape relative to its centre of mass, the radiation torque can be kept at a very low value.

Subject of a numerical example is once more the satellite discussed in ref. 10, see Figure 5. The centre of mass of the satellite is again assumed to lie 30,5 cm from the geometric centre. It turns out that at altitudes below 2000 km the torque due to radiation pressure is 20 times as small on the average as the magnetic torque discussed earlier. At synchronous altitude, however, the radiation torque in this example would be 15 times as great as the magnetic torque.

3.4. Gravity-gradient.

The next torque to be discussed is caused by the fact that the earth's gravity field is not exactly equal at all mass elements of the satellite. An expression for the gravity torque thus developed can be derived as follows, ref. 11.

Suppose the satellite's centre of mass is at a distance \vec{r}_0 from the earth's centre of mass, whereas a mass element dm of the satellite

is at a distance \vec{r} from the earth's centre and at $\vec{\rho}$ from the corresponding satellite's centre. Then, see also Figure 7:

$$\vec{r} = \vec{r}_0 + \vec{\rho}$$

\vec{r}_0 is directed along the negative Z_0 -axis of the orbital-plane system of reference axes, introduced in section 2. If \vec{i} , \vec{j} and \vec{k} are unit vectors along the satellite's principal axes and the angles ψ , θ and φ indicate the satellite's attitude with respect to the orbital-plane axes, the components of \vec{r}_0 along the satellite's axes are:

$$\vec{r}_0 = r_0 (\vec{i} \cdot \sin \theta - \vec{j} \cdot \cos \theta \sin \varphi - \vec{k} \cdot \cos \theta \cos \varphi)$$

The components of $\vec{\rho}$ are:

$$\vec{\rho} = \vec{i} \cdot x + \vec{j} \cdot y + \vec{k} \cdot z$$

The force of gravity exerted on dm by the (spherical) earth is directed along r :

$$\vec{dF} = - \frac{\gamma m_e \cdot dm}{r^3} \cdot \vec{r}$$

and the moment of \vec{dF} about the satellite's centre of mass is:

$$\vec{dM} = - \vec{\rho} \times \frac{\gamma m_e \cdot dm}{r^3} \cdot \vec{r}$$

where \times indicates the vector product.

$$\begin{aligned} \vec{dM} &= - \frac{\gamma m_e \cdot dm}{r^3} \cdot \vec{\rho} \times (\vec{r}_0 + \vec{\rho}) \\ &= - \frac{\gamma m_e \cdot dm}{r^3} \cdot \vec{\rho} \times \vec{r}_0 \end{aligned}$$

The scalar r^{-3} can be expressed as follows:

$$\begin{aligned}
 r^2 &= (\vec{r}_o + \vec{\rho}) \cdot (\vec{r}_o + \vec{\rho}) \\
 &= r_o^2 + \rho^2 + 2 \vec{r}_o \cdot \vec{\rho} \\
 &= r_o^2 \left\{ 1 + \left(\frac{\rho}{r_o}\right)^2 + \frac{2 \vec{r}_o \cdot \vec{\rho}}{r_o^2} \right\} \\
 \frac{1}{r^3} &= \frac{1}{r_o^3} \left\{ 1 + \left(\frac{\rho}{r_o}\right)^2 + \frac{2 \vec{r}_o \cdot \vec{\rho}}{r_o^2} \right\}^{-3/2}
 \end{aligned}$$

The second-order term $\left(\frac{\rho}{r_o}\right)^2$ may be neglected and the remaining terms may be expanded in a series. Omitting higher-order terms, the result is:

$$\frac{1}{r^3} = \frac{1}{r_o^3} \left(1 - 3 \frac{\vec{r}_o \cdot \vec{\rho}}{r_o^2} \right)$$

Substituting in dM and integrating over the entire mass of the satellite yields:

$$\vec{M} = - \frac{\gamma m_e}{r_o^3} \int \left(1 - 3 \frac{\vec{r}_o \cdot \vec{\rho}}{r_o^2} \right) \cdot (\vec{\rho} \times \vec{r}_o) dm$$

Because of the choice of the origin of the satellite's system of axes, $\int \rho \, dm = 0$, therefore:

$$\begin{aligned}
 \vec{M} &= \frac{3\gamma m_e}{r_o^3} \int \frac{\vec{r}_o \cdot \vec{\rho}}{r_o^2} (\vec{\rho} \times \vec{r}_o) dm \\
 &= \vec{i} \cdot M_x + \vec{j} \cdot M_y + \vec{k} \cdot M_z
 \end{aligned}$$

Since:

$$\vec{r}_o \cdot \vec{\rho} = r_o (x \sin \theta - y \cos \theta \sin \varphi - z \cos \theta \cos \varphi)$$

and

$$\begin{aligned}
 \vec{\rho} \times \vec{r}_o &= r_o \left\{ \vec{i} (-y \cos \theta \cos \varphi + z \cos \theta \sin \varphi) + \vec{j} (z \sin \theta + x \cos \theta \cos \varphi) \right. \\
 &\quad \left. + \vec{k} (-x \cos \theta \sin \varphi - y \sin \theta) \right\}
 \end{aligned}$$

the resulting components of M are found to be:

$$M_x = \frac{3}{2} \omega_o^2 (I_z - I_y) \sin 2\phi \cdot \cos^2 \theta \quad (3-1a)$$

$$M_y = \frac{3}{2} \omega_o^2 (I_z - I_x) \sin 2\theta \cdot \cos \phi \quad (3-1b)$$

$$M_z = \frac{3}{2} \omega_o^2 (I_x - I_y) \sin 2\theta \cdot \sin \phi \quad (3-1c)$$

where:

$$\omega_o = \sqrt{\frac{\gamma m_e}{r_o^3}}$$

is the angular rate of the orbit radius for circular orbits.

From these expressions it may be seen that the gravitational torque vanishes if θ and ϕ are 0 or 90°. To simplify these expressions it will be assumed that $\phi = 0$. Then:

$$M_x = 0$$

$$M_y = \frac{3}{2} \omega_o^2 (I_z - I_x) \sin 2\theta$$

$$M_z = 0$$

The two possible equilibrium attitudes are shown in Figure 8, for a satellite for which I_x is greater than I_z .

An important difference between the two attitudes exists. The equilibrium must be stable. This simply means that a small increase in θ must give rise to a restoring torque, so the condition for (static) stability is:

$$\frac{dM_y}{d\theta} < 0$$

Since

$$\frac{dM_y}{d\theta} = 3 \omega_o^2 (I_z - I_x) \cos 2\theta$$

$\frac{dM_y}{d\theta}$ is negative for $I_x > I_z$ if $\theta = 0^\circ$ and positive if $\theta = 90^\circ$. Evidently the stable attitude is the one in which the axis with the smaller moment

of inertia is vertical.

In order to maintain this equilibrium attitude, the satellite is in a continuous rotation about its Y-axis, with angular velocity ω_o . This rotation somewhat complicates the stability about the X- and Z-axes. It will be shown in section 4, however, that for complete stability the moment of inertia about the Y-axis must be the greatest of the three. The requirement for stability as regards gravity torque then appears to be:

$$I_z < I_x < I_y$$

Further consideration of the gravity torque shows the following. The maximum torque is obtained for $\theta = 45^\circ$. The satellite's weight is:

$$W = \frac{\gamma m_e m}{r_o^2}$$

The moments of inertia can be expressed in the radii of gyration:

$$I_x = m.k_x^2$$

$$I_z = m.k_z^2$$

The maximum value of M_y is, therefore:

$$M_{y_{\max}} = \frac{3}{2} \cdot W \cdot \frac{k_z^2 - k_x^2}{r_o}$$

This moment can be thought to be caused by the weight of the satellite, acting at a horizontal distance c from the centre of mass:

$$c = \frac{3}{2} \cdot \frac{k_z^2 - k_x^2}{r_o}$$

A numerical example may illustrate the foregoing. Use is made again of the satellite shown in Figure 4. The moments of inertia are given in ref. 10 as:

$$I_x = I_y = 1,28 \times 10^{11} \text{ gcm}^2$$

$$I_z = 4,08 \times 10^9 \text{ gcm}^2$$

Figure 5 presents the gravity torque developed at $\theta = 1^\circ$ as a function of altitude.

For a determination of the maximum value of the gravity torque, an estimate had to be made of the satellite's mass. Supposing a uniform mass distribution in cross sections perpendicular to the Z-axis, the mass was estimated at $m = 1430 \text{ kg}$. This leads to a value of $c = 2.10^{-3} \text{ cm}$ at an altitude of 185 km. The gravity torque is then ($\theta = 45^\circ$):

$$M_{y_{\max}} = -2,64.10^5 \text{ dyne cm.}$$

Gravity torque can very well be used to stabilize a satellite in a given attitude relative to the earth. This will be studied further in section 4. The torque is, however, like the magnetic torque proportional to $1/r^3$. If the torque due to solar radiation pressure can be kept sufficiently small, it appears possible to use gravity torque for stabilization purposes also at great altitudes. Application even for a 24-hour satellite at 36000 km has been considered, ref. 19.

3.5. Micrometeorites.

To complete the picture of the torques acting on a satellite, mention must be made of the torque generated by micrometeorites or cosmic dust. This torque has been estimated to be so small, however, see Figure 5 and ref. 20, as to warrant no further discussion.

3.6. A comparison of the various torques.

At the end of this section it is possible from Figure 5 to draw a conclusion as regards the relative magnitudes of the various torques, at least for the hypothetical satellite used as an example in the previous paragraphs.

It may be seen, that the aerodynamic torque dominates at altitudes less than about 500 km. If only one ampère-turn is used to generate the

magnetic torque, this torque will have at all altitudes nearly the same magnitude as the gravity torque produced by a deviation of 1° from the vertical attitude. Using more electrical power, however, the magnetic torque can be made much greater.

Above an altitude of approximately 1000 km the aerodynamic torque is smaller than the torque due to solar radiation pressure and at an altitude of 2000 to 3000 km the aerodynamic torque has even become as small as the torque due to the collision with micrometeorites.

If the altitude is greater than 1000 km, only three torques remain of importance: those due to gravity-gradient, magnetic induction and solar radiation pressure, the latter initially being smaller than the other two. At about 10000 km all three torques have become equally important and at even greater altitudes the radiation torque dominates. It should be kept in mind that these conclusions hold true only for the configuration considered as an example.

For an earth satellite intended to remain in a fixed attitude relative to the earth, radiation torque contains a periodic component, unless the direction of radiation is exactly normal to the orbit-plane. Radiation torque, therefore, generally excites the satellite periodically about the axis normal to the orbit-plane. This may lead to intolerably large attitude-deviations, even if the exciting radiation torque is smaller than the stabilizing gravity torque.

With the exception of the magnetic torque it can generally be said that all torques acting on the satellite are smaller, if the satellite has a more nearly spherical shape. A slender shape generally tends to increase the torques.

4. Some methods to stabilize and control a satellite's attitude.

In this section some methods to stabilize and control a satellite's attitude will be discussed. Because of the great variety of methods involved, no attempt has been made to be complete.

Several ways can be followed to describe the different control methods used in the past or contemplated for future use. A division according to the reference-system with respect to which the satellite's

attitude must be constant, has been mentioned already in the Introduction.

Another useful manner to describe the various methods, distinguishes between passive and active control methods. The characteristic difference is, that passive methods - such as spin-stabilization and gravity-gradient stabilization - require no energy from the satellite, whereas systems based on active control methods have to be supplied with some kind of energy from the satellite. Hybrid systems also exist, however, see paragraph 4.2.

It can generally be said, that an attitude-stabilized satellite poses no new problems as regards control theory, ref. 21. Systems based on active control methods usually are error-actuated feedback control systems. Certain complications may exist in the analysis of such a system, because of the coupling between the motions about several axes, refs. 22, 23. The main problems, however, arise in the design of the physical elements of the control system, which must work properly and reliably under severe environmental conditions.

Control systems as employed for active control in a satellite show the usual elements: sensors, computers and actuators. In this report only some types of actuators will be considered. For a discussion of the various types of sensors and computers as used in satellites reference is made to the literature, see for instance refs 1, 5, 24, 25.

The following subjects will be studied in some detail.

1. Spin-stabilization.
2. Gravity-gradient stabilization.
3. The use of electromagnetic induction for attitude control.
4. Reaction-jets.
5. Flywheels.
6. The yo-yo de-spin device.

In order to provide some idea of the accuracies to be obtained by various methods of control the following Table is given, see refs. 7 and 4.

Table 2

Stabilization accuracies and reliabilities

	Pointing accuracy	Relative reliability ¹⁾
Gravity-stabilization (no damping)	$> \pm 6^\circ$	1 most reliable
Spin-stabilization (no damping)	$\leq \pm 1^\circ$ or less	2
Spin-stabilization (with damping)	$\leq \pm 1^\circ$	3
Gravity-stabilization (with damping)	$\leq \pm 1^\circ$	4
Horizon and area scanning	$\leq \pm 1^\circ$	5
Sun, moon, star tracking	$\pm 1^\circ$ to $\pm 1'$	5

1) Indicates only orders of magnitude and ignores system optimization.

4.1. Spin-stabilization.

A relatively simple method to place one axis of a satellite in a fixed attitude in space is based on the properties of a rotating body. If the satellite has a an angular velocity about one of it's principal axes, this axis will maintain its attitude in space in the absence of disturbing torques.

As has been discussed before, several torques may act on the satellite, tending to interfere with the rotation. The resulting motion is governed in the first place by the question whether the torque-free motion is stable. This subject will now be studied. The satellite is supposed to be a rigid body containing no internal moving parts.

If no external torques act on the satellite, the Euler's equations (2-1) can be written as:

$$I_x \dot{p} = (I_y - I_z)qr$$

$$I_y \dot{q} = (I_z - I_x)rp$$

$$I_z \dot{r} = (I_x - I_y)pq$$

It follows, that p is constant ($\dot{p} = 0$) if $q = r = 0$. Also q is constant if $r = p = 0$ and r is constant if $p = q = 0$. This means that a steady rotation is possible about each of the satellite's principal axes. The stability of these steady motions will become clear from the following.

Suppose the satellite initially possesses an angular velocity p_0 about the X-axis. Due to a disturbance it acquires small additional velocities about each of the three axes, Figure 9. Then:

$$p = p_0 + dp$$

$$q = dq$$

$$r = dr$$

Neglecting products of small quantities in the equations of motion, these equations now become:

$$I_x \dot{p} = 0$$

$$I_y \dot{q} = (I_z - I_x)p_0 \cdot r$$

$$I_z \dot{r} = (I_x - I_y)p_0 \cdot q$$

From the first of these equations follows:

$$p = \text{constant}$$

The angular velocity about the axis of initial rotation has no tendency to increase any further, but neither will it return to its original value.

The two remaining equations can be combined:

$$\ddot{q} + \omega^2 q = 0$$

and:

$$\ddot{r} + \omega^2 r = 0$$

where:

$$\omega^2 = p_0^2 \cdot \frac{I_z - I_x}{I_z} \cdot \frac{I_y - I_x}{I_y}$$

If ω^2 is positive, the two above differential equations possess the following periodic solutions:

$$q = q(0) \cdot \cos \omega t + \frac{\dot{q}(0)}{\omega} \cdot \sin \omega t$$

$$r = r(0) \cdot \cos \omega t + \frac{\dot{r}(0)}{\omega} \cdot \sin \omega t$$

which express undamped oscillations. After a disturbance, q and r vary harmonically but they do not grow beyond all bounds, so that original steady motion may be termed stable.

If ω^2 is negative, the resulting motion after a small disturbance consists of two aperiodic parts: a damped, converging motion and an undamped, diverging motion. This implies that the original steady motion is unstable if ω^2 is negative.

The stability condition $\omega^2 > 0$ is satisfied if:

$$\frac{I_z - I_x}{I_z} \cdot \frac{I_y - I_x}{I_y} > 0$$

or:

a. $I_x > I_y$ and $I_x > I_z$

In this case I_x is the greatest moment of inertia

b. $I_x < I_y$ and $I_x < I_z$

Now I_x is the smallest moment of inertia.

The result of this simple analysis is, that for stability the moment of inertia about the axis of initial rotation must be either the smallest or the largest of the three. These two possibilities are shown in Figure 10.

A further investigation shows, however, that the conclusion reached so far has to be modified somewhat, if the satellite is not perfectly rigid and consequently can dissipate some energy internally. Then, the

only stable rotation possible is about the axis of the greatest moment of inertia (Figure 10a). This will be demonstrated for the usual case where the satellite is symmetrical about the axis of rotation ref. 8. If this axis is the X-axis, $I_y = I_z$.

The magnitude of the satellite's angular momentum is:

$$B = \sqrt{I_x^2 \cdot p^2 + I_y^2 (q^2 + r^2)}$$

If no torque is acting on the satellite, the angular momentum does not change its magnitude nor its direction in space.

Due to the rotation, the satellite has a kinetic energy E:

$$E = \frac{1}{2} \left\{ I_x p^2 + I_y (q^2 + r^2) \right\}$$

Combining the expressions for B and E yields:

$$B^2 - 2E I_y = (I_x^2 - I_x I_y) p^2$$

If the satellite rotates not only about the X-axis but also about the Y- and Z-axes, the X-axis does not coincide with the angular momentum vector \vec{B} , Figure 11.

From this Figure it follows that:

$$I_x p = B \cos \beta$$

Due to the initial disturbance, β differs from zero. If the original motion is stable, however, β will return to zero. This means that the condition for stability can be expressed as: $\dot{\beta} < 0$. Whether this condition is satisfied can be seen as follows.

The expression (4-1) can now be written as:

$$B^2 - 2E I_y = B^2 \cos^2 \beta \left(1 - \frac{I_y}{I_x} \right)$$

Whereas B is constant, E may decrease due to internal dissipation of energy, caused for instance by hysteresis in the deforming material of

the satellite. Differentiating the above expression results in:

$$\dot{E} = B^2 \cos \beta \sin \beta \frac{I_x - I_y}{I_x \cdot I_y} \cdot \dot{\beta}$$

As \dot{E} can only be negative, $\dot{\beta}$ is positive if $I_x < I_y$ and $\dot{\beta}$ is negative if $I_x > I_y$. For stability, i.e. $\dot{\beta} < 0$, the required condition is $I_x > I_y$. This means that stability of a rotating satellite, able to dissipate its kinetic energy, occurs only if the axis of rotation has the largest moment of inertia.

The foregoing implies that for the stable case any small angle between the satellite's principal axis and the angular momentum vector existing initially, will gradually disappear. This is, of course, a very desirable characteristic.

In the unstable case, the rotation starts about the axis of the smallest moment of inertia. Now the angle β between the satellite's principal axis and the angular momentum vector will increase after any infinitesimal small disturbance, until the satellite no longer rotates about the initial axis, but about an axis normal to it, β then has become 90° . This phenomenon has occurred with the Explorer I, a satellite spin-stabilized about its axis with the smallest moment of inertia. The flexible antennae of the satellite dissipated some energy through hysteresis in the material. This was sufficient to cause divergence of the entire satellite's rotation.

The foregoing conclusions may yet be described in another way. To this end two parameters are introduced, expressing the relative magnitudes of the satellite's three principal moments of inertia:

$$R_x = \frac{I_x}{I_y}$$

$$R_z = \frac{I_z}{I_y}$$

The quantity used in the denominator is the moment of inertia about the axis normal to the orbit-plane. The parameters R_x and R_z may be used as the ordinates of a point in the R_x, R_z -plane. For any rigid body the

following inequalities hold true:

$$I_x + I_y \gg I_z$$

$$I_y + I_z \gg I_x$$

$$I_z + I_x \gg I_y$$

The lines:

$$R_x + 1 = R_z$$

$$1 + R_z = R_x$$

$$R_z + R_x = 1$$

therefore mark a region in the R_x, R_z -plane within which all possible satellite configuration must lie. R_x and R_z may indeed be used to indicate roughly the shape of the satellite, as can be seen from the extreme shapes represented by certain characteristic points in the R_x, R_z -plane, Figure 12.

In the preceding paragraph the stability conditions for a rotating satellite were expressed as certain relations between the moments of inertia which have to be satisfied. They may now be summarized as follows for rotations about the X-axis, in the orbit-plane.

If there is no dissipation of kinetic energy the conditions are:

- a) $I_x < I_y$ and $I_x < I_z$, equivalent to $R_x < 1$ and $R_x < R_z$,
- or b) $I_x > I_y$ and $I_x > I_z$, equivalent to $R_x > 1$ and $R_x > R_z$.

The regions in the R_x, R_z -plane determined by these conditions have been marked a and b in Figure 13.

Assuming the satellite to dissipate kinetic energy, stability was studied under the assumption $I_y = I_z$, or $R_z = 1$. Attention was, therefore, restricted to the line ABC in Figure 13. Stability was found to exist only for $I_x > I_y$, or $R_x > 1$: only points on the line-segment BC represent stable configurations.

In view of the next paragraph it may be useful to consider briefly the case where rotations take place about the Y-axis, normal to the

orbit-plane. The results are as follows. If no kinetic energy is dissipated:

- a) $R_x > 1$ and $R_z > 1$,
or b) $R_x < 1$ and $R_z < 1$.

The two corresponding regions have been marked a and b in Figure 14.

With dissipation of kinetic energy, attention is restricted to the case $R_x = R_z$. Stability now occurs only if $R_x < 1$. This corresponds to the linesegment AB in Figure 14.

4.2. Gravity-gradient stabilization.

In an earlier section it has been shown that the earth's gravity-gradient can provide restoring torques on a satellite in a circular orbit, if the satellite's axis of the smallest moment of inertia points to the earth's centre. In order to perform a steady motion in this particular attitude, the satellite has to have an angular velocity ω_o about the axis normal to the orbit-plane:

$$\omega_o = \sqrt{\frac{\gamma_m e}{3r}}$$

In the following, the stability of this particular steady motion will be studied in some detail. Only this case will be considered, although other steady motions are possible in which the satellite rotates about the axis normal to the orbit-plane at an angular velocity differing from ω_o , refs. 11, 26.

Suppose the satellite is in a circular orbit. Its attitude relative to the orbit-plane axes can be described by the angles ψ , θ and ϕ , Figure 15, as introduced in section 2. The three angles are zero in the attitude required for equilibrium. At a certain moment, however, the satellite's attitude differs from the equilibrium attitude, the deviations ψ , θ and ϕ are assumed to be small. It was shown in section 2, that the rates of change of the three angles are related to the angular velocities about the satellite axes. For small angular rates $\dot{\phi}$, $\dot{\theta}$, $\dot{\psi}$ eq. (2-2) become:

$$\begin{aligned}
 p &= \dot{\phi} - \omega_o \psi \\
 q &= \dot{\theta} - \omega_o \\
 r &= \dot{\psi} + \omega_o \phi
 \end{aligned}
 \tag{4-2}$$

From these expressions follow the angular accelerations (ω_o is constant):

$$\begin{aligned}
 \dot{p} &= \ddot{\phi} - \omega_o \dot{\psi} \\
 \dot{q} &= \ddot{\theta} \\
 \dot{r} &= \ddot{\psi} + \omega_o \dot{\phi}
 \end{aligned}
 \tag{4-3}$$

Due to the attitude deviations, the following gravity torques act about the satellite axes, as can be deduced from section 3, eq. (3-1):

$$\begin{aligned}
 M_x &= 3 \omega_o^2 (I_z - I_y) \phi \\
 M_y &= 3 \omega_o^2 (I_z - I_x) \theta \\
 M_z &= 0
 \end{aligned}$$

The satellite's motions caused by these torques are described by the Euler's equations (2-1). In these equations the above expressions for the gravity torque can be substituted and the angular velocities and acceleration about the satellite axes can be replaced by the functions (4-2) and (4-3). The result is:

$$I_x \ddot{\phi} + 4 \omega_o^2 (I_y - I_z) \phi + \omega_o (I_y - I_z - I_x) \dot{\psi} = 0
 \tag{4-4a}$$

$$I_y \ddot{\theta} + 3 \omega_o^2 (I_x - I_z) \theta = 0
 \tag{4-4b}$$

$$I_z \ddot{\psi} + \omega_o^2 (I_y - I_x) \psi - \omega_o (I_y - I_z - I_x) \dot{\phi} = 0
 \tag{4-4c}$$

The second of these three equations, eq. (4-4b), shows that the disturbed motions about the Y-axis, consisting of variations in θ only, are quite independent of the motions about the other two axes. The disturbed motions about the X- and Z-axes, however, consisting of

variations in ϕ and ψ respectively, are mutually coupled. This is indicated by the equations (4-4a) and (4-4c).

The two independent motions will now be discussed separately.

The equation for the motion about the Y-axis normal to the orbit-plane can be written as:

$$\ddot{\theta} + 3 \omega_o^2 \frac{I_x - I_z}{I_y} \cdot \theta = 0$$

The solution of this differential equation is an undamped oscillation if $I_x > I_z$:

$$\theta = \theta(o) \cdot \cos \omega t + \frac{\dot{\theta}(o)}{\omega} \cdot \sin \omega t$$

where the circular frequency of the oscillation is:

$$\omega = \omega_o \sqrt{3 \frac{I_x - I_z}{I_y}}$$

Provided I_x is greater than I_z , gravity torque can indeed be used to stabilize the satellite's motions about the Y-axis.

The requirement $I_x > I_z$ can be expressed also in the R_x, R_z -plane introduced in paragraph 4.1. The region $R_x > R_z$ has been indicated in Figure 16.

A study of the stability of the motions about the X- and Z-axes, as determined by the equations (4-4a) and (4-4c), requires a somewhat more elaborate approach.

The solution of these equations is of the general type:

$$\begin{aligned} \phi &= A_{\phi} \cdot e^{\lambda t} \\ \psi &= A_{\psi} \cdot e^{\lambda t} \end{aligned} \tag{4-5}$$

where λ is a real or complex number. Stability requires that the real part of λ shall not be positive, in order to prevent a diverging solution. Substitution of (4-5) in the equations (4-4a) and (4-4c) leads to:

$$\begin{cases} \{ I_x \lambda^2 + 4 \omega_o^2 (I_y - I_z) \} \phi + \omega_o (I_y - I_z - I_x) \lambda \cdot \psi = 0 \\ \{ I_z \lambda^2 + \omega_o^2 (I_y - I_x) \} \psi - \omega_o (I_y - I_z - I_x) \lambda \phi = 0 \end{cases}$$

The values of λ making these two homogeneous equations dependent determine the stability. They are found by equating the characteristic determinant to zero:

$$\begin{vmatrix} I_x \lambda^2 + 4 \omega_o (I_y - I_z) & \omega_o (I_y - I_z - I_x) \lambda \\ - \omega_o^2 (I_y - I_z - I_x) \lambda & I_z \lambda^2 + \omega_o (I_y - I_x) \end{vmatrix} = 0$$

or, after dividing by I_y :

$$R_x R_z \lambda^4 + (2 R_x R_z - 3 R_z^2 - R_x + 2 R_z + 1) \omega_o^2 \lambda^2 + 4(1-R_x)(1-R_z) \omega_o^4 = 0$$

It may be seen that this is a quadratic equation in λ^2 . The conditions to be met, in order to make sure the roots of this characteristic equation have no positive real parts, are as follows:

$$1. (2 R_x R_z - 3 R_z^2 - R_x + 2 R_z + 1)^2 \omega_o^4 - 16 R_x R_z (1-R_x)(1-R_z) \omega_o^4 > 0$$

to obtain two real values of λ^2 , and:

$$2. R_x R_z > 0$$

$$3. (2 R_x R_z - 3 R_z^2 - R_x + 2 R_z + 1) \omega_o^2 > 0$$

$$4. 4(1-R_x)(1-R_z) > 0$$

to obtain two values of λ^2 , which both are negative. If these four conditions are satisfied, two pairs of conjugate imaginary values of λ result. They correspond to two undamped oscillations of the satellite about the X- and Z-axes.

The four above conditions, combined with the requirement $R_x > R_z$ necessary for stability about the Y-axis, together leave two regions in the R_x, R_z -plane, marked a and b in Figure 17, see also ref. 26.

From this figure it can be seen that the satellite is stabilized about all axes by gravity torque, if its configuration is depicted in region a, where $R_x < 1$, $R_z < 1$ and $R_x > R_z$. This region may be described as follows. The axis of the smallest moment of inertia (Z-axis) is vertical and the axis of the greatest moment of inertia is normal to the orbit-plane (Y-axis). The intermediate axis (X-axis) points along the velocity vector in the orbit-plane. It may be of interest to remark here, that the moon belongs to this category of earth satellites.

A limited stable region b exists, where I_z is greater than I_y ($R_z > 1$). Although the satellite now is statically unstable about the X-axis, as can be seen from eq. (3-1a), the stabilizing influence of the rotation about the Y-axis dominates in this region. From Figure 14 it follows, however, that this is true only for a satellite which does not dissipate kinetic energy. If it does, only region a contains configurations which can be fully stabilized by the gravity torque.

In the previous discussion a satellite's motion has been called stable if the amplitudes of angular oscillations about the steady state do not increase with time. However, this is a necessary but not a sufficient condition. The oscillations must have a certain damping if the satellite is to serve a useful purpose. This damping can be obtained through the satellite's interaction with another field, able to produce torques in the correct phase relationship with the gravity-gradient torques.

There are advantages in using the earth's gravity field for this secondary interaction, in preference to either the magnetic or the solar radiation fields. The gravity field can be employed by attaching an auxiliary mass to the satellite and providing a means for energy dissipation between the satellite and this auxiliary mass.

The secondary mass may take the form of one or more gyros, as proposed in ref. 23. A damping scheme based on such a so called "control moment gyro" has been termed "semi-passive" in ref. 23 because energy is used to spin the gyro but not to provide a torque on the satellite. Although the primary function of the control moment gyro is to damp the satellite's oscillations, it has a secondary function to stiffen the roll and yaw axes of the satellite. The angular momentum of

these gyros is of the same order of magnitude as the angular momentum of the satellite due to its rotation in orbit. A full discussion of the control moment gyro is, however, beyond the scope of this paper, see refs. 27, 28.

The secondary mass to damp the satellite's oscillations can also consist of one or more rigid bodies. The dissipation of energy can be produced in a hinge connecting the satellite with the auxiliary bodies, Figure 18a and refs. 29, 30. In another variant described in refs 19, 31, a secondary mass is attached to the satellite via an energy dissipating spring fastened to the end of a long boom, Figure 18b.

Still another possibility, suggested in ref. 32, is to use two auxiliary bodies in the form of long rods attached to the satellite by hinges, Figure 18c. Both damper rods lie in the horizontal plane when in equilibrium. One of them is aligned with the velocity vector and damps oscillations about the axis normal to the orbit-plane. The second damper rod is normal to the first and permits damping of the other two angular oscillations. The vertical rod in the satellite serves to increase the moments of inertia about the two horizontal principal axes.

A study of the maximum damping to be obtained with such a configuration has been made in ref. 33. In ref. 34 it has been shown that damping of the transient motions about all axes is even possible, using only a single rod constrained to move in the vertical plane only and to be in the horizontal plane when in the equilibrium position.

If the satellite's orbit is not purely circular, as previously assumed, the Z-axis can no longer be vertical at all times. The angular velocity of the radius connecting the earth's centre with the satellite now becomes, see ref. 9:

$$\omega = \omega_0 \left\{ 1 + 2 e \cos \omega_0 (t-t_0) + \frac{5}{2} e^2 \cos 2 \omega_0 (t-t_0) + \dots \right\}$$

where

$$\omega_0 = \sqrt{\frac{\gamma m_e}{3a}}$$

a is the major semi axis and t_0 the time of passage through the orbit's perigee. The eccentricity e of the orbit can be expressed in the major

and minor semi axes a and b:

$$e = \frac{\sqrt{a^2 - b^2}}{a}$$

or in the values r_{\max} and r_{\min} of r at apogee and perigee:

$$e = \frac{r_{\max} - r_{\min}}{r_{\max} + r_{\min}}$$

Clearly, for a circular orbit $e = 0$ and $\omega = \omega_0$.

The orbit's eccentricity causes periodic variations of the gravity torque, which lead to oscillations of the satellite about the Y-axis normal to the orbit-plane, see ref. 35.

The required accuracy of the satellite's attitude may be one of the factors determining the allowable eccentricity of the orbit, if the satellite is to be stabilized by the gravity torque.

4.3. The use of electromagnetic induction for attitude control.

In this paragraph attention will be paid to the use of magnetic fields to generate torques for control purposes. Systems using such torques may be either passive or active.

For some missions it may be desirable to align one of the satellite's axes with the direction of the earth's magnetic field. To this end either a permanent magnet or an electromagnet has to be mounted along that particular axis. An electromagnet has been used in the Transit A and B for temporary alignment with the magnetic field direction, refs. 19, 31. Attitude control of the ESRO I scientific satellite will be based on the same principle using a permanent bar magnet, Figure 19. The satellite thus behaves much like a compass needle in the vertical plane.

The earth's magnetic field can be used not only to control the satellite's attitude in the manner just described. By employing rods of hysteresis material in the satellite, eddy currents will be generated which damp the angular oscillations about the centre of mass, as has been mentioned already in paragraph 3.2. A slightly different

arrangement has been discussed in ref. 36.

With the above systems of passive attitude stabilization the transition from an initial spin-stabilized motion at the end of the powered flight to the final magnetically stabilized motion may represent a problem requiring special attention.

A current flowing through one or more coils in the satellite also produces torques through interaction with the earth's magnetic field, as discussed in paragraph 3.2. In the spin-stabilized weather-observation satellites Tiros II and III torques generated in this way were used to change the attitude of the satellite's longitudinal axis with respect to the earth, ref. 37.

In ref. 38 an active control scheme has been proposed, using three mutually perpendicular coils, Figure 20. In principle, relatively large variations are possible in the components of the earth's magnetic field acting along the axes of the coils. Therefore, magnetometers are provided to measure the instantaneous flux density along each axis. This measurement cannot be made simultaneously with the generation of a torque, as the magnetic field produced by the current in the coil would seriously interfere with the measurement. Consequently, the two actions of field measurement and torque generation must be time shared. Attitude control by means of three current-carrying coils also has been studied in ref. 39.

Instead of coils, a permanent bar magnet mounted in gimbals can be used to produce a variable torque. The magnet may have two modes of operation, ref. 40. It may be used in a "trim mode" to establish the direction of the external field, and in a "operate mode" in which the magnet torque of the desired magnitude is applied about the proper axis. A similar arrangement, using a separate small "sensing magnet", has been described in ref. 41.

It should be remembered, however, that no torque can be generated about an axis parallel to the local direction of the earth's magnetic field.

Systems using coils or a permanent magnet of variable orientation may find application in conjunction with flywheel-systems, to be discussed in paragraph 4.5.

4.4. Reaction-jets.

Reaction-jets are particularly suitable for intermittent use, for instance to remove errors in the satellite's attitude and angular velocity at the moment of injection into orbit. If the satellite has been spin-stabilized during some part of the powered flight, jets may be used to de-spin the satellite. Reaction-jets are also used to periodically off-load flywheels in the case of external torques acting predominantly in one direction, as will be discussed in the next paragraph.

Figure 21 shows a typical cold-gas reaction-jet system. Its main components are a storage tank, pressurized on the ground prior to flight, a regulator and a number of nozzle-valves with interconnecting piping.

To simplify the following discussion it is assumed that the satellite is to be controlled by a number of jets, each parallel to one of the satellite's principal axes and all energing at the same distance l from the centre of mass, see Figure 22.

The exhaust speeds relative to the satellite are all V_e , and the mass expelled through one jet-pipe per second is \dot{m}_x , \dot{m}_y and \dot{m}_z respectively (to be taken as positive).

In order to avoid the reaction forces to interfere with the satellite's orbital motion, it may be preferable to use always two parallel jets placed at opposite sides of the satellite and acting in opposite directions. In this way a torque without a resulting force is generated. As a jet-pipe can produce a force in one direction only, twelve jet-pipes in total are required for complete control of the satellite's attitude. In Figure 22 only three of these have been indicated.

Due to the satellite's angular velocities, the mass issuing from a jet-pipe has a velocity-component normal to V_e . Taking as an example the jet at the positive X-axis, exhausting parallel to the positive Z-axis the velocities are as follows:

1. along the X-axis: 0
2. along the Y-axis: $l.r$
3. along the Z-axis: $V_e - l.q$

The contributions of this jet to the reaction-torque on the satellite are:

1. about the X-axis: 0
2. about the Y-axis: $\dot{m}_z (V_e - l \cdot q) \cdot l$
3. about the Z-axis: $-\dot{m}_z l^2 r$

Taking all jets together, the Euler's equations now become, see also ref. 42:

$$M_x + 2 \dot{m}_y V_e l - 2 l^2 (\dot{m}_x + \dot{m}_y) p = I_x \dot{p} + (I_z - I_y) q r$$

$$M_y + 2 \dot{m}_z V_e l - 2 l^2 (\dot{m}_y + \dot{m}_z) q = I_y \dot{q} + (I_x - I_z) r p$$

$$M_z + 2 \dot{m}_x V_e l - 2 l^2 (\dot{m}_z + \dot{m}_x) r = I_z \dot{r} + (I_y - I_x) p q$$

Similar but not quite identical equations result if the jet-pipes are arranged in a somewhat different manner. The selection of a plus or minus sign in the second terms of the left hand sides determines whether a positive or negative torque is generated.

As the exhaust velocity V_e is much greater than the velocities l_p , l_q or l_r , the third terms in the left hand sides may be neglected without any appreciable loss of accuracy. As a consequence, reaction-jets - if properly placed - exert a torque about one axis only. Control of the satellite's attitude can thus be split up in three separate problems.

Usually reaction-jets employed for attitude control are part of an on-off control loop. The flow through the jet-pipe is shut off by a control valve, which may be either entirely open or entirely closed. The valve's position is determined by the sign of a combination of the satellite's deviation in attitude and the rate of change of this deviation. A block-diagram of a typical attitude control system using reaction-jets is given in Figure 23. The dynamic characteristics of such a control system have been studied extensively in the literature, see refs. 22, 43, 44, 45.

The force produced by the jets usually has a magnitude of between 50 and 50.000 dynes, ref. 5. The required thrust level may be determined by the desired angular acceleration of the satellite, or by the maximum disturbance torque. If orbital propulsion is used on the satellite,

thrust vector misalignment may produce the maximum disturbance torque, see also ref. 46. The gas used in the system in most cases is cold nitrogen.

The principal disadvantage of reaction-jets is their relatively high massconsumption, making them less suitable for long missions.

4.5. Flywheels.

In many satellites actually launched or still being designed flywheels are part of the stabilization system. The Nimbus weather-observation satellite uses three of these devices, one for each axis. Fine control of the O.A.O.'s attitude will also be obtained by means of flywheels.

To bring out the salient points of this method of control, a satellite is assumed to be provided with three flywheels, each oriented along one of the satellite's principal axes. The moment of inertia of a flywheel about its own axis of rotation is I , the angular velocities of the flywheels relative to the satellite are ω_x , ω_y and ω_z , Figure 24.

The Euler's equations now have to be slightly modified, to allow for the presence of the flywheels, ref.42. A derivation of these equations is based on the simple fact that the action of the flywheels does not change the total angular momentum of the combination of the satellite and the flywheels. The latter can merely interchange the angular momentum between the satellite and themselves.

$$\begin{aligned}M_x &= I_x \dot{p} + (I_z - I_y)qr + I(\dot{\omega}_x + \omega_z q - \omega_y r) \\M_y &= I_y \dot{q} + (I_x - I_z)rp + I(\dot{\omega}_y + \omega_x r - \omega_z p) \\M_z &= I_z \dot{r} + (I_y - I_x)pq + I(\dot{\omega}_z + \omega_y p - \omega_x q)\end{aligned}\tag{4-6}$$

In these equations I_x , I_y and I_z include the contributions due to the mass of the flywheels. The ratio of the moments of inertia of the flywheel and the satellite may be very small, however, in the order of

10^{-5} : 1.

From the above equations it can be seen that the influence of an external torque (M_x , M_y , M_z) can be compensated by an appropriate change in the angular acceleration of one or more of the flywheels. In principle the satellite's attitude or angular velocities need not change if the external torque could be measured directly. The flywheels can thus be considered as a means to isolate the satellite from disturbing torques. In practice the satellite is stabilized in a certain attitude by making the flywheel's acceleration depend on the satellite's deviations from the desired attitude, as well as on the rates of change of these deviations.

A simplified block-diagram of a single-axis control system using a flywheel is shown in Figure 25. Analyses of flywheel control systems have been presented in refs. 22, 47, 48, 49.

The modified Euler's equations (4-6) also indicate that in the general case, a change in angular velocity of one flywheel may have a rather complicated influence on the motions about the other axes. This disadvantage is avoided if a single inertia - sphere is employed, as proposed in refs 50, 51, instead of three inertia-wheels. The use of this single control element, free to rotate about any axis relative to the satellite, eliminates the cross-coupling terms otherwise present in the Euler's equations.

Finally a rather important conclusion can be drawn from the equations (4-6). An external torque acting all the time in the same direction has the effect of continuously increasing the angular velocity of at least one flywheel. For practical reasons, however, there is a maximum allowable speed for the flywheels, which simply means that a flywheel may become "saturated". If disturbing torques are expected to act in one direction only, the satellite has to be provided with still another mechanism to exert controllable torques. Magnets or coils generating torques through interaction with the earth's magnetic field may be reverted to, refs. 40, 41. Also reaction-jets - as discussed in the preceding paragraph - have been employed to this end, refs. 52, 53. Using the jets from time to time, the flywheels may be desaturated and their angular velocities brought near to zero again. Figure 26

shows the block diagram of such a dualmode control system.

It may be concluded from the foregoing that flywheels are most suitable to compensate for torques periodically changing in sign. Several of the disturbing torques acting on an orbiting satellite are of this character.

Finally in Table 3 a brief comparison has been made of reaction-jets, momentum-exchange devices and solar radiation pressure to control the satellite's attitude, see ref. 25.

Table 3. Actuation techniques for space vehicle attitude control.

Capability →		Force characteristic	Useful torque range dyne-cm (Nm)	Application	Comments
Technique					
Mass expulsion	Cold gas	$I_{sp}=80\text{sec}$	$1,5 \cdot 10^4$ to $35 \cdot 10^7$ (0,0015 to 35)	complete system	simple; well developed; leakage a problem for long missions; storage tank is heavy
	Hot gas	$I_{sp}=275\text{sec}$	$1,5 \cdot 10^5$ to 10^9 (0,0015 to 0,15)	reset momentum device or complete system	presently useful only for intermittent short-term operation because of corrosion
	Vapour pressure	$I_{sp}=80\text{sec}$	$1,5 \cdot 10^4$ to $1,5 \cdot 10^6$ (0,0015 to 0,15)	reset momentum device or complete system	new; requires large solar heating area or electrical power; storage tank is light weight
Momentum inter- change	reaction wheels	-	0 to $1,5 \cdot 10^7$ (0 to 1,5)	used with auxiliary reset mechanism	new; provides continuous control (no limit cycle)
	reaction sphere	-	0 to $5 \cdot 10^6$ (0 to 0,5)	used with auxiliary reset mechanism	new; provides continuous control (no limit cycle); no precession torques
Solar pressure (near the earth's orbit)		$4,3 \cdot 10^{-5}$ dyne/cm ²	0 to 300 (0 to $3 \cdot 10^{-5}$)	reset momentum device	new; solar sail may interfere with other field- of -view requirements

4.6. The yo-yo de-spin device.

In many cases the spin rate of a satellite has to be reduced appreciably while in orbit, to allow proper operation of the satellite's payload. Despinning may be achieved by means of reaction-jets, but also a simple so called "yo-yo device" exists to accomplish this task, ref. 55, 8, 11. It consists of two small masses attached to the satellite via a light cord, initially wrapped around the spinning satellite. When the masses are released, the angular speed of the satellite will decrease as the chords unwind, the total angular momentum and kinetic energy remaining constant, Figure 27.

When the chords are completely unwound they are released and allowed to fly away. By choosing the length of the chord properly, the angular speed of the satellite can be reduced to any value less than the initial value. It has been shown in ref. 8 that the length of the chord required to reduce the spin rate from an initial value ω_o to a final value ω_f , is:

$$l = R \sqrt{\left(\frac{I}{m R^2} + 1\right) \cdot \frac{\omega_o - \omega_f}{\omega_o + \omega_f}}$$

If no angular velocity is required at the end of the despinning process, $\omega_f = 0$, and the required length of the chord is:

$$l = \sqrt{\frac{I}{m} + R^2}$$

A further developed version of the yo-yo device, the "stretch yo-yo" has been described in refs. 55, 56, 57. Here a spring has been inserted between the mass and the chord to decrease the sensitivity to errors in the satellite spin-up and in the moment of inertia.

If the aim is to reduce the spin rate exactly to zero, any remaining angular velocity, resulting from the inaccuracies just mentioned may be removed by means of the magnetic hysteresis rods already referred to in paragraph 4.2. These rods also will damp the satellite's angular oscillations.

5. Concluding remarks.

The foregoing survey may be concluded by the observation that a space environment as encountered by earth satellites differs in a few important respects from a terrestrial environment. Due to the virtual absence of a sensible atmosphere and the condition of continuous free fall, the mathematical equations of theoretical mechanics hold to a high degree of perfection. Their applicability is not hampered by overriding aerodynamic torques or by parasitic friction effects.

This fact may explain largely why in recent years satellite attitude stabilization and control has become a "pet subject of many space enthusiasts", ref. 1. Some results of the work created in this vein have been included in this paper.

Nevertheless a sobering word of caution might be sounded here. Environmental conditions in space are different also in other respects. The hard vacuum affects the behaviour of structural materials. Cosmic radiation may interfere with the proper operation of electronic equipment. As a consequence there is an imperative need of intensive environmental testing of all hardware designed for operation in space. Only if a satellite and all its systems have successfully passed such tests, can they be expected to function properly in space. In particular this holds true for a satellite's attitude stabilization and control system. It also explains the emphasis in this paper laid on passive stabilization systems.

6. Appendix.

In this Appendix, relations are derived between the angular rates $\dot{\phi}$, $\dot{\theta}$, $\dot{\psi}$ and the angular velocities p , q , r about the satellite's axes relative to inertial space, using inertial reference axes as well as orbit-plane reference axes to indicate the satellite's attitude.

1. Inertial reference axes.

From the definition of the angles ψ , θ and ϕ it may be seen, Figure A-1, that a rotation ψ takes place about the Z_{ref} -axis. Therefore $\dot{\psi}$ is directed along that axis. In the same way, $\dot{\theta}$ is

directed along the intermediate position of the Y-axis and $\dot{\phi}$ is directed along the final position of the X-axis.

The relations between $\dot{\phi}$, $\dot{\theta}$, $\dot{\psi}$ and p, q, r are found by considering the components of the vectors $\dot{\phi}$, $\dot{\theta}$ and $\dot{\psi}$ along the satellite's OXYZ-axes, see Figures A-2 a,b,c.

From these figures the following components of $\dot{\phi}$, $\dot{\theta}$ and $\dot{\psi}$ are read:

$$\begin{array}{lll} \dot{\phi}_x = \dot{\phi} & \dot{\theta}_x = 0 & \dot{\psi}_x = -\dot{\psi} \sin \theta \\ \dot{\phi}_y = 0 & \dot{\theta}_y = \dot{\theta} \cos \phi & \dot{\psi}_y = \dot{\psi} \cos \theta \sin \phi \\ \dot{\phi}_z = 0 & \dot{\theta}_z = -\dot{\theta} \sin \phi & \dot{\psi}_z = \dot{\psi} \cos \theta \cos \phi \end{array}$$

Therefore:

$$\begin{array}{ll} p = \dot{\phi} & - \dot{\psi} \sin \theta \\ q = & \dot{\theta} \cos \phi + \dot{\psi} \cos \theta \sin \phi \\ r = & -\dot{\theta} \sin \phi + \dot{\psi} \cos \theta \cos \phi \end{array}$$

and:

$$\begin{array}{ll} \dot{\phi} = p + (q \sin \phi + r \cos \phi) \operatorname{tg} \theta \\ \dot{\theta} = & q \cos \phi - r \sin \phi \\ \dot{\psi} = & (q \sin \phi + r \cos \phi) \cdot \frac{1}{\cos \theta} \end{array}$$

2. Orbit-plane reference axes.

These reference axes perform a steady rotation in space, the constant angular velocity ω_0 is directed along the negative Y_{ref} -axis. Therefore, the angles ψ , θ and ϕ between the reference and the satellite's axes vary also due to ω_0 . The components of ω_0 along the satellite's axes now have to be subtracted from p, q and r to find $\dot{\phi}$, $\dot{\theta}$ and $\dot{\psi}$.

From Figures A-3a, b, c the components of ω_0 along the OXYZ-axes are found to be:

$$\omega_{o_x} = -\omega_o \sin \psi \cos \theta$$

$$\omega_{o_y} = -\omega_o \cos \psi \cos \varphi - \omega_o \sin \psi \sin \theta \sin \varphi$$

$$\omega_{o_z} = +\omega_o \cos \psi \sin \varphi - \omega_o \sin \psi \sin \theta \cos \varphi$$

In the relations between p, q, r and $\dot{\phi}$, $\dot{\theta}$, $\dot{\psi}$ previously derived, the satellite's angular velocities now have to be replaced by $p - \omega_{o_x}$, $q - \omega_{o_y}$, $r - \omega_{o_z}$.

Therefore:

$$p = \dot{\phi} - \dot{\psi} \sin \theta - \omega_o \sin \psi \cos \theta$$

$$q = \dot{\theta} \cos \varphi + \dot{\psi} \cos \theta \sin \varphi - \omega_o (\cos \psi \cos \varphi + \sin \psi \sin \theta \sin \varphi)$$

$$r = -\dot{\theta} \sin \varphi + \dot{\psi} \cos \theta \cos \varphi - \omega_o (-\cos \psi \sin \varphi + \sin \psi \sin \theta \cos \varphi)$$

And:

$$\dot{\phi} = p + (q \sin \varphi + r \cos \varphi) \operatorname{tg} \theta + \omega_o \frac{\sin \psi}{\cos \theta}$$

$$\dot{\theta} = q \cos \varphi - r \sin \varphi + \omega_o \cos \psi$$

$$\dot{\psi} = (q \sin \varphi + r \cos \varphi) \cdot \frac{1}{\cos \theta} + \omega_o \sin \psi \operatorname{tg} \theta$$

7. References.

1. W.Haeussermann: Recent advances in attitude control of space vehicles, ARS Journal 1962, p. 188-195.
2. A.Dzilvelis: Satellite attitude control systems. Astronautics and aerospace engineering, March 1963, p. 78-82.
3. E.I.Ergin: Current status of progress in attitude control. Progress in astronautics and aeronautics - Volume 13: Guidance and control II p. 7-36 Academic Press, New York, 1964.
4. T.H.Chin: Spacecraft stabilization and attitude control. Space/Aeronautics, June 1963, p. 88-93, July 1963, p. 144-147.
5. R.K.Whitford: Attitude control of earth satellites. I-Sources of torque, II-Sensing and modes of control. Control Engineering, Febr. 1962 p. 93-97, April 1962 p. 97-101.
6. W.E.Frye, E.V.B.Stearns: Stabilization and attitude control of satellite vehicles. ARS Journal 1959, p. 927-931.
7. W.Gillespie, Jr., D.E.Eide, A.B.Churgin: Some notes on attitude control of earth satellite vehicles. NASA Technical Note D-40, 1959.
8. W.T.Thomson: Introduction to space dynamics. J.Wiley and Sons, New York, 1961.
9. H.H.Koelle (ed.): Handbook of astronautical engineering. McGraw-Hill Book Cy., New York, 1961.
10. L.E.Wiggins: Relative magnitudes of the space-environment torques on a satellite, AIAA Journal 1964, p. 770.
11. C.Leondes (ed.): Guidance and control of aerospace vehicles. Chap.7: Passive attitude control of satellite vehicles, by W.T.Thomson. McGraw-Hill Book Cy., New York, 1963.
12. R.E.Fischell: Magnetic damping of the angular motions of earth satellites. ARS Journal 1961, p. 1210-1217.
13. L.H.Grasshoff: Eddy current torque compensation in a spin stabilized earth satellite. ARS Journal 1961, p. 290-293.
14. R.L.Sohn: Attitude stabilization by means of solar radiation pressure. ARS Journal 1959, p. 371-373.
15. R.T.Newton: Stabilizing a spherical satellite by radiation pressure. ARS Journal 1960, p 1175-1177.

16. H.B.Holl: The effect of radiation force on satellites of convex shape. NASA Technical Note D-604, 1961.
17. N.E.Ives: The effect of solar radiation pressure on the attitude control of an artificial earth satellite. Reports and Memoranda no. 3332, 1963.
18. J.D.Acord, J.C.Nicklas: Theoretical and practical aspects of solar pressure attitude control for interplanetary spacecraft. Progress in astronautics and aeronautics - Volume 13: Guidance and control-II p. 73-91. Academic Press, New York, 1964.
19. R.B.Kershner: Gravity-gradient stabilization of satellites. Astronautics and aerospace engineering, September 1963, p. 18-22.
20. R.Deutsch: Orbital dynamics of space vehicles, p.222-224. Prentice-Hall Inc., Englewood Cliffs, N.Y., 1963.
21. R.E.Roberson: Methods for the control of satellites and space vehicles. Vol.1, 2 and 3. Wright-Patterson AFB, Ohio, WADD TR 60-643, 1960.
22. C.Leondes (ed.): Guidance and control of aerospace vehicles. Chap. 8: Active satellite attitude control, by M.J.Abzug. McGraw-Hill Book Co., New York, 1963.
23. E.G.C.Burt: On the attitude control of earth satellites. R.A.E. Techn. Note Space 3, 1962.
24. C.E.White: Spacecraft sensors. Space/aeronautics, December 1962, p. 70-72.
25. N.Sirri: Space vehicle attitude control, in: Navigation systems for aircraft and space vehicles, by T.G.Thorne (ed.). AGARDograph 55. Pergamon Press, Oxford, 1962.
26. K.Magnus: Beiträge zur Untersuchung der Drehbewegungen starrer Satelliten auf kreisförmigen Umlaufbahnen. Jahrbuch 1963 der Wissenschaftlichen Gesellschaft für Luft- und Raumfahrt (WGLR) p. 174-180.
27. E.D.Scott: Control moment gyro gravity stabilization. Progress in astronautics and aeronautics - Volume 13: Guidance and control-II p. 103-148, Academic Press, New York, 1964.
28. J.E. De Lisle, E.G.Ogletree, B.M.Hildebrant: Applications of gyro-stabilizers to satellite attitude control. Progress in astronautics

- and aeronautics - Volume 13: Guidance and control-II p. 149-184. Academic Press, New York, 1964.
29. B.Etkin: Attitude stability of articulated gravity-oriented satellites. Part I-General theory, and motion in orbital plane. UTIA Report no. 89, Toronto, 1962.
 30. H.Maeda: Attitude stability of articulated gravity-oriented satellites. Part II - Lateral motion. UTIA Report no. 93, Toronto, 1963.
 31. R.E.Fischell, F.F.Mobbey: A system for passive gravity-gradient stabilization of earth satellites. Progress in astronautics and aeronautics - Volume 13: Guidance and control-II p. 37-71. Academic Press, New York, 1964.
 32. L.J.Kamm: "Vertistat": An improved satellite orientation device. ARS Journal, 1962, p. 911-913.
 33. E.E.Zajac: Damping of a gravitationally oriented two-body satellite. ARS Journal, 1962, p. 1871-1875.
 34. B.E.Tinling, V.K. Merrick: Exploitation of inertial coupling in passive gravity-gradient-stabilized satellites. J.Spacecraft, 1964, p. 381-387.
 35. P.H.Savet: Attitude control of orbiting satellites at high eccentricity ARS Journal, 1962, p. 1577-1582.
 36. R.G.Moyer, R.J.Katucki: A system for passive control of satellites through the viscous coupling of gravity gradient and magnetic fields. AIAA Paper no. 64-659, 1964.
 37. L.H.Grasshoff: A method for controlling the attitude of a spin-stabilized satellite. ARS Journal, 1961, p. 646-649.
 38. L.J.Kamm: Magnetorquer - a satellite orientation device. ARS Journal 1961, p. 813-815.
 39. J.S.White, F.H.Shigemoto, K.Bourquin: Satellite attitude control utilizing the earth's magnetic field. NASA Technical Note D-1068, 1961.
 40. J.J.Adams, W.E.Howell, H.P.Bergeron: Simulator study of a satellite attitude control system using inertia wheels and a magnet. NASA Technical Note D-1969, 1963.

41. J.J.Adams, R.F.Brissenden: Satellite attitude control using a combination of inertia wheels and a bar magnet. NASA Technical Note D-626, 1960.
42. N.E.Ives: Principles of attitude control of artificial satellites. Report and Memoranda no. 3276, 1962.
43. J.S-Pistiner: On-off control system for attitude stabilization of a space vehicle. ARS Journal, 1959, p. 283-289.
44. L.W.Taylor, Jr., J.W.Smith: An analytical approach to the design of an automatic discontinuous control system. NASA Technical Note D-630, 1961.
45. S.C.Brown: Predicted performance of on-off systems for precise satellite attitude control. NASA Technical Note D-1040, 1961.
46. C.N.Tripp, W.P.Boardman: Attitude control rockets requirements for space vehicles. National IAS/ARS Joint meeting, 1961. Paper no 61-205-1899.
47. J.S.White, Q.M.Hansen: Study of systems using inertia wheels for precise attitude control of a satellite. NASA Technical Note D-691, 1961.
48. R.H.Cannon, Jr.,: Some basic response relations for reaction wheel attitude control. ARS Journal, 1962, p. 61-74.
49. M.J.Abzug: Satellite inertia-wheel attitude control on elliptical orbits. Engineering paper no. 1384. 1962 Symposium on ballistic missile and space technology, Colorado Springs.
50. R.D.Ormsby, M.C.Smith: Capabilities and limitations of reaction spheres for attitude control. ARS Journal, 1961, p.808-812.
51. K.W.Hering, R.E.Hufnagel: Inertial sphere system for complete attitude control of earth satellites. ARS Journal, 1961,p.1074-1079.
52. W.Haeussermann: An attitude control system for space vehicles. ARS Journal, 1959, p. 203-207.
53. C.Grubin: Exact limit cycle solutions for the single-axis reaction wheel attitude control system. XIth International Astronautical Congress Stockholm, 1960. Proceedings, Vol I, p.537-548.
54. J.V.Fedor: Theory and design curves for a yo-yo de-spin mechanism for satellites. NASA Technical Note D-708, 1961.
55. H.J.Comille, Jr.: A method of accurately reducing the spin rate of a rotating spacecraft. NASA Technical Note D-1420, 1962.

56. J.V.Fedor: Analytical theory of the stretch yo-yo for de-spin of satellites. NASA Technical Note D-1676, 1963.
57. W.R.Mentzer: Analysis of the dynamic tests of the stretch yo-yo de-spin system. NASA Technical Note D-1902, 1963.

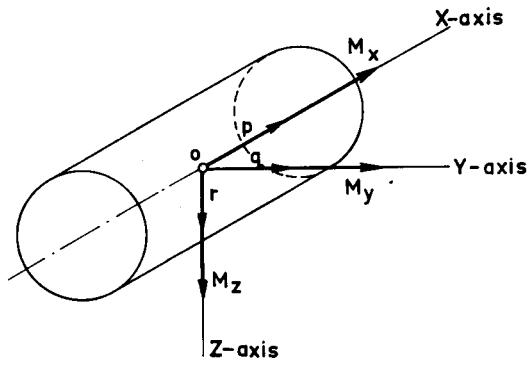

Figure 1 Angular velocities p , q , r and moments M_x , M_y , M_z acting on the satellite.

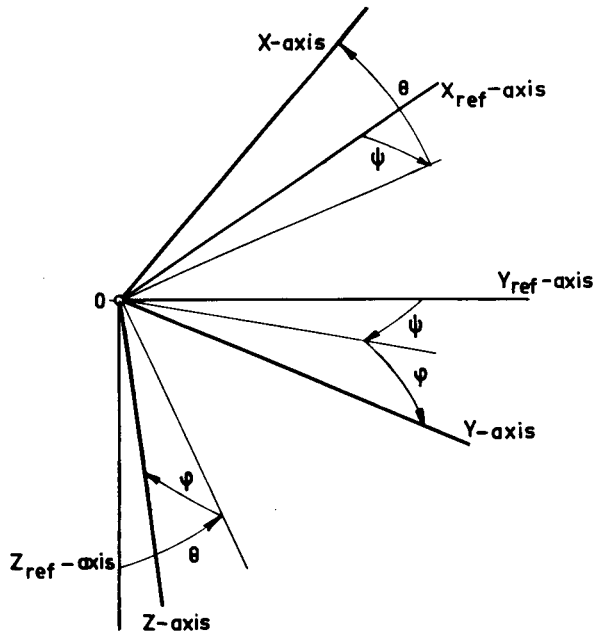

Figure 2 Angles ψ , θ , ϕ describing the satellite's attitude.

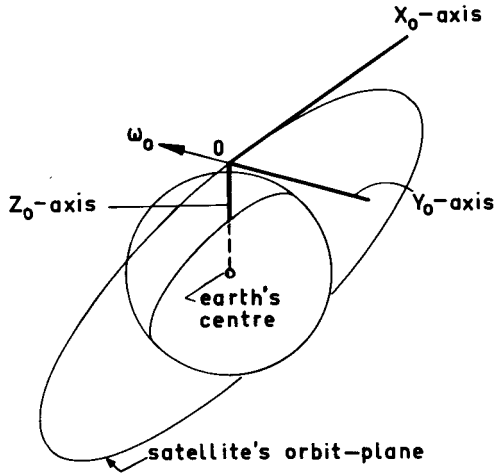

Figure 3 Satellite's orbit-plane axes.

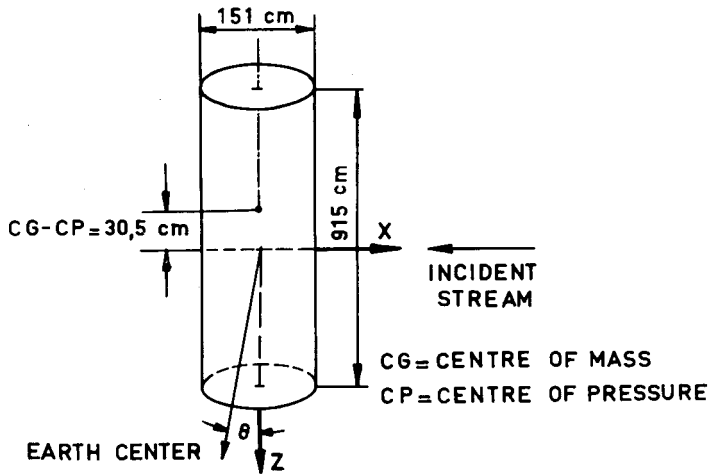

Figure 4 Satellite used for numerical examples.

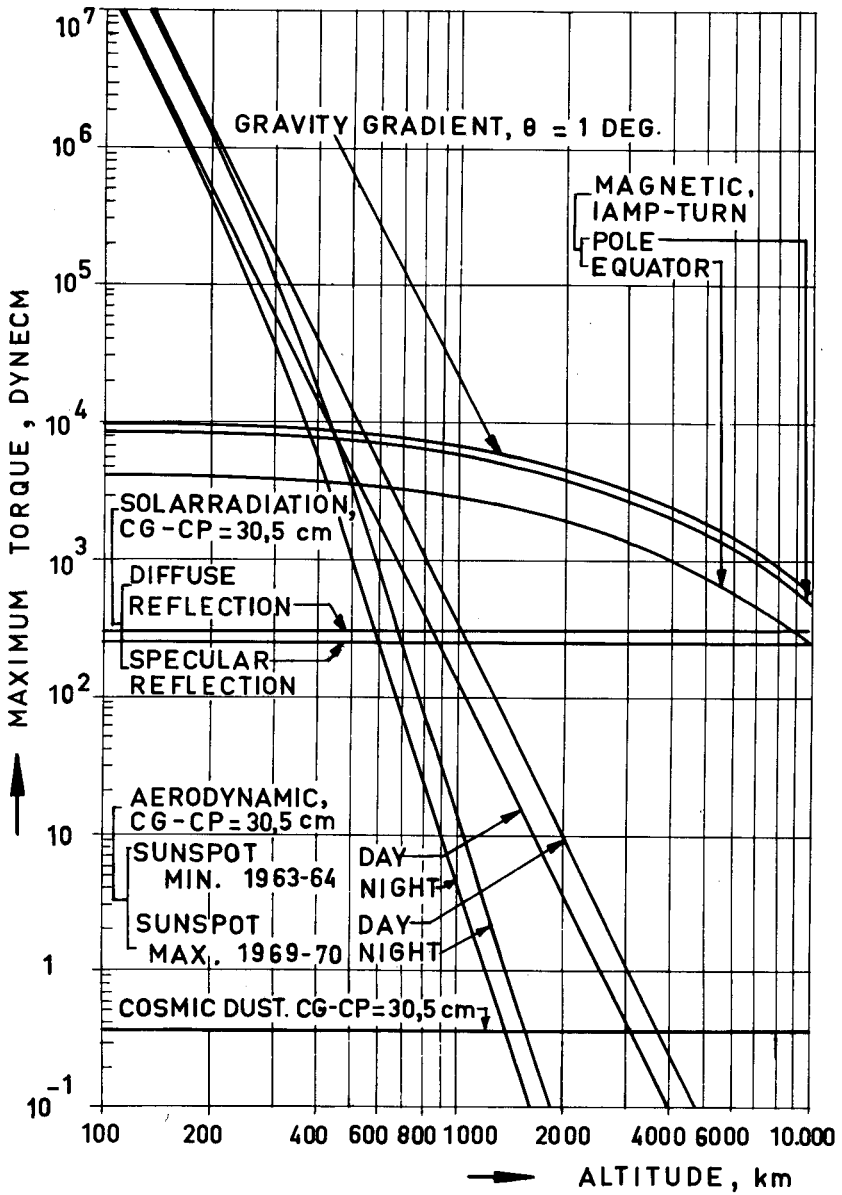

Figure 5 Relative magnitudes of the environmental torques on an earth satellite.

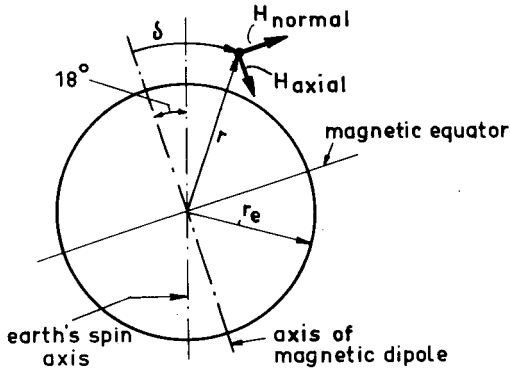

Figure 6 Components of the earth's magnetic field intensity H.

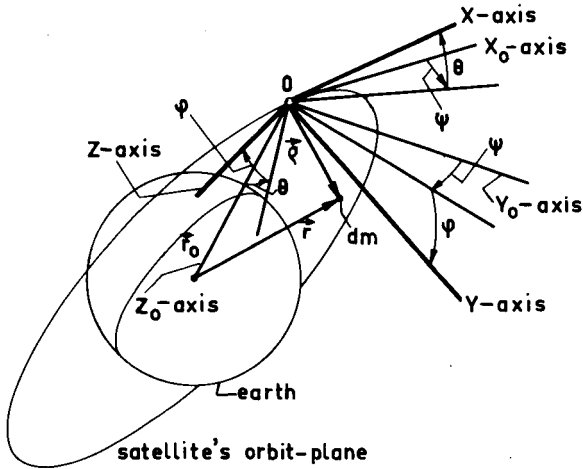

Figure 7 Determination of gravity torque on a satellite.

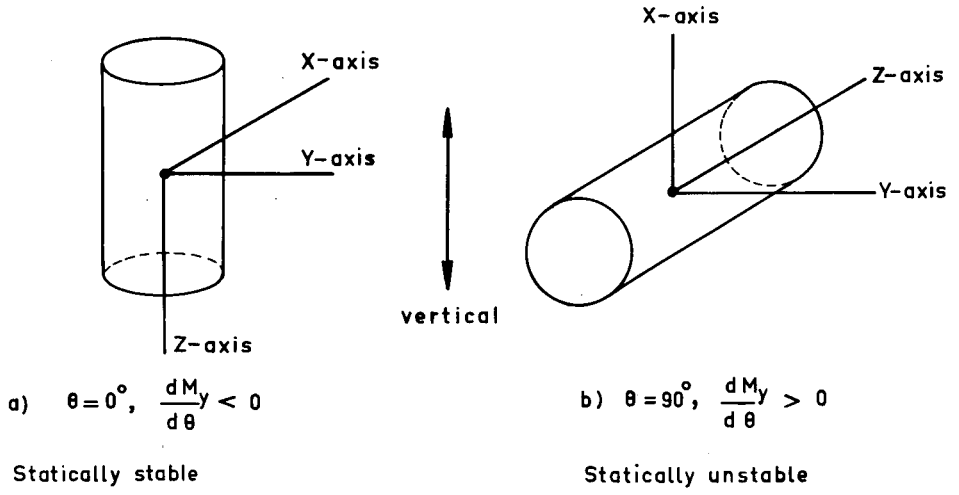

Figure 8 Stability of two possible equilibrium attitudes.

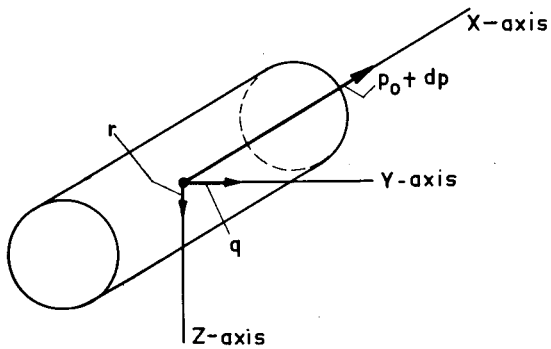

Figure 9 Angular velocities of the disturbed motion of a spin-stabilized satellite.

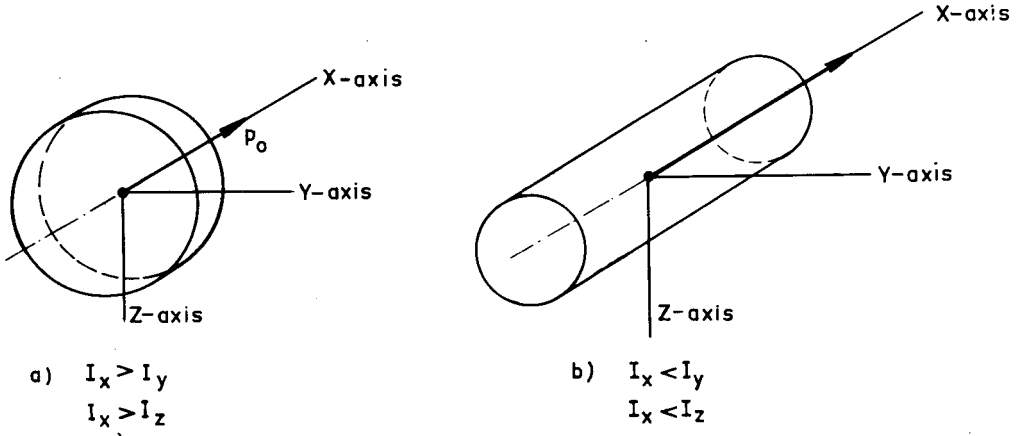
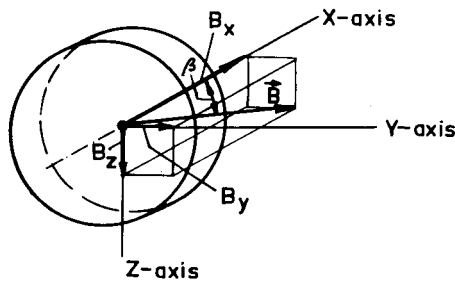

Figure 10 Two stable rotations of a spin-stabilized satellite without dissipation of energy.



$$B_x = I_x \cdot p$$

$$B_y = I_y \cdot p$$

$$B_z = I_z \cdot r$$

Figure 11 Angular momentum of the disturbed motion of a spin-stabilized satellite.

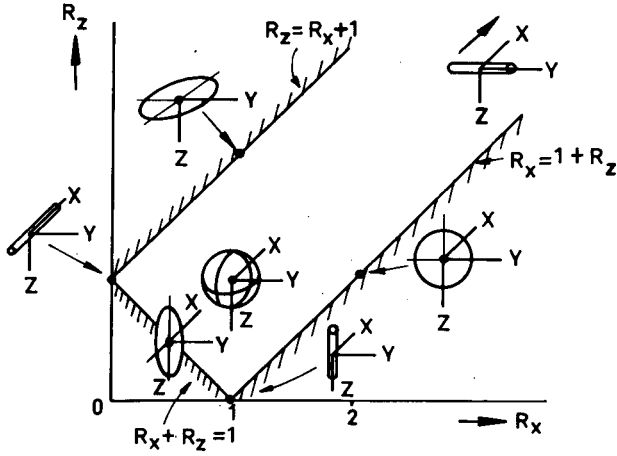

Figure 12 Various satellite shapes, depicted in the R_x, R_z -plane.

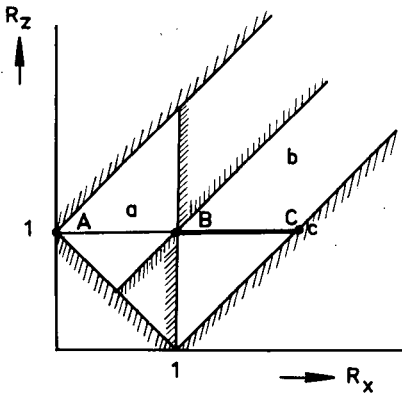

Figure 13

Stability-regions in the R_x, R_z -plane of a satellite spin-stabilized about its X-axis.

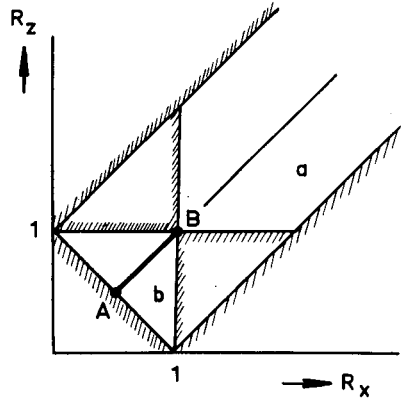
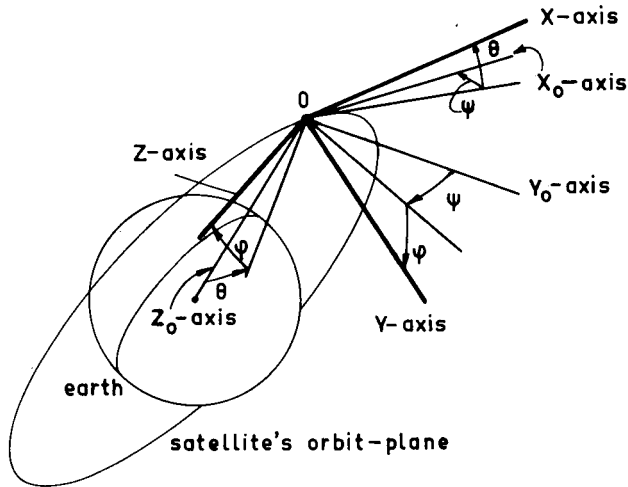

Figure 14

Stability-regions in the R_x, R_z -plane of a satellite spin-stabilized about its Y-axis.



$O X_0 Y_0 Z_0$: orbit-plane axes
 $O X Y Z$: satellite's principal axes

Figure 15 Disturbed attitude of the principal axes of a satellite stabilized by gravity torque.

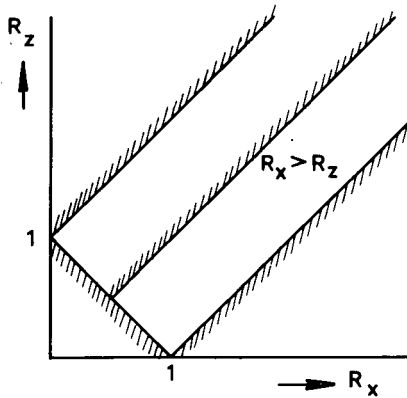

Figure 16

Stability-regions in the R_x , R_z -plane of a satellite stabilized about the Y-axis by gravity torque.

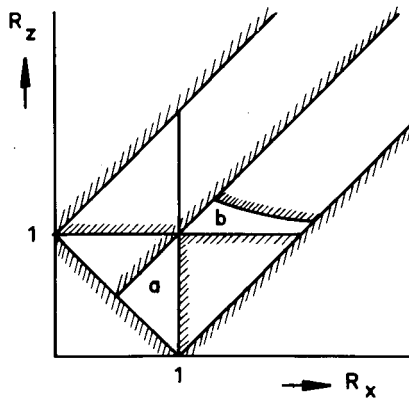

Figure 17

Stability-regions in the R_x , R_z -plane of a satellite stabilized about all axes by gravity torque.

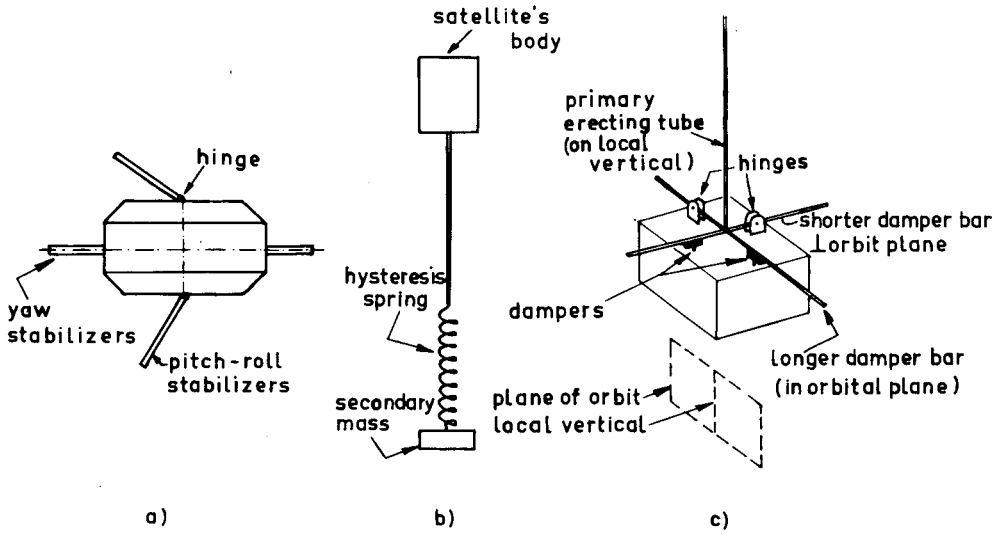

Figure 18 Various mechanisms to damp a satellite's oscillations.

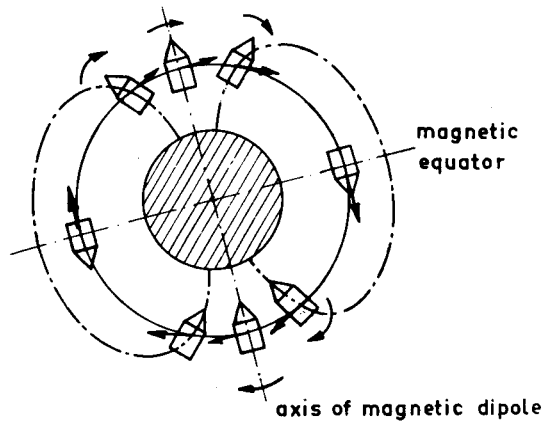

Figure 19 Angular motions of the magnetically stabilized ESRO I satellite.

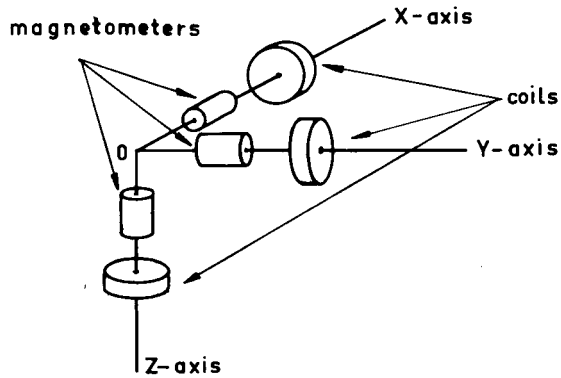

Figure 20 Control system using magnetometers and coils.

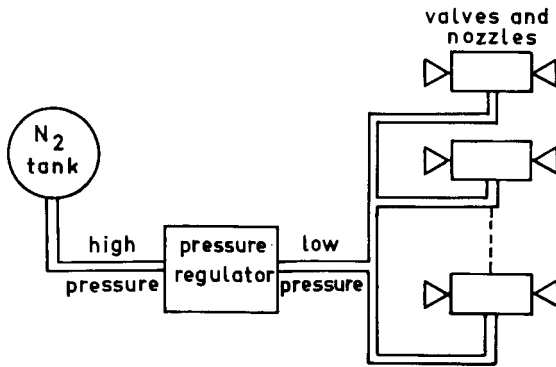

Figure 21 Cold-gas actuation system.

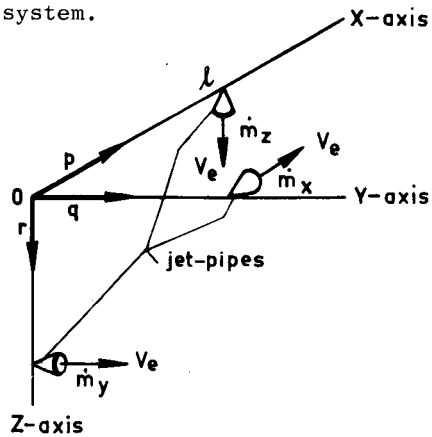

Figure 22 Simplified arrangement of reaction-jets.

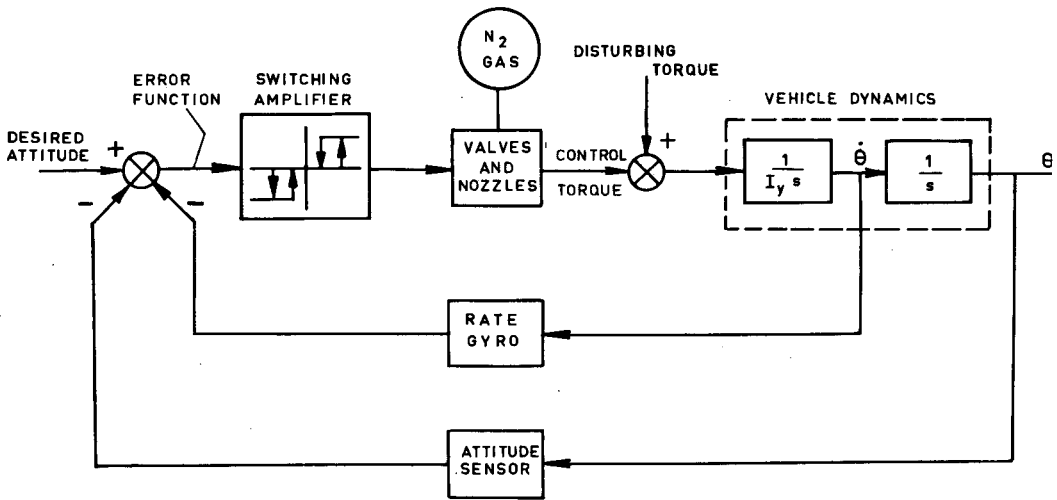

Figure 23 Block diagram of a single-axis reaction-jet control system.

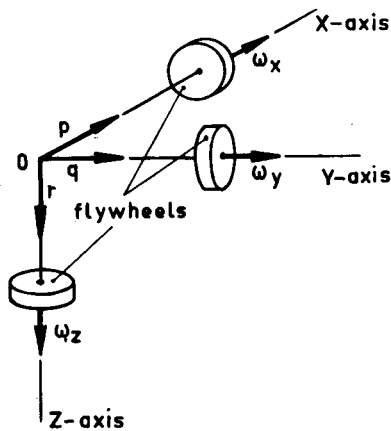

Figure 24 Simplified arrangement of flywheels.

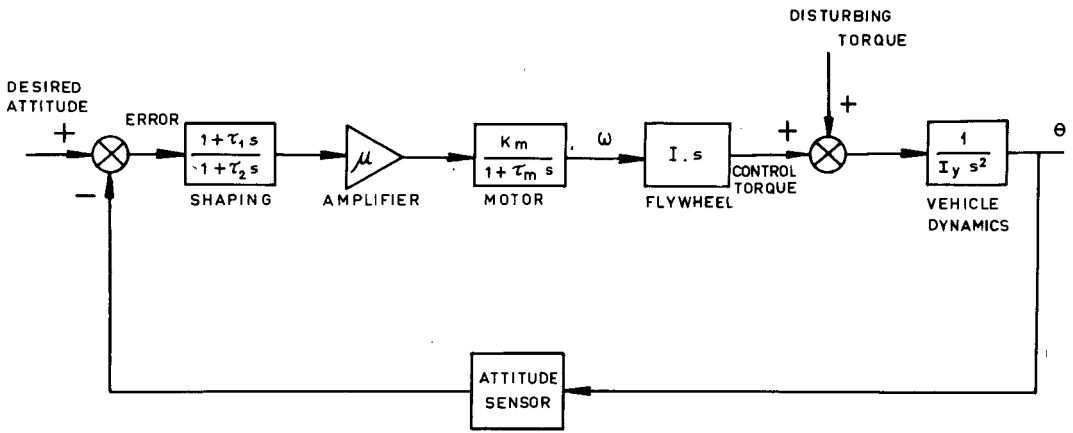

Figure 25 Block diagram of a single-axis flywheel control system.

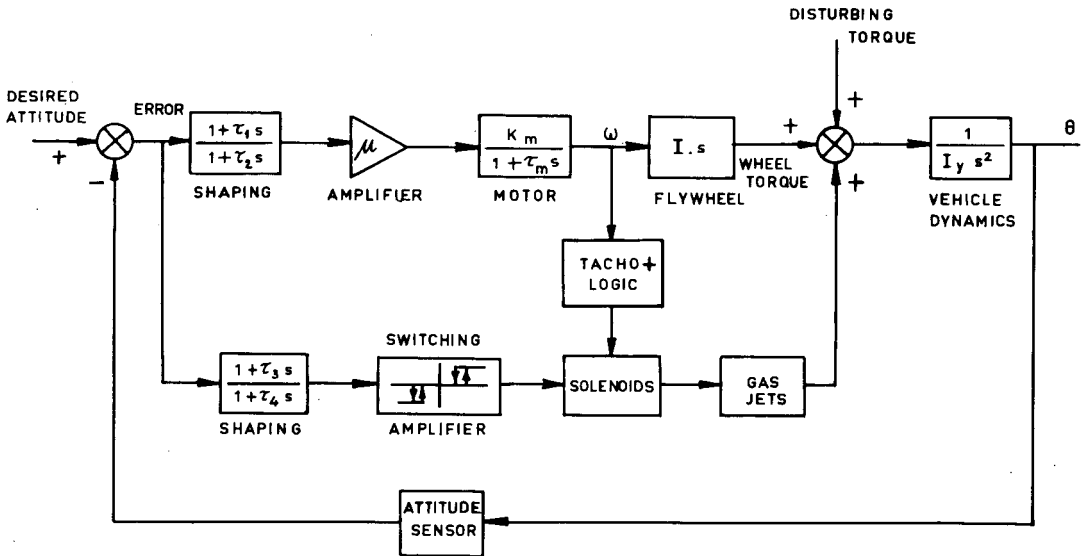

Figure 26 Block diagram of a single-axis dual-mode control system.

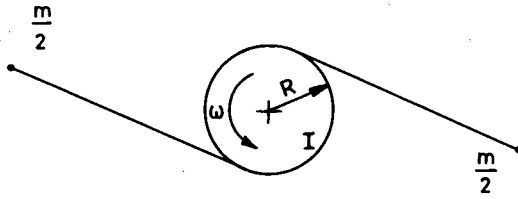

Figure 27 Yo-yo de-spin mechanism.

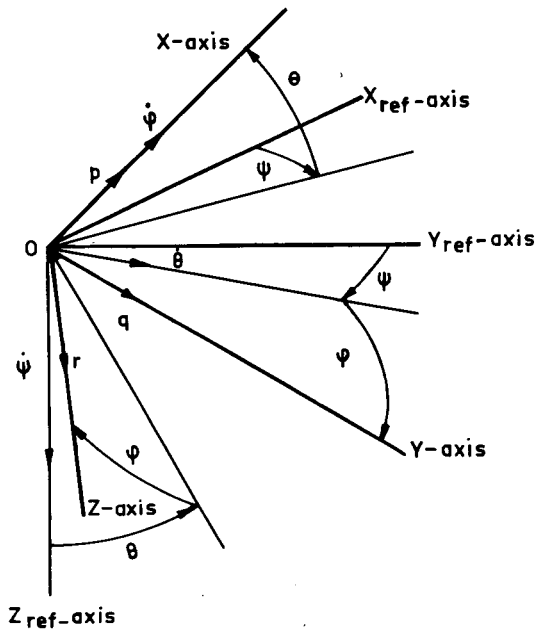

Figure A-1 Angular velocities p , q , r and $\dot{\phi}$, $\dot{\theta}$, $\dot{\psi}$.

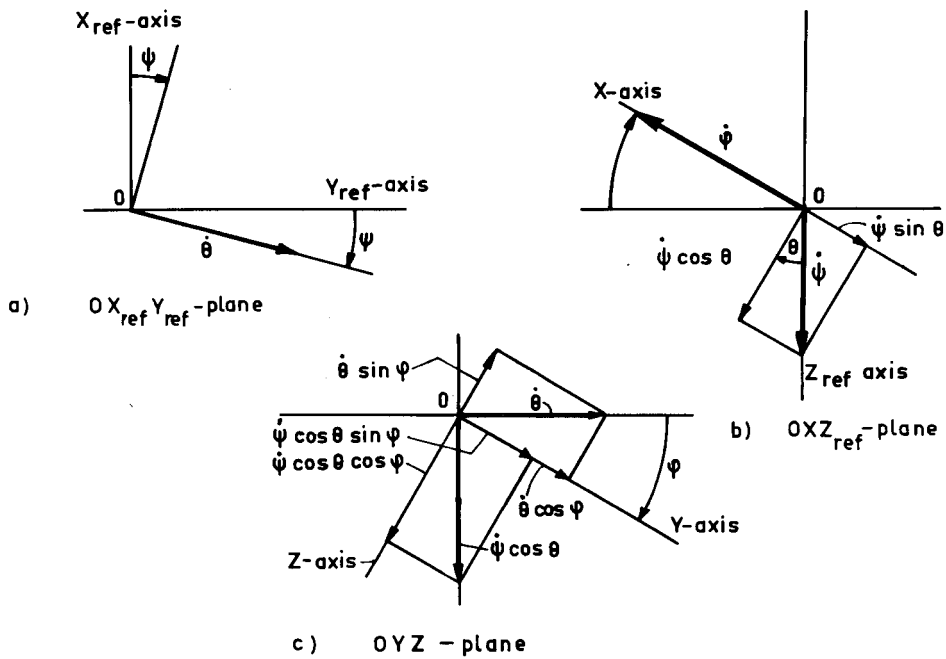

Figure A-2 Components of $\dot{\phi}$, $\dot{\theta}$, $\dot{\psi}$ along the satellite's axes.

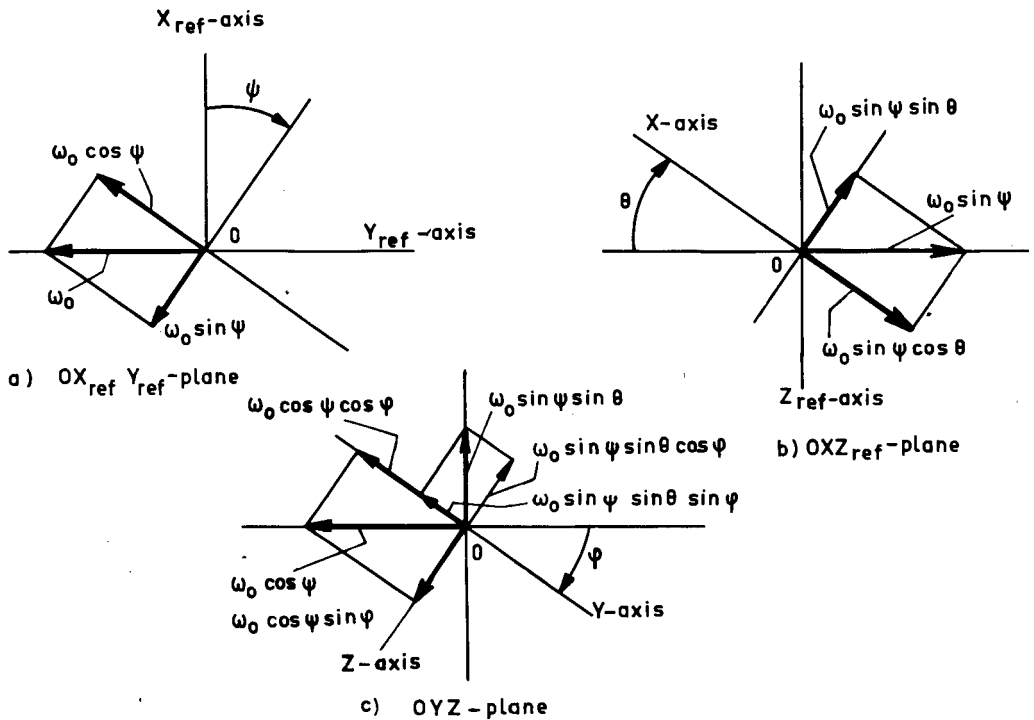

Figure A-3 Components of ω_0 along the satellite's axes.

