

MASTER OF SCIENCE THESIS

Maneuvering of Automated Vehicles in an Unsignalized Intersection

A Distributed Control Strategy

Lenin Mishra

Faculty of Transport & Planning · Delft University of Technology



Maneuvering of Automated Vehicles in an Unsignalized Intersection

A Distributed Control Strategy

MASTER OF SCIENCE THESIS

For obtaining the degree of Master of Science in Transport,
Infrastructure and Logistics at Delft University of Technology

Lenin Mishra

30/8/2016

The work in this thesis was supported by Technolution. Their cooperation is gratefully acknowledged.



Copyright © Lenin Mishra
All rights reserved.



DELFT UNIVERSITY OF TECHNOLOGY
FACULTY OF TRANSPORT & PLANNING
DEPARTMENT OF CIVIL ENGINEERING AND GEOSCIENCES

GRADUATION COMMITTEE

Dated: 30/8/2016

Chair holder:

Prof.dr.ir.Bart van Arem

Committee members:

Dr.ir. Meng Wang

Dr.ir. Riender Happee

Dave Marples

Martijn van den Heuvel

Summary

The main objective of this research is to develop a distributed control strategy for automated vehicles to maneuver in an unsignalized intersection using Vehicle to Vehicle (V2V) communication. There are three important aspects of this research. The first important aspect is the development of a distributed strategy that is feasible to be implemented on automated vehicles and is efficient in avoiding collisions at the intersection. Based on relevant literature review and experimentation, a strategy is designed that is easy to implement and yet effective for avoiding collisions. The second is the networking aspect that deals with setting up a V2V communication among the automated vehicles and ensuring that indeed the distributed control strategy is feasible to be implemented by means of V2V communication among the vehicles in the absence of a central controller. This objective is achieved by the use of a high fidelity simulator called the Urban Search and Rescue Simulation (USARSIM) where automated robots can be controlled through an external running script. The third important aspect of this research is assessing the effectiveness of the developed strategy in realistic traffic scenarios. For the purpose of achieving this objective, VISSIM a microscopic traffic simulator is used.

The entire research is divided into three parts. The first part discusses the design framework for the present research. The second part deals with the implementation part of the developed strategy for the intersection. The third part assesses the effectiveness of the developed strategy in a traffic scenario on the grounds of traffic flow efficiency, sustainability and surrogate safety.

Design Framework

The research begins with the development of an architecture that will support the developed strategy at different levels. The three important layers of the developed architecture are the traffic management layer, vehicle management layer and the vehicle control layer.

- The traffic management layer provides the basic rules and constraints for the automated vehicles to maneuver in the network. Vehicle with the lowest time to a conflict point in the intersection is sent the highest priority. If the time to conflict point is same for

more than one vehicle, vehicles have to yield to their vehicles to their right. Overtaking of vehicles in the same lane is also not allowed by the traffic management layer.

- The vehicle management layer takes care of the V2V communication necessary for the automated vehicles to decide the necessary speed to maneuver the intersection without colliding. Vehicles exchange their trajectory, speed and time to the conflict point details with other relevant vehicles in the network. This relevance is decided by creating a collision group. After sharing the trajectory details with other vehicles, if the same conflict point arises for more than one vehicle, the collision group is created by taking into account the conflict point and the vehicles that share the conflict point. Based on the received details, priority is decided cooperatively among the vehicles and the vehicles with lower priority slow down to let the vehicles with higher priority to maneuver the intersection first. The developed strategy is completely distributed and only V2V communication is used for implementing it. Therefore no communication happens between the traffic management Layer and the vehicle management Layer.
- The lowest layer in the developed architecture is the vehicle control layer. The vehicle control layer adjusts the position, speed, lateral and longitudinal control of the vehicle in such a way that the decisions made at the Vehicle Management layer is respected and vehicles maneuver without any collision at the intersection.

The distributed strategy developed for the intersection is “**Time to Conflict point based Gap Adjustment Logic**”. Based on the rules and constraints provided by the traffic management layer, the strategy is developed. Every vehicle calculates the time to the conflict point and shares this detail with other vehicles in the same collision group. Based on the time to conflict point, priority is decided for the vehicles in the same collision group. The time difference necessary for allowing vehicles to maneuver the intersection is the safe time interval. The safe time interval is calculated based on the fact that the time required for a vehicle to cross a conflict point is the length of a vehicle divided by its speed at the conflict point. An extra marginal time is added to the safe time interval to ensure that no collisions happen. The extra marginal time in this research is half of the calculated safe time interval. Once a delay is added to a vehicle, vehicles with lower priority are also added with the same delay. This practice continues till the last vehicle.

Implementation of the strategy

For the purpose of implementing the developed strategy, two simulation platforms are used. First the strategy is implemented on three differential drive robots in USARSIM to establish the networking aspect of the research. V2V communication is established among the robots with the use of UDP sockets in Python. There are four message types used for the purpose of sharing necessary information among the robots. Three of the message types are used by individual robots. These message types deal with the trajectory of the robots, time to the conflict point and updated location of the robots. For the purpose of a special scenario with platoons in the intersection, the last message type is used for sharing the number of robots that are member of the platoon with other robots in other lanes. A virtual intersection is created in the simulation platform of USARSIM. Three zones are taken into account. The first zone is where the robots are out of V2V range and maintain their own speed. In the

second zone, robots come in V2V range with other vehicles in other lanes and engage in negotiations for maneuvering the intersection without colliding through V2V communication. The third zone is the intersection box where a potential conflict point is located. Once the decision has been made, the vehicle control layer of every individual robot adjusts its own speed accordingly so as to ensure that the decision made cooperatively is respected. In the case involving platoons, two separate scenarios are taken into account. In the first scenario, the platoons have to adjust their speeds based on the strategy developed. In the second scenario, platoon is given full priority and cross the intersection first. Robots in other lanes therefore either wait or slow down depending on the number of robots in the platoon to allow the platoon to pass.

For every scenario modeled in USARSIM, the trajectories of robots in the simulation platform are collected to do a post analysis of the maneuvering behavior. Based on the received data, the trajectory, speed and in the case of platoons, the inter robot distance is plotted. For the purpose of plotting the speed profiles, the method of finite differencing is used. On plotting the speed profiles it was found that due to insufficient sampling time there are approximation errors found which leads to fluctuations in the speed profiles. Basically, the assumption that

$$\frac{\partial x}{\partial t} \equiv \frac{x_2 - x_1}{t_2 - t_1}$$

does not provide satisfactory results in this case. Therefore the average result of multiple simulation runs are used to analyze the speed profiles. Based on the simulations carried out in USARSIM it is established that the developed strategy is feasible to be implemented as a distributed strategy through V2V communication. However there is an added caveat that no packet losses are considered in this research. Therefore the entire research assumes that there is no communication loss or delay during the entire operation.

Once the networking aspect of this research is established, the strategy is then implemented in VISSIM to assess the impact of the strategy in a more realistic traffic scenario. For the purpose of implementation in VISSIM, a more realistic intersection is designed as compared to the virtual intersection in USARSIM. Vehicles are introduced into three links and are allowed to maneuver the intersection by adhering to the developed strategy. The V2V range is considered to be 100 meters from the intersection. Speed and acceleration constraints were defined that vehicles maneuvering in the network should not violate. For the purpose of controlling the acceleration of individual vehicles, a Proportional–Derivative (PD) controller is used. For the purpose of modeling platoons in the network, a Cooperative Adaptive Cruise Controller (CACC) is used. All the scenarios modeled in USARSIM are again recreated in VISSIM but with more vehicles. Since there is no provision in VISSIM to implement V2V communication among the vehicles in general, it is assumed that vehicles are engaging in V2V communication. Based on the maneuvering of vehicles in the designed network, necessary data is collected. With the help of collected data, the trajectory, speed, acceleration and jerk profiles are analyzed.

Measuring Effectiveness

One of the major reasons for implementing the developed strategy in VISSIM was to measure the effectiveness of the developed strategy on the grounds of traffic flow efficiency, sustainabil-

ity and surrogate safety. For every ground, potential performance indicators are identified. For the purpose of measuring traffic flow efficiency the two indicators used are throughput and total delay in the network. These two indicators are directly extracted from the simulation in VISSIM. For the purpose of measuring the sustainability, emission values of four pollutants are used. They are CO_2 , NO_x , PM_{10} and hydrocarbons. To calculate the amount of hydrocarbons released, a regression model is used. The regression model calculates the amount of hydrocarbon released by taking into account different Measure of Effectiveness (MOE) based on whether the acceleration is positive or negative. For calculating the emission values of other pollutants, Enviver Pro developed by TNO is used. Enviver is a database that calculates the values of emissions from microscopic traffic simulation models by taking into account various factors like speed, acceleration, vehicle's average age, emission legislations and type of fuel. With regards to measuring Surrogate Safety, two main indicators used are Post Encroachment Time (PET) and Time to Collision (TTC). For the purpose of measuring the above indicators Surrogate Safety Assessment Model (SSAM) is used which is developed by Federal Highway Administration (FHWA), USA. Conflicts are identified by considering the maximum PET value as 5 seconds and TTC as 1.5 seconds.

Two comparison studies are conducted. The scenario of an intersection with the strategy implemented is compared with a traffic lights scenario. A fixed time signal controller is designed for this purpose. For every lane from which the vehicles are originating, a signal head is installed. The total cycle time of a signal controller is 60 simulation seconds and for every signal head it is 20 simulation seconds. Upon comparison, it was found that intersection with the strategy implemented performs better than a traffic lights scenario in terms of traffic flow efficiency and sustainability. The throughput values for the intersection with the strategy was approximately 24% higher than that of the traffic lights scenario. The total delay in the network decreased by almost 44%. In terms of emissions, the percentage of hydrocarbons decreased by 29%, CO_2 by 6.7%, NO_x by 16.7% and PM_{10} by 3.7%. However in terms of surrogate safety, the traffic lights scenario performed better than the intersection with the strategy implemented. No conflicts were found for the traffic lights scenario where as 6 conflicts were found for the intersection with the strategy implemented. For the 6 conflicts, the average PET value was 0.4 seconds and the average TTC was 0.37 seconds. Therefore it was concluded that the traffic lights scenario was safer compared to the intersection with the strategy implemented. However this benefit related to safety is being achieved by compromising with the traffic flow efficiency and sustainability issues.

The second comparison study took into account the special scenarios where platoons are introduced in the network. In the first scenario, platoons had to adhere to the developed strategy for the intersection and in the second scenario, the platoons were given the full priority. It is to be noted that an assumption was made stating that only one platoon enters the intersection and the number of vehicles in the platoon does not change before the intersection. It was found that the second scenario performed better than the first scenario in terms of traffic flow efficiency. The throughput improved by almost 10% and the delay decreased by almost 26%. However in terms of sustainability the only pollutant that was found less for the second scenario was the Hydrocarbons. For the other three pollutants, the second scenario performed worse than the first scenario. The CO_2 values increased by 4.5%, NO_x values by 5% and PM_{10} values by 4.2%. Therefore platoon without priority seemed to perform better on the grounds of sustainability than the scenario where platoon was given priority. For surrogate safety, it was difficult to come to any solid conclusion. The number

of conflicts found in the first scenario were 7 whereas in the second scenario, the number of conflicts found were 13. However for the first scenario the average TTC and PET values were 0.4 seconds and 0.3 seconds respectively and for the second scenario the average TTC and PET values were 1.3 seconds and 1.28 seconds respectively. It can be seen that the number of conflicts are less in the first scenario as compared to the second scenario. However the severity of the conflicts are higher in the first scenario than in the second scenario. Therefore it was difficult to make conclusions in this regard.

This basic objective of this research was to develop a distributed control strategy for the automated vehicles to maneuver in an intersection without the aid from traffic lights by engaging in V2V communication. The three important aspects of this research were development of a distributed strategy, ensuring whether the strategy is feasible to be implemented in a way it is intended to by using V2V communication and assessing whether the strategy is actually effective in traffic scenarios. All the three aspects have been covered in this research. It was found that the strategy is feasible for implementation using V2V communication and the strategy does provide benefits in terms of traffic flow efficiency and sustainability. For the scenarios where platoons are introduced, the comparison study did show improvements in traffic flow efficiency for the platoon with priority scenario. However in terms of sustainability it did not perform better than the platoon without priority scenario. In terms of surrogate safety no solid conclusions could be drawn from the results provided by the SSAM software. The special scenario of platoons in the network therefore requires further research to come to a proper conclusion.

Table of Contents

Acknowledgments	xix
1 Introduction	1
1.1 The Present Scenario in Traffic	1
1.2 Automated Vehicles – A Possible Solution	1
1.3 Importance of Simulation	2
1.4 Problem Relevance & Description	2
1.5 Research Objective	4
1.6 Methodology	4
1.7 Thesis Outline	6
2 Literature Review	7
2.1 Networking aspects in scientific literature	7
2.2 Scientific literature dealing with effectiveness of a strategy in traffic	10
2.3 Overview	13
3 Development of the strategy for the Intersection	17
3.1 Problem Definition	17
3.2 Assumptions	18
3.3 Development of the Distributed Strategy	19
3.3.1 Scenario Description	20
3.3.2 Time to Conflict Point based Gap Adjustment Logic	21
3.4 Architecture	24
3.5 Platoons in the network	26
3.5.1 Number of vehicles in a platoon	26
3.6 Overview	28

4	Validation of V2V communication - Implementation in USARSIM	29
4.1	USARSIM	29
4.2	Higher Level Software	31
4.2.1	V2V communication module	33
4.3	Implementation of Strategy	35
4.3.1	Classical Intersection Scenario	35
4.3.2	Platoons in the intersection	36
4.4	Overview	40
5	Microscopic Traffic Simulation Model - Implementation in VISSIM	45
5.1	Setting up the VISSIM environment	46
5.2	Vehicles approaching an intersection	48
5.3	Vehicles approaching in Platoon	52
5.3.1	Platoon following the strategy	54
5.3.2	Platoon with higher priority	55
5.4	Measuring Scalability	57
5.5	Overview	59
6	Effectiveness assessment from VISSIM implementation	61
6.1	Performance Indicators	61
6.2	Intersection with Strategy versus Traffic Lights	64
6.3	Platoon with Priority versus Platoon without Priority	67
6.4	Overview	70
7	Conclusion and Recommendation	71
7.1	Theoretical Framework	71
7.2	Design Framework	72
7.3	Implementation and Measuring Effectiveness	73
7.4	Critical Reflection	76
7.5	Recommendations for further research	77
	References	79
	References	81
A	Appendix : Pseudo Codes	85
A.1	Pseudo code for V2V communication	85
A.2	Pseudo code for deciding preference	85
A.3	Pseudo code for determining safe crossing time and new speed	87
B	Appendix Title	89
B.1	Separating Axis Theorem	89

List of Figures

1.1	Garonne robot developed by Technolution	3
1.2	Vehicles at an Intersection	5
3.1	Vehicles at an intersection	18
3.2	Different Network Types	19
3.3	A basic Intersection scenario	20
3.4	Trajectory of two vehicles at an intersection	21
3.5	Time to conflict point based gap adjustment logic	23
3.6	Developed Architecture	25
3.7	Identifying vehicles in a platoon	27
4.1	Architecture of USARSIM	30
4.2	Structure of the code	31
4.3	Calculation of desired heading	32
4.4	Robot trajectories in the intersection	35
4.5	Instantaneous Speed profiles of robots	36
4.6	Platoons adhering to the strategy	37
4.7	Trajectories of robots - Platoon without priority	38
4.8	Inter robot distance - Platoon without priority	39
4.9	Instantaneous speed profiles - Platoon without priority	40
4.10	Priority to platoon	41
4.11	Platoon approaching an intersection	41
4.12	Platoon approaching an intersection	42
4.13	Trajectories of robots - Platoon with priority	42
4.14	Inter robot distance - Platoon with priority	43
4.15	Instantaneous Speed Profiles - Platoon with priority	43

5.1	Hierarchichal model for implementation in VISSIM	46
5.2	Developed intersection in VISSIM	48
5.3	Vehicles maneuvering in the network	49
5.4	Vehicle trajectories in the network	51
5.5	Instantaneous Speed Profiles	51
5.6	Acceleration profiles	52
5.7	Jerk profiles	52
5.8	Vehicle trajectories - Platoon without priority	54
5.9	Instantaneous speed profiles - Platoon without priority	55
5.10	Acceleration profiles - Platoon without priority	55
5.11	Jerk profiles - Platoon without priority	56
5.12	Vehicle trajectories - Platoon with priority	56
5.13	Instantaneous speed profiles - Platoon with priority	57
5.14	Acceleration profiles - Platoon with priority	57
5.15	Jerk profiles - Platoon with priority	58
5.16	Comparison of CPU vs Simulation time	58
6.1	A visual representation of different measures for surrogate safety	64
6.2	Sample model regression coefficients for Hydrocarbon	66
B.1	Separating Axis Theorem	89

List of Tables

2.1	Summary of literature dealing with the networking aspect of automated vehicles .	11
2.2	Summary of literature dealing with effectiveness of a strategy in traffic	14
6.1	Comparison of Performance Indicators for Traffic Flow Efficiency	65
6.2	Comparison of Performance Indicators for Sustainability	66
6.3	Performance Indicators for Surrogate Safety for Intersection with Strategy	67
6.4	Comparison of Performance Indicators for Traffic Flow Efficiency in the platoon scenario	68
6.5	Comparison of Performance Indicators for Sustainability in the platoon scenario .	68
6.6	Performance Indicators for Surrogate Safety for scenario with Platoon without priority	69
6.7	Performance Indicators for Surrogate Safety for scenario of Platoon with priority	69

Acknowledgments

I would like to express my sincere gratitude towards my daily supervisor Dr.ir. Meng Wang for his assistance during the entire duration of this thesis. His invaluable contribution and constant guidance have been the compelling forces behind the successful completion of this thesis. He always had a solution to every problem and encouraged me to push my boundaries as a researcher. I thank him for his valuable insights and especially for teaching me not to give up at any point, a valuable trait that will help me grow as a researcher and a human being.

I would like to thank Martijn van den Heuvel from Technolution, for being such a wonderful coach and for having patience with me during the entire duration of this research. His input during the course of this research has not only led to good results but has also helped me develop my programming and decision making skills to a great extent. He always made sure that I am comfortable as an intern. Moreover he made sure that the expectations of the university and company are in line with each other so that things do not get highly complicated for me. I hope every student gets a coach like him. I would also like to thank Technolution for giving me this opportunity and the resources to conduct my research program at their company. My entire experience has been surreal and I have learnt a lot from being in such a professional environment.

To Prof.dr.ir.Bart van Arem and Dr.ir. Riender Happee, I would like to provide my sincere appreciation for being on my thesis committee and for their guidance during the entire process. I feel privileged to be under the tutelage of such brilliant academicians who have made me a true Transportation Engineer, that I am today.

Last but not the least, I thank my parents Mr. Sarat Kumar Mishra, Mrs. Chinmoyee Mishra and my younger sister Darshana Mishra for encouraging me during the entire course of the Masters program and for having faith in me even when I failed miserably.

Chapter 1

Introduction

This chapter provides an overview behind the motivation for choosing this topic for research. Firstly an overview of the various problems that people are facing in day-to-day traffic is explained. Intersections are given special attention. This is followed by an overview of how automated vehicles can be useful in solving some of these problems. A brief explanation of how simulation can be used to verify various strategies before implementing those strategies in real life is provided. Afterwards, the problem relevance, the research objective and the methodology followed to achieve the objective is mentioned. Finally, an outline of the entire thesis will also be presented.

1.1 The Present Scenario in Traffic

Over the years, there has been an increase in urban road traffic. Problems like congestion and accidents on roads are a result of this phenomenon. Mobility, Safety and sustainability are highly important in the field of transportation as they have a significant effect on the economic growth of a country and quality of civilian life [1]. Study shows that the Americans have spent nearly 4.8 billion hours of extra time and 3.9 billion gallons of extra gas due to congestion, which is almost 26–30% more than the previous decade [2]. According to the Fatality Analysis Reporting System (FARS) and the General Estimates System (GES) in 2009, 40.1% of all crashes in USA were intersection related crashes [3]. In 2010, a study was conducted by National Highway Traffic Safety Administration (NHTSA) and it was found that 44.1% of intersection related crashes were mostly due to inadequate driver surveillance [4] compared to only 7.3% in non-intersection related crashes. Therefore, finding solutions to ensure efficiency and safety in an intersection is very much imminent.

1.2 Automated Vehicles – A Possible Solution

Over the last few years, lot of research has been carried out in the field of Intelligent Transportation Systems. Automated vehicles form an important part of this domain. In au-

onomous driving, the driving tasks of the driver are taken over partly or completely by the vehicle. The possible advantages of introducing autonomous vehicles on roads have been well documented in various scientific studies. The Dutch Automotive Vehicle Initiative (DAVI) provides the following possible advantages [5].

- With introduction of automated vehicles on roads, the congestion can be reduced up to 50%.
- Automated vehicles are expected to react to hazardous circumstances faster than human drivers. Thus, it aims at complete reduction of accidents of vehicles on roads.
- With decreased level of congestion, the variability of speed of the vehicles will also reduce. Moreover, owing to their efficiency and speed control mechanisms, automated vehicles are expected to improve energy efficiency by 20%.
- Automated Vehicles will also provide better travelling experience.

All the above factors, encourage the introduction of automated vehicles on roads. However, it is to be understood that the above advantages have been concluded based on theoretical studies and comparing real life situations with modeling of systems related to automated vehicles. It is not easy to draw straightforward relationship between traffic flow scenarios and automated vehicles [5]. Different factors shall influence the adaptation of automated vehicles on roads. Therefore, determining the effect of autonomous driving in real world scenario is necessary. Though traffic regulations and strategies for controlling traffic flow have been defined for a lot of countries by their respective government and researchers, the evaluation of different strategies at real locations is difficult owing to various issues such as legal restrictions, user acceptance, availability of vast possibilities, limitations of the controllers and financial constraints [6].

1.3 Importance of Simulation

As mentioned above, evaluation of strategies at real location gets difficult and tedious due to various reasons. In such cases, simulation can play an important role in determining the effectiveness of the proposed strategy. Simulation is imitating a real world system and studying its evolution over time [7]. Over the years, simulation has been used by transportation engineers to model networks, strategies, traffic flows and analyze changes in these paradigms in many ways. The impact of any strategy, network design or a new plan to be implemented can be first modeled in a simulation platform and its various effects can be foreseen. Moreover, comparison studies can be carried out between different designs and strategies to identify the various advantages and disadvantages involved in each of them. This way necessary changes can be made to the strategies before implementing them in real life.

1.4 Problem Relevance & Description

As statistics go, intersections represent the bottleneck of flow of traffic in many cities [8]. Therefore, evaluation of strategies for efficient maneuvering of vehicles at the intersections

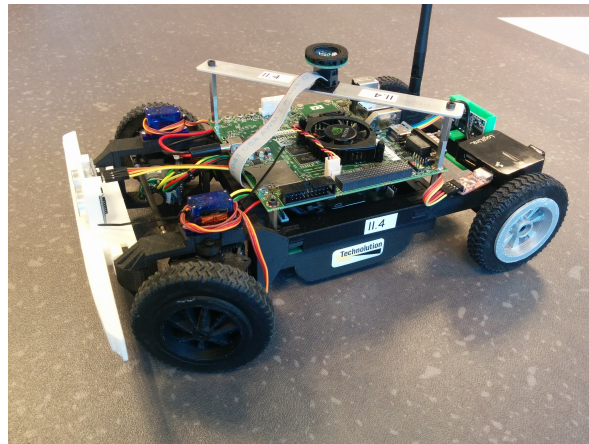

Figure 1.1: Garonne robot developed by Technolution

becomes really important. The usual method of using traffic lights in intersection is inefficient as it requires vehicles to remain stopped even at times there are no cars at the intersection [9]. As described above, with the introduction of automated vehicles, a lot of these problems can be solved.

The research aims at developing a distributed control strategy for the automated vehicles to maneuver in an unsignalized intersection using Vehicle to Vehicle(V2V) communication. The two main aspects of this research are establishing a V2V communication among the robots that allows them to exchange information and be involved in decision making. Subsequently, the developed strategy shall be tested for scalability and effectiveness in a simulator that supports real traffic conditions. The strategies shall first be tested in USARSim (Urban Search and Rescue Simulation) which is a high fidelity robot simulator that is built on top of a game engine [10] for demonstrating the aspects of V2V communication. Once the networking aspect of the research has been established, the strategy shall be implemented in VISSIM which is a microscopic traffic simulator [11] for assessing the scalability and effectiveness of the strategy in realistic traffic scenarios. After the simulation results are deemed to be successful and the strategies have been assessed on the grounds of effectiveness, practical experiments shall be carried out with the Garonne robots. The model based implementation part using Garonne robots has been kept out of the scope of this research. However a basic description of the developed environment for model based testing has been provided below.

Figure 1.1 shows a Garonne robot. The tires to the left are its front wheels. The specifications of the vehicle are as follows.

- Scaled to 1/20 of actual vehicle size
- Four wheel drive and brake
- Regenerative Battery Power
- G5 802.11p communication for realism
- ARM Cortex M0 Wheel Controllers
- ARM Cortex M4 Low Level Controller

- NVIDIA Tegra K1 High Level Controller

The final objective is to implement the developed strategy on the robots developed by Techno-lution. However this research only deals with developing the necessary strategy and assessing the various impacts through simulation. Therefore the model based testing part is kept out of the scope of this research.

1.5 Research Objective

The main objective of this research is to develop a distributed control strategy for easy maneuvering of automated vehicles at the intersections without the use of traffic lights using V2V communication and assess its effectiveness in traffic. Since the strategy needs to be distributed in nature, every vehicle acts as an individual agent and needs to make suitable decisions based on negotiations with other vehicles in the network using V2V communication. Based on the above description, the research question for the assignment can be formulated as follows.

How to develop a distributed control strategy for aiding automated vehicles to maneuver in an unsignalized intersection using V2V communication?

The sub research questions are:-

- What is a distributed control strategy and how is this strategy being used from the point of this research?
- What are the various strategies proposed in literature to solve the problem of maneuvering of automated vehicles in the intersection?
- What is the strategy proposed in this assignment for developing a distributed control system for the intersection?
- What are the various assumptions made to aid this research?
- What is the requirement for incorporating two simulation test beds into the system?
- What are the various grounds for evaluating the effectiveness of the developed strategy?
- What are the impacts (advantages and disadvantages) of the developed distributed control system for the vehicles maneuvering in intersections?

1.6 Methodology

The goal of the assignment is to develop a real time control strategy for the automated vehicles to maneuver efficiently in an intersection towards their destination without requiring guidance from the traditional traffic control systems of the intersection. Both USARSIM and VISSIM shall be used for analyzing the strategy. Using two simulation environments has its own

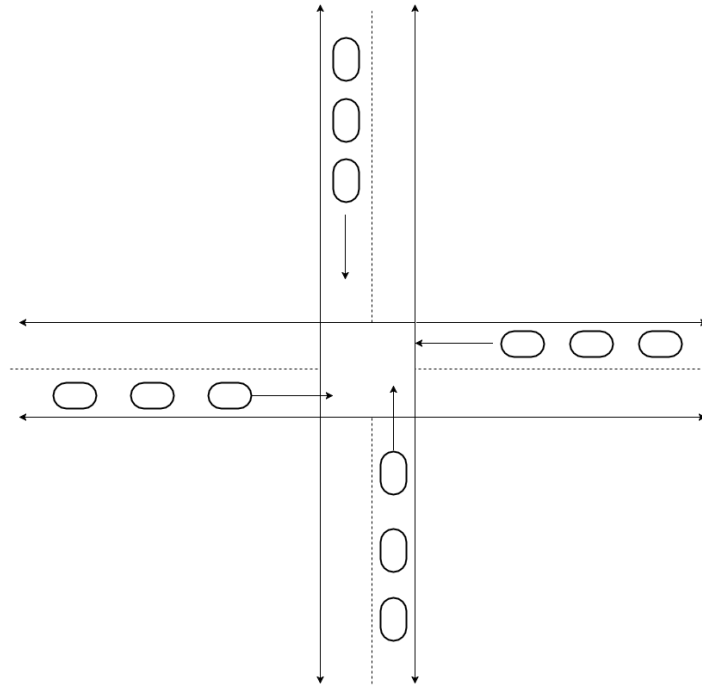

Figure 1.2: Vehicles at an Intersection

benefits. USARSIM shall allow visualization of robots maneuvering in a virtual intersection scenario using V2V communication. The process of decision making and networking among the robots can be assessed through USARSIM and therefore it can be established whether such a strategy is possible to be implemented using V2V communication. Since the developed strategy shall be tested with automated robots moving in an environment without relevant infrastructure, part of the strategy would be to find the possible points of collisions while the robots are maneuvering. Those points will serve as intersections for this research. Since this research is being done from an intersection point of view, the trajectory of robots will not be changed. Proper strategy shall be defined to first find the collision spots and then based on priority reduce the speed of one or more robots. It may be fair to conclude that it is not practical to assess the scalability and efficiency of the developed strategy in USARSIM due to space and CPU memory constraints. Also developing a true intersection scenario is difficult in USARSIM. Therefore to assess the effectiveness of the strategy in true traffic conditions, VISSIM shall be used. For the purpose of the research, an example of a potential intersection has been shown below. Automated vehicles are originating on every link and moving towards the same goal. Figure 1.2 provides an illustration of the above description.

It is to be noted that, the figure is an example of a scenario which shall be created in USARSIM. For assessing the effectiveness of the strategy in VISSIM a more realistic scenario shall be used.

To begin the research, a literature survey has to be carried out. Relevant concepts and implementation of various strategies in traffic and specially at intersections shall be studied. Analysis of different strategies suggested in literature shall be a stepping stone towards developing a strategy for the automated vehicles to maneuver in the intersection using V2V communication. Based on concepts and ideas from the literature study, an architecture shall

be designed that explains the functioning of the entire research at every level. Every level in the developed architecture shall play an important role in determining the effectiveness and efficiency with which the strategy is implemented. Upon developing the architecture, the main strategy shall be discussed and developed. This strategy shall constitute the core of this research. Various assumptions that are necessary to aid the implementation of strategy shall also be presented. Once the strategy has been established, it will be implemented in both USARSIM and VISSIM.

The other two main aspects of this research are use of V2V communication by automated vehicles to adhere to the strategy and maneuver the intersection by avoiding collisions with other vehicles and assessment of the effectiveness of the developed strategy in proper traffic conditions on the grounds of traffic flow efficiency, sustainability and surrogate safety. To check whether automated vehicles are able to follow the developed strategy in the absence of any central controller, the platform of USARSIM shall be used. Automated robots in USARSIM shall be allowed to negotiate with each other using V2V communication and take proper decisions for maneuvering of the desired intersection. Based on their maneuver, trajectories shall be extracted and the behavior of vehicles shall be analyzed.

Upon successful implementation of the developed strategy in USARSIM, the strategy shall be applied to VISSIM to assess the effectiveness of the strategy in real traffic conditions. This process shall include the design of a more realistic intersection where vehicles shall be introduced from different lanes. Based on the results of the VISSIM simulation, the developed strategy shall be assessed on three important grounds. They are Traffic Flow Efficiency, Sustainability and Surrogate Safety Assessment. Various performance indicators shall be used in each of those areas to suggest the effectiveness of the developed strategy. This effectiveness study shall be carried out based on comparison with traditional system of using traffic lights at an intersection.

All the simulations have been carried out through the external codes written in Python 2.7. All the softwares are installed and operated on a 64-bit Operating System with 8GB RAM processor.

1.7 Thesis Outline

The following is the outline of the entire thesis. Chapter 2 provides a summary of relevant literature in this field. Chapter 3 deals with a detailed research approach for formulating a proper strategy for the problem at hand. Chapter 4 deals with the implementation of the developed strategy in USARSIM and its results. Chapter 5 deals with the implementation of the strategy in VISSIM and discussion of its various results. Chapter 6 provides an effectiveness study of the developed strategy through proper comparison in real traffic conditions in the VISSIM environment. Chapter 7 presents the overall result of the research, concluding remarks, critical reflection and scope for further research.

Chapter 2

Literature Review

This chapter provides the literature review for the relevant concepts used in this research. The research deals with developing strategies for the automated vehicles to maneuver in an intersection without colliding by engaging in V2V communication among each other. Besides developing a distributed control strategy, the two other important aspects of this research are establishing the networking aspect and assessing the effectiveness of developed strategy in traffic conditions. For both the above mentioned aspects, inspiration shall be drawn from other related research available in scientific literature.

The chapter has been divided into two sections. The first section showcases literature reviews that deal with implementation of different communication protocols among automated vehicles or robots and the infrastructure to pursue a developed strategy. Even though the research deals with only the implementation of V2V communication, research related to the use of both V2V and V2I communication has been studied. The second section deals with specific research work that assess the effectiveness of a strategy on the grounds of traffic flow efficiency, sustainability and safety. Information gained from these research works shall form the stepping stone towards developing a distributed control strategy for the focused research problem and verifying the utility of the developed strategy on various grounds.

2.1 Networking aspects in scientific literature

Kato *et al.* [12] have proposed a vehicle control algorithm for automated vehicles to drive cooperatively using inter vehicle communication. Special attention has been devoted to platoon formations by automated vehicles in traffic. Various aspects like lane changing, merging and exiting of vehicles from a platoon have been studied using the algorithm proposed. The automated vehicles are equipped with proper lateral and longitudinal control functions. For the purpose of inter-vehicle communication, the protocol used is based on carrier sense multiple access(CSMA). The CSMA is of two types, the non persistent CSMA and p-persistent CSMA. Through simulation it was found that the non persistent CSMA has better performance during packet loss. The developed algorithm was implemented on five automated vehicles in

Japan. It was concluded that the inter vehicle communications play an important role in the efficiency of the platoon behavior.

Grünwald *et al.* [13] have used Khepra mini robots to demonstrate their algorithm for autonomous intersection management of vehicles. Radio communication is used by Khepra robots for communicating with each other and finding a collision free path to maneuver in an optimal time. The algorithm proposed is distributed in nature. Every robot makes a decision on the path that it wants to travel. The intersection is divided into four sectors and the path of the robot is stored as a list of sectors that it passes. Every robot tries to identify other robots that are in the planning zone. This is accomplished by broadcasting the entire list of the possible trajectory of other robots in the planning zone. The robots that receive this path stores the received trajectory and then assigns priority to each robot. The priorities assigned are based on right of way. Based on the priority assigned, robots maneuver the intersection or stop to allow higher priority robots to maneuver first. The experiments conducted with mini Khepra robots concluded that the algorithm has a good impact if proper bandwidth is available for radio communication.

Raravi *et al.* [14] have proposed an algorithm for merging of intelligent vehicles in a cooperative vehicle infrastructure environment. This algorithm ensures safe maneuver of vehicles where two roads intersect. For the purpose of implementing the strategy, the authors assume the presence of V2V and V2I communication. Two approaches towards devising this algorithm has been proposed where both aim at minimizing the driving time to the intersection. The first approach is based on formulation of an objective function that minimizes the driving time to the intersection using vehicle kinematics and the second approach is more of an intuitive approach known as the "Head of Lane (HOL)" algorithm. The HOL algorithm is based on a *first come first serve* basis. It can be related to the way in which manually driven vehicles behave at an intersection scenario. Using the MATLAB Optimization toolbox and a simulation platform . The HOL algorithm is able to incur less computational power as compared to the optimization approach.

Milanés *et al.* [15] have developed a controller for urban intersection using V2V communication and fuzzy logic. The developed concept is used for implementing an intelligent crossroad-traversing system that can help in improving traffic flow and reduce jams. The V2V communication is used to share the position and speed of vehicles with each other in an intersection. Based on the shared data, the conflict points are estimated. Based on the estimated conflict point, the fuzzy logic based controller calculates new speed for vehicles with right of way. The developed concept was implemented in a car using a low cost system with a DGPS and wireless communication. Based on the practical experiments, it was concluded that the fuzzy controller is able to provide excellent results and proper maneuvering in the intersection.

Milanés *et al.* [16] have demonstrated the result of using both V2V and V2I communication on the problem of crossing an intersection of 3 automated vehicles developed by Spain, France and The Netherlands. This test was conducted in France. These vehicles communicated via Wi-Fi using the OLSR (Optimized Link State Routing) ad hoc protocol. A cooperative control logic was designed to manipulate the maneuvers of the automated vehicles in a two way single lane approach. The cooperation among the three vehicles was achieved by using a 4G cube communication architecture. Two of the experiments were conducted with Adaptive Cruise Control (ACC) with the stop and go extension based on V2V communication. It was

demonstrated that those vehicles were able to drive at low speed in a closed environment and were also able to follow a leading vehicle. Two experiments were conducted to test the maneuvering of the automated vehicles in an intersection. It was demonstrated that when a vehicle was crossing the intersection possessing the right of way, the automated vehicles responded and stopped at the intersection to allow the vehicle to pass. One of the experiment was conducted to demonstrate the functionality of V2I communication. All the three vehicles started from different points in the network. Once the central controller detected a risky situation, it used to activate the emergency stop signal and all the vehicles came to a halt. The central controller sent various commands to the automated vehicles while maneuvering and the vehicles responded properly in the network according to the received messages. The experiments conducted properly demonstrated the fact that using V2V and V2I communication among vehicles in a network allows minimizing the impact of accident and improves safety.

Wu *et al.* [17] have suggested an ant colony system for the purpose managing an autonomous intersection. The developed system makes an explicit assumption that vehicles negotiate according to the right of way. The proposed strategy aims to control the traffic through an intersection using the positioning data of the vehicles and wireless communication. The strategy uses a heuristic based approach through an ant colony system algorithm in order to obtain sequences of passing vehicle through the network quickly. It is stated based on review from literature that a proper arrangement of passing sequence shall help in enhancing the efficiency of traffic. The basic objective of the algorithm is to come up with the best solution possible for the optimization problem using the concept of ant colony. The distance of a vehicle to a possible conflict point and headway time of each vehicle is used by the ant colony algorithm to improve the sequence of vehicles that are passing through the network. Through simulation, it was concluded that the proposed system is more efficient than the adaptive traffic light controller.

Neuendorf *et al.* [18] have proposed a decentralized autonomous intersection management platoon controller that carries out various optimization procedures to find optimum maneuver through the intersection while approaching it. To meet such a requirement the controller takes into account the temporal distance between two vehicles for analysis except for the spatial distance. The temporal distance is defined as the time required by a following vehicle to reach the position of its leading vehicle. The controller behavior is similar to human behavior based on the fact humans also try and maintain a temporal distance with the vehicle that is ahead of it. The controller has to maintain a minimum temporal distance between their leading vehicles such that even at full braking conditions there is no collision. Two variations of platoon controller are developed for this process. The first variation of the speed of the following vehicle is derived taking into account its acceleration. The second variation is derived by assuming that the acceleration of the following vehicle is not taken into account. Both the variations were examined through simulation. On performing simulations it was concluded that the controller that calculates the speed based on acceleration was able to compensate for deviations in the temporal distance faster than the variation of the controller where acceleration of the vehicle is not taken into account.

Michaud *et al.* [19] have proposed a coordination strategy for the maneuvering of automated vehicles in a platoon. The developed strategy was distributed and no central controller was used. Therefore instead of assuming that the leader vehicle of the platoon monitors all the activities, the individual vehicles were in charge of decision making based on their possible

maneuvers. The coordination strategies were applied with different variations of communication like no communication, unidirectional communication, bidirectional and centralized communication and subsequently compared. Practical experiments were conducted with three mobile robots and it was concluded that automated vehicles in a platoon should be able to localize each other. Therefore proper communication among vehicles is necessary. The robots performed worst when there was no communication among them. It was also found that the distributed strategy with unidirectional and bidirectional communication were not as effective as a centralized strategy, however they enabled robots to maneuver properly in the platoon. Unidirectional communication was better when a vehicle is merging into the platoon and a bidirectional communication was better when a vehicle is leaving the platoon. Therefore it was concluded that instead of using one strategy, multiple strategies should be used for vehicles in platoons to increase the robustness and efficiency of the system.

Table 2.1 presents a brief explanation of all the studied literature reviews in a tabular form regarding the networking aspect.

2.2 Scientific literature dealing with effectiveness of a strategy in traffic

Lee *et al.* [1] have developed a Cooperative Vehicle Intersection Control(CVIC) Algorithm that engages in both V2V and V2I communication for allowing automated vehicles to maneuver safely in the intersection without colliding with each other. Vehicles are assumed to be only passenger cars and fully automated. The CVIC algorithm manipulates the trajectory of individual vehicles and eliminates the potential overlap of vehicular trajectories so that the collisions can be prevented at the intersection. The algorithm is implemented through a "Predictive Trajectory based Optimal Safe Gap Adjustment Logic". A non linear constrained objective function has been formulated that minimizes the trajectory length of individual vehicles by taking into account various constraints like the allowed maximum acceleration and deceleration rates, maximum and minimum speed of the vehicles and maintaining a minimum headway between the vehicles. The objective function is solved three different ways using an Active Set Method, Interior Point Method and by using Genetic Algorithm. An important part of the CVIC algorithm is the recovery mode where the algorithm is able to handle exceptional solution failure cases. If an optimized solution is found, the optimization process terminates and the solution is stored in a database. However, if no solution is found, a previous solution is used from the database. On comparison with a conventional actuated intersection control, it was found that the CVIC algorithm improved the intersection performance for stop delays by 99% and the travel time reductions by 44%. Additionally 44% decrease was found in both the CO₂ emissions and fuel consumptions.

Zohdy *et al.* [20] have developed a simulation/optimization tool called iCACC that optimizes the movement of vehicles equipped with CACC. The developed system uses both V2V and V2I communication for ensuring that vehicles are able to maneuver the intersection without colliding with each other. The intersection controller receives requests from vehicles to maneuver the intersection and provides an optimum course of action to each vehicle which ensures that not only crashes are avoided at the conflict points, but also that intersection delay is minimized. The research also takes into account vehicle dynamics, weather conditions and

Author	Developed Strategy	Implementation Technique	Results
Kato <i>et al.</i> [12]	Vehicle control algorithms for Platoons	Tested on 5 automated vehicles	The robustness of inter vehicle communication is important
Grünewald <i>et al.</i> [13]	Zone approach distributed control algorithm based on analysis of robot's path	Model Based Testing using Khepra mini robots	Communication bandwidth influences the success/failure
Raravi <i>et al.</i> [14]	Automatic Merge Control System with two approaches. 1) Minimizing driving time using vehicle kinematics. 2) Head of lane (HOL) algorithm	Simulation	Both approaches ensure safe vehicle maneuvering. However, HOL incurs less computational power compared to the other approach
Milanés <i>et al.</i> [15]	A controller based on fuzzy logic for autonomous vehicles in urban intersection	Experimented on one manual and one automated mass produced cars on real circuit	Automated vehicle outperforms the manual vehicle in terms of efficient braking and accelerating.
Milanés <i>et al.</i> [16]	A controller based on fuzzy logic for autonomous vehicles in urban intersection	Experimented on one manual and one automated mass produced cars on real circuit	Automated vehicle outperforms the manual vehicle in terms of efficient braking and accelerating.
Wu <i>et al.</i> [17]	Heuristics based approach towards managing an autonomous intersection using ant colony optimization	Simulation	Proposed strategy outperforms adaptive traffic light controller
Neuendorf <i>et al.</i> [18]	Decentralized autonomous intersection management platoon controller	Simulation	Better control when acceleration is taken into account for calculating desired speed
Michaud <i>et al.</i> [19]	Coordination strategy for maneuvering of automated vehicles in a platoon	Practical experiments with three mobile robots	Combination of different network types are more efficient than using a single network type

Table 2.1: Summary of literature dealing with the networking aspect of automated vehicles

penetration rate of automated vehicles in traffic flow scenarios. Four case scenarios related to intersection were compared; a traffic signal, an all way stop control(AWSC), a roundabout and an iCACC control scenario. It was concluded that the developed iCACC system is able to reduce the average intersection delay by 90% and fuel consumption by 45%.

So *et al.* [21] have integrated a vehicle dynamics model with a microscopic traffic simulation model in order to assess surrogate safety. The integration of vehicle dynamics into the microscopic simulation model allows generation of realistic vehicle trajectories which was validated by comparing vehicle trajectories from VISSIM with NGSIM (Next Generation Simulation) data for a straight road section. Along with the vehicle dynamics model, a driver aggressiveness model was also incorporated into the microscopic simulation model. Vehicle trajectories were then extracted and possible conflicts were identified through the SSAM (Surrogate Safety Assessment Model) developed by Federal Highway Authority, USA. The proposed integrated approach had 9.5% fewer traffic conflicts compared to the microscopic simulation model only approach.

Guler *et al.* [22] have proposed an algorithm to optimize traffic operations at an intersection using connected vehicle technology assuming a certain penetration rate. Two types of information are recorded from each vehicle having the technology. They are the time at which the vehicle enters the zone of interest, which is an area within a certain radius of the intersection and the distance from the intersection where the vehicle joins the queue. For collecting information from the vehicles that are not equipped with the technology, loop detectors are assumed to be present on each approach to the intersection. Information from the loop detectors can also be used to estimate the departure time of the vehicles in the network from the intersection. The basic objective of the developed algorithm is to minimize the delay or stops during the maneuver by utilizing the received information. Simulation studies are carried out in order to realize the effect of changing the minimum green time at the intersection and the penetration rate of connected vehicles at different demand levels. The results from the simulation have indicated that with a penetration upto 60% for connected vehicles, drastic decrease in delay can be observed.

Lee *et al.* [23] have implemented the connected vehicle intersection control (CVIC) algorithm [1] to a corridor consisting of multiple intersection. The safety and sustainability aspects of the implementation have also been investigated by incorporating the SSAM software developed by FHWA, USA for analyzing the possible conflicts by taking into account the trajectories of the simulation and VT-Micro Model [24]. The simulation is carried out in VISSIM using the Component Object Model (COM) interface, enabling real time data exchange among the individual vehicles in the simulation environment. The optimization methods were implemented using the MATLAB scripting language. On implementation of the algorithm for the corridor, it was found that the CVIC algorithm was able to reduce the total delays from 82% to 100% compared to actuated signal control. The rear end crashes reduced from 30% to 87% and the fuel consumption decreased from 11% to 37%.

Ahmane *et al.* [25] have proposed a new traffic control concept involving cooperative vehicles for an intersection. The proposed model is based on Timed Petri Nets with Multipliers (TPNM) Each vehicle is assumed to be equipped with proper equipments to communicate wirelessly with other vehicles in their neighborhood. Every vehicle on arriving at the intersection requests a "right of way". The negotiation among the vehicles consists of information exchange related to the latest position of the vehicles. There are two colors taken into ac-

count. "Red" when the vehicle does not have a right of way and "Green" when the vehicle has received a right of way. The sequence of vehicles that are allowed to traverse the intersection are formed dynamically through real time application. Results from microscopic simulations and practical experiments with 4 vehicles prove that the developed strategy performs almost as good as the classical scheduling algorithms applied to isolated intersections.

Kamal *et al.* [26] have proposed a coordination scheme for maneuvering of automated vehicles at an unsignalized intersection. The important characteristic of the proposed scheme is the global coordination which is accounted for by considering the states of all the vehicles together. The objective is to minimize the cross collision risks of the autonomous vehicles at the intersection without taking aid from traffic lights. Instead of reserving the whole intersection, Cross Collision Points (CCP) are estimated from the states of the vehicle and the coordination scheme tries to prevent collision by maintaining a time gap between two vehicles to reach the same point. Relevant constraints are introduced that ensure turning movements of vehicles in the intersection under the proposed velocity limits. Communication among the vehicles happen in a centralized manner through an intersection coordination unit (ICU) that stores basic information like position, speed and destination of the vehicles and also sends proper commands to them after the computing their control inputs. A risk function is introduced into the scheme that quantifies the risk of a collision when a pair of vehicles are around their CCPs. If the distance between the vehicles is less, the value of the risk function is high and if the distance is large, a negligible value is returned. By taking into account the states of the vehicles, a non liner optimization problem is solved in a Model Predictive Control framework. The AIMSUN microscopic traffic simulator is used to implement the developed strategy for the intersection. The results from the simulation indicate that the efficiency of the the proposed framework is better than a traditional signalized intersection scheme in terms of flows, idling time, crossing time and fuel consumption.

Table 2.2 presents a brief explanation of all the studied literature reviews that deal with analyzing the effectiveness of any strategy in traffic scenarios.

2.3 Overview

A lot of researchers have contributed to the research of maneuvering of automated vehicles at the intersection through different strategy types and procedures. Review of relevant literature indicates that improving flows at intersection do have significant impact on the overall traffic flow. Significant amount of work has been found that suggest different strategies by taking into account different network types like centralized, decentralized, distributed and their possible combinations. A lot of research has also been carried out from an experimental point of view where robots or automated vehicles use radio communications to negotiate among each other and to maneuver in an intersection without colliding. These research do establish the networking aspect of the developed strategy. Finally, a lot of research is based on experiments using microscopic traffic simulators to study the impact of the developed strategy in traffic scenarios. It was found that a lot of researchers use the assumption of both V2I and V2V communication for the purpose of cooperative driving.

Very few research was found that provide an overview on all the important aspects. The important aspects from the point of view of this research is developing a strategy that is

Author	Developed Strategy	Implementation Platform	Results
Lee <i>et al.</i> [1]	Connected Vehicles Intersection Control (CVIC) algorithm	VISSIM	99% reduction in stop delays, 44% reduction in travel time, 44% reduction in both CO_2 emission and fuel consumption
Zohdy <i>et al.</i> [20]	Intersection Cooperative Adaptive Cruise Control Concept	iCACC Simulation/Optimization tool	Decrease in average intersection delay by 45% and fuel consumption by 90% compared to traditional traffic signals
So <i>et al.</i> [21]	Integration of vehicle dynamics to a microscopic simulation model to measure the impact on safety	VISSIM	9.5% fewer traffic conflicts for the vehicle dynamics integrated environment
Guler <i>et al.</i> [22]	Optimization of traffic operations using connected vehicle technology	Matlab Simulation	Drastic decrease in delay for a penetration rate upto 60% for automated vehicles
Lee <i>et al.</i> [23]	Extension of the CVIC algorithm to measure sustainability	VISSIM	Reduced total delays from 82% to 100%, rear end crashes from 30% to 87% and the fuel consumption from 11% to 37% compared to actuated signal control
Ahmane <i>et al.</i> [25]	Cooperative traffic control concept based on Timed Petri Nets with Multipliers	Practical experiments and microscopic simulation	Results as good as classic scheduling algorithms
Kamal <i>et al.</i> [26]	Automated vehicles coordination scheme at an unsignalized intersection	AIMSUN Traffic simulator	Better results in terms of flow, idling time, crossing time and fuel consumption compared to a traditional signal controller

Table 2.2: Summary of literature dealing with effectiveness of a strategy in traffic

possible to be implemented for the present problem at hand, ensuring that the networking aspect of the strategy is feasible to be implemented using a distributed approach and measuring the effectiveness of the developed strategy in realistic traffic scenarios on various grounds. Therefore this research aims to provide an insight into all the important points related to the problem of maneuvering of automated vehicles at an intersection. Based on relevant concepts from literature, first a strategy shall be developed. Once the strategy is in place, the networking aspect of the research shall be validated. Using the platform of USARSIM, V2V communication shall be set up among differential drive robots to ensure that indeed it is possible to execute the strategy through V2V communication and without the presence of any central controller. Once the networking aspect of this research has been established, simulation experiments shall be conducted in VISSIM, a microscopic traffic simulator. The strategy shall be implemented in more realistic traffic networks designed in VISSIM and based on the results, the effectiveness of the strategy shall be assessed on the grounds of traffic flow efficiency, sustainability and surrogate safety.

Development of the strategy for the Intersection

This chapter describes the development of the distributed strategy for automated vehicles to maneuver in an intersection. Based on review of relevant literature, certain concepts will be used to develop the distributed strategy. It is to be noted that various factors will influence the success or failure of the proposed strategy. Since consideration of all such possible factors is not feasible in the scope of this research, certain assumptions will be made to aid the development of the strategy and its implementation. The strategy developed will form the base for this research. Once the strategy is in place, an architecture will be defined that will support the strategy at various levels. Subsequently the approach used to considering special scenarios like when vehicles are part of a platoon are also discussed.

3.1 Problem Definition

Figure 3.1 shows a possible intersection scenario where vehicles are approaching the intersection box from different lanes with a certain speed. If the speed of the vehicles are unaltered, a potential collision can be expected at the conflict point as shown in the figure. One of the traditional ways of avoiding such collisions at an intersection is the use of traffic lights. Vehicles approaching on different lanes are enabled to maneuver the intersection safely through the display of green signals. However as mentioned before, such methods are not efficient enough to improve the overall traffic flow due to frequent stopping and idling of vehicles during the entire process. Moreover, unnecessary stopping and idling of vehicles at intersections lead to queuing and stop delays for vehicles, which in turn lead to increased vehicular emissions [27]. Therefore a proper strategy needs to be in place that helps automated vehicles to maneuver the intersection without any guidance from traffic lights.

Obstacle avoidance is an integral objective of any intersection management system. However it should not be the only concerning issue. Once a strategy has been developed, it is necessary to ensure that implementation of such a strategy is practically feasible in the necessary

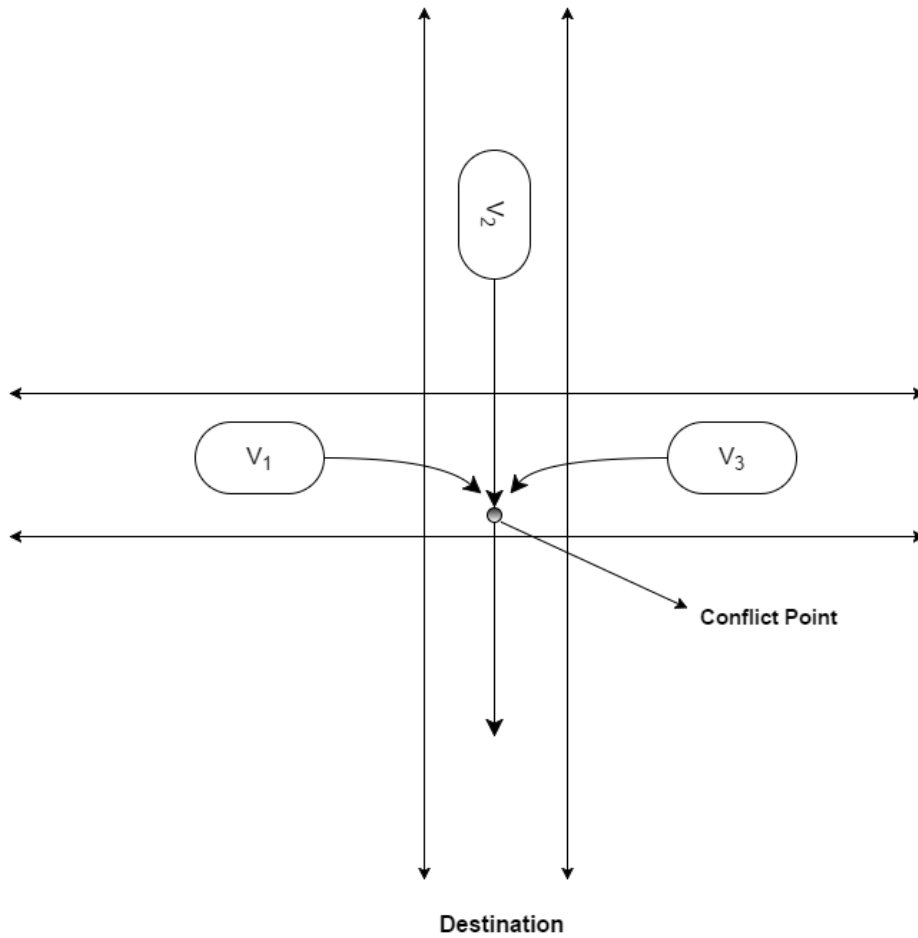

Figure 3.1: Vehicles at an intersection

environment. Moreover once the strategy is at place, it is necessary to examine whether the implementation of such a strategy is advantageous in terms of improving the overall transport efficiency in various facets like traffic flow, sustainability and safety.

3.2 Assumptions

For the purpose of developing the relevant strategy for the above problem, various factors have to be taken into account. Elements like vehicle type, level of automation, vehicle dynamics, weather conditions, networking capabilities and constraints of the traffic will play an important role in determining the effectiveness with which the developed strategy is pursued. However not all the above factors have been taken into account in the scope of this research. The following assumptions form the basis for the development process of the strategy.

- Vehicles are fully automated and are equipped with appropriate networking systems to communicate with other vehicles in the network.

- Every vehicle in the network has access to a global map with global coordinates of the network.
- Communication among the vehicles is assumed to be robust and efficient. No communication delay or packet loss is taken into account.
- Vehicles are assumed to obey the rules of the intersection for safe maneuvering.
- Only passenger cars are considered for this research.
- The terrain on which the vehicles travel is completely leveled. So there is no acceleration or deceleration due to the force of gravity.
- Wear and tear of the tires of passenger cars and dynamic weather conditions are not taken into account.

3.3 Development of the Distributed Strategy

The strategy to be developed for the purpose of this research is distributed in its fashion. The other different approaches that are possible to take into account are designing the strategy either as a centralized or decentralized network. Figure 3.2 shows the different network types that are possible to be taken into account [28].

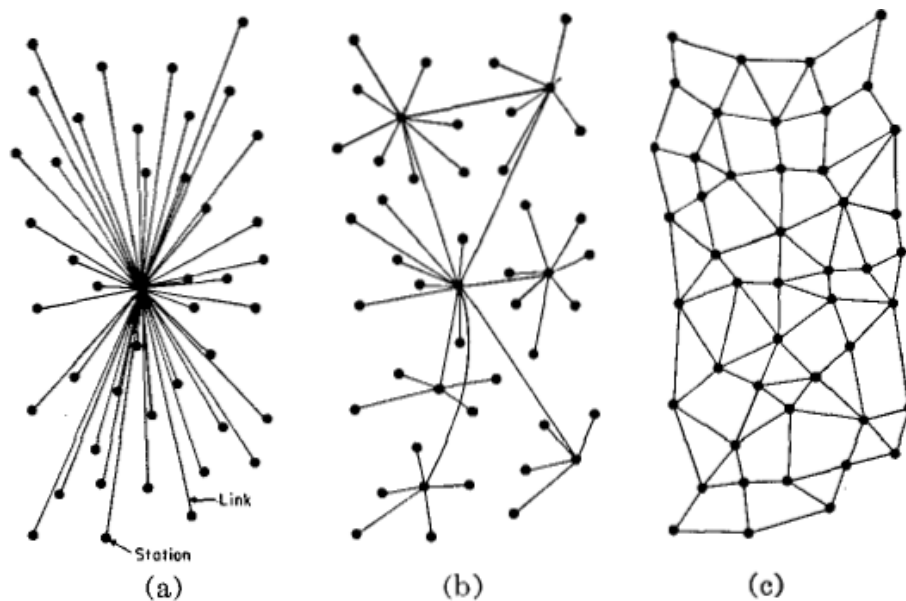

Fig. 1—(a) Centralized. (b) Decentralized. (c) Distributed networks.

Figure 3.2: Different Network Types

It is to be realized that every network type has its own advantages and disadvantages. This research does not focus on deciding which network type is best for the problem at hand. The goal of this research is to develop a distributed strategy for maneuvering of automated

vehicles at an intersection. Therefore, no central controllers are present in the system. Every vehicle acts as an individual agent in the network. Every vehicle in the network is connected to other vehicles by means of Vehicle to Vehicle (V2V) communication. Decisions for safe maneuvering at the intersection are taken by vehicles individually based on their negotiations with other vehicles within their V2V range in the network.

3.3.1 Scenario Description

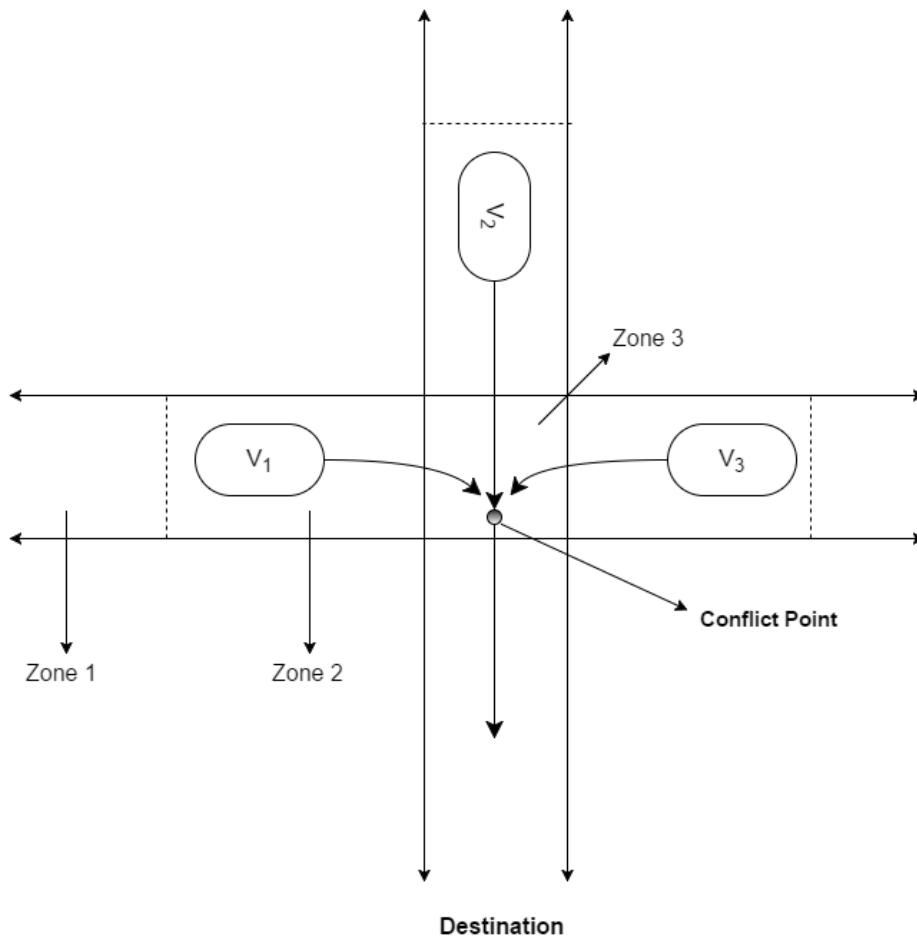

Figure 3.3: A basic Intersection scenario

Figure 3.3 shows the description of a basic intersection divided into various zones. Zone 1 is the region where the vehicles keep moving at their initial speed. The vehicles are aware of the intersection ahead however are oblivious to possible conflict points in the intersection box. Once vehicles have reached Zone 2, they start communicating with other vehicles in other lanes using V2V communication and possible conflict points are identified. In Zone 2, the vehicles start broadcasting their present location and their entire trajectory beyond the intersection to other vehicles on other links in Zone 2 using V2V communication. In Zone 2, vehicles can either maintain their present speed or decelerate based on whether a conflict arises at the intersection. Therefore no speed changes occur in Zone 1. The strategy applied

to the intersection changes the speed of the necessary vehicles such that vehicles are able to maneuver the intersection without colliding at the new speed. Once the vehicles have adjusted their speed such that no collisions occur at the intersection, they maintain their speed till the conflict has been resolved. Once all the conflicts on their respective trajectories have been resolved, vehicles regain their original speed.

3.3.2 Time to Conflict Point based Gap Adjustment Logic

In general, distance traveled by a body in time t can be written as Equation 3.1:

$$x(t) = v_0 * t + 0.5 * a * t^2 \quad (3.1)$$

where $x(t)$ is the distance traveled by the vehicle in time t , v_0 is the initial speed of the vehicle and a is the acceleration.

The network considered in this research is an intersection. Let $x(0)$ represents the initial distance from the intersection. So at every time instant t , the distance left to the intersection is shown in Equation 3.2.

$$\begin{aligned} \text{distance left} &= x(0) - x(t) \\ &= x(0) - v_0 * t - 0.5 * a * t^2 \end{aligned} \quad (3.2)$$

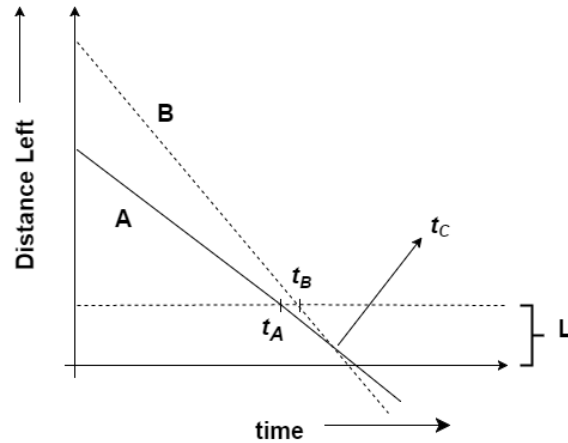

Figure 3.4: Trajectory of two vehicles at an intersection

Figure 3.4 shows the trajectories of two vehicles A and B at an intersection. The y -axis represents the distance left to the end of intersection and the x -axis denotes the time taken by the vehicles to reach specific points. The distance L represents the length of the intersection box. Vehicles A and B enter the intersection at time t_A and t_B respectively. After the vehicles have entered the intersection, it can be seen that since they do not change their speeds, they collide at time t_C . The point at which such a collision may happen among two or more vehicles at an intersection is referred to as a **Conflict Point**. The entering and exiting time of vehicles in and out of the intersection can be easily seen. The objective of the research is to devise a strategy such that proper time gap is maintained between the entry times of the

vehicles at the intersection. Therefore the Gap adjustment logic applied to the intersection in this research is based on the fact that no more than one vehicle should occupy the conflict point in the intersection at a particular time instant.

To achieve the above objective, vehicles will engage in V2V communication with other vehicles in the V2V range. Every vehicle is assumed to have knowledge of its entire trajectory and upon arrival at the intersection starts to broadcast its trajectory details to other vehicles in its V2V range. Similarly, it also receives the trajectory of other vehicles in its neighborhood. Based on the received trajectory, every vehicle identifies the conflict points on its path. Based on the identified conflicts points with other vehicles in the networks, a **Collision Group** is formed. A collision group stores the information of every conflict point of interest for a vehicle along with the details of other vehicles that are part of the same conflict point. Equation 3.3 shows a collision group.

$$\text{Collision Group} = (x_1, y_1) : (V_1, V_2, \dots V_n) \quad (3.3)$$

where (x_1, y_1) represents the conflict point and $(V_1, V_2, \dots V_n)$ represents the vehicles that share the same conflict point.

Once the conflict points have been identified, every vehicle calculates its own time to the conflict point and broadcasts this information to the respective vehicles that are part of the collision group. Based on time to reach the conflict point, the vehicles cooperatively maintain or reduce their speed to maneuver safely inside an intersection. The decision to maintain or reduce the speed is decided cooperatively by allocating preferences to each vehicle in the collision group. The sequence in which the vehicles approaching the intersection shall occupy the conflict point is decided based on the **Rule of Preference**.

After a vehicle has received the time to intersection for all the vehicles in Zone 2, preference of vehicles is decided based on the time to intersection. The vehicle with the lowest time to the intersection gets the highest preference and the vehicle with the longest time to intersection gets the lowest preference. If all the vehicles have the same time to the conflict point, then the rule of the traffic management layer is followed. Vehicles yield to the vehicles coming from right. This is the rule of the intersection that every vehicle must follow. As explicitly mentioned, it is assumed that all the vehicles obey the rules of the intersection.

After the preference values have been assigned to the vehicles, the time gap strategy is applied to every pair of vehicles in Zone 2. Every vehicle checks the time gap of occupying the collision point with the vehicle with the preceding preference value. If the time gap falls below a certain time interval, an extra time gap is added to the lower preferred vehicle. The speed of the lower preferred vehicle is adjusted such that it reaches the conflict point, only after the higher preferred vehicle has crossed the conflict point. The time gap that is added to the lower preferred vehicles is decided on the fact that, the time required by a vehicle to cross a conflict point is equal to the length of the vehicle divided by its speed at that instant. An additional marginal time is also added for extra safety reasons. For this research, the additional marginal time is half of the calculated minimum time gap. The marginal time added with the minimum time gap is referred to as the **Safe Time Gap**.

$$\delta t = \frac{1.5 * l_p}{v_p} \quad (3.4)$$

where δt refers to the safe time gap, l_p is the length of the higher preferred vehicle and v_p refers to the speed of the higher preferred vehicle.

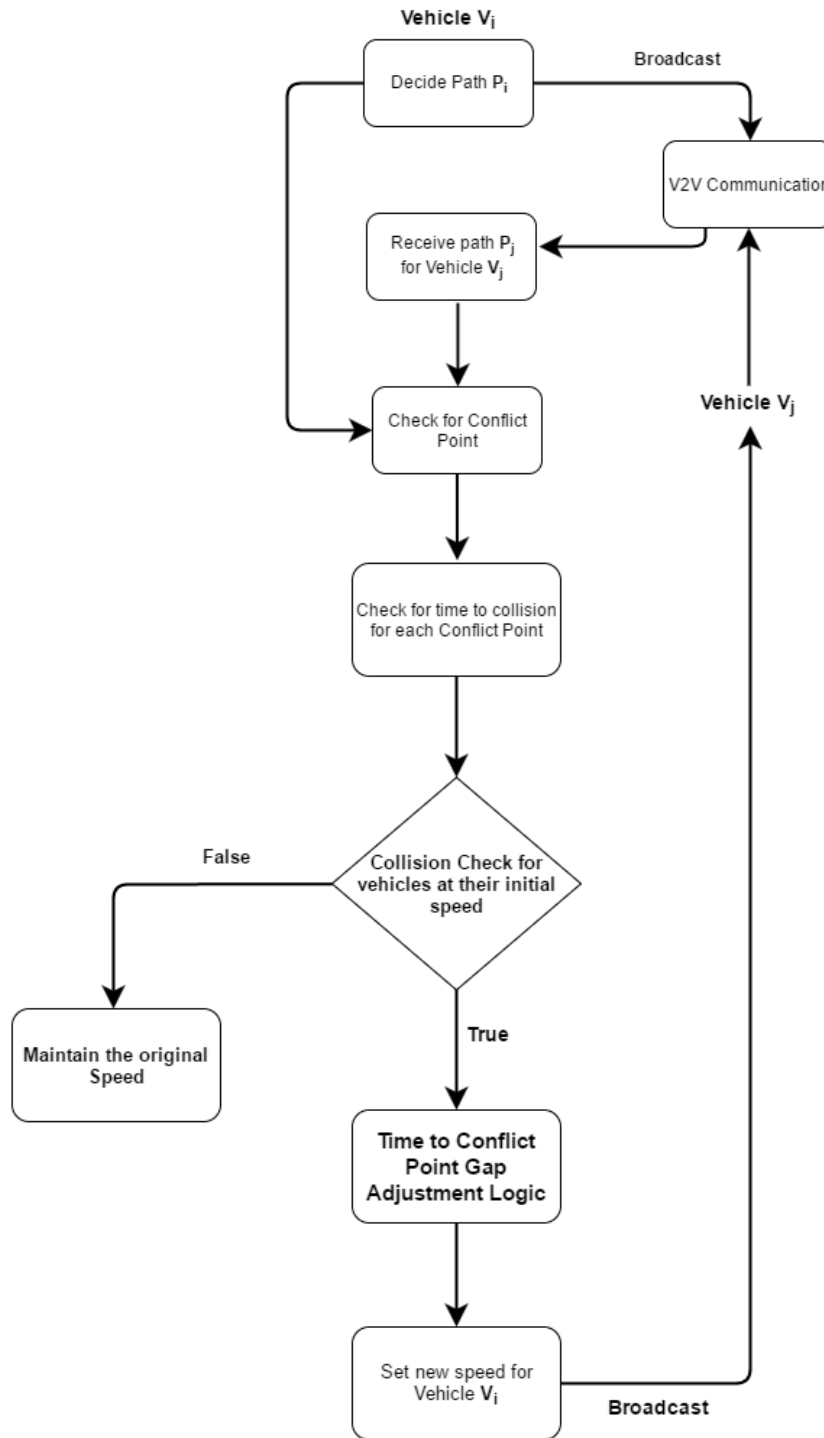

Figure 3.5: Time to conflict point based gap adjustment logic

Figure 3.5 shows the strategy developed for the intersection in the form of a flowchart. The flowchart has been inspired from [29]. It is to be noted that, for vehicles originating from the

same link, if a vehicle in Zone 2 is delayed by a certain time interval, all the vehicles behind the delayed vehicles shall also be delayed by the same time interval to maintain a minimum inter vehicle between the vehicles. It is also important to assume that vehicles traveling on the same link obey the rule of FIFO (First In First Out).

3.4 Architecture

The previous section demonstrated the development of a cooperative strategy with which automated vehicles can maneuver the intersection without the aid from traffic lights. The strategy is cooperative in ways that vehicles will negotiate with other vehicles through V2V communication to decide the speed necessary for maneuvering the intersection without colliding. However while in pursuit of the develop strategy, vehicles have to abide by the various constraints of the network. In order for the vehicles to adhere to the strategy, various functionalities and constraints are necessary to be defined at various levels. These functionalities and constraints from various levels shall support the vehicles in following the strategy during their entire maneuver.

Figure 3.6 demonstrates the developed architecture for the purpose of this research. The architecture consists of three layers. They are the traffic management layer, vehicle management layer and vehicle control layer.

Traffic Management Layer

The traffic management layer dictates the rules of the traffic and the intersection network that are to be followed by the automated vehicles. The important characteristics of the vehicle management layer have been mentioned below.

- A map of the network with global coordinates is made accessible to all the vehicles in the network. The advantage of using such a map is that all the vehicles know the global position of other vehicles in the intersection zone. Therefore the decisions made in the intersection zone by individual vehicles shall be by using a global frame of reference.
- Vehicle with the lowest time to conflict point gets the highest preference. In case where more than one vehicles have the same time to a conflict point, "Priority to the right" is followed [30].
- The traffic management layer provides the speed and acceleration constraints to all the vehicles maneuvering in the network. Every time a conflict is detected, relevant vehicles have to decelerate and then accelerate within the specified constraints of speed and acceleration. This will ensure that vehicles do not behave erratically in the network and undergo a smooth transition to different speeds.

Vehicle Control Layer

The vehicle control layer keeps track of the change of state of the vehicle over time. The basic functionality of this layer is to take care of the longitudinal and lateral control of the vehicle.

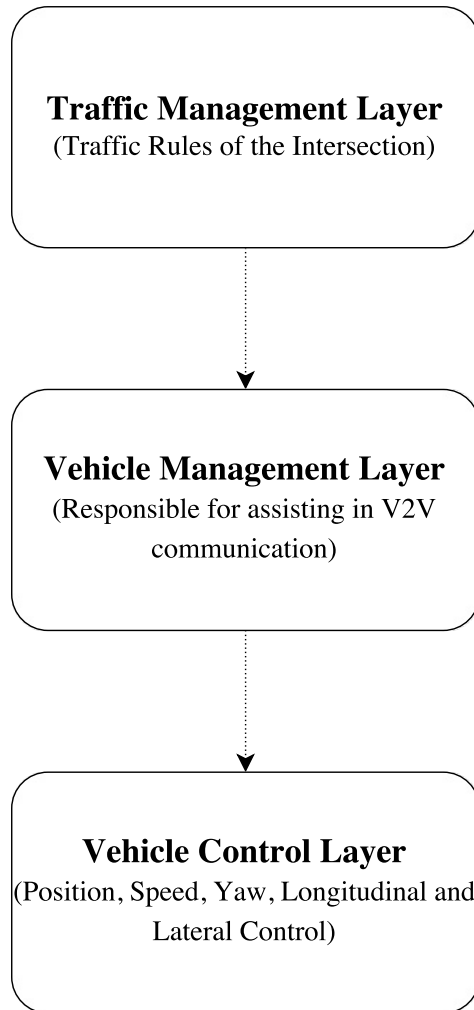

Figure 3.6: Developed Architecture

This layer keeps track of speed, yaw, change in position and desired heading of the vehicle at every time instant. The measurements of this layer are used at the vehicle management layer for making appropriate decisions cooperatively with other vehicles to maneuver without colliding in the intersection.

Vehicle Management Layer

The vehicle management layer consists of the entire decision making framework of the vehicles. Vehicles shall engage in V2V communication to take decisions for safe maneuvering of the intersection. From the sensor data received from the vehicle control layer, the data is shared among the vehicles in the intersection zones. Based on the shared data, vehicles cooperatively take decisions to maneuver in the intersection without colliding with each other. The global coordinates of the map provided by the traffic management layer is used for decision making by the vehicles. The only relation between the Vehicle Management layer and the traffic management layer is that the former functions in the constraints set by the later. In order to

implement the strategy only by the use of V2V communication, there is no communication allowed between the traffic management layer and the vehicle management layer. The entire system is therefore managed only by V2V communication.

3.5 Platoons in the network

A platoon can be defined as a collection of vehicles that follow a lead vehicle both laterally and longitudinally [31]. The lateral and longitudinal control is adjusted such that every vehicle in the platoon tries to maintain a desired inter vehicle distance with its leading vehicle. In such scenarios, V2V communication plays an important role during the control process. Vehicle signals like speed and sensor data are shared among the vehicles which are then used in the vehicle control algorithms for desired platooning. The developed strategy in this research can also be applied to platoons. However in order to reduce complications, certain assumptions have been made for modeling platoons in this research.

- Not more than one platoon is approaching the intersection.
- Merging or exiting of individual vehicles from the platoon is not allowed before the intersection.

3.5.1 Number of vehicles in a platoon

As explicitly stated above, the change in size of the platoon is not allowed before the intersection. For a platoon of vehicles to adhere to the strategy, it is important for vehicles in other lanes to identify the number of vehicles in the platoon. Therefore such an assumption will help reduce the over complication of the decision framework. The Central controller could have kept track of all the vehicles originating from every lane and based on that suitable maneuvers would have been decided for all the vehicles to cross the intersection without collision. Since there is no central controller and therefore no V2I communication, a framework needs to be in place for realizing the number of vehicles entering the intersection as a member of the platoon.

A visualization of a specific situation involving a platoon approaching the intersection is provided in Figure 4.6. [12] in their research on vehicle control algorithms for cooperative driving have mentioned that under steady state conditions of cooperative driving on a single lane roadway, the vehicles arrange themselves in string format with short inter-vehicle distances. Assume that the reference value(*ref*) for inter vehicle distance in such a platoon formation is d . In the figure it can be seen that vehicles numbered from 1 to 3 are maintaining a distance of d with each other whereas vehicle 4 has a distance more than d from vehicle 3.

In such situations, the vehicle traveling on other lanes might be interested in knowing the number of vehicles that are part of the platoon. Even though it is assumed that every vehicle is in the sensor range of every vehicle in the network and all vehicles communicate with each other, there might be circumstances where a knowledge about the number of vehicles might be useful for merging into a platoon.

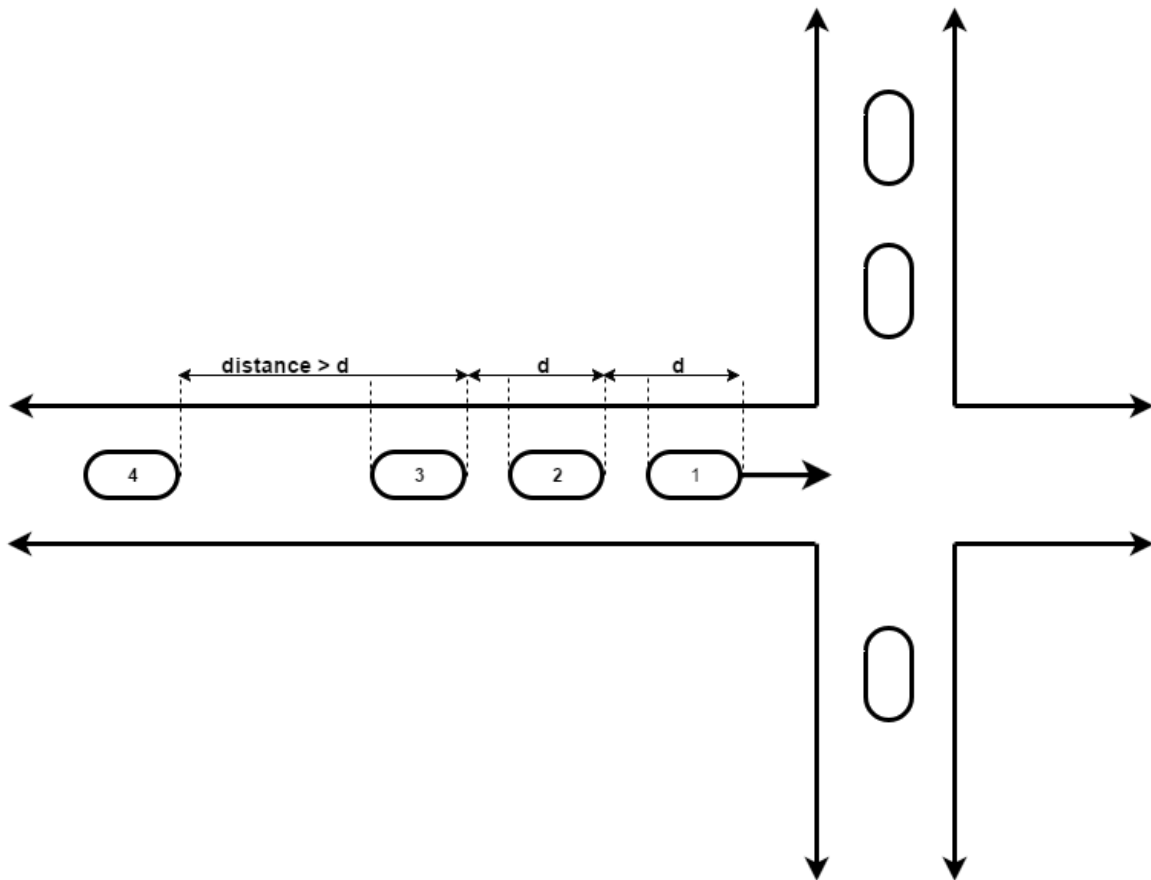

Figure 3.7: Identifying vehicles in a platoon

There are various advantages of platoons in traffic. Platoons are termed as key to achieving higher capacity by tightly packing cars [32]. Using the concept of platooning, the mean inter-vehicle distance between vehicles can be reduced and therefore a capacity upto 8000 vehicles/hour/lane can be achieved. Platooning also enables to enhance safety on roads. This can be deduced from the fact that with less inter-vehicle distance, the impact velocity in case of a collision is also small and therefore, the impact energy is small. [33] also mention that with the help of platooning fuel consumptions and emissions can also be lowered since it helps in reducing the aerodynamic drag.

Logic for calculating the number of vehicles in a platoon

Every vehicle in a specific lane communicates with its preceding vehicle and the succeeding vehicle. Since no overtaking is taken into account, for vehicles traveling in a specific lane, the trajectory to the start of the intersection box can be considered same. Assume the vehicle in consideration as the “ego vehicle” and the vehicle to its front as the “target vehicle” [34]. Now the “ego” vehicle also acts as a “target” vehicle for the vehicle following it. Figure 4.6 provides a specific situation for easy understanding.

Vehicle 4 serves as an ego vehicle for vehicle 3 which is the target vehicle. While engaging

in V2V communication, every ego vehicle sends its present location to the target vehicle. The target vehicle then calculates its own distance from the ego vehicle. If the inter-vehicle distance is within the range of desired inter vehicle distance plus a safe margin, the ego vehicle is considered a part of the platoon. In this situation, vehicles 2 and 3 are part of a platoon where as vehicle 4 is not since it is too far from vehicle 3. It is to be noted that while considering vehicles part of the platoon, a safe margin is also taken into account along with the set inter vehicle distance.

The above process continues till the leading vehicle of the platoon. Every target vehicle keeps track of the number of vehicles following it. In this way the leading vehicle is aware of the number of vehicles that are part of its platoon. When communicating with the other vehicles in other lanes, this information is also shared as a message type. The various message types used in V2V communication are explained in the next chapter. Based on the above designed logic, vehicles are able to know the number of vehicles originating from other lanes.

3.6 Overview

This chapter discusses the development of the distributed strategy used for maneuvering of automated vehicles using V2V communication. The chapter begins with the assumptions that are taken into account for the development of the strategy. Based on the trajectory of vehicles at an intersection, conflict points are identified and collision groups are defined. A strategy called "Time to optimal point based gap adjustment logic" is developed which allows only one vehicle to cross a possible conflict point at one time instant. Preference is decided cooperatively among vehicles using V2V communication and the higher preferred vehicle is allowed to cross the conflict point first. The lower preferred vehicle slow down accordingly in the network. In such a fashion, potential collision can be avoided at the intersection. Subsequently an architecture is developed that will support the strategy at various levels. At the top is the traffic management layer that provides the rules and constraints for the network. The middle layer is the vehicle management layer that is responsible for following the developed strategy and manages the information shared using V2V communication among the vehicles in the network. Lastly there is the vehicle control layer that takes care of the lateral and longitudinal control of the vehicles to adhere to the decisions made in the vehicle management layer. The last section of the chapter describes the consideration of platoons in the network and the logic behind calculating the number of vehicles that are present in a platoon.

The next chapter deals with implementing the strategy in an simulation environment and establishing the networking aspect. Even though the strategy is in place, it is necessary to confirm that such a strategy is feasible to be implemented using V2V communication without the presence of any central controller. The next chapter therefore focuses on establishing V2V communication among vehicles and implementing the strategy.

Validation of V2V communication - Implementation in USARSIM

Since the developed strategy is to be implemented in a distributed fashion, V2V communication among robots will play an important role in the entire process. Relevant information like present location, trajectory, speed and time to conflict point needs to be shared among the robots during their maneuver. Based on these available information, robots will make appropriate decisions for crossing the intersection without colliding with other robots in the network. Therefore it is necessary to ensure that the strategy developed for the intersection is feasible to be implemented in a distributed fashion using V2V communication and without the aid from any central controller.

This chapter deals with establishing the networking aspect of this research. The environment of USARSIM (Urban Search and Rescue Simulation) will be used for establishing V2V communication among three Ackerman steered robots. A virtual intersection shall be created in the arena in which these robots will operate. Based on information exchanged through V2V communication, robots will decide cooperatively by adhering to the developed strategy in various scenarios.

4.1 USARSIM

USARSIM is a high fidelity physics simulator that is built on top of a game engine known as *Unreal Engine 2.0* [35]. Game engines are excellent tools for developing robot simulators. The cost of developing realistic simulations is huge. Therefore generic game engines are developed that are modular simulation codes written for a particular game but can be used for a family of similar games [36]. This makes the game engines extremely customizable and therefore excellent for scientific investigations. USARSIM is widely used in the field of autonomous robotics and for development of human robot interfaces. Various models of differential drive robots, sensors and arenas are present in the USARSIM environment. Figure 4.1 showcases the architecture of USARSIM.

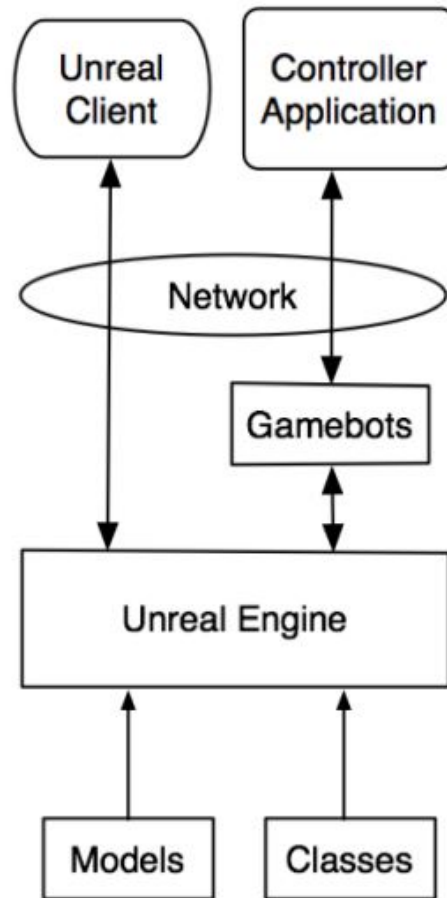

Figure 4.1: Architecture of USARSIM

When the Unreal engine is initiated, geometrical models describing the objects in the engine and classes of compiled scripts that govern the behavior of loaded models in the environment are loaded on into the system. Once the startup phase is over, connections can be accepted from client applications. An interface known as *Gamebots* exists which permits bidirectional exchange of information between the engine and external applications [37]. For the purpose of exchanging information, any language that is able to read and write a Transmission Control Protocol (TCP) socket can be used. In this research, Python 2.7 is used for the purpose of developing the external application that provides the coordination logic for the maneuvering of robots in the arena.

For the purpose of implementing the developed strategy and testing V2V communication, a special robot model called the “ICARUS” developed by Technolution shall be used. The ICARUS robot model is an extension of the Ackerman steering robots. The sensor used for analyzing the true trajectory of the robots in the arena is Ground Truth. The ground truth sensor provides the actual location of the robots in the arena without adding any noise to the measurements. Other sensors available in USARSIM are Range Scanner, Odometry, GPS, INS, Encoder, Touch and RFID. However, none of these sensors are being used in this

research.

For the purpose of maneuvering of the robots in the USARSIM arena, a higher level software shall be developed that will provide the control logic to the robots. Every robot will be provided with a set of waypoints that they will cover during their maneuver. The last waypoint will be the destination for the respective robots. The waypoint provided to the robots will be such that a virtual intersection scenario is created in the arena. Robots will engage in V2V communication and based on the information gained in the process decide the best maneuvering speed for themselves towards their destination. The next section describes the development of the higher level software.

4.2 Higher Level Software

Figure 4.2 shows the structure of the controller application. This structure substitutes the controller application in Figure 4.1.

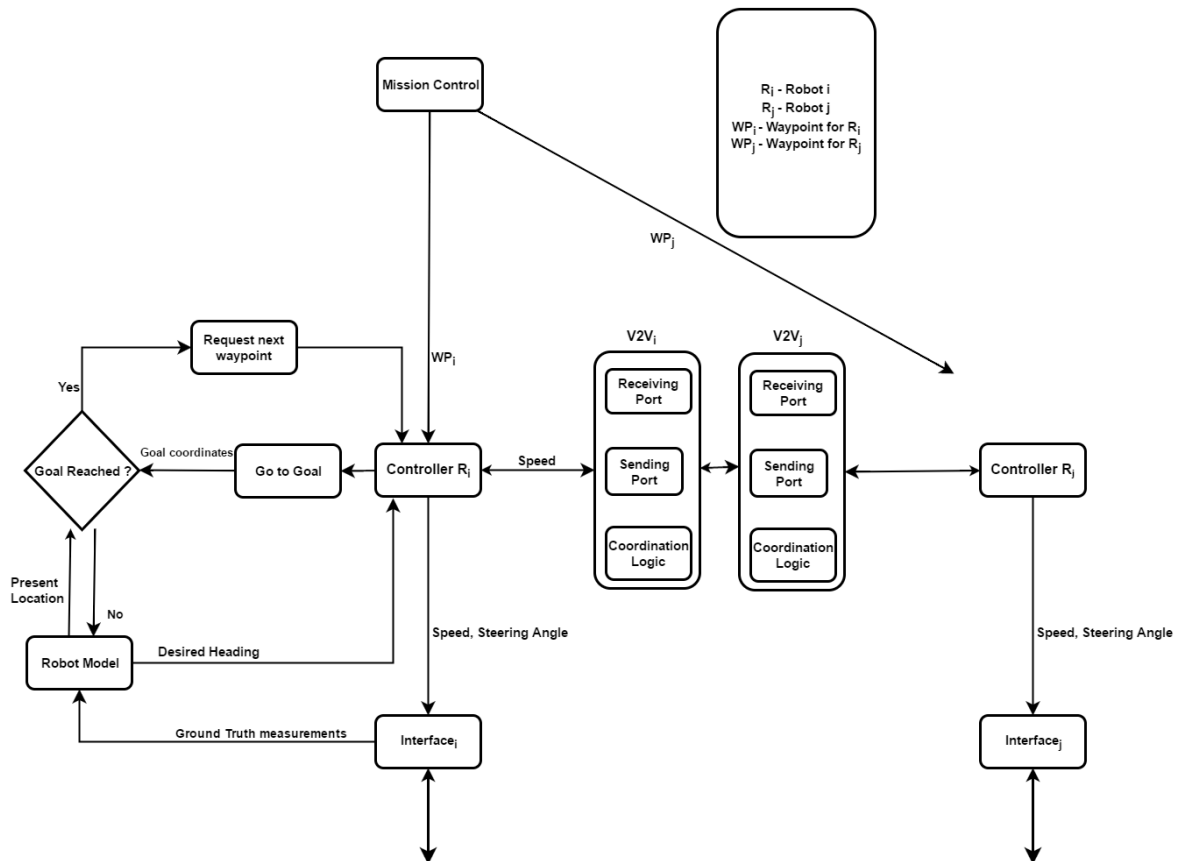

Figure 4.2: Structure of the code

The strategy developed is distributed in its approach. Therefore no central controller is present in the entire scenario. Every robot interacts with other robots in its surrounding using V2V communication. As shown in Figure 4.2, V2V element for every robot consists of a receiving port, sending port and the coordination logic for the robots. Every robot in

the USARSIM arena receives a trajectory from the Mission Control. It is to be noted that the Mission Control is not any kind of central controller but just an element that provides the trajectories to the robots. The trajectories for the robots are decided in such a way that a virtual intersection scenario is created on the arena. Every trajectory consists of a set of waypoints that every robot has to cover during its maneuver. After a robot has received its trajectory, the go to goal module is activated. All the waypoints present in the trajectory are covered by the robot from start to the end. To move towards every goal, the desired heading is provided by the robot model module. The robot model module takes in the present location of the robot as ground truth measurements from the interface and based on the goal coordinates, calculates the desired heading to reach the goal. The interface is the module that connects to the Unreal Engine and allows sharing of information between the controller and the Unreal Engine. Figure 4.3 provides an analysis of calculating the desired heading of a robot.

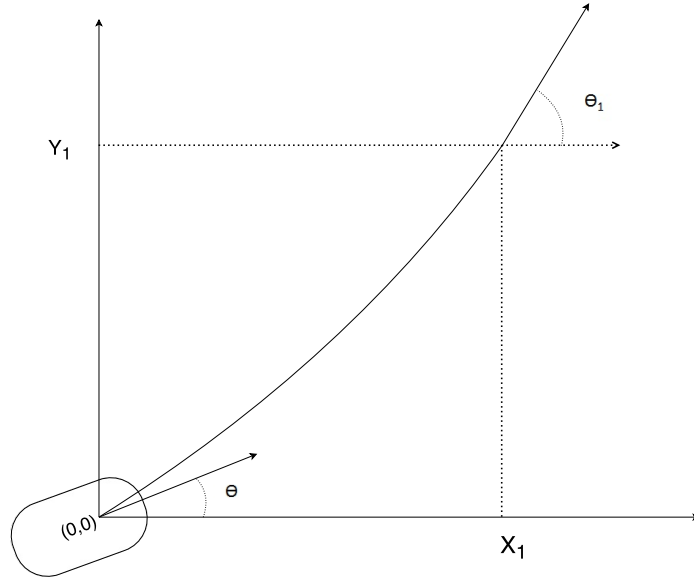

Figure 4.3: Calculation of desired heading

To move from one waypoint to the other, δ , the desired heading is calculated. Suppose the present position of the robot is $(0, 0)$ with a heading of 0 after translation and rotation of the fixed reference frame. To move from $(0, 0)$ to (x_1, y_1) with a heading of θ_1 , the required δ is provided in Equation 4.1 [38].

$$\delta = \arctan[2l(3y_1 - x_1 \tan(\theta_1)/x_1^2)] \quad (4.1)$$

where l is the length of the wheelbase.

Every time the robot moves from one waypoint to the other, this procedure of translating and rotating the frame of reference is continued and δ is calculated. This procedure is carried on till the robot reaches the last waypoint.

4.2.1 V2V communication module

It is crucial to set up a robust communication system so that relevant data can be exchanged among the robots properly and efficiently. In general VANET technologies are used for setting up V2V communication among robots. In VANET, every robot becomes an individual router that is able to send and receive data to and from other robots in the network that are in its sensor range. The same concept shall be used in this research. Sockets have been used to allow communication among robots. User Datagram Protocol (UDP) is used as a protocol to facilitate this communication. Every robot has a socket that is able to send and receive UDP messages to/from other sources in the network. The following are some of the properties of the UDP protocol [39].

- Service is unreliable, thus no guarantee of message delivery is provided.
- UDP is connectionless. So no end-to-end connection is established between the systems.
- Packets may be lost or delivered out of order.
- There is no buffer required at the sending and receiving side.
- Unlike TCP protocols, UDP doesn't facilitate error and congestion handling. Therefore it is faster.

The above properties clarify that, even though UDP is unreliable, it is faster. The reason for using UDP protocol in this research is based on the fact that even though some data packets are lost during the process, it is ensured that every robot always uses the latest data it receives to take decisions. In TCP, the data recipient sends an acknowledgment to the sender in order to verify that the data has been successfully received. If no acknowledgment is sent before a certain time interval, the packet is sent again by the sender. However, within that time interval the states of the robots might have changed in the network. Therefore, old data is used by the robots to take decisions and the rest of the data are queued until an acknowledgment is sent for the lost data. This protocol is therefore not very useful in such situations. The pseudo code for setting up V2V communication using sockets can be found in Appendix A.

Message Types

Various types of messages are exchanged among robots while maneuvering the intersection. Every message has its own functionality. The controller for every robot should therefore be designed such that it is able to differentiate properly between different messages. It is also necessary to ensure that relevant data is used for decision making. Failing to process the relevant data, the entire system might fail. Therefore, it is necessary to construct data in such a way that proper distinction can be made for every received packet.

Every message exchanged among the robots consist of a header and the actual message. The header is basically a description that signifies to what category does the data belongs to and therefore allows the controller to store it in the proper place for analysis. There are four message headers in this research that are used with every message to properly . They are explained as follows.

1. **'WP'**

The first information that is shared among the relevant robots is the trajectory. Every robot in the intersection network shares this data with other relevant robots. Using the trajectory data of other robots, the robots are able to calculate the conflict points and therefore are able to identify the collision groups. The packets that contain the trajectories of the robot have the above header. Once the robots have entered the intersection zone, they start broadcasting their trajectory to the other robots. If the other robot has already received this data, it ignores the packet and the packet is lost. After the robots have safely maneuvered their trajectory beyond the conflict point, the robots stop broadcasting their trajectory and get rid of the stored trajectories of other robots.

2. **'TC'**

After the trajectories have been exchanged with the robots, every robot finds the conflict points and then forms the collision groups. For every conflict point, the robot calculates its time to collision to every conflict point on its trajectory. After calculating the time to collision, this data is shared with all the relevant robots in the collision group. The exchange of the packets containing this data is done through the 'TC' header. Once the exchange of the packets have taken place, the data is compared and if necessary delays are inserted to relevant robots by deciding preference. The rule of preference is described in the next section.

3. **'CC'**

This header is used to represent the packets that have the present location of the robot. Once the conflict point has been identified and the collision groups have been established, every robot is in constant collision check with the other robots of the collision group. The Separating Axis Theorem described in Appendix B is used to check for collision at every time instant. The information required for collision check is the present location of the robot. This data is therefore shared with the relevant robots using this header.

4. **'VF'**

This header is used by a robot to represent the number of robots that are following the robot in a particular lane. This message is used when there is a platoon of robots entering the intersection and priority has to be decided. Based on the number of robots in the platoon, robots in other lanes either slow down or stop before the intersection box to allow the platoon to maneuver the intersection and avoid collisions at the conflict points in the intersection box.

As discussed in the previous chapter, the time to conflict point based gap adjustment logic is used for this research. Conflict points are identified, collision groups are defined and relevant information using the above mentioned message types are shared among the robots. Based on the shared information among the robots using V2V communication, preference is decided mutually among the robots to maneuver the intersection without colliding. Every robot checks the time gap of occupying the conflict point with the robot with the higher preference value. If the time gap falls below a certain time interval, a safe time gap is added to the lower preferred robot. The speed of the lower preferred robot is adjusted such that it reaches the conflict point, only after the higher preferred robot has crossed the conflict point. The pseudo code dealing with the addition of the safe time gap is provided in Appendix A.

4.3 Implementation of Strategy

4.3.1 Classical Intersection Scenario

A classical intersection scenario deals with robot approaching an intersection from different lanes. In such a scenario, platoons are not taken into account. Every robot is considered as an individual robot. Three robots were spawned in the arena of USARSIM for this purpose. Trajectories were provided to the robots such that a virtual intersection was created in the arena. Every robot was provided with an initial speed of 20 cm/s. Based on the zones in which they are located and state of other robots in the network, individual robots alter their speed accordingly by engaging in V2V communication. The relevant zones taken into consideration is explained in Chapter 3.

Upon implementing the developed distributed strategy, it was found that initially all the robots were moving at a similar speed in Zone 1. Once the robots had crossed Zone 1 and entered Zone 2, robot 2 and 3 slowed down to allow robot 1 to maneuver the intersection first. This decision was made mutually among the robots by engaging in V2V communication. Once robot 1 had crossed the conflict point, the speed of robot 2 also increased and once robot 2 had crossed the conflict point, robot 3 also picked up speed. All the robots were able to avoid collision at the intersection using the developed strategy and V2V communication. Figure 4.4 shows the trajectories of the robots during the entire process.

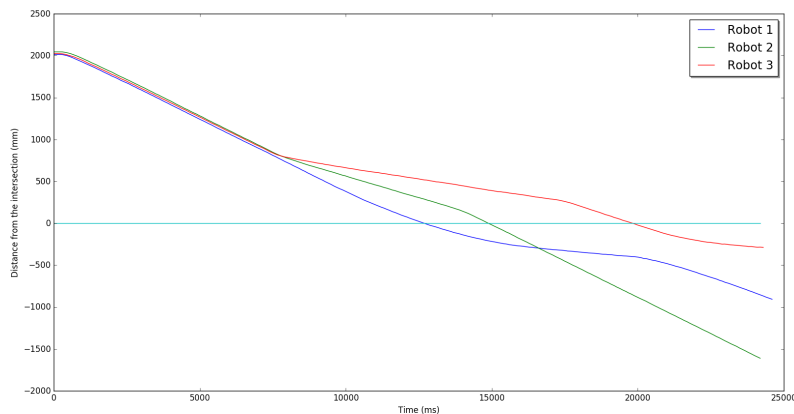

Figure 4.4: Robot trajectories in the intersection

Figure 4.5 shows the instantaneous speed profile of the individual robots involved in the simulation. The graph for the speed profiles were calculated by computing the average of 10 simulation runs. In every simulation run, the instantaneous speed is calculated by using finite differencing method.

It can be seen that robot 2 moves at a lower speed till robot 1 has not crossed the conflict point. Once robot 1 has crossed the conflict point, robot 2 speeds up. Similarly, once robot 2 has crossed the conflict point, robot 3 also speeds up to it's original speed. This way collision is avoided at the intersection.

One can observe fluctuation in the instantaneous speed graph. The fluctuation is due to approximation error caused by discretization of state space. As mentioned earlier, finite

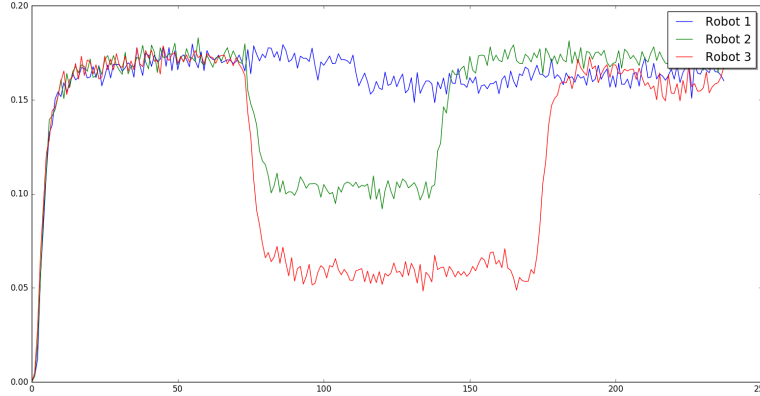

Figure 4.5: Instantaneous Speed profiles of robots

differencing is used to calculate the instantaneous speed of the robot at every instant in time. The assumption that

$$\frac{dx}{dt} \approx \frac{x_2 - x_1}{t_2 - t_1}$$

does not provide proper results here. One of the reasons for this abnormality is also insufficient sampling time in USARSIM. Therefore, average result of multiple simulation results are used to analyze the instantaneous speed graph. This practice is continued throughout the research.

4.3.2 Platoons in the intersection

In situations where platoons are entering the intersection, decision making could be quite tricky. Vehicles that are member of a platoon might behave as individual robots at the intersection and abide by the constraints of the developed strategy. However there might be situations where giving full priority to a platoon of robots seem more advantageous. Therefore different scenarios need to be analyzed by taking into account the platoons in the network. The assumptions mentioned in Chapter 3 regarding considering platoons in the network have been taken into account in the implementation.

Speed controller for robots in platoon

For platoons moving in the network, the speed command for the robots is calculated by taking into account the inter robot distance and instantaneous speed. For all the robots following a leader robot, the speed command is calculated as follows [38].

Suppose u_n is the speed command to a particular robot, v_n is the actual speed of the robot, d_n represents the inter robot distance for a control period n , ref is the desired inter robot distance required between two robots in the same lane for the research and T be the time of a control interval. Then,

$$u_n = [v_{n-1} + (d_{n-1} - d_{n-2})/T](d_{n-1}/(ref))^2 \quad (4.2)$$

If d_{n-1} is lower than the ref beyond a lower limit, the speed command is set to zero. Once the minimum inter robot distance is regained, a new speed command is provided again.

Platoons adhering to the developed strategy

Figure 4.6 shows the case of robots entering an intersection box and then forming a platoon. Along with maintaining the required inter robot distance, the robots also have to prevent colliding with each other at the intersection box. The conflict point based time gap strategy is applied in this context. The experiment conducted has robot 1 and 2 arriving at the intersection box at the same time. In the present scenario, no priority is given to the platoon. So robots behave according to the designed strategy for the intersection. Since robot 1 and 2 are equidistant from the intersection, robot 2 yields to robot 1 which is to its right. Therefore, in such a scenario, robot 1 gets the higher priority, robot 2 gets the second priority and robot 3 gets the last priority.

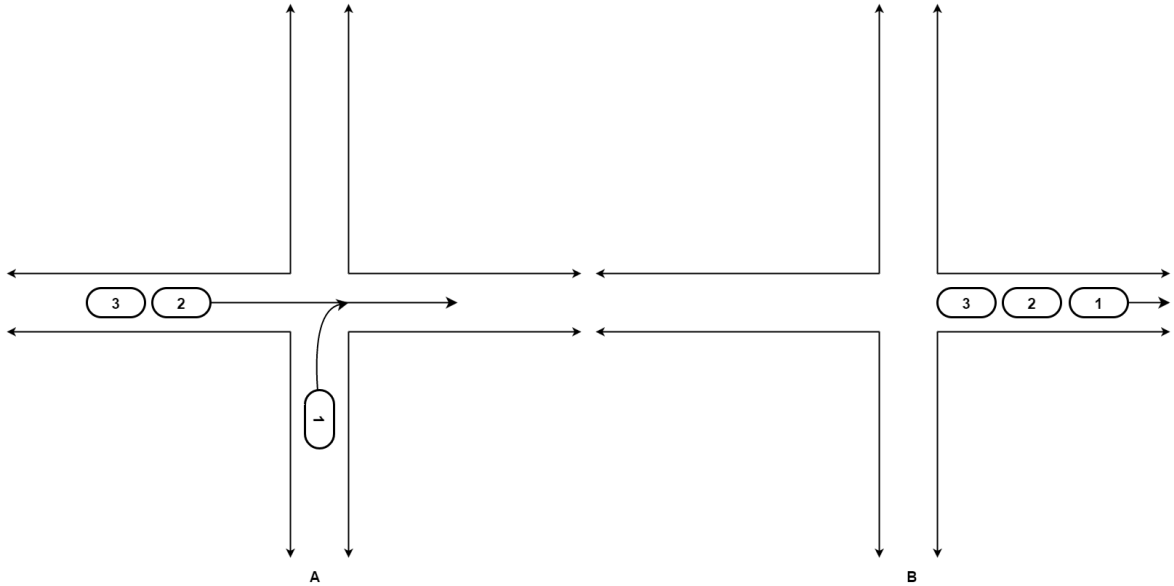

Figure 4.6: Platoons adhering to the strategy

On applying the strategy for the intersection and the strategy for platooning post resolving the conflicts at the intersection, it was found that robot 1 maintains its original speed throughout its maneuver. Robot 2 and 3 are in a platoon. Robot 2 slows down to avoid collision with robot 1 and robot 3 adjusts its own speed accordingly with respect to robot 2 for maintaining the desired inter robot distance. For the implementation in USARSIM, the desired inter robot distance is set to 400 mm. Figure 4.7 shows the trajectories of robots with respect to time.

Figure 4.8 shows the inter robot distance of the robots with their respective leading robots. It can be seen in the graph that since robot 1 gets higher priority, robot 2 slows down before the intersection. Once robot 1 has crossed the possible conflict point, robot 2 speeds up and

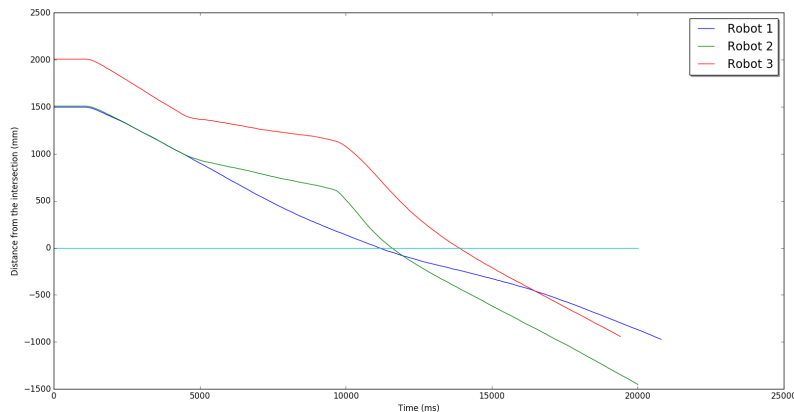

Figure 4.7: Trajectories of robots - Platoon without priority

maintains an inter robot distance of 400 mm with robot 1. Robot 1 therefore becomes the leading robot of the platoon. For robot 3 which is following robot 2, the inter robot distance between both the robots suddenly increases when robot 2 speeds up before the intersection. However robot 3 also speeds up and soon adjusts the inter robot distance with robot 2. The same behavior can be confirmed by seeing the instantaneous speed profiles of the robots.

Figure 4.9 shows the speed profiles of robots in the platoon scenario described above. Initially the distance between robot 2 and 3 that are in platoon is greater than the desired inter robot distance of 400 mm. Therefore robot 3 speeds up to maintain the gap. Once robots 1 and 2 are in Zone 2, robot 1 gets the highest priority and robot 2 slows down. Since robot 3 adjusts its speed based on inter robot distance with robot 2, it also slows down. Once robot 1 has crossed the conflict point, robot 2 speeds up and so does robot 3. Subsequently both robots 2 and 3 adjust their speed to maintain the desired inter robot distance with their respective leading robots.

In the above simulation experiment, "Priority to the Right" rule was followed and robots from other lanes were merged into the platoon based on their time to the conflict point. It can be observed that due to this process, both robots 2 and 3 were slowed down. Another strategy that could be followed is to allow the platoon of robots to pass at their desired speed maintaining the inter robot distance and then allowing robots from other lanes merge into the intersection. In such situations, only the robots from other lanes have to be slowed down. Therefore a comparison is necessary to see which of the strategy is better.

Priority to a platoon

This section provides an analysis of a situation, where a platoon of robots is given priority at the intersection. In such scenarios, the platoon is allowed to maneuver the intersection at their desired speed and other robots merge into the platoon only when the platoon has crossed the intersection. Figure 4.10 demonstrates the above mentioned scenario.

Every robot in the lane also obeys the rule of not overtaking any robot in the lane. Using the logic described in the previous chapter, the number of robots in a lane are calculated and the

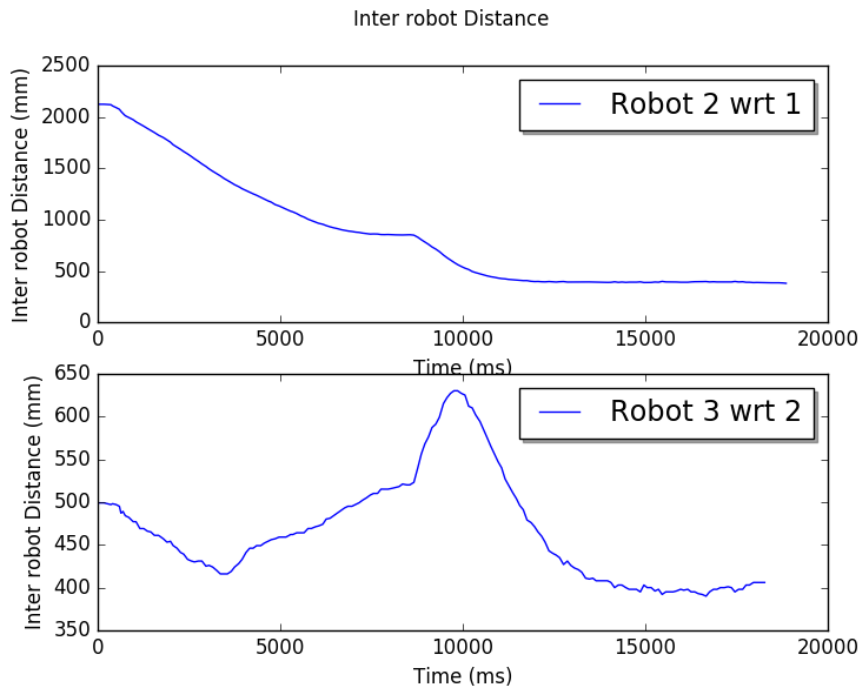

Figure 4.8: Inter robot distance - Platoon without priority

data is communicated to other robots in the lane. An important factor here to be considered is the number of robots in the queue. If the number of robots are such that the robots from other lanes are in the communication range of the last robot in the platoon, then the robots adjust their speed based on the time to the conflict point of the last robot in the platoon. However if the robots are not in communication range of the last robot from the platoon, robots have to stop at the intersection and keep track of the number of robots that have crossed the conflict point. Once the last robot in the platoon are again in the communication range, the robot starts moving at a speed according to the logic of time to conflict point based gap adjustment. Once the last robot in the platoon has crossed the conflict point, the other robots from other lanes also join the platoon and manage their speed based on the equation defined for platooning in the previous chapter.

Figure 4.11 describes a general situation where a platoon is approaching from Lane 1. Figure 4.12 demonstrates how the robots in Lane 1 communicate the number of robots following them to the robot in Lane 3. To identify the leading robot, the robot in Lane 3 identifies the robot based on the maximum number of following robots. This process is repeated for every lane and the leader robots in every lane is identified by the leader robots in other lanes. Once the leader robots in every lane has been identified, the lane with the maximum number of following robots get the first preference. Once all the robots in that specific lane have crossed the conflict point, robots from other lanes merge into the platoon based on the time to conflict point gap adjustment logic.

The length of the platoon plays an important role in determining whether the robots in the other lanes move slowly or stop before the intersection box. If the leading robots in other lanes are not in the communication range of the last robot in the platoon, they keep track

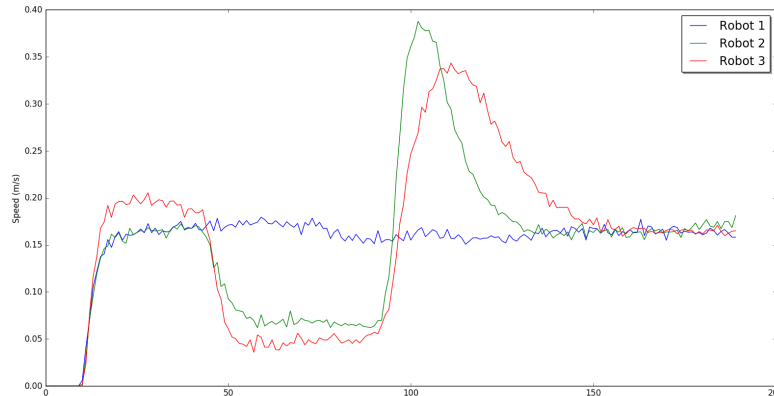

Figure 4.9: Instantaneous speed profiles - Platoon without priority

of the number of robots that have crossed the conflict point from the platoon. Once all the robots in the intersection have crossed the conflict point, robots in other lanes start moving according to the developed strategy for the intersection.

The above described scenario was implemented in USARSIM according to Figure 4.10. The trajectory of the robots while maneuvering the intersection is demonstrated in Figure 4.13. It can be seen that the last robot to cross the maneuver is 1. Full priority is given to the platoon in this scenario. Robot 1 adjusts its own speed so that it crosses the intersection without colliding with any other robots in the network. Figure 4.14 shows the inter robot distance of robots with respect to their leading robots. It can be seen that both the robots try to maintain the desired inter robot distance of 400 mm with their respective leading robots.

Figure 4.15 shows the speed profiles for the robots in platoon priority scenario. It can be seen that robot 3 initially speeds up to maintain the desired inter robot distance with robot 2. Afterwards, the speed of robots 2 and 3 does not change throughout their maneuver. Compared to the scenario explained earlier, in this case robot 1 slows down, thus allowing the platoon to maneuver the intersection first. Once the platoon has crossed the possible conflict point, robot 1 speeds up and adjusts its own speed in order to maintain the desired inter robot distance with its leading robot.

4.4 Overview

This chapter demonstrated the implementation part of the developed strategy in USARSIM. V2V communication was set up within 3 differential drive robots that are maneuvering in the virtual intersection designed in USARSIM. The results of the simulation confirm that it is feasible to implement the developed strategy in a distributed fashion using V2V communication and in the absence of a central controller. However there is an added caveat to the implementation procedure. It is assumed that there is no packet loss or packet delays among the robots during the entire course of their maneuver. Moreover, since the entire simulation is running on a single host, there is no error or delay in the communication. However, in real life, packet losses will certainly play an important role in determining the robustness of

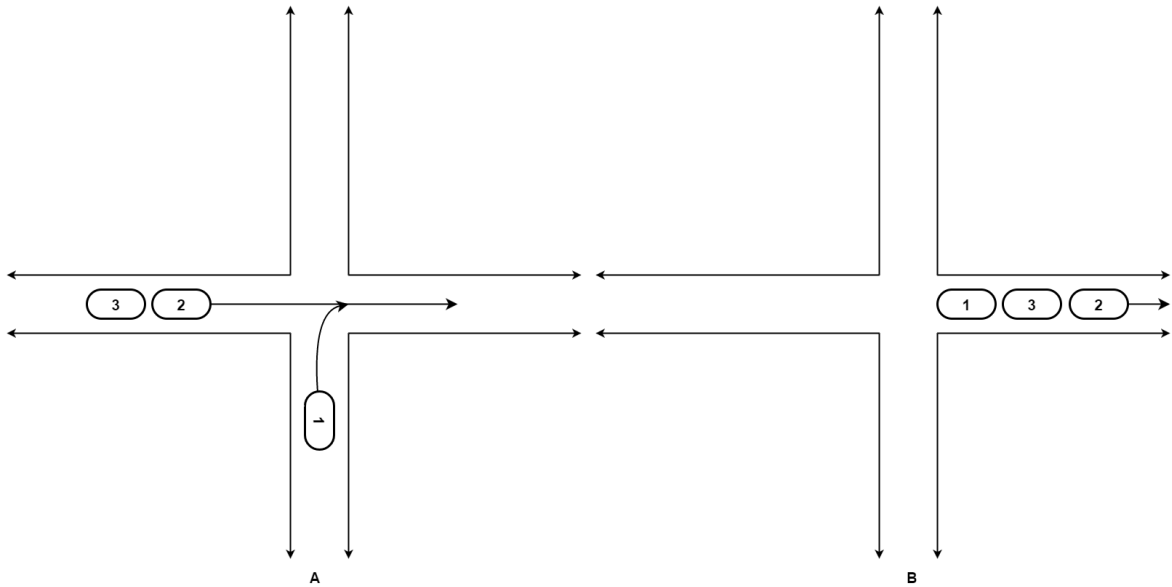

Figure 4.10: Priority to platoon

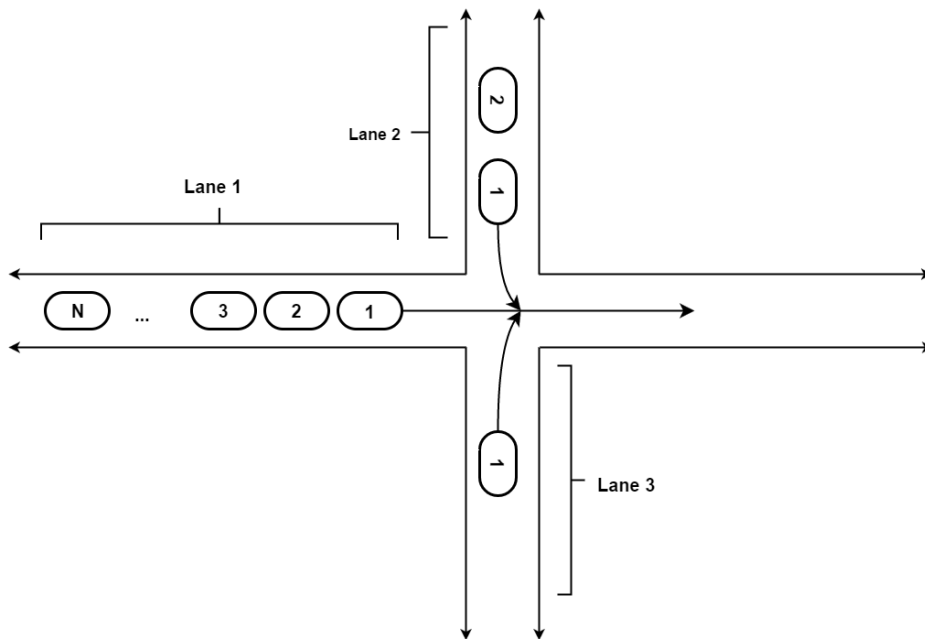

Figure 4.11: Platoon approaching an intersection

the strategy. Moreover it is to be realized that only 3 robots are taken into account for the purpose of setting up V2V communication. As the number of robots increase in the network, more information will be exchanged among the robots and the system will keep getting complicated. Therefore the scalability side of networking is also not taken into account and should be accounted for in further research.

Establishment of the fact that such a strategy is indeed possible to be implemented for collision

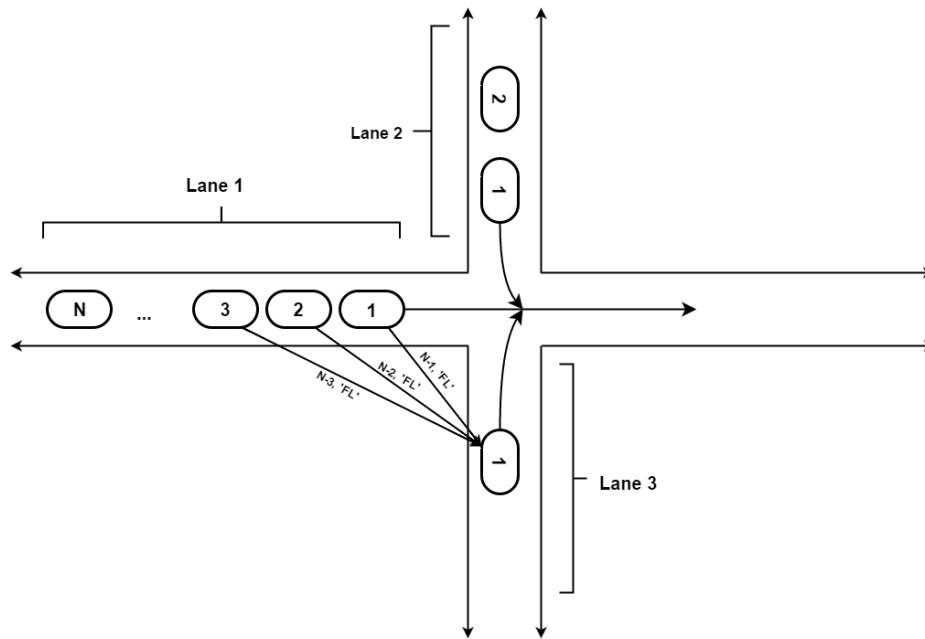

Figure 4.12: Platoon approaching an intersection

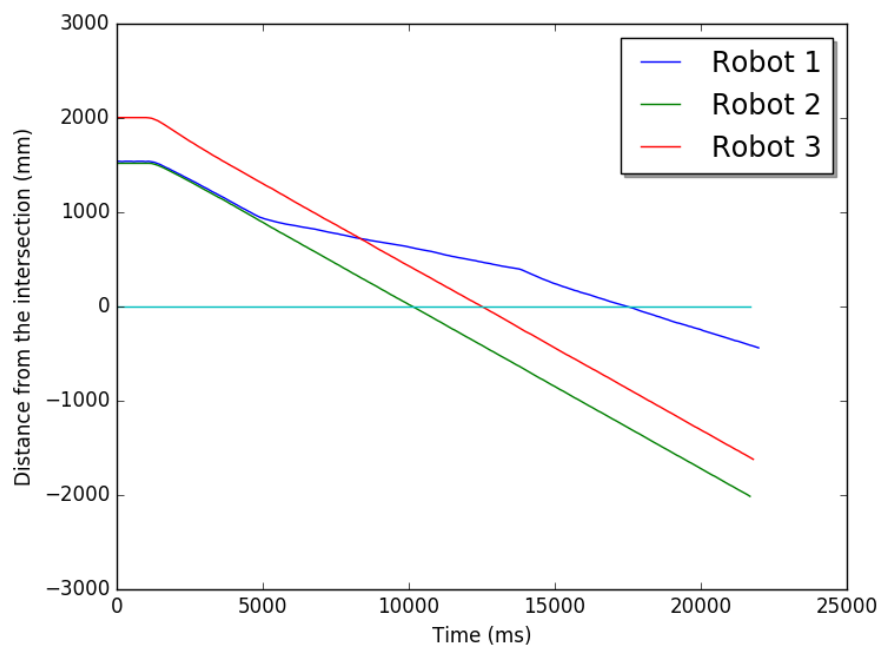

Figure 4.13: Trajectories of robots - Platoon with priority

avoidance among vehicles at an intersection is not enough. The implemented strategy has to be implemented in realistic traffic scenarios where more than 3 vehicles are approaching the intersection. Moreover, an analysis is required whether such a developed strategy is effective

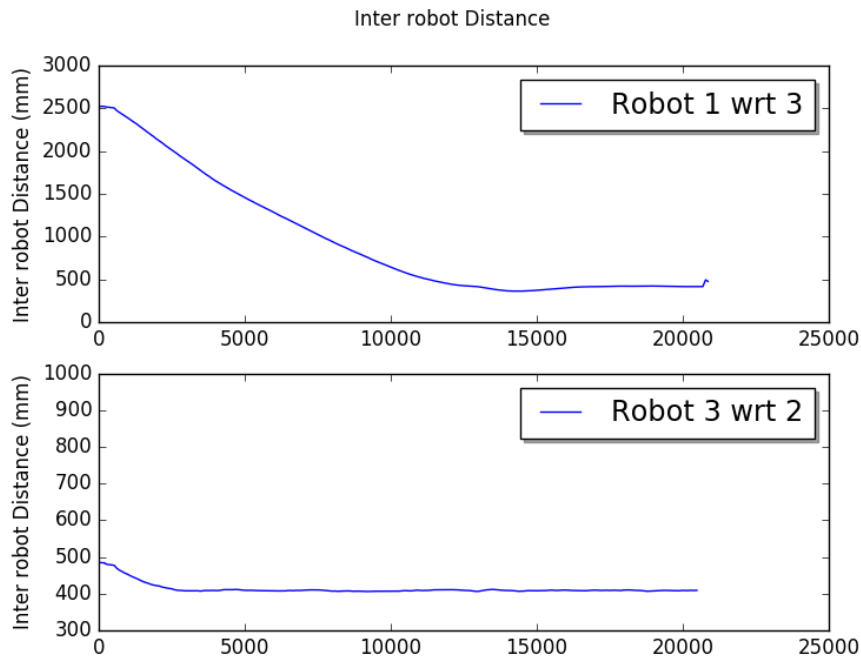

Figure 4.14: Inter robot distance - Platoon with priority

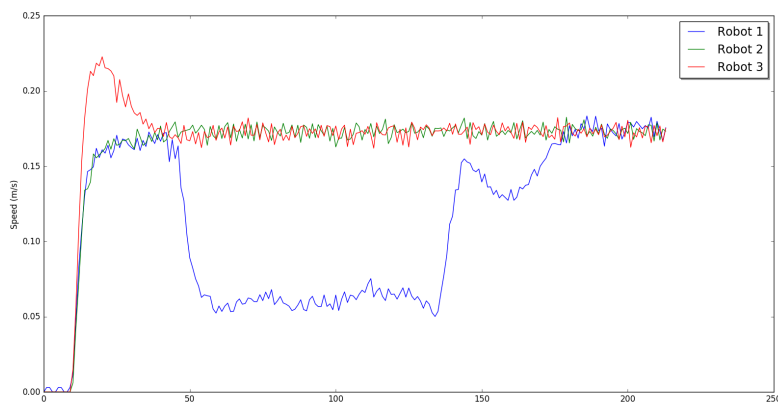

Figure 4.15: Instantaneous Speed Profiles - Platoon with priority

in terms of improving the traffic flow, decreasing emissions and improving safety. For the purpose of ensuring the above, the strategy shall be implemented in VISSIM. Next chapter deals with the implementation part in VISSIM.

Microscopic Traffic Simulation Model - Implementation in VISSIM

This chapter showcases the application and results of implementing the developed strategy in VISSIM. Vissim is a microscopic traffic simulator that can be used for analysis of various traffic flow scenarios. Visualization of complex traffic conditions are possible through the support of realistic traffic models [40]. [40] mentions various situations where VISSIM can be used.

- Identifying system performance in corridor studies based on heavily utilized motorway.
- Analyzing various management strategies on motorways.
- Analysis of various designs and traffic flow in signalized and un signalized intersection.
- Signal priority schemes for public transport with multimodal studies.
- Analysis and comparison of various actuated and adaptive signal control strategies in different networks.

Truthfully, the application of VISSIM is far more spread out than mentioned above. For the research at hand, VISSIM shall be used for analyzing the developed strategy for the intersection. Both scenarios where vehicles enter an intersection without being a member of the platoon and being a member of the platoon shall be analyzed and compared.

It is to be noted that V2V aspect of the research is not implemented in VISSIM. The implementation of the strategies in VISSIM is only to identify whether or not the developed strategy seems reasonable enough to be implemented in real traffic scenarios. Therefore it is assumed that vehicles are in V2V communication with each other. The functioning of vehicles by negotiating in V2V communication is already presented in Chapter 4 using USARSIM.

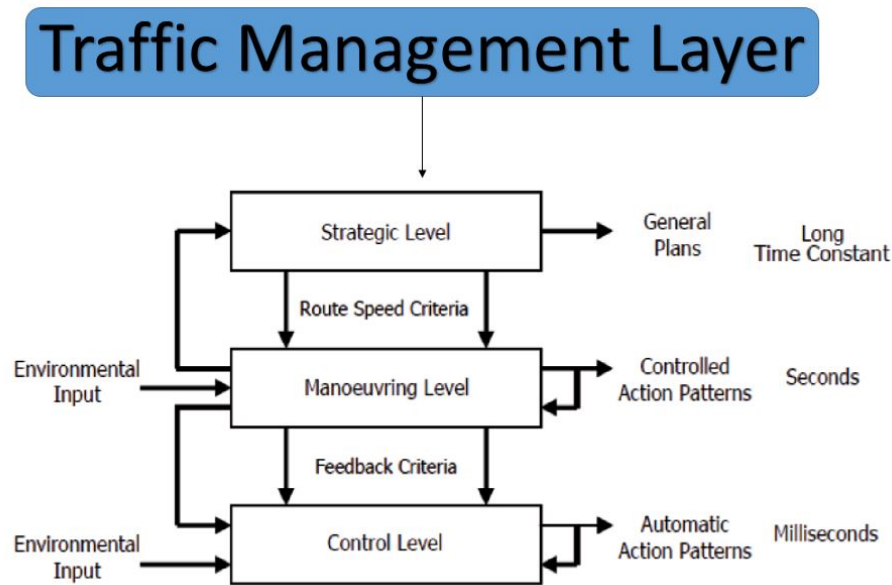

Figure 5.1: Hierarchical model for implementation in VISSIM

5.1 Setting up the VISSIM environment

Figure 5.1 describes the Michon's hierarchical model that shows the various levels involved in a driver behavioral model [41]. The three different levels as suggested by Michon are the Strategic Level, Maneuvering Level and the Control Level. In the strategic level the basic decisions made are the general planning stages of the trip like route choice, destination choice and mode choice. The maneuvering level consists of the maneuvering decisions made by the drivers during the trip. This level consists of decisions like lane changing, obstacle avoidance and gap acceptance. These decisions are aided by the strategy, Time to Conflict Point Based Gap Adjustment Logic which is at the core of this research. Vehicles get involved in V2V communication to implement this developed strategy and cross the intersection without colliding with other vehicles in the network. The Control Level consists of the control actions undertaken to aid the maneuver of vehicles without violating the various constraints of the network like maximum speed, acceleration and inter vehicle distance. The Control Level is the lowest level in the Michon's driving behavior model.

As described in Figure 5.1 the entire driving behavior model operates under the Traffic Management Layer. It is assumed that vehicles in the network, adhere and obey to the rules of the intersection. The vehicles in the network are subjected to various constraints from the traffic management layer like maximum and minimum speed, acceleration and lane changing rules. Since vehicles shall be in interaction with each other, these constraints and rule shall be useful in making maneuvering decisions by the vehicles using V2V communication through a distributed process. The rules and constraints have been stated below.

- **Acceleration Constraints** Vehicles maneuvering through the network are expected not to violate the maximum and minimum acceleration rates as suggested by the traffic

management layer. For the purpose of this research, the maximum and minimum values of acceleration considered are 2 and -2 m/s^2 .

$$a \geq a_{min}(= -2\text{m/s}^2)$$

$$a \leq a_{max}(= 2\text{m/s}^2)$$

- **Speed Constraints** An important parameter that will affect the acceleration of the vehicles are allowed minimum and maximum speed of vehicles in the network. For the purpose of this research, the maximum and minimum speed allowed in the network are 25 km/hour and 0 km/hour. For the scenarios where platoons are to be modeled, the maximum speed that a vehicle can attain to merge into the platoon shall be 25km/hour. It is to be noted that negative speeds are not allowed. This would mean that vehicles are moving backwards.

$$v \geq v_{min}(= 0 \text{ km/hour})$$

$$v \leq v_{max}(= 25 \text{ km/hour})$$

- **Priority to the Right** Vehicles entering the network have to adhere to the rule of "Priority to the Right" concept. If travel time of vehicles in the intersection to a point are the same, vehicles have to yield to the vehicles to their right. In the present scope of this research, the route choice of the vehicles have been decided prior to the maneuvering of the vehicles. For implementing the priority to the right concept, links have been allotted strengths based on their spatial location. If there is a possible conflict point, the link strengths are used as parameters to decide the right priority of the vehicles.
- Overtaking of vehicles in the same lane is not allowed.

Since the vehicles generated in VISSIM have to adhere to the an external control strategy and not maneuver in the simulation using the widely used Wiedemann Model, COM (Component Object Model) functionality shall be used for this purpose. COM allows components of a program to interact with the components of another program without having to know the intrinsic details associated with it.

For the implementation and analysis of the developed strategy, it is necessary to design a more realistic intersection. Figure 5.2 provides a wire frame view of the developed intersection for this research. A four legged intersection has been designed for the purpose of this research. Vehicles shall be entering the intersection from different links and move into their respective destination links. Each link in the network is approximately 270 m and width of 3.5 m. The intersection box is a square with sides 7 m.

Vehicles are introduced into the links and are allowed to maneuver in their own respective direction by following the rules of the traffic management layer as mentioned above. The static routing of the vehicles from every link is decided prior to the start of the simulation as mentioned. This is done because the destination of the vehicles shall play an important role in determining the way which vehicles slow down before the intersection box to avoid collision. For the implementation of the strategy in VISSIM, it is assumed that vehicles are in V2V range within 100 m from the intersection box.

For all the conducted simulation in VISSIM, the simulation speed is set to 10 Simulation seconds per second. The Simulation resolution is set to 10 time steps per simulation second.

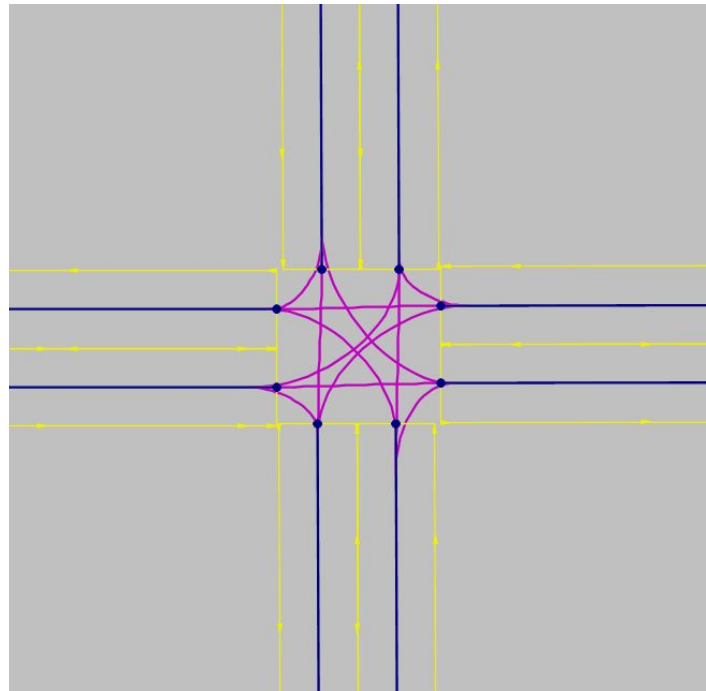

Figure 5.2: Developed intersection in VISSIM

Moreover as mentioned above, the destination of the vehicles entering the intersection is known.

5.2 Vehicles approaching an intersection

In the intersection presented in the earlier section, vehicles enter the intersection from three links and move towards their respective destination by adhering to the developed strategy for the intersection. Once the vehicles are in V2V range with other vehicles in different lanes, priority is decided based on time to the conflict point. If the time to the conflict point is same for two or more vehicles, vehicles yield to the vehicles to their right. Figure 5.3 provides a demonstration of how vehicles maneuver in the developed network and the possible conflict points that will arise as a result of the route choice.

The possible conflict points that can arise due to such a maneuver have been shown in gray. These are the conflict points where vehicles from different lanes shall collide unless the strategy is applied.

PD Controller for acceleration and braking maneuvers

For the performance of acceleration and braking maneuvers, a PD(Proportional-Derivative) controller has been implemented. The specific decisions for acceleration and braking actions shall depend on the position of the vehicles and the decisions made cooperatively based on V2V communication among the vehicles. The implementation of this controller is inspired from [42].

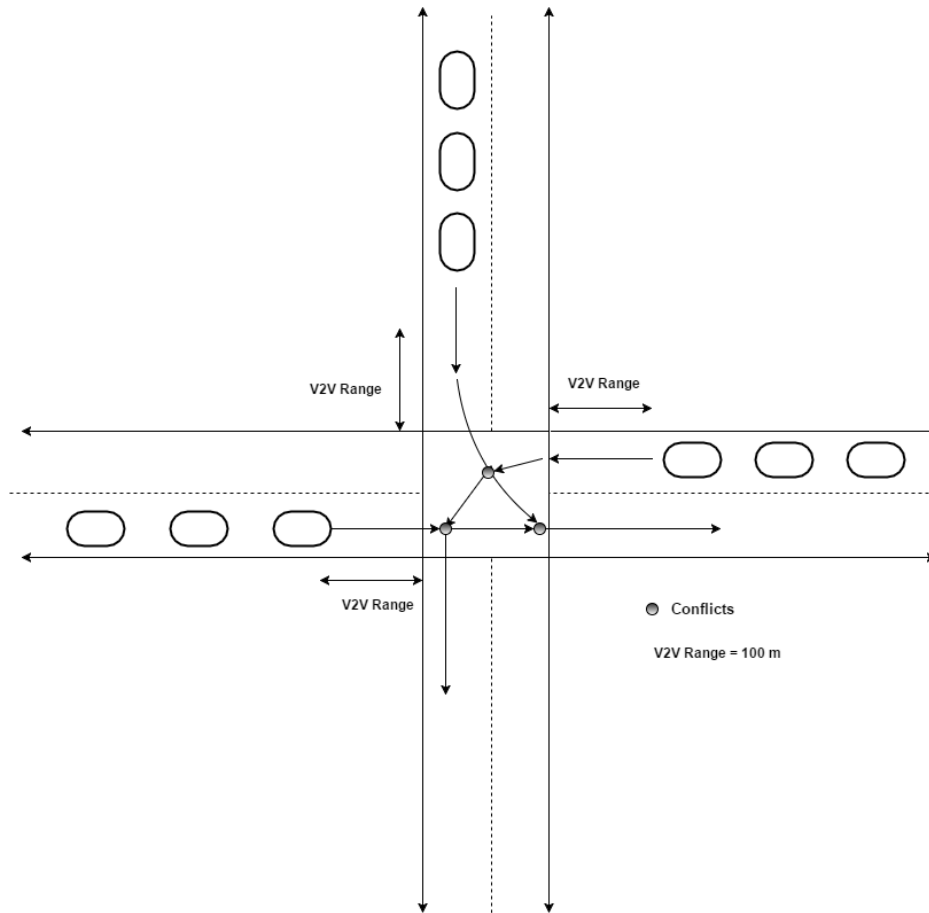

Figure 5.3: Vehicles maneuvering in the network

During the duration of the entire maneuver, a reference speed is established for the vehicles that they should try to maintain. Along with the reference speed, a reference distance is also decided for the vehicles. Upon being introduced into the network, the vehicles try to maintain the reference speed by taking into account the reference distance through proper selection of acceleration or deceleration values from the PD controller.

Let u_r be the reference speed and d_r be the reference distance. The necessary acceleration a_r is calculated by using the equation of motion

$$a_r = \frac{u_r^2 - u^2}{2d_r}$$

where u is the present speed of the vehicle. The reference acceleration value, a_r is then passed through the PD controller. The PD controller is designed as:-

$$acc = k_p * a_r + k_d * \frac{da}{dt}$$

where,

acc - final acceleration

k_p - Proportional constant

k_d - Derivative constant

$\frac{da}{dt}$ - Jerk

The final acceleration value acc received from the PD controller is then used for acceleration or braking maneuvers by the vehicles. Every time the values of the final acceleration acc violates the constraints of the acceleration as specified in the previous section, the acc value is set to maximum or the minimum acceleration based on its value. The value of k_p and k_d has been found out based on trial and error. It is to be noted that the value of k_p is not directly used. Every time the reference speed for a vehicle changes, k_p is varied from 0 to the set value in 100 time steps. This ensures that the maneuvers undertaken by vehicles are smooth and jerks are reduced from the vehicle. It can be seen that the derivative part of the controller is used for minimizing the jerk.

Implementation and Evaluation

The above mentioned concepts were implemented to the designed network in VISSIM. The strategic level of the implementation deals with the route choice, destination choice and mode choice. The maneuvering level takes care of the developed strategy using which vehicles will avoid collision with other vehicles in the network at the intersection and move towards their respective destination. The control level, which is the lowest level deals with the functioning of the PD controller.

Initially three vehicles were introduced in three links which are link 1, 4 and 5. Upon introduction vehicles travel at their original speed. For the entire part of the maneuver where vehicles are not in V2V range, the reference speed u_r is set to the their original speed. Once vehicles are in the V2V range of the other vehicles, strategy is applied and new speed values are assigned. During the crossing of the intersection, the new speed values assigned to the vehicles serve as the reference speed. Once the conflict for the respective vehicles are solved, the reference speed for the vehicles are again set to the original speed and vehicles accelerate towards their destination.

During the entire simulation run, their coordinates were extracted and saved. After the simulation was over, the coordinates of the vehicles were used to plot the trajectory graph of the vehicles in the network. Figure 5.4 shows the trajectory of the 9 vehicles in the network.

The shaded black line in the middle of the graph represents the intersection box. It can be seen that all the vehicles keep moving towards the intersection at a constant speed. Once they are in V2V range with vehicles from other links, they cooperatively change their speed before the intersection box to maneuver the intersection without colliding with each other. As soon as the higher preferred vehicle has crossed the conflict point, the next vehicle speeds up to its original speed. The behavior of vehicles in the intersection box is also visible through this trajectory graph.

Figure 5.5 demonstrates the speed profile of the vehicles in the intersection. Speed profiles of same color represent different vehicles from the same link. It can be seen that by using the PD controller, vehicles are very smoothly attaining to their desired speeds in the network. Along with the PD controller, varying the proportional constant (k_p) also helps in achieving smoother

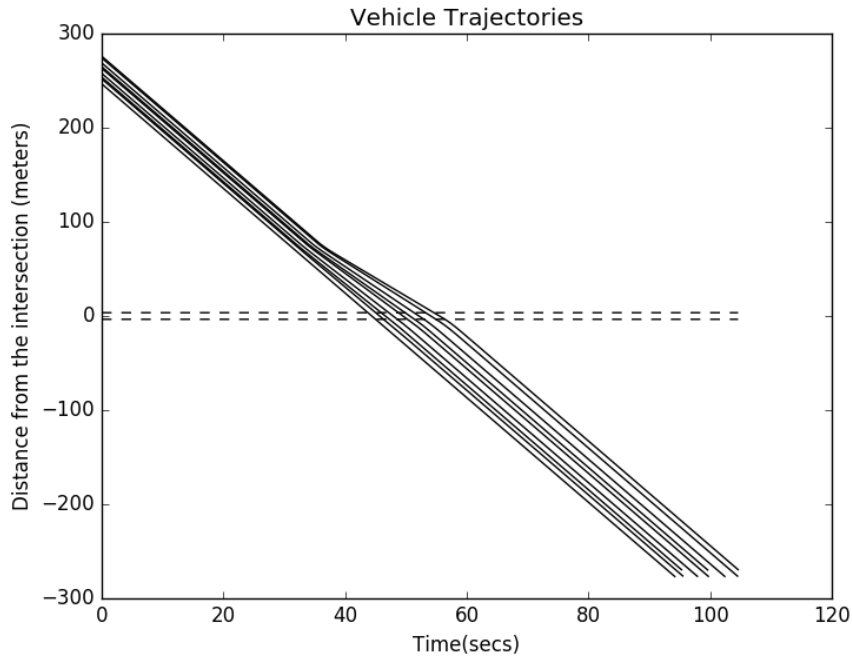

Figure 5.4: Vehicle trajectories in the network

profiles of speed, acceleration and jerk. Figure 5.6 and 5.7 demonstrate the acceleration and jerk profiles respectively of the vehicles in the network.

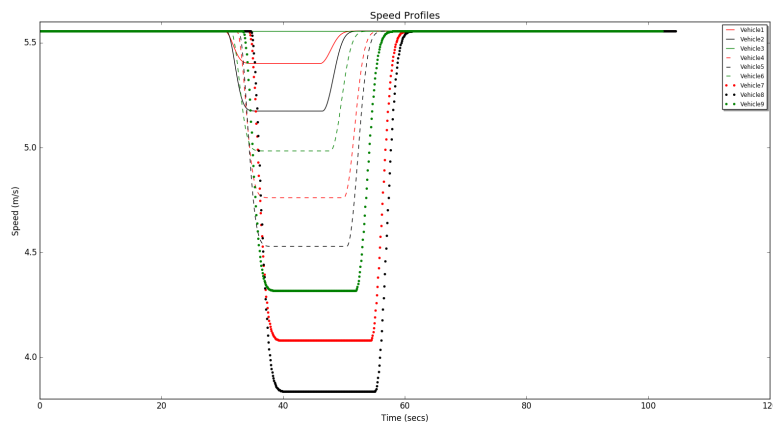

Figure 5.5: Instantaneous Speed Profiles

It can be seen that once vehicles are in V2V range vehicles adjust their speed. Once the higher preferred vehicle has crossed the conflict point, vehicle regain their original speed towards the end of their maneuver. During the entire maneuver, none of the stated constraints have been violated and vehicles are able to avoid collision with other vehicles without the presence of any kind of maneuvering support system like traffic lights.

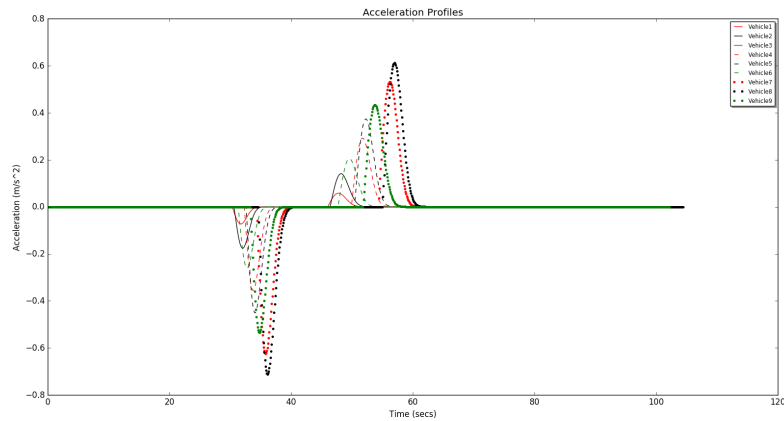

Figure 5.6: Acceleration profiles

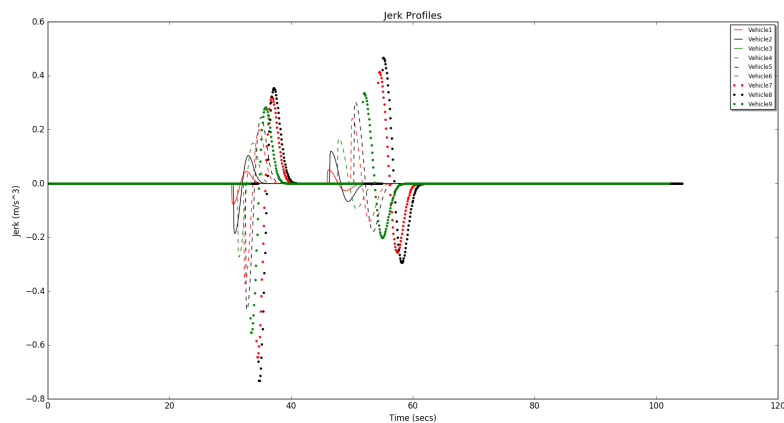

Figure 5.7: Jerk profiles

5.3 Vehicles approaching in Platoon

Similarly to the implementation in USARSIM, scenarios are also modeled where vehicles are entering the intersection being a member of the platoon. Two scenarios are considered.

- Platoons adhere to the strategy. Before crossing the intersection, platoon members break from the platoon and behave as individuals. Through the V2V communication, new speed is decided for the vehicles and vehicles attain that speed before the intersection to avoid collisions with other vehicles. Once the conflict for a vehicle in platoon has been solved and it is in the V2V range of its leader vehicle from the platoon, it accelerates or decelerates accordingly to merge back into the platoon. In the entire process, the maximum speed allowed for the vehicle is 25 km/hour.
- In the second scenario, a platoon is given full priority and is allowed to cross the intersection first without disengaging from the platoon. Vehicles from other lanes slow down

in a fashion such that they don't reach the intersection box before the last vehicle of the platoon has crossed the intersection. Once the platoon has crossed the intersection, vehicles of the other lanes engage in V2V communication and attain a new speed based on the developed strategy.

As mentioned in Chapter 3, there are two assumptions made for considering platoons entering an intersection. It is assumed that only one platoon is entering the intersection and the number of vehicles in a platoon does not change after entering the network and before crossing the intersection. Situations where more than one platoon approaches the network and vehicles are able to dynamically merge and exit from the platoon continuously are considered out of scope for this research.

For every scenario modeled with platoons entering the network, it is assumed that vehicles maintain a desired inter vehicle distance of 5 m with their respective leading vehicles. The speed controller used for the vehicles is a Cooperative Adaptive Cruise Controller (CACC) as suggested in [34]. However, vehicles also have to adhere to the traffic rule of the intersection regarding maximum speed in the network. A vehicle can attain a maximum speed of 25 km/hour and should not violate the acceleration constraints.

CACC Controller

As mentioned above, the controller used to manage platoons in the VISSIM environment is the CACC controller. The accepted value of acceleration (acc) is based on the comparison between two different acceleration values, one which is computed based on the difference between the desired and the present speed (acc_v) and the other which is computed based on the inter vehicle distance and speed difference between a leading and a following vehicle (acc_d). The accepted value of acceleration is defined as:-

$$acc = \min(acc_v, acc_d)$$

Let v_d represent the desired speed of the vehicle and v_p represent the present speed of the vehicle. acc_v is calculated based on the equation:-

$$acc_v = k * (v_d - v_p)$$

where k is the constant speed error factor.

Let v_l and a_l denote the speed and acceleration of the leading vehicle respectively. Let d and d_{ref} denote the present inter vehicle distance and the reference inter vehicle distance of the following vehicle with the leader vehicle. So acc_d can be computed based on the equation:-

$$acc_d = k_a * a_l + k_v * (v_l - v_p) + k_d * (d - d_{ref})$$

If the desired acceleration acc is violating the maximum and minimum acceleration constraints, the desired acceleration is set to the limits.

$$if \ acc > 2m/s^2, \ acc = 2m/s^2$$

$$if \ acc < -2m/s^2, \ acc = -2m/s^2$$

5.3.1 Platoon following the strategy

In this scenario, a platoon of vehicles enter the network and move towards the intersection. Once the platoon is in V2V range with vehicles from other lanes in the network, they adjust their speed according to the developed strategy so as to cross the intersection without colliding with each other. Once each of the platoon member has crossed its conflict point, they speed up accordingly so as to maintain the desired inter vehicle distance with their respective leading vehicles. 9 vehicles are entering the network in the present case. 3 of the vehicles are in a platoon. Figure 5.8 shows the trajectories of different vehicles in the network. Vehicles that are not member of the platoon can be seen to behave similarly as the earlier scenario where no platoons are considered. For vehicles as part of the platoon, it can be seen that post crossing the intersection, each vehicle adjusts its speed so as to become a member of the platoon again.

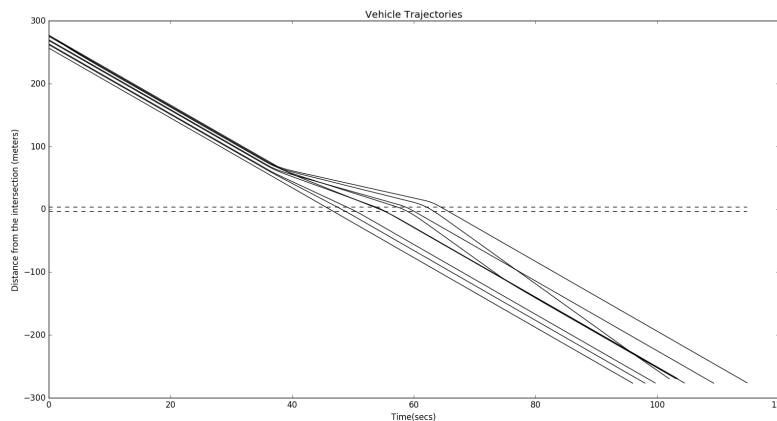

Figure 5.8: Vehicle trajectories - Platoon without priority

The above conclusion is also supported by the instantaneous speed profile of the vehicles as shown in Figure 5.9. Vehicles represented in black are the vehicles that are member of the platoon. Speed profiles of vehicles that are not a member of the platoon are similar to the speed profiles of the scenario where no platoon is entering the intersection. For vehicles in the platoon, while entering the network they increase their speed in order to maintain the desired inter vehicle distance of 5 m and slowly attain the reference speed of 20 km/hour. Once they are in V2V range, they adjust their speeds accordingly so as to avoid the collision at the intersection. Once the conflict point for every vehicle is solved, the vehicles of the platoon speed up to 25 km/hour so as to reduce the big inter vehicle distance gap that was created during adhering to the strategy. It can be seen that Vehicle 5 is able to merge back into the platoon. However, Vehicle 8 is not able to merge back completely into the platoon. With the help of the CACC controller, vehicles are able to attain smooth speed and acceleration profiles. Figure 5.10 and 5.11 show the acceleration and jerk profile of the vehicles during the simulation run.

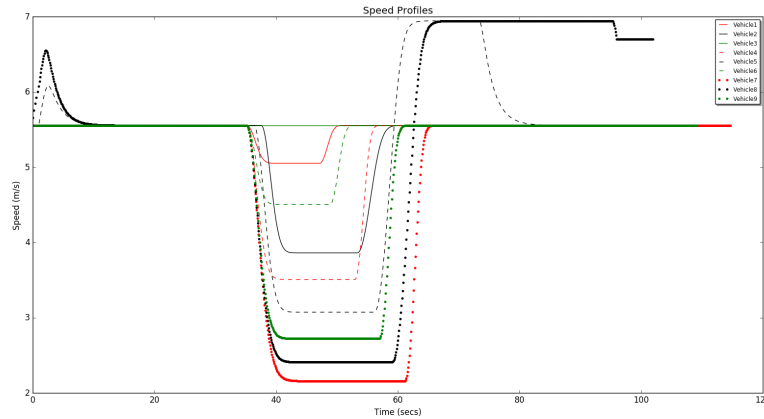

Figure 5.9: Instantaneous speed profiles - Platoon without priority

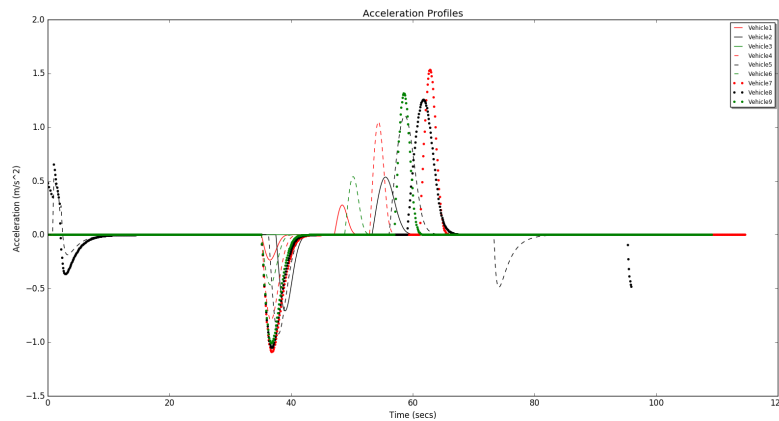

Figure 5.10: Acceleration profiles - Platoon without priority

5.3.2 Platoon with higher priority

In this scenario, the platoon approaching the intersection is provided the highest priority. With the assumption that there is V2V communication among vehicles, the vehicles from other lanes slow down once they detect a platoon approaching the intersection. The method of identifying the leading vehicle and number of vehicles in the platoon is same as explained in the USARSIM implementation. Based on the number of vehicles in the platoon, vehicles from other lanes either slow down or stop in such a manner that the last vehicle of the platoon crosses the intersection box before they maneuver into the intersection box. Once the entire platoon has crossed the intersection, other vehicles follow the developed strategy for the intersection and maneuver safely through the intersection towards their respective destination. Therefore the assumption that the number of vehicles in the platoon don't change before the intersection box plays a very important role in this scenario.

Same like the earlier scenario, 9 vehicles enter the network, 3 of which are members of the platoon. However in this scenario, full priority is given to the platoon and the vehicles from

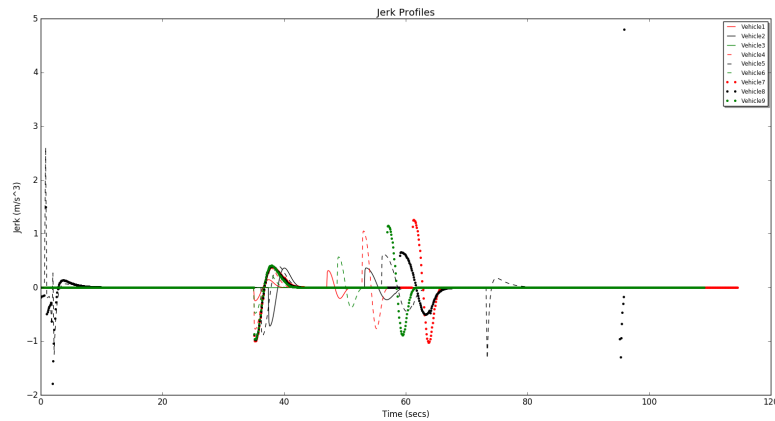

Figure 5.11: Jerk profiles - Platoon without priority

other lanes slow down in order to let the platoon cross the intersection first. Figure 5.12 shows the trajectories of different vehicles during the simulation run. It can be seen that vehicles in the platoon do not witness any change in their speed throughout their maneuver and therefore the trajectory lines are completely straight.

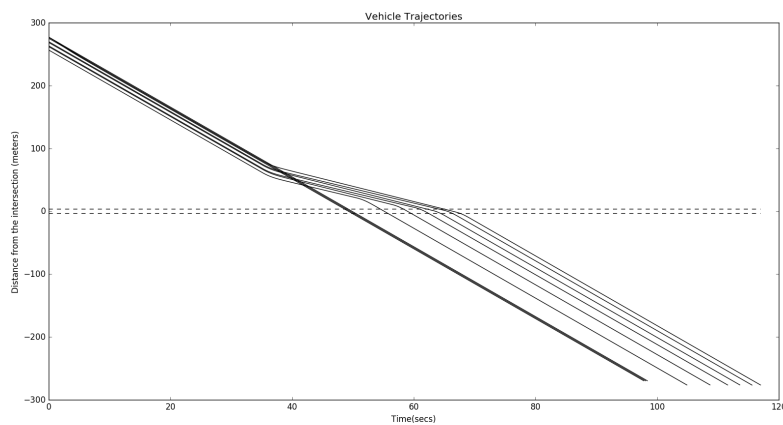

Figure 5.12: Vehicle trajectories - Platoon with priority

Figure 5.13 shows the instantaneous speed profile of the vehicles in this scenario. It can be seen that vehicles in platoon maintain a constant speed throughout their maneuver except at the beginning, where they are adjusting their speed to maintain the desired inter vehicle distance with their respective leading vehicles. For the vehicles that are not in platoon, they change their speed two times during the maneuver. The first time, they adopt a speed such that don't reach the intersection box before the last vehicle of the platoon has crossed the intersection. Once the entire platoon has crossed the intersection, they attain a new speed based on the developed strategy for the intersection. Once the higher preferred vehicle has crossed the conflict point, the lower preferred vehicle attains its own original speed and continues towards its destination.

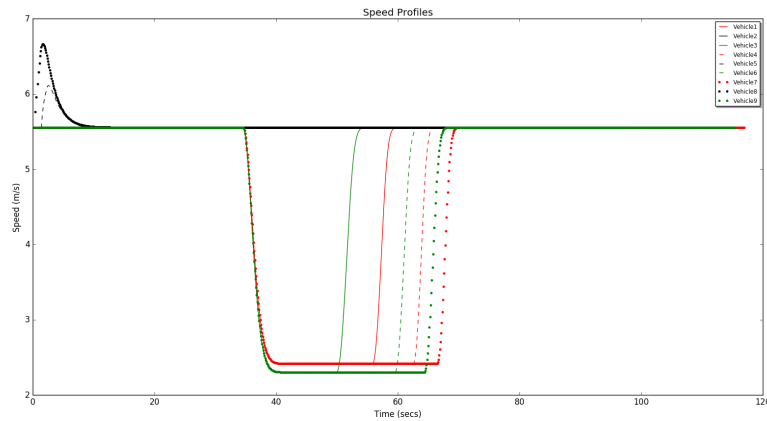

Figure 5.13: Instantaneous speed profiles - Platoon with priority

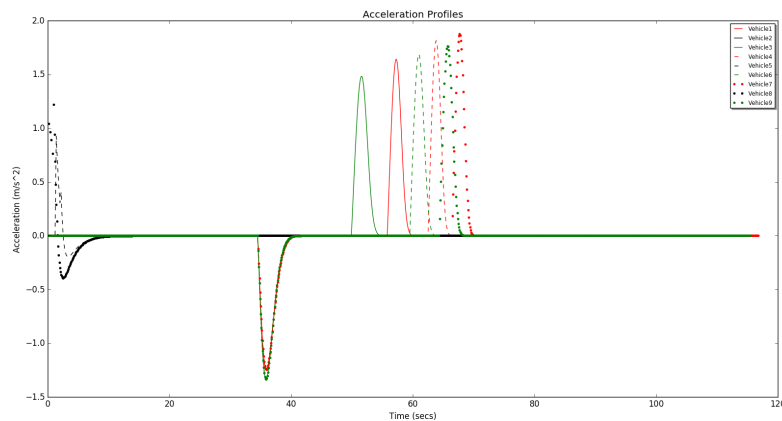

Figure 5.14: Acceleration profiles - Platoon with priority

This chapter dealt with implementation of the developed strategy in different scenarios in VISSIM, a microscopic traffic simulator. In the previous chapter the similar strategy was applied in USARSIM and it was checked whether the developed strategy and such scenarios were possible practically through V2V communication. Based on the results presented in that chapter, it can be confirmed that vehicles can maneuver and adhere to the strategy through V2V communication and without any centralized control. The implementation in this chapter reveals whether such a strategy is possible in an actual traffic condition. A realistic traffic scenario was created and the strategy was applied. The results of simulation confirm that such a developed strategy can be applied to real life traffic scenarios.

5.4 Measuring Scalability

Another important reason for implementing the strategy in VISSIM is to measure the scalability of the developed strategy. Due to lack of space and expensive computational power, the

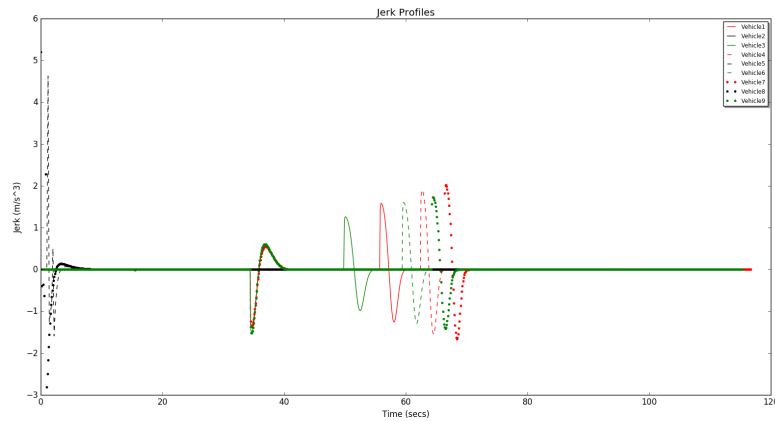

Figure 5.15: Jerk profiles - Platoon with priority

scalability of the developed strategy cannot be measured effectively in USARSIM. However, this can be checked in VISSIM. The central theme of the entire research is the developed strategy. The strategy was applied to different number of vehicles in the network and simulation time and actual CPU time was noted.

Simulation Time - Simulation time refers to the time required by the computer model of the physical system being modeled for simulation. This is measured in Simulation Seconds.

CPU Time - The actual CPU time spent in the entire simulation process.

Figure 5.16 show graphs showing the CPU times, Simulation time and their comparison for different number of vehicles through the network. It can be seen that as the number of vehicles increase, computational power becomes highly expensive and therefore the CPU time increases comparatively.

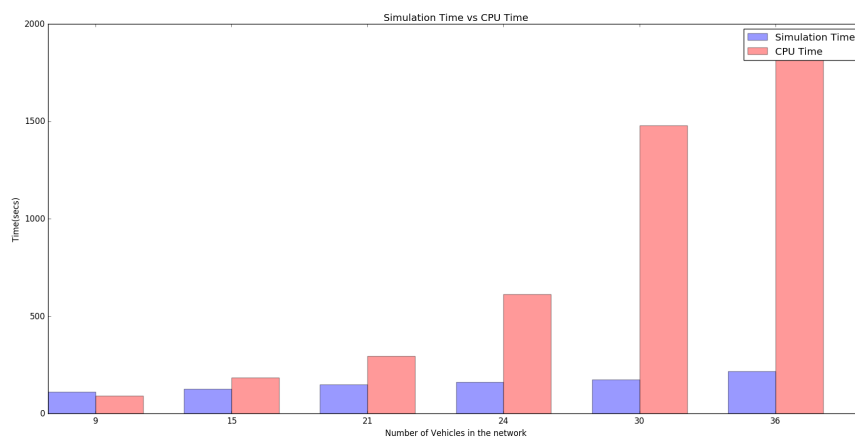

Figure 5.16: Comparison of CPU vs Simulation time

5.5 Overview

This chapter demonstrates the implementation of the developed strategy in VISSIM. The developed strategy is applied for both individual vehicles and vehicles as part of a platoon. The entire modeling framework in VISSIM is based on Michon's hierarchical model as shown in Figure 5.1. The strategic level deals with the route, mode and destination choice for the developed scenarios. Obstacle avoidance at the intersection through the developed strategy functions at the maneuvering level. The control level takes care of the speed of the vehicles that are necessary for successful maneuvering of vehicles at the intersection without collision. For the implementation part in VISSIM, extra traffic constraints are applied related to speed and acceleration that vehicles should not violate during their maneuver. For controlling the acceleration of vehicles in the network, a PD controller is used. For the purpose of modeling platoons, a CACC controller is used. From the speed, acceleration and jerk profiles as shown in this chapter, it is evident that vehicles are able to maneuver the intersection with the developed strategy and attain smooth transitions to different speed and acceleration. Moreover, compared to the implementation part in USARSIM, no huge fluctuations are found in speed graphs for the implementation in VISSIM.

Based on the simulations performed which are demonstrated in this chapter, trajectory files shall be exported from VISSIM that shall be used for assessing the effectiveness of the developed strategy on various grounds. They are traffic flow efficiency, sustainability and surrogate safety. The entire description has been provided in the next chapter.

Effectiveness assessment from VISSIM implementation

This chapter deals with evaluation of the developed strategy and measuring its effectiveness in real traffic scenarios. The effectiveness of the different simulation scenarios in the last chapter shall be measured in terms of traffic flow efficiency, sustainability and surrogate safety assessment.

For measuring the effectiveness of the developed strategy in real traffic scenarios, the simulation results presented in the previous chapter shall be used. Two different comparison studies shall be carried out. Every comparison study has two different scenarios. In the first comparison study, the scenario of an intersection with the strategy implemented shall be compared with the same intersection with traffic lights. Both these scenarios shall be judged upon various performance indicators that have been mentioned in the next section. The second comparison study shall be carried out to answer the question, whether the platoons should be provided priority at the intersection or not. Both the scenarios where platoons adhere to the strategy and cross the intersection like individual vehicles and the scenario where platoons are given priority to cross the intersection first shall be compared based on those performance indicators. For the comparison study, 30 vehicles in the network are being considered.

6.1 Performance Indicators

For measuring the effectiveness of the strategy in different scenarios, comparison shall be made on three important grounds that consist of different performance indicators. The three different grounds, the performance indicators and the tools to assess those indicators have been explained below.

Traffic Flow Efficiency

One of the major aspects of measuring effectiveness of the developed strategy is to assess the efficiency achieved or lost in the traffic flow in the presence or absence of the developed strategy. For both the comparisons that are the intersection with strategy versus Intersection with traffic lights and Platoon without priority versus Platoon with priority it is essential to measure the impact that various scenarios have on traffic flow. For the purpose of measuring the efficiency of different scenarios, two performance indicators shall be used. They are:-

- **Throughput**

The throughput of the network in different scenarios shall play an important factor in determining which strategy is more efficient in terms of increasing the flow of vehicles through the network. For simulation run of every scenario, the total simulation time shall be taken into account and based on the data received, the total flow of vehicles that is possible in 3600 simulation seconds shall be calculated.

- **Total Delay in the network**

The total delay in the network is an important indicator of how good a strategy is for any network. The total delay in the network is calculated by taking into account the different speed achieved by the vehicle in the intersection. Suppose a vehicle enters the intersection at 20 km/hour, maintains the speed throughout the network and exits at the same speed, the total delay of the vehicle is 0. The total delay in the network shall indicate the difference in delays for different case scenarios. The scenario where the delay is less is deemed to be more efficient.

These performance indicators for judging the traffic flow efficiency can be directly achieved from the simulation runs in VISSIM.

Sustainability

Emissions in traffic have become a serious issue in the present day scenario. Sustainability has become an important aspect in the field of road transport. Research has indicated that almost 45% of the pollutants emitted in the United States are a direct consequence of the vehicular emissions [43]. It is therefore important that sustainability effects of the developed strategy are also taken into account while comparing effectiveness. Some of the pollutants that are released as vehicular emissions are Carbon dioxide(CO_2), Nitrous Oxide(NO_x), Particulate Matters(PM_{10}) and other hydrocarbons. A lot of factors like vehicle speed, acceleration, stops, delays, age of the vehicle, engine quality and the kind of fuel used have an impact on the amount of vehicular emissions.

Various regression models have been suggested in literature to calculate the emissions of vehicles using speed and acceleration values. For computing the amount of hydrocarbons released during an entire simulation run, a hybrid regression model suggested by [43] shall be used. The hybrid regression model is stated as:-

$$\ln(MOE_e) = \begin{cases} \sum_{i=0}^3 \sum_{j=0}^3 (L_{i,j}^e \times s^i \times a^j) & \text{if } a \geq 0 \\ \sum_{i=0}^3 \sum_{j=0}^3 (M_{i,j}^e \times s^i \times a^j) & \text{if } a < 0 \end{cases}$$

where, MOE_e is the emission rate in mg/s, $L_{i,j}^e$ and $M_{i,j}^e$ are the model regression coefficients for calculating MOE at speed power i and acceleration power j at positive and negative acceleration values respectively, s is the instantaneous speed and a is the instantaneous acceleration of the vehicle.

This regression model can be used to calculate emission of different pollutants. However one important step in the process of calculation is calculating the model regression coefficients. The researchers have come up with these coefficients by conducting a goodness of fit with the Oak Ridge National Laboratory(ORNL) data that is responsible for collecting data regarding fuel consumption and emission models. This process has been kept out of the scope of this research. [43] has provided the the sample model regression coefficients for calculating Hydro carbons and therefore only hydro carbons are being calculated through the regression equation.

The other important pollutants released during vehicular emissions are CO_2 , PM_{10} and NO_x . For calculating the amount of these pollutants that are expected to release during every simulation run, Enviver Pro software is used. Enviver is a software that calculates the amount of CO_2 , PM_{10} and NO_x released during every simulation run by using a emission database which is maintained by TNO. The emission model that is used by Enviver is known as VERSIT+ which calculates the amount of emissions based on traffic micro simulation. Trajectory files from VISSIM can be extracted and fed into the software. Based on the information available from the files like the vehicle types, coordinates, speed and acceleration values, a general estimate of the amount of emissions can be achieved.

It is to be noted that all the above calculations for measuring sustainability are to taken as comparisons rather than absolute measure of emissions. The basic idea is to show the emission differences between two different scenarios with the same tool and parameters.

Surrogate Safety Assessment

One of the most challenging areas of research in the field of traffic is assessment of safety. It is one of the important parameters considered while evaluating various designs and strategies that are applied to traffic flow scenarios. For the analysis of surrogate safety measures, below are some definitions that are to be considered while doing the analysis [44].

Safety The expected number of accidents, by type expected to occur on the entity in a certain period per unit time.

Accident An unintended collision between two or more motor vehicles.

Conflict An observable situation in which two or more road users approach each other in time and space for such an extent that there is risk of collision if their movements remain unchanged.

Figure 6.1 demonstrates the various surrogate safety measures. The two parameters that are taken into account for measuring surrogate safety are Post Encroachment Time (PET) and Time to Collision (TTC). Definitions of these measures are provided below based on the figure presented above.

Time to Collision(TTC)

Two vehicles A and B are taken into account. The time to collision is shown as $t_4 - t_3$. The

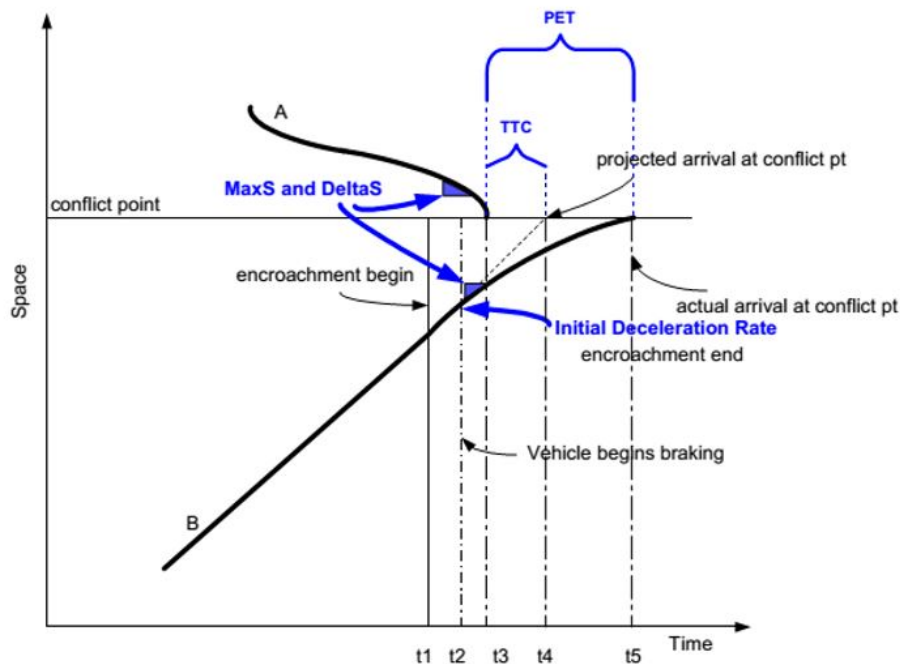

Figure 6.1: A visual representation of different measures for surrogate safety

projected arrival of vehicle B is calculated in case it had not started braking and continued at the same speed. The time to collision is calculated as the difference between the encroachment end time of vehicle A and projected arrival time of vehicle B, keeping in mind the right of way at the conflict point. Lower time to collision would mean higher severity of collision.

Post Encroachment Time (PET)

Post Encroachment time can be defined as the difference in time of a road user leaving a potential area of collision and the moment of arrival of a second road user to the potential area of collision with the right of way [45]. Figure 6.1 showcases PET for a conflict point as $t_5 - t_3$. This time is represented as the departure time of the encroaching vehicle from the conflict point and arrival at the conflict point with the right of way. Lower PET would mean higher probability of collision.

For analysis of the various measures, the SSAM software which is developed by Federal Highway Administration of US Department of Transport shall be used [46]. Trajectory files can be exported from VISSIM and fed into the SSAM software. The user is provided with the details of conflicts between the range of PET and TTC values specified by the user. All the above measures can be directly sought from the SSAM software.

6.2 Intersection with Strategy versus Traffic Lights

For evaluating the benefits of implementing the developed strategy in an intersection a comparison is being made with a similar intersection where vehicles move with the aid from traffic lights. A scenario with traffic lights was created in VISSIM. Vehicles originate from the same

Comparison of Performance Indicators			
Performance Indicators	Intersection with Traffic Lights	Intersection with Strategy	Gain/Loss
Throughput	506	628	≡ +24.11%
Total Delay	1216	680	≡ +44%

Table 6.1: Comparison of Performance Indicators for Traffic Flow Efficiency

links in both the scenarios. For the scenario with traffic lights, a fixed time signal controller is used. For every link from which vehicles are originating, a signal group is created. For every signal group, a sequence of *red* > *red/amber* > *green* > *flashing green* > *amber* lights are used. The total cycle time of the signal controller is 60 simulation seconds and for every signal group, 20 simulation seconds are allotted.

Evaluating Traffic Flow Efficiency

For both the scenarios, intersection with strategy and intersection with traffic lights, 30 vehicles are generated from the same links and are allowed to maneuver. Based on the output from VISSIM, the different performance indicators for measuring traffic flow efficiency were noted. The throughput for every scenario was calculated by noting the total simulation time for the 30 vehicles to exit the network and use the information to predict the number of vehicles that can exit the network in 3600 simulation seconds (1 simulation hour). The total delay of the vehicles in the network is directly provided by VISSIM. The results are presented in Table 6.1. The units of throughput are in vehicles/simulation hour and the units for delay in the network are in simulation seconds. The gain or loss occurred in implementing the strategy is also considered. If the throughput of the intersection with strategy scenario is more than the throughput of the traffic lights, it is considered a gain. Similarly, if the total delay of the intersection with strategy scenario is less than intersection with traffic lights, it is also considered a gain.

It can be seen that both the performance indicators are showing a substantial gain for the scenario where the strategy is implemented. The throughput has increased by almost 24% and delay in the network has decreased by 44%. Therefore taking into account, the above mentioned performance indicators, implementing the strategy for the designed intersection seems to be a good idea.

Evaluating Sustainability

As mentioned above, vehicular emissions are a key factor for consideration while comparing different strategies and designs for any traffic. For calculating the emissions of hydrocarbons, the hybrid regression model presented in the previous section. The sample model regression coefficients as provided by [43] shall be used for the calculation of the hydrocarbon emissions. The coefficients are shown in Figure 6.2.

For the calculation of CO_2 , PM_{10} and NO_x emissions, Enviver software is used. The trajectory files from VISSIM are extracted and fed into the database. Calculations of the emissions

Coefficients	Constant	Speed	Speed ²	Speed ³
Positive acceleration				
Constant	-0.87605	0.03627	-0.00045	2.55E-06
Acceleration	0.081221	0.009246	-0.00046	4.00E-06
Acceleration ²	0.037039	-0.00618	2.96E-04	-1.86E-06
Acceleration ³	-0.00255	0.000468	-1.79E-05	3.86E-08
Negative acceleration				
Constant	-0.75584	0.021283	-0.00013	7.39E-07
Acceleration	-0.00921	0.011364	-0.0002	8.45E-07
Acceleration ²	0.036223	0.000226	4.03E-08	-3.5E-08
Acceleration ³	0.003968	-9E-05	2.42E-06	-1.6E-08

Note: Speed: km/h; acceleration: km/h/s; HC emission rate: mg/s.

Figure 6.2: Sample model regression coefficients for Hydrocarbon

Comparison of Emission values			
Performance Indicators	Intersection with Traffic Lights	Intersection with Strategy	Gain/Loss
Hydro Carbon	0.041	0.029	≡ +29%
CO ₂	224.3	209.2	≡ +6.7%
NO _x	0.1305	0.1086	≡ +16.7%
PM ₁₀	0.054	0.052	≡ +3.7%

Table 6.2: Comparison of Performance Indicators for Sustainability

are carried out on the assumption that all are passenger cars and only run on gasoline. Table 6.2 shows the different emissions calculated for the two scenarios under comparison. The gain or loss of the scenario where the strategy is implemented compared to the traffic lights scenario is also presented. Any decrease in emissions is considered a a gain.

Based on the results from Enviver, it is seen that the values of CO₂ are in excess of the standards set by the European Union. For 2015, EU had set the CO₂ emission standards at 130 g/km. However the values received are way above the set standards. Some reasons for this are pointed below.

- One of the parameters in calculating emissions in Enviver is the vehicle age. The maximum distribution for cars with age less than a year is 17.7%, the average age is taken a 5 years and the maximum age is set to 40 years. As mentioned earlier, vehicle's age does play a role in the amount of emissions.
- Enviver assumes a distribution of cars having different emission legislations from Euro 1 to Euro 6. Distribution in such legislations could also be responsible for such a high value of CO₂.

Comparison of Surrogate Safety Measures			
Performance Indicators	Min Value	Max Value	Average Value
TTC	0.20	1.40	0.37
PET	0.30	1.70	0.4
MaxS	1.16	5.54	4.59
DR	0.0	0.0	0.0
DeltaS	0.24	10.4	3.55

Table 6.3: Performance Indicators for Surrogate Safety for Intersection with Strategy

It is to be understood that the above emission values are not being presented as an absolute reality and has to be only taken into considerations for comparison reasons. The core of the comparison is that the same tool with the same parameters are providing results that are in favor of the developed strategy rather than the intersection with traffic lights scenario.

Suurogate Safety Safety Assessment

As mentioned above, assessment of surrogate safety measures shall be carried out by the use of the SSAM software developed by FHWA. Vissim trajectory files for both the scenarios are exported and fed into the software. For both the scenarios conflicts are identified with time to collision less than 1.5 seconds and PET less than 5 seconds.

On assessing the intersection with strategy through the SSAM software, 6 conflicts were found. All of the found conflicts were crossing conflicts. The minimum and maximum values for different surrogate safety measure have been listed out in Table 6.3.

For the scenario with traffic lights, no conflict were found. Obviously such a result was expected since vehicles obey the traffic lights and do not try to maneuver while vehicles from other lanes are in the intersection. Compared with the traffic lights scenario, the intersection with the developed strategy is definitely less safe. However it is also to be noted that for the purpose of safety, other important parameters like throughput, travel time delay and emissions are being compromised.

6.3 Platoon with Priority versus Platoon without Priority

Similar to the earlier described assessment of effectiveness, this comparison deals with comparing scenarios where either a platoon has to adhere to the developed strategy or a platoon gets the full priority at the intersection and is allowed to maneuver first. The performance indicators described above are calculated for this comparison study as well.

Traffic Flow Efficiency

Table 6.4 showcases the values of the various performance indicators for assessing the traffic flow efficiency in the platoon case.

Comparison of Performance Indicators			
Performance Indicators	Platoon without Priority	Platoon with Priority	Gain/Loss
Throughput	612	682	$\equiv +10\%$
Total Delay	576	425	$\equiv +26.2\%$

Table 6.4: Comparison of Performance Indicators for Traffic Flow Efficiency in the platoon scenario

Comparison of Emission values			
Performance Indicators	Platoon without Priority	Platoon with Priority	Gain/Loss
Hydro Carbon	0.0302	0.029	$\equiv +4\%$
CO_2	209	218.6	$\equiv -4.5\%$
NO_x	0.107	0.1123	$\equiv -5\%$
PM_{10}	0.05021	0.0523	$\equiv -4.2\%$

Table 6.5: Comparison of Performance Indicators for Sustainability in the platoon scenario

It can be seen that on giving priority to the platoon, the throughput of the entire network increases by almost 10% and the delay decreases by almost 26%. This was expected as the vehicles that are part of the platoon get full priority and are not delayed at the intersection. In the simulation carried out, one-third of the vehicles are in the platoon. Therefore delay is witnessed by only two-thirds of the vehicles.

Sustainability

For measuring sustainability, the same process was followed as followed in the previous comparison. The different emission values are provided in Table 6.5. All the values in g/km.

It can be seen that Platoon with Priority is not performing better than the platoon without the priority scenario. The CO_2 , NO_x and PM_{10} values are higher in the scenarios where platoon has the highest priority. The only gain is seen in the percentage of hydrocarbons released.

This probably can be explained by the fact that the scenario where platoon is given full priority almost resembles a scenario with traffic lights. To provide full priority to the platoons, the vehicles in other lanes have to wait until the platoon has crossed. As one goes on increasing the number of vehicles in the platoon, more delay is added to the vehicles in other lanes and lesser is their speed. However once the platoon has crossed the intersection, the vehicles speed up based on priority and move towards their destination. Vehicles in that situation do not wait anymore. Therefore the emission values are still better than the emission values for the traffic lights scenario.

Comparison of Surrogate Safety Measures			
Performance Indicators	Min Value	Max Value	Average Value
TTC	0.0	1.1	0.4
PET	0.0	1.20	0.3
MaxS	0.83	2.16	1.4
DR	0.0	0.0	0.0
DeltaS	0.24	7.4	3.2

Table 6.6: Performance Indicators for Surrogate Safety for scenario with Platoon without priority

Comparison of Surrogate Safety Measures			
Performance Indicators	Min Value	Max Value	Average Value
TTC	1.1	1.5	1.3
PET	1.0	1.4	1.28
MaxS	1.52	2.31	1.61
DR	0.0	0.0	0.0
DeltaS	0	0.32	0.02

Table 6.7: Performance Indicators for Surrogate Safety for scenario of Platoon with priority

Surrogate Safety Assessment

The trajectory files outputted from VISSIM for both the scenarios with platoon were analyzed for surrogate safety. For the scenario where platoon is not given priority, 7 conflicts were found. 4 of them were crossing conflicts and 3 of them were rear end conflicts.

The values of different performance indicators for measuring surrogate safety are provided in Table 6.6.

Conflicts with PET value less than 5 seconds and time to conflicts less than 1.5 seconds are considered for this research. It can be seen that the average PET value is 0.3 seconds where as the average time to collision value is 0.4 seconds.

For the scenario where platoon holds the highest priority, 13 conflicts were found. All the 13 conflicts were rear end conflicts. The values for the 13 conflicts are provided in Table 6.7.

It can be seen that the average values of PET is 1.28 seconds and the average time to collision is 1.3 seconds for this scenario.

In terms of number of conflicts, the platoon without priority seems to be performing better than the platoon with priority. However the average PET and TTC values are more for the scenario where platoons have the highest priority. Higher TTC and PET values would suggest that the severity of the conflict is less compared to lower TTC and PET values.

6.4 Overview

Based on the above performed effectiveness study it can be easily concluded that the developed strategy seems to be performing better than the intersection with traffic lights scenario on the grounds of Traffic Flow Efficiency and Sustainability. In terms of Surrogate Safety Assessment, 6 conflicts were found in the intersection with the developed strategy where as no conflicts were found for the intersection with traffic scenario. In terms of Safety, the scenario with traffic lights is better than the scenario with the developed strategy. However, this benefit is being achieved by reduced efficiency in traffic flow efficiency and sustainability.

With regards to the scenario where platoons are being modeled, the scenario where platoon has the highest priority outperforms the scenario where platoon has no priority in terms of Traffic Flow Efficiency. However in case of sustainability, the opposite happens. Though the the difference in emissions are not too large, platoon without priority is performing better than platoon with priority in terms of vehicular emissions. Only in the emissions of hydro carbons, the platoon with the priority scenario is emitting less. In terms of surrogate safety assessment, the number of conflicts found in the scenario where platoons don't have priority are less than the scenario where platoons have priority. However based on the values of TTC and PET, it is found that the severity of conflicts are less in the scenario where platoons are having complete priority. Therefore it is difficult to make conclusions in this regard.

Based on the results of the carried out effectiveness study it can be concluded as compared to an intersection with traffic lights, an intersection with the implemented strategy performs better in terms of traffic flow efficiency and sustainability. However in terms of surrogate safety, traffic lights provide a much safer way of maneuvering. However this benefit is achieved by compromising on the traffic flow efficiency and emissions.

Regarding the comparison dealing with platoons, on providing platoon the full priority the traffic flow certainly improves. There is a gain seen in both the throughput and delay. However it does not perform well in terms of emissions. The emission values are higher as compared to the scenario where the platoon adheres to the strategy. Regarding safety, no solid conclusions can be made since in the case of platoon without priority, the number of conflicts are less but are of high severity and in the case of platoon with priority, the number of conflicts are higher but with lower severity.

Conclusion and Recommendation

This chapter presents the conclusions of this research, critical reflection and states the recommendations and scope for future research.

The main research question relevant for this research is:-

How to develop a distributed control strategy for aiding automated vehicles to maneuver in an unsignalized intersection using V2V communication?

The two main aspects of this research are implementing the strategy using V2V communication and assessing the effectiveness of the developed strategy for an intersection from the perspective of traffic flow efficiency, sustainability and surrogate safety assessment. For the purpose of evaluating both the aspects of the research, two different simulation platforms have been used. The first two sub research questions of the research are theoretical framework that showcase the core of this research. These two sub research questions have been discussed in Section 8.1. The 3rd and 4th sub research questions deal with the design framework of the strategy and the various assumptions made to aid this research. They have been explained in Section 8.2. The last three sub research question are based on the implementation and assessing the effectiveness of the developed strategy for an intersection and have been addressed in Section 8.3.

7.1 Theoretical Framework

1) What is a distributed control strategy and how is this strategy being used from the point of this research?

A Distributed control system can be defined as a system with no central supervisor. The agents that are part of the system are supervisor by themselves. Flow of information does not happen through a single supervisor agent. All the agents are involved in sharing information with each other. All the agents involved in the control system are involved in decision making through the share of information.

The research uses Vehicle to Vehicle(V2V) communication for implementing a distributed strategy in the network for automated vehicles to maneuver in an intersection without colliding with each other. Vehicles on coming in communication range with each other share their trajectory and speed based on which the time to conflict point is calculated. The vehicle with lowest time to conflict point gets the higher priority and the other vehicle slows down in the network.

2) What are the various strategies proposed in literature to solve the problem of maneuvering of automated vehicles in an intersection?

A lot of research has been carried out on maneuvering of vehicles in an intersection. Regarding control strategies, various algorithms have been developed by researchers to deal with the issue of control and collision avoidance of automated vehicles at the intersection. From the V2V aspect, research has been carried out in a model based environment where automated robots or automated vehicles maneuver in a constructed intersection using V2V communication. From the perspective of measuring the effectiveness of the developed strategy, a lot of research also includes measuring traffic flow efficiency, sustainability and surrogate safety in a micro simulation environment assuming both V2V and V2I communication. The issue that arises is that there are a very few research that cover all the aspects mentioned above. This issue has been addressed in this research. The research aims at developing a distributed control strategy for maneuvering of automated vehicles in an un-signalized intersection. The developed strategy is then implemented in automated robots in an apt simulation environment to assess the V2V communication aspect. Once the V2V aspect of this research was established, the developed strategy is then implemented in a microscopic traffic simulation environment to assess th effectiveness of the strategy on various grounds like traffic flow efficiency, sustainability and surrogate safety.

7.2 Design Framework

3) What is the strategy proposed in this assignment for developing a distributed control system for the intersection?

This research starts with the development of an architecture to aid the developed strategy at various levels. The top level is the Traffic Management Layer that provides the various rules and constraints for the automated vehicles to maneuver in the intersection. Those rules include the speed and acceleration constraints and a "Priority to the Right" rules that states that if the time to conflict point is same for two vehicles, the vehicle should yield to the vehicle to it's right. The next layer in the architecture is the Vehicle Management layer that is responsible for V2V communication with other vehicles. Based on negotiations with other vehicles in the V2V range in the network, proper decisions are taken based in order to maneuver the intersection without colliding. The last layer in the architecture is the Vehicle Control layer which is responsible for adjusting the speed, position, longitudinal and lateral control of the vehicles to properly adhere to the decisions made cooperatively by the vehicles.

The strategy developed for this research is "Time to conflict point Gap Adjustment Logic". Vehicles with the help of V2V communication share their trajectory and speed with other vehicles in the network. After having received the trajectory from other vehicles in the network, the conflict point is identified and collision group is formed. The vehicle then shares

its own time to conflict point with the member vehicles of the collision group. Based on the received information about the time to conflict point and position of the vehicles, priority for the vehicles are decided cooperatively among the vehicles. The vehicle with the lowest time to intersection gets the highest priority. Based on the decided priority and information about the time to conflict point of higher preferred vehicle in the network, vehicles adjust their speed in order to avoid collision at the intersection. It is to be noted that no central supervisor is used in the entire strategy and the entire decision making is done individually by vehicles as individual agents in distributed control system.

4) What are the various assumptions made to aid this research?

For the purpose of the research, various assumptions have been made. Those are:-

- Vehicles are fully automated and are equipped with appropriate networking systems to communicate with other vehicles in the network.
- The Traffic Management layer consists of a map with global coordinates that is used by all the vehicles entering the intersection zone.
- All vehicles entering the intersection are assumed to be in communication range with all other vehicles in the intersection.
- Vehicles are assumed to obey the rules of the intersection for safe maneuvering.
- It is assumed that vehicles are traveling at a constant speed and shall only decelerate in case a conflict is found.
- Only passenger cars are considered for this research.
- The terrain on which the vehicles travel is completely leveled. So there is no acceleration or deceleration due to the force of gravity.
- Wear and tear of the tires of passenger cars and dynamic weather conditions are not taken into account.

7.3 Implementation and Measuring Effectiveness

5) What is the requirement for incorporating two simulation test bed into the system?

As mentioned in the answer to the 2nd sub research question, a lot of research has been done in individual fields like in development of a strategy for the intersection, decision making through V2V communication and measuring effectiveness of the developed strategy in microscopic traffic simulation software assuming there is V2V and V2I communication. However, very few research showcase all the three aspects mentioned above. A developed strategy using V2V communication may be providing excellent results in terms of its effect in traffic through a microscopic simulation model, however it is imperative to check whether such a strategy can be implemented in practice and if decision making involved in the strategy is possible through V2V communication. Similarly, a strategy may be well supported through V2V communication but if there are no benefits of the strategy from the perspective of traffic,

sustainability and safety, it might not be a very useful strategy to implement in practice. Therefore the needful thing to do is check the strategy from all the different important aspects. The two main important aspects of this research are implementation of strategy through V2V communication and the assessing the effectiveness of the developed strategy through traffic simulation models. For the purpose of satisfying both the requirements, two simulation platforms are being used in this research.

USARSIM is a robotics simulation platform that allows external strategies to be implemented in on the differential drive robots through an external script. It is also possible to set up V2V communication among the robots running in the simulation environment through the concept of networking by using sockets. Therefore the V2V aspect of the research was assessed through the implementation of the strategy in USARSIM. Three differential drive robots were used for the purpose. A virtual intersection was created in the USARSIM environment and vehicles were allowed to maneuver through the intersection by making cooperative decisions using V2V communication. One important assumption made in this research was that there were no packet loss which was supported by the fact that the entire operation was happening on a local host. Based on the implementation, it was found that vehicles can follow the strategy, make cooperative decisions and maneuver without collisions in the developed network by engaging in V2V communication. Also special scenarios like platoons can be modeled and based on set of rules and constraints provided by the traffic management layer, priority can be decided in different scenarios. The implementation in USARSIM therefore explains the V2V aspect of this research.

Once the V2V aspect has been established, it becomes necessary to evaluate the effectiveness of the strategy in traffic. For this purpose, VISSIM a microscopic traffic simulator is used. A more realistic intersection is designed, where vehicles are entering from different links and have to maneuver at the intersection without the aid from traffic lights. For the implementation part in VISSIM, it is assumed that there is V2V communication among the vehicles and there is no packet loss. The scenario with vehicles adhering to the strategy, a platoon adhering to the strategy and a scenario where a platoon is given full priority at the intersection are modeled. For individual vehicles moving in the network, a PD controller is used to control the acceleration of the vehicles in the network. Similarly for platoons, a CACC(Cooperative Adaptive Cruise Control) controller is used. Based on the trajectory outputs from VISSIM, the effectiveness of different scenarios are assessed.

6) What are the various grounds for evaluating the effectiveness of the developed strategy?

Based on the simulation results from VISSIM, the developed scenarios are assessed for effectiveness on three major grounds; Traffic Flow Efficiency, Sustainability and Surrogate Safety. These three grounds are important to cover while selecting a proper strategy for any traffic scenario. For every proposed ground of effectiveness, performance indicators have been defined that will reflect on how effective(ineffective) the scenario is for the intersection. For measuring the various performance indicators, various tools have been used.

For the purpose of evaluating the traffic flow efficiency, two performance indicators are used. They are throughput and total delay in the network. The total delay in the network is directly received from VISSIM. The throughput is calculated by collecting the time at which the last vehicle leaves the intersection and using the unitary method to calculate the number of vehicles that will pass the intersection in one simulation hour(3600 simulation seconds).

In regards to assessing the scenarios on grounds of sustainability, the total emissions of the network are calculated. For the purpose of calculating hydrocarbon emissions, a regression model is used as suggested in literature. For the purpose of calculating the emissions regarding CO_2 , NO_x and PM_{10} , Enviver Pro software is used. Enviver is a database which is maintained by TNO. It uses the VERSIT+ emission model to calculate the amount of emissions from the trajectory files from a microscopic simulation model. The various factors taken into account by Enviver are vehicle type, average age of vehicles, emission legislations, speed and acceleration values.

In regards to assessing the different the surrogate safety of the scenarios, Surrogate Safety Assessment Model(SSAM) software developed by Federal Highway Administration(FHWA), USA is used. The two important performance indicators for assessing the surrogate safety of scenarios are Post Encroachment time and Time to Collision.

7) *What are the impacts (advantages and disadvantages) of the developed distributed control strategy for the vehicles maneuvering in an intersection?*

Based on the simulation experiments carried out in VISSIM, two comparison scenarios were defined. In the first scenario, an intersection with traffic lights were compared with the intersection with the developed strategy. For the traffic lights, three signal heads were used for the three lanes from where vehicles are entering the intersection. The total cycle time of the signal controller is 60 simulation seconds and for every signal head 20 simulation seconds are allotted. Based on the performance of both scenarios, it was found that the effectiveness of intersection with the developed strategy surpassed the intersection with traffic lights in terms of traffic flow efficiency and sustainability. There was 24% gain in throughput, 44% reduction in total delay in the network, 29% reduction in emission of hydrocarbons, 6.7% reduction in CO_2 , 16.7% reduction in NO_x and 3.7% reduction in PM_{10} . In terms of surrogate safety however, the traffic lights scenario performed better with no conflicts compared to the intersection with developed strategy which had 6 conflicts. All of the found conflicts were crossing conflicts. The average PET value was found to be 0.4 seconds and the average time to collision was found to be 0.37 seconds. Even if there were no crashes noticed in the simulation, there are conflicts found that need to be taken into account for consideration. Therefore the only ground on which a traffic lights scenario performed better than the developed strategy was on the grounds of Surrogate Safety.

The second comparison was carried out for a special scenario where platoons are entering the intersection. In the first scenario, no priority is provided to the platoons and in the second scenario, complete priority is provided to the platoons. The later scenario outperforms the first scenario in terms of the traffic flow efficiency. Gains are found both in the throughput and delay in the network. The throughput has increased by 10% and the delay in the network has decreased by 26.2%. In terms of sustainability, the platoon without priority performs better than the platoon with priority. The emission values for CO_2 , NO_x and PM_{10} are less in the case where platoons maneuver without priority. Only in terms of Hydrocarbon there is a decrease of 4% in the scenario where platoons have higher priority. In terms of assessing the performance indicators for surrogate safety, the number of conflicts found in the scenario where platoons do not have priority is less compared to the scenario where the platoon has priority. The number of conflicts in the scenario of platoon without priority is 7 whereas the number of conflicts is 13 for the scenario where platoon has the higher priority. However if the TTC(Time to Collision) and PET(Post Encroachment Time) values are taken into account,

it is found that the severity of conflicts are less in the scenario where platoons are having the priority. The average TTC and PET values for platoon without priority are 0.4 and 0.3 seconds. For the scenario where platoon is having the highest priority, the average TTC and PET values are 1.3 seconds and 1.28 seconds. Therefore it is very hard to comment on which scenario is more safer in this situation.

All the 7 sub research questions collectively answer the main research question of this research. This research begins with developing a strategy for the intersection for aiding automated vehicles in maneuvering without the use of traffic lights and without colliding. The developed strategy is called "Time to Conflict Point Based Gap Adjustment Logic". After the strategy has been developed two important aspects of the research, the networking aspect and the effectiveness of the strategy in traffic are assessed. The networking aspect of this research is evaluated by implementing the strategy in USARSIM and the effectiveness of the strategy in traffic are assessed by implementing the strategy in VISSIM. It is concluded that the developed strategy is feasible to be implemented by vehicles through V2V communication and without the use of any central controller. It is also found that the developed strategy does perform better compared to a traditional intersection with fixed time signal control traffic lights in terms of traffic flow efficiency and sustainability.

7.4 Critical Reflection

This section presents the a critical reflection on the research carried out. The entire research has been an iterative and continuous process. New insights into how things can be managed and necessary changes to be made were found through continuous literature study and analyzing at every step the important thing lacking from the research. Obviously a lot of assumptions have been made and are considered out of the scope for this research. However it is to be realized that they are no less relevant.

During the design process of the strategy, an architecture was designed to aid the strategy at various levels. The top layer was the Traffic Management Layer. The traffic management layer provides the basic rules and constraints for the vehicles maneuvering in the network. It is true that many important rules have been taken into account like priority to the right and time to conflict point. However many important rules and constraints have not been considered in this research. One constraint not taken into account is the headway constraint between vehicles in the same lane. It is assumed that there is no overtaking happening in a lane. While modeling large flows, the headway constraint will play an important role in checking the rear end conflicts with vehicles in the same lane. Another important thing to notice is that extra traffic constraints have been applied to the implementation in VISSIM but they are not implemented in USARSIM. They are speed and acceleration constraints. The reason is that the only objective while implementing the strategy in USARSIM was to establish V2V communication and check if it is feasible for the robots to avoid collisions at the intersection by engaging in V2V communication. Since no real traffic scenarios can be created in USARSIM, these constraints were not taken into account. However these constraints are implemented in VISSIM.

In the implementation part of USARSIM where the networking aspect of the research is established, an important assumption made is that there are no packet losses. Every packet

of data sent is received by vehicles during the course of communication. However in real life this may not be very realistic. Packet loss will happen and the effectiveness with which vehicles operate in real traffic conditions shall be affected. Therefore it is necessary to do further research on what is the impact of packet loss on the developed strategy. Moreover in the environment of USARSIM only three vehicles are taken into account for setting up the V2V communication. In the presence of more than three vehicles, there will be more sharing of information and the system will keep getting complicated as the number of vehicle increases in the network. Therefore the question of scalability should not be ignored in terms of the networking aspect.

While plotting the speed profiles of vehicles in USARSIM, a lot of fluctuations were seen in the profiles. It was established through research that the inherent fluctuations are due to insufficient sampling. Therefore approximation errors are found while using finite differencing for calculating the speed values. To solve this problem, results from multiple simulations were used. However it is still relevant that other control strategies are tried and tested to confirm the above logic. Research needs to be done on whether such problems can be solved by any other means without taking the long route of performing multiple simulation runs.

A section of this research focuses on platoons. Two very important assumptions have been made regarding modeling platoons in both the simulation environments. The first assumption is that only one platoon enters the intersection and the second assumption is that the number of vehicles in the platoon does not change before the intersection. Though it has been shown that modeling of platoons is possible in various simulation platforms, it is also true that with the above assumptions no solid conclusions can be made regarding platoons adhering to the strategy. A separate research with complete focus on platoons is necessary to come to a proper conclusion in this matter.

7.5 Recommendations for further research

Based on the conclusions presented above and critical reflection presented in the previous chapter, various recommendations are made for future research. The recommendations presented are divided into two aspects. The first is from the aspect of networking and the second is from the aspect of implementation of strategy in traffic.

Networking

One of the major goals of the research was to check whether the developed strategy is feasible to be implemented as a distributed strategy through the process of V2V communication among individual automated vehicles. The chapter that deals with the implementation in USARSIM does confirm that it is feasible and vehicles are able to communicate and negotiate in the virtual network to maneuver without colliding. However one of the major assumptions that support this implementation is the assumption that there is no packet loss while engaging in V2V communication. The fact that the entire simulation runs on a single host also supports the assumption. However, in real life scenarios, it might not hold. Packet loss is an important phenomenon that can have a considerable effect on the performance of the vehicles in the network. Therefore further research should focus on the impact that packet loss has on the

vehicles while they are adhering to the strategy. Another important aspect in the field of networking is to study the behavior of robots when there are packet loss. The developed strategy and the controller used in the automated robots should be robust and stable in such a way that even in the absence of information from other vehicles, it should be able to make considerable and quick decisions.

The present research has used 3 automated robots to demonstrate the setting up of V2V communication and the information exchanged. Further research should consider using more than 3 robots in the scenario and checking whether the V2V implementation is still robust. More robust the networking is, better will be the performance of the vehicles.

The proof of the pudding is in the eating.

Simulations certainly provide a general idea on how the system is performing and allows to make necessary changes to develop the system in the best possible way. However actual model based testing will demonstrate how good or bad is the developed strategy. The developed strategy should be implemented on the Garonne robots as mentioned in the introduction by Technolution. Based on the results from the model based testing, it can be made certain upon what is the behavior of actual robots while adhering to the strategy. An idea can be formed on the various aspects of the research and proper steps can be taken to improve it in the best way possible.

Implementation in Traffic

Attempts have been made to implement the strategy in real traffic conditions through the use of a microscopic traffic simulation software, VISSIM. Though the developed network is more realistic than the virtual network set up in USARSIM, future research should take into account better networks into consideration. Choice of network will also have an impact on the performance of the developed strategy.

As mentioned in the assumption, there are various points not considered in this research. Those are vehicle dynamics, different vehicle types, pedestrians and real life conditions like dynamic weather. These factors should also be taken into account and based on that proper analysis should be done in terms of measuring effectiveness in traffic.

Another important concept not taken into account in this research is the headway constraint among vehicles in the same link. While simulating large number of vehicles in the network, the headway constraints will play an important role in checking rear end collisions within the lane. This concept has been kept out of the scope of this research.

This research does consider platoons in the intersection scenario. However, there are other assumptions made to aid the implementation of platoon. The two main assumptions made are only one platoon is entering the network and the size of the platoon does not change before the intersection box. However this is not a very realistic assumption. Moreover based on the effectiveness of the scenario involving platoons, no proper conclusions can be drawn in terms of sustainability and surrogate safety assessment. Therefore a further research should be conducted that focuses completely on platoons and the behavior of the platoons adhering to such a developed strategy.

In this research, the flow is initially set to 0 and vehicles are introduced into the links at regular time intervals. Further research should take into account flows in the network and it should be checked if the developed strategy is feasible for implementation when an entire flow is considered for a network.

References

- [1] J. Lee and B. Park. Development and evaluation of a cooperative vehicle intersection control algorithm under the connected vehicles environment. *IEEE Transactions on Intelligent Transportation Systems*, 13(1):81–90, 2012.
- [2] D. Schrank, T. Lomax, and B. Eisele. 2011 urban mobility report. 2011.
- [3] National Highway Traffic Safety Administration et al. Traffic safety facts: 2007 data: pedestrians. page 203, 2007. <https://crashstats.nhtsa.dot.gov/Api/Public/ViewPublication/810994>.
- [4] E.H. Choi. Crash factors in intersection-related crashes: An on-scene perspective. Technical report, 2010. <https://crashstats.nhtsa.dot.gov/Api/Public/ViewPublication/811366>.
- [5] R. Hoogendoorn, B. van Arem, R. Happee, M. M. Espinoza, and D. Kotiadis. Towards safe and efficient driving through vehicle automation: The dutch automated vehicle initiative, 2013.
- [6] M. Fellendorf. Vissim: A microscopic simulation tool to evaluate actuated signal control including bus priority. In *64th Institute of Transportation Engineers Annual Meeting*, pages 1–9. Springer, 1994.
- [7] A. Maria. Introduction to modeling and simulation. In *Proceedings of the 29th conference on Winter simulation*, pages 7–13. IEEE Computer Society, 1997.
- [8] R. Ball and N. Dulay. Enhancing traffic intersection control with intelligent objects. *Urban Internet of Things Towards Programmable Realtime Cities*, 2010.
- [9] K. Dresner and P. Stone. Multiagent traffic management: A reservation-based intersection control mechanism. In *Proceedings of the Third International Joint Conference on Autonomous Agents and Multiagent Systems-Volume 2*, pages 530–537. IEEE Computer Society, 2004.

-
- [10] S. Carpin, T. Stoyanov, Y. Nevatia, M. Lewis, and J. Wang. Quantitative assessments of usarsim accuracy. In *Proceedings of PerMIS*, volume 2006, 2006.
- [11] PTV VISION. Ptv vissim 7 user manual, 2014.
- [12] S. Kato, S. Tsugawa, K. Tokuda, T. Matsui, and H. Fujii. Vehicle control algorithms for cooperative driving with automated vehicles and intervehicle communications. *IEEE Transactions on Intelligent Transportation Systems*, 3(3):155–161, 2002.
- [13] M. Grünewald, C. Rust, and U. Witkowski. Using mini robots for prototyping intersection management of vehicles. In *Proceedings of the 3rd international symposium on autonomous minirobots for research and edutainment (AMiRE 2005)*, pages 287–292. Springer, 2006.
- [14] G. Raravi, V. Shingde, K. Ramamritham, and J. Bharadia. Merge algorithms for intelligent vehicles. In *Next Generation Design and Verification Methodologies for Distributed Embedded Control Systems*, pages 51–65. Springer, 2007.
- [15] V. Milanés, J. P. Rastelli, E. Onieva, and C. González. Controller for urban intersections based on wireless communications and fuzzy logic. *IEEE Transactions on Intelligent Transportation Systems*, 2010.
- [16] V. Milanés, J. Alonso, L. Bouraoui, and J. Ploeg. Cooperative maneuvering in close environments among cybercars and dual-mode cars. *IEEE Transactions on Intelligent Transportation Systems*, 12(1):15–24, 2011.
- [17] J. Wu, A. Abbas-Turki, and A. El Moudni. Cooperative driving: an ant colony system for autonomous intersection management. *Applied Intelligence*, 37(2):207–222, 2012.
- [18] N. Neuendorf and T. Bruns. The vehicle platoon controller in the decentralised, autonomous intersection management of vehicles. In *Mechatronics, 2004. ICM'04. Proceedings of the IEEE International Conference on*, pages 375–380. IEEE, 2004.
- [19] F. Michaud, P. Lepage, P. Frenette, D. Létourneau, and N. Gaubert. Coordinated maneuvering of automated vehicles in platoons. *Intelligent Transportation Systems, IEEE Transactions on*, 7(4):437–447, 2006.
- [20] I. H. Zohdy and H. A. Rakha. Intersection management via vehicle connectivity: The intersection cooperative adaptive cruise control system concept. *Journal of Intelligent Transportation Systems*, 20(1):17–32, 2016.
- [21] J. So, B. Park, S. M. Wolfe, and G. Dedes. Development and validation of a vehicle dynamics integrated traffic simulation environment assessing surrogate safety. *Journal of computing in civil engineering*, 29(5):04014080, 2014.
- [22] S. I. Guler, M. Menendez, and L. Meier. Using connected vehicle technology to improve the efficiency of intersections. *Transportation Research Part C: Emerging Technologies*, 46:121–131, 2014.
- [23] J. Lee, B.B. Park, K. Malakorn, and J.J. So. Sustainability assessments of cooperative vehicle intersection control at an urban corridor. *Transportation Research Part C: Emerging Technologies*, 32:193–206, 2013.

-
- [24] H. Rakha, K. Ahn, and A. Trani. Development of vt-micro model for estimating hot stabilized light duty vehicle and truck emissions. *Transportation Research Part D: Transport and Environment*, 9(1):49–74, 2004.
- [25] M. Ahmane, A. Abbas-Turki, F. Perronnet, J. Wu, A. El Moudni, J. Buisson, and R. Zeo. Modeling and controlling an isolated urban intersection based on cooperative vehicles. *Transportation Research Part C: Emerging Technologies*, 28:44–62, 2013.
- [26] Md. A. S. Kamal, J. Imura, T. Hayakawa, A. Ohata, and K. Aihara. A vehicle-intersection coordination scheme for smooth flows of traffic without using traffic lights. *IEEE Transactions on Intelligent Transportation Systems*, 16(3):1136–1147, 2015.
- [27] S. Pandian, S. Gokhale, and A.K. Ghoshal. Evaluating effects of traffic and vehicle characteristics on vehicular emissions near traffic intersections. *Transportation Research Part D: Transport and Environment*, 14(3):180–196, 2009.
- [28] P. Baran. On distributed communications networks. *IEEE transactions on Communications Systems*, 12(1):1–9, 1964.
- [29] Y. Guo and L.E. Parker. A distributed and optimal motion planning approach for multiple mobile robots. In *Robotics and Automation, 2002. Proceedings. ICRA'02. IEEE International Conference on*, volume 3, pages 2612–2619. IEEE, 2002.
- [30] Priority to the Right. https://en.wikipedia.org/wiki/Priority_to_the_right.
- [31] C. Bergenheim, S. Shladover, E. Coelingh, C. Englund, and S. Tsugawa. Overview of platooning systems. In *Proceedings of the 19th ITS World Congress, Oct 22-26, Vienna, Austria (2012)*, 2012.
- [32] R. Horowitz and P. Varaiya. Control design of an automated highway system. *Proceedings of the IEEE*, 88(7):913–925, 2000.
- [33] M.A. Zabat, N.S. Stabile, and F.K. Browand. Estimates of fuel savings from platooning. In *Intelligent Transportation: Serving the User Through Deployment. Proceedings of the 1995 Annual Meeting of ITS America.*, 1995.
- [34] B. van Arem, C.J.G. van Driel, and R. Visser. The impact of cooperative adaptive cruise control on traffic-flow characteristics. *IEEE Transactions on Intelligent Transportation Systems*, 7(4):429–436, 2006.
- [35] S. Carpin, M. Lewis, J. Wang, S. Balakirsky, and C. Scrapper. Usarsim: a robot simulator for research and education. In *Proceedings 2007 IEEE International Conference on Robotics and Automation*, pages 1400–1405. IEEE, 2007.
- [36] M. Lewis and J. Jacobson. Game engines in scientific research. *Communications of the ACM*, 45(1):27, 2002.
- [37] R. Adobbati, A. N. Marshall, A. Scholer, S. Tejada, G. A. Kaminka, S. Schaffer, and C. Sollitto. Gamebots: A 3d virtual world test-bed for multi-agent research. In *Proceedings of the second international workshop on Infrastructure for Agents, MAS, and Scalable MAS*, volume 5. Montreal, Canada, 2001.

-
- [38] S. Tsugawa, S. Kato, T. Matsui, H. Naganawa, and H. Fujii. An architecture for cooperative driving of automated vehicles. In *Intelligent Transportation Systems, 2000. Proceedings. 2000 IEEE*, pages 422–427. IEEE, 2000.
- [39] A.S. Tanenbaum et al. Computer networks, 4-th edition. *ed: Prentice Hall*, 2003.
- [40] M. Fellendorf and P. Vortisch. Microscopic traffic flow simulator vissim. In *Fundamentals of traffic simulation*, pages 63–93. Springer, 2010.
- [41] J.A. Michon. A critical view of driver behavior models: what do we know, what should we do? In *Human behavior and traffic safety*, pages 485–524. Springer, 1985.
- [42] J. Maroto, E. Delso, J. Félez, and J.M. Cabanellas. Real-time traffic simulation with a microscopic model. *Intelligent Transportation Systems, IEEE Transactions on*, 7(4):513–527, 2006.
- [43] K. Ahn, H. Rakha, A. Trani, and M. van Aerde. Estimating vehicle fuel consumption and emissions based on instantaneous speed and acceleration levels. *Journal of transportation engineering*, 128(2):182–190, 2002.
- [44] D. Gettman and L. Head. Surrogate safety measures from traffic simulation models. *Transportation Research Record: Journal of the Transportation Research Board*, (1840):104–115, 2003.
- [45] A. Kassim, K. Ismail, and Y. Hassan. Automated measuring of cyclist–motor vehicle post encroachment time at signalized intersections. *Canadian journal of civil engineering*, 41(7):605–614, 2014.
- [46] Douglas Gettman, Lili Pu, Tarek Sayed, and Steven G Shelby. Surrogate safety assessment model and validation: Final report. Technical report, 2008.
- [47] Hyperplane Separation theorem . https://en.wikipedia.org/wiki/Hyperplane_separation_theorem.

Appendix : Pseudo Codes

A.1 Pseudo code for V2V communication

This pseudo code is useful for initiating the sockets for the purpose of enabling V2V communication among the robots. UDP sockets have been used. The following pseudo code has been implemented in Python, but can be used in any other programming language.

Algorithm 1 Setting up V2V

```
#Find the number of relevant vehicles in the network
number_of_vehicles = n
#Initialize UDP sockets for broadcasting and receiving data
self.socket = socket.socket(socket.AF_INET, socket.SOCK_DGRAM)
self.socket.bind((host, self.port))
ports = [V1, V2, V3.....Vn] {list containing ports of all vehicles}
function sending_data (message):
if number_of_vehicles > 1 then
    self.socket.sendto(message,server)
else
    print No V2V necessary
end if
function receiving_message():
try:
data, address = self.socket.recvfrom(buffer)
except socket.timeout as e: pass
```

A.2 Pseudo code for deciding preference

When the vehicles are in V2V range, the following pseudo code is used for deciding preference among the vehicles in a mutual way using V2V communication.

Algorithm 2 Deciding preference

```

self.trajectory = [( $x_1, y_1$ ), ( $x_2, y_2$ ), ..., ( $x_n, y_n$ )]
collision_group = {} {for storing the conflict points}
time_to_collision = {} {for storing time to conflict point}
time_comparison_dict = {} {time to same conflict for vehicles}
self.sending_data(message = self.trajectory, 'WP')
self.receiving_data()
if conflict_point = ( $X_1, Y_1$ ) then
    Store the conflict point along with the info of the participating vehicles
    collision_group = {( $X_1, Y_1$ ) : [ $V_1, V_2, \dots, V_n$ ], ...}
end if
#Calculate the time to conflict
if time to ( $X_1, Y_1$ ) =  $t_1$  then
    time_to_collision = {( $X_1, Y_1$ ) :  $t_1, \dots$ }
end if
for conflict_point ( $X_1, Y_1$ ) do
    #Send the data to other vehicles in the collision groups
    self.sending_data(message = time_to_collision, 'TC')
    self.receiving_data()
    pref = 1
    for values in time_comparison_dict.values() do
        if time_comparison_dict[key] = min(values) then
            key = pref {the keys are Vehicle IDs}
        end if
        pref + = 1
    end for
    Set self.preference
end for

```

A.3 Pseudo code for determining safe crossing time and new speed

Algorithm 3 Determining safe crossing time and new speed

```
self.preference = N
for vehicle with preference == N - 1 do
  Compare the time to conflict point
   $\delta t = \text{time\_comparison\_dict}[N - 1] - \text{time\_comparison\_dict}[N]$ 
  if  $\delta t \leq \text{safe\_time\_interval}$  then
     $\text{time\_comparison\_dict}[N] += \text{safe\_time\_interval} - \delta t$ 
     $\text{new\_speed} = \text{distance\_to\_conflict} / \text{time\_comparison\_dict}[N]$ 
    return new_speed
  else { $\delta t \geq \text{safe\_time\_interval}$ }
    No changes
    return Nothing
  end if
end for
```

Appendix Title

B.1 Separating Axis Theorem

It is necessary to initialize a collision check procedure to realize when the collision is happening. The Separating Axis Theorem is being used for this purpose. According to [47], if a line can be drawn between two polygons, it can be ensured that they are not colliding. The polygons are first projected on two imaginary perpendicular axis. If both the projections swap over each other, it can be confirmed that there has been a collision. The code has been implemented in such a way that the entire program stops when a collision occurs. This is beneficial in a way that it allows us to validate the implemented strategy. Since the collision check keeps looping during the entire duration of the program, any kind of anomaly can be easily detected during the simulation run.

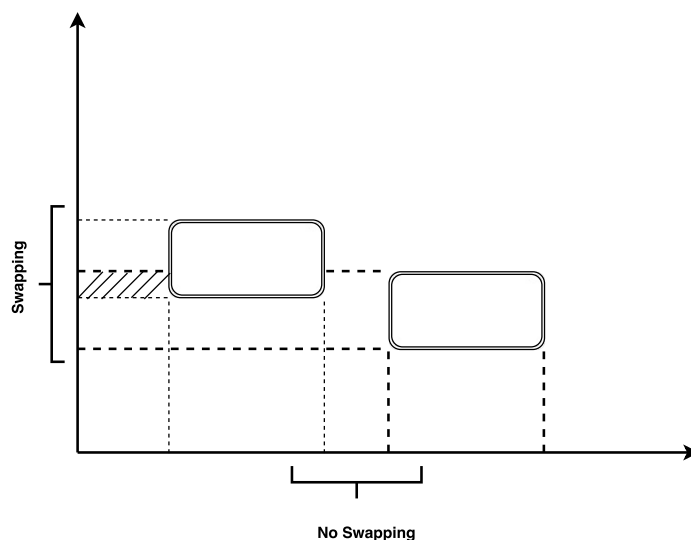

Figure B.1: Separating Axis Theorem

References

- [1] J. Lee and B. Park. Development and evaluation of a cooperative vehicle intersection control algorithm under the connected vehicles environment. *IEEE Transactions on Intelligent Transportation Systems*, 13(1):81–90, 2012.
- [2] D. Schrank, T. Lomax, and B. Eisele. 2011 urban mobility report. 2011.
- [3] National Highway Traffic Safety Administration et al. Traffic safety facts: 2007 data: pedestrians. page 203, 2007. <https://crashstats.nhtsa.dot.gov/Api/Public/ViewPublication/810994>.
- [4] E.H. Choi. Crash factors in intersection-related crashes: An on-scene perspective. Technical report, 2010. <https://crashstats.nhtsa.dot.gov/Api/Public/ViewPublication/811366>.
- [5] R. Hoogendoorn, B. van Arem, R. Happee, M. M. Espinoza, and D. Kotiadis. Towards safe and efficient driving through vehicle automation: The dutch automated vehicle initiative, 2013.
- [6] M. Fellendorf. Vissim: A microscopic simulation tool to evaluate actuated signal control including bus priority. In *64th Institute of Transportation Engineers Annual Meeting*, pages 1–9. Springer, 1994.
- [7] A. Maria. Introduction to modeling and simulation. In *Proceedings of the 29th conference on Winter simulation*, pages 7–13. IEEE Computer Society, 1997.
- [8] R. Ball and N. Dulay. Enhancing traffic intersection control with intelligent objects. *Urban Internet of Things Towards Programmable Realtime Cities*, 2010.
- [9] K. Dresner and P. Stone. Multiagent traffic management: A reservation-based intersection control mechanism. In *Proceedings of the Third International Joint Conference on Autonomous Agents and Multiagent Systems-Volume 2*, pages 530–537. IEEE Computer Society, 2004.

-
- [10] S. Carpin, T. Stoyanov, Y. Nevatia, M. Lewis, and J. Wang. Quantitative assessments of usarsim accuracy. In *Proceedings of PerMIS*, volume 2006, 2006.
- [11] PTV VISION. Ptv vissim 7 user manual, 2014.
- [12] S. Kato, S. Tsugawa, K. Tokuda, T. Matsui, and H. Fujii. Vehicle control algorithms for cooperative driving with automated vehicles and intervehicle communications. *IEEE Transactions on Intelligent Transportation Systems*, 3(3):155–161, 2002.
- [13] M. Grünewald, C. Rust, and U. Witkowski. Using mini robots for prototyping intersection management of vehicles. In *Proceedings of the 3rd international symposium on autonomous minirobots for research and edutainment (AMiRE 2005)*, pages 287–292. Springer, 2006.
- [14] G. Raravi, V. Shingde, K. Ramamritham, and J. Bharadia. Merge algorithms for intelligent vehicles. In *Next Generation Design and Verification Methodologies for Distributed Embedded Control Systems*, pages 51–65. Springer, 2007.
- [15] V. Milanés, J. P. Rastelli, E. Onieva, and C. González. Controller for urban intersections based on wireless communications and fuzzy logic. *IEEE Transactions on Intelligent Transportation Systems*, 2010.
- [16] V. Milanés, J. Alonso, L. Bouraoui, and J. Ploeg. Cooperative maneuvering in close environments among cybercars and dual-mode cars. *IEEE Transactions on Intelligent Transportation Systems*, 12(1):15–24, 2011.
- [17] J. Wu, A. Abbas-Turki, and A. El Moudni. Cooperative driving: an ant colony system for autonomous intersection management. *Applied Intelligence*, 37(2):207–222, 2012.
- [18] N. Neuendorf and T. Bruns. The vehicle platoon controller in the decentralised, autonomous intersection management of vehicles. In *Mechatronics, 2004. ICM'04. Proceedings of the IEEE International Conference on*, pages 375–380. IEEE, 2004.
- [19] F. Michaud, P. Lepage, P. Frenette, D. Létourneau, and N. Gaubert. Coordinated maneuvering of automated vehicles in platoons. *Intelligent Transportation Systems, IEEE Transactions on*, 7(4):437–447, 2006.
- [20] I. H. Zohdy and H. A. Rakha. Intersection management via vehicle connectivity: The intersection cooperative adaptive cruise control system concept. *Journal of Intelligent Transportation Systems*, 20(1):17–32, 2016.
- [21] J. So, B. Park, S. M. Wolfe, and G. Dedes. Development and validation of a vehicle dynamics integrated traffic simulation environment assessing surrogate safety. *Journal of computing in civil engineering*, 29(5):04014080, 2014.
- [22] S. I. Guler, M. Menendez, and L. Meier. Using connected vehicle technology to improve the efficiency of intersections. *Transportation Research Part C: Emerging Technologies*, 46:121–131, 2014.
- [23] J. Lee, B.B. Park, K. Malakorn, and J.J. So. Sustainability assessments of cooperative vehicle intersection control at an urban corridor. *Transportation Research Part C: Emerging Technologies*, 32:193–206, 2013.

-
- [24] H. Rakha, K. Ahn, and A. Trani. Development of vt-micro model for estimating hot stabilized light duty vehicle and truck emissions. *Transportation Research Part D: Transport and Environment*, 9(1):49–74, 2004.
- [25] M. Ahmane, A. Abbas-Turki, F. Perronnet, J. Wu, A. El Moudni, J. Buisson, and R. Zeo. Modeling and controlling an isolated urban intersection based on cooperative vehicles. *Transportation Research Part C: Emerging Technologies*, 28:44–62, 2013.
- [26] Md. A. S. Kamal, J. Imura, T. Hayakawa, A. Ohata, and K. Aihara. A vehicle-intersection coordination scheme for smooth flows of traffic without using traffic lights. *IEEE Transactions on Intelligent Transportation Systems*, 16(3):1136–1147, 2015.
- [27] S. Pandian, S. Gokhale, and A.K. Ghoshal. Evaluating effects of traffic and vehicle characteristics on vehicular emissions near traffic intersections. *Transportation Research Part D: Transport and Environment*, 14(3):180–196, 2009.
- [28] P. Baran. On distributed communications networks. *IEEE transactions on Communications Systems*, 12(1):1–9, 1964.
- [29] Y. Guo and L.E. Parker. A distributed and optimal motion planning approach for multiple mobile robots. In *Robotics and Automation, 2002. Proceedings. ICRA'02. IEEE International Conference on*, volume 3, pages 2612–2619. IEEE, 2002.
- [30] Priority to the Right. https://en.wikipedia.org/wiki/Priority_to_the_right.
- [31] C. Bergenheim, S. Shladover, E. Coelingh, C. Englund, and S. Tsugawa. Overview of platooning systems. In *Proceedings of the 19th ITS World Congress, Oct 22-26, Vienna, Austria (2012)*, 2012.
- [32] R. Horowitz and P. Varaiya. Control design of an automated highway system. *Proceedings of the IEEE*, 88(7):913–925, 2000.
- [33] M.A. Zabat, N.S. Stabile, and F.K. Browand. Estimates of fuel savings from platooning. In *Intelligent Transportation: Serving the User Through Deployment. Proceedings of the 1995 Annual Meeting of ITS America.*, 1995.
- [34] B. van Arem, C.J.G. van Driel, and R. Visser. The impact of cooperative adaptive cruise control on traffic-flow characteristics. *IEEE Transactions on Intelligent Transportation Systems*, 7(4):429–436, 2006.
- [35] S. Carpin, M. Lewis, J. Wang, S. Balakirsky, and C. Scrapper. Usarsim: a robot simulator for research and education. In *Proceedings 2007 IEEE International Conference on Robotics and Automation*, pages 1400–1405. IEEE, 2007.
- [36] M. Lewis and J. Jacobson. Game engines in scientific research. *Communications of the ACM*, 45(1):27, 2002.
- [37] R. Adobbati, A. N. Marshall, A. Scholer, S. Tejada, G. A. Kaminka, S. Schaffer, and C. Sollitto. Gamebots: A 3d virtual world test-bed for multi-agent research. In *Proceedings of the second international workshop on Infrastructure for Agents, MAS, and Scalable MAS*, volume 5. Montreal, Canada, 2001.

-
- [38] S. Tsugawa, S. Kato, T. Matsui, H. Naganawa, and H. Fujii. An architecture for cooperative driving of automated vehicles. In *Intelligent Transportation Systems, 2000. Proceedings. 2000 IEEE*, pages 422–427. IEEE, 2000.
- [39] A.S. Tanenbaum et al. Computer networks, 4-th edition. *ed: Prentice Hall*, 2003.
- [40] M. Fellendorf and P. Vortisch. Microscopic traffic flow simulator vissim. In *Fundamentals of traffic simulation*, pages 63–93. Springer, 2010.
- [41] J.A. Michon. A critical view of driver behavior models: what do we know, what should we do? In *Human behavior and traffic safety*, pages 485–524. Springer, 1985.
- [42] J. Maroto, E. Delso, J. Félez, and J.M. Cabanellas. Real-time traffic simulation with a microscopic model. *Intelligent Transportation Systems, IEEE Transactions on*, 7(4):513–527, 2006.
- [43] K. Ahn, H. Rakha, A. Trani, and M. van Aerde. Estimating vehicle fuel consumption and emissions based on instantaneous speed and acceleration levels. *Journal of transportation engineering*, 128(2):182–190, 2002.
- [44] D. Gettman and L. Head. Surrogate safety measures from traffic simulation models. *Transportation Research Record: Journal of the Transportation Research Board*, (1840):104–115, 2003.
- [45] A. Kassim, K. Ismail, and Y. Hassan. Automated measuring of cyclist–motor vehicle post encroachment time at signalized intersections. *Canadian journal of civil engineering*, 41(7):605–614, 2014.
- [46] Douglas Gettman, Lili Pu, Tarek Sayed, and Steven G Shelby. Surrogate safety assessment model and validation: Final report. Technical report, 2008.
- [47] Hyperplane Separation theorem . https://en.wikipedia.org/wiki/Hyperplane_separation_theorem.