

**THE ACTIVE
MUSEUM OF
ART**

A NEW MUSEUM IN 2021

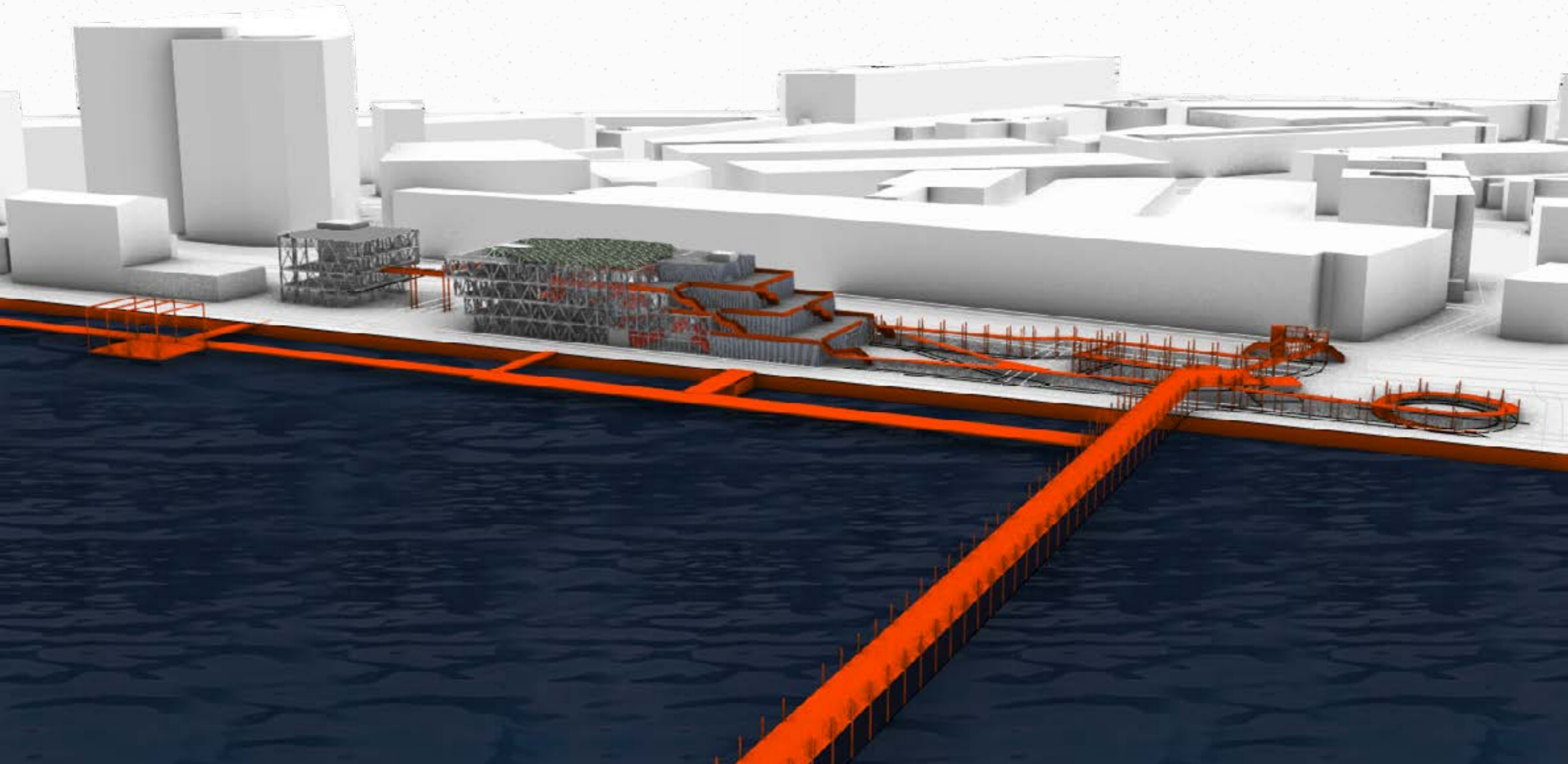

A NEW MUSEUM FOR MAASHAVEN ROTTERDAM



MAASHAVEN ROTTERDAM: RESEARCH

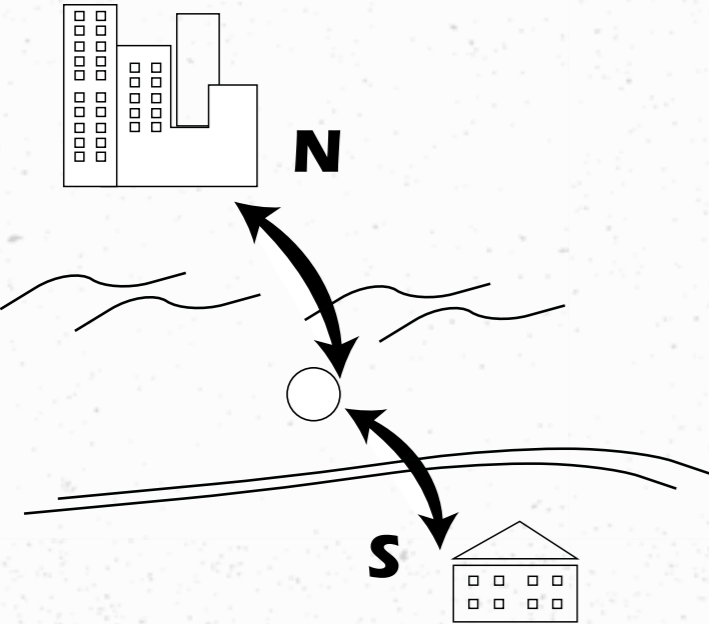

CONNECTION: • Improve (mental) connection of the North and South, water, and the neighbourhood

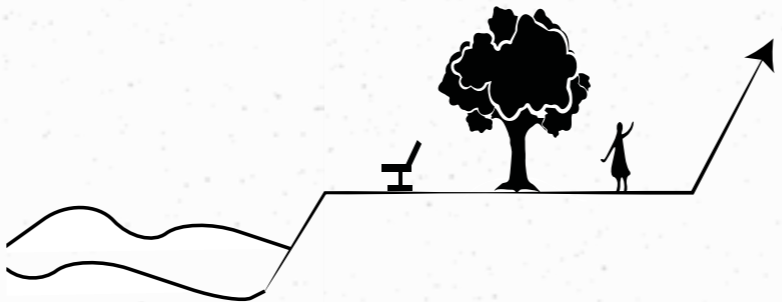

CITY: • Improve public outside space and the waterfront



HISTORY: • Water, Industrial, harbour, and producing

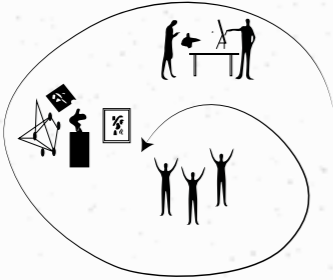

CULTURE: • Narrow the gap between high art and local culture

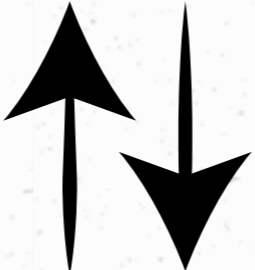

POWER: • Bottom-up tourism approach, Culture as representation.



PEOPLE: • Increase neighbourhood opportunities

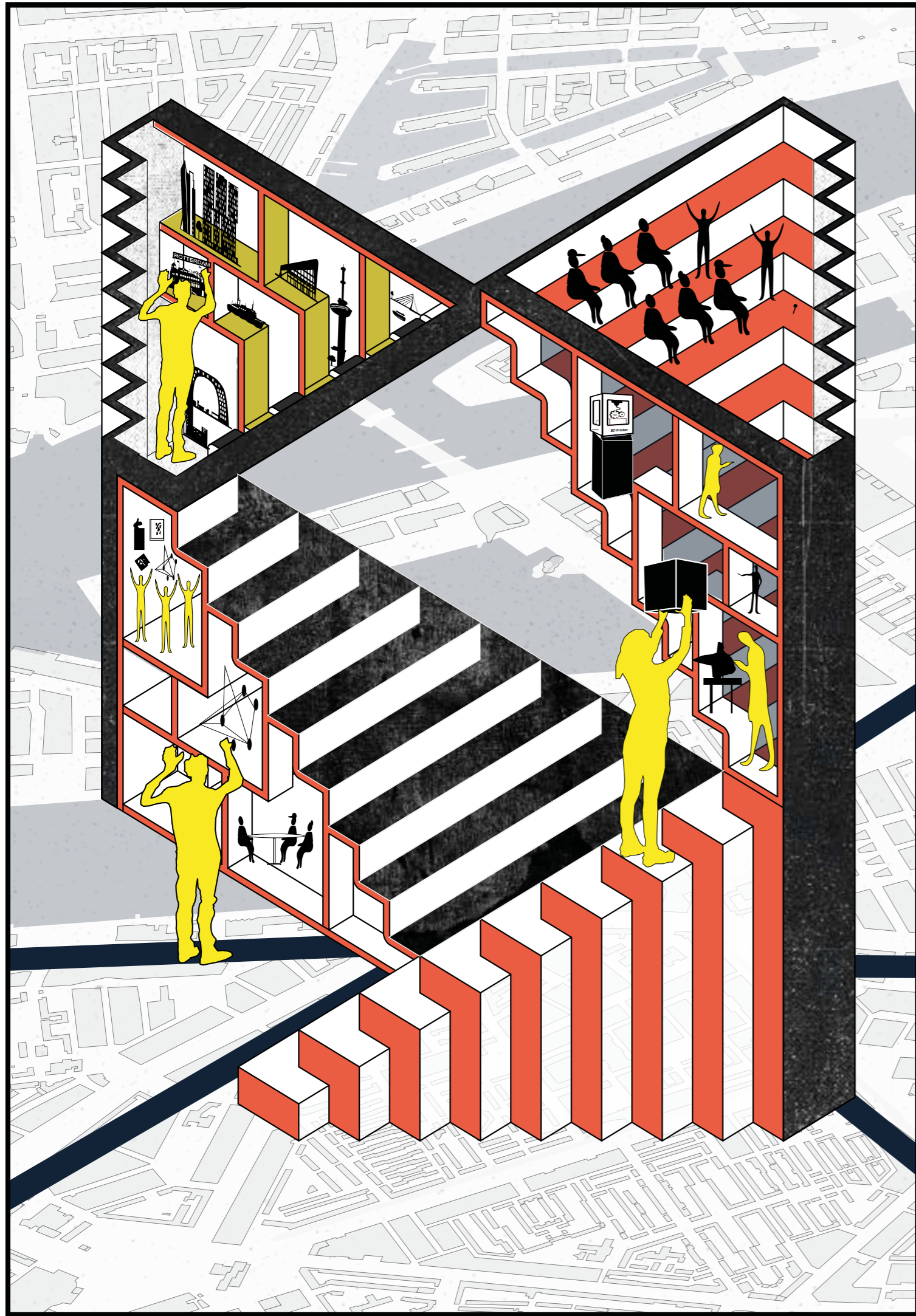

WHAT KIND OF
MUSEUM SHOULD
THIS BE....

GOALL

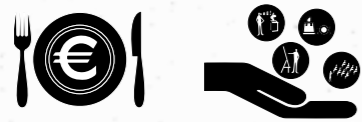

Co-offices, shop & dining in business model

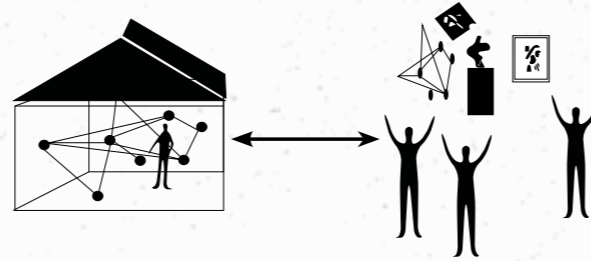

New relationships

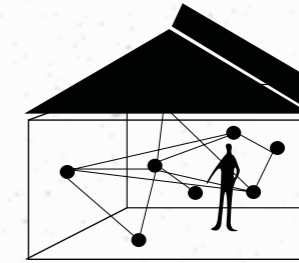

Participatory installation, art exhibition, sculptures, digital art, and interactive art

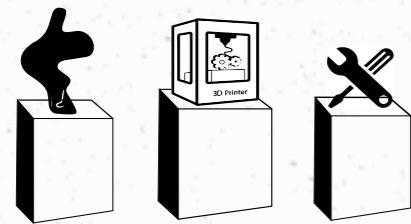

Learning new Techniques



Space for event and art talks

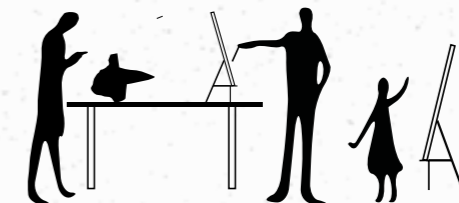

Active experiences from visiting the art museum

Design principles based on case studies and research

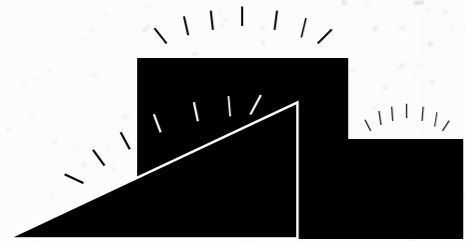

Active building or building as performance, accessible roof



Reflect to the city's structure & history

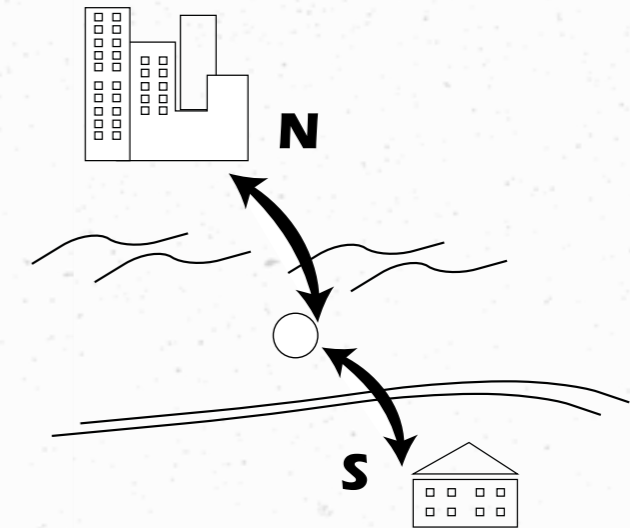

Connecting the North and South, water and the neighbourhood



Merging contemporary art disciplines

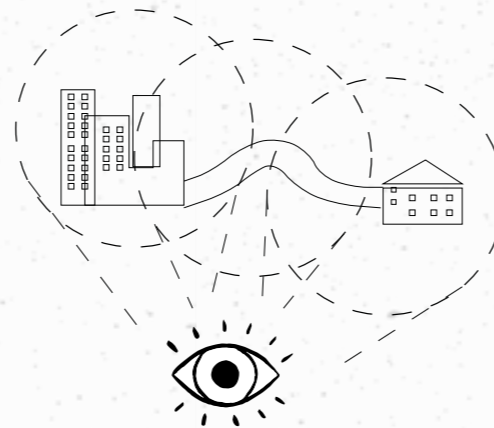

Transparency to/trough the building, N/S neighbourhood

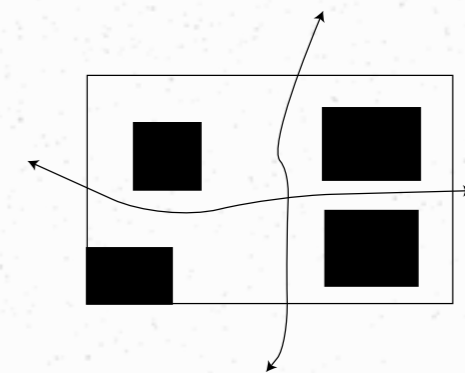

Strong center point, open space of encounter, atrium/square, vertical or horizontal

GOALL

PARTICIPATORY ART

THE DESIGN CONCEPT

THE SITE

SITE SECTIONS

THE BUILDING

BUILDING ELEMENTS

CLIMATE

BUILDING IN DETAILS

ACTIVE MUSEUM OF ART

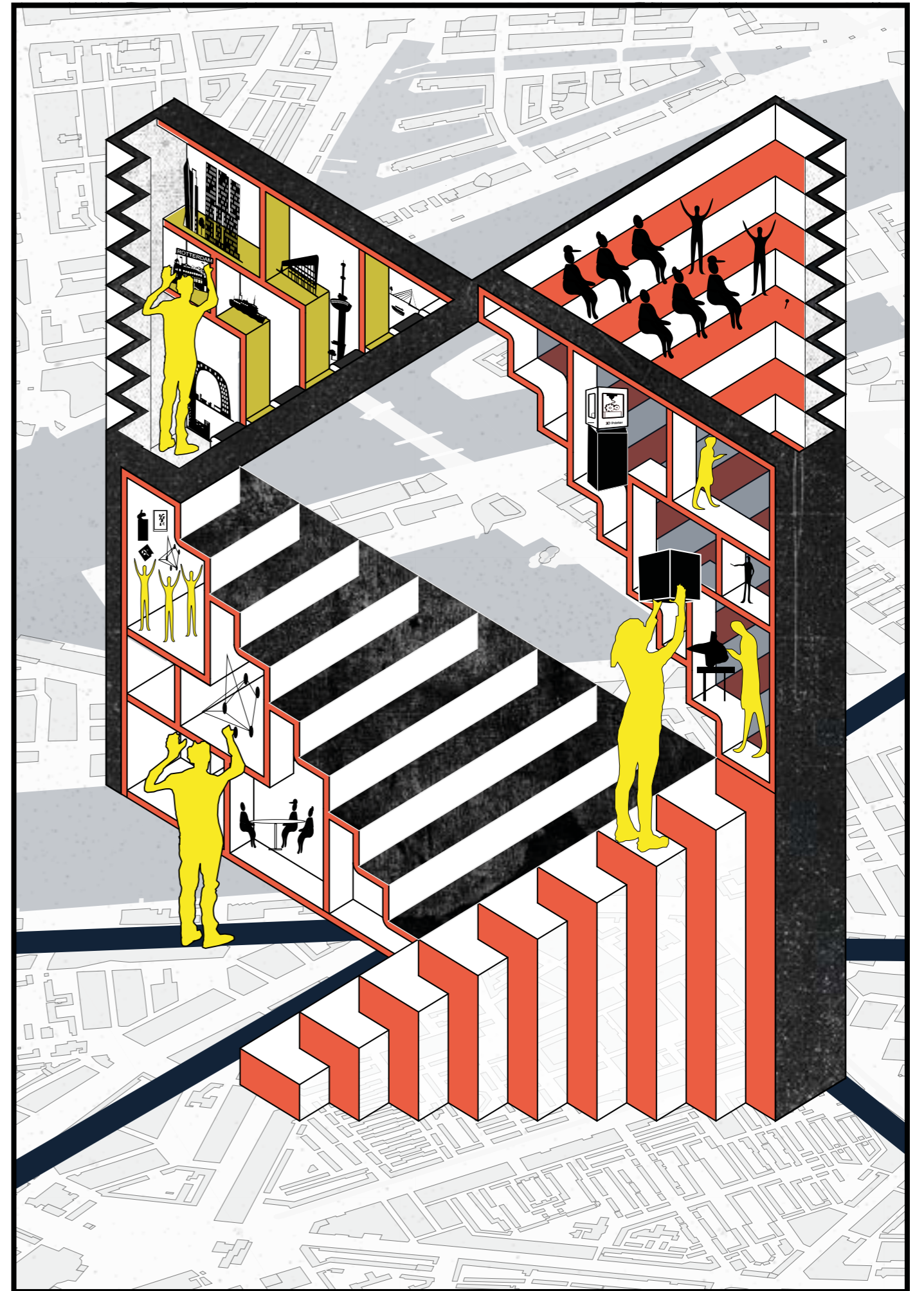

PARTICIPATION IN ART

PARTICIPATORY ART

Sculpture & Installation: Bliss / The kiss



PARTICIPATORY ART

Digital Interaction: Participation TV



PARTICIPATORY ART

Co-creation: Indiosycotische knip machine



PARTICIPATORY ART

Architecture: the favela & sculpting the void

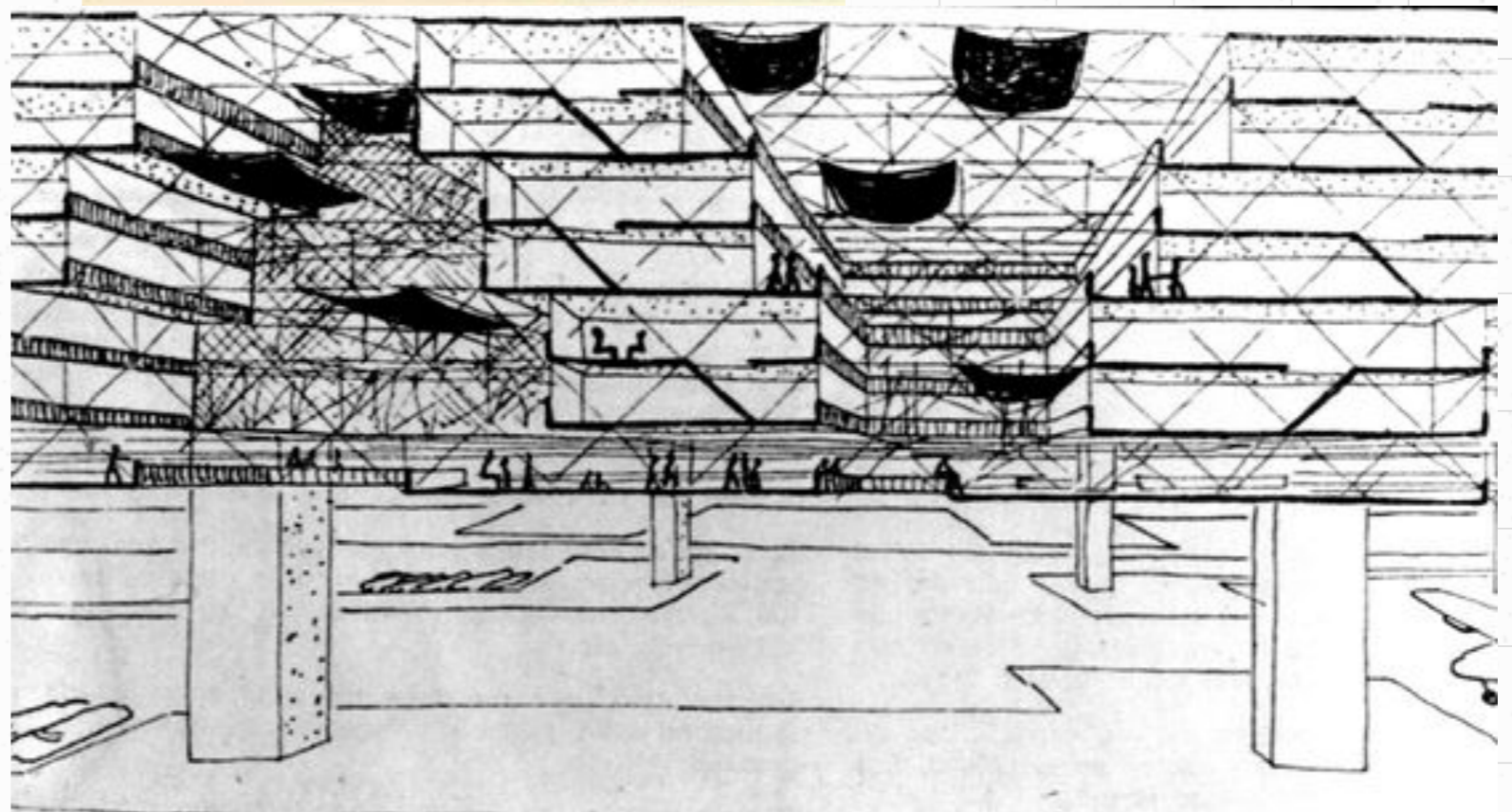

PARTICIPATORY ART

The ladder of Participation

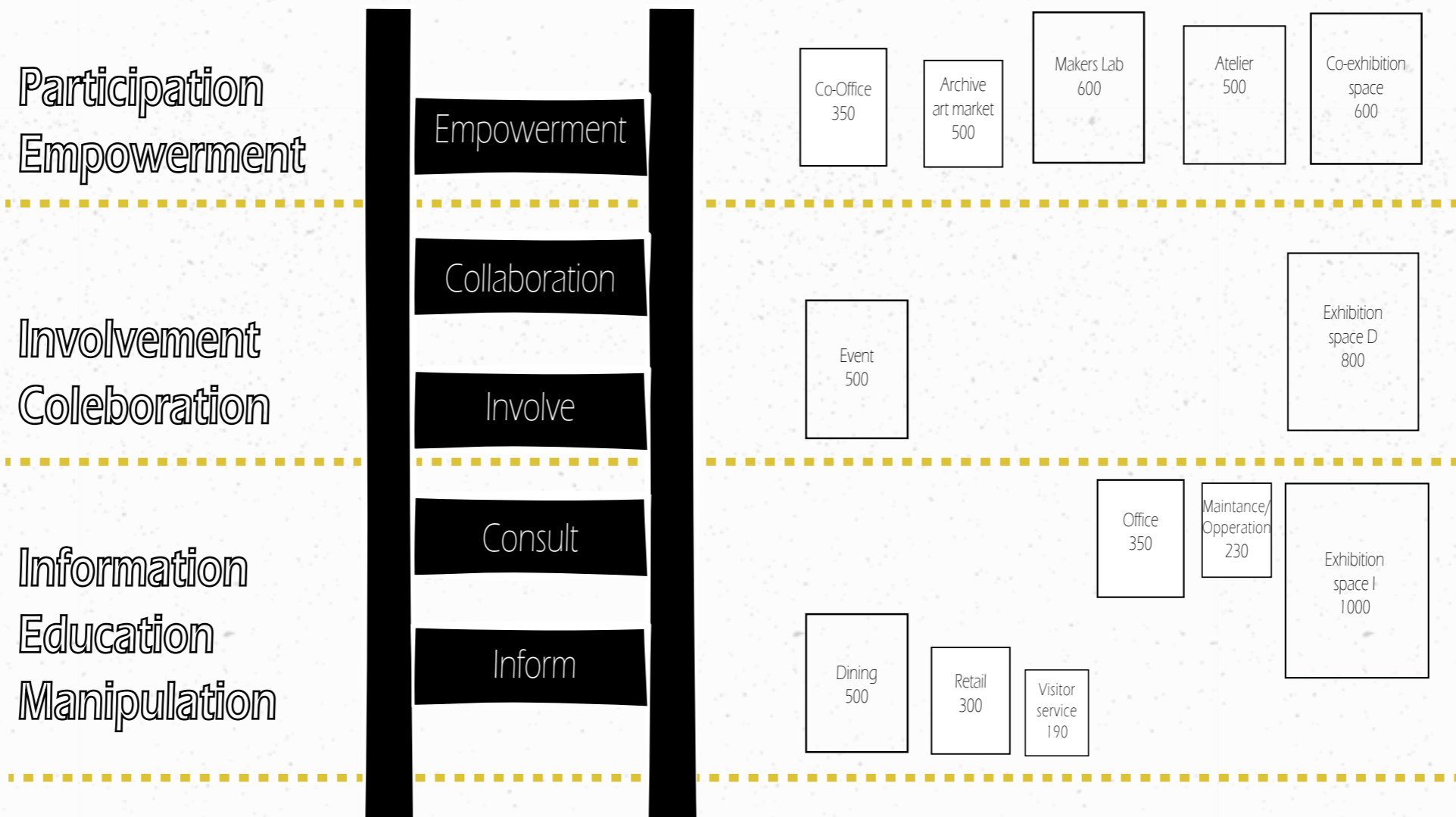

GOALL
PARTICIPATORY ART
THE DESIGN CONCEPT

THE SITE
SITE SECTIONS
THE BUILDING
BUILDING ELEMENTS
CLIMATE
BUILDING IN DETAILS
ACTIVE MUSEUM OF ART

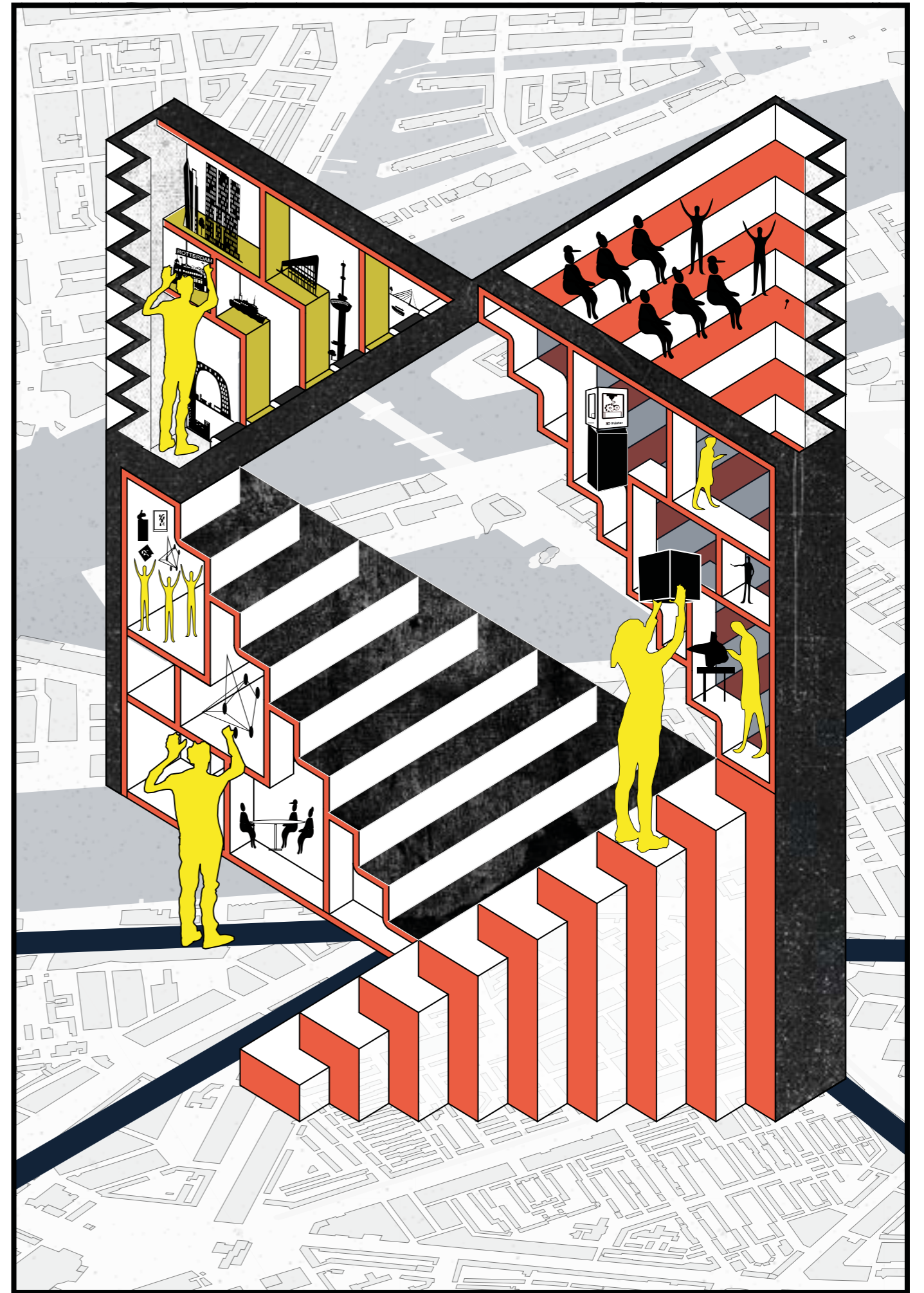

THE DESIGN CONCEPT

Participation in this museum

Top down-Bottom up

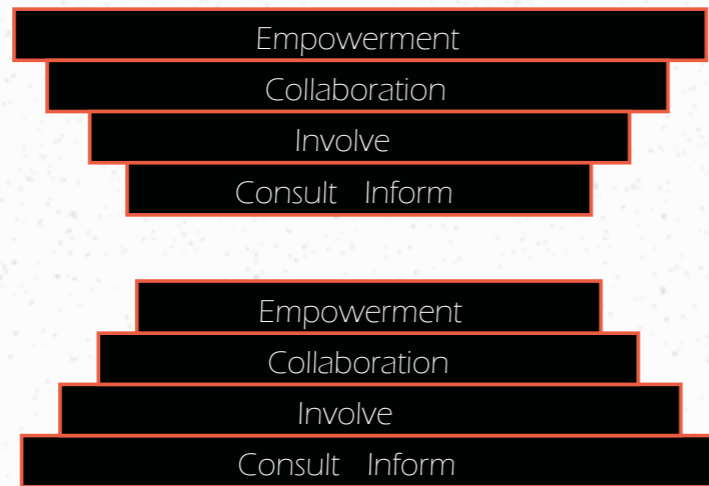
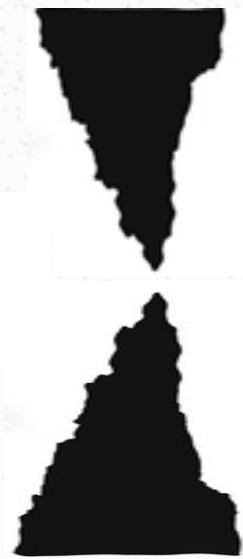

Program divided based on level of participation

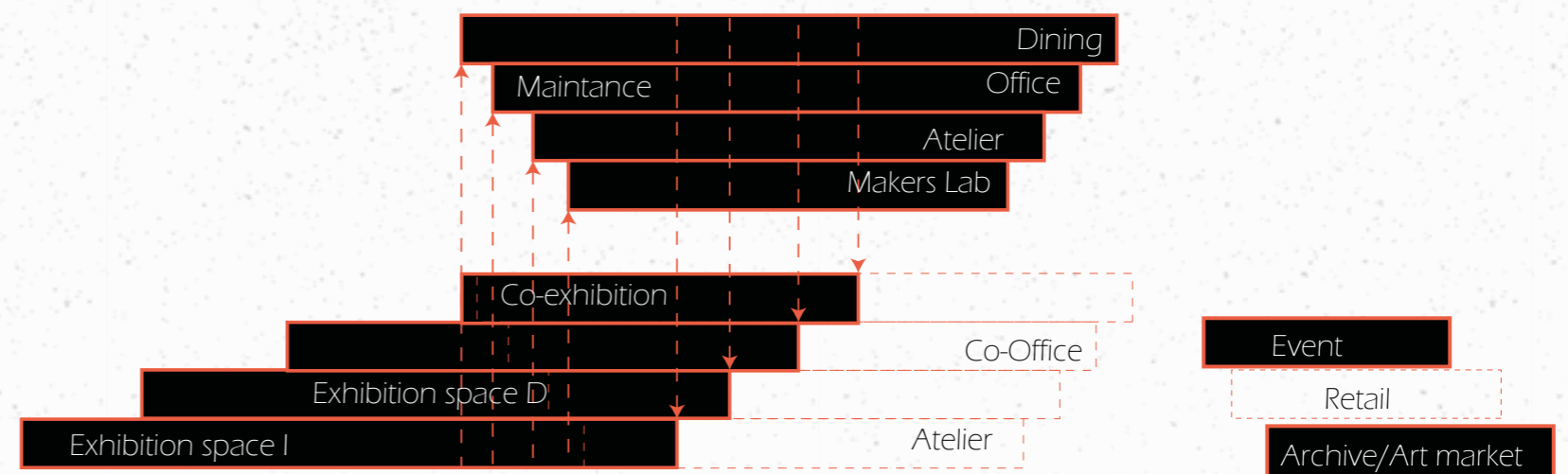

THE DESIGN CONCEPT

Reflecting the city

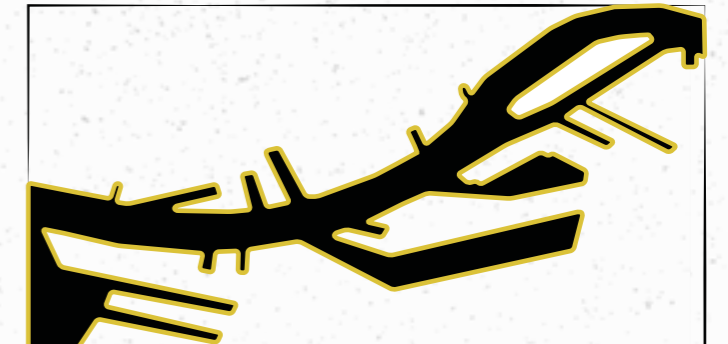
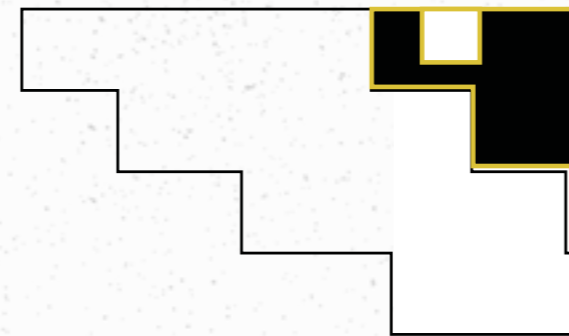
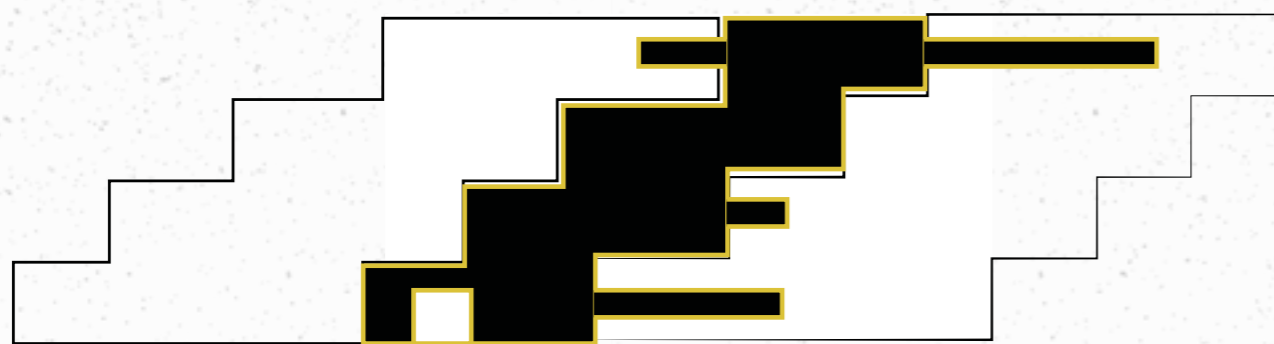

Three floating volumes reflecting the river

THE DESIGN CONCEPT

Connecting platforms

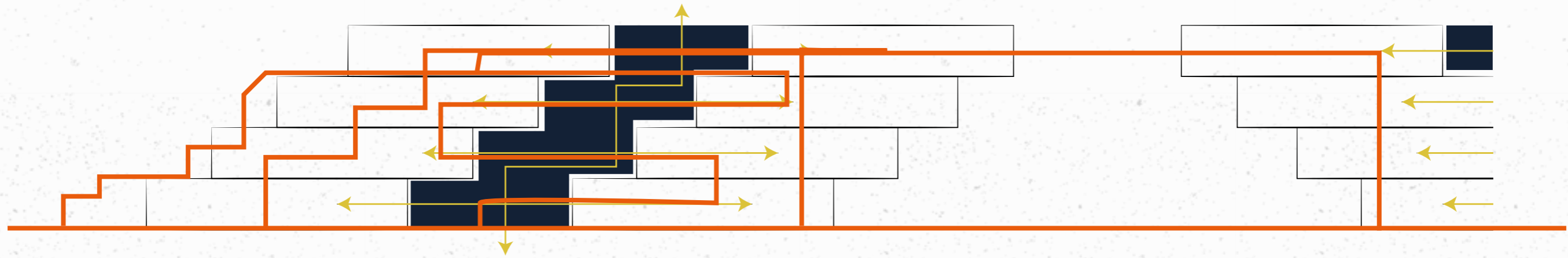

The volumes connected through art platforms

GOALL
PARTICIPATORY ART
THE DESIGN CONCEPT

THE SITE

SITE SECTIONS
THE BUILDING
BUILDING ELEMENTS
CLIMATE
BUILDING IN DETAILS
ACTIVE MUSEUM OF ART

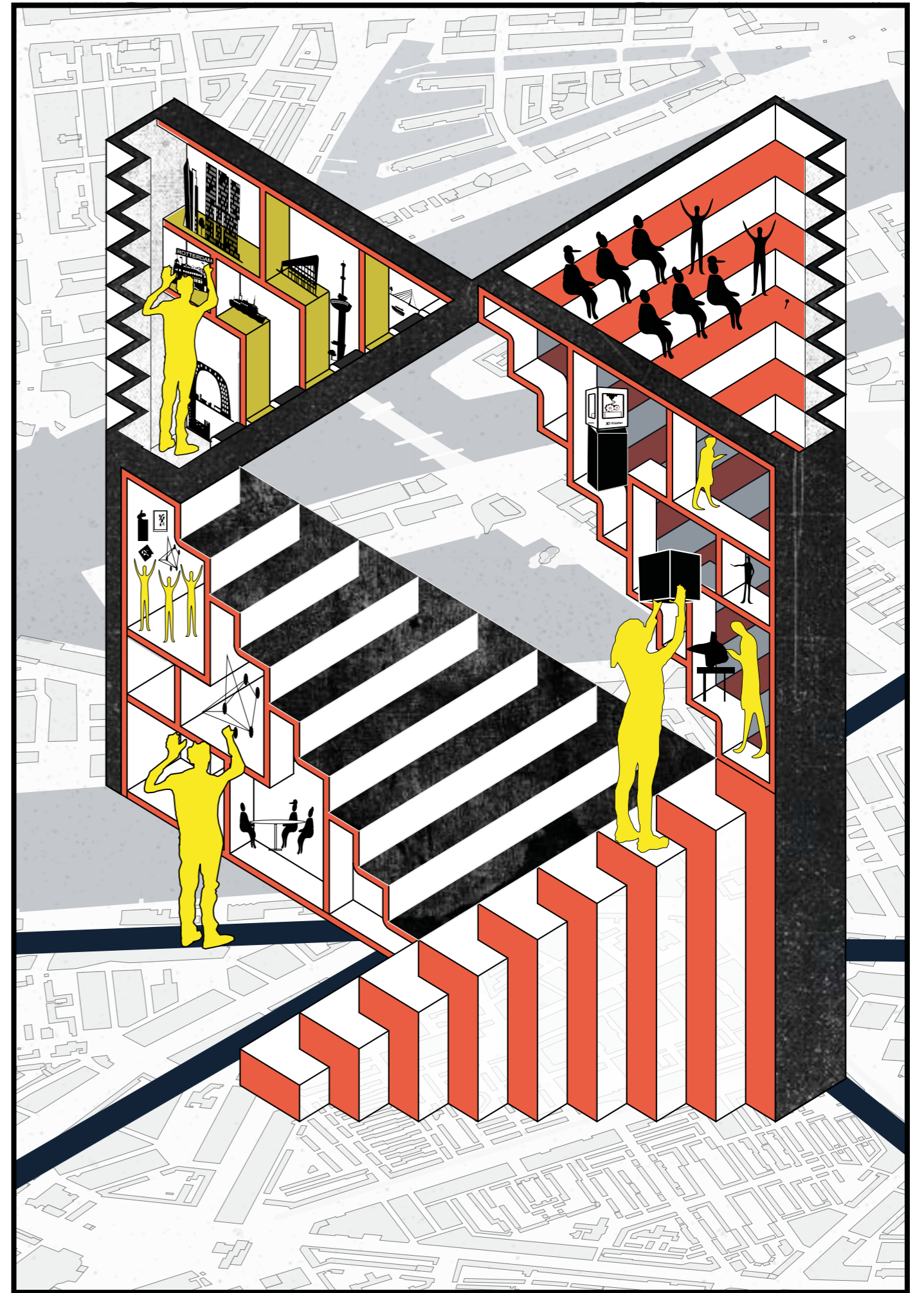

THE SITE

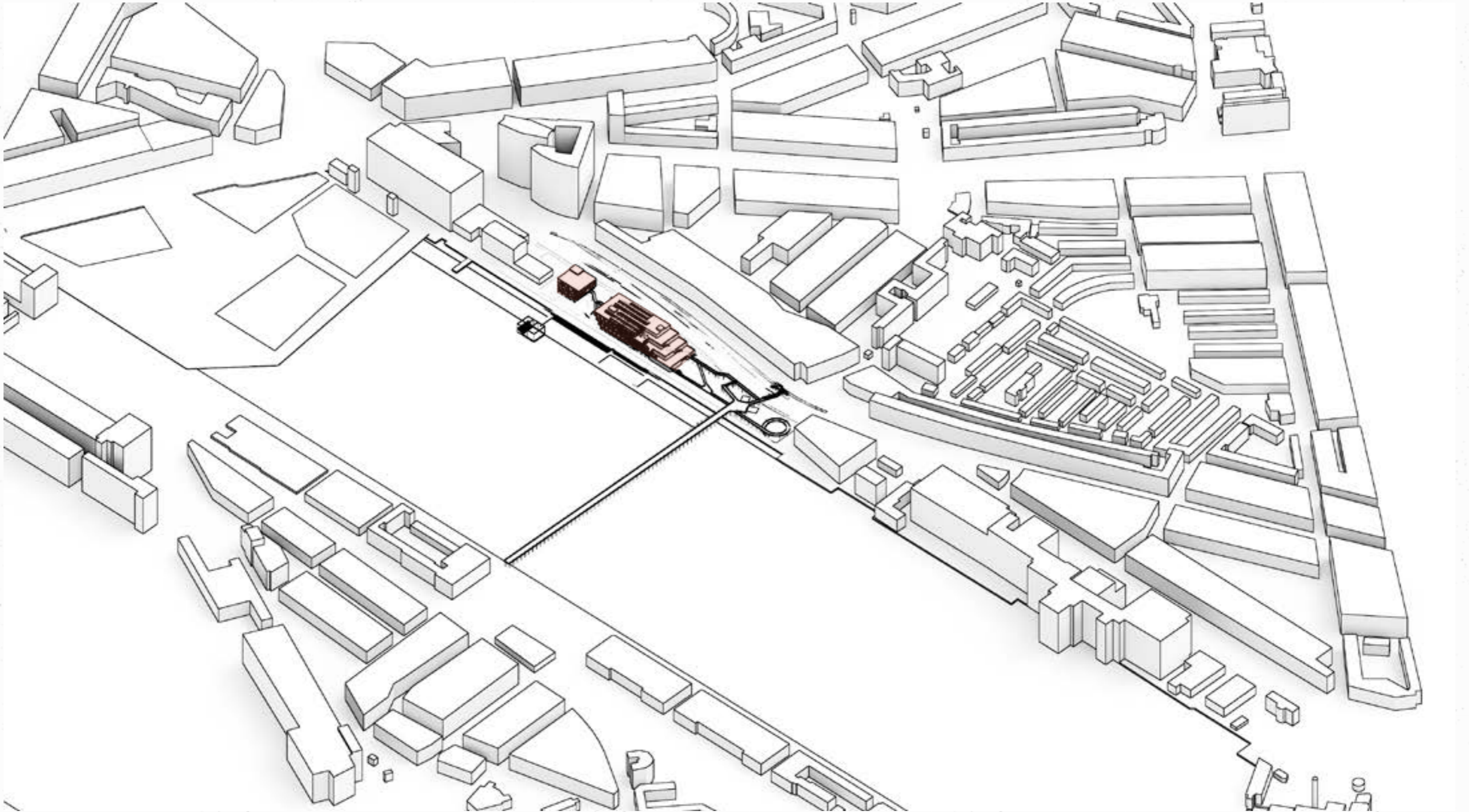

THE SITE

In the context

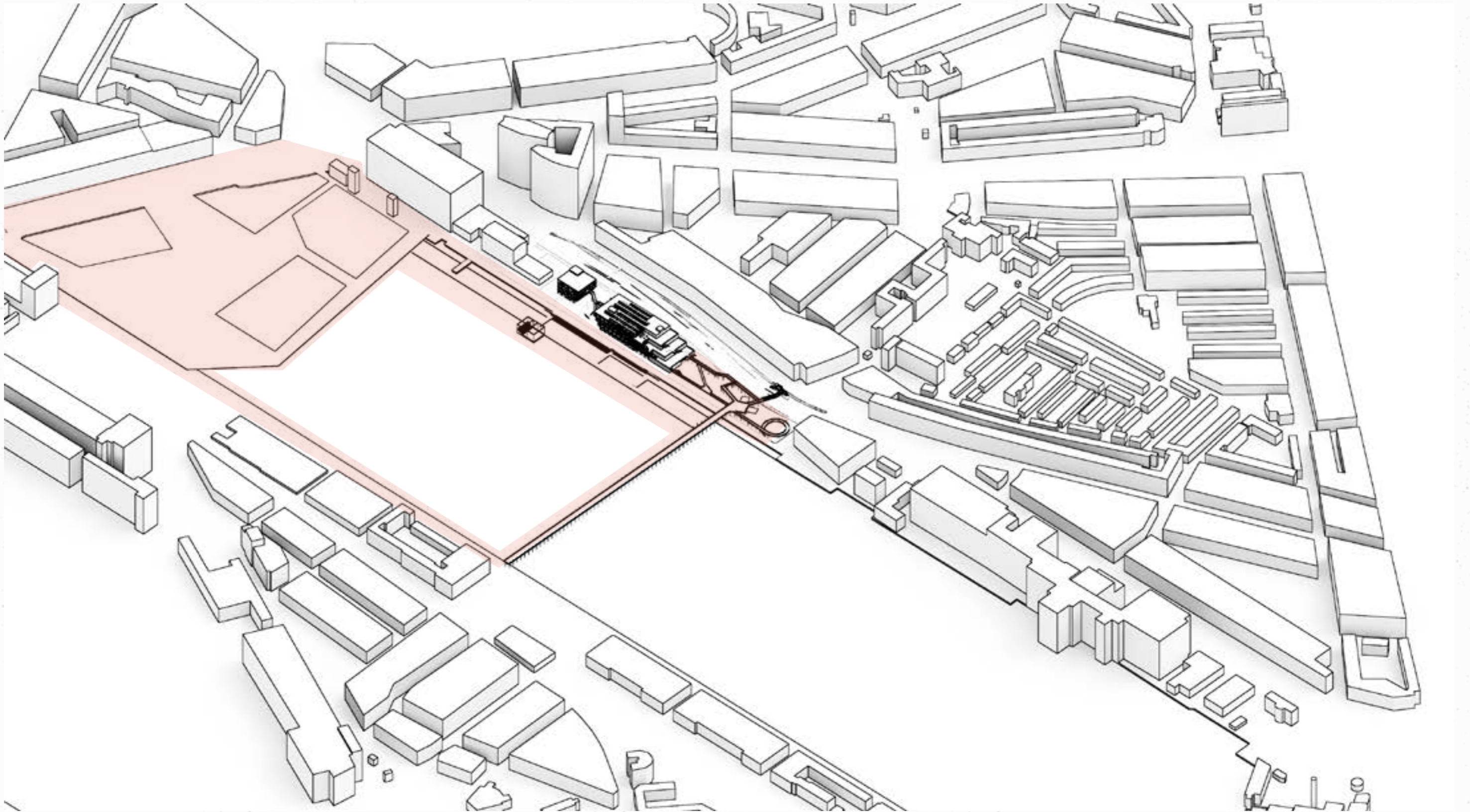

THE SITE

Public vs private

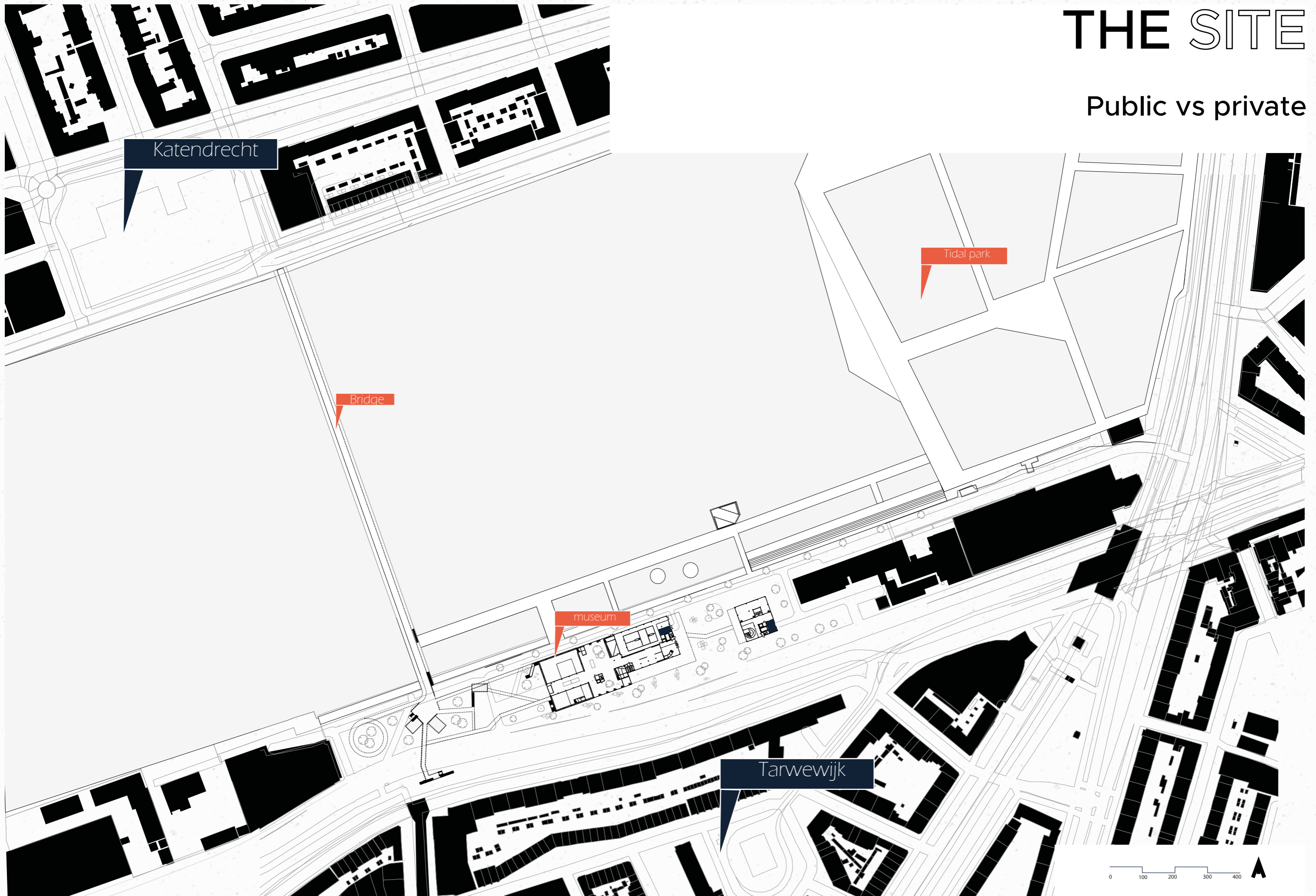

THE SITE

Main visitor route

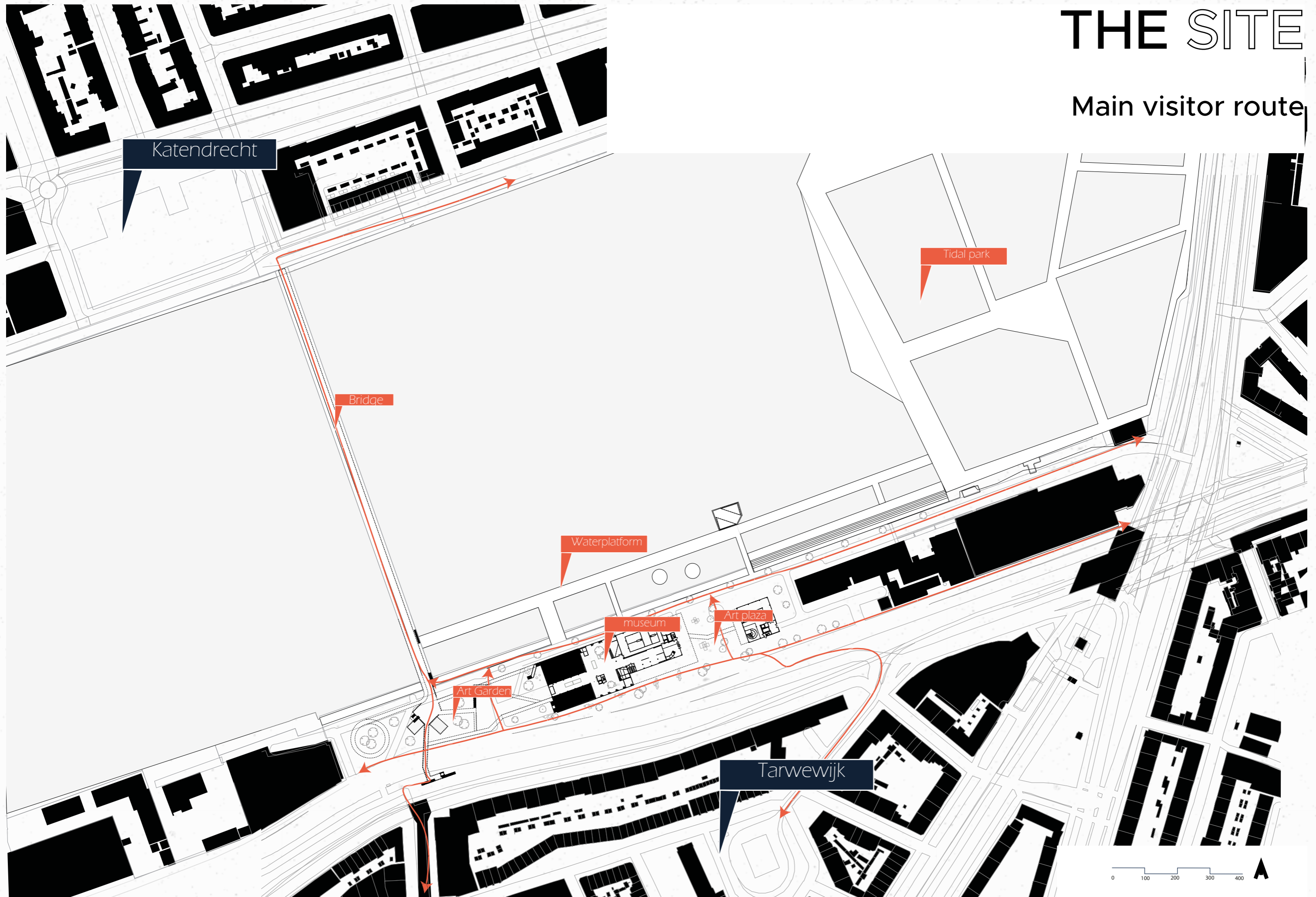

THE SITE

Visitor routes



THE SITE

Helicopter view



THE SITE

South/West impression



THE SITE

South/East impression



THE SITE

East impression



THE SITE

North/East impression



THE SITE

The zones

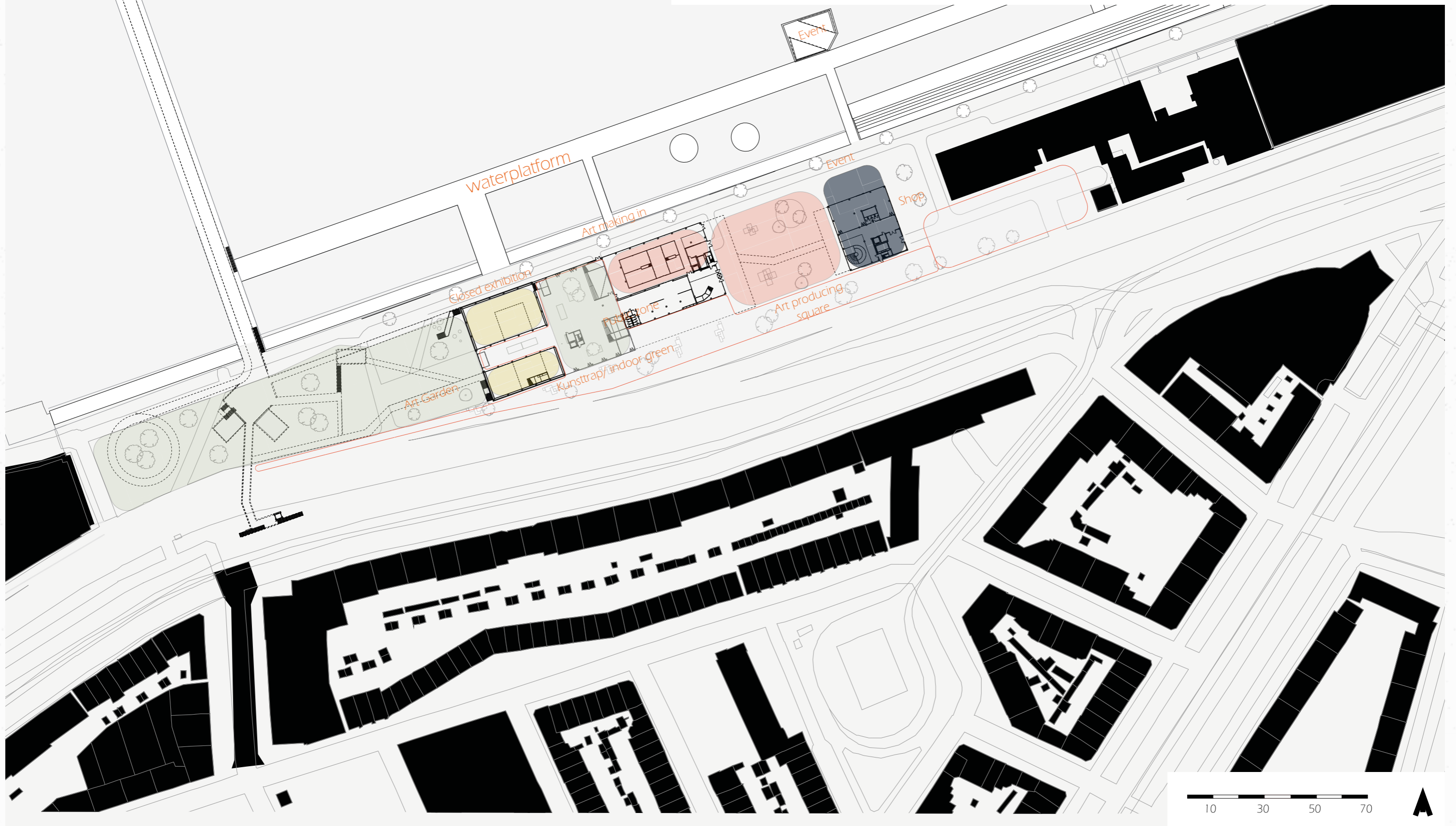

THE SITE

Different zones

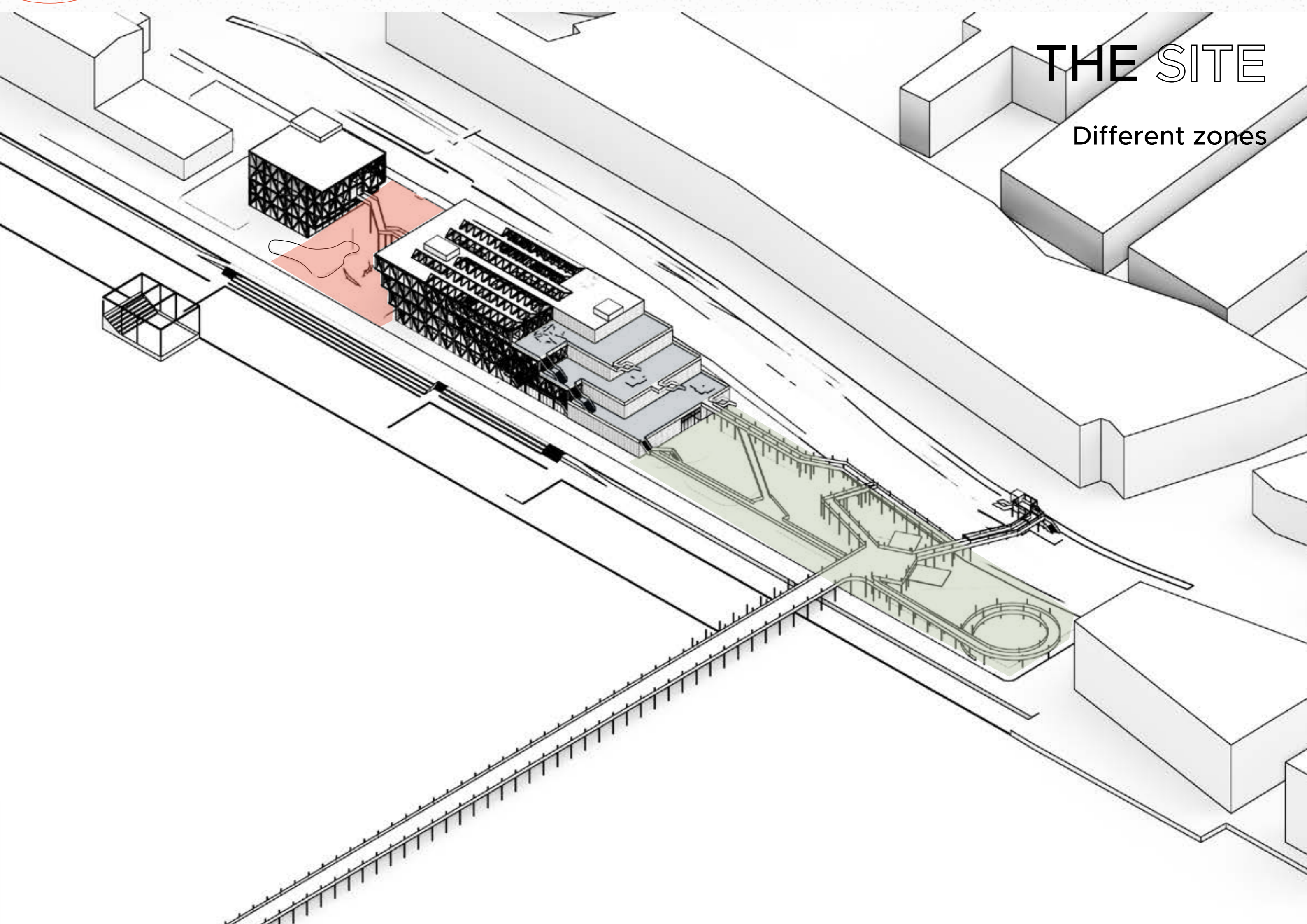

THE SITE

Art producing plaza

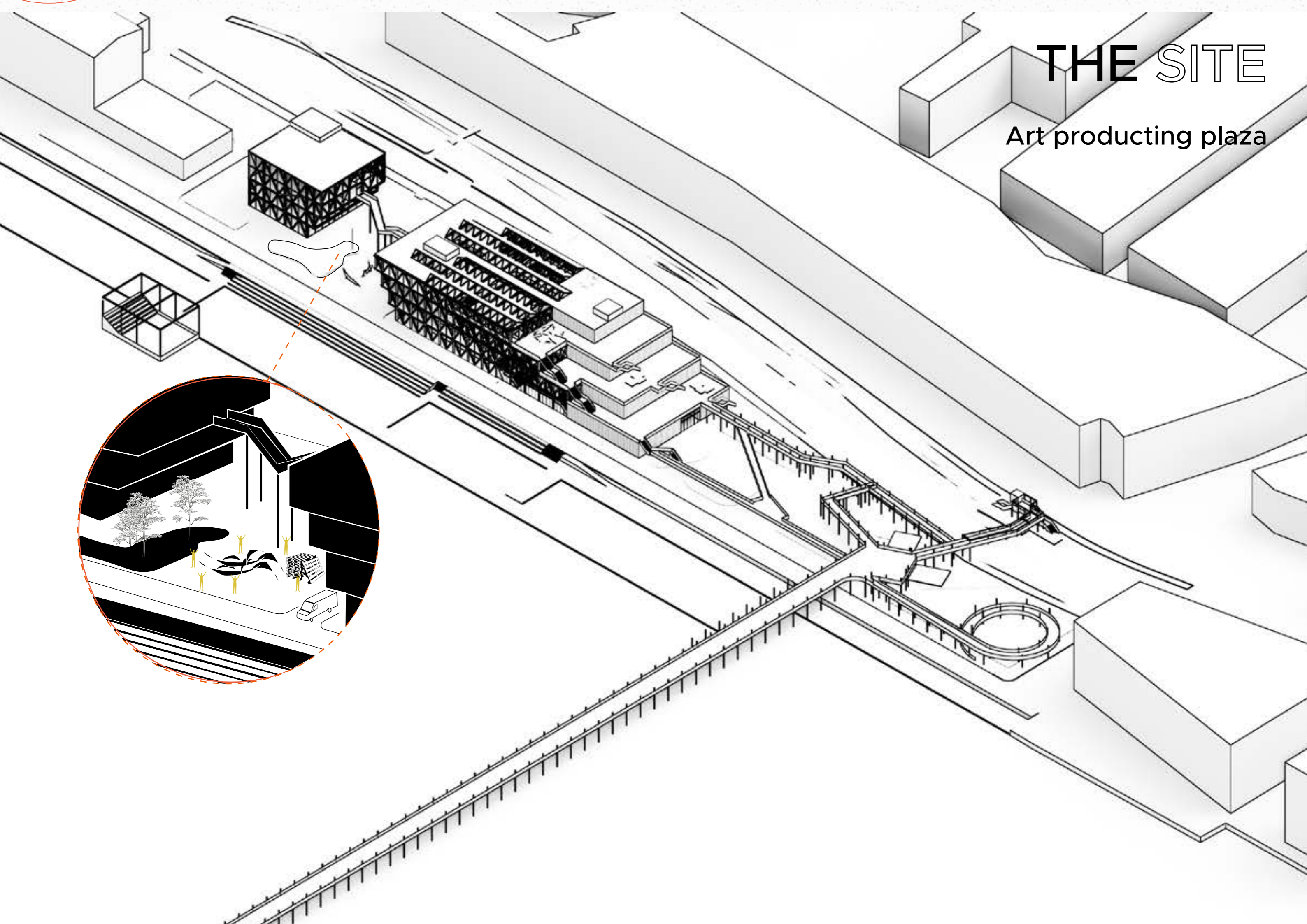
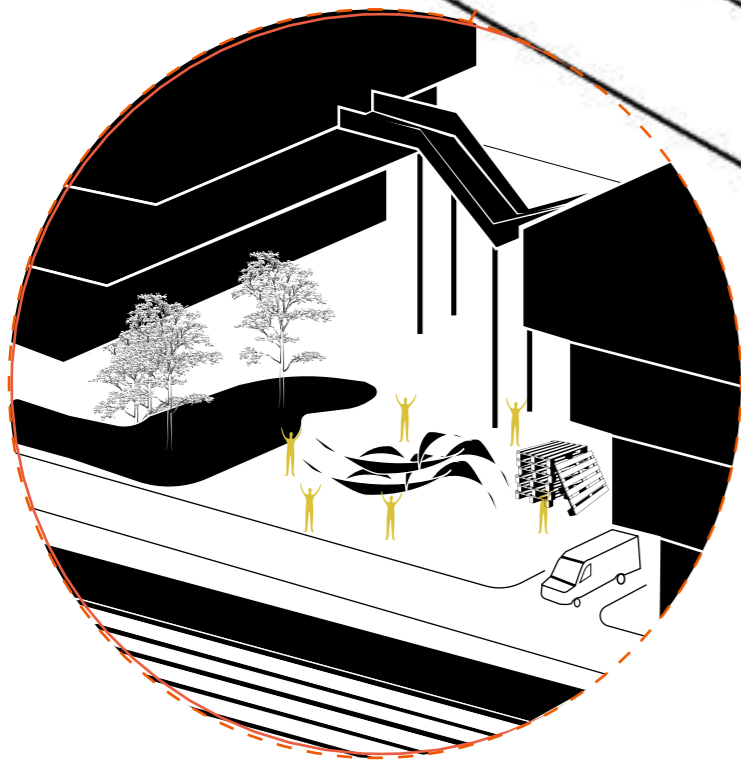

THE SITE

Art producing plaza impression



THE SITE

Rooftop terraces

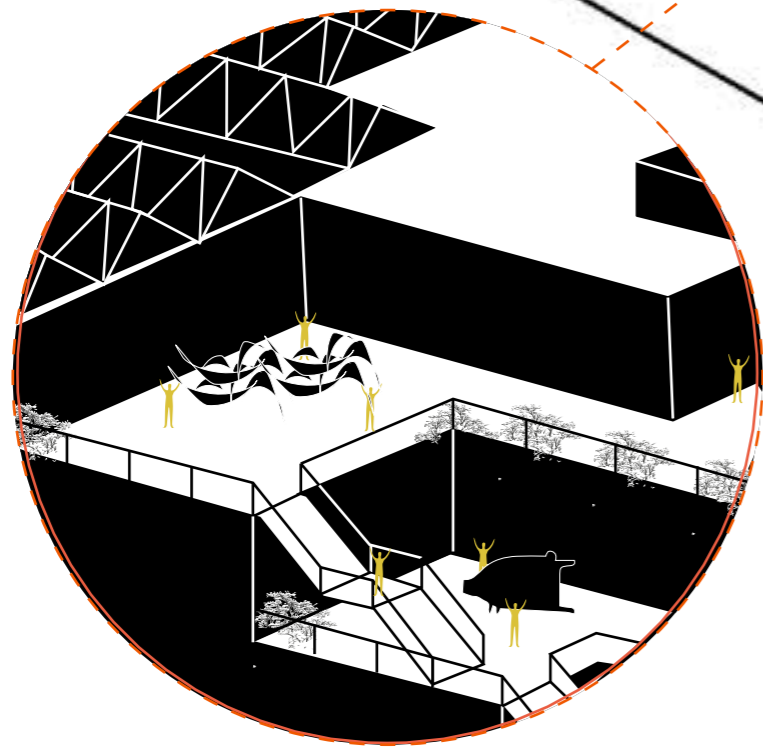
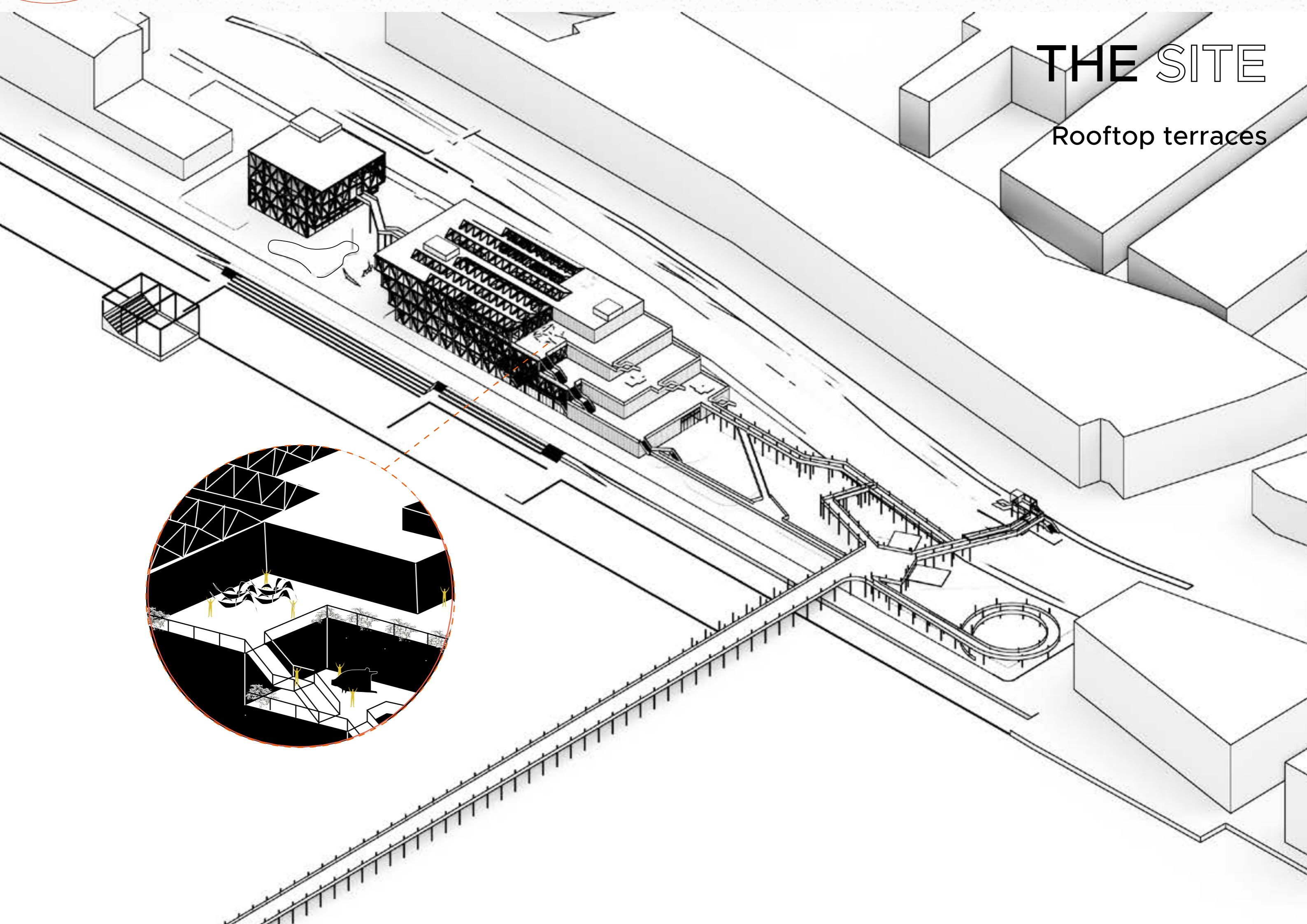

THE SITE

Rooftop terraces impression



THE SITE

Platform Art Garden

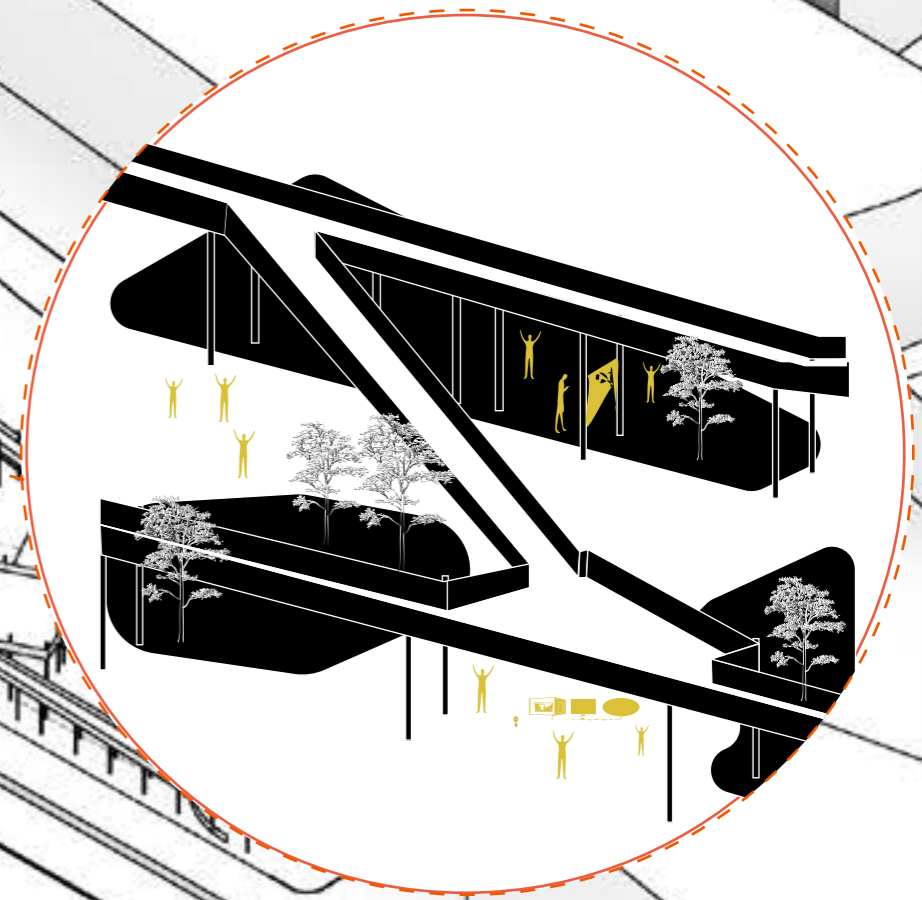
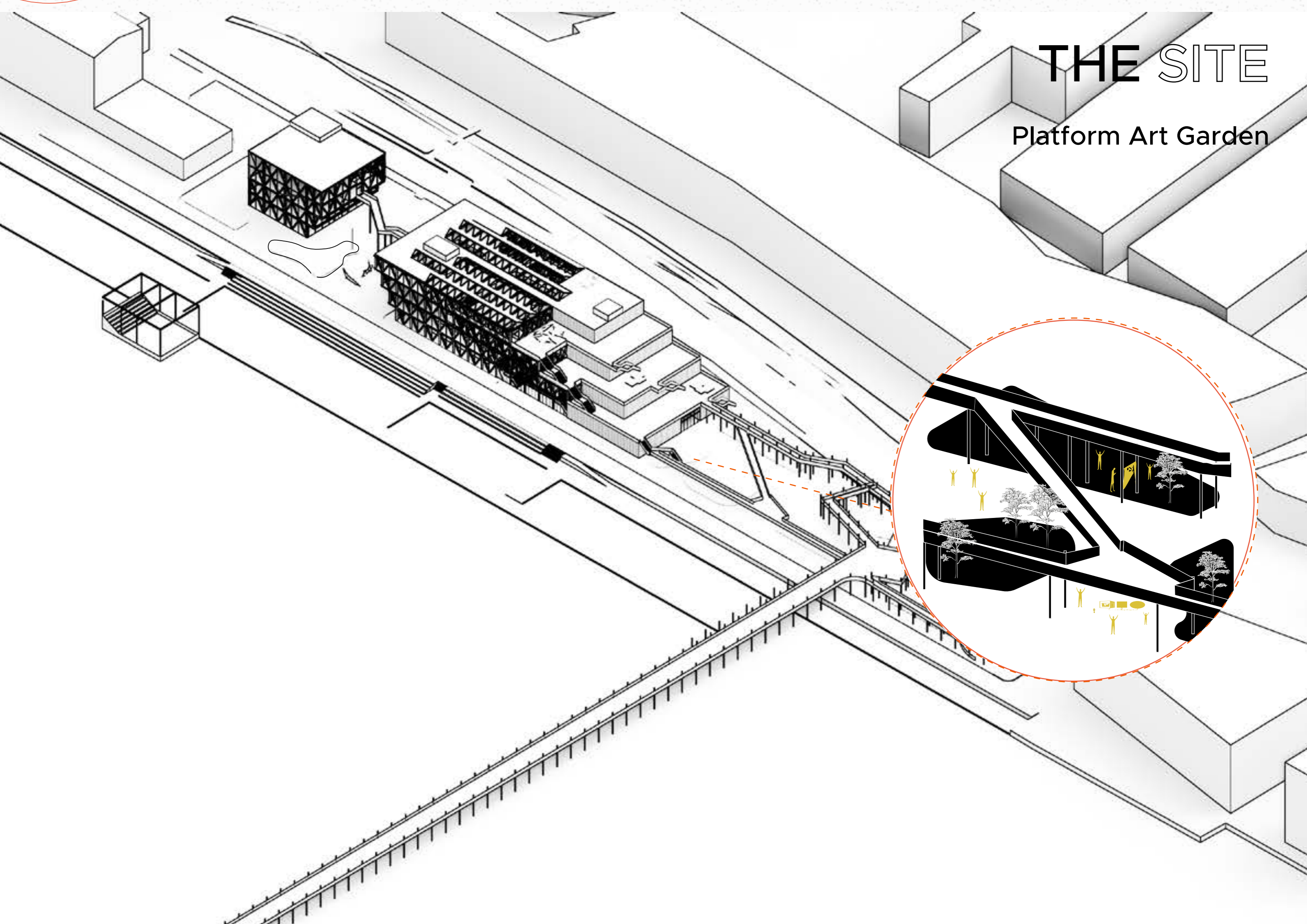

THE SITE

Platform Art Garden



GOALL
PARTICIPATORY ART
THE DESIGN CONCEPT
THE SITE
SITE SECTIONS
THE BUILDING
BUILDING ELEMENTS
CLIMATE
BUILDING IN DETAILS
ACTIVE MUSEUM OF ART

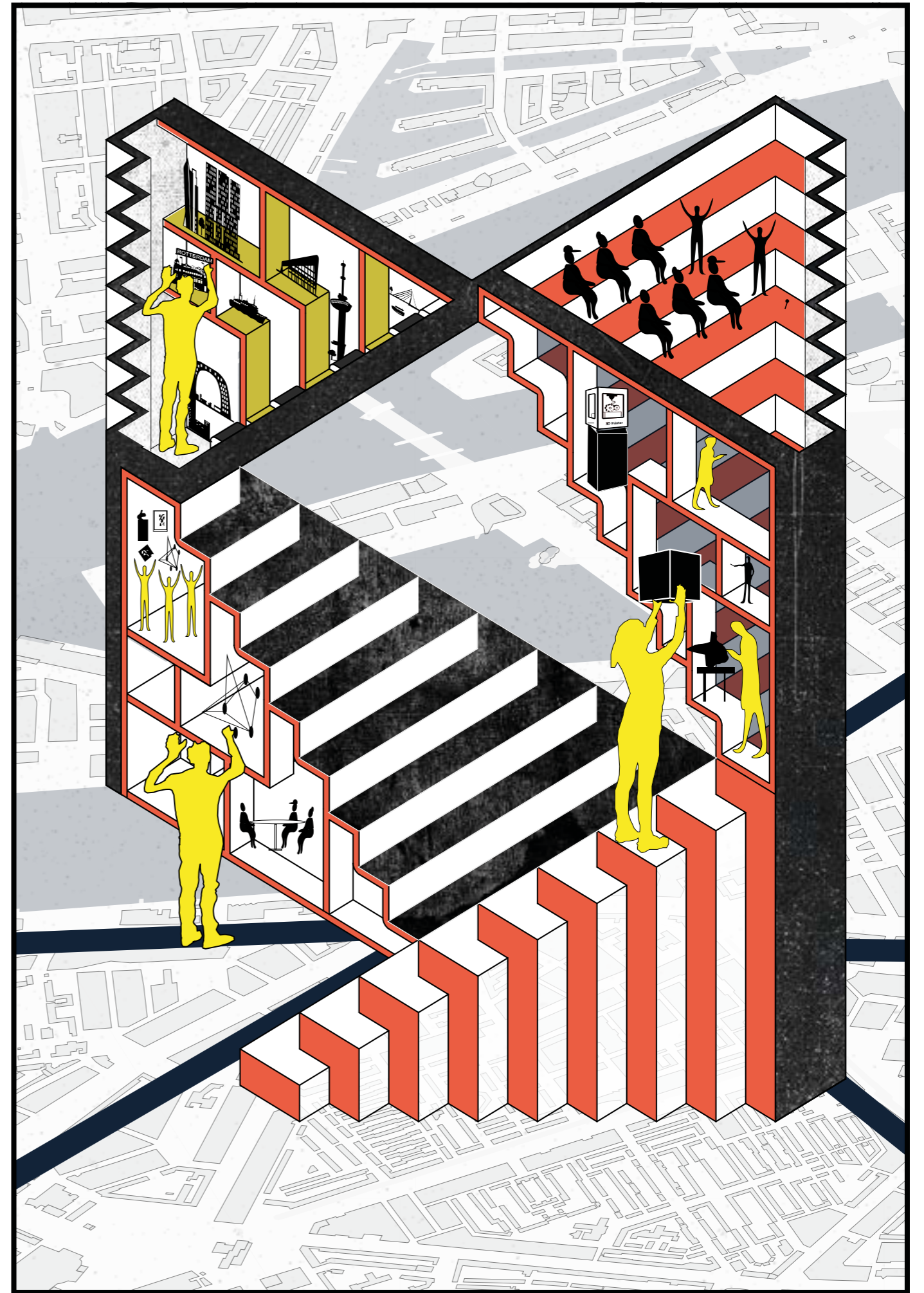

SITE SECTIONS

In the context

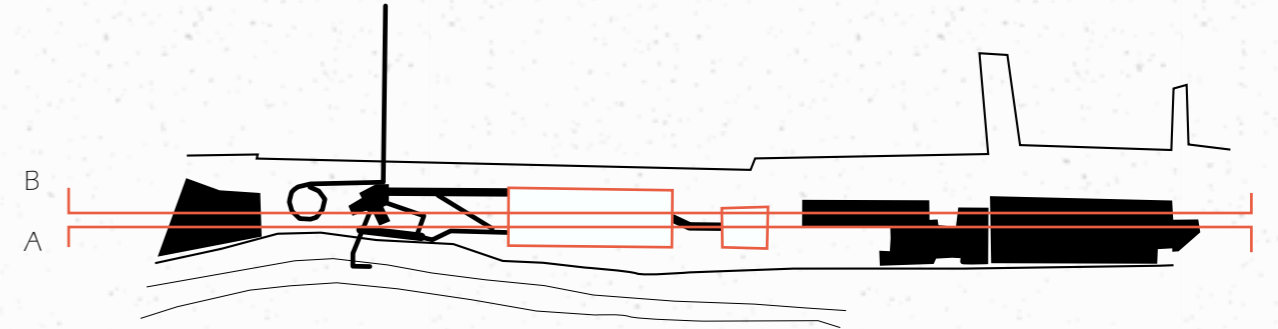

A. From the waterside

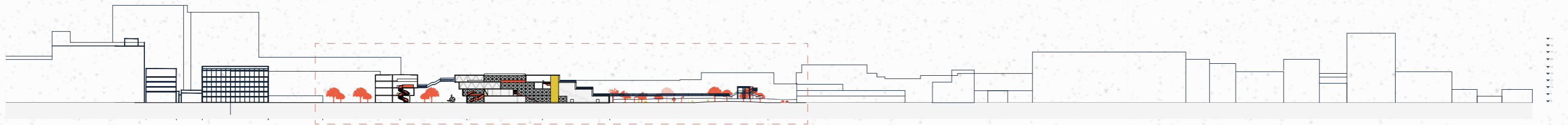

B. From the Briesselaan

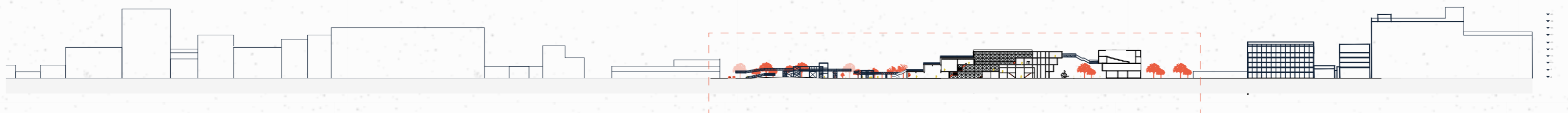

SITE SECTIONS

Zoomed to location

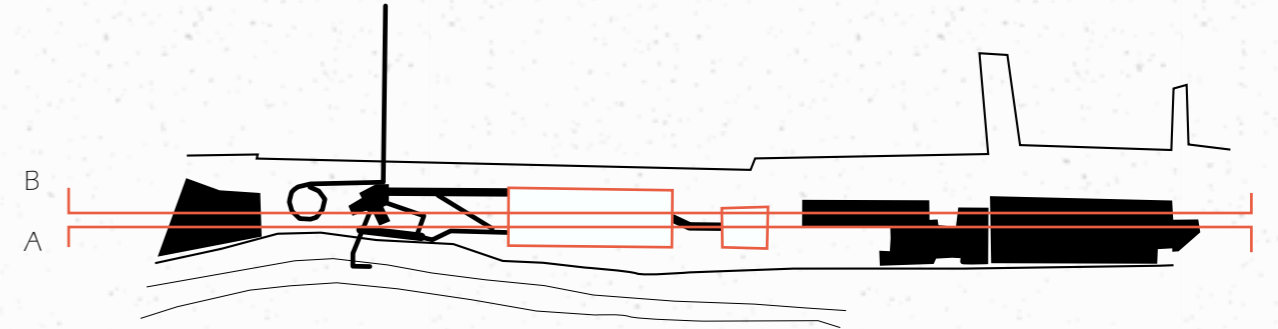

From the waterside

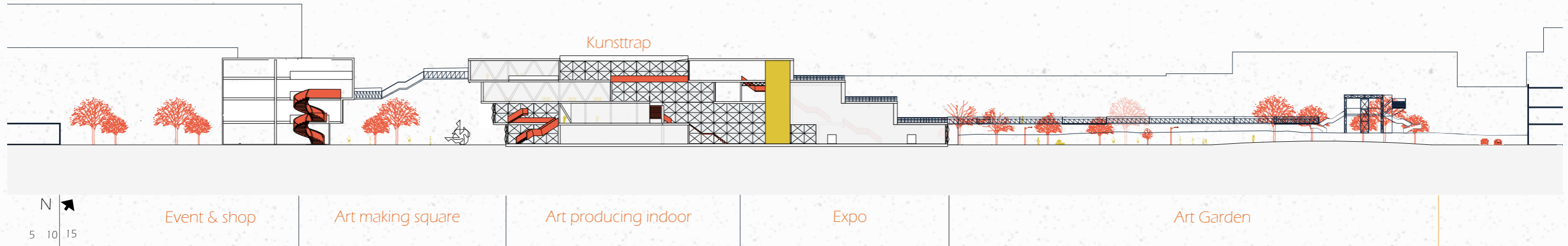

From the Briesselaan

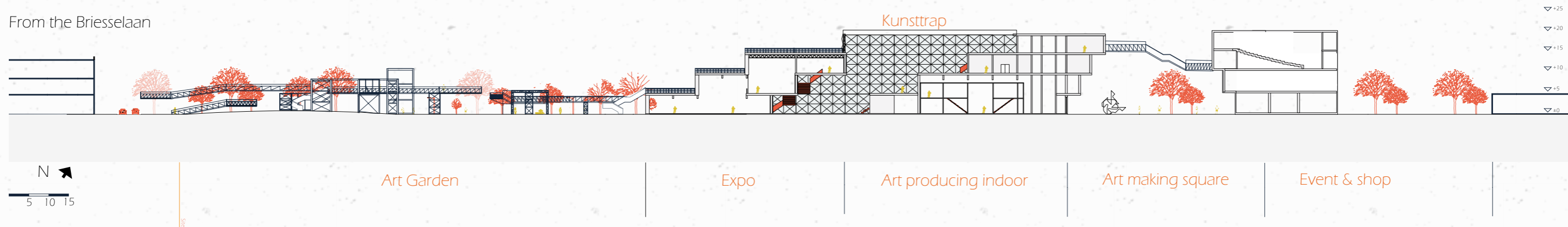

SITE SECTIONS

Zoomed to location

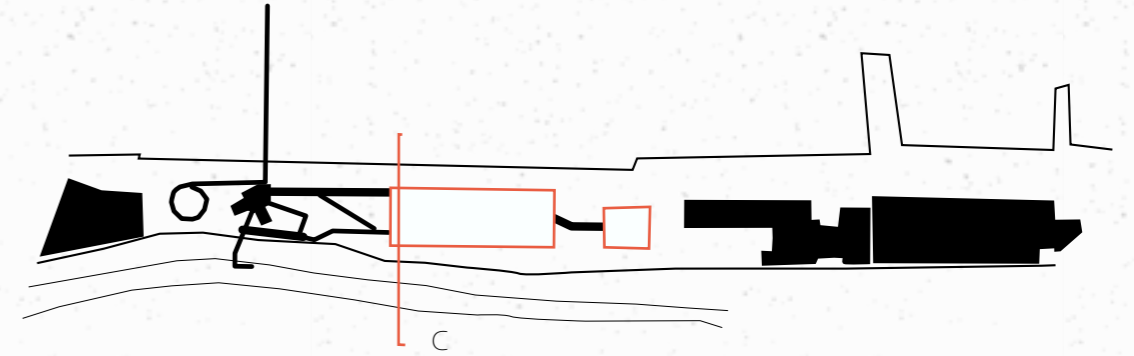

From the east side



THE BUILDING

From the site to the inside

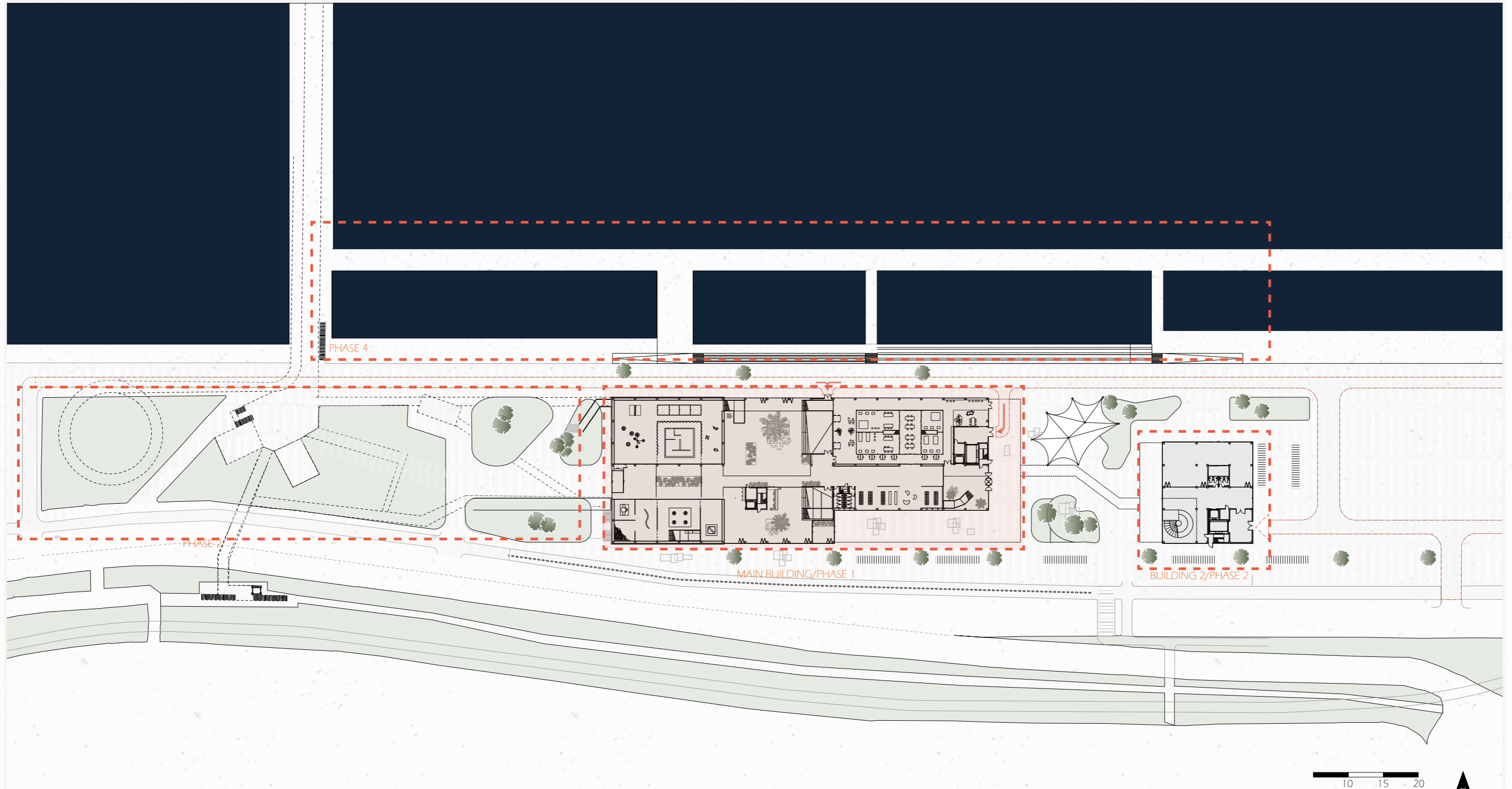

GOALL
PARTICIPATORY ART
THE DESIGN CONCEPT
THE SITE
SITE SECTIONS
THE BUILDING
BUILDING ELEMENTS
CLIMATE
BUILDING IN DETAILS
ACTIVE MUSEUM OF ART

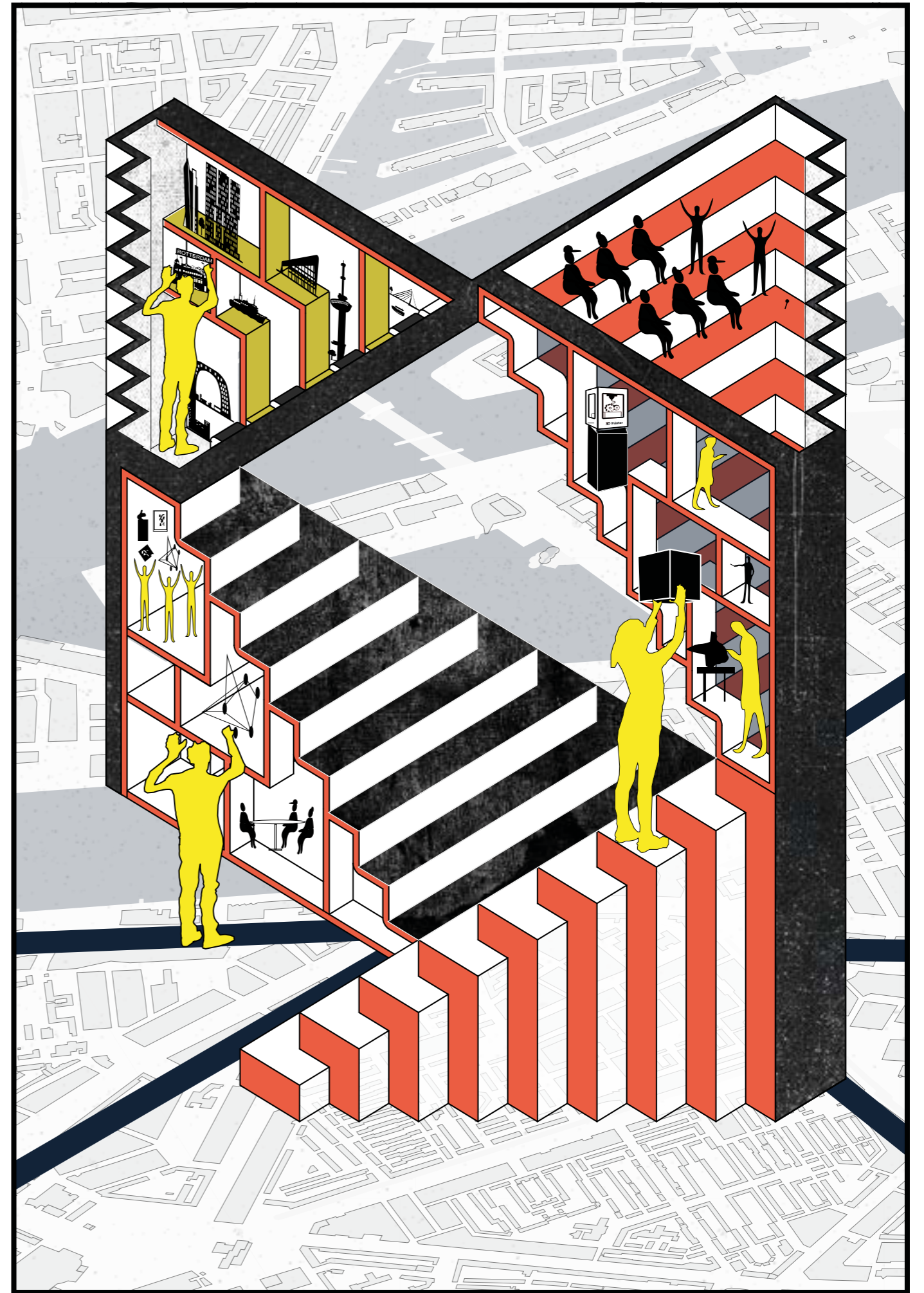

THE BUILDING

From concept to experience: life size cabinet the curiosity

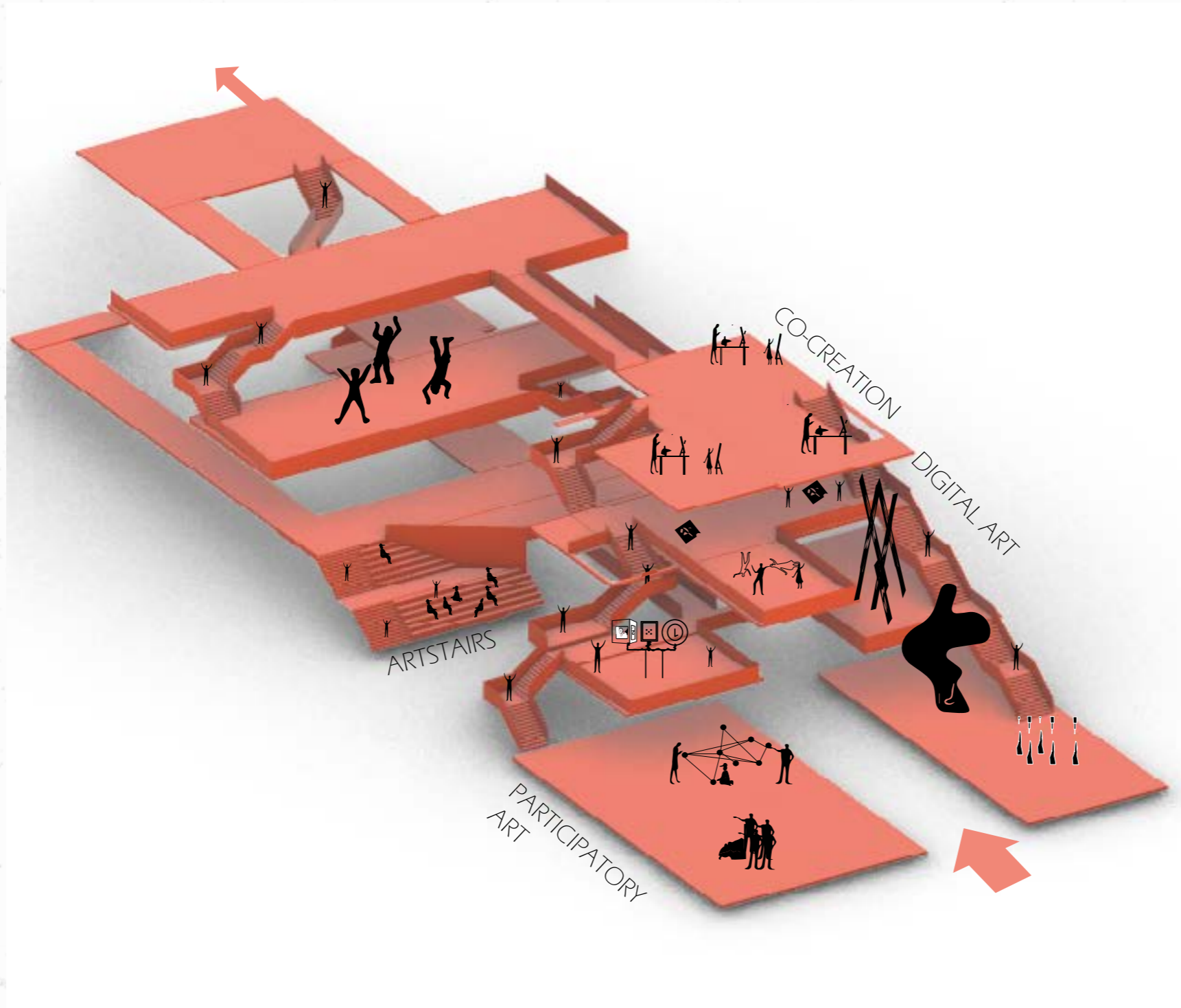

THE BUILDING

From concept to experience: Art display

Dark spaces

Light spaces

Level 3 Co-Create art

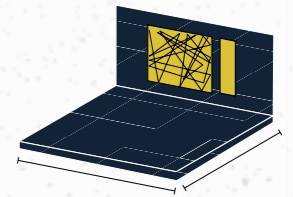
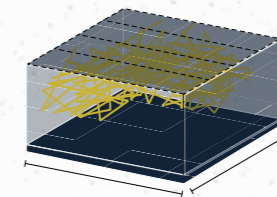
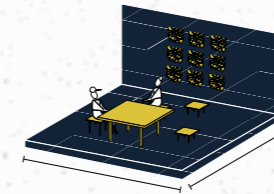
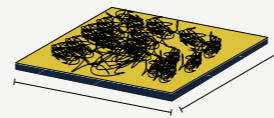

Level 2 Digital interactive Art

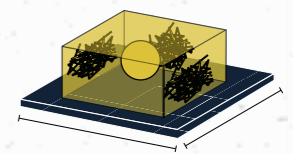
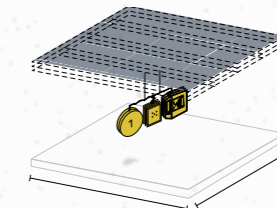
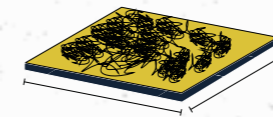
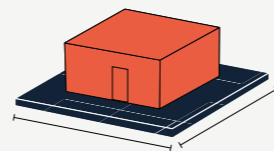
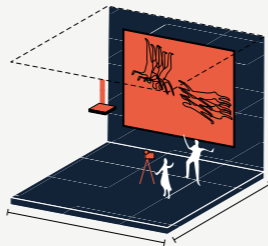
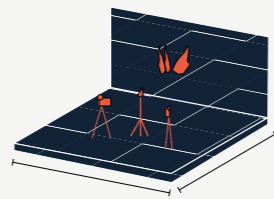

Level 1 interactive sculpture and installation art

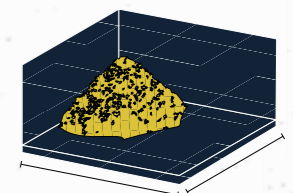
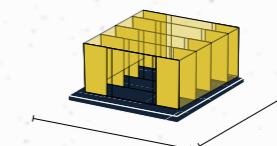
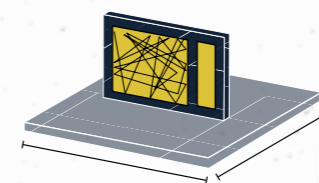
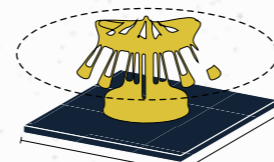
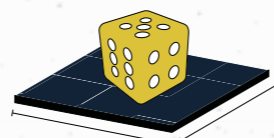
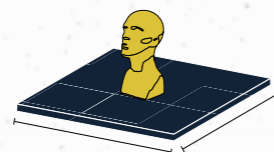

THE BUILDING

Program division

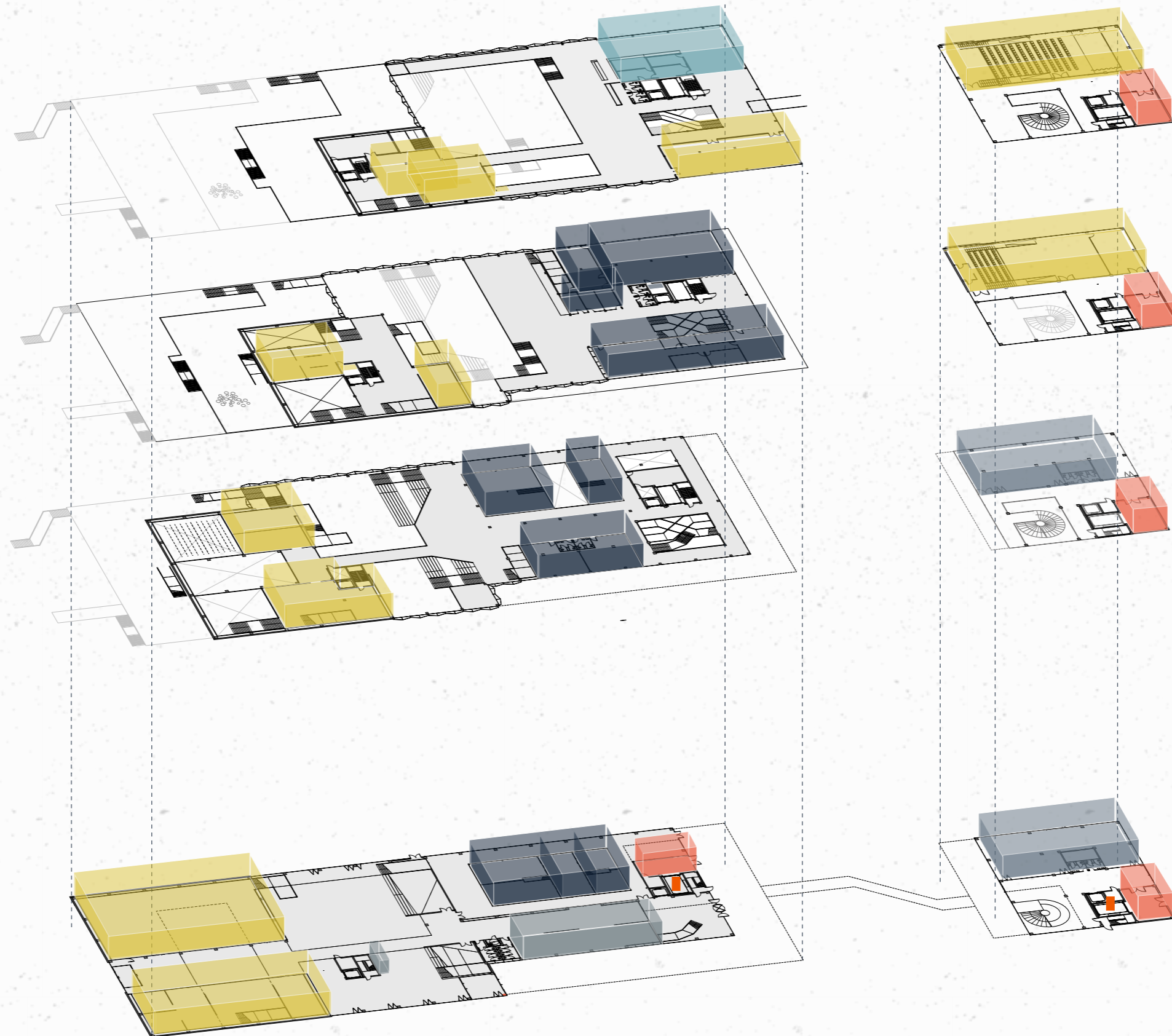

THE BUILDING

Art stairs/ neighbourhood gardening

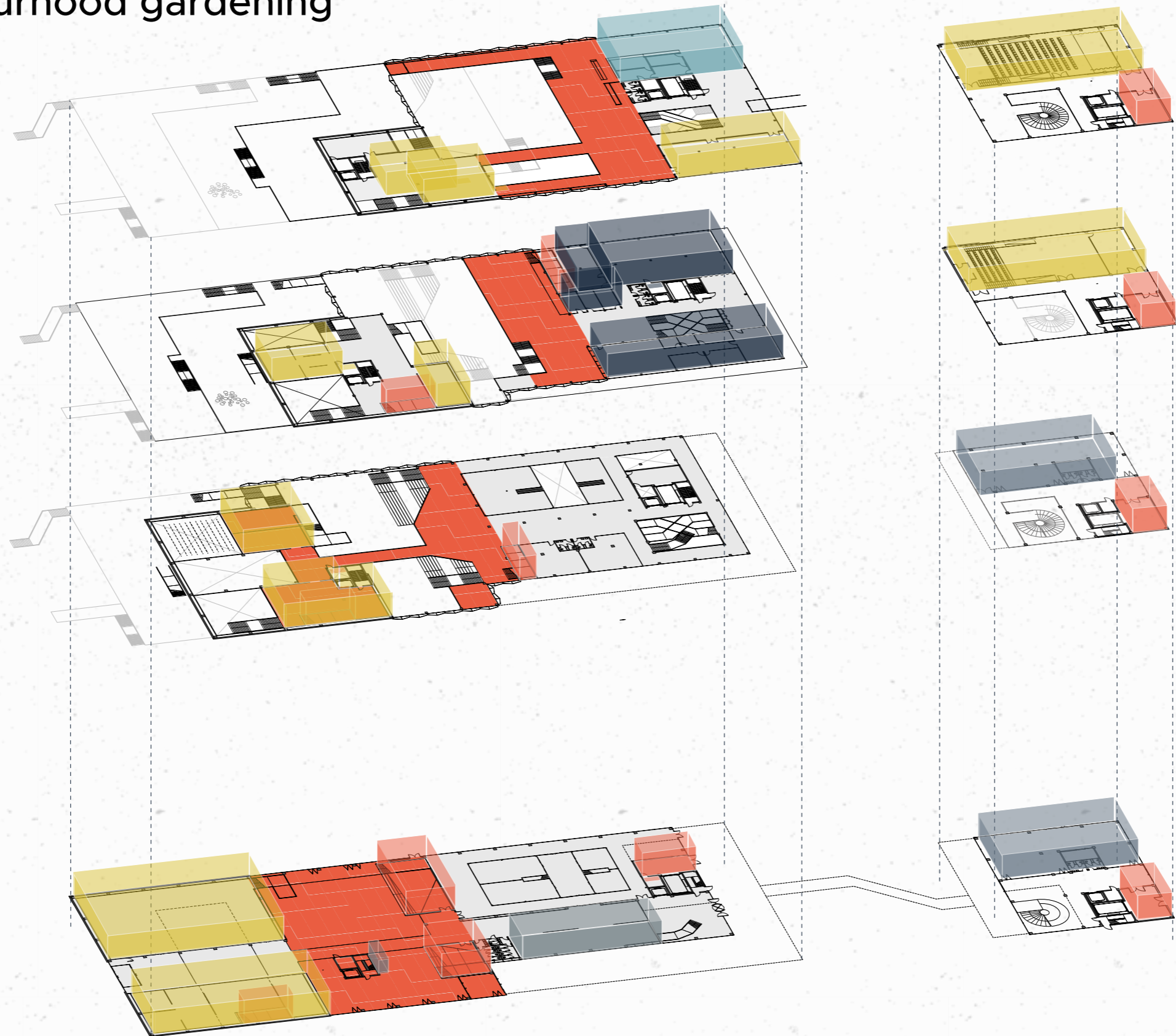

THE BUILDING

Not only participatory art also participatory green

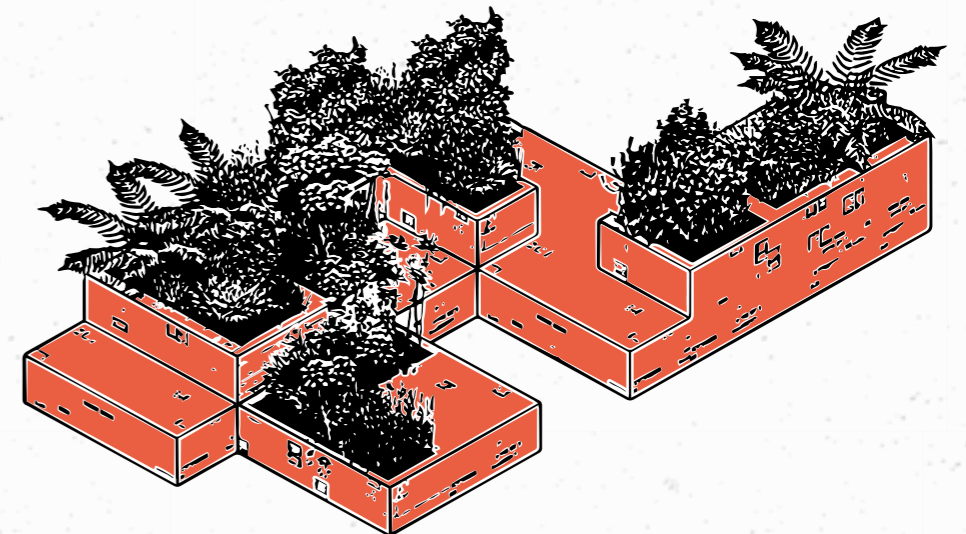
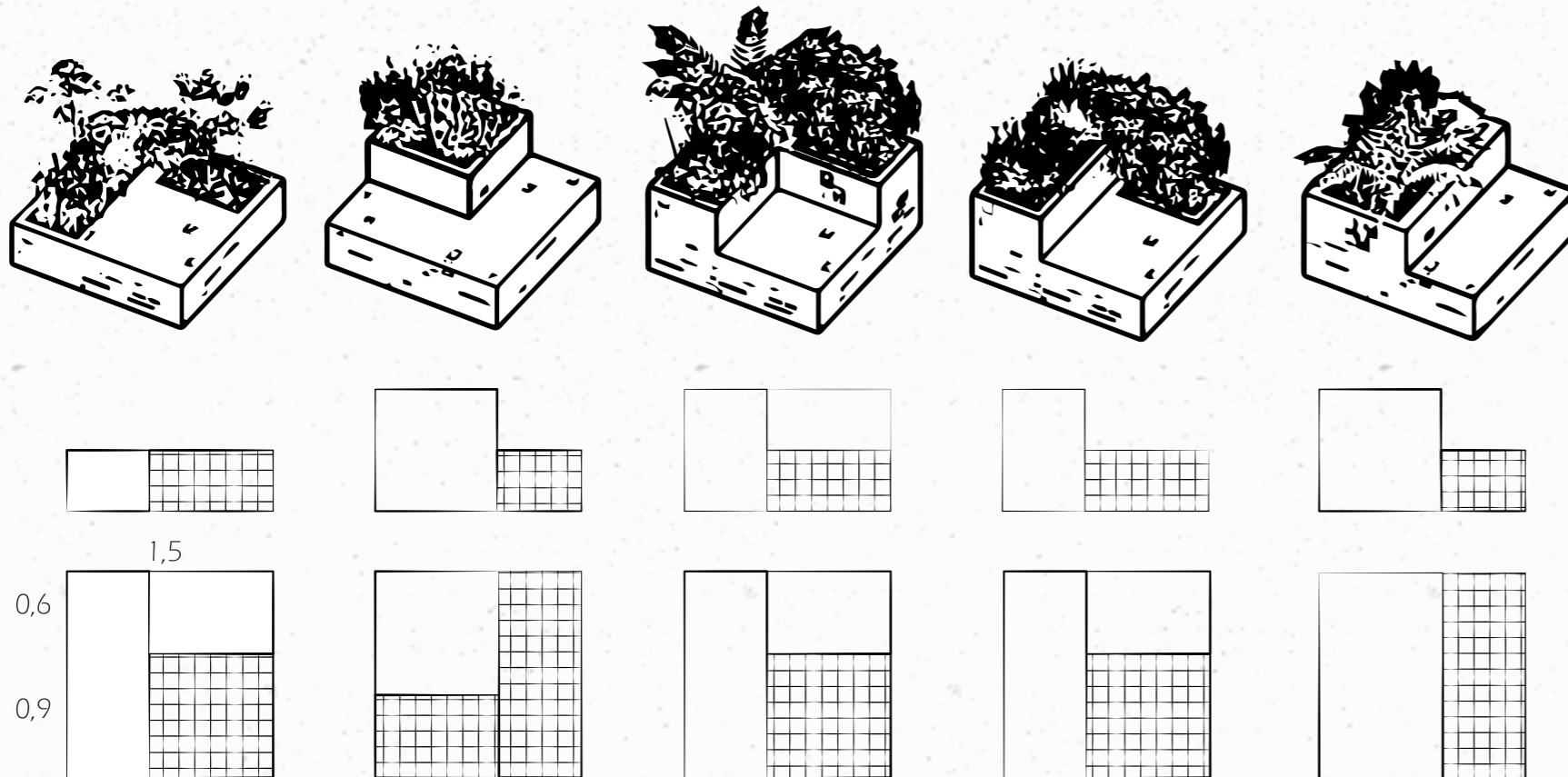
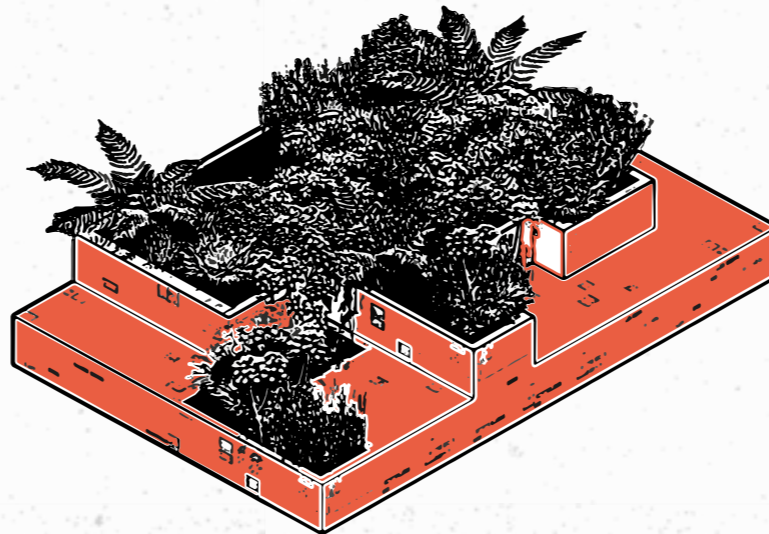

THE BUILDING

How to get art in the museum

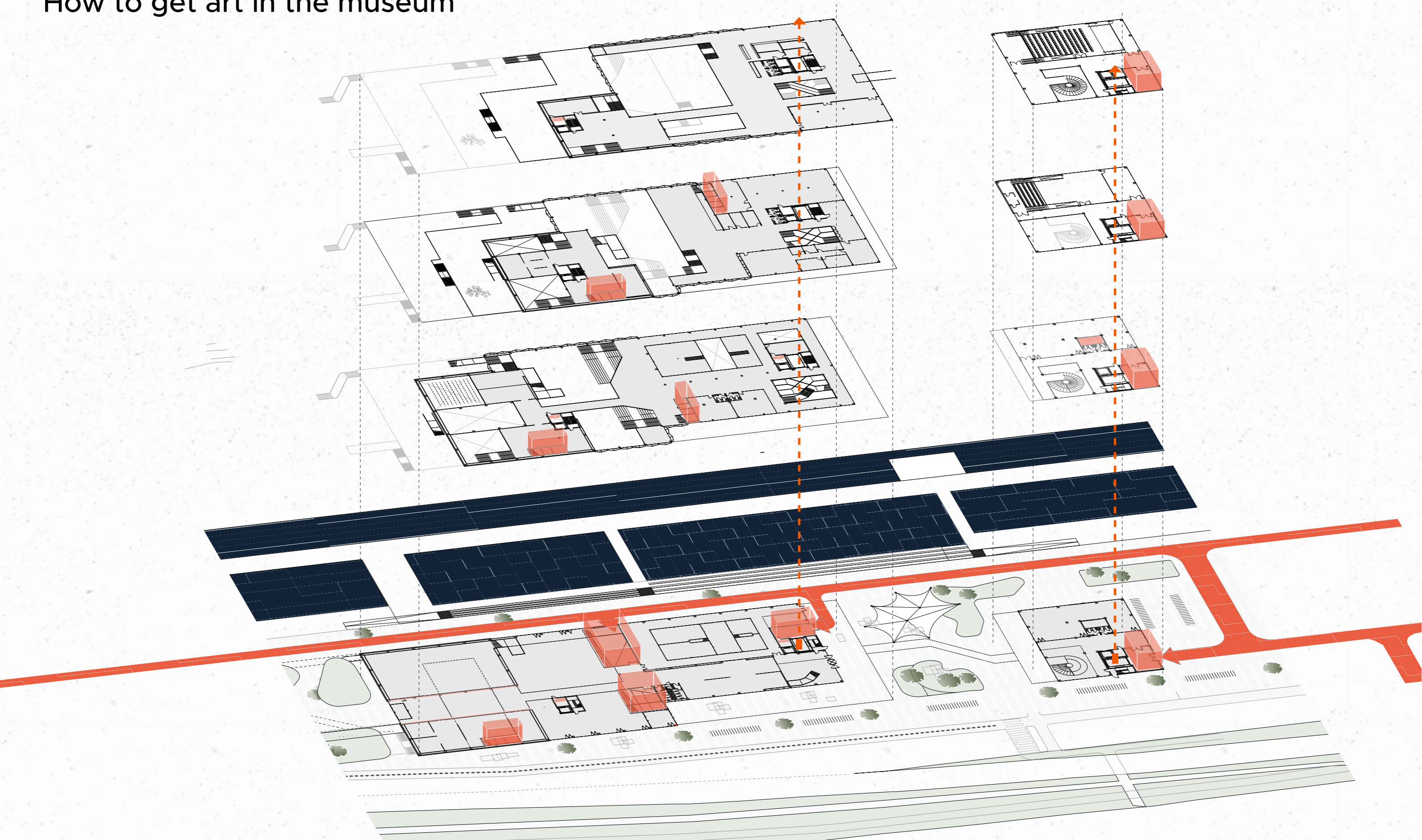

THE BUILDING

Experience routes

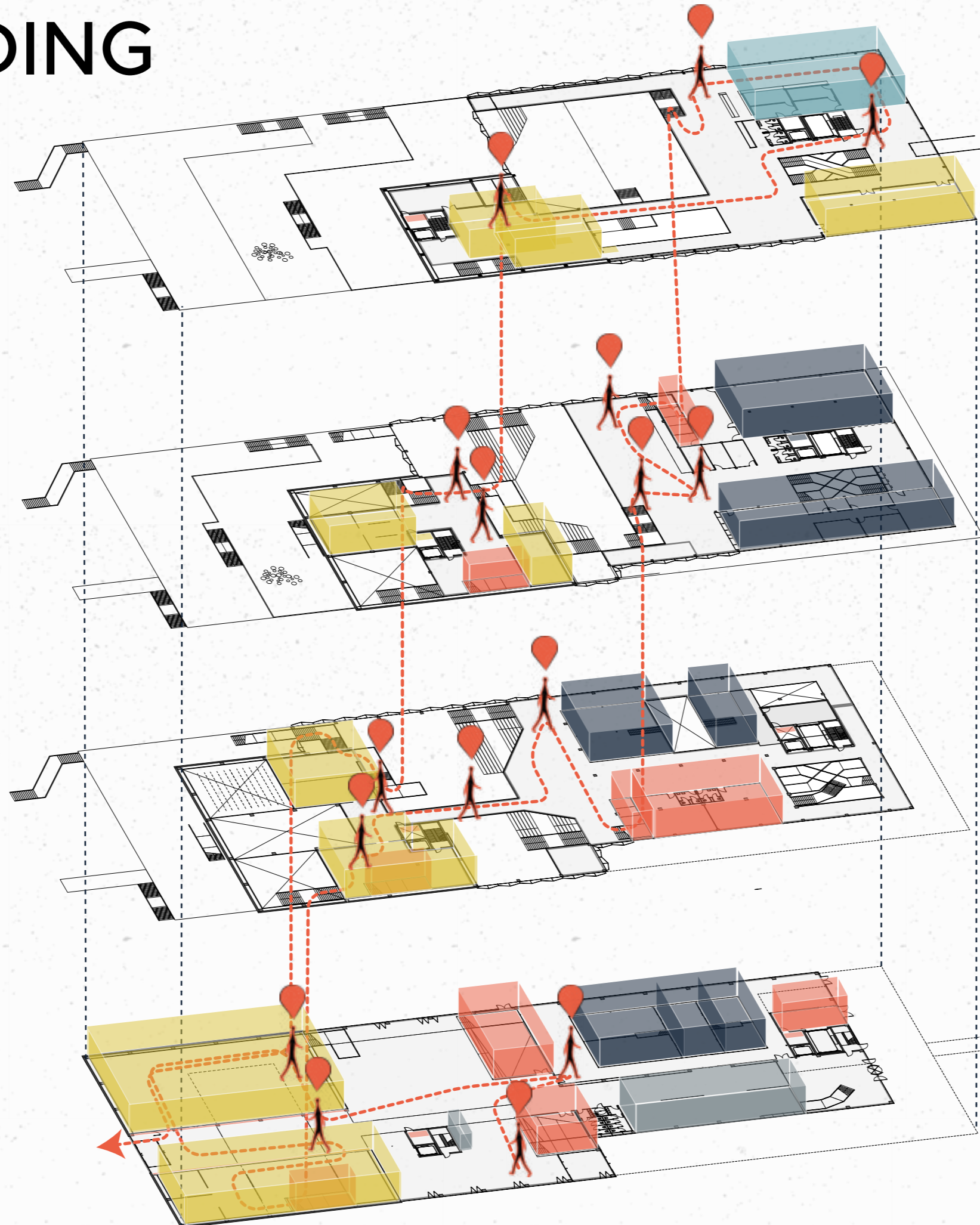

THE BUILDING

Floor plan: ground floor



THE BUILDING

Impression: Ticket area



THE BUILDING

Impression: Exhibition space



THE BUILDING

Impression: Exhibition space II



THE BUILDING

Impression: Makers lab



THE BUILDING

Floor plan: 1st floor

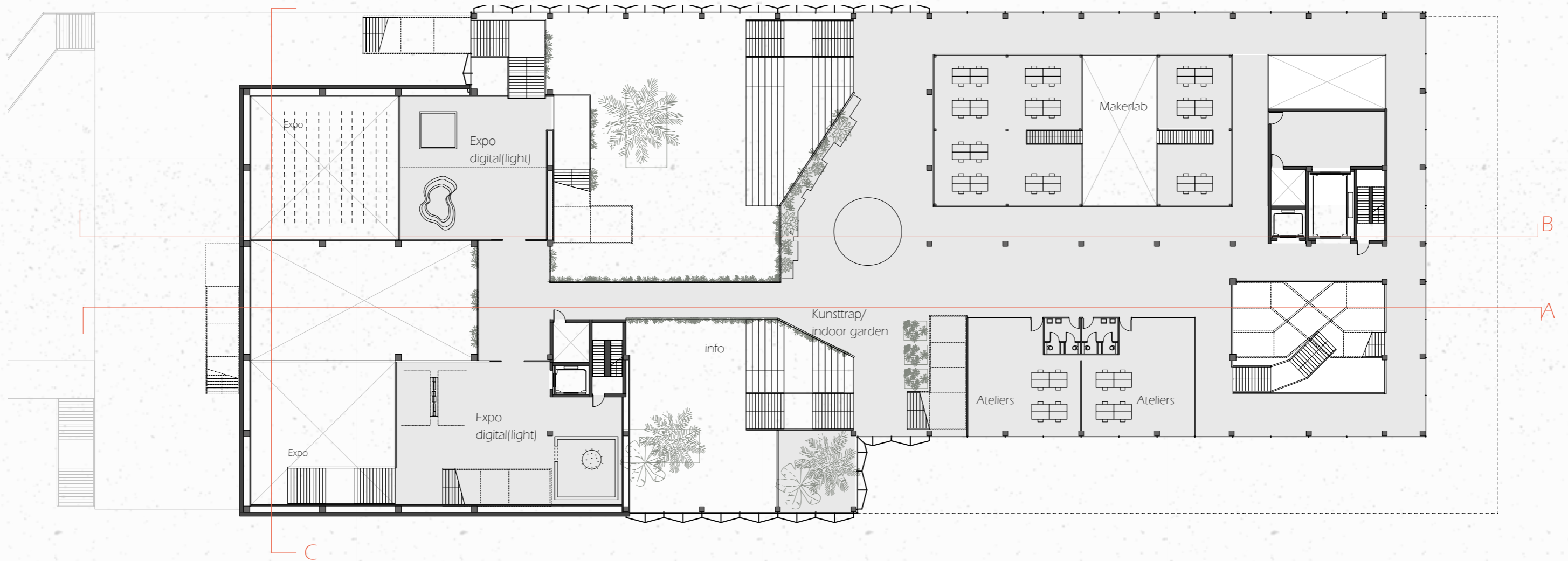

THE BUILDING

Impression: Exhibition space III



THE BUILDING

Impression: Makers lab



THE BUILDING

Impression: Transition space between digital exhibition spaces



THE BUILDING

Impression: Participatory art & Art stairs



THE BUILDING

Impression: Participatory garden & Green Long



THE BUILDING

Impression: Transition from 1st to 2nd floor

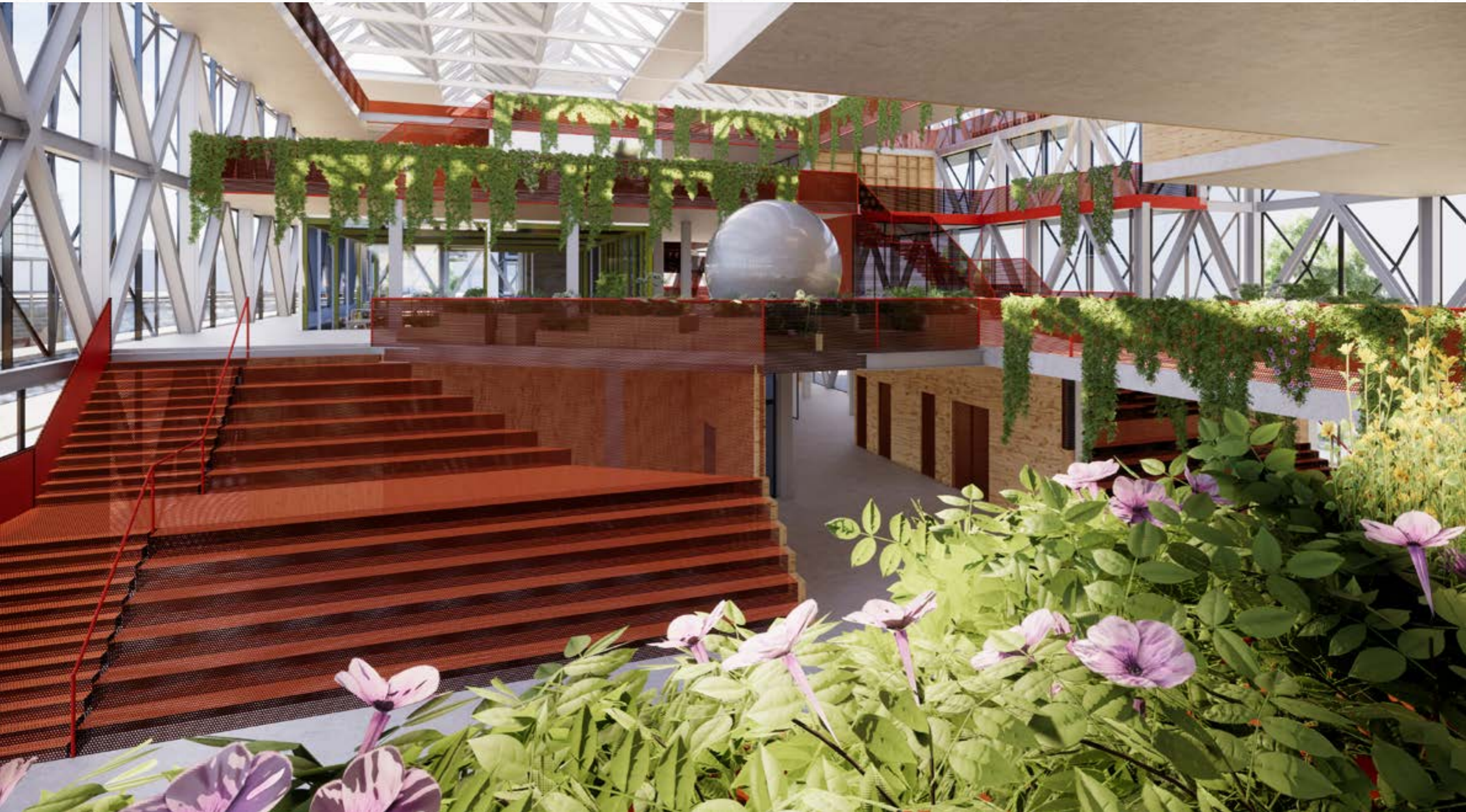

THE BUILDING

Floor plan: 2nd floor

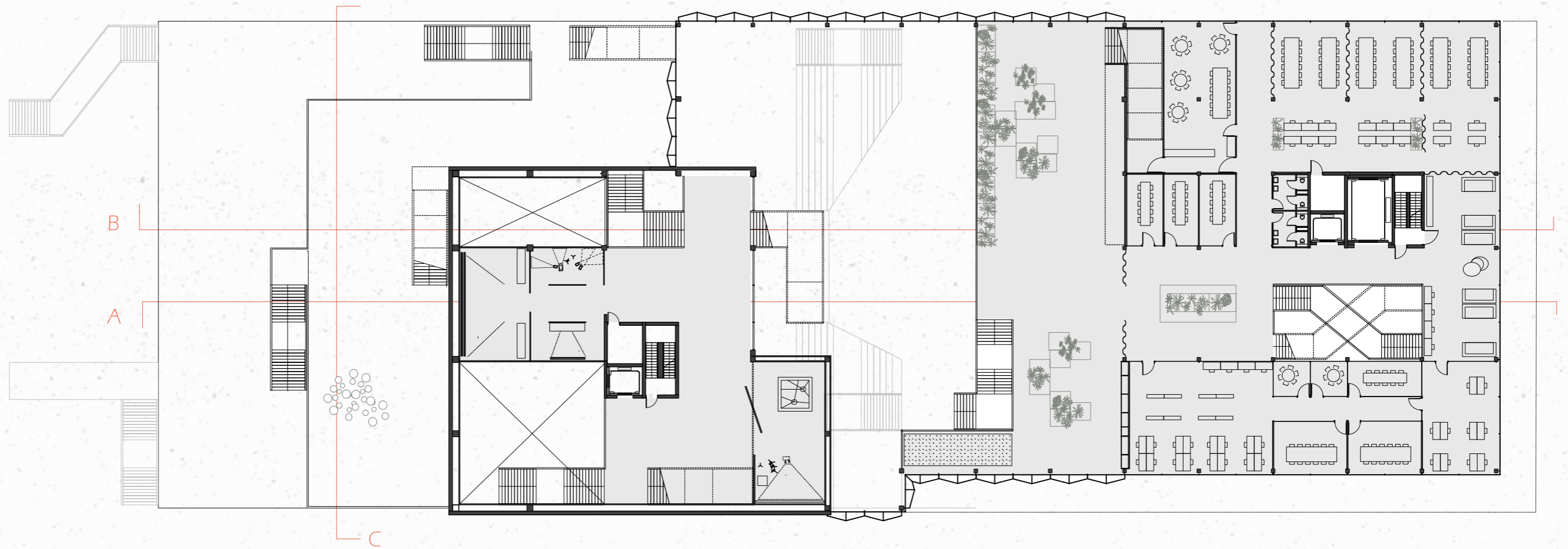

THE BUILDING

Impression: Digital dark exhibition space



THE BUILDING

Impression: Transition zone dark exhibition space



THE BUILDING

Impression: Transition zone (co-)offices



THE BUILDING

Floor plan: 3rd floor

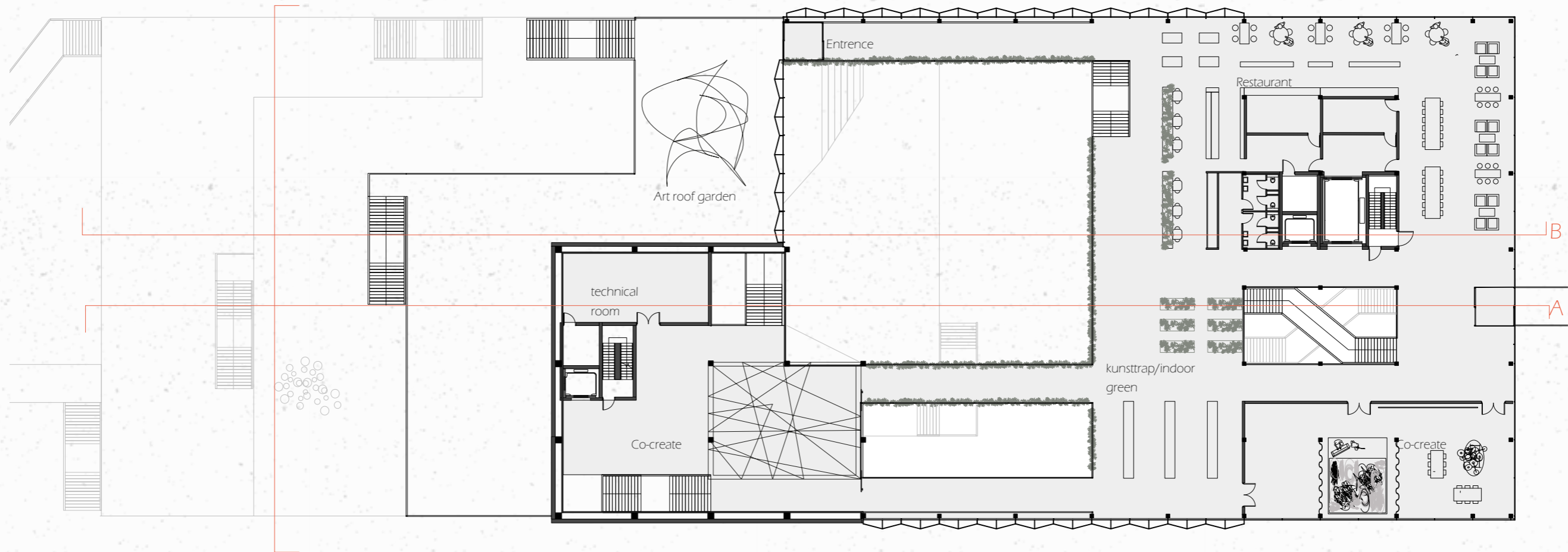

THE BUILDING

Impression: Co-creation



THE BUILDING

Floor plan: Building II

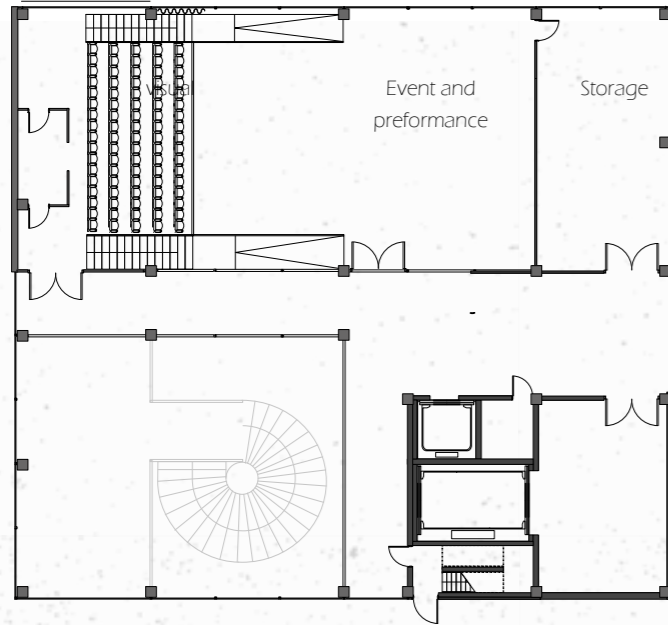

THIRD FLOOR

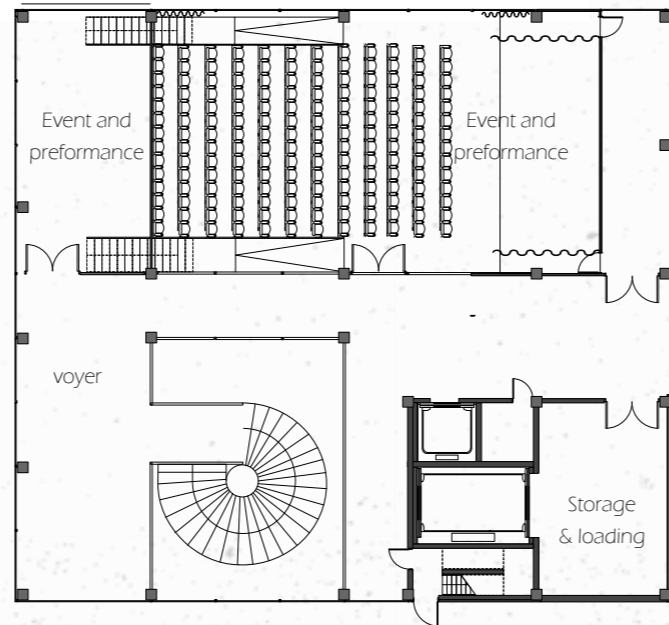

SECOND FLOOR

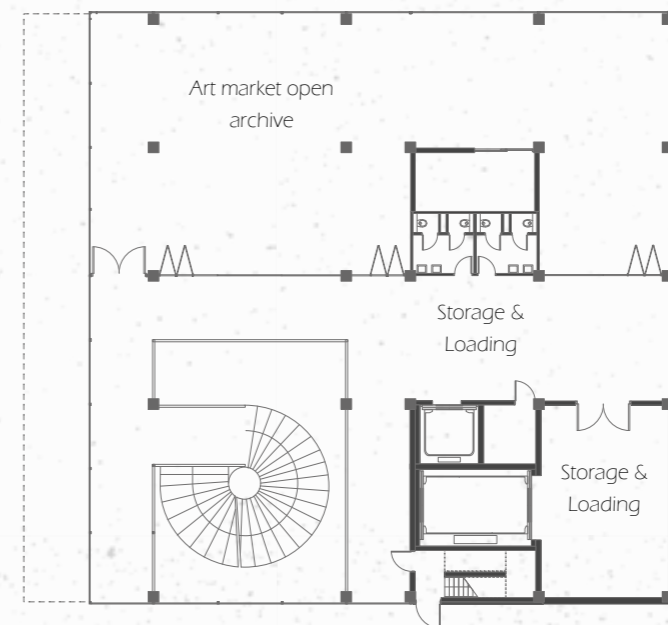

FIRST FLOOR

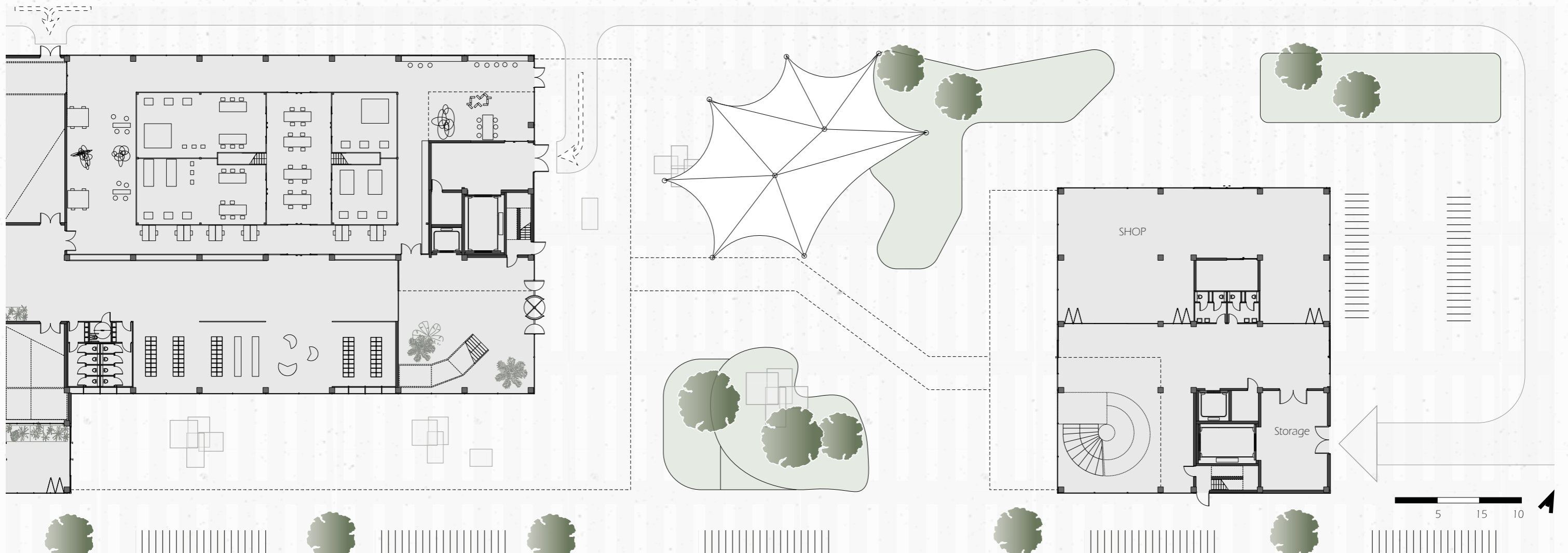

THE BUILDING

Impression: Building II



THE BUILDING

Section A

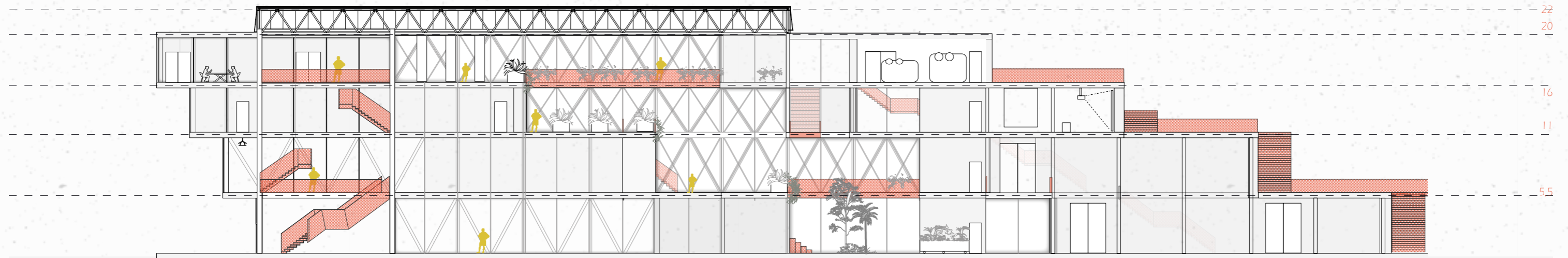
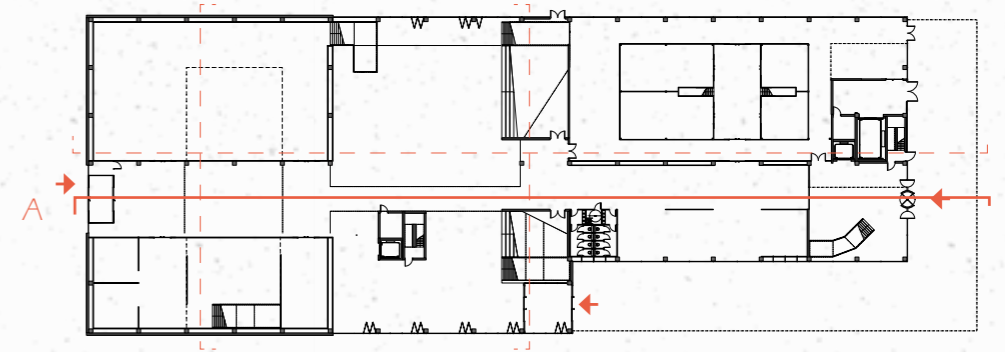

Section A

THE BUILDING

Section B

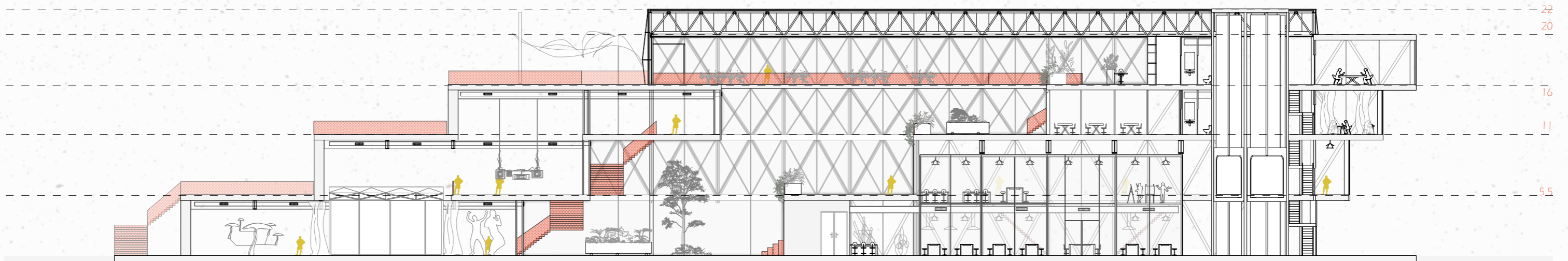
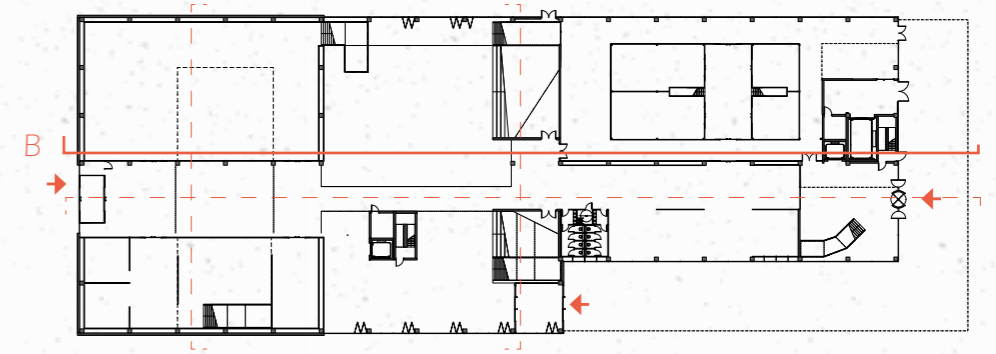

THE BUILDING

Section C

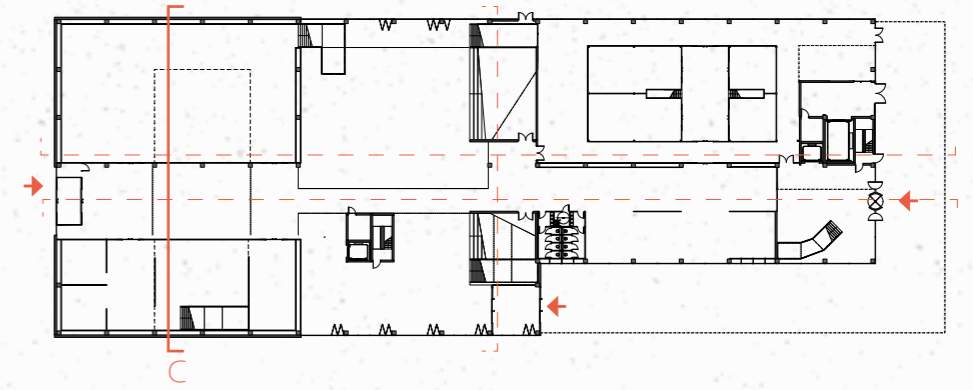

THE BUILDING

Section D

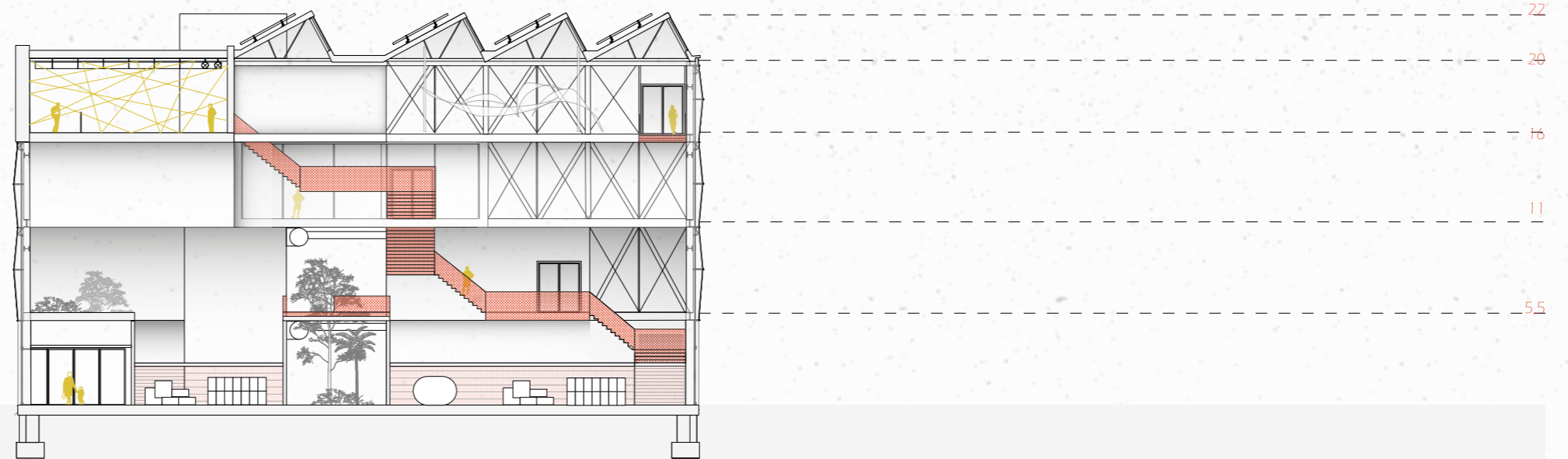
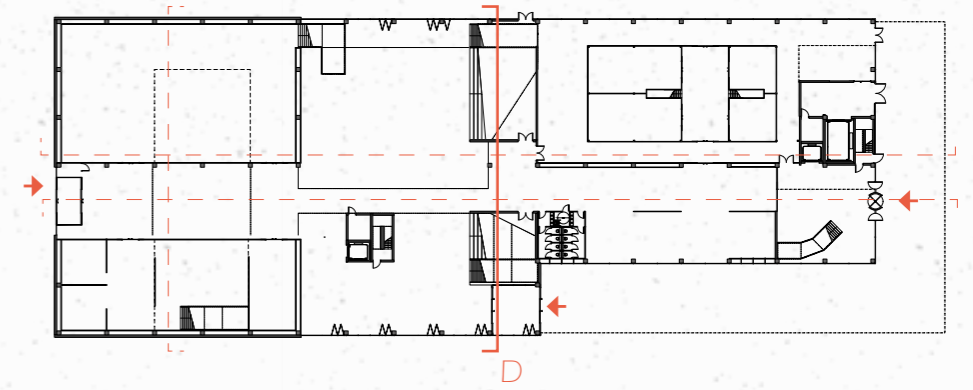

Section C

THE BUILDING

Elevation: West side



THE BUILDING

Elevation: South side

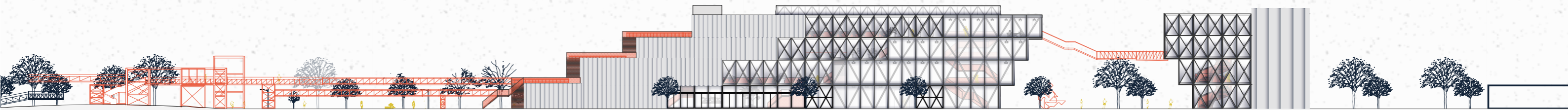

THE BUILDING

Elevation: South side

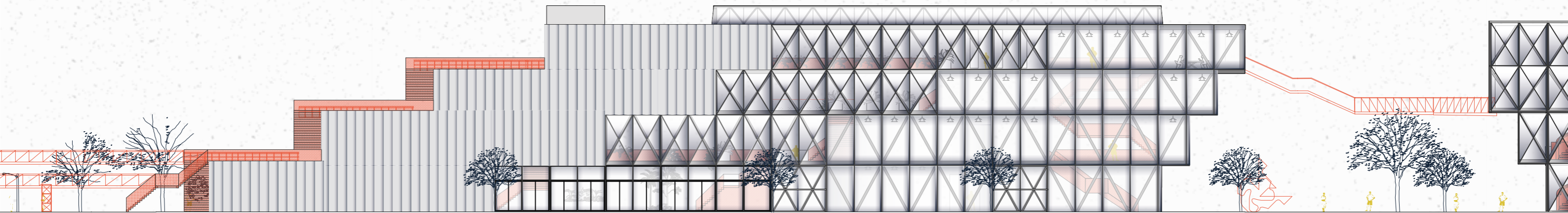

THE BUILDING

Elevation: North side

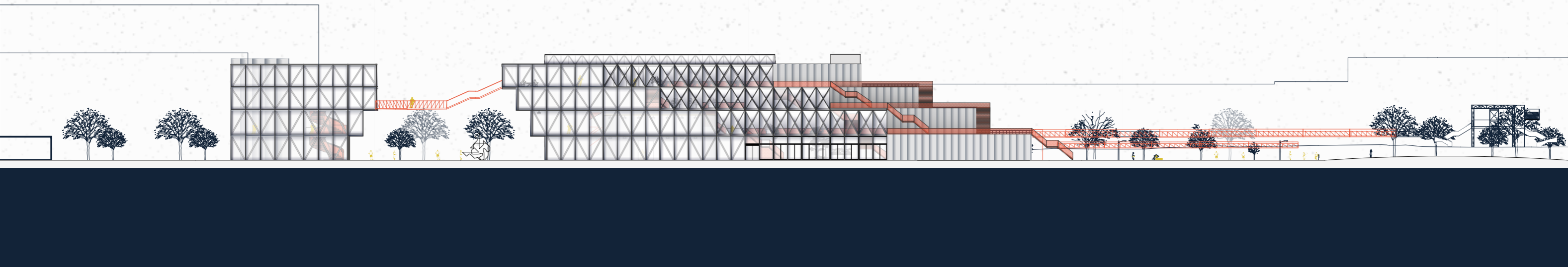

THE BUILDING

Elevation: North side

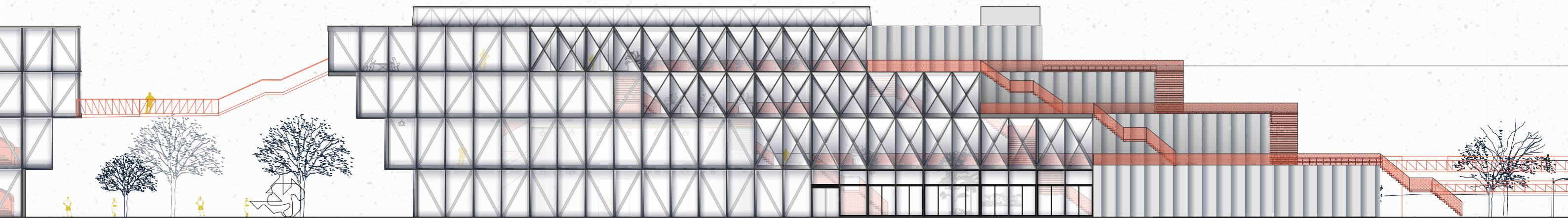

GOALL
PARTICIPATORY ART
THE DESIGN CONCEPT
THE SITE
SITE SECTIONS
THE BUILDING
BUILDING ELEMENTS
CLIMATE
BUILDING IN DETAILS
ACTIVE MUSEUM OF ART

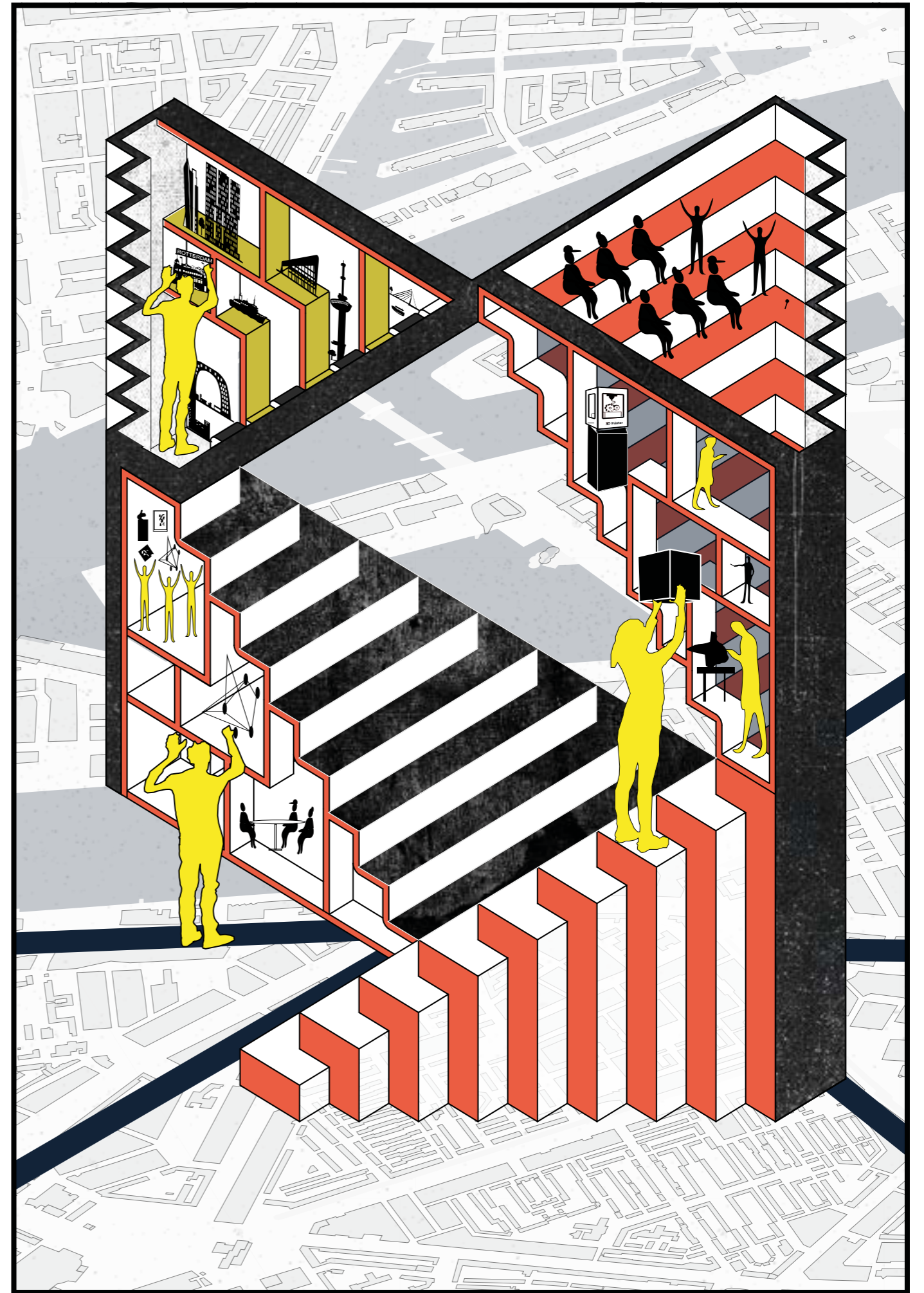

BUILDING ELEMENTS

Building materials



plywood wall covering



polished floor

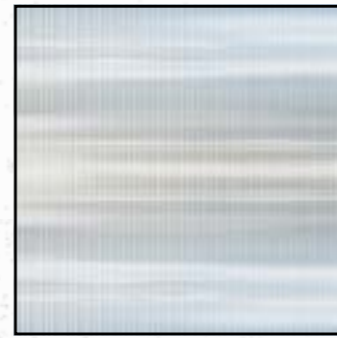

polycarbonaat single click system



polycarbonaat tubes



translusant insulation polycarbonaat danpal

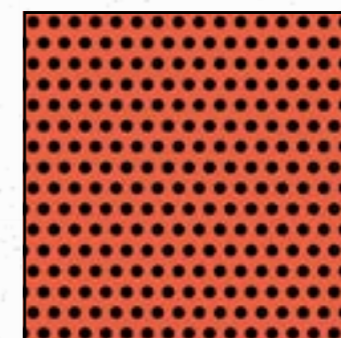

Prerforated steal

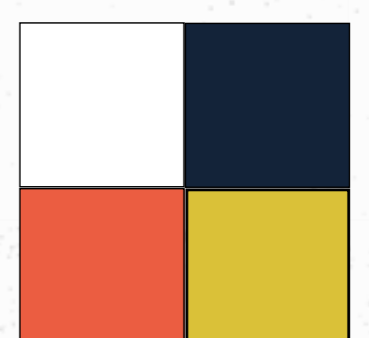

flexible wall paint

BUILDING ELEMENTS

Concept

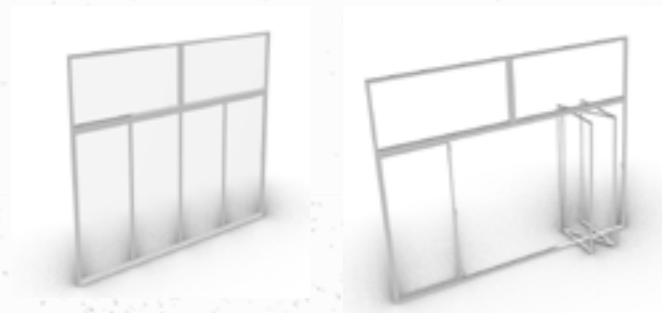

Folding doors ground floor kunsttrap

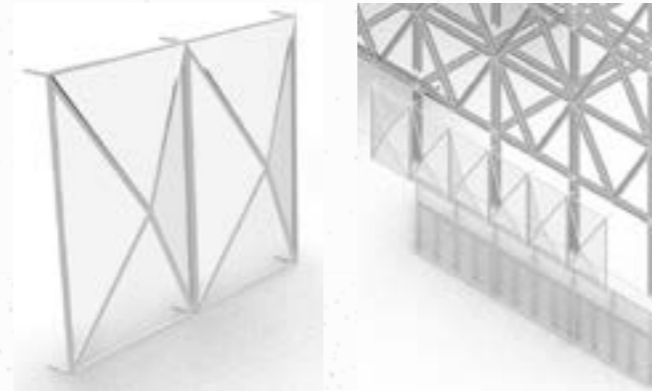

Expressive facade structure showing honest building and scale divergence in function



Coloured curtains for flexibility closed/open spaces, transparency and isolation



Translusant polycarbonaat and panels glass

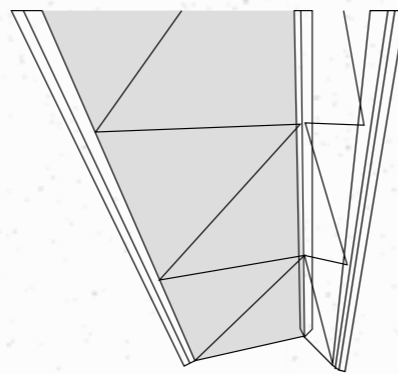

Shed roof reflect to industrial site and, natural light



BUILDING ELEMENTS

Structure

1. Diagrid structure in the facade and vierendeel beam to create stability and a flexible envelope

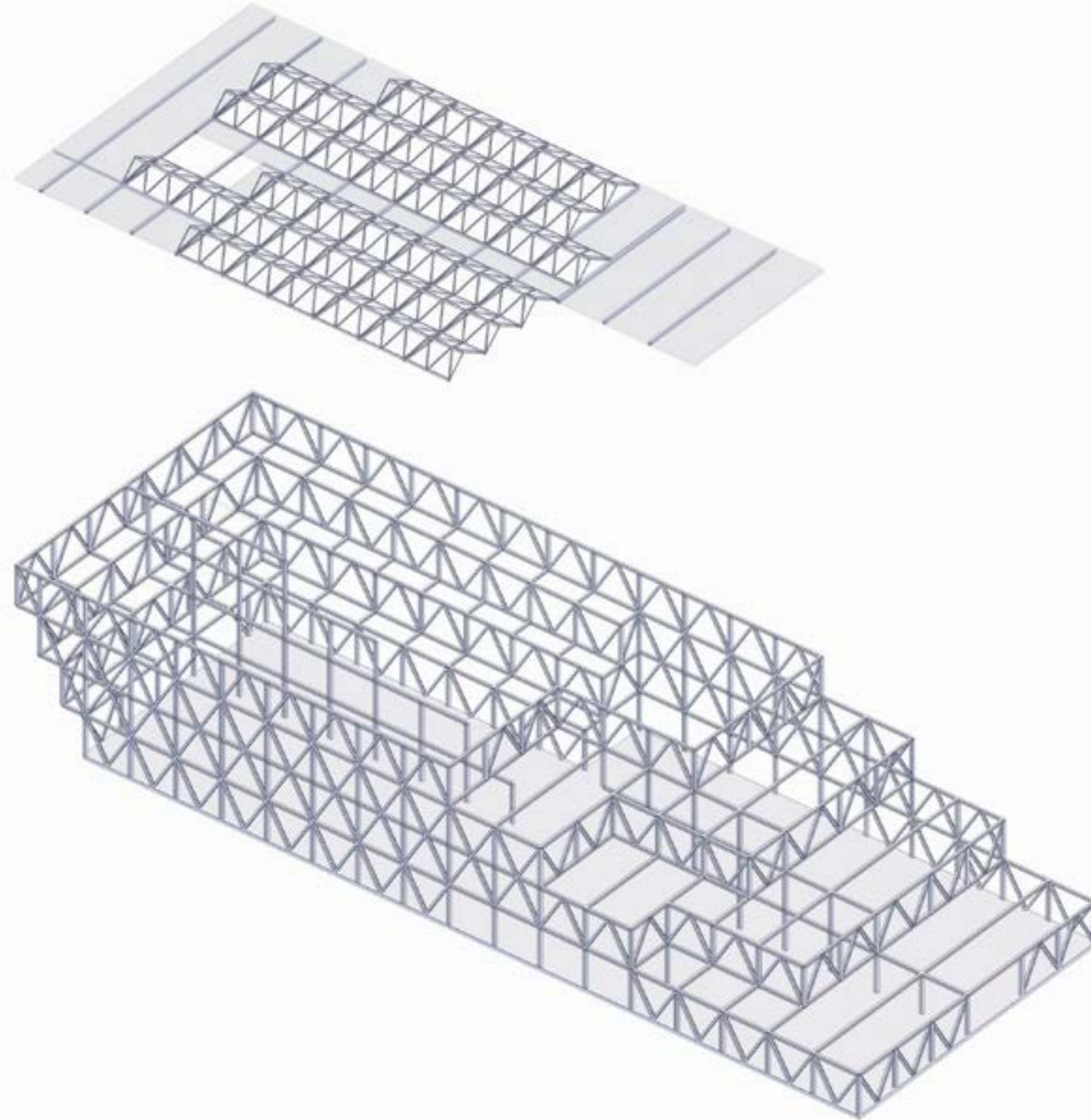

BUILDING ELEMENTS

Structure

2. Integrated flexible structure to hold platforms

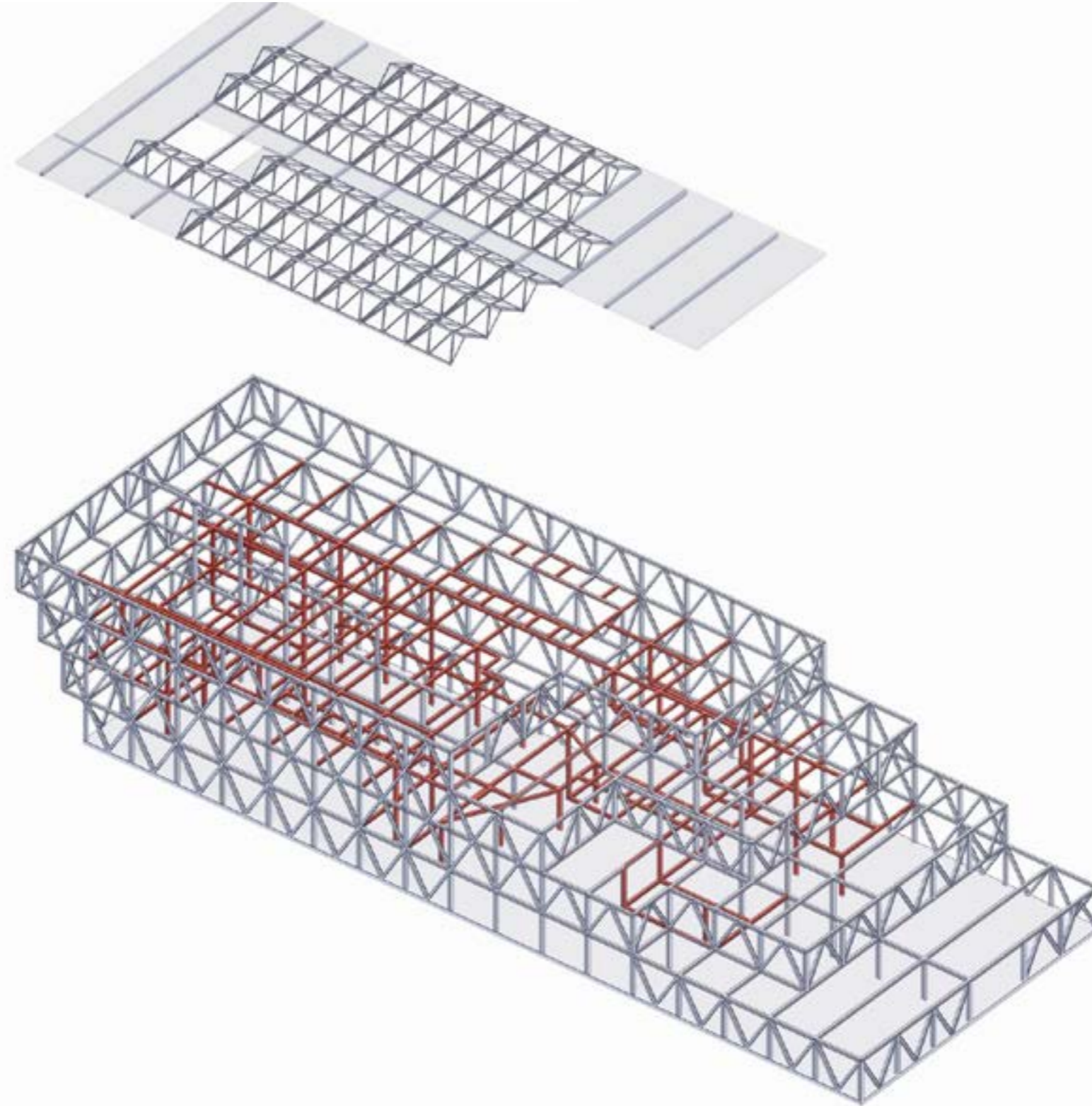

BUILDING ELEMENTS

4. Two cores

Structure

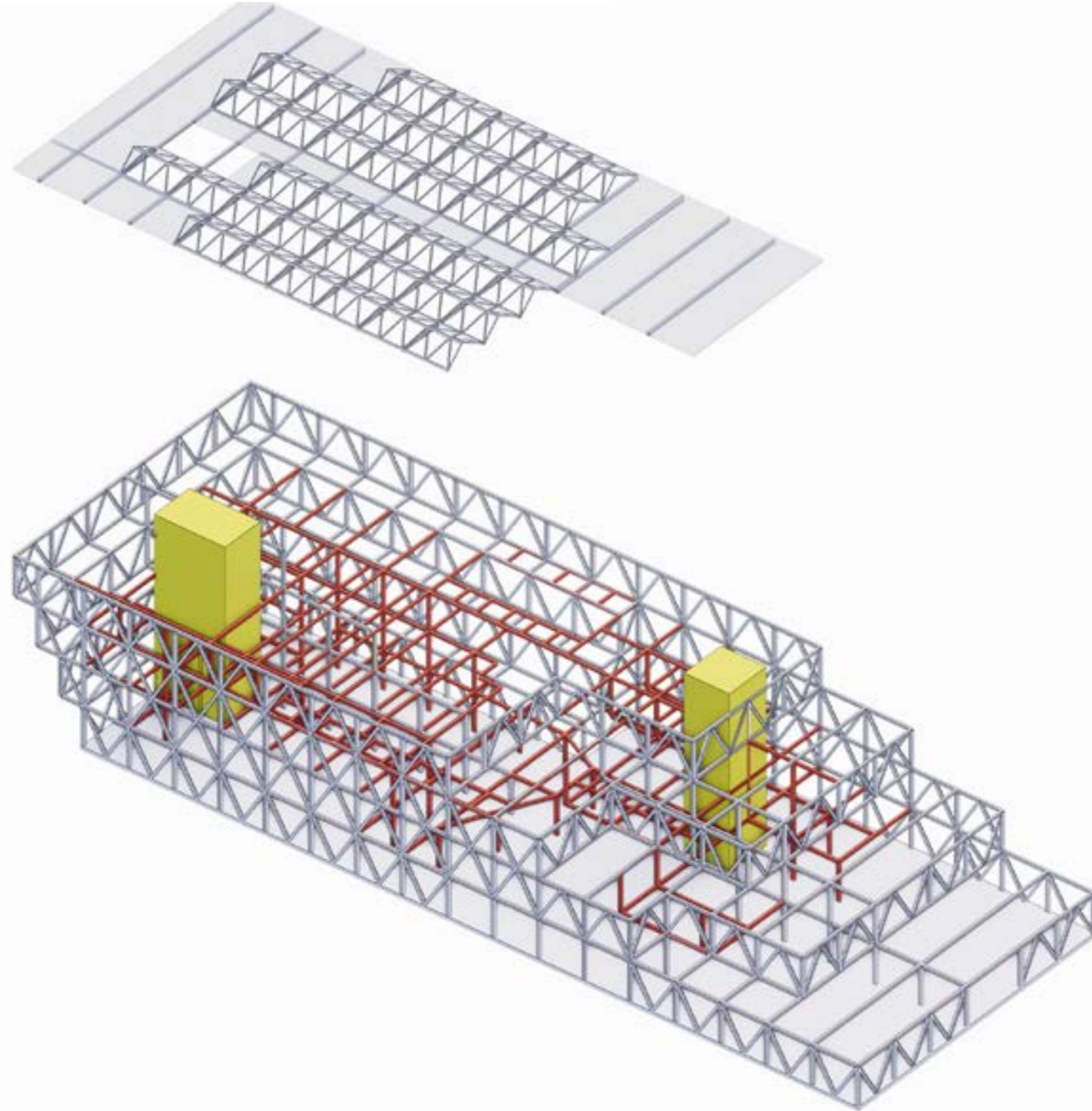

BUILDING ELEMENTS

Structure

3. Floors and art stairs are added to the platforms

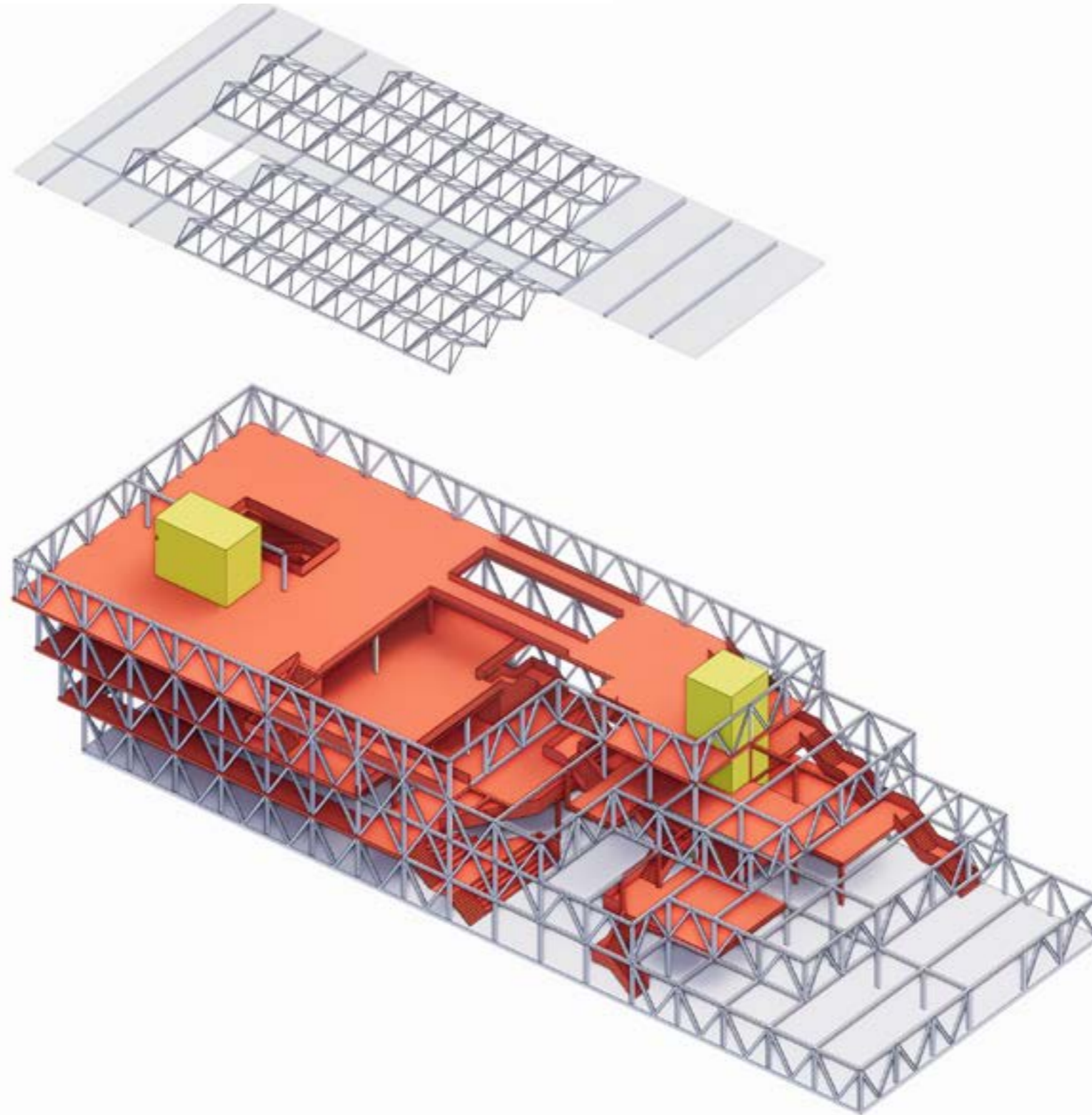

BUILDING ELEMENTS

Structure

5. Finalize the floors and art stairs to create a complete structure.

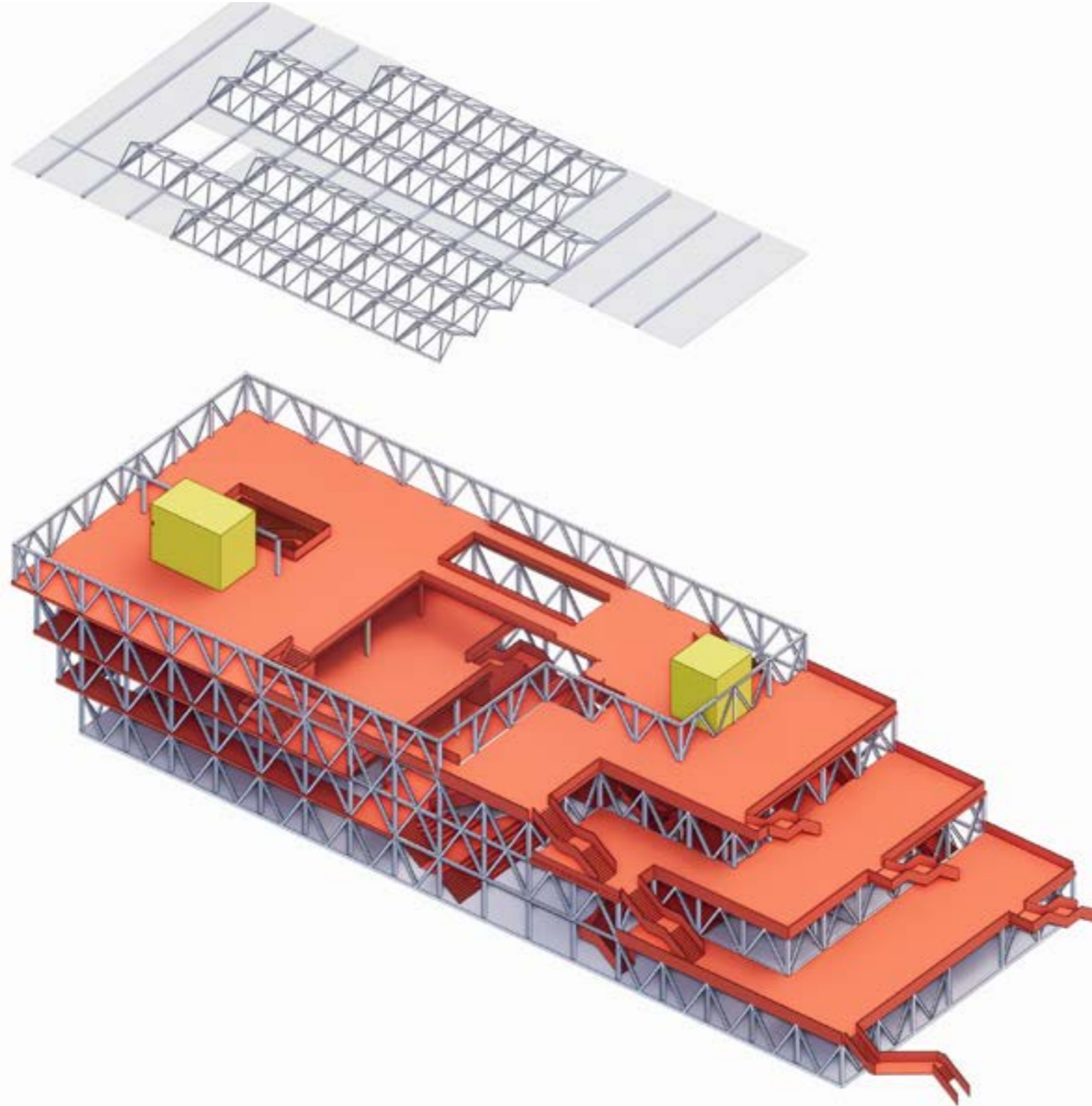

BUILDING ELEMENTS

Structure

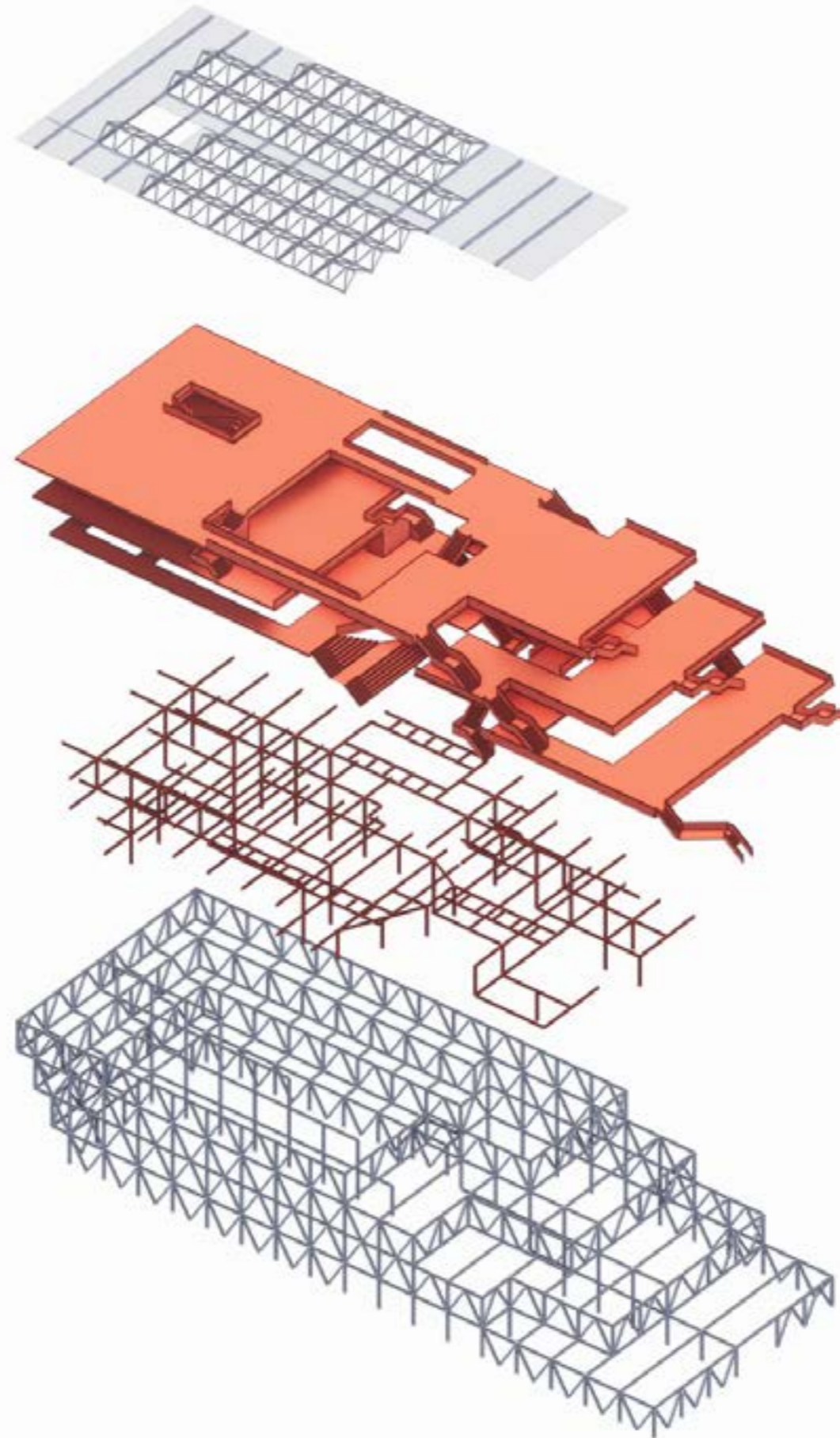

GOALL
PARTICIPATORY ART
THE DESIGN CONCEPT
THE SITE
SITE SECTIONS
THE BUILDING
BUILDING ELEMENTS
CLIMATE
BUILDING IN DETAILS
ACTIVE MUSEUM OF ART

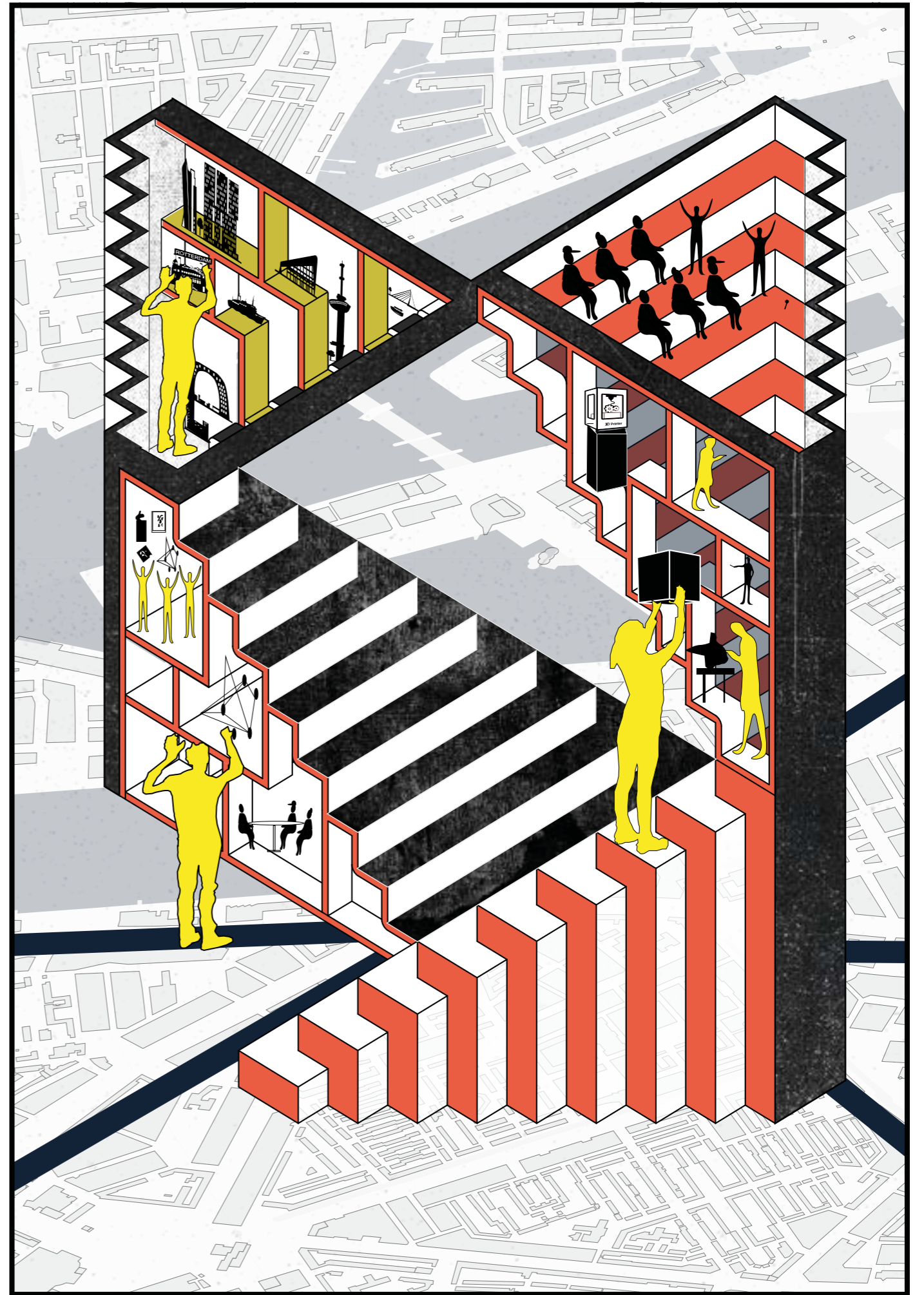

CLIMATE

Zones

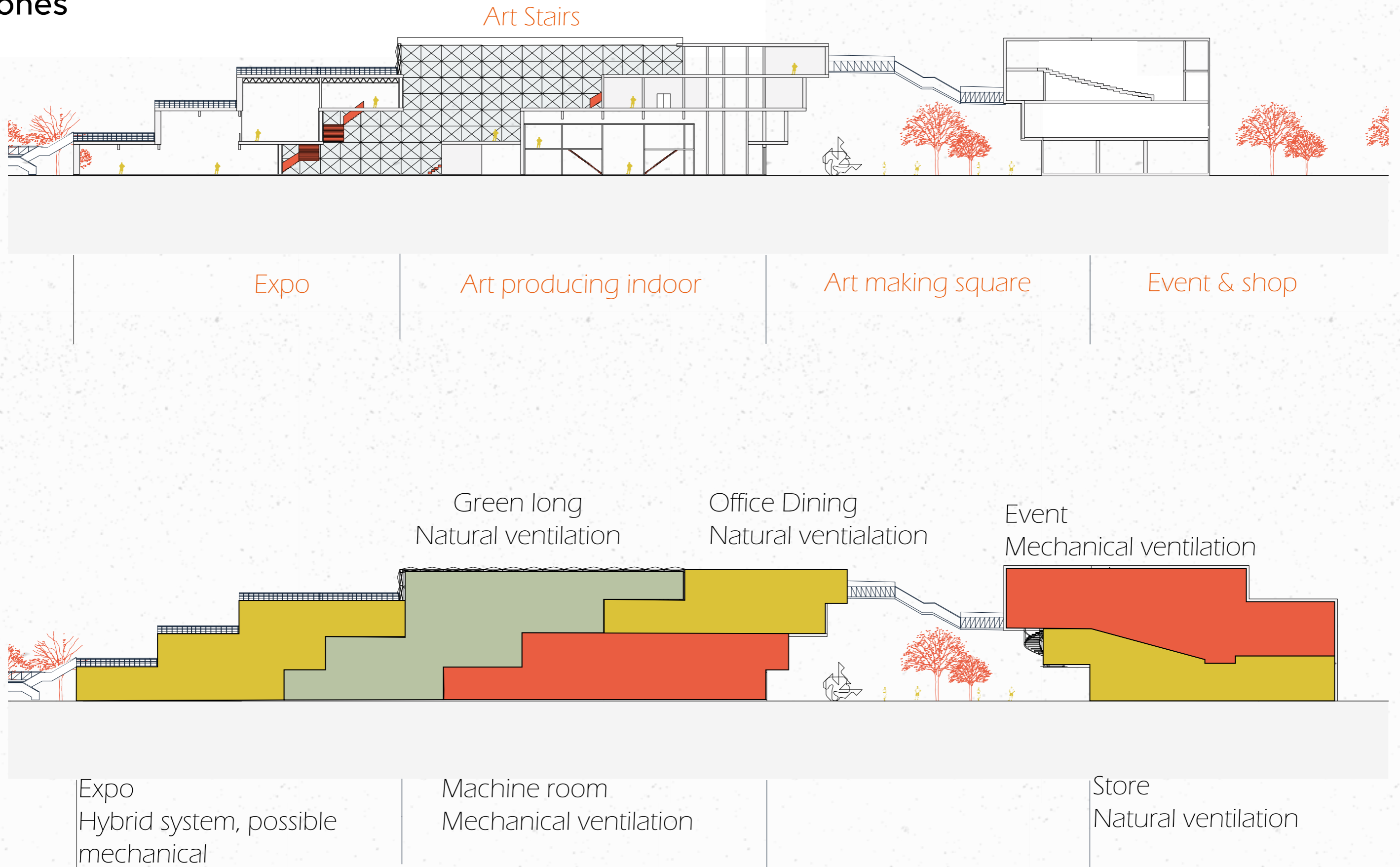

CLIMATE

Climate concept

winter

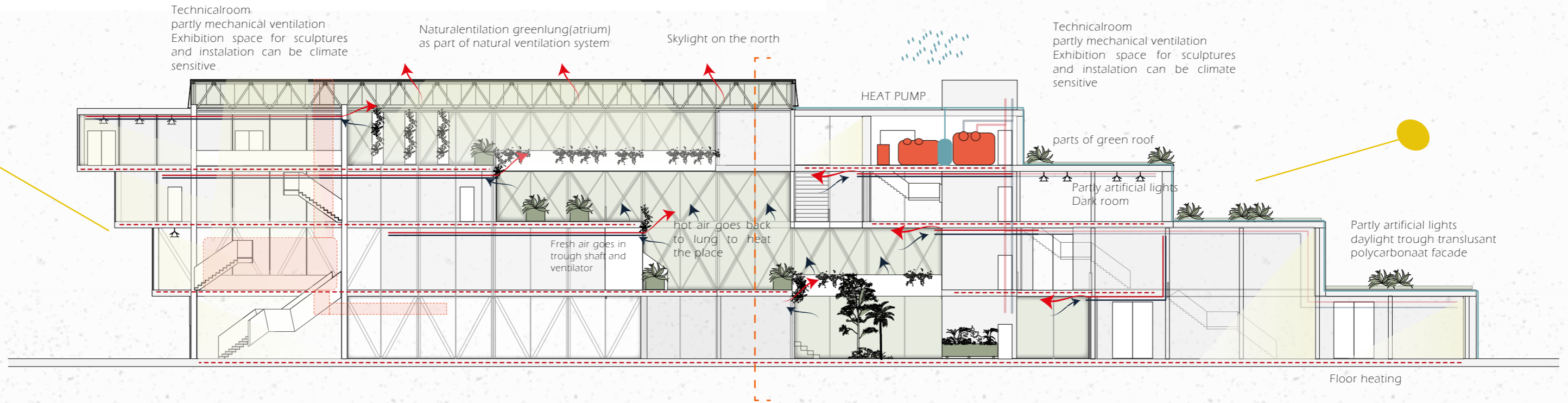

Summer

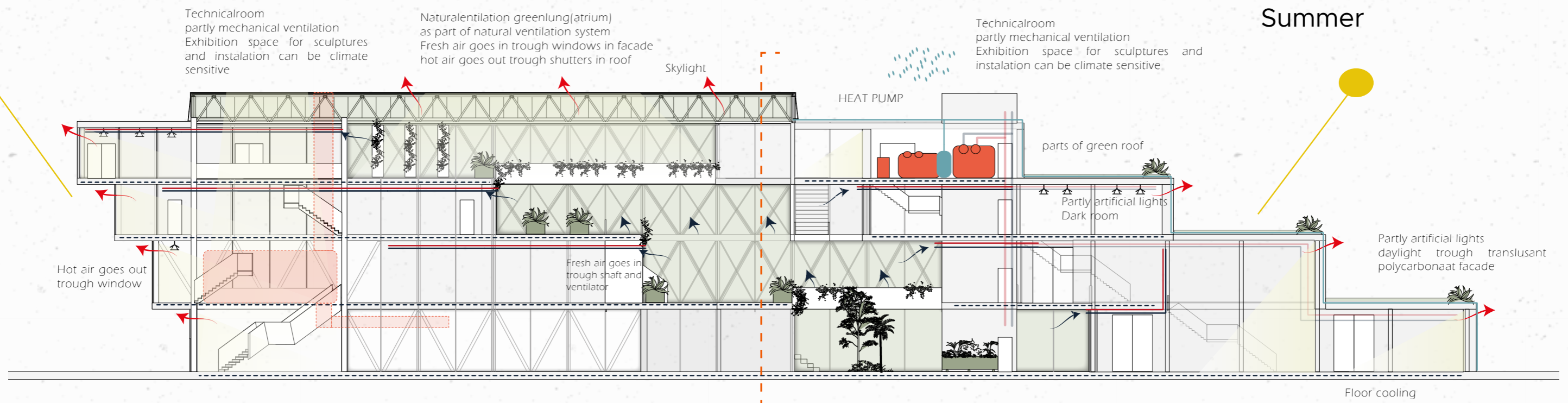

CLIMATE

Green Lung

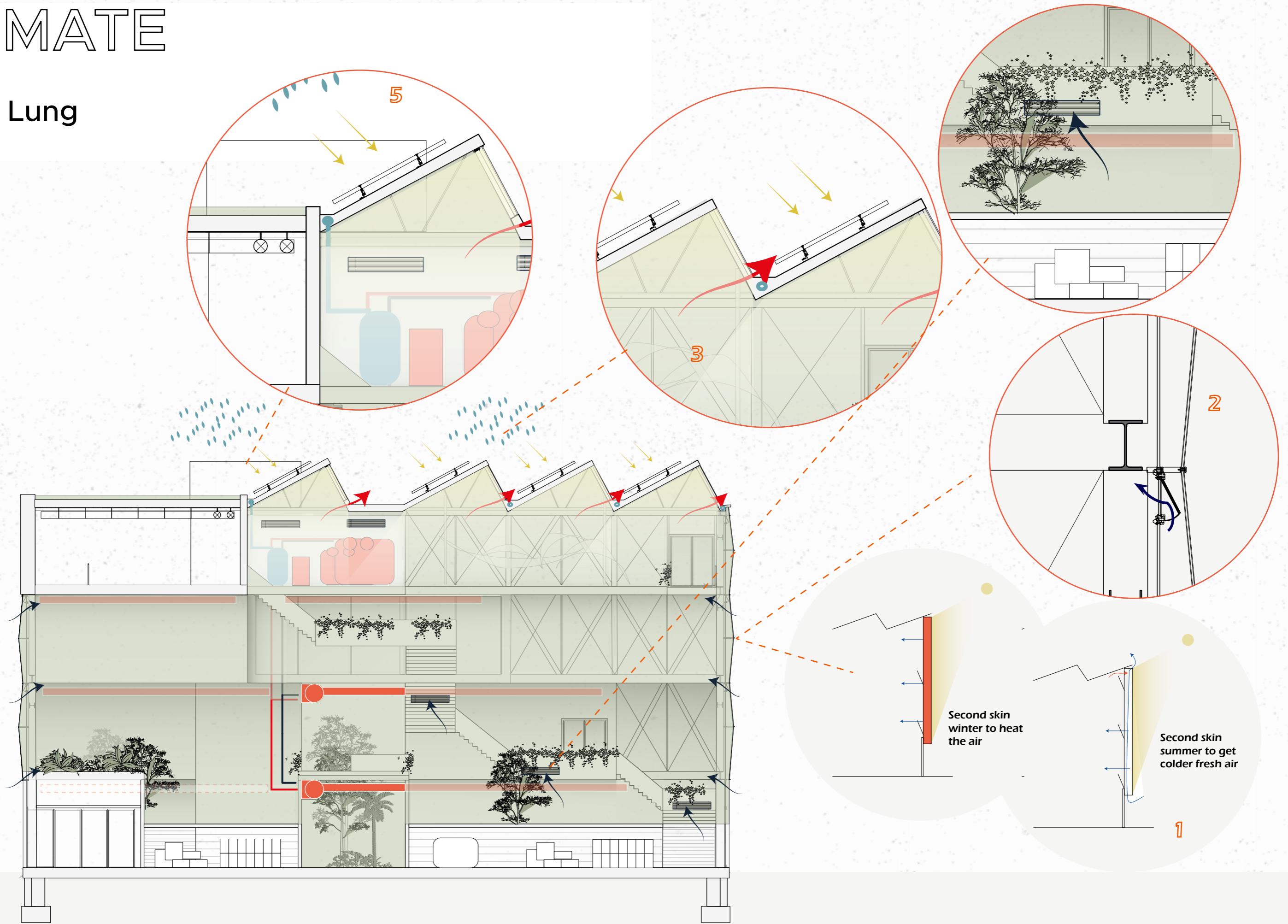

GOALL
PARTICIPATORY ART
THE DESIGN CONCEPT
THE SITE
SITE SECTIONS
THE BUILDING
BUILDING ELEMENTS
CLIMATE
BUILDING IN DETAILS
ACTIVE MUSEUM OF ART

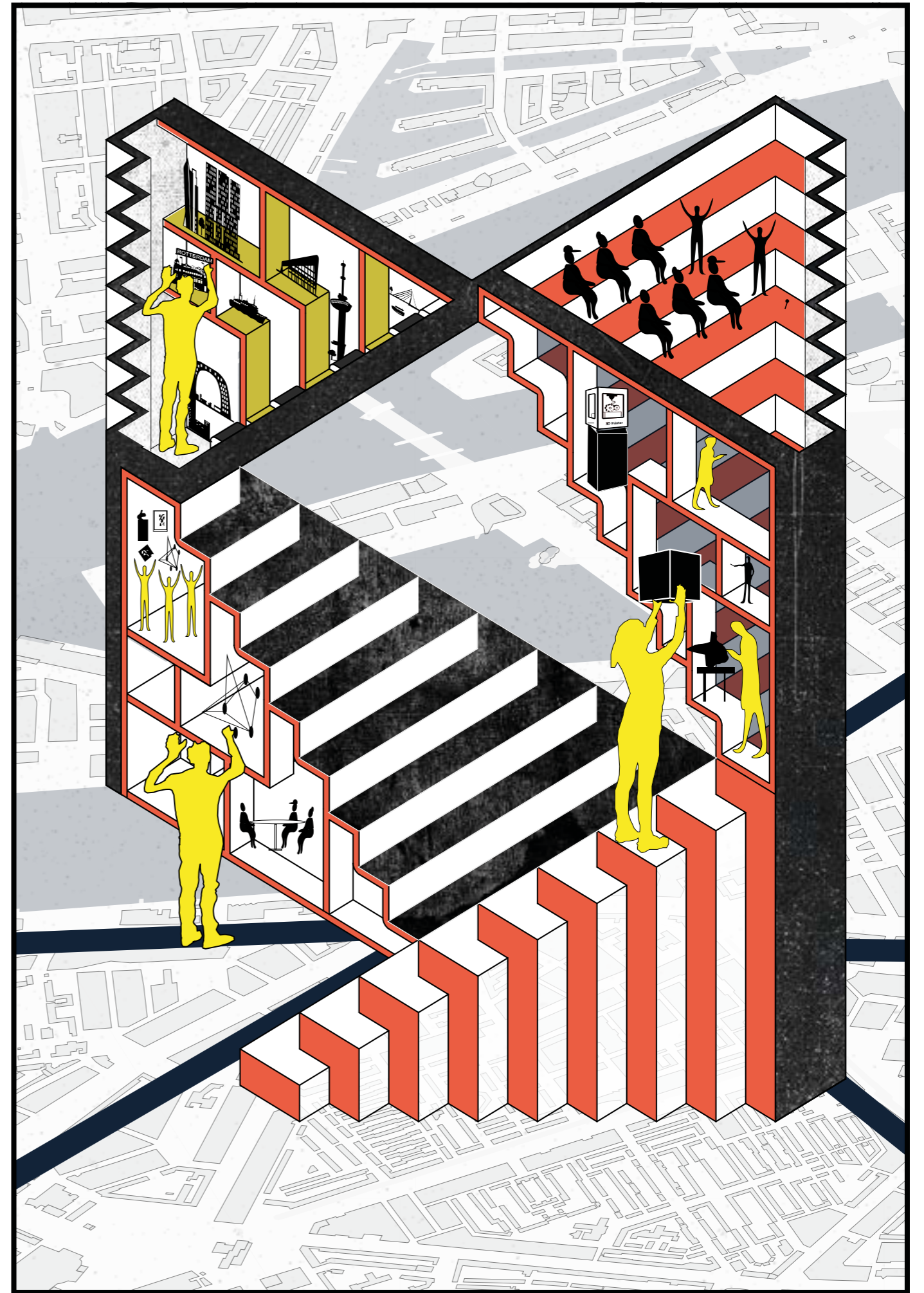

1:20 section

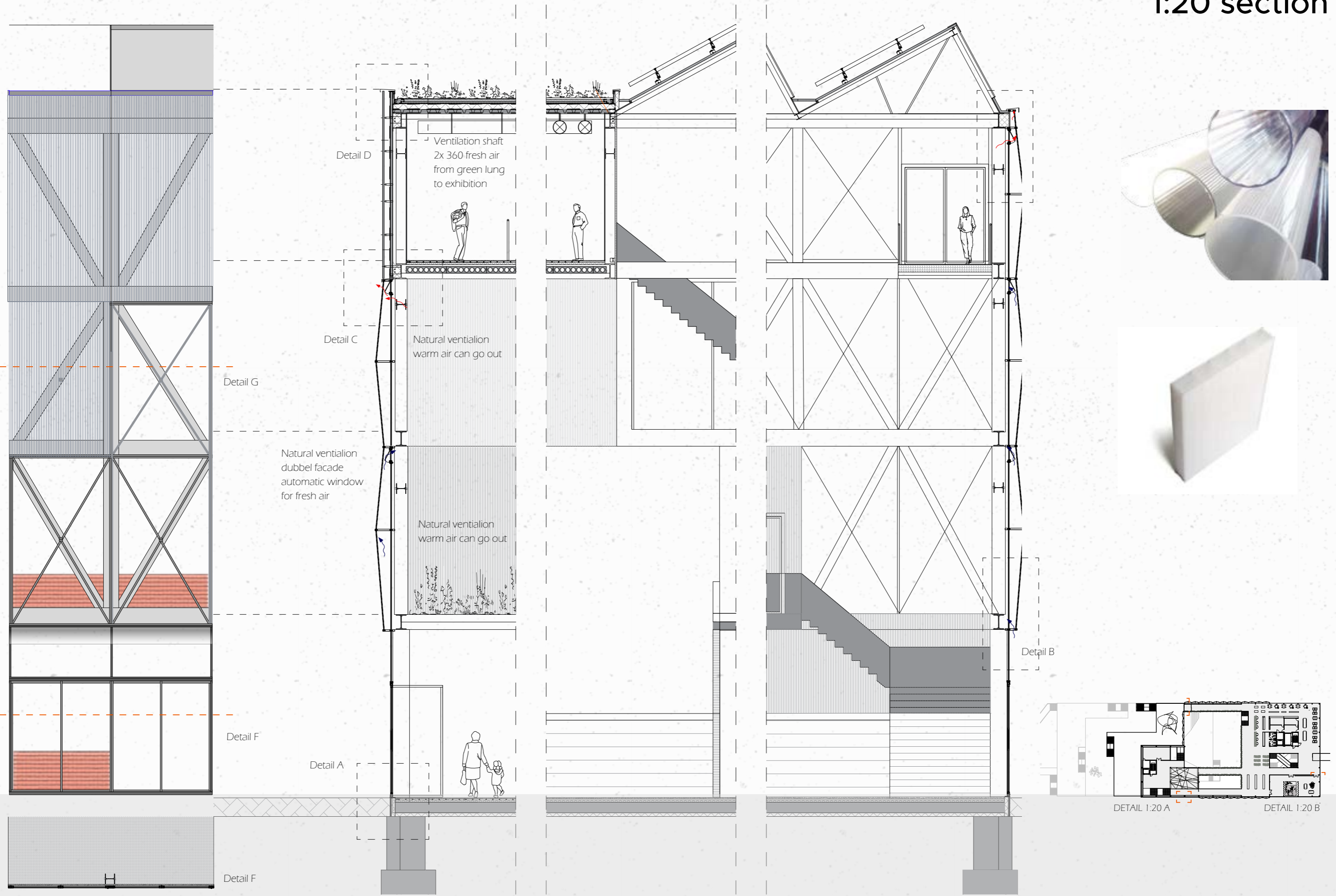

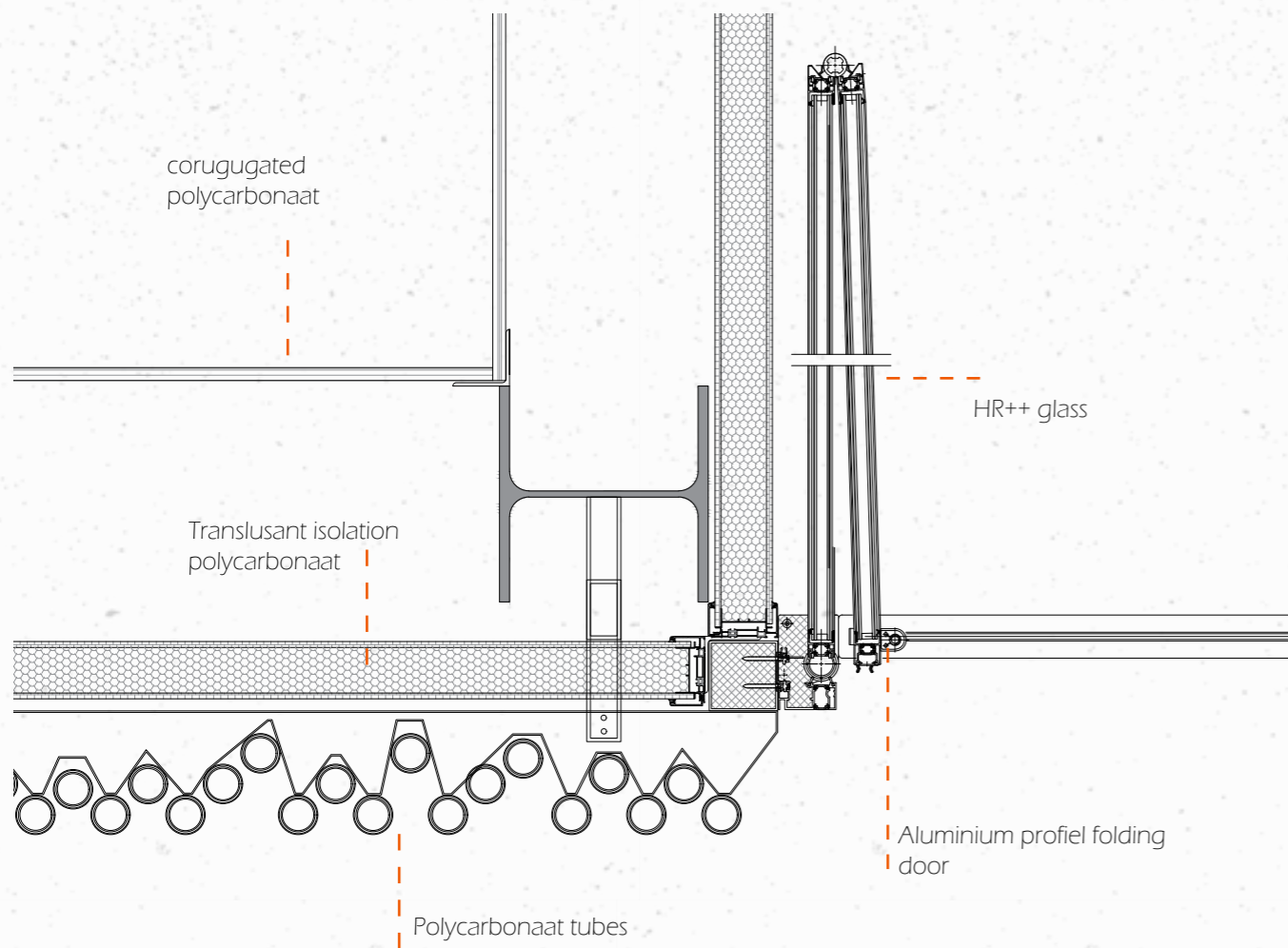
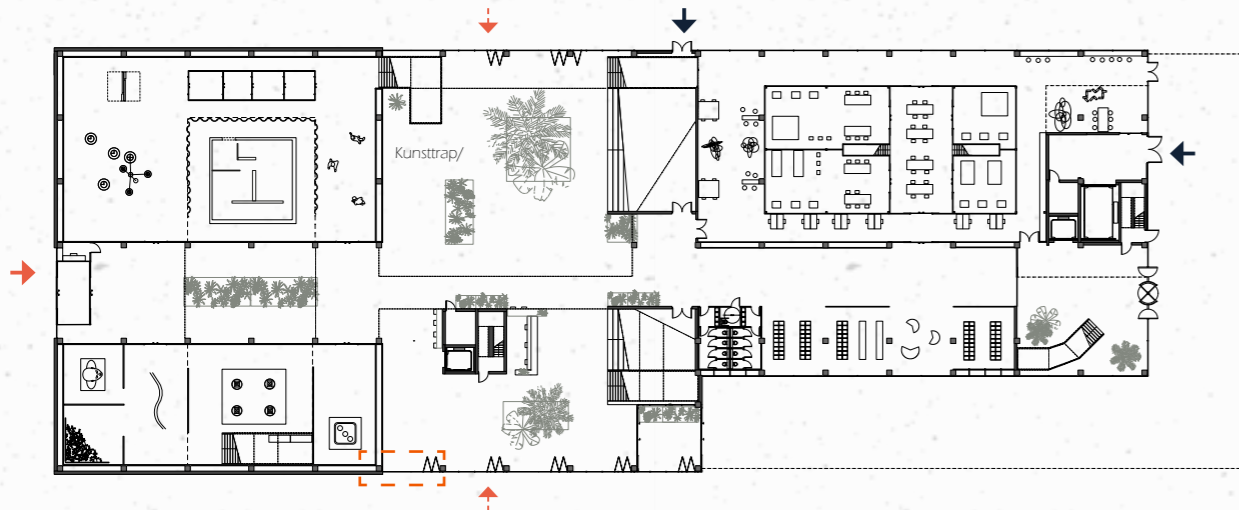

Detail F 1:10 two way folding door

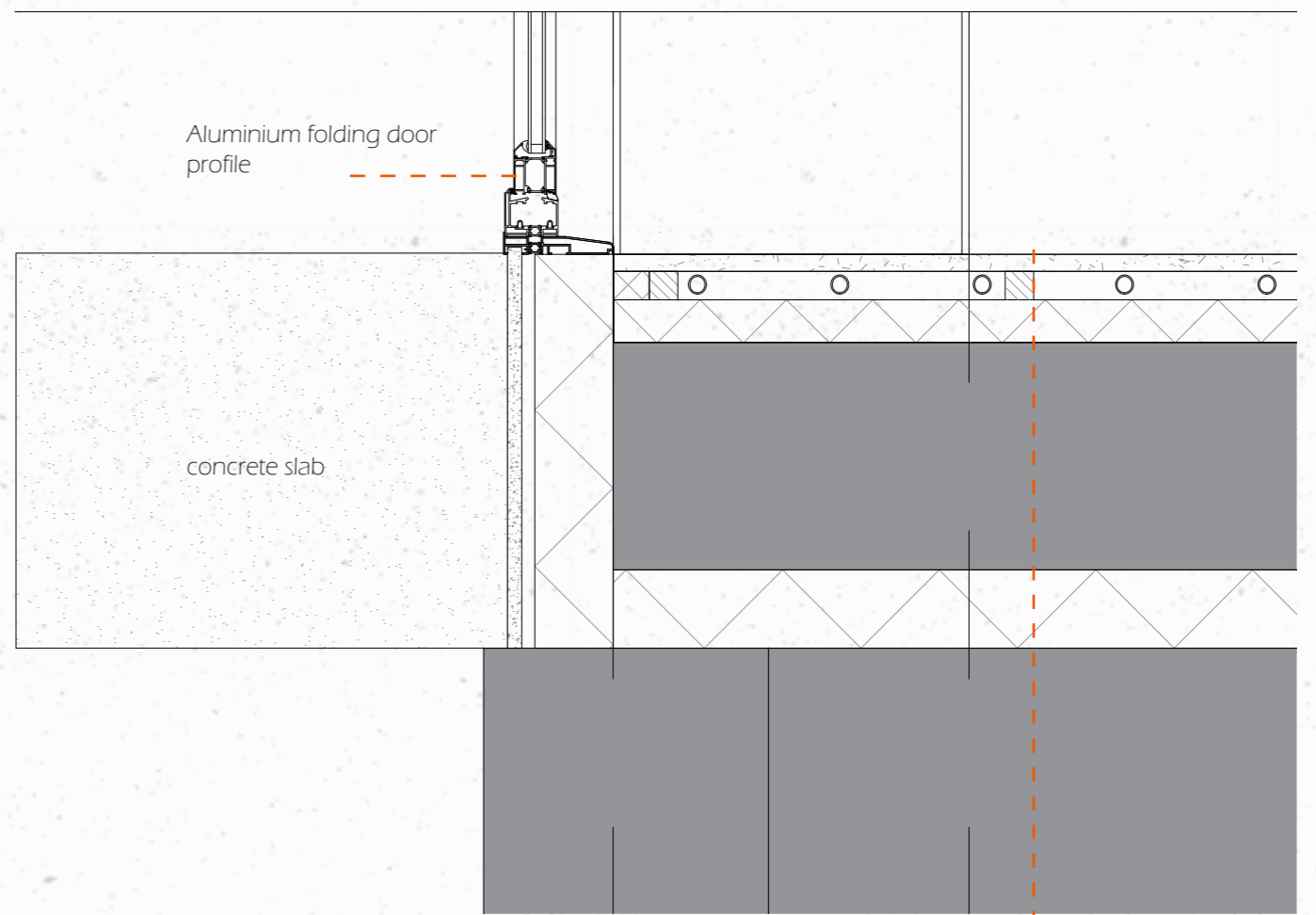

Concrete top floor 20 mm
 batten and floor heating
 isolation 60mm
 concrete floor 200
 Isolation rockwool 110mm
 Concrete foundation

DETAIL A 1:10 foundation

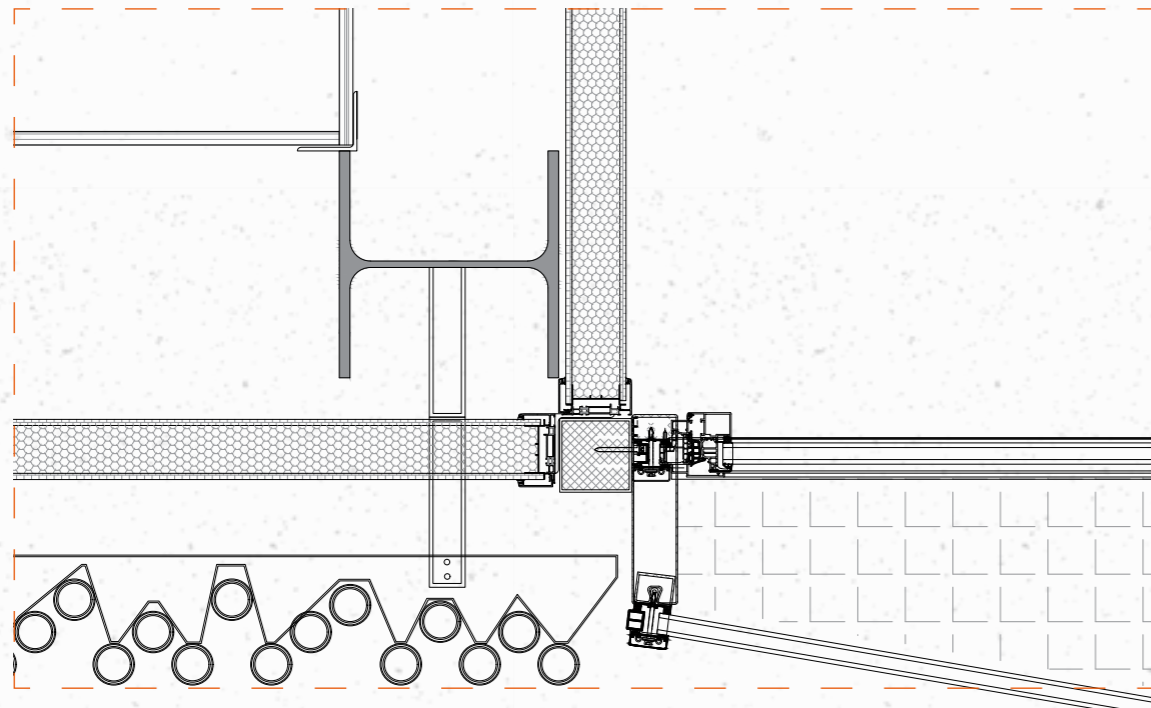

Detail F 1:10 horizontal dubbel facade



DETAIL G 1:20 horizontal

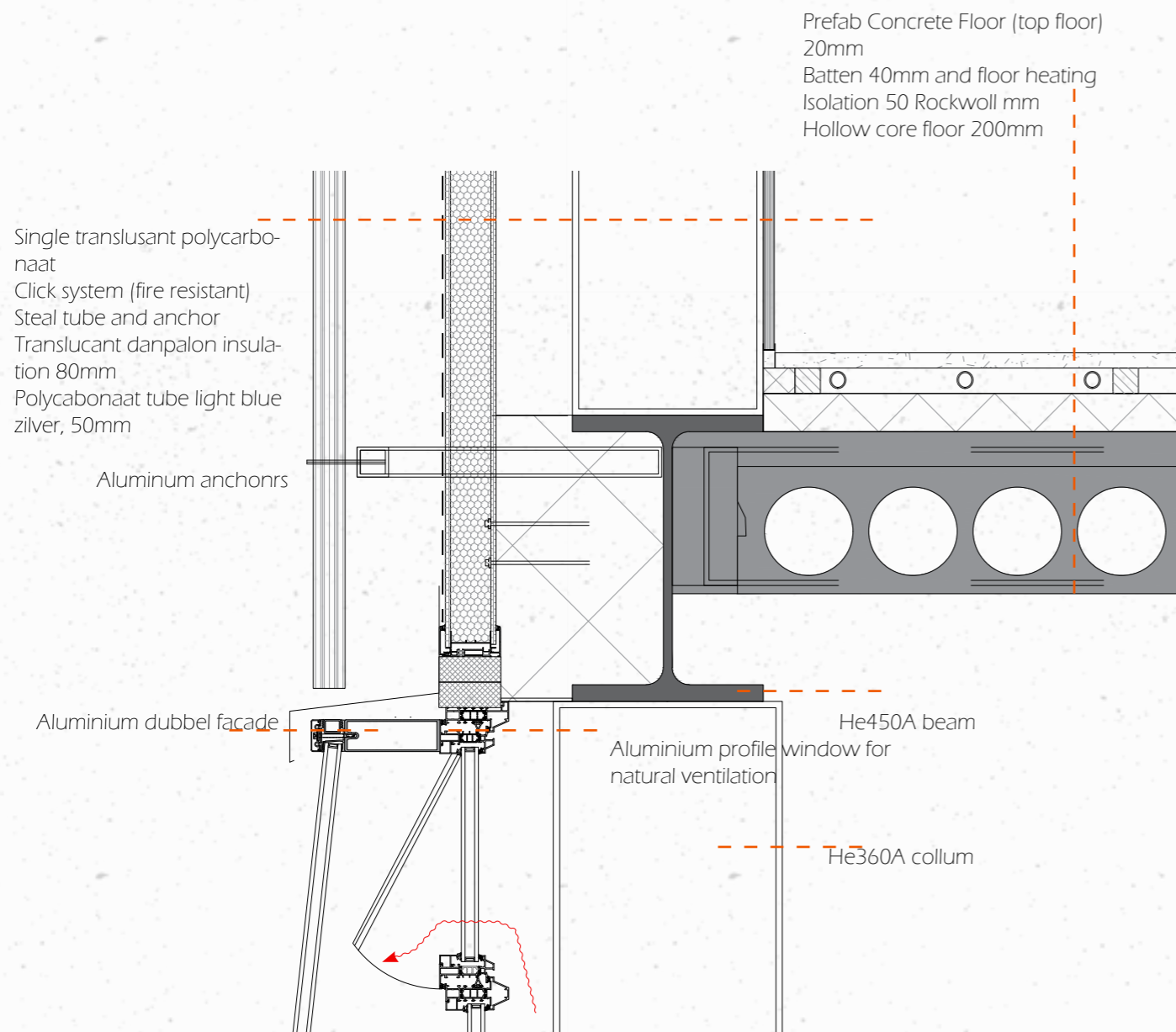

DETAIL C

1:10 floor and dubbel facade green lung

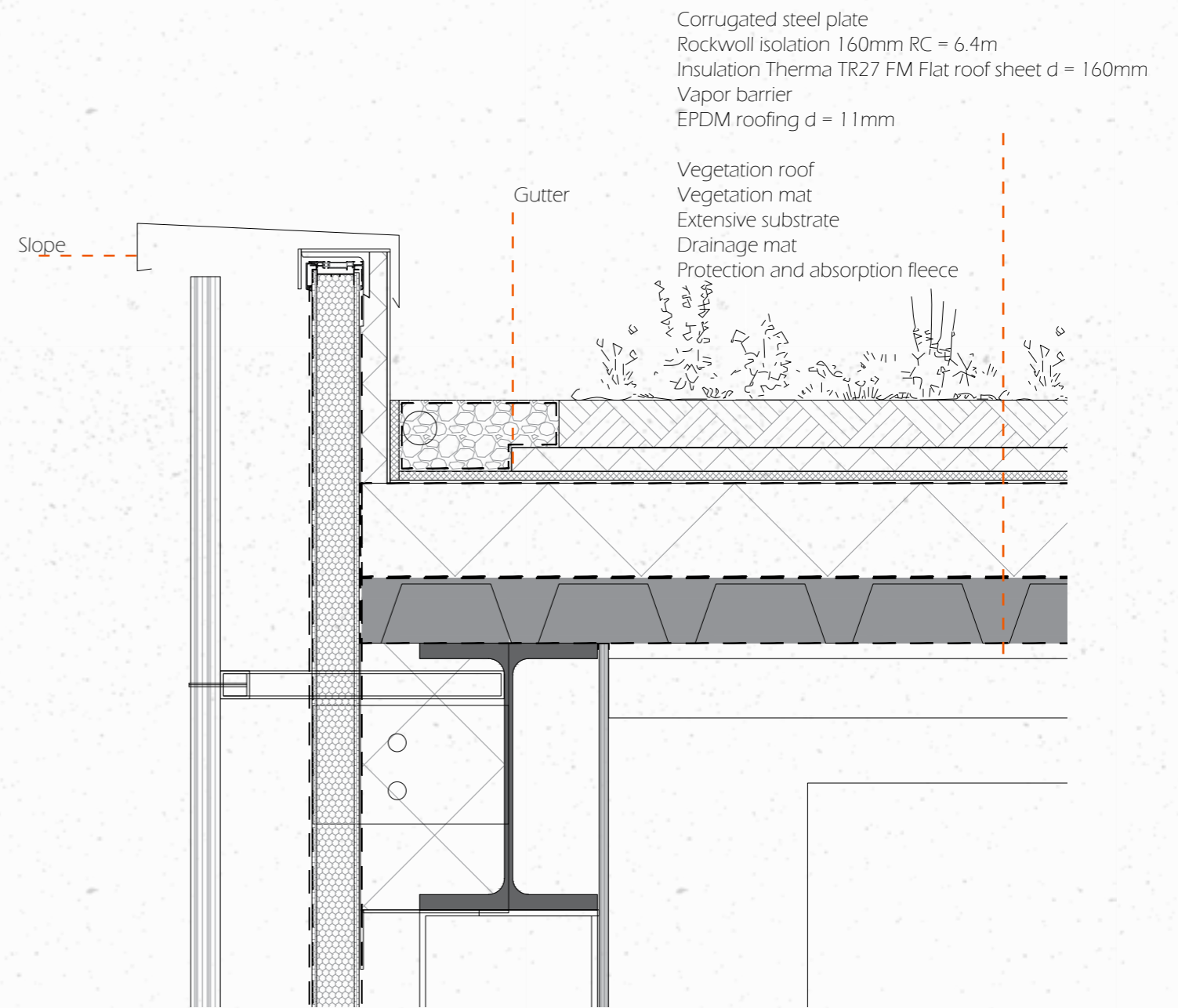

Detail D

1:10 roof

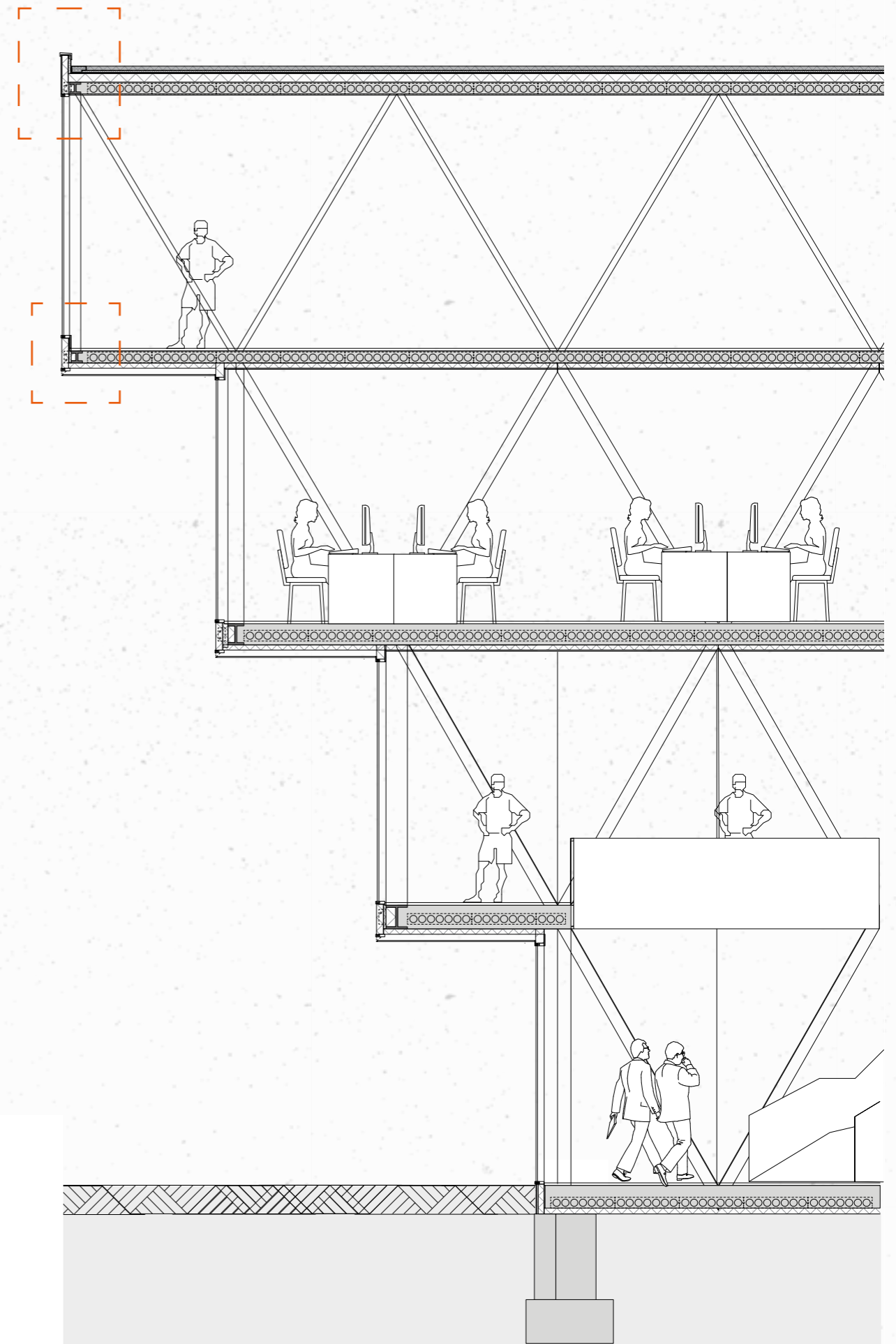
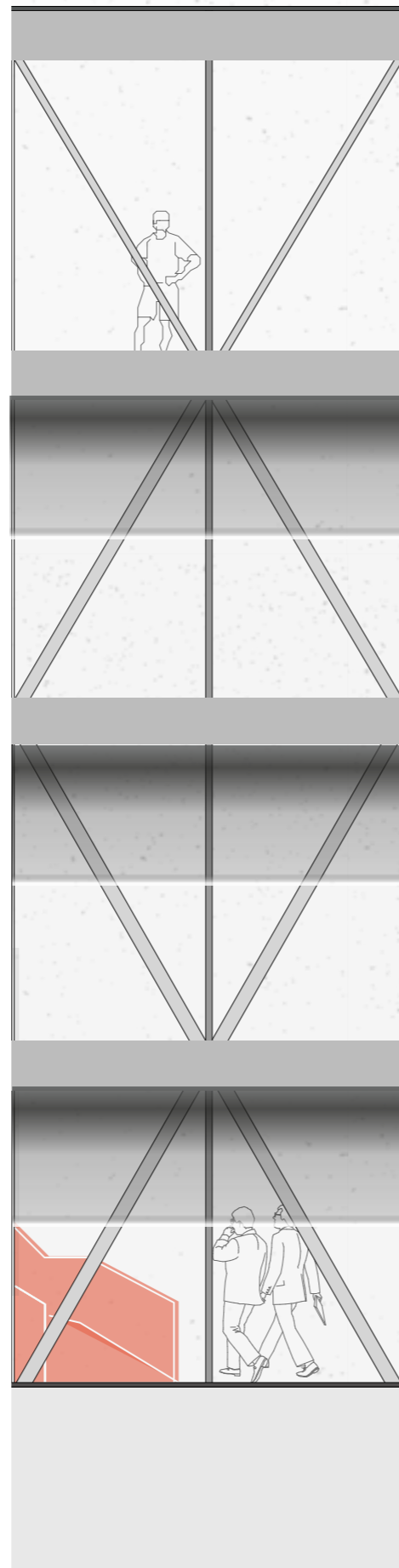
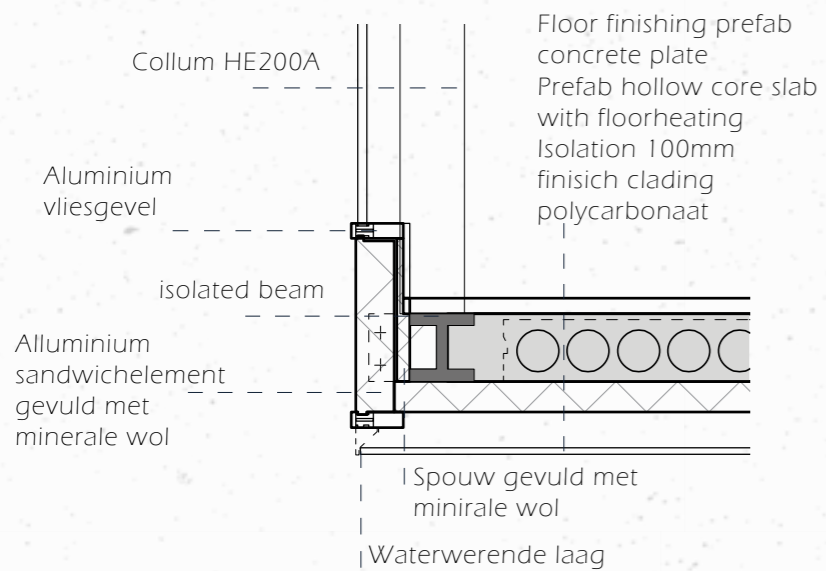
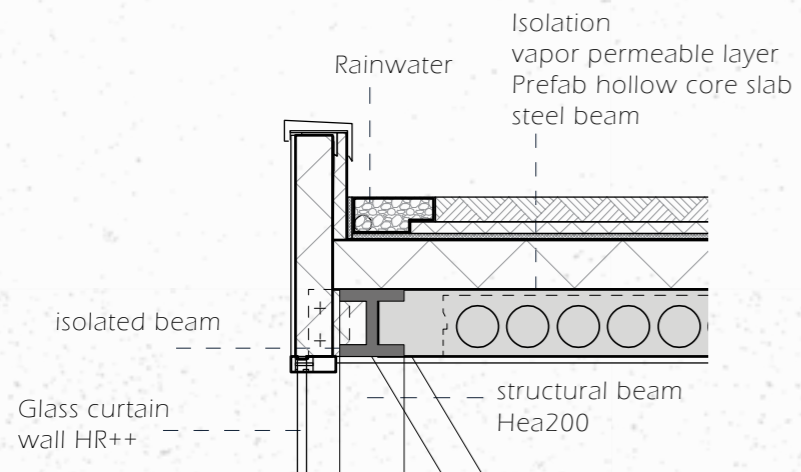
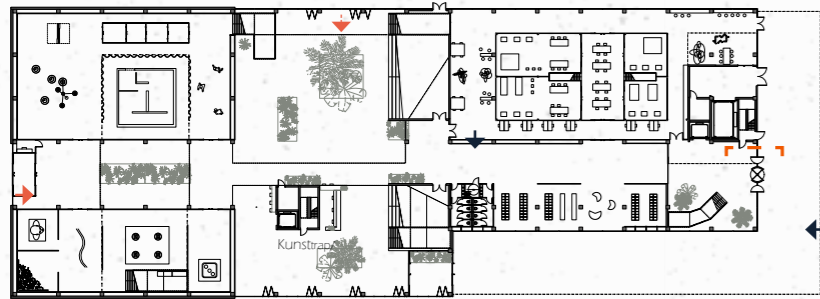

Detail B 1:20

GOALL
PARTICIPATORY ART
THE DESIGN CONCEPT
THE SITE
SITE SECTIONS
THE BUILDING
BUILDING ELEMENTS
CLIMATE
BUILDING IN DETAILS
ACTIVE MUSEUM OF ART

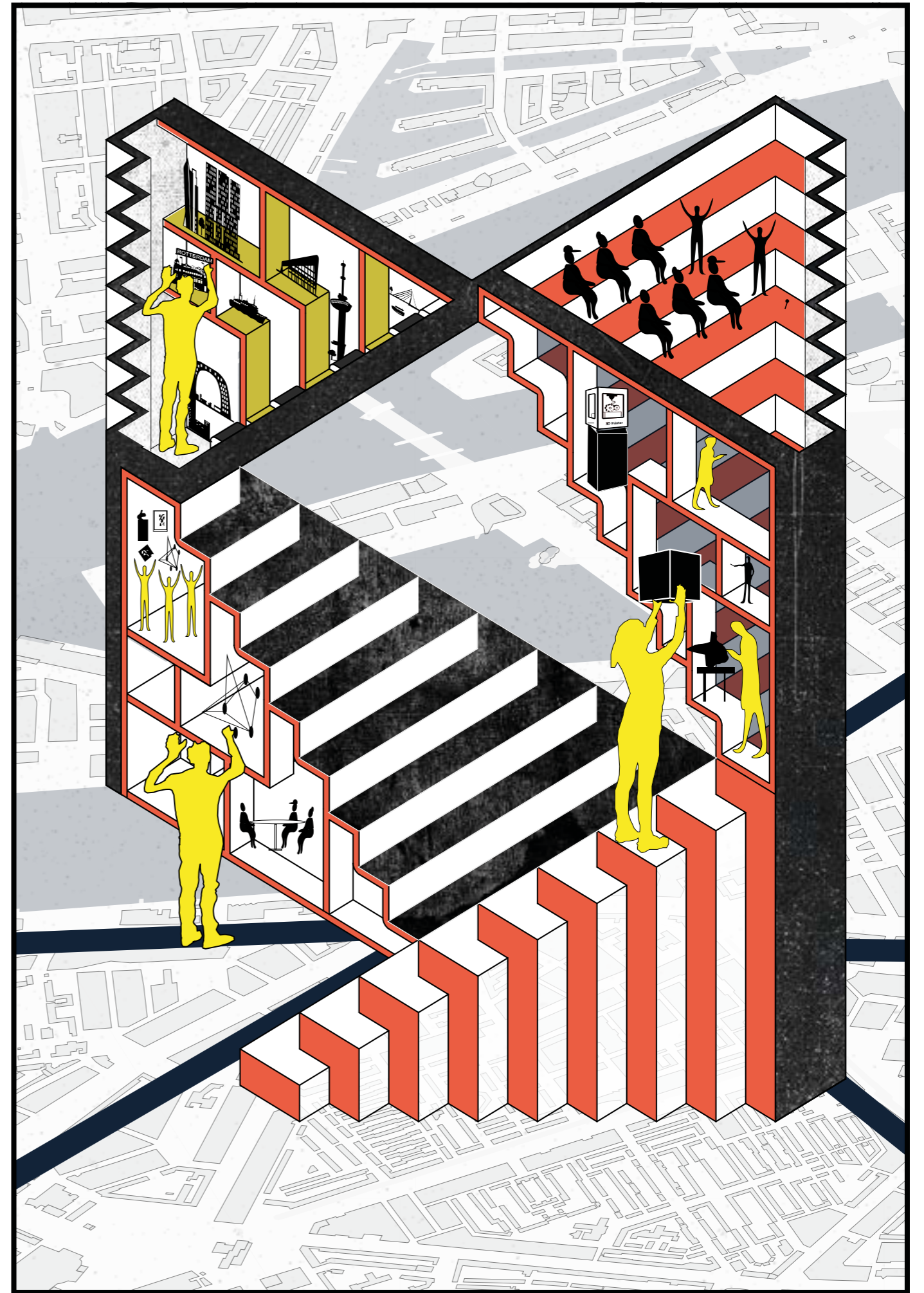

ACTIVE MUSEUM OF ART

Art Stairs collection & Green Long



Winding/ moving stairs
(constant, favela)



crossing stairs for so-
cial interaction

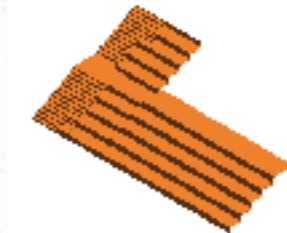

Social interaction

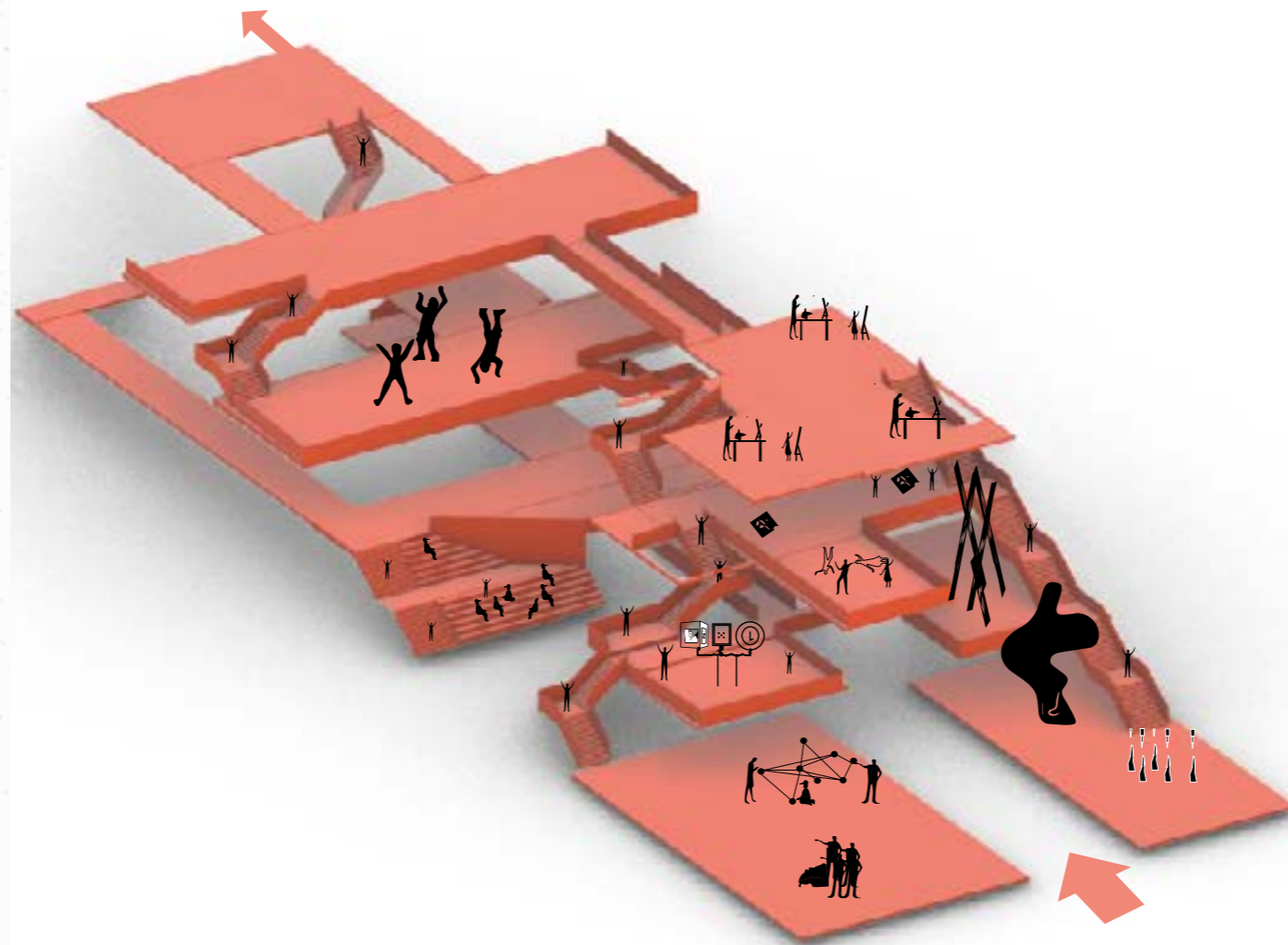

ACTIVE MUSEUM OF ART

Art Stairs collection & Green Long



ACTIVE MUSEUM OF ART

Art Stairs collection & Green Long



ACTIVE MUSEUM OF ART

Art Stairs collection & Green Long



ACTIVE MUSEUM OF ART

Art Stairs collection & Green Long



ACTIVE MUSEUM OF ART

Art Stairs collection & Green Long

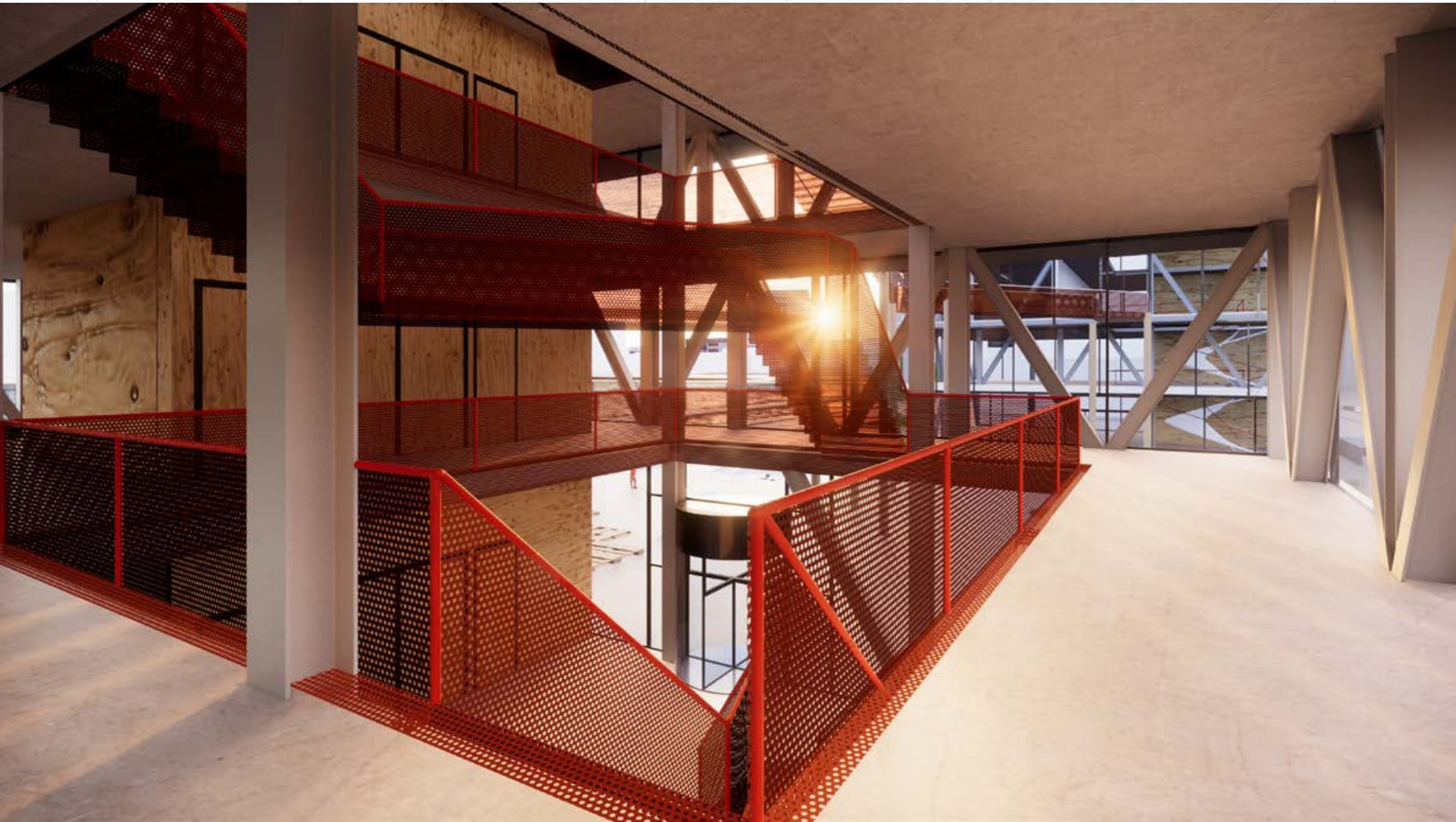

ACTIVE MUSEUM OF ART

Art Stairs collection & Green Long



THANK YOU FOR
PARTICIPATORY
PARTICIPATION