

Integrated Concentrating Solar Facade  
Cast glass component,  
embedded photovoltaic solar cells

Master Thesis

Akos Szabo  
4630424





## Abstract

This document contains the outcome of the graduation project titled „*Integrated Concentrating Solar Facade, Cast glass component, embedded photovoltaic solar cells*“. This thesis is made as a completion of the MSc in Building Technology at the Faculty of Architecture and the Built Environment, TU Delft.

Glass is one of the most remarkable building material in modern architecture. It has become more and more valued as a major construction material. It does not only provide continuous transparency but it can be applied as a main structural element due to its high load-bearing capacity. The structural system has already been realized in several architecture projects, but it is still limited. The main issue of a fully transparent glass facade is its poor thermal properties which would result a poor indoor environmental quality.

Therefore, the current research is focusing on the development of a cast glass component with an integrated solar energy system. The new unit would work as a solar concentrator/ optical device, therefore it redirects the light rays into a certain area. As an implementation of the new unit, Crystal House is used as a case study where the existing glass components are replaced with the new smart bricks.

The research has been done several levels with the main aim to create an innovative solar facade that can improve the indoor environmental quality and at the same time it can produce electricity to overcome the additional cooling cost.

# Acknowledgement

It was a long journey from searching a graduation project to writing the acknowledgements. It is not only the end of the thesis but the end of my studies at TU Delft. Studying at TU Delft throughout this 2 years was challenging, amusing and enlightening.

During an eight months of research, I have attempted to understand the behaviour of light as it interacts with solid cast glass, and it would not be possible for me if it was not for the contribution of so many people.

I would like to express my gratitude to my supervisors, Faidra Oikonomopoulou and Michela Turrin for their excellent guidance and support during the development of the thesis. I would like to thank for their enthusiasm and that they always encouraged me and shared their knowledge and innovative ideas.

I am especially grateful to Telesilla Bristogianni, my third mentor, who introduced me the topic. I would like to thank for her help during the manufacture of the prototype and providing guidance and practical help. She always supported and encouraged me to keep working.

I would like to thank Dr. Rudi Santbergen and Shreea Sharma who introduced me LightTools software and provided me valuable information about photovoltaic technology.

Finally, I must express my very profound gratitude to my beloved parents and my family for believing and providing me with unfailing support and continuous encouragement throughout this two years of study at TU Delft and through the process of researching and writing this thesis. This accomplishment would not have been possible without them.

Integrated Concentrating Solar Facade  
Cast glass component,  
embedded photovoltaic solar cells

Faculty of Architecture and the Built environment

Master of science in Architecture, Urbanism and Building Sciences

Track: Building Technology track

Tutors

Faidra Oikonomopoulou  
F.Oikonomopoulou@tudelft.nl  
Departure of Structural Mechanics  
Architecture and the Built Environment

Michela Turrin  
M.Turrin@tudelft.nl  
Departure of Design Informatics  
Architecture and the Built Environment

Telesilla Bristogianni  
T.Bristogianni@tudelft.nl  
Applied Mechanics  
Faculty of Civil Engineering and Geosciences

External examiner

Jan Jacob Trip  
J.J.Trip@tudelft.nl  
Departure of Urban and Regional Development  
Architecture and the Built Environment

Author

Ákos Szabó  
Student number: 4630424  
saboakos@gmail.com

## Table of content

<b>1. Introduction.....</b>	<b>3</b>
1.1 Problem statement.....	4
1.2 Objective.....	7
1.3 Research question.....	7
1.4 Methodology.....	8
<b>2. Glass.....</b>	<b>9</b>
2.1.1 History of glass.....	10
2.1.2 What is glass.....	14
2.1.3 Types of glass.....	16
2.1.4 Production technique.....	18
2.1.5 Casting glass.....	22
2.1.6 Post-process.....	23
2.2.1 Glass as a structural material.....	25
2.2.1 Strengthening of glass.....	25
2.2.2 Connections.....	29
2.2.3 Dry assembly- Interlocking system.....	31
<b>2.2 Cast glass case studies.....</b>	<b>35</b>
<b>2.3 Lenses.....</b>	<b>44</b>
2.3.1 Theory of light.....	45
2.3.2 Shape of lenses.....	48
2.3.3 Optical glass.....	50
2.3.4 Production of lens.....	51
<b>2.4 Photovoltaic system.....</b>	<b>59</b>
2.4.1 Introduction.....	60
2.4.2 New trends on the Photovoltaic technology.....	63
2.5 Case studies.....	67
<b>2.6 Design strategies.....</b>	<b>70</b>
2.6.1 Structural principle.....	71
2.6.2 Glass material for lenses.....	72
2.6.3 Type of photovoltaic.....	73
2.6.4 Type of lenses.....	74
<b>3. Environmental analysis.....</b>	<b>76</b>
3.1 Introduction.....	76
3.2 Location/ Climate.....	78
3.3 Site Analysis.....	81
<b>4. Light simulation.....</b>	<b>82</b>
4.1 Introduction.....	83
4.2 Grasshopper model.....	91
4.3 LightTools simulation.....	92
4.4 Geometry study.....	100
<b>5. Final design.....</b>	<b>110</b>
5.1 Further Development.....	110
5.2 Light simulation of the final design, comparison with a simple brick.....	114
5.2 Wall Design.....	120
5.3 Calculating the amount of redirected light.....	121
5.4 Discussion of the results.....	123
<b>6. Feasibility of the design.....</b>	<b>125</b>
6.1 Fabrication method.....	126

<b>7. Prototype.....</b>	<b>131</b>
<b>8. Conclusion.....</b>	<b>135</b>
<b>BIBLIOGRAPHY.....</b>	<b>142</b>
<b>Appendix.....</b>	<b>144</b>

# 1. Introduction

Introduction of the research topic and its relevance in innovation. Problem statement, research objectives and methodology are presented in this chapter.

## 1.1 Problem statement

Recent developments in cast glass technology might offer a novel, fascinating and homogeneous solution for buildings, renovations or even for monuments, redefining the use of glass in the architecture. Cast glass can be applied as a structural element, such as masonry bricks or columns due to its high load-bearing capacity. A masonry glass facade has already been realized in several architecture projects as an answer to the continuous transparency, namely Crystal House in Amsterdam, Atocha Memorial in Madrid, the Crown Fountain in Chicago, and the Optical House in Japan. Nevertheless, cast glass is very suitable as a load bearing material for such applications, the structures are still very limited. One of the limitations is the size of the design. A masonry wall with a high slenderness ratio can be susceptible to buckling due to self-weight, and visually disturbing steel elements have to be introduced which are providing impeded transparency. Furthermore, lack of insulation due to the monomaterial nature of solid glass blocks and the absence of a cavity can deteriorate the indoor environmental quality, and introduce more mechanical ventilation.

A promising solution would be the engineering of a cast glass component with an embedded/integrated solar energy system, making it particularly useful for capturing solar energy in urban areas.

The application will not only be able to allow great amounts of daylight but generates electricity that can compensate the energy loss due to the poor insulation properties of the envelope. Casting glass can provide great freedom in the geometry, including geometries with convex surfaces that can work as lenses.



Figure 1: Crystal House, Amsterdam



Figure 2: Glassfacade of the Crystal House



Figure 3: The Optical House, Japan



Figure 4: Atocha Monument in Spain.



Technology plays a vital role in sustainability to utilize renewable energy in order to develop sustainable or even self-sustainable technologies. The question of sustainability is indubitable. The quickly growing global energy use has already raised several concerns over supply difficulties, exhaustion of energy resources and massive environmental impacts all over the world. Furthermore, some of these impacts are already irreversible. Climate change, desertification, or even resource exhaustion are some examples of the severe problems which are happening. The energy consumption and the CO<sub>2</sub> emissions are continuously raising with an average annual increase of 2% and 1.8% respectively, according to the data of International Energy Agency (Luiz Pérez-Lombard et al., 2008). Economically developing countries will grow at an average annual rate of 3.2% and will exceed by 2020 at an average growth rate of 1.1% (Luiz Pérez-Lombard et al., 2008). World Energy Council reported that the buildings are the largest consumers of electricity, which can reach 40% of the energy consumption of the country.

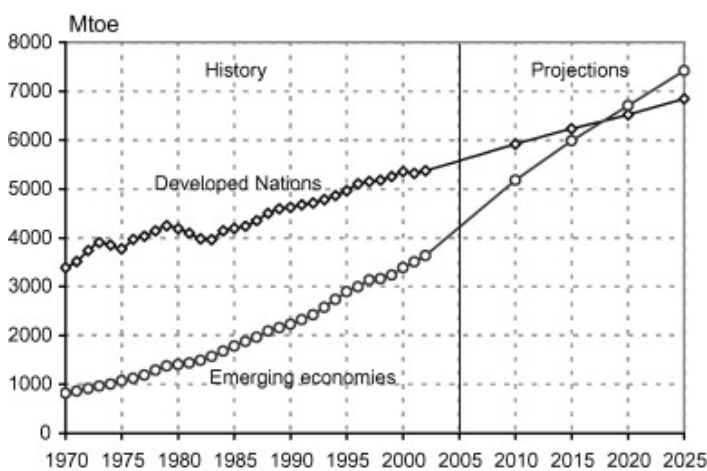

Figure 5: Growing energy use in the world

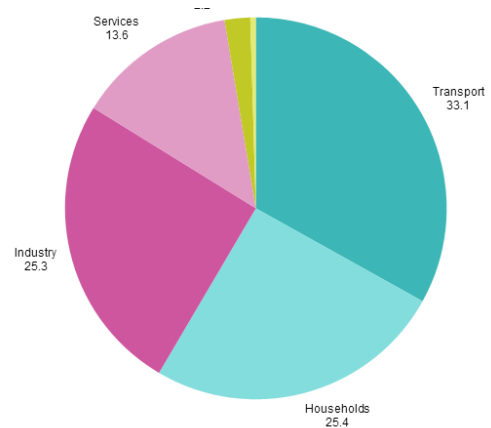
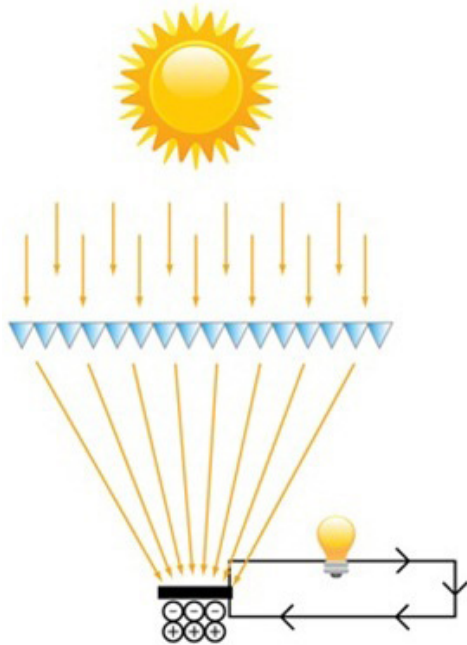

Figure 6: Final energy consumption in 2015, in Europa

Thus, architectural design with integrated renewable energy measures can have a great impact on the reduction of the overall energy consumption, contributing to the sustainable growth of our cities. All the renewable energy resource are available, but the most promising, abundant, clean one is the solar energy. In a single second, the Sun delivers 120 Petajoules of energy to the Earth. That means in one hour the delivered energy to the Earth could cover the energy consumption over the whole year (Katie Shanks et al., 2016). One of the challenges is how to collect the energy at reasonable cost. One of the solutions is the Photovoltaics technology, which collects the sunlight directly, then it converts into electricity without affecting the environment. However, these PV modules require big areas/ surfaces in order to collect the light, sometimes with one or two axis tracking systems which make the entire installation more expensive. The aesthetic qualities of the building should also be considered for the installation's location as it can have a big visual impact.

A system employing concentrated photovoltaics might be able to tackle these problems. They are more environmentally friendly than the regular flat PV modules, as they use fewer semiconductor components which are made from heavily mined and relatively rare metals, and it has a smaller impact on the albedo change in an area than flat-plate PV panels (Katie Shanks et al., 2016). Although this system can work in higher efficiency, it needs a very sophisticated concentration system. A typical CPV system includes an optical device as well. Furthermore, its efficiency is affected by its tracking system, therefore it is fundamental that the solar energy can concentrate on the proper point of the installation.





### Fresnel Concentrator

Figure 7: Concentrator device redirects the light to the PV cell.



Figure 8: Current solution, solar-cell-embedded glass bricks.

The thesis focuses on the design of the cast glass component with an embedded solar energy technology which becomes a part of the building's envelope, having a minimal impact on the landscape and environment. Promising solution for combination of concentrated photovoltaics system and structural cast glass would be a new component which would work as an optical device as well as a structural element. It can be applied either in small part of the building, or it can be used in an entire facade. The component can be the combination of transparency-structure- and -energy production. Furthermore glass component can be reused, recycled for another purpose.

As a proof of concept, a relevant study will be made where the developed component will replace the current solid cast glass bricks of the Crystal Houses facade. The two facades will be assessed in terms of energy and structural performance and based on the results proposals will be made for the further development of the concept.

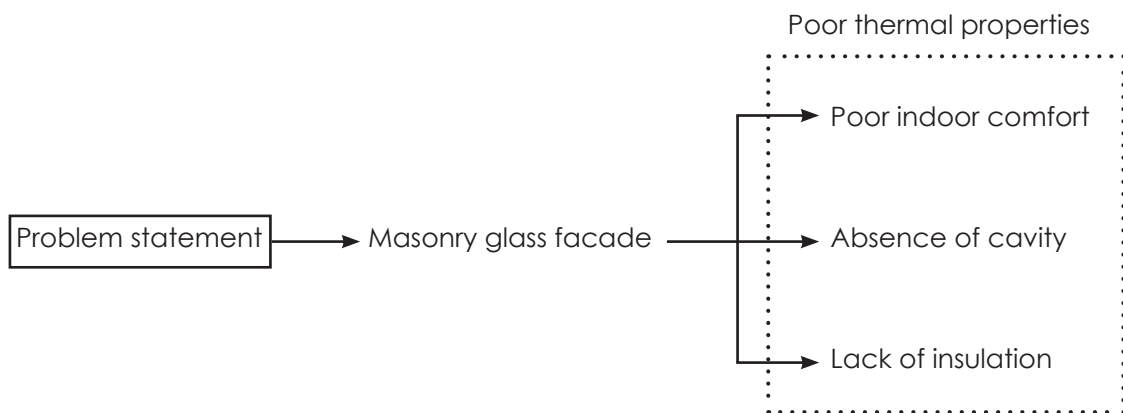

Figure 9: Diagram of problem statement.

## 1.2 Objective

The thesis conducted research on sustainability and light behaviour as it interacts with solid cast glass brick with the focus on energy production. The goal is to analyse the light behaviour in solid glass as it is refracted inside the glass and changes its direction when it bounces on different surface at a certain angle.

Research will be conducted on how different glass components with different surface can redirect the light to a certain area. Thus a fully glass facade like Crystal House in Amsterdam, not only generates energy with the integration of photovoltaics but it can maximize the energy production due to the concentrator. An embedded solar system in cast glass component would give the possibilities to design sustainable, self-sustainable buildings and decrease the additional cooling cost.

Combination of concentrated photovoltaics system and structural cast glass would result a new component which works as an optical device as well as a structural element. The proposed system would be applied in small part of the building, or it can be used in an entire facade. The component can be the combination of transparency-structure- and -energy production.

## 1.3 Research question

Based on the research objectives and problem statement the following research question was formulated:

**-In what ways can a cast glass component redirect the light in order to maximize the energy production in a facade, and improve its sustainability and decrease the need of additional external cooling sources.**

Sub-questions:

- What manufacturing process should be employed to produce a block of the given complex geometry and high accuracy
- What type of Photovoltaics is more appropriate for such an application?
- In what ways do influence the geometry of the glass brick components the redirection of the light?
- What are the shapes and forms that are optimum for such a solar energy system that can be achieved in cast glass ?

The structure of the research consists of four parts and some parts are divided into smaller phases that they needs take into account. The structure has to be clear and it follows a linear method. Every decesion-making has to based on the previous steps.

### **P1-P2 ( Part1 )**

In the first part, the most important and fundamental principles are investigated from various sources in order to provide deeper knowledge. The literature study can be divided into two parts: Glass, and Concentrated Photovoltaics (CPV). The research focuses mainly on the properties of the glass, such as the types of glasses safety, types of glass, strengthening, manufacturing of glass and a topology of interlocking system. In the second part, the principles of the Concentrated Photovoltaic modules are researched as well as the developments and the current stages.

### **P2-P3 ( Part2 )**

During this period, the research focuses on the component design/ simulations which will be applied on a case study, on an existing building (Crystal House, Amsterdam). The approach consists of 5 steps:

1, First step is to model the location of the building as well as the building itself. Reasonable model which is useful for the simulations

2, Analyze the current situation of the building is an essential part of the design (weather conditions, movement of the sun, urban environment,) this will provide relevant information to go further in the design

3, After the analysis, the simulation will show which the best part of the facade is to apply CPV components.

4, Subdivisions of the facade to get a more accurate place ( draft boundaries of the geometry)

5, Lastly, several different component designs, focusing on converting the glass blocks to solar concentrator devices will be tested and evaluated. The most promising design will be selected to be further developed.

These steps are essential for the component design as well as the most appropriate location on the facade in order to maximize the electricity income. At the end of the period, the necessary moulds, models and tools have to be prepared to start the casting.

### **P3-P4 ( Part3 )**

The selected design will be casted and then the physical prototype will be tested. The prototype will be tested on how light interacts with the final component. Then the experimental results will be compared with the simulations.

### **P4-P5 ( Part4 )**

No further developments will be made. Finalization of the proposed and tested design, and verify how the design component fulfills the previously formulated research questions.

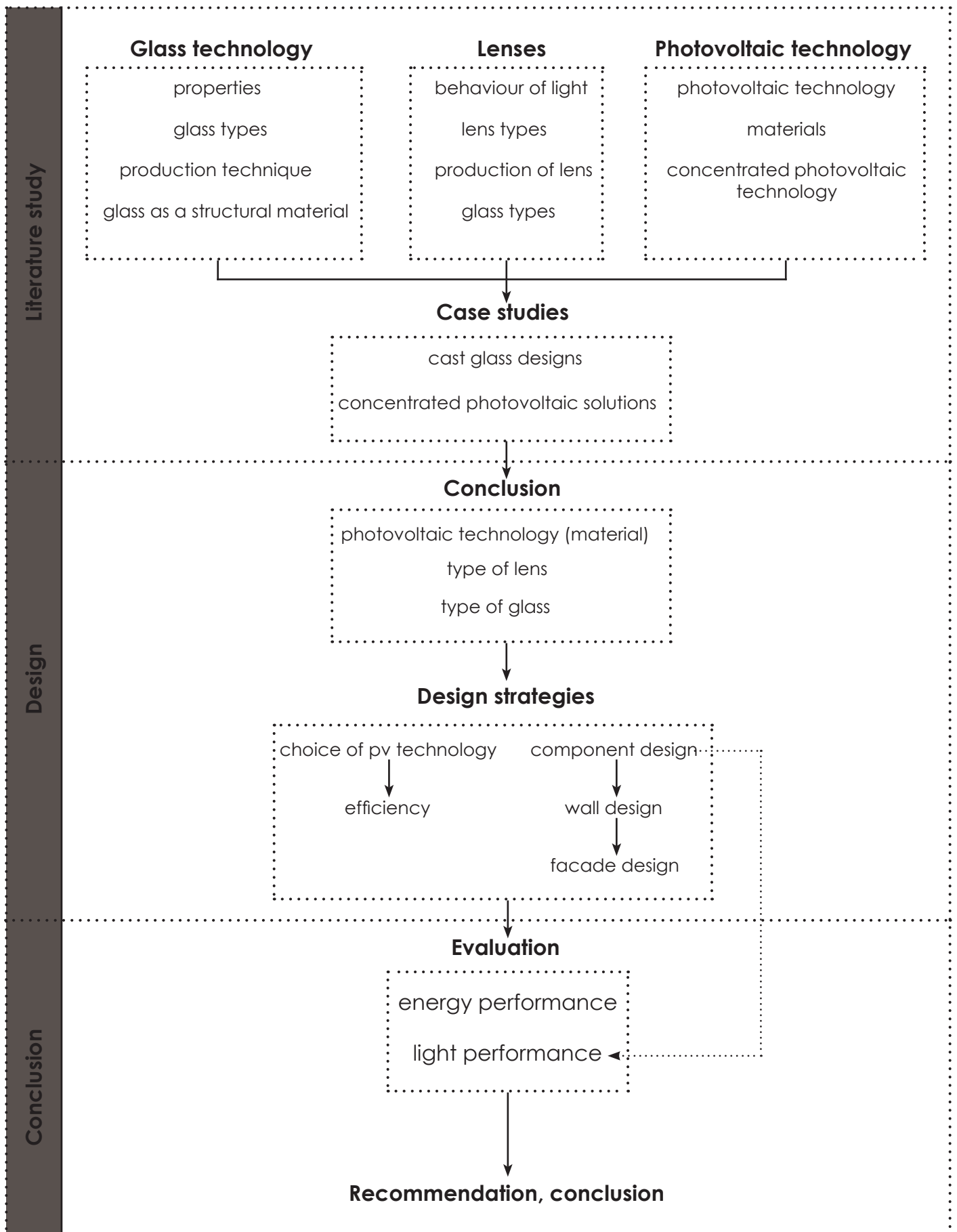

Figure 10: Research and methodology

## 2. Literature study

In the first chapter theoretical research has been done and described as the beginning of the design. The research was a key element of the thesis. This chapter represents the properties of glass as a structural material and different glass technologies. Afterwards, sustainable solutions, especially photovoltaics system is described.



## 2.1.1 History of glass

In nature, glass can be found in many forms such as volcanoes spew molten rock, lightning strikes desert sands, meteorites, or even in sea sponges and microscopic organisms inhabit the water. Glasses are formed when sand or rock are heated to high temperatures and then cooled rapidly. For instance, volcanic glass is molten rock which has quickly cooled down and becomes rock in a glassy state. Fulgurites is also an interesting form of glass. This material comes from the discharge phase of lightning strikes propagation into sand. Since glass was discovered by human, it has rapidly started its development to nowadays.

The history of glass making is uncertain, but it can be traced back to 3500 BC in Mitannian or Hurrian region in Mesopotamia where the first glass was developed as an extension of the production of glazes. New material was developed at that time, called faience, which was produced by utilizing a variety of techniques to create a glaze layer over a silica core. „Faience can be thought of as an intermediate material between a glaze and glass” (Lambert JB. et al., 2005). The glass objects dated back to 2500 BC, found in Syria. Then came later in Egypt with its manufacture appearing as a major industry around 1500 BC (Lambert JB. et al., 2005). From this time until now the development of the glass has not been stopped.

Glass has always been used as a design element in the building industry, and since buildings tend to have more complex shapes which sometimes go further than human imagination, glass is used more frequently as a structural element. In addition, glass engineering can be traced back to 1700s when Kew Gardens was constructed in London. It was designed by Richard Turner and the building is considered one of the most important Victorian glass and iron structure. All of the structure’s panes are hand-blown, and due to its transparency it removes the „boundaries” between exterior and interior.

Since that time, glass as a main load-bearing structure is commonly used nowadays. A great example of Apple stores show, how glass structure can be used by performing the request of the customer. In New York City the Glass Cube has all the necessary load-bearing functions without using any sub-structures. Each side of the cube has three slabs of laminated safety glass, in five layers and it perfectly fulfils its load-bearing function. Meanwhile, it is fully transparent.

Table 10. describes clearly the most important events in the history of glass over the centuries.

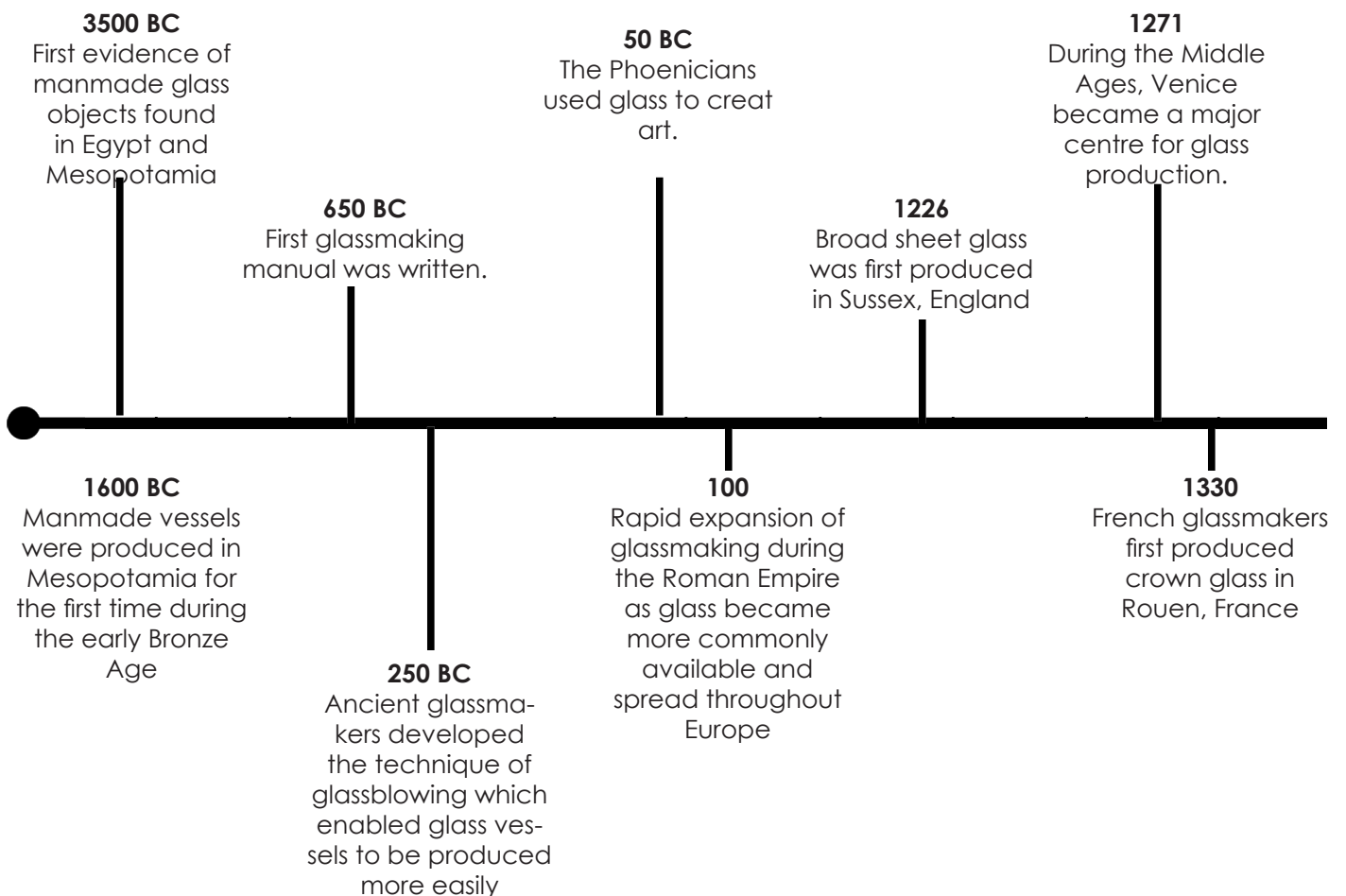

Figure 11: Nature form of glass.  
Left: Fulgurite, Right: Obsidian,



Figure 12: Technology development on glass.

Top left: Fulgurite, Top right: Obsidian, Bottom left: Kew Gardens , Bottom right: Apple Cube.



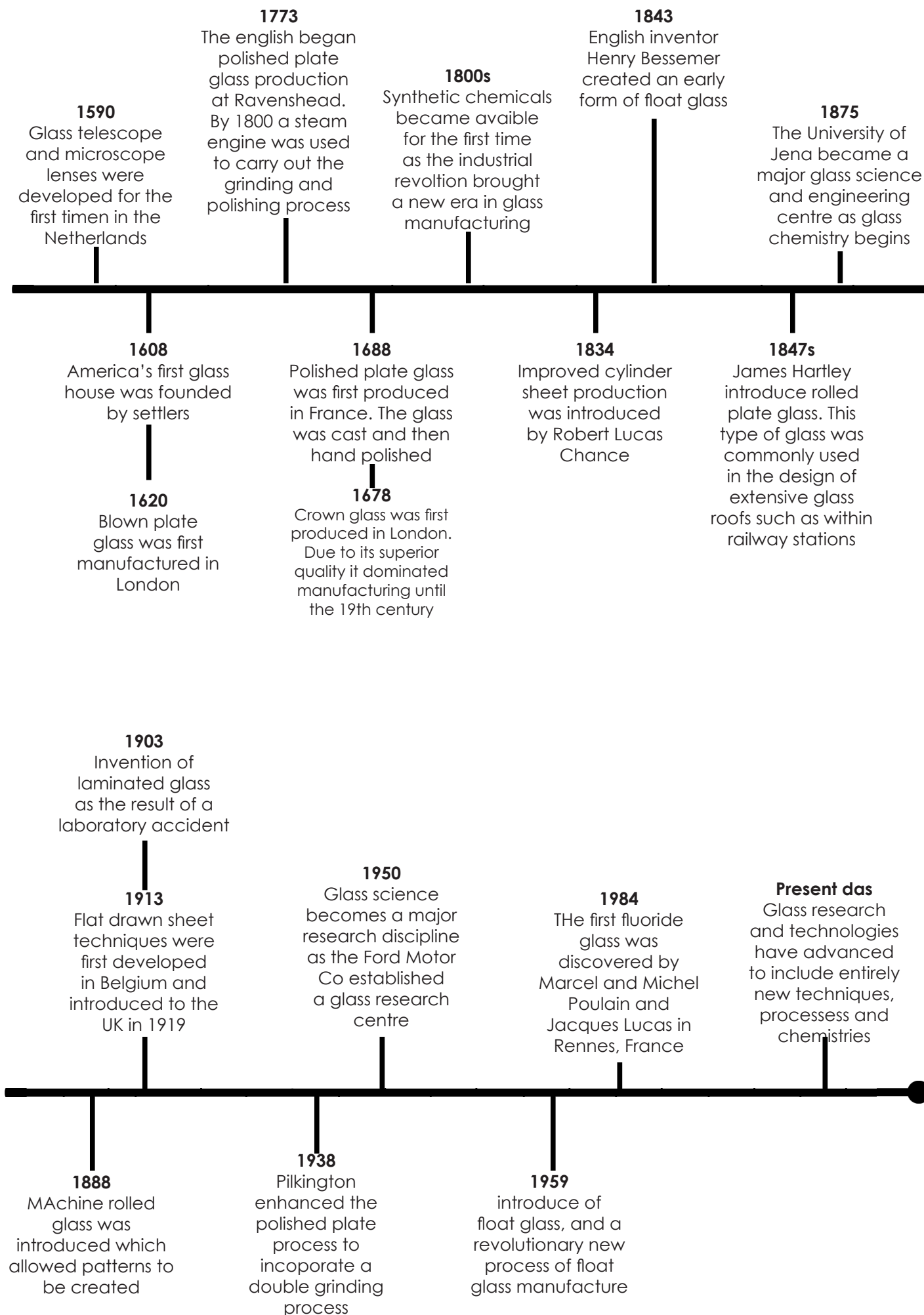

Figure 13: History of the glass (<http://glass.com.ng/>).



## 2.1.2 What is Glass?

*„Leveraging the ability of the glass to bring natural light deep into the building and provide an unprecedented view of the outside world. By leveraging the beauty of glass, it can help to create a project that is a fascinating work of art that maintains, and even reflects, its functionality. Glass has the power to alter of the cityscapes, from the tallest, skyscrapers to low-rise.“*

Glass is a solid-like and transparent material that is used in numerous applications in our daily lives. It is a combination of sand and other minerals (limestone, soda) that are melted together at a very high temperature which is ideal for different applications. In nature, glass can be found in volcano when the intensive heat of an eruption melts sand.

At high-temperature glass is structurally similar to liquids, however, at ambient temperature, it behaves like solids.

The beauty of the glass was discovered centuries ago, where the transparent and colouration had made it best suitable for lighting purpose in the early stage (Anas Khan). Nowadays glass is used for various applications, such as windows, car windscreen, computer screens, smartphones, light bulbs; all in all glass can be found everywhere.

Taking advantages of the unique properties of glass regarding structural behaviour and its transparency, it plays a vital role in many architecture and engineering project.

As other material, glass also has certain characteristics and properties, which affect the behaviour of the material. This section, therefore, will describe and focus on the classification composition and behaviour of glass.

### Chemical behaviour

Materials in nature exist in three states of aggregation: gas, liquid and solid. Solids can be amorphous or have different crystalline forms.

While the crystalline form is a well ordered atomic level, amorphous solids are disordered at an atomic level, where the atoms held together in a completely random formation.

Glass and quartz can show the different atomic bonds.

Glass is a non-crystalline solid, structurally disordered material, due to its microstructure.

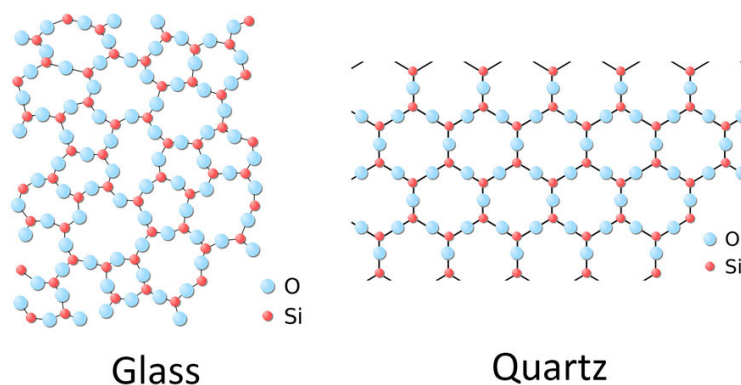

Figure 14: The atomic-level of glass and quartz.  
(R. Bernstein, A. Capri, 2015)

The fundamental difference between crystalline and amorphous bond is how they are made. The quartz forms on a very slow timescale, so the atoms have time to achieve a highly ordered form. On the other hand, glass is a combination of sand and other minerals that are melted together and letting it cool quickly, resulting disordered bonds ( R. Bernstein, A. Capri, 2015). „Furthermore, amorphous solids break unpredictably and produce fragments with irregular, often curved surfaces, while crystalline solids break along specific planes and at specific angles defined by the crystal’s geometry” ( R. Bernstein, A. Capri, 2015).

There are certain types of glass, which have a different level of transparency, due to the atomic structure of the glass. Given an atom, surrounded by electrons which are occupying different energy levels. To move from lower to a higher energy level, the electron must gain energy. On the other way, when it moves to a lower energy level, it gives up energy. There are three options when a photon is moving toward and interacts with a solid substance. Option one is „The substance absorbs the photon”, option two is when „The substance reflects the photon, and the last one is „then substance allows the photon to pass through unchanged. As for glass, the last option is applicable. The photons pass through the material due to the fact that they do not have sufficient energy to excite a glass electron to a higher energy level. This is called as a band theory, where the energy levels exist together in a regions. Between these regions there are band gaps where the energy for electrons do not exist at all. Glass is one the material where these gaps are large, thus the electrons require more energy before they can skip from one energy band to another one and back again. Photons of visible light do not have enough energy to cause this skipping. Therefore the photons travel through the glass instead of being absorbed reflected.

Smaller wavelengths than visible light, the photons have enough energy to move glass electrons from one energy band to another one, thus the light with a visible wavelength cannot travel through the window.

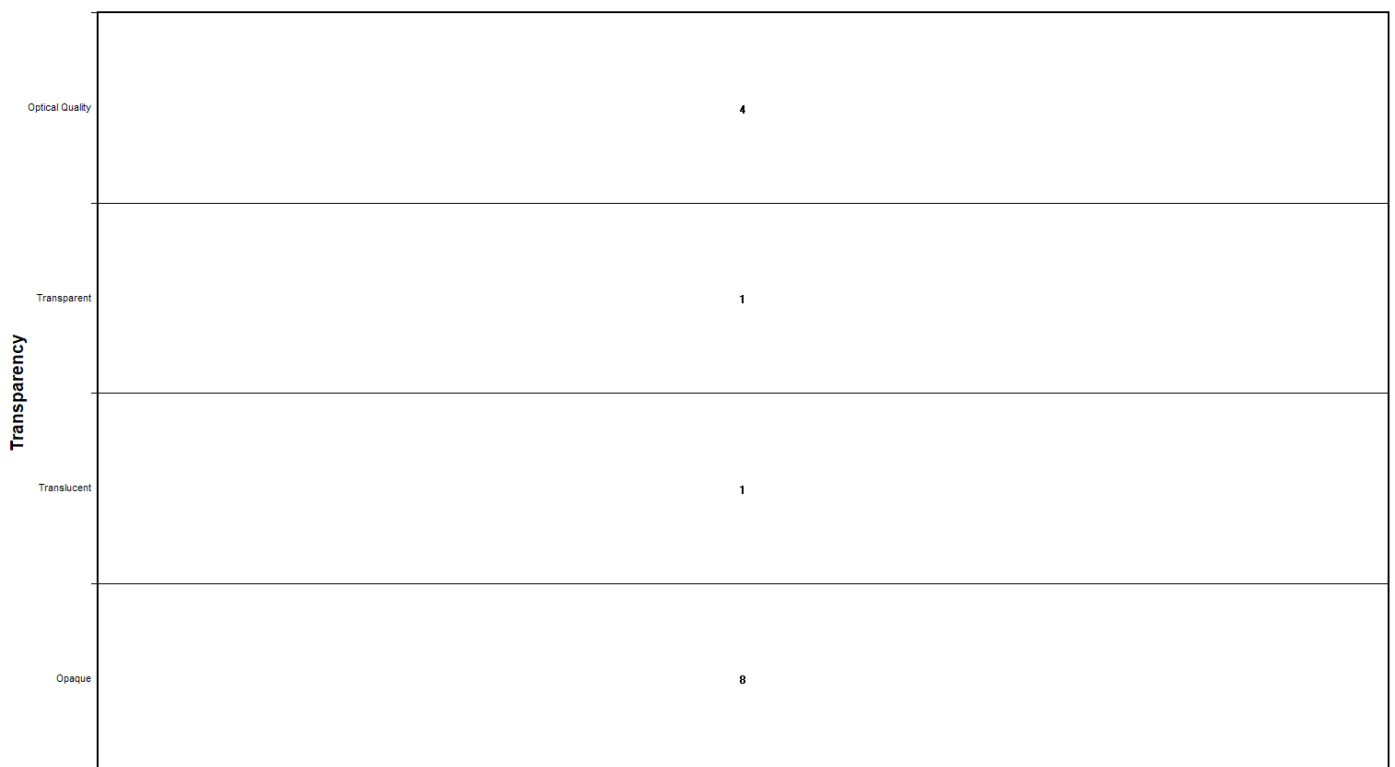

Figure 15: The transparency of the glass.  
(CES 2017)

Glass does not have a unique atomic bond, but does not have a standard chemical formula. The most commonly used of glass is soda-lime glass. The typical composition of soda lime-glass is the following: -silicon dioxide, -sodium oxide, -calcium oxide, and aluminium oxide. By adding further additives or changing the portion of the previously mentioned materials can influence the properties of the glass, therefore it can obtain different types of glass for different applications.

### 2.1.3 Types of glass

There are many different types of glass with different chemical and physical properties and each can be made by a suitable adjustment to chemical compositions. For the different, specialised applications, choosing the right type of glass is crucial. The most important groups of materials, which are used for glass products are the following:

- sodalime glass
- borosilicate glass
- aluminosilicate glass
- quartz glass
- lead glass

#### Soda lime glass

Soda-lime glass is the most common type of glass that is produced. It is relatively inexpensive, chemically stable and it can be processed at lower temperatures (1200- 1400° C) therefore it is much more cost-effective to be produced. However, due to the higher thermal expansion coefficient of soda-lime, it requires a considerably longer annealing time, which would affect the manufacturing time. Another limitation is that it has a lower thermal resistance than the other types of glass.

A typical use of this glass is: windows, bottles, containers, tubing, lamp bulbs, lenses, mirrors, bells, glazes and tiles ( CES 2017 ).

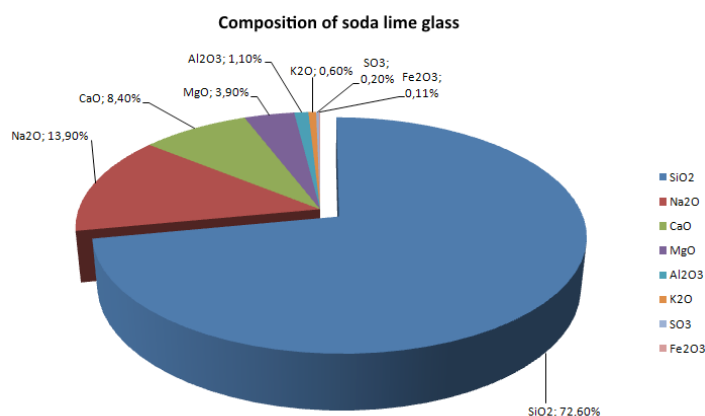

Figure 16 : Possible composition of soda-lime glass.

#### Borosilicate glass

Borosilicate glass has been widely used due to the high chemical resistance and better resistance to thermal shock. Boron oxide (7- 13% ) is used in the recipe of glass which provides enhanced durability and diminished coefficient of thermal expansion. The working temperature is approximately 1200-1400° C which is significantly higher than soda-lime glass. A typical use of this glass is laboratory apparatus, optics, lighting applications, ovenware.

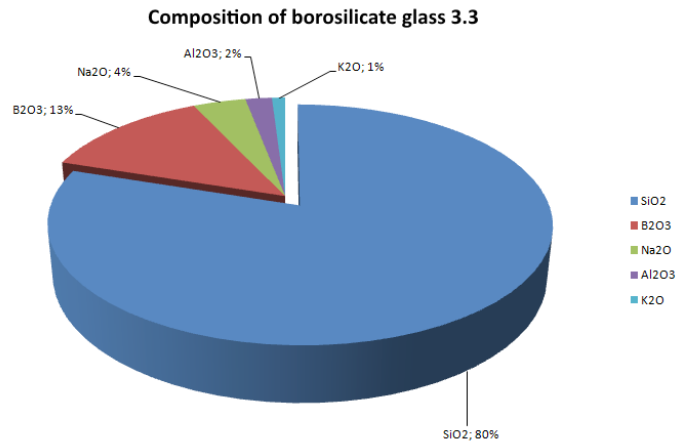

Figure 17 : Possible composition of borosilicate glass.

## Aluminosilicate glass

Aluminosilicate glass has a composition of 20% aluminium oxide, calcium oxide, magnesium oxide, and boric oxide. It has similar properties as borosilicate glass, but it has better chemical resistance and higher operating temperature of up to 600 ° C. It is able to withstand high temperatures and thermal shocks. This type of glass is considered to be the intermediate between soda-lime and quartz. Compared to borosilicate glass aluminosilicate glass is more difficult to manufacture, in addition it is very expensive.

The typical use of this glass is combustion tubes, gauge glasses for high-pressure steam boilers, halogen- tungsten lamps.

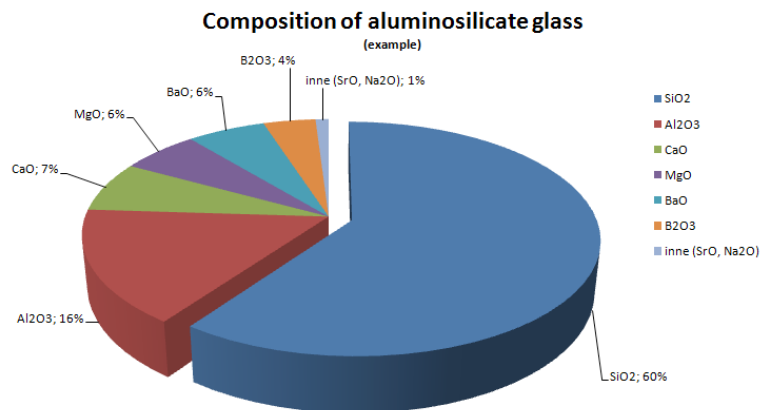

Figure 18 : Possible composition of aluminosilicate glass.

## Quartz glass

This type of glass has a very high content of pure silica ( SiO<sub>2</sub> ~99,9%). Quartz glass has a high melting point and a low coefficient of thermal expansion, which makes it resistant to thermal shock. It is a material for variety of applications in several industries because of its exceptional properties.

The typical use of this glass is windows, lenses/ optics, metrology components.

## Lead glass

Lead glass is commonly used to make decorative glass objects. It is made by using lead oxide instead of calcium-oxide and potassium oxide instead of sodium oxide. Any glass which contains at least 24% of PbO can be described as a lead crystal, less than 24% of PbO is known as crystal glass. Glass with even higher lead oxide contents ( typically 65% ) can be used as radiation shielding. Thus it can absorb gamma rays and other harmful radiations. The lead is locked into the chemical structure of the glass, so there is no risk to human health (Britglass.org.uk, 2018)

The typical use of this glass is medical industry, decorative glass objects.

	Tensile strength MPa	Yield strength MPa	Young's modulus GPa	Density kg/m <sup>3</sup>	Hardness kg/mm <sup>2</sup>	Price eur/kg
Quartz	45-155	45-155	68-74	2170-2200	450-950	5140-8580
Soda-lime glass	30-35	30-35	68-72	2440-2490	440-485	1160-1370
Borosilicate glass	22-32	22-32	61-64	2200-2300	84-92	3430-5150
Lead glass	23-24	23-24	53-55	3950-3990	472-525	3300-5100
Alumino silicate glass	40-44	40-44	85-89	2490-2300	68-75	1170-1370

Table 1 : Properties of different types of glass.  
(Glass Construction Manual, 2007)

## 2.1.4 Production technique

The evolution of glass production can be seen at Figure 10. From the ancient time the production of glass has been improved a lot. The most advanced developments in glass manufacture are the results of the industrial revolution. The technical level of furnaces, chemistry and mass production method have been improved.

Glass is fluid at high temperature, and when the temperature reduces the fluidity of the glass decreases, it becomes solid. Melting the raw materials together is the start of the production. There are several production technique of how glass can be made. These methods usually based on multiply factors; what raw materials are used, what heat energy is required, and also what the final product is. According to the requirements and the use of product (glass), the techniques are the following: - ; **-Float Glass Manufacture;** **-Container Glass Manufacture;** **-Extruded Glass;** **-Drawn Glass;** **- Rolled Glass;** **- Cast Glass,**



Figure 19 : Proces of glass blowing

## Container Glass Manufacture

The first method is the container glass manufacture.

The most common process to make bottles was by hand gathering, blowing and finishing until the second half of 19th century. In the second half of the century the process became semi-automatic, then it has become fully automatic. In this method, there are two kinds of process of making glass. The „Blow and Blow” and the „Press and Blow” method.

### Blow and Blow method

The method starts with heating the glass until it reaches its plastic stage. Then the heated glass is cut and shape it into a cylindrical shape, called gob. The gob is taken to a blank or a parison mould where due to the gravity it falls. Afterwards, puff of compressed air blows the glass into the base of the mould to form the neck part of the bottle. „A second puff of compressed air is applied through the already formed neck of the bottle to form the parison of pre-form for the container against the walls of the parison mould cavity” (Britglass.org.uk, 2018). Next, the parison is moved into a final mould where it is blown again into the mould to get the final dimensions.

### Press and Blow

The difference is between the previously mentioned method and this method is the beginning of the process. Here, the gob is delivered into the parison mould and a plunger is used to press the glass into the parison shape. Then the following steps are the same as the blow and blow method.

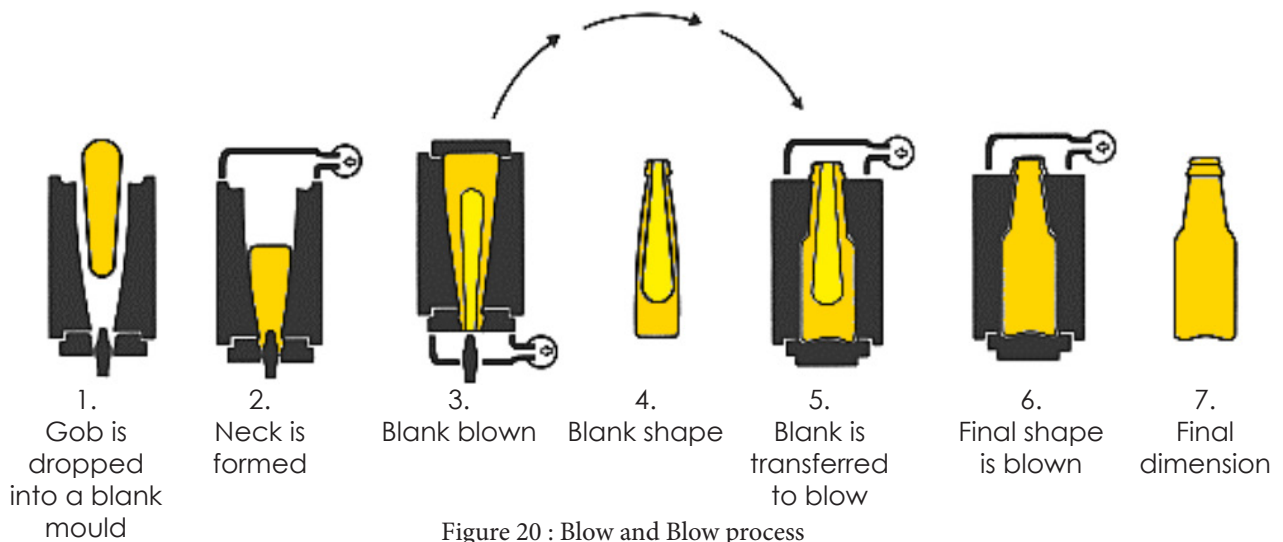

Figure 20 : Blow and Blow process

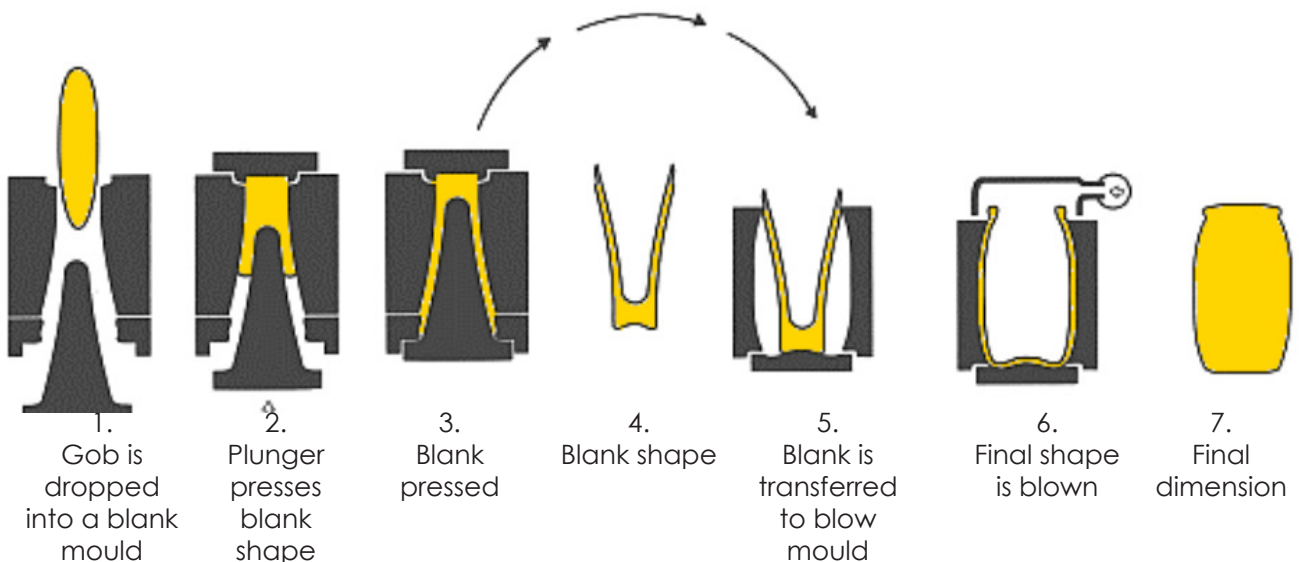

Figure 21 : Press and Blown process



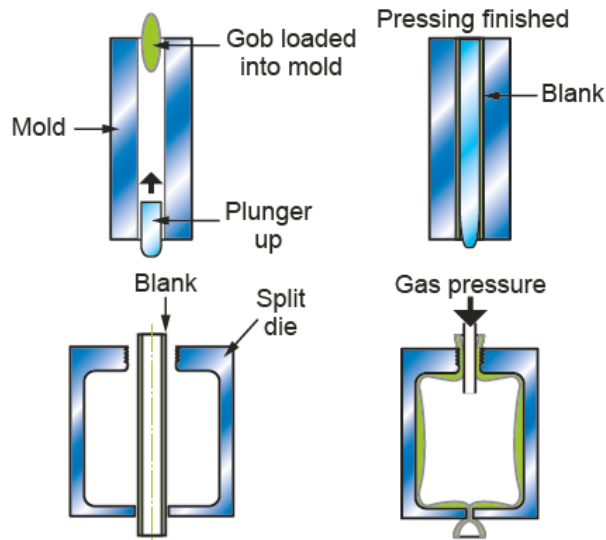

Figure 22 : Container Glass Manufacture.  
(CES 2017)

### Float Glass Manufacture

The most common production technique is the float glass manufacture.

Flat glass products can be found everywhere around in the world. It was invented by Sir Alastar Pilkington in 1952. The main advantages of the float glass are its low cost and the high optical quality.

The main ingredients are melted together in a large furnace approximately at the temperature of 1500°C. Once, it gets melted, and the glass is free from bubbles the glass is cooled down to the temperature of 1100-1200°C. When it achieves the desired temperature, the ribbon is formed by a pair of rollers to prepare for the float bath. There, the glass floats on a molten tin and the atmosphere is filled with nitrogen and hydrogen to prevent the oxidation of the tin and coatings, chemical treatments and polishing takes place in the float bath. Then, ribbon is further cooled and goes to the annealing lehr at the temperature of 600°C, where the glass is cooled uniformly to room temperature to prevent internal stresses. When the annealing process is finished, inspection takes place to ensure that the quality of the glass whether is acceptable or not. The last stage of the process is to cut the glass into the required dimension.

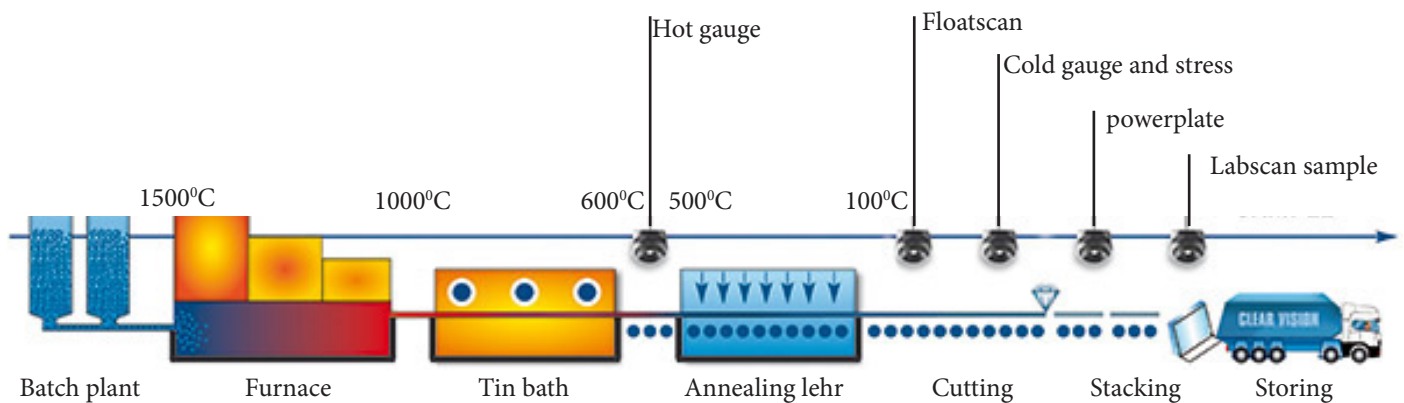

Figure 23 :S Process of the Float glass manufacture.

## Rolled glass

The process is used for the manufacture of patterned and wired glass.

### Patterned glass

The glass is heated up to the temperature of  $1100^{\circ}\text{C}$ , then the continuous stream of molten glass is poured between water cooled, contra-rotating rollers. The bottom roller is responsible for the pattern, thus it is engraved with the negative of the pattern, meanwhile the top roller is smooth. The thickness of the glass is controlled by the distance of the two rollers. Then, the glass goes to the annealing lehr to be cooled down to room temperature. (Britglass.org.uk, 2018).

### Wired glass

In the process two sheets of glass are used which are attached together and between them wires are placed. Two pairs of cooled rollers are used. The first pair produces the continuous ribbon of glass and it is overlaid with the wires. The second pair of rollers produce the same glass thickness as the first pair and then they are attached together. Therefore, the wire is closed between the two sheets of glass.

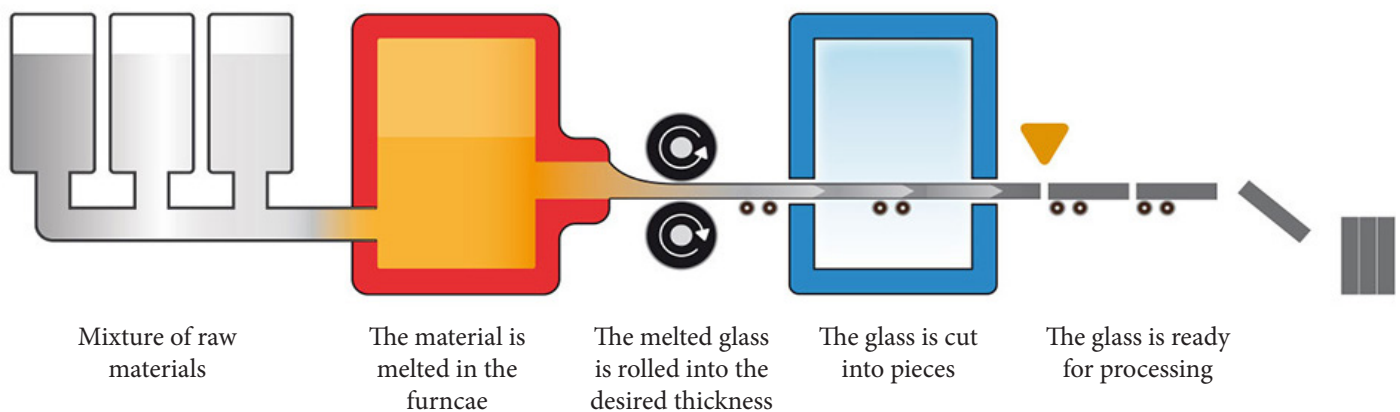

Figure 24 : Process of Rolled glass manufacture.

## Extruded glass

Extrusion of glass can be produced with a variety of wall thickness which are applicable for thin glass profiles, tubes, or rods. These products can be used for glass apparatus, photovoltaics technology (as a receiver), electrotechnology/ electronics, architecture applications, lightning, and laboratory/ industrial usage.

Extruded glass is a very sophisticated product. The main advantages are high thermal shock resistance, high optical quality, wide geometrical dimension range and tight tolerances. [SCHOTT, 2015]. There are two processes making extruded glass: - the Danner process; -Vello process.

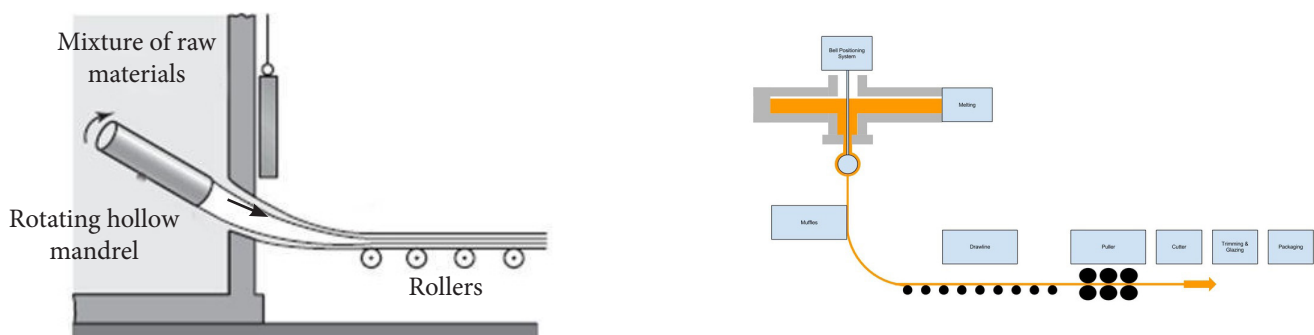

Figure 25 : Process of Extruded glass manufacture.  
Left: Danner process; ; Right: Vello process



## Drawn Glass

This type of method is not that common in the building industry, due to the low optical quality of the glass. A ribbon of glass is drawn upwards from the furnace, where along of rollers it is shaped into the desire thickness. The glass is then annealed and cut into pieces as well.

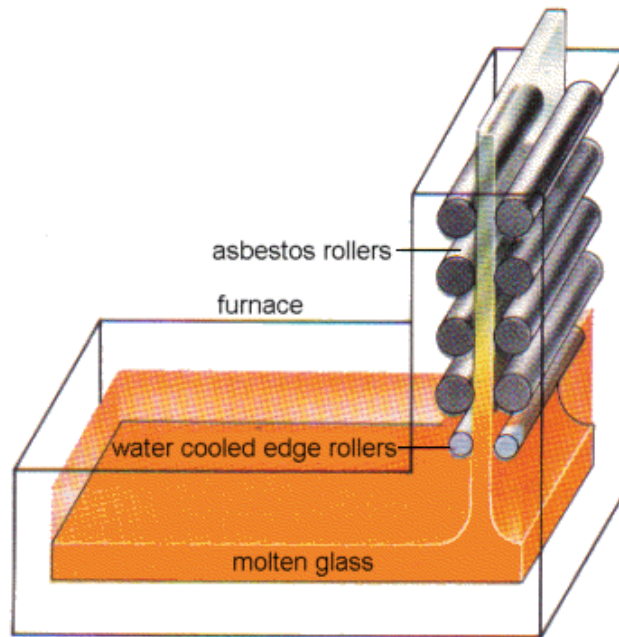

Figure 26 : Process Drawn glass.

## 2.1.5 Casting glass

Casting glass can ensure a great freedom in forming unique monolithic glass objects. Glass casting is the process in which glass is poured into a preformed mould where it solidifies. There are two basic techniques for casting glass objects, hot-pour and kiln-casting.

### Kiln-casting

During the process, the mould is placed into a kiln and remains until at the end of the casting. The mould is usually made of solid material which can withstand the high temperature in the kiln. There are two different techniques of kiln-casting. One of them is when broken glass is placed on top of the mould and directly fill the mould as the viscosity of the glass decrease while heating the kiln ( Sombroek, 2016). Alternatively, the broken glass pieces are placed in a pot which is above the mould. The glass pieces slowly melt and fill the mould. Once the mould is full of liquid glass, the oven is slowly cooled down to avoid sudden heat changes, which can result cracking.

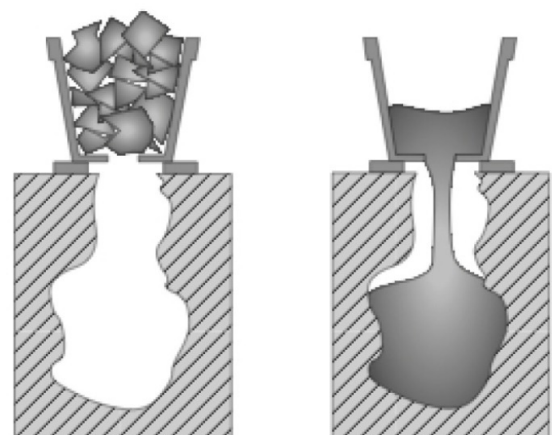
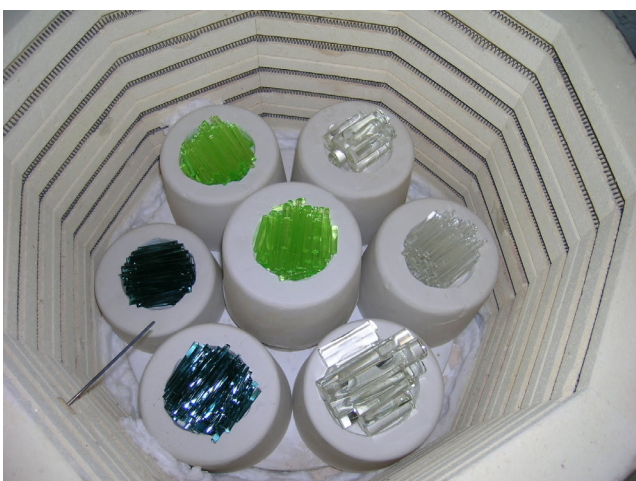

Figure 27 : Kiln casting technics.

## Hot-pouring

Molten glass is poured directly into a preformed mould at the temperature of 1200 ° C. The mould has to be heated in advance to avoid temperature changes. When the glass cooled down rapidly to the temperature of 700 ° C, the glass is removed from the mould and it can be taken into the kiln for the annealing process. In the kiln, the glass can slowly cool down to the room temperature.



Figure 28 : Hot-pour technique.

In both casting techniques, moulds have to be prepared in advance which can be either disposable or permanent mould.

Disposable moulds are positive models that usually made of soft materials like wax or direct pour of gypsum which can withstand high temperatures. The method is that after hardening of the negative mould is to burn out the positive, then the glass can be poured into the negative mould. The surface quality of the mould influences the surface of the glass, therefore the mould has to be polished in order to achieve good result.

As it was mentioned the other type of mould is the permanent mould. This mould is made from stainless steel or graphite in order to withstand the high temperatures. The end result will have a good surface quality. The drawback of these moulds is that they are expensive, especially the graphite one. These moulds should be preheated in order to avoid the sudden temperature changes which result crack in the glass.

## 2.1.6 Post-process

### Cutting and Grinding

As it was mentioned after the annealing process, the float glass is usually cut into the desired dimension. The cutting process can be done either with CNC machine or with water jet cutting technology.

Waterjet cutting is a non-thermal cutting method where natural sand and water are used for cut the objects. The water is cleaned and pressurized in a pump. The water is delivered to the water jet cutting head which has a small hole, thus the water beam can be concentrated on a very small point and the pressure turns into velocity. With water jetting cut method smooth cutting edge can be achieved as well as it provides no micro cracks or stresses on the surface. It provides a high precision cut.

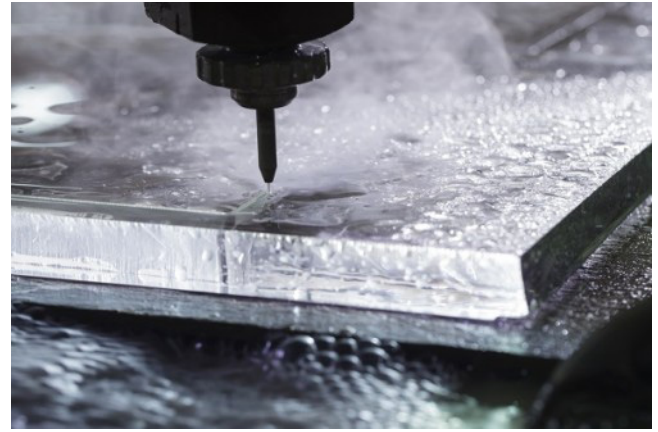

Figure 29 : Water jet cutting method.

However, water jet cutting provides a smooth edge but most of the times glass planes has to be grinded and polished after the cut process. Grinding the glass gives different types of edges and polishing gives better visual quality.

The formed edge of the glass can impact the structural performance of the glass. The following table shows the types of the edge and provides information which edge can be use for what.

Edge Diagram	Description	Typical Application
	Flat ground	Silicone structural glazin with exposed edges
	Flat polish	Silicone structural glazin where edge condition is critical for aesthetic purposes
	Ground pencil edge	Mirrors, decorative furniture glass
	Polished pencil edge	Mirrors, decorative furniture glass
	Ground Miter	Silicone structural glazing
	Bevel	Mirrors, decorative furniture glass
	Seamed Edges	Normal edge treatment for heat-treated glass

Figure 30 : An overview of the glass edges.  
( GuardianGlass)



## 2.2.1 Glass as a structural material

Glass is an elastic, isotropic material and exhibits brittle fracture. Compared to other materials, no plastic deformation occurs prior to failure. The brittle characteristic of glass is of concern when glass is used as a main load-bearing element.

Theoretically, glass can have a very high tensile strength up to 32 GPa (FRÖLING, 2013). However, the tensile strength depends on the influence of mechanical surface flaws. The compressive strength of the glass is significantly higher than the tensile strength due to there is no surface flaw growth or failure under compression.

Moreover, glass is superior to some materials such as concrete. It is stiffer, stronger in tension and less brittle.

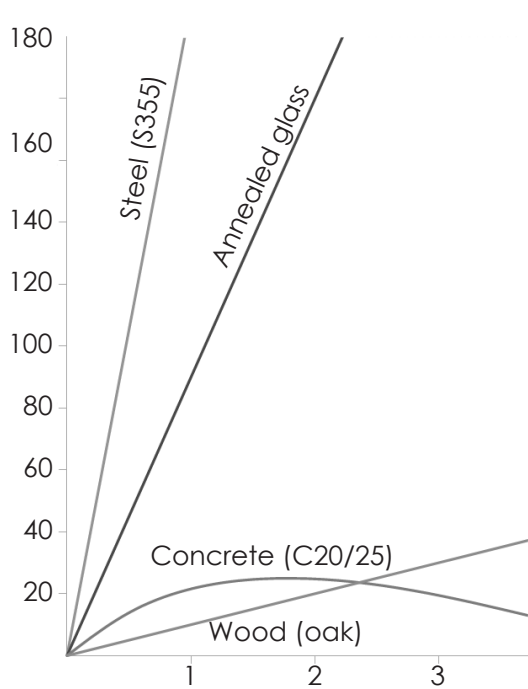

Figure 31 :Modulus of Elasticity of steel, glass, concrete and wood (Felekou, 2016)

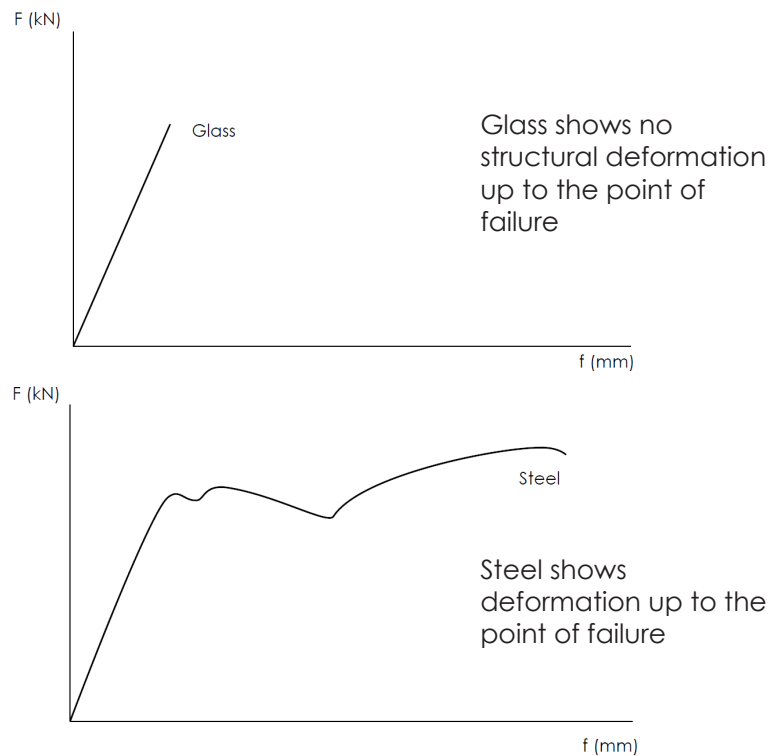

Figure 32 :Mechanical behaviour of glass (top) and steel (bottom) (Doulkari, 2013).

### 2.2.1 Strengthening of glass

Glass can be used as a structural material, but in order to achieve proper strength, it has to be strengthened. There are three primary methods for strengthening glass: chemical strengthening, thermal tempering and laminating. These methods have the same principle. All of the processes alter the outer surface of the glass, causing it to have higher compression than the interior glass, which is in a state of tension. Depending upon the specific treatment, these three processes have different impact on the material.

#### Heat treatment

One of the heat treatments is the fully tempered glass. It is also known as „ safety glass“. The glass is heated up, and it is rapidly cooled down. Thus the core of the glass cools down later an resulting tension in it while the outer surfaces are under compression. Therefore, this results in an overall higher tensile strength. It has the highest level of residual stress and tensile strength as well. Fully tempered glass breaks into many small pieces, eliminating the risk of dangerous shards. That makes tempered glass an ideal choice for many applications.

The other kind of heat treatment is the heat strengthened glass. Heat strengthened glass undergoes a slower cooling process than the tempered glass resulting in lower compression strength. The heat strengthened glass breaks into bigger pieces.

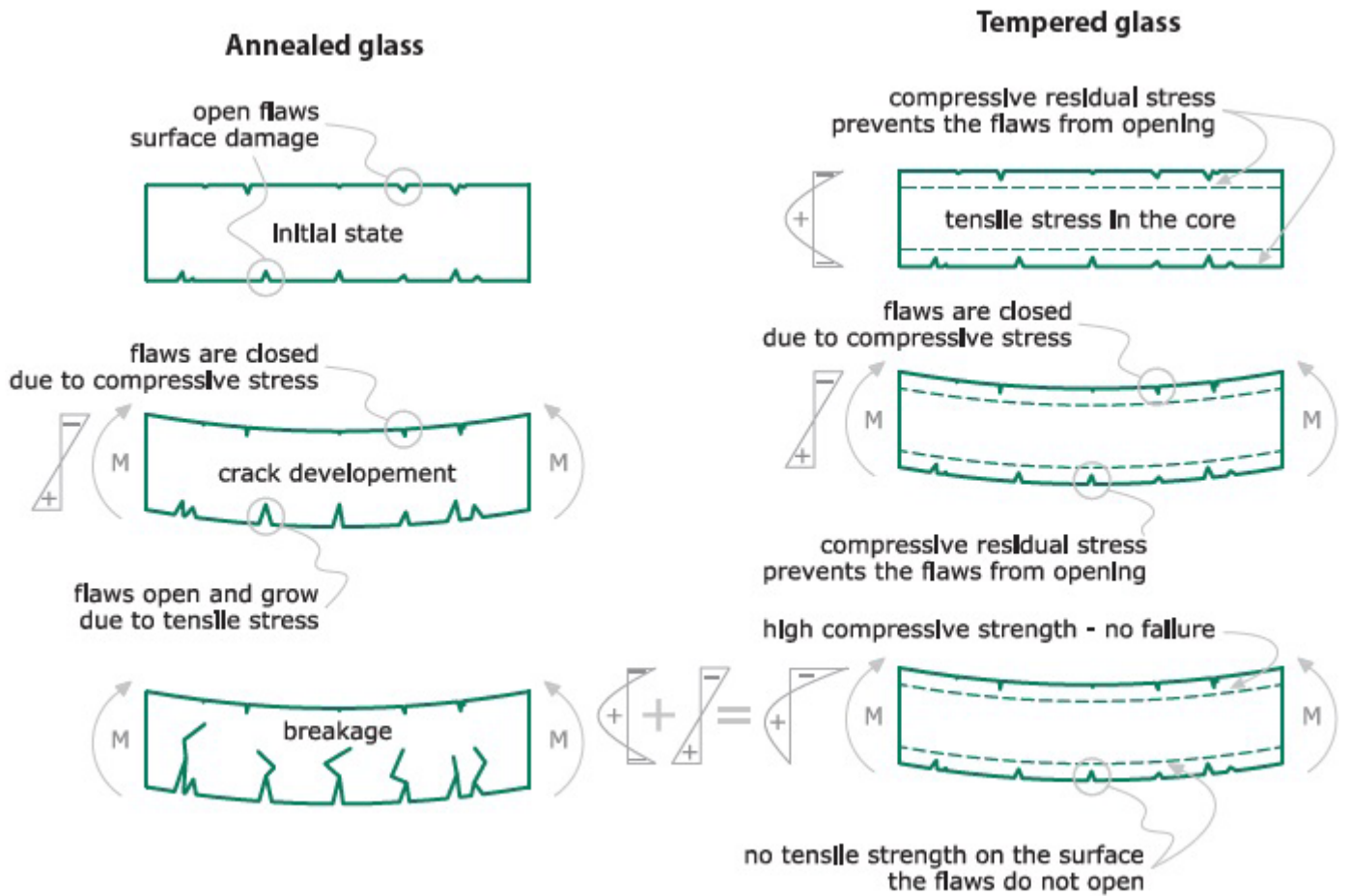

Figure 33: Behaviour of anneal and tempered glass.  
(Felekou, 2016)

## Chemical treatment

Glass is submersed in in a molten potassium salt bath at the temperature of 300°C, causing sodium ions in the glass to be replaced by potassium ions from the bath (Swift Glass, 2018). Therefore, the replacement of ions causes the surface of the glass to be in the state of compression and the core under tension. The process increases the strength of the glass by six times. Chemically treatment glass breaks into large pieces.

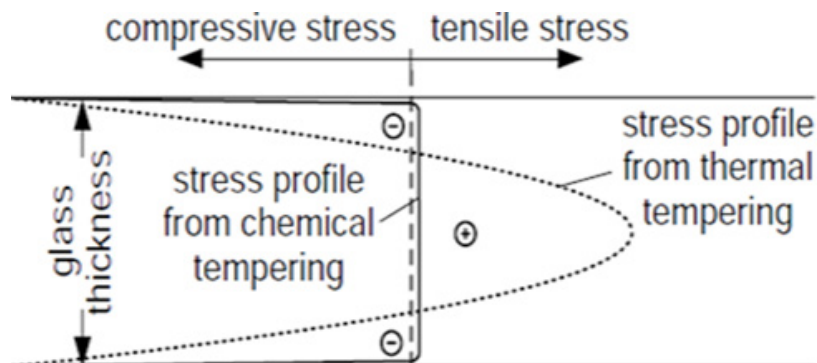

Figure 34: The stress distribution of the different strengthening treatment.

## Lamination of glass

Laminated glass is a safety glass where at least two layers of glass are bonded together. It has a better load-bearing capacity than monolithic glass and by laminating together the layers the post-breakage behaviour is enhanced. The structure consists of two or more sheets of glass bonded together by a plastic interlayer. The purpose of the interlayers are to retain the fragments after fracture in the laminated glass, which would prevent the risk of injury due to the sharp glass shards and the structure can still bear the additional loads. The thickness of the glass panes can be equal or unequal and the different panes can be heat-treated glass, annealed glass or the combination of the two. The interlayers in laminated glass are usually soft polymers like Polyvinyl Butyral (PVB) or Ethylene-Vinyl Acetate (EVA)

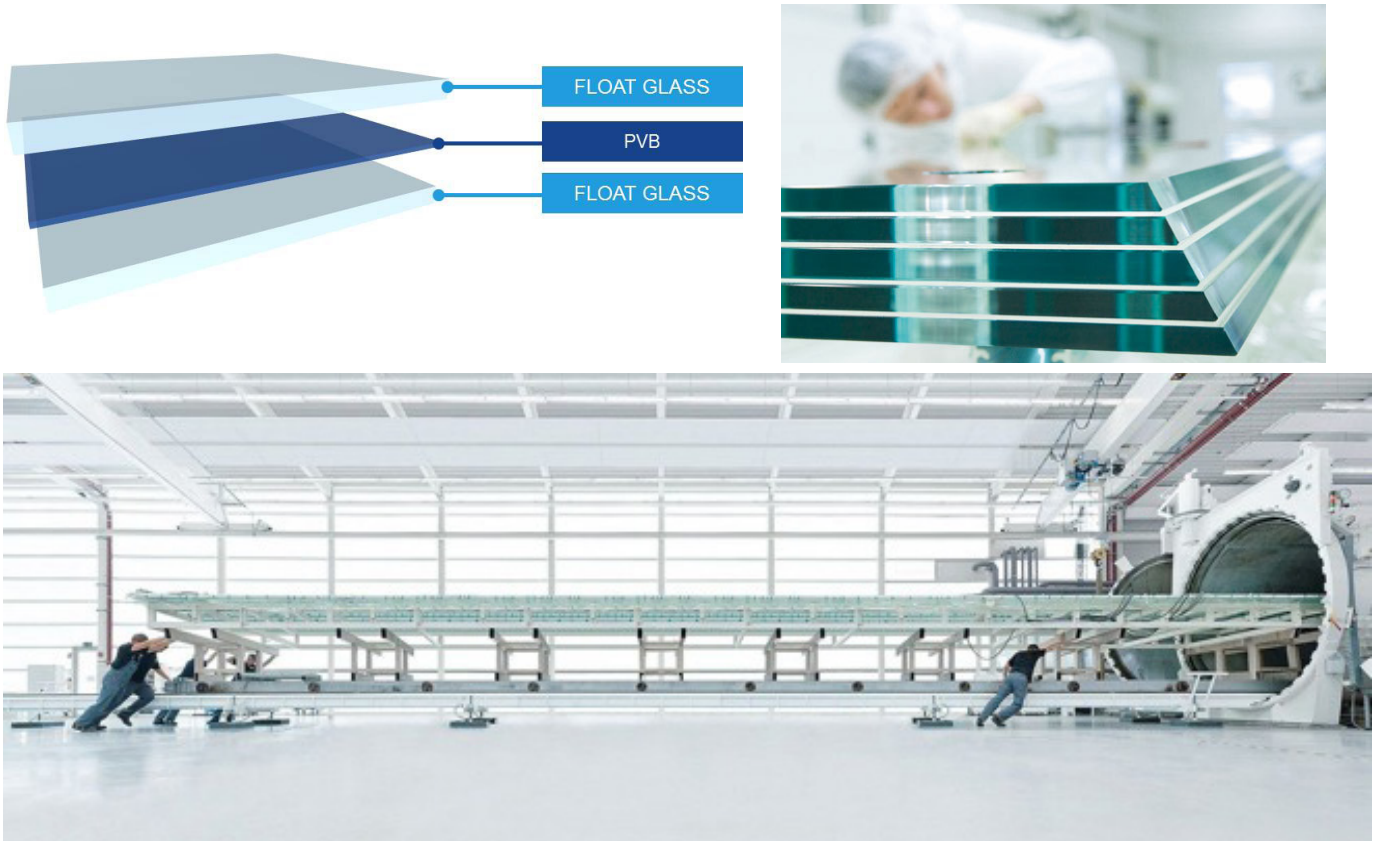

Figure 35: Laminated glass.

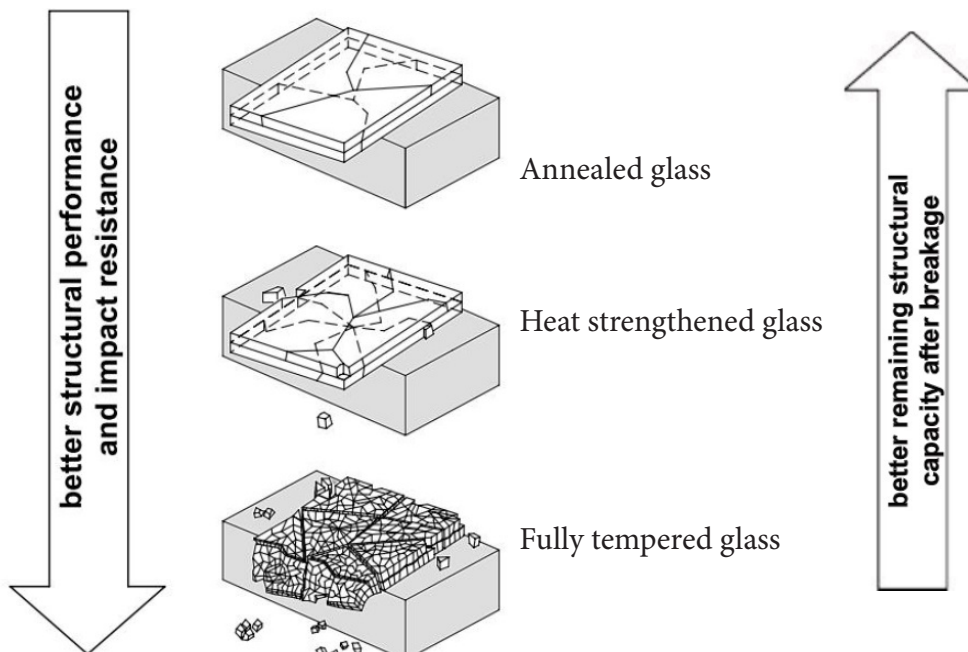

Figure 36: Breakage behaviour of different strengthened glass types

	Annealed glass	Heat-strengthened glass	Fully tempered glass
Compressive strength	120 MPa	120 MPa	120MPa
Tensile strength	20 MPa	40 MPa	80 MPa
Cost	low	high	higher

Table 2: Characteristics of the strengthened glass

Glass is a brittle material and never exhibits a warning before the failure. Therefore it needs to take into account some worst scenario. For that reason, safety is increased to reduce the risk. One possible option can be that making the structure safer (which makes the design more expensive) or applying such external objects or structures which defend the main structure.

A risk analysis works out the probability of failure due to variation in factors such as human-caused damage or unpredictable loads. These variables can be characterized by random distributions which characterize all things unknown about the particular variable assuming independence from other variables.

Risk= probability \* consequence

The risk is defined as the expected consequences associated with a given activity. Considering an activity with only one event with potential consequences risk "RD" is thus the probability that this event will occur "WS" multiplied with the exposure structural element "BS" and with the consequences given the event occurs "C".

Probability (WS) \* Exposure (BS) \* Consequence (C)

<b>Probability intentionally or unintentionally</b>	<b>WS</b>	<b>Exposure structural element</b>	<b>BS</b>	<b>Consequence complete failure</b>	<b>ES</b>
Virtual impossible	0.1	Very rarely	0.5	First aid	1
Practically impossible	0.2	Several times a year	1	Minor injury	3
Possible, but very unlikely	0.5	Monthly	2	Serious injury	7
Only possible in the longer term	1	Weekly	3	One dead	15
Uncommon, but possible	3	Daily	6	More than one dead	40
The best possible	6	Constant		Catastrophe, many deaths	100
Can be expected	10				

Table 3: Risk analysis table.



## 2.2.2 Connections

Connections between glass components are one of the most difficult and critical part in designing a glass structure. Glass as a material is fragile, and cannot redistribute the stress peaks where forces are transferred between the different components (Santarsiero, Louter and Nussbaumer, 2016). Therefore, steel or other metals are tackled the role of connection. Connections between glass components can be either bolted or adhesively bonded connections. As bolted connection, holes are drilled through the glass where metallic bolts are placed to transfer the forces properly. Usually, soft materials are placed between the glass and the metallic components, thus both hard surfaces do not meet together directly.

The other connection type is the adhesive connection. Between the glass elements, an interlayer is applied (adhesive), which can be a liquid adhesive or an adhesive foil. The interlayer keeps the glass structure together and ensure the structural requirements.

Comparison both type of connections, adhesive connection has the following advantages over bolted connection:

- the transferred forces are more distributed over the fully bonded area hence avoiding contact stress intensification;
- the drilling process and the subsequent reduction of the glass strength at the hole edge is avoided;
- the architectural flushness is enhanced because the metal parts do not go through the glass;
- thermal bridges and thermal losses are also reduced because the metal part does not go through the entire glass thickness ;
- the residual stress field distribution of the tempering is unaltered at the connection and ;
- gas losses occurring in IGU bolted panels are reduced since the glass is not drilled Santarsiero, (Louter and Nussbaumer, 2016).



Figure 37: Bolted glass connection.

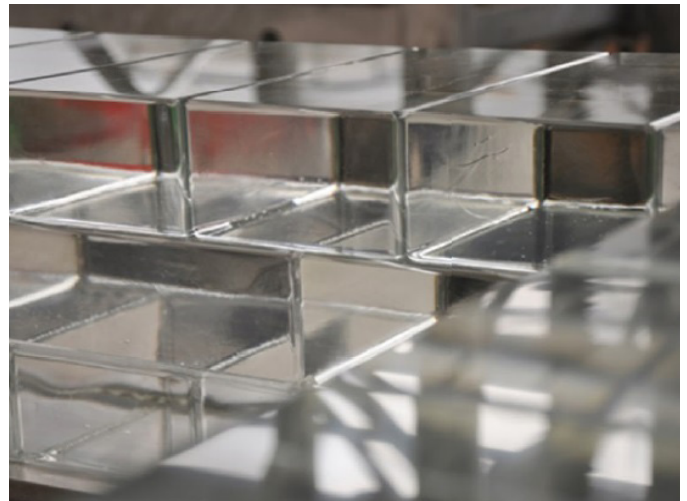

Figure 38: Adhesive connection.



## Adhesive joint

The adhesive joint has big advantages especially from the aesthetic point of view, since the glass structure are kept together smooth and the joints are invisible. Adhesives connections show some yield capacity, therefore it can redistribute and lower the stress concentration which can occur in the joints. Furthermore, it is watertight and air-tight joint. On the other hand, the long- and short-term effects are still a problem. The process of „gluing” together the glass planes is a very sensitive process. Any kind of unexpected dirt might deteriorate the adherence which result failure after a while. In addition, the adhesive should be placed with a certain thickness equally.

In glass technology, there six different liquid adhesives used for glass, namely acrylic adhesive, anaerobic adhesives, cyanoacrylates adhesives, epoxy adhesives, polyester adhesives, and polysulfide adhesives ( CES 2017).

**Acryl adhesives** have a good durability and very high optical quality. It has an excellent shear resistance and shock resistance. However it is very expensive (CES 2017).

**Cyanoacrylates adhesives** is known as a „super glue”. „Alpha cyanoacrylates are low viscosity liquids which polymerize or cure rapidly in the presence of moisture or many metal oxide (CES 2017). This type of adhesive is also very expensive.

**Epoxy adhesives** have high tensil strenghts (upt to 45 MPa) and low peel strenghts (1.8 kg/mm). It withstands acids, solvents, bases and salts.

**Polyester adhesives** provide a strong bonds to repair polyester-matrix structures, ABS, concrete and occasionally metals (CES 2017).

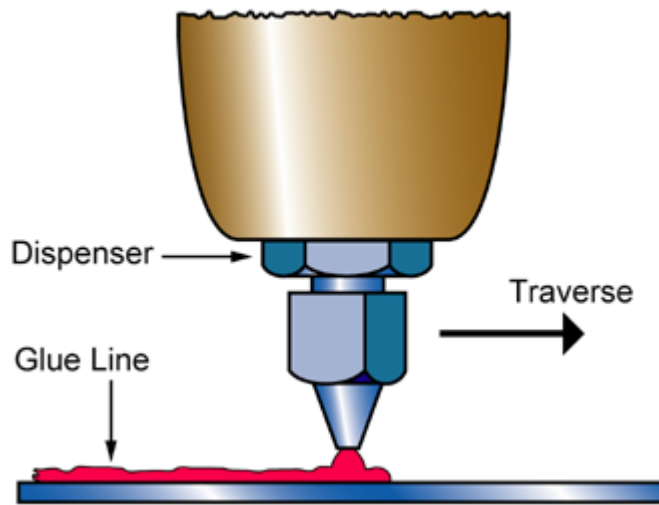

Figure 39: Schematic picture of adhesive process.

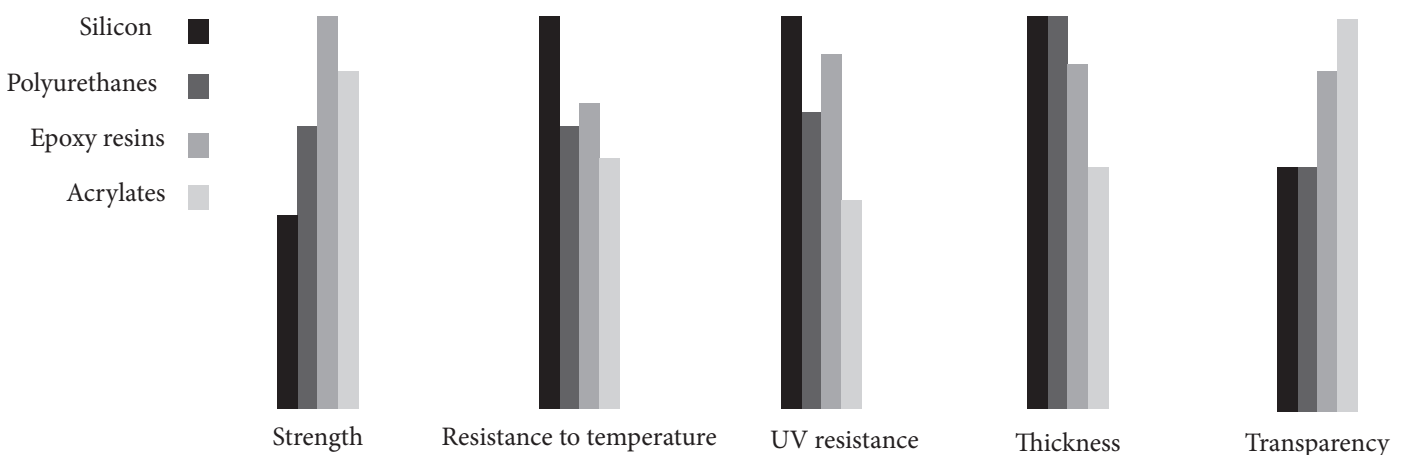

Table 4 : An overview of the adhesives (Barou, 2016).

## Bolted connection

In this type of connection metal is designed in the glass structure and the final product is a composite element. For the application, stainless steel aluminium and titanium are used. From these materials, titanium would be the most proper one due to it has similar thermal coefficient as glass, therefore less stress would occur during the lamination cycle (Felekou 2016).

In principle, hole(s) is drilled in the glass, thus through the holes steel elements can be placed. Drilling holes in the glass also introduce stress concentrations around the holes. That means crack can occur which result failure in the structure. Therefore, the area around the hole has to be tempered uniformly as well.

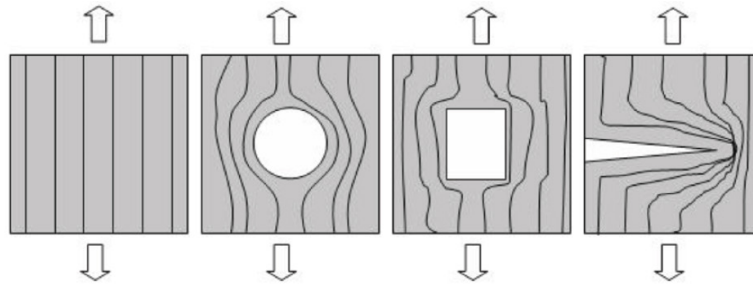

Figure 40 : Stress distribution around holes.



Table 41 : Bolted glass connctetions.

## 2.2.3 Dry assembly- Interlocking system

Traditionally, masonry structures are based on a centuries-old method of assembling a structure, where the building blocks strongly connected to each other (Dyskin, Pasternak and Estrin, 2012). „It is the underlies both the ubiquitous brick and mortar construction” (Dyskin, Pasternak and Estrin, 2012). The main role of the mortar is to prevent sliding the elements relative to each other. „Furthermore, given the usual low tensile strength of mortar and connectors, the resistance to tensile stresses is primarily ensured by the weight if the structure aided in some cases by the arch effect” (Dyskin, Pasternak and Estrin, 2012). On the other hand, mortar also makes the structure stiffer, therefore reduces its resilience to vibrations and seismicity.



Figure 42 : Masonry structure.

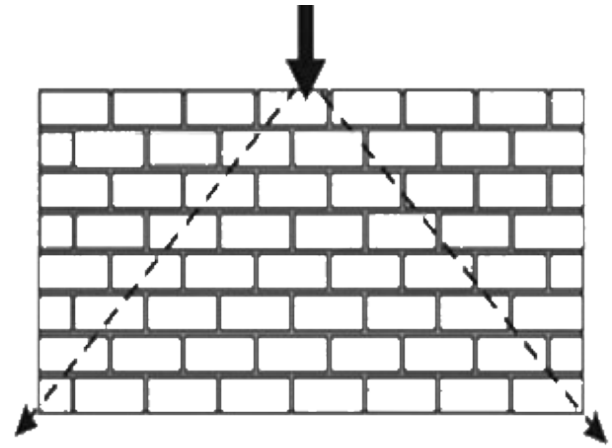

Figure 43 : The point force distribution in a masonry wall

Concept of interlocking is based on a design principle „by elements of special shape are arranged in such a way that the whole structure can be held together by a global peripheral constraint, while locally the elements are kept in place by kinematic constraint imposed through the shape and mutual arrangement of the elements”, (Dyskin, Pasternak and Estrin, 2012 ). The idea of using interlocking structure is not new. Implementation of the idea in buildings can be traced back to the Inca structures. The self-supporting structure consists of heavy stones that are held in place by their weight. These structures are stable, self-aligning structures without any use of mortar (Weizmann, Amir and Grobman, 2015). Furthermore, it shows high seismic resistance.



Figure 44 : Inca interlocking masonry walls.

Reciprocal structural system was brought to the early Renaissance by several scientists, including Leonardo da Vinci. The purpose of the structure was to cover large area with the elements that were shorter than the span, and each beam would lean on two other beams and support two other units (Weizmann, Amir and Grobman, 2017). The structure was not efficient due to the elements could move freely along the beam's direction.



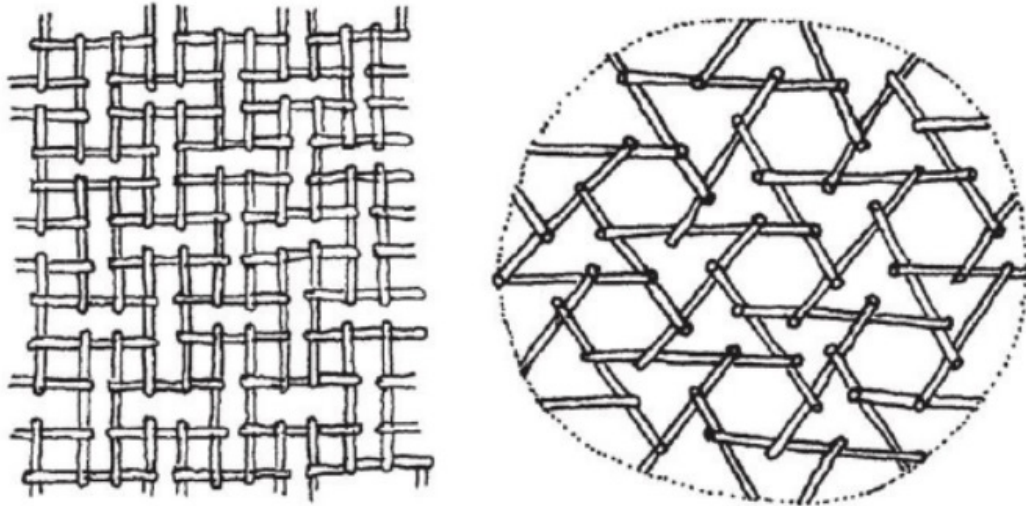

Figure 45 : Inca interlocking masonry walls.

Similar structure was invented, called Abeille's flat, by a French architect Joseph Abeille in 1735. The principle of the system was to cover large span with shorter elements, particularly in stone building. „The geometry of Abeille's flat vault is based on a square tiling obtained through translation and rotation of a single ashlar type, a polyhedron having two orthogonal cross sections (both vertical and passing through the centroid) in the shape of isosceles trapezia with the longer bases at opposite sides” (Brocato and Mondardini, 2012). The elements are locked in both positive and negative „z” axis and in any direction parallel to the plane (Weizmann, Amir and Grobman, 2017).

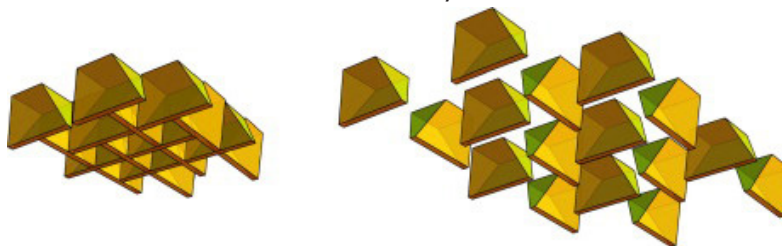

Figure 46: The Abeille's flat vault from a perspective views.

One of the most well-known construction toys is LEGO. The toy is a flagship product, consists of colourful interlocking bricks. Lego pieces can be assembled and connected in many ways to construct buildings vehicles and any kind of objects. Then it can be taken apart to reuse the elements to make new objects.



Figure 47 : Interlocking bricks designed by LEGO



Figure 48 : The Big Ben made of lego interlocking bricks.

As it was seen dry-assembly works perfectly as a load-bearing system. However, the dry connection in a glass structure is slightly different. Directly, glass and glass connection is not considered as safe method. The unevenness of the glass surface would result peak stresses that could lead to cracks. An interlayer has to be used between two glass elements in order to transfer the forces correctly between the elements. Furthermore, the interlayer should be UV resistance and transparent that it does not deteriorate the visual comfort.

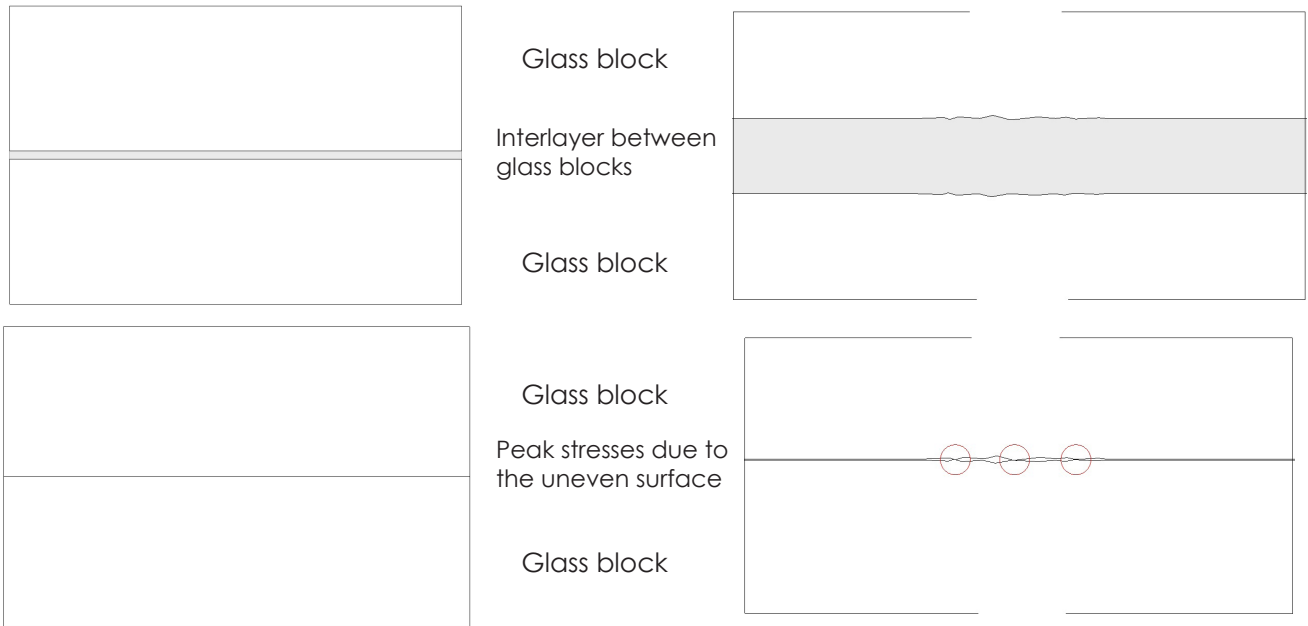

Figure 49 : The importance of the interlayer between glass blocks.



Figure 50 : Poly-bricks by Jenny.E Sabin

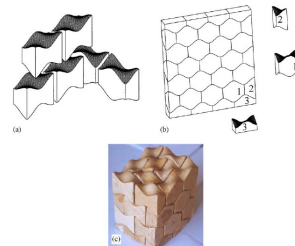

Figure 51 : Masonry structures assembled from osteomorphic brick.

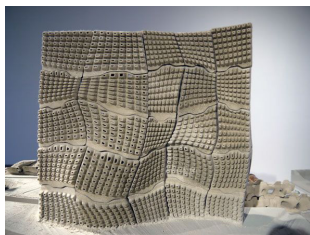

Figure 52 : Cool-brick by Virginia San Fratello and Ronald Rael

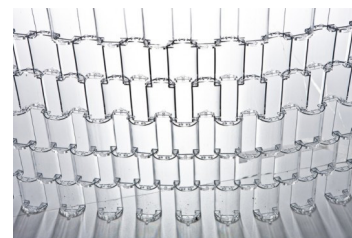

Figure 53 : LEGO Chandelier by Tobias Tostesen

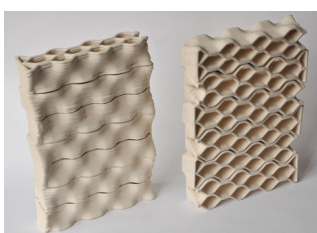

Figure 54 : Building bytes by Brian Peters.

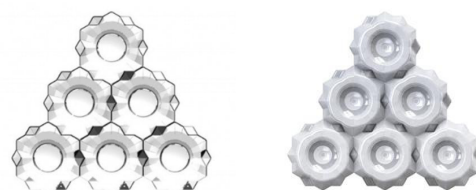

Figure 55 : Polli-Brick interlocking system

## 2.2 Cast glass case studies

Research has been done and described on the most important properties of the glass and its technology, which gives an overall view that what can be done with glass. In this chapter, some of the most significant examples will be analyzed in order to show the feasibility of a cast glass design. The case studies focus on cast glass and its development.

Four case studies, namely Optical House, Atocha Memorial, Crystal House and Hermes store are described, and each design has a challenge to cope with the limitations of cast glass.



## Optical house, Japan



*„The facade appears like a waterfall flowing downward, scattering light and filling the air with freshness”*

*Hiroshi Nakamura*

Figure 56: Facade of the Optical House.

The Optical House was designed by Hiroshi Nakamura, and it was completed in 2012. The house is surrounded by tall buildings in downtown Hiroshima. Therefore the architect wanted to create a private oasis „where residents could still make out the movements of people and traffic beyond the wall”. An optical glass facade made of suspended glass blocks was designed to obtain the privacy and tranquillity.

The glass facade is made of borosilicate glass, and it has around 6000 glass block with the dimension of 50\*235\*50mm (ArchDaily, 2018). Due to the large facade, 8.6m by 8.6m, the glass blocks could not fulfill its structural requirements. Therefore, glass blocks were punctured from below in a pre-tensioned stainless steel rods and stainless steel flat bars were embedded within the glass wall thickness to withstand lateral loads.



Figure 57: The process of casting glass.  
Glass is poured into the mould.



Figure 58: The cooldown process.

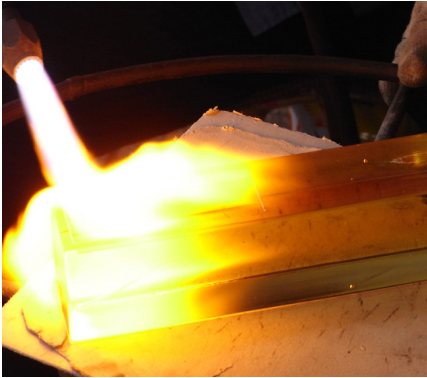

Figure 59: Brick is heated to prevent fast cooling.

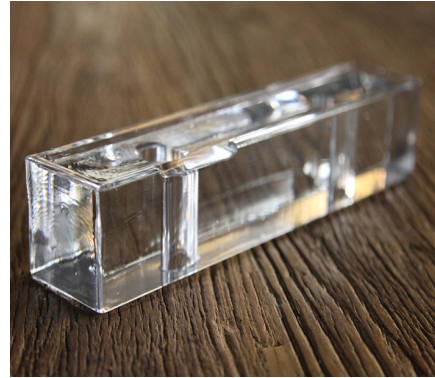

Figure 60: The final glass brick.

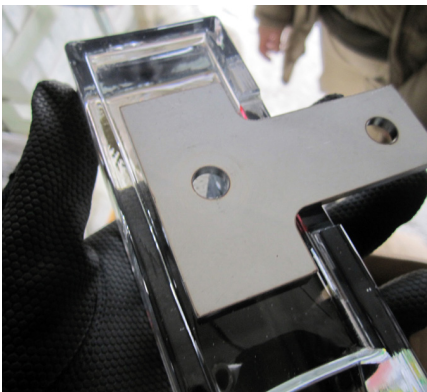

Figure 61: The embedded metal plate in the glass.



Figure 62: The assembly of the glass masonry.

## Conclusion

The project shows a great potential in cast glass especially to produce complex glass shapes. It was proved that even in a relatively small dimension can be feasible from a production point of view, and the result can fulfil its requirements. However, due to the scale of the project, the glass wall as a self-support structure cannot be used without any additional sub-structure.



## Atocha Station Memorial, Spain

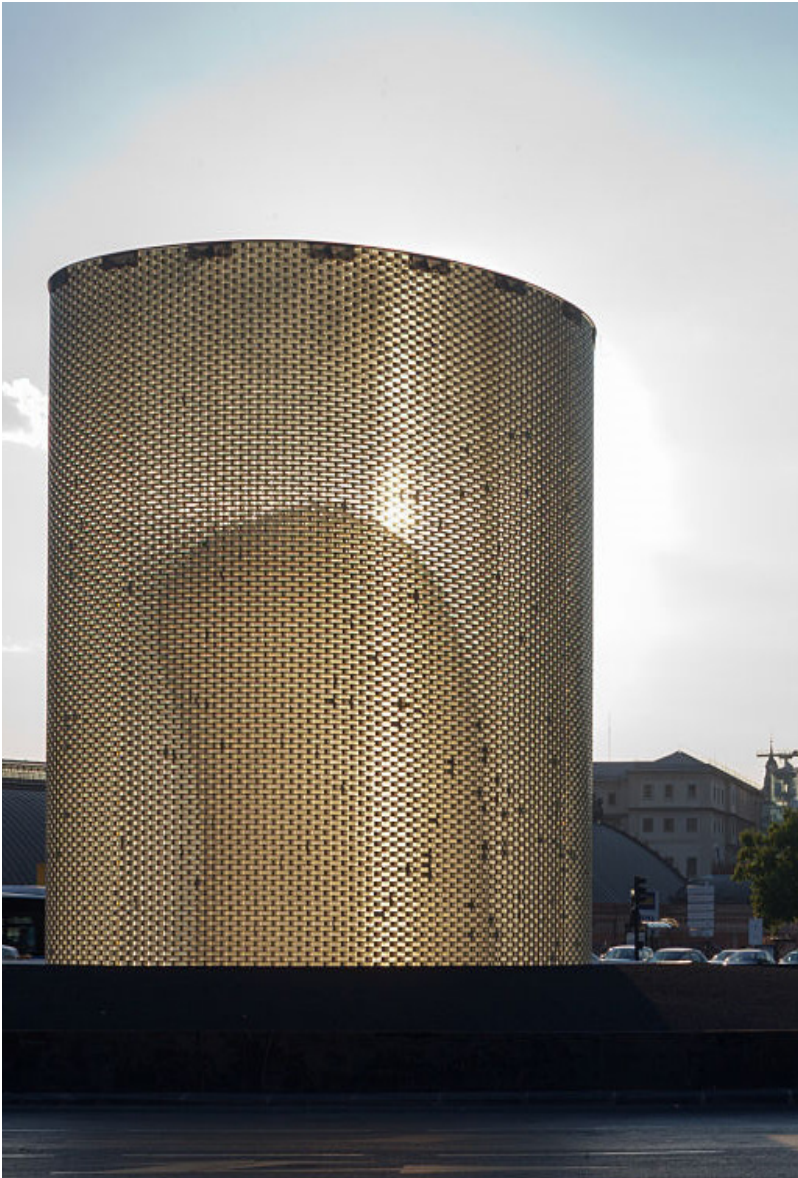

Figure 63: The Atocha monument.

After three years that the terrorist attack had happened in Madrid, a monument for remembrance of the victims was built next to the Atocha railway station. The designer of the monument is the Estudio FAM architecture firm.

The oval-shaped glass cylinder is 11 meters high and has a diameter of 8 by 10.5 meters. The monument consists of two parts, the glass cylinder and the underground meditation room. „Through the outer shell, daylight floods in the meditation room below the street level. At night the effect is inverse: the outer glass shell becomes a luminous artwork” (Bellapart.com et al., 2018).

From the structural point of view, this was the first time when massive glass structure was designed without any additional supporting structure. It consists of 15100 glass blocks that are glued together with a transparent acrylic adhesive. Due to the shape of the design, the curvature gives an appropriate rigidity and provide continuous transparency.

The glass blocks are made of borosilicate glass due to its lower thermal expansion coefficient value than soda-lime glass. The glass blocks are produced with the dimension of 200\*300\*70mm, under pressure in a special mould.

On top of the glass structure, glass roof is placed using five glass beams to stiffen the upper part and prevent buckling.

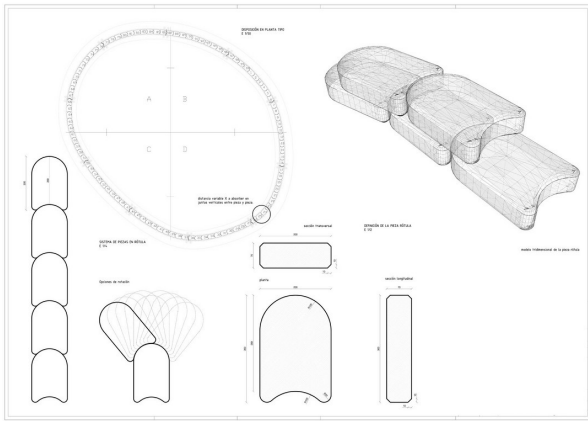

Figure 64: The structural concept of the monument.

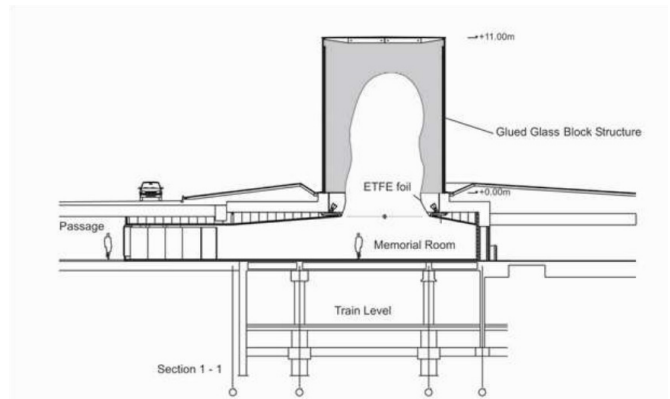

Figure 65: The elevation of the design.



Figure 66: The distribution of adhesive on the glass blocks.



Figure 67: The process of the sealing.



Figure 68: The meditation room below the street level.

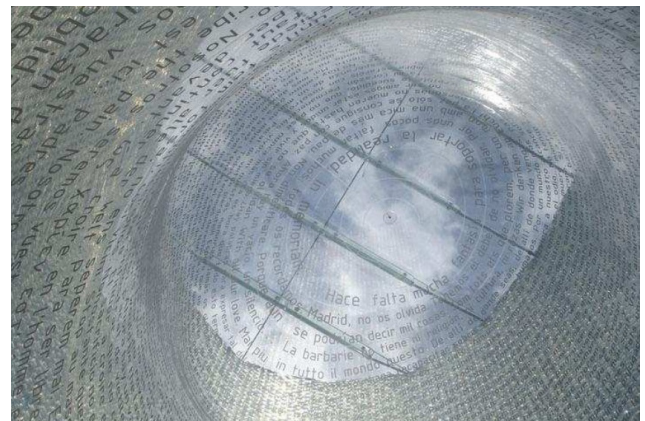

Figure 69: The interior view of the monument.

## Conclusion

The project of Atocha is fascinating engineering design, where no additional substructure added to the glass structure due to its curvature geometry which gives the rigidity to the structure. Choosing the right type of glass was crucial. Borosilicate glass was chosen due to its low thermal expansion coefficient ( $4.3 \cdot 10^{-6}$ ), which is half of the value of sodalime glass. Furthermore, choosing the right glass and special molds resulted a very tight tolerance of 1mm.

In general Atocha Monument is a great example how pure cast glass can be used in a big construction. Choosing the proper type of glass, which provides the required tolerances, and thermal properties are crucial for the whole design. In addition, it had an organized construction plan which prevented the possible deflection (applying preloads), and a control management to ensure proper end quality of the glass.



## Crystal House



Figure 70: The facade of Crystal House.

*„Let's bring back what will be demolished but develop it further”  
„Crystal Houses make space for a remarkable flagship store, respect the structure of the surroundings and bring a poetic innovation in glass construction”  
Winy Maas*

The design of Atocha monument has proved that structural cast glass can be used without any additional sub-structure. The design goal was the same when a 19th-century old building envelope had to redesign in a new engineering way.

The building is located on the historic Pieter Cornelisz Hoofstraat in Amsterdam. The design concept had to follow a strict planning regulations that required the same organization, rhythm and composition as the one previous 19th-century building (Oikonomopoulou et al., 2015). The facade was redesigned by MVRDV and Gietermans & Van Dijk architecture firm, who came up with an idea to redesign the whole facade with glass. The result was a copy of the century-old building envelop, making of full of glass.

In principle, solid glass blocks were used due to its high compression strength (over 200 MPa), which can able to carry the dead load of the wall without any sub-structure. For the material of the glass, soda-lime was chosen, in contrast to borosilicate glass, which is more preferred in architecture projects. The choice was based on that soda-lime glass is least expensive and requires lower working temperature than borosilicate. Furthermore, soda-lime glass has higher compressive and tensile strength than borosilicate (Oikonomopoulou et al., 2015). The drawbacks of using soda-lime are that it has a higher thermal expansion coefficient, and longer annealing time is needed.

The production of the approximately 7500 glass blocks was performed by an Italian company, called Poesia. In each casting, high precision, open steel moulds were used. These moulds were preheated the temperature of 650-750° C in order achieve the glass the desired smooth. After the glass was poured into the mould, it was left to rapidly cool down until 700° C. At the temperature of 700° C the glass was removed from the mould and was taken into the annealing oven, where it was cooled down slowly to the room temperature. (Oikonomopoulou et al., 2017)

After annealing, surface treatment followed the process. The surface treatment was done by a CNC machine to obtain the precise height on both top and bottom surface, then it was polished as well.

Before the construction started, the choice of the adhesive was crucial due to the interaction between the glass block and the adhesive. A transparent, UV-modified acrylate adhesive was used. This adhesive is photocatalytically cured and moisture- water resistant (Oikonomopoulou et al., 2015). This specific adhesive is applied in a layer of approximately 0.1-0.3mm thickness. Due to the specific thickness of the adhesive, the glass blocks are needed to cast with high dimensional accuracy.

The innovative facade illustrates the great potential of using glass as a structural system in architecture applications. The system can be further engineered to explore how the glass can be improved to achieve better thermal properties.

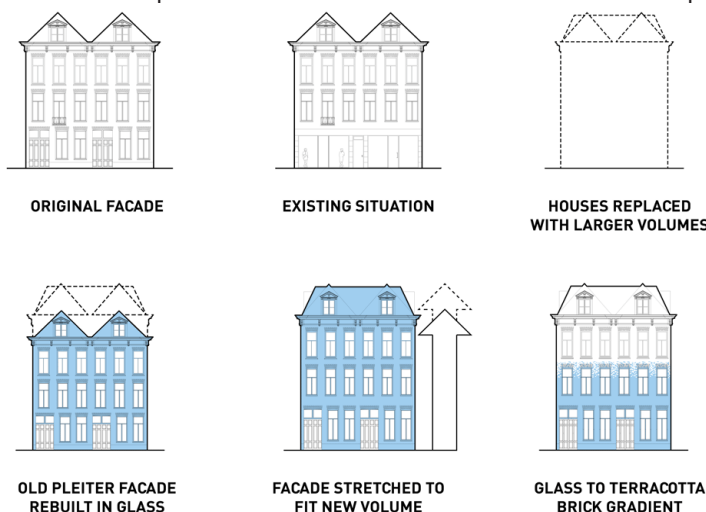

Figure 71: Concept of Crystal House

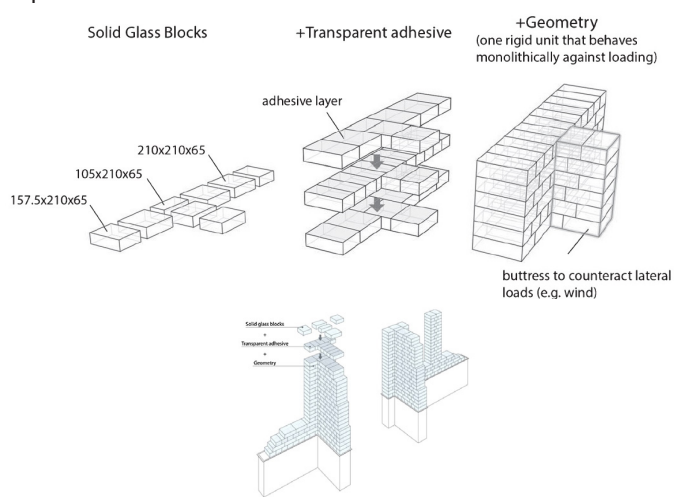

Figure 72: The principle of the glass structure system.



Figure 73: The casting of the soda-lime glass blocks.



Figure 74: The final result of the bonding method.

## Conclusion

The projects shows that cast glass is applicable to design a fully transparent self-supporting masonry wall. Like in any project the cost is crucial, as well as the time. That is why soda-lime glass was chosen due to its low price and low working temperature. Dimensional tolerance shows that even 0.25mm can be reached with special high precision open steel mould. The developments of the new construction method lead further possibilities for the future architecture. Glass is a sustainable material, hence the whole facade is completely recycable.



## Masion Hermés, Tokyo



*„THE GREATEST CONTRIBUTION TO  
GLASS BLOCK ARCHITECTURE MADE  
IN THE WORLD TO DATE.”*

*Renzo Piano*

Figure 75: Masion Hermés.

Thin, tall, and elegant. These characterize the eleven storeys building in Tokyo. With the earthquake resistant glass brick facade, Maison Hermés becomes the magic lantern of the city at night. The entire facade is made of 45\*45cm specially designed glass blocks which provide continuous and luminous screen between the peaceful inner space and the busy city.

The main structure of the building is a flexible steel structure, which is articulated at structurally strategic locations with viscoelastic dampers, from which cantilevered floors span to support the suspended glass block facade. The whole building can move during an earthquake according to the predefined deformations uniformly distributed throughout the structure. The envelope of the building consists of 13000 individual glass blocks, covering a total surface area of more than 2600m<sup>2</sup>. Each block is 45cm square by 12cm thick translucent glass block and it is supported by a concealed network of thin steel channels embedded within the joints between blocks. The system is designed to accommodate the seismic movement in Tokyo. Therefore, the glass block can absorb its share and the steel mesh allows them to move up to 4mm during an earthquake.

### **Conclusion**

In conclusion hollow glass blocks still are not considered as a main load bearing components due to their low compressive strength. Usually, additional steel structure is required if hollow blocks are used. However, the hollow blocks also have benefits. In Masion Hermés, the glass blocks are typically hollow, fabricated from two dishlike pieces which are fused together under intense heat. Fusing the two halves into one while forming a sealed interior air chamber gives the glass block its good thermal and acoustical insulating qualities.

### Conclusion of case studies

Different examples of cast glass structures have been explored in the case studies, namely Optical House, Atocha Monument, Crystal House and Hermes storage. From these fascinating designs, it is clearly stated that the structural performance of a glass facade is based on the use of glass block and the geometry of the structure.

Glass blocks which are produced in hollow form cannot fulfil any structural requirements due to its low wall thickness which results low compressive strength value. That means, additional sub-structures are always needed to stabilize the structure. However, the benefits of these blocks are the good thermal and acoustic properties (Maison Hermés).

As a self-supporting, fully transparent solid glass block facade does not require any supporting elements. The solid blocks are stabilized with transparent adhesives, allows to behave the structure as a single rigid unit (Crystal House). Furthermore, not only the dimension of the glass is important, but the geometry of the structure is also an essential role in the overall structural performance (Atocha Monument). Unfortunately, the drawback of these monolithic structures is the poor thermal performance compared to hollow glass blocks.

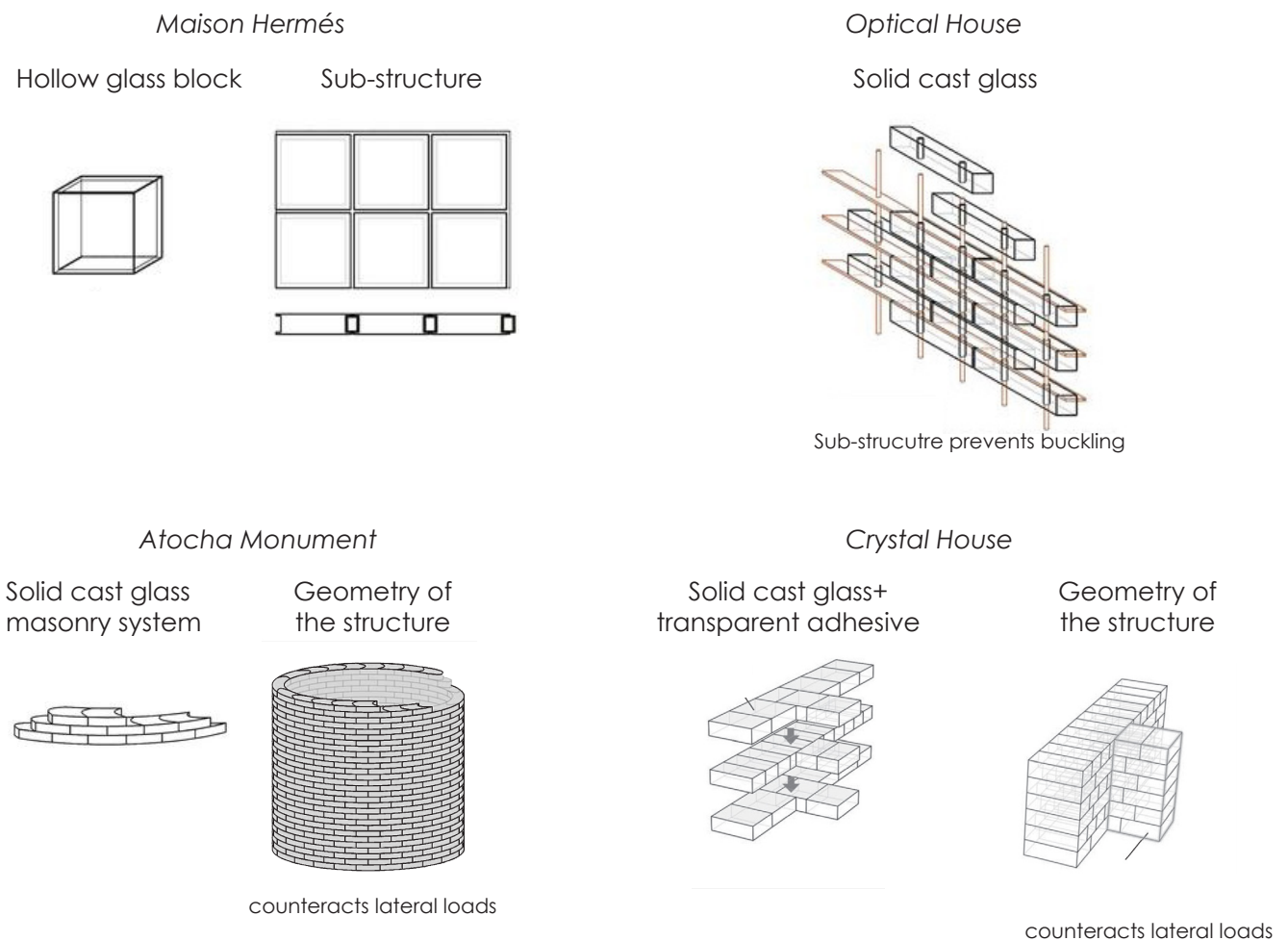

Figure 76: The principle of the glass structure systems. (Oikonomopoulou et al., 2017)



## 2.3 Lenses

To better understand the behaviour of light, this chapter introduces how light interacts with different lenses and materials, explaining the most important phenomena such as reflection, refraction and total internal reflection. The chapter presents different glass materials and the whole process of lens production.

### Introduction

Optics is branch of physics which examines the interactions of light with other substance. The two basic theories of optical phenomena are described by the electromagnetic behaviour of light. These phenomena are the geometric optics and physical optics.

In physical optics or wave optics the light is described as a wave and it can be explained important phenomena such as interference, diffraction or polarization. The investigation of these occurrence lays the foundation for an understanding of such devices and concepts as holograms, thin-film interference, coatings on lenses to enhance or suppress reflection (AR or HR) , polarizers.(Pedrotti, Pedrotti, S. J. and Lakshminarayanan, 1999)

In contrast, geometrical optics do not take into account the previously mentioned phenomena, but it helps to understand the light propagation in terms of rays.

The following three specific behaviours of light are essential to understand of the strange duality of the light: reflection, refraction and total internal reflection.

### Reflection of light

Reflection of light occurs when waves encounter a surface which does not absorb the energy of the radiation and the wave bounces back into the medium from which it is originated. Simple experiment of light reflection is a smooth surface of a lake, where the incident light is reflected in a lake to provide a clear image of the scenery surrounding the lake.

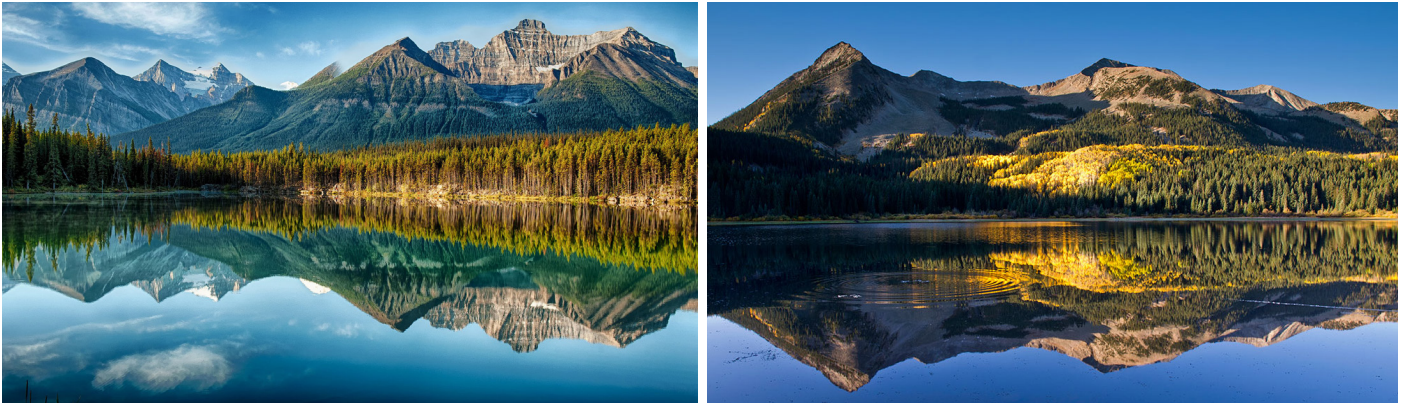

Figure 77 : Reflection in nature.

The incoming light is referred to as an incident wave, and the wave which is bounced away (reflected) is the reflected wave. The light which is directed onto the surface of the material at an angle is reflected back by the surface at another angle which is equal to the incident angle. Thereby, the angle of the incidence wave is equal to the angle of reflection ( $\theta_i = \theta_r$ ) for light as well as for all other wavelengths of the electromagnetic radiation. This effect is the Law of Reflection.

$$\theta_i = \theta_r$$

$\theta_i$  = angle of incident light  
 $\theta_r$  = angle of reflected light

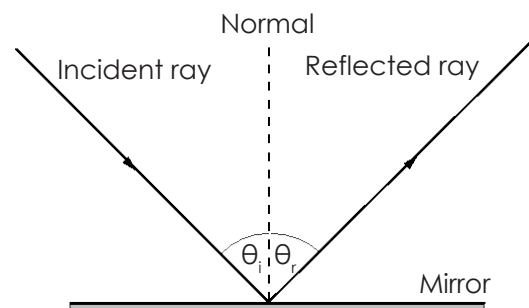

Figure 78 :Law of reflection.

The texture of the surface or the degree of its smoothness highly influences how much light is reflected and how those light rays are reflected. When the defects of the surface are smaller than the wavelength of the incident light, all of the light is reflected equally.

The reflection of light can be categorized into two types of reflection. One of them is the specular reflection and the other one is the diffuse reflection.

Specular reflection is the reflection where the light is reflected from a smooth surface at a certain angle, meanwhile diffuse reflection is produced by rough surface that tends to reflect light in all directions. In everyday environment diffuse reflection occurs more than specular reflection.

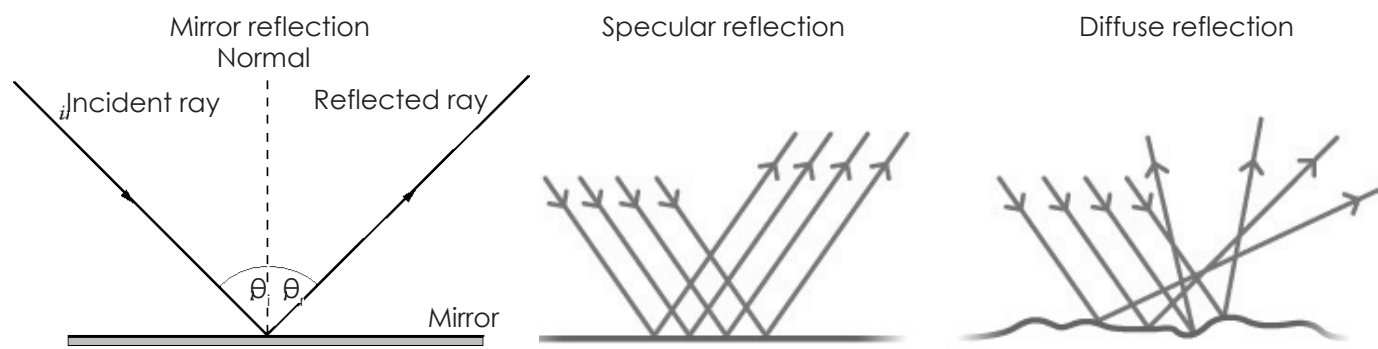

Figure 79 :Law of reflection.

### Refraction of light

When waves pass from one medium into another medium, the light waves undergo a phenomenon known as refraction. It occurs when the light passes from one substance to another one at an oblique angle where there is a difference in the index of refraction between the two materials. Thus, the phase velocity of the wave is altered and causing a change in direction. The wavelength can either decrease or increase, but the frequency of the wave remains constant.

Early scientists noticed that there is a ratio between „the angle at which the light crosses the media interface and the angle produced after refraction is a very precise characteristic of the material producing the refraction effect” (Olympus-lifescience.com, 2018).

In the 1600s, Willebrord Snell, a dutch mathematician, developed a law, which defined a value related to the ratio of the incident and refracted angles, which has been termed the bending power or refractive index of the substance. The consequence of the theory is the more a medium is able to bend light, the larger its refractive index value is. Unfortunately, Snell could not finish his theory, but another dutch scientist, mathematician, Christiaan Huygens devised Snell’s observation and proposed a new theory. Huygens determined that the velocity of light through a material is inversely proportional to its refractive index, thereby, light would travel more slowly through a material which has a greater refractive index.

Based on these observations, the refractive index can be defined through this equation:

$$n = \frac{c}{v}$$

**n**= refractive index

**c**= speed of light (in vacuum)

**v**= velocity of the light

In the following table some common transparent material are presented and their refractive index.

Material	Refractive index
Air	1.0003
Water	1.333
Glycerin	1.473
Immersion Oil	1.515
Glass (Crown)	1.520
Glass (Flint)	1.656
Zircon	1.920
Diamond	2.417
Lead sulfide	3.910

Table 5 : Represents the refractive index for different materials.

The velocity of the light is different when it passes from one medium to another one. If the wave passes from a less refractive substance to a more refractive substance the velocity of the wave will decrease, and when the wave passes from a more refractive substance to a less refractive substance the velocity of the wave increases. Furthermore, if the wave passes from a less refractive substance to a higher refractive substance the wave is bent toward the normal, and if the wave comes from a higher refractive substance to a lower substance the wave is bent away from the normal. Snell's Law formula is used to describe the relationship between the angles of the two light waves and the indices of refraction of the two medium.

$$n_1 \times \sin(\theta_1) = n_2 \times \sin(\theta_2)$$

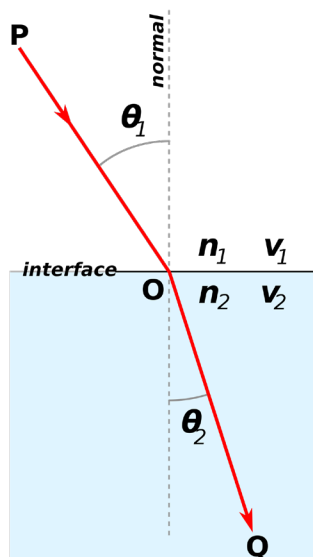

$n_1$ = refractive index of the medium in which the incident wave travels

$n_2$ = refractive index of the medium through which the refracted wave travels

$\theta_1$ = incident angle

$\theta_2$ =angle at which the refracted wave travels

$n_1 < n_2$ = angle of refraction is always smaller than the angle of incidence (bending toward normal)

$n_1 > n_2$ =angle of refraction is always greater than the angle of incidence ( bending away from the normal)

$n_1 = n_2$ = the two angles are equal, enabling the light to pass through without refraction

Figure 80 :Law of refraction.

### Total Internal Reflection (TIR)

Another phenomenon was observed during the examination of reflection and refraction. When the incident angle of the wave increases and reaches a specific value at which the angle is large, no lights are refracted into the lower refractive medium. The largest angle of the incidence which results refraction in the wave is called critical angle. The critical angle occurs when the angle of refraction becomes equal to 90 degrees, and the light is reflected in the boundary between the two substance. If the critical angle is exceeded, the wave will not pass through the substance but it will be entirely reflected in the same material. It can only happen when the wave from a medium which has higher refractive index reaches another medium with a lower refractive index. For instance, that is why light ray can be trapped in a solid glass and reflected only inside the glass.

$$n_1 \times \sin \theta_1 = n_2 \times \sin \theta_2$$

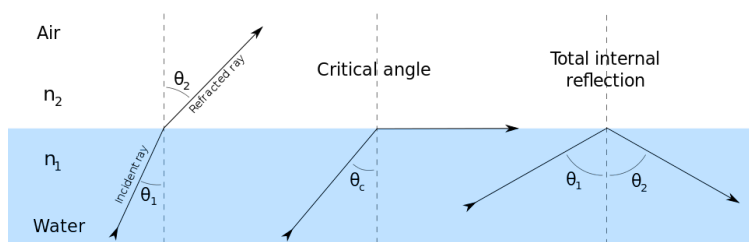

$n_1$ = refractive index of the medium in which the incident wave travels

$n_2$ = refractive index of the medium through which the refracted wave travels

$\theta_1$ = incident angle

$\theta_2$ =angle at which the refracted wave travels

$\theta_c$ = critical angle

Figure 81 :Total internal reflection.

These fundamental laws in the behaviour of light have been developed for centuries and still they are the determinative concepts for designing optical devices. Classical optics are based on the law of reflection and the law of refraction. These optical equipments usually focus or disperse the light beams by the means of refraction. Most of the lenses are spherical lenses and it can be either convex, concave or planar lens.

## 2.3.2 Shape of lenses

### Concave lens (diverging lens)

When a concave lens is used, the parallel beam of light passes through the lens and it is spread away behind the lens, thus it is not a proper lens to use to redirect the light into a certain point. This type of lens makes the object smaller, further and the image is virtual, diminished and upright.

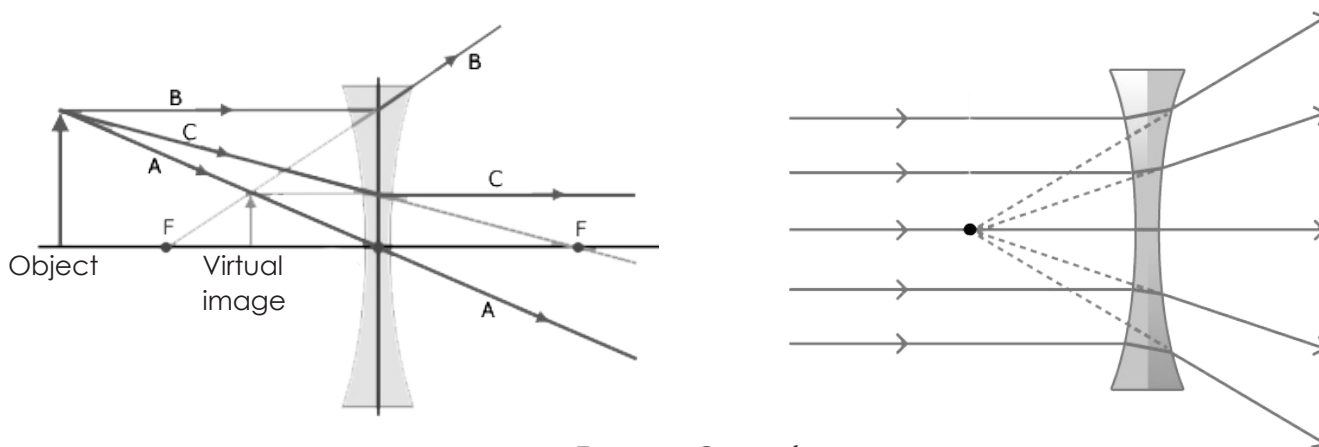

Figure 82 : Concave lens

### Convex lens (converging lens)

This type of lens is a good example of how light can be focused into one point, and basically this is the principle of how optical devices work in a concentrated photovoltaics. The lens converges the light rays to a point ( focal point) behind the lens. The lens generates a real and inverted image. However, if the object is placed too close to the lens, the image will be virtual.

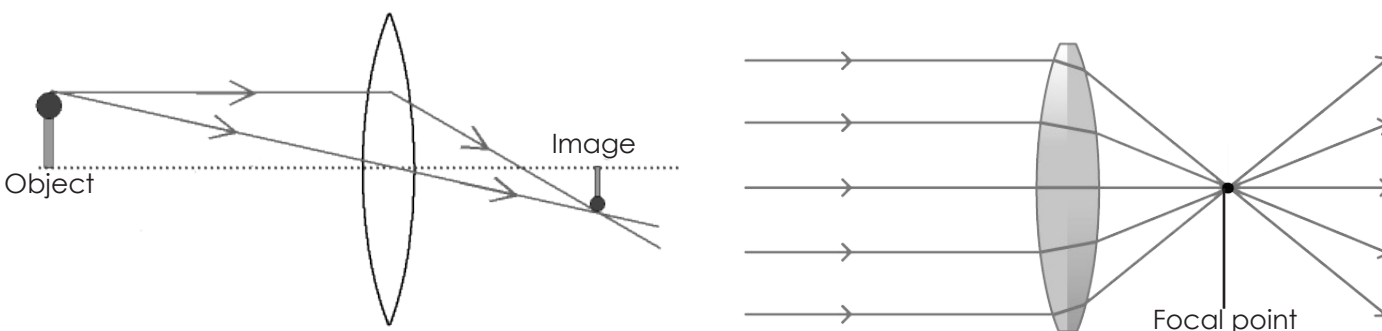

Figure 83 : Convex lens.

### Fresnel Lens

Augustin-Jean Fresnel a french physicist invented fresnel lens which is comprised of a series of concentric grooves etched into plastic or glass. The first lenses of fresnel lens were used at the top of the Lighthouse where, the light could be seen more than 32km. The principle of fresnel lens based on the idea of telescope, but the opposite way. A light source is surrounded of multi-part lenses and it concentrates the light rays into a powerful and parallel beam.



Therefore the Lighthouse could show the way for those who are sailing on the sea.

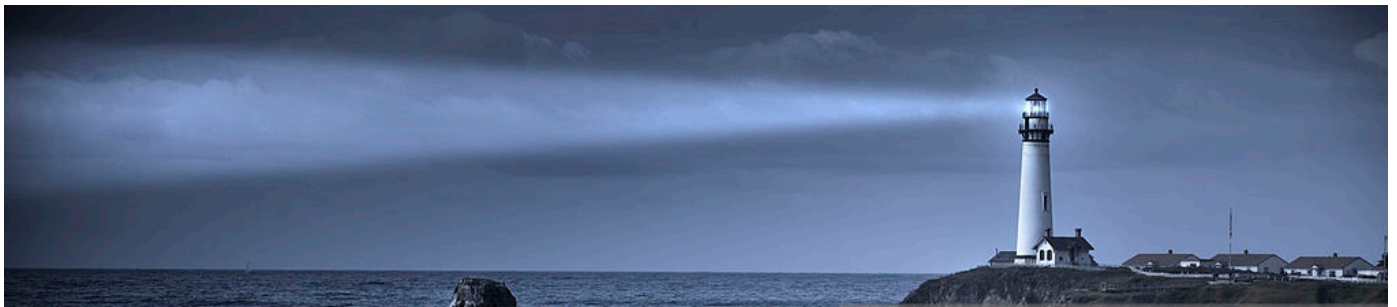
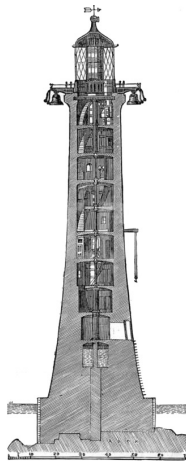

Figure 84 : LightHouse fresnel lens.

In optical devices, fresnel lens works the same way as the lens in the Lighthouse, but it is usually one object. The concept of fresnel lens reduces the amount of material compared to a conventional lens by applying the concentric annular sections. These concentric annular sections provides that the light is redirected into a point, thus it works as a convex lens. Furthermore, fresnel lenses are commonly used in concentrated photovoltaics system as an optical device.

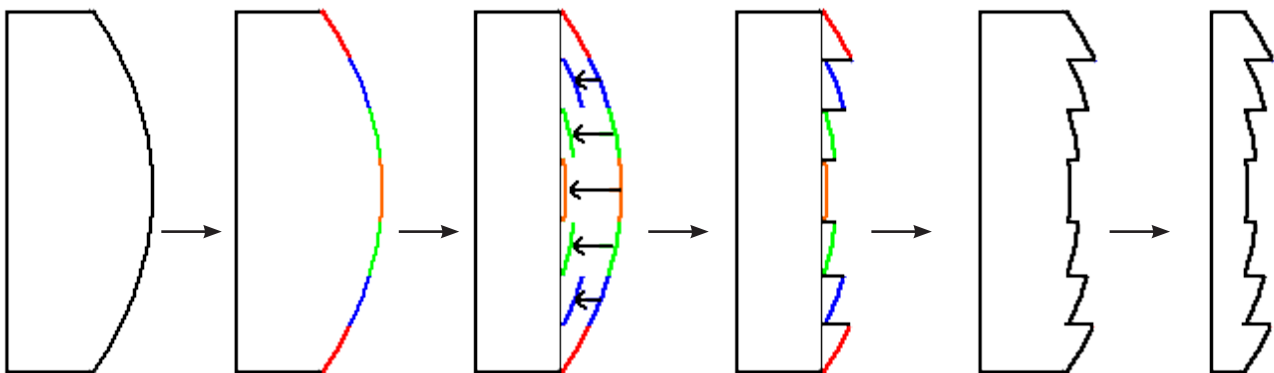

Figure 85 : Shape of fresnel lens.



Figure 86 : Fresnel lens

### 2.3.3 Optical glass

The selection of optical glass material is crucial since different glass types have different characteristics. The refraction index and the Abbe number of the glass commonly determines which type of glass should be used. A material which has higher index of refraction bends the light more efficiently, therefore there is less of need of curvature in the lens. A high abbe number results less color dispersion and reduces color aberration.

Moreover, the coefficient of expansion is also a key factor due to under certain circumstances the lens has to withstand extreme temperatures and sudden temperature differentials.

The density of the glass is quite important as well as it becomes critical for weight sensitive applications. However, the density of the glass is not taken into account in this case.

The most common types of glasses used in optics are crown glass and flint glass.

#### Flint optical glass

Flint glass is usually composed of either lead or potassium silicate. The blend results a glass which has relatively high refractive index due to the higher lead-oxide (PbO) ratio and low Abbe number compared to other type of glass. Flint glass is usually coated with an anti-reflection coating in order to decrease the effect of Fresnel reflection loss.

#### Crown optical glass

Crown glass is usually produced from silicates of alkali-lime and contains around 10% of potassium oxide. Due to the absence of lead-oxide the refractive index is lower, but the value of Abbe number is higher compared to flint glass. One of the most commonly used crown glass in precision lenses is Borosilicate glass due to its excellent transmission and optical characteristics. It can resist chemical and environmental damages.

Table 6 illustrates a variety of typical glasses which have been developed for commercial applications in optics.

Material	Refractive index	Relative dispersion
Borosilicate crown	1.51700	64.5
Crown	1.52300	58.6
Light barium crown	1.54110	59.9
Dense barium crown	1.61700	54.9
Extra dense barium crown	1.65611	50.7
Crown flint	1.52860	51.6
Light barium flint	1.56210	51.0
Barium flint	1.60530	43.6
Dense barium flint	1.61700	38.6
Extra light flint	1.55850	45.5
Light flint	1.57250	42.5
Dense flint	1.61700	36.6
Extra dense flint	1.75060	27.7
Phosphate flint	1.98020	22.2

Table 6 : Optical glasses and their properties (Musikant and Thompson, 1990)

## 2.3.4 Production of lens

Lenses are very sensitive and sophisticated objects, and usually, it is made of glass or other transparent substance like plastic. These optical devices focus or disperse the light beam by means of the refraction. Therefore it is quite common to use in applications where the light has to be redirected such in concentrated photovoltaics, or in another field like physics. Usually, the surface of the lens is spherical in shape, and either it can be concave or convex. Single lenses can be used for eyeglasses, contact lenses, projectors, cameras, telescopes or microscopes.

First the conventional production technique than an accurate and high-performance technique is going to be introduced.

### Precision glass moulding

The precision glass moulding is commonly used for producing optical components and the whole process is cost-effective.

First, the material of the blank, the size, the shape can be defined based on what it will be used for. It is very crucial to choose the right material of the lens, due to its refractive index, Abbe number, availability and cost.

A piece of glass blank is inserted into the molding tool both are preheated carefully to the working temperature which is the temperature between the transition temperature and the softening point of glass. Then the two parts of the mould are pressed together to form the component. To prevent any crack in the component, the mould and the glass are cooled down by gas. Once the temperature is low the molding chamber opens and the component is removed and it is ready for further processes.

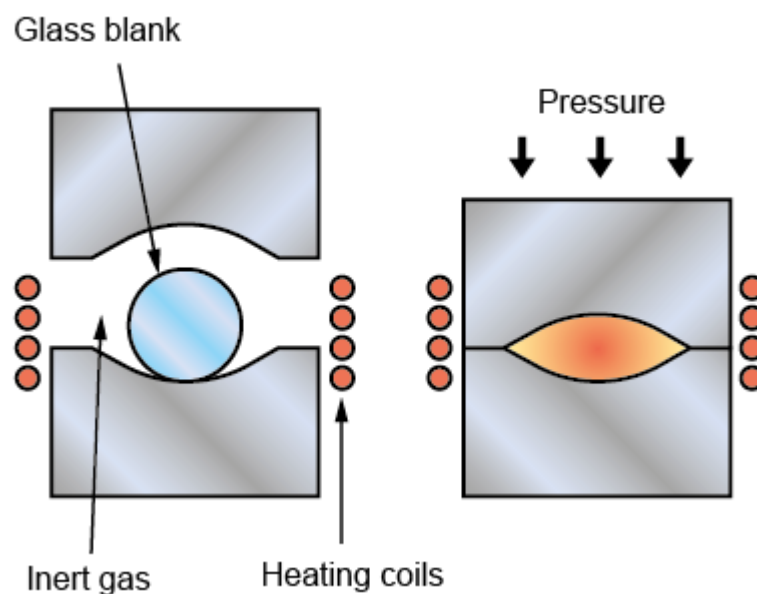

Figure 87 : Precision glass moulding

### Polishing

The next step is the polishing process. The aim of the process is to modify or to smooht the surface of the material in order to obtain an even surface. Among the various polishing methods, there are three commonly used methods for glass materials. In mechanical polishing the surface is rubbed with a hard abrasive. In acid polishing or chemical polishing the surface is processed directly by using an acid and chemical reactions. The last type of polishing is based on melting, where the surface of the material is melted with a heat source to creater an even surface.

Additional polising techniques are Fluid Jet polising and Precision polishing for optical glass.

## Mechanical polishing

In mechanical polishing, the workpiece is held in place and it is polished by a slab of very fine abrasive. The process removes surface imperfections and scratches. In lapping, a lap is moving in a continuous random pattern over the surface of the workpiece. Usually, the lap is made of softer material than the surface of the material. In burnishing, hardened rollers are forced to roll across the surface, locally exceeding its yield stress in a thin layer. The dimensional precision of mechanical polishing is excellent.

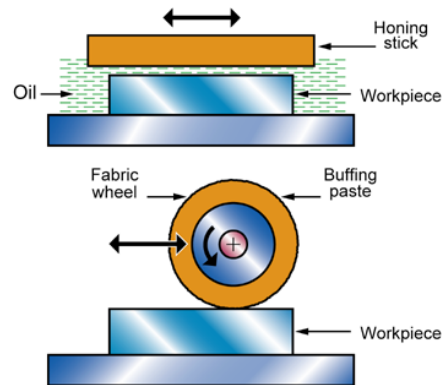

Figure 88 : Mechanical polishing. (CES 2017)

## Chemical polishing (Acid polishing)

Chemical polishing is a process whereby the surface is smoothed by the use of acids. The chemical reaction of the acid on the glass forms a thin layer comprised of calcium fluoride, sulfate of lead and sodium of potassium fluoride. Then this layer is removed by purifying with water, after which the pieces are washed off in clean water and dipped again in the acid. These chemical polishing bath usually uses harmful chemicals such as sulfuric and hydrofluoric acid. Furthermore, the process only polish the surface and does not smooth it. Thus the surface quality of fabricated glass has to be excellent to get an ideal finish.

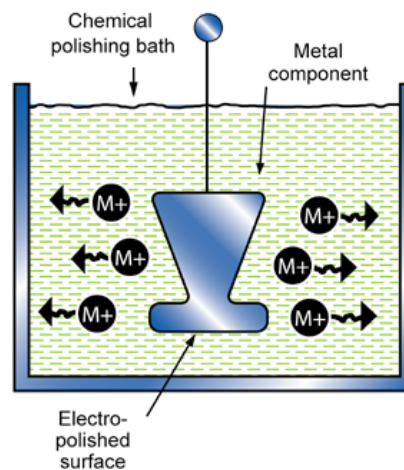

Figure 89 : Chemical polishing. (CES 2017)

## Polishing based on melting

There are two kind of melting polishing, laser polishing and fire polishing. Laser polishing based on melting a thin layer of the surface of the material and smoothing it under surface tension. The thickness of the melted zones is around 20-100 micrometers and the surface tension of the melted material ensures that it will reset evenly. The advantage of the method that it is very fast, but on the other the quality of the surface is not as good as other polishing technique.

Flame polishing also melts a thin layer of the material. The surface tension on the molten layer removes small defects on the surface. It is a costeffective method, but the quality is also poor. (Esmaeili Amin, 2013)

## Fluid jet polishing

In fluid jet polishing the material is removed by a high speed stream of abrasive particles in an air or gas jet. Fluid jet can be used for cleaning, cutting and machining the surface of the material. Abrasive jet machining (AJM), abrasive water jet (AWJ) and abrasive slurry jet (ASJ) are the common techniques.

Abrasive jet machining is an inexpensive technique for polishing materials." In this technique an abrasive is added to a pressurized inert gas, which passes through an orific and forms a jet" (Esmaeili Amin, 2013).

Abrasive water jet is similar to AJM. Various kinds of abrasives with different weight percentage is added to the water which is pumped at high pressure through a sapphire nozzle. The process has the advantage of the temperature of the work piece remains constant and it is suitable for polishing various complex surfaces and cavities.

The last type of fluid jet polishing is the abrasive slurry jet. „The abrasives and the water are premixed to form a suspension (slurry) in order to increase the power density comparing to the AWJ process" (Esmaeili Amin, 2013). It is a faster method than AWJ.

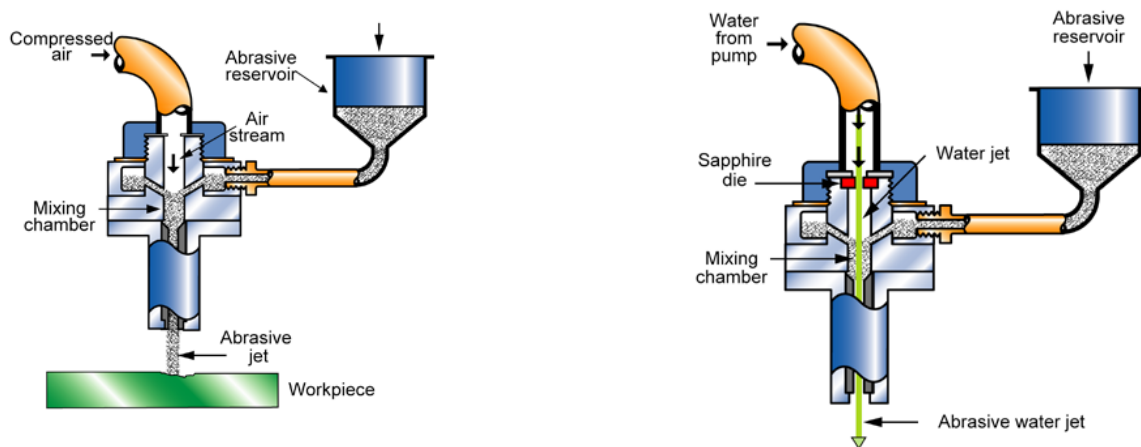

Figure 90 : Abrasive jet machining( left), Abrasive water jet (right)(CES 2017)

## Precision polishing for optical glass

Precise, flat and sphere glass materials can be polished with the following techniques.

The most commonly used polishing method for lenses is the pitch polishing. Pitch is a compound which can be made synthetically or found naturally. The material is comprised of mixture of wood tar pitch and colophonium (resin) (Schwartz, 2008). In the process a spherical visco -plastic lap made of pitch material is fitted to the workpiece. Slurry containing abrasives is also applied in the process and the motion of the lap and the work piece applies pressure on the surface which removes surface imperfections and scratches, leaving a high quality finish.

New cutting-edge polishing technology is Magneto Rheological Figuring (MRF). The slurry, which contains microscopic magnetic and diamond particles, runs over a belt on a spinning and „ lenses lowered into the slurry from above" (Schwartz, 2008). The hardness of the slurry can be changed by a magnet beneath the spinning belt, therefore the polishing compound can be either harder or softer by altering the strength of the magnet. The advantage of this polishing technique is it is very accurate, but the process is expensive.



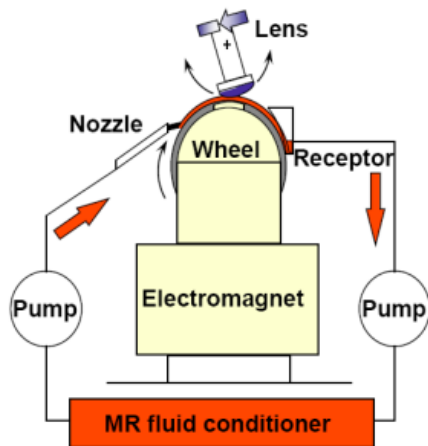

Figure 91 : Magneto Rheological Figuring.



Figure 92 : Pitch polishing.

When the process of polishing is finished, the lens is observed. Surface quality (accuracy, defects) are checked by using an interferometer in order to process further.

### Centering the lens

„A lens has both a mechanical axis, defined by the outer edges of the lens and an optical axis, defined by the centre of curvatures of each surface of the lens” (Schwartz, 2008). Centering the lens means that the optical axis is lying in the same straight line with the mechanical axis. It can be done either mechanically or optically. In the mechanically process the lens is placed between two chucks and „ and it will slide to the point where there is even edge thickness” ( Schwartz, 2008).

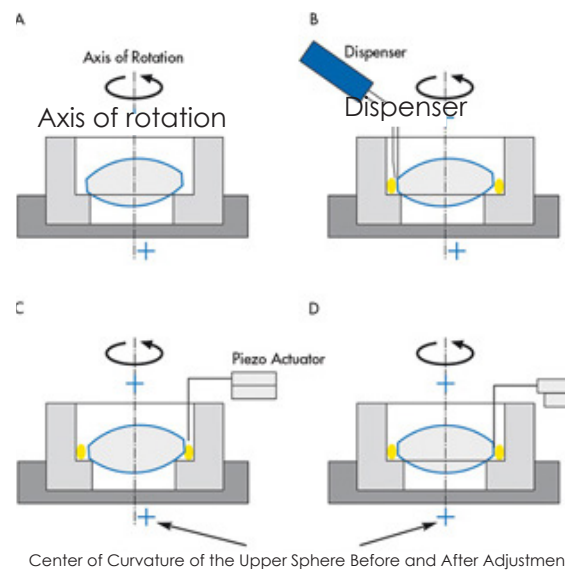

Figure 93 : Mechanically centering the lens.

It was mentioned the other method is centering optically. „Using the optical method, the lens is mounted on a mandrel, or spindle, and light is passed up through the optic to the operator’s eye (a lit target can also be used). As the mandrel and optic rotate, the collimated beam will appear to move unless the optic is centered. The operator will move the optic while looking at the beam until there is no motion and then the optic is fastened in place and edged.” (Schwartz, 2018).

In both techniques the edges of the lens are quite important to be beveled, thereby damages can be prevented.

When the lens is centered, cleaned and observed, the last step is to put the coating on the lens. The aim of putting coating on the lens is lens can perform at a specified wavelengths.

## Coatings

Coatings on optical devices are comprised of combination of thin film layers which enhance the effect of transmission or reflection of the optical system. The performance is dependent on the number of layers, the thickness of the layers and the refractive index difference at the layer interfaces. The most commonly used coatings on precision optics are Anti-Reflection Coatings, High Reflective Coatings, Beamsplitter Coatings and Filter coatings. The process takes place in a vacuum chamber and the lens has to be cleaned therefore any stains and dirt on the lens have to be removed to ensure the highest level of surface quality. Coating material is heated in the chamber and it is evaporated on the surface of the lens.

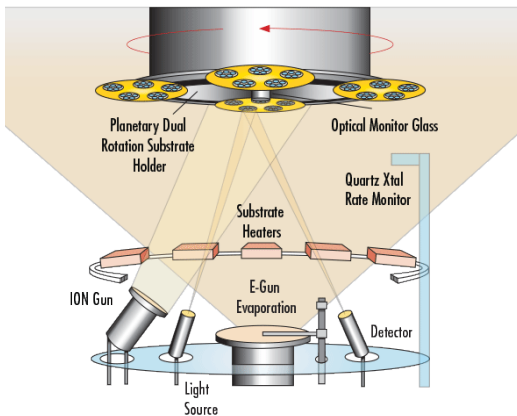

Figure 94 : Vacuum chamber and planetary optic holder

## Anti-Reflection coating

The coating significantly improves the performance of an optical system by increasing transmission, enhancing contrast. Therefore, imaging system efficiency is improved through less light is lost due to reflection. The reduction in reflection is very important especially in planetary astronomy.

„A single quarter wavelength coating of optimum index can eliminate reflection at one wavelength” (Hyperphysics.phy-astr.gsu.edu, 2018). Multiple layer of coatings can reduce the loss over the visible spectrum.

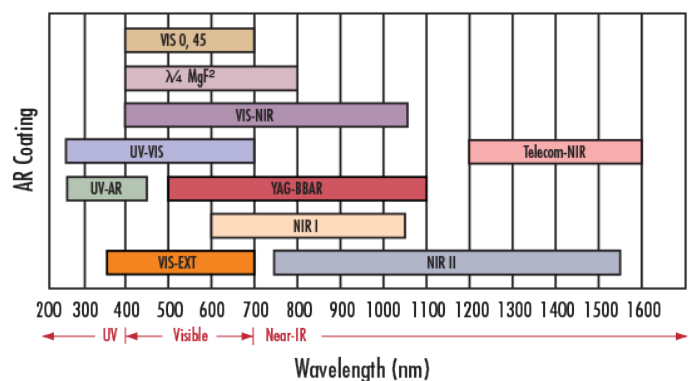
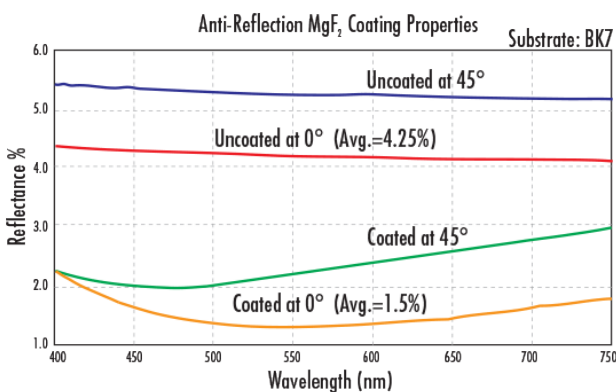

Figure 95 : Anti-Reflection coating performance (left), Wavelength selection chart (right) (Coatings et al., 2018)

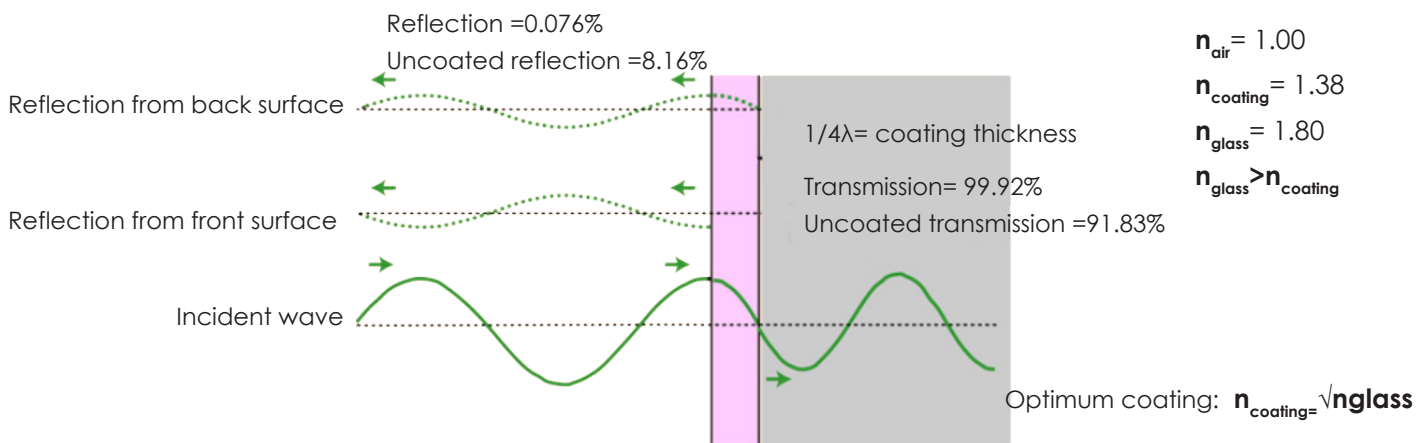

Figure 86 : Example of a single layer of Anti reflection coating.

### High Reflective Coating

High Reflective coating works the opposite way to anti-reflective coating. These type of coatings enhance the reflectivity of the surface in a certain wavelength, and it offers variety of metallic and dielectric coatings to suit all the requirements in different applications. The thickness of the coating is usually one-quarter wave and it can be applied on the first surface or the second surface. The differences are that the light is reflected on the first surface when the coating is applied on the first surface, thereby first surface mirrors are recommended to use for precision optics applications. The second surface mirror works the same way, but the incident light first passes through the substance before it is reflected on the second surface. In this case the coating is protected from oxidization and damages. However, this type of mirror is not suitable for precision optics applications.

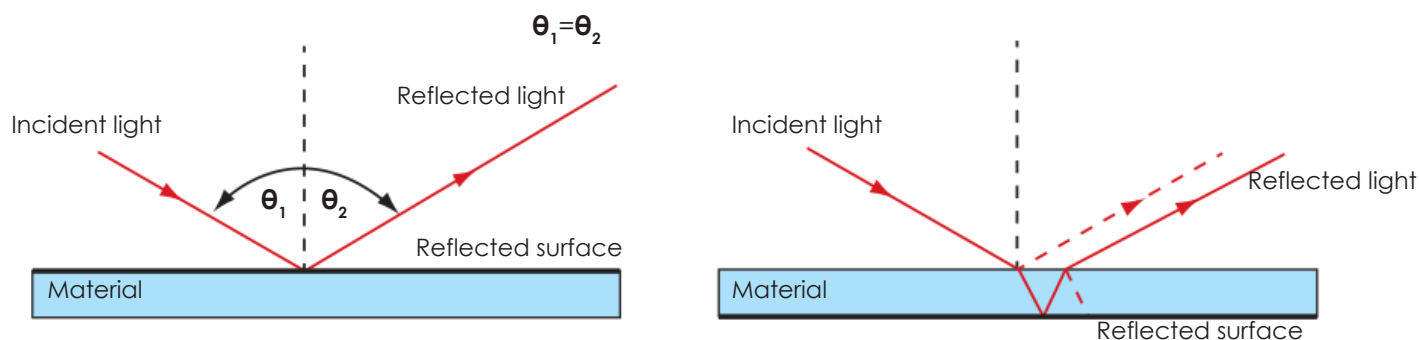

Figure 87: Reflection on first surface mirror (left), and second surface mirror (right)

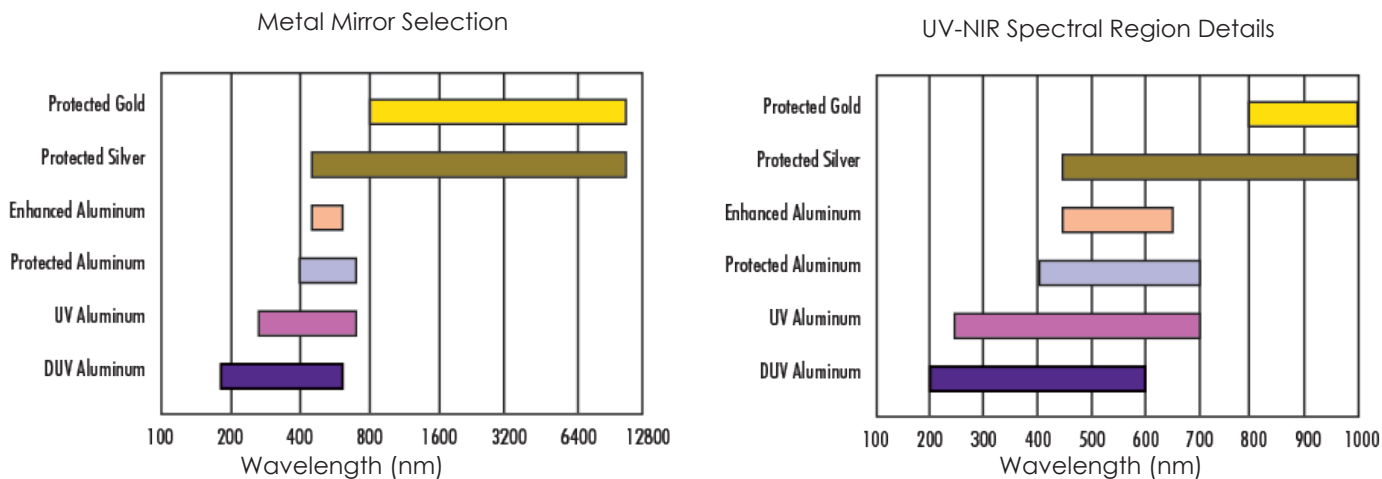

Figure 88 : Metallic Mirror Coating Reflectance Curves.

Each lens is inspected after the process of coating before the use of lens. It includes visual inspection for dust, damage, and the right residual reflection color. In addition, machines are used to check whether the lenses meet the requirements such as refractive index, axis, shape, thickness.

Precision glass moulding technique is quite commonly used to produce concave or convex lenses for optical devices due to the simple shape of these lenses. Unfortunately, fresnel lenses are difficult to fabricate due to the surface rings, which are usually small and steep. Before the process starts, a special mould has to be prepared to get the fresnel shape and a precise diamond grinding process with a special wheel is usually used to fabricate this mould.

### Production of Fresnel lens

Precise glass molding technique is one of the appropriate methods for fabricating high precision glass elements by using precision moulds made of stainless steel or tungsten carbide. To obtain a precise profile on a hard, brittle mould, diamond grinding technique is used.

A disk shape of diamond grinding wheel is used and the wheel moves vertically along the workpiece radial position. The wheel rotates vertically and the workpiece rotates horizontally. The characteristic of the method is that the wheel rotates in parallel with the workpiece rotational direction at the grinding point. Therefore the axis-symmetric fresnel lens of the mould is generated by the grinding wheel. (Suzuki et al., 2012)

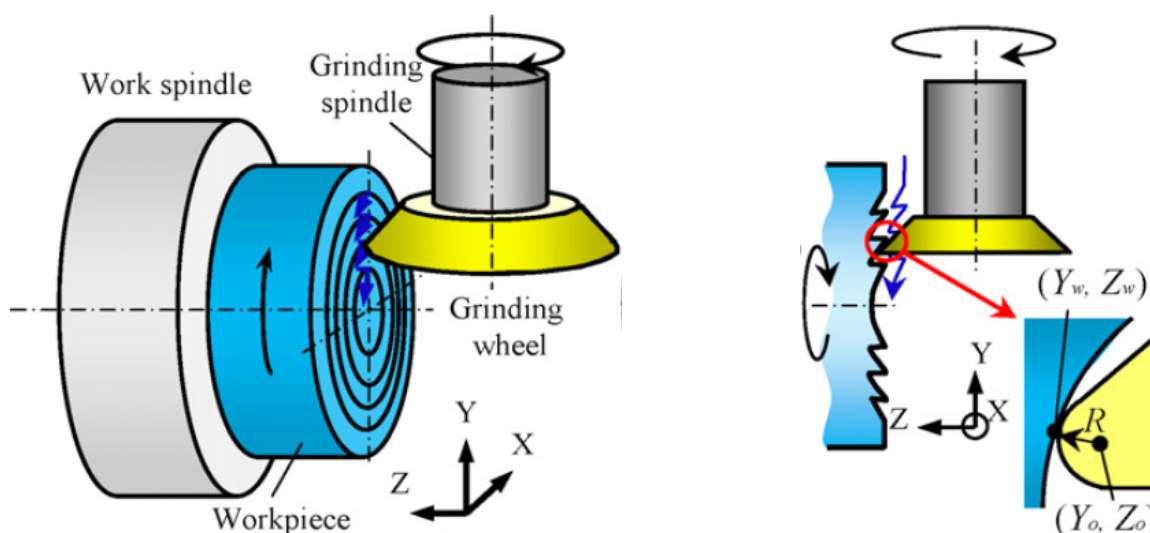

Figure 89 : Fresnel shape grinding of 2-axis (Y,Z) control using diamond wheel having sharp edge. (Suzuki et al., 2012)

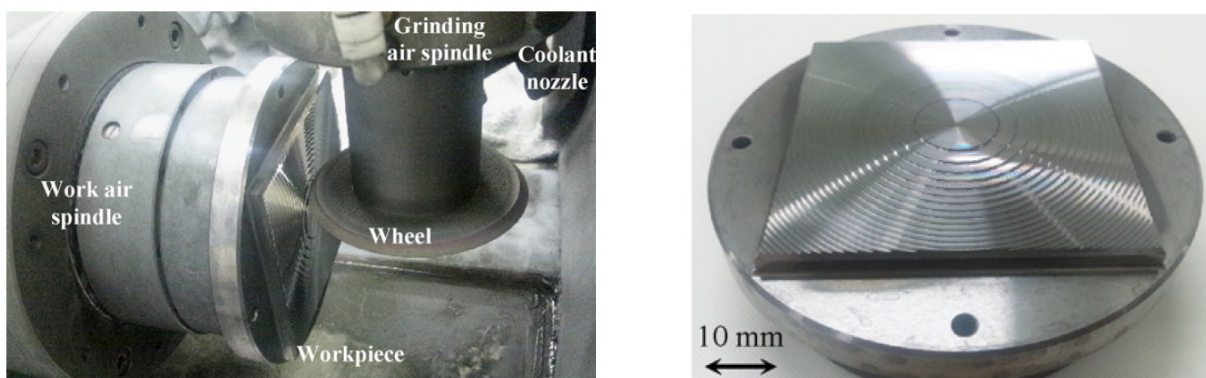
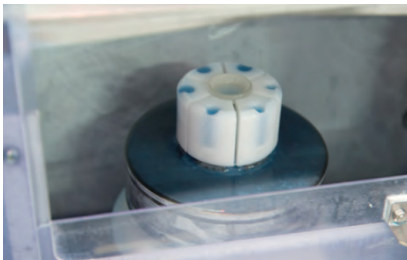
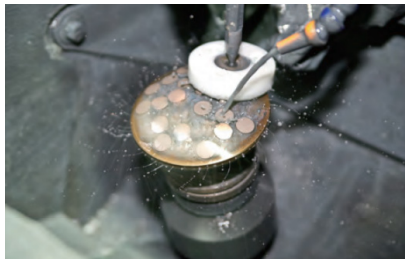

Figure 90 : View of Fresnel grinding (left) and view of Fresnel lens mold for structured grinding (right). (Suzuki et al., 2012)





Rough grinding of glass-  
rough thickness of the lens core



Precision grinding-  
give the radius of the lens,



Polishing-  
completes the appearance and  
performance



Cleaning-  
clean the surface from dust and  
dirt



Process inspection-

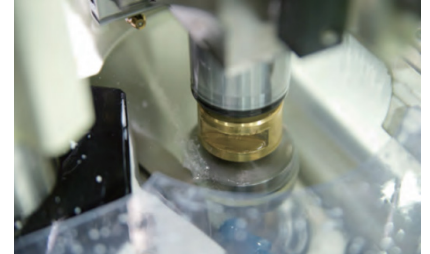

Centering and cleansing-  
set up the optical axis of the lens



Compounding-  
prevent aberrations

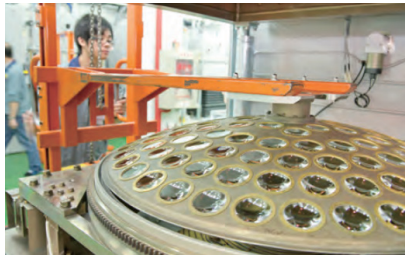

Coating-  
characteristics of the lens



Inspection-  
Optical performance

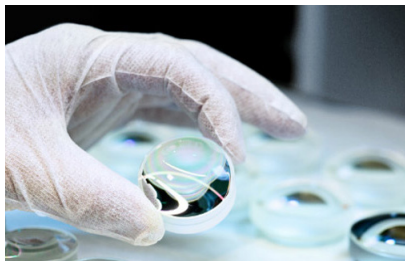

Ready to be delivered

Figure 91 : Overview of the production of lenses.

The science of optics is studied in many disciplines including astronomy, photography or any kind of imaging systems. In classical optics the lenses can be either converging or diverging lens which focuses or disperses the light beam by the means of refraction. In photovoltaics applications these lenses are specially used to concentrate solar energy on a small photovoltaic cells, producing more energy than a conventional photovoltaic module.

The next chapter is investigating the photovoltaic technologies and their properties. Special emphasis will be put on concentrated photovoltaic systems.



## 2.4 Photovoltaic system

Sustainable solution has been investigated through exploring photovoltaics technology. The investigation tries to find the proper system which can be applied on small surface. The literature study especially focuses on solar concentrator technologies, applications and the possible choice of semiconductor materials.

## 2.4.1 Introduction

One of the most abundant, inexhaustible and clean renewable energy resources is the solar energy. In one day the irradiation from the sun on the Earth gives about 10000 times more energy than the daily use of the population (Petter Jelle, Breivik and Drolsum Røkenes, 2012). One of the promising technologies which can produce electricity on site directly from the sun is the Photovoltaics. Photovoltaic is a term which as it was mentioned it converts the light into electricity using semiconducting materials that exhibit the photovoltaic effect. These solar photovoltaics have specific advantages as an energy source. The installation generates no pollution and no greenhouse gas emission. Typically, solar panels consist of solar cells, which collect the light. PV installations can be ground-mounted, rooftop mounted or even wall mounted. Furthermore, to maximize the light collection, sun tracking system can be built to follow the sun.

This section elaborates the theoretical context required to understand the photovoltaic technology and it provides informations to properly understand the reasons of the chosen solar cell.

### How it works?

Photovoltaic offers customer the opportunity to generate electricity in a clean and sustainable way. The word itself comes from the „photo“ which means light and the voltaic which refers to producing electricity. The system is comprised of photovoltaic cells and devices which convert the light energy directly into electricity without creating any air or water pollution. The photovoltaic cells are made of at least two layers of semiconductor. One of them has positive charge and the other has a negative one. When the light from the Sun enters the cell, some of the photons in the light are absorbed by the semiconductor and reacts with the negative layer of the cell, thereby the electrons flow through the external circuit and back to the positive layer. The flow of the electrons produces electric current. The block of solar electricity are modular in nature, and it allows great flexibility in application. To increase the utility of the system, group of individual PV cells are interconnected together in a closed, waterproof module. In order to achieve the desired voltage and current, the modules are wired in series and parallel into a PV array. Otherwise, if two modules are only wired together in series, their voltage will be doubled but the current stays constant. If it is only wired in parallel, their current is doubled but their voltage stays constant. That is why it is wired together in series and parallel.

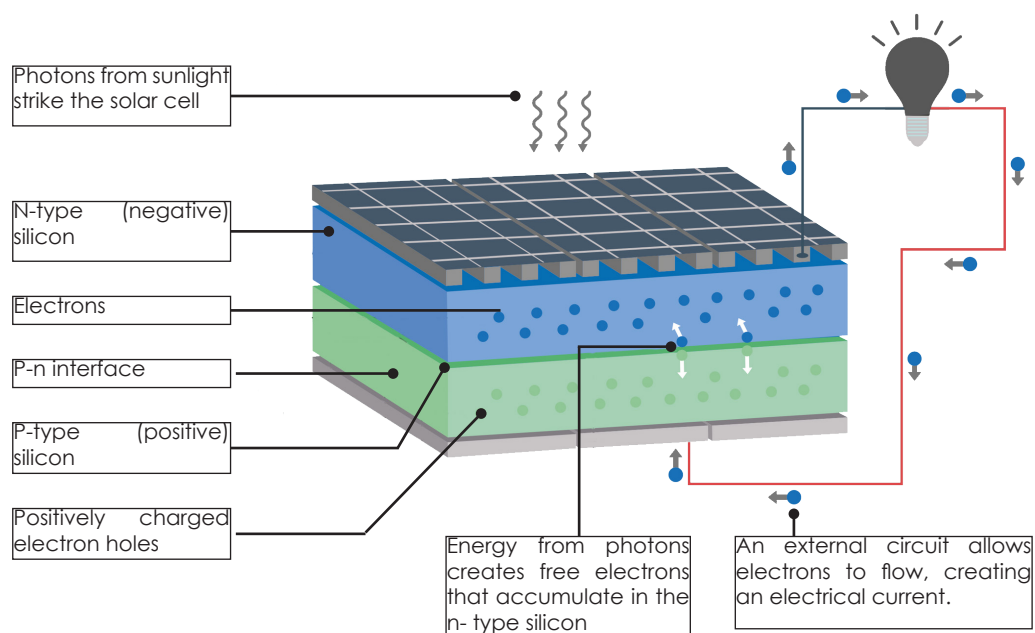

Figure 92: Solar cell turns light into electricity.

## Photovoltaic module

All modules are comprised of layers from the outer light-facing side to the back. The first layer is commonly made of thin glass or plastic. This layer allows the light to penetrate the protective layer and protects the surface from damages. The protection layer is followed by a transparent front contact layer which allows the light to enter the cell. Then the next layer is the most important part of the system which is the adsorption material. This layer absorbs the light and converts it into electric current. This is also called the semiconductor. In order to complete the electric circuitry a metal back contact is placed at the back of the semiconductor.

The last two layers protect the module from any damages. Laminated film is placed on the metal back contact which ensures that the structure is waterproof and insulated. Furthermore, another glass, aluminium, or plastic layer is placed on the backside of the module and protects the whole structure.

## Materials of semiconductor

The choice of the material of the semiconductor is an essential part of the system. It determines the efficiency of the modules, the cost of the system, and also the economic impact on the environment. The literature of photovoltaic cell technology reviews three different generations of the main PV technologies. The first generation systems use crystalline silicon on both simple crystalline form and poly-crystalline. The second generation systems use thin photovoltaics and it is divided into three major families: 1;amorphous silicon, cadmium telluride, indium copper , 2;selenide, indium and 3;gallium diselenide. The last, third generation systems use organic photovoltaic cells which are still under development (Sampaio et al., 2018).

Generation	Technology	Description
First Generation	Monocrystalline silicon	Among the silicon based cells Monocrystalline cells have the highest efficiency rates and the panels have a long lifespan. It is also well developed. However, it has a high manufacturing cost, longer energy return time, and it requires perfect crystal structure.
	Polycrystalline silicon	Polycrystalline is more attractive to use compared to monocrystalline due to the lower production cost. It is less efficient, but it consumes less energy during its life cycle. Embedded energy is also less in its manufacture and the crystal structure does not have to be perfect.
Second generation	Silicon nanowires	It can allow a new way to convert solar radiation to electricity with high efficiency and low cost. It requires less silicon to achieve the same amount of absorption compared to other technologies. The energy losses are also less when the light passes through a photovoltaic cell without being absorbed. Furthermore, it can be produced with excellent electrical characteristics. These advantages can considerably reduce the cost of silicon nanowires.
	Amorphous silicon	The advantage of amorphous silicon solar cells is their low manufacturing cost which makes it cost competitive. This technology differs from crystalline silicon in the fact that the atoms are located randomly to one another, causing a larger gap. Unfortunately, the panels have lower efficiency than MonoCrystalline cells or PolyCrystalline cells.

Generation	Technology	Description
Second generation	Cadmium telluride (CdTe)	One of the most promising approaches to manufacturing low cost and high efficiency solar cells. It has an ideal gap with a high coefficient of absorption of the solar spectrum being one the best type of thin film cells. However, it has some environmental issues. The Cadmium is toxic, and the availability of telluride, which would affect the cost of the module.
	Copper indium diselenide or copper indium gallium diselenide or copper indium gallium selenide (CIS, CIGs)	This type of semiconductor contains elements from the I, III, VI of the periodic table. These materials have high optical absorption coefficients. The major challenges of the technologies have been the limited ability to expand the process of high yield and low cost. Under wet conditions, it degrades and promotes changes in the properties of the material
Third generation	Organic photovoltaic cells	Organic cells usually have a flat layered structure where the light absorbing layer is closed between two different electrodes. One of them has to be transparent and indium tin oxide is normally used for it. They are structured from thin films of organic semiconductors such as polymers. The manufacturing process is less expensive due to the low cost of the material compared with silicon based cells and they can be flexible, thus it provides proper integration into different devices. Furthermore it has better ecological and economic impact. The drawback of the system is the cells have limited durability and they are not capable of converting sunlight into electricity with the same efficiency as silicon cells due to the low absorption of incident sunlight (large energy gap).
	Dye sensitized solar cell	This technology rather contains of hybrid solar cells due to the organic and inorganic materials. The main difference between the conventional solar cells and this type of cells is the functional element which is responsible for the absorption of light is separated from the transport mechanism of the charge carriers. Low cost titanium dioxide is used in the manufacture process compared to silicon which reduces the cost of the devices. Organometallic dyes such as ruthenium and porphyrins show exceptional conversion efficiency from solar radiation to electricity. The cells are thin and flexible and transparent. The drawback of the technology of the availability of the materials and the inchoate of the technology.
	III- V compound	III-V multijunction solar cells reach the highest efficiencies of any photovoltaic technology. Multijunction cells are more sensitive to a wider spectrum of the incoming sunlight. „This sensitivity is achieved by means of the implementation of several layers of different materials with a specific band gap” (Pérez-Higueras et al., 2011). As the name indicates, it is produced from the elements of third and fifth group of the periodic table, like gallium, indium, phosphorus and arsenic (Zubi, Bernal-Agustín and Fracastoro, 2009). These elements have a high light absorption capacity, few micrometres are sufficient to achieve high light power conversion efficiencies than Silicon solar cells. Germanium is used as an active layer in triple-junction cells. Unfortunately, this type of technology is quite expensive, and specially used in concentrator technology.

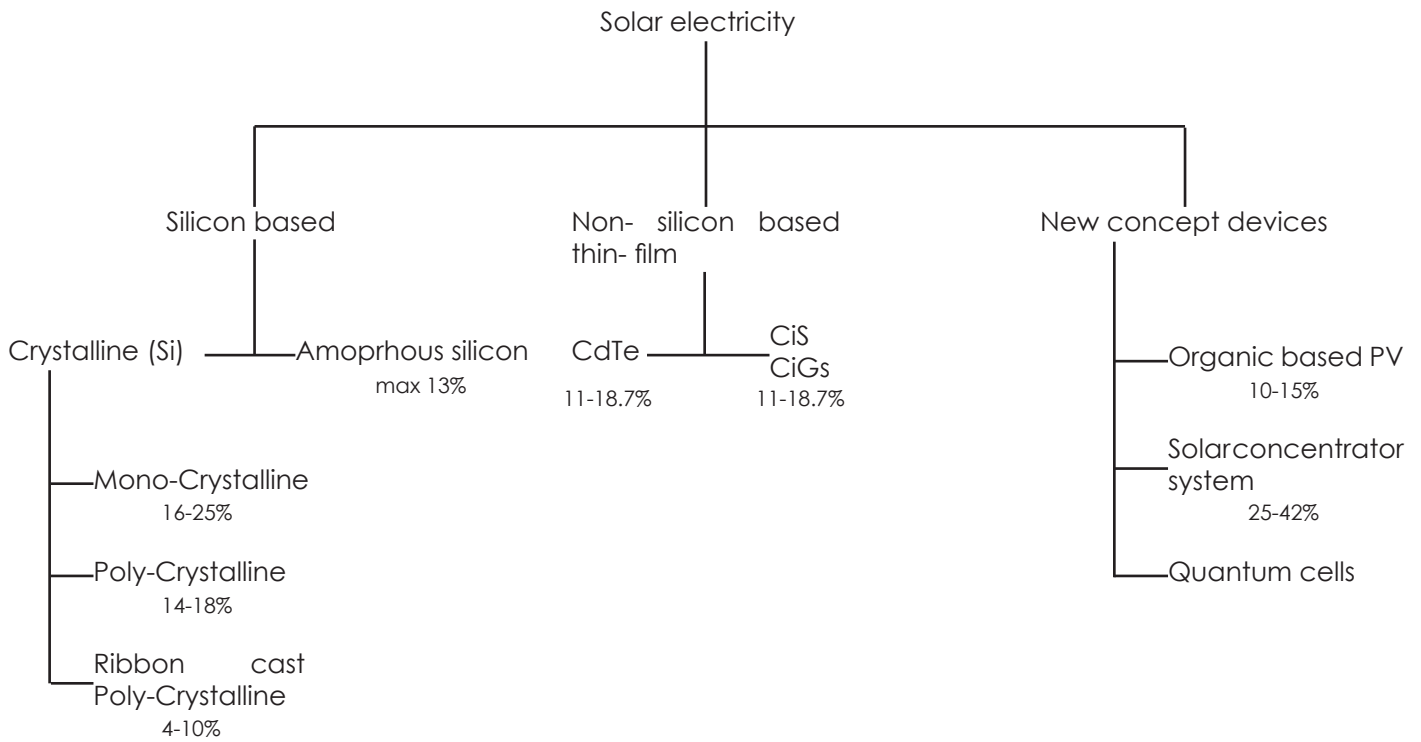

Figure 93: Semiconductor materials

### Efficiency

The solar cells work best at low temperature. When the temperature of the cell rises the efficiency decreases, which means the efficiency reduces with the rate of 0.5% in every 1°C. Moreover, the high cell temperature result permanent structural damage due to the thermal stresses which decreases the lifetime of the cell. The overall electric cell efficiency can be formulated as a following:

$$\eta_{\text{cell}} = \frac{P(W)}{G_X(W/m^2) \cdot A_R(m^2)}$$

- P**= ratio between the electric power supplied by the cell
- G<sub>x</sub>**= sun radiation falling on top of the surface
- A<sub>r</sub>**= cell area

Figure 94: The overall electric efficiency of the cell.

In order to prevent the overheating of the cell which significantly affects its performance, cooling system are applied to cool down the panel. The additional cooling system costs extra since it is not always part of the whole PV system. Cooling techniques can be air cooling, water cooling and conductive cooling. These techniques are applied especially in hot arid regions, or in high concentrated photovoltaic technology.

## 2.4.2 New trends on the Photovoltaic technology

The photovoltaic devices are under a technological development stage and the aim is to achieve higher efficiency to compete against other renewable energy sources. One of the technologies could be the High Concentrated Photovoltaic technology (HCPV), which is based on the use of optical devices that increases the light received on the cell and has a potential to reach high levels of energy conversion performance.

The other technology is the Luminescent Solar Concentrator, which collects the light from a large area and focuses it into a small area while avoiding the need of suntracking system and the large size of PV panels on the buildings.



## Concentrator Photovoltaics

System using High concentration photovoltaics (HCPV) have a potential to become competitive in the future, rather than the usual PV panels. They are more energy efficient and cost-effective. It is more environmentally friendly since it uses fewer semiconductor components which are made from heavily mined and relatively rare metals, and it has a smaller impact on the albedo change in an area than flat PV panels (Shanks, Senthilarasu and Mallick, 2016). Concentrating photovoltaic technologies consist of an optical device which is used to concentrate the light on small but high-efficiency photovoltaic cells. Thus it is maximize the energy production more than the regular PV panels.

„To classify the CPV system according to the concentration ratio of the solar radiation incident onto the cell. This ratio indicates the number of times that the solar light is concentrated and it is usually known as ‚Suns’” (Pérez-Higueras et al., 2011). According to the concentration factor, three different CPV systems can be defined:

- Low Concentration (LCPV) : concentration of the light is between 1-40
- Medium Concentration (MCPV): concentration of the light is between 40-300
- High Concentration (HCPV) : concentration of the light is between 300-2000

## Material of Concentrator Photovoltaics

III-V multijunction solar cells are preferred to use in concentrator technology due to it reaches the highest efficiencies of any photovoltaic technology. Multijunction cells are more sensitive to a wider spectrum of the incoming sunlight. „This sensitivity is achieved by means of the implementation of several layers of different materials with a specific band gap” (Pérez-Higueras et al., 2011). As the name indicates, it is produced from the elements of third and fifth group of the periodic table, like gallium, indium, phosphorus and arsenic (Zubi, Bernal-Agustín and Fracastoro, 2009). These elements have a high light absorption capacity, few micrometres are sufficient to achieve high light power conversion efficiencies than Silicon solar cells. The other material is the Crystalline-Silicon based semiconductors. Compared to the III-V multijunction solar cell it has lower cell efficiency around 16-25%, and only it can be used for Low Concentration (LCPV).

## Efficiency of Multijunction solar cell

The efficiency of the solar cell also depends on the temperature of the cell and on the concentrator factor, but for commercial available multijunction solar cells the efficiency can be between 26-42% (Pérez-Higueras et al., 2011). The temperature of the cell as it was mentioned previously deteriorates the performance of the cell. Increasing the temperature in cell results a reduction of the open-circuit voltage of the cell, which affects the maximum electrical power delivered by the cell, thus the efficiency drops. Every +10°C, the efficiency drops down by 0.5% (Pérez-Higueras et al., 2011).

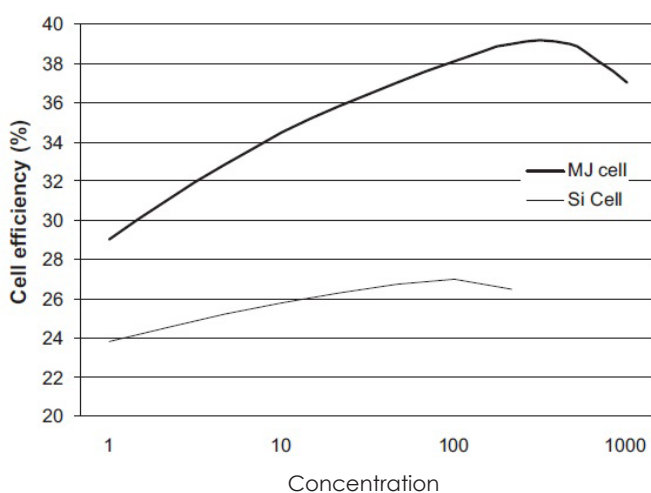

Figure 95: The typical cell efficiency evolution versus concentration ratio for different technologies

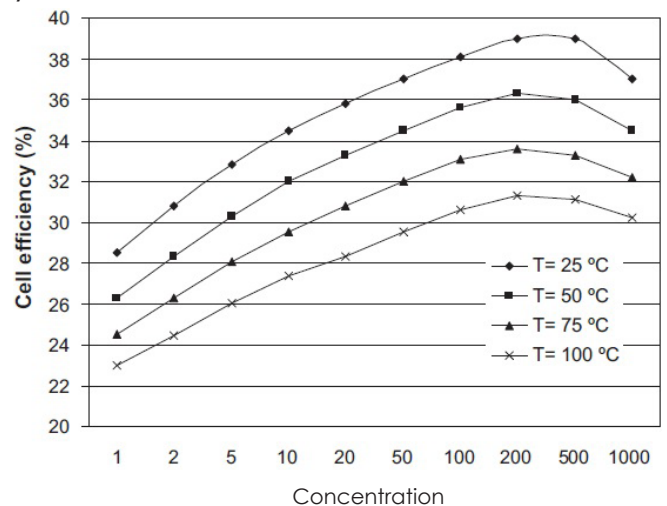

Figure 96: The differences in the efficiency evolution versus concentration ratio with the multijunction cell temperature.

Concentrator technology differs from the conventional flat, mounted Pv technology. In the market there are several concentrator technology. The differences are which optical devices are used in the system. Commonly fresnel lens, parabolic mirrors or reflectors are used in these applications. Although there might be differences in execution or materials used in the market, most designs follow one of these concepts or develop a new one based on the same principle.

## Fresnel lens

The Fresnel lens was invented in 1882 by a French mathematician and physicist Augustin Jean Fresnel. The lens comprises several sections with different angles, thus reducing weight and thickness in comparison to standard lenses. With Fresnel lens, it is possible to achieve short focal length and large aperture while keeping the light lines. It can be constructed in a shape of circle to provide a point focus with the concentration of 500, or it can a cylindrical shape to provide line focus with lower concentration.

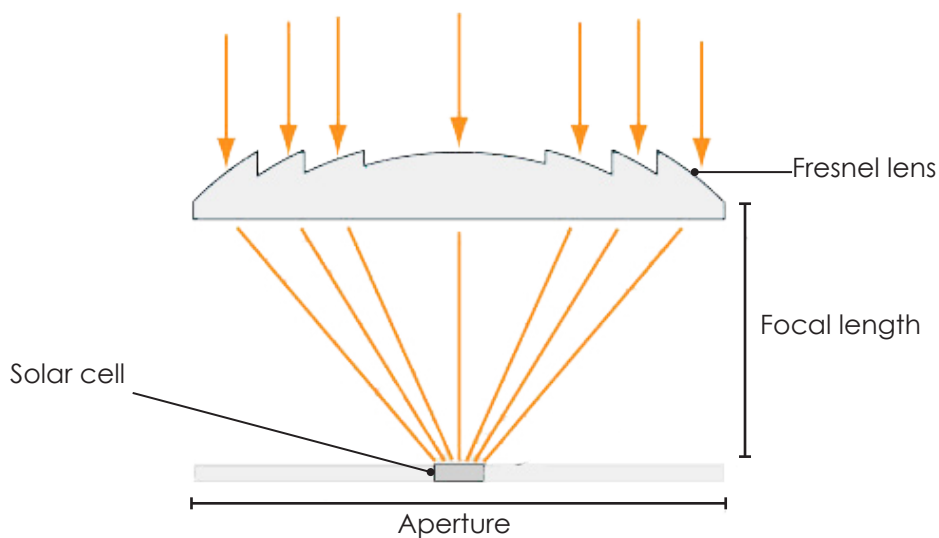

Figure 97: Principle of fresnel lens.

## Parabolic mirrors

In this idea, the principle is that all the incoming parallel light is reflected by a collector (first mirror) through a focal point onto a second mirror. Thus the second mirror which is also a parabolic mirror with the same focal point reflects the light beams to the middle of the first parabolic mirror where the solar cell is located. The advantage of the system is that no optical device is required. However, losses will occur in both mirrors.

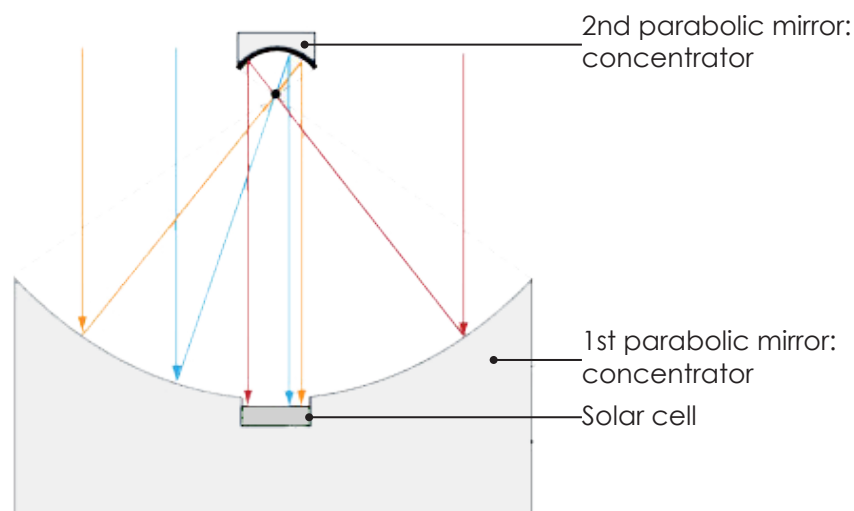

Figure 98: Principle of parabolic mirrors.

## Reflectors

This system is a low concentration photovoltaic modules with two reflectors which concentrate the sunlight onto the solar cell. These reflectors can be manufactured with silicone-covered metal. This technique lowers the reflection losses by efficiently providing a second internal mirror (Greenrhinoenergy.com, 2018). The angle and the reflectors are typically fixed. Due to it is a low concentration system monocrystalline silicon cells can be used instead of multijunction cells.

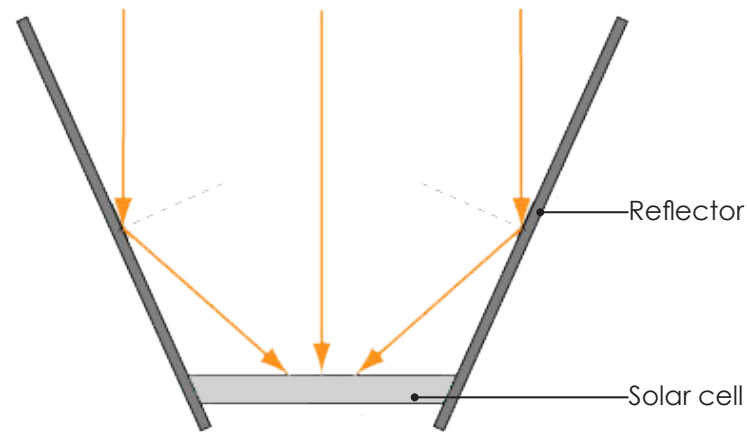

Figure 99: Principle of reflectors

## Luminescent Solar Concentrator

A promising solution to concentrate sunlight is the luminescent technology. The principle is that the chemical treatment glass allows sunlight to penetrate the top surface of a glass waveguide. This light is absorbed by luminescent molecules, which are embedded in the waveguide." *The absorbed light is re-emitted at a longer wavelength, and a fraction of the re-emitted light is trapped in the waveguide by total internal reflection, becoming concentrated along the edges of the plate*" (Debije and Verbunt, 2011). Along the edges, small PV cells can be attached to collect the light and convert it to electricity. In addition, the system is functioning well in both direct and diffuse light, making the technology more interesting for cities with frequent cloud coverage or areas of persistent shady conditions (Debije and Verbunt, 2011).

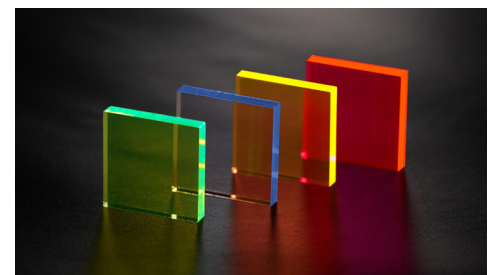
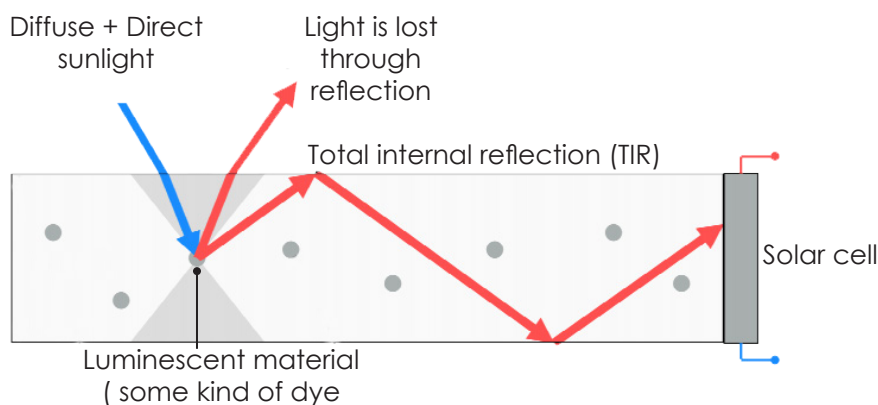

Figure 100: Principle of luminescent solar concentrator.

## 2.5 Case studies

In this chapter, some of the newest researches will be analyzed in order to show the feasibility of concentrated photovoltaic system. The case studies focus on how concentrated photovoltaic system can be applied in the building industry having a minimal impact on visual comfort.



## Glass brick, embedded with photovoltaic solar cells



Figure 101: Solar-cell-embedded glass brick.

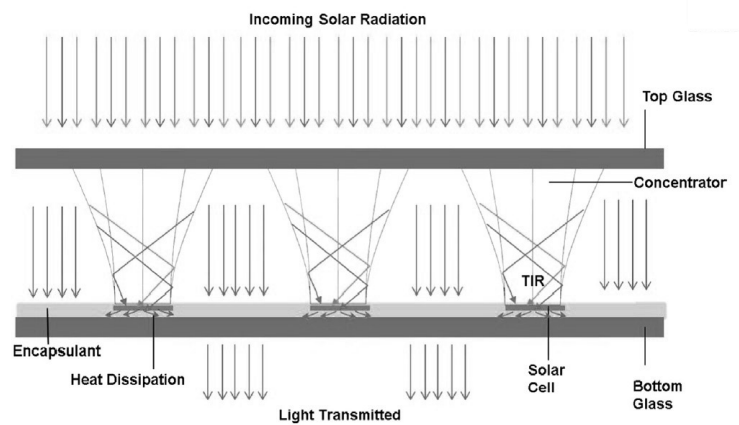

Figure 102: Total internal reflection of light rays to the solar cell.

As a solar concentrator, innovative solution can be a smart brick which produce electricity and it provides very good daylight quality. Researchers at Exeter University developed a solar brick where solar technology is embedded in hollow glass brick.

With the product, there is a capability to integrate attractive, solar technologies as part of the building where the energy demand is the highest while having minimal impact on the visual comfort.

The system consists of a concentrator and a solar cell which are placed between two glass sheets. The light incident on the surface is refracted through the top glass layer, the optical element below concentrates the light by total internal reflection to the cells. Thus, the solar cell converts the light to electricity. The block has an array of optical elements, but still, there is some spacing between them to provide light for the interior.

The research is quite new in the field and it is a promising solution/ idea to further develop. The combination of the transparency and energy production are valuable values in the architecture field. The technology can be the combination of form and function. The component can store energy while letting natural light into the building. The structure would capture solar energy even in dense urban context.

## Wellsun Lumidect panel

Wellsun is a dutch company who has developed a transparent sun screen which enables complete glass facades to generate more energy than the conventional solar panels and provides excellent indoor building climate.

The panel is 2 axis tracking system with the panel efficiency of 30%. The panel consists of 4 layers and the key parts are the fresnel lens and the cells. The system is 2 axis sun- tracking, therefore, it can utilize as much as possible diffuse light. Furthermore, the panels are also environmentally friendly. The material of the optics (fresnel lens) is made of PMMA and the protective layer is made of glass, both are recyclable, only the cells are not recyclable but it is a non toxic material.

In conclusion, Lumiduct can save energy and can create an ideal indoor climate by shielding the intense direct light which would overheat the building and at the same time it turns direct light into electricity. On the other hand, it is a transparent module which can let the light into the building.

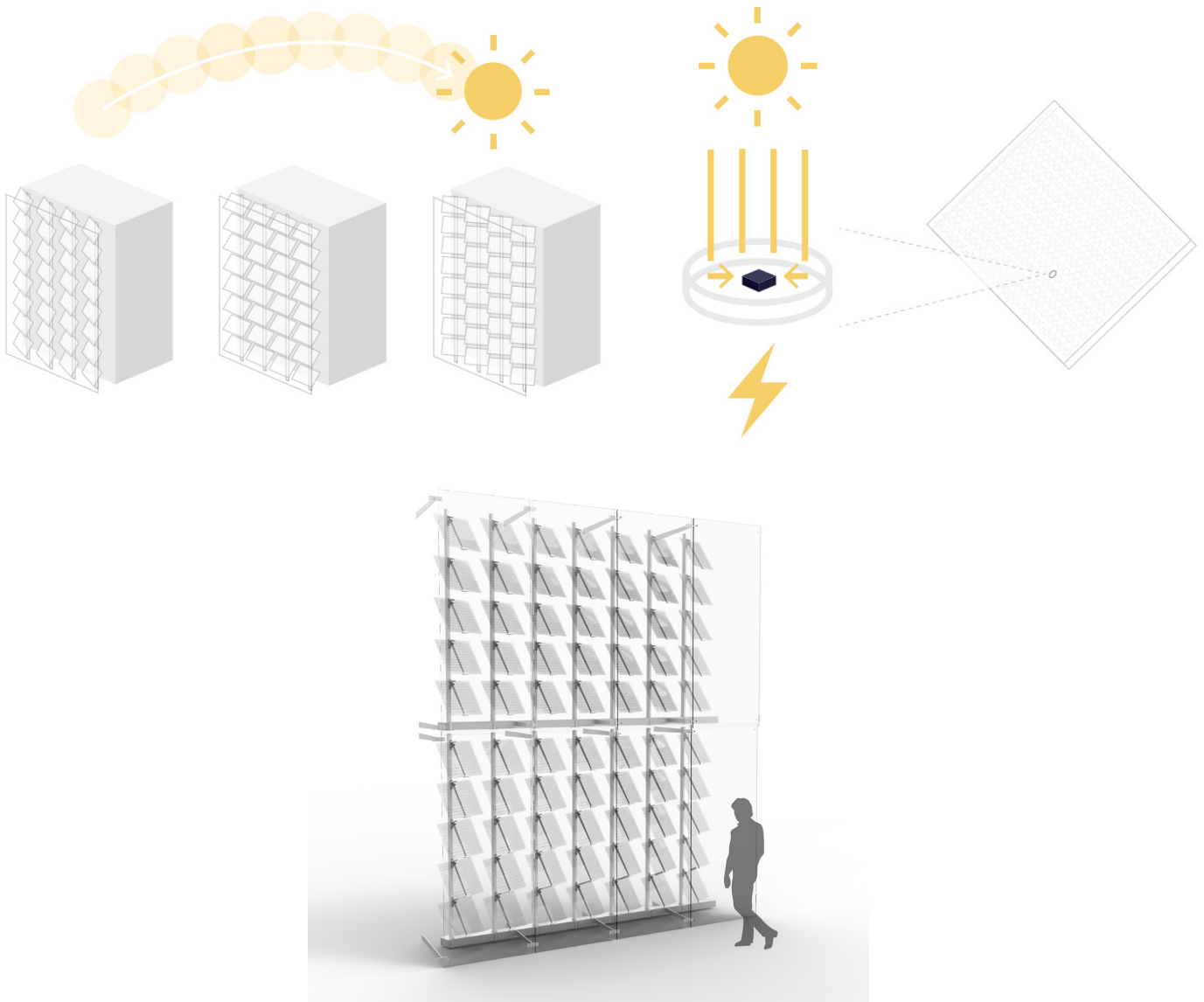

Figure 103: Wellsun- Lumid

## 2.6 Design strategies

In this chapter, general conclusions based on the literature studies are presented. Every chapter summarizes the given possibilities in different technology and proposal is made regarding which system would be efficient to design a cast glass solar concentrator unit (structural system, glass type, lens type, and photovoltaic type).

## 2.6.1 Structural principle

The overall structural and visual performance of a glass facade is determined by the type of the glass block used -hollow or solid-, the type of the substructure or transparent mortar, and the form of the geometry.

Regarding the structural performance of hollow glass block, it is not considered as a load-bearing component due to its relatively low compressive strength value. Moreover, due to the low wall thickness of the hollow glass blocks it is susceptible to internal buckling and failure from vertical loads. Hence, an additional supporting structure is required to reinforce the structure. From the transparency point of view, the block consists of multiple layers (glass-air-glass) which results optical distortion. The light ray is reflected and redirected within every substance producing visual obscuration. However, the main advantage of the hollow glass blocks is the block has a better thermal and acoustic insulating properties than solid glass units. (Oikonomopoulou et al., 2015)

The design of Hermes store (Japan) improved that hollow glass blocks can be used even in seismic sensitive area, but only as a secondary structure not as main load-bearing structure. In the facade of Hermes Store, each glass block is supported by a concealed network of thin steel channels embedded within the joints between blocks and the system designed to accommodate the anticipated seismic movement.

In contrast, solid glass blocks show much higher compressive strength which allows them to use as a main load-bearing components. Each block is produced by pouring molten glass into a steel mould, then it is cooled down uniformly to avoid any cracks in the glass. Compared with hollow block unit, solid block has less optical distortion due to its monolithic mass, and the absence of additional substructure further improves the visual comfort. The only drawback of the solid block is the poor thermal properties. (Oikonomopoulou et al., 2015) Due to its poor thermal performance, solid cast glass has been scarcely applied and actually there is only one building where it was used in a closed facade (Crystal House).

Comparative analyses have been completed on hollow and solid glass in the literature study especially from the structural performance point of view. In conclusion, the properties of hollow glass blocks do not allow to use them as a main load-bearing system and there is always the need of additional structures. In a fully transparent facade, these substructures in the blocks would deteriorate the visual comfort, where the transparency is crucial. In this sense, solid cast glass units are more appropriate structural components compared to hollow units.

Therefore, the research does not tend to change the existing structural principle of the glass facade where the adhesive and glass bricks fully cooperate and the facade behaves a single rigid unit, but it does tend to improve its performance. Previous examples such as Atocha Monument, Optical House has proved that casting glass provides an enormous freedom in the geometry which would facilitate to design complex geometries. A new cast glass unit, including geometries with convex surfaces not only would able to fulfil its load-bearing capacity but it can work as a solar concentrator. Therefore, it can generate electricity that can compensate the energy loss due to the poor insulation properties.

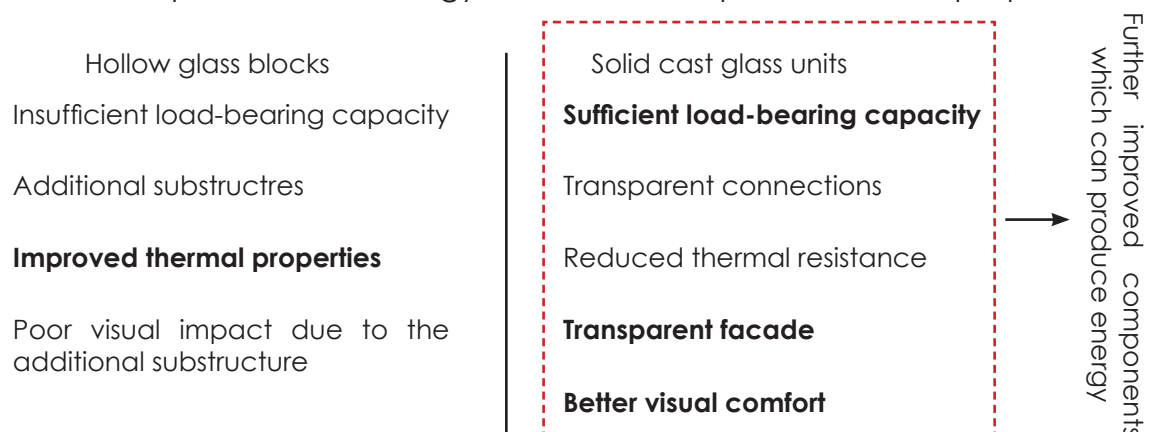



## 2.6.2 Glass material for lenses

In optical systems, a relatively wide range of glass materials are available in the market. Typically, these glass materials can be classified by their index of refraction and Abbe number. The index of refraction refers to the ratio of the speed of light in vacuum to the speed of light in a specified material at a given wavelength. The higher index of refraction bends the light more efficiently than a material which has lower index of refraction. Materials with low index of refraction are commonly called as crown glass and materials with high index of refraction are referred to as flint glass. In addition, crown glass has lower dispersion than flint glass.

In optics, the Abbe number is also known as V-number or constringence of the material. It is also used to classify glass and other optical materials in terms of their chromaticity. A low Abbe number generally gives higher colour dispersion which causes chromatic aberration in lenses. This effect would degrade images in microscopes, telescopes. Furthermore the chromatic aberration from dispersion results a failure of a lens to focus all colours to the same convergence point. It occurs due to lenses have different refractive indices for different wavelengths of light.

In photovoltaic technology, chromatic aberration of the optical device leads to an essential decrease of the energy efficiency of the solar cells. To minimize the impact of the aberration either it can combine more than two lenses of different composition or the material of the glass should be chosen carefully.

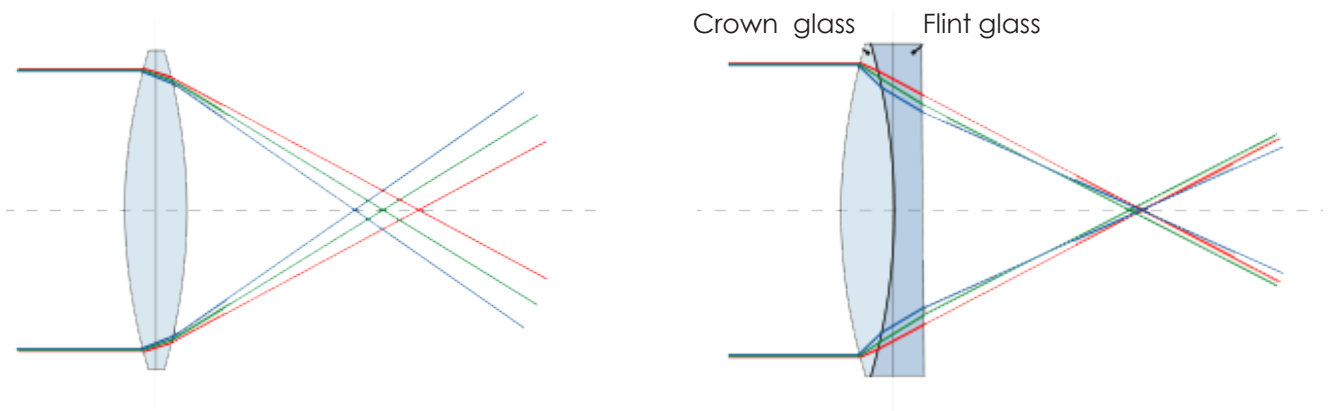

Figure 104: Chromatic aberration (left), correctness of chromatic aberration (right).

The combination of lenses is not feasible in the design since the new glass brick is going to be a single component and not a combination of lenses. Hence, the material of the component is more important.

The types of glass which reduce the chromatic aberration are the low dispersion glass. Typically, crown glass is a low dispersion glass. One of the most commonly used crown glass in precision optics is borosilicate glass.

The best option is to use borosilicate glass which is a clear and transparent colourless glass, ideal for a wide range of application in optics as well as in the building industry. It has a low thermal expansion coefficient which results less natural shrinkage during cooling and higher dimensional accuracy. Moreover, the temperature changes very quickly in The Netherlands, thus glass with lower thermal expansion coefficient is suggested to withstand the thermal shock.

Thermal expansion coefficient $10^{-6}/K$	Tensile strength MPa	Compressive strength MPa	Young's modulus GPa	Hardness kg/mm <sup>2</sup>	Abbe number	Refraction index
3.1-4	22-32	260-350	61-64	84-92	63.96	1.5168

Table 7: Properties of borosilicate glass.

## 2.6.3 Type of photovoltaic

In chapter 2.5 different photovoltaic technologies have been investigated, and highlighted the current stage of the technology. A photovoltaic module consists of several elements and the key component of the system is the use of semiconductor which produces electricity. The semiconductor can be made of different materials and each material has its own properties. However, when the type of the semiconductor is chosen, there are some design criteria which are taken into account. Price, application, payback time efficiency is the most important facts. The following table summarise the materials of semiconductor to get an overview which material should be used in the design.

		Material	Efficiency	Cost	Tracking	Payback time
First generation	Mono-Crystalline	Crystalline-Silicon	16-24 %	Expensive	Non-tracking	~ 0.75-2.5
	Poly-Crystalline	Crystalline-Silicon	14-18 %	Less expensive	Non-tracking	~ 1.5-3.0
Second generation	Amorphous silicon	Silicon	max 13 %	Cost efficient	Non-tracking	~ 2.5
	CdTe	Cadmium telluride	11-18.7 %		Non-tracking	~ 1.2
	CiS CiGs	Copper indium diselenide copper indium gallium Copper indium-gallium diselenide copper indium gallium selenide	11-18.7 %		Non-tracking	~ 1.7
Third generation	Solar concentrator	Gallium, Indium, Germanium, Phosphorus, Arsenic	25-42 %	Expensive	Non-tracking 1 axis-tracking 2 axis-tracking	~ 1.0
	Organic based PV	Polymer	10-15 %	Cost efficient	Non-tracking	

Table 8 : Overview of photovoltaics technology.

Photovoltaic technology is still in a development stage, but can provide a sustainable solution in long-term for the built environment. Companies offer several photovoltaic technologies with different module efficiency and every technology has its own properties. The current thesis also conducts research on concentrator photovoltaics technology and which semiconductor material would be the best for such an application. In conclusion, Mono-Crystalline and III-V multijunctional solar cells are the most appropriate, since these materials have the highest efficiency rate. Unfortunately, the other materials could not fulfil the technology requirements due to their low efficiency rate, thus they are not commonly used in a concentrator system.

Compared to Mono-Crystalline and III-V multijunctional cells, III-V multijunctional material is preferred to use than Mono-Crystalline in the market of solar concentrator systems. It has higher efficiency rate and the temperature affects less the cells (every +10°C, the efficiency drops down by 0.5%).

According to the literature study the efficiency of multijunctional cell is varied. It is between 25-42%., but the efficiency depends on the sun concentration and the environment. Only high concentration system can work around 40% of efficiency. The Crystal House in Amsterdam would consider as medium or low concentration system, thereby the efficiency of the cells will be less. Fraunhofer ISE is one the of the leading companies in multijunctional solar cell research and the company last year achieved 31.3% of efficiency using this type of material.

During the energy simulation, 31.3% will be used as the efficiency of the PV cells.

## 2.6.4 Type of lenses

In general, lens is a curved and transparent piece of glass or plastic which can focus and refracts light rays in a certain manner. The curvature of the lens ascertains the extent to which light is bent and in which direction. These lenses are commonly used in spectacles, telescopes, microscopes or in concentrated technology. Based on the shape, lenses can be grouped as convex lenses or concave lenses. In concentrated photovoltaic technologies both convex and concave lenses are used, but in a different way.

Concave lenses disperse the light, hence it cannot be used as a concentrator lens. However, concave shape is widely adopted design concept as a use of parabolic mirror. Parabolic solar concentrator continuously tracks the sun throughout the day using a 2-axis tracker system enabling the concept to produce maximum solar energy. The reflective surface of the dish is usually made of glass mirrors, aluminium sheets, stainless sheets, stretched coated, or stretched membranes. (Hijazi, Mokhiamar and Elsamni, 2016). Unfortunately, the use of parabolic solar concentrator as a transparent facade element is not feasible.

Convex lenses are more preferred to use in concentrated systems especially fresnel lenses. The lens is obtained by dividing a spherical lens into appropriate concentric annular sections, thus material can be saved with the optimization. The use of this unique lens makes it possible to concentrate the solar radiation onto a small surface with high efficiency. The only drawback of the lens is its sophisticated design and manufacture as it was described in chapter 2.4.

According to the literature study, the most reasonable shape which can be used as a concentrator in a cast glass component is convex shape and its different configurations. The shape of the lens is simple and its manufacturing is not as complex as fresnel lens. Accordingly, convex lens seems the most reasonable type of lens to use in the design.

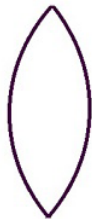
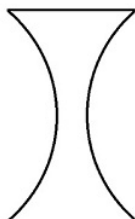
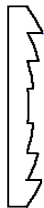
Type	Convex lens	Concave lens	Fresnel lens
Meaning	Merges the light rays at a particular point.	Disperses the light rays at a particular point.	Merges the light rays at a particular point.
Curve	Outward	Inward	Concentric annular section
Light	Converges	Diverges	Converges
Focal length	Positive	Negative	Positive
Image	Appear closer and larger	Appear smaller and further	Appear closer and larger
Figure			
Concentrator system	Optical device, concentrator	Parabolic dish/ mirror	Optical device, concentrator
Manufacture	Not complex cheap	Not complex cheap	Complex expensive

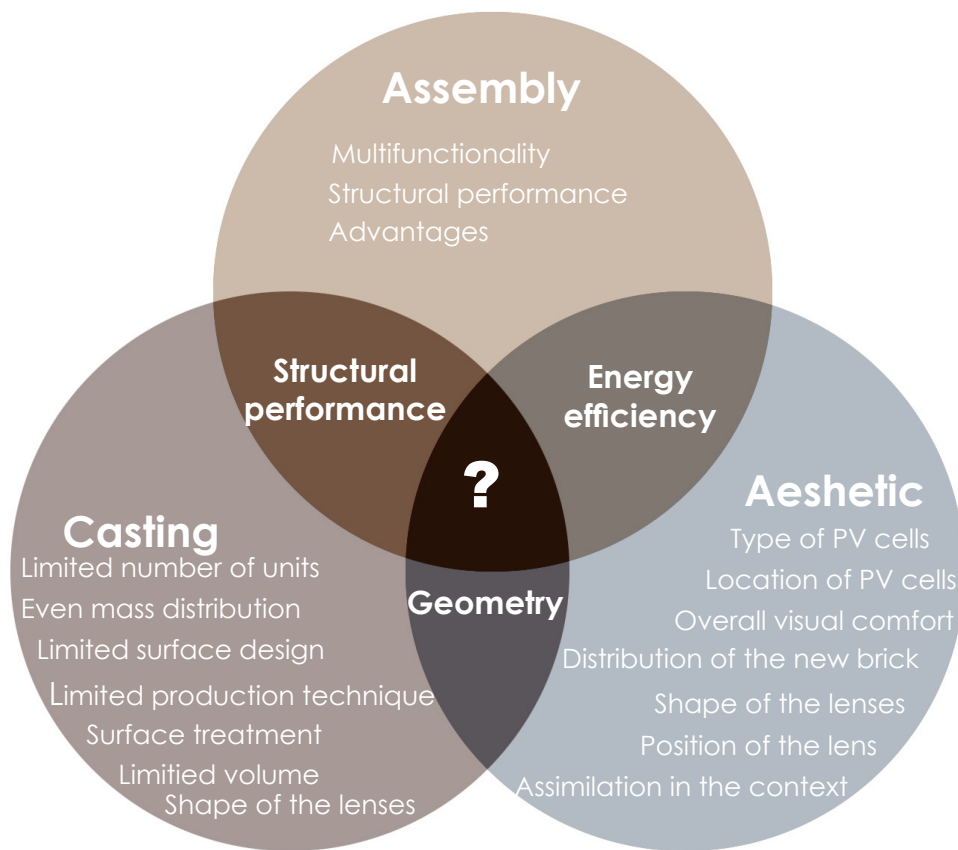

Figure 105: Design criteria.



### 3. Environmental analysis

The design starts with the environmental analysis to understand the solar potential in the area. Crystal House is going to be analysed from the solar radiation point of view both in building and facade scale. Furthermore, the energy consumption of the building is calculated in order to compare the results in later stage.

### 3.1 Introduction

Transparency in architecture has a significant effect in the twenty-first century architectural practise. The concept of transparency has been already noticed in the modern architecture where construction and materials are particularly based on glass, steel, and reinforced-concrete. Furthermore, transparency and lightness are two major aspects in architecture, and nowadays the use of glass has a vital role in both designing new buildings or renovate old buildings. With the aspect of using glass, new buildings can be literally become fully transparent (Sadeghi, Sani and Wang, 2015). However, glass has an integral part of the structure of the building, it has to find its balance in architecture. Architecture is not only designing buildings, but it tries to find the balance between Function-Form and -Meaning (Sadeghi, Sani and Wang, 2015). The function is always affected by the given social and natural context. The form which determines the structure of the building and its functional zones, and the meaning which is acquired from the explanation from the appearance of the form.

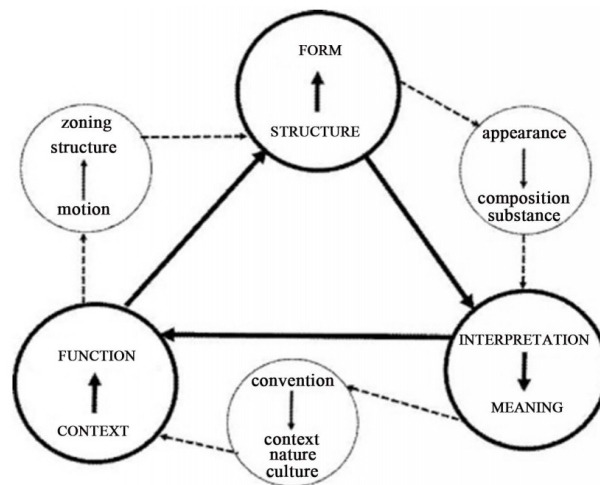

Figure 106: The aspects of form, function, and meaning (Salura & Fauzy, 2012).

By understanding the historical origin and the combination of meaning-form- and -structure a novel glass brick facade was designed, keeping the historical rhythm of the facade. It is a great example how architecture can use transparency as an integrated building element. The improved quality of daylight, view and the aesthetics makes the building fascinating. However, glass can affect the indoor climate in several way. Introducing more sun into a place means the solar load will increase, therefore in summertime the place can be overheated easily and mechanical ventilation has to be used. Using more mechanical ventilation is an extra energy demand. As it was stated in the research question, the object of the thesis is to overcome or save the extra expenses by using photovoltaics panels. In the environmental analysis the sunlight, sun path and the solar radiation on the Crystal House are analysed, which give an overview about the solar potential on the facade.

Charachteristics of Crystal House	Advantages	Disadvantages
Unique in the case of architecture Bridge between historical and modern It is an iconic building Cast glass as a self-supporting structure	Aesthetics Solar heat gain in winter High daylight level Assimilation in the context	Overheting summer Extra energy demand

Table 8 : Charachteristics of Crystal House

## 3.2 Location/ Climate

Crystal House is situated in Amsterdam in the district of Amsterdam-Zuid, which is also known as „Old South”. The neighborhood is mostly built with three to five-story houses therefore there is no high-rise building which would block the direct sun light. The street is also well known for its expensive shops.



Figure 107: The context of the building.

According to the climate conditions, Amsterdam has an oceanic climate condition, where the summer and winter are both mild. The average annual precipitation is 838 millimetres. Furthermore, wind is also very common through the whole year as well.

### Solar radiation

According to the literature study, Sun provides 10000 times more energy than the daily use of the population (Petter Jelle, Breivik and Drolsum Røkenes, 2012). Therefore solar radiation is an important factor to achieve a high performance design. It helps to understand how the mass should be orientated and it determines the characteristic of the indoor climate. Furthermore, solar radiation is used to produce electricity by using an array of PV panels. Solar power or solar irradiance is the energy which reaches a unit area at the earth. This energy is usually measured in  $W/m^2$ . In addition, the solar energy is also known as solar radiation or irradiation which is the amount of energy on a certain surface in a given period measured in  $kWh/m^2$ . This solar power can be high, up to 2000  $kWh/m^2$  especially in the southern countries, or moderate around 1000-1150  $kWh/m^2$  for instance in The Netherlands. This value is varied due to the location and different weather conditions. The following diagram shows the global irradiation incident in 25 European Union countries.

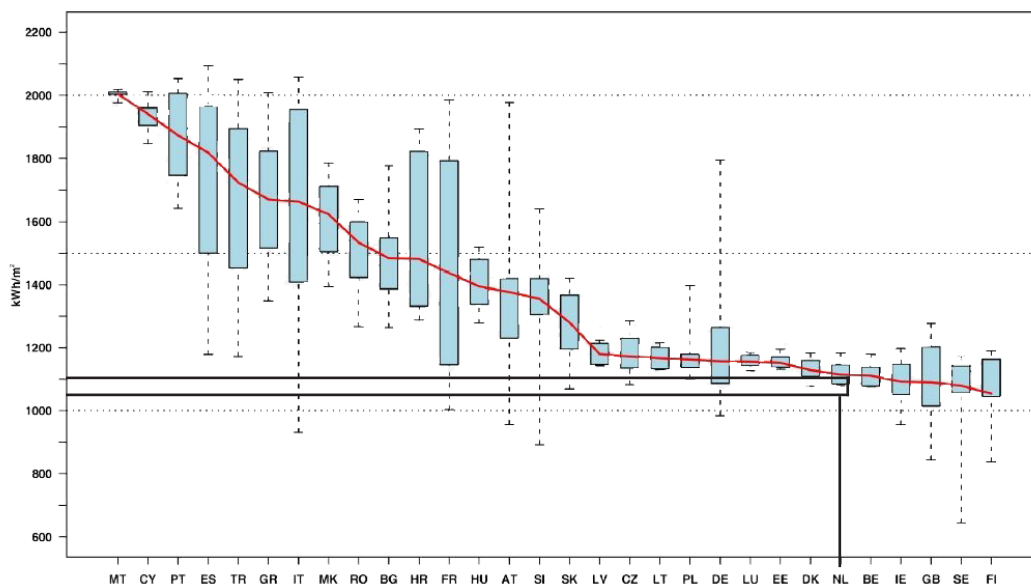

Figure 108: Global irradiation incident on 25 European countries.

As it is shown above the amount of solar radiation can be very high. However, these are not the maximum amount of percentage of the total radiation which the Earth receives. Few percents of solar radiation are absorbed, reflected, and scattered when it enters the atmosphere (Stine and Geyer, 2001). In addition, the weather condition also affects the intensity of the solar radiation. On a clear sky day, this could be direct radiation (direct beam radiation), or it can be diffuse radiation which is scattered by the clouds and the atmosphere. The loss is caused by the atmosphere. For instance, clear sky allows the direct light to reach the built environment, meanwhile a cloudy weather filters the sunlight and scatters the diffuse light around an area. Generally, not 100% of the solar radiation reaches the ground when the sky is clear. On a clear day 80-90% of the maximum solar energy is reaching the surface of the Earth (Stine and Geyer, 2001). The following figure shows how different part of the atmosphere affects the distribution of the solar energy.

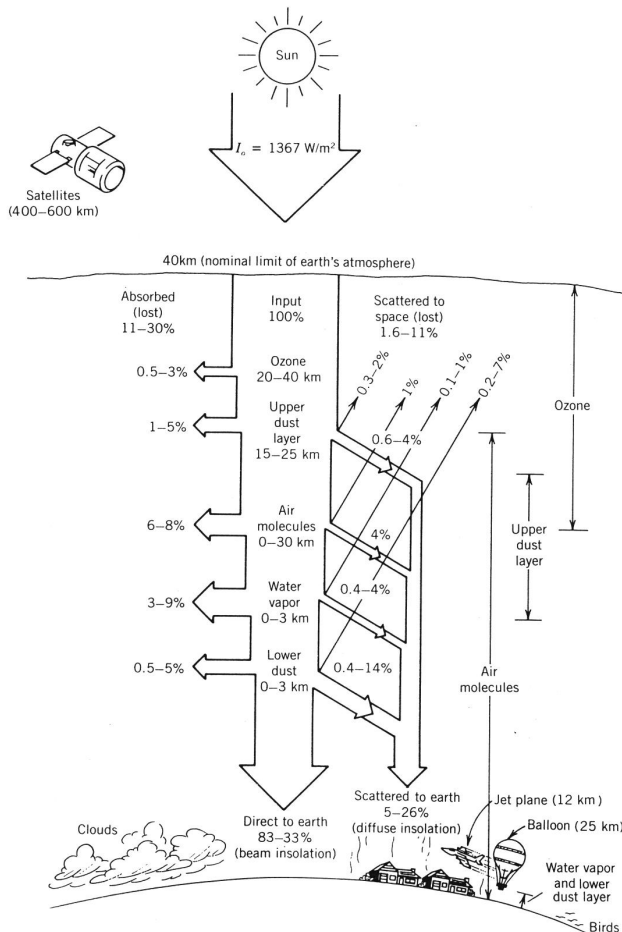

Figure 108: Absorption and scattering of incident solar energy. (Stine and Geyer, 2001)

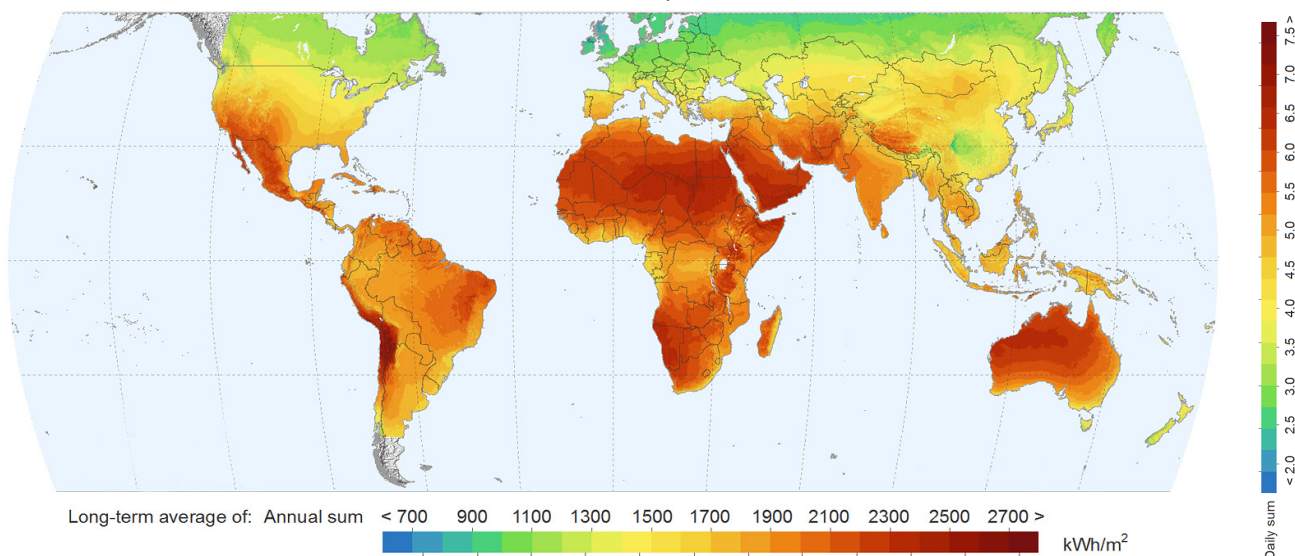

Figure 109: Solar potential around the world (solargis.info, 2013)

## Sun path

Earth rotates on its axis and orbits around the Sun. This results that Sun appears in different position on the sky and it affects the length of the daytime/ nighttime. The position of the sun can be determined by the azimuth and the altitude. Azimuth is an angle between a reference direction and a line from the observer to the point, and altitude assigns to the angle of the sun relative to the horizon of the Earth.

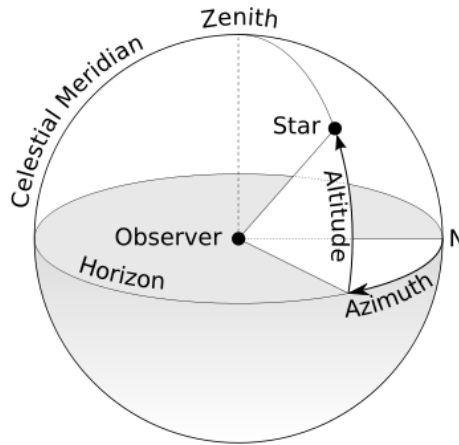

Figure 110: The position of the Sun.

The position of the sun can be calculated using the sun path diagram. The diagram represents the top view, where azimuth, altitude, date, and hour line can be seen. In the following diagram the steps are shown how to determine azimuth and altitude in a certain day and in a certain time. The chosen time is 20th of March at noon.

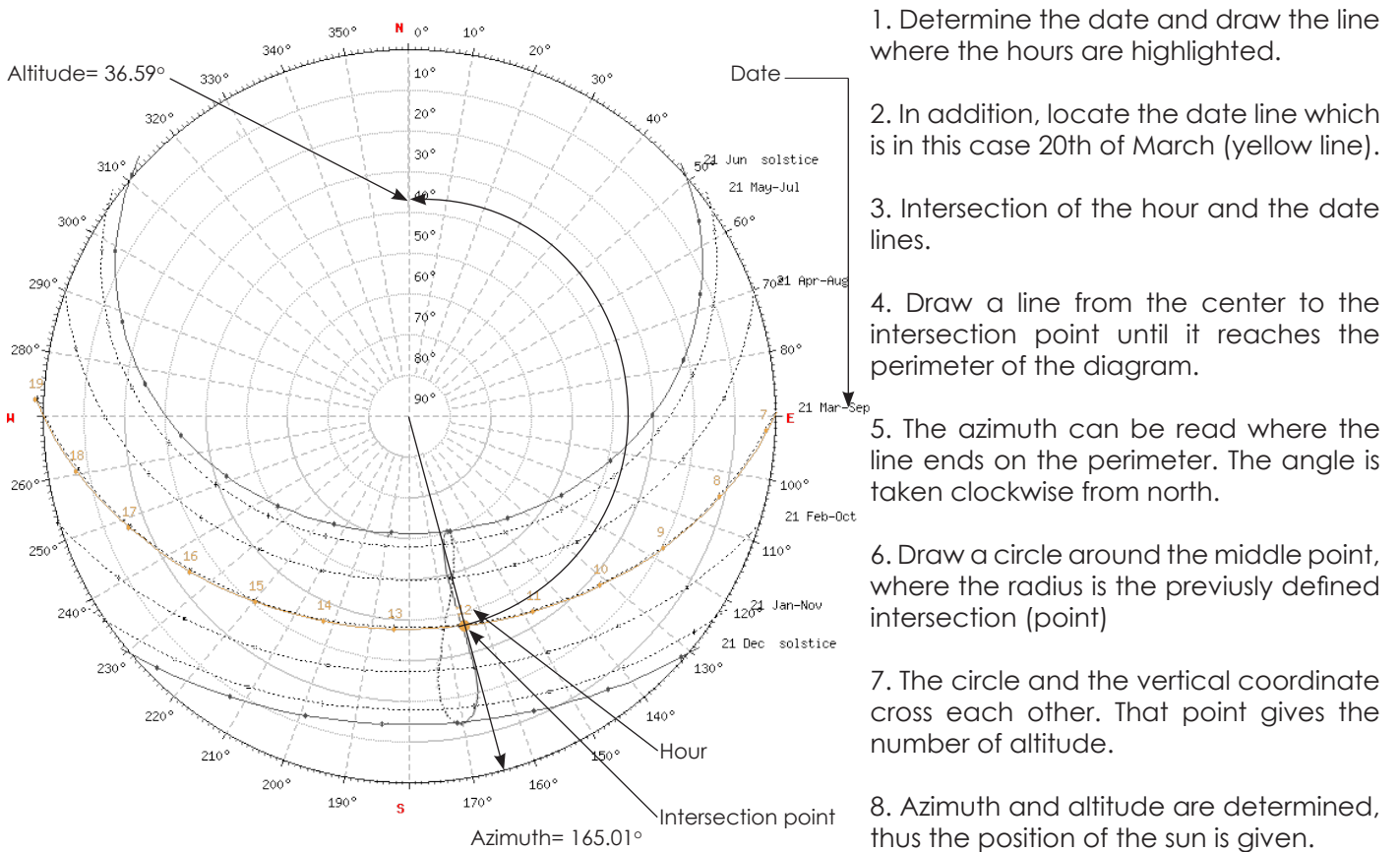

Figure 111: Determination of the Sun position manually.



Moreover, the daylight hours and the solar radiation respectively to the surface can be calculated in the following way (Broersma, 2008) :

$$N = \frac{2}{15} \cos^{-1}(-\tan \varphi \tan \delta)$$

$$\delta = 23.45 \sin\left(360 \frac{284 + n}{365}\right)$$

N = number of daylight hour

$\varphi$  = latitude

$\delta$  = declination of sun

n = n day of the year

Figure 112: Formula to determine daylight hours.

Fortunately, nowadays it has not to be calculated by hands, due to the efficient environmental analysis tools in Rhino/ Grasshopper. These plugins support the design during the initial stage of the design. The data can be visualized easily showing 2D and 3D graphics and it ensures better decision-making. These results are based on recorded reliable weather datas. During the environmental analysis especially Ladybug and Honeybee plugins are used (Roudsari, Pak and Smith, 2013)

Process	Analysis tool		
	Ladybug	Honeybee	Diva
Climate analysis	✓	✓	
Massing, Orientaton study	✓	✓	✓
Daylightning study	✓	✓	✓
Energy modeling	✓	✓	limited

Figure 113: Existing environmental analysis tools for Rhino/Grasshopper (Roudsari, Pak and Smith, 2013)

### 3.3 Site Analysis

#### Sun path analysis

The area is a medium-density commercial zone. By analysing the orientation of the building, it clearly shows that the building is facing to the South-East direction. There are no high-rise buildings in the area which could block the daylight for the building.

#### Solar analysis

The solar analysis of the building is conducted in two levels: 1) the solar analysis of the whole building in its urban context, and 2) solar analysis of the envelope of the building.

The urban context is modelled and the building is analysed in its environment, where the roof of the building receives the highest radiation. Particularly those sides of the roof, which are facing to South-East direction. The analysis period is set to one year and the maximum radiation on the roof is 1101 kWh/m<sup>2</sup>. This value corresponds to the value which can be achieved in Amsterdam according to the global measurement (see Figure 94.), thus the used weather data is correct.

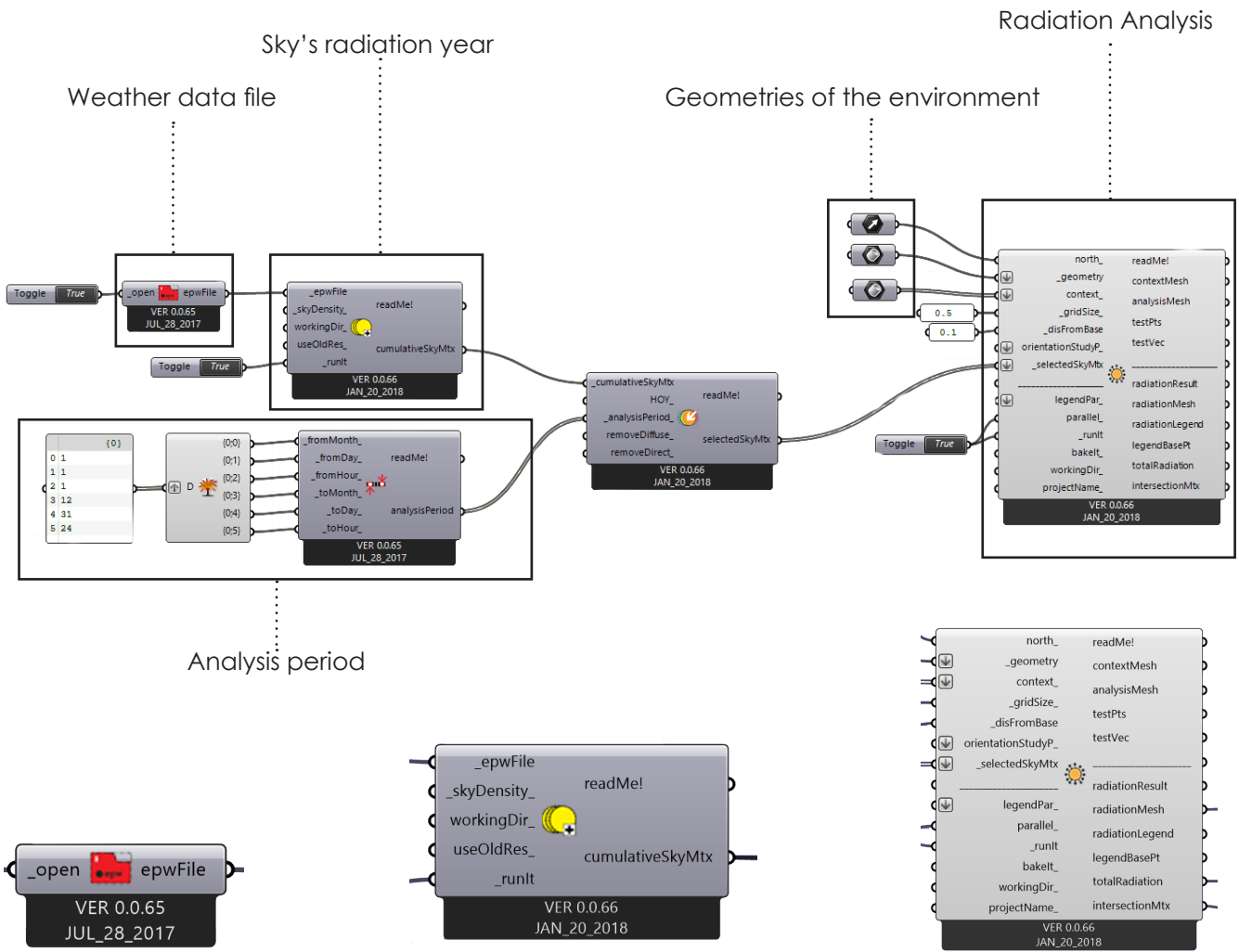

Weather file  
 .epw weather file contains the specific climate condition for a certain location

GenCumulativeSkyMtx  
 The grasshopper component collects the data from .epw file which contains relevant climate data. It calculates the radiation of the sky for each hour of the year

Radiation Analysis  
 The component calculates the radiation on the geometry. It is useful for solar heat gain or solar panels. It takes only the direct radiation into account

Figure 114: Grasshopper components.

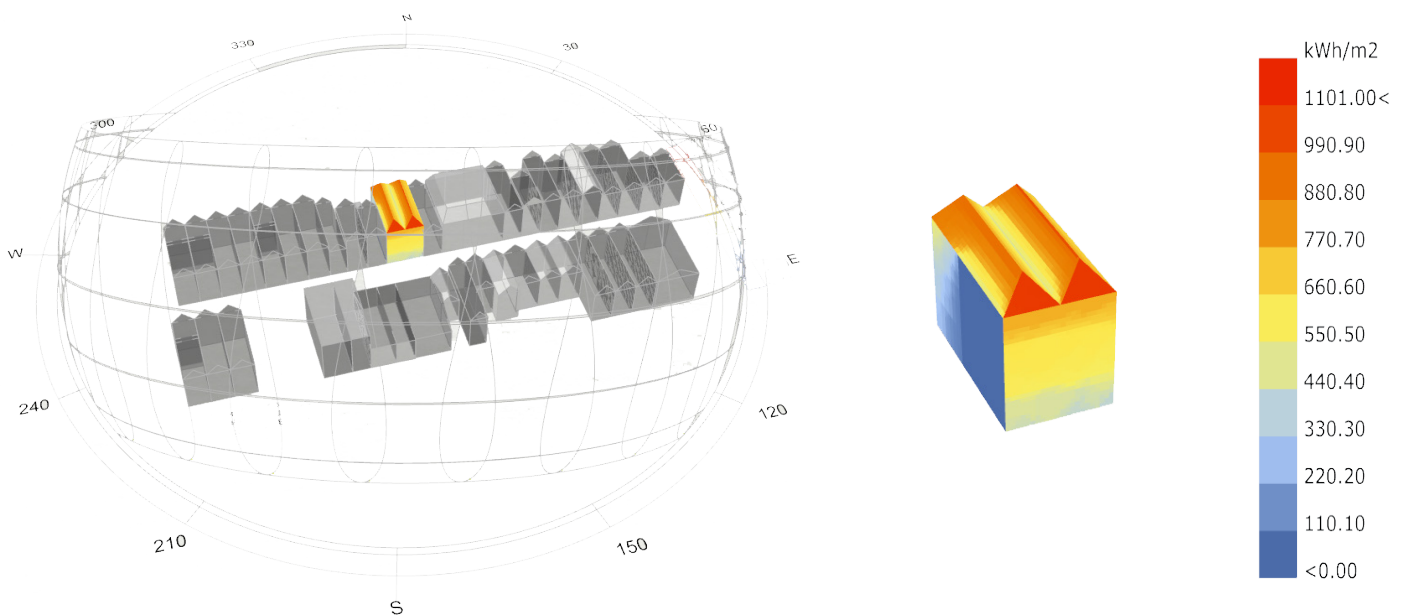

Figure 115: Sun path analysis (left), solar potential on the building (right).

The first study of the simulation shows the solar potential of the whole building. It shows which surfaces are the best (red) and which part does not even receive any radiation or just a small amount of it (dark blue).

The front facade of the building receives the highest solar radiation, especially the top part of the envelope.

The main facade of the building is divided into three parts, thereby, it provides more detailed radiation resolution and the zones facilitate where to position the new, smart bricks. From the design point of view, only the first and the second floor should be taken into account. The third floor constructed with traditional brick material and it is not part of the glass design

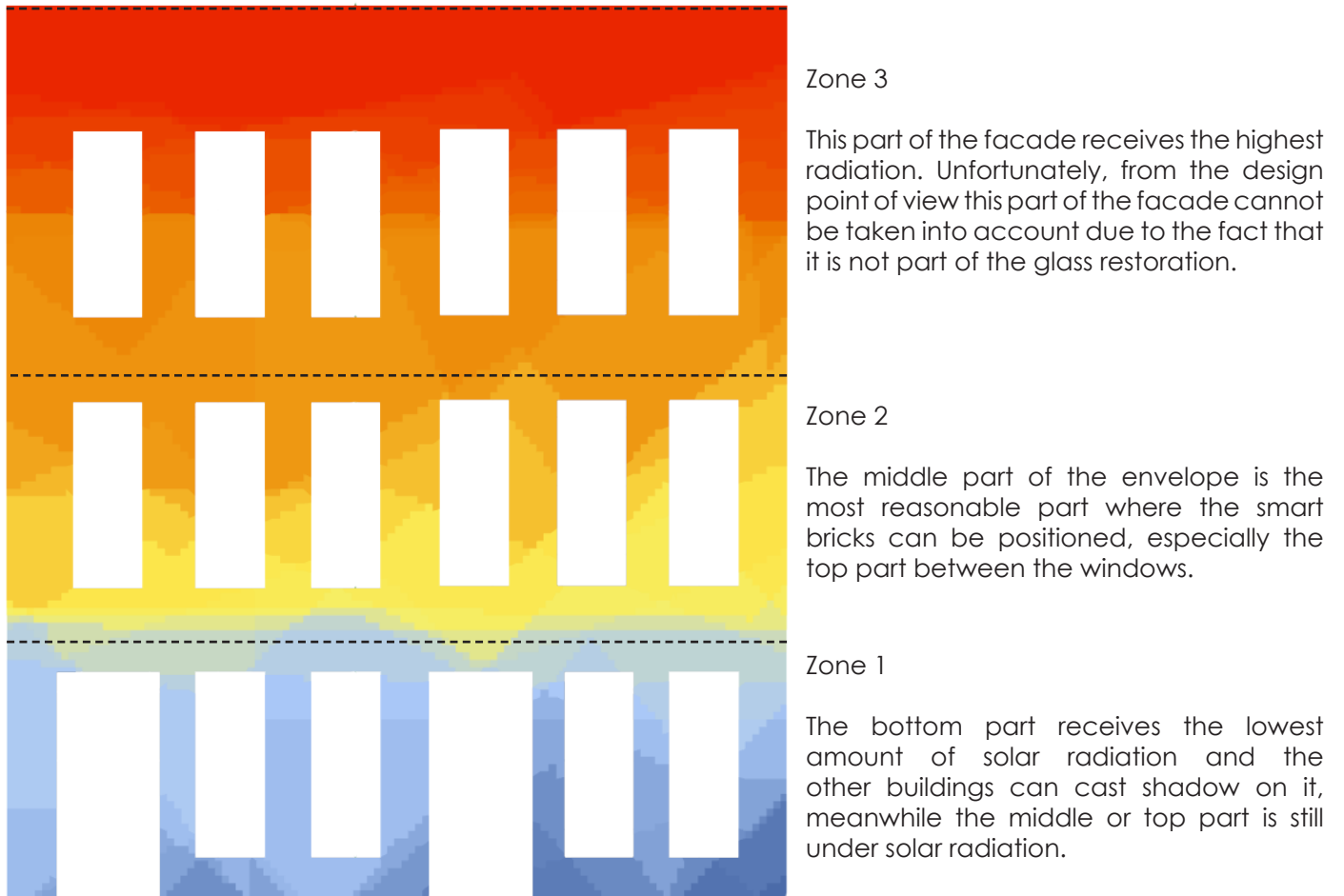

Figure 116: Solar potential on the facade.

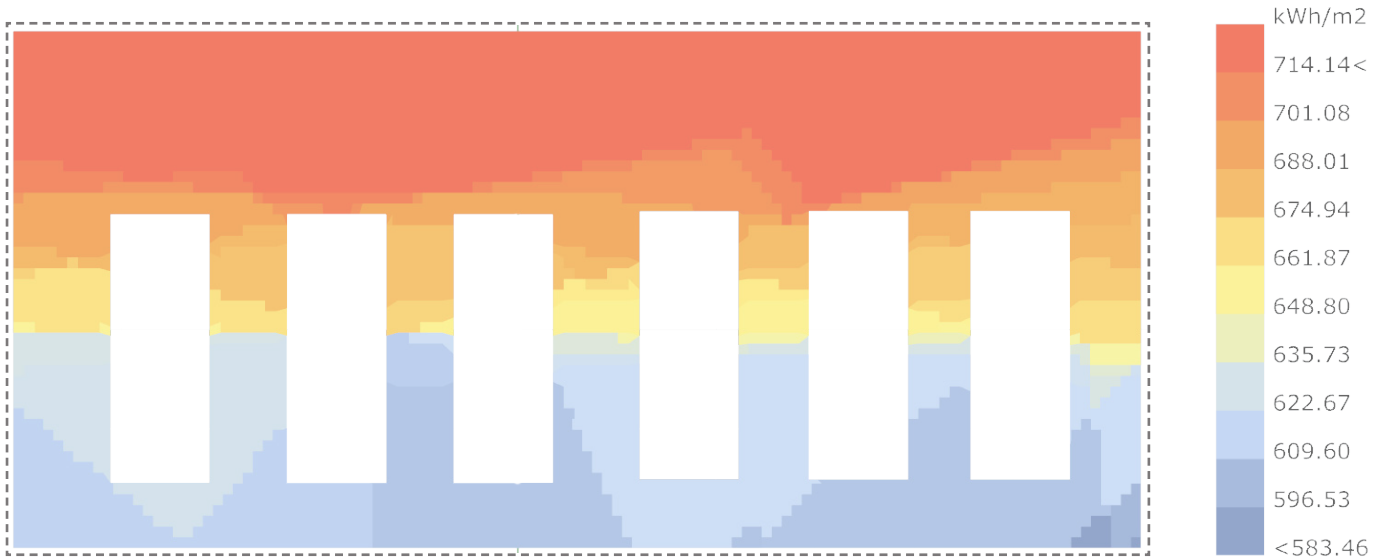

Figure 117: Solar potential on the top part of the facade.

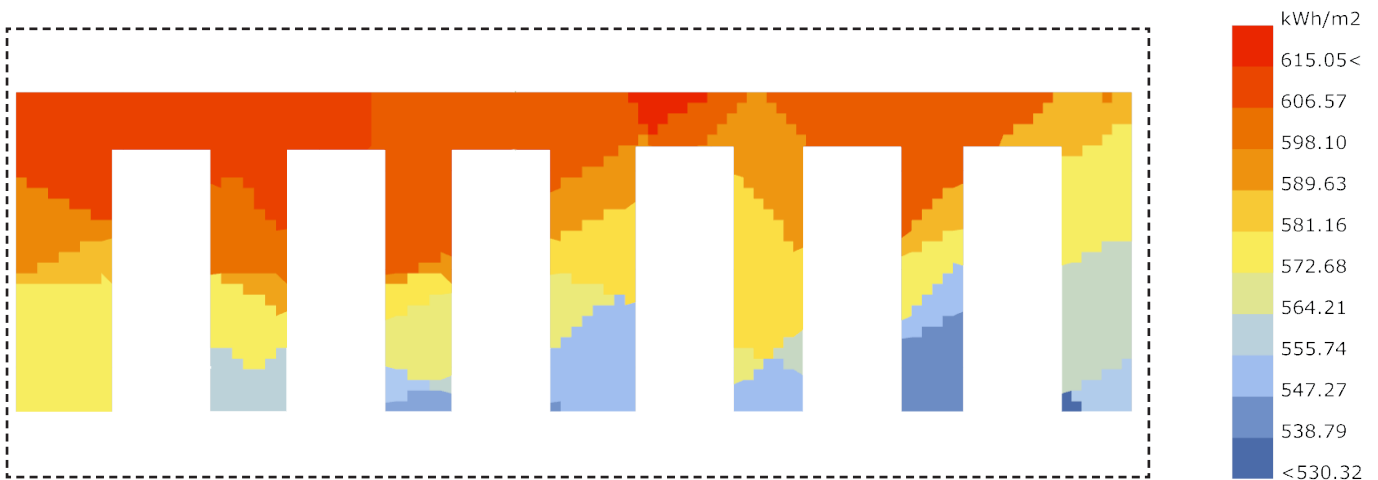

Figure 118: Solar potential on the middle part of the facade

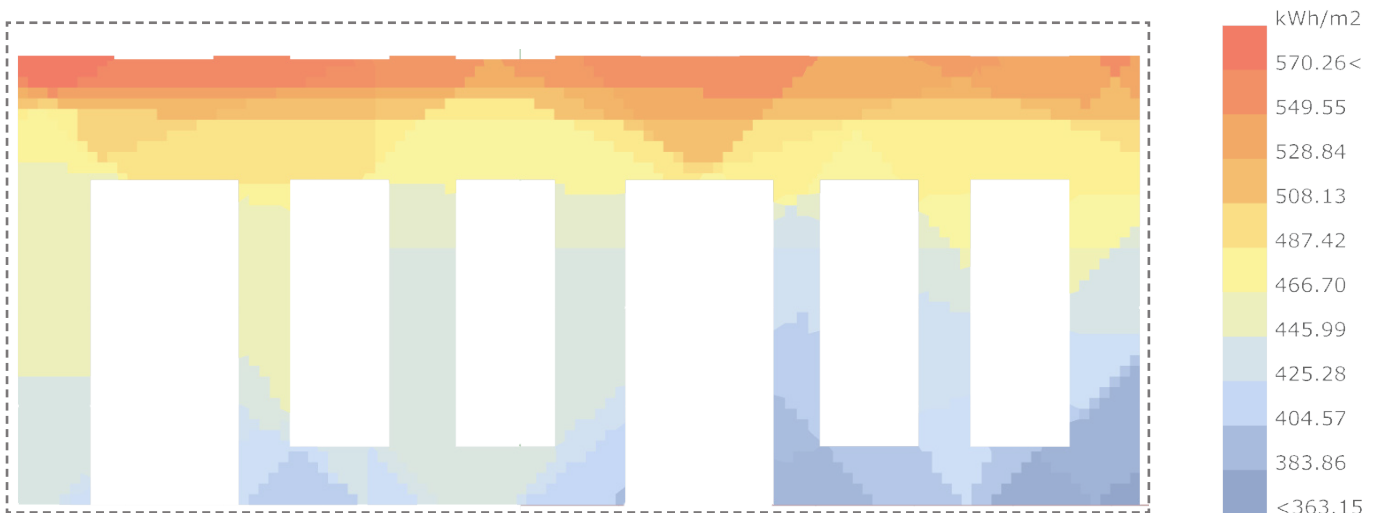

Figure 119: Solar potential on the bottom part of the facade

There is a clear distinction between the zones. This difference is mainly caused by the adjacent buildings and the altitude of the sun. The lower part receives a lower amount of radiation due to the lack of morning sun rays and the low altitude of the sun at winter. To prevent partial shading of the photovoltaic panels, the second zone is the most suitable to position them.

## Energy consumption

In general, heating and cooling in buildings reports for a big part of the total energy consumption. The proposed performance measures the estimated energy use by a building to provide appropriate thermal comfort in the building. The indoor environment quality is a fundamental requirement for indoor spaces. Therefore, the building has to provide a sufficient level of comfort by using mechanical cooling and heating. According to the Dutch Standard ISSO 51, the comfort temperature for offices should be between 20°C and 25°C. Nevertheless, this temperature set-points might be different depending on occupant's preference, but the same temperature range is used for the measurement of the mechanical system in the building.

	Heating	Cooling
Setback temperature	20°C	25°C

Table 9 : Table of set-back temperature.

## Glazing ratio

The glazing ratio is representing the percentage of the glazed surface. The building has two facades with different glazing ratio. The ground and the first floor of the main (front) facade has a glazing ratio of 100% and the second floor has a 30% of glazed surface. Each floor at the backside of the building has a glazing ratio of 30%.

## Ventilation schedule

The ventilation schedules refers to the number hours of a day during which mechanical ventilation is introduced within the building. The calculation is considering 9 working hours per day. Furthermore there is an extra hour in the morning to set up an ideal temperature.

Days	Occupancy hours
Week days (5 days)	9:00 - 18:00
Saturday	10:00 - 18:00
Sunday	Closed

Table 10 : Table of occupancy hours.

## Thermal zones

The thermal zones are created accordingly to the individual spaces in the building. There are five different zones correspond to the four different floors. The function of the building is a combination of residential and commercial use. Therefore, it is not necessary to analyse all of the zones, but only the ground and the first floor.

Ground floor: 175m<sup>2</sup>

First floor: 150m<sup>2</sup>

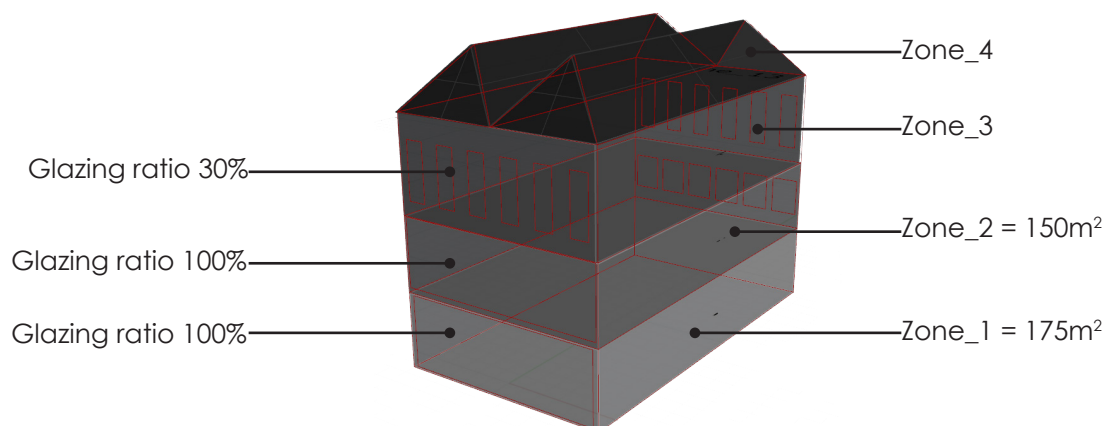
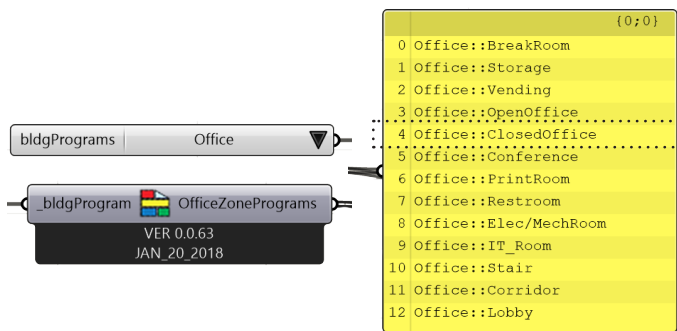

Figure 120: Thermal zones.



### Thermal zones program



The function of the building is residential and commercial. The analysed zones are set up as an office zone program.

### Probability of occupied hours

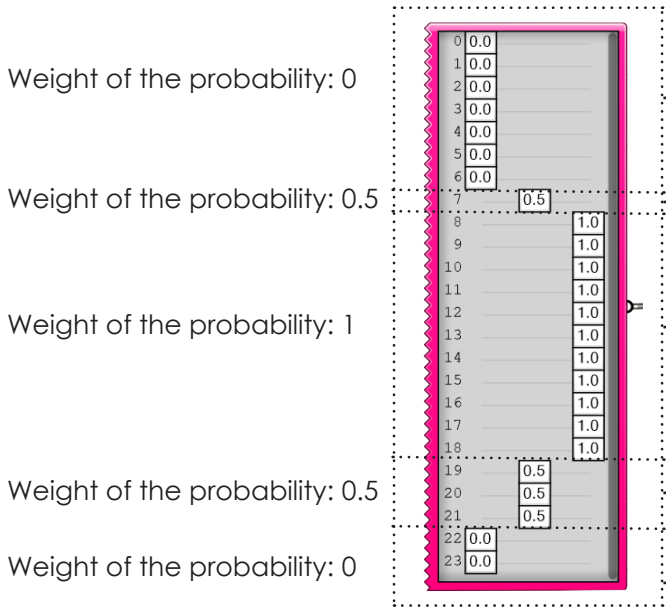

The probability of that someone being present during the night is zero

The working hours can be extended due to special occasion. The probability is 50% that the shop is open in these hours.

Opening hours

The working hours can be extended due to special occasion. The probability is 50% that the shop is open in these hours.

The probability of that someone being present during the night is zero

### Set-back temperatures

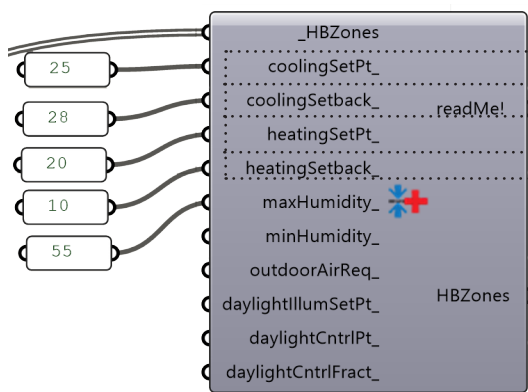

Indoor temperature above which the cooling system is turned on.

Indoor temperature that the space will kept when it is unoccupied.

Indoor temperature below which the heating system is turned on.

Indoor temperature that the space will kept when it is unoccupied.

### Estimating of the energy consumption

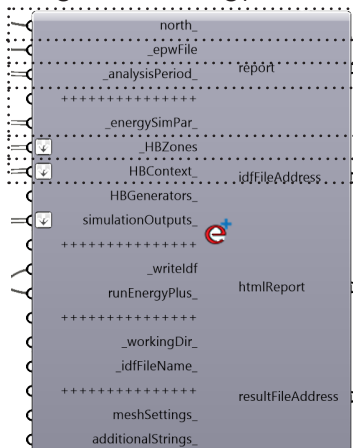

Direction of north

Specific climate data

Annual and monthly analysis period

Four different thermal zones

Urban context

Figure 121: Grasshopper components for energy simulations.

Month	Cooling/ Heating KWh
January	0 310.32
February	0 273.10
March	0 169.00
April	3.8 86.34
May	68.31 13.72
June	148.36 4.67
July	357.03 0
August	357.03 0.17
September	107.24 2.10
October	34.73 84.54
November	2.20 186.73
December	0 302

**$\Sigma=2470.0$  KWh**

Table 10 : Total energy consumption in a year.

The total energy consumption of the shop is 2470.0 KWh in a year. The aim as it was already formulated in the research question is to cover some percentage of the total consumption by applying photovoltaics panels on the facade.

## 4. Light simulation

This chapter describes the workflow of the design, especially how the geometry was shaped and analyzed both in 2d and 3d from the interaction between light and solid glass point of view. Different components are designed in order to redirect the light and a comparison is made which performance would be the best for the research.

## 4.1 Introduction

The prediction of the propagation of the light is a very complex question. In optics, the refractive index of the material defines how the light will propagate through the material. It can be described as a following:

$$n = \frac{c}{v}$$

$n$  = refractive index

$c$  = speed of light (in vacuum)

$v$  = velocity of the light

The refractive index shows how much the light is bent when it enters a new substance. Many materials have a well-characterized refractive index and they are chosen for different applications. In the literature study, it was concluded that crown glass is the most suitable type of glass to use in precision optics. More in depth, borosilicate glass (the most common crown glass) is used for the simulation to analyse how light interacts with this specific type of glass.

### Preparation of the model

In the early stage, both 2D and 3D simulations have been done. The aim of the 2D simulations are to set up expectations in advance which would not only facilitate the workflow, but it gives an overview about light behaviour. It can be a preliminary design, thus the geometry study can be narrowed down. Therefore, in 3D simulation, it can be checked how the presumed results match with the 2D analysis. An online, free-source simulation called „Ray Optics Simulation” is used for the behaviour of the light in 2D. It has a 2D interface where the section of the component can be drawn and it allows to set up some properties like the type of the light, the properties of the lens (very limited) and the refractive index of the material which is the most important. It is an efficient tool to simulate geometries/ lenses or custom geometries.

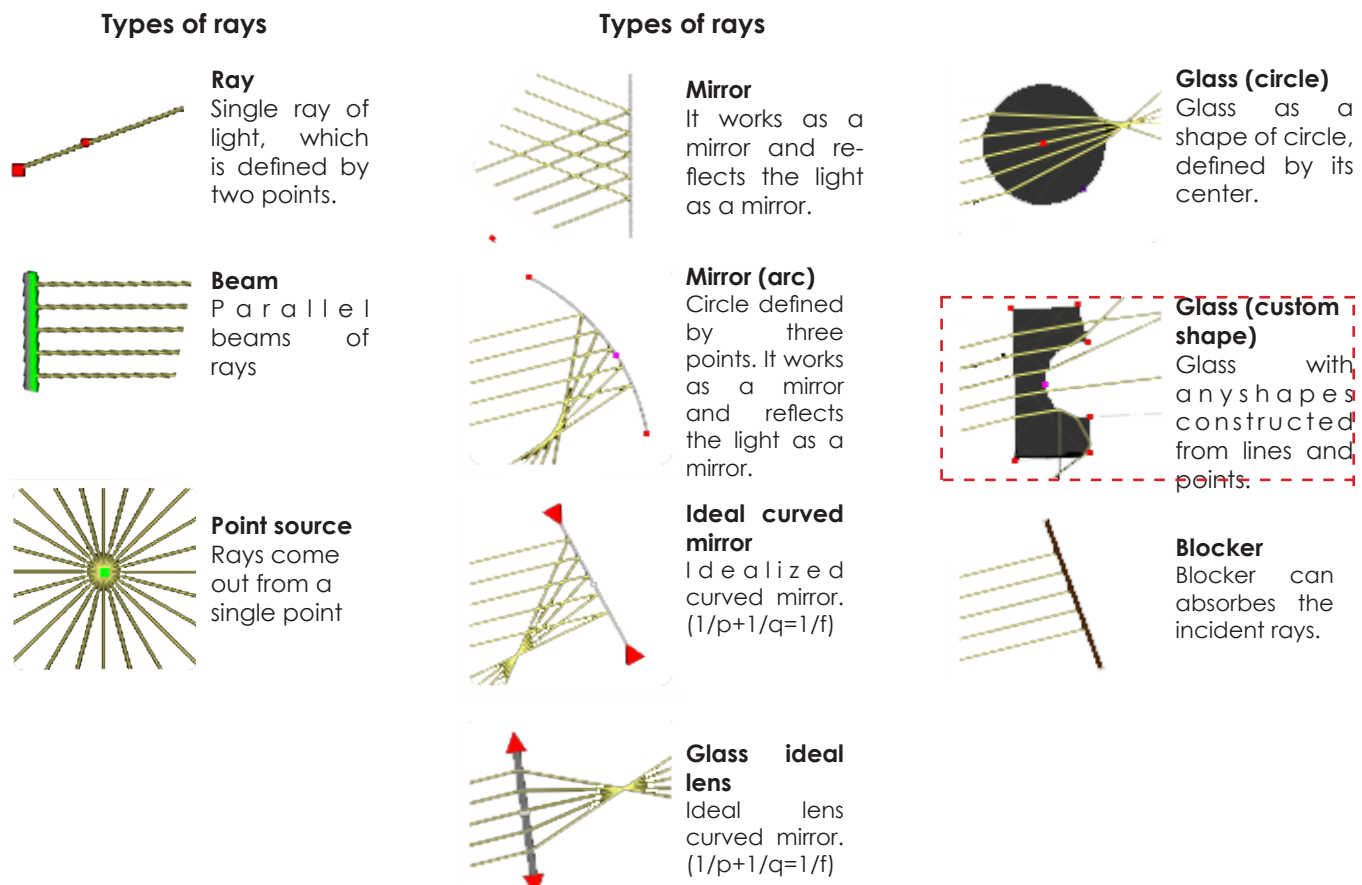

Figure 122: Settings of the online simulation.

The first experiments are made with concave and convex lens, using one or two holes. The visualization provides very good feedback how the light can be redirected by using different type of lens or by changing the radius of the curvature of the lens. The section is simple drawn with the same proportion as the real section of the brick has.

Real brick--> $210/65 = 3.23$  Drawn section--> $970/300 = 3.23$

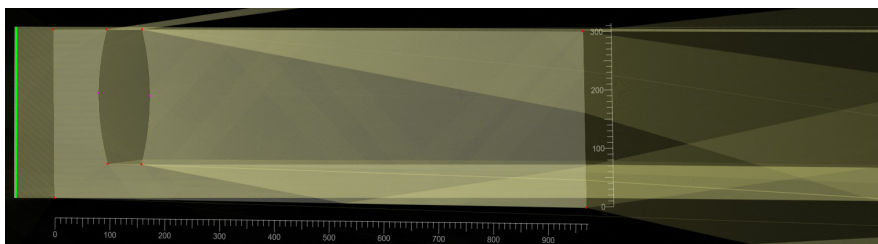

Figure 123: 2D section of the component with concave lens

**Convex lens**

Using shape of the convex lens makes the light spread. It will not focus on one area or one focal point as the picture shows, thus it is not a good idea to use only concave lens. Furthermore the bigger the radius of the inner shape the more light spread.

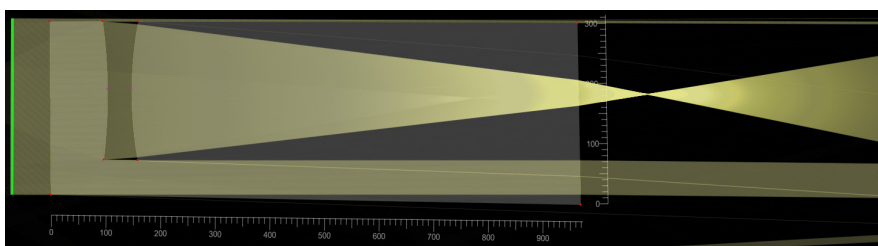

Figure 124: 2D section of the component with convex lens

**Concave lens**

Using shape of the concave lens works differently than convex. As it can be seen the light focuses on the focal point thus it is better to use concave lens that convex lens as a concentrator. The bigger the radius of the inner shape the more light is focused (focal point is closer).

In the following simulations are shown how two holes influence the light. Since the possibilities are infinite, it is not going to show all of them only highlight the most essential facts.

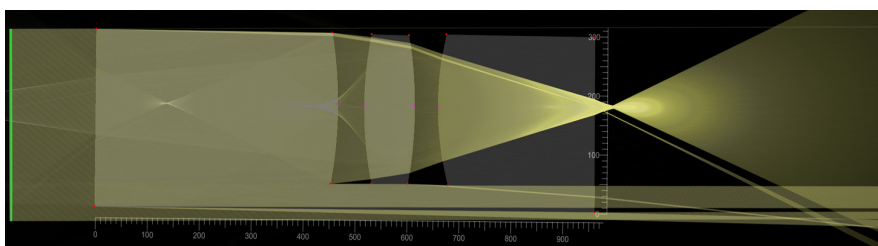

Figure 125: 2D section of the component with two convex lens

**Two concave lenses**

Using two lenses the effect is further improved. Changing the radius of the curvature is the same as the previous one, the more curved the closer the focal point is.

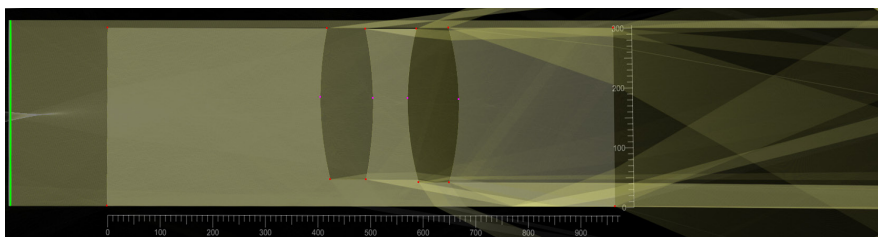

Figure 126: 2D section of the component with two concave lens

**Two convex lenses**

The differences can be seen easily. The two concave lenses spread the light more and also the more curved the more spread the light is.

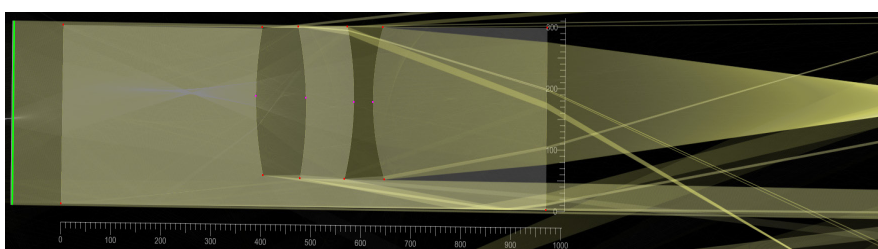

Figure 127: 2D section of the component with one concave and one convex

**Concave and Convex lens**

Combination of the lenses work very well. The light is focusing on the focal point but the point is farther than the previous study, which is better due to the bigger area covering behind the brick.

Note: As it was mentioned the program an online open-source program, thus everybody can try their design and see how these different shapes work.



The 2D light study shows reasonable results and provides an insight in the expected behaviour of the model which then can be studied further. The question is how these components work when they are analysed in a 3D environment, since the light rays are never perpendicular to a mounted surface, unless it has a sun tracking system.

## 4.2 Grasshopper model

The first geometry is generated through a Grasshopper script, where the properties of the lens can be set up parametric. It facilitates the work since different variables, and design options can be checked. The circumstances are addressed like the dimension of the brick and the lens, so the 2D design can be translated into a 3D model to visualize the situation. The original piece of brick has a dimension with 210\*105\*65 mm and the same dimension is modelled in grasshopper. The following steps are discussing how the model was created.

### Step1

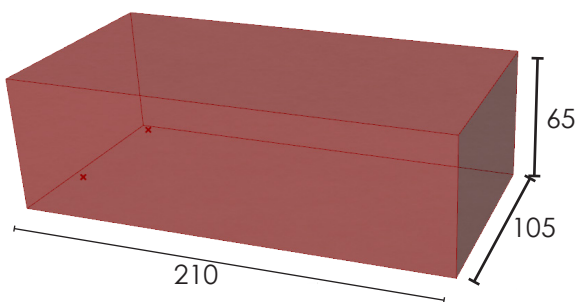

Simple brick, defined by width, length, height in grasshopper

### Step2

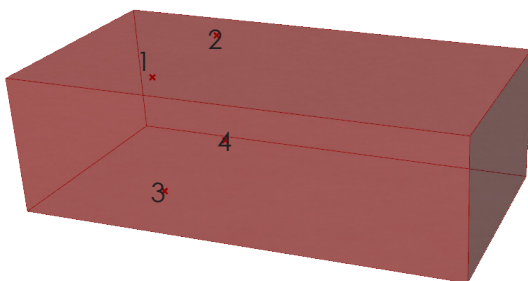

Four points defined on the top and bottom surface of the brick which are the edge points of the lens (hole). Furthermore point „3" and „4" are moved in „Z" direction in order to leave 10mm glass from the bottom.

### Step3

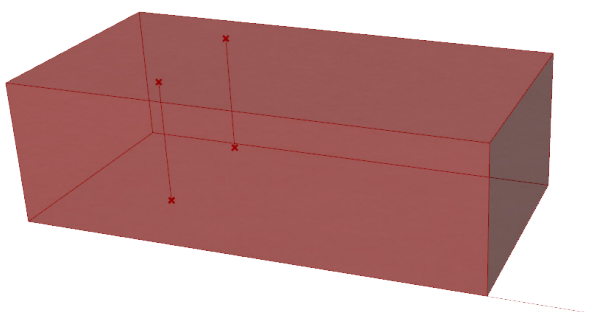

Lines are created between the points.

### Step4

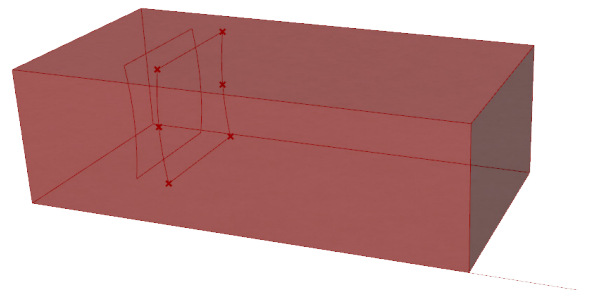

Two sides represent the side surface of the lens, changing the position of the middle points defines the radius of the lens.

### Step5

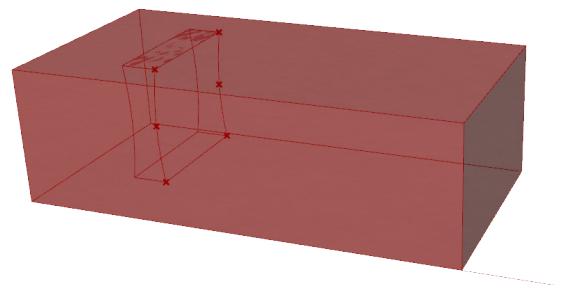

The final stage is to loft the two surfaces, thus the form of the lens can be achieved. It can change the width, length, radius, position of the lens.

### Step6

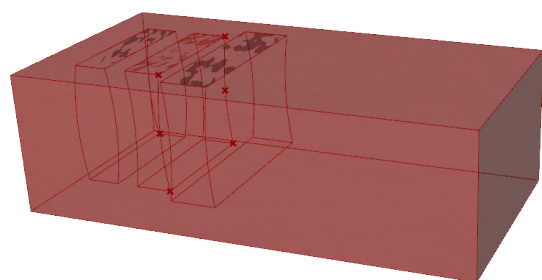

As it shows the possibilities are varied and it can make either concave or convex lens with different length and width.

For the first design in LightTools the following two components are going to be tested tested in order to make comparison between the 2D and 3D simulations, in addition which lens type would work better.

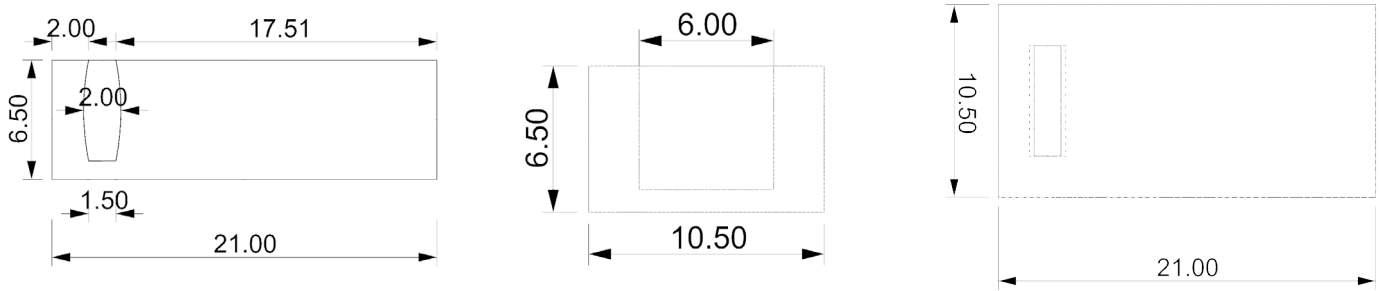

Figure 128: 2D sections of the component with concave lens

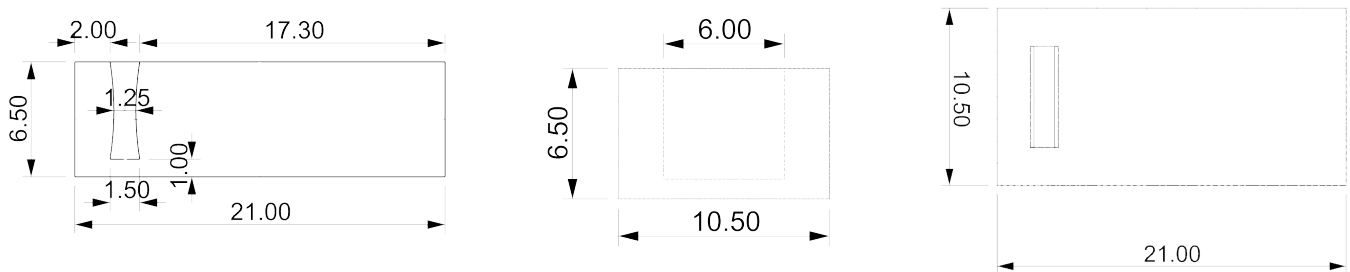

Figure 129: 2D section of the component with convex lens

## 4.3 LightTools simulation

### Introduction

Currently, there are no programs which can immediately tell us how the light behaves in solid, transparent material. This is rather a question of physics and multiphysics simulations are needed to evaluate the results and provides reasonable feedbacks. In the market there are two (can be more) acknowledged software which can solve light design in the engineering field. One of them is Comsol Multiphysics, and the other one is Synopsys LightTools. During the design, LightTools was chosen due to the complexity of Comsol. Comsol is not only invented to simulate certain process but it covers a lot of engineering applications such as structural mechanics, acoustics, fluid flow, heat transfer, and even chemical engineering behavior.

LightTools is a 3D optical engineering software which supports virtual prototyping, simulations, optimizations, and photorealistic renderings of illumination applications. Therefore LightTools is more relevant in the design. In this chapter a very well-detailed steps are introduced, how the model should be prepared and what steps are needed to do the simulation in LightTools.

Firstly, it is advised to check whether the 2D simulations are proper or not and how it can help for further design. Through this preliminary test it can be seen how the two results match.

# Modelling a simple glass brick with one lens

## Geometry import

There are two ways to make a geometry to be analysed. It can be either made in LightTools or in any other 3D modeller program where the object(s) can be saved as a „step” file. It is suggested that if the component is unique or complex, it should be made in Rhino. Then it is saved as a „dwg” which can be read by Autocad Mechanical. In Autocad Mechanical the object is saved as a „step.” file and it can be imported to LightTools.

## Interface

When the program is open the interface can be seen which consists of several tabs and toolbars. System Navigator, Preferences Navigator, Window Navigator, Output window are the default settings. The model which is made in advance can be imported now, *File--> Import-->Step. file*. Then the model will appear on the layout-pane. It is very important to mention, that the program uses different coordinate system. While in other programs, the world coordinates follows the *right-hand rule* which means the „z” direction faces to the top, „y” and „x” direction faces to the side directions, in LightTools these directions are different. The direction which faces to the top is „x” direction, thus „z” and „y” faces to the sides.

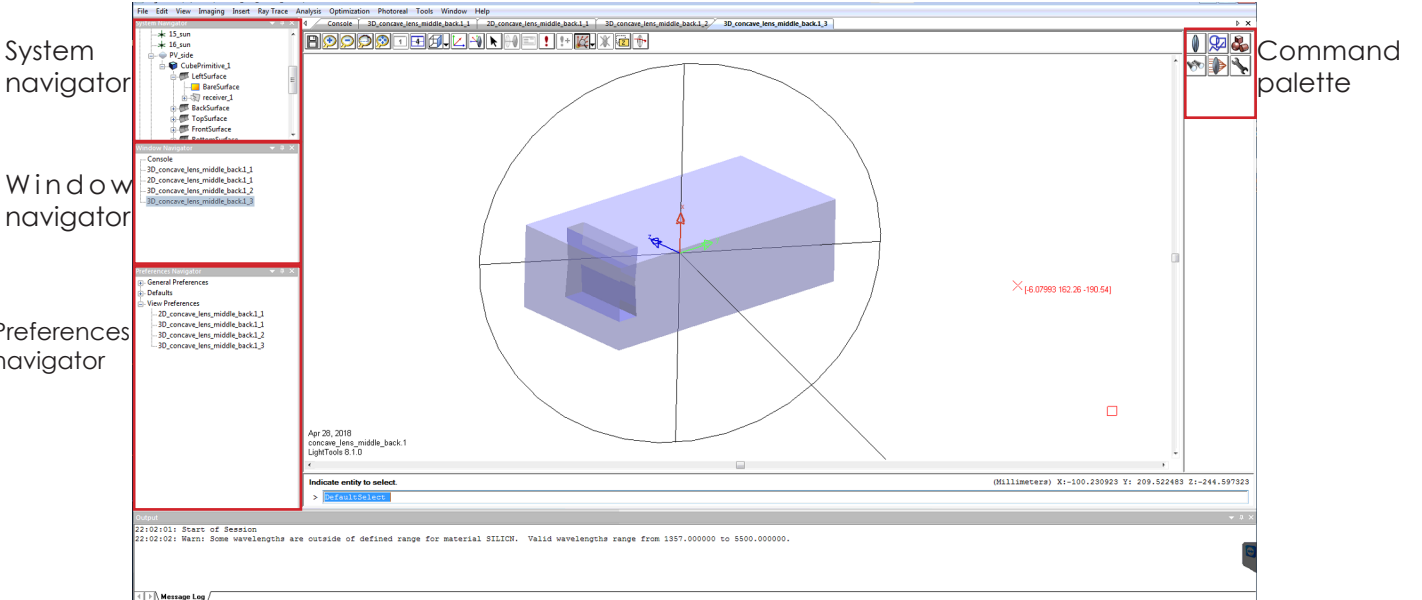

Figure 130: Interface of LightTools.

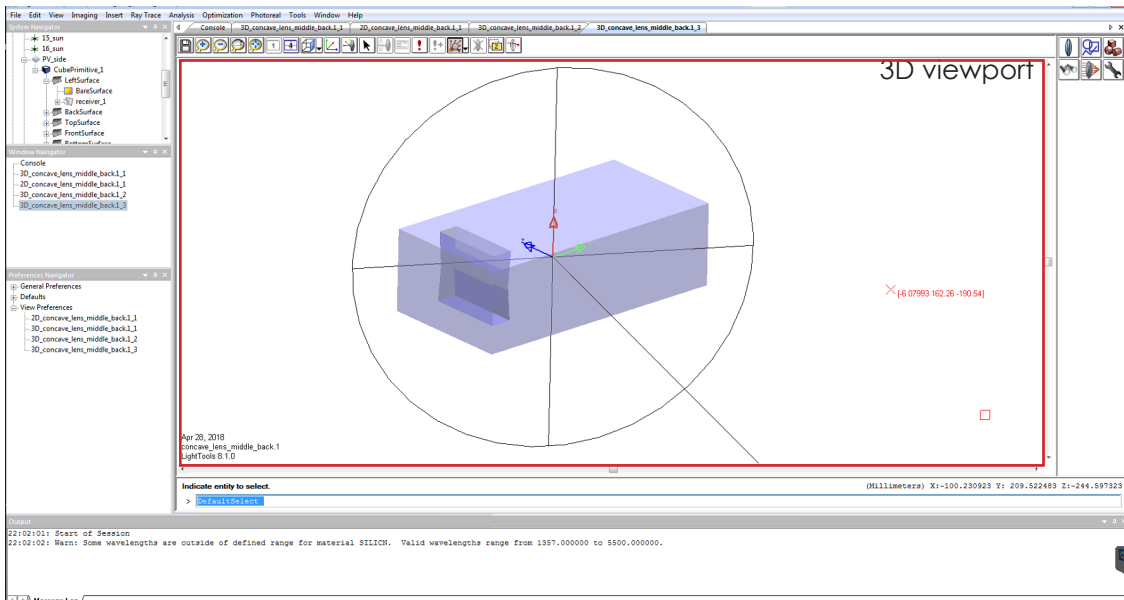

Figure 131: Interface of LightTools.



Optical properties of the surfaces

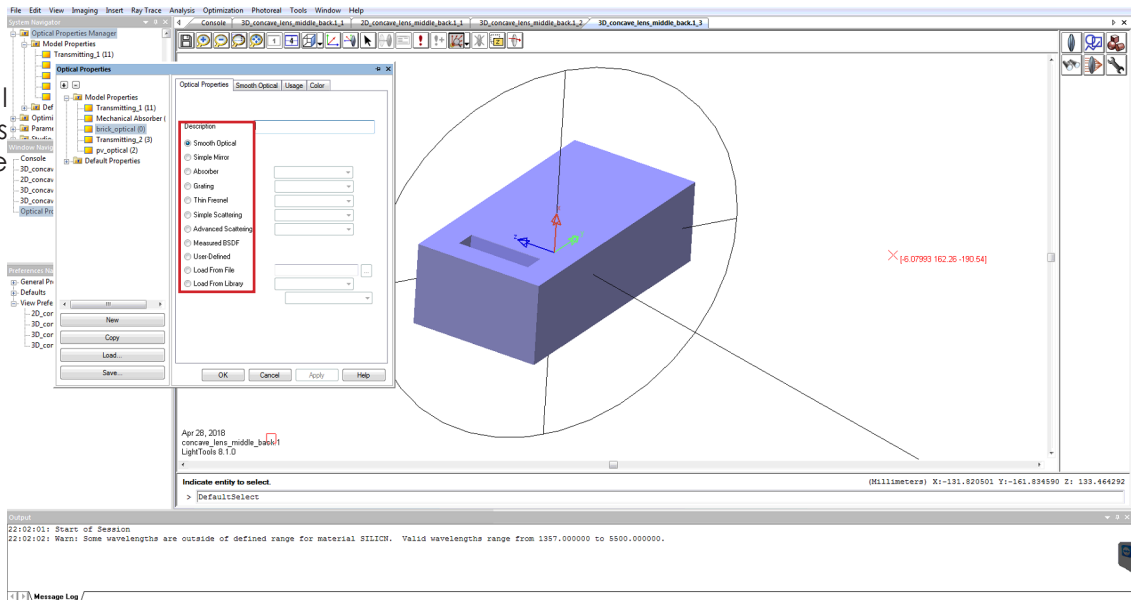

Figure 134: Optical properties of the object.

## Light source

There are multiple ways to create a light source in LightTools. In the simulations Cylindrical light source is used all the time since that is the most effective light to simulate the Sun. In the properties window of the source, it can be customized the aim area, the power of the source, and the size of the source. To calculate the intensity of light source the following formula has to be used:  $1000 \cdot \pi \cdot r^2$ , where  $\pi \cdot r^2$  is the area of the sphere. In order to cover the whole brick with the light rays, the radius of the light source is  $r=150$ , therefore the power is  $1000 \cdot \pi \cdot 150^2 = 7.0686 \cdot 10^7$  W

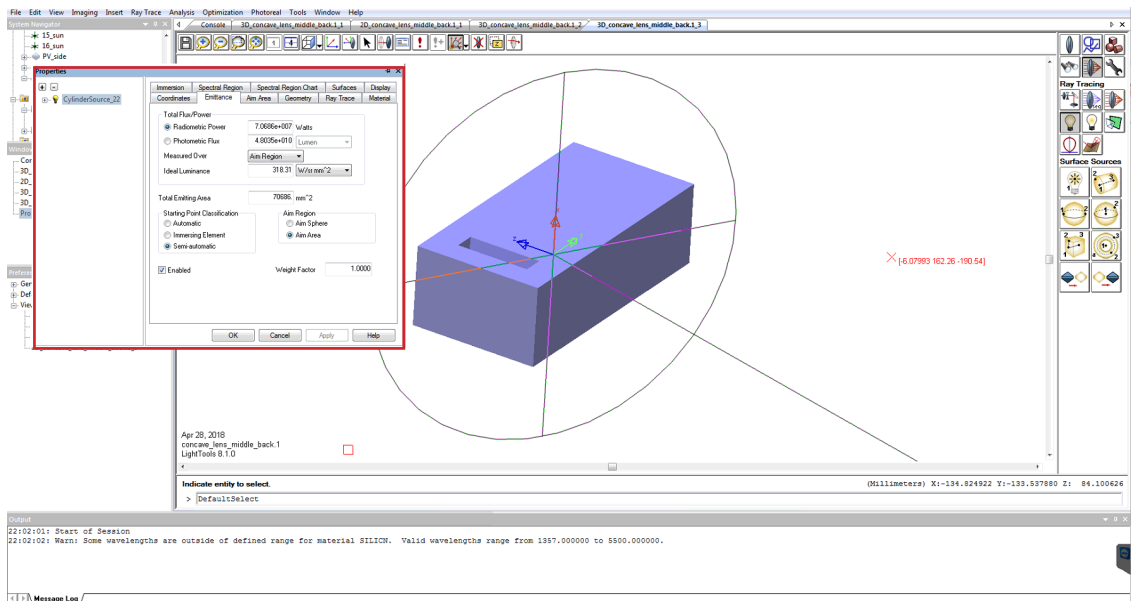

Figure 135 : Settings of the light source.



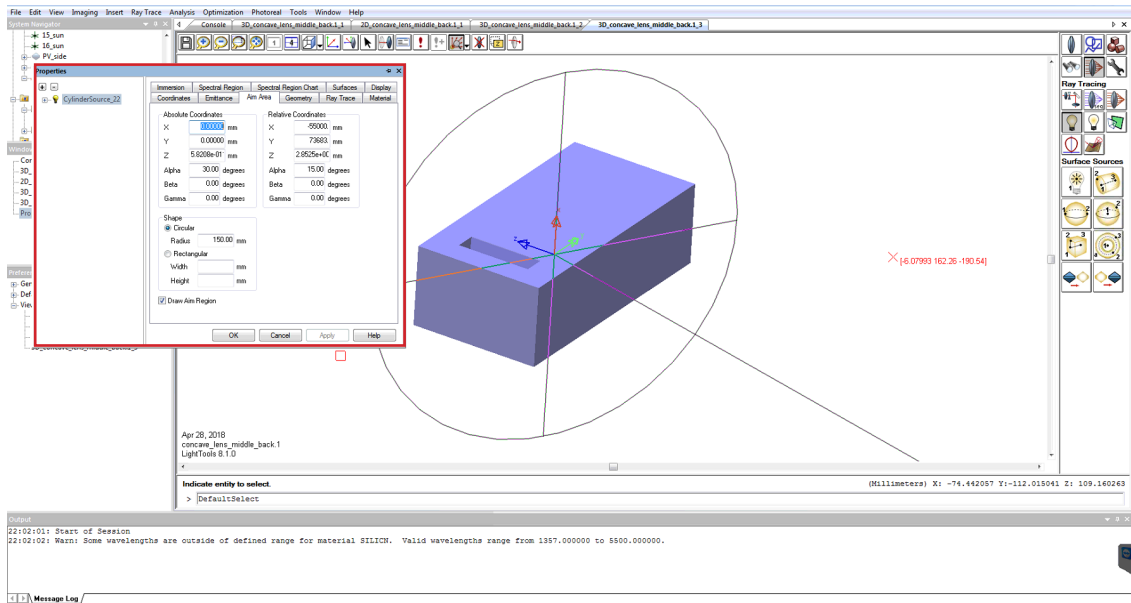

Figure 136: Simulation in LightTools.

## Simulate sun positions

There are two ways of simulate the position of the sun. The first one is making a reference points in the middle of the object, and grouping together with the light source. Therefore, the whole light source is rotating around the reference point. To simulate the real sun, alpha and beta angle have to change. Alpha represents azimuth angle and beta represents zenith angle.

The other way is to model the position of the sun. This can be done in Rhino with a sun path analysis with ladybug, grasshopper. 20th of March (the equinox) has been chosen where the daytime and nighttime is equal to each other. The sun path analysis in grasshopper also shows when the facade gets direct light. This specific day the facade gets direct light from 8:00 in the morning until 17:00 in the afternoon, so between this period all of the sun positions are baked and imported to LightTools. In LightTools these positions can be seen, thereby the light source can be placed there.

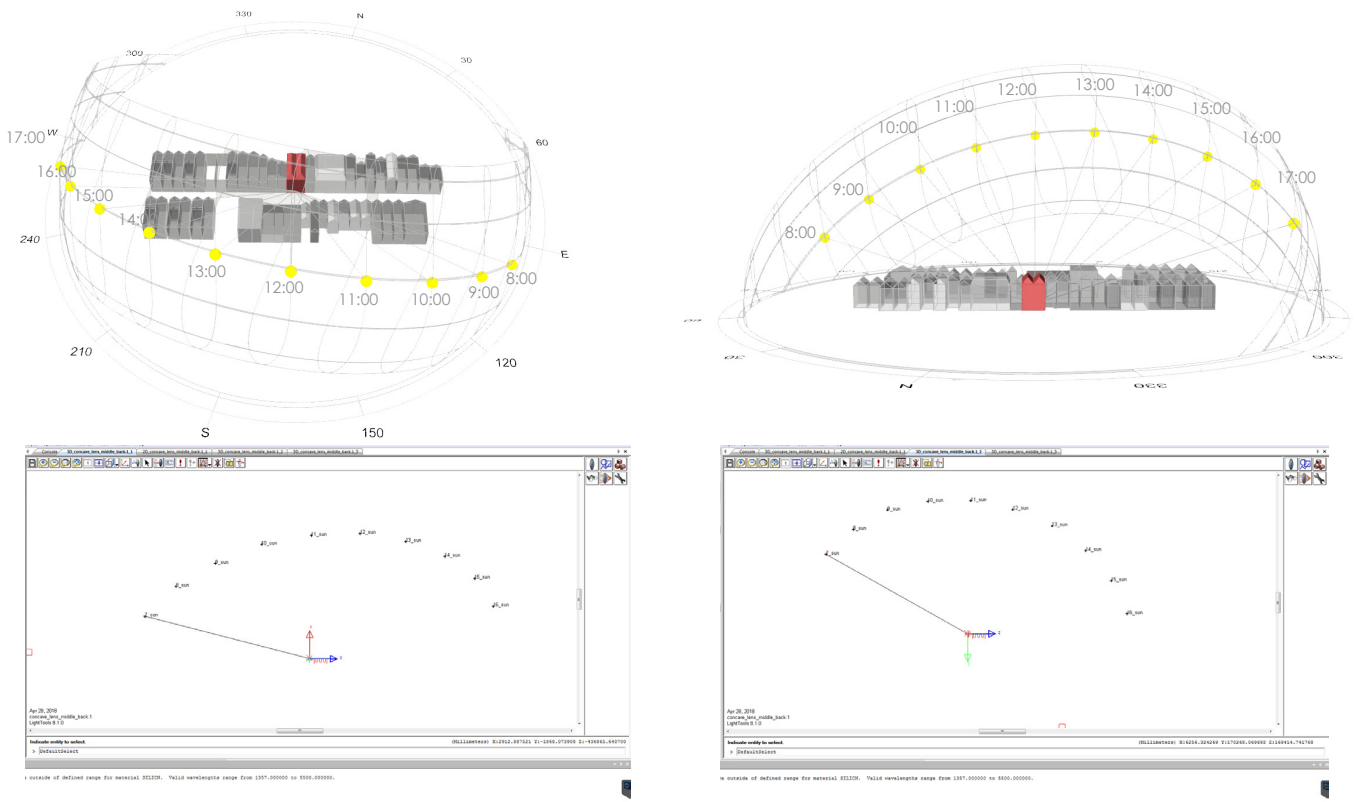

Figure 137: The position of the sun in grasshopper (top) and in LightTools (bottom).

## Finishing the settings

The last step is to apply receiver on one of the surfaces and set up the raytracing. To put a receiver, one surface has to be chosen and then put a receiver on it. Without a receiver the simulation cannot be started. The receiver generates a detector which shows the appropriate results.

To increase the total rays towards the component  $2.5 \cdot 10^6$  million rays is set up. The more rays are applied the more accurate results can be got.

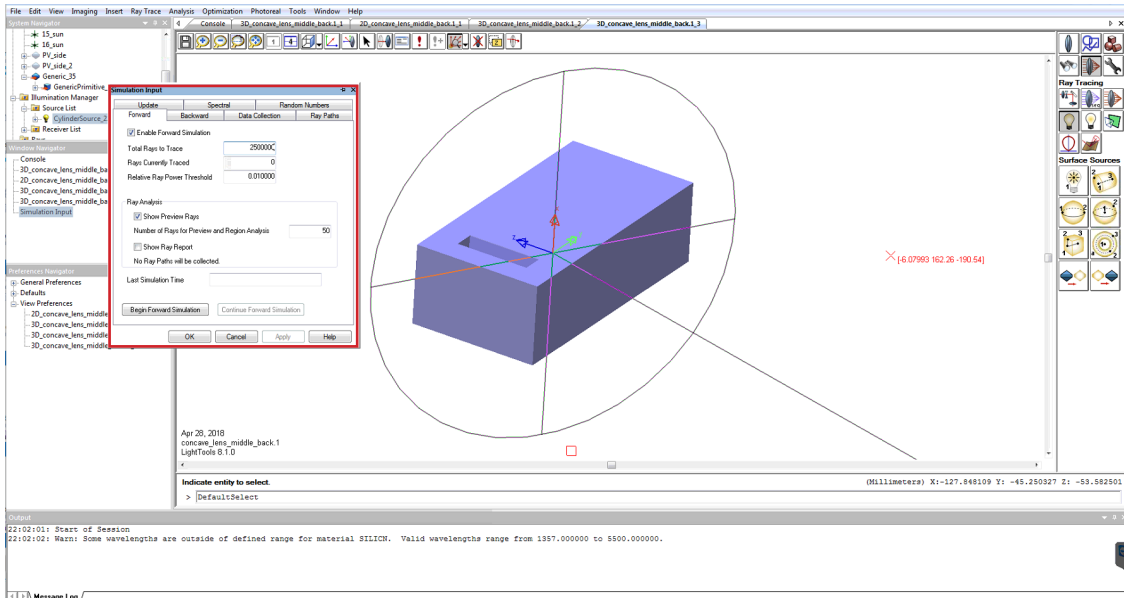

Figure 138: Number of rays on the simulation

All the settings has been set up, thereby the simulation can start.

## Preliminary test

As it was mention firstly, the 2D design is going to be checked whether LightTools is a proper software to simulate the light or not. All the steps are the same, but the position of the Sun is perpendicular to the front surface as the picture shows.

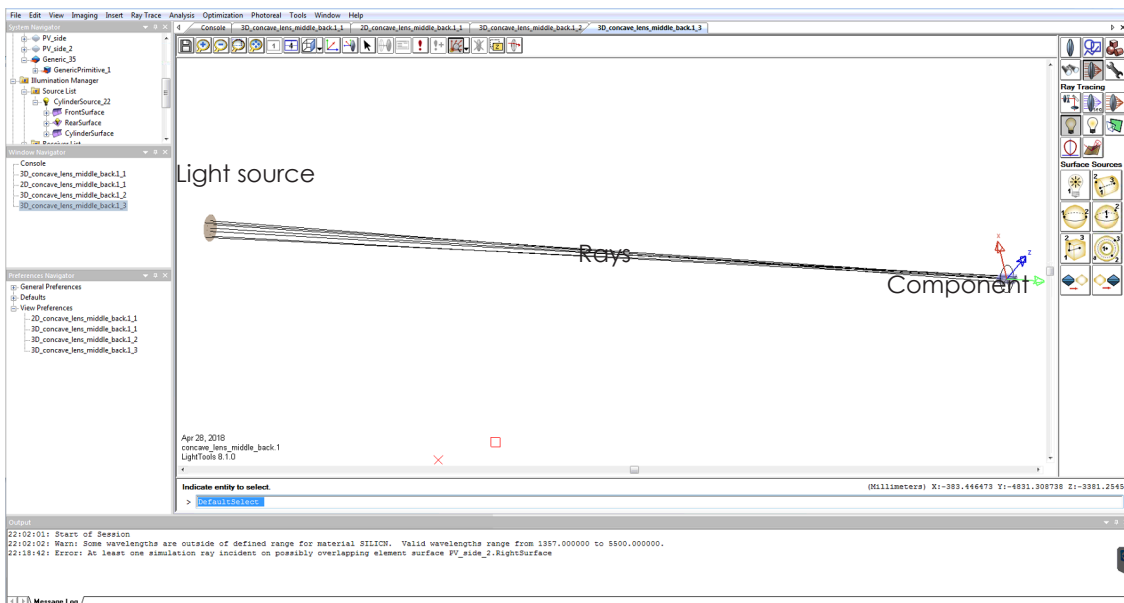

Figure 139: Light rays in LightTools.

The reason that the light source is far away from the component is that to prevent false lights rays which can affect the results. All of the rays should be perpendicular to the aim area of the source. When the simulation is ready it is possible to check how the light goes through, bounces, or reflects in the component. There are two pictures to better understand, the left picture shows the component with the hole in a solid way. It can be seen that the light enters the object only from the front surface. On the right picture, where the component is

translucent, all the rays continue their move inside the solid material.

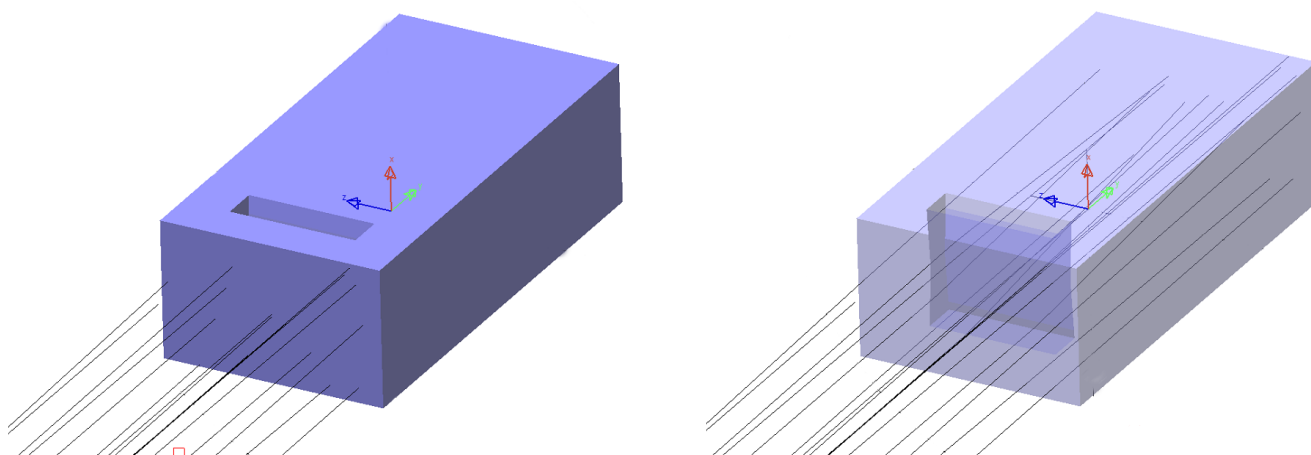

Figure 140: Result of the simulation in LightTools.

The surface of the hole works as a convex lens in the brick, thus it focuses the light rays into one point, to the focal point. Comparing the LightTools result with the preliminary 2d design, it shows the simulation matches with the 2D simulation, thereby LightTools is proper to use for further investigation. As it can be seen below in both case the light rays are redirected by the lenses and focuses in one point outside of the brick.

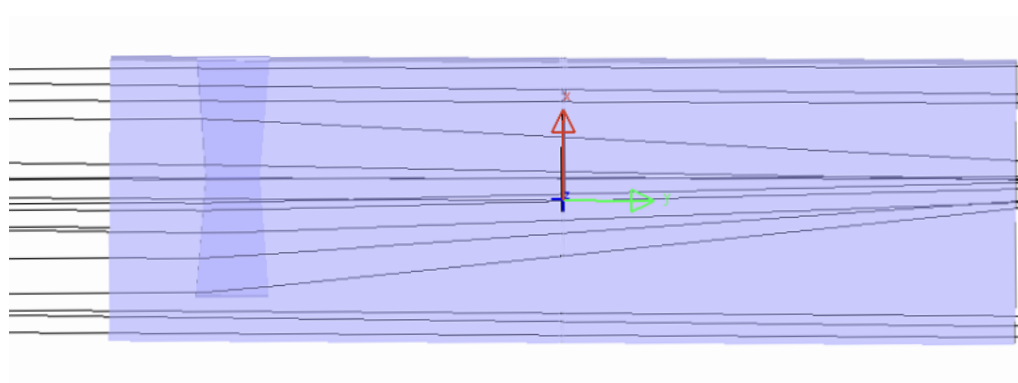

Figure 141: Translucent view of the brick in LightTools

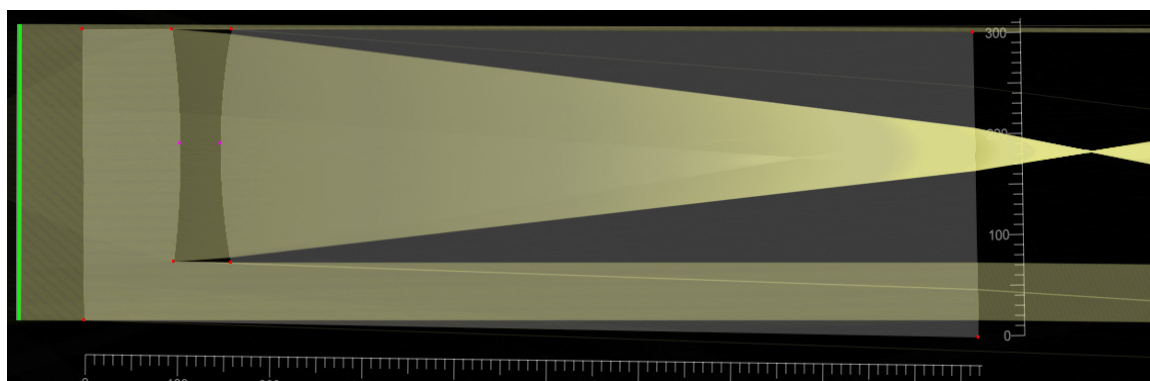

Figure 142: Result of the 2D simulation.

## Further simulations

The matching of the two design proves that LightTools is useful and efficient program for ray-tracing. Furthermore it is possible to evaluate optical experiments using different shapes. For further geometrical studies, how light behaves in different components are going to be shown, highlighting the most important facts.

In the previous part ,experiment has been done only on the light path in solid glass. In the next step one more material is added to the glass brick which is the photovoltaics panels. Thereby not only the behaviour of the light rays can be seen, but the amount of radiation The material of the photovoltaics is silicon, but it has two different optical properties. The side which faces to the glass is (receiver) absorber->optical, and the rest surfaces are absorber->mechanical.

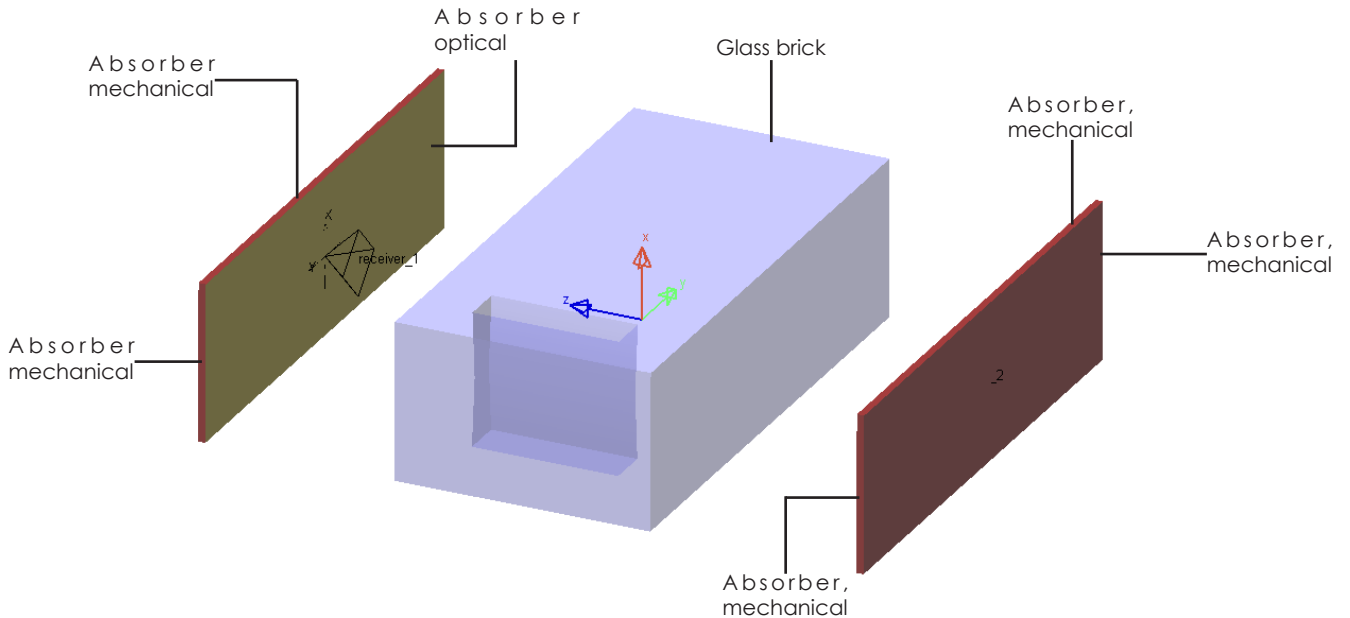

Figure 143: Combination of pv panels in LightTools.

With the additional photovoltaics panels, the amount of irradiance can be measured in  $W/mm^2$ . Firstly, the light enters the glass brick and it bounces inside the solid material until it goes out from the material. It is not guaranteed that all of the light rays are ended up on the photovoltaics surfaces due to the incident angle. However, those light rays which go out from the two sides of the brick ends up on the photovoltaics surfaces, thus it can be transformed to electricity. Furthermore, the Lumviewer shows the distribution of the illumination and where the highest radiation is on the surfaces highlighting them with different colors. The very dark blue represents zero (no illumination), and red represents the highest illumination in  $W/mm^2$ .

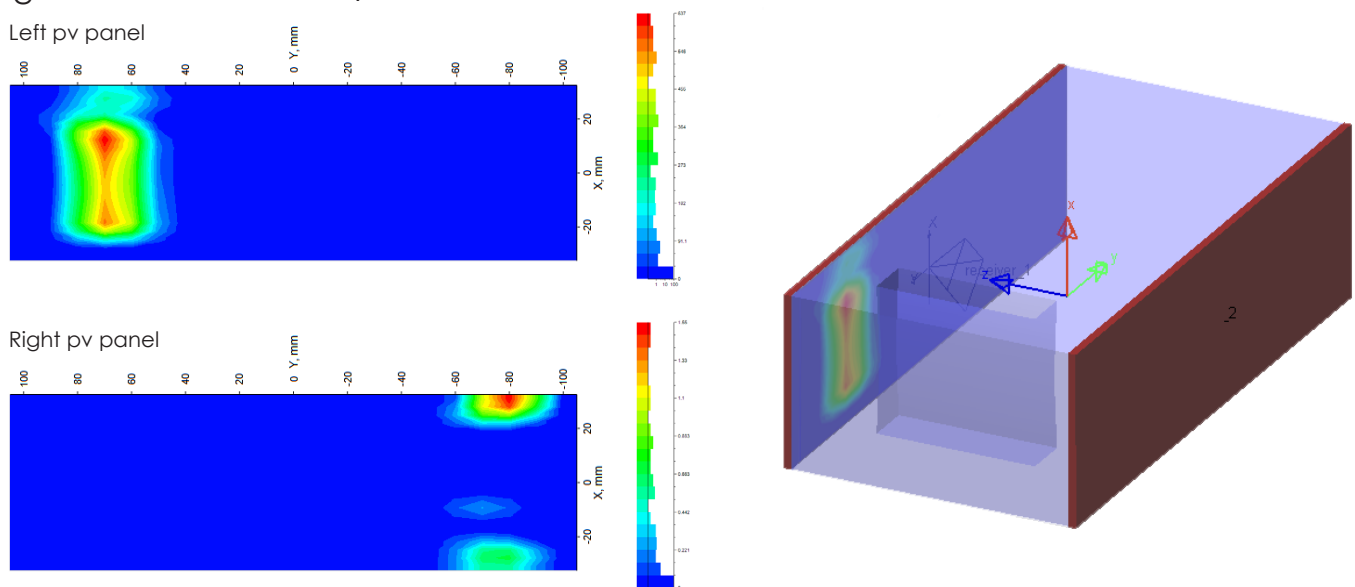

Figure 144: Results of the irradiation. Left: radiation map; Right: how the hole redirect the light.

## 4.4 Geometry study

In the previous research on multiphysics simulations based on light behaviour is crucial for the next step of the thesis where more glass bricks are going to be investigated with different shape of holes.

The first steps of the design process are to affect the visual impact of the glass facade at least as possible. The main factor which can change the visual effect of the facade is the photovoltaic panels. Moreover, each component has its own properties which can influence the propagation of light rays, thereby it defines the position of the photovoltaics as well.

Secondly, after the final component will be chosen and it will be further developed. The last stage in the process is the wall design, where different configurations are analysed which would be the best distribution of the new component on the facade. Figure 128. shows the methodology of the design.

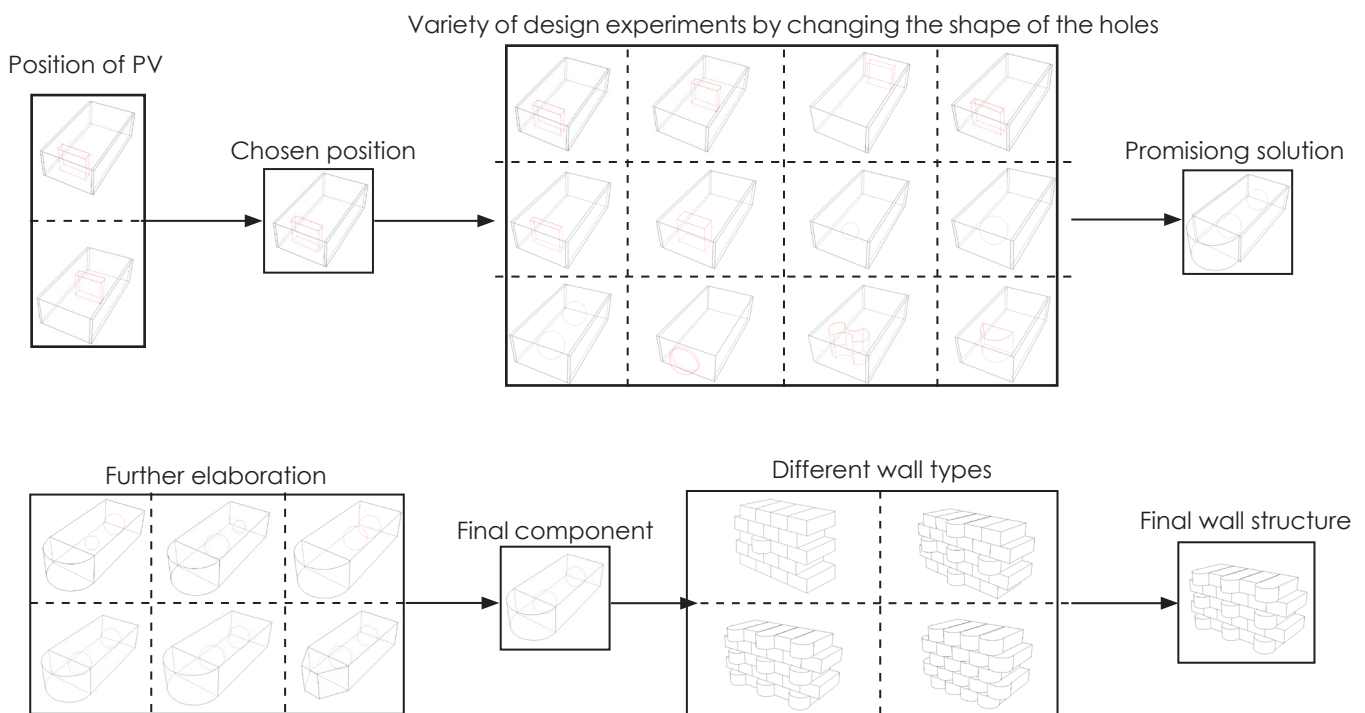
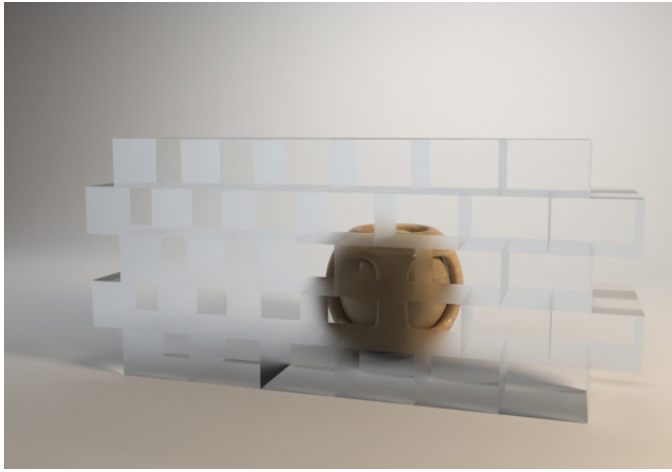

Figure 145: Methodology of the geometry study.

As it was mentioned above the first step is to define where the photovoltaics panels should be placed on the brick. It can be either on the back side of the brick (inside part of the room), or on the two sides of the brick. Placing the panels on the back of the brick results two negative consequences. One of them is if the panels are placed to the back of the brick it will deteriorate the visual impact. Thereby it will not be transparent the structure anymore due to the panels block the view. On the other hand, during the simulations it turns out that the lenses do not really redirect the light rays to the panel as it was expected, therefore the geometry studies would not fulfil the requirements. However, it has some advantages as well, for instance the accessibility of the panel. It would be replaced or maintained easily. The second option is to put the panels on both sides of the brick. This still results transparent structure, and the brick can work as a concentrated component. The redirection of the light by the component clearly visible. Based on these results and design concept, for further research on the component only panels on the sides are taken into account. At the beginning of the design concave and convex lenses have been simulated by changing the number of the lenses and their positions. For further study, different and more complex shapes have been investigated in order to extend the geometry study. Not only the shape of the holes have been changed, but the external surface as well. On the following pages all of the design components can be seen which have been tested during the study and their most important properties.





Current situation

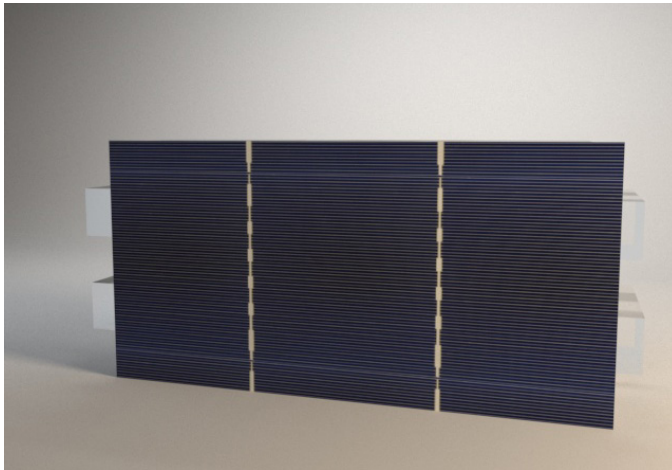

Photovoltaic panels are on the front side of the bricks



- Best energy production
- Poor visual comfort
- Panels can be ruined due to the outdoor environment

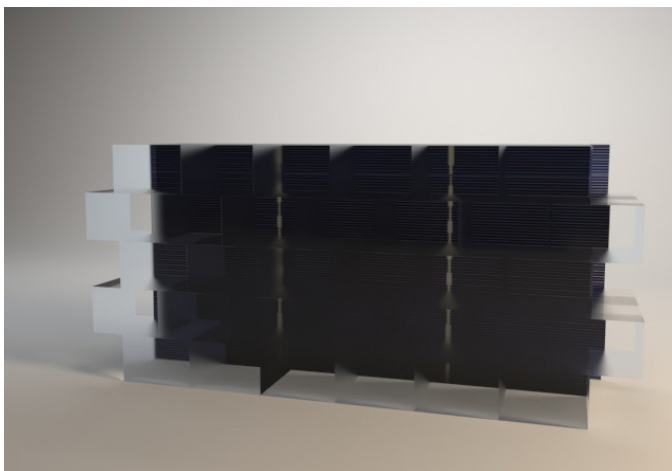

Photovoltaic panels are on the backside of the bricks



- Poor visual comfort
- Easy maintenance

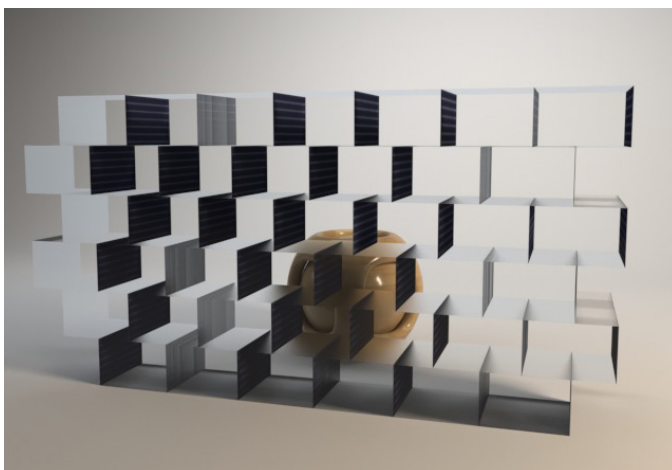

Photovoltaic panels are on the sides side of the bricks



- Good visual comfort
- Panels are protected

Figure 146: Experiment on the visual impact of the position of the pv panels.

# Geometry study

Geometry of the lens/ hole

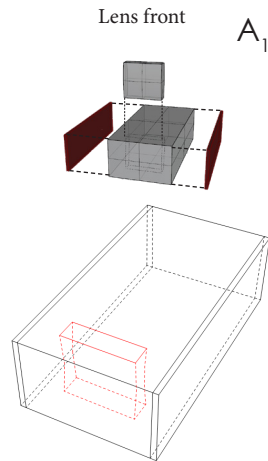
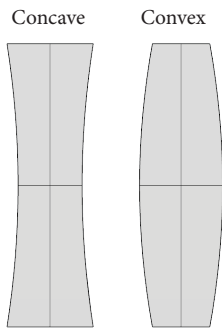

Lens is located at the front of the brick ( closer to the facade surface). In both situation the lens redirects more light due to the light rays which enters the glass from the front surface

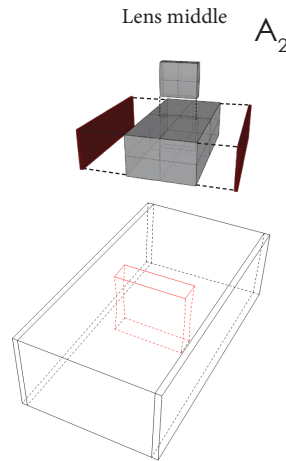

Lens is located at the middle of the brick. Less light rays are redirected due to only the rays from the top surface are redirected.

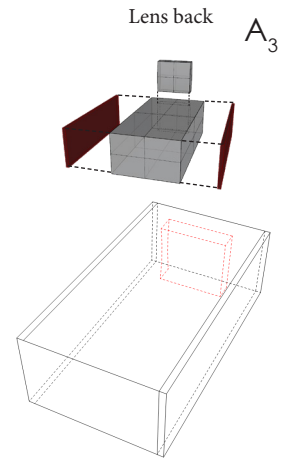

Lens is located at the back of the brick. It can still redirect the light, but the taking the lens to the back of the brick is not the most effective position.

Geometry of the lens/ hole

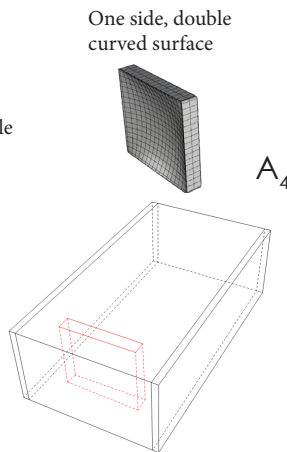
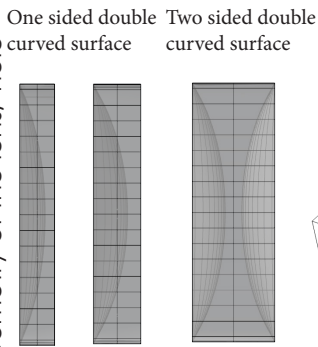

Lens is located at the front of the brick ( closer to the facade surface). The lens is similar to telescope lenses, due to its shape. However using this shape it does not provide as much radiation as a simple lens.

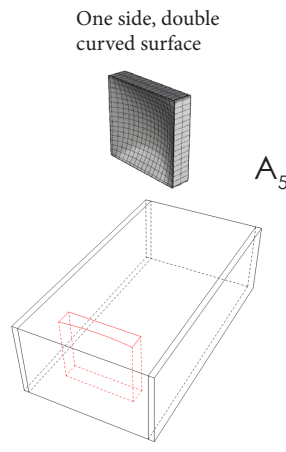

The inner radius of the curvature is bigger and provides higher radiation than with smaller radius.

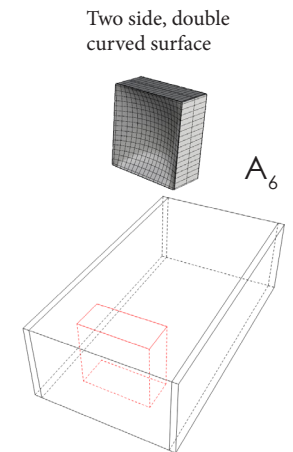

Both surface (front back) is curved and is used the same radius as the previous one. Thus the radiation is bigger as well due to shaping both surface.

Geometry of the lens/ hole

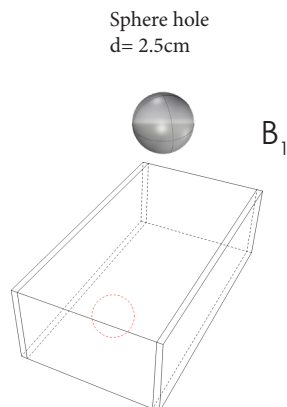
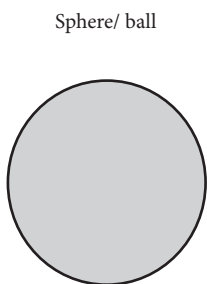

Using sphere as a hole results big redirection of the light on the surface, as well as higher radiation.

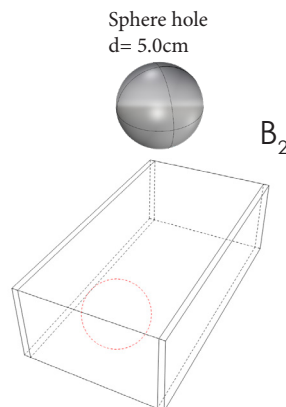

Increasing the radius of the ball provides bigger area covering and higher radiation.

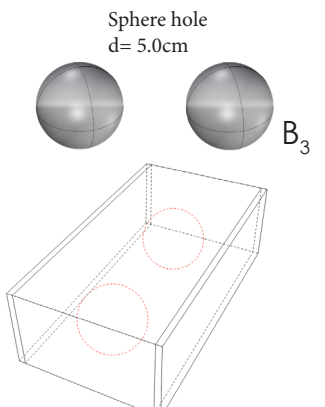

With two holes the effect can be further increased.

Geometry of the lens/ hole

Sphere/ "lamp"

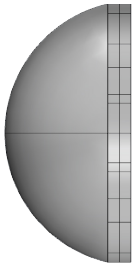

Combination of concave and convex lens

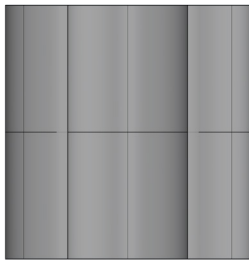

Sphere on the facade surface

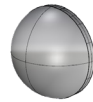

B<sub>4</sub>

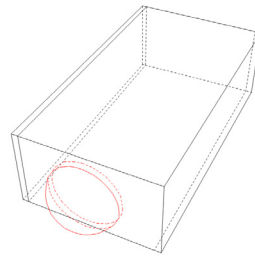

„Lamp” lens as an external surface does not affect the way how it was expected. It does not work very well.

Combination of concave and convex lens

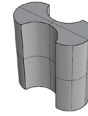

B<sub>5</sub>

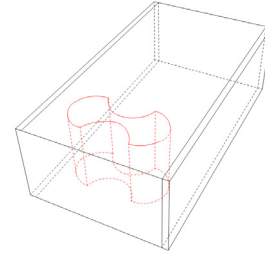

It is difficult to determine how the light is redirected when complex shape is used, however it gives good results in both area covering and radiation.

Geometry of the lens/ hole

Curved shape



Curved shape plus sided and back surface



Sphere on the facade surface

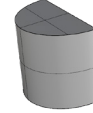

B<sub>6</sub>

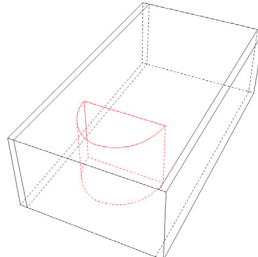

Simple semi-circle shape is used in the brick. Due the big radius of the curvature the effectiveness is very good of the shape.

Combination of concave and convex lens

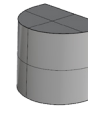

B<sub>7</sub>

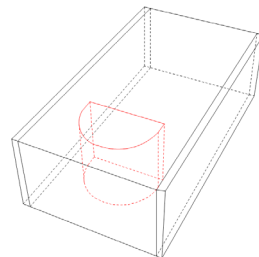

The difference is there are straight surfaces on both sides of the curvature. However, there are not that many differences in the effectiveness.

Position of the lens

Geometry of the lens/ hole

Convex

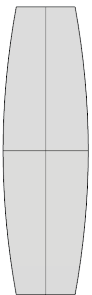

Lens front and middle

C<sub>1</sub>

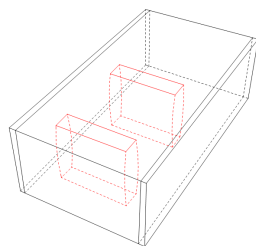

Double the lenses improves the efficiency of the component significantly. Using two simple lens can substitute a complex shape.

Lens front and back

C<sub>2</sub>

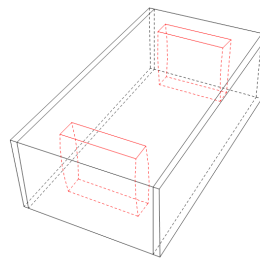

Different position of the lenses shows different radiation map/ values. nevertheless there is slightly differences in these values.

Lens front and back

C<sub>3</sub>

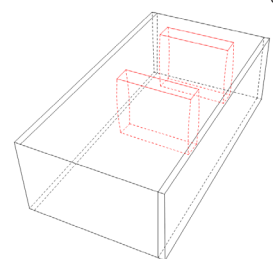

Among these configuration, this type of positioning is less good than the previous two configuration.

## Position of the lens+ external surface addition

Geometry of the lens/ hole

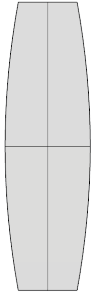

External surface  $D_1$

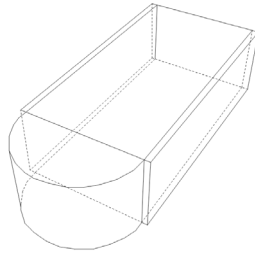

An external addition significantly improves the performance. Due to the external part, the light is focused on a small area resulted high radiation.

External surface+ lens  $D_2$

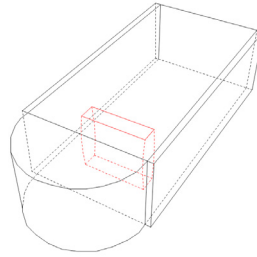

Furthermore using lenses on the component the efficiency can be further improved.

External surface+ lens  $D_3$

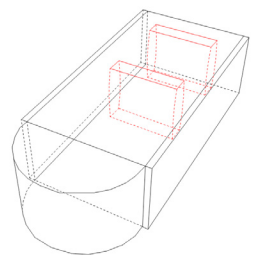

The previous component improvement can be seen using one lenses. This can be further increased with two lenses, thereby more more light is redirected to the surface of the panels.

External surface+ lens  $D_4$

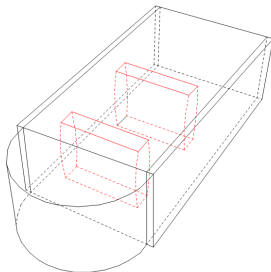

The position of the lenses have been changed. The first lens has to be placed carefully in order to not to affect the light rays which are redirected by the external surface.

Geometry of the lens/ hole

Sphere/ ball

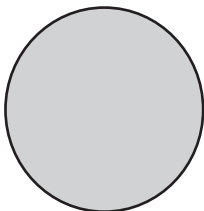

External surface+ spheres  $D_5$

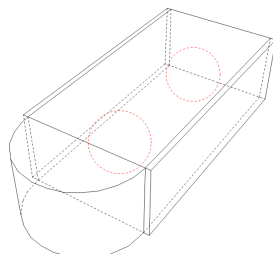

In the previous studies, the sphere works very well inside the component. It makes better with the combination of external addition.

External surface+ spheres  $D_6$

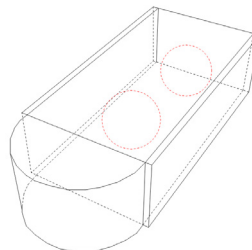

The position of the ball can be crucial since the sphere spreads the light. If the redirected light through the extension part hits the surface of the sphere it can go out from the brick instead of goes to the surface of the pv.

External surface+ spheres  $D_7$

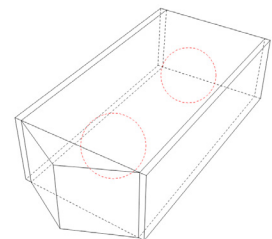

Imitation of the curve external shape is using straight external surfaces. It results that all light rays scatter by the sphere covering big area on the panels. However the concentration is not as much as using the curved part.



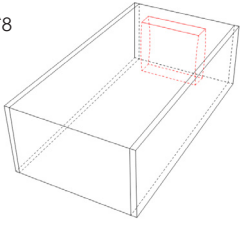
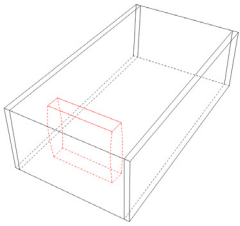
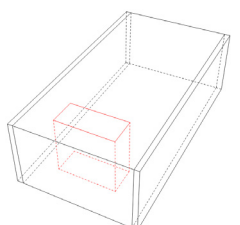
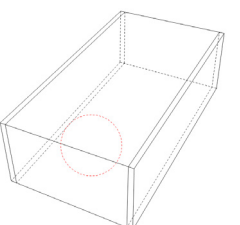
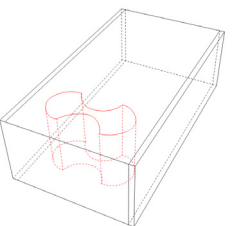
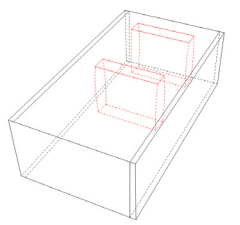
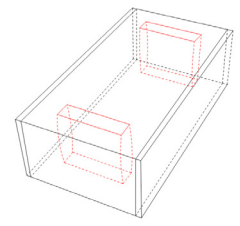
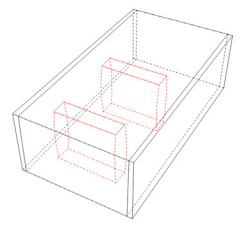

	Fabrication	Aesthetic	Redirected light/ Radiation	
A <sub>8</sub> 	+++	+++	11.7% 4.97*10 <sup>6</sup> W	↓ better performance
A <sub>9</sub> 	+++	++++	16.6% 5.44*10 <sup>6</sup> W	
A <sub>6</sub> 	++++	+++	17.0% 7.0*10 <sup>6</sup> W	
B <sub>2</sub> 	++	+++	17.5% 8.10*10 <sup>6</sup> W	↓ better performance
B <sub>5</sub> 	+++	+++	20.0% 9.31*10 <sup>6</sup> W	
C <sub>3</sub> 	+++	++++	20.7% 9.63*10 <sup>6</sup> W	
C <sub>2</sub> 	+++	+++	20.9% 9.70*10 <sup>6</sup> W	
C <sub>1</sub> 	+++	+++	21.0% 9.75*10 <sup>6</sup> W	↓

←                      →  
 worst visual impact/complex manufacture    +++++    better visual impact/easy manufacture

	Fabrication	Aesthetic	Redirected light/ Radiation	
B <sub>6</sub>	+++++	+++++	21.6% 10.02*10 <sup>6</sup> W	↓ better performance
B <sub>7</sub>	+++++	+++++	22.4% 10.40*10 <sup>6</sup> W	
D <sub>1</sub>	+++++	+++++	30.2% 14.0*10 <sup>6</sup> W	
B <sub>3</sub>	++	+++	31.7% 14.70*10 <sup>6</sup> W	↓ better performance
D <sub>2</sub>	+++	+++	35.1% 16.30*10 <sup>6</sup> W	
D <sub>7</sub>	++	+++	40.9% 19.0*10 <sup>6</sup> W	
D <sub>3</sub>	+++	+++	45.4% 21.07*10 <sup>6</sup> W	
D <sub>4</sub>	+++	+++	50.5% 23.42*10 <sup>6</sup> W	↓ better performance

←                      →  
 worst visual impact/complex manufacture    +++++    better visual impact/easy manufacture

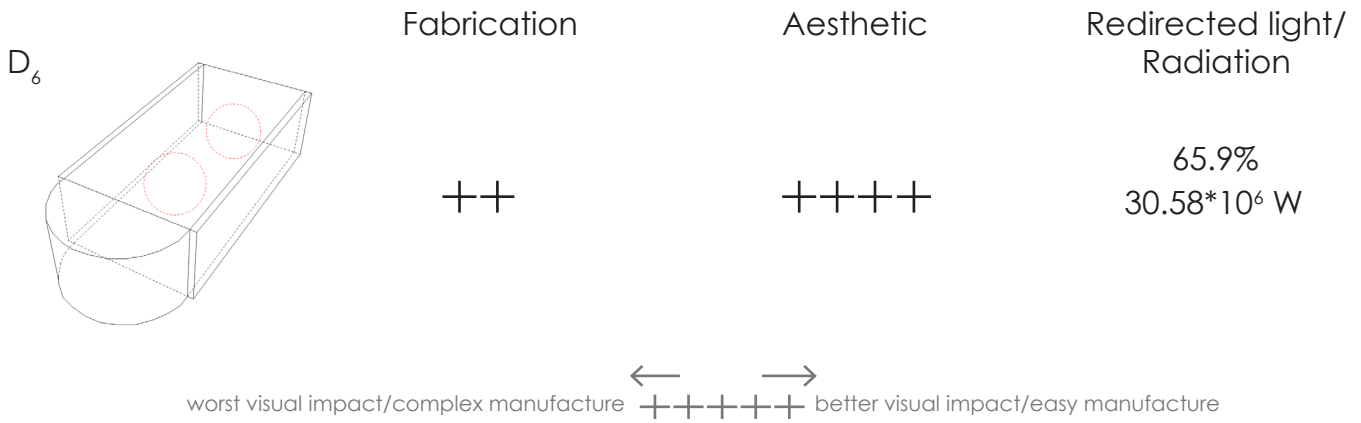

Figure 128: Overview of the geometry study.

Different geometries have been investigated in an attempt to find an efficient one that suits best in the design. The components are evaluated according to the aesthetic, amount of redirected light and the complexity in terms of manufacture. It appears that even a simple convex hole can affect the performance of the brick and it makes the brick as a solar concentrator. As one of the big advantages of the convex holes is the manufacture. It is a vital parameter, thus the component can be fabricated as one single unit. However, fabricating the unit as a single element would make the accessibility of the inside surface difficult to post-process due to the small dimension of the holes. Only using convex holes in a brick can already significantly improve its performance.

To further increase the amount of redirected light, the front surface has been changed as well as hollow spheres have been placed into the brick. Both shaping techniques significantly increase the performance of the brick and 65.9% of the light can be redirected. Regarding the manufacture of the unit, it should be fabricated only in two pieces in order to post-process the inside surface of the hollow part when hollow spheres are designed in the brick.

The correlation between the manufacture and the performance of the shape, therefore, is worth noting, because they affect significantly each other. The less complex of the manufacture of the shape results lower performance, meanwhile higher performance results complex manufacture.

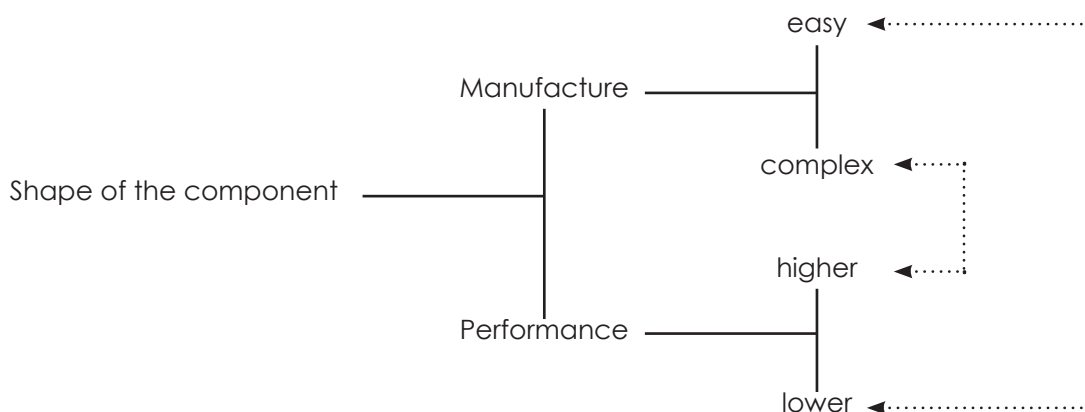

Figure 147: Relationship between the manufacture and the performance of the shape

After analysing each design configuration separately and in comparison with each other, it is now possible to make a decision regarding the final design. The most essential factors to choose the right components are the complexity of manufacture and the performance of the unit. The following components are the most promising solutions among the geometries. As a production point of view,  $B_7$  and  $D_1$  is the easiest to fabricate due to their simple shape. Especially  $D_1$ , because there are no holes situated in the brick.  $D_4$  and  $D_6$  stands out due to their high performance, but they are more difficult to fabricate.

	Fabrication	Aesthetic	Conclusion
$B_7$ Simple convex lens 	easy manufacture method	small visual impact	easy fabrication  good performance 22.4%
$D_1$ Simple curved surface 	easy manufacture method	small visual impact	<b>Most promising</b>  <b>easiest component to manufacture</b>  good performance 30.2%
$D_4$ Small convex lenses, curved surface 	difficult manufacture method	small visual impact	complex fabrication  very good performance 50.5%
$D_6$ Hollow spheres, curved surface 	complex manufacture method	small visual impact	<b>Most promising</b>  complex component to manufacture  <b>best performance 65.9%</b>

Figure 148: The most promising solutions.

Several simulations have been carried out to analyze different geometries. Based on the initial findings, number  $D_6$  and  $D_1$  components are the most promising regarding their performance and manufacture. However,  $D_1$  would be the best for fabricating, but  $D_6$  has the highest performance. More than double the performance comparing with  $D_1$ . To obtain higher performance in the research, this type of geometry is chosen and will be further developed in the next chapter.

## 5. Final design

As discussed in the previous chapter, the final design will include the configuration of  $D_6$  component and it will be further developed in this chapter. Moreover, the design will propose different wall configurations in order to implement in a case study.

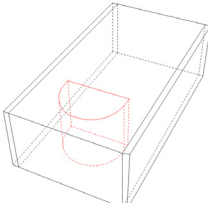
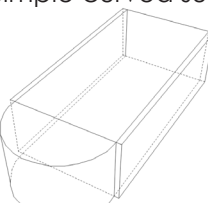
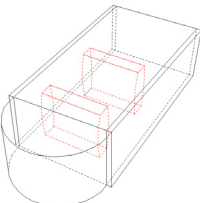
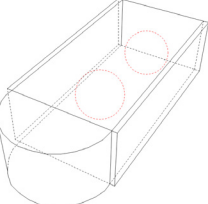

## 5.1 Further Development

In the previous chapter, different components have been investigated to find an efficient one which suits best in the design. One of the biggest advantages of the chosen component is the high concentrating factor. It does not only concentrate the light rays on a small part of the surface, but the spheres redirect the light rays onto a bigger surface. However, the chosen concept works very well, still further development is needed.

Light behaviour is a very complex task, and complex, multiphysics programs are needed to simulate it. Making a parametric model of the component would facilitate the workflow of the design, but unfortunately grasshopper and its plugins cannot be able to handle multiphysics problem yet. Therefore, the properties of the components has to be changed manually.

The further evaluation consists of six more components to analyze how they interact with light. Three properties of the brick have been changed : the size of the spheres, the position of the spheres and the shape of the external surface.

Two different sizes of spheres have been analysed with the diameter of 2.5cm and 4.5cm. In conclusion, using smaller sphere results smaller radiation and scatters the rays on a smaller area than a sphere with a bigger diameter. Thereby, the bigger the sphere the more efficient the component is. However the size of the sphere is limited since it has to take into account the annealing process. If there are only a few millimeters between the sphere and the sides, the glass can break due to the stress. Considering this limitation 1.0cm has been left between the sphere and the sides to prevent fracture in the glass.

The position of the spheres does not affect the efficiency as much as the size of the sphere. Slightly differences occurs, but it is not the first key factor.

The last property which has been changed is the external surface. The external part is a semi-circle with the maximum diameter of 10.5cm. This allows to concentrate the light rays onto a smaller area. When the curvature gets smaller the concentration gets smaller as well and the light rays are redirected rather to the middle of the glass, which does not guarantee that it will end up on the photovoltaics panels due to the incident angle.

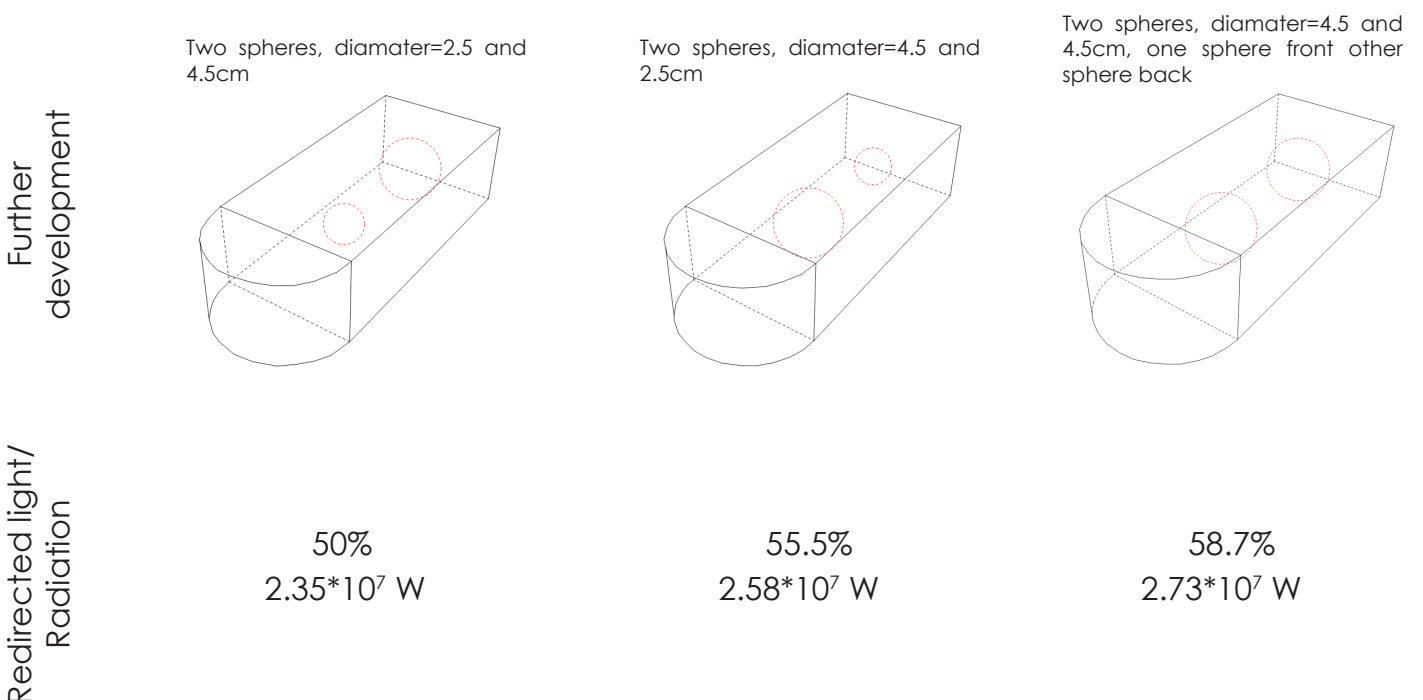

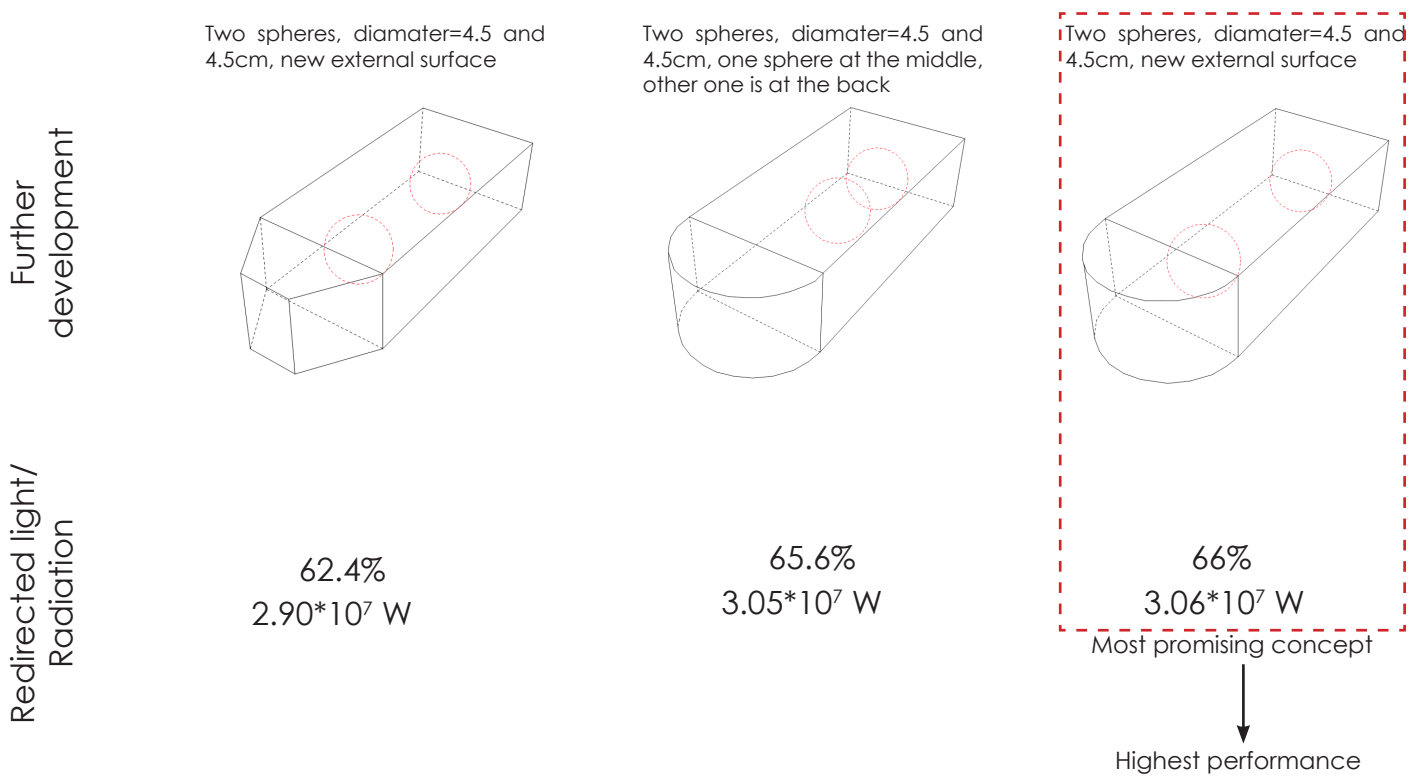

Figure 149: Further development of the final design.

### Integration with photovoltaic panel

The photovoltaic panels are fully integrated into the design and are located at both sides of the brick. This system was chosen due to have less visual disturbance (see chapter 4.4). III-V type of photovoltaic cells are very thin, less than a millimeter, and the glass bricks protect it from any damages. Thus, additional protective layers are not necessary to put on the photovoltaic panels and it can be glued directly on the glass. The two sides of the brick are 3-3mm smaller than the other bricks in order to place pv panels on both sides.

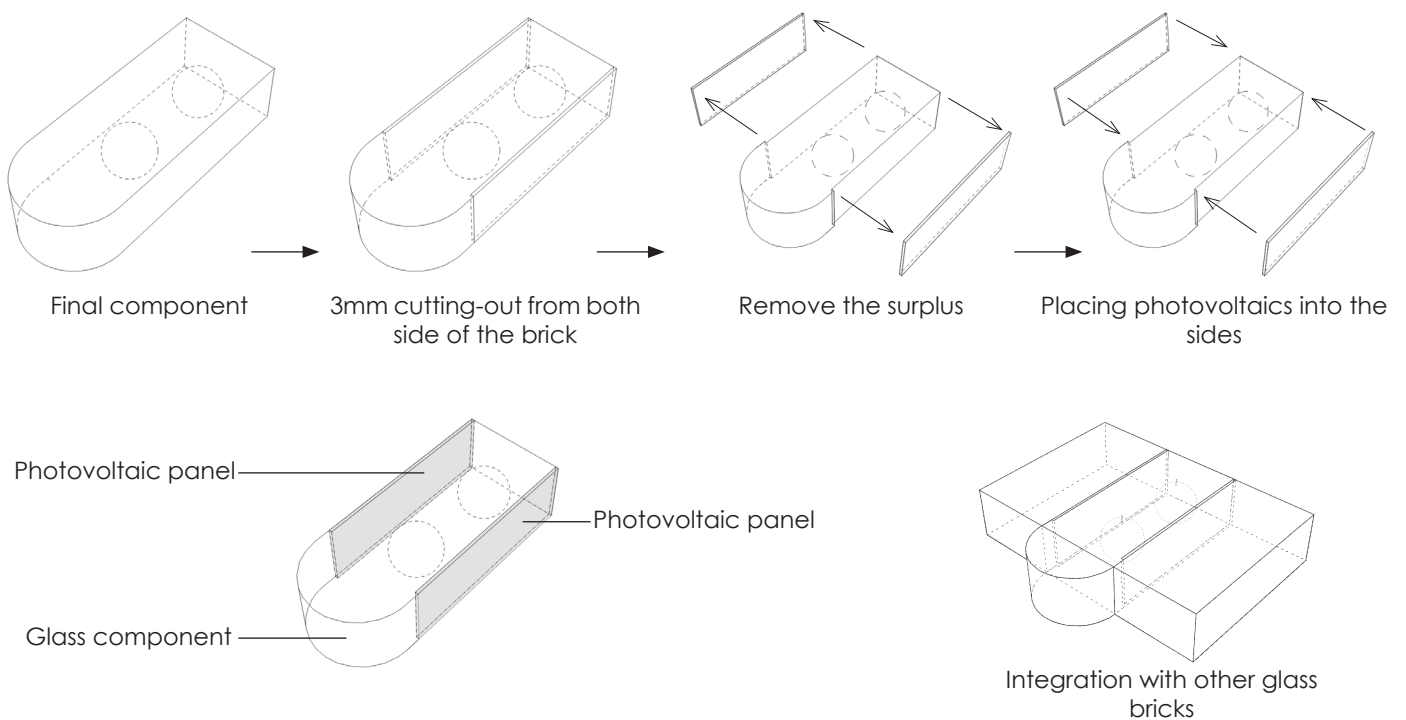

Figure 150: Final design.

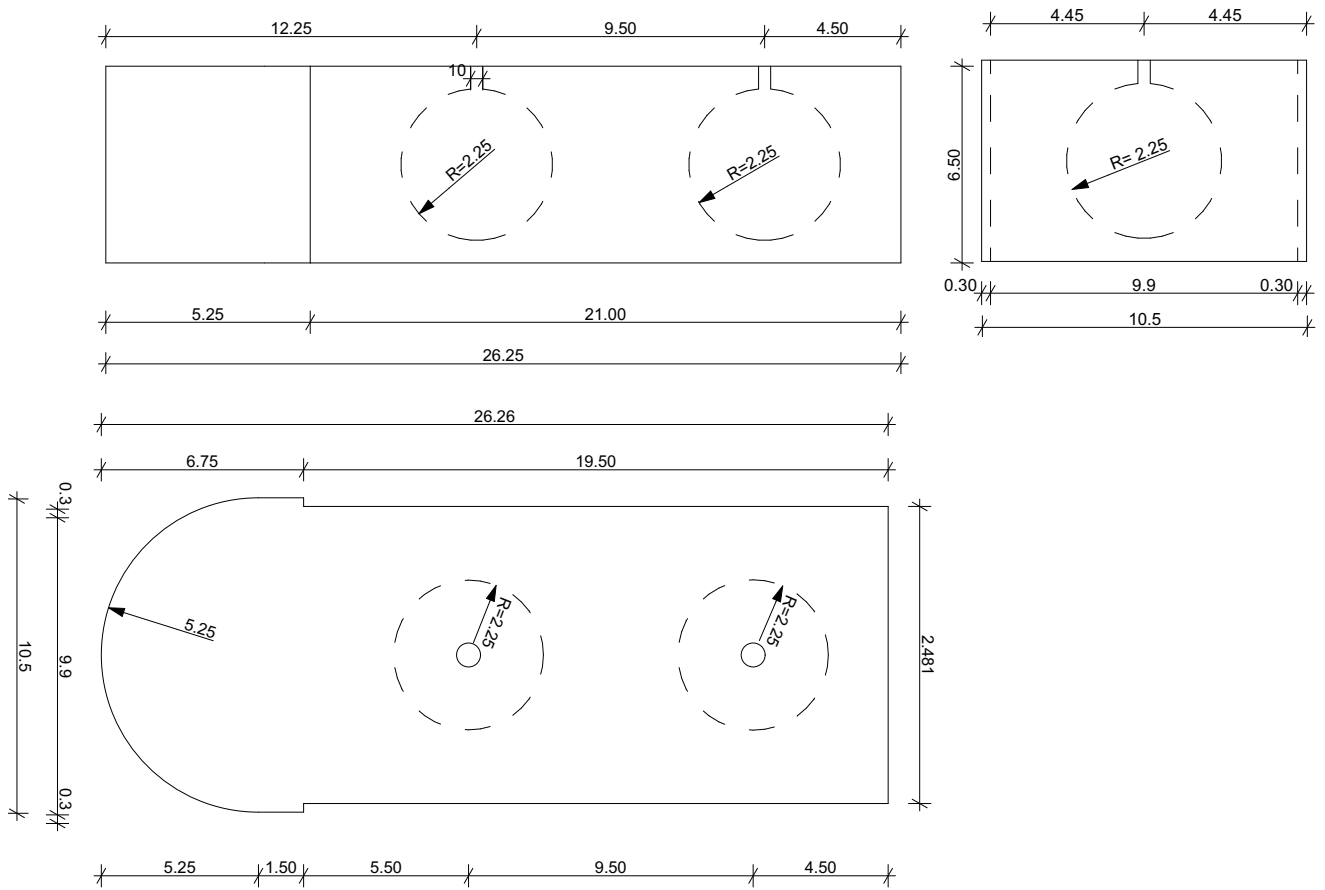

Figure 151: Dimension of the final component.

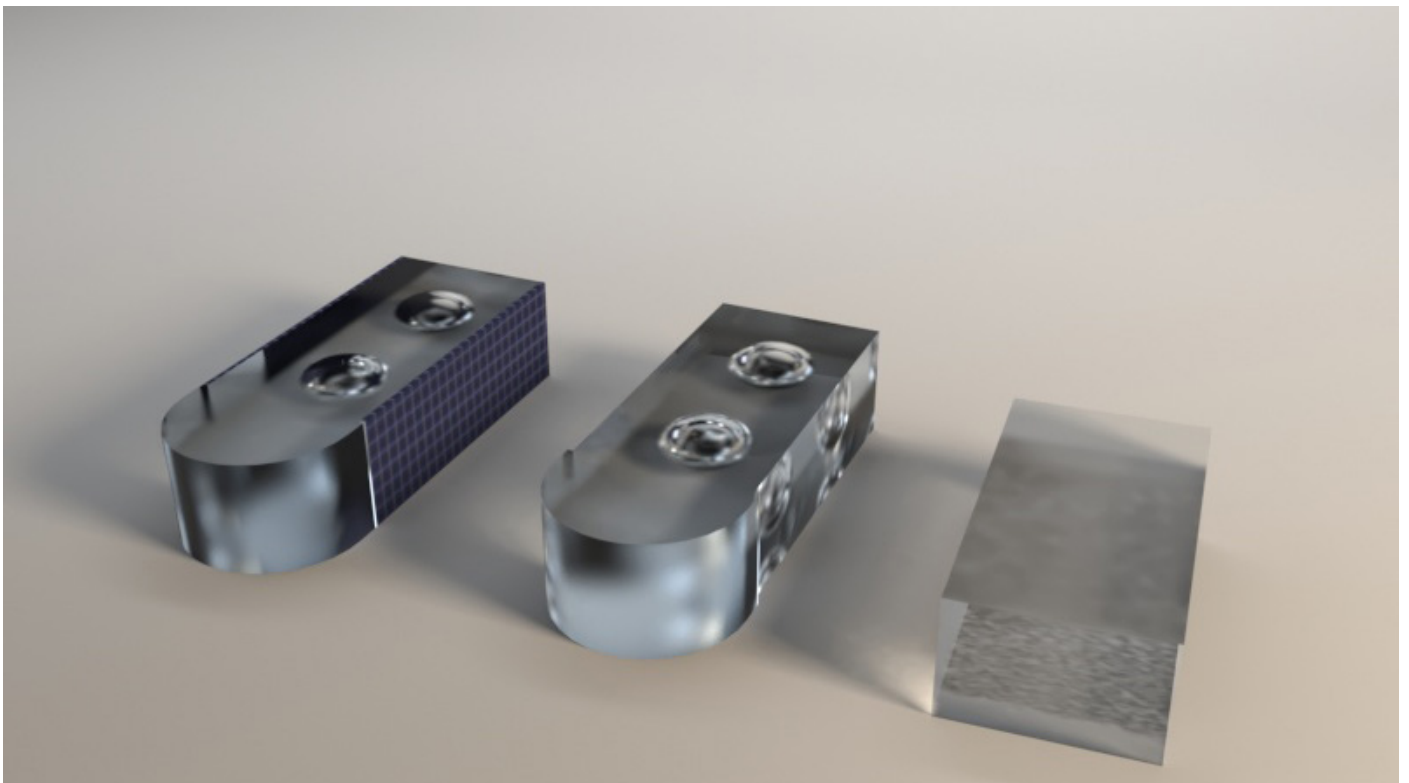

Figure 152: Visualization of the final component (left, middle) and the a simple brick (right).

## 5.2 Light simulation of the final design, comparison with a simple brick

The validation test represents the experiment with the final design. LightTools has been already introduced in chapter 4. Based on that research, the final component and a simple brick is going to be checked, using the same principle.

### Numerical analysis of light behaviour

The numerical analysis of Lighttools is based on numerical approximation. These calculations are used to solve advanced physical and mathematical problems like light propagation in different substance. The program provides interactive ray tracing for creating and visualizing optical systems, including the capability to specify properties for materials and optical surface.

The aim of the numerical analysis is to show how the light interacts with the final component.

### Input

#### Model

The model is made in Rhino as a solid component with the two hollow spheres inside of it. This model is converted into DWG.-file then STEP. file which can be imported into LightTools. (Extra attention to the coordinates of the object, see chapter 4).

#### Glass type

It was concluded in the literature study, that one of the best type of glass for precesion optical devices is borosilicate glass. Therefore, *Pilkington- BSC517642C*.

#### Surface properties

The model has six surfaces and all of them correspond to smooth optical surface property.

#### Light source

The size of the light source has to cover the whole component in order to avoid errors in the simulation. The radius of the light source is  $r=150$ . The size of the source also determines the power of the light in watt:  $1000 * \pi * 150^2 = 7.0686 * 10^7$  W.

#### Sun position

Specific day has been chosen for the simulations, where the number of hours of daytime is approximately equal to the number of hours at nighttime, 20th of March.

In chapter 3, the position of the Sun was analysed. This analysis provides the position of the Sun in this specific day in LightTools, especially when the facade gets direct light from 8:00 in the morning until 17:00 in the afternoon)

#### Photovoltaic panel

The type of the photovoltaic is III-V multijunctional cells. Unfortunately, the program only offers silicon, thereby silicon is used instead of III-V material. However, this slightly change does not affect the behaviour of the light with the glass component.

The model which represents the panel has two optical property. The side which receives the light rays and converts it into electricity is an optical absorber, and the other sides are mechanical absorber.

Settings of the simulations		
Type of glass	Borosilicate glass, <i>Pilkington- BSC517642C</i>	
Surface properties	Smooth optical	
Light source	Radius= 150	Power= $7.0686 * 10^7$ W
Day	20th of March	From 8:00 until 17:00

Figure 153: Settings of the sumilation.

Simulation results of the simple brick component.

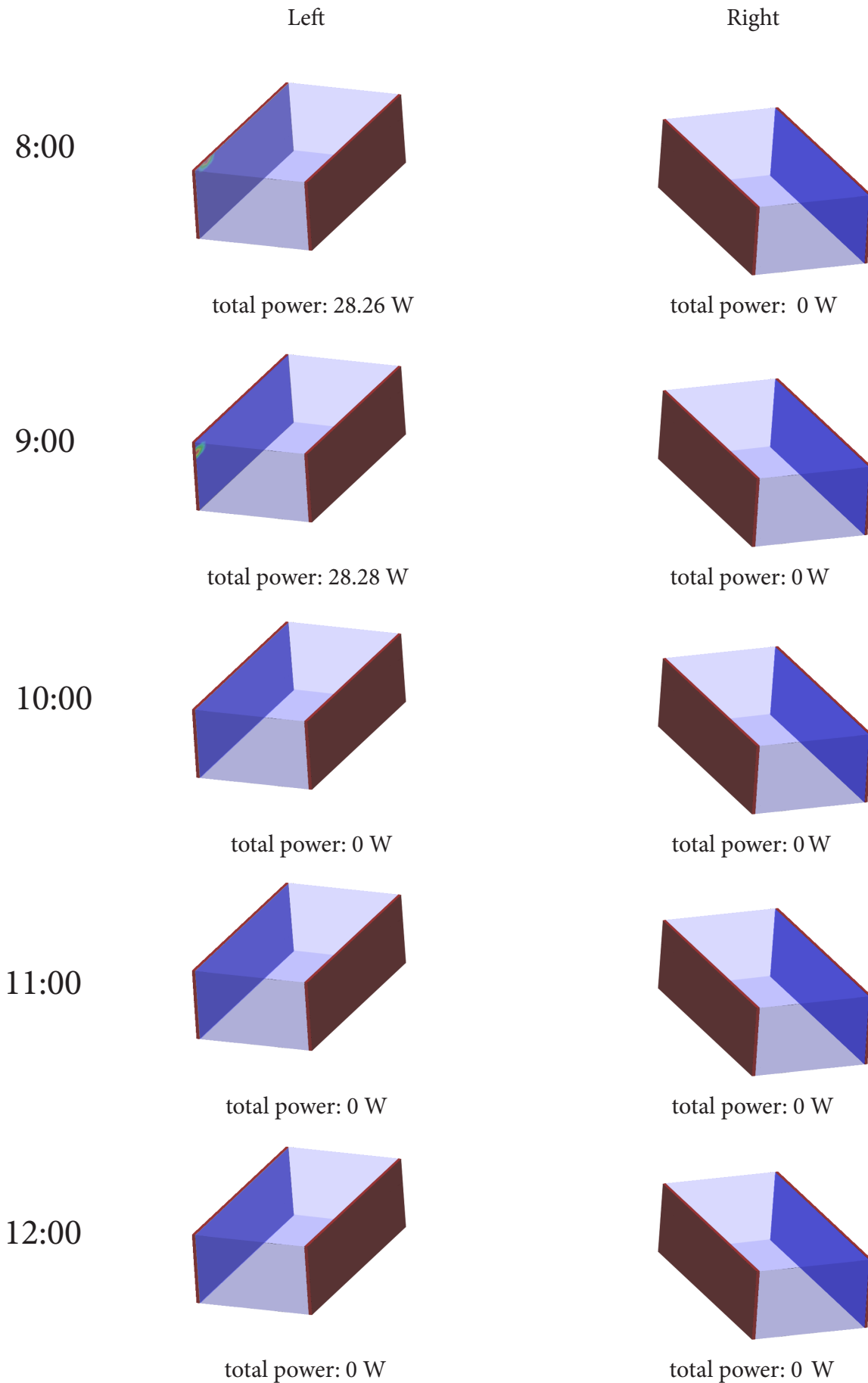

Figure 154: Light redirection by a simple component on the 20th of March

Lumviewer shows the distribution of the illumination and where the highest radiation is on the surfaces highlighting them with different colors. The very dark blue represents zero (no illumination), and red represents the highest illumination in  $W/mm^2$ .



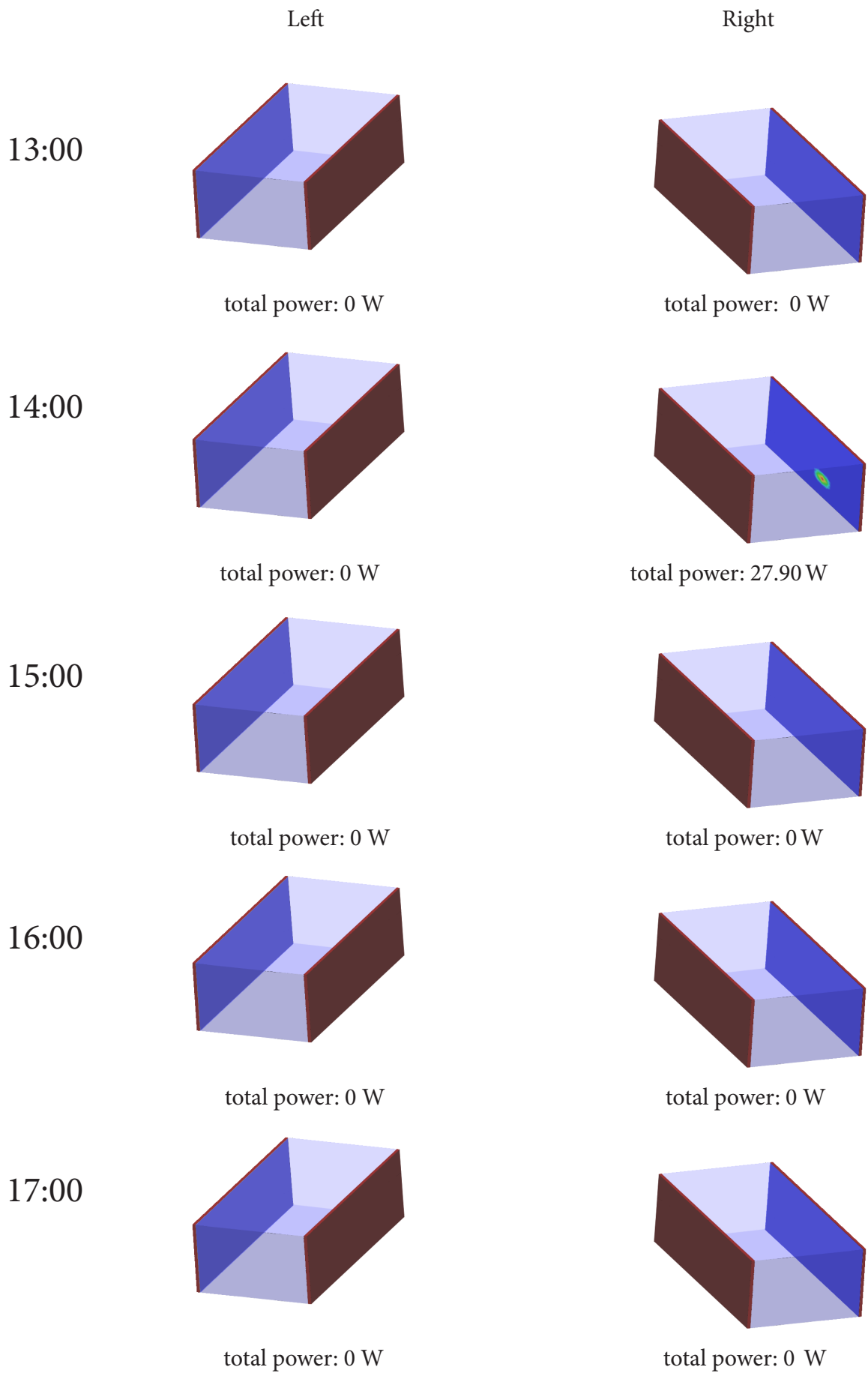

Figure 155: Light redirection by a simple component on the 20th of March

Lumviewer shows the distribution of the illumination and where the highest radiation is on the surfaces highlighting them with different colors. The very dark blue represents zero (no illumination), and red represents the highest illumination in  $W/mm^2$ .

Simulation results of the final component.

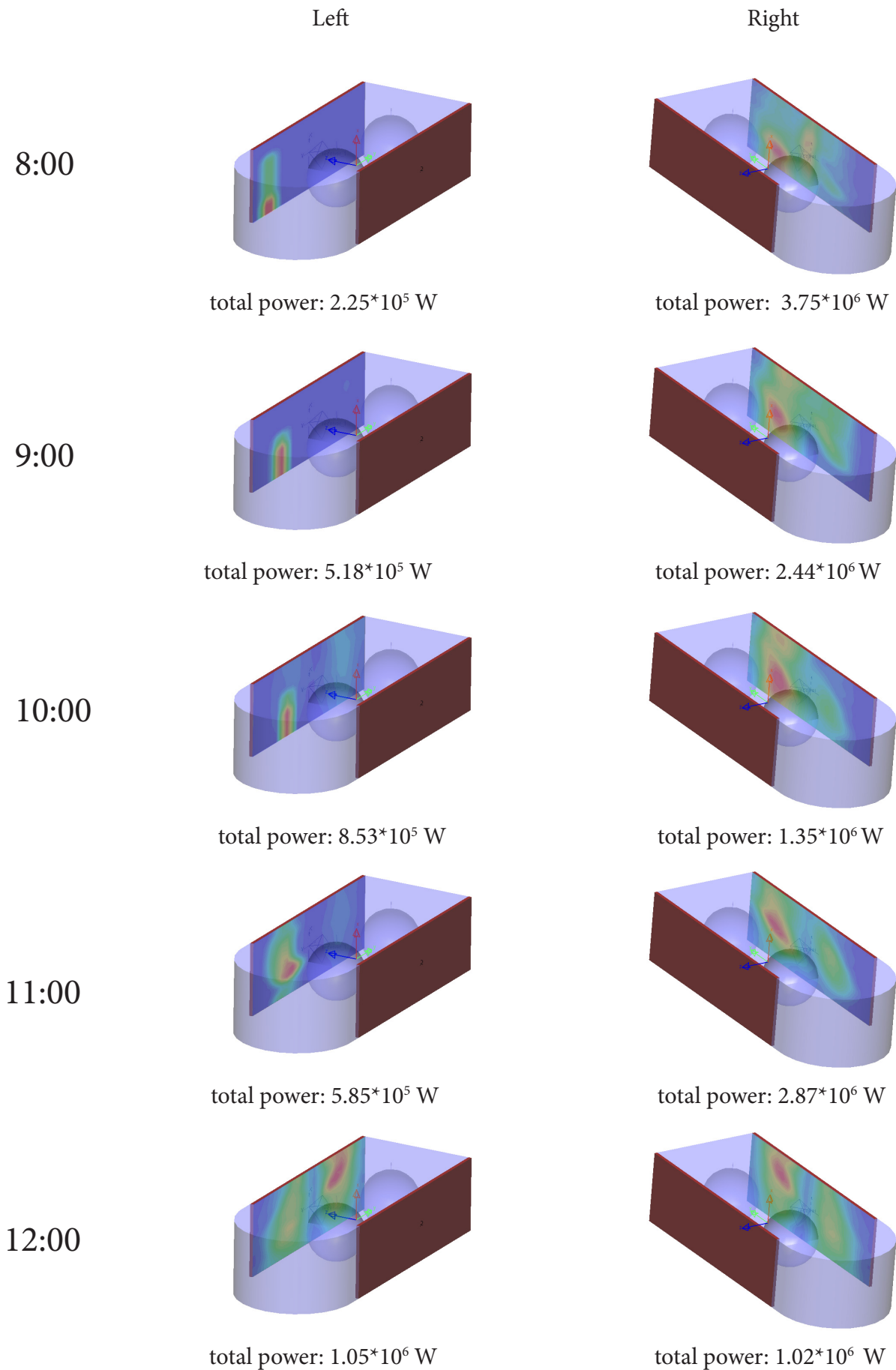

Figure 156: Light redirection by the new component on the 20th of March

Lumviewer shows the distribution of the illumination and where the highest radiation is on the surfaces highlighting them with different colors. The very dark blue represents zero (no illumination), and red represents the highest illumination in  $W/mm^2$ .

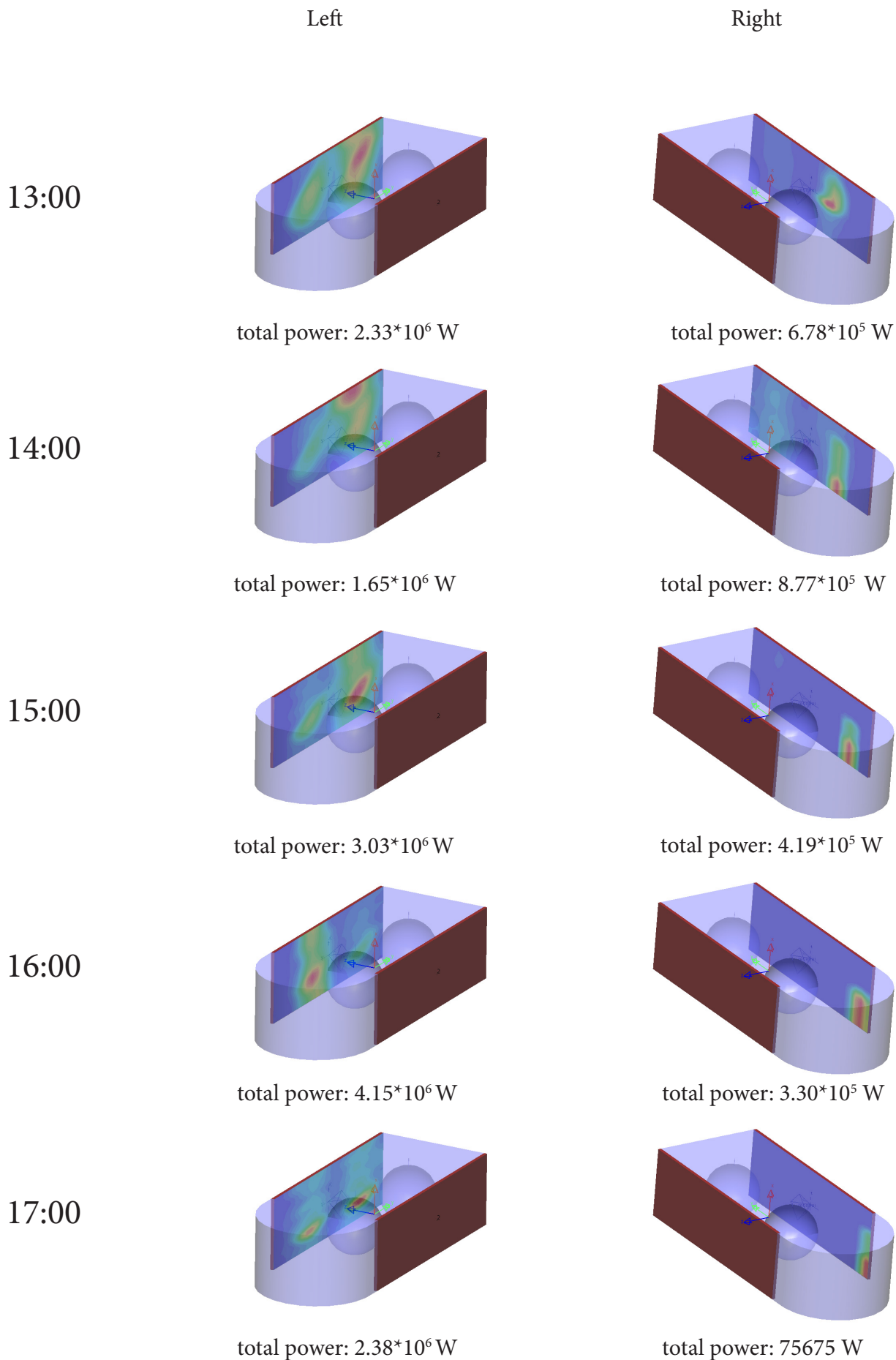

Figure 157: Light redirection by the new component on the 20th of March

Lumviewer shows the distribution of the illumination and where the highest radiation is on the surfaces highlighting them with different colors. The very dark blue represents zero (no illumination), and red represents the highest illumination in  $W/mm^2$ .

## Output

According to the simulations, there is a significant performance improvement comparing the two components. Generally, a simple brick does not redirect the light rays and the light is only bouncing in the inside of the brick until it leaves it. This phenomenon can be described with the total internal reflection. Meanwhile, the new component works perfectly as a lens, as it was expected. The curved external part works as a convex lens and it focuses the light rays into a small area as it can be seen in the early hours. Then, in the late afternoon, it focuses the light rays onto the right panel based on the same principle. The two hollow parts of the brick also redirect the light rays, but instead of focusing, they scatter them away, covering larger area on the photovoltaic panels.

In the previous sections, the final component has been investigated, optimised and tested how it interacts with light. The improvement has been already worth-mentioning, but further research should be done in a facade scale. Examples of wall configurations are going to be further tested which can be implement in the case study.

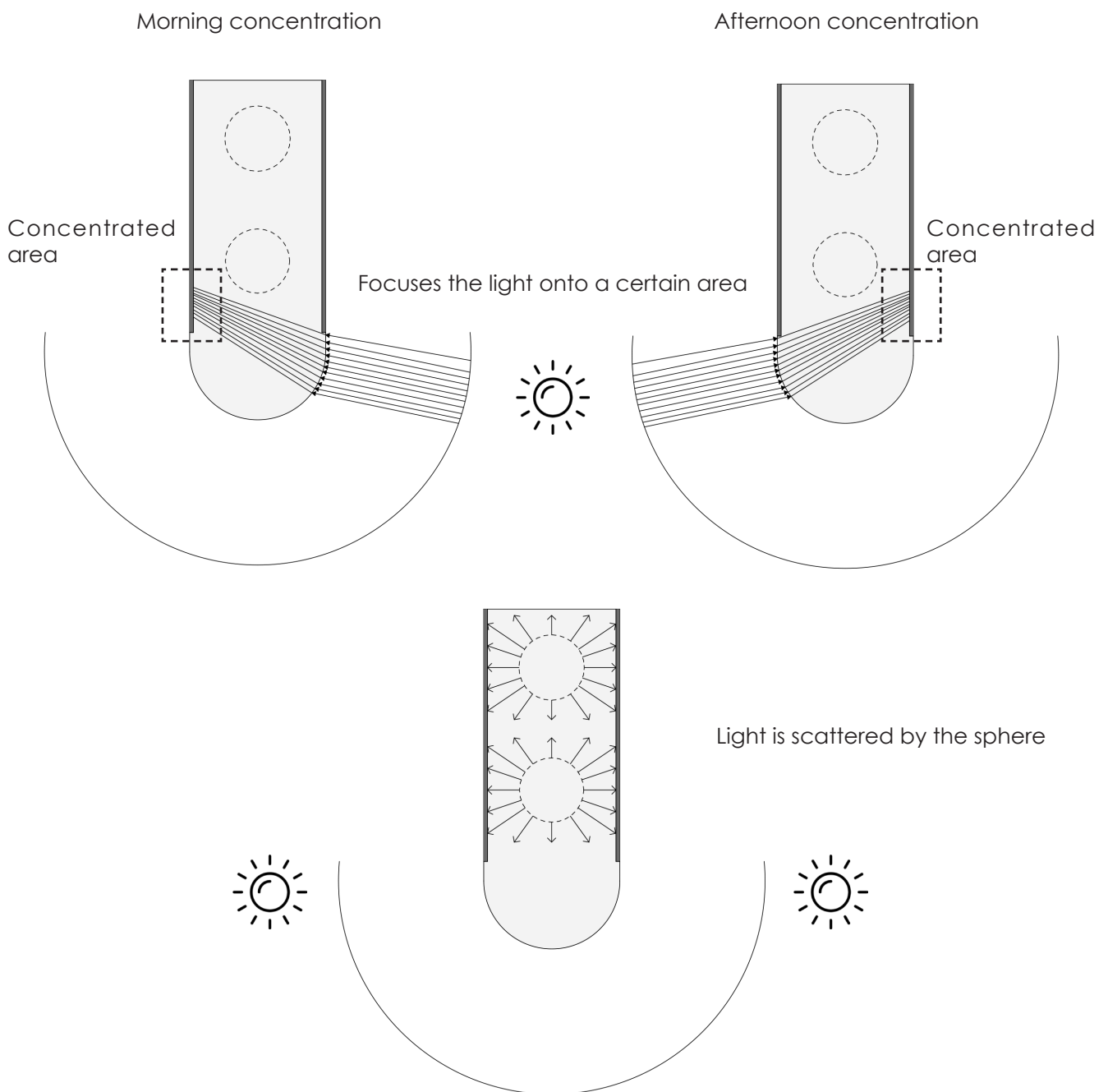

Figure 158: Principle of the light propagation in the component

## 5.2 Wall Design

The evaluation of the wall design aims to give an extended perspective on the applicability of the facade design. A small part of the facade is chosen for the experiment, more precisely a 5\*5 brick layout. Four different configurations have been tested, and especially the amount of radiation has been checked during the simulations. All of the configurations have two kinds of glass brick, the existing one and the new „smart” brick. As the pictures show the distribution of the new brick has been changed and always the middle brick had been taken into account which is the worst scenario.

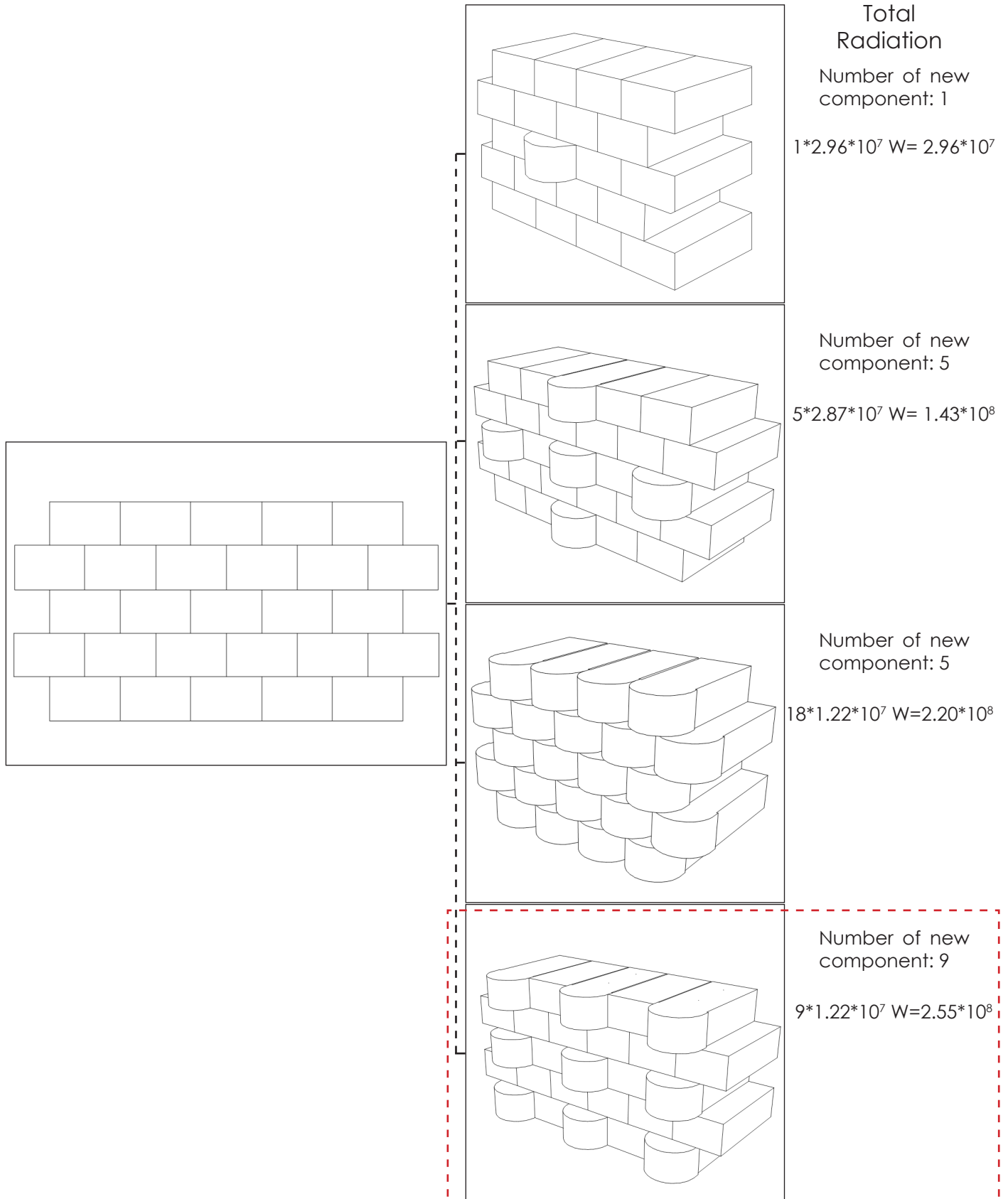
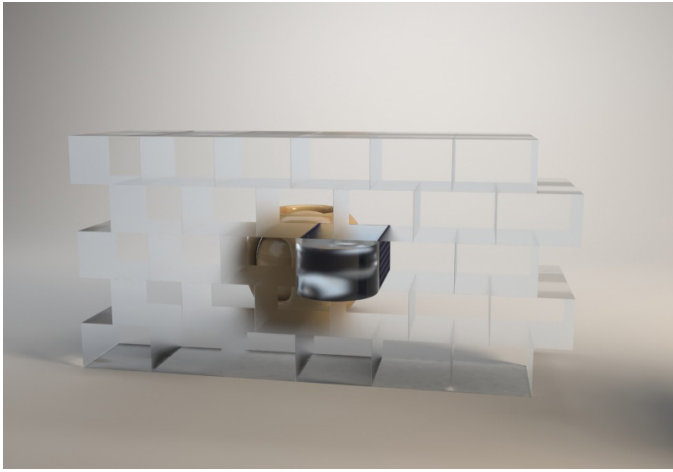

Figure 159: Wall design.





One component



- Low performance
- Very good visual impact



Five component



- Good performance
- Good visual impact

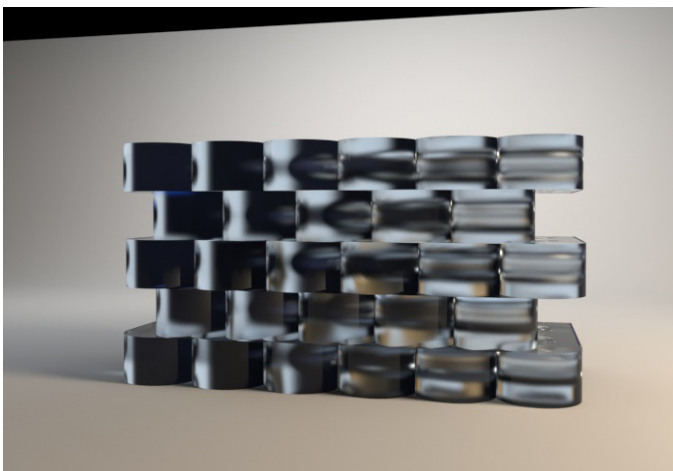

Eighteen component



- Very good performance
- Poor visual impact

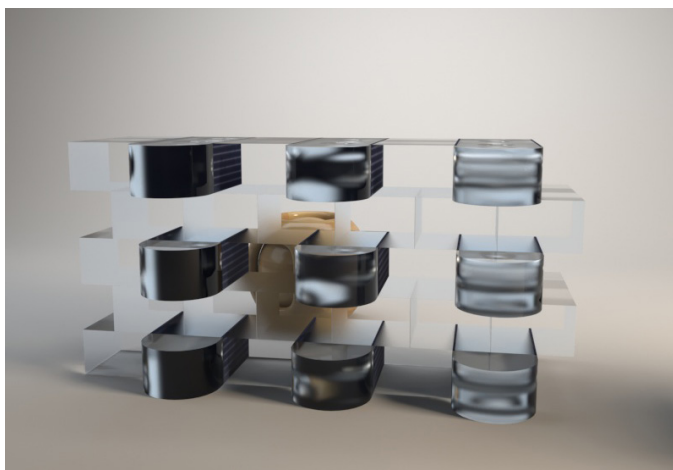

Nine component



- Excellent performance
- Good visual impact

Figure 160: Experiment on the distribuion of the new component.

### 5.3 Calculating the amount of redirected light

Previously, different wall design were judged by taking into account the best performance. The most efficient configuration of using the new component is when 9 smart bricks are used in a 0.2m<sup>2</sup> as the picture shows in the previous section. This configuration is the most efficient, thereby the bricks do not affect each other and the appearance of the wall is not ostentatious.

The section of the wall has been only tested on one day which is the 20th of March (equinox). In order to figure out how much light can be redirected in the given context, the section of the wall has been tested through the entire year in LightTools. The method is the same as the previous simulations. In every month, the position of the Sun is modelled twice ( first day and the last day) and imported into LightTools. Before the simulation starts December has been chosen to check how much the error is if the component is tested in every five days or only the first and the last day in December.

December	Radiation W	Redirecton %
1	11.95*10 <sup>6</sup>	26%
5	11.68*10 <sup>6</sup>	25%
10	11.39*10 <sup>6</sup>	24%
15	11.24*10 <sup>6</sup>	24%
20	11.16*10 <sup>6</sup>	24%
25	11.12*10 <sup>6</sup>	24%
30	11.13*10 <sup>6</sup>	24%

Average redirection ≈ **24.42%**

December	Radiation W	Redirecton %
1	11.95*10 <sup>6</sup>	26%
30	11.13*10 <sup>6</sup>	24%

Average redirection ≈ **25%**

Table 11: Evaluation of an error in December.

As the tables indicates the differences only 0.7%, thus it is enough to analyse the model in the first and the last day in each month. The total percentage of redirection of the light can be seen in the following tables.

Month	Redirecton %
January	42%
February	59%
March	68%
April	72%
May	76%
June	75%

Month	Redirecton %
July	69%
August	62%
September	46%
October	30%
November	26%
December	25%

Table 12: Amount of redirected light in each months.

The final step is to implement the whole design in the existing facade. In the environmental study, it was concluded that the best place to position the new bricks is the upper part of the glass facade. Thereby, it would not deteriorate the visual impact of the ground floor, but can achieve higher radiation.

In the facade there were some prohibited areas for instance the lintels, where the bricks cannot be replaced with the new bricks due to its structural principle and different pattern. All in all 822 bricks have been replaced with the new component.

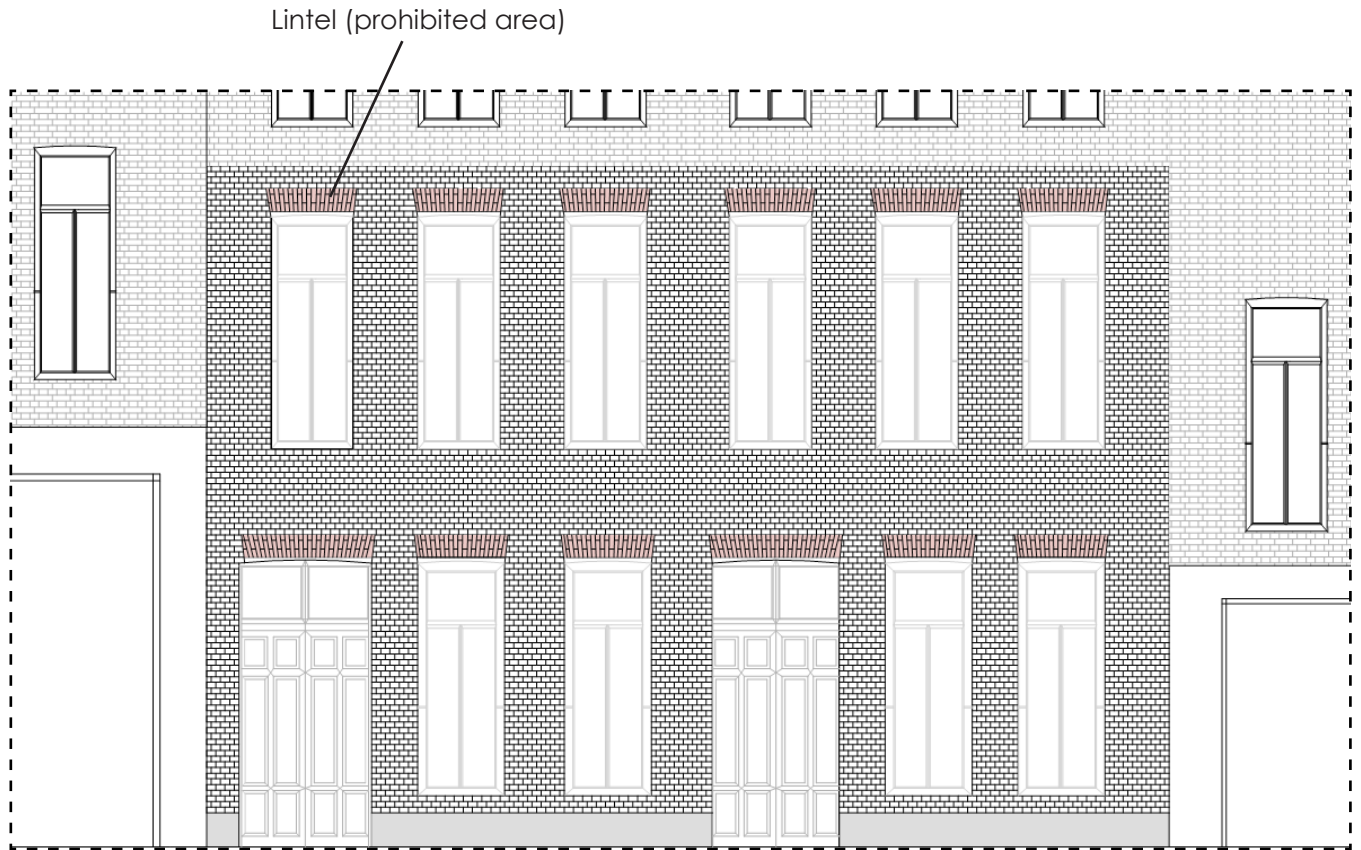

Figure 161 : Elevation of the existing situation.



Figure 162: New elevation with the new components in the upper part of the glass facade

With the new components the facade have been analysed in each month from the solar radiation point of view. Unfortunately, not 100% percentage of solar radiation can be transformed into electricity due to the efficiency of the photovoltaics. As it was mentioned in the literature study III-V multijunctional solar cells are used which has an efficiency of 31.3%. Thereby, the final electricity production can be calculated by solar radiation\*percentage of the redirected light\* efficiency of the solar panels.

Month	Total radiation KWh	Redirecton %	PV efficiency %	Total Power KWh
January	125.51	42%	31.3%	16.50
February	232.07	59%	31.3%	42.44
March	370.0	68%	31.3%	78.75
April	340.16	72%	31.3%	76.75
May	400.13	76%	31.3%	95.18
June	335.65	75%	31.3%	78.80
July	365.40	69%	31.3%	78.91
August	378.87	62%	31.3%	73.52
September	329.95	46%	31.3%	47.50
October	234.24	30%	31.3%	22.00
November	149.39	26%	31.3%	12.15
December	84.79	25%	31.3%	6.63

**Σ=629.13 KWh**

Table 13: The amount of energy that is produced by the new bricks.

## 5.4 Discussion of the results

The aim of the case study is to evaluate how a solid glass brick can work as a solar concentrator in a city context, using as a facade element. Crystal House has been chosen to replace the existing bricks with the new smart bricks. The concept proposes to transform the middle part of the south-east facade of the building as it was proposed in the environmental study. With this intervention, electricity production can be achieved meanwhile daylight can be still admitted into the inside of the shop.

Several shapes have been tested from the light behaviour point of view. The most promising solution is when the brick is made with an external semi-circle part and with two circular hollow holes. The chosen component has the highest rate of redirected light, thus it was proper for further development. Small part of the facade was chosen to check how the elements work in the context. The results of the experiment have shown the most efficient way to use it. This

means in every 0.20m<sup>2</sup>, 9 new bricks are used.



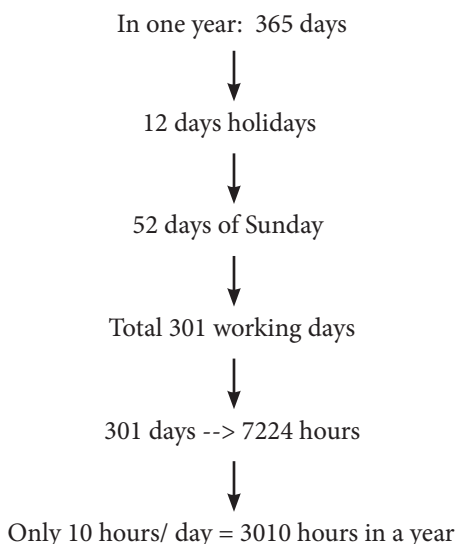

The facade has around 7500 bricks and 822 brick has been replaced with the new "smart" bricks. The electricity production has been tested through an entire year and it results 629.13 KWh/ year. In the following examples are shown what special equipments can be covered in a shop.

Fist of all the shop is not open all the time. One year is 365 days but there are certain days, occasions when the shop is closed. The amount of days when the shop is closed is 12 days due to the holidays, furthermore there are 52 sundays in the year when the shop is closed as well. Therefore, the opening days are 301 days, which is 7224 hours in one year. In these days not all the time the shop is open. The calculation is considering to 10 opening hours per day. 3010 hours in one year. The following graphs show how much energy can be saved by using that amount of smart bricks.



**Electrical equipments work 3010 hours in one year**

Table 15: Opening hours of the shop

	Type of source	Usual Energy consumption	Energy consumption in one year	Amount energy can be saved
	Lamp (spot lamp)	Usual consumption: 4-6 KWh/1000 hour	$4-6 \times 3010 / 1000 = 12-18 \text{ KWh/ year}$	$603.30 / 12 \text{ or } 18 = 33-50 \text{ pieces of lamp can be covered}$
	Desktop	Usual consumption: 213kWh/ year	Usual consumption: 213kWh/ year	Power managed computer. 3 computers can be covered.
	Heating and Cooling	Usual consumption: 2470.0 KWh/ year	Usual consumption: 2470.0 KWh/ year	25.5% can be saved of the total heating and cooling energy
	Small equipments (printer, coffe/tea machines)	Usual consumption: less than 100KWh/ year		100% of the energy consumption can be covered



## 6. Feasibility of the design

The feasibility of the new component in terms of real fabrication and construction is described in this chapter.

## 6.1 Fabrication method

The proposed component follows a simple concave and flat shape which would not be difficult to fabricate. The complexity of the shape is given by the inside hollow surfaces which have to be accessible to post-process it. That indicates that the unit should be fabricated in two pieces.

In the chapter of glass production, it clearly shows that glass can be made in different ways. For cast glass elements, this method is usually hot pour casting or kiln casting. For experimental purposes kiln casting is more affordable in terms of cost and time, but for real fabrication of the component hot pour casting method would be appropriate

In the process, permanent moulds are usually used which made of stainless steel or graphite. It has a benefit to produce better surface quality than disposable mould. This type of mould should be sufficiently preheated to prevent cold interaction between steel and glass. Otherwise the glass would be cooled quickly which results rough, uneven surfaces.

To obtain better surface quality, high precision mould that work under pressure is the most sufficient. This type of technique is applied when lenses are made. ( see chapter 2.4.4.)

An alternative solution can be the use of 3D printed sand mould technology. Printing the mould would provide to fabricate the component in one piece. The benefits of 3D printed sand mould technique are that it is cost-effective and it is a rapid solution.



Figure 163 : 3D printed sand mould (left), high precision mould.

### Hot pour casting- Permanent steel mould

The advantages of using this method is that it ensures high accuracy at the surfaces of the glass which contact to the mould. In addition the mould can be reusable. Unfortunately, the component cannot be cast in one piece due to the complexity of the shape. The brick should be cut horizontally or vertically and each part has to be cast individually. Then, the two pieces can be glued together.

A good example of using high precision steel mould is the Crystal House. An Italian company, called Poesia, was responsible for making the glass units. In our case, the method is the same.

Molten glass is poured directly into a preformed mould at the temperature of 1200°C. The mould has to be pre-heated around 700-800 degrees to result a smooth surface. When the glass cools down to the temperature of 700°C it is released from the mould and taken to the kiln for the annealing process. The glass slowly cools down in the annealing process to the room temperature.

After the annealing procedure, the units are polished by using abrasive water jet technique. The process has the advantage of polishing various complex surfaces and cavities which makes it suitable to polish the curved surfaces.

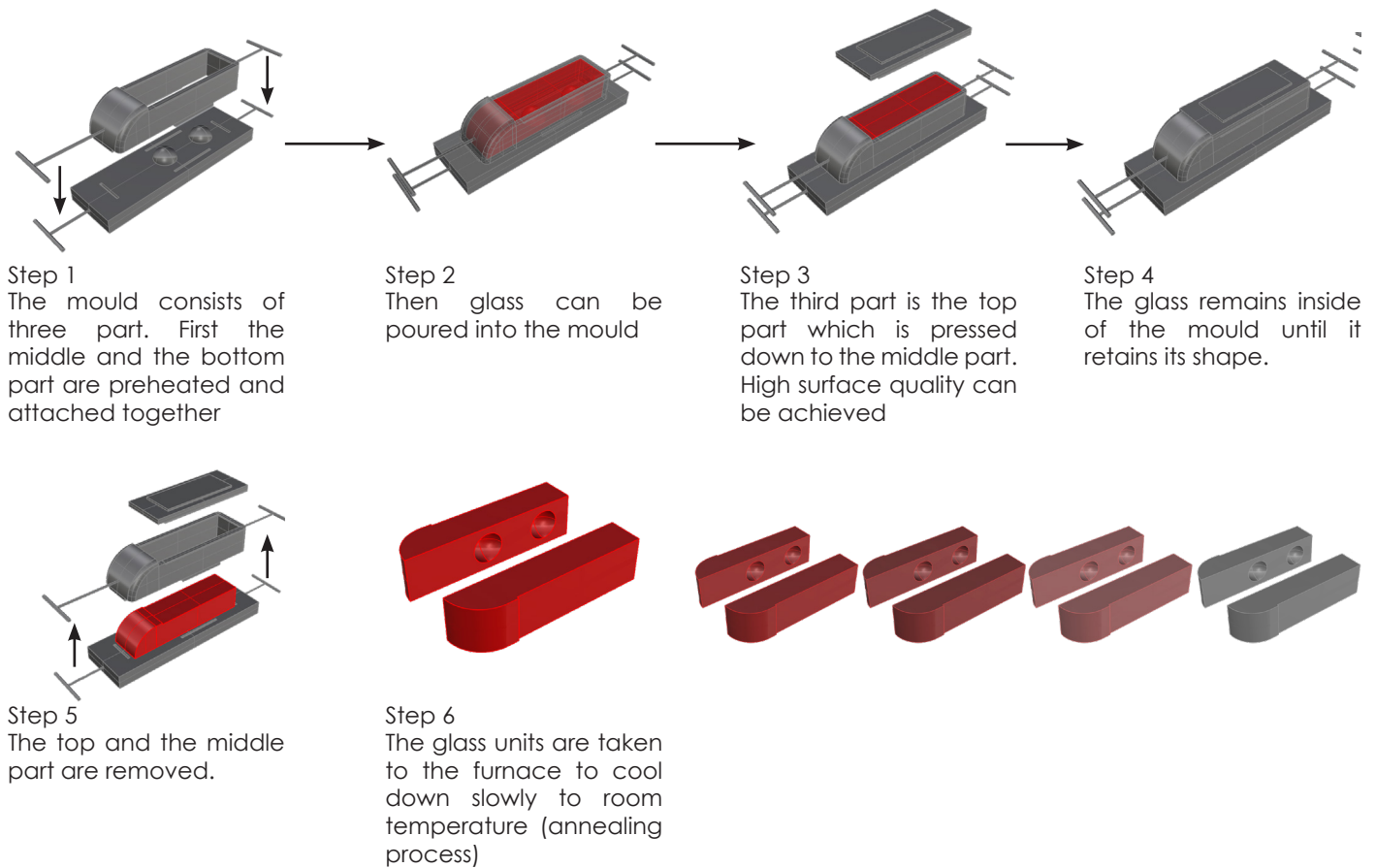

Figure 164 : Fabrication process

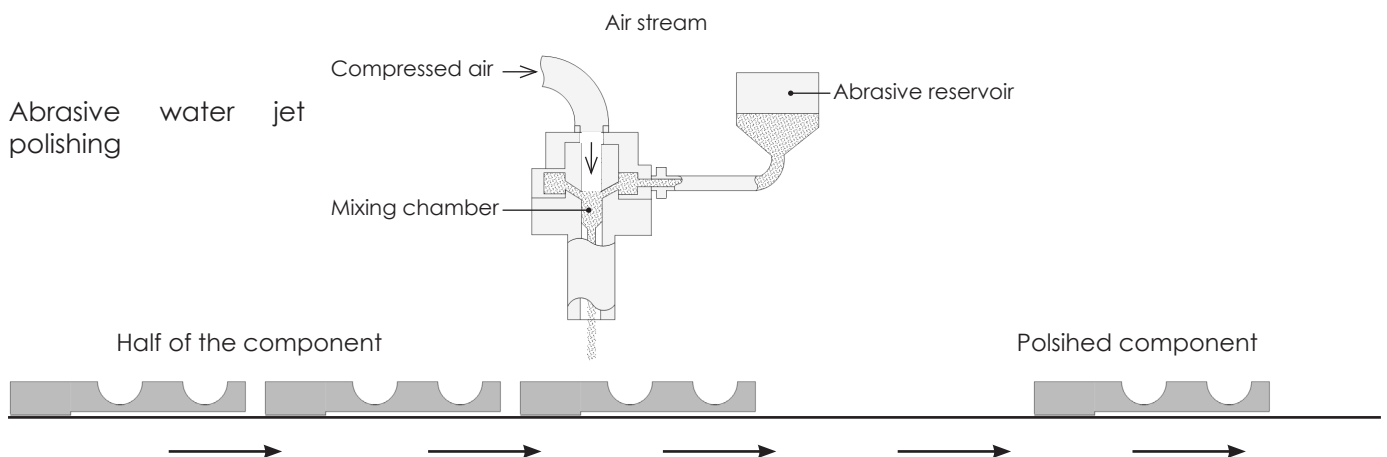

Figure 165 : Polishing process

As an option, anti-reflecting coating can be applied on the surfaces to enhance better light transmission. This would take place in an vacuum chamber where the coating material is heated and evaporated on the surface of the brick.

The last step to get the final component is to glue together the two pieces. The choice of the adhesive layer is also critical to the glass blocks. Not only influences the structural capacity of the system, but can influences the preformance of the new smart brick. An extended research was conducted on various adhesive types during the construction of the facade. The selected adhesive was Delo Photobond 4468 which colorless, UV-curing adhesive. „It presents high shear stiffness, good short and long term compressive behaviour and high humidity resistance” (Oikonomopoulou et al., 2015). The benefit of using this tpe of adhesive is that it has similar refractive index to glass (1.5) (Oikonomopoulou et al., 2015).

### Hot pour casting- Disposable mould, 3D printed sand mould

The other technique is quite new in the market using a disposable mould. 3D printed sand mould is quite different from other casting methods. It completely removes an entire step in casting process by eliminating the need for a casting pattern. Sand mould allows tremendous freedom in the design of the product due to that flexibility of the 3D printed sand. Furthermore, the process is cheap, saves energy and takes less time compared to the traditional manufacturing. It is sustainable as well due to the reduction of the waste.

The steps are quite simple. 3D mould has to be provided to the manufacturer where the sand mould is printed. When the mould is ready, melted glass is poured into the mould. The sand mould can withstand high temperature, therefore, it is not a problem to pour the melted glass. When the glass is around 700°C degree, the mould is removed, and the glass is taken to the kiln for the annealing process, where it cools down to room temperature. Another advantage of the mould that the glass can be cast in one piece, no further glueing is necessary.

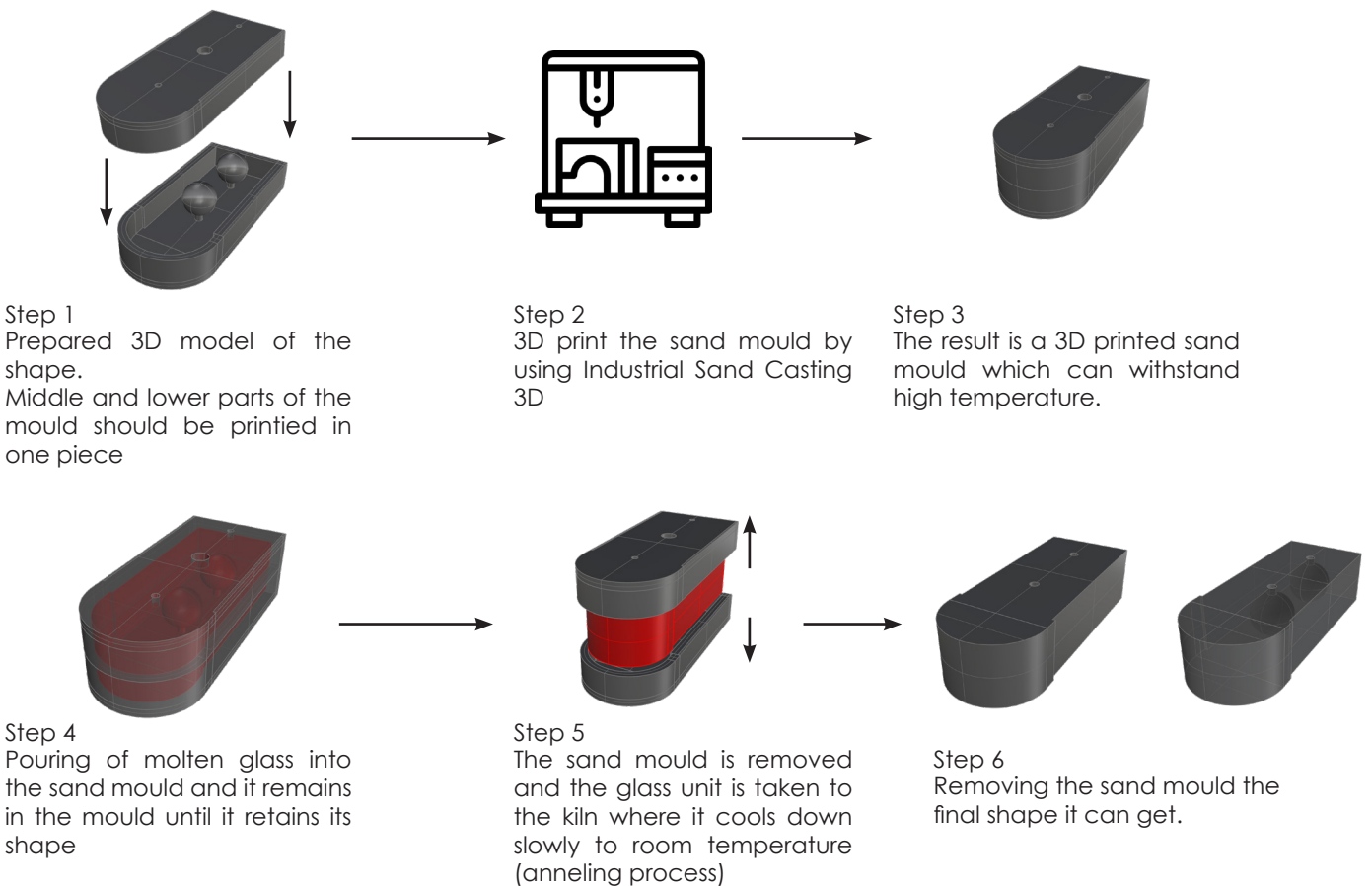

Figure 166: Process of 3D printed sand mould.





To obtain completely smooth surfaces, it has to polish as well. The outer surfaces are easy to polish, but the limited accessibility of the inside surfaces makes it difficult to polish them. Therefore, some parts will be unpolished. Moreover, it cannot be guaranteed that the layers of coating distribute evenly in the inside surface.

822 bricks were replaced with the new bricks. In addition, all the new components have photovoltaic cells on their sides. Pv systems contain a large amount of supporting equipment. These equipments serve to balance the system and make it sustainably operational.

The design proposes an off-grid (stand-alone) pv system to provide electricity only for the shop. The system is comprised of the pv panels, control and safety equipment, battery, and an inverter.

Safety equipments are responsible for controlling the electrical input and to prevent any over charging of the batteries. These batteries store electrical energy for the time when it is not possible to produce energy. The most important part of the system is the inverter. It converts low voltage DC (direct current) power that is produced by the pv panels and turns it into AC (alternating current) which provides electricity for the shop.

All of the cells are linked together from the bottom to the top with cables. The diameter of the cables is around 1 cm and it is fixed on edges of the bricks to have less visual impact on the facade .

- |   |  |   |   |
|---|--|---|---|
| 1 |  Solar module- converts sunlight directly into direct current electricity.                | 3 |  Battery- stores current electricity to supply power at low sun conditions (nighttime or low irradiance) |
| 2 |  Charge controller- regulates voltage and current from solar arrays, charges the battery. | 4 |  Inverter- converts DC power output of solar arrays into AC, which is used for electrical equipments     |

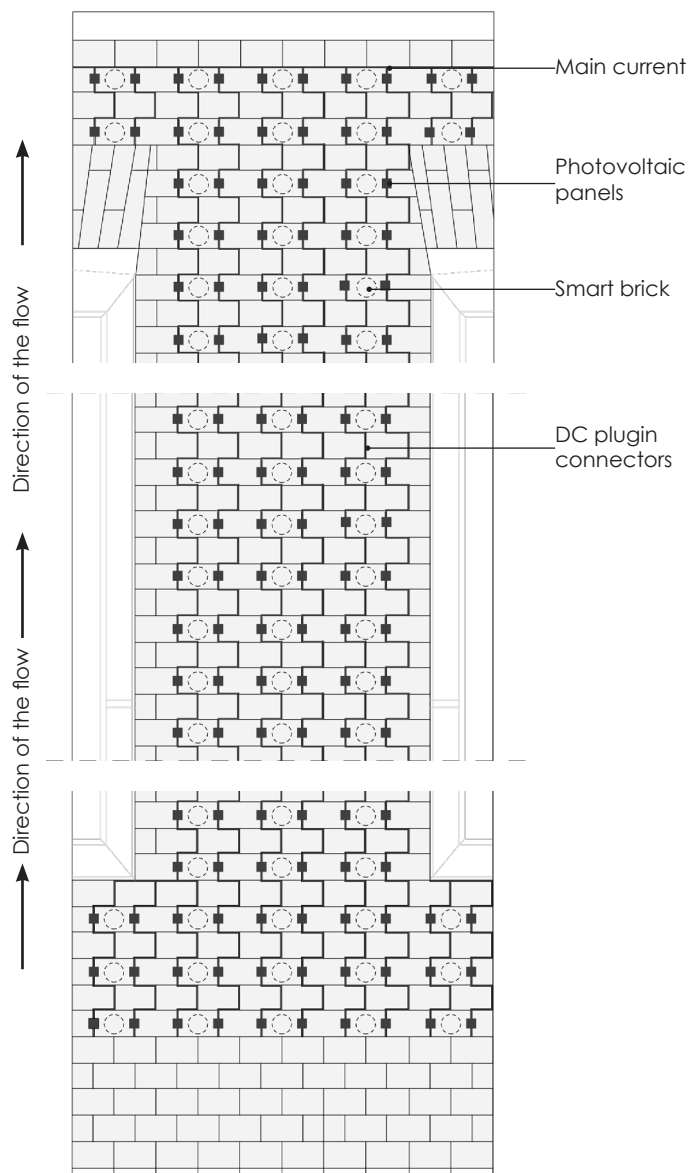

Figure 167: Front view of the facade ( visual impact after applying the pv panels, small detail)

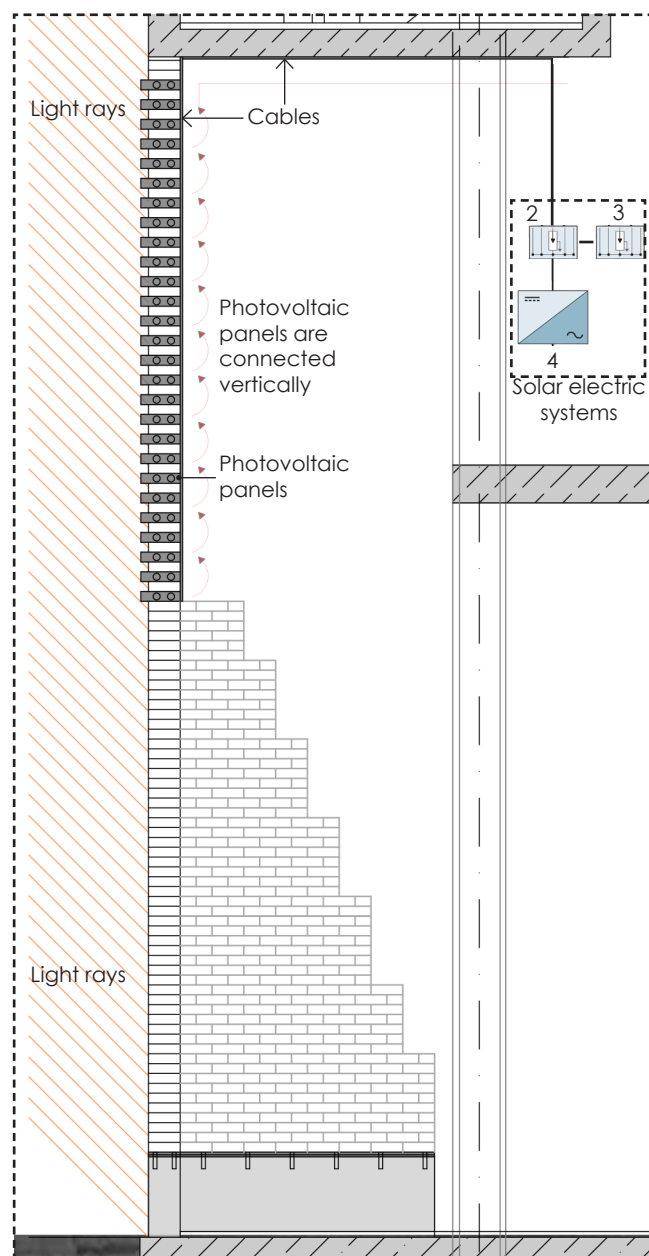

Figure 168: Schematic section of the facade and the photovoltaic system.



## 7. Prototype

During the design, the final component was fabricated. However, the production technique is different from the final production technique which was proposed in the previous chapter since for the real fabrication high steel precision press mould should be used. Making the prototype, resin has been used which was a cost-effective and fast method.

One model was constructed at the Glass Lab, in the faculty of civil engineering. The model is made of resin in a 1:2 scale and the steps are describing the procedure of the fabrication.

### Step 1- 3D printing

The process starts with a 3D model which was prepared in Rhinoceros. The 3D printed model is a positive volume of the component which is needed to create a negative volume. The final geometry is cut horizontally and only half of it should be printed. This is similar to the real fabrication, where also only half of the component is cast first.

Furthermore, the printed model has to have an excellent surface quality to ensure smooth surface in the silicon mould. To improve its quality, it can be further polished (the 3d printed unit).



Figure 169: 3D printed PLA model.

### Step 2- Silicon mould

When the surface of the 3D printed element is smooth, the silicon mould can be prepared. First, the 3D model should be sprayed with a special spray so it will come out easily from the mould. Then the element can be fixed on a table. Around the edges which contact with the table, clay is put to prevent up-lifting of the 3D model during pouring the silicon. Moreover, the clay is treated with soap water to separate them afterwards. When the model is fixed, four wooden planks which are covered with vaseline are placed around the model. These planks are kept in position with clamps. In addition, it has to keep two centimetres between the model and the wooden planks. When they are in the right position, the planks are also covered with clay at the edges to prevent any leakage.

Silicon is comprised of two compounds with the ratio of 1:10. Then the mixture has to be stirred together well and silicone composition is poured one side to the mould to minimise the number of bubbles in the silicon when it solidifies. After 16-18 hours it becomes solid and the wooden planks can be removed as well as the 3D printed model.



Figure 170: Preparation of the silicon mould.



Figure 171: Silicon mould.

### Step 3- Resin model

The silicon has to be cleaned with water to remove the dirt and make it dry with a high-pressure air blower. When it is dry, the resin can be poured into the silicon mould. The resin consists of two compounds, A and B. The proportion of these components has to be 100(A): 90(b). The volume of the component is  $123\text{cm}^3$ . Therefore, 65ml of A and 59ml of B is used for the mixture. Before the resin is poured into the silicon mould, the mould can be sprayed with universal mould release spray in order to take the solid component out easily. Then the resin can be poured into the mould one side, and it is advised to leave it for a couple of days (one week is advised to reach the highest quality).



Figure 172: Pouring resin.



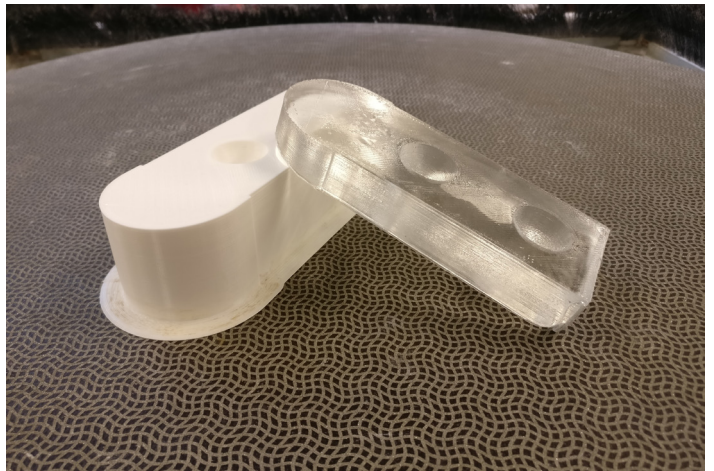

Figure 173: Final component.

## 8. Conclusion

The current thesis proposes an innovative way to develop structural cast glass. According to the objects and to the research questions, final conclusion is formed on the research.



Transparency in architecture has a significant effect in the twenty-first-century architectural practice. Transparency and lightness has become two major aspects in the design. With the aspect of using glass in new buildings, pavilions or some parts of the building can be fully transparent due to the innovative researches and developments. Furthermore, transparency improves the quality of indoor daylight, view, and it makes the building appealing.

However, the more transparent the building the more solar load reaches the inside of the place. Therefore, in summertime the room can be overheated easily due to the solar load, and more mechanical ventilation needs to be introduced. Introducing more mechanical ventilation is not only sustainable solution due to the extra energy/ environment demand and the extra expenses.

A promising solution would be the engineering of a cast glass component with an embedded/integrated solar energy system, making it particularly useful for capturing solar energy.

The current thesis conducted research on sustainability and cast glass as it interacts with light rays with the focus on energy production. The objective was to analyse the light behaviour in solid glass as it is refracted inside the glass and changes its direction when it bounces on different surfaces at a certain angle. The results from how a cast glass component can work as a solar concentrator were then translated into a case study design, namely the Crystal House in Amsterdam. The envelope of the building were analysed from the solar radiation point of view to obtain the best places to position the new smart bricks. The final result is the transformation of the upper part of the glass facade where these new smart bricks are applied with the photovoltaic panels.

According to the research aims and goals the following research questions have been formulated and answered.

***-In what ways can a cast glass component redirect the light in order to maximize the energy production in a facade, and improve its sustainability and decrease the need of additional external cooling sources***

Concentrated photovoltaic technology is an impressive solution how light can be manipulated by using different optical devices. The principle of these optical devices is based on geometrics optics which describes the most important phenomena of light : refraction, reflection and total internal reflection. These optical devices are the key element of the system. It was concluded that for such a system, cast glass can provide a great freedom in geometry in order to redirect the light.

During the geometry study, it was realized that the most promising geometries followed convex shapes. Variety of different convex shapes were applied in the brick based on this observation to obtain higher energy performance and the most remarkable result was when the brick had an external semi-circle surface with two hollow spheres in it.

For further evaluation, the size of the external part and the holes were changed and simulated. The size of the holes significantly influences the performance of the brick. In conclusion the bigger the size of the hole is, the more light can be redirected. Regarding the position of these hollow holes, there are only a slight differences which do not affect the overall performance.

The other approach was to shape the external surface of the brick to concentrate the light rays. The straight external part was divided into three surfaces and each surface faced to the sun at different time during the day. With this technique, the component could track the sun without using any mechanical part. However, curved external works more as a concentrator as it redirects the light rays into a certain area. The radius of the semi circle is 5.25cm. Decreasing the radius of the curvature decreases the effect of it. That is why the diameter is equal to the width of the brick.

All in all 822 bricks were replaced with the new smart brick and the maximum energy that can produce is 629.13 KWh/ year.

That means, it is sufficient to cover all of the energy needs of lightning, of maximum 3 desktop, and additional small equipments. For only heating and cooling the system can cover 25.5% of the total energy needs in a year.

From the transparency point of view, the photovoltaics deteriorates the overall visual effect of the glass facade. Introducing cables and supporting equipment make the facade less transparent. It was proved that cast glass can be used as a solar concentrator, but introducing other material like pv panels make the facade rather translucent than transparent.

#### **- What manufacturing process and glass type should be employed to produce a block of the given complex geometry and high accuracy?**

The most appropriate manufacturing method is hot pour casting using high precision molds that can work under pressure. This method is usually used for high precision optical components. The component has to be fabricated in two pieces to post-process the hollow surfaces. Even though, high precision mould ensures very good surface quality, the surface has to be polished by Abrasive water jet technique. For better light transmission, the component should be coated with anti-reflective coating to reduce reflection.

Borosilicate glass is preferred in the design due to its excellent optical properties. It a clear, colourless glass and ideal for optical applications.

The best option is to use borosilicate glass which is a clear and transparent colourless glass, ideal for a wide range of application in optics. With this type of glass, the color aberration can be minimize which can deteriorate the efficiency of the photovoltaic sells. Moreover, It is resistan to chemical and environmental damages and due to its low thermal expansion coefficient [around 3.2 - 4 K-1] it can withstand thermal shocks which can occur in The Netherlands.

#### **What type of Photovoltaics is more appropriate for such an application?**

The reviewed literature study on existing photovoltaic technologies clearly shows that the most appropriate type of photovoltaic is the III-V multijunctional solar cell.

This type of photovoltaic is more common to use in a concentrated applications due to its higher efficiency rate compared with silicon based photovoltaics. The efficiency can be 25%- up to 40% based on the sun concentration ratio.

The reason that it has the highest efficiency in the photovoltaic technology is the use of materials of the solar cell. III-V solar cells consist of compounds of elements from the group III and V of the periodic table and the combination of these materials so called multijunctional cells are more sensitive to the wider spectrum of the incoming light, and each layer reacts with particular range of the solar spectrum. The cells have a comparatively low heat coefficient than Silicon cells, 0.2%/ °C.

Fraunhofer ISE is one of the leading solar energy research institute in Europe. They have achieved an efficiency of 31.3% on multi-junction solar cell, last year. The highlight of the cell is the ultra- thin semiconductor layer. Therefore, it facilitates proper integration in the project.

#### **In what ways do influence the geometry of the glass brick components the redirection of the light?**

It was very important to figure out where the photovoltaic panels had to be placed on the brick. When it was placed on the back of the brick the, shape of the hole did not redirect the light that much as it had been expected. Much more impact can be achieved if it was placed on the sides of the brick. This was rather a question of the position of the panels.

Different types of shapes were tested from the simple to the more complex one. In general all of the shapes redirected the light in the brick with different intensity. Holes which have straight surface have lower intensity than curved surfaces. In the geometry study it can be seen clearly that straight surfaces have the smallest impact.

Secondly, not only the inside holes have an impact on the redirected light, but the external surfaces. Few types of configurations had been tested, from the straight one to the curved external. In both case the redirection of the light was successful and especially the curved external redirected the light into a certain area having the highest irradiance among the components. Placing hollow spheres in the component improves the performance. It scatters the light rays.

**- What are the shapes and forms that are optimum for such a solar energy system that can be achieved in cast glass ?**

Usually when concentrated photovoltaics system is applied, it is designed with a sun tracking system. This could be either one or two axis tracking. In a case of a cast glass facade this cannot really happen. The structural cast glass cannot move otherwise it would not fulfil its structural requirements. Therefore, such a system or component should be designed which covers as much as possible area of the PV panels.

All of the tested geometries try to fulfil these requirements and finds a balance between structural and energy concept. From the structural point of view the load can be transferred from the middle to the edges. Therefore, it allows to shape the middle part of the brick.

As on optimal shape, it was observed that different convex geometries are the finest shapes. However, the most intriguing finding was how an external surface can redirect the light and improve the performance of the brick a lot.

# REFLECTION

## **Aspect 01: The relationship between research and design.**

The thesis conducted research on sustainability and light behaviour as it interacts with solid cast glass brick with the focus on energy production. The goal was to analyse the light behaviour in solid glass as it is refracted inside the glass and changes its direction when it bounces on different surface at a certain angle.

The literature study has been a fundamental part of the thesis, thereby different glass technology and sustainable solutions were investigated. Then the literature study was integrated into the design. Research techniques that were used, are both individual concepts and experiments by applying reference projects. Exploring both directions provided proper knowledge to solve the challenges, which were formed in the design question. The conclusion of the geometry study led the way for further evaluation of the project in a building scale, and Crystal House was chosen for the case study. Every decision which was made during the process based on researches and simulations, therefore the thesis can be characterised as „*Design by Research*“.

## **Aspect 02: The relationship between the theme of the graduation lab & the subject/case study chosen by the student within its framework.**

Sustainable design graduation is part of the Building Technology master program. The studio explores innovative technologies in three different types of disciplines, namely Facade design, Structural design, Climate design and Computational design. The object of the thesis is structural cast glass focusing on energy production. Therefore, it takes the structural design and climate design into account. Nevertheless, it has to mention the importance of the computational part which facilitated the workflow from the beginning to the end of the thesis.

Structural cast glass is a new approach to use glass as a main load-bearing system in architecture. The goal of the thesis is to further discover the possibilities of structural cast glass through analysing solid glass as it interacts with light rays. Designing a new type of cast glass which can work as a solar concentrator not only can fulfil its structural task but it can redirect the light into specific areas/ points where photovoltaics panels can be placed. Several geometries were studied and simulated to check the interaction with light. The project explores the feasibility of new innovative technologies with sustainable approach.

## **Aspect 03: The relationship between the methodical line of approach of the graduation lab and the method chosen by the student in this framework**

In each period of the graduation project was dedicated to solve certain problems. The design project was based on design by research method, thus several scientific articles and acknowledged journals were used during the literature study to get proper knowledge to move on. Companies were asked about the current status of the technologies as well as exhibitions were visited.

In the design phase, research was done on several components and each decision-making narrowed down the project and led to find the final component which fits best in the context. In all steps in the design, research was a key factor to solve the dedicated designs.

#### **Aspect 04: The relationship between the project and the social context**

Technology plays a vital role in sustainability to utilize renewable energy in order to develop sustainable or even self-sustainable technologies. The question of sustainability is indubitable. The quickly growing global energy use has already raised several concerns over supply difficulties, exhaustion of energy resources and massive environmental impacts all over the world. Therefore, sustainability has become an essential concept in everyday life.

One of the most abundant, inexhaustible and clean renewable energy resources is the solar energy. In one day the irradiation from the sun on the Earth gives about 10000 times more energy than the daily use of the population. One of the promising technologies which can produce electricity on site directly from the sun is the Photovoltaics. The project focuses on a special kind of photovoltaics technology called concentrated photovoltaics system. This system usually consists of an optical device as well, which concentrates the light into one point (to the panels). Due to the variety size of the panels, it can be easily integrated in the facade or on the roof without having a big visual impact.

Nowadays the daylight and the visual comfort is very important for the occupants of the building in order to achieve proper indoor comfort. It is a great opportunity design a fully transparent facade especially if it is made of structural glass. Not only fully transparent structure can be achieved but a fascinating, unique facade as well. The fully transparent facade improves the quality of daylight and the view too.

Combination of concentrated photovoltaics system and structural cast glass result a new component which works as an optical device as well as a structural element. The proposed system is not ostentatious and can be applied in small part of the building, or it can be used in an entire facade.

The only drawback of the system is that the additional photovoltaic panels would deteriorate the visual effect of the glass facade. Therefore, the position of the panels is crucial and it has to find the most appropriate place in order to have the lowest visual impact on the transparent facade.



## **Possible further researches**

During the research many experiments have been done, but there are still further researches to expand the knowledge of optical performance of masonry glass facade wall. Therefore the following possible researches are formulated:

-There is a significant potential in dry-assembling method or as it known interlocking structure. Unfortunately, due to the limitation of the time the project could not explore the possibilities in interlocking structure. Using interlocking components provide tremendous freedom in shaping the units. Not only with the holes inside the brick but with the shape of the component can make the whole object work as an optical device.

-Implementation of non-structural element in the facade would be another approach. It can be hollow glass element which works as an optical device as well. The question of tracking system inside the glass could be also a further development in the field.

-In the literature study luminescent technology was described. Using this type of improvement on the glass would also lead fascinating design. The research would be based on material science in cast glass technology. Therefore, no shaping process on the glass would happen.

-Exploration of the new method on casting glass such as 3D printed sand mould and analyse of its properties and the quality of the end result.

-For more precise energy simulation, solar sensitivity map could be used in LightTools. This method would give more accurate numbers and it could eliminate grasshopper simulations.

## **Limitation**

- One of the limitations of the project is the use of programs, especially grasshopper. Unfortunately, parametric design does not provide multiphysics simulations like light behaviour, thus the workflow of the project is more complex.

- Limitations were found in the use of software from the multiphysics simulation point of view. Only Comsol and LightTools could deal this kind of simulations which require deeper knowledge.

# BIBLIOGRAPHY

## Papers, articles:

- 1, Oikonomopoulou, F., Veer, F., Nijse, R. and Baardolf, K. (2015). A completely transparent, adhesively bonded soda-lime glass block masonry system. *Journal of Facade Design and Engineering*, 2(3-4), pp.201-221.
- 2, Baig, H., Heasman, K. and Mallick, T. (2012). Non-uniform illumination in concentrating solar cells. *Renewable and Sustainable Energy Reviews*, 16(8), pp.5890-5909.
- 3, Dyskin, A., Pasternak, E. and Estrin, Y. (2012). Mortarless structures based on topological interlocking. *Frontiers of Structural and Civil Engineering*.
- 4, Baig, H., Sellami, N. and Mallick, T. (2015). Performance modeling and testing of a Building Integrated Concentrating Photovoltaic (BICPV) system. *Solar Energy Materials and Solar Cells*, 134, pp.29-44.
- 5, Almonacid, F., Pérez-Higueras, P., Fernández, E. and Rodrigo, P. (2012). Relation between the cell temperature of a HCPV module and atmospheric parameters. *Solar Energy Materials and Solar Cells*, 105, pp.322-327.
- 6, Estrin, Y., Dyskin, A. and Pasternak, E. (2011). Topological interlocking as a material design concept. *Materials Science and Engineering: C*, 31(6), pp.1189-1194.
- 7, Dyskin, A., Estrin, Y., Kanel-Belov, A. and Pasternak, E. (2001). Toughening by Fragmentation—How Topology Helps. *Advanced Engineering Materials*, 3(11), p.885.
- 8, Hill, J. M., Angel, J. R., Lutz, R. D., Olbert, B. H., & Strittmatter, P. A. (1998). . *Advanced Technology Optical/IR Telescopes VI*. doi:10.1117/12.319295
- 9, Oikonomopoulou, F., Bristogianni, T., Veer, F. and Nijse, R. (2017). The construction of the Crystal Houses façade: challenges and innovations. *Glass Structures & Engineering*.
- 10, Zubi, G., Bernal-Agustín, J. and Fracastoro, G. (2009). High concentration photovoltaic systems applying III–V cells. *Renewable and Sustainable Energy Reviews*, 13(9), pp.2645-2652.
- 11, Pérez-Higueras, P., Muñoz, E., Almonacid, G. and Vidal, P. (2011). High Concentrator PhotoVoltaics efficiencies: Present status and forecast. *Renewable and Sustainable Energy Reviews*, 15(4), pp.1810-1815.
- 12, Debije, M. and Verbunt, P. (2011). Thirty Years of Luminescent Solar Concentrator Research: Solar Energy for the Built Environment. *Advanced Energy Materials*, 2(1), pp.12-35.
- 13, Chemisana, D. (2011). Building Integrated Concentrating Photovoltaics: A review. *Renewable and Sustainable Energy Reviews*, 15(1), pp.603-611.
- 14, Petter Jelle, B., Breivik, C. and Drolsum Røkenes, H. (2012). Building integrated photovoltaic products: A state-of-the-art review and future research opportunities. *Solar Energy Materials and Solar Cells*, 100, pp.69-96.

- 15, Shanks, K., Senthilarasu, S. and Mallick, T. (2016). Optics for concentrating photovoltaics: Trends, limits and opportunities for materials and design. *Renewable and Sustainable Energy Reviews*, 60, pp.394-407.
- 16 Kumar, V., Shrivastava, R. and Untawale, S. (2015). Fresnel lens: A promising alternative of reflectors in concentrated solar power. *Renewable and Sustainable Energy Reviews*, 44, pp.376-390.
- 17, Heinzelmann, F., Bristogianni, T. and Teuffel, P. (2014). Adaptive Liquid Lens and Sunlight Redirection. *International Journal of Architectural Computing*, 12(2), pp.129-153.
- 18, Suzuki, H., Okada, M., Yamagata, Y., Morita, S. and Higuchi, T. (2012). Precision grinding of structured ceramic molds by diamond wheel trued with alloy metal. *CIRP Annals*, 61(1), pp.283-286.
- 19, Musikant, S. and Thompson, B. (1990). *Optical materials*. New York, NY [u.a.]: Dekker.
- 20, FRÖLING, M. (2013). *STRENGTH DESIGN METHODS FOR GLASS STRUCTURES*. Doctoral Thesis. Lund University.
- 21, Hijazi, H., Mokhiamar, O. and Elsamni, O. (2016). Mechanical design of a low cost parabolic solar dish concentrator. *Alexandria Engineering Journal*, 55(1), pp.1-11.
- 22, Pedrotti, L., Pedrotti, S. J., F. and Lakshminarayanan, V. (1999). *Optics and Vision*. *American Journal of Physics*, 67(6), pp.552-553.
- 23, Esmaeili Amin, A. (2013). *Fluid jet polishing for glass material*. Undergraduate. Blekinge Institute of Technology.

### **Webpages:**

- 1, Anon, (2018). [online] Available at: <http://Origins of Glass: Myth and Known History> [Accessed 8 Jan. 2018].
- 2, Bellapart.com. (2018). Glass monument in remembrance of the terrorist attack. Available at: <http://www.bellapart.com/uploads/files/entradas/glass-monument-in-remembrance-of-the-terrorist-atta.pdf> [Accessed 8 Jan. 2018].
- 3, lse.fraunhofer.de. (2018). CPV report. [online] Available at :<https://www.ise.fraunhofer.de/content/dam/ise/de/documents/publications/studies/cpv-report-ise-nrel.pdf> [Accessed 8 Jan. 2018].
- 4, People.isy.liu.se. (2018). Photovoltaic Devices. [online] Available at: [https://people.isy.liu.se/eks/ted/State-of-the-art\\_Presentations/ch16.pdf](https://people.isy.liu.se/eks/ted/State-of-the-art_Presentations/ch16.pdf) [Accessed 8 Jan. 2018].
- 5, People.isy.liu.se. (2018). Photovoltaic Devices. [online] Available at: [https://people.isy.liu.se/eks/ted/State-of-the-art\\_Presentations/ch16.pdf](https://people.isy.liu.se/eks/ted/State-of-the-art_Presentations/ch16.pdf) [Accessed 8 Jan. 2018].
- 6, Astro1.panet.utoledo.edu. (2018). Photovoltaics under concentrated sunlight. [online] Available at: [http://astro1.panet.utoledo.edu/~relling2/teach/archives/4400.2013/20130402\\_PHYS4400\\_](http://astro1.panet.utoledo.edu/~relling2/teach/archives/4400.2013/20130402_PHYS4400_)
- 7, Hyperphysics.phy-astr.gsu.edu. (2018). Anti-Reflection Coatings. [online] Available at: <http://hyperphysics.phy-astr.gsu.edu/hbase/phyopt/antiref.html> [Accessed 15 Jun. 2018].v

# Appendix

1

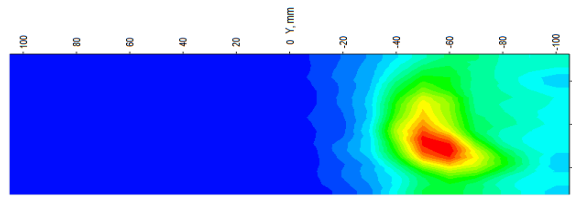

right  
total power: 97665 W/mm2

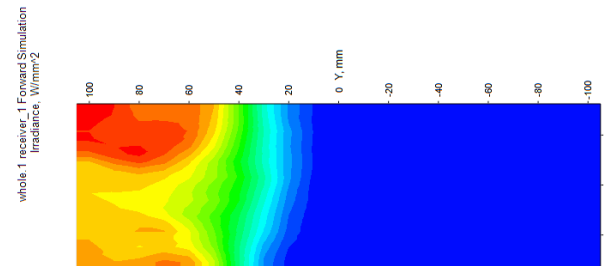

left  
total power:  $4.3 \times 10^5$  W/mm2

2

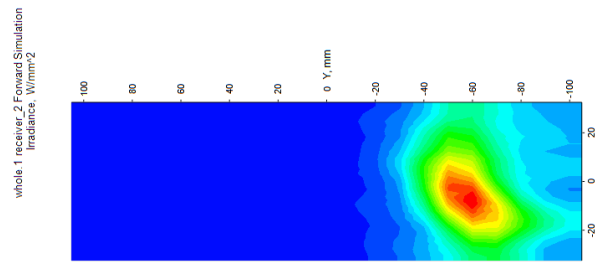

right  
total power:  $1.62 \times 10^5$  W/mm2

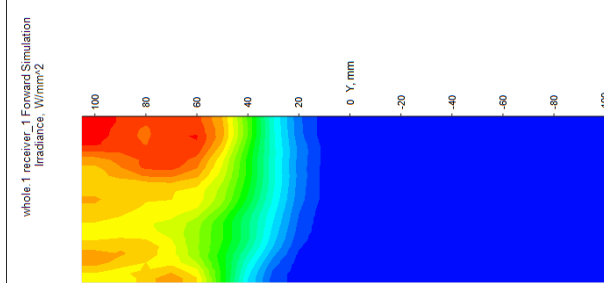

left  
total power:  $9.09 \times 10^5$  W/mm2

3

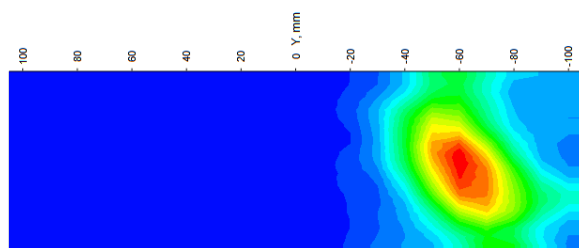

right  
total power:  $2.52 \times 10^5$  W/mm2

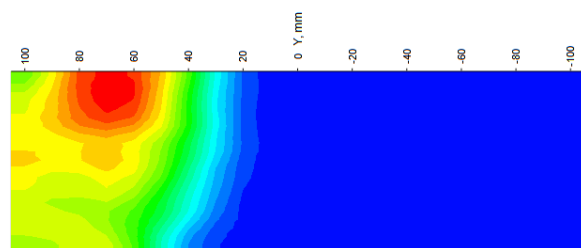

left  
total power:  $5.86 \times 10^5$  W/mm2

4

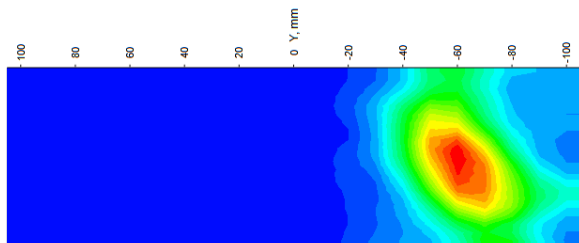

right  
total power:  $2.52 \times 10^5$  W/mm2

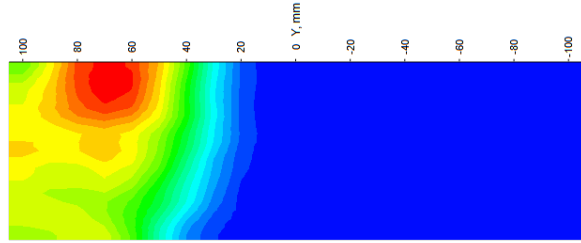

left  
total power:  $5.86 \times 10^5$  W/mm2

5

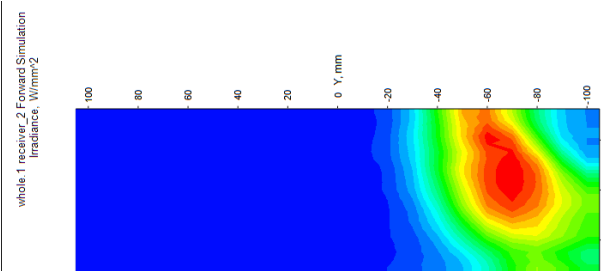

right  
total power:  $5 \times 10^5$  W/mm2

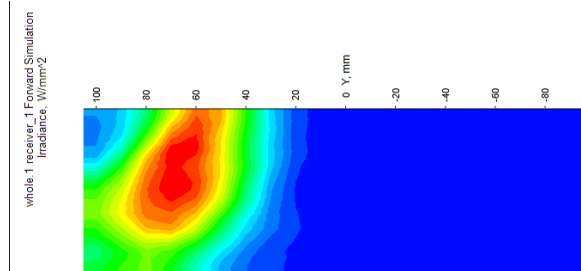

left  
total power:  $5 \times 10^5$  W/mm2

6

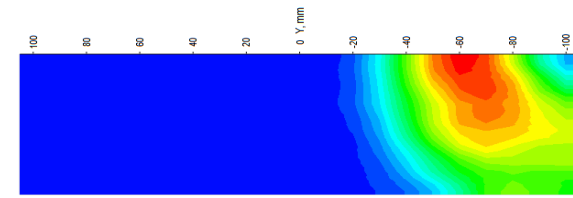

right  
total power:  $6.22 \times 10^5$  W/mm2

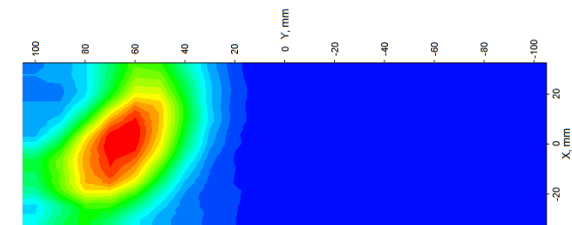

left  
total power:  $4.04 \times 10^5$  W/mm2

7

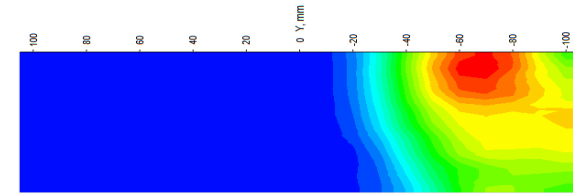

right  
total power:  $6.81 \times 10^5$  W/mm2

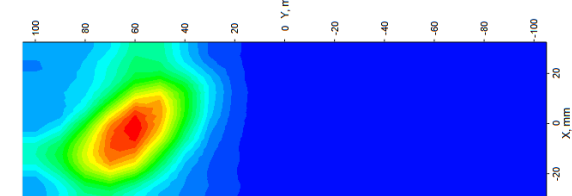

left  
total power:  $2.95 \times 10^5$  W/mm2

8

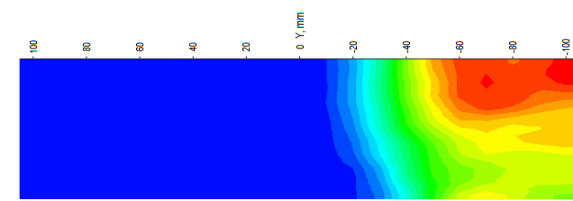

right  
total power:  $6.54 \times 10^5$  W/mm2

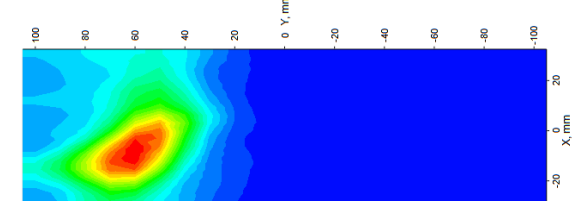

left  
total power:  $1.95 \times 10^5$  W/mm2

9

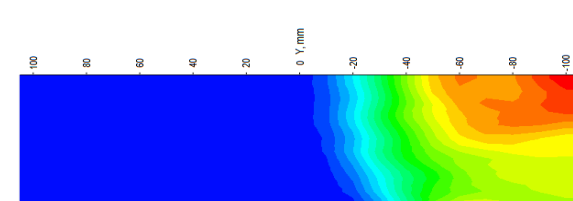

right  
total power:  $5.16 \times 10^5$  W/mm2

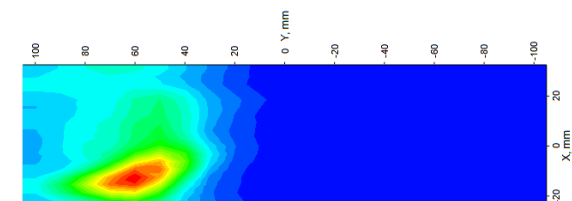

left  
total power:  $1.15 \times 10^5$  W/mm2

10

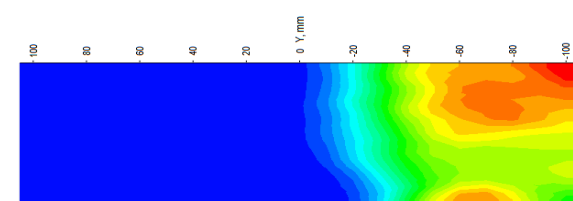

right  
total power:  $3 \times 10^5$  W/mm2

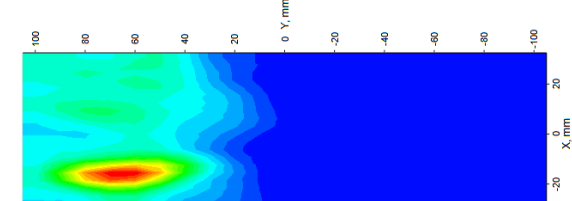

left  
total power: 52390 W/mm2

Radiation maps of  $B_6$  component



1

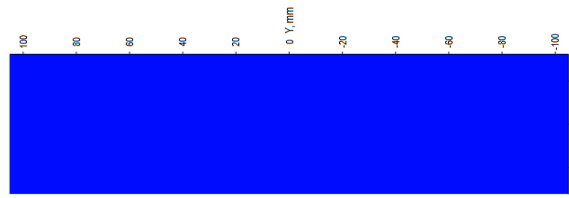

right  
total power: 0 W/mm2

external\_simple\_concave\_pv\_side\_1\_receiver\_1\_Fornan  
Irradiance, W/mm^2

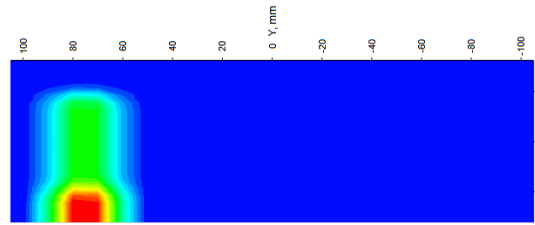

left  
total power:  $3.4 \times 10^6$  W/mm2

2

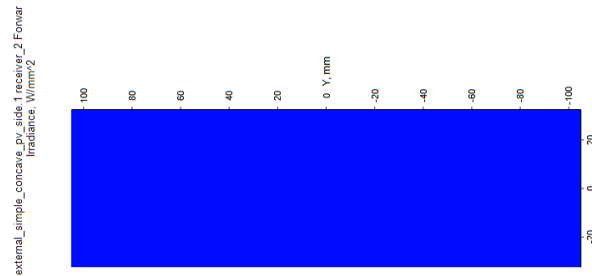

right  
total power: 0 W/mm2

external\_simple\_concave\_pv\_side\_1\_receiver\_1\_Fornan  
Irradiance, W/mm^2

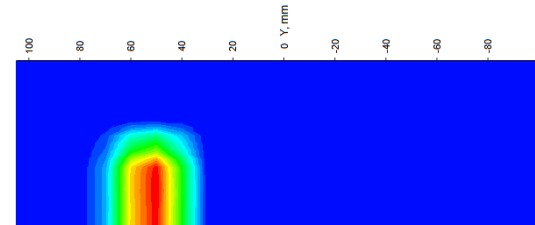

left  
total power:  $1.8 \times 10^6$  W/mm2

3

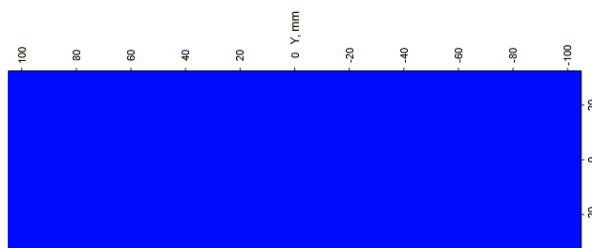

right  
total power:  $2.52 \times 10^5$  W/mm2

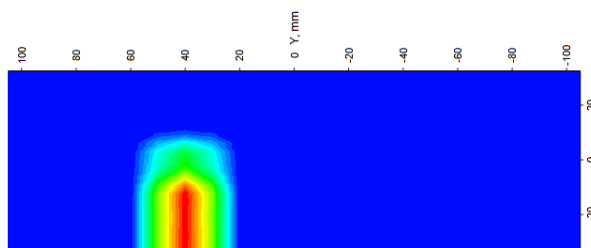

left  
total power:  $4.81 \times 10^5$  W/mm2

4

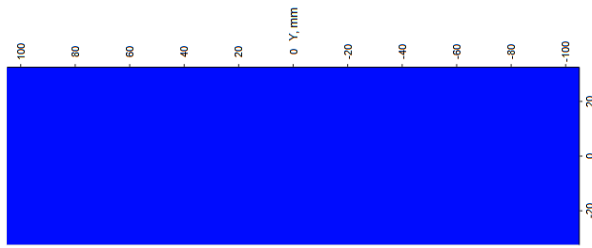

right  
total power: 0 W/mm2

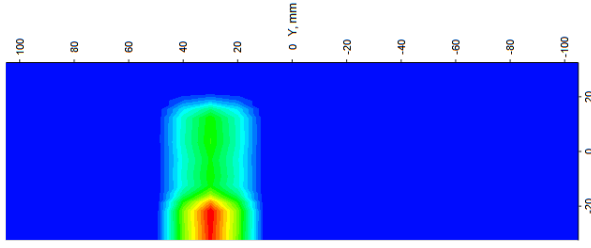

left  
total power: 48134 W/mm2

5

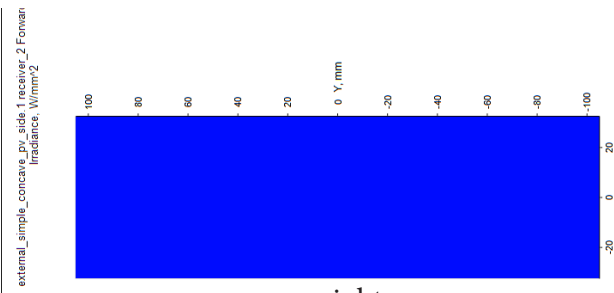

right  
total power: 0 W/mm2

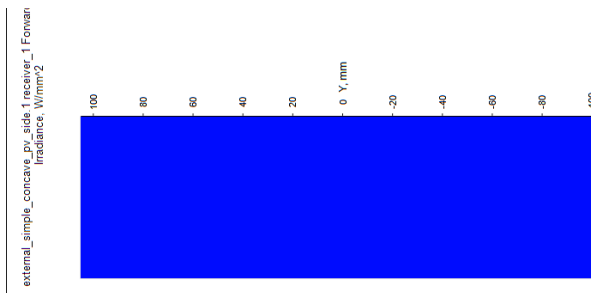

left  
total power: 0 W/mm2

6

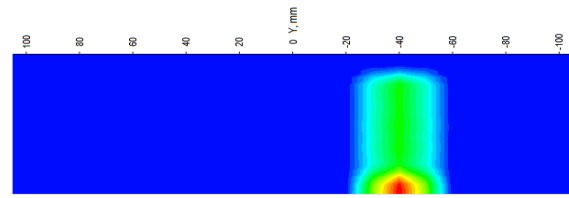

right  
total power: 55468 W/mm2

external\_simple\_concave\_pv\_side\_1\_receiver\_1\_Fornan  
Irradiance, W/mm^2

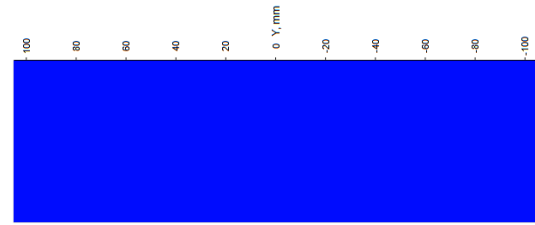

left  
total power: 0 W/mm2

7

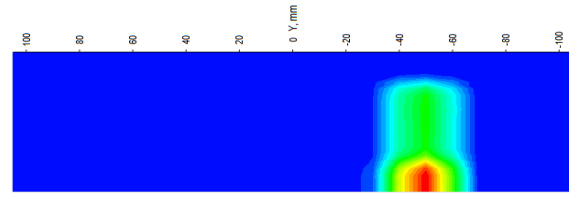

right  
total power:  $5.93 \times 10^5$  W/mm2

external\_simple\_concave\_pv\_side\_1\_receiver\_1\_Fornan  
Irradiance, W/mm^2

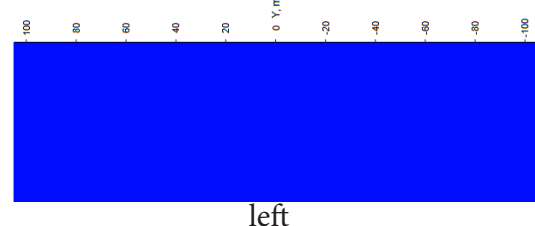

left  
total power: 0 W/mm2

8

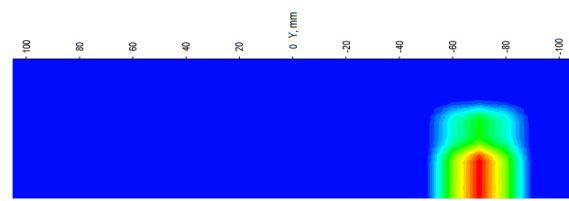

right  
total power:  $2.17 \times 10^6$  W/mm2

external\_simple\_concave\_pv\_side\_1\_receiver\_1\_Fornan  
Irradiance, W/mm^2

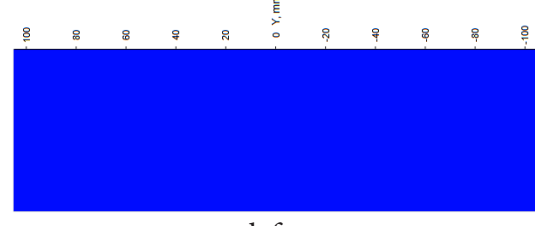

left  
total power: 0 W/mm2

9

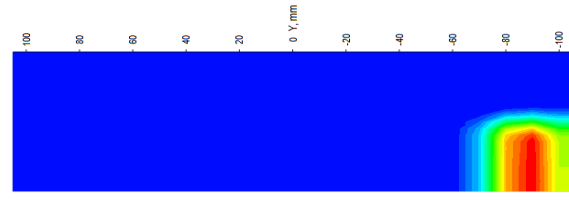

right  
total power:  $3.52 \times 10^6$  W/mm2

external\_simple\_concave\_pv\_side\_1\_receiver\_1\_Fornan  
Irradiance, W/mm^2

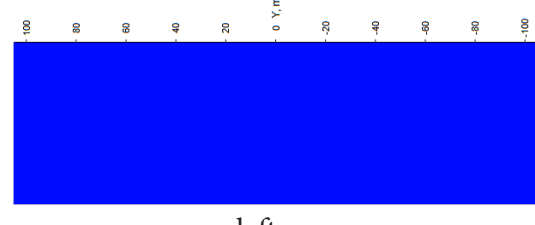

left  
total power: 0 W/mm2

10

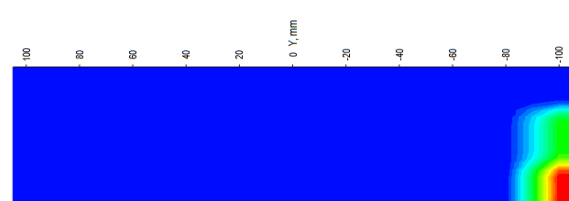

right  
total power:  $1.97 \times 10^6$  W/mm2

external\_simple\_concave\_pv\_side\_1\_receiver\_1\_Fornan  
Irradiance, W/mm^2

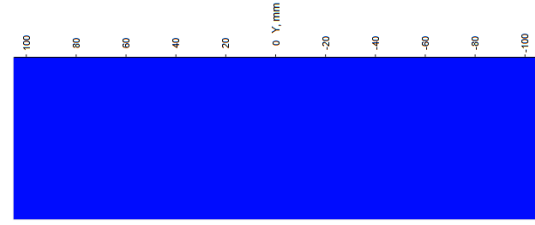

left  
total power: 0 W/mm2

Radiation maps of  $D_1$  component

1

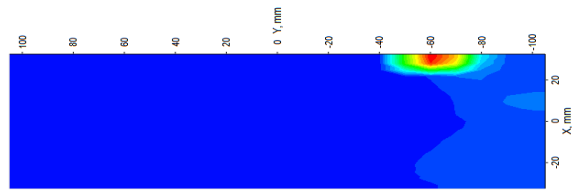

right  
total power: 85099 W/mm2

front\_double\_concave\_lens\_1.receiver\_1.Forward S  
Irradiance, W/mm^2

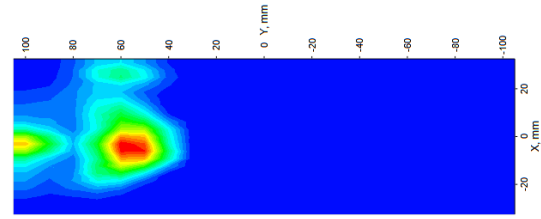

left  
total power:  $1.65 \times 10^6$  W/mm2

2

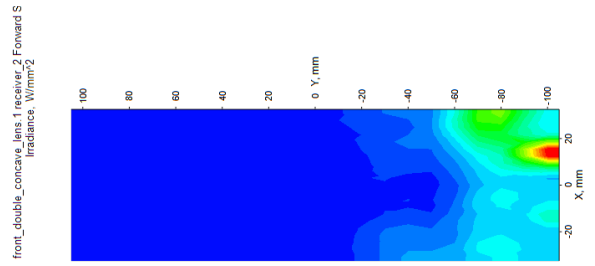

right  
total power: 42278 W/mm2

front\_double\_concave\_lens\_1.receiver\_1.Forward S  
Irradiance, W/mm^2

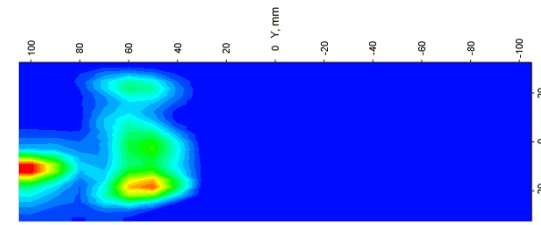

left  
total power:  $1.06 \times 10^6$  W/mm2

3

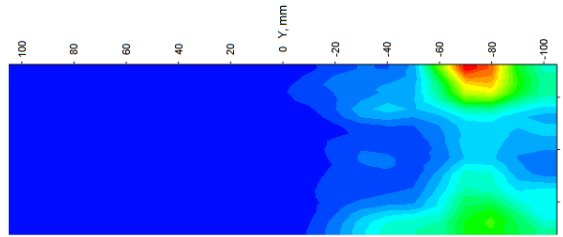

right  
total power: 38306 W/mm2

front\_double\_concave\_lens\_1.receiver\_1.Forward S  
Irradiance, W/mm^2

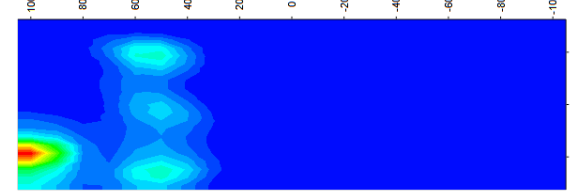

left  
total power:  $6.55 \times 10^5$  W/mm2

4

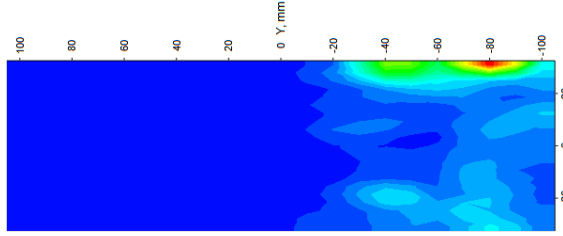

right  
total power: 11097 W/mm2

front\_double\_concave\_lens\_1.receiver\_1.Forward S  
Irradiance, W/mm^2

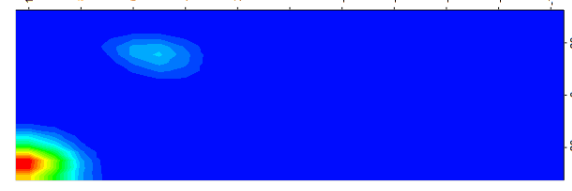

left  
total power: 3.0 W/mm2

5

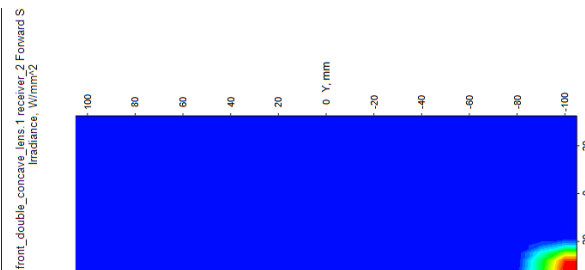

right  
total power: 69882 W/mm2

front\_double\_concave\_lens\_1.receiver\_1.Forward S  
Irradiance, W/mm^2

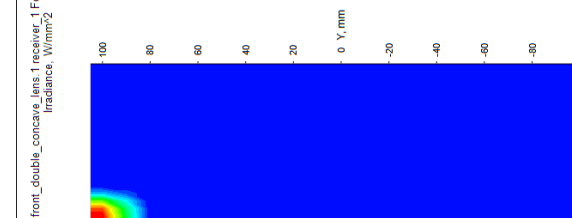

left  
total power: 61288 W/mm2

6

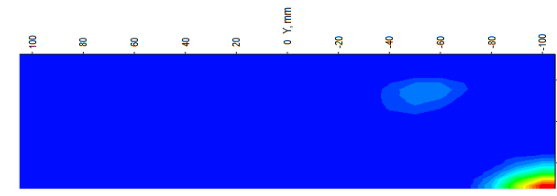

right  
total power:  $3.23 \times 10^5$  W/mm2

front\_double\_concave\_lens\_1.receiver\_1.Forward S  
Irradiance, W/mm^2

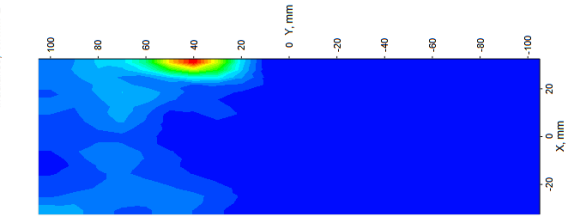

left  
total power: 17436 W/mm2

7

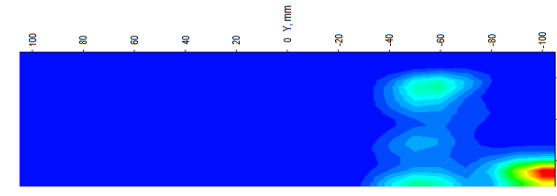

right  
total power:  $6.76 \times 10^5$  W/mm2

front\_double\_concave\_lens\_1.receiver\_1.Forward S  
Irradiance, W/mm^2

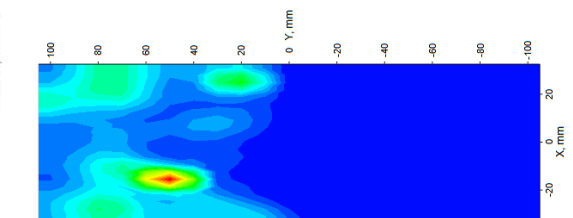

left  
total power: 82950 W/mm2

8

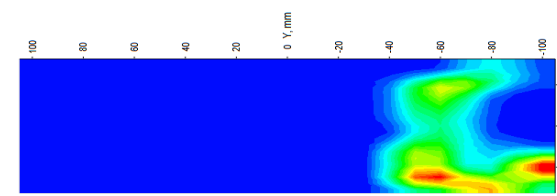

right  
total power: ? W/mm2

front\_double\_concave\_lens\_1.receiver\_1.Forward S  
Irradiance, W/mm^2

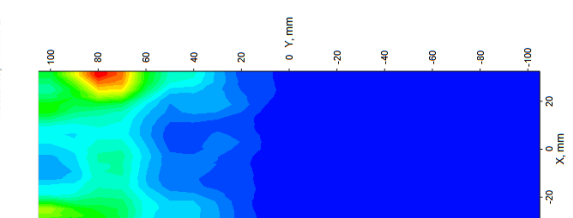

left  
total power: ? W/mm2

9

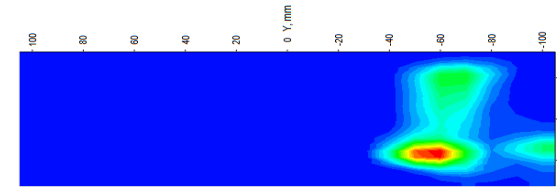

right  
total power:  $1.18 \times 10^6$  W/mm2

front\_double\_concave\_lens\_1.receiver\_1.Forward S  
Irradiance, W/mm^2

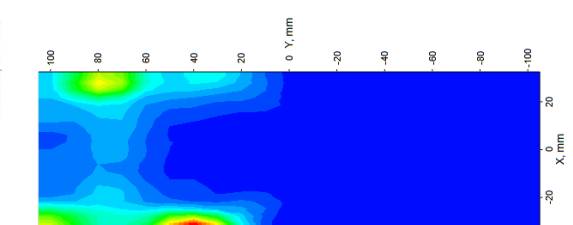

left  
total power:  $1.07 \times 10^5$  W/mm2

10

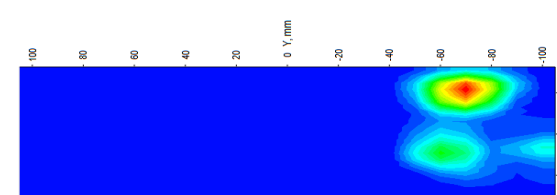

right  
total power:  $6.01 \times 10^5$  W/mm2

front\_double\_concave\_lens\_1.receiver\_1.Forward S  
Irradiance, W/mm^2

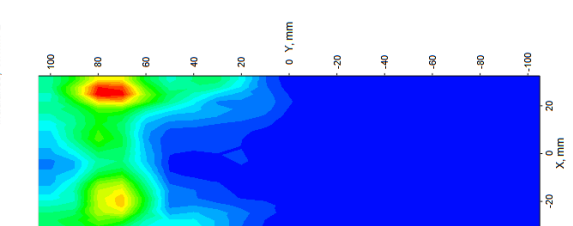

left  
total power: 42879 W/mm2

Radiation maps of  $A_6$  component

1

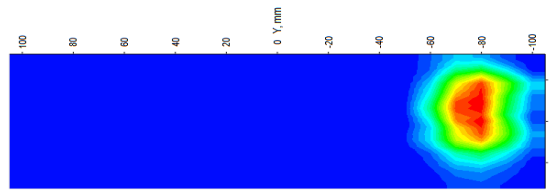

right  
total power: 8160 W/mm2

front\_lens\_concave\_1\_receiver\_1\_Foward Simul  
Irradiance, W/mm^2

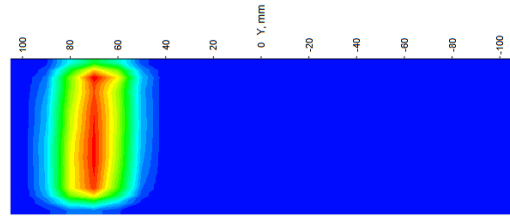

left  
total power:  $8.07 \times 10^5$  W/mm2

2

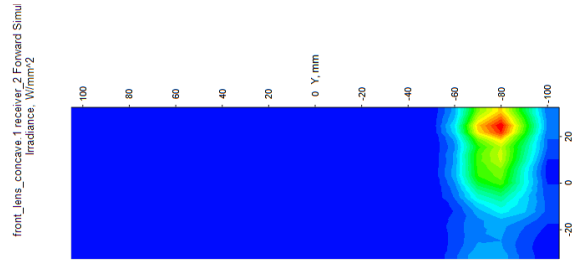

right  
total power: 18888 W/mm2

front\_lens\_concave\_1\_receiver\_1\_Foward Simul  
Irradiance, W/mm^2

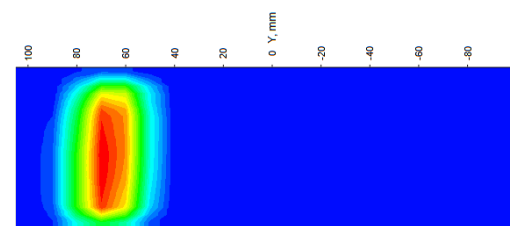

left  
total power:  $6.68 \times 10^5$  W/mm2

3

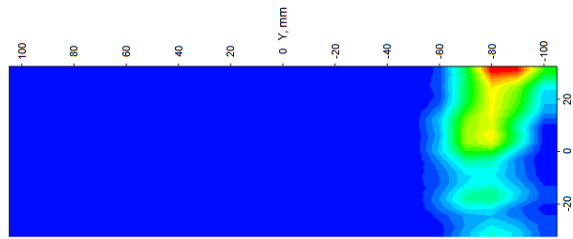

right  
total power: 8958 W/mm2

front\_lens\_concave\_1\_receiver\_1\_Foward Simul  
Irradiance, W/mm^2

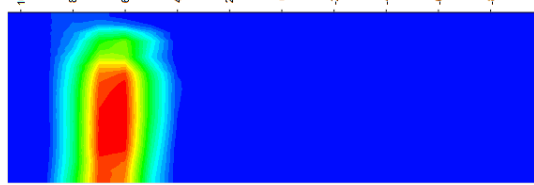

left  
total power:  $5.05 \times 10^5$  W/mm2

4

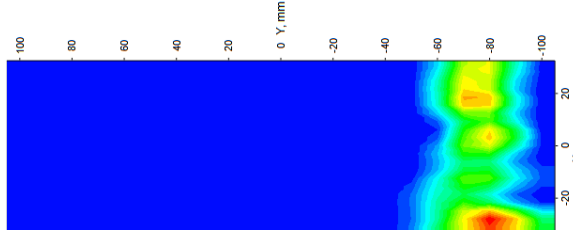

right  
total power: 8010 W/mm2

front\_lens\_concave\_1\_receiver\_1\_Foward Simul  
Irradiance, W/mm^2



left  
total power:  $2.63 \times 10^5$  W/mm2

5

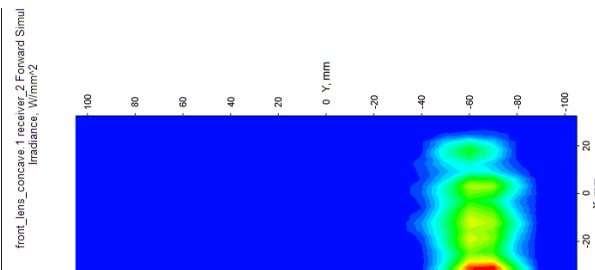

right  
total power: 4887 W/mm2

front\_lens\_concave\_1\_receiver\_1\_Foward Simul  
Irradiance, W/mm^2

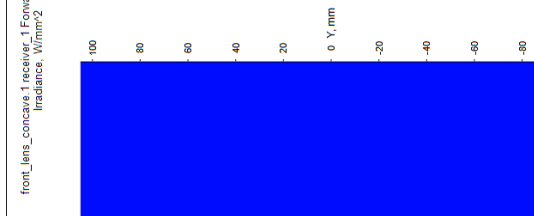

left  
total power: 0 W/mm2

6

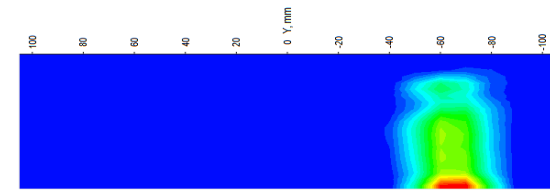

right  
total power:  $2.77 \times 10^5$  W/mm2

front\_lens\_concave\_1\_receiver\_1\_Foward Simul  
Irradiance, W/mm^2

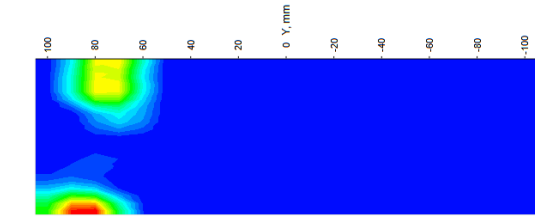

left  
total power: 7576 W/mm2

7

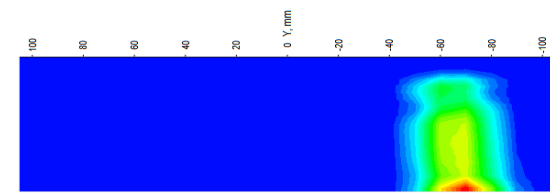

right  
total power:  $5.08 \times 10^5$  W/mm2

front\_lens\_concave\_1\_receiver\_1\_Foward Simul  
Irradiance, W/mm^2



left  
total power: 7128 W/mm2

8

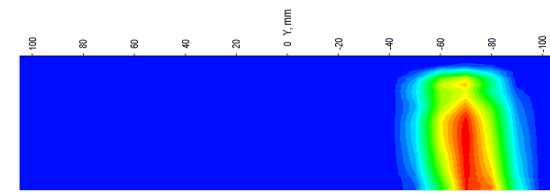

right  
total power:  $6.61 \times 10^5$  W/mm2

front\_lens\_concave\_1\_receiver\_1\_Foward Simul  
Irradiance, W/mm^2

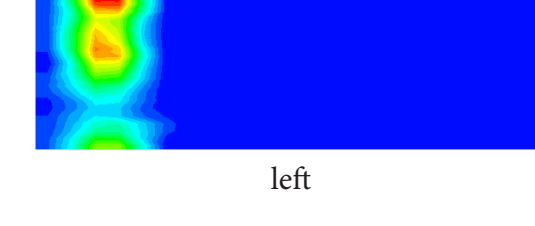

left  
total power: 14001 W/mm2

9

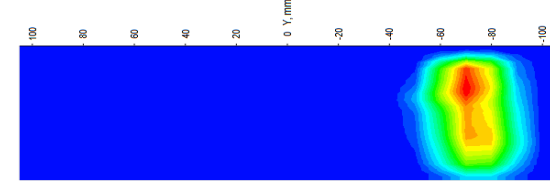

right  
total power:  $7.0 \times 10^5$  W/mm2

front\_lens\_concave\_1\_receiver\_1\_Foward Simul  
Irradiance, W/mm^2



left  
total power: 43379 W/mm2

10

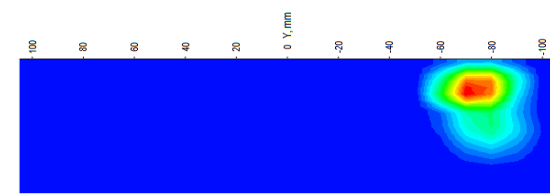

right  
total power:  $4.4 \times 10^5$  W/mm2

front\_lens\_concave\_1\_receiver\_1\_Foward Simul  
Irradiance, W/mm^2

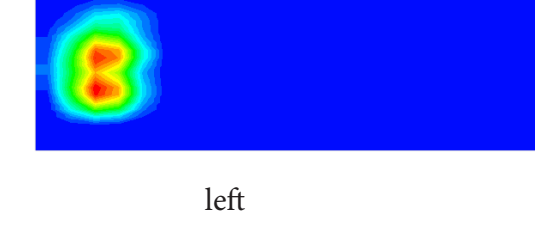

left  
total power: 22507 W/mm2

Radiation maps of  $A_9$  component

1

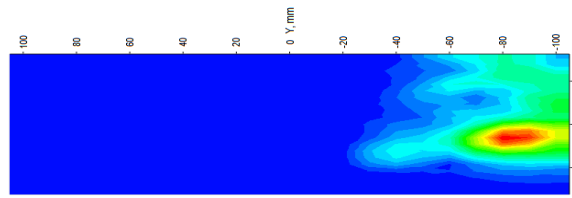

right  
total power: 4837 W/mm<sup>2</sup>

big\_hole\_1\_receiver\_1\_ForwardSimulation\_Irradiance, W/mm<sup>2</sup>

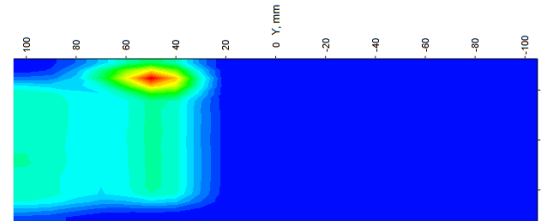

left  
total power:  $8.79 \times 10^5$  W/mm<sup>2</sup>

2

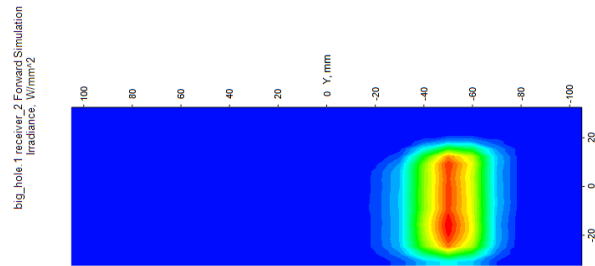

right  
total power:  $1.62 \times 10^5$  W/mm<sup>2</sup>

big\_hole\_1\_receiver\_1\_ForwardSimulation\_Irradiance, W/mm<sup>2</sup>

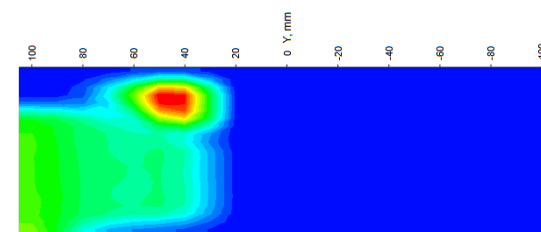

left  
total power:  $9.09 \times 10^5$  W/mm<sup>2</sup>

3

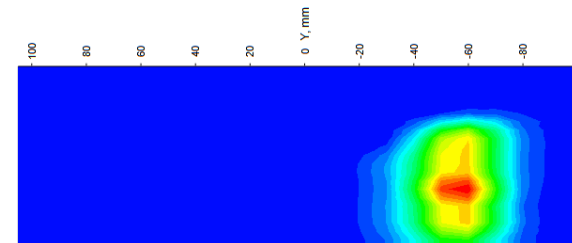

right  
total power:  $3.06 \times 10^5$  W/mm<sup>2</sup>

big\_hole\_1\_receiver\_1\_ForwardSimulation\_Irradiance, W/mm<sup>2</sup>

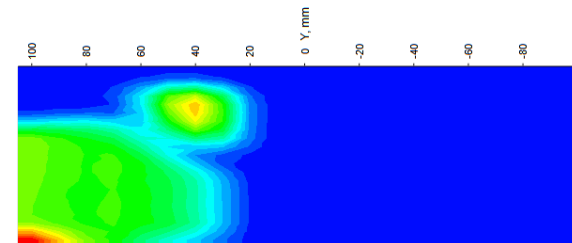

left  
total power:  $8.1 \times 10^5$  W/mm<sup>2</sup>

4

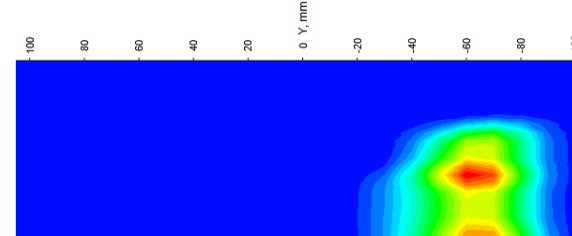

right  
total power:  $4.4 \times 10^5$  W/mm<sup>2</sup>

big\_hole\_1\_receiver\_1\_ForwardSimulation\_Irradiance, W/mm<sup>2</sup>

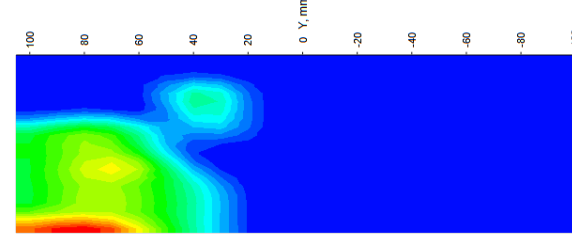

left  
total power:  $6.67 \times 10^5$  W/mm<sup>2</sup>

5

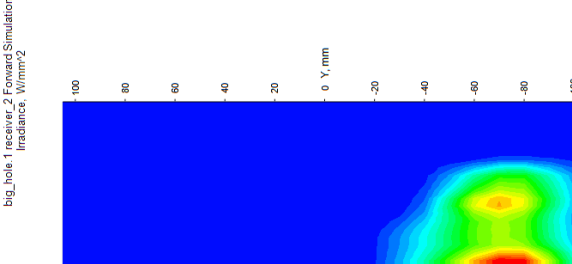

right  
total power:  $5.47 \times 10^5$  W/mm<sup>2</sup>

big\_hole\_1\_receiver\_1\_ForwardSimulation\_Irradiance, W/mm<sup>2</sup>

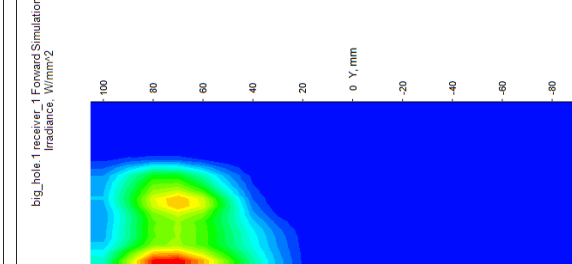

left  
total power:  $5.44 \times 10^5$  W/mm<sup>2</sup>

6

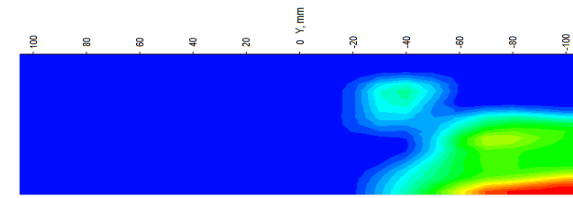

right  
total power:  $6.86 \times 10^5$  W/mm<sup>2</sup>

big\_hole\_1\_receiver\_1\_ForwardSimulation\_Irradiance, W/mm<sup>2</sup>

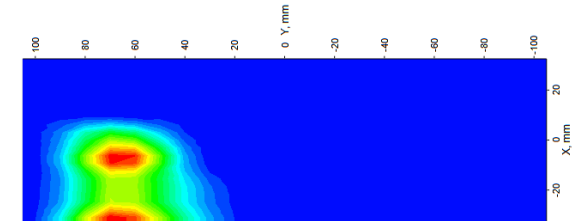

left  
total power:  $4.47 \times 10^5$  W/mm<sup>2</sup>

7

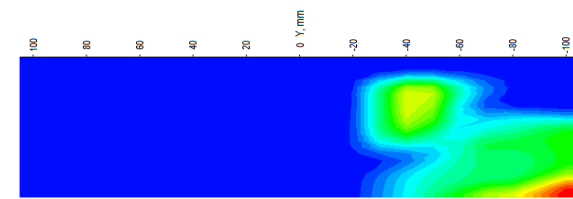

right  
total power:  $8.49 \times 10^5$  W/mm<sup>2</sup>

big\_hole\_1\_receiver\_1\_ForwardSimulation\_Irradiance, W/mm<sup>2</sup>

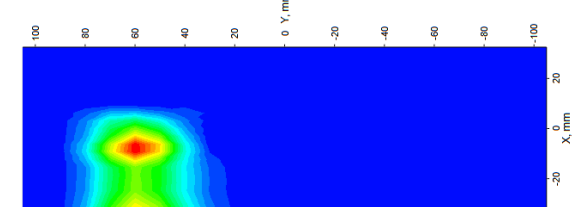

left  
total power:  $3.13 \times 10^5$  W/mm<sup>2</sup>

8

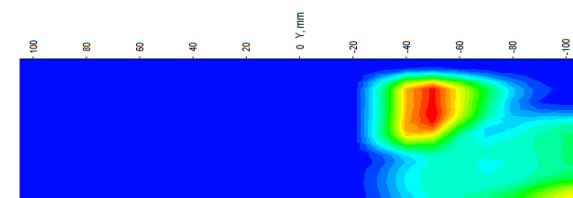

right  
total power:  $1.02 \times 10^6$  W/mm<sup>2</sup>

big\_hole\_1\_receiver\_1\_ForwardSimulation\_Irradiance, W/mm<sup>2</sup>

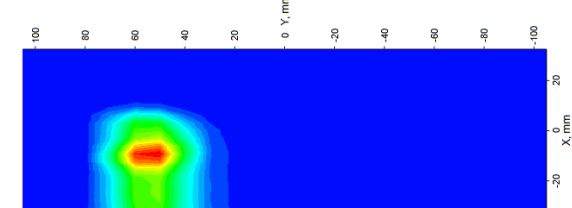

left  
total power:  $1.41 \times 10^5$  W/mm<sup>2</sup>

9

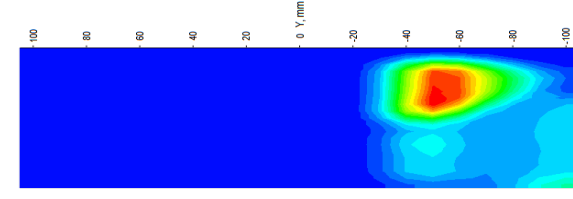

right  
total power:  $1.01 \times 10^6$  W/mm<sup>2</sup>

big\_hole\_1\_receiver\_1\_ForwardSimulation\_Irradiance, W/mm<sup>2</sup>

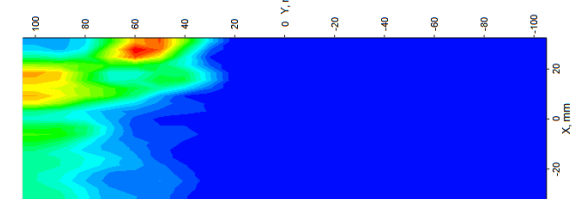

left  
total power: 8636 W/mm<sup>2</sup>

10

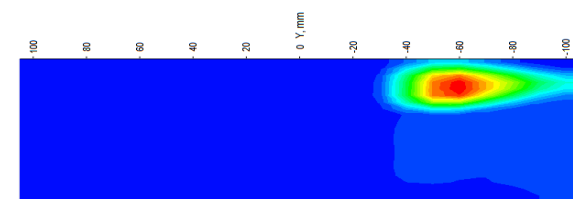

right  
total power:  $6.87 \times 10^5$  W/mm<sup>2</sup>

big\_hole\_1\_receiver\_1\_ForwardSimulation\_Irradiance, W/mm<sup>2</sup>

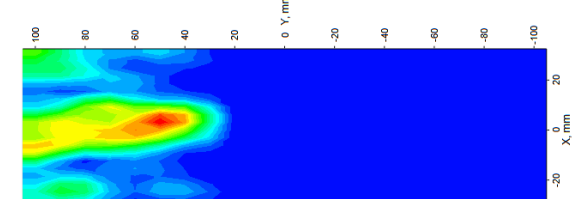

left  
total power: 2823 W/mm<sup>2</sup>

Radiation maps of B<sub>6</sub> component

1

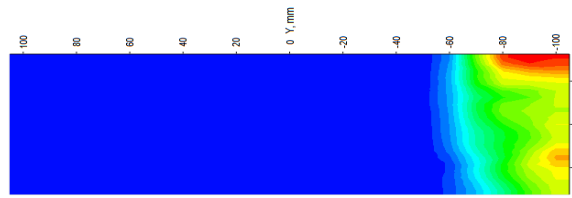

right  
total power: 37746 W/mm2

lens\_back\_pv\_side\_1\_receiver\_1 Forward Str Irradiance, W/mm^2

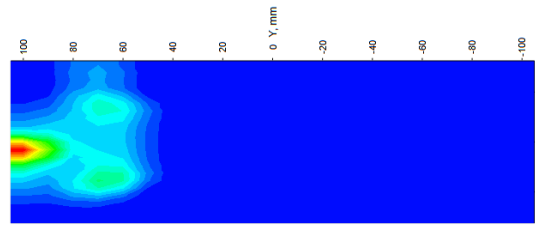

left  
total power:  $7.0 \times 10^5$  W/mm2

2

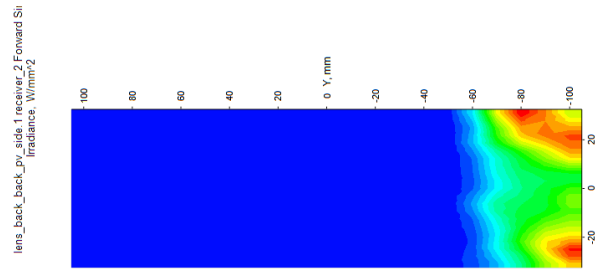

right  
total power: 28697 W/mm2

lens\_back\_pv\_side\_1\_receiver\_1 Forward Str Irradiance, W/mm^2

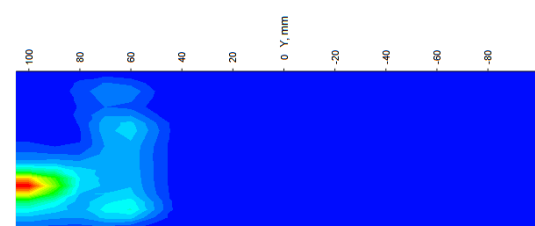

left  
total power:  $6.18 \times 10^5$  W/mm2

3

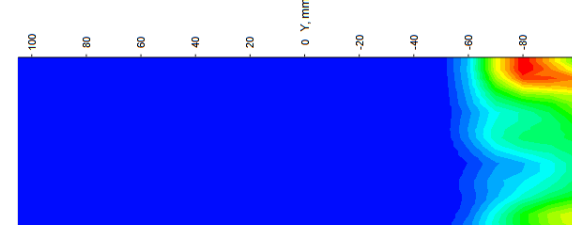

right  
total power: 22319 W/mm2

lens\_back\_pv\_side\_1\_receiver\_1 Forward Str Irradiance, W/mm^2

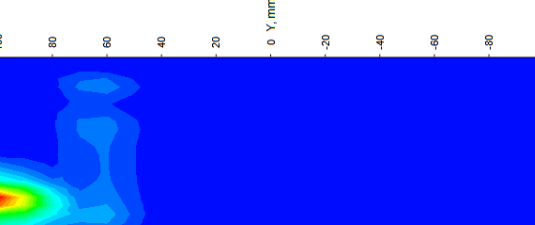

left  
total power:  $4.67 \times 10^5$  W/mm2

4

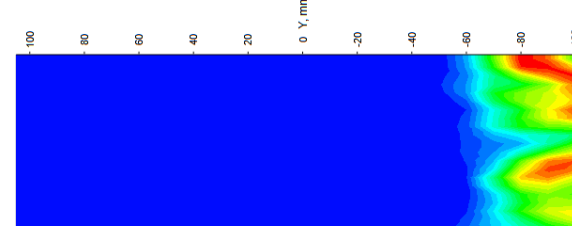

right  
total power:  $3343 \times 10^5$  W/mm2

lens\_back\_pv\_side\_1\_receiver\_1 Forward Str Irradiance, W/mm^2

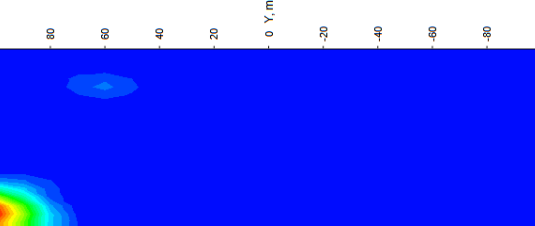

left  
total power:  $2.01 \times 10^5$  W/mm2

5

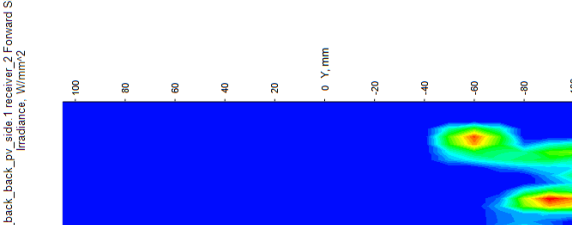

right  
total power:  $326 \times 10^5$  W/mm2

lens\_back\_pv\_side\_1\_receiver\_1 Forward Str Irradiance, W/mm^2

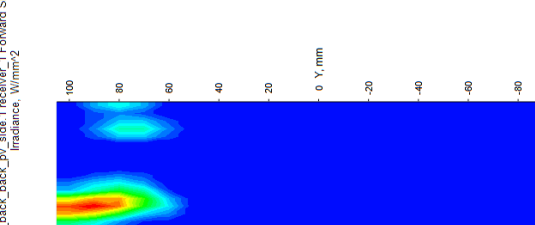

left  
total power: 419 W/mm2

6

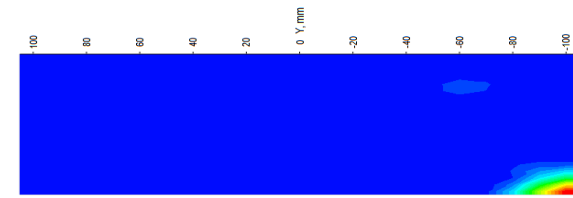

right  
total power:  $2.21 \times 10^5$  W/mm2

lens\_back\_pv\_side\_1\_receiver\_1 Forward Str Irradiance, W/mm^2

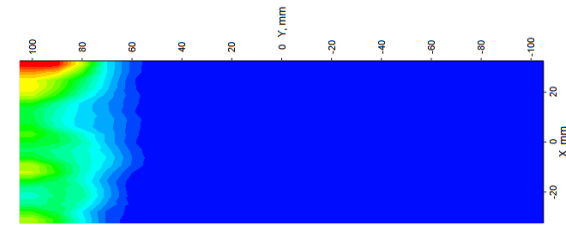

left  
total power: 6614 W/mm2

7

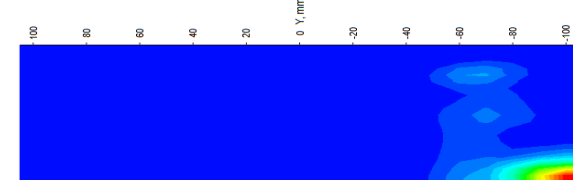

right  
total power:  $4.78 \times 10^5$  W/mm2

lens\_back\_pv\_side\_1\_receiver\_1 Forward Str Irradiance, W/mm^2

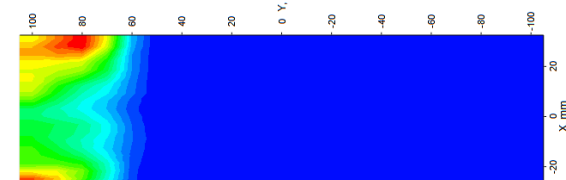

left  
total power: 22189 W/mm2

8

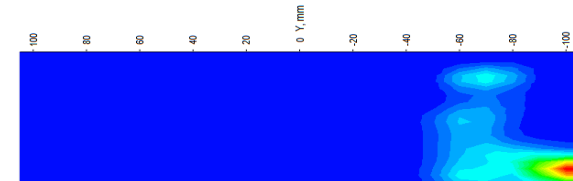

right  
total power:  $5.4 \times 10^5$  W/mm2

lens\_back\_pv\_side\_1\_receiver\_1 Forward Str Irradiance, W/mm^2

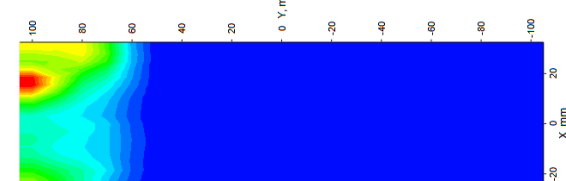

left  
total power: 39918 W/mm2

9

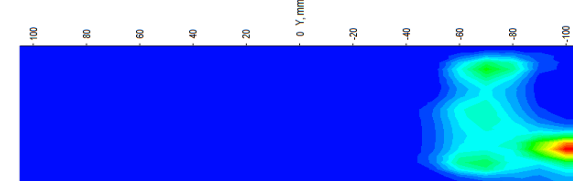

right  
total power:  $5.44 \times 10^5$  W/mm2

lens\_back\_pv\_side\_1\_receiver\_1 Forward Str Irradiance, W/mm^2

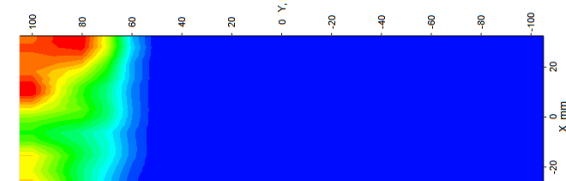

left  
total power: 38114 W/mm2

10

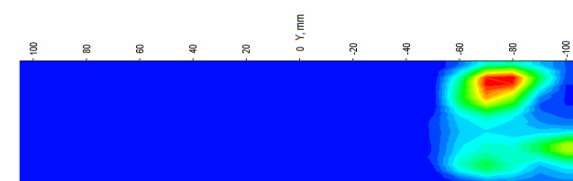

right  
total power:  $3.55 \times 10^5$  W/mm2

lens\_back\_pv\_side\_1\_receiver\_1 Forward Str Irradiance, W/mm^2

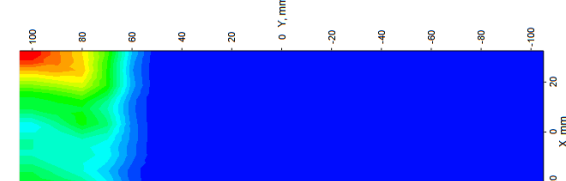

left  
total power: 27605 W/mm2

Radiation maps of  $A_4$  component



1

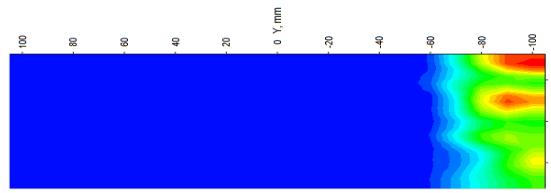

right  
total power: 33626 W/mm2

telescope\_mirror\_1\_receiver\_1\_FowardSimulat  
Irradiance, W/mm^2

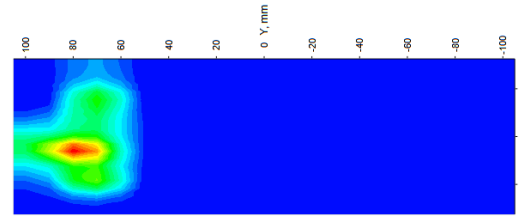

left  
total power:  $5.93 \cdot 10^5$  W/mm2

2

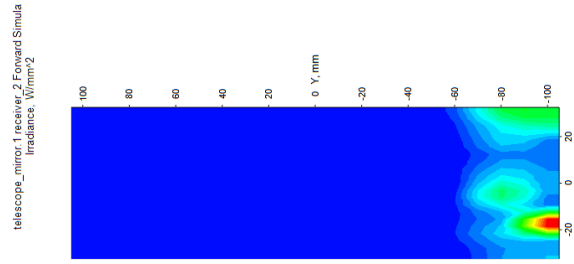

right  
total power: 10814 W/mm2

telescope\_mirror\_1\_receiver\_1\_FowardSimulat  
Irradiance, W/mm^2

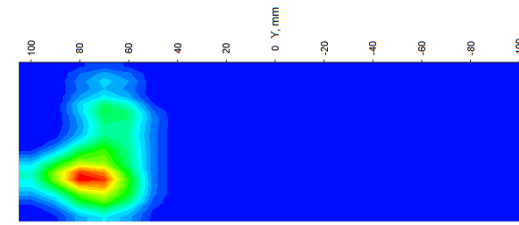

left  
total power:  $4.57 \cdot 10^5$  W/mm2

3

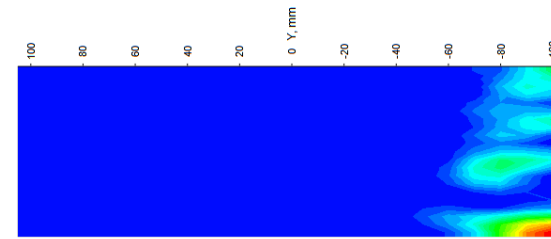

right  
total power: 664 W/mm2

telescope\_mirror\_1\_receiver\_1\_FowardSimulat  
Irradiance, W/mm^2

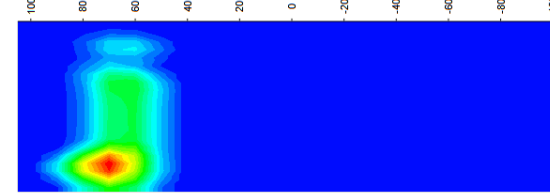

left  
total power:  $2.22 \cdot 10^5$  W/mm2

4

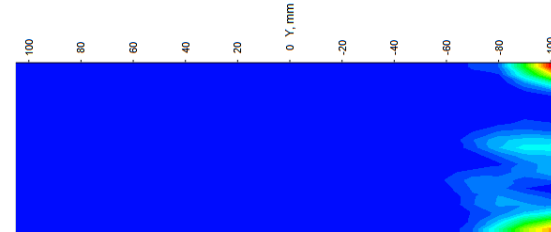

right  
total power: 699 W/mm2

telescope\_mirror\_1\_receiver\_1\_FowardSimulat  
Irradiance, W/mm^2

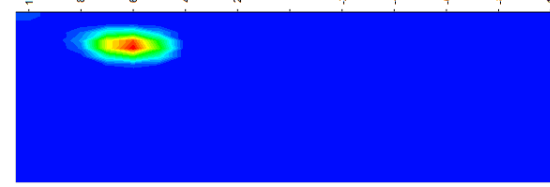

left  
total power: 10436 W/mm2

5

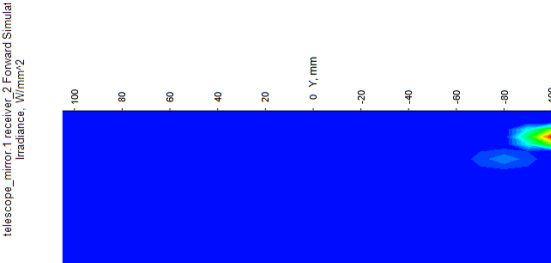

right  
total power: 15 W/mm2

telescope\_mirror\_1\_receiver\_1\_FowardSimulat  
Irradiance, W/mm^2

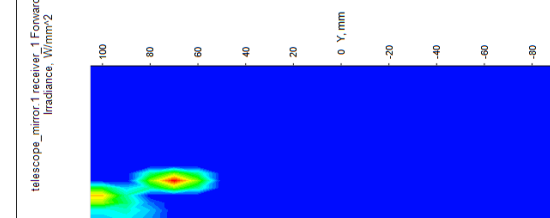

left  
total power: 45 W/mm2

6

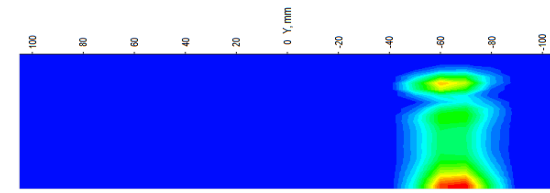

right  
total power: 53278 W/mm2

telescope\_mirror\_1\_receiver\_1\_FowardSimulat  
Irradiance, W/mm^2

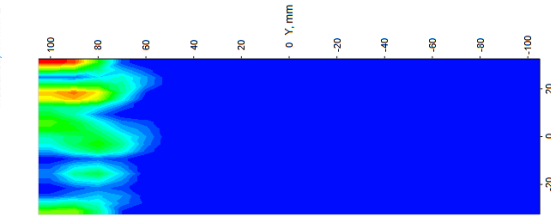

left  
total power: 734 W/mm2

7

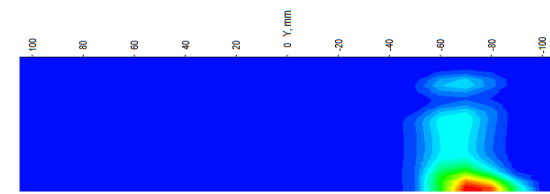

right  
total power:  $2.57 \cdot 10^5$  W/mm2

telescope\_mirror\_1\_receiver\_1\_FowardSimulat  
Irradiance, W/mm^2

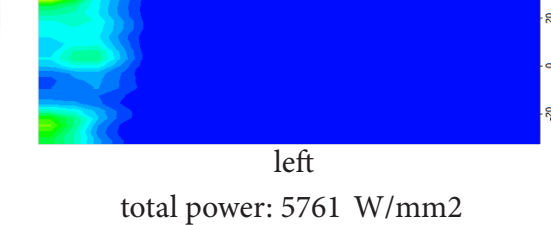

left  
total power: 5761 W/mm2

8

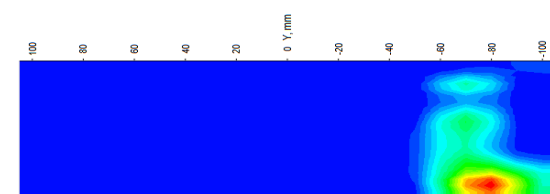

right  
total power:  $4.51 \cdot 10^5$  W/mm2

telescope\_mirror\_1\_receiver\_1\_FowardSimulat  
Irradiance, W/mm^2

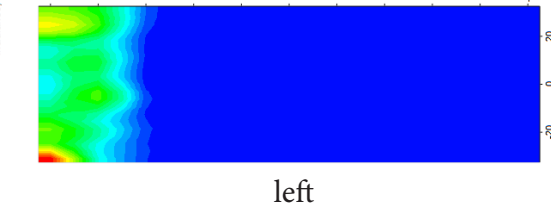

left  
total power: 37357 W/mm2

9

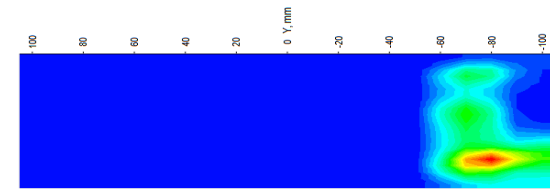

right  
total power:  $4.90 \cdot 10^5$  W/mm2

telescope\_mirror\_1\_receiver\_1\_FowardSimulat  
Irradiance, W/mm^2

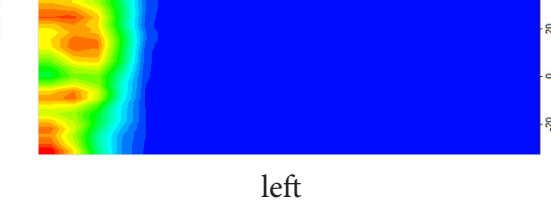

left  
total power: 37585 W/mm2

10

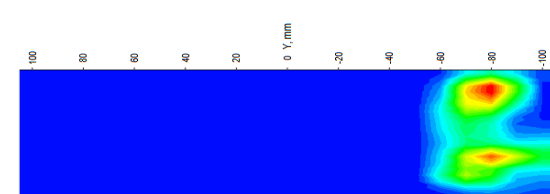

right  
total power:  $3.32 \cdot 10^5$  W/mm2

telescope\_mirror\_1\_receiver\_1\_FowardSimulat  
Irradiance, W/mm^2

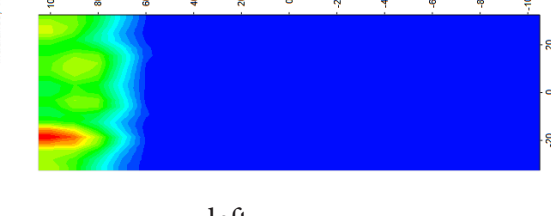

left  
total power: 21151 W/mm2

Radiation maps of  $A_5$  component

1

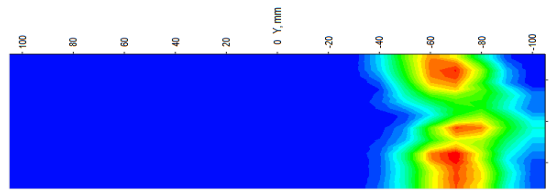

right  
total power: 8625 W/mm2

front\_double\_concave\_lens\_1.receiver\_1.Forward S  
Irradiance, W/mm^2

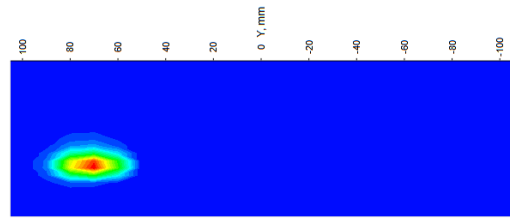

left  
total power: 1.08\*10<sup>6</sup> W/mm2

2

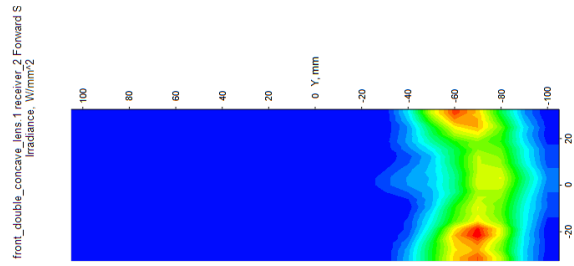

right  
total power: 14146 W/mm2

front\_double\_concave\_lens\_1.receiver\_1.Forward S  
Irradiance, W/mm^2

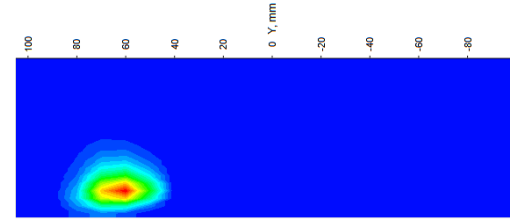

left  
total power: 4.68\*10<sup>5</sup> W/mm2

3

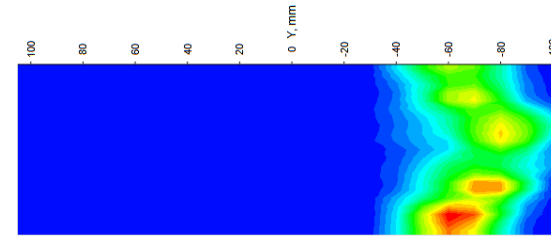

right  
total power: 10191 W/mm2

front\_double\_concave\_lens\_1.receiver\_1.Forward S  
Irradiance, W/mm^2

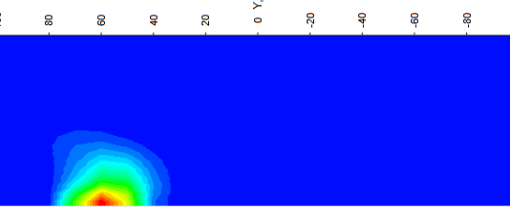

left  
total power: 99538\*10<sup>5</sup> W/mm2

4

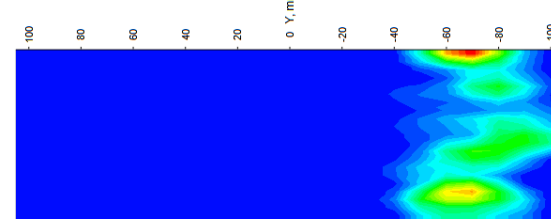

right  
total power: 4992 W/mm2

front\_double\_concave\_lens\_1.receiver\_1.Forward S  
Irradiance, W/mm^2



left  
total power: 22034 W/mm2

5

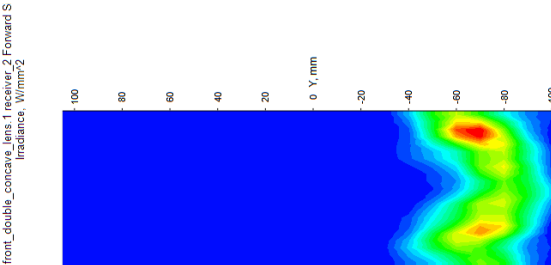

right  
total power: 5190 W/mm2

front\_double\_concave\_lens\_1.receiver\_1.Forward S  
Irradiance, W/mm^2

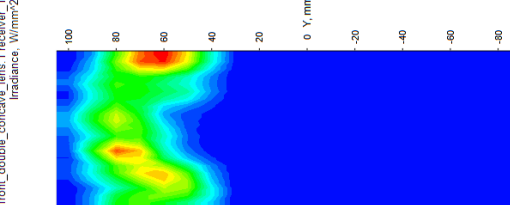

left  
total power: 5090 W/mm2

6

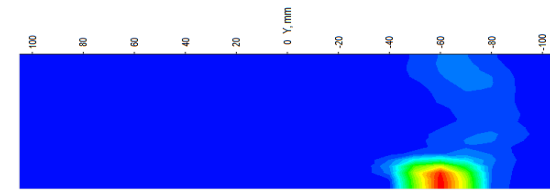

right  
total power: 23088 W/mm2

front\_double\_concave\_lens\_1.receiver\_1.Forward S  
Irradiance, W/mm^2

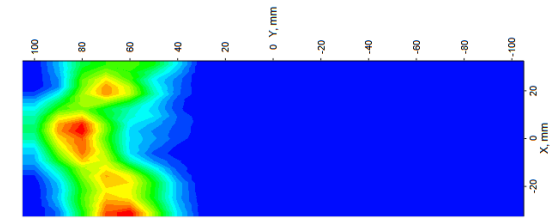

left  
total power: 7822 W/mm2

7

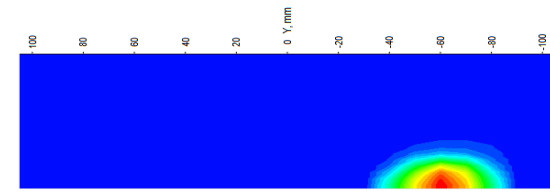

right  
total power: 1.24\*10<sup>5</sup> W/mm2

front\_double\_concave\_lens\_1.receiver\_1.Forward S  
Irradiance, W/mm^2

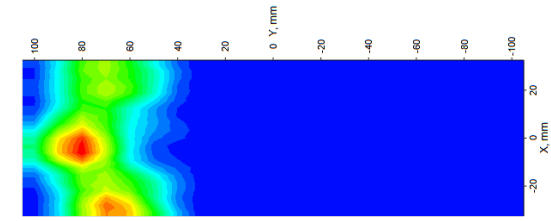

left  
total power: 18253 W/mm2

8

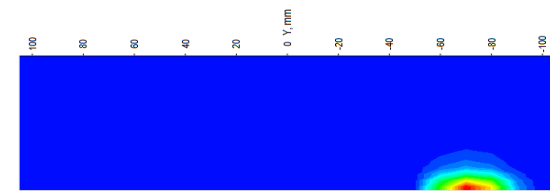

right  
total power: 5.16\*10<sup>5</sup> W/mm2

front\_double\_concave\_lens\_1.receiver\_1.Forward S  
Irradiance, W/mm^2

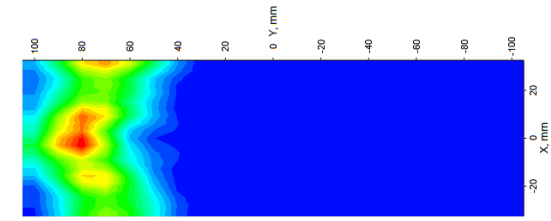

left  
total power: 21075 W/mm2

9

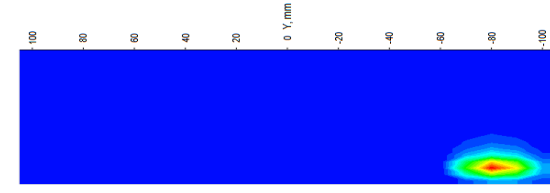

right  
total power: 1.07\*10<sup>6</sup> W/mm2

front\_double\_concave\_lens\_1.receiver\_1.Forward S  
Irradiance, W/mm^2

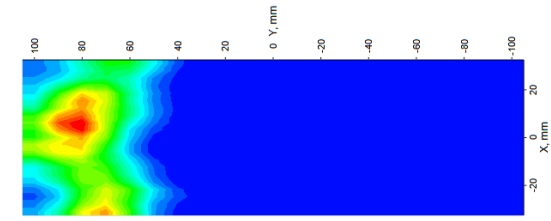

left  
total power: 10617 W/mm2

10

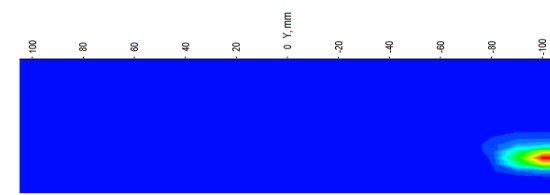

right  
total power: 9.86\*10<sup>5</sup> W/mm2

front\_double\_concave\_lens\_1.receiver\_1.Forward S  
Irradiance, W/mm^2

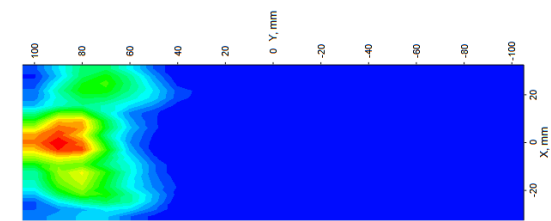

left  
total power: 3415 W/mm2

Radiation maps of B<sub>4</sub> component

1

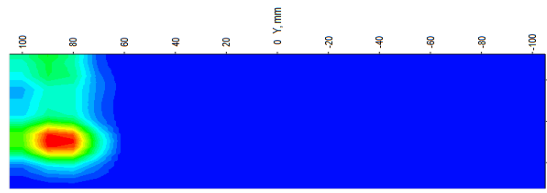

right  
total power:  $6.18 \times 10^5$  W/mm<sup>2</sup>

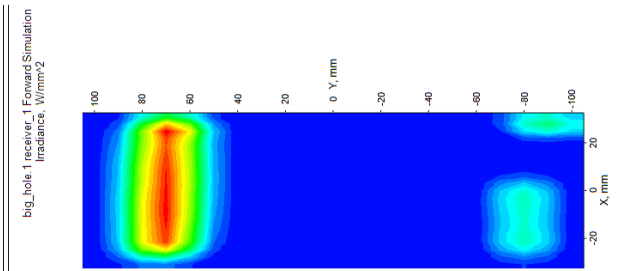

left  
total power:  $9.83 \times 10^5$  W/mm<sup>2</sup>

2

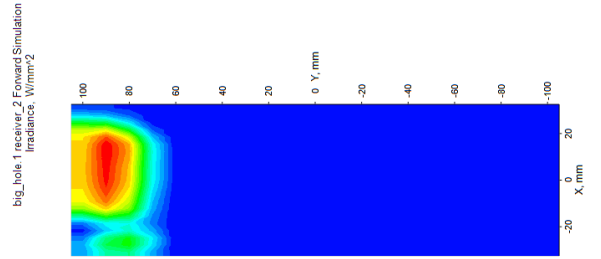

right  
total power:  $5.57 \times 10^5$  W/mm<sup>2</sup>

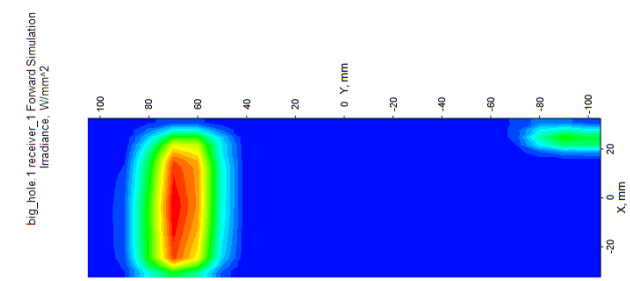

left  
total power:  $7.44 \times 10^5$  W/mm<sup>2</sup>

3

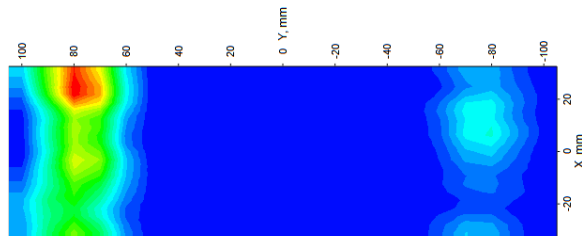

right  
total power: 59662 W/mm<sup>2</sup>

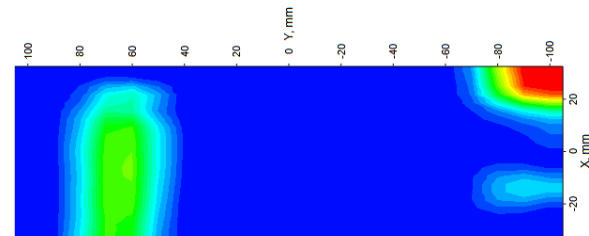

left  
total power:  $8 \times 10^5$  W/mm<sup>2</sup>

4

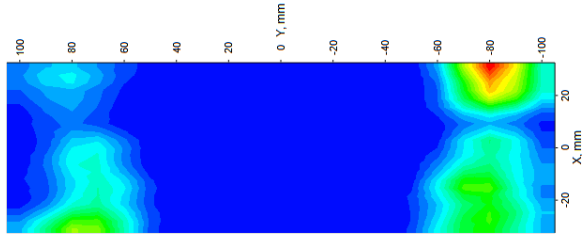

right  
total power: 21314 W/mm<sup>2</sup>

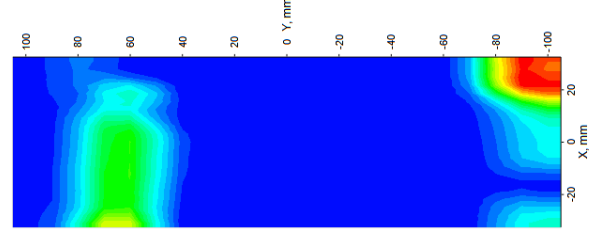

left  
total power:  $5.43 \times 10^5$  W/mm<sup>2</sup>

5

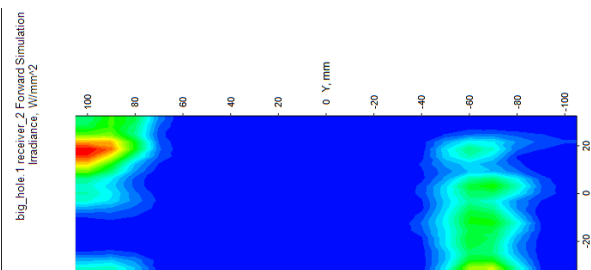

right  
total power: 9937 W/mm<sup>2</sup>

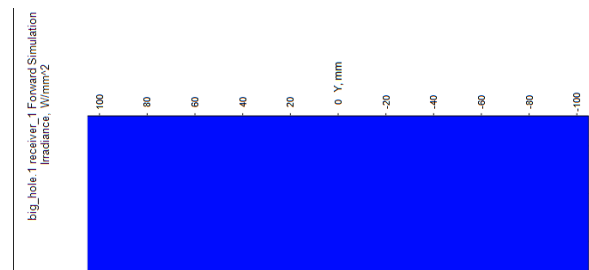

left  
total power: 0 W/mm<sup>2</sup>

6

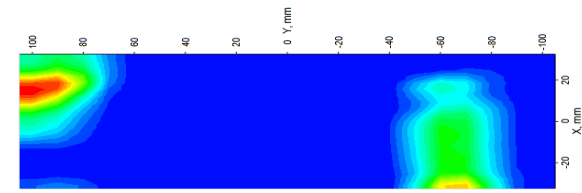

right  
total power:  $5.62 \times 10^5$  W/mm<sup>2</sup>

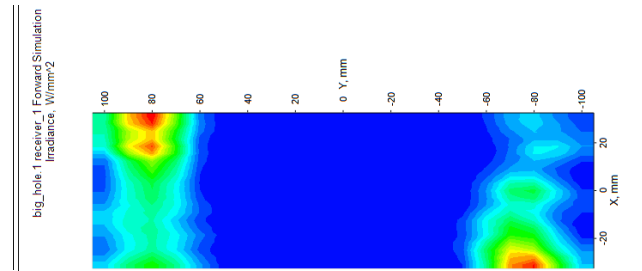

left  
total power: 22820 W/mm<sup>2</sup>

7

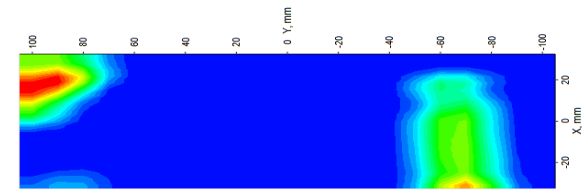

right  
total power:  $8.94 \times 10^5$  W/mm<sup>2</sup>

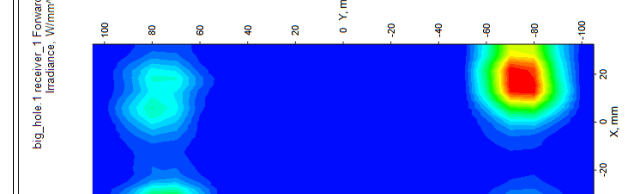

left  
total power: 28254 W/mm<sup>2</sup>

8

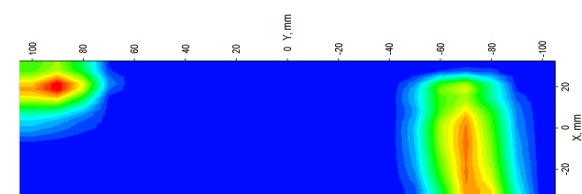

right  
total power:  $9.4 \times 10^5$  W/mm<sup>2</sup>

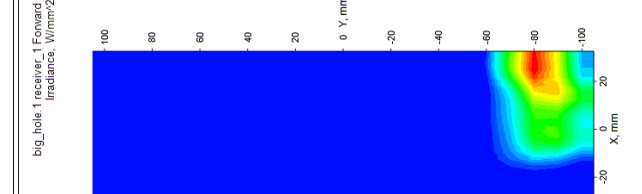

left  
total power:  $6.3 \times 10^5$  W/mm<sup>2</sup>

9

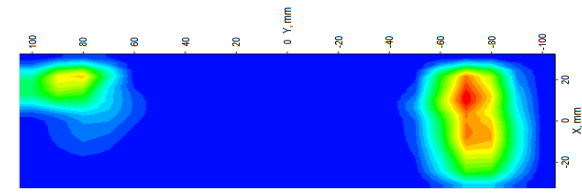

right  
total power:  $1.02 \times 10^6$  W/mm<sup>2</sup>

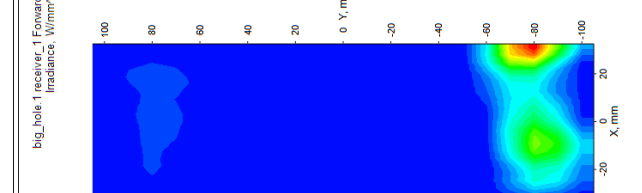

left  
total power:  $3.77 \times 10^5$  W/mm<sup>2</sup>

10

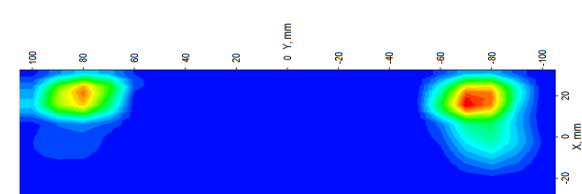

right  
total power:  $7.39 \times 10^5$  W/mm<sup>2</sup>

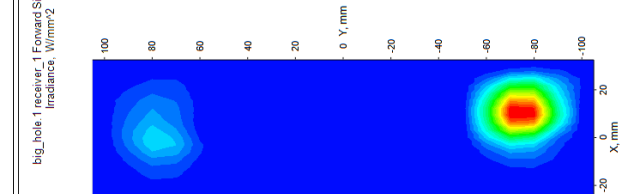

left  
total power:  $1.58 \times 10^5$  W/mm<sup>2</sup>

Radiation maps of C<sub>2</sub> component

1

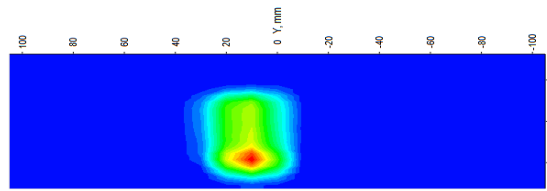

right  
total power:  $2.78 \times 10^5$  W/mm<sup>2</sup>

1

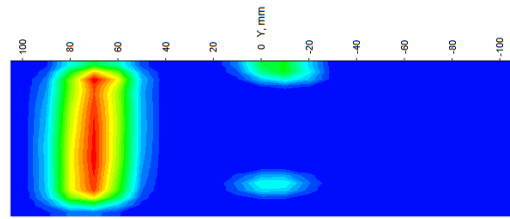

left  
total power:  $9.18 \times 10^5$  W/mm<sup>2</sup>

6

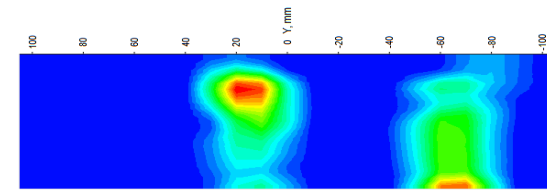

right  
total power:  $6.44 \times 10^5$  W/mm<sup>2</sup>

6

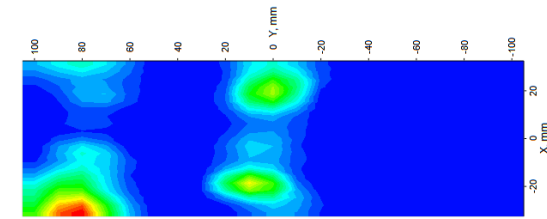

left  
total power: 8933 W/mm<sup>2</sup>

2

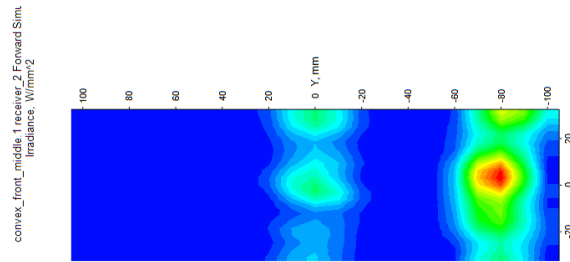

right  
total power: 47660 W/mm<sup>2</sup>

2

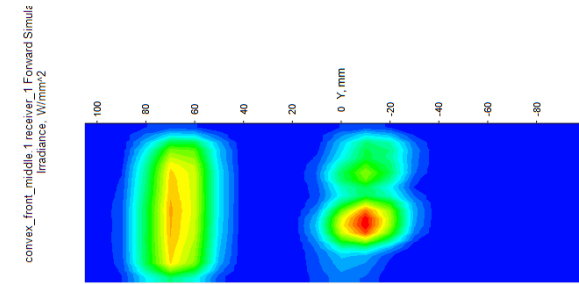

left  
total power:  $1.16 \times 10^6$  W/mm<sup>2</sup>

7

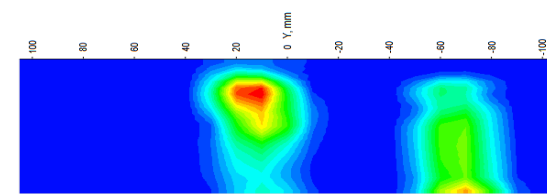

right  
total power:  $1.11 \times 10^6$  W/mm<sup>2</sup>

7

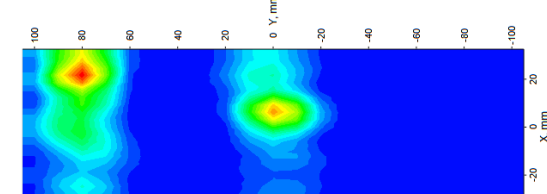

left  
total power: 31980 W/mm<sup>2</sup>

3

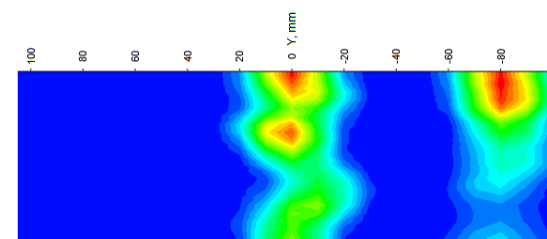

right  
total power: 50027 W/mm<sup>2</sup>

3

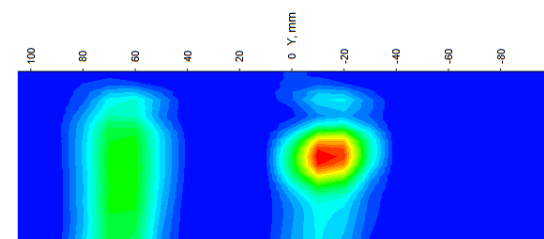

left  
total power:  $1.04 \times 10^6$  W/mm<sup>2</sup>

8

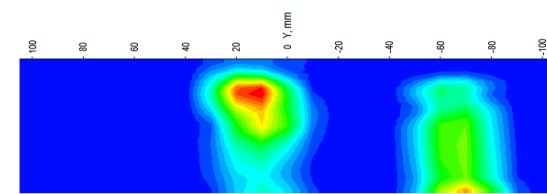

right  
total power:  $9.4 \times 10^5$  W/mm<sup>2</sup>

8

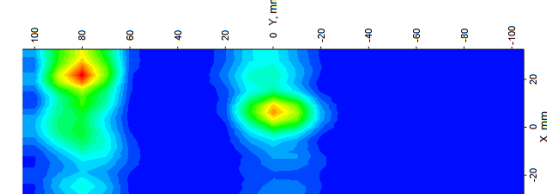

left  
total power:  $6.3 \times 10^5$  W/mm<sup>2</sup>

4

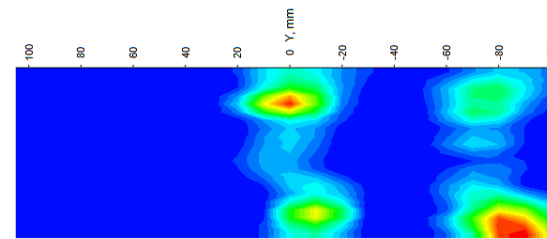

right  
total power: 5491 W/mm<sup>2</sup>

4

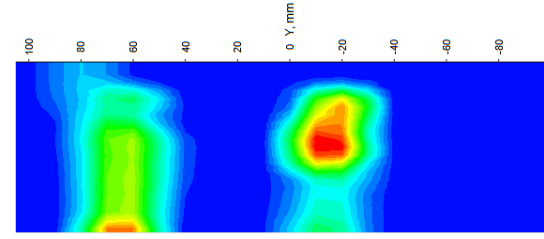

left  
total power:  $6.00 \times 10^5$  W/mm<sup>2</sup>

9

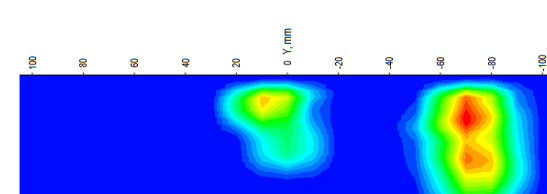

right  
total power:  $1.03 \times 10^6$  W/mm<sup>2</sup>

9

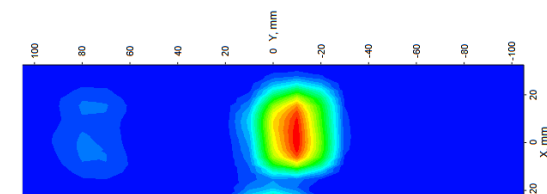

left  
total power:  $3.42 \times 10^5$  W/mm<sup>2</sup>

5

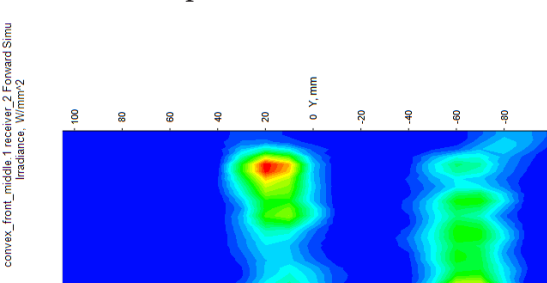

right  
total power: 11426 W/mm<sup>2</sup>

5

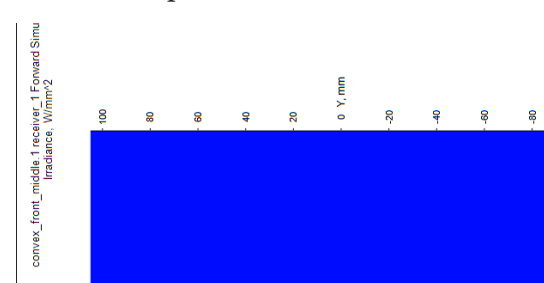

left  
total power: 0 W/mm<sup>2</sup>

10

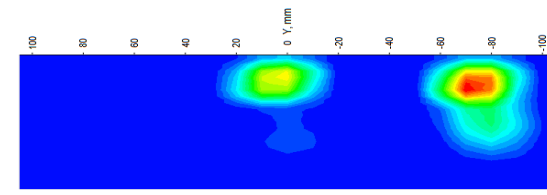

right  
total power:  $7.17 \times 10^5$  W/mm<sup>2</sup>

10

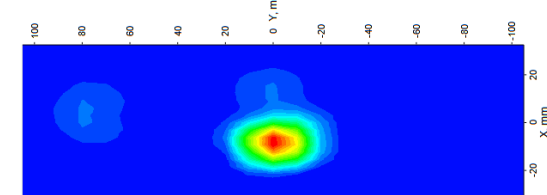

left  
total power:  $1.93 \times 10^5$  W/mm<sup>2</sup>

### Radiation maps of $C_1$ component

1

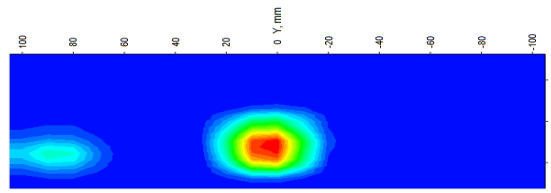

right  
total power:  $2.42 \times 10^5$  W/mm<sup>2</sup>

external\_curved\_f\_l1\_receiver\_1 Forward Simul  
Irradiance, W/mm<sup>2</sup>

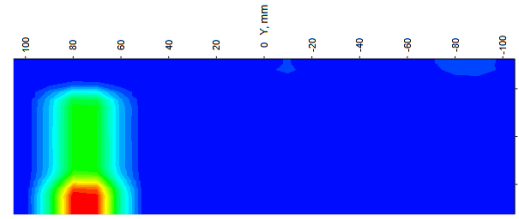

left  
total power:  $3.5 \times 10^6$  W/mm<sup>2</sup>

2

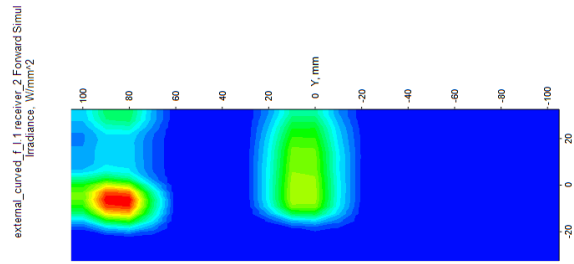

right  
total power:  $5.70 \times 10^5$  W/mm<sup>2</sup>

external\_curved\_f\_l1\_receiver\_1 Forward Simul  
Irradiance, W/mm<sup>2</sup>

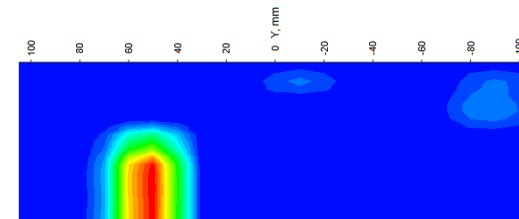

left  
total power:  $2.00 \times 10^6$  W/mm<sup>2</sup>

3

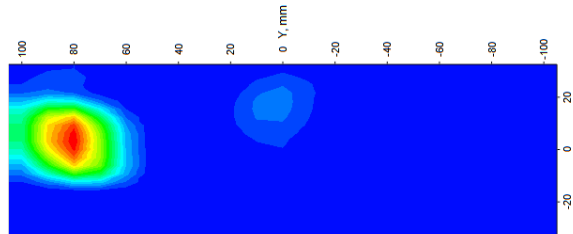

right  
total power:  $6.10 \times 10^5$  W/mm<sup>2</sup>

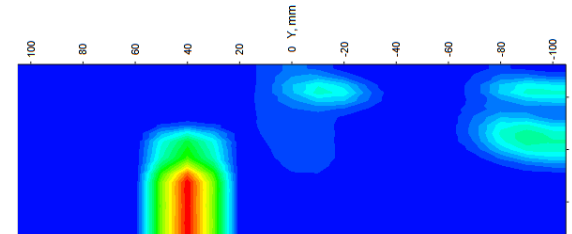

left  
total power:  $7.95 \times 10^5$  W/mm<sup>2</sup>

4

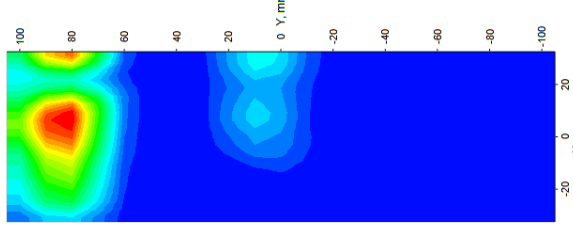

right  
total power:  $3.36 \times 10^5$  W/mm<sup>2</sup>

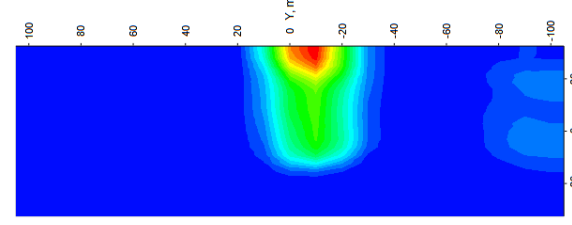

left  
total power:  $1.62 \times 10^6$  W/mm<sup>2</sup>

5

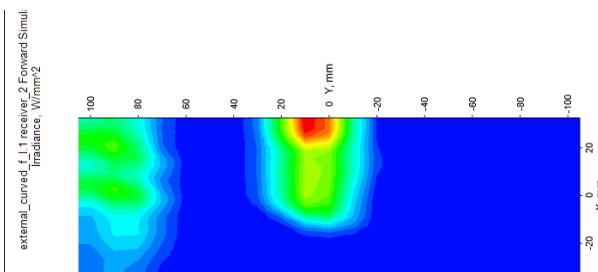

right  
total power:  $6.86 \times 10^5$  W/mm<sup>2</sup>

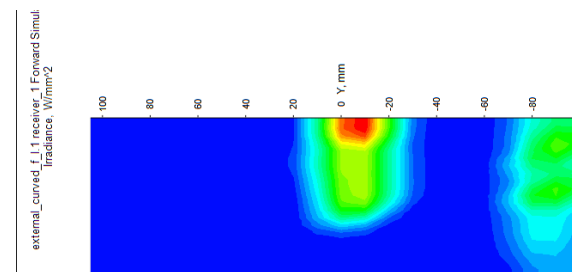

left  
total power:  $6.57 \times 10^5$  W/mm<sup>2</sup>

6

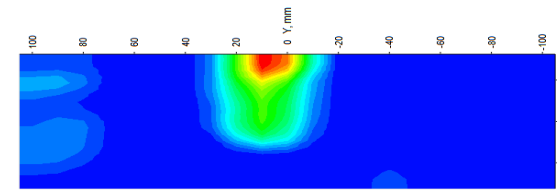

right  
total power:  $1.23 \times 10^6$  W/mm<sup>2</sup>

external\_curved\_f\_l1\_receiver\_1 Forward Simul  
Irradiance, W/mm<sup>2</sup>

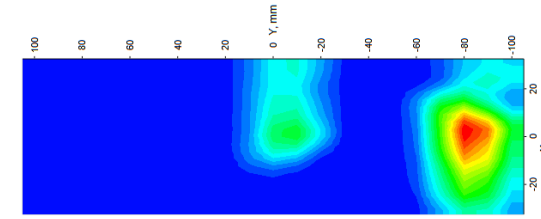

left  
total power:  $3.47 \times 10^5$  W/mm<sup>2</sup>

7

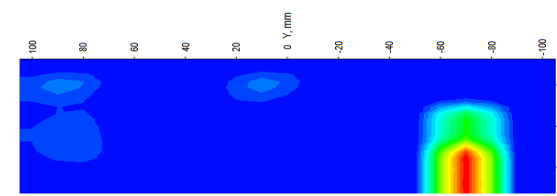

right  
total power:  $9.82 \times 10^5$  W/mm<sup>2</sup>

external\_curved\_f\_l1\_receiver\_1 Forward Simul  
Irradiance, W/mm<sup>2</sup>

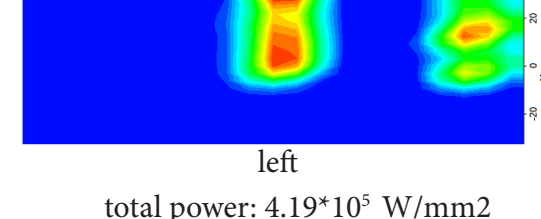

left  
total power:  $4.19 \times 10^5$  W/mm<sup>2</sup>

8

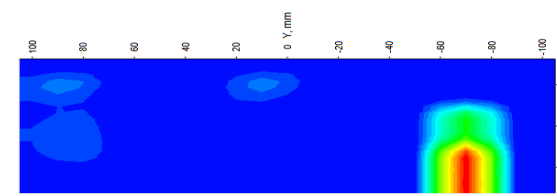

right  
total power:  $2.59 \times 10^6$  W/mm<sup>2</sup>

external\_curved\_f\_l1\_receiver\_1 Forward Simul  
Irradiance, W/mm<sup>2</sup>

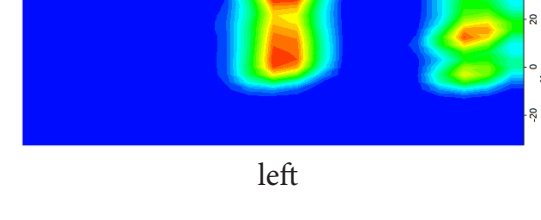

left  
total power:  $3.6 \times 10^5$  W/mm<sup>2</sup>

9

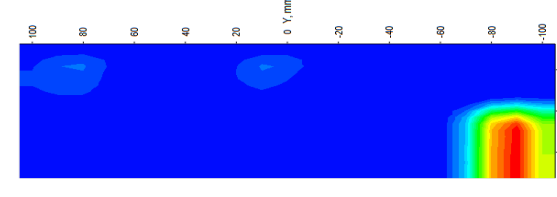

right  
total power:  $3.94 \times 10^6$  W/mm<sup>2</sup>

external\_curved\_f\_l1\_receiver\_1 Forward Simul  
Irradiance, W/mm<sup>2</sup>

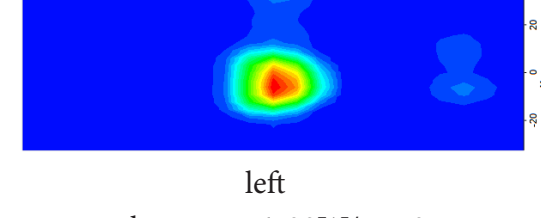

left  
total power: 76722 W/mm<sup>2</sup>

10

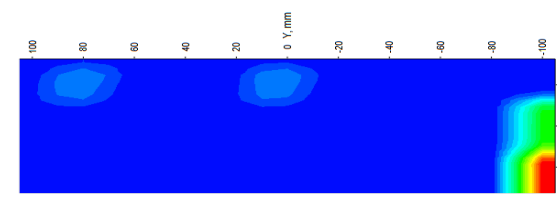

right  
total power:  $2.45 \times 10^6$  W/mm<sup>2</sup>

external\_curved\_f\_l1\_receiver\_1 Forward Simul  
Irradiance, W/mm<sup>2</sup>

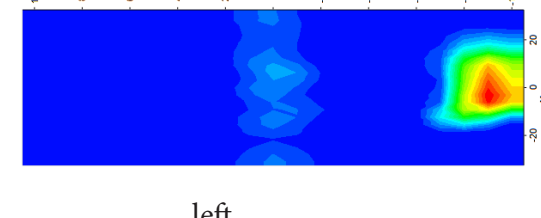

left  
total power: 11501 W/mm<sup>2</sup>

Radiation maps of C<sub>3</sub> component



1

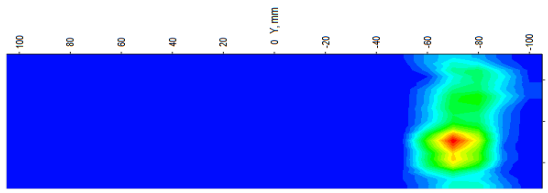

right  
total power: 3326 W/mm2

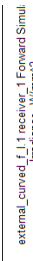

left  
total power:  $3.33 \times 10^6$  W/mm2

2

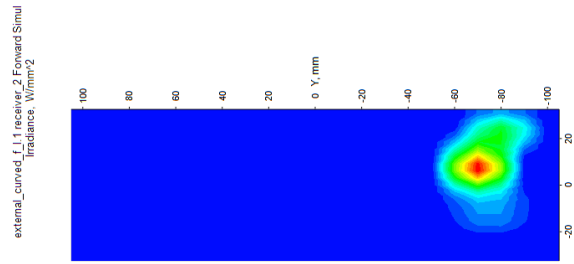

right  
total power: 39454 W/mm2

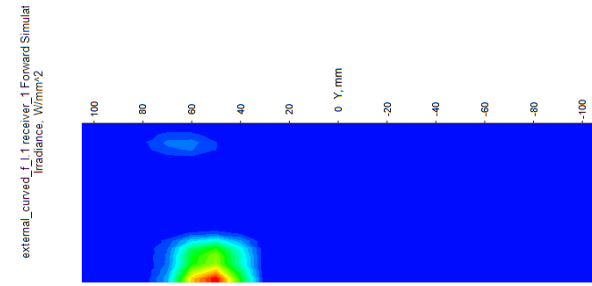

left  
total power:  $6.39 \times 10^5$  W/mm2

3

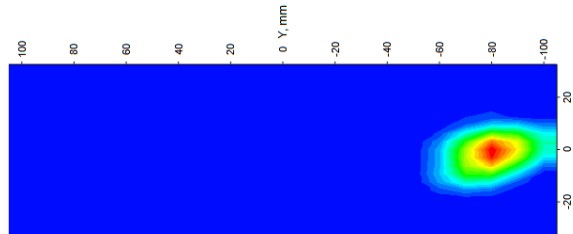

right  
total power: 78242 W/mm2

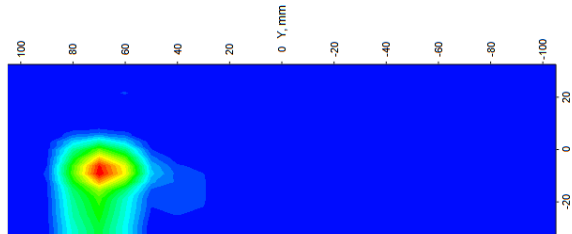

left  
total power:  $2.41 \times 10^6$  W/mm2

4

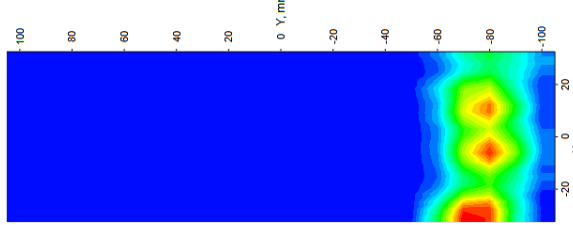

right  
total power: 11580 W/mm2

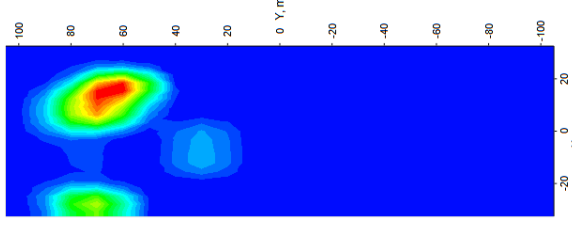

left  
total power:  $1.60 \times 10^5$  W/mm2

5

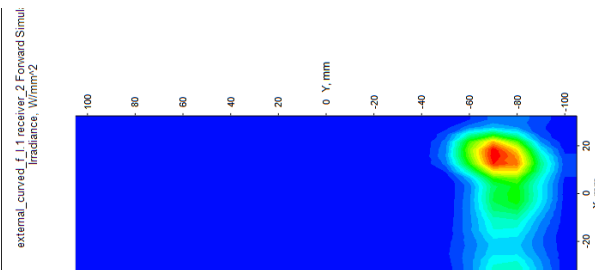

right  
total power: 41948 W/mm2

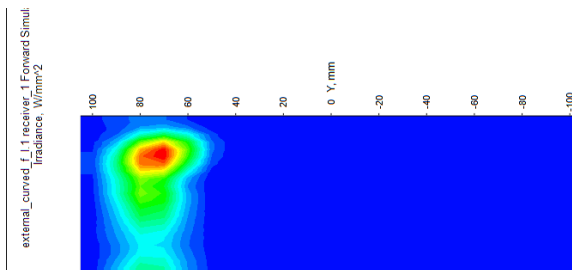

left  
total power: 40328 W/mm2

6

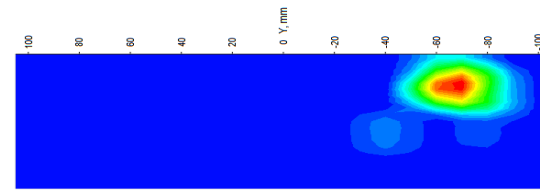

right  
total power:  $2.23 \times 10^5$  W/mm2

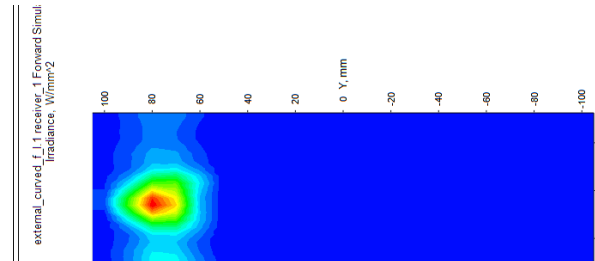

left  
total power: 29861 W/mm2

7

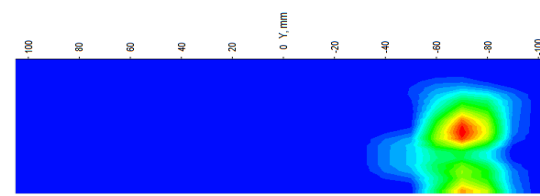

right  
total power:  $2.00 \times 10^6$  W/mm2

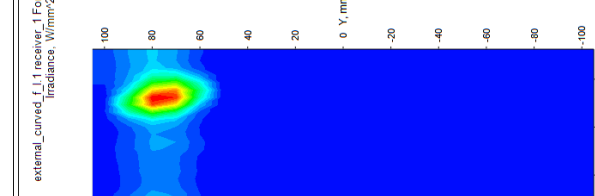

left  
total power: 44674 W/mm2

8

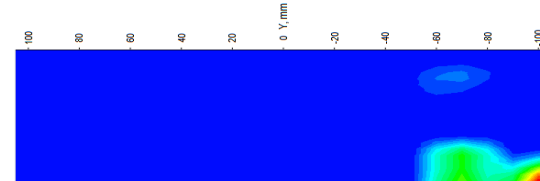

right  
total power:  $1.25 \times 10^6$  W/mm2

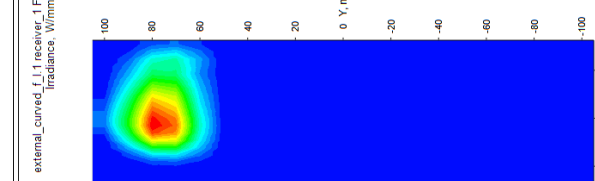

left  
total power:  $1.2 \times 10^5$  W/mm2

9

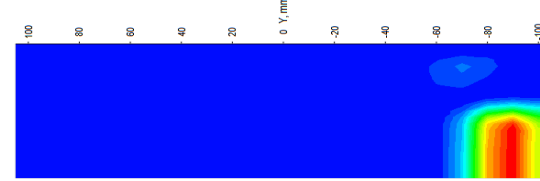

right  
total power:  $3.69 \times 10^6$  W/mm2

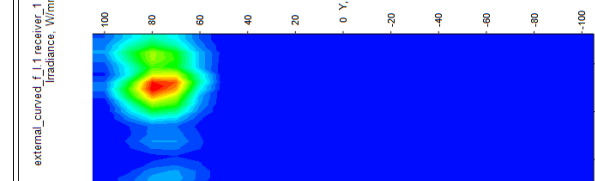

left  
total power: 3445 W/mm2

10

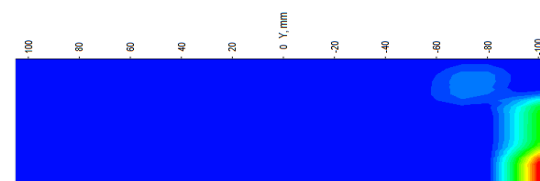

right  
total power:  $2.19 \times 10^6$  W/mm2

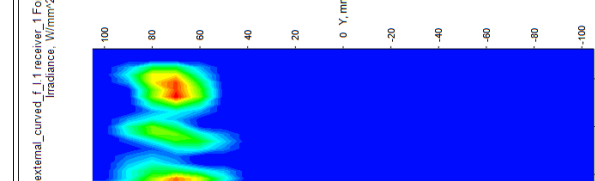

left  
total power: 322 W/mm2

Radiation maps of  $D_2$  component

1

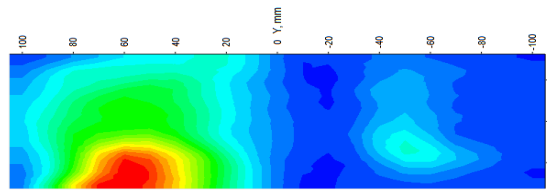

right  
total power:  $4.38 \times 10^5$  W/mm<sup>2</sup>

front\_new\_1\_receiver\_1 Forward Simulation  
Irradiance, W/mm<sup>2</sup>

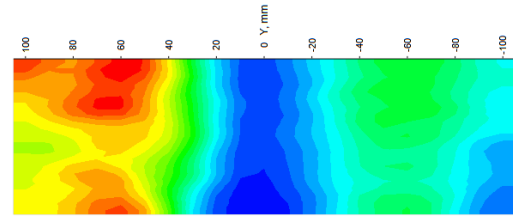

left  
total power:  $6.25 \times 10^5$  W/mm<sup>2</sup>

2

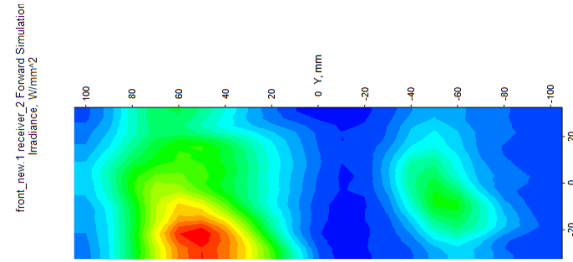

right  
total power:  $6.29 \times 10^5$  W/mm<sup>2</sup>

front\_new\_1\_receiver\_1 Forward Simulation  
Irradiance, W/mm<sup>2</sup>

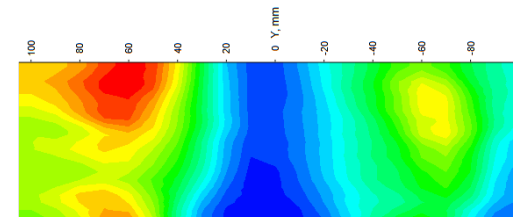

left  
total power:  $9.16 \times 10^5$  W/mm<sup>2</sup>

3

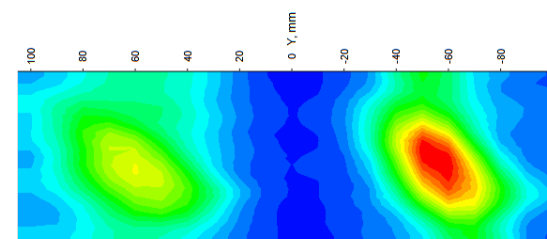

right  
total power:  $5.15 \times 10^5$  W/mm<sup>2</sup>

front\_new\_1\_receiver\_1 Forward Simulation  
Irradiance, W/mm<sup>2</sup>

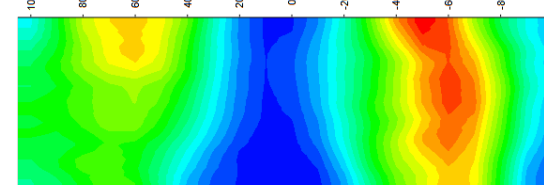

left  
total power:  $1.30 \times 10^6$  W/mm<sup>2</sup>

4

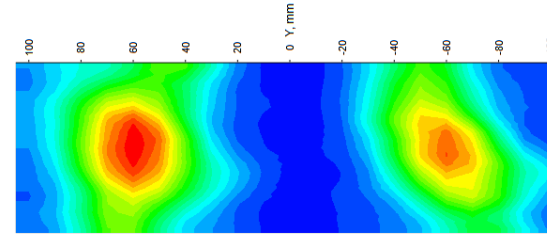

right  
total power:  $8.05 \times 10^5$  W/mm<sup>2</sup>

front\_new\_1\_receiver\_1 Forward Simulation  
Irradiance, W/mm<sup>2</sup>

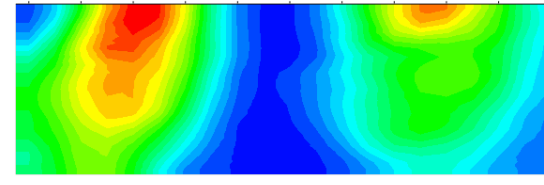

left  
total power:  $9.86 \times 10^5$  W/mm<sup>2</sup>

5

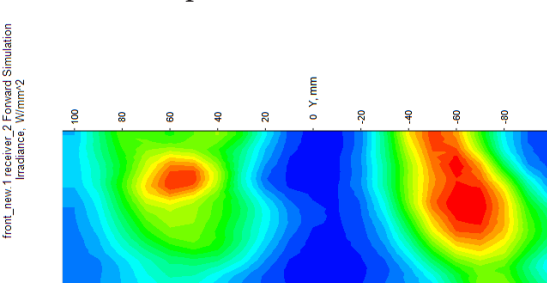

right  
total power:  $8.9 \times 10^5$  W/mm<sup>2</sup>

front\_new\_1\_receiver\_1 Forward Simulation  
Irradiance, W/mm<sup>2</sup>

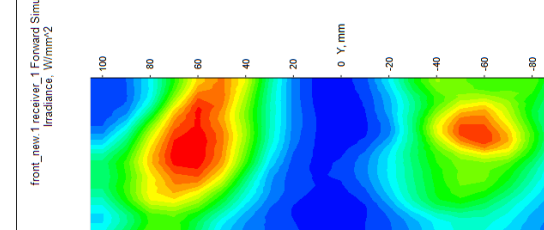

left  
total power:  $8.95 \times 10^5$  W/mm<sup>2</sup>

6

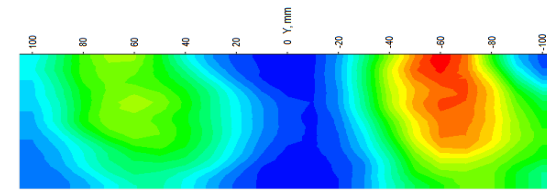

right  
total power:  $1.03 \times 10^5$  W/mm<sup>2</sup>

front\_new\_1\_receiver\_1 Forward Simulation  
Irradiance, W/mm<sup>2</sup>

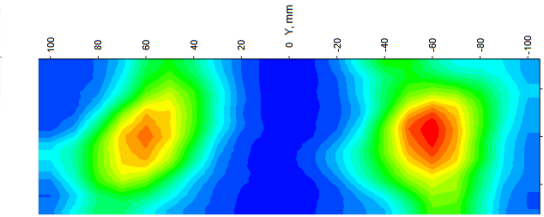

left  
total power:  $8.84 \times 10^5$  W/mm<sup>2</sup>

7

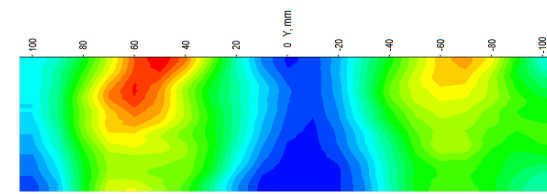

right  
total power:  $1.44 \times 10^6$  W/mm<sup>2</sup>

front\_new\_1\_receiver\_1 Forward Simulation  
Irradiance, W/mm<sup>2</sup>

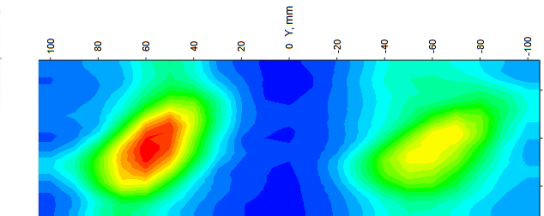

left  
total power:  $5.94 \times 10^5$  W/mm<sup>2</sup>

8

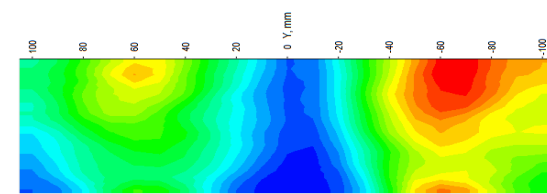

right  
total power:  $1.08 \times 10^6$  W/mm<sup>2</sup>

front\_new\_1\_receiver\_1 Forward Simulation  
Irradiance, W/mm<sup>2</sup>

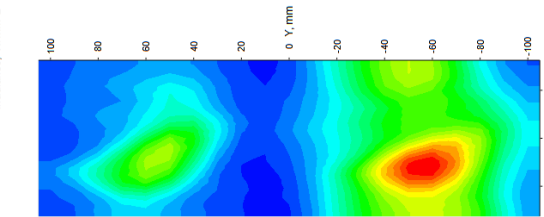

left  
total power:  $6.51 \times 10^5$  W/mm<sup>2</sup>

9

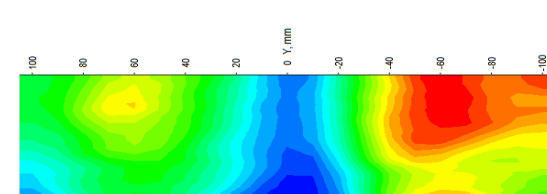

right  
total power:  $8.69 \times 10^5$  W/mm<sup>2</sup>

front\_new\_1\_receiver\_1 Forward Simulation  
Irradiance, W/mm<sup>2</sup>

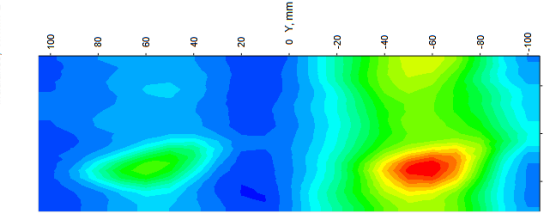

left  
total power:  $4.09 \times 10^5$  W/mm<sup>2</sup>

10

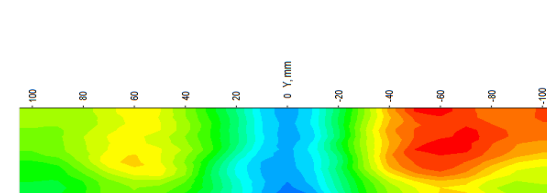

right  
total power:  $5.25 \times 10^5$  W/mm<sup>2</sup>

front\_new\_1\_receiver\_1 Forward Simulation  
Irradiance, W/mm<sup>2</sup>

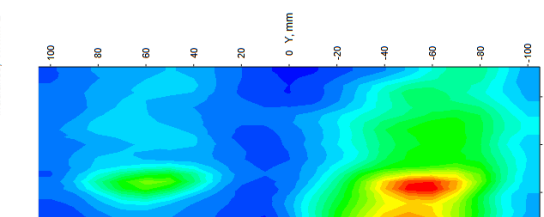

left  
total power:  $1.89 \times 10^5$  W/mm<sup>2</sup>

Radiation maps of  $B_3$  component

1

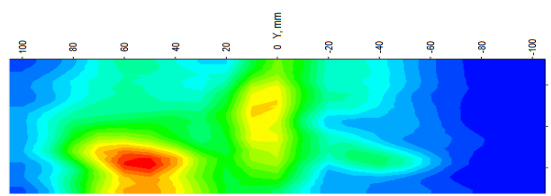

right  
total power:  $2.25 \times 10^5$  W/mm<sup>2</sup>

external\_holes\_middle\_back\_1.receiver\_1.Forward S  
Irradiance, W/mm<sup>2</sup>

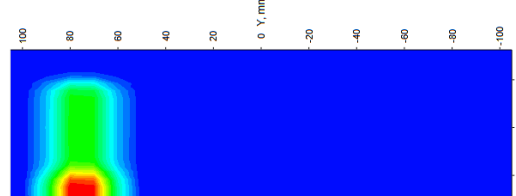

left  
total power:  $3.75 \times 10^6$  W/mm<sup>2</sup>

2

external\_holes\_middle\_back\_1.receiver\_2.Forward S  
Irradiance, W/mm<sup>2</sup>

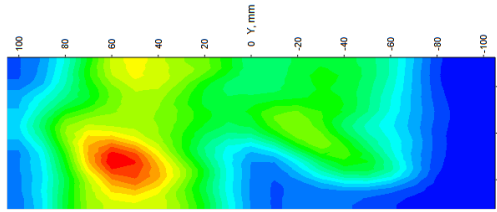

right  
total power:  $5.18 \times 10^5$  W/mm<sup>2</sup>

external\_holes\_middle\_back\_1.receiver\_1.Forward S  
Irradiance, W/mm<sup>2</sup>

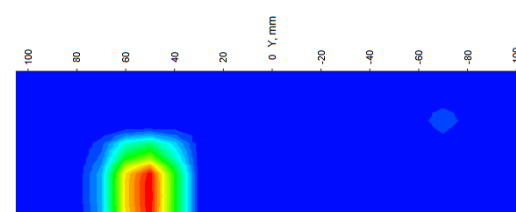

left  
total power:  $2.44 \times 10^6$  W/mm<sup>2</sup>

3

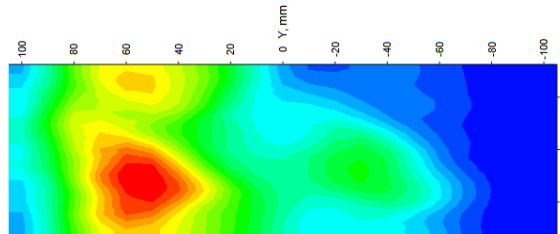

right  
total power:  $8.53 \times 10^5$  W/mm<sup>2</sup>

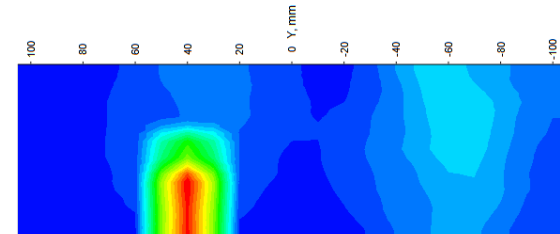

left  
total power:  $1.35 \times 10^6$  W/mm<sup>2</sup>

4

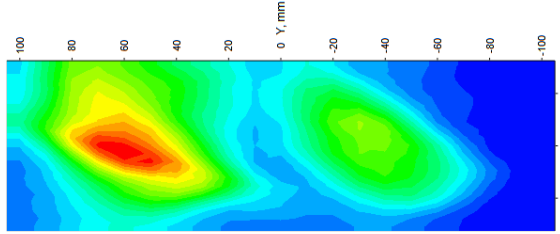

right  
total power:  $5.85 \times 10^5$  W/mm<sup>2</sup>

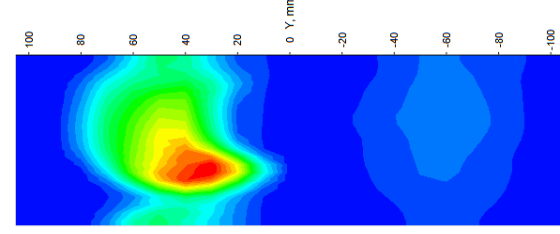

left  
total power:  $2.87 \times 10^6$  W/mm<sup>2</sup>

5

external\_holes\_middle\_back\_1.receiver\_2.Forward S  
Irradiance, W/mm<sup>2</sup>

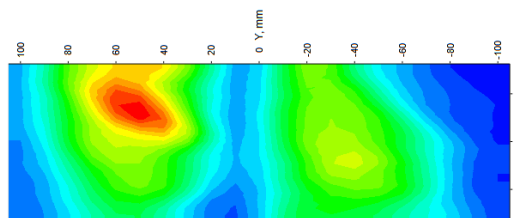

right  
total power:  $1.05 \times 10^6$  W/mm<sup>2</sup>

external\_holes\_middle\_back\_1.receiver\_1.Forward S  
Irradiance, W/mm<sup>2</sup>

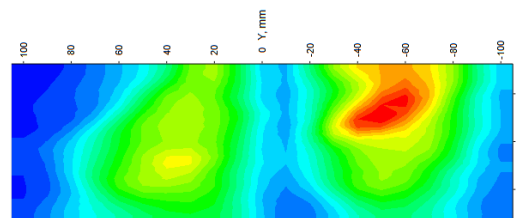

left  
total power:  $1.02 \times 10^6$  W/mm<sup>2</sup>

6

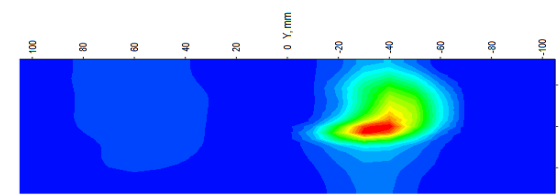

right  
total power:  $2.33 \times 10^6$  W/mm<sup>2</sup>

external\_holes\_middle\_back\_1.receiver\_1.Forward S  
Irradiance, W/mm<sup>2</sup>

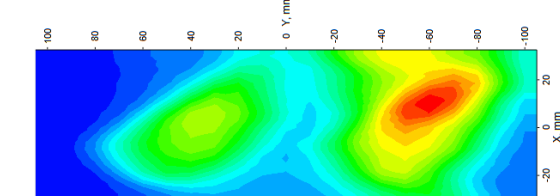

left  
total power:  $6.78 \times 10^5$  W/mm<sup>2</sup>

7

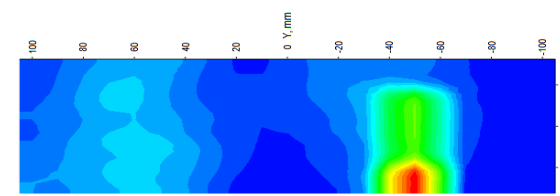

right  
total power:  $1.65 \times 10^6$  W/mm<sup>2</sup>

external\_holes\_middle\_back\_1.receiver\_1.Forward S  
Irradiance, W/mm<sup>2</sup>

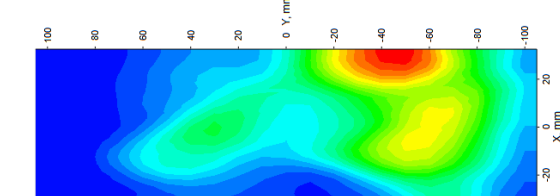

left  
total power:  $8.77 \times 10^5$  W/mm<sup>2</sup>

8

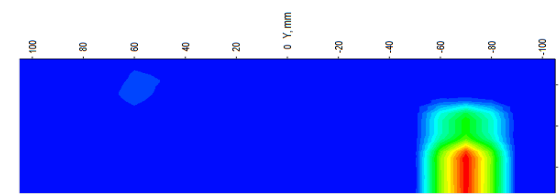

right  
total power:  $3.03 \times 10^6$  W/mm<sup>2</sup>

external\_holes\_middle\_back\_1.receiver\_1.Forward S  
Irradiance, W/mm<sup>2</sup>

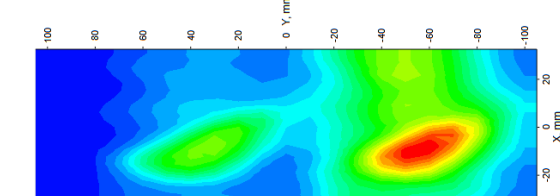

left  
total power:  $4.19 \times 10^5$  W/mm<sup>2</sup>

9

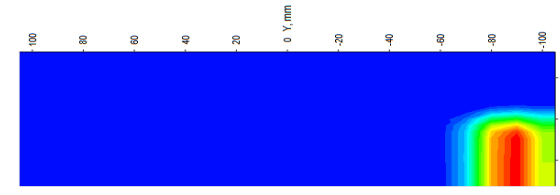

right  
total power:  $4.15 \times 10^6$  W/mm<sup>2</sup>

external\_holes\_middle\_back\_1.receiver\_1.Forward S  
Irradiance, W/mm<sup>2</sup>

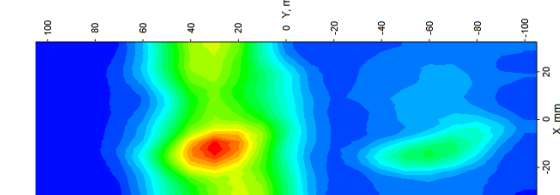

left  
total power:  $3.30 \times 10^5$  W/mm<sup>2</sup>

10

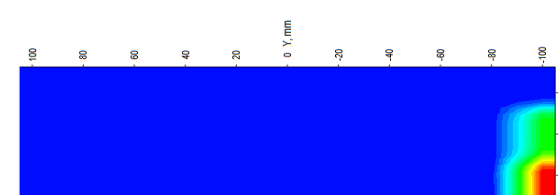

right  
total power:  $2.38 \times 10^6$  W/mm<sup>2</sup>

external\_holes\_middle\_back\_1.receiver\_1.Forward S  
Irradiance, W/mm<sup>2</sup>

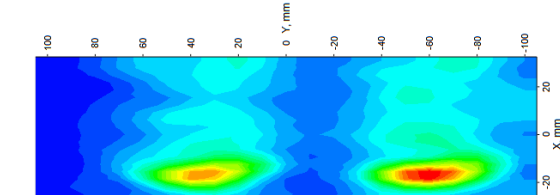

left  
total power: 75675 W/mm<sup>2</sup>

## Radiation maps of D<sub>6</sub> component

1

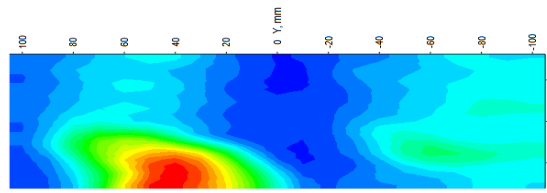

right  
total power:  $2.44 \times 10^5$  W/mm<sup>2</sup>

front\_lens\_concave\_1\_receiver\_1\_Forward Simul  
Irradiance, W/mm<sup>2</sup>

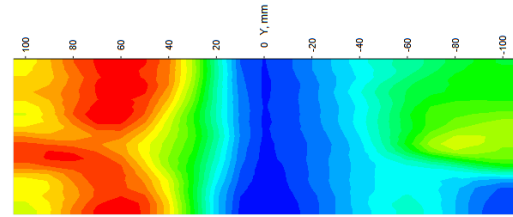

left  
total power:  $9.30 \times 10^5$  W/mm<sup>2</sup>

2

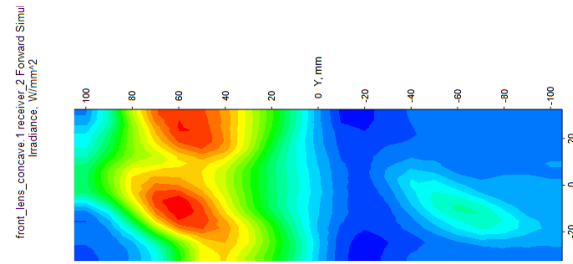

right  
total power:  $6.22 \times 10^5$  W/mm<sup>2</sup>

front\_lens\_concave\_1\_receiver\_1\_Forward Simul  
Irradiance, W/mm<sup>2</sup>

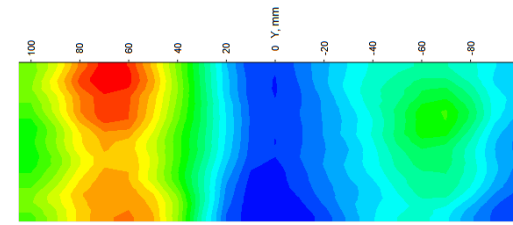

left  
total power:  $1.04 \times 10^6$  W/mm<sup>2</sup>

3

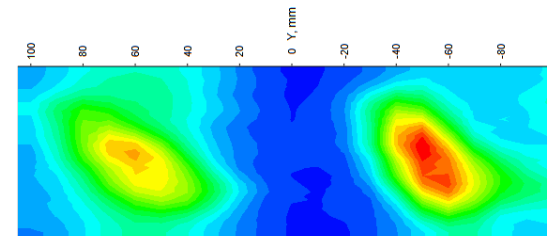

right  
total power:  $4.54 \times 10^5$  W/mm<sup>2</sup>

front\_lens\_concave\_1\_receiver\_1\_Forward Simul  
Irradiance, W/mm<sup>2</sup>

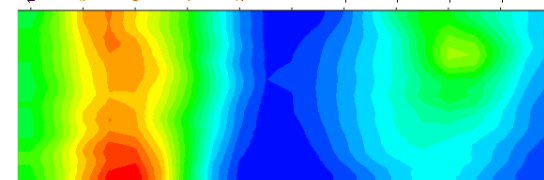

left  
total power:  $1.18 \times 10^6$  W/mm<sup>2</sup>

4

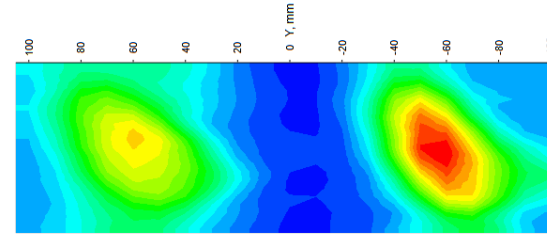

right  
total power:  $6.59 \times 10^5$  W/mm<sup>2</sup>

front\_lens\_concave\_1\_receiver\_1\_Forward Simul  
Irradiance, W/mm<sup>2</sup>

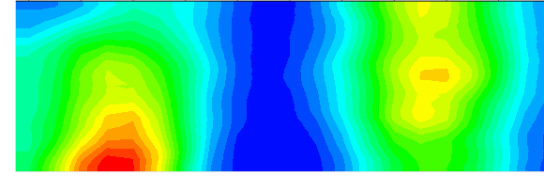

left  
total power:  $1.59 \times 10^6$  W/mm<sup>2</sup>

5

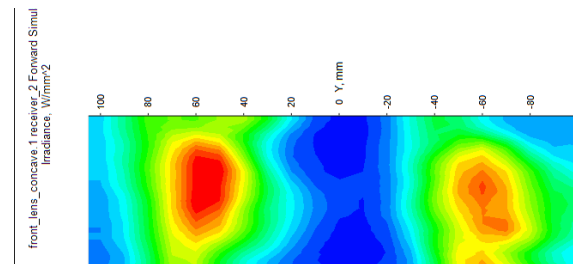

right  
total power:  $1.04 \times 10^6$  W/mm<sup>2</sup>

front\_lens\_concave\_1\_receiver\_1\_Forward Simul  
Irradiance, W/mm<sup>2</sup>

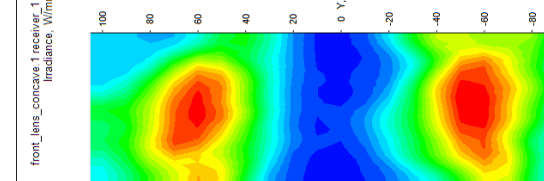

left  
total power:  $1.01 \times 10^6$  W/mm<sup>2</sup>

6

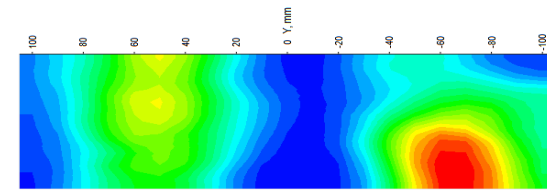

right  
total power:  $1.60 \times 10^6$  W/mm<sup>2</sup>

front\_lens\_concave\_1\_receiver\_1\_Forward Simul  
Irradiance, W/mm<sup>2</sup>

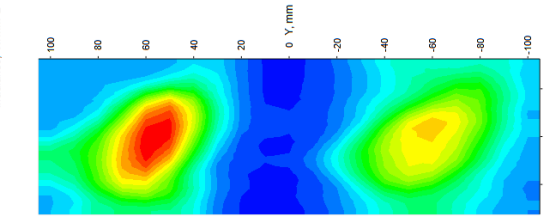

left  
total power:  $7.01 \times 10^5$  W/mm<sup>2</sup>

7

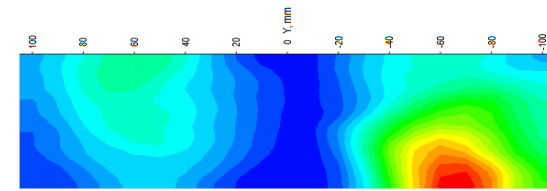

right  
total power:  $1.33 \times 10^6$  W/mm<sup>2</sup>

front\_lens\_concave\_1\_receiver\_1\_Forward Simul  
Irradiance, W/mm<sup>2</sup>

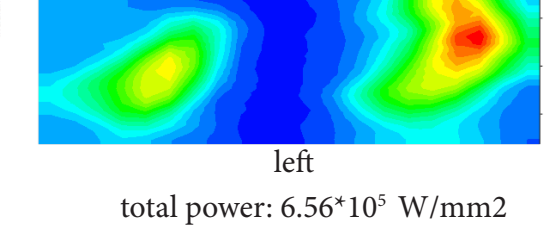

left  
total power:  $6.56 \times 10^5$  W/mm<sup>2</sup>

8

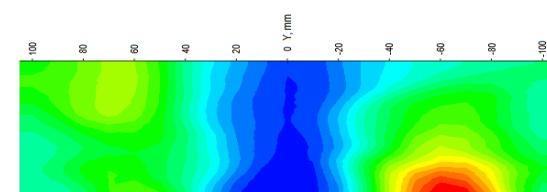

right  
total power:  $1.6 \times 10^6$  W/mm<sup>2</sup>

front\_lens\_concave\_1\_receiver\_1\_Forward Simul  
Irradiance, W/mm<sup>2</sup>

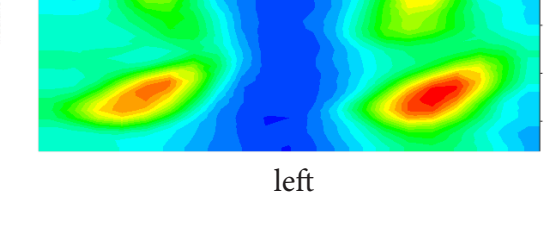

left  
total power:  $3.64 \times 10^5$  W/mm<sup>2</sup>

9

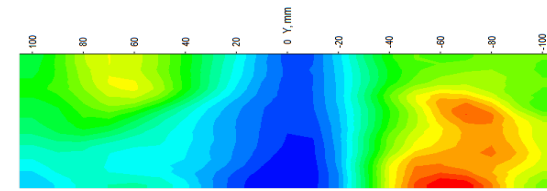

right  
total power:  $1.32 \times 10^6$  W/mm<sup>2</sup>

front\_lens\_concave\_1\_receiver\_1\_Forward Simul  
Irradiance, W/mm<sup>2</sup>

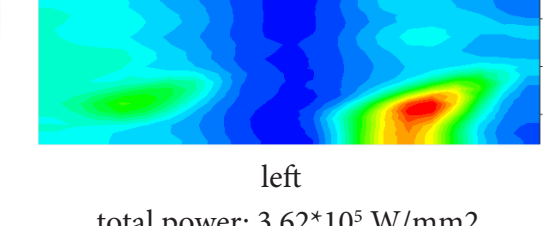

left  
total power:  $3.62 \times 10^5$  W/mm<sup>2</sup>

10

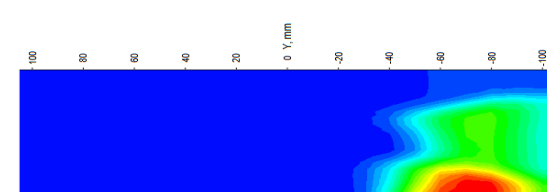

right  
total power:  $2.28 \times 10^6$  W/mm<sup>2</sup>

front\_lens\_concave\_1\_receiver\_1\_Forward Simul  
Irradiance, W/mm<sup>2</sup>

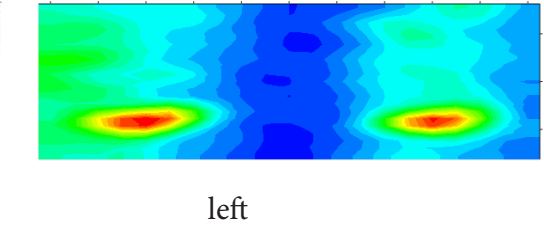

left  
total power: 96872 W/mm<sup>2</sup>

Radiation maps of D<sub>7</sub> component