

9

Appendices

List of Appendices

Appendix A	4
Questionnaires captains and observations	
Appendix B	8
Interview doctor ECMT	
Appendix C	10
Interview doctor RMS	
Appendix D	14
Small test 2-way-AR	
Appendix E	16
First large test 2-way-AR	
Appendix F	32
Acute vs non-acute medical scenarios	
Appendix G	36
Sketches doctor set-up	
Appendix H	38
Mallen test set-up tablet position doctor	
Appendix I	39
Test set-up tablet position doctor	
Appendix J	42
Test results Tablet position doctor	
Appendix K	46
Test set-up stitching	
Appendix L	51
Test results stitching	
Appendix M	54
Test set-up camera position captain	
Appendix N	59
Test results camera position captain	
Appendix O	65
Final test set-up	
Appendix P	71
Final test question side	
Appendix Q	74
Final test results	

Appendix A

Questionnaires captains and observations

1.1 Set-up

Goal of test

The goal of the questions is to have a guide from which, in an informal matter, experiences around medical procedures on the ships of the captains/first mates can be discussed. With these questions the idea is to get a better feel of the context in which the AR application would be used. The ultimate thing would be to identify the insights of an issue from the perspective of participants of end-users. (<http://designresearchtechniques.com/casestudies/semi-structured-interviews/>)

The interviewees are 4 captains or first mates who are following a week of medical training at the Emergency Control - Maritime Training centre. I will personally participate in one day of training and use the opportunity to talk with them about some of their experiences. The style will be very informal and the only documentation will be written and the goal is not to ask all questions with every participant but use the questions as a guide to get valuable insights.

Non probing questions

1. How many years of experience do you have?
2. What type of ship do you work on?
 - a. 2 guys on a ferry from P&O as second mate. Sometimes have to replace the first mate so they need the training
 - b. first mate on a bagger ship
 - c. first mate on a cargo ship Wagenborg
3. What is your role on the ship?

Interview questions

1. How many events per year do you experience during which the training is valuable?

For the P&O guys the training is important but they experience much less medical situations because many of the smaller incidents are handled by the 'boat police' travelling with them. Often these injuries are related to sliding and moving doors. Due to the short travel times of these boats around Europe (2-3) days, it is easier to evacuate. The people on board are passengers which does lead to an increased variety of diagnosis because people bring a past. There are many elderly on board and probably a lot of lifestyle related situations. What they often do in case of more serious situation is ask if there is a doctor on board, which is often the case.

2. What are your first thoughts when you hear about a medical situation?
3. How comfortable are you with medical emergencies on the ship?
4. What are some of the most common incidents at the ship?
5. How do you usually find out about an 'emergency' situation on the ship?
6. What is your opinion on having the responsibility for the medical care of the crew?
7. What are the biggest challenges when there is an accident at the ship?

Important to realize that in some cases the injured is in a dangerous situation to be approached also for the rest of the crew, especially after an incident.

8. Do you have any concerns during the medical procedure?
9. Can you take me through a recent event during which you had to apply the medical training?

1.2 Results

Training related insights & observations

There are different levels of emergencies and moments in the journey at which the communication can be valuable and of different function

- o For example when someone fell from the stairs and is lying in an unnatural position and it is hard to make a good assessment about any damages to the spine it can be valuable to have an experts judge the situation
- Journey: During any event the 1 st mate first goes through the ABCDE, than goes more into depth using X score and then calls the RMA or if critical situation calls immediately
 - o After consultation they can go into more action and this is the moment they could use the skills app for support
 - o IMPORTANT TO LEARN WHEN THEY DO ACTIONS FIRST AND WHEN CONSULT
- The EM-CT training is to identify acute situations and act accordingly. Simple EHBO is in there but can also be taken care of by others
- During the training the participants were instructed and invited to make use of the skills app which was an opportunity for me to get some insights in how they use it
 - o The app is fairly time consuming
 - Find the right procedure > Watch Video > Use pictures as guide
 - o The app takes a lot attention and it seems like the user is no longer thinking by themselves about the procedure
 - o It is a hassle to hold and place it somewhere
 - This is not even on a ship
 - o It will probably be valuable to talk some people who have used the app in a medical situation > This will give better insight into when they use it, how easy to use it is and what the main value of it is
- If contact is made with the RMA an indication has to be given about the urgency which determines the speed of response of the general practitioner
 - o It would probably make sense if the GP would also get the AR app and be the contact person
 - o Or a pool of contractors, but this would mean salaries have to be paid
- In many cases is it not impossible to have multiple people on location to assist in the care of the patient
- For many of the procedures around the patient multiple people are needed, this is not a problem because usually someone can be found. It is also an opportunity for the AR-app since assistance is nearby
- Some insights from a test situation with a LOTUS:
 - o Important to bring/prepare the right gear
 - o Hard to balance asking questions and making patient comfortable
 - o There is no clear protocol for the communication with the RMD

New interview questions

The first set-of questions did not work as expected. They were either unable to answer the question or did not feel comfortable answering the question. The questions were made more specific after reconsidering the insights I was looking for. In the end the answers were often evasive in answering the questions or simply unable to.

1. How many events per year do you experience on the ship?
2. Can you give me some examples of medical situations you have experienced on the ship?
3. Can you take me through the steps of one of the examples?
4. How did you feel before, during, after providing medical aid?
5. Do you ever worry for medical emergencies on the ship?
6. What are concerns you have about medical procedures on the ship?

Asking in more detail with one of the participants of the training who operates on a cargo transport vessel it is clear that many of the incidents are minor. These events relate better to the first two days of the training which focusses on basic first aid. He was involved in two more major events one was a cardiac arrest and the other food poisoning. He was very chill about the events but also did not really like to go into much detail. He said it was a little difficult because it is a close colleague but for the rest it was not hard. You just do your checks and call the RMA. Especially because in these events the patient was conscious and could communicate. For the cardiac arrest they could easily spot the signals and give the guy the right pill and call for the next steps.

1.3 Round 2 - captain interviews

Part A

Goal

The goal of the second round of interviews is to get a clearer understanding of the challenges the captains experience during medical care on board.

Questions

1. What kind of ship do you work at?
2. What is your role/responsibility at the ship?
3. Have you ever experienced a medical emergency on board?
4. What do you think of the training provided here?
 - a. Does it support you enough for emergencies at sea?
 - i. Why?
5. Can you take me through a medical situation on board that you were part of or witnessed?
6. What were you feeling during the emergency?
7. What are the main challenges you experienced on board?
 - a. What challenges are different from the same situation on land?

Part B

Goal

Give the captains the skills app, allow them to perform a medical procedure and ask for their experience.

The test

1. The participant will be asked to put a stitch in a piece of pork
2. They will first have to do it only having had the basic training
3. They will be asked to do the procedure now with the guidance of the app
4. Then they will answer a set of questions, or after both of the procedures and compare the results.
 - a. Maybe better to do one semi-structured interview due to the small group of participants

Questions

1. Which of the two procedures went better and why?
2. How did you feel going through the steps by hand?
 - a. Did you feel comfortable? Secure?
3. How did you feel going through the steps using the application?
 - a. Did you feel comfortable? Secure?
4. What is in your opinion the main value of the application?
5. If you had to do the procedure again how would you use the app?
6. How can using the app improve the outcome?

1.4 Results

Captain on large sailing boats for vacation

He works on a 58 meter long sailing boat with, at maximum, 28 passengers and 10 people personnel. He is the captain and determines the route and where they stop, this is not defined but changes depending on the weather and needs. They do Atlantic crossings when they sail to the Caribbean in about three weeks. There is no real internet on board, they have an antenna but this does not function very well. For internet they depend on the mobile network based on land based poles.

He has experienced some minor incidents and some major. Sometimes fingers get jammed or people or personnel step into glass. In some cases people get seasick for a prolonged time. Two more major emergencies, one time some one went to bed slightly nauseous and turned out to have passed during the night due to a heart attack. The other was a piece of glass stuck in a crew members foot which had to be stitched.

During the heart attack he did not consider this as an option. During the glass incident he got nervous and did not remember how to stitch. When he practiced the crewmember said, you are definitely not touching my foot. So, they bandaged it and got her to land the next day. He experienced also pressure from the people on board who all expected he knew what to do.

He says it is 'spannend' when you have to do it, you don't remember everything or all skills. It is really hard to know if you are doing it right.

Skills is an issue to remember, believes the app could facilitate this. But the value of the AR app is mainly in having a medical expert being able to confirm your actions.

Am I doing it right? Do I see it right? > Looking for confirmation from the medical expert, that is the biggest part. It was hard for him to imagine the action part of the incident.

Appendix B

Interview doctor ECMT

1.1 Set-up

Interview questions

1. Biggest challenge with remote care?
2. What is the biggest value of the RMD and how is it created?
3. What is the biggest limitation of the RMD?
4. What in your view is the biggest challenge for the captains on board?
 - a. Treatment?
 - b. Diagnosis?
5. What is the biggest value you can add in each of the phases?
 - a. Diagnose and stabilise
 - b. Treatment
 - c. Aftercare
6. What kind of emergencies are in your perspective best guided with the AR app?
7. What do you need from the app in any of the phases?
 - a. Information from the patient?
 - b. Information about the ship?

1.2 Results

Notes conversation

Biggest challenge with remote care?

- The captains see things they have never seen before
 - o They do not have the expertise

What is the biggest value of the RMD and how is it created?

- The biggest value is being able to share the responsibility with a doctor

What is the biggest limitation of the RMD?

- You have to make a diagnosis on the limited information provided by the captain
 - o The limited information can create tunnel vision on setting the diagnosis
- There is a lot of pressure on the doctor in making the right decisions
 - o Since the captain is no expert and could struggle with the descriptions of findings a photo can sometimes already be extremely valuable

What is the biggest value the AR application can add in each of the phase? Stabilising

- Help find the right things
- You always treat first what kills first, then you move on and compare with the first ABCDE you made

What is the biggest value the AR application can add in each of the phase? Treatment

- For the captain it is 'fijn' to discuss with a medical expert

What is the biggest value the AR application can add?

- The doctor is usually looking for a first impression, this is often already very valuable
- It shows direct feedback of the response to the treatment of the patient as well it allows the doctor to get an understanding of the quality & credibility of the measurements done by the captain. If the captain is using an apparatus in the wrong way it immediately puts the rest of the results in question
- The doctor can see and respond much faster with the video and audio, if he notices the issue might be elsewhere in the body he can respond immediately
- The captain is mainly looking for tips and coaching in the treatment for example with an open wound which requires stitching
 - o In this it is especially valuable to precisely pin point the area of action
 - o But also showing a technique again. For example making a stitch
- It would be cool to immediately be live when there is a serious incident, but it should not take too much time from either party and also be practical
 - o Maybe better to have the captain make a first judgement of the situation and from there decide the timing for contact
- When does the doctor have enough info and when is a good moment to decide to determine if the patient is really stable?
- Maybe the application should have different options for different scenarios
 - o Acute situation
 - o Acute > Do first
 - o Acute > Need help
 - o Semi-acute > Need help getting the story complete
 - o Non acute > but in need of support

Other

- ABCDE information you want to review repeatedly with acute patients but with stable patients you might wait a little longer. The retuning reviews of the data allow to see a trend.
- There is not always a need for a live video connection
 - o In some situations a picture is enough
 - o The video feed could also become an overkill of information
- There might be a need for additional attributes for the doctor > For example to show how to perform the stitching
- At that moment you can send a movie or foto of the skill

Appendix C

Interview doctor RMS

1.1 Set-up

Interview questions

I would like to start by thanking you to take the time to give this interview. My name is Tom Slijkhuis, I am a graduate student at TU Delft from the master Integrated Product design. For my graduation I am working with MedAssist. Online on a new service to improve medical care at sea. Part of my analysis has been to understand the current treatment process the captains follow to take care of crewmembers and the interaction with the RMS doctor. In today's interview I hope to get a better insight in your role as a RMS doctor, the cases you handle and how you experience the communication.

The results of the interview will be used for analysis, no transcript will be made just takeout's from the interview will be used to answer my questions. Quotes from the interview might be used to illustrate a point in the thesis, is it okay if I use your name? Is it okay if I record the interview?

Introduction

1. Can you give a brief introduction of yourself?
 - a. Studies
 - b. Practices
 - c. Experience as RMS doctor
2. What are some of the most common cases you come across?
3. How much time do you spend on being a RMS doctor?

Description of role and responsibility

1. How would you define your role as a radio medical service doctor?
2. What is the biggest challenge about being a radio medical service doctor?
3. What do you think is the biggest value you bring to the captain?
4. Can you explain your responsibility as a RMS doctor?
5. Do you think you are involved enough in the treatment process?

Experiences with captains

1. What are the hardest cases to handle?
2. Do you always get enough information from the captain?
3. How many calls do you have with the captain?
4. What is the length of the calls?
5. Do you think the phone call provides enough support for the captain? Why?
6. If you could provide any extra support to the captain what do you think would be most valuable?
7. What happens at the end/after the call?

Most important information

1. Can you roughly walk me through the sequence of the phone call?
2. What is the (most important) information you are looking for during the phone call?
3. Is there information that is in some cases too shallow?
4. What information would you like to have that is currently not provided during the calls?
5. How do you judge the quality of the information from the captain?

With new service

1. Do you believe more contact with the captain could improve the outcomes of the treatment? Why/Why not?
2. What is the maximum time you like to spend on a case?
3. How confident do you feel in your judgements over the phone? Any doubts?
4. Do you have any concerns when you leave the captain with a treatment advice?

Privacy & Responsibility

1. Are you responsible for the diagnosis?

2. Would you want to be more involved in the treatment process?
3. Would you feel more responsible if you were more involved in the treatment process?
4. What information from the patient do you think is valuable to record?
 - a. How long can it be stored in line with new regulations?
 - b. Is there any data from the ship in your opinion which is valuable to document?
5. What are your thoughts on logging more information about a case?

1.2 Results

- Gp combined with maritime gp.

- 1 shift per 5 weeks, 24/7.

- They have a beeper, iPad and phone.

- Around 12-20 cases per week

- Much of the contact used to be mail, but it is becoming more voice. Not all the contact needs to be through calling. He wonders sometimes why they call. Calling is a big intrusion on his work

- There are priority levels, but he does not really look at it. He tries to call within a minute

- o Through mail this is much more clear. Between non-urgent which is just a question, a regular case and the question for evacuation.
- o This is separated in three different email addresses
- o In case of evacuation he drops everything, otherwise he just finishes

- Depending on the use of the form the help is very much influenced.

- o For example in the fishing industry it happens a lot
 - Jan has a sore throat can we give antibiotics, but we need RMS green light
 - The RMS doctor in turn wants to know how old is Jan, what is his heart rate, how healthy is he, does he have any allergies etc.? Does he have koorts?
 - Then he needs to reply and ask these questions so it needs at least 4 emails.
 - But in case of correct use of the form it can be done in 2
- o Sometimes he asks for a follow up after 24 hours. But this means the time spent on the case increases significantly

- What happens a lot?

- o Wounds
- o Crushed toes/fingers
- o Stung from a fish
- o Lot of infections, urinary tract, skin
- o Infected teeth
- o KNO, coughing

- The more urgent

- o Steel cable breaks and hits legs
- o Amputations
- o Heart infarct
- o Epleptic attack
- o Internal bleedings

- When the case is handed over to another area for evacuation they usually take over completely. He does not always hear something back. Sometimes it is nice to hear something back. He asks for an update every now and then.

- o Example where updates were able to make a good plan for action. These go well through email
- o Another case with rectal blood loss and puking of blood. They turned around and a ship with medical care started heading towards them. In this case he had contact every four hours with the captain, which the captain experienced as valuable since he felt supported.
 - Captain was unable to put the IV. Is very heard with a person in shock.

- Main role/responsibility
 - o Remotely estimating/forming, a probability diagnosis. Medical support in general, sometimes there is no need for a diagnosis if it is just a question. With ill people a probability diagnosis with a plan for treatment. If the treatment is followed up I do not know and do not want to know. Is not my responsibility.
 - o One case where he gave the advice to take of board. But this was around the coast of Algeria so he advised to go north. In the end the patient was taken of five days later in the Adriatic sea. It probably did not work for the ship..
- Biggest challenge?
 - o Language
 - First mate, sometimes captain
- He does not have direct contact with the patient because he is not the responsible care taker of the patient. The first mate is the spokesperson and I am a supporter of him, not a direct care taker of the patient. Through there has been a recent ruling that there is "treatment relation"
- The first mate has to do his work, they just call saying "he has an headache". They have to follow protocol and be prepared. Rather than giving the phone to the patient.
- Biggest addition is knowledge and experience with similar cases.
- Phone call lasts about 10-15 min.
- RMS doctor is now more or less the coordinator of the evacuation
- If the preparation has been done the doctor has enough to make a diagnosis. Sometimes he asks for a photo, but not to often. He does ask questions during the call but these are often questions already in the list
- He hardly doubts the measurements the captain takes
- Language is difficult. Sometimes he has to work with so little info, even asking more but due to bad connection or understanding this information is just not provided.
 - o Especially for dutch coastal area for evacuation is a hard decision
 - Captain says "I am on the bridge and the patient is in the hospital, I just know he needs to be taken of"
 - Uit "armoede", the heli is sent just to be sure
- He never worries how the treatment goes for after his advice. For stitching for example, you can make a beautiful stitch or not so beautiful but the wound will heal. Not as fast and not as clean but it will heal. As long as the bring the wound edges closer together, he thinks it is a big step forward to limit infection and speed up recovery
- Most important information about the patient is: is it life threatening or not?
 - o If it is not life threatening actions follow which are uncomfortable but not life threatening.
 - If the captain does not have this clear he needs to identify this
 - o Most important is triage
 - What is the problem and is it life threatening
 - o After that the rest becomes important
- He asks for update if he thinks they are necessary, but they do not always get them.

- Saved in case
 - o Name
 - o Date of birth
 - o Country
 - o Name ship
 - o Last port
 - o Destination
 - o ETA
 - o Position
 - o Probability diagnosis, coded through IPSC (coding system for diagnosis)
 - o Journal of communication
 - o Summary to not have to go through all correspondence
- The conversation over the phone very much depends on the preparation of the captain. If the preparation is good he will just ask 1 or 2 questions. If it is bad he will go through many more questions. Sometimes he will leave the captain with some more questions and ask to email them. Email is better since than it is also immediately recorded for the documentation.
- If he asks for feedback emails, they usually arrive a week later when the next doctor is in
- More contact probably improves the care, but it needs to work with rest of work. But the question also remains if contact is kept from other side.
 - o Sometimes he gives heavy medication, you want to hear later how the response is, much like in general practitioner actions.
- Italian RMS are sitting in an office waiting for analyses etc. This is not the way it is set up in the Netherlands, so a constant live connection is not wished.
- Abdominal issues are hard, internal problems are hard for the captain to asses even for a doctor is hard to do a good analysis. Situations where is might be worse than it looks at first sight.

Appendix D

Small test with 2-way-AR

1.1 Set-up

Goal of tests: Test the value of a visual and audio live connection by limiting or eliminating the connections. The other part of the test is to test some of the functionalities

For the test there is pdf with a swimming lane model which has the functions and the corresponding actions and logs required from the application. This is not a flow chart for the application nor a template for the design, but it does give guidance for the current functionalities necessary for the test.

For part 1 of the test there are requirements of the app which might not yet be integrated. If this is not possible we will think of a way to simulate the test scenario. The goal here is to see what the experience is for the captain. The second part of the test there are similar requirements there the goal will be to test if the functionality works.

Test part 2 – Flow

Goal: Test the functionality of the app from the captains perspective, and a bit on the doctors side, on the experience of setting up the connection with the doctor. The goal is to learn what their thoughts are on some of the functionalities.

Requirements app:

1. Log in screen
 - a. For the doctor
 - b. For the captain
2. Call button from the captain
3. Audio and video control button
4. End call button

Test Scenario:

Introduction

Imagine you are 1000 miles at sea and one of your crewmembers is in a medical incident and you need to give the best care possible. Here at MedAssist.online we try to give you're the right support to do this as best as you can. During the training you have experienced the skill app which is meant to support you during medical incidents on board of the ship. Participants of the training were looking for a tool to help them be more confident during the treatments as well as perform better. At MedAssist.online we are looking at the next step of supporting you on board during medical situation. One way we are developing is using Augmented Reality through which we try to virtually bring the doctor next to you during medical care. For us to be able to develop the best support products we are always looking for input from you. In this test you will go through a scenario using a prototype of the application to help you perform some actions. After the protocol we will discuss your experiences and thoughts on the application.

Protocol

1. Open application
2. Push call button
3. Log in (if necessary)
4. Log any details(if necessary)
5. Confirm connection with other side

6. Move the papers according to what is told and pointed out
 - a. In a roster
 - b. Diagonally right bottom, left top

7. Turn audio off
8. Move the papers according to is pointed out
 - a. In a roster
 - b. On top of each other in a special order

9. Turn audio on

10. Turn hands off
11. Move papers according to audio instructions

12. Turn hands on
13. Move papers according to sound and visual instructions
 - a. In a roster
 - b. In a row from left to right

14. End call
15. Discuss experience with the tester

Questions

1. What are you first thoughts on the application? (What do you like? / What don't you like?)
2. Can you see it being used for some of the skills you are learning in the training?
3. Do you think there is anything missing in the application?
4. Do you prefer working with the hands or just the audio? Why?
5. What, in your opinion, is the biggest value of the application?
6. In your experience what is most important in a medical situation?

1.2 Results

Two captains were interviewed

- P&O and role is 2nd engineer/machinist
- Jan de Nul and role is 2nd engineer/machinist

1. What are you first thoughts on the application? (What do you like? / What don't you like?)
 - Potentially very helpful
 - o Especially for advice
 - The threshold is lower to take away insecurities
 - Very valuable, sometimes sound a bit low
2. Can you see it being used for some of the skills you are learning in the training?
 - Hard because both of them only do the medical first aid, not the skills
 - Could work for going through the evaluation form
 - o The doctor can immediately respond to what he sees and direct
3. Do you think there is anything missing in the application?
 - Maybe the face of the doctor which could add more confidence and a positive feeling
 - Jeroen(Trainer): There is some uncertainty when who is talking etc. maybe be some protocol and a chat function when the audio connection is lost to confirm there is still some connection
4. Do you prefer working with the hands or just the audio? Why?
 - Both is definitely the easiest
 - If only one the hands they are clear but with audio you can ask questions and get confirmation 2 know more than one
 - o So the voice is more clear than just the hands
 - The hands are especially good, the pointing works very well
 - o But the audio works just as fast for the tasks in this test
5. What, in your opinion, is the biggest value of the application?
 - The voice of the doctor there live works very calming and creates trust
 - o You are looking for
 - Faster professional care nearby, if it would be more instant
6. In your experience what is most important in a medical situation?
 - Live medical support is immediately obvious

Appendix E

First large test 2-way-AR

1.1 Set-up

Where and When: Thursday 19/07 and Tuesday 24/07. In the back of the training room and in the meeting room.

Participants: 5 captains from the ECMT trainings program

Documentation: Questionnaire, Recordings with camera

Required props:

- Green screen
- 2 ipads
- Ipad stand
- Ipad holder
- Procedure material(arm or lego)
- 5 questionnaires
- 2 scripts, for each side
- 2 people
- 1 camera with stand
- Ipod stand
- Ipad
- Cookies

Scope: The focus of the test is the usability of the AR-application which is now on two handheld devices as an MVP. The scope is the 2-way AR functionality and their experiences when using it. Most important is to have them experience the same actions with and without the application.

Goal: Review the added value of AR in performing a task and trigger the participants to think about the functionalities and performance of the application in a medical setting.

Hypothesis: Overall the use of the MVP AR application has very limited added value on top of a video conferencing for the experienced confidence.

Test scenarios

- Do one lego scenario with facetime
- Do one lego scenario with AR
- Do one medical scenario with AR

1.2 Test introduction

Thank you for participating in this test for MedAssist. Online. MedAssist. Online is the part of the company which has developed the skills app, which you probably have experienced in the training. Today we will be working with a new app that we are developing which uses augmented reality to bring an experts hands, and voice, live with you. For the test you will experience three scenarios. For the first two tests you will be assembling a lego structure with guidance of an expert through a digital connection. You will experience two different application and will be asked to answer some questions afterwards. The focus of the test is how you experience the communication during the steps in the procedure. In the third scenario you will experience and complete a medical scenario you have experienced in

training. There is no right or wrong in the test or answering the questions, just try to communicate as well as possible with the expert on the other side. During the test it might be the case that the applications freeze, might this be the case the test will be paused for a second to restart and reconnect.

Introduction Questions:

1. Where do you work?
2. What is your role on the ship?
3. What gender do you identify with?
4. How old are you?
5. Are you okay with the test being filmed?

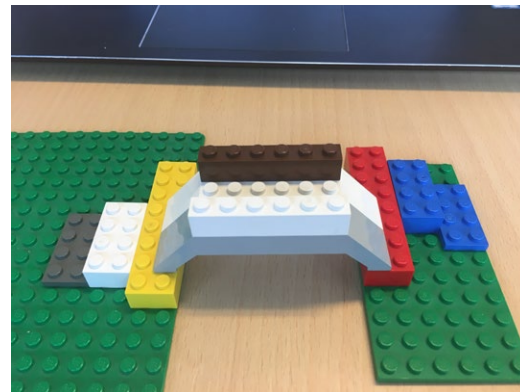

Figure X: Front side of bridge Facetime scenario

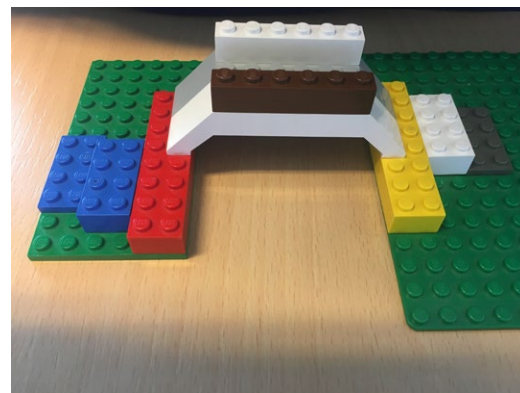

Figure X: Back side of bridge Facetime scenario

Side captain:

1. Call with Facetime
2. Say hello, confirm the connection
3. Ask for instructions

Side doctor:

1. Pick up
2. Say hello and confirm the connection
3. Start instructions
 - a. Your task is to build a bridge like construction with the Lego pieces in front of you
 - b. I will communicate how the bridge will be built
 - i. Take the large green plate and put it in front of you
 - ii. Take the small green plate and put this vertically next to the other green plate
 - iii. Leave about 4cm space between the plates
 - iv. Take the long yellow block, click it all the way to the right of the large green plate so that above and beneath there are four holes be open
 - v. Take the long red block and place it to the left side of the small green plate, so that there are no circles open above and 4 on the under side
 - vi. Take the grey bridge part and place it on top of the red and yellow block on the inside of both, so that there are no circles underneath the red one and one circle underneath on the yellow
 - vii. Take the white bridge part and place it directly behind the grey one
 - viii. Take the white, 1 circle wide piece, and place it on the front side of the grey bridge part
 - ix. Place the brown, 1 circle wide, on the other side on the white bridge part
 - x. Take the blue block with 8 circles and place it vertically, right of the red block, keep one circle of the green plate on the upper side of the blue piece
 - xi. Take the thin blue plate and place it next to the blue block, but now keep two circles free on the green plate above the thin blue part
 - xii. Take the white block and place this parallel to yellow block and make sure it is three circles lower than the yellow block
 - xiii. Take the grey plate and place it directly next to the yellow block
 - c. We will now review the result
 - i. Turn the house around
4. You have successfully finished the first scenario, thank you the connection will be broken and you will be asked to fill in the questionnaire.
(The house built by the captain in the second scenario is similar to the first scenario but uses different colours and a different width and height. The added change is the hands of the doctor side which will, next to the verbal explanation, help point out the actions for additional support. The first and second scenario should have similar size house and number of actions to make them comparable.)

1.4 Scenario B - 2-way-AR lego

Side captain:

1. Call with the application
2. Say hello, confirm the connection
3. Ask for instructions

Side doctor:

1. Pick up
2. Say hello and confirm the connection
3. I will now start the instructions
 - a. Take the large green plate and put it in front of you
 - b. Take the small green plate and put this vertically next to the other green plate
 - c. Leave about 4cm space between the plates
 - d. Take the thin blue block and place it all the way to the right of the large green plate so that there are 2 circles open on the green plate underneath
 - e. Take the grey thin piece and place it all the way on the left of the small green plate, so that there are 3 circles free on the top and five on the bottom
 - f. Take the grey bridge part and place it from blue to the grey so that there is one circle left on the inside of both the thin plates, and place the grey part all the way to the bottom of the pieces
 - g. Take the white bridge part and place it directly behind the grey
 - h. Take the blue 8 circle block and place it in the middle and connect the grey and white part
 - i. Take the long red piece and place on the small green plate, vertically and so that it is directly connected to the grey and white bridge part so that the top red part aligns with the top of the white bridge
 - j. Take the yellow part and place it like the red block but mirrored, so that the bottom aligns with the bottom part of the grey bridge part
 - k. Take the white block with 8 circles and place it horizontally above the large yellow block, so that the left top of the yellow part and right bottom of the white part touch
 - l. Take the white part, 1 circle wide, and place it on the yellow block so that it overhangs 1 circle on the right top of the yellow block
 - m. Take the brown piece, 1 circle wide, and place it on the white block in the same direction so that it overhangs 2 circles on the right of the white block and 0 blocks on the left.
4. You have successfully finished the first scenario, thank you the connection will be broken and you will be asked to fill in the questionnaire.

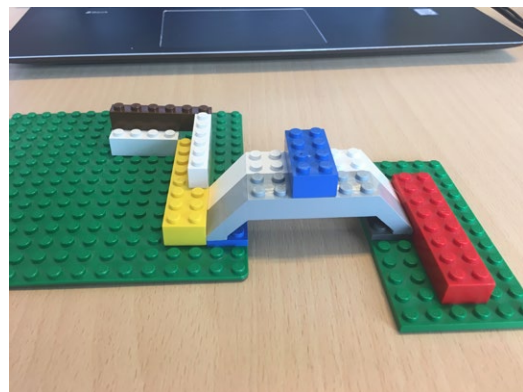

Figure X: Back side of bridge 2-way-AR scenario

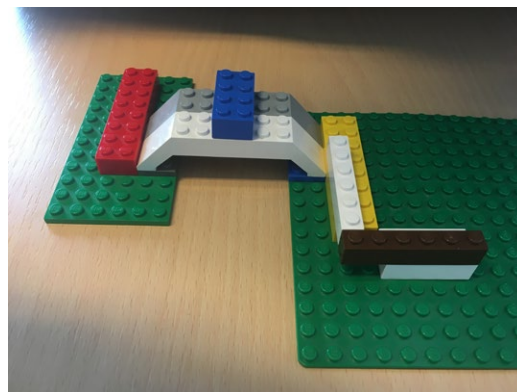

Figure X: Back side of bridge 2-way-AR scenario

1.5 Scenario C - 2-way-AR medical procedure

Intro (make them think about the experience in the training):

In the next scenario you will perform part of the actions related to an intramuscular injection. Have you already done an intramuscular injection in the training? Do you think it was one of more difficult procedures, or more easy? Can you remember the steps in the procedure?

For this test you will only go through a part of the steps, but this will be indicated by the prepared set of tools and the live connection with the doctor.

Side captain

1. Open the application
2. Call for help
3. Say hello, confirm connection

Side doctor:

1. Pick-up
2. Say hello and confirm the connection
3. To treat the patient you have to inject medicine with an intramuscular injection. The syringe with the medicine has been readied for you. You will now need to remove the air from the syringe, put the right needle on the syringe and inject the medicine.
 - a. Take the needle from the syringe
 - b. Put on the injection needle
 - c. Get the air from the syringe
 - d. Put on gloves
 - e. Disinfect the leg
 - f. Take a piece of leg
 - g. Push the needle in 2-3 cm at a 90 degree angle
 - h. Pull the syringe backward a little to check for blood
 - i. If no blood, push the medicine in in about five seconds
 - j. Pull the needle back with a smooth movement and massage the area with the gauge
 - k. Stick the gauge with tape
 - l. Release the needle in the needle container
4. You have successfully finished the third scenario, thank you the connection will be broken and you will be asked to fill in the questionnaire.



Figure X: Back side of bridge 2-way-AR scenario

1.6 Scenario B - 2-way-AR lego

Side captain:

1. Call with the application
2. Say hello, confirm the connection
3. Ask for instructions

Side doctor:

1. Pick up
2. Say hello and confirm the connection
3. I will now start the instructions
 - a. Take the large green plate and put it in front of you
 - b. Take the small green plate and put this vertically next to the other green plate
 - c. Leave about 4cm space between the plates
 - d. Take the thin blue block and place it all the way to the right of the large green plate so that there are 2 circles open on the green plate underneath
 - e. Take the grey thin piece and place it all the way on the left of the small green plate, so that there are 3 circles free on the top and five on the bottom
 - f. Take the grey bridge part and place it from blue to the grey so that there is one circle left on the inside of both the thin plates, and place the grey part all the way to the bottom of the pieces
 - g. Take the white bridge part and place it directly behind the grey
 - h. Take the blue 8 circle block and place it in the middle and connect the grey and white part
 - i. Take the long red piece and place on the small green plate, vertically and so that it is directly connected to the grey and white bridge part so that the top red part aligns with the top of the white bridge
 - j. Take the yellow part and place it like the red block but mirrored, so that the bottom aligns with the bottom part of the grey bridge part
 - k. Take the white block with 8 circles and place it horizontally above the large yellow block, so that the left top of the yellow part and right bottom of the white part touch
 - l. Take the white part, 1 circle wide, and place it on the yellow block so that it overhangs 1 circle on the right top of the yellow block
 - m. Take the brown piece, 1 circle wide, and place it on the white block in the same direction so that it overhangs 2 circles on the right of the white block and 0 blocks on the left.
4. You have successfully finished the first scenario, thank you the connection will be broken and you will be asked to fill in the questionnaire.

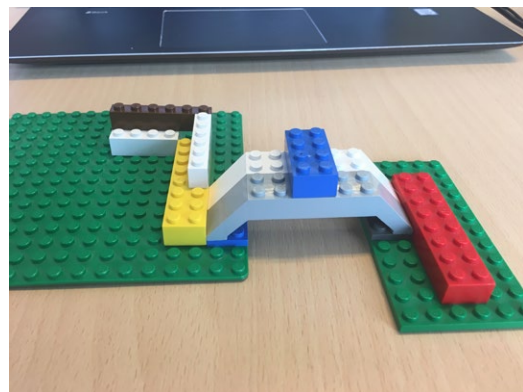

Figure X: Back side of bridge 2-way-AR scenario

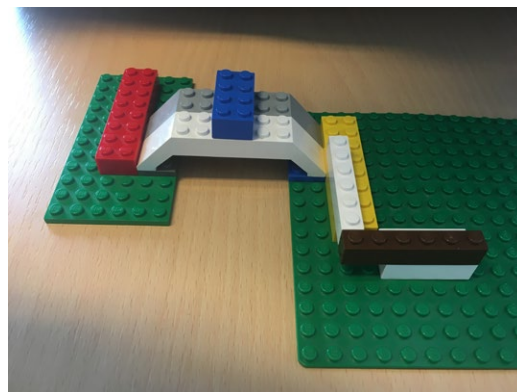

Figure X: Back side of bridge 2-way-AR scenario

1.5 Scenario C - 2-way-AR medical procedure

Intro(make them think about the experience in the training):

In the next scenario you will perform part of the actions related to an intramuscular injection. Have you already done an intramuscular injection in the training? Do you think it was one of more difficult procedures, or more easy? Can you remember the steps in the procedure?

For this test you will only go through a part of the steps, but this will be indicated by the prepared set of tools and the live connection with the doctor.

Side captain

1. Open the application
2. Call for help
3. Say hello, confirm connection

Side doctor:

1. Pick-up
2. Say hello and confirm the connection
3. To treat the patient you have to inject medicine with an intramuscular injection. The syringe with the medicine has been readied for you. You will now need to remove the air from the syringe, put the right needle on the syringe and inject the medicine.
 - a. Take the needle from the syringe
 - b. Put on the injection needle
 - c. Get the air from the syringe
 - d. Put on gloves
 - e. Disinfect the leg
 - f. Take a piece of leg
 - g. Push the needle in 2-3 cm at a 90 degree angle
 - h. Pull the syringe backward a little to check for blood
 - i. If no blood, push the medicine in in about five seconds
 - j. Pull the needle back with a smooth movement and massage the area with the gauge
 - k. Stick the gauge with tape
 - l. Release the needle in the needle container
4. You have successfully finished the third scenario, thank you the connection will be broken and you will be asked to fill in the questionnaire.



Figure X: Back side of bridge 2-way-AR scenario

1.7 Questions and questionnaires

After scenario 1 and 2:

	1. Totally disagree	2.	3.	4. Neutral	5.	6.	7. Totally agree
The explanation of the expert was easy to follow							
During the building I made very little mistakes							
I felt calm during the procedure							
The communication with the expert was very effective							
I had a lot of confidence during the building							
The building went very smoothly							
Building the bridge was easy							

Questions

Looking back at building both bridges, which, in your opinion, went better? And why?

What differences did you experience between the two scenario's?

What were positive and negative sides of the directions with the hands?

In what way(s) was AR an addition in the communication and guidance during the building?
Did you think it added value? Or do you think just a live connection is enough?

After scenario 3:

	1. Totally disagree	2.	3.	4. Neutral	5.	6.	7. Totally agree
The communication with the expert was very effective							
During the procedure I made very little mistakes							
I felt very calm during the treatment							
I had a lot of confidence during the treatment							
The hands of the expert were very helpful							
I would use application in a medical situation							

Questions

Can you compare the experience with the AR application compared to the training situation?
Was it easier or harder with the addition of AR?

Have you experienced the hands as a valuable addition and why?
Did you miss anything in the AR communication which could make it easier?
For examples tools at the expert side to aid the communication

What was it like to have someone viewing your actions live?

How did the AR experience differ in the medical scenario from building the bridge?

Do you see yourself use the application in the future? Why?

1.8 Results Test person 1

1. Seatrade
2. Captain
3. 43

Test 1

	1. Totally disagree	2.	3.	4. Neutral	5.	6.	7. Totally agree
The explanation of the expert was easy to follow							X
During the building I made very little mistakes							X
I felt calm during the procedure							X
The communication with the expert was very effective							X
I had a lot of confidence during the building							X
The building went very smoothly							X
Building the bridge was easy							X

Observations

- The explanation of the bridge building is not easy with just audio on the captains side, especially since there has not been discussed a protocol for communication
- Based on video
- o "That is because she is looking as well"
The expert is able to guide, especially correct and confirm the actions

Test 2

Observations

- Smooth test, better communication
- The hands make the captains side more patient, he is waiting more to see what is communicated before taking action. He is asking more question (might be because of the loss of audio)
- It seems to take longer(potentially due to the lack of training of the expert)
- Based on the video observations
- o "Deze platte hoor ik, dat zal die blauwe wel zijn"
He knows, based on the hands
Also the expert changes the communication because there are also the hands involved
- o The captain still relies a lot on the audio, is counting the circles on the legos to place everything right. The hands are not able to direct exactly where the legos should go.
- o Because of the position of the AR he is not able to look at the screen during his action. He checks the screen, than takes action
- o The position of the hands in relation to the legos, does not allow for the hands to point very well. A different camera set-up, for example from above, would maybe have made it easier to do.

	1. Totally disagree	2.	3.	4. Neutral	5.	6.	7. Totally agree
The explanation of the expert was easy to follow					X		
During the building I made very little mistakes						X	
I felt calm during the procedure							X
The communication with the expert was very effective						X	
I had a lot of confidence during the building							X
The building went very smoothly						X	
Building the bridge was easy						X	

Questions after test 1 and 2

1. Looking back at building both bridges, which, in your opinion, went better? And why?
The communication with the AR communication often dropped(audio) which made it hard to work with.
2. What differences did you experience between the two scenario's?
You knew later what to do without the hand because you could not see it –
The hands help, because it allows you to ask a question again if something was not clear.
3. What were positive and negative sides of the directions with the hands?
The hands did not bother me. She(the expert) did point at something, but you still (have to) check yourself based on the audio and hands. The hands are not that exact that you know exactly where to put it. The explanation by voice has already a lot of information in it.
4. In what way(s) was AR an addition in the communication and guidance during the building?
a. Did you think it added value? Or do you think just a live connection is enough?
It helped with asking the right questions when something was not clear. But in the and the actions take place on this side so you still have to do it and you still check everything to make sure it goes the right way.

Test 3

	1. Totally disagree	2.	3.	4. Neutral	5.	6.	7. Totally agree
The communication with the expert was very effective					X		
During the procedure I made very little mistakes							X
I felt very calm during the treatment							X
I had a lot of confidence during the treatment							X
The hands of the expert were very helpful							X
I would use application in a medical situation				X			

Observations

- o The ipad is even more in the way of the actions, really hard to work around
- o But this is the only way the ipad has a clear view of the whole situation
- o "Ik hoor niks, maar.." (clears air from syringe based on actions from hands on the screen)
- o Hard sometimes for the expert to perform guidance with hands when parts are outside the field of view
- o When setting the syringe in the ass, the captain is grabbing a piece of the muscle as indicated by the expert. Is then waiting for further instructions in a very weird position so he can keep watching the screen. It might be better to perform the tasks in steps, so the expert shows a few steps which are then performed by the captain and so on.
- o The expert is sometimes even a bit too slow because not everything is in screen and the audio delays. The app also seems to cut out a large part of the actual capabilities of the camera (side note). This was seen when testing the camera position with the tablet using the camera feature, and later seeing the actual view in the app.

Questions

1. Can you compare the experience with the AR application compared to the training situation?
 - a. Was it easier or harder with the addition of AR?

Overall it takes longer, because of the delay and audio loss. "Ik zou zelf een aantal handelingen doen en dan ben je al klaar met injecteren, nu duurt het extra lang".
 "De communicatie viel af en toe weg, maar daar hielpen de handen dan weer mee". He filled the gaps in the audio communication with the information from the hands. What you see and hear adds to each other.
 He could have done the medical procedure by hand because they just learned it, so this influences the coaching value of the app.

 2. Have you experienced the hands as a valuable addition and why?
 - a. Did you miss anything in the AR communication which could make it easier?
 - b. For examples tools at the expert side to aid the communication

I think for more complex scenarios it could be helpful. A complex action would be stitching for him. When you have to work sterile, and you might forget those, if someone is watching that could help. So the expert would have more of an overseeing role to check and coach when necessary.
 "Dus als er iemand mee kijkt, dat doen we normaal zelfstandig na de RMA, maar wat we nu doen is eigenlijk wel een beetje hetzelfde als in de training. Jacqoline (Trainster) kijkt mee en wij doen het een beetje, dat is eigenlijk een beetje hetzelfde.
 Could you interpret the hands easily?
 I did not always pay a lot of attention to the hands, but for example the squishing of the butt was very clear and easy to see. Also she can not see everything, I had already taken the needle from the syringe but this was outside the view so she told to do this. But the hands were helpful.

 3. What was it like to have someone viewing your actions live?

- In principle the doctor is giving directions, but in essence you can do it yourself which saves time
- In complex actions it could be helpful
- He felt no extra pressure from the expert watching, but he never experiences this he says

4. How did the AR experience differ in the medical scenario from building the bridge?

Not really, it is pointing in both scenario. The squishing of the skin was clear from the hands, even though the audio fell out sometimes there was still information which was helpful. If you can only listen and you miss a lot of words you it is much harder.

5. Do you see yourself use the application in the future? Why?

If you are filming, intimate parts, does the patient want this filmed? Who is watching on the other side at the doctor.

1.9 Test person 2

1. Jumbo
2. Captain
3. 49

They are testing with a HoloLens already to place special freight on board of the ship and help with the positioning.

Test 1

	1. Totally disagree	2.	3.	4. Neutral	5.	6.	7. Totally agree
The explanation of the expert was easy to follow							X
During the building I made very little mistakes						X	
I felt calm during the procedure							X
The communication with the expert was very effective							X
I had a lot of confidence during the building						X	
The building went very smoothly						X	
Building the bridge was easy						X	

Observations

- Just having an 'expert' being able to see what you are doing is already of tremendous value. This allows the two to communicate about the same situation
 - o It allows the expert to correct actions when they happen
 - o It allows the captain to take an action while asking for confirmation
- Overall this captain performs very well, the building went fast and seemed accurate. He was easily coached by the directions.

Test 2

	1. Totally disagree	2.	3.	4. Neutral	5.	6.	7. Totally agree
The explanation of the expert was easy to follow							X
During the building I made very little mistakes						X	
I felt calm during the procedure						X	
The communication with the expert was very effective						X	
I had a lot of confidence during the building						X	
The building went very smoothly						X	
Building the bridge was easy						X	

Observations

This captain is moving the ipad, as instructed to be allowed, so that the view best aids the communication. Also he is listening and watching the coaching and waiting for the instructions before taking action.

Asks for to repeat when necessary. "Je wijst m aan dus zal die zijn.." The communication drops but he still knows which piece of Lego to grab because of the hands

There is a slightly harder part in the second bridge, where the white piece with width one has to be put on the yellow block with an overhang of one circle. This is not completely clear to him from the explanation. From the video it is clear that the experts hands block the view to where she is pointing, at the same time, when the captain is putting the block down his hands are very much in the way for any more guidance.

Questions after test 1 and 2

- Looking back at building both bridges, which, in your opinion, went better? And why?
It does not matter so much, if the instructions are clear you cannot really go wrong. But, if you follow the instructions very literally you sometimes do not do what you think you should do and what she actually wants you to do.
- What differences did you experience between the two scenario's?
The hands are a double control for the builder. Especially good when something is hard. The hands help to confirm what you hear, if she says one to the right and points where it is makes it even clearer.
The situation is out-of-comfort for the captains and that is why the additional confirmation is so valuable.
You can use the pointing for extra info, but this is still not enough when the audio drops because then the pointing is not clear enough. Because of the audio loss, you at least know roughly what you have to do because of the video. Then the expert can see it and coach again to make it more exact, step by step.
- What were positive and negative sides of the directions with the hands?
If she points with her finger you still are not able to see it because the hand is in the way, due to the camera set-up.
- In what way(s) was AR an addition in the communication and guidance during the building?
 - Did you think it added value? Or do you think just a live connection is enough?
He thinks it can definitely be of added value the AR, because it is this out of comfort situation you are looking for confirmation,

the more the better basically.

"Het heft zeker een functie, omdat je gewoon een dubbele controle hebt?" (voor jou als bouwer?), Ja, en het is altijd fijn als je iets nieuws, en dan wat, dit is natuurlijk heel simpel met lego, om iets wat je niet vaak doet waar je uit je comfort zone bent om dan ook een beeld the hebben. Zet de snede 3 mm , of ze het dan ook nog even aanwijzen ik hoor het toch goed. Het gat vooral om ondersteuning bij praktijken die buiten onze comfort zone liggen. Voor nu maakt het niet uit, maar als het moeilijker wordt dat het zeker waardevol wordt.

Test 3

	1. Totally disagree	2.	3.	4. Neutral	5.	6.	7. Totally agree
The communication with the expert was very effective					X		
During the procedure I made very little mistakes							X
I felt very calm during the treatment							X
I had a lot of confidence during the treatment							X
The hands of the expert were very helpful							X
I would use application in a medical situation				X			

Observations

Also for this scenario this captain takes his time to readjust the camera position so that it matches the situation. He first turns the ipad away from the situation, so he can sit and see the screen and the patient. But then realises the expert cannot see the situation so he readjusts.

Also here the ipad is almost positioned behind the captain while doing his actions. So he can not see then hands during the actions. The hands work very well to point a specific are on the patient butt for example to make clear where to do. Actions like taking the cover of the needle do not really need the hands. Overall the captain is very quiet in the scenario, not really asking questions a lot. Just listening and taking actions sometimes confirming he reached the step.

He has already taken the needle of, but the expert has not seen this so when she asks he has to explain he has already done it. Maybe also requires the captain to explain more of what he is doing.

Questions

- Can you compart the experience with the AR application compared to the training situation?
 - Was it easier or harder with the addition of AR?
The captain left some air in the syringe, after having been instructed to remove the air there was still some left. After the test I asked him if he had noticed the air to which he responded with "yes". So, I asked if he had considered to take the air from the syringe, to which he responded "I did not really think about it". From where he continued it should not matter, since it was very little and intramuscular, not intravascular. But, it is clear that he was already relying on the experts instructions and corrections. You cannot compare the training situation with the AR app scenario. Because you start to start to rely on the expert on the other side. Some things you think about and others you do not. He did think about removing the needle without instruction but did not consider to remove the last bit of air from the syringe.
You are not thinking about everything anymore
 - Have you experienced the hands as a valuable addition and why?
 - Did you miss anything in the AR communication which could make it easier?
 - For examples tools at the expert side to aid the communication

Did not really miss anything

It would be even better if you could put the screen behind the patient, so you can watch the patient and the screen at the same time, but it would require a webcam of some sort.

He did not think the AR was a really supportive. He does think it could help very well is when you can put the screen behind the patient.

3. What was it like to have someone viewing your actions live?

He thought it was 'prettig' to have someone watch his actions, it creates confidence that there is someone watching with you. He says he assumes the other person is more trained and experienced than you are and that creates the added confidence.

He also believes having someone perform the actions with you is an added value, not just having someone watch. Even if it is just that little bit of extra confirmation, you are still out of the comfort zone. It has to do with humans, and it is something you never hope to do. But the extra eyes really help. In the future we might also sail more with foreigners and it is the question if you can rely on the rest of the crew.

4. How did the AR experience differ in the medical scenario from building the bridge?

The medical scenario is much more specific, the lego is relatively simple, in the information in the steps. Also the work area is much larger which requires you to steer the camera along during the actions.

5. Do you see yourself use the application in the future? Why

2.1 Conclusions

Test person 1

- Compared to building with skype
- o Thought the explanation was harder to follow
- o Felt he made slightly more mistakes
- o The communication was not as effective
- o The building went not as smooth
- o It was slightly harder to build the bridge
- The hands do add clarity, which is clear when the audio drops. Pointing to the lego's works well
- The captain is still relying a lot on the audio, later he explains the hands are not exact enough
- During action it is hard to look at the screen at the same time
- Audio drop is a big issue
- Without the hands he felt like he had to wait longer before knowing what action to take
- o But the hands are not the final guide, he still relied on his own accuracy
- o The AR also helped to ask the right questions, when the audio drops

- For the third test the scales are very positive. All of them are totally agree, except the communication was not very effective and he is uncertain about the use in the future. The results can partly be attributed to the fact they had just learned the skill in training,
- The iPad is in a very uncomfortable position
- Because he knew the skill from the training, he had to wait a lot on the expert. So the coaching from the expert should not always be a step by step









Test person 2

- Compared to the first scenario he feels slightly less calm with the AR and felt the communication was slightly less effective
- Observation: Just having an expert see what you do is already of tremendous value
- o Allows for corrections live in the actions
- o Allows for the captain to ask for confirmation
- Also hear uses the hands to fill the audio loss
- The hands of the expert clearly block the view of the captain
- He feels there is not much difference between the AR and non-AR both are very clear
- The AR add an extra layer of control
- o Especially good in more difficult scenarios, it is extra confirmation

- In the medical scenario he feels very confident, the communication is not very effective and he is neutral if he would use it in a medical situation
- The iPad is very much in the way
- The iPad is not moving with the captain so sometimes actions happen outside the field of view of the captain Screen behind patient
- Start relying on the expert(Syringe)
- Neither minded having someone watching, the second captain really liked the extra pair of eyes

Appendix F

Acute vs non-acute medical scenarios

-Non Acute	Judge & Stabilise	Analyse & diagnose	Treatment	After care							
The narrative	There is an incident on board which requires medical attention. Immediate action is taken to judge the status of the patient, stabilise him and prepare for the next step.	In the analyse and diagnose phase the patient is researched in more detail, additional information is gathered on the patient to help build a good diagnose	Apart from the first treatment actions in the Judge and stabilise phase, this is the phase during which the next steps of treatment are taken based on the diagnose and advice	During the aftercare the patient is reviewed on their progress by analysing some of the vitals which are also considered during the analyse and diagnose phase							
The actions	Captain <ol style="list-style-type: none"> 1. Is notified about the incident 2. Approaches patient (SAFE) 3. Goes through a fast ABCD 4. If necessary contact RIMS 5. Treat what kills first 	Doctor <ol style="list-style-type: none"> 1. In the current set-up the doctor has no responsibility at this point yet 	Doctor <ol style="list-style-type: none"> 1. Accept contact captain 2. Review the data given by the captain 3. Ask additional questions 4. Form a diagnose 	Doctor <ol style="list-style-type: none"> 1. Give the best information on possible 	Doctor <ol style="list-style-type: none"> 1. If necessary review the progress of the patient 	Patient <ol style="list-style-type: none"> 1. Give best information on possible 					
THOUGHTS/ CONCERNS	Captain <ol style="list-style-type: none"> 1. Feels uneasy 2. Is likely to see a situation he has never seen before 	Doctor <ol style="list-style-type: none"> 1. Feels uncertain about the steps 2. Looking for support 3. Hopes he is doing it right 4. Feels good to share some responsibility 	Doctor <ol style="list-style-type: none"> 1. Feels he has limited information to make a decision 2. Questions the accuracy of the captain 3. Concerned about tunnel vision 4. Feels pressure to make the right decision 	Doctor <ol style="list-style-type: none"> 1. Wonders if he gave the right advice 2. Hopes the captain can follow the advice he gave 	Doctor <ol style="list-style-type: none"> 1. Did I do a good job? 	Doctor <ol style="list-style-type: none"> 1. Know the status of the patient 2. The response to the treatment complications which might have arisen 	Doctor <ol style="list-style-type: none"> 1. Will I have any after effects? 				
Emotion											
Interactions with others	Communicates with patient Communicates with other colleagues	-	Talk with captain patient physically and through questions Talk with doctor over phone Ask more questions	Talk with captain over the phone	Talk with captain	Communicate actions with patient	-	Communicate with doctor	Communicate with patient Talk with doctor on phone Communicate with patient	Talk with captain over phone	Communicate with doctor
INFORMATION NEEDED/LOOKING FOR	<ol style="list-style-type: none"> 1. What happened 2. Any major complications which have to be taken care of 3. Confidence and positive feeling 	<ol style="list-style-type: none"> 1. Treat what kills first 2. First impression 	<ol style="list-style-type: none"> 1. Will I be alright? 	<ol style="list-style-type: none"> 1. Looking for more certainty in his analyses (klankbord) 2. Need a clear diagnose of all indications the patient is dealing with 	<ol style="list-style-type: none"> 1. Live response to the analyses 2. An indication of the level and quality of the captains measurements 	<ol style="list-style-type: none"> 1. Certainty in the diagnosis 	<ol style="list-style-type: none"> 1. Guidance and confirmation during the practicing of the skills 2. Warnings if the status of the patient changes during treatment 	<ol style="list-style-type: none"> 1. Live response of the patient to the treatment 2. Feedback if the captain is doing the treatment right 	<ol style="list-style-type: none"> 1. Confidence that the captain is able to treat him well 	<ol style="list-style-type: none"> 1. Confirmation and feedback about the treatment on how to evaluate the patient 2. Information on how to evaluate the patient 3. Any other complications which might have arisen 	<ol style="list-style-type: none"> 1. The next steps in his treatment 2. The duration of recovery 3. Any future side-effects
METAPHOR for the communication between doctor and captain	<p>"The encouraging nod of your parents in the crowd right before you are about to perform"</p> <ul style="list-style-type: none"> - You have to do it - You are not alone - There will be support after - We know what happened 		<p>"The math teacher walking through class ready to answer your questions and sometimes looking over your shoulder to check if you are doing it right and to give some tips"</p> <ul style="list-style-type: none"> - You have to do it - Support nearby to fall back on - Confirmation and guidance if needed - Overview of the process 		<p>"The chief in surgery looking over the shoulder of the resident who is performing the surgery"</p> <ul style="list-style-type: none"> - 2 pair of eyes see more than one - Confirm & correct/guide - Overview of the situation - Control remains with the actor - Expertise is used to keep control over situation 		<p>"The more experienced hairdresser comes to review the work of the student hairdresser"</p> <ul style="list-style-type: none"> - The results are reviewed and discussed with a more experienced person - There is room for additional input from the customer - Confirmation, tips and next steps can be given 				

Acute	Judge & Stabilise		Analyse & diagnose		Treatment		After care					
The narrative	There is an incident on board which requires immediate medical attention with a fast response to secure the safety of the patient. Immediate action is taken to judge the status of the patient, stabilise him and treat what kills first so the patient is stable for the next step.		In the analyse and diagnose phase the patient is researched in more detail, additional information is gathered on the patient to help build a good diagnose		Apart from the first treatment actions in the judge and stabilise phase, this is the phase during which the next steps of treatment are taken based on the diagnose and advice		During the aftercare the patient is reviewed on their progress by analysing some of the vitals which are also considered during the analyse and diagnose phase					
The actions	Captain	Doctor	Patient	Captain	Doctor	Patient	Captain	Doctor	Patient			
	6. Is notified about the incident	In the current set-up the doctor has no responsibility at this point yet	3. Respond to the questions of the captain	3. Go through ABCDE in more detail	5. Accept contact captain	2. Give the best information possible	3. Prepares the treatment steps provided by the doctor	In the current set-up the doctor has no responsibility at this point yet	3. Accept the treatment	3. Get the first new measurements of the patient	2. If necessary review the progress of the patient	2. Give best information possible
	7. Approaches patient (SAFE)		4. If possible explain the event	4. Fill in AMPLE by the captain	6. Review the data given by the captain	4. Additional questions	4. Goes through the steps of the treatment with the skills learned in training		4. Provide best feedback possible	4. If necessary consult with doctor		
	8. Goes through a fast ABCD				7. Ask additional questions							
	9. If necessary contact RMS				8. Form a diagnose							
	10. Treat what kills first											
	11. Exception: no heart beat or breathing or large wounds											
THOUGHTS/ CONCERNS												
	3. Feels uneasy		3. Is scared	5. Feels uncertain about the steps	5. Feels he has limited information to make a decision	2. Questions the ability of the captain	4. Feels out of his depth/insecurity	3. Wonders if he gave the right advice	2. Wonders if the captain can fulfill the treatment to save his life	2. Did I do a good job?	2. Is the patient stable?	2. Will I have any after effects?
	4. Is likely to see a situation he has never seen before		4. Hopes he gets the best care	6. Looking for support	6. Questions the accuracy of the captain		5. Wonders if he can still do the actions learned in training	4. Hopes the captain can follow the advice he gave				
				7. Hopes he is doing it right	7. Concerned about tunnel vision		6. Feels left alone from the previous step					
				8. Feels good to share some responsibility	8. Feels pressure to make the right decision							

Emotion												
Interactions with others	Communicates with patient Communicates with other colleagues	-	Talk with captain	Communicate with patient physically and through questions Talk with doctor over phone Ask more questions	Talk with captain over the phone	Talk with captain	Communicate actions with patient	-	Communicate with doctor	Communicate with patient Talk with doctor on phone Communicate with patient	Talk with captain over phone	Communicate with doctor
INFORMATION NEEDED/LOOKING FOR	4. What happened 5. Any major complications which have to be taken care of 6. Confidence and positive feeling	Treat what kills first First impression	2. Will I be alright?	3. Looking for more certainty in his analyses (Klankbord) 4. Need a clear indication of all indications the patient is dealing with	3. Live response to the analyses 4. An indication of the level and quality of the captains measurements	2. Certainty in the diagnosis	3. Guidance and confirmation during the practicing of the skills 4. Warnings if the status of the patient changes during treatment	3. Live response of the patient to the treatment 4. Feedback if the captain is doing the treatment right	2. Confidence that the captain is able to treat him well	3. Confirmation and feedback about the treatment 4. Information on how to evaluate the patient	4. Know the status of the patient 5. The response to the treatment 6. Any other complications which might have arisen	4. The next steps in his treatment 5. The duration of recovery of future side-effects
METAPHOR for the communication between doctor and captain	"The encouraging nod of your parents in the crowd right before you are about to perform" - You have to do it - You are not alone - There will be support after - We know what happened			"The math teacher walking through class ready to answer your questions and sometimes looking over your shoulder to check if you are doing it right and to give some tips" - You have to do it - Support nearby to fall back on - Confirmation and guidance if needed - Overview of the process			"The chief in surgery looking over the shoulder of the resident who is performing the surgery" - 2 pair of eyes see more than one - Confirm & correct/guide - Overview of the situation - Control remains with the actor - Expertise is used to keep control over situation				"The more experienced hairdresser comes to review the work of the student hairdresser" - The results are reviewed and discussed with a more experienced person - There is room for additional input from the customer - Confirmation, tips and next steps can be given	

Appendix G

Sketches doctor set-up

Hypothesis:

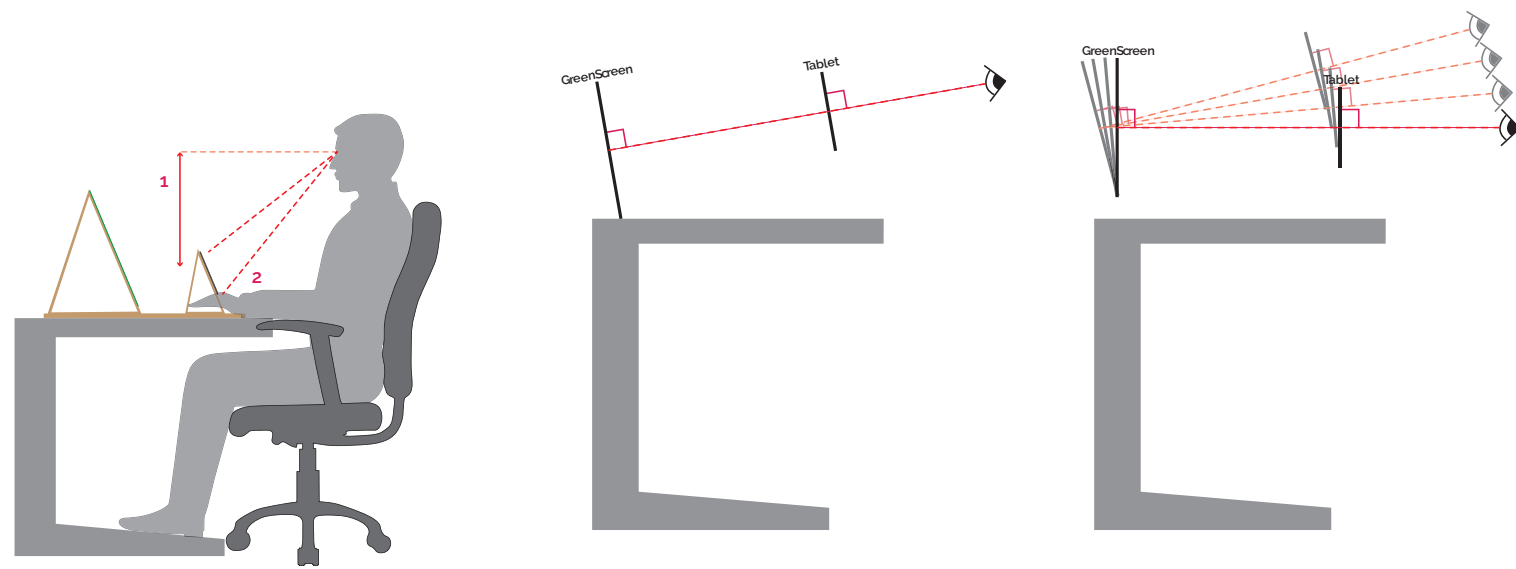

Side view test set-up

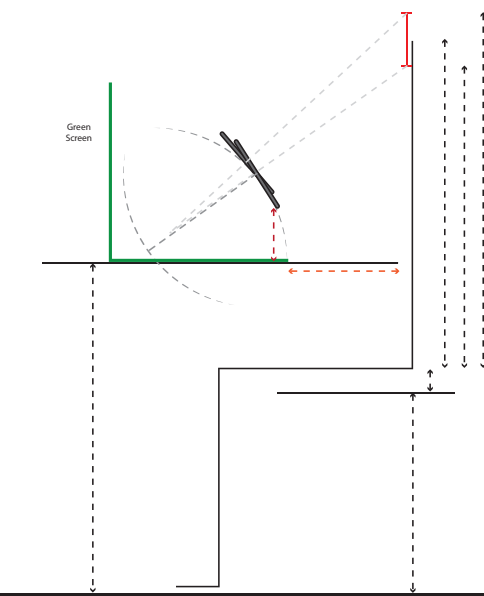
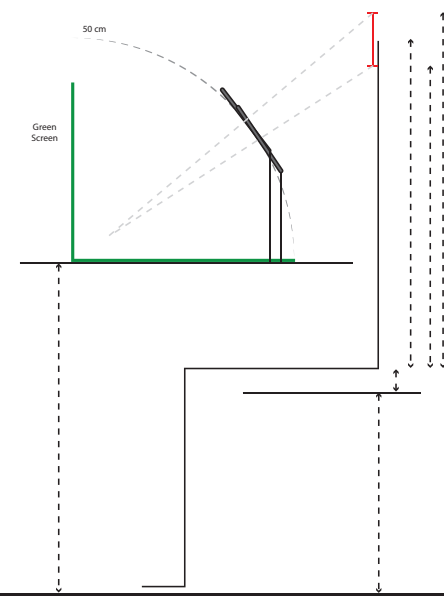
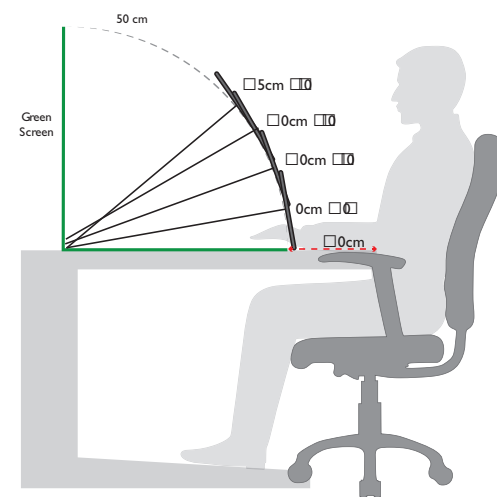
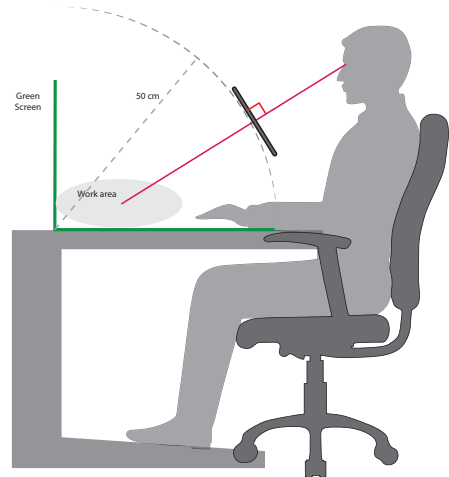
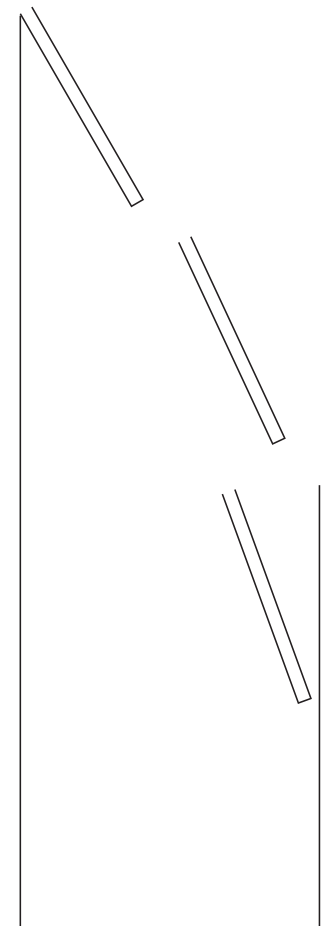
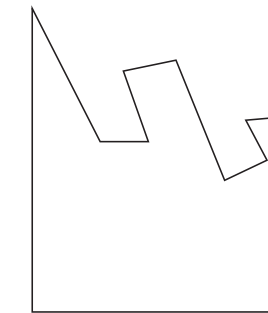
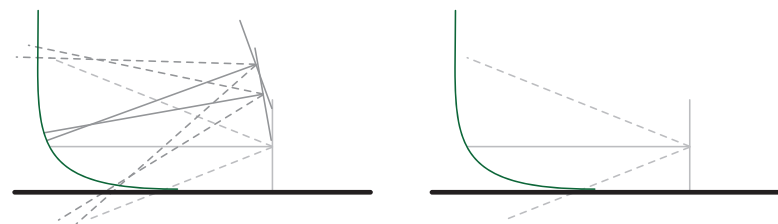
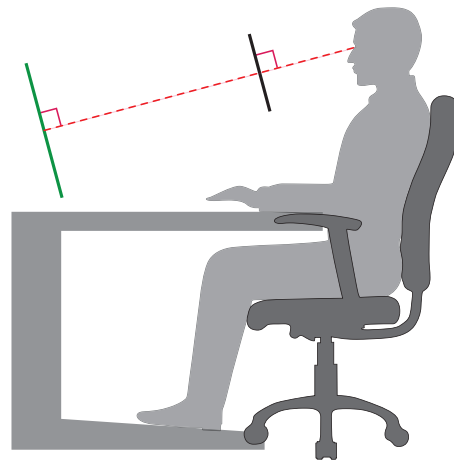
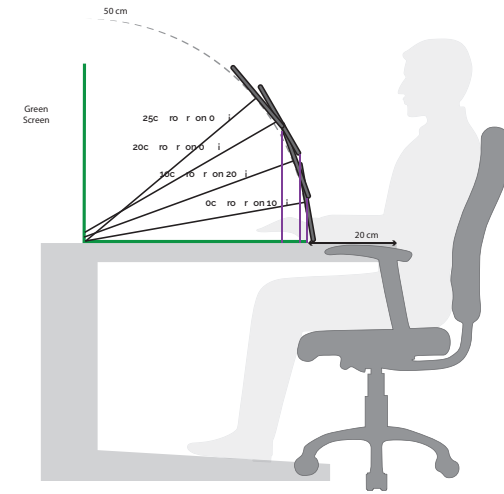
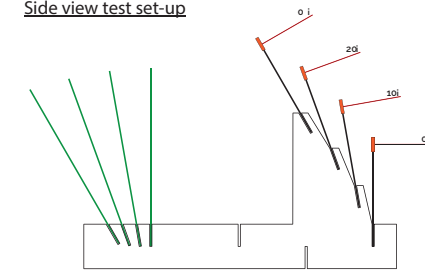

Appendix H

Mallen test set-up

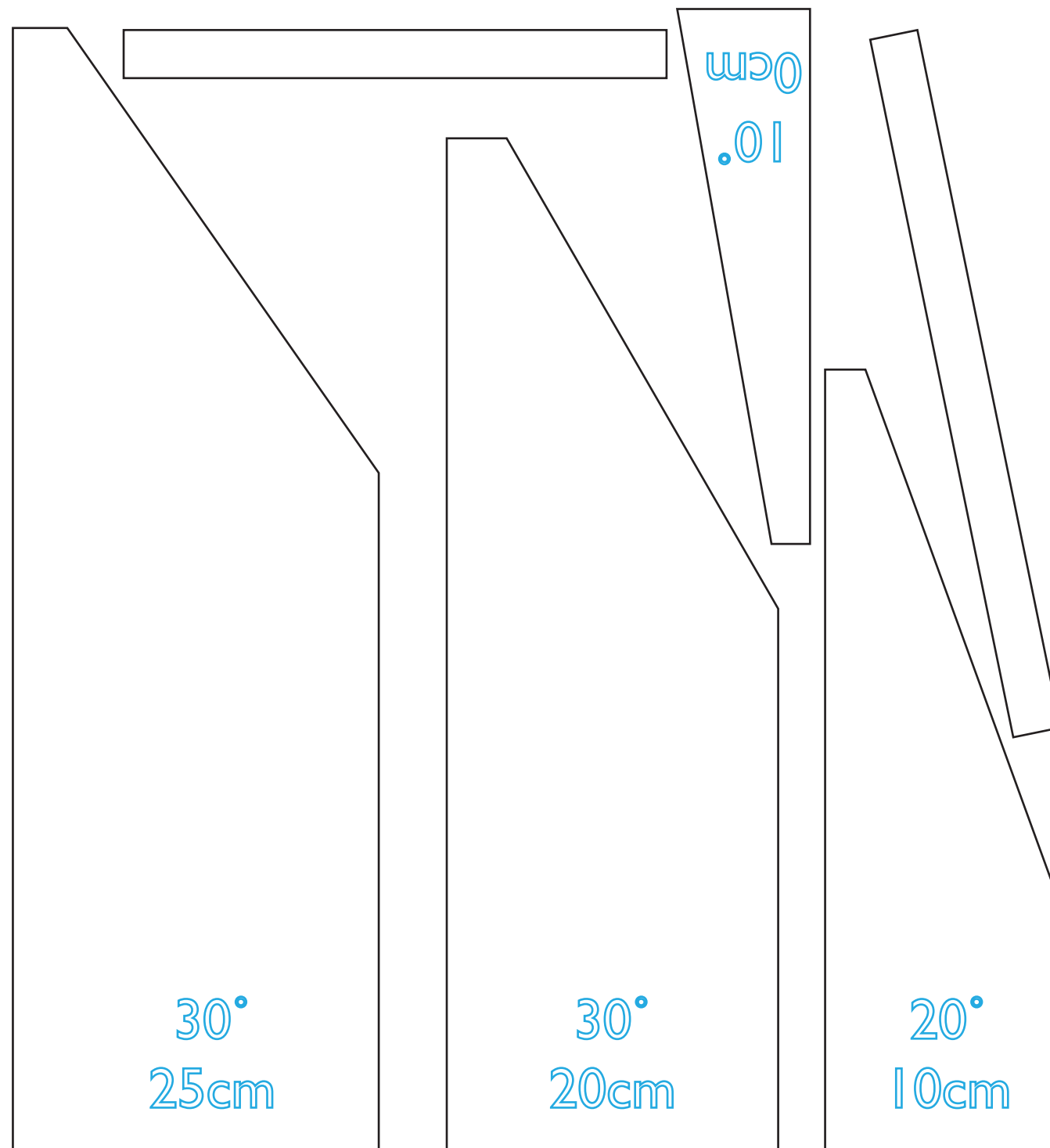

Appendix I

Test set-up tablet position doctor

1.1 Set-up

Where and When: 22/10 at the University of technology in Delft

Participants: 10 students of different heights

Documentation: Camera with stand, questionnaires, candy/drinks

Required props:

- Camera, charger with battery
- Stand
- Candy
- Tablets
- Tablet stand

Triangulation

Scope:

The scope of this test is to learn more about the tablet position which is preferred for the doctor. The main parameters are the distance between the eyes and iPad, the height of the table or height difference with the eyes and the angle of the tablet. The original scope for this test was testing various angles of the iPad, which automatically changed the height of the iPad in relation to the person. But, the test set-up proves to be not ideal for testing and the height of the tablet changes so much it becomes too high to look at. For the test 3 set-ups will be compared to see what gets the best results and work from there to learn more about the adjustability of the height and angle.

Goal:

The goal of the test is to find out where the doctor wants the iPad to be positioned so they can reach far enough with their hands, control the size of their hands and at the same time look at the iPad comfortably.

Hypothesis: The hypothesis is that the doctor would like to have the iPad in a 90 degree angle with his view to his work area as shown in the image below. There needs to be an area of the green screen which is 50cm from the tablet.

Relevant parameters

1. Height person
2. Height chair
3. Height table
4. Length arms
5. How much they have to lift their arms
Strain on neck, shoulders and arms
6. Smoothness of moving hands
7. Speed of performing the task

Observations

The observations of this test are focused on the position of the arms, neck and head to see if there are any unnatural positions. The other focus is to see if they can keep looking at the screen comfortably. One important observation is which of the 4 set-ups is closest to the hypothesis. The 20cm from ground at 30 degree and 25cm from ground at 40 degree are especially important as those are closest to the sketched based on the Dined data. The 20cm is important as this, together with the 50cm reach to the green screen is the max reach people have based on Dined data.

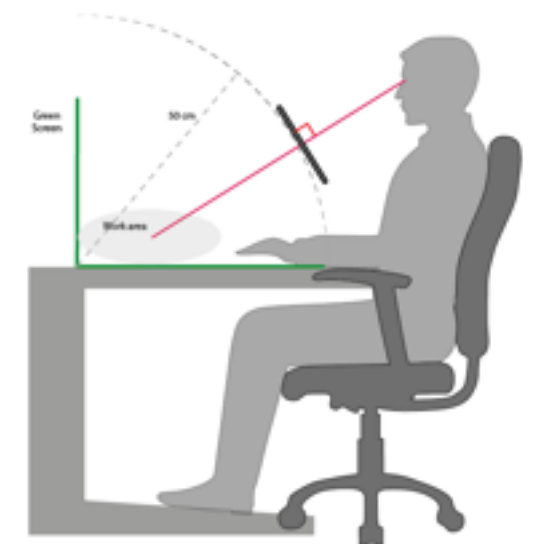

Set-up

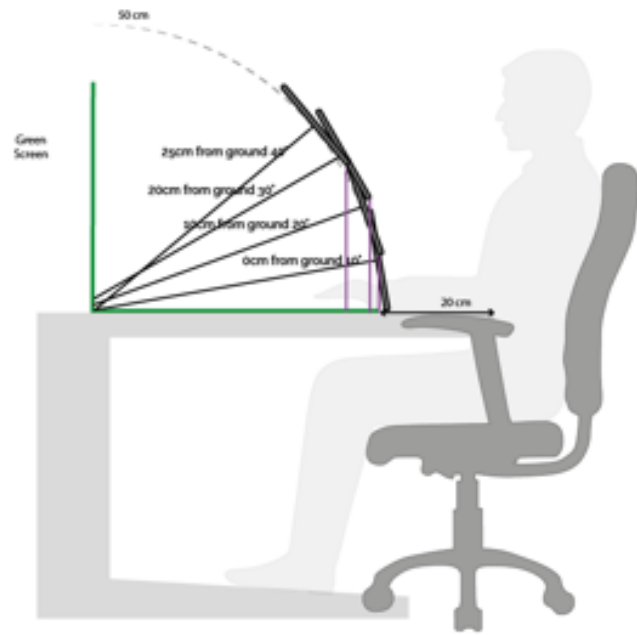

Localised Postural Discomfort Form (Heleen H. Hamberg-van Reenen et.al)
Revised by Applied Ergonomics & Design Section, Delft University of Technology

1. Concentrate on your body and try to perceive discomfort in each of the body regions.
2. For each, choose a word that represents the amount of discomfort at best per body region.
3. Choose the rating of discomfort that belongs with the chosen word representing the amount of discomfort.

Example:

7 = very high discomfort
6 = dreadful discomfort
5 = high discomfort
4 = somewhat high discomfort
3 = moderate discomfort
2 = little discomfort

This rating means that you feel somewhat high discomfort on your right eye, and feel moderate discomfort on your left eye.

maximum
10 = extreme discomfort
(almost maximum)
9 =
8 = horrible discomfort
7 = very high discomfort
6 = dreadful discomfort
5 = high discomfort
4 = somewhat high discomfort
3 = moderate discomfort
2 = little discomfort
1 = very little discomfort
½ = extremely little discomfort
0 = no discomfort at all

Instrument: Laparoscopic Box Laparoscopic simulator Virtual Operation Room

Evaluation

NASA Task Load Index (TLX) method assesses mental load on five 7-point scales. Increments of high, medium and low estimates for each point result in 21 gradations on the scales. Please marking an "X" in the appropriate box.

Mental Demand How mentally demanding was the task?

1.	2.	3.	4.	5.	6.	7.	8.	9.	10.	11.	12.	13.	14.	15.	16.	17.	18.	19.	20.	21.
Very Low										Very High										

Physical Demand How physically demanding was the task?

1.	2.	3.	4.	5.	6.	7.	8.	9.	10.	11.	12.	13.	14.	15.	16.	17.	18.	19.	20.	21.
Very Low										Very High										

Temporal Demand How hurried or rushed was the pace of the task?

1.	2.	3.	4.	5.	6.	7.	8.	9.	10.	11.	12.	13.	14.	15.	16.	17.	18.	19.	20.	21.
Very Low										Very High										

Performance How successful were you in accomplishing what you wanted to do?

1.	2.	3.	4.	5.	6.	7.	8.	9.	10.	11.	12.	13.	14.	15.	16.	17.	18.	19.	20.	21.
Very Low										Very High										

Effort How hard did you have to work to accomplish your level of performance?

1.	2.	3.	4.	5.	6.	7.	8.	9.	10.	11.	12.	13.	14.	15.	16.	17.	18.	19.	20.	21.
Very Low										Very High										

Frustration How insecure, discouraged, irritated, stressed, and annoyed were you?

1.	2.	3.	4.	5.	6.	7.	8.	9.	10.	11.	12.	13.	14.	15.	16.	17.	18.	19.	20.	21.
Very Low										Very High										

Questionnaire

1. How tall are you?
2. Height of the table
3. Height of the seat
4. Arm length

Open questions

- Did the position of the iPad influence your actions a lot?
- Did you feel like the tasks were straining in any of the scenarios?
- What is your preferred position of the iPad?
- Did you for any scenario feel the iPad was in a strange position?
- Did you for any of the set-ups feel like the iPad was hard to

Appendix J

Test results tablet position doctor

1.1 Results

	1	2	3	4	5
Length(cm)	182	170	182	178	182
Arm length(cm)	64	60	61	62	62
Age(years)	26	46	42	20	36
Gender(M/F)	M	F	F	M	M
Height of table(cm)	75.5	75.5	75.5	75.5	75.5
Height of seat(cm)	44	44	44	44	44

Table X: participants doctor set-up test

The test was performed with five participants with a relatively small height variation with 4 out of five participants being around 180 cm and one being 170. The different age groups are relatively well represented with 2 in their 20's, 1 in his 30's and 2 in their forties with a 2 vs. 3 female male distribution.

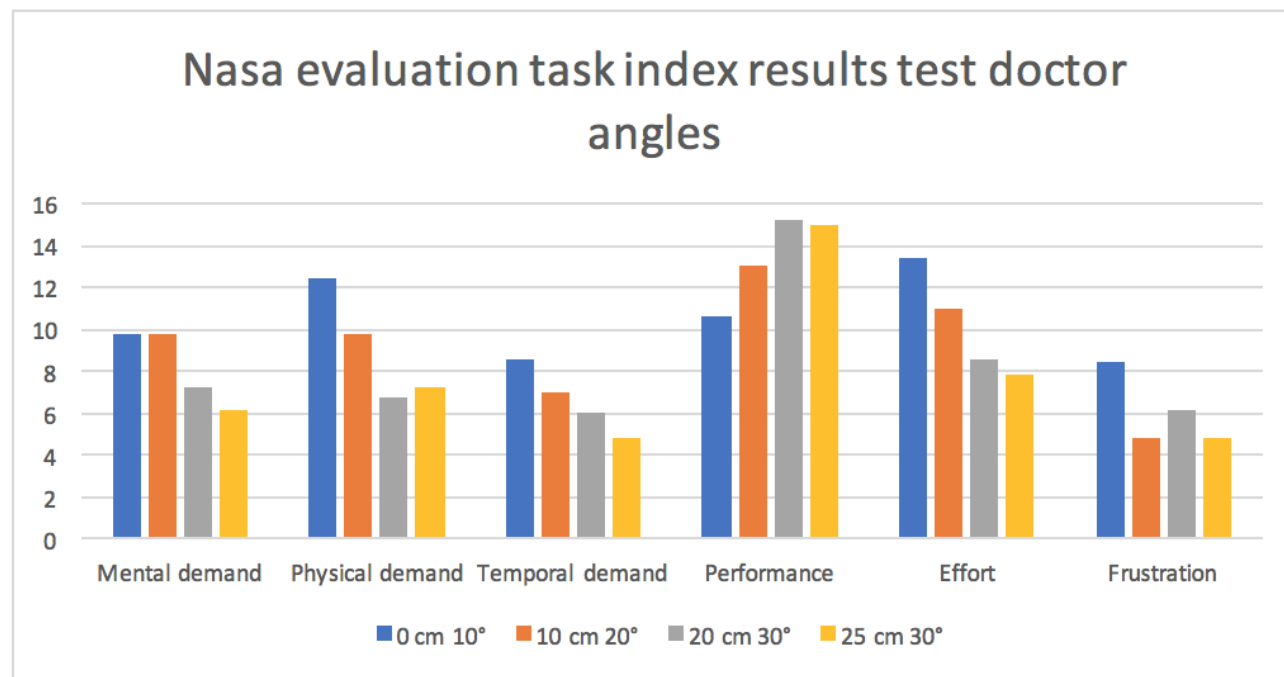

Mental demand is a lot lower for scenarios 3 and the same holds for the physical demand, these both are confirmed with the evaluation of effort which is also scored by far the best for the 3rd and 4th set-up

- o For temporal demand the trend line over the four scenarios is similar. Temporal demand refers to how rushed or hurried the task felt. There was no additional pressure in any of the scenarios, just the additional mental and physical demand, this might have led to the feeling that it took longer to achieve the desired results.

For performance the results reflect the same trend only in the opposite direction and the perceived performance was highest in set-ups three and four.

- o The highest performance and previously mentioned feeling of rush is not necessarily reflected in the times spent per scenario. Looking at the averages (if scenario is corrected for one high outlier) scenario two, three and four show very similar times. Also looking at the graph in figure X, it is clear that the results per scenario have very similar distributions and there are no significant differences.

Time

Times(s)	Participant 1	Participant 2	Participant 3	Participant 4	Participant 5	Average
Scenario 1	115	76	68	60	57	75.2
Scenario 2	95	81	65	44	45	66
Scenario 3	85	141	78	40	39	76.6/64.4
Scenario 4	86	57	71	49	55	63.6

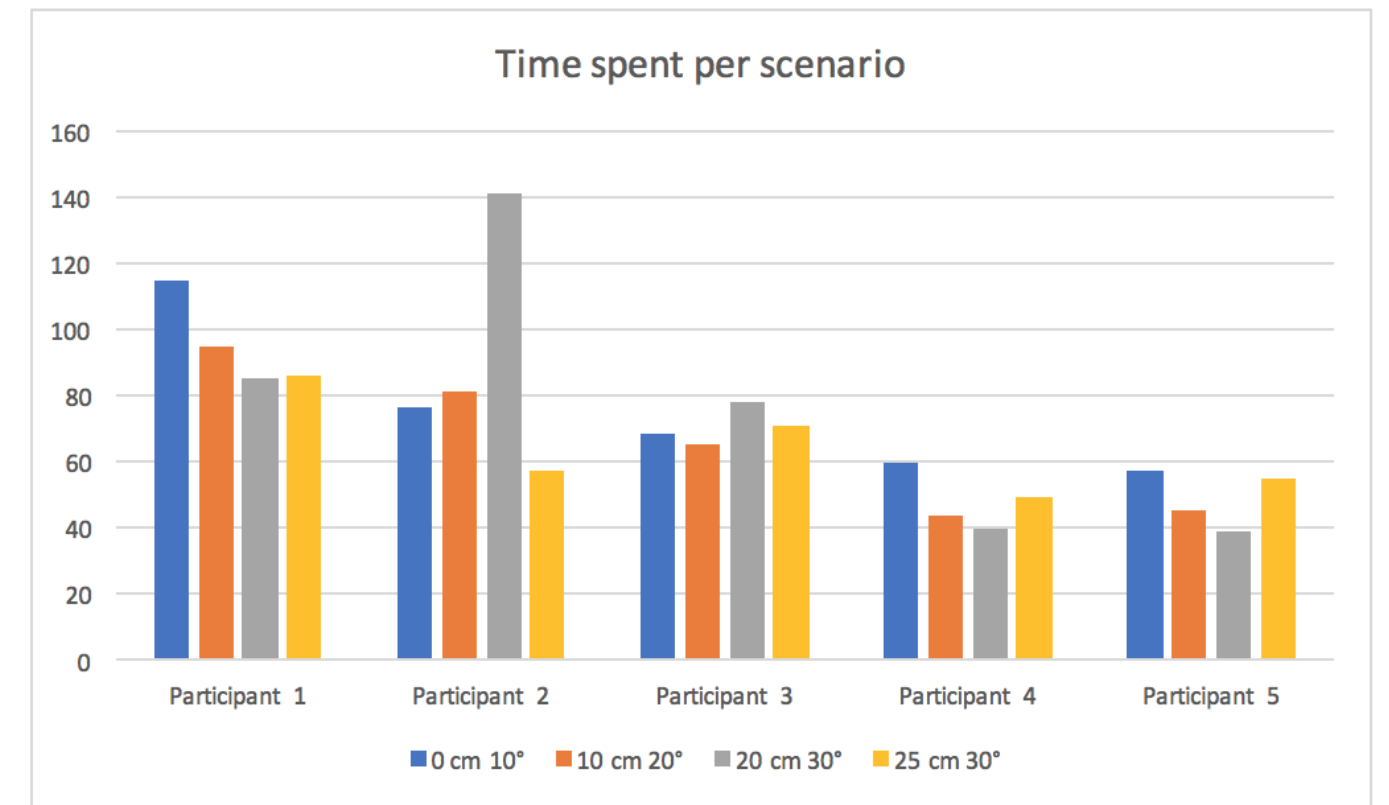

Figure X: Time in seconds spent per scenario per participant

The times spent on the activities per scenario per participant have been depicted in table X and graphically represented in figure X. The grouped bars look very similar for every scenario, meaning the participants scored every scenario very similarly just on other levels. This is also confirmed by looking at averages. If correcting for the outlier in scenario 3 by participant 2, move from 141 to 81 which is in line with the times of this participant in the other scenarios in relation to the other participants (between participant 1 and 3) than the average times of scenario two, three and four are all roughly 65 while scenario 1 is the clear outlier at 75.

Results interviews

Did the position of the iPad influence your actions a lot? Why?

Was there any scenario which you felt went much better than the others?

1.Participant 1

- a.Scenario 3 were easiest, arms and hands can move underneath, more room to go in the depth of the work area

Did you feel like the tasks were straining in any of the scenarios?

1.Participant 1

- a.You have to check what to do but it is not straining or hard. No cramps or complaints in shoulders or arms

What is your preferred position of the iPad?

1.Participant 2

- a.iPad more or less at eye level is better, sometimes you have to move forward with the body a bit and it is easier to keep the iPad in view than.
- b.4 or 3 were the best, easier to get the hands in position without any physical strain.

2.Participant 4

- a.3rd highest is best, 4th was also good. But the third was easiest

3.Participant 5

- a.3rd scenario was best, easy to go underneath with his hands and large volume to work in with the hands

Did you for any scenario feel the iPad was blocking your actions? Why?

1.Participant 1

- a.Scenario 1, the table gets too close so you cannot achieve all scenarios

2.Participant 2

- a.With the lowest iPad position you cannot achieve all scenarios
- b.When the hands are further away it is not so much a problem because there is still freedom underneath the iPad in other scenarios

3.Participant 3

- a.iPad in both scenarios 1 & 2 is bit low to move freely underneath. Especially with 1 and in combination with the iPad stand it is hard to get the iPad in the right position.
- b.The iPad stand was blocking some of her actions to make the right angle with her arm

4.Participant 5

- a.In scenario 1 the work area was not large enough

Did you for any of the set-ups feel like the iPad was hard to focus on?

1.Participant 1

- a.I focusses only on the iPad, did not look at his hands just through the iPad.
- b.Distance iPad to eyes was perfect

2.Participant 2

- a.She really had to twist her body, but did not have problems to focus on the iPad well
- b.She only looked at the iPad not at the

3.Participant 3

- a.No problem to see the iPad and keep focus on the iPad.

4.Participant 4

- a.Sometimes the iPad came a bit close when he had to reach with his hands
- b.Only looked at the iPad

5. Participant 5

- a.Slightly confusing that the tablet camera is not in the centre

By far, the 3rd and 4th scenario are the preferred setups as they give the most room underneath the iPad to move the hands around freely. In the 1st set-up the iPad is at table level, so when they have to reach with their hands they start hanging over the iPad and can no longer see the iPad very well. Also the width of the iPad in combination with the arm in the set-up was hindering the actions of the participants. The other issue with the first set-up was that they were not able to achieve all actions was because the work area was too small, the green screen was too close to the camera. The second scenario did not have the issue of the work area being too small but the participants do feel they do not have enough room underneath the iPad to work with.

All of the participants have no problems keeping their eyes on the iPad in any of the set-ups. Only participant 4 mentions that the iPad comes a bit close to the face when having to reach for some of the farther actions. In the observations it is clear that, though the participants feel they can keep their focus on the iPad they do have to move to twist and turn their bodies in some scenarios to keep their view on the iPad. Keeping a good view on the tablet is key as all only look at the iPad when performing their actions, not their physical hands.

Observations

Distance between iPad and eyes in different scenarios

Head position, moving head back or forth to focus

Changing focus of eyes between iPad and live hands

Ability to reach to end of green screen

The iPad is often too close to the head, the participants have to lean forward to perform some of the actions and because of this get really close to the tablet(Figure X). For this reason they sometimes struggle to keep their eyes on the iPad. This makes for some weird positions they have to put themselves in(Figure X). Even though the participants say they had no problem keeping their focus on the iPad, the set-up shows it does require some effort.



Appendix K

Test set-up stitching

1.1 Set-up

Where and When: Monday 24/10 or Wednesday 26/10 in the back of the training room and in the 2nd meeting room at the office/training location of MedAssist.online

Participants: 2 captains from the ECMT training program

Documentation: Questionnaire, Recordings with the camera for video and photos.

Required props:

- Green screen
- 2 iPads
- 2 iPad stands
- Procedure material
 - o Pork belly(s) with 4 difficult stitches
 - o Stitching tools
- Photo instructions
- 4 questionnaires
- 2 scripts, for each side
- 2 people
- 1 camera with stand

Scope:

After the first tests with two-way-AR the realization came that the medical procedure used for the test (intramuscular injection) was not complicated enough to really test the value of 2-way-AR. IT was also found that the iPad stand was not flexible enough to work with. For this test new stands will be used and evaluated. Talking with a doctor from the Radio Medical Services (RMS) he explained that the sometimes draws lines and arrows on images of wounds to help with the stitching process for more complex wounds. For this test, such a scenario will be created for the captain.

Goal:

For the test, there are two goals. The first is to set a baseline for the value of two-way-AR over the current visual aid methods using pictures and paint. The other goal is to see 2-way-AR in action when doing a more complex

Hypothesis:

Using two-way-AR to support stitching a complex wound is faster, leads to better results and the captain feels more supported during the act.

1.2 The test

Introduction

Thank you for participating in this test for MedAssist.Online. MedAssist.Online is the part of the company which has developed the skills app, which you have or will experience(d) in training. Today we will be working with a new app that we are developing which uses augmented reality to bring an experts hands, and voice, live with you. For the test, you will experience two scenarios. During both scenarios, you will be asked to apply stitches to a wound in a piece of pork belly. During the first scenario, you will have a picture of the wound withdrawn information and instructions from the doctor. In the second scenario, you will use the two-way-AR application where there is a doctor ready to give you live support. The focus of the test is how good you feel performing both actions. After both scenarios, you will be asked to answer a set of questions.

There is no right or wrong in performing the test nor answering the questions just try to communicate as well as possible and try your best. If you have any questions during the test you can always ask me. During the test, it might be the case that the applications freeze, might this be the case the test will be paused for a second to restart and reconnect.

Introduction Questions

1. What company do you work for?
2. What kind of business do you do?
3. What is your role on the ship?
4. What gender do you identify with?
5. How old are you?
6. Are you okay with the test being filmed?

Scenario Photo instructions(A)

Preparation

One of your crewmembers has cut in his leg with an angle grinder. The cut requires stitches but first needs to be cleaned and prepared before the stitching can happen. Also it is not a straight line as you can see but the cut has a 90 degree angle. You have sent an image to the radio medical services to ask for advice. In their answer they have provided some pointers on what to do accompanied with some instructions. The tools necessary for the procedure like gloves, the needle, wire and pincer are ready for you.

Instructions

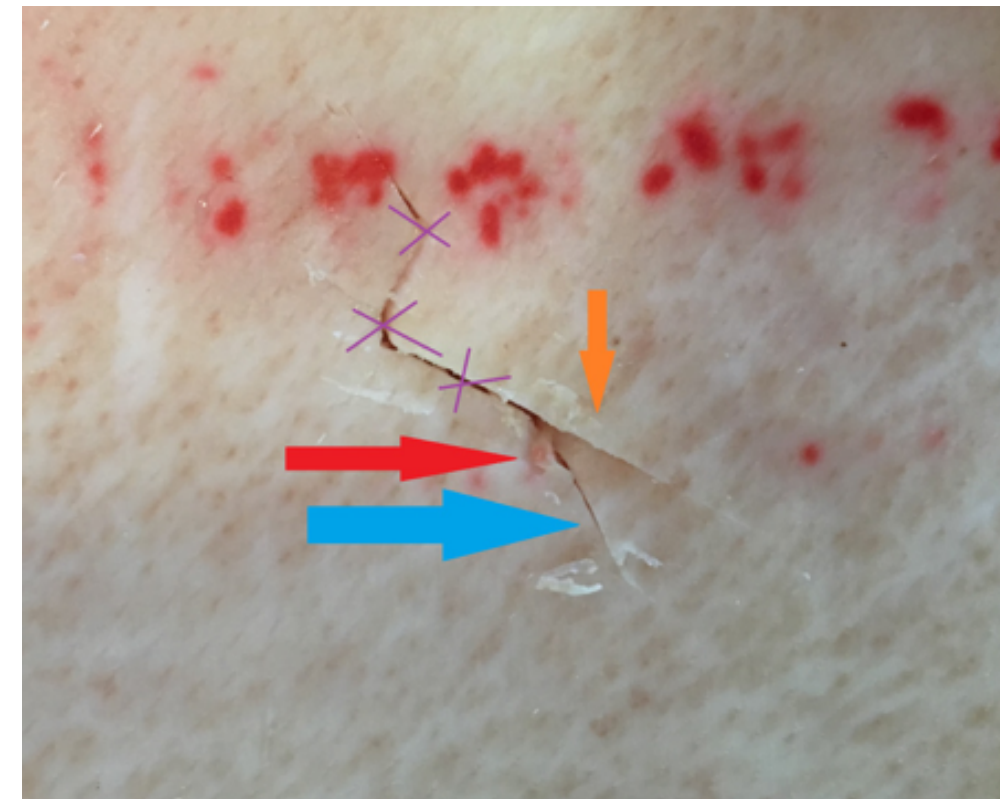

1. Remove the rough edge of skin at the red arrow
2. Put the first stitch at the blue arrow
3. Place the second stitch at the orange arrow
4. Add three stitches at the purple indicated crosses

Scenario Photo instructions(A)

Preparation

One of your crewmembers has cut in his leg with an angle grinder. The cut requires stitches but first needs to be cleaned and prepared before the stitching can happen. Also it is not a straight line as you can see but the cut has a 90 degree angle. You have sent an image to the radio medical services to ask for advice. In their answer they have provided some pointers on the image on what to do accompanied with some instructions. The tools necessary for the procedure like gloves, the needle, wire and pincer are ready for you.

Instructions

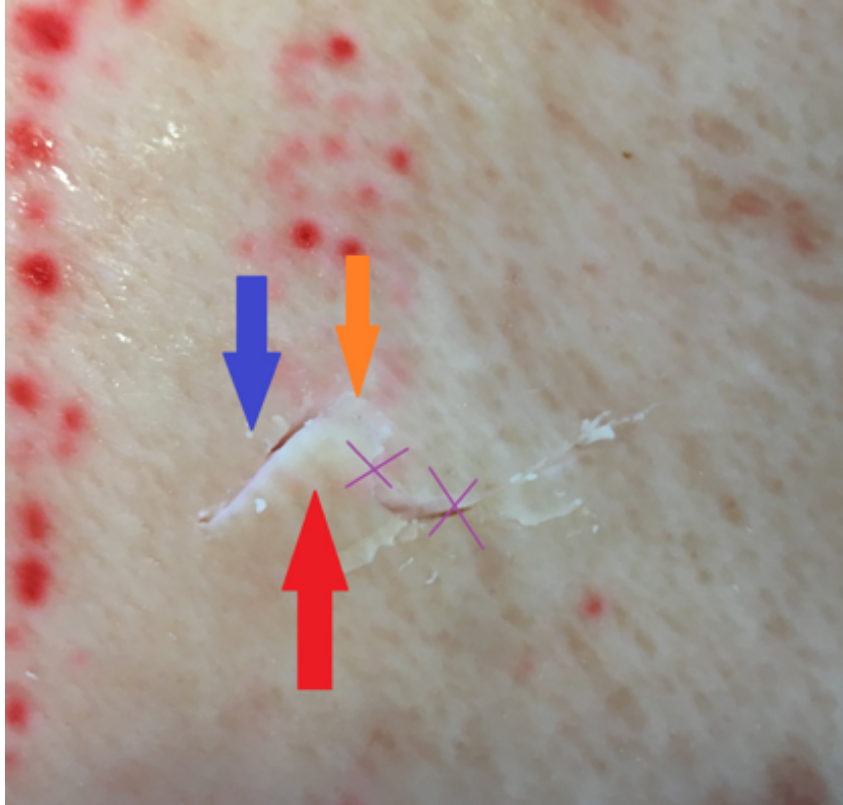

1. Remove the rough edge of skin at the orange arrow
2. Put the first stitch at the blue arrow
3. Place the second stitch from the red arrow to the orange arrow
4. Add two stitches at the purple indicated crosses

Scenario 2-way-AR instructions

Side captain

1. Call with application
2. Say hello, confirm the connection
3. Describe situation

1. Describe the steps you are thinking to take

Side doctor:

1. Pick up
2. Say hello and confirm the connection
3. Start instructions > Important to have multiple corrections and suggestions
 - a. Ask to clean
 - b. Point where to clean more
 - c. Ask captain for action steps he is planning
 - d. Indicate are where to take away some excess skin
 - e. Check if all skin has clear edges together with the captain
 - f. Explain:
 - i. It is not a clean cut so we need to pull some of the edges together first before going into the regular stitching process
 - g. Show which edges to pull together
 - h. Show where to put the first stitch
 - i. Indicate the next stitches
 - j. Provide constant feedback
 - k. Correct the position of some stitches just to help the captain experience 2-way-AR
4. You have successfully finished the second scenario, thank you the connection will be broken and you will be asked to fill in the questionnaire.

Questionnaire

To be filled in by tester

Length of procedure:

Image of final stitches:

Judgement of quality of the stitching/wound:

Questions for captain after each scenario

The questions are used to get a better insight in the performance of the application over the photo based on the perceived feelings and experiences of the doctor.

Want to know:

- Did they feel confident?
- Did they feel supported?
- Did they feel alone?
- Was the information clear?

	1. Totally disagree	2.	3.	4. Neutral	5.	6.	7. Totally agree
The information from the doctor was easy to implement							
During the procedure I made very little mistakes							
I felt very calm during the treatment							
I had a lot of confidence during the treatment							
The doctor was able to support me enough to do the treatment							
I felt as if I was on my own during the procedure							
Overall the procedure went very smooth							

Appendix L

Test results stitching

1.1

	1. Totally disagree	2.	3.	4. Neutral	5.	6.	7. Totally agree
The information from the doctor was easy to implement							X
During the procedure I made very little mistakes						X	
I felt very calm during the treatment							X
I had a lot of confidence during the treatment							X
The doctor was able to support me enough to do the treatment							X
I felt as if I was on my own during the procedure						X	
Overall the procedure went very smooth						X	

General Questions after both scenarios

Looking back at both procedures, which, in your opinion, went better? And why?

What differences did you experience between the two scenarios?

What were positive and negative sides of the directions with the hands?

What do you think is the biggest value of the AR app?

In what way(s) was AR an addition in the communication and guidance during stitching?
Did you think it added value? Or do you think just a live connection is enough?

Did you experience any hinder from using 2-way-AR application?

How did you experience having someone working live with you?

If you could make any change what would it be?

1.2

	1. Totally disagree	2.	3.	4. Neutral	5.	6.	7. Totally agree
The information from the doctor was easy to implement		X					
During the procedure I made very little mistakes						X	
I felt very calm during the treatment							X
I had a lot of confidence during the treatment							X
The doctor was able to support me enough to do the treatment				X			
I felt as if I was on my own during the procedure							X
Overall the procedure went very smooth		X					

2.1

	1. Totally disagree	2.	3.	4. Neutral	5.	6.	7. Totally agree
The information from the doctor was easy to implement						X	
During the procedure I made very little mistakes		X					
I felt very calm during the treatment					X		
I had a lot of confidence during the treatment					X		
The doctor was able to support me enough to do the treatment				X			
I felt as if I was on my own during the procedure					X		
Overall the procedure went very smooth				X			

2.2

	1. Totally disagree	2.	3.	4. Neutral	5.	6.	7. Totally agree
The information from the doctor was easy to implement							X
During the procedure I made very little mistakes						X	
I felt very calm during the treatment						X	
I had a lot of confidence during the treatment						X	
The doctor was able to support me enough to do the treatment				X		X	
I felt as if I was on my own during the procedure		X					
Overall the procedure went very smooth						X	

Open questions

Person 1

- Paper is very easy to follow, you can just execute. Own speed. Wound is fairly straight forward
- Maybe with more complex situations it is nice to have the images
- If the connection is very smooth it could be very helpful, but if you lose connection it might be very hard
- The finger is to big and rough, with a wound like this you need to point with a pincer like over here.
- After a while the expert does not realize if the captain is looking at the screen or not, since the captain is also looking around a preparing stuff
- You have to be very slow, or even introduce closed loop communication. Any order or instruction is repeated by the other.
 - o A seaman on the other side will almost certainly do this automatically
- There is a communication phase and a action phase, they could be disconnected
- Tablet hanging above the working area is not optimal. The ipad is in the way, and it is not really possible to look through the screen, it is not so clear.
- For him it does not really matter if it is on paper or through the app, in the end you have to perform the actions. You can take a photo from the end result
- Biggest addition is the instructions, accurate instructions for example the distance between the stitches and step by step. Not having to come up with it yourself.
- Hesitate about his thoughts, what he thinks about someone watching over him. Partly because he did not experience it like someone was watching with him all the time.
- Moving images are even more unclear. Sometimes it is hard for both sides to see clearly what to see.

Person 2

- The second one was a lot easier. You can questions immediately. You can both point at stuff and see each other where you point
- In the scenario with the image he thought he made an error and he was unable to ask if this was true or not.
 - o But then he just did it different so solved it
- Direct contact, point and ask. Not just form the captain's side but also the doctor is able to point to ask for example can you lift this up please.
- Together, or the doctor, can judge the wound and discuss what to do next.
- Both pointing and discussing were equally valuable
- Ipad locks after a while in use, sound is a bit difficult
- He found a way to put the tablet in such a way that it was still visible what was happening while it was not hindering his actions
- He did not mind having someone watching because he did not get any comments. So they feel more or less working on their own. Maybe add some comments in this phase as well next time.
- The stand could be a bit tighter, did not keep its position.

Conclusions

- Fingers/hands are a bit rough to give instructions with
- It can be hard to realize what the captain is looking at, if he is looking at the screen for instructions or if he is looking at his work area
- There is an opportunity to improve communication, maybe with a protocol. This also came forward in the test of 04-10.
- iPad is not in a great position, hard to work and have the iPad in a good position
- 2-way-AR for the other captain was much easier. You can point at stuff and see exactly see what he means
- Both captains did not mind someone looking over them. They even forgot about it. Maybe add more comments in the treatment phase next time.

Appendix M

Test set-up camera position captain

1.1 Set-up

Where and When:

Thursday 04/10 in the back of the training room and in the 2nd meeting room at the office/training location of MedAssist.online

Participants: 2 captains from the ECMT training program

Documentation: Questionnaire, Recordings with the camera for video and photos.

Required props:

- Green screen
- 3 Tablets
 - o 1 windows
 - o 2 Samsung
- 2 iPad stands
 - o Lego
- Photo instructions
- 4 questionnaires
- 2 scripts, for each side
- 2 people
- 1 camera with stand
- One pair of sunglasses without glasses
- Camera

Scope:

Within this test the focus is on using a different camera angle on the captain side to see if this improves the understanding of either side and makes it easier to understand the guidelines. Also this opens up the opportunity to position the iPad behind the patient to make it easier to work with, based on a suggestion from an earlier test. The position of the iPad has been an issue from the beginning and the new stand has improved the workability but can still be in the way of the hands. To make the scenario more realistic the working field will be simulated to be bigger than it needs to be so there is a need to work with the position of the camera.

Goal:

The goal for the test is to find out if a camera perspective aligned with the eyes of the captain makes it easier for the doctor to get a good overview of the situation and for the captain to understand the instructions. At the same time this creates the opportunity to observe and experience a new set-up of the iPad.

Hypothesis:

Using a camera which is in line with the eyes of the captain makes it easier for him to interpret the instructions and gives him more freedom to work with the application.

1.2 The test

Introduction

Thank you for participating in this test for MedAssist.Online. MedAssist.Online is the part of the company which has developed the skills app, which you have or will experience(d) in training. Today we will be working with a new app that we are developing which uses augmented reality to bring an experts hands, and voice, live with you. For the test, you will experience two scenarios. During both scenarios, you will be asked to build two "structures" with Lego using just the visual instructions from the expert. In the first scenario you will use the tablet to film and get the instructions. In the second scenario you will get glasses on with a camera and use the tablet to get the instructions. After both scenarios, you will be asked to answer a set of questions.

There is no right or wrong in performing the test nor answering the questions just try to communicate as well as possible and try your best. If you have any questions during the test you can always ask me. During the test, it might be the case that the applications freeze, might this be the case the test will be paused for a second to restart and reconnect.

Introduction Questions

1. What company do you work for?
2. What kind of business do you do?
3. What is your role on the ship?
4. What gender do you identify with?
5. How old are you?
6. Are you okay with the test being filmed?

Scenario without glasses

Intro

In the introduction it was already mentioned that you will be building with lego. The expert on the other side has instructions and pictures on how to build the construction. You will get instructions on screen but will not be able to communicate through voice for this test to focus on the visual input.

Instructions

Side captain

1. Call with application
2. Confirm connection with a thumbs up

Side doctor:

1. Pick up
2. Turn of audio input and output
3. Confirm the connection with a thumbs up
4. Show steps
 - a. See image left
 - b. Point to big green plate
 - c. Show to put green plate in front
 - d. Point to grey bridge part and point to left bottom corner
 - e. Point to yellow part and point where to place
 - f. Show to turn the whole plate
 - g. See second image right
 - h. Point to red plate and show where to put
 - i. Point to white block and point to right position
 - j. Point to yellow long block and point, with 4 circles outside the green
 - k. Point to red block and show to put on top yellow and white
 - l. Point to the blue block and point to put on top of yellow next to the red block
 - m. Point to the long blue block and show to put from red plate to yellow block
 - i. Make sure it is one circle below yellow bridge
 - n. Point to red thin block and point to put on top
 - o. Point to grey sloped block and show where to put
 - p. Put thumb up when finished

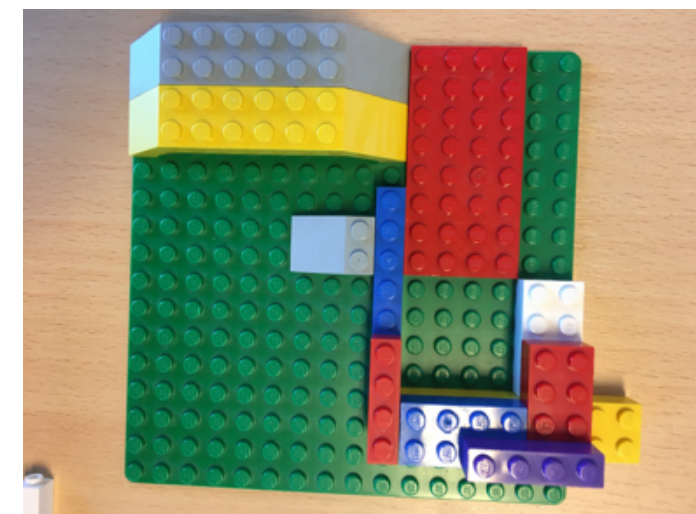
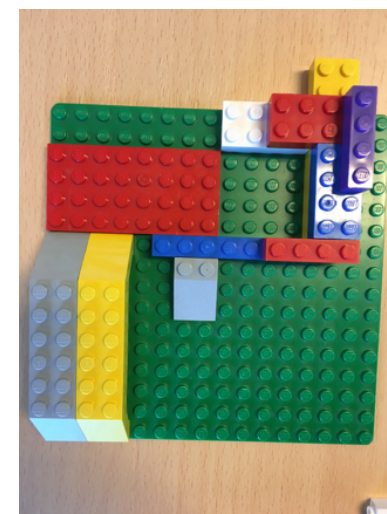

Scenario without glasses

Intro

In the introduction it was already mentioned that you will be building with lego. The expert on the other side has instructions and pictures on how to build the construction. You will get instructions on screen but will not be able to communicate through voice for this test to focus on the visual input.

Instructions

Side captain

1. Call with application
2. Confirm connection with a thumbs up

Side doctor:

1. Pick up
2. Turn of audio input and output
3. Confirm the connection with a thumbs up
4. Show steps
 - a. See image left
 - b. Point to green plate and show to put in front
 - c. Point to yellow bridge part and show top put in middle of top plate
 - d. Point to grey bridge part and point to put length wise below the yellow bridge
 - e. Point to red block and show to put in corner of bridges to the right
 - f. Point to long yellow block and put in parallel with grey bridge part
 - g. Point to white block and show to put next to and in line with red block
 - h. Show to turn whole plate
 - i. See image right
 - i. Point to red plate and show to put it one row below the grey bridge and one row left of the yellow bridge on top of the bricks in place
 - j. Point to the purple thin part and show to put horizontally in line with the red plate
 - k. Point to the blue brick and put on bottom overhanging part of the red plate
 - l. Point to grey sloping part and put show to put on top of blue block
 - m. Point to red thin part and show to put vertically on the thin purple part al the way on the left
 - n. Point to blue thin long part and show to put on red plate and have it stop in line with thin red part

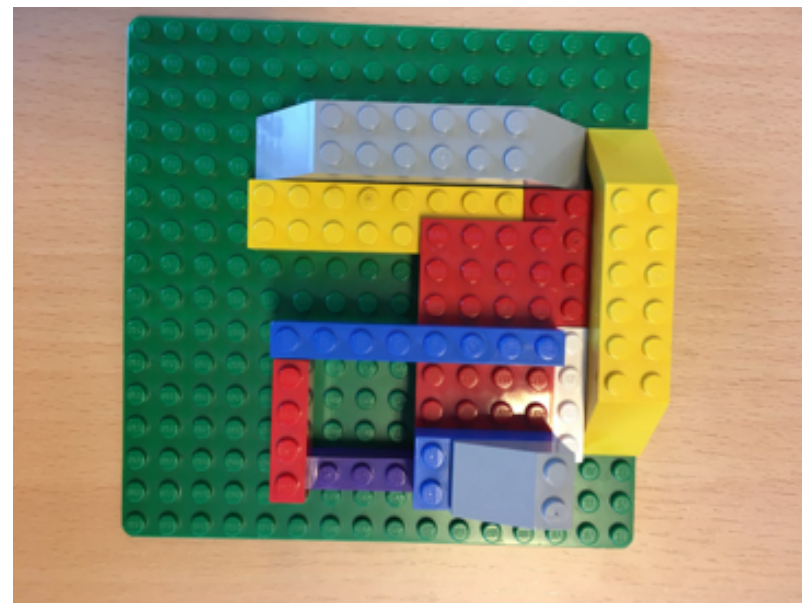
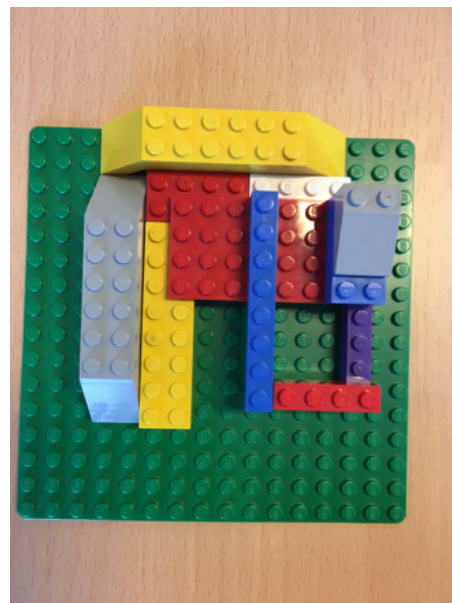

Questionnaires

Questions for captain after scenario 1

	1. Totally disagree	2.	3.	4. Neutral	5.	6.	7. Totally agree
The information from the expert was easy to implement							
During the examination I made very little mistakes							
I felt very calm during the examination							
I had a lot of confidence during the examination							
The expert was able to support me enough to do examination							
I felt as if I was on my own during the examination							
Overall the examination went very smooth							
I felt very accurate during the examination							

Questions for captain after scenario 2

	1. Totally disagree	2.	3.	4. Neutral	5.	6.	7. Totally agree
The information from the expert was easy to implement							
During the building I made very little mistakes							
I felt very calm during the building							
I had a lot of confidence during the building							
The expert was able to support me enough to do the building							
I felt as if I was on my own during the treatment							
Overall the building went very smooth							
I felt very accurate during the building							

Open questions after both scenarios

Captain

The instructions of what scenario were easiest to implement in your experience?

How did you like the camera position in either scenario?

Which in your experience went smoother?

What did you like most about using 2-way-AR?

Did you experience any limitations in either scenario?

Doctor

Which scenario was easiest to give the instructions?

In what scenario was it easier to follow/understand the progress of the captain?

In what scenario did you feel the captain found it easier to understand your instructions?

Did you experience any limitations in either scenario?

Appendix N

Test results camera position captain

Modification

During the test two important modifications were implemented which were not part of the original scenario. The first is that the participants, one being the doctor and the other the captain, were given the chance to practice. For a good two minutes the doctor gave the captain some instructions, non-scripted, through the AR app without talking. As they were going to experience in the test. The reason for this is to take away any bias between the first and second scenario due to learning how to communicate over AR.

The second modification was made during the first scenario and copied into the second. The first scenario using the the tablets cameras took so long I decided mid-test to stop it at 6 minutes. After this 6 minutes I checked the progress they made and had them fill in a questionnaire. After filling in the questionnaire they were asked to continue with the scenario, but now they were allowed to also voice chat. I timed this part of the scenario as well to potentially see differences between the first and second scenario, and they were asked to fill in the same questions after this part to identify the influence on the experience.

1.1 Results scenario 1.1

Length of procedure: 6 min, 2 blocks were placed of which one was not in the right spot yet

Captain

	1. Totally disagree	2.	3.	4. Neutral	5.	6.	7. Totally agree
The information from the expert was easy to implement			X				
During the building I made very little mistakes				X			
I felt very calm during the building					X		
I had a lot of confidence during the building				X			
The expert was able to support me enough to do the building			X				
I felt as if I was on my own during the treatment		X					
Overall the building went very smooth				X			
I felt very accurate during the building					X		

Notes

- The iPad is just not very easy to move

Doctor

	1. Totally disagree	2.	3.	4. Neutral	5.	6.	7. Totally agree
It was easy to give the instructions to the captain						X	
It was easy to understand the captains progress					X		
I felt very calm during giving the instructions					X		
I felt confident in giving the instructions					X		
I felt we were doing the building together					X		
Overall the building went very smooth				X			
I felt very accurate during the instructions					X		

Notes

- The hand signals work quiet well, especially with the addition of the pen
- It is hard for the doctor to be super accurate, especially with the tablet being pointed straight over the work field. The camera of the captain is not filming a good perspective for the doctor to work with.

1.1 Results scenario 1.2

Length of procedure: 8:18 to finish

Captain

	1. Totally disagree	2.	3.	4. Neutral	5.	6.	7. Totally agree
The information from the expert was easy to implement						X	
During the building I made very little mistakes							X
I felt very calm during the building						X	
I had a lot of confidence during the building							X
The expert was able to support me enough to do the building						X	
I felt as if I was on my own during the treatment		X					
Overall the building went very smooth							X
I felt very accurate during the building							X

Notes

- With talking overall it is just much easier
 - o There is confirmation > Like this?
- The position of the iPad is still not great

Doctor

	1. Totally disagree	2.	3.	4. Neutral	5.	6.	7. Totally agree
It was easy to give the instructions to the captain							X
It was easy to understand the captains progress							X
I felt very calm during giving the instructions							X
I felt confident in giving the instructions						X	
I felt we were doing the building together							X
Overall the building went very smooth							X
I felt very accurate during the instructions						X	

Notes

- With sound the doctor side goes very much in descriptive mode, not using the live video connection enough. There is limited pointing going on
- Perspective for captain and doctor might be different needs

1.1 Results scenario 2.1

Length of procedure: 6 min, 4 blocks were placed correctly

Captain

	1. Totally disagree	2.	3.	4. Neutral	5.	6.	7. Totally agree
The information from the expert was easy to implement				X			
During the building I made very little mistakes						X	
I felt very calm during the building					X		
I had a lot of confidence during the building					X		
The expert was able to support me enough to do the building					X		
I felt as if I was on my own during the treatment		X					
Overall the building went very smooth						X	
I felt very accurate during the building						X	

Notes

- The captain is holding the glasses to control the position a bit more, it is not aligning exactly with his eyes since it is a prototype
- It does not work perfectly since when the captain is looking at the tablet screen the camera is not pointing at the build or parts so it does not work with pointing
 - o To combat this he put the glasses further on his nose so he can keep the glasses on the situation while looking at the iPad

Doctor

	1. Totally disagree	2.	3.	4. Neutral	5.	6.	7. Totally agree
It was easy to give the instructions to the captain					X		
It was easy to understand the captains progress						X	
I felt very calm during giving the instructions					X		
I felt confident in giving the instructions					X		
I felt we were doing the building together						X	
Overall the building went very smooth						X	
I felt very accurate during the instructions					X		

Notes

- The perspective of seeing it like the captain is seeing makes way more sense
- The doctor in this case is not moving the iPad to optimize his view and size of hands, though he can and should

1.1 Results scenario 2.2

Length of procedure: 9:36, the time was stopped with 2 blocks left. Somehow they got really stuck on their communication and were unable to get the details across.

Captain

	1. Totally disagree	2.	3.	4. Neutral	5.	6.	7. Totally agree
The information from the expert was easy to implement					X		
During the building I made very little mistakes				X			
I felt very calm during the building						X	
I had a lot of confidence during the building					X		
The expert was able to support me enough to do the building				X			
I felt as if I was on my own during the treatment			X				
Overall the building went very smooth					X		
I felt very accurate during the building				X			

Notes

- Has to move his heat to the work for the doctor to really see the situation but can no longer see the tablet screen with the instructions.

Doctor

	1. Totally disagree	2.	3.	4. Neutral	5.	6.	7. Totally agree
It was easy to give the instructions to the captain					X		
It was easy to understand the captains progress					X		
I felt very calm during giving the instructions					X		
I felt confident in giving the instructions					X		
I felt we were doing the building together							X
Overall the building went very smooth						X	
I felt very accurate during the instructions				X			

Notes

- He is too focussed on the instructions and not enough on the AR-feed and using this for communication with the captain.

1.2 and 2.2

Captain

	1. Totally disagree	2.	3.	4. Neutral	5.	6.	7. Totally agree
The information from the expert was easy to implement					X	X	
During the building I made very little mistakes				X			X
I felt very calm during the building						XX	
I had a lot of confidence during the building					X		X
The expert was able to support me enough to do the building				X		X	
I felt as if I was on my own during the treatment		X	X				
Overall the building went very smooth					X		X
I felt very accurate during the building				X			X

Doctor

	1. Totally disagree	2.	3.	4. Neutral	5.	6.	7. Totally agree
It was easy to give the instructions to the captain					X		X
It was easy to understand the captains progress					X		X
I felt very calm during giving the instructions					X		X
I felt confident in giving the instructions					X	X	
I felt we were doing the building together							XX
Overall the building went very smooth						X	X
I felt very accurate during the instructions				X		X	

1.2 Open questions

Captain

The instructions of what scenario were easiest to implement in your experience?

From captain view, it takes some time to get used to looking at the screen and the patient. When looking at the screen the doctor cannot see the patient and vice versa. Once you get used to it, it gets a little bit easier but still hard. So for that reason probably easier with the tablet.

How did you like the camera position in either scenario?

Maybe put a camera on a collar, so you can still move your head but have the camera still. It is important to have an external camera to keep a good view of the situation and at the same time looking at the screen.

The scenario with tablets seemed a bit easier since the screen had a constant position. But it was hard because the view was just not optimal for the doctor it is filming over the situation.

Having voice makes you depend less on the screen. But, in the second scenario it was easier to depend on the iPad.

Which in your experience went smoother? > More blocks were placed

It was definitely easier to implement the instructions because he felt he could show the doctor better so the instructions were better. With the iPad camera it is just flat, so you do not have a top perspective of the situation. One benefits the doctor and the other the captain.

Doctor

Which scenario was easiest to give the instructions?

Easiest is pointing and speech combined, additionally with glasses to see. The glasses is easiest because of the point of view, it is easier to work with captain if you see exactly what he sees and the screen(view) switches smoothly.

In what scenario was it easier to follow/understand the progress of the captain?

It is not necessarily harder to understand the progress of the captain when using the tablets, but it is more difficult because it takes time for the captain to move the camera so you lose smoothness in the process.

In what scenario did you feel the captain found it easier to understand your instructions?

Not really sure if it is more difficult to follow, but thinks it is easier to follow the steps when using the glasses because of practicality issues.

He felt it was slightly easier for the captain to follow, thinks it is easier for the captain.

Did you experience any limitations in either scenario?

Without a clear set of guidelines or with a clear set it is easier to direct and guide. A set of rules will smoothen the process.

The Lego block is pretty difficult because it is pretty detailed. For certain procedures it might be easier like injecting medicine or not to detailed operation. On the contrary for stitching the level of difficulty will be similar.

1.3 Conclusions

Tablet

- 1.Pro's
 - a. Stable view for both parties
- 2.Con's
 - a. Takes effort to move around
 - b. Changing perspective for doctor
 - c. Hard to position right so that it works for both the captain and doctor

Glasses

- 1.Pro's
 - a. Having the doctor see exactly see what the captain sees helps for him to understand and makes it easier to give good instructions
 - b. Having the tablet in a fixed position and not need much alteration works well, also having it placed behind the work field
- 2.Con's
 - a. It is not possible to look at the screen and situation at the same time

Appendix O

Final test set-up

1.1 Set-up

Where and When: 20/12 November in the office

Participants: 6 captains, 2 medical professionals hopefully

Documentation: Photos and film, questionnaires and interview questions

Scope:

The scope of this test is to see the full set-up in action in comparison with the previously envisioned set-up. This is done with an as realistic possible medical scenario so that it really requires communication.

Goal:

The goal of the test is to see how well the set-up performs compared to the original set-up. What do I want for find?

- How well each set-up works compared to each other
- What more needs to improve on the set-up side
 - o If the set-up improves it a lot or that it is necessary to have an even better AR-interface

Hypothesis:

The hypothesis is that the new set-up works better than the current set-up

Relevant parameters

1. Communication
2. Understanding between captain and doctor
3. Ease of use/focus with camera
4. Performance (speed, feeling of smoothness, number of corrections)
5. Communication
6. Understanding of the situation (Doctor)
7. Understanding of directions(Captain)

Required props:

- Documentation
 - o Camera, charger with battery
 - o Camera stand
 - o SD-cards
 - o Questionnaires
 - o Pens
 - o iPhone with charger for internet
- Set-up Doctor
 - o Doctor stand
 - o Tablet
 - o Tablet arm
 - o Green screen
- Set-up Captain
 - o Tablet
 - o Tablet stand
 - o Camera arm
- Food/candy
- IV set-up
 - o IV arm
 - o Tourniquet
 - o Infusion cannula
 - o Infusion set
 - o Infusion bag
 - o Scissors
 - o Needle dispenser
 - o Plasters

Triangulation > Action measured in quality, ratings on scale, interviews/observations

Test set-up requirements & ideation

1. Captain set-up needs to change twice
2. Doctor set-up needs to change twice

So there are different tests possible. There are three variables to the test. The first is the participants. One option is to use 2 participants who are doing the test together, one representing the doctor side and the other captain. The other option is that only one participant is used per test who is either the captain or doctor, the other role is represented by one of the testers. The second variable is the set-up which on both sides has two variants, the old and the improved set-up. In every test the old and new set-ups are compared, the variable is that during the test the set-up is changed on both sides or only on one. The last variable is the medical scenario, the captain side and one on the doctor side performing in one test

- One option is to have 2 people, who have never worked with the system try one medical scenario with one of being the doctor and the other the captain and they try the medical scenario with the old and new set-up on both sides.
- The other option is to have 2 people, who have never worked with the system try one medical scenario with one of them being the doctor and the other the captain and they try the medical scenario with the old and new set-up on one side
- The other option is to have only one side(doctor/captain) represented by a participant and the other by an interviewer, and try a medical scenario with the old new set up on both sides
- The other option is to have only one side(doctor/captain) represented by a participant and the other by an interviewer, and try a medical scenario with the old set-up and changing the set-up on one side.

If possible the test is performed with a trained medical professional and a captain. The medical professional is part of the ECMT training centre and experienced with explaining medical skills to trainees. There is most likely only a limited number of medical professionals available, so then the doctor side will be performed by the interviewer. The captain might have experience with performing the medical skill but this is not a problem, this is also the case when he is on board. It might be that the IV setting is slightly too easy, but they will still have to follow closely what the instructor tells them.

1.2 Test protocol Captain

Set-up

1. Have the captain read the introduction
2. Ask to sign consent form
3. Ask introduction questions
4. Explain the test
 - a. No pressure on performance
 - b. You will be setting an IV with the instructions of an expert
 - c. If the app fails at any time just let me know and we reset it and continue
5. Ask what they think of the set-up

Part 1

1. Put iPad with arm ready in a position which is not focussed on the arm
 - a. Let the captain put the iPad ready himself
2. Apps are logged in already
3. They only have to call

Part 2

1. Tell them to pause
2. The new set-up is created while they answer questions
 - a. Answer the Localised Postural Discomfort Form and NASA task load index
3. Place the arm with other tablet behind the arm

Documentation

1. Answer the Localised Postural Discomfort Form and NASA task load index
2. Go through the open questions
3. Make sure the answers to the open questions are recorded

1.3 Test protocol Doctor

The doctor side is either performed by a medical professional, if available, or by the tester personally if not available.

Set-up

1. Have the captain read the introduction
2. Ask to sign consent form
3. Ask introduction questions
4. Explain the test
 - a. No pressure on performance
 - b. You will be instructing the captain to set an IV with a slightly minimized version of the process
5. Ask what they think of the set-up

Part 1

1. Place tourniquet around arm
 - a. Place two fingers under tourniquet and tighten in such a way that you can still feel pulse
2. Look and feel for blood vessel which is appropriate to put the needle in
 - a. Change camera position to review the vein even better
3. Remove IV cannula from the packaging
4. Put the wings of the cannula in horizontal position
5. Hold the cannula with a three point grip

Part 2

1. Remove the protective cover of the IV cannula'
2. Put the needle on the skin at an angle of 10 degree
 - a. With the wings of the needle underneath
 - b. Put the needle lengthwise to the vein
3. Ask to move the camera position to review the angle of the cannula to the skin
4. Puncture the skin near the blood vessel on one fluent movement
5. Bring needle back in horizontal position
6. Put the 2 pieces of tape on the wings of the cannula

Documentation

1. Answer the Localised Postural Discomfort Form and NASA task load index
2. Go through the open questions
3. Make sure the answers to the open questions are recorded

Set-up 1

The first set-up of the test is the envisioned set-up which the project was once started with and is shown in the figure below. The doctor has a downward facing iPad which is held up with an iPad stand. The captain has the same iPad stand with an iPad in there.

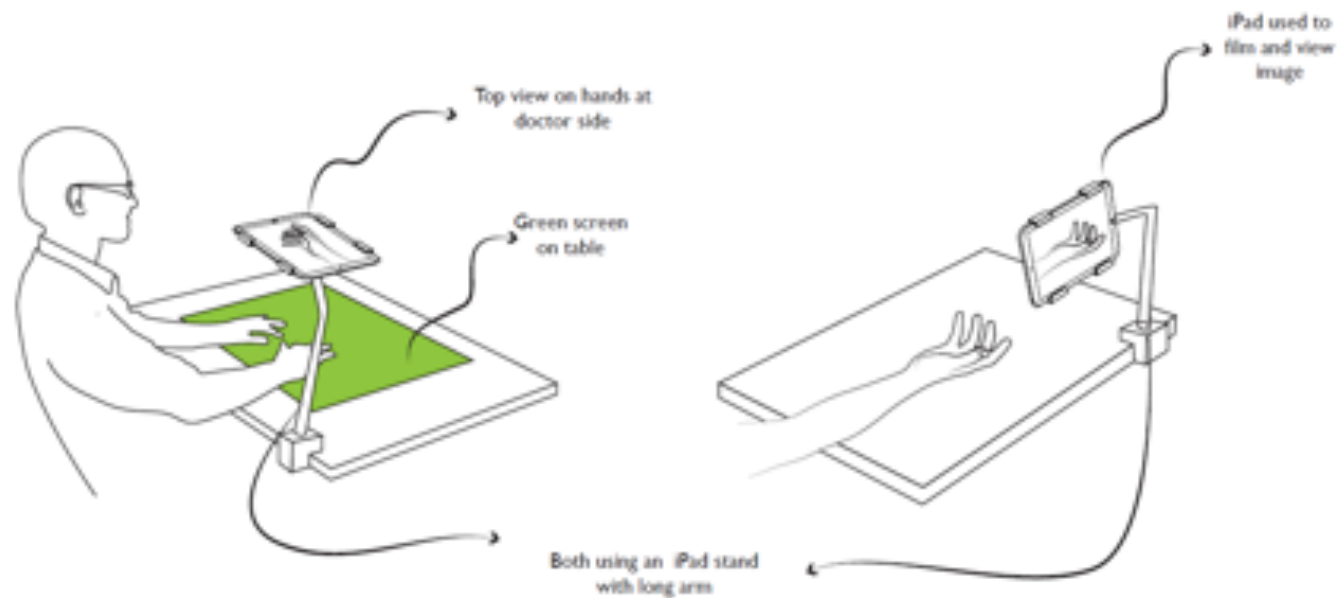

Set-up 2

The second set-up in the test is the improved set-up where the doctor has a stand which allows for the iPad to be put up-right in front of him. On the captain's side there is the addition of an extra camera with an adjustable arm.

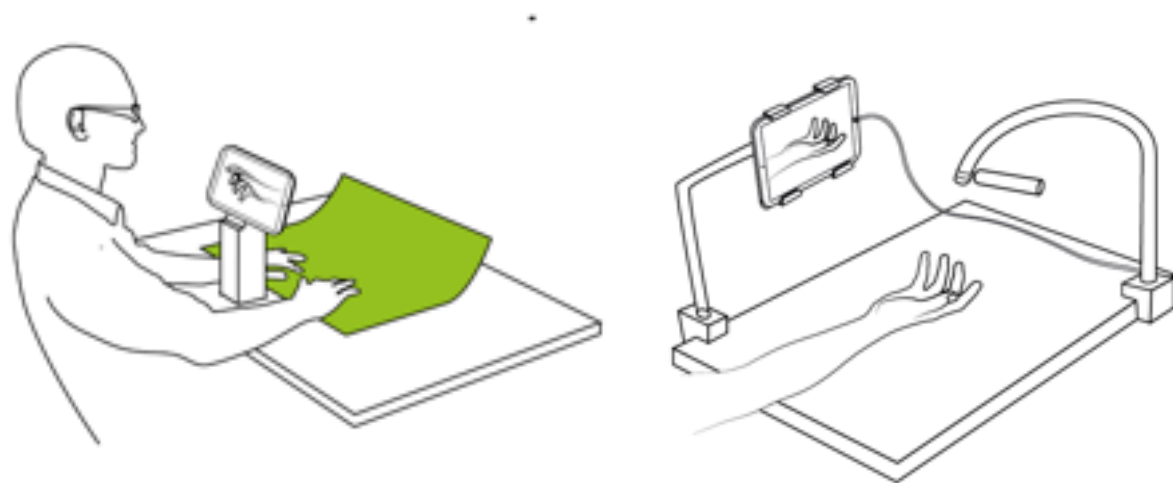

Scenario setting an IV

Put an IV in a training arm from the training centre has roughly the steps described below. For the test a smaller protocol is used to keep the focus on the skills that are performed rather on the steps like for example putting the gloves on. After discussing with

Needed props:

- Non-sterile gloves
- Towel
- Tourniquet
- Sterile gauze
- AN IV stand
- Disinfectant
- Infusion cannula
- Infusion set
- Infusion bag
- Scissors
- Needle dispenser
- Plasters

Steps to be described by doctor

1. Put on gloves
2. Place towel under arm for support
3. Place tourniquet around arm
 - a. Place two fingers under tourniquet and tighten in such a way that you can still feel pulse
4. Look and feel for blood vessel which is appropriate to put the needle in
5. Disinfect the area where you insert the cannula
6. Remove IV cannula from the packaging
7. Put the wings of the cannula in horizontal position
8. Hold the cannula with a three point grip

Pause and switch set-up

9. Remove the protective cover of the IV cannula'
10. Put the needle on the skin at an angle of 10 degree
 - a. With the wings of the needle underneath
 - b. Put the needle lengthwise to the vein
11. Puncture the skin near the blood vessel on one fluent movement
12. Bring needle back in horizontal position
13. Check if there is blood in the cannula
14. If there is release tourniquet
 - a. If not try again
15. Pull out the needle carrier
16. Take the IV fusion tube and connect it to the cannula
17. Put some folded gauze under the cannula and fixate it with some plasters

1.4 Open Questions

Setup: Captain

Did the position of the iPad influence your actions a lot? Why?

Did you feel that one of the two set-ups works better for you?

How easy was it to position the tablet/camera for each of the scenarios?

What challenges did you encounter when setting the IV?

Were there different challenges for the different set-ups?

How easy was it to implement the instructions of the doctor?

What differences did you experience for each of the scenarios?

What did you think of the hands/pen used for the instructions?

Were the hands in the way of your actions at any point?

How valuable were the hands for the instructions?

What is your preferred position of the iPad?

Did you for any scenario feel the iPad was blocking your actions? Why?

Can you imagine using this application in a real life situation?

Why/why not? What is the value?

Setup: Doctor

Did you feel that one of the two set-ups works better for you?

How easy was it to position the tablet/camera for each of the scenarios?

How easy was it to give instructions with your hands?

Did you experience any difference between the two scenarios?

Did you feel the hands are too big/small in screen?

How easy was it to get a good understanding of the situation on the captain?

Did you feel the hands made it easier to give your instructions than just audio?

Any suggestions for improvement?

Did you feel like your hands were too big at any point?

Did you for any of the set-ups feel like the iPad was hard to focus on?

Observations

Setup: Doctor/Captain

Putting the tablet and camera in the right position

Communication between expert and captain

Adjusting of the size of hands

Performance

Appendix P

Final test question side



2-way Augmented Reality test

Imagine you are 1000 miles at sea and one of your crewmembers is in a medical incident and you need to give the best medical care possible. Here at MedAssist.online we try to give you're the right support to do this as best as you can. One of the solutions ~~MedAssist.online~~ provides is the skills app which has a selection of medical skills explained with videos and photos to help you guide through the steps. At MedAssist.online we are looking at the next step of supporting you on board during medical situation. One way we are developing is using Augmented Reality through which we try to virtually bring the doctor next to you during medical care. For us to be able to develop the best support products we are always looking for input from you. In this test you will go through a medical scenario using two different set-ups with the prototype AR-application.

Consent for participation in test with 2-way-AR application

#01. I volunteer to participate in a product evaluation experiment conducted by Integrated Product Design Master student Tom Slijkhuis from the TU Delft

#02. I understand that the validation is designed to gather feedbacks on the experience of using the 2-way-AR set-up in two different set-ups

#03. My participation in this validation is voluntary. I understand that I will not be paid for my participation. I may withdraw and discontinue participation at any time without penalty.

#04. I understand that the participation involves answering some personal questions and discussion your experience

#05. I understand that all research data will remain completely confidential and will be processed anonymously.

#06. I understand that the experiment will be video & audio taped and photos will be taken for analysis afterwards and might be used for presentation and documentation purposes

#07. I understand that the experiment does not intend to measure my performance, but the performance of the application

#08. I have read and understand the explanation provided to me. I have had all my questions answered to my satisfaction, and I voluntarily agree to participate in this study.

My Name, Signature and Date

Participant Code

For further information, please contact:

Tom Slijkhuis

+31631529743

Evaluation Participant: Setup:

NASA Task Load Index

NASA Task Load Index (TLX) method assesses mental load on five 7-point scales. Increments of high, medium and low estimates for each point result in 21 gradations on the scales. Please marking an "X" in the appropriate box.

Mental Demand How mentally demanding was the task?

1.	2.	3.	4.	5.	6.	7.	8.	9.	10.	11.	12.	13.	14.	15.	16.	17.	18.	19.	20.	21.
Very Low											Very High									

Physical Demand How physically demanding was the task?

1.	2.	3.	4.	5.	6.	7.	8.	9.	10.	11.	12.	13.	14.	15.	16.	17.	18.	19.	20.	21.
Very Low											Very High									

Temporal Demand How hurried or rushed was the pace of the task?

1.	2.	3.	4.	5.	6.	7.	8.	9.	10.	11.	12.	13.	14.	15.	16.	17.	18.	19.	20.	21.
Very Low											Very High									

Performance How successful were you in accomplishing what you wanted to do?

1.	2.	3.	4.	5.	6.	7.	8.	9.	10.	11.	12.	13.	14.	15.	16.	17.	18.	19.	20.	21.
Very Low											Very High									

Effort How hard did you have to work to accomplish your level of performance?

1.	2.	3.	4.	5.	6.	7.	8.	9.	10.	11.	12.	13.	14.	15.	16.	17.	18.	19.	20.	21.
Very Low											Very High									

Frustration How insecure, discouraged, irritated, stressed, and annoyed were you?

	2.	3.	4.	5.	6.	7.	8.	9.	10.	11.	12.	13.	14.	15.	16.	17.	18.	19.	20.	21.
Very Low											Very High									

Evaluation questions

Example: please mark your selection direct on the option, like Male / Female

- Your age: _____
- Your gender: Male Female
- Your experience with medical training
 - Medical Care
 - Basic safety(EHBO)
 - None
- Your experience with setting an IV
 - 1-5 times
 - 5 times or more
 - Never
- Your experience on Virtual Reality or Augmented Reality or Mixed Reality technology:
 - Never;
 - Rare;
 - Several times;
 - 3-4 time per year;
 - Once per month;
 - More than twice per month

Thank you again for your contribution!

Appendix Q

Final test

1.1 Captain side

	C1	C2	C3	C4	C5	C6
Age	34	59	25	26	48	37
Gender	F	M	M	M	M	M
Experience medical training	Basic Safety	Medical Care	Medical Care	None	Medical care	Medical Care
Experience setting an IV	Never	1-5 times	1-5 times(in training)	1-5 times	5 times or more	1-5 times
Experience VR, AR or MR	Rare	Never-rare	Several times	Rare	Never/Rare	Never

Table X: participants captain side in final test

Participating in the test were X number of captains who were taking part in the trainings courses. Participants C1-C3 were all tested on day one and the role of the medical expert was taken up by the

NASA EVALUATION TASK LOAD INDEX RESULTS

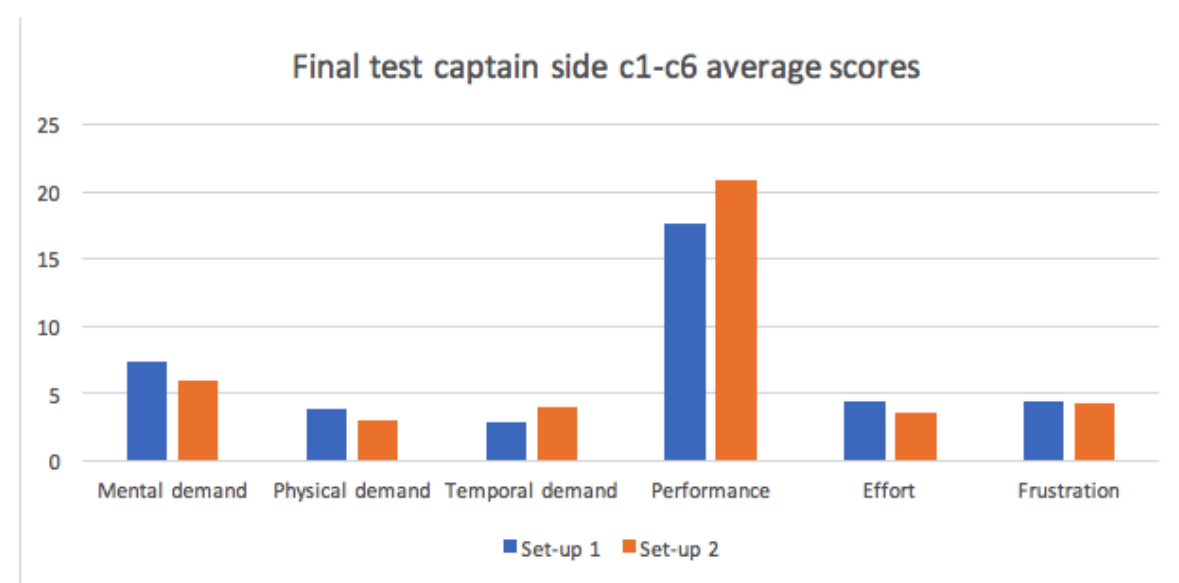

Observations

- Communication
- Understanding between captain and doctor
- Ease of use/focus with camera
- Performance (speed, feeling of smoothness, number of corrections)
- Communication
- Understanding of the situation (Doctor)
- Understanding of directions(Captain)

Captain 1

Experience with the procedure affects the duration a lot.

Scenario A

- Putting iPad in position in scenario A is hard, but when it is known how the iPad stand works it is easier.
- iPad is very high and close to face(image)
- Some instructions are missed: "Please show again".
 - o Again not clear when the captain is in action mode and when viewing the iPad
- It is valuable though, some instructions are implemented in the wrong manner and can be corrected when the doctor is reviewing live. The tourniquet was tightened by the participant on her own fingers until it did hurt, but when she removed her fingers the tourniquet was clearly very loose and needed more tightening.
- No way for the captain to understand turning the needle around. The hands do not allow to show this, or at least she could not understand also not from explanation.

Scenario B

- To adjust the camera she does not use the handle but grips it carefully between her fingers
 - o The tablet was never moved
- Very little head movement is required to watch the arm and the tablet
 - o You can never see both at the same time
 - o The doctor is working through the iPad but the captain is not

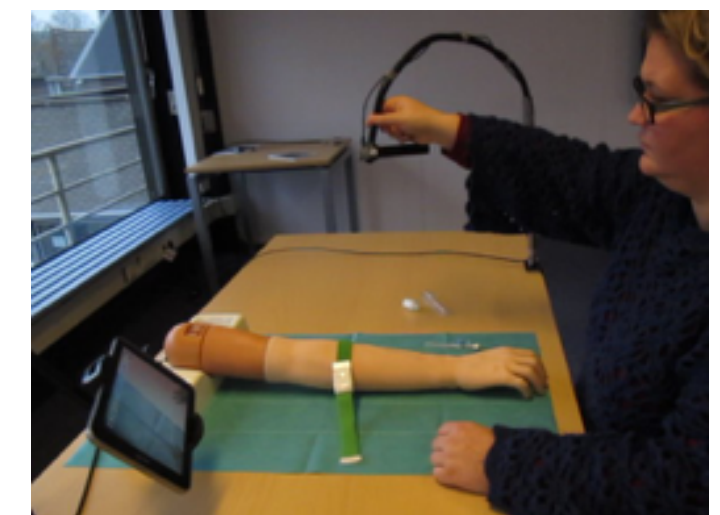

Interview

- No real difference between two scenarios
- For both scenarios, the way she receives instructions is the same. You see the fingers, hear the instructions. The only difference is the camera position
- Saw no difference how the hands looked for either set-up
- Set-up B was slightly easier to position the camera but not a big difference
- She says it is maybe not so easy to have an additional camera since on her ship they do not have so much equipment to place both the camera and the tablet
- Verbal instructions are very important, the hands were not sufficient alone. But for her just words would not have been enough, she was looking at the screen a lot
- Delay was not limiting
- She did feel like she was missing some instructions. She suggests for the doctor to say: Please look at my hands, look at the screen. Something like this so the captain knows when to view the screen.

Captain 2

Scenario A

- iPad adjusting is rather smooth, the iPad does end up high and behind the eyes
 - o He has to lean back to keep his eyes on the iPad
- You can hear the doctor giving instructions but the captain is focussed on the arm
- Asked to change iPad position so a better view is created
 - o This is hard since it is still in line with his own perspective and his hand is blocking the view
 - o In the end he changes the position of the arm and himself, improving the view for the doctor but making it near impossible for him to see the screen
- Needs very little correction from the application

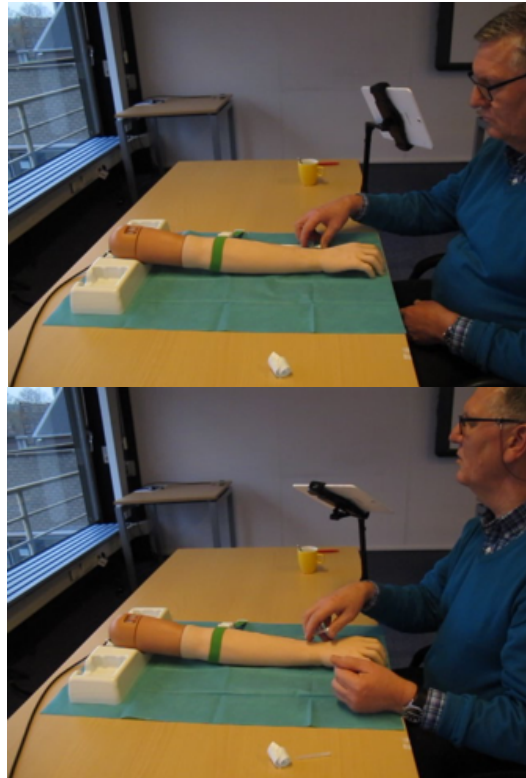

Scenario B

- Is using the handle
 - o Goes quiet well but the arm drops slightly when he takes his hand of
 - o Easy to adjust and get the camera in the right position
- Very little movement of the body, camera is not in the way
- He is very accurate because he has experience with the actions

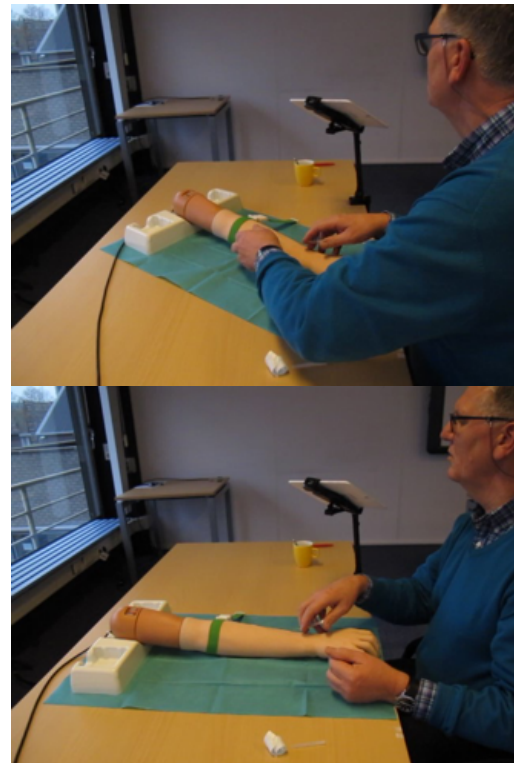

Interview

- Would like to have the iPad on the other side because he is right handed and it sometimes blocks his actions
 - o Take the camera away from the tablet, maybe from above, so the tablet is not in his work area
- Scenario B is much better to position the camera and make sure the iPad is not in the way
- The instructions were valuable
 - o How to hold the cannula
 - o The angle of the needle on the skin
- Position is taken from hands but the movement of pushing it in is taken from the verbal instructions
- If I really go wrong I now know the doctor will and can correct me, he thinks that will be valuable
- Thinks it is easier to see when the tablet is behind the work area, requires less body movement
- Does not feel like he missed instructions because there was no time pressure, even moving to make sure he can see the screen was no problem but the other set-up(B) is easier.

Captain 3

Scenario A

- iPad again very far behind work area
- Never watching the iPad when moving his own hands, always focussing on his own hands or on the iPad
- Doctor has to explain 3-point grip verbally. Hard to show with hands



Scenario B

- Ease of placing of the camera is high
- Camera was adjusted to the side to give a better perspective
 - o This goes fairly easy
 - o The image does turn upside down, so this should be more controlled when moving the
- Again a moment of focus on his own work and not the iPad

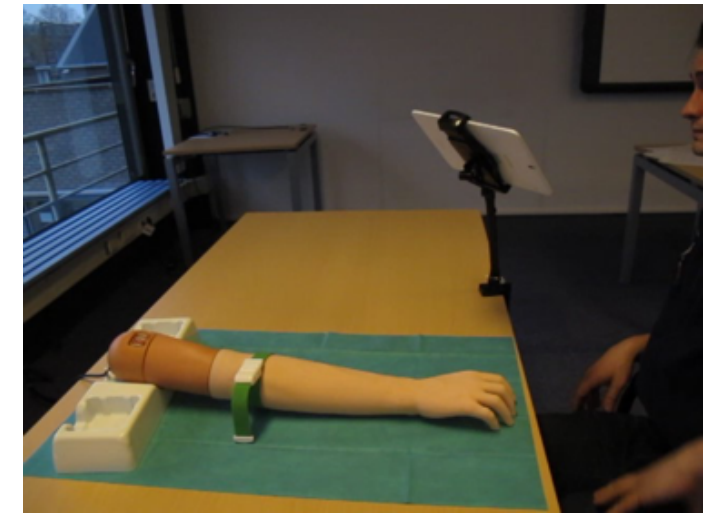

Interview

- Set-up B is a bit easier to view a long
- So you have extra stuff which needs to be placed and could break
- Set-up A, the quality is much better
- If you manage to place the iPad in the right position the set-ups do not differ a lot and you are able to keep overview over everything
- Instructions were experienced as the same and the both set-ups were just as easy
- Hands were easy to use for pointing, but for showing how to hold a needle maybe make sure the doctor also has a needle to show this because it is hard to see what is meant

Captain 4 together with Doctor 1

Scenario A

- The first step of the a scenario they take is repositioning the arm of the patient to make it easier to perform the actions. Not sure if AR related or because the medical professional considers this to be a better position for the IV
 - o Compared to some of the other participants, changing the position of the arm does make it a lot easier to keep eyes on the tablet as well as on the patient without putting body in strange positions
 - o The camera angle also works well for the doctor
- Ipad is in the way to perform his actions comfortably, since he has no experience he really depends on the instructions on the iPad
- The doctor asks him to reposition the camera so the hands of the captain are not in his view. Again the arm is moved, than the iPad position changed. The view is not ready for the doctor yet to see the angle of the needle so it is moved.

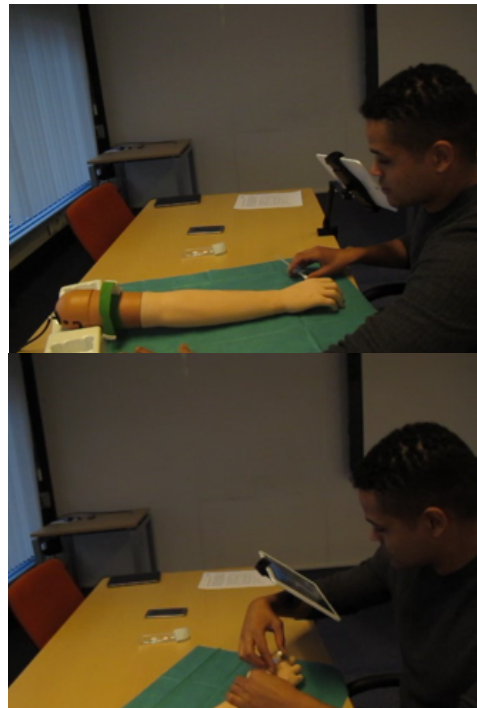

Scenario B

- Positioning of camera is easy, is also adjusted by himself when a different screen is required
- What works well is that C4 follows the instructions by also laying down the tourniquet so the doctor can also see this. More collaborative than other this way
- Doctor asks if he was able to find a spot where to put the IV, but does not confirm this through the screen it seems
- Body of C4 is very stable, all the time sitting comfortably in front of his work area

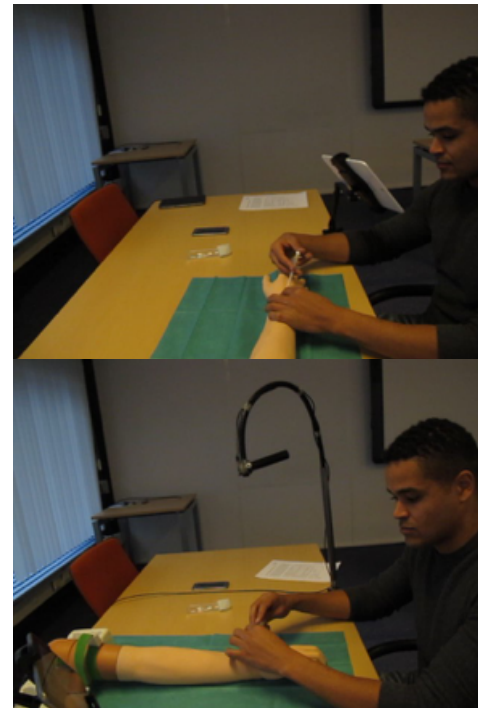

Interview

- Set-up B is easier because it is filming from above which gives more freedom to move and perform the skills
 - o Set-up A is harder because it is more difficult to position your body to move around the iPad and keep working on the patient
- Did not experience a lot of difference in looking at the iPads
 - o Some of the steps you can do by watching the iPad and not look at the real life. He was mainly looking at the iPad screen
- It was easy to interpret the instructions. The AR instruction is beneficial with the pointing how to place it.
- If he could change something about the AR-functionality he mentions the arm to which the iPad is connected so it is easier to position well.
- No difference in experience in instructions from the doctor. The size of the hands was good, all the time.

Captain 5 together with Doctor 2

Scenario A

- Position of iPad is okay, but the iPad is again very far behind him
- They had some internet issues as well
- The captain is struggling to implement the instructions for a few reasons, the internet is making the hands of the doctor stutter and slow and the camera position was not allowing the doctor to clearly point what he wants to show
- The tablet is repositioned
- He has to view the instructions far behind him on the tablet. So he looks at the instructions and implements them but is not able to get live instructions during the process
- With this captain, who is very experienced, it is enough to just view his actions and give corrections where necessary. He is watching the instructions but only because the doctor side is asking him to



Scenario B

- When repositioning the camera the set-up provides a lot of freedom for the captain and he is able to put it very low next to the arm while he is checking the impact of his actions on screen

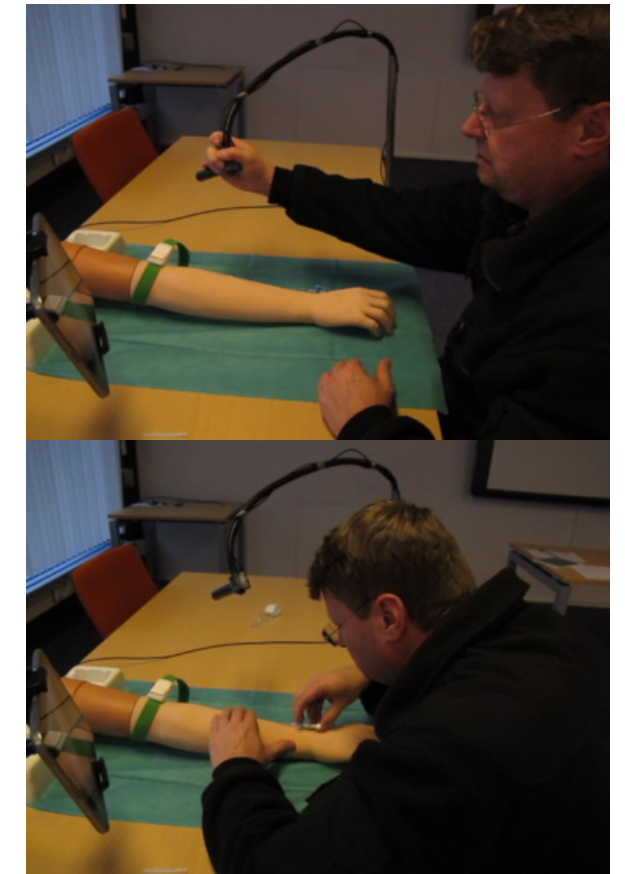

Interview

- Camera in set-up B is a bit worse
- The connection was not great, the hands were stuttering. The connection was
- Hard to implement because the doctor has nothing to show with
- The tablet being behind the work area is easier, depends a bit on the actions you have to take what you want.
- Says he hardly focussed on the hands, mainly on the audio because he has experience

Doctor 2 with a doctor who is fulfilling the role of doctor

The trainer(D2) is fulfilling the role of the captain and acting as if he is not familiar with the steps and lets the doctor guide him through the steps. At some point in the interactions he puts the tablet parallel with the arm to give the best view for the doctor. This position does put the tablet in the perfect position for the doctor to see the captains actions but makes it impossible for him to look at it. Because he is acting like he has no clue what he is doing she is really struggling to give him good instructions.



Captain 6 together with Doctor 2

Scenario A

- He is very much struggling to find a position for the iPad that matches. He is trying all kinds of positions and also ends up putting it parallel with the arm. He concludes: "This way I cannot see anything myself."
- The doctor confirms at some point that the position is perfect for him and asks if it is 'workable' for the captain so they can continue
- To make it work the captain switches hands with setting the IV, which is not possible for everyone to do this
- The position of the captains body is undesirable when puncturing the skin with the needle

Scenario B

- He is focussing on the screen and using the instructions very well, he is even looking just at the screen sometimes to position his hand the right, matching it with the view of the captain



Interview

- The position of the iPad is especially different, set-up B probably better
 - o Hard to position with set-up A
 - o But on board you probably have an extra pair of hands to work with who can hold the tablet
- Easy to implement his instructions, the visual images give extra confirmation. Without it would have worked but for the feeling it is good
- Hands were never in the way
 - o Especially nice to match his own hands with the hands of the doctor, double confirmation
- In set-up A it is hard to switch between viewing the work area and the general area
- I know what to do but am not always 100% certain, the double confirmation is really great for this

1.2 Overall conclusions captains side

- Need for a way to make sure that it is clear when the captain is viewing the screen
 - o For example turning on the front camera on the captain side when it is behind work field

2.1 Doctor side

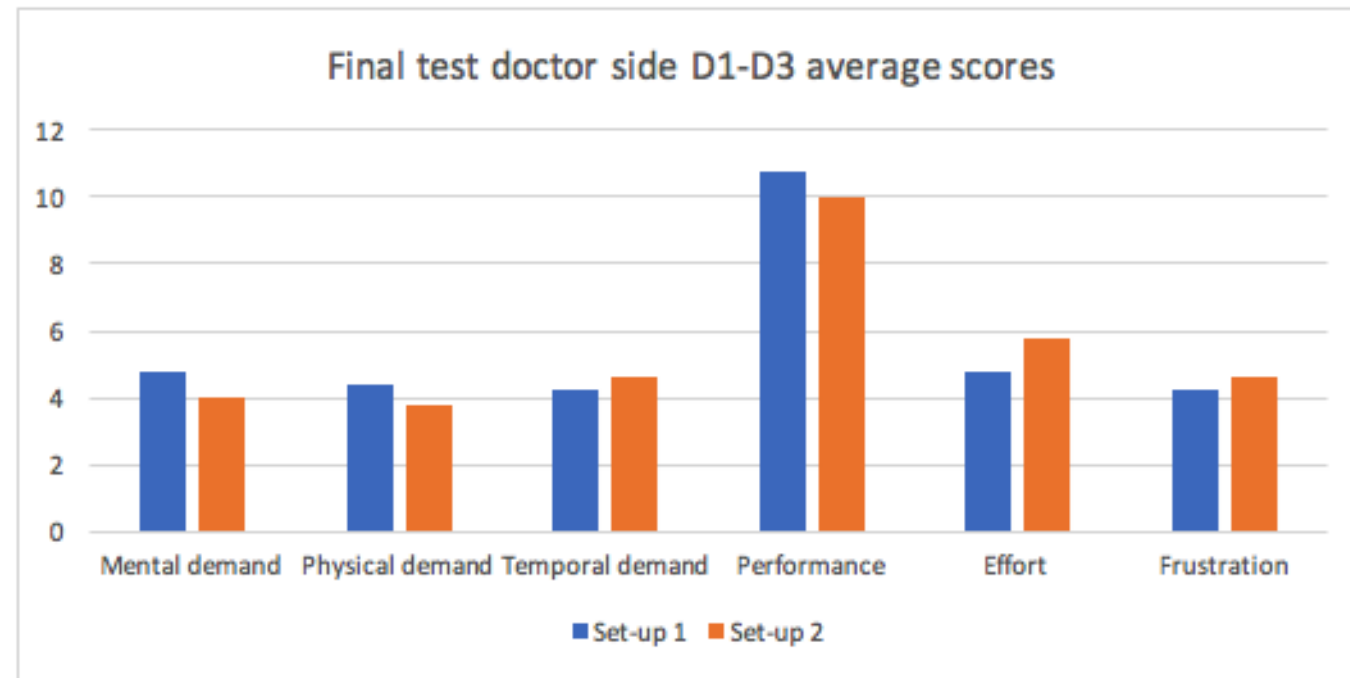

Doctor 1 with Captain 4

Experience with the procedure affects the duration a lot.

Scenario A

- His first action is putting the tablet in the stand at a angle and re-positioning the green screen
 - o The green screen is actually not big enough, but neither party seem to be bothered by the
- He suggest to move the patient rather than the camera
 - o This might be because he can see the position of the captain and knows what is possible
- In this case the doctor is not really judging what he is seeing, until it is pointed out that the camera can be moved. He is just giving instructions and overseeing.
 - o After changing the position the situation is much easier to oversee
- The doctor is at some point giving an instruction but this cannot be seen by the captain because the movement is not in screen. Not sure why the doctor did not move his hand further to redo this.

Scenario B

- D1 is using the work area very well it seems
- Sometimes forget to use hands
- He communicates well saying: "If I can just show you"
- Sometimes it is a bit hard that the camera is off centre
- For this part of the scenario the doctor seems to have a clear view all the time

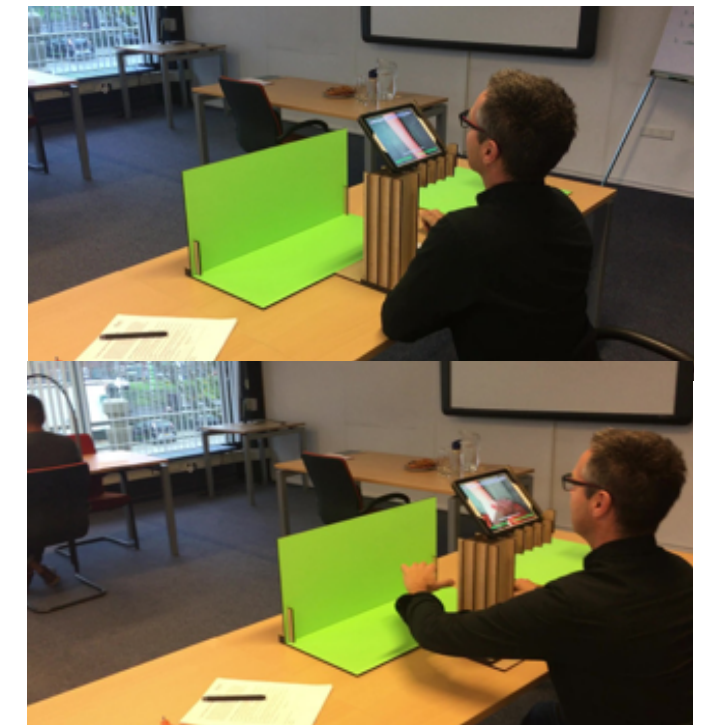
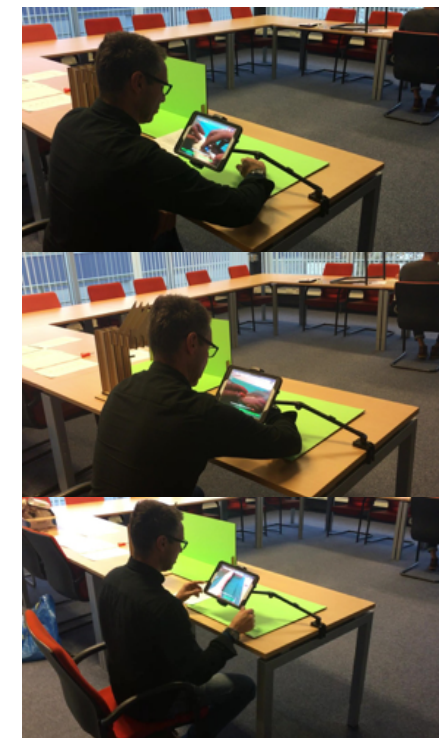

Interview

- He felt his hand were fairly large compared to the subject of the captain on screen
 - o The explanation misses sometimes the detail because of the large hands
- He felt no difference between the two set-up. Set-up B for him is actually harder because it is far to reach. Does not realize that this allows for more freedom of movement
- The screen in set-up B also makes the light reflect rather quickly
- The explanation would have been easier if he would have had one as well, to explain the different parts to the cannula and what to do

Doctor 2 with Captain 5

Scenario A

- The position of the iPad has been put so that it aligns with the captain's view and the whole arm can be seen
 - o But as soon as the captain goes to perform an action he is blocking the whole screen
- He is giving instructions, but the view is so far from the arm it is hard for him to show. So he asks to reposition the camera slightly
- For some reason, at some point, he tilts the tablet slightly so he can see the screen better. Not realizing this might jeopardize the green screen ability
- Also he communicates: If you can just look at the screen for a moment



Scenario B

- Realizes the screen is not of the best quality
- He is not using his hands at all in this scenario
- The iPad height seems to be comfortable for him, but this is also
- The doctor has to indicate the view that he is looking for #



Interview

- Set-up A was good, but as soon as the captain was performing his actions the captain was completely in the view
- It took some time to get used to where the hands have to be to be in screen
- The internet connection created a delay in the hands entering on screen
- Set-up B was very clear, easy to see the situation
 - o Easier to give instructions as well
 - o Easier to tell the captain where the doctor would like the camera position
- Did not do much with his hands
 - o Set-up B is a bit high and the light is reflecting on the screen

Doctor 3 (same as doctor 2 but now with captain 6)

Scenario A

- It is a lot about observing and confirming
- Pointing is used a lot
- He uses his finger to show the angle on the arm, which works well but the hand is very large on screen
- He is in a very comfortable position with the tablet slightly tilted and his elbows resting on the table
- The camera position is really nice for the doctor, but the captain can not really work



Scenario B

- Realizes the screen is not of the best quality
- He is not using his hands at all in this scenario
- The iPad height seems to be comfortable for him, but this is also
- The doctor has to indicate the view that he is looking for



Interview

- Felt in control of his hands, especially because the internet was better now
- Did not experience difference between set-up A and set-up B.
- He felt like his hands were larger on screen than real
 - o This was especially with set-up A
 - o Did not consider moving his hands a bit further away
- He felt it went better than previous time because he gave instructions and held his hands in the screen until the captain saw them
 - o He was looking at the captain in the room for this confirmation, so this is not possible in real life
- In set-up A, the captain put the tablet in such a position as he needed it. But this was a very difficult position for the captain. In theory he says, he will get the optimal view, but it has to work for the captain as well.
- The captain is always positioned on the side of the injury, so if you want them to be able to see the screen the screen has to be on that side as well.
- Important to consider the scenario which it is used for, the angles and position depend on this very much
 - o Vein indicating is done from above
 - o The angle of the needle has to be done from the side