

*O stad Amsterdam, omarm je noorderoever:
de Noorderzon schenkt je een horizon in wording,
de Overkant van 't IJ niet langer ondergeschoven of verborgen,
maar een bron waaraan nieuw leven ontspringt.*

'Simon Vinkenoog - O Amsterdam'

A PUBLIC EXPERIENCE
TO THE OTHER SIDE



PROBLEM STATEMENT
URBAN INTERVENTION
ARCHITECTURAL ASSIGNMENT
ARCHITECTURAL PROPOSAL
TECHNICAL INTEGRATION

INDEX



PROBLEM STATEMENT

A PUBLIC EXPERIENCE
TO THE OTHER SIDE

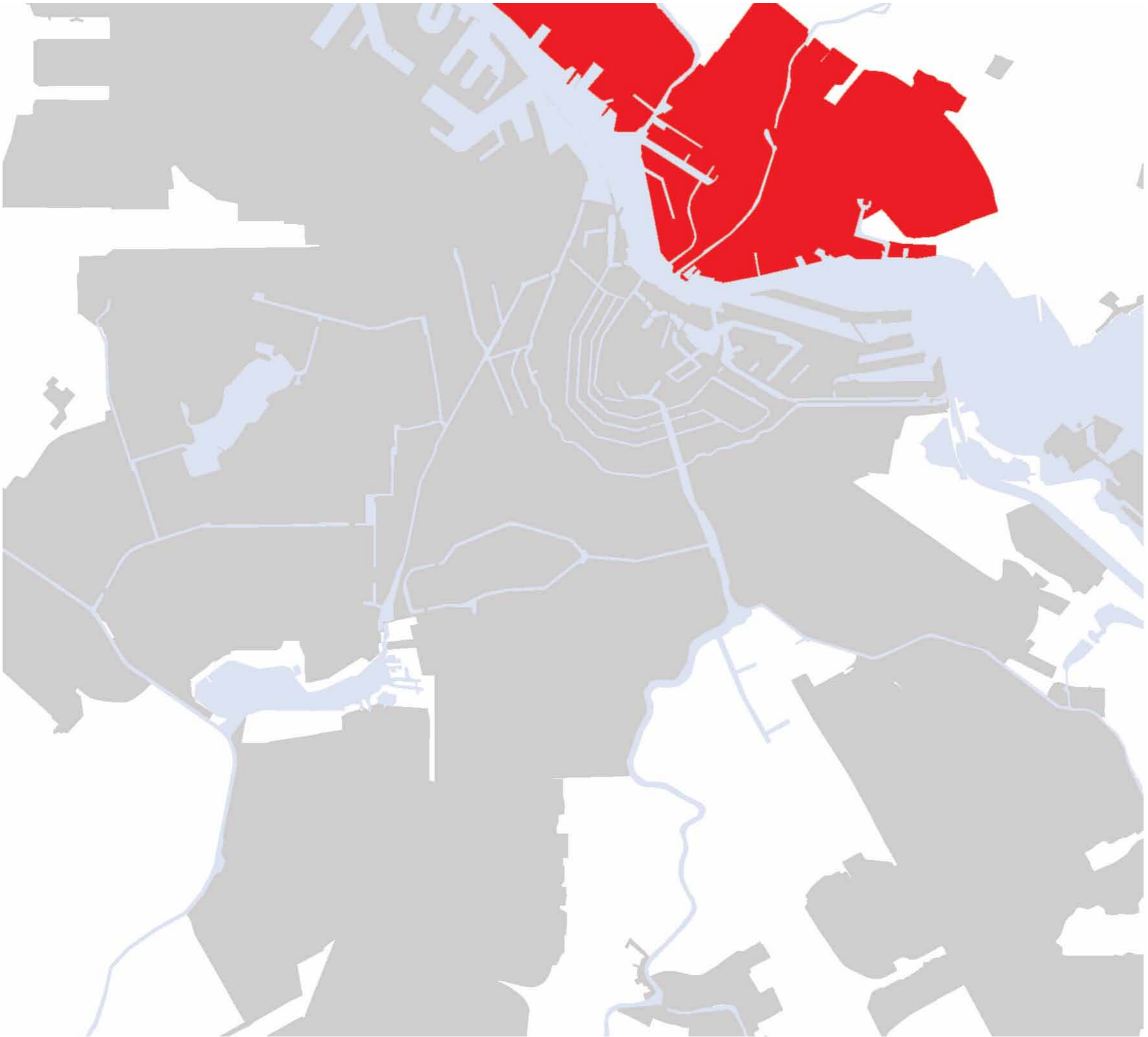

PROBLEM STATEMENT



PROBLEM STATEMENT



PROBLEM STATEMENT

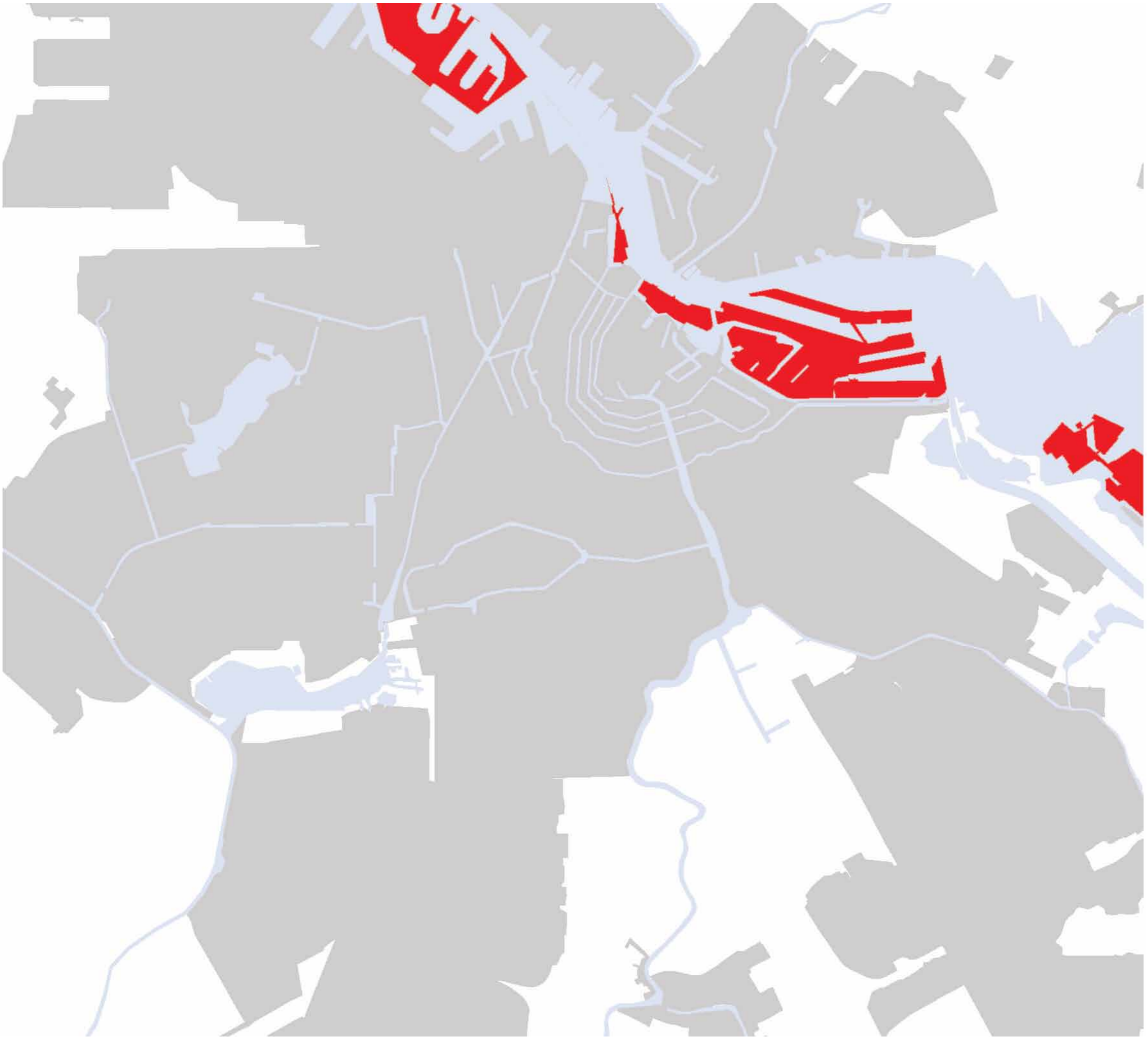

PROBLEM STATEMENT

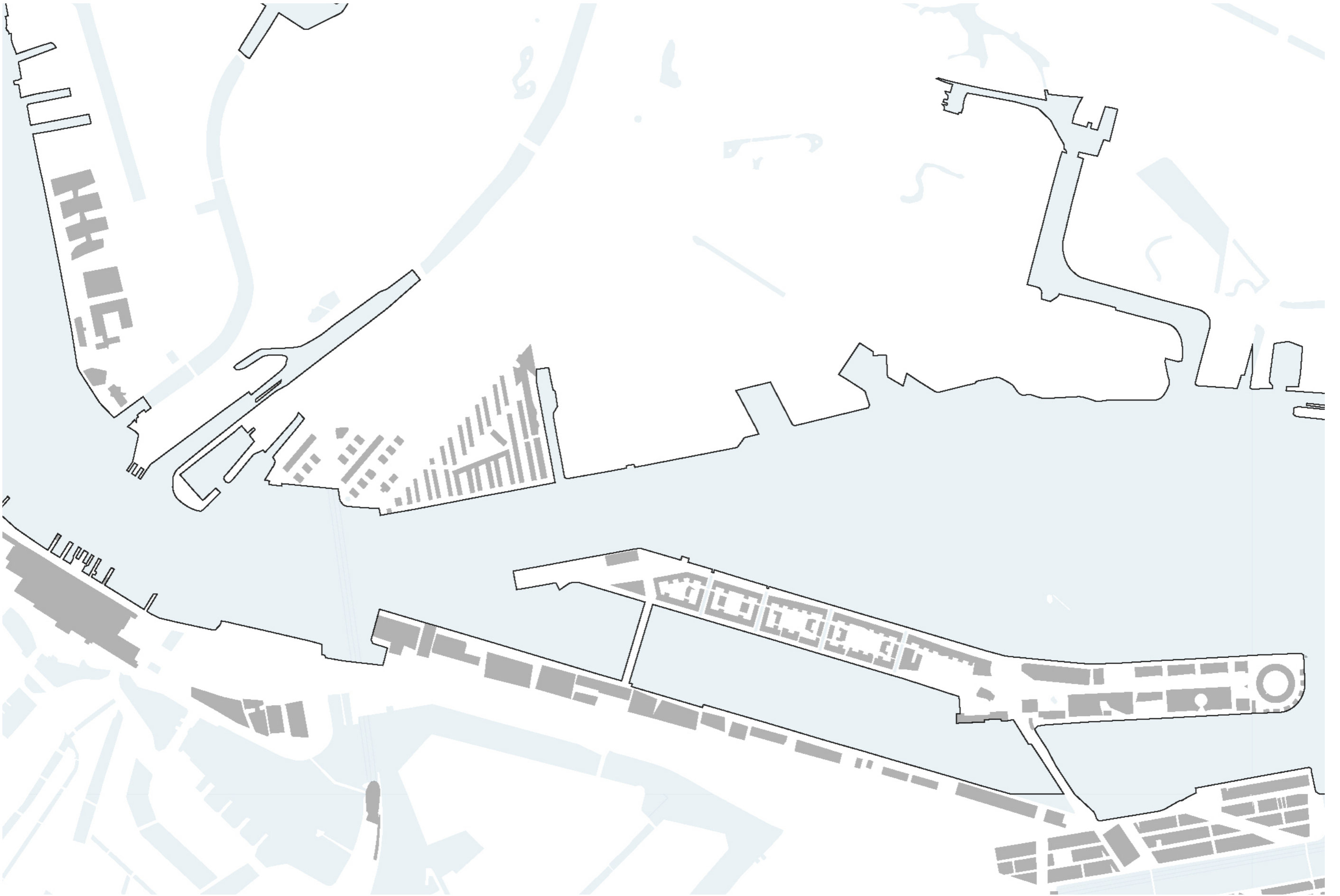

PROBLEM STATEMENT

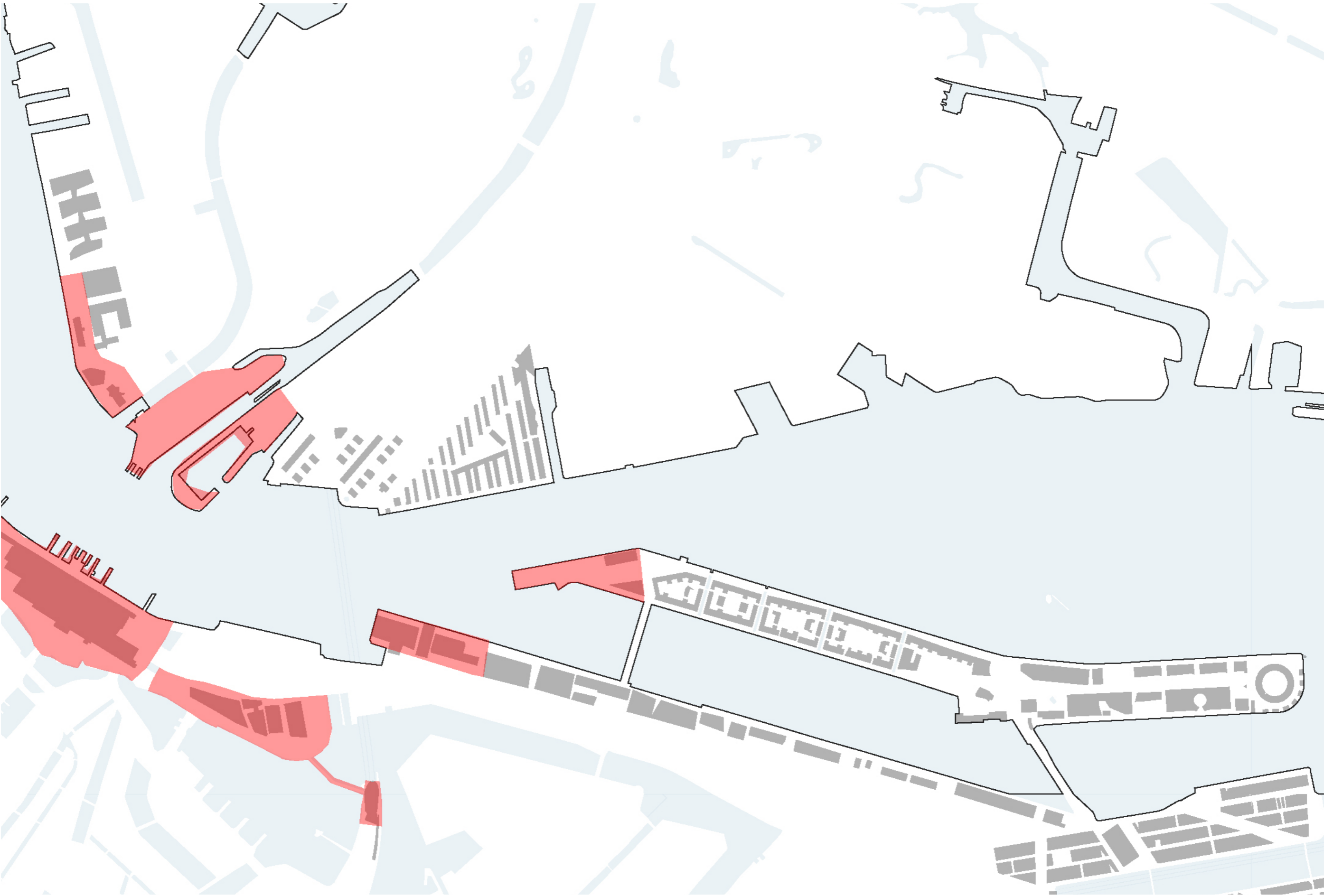

PROBLEM STATEMENT



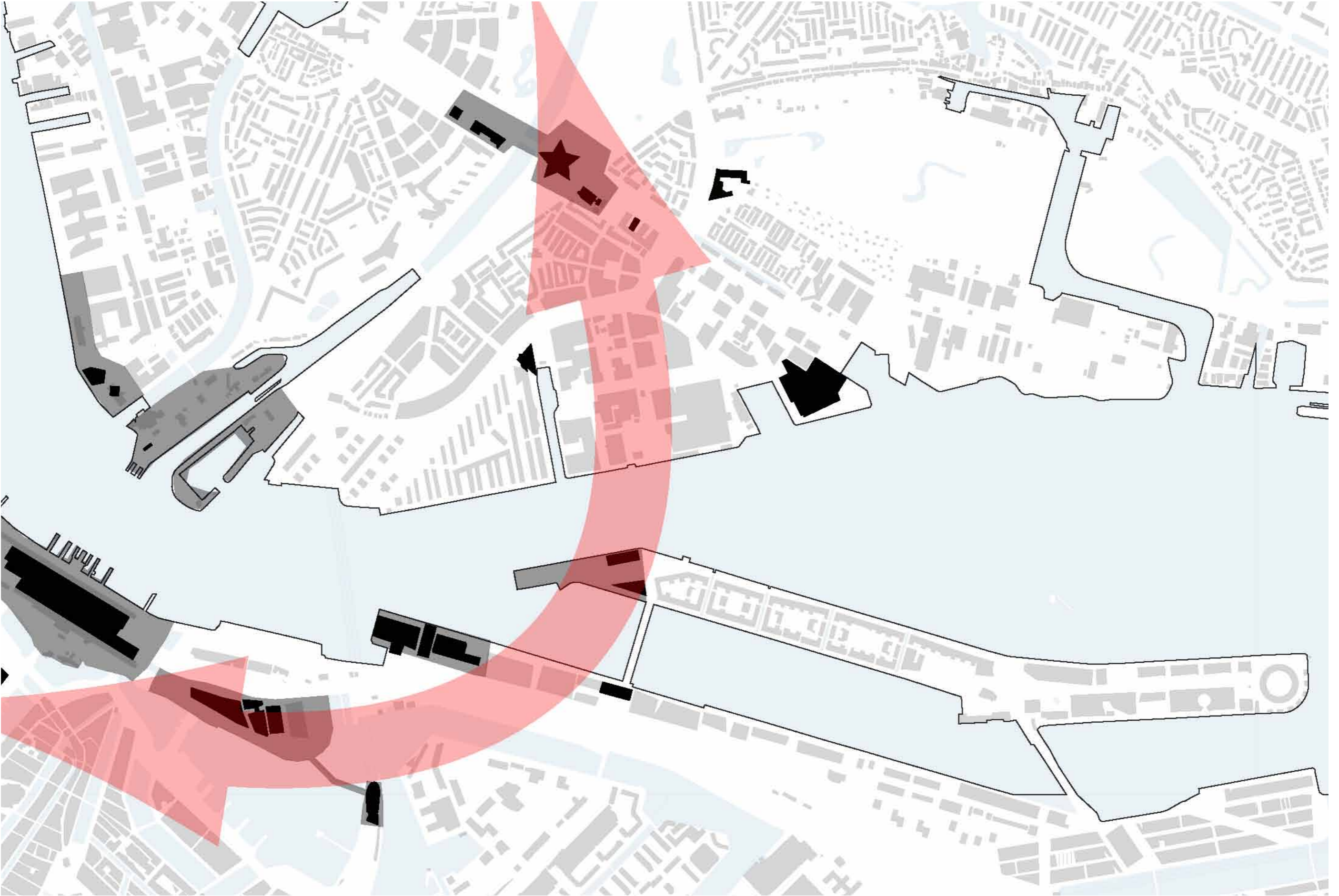

URBAN INTERVENTION

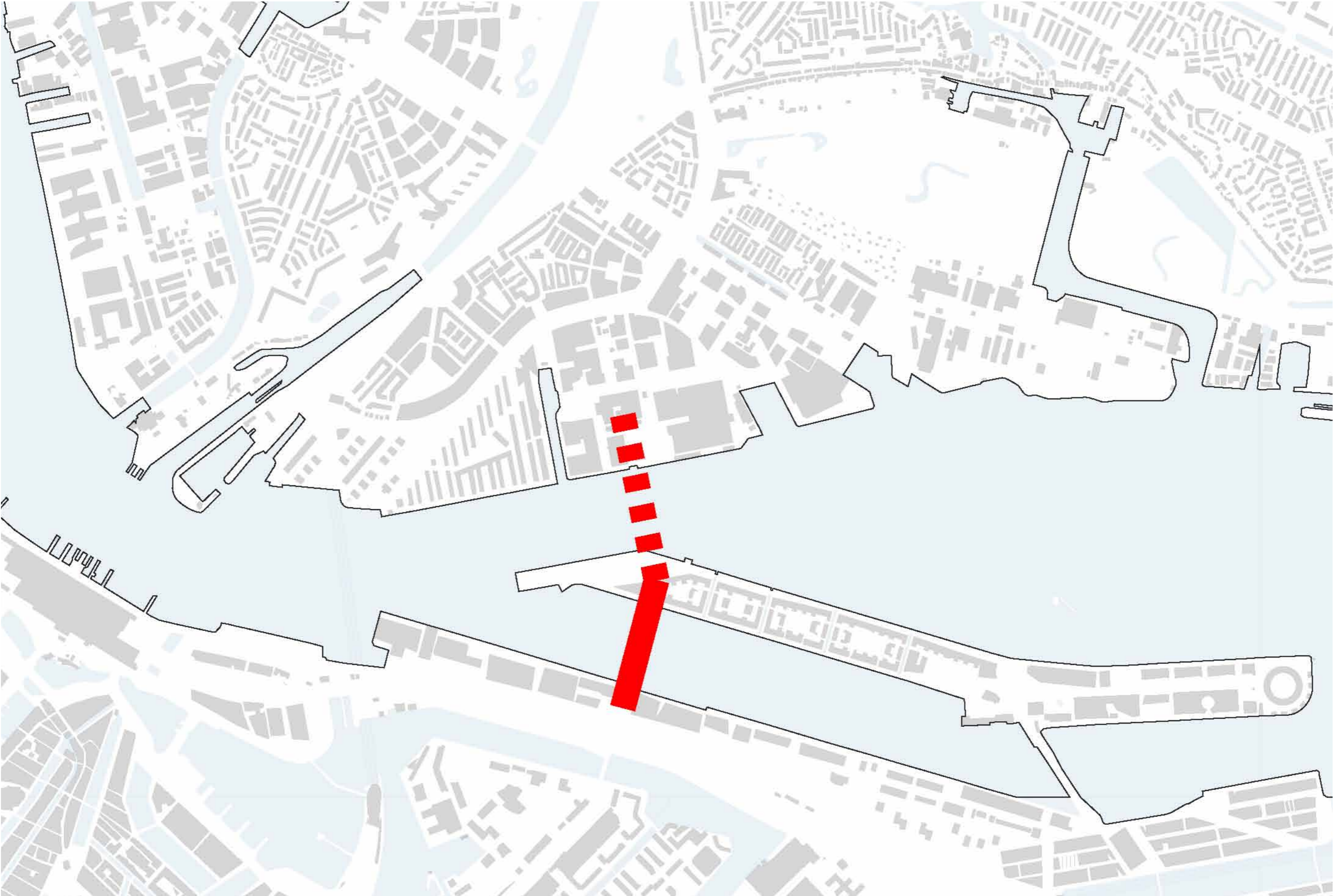

URBAN INTERVENTION



URBAN INTERVENTION

A PUBLIC EXPERIENCE
TO THE OTHER SIDE

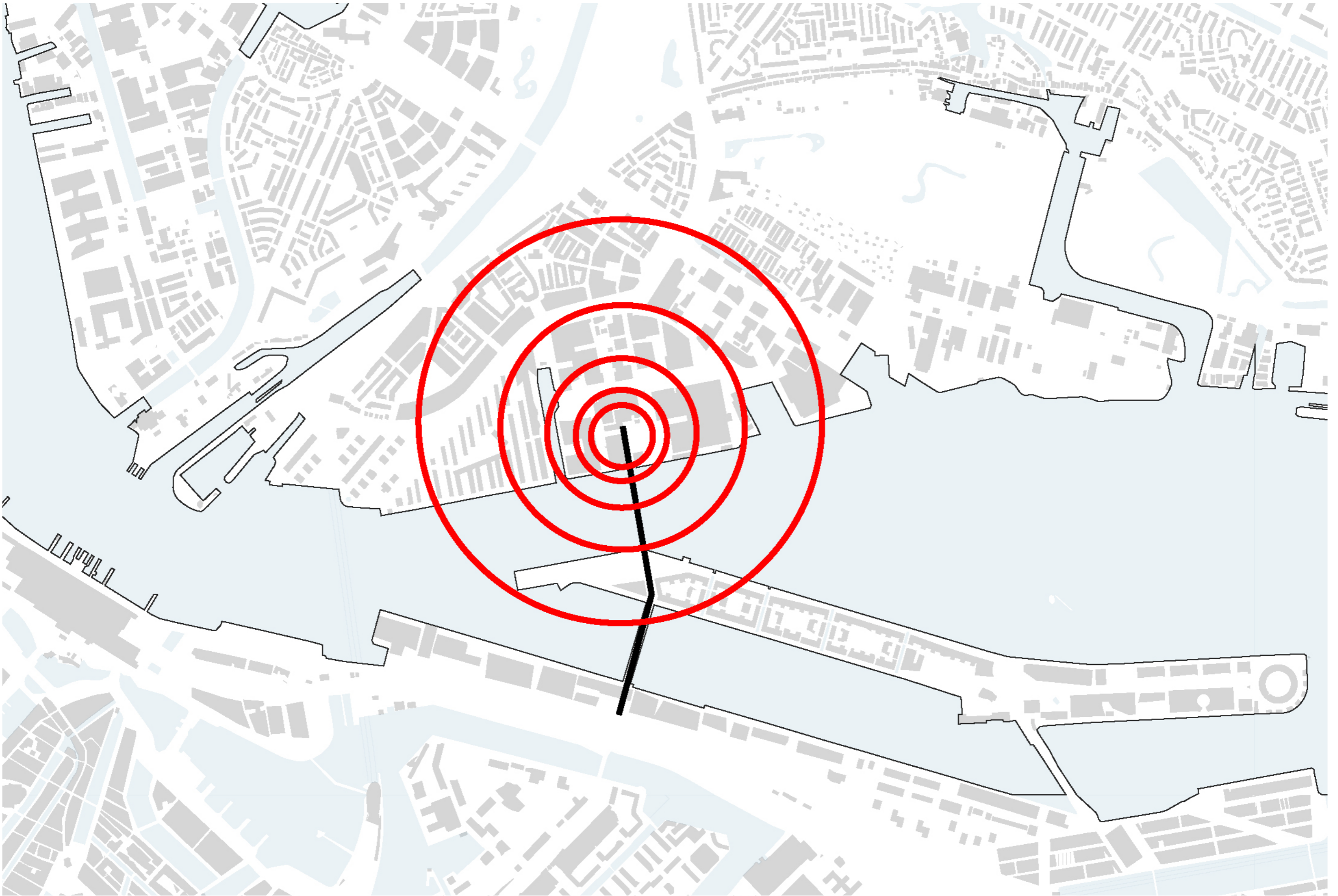

URBAN INTERVENTION

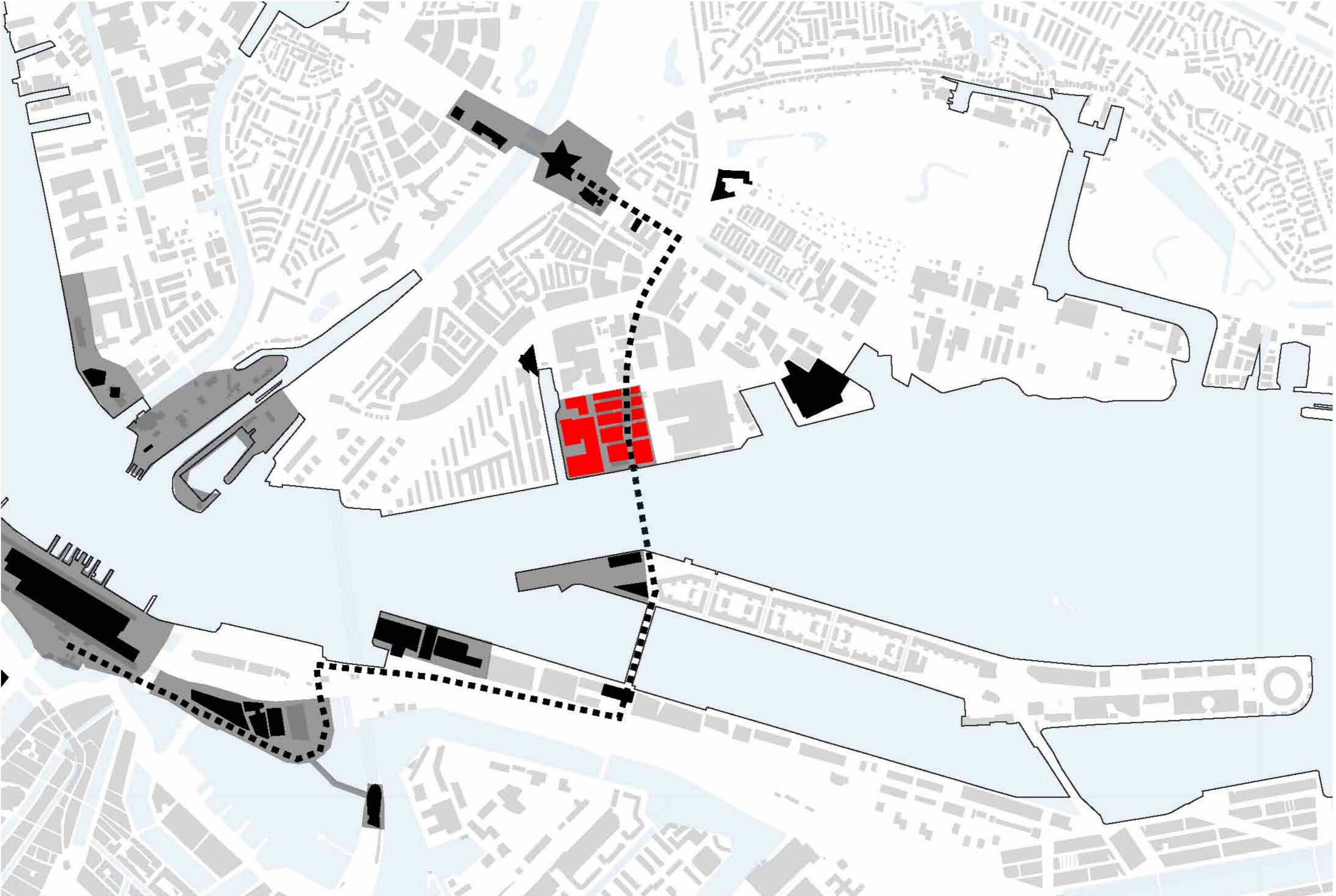

URBAN INTERVENTION



URBAN INTERVENTION

URBAN INTERVENTION

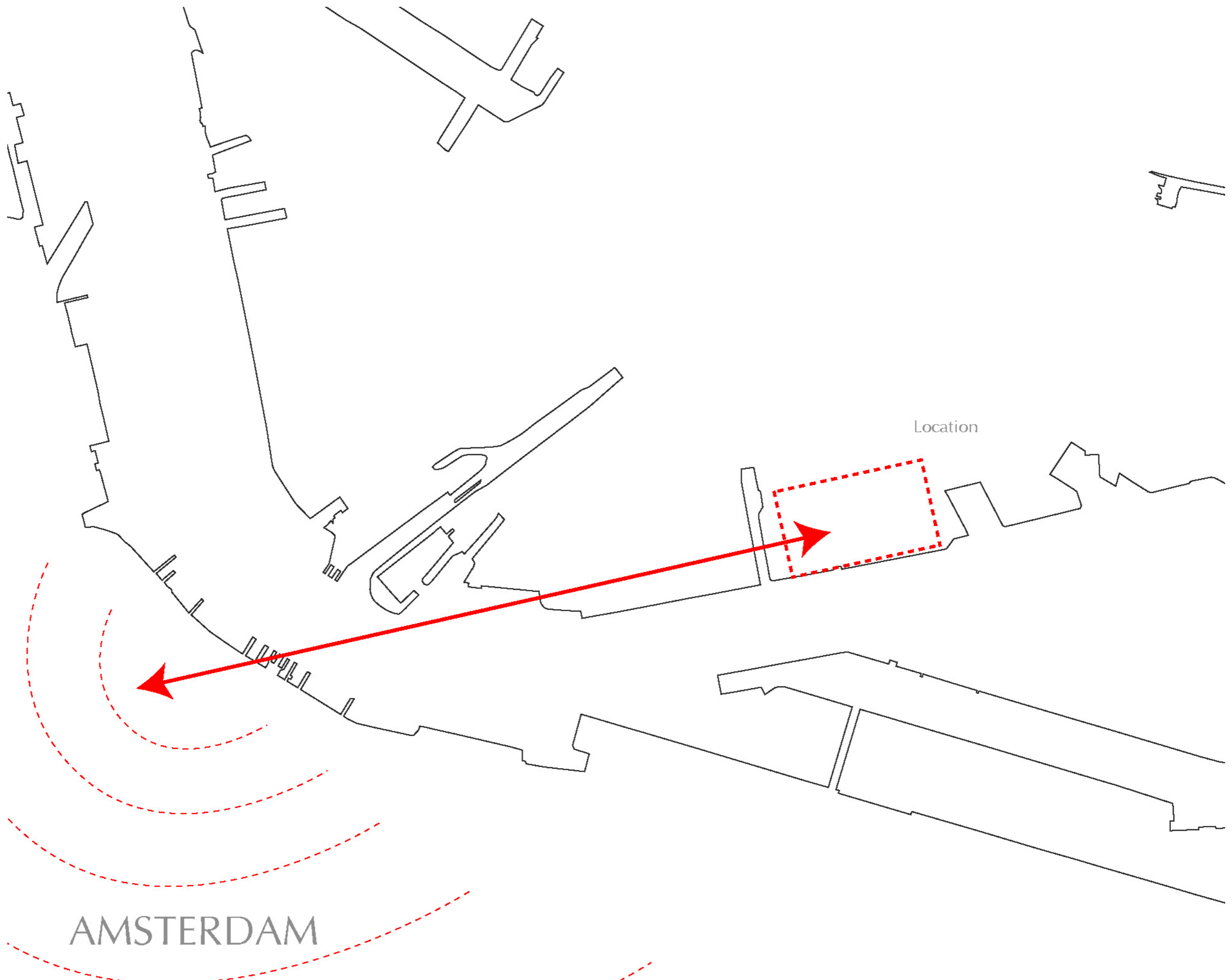

AMSTERDAM

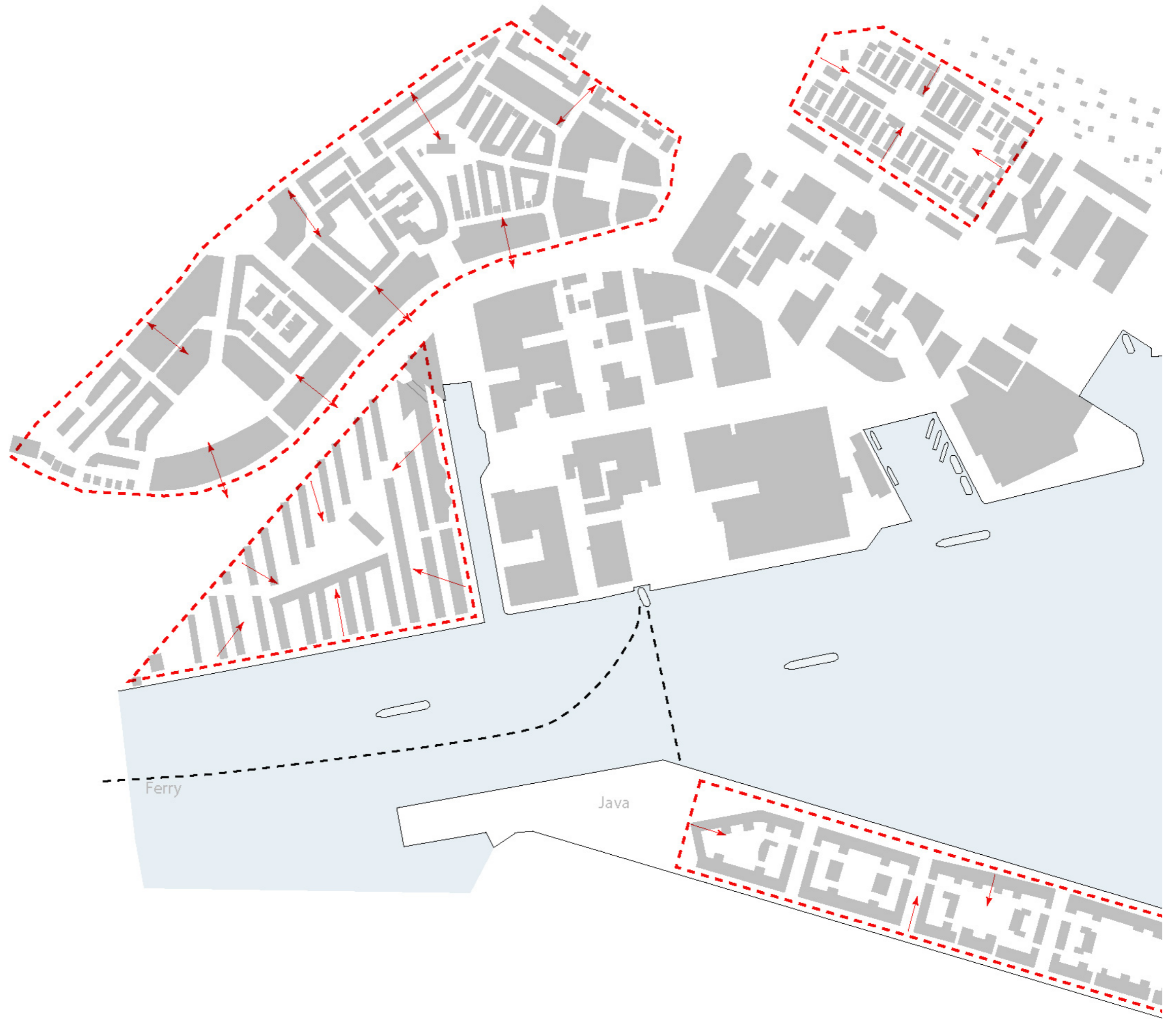

URBAN INTERVENTION







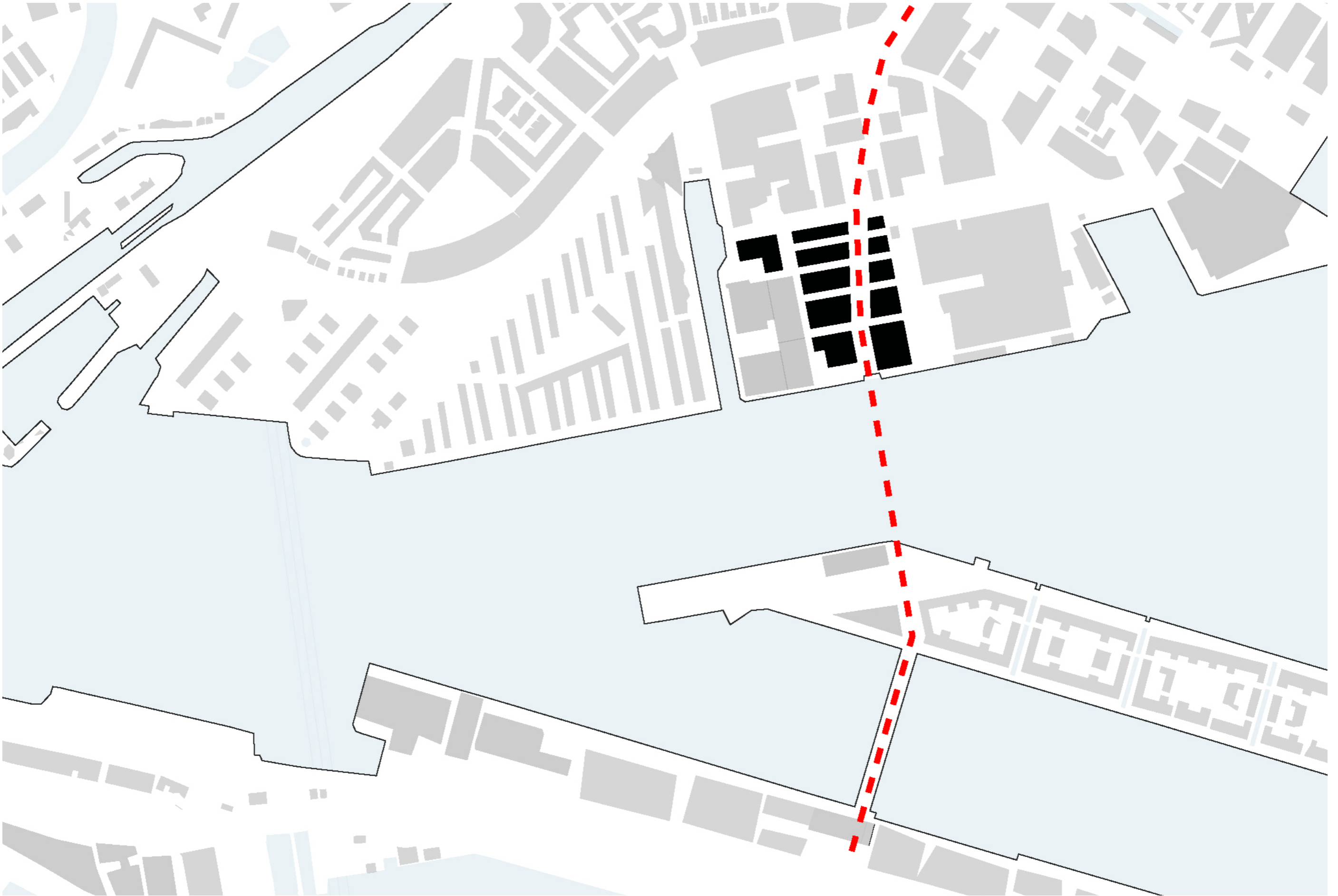

URBAN INTERVENTION

A PUBLIC EXPERIENCE
TO THE OTHER SIDE

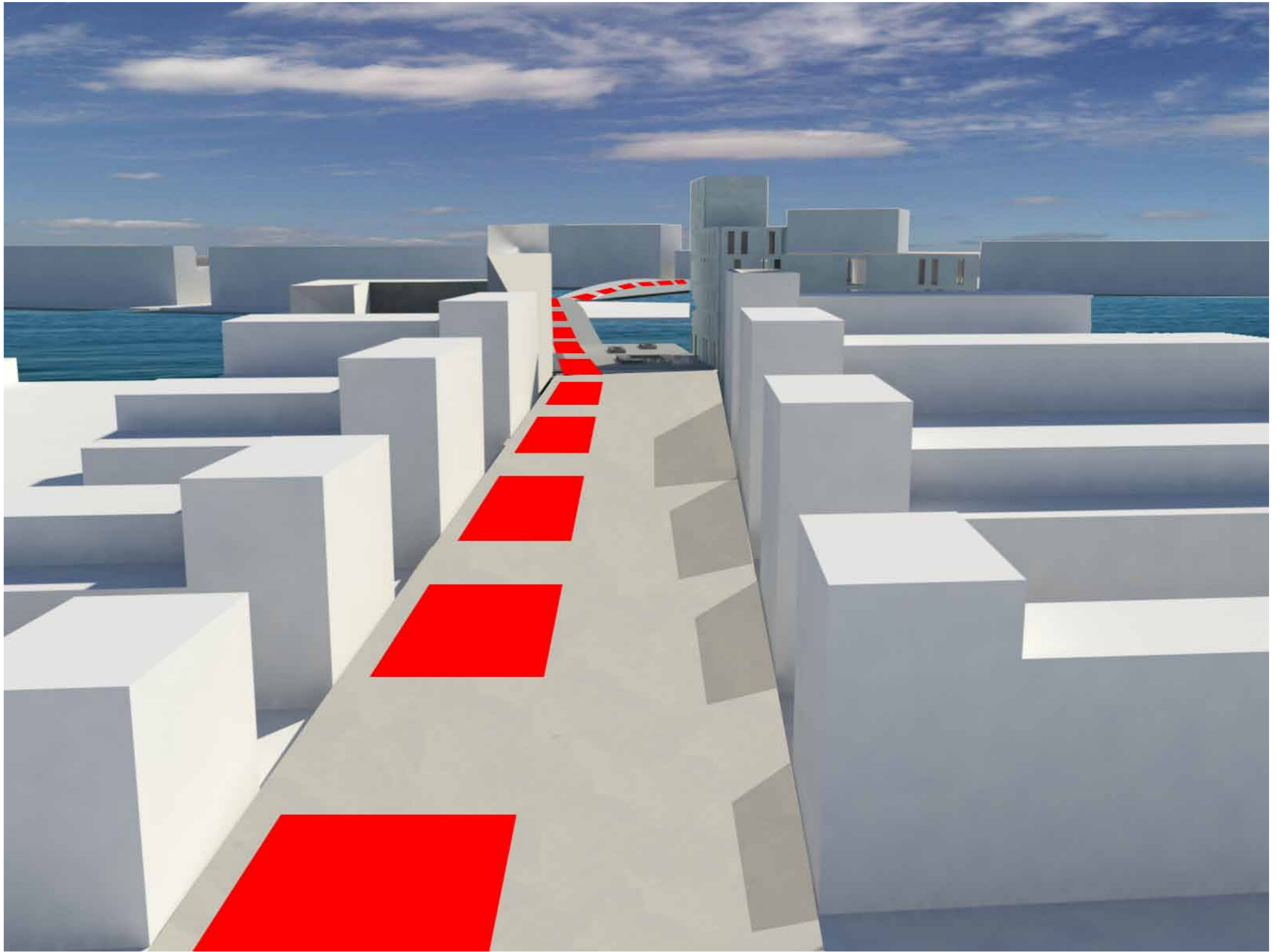

TOTAL AREA
50.000 M2

URBAN PLOT
52% FROM TOTAL AREA

TOTAL M2
75.000 M2

PARKING
13% FROM TOTAL M2

URBAN INTERVENTION

A PUBLIC EXPERIENCE
TO THE OTHER SIDE



URBAN INTERVENTION

A PUBLIC EXPERIENCE
TO THE OTHER SIDE



URBAN INTERVENTION

A PUBLIC EXPERIENCE
TO THE OTHER SIDE

ARCHITECTURAL ASSIGNMENT

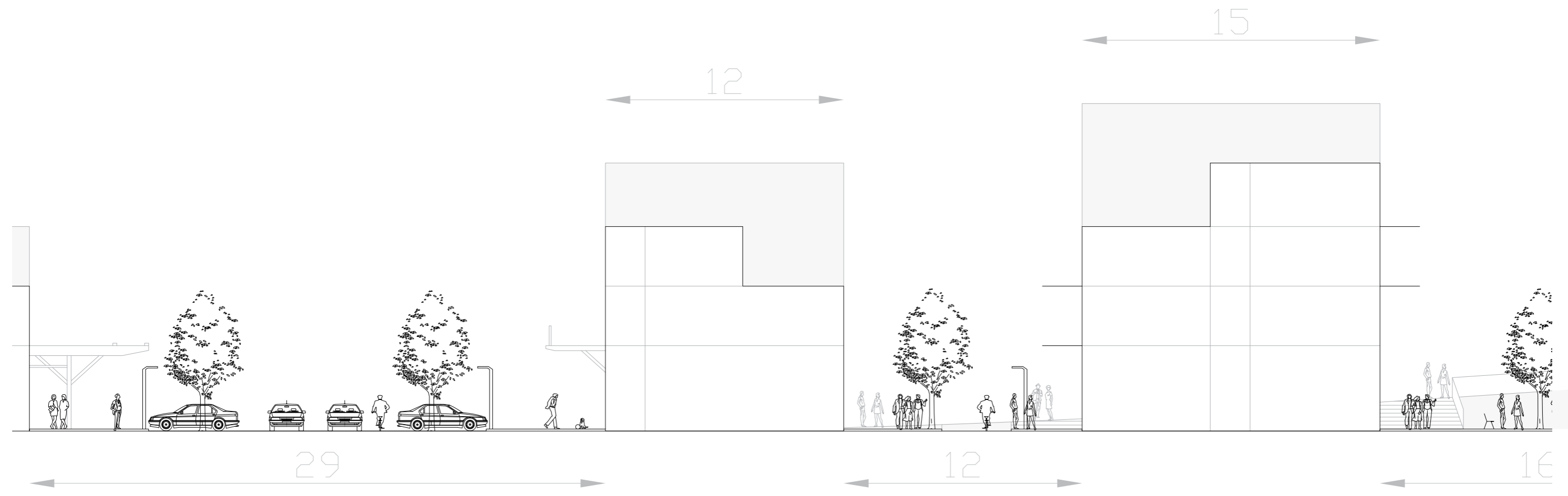

HAMERSTRAAT
DOUBLE STREET WITH PARKING

PLOT 5
WORK/LIVING
GROUND FLOOR
APARTMENTS
50-100M2

4TH STREET
RESIDENTIAL STREET

PLOT 4
WORK/LIVING
GROUND FLOOR
STUDIO'S
30-50M2

3RD STREET
ENTRANCE PARKING

ARCHITECTURAL ASSIGNMENT

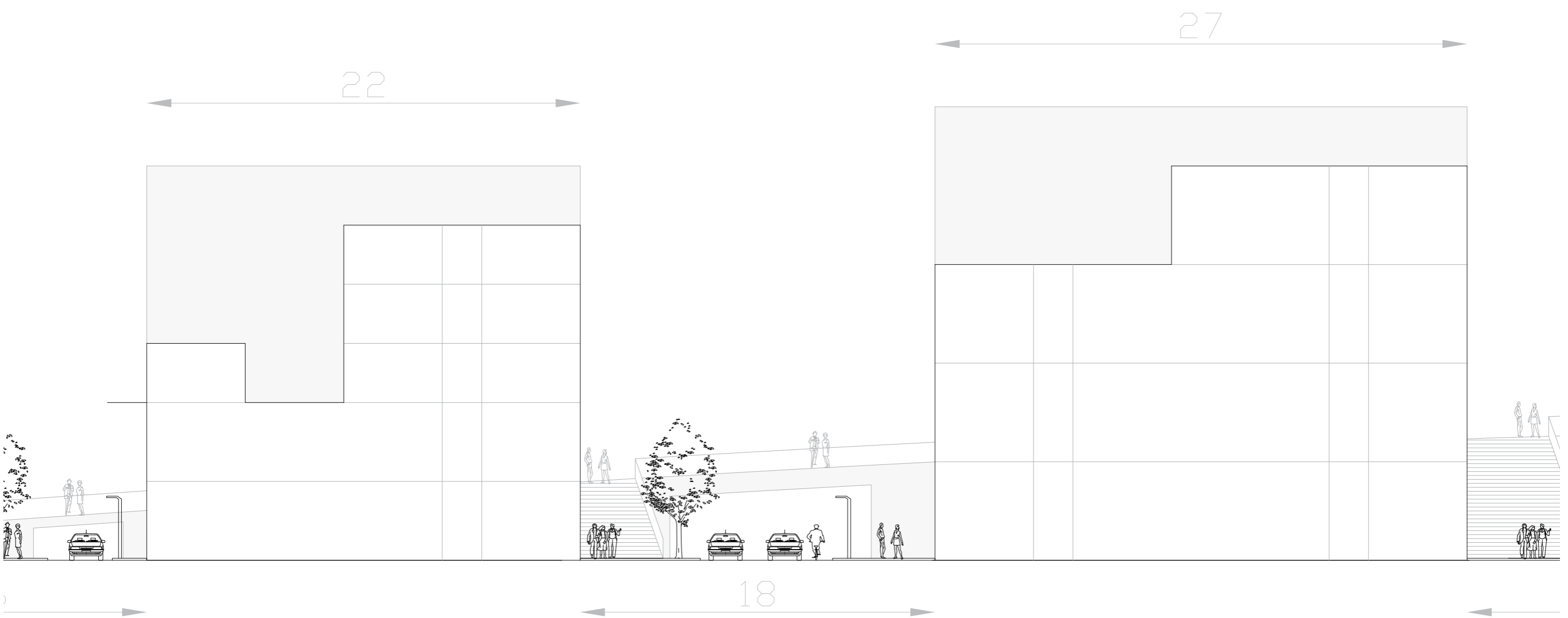

3RD STREET
ENTRANCE PARKING

PLOT 3

SPA/FITNESS
FIRST TWO FLOORS

STUDIO'S
30-50M2

2ND STREET
DOUBLE LANE

PLOT 2

FILM SCHOOL
WITH RECORDING STUDIO'S

1ST STREET
DOUBLE LANE WITH EXPEDITION

35

ARCHITECTURAL ASSIGNMENT

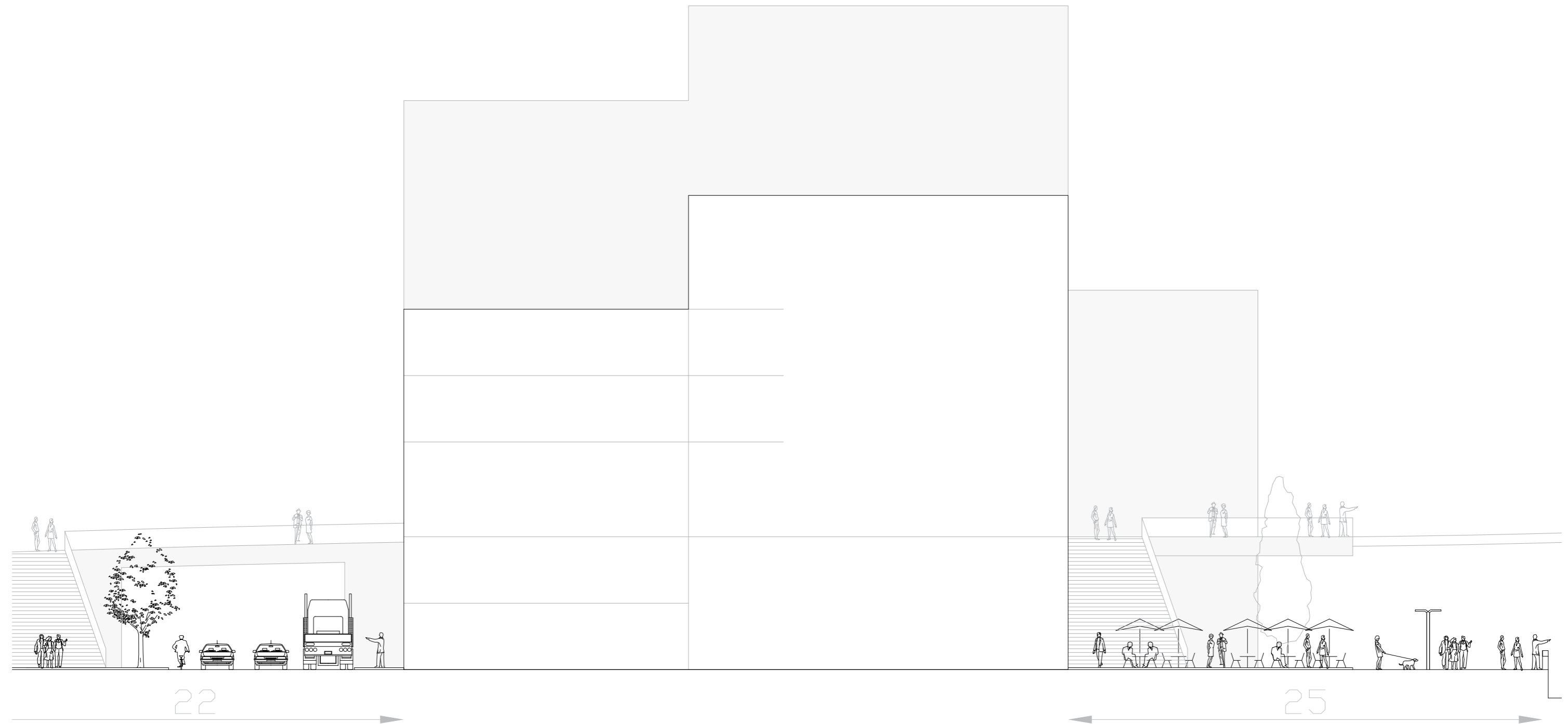

22

25

1ST STREET
DOUBLE LANE WITH EXPEDITIC

PLOT 1

CONFERENCE CENTER
DIFFERENT HALLS

STUDIO'S
FILM, MUSIC AND CRAFTMANSHIP

CAFE

BOULEVARD
TERRACES AND PLATFORM

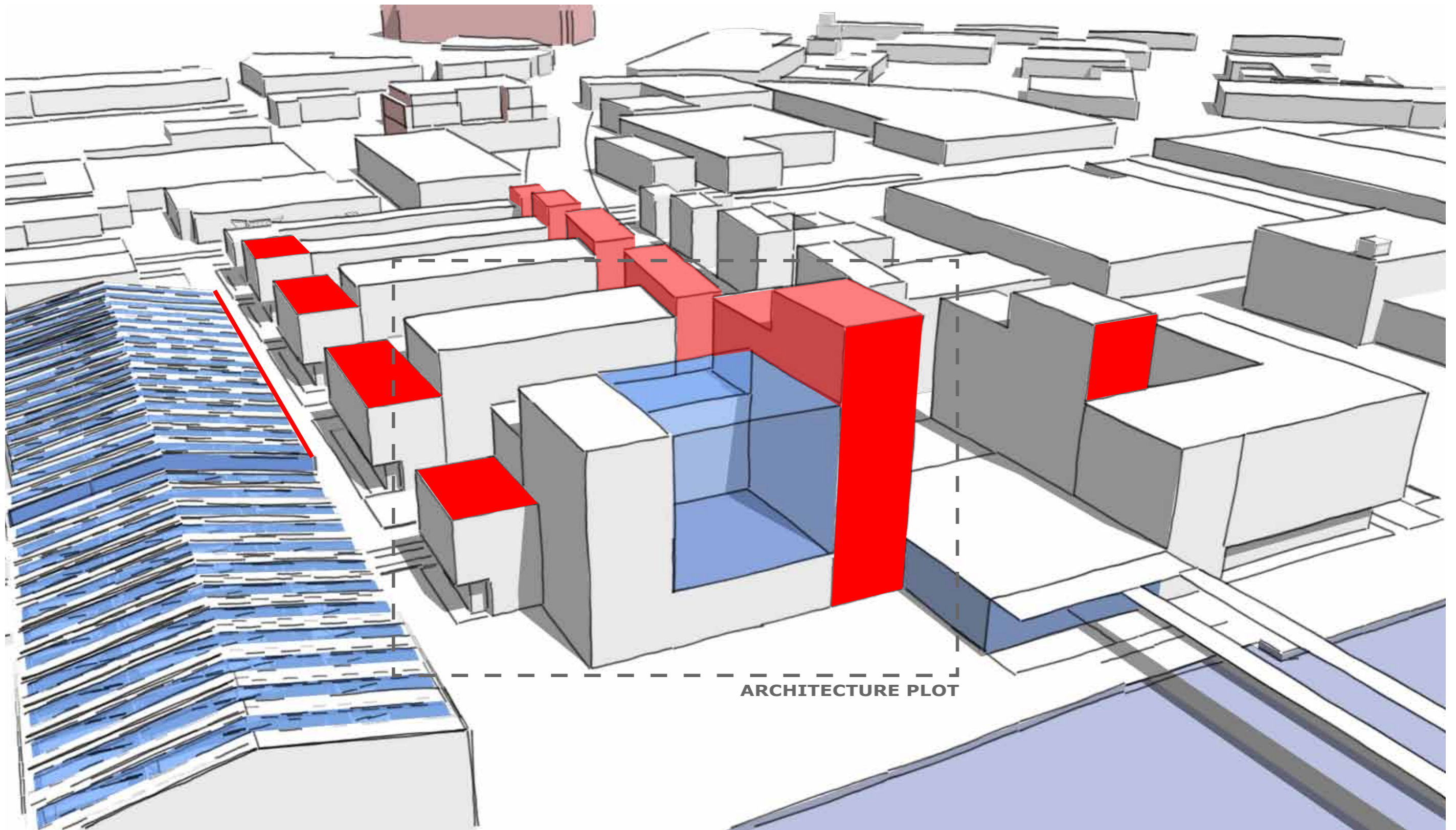

ARCHITECTURAL ASSIGNMENT



A PUBLIC EXPERIENCE
TO THE OTHER SIDE

ARCHITECTURAL PROPOSAL

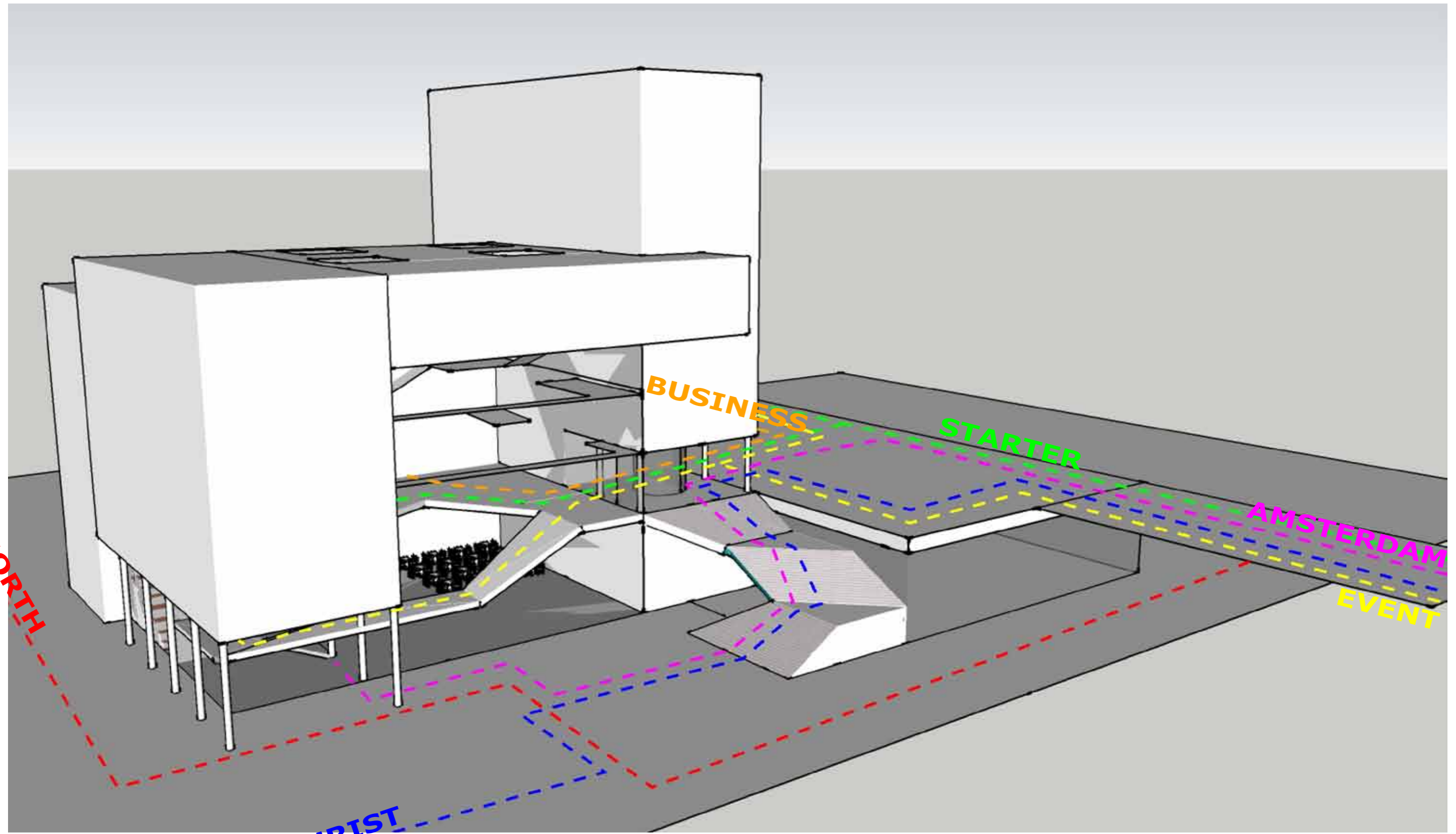

TOURIST

BUSINESS

STARTER

AMSTERDAM

EVENT

NORTH

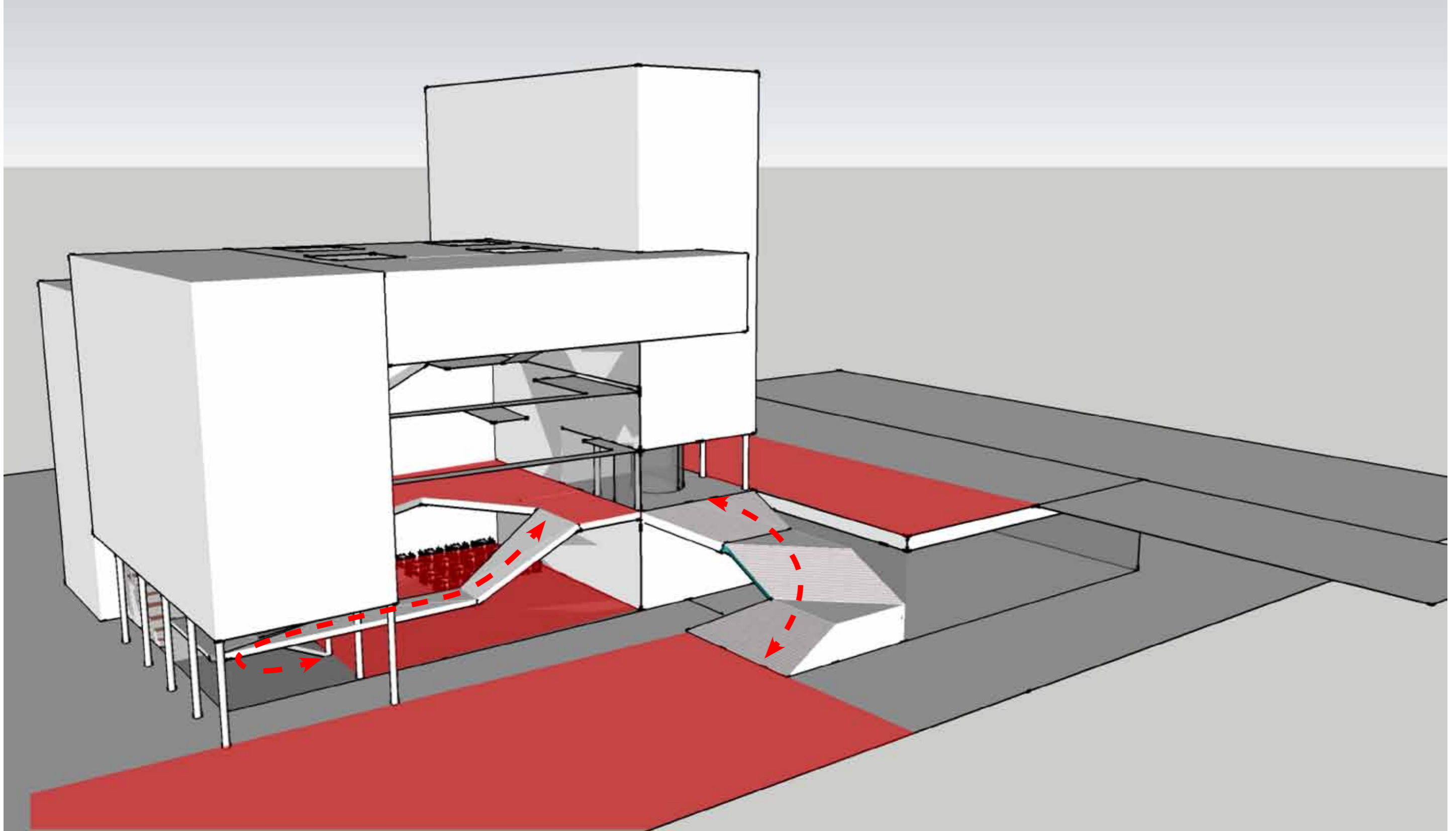

ARCHITECTURAL PROPOSAL

FILM INDUSTRY



CRAFTSMANSHIP

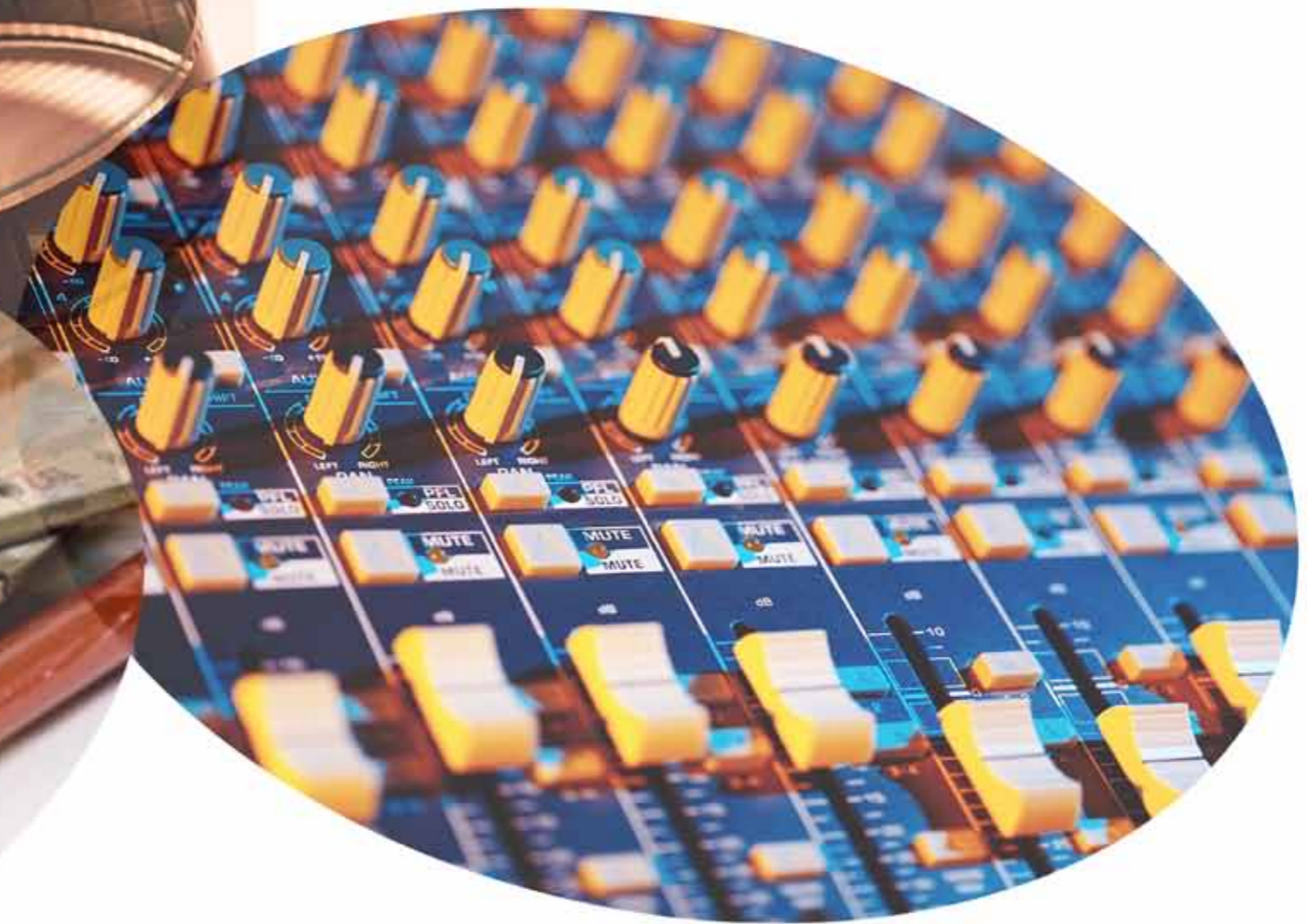

MUSIC INDUSTRY

ARCHITECTURAL PROPOSAL

FILM INDUSTRY

ARCHITECTURE PLOT

CRAFTSMANSHIP

MUSIC INDUSTRY

ARCHITECTURAL PROPOSAL

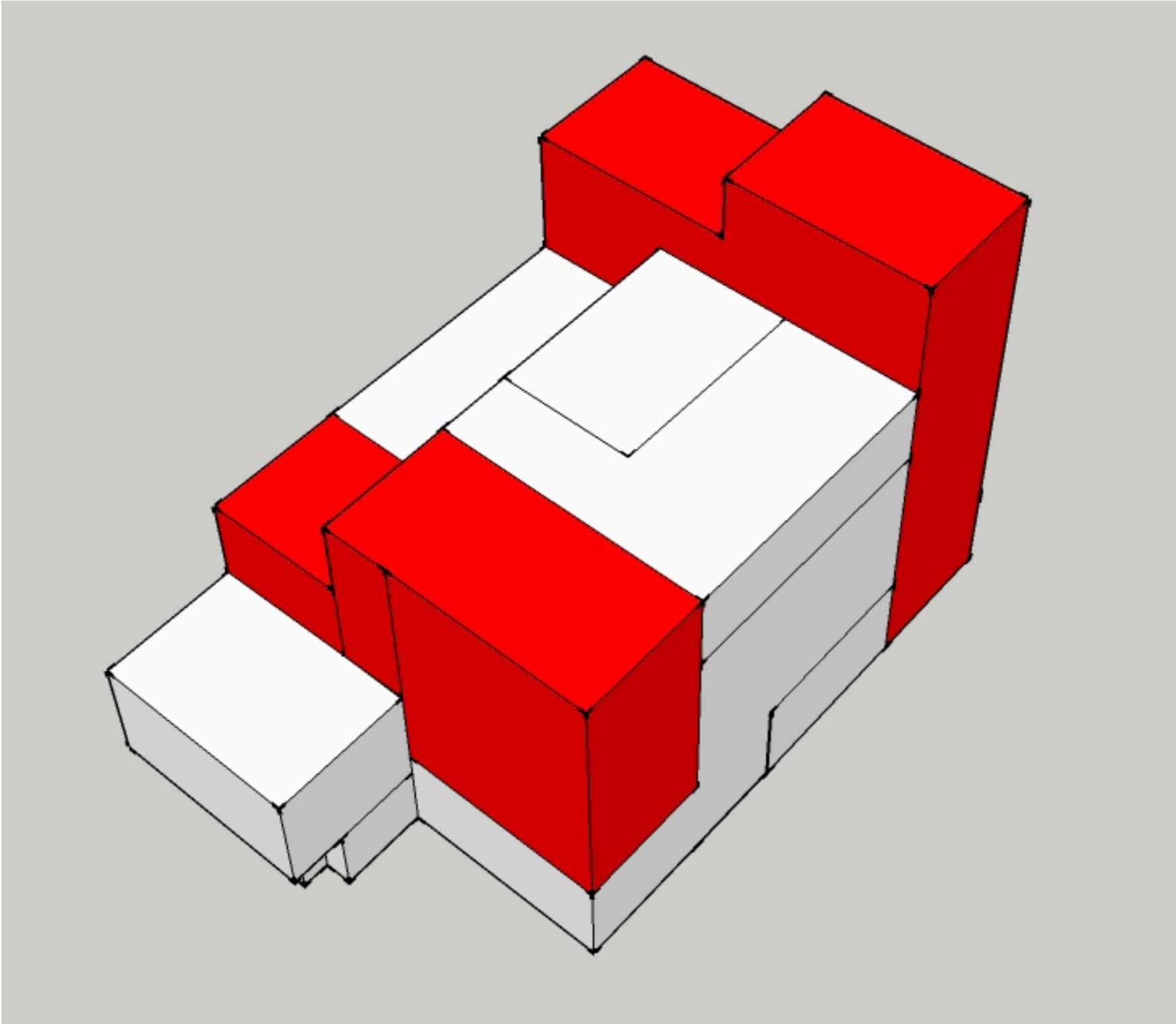

ARCHITECTURAL PROPOSAL

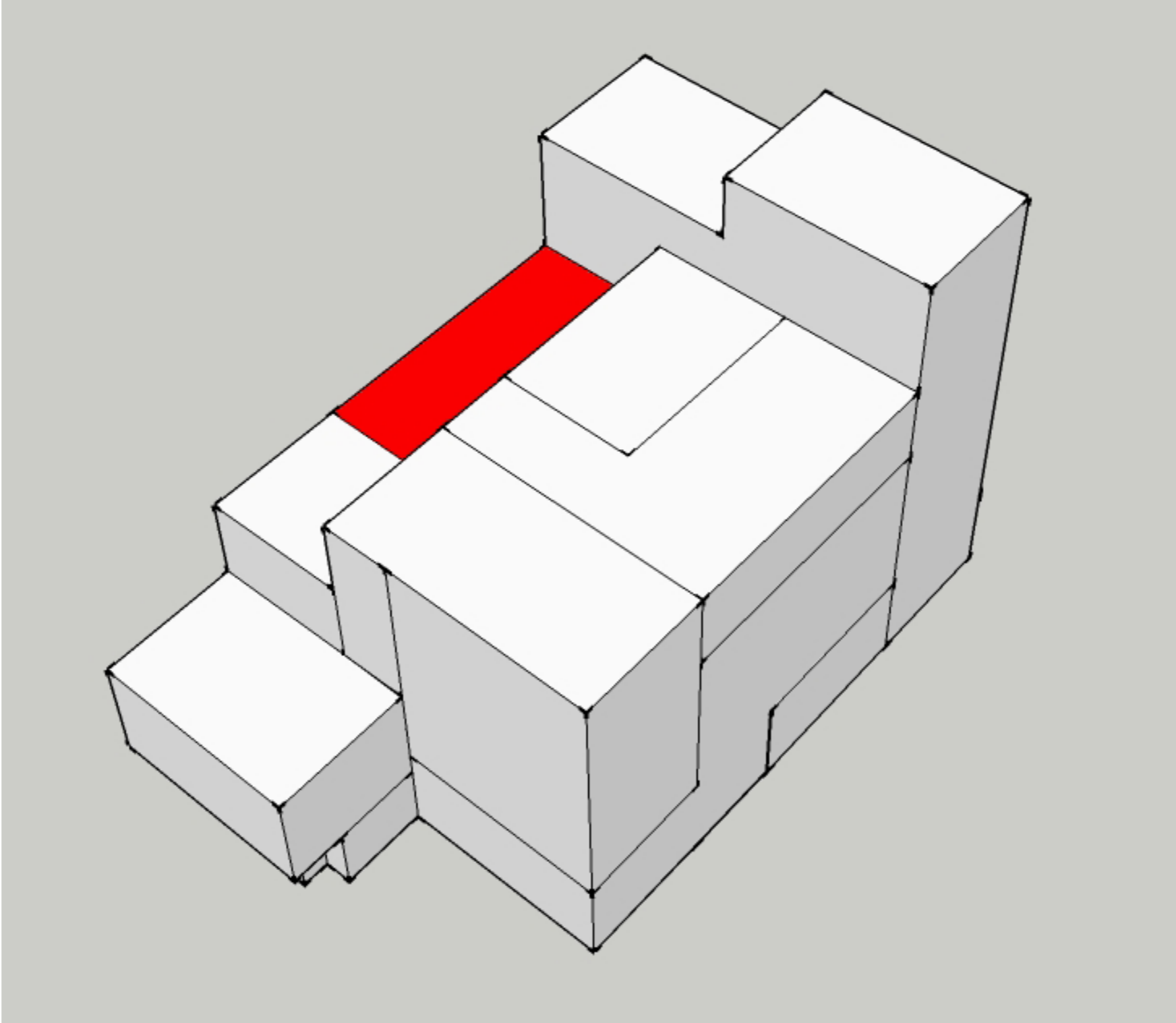

ARCHITECTURAL PROPOSAL

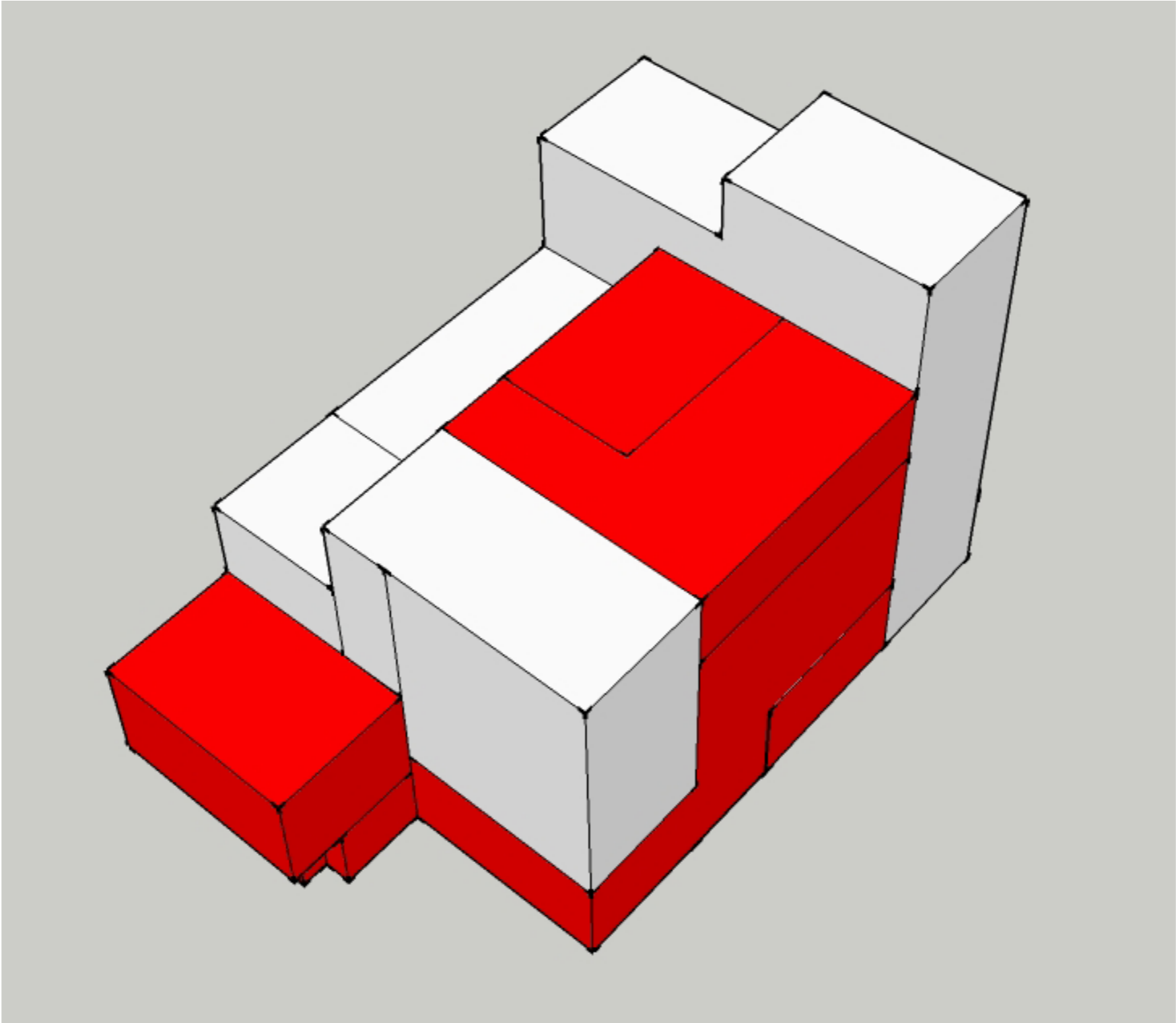

ARCHITECTURAL PROPOSAL



9450 9450 5000 5000 5000 5000 9450

ARCHITECTURAL PROPOSAL

A PUBLIC EXPERIENCE
TO THE OTHER SIDE

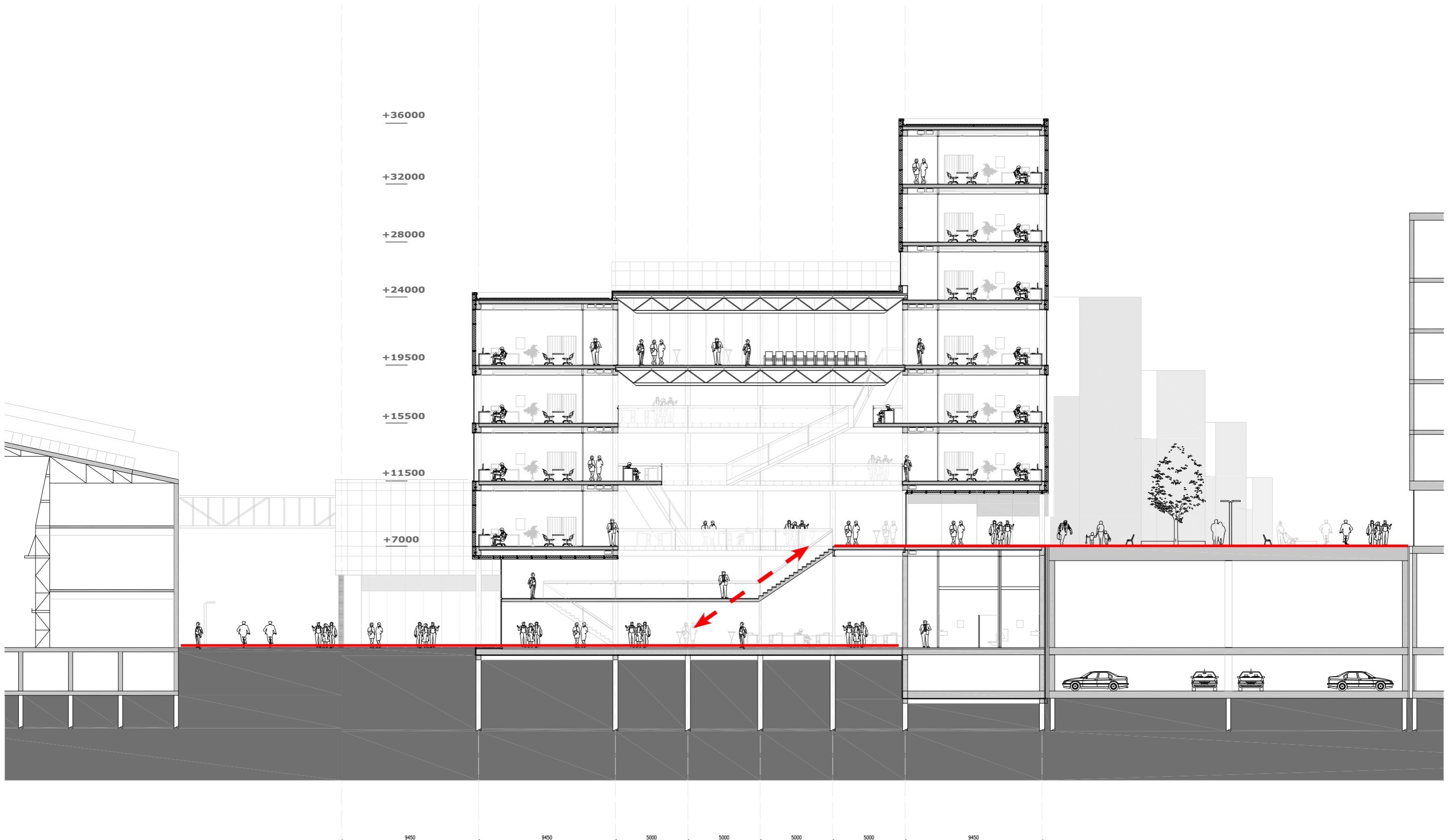

ARCHITECTURAL PROPOSAL

A PUBLIC EXPERIENCE
TO THE OTHER SIDE

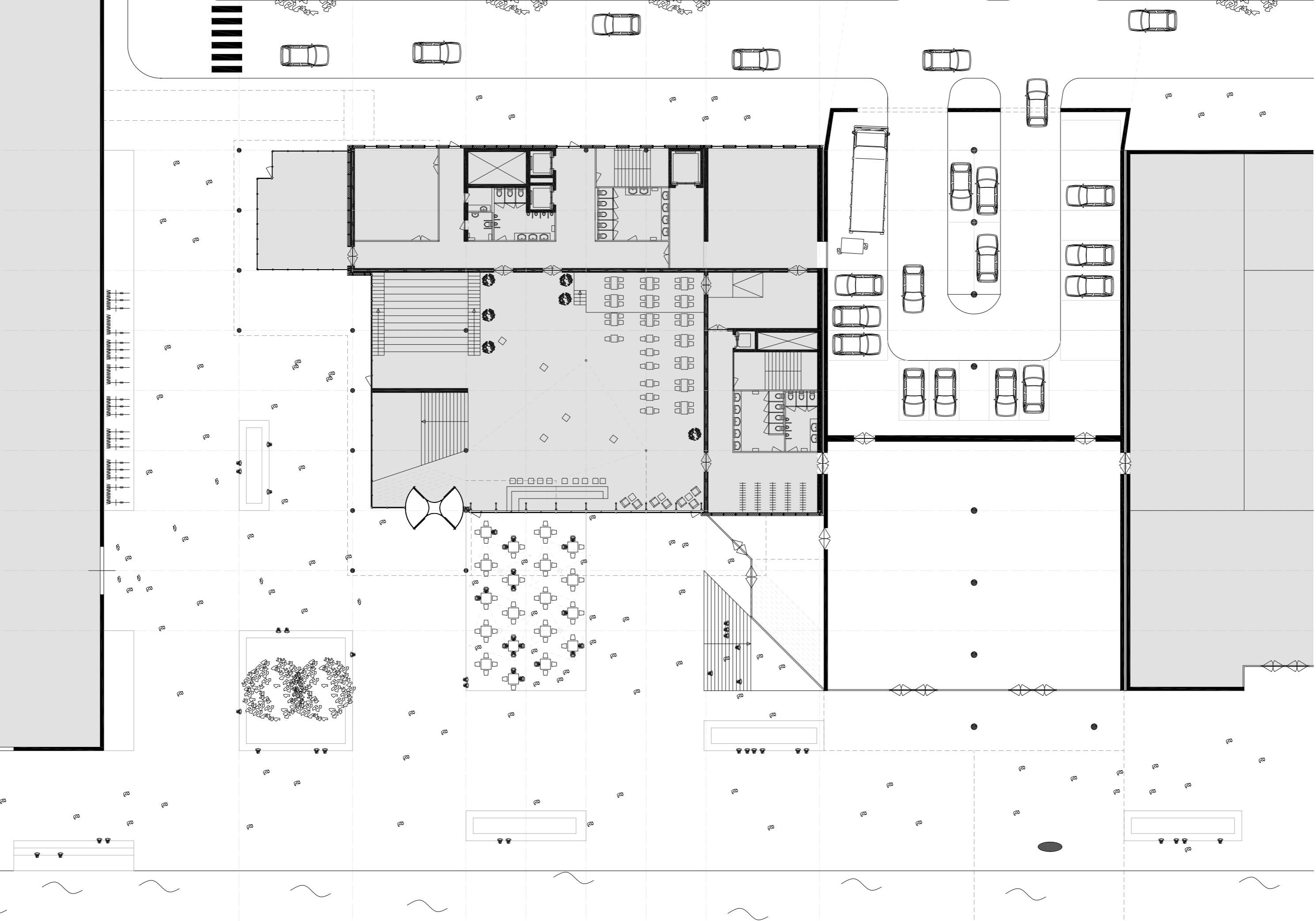

ARCHITECTURAL PROPOSAL

A PUBLIC EXPERIENCE
TO THE OTHER SIDE

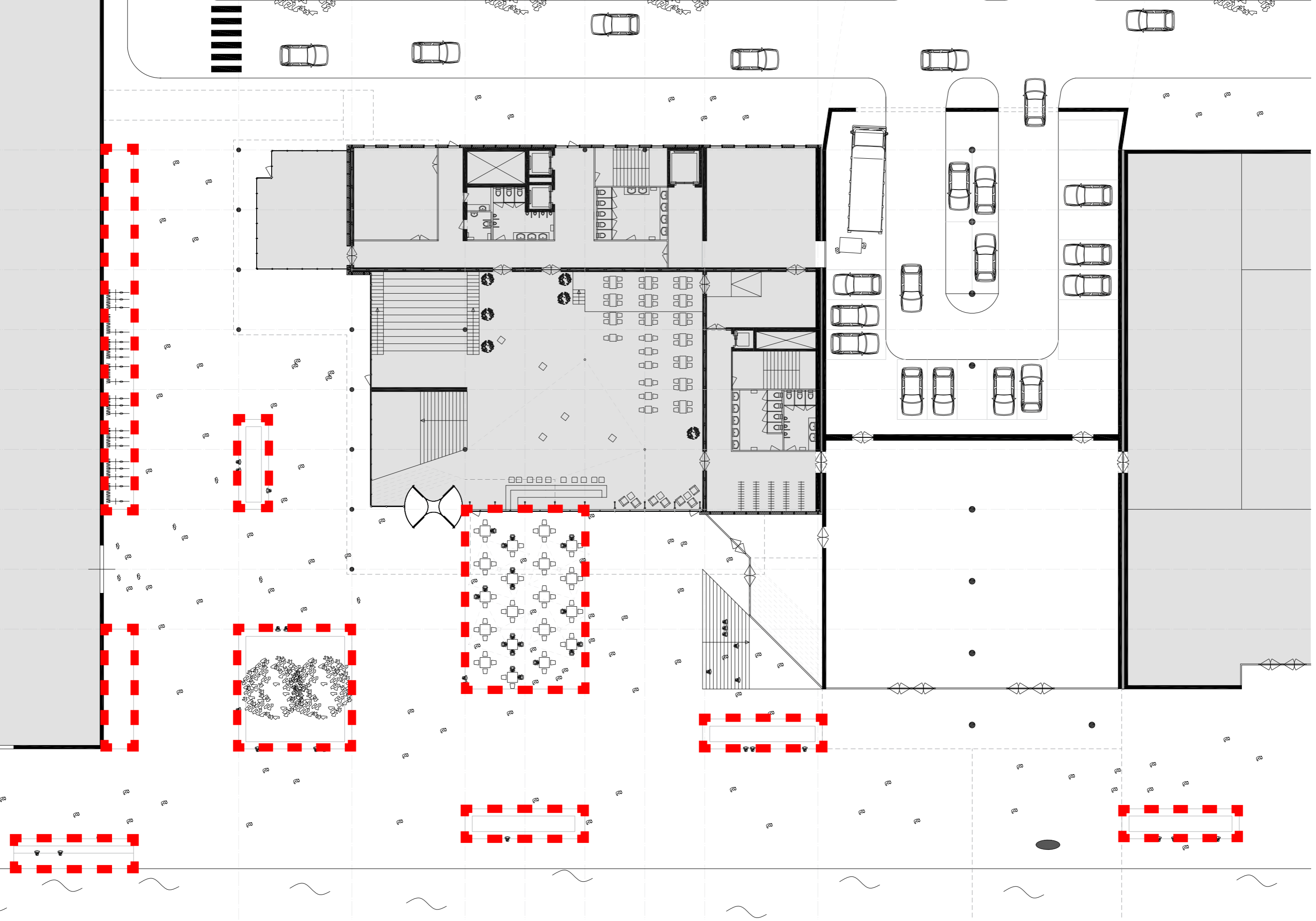

ARCHITECTURAL PROPOSAL

A PUBLIC EXPERIENCE
TO THE OTHER SIDE

ARCHITECTURAL PROPOSAL

**A PUBLIC EXPERIENCE
TO THE OTHER SIDE**

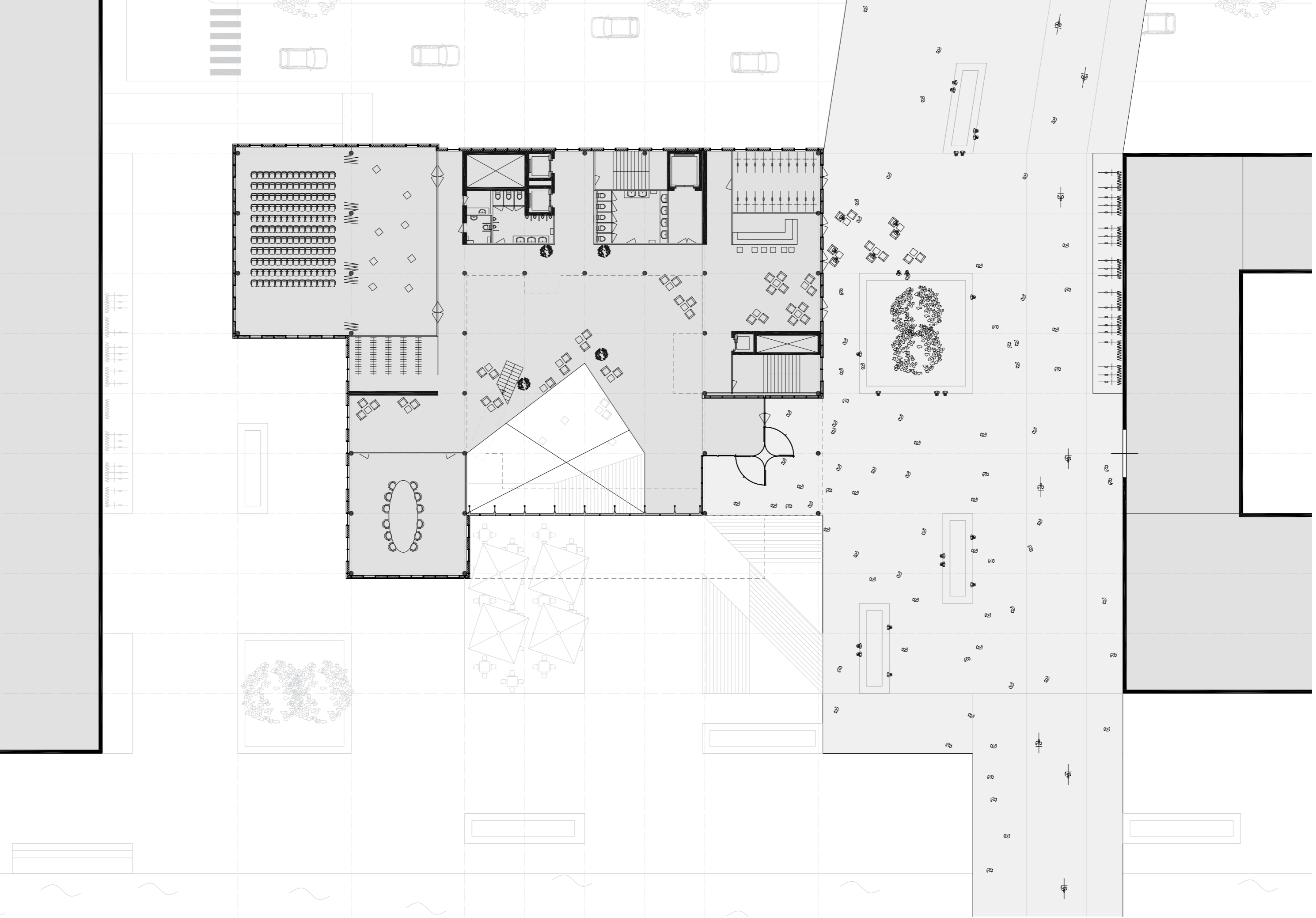

ARCHITECTURAL PROPOSAL

A PUBLIC EXPERIENCE
TO THE OTHER SIDE

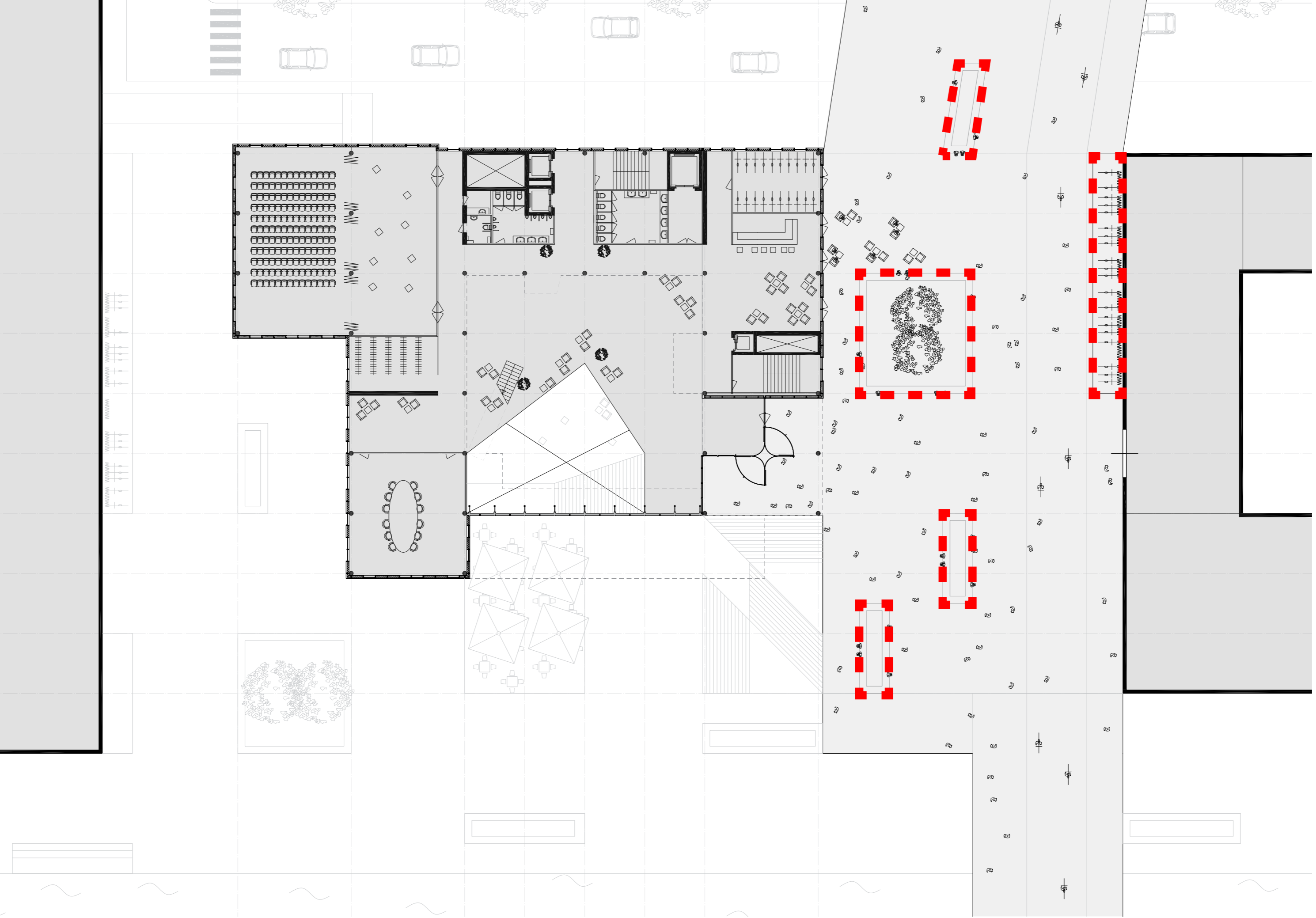



A PUBLIC EXPERIENCE
TO THE OTHER SIDE

ARCHITECTURAL PROPOSAL

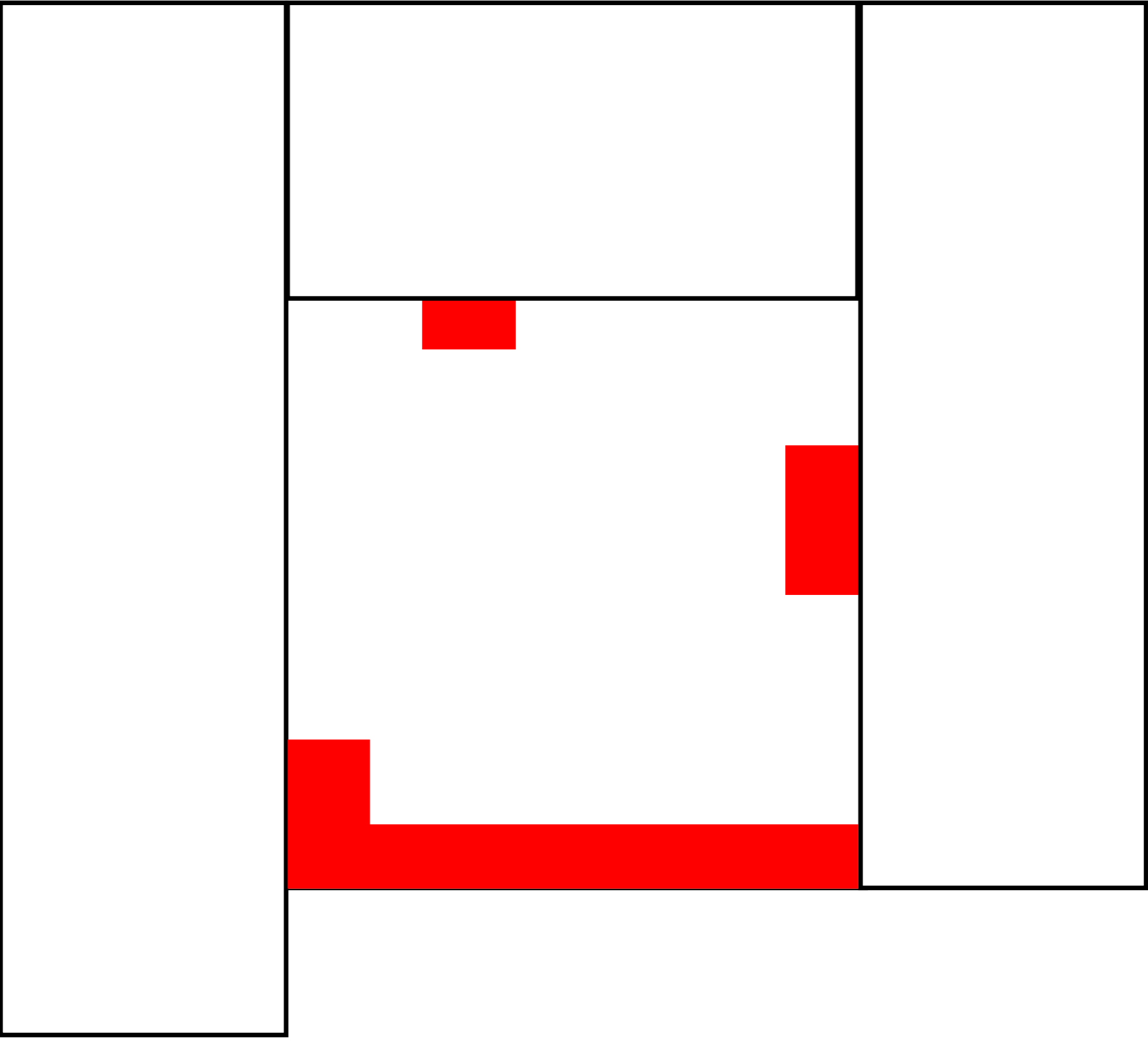

9450

9450

5000

5000

5000

5000

9450

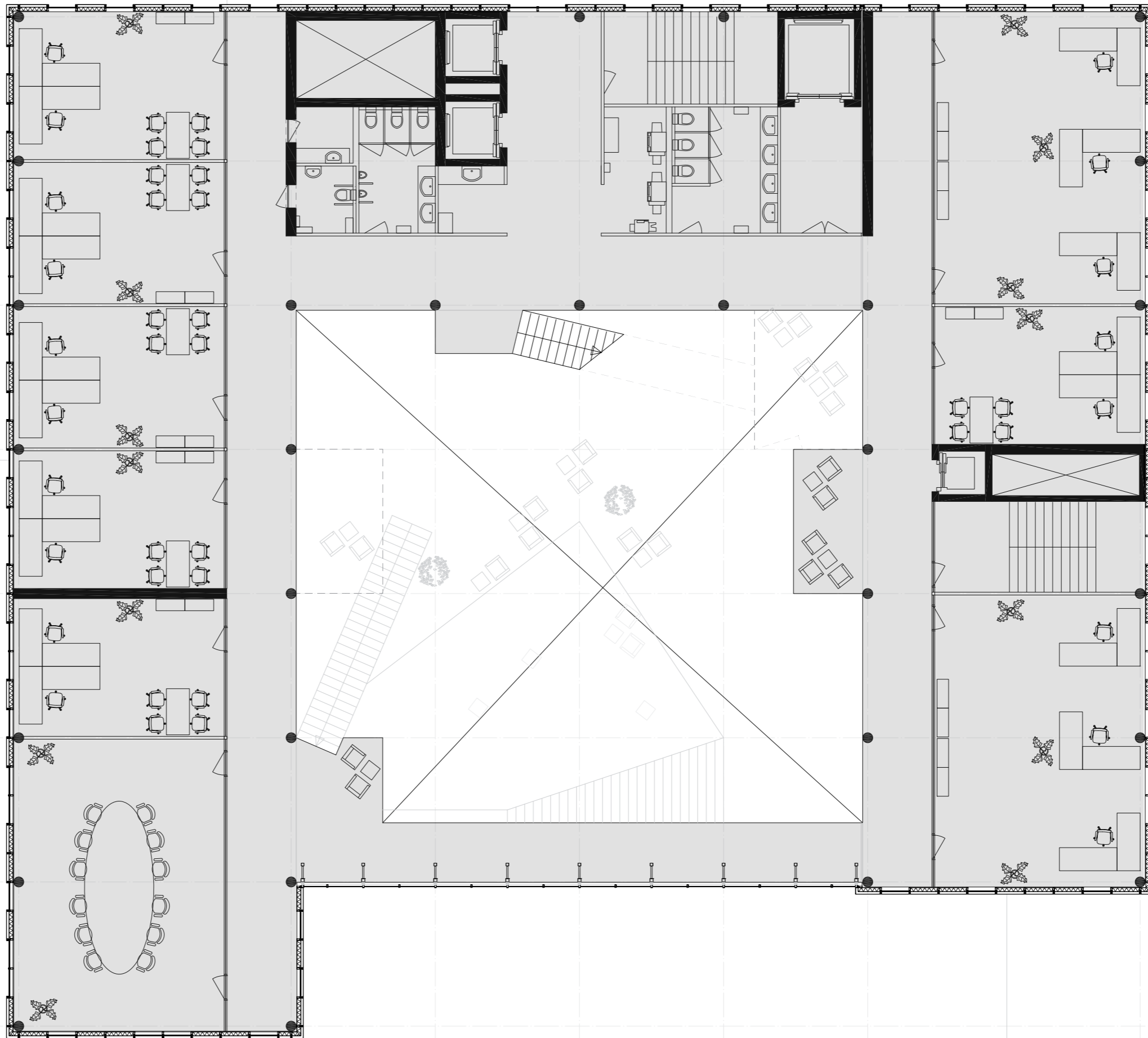

5000

5000

5000

5000

5000

5000

5000

ARCHITECTURAL PROPOSAL

9450

9450

5000

5000

5000

5000

9450

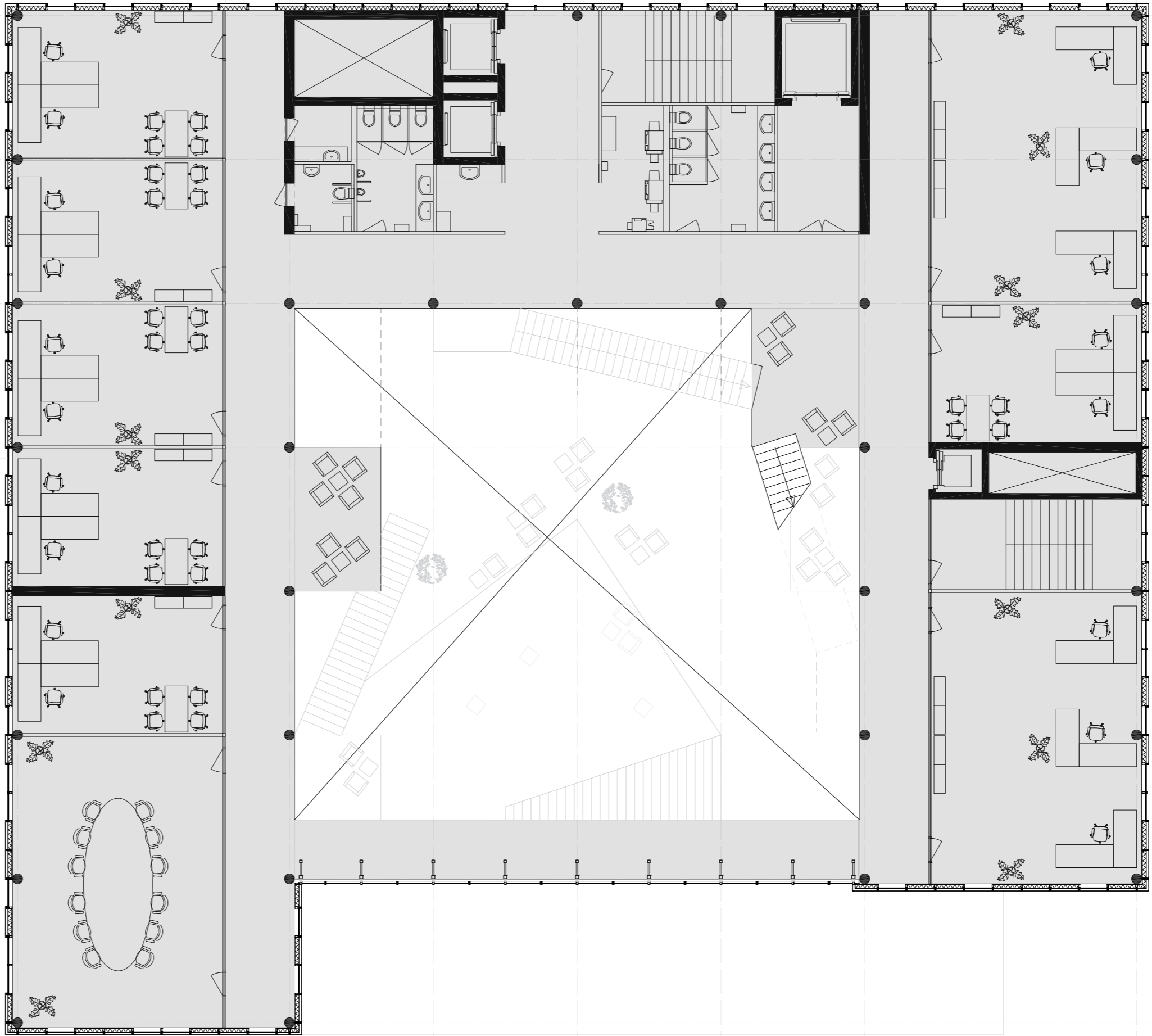

5000

5000

5000

5000

5000

5000

5000

ARCHITECTURAL PROPOSAL

9450

9450

5000

5000

5000

5000

9450

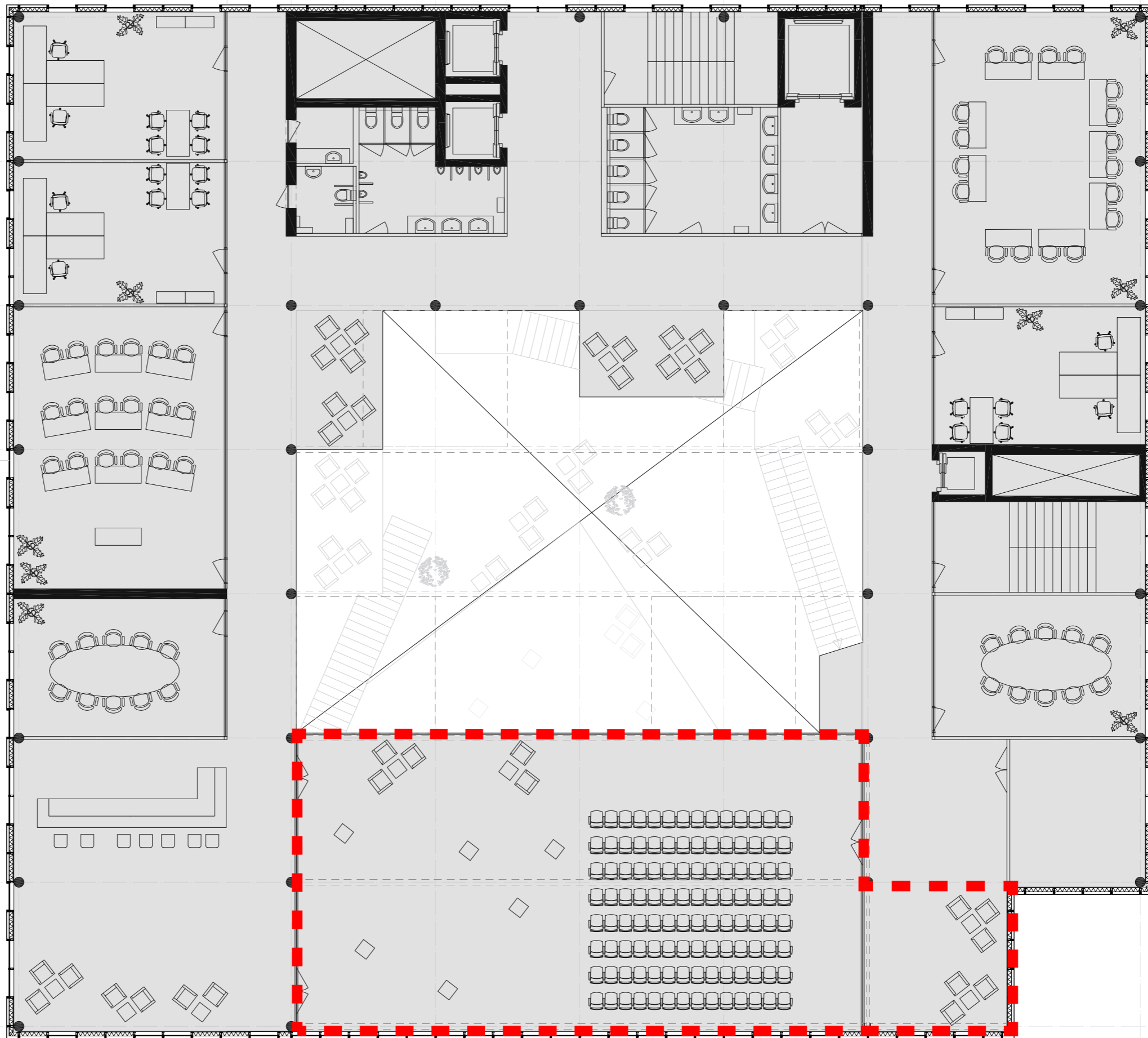

5000

5000

5000

5000

5000

5000

5000

ARCHITECTURAL PROPOSAL



A PUBLIC EXPERIENCE
TO THE OTHER SIDE

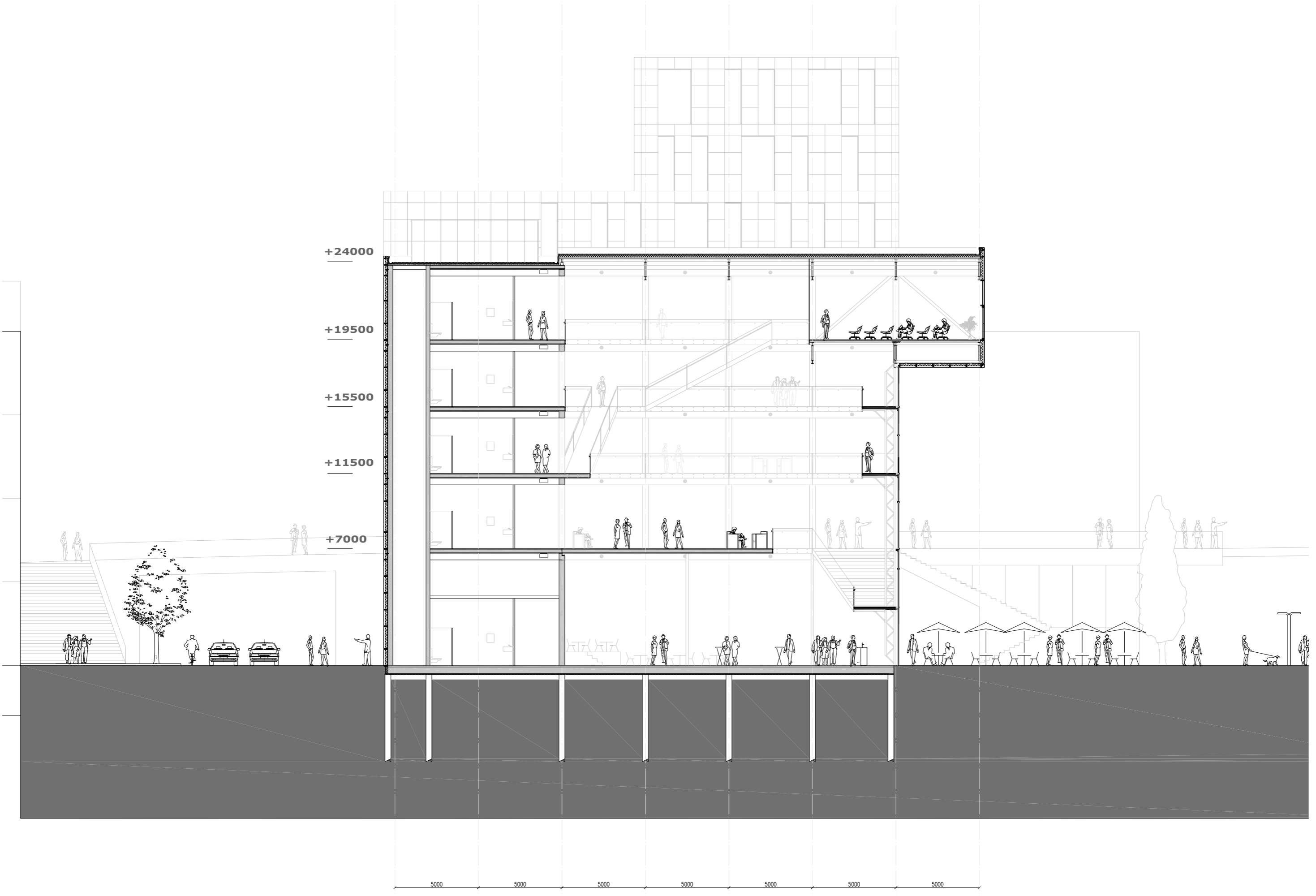

ARCHITECTURAL PROPOSAL

A PUBLIC EXPERIENCE
TO THE OTHER SIDE



ARCHITECTURAL PROPOSAL

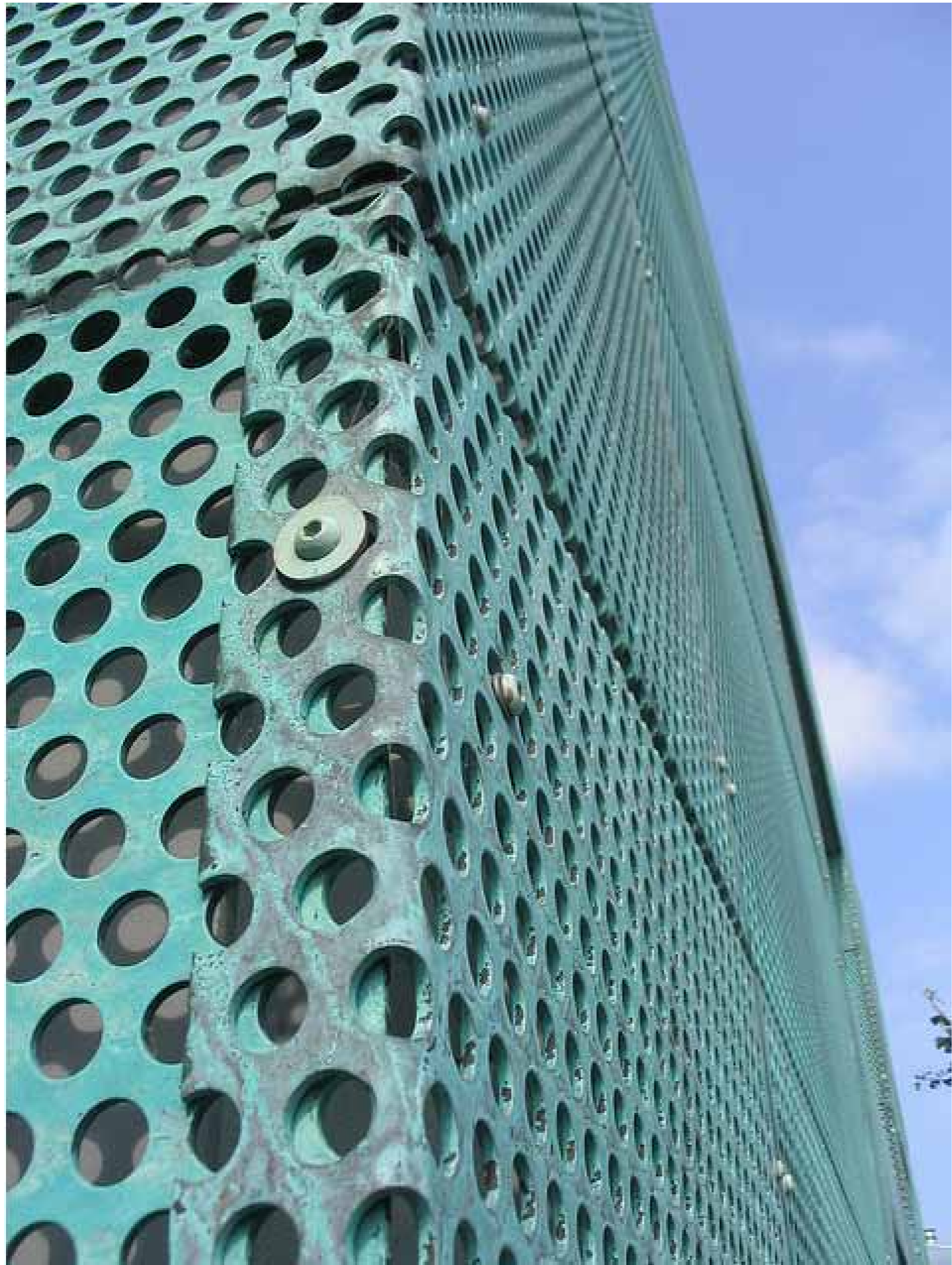

ARCHITECTURAL PROPOSAL

A PUBLIC EXPERIENCE
TO THE OTHER SIDE

ARCHITECTURAL PROPOSAL

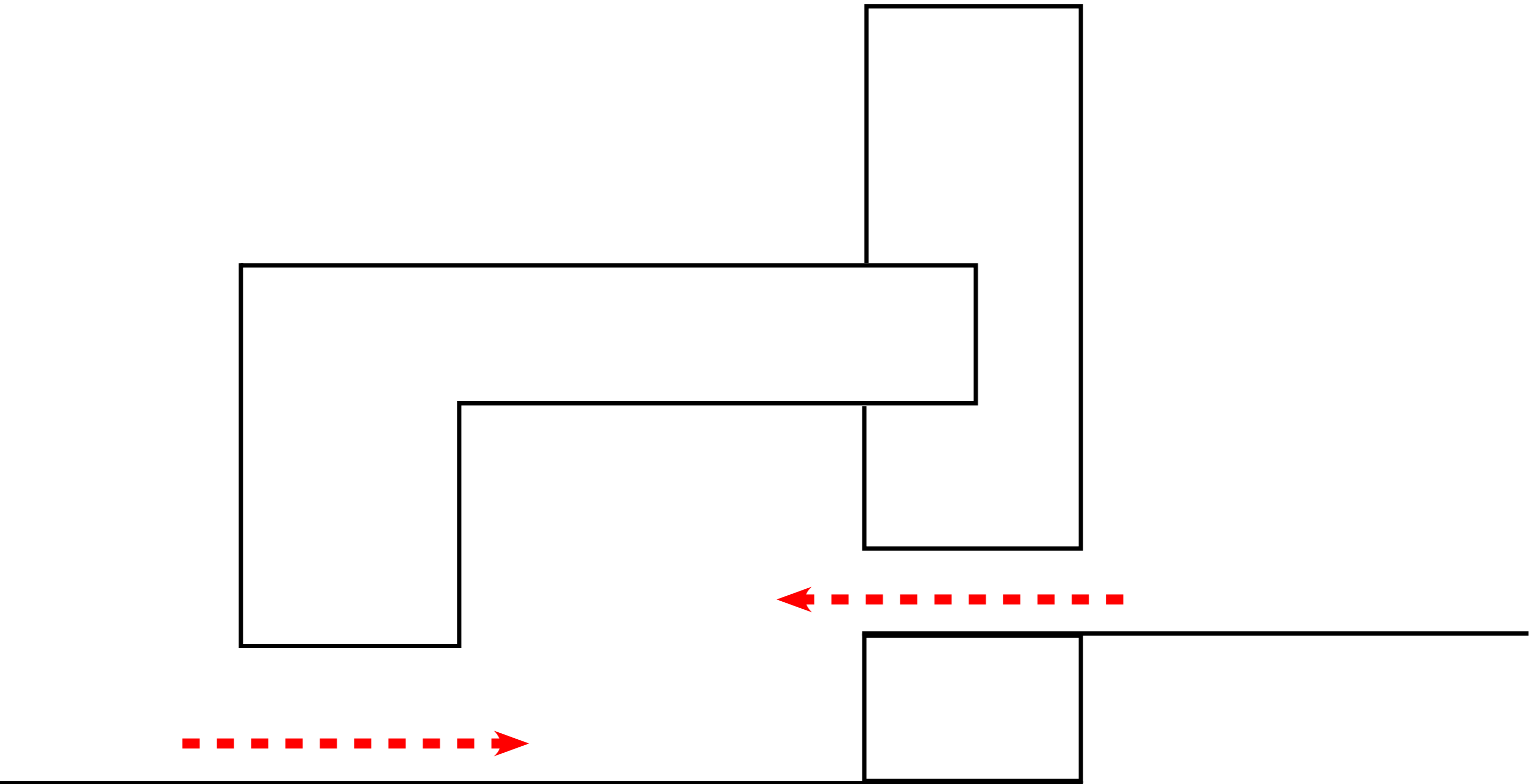



ARCHITECTURAL PROPOSAL

A PUBLIC EXPERIENCE
TO THE OTHER SIDE



ARCHITECTURAL PROPOSAL

A PUBLIC EXPERIENCE
TO THE OTHER SIDE

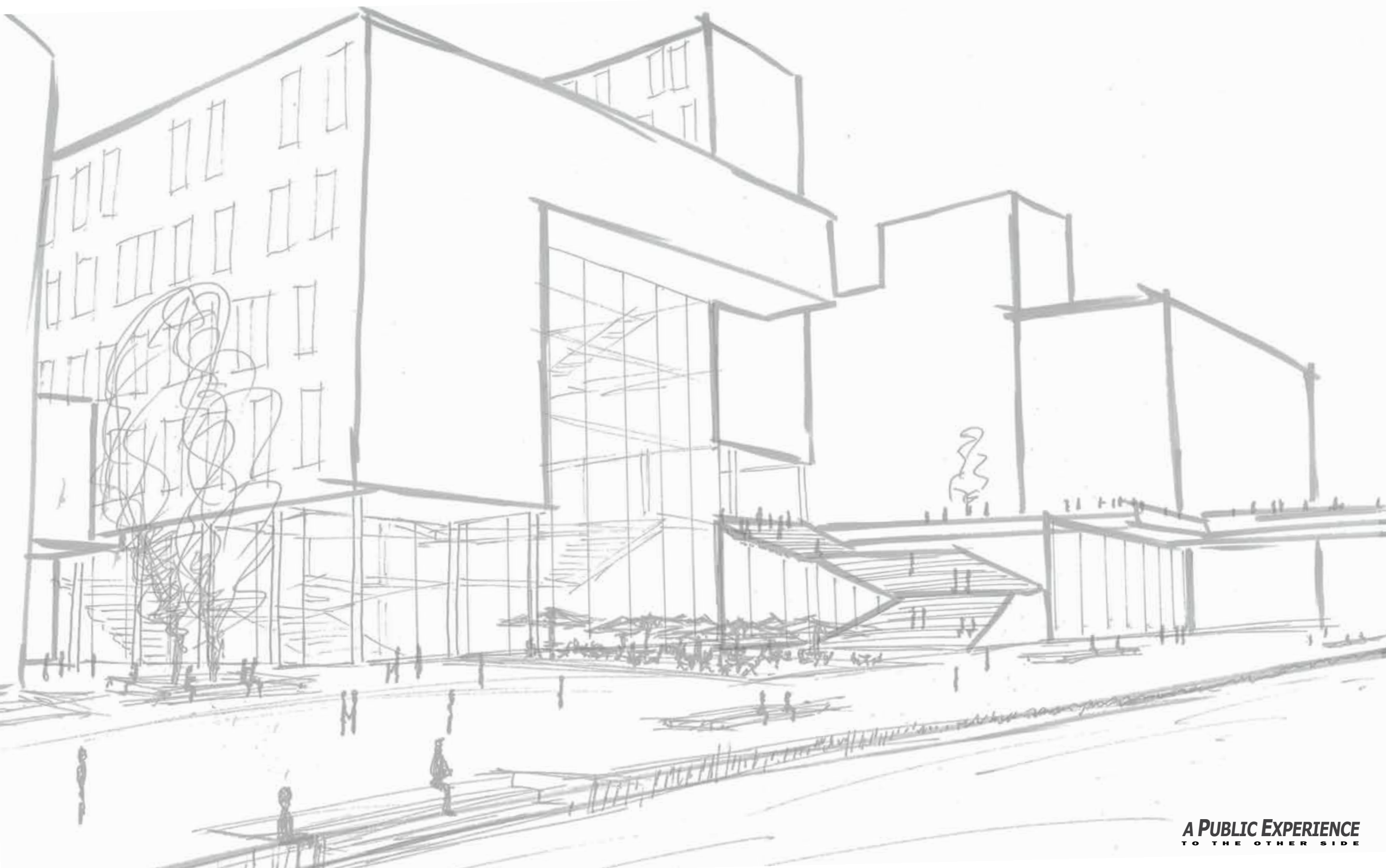

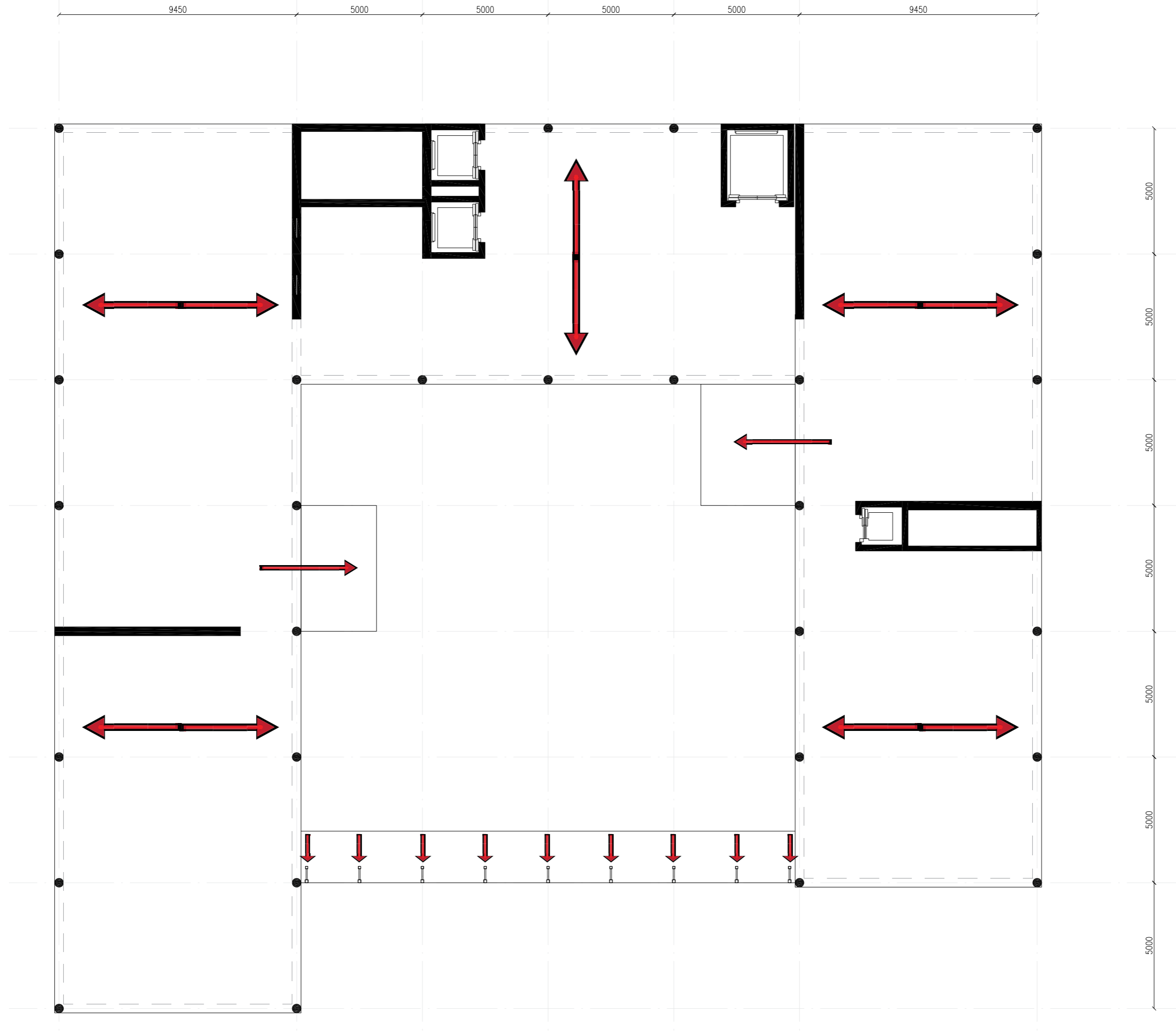

TECHNICAL INTEGRATION

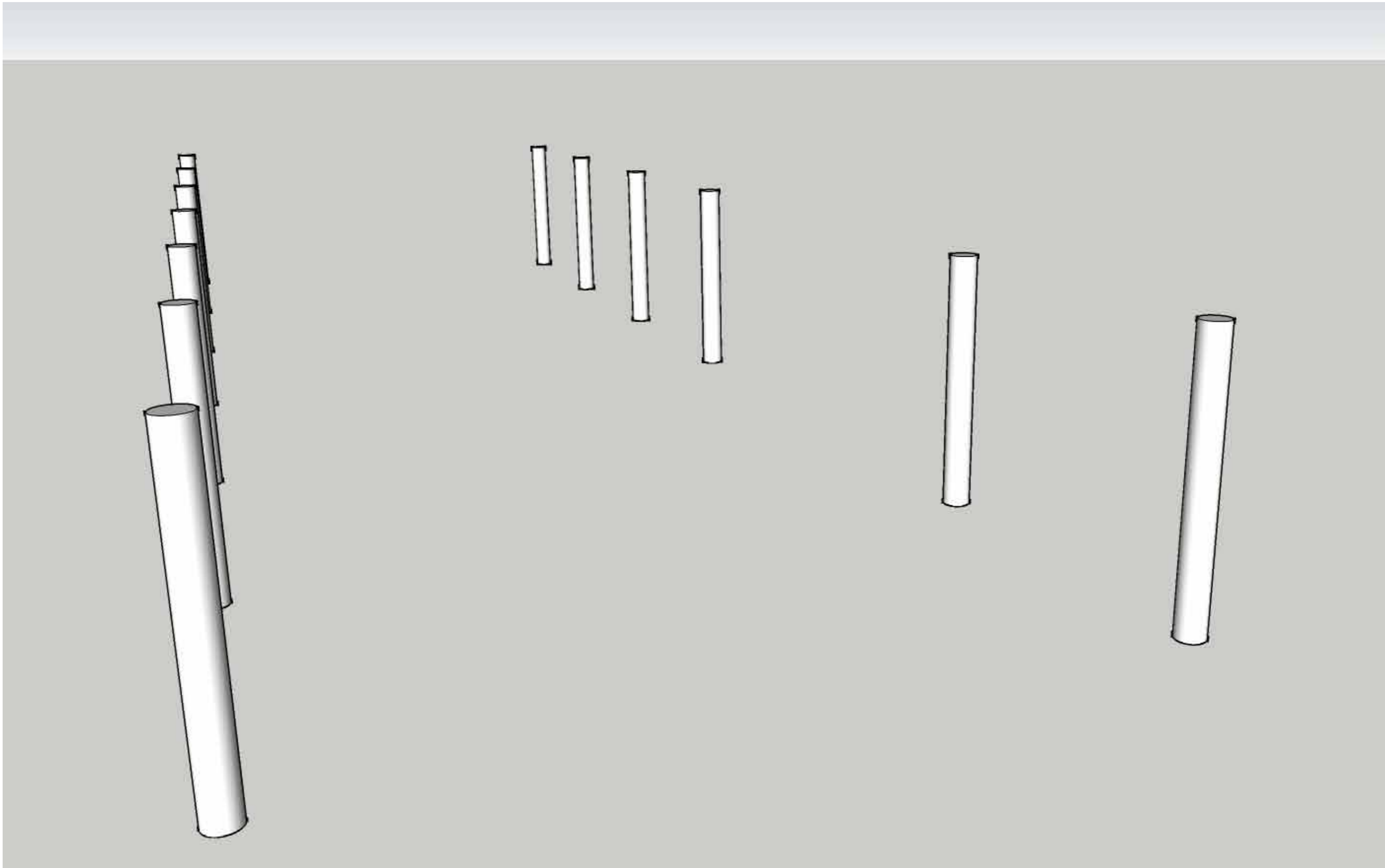

TECHNICAL INTEGRATION

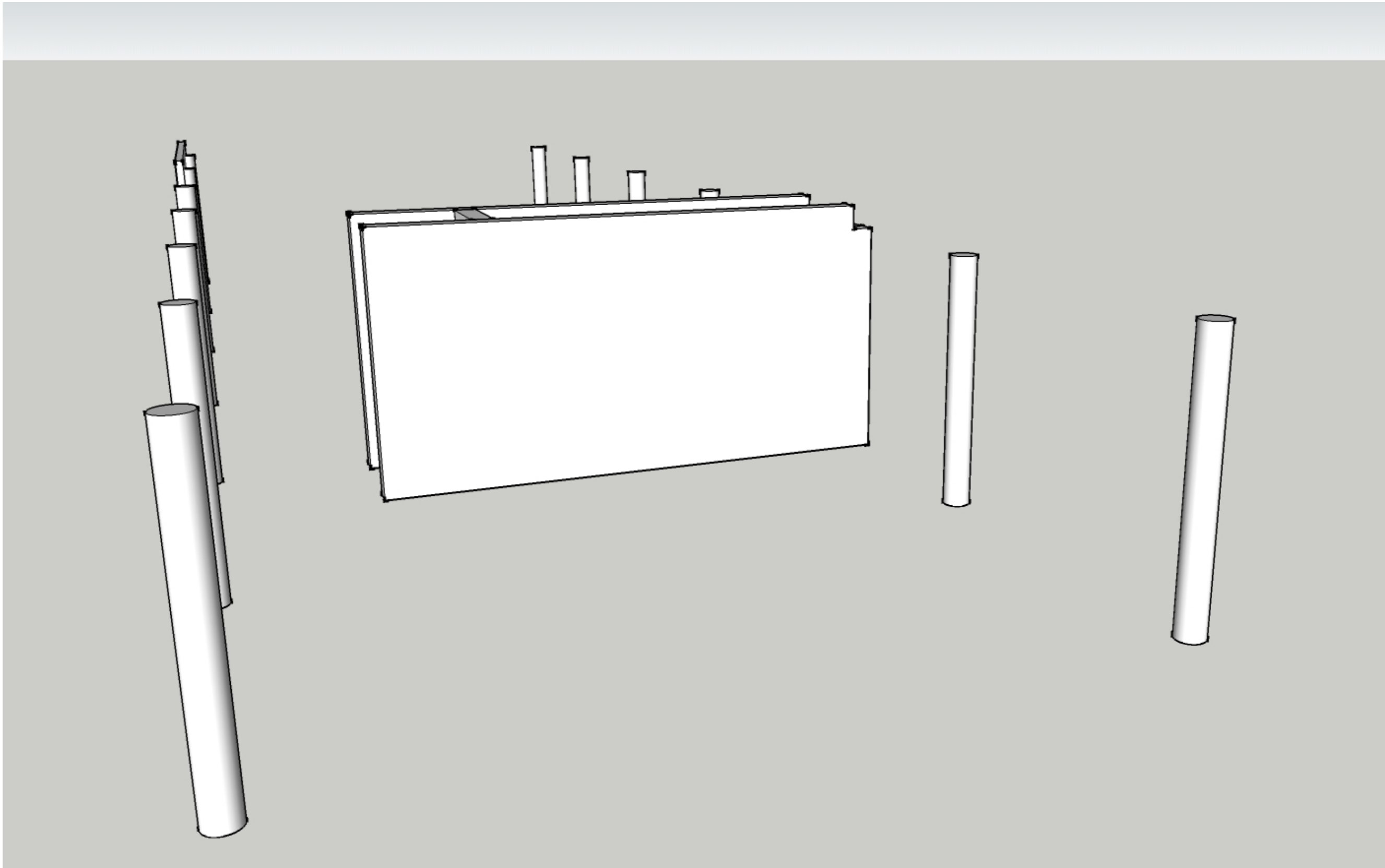

TECHNICAL INTEGRATION

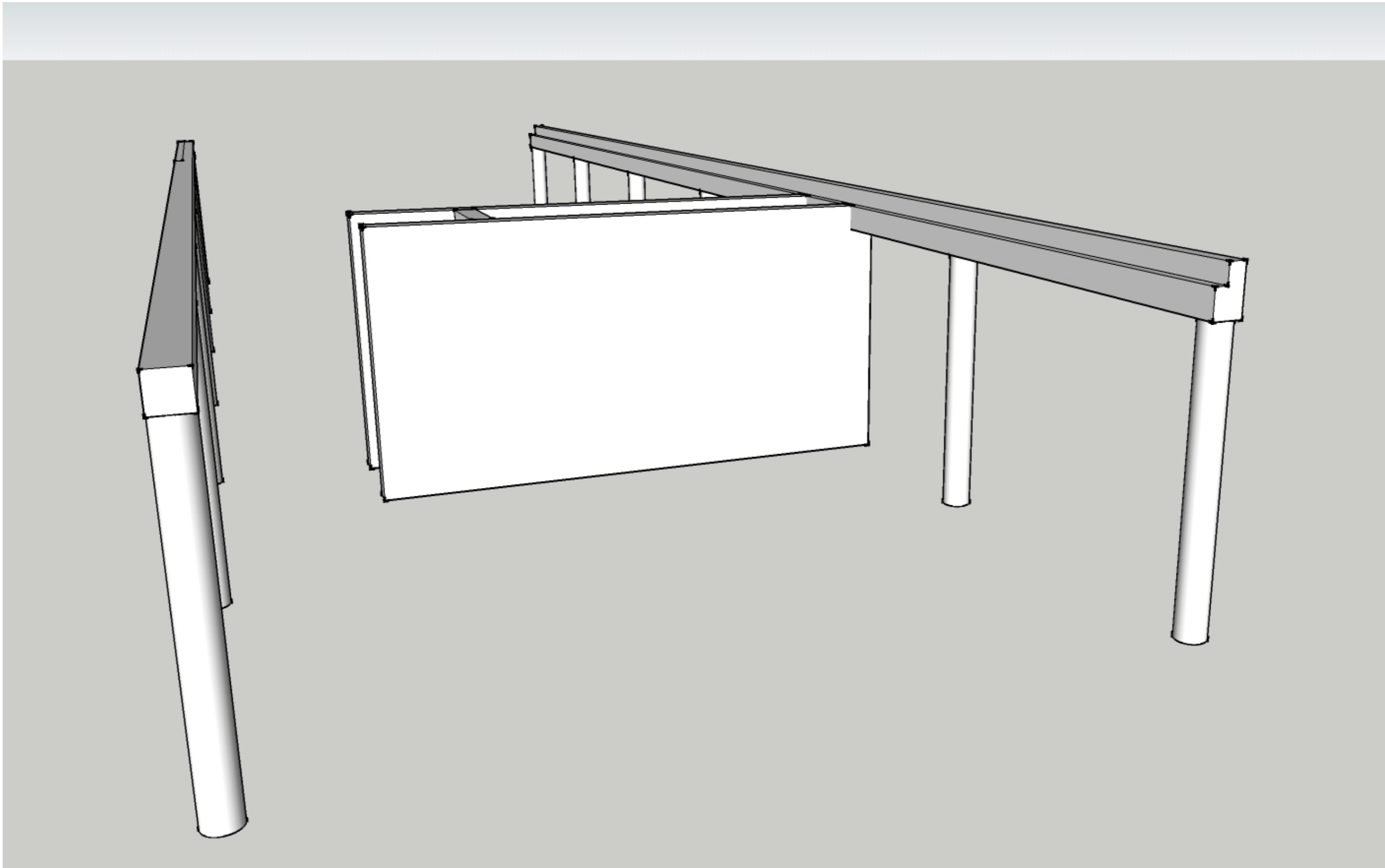

TECHNICAL INTEGRATION

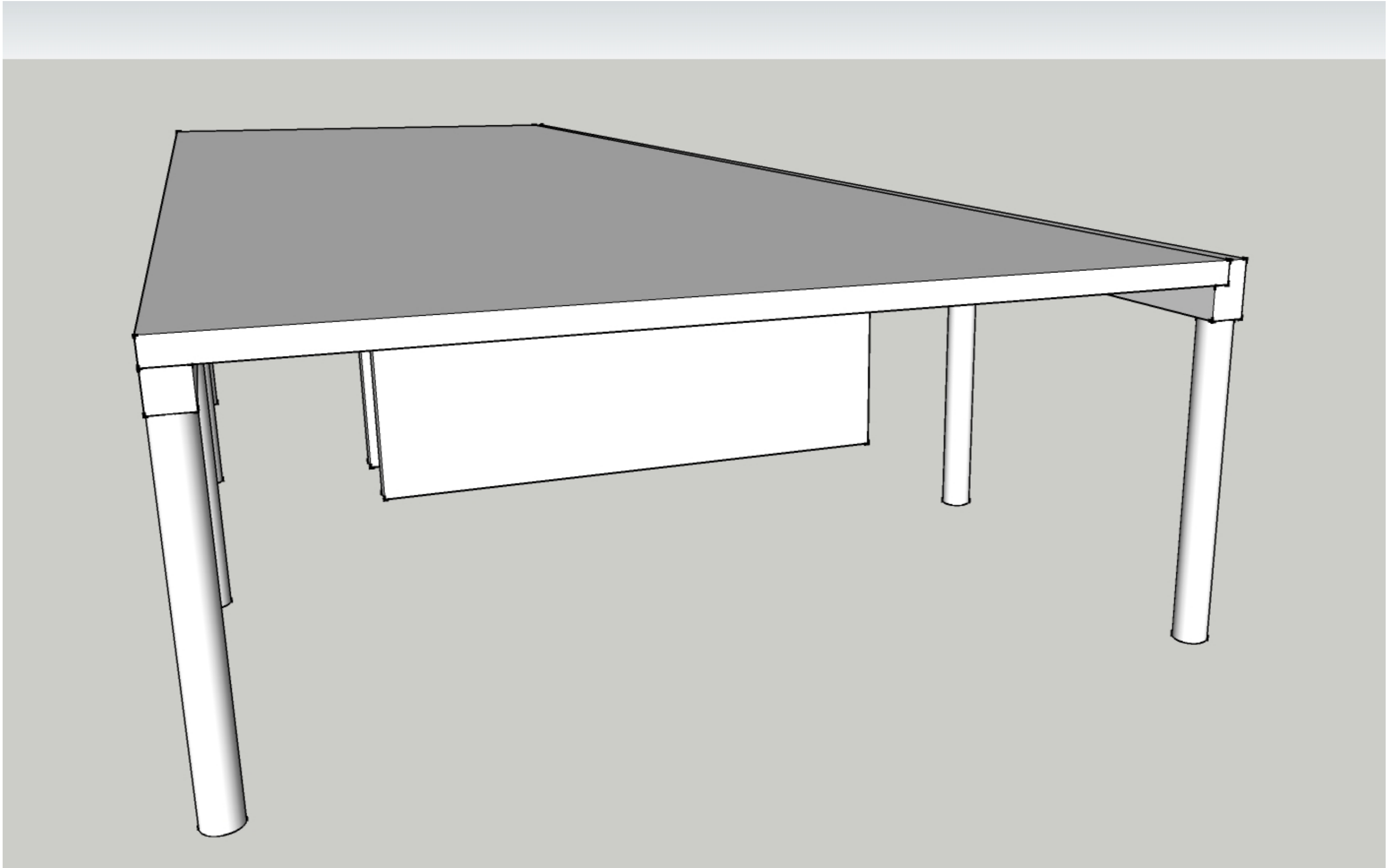

TECHNICAL INTEGRATION

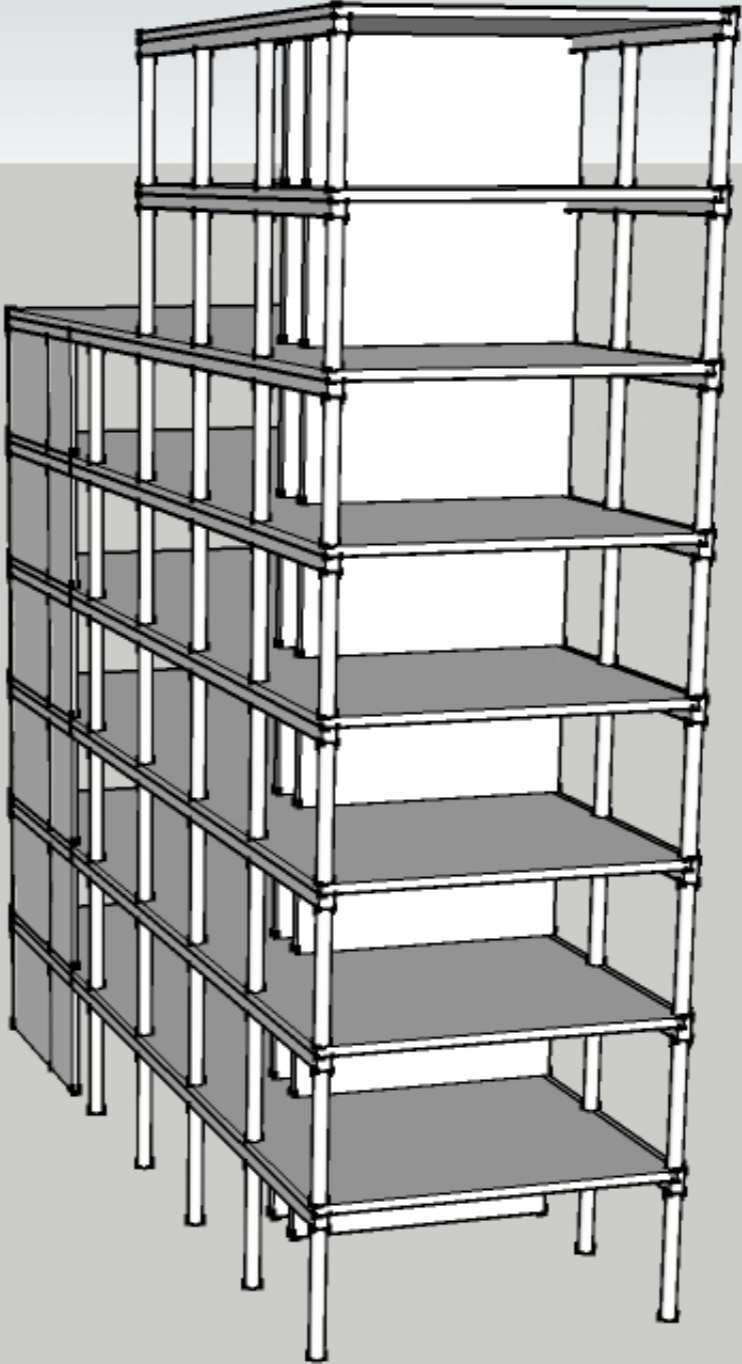

TECHNICAL INTEGRATION

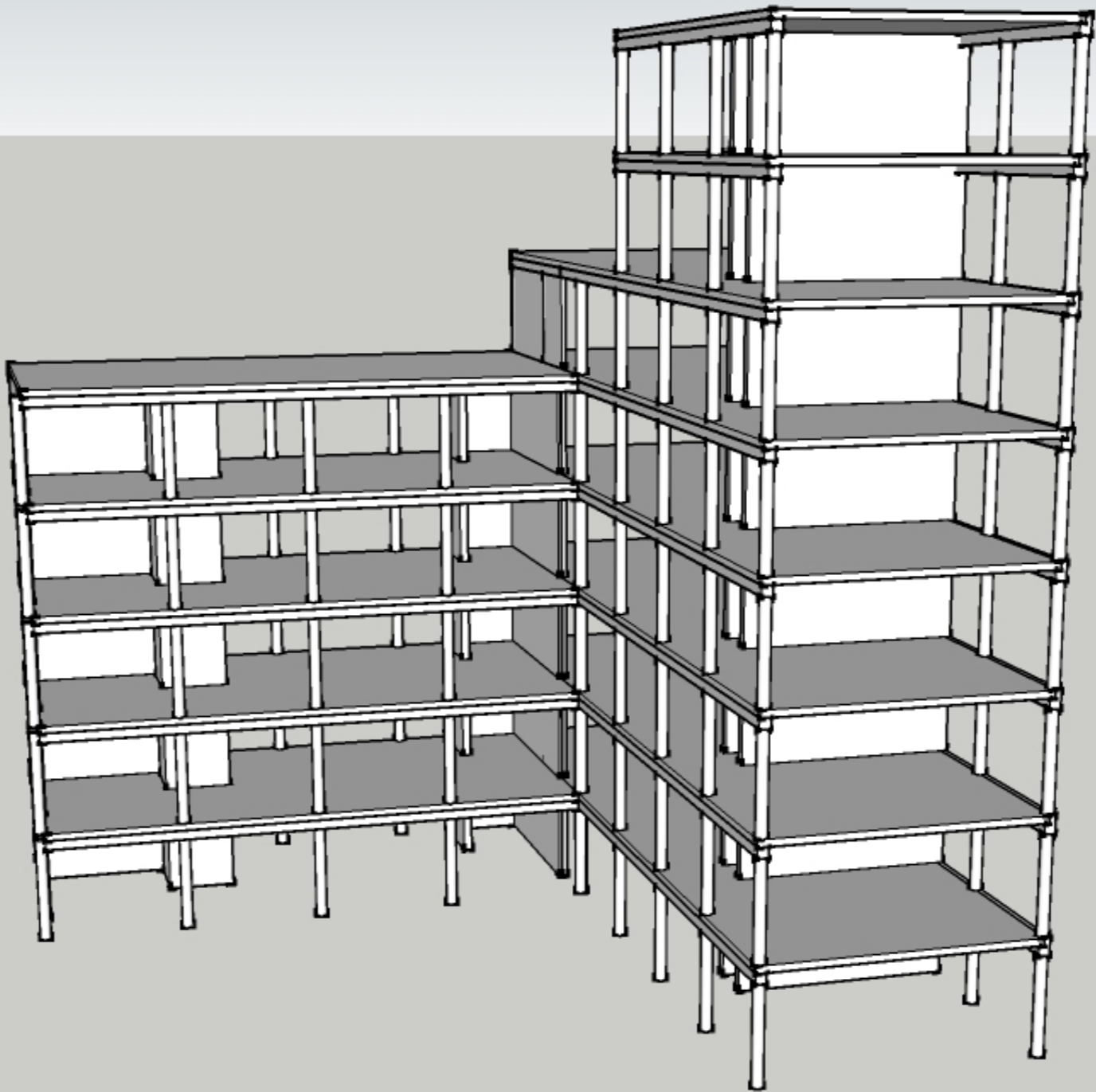

TECHNICAL INTEGRATION

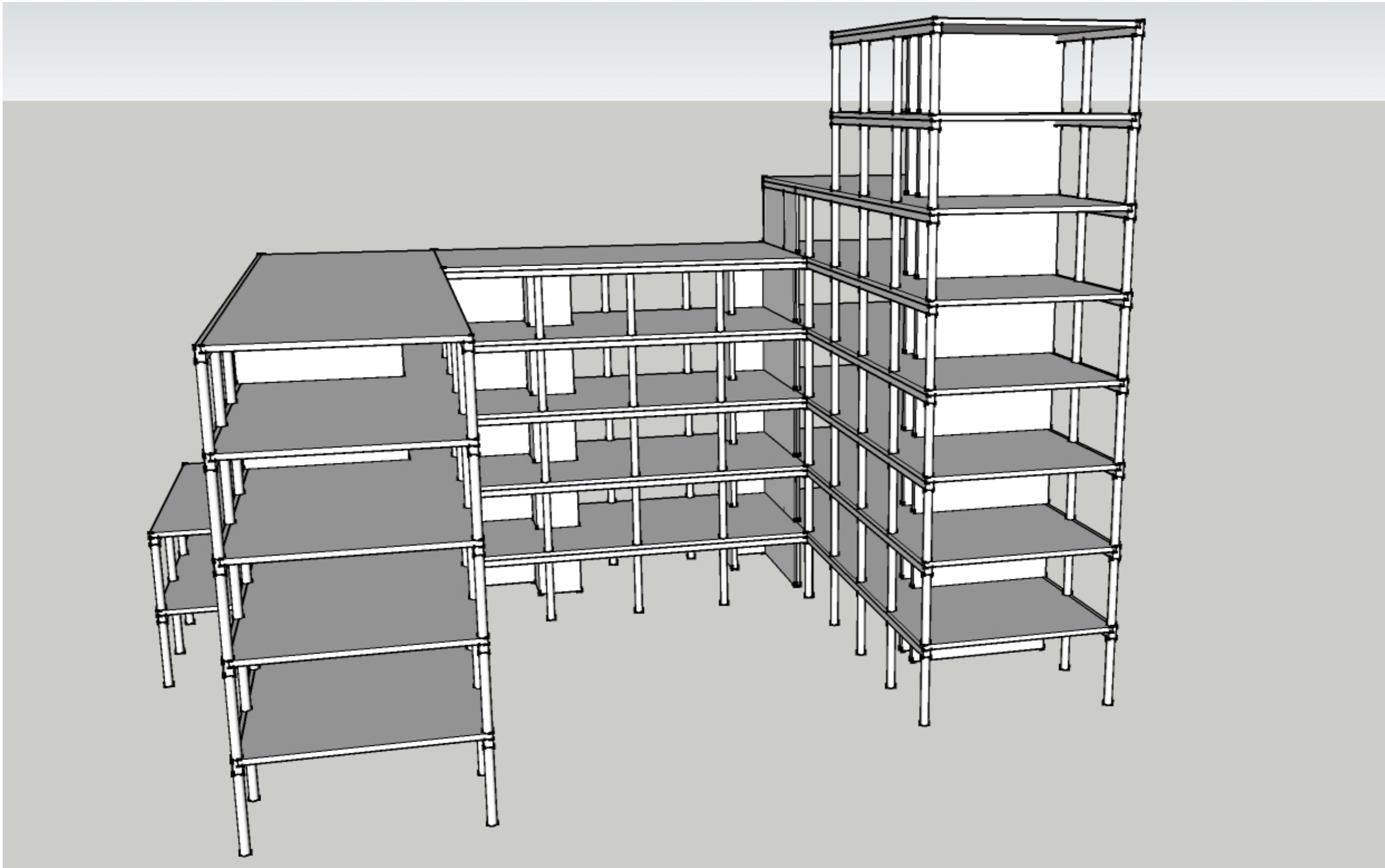

TECHNICAL INTEGRATION

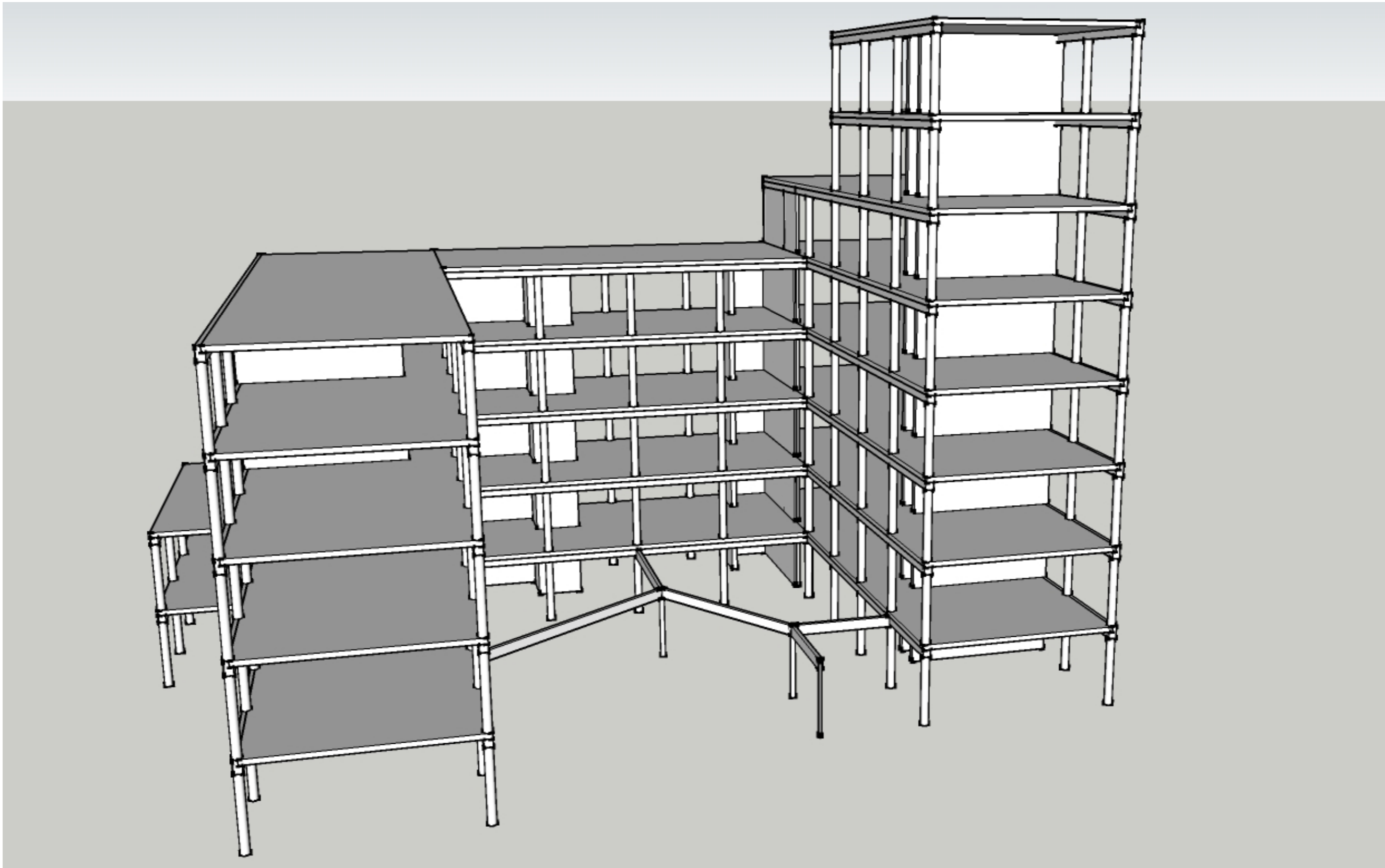

TECHNICAL INTEGRATION

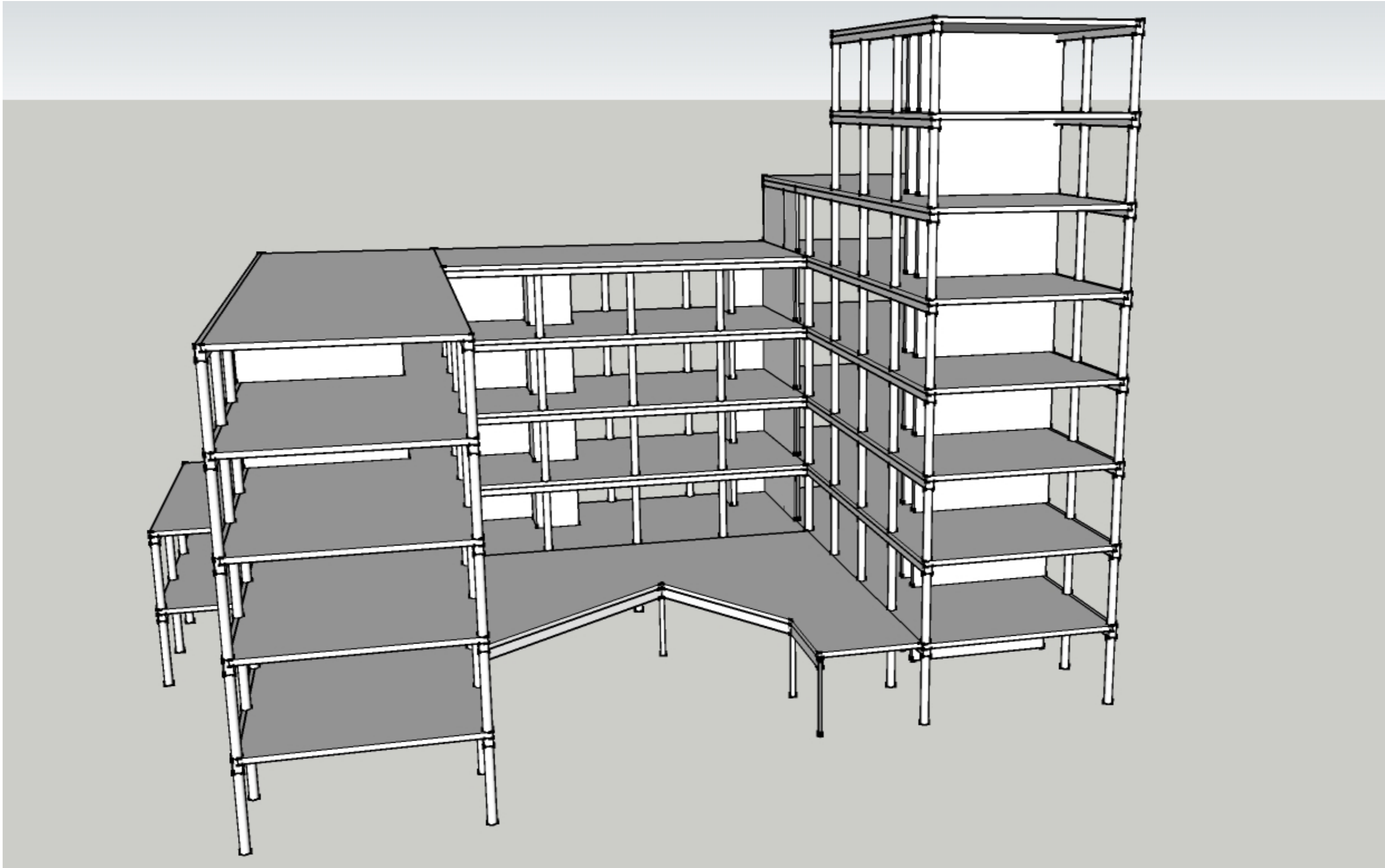

TECHNICAL INTEGRATION

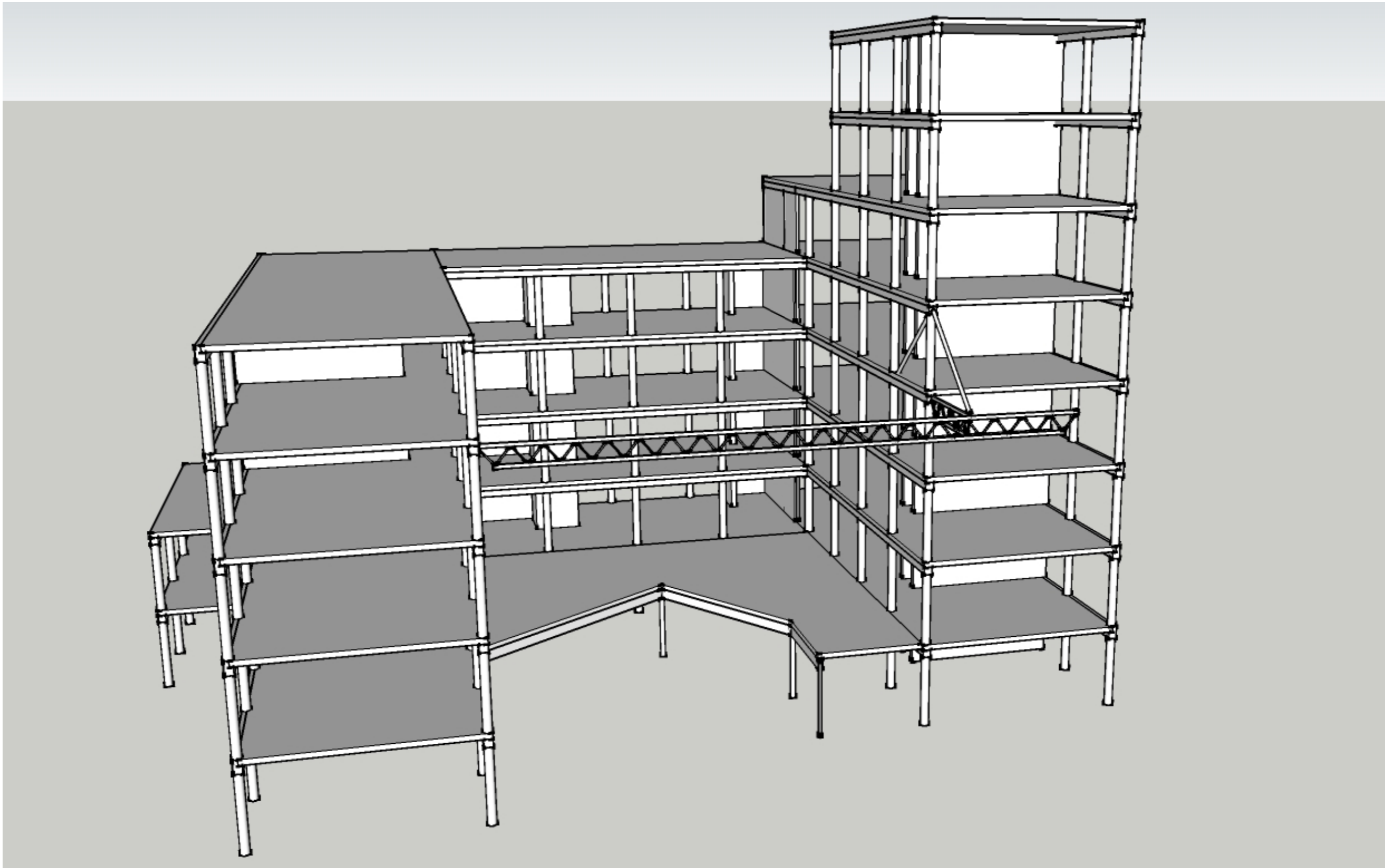

TECHNICAL INTEGRATION

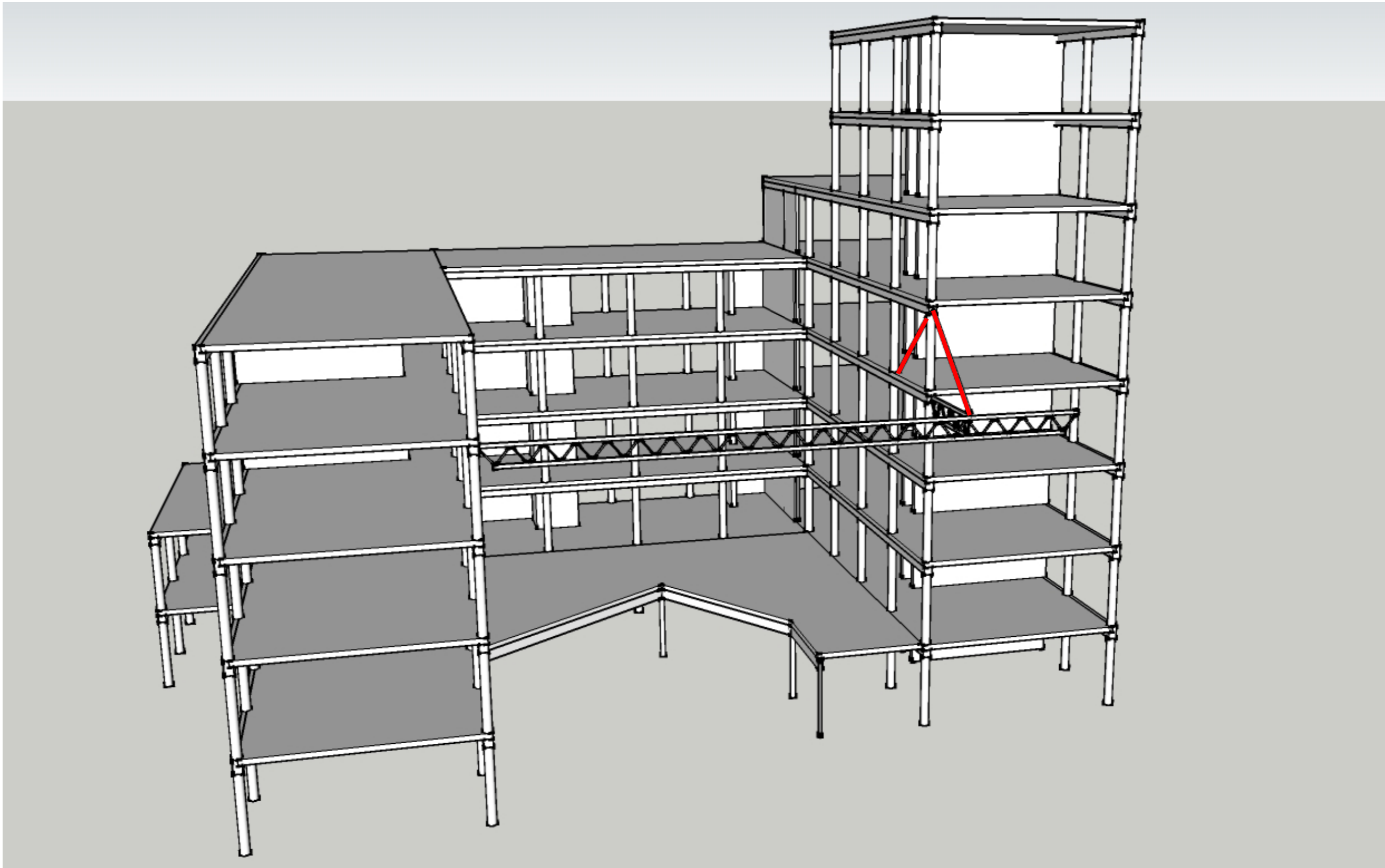

TECHNICAL INTEGRATION

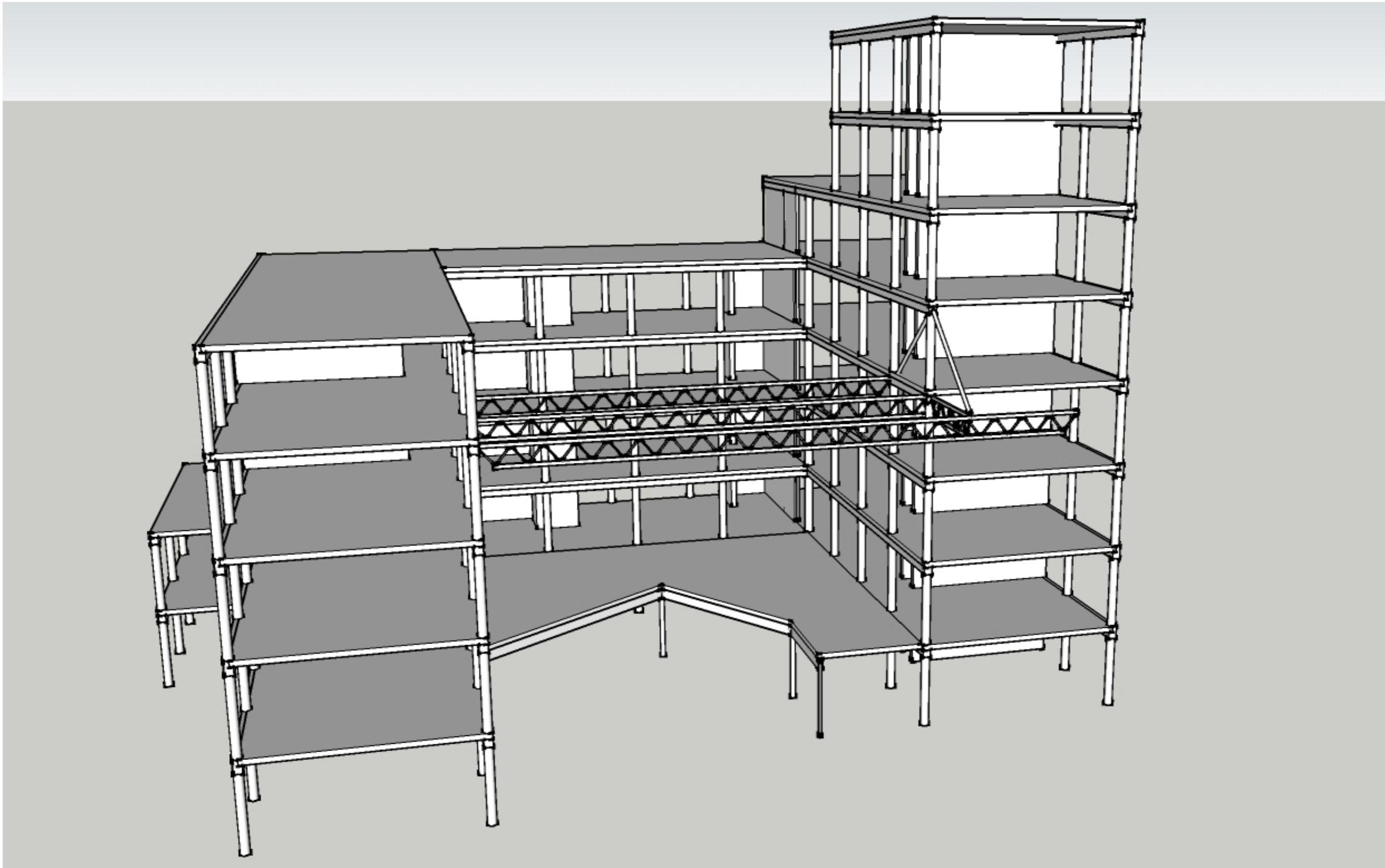

TECHNICAL INTEGRATION

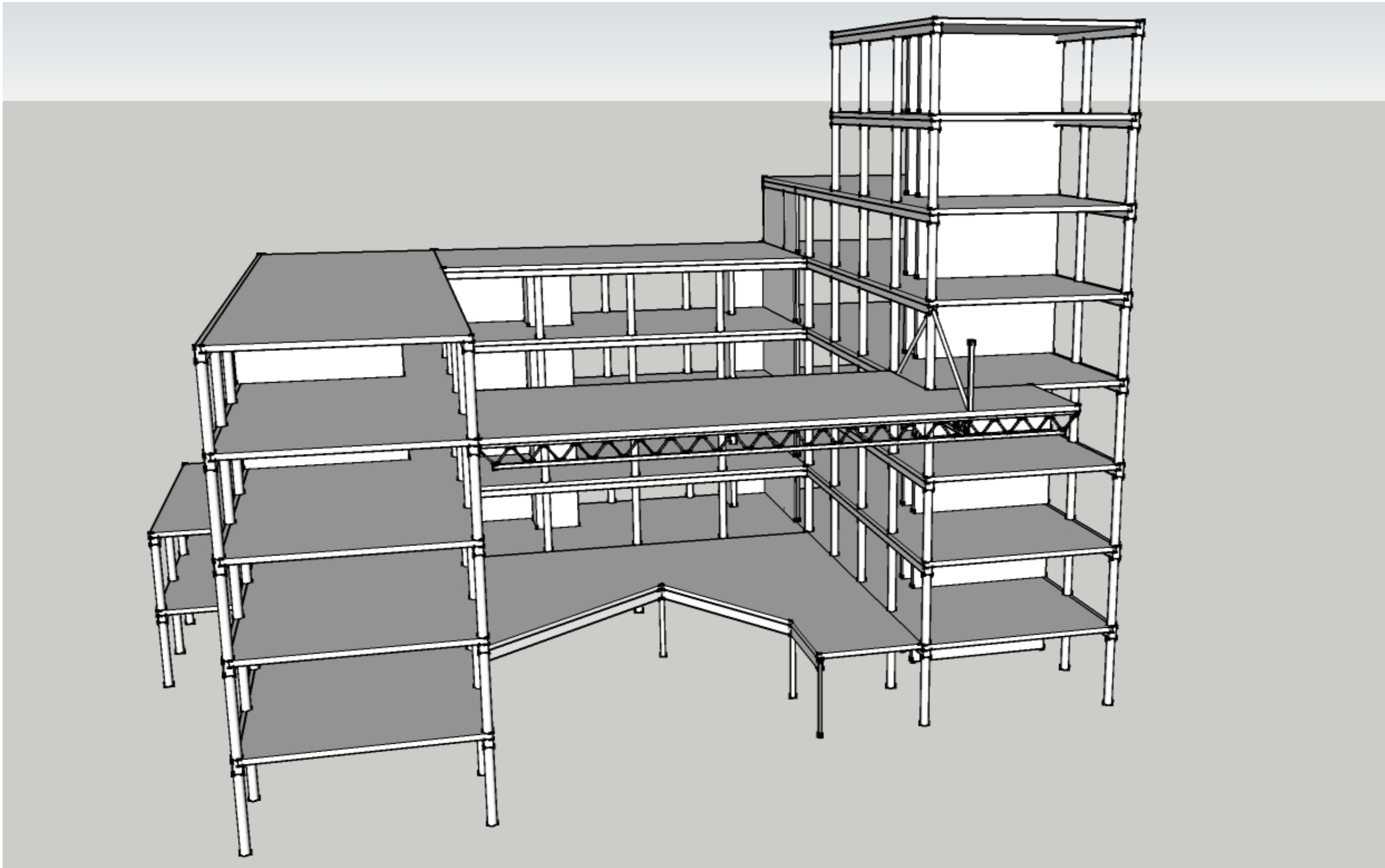

TECHNICAL INTEGRATION

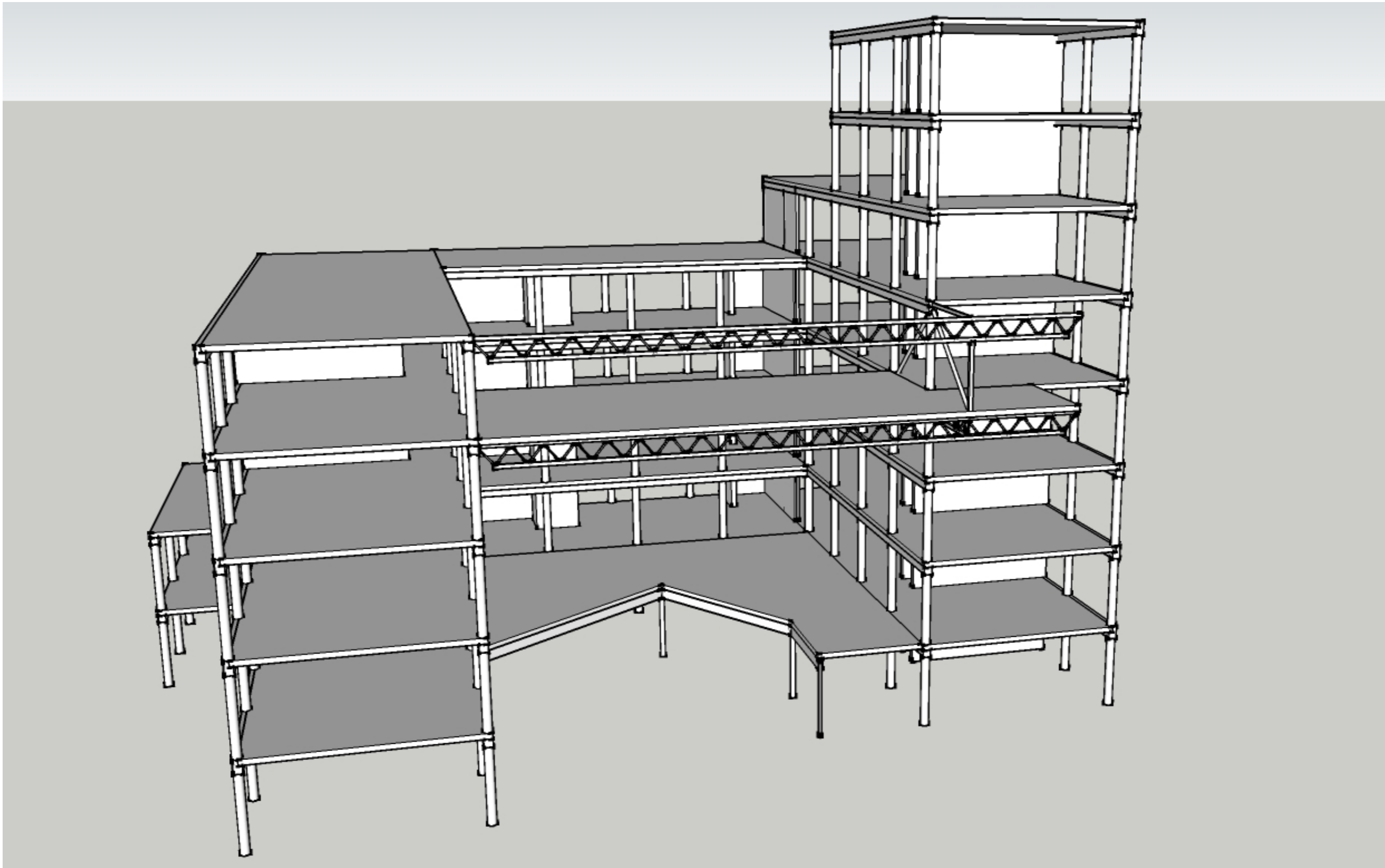

TECHNICAL INTEGRATION

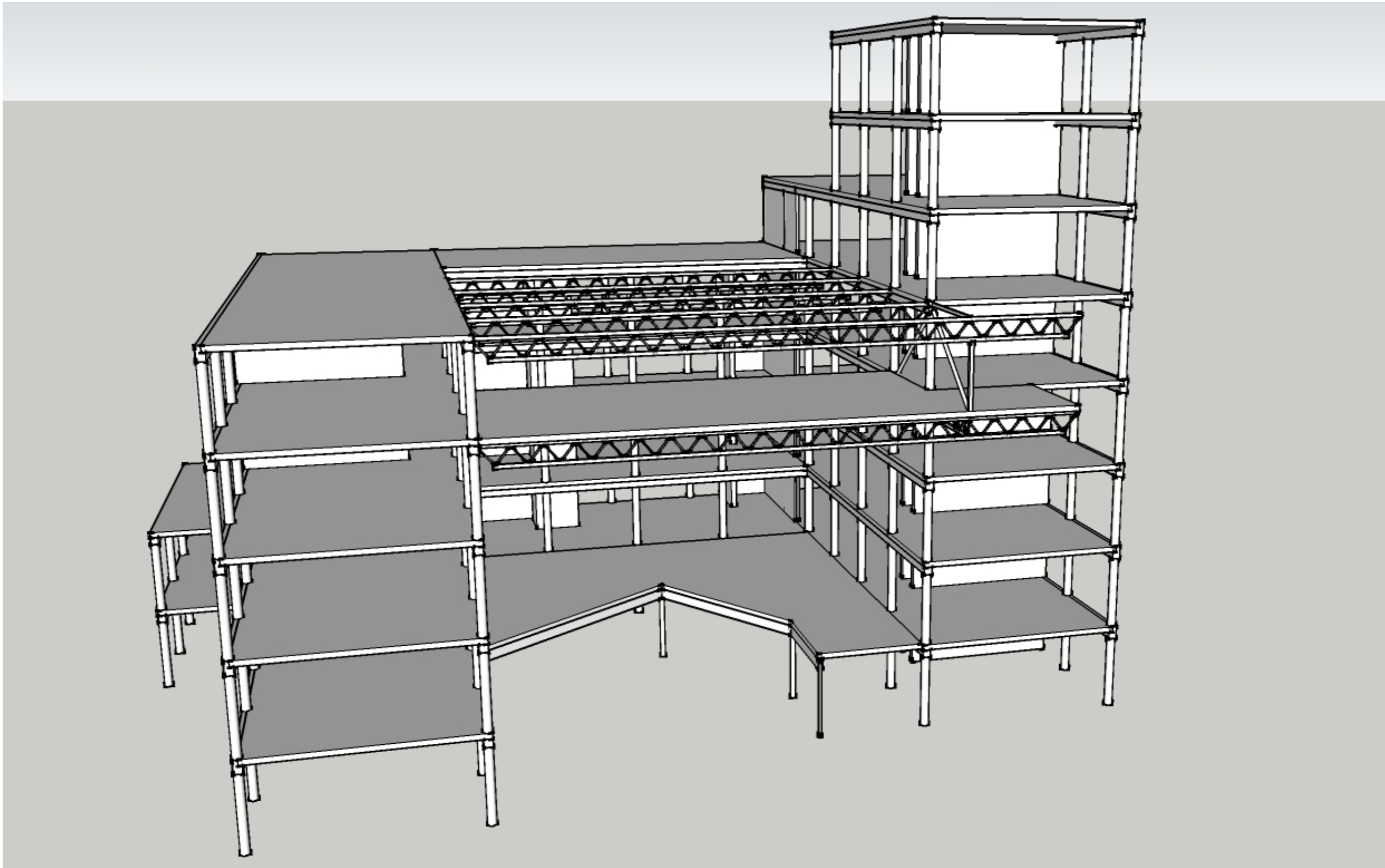

TECHNICAL INTEGRATION

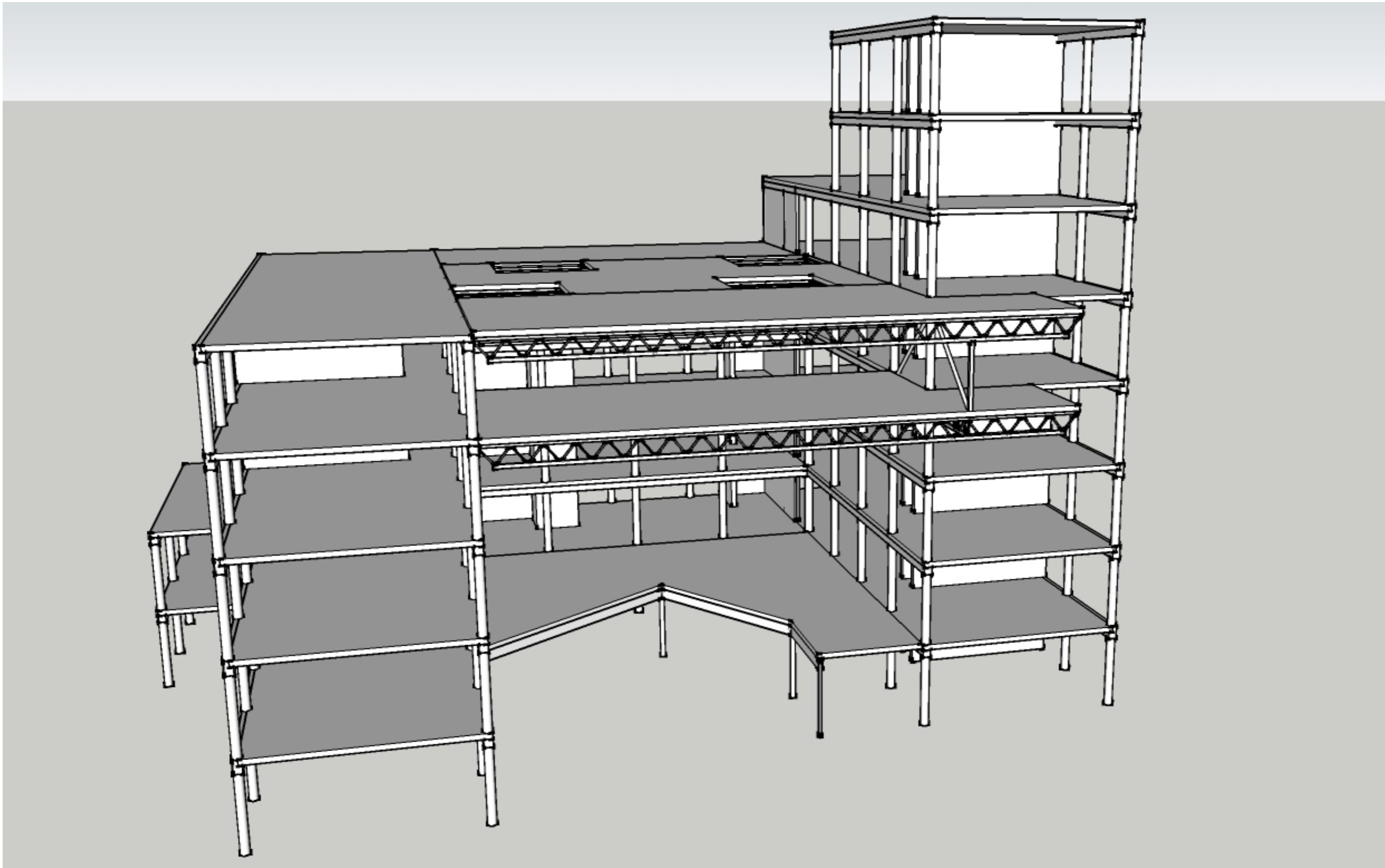

TECHNICAL INTEGRATION

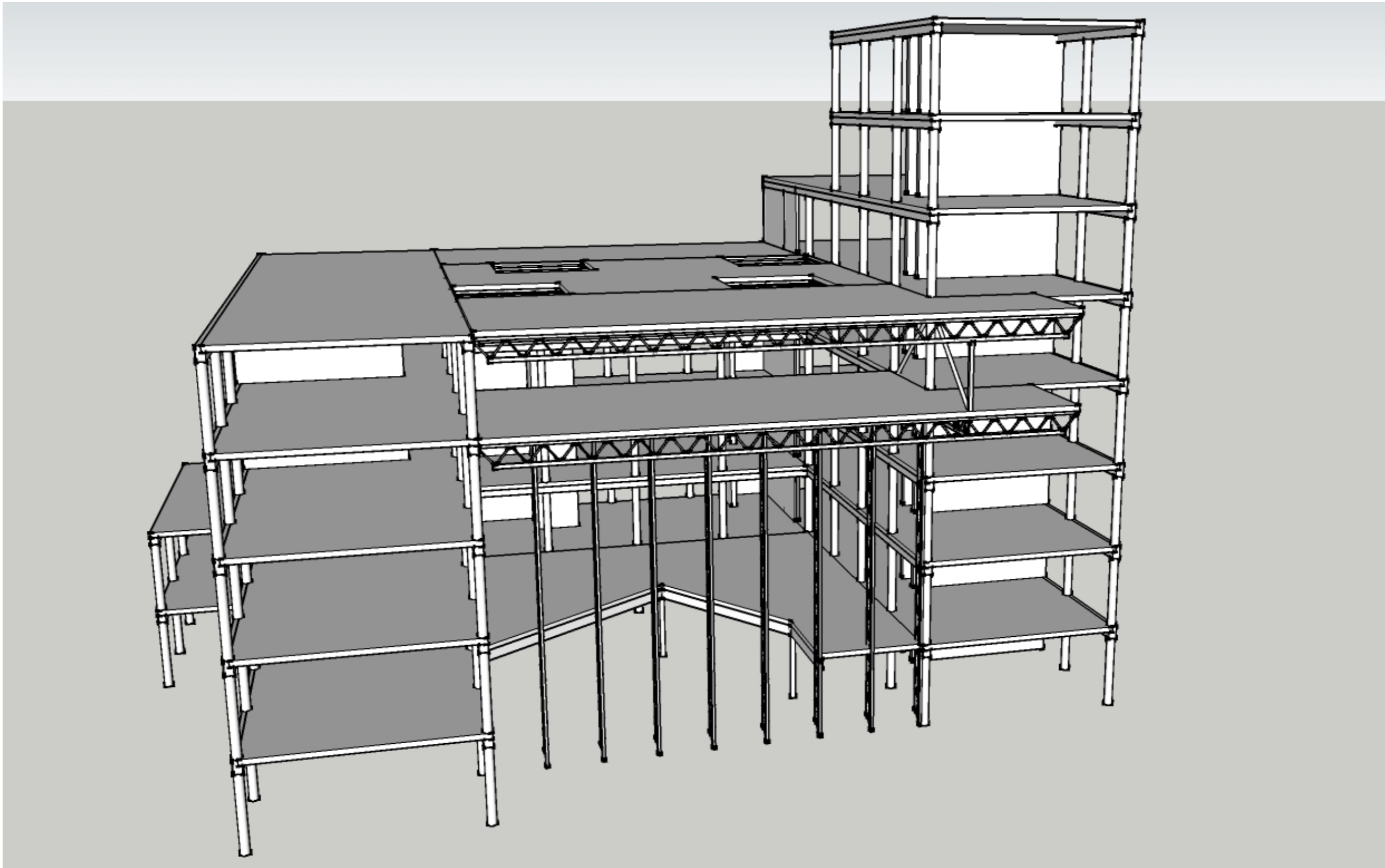

TECHNICAL INTEGRATION

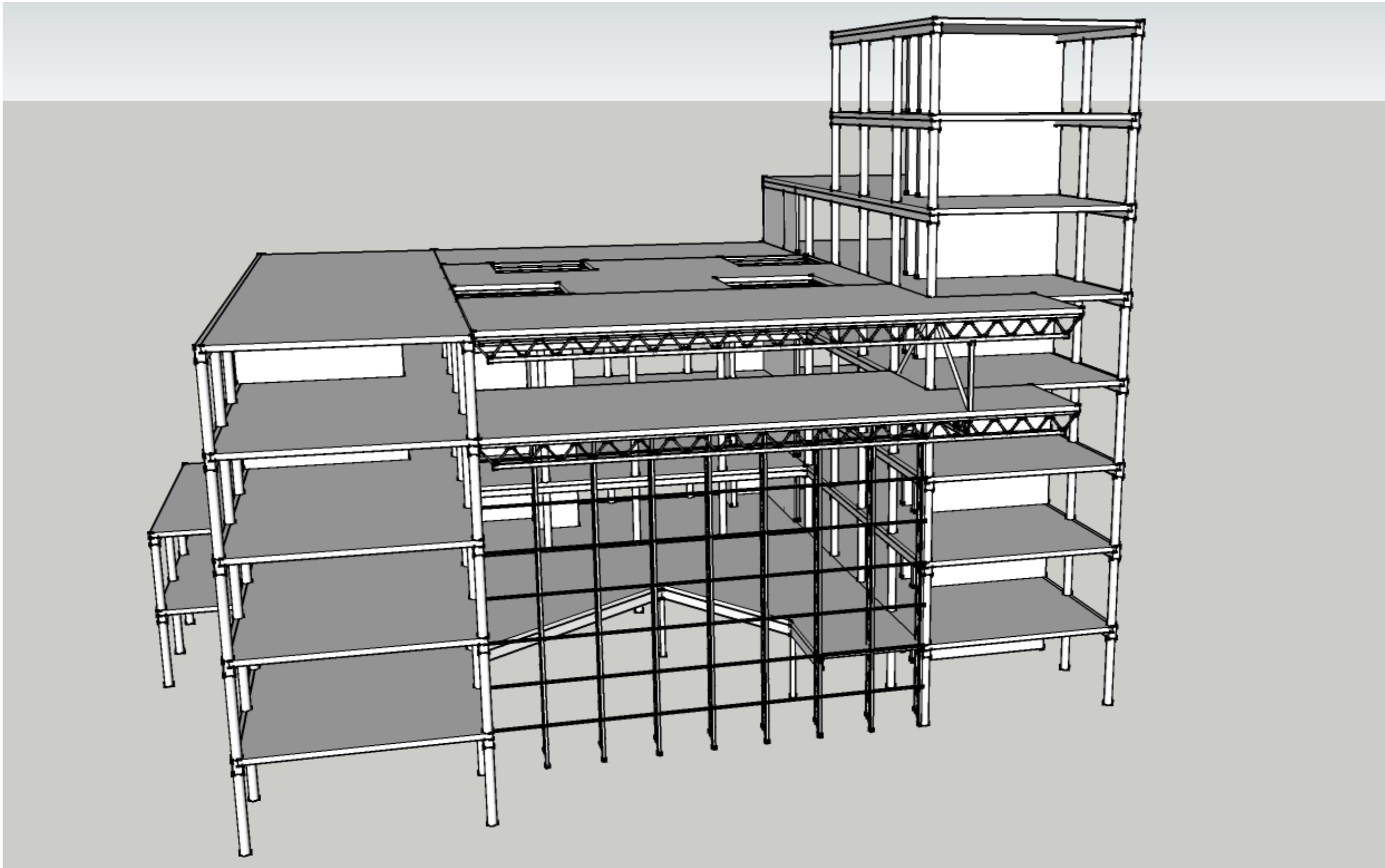

TECHNICAL INTEGRATION

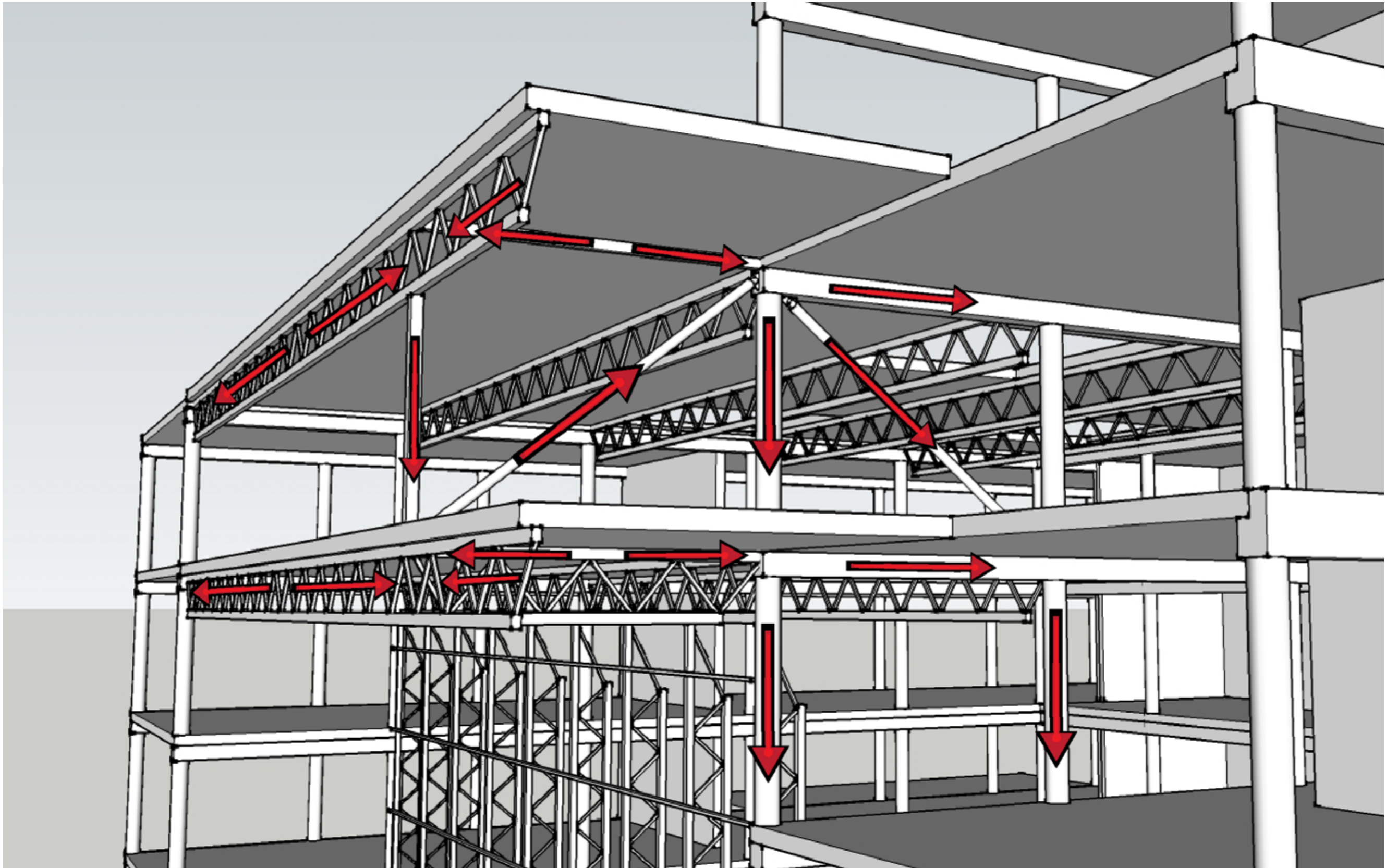

TECHNICAL INTEGRATION

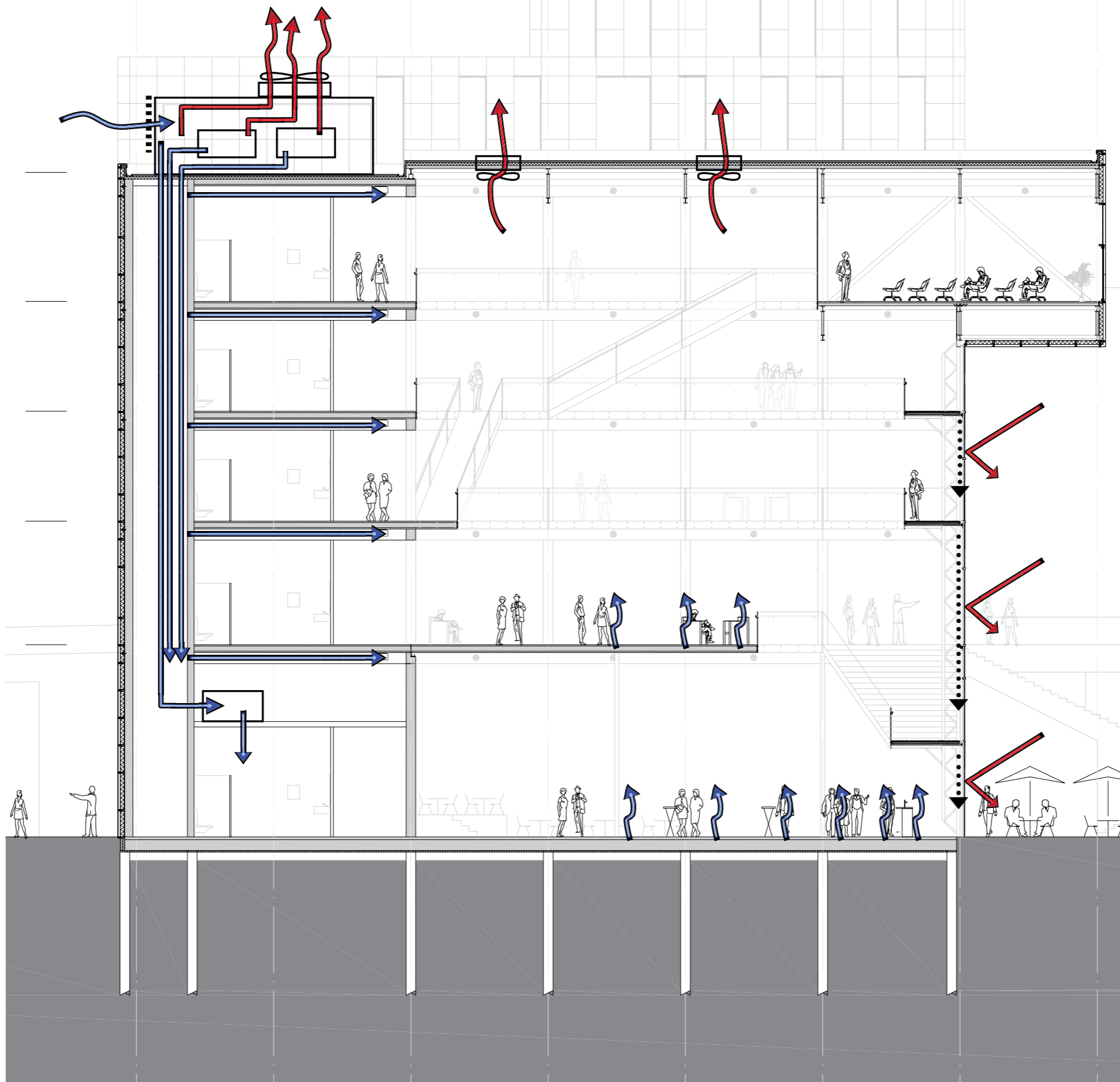

TECHNICAL INTEGRATION

9450

9450

5000

5000

5000

5000

9450

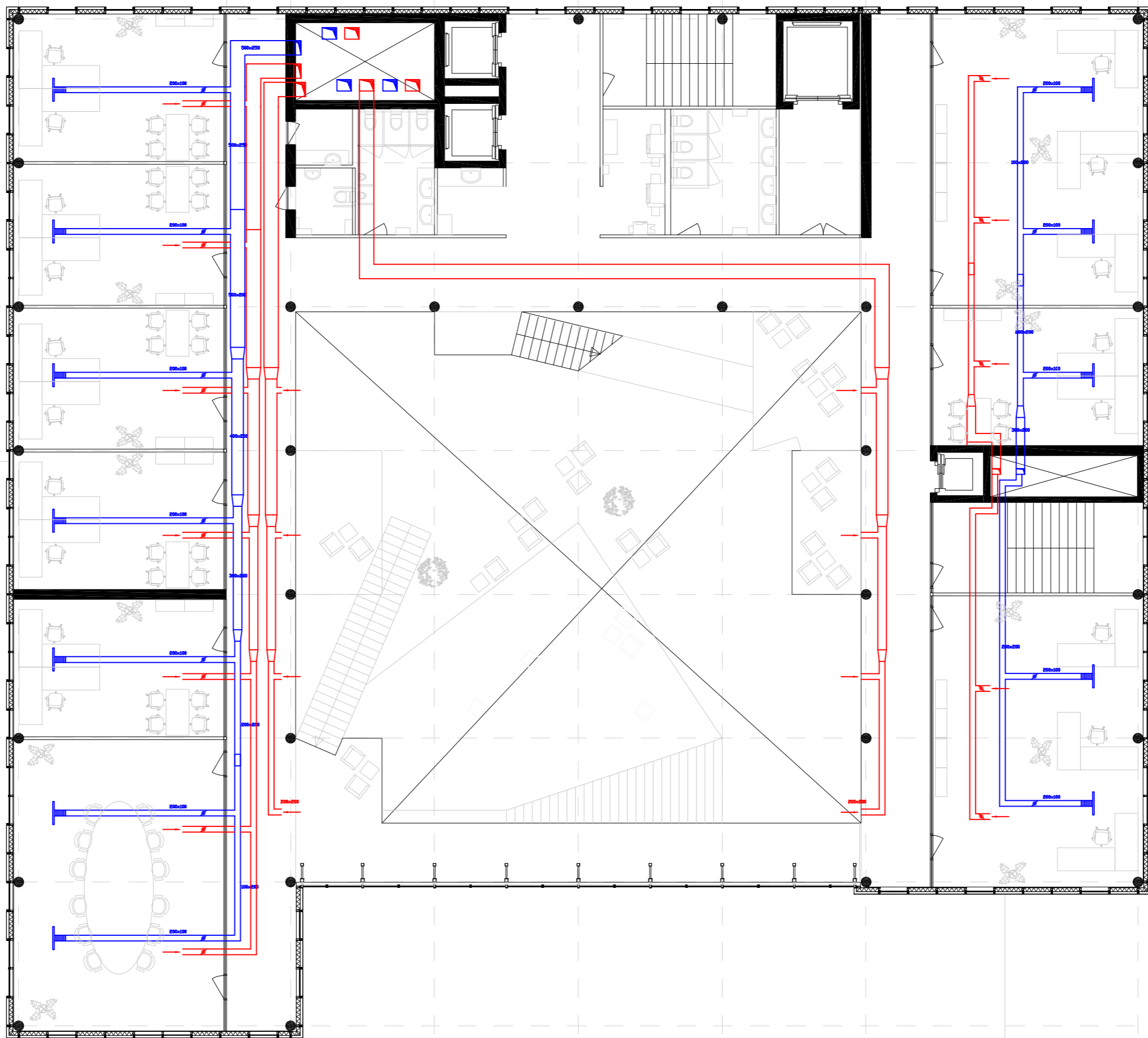

5000

5000

5000

5000

5000

5000

5000

TECHNICAL INTEGRATION

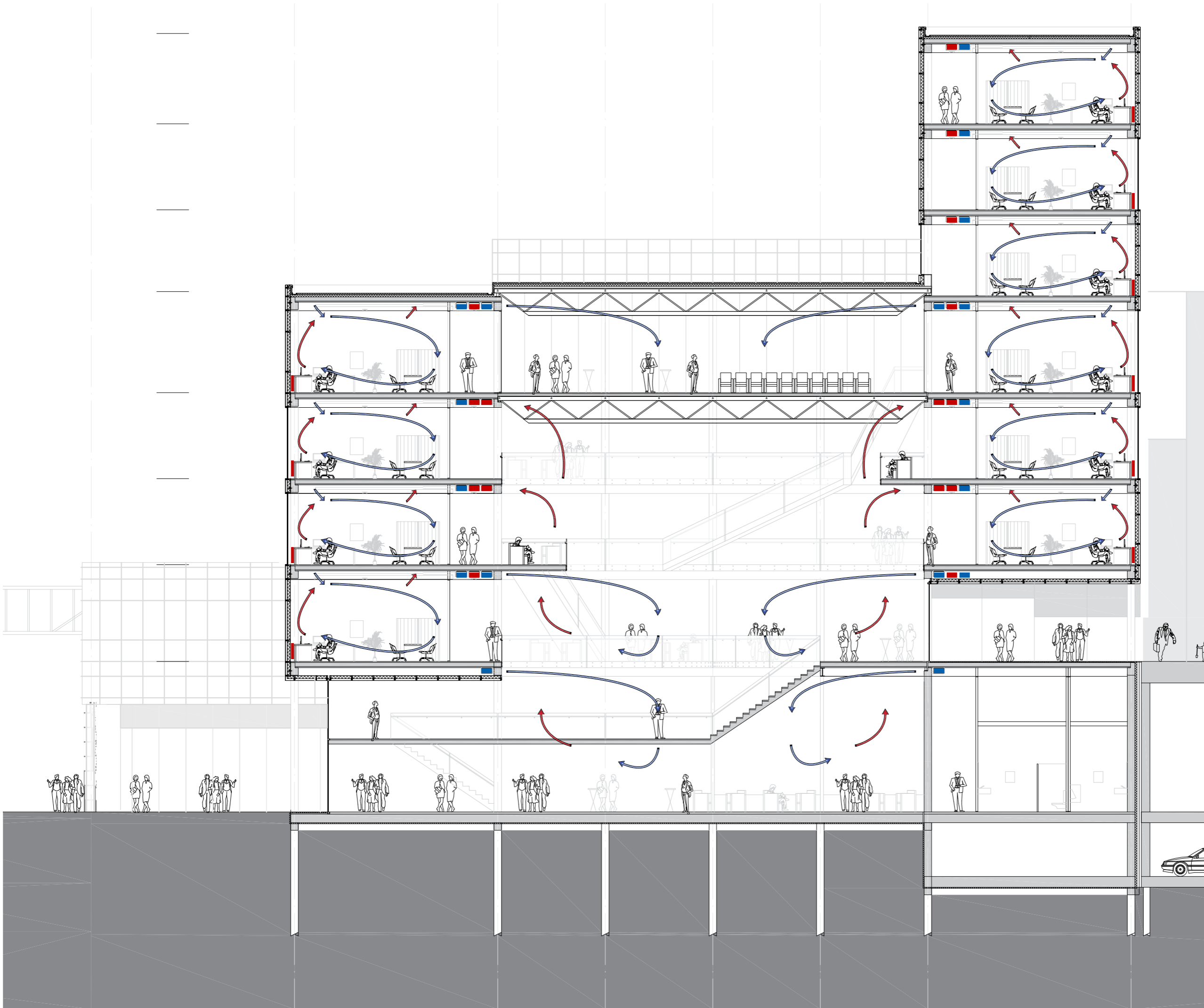

TECHNICAL INTEGRATION

A PUBLIC EXPERIENCE
TO THE OTHER SIDE

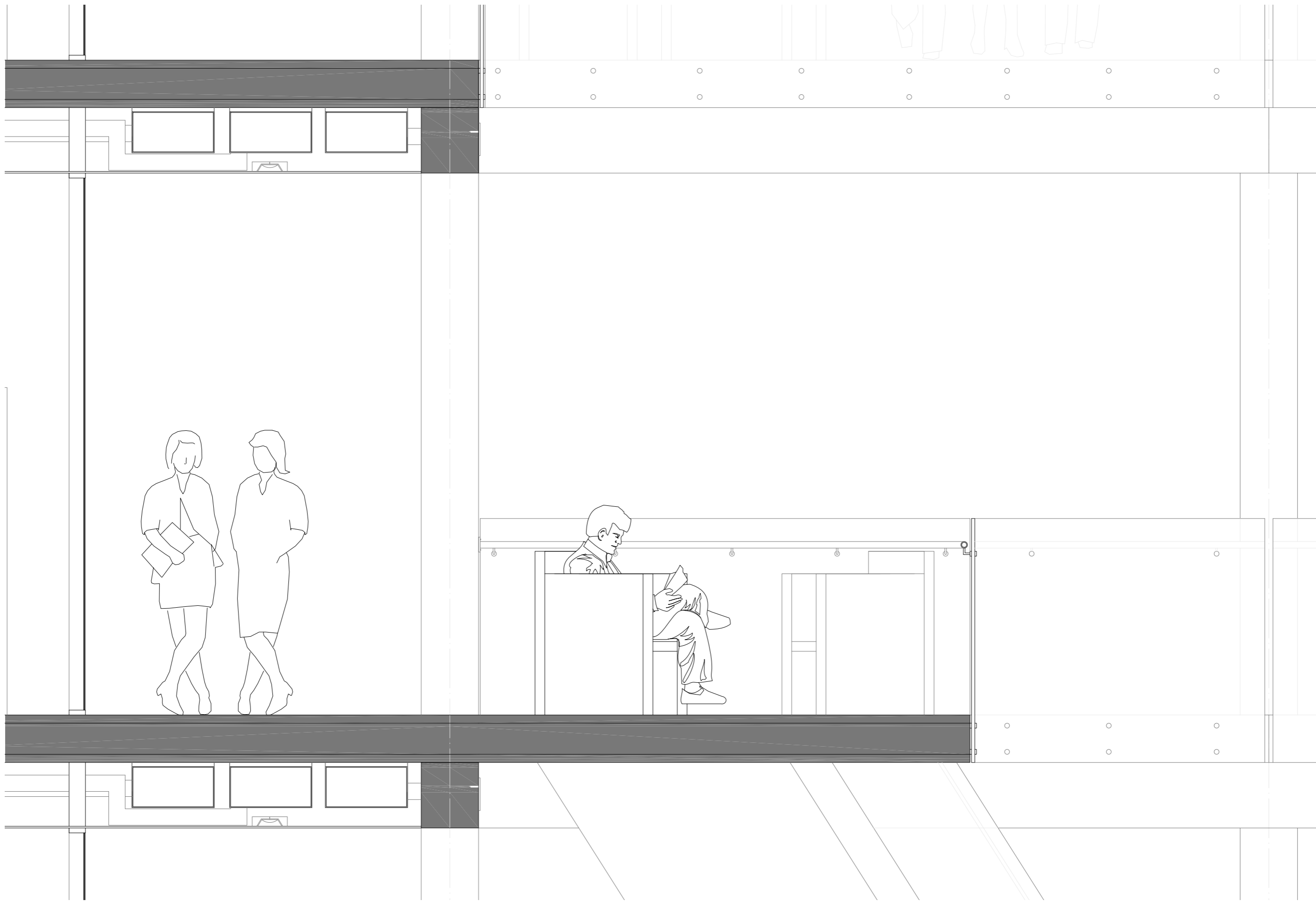

TECHNICAL INTEGRATION

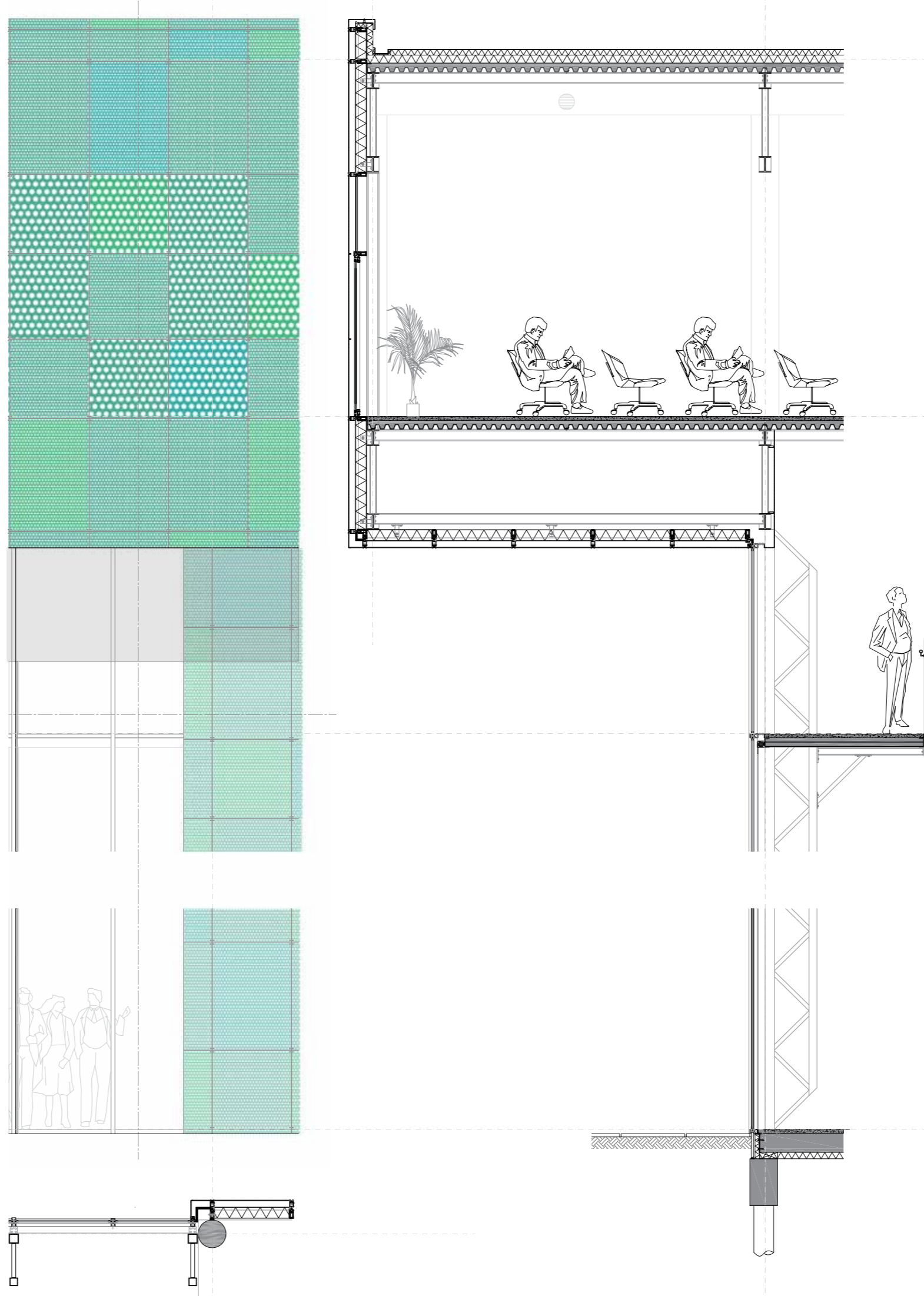

TECHNICAL INTEGRATION

A PUBLIC EXPERIENCE
TO THE OTHER SIDE

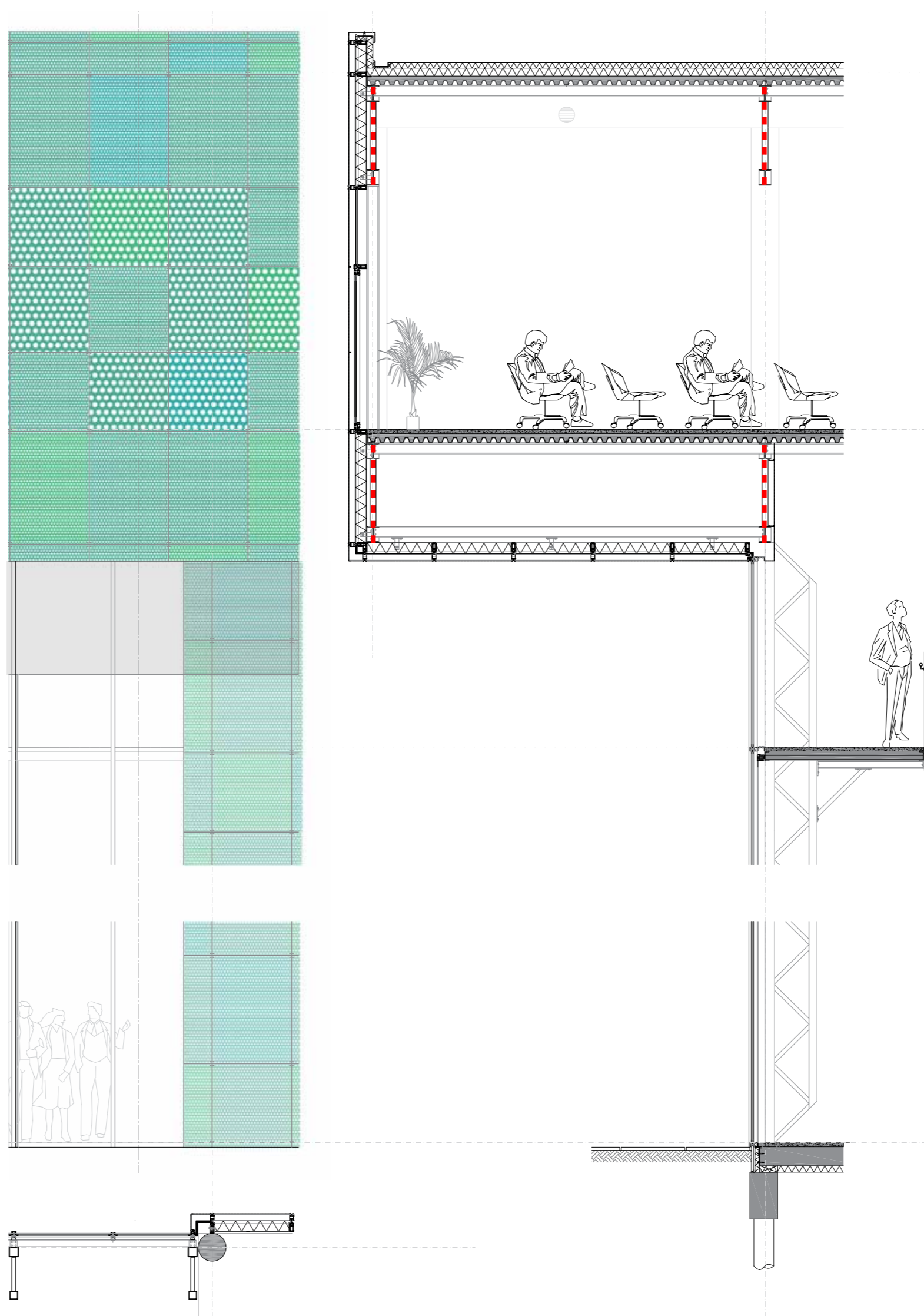

TECHNICAL INTEGRATION

A PUBLIC EXPERIENCE
TO THE OTHER SIDE

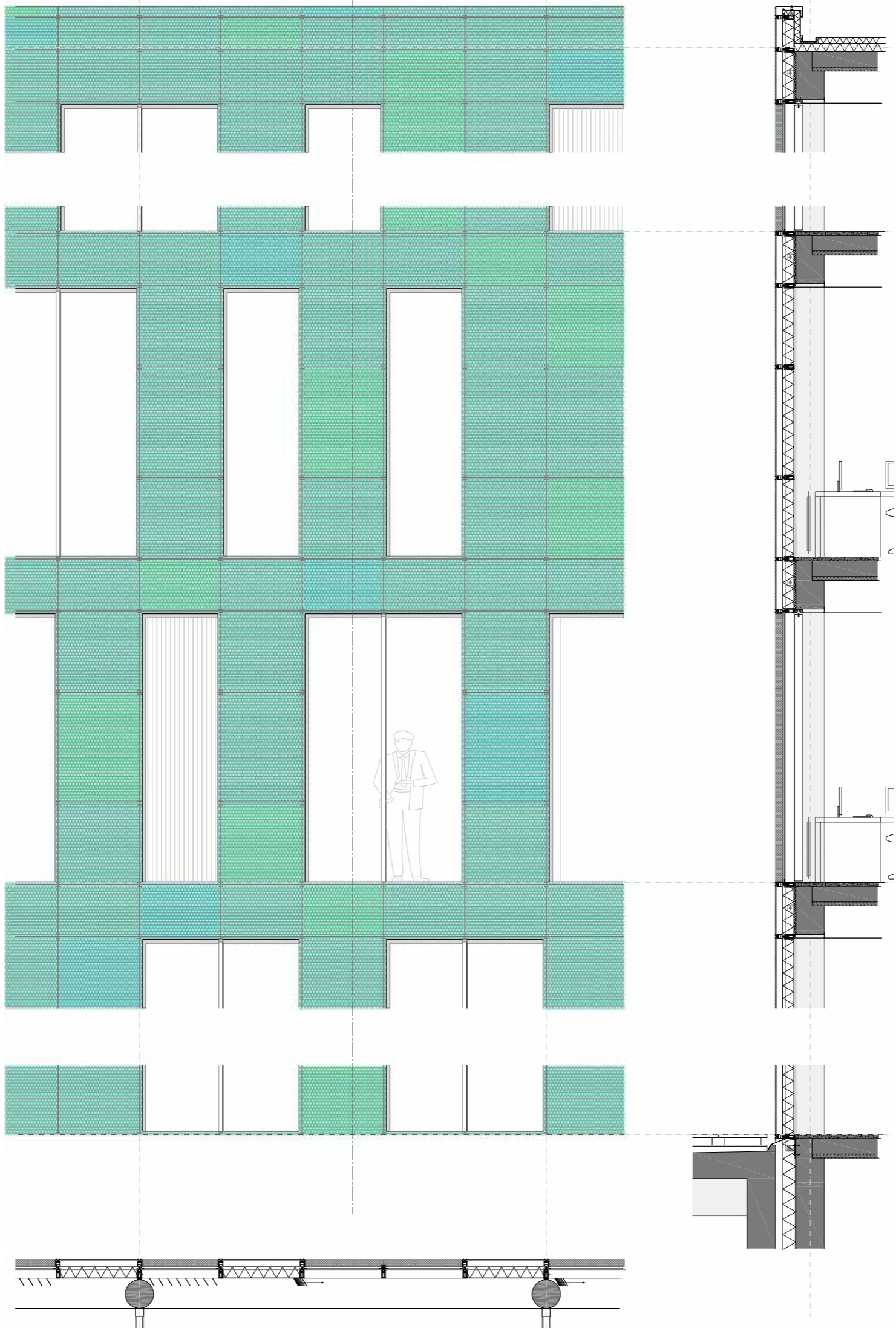

TECHNICAL INTEGRATION

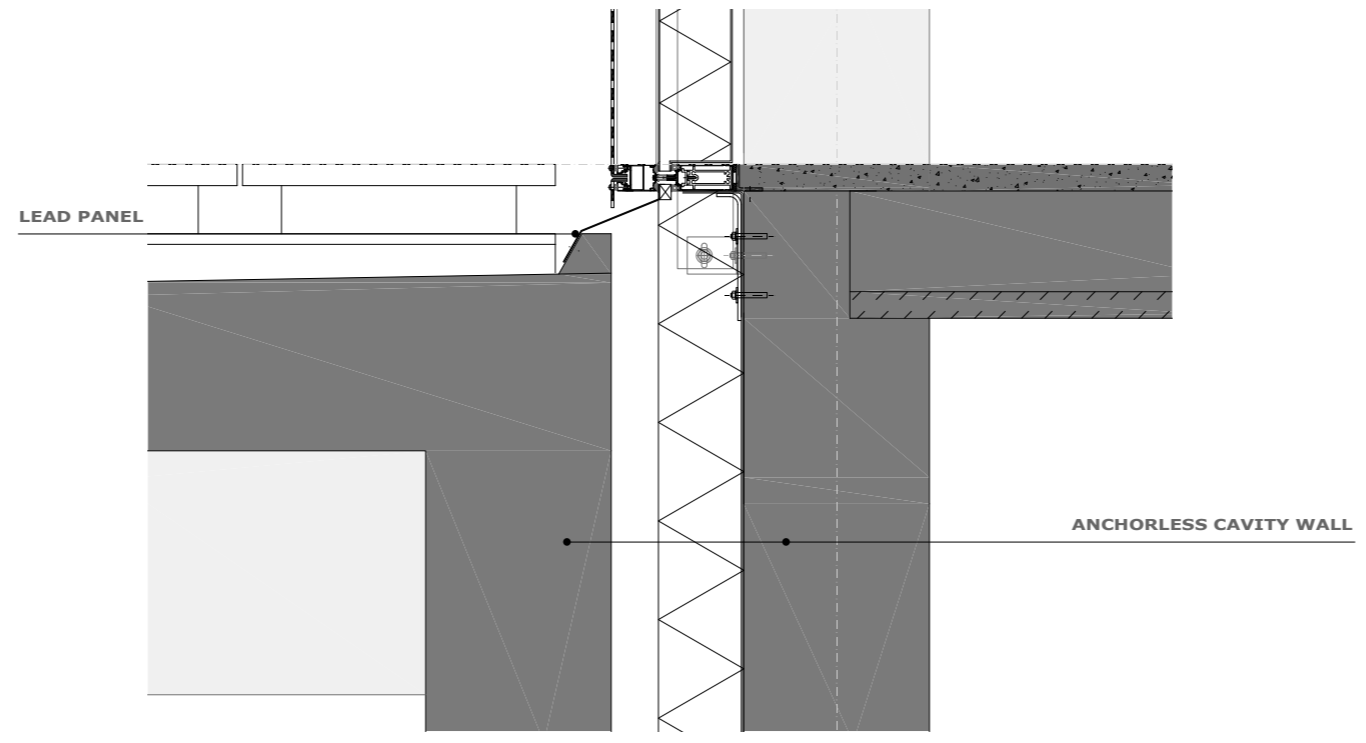
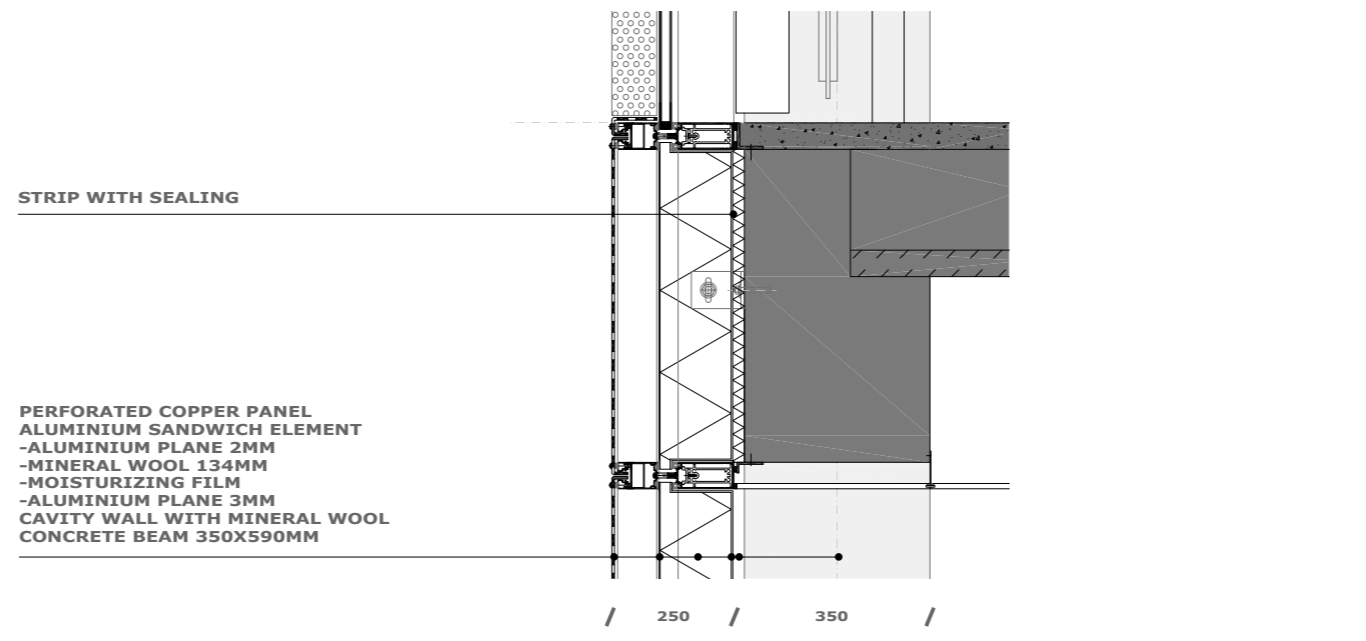
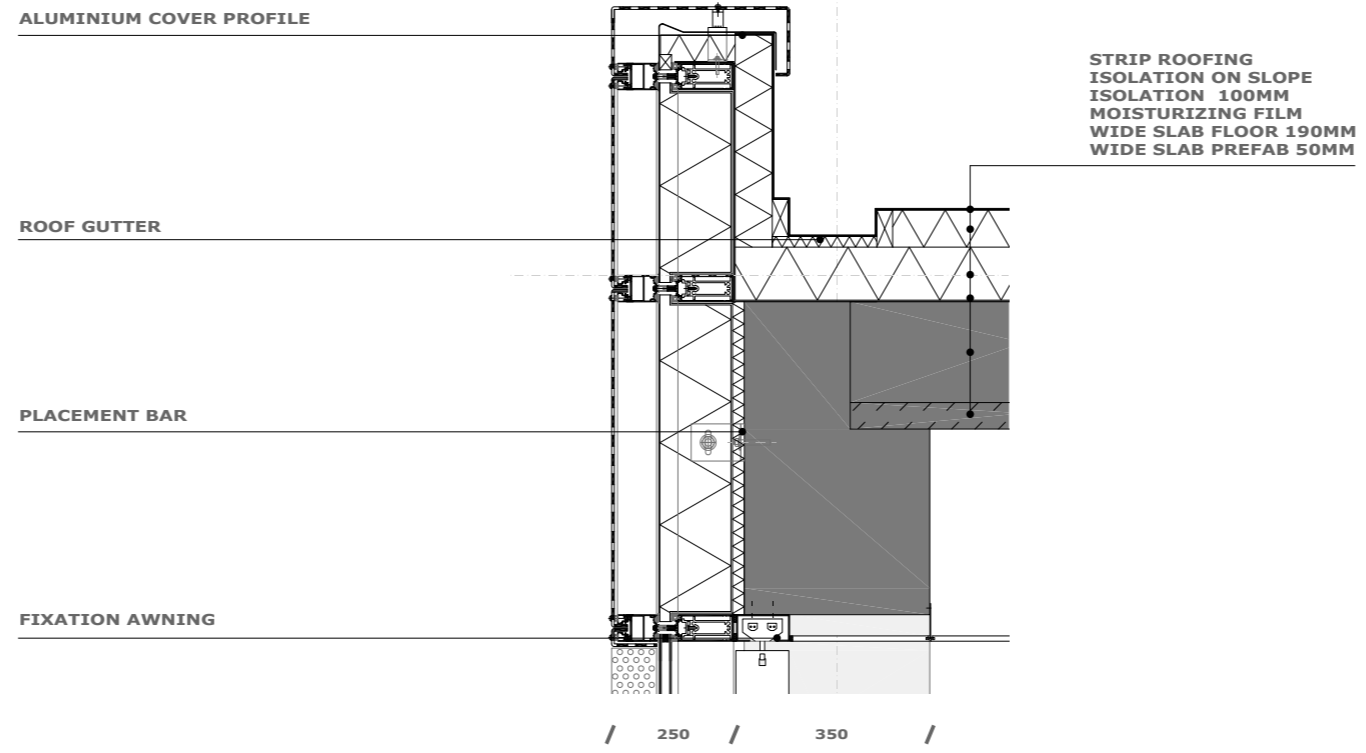

TECHNICAL INTEGRATION

ALUMINIUM COVER PROFILE

ROOF GUTTER

PLACEMENT BAR

FIXATION AWNING

STRIP ROOFING
ISOLATION ON SLOPE
ISOLATION 100MM
MOISTURIZING FILM
WIDE SLAB FLOOR 190MM
WIDE SLAB PREFAB 50MM

/ 250 / 350 /

STRIP WITH SEALING

PERFORATED COPPER PANEL
ALUMINIUM SANDWICH ELEMENT
-ALUMINIUM PLANE 2MM
-MINERAL WOOL 134MM
-MOISTURIZING FILM
-ALUMINIUM PLANE 3MM
CAVITY WALL WITH MINERAL WOOL
CONCRETE BEAM 350X590MM

/ 250 / 350 /

LEAD PANEL

ANCHORLESS CAVITY WALL

TECHNICAL INTEGRATION



INFOCENTER NOORD

A PUBLIC EXPERIENCE
TO THE OTHER SIDE

**THANKS
FOR YOUR ATTENTION !**



INFOCENTER NOORD

**A PUBLIC EXPERIENCE
TO THE OTHER SIDE**