

A multi-state train-following model for the analysis of Virtual Coupling railway operations

Quaglietta, Egidio; Wang, Meng; Goverde, Rob

Publication date

2019

Document Version

Accepted author manuscript

Published in

Proceedings of the 8th International Conference on Railway Operations Modelling and Analysis

Citation (APA)

Quaglietta, E., Wang, M., & Goverde, R. (2019). A multi-state train-following model for the analysis of Virtual Coupling railway operations. In A. Peterson, M. Joborn, & M. Bohlin (Eds.), *Proceedings of the 8th International Conference on Railway Operations Modelling and Analysis: Rail Norrköping 2019* (pp. 1382-1401)

Important note

To cite this publication, please use the final published version (if applicable).
Please check the document version above.

Copyright

Other than for strictly personal use, it is not permitted to download, forward or distribute the text or part of it, without the consent of the author(s) and/or copyright holder(s), unless the work is under an open content license such as Creative Commons.

Takedown policy

Please contact us and provide details if you believe this document breaches copyrights.
We will remove access to the work immediately and investigate your claim.

A multi-state train-following model for the analysis of Virtual Coupling railway operations

Egidio Quaglietta^{a,1}, Meng Wang^a, Rob M.P. Goverde^a

^a Department of Transport and Planning, University of Technology
P.O. Box 1111, 2222 GA Delft, The Netherlands

¹ Corresponding author, e-mail: e.quaglietta@tudelft.nl, Phone: +31152784981

Abstract

The increasing need for capacity has led the railway industry to explore next generation signalling concepts such as Virtual Coupling which takes moving-block operations further by separating trains by a relative braking distance, like cars on the road. By means of a Vehicle-to-Vehicle (V2V) communication architecture trains can move in a virtually coupled platoon which can be treated as a single convoy at junctions, to improve capacity. This concept however introduces the need for additional safety constraints, especially at diverging junctions, which could make actual capacity improvements insufficient to justify investments. Hence, there is a need to understand capacity performances of Virtual Coupling and potential gains over state-of-practice signalling systems. This paper addresses this need by developing an innovative train-following model that captures operational states and corresponding transitions of trains running under Virtual Coupling. A comparative capacity analysis has been conducted for a portion of the South West Main Line in the UK. Promising results have been obtained, showing that the biggest capacity gains returned by Virtual Coupling relate to operational scenarios normally found in practice with trains having service stops and using different routes.

Keywords

Virtual Coupling, train-following model, train separation, railway capacity

1 Introduction

The ever-increasing railway transport demand of passengers and goods has been challenging infrastructure managers to continuously expand capacity of existing networks, which already operate in near-to-saturation conditions. Infrastructure enhancements are costly and not always possible, especially because of lack of space in densely built areas. The railway industry is therefore looking into the adoption of advanced signalling systems which could reduce train separation while increasing reliability and safety of railway operations. Radio-based fixed-block signalling systems like ETCS Level 2 (Theeg and Vlasenko, 2009) have already seen several implementations throughout Europe and showed significant capacity gains due to dynamic supervision of the braking curve. Technological developments are however heading towards moving-block signalling which overcomes traditional fixed-block train separation by replacing vital track-side track vacancy detection with on-board devices for Train Integrity Monitoring (TIM). The European standard ETCS Level 3 (Theeg and Vlasenko, 2009) can implement moving block operations allowing trains to be separated by an absolute-braking distance (i.e. the distance needed to reach a standstill from current speed). Capacity benefits provided by such a system are however limited for high-speed lines, where absolute-braking distances can reach up to 4-5 km when

operating at speeds around 300 km/h. The concept of Virtual Coupling is hence gaining in popularity since it builds on the principle that trains are separated by a relative-braking distance, i.e. the distance needed to slow down to the speed of the train ahead. Such a concept entails platoons (here referred as convoys) of trains linked via a V2V communication to slow down synchronously with the train ahead to keep a safety margin in between. Given the relative short distances in between trains, the concept of Virtual Coupling implies trains to be automatically driven by an Automatic Train Operation (ATO) to substantially reduce sight and reaction times of human drivers which would be unsafely long for this kind of operations. Similar setups have been proved already in the road sector for automated cars under cooperative adaptive cruise control (Herman et al. 2017). However, non-negligible safety issues arise when applying this concept in railways which might limit actual capacity improvements. Whilst Virtual Coupling is more effective than moving-block on plain tracks, the same cannot be said for instance at diverging junctions, where trains in a convoy need to be outdistanced to safely move and lock switches in between. So far, little research has been done on Virtual Coupling. The railway industry is asking to identify whether actual capacity gains returned by this concept will be enough to justify potential investments. The objective of this paper is hence to provide a wider understanding of operational issues and capacity performances of Virtual Coupling as well as possible gains over state-of-the-practice signalling systems. To this end, a multi-state train-following model is developed which overcomes limitations of state-of-the-art car-following models by considering non-linear vehicle movement dynamics, realistic power characteristics of the traction unit, safety constraints at junctions as well as line resistances due to track gradient and curvature. Different Virtual Coupling operational states and transitions are defined and mathematically modelled. Also, the concept of Virtual Coupling Movement Authority is introduced and an innovative formalisation of V2V messages exchanged among trains is given. A comparative capacity analysis is performed for a portion of the South West Main Line in the UK for different operational scenarios considering stopping and non-stopping train services having the same or a different route. Capacity impacts of Virtual Coupling are benchmarked against traditional (Train Protection Warning System, TPWS) and radio-based (ETCS Level 2) fixed-block as well as moving-block (ETCS Level 3) signalling systems. Outcomes from the model return meaningful insights to support the railway industry during early investment decisions as well as for the development of operational and technological system specifications.

2 Literature review on technology and models for moving-block railway signalling

Virtual Coupling signalling advances the concept of moving-block railway operations introduced by ETCS Level 3, allowing trains to be separated by a relative braking distance rather than by an absolute braking distance. Figure 1 illustrates a schematic system architecture for ETCS Level 3 (a) and Virtual Coupling (b) signalling. In this paper we refer to the moving-block implementation of ETCS Level 3, where vital track-side train detection and line-side signals are totally replaced by on-board devices such as Train Integrity Monitoring (TIM) and the European Vital Computer (EVC). TIM continuously checks that no car is accidentally split from the trainset and dangerously stranded on the way. Trains have a radio-based Vehicle-to-Infrastructure (V2I) communication with the Radio-Block Centre (RBC) reporting train position updates every few seconds (usually every 1 to 5 s). In return the RBC provides each train with a Movement Authority (MA) providing the

maximum distance that a train can safely cross without colliding with another train on the route.

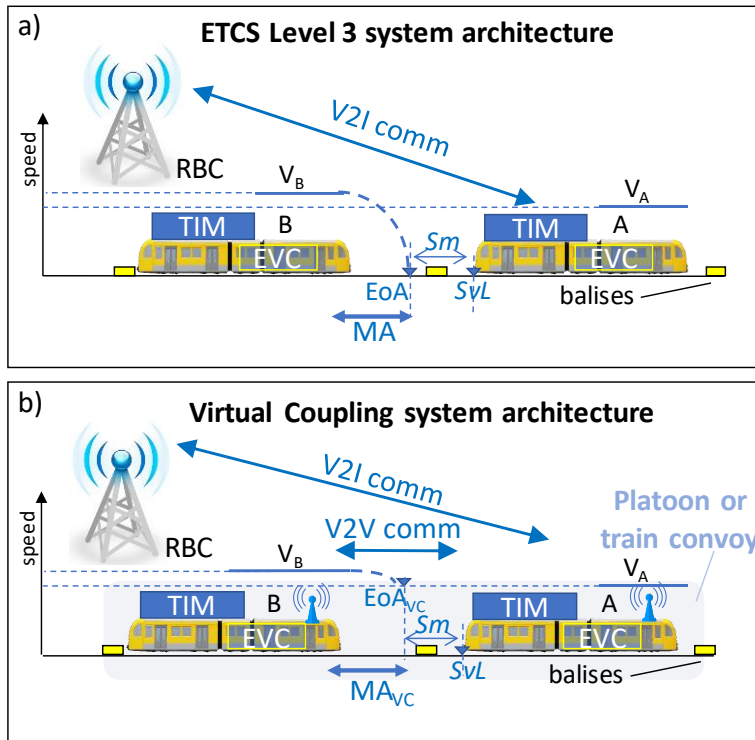

Figure 1. Schematic system architecture for ETCS Level 3 and Virtual Coupling.

The MA is given in the form of an encrypted message containing the last safe location until which the train can move, namely the End of Authority (EoA). The EoA is at a safety margin (sm) from the Supervised Location (SvL) which represents a potential danger on the train route such as the front or the tail of a nearby train, a speed or track access restriction and/or an unset switch. The EVC elaborates MA messages in order to compute and supervise in real-time a braking curve ensuring that the train does not overrun the EoA. Train location is continuously monitored by the EVC by means of an on-board odometer which is regularly re-calibrated any time the train crosses a track-side transponder (named balise) acting as a fixed geographical reference point.

This paper assumes that Virtual Coupling encompasses the same systems and functionalities of ETCS Level 3 plus an additional V2V communication layer by which trains exchange information about their kinematic parameters (i.e. speed and acceleration), as well as their routes. Additional on-board antennas are hence considered to enable such a communication. By combining the information broadcasted by both the RBC and the V2V communication layers, trains get an upgraded MA containing the maximum safe movement distance as well as speeds, accelerations and routes of neighbouring trains, to enable virtual coupling “on-the-fly”. Such an upgraded Movement Authority will be here referred to as Virtual Coupling Movement Authority (MA_{VC}) to distinguish it from the standard MA

defined for ETCS signalling. The end of MA_{VC} is here called Virtual Coupling End of Authority (EoA_{VC}). Differently from the standard ETCS EoA where the train is enforced to stop (V_B needs to be reduced to 0), the EoA_{VC} imposes that the train reaches the same speed of the train ahead (V_B needs to reach V_A) to allow virtual coupling. Clearly, the main purpose of the EoA_{VC} is to improve capacity utilisation by virtually coupling trains together, while the standard EoA has a safety-critical role by guarding trains from any danger point on the route. In Virtual Coupling the EVC shall supervise both the EoA_{VC} when two trains are trying to couple up, as well as the ETCS EoA in case a train is running under ETCS Level 3 and/or two coupled trains need to split when approaching a potential danger point. More details about the different operational modes identified for Virtual Coupling are provided in the next section.

The main concept behind Virtual Coupling is that trains can synchronously move together in a V2V-linked train convoy which can be treated as a single train at junctions with the aim that capacity can be increased at critical infrastructure bottlenecks. The whole idea of Virtual Coupling mainly builds on the assertion that it is unrealistic that a train stops instantly, hence allowing for trains behind to safely arrest before a collision, even in case of derailment of the train ahead. The Institution of Railway Signal Engineers (IRSE 2016) state that the principal hurdle to such a concept does not derive from technology but from a missing definition of clear principles for safe and effective Virtual Coupling train operations. Emery (2010) proposes operational principles for a hybrid version of ETCS L2 and Level 3 aiming to separate trains by an absolute emergency braking distance in order to overcome safety risks that a relative braking distance separation would raise at diverging junctions. Although such a proposition could return some capacity gains over ETCS Level 3, relying on an emergency braking can cause substantial discomfort to passengers while damaging the tracks and the rolling stock. Quaglietta (2018) provides instead an initial definition for safe Virtual Coupling operational principles and an infrastructure occupation model, showing that significant capacity gains can be achieved over ETCS Level 3 when separating trains by a relative braking distance. The model formulated in Quaglietta (2018) refers however to nominal conflict-free fixed-speed train diagrams which do not consider dynamic interaction among trains. Major safety-related risks are however likely to be observed when trains interact within perturbed traffic conditions. Variable-speed models adjusting train speeds as function of nearby trains' kinematics can hence provide more insight in the safety risks and the actual capacity benefits of Virtual Coupling. Ning (1998) proposes the adoption of Car-Following (CF) models to study train operations under relative-braking distance separation, without providing any scientific application to support such a proposition.

In road traffic flow theory several car-following models have been developed. These models are classified into different groups (Brackstone, 2001): safety-distance/speed models, stimulus-response models, psycho-spacing models, and strategy-based models. The most widely used safety-distance/speed model is the Gipps' model (Gipps, 1981). It assumes constant braking rate and reaction time and drivers choose safe speed such that even in the worst-case scenario where the leading vehicle suddenly decelerates to a standstill, a collision can still be avoided. Stimulus-response models describe the reaction of drivers as a function of stimuli. The Helly model (Helly, 1959) belongs to this family, in which the acceleration of a vehicle maintains a linear relationship with the deviation from a desired headway and the deviation from the speed of the leader. Helly's model has been used recently to describe vehicle platoon behaviour (Xiao et al., 2018). The CF model from Wiedemann is a widely used psycho-spacing model (Leutzbach and Wiedemann, 1986). Car-following behaviour is described here on a relative speed - headway distance plane, and

the model incorporates human perception thresholds and imperfect human control of the car. Strategy-based models include the Intelligent Driver Model (IDM) (Treiber et al., 2002) and optimal control models (Wang et al., 2016). IDM follows an intelligent braking strategy that ensures that braking is sufficient to bring risky situations back to safe conditions when approaching the leading vehicle at small headways, while optimal control models assume that drivers anticipate on the driving environment to make optimal acceleration in a predicted future. All the mentioned CF models build on the assumption of linear dynamics for cars making them not applicable to describe train dynamics which are strongly non-linear. CF models also neglect factors which are relevant for trains such as traction power limits, gradient and curvature resistances as well as safety constraints at diverging/merging junctions.

To this end, a novel train-following model is developed in this paper which overcomes the limitations of car-following models currently available in literature by specifying multiple modes of operations while considering all factors that mainly influence train dynamics in real-life.

3 Definition of Virtual Coupling operational states and transitions

The train-following model developed in this paper defines multiple operational states and corresponding transition phases that a train needs to go through when coupling/uncoupling to/from another train under Virtual Coupling signalling. Figure 2 reports a complete flow diagram of the different Virtual Coupling operational states which have been identified and described in our model. In default operational conditions (State 1) a train is assumed to be running independently under moving-block ETCS Level 3. In this operational state the EVC will always compute and supervise an absolute braking distance (Abd) allowing the train to safely stop at any EoA reported by the RBC. The EoA is always located at a given safety margin (sm) from the supervised location SvL (i.e. the potential danger point). The safety margin is needed to prevent that potential train location errors might cause the train to overshoot the SvL and cause derailments and/or train collisions. This safety margin will hence be considered when computing braking curves in any of the Virtual Coupling operational states identified in our model.

Whenever a train is approaching a train ahead, conditions for virtually coupling the two trains are checked. A first necessary condition for virtual coupling is that the train has the next stretch of its route in common with the train ahead. Indeed, it would not make any sense to couple two trains soon diverging at a fast-approaching junction. When a train shares the next part of route with the train ahead, a transition from “ETCS Level 3 running” to a “Coupling” operational state (State 2) will occur. In a “Coupling” operational state the EVC will supervise the train so to attain the speed of the train ahead at the EoA_{VC} located at a safety margin sm from the tail of the leading train. It must be noticed that the train behind (train B) will take some time to reach the same speed of the train ahead (train A). Specifically, this is the time to cross the so-called *Coordination distance* (Cd) needed by train B to coordinate its speed with the leading train. If train B has a speed V_B lower than the leader’s speed V_A (see State 2 in Figure 2), then Cd includes the distance to catch the train ahead by accelerating to a higher speed V'_B plus the distance to brake to the leader’s speed V_A . If train B is running faster than the leading train A then Cd is merely the distance to slow down to the speed of train A.

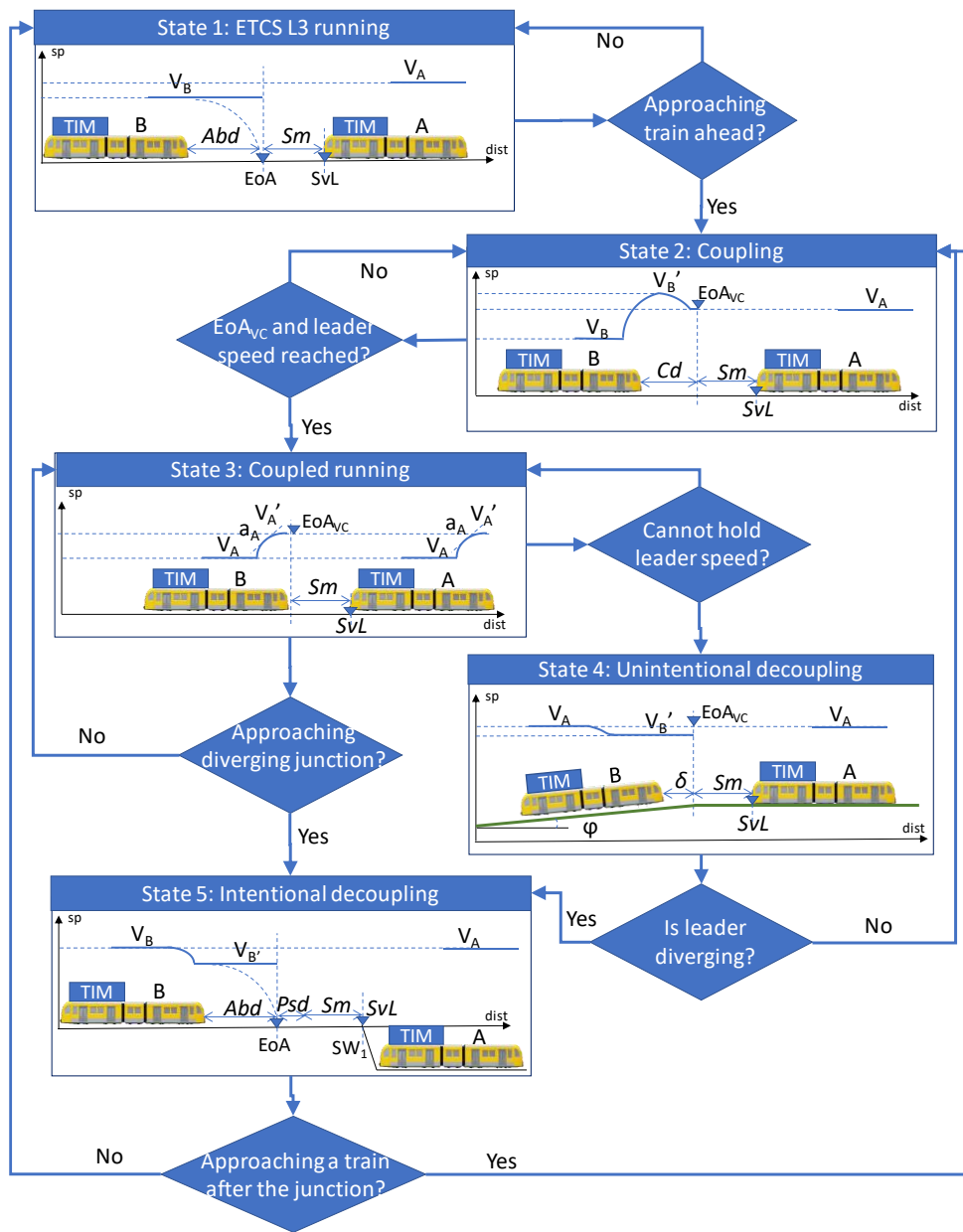

Figure 2. State flow-diagram of the Virtual Coupling train-following model.

The EoA_{VC} enabling the two trains to couple needs to refer to a prediction of position and speed of the leading train A at the time the follower train B has crossed the entire coordination distance Cd . During coupling operations, the EVC shall therefore consider such a prediction and not the current position and speed of the leading train.

Once the train behind reaches the speed of the leading train at the predicted EoA_{VC} ,

within a given tolerance, then it is considered into a “Coupled running” state (State 3). In coupled running the EVC will supervise the train to follow current speed and acceleration of the train ahead, so to keep their separation in a certain threshold from the safety margin sm . Differently from the “Coupling” operational state, the EoA_{VC} considered by the EVC does not refer to any prediction but to the actual speed, position and acceleration currently held by the leading train. While in a “coupled running” state, two state transitions are possible, namely an “Unintentional decoupling” (State 4) or an “Intentional decoupling” (State 5). An unintentional decoupling state is reached any time a virtually coupled train is not able to hold the same speed of the train ahead because of higher motion resistances (due to e.g. a steep uphill gradient ϕ) and/or power limitations of the traction unit. The separation between the two trains increases by a distance δ (larger than the coupling threshold) proportional to the speed difference $V_A - V_{B'}$ (see State 4 in Figure 2), leading to a state of unintentional decoupling. In such a state a train will be driven at the maximum traction power in order to catch up with the train ahead. When dynamic conditions of traction power and motion resistances allow the train to be coupled again to the leading train, a transition to a “Coupling” state will occur. The transition to an “Intentional decoupling” state happens instead when two (or more) coupled trains approach a diverging junction where the leading train will switch over a different route. Such a situation leads to a safety critical issue given that the switch might not have enough time to be safely moved and locked in between the two trains, potentially causing derailments. Within a state of “intentional decoupling” the train behind will need to be decoupled from the leading train by being outdistanced by an absolute braking distance (Abd) plus the Point switching distance (Psd) necessary to move and lock the point in the correct position. Afterwards, the EVC will supervise the standard EoA since safety-critical track conditions apply. After the train has been intentionally decoupled from the train ahead, it will keep on running under ETCS Level 3 until potential conditions for coupling to another train occur.

4 A multi-state train-following model for Virtual Coupling: general description

A microscopic multi-state train-following model has been developed to describe Virtual Coupling operations while considering accurate details of the railway infrastructure, the RBC and the V2V communication layers as well as the rolling stock. The railway network is modelled as a directed-graph where nodes represent elements like balises, switches, stopping boards at station platforms or line-side signals and/or marker boards in case fixed-block signalling is considered. Any node is characterised by several attributes specifying the geographical position and the type of element it represents (e.g. switch, balise, etc.). Arcs of the graph depict rail tracks connecting two adjacent nodes. Arc attributes capture physical parameters of the track such as the gradient, the curvature radius, the length as well as operational characteristics like the maximum speed limit. Both links and nodes of the graph are identified by means of a unique identification number (ID).

The RBC and the V2V communication layer are represented in terms of the communication delay and the messages they receive/broadcast from/to trains. The RBC receives information about current train positions and broadcasts MA updates to all trains on the network. The V2V communication layer instead, exchanges MA_{VC} messages among trains running under Virtual Coupling.

Trains are modelled according to an object-oriented paradigm which includes all train characteristics (e.g. traction effort/speed curve, max braking rate, mass), dynamic

parameters (e.g. air resistance factors) and operational features (e.g. route, stopping pattern, scheduled station arrival/departure times). A complete description of the MA_{VC} is provided in the following together with a discrete-time formulation of the train-following model for each of the Virtual Coupling operational states identified in Section 3.

4.1 Modelling the Virtual Coupling Movement Authority MA_{VC}

Before introducing the train-following model, it is necessary to have a clear picture of the information available to trains for each of the defined Virtual Coupling operational states. Both in moving-block ETCS Level 3 and Virtual Coupling, trains receive a message from the RBC containing a track description for the EVC to accurately compute and supervise a safe braking curve for a given EoA (or EoA_{VC}).

When running under ETCS Level 3, the RBC sends a standard ETCS MA which has here been modelled in line with the specifications provided for Packet Number 15 by the ERTMS/ETCS SRS Subset-026-7 version 3.6.0 (2016).

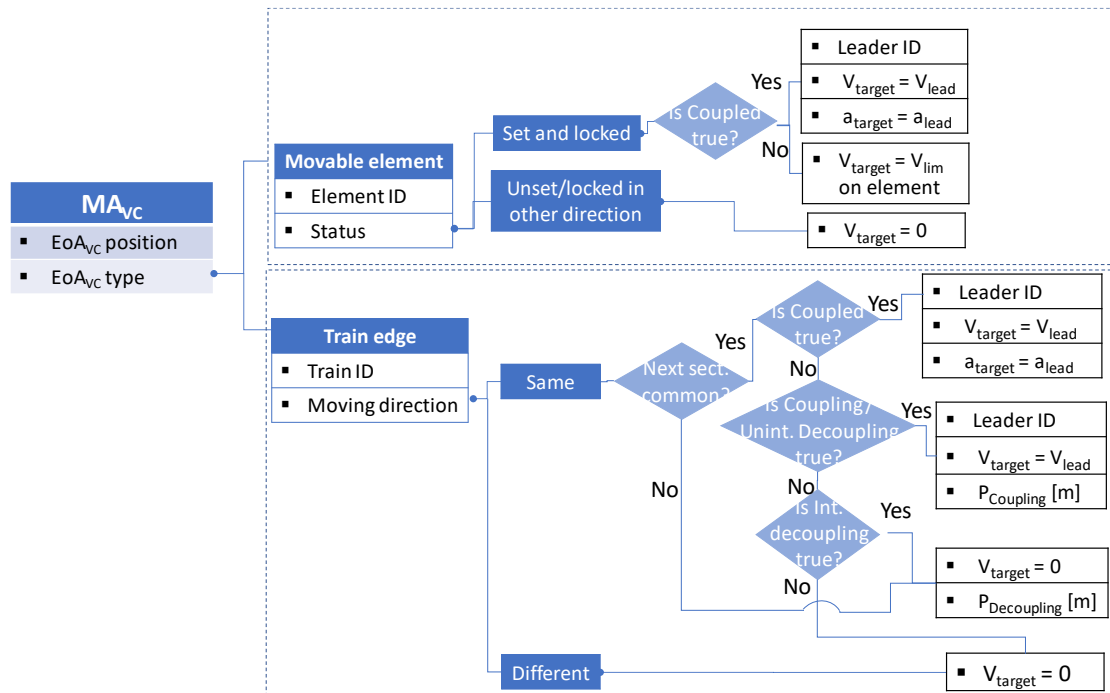

Figure 3. Data Structure and formalisation of the Virtual Coupling Movement Authority

The MA contains the position of the EoA and data about type and location of the corresponding danger point. When switching to Virtual Coupling operations, the V2V communication layer enriches the standard ETCS MA with a series of additional information providing target speeds (v_{target}) and accelerations (a_{target}) that allow a train to virtually couple/decouple to/from other trains. This yields a novel type of message, defined here as Virtual Coupling Movement Authority MA_{VC} . No specification exists yet for this type of message since this is the first time that such a concept is introduced in literature. A

data structure has therefore been formalised for the MA_{VC} as illustrated in Figure 3. Such a formalisation provides concepts that can be taken forward by the railway industry to define requirements and specifications for Virtual Coupling messages to be exchanged during operations. The basic MA_{VC} message is composed of two parameters respectively specifying the geographical position and the type of the last safe location of the MA_{VC}, namely the EoA_{VC}. As for the standard ETCS EoA, the EoA_{VC} is located at a safety margin from a danger point. The type of danger point can either be a movable infrastructure element (i.e. a switch, a level crossing) or the edge (i.e. front or tail) of another train. The RBC is assumed to send basic MA_{VC} information together with the status of movable elements. The V2V broadcasts instead information on kinematics of neighbouring trains when a train operates under Virtual Coupling.

When the EoA_{VC} refers to a movable element the MA_{VC} gives the unique identification number (*ID*) and the current direction (*Status*) of the element itself. If the train is coupled to a train ahead (named leader) and the element is already set and locked in the correct direction the MA_{VC} indicates the last known speed (v_{lead}) and acceleration (a_{lead}) of the leader as target speed and acceleration to be achieved by the train. In case the element is correctly set but the train is in a Virtual Coupling operational state different than coupled running, then the MA_{VC} provides the speed limit on the element (v_{lim}) as the target speed for the train. If the element is instead unset or set in a different direction, the MA_{VC} will indicate the train to stop before the element ($v_{target} = 0$), independently from the operational state, since this represents a safety-critical condition. When the EoA_{VC} relates to a train edge, the MA_{VC} supplies the *ID* of the train as well information on its *moving direction*. If the train moves in the same direction of the train ahead and shares the next portion of route with it, then the MA_{VC} will provide different information depending on the operational state of the train. If the train is in *coupled running*, the last known speed and acceleration of the leader will be notified as target speed and acceleration to be attained. In case the train is *coupling* or *unintentionally decoupling* to/from the leader, then the MA_{VC} provides the speed of the leader together with the predicted coupling point ($P_{coupling}$) where the trains are expected to start coupling. The location $P_{coupling}$ is the EoA_{VC} referring to the forecasted position of leader's tail at the time that the follower train has fully coordinated its speed with the leader (that is the time needed to cross the coordination distance Cd).

When a train is instead *intentionally decoupling* from the train ahead, the MA_{VC} will indicate the train to stop ($v_{target} = 0$) before the decoupling location $P_{decoupling}$ (e.g. a diverging junction or a station) to allow the trains to be safely decoupled. If a train moving in the opposite direction enters the vicinity of a train operating in Virtual Coupling, then the MA_{VC} indicates to reach a standstill ($v_{target} = 0$) to avoid collisions and ensuring flank protection.

4.2 Modelling train operations under ETCS Level 3 and Virtual Coupling

To describe train operations under ETCS Level 3 and Virtual Coupling, a multi-state train-following model has been developed. The model builds on a discrete-time solution of Newton's motion differential equations (Hansen and Pachl, 2014), providing a set of mathematical expressions which capture train dynamics for the identified operational states as well as for state transitions. Input to the model is the information deriving from the broadcasted MA (when in ETCS Level 3) or the MA_{VC} (when in Virtual Coupling) as well as characteristics and dynamic parameters of the trains. The ETCS MA provides the End of Authority (*EoA*) at a safety margin (*sm*) from a danger where the train needs to reach a standstill. The MA_{VC} supplies instead the last received speed (v_{lead}) and acceleration

(a_{lead}) of the train ahead, together with the EoA_{VC} at a safety margin from the train edge (tail or front). Also, the locations where trains are expected to start coupling ($P_{coupling}$) and where they decouple ($P_{decoupling}$) are provided.

Physical characteristics of the trains include mass (M), the rotating mass factor (f_p), the service (b) and max (b_{max}) braking rates, and the tractive effort-speed curve of the traction unit ($T(v)$). Dynamic parameters refer instead to speed (v_t), acceleration (v_t) and front position (s_t) of the train at current time instant (t) as well as motion resistances ($R(v, \varphi, r)$) due to air drag (depending on the speed v), track gradient (φ) and curvature (r). Track characteristics such as gradient, curvature radius and speed limit (v_{lim}) are reported by the track description message broadcasted together with the MA and the MA_{VC} . All these input parameters are used by the onboard EVC to compute and supervise a safe braking curve that lets the train reach a standstill before the ETCS EoA or attain a given target speed (v_{target}) at the EoA_{VC} . The ATO also relies on these parameters to control the train to meet target speeds and accelerations (a_{target}) which satisfy operational and safety conditions. The multi-state train-following model here described, can take into account communication delays of the RBC and the V2V communication layer. In case a communication delay ε is considered, the information contained in the MA and the MA_{VC} will refer to kinematic characteristics (position, acceleration, speed) of trains at time instant ($t - \varepsilon$), rather than to time t . Also, the model can reproduce train operations with both manual and automatic train driving by accordingly modifying the integration time interval (or the reaction time) of the follower train.

State 1: ETCS Level 3 running

In ETCS Level 3, the EVC enforces the train to start braking at the Braking Indication Point BIP so to safely reach a target speed v_{target} before a location L , which can either be an EoA or the start of a section with a reduced speed limit v_{lim} . The train will need to reach a target speed $v_{target} = v_{lim}$ if L refers to a track speed reduction, or a standstill ($v_{target} = 0$) when L refers to an EoA . A mathematical expression for BIP is provided in equation (1):

$$(1) \quad BIP = L - \int_{v_{t-1}}^{v_{target}} \frac{M \cdot f_p}{M \cdot f_p \cdot b - R(v, \varphi, r)} \cdot v \cdot dv$$

which asserts that the distance between BIP and L shall at least be the braking distance to bring the train from speed v_{t-1} (held at the previous time instant $t-1$) to $v_{target} = 0$. This braking distance is given by the integral in equation (1).

Train movements under ETCS Level 3 can then be computed by means of the algorithm illustrated below, which relies on a finite-difference method to get train kinematics during acceleration, braking and cruising phases. A train will be in an *acceleration phase* if at the previous time step ($t-1$) its speed (v_{t-1}) is lower than v_{target} and its front position (s_{t-1}) has not yet reached point BIP . Considering an integration step Δt , train speed (v_t) and front position (s_t) at current time step t are computed as in (2), where equation parameters assume the meaning introduced before in Section 4.2.

$$(2) \quad \begin{cases} \text{Acceleration phase} \\ v_t = v_{t-1} + \frac{T(v_{t-1}) - R(v_{t-1}, \varphi, r)}{M \cdot f_p} \cdot \Delta t; \\ s_t = s_{t-1} + \frac{M \cdot f_p}{T(v_{t-1}) - R(v_{t-1}, \varphi, r)} \cdot v_{t-1} \cdot (v_t - v_{t-1}) \end{cases}$$

$$(3) \quad \begin{cases} v_t = v_{t-1} + \frac{M \cdot f_p \cdot b - R(v_{t-1}, \varphi, r)}{M \cdot f_p} \cdot \Delta t; \\ s_t = s_{t-1} + \frac{M \cdot f_p}{M \cdot f_p \cdot b - R(v_{t-1}, \varphi, r)} \cdot v_{t-1} \cdot (v_t - v_{t-1}); \end{cases} \quad \text{with } b < 0$$

Braking phase

$$(4) \quad \begin{cases} v_t = v_{t-1}; \\ s_t = s_{t-1} + v_{t-1} \cdot \Delta t; \end{cases} \quad \text{Cruising phase}$$

Cruising phase

If at the previous time step the train is instead running faster than v_{target} or its front position s_{t-1} is beyond point BIP , the train enters a *braking phase* until it reaches the target speed before location L . During a braking phase, train speed (v_t) and front position (s_t) at current step t are returned by equation (3). In case at the previous time step a train has reached the target speed before reaching point BIP , then the train will cruise (*cruising phase*) at a constant speed v_{target} until location L . While in a cruising phase, train speed v_t and front position s_t at current time step t are given by equation (4).

State 2: Coupling

The operational state of a train switches from *ETCS Level 3* to *Coupling*, whenever it approaches an *EoA* referring to the tail of a train ahead which moves in the same direction over a common stretch of route. When this condition occurs, alongside with the safety-critical MA, a MA_{VC} is also broadcasted which indicates the last known speed of the leading train (v_{lead}) to be achieved ($v_{target} = v_{lead}$) and the location where the trains are predicted to start coupling up ($P_{coupling}$). As reported in (5) the predicted coupling point is the location where the tail of the leading train ($Tail_{lead}$) will be positioned at the time the follower reaches the same running speed v_{lead} .

$$(5) \quad P_{coupling} = EoA_{VC} + t_{coord} \cdot v_{lead}; \quad EoA_{VC} = Tail_{lead} - sm$$

In such a prediction a safety margin sm is considered to prevent that calculation errors or exogenous variables (e.g. weather conditions) could result in an unsafe train control. The time needed by the follower for coordinating its speed is called coordination time (t_{coord}) which is calculated as in equations (6).

$$(6) \quad \begin{cases} t_{coord} = \int_{v_{t-1}}^{V_B} \frac{M \cdot f_p}{T(v) - R(v, \varphi, r)} dv + \int_{V_B}^{v_{target}=v_{lead}} \frac{M \cdot f_p}{M \cdot f_p \cdot b - R(v, \varphi, r)} dv, & \text{if } v_{t-1} \leq v_{lead} \\ t_{coord} = \int_{v_{t-1}}^{v_{target}=v_{lead}} \frac{M \cdot f_p}{M \cdot f_p \cdot b - R(v, \varphi, r)} dv, & \text{if } v_{t-1} > v_{lead} \end{cases}$$

If at the previous time step (t-1) the follower is not running faster than the leader ($v_{t-1} \leq v_{lead}$) the coordination time (see first row in (6)) will take account for the time needed to accelerate at a higher speed V_B , to get closer to the leader (integral at the first term) and the time to slow down to the leader's speed (integral at the second term). When instead the

follower runs faster than the leader ($v_{t-1} > v_{lead}$) the coordination time (second row in (6)) is merely given by the braking time to reach leader's speed (expressed by the integral). During coupling operations speed (v_t) and front position (s_t) of the train at current step t , are still computed by means of equations (2)-(4) while targeting coupling speed and location $P_{coupling}$.

State 3: Coupled running

The operational state of a train will switch to "Coupled running" when at the previous time step ($t-1$) it reaches leader's speed and location $P_{coupling}$, within a certain speed (th_v) and space (th_s) tolerances, respectively. Such a condition is mathematically expressed as:

$$(7) \quad \text{if } |v_{t-1} - v_{lead}| \leq th_v \quad \text{and} \quad |s_{t-1} - P_{coupling}| \leq th_s$$

$$\begin{cases} v_t = v_{t-1} + a_{t-1} \cdot \Delta t; \\ s_t = s_{t-1} + v_{t-1} \cdot \Delta t; \end{cases}$$

Equations (7) provide train speed v_t and front position s_t at current time step t , when the train is in a state of pure coupled running. Such equations describe actual train-following operations. In coupled running, the follower will need to accelerate at the same rate of the leader (a_{lead}) so to keep their separation within a certain threshold. However, this is not always possible because of different track characteristics, train resistances or insufficient traction power. Train accelerations a_{t-1} are indeed computed as in (8):

$$(8) \quad \begin{cases} a_{t-1} = a_{lead} & \text{if } a_{lead} > a_{t-1}^{max} \\ a_{t-1} = a_{t-1}^{max} & \text{if } a_{lead} > a_{t-1}^{max} \\ a_{t-1} = a_{t-1}^{min} & \text{if } a_{lead} < a_{t-1}^{min} \end{cases}$$

$$a_{t-1}^{max} = \frac{T(v_{t-1}) - R(v_{t-1}, \varphi, r)}{M \cdot f_p}$$

$$a_{t-1}^{min} = \frac{M \cdot f_p \cdot b_{max} - R(v_{t-1}, \varphi, r)}{M \cdot f_p}$$

which asserts that the follower will always accelerates at leader's acceleration rate ($a_{t-1} = a_{lead}$) unless this latter exceeds maximum a_{t-1}^{max} and minimum a_{t-1}^{min} acceleration boundaries, which depend on train characteristics and motion resistances.

It is worth mentioning that in case the follower cannot brake as much as the leader, then it is assumed that the two trains brake at the same rate. This means that the V2V layer shall also provide the leader with the maximum braking rate of the coupled follower. In such a way a safe separation is ensured between the two coupled trains, avoiding that the follower collides with the leader because of poorer braking performances.

State 4: Unintentional decoupling

A train transitions from coupled running to a state of unintentional decoupling when at the previous time step ($t-1$) its front position s_{t-1} goes beyond a certain threshold th_s from the EoA_{VC} . The condition for unintentional decoupling is mathematically expressed as:

$$\text{if } |s_{t-1} - EoA_{VC}| > th_s \quad \text{then switch to State2: Coupling}$$

where EoA_{VC} is in this case set at a safety margin from leader's tail $Tail_{lead}$ ($EoA_{VC} = Tail_{lead} - sm$).

As mentioned, the decoupling is defined "unintentional" since it is not intentionally triggered by the signalling system to meet safety constraints (e.g. to prevent derailments at diverging junctions) but merely occurs because of temporary constraining operational

conditions due to increased motion resistances (e.g. on a steep uphill) or limited traction power. When a train is unintentionally decoupled, then it will attempt to couple up again with the train ahead as soon as operational conditions of the track and the train will allow it. Hence, if the train still has a stretch of route in common with the train ahead, it will switch again to a “coupling” operational state so to re-set a coupled running with the leader. In this operational state, speed v_t and front position s_t of the train at current time step t , are again computed by means of equations (2)-(4), since the train is momentarily decoupled from the leader.

State 5: Intentional decoupling

When a coupled train convoy approaches a diverging junction where trains split over different routes, non-negligible safety risks arise. Switches might not have enough time to be safely moved and locked in between trains, potentially causing derailments. For safety reasons, trains will need to be outdistanced by an absolute braking distance at diverging junctions so that a train can safely stop should the switch not properly be set and locked. In case a coupled train is going to diverge from its leader, the V2V layer will provide the location ($P_{decoupling}$) of the diverging junction, for the EVC to compute the Braking Indication Point where the train needs to start braking to intentionally decouple from the leader ($BIP_{decoupling}$). The point $BIP_{decoupling}$ is computed as:

$$(9) \quad BIP_{decoupling} = P_{decoupling} - \int_{v_{t-1}}^0 \frac{M \cdot f_p}{M \cdot f_p \cdot b - R(v, \varphi, \tau)} \cdot v \cdot dv, \quad b < 0;$$

which shows that the decoupling braking indication point is located at least at an absolute braking distance (integral at the second term) from the decoupling location $P_{decoupling}$.

The condition triggering intentional decoupling is hence mathematically expressed as:

if ($s_{t-1} \geq BIP_{decoupling}$) and ($v_{t-1} > v_{target} = 0$) then switch to State 1: ETCS Level 3 running;

which asserts that intentionally decoupling is triggered when at the previous time step ($t-1$) a train is moving ($v_{t-1} > v_{target} = 0$) and its front position s_{t-1} goes beyond location $BIP_{decoupling}$. Once the train satisfies the conditions for intentional decoupling, it switches to an operational state of “ETCS Level 3 running” with a full-braking distance supervision. While in a state of intentional decoupling, current speed v_t and position s_t of the train are returned by equations (2)-(4), given that the train goes back to ETCS Level 3 operations.

5 Case study

A C++ object-oriented implementation of our multi-state train-following model has been embedded in the EGTRAIN platform (Quaglietta 2014), to perform a capacity assessment of Virtual Coupling signalling.

EGTRAIN is a microscopic environment for detailed synchronous (i.e. time-driven) railway traffic simulations, featuring an API module to add/customise functions and interface external tools (e.g. for optimal traffic management or planning). Several fixed-block signalling systems are already implemented in EGTRAIN among which the British three and four-aspect with TPWS, ETCS Level 2 as well as the moving-block ETCS Level 3. A comparative analysis of these signalling systems has been performed versus Virtual Coupling to identify capacity benefits that this latter system can provide over state-of-the-practice signalling technologies. The analysis has been conducted for the 20 km long

corridor between London Waterloo (WTL) and Surbiton (SBT) on the South West Main Line (SWML) in the UK (Figure 4). This corridor develops over four tracks with a very hilly altimetric profile, especially after Clapham Junction. Currently, more than 40 trains per hour operate on the line, including intercity, regional, suburban and commuter trains.

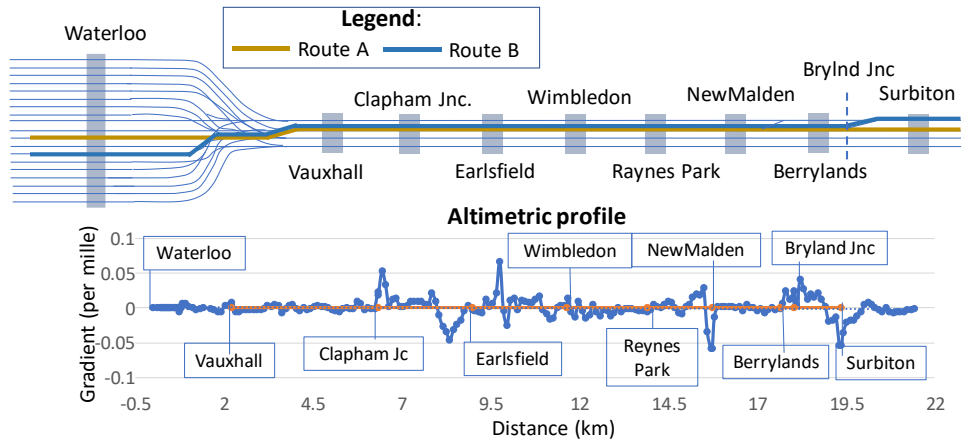

Figure 4. Schematic layout and altimetric profile of the London Waterloo – Surbiton railway corridor on the South West Main Line in the UK.

The objective of our analysis is applying the developed multi-state train-following model to understand operational implications of Virtual Coupling and the sensitivity of capacity gains to relevant service characteristics such as the *choice of train routes* and the *presence of service stops*. If two trains of a virtually coupled convoy need indeed to diverge over different routes, an absolute-braking distance separation is imposed at the junction which might result in negligible capacity improvements of Virtual Coupling when compared to plain moving-block ETCS Level 3. The same can happen when trains have service stops along their routes. When approaching station areas at lower speeds the difference between relative and absolute braking distances significantly reduces at the point that capacity gains of Virtual Coupling might be practically irrelevant to justify investments. To this end, our investigation refers to two main scenarios. The first scenario considers only non-stop train services while the second scenario assumes that trains perform four service stops at Clapham Junction (*CpJ*), Wimbledon (*Wbn*), Reynes Park (*RnP*), and Surbiton (*Sbn*), respectively. All trains depart from Waterloo (*Wtl*) passing by timetabling locations such as Vauxhall (*Vxl*), Earlsfield (*Eld*), New Malden (*NMn*) and Berryland (*BlD*). For each scenario we then compare the case in which trains have the same route (*Route A*), versus the case in which trains operated on different routes (*Route A* and *B*) that are only partially shared and diverge at Berrylands Junction (*BlJ*). Capacity is measured in terms of space separation and time headway between consecutive trains. Simulation experiments hence consider just two consecutive trains, since this is sufficient to achieve our investigation objectives. Also, limiting the number of simulated trains makes the analysis of Virtual Coupling operations clearer, allowing a better understanding of how specific train dynamics can affect capacity measures. The two train services (respectively named *A3-Wtl-Surbiton-1* and *A3-Wtl-Surbiton-2*) use the same rolling stock, namely a 161.8m long eight-car British Rail Class 455. In the experiments we assume that the follower train enters the network as

soon as the signalling system allows it. The MA and the MA_{VC} are broadcasted with an update interval of 1s and a communication delay of 1s. A safety margin sm of 50 m is used for both the EoA and the EoA_{VC}. A space tolerance (th_s) of 30 m and a speed tolerance (th_v) of 0.278 m/s (i.e. 1 km/h) have been adopted in the train-following model to identify whether a follower train is coupled/unintentionally decoupled to/from the train ahead. In ETCS Level 3 and Virtual Coupling, trains are automatically driven by ATO with a reaction time of 0.5 s. In addition, for these signalling systems we allow the two trains to enter a station area together and line up at the same platform to perform their stop. Such an assumption has been made to estimate capacity gains when using the entire potential of moving-block operations. For ETCS Level 2 and TPWS a human driver is instead considered with a sight and reaction time of 2.5 s. For these fixed-block signalling systems state-of-practice rules have been used for modelling stopping operations where a train cannot enter a platform if it is already occupied by another train.

5.1 Analysis of Virtual Coupling operational states

Simulation results produced by the Virtual Coupling multi-state train following model are reported for the first (non-stopping trains) and second scenario (stopping trains) in Figure 5 and Figure 6, respectively.

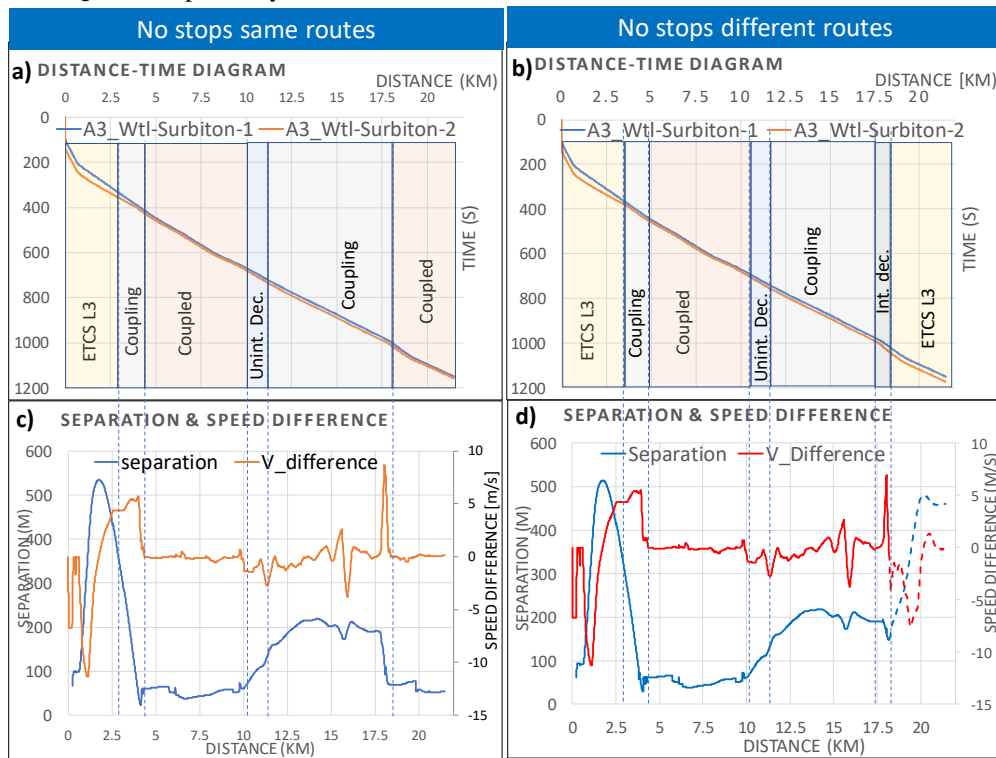

Figure 5. Distance-time diagram (top), separation and speed differentials (bottom) between leader and follower for non-stopping trains with the same (left) or a different route (right).

Simulated time-distance diagrams of the two trains and the sequence of operational states of the follower (letters (a) and (b) at the top) are illustrated, together with the speed

difference and the separation between the trains over their route (letters (c) and (d) at bottom). The diagrams on the left-side refer to the case in which trains have the same route (*route A*), while those on the right-side relate to the case of different train routes where the leader runs over *route A* and the follower on *route B*.

The diagrams show that the developed train-following model captures the different operational states of a train when running under Virtual Coupling. The sequence of operational states always starts with the follower train running under ETCS Level 3, switching to a “coupling” state as soon as it approaches the train ahead. When the conditions for coupling are satisfied (see condition (10)), the train enters a state of “coupled running” assuming the same accelerations and speed of the leader.

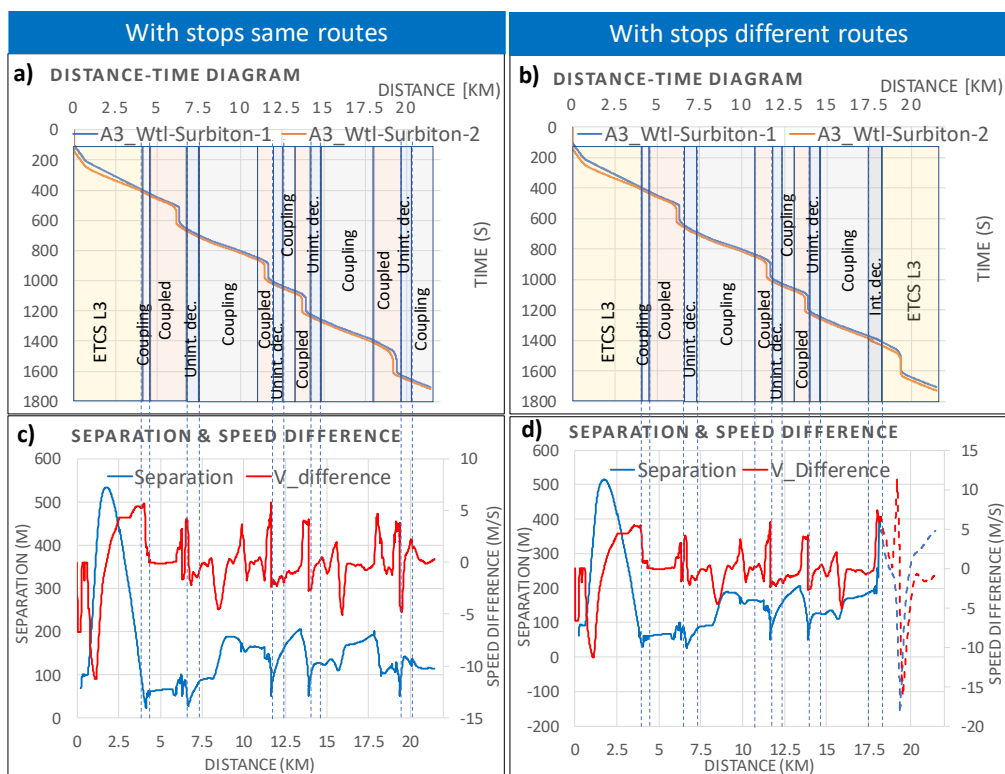

Figure 6. Distance-time diagram (top), separation and speed differentials (bottom) between leader and follower for stopping trains with the same (left) or a different route (right).

Speed difference diagrams (red line) reported in letters c) and d) of Figure 5 and Figure 6, clearly illustrate that speed differentials between leader and follower oscillate around zero while in coupled running. Trains travel in a virtually linked convoy until motion resistances increase at the point that the follower cannot longer hold leader’s speeds, resulting in an increasing train separation. A state of unintentional decoupling is hence obtained, that for our railway corridor is due to a very hilly altimetric profile which makes it hard for the follower on a steep uphill to catch up with the leader running instead on a flatter ground or even downhill. As shown by the separation diagrams (blue line) in letters c) and d) of Figure 5 and Figure 6, the unintentional separation between the two trains keeps however below

215 m at an average train speed of 22 m/s (≈ 80 km/h) that is anyway a much shorter separation when compared to existing fixed-block signalling systems and ETCS Level 3 (which would at least require 405 m for the same braking rate of 0.6 m/s^2). After having been unintentionally decoupled, the follower train switches again to a coupling state driving at maximum power in the attempt to catch up and couple with the leader. In the scenario of non-stopping trains (Figure 5) the follower will steadily stay in a “coupling” state until track and vehicle conditions allow the train to couple again with the leader (if they have the same route) or to intentionally decouple from it before the diverging junction in Berryland (when using different routes). The transition to the state of “intentional decoupling” is immediately visible in Figure 5d) where separation and speed difference between the two trains reach a peak before the diverging junction. Dashed lines represent separation and speed differential after the two trains have decoupled and run over different routes again under the supervision of ETCS Level 3.

In the scenario of stopping trains (Figure 6), the follower unintentionally decouples from the leader every time they leave a stopping station. From a state of “unintentional decoupling” the follower then switches to a “coupling” state, until it catches up with the leader as this latter reduces its speed to approach the next stop. The two trains manage to couple just before any stopping station, meaning that they approach, cross and leave any of those stations as a virtually-coupled train convoy. When performing a stop, our model allows the two trains lining up at the same platform, as well as leaving the station together as if they were physically coupled. Of course, in the case of trains having different routes, the follower train transitions to an “intentional decoupling” state before Berryland Junction so to diverge to a different stopping platform in Surbiton. The intentional decoupling can be seen in Figure 6d) where the diagrams of separation and speed differential have a peak before the trains undertake different routes. From that point on, trains operate on separate routes (dashed lines in the diagram) switching to ETCS Level 3.

5.2 Comparative capacity analysis

A specific analysis has been carried out to assess capacity performance of Virtual Coupling and potential gains that such a concept can provide when compared with moving-block ETCS Level 3, as well as the radio-based fixed-block signalling ETCS Level 2 and the multi-aspect fixed-block system with TPWS. As already mentioned, capacity is here evaluated in terms of train separation over the route and time headways (HW) at main interlocking areas, experienced by the trains during simulation experiments. Outcomes from the capacity analysis are depicted in Figure 7 for the scenarios of non-stopping (top) and stopping trains (bottom), and for the cases in which trains have the same (letters (a) and (c)) or a different route (letters (b) and (d)). Train separation over the entire route (distance is given on the x-axis) is represented with solid lines while a histogram is used to report time headways at main interlocking areas. Results for Virtual Coupling are reported in blue, while those for ETCS Level 3, ETCS Level 2 and TPWS are given in orange, grey and gold, respectively. For all scenarios and cases, Virtual Coupling massively reduces train separations and time headways, when compared to the other signalling systems. A fair comparison with ETCS Level 3 shall however exclude the area of Vauxhall (Vxl), since when simulating Virtual Coupling the follower crosses that location while still being supervised by ETCS Level 3 and just transitioning to a “coupling” operational state. Given that in such a location Virtual Coupling train separation is still governed by an absolute braking distance, a comparison with ETCS Level 3 does not make much sense, since it would practically mean to compare ETCS Level 3 to itself. For this reason, capacity measures of Virtual Coupling and ETCS Level 3 in Vxl are similar. Also, in the case of

trains with different routes, it makes sense to compare train separation and time headways only for those location along common portions of infrastructure. This means for instance that Surbiton (*Sbn*), where routes A and B use different tracks, is excluded when computing the most critical experienced headway for the different signalling systems.

In the case of non-stopping trains having the same route (Figure 7a) we observe that the capacity bottleneck (i.e. the location with the maximum experienced time headway) shifts from Vauxhall (*Vxl*) to Berryland Junction (*BIJ*) when passing from fixed-block signalling (TPWS and ETCS Level 2) to moving-block (ETCS Level 3 and Virtual Coupling).

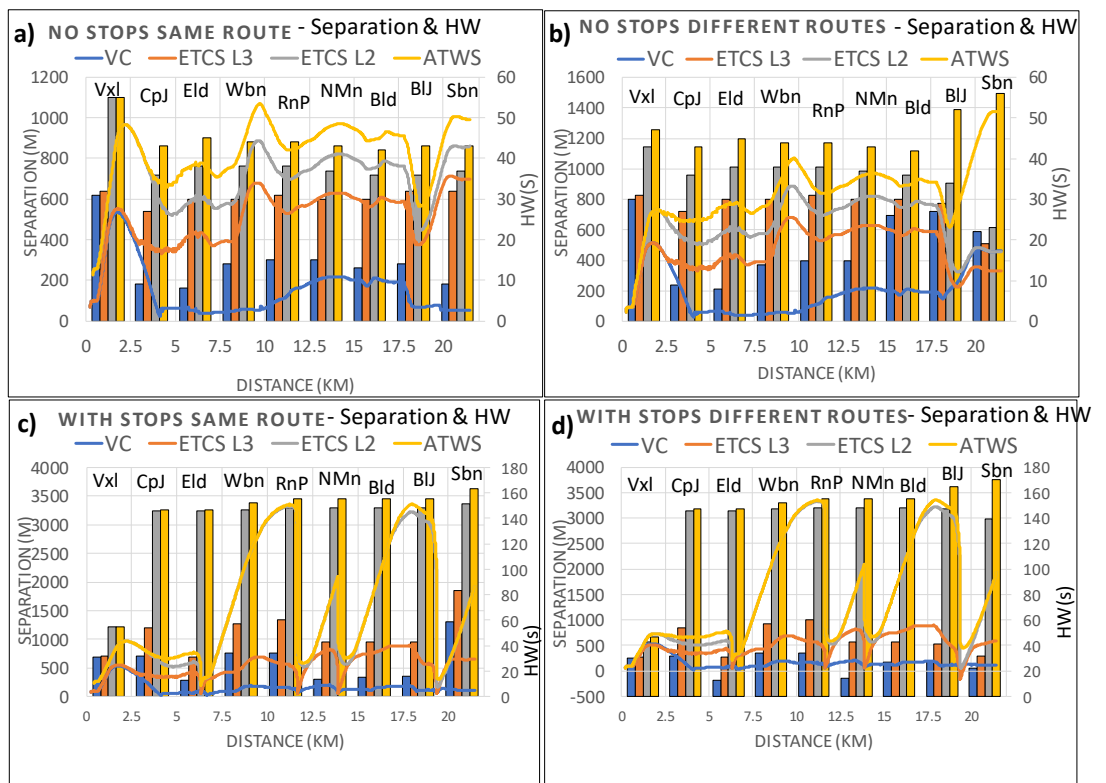

Figure 7. Train separation and time headway (HW) at main interlocking areas for non-stopping (top) and stopping trains (bottom) using the same (left) or a different route (right).

The maximum headway reduces from 55s for fixed-block signalling to 32 s if ETCS Level 3 is implemented, getting down to only 15 seconds when referring to pure Virtual Coupling operations. Virtual Coupling reduces critical headways by 67%, 61% and 53% when compared with TPWS, ETCS Level 2 and ETCS Level 3, respectively. In terms of maximum train separation, this translates into a corresponding decrease of 50%, 44% and 25%.

When non-stopping trains have different routes (Figure 7b) the location with the most critical headway changes from BIJ for TPWS to *Vxl* for ETCS Level 2, and from *RnP* for ETCS Level 3 to again *BIJ* when pure Virtual Coupling operations are considered (so excluding *Vxl* where trains still operate under ETCS Level 3). As already said, in this case

Sbn is not considered, given that in that location trains use different tracks. A maximum time headway of 21 s is experienced by trains under Virtual Coupling, which means a reduction by 60%, 51%, and 32% versus TPWS (with a max HW of 52s), ETCS Level 2 (max HW = 43s) and ETCS Level 3 (max HW = 31s), respectively. When referring to maximum train separation, it means a respective reduction by 62%, 42% and 24%. Capacity benefits of Virtual Coupling are even more significant for the scenario of stopping trains. In this scenario we also observe that TPWS and ETCS Level 2 have a very similar performance, especially in terms of train separation, as their separation diagrams are almost entirely overlapped.

In the case in which trains have the same route (Figure 7c), *Sbn* is the most critical location for all the signalling systems. The time headway in this location decrease from 163 s for TPWS to 151s for ETCS Level 2 and from 83s for ETCS Level 3 to 59s when considering Virtual Coupling. This latter signalling system hence reduces the maximum headway on the line by 63%, 61% and 28% when referenced to TPWS, ETCS Level 2 and Level 3, respectively. This translates into a corresponding decrease in the maximum train separation that equals 85%, 84%, and 40%. When trains have different routes instead (Figure 7d), the location with the largest headway moves from *BIJ* in the case of TPWS to *RnP* when considering ETCS Level 2, Level 3 and Virtual Coupling. In such a case, Virtual Coupling has a maximum experienced headway of 34 s, corresponding to a reduction of 79%, 77% and 43% when compared with TPWS (max HW= 165s), ETCS Level 2 (max HW= 148s) and Level 3 (max HW=60s), respectively. Referring to maximum train separations on the line this means a respective decrease by 85%, 64% and 43%.

6 Conclusions

This paper introduces a detailed capacity analysis of the Virtual Coupling concept which upgrades moving-block train operations by imposing a relative braking distance separation rather than an absolute one. An innovative train-following model has been developed that overcomes limitations of car-following models currently available in road traffic literature by considering non-linear train dynamics and relevant factors such as motion resistances due to track gradient and curvature as well as power limitations of the traction unit and safety constraints at junctions. Different states and corresponding transitions have been defined and mathematically modelled to describe trains operating under Virtual Coupling signalling. The novel concept of Virtual Coupling Movement Authority MA_{VC} has been introduced together with an innovative formalisation of the messages exchanged among trains via the V2V communication layer. The developed train-following model has been then applied to part of the South West Main Line in the UK to simulate train operations under Virtual Coupling with the aim of identifying capacity performances of this concept and potential benefits over state-of-practice signalling systems. Simulation experiments referred to different scenarios considering non-stopping and stopping trains having the same or a different route. Outcomes show that Virtual Coupling significantly reduces train separation and time headways for all considered scenarios, when compared to TPWS, ETCS Level 2 and Level 3. The biggest capacity benefits have been however found for the scenario of trains having service stops and using different routes, where Virtual Coupling can decrease by 79%, 77% and 43% the maximum headways when compared to TPWS, ETCS Level 2 and Level 3, respectively. This represents a very promising result since Virtual Coupling provides the best capacity improvements for the operational scenario more frequently seen in practice for real-life operations (i.e. the one with stopping trains having different routes). Future research will be devoted to understanding implications of V2V

communication delays on safety and capacity. A sensitivity analysis of the train-following model will be performed to identify how outputs can change if trains are modelled as a homogeneous strip with a length, rather than a point-mass, as traditionally assumed. Also, a multi-criteria analysis of Virtual Coupling will be made to assess potential impacts on the transport demand and the railway business.

7 References

- [1] Brackstone M., McDonald M., Car-Following: a historical review. *Transportation Research Part F*, Vol. 2, pp. 181-196, 1999.
- [2] Emery D., Enhanced ETCS L2/L3 Train Control System, *WIT Transactions on State-of-the-art in Science and Engineering*, Vol. 46, pp.112-122, 2010.
- [3] *ERTMS/ETCS System Requirements Specification - Subset 026*, Issue 3.6.0, May 2016.
- [4] Gipps P.G., A behavioural car-following model for computer simulation, *Transportation Research Part B: Methodological*, Vol.15 (2), pp.105-111, 1981.
- [5] Hansen I.A., Pachl J., *Railway Timetabling and Operations*, Eurail Press, Hamburg, 2014.
- [6] Helly W, Simulation of Bottlenecks in Single Lane Traffic Flow, *Proceedings of the Symposium on Theory of Traffic Flow. Research Laboratories General Motors*, pp. 207-238, 1959.
- [7] Herman I., Martinec D., Huràk Z., and Sebek, M., Scaling in bidirectional platoons with dynamic controllers and proportional asymmetry, *IEEE Transactions on Automatic Control*, Vol. 63 (4), pp. 2034–2040, 2017.
- [8] IRSE International Technical Committee, ERTMS Level 4, Train Convoys or Virtual Coupling-Report on topic 39, *IRSE News*, Issue 219, pp. 1-3, 2016.
- [9] Leutzbach, W., Wiedemann R., Development and Applications of Traffic Simulation Models at the Karlsruhe Institute fuer Verkehrswesen, *Traffic Engineering and Control*, May, pp. 270-278, 1986.
- [10] Ning B., Absolute braking and relative distance braking – train operation control modes in moving block systems, *Transactions on the Built Environment*, Vol. 34, pp. 991-1001, 1998.
- [11] Quaglietta E., An approach to design the layout of railway signaling system to maximize the economic efficiency of the network, *Simulation Modeling Practice and Theory*, vol. 46, pp. 4-24, 2014.
- [12] Quaglietta E., Analysis of Platooning Train Operations under V2V communication-based signalling: fundamental modelling and capacity impacts of Virtual Coupling, *Proceedings of the 98th Transportation Research Board Annual Meeting*, Washington DC, 13th-17th January 2019.
- [13] Theeg G., Vlasenko S., *Railway Signalling and Interlocking International Compendium*, Eurail Press, 2009.
- [14] Treiber M., Hennecke A., Helbing, D., Congested traffic states in empirical observations and microscopic simulations, *Physical review E*, Vol. 62(2), p.1805, 2000.
- [15] Wang M., Daamen W., Hoogendoorn S. P., van Arem B., Cooperative car-following control: Distributed algorithm and impact on moving jam features, *IEEE Transactions on Intelligent Transportation Systems*, Vol. 17(5), pp.1459-1471, 2016.
- [16] Xiao L., Wang M., Schakel W., van Arem B., Unravelling effects of cooperative adaptive cruise control deactivation on traffic flow characteristics at merging bottlenecks, *Transportation Research Part C*, Vol. 96, 380-397, 2018.