

THE ALL TRANSPARENT COLUMN

Exploring the effect of post-tensioning an all glass column of the bundled type to enhance slenderness and promote safe failure behavior

Symbiosis Architecture and Engineering

Two fields of engineering

Great feats of strength



Architect versus Engineer

Discrepancies between two fields

Large uninterrupted spaces

Load bearing elements blocking the view



Glass as ultimate compromise

Transparent

Visually pleasing

Load bearing capacities

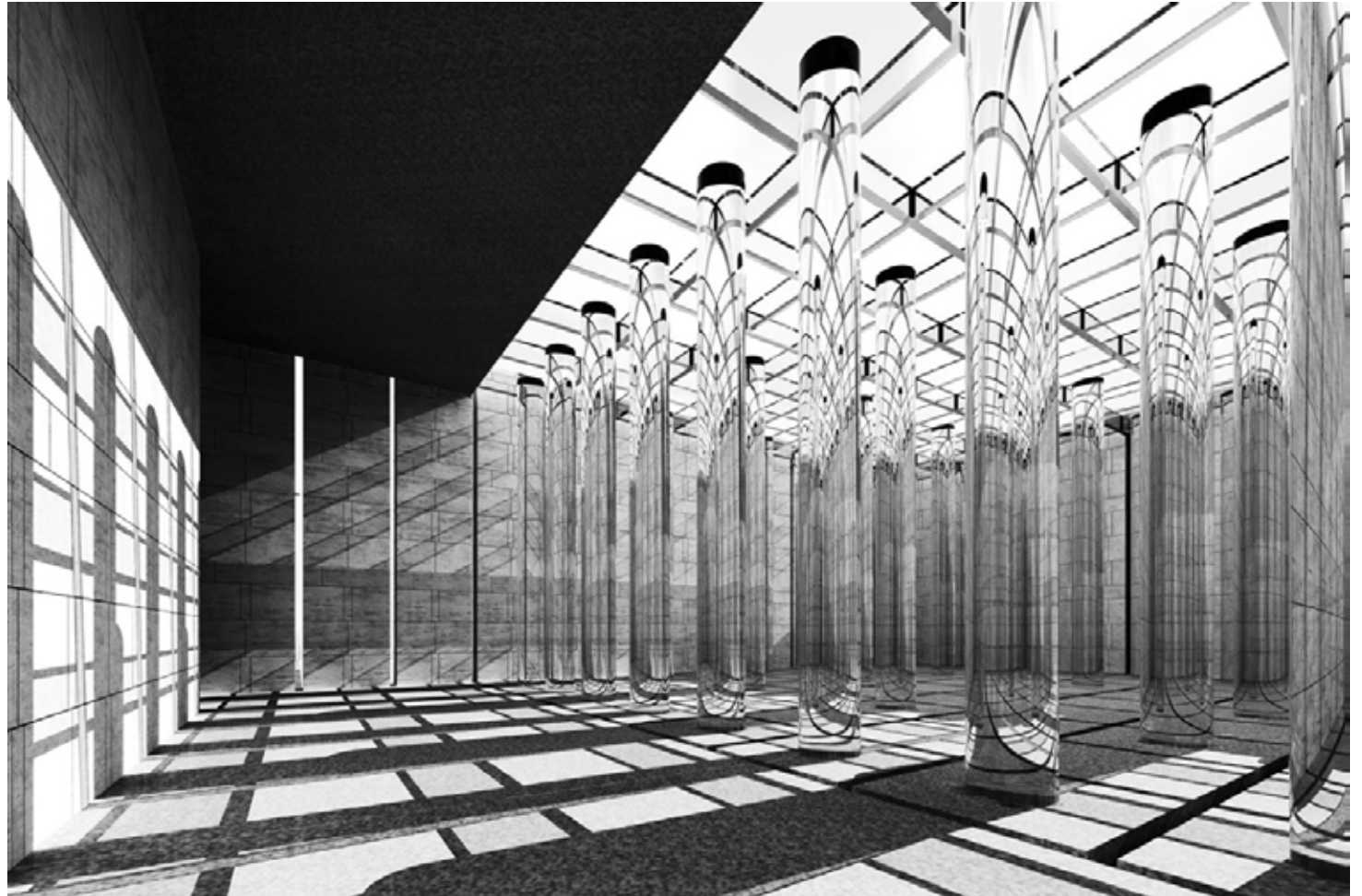

Mechanical properties of glass

Transparent

Great compressive strength

Why not commonly used?

Lacks tensile strength



Problems with all glass columns

Glass' weak properties
Explosive failure and no tensile strength

Very high safety factors

No legislation

3D-oriented design with a 2D material



Possible types of glass columns

Profile type mechanically inefficient

Stacked architecturally undesirable

Torsional rigidity

Visual quality

Bundled least explored

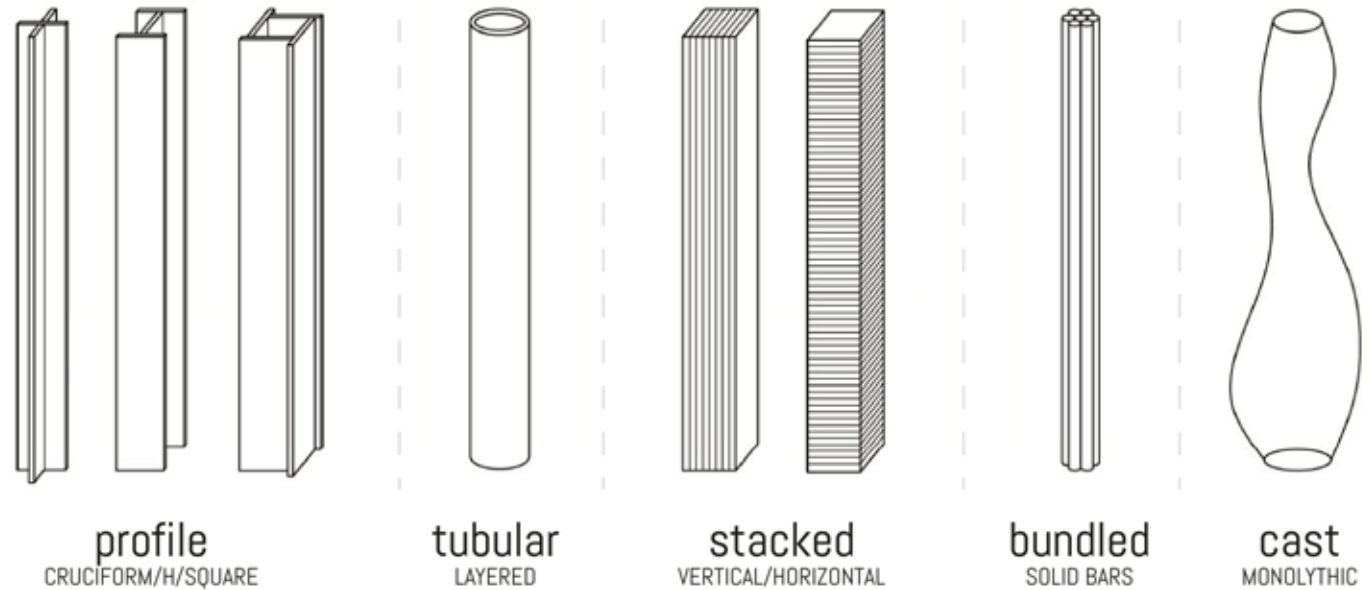

| | | Profile | Tubular | Stacked (H) | Stacked (V) | Bundled | Cast |
|-----------------------------------|----------------------|---------|---------|-------------|-------------|---------|------|
| Architectural Desirability | Transparency | | ■ | | | ■ | ■ |
| | Form freedom | | | ■ | | ■ | ■ |
| Mechanical Desirability | Buckling resistance | | ■ | | | ■ | ■ |
| | Torsional resistance | | ■ | | | ■ | ■ |
| | Safe failure | | ■ | | | ■ | ■ |
| Financial Desirability | Production time | ■ | | | | ■ | |
| | Production cost | ■ | ■ | ■ | ■ | ■ | |

Glass elements

Extruded borosilicate

Produced by SCHOTT, Germany

1500mm lengths

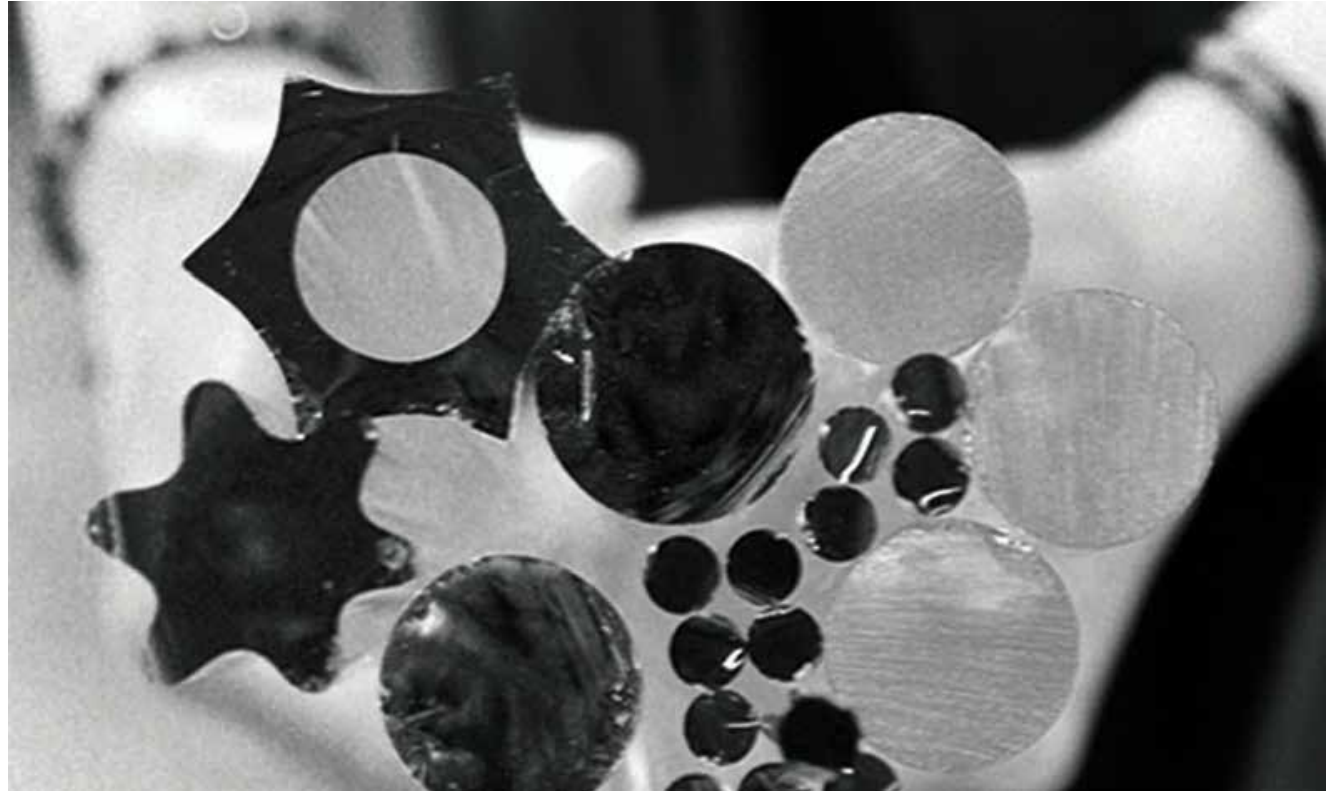

Issue 1: Eccentricities

Eccentric elements

Large deviations

Careful design and assembly required

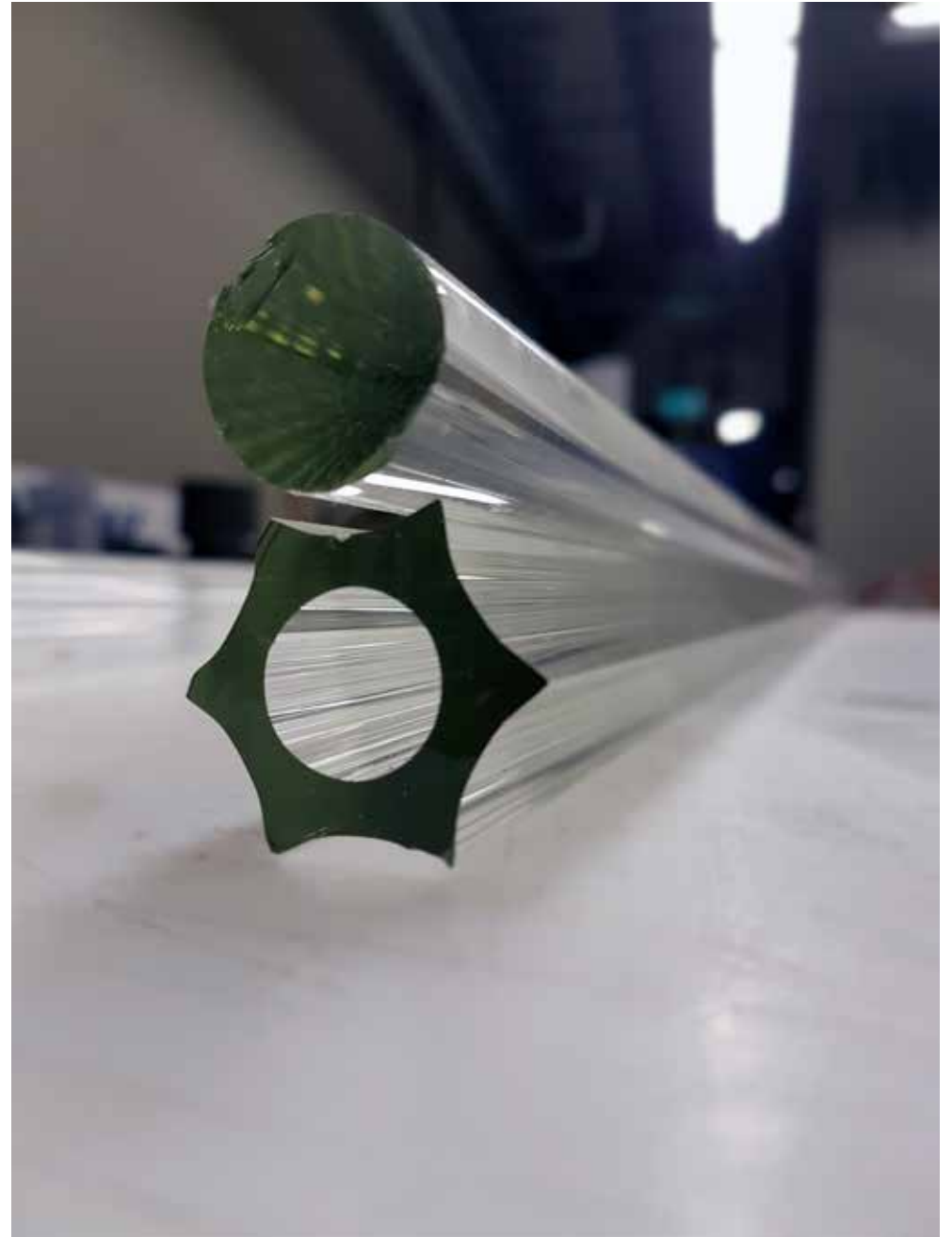

Issue 2: Limited cross section

Extruded elements currently not bigger

Results in very slender column



Issue 3: Limited height

Elements are 1500mm
Column design height is 2400mm

Split lamination
Helix of weakpoints

What happens at these gaps?

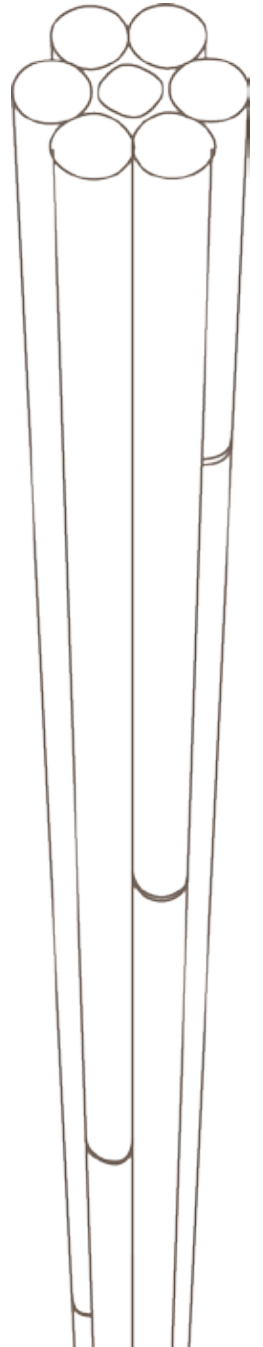
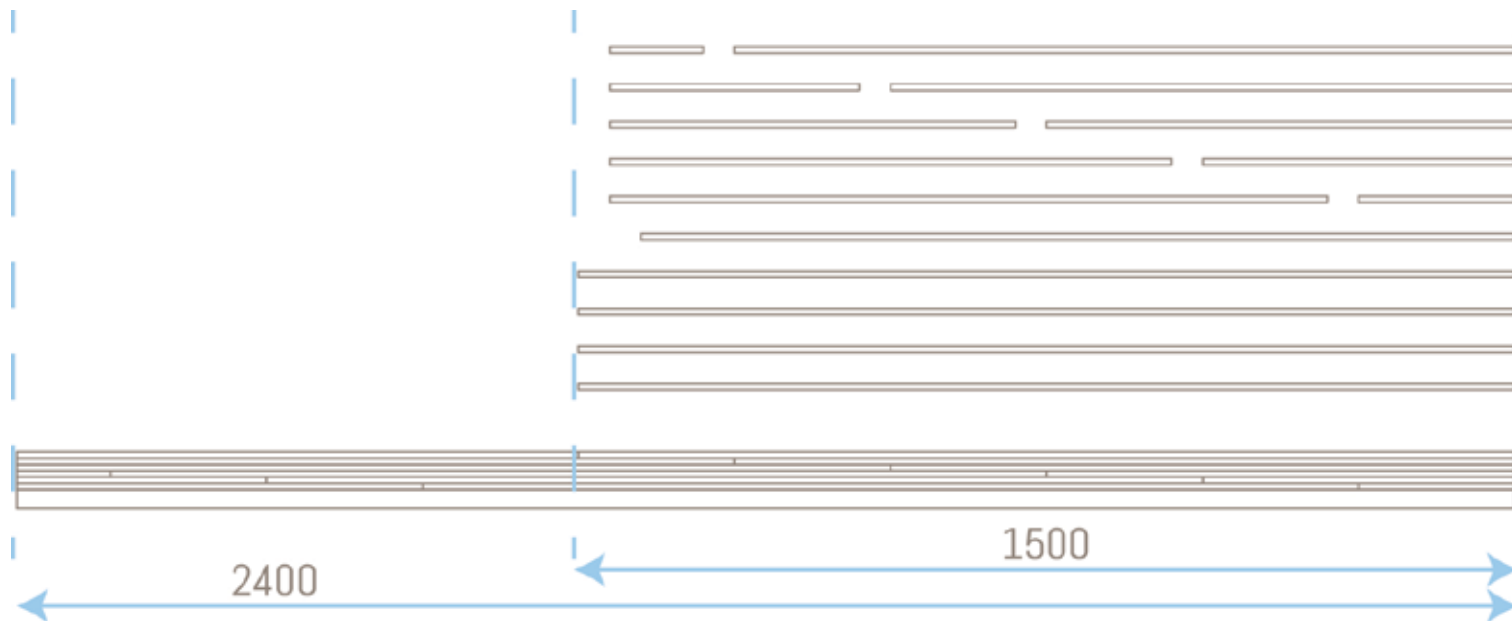

Split lamination gaps

Statistically impossible to prevent peak stresses

Open gap is significant weakness

Three options proposed

- 1 Empty
- 2 Adhesive
- 3 Aluminum

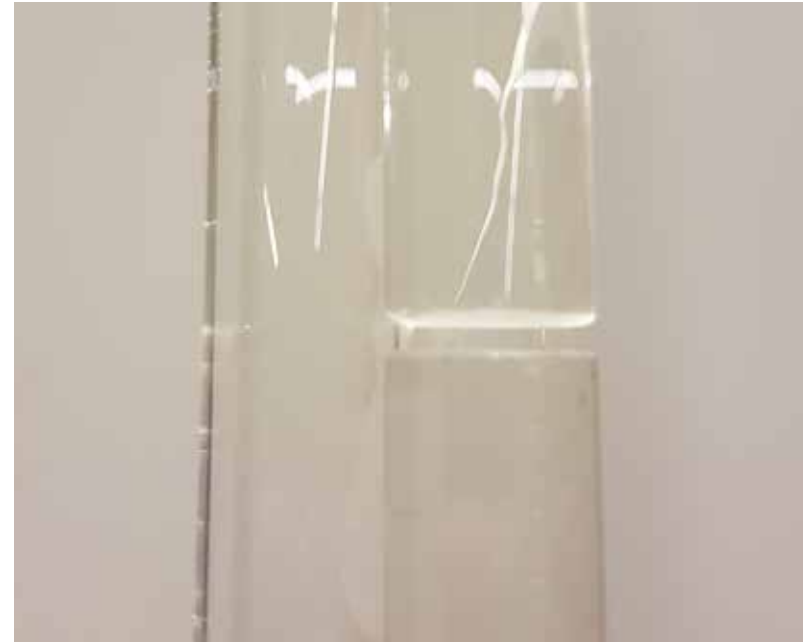
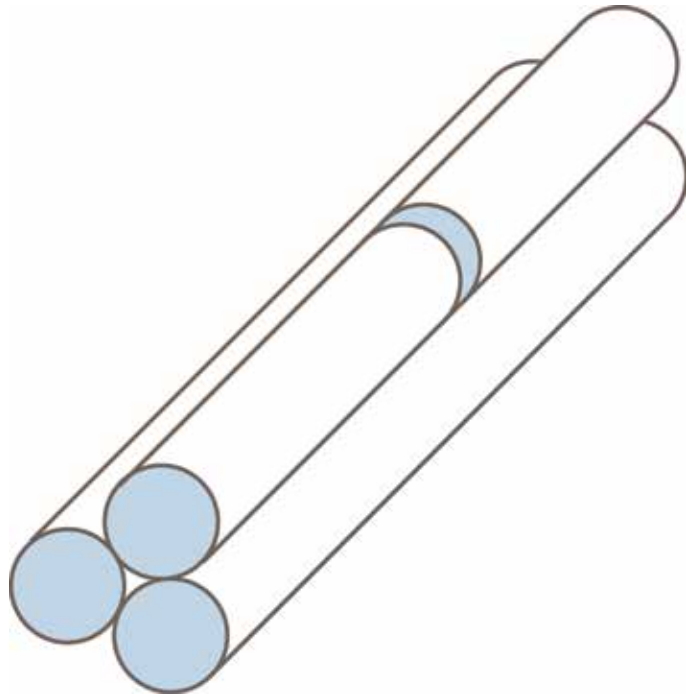

Gap options testing

Three samples per option

470mm tall samples

Aluminum expected to be the best

Slightly softer material

Still transfers loads

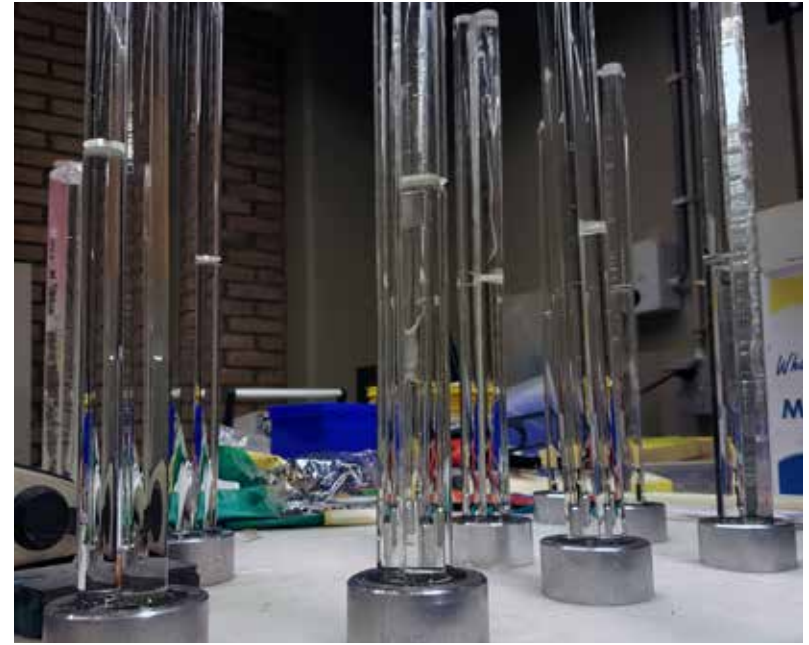

Gap options results

Results ranging between:
9000 and 27.000 kg

Aluminum disc clearly the best

85% monolithic behavior

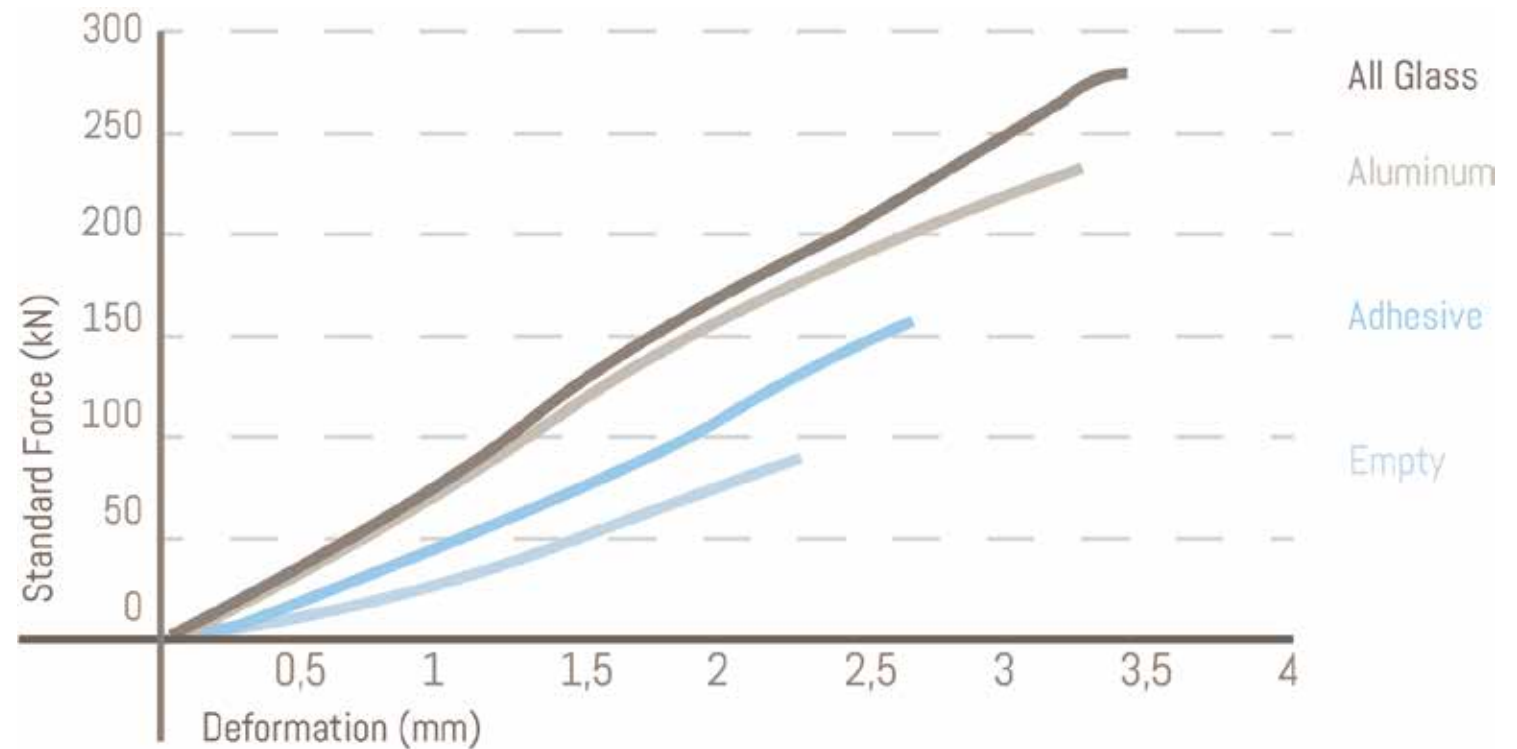

Production of complete column

Column design respects research

Following the split lamination scheme

Aluminum discs at gaps



Expectations mechanical behavior

Previous tests show buckling as leading failure mode

Inaccurate material properties make it hard to predict

Generally exceeds expectations

Euler's critical buckling force: ~70kN

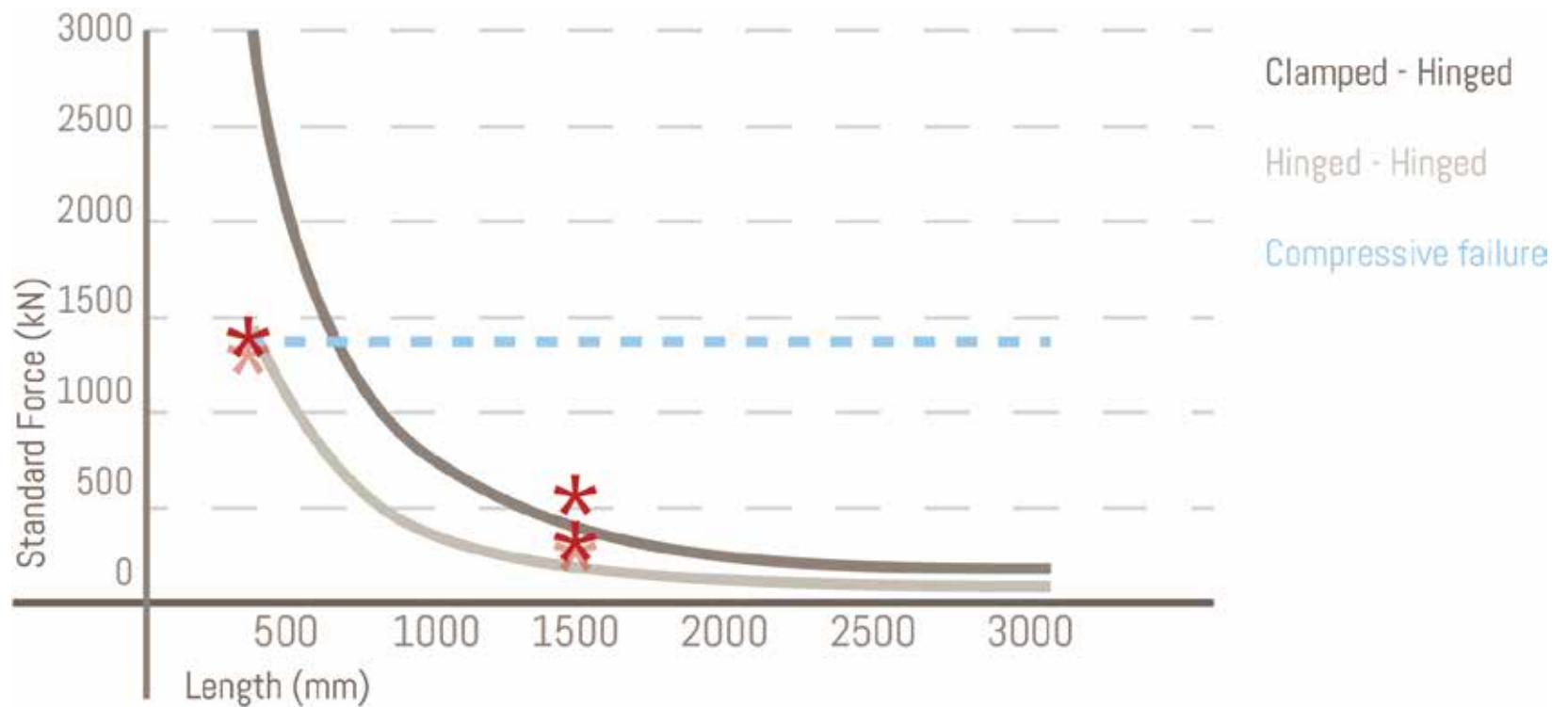

Physical test

Test conducted at Faculty of Civil Engineering

Video time!



Results mechanical behavior

Failure by buckling

Exceeded expectations, as expected

9000 kg

Reverse calculating Euler:
Glass has Young's Modulus of ~80

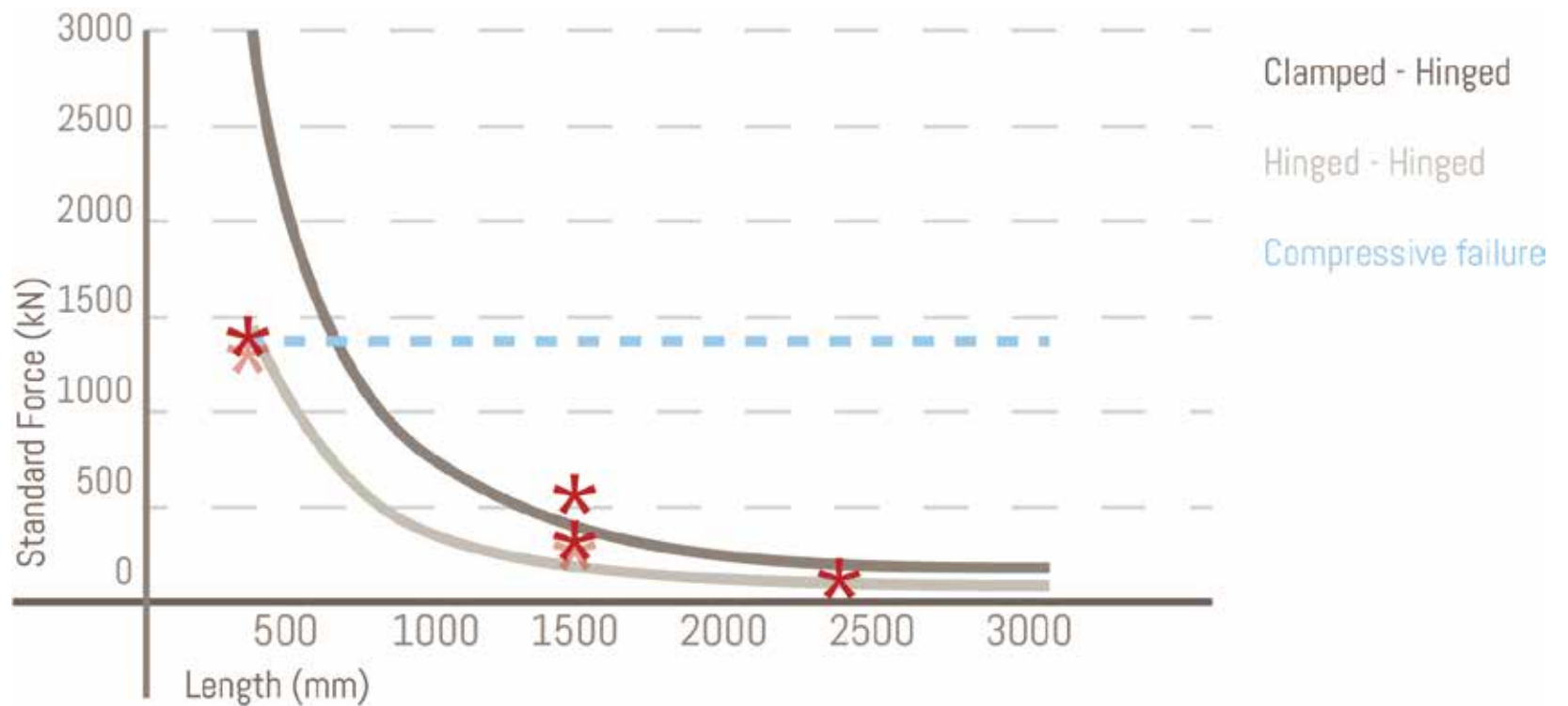

Case study ABT office

ABT Delft

Ultimate limit state of 112 kN

Achievable in a clamped situation

Almost there?

Safety factors!



Improving the failure behavior

Issue 2: Slender column

Why? So we can lower the safety factors

Making it better possible without increasing cross section

No needlessly large and costly elements

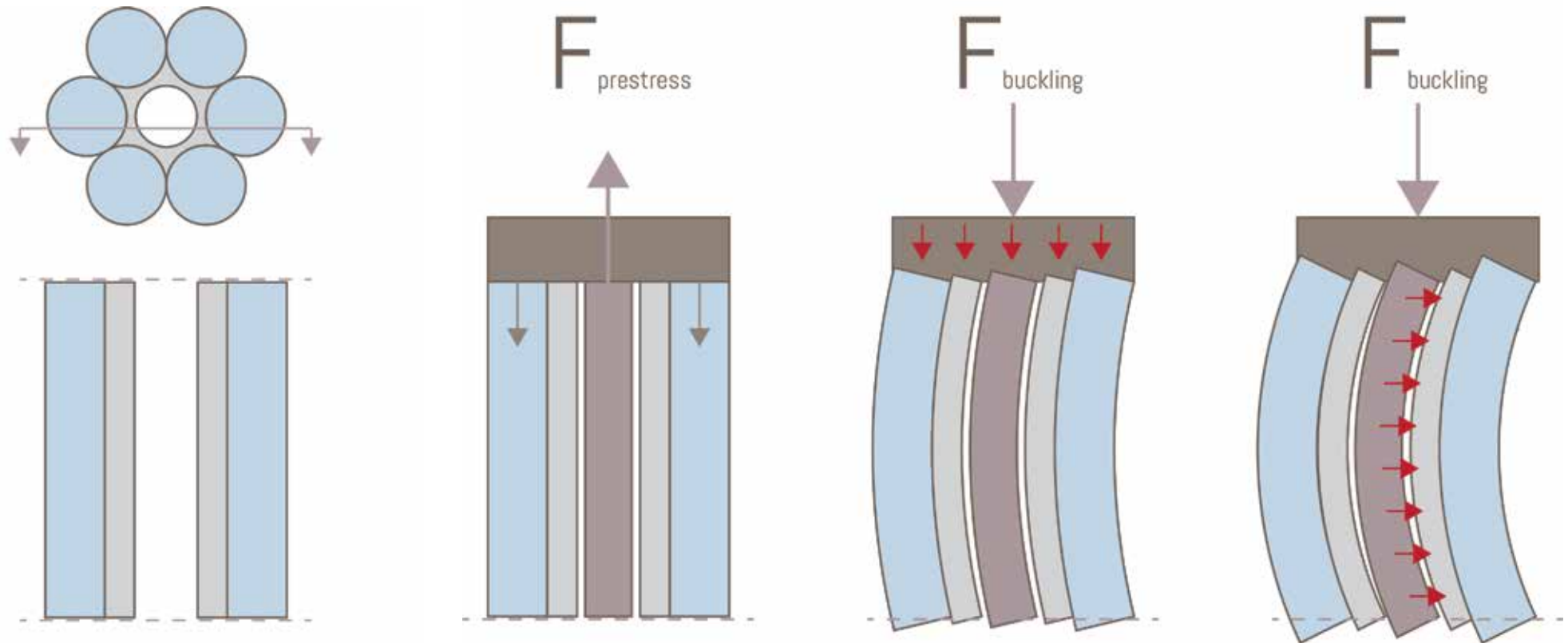

Expected behavior

Column will fail by buckling

Introducing a tensile element can slow this down

Increased deformations



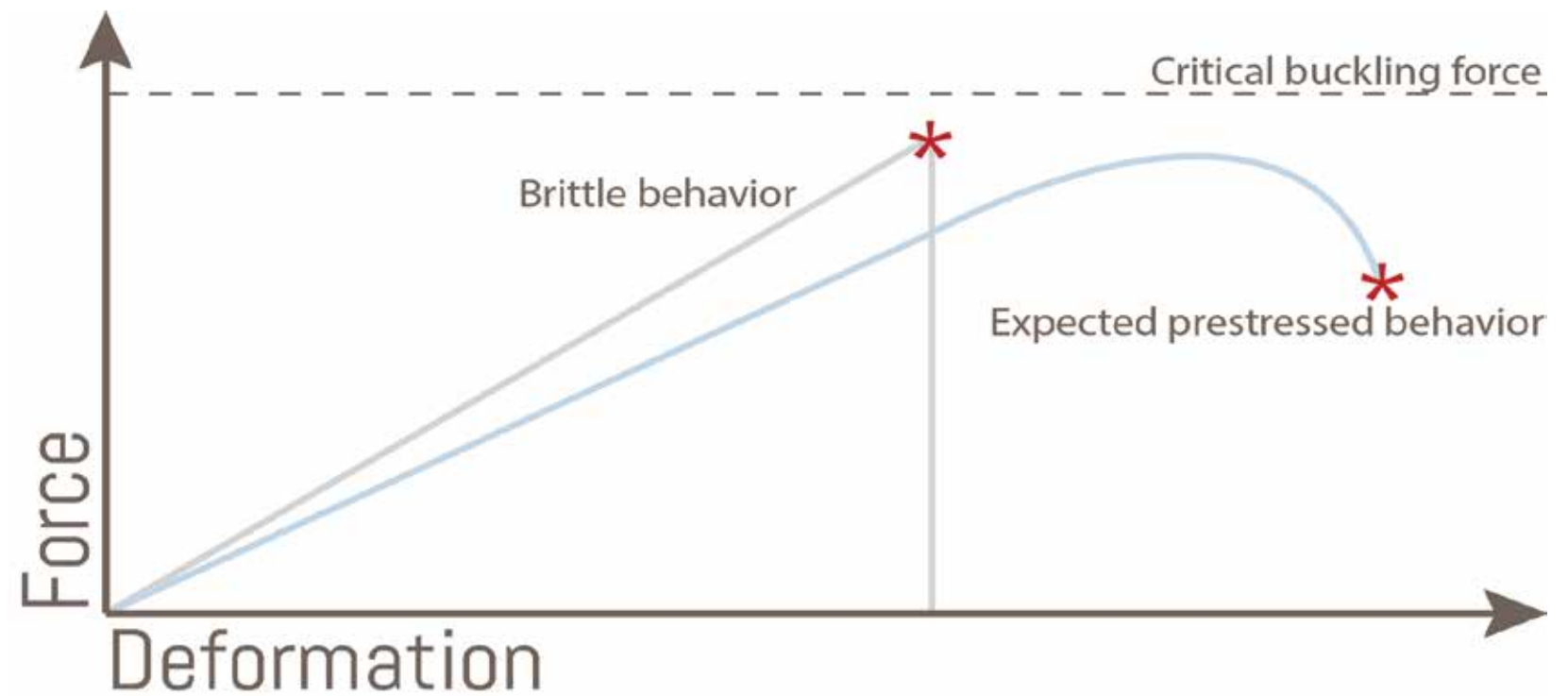

Visibility of failure increased



Implication issues

Issue 1: Eccentricities

On paper vs real-life

| Profile Type | Profile Number | Dimensions and Tolerances [mm] |
|---|----------------|----------------------------------|
|  | 001 | W 25.00 ± 1.50 |
|  | 002 | W 31.00 ± 2.00 |
|  | 003 | W 10.00 ± 0.50 W 29.00 ± 1.00 |
|  | 004 | W 30.00 ± 2.00 / ID 17.00 ± 2.00 |

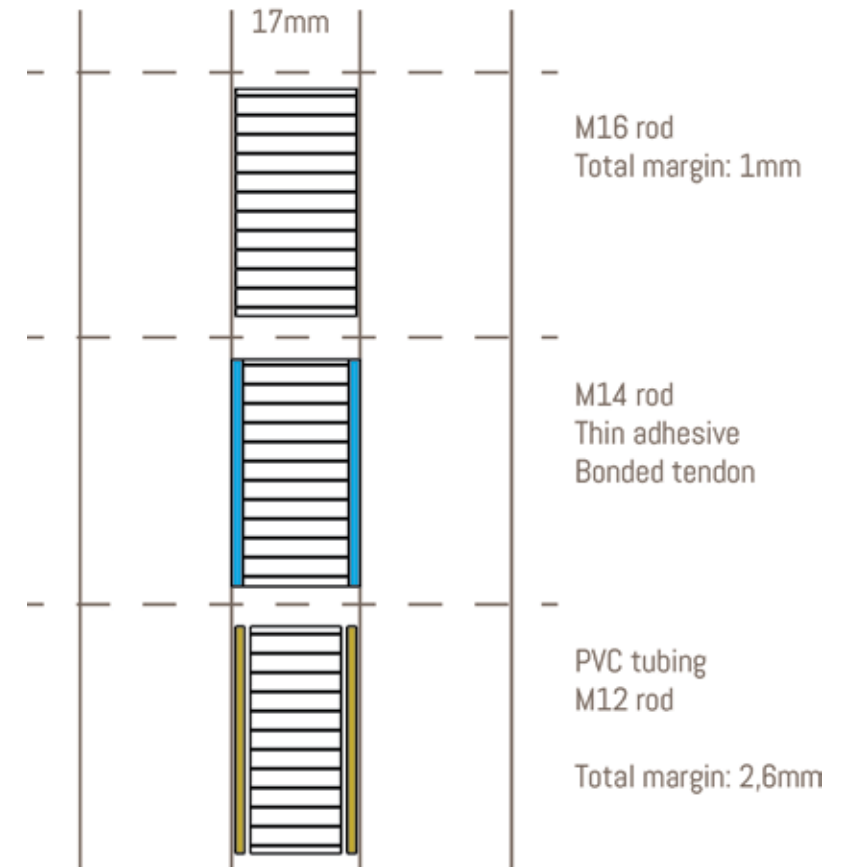

Proof of concept design

PVC tubing with steel tendon

Prestress of 35kN applied (30% of critical buckling force)

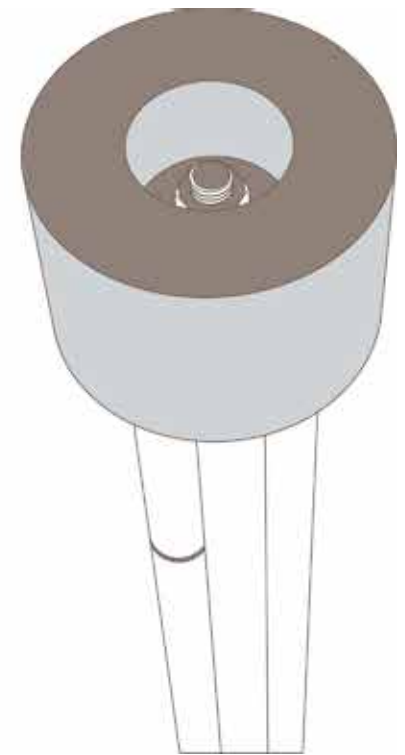
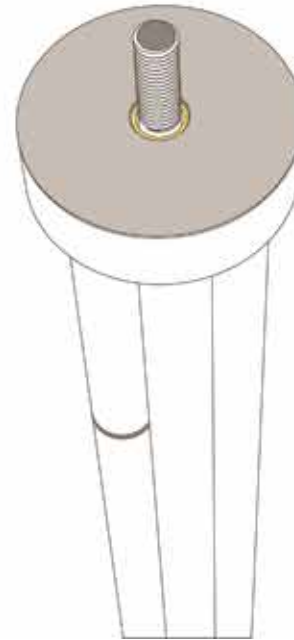
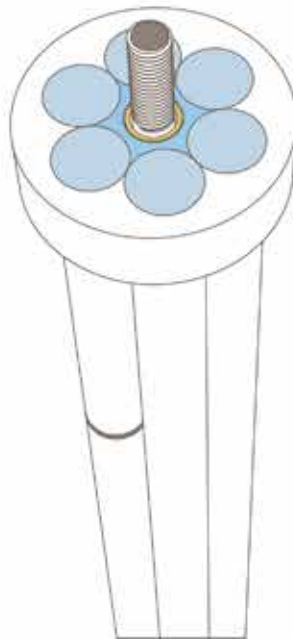
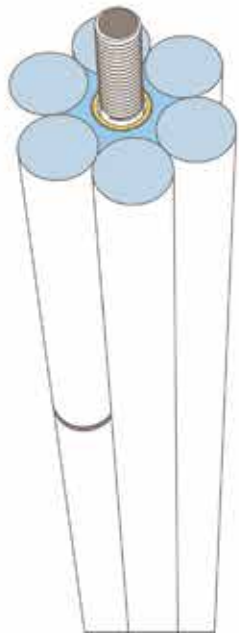
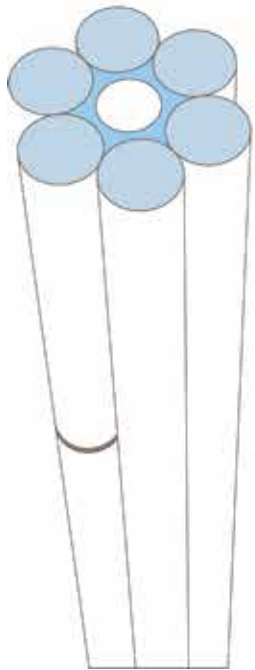

Physical test date

Three samples produced

Test date 12th and 14th afternoon

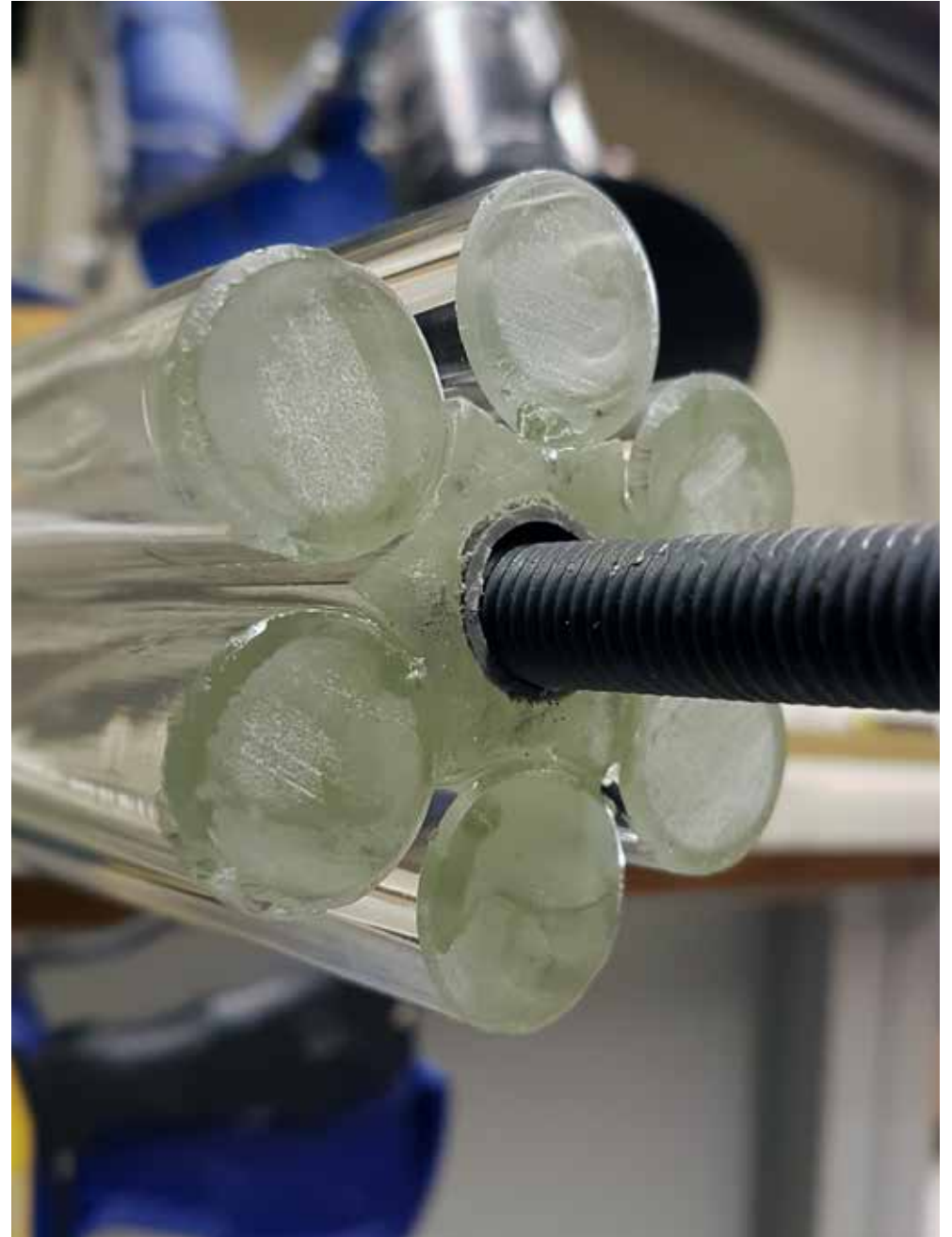

Design by Research results

Proposed design for 2400mm column

Significant load bearing capacities

Buckling leading cause of failure

If succesful, buckling more ductile

Reduced safety factor makes a 2400mm column possible for ABT in a clamped situation

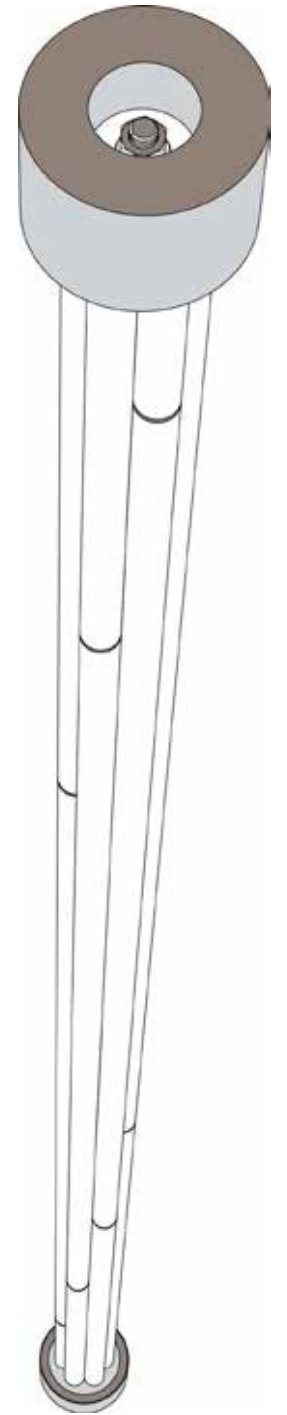

What's next?

Proven mechanical behavior, now increase architectural value

Support condition research

Implementation

Future uses?

Supports: Topology optimization

Define support and load

Defined zone that can be used for optimization

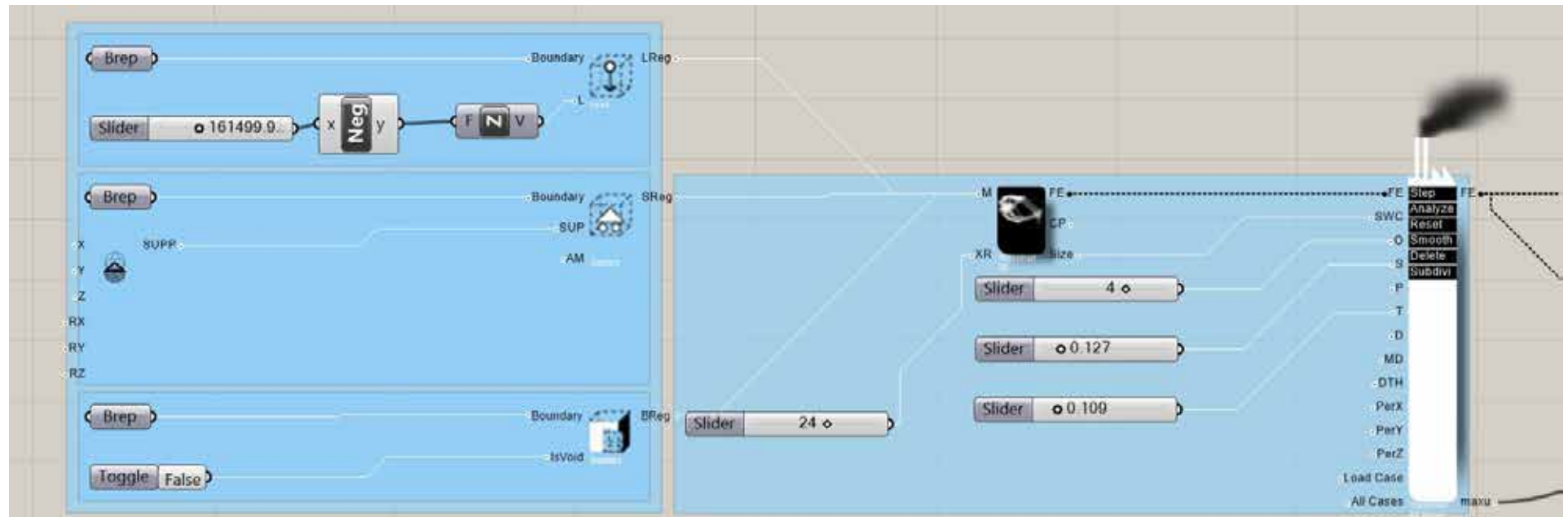
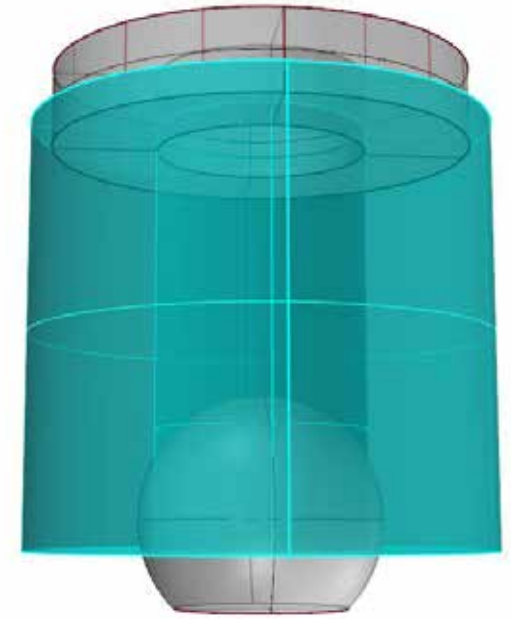

Optimization analysis

Single load case

Optimized shapes are very prone to other load cases

Risk = Probability * Consequence

Too dangerous for this subject

Note: Best flow of forces is a straight connection between the two

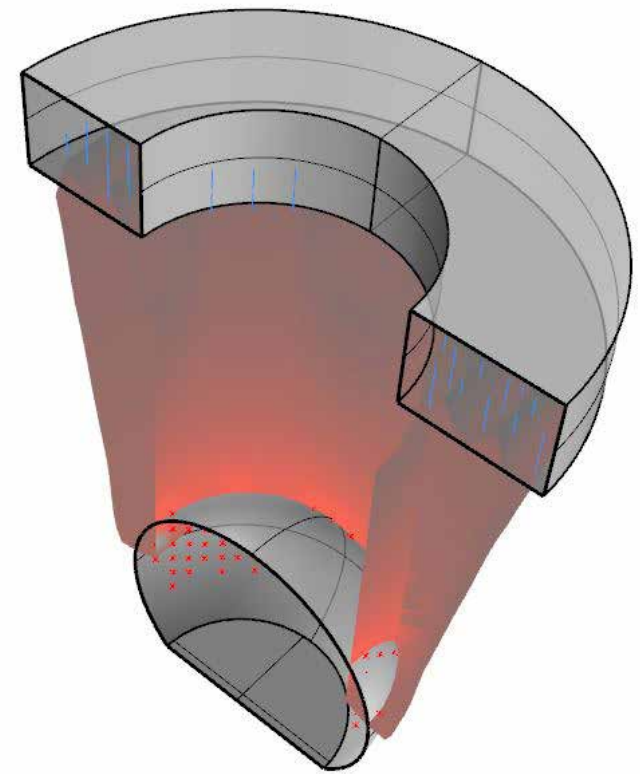
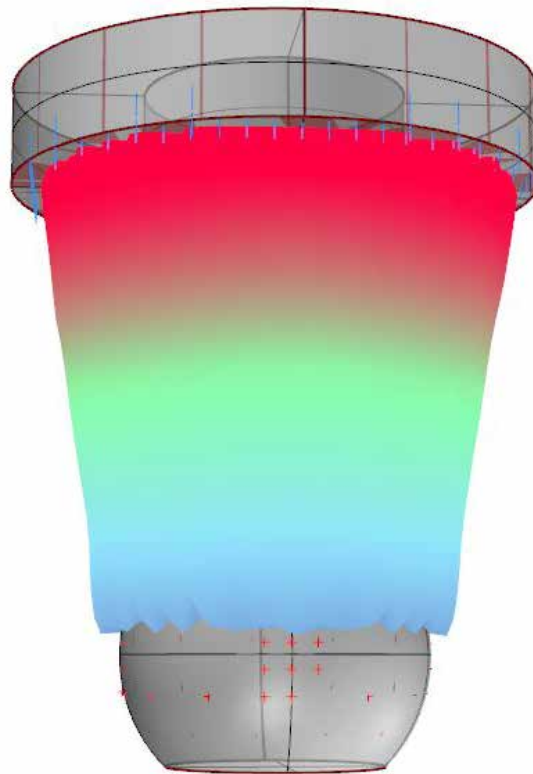

Designed supports

Glass parts are main focus

No glass in connections

Draw attention to slenderness



Exploded view

Glass column

Lead protective interlayer

Steel holder

Height adjustable holder

Adjustment bolts
Adjustment thread

Bottom plate

High duty concrete anchor bolts

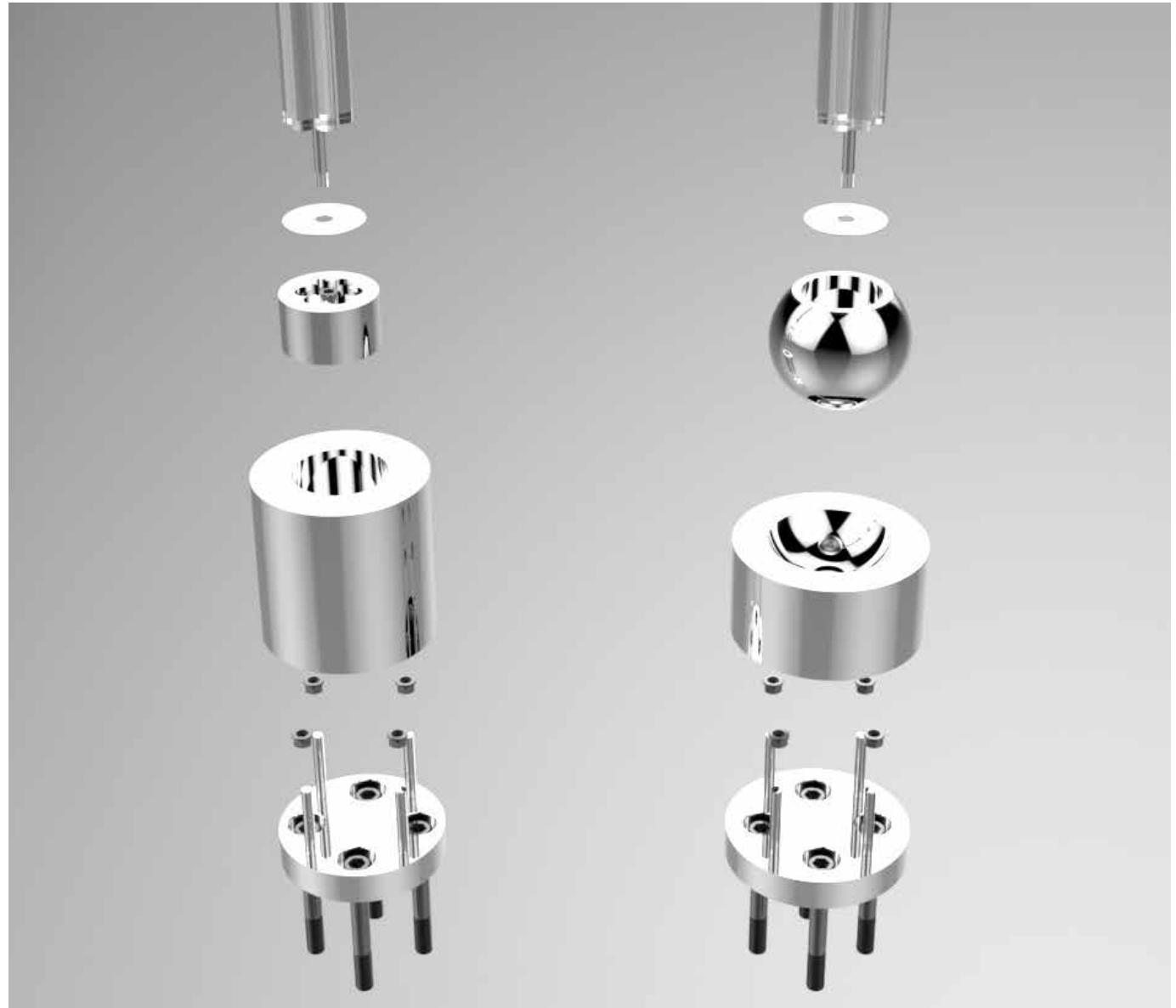

Glass column in Faculty of Architecture

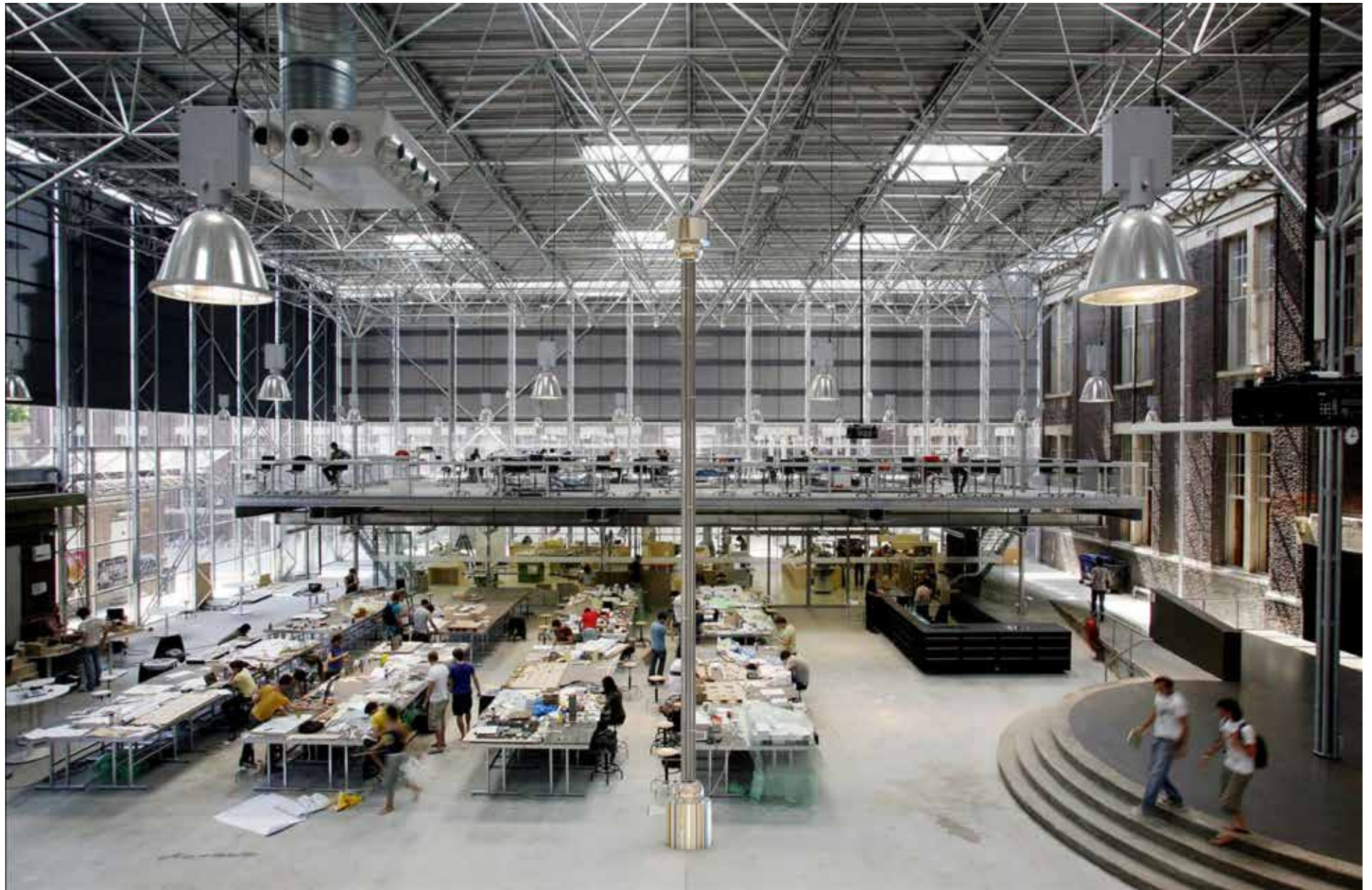

Close-up glass column in Faculty of Architecture

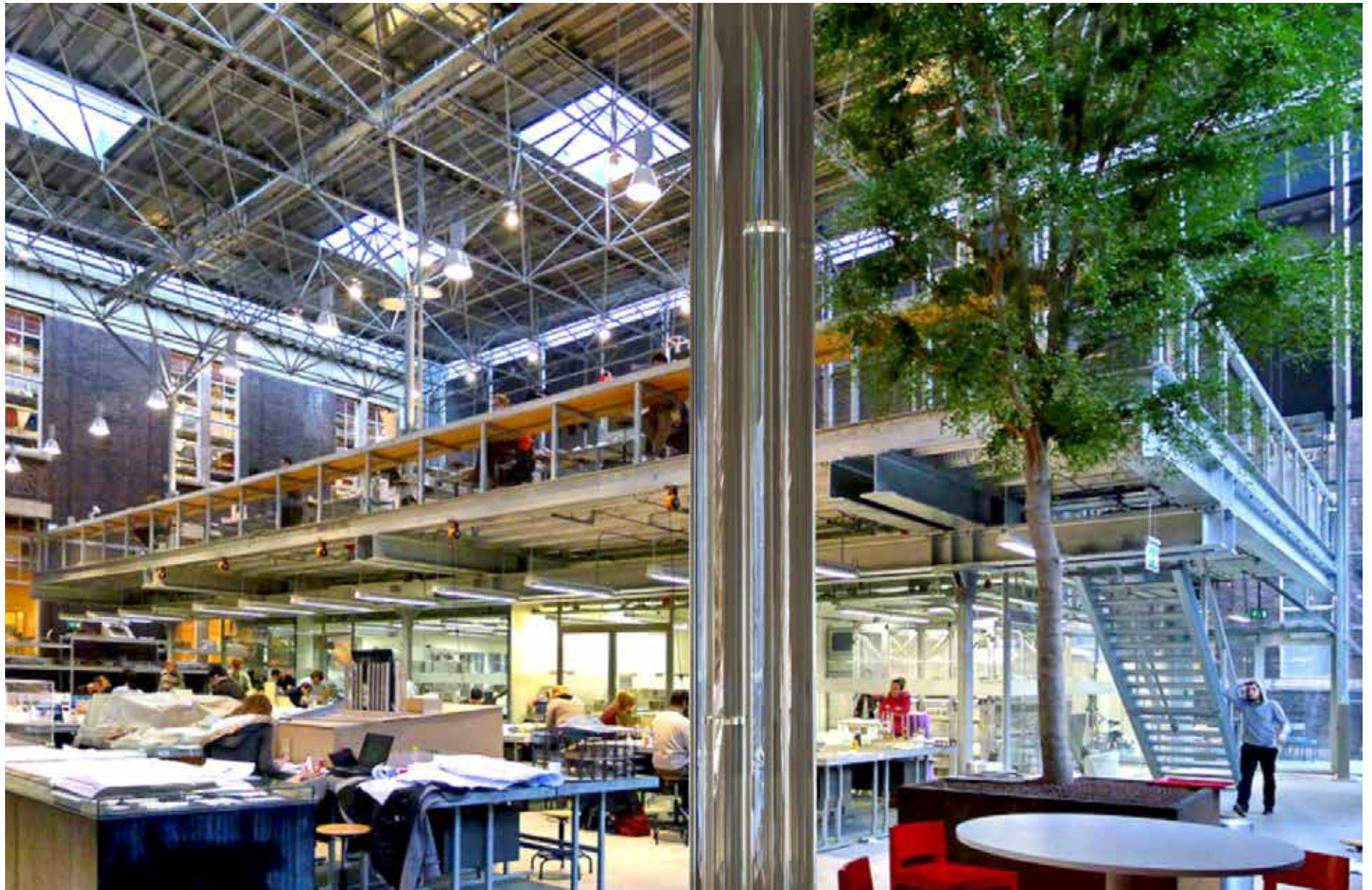

Social context

Not just a novel feature in contemporary architecture

Deepen the trust people have in glass

Prove the structural integrity of glass as structural material

Do so with a 100% recyclable material

But, what are other uses of this column?



General compressive members



Tensegrity art objects or structures

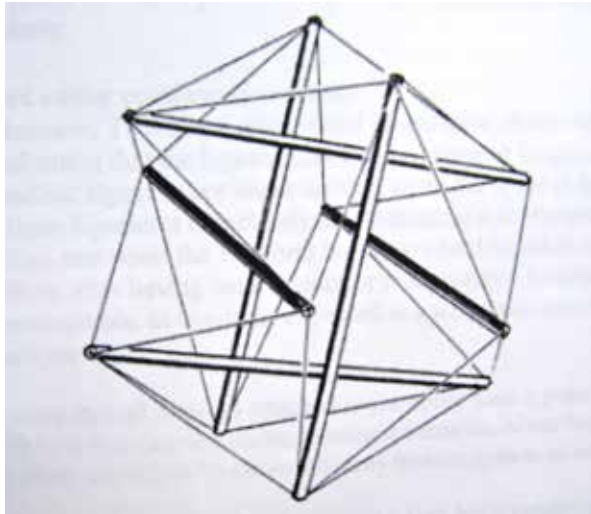

Sustainable renovation of gothic churches



Close-up sustainable renovation of gothic churches

