

Sustainable primary school

Intervention to enhance value for disappearing green in peri-urban Bandung
by Elmar van Cleynebreugel

Teachers
Architecture
Research
Building Technology

Monique Smit
Peter Teeuw
Maarten Meijs



Context
Problems
Objective
Relevance
Research
Design

Context

Indonesia

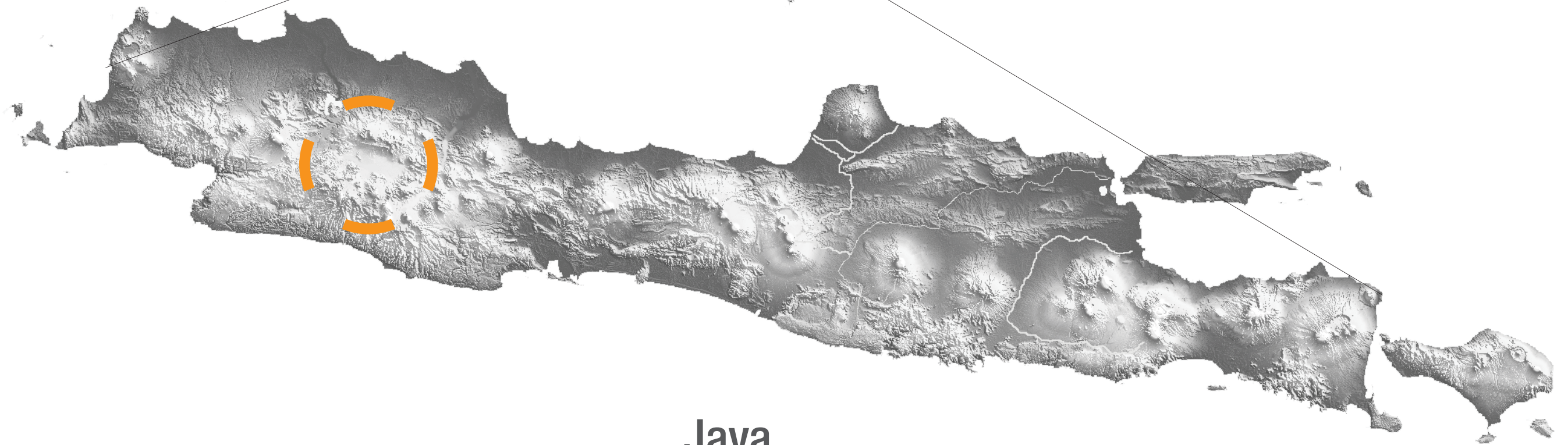

Java



Bandung

Citarum

Cigondewah

Kampung Cigondewah



Problems

Disappearing Green

Waterpollution

Dependency on textile industry

Lack of schools and environmental ignorance

Disappearing Green

Remaining agricultural in periphery



Ricefields

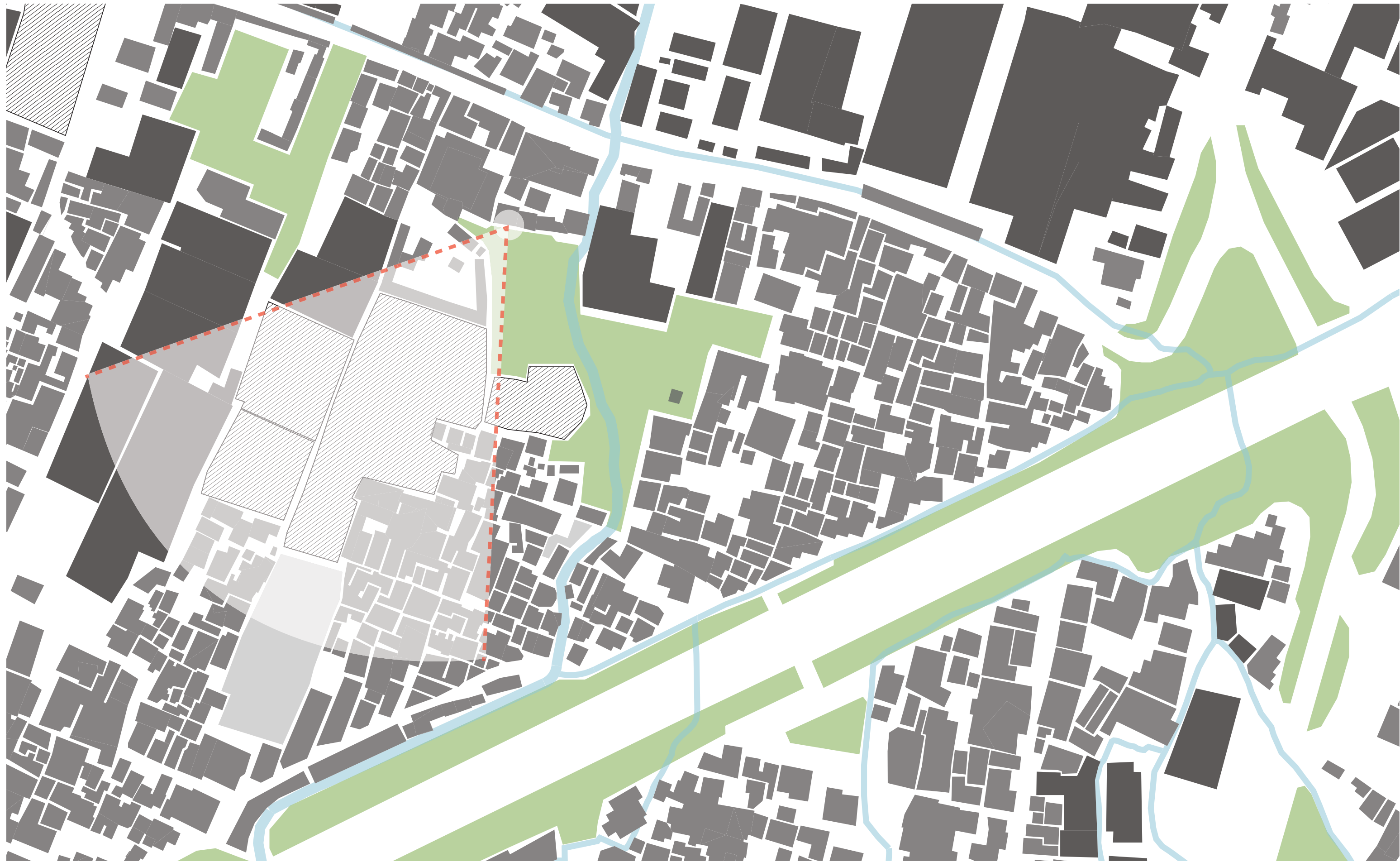

Remaining green

- has little value for the community
- is polluted and dangerous for children
- is declining further with a loss of cultural identity, food security and biodiversity, and increased stress on watermanagement



Landscape of
factories



Overall lack of safe and public green areas



Waterpollution

Irrigation



Recreation



Municipal water



Open sewage



Well and washing area



Irrigation with polluted water



Dependency on textile industry



Will the *new generation* also be dependent on textiles?

**Lack of schools and
environmental ignorance**



Will disconnection with nature increase?

Future

37%↑
population
by 2031

Will the build houses,
factories or
keep the ricefields?







Objective

To create a valuable green space for the community with an educational function (primary school)

Research Question

How can plants play a role as building material, water management and spatial component in the peri-urban region of Bandung?

Relevance

	Impact trend	Impact on ecosystems	Illustrative actions driving the trend	Impact on poor or vulnerable
	Rising waste	<ul style="list-style-type: none"> • Toxic waste, open-site dumping degrades soil, contaminating livestock and land 	<ul style="list-style-type: none"> • Mining and extractive activities for construction • Slaughterhouses 	<ul style="list-style-type: none"> • Limit food production for incomes and consumption • Declining air/health quality • Declining resource access
	Rising natural resource consumption	<ul style="list-style-type: none"> • Ecosystem degradation and collapse upon over-extraction 	<ul style="list-style-type: none"> • Deforestation • Increased demand for meat and water 	<ul style="list-style-type: none"> • Decline in air/health quality • Rising prices for resources • Increased pressure on land from outside parties
	Disruption of ecosystem functioning	<ul style="list-style-type: none"> • Cessation of essential ecological functions; recycling of nutrients and aquifers recharge 	<ul style="list-style-type: none"> • Conversion of soil/vegetation to impermeable land; rerouting rainwater 	<ul style="list-style-type: none"> • Limit food production for incomes and consumption • Strain water access
	Decline in prevalence of natural ecosystems	<ul style="list-style-type: none"> • Elimination of arable, productive land, full destruction of ecosystems 	<ul style="list-style-type: none"> • Conversion of open horticulture fields for residential development 	<ul style="list-style-type: none"> • Force livelihood transition • Eliminate food supply

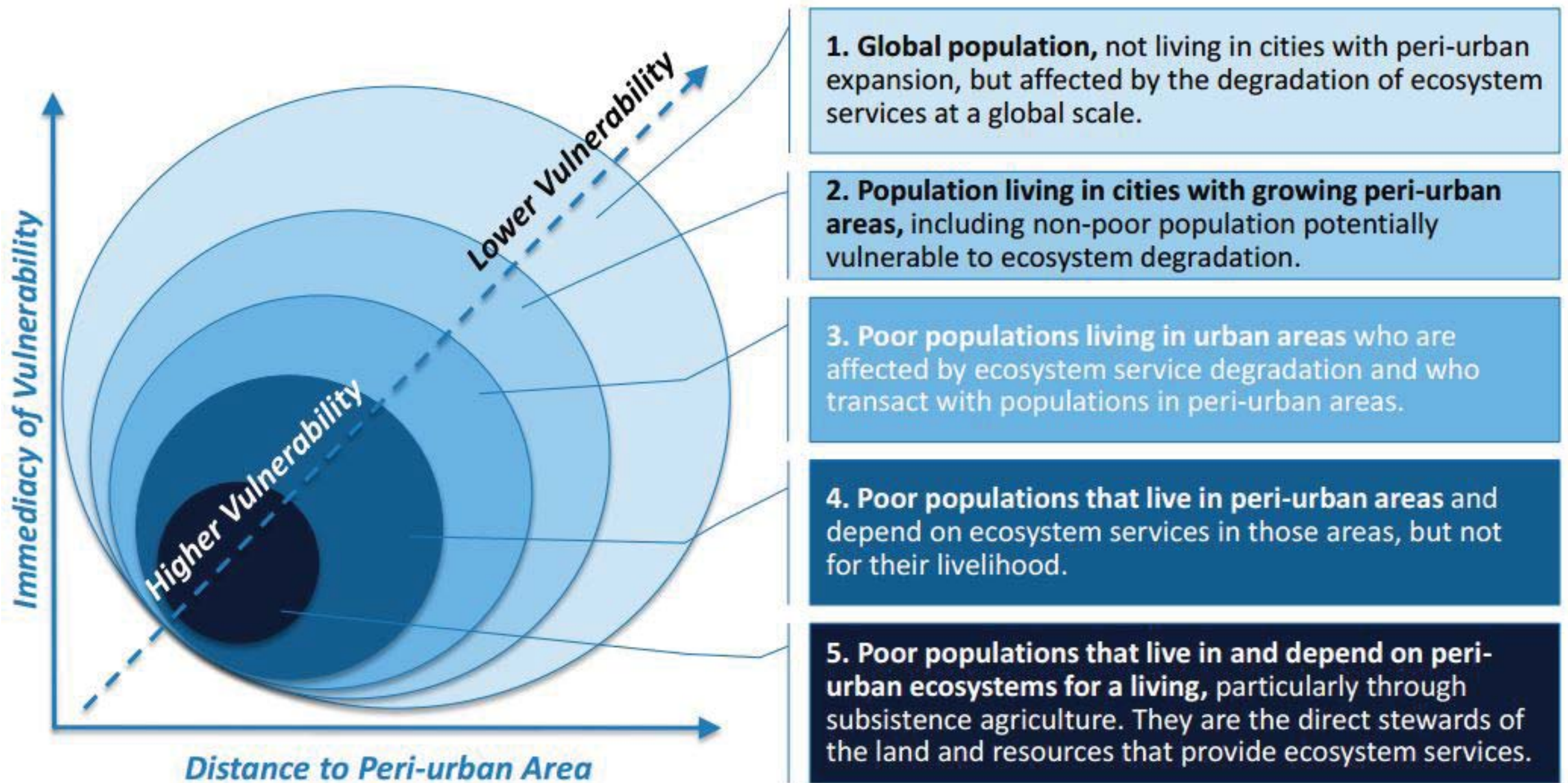



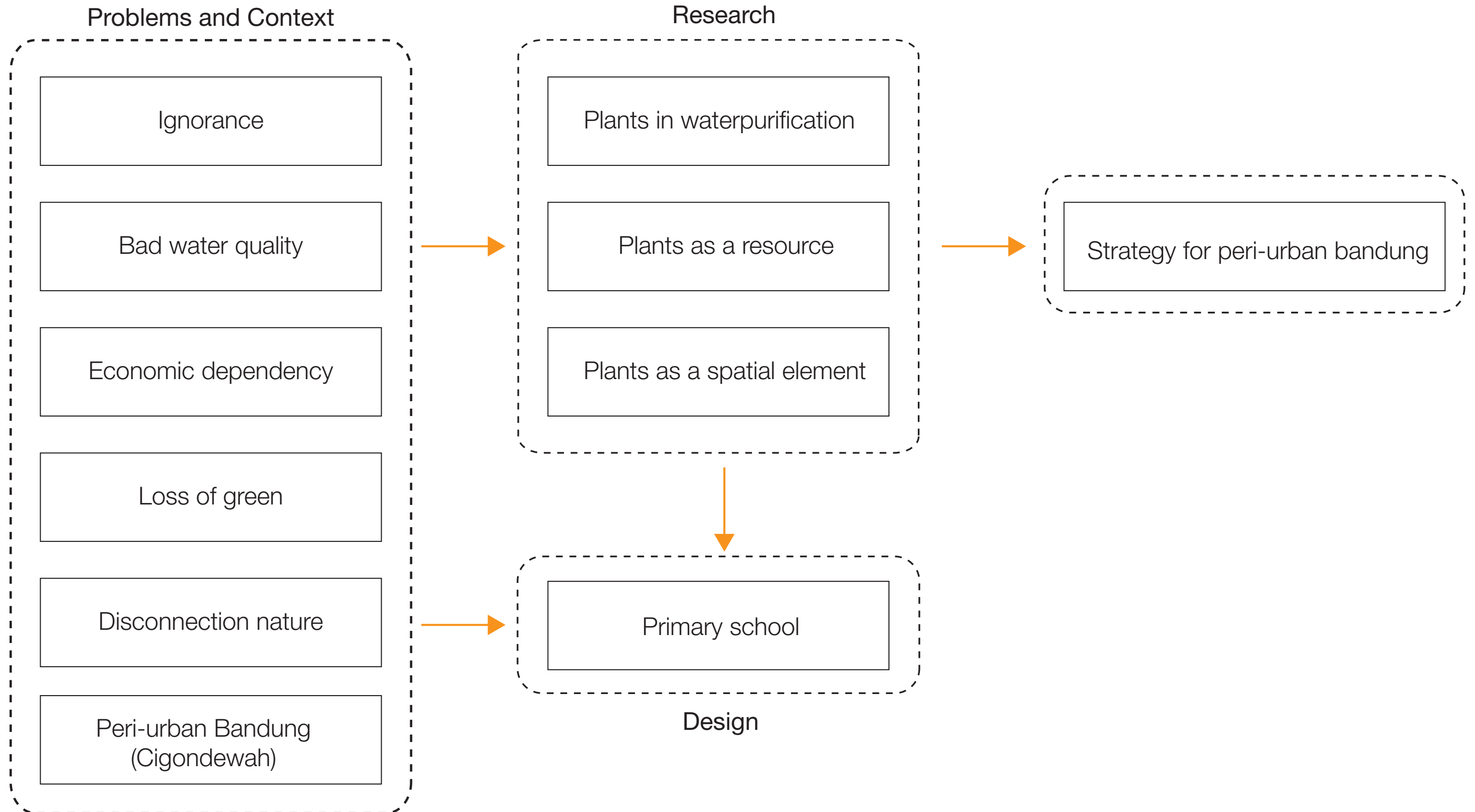

Methodology



Research

How can plants play a role as building material, water management and spatial component in the peri-urban region of Bandung?

-  Plants as waterpurification
-    Plants as a resource
-  Plants as spatial element

WT **Plants as waterpurification**

HFCW

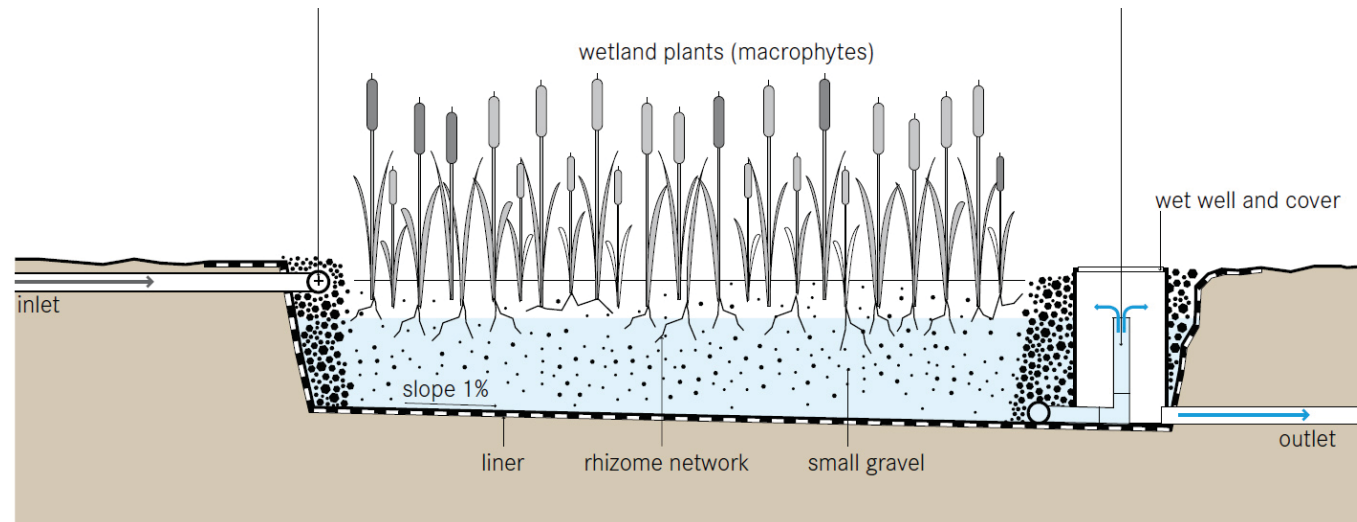

Rice

FWCW

Reduces
BOD, COD,
phosphates.



VFCW

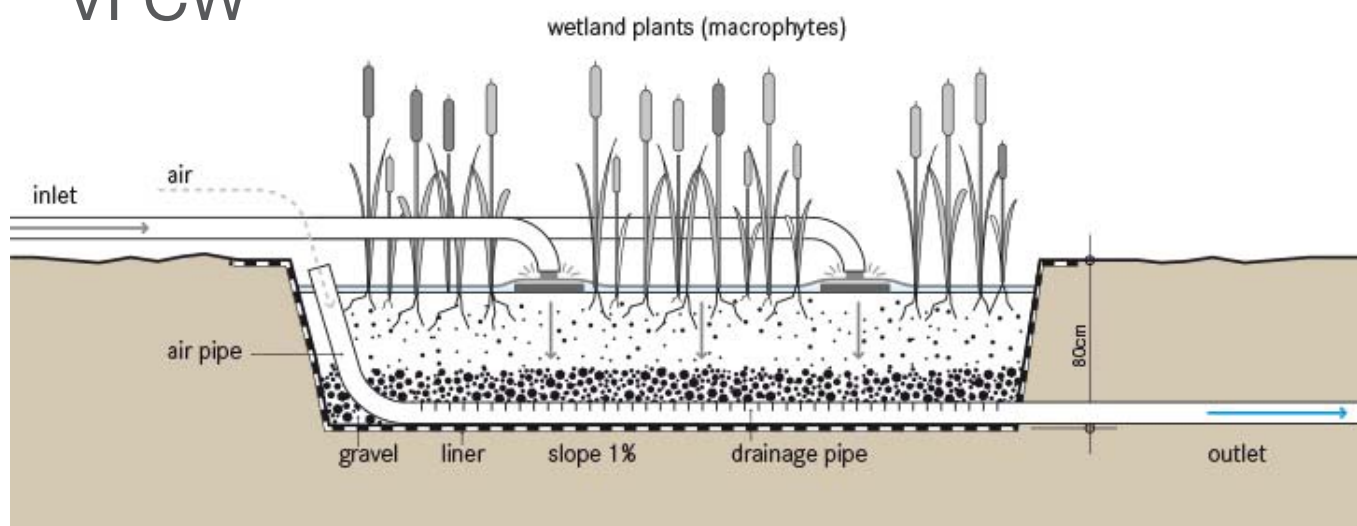

Reed

VFCW
HFCW

Accumulates
Lead(Pb) Copper(Cu)
Zinc(Zn), Arsenic(As),
and Tin(Sn)



FWCW

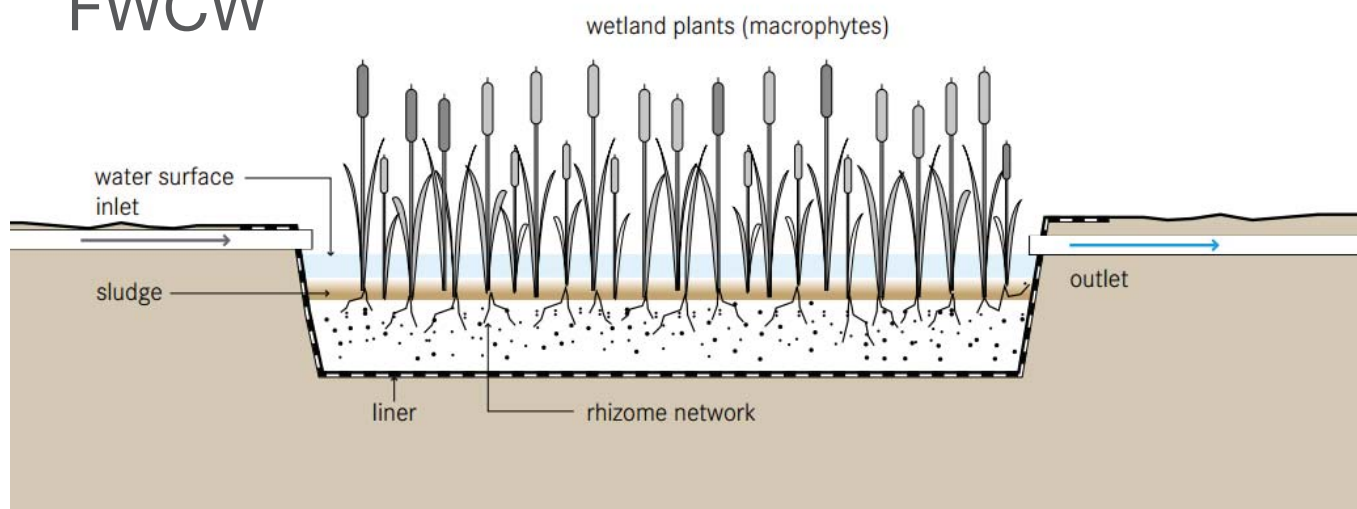

Bamboo

VFCW
HFCW

Reduces
BOD, COD,
phosphates.



WT

Plants as waterpurification

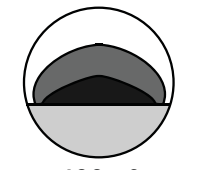

Primary school and community building
 Water treatment with constructed wetlands
 Education
 Community facility
 Gardens
 Fishpond

400m²
600m² outside



Bamboo
 Water treatment
 Bamboo shoot production
 Biomass
 Public bamboo park

4300m²



Agroforestry
 Fruit production
 Timber production
 Biomass
 Public Park

4500m²



Reed filters
 Watertreatment: Helophyte filters with subsurface flow
 Thatching materials
 Biomass

1400m²



Rice fields
 Watertreatment: Free surfacewater flow
 3000kg rice/ year (1500\$/ year net.)
 Biomass from husks

2000m²









Community gardens
 Use of cleaned water
 Vegetable and fruit production for educational and communal food security
 Biomass

1500m²



Kampung community
 Workforce
 Teachers
 Volunteers
 Partners

-  **WT** Watertreatment
-  **BM** Building material
-  **Fd** Food
-  **KG** Biomass (compost etc.)
-  **SE** Spatial element
-  **\$** Income from sales



BM

Fd

KG

Plants as a resource

BM



Bamboo

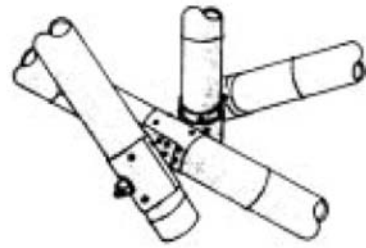

- reliable structural material
- broad application possibilities
- readily available
- ecological benefits
- 'poor men's timber' image

Reed

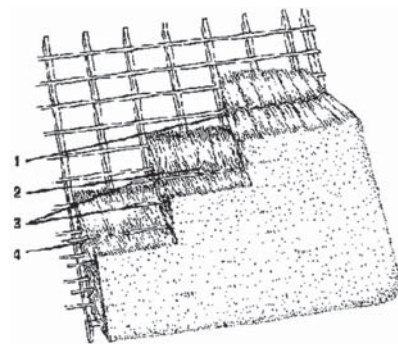

Rice

Fd



KG



- culms 65%
 - branches 17.5%
 - leaves 17.5%
- As biofuels, fodder or compost

Cuttings or surplus can be used as biofuels, fodder or compost

Husks can be used as biofuels, fodder or compost

BM Plants as building material

Primary school and community building
 Water treatment with constructe wetlands
 Education
 Community facility
 Gardens
 Fishpond

400m²
 600m² outside

Bamboo
 Water treatment
 Bamboo production 430 culms/ year
 Bamboo shoot production
 Biomass production
 Public bamboo park

4300m²

Agroforestry
 Fruit production
 Timber production
 Public Park

4500m²

Reed filters
 Watertreatment: Helophyte filters with subsurface flow
 Thatching materials
 Biomass

1400m²

Rice fields
 Watertreatment: Free surfacewater flow
 3000kg rice/ year (1500\$/ year net.)
 Biomass

2000m²

Community gardens
 Water treatment
 Vegetable and fruit production for educational and communal food security

1500m²

Kampung community
 Workforce
 Teachers
 Volunteers
 Partners

- WT Watertreatment
- BM Building material
- Fd Food
- KG Biomass (compost etc.)
- SE Spatial element
- \$ Income from sales



Fd Plants as food

Primary school and community building
 Water treatment with constructed wetlands
 Education
 Community facility
 Gardens
 Fishpond

400m²
 600m² outside

Bamboo
 Water treatment
 Bamboo production 430 culms/ year
 Bamboo shoot production
 Biomass production
 Public bamboo park

4300m²

Agroforestry
 Fruit production
 Timber production
 Public Park

4500m²

Reed filters
 Watertreatment: Helophyte filters with subsurface flow
 Thatching materials
 Biomass

1400m²

Rice fields
 Watertreatment: Free surface water flow
 3000kg rice/ year (1500\$/ year net.)
 Biomass

2000m²

Community gardens
 Water treatment
 Vegetable and fruit production for educational and communal food security

1500m²

Kampung community
 Workforce
 Teachers
 Volunteers
 Partners

- WT Watertreatment
- BM Building material
- Fd Food
- KG Biomass (compost etc.)
- SE Spatial element
- \$ Income from sales

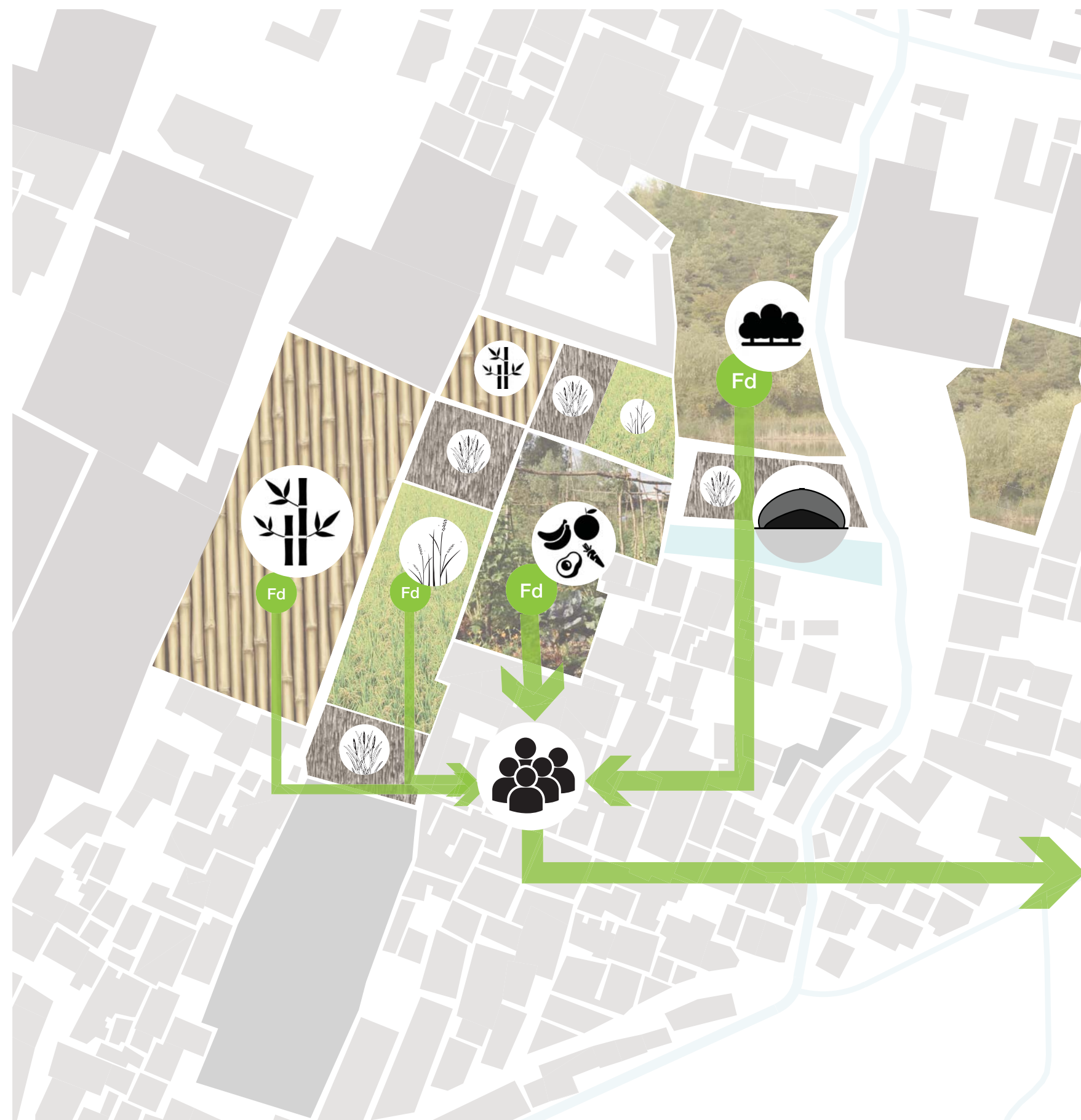

KG Plants as biomass

Primary school and community building
 Water treatment with constructe wetlands
 Education
 Community facility
 Gardens
 Fishpond

400m²
 600m² outside

Bamboo
 Water treatment
 Bamboo shoot production
 Biomass
 Public bamboo park

4300m²

Agroforestry
 Fruit production
 Timber production
 Biomass
 Public Park

4500m²

Reed filters
 Watertreatment: Helophyte filters with subsurface flow
 Thatching materials
 Biomass

1400m²

Rice fields
 Watertreatment: Free surfacewater flow
 3000kg rice/ year (1500\$/ year net.)
 Biomass from husks

2000m²

Community gardens
 Water treatment
 Vegetable and fruit production for educational and communal food security
 Biomass

1500m²

Kampung community
 Workforce
 Teachers
 Volunteers
 Partners

- WT Watertreatment
- BM Building material
- Fd Food
- KG Biomass (compost etc.)
- SE Spatial element
- \$ Income from sales

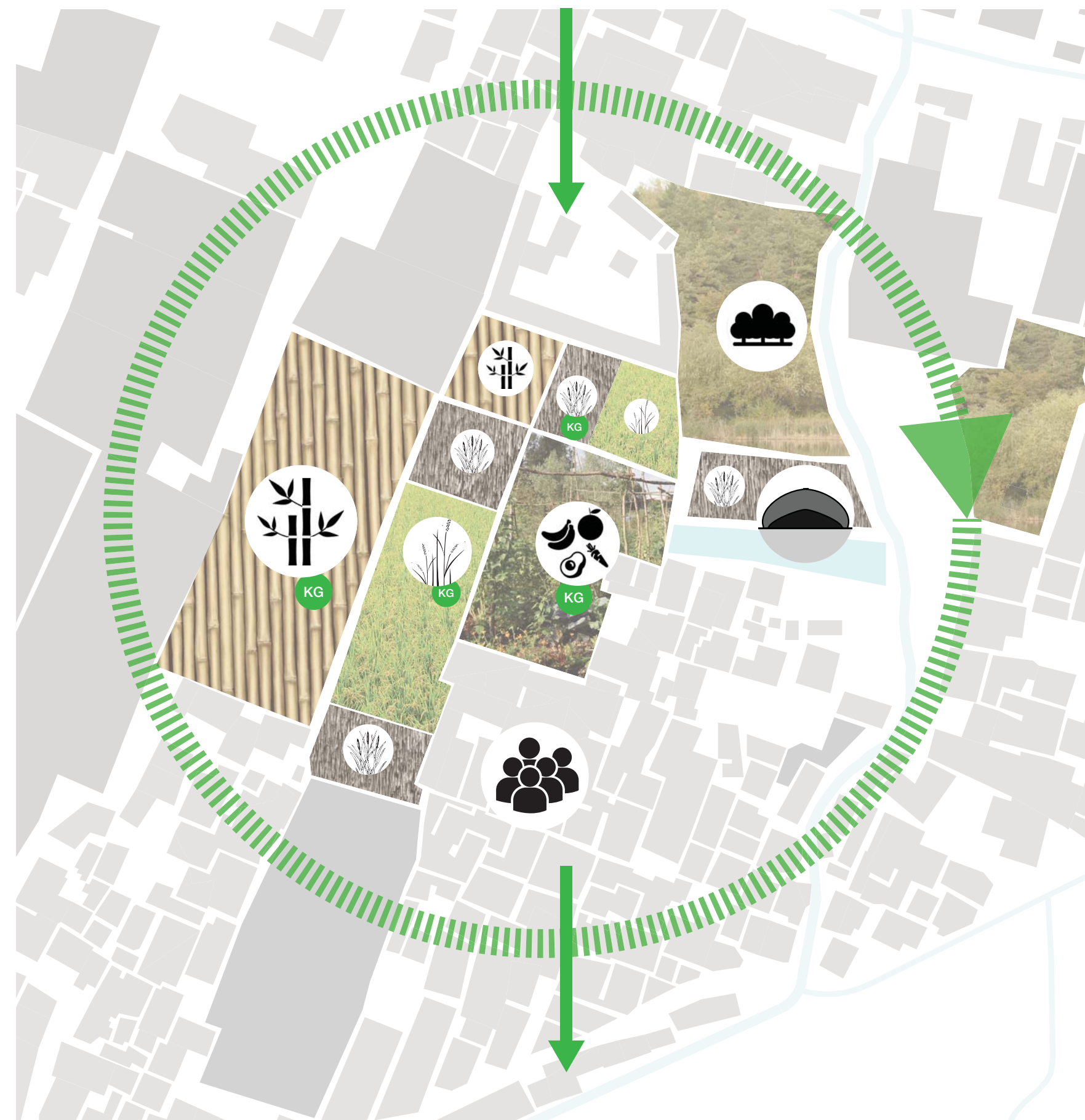

SE Plants as spatial element

Bamboo

- Wind barrier
- Prevents erosion
- Block or frame visually
- Spatial point
- Patch as bamboo park



Gigantochloa Apus
12-14m
Clump Specie

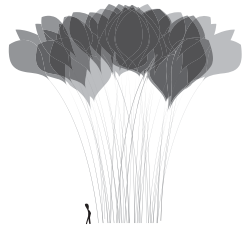

Dendrocalamus As
20-30m
Clump Specie



Reed & Rice

- patchlike structure for reed (high efficiency)



HFCW/ VFCW



FSCW

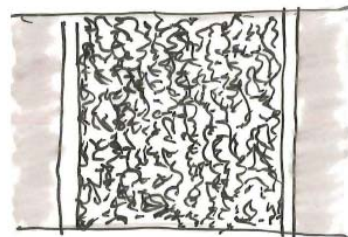
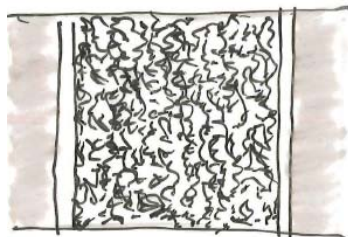

- patchlike structure for rice (higher yields)

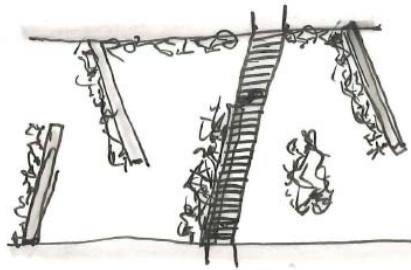

Plants for the community

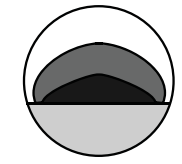

400m²
600m² outside

Primary school and community building

Water treatment with constructed wetlands
Education
Community facility
Communal urban agriculture
Fishpond



4300m²

Bamboo

Water treatment
Bamboo shoot production
Biomass
Public bamboo park
Bamboo park management



4500m²

Agroforestry

Fruit production
Timber production
Biomass
Public Park
Park management



1400m²

Reed filters

Watertreatment: Helophyte filters with subsurface flow
Thatching materials
Biomass
Visual fields of reed
System management and harvesting



2000m²

Rice fields

Watertreatment: Free surfacewater flow
3000kg rice/ year (1500\$/ year net.)
Biomass from husks
Cultural landscape
Rice farmers



1500m²

Community gardens

Use of cleaned water
Vegetable and fruit production
Biomass
Urban gardens



Kampung community

Workforce
Teachers
Volunteers
Partners

WT Watertreatment

BM Building material

Fd Food

KG Biomass (compost etc.)

SE Spatial element

\$ Income from sales

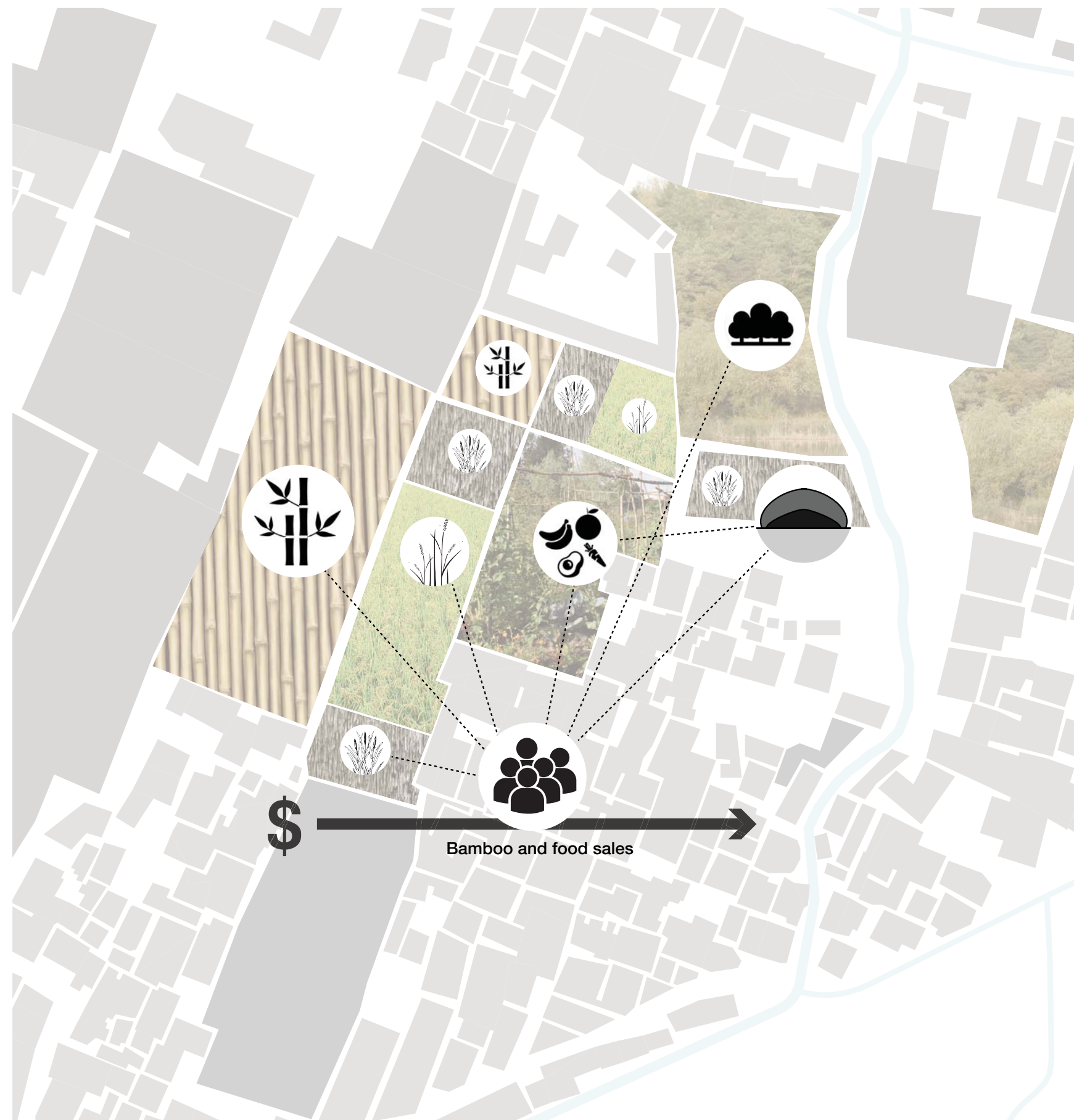

Architectural Design

Landscape

Domes and the in-between

Function and interior

Overall design question

How can I design a primary school/ community center that integrates locally grown materials and local watermanagement into its design?

Landscape Concept

Plants as waterpurification

Urban scale

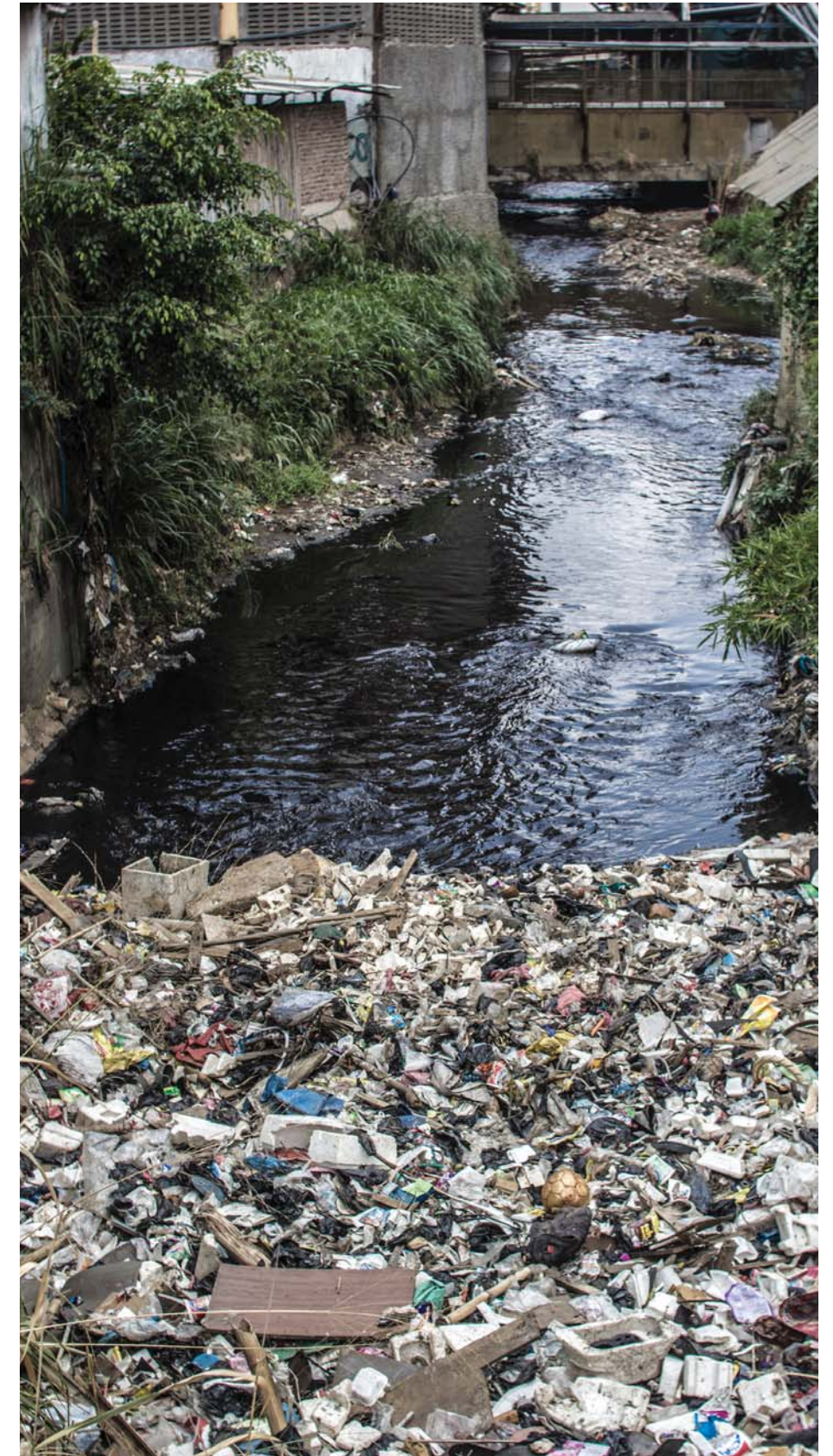

Landscape Concept

Plants as waterpurification
Urban scale

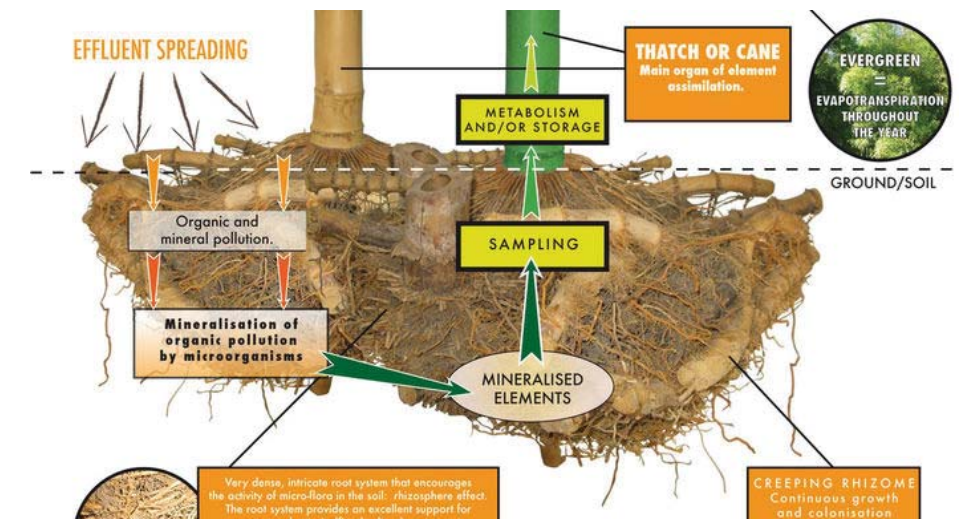
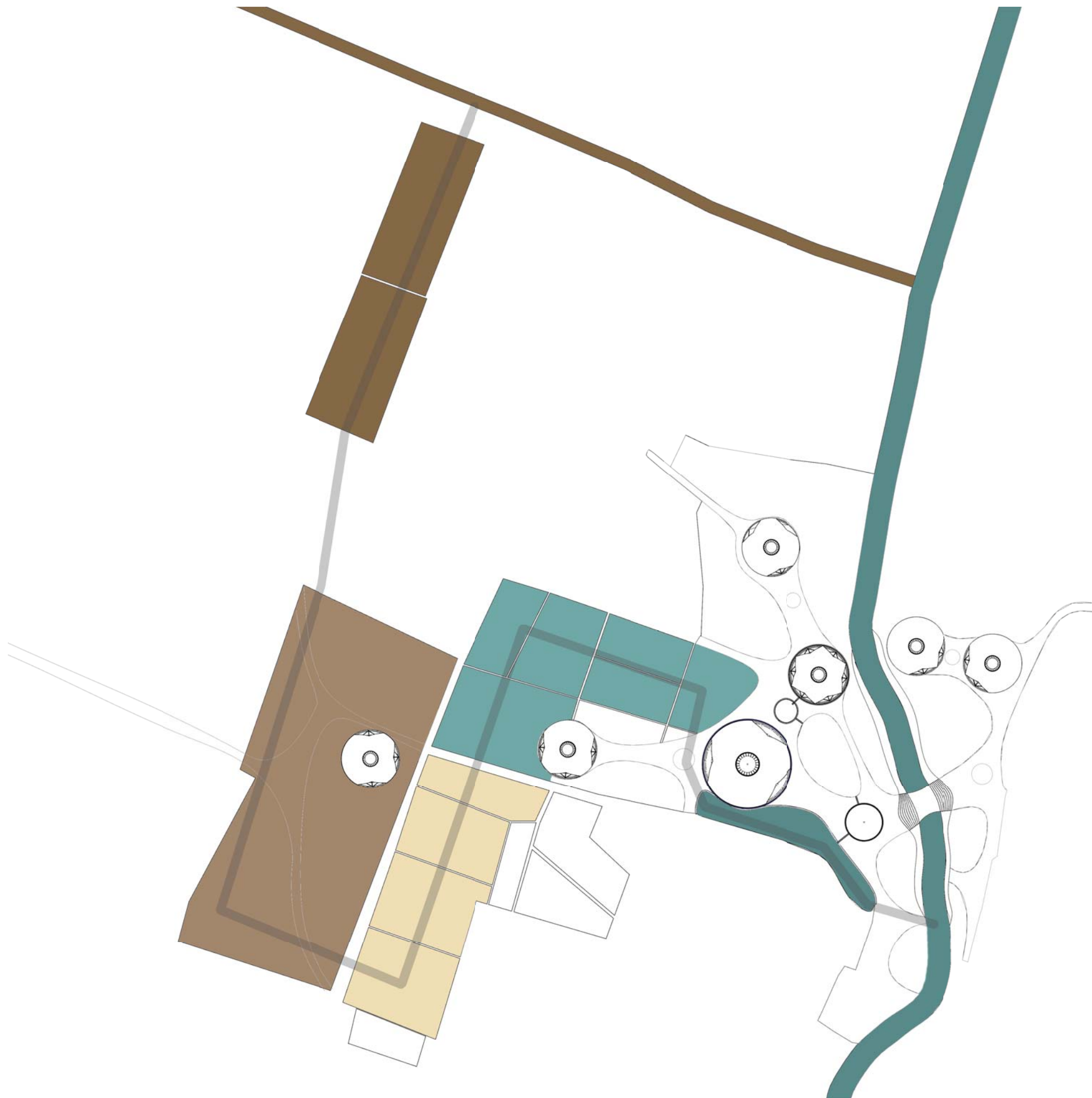

Phytoremediation with bamboo

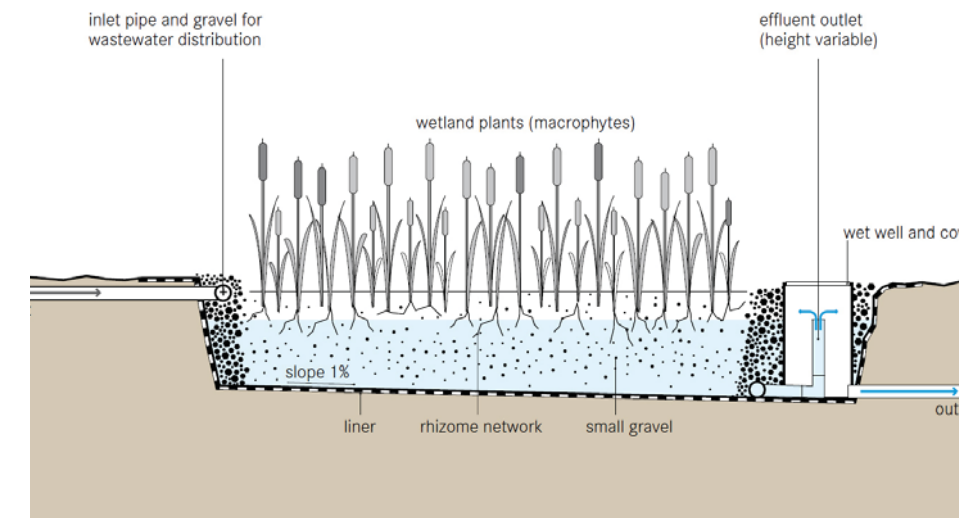

Vertical subsurface flow wetlands

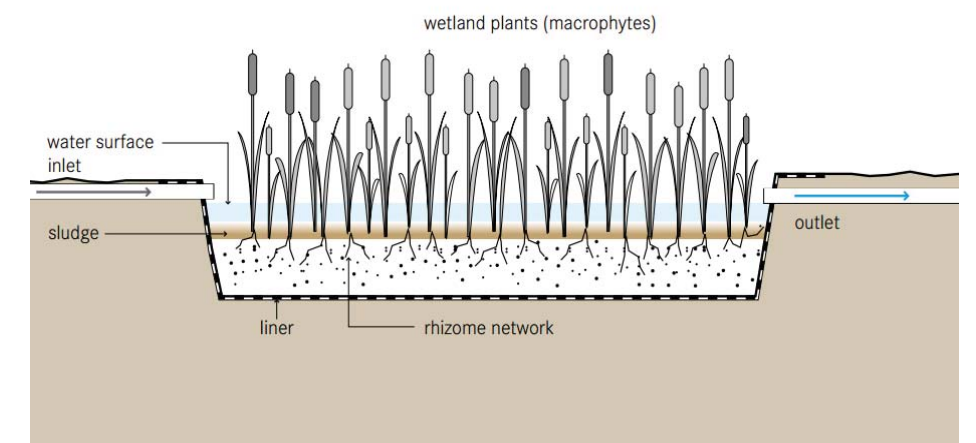

Open water wetland

Aboveground

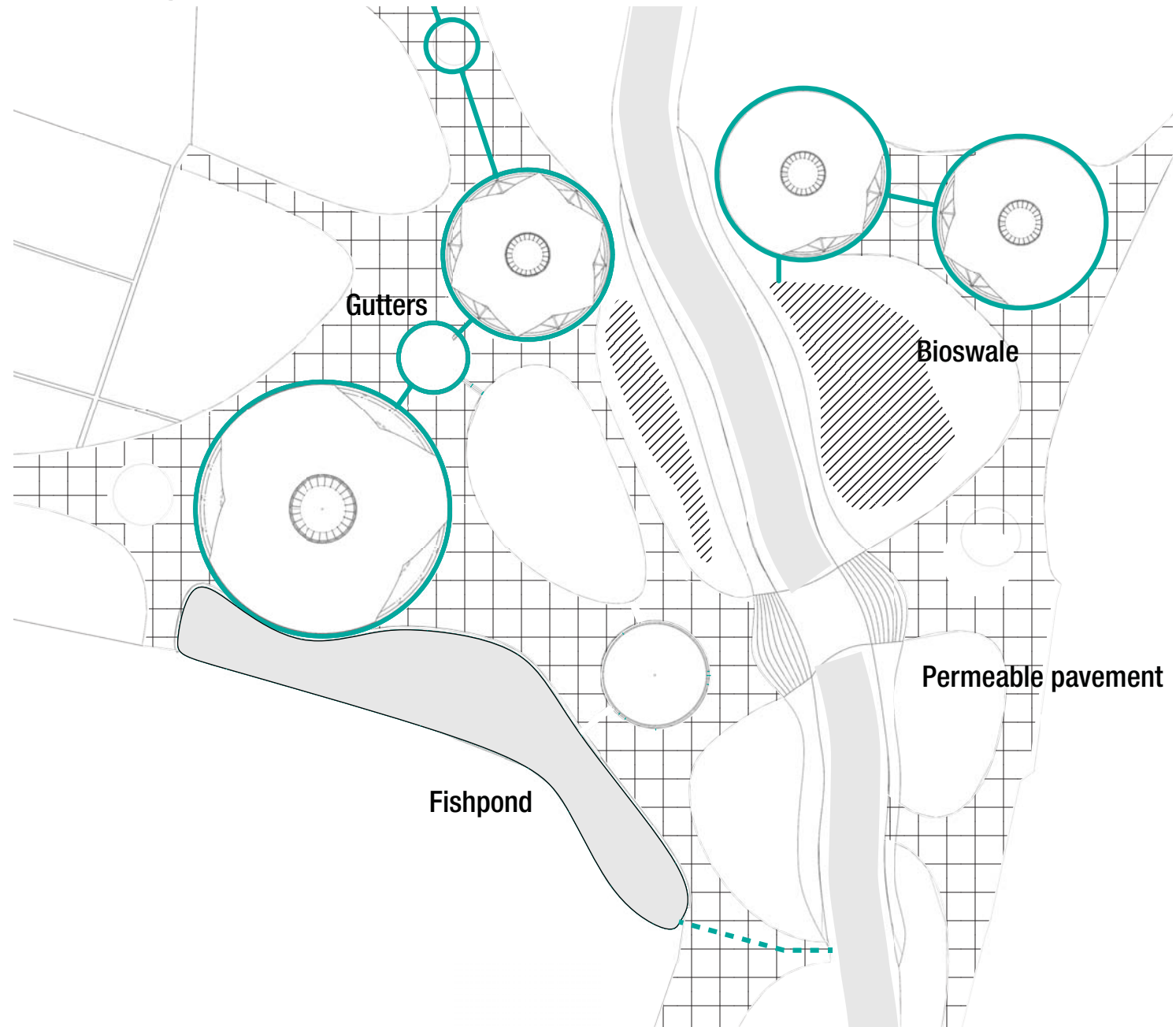

Underground

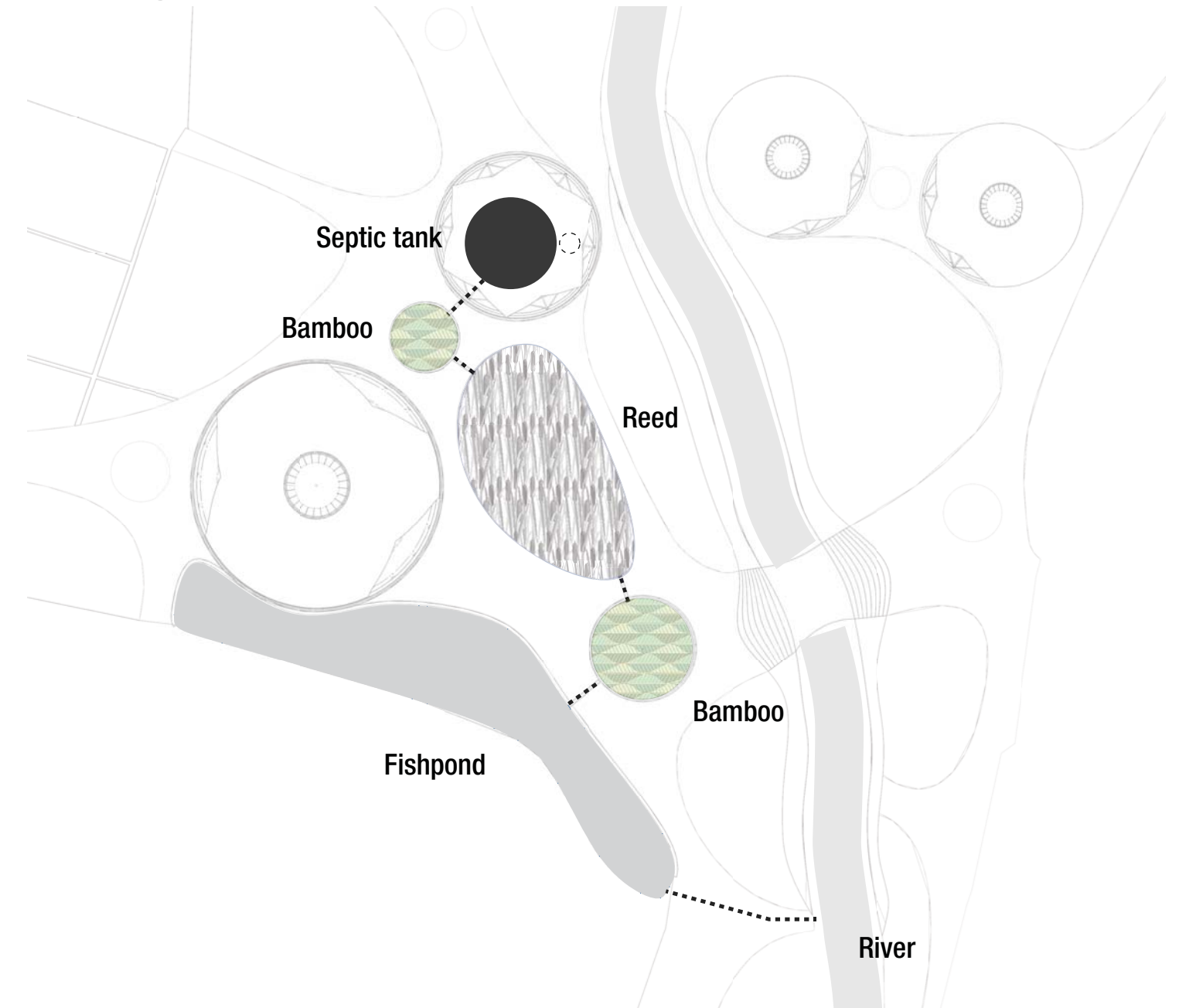

Waterconcept school



Permeable pavement



Bioswales

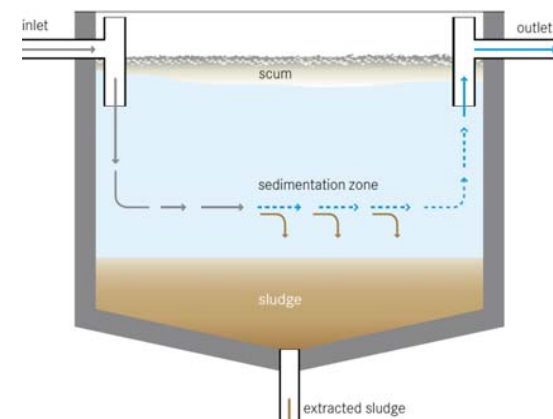

Septic tank for toilets



Fishpond

Plants spatially

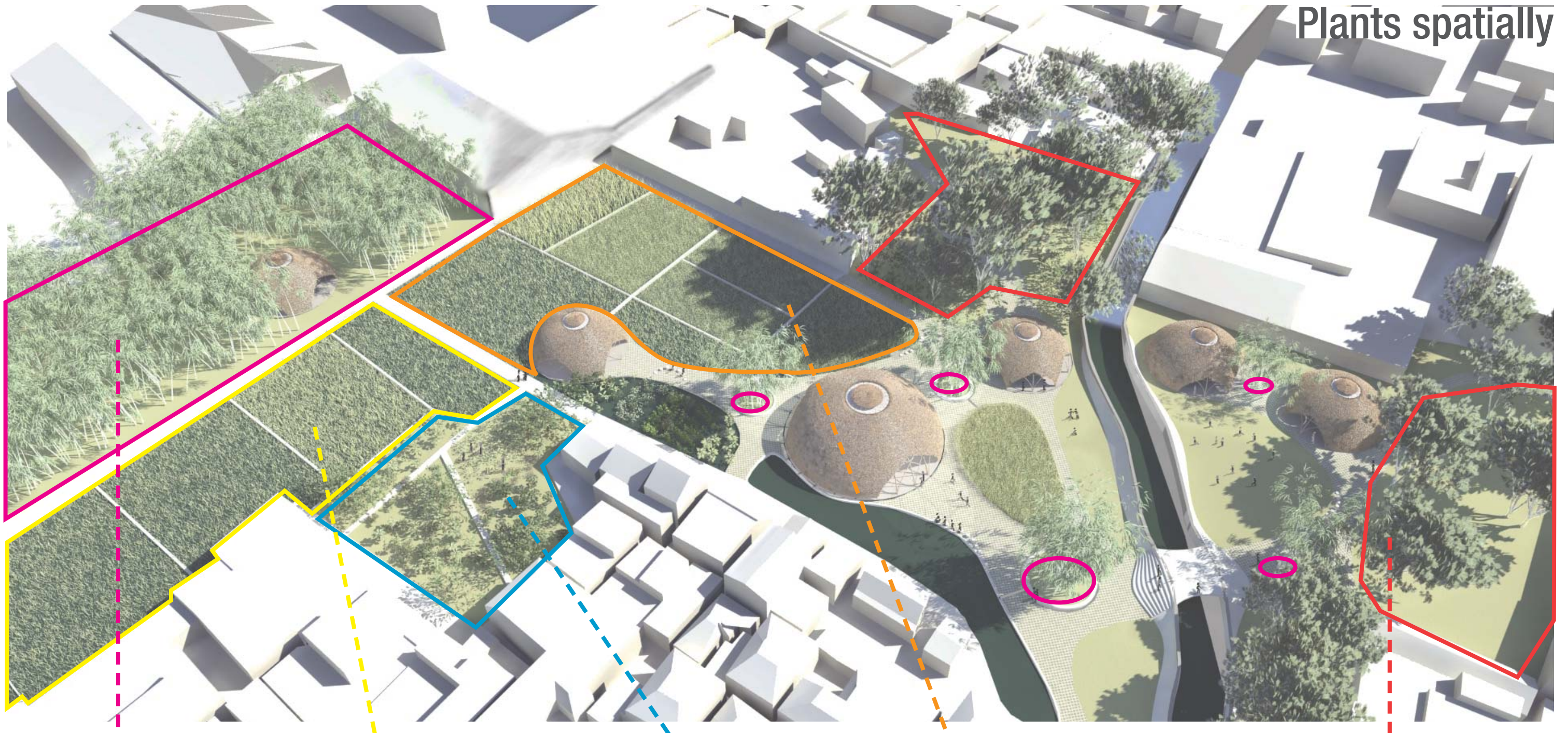

Bamboo



Reed



Urban agriculture



Rice



Trees (fruit)



Bamboo plantation

Rice and reed

Trees

Urban Agriculture

Domes and the in-between

One volume

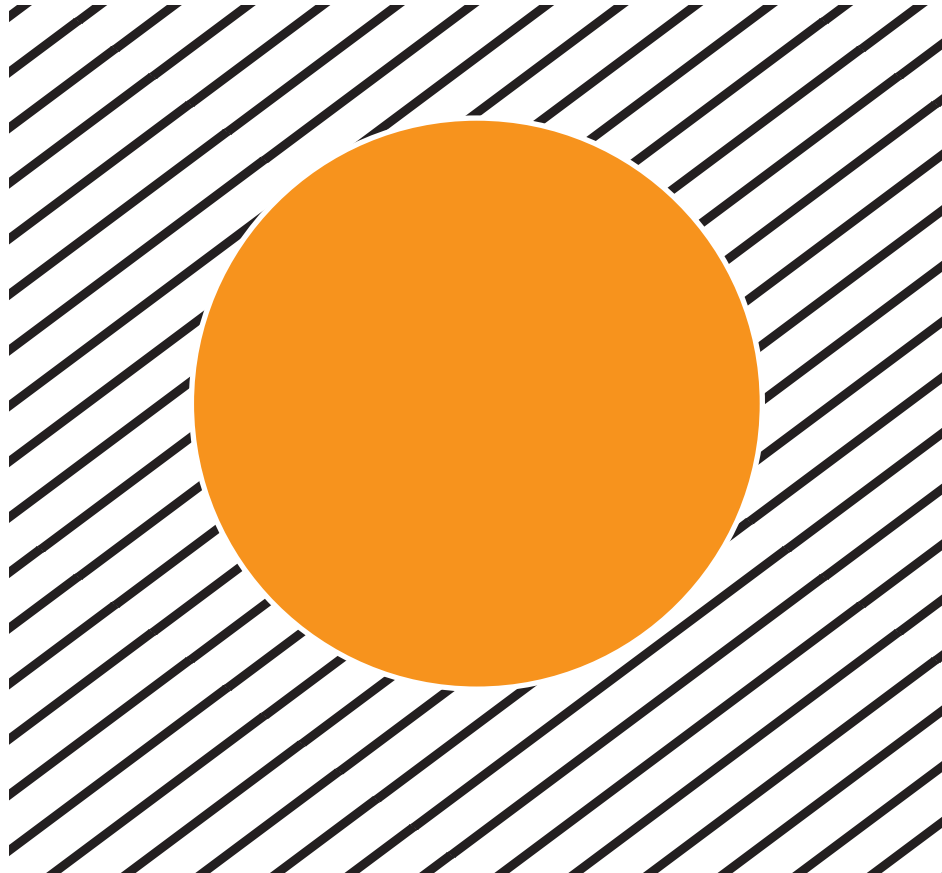

Optimal surface space ratio
Longer spans required

Multiple volumes

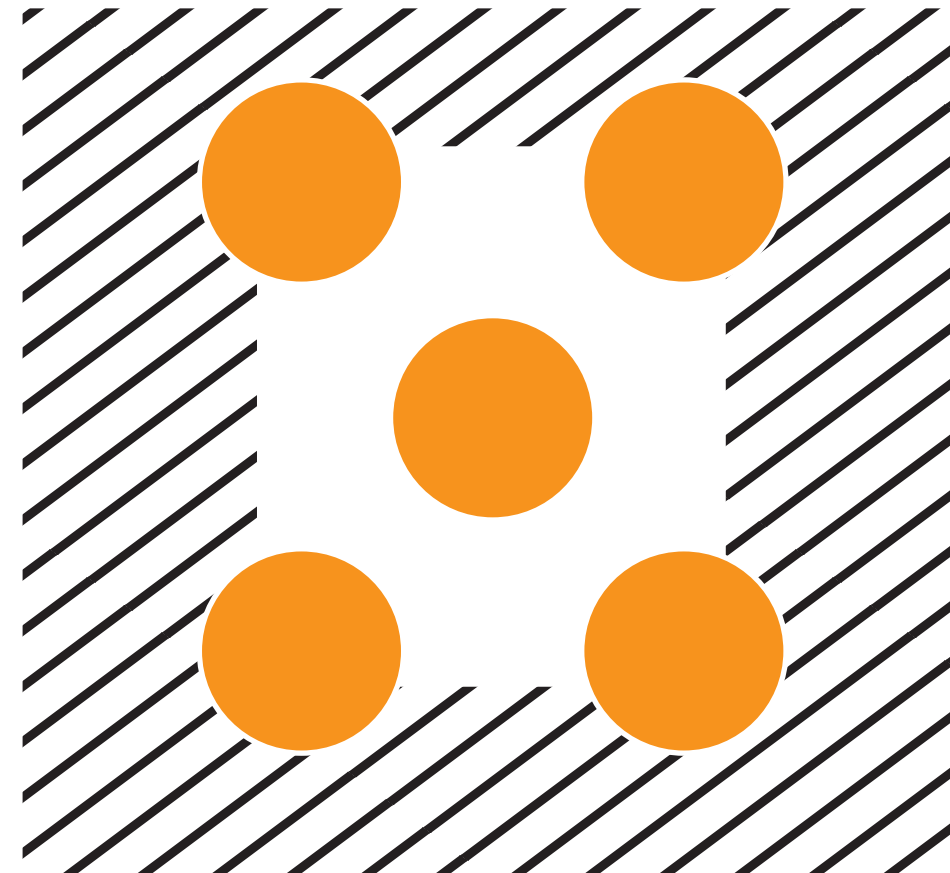

VS

Easier to expand
Intermediate space
Function separation
Sound insulation by distance

Physical connection

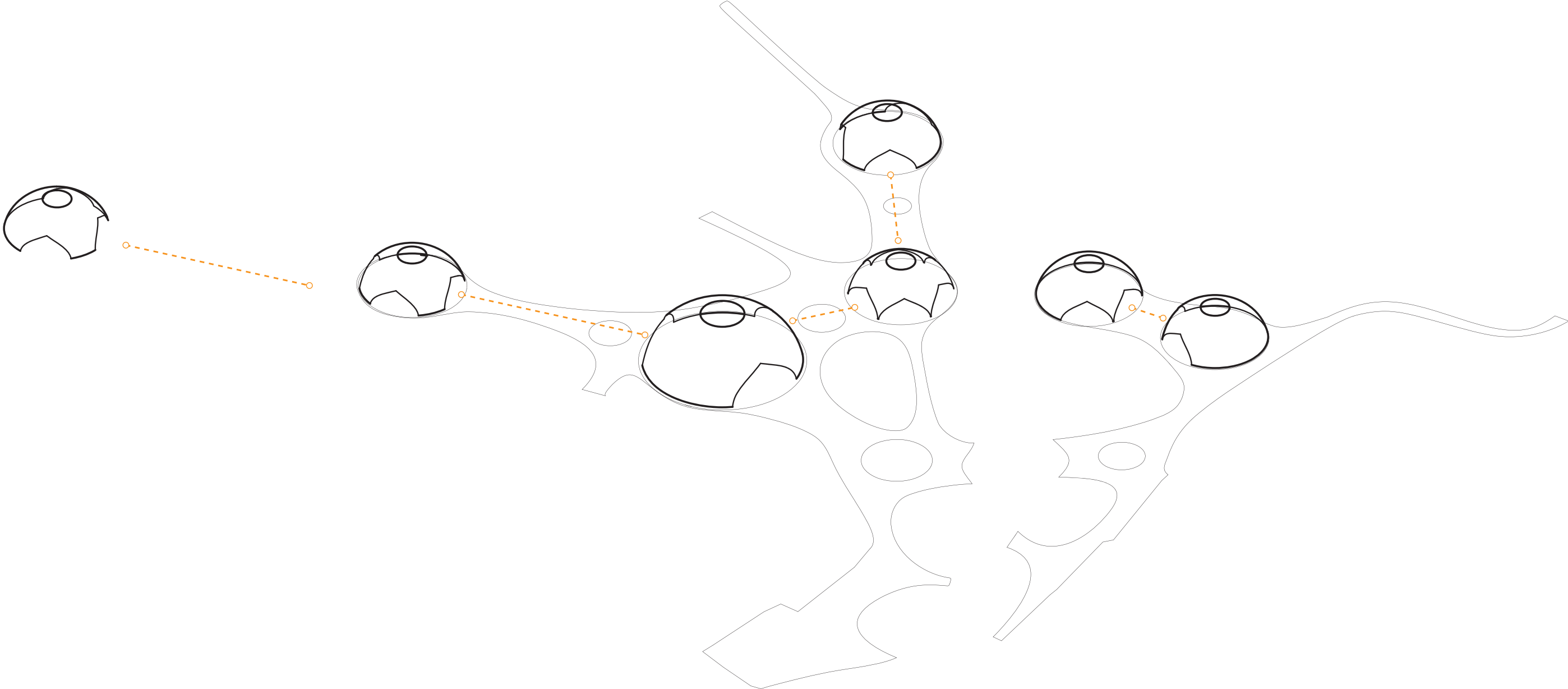

Visual connection to landscape

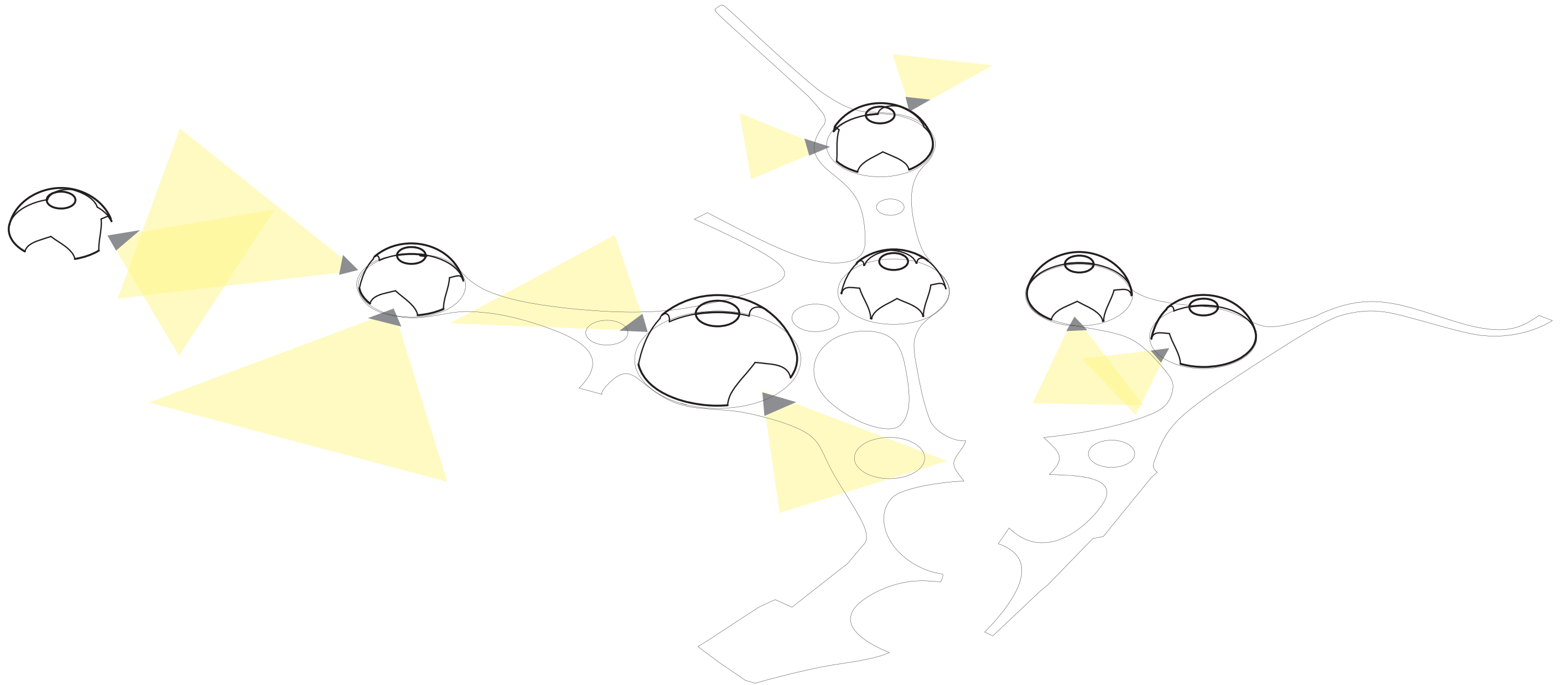

Cut openings



Public routes

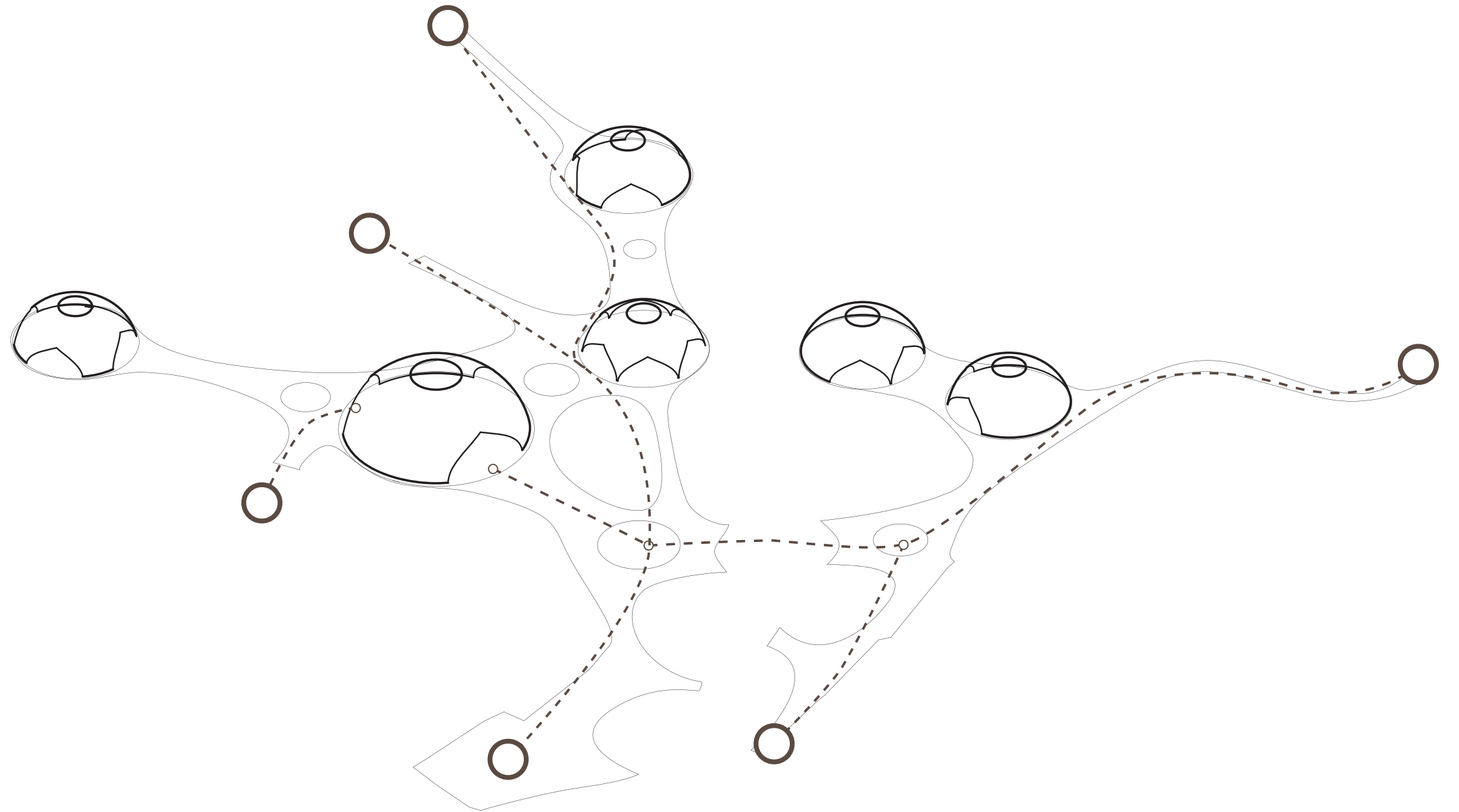

Playground and public space

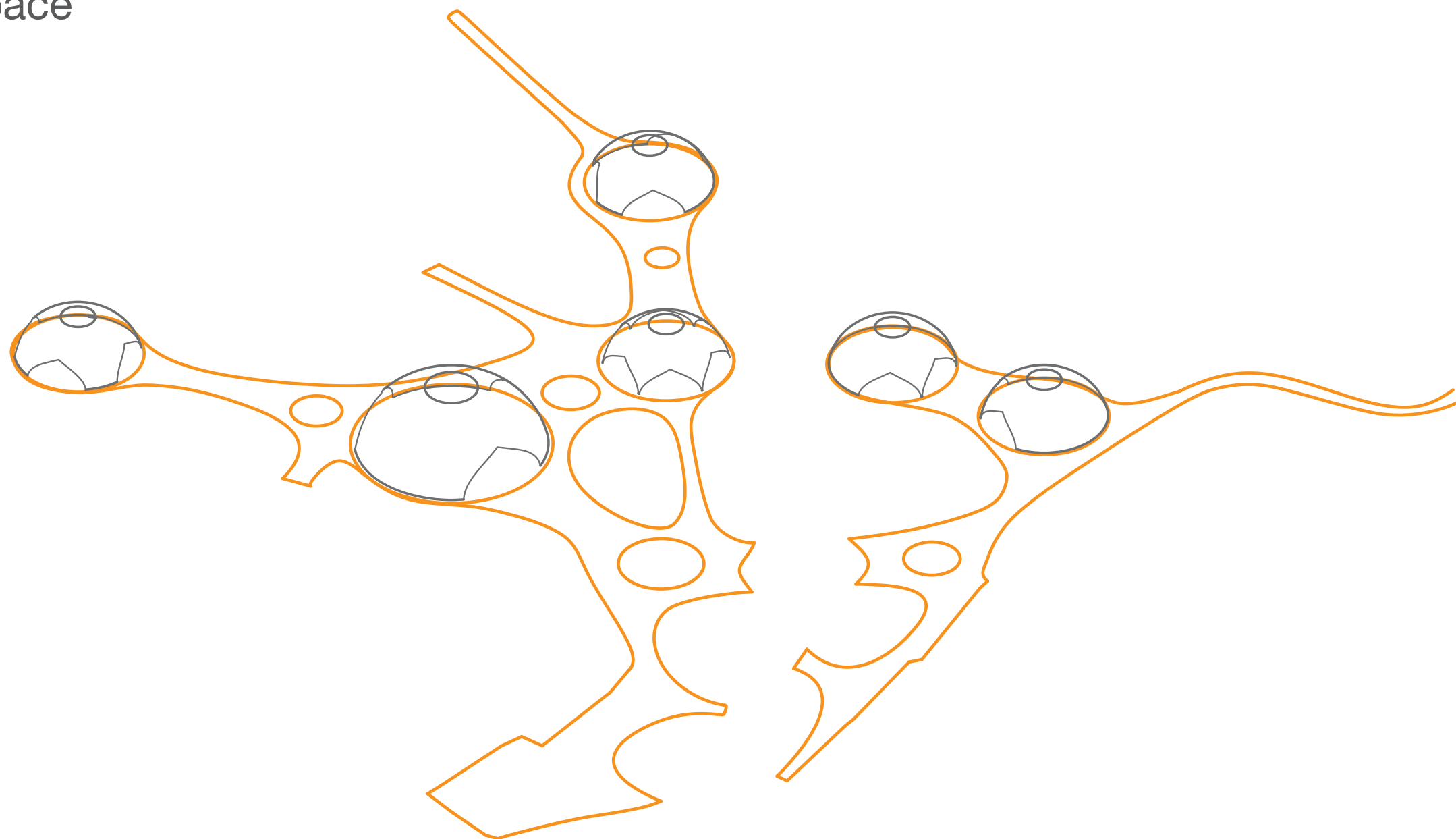

New architectural expression in the Kampung
Show intricate structures partly from the outside

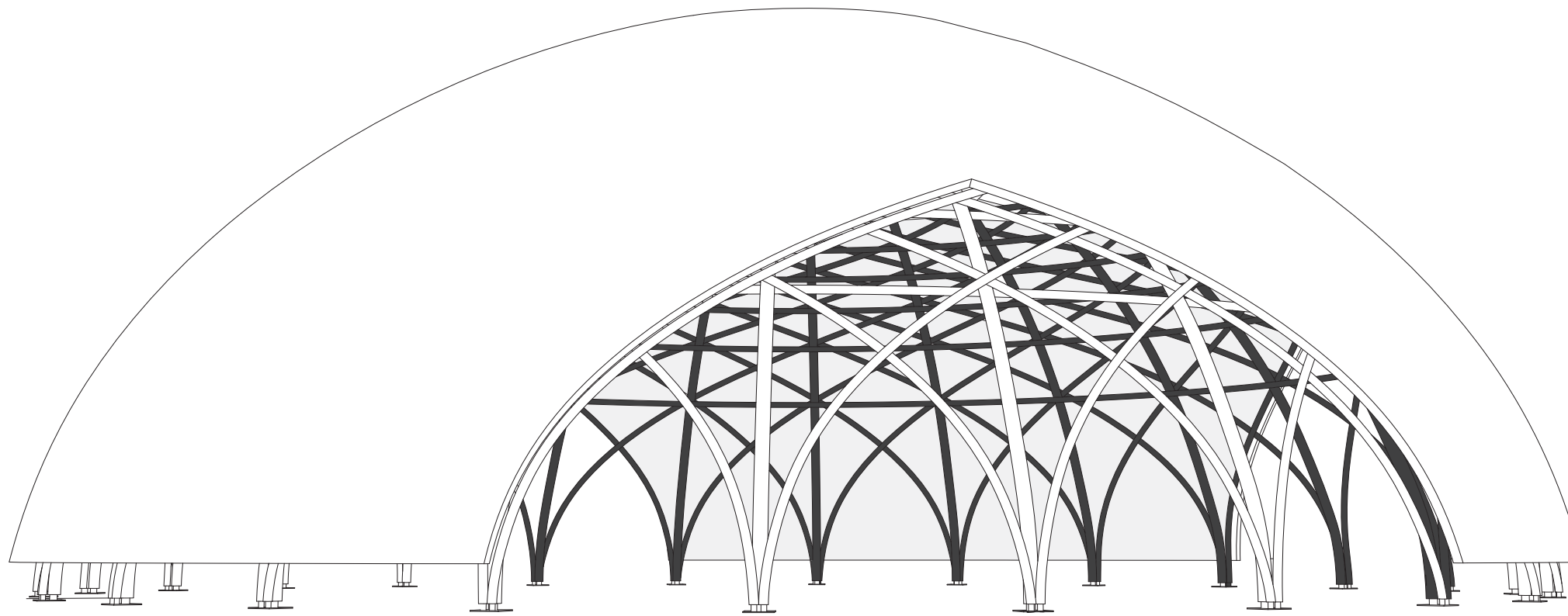

Openings that cut away structure cause Asymmetrical deformations

1.

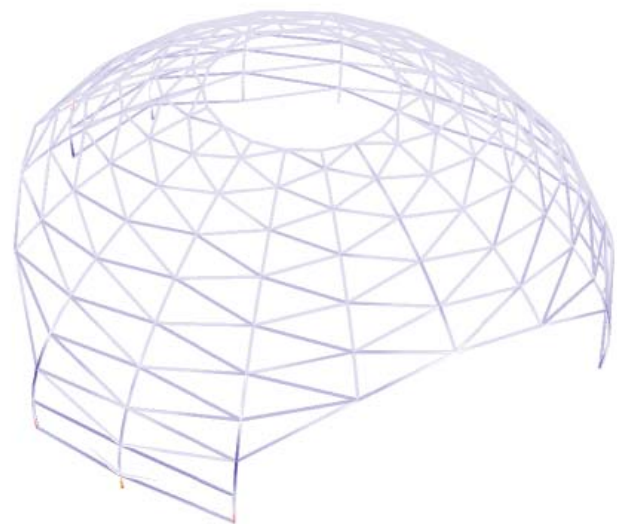

2.

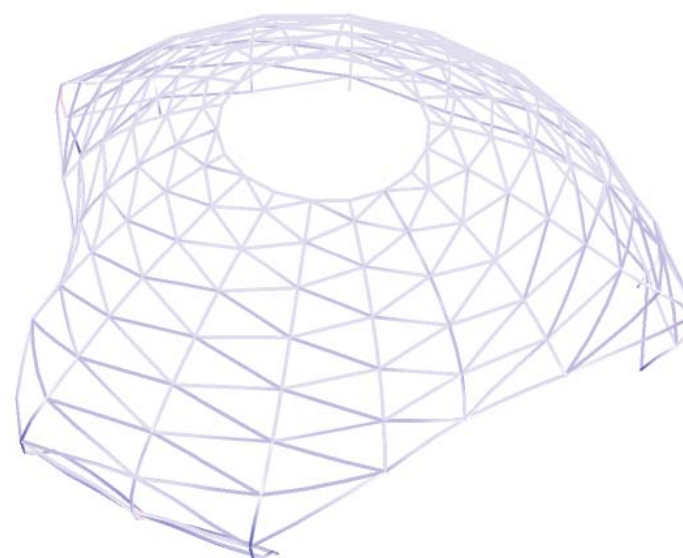

Layering of dome

Thatching

Substructure

Diagrid CCW

Diagrid CW

Ribs and Rings



Benefits

Easy construction
light construction
rope connections
built layer by layer

Can be built by any layman

Construction of diagrid

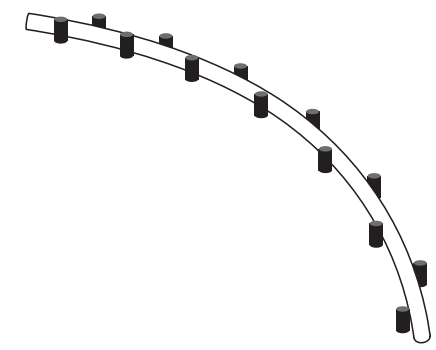

+



Heat the nodes

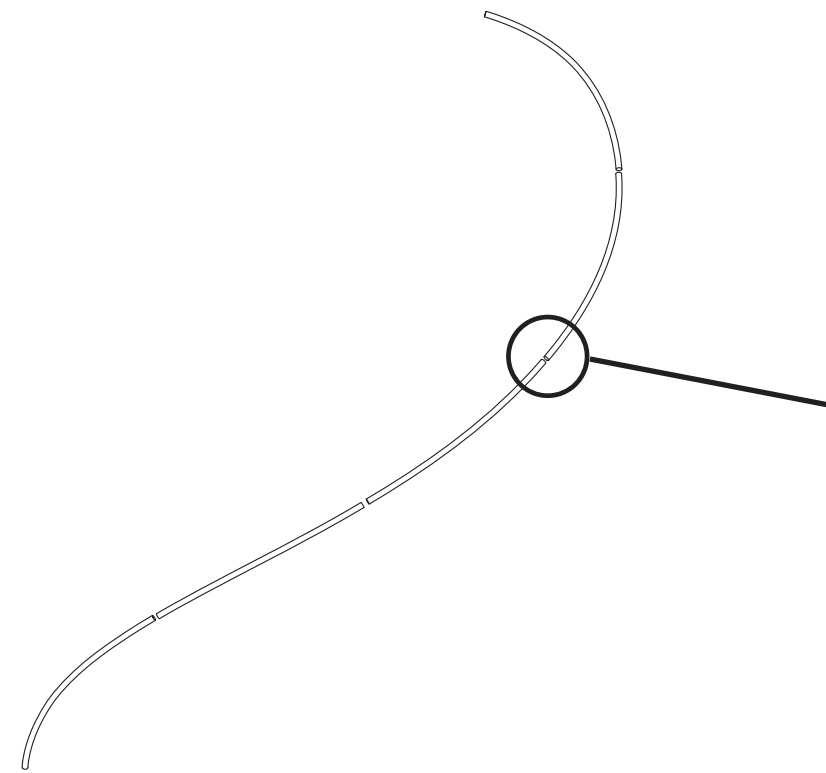

Segmented curved beam

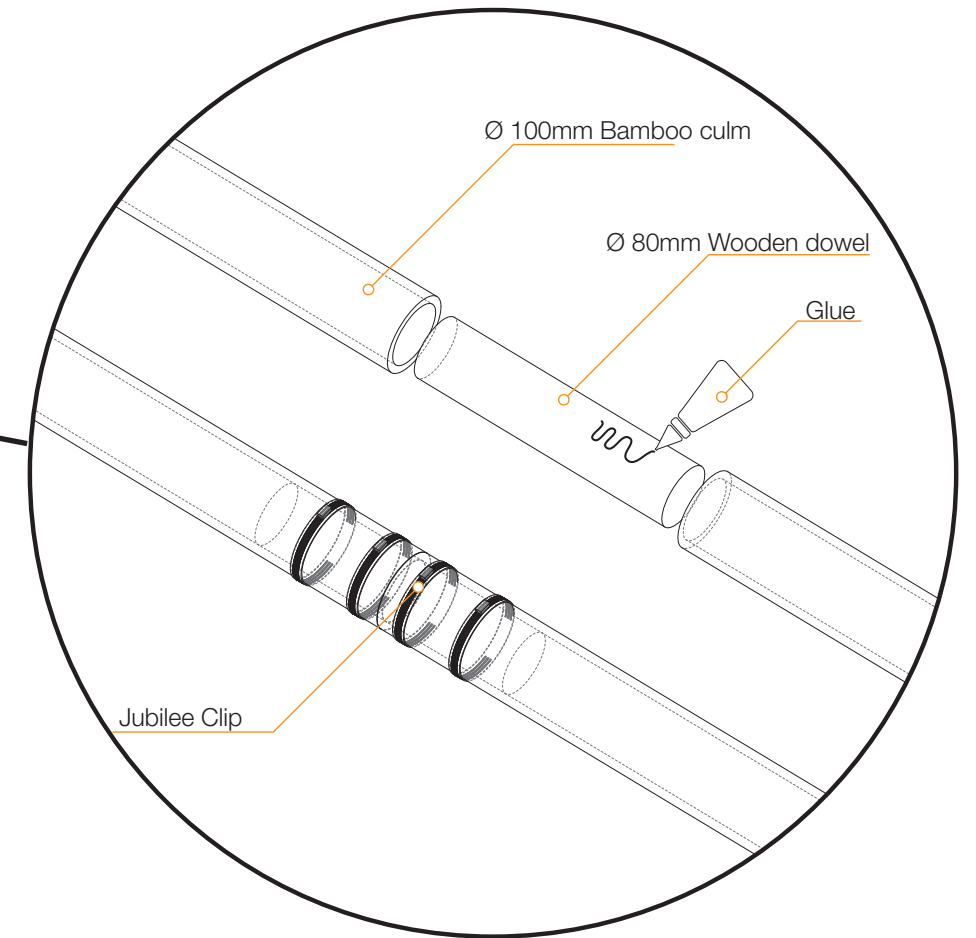

Connect the segments

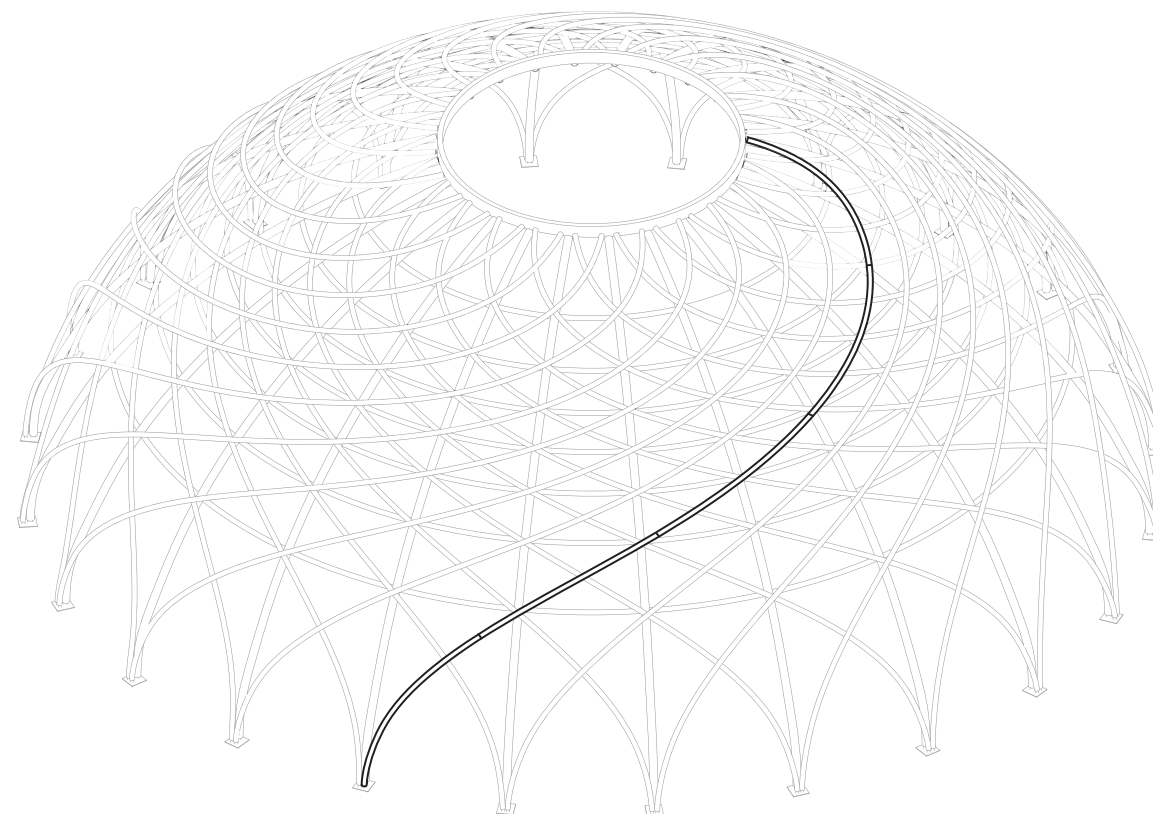

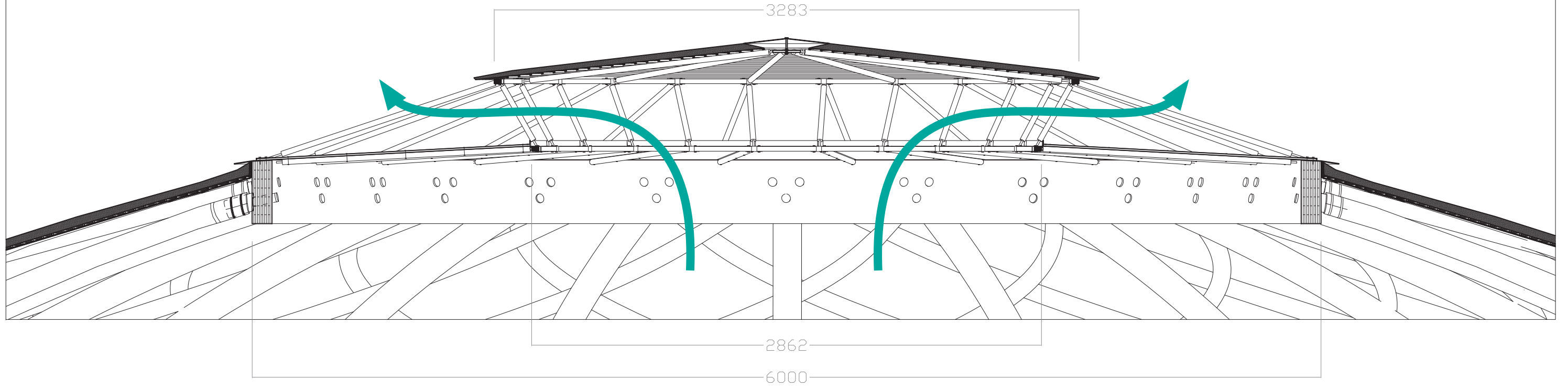

30mm bamboo culm

10mm polycarbonate panel
3mm Aluminium edge

40mm Alang-alang thatch

10x10mm Wooden Lath
20x5mm Bamboo subgrid
100x360mm Laminated bamboo beam

80mm bamboo culm

120mm bamboo culm
Wooden dowel

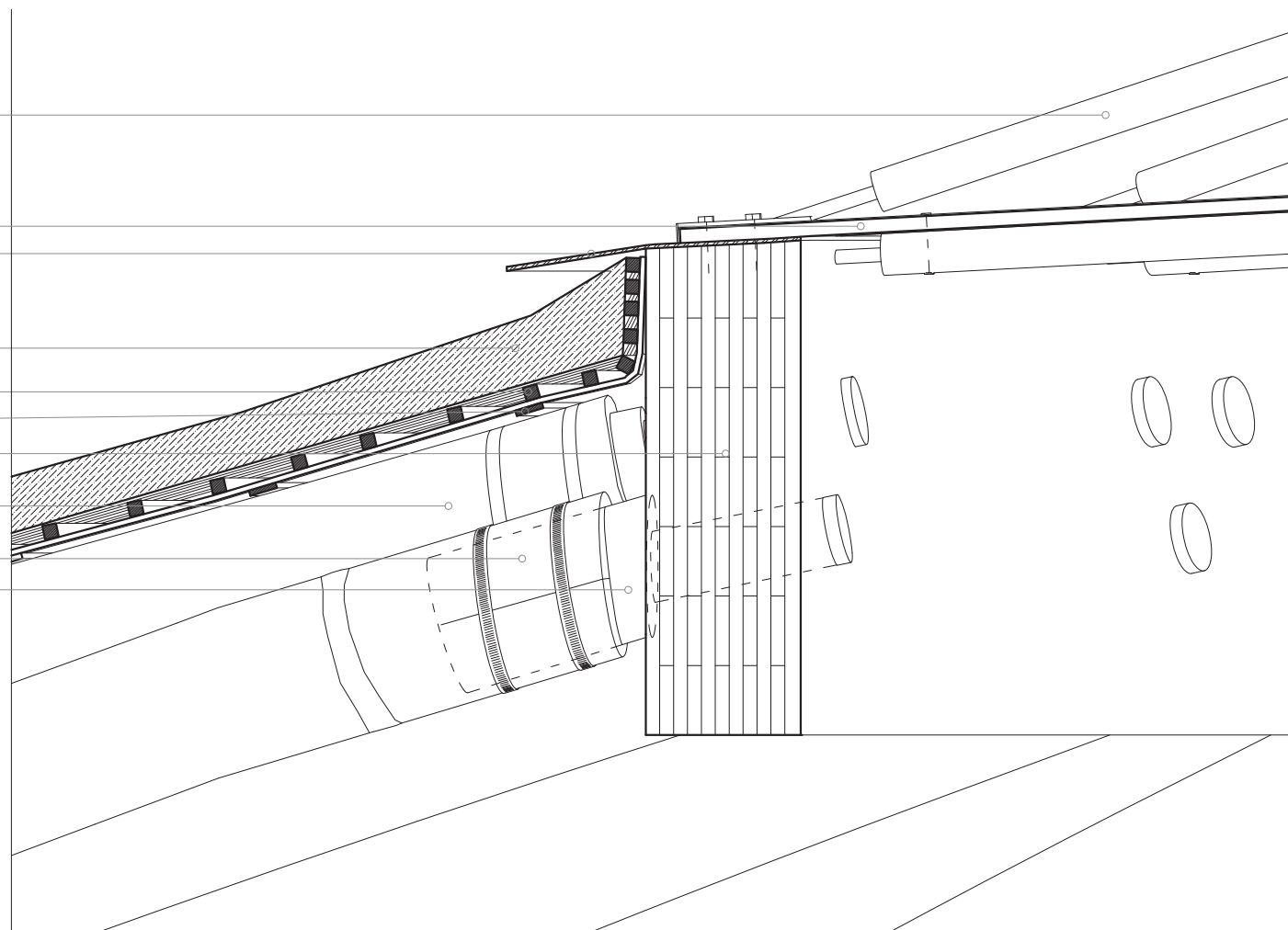

Construction of top element

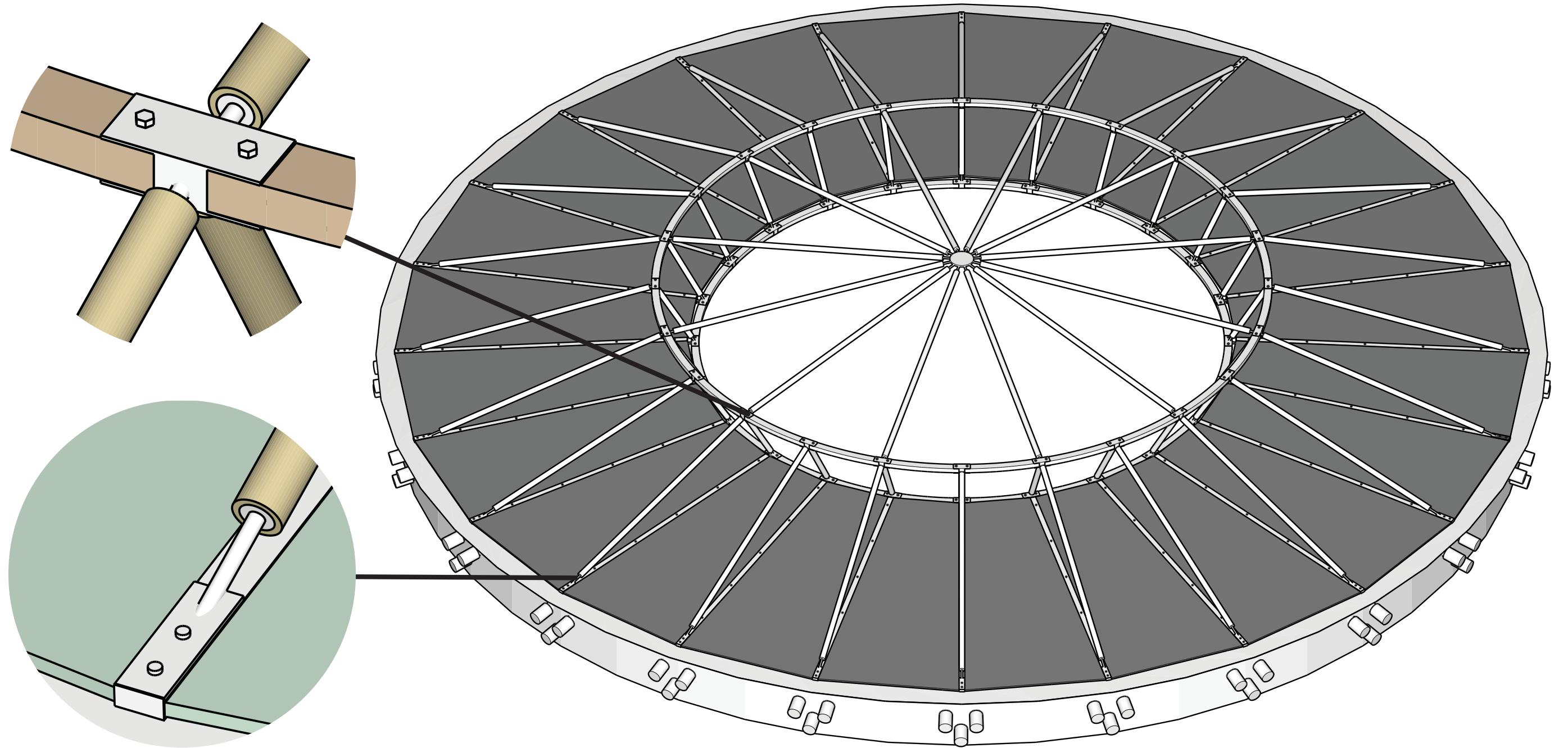

Construction of foundation

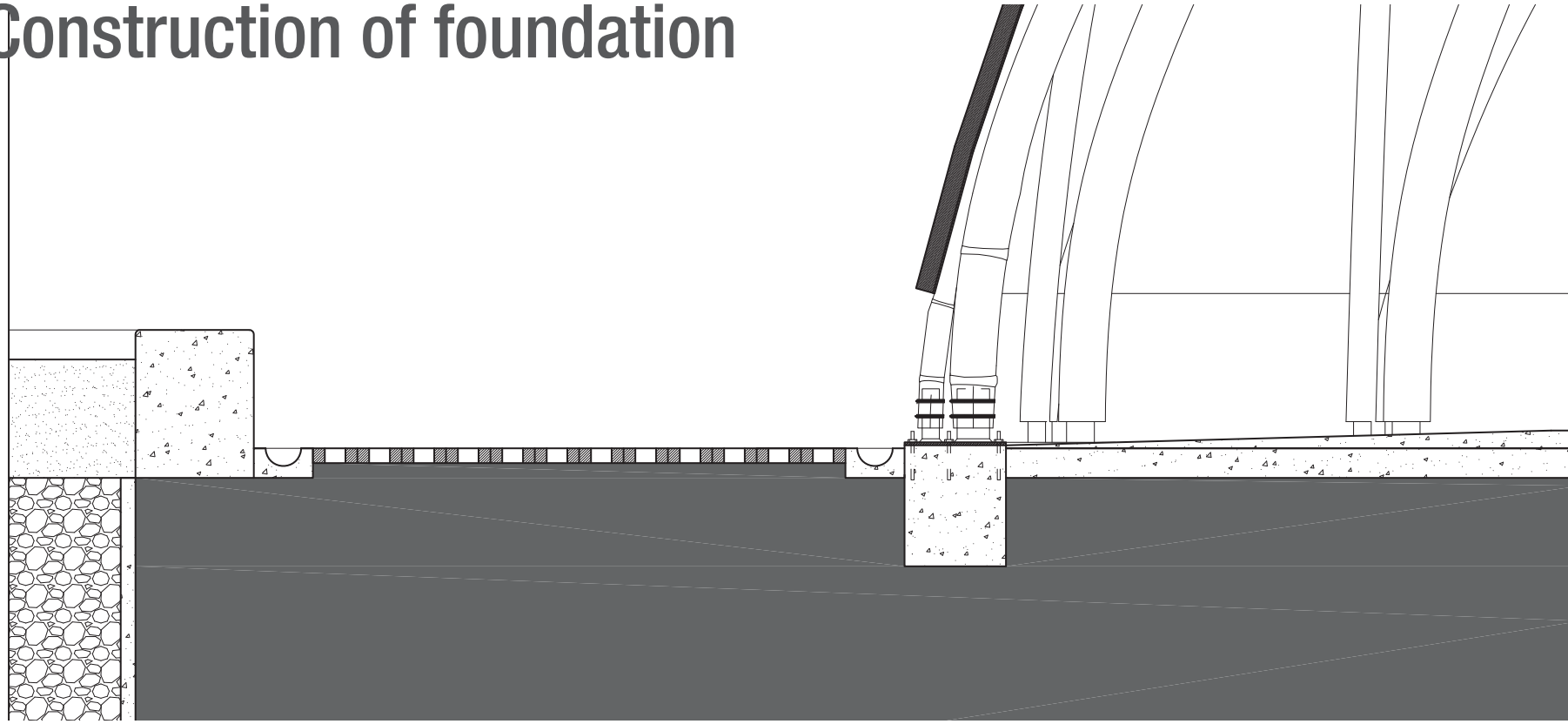

Jubilee Clip

60mm soldered tube
105mm soldered tube

10mm Steel base plate

Permeable paving blocks

10mm steel bolts

Pre-cast Concrete gutter

300mm concrete foundation

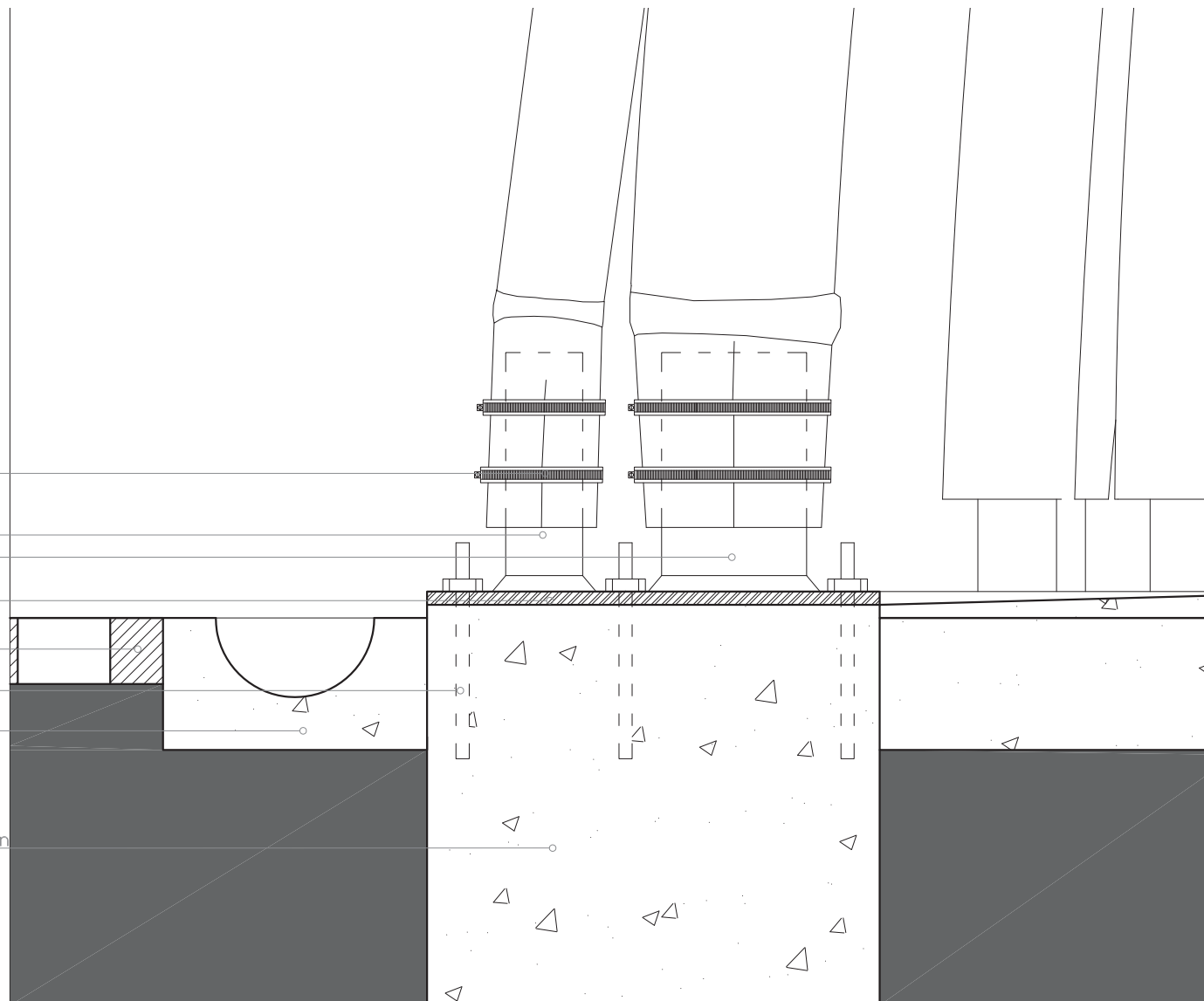

Functions and interior

Protective Shell
against sun and
rain

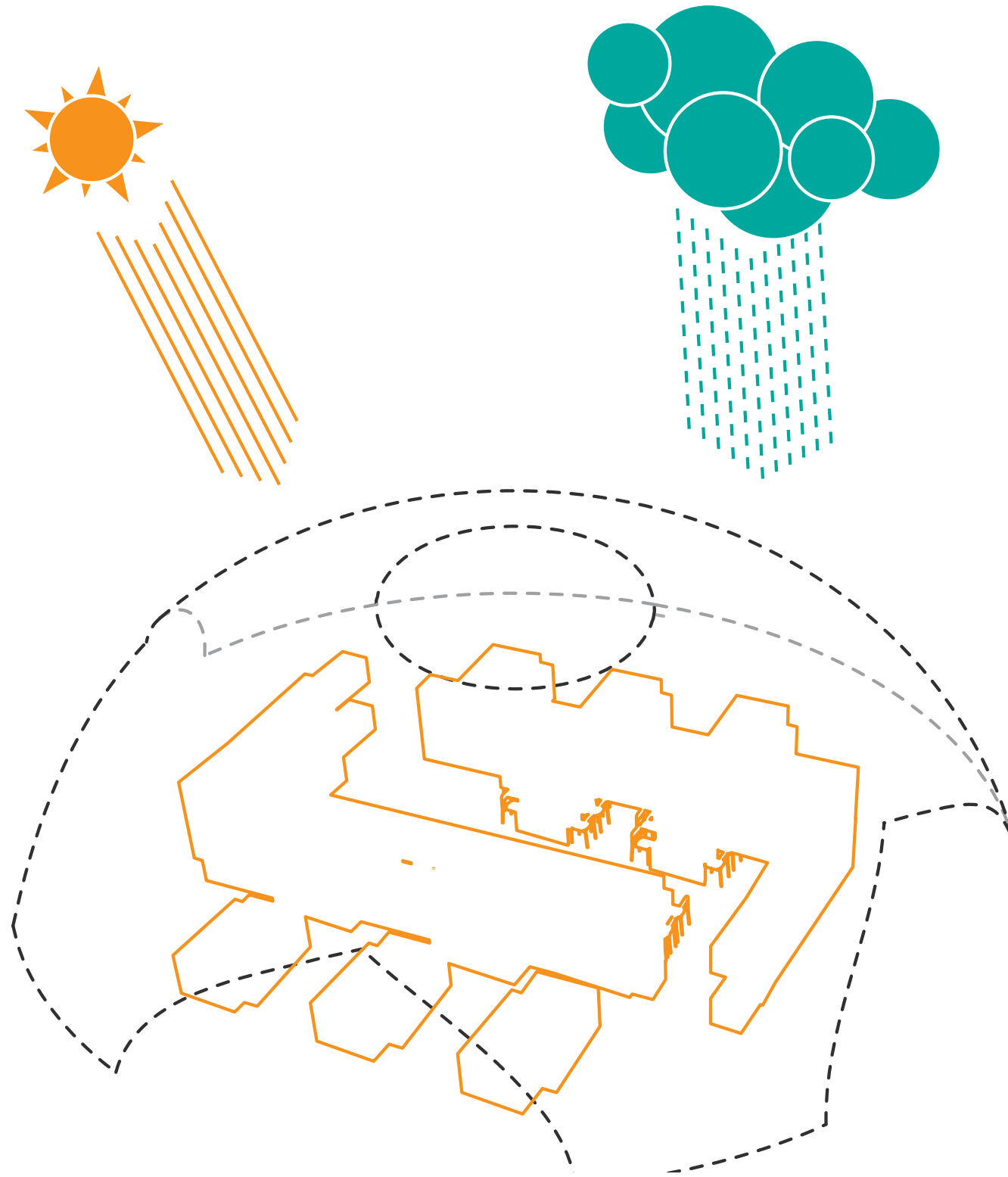

Modular wall system
Diverse options
Flexible
Multifunctional

Multifunctional modular wall system

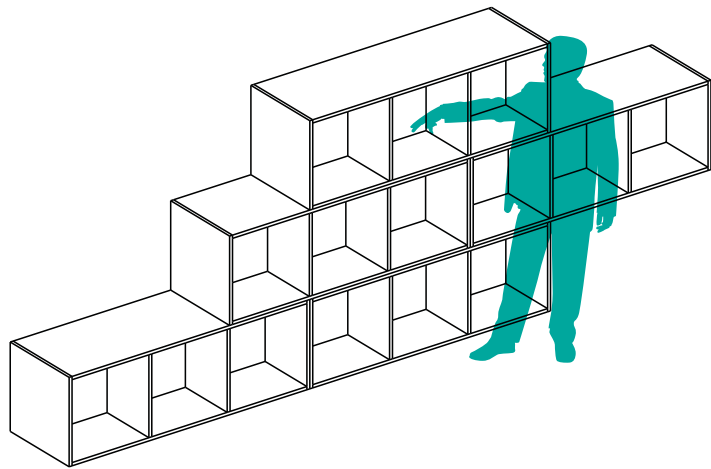

Shelves

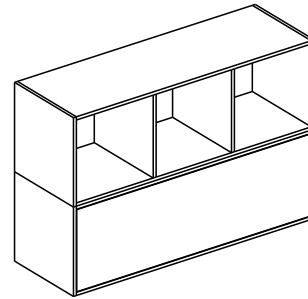

Standing table (adult)

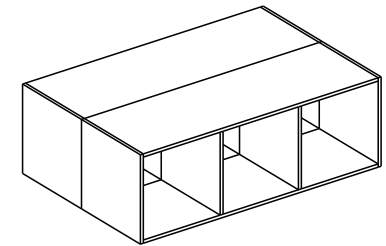

Sitting table (child)

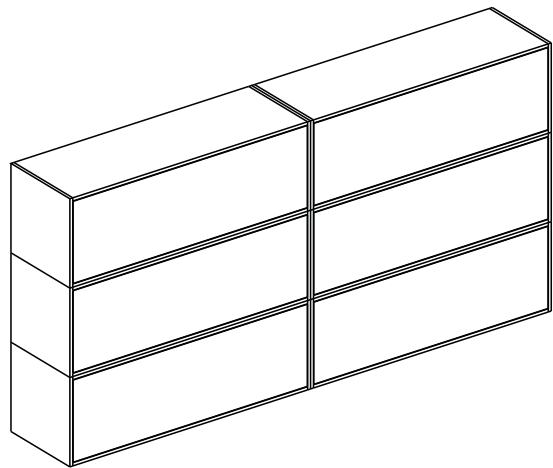

Acoustic absorption wall

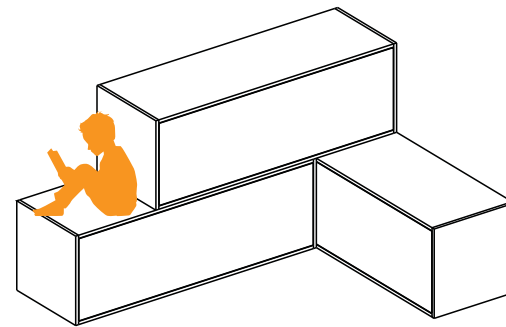

Sitting/ standing/ climbing

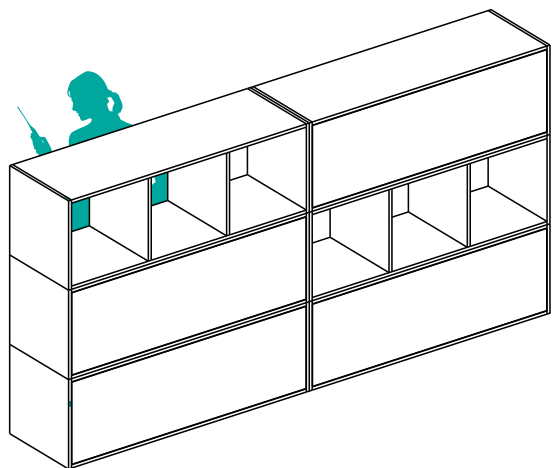

Windows

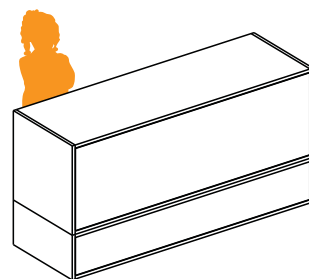

Standing table (child)

Wall-system benefits for interior acoustics

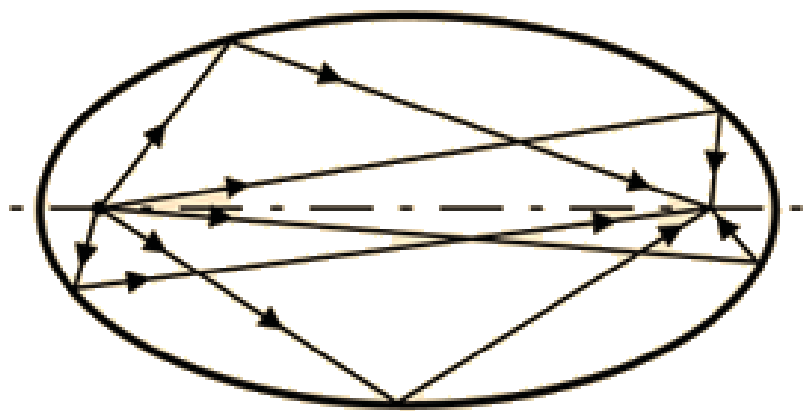

Unwanted focus of reflections

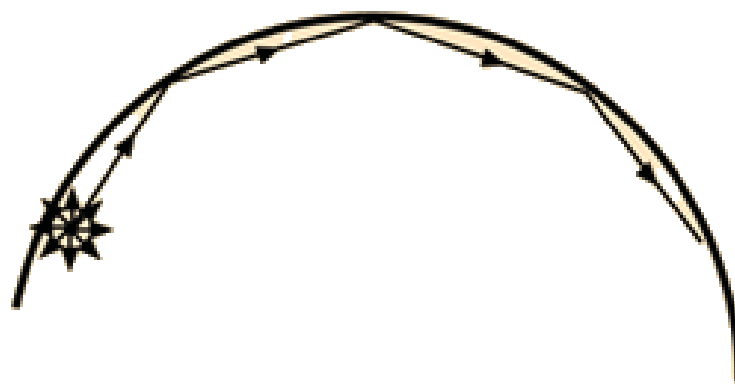

Rotunda effect

Sabine Formula

$$T_r = 0.161(V/A)$$

$$A = \alpha_1 * A_1 + \alpha_2 * A_2 \dots \text{etc}$$

$$200 * 0.7 = 140$$

$$100 * 0.4 = 40$$

$$0.161(466/180) = 0.42s @ 500Hz$$

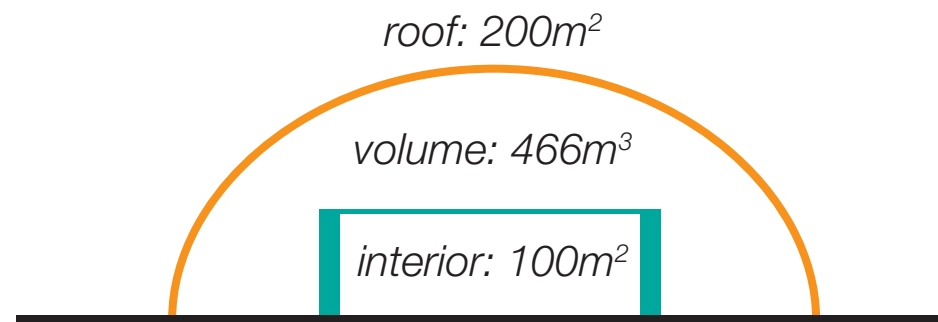

$T_r = 0.42s @ 500 Hz$

Optimal is 0.35s in classrooms

Coconut-fibre Batts

Absorption coefficient: avg. 0.6 @ speech frequencies

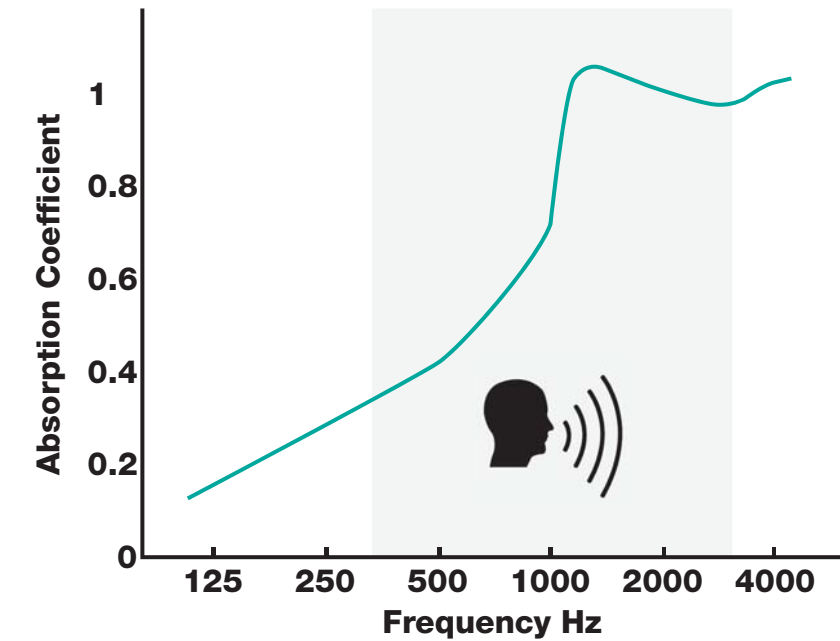

Reeds

Absorption coefficient: avg. 0.75 @ speech frequencies

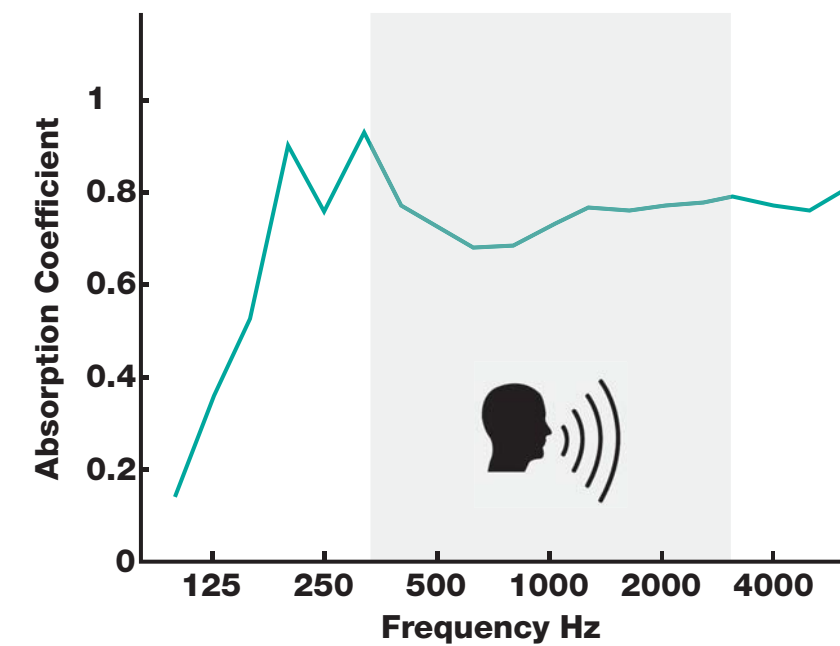

Modular assembly

Box assembly

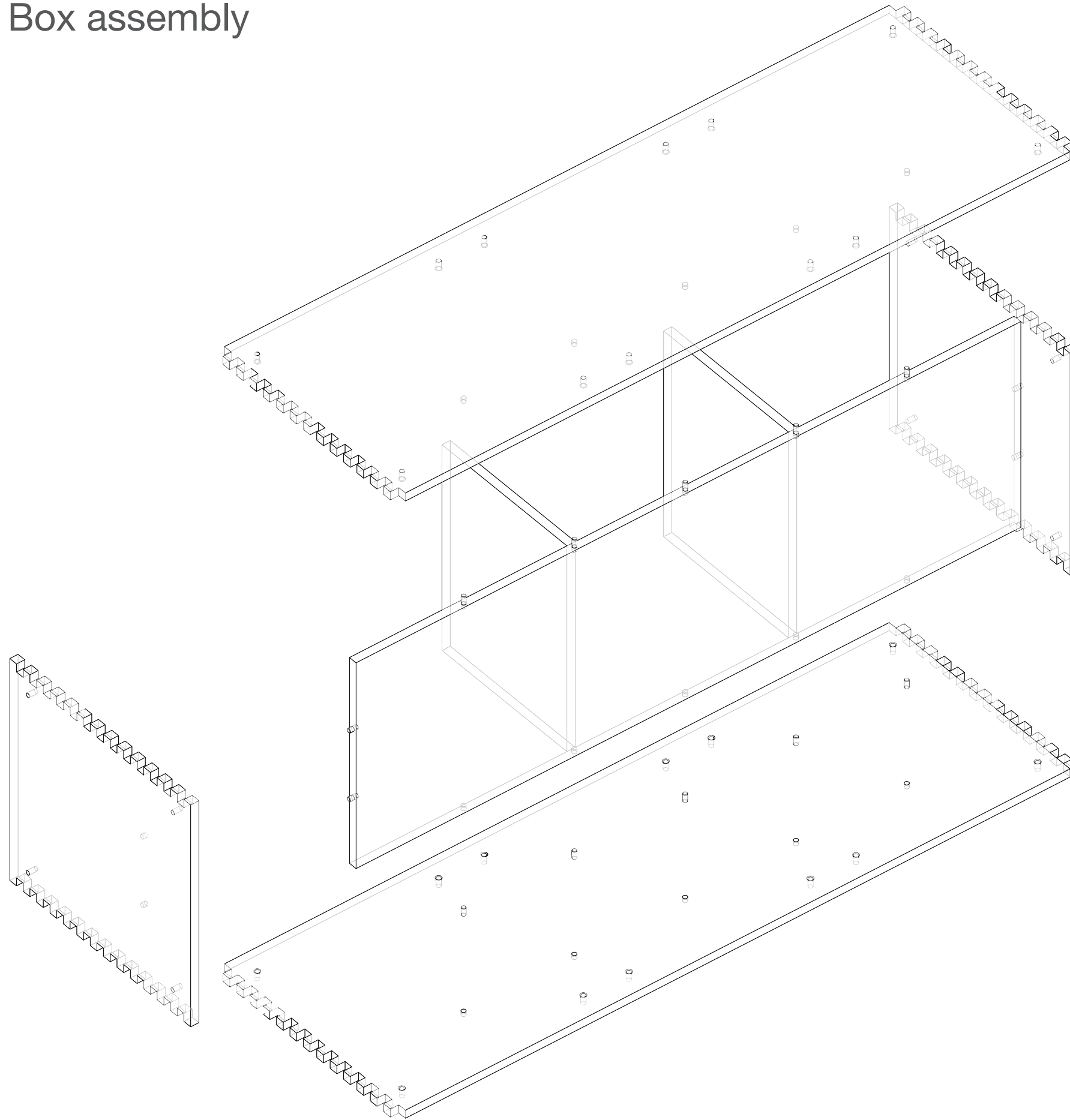

Box-box connection

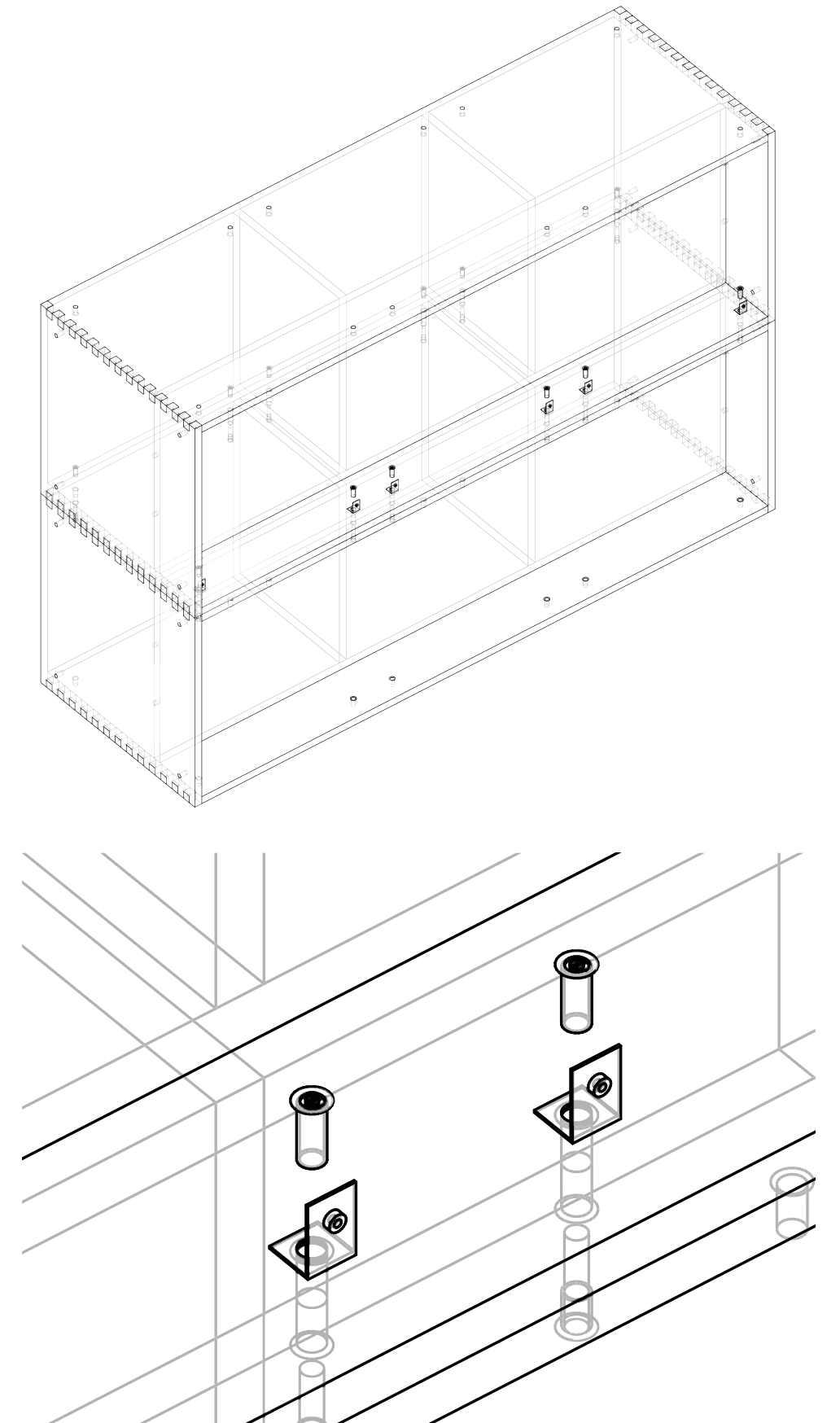

Layout typologies

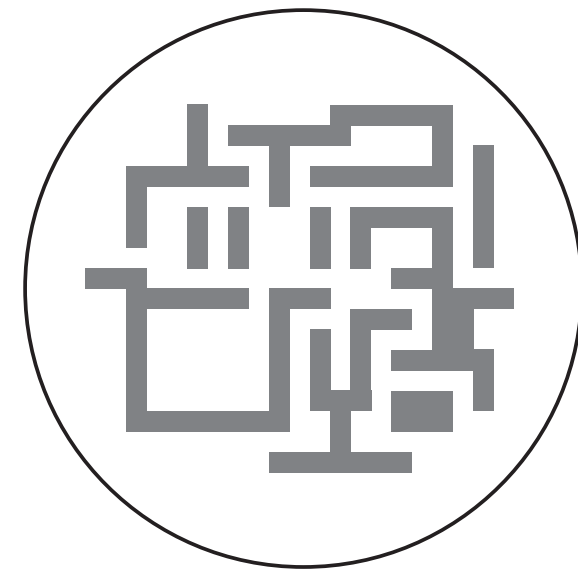
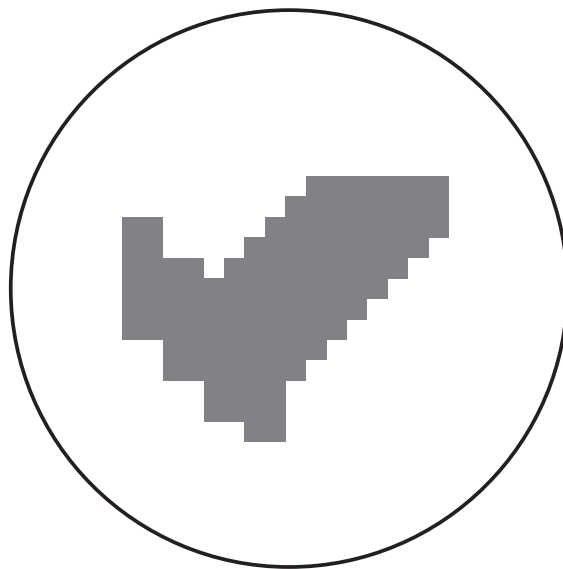
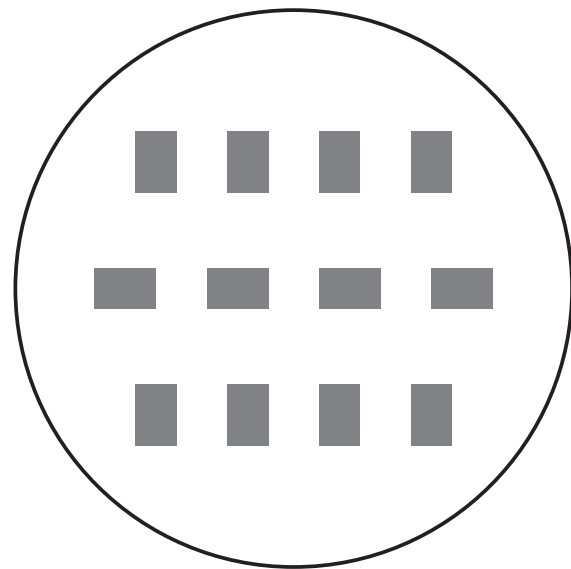
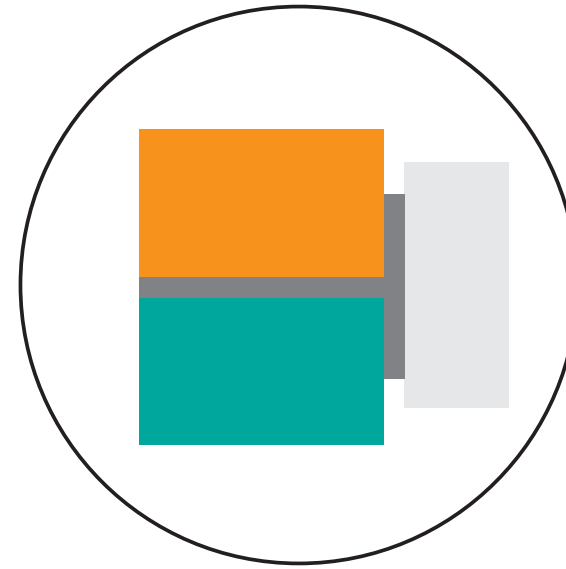
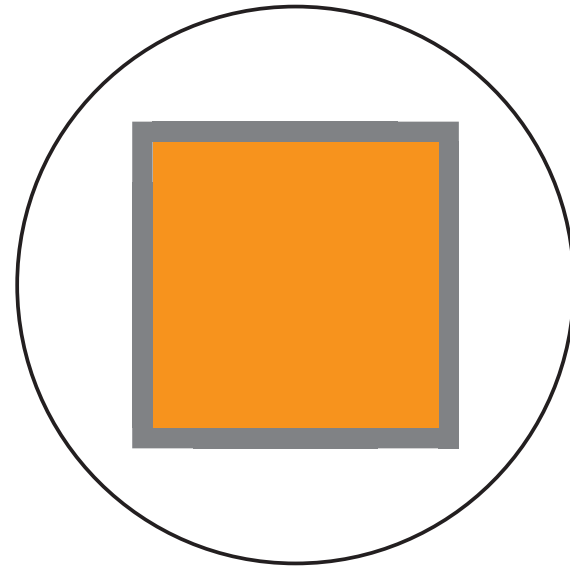

Functions school

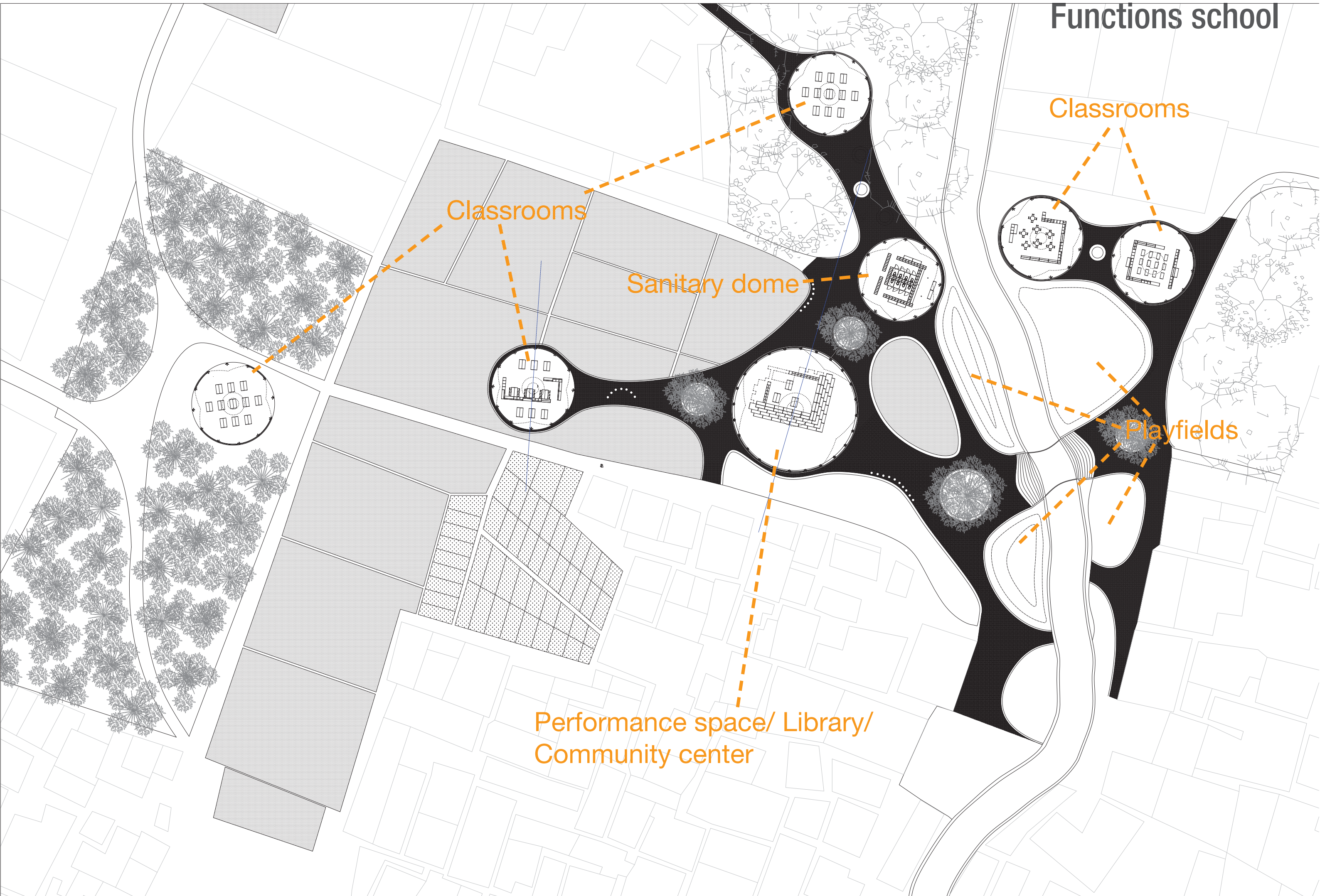

Classrooms

Sanitary dome

Classrooms

Playfields

Performance space/ Library/
Community center

Performance space/ Library/
Community center

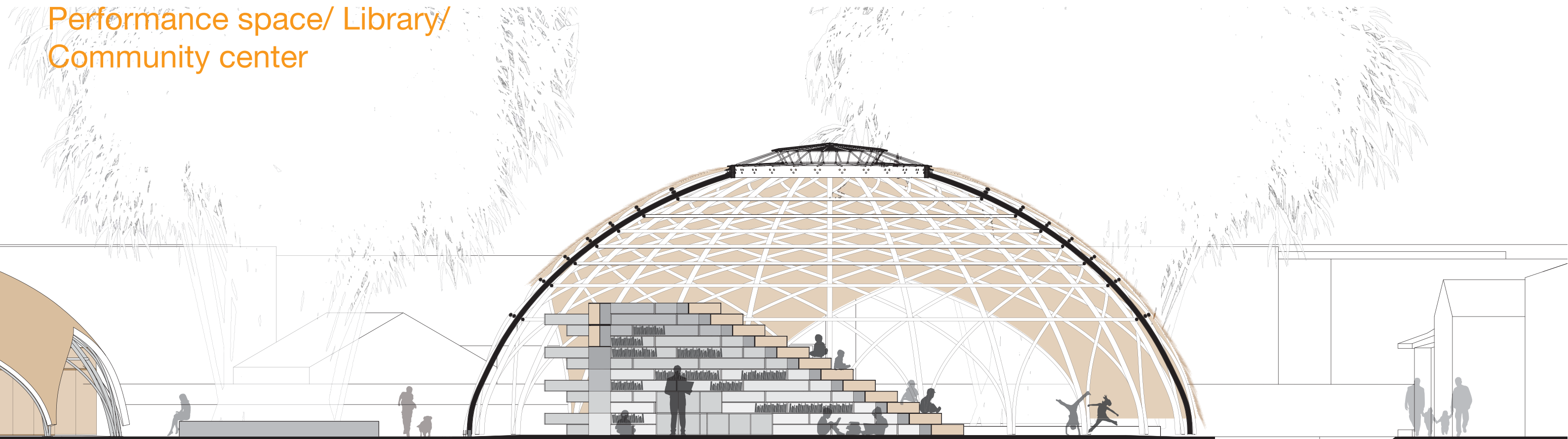

Classroom

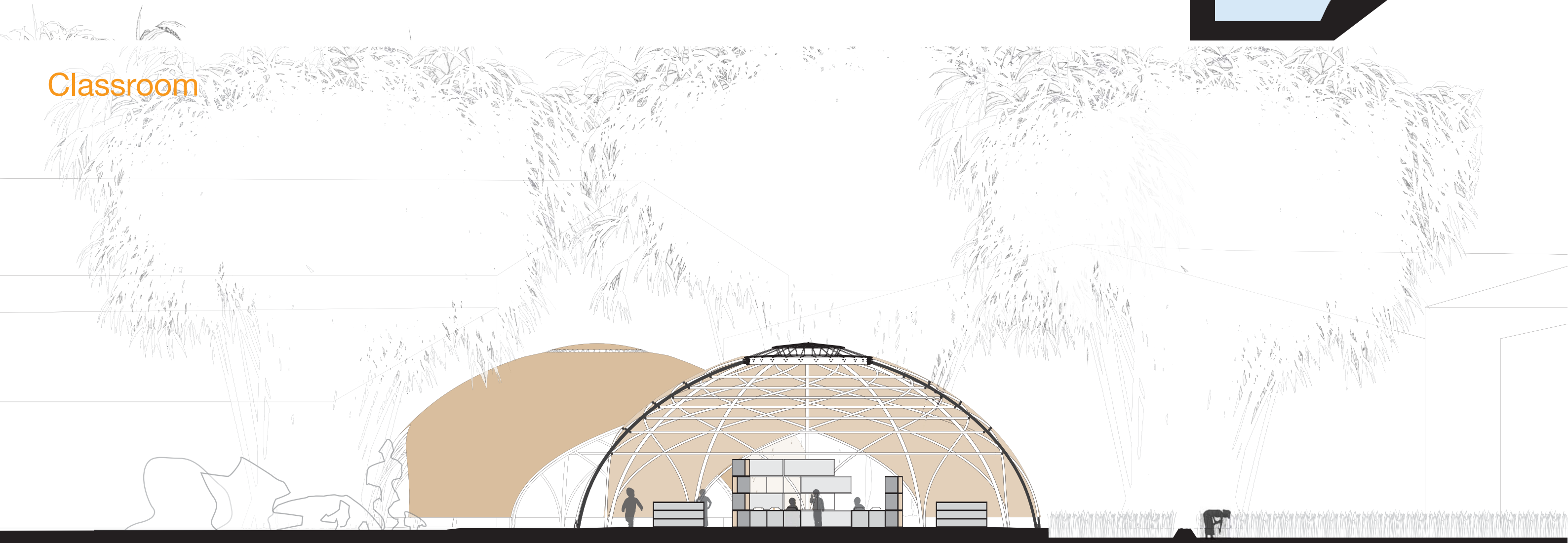





Thatching with reed

Laminated bamboo
Coconut coir

Bamboo construction
Wood connections