



**‘FORGOTTEN HERITAGE’**  
Creating a place for people with dementia

RESEARCH PROJECT



# CONTEXT STUDIO

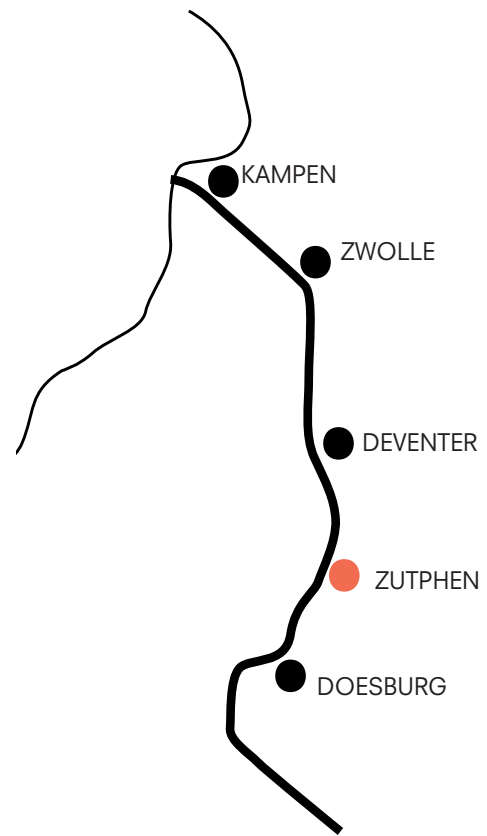
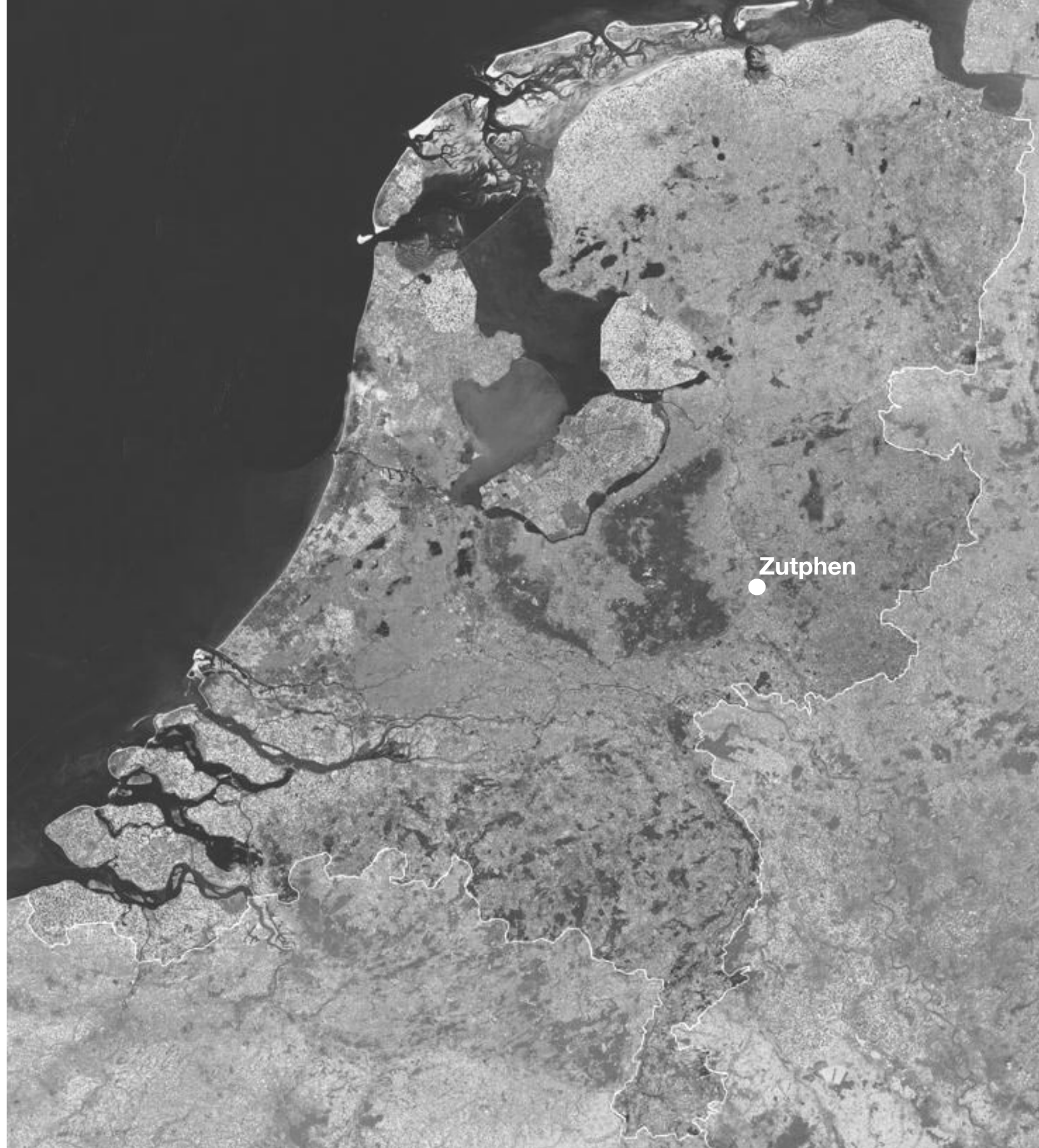
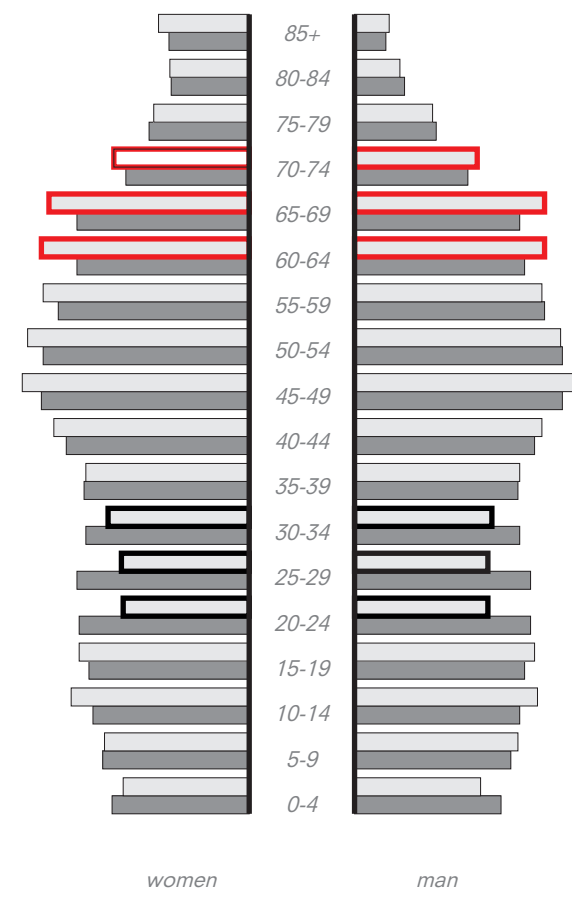

Figure  
Hanseatic cities next to the IJssel

Image  
Satellite view of the Netherlands (kaartenatlassen.nl, own editing)



# ZUTPHEN



**Figure**  
Population pyramid of Zutphen and the Netherlands (C.B.S. & Zutphen municipality)

**Image**  
Aerial photo of Zutphen (Patrick van Gemert, Zutphens Pers, own editing)



## FOCUS AREA



Image  
Overview of Zutphen (screenshot Google Maps, own editing)

# NIEUWSTAD



Figure  
North-eastern part of the Nieuwstad



# NIEUWSTAD



Image  
Nieuwstadstraat (Own photo)

# NIEUWSTAD



Image  
Isendoornstraat (Own photo)



# KLEIN VATICaan



Nieuwstadkerk

St. Anna school

St. Jozef school

St. Mariaschool

'Pastorie'

St. Elisabethkapel

'Garden'

St. Elisabethgesticht

# OBSERVATIONS



Image  
1 - Aerial Photograph of the Ensemble (own photo, december 20th, 2017)

# OBSERVATIONS



Image  
1 - View on the tengnagelshoek (own photo, october 20th, 2017)  
2 - Dieserstraat (screenshot google maps, own editing)

## OBSERVATIONS



### Image

- 1 - Schoolyard St. Jozef with on the right the Pastorie (own photo, october 20th, 2017)
- 2 - View on the St. Jozef seen from the Isendoornstraat (own photo, october 20th, 2017)

## OBSERVATIONS



Image  
1 - Garden of the Pastorie(own photo, october 20th, 2017)  
2 - Front facade of the pastorie (screenshot google maps, own editing)

## OBSERVATIONS



Image  
1 - Garden of the Pastorie(own photo, october 20th, 2017)  
2 - Front facade of the pastorie (screenshot google maps, own editing)

## 2. CULTURAL VALUES

# CULTURAL VALUE MATRIX

	Age	Historical	Commemorative	Social	Use	Spiritual	Aesthetical
Surroundings	Dark	Dark	Light	Dark	Light	Dark	Light
Site	Dark	Dark	Light	Dark	Light	Dark	Dark
Skin	Light	Dark	Light	Light	Dark	Dark	Dark
Structure	Light	Dark	Light	Light	Dark	Light	Light
Space plan	Light	Light	Light	Light	Dark	Light	Light
Surfaces	Dark	Dark	Light	Light	Dark	Dark	Light
Services	Light	Light	Light	Light	Dark	Light	Dark
Stuff	Light	Dark	Light	Light	Light	Light	Light
Spirit of the place	Light	Light	Light	Dark	Light	Dark	Light



# TRANSFORMATION FRAMEWORK

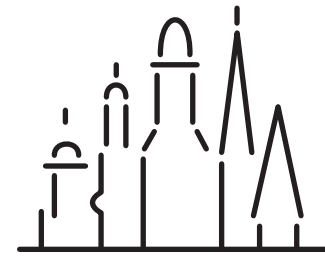

URBAN / SITE

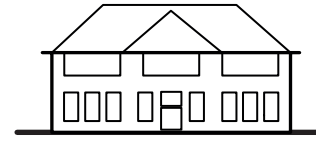

ENSEMBLE



SPIRIT OF PLACE

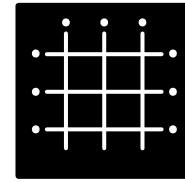

Grid Structure

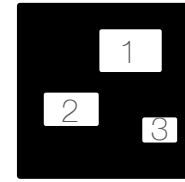

Solitary Buildings

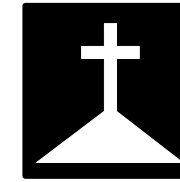

Belief

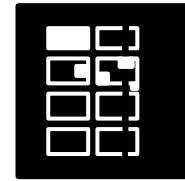

Building Block

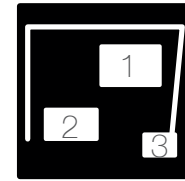

Disappeared Building block



Education

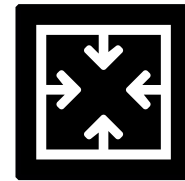

Introvert

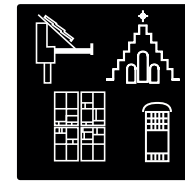

Ornamentation



Care

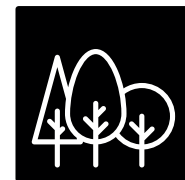

Park



Timber Roof construction



Community

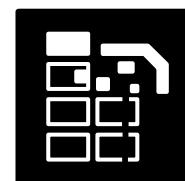

Floating buildings

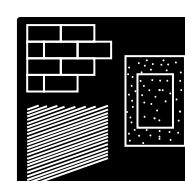

Floor finishes

# TRANSFORMATION FRAMEWORK

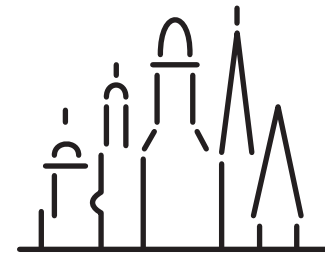

URBAN / SITE



ENSEMBLE



SPIRIT OF PLACE

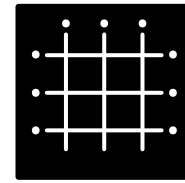

Grid Structure

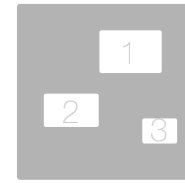

Solitary Buildings



Belief

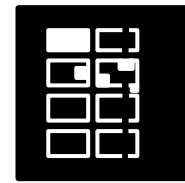

Building Block

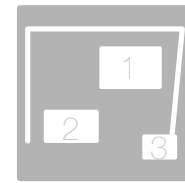

Disappeared Building block



Education

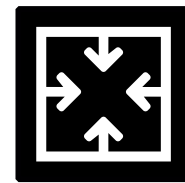

Introvert

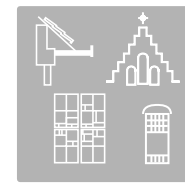

Ornamentation



Care

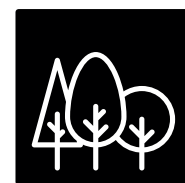

Park



Timber Roof construction



Community

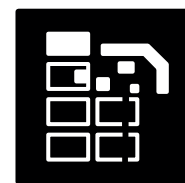

Floating buildings

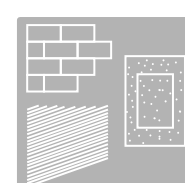

Floor finishes

# SPATIAL DEVELOPMENT



1649

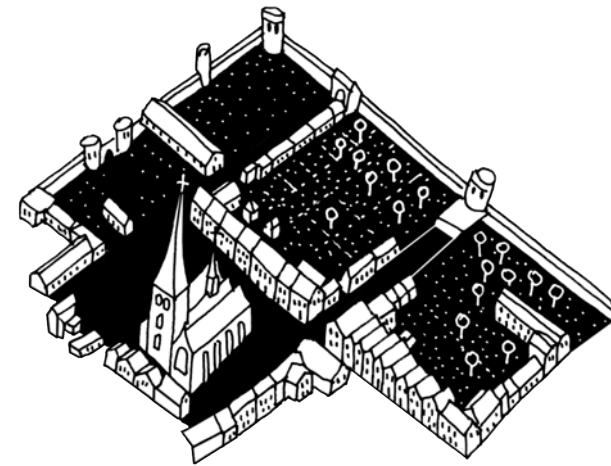

1823

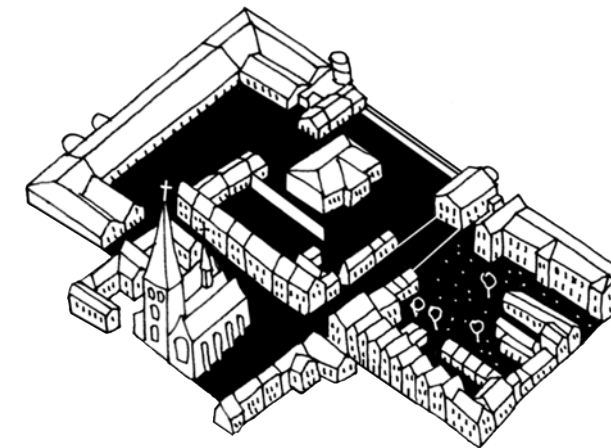

1900

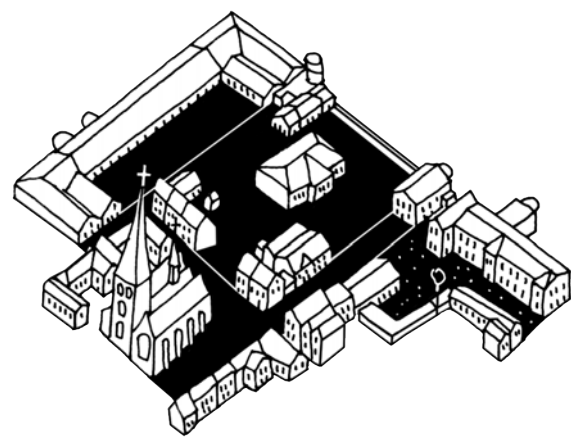

1909

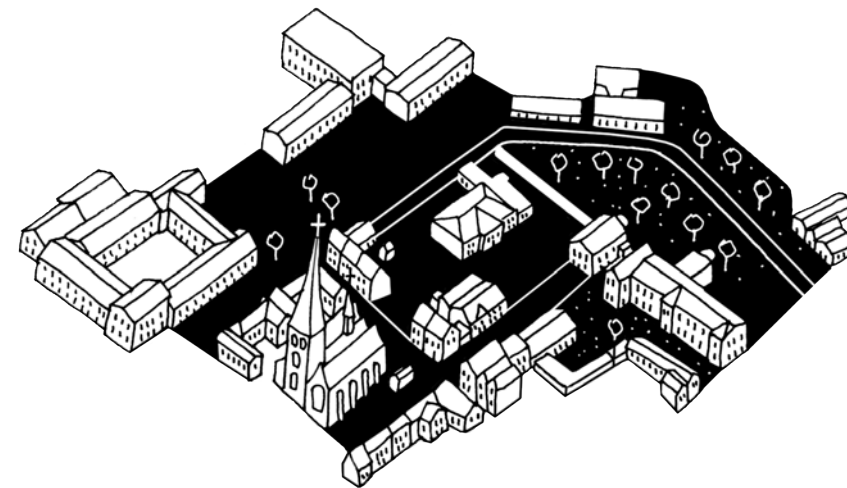

1950

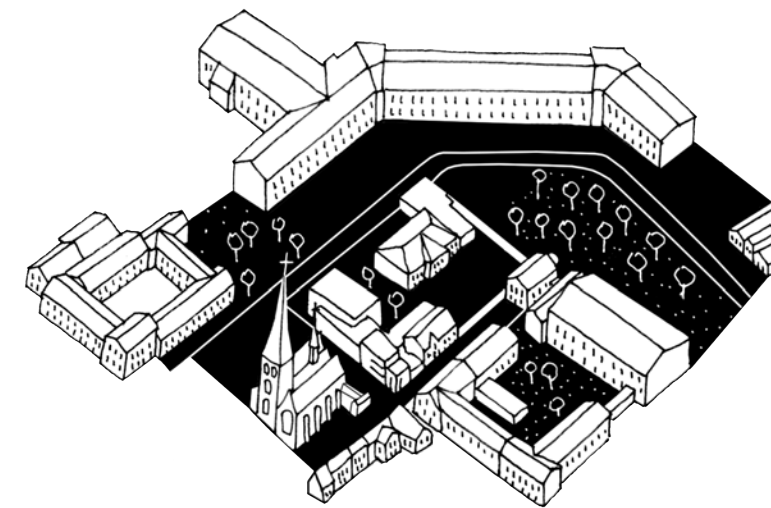

2017

Figures  
Spatial development of the north eastern border



# J. BLAEU

DRAWING OF NIEUWSTAD 1649

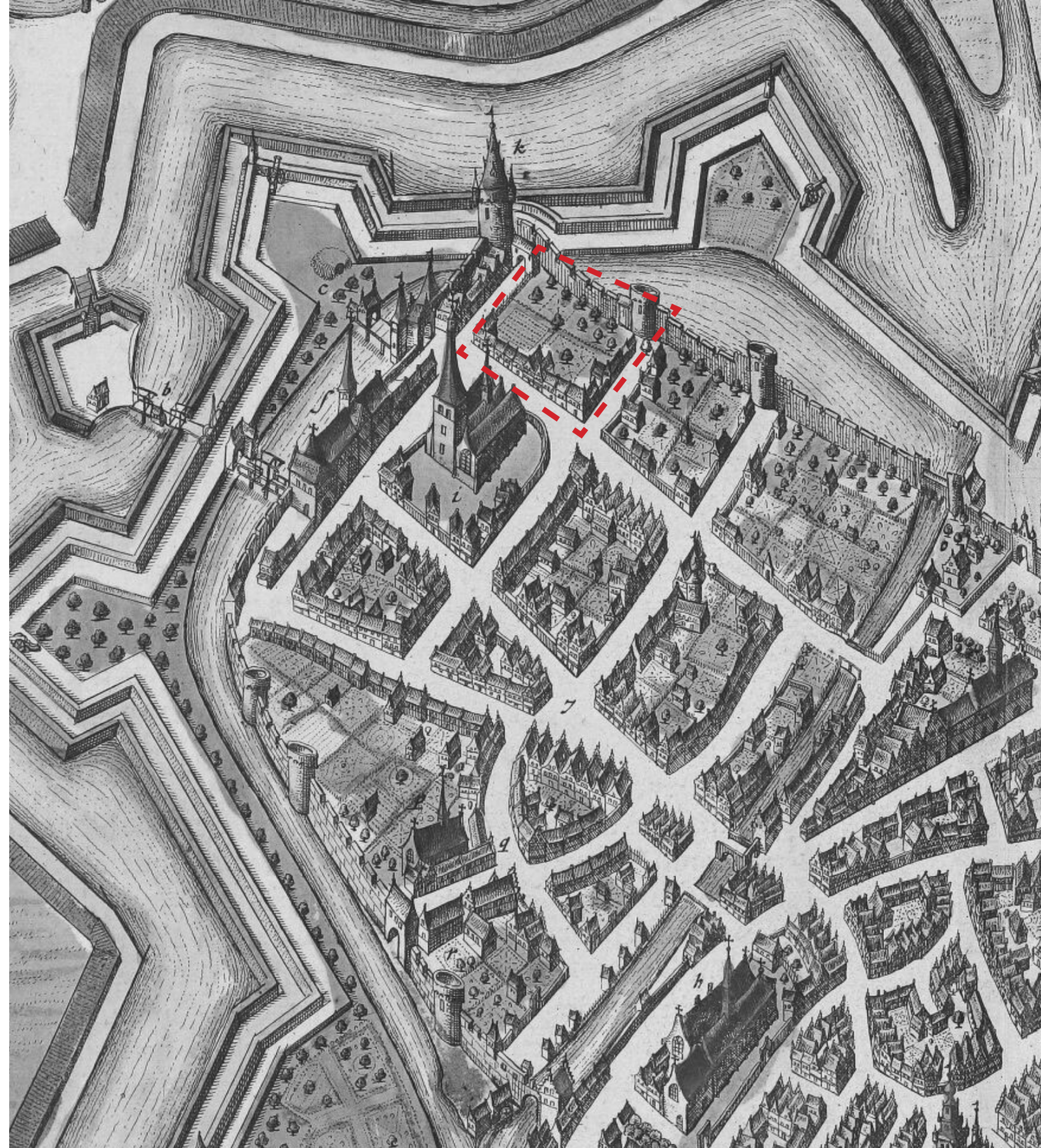
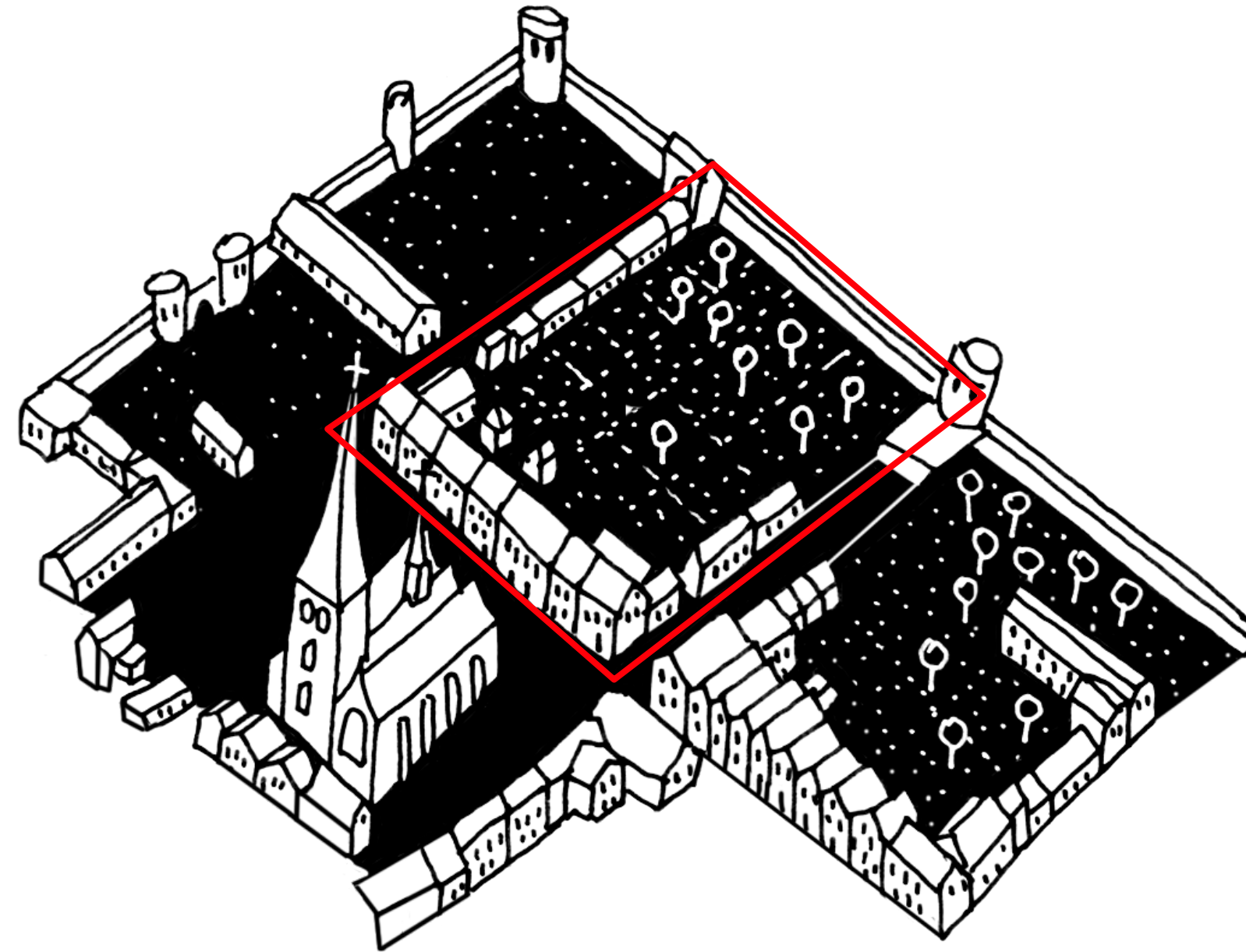

Image  
Stadsplattegrond van Zutphen by J. Blaeu 1649  
(Regionaalarchiefzutphen, own editing)

# HISTORICAL DEVELOPMENT

STARTING POINT - 1823



# HISTORICAL DEVELOPMENT

STARTING POINT - 1900

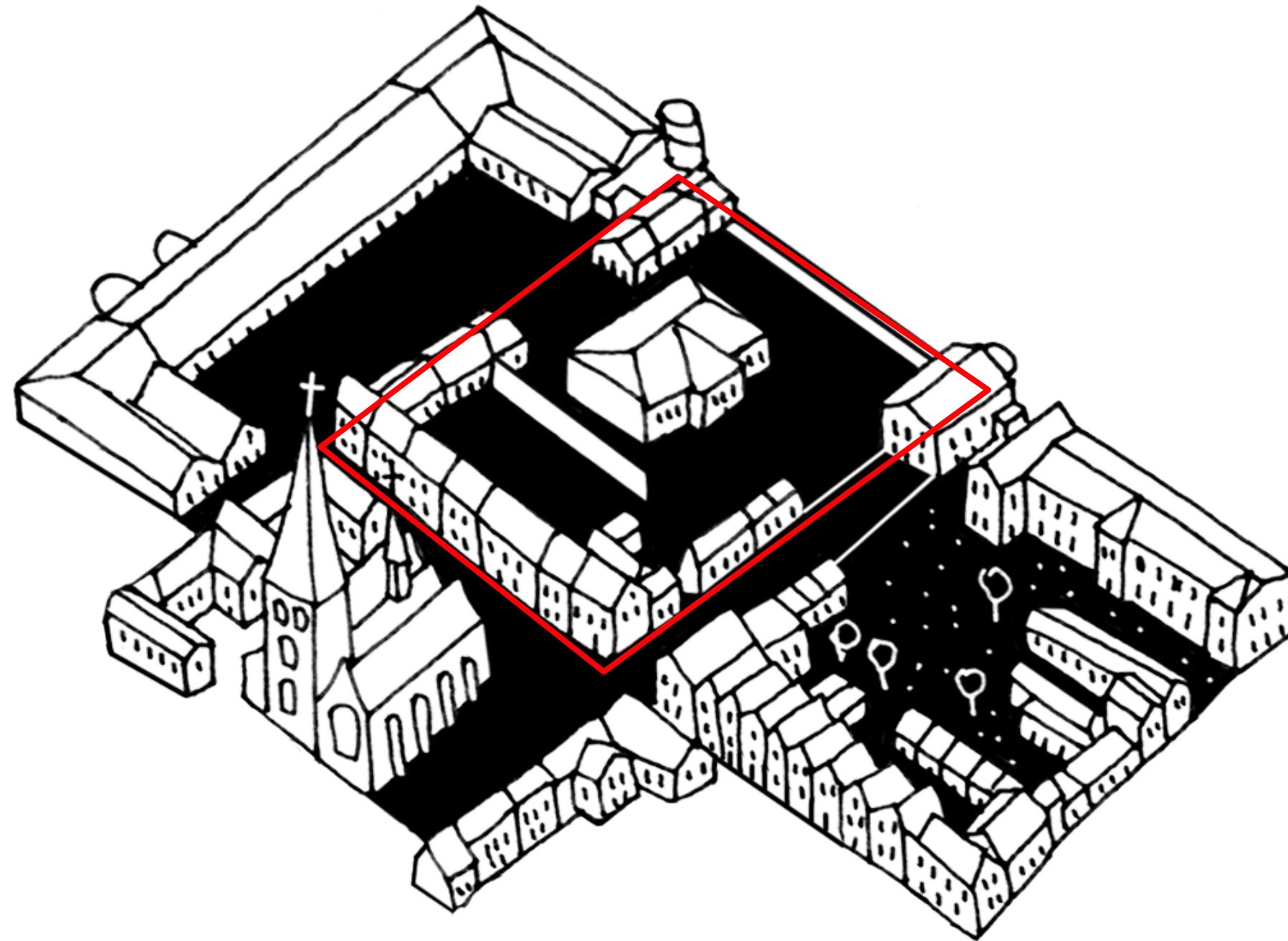

# HISTORICAL DEVELOPMENT

STARTING POINT - 1950s

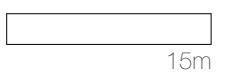
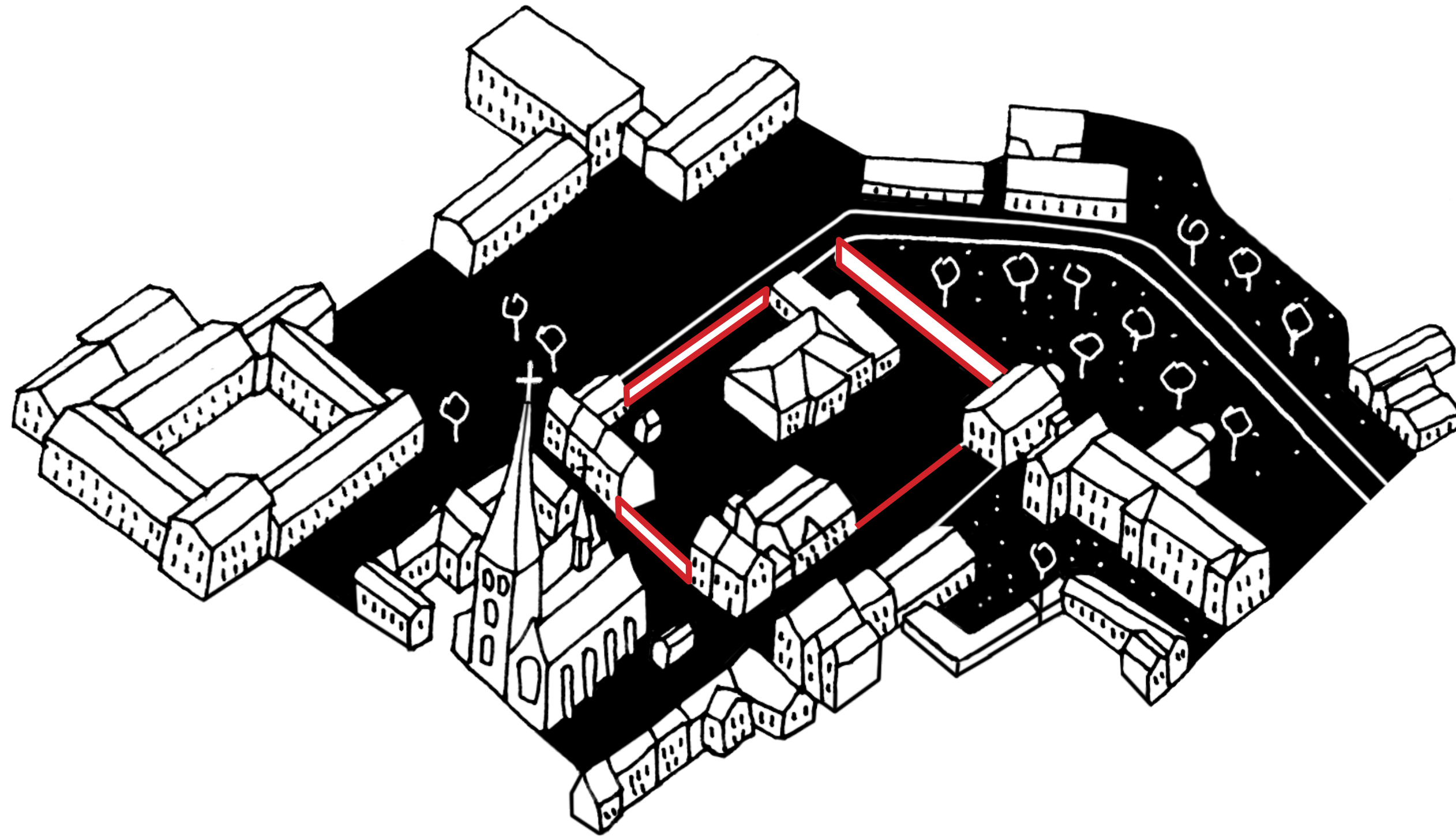

# HISTORICAL DEVELOPMENT

UPGRADE OF ST. JOZEF - 1950s



## Image

1. Aerial view of the Klein Vaticaanschoolen around the 1960s (regionaalarchiefzutphen)
2. Isendoornstraat around the 1960s (regionaalarchiefzutphen)



# HISTORICAL DEVELOPMENT

ST. ANNA EXTENSION - 2000

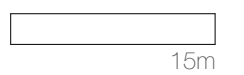
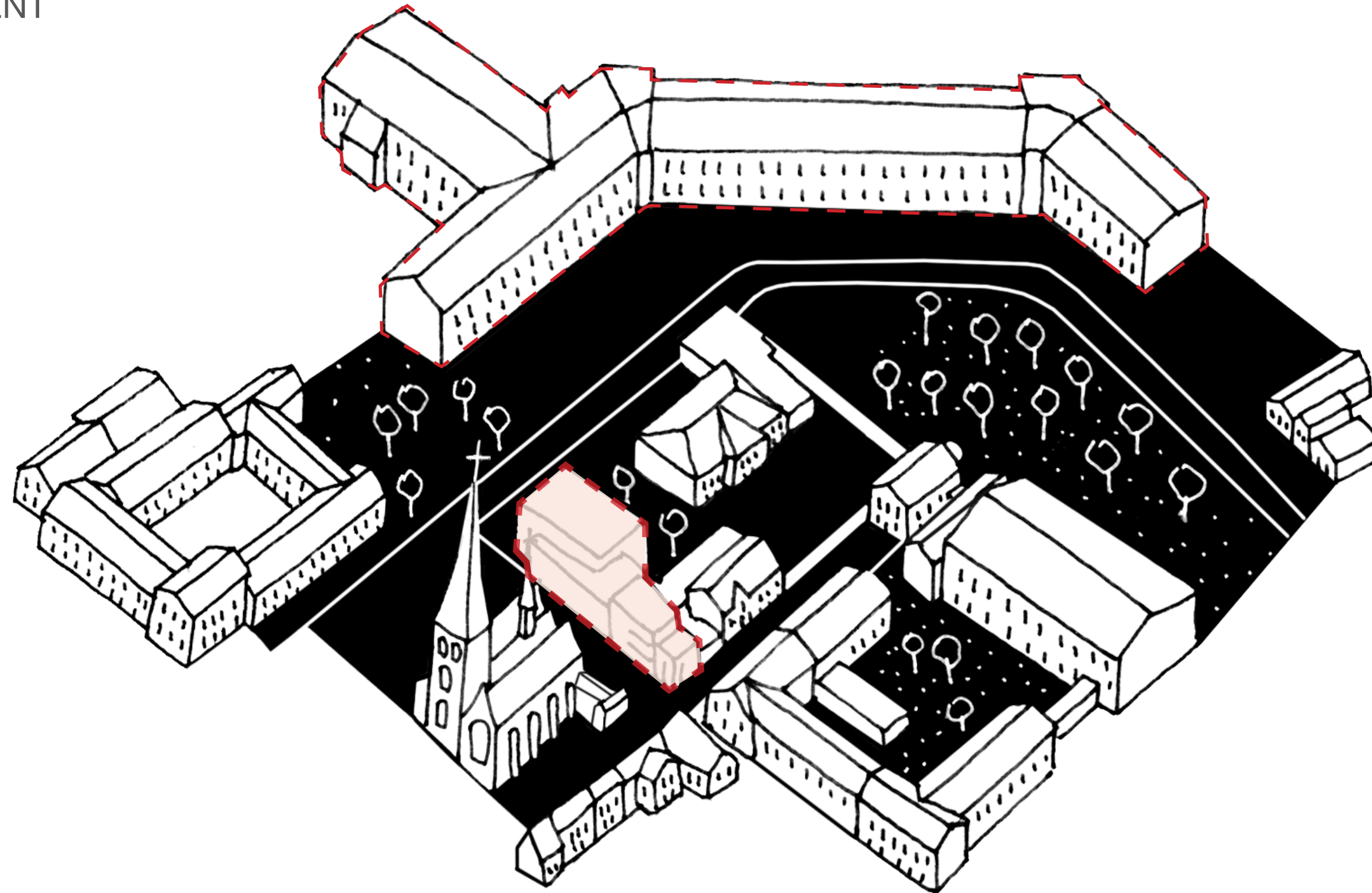

# HISTORICAL DEVELOPMENT

ST. ANNA EXTENSION - 2000

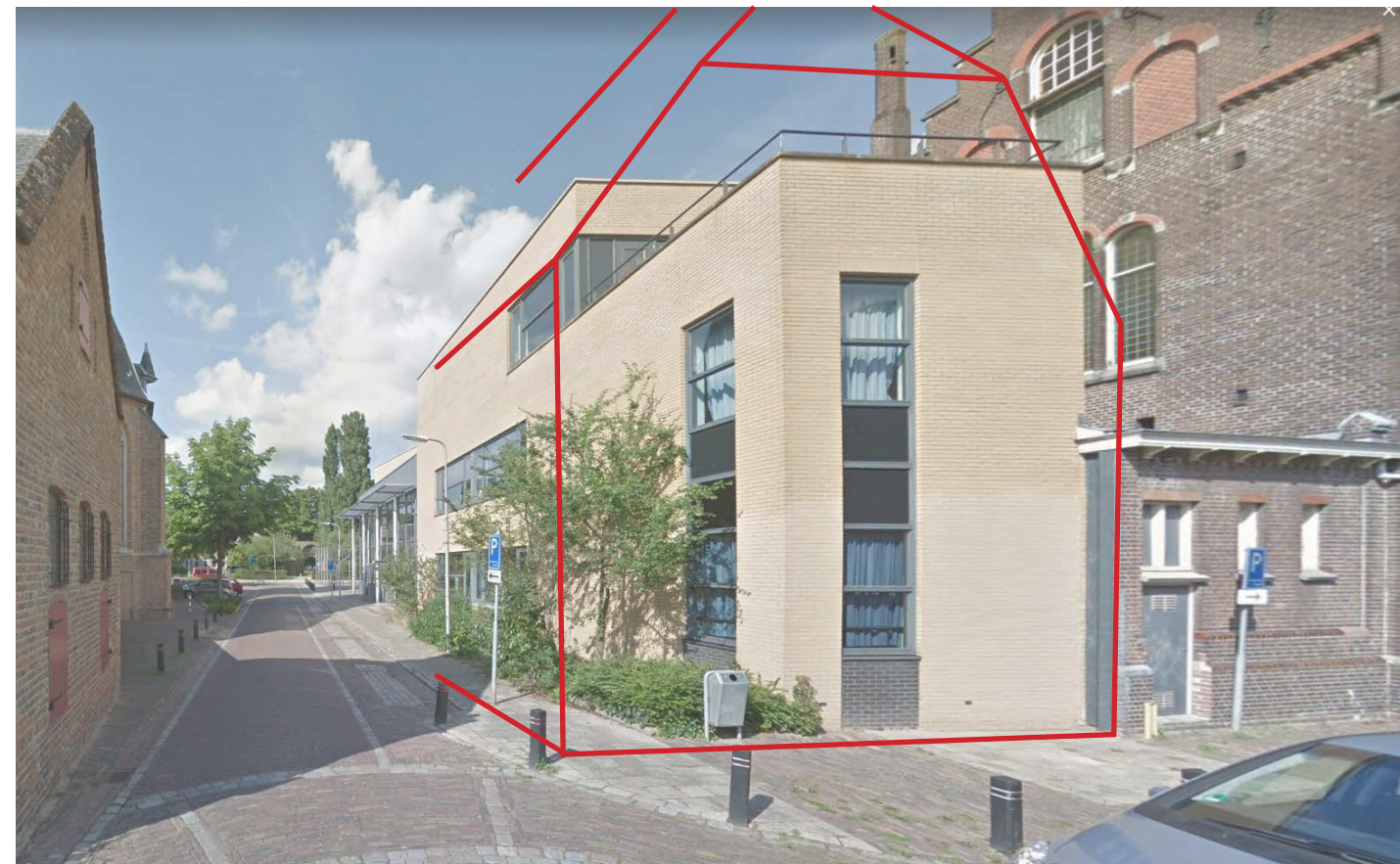

## Image

1. Dieserstraat around 1915 (reidinga.nl)
2. Dieserstraat screenshot from google maps (own editing)

# URBAN CHARACTERISTICS

GRID STRUCTURE WITH BUILDING BLOCKS

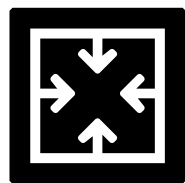

Closed/ Introvert character

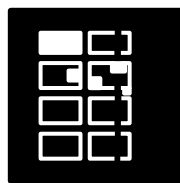

Building Block

# URBAN CHARACTERISTICS

GRID STRUCTURE WITH BUILDING BLOCKS

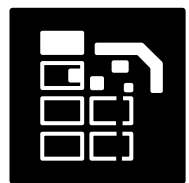

Floating buildings

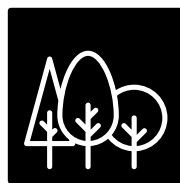

Park

# TRANSFORMATION FRAMEWORK

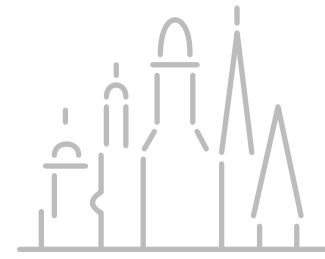

URBAN / SITE

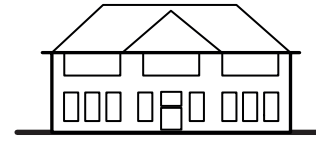

ENSEMBLE



SPIRIT OF PLACE

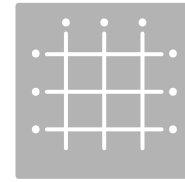

Grid Structure

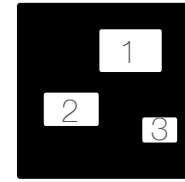

Solitary Buildings

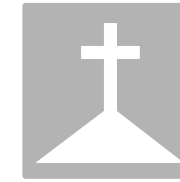

Belief

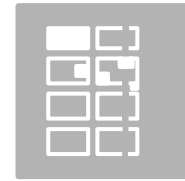

Building Block

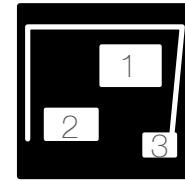

Disappeared Building block



Education

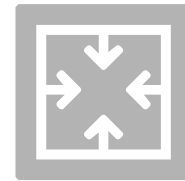

Introvert

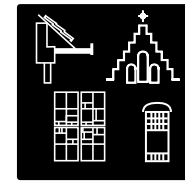

Ornamentation



Care



Park



Timber Roof construction



Community



Floating buildings

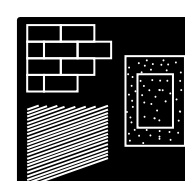

Floor finishes

# SITE CHARACTERISTIC

ARCHITECTURAL ENSEMBLE

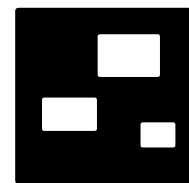
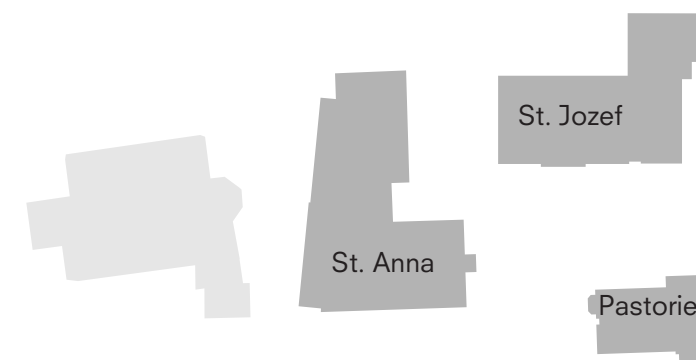
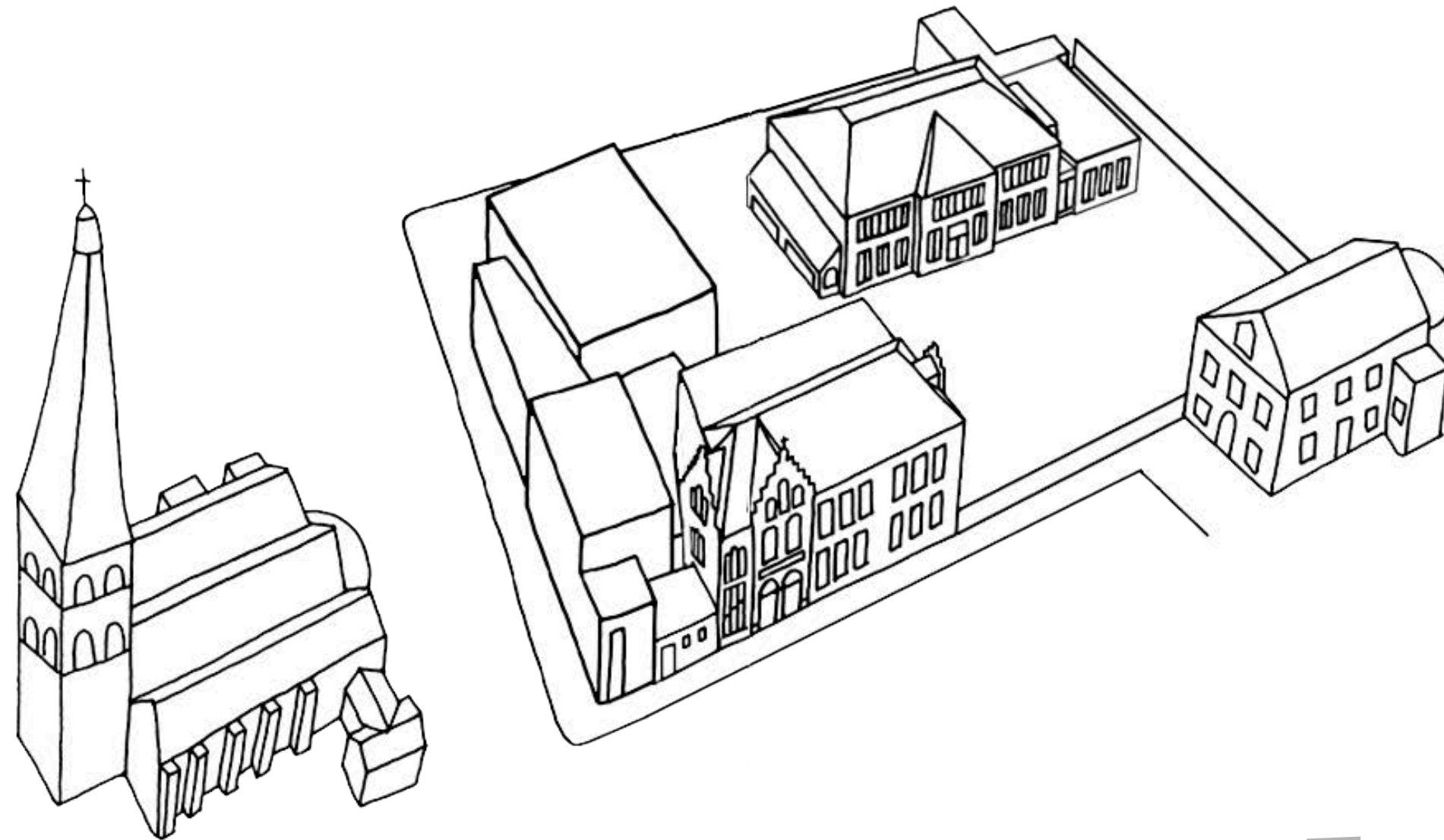

Architectural Ensemble



# BUILDING CHARACTERISTIC

CHARACTERISTICS - ENSEMBLE

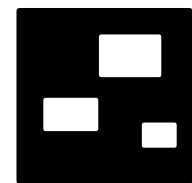

Architectural Ensemble

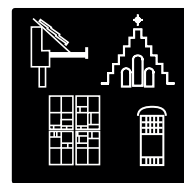

Ornamentation

## Image

- 1 - The south facade of the St. Jozef after 1934. (regionaalarchiefzutphen)
- 2 - The south facade of the St. Anna with the new extension by LKS-VDD on the west. (own photo, 2017)
- 3 - The west facade of the Pastorie (own photo, 2017)

# BUILDING CHARACTERISTIC

CHARACTERISTICS - CLASSROOMS

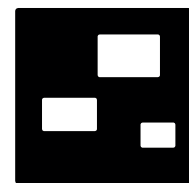

Architectural Ensemble

Images  
Classrooms of the St. Jozef (own photo, 2017)



# BUILDING CHARACTERISTIC

CHARACTERISTICS - CONSTRUCTION

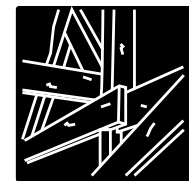

Timber Construction

Image  
1 - Timber roof construction of St. Jozef (own photo, 2017)  
2 - Timber roof construction of St. Anna (own photo, 2017)

# BUILDING CHARACTERISTIC

CHARACTERISTICS - FLOOR FINISHING

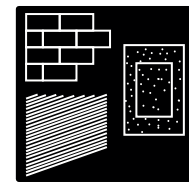
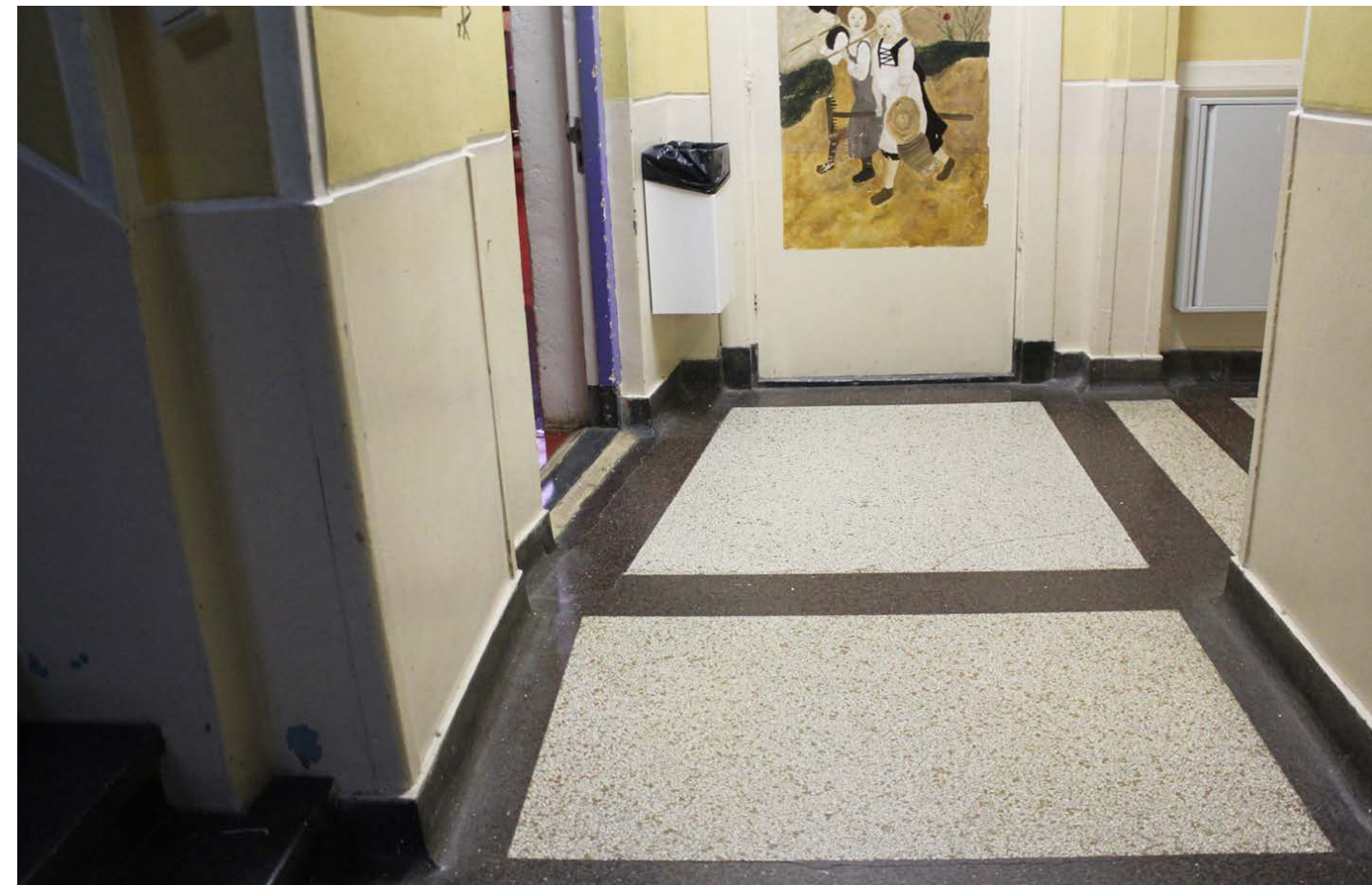

Floor Finishes

- Image
- 1 - Ceramic flooring St. Jozef (own photo, 2017)
  - 2 - Terazzo flooring St. Anna (own photo, 2017)
  - 3 - Linoleum flooring extension St. Anna (own photo, 2017)

# BUILDING CHARACTERISTIC

CHARACTERISTICS - STAIRCASES

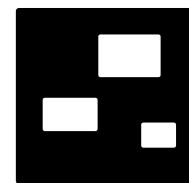

Architectural Ensemble

Image  
1 - Art Nouveau Staircase of St. Anna (own photo, 2017)  
2 - Staircase St. Jozef (own photo, 2017)

# TRANSFORMATION FRAMEWORK



URBAN / SITE



ENSEMBLE



SPIRIT OF PLACE

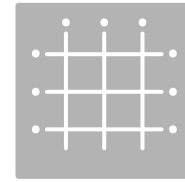

Grid Structure

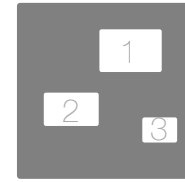

Solitary Buildings

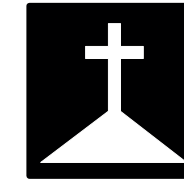

Belief

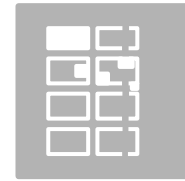

Building Block

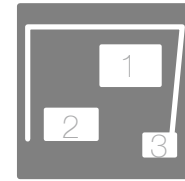

Disappeared Building block



Education

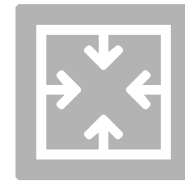

Introvert

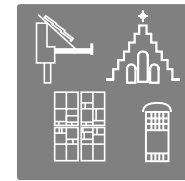

Ornamentation



Care



Park

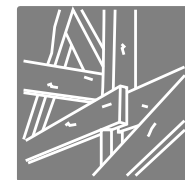

Timber Roof construction



Community



Floating buildings

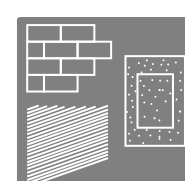

Floor finishes

# SPIRIT OF THE PLACE

CATHOLIC HERITAGE

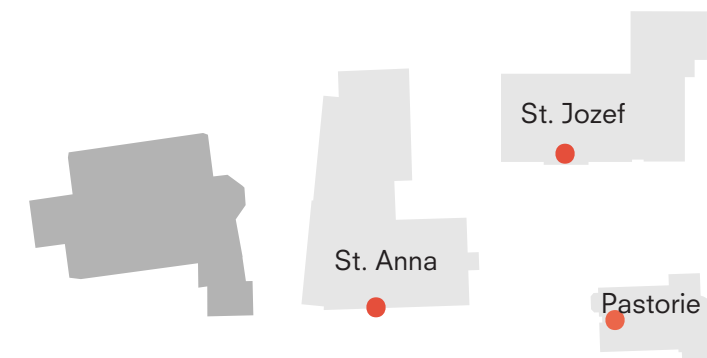
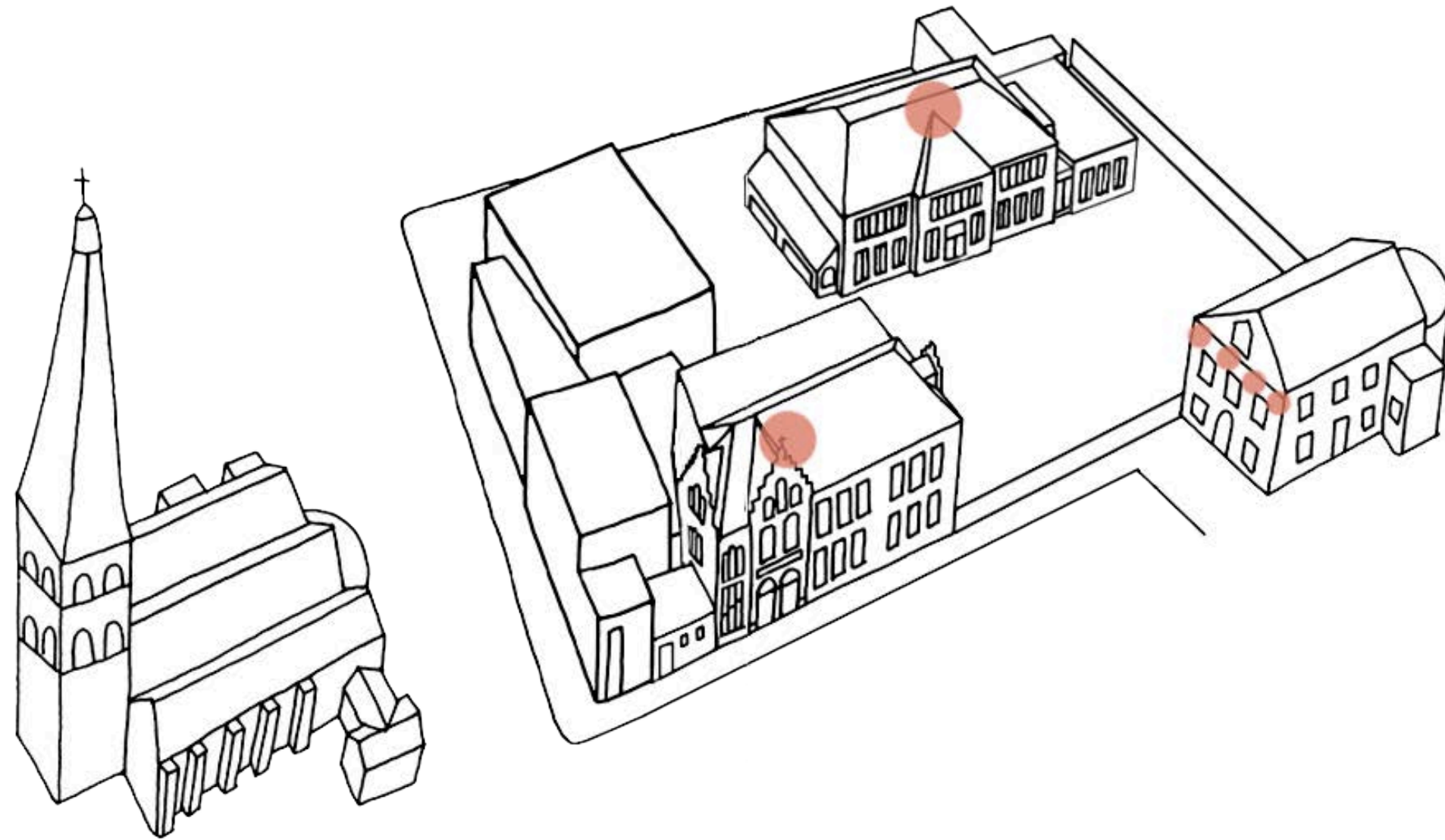

Being part of a community

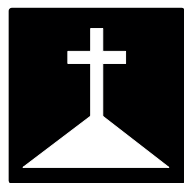

Catholic Heritage



# SPIRIT OF THE PLACE

CHARACTERISTICS - ENSEMBLE



Being part of a community

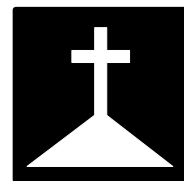

Catholic Heritage

## Image

- 1 - Cross symbol on the roof pitch of the St. Jozef. With the church tower in the background (own photo, september 29th, 2017)
- 2 - Cross symbol on the roof pitch of the St. Anna. (own photo, september 29th, 2017)
- 3 - Cross symbol ornamentation on the Pastorie. (own photo, december 20th, 2017)

### 3. BRIEF

Research Question:

How can an ensemble of Heritage buildings be transformed in order to create a coherent and resilient site, which reconnects with the city?



# COMMUNAL HERITAGE

SOCIETAL CHARACTERISTICS OF THE KLEIN VATICCAAN

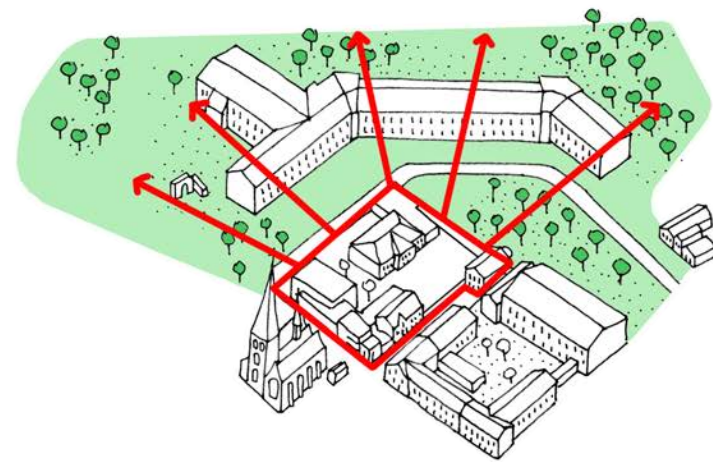

Being part of a community

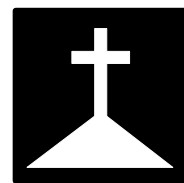

Catholic Heritage

## Dementia Netherlands

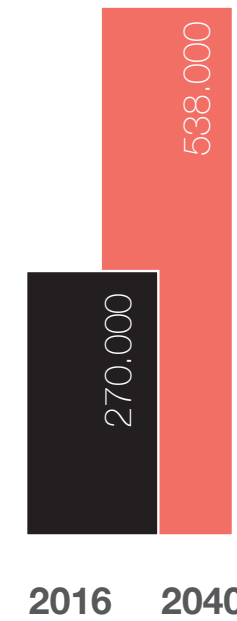

Avarage rate of people getting  
dementia in the Netherlands

## Zutphen



## Family Care

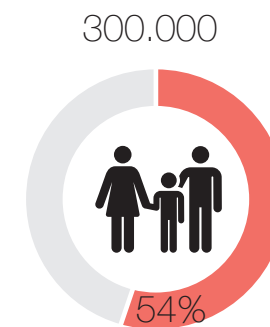

54% of the 300.000 Family care  
givers are under high pressure  
4% is under extreme pressure



Time spent on giving care by  
Family Care givers



Care

# CARE CENTRES

DEMENTIACARE



Image  
1 - Herbergier Ehze (herbergier.nl, accessed on december 30th, 2017)  
2 - Sutfene, de Lunette (koopmans.nl, accessed on june 18th, 2018)  
3 - Zorgcentrum Hogeweyk (architectenweb.nl, accessed on december 30th, 2017)

# PROGRAMME

PROGRAMME BASED ON REFERENCES



PRIVATE ROOMS

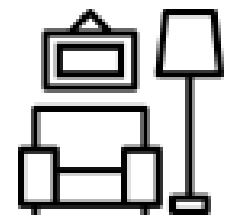

LIVING ROOMS

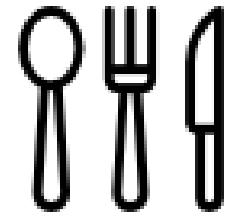

KITCHEN



LEISURE AREA / DAYTIME CARE



GROCERY STORE / PHARMACY

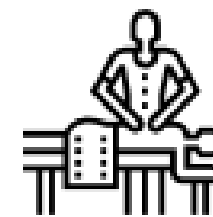

FYSIOTHERAPY



GYM



OUTDOOR AREA

# PROGRAMME

PROGRAMME BASED ON REFERENCES

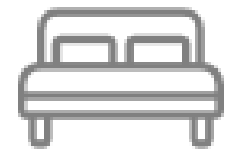

PRIVATE ROOMS

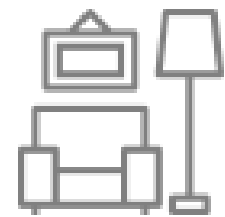

LIVING ROOMS

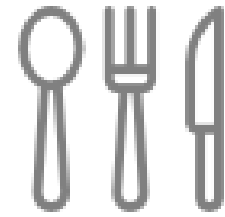

KITCHEN



LEISURE AREA / DAYTIME CARE



GROCERY STORE / PHARMACY



FYSIOTHERAPY



GYM



OUTDOOR AREA



FAMILY CARE

# FAMILY CARE

FAMILY CARE CONCEPT

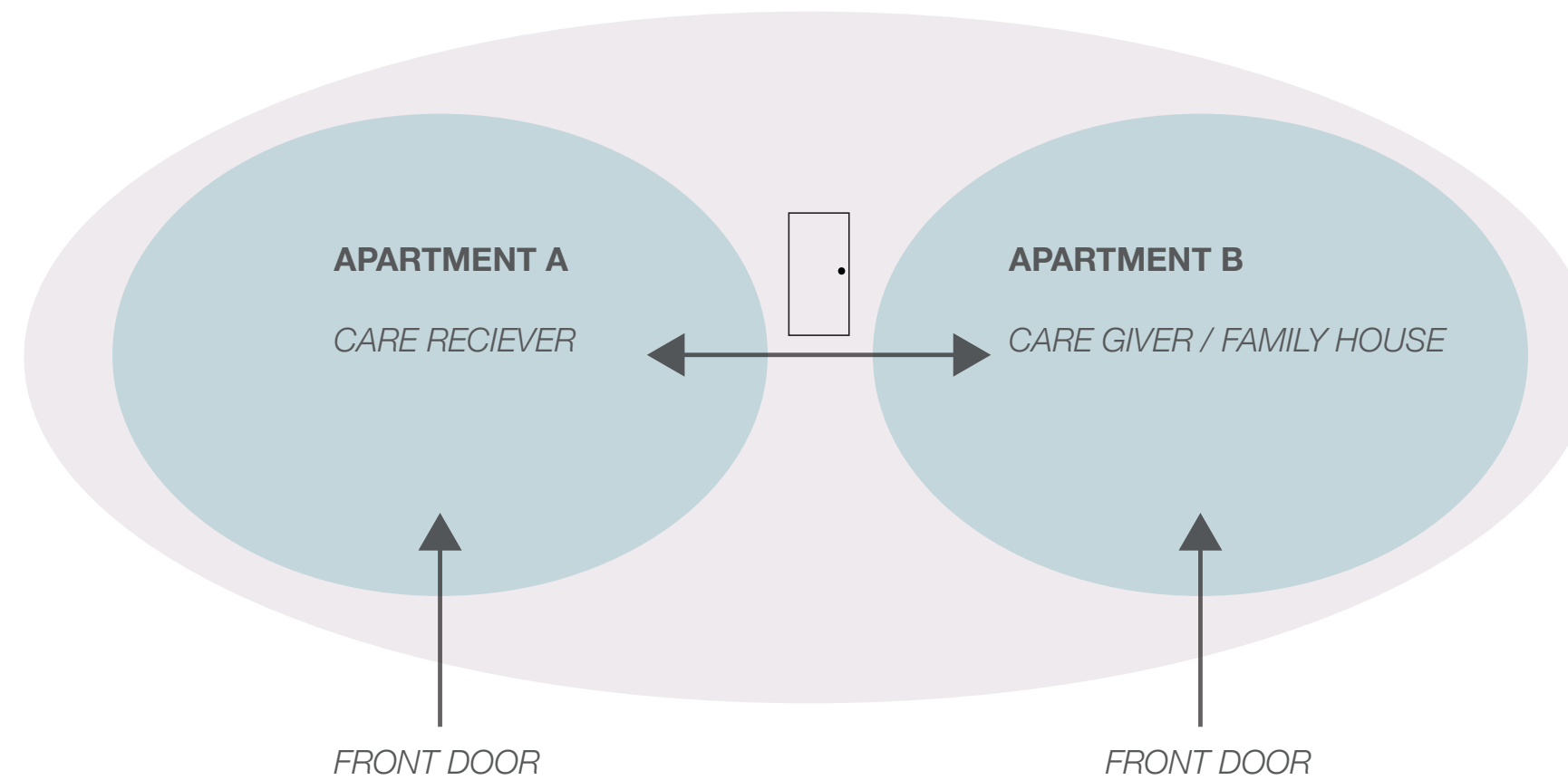
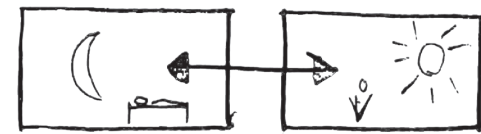

Image  
1 - Zorgeloos mantelzorgen, Groningen (kaw.nl, accessed on december 30th, 2017)

# DEMENTIA

## ARCHITECTURAL CHARACTERISTICS



Spatial routine

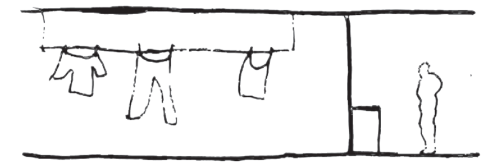

Clear distinction between functions

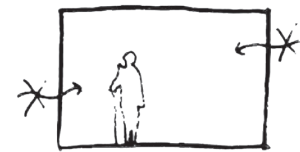

Create rooms with controllable stimulus

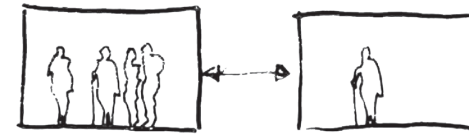

Create different scale levels

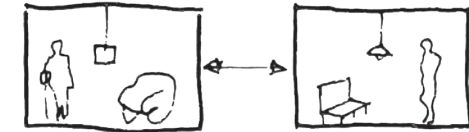

Customization of rooms

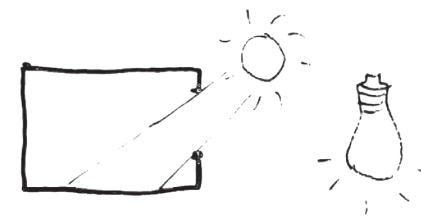

Create sufficient daylight



Make the entry doors recognizable

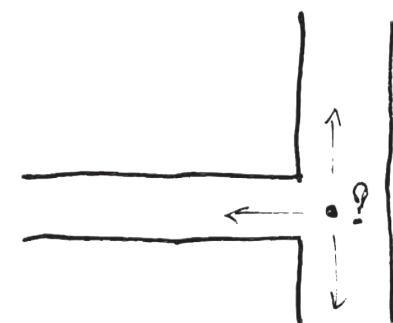

Avoid intersections, they can cause confusion. If not avoidable create a good orientation.

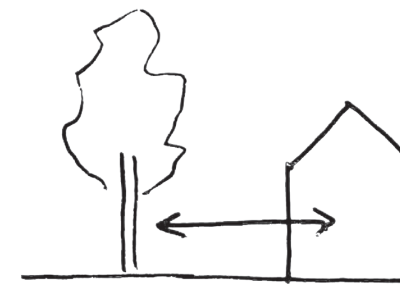

Contact with nature

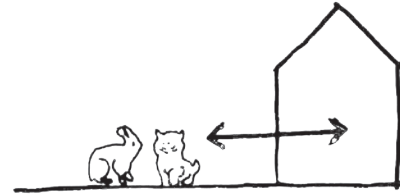

Contact with animals

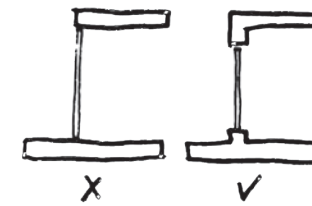

Floor to ceiling windows, can create confusion

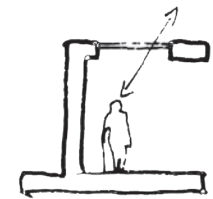

Roof windows, can create confusion

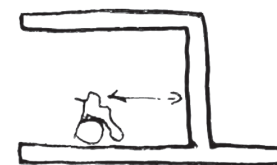

Take people in a wheelchair into account

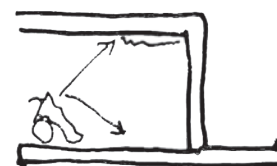

People in a wheelchair experience the rooms differently

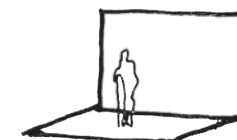

Make a clear distinction between wall and floor

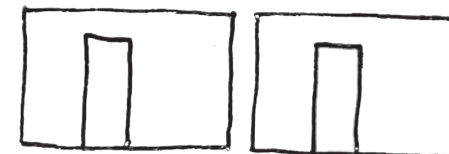

Create a contrast between door and wall when the room is for the patients

### Diagrams

Design aspects on dementia based on the research by Renske van Dieren (own illustrations)

DEMENTIA  
ARCHITECTURAL CONCEPT

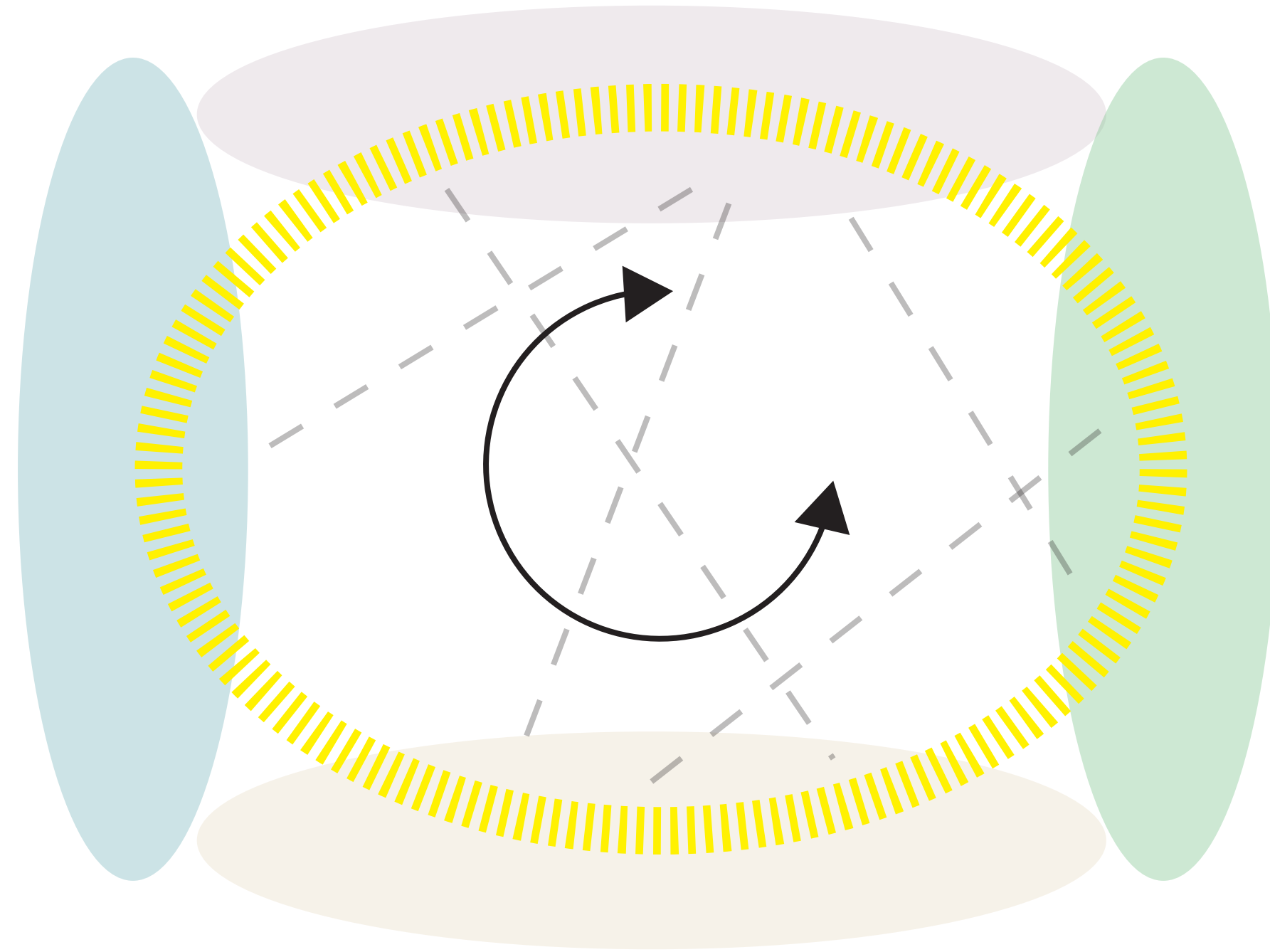



## 4. STRATEGY

# STRATEGY

1. STARTING POINT

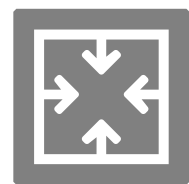

Closed/ Introvert character is lost

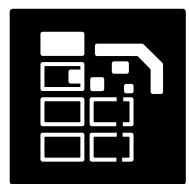

Floating Buildings



# STRATEGY

## 2. DENSIFICATION - STUDIES

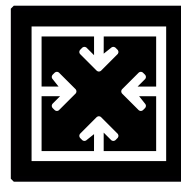
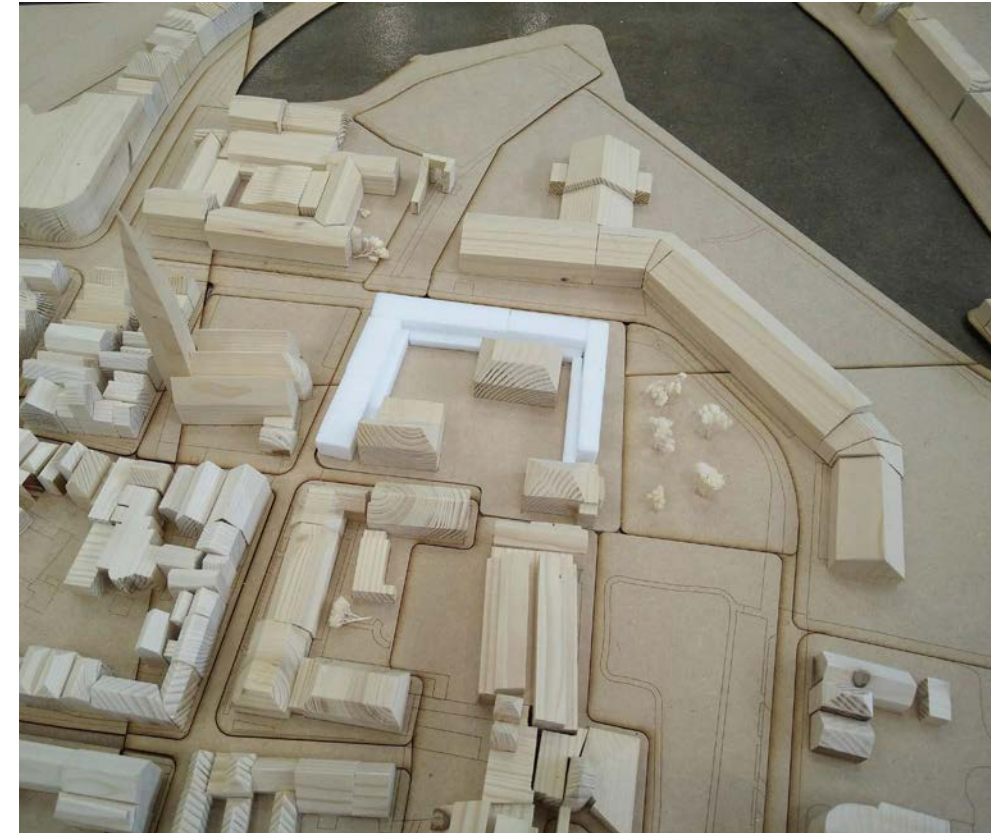

Closed/ Introvert character

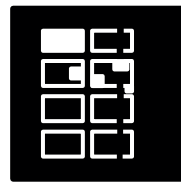

Building block

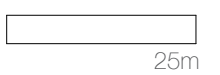

# STRATEGY

## 2. DENSIFICATION - BUILDING BLOCK

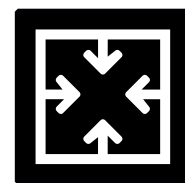
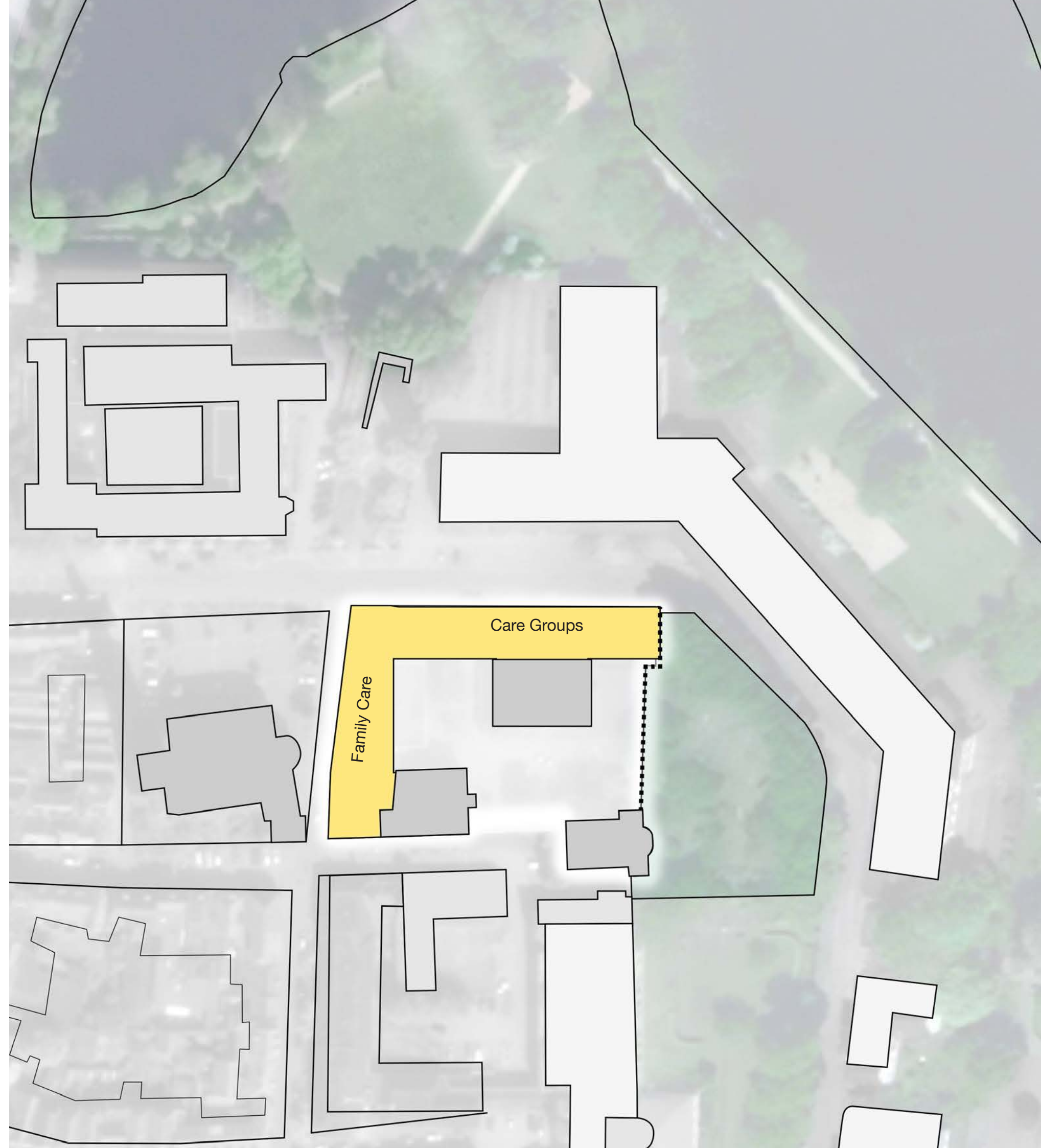

Closed/ Introvert character

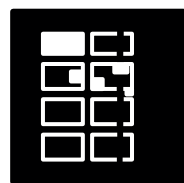

Building block



# STRATEGY

## 3. EMPHASIZING THE BORDER

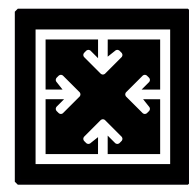

Closed/ Introvert character

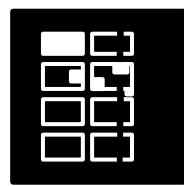

Building block

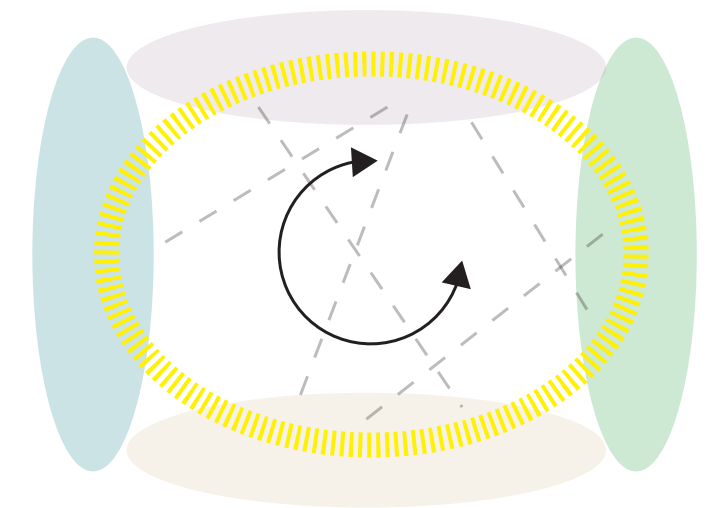
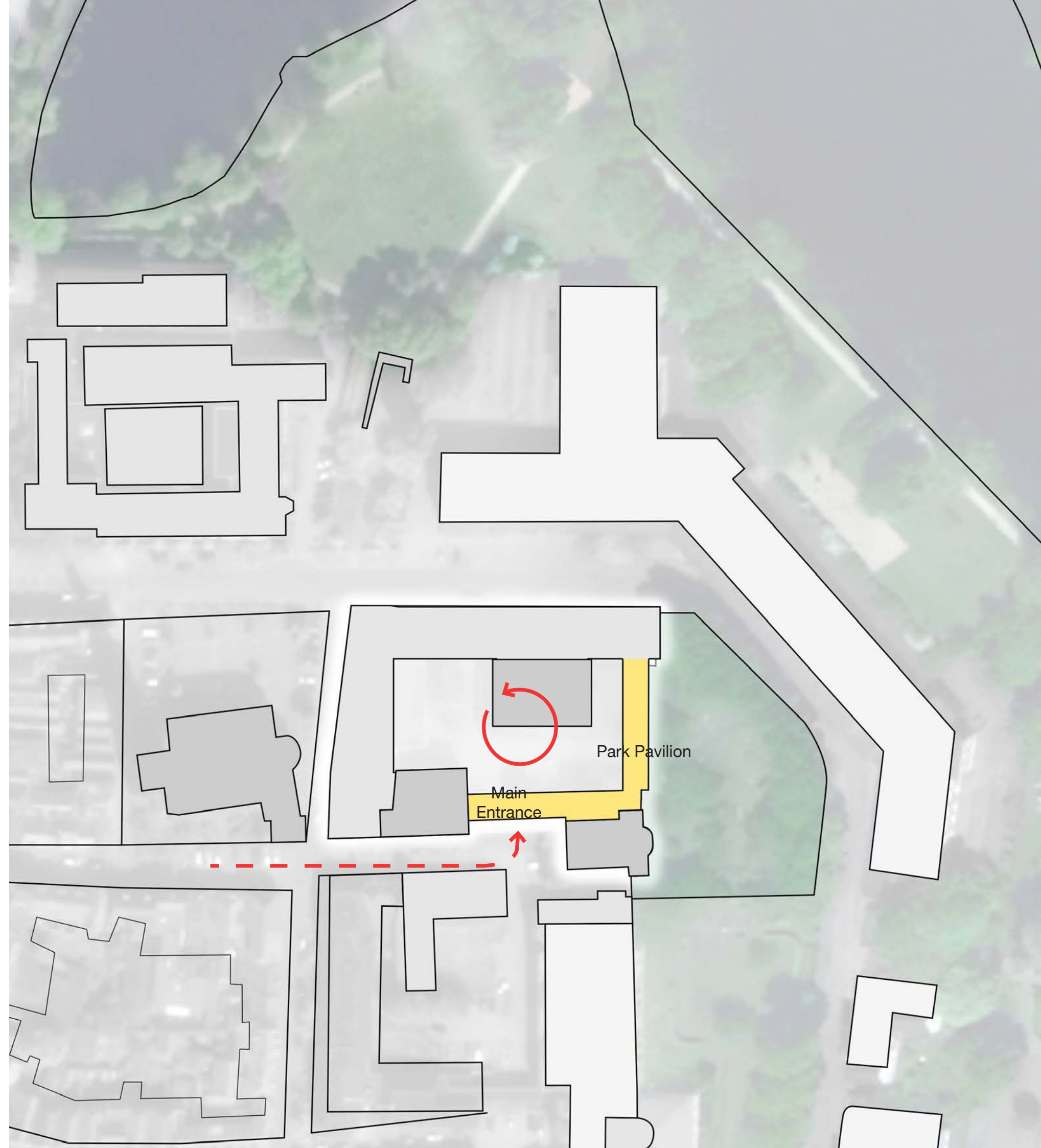

Organisation Concept



# STRATEGY

## 3. EMPHASIZING THE BORDER

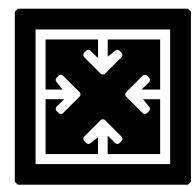

Closed/ Introvert character

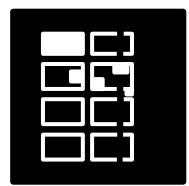

Building block

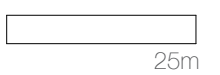
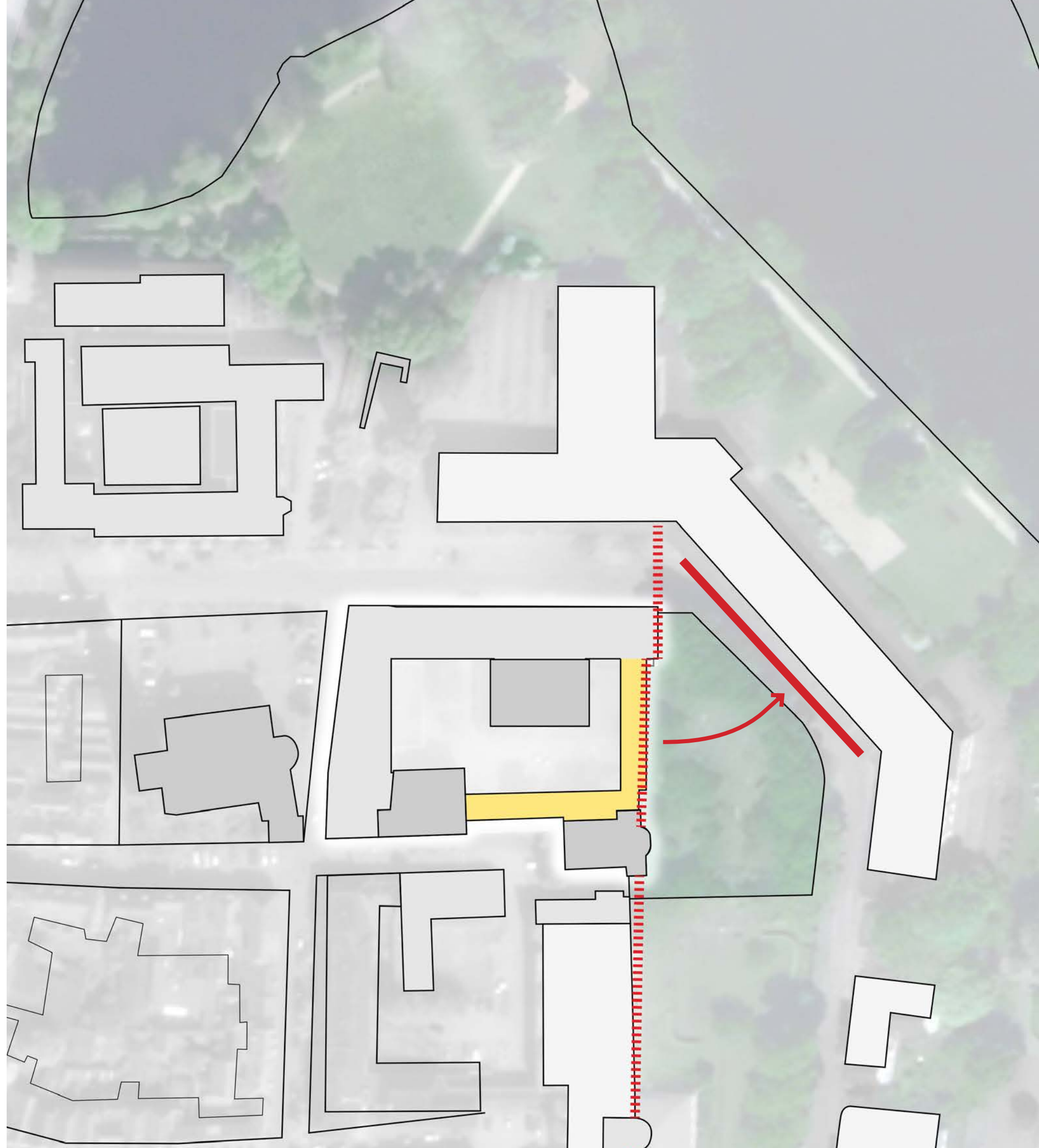

# STRATEGY

## 4. HEALING ENVIRONMENT

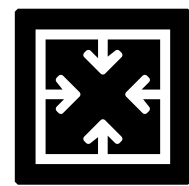

Closed/ Introvert character

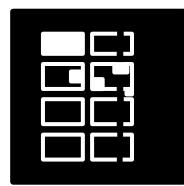

Building block

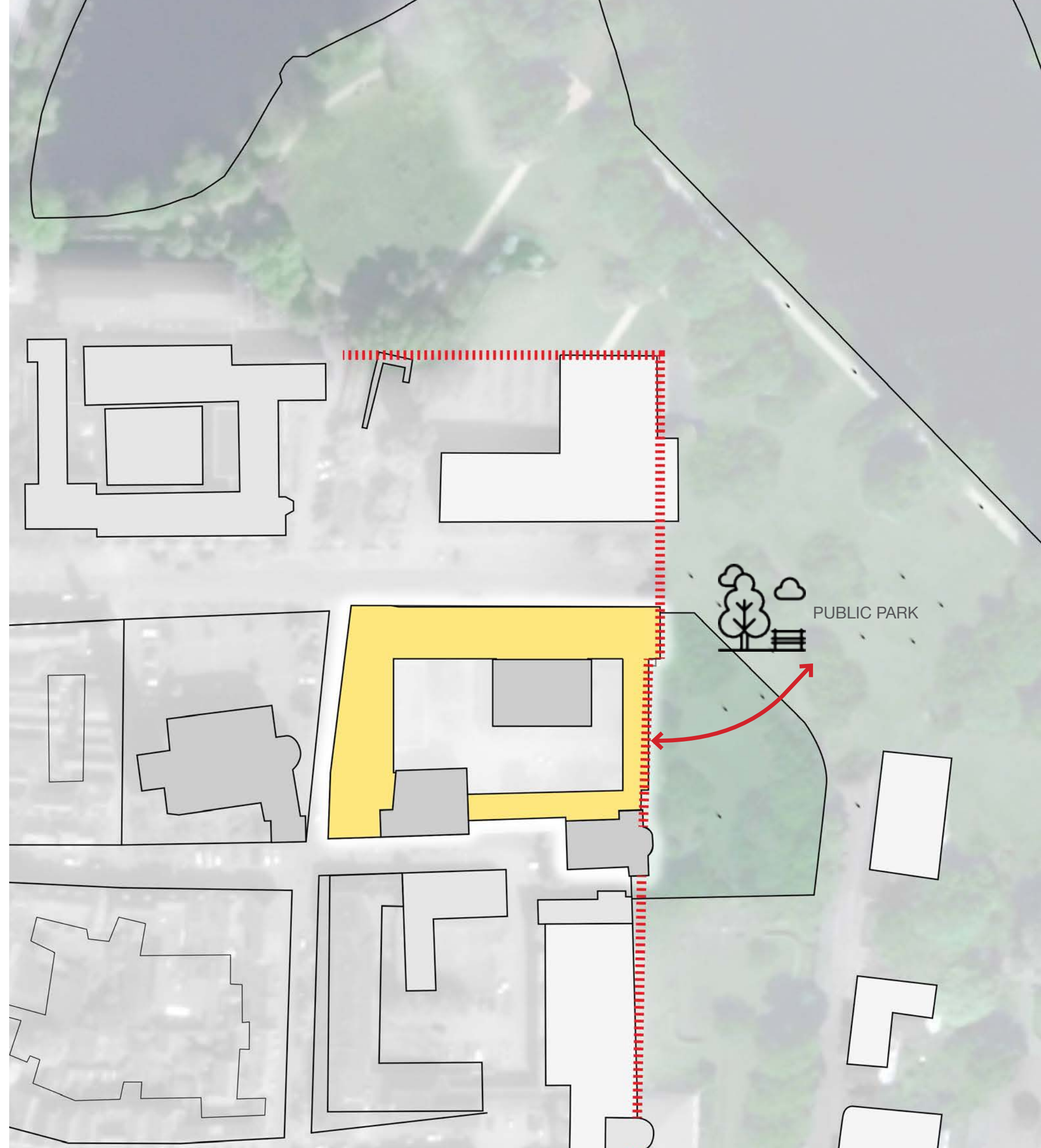

# STRATEGY

## 6. NEW FUNCTIONS AT THE NORTH

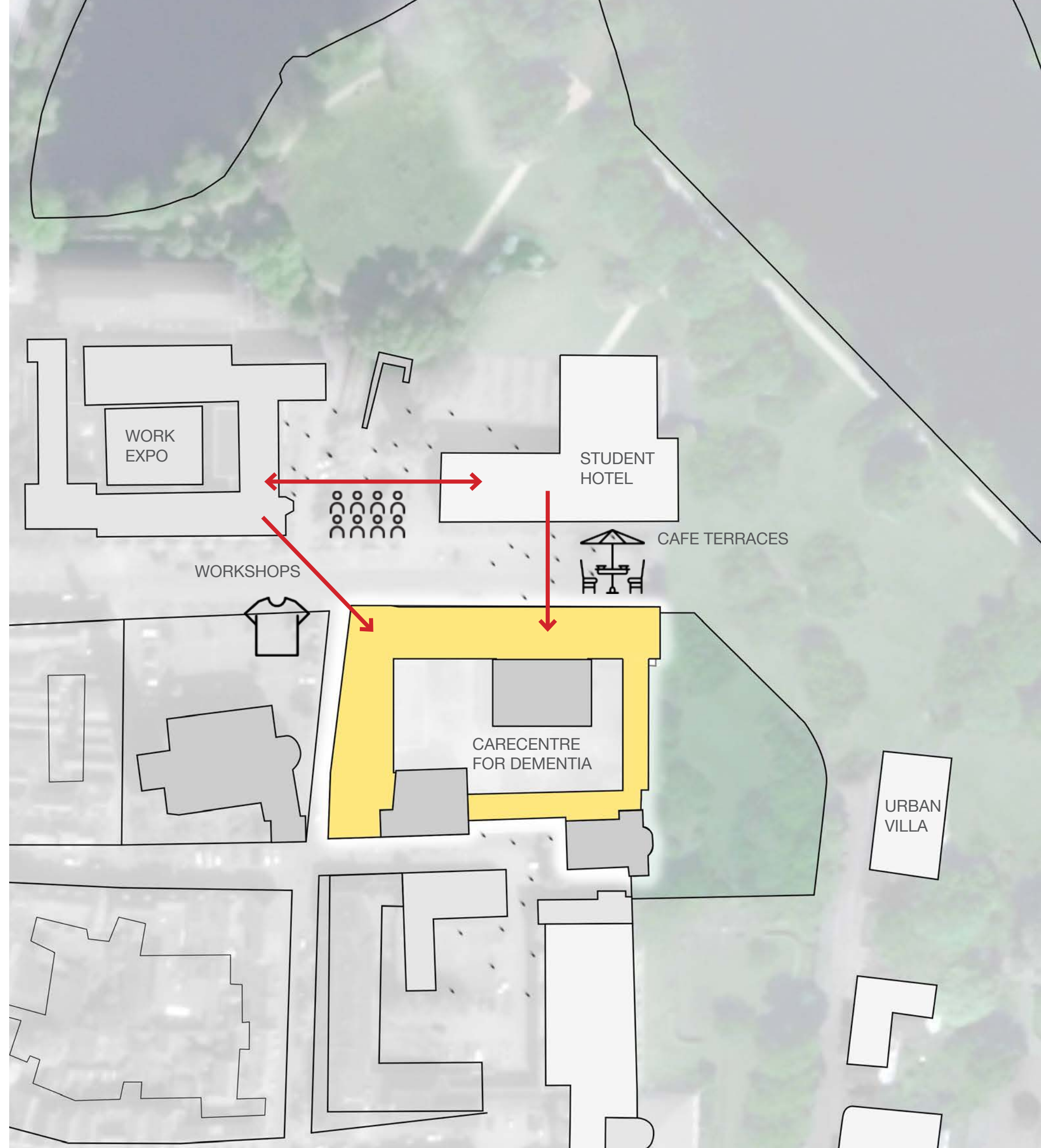

Being part of a community

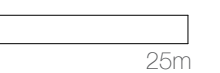



# STRATEGY

## 7. CONNECTION TO THE CARE ENCLAVE



Being part of a community

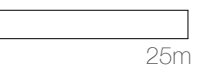
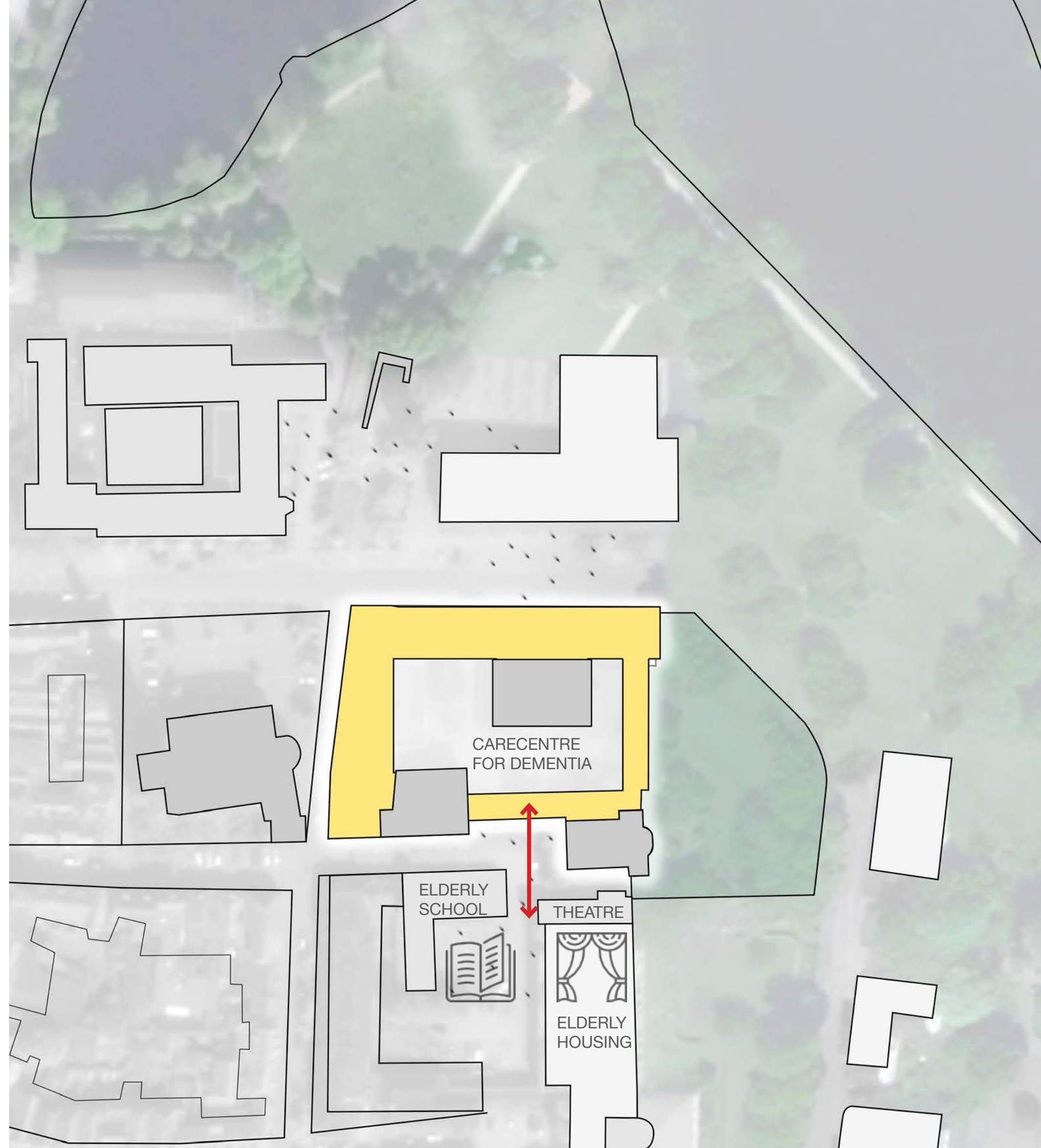

# STRATEGY

## 8. COMMUNAL THOUGHT

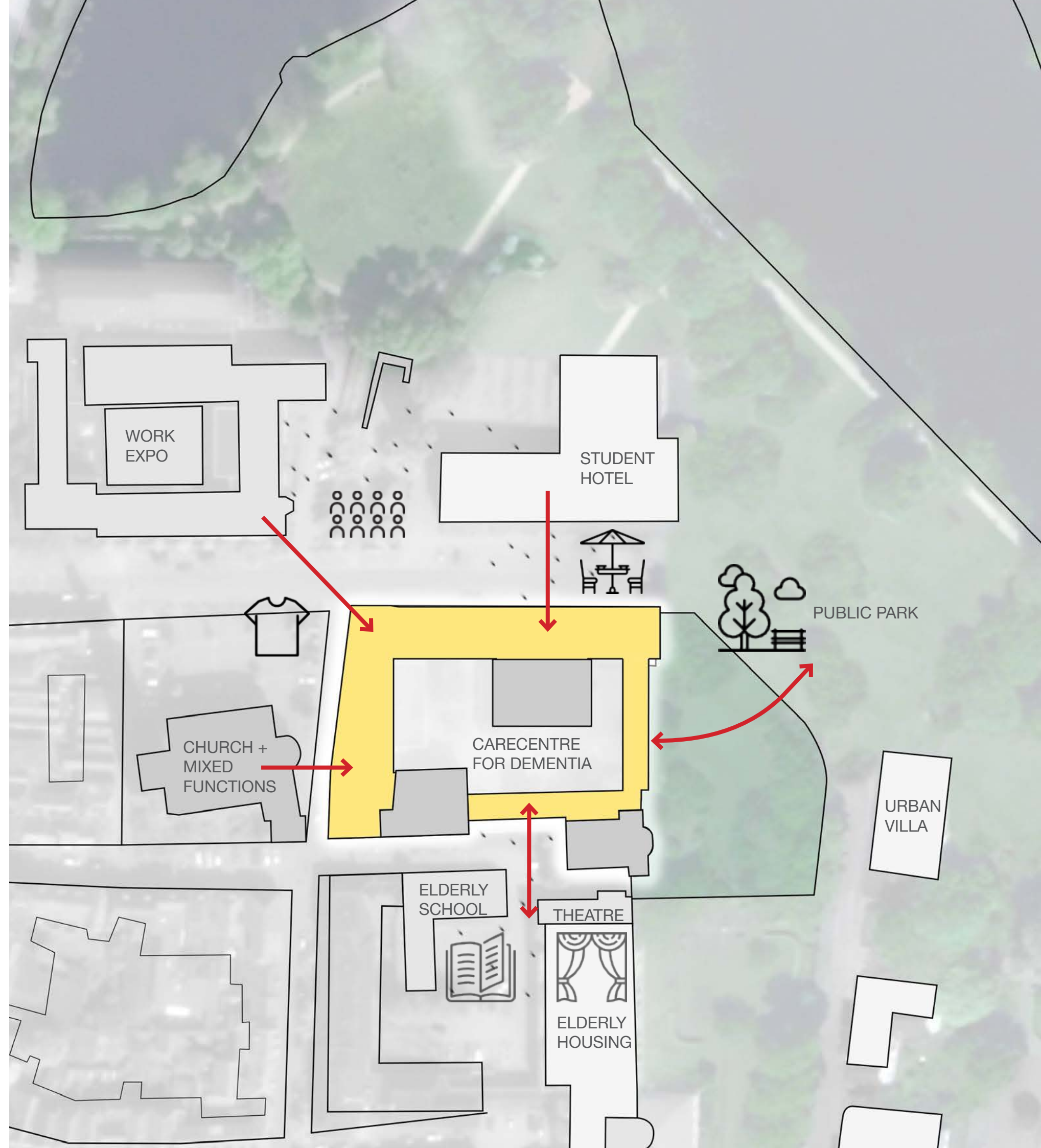

Being part of a community

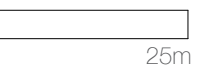

# DESIGN CONCEPT

STARTING POINT- SITU AFTER DEMOLISHMENT

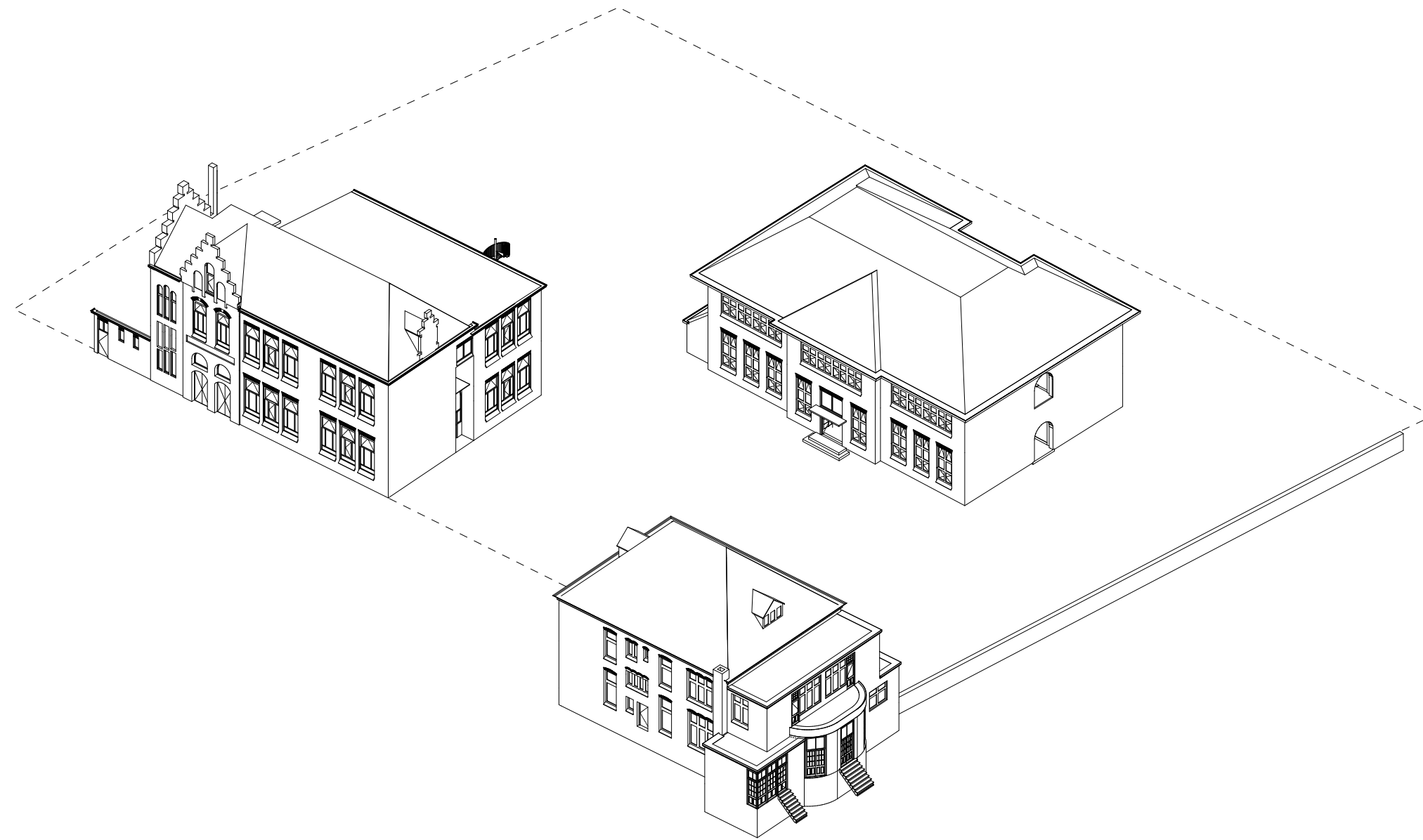

DESIGN CONCEPT  
RECREATING THE BUILDING BLOCK

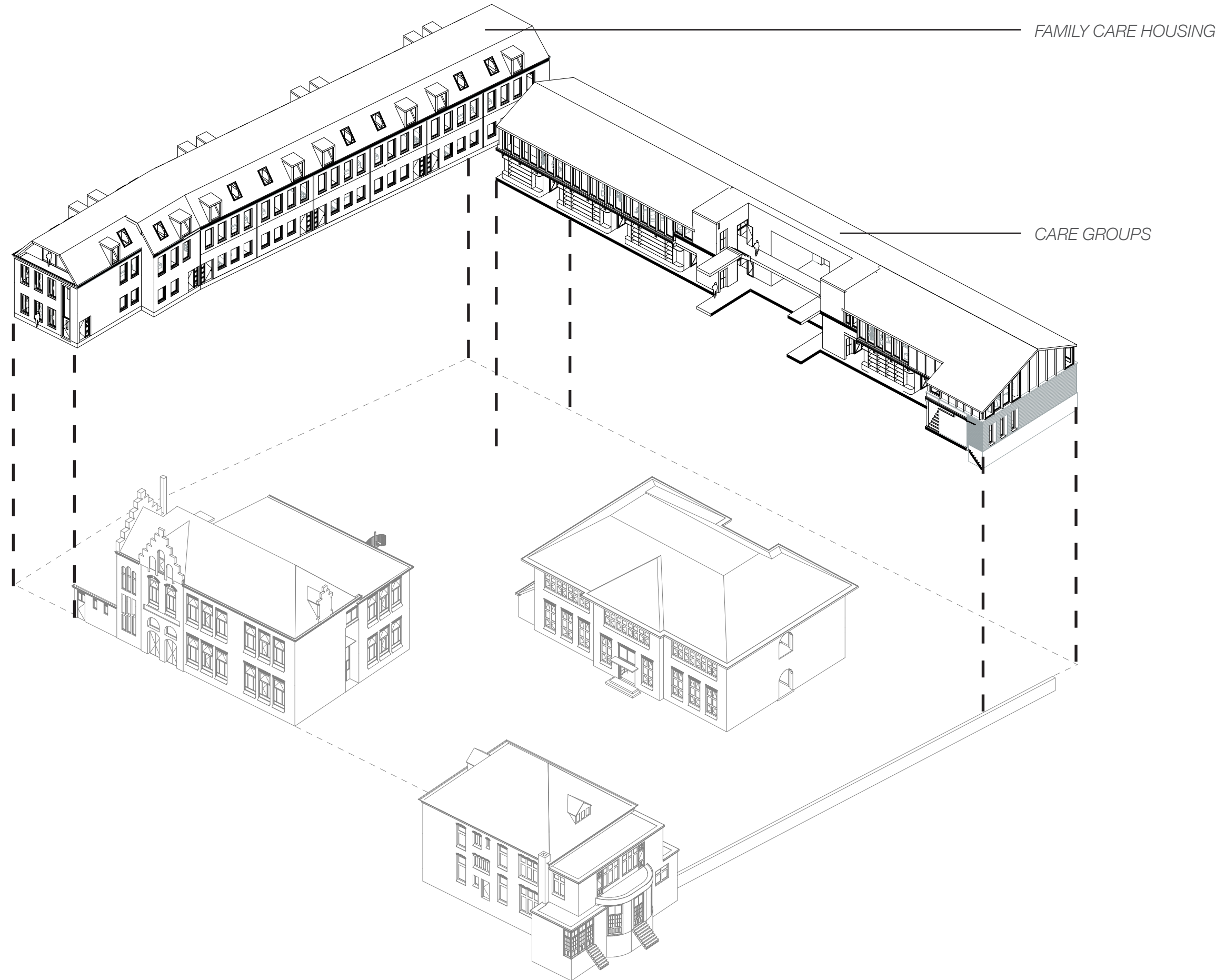

# DESIGN CONCEPT

CONNECTING THE ENSEMBLE

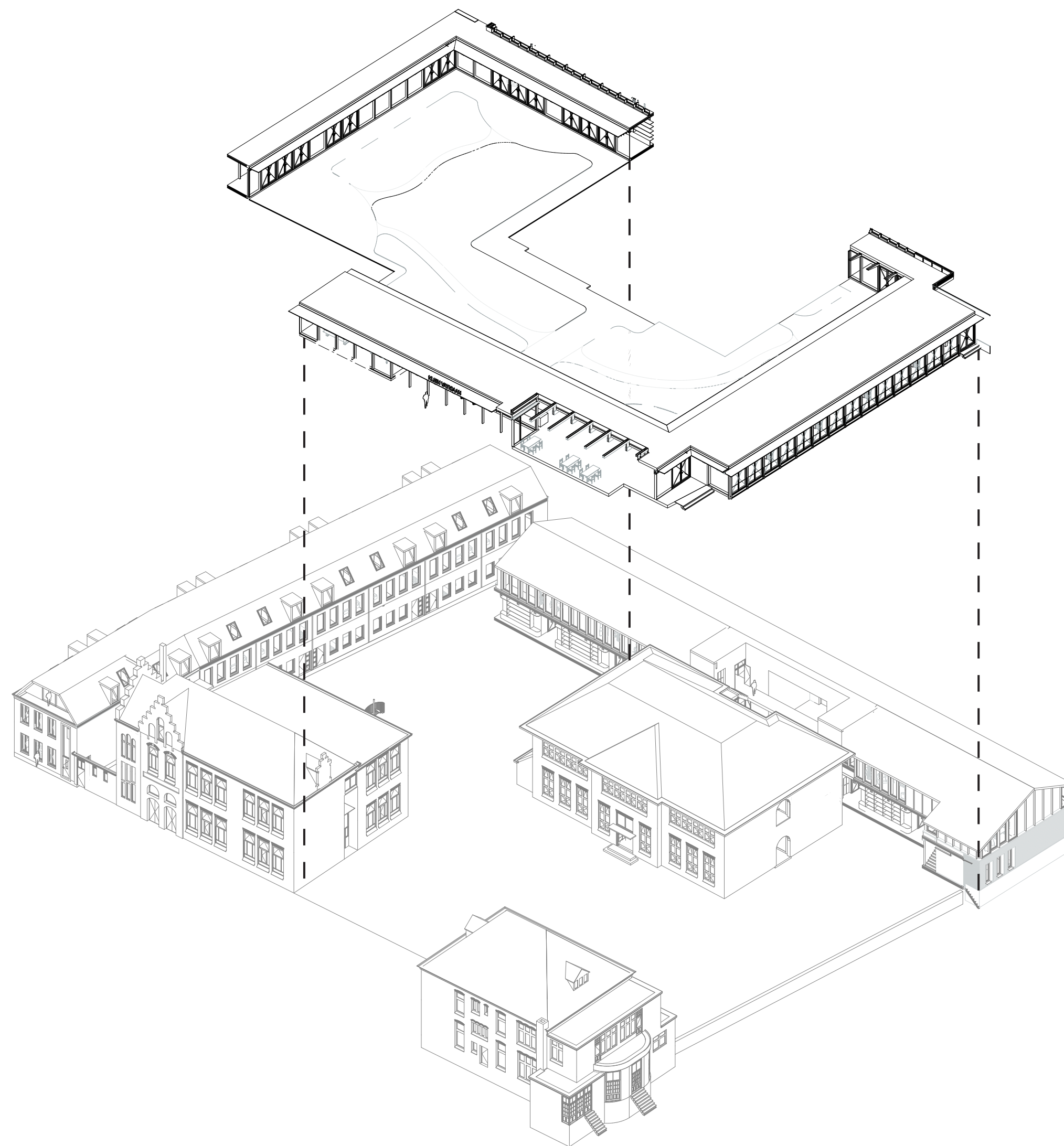

# DESIGN CONCEPT

AXONOMETRIC VIEW

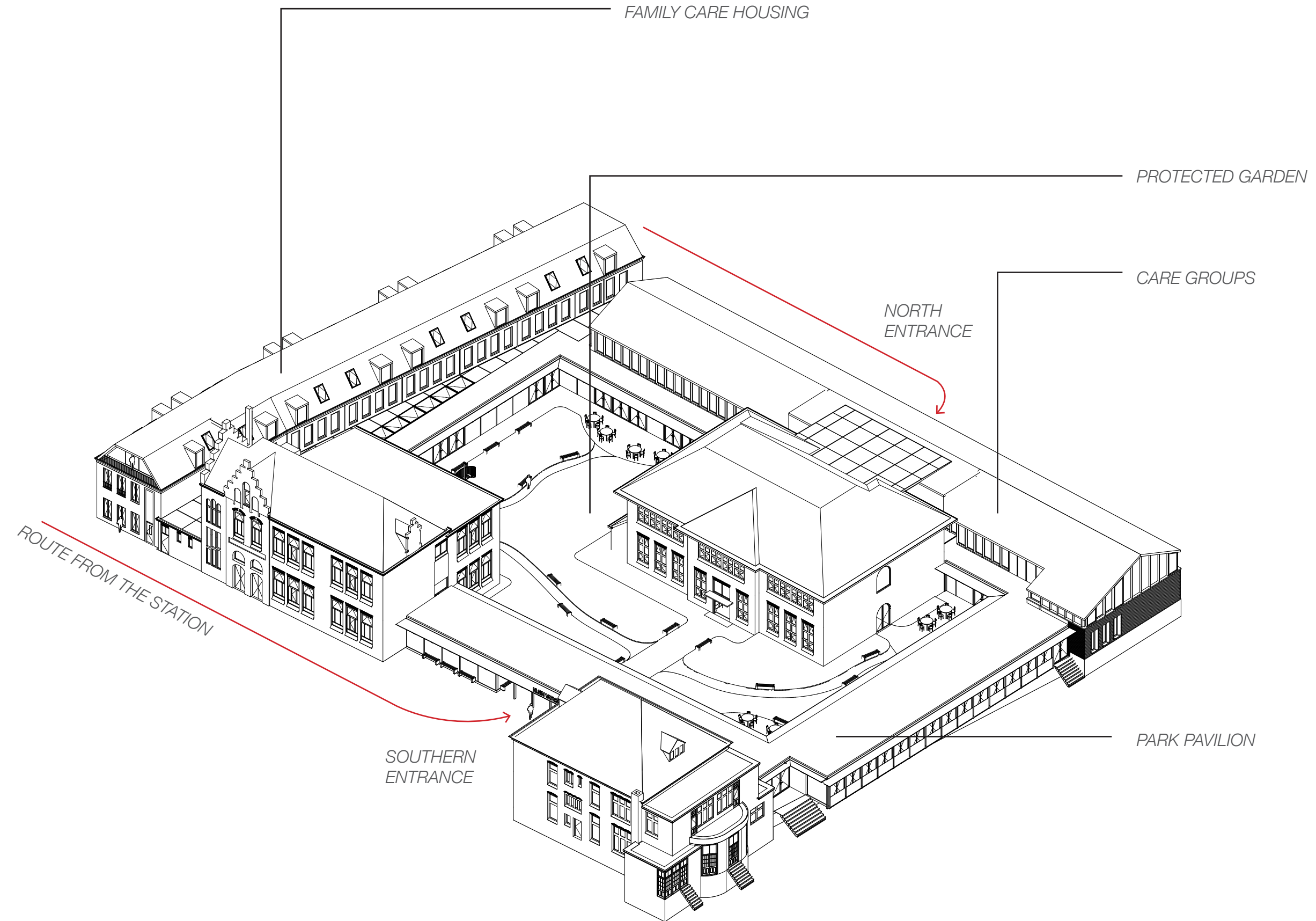

## 6. DESIGN

# NEW SITUATION

GROUND FLOOR

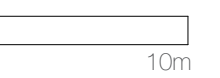
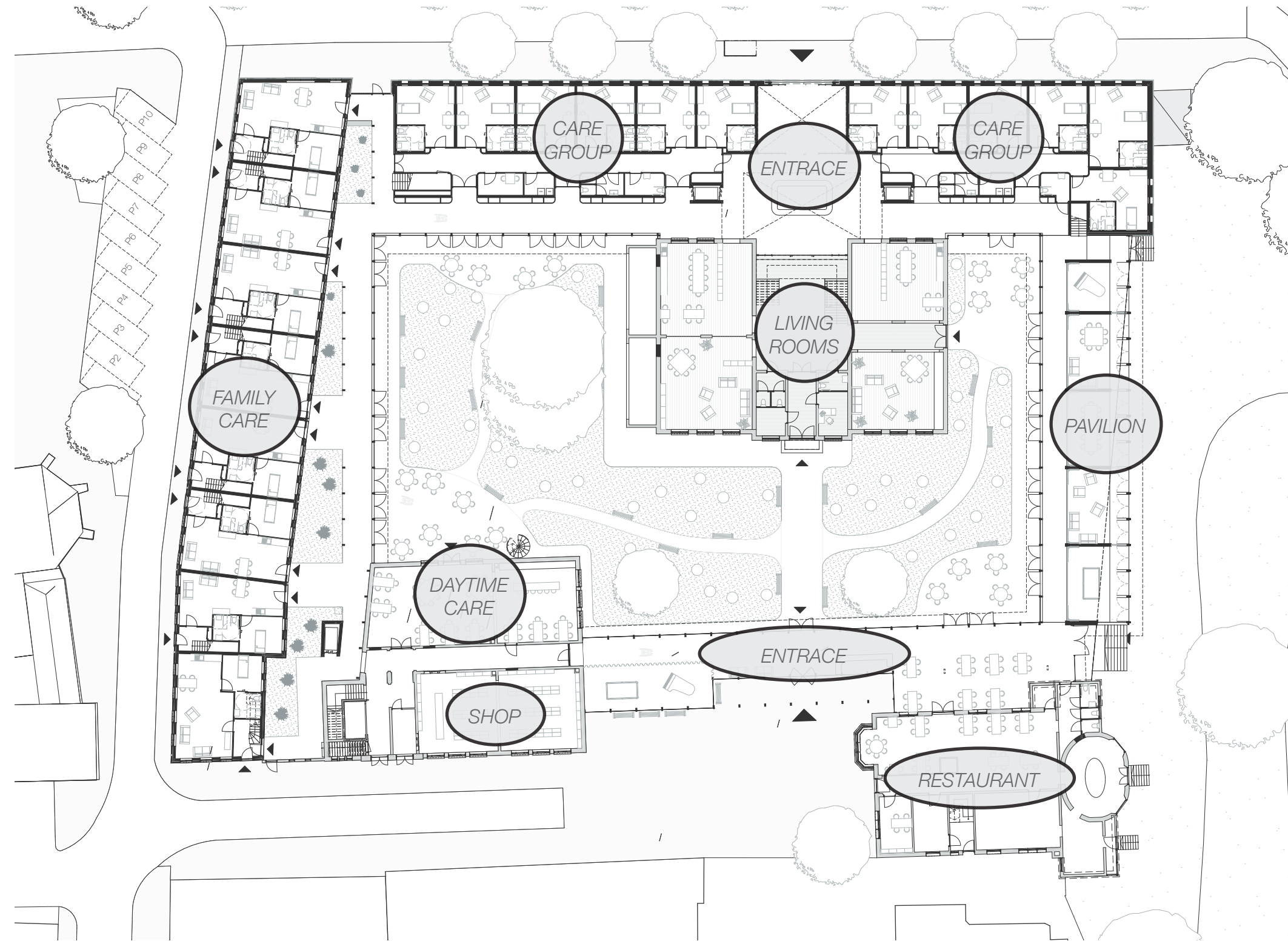



# FAMILY CARE

DIESERSTRAAT

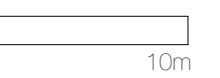



DIESERSTRAAT  
*REINTERPRETATION OF THE PAST*



# FACADE STUDY

CORNER DIESERSTRAAT - TENGNAGELSHOEK





# ENTRANCE ENSEMBLE

SOUTH ENTRANCE

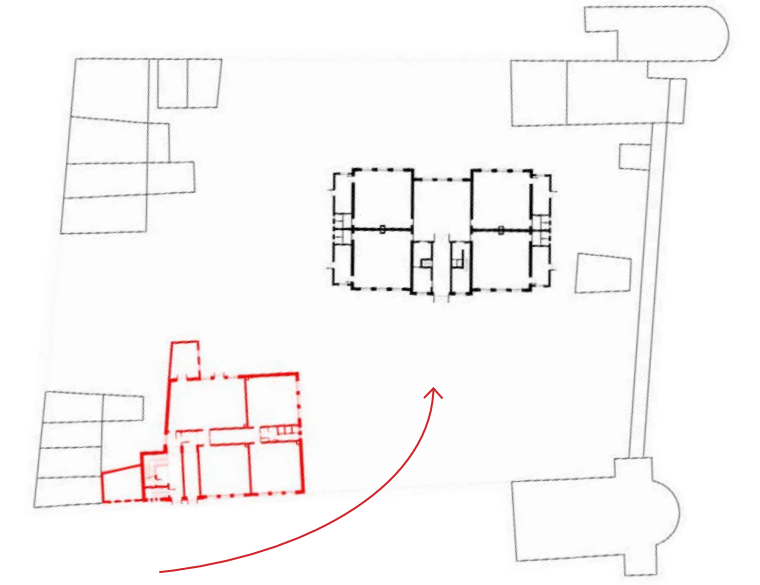
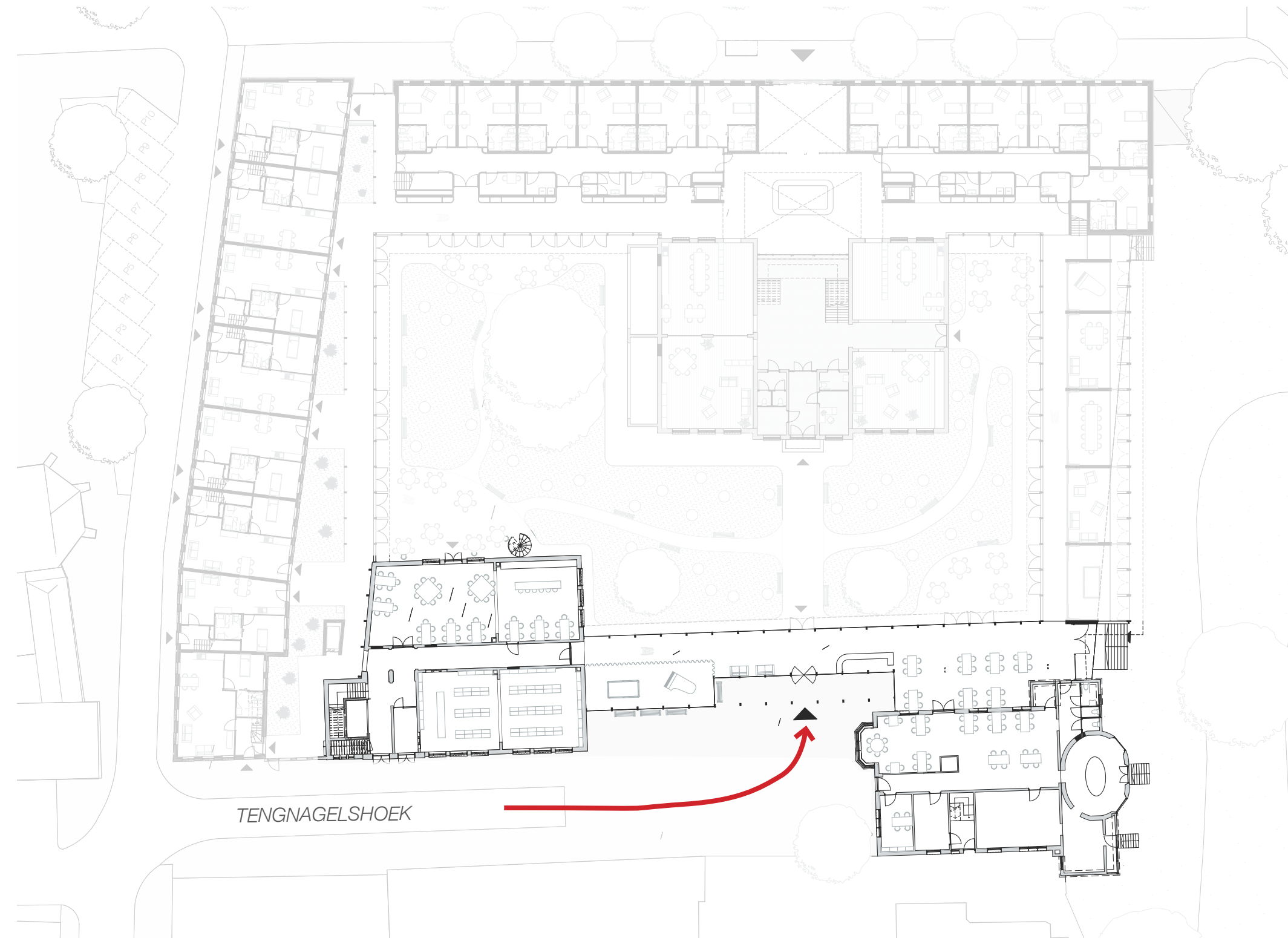

Entrance to the ensemble 1891



# FOYER & RESTAURANT

ST-ANNA & PASTORIE

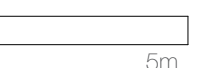
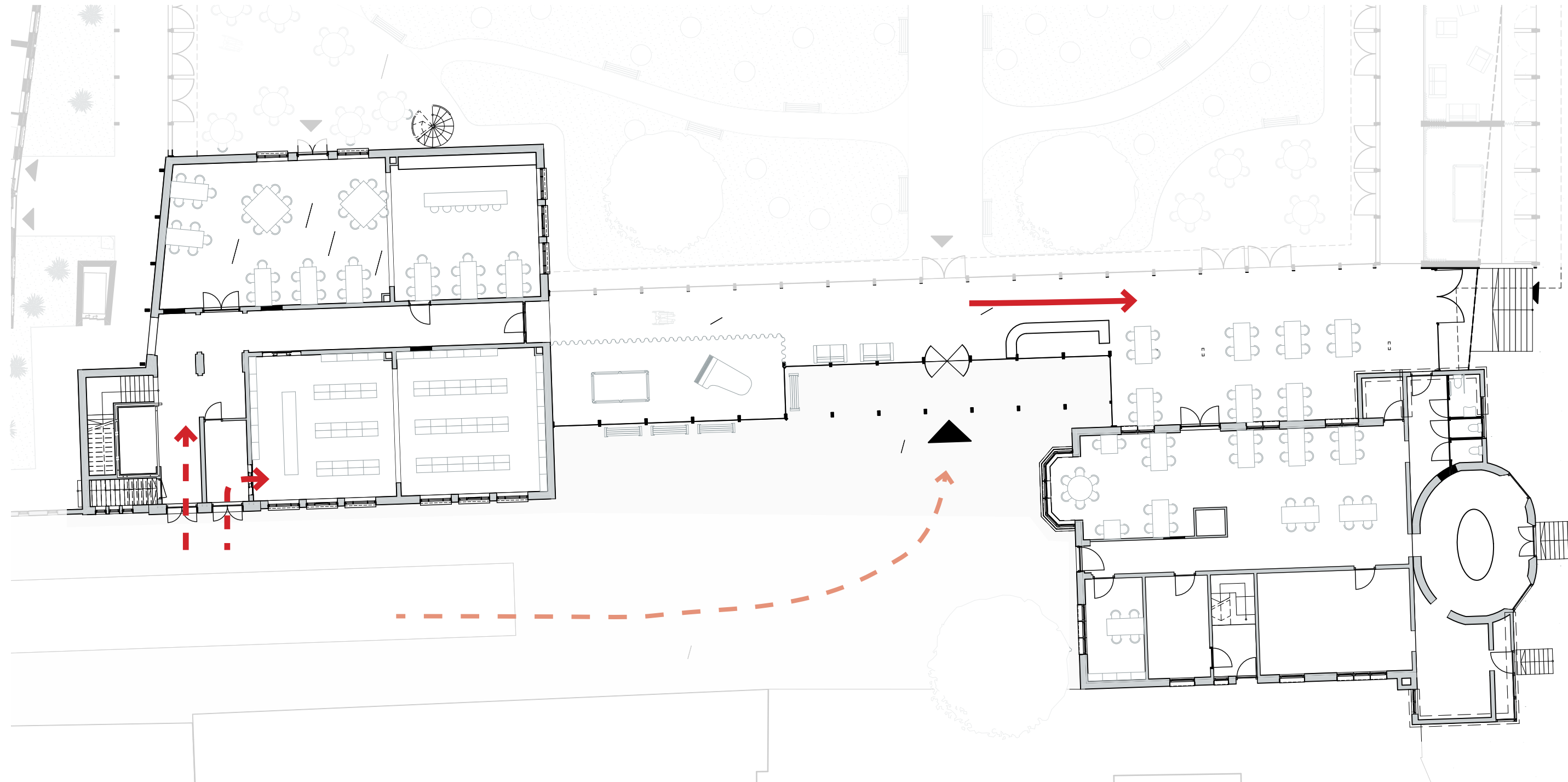





# PARKSIDE PAVILION

GROUND FLOOR

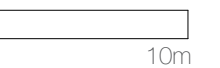
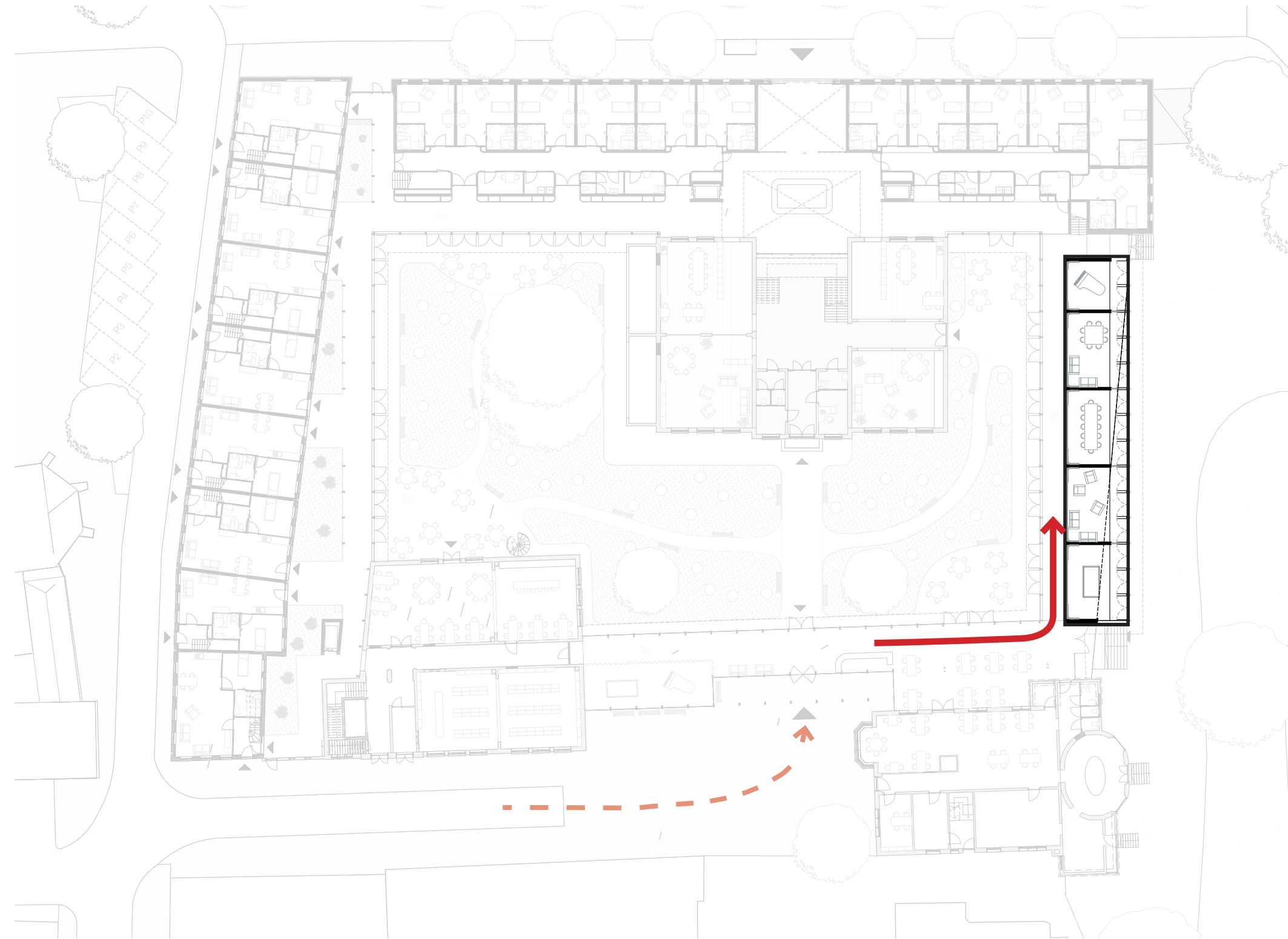



# PARKSIDE PAVILION

AXONOMETRY

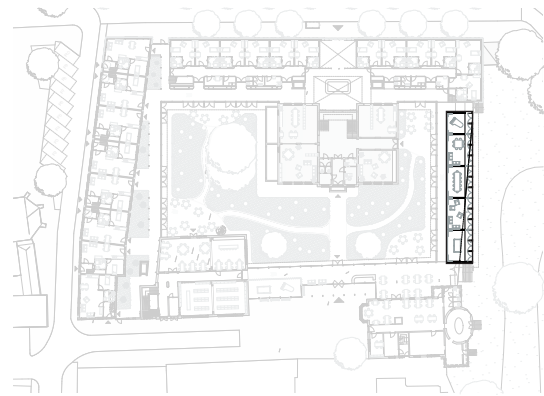
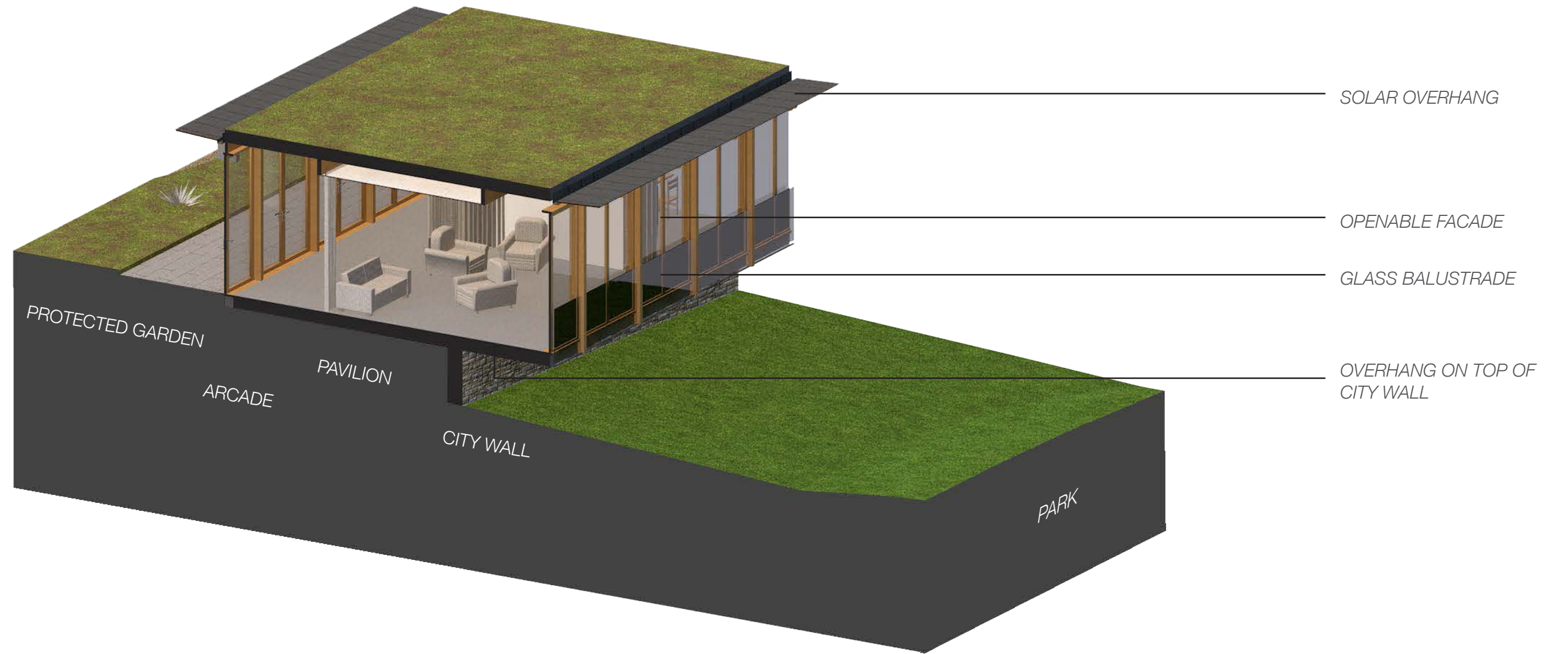

# PARK PAVILION

OVERHANG CITY WALL

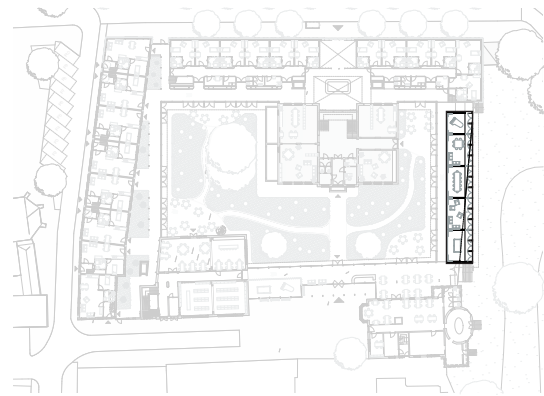
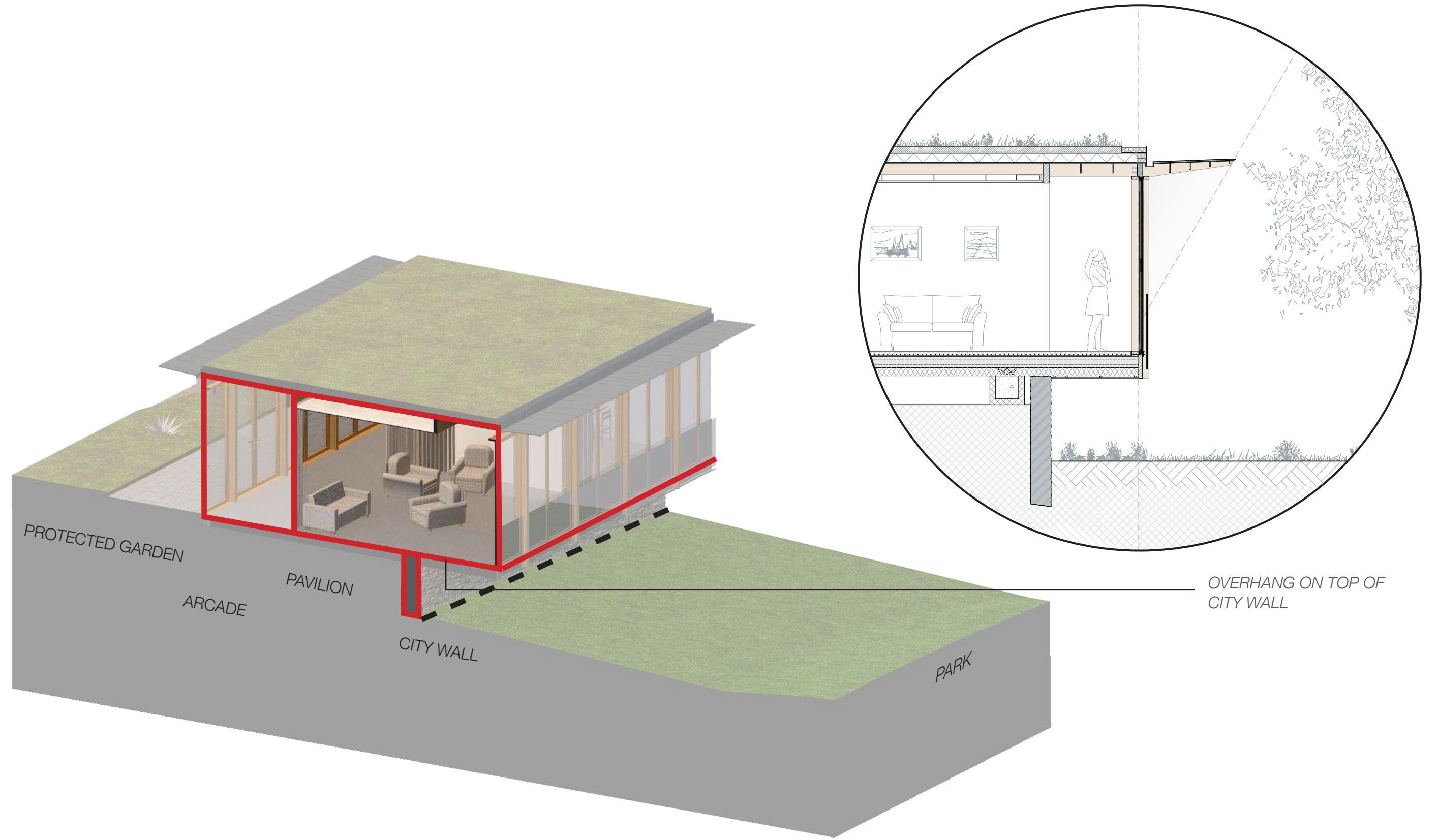

# PARK PAVILION

OVERHANG CITY WALL

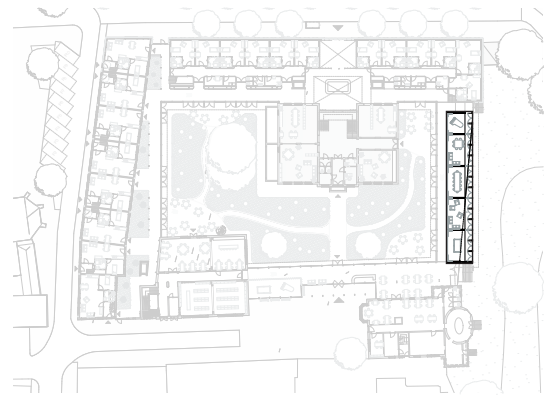
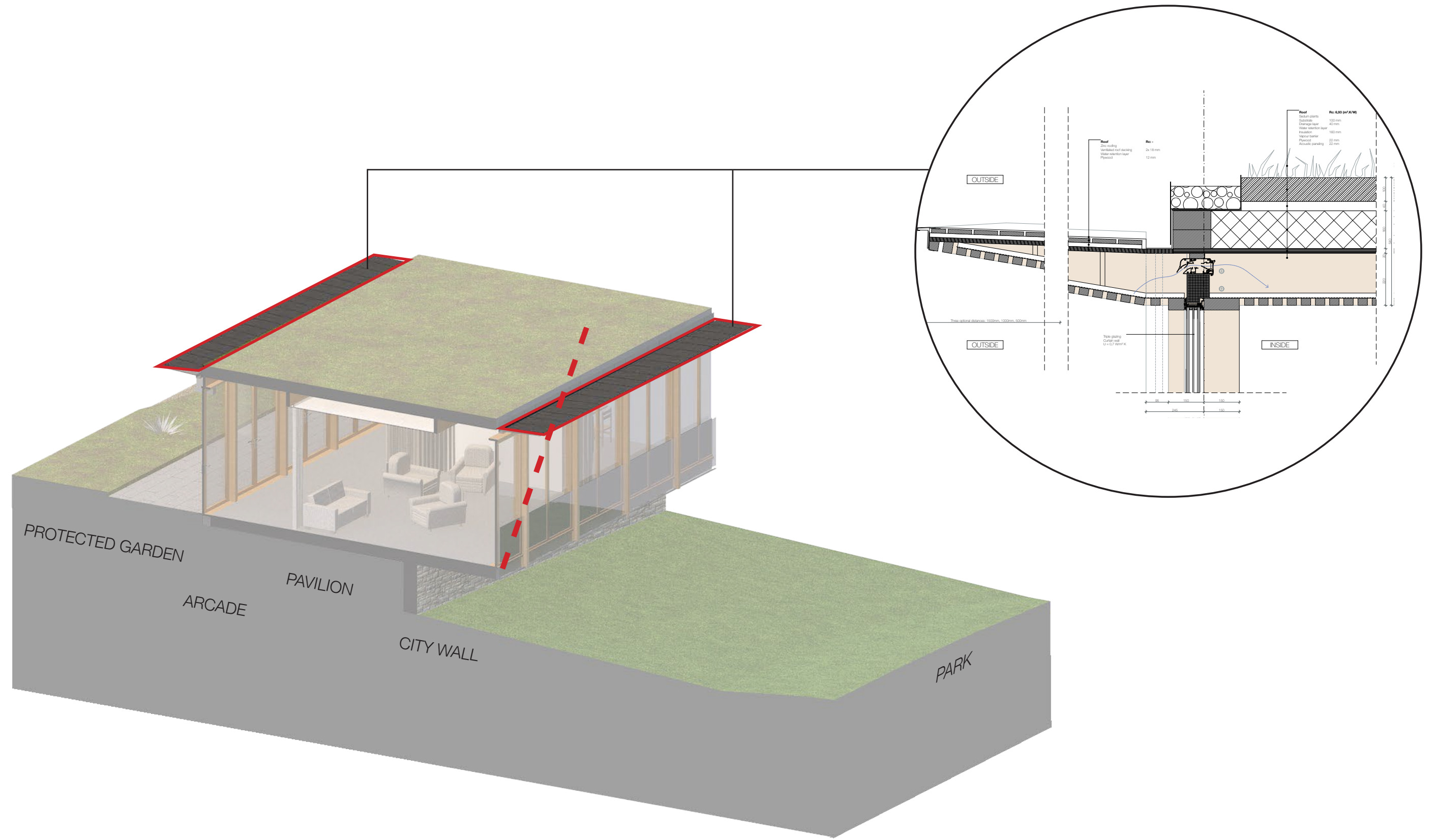

# PARK PAVILION

## OVERHANG DETAIL

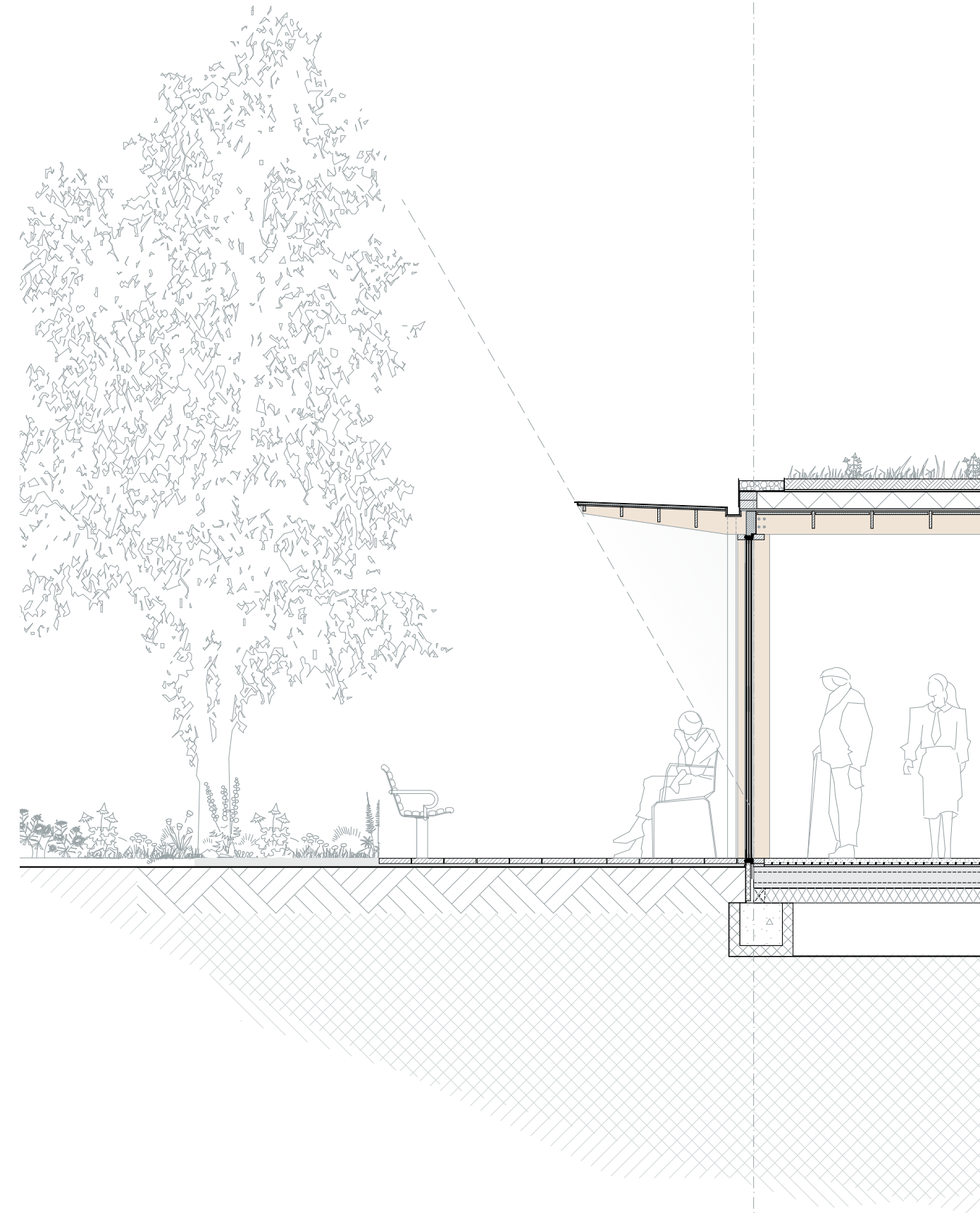
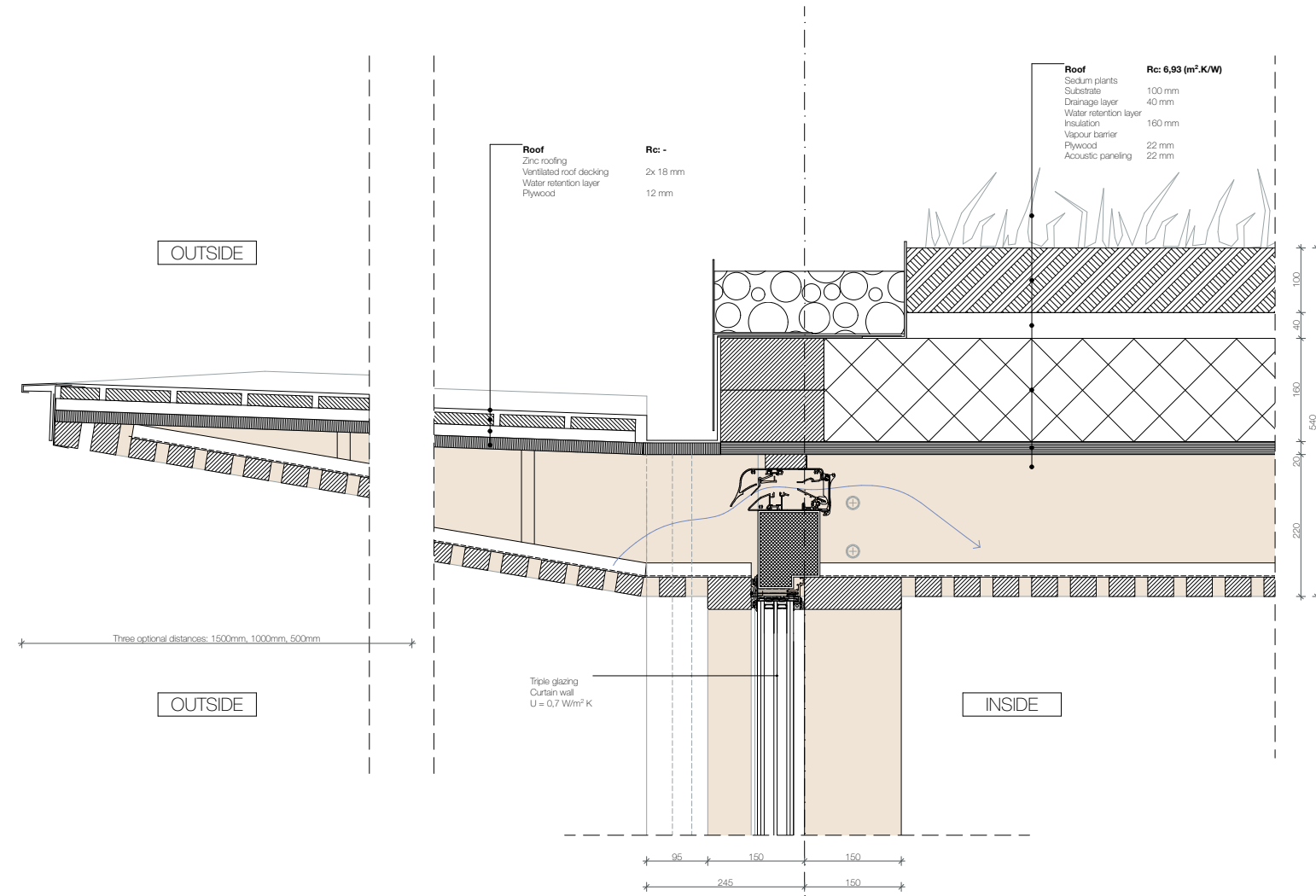

# PARK PAVILION

VENTILATION

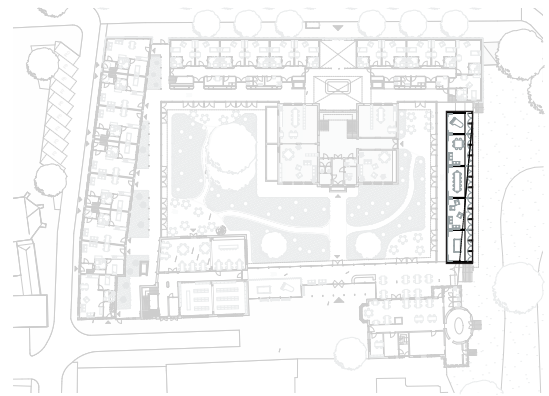
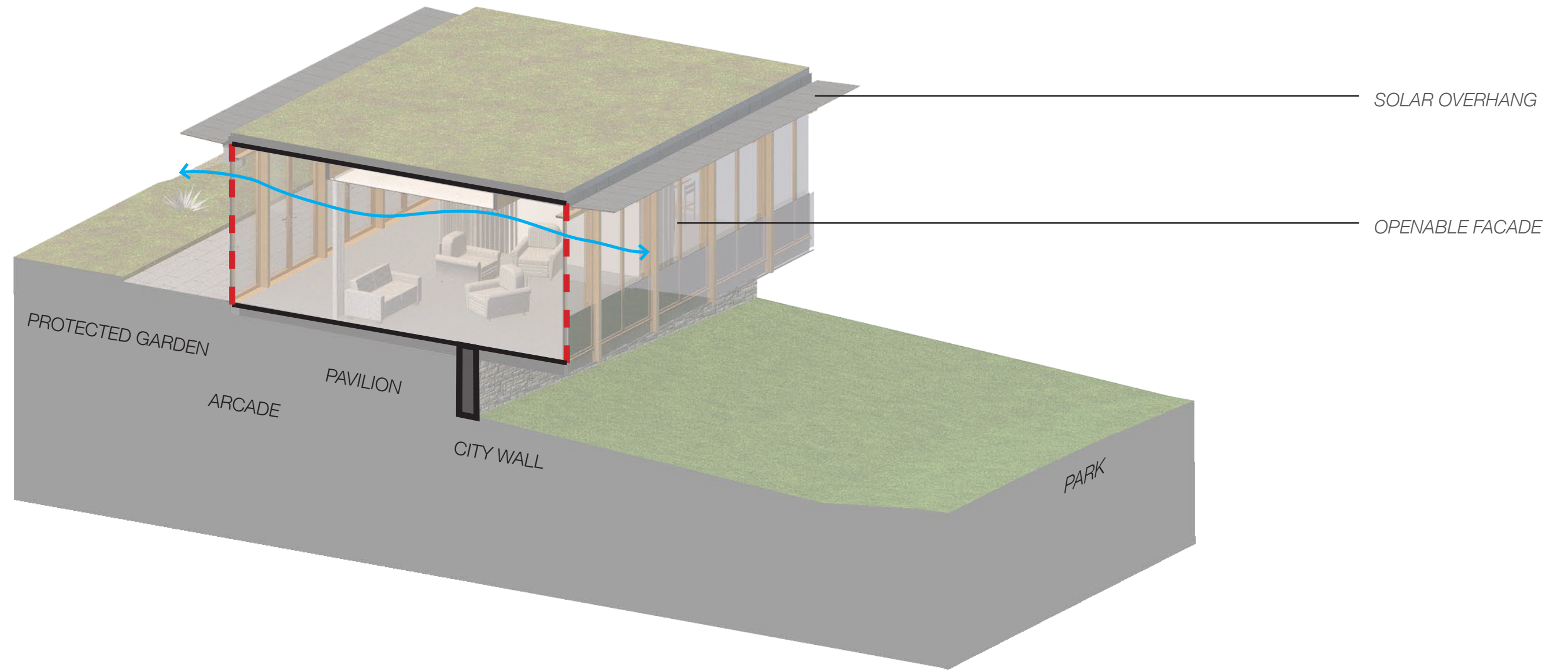



# CARE GROUPS

AXONOMETRIC VIEW

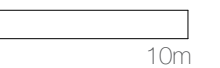
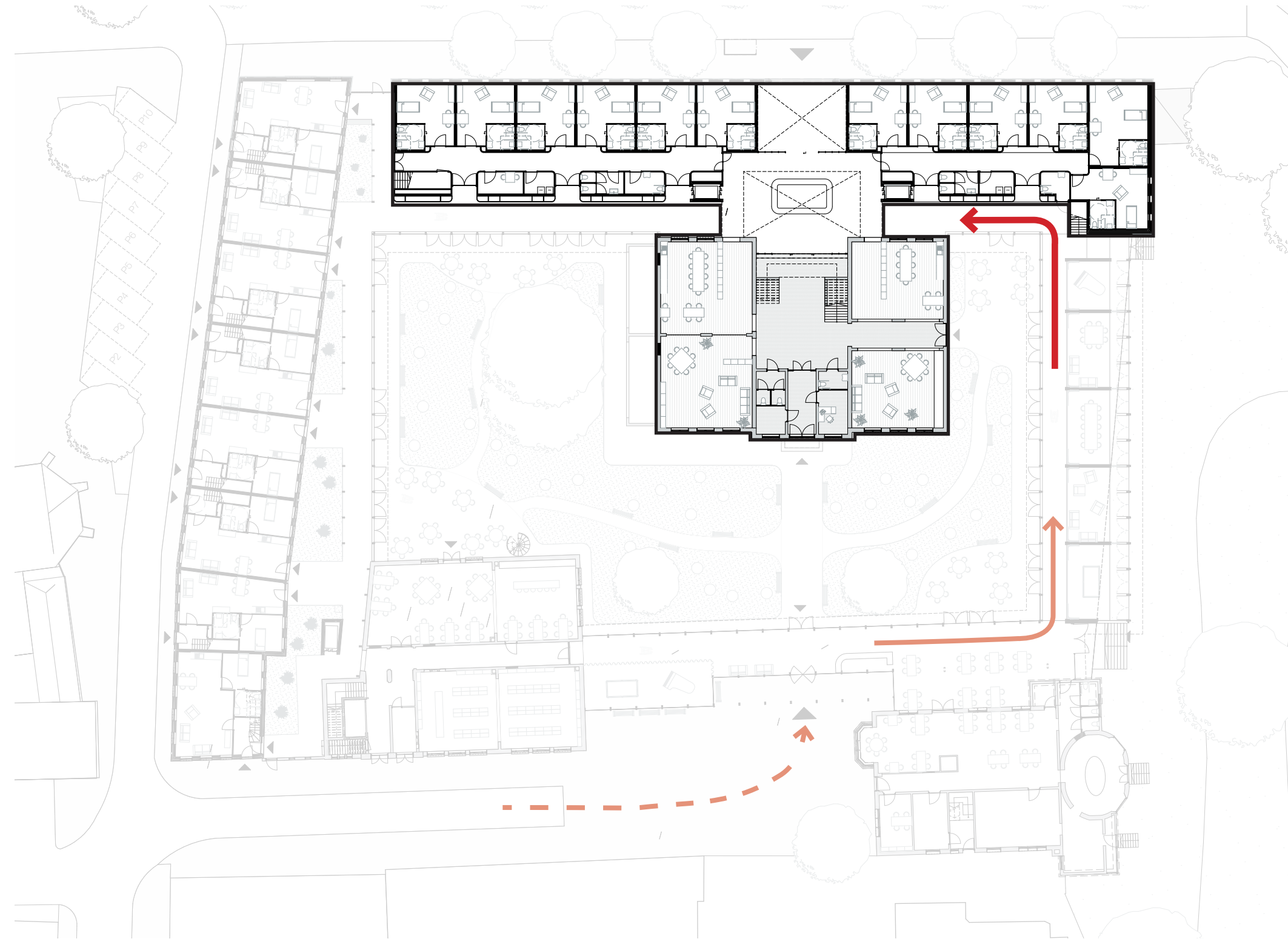



# CARE GROUPS

AXONOMETRIC VIEW

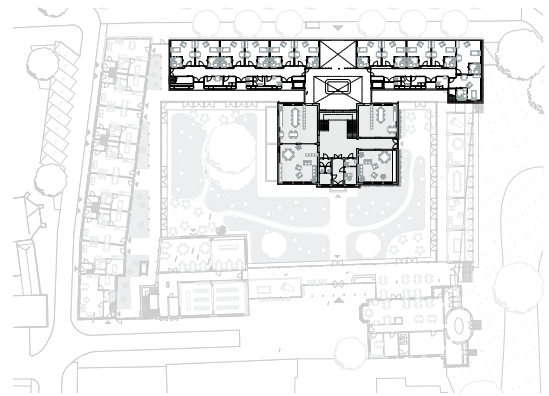

# CARE GROUPS

PERSONAL ROOMS

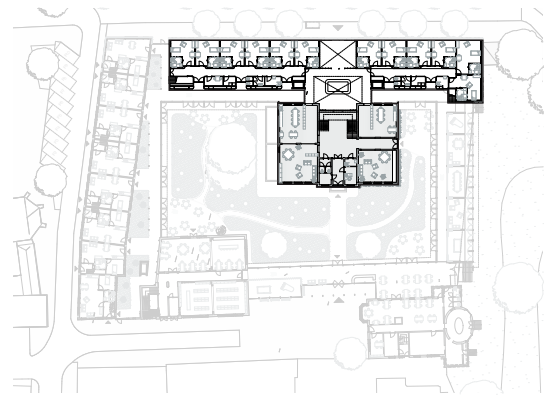
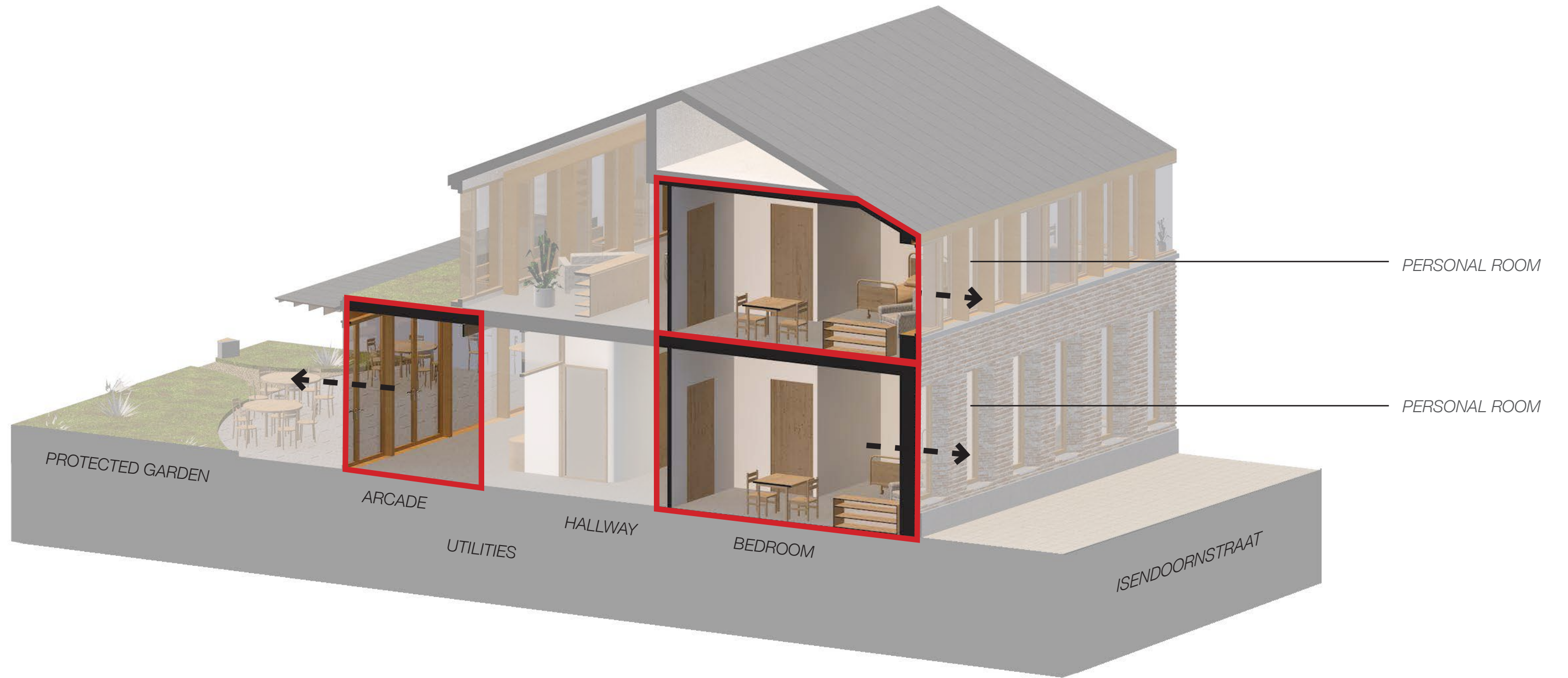

# CARE GROUPS

UTILITIES AS A DIVIDER OF SPACE

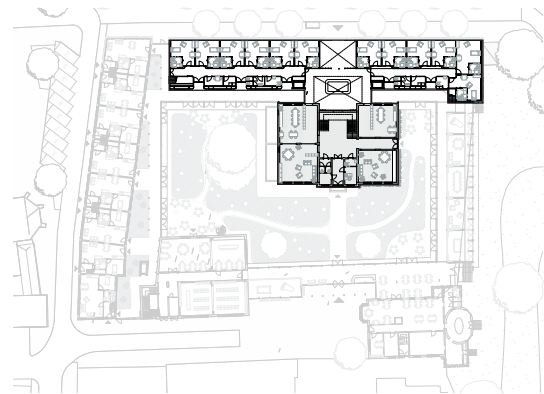
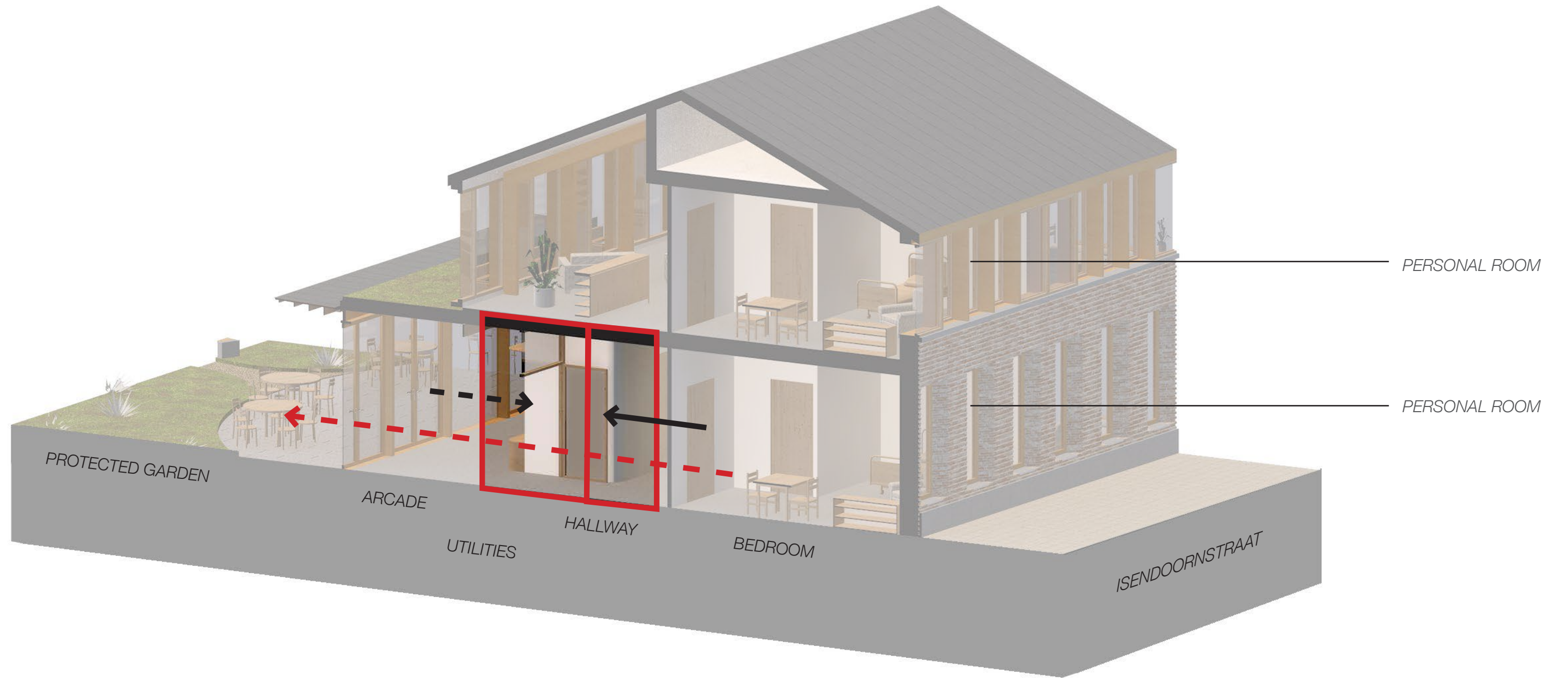

# CARE GROUPS

SECTION DETAIL

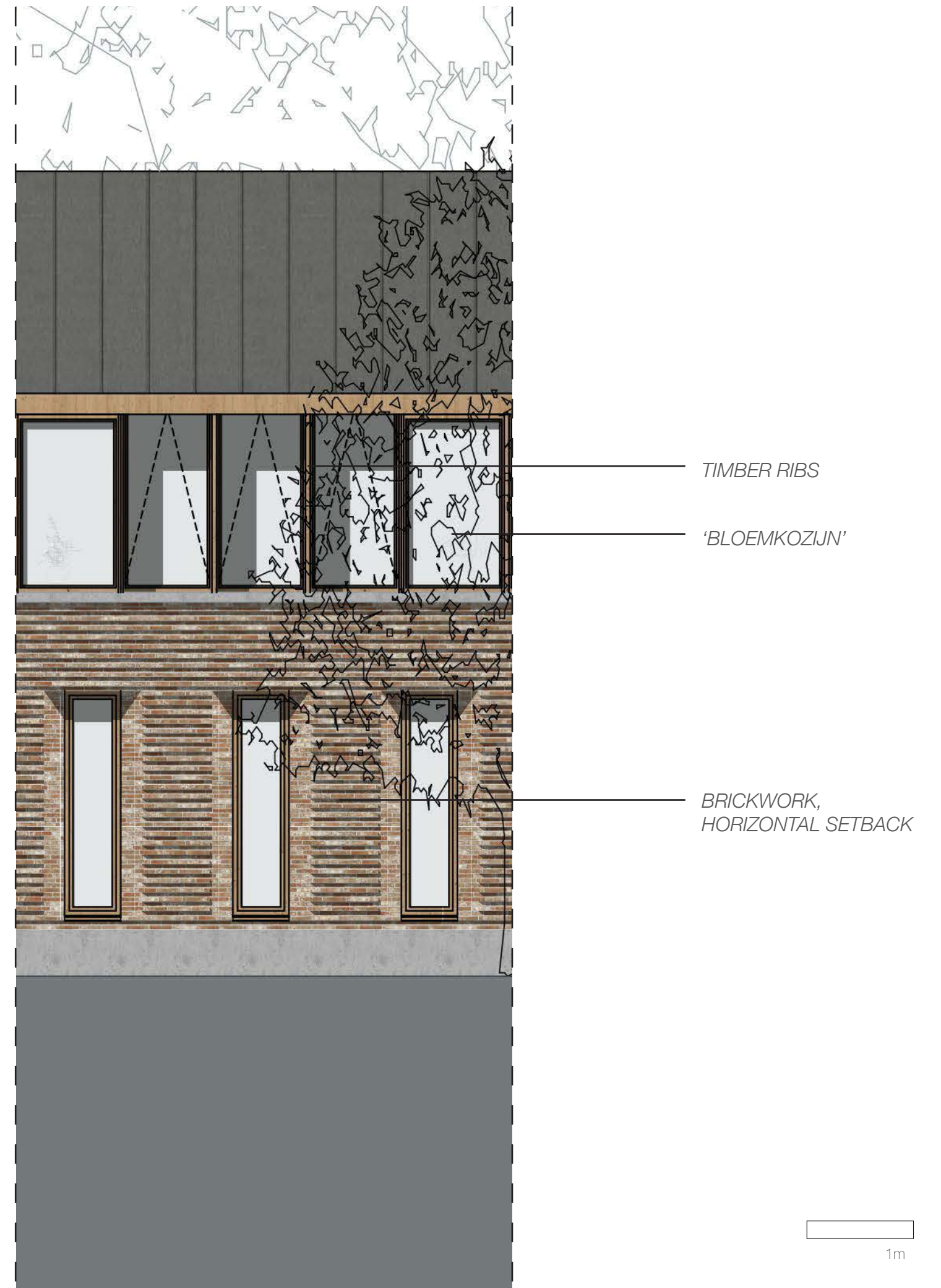
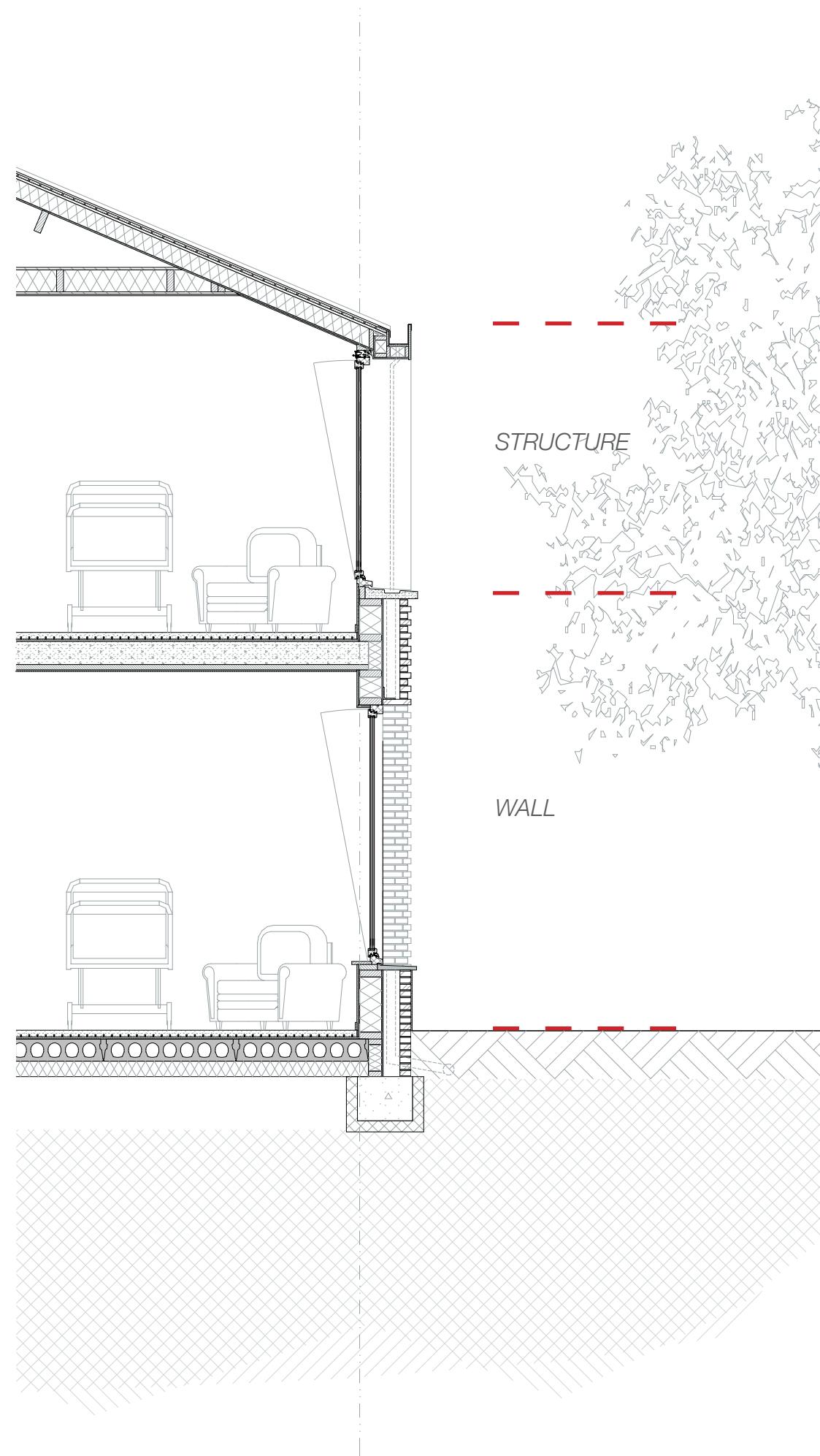

# CARE GROUPS

SECTION DETAIL

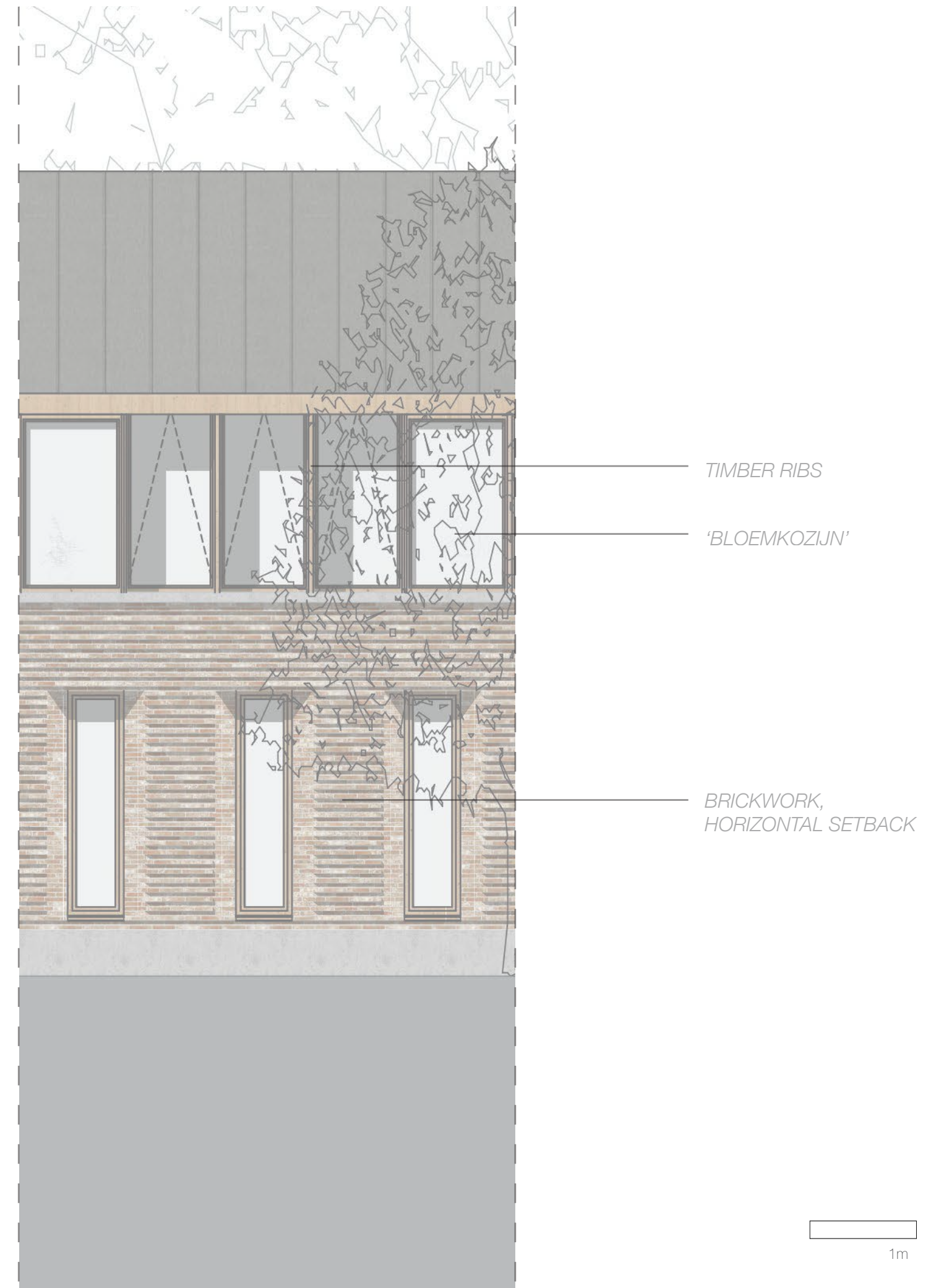
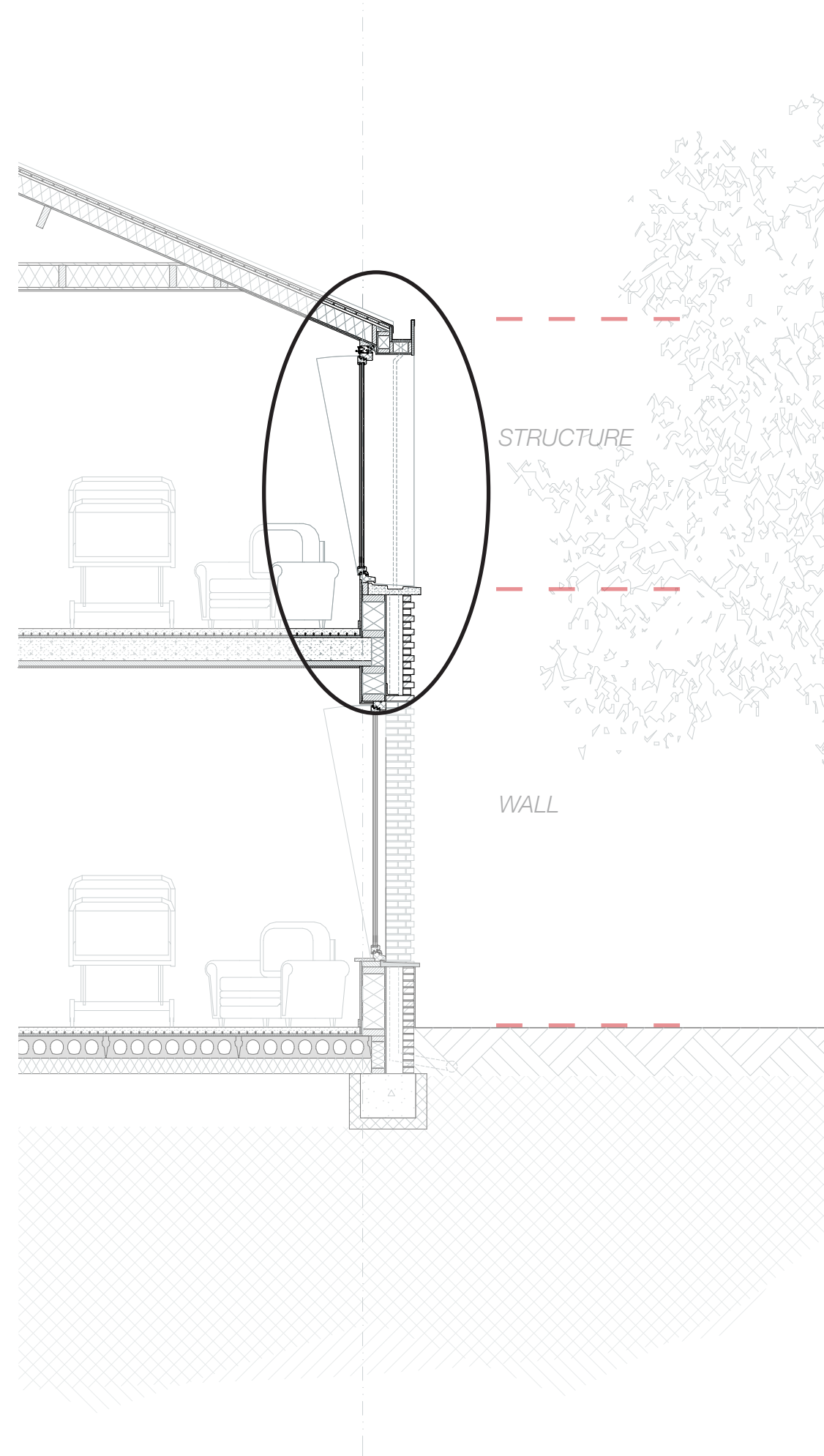

# CARE GROUPS

## SECTION DETAIL - 'BLOEMKOZIJN'

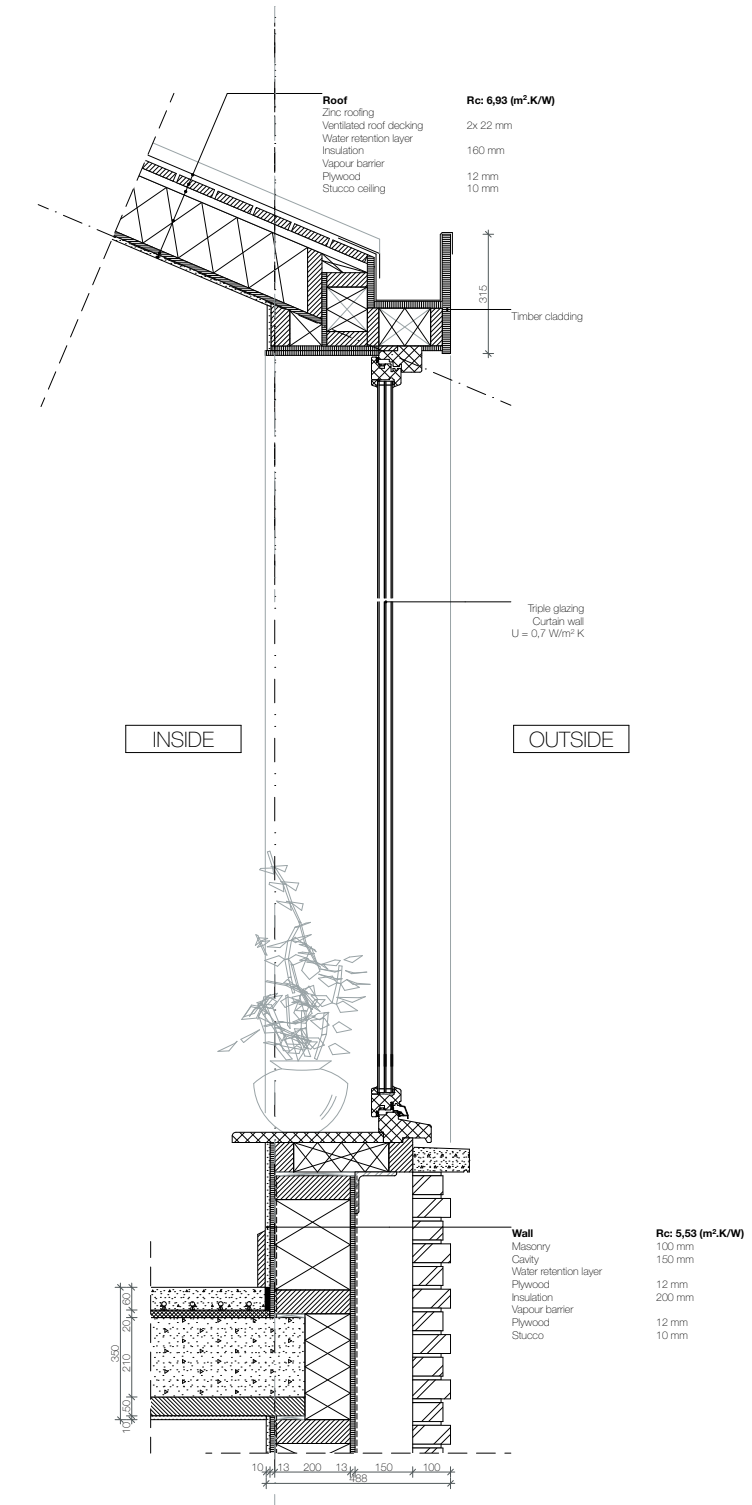
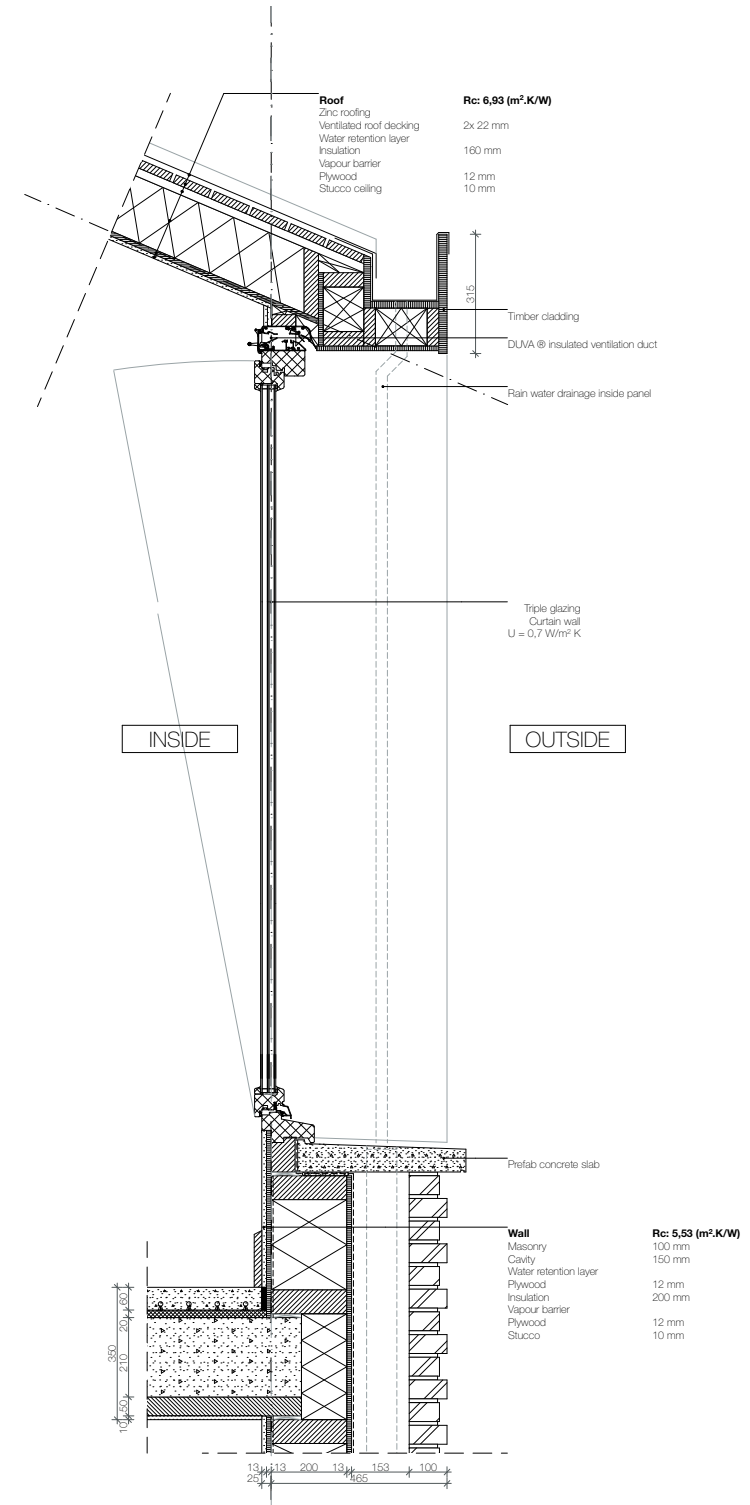



# CARE GROUPS

LIVING AREA

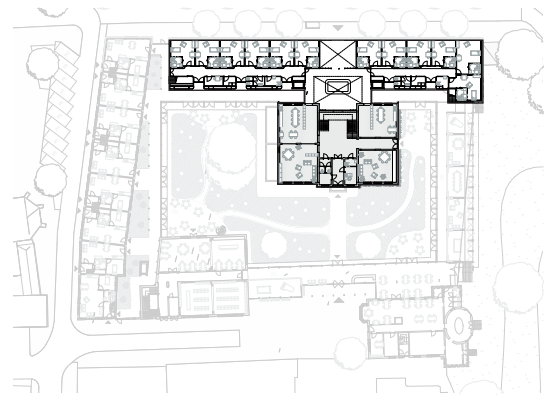
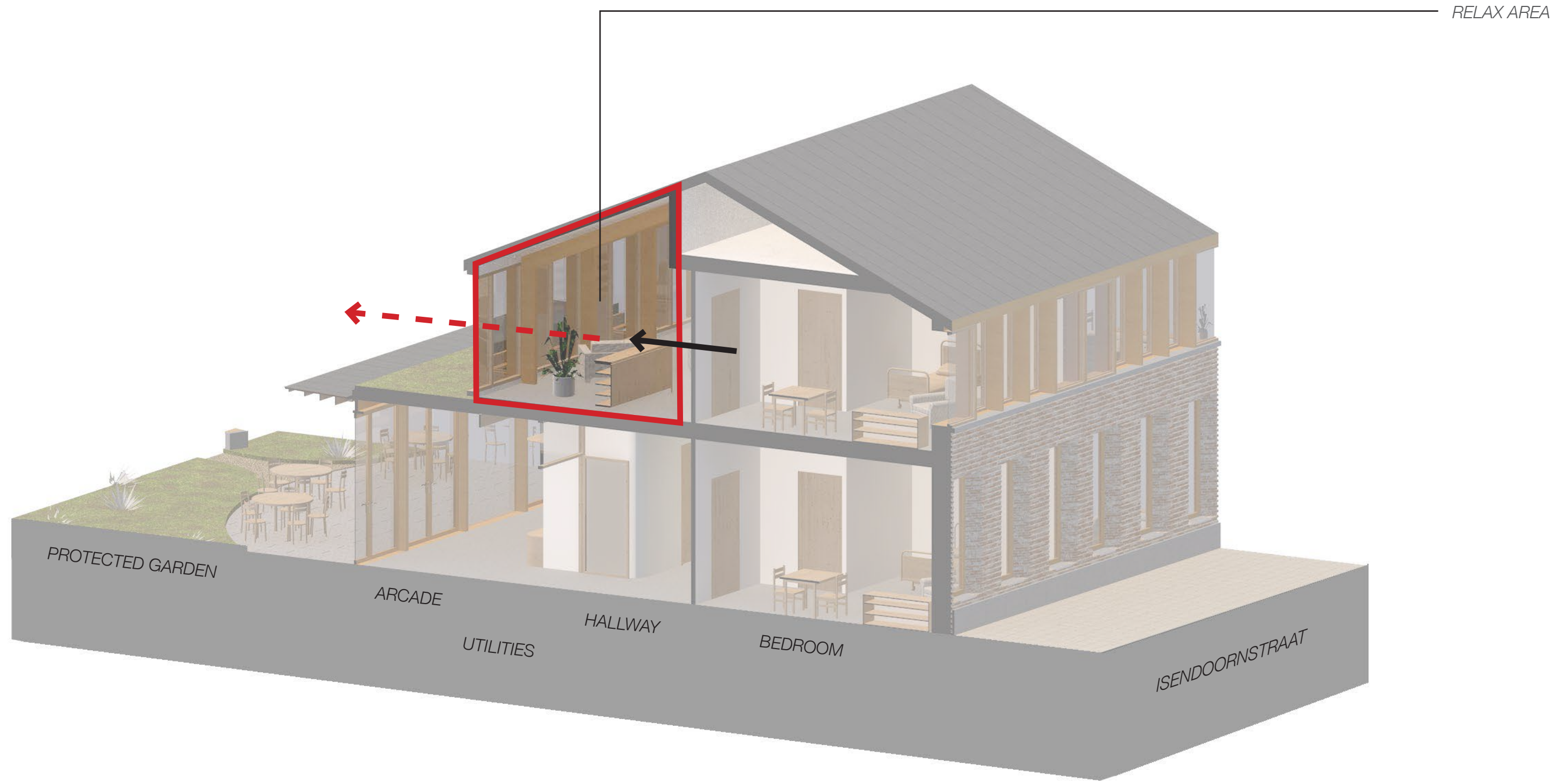

# CARE GROUPS

CLIMATE DESIGN

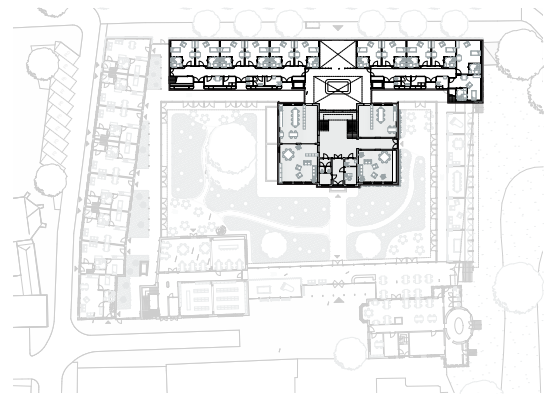
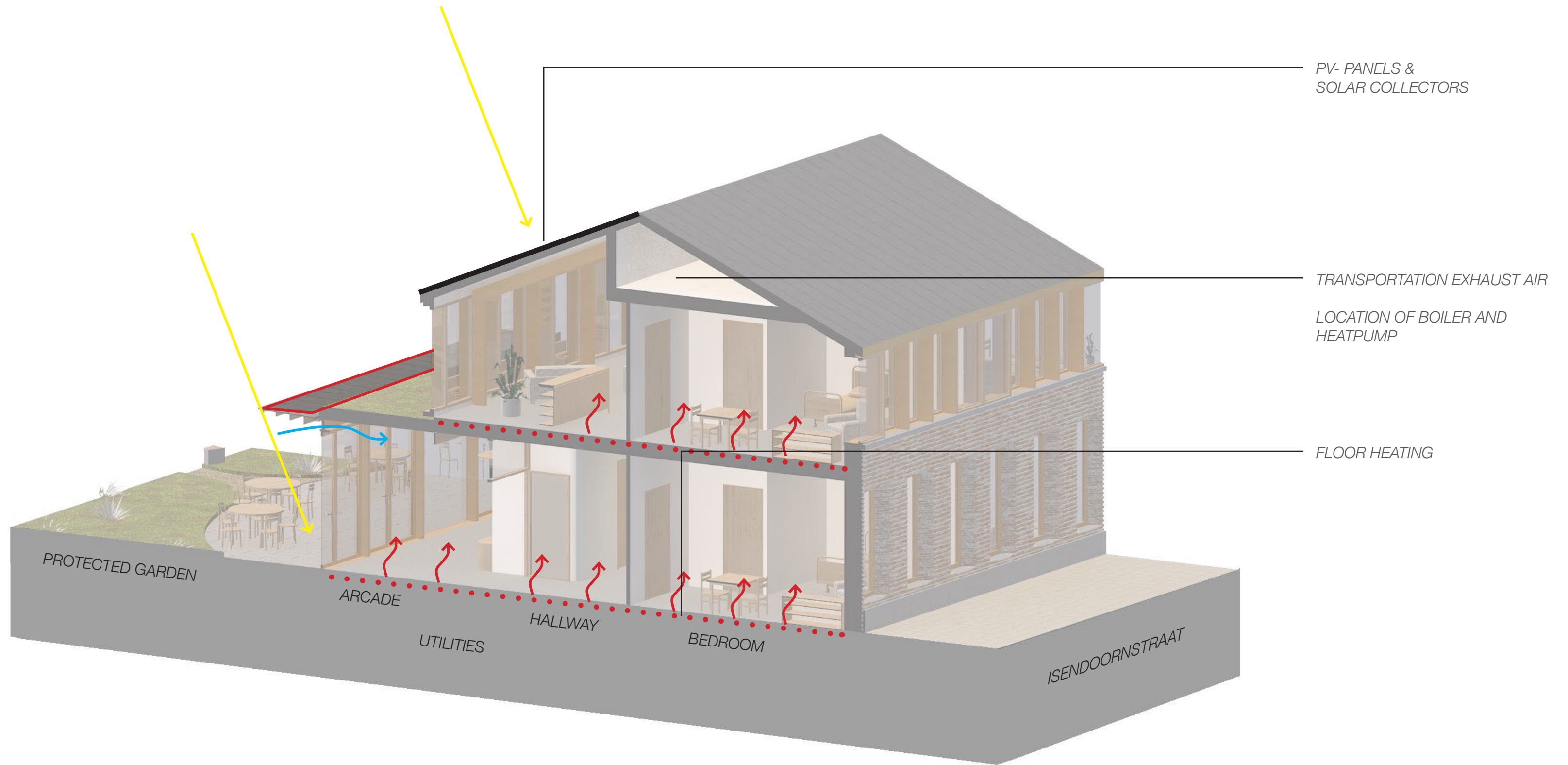

# CARE GROUPS

FLOOR PLAN

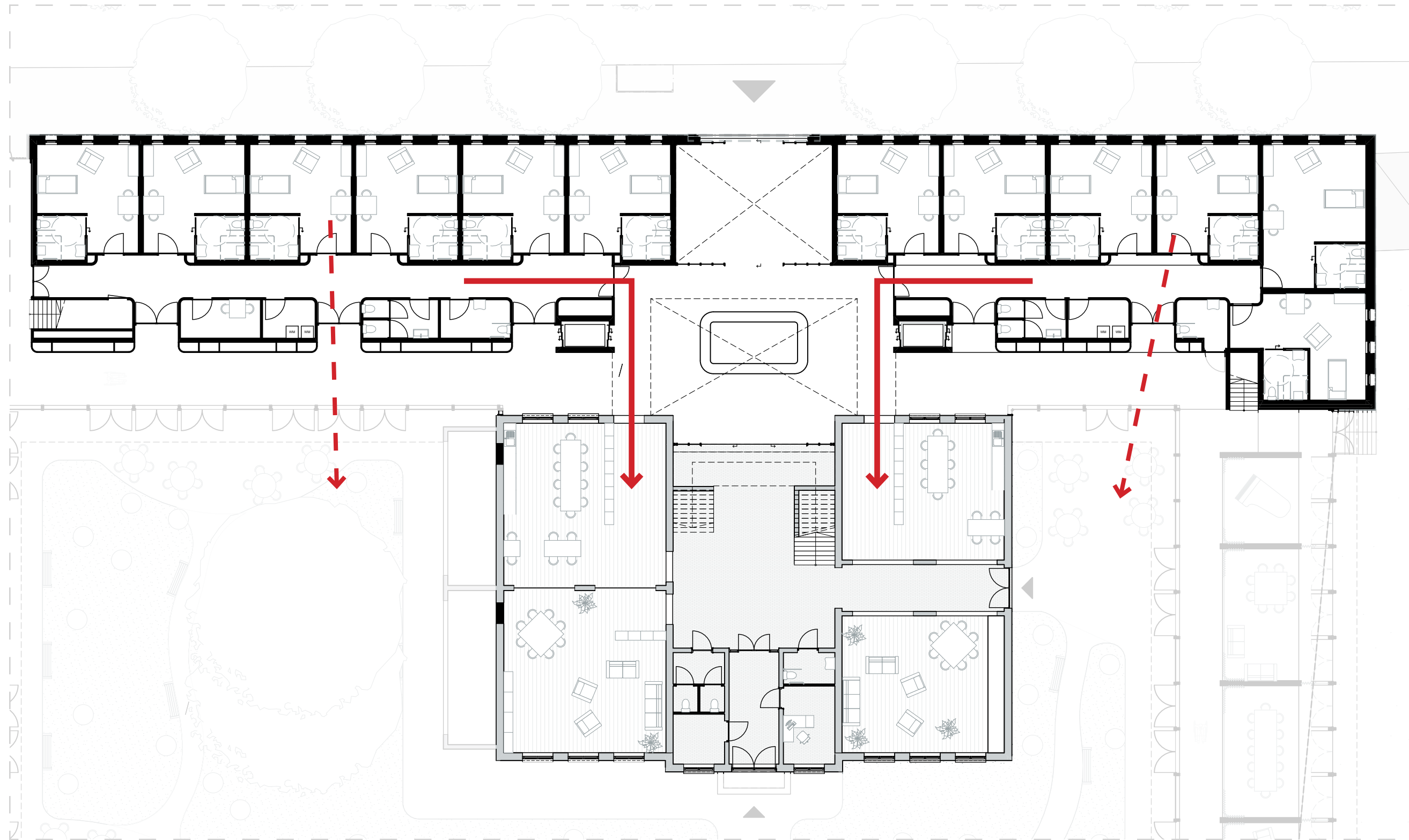



# RELATION WITH THE EXISTING

ST. JOZEF - CARE GROUP

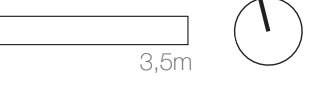
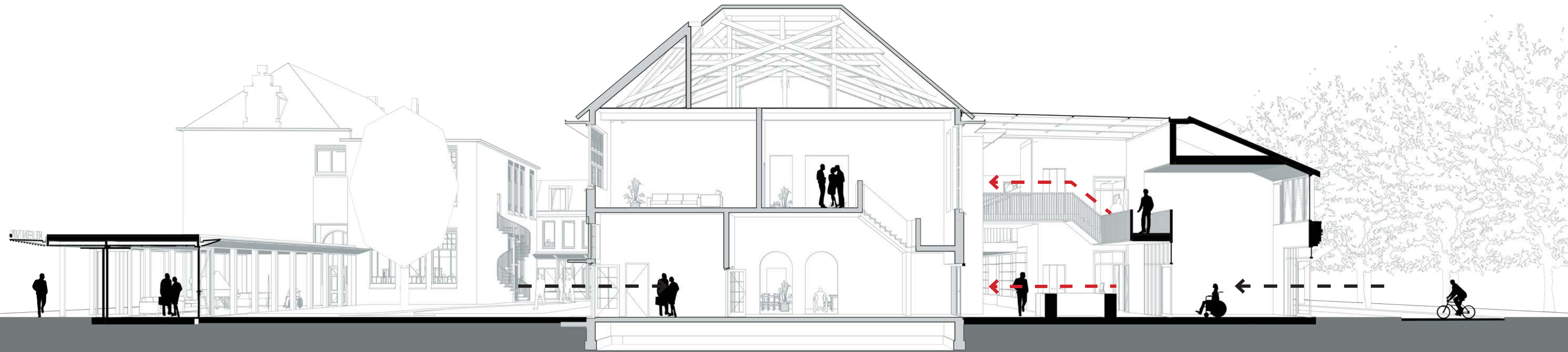

# LIVING ROOMS

MINOR INTERVENTIONS

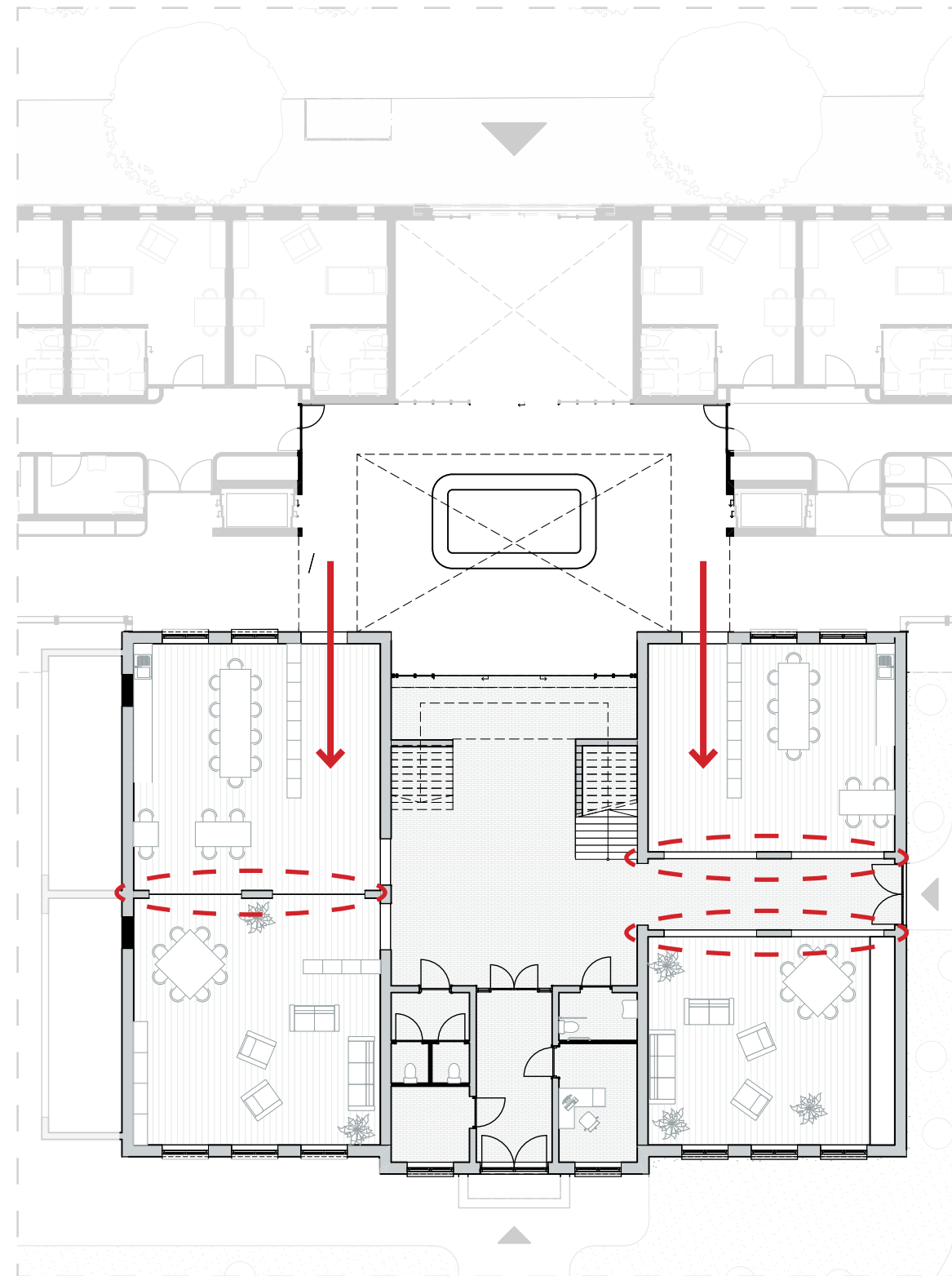
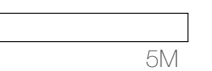
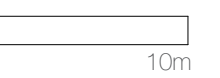
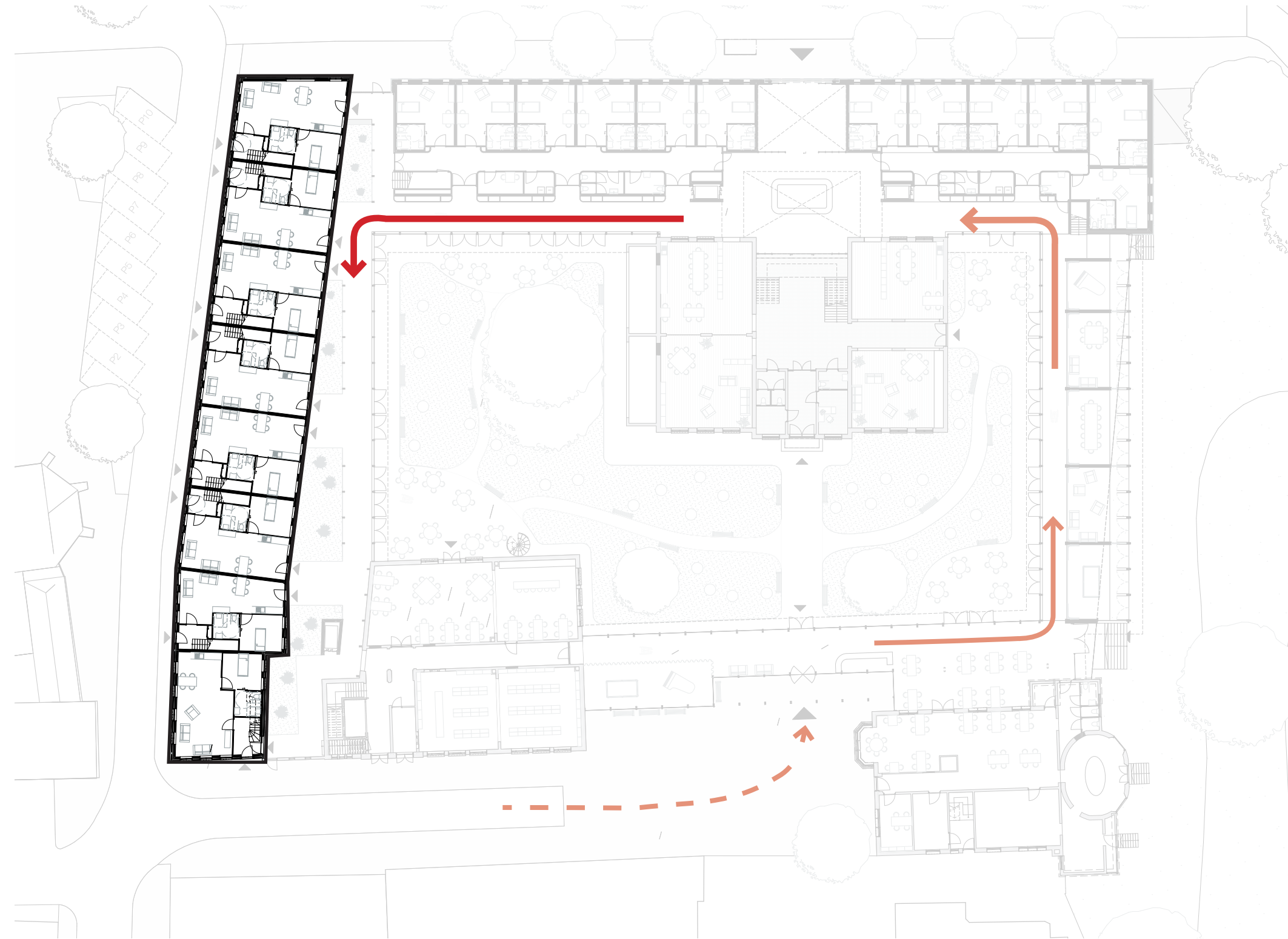

Image  
Herbergier Delft, Living room (herbergier.nl, accessed december 30th, 2017)



**PROGRAM**  
FAMILY CARE HOUSE







# FAMILY CARE HOUSE

CONCEPT

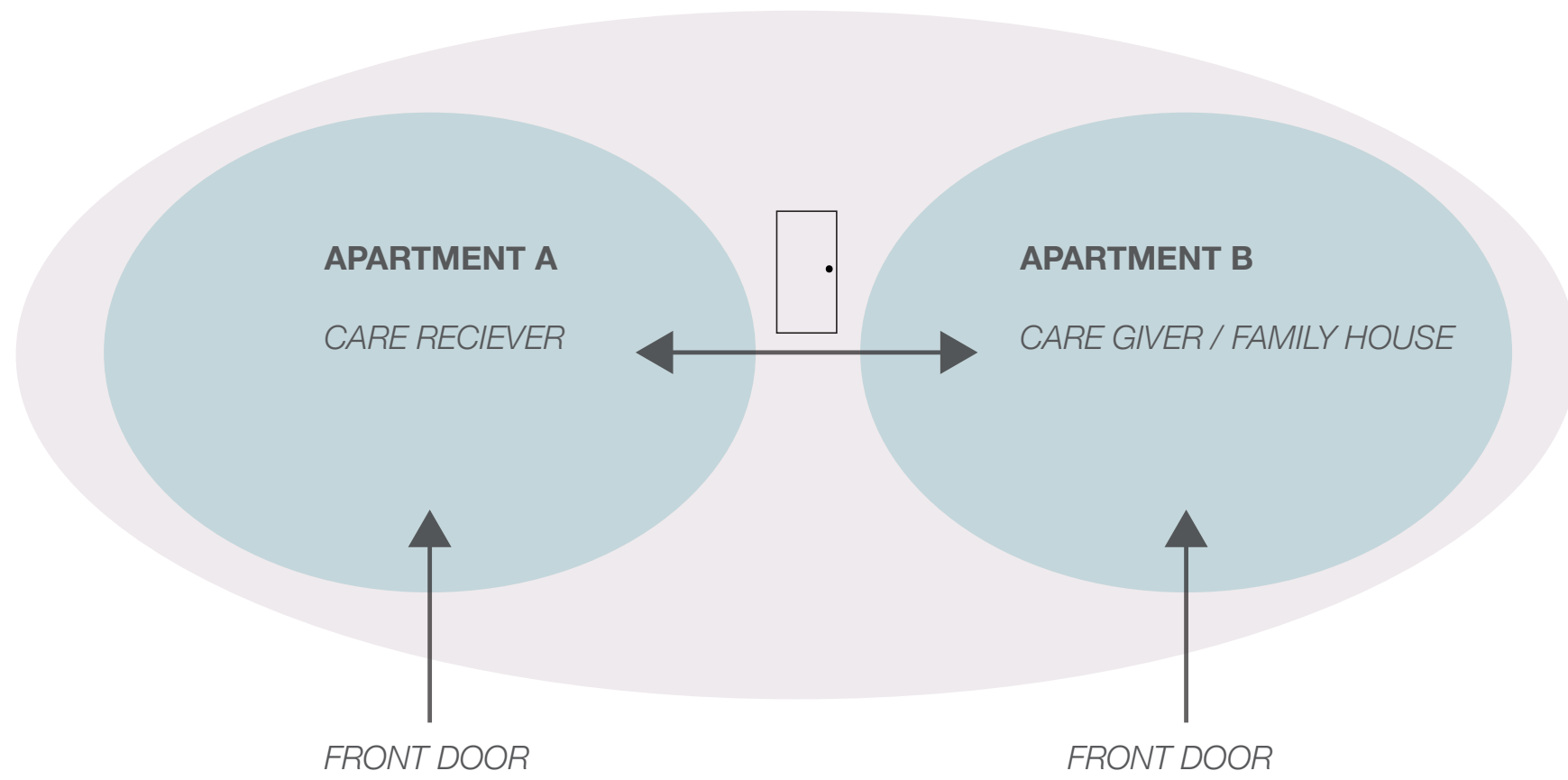

GENERAL CONCEPT

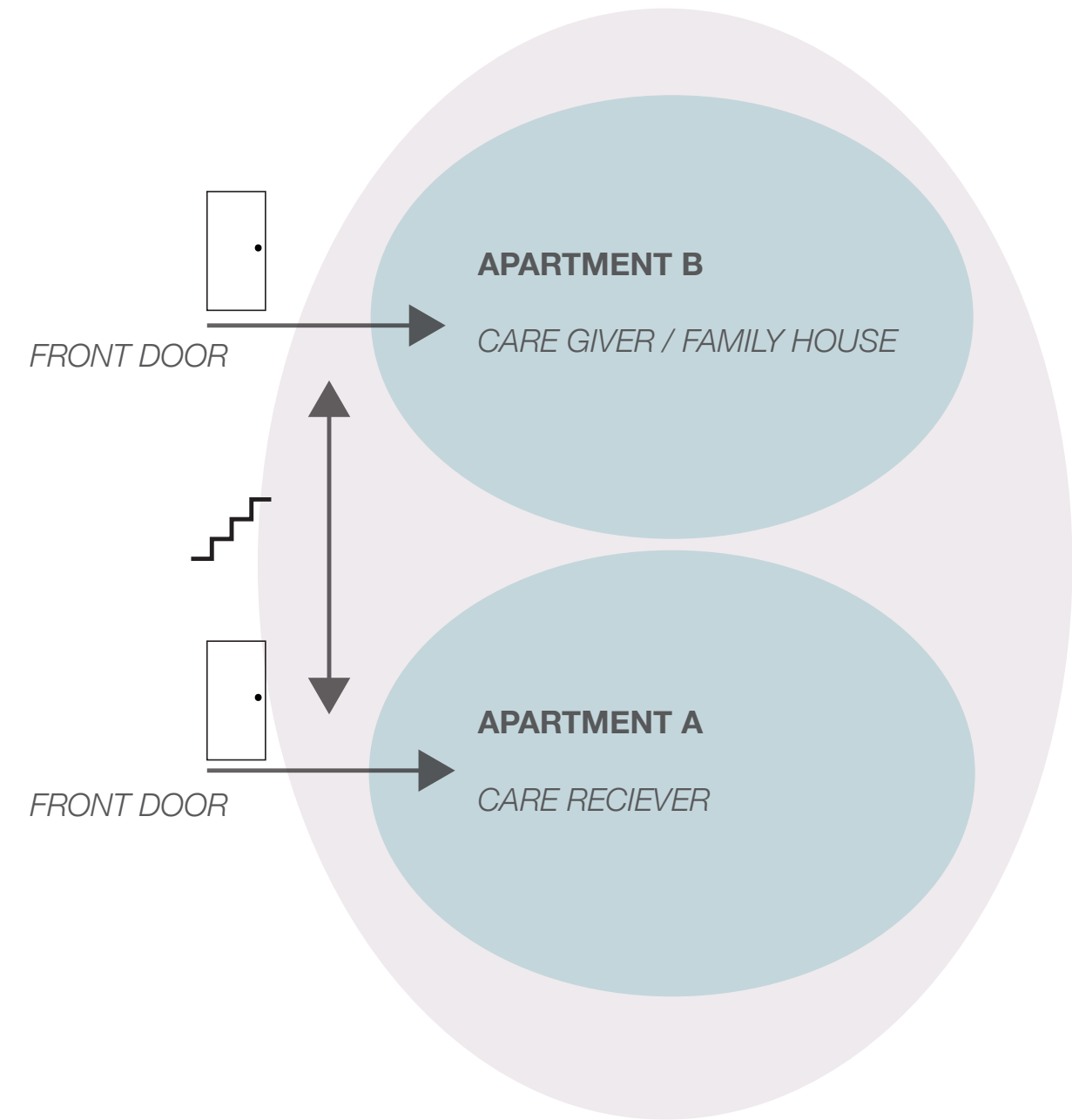

KLEIN VATICAANS CONCEPT

# FAMILY CARE HOUSE

AXONOMETRIC VIEW

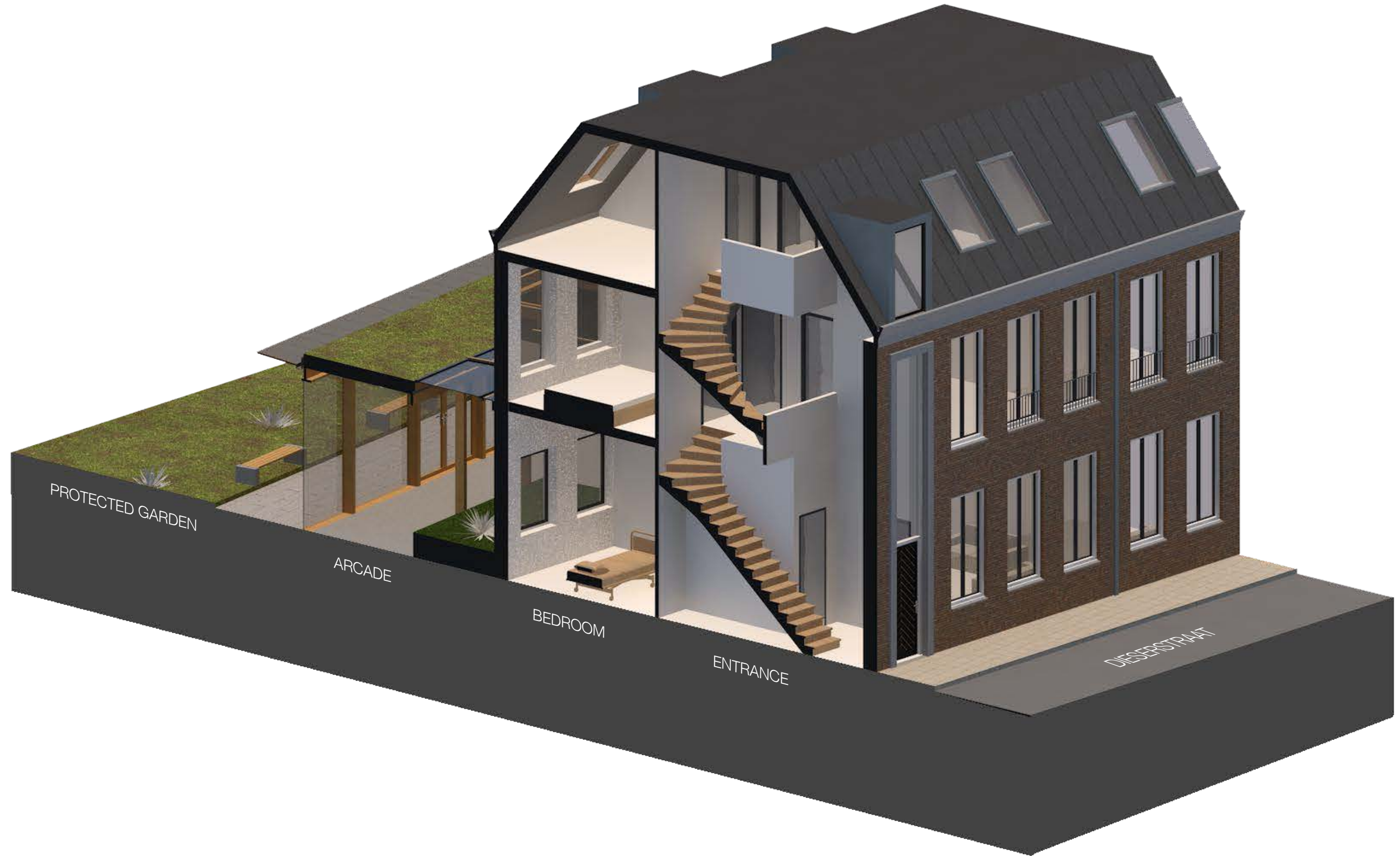

# FAMILY CARE HOUSE

ACCES TO THE CARE RECIEVER

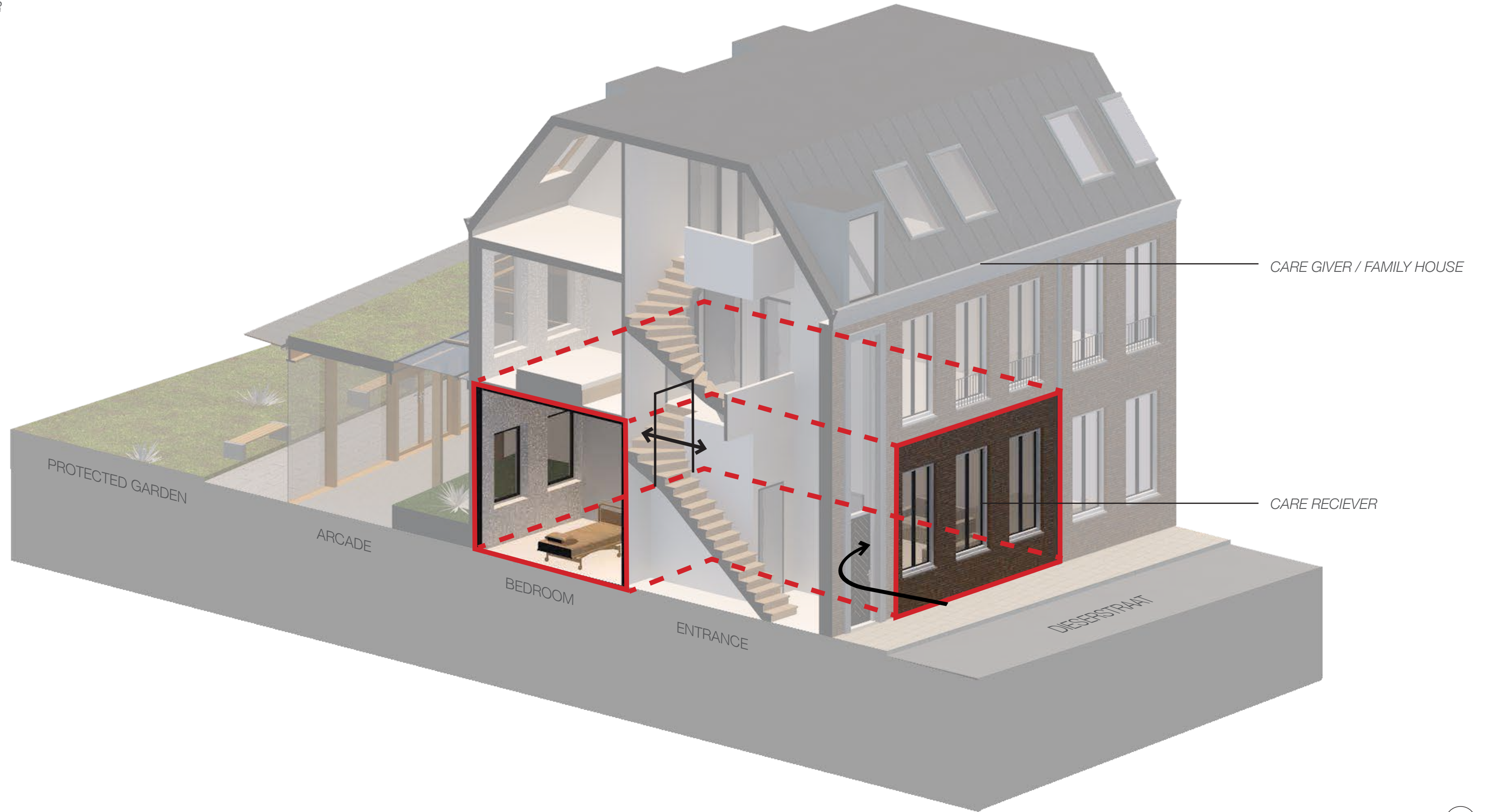

# FAMILY CARE HOUSE

ACCES TO THE FAMILY HOUSE

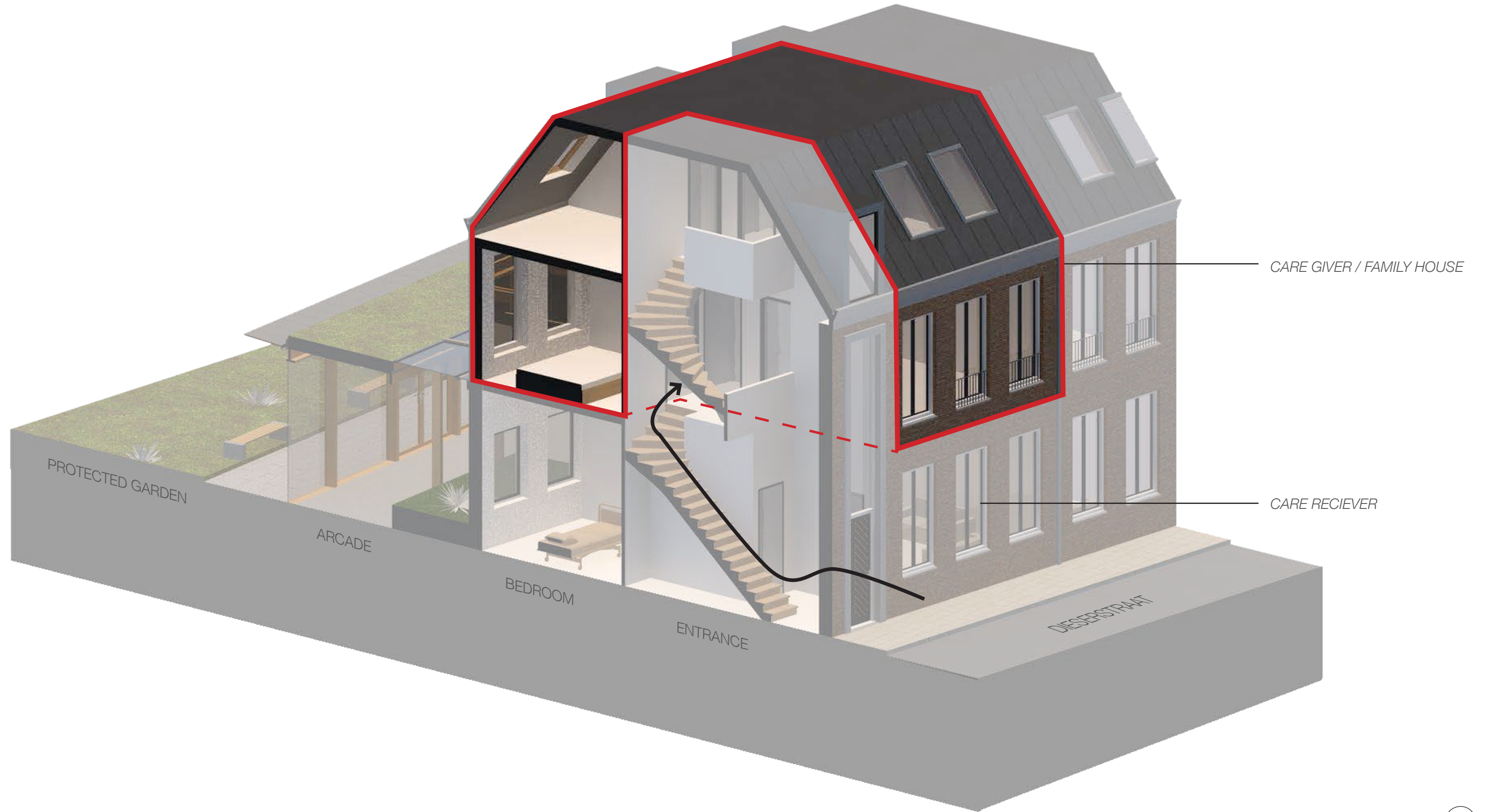

# FAMILY CARE HOUSE

RELATION BETWEEN THE TWO HOUSES

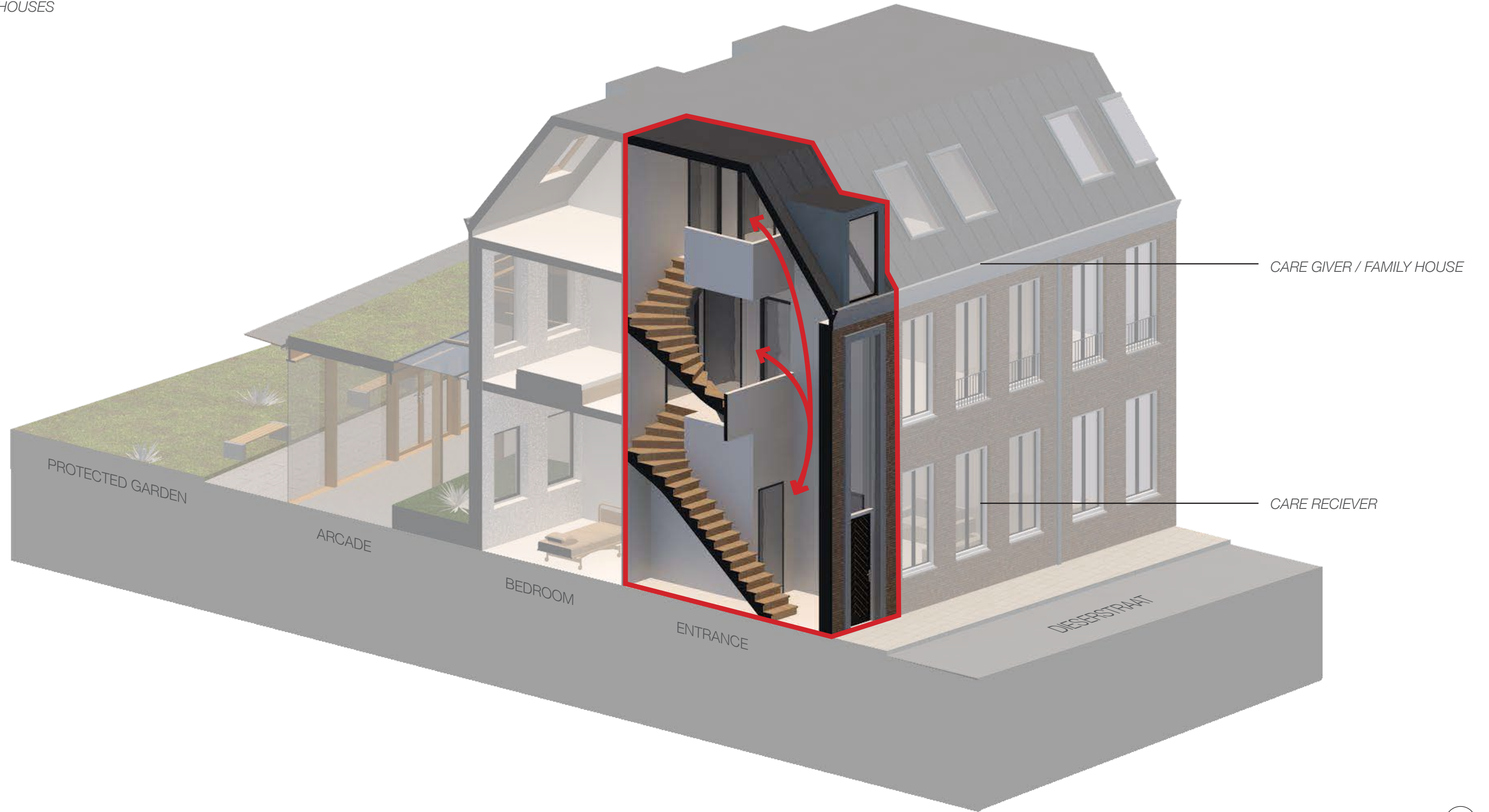

# FAMILY CARE HOUSE

FACADE VIEW

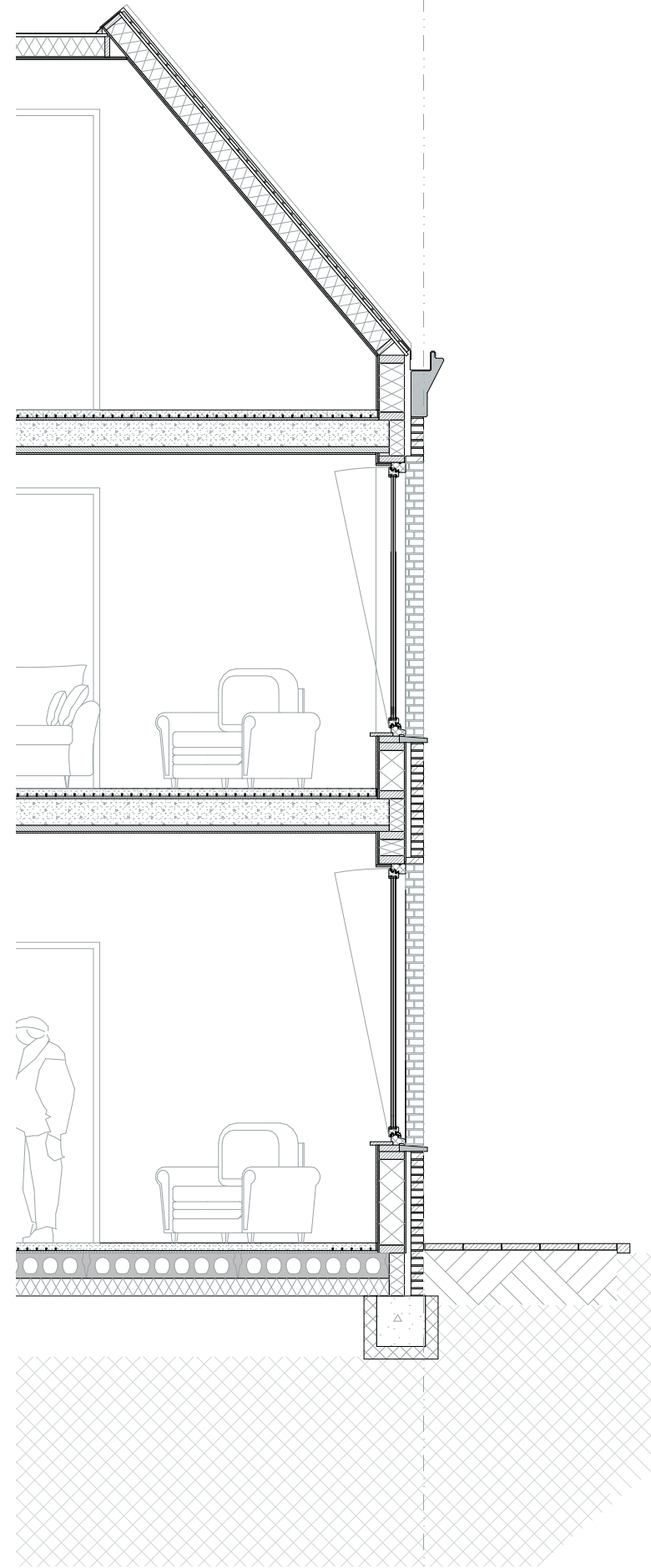

PATINATED ZINC ROOF

CONCRETE GUTTER

TIMBER WINDOW FRAME

CONCRETE FRAME

# FAMILY CARE HOUSE

ACCES TO THE CARE RECIEVER

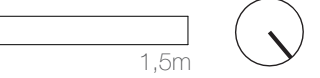
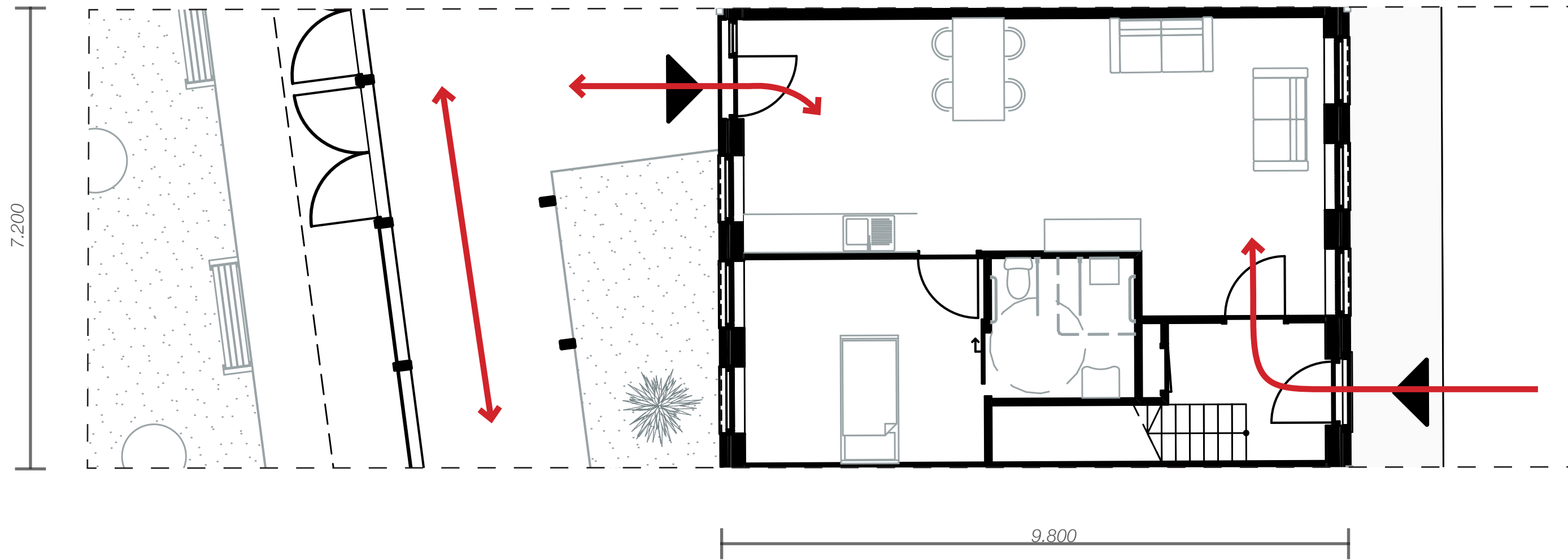





# WANDERING AROUND

ARCADE & GARDEN

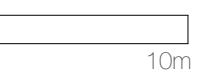
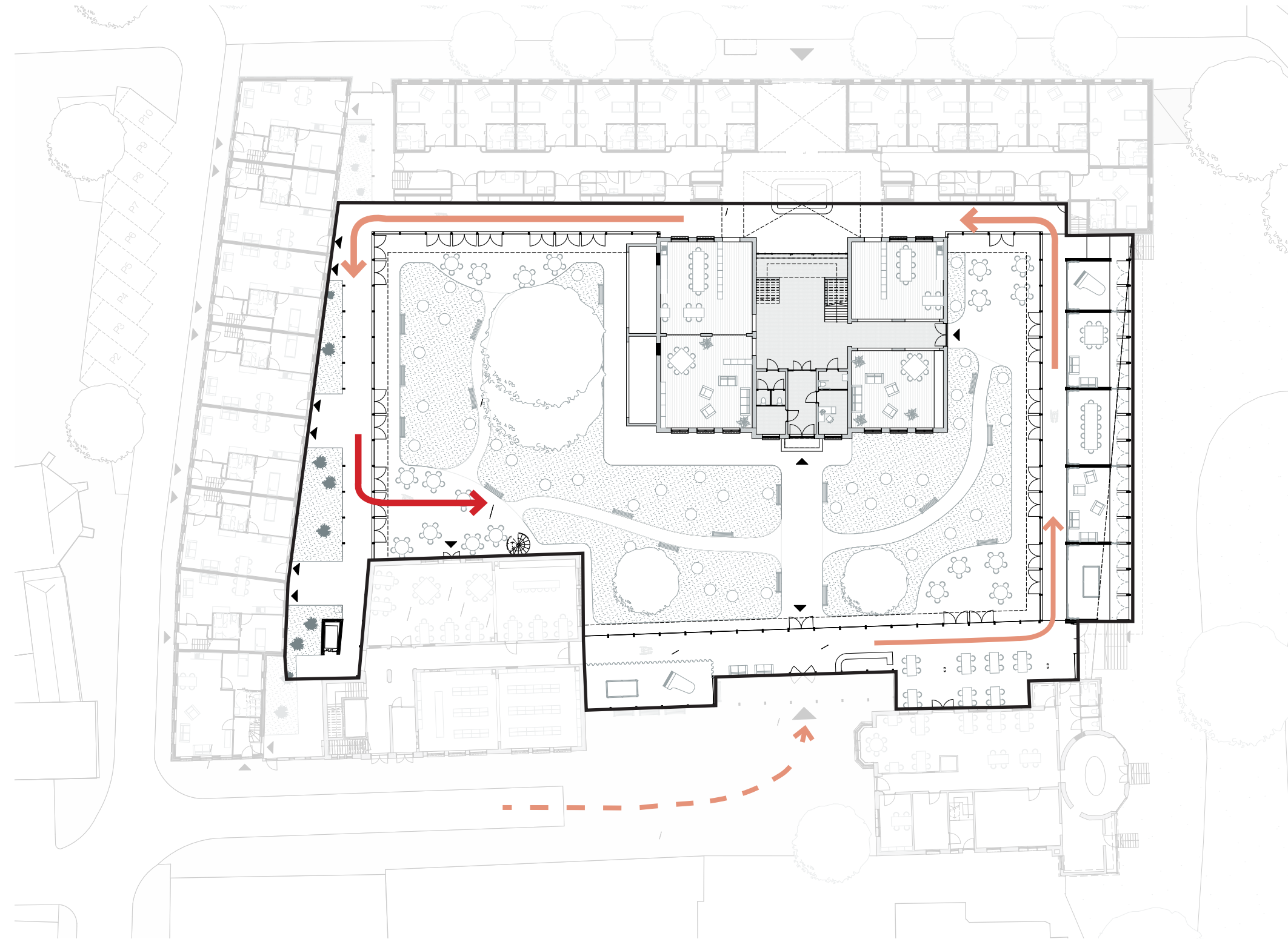

ARCADE  
PROTECTED GARDEN

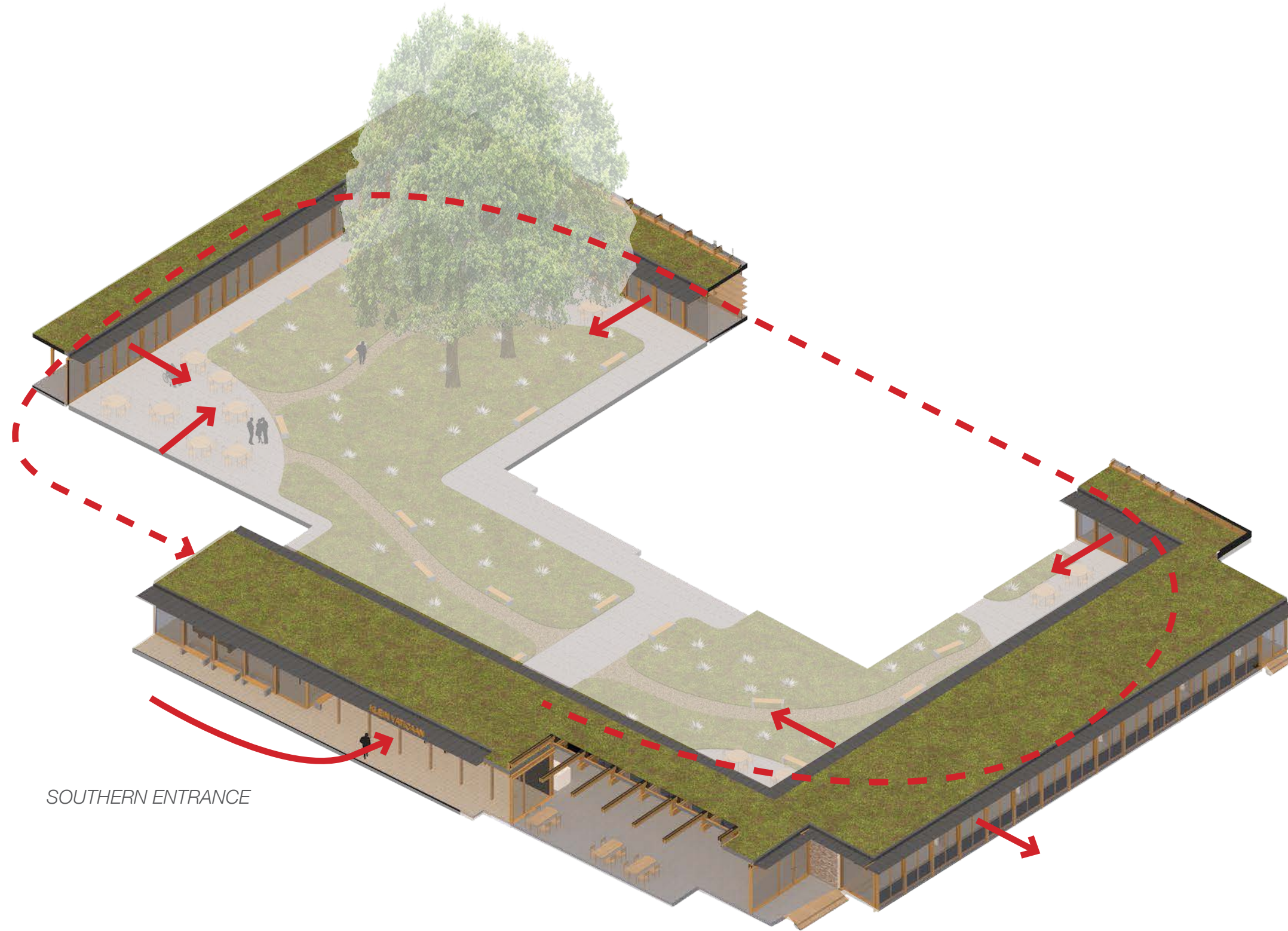

SOUTHERN ENTRANCE

# PROTECTED GARDEN

FUCNTIONS

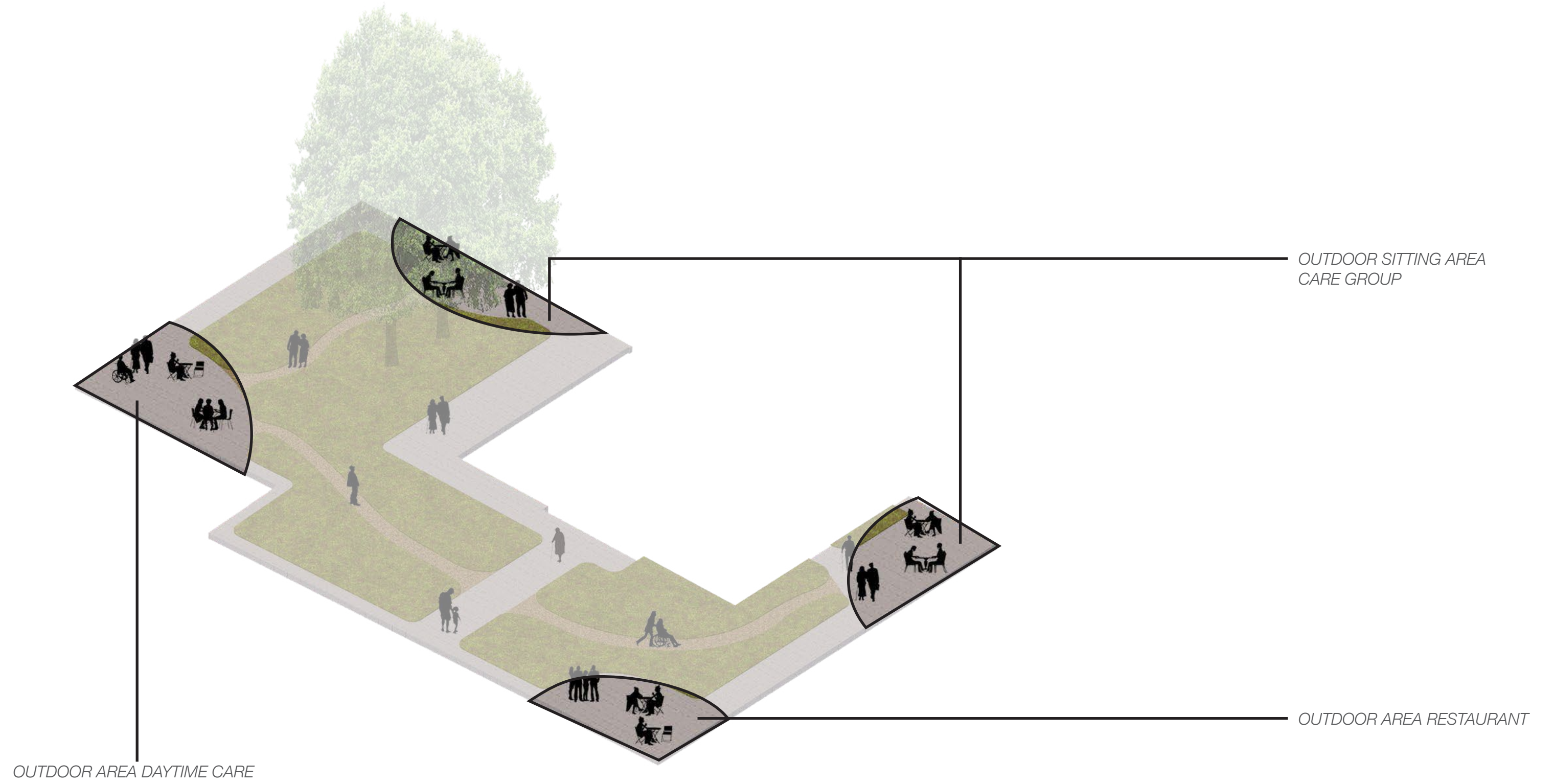

GARDEN  
WANDERING AROUND

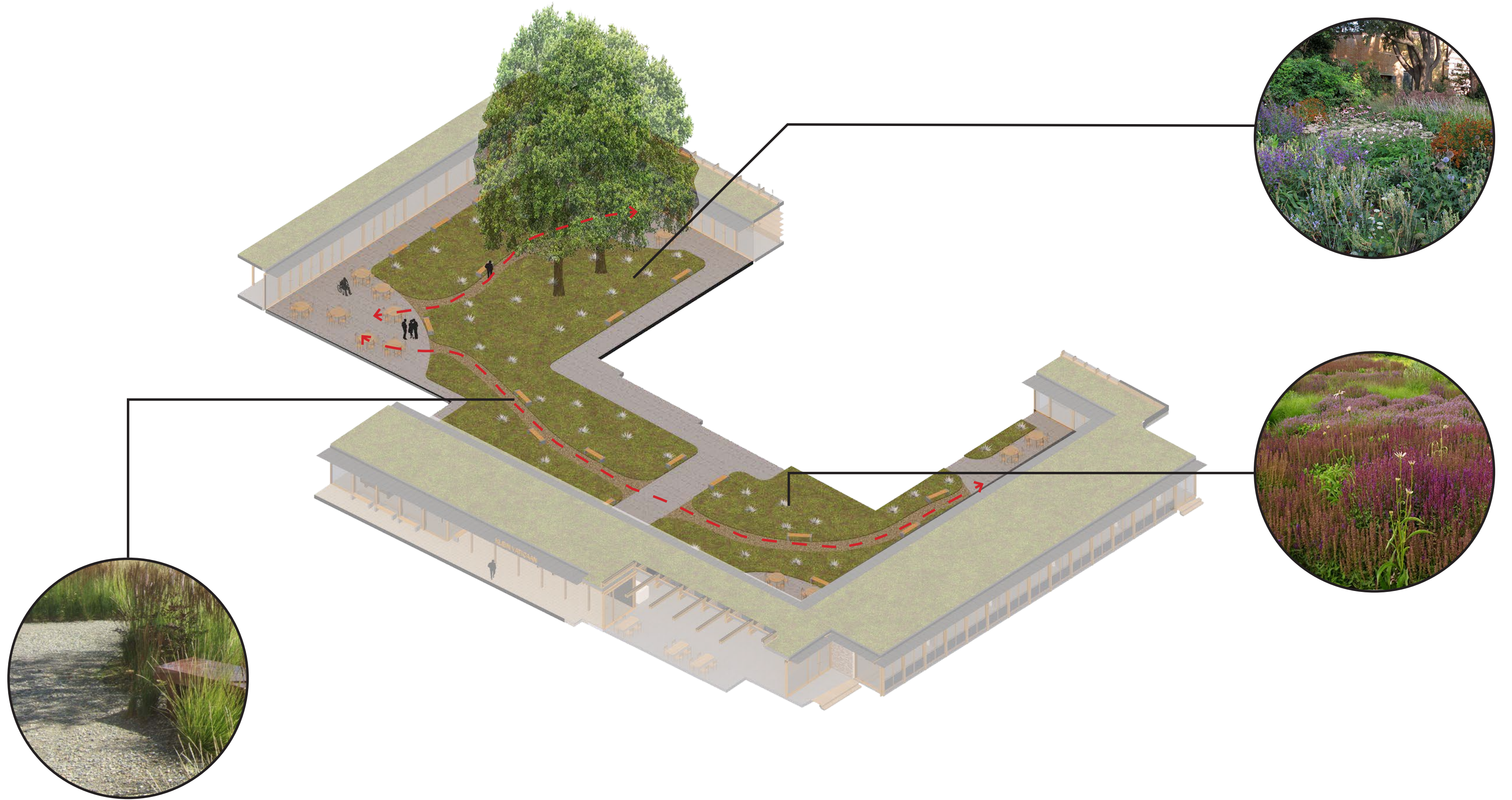



# IENDOORNSTRAAT

NORTH FACADE

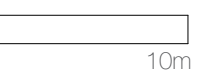
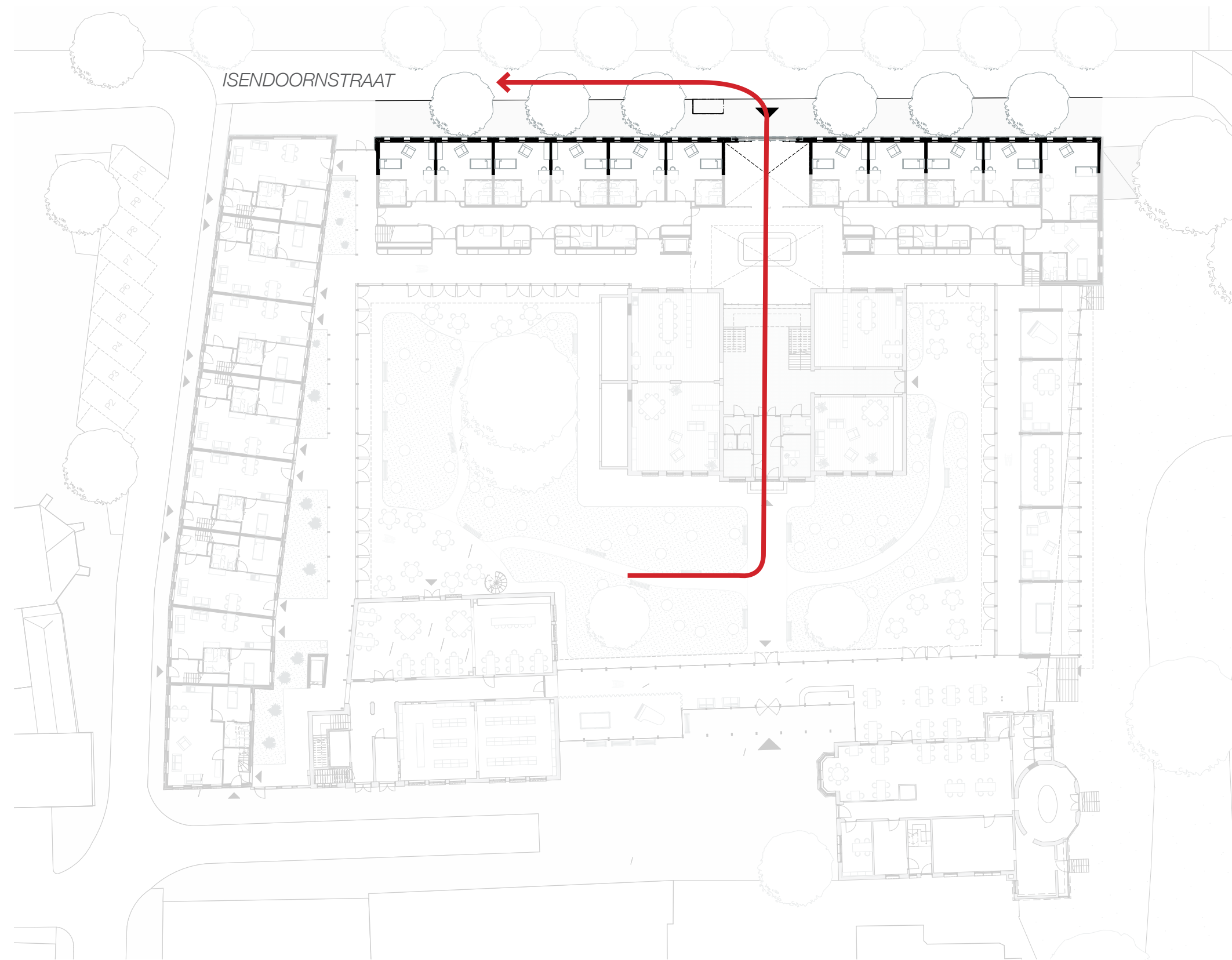



## 7. REFLECTION



# REFLECTION

DESIGN



BUILDING BLOCKS WITH COURTYARD



ISENDOORNSTRAAT 1950s



DIESERSTRAAT 1920s

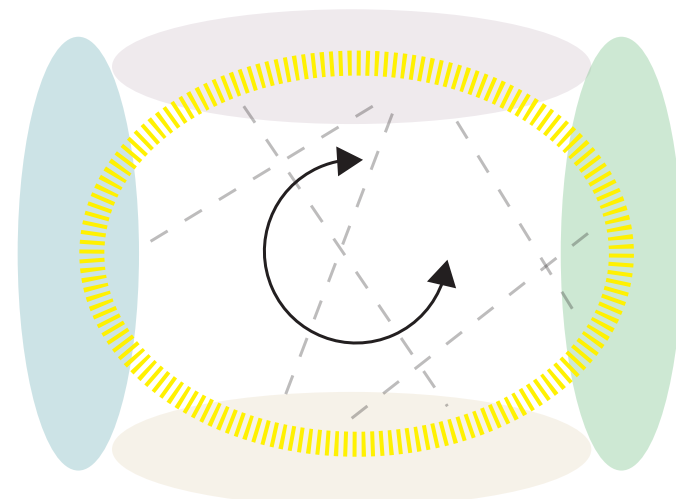

ORGANISATION CONCEPT

## Zutphen

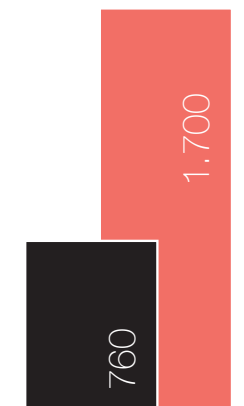

2016 2040

DEMOGRAPHICS

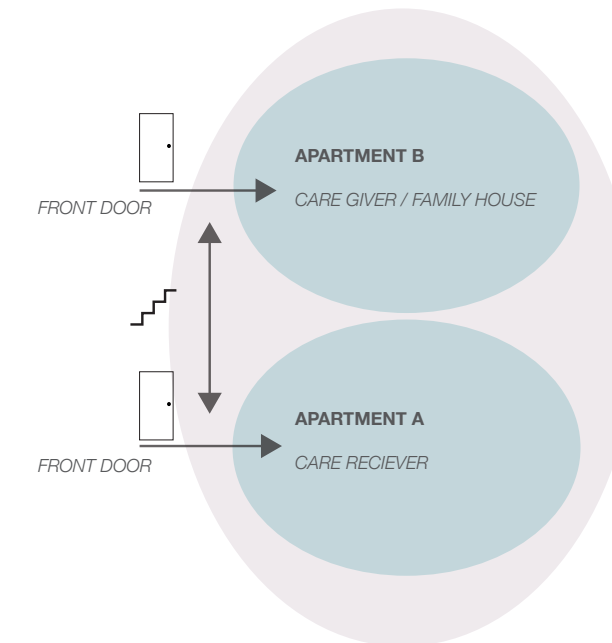

FAMILYCARE HOUSING

# REFLECTION

DESIGN





WELCOME TO THE KLEIN VATICAN



Research Question:

How can an ensemble of Heritage buildings be transformed in order to create a coherent and resilient site, which reconnects with the city?

# GROUND FLOOR

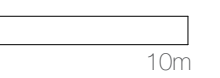
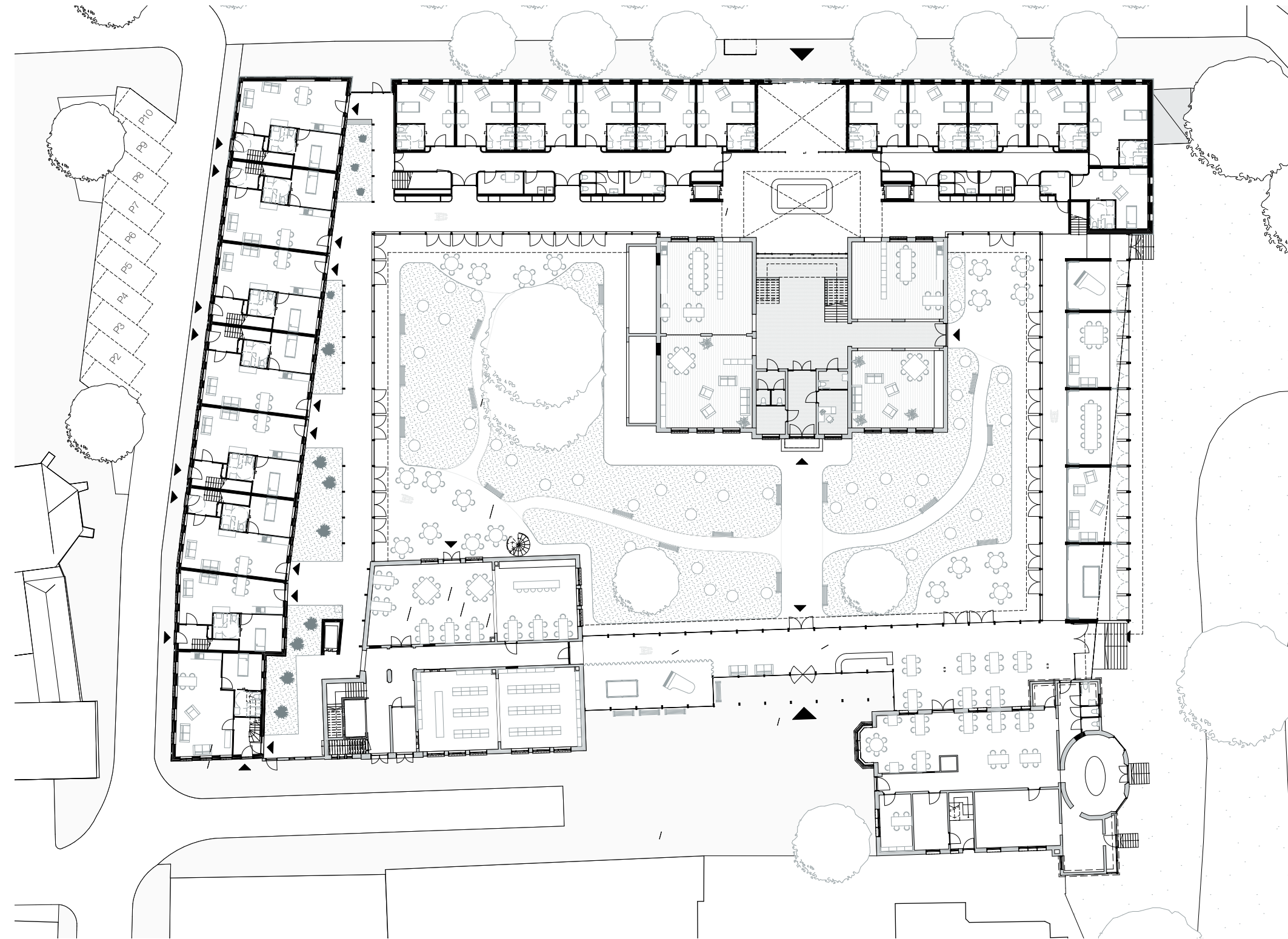

# FIRST FLOOR

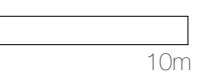
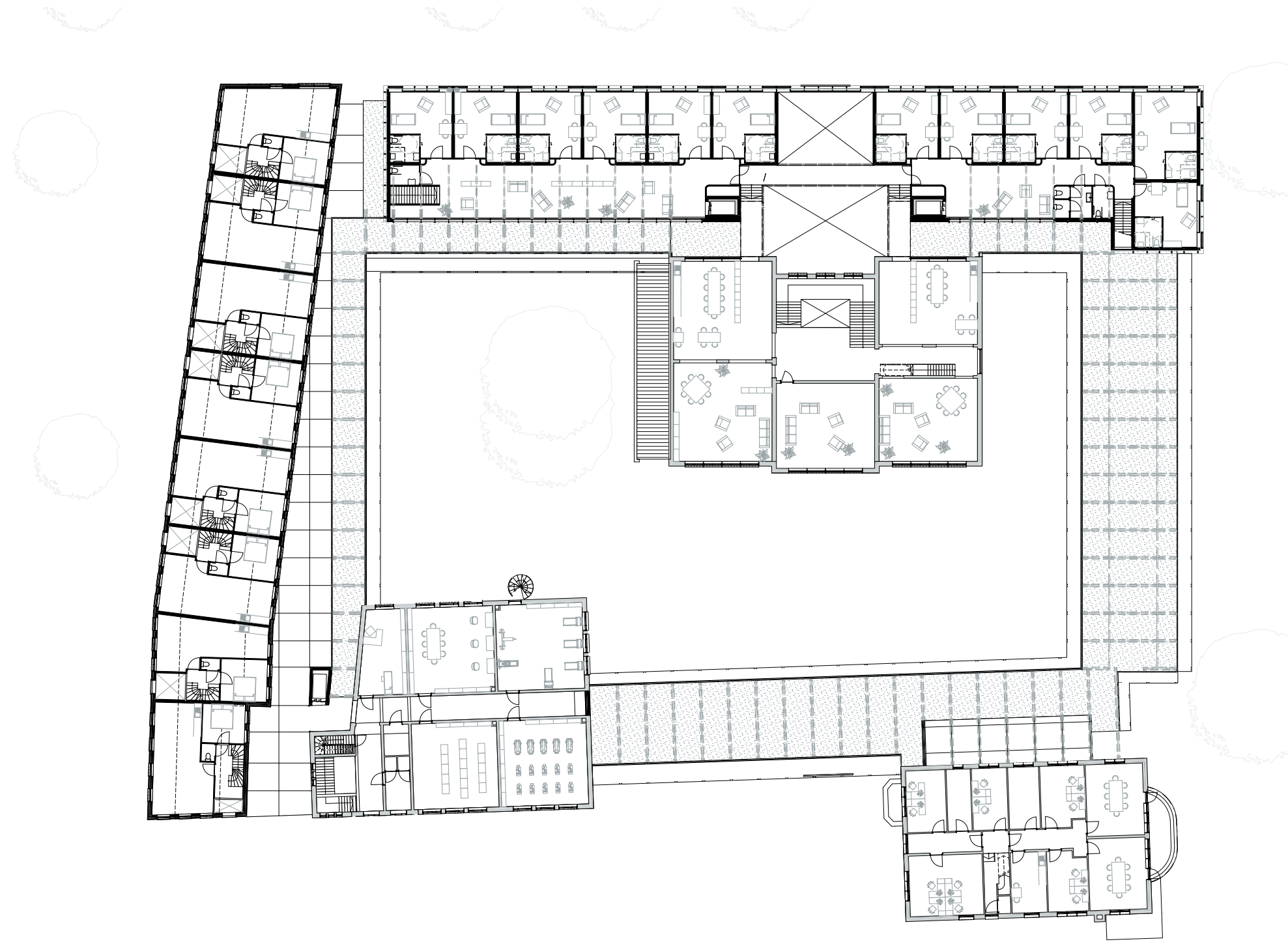

# CLIMATE

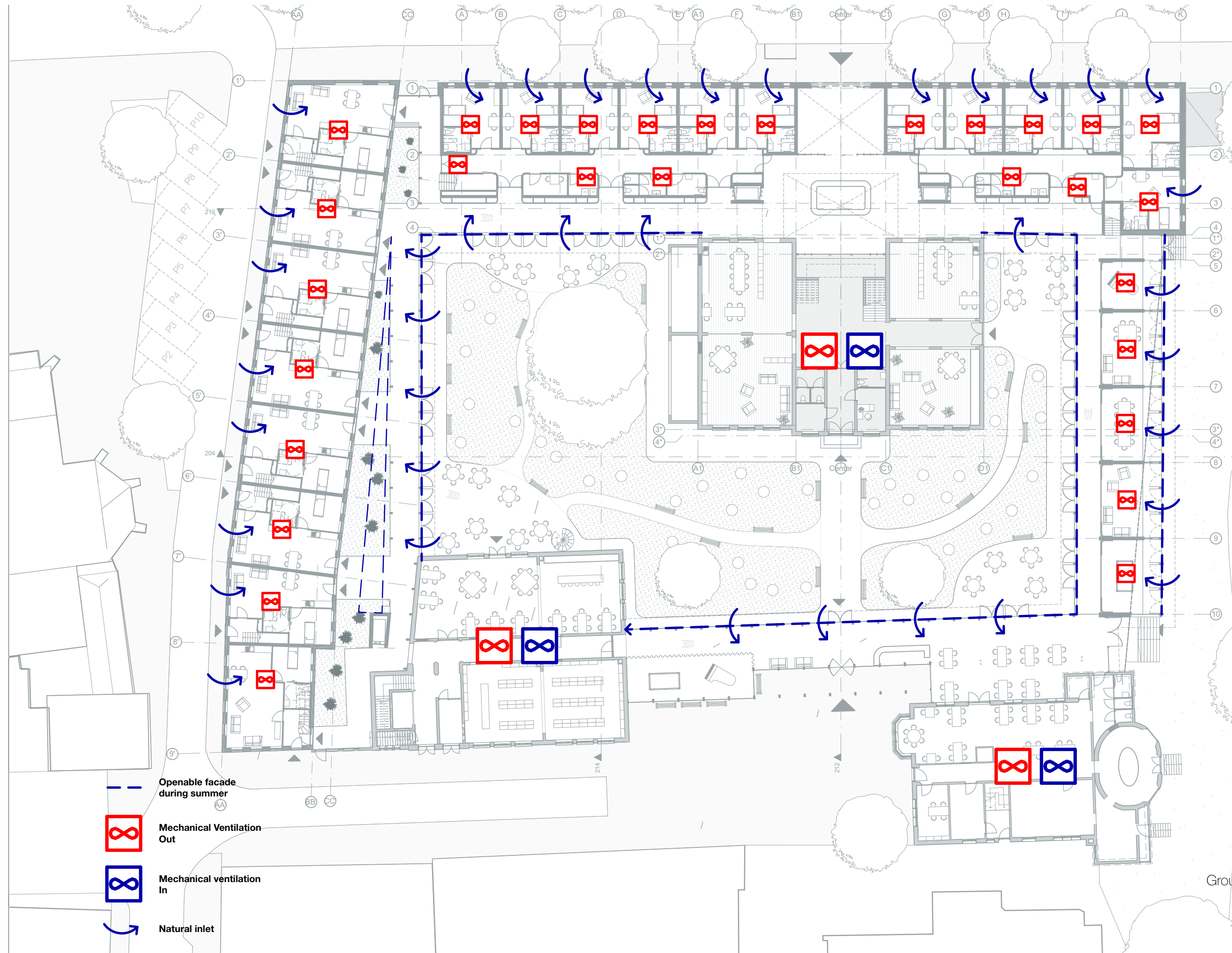

- Openable facade during summer
- ∞ Mechanical Ventilation Out
- ∞ Mechanical ventilation In
- ↪ Natural inlet



# CONSTRUCTION

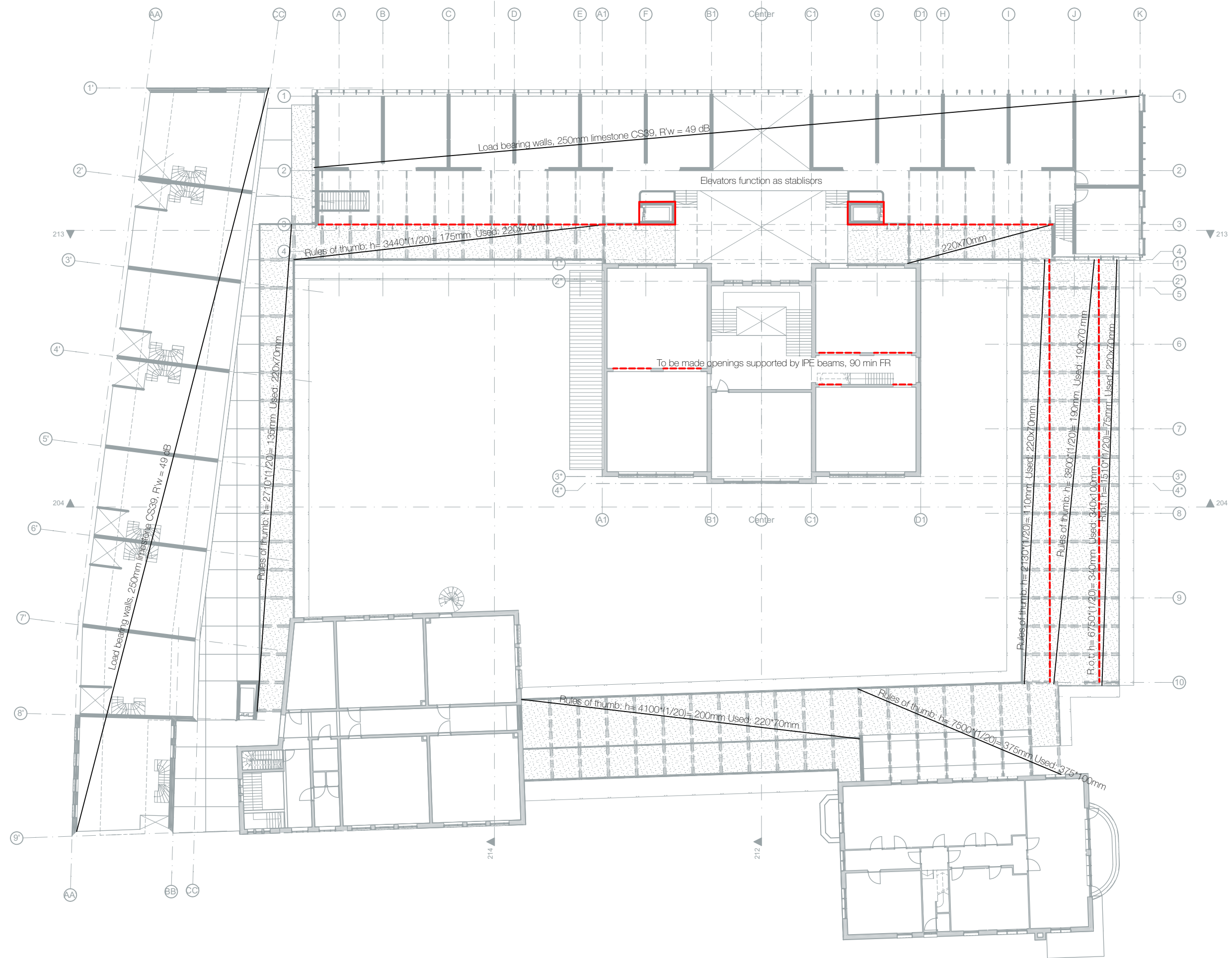

# VALUE MAPPING

## ENSEMBLE

The analysis formed the basis for the value mapping of the ensemble.

The front and back facades of all the buildings are highly valued and the side facades are positively valued. This has to do with the ornamentation and the function of the facades. The side facades had a less prominent function.

Other aspects like the roofconstruction of the St. Jozef or the double door entrance of the St. Anna are also highly valued. The values of the buildings have to be taken into account when designing.



South Facade St. Jozef



South Facade St. Anna

- High Value
- Positive Value
- Indifferent Value

Image  
Value diagram of the Ensemble (own illustration)

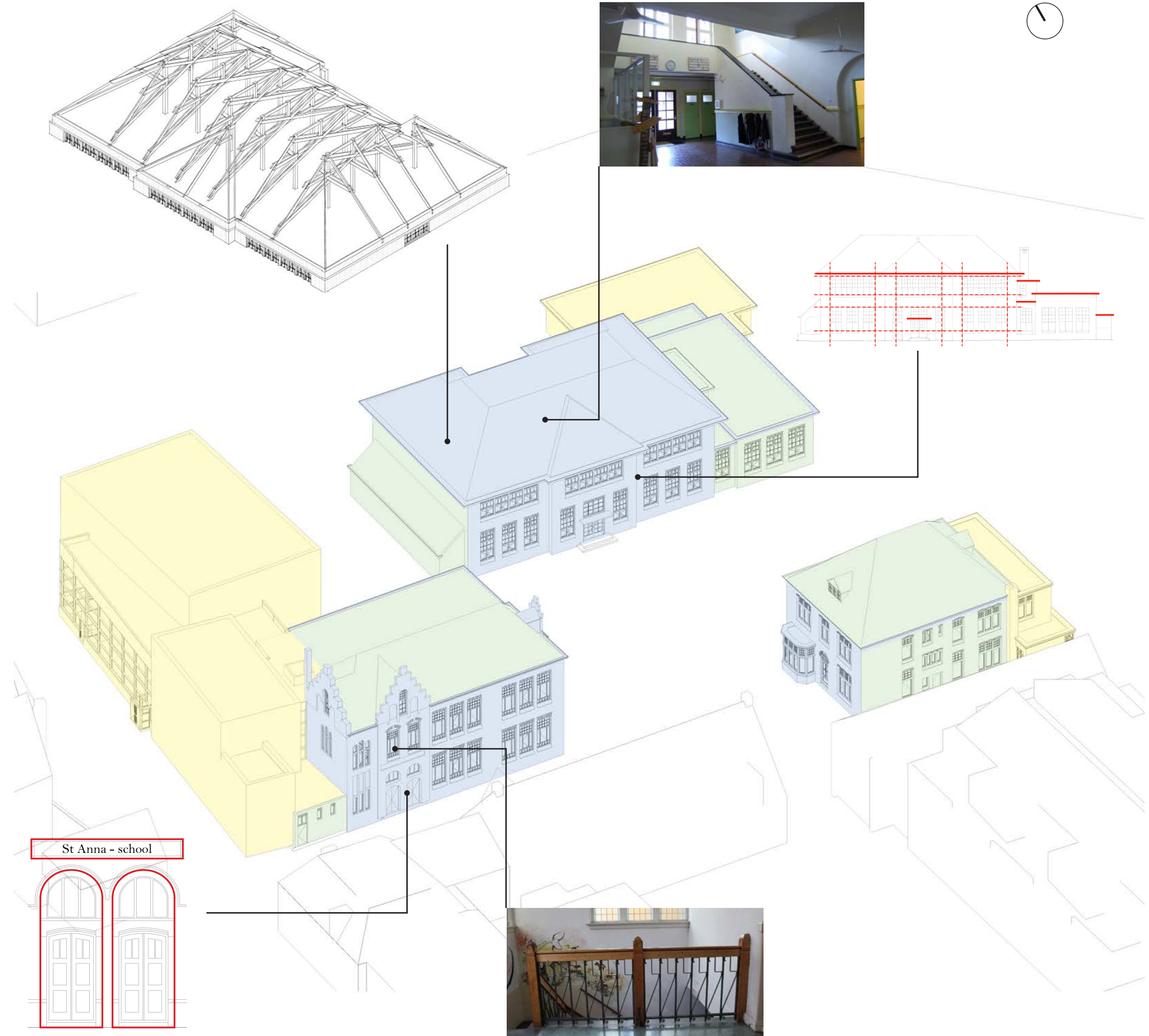

# PROGRAM

## DEMENTIA CARE

The main goal of a dementia care centre is to create a protected environment for its patients. It should be a centre where the patients can wander around without getting desorientated. Often desorientation leads to stress, which can cause aggression or panic attacks. The program is based on regular dementia centres.

- Care Groups
- Activity Space
- Therapy
- Cafe
- Store
- Restaurant
- Facilitating Services
- Office

The Klein Vaticaans area offers the opportunity to connect with the neighbourhood, functions like the Cafe, the Restaurant and the Store could function as the connecting elements.

I want to add Family Care housing as extra function to the ensemble. This to solve the demographic of the increasing amount of Family Care givers with are under high pressure. To connect these houses with the ensemble the care receiver could use the facilities of the ensemble as well.



### Image

Herbergier Delft, entrance (herbergier.nl, accessed december 30th, 2017, own editing)

ARCADE  
RELATION GARDEN

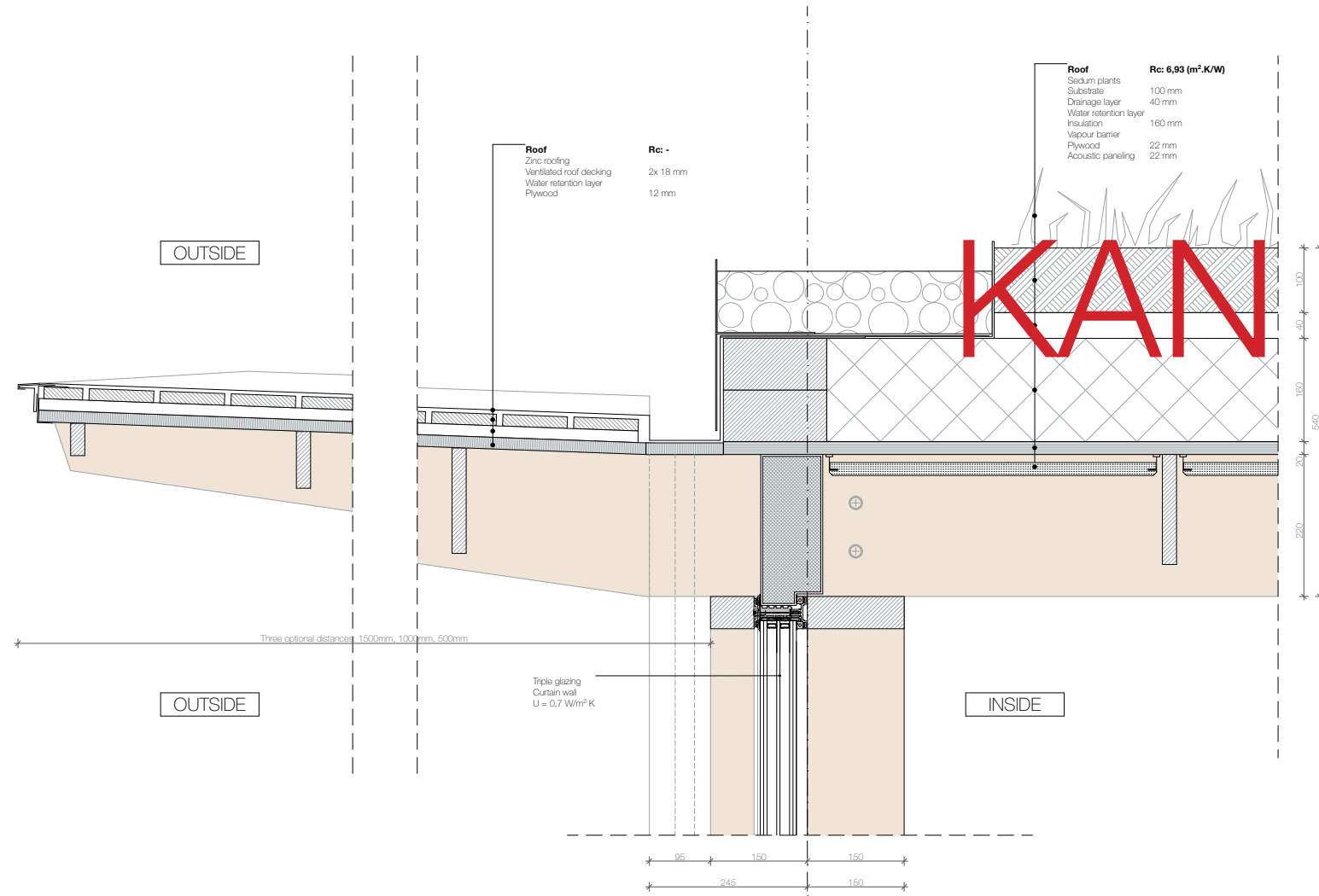

KAN WEG????

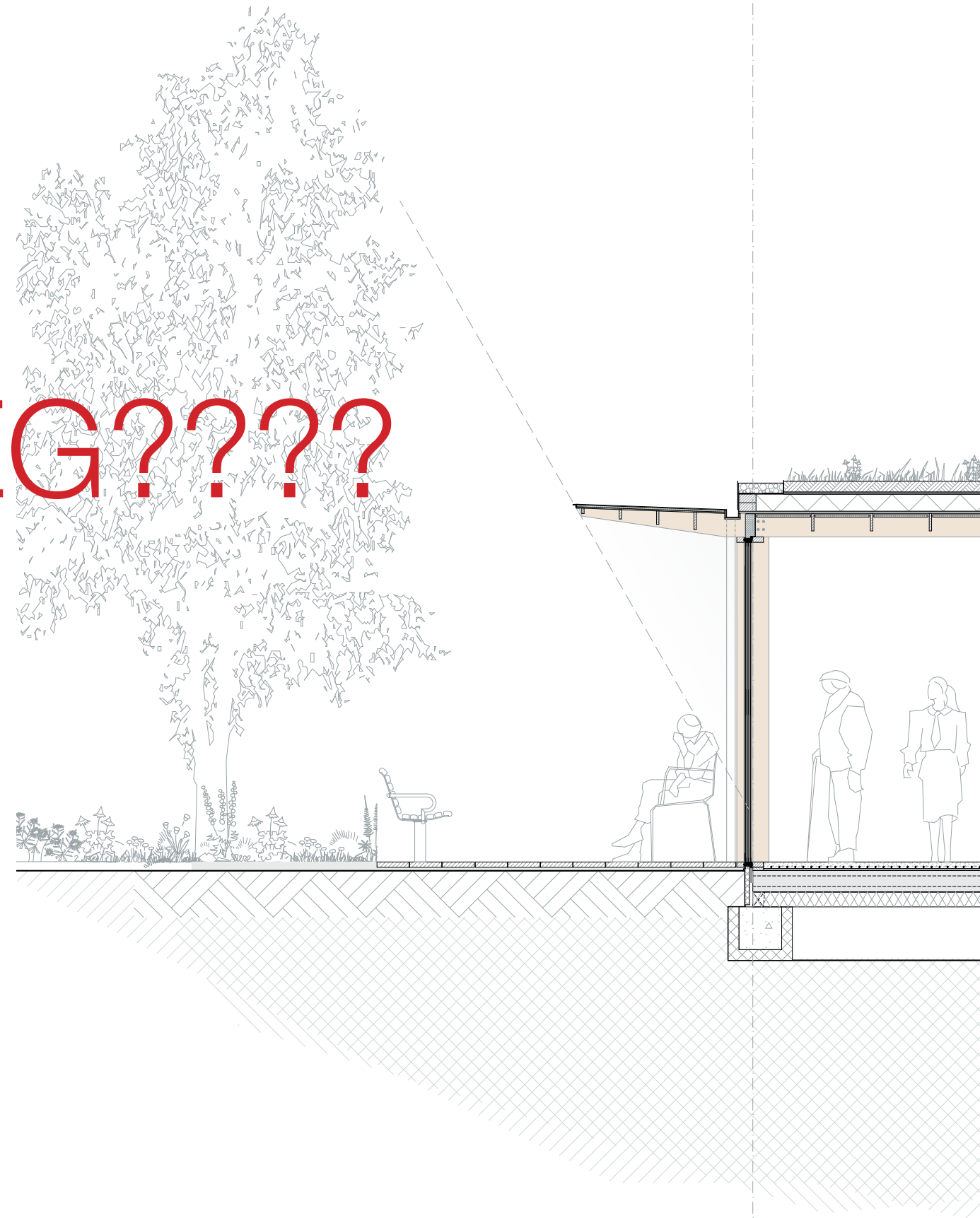

1m