

Lydia Polykandrioti

FOLDING

FROM THE DESIRE OF THE CITY TO THE CITY OF DESIRE

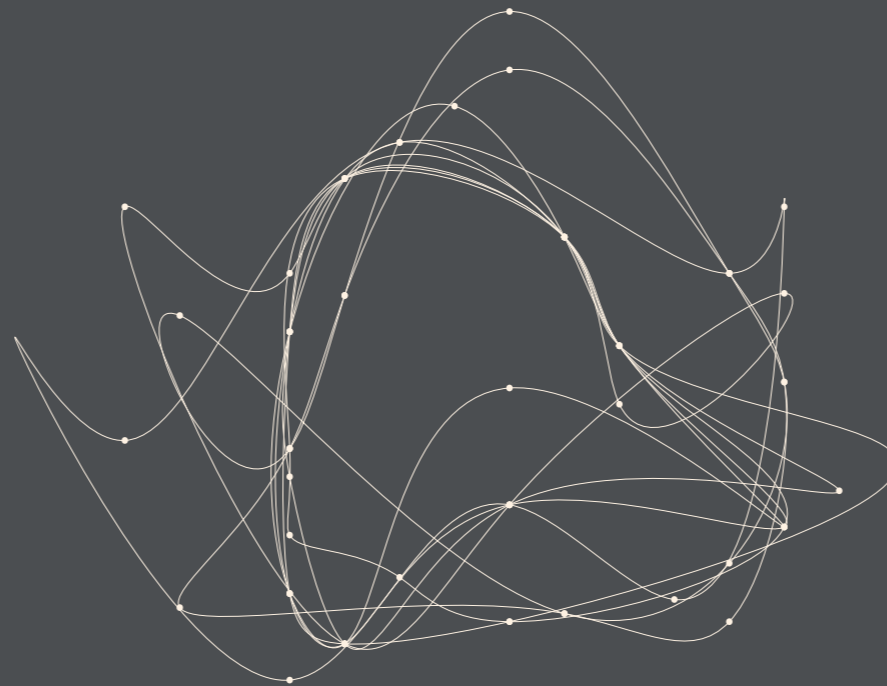

Tutors: Heidi Sohn (main), Hubert van der Meel (second), Stavros Kousoulas (research)





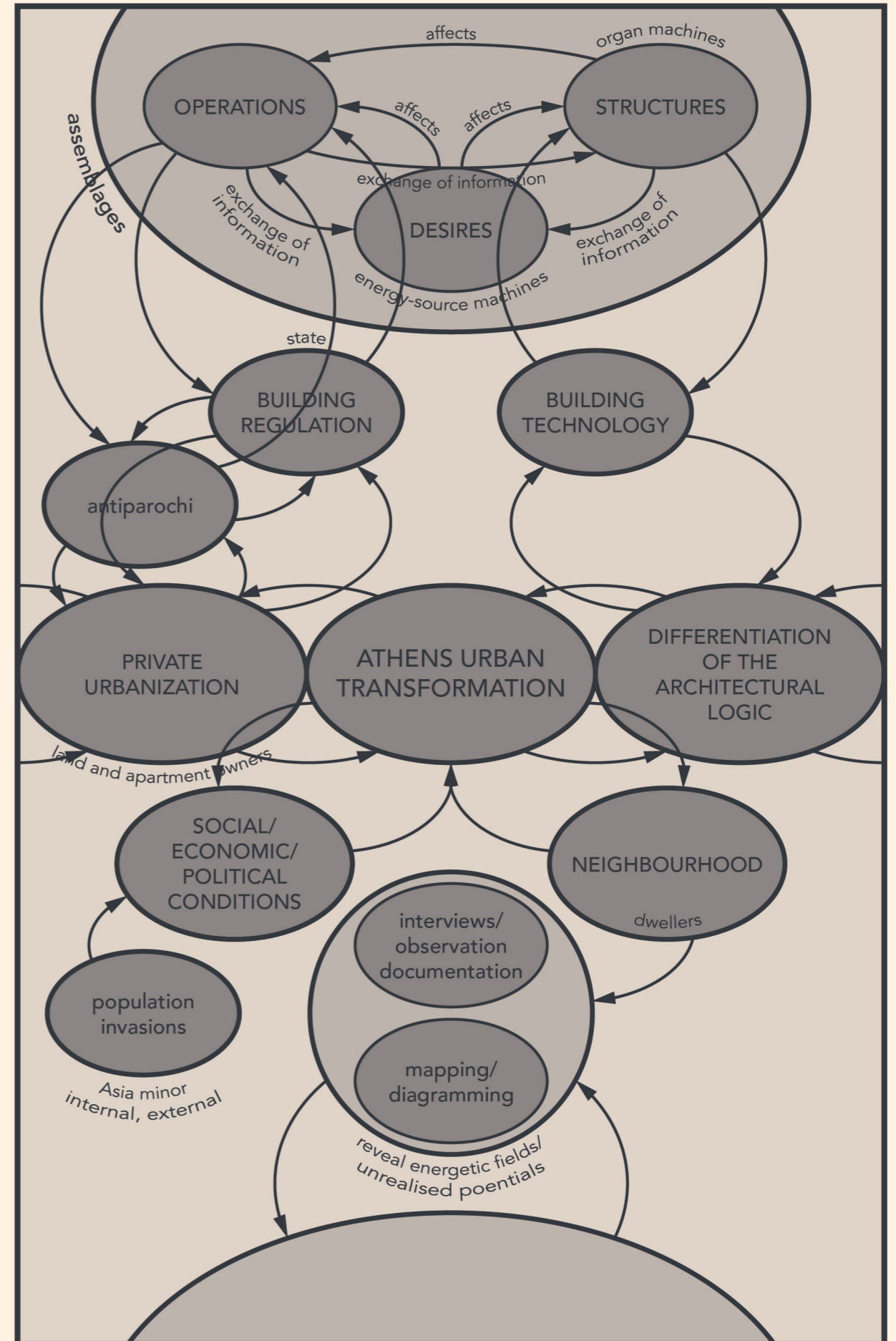

- Athens urban transformation -

ΕΛΛΗΝΙΚΗ ΔΗΜΟΚΡΑΤΙΑ
ΥΠΟΥΡΓΕΙΟ ΟΙΚΟΝΟΜΙΑΣ ΚΑΙ ΟΙΚΟΝΟΜΙΚΩΝ

Αρ. Καταχώρησης /

Προς Δ.Ο.Υ. 18 ΑΘΗΝΩΝ
(ακινήτου)Αριθμός Δήλωσης:
Ημ/νία Υποβολής:
Ημ/νία Φορολογίας:
Αρ. Σχετ. Δήλωσης/Έτος:
Δ.Ο.Υ.:

ΑΡΧΙΚΗ: ΤΡΟΠΟΠΟΙΗΤΙΚΗ:

ΔΗΛΩΣΗ ΜΕΤΑΒΙΒΑΣΗΣ ΑΚΙΝΗΤΟΥ

Υποβάλλεται ως Ειδική δήλωση Φ.Π.Α. Δήλωση Φ.Μ.Α.:ΕΙΔΟΣ ΣΥΝΑΛΛΑΓΗΣ ΜΕΤΑΒΙΒΑΣΗ

Όνοματεπώνυμο Συμβολαιογράφου: <u>ΥΥΥΥΥΥ</u>	Α.Φ.Μ. <u>ΥΥΥ</u>	Διεύθυνση Οδός-Αριθμός-Τ.Κ.-Πόλη <u>ΥΥΥ</u>	Τηλέφωνο <u>ΥΥ</u>
Υποθηκοφυλακείο/Κτηματ. Γραφείο: <u>ΥΥΥ</u>	Αρ. ημ/νία αδείας οικοδομής <u>246/63-2006</u>	Πολεοδομική αρχή <u>ΑΘΗΝΩΝ</u>	
Υποκείμενος/Υπόχρεος: Δ.Ο.Υ. (έδρας ή κατοικίας):	<u>ΤΕΧΝΟΟΙΚΟΔΟΜΗΜΗ ΕΠΕ</u> <u>67ΤΕΡΡΗΣ 18 ΧΟΛΑΡΓΟΣ</u>	Α.Φ.Μ. <u>ΥΥΥ</u>	Α/Α υποκ/τος <u>002</u>

ΟΔΗΓΙΕΣ ΓΙΑ ΤΗΝ ΣΥΜΠΛΗΡΩΣΗ ΤΗΣ ΔΗΛΩΣΗΣ

- I. Αρμόδια Δ.Ο.Υ. υποβολής: Η Δ.Ο.Υ. της τοποθεσίας του ακινήτου. Η δήλωση μπορεί να υποβληθεί και στη Δ.Ο.Υ. φορολογίας εισοδήματος του αγοραστή προκειμένου για δήλωση Φ.Μ.Α. εφόσον το ακίνητο βρίσκεται σε περιοχή που εφαρμόζεται το αντικειμενικό σύστημα και είναι προδήλως δυσχερές η υποβολή της αρμοδίως.
- II. Για κάθε οριζόντια ή κάθετη ιδιοκτησία υποβάλλεται ξεχωριστή δήλωση.
- III. Ως Είδος Συναλλαγής συμπληρώστε αντίστοιχα:
- | | |
|----------------------------------------------------------------|---------------------------------------------------------|
| 1. Μεταβίβαση σε εκτέλεση προσηφώνου | 13. Σύσταση επικαρπίας / δικαιώματος οικησης / δουλείας |
| 2. Χρηστική | 14. Παραίτηση από κυριότητα με αντάλλαγμα |
| 3. Μεταβίβαση μετά από δικαστική απόφαση | 15. Ανταλλαγή προκείμενου ακινήτου |
| 4. Μεταβίβαση ακινήτου με δικαστικό συμβόλαιο | 16. Μεταφορά συντελεστού δόμησης |
| 5. Μεταβίβαση πολλών οικοπέδων λόγω εργαζομένων ανταλλάγματος | 17. Εξώνηση |
| 6. Επανάληψη ή διάρθρωση συμβολαίου | 18. Παραχώρηση ακινήτου στο Δημόσιο |
| 7. Διανομή / σύσταση οριζόντιας ιδιοκτησίας και διανομή | 19. Μεταβίβαση λόγω ακύρωσης συμβολαίου |
| 8. Μεταβίβαση ακινήτου υπό διάλυση εταιρείας στα μέλη της | 20. Μεταβίβαση ακινήτου |
| 9. Ανταλλαγή | 21. Μετατροπή Ε.Ε., Ο.Ε., Ε.Π.Ε., σε Α.Ε. |
| 10. Σύσταση οριζόντιας / κάθετης ιδιοκτησίας με / χωρίς κτίσμα | 22. Πλασματική μεταβίβαση |
| 11. Συγχώνευση | 23. Απορρόφηση Α.Ε. από άλλη εταιρεία |
| 12. Απολλοτριώση για δημ. χρήση / αναγκαστική προακύρωση | 24. Παραχώρηση ακινήτου σε ιδιώτη με ειδικές διατάξεις |
| | 25. Αυταπαράδοση |

IV. Διαγραμμίσατε αναλόγως αν η δήλωση υποβάλλεται ως ειδική δήλωση ΦΠΑ ή ως δήλωση Φ.Μ.Α.

* Συμπληρώνεται από την Υπηρεσία



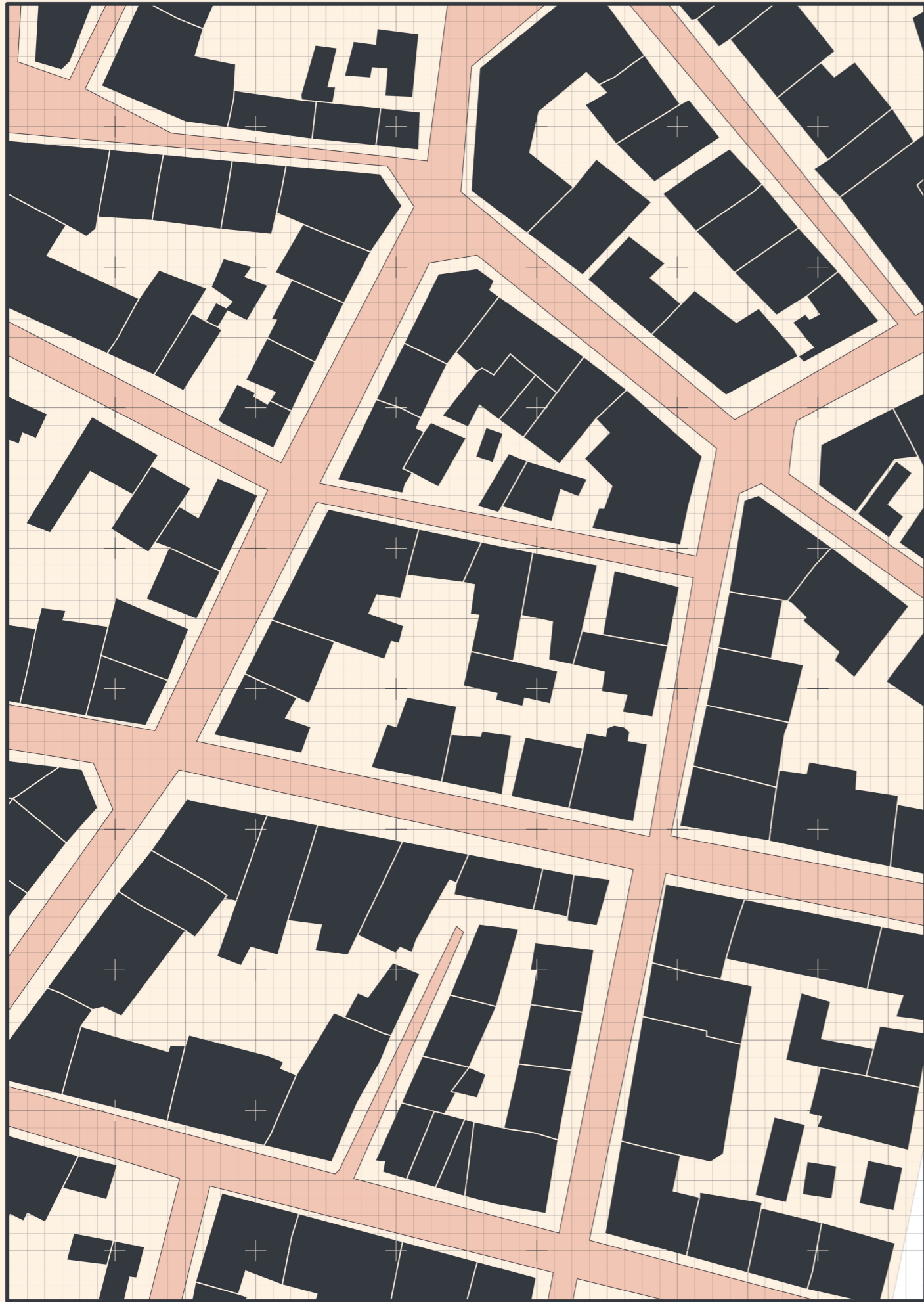

- urban plan, Sepolia | scale 1:500 -

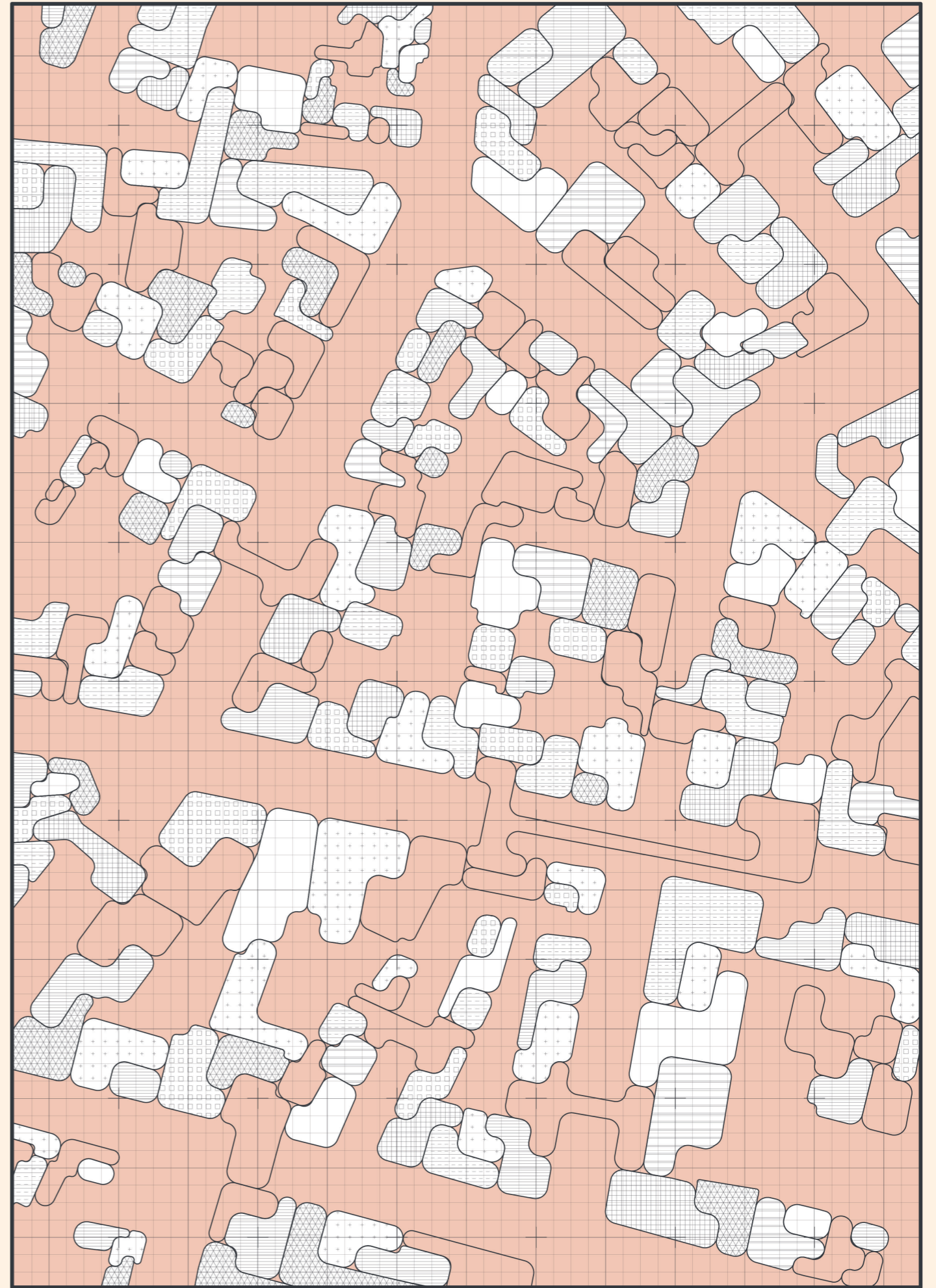

- a succession of enclosures, Sepolia | scale 1:500 -

To what extent is the notion of desire related to urban processes that make the neighbourhood?

How is the analysis of structures and operations of a specific ecology leading to a transition in the perception of its production, from a process that reproduces urban subjects, to a process that generates new ones?

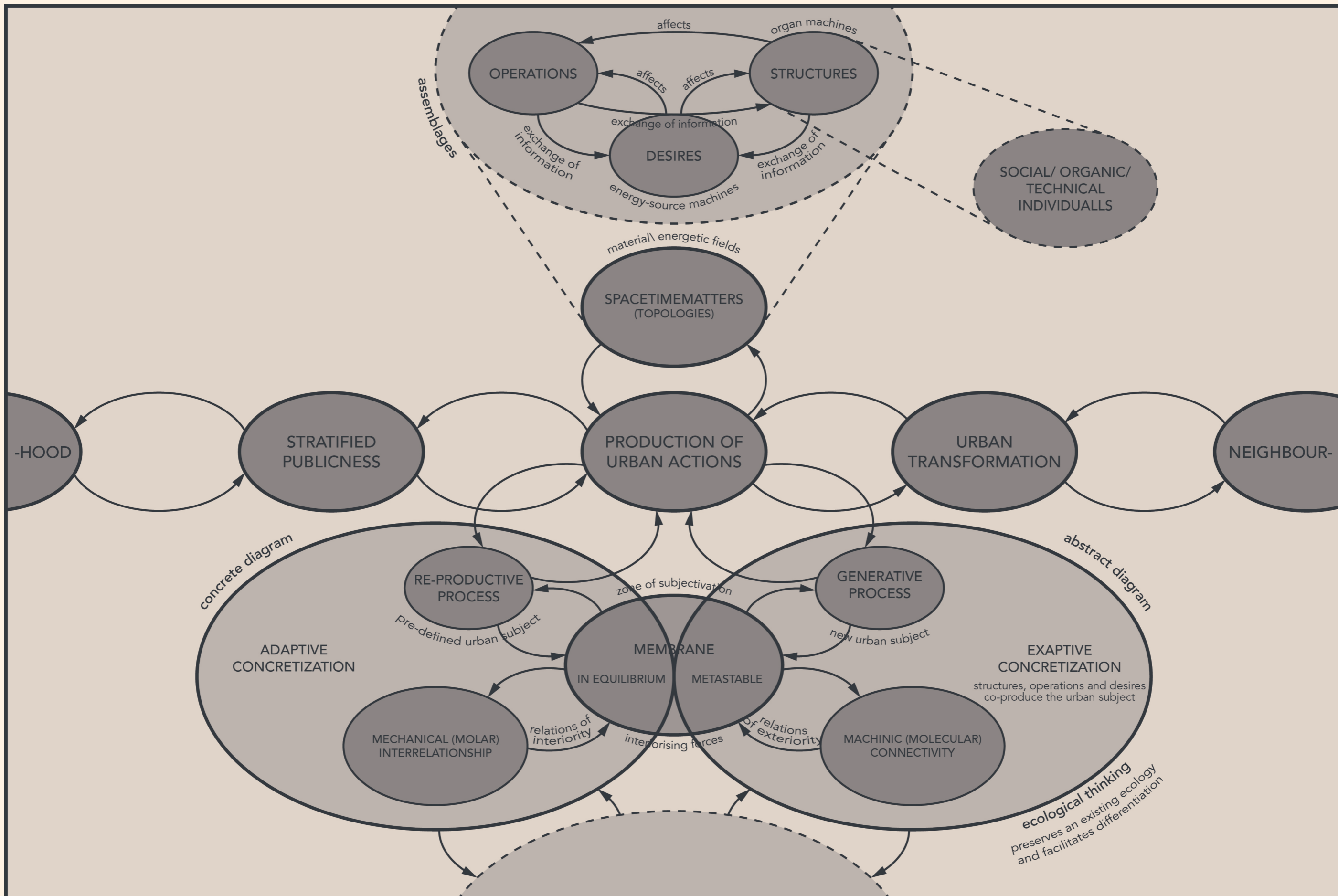

- individuation process -

general

- | | |
|----------------------------------------------------------|-------------------------------------------------------------------------------------------------------------------------------------------------------------|
| 1. For how many years have you been living in this area? | 12 years, since 2006. It used to farmland here. The apartment block was built together with the metro with antiparochi. The plot owner is our neighbor now. |
| 2. Where do you come from? | From Kypseli (another neighbourhood of Athens). |
| 3. Why did you leave to come here? | We wanted to buy a new house with my husband and this was a good opportunity, just built and close to my mother in law. |
| 4. Why did you choose this area? | It is close to my mother in law, there is metro and the neighbourhood is newly built. |
| 5. Do you own or rent the apartment? | Own |

urban life: private/ communal/ public space

- | | |
|---------------------------------------------------------------------------------------------------------------------------------|-------------------------------------------------------------------------------------|
| 6. How/ where do you spend your free time? | I spend time with the kids and their activities. I don't have free time for myself. |
| 7. Can you describe the relationship and contact with your neighbours? | Very good and some of them more personal, where we trust and help each other. |
| 8. Do you meet often with people from the building in order to discuss or make decisions about the building? Where do you meet? | There are general meetings in the entrance lobby, at least once per year. |
| 9. Do you meet often with people from | I know that there is the 4th municipal |

the neighbourhood in order to discuss or make decisions about the neighbourhood? Where do you meet?

community of residents but I don't take part. I have heard that the cafes of the neighbourhood, mostly in the past but it still happens, they function as places for finding a job. People go there, socialise and find jobs in the neighbourhood, by word of mouth.

10. Which are the public/ communal space in the neighbourhood? Do you use them? Do you go somewhere else?

The playground of Triton and the Tritsi park. But the park is not clean, there is no ward or sufficient lighting. Nor do I take my kids to the playground because it is full of Albanians. They came in the 70s and now they are countless. They work as builders and housekeepers mainly. They go all together to the playground, which is small, and stay there all day. I feel like there is no space for us. I take my kids to the Stavros Niarchos Foundation Cultural Center.

space/ participation

11. What would you change in the neighbourhood?

More green, place for walking. Recycle bins, better lighting, more nightlife, I mean restaurants and bars.

12. How do you imagine the ideal neighbourhood? Where would you like to live ideally?

I like the urban environment of Athens, I wouldn't change that. I wouldn't want to live in a rural area, I don't like the closed environment, I prefer the anonymity of the city. However, I would like to live in a town house in the center of Athens instead of an apartment, to have my own garden.

13. Which spaces are unused in the neighbourhood?

The Saint Ioannis Theologos chapel in Amfiaraou street. I think something nice could happen there.

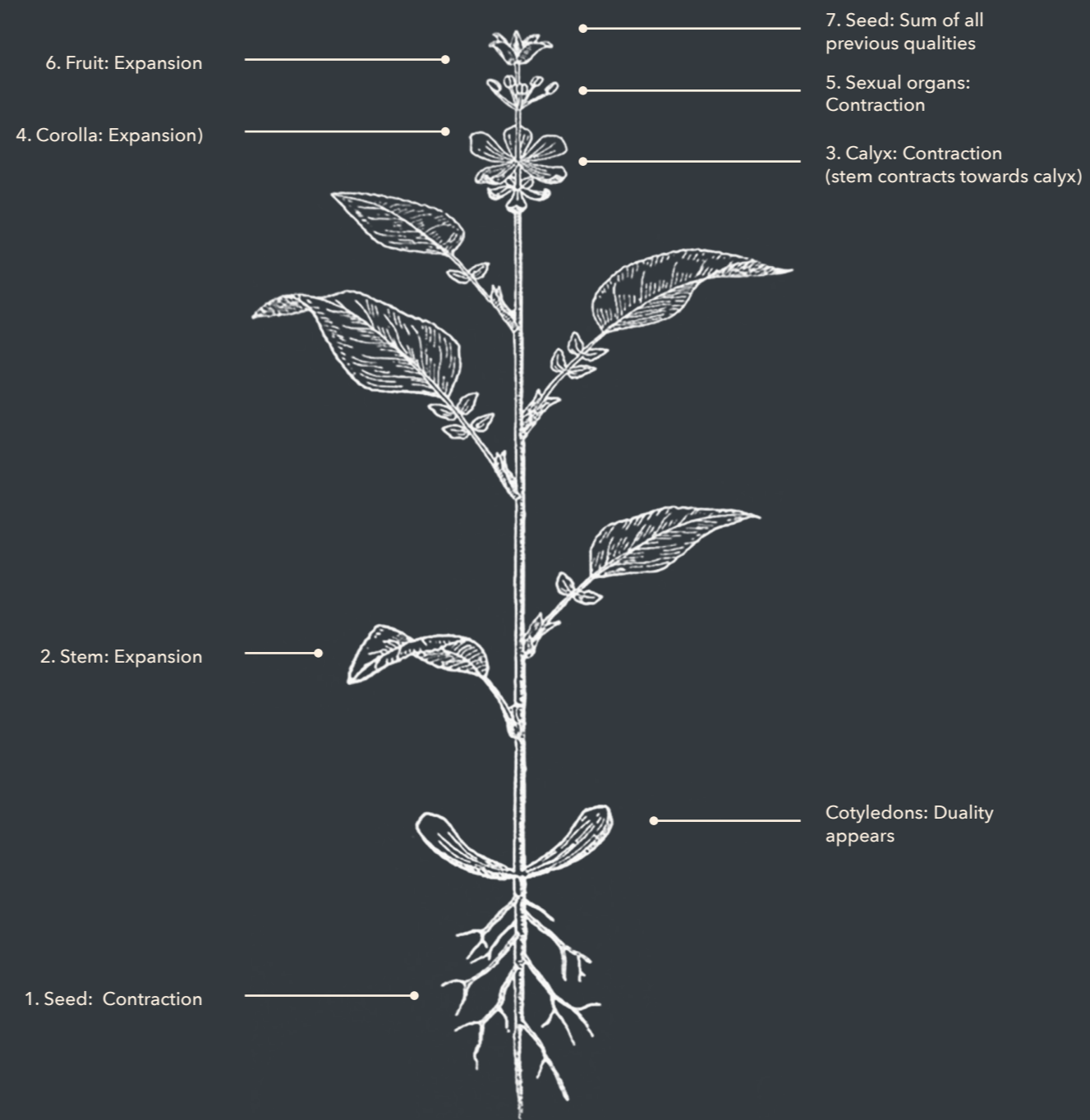

Goethe's Essential Plant: Essential features described in terms of potentials.
 Reiser and Umemoto (2006). Illustration by Wilhelm Troll (1837).

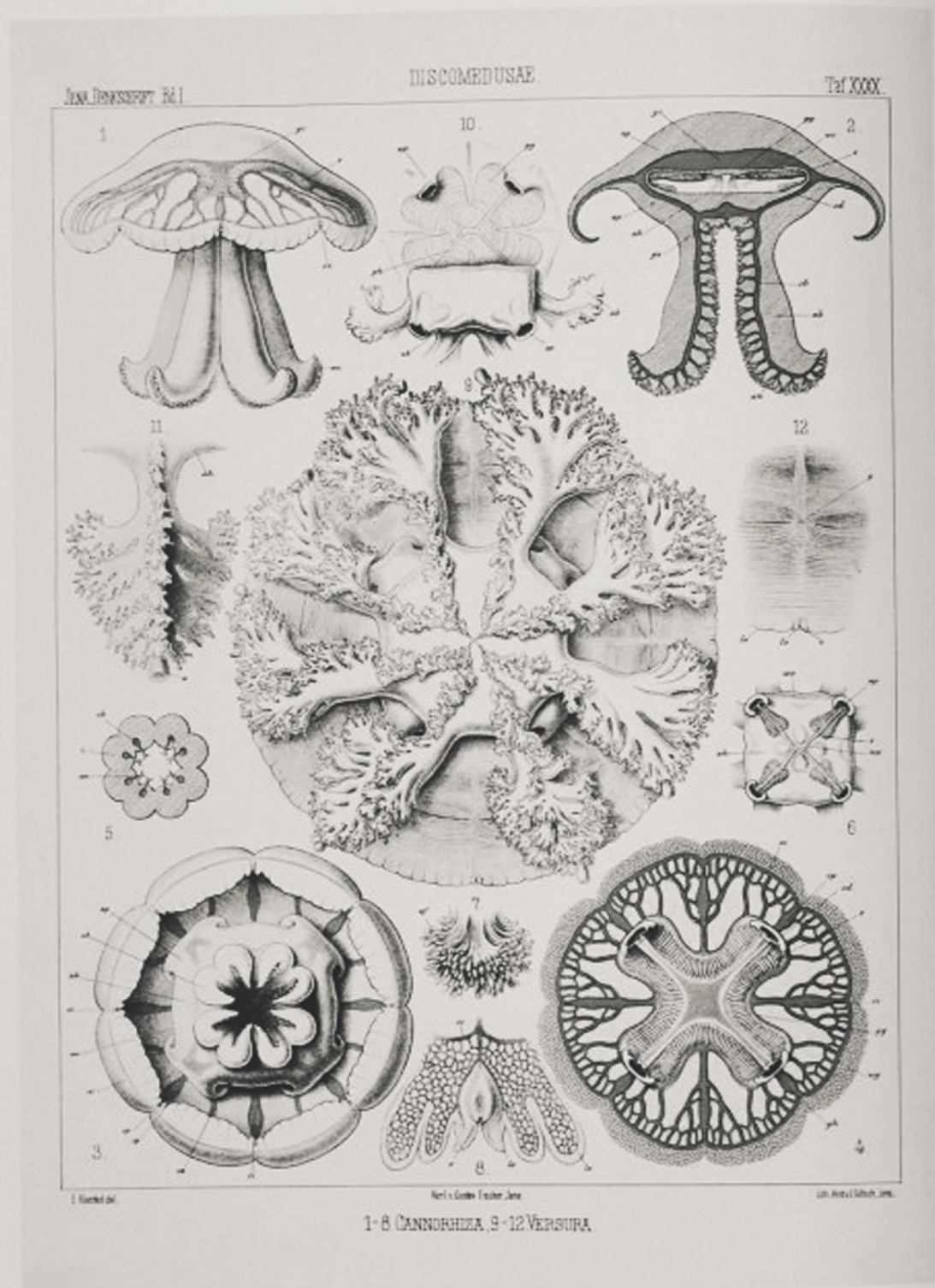
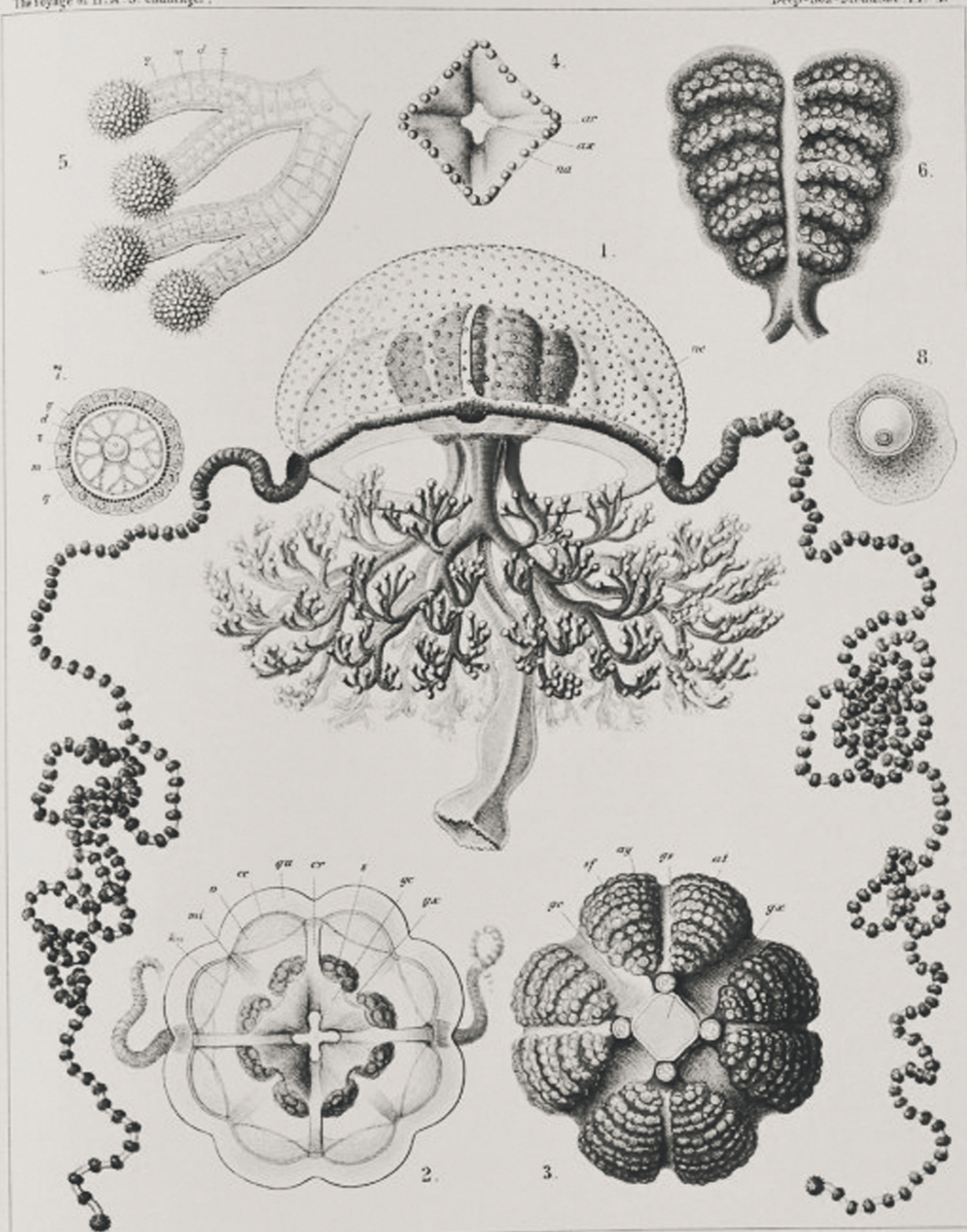

PLATE XX
 1-8 Cannonheza cornuta, WASSERLI. - Cannonheza cornuta WASSERLI, 1880
 9-12 Versura palmata, WASSERLI. - Margaria scollata (WASSERLI, 1880)
 Golden medusa, Spence & Peck. - Gopandev's Rhizomorphidae.

PLATE I
 Thamnostylus dinema. - Thamnostylus dinema WASSERLI, 1879



Thamnostylus dinema.

THAMNOSTYLUS DINEMA.

Ehrlich's lith.



Grocery store, Sepolia, Athens (2018).



Aghios Meletis square, Sepolia, Athens (2018).



Wor(th)ship, Athens. Tassos Vrettos (2015-2016).



ΚΑΡΟΣ ΟΙΚΟΔΟΜΗΤΙΚΗΣ ΒΑΣΗΣ
ΚΑΙ ΑΝΑΒΑΘΜΙΣΤΙΚΗΣ ΜΕΤΡΗΣ

ΚΑΡΟΣ ΤΡΟΧΕΙΟΥ

ΜΕΤΟΧΗ

ΧΑΤΖΗΠΟΥ

ΤΡΙΑΝΤΑ

ΠΟΠΟΥ

ΕΙΡΑΚΙΟΥ

ΕΠΙΣΤΗΜΟΝΕΣ

ΤΕΡΣΙΟΥ

ΑΔΑΜΑΝΤΟΣ

ΤΕΜΠΙΝ

ΚΑΡΟΛΙΝΟΥ

Κ.Π. ΠΙΛΑΝΟΥ ΧΑΡΑ

Κ.Π. ΠΙΛΑΝΟΥ ΧΑΡΑ

ΑΝΤΙΣΤΑΝΤΕ

ΚΑΡΟΣ ΤΡΑΦΙΝΟΥ

ΕΤΑΚΙΟΥ

ΑΧΙΛΛΕΟΥ

ΝΕΡΟΣΟΥ

ΜΙΛΗΤΟΥ

ΕΤΑΘΜΟΣ ΑΤΤΙΚΗΣ

ΤΕΜΠΙΝ

ΝΕΡΟΣΟΥ

ΜΙΛΗΤΟΥ

ΑΦΟΡΑΡΤΟΥ

ΒΑΡΕΙΑ ΤΥΦΟΣ



- 37.998710,23.720666 -

the event, section, 1:50

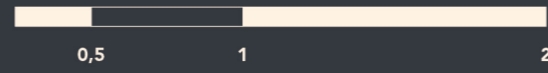

On the 26th of December 2018, in one of the walks that were part of the observational study of the neighborhood, people were found sleeping in one of the green open spaces that are formed by the structure of the streets. It was a cold day and for that reason they were using transparent plastic covers to keep warm. One of them was asleep and was noticeably irritated by the fact that a person was looking at them.

the event | plan , 1: 100

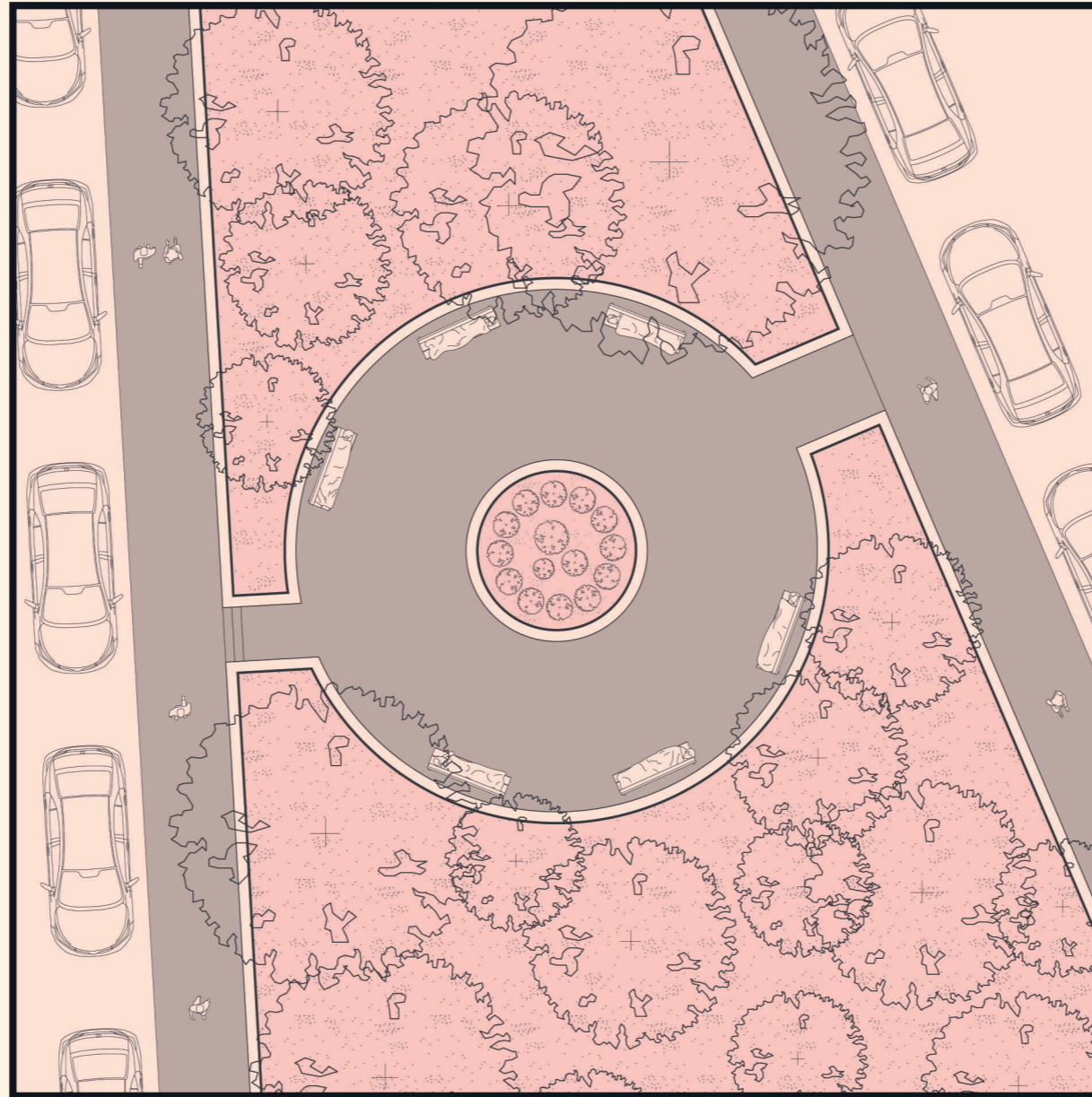

stratification of publicness

P1: resting
P2: resting
P3: resting
P4: resting
P5: resting
P6: resting

P7: shadowing and blocking view
P8: shadowing and blocking view
P9: shadowing and blocking view
P10: shadowing and blocking view
P11: shadowing and blocking view
P12: shadowing and blocking view

P13: hearing
P14: smelling
P15: talking
P16: hearing
P17: looking
P18: hearing

P19: hearing
P20: resting
P21: walking
P22: talking
P23: smelling
P24: looking

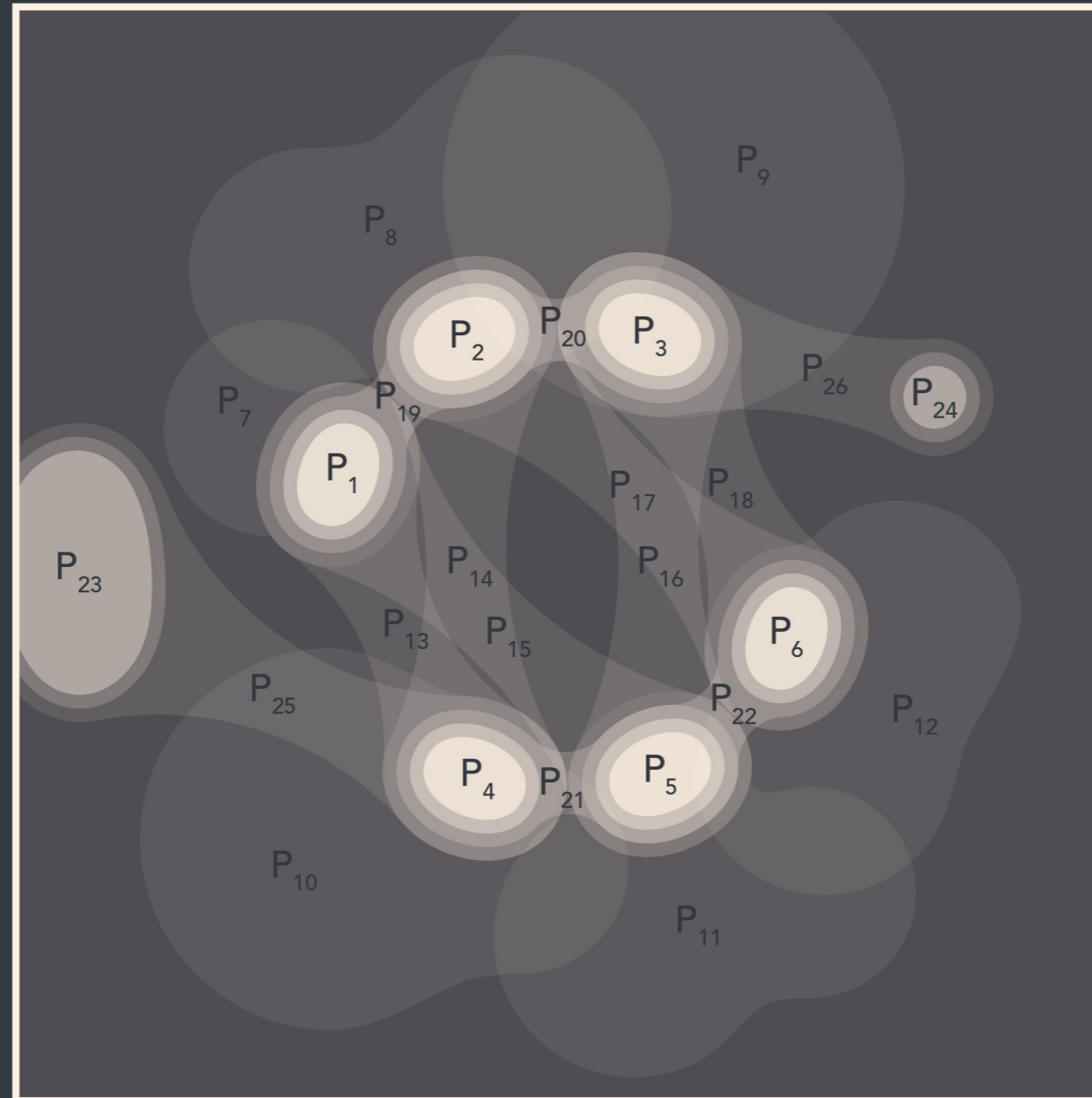

the associated milieu

material (tangible)

others resting
free bench
tree
bush
blanket
extra plastic cover

energetic (intangible)

fatigue
boredom

the new associated milieu

material (tangible)

free bench
occupied bench

energetic (intangible)

memory of a resting place
social encounter
restfulness

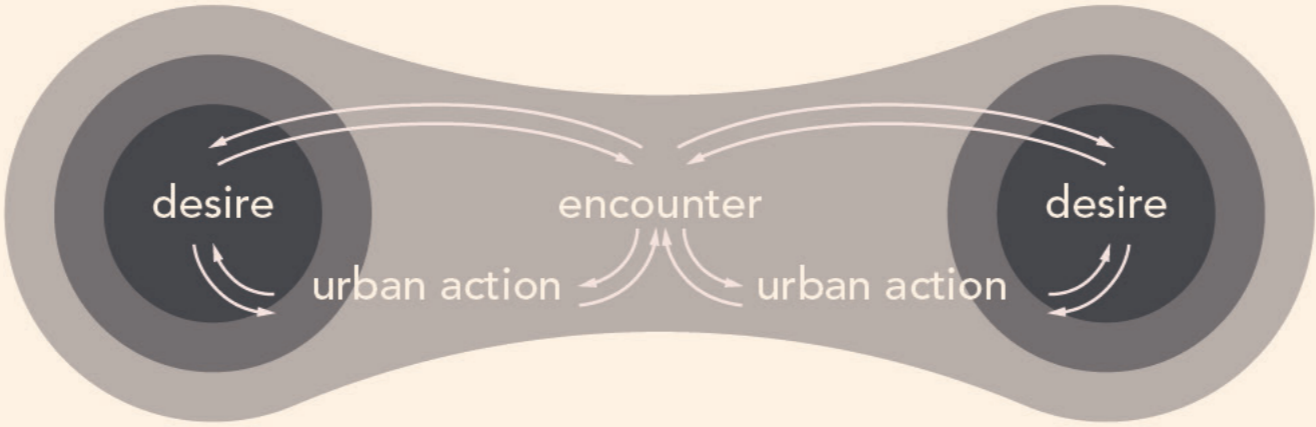

stratified publicness

the new associated milieu

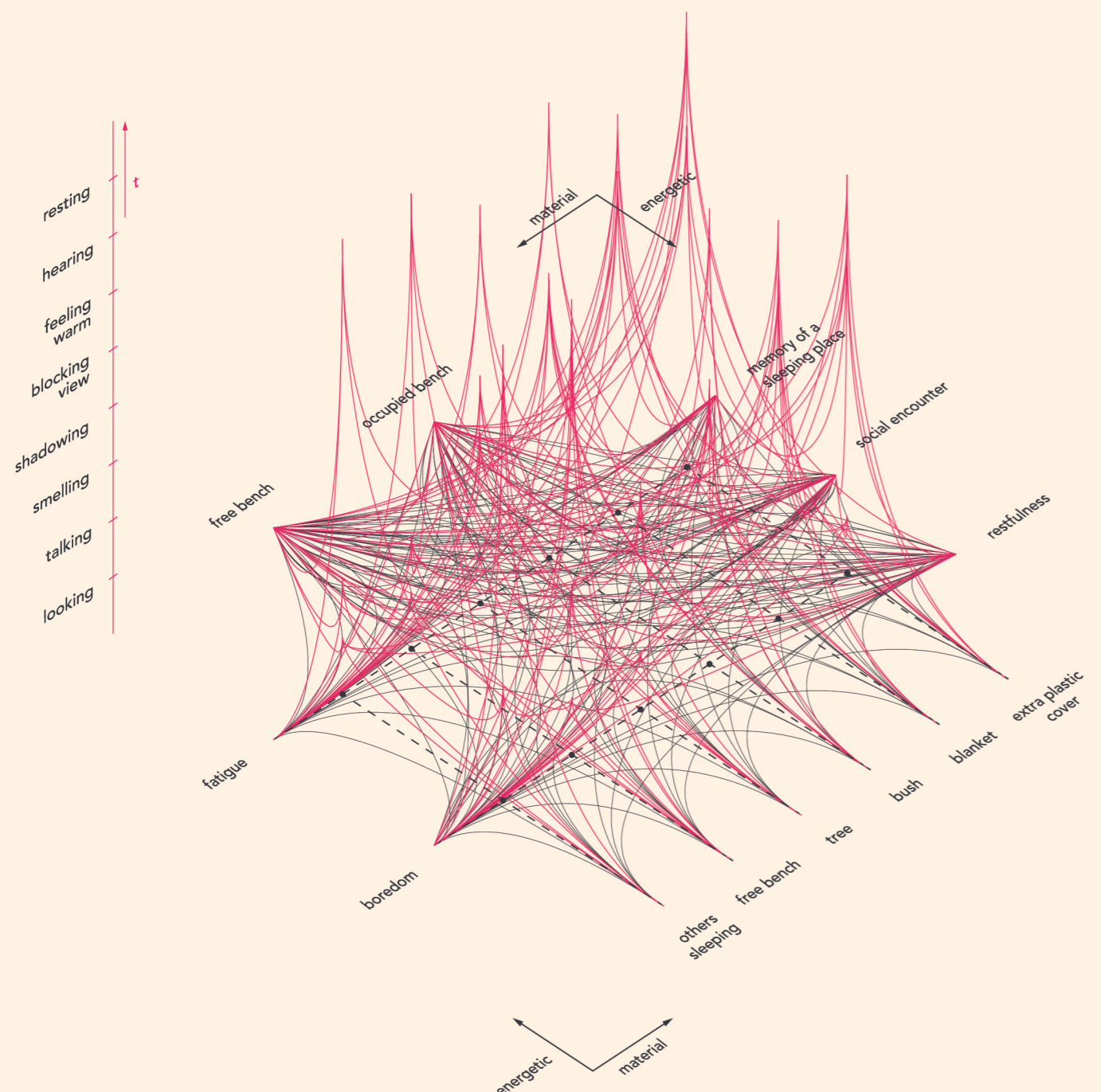

the associated milieu

(t) internal duration from a previous state to another

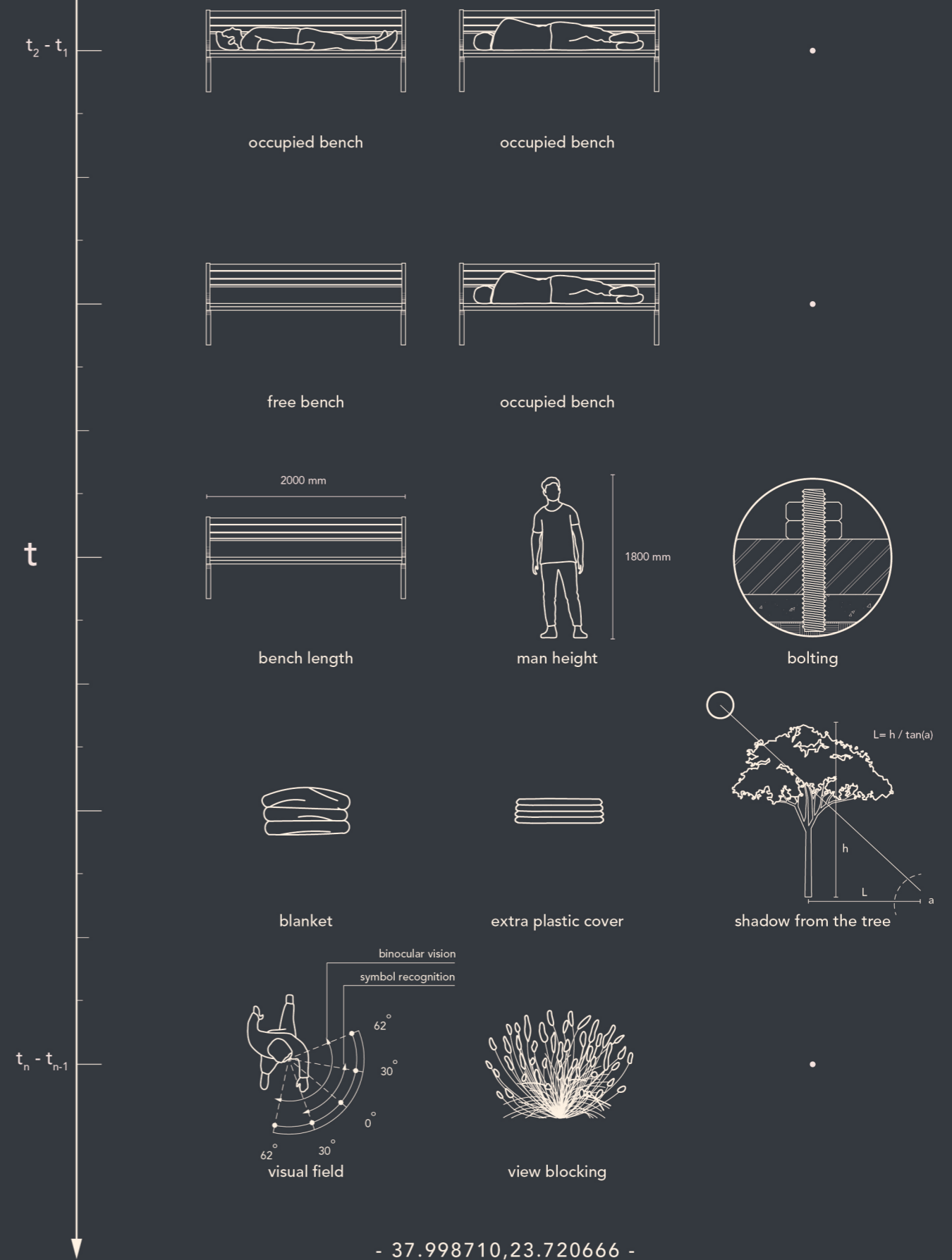

the new associated milieu

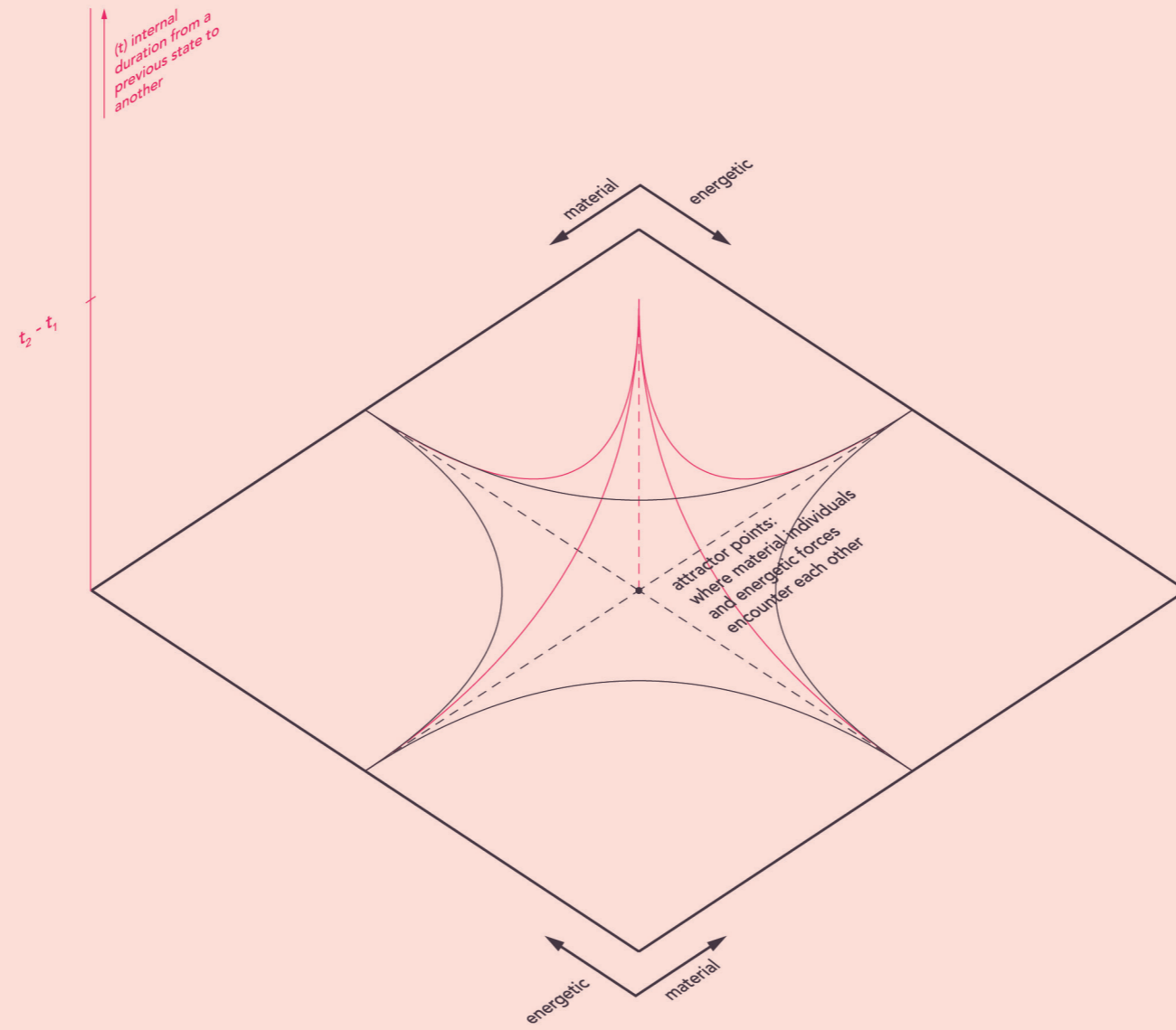

the associated milieu

the new associated milieu

$t_n - t_{n-1}$
(t) internal duration from a previous state to another

$t_2 - t_1$

material
energetic

attractor points:
where material individuals
and energetic forces
encounter each other

energetic
material

the associated milieu

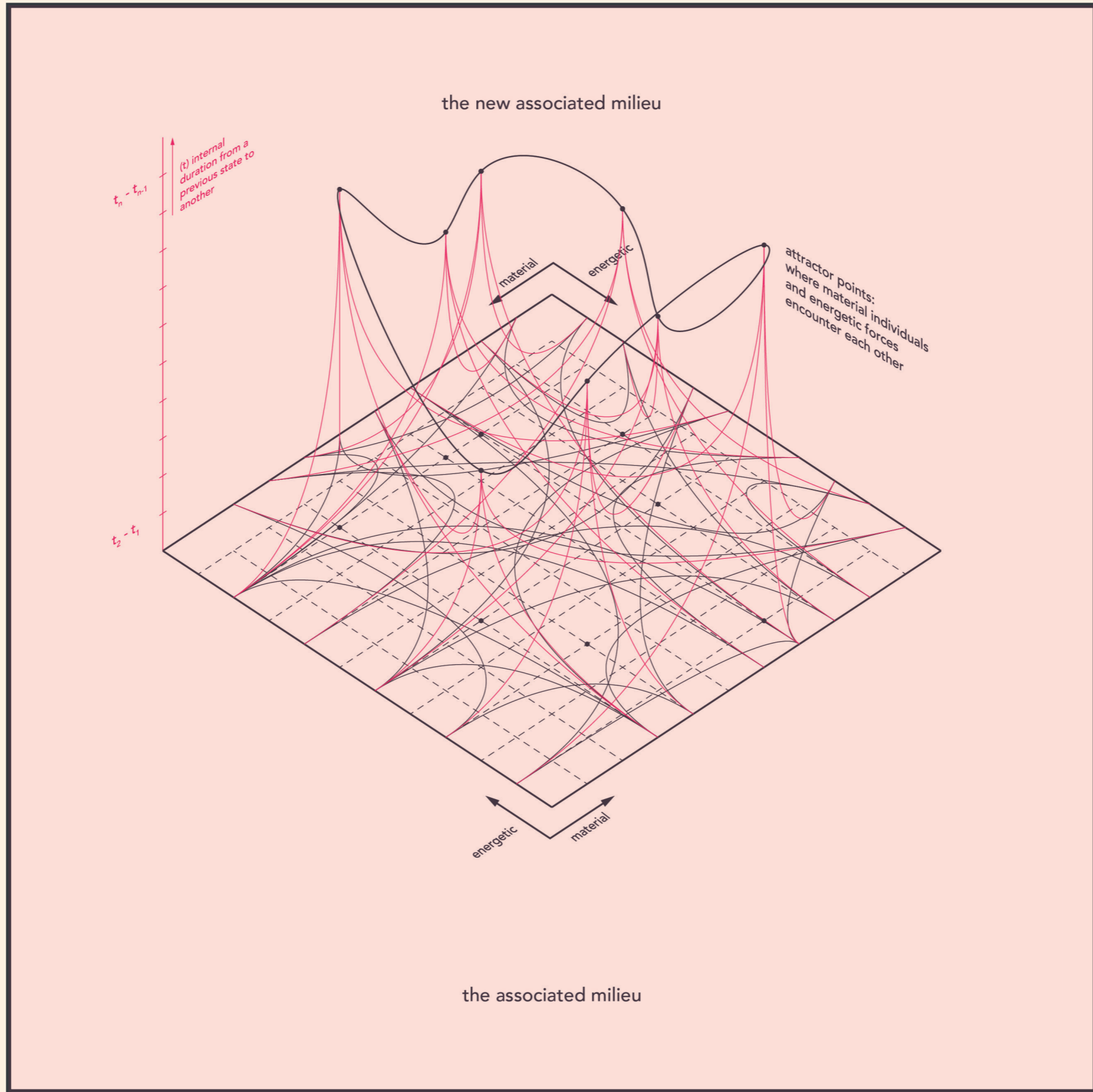

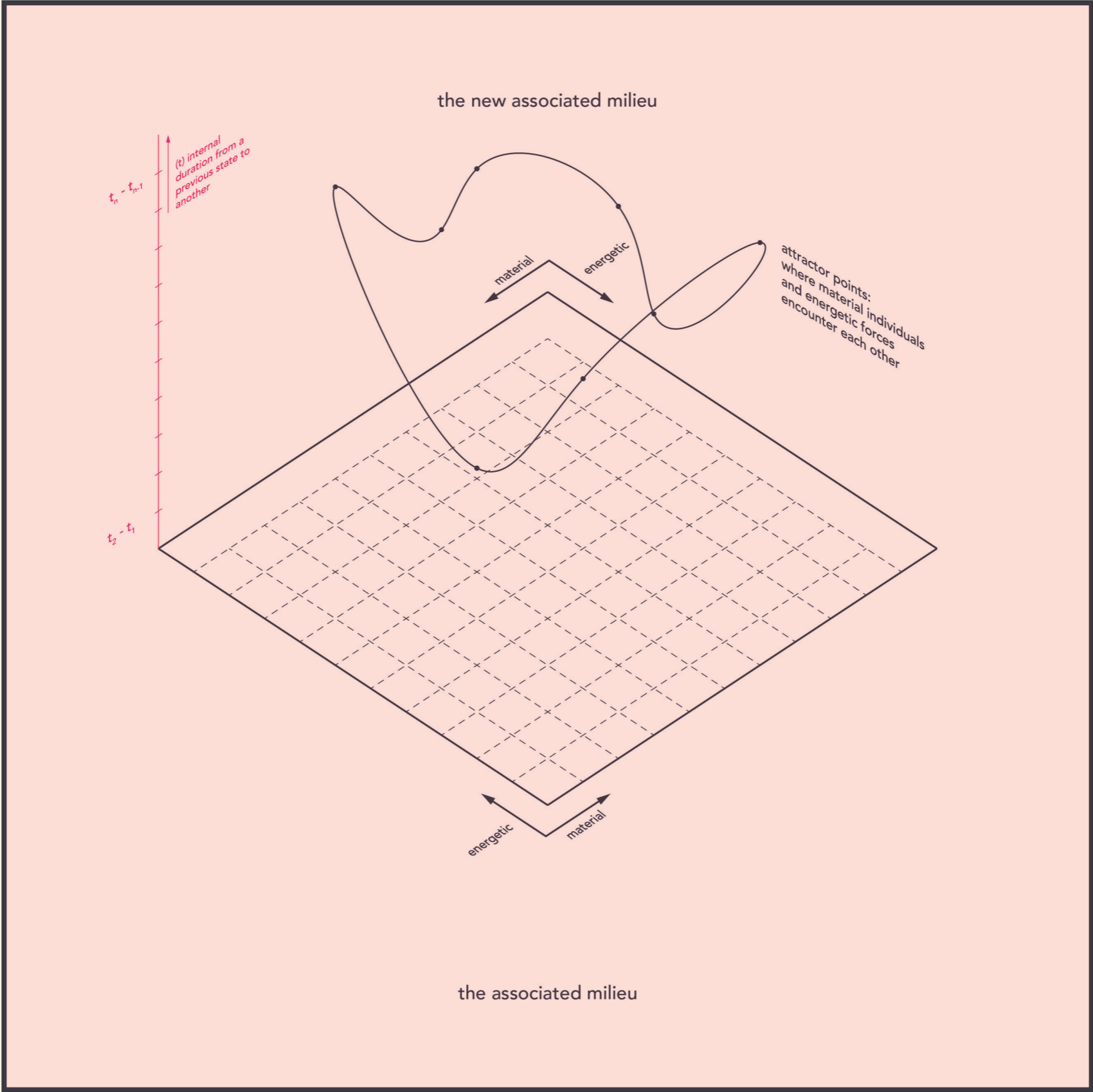

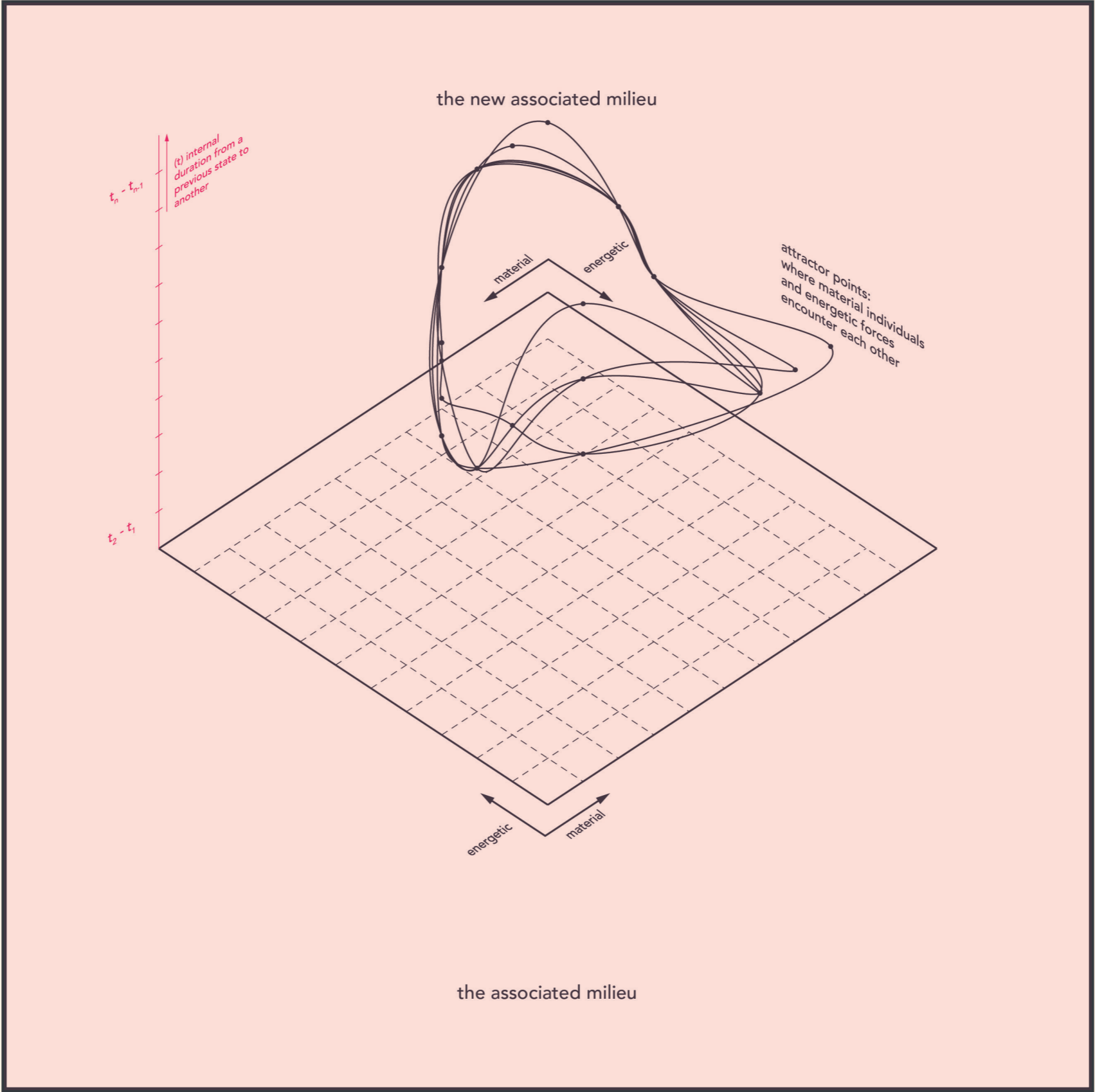

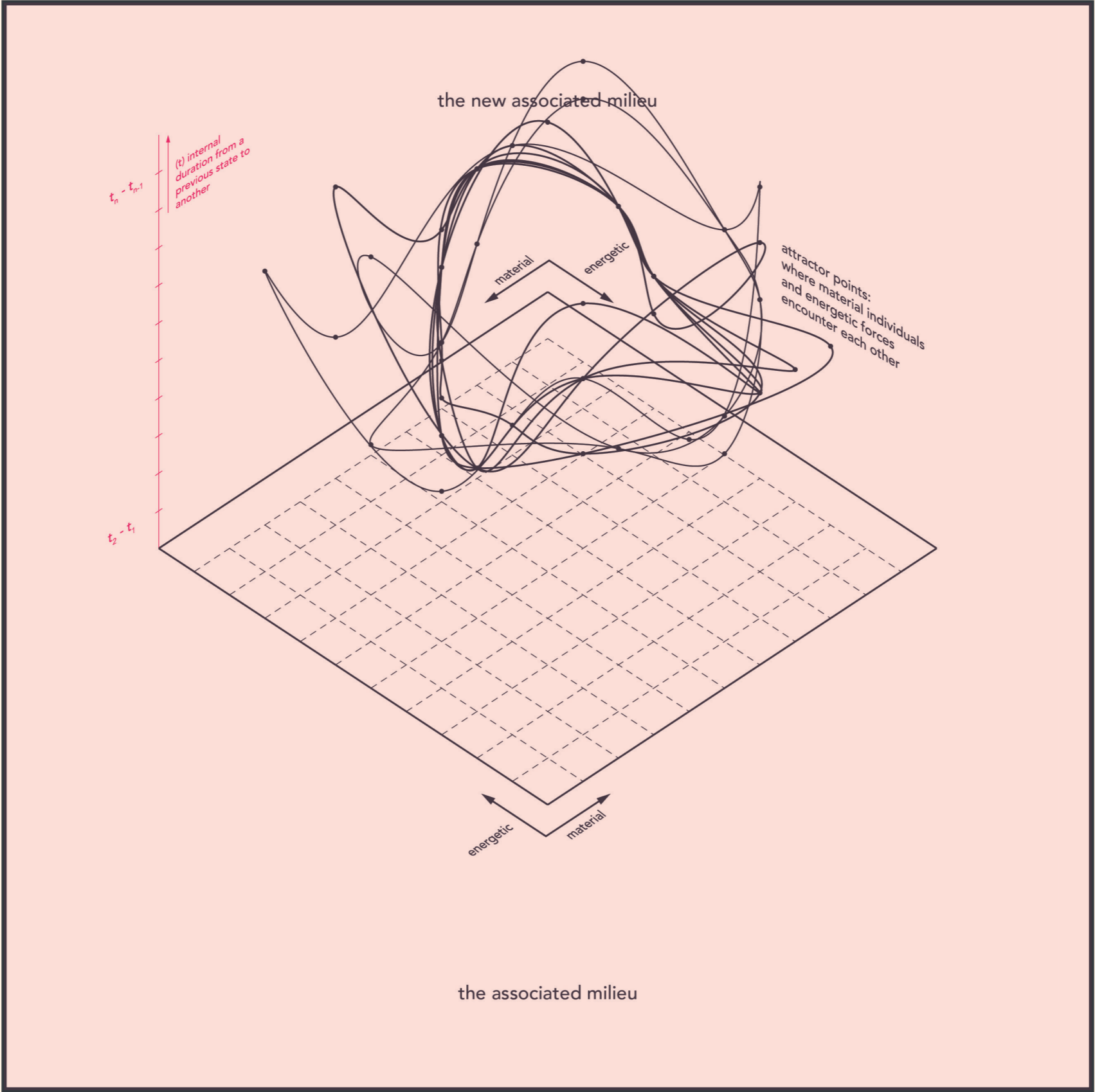



- 38.002454, 23.716753 -



- 38.002491, 23.717023 -

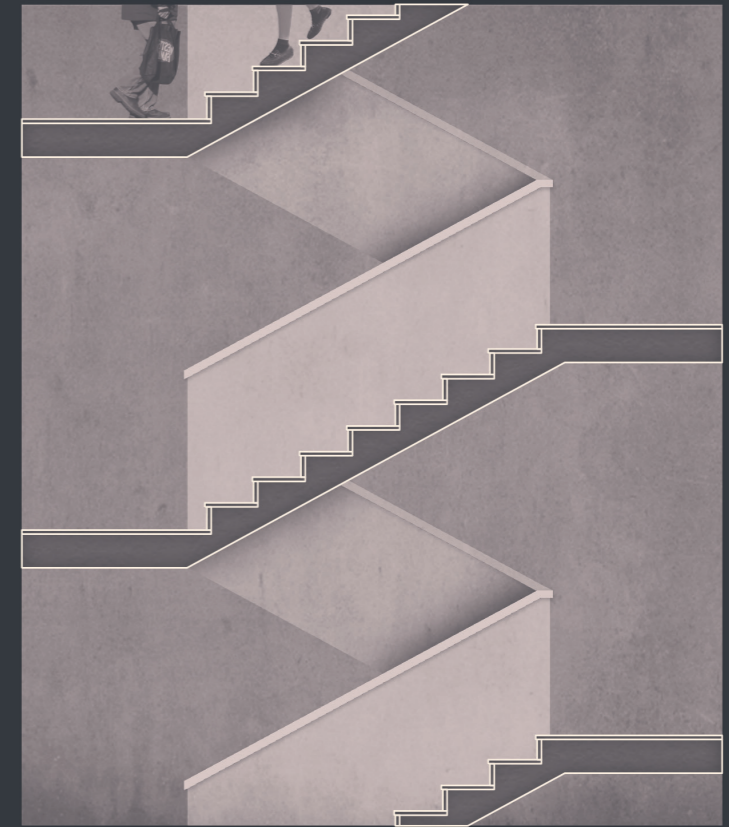

- 38.002491, 23.717023 -



- 38.002485,23.717368 -



- 38.000961, 23.719439 -



- 38.002454,23.716753 -



- 37.998710, 23.720666 -



- 37.992835, 23.714041 -



- 38.006306, 23.717190 -



- 37.992835, 23.714041 -

the event, section, 1:50

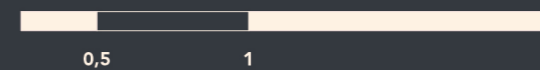

"O allos anthropos" is a nomadic soup kitchen that prepares and offers food in public places in Athens. Often, this kitchen is set up in Kolonos, near the neighborhood of Sepolia, in the open space that is found around Aghios Konstantinos church.

stratification of publicness

- | | | | |
|--------------------|--------------------|---------------------|---------------|
| P1: cooking | P5: feeling hungry | P9: feeling hungry | P13: watching |
| P2: offering food | P6: feeling hungry | P10: feeling hungry | P14: watching |
| P3: eating | P7: feeling hungry | P11: feeling hungry | |
| P4: feeling hungry | P8: feeling hungry | P12: talking | |

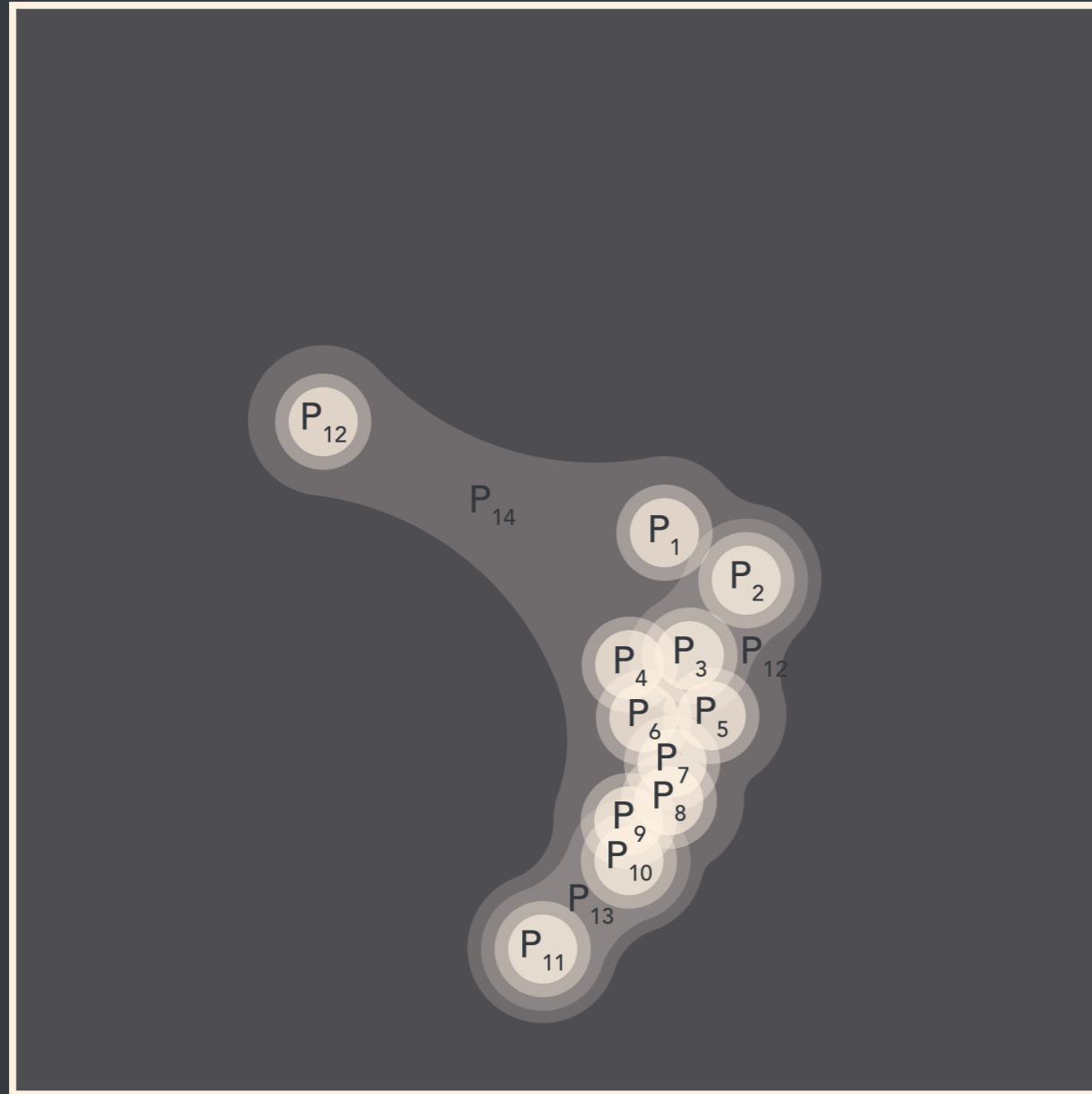

the associated milieu

material (tangible)

- gas bottle
- gas burner
- cooking utensils
- cooking ingredients
- others cooking
- others eating

energetic (intangible)

- hunger
- food envy
- altruism

the new associated milieu

material (tangible)

- others eating

energetic (intangible)

- energy
- memory of eating
- social encounter

the event | plan , 1: 100

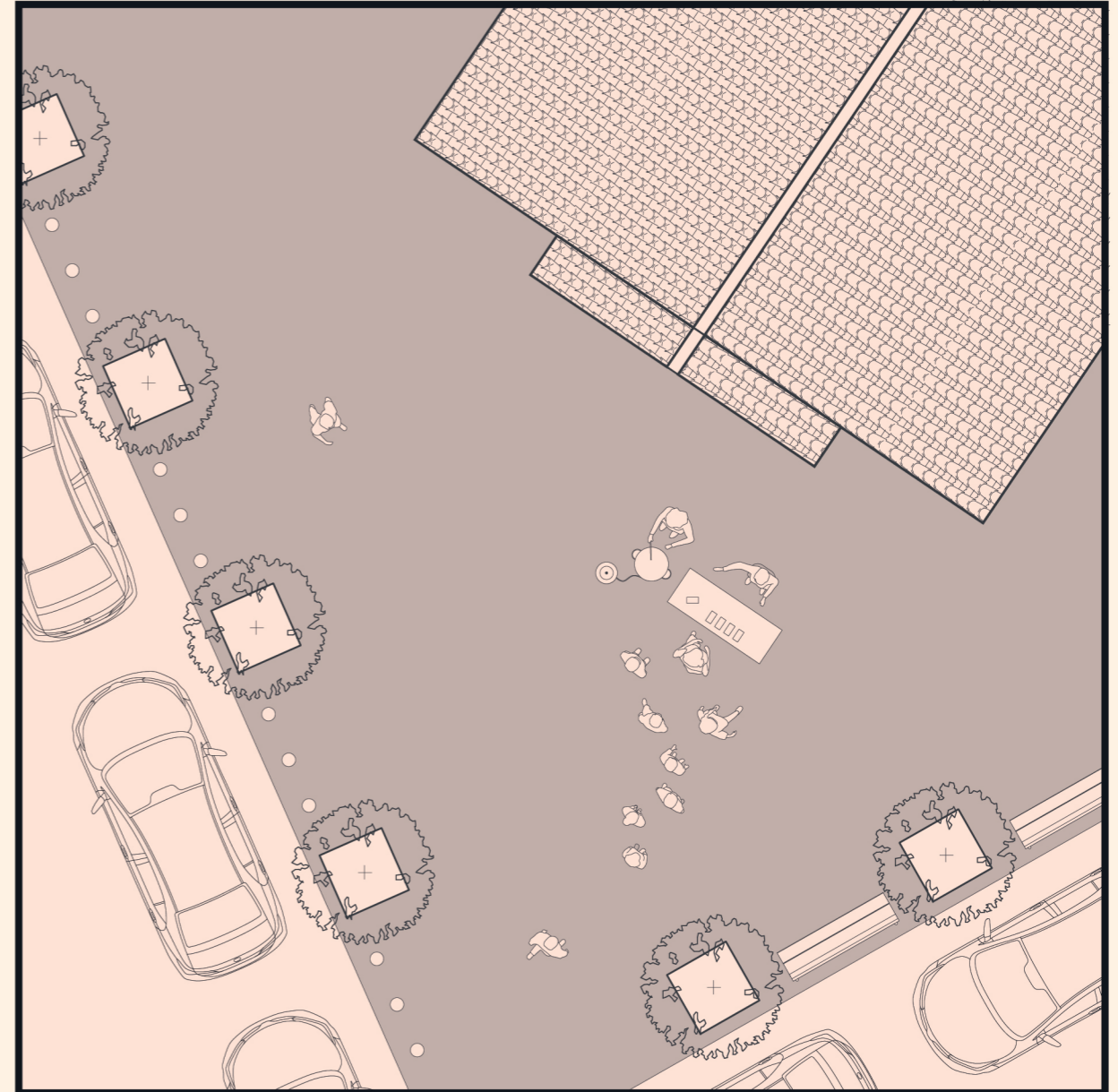

the new associated milieu

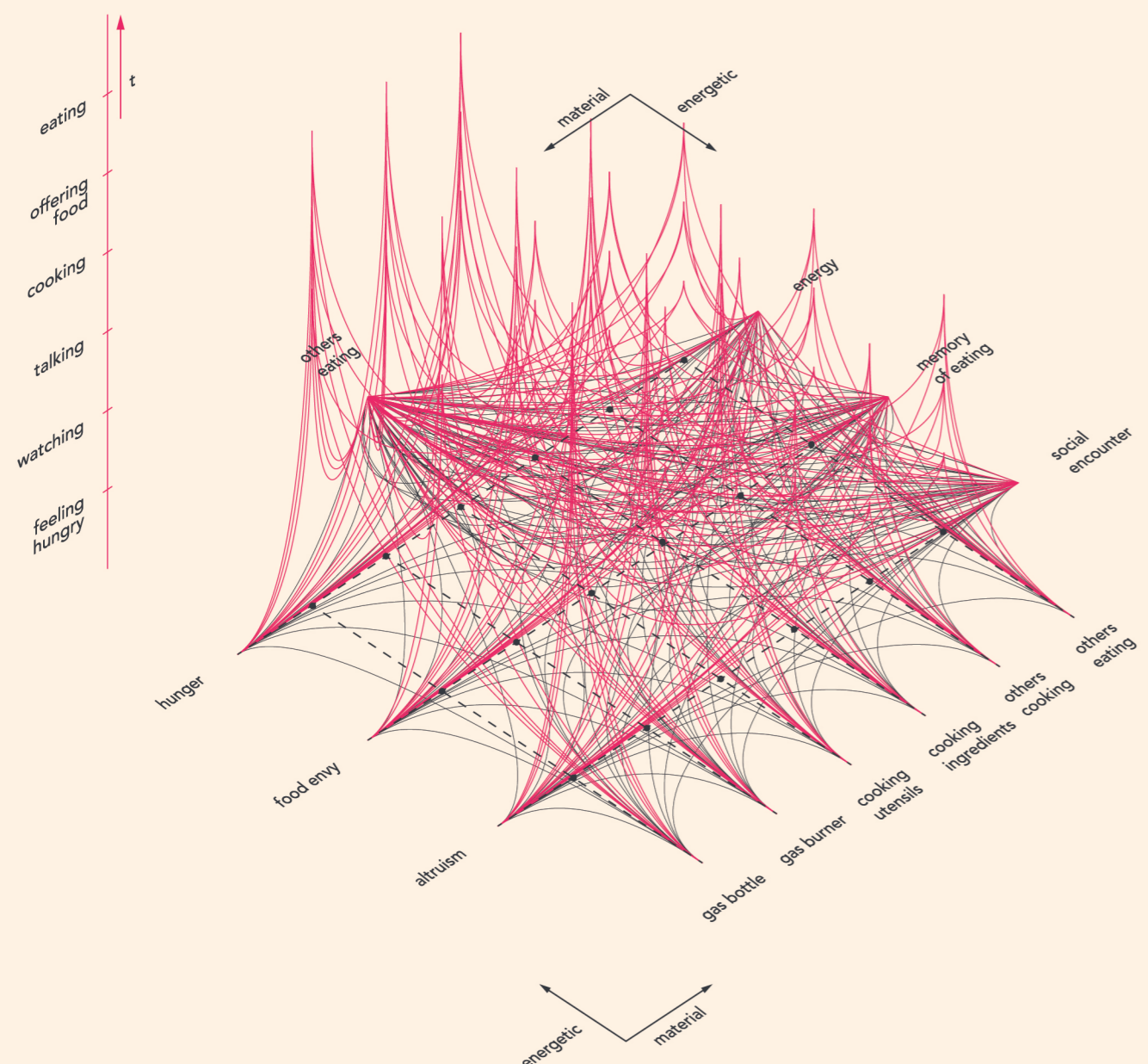

the associated milieu

(t) internal duration from a previous state to another

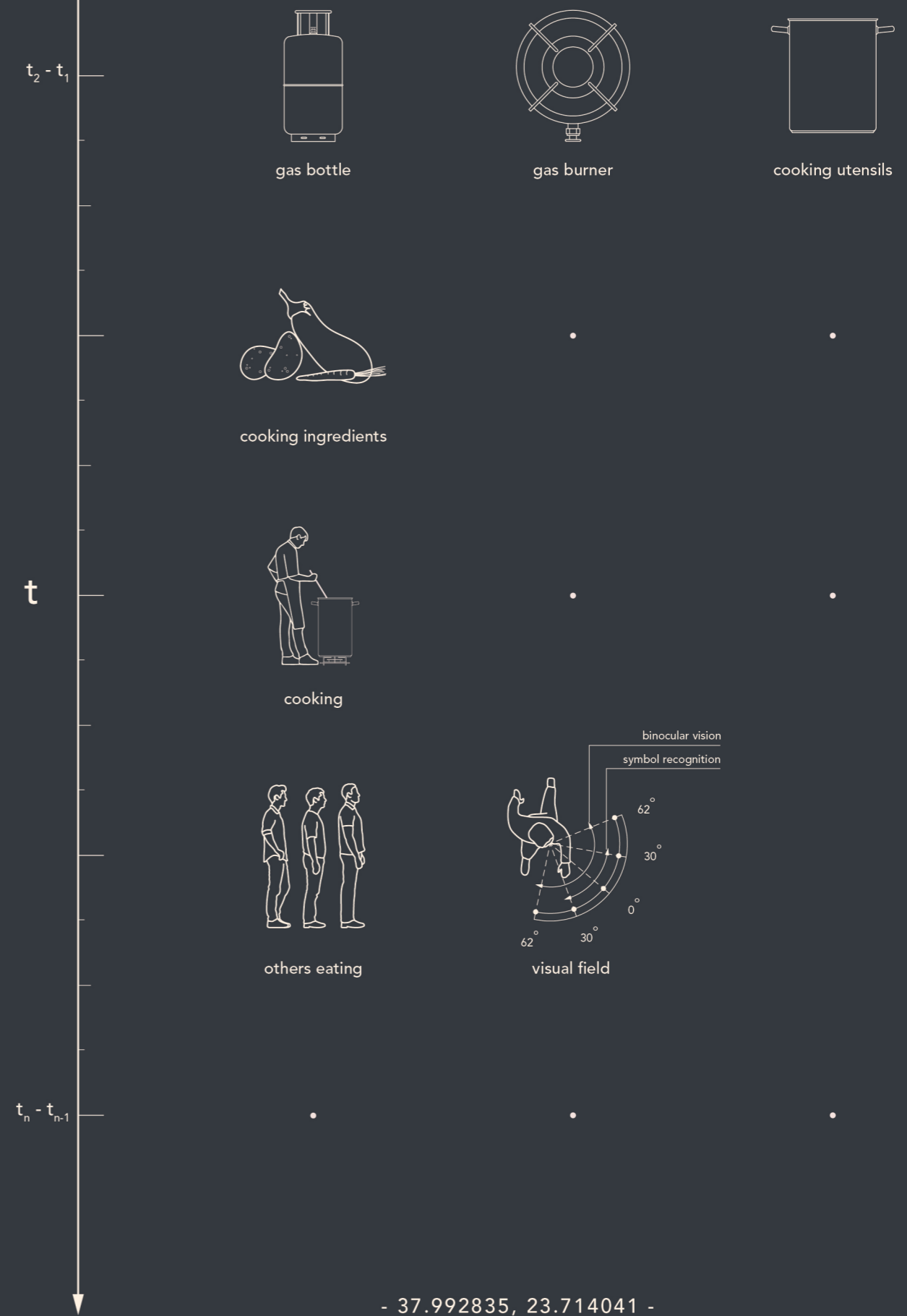

- 37.992835, 23.714041 -





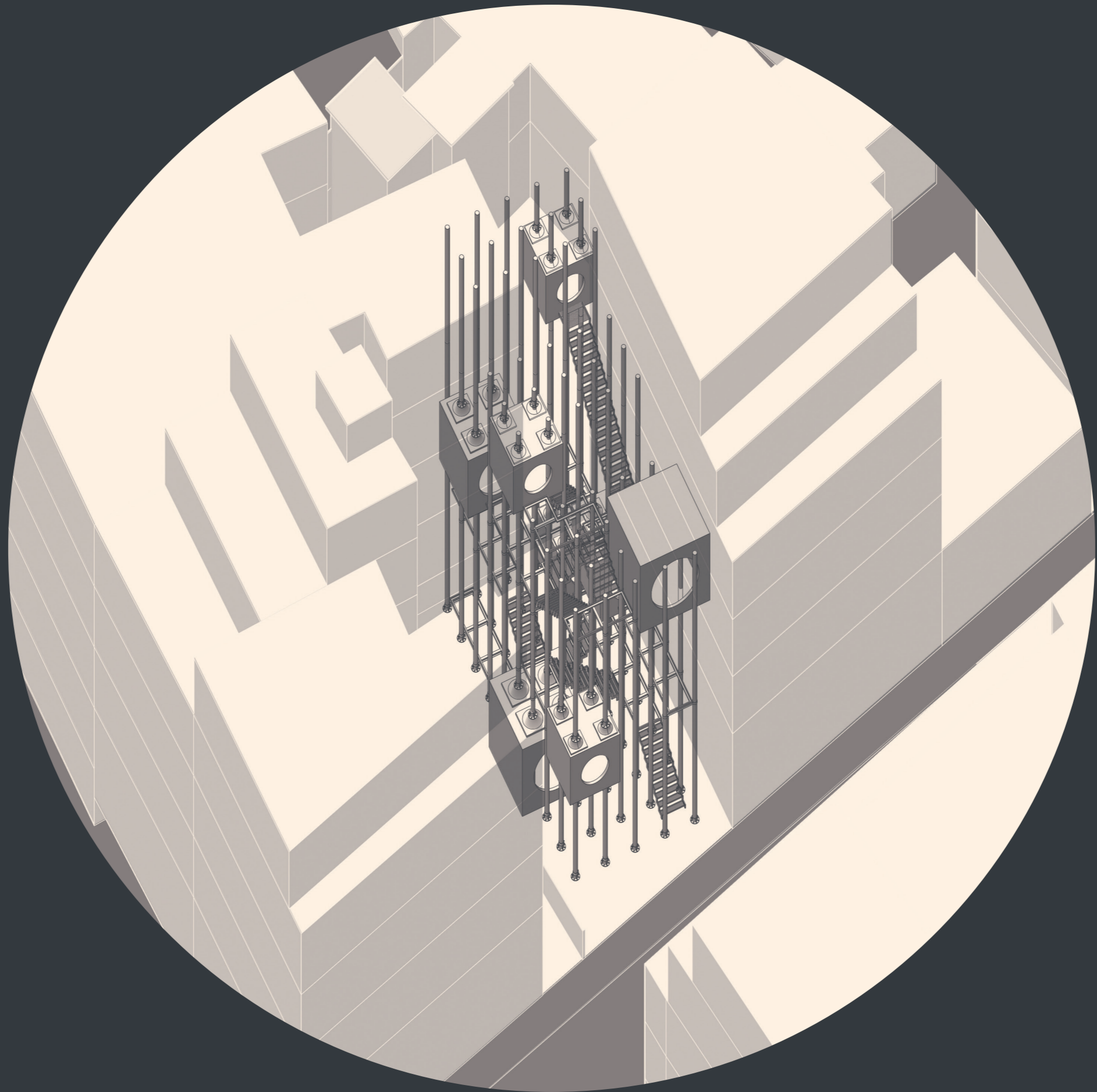

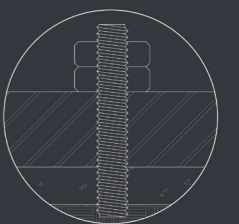
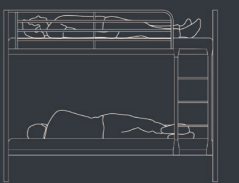
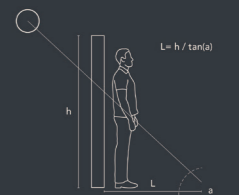
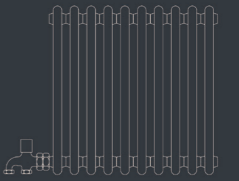
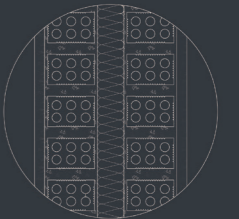
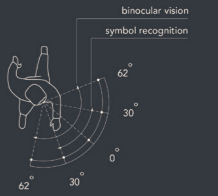
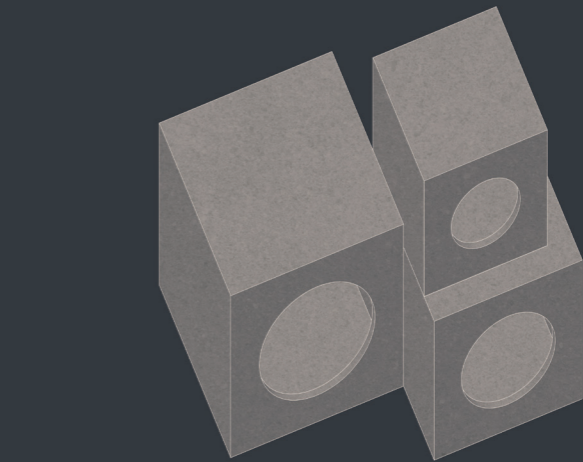
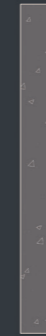
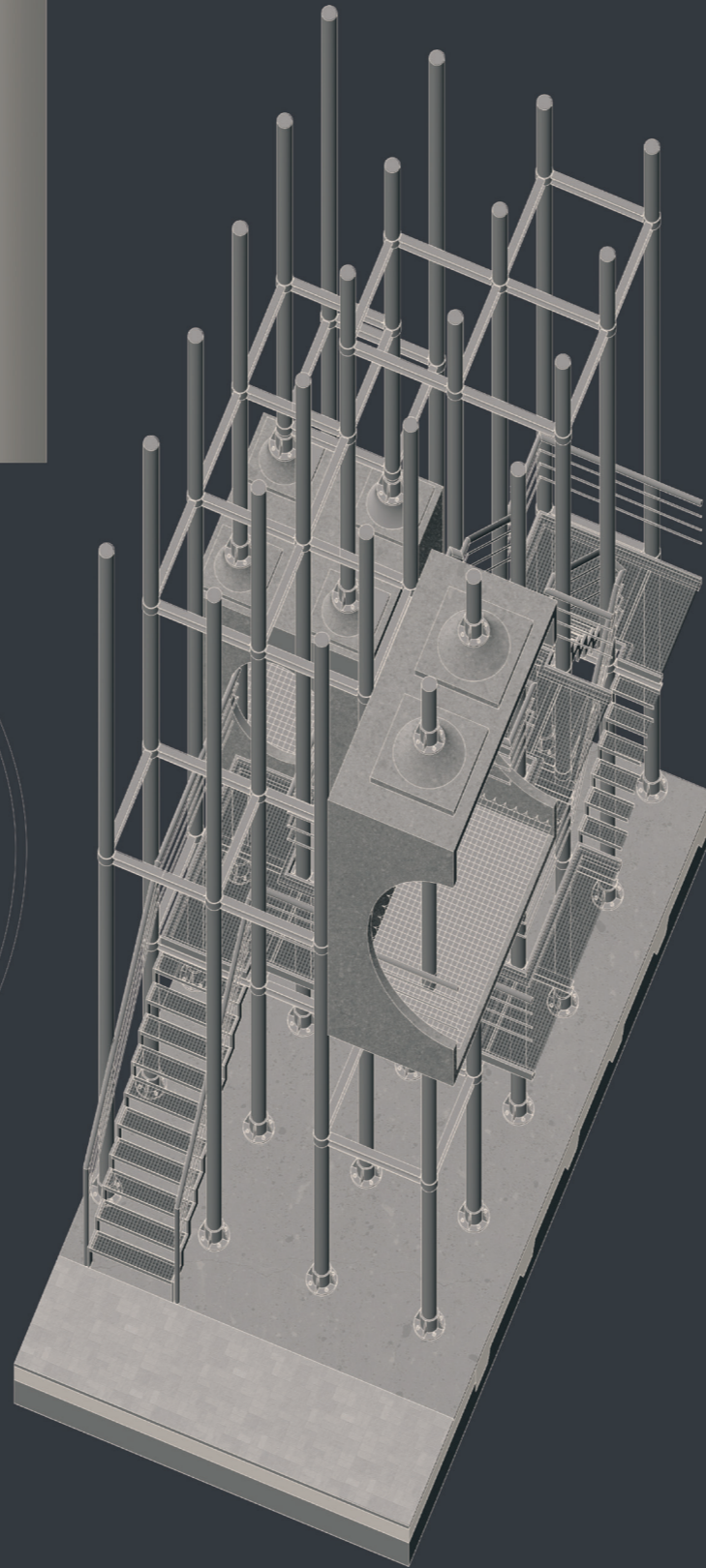
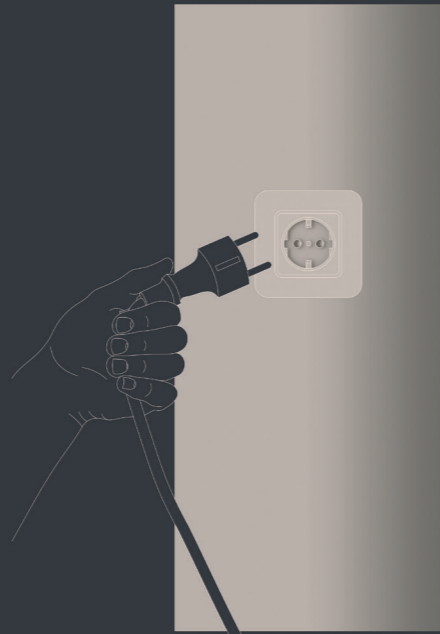
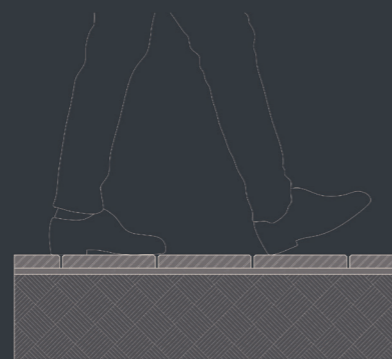
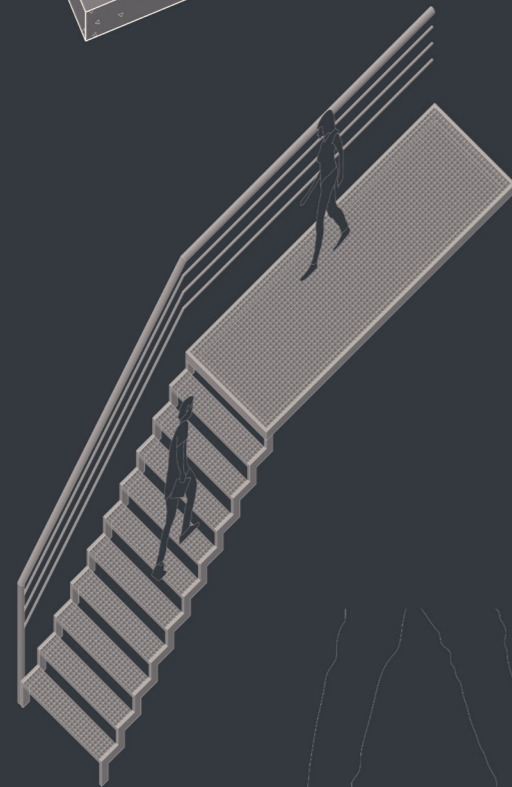
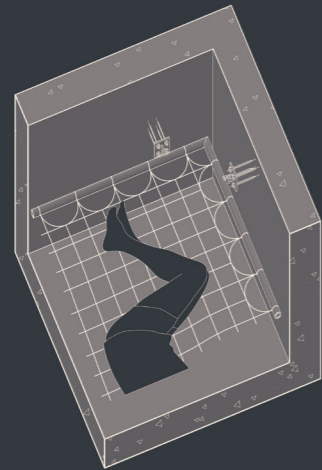
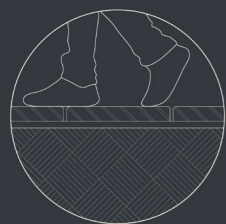
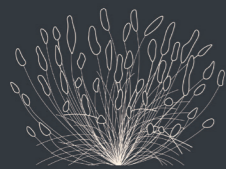
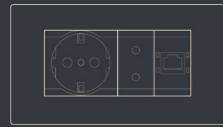
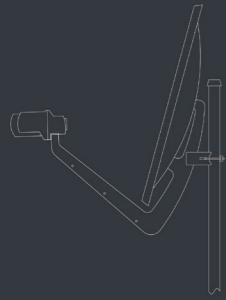

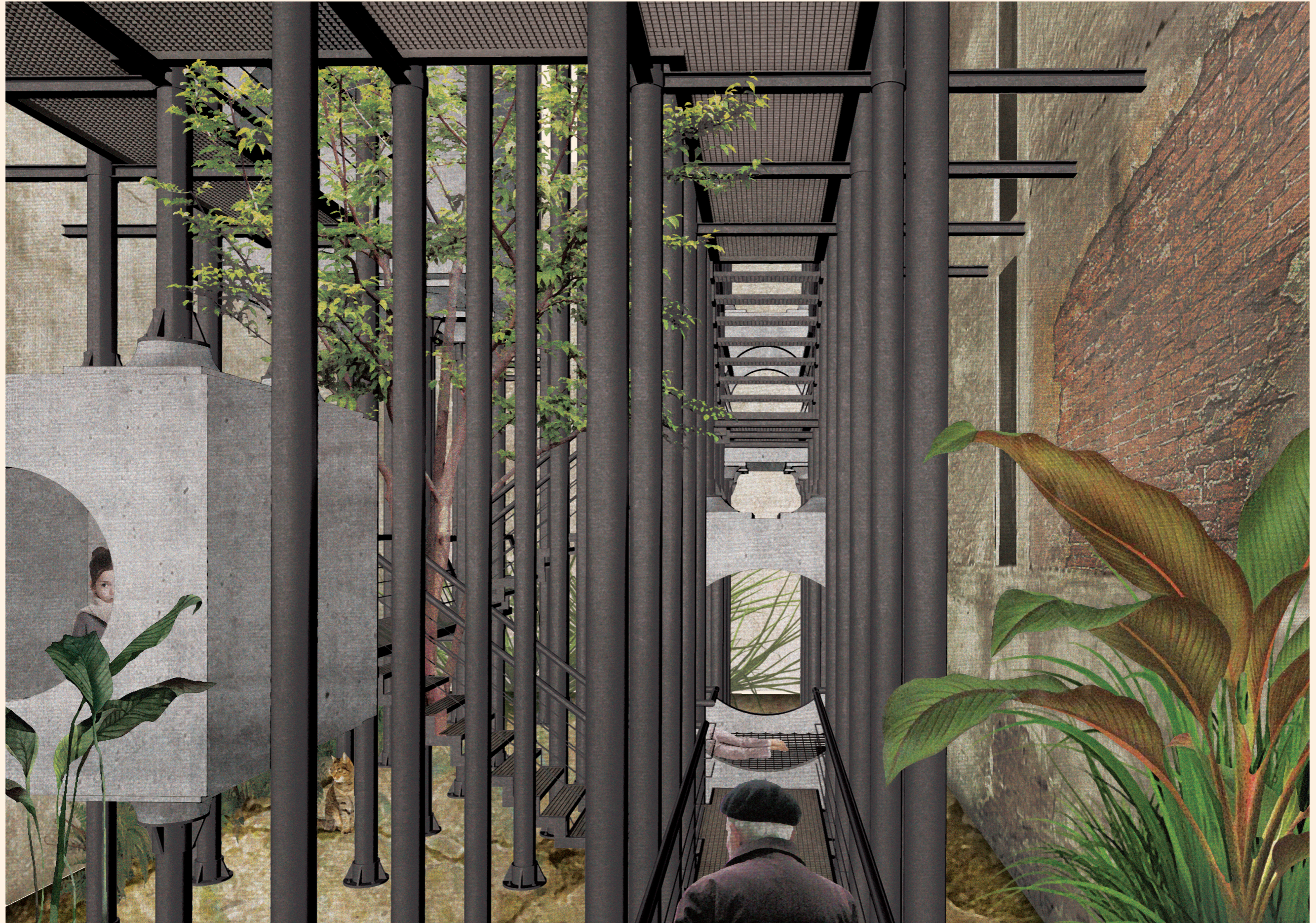



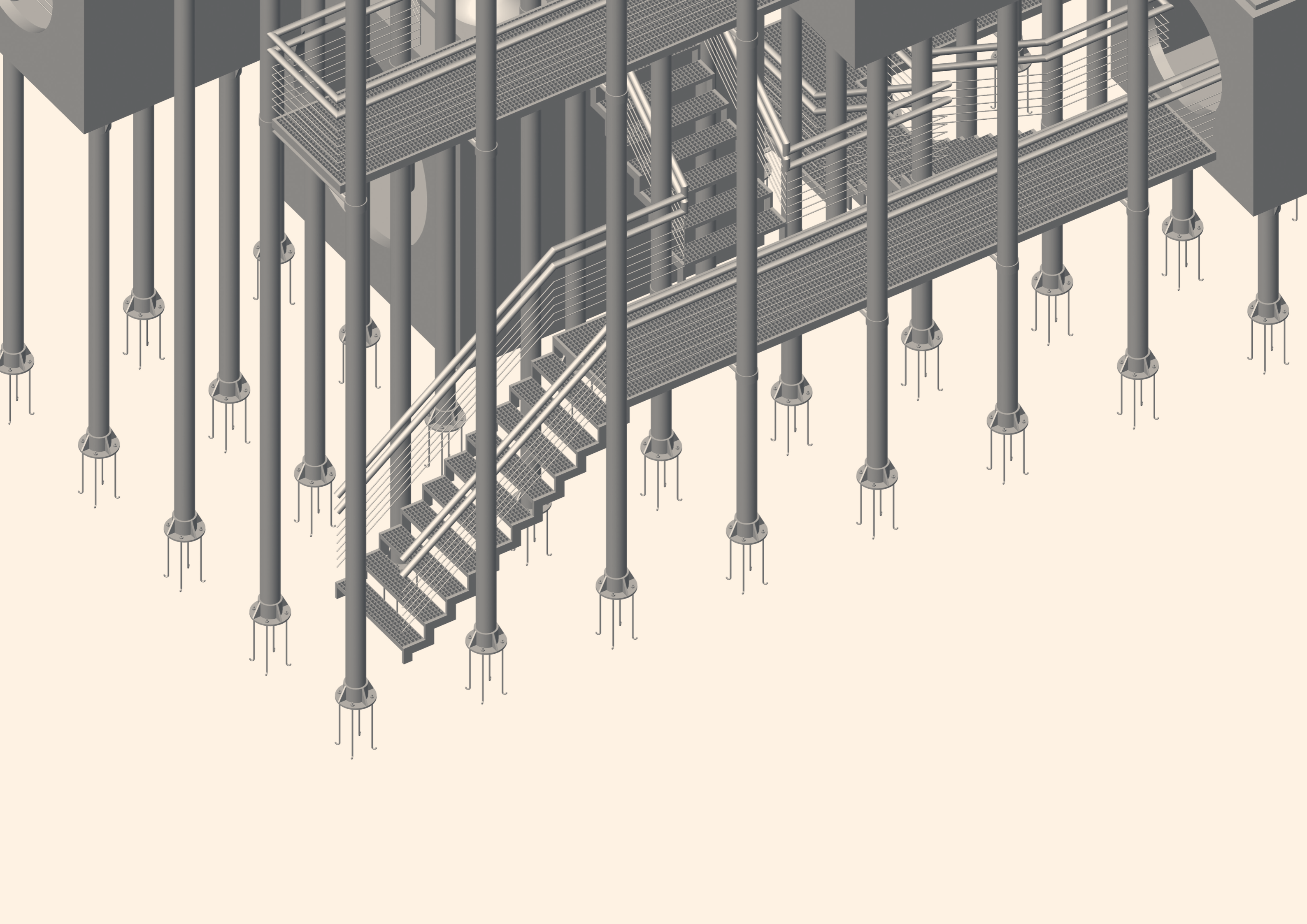

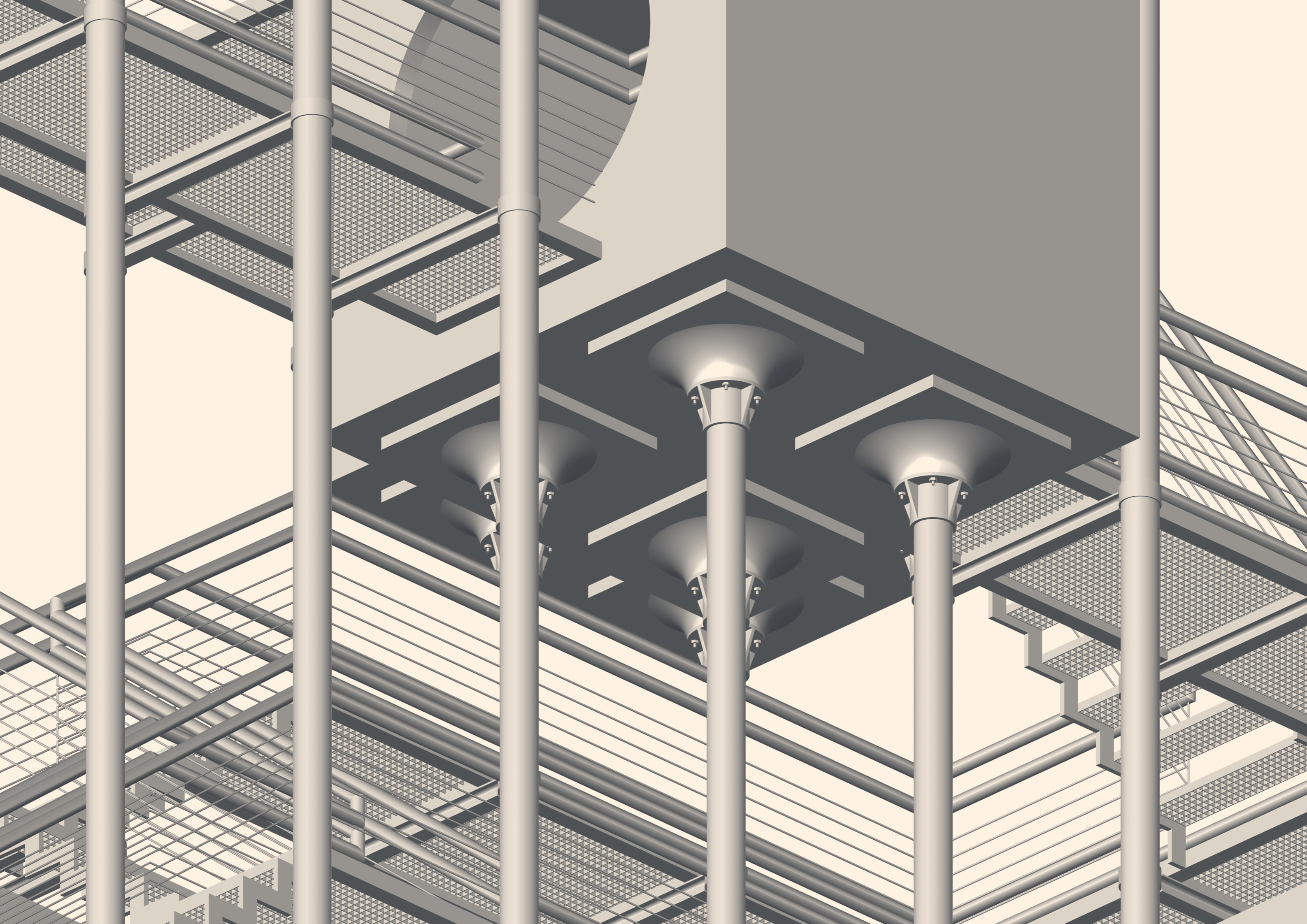

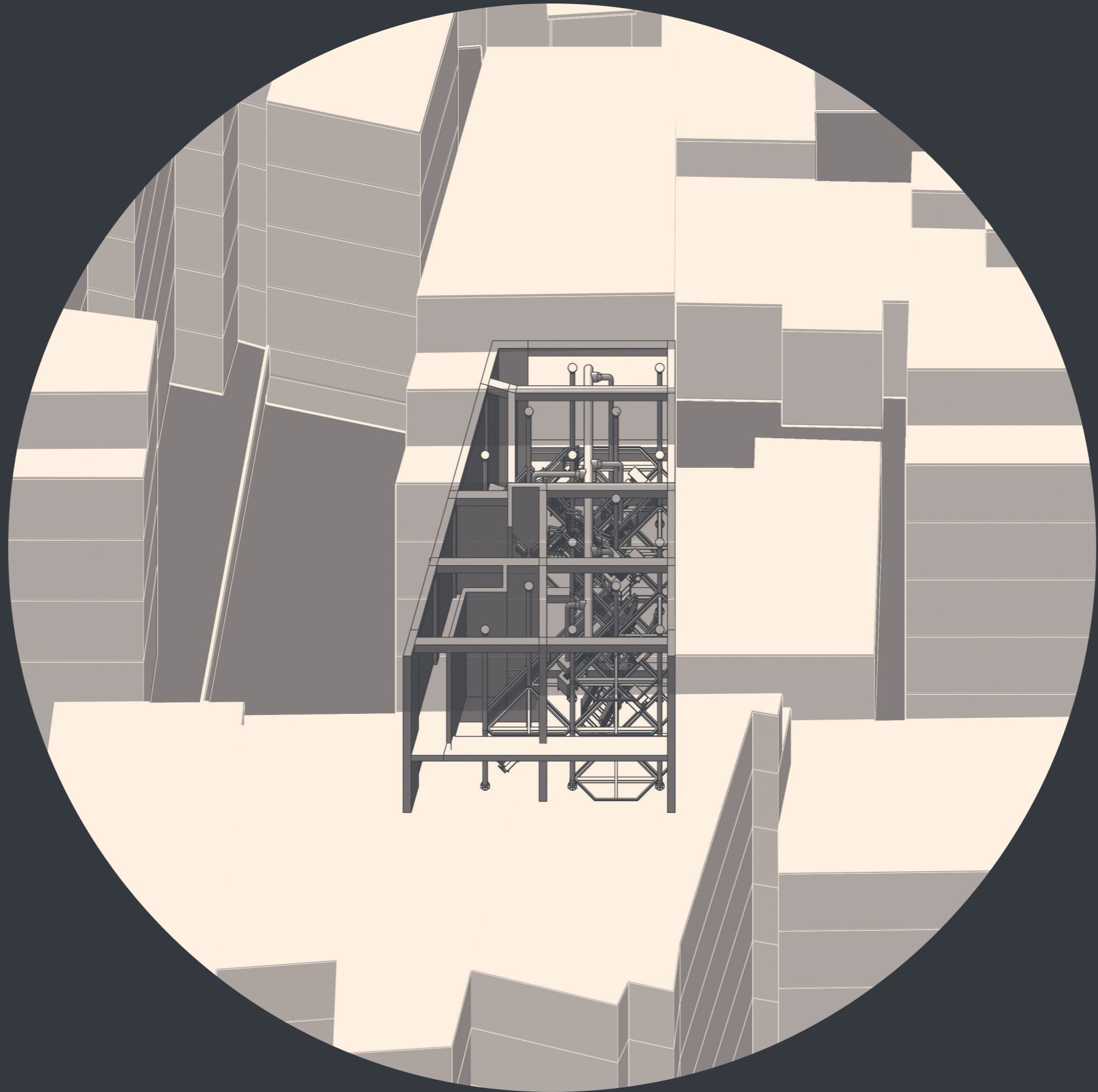

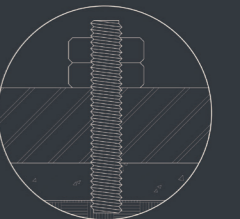
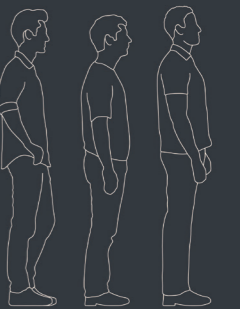
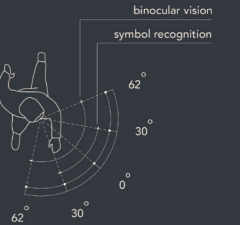
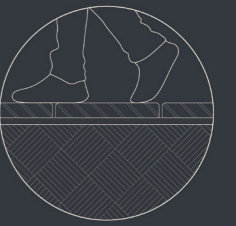
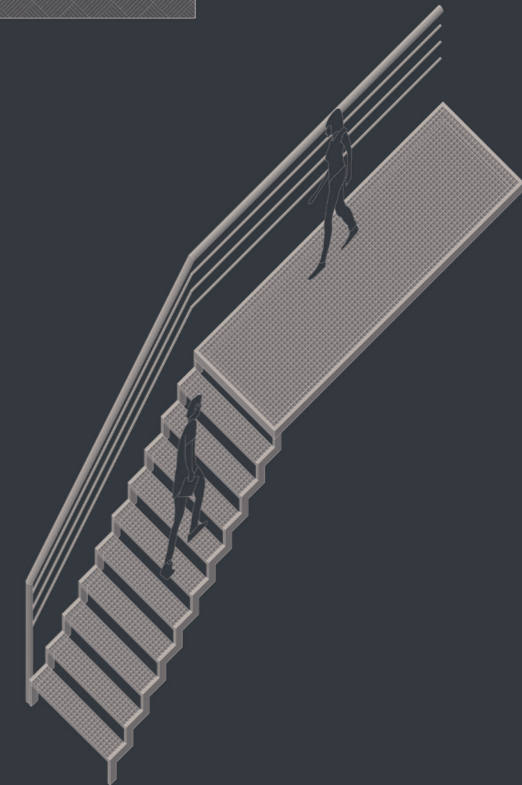
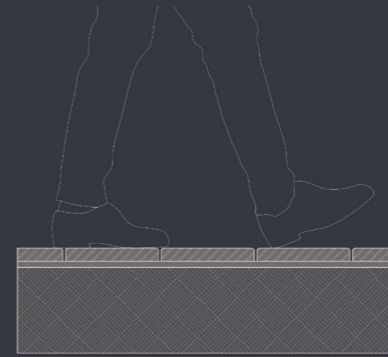
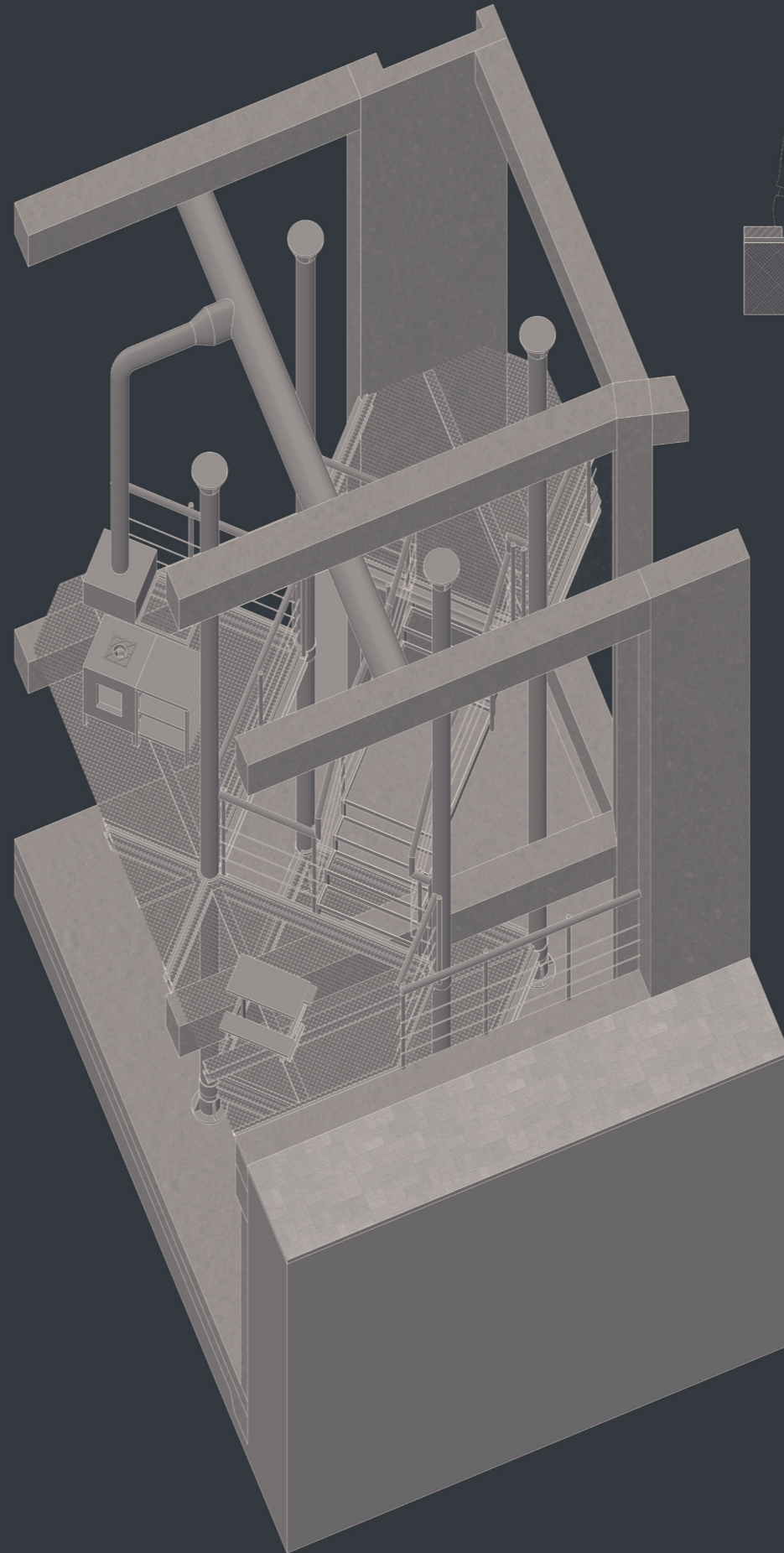
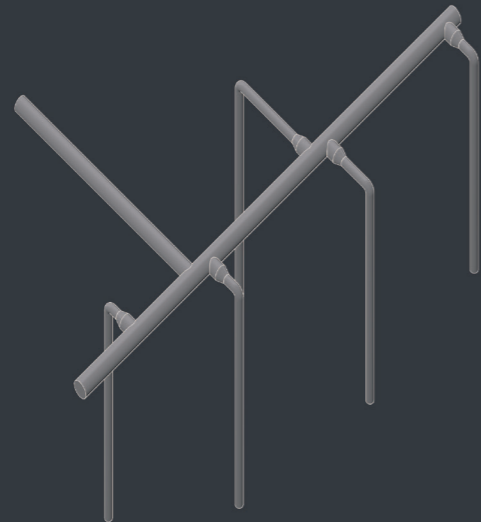
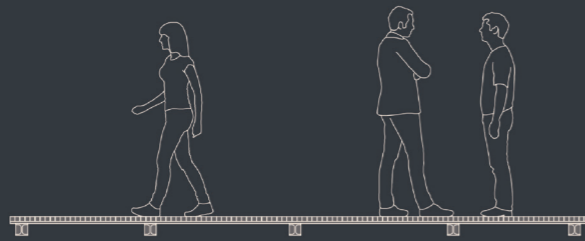
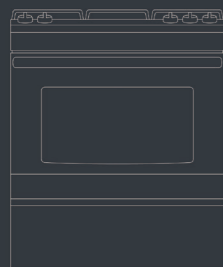
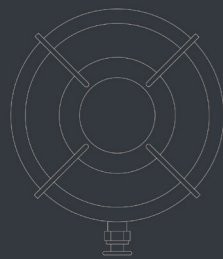
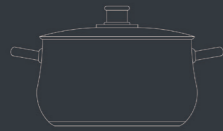
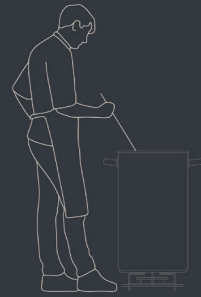



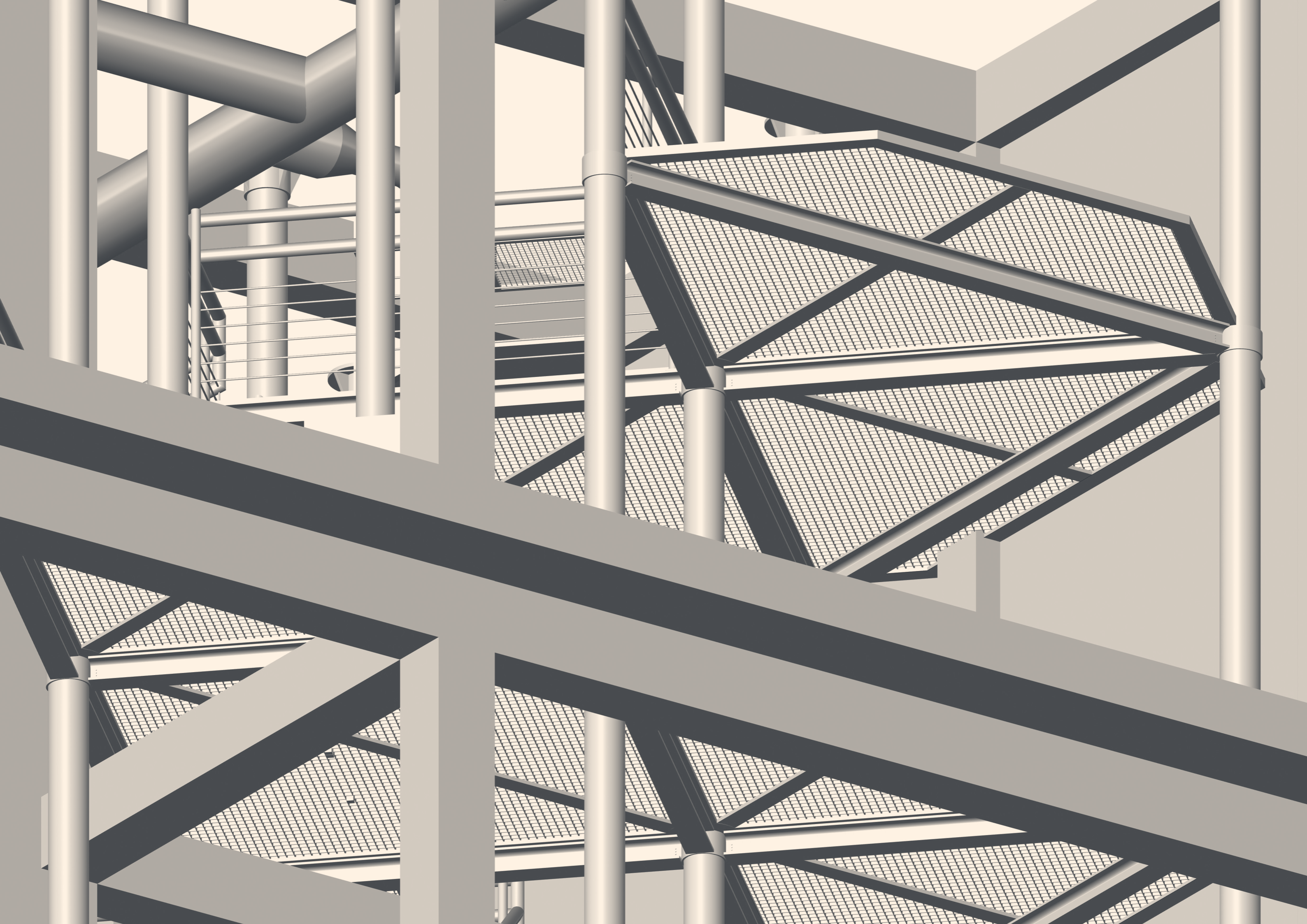

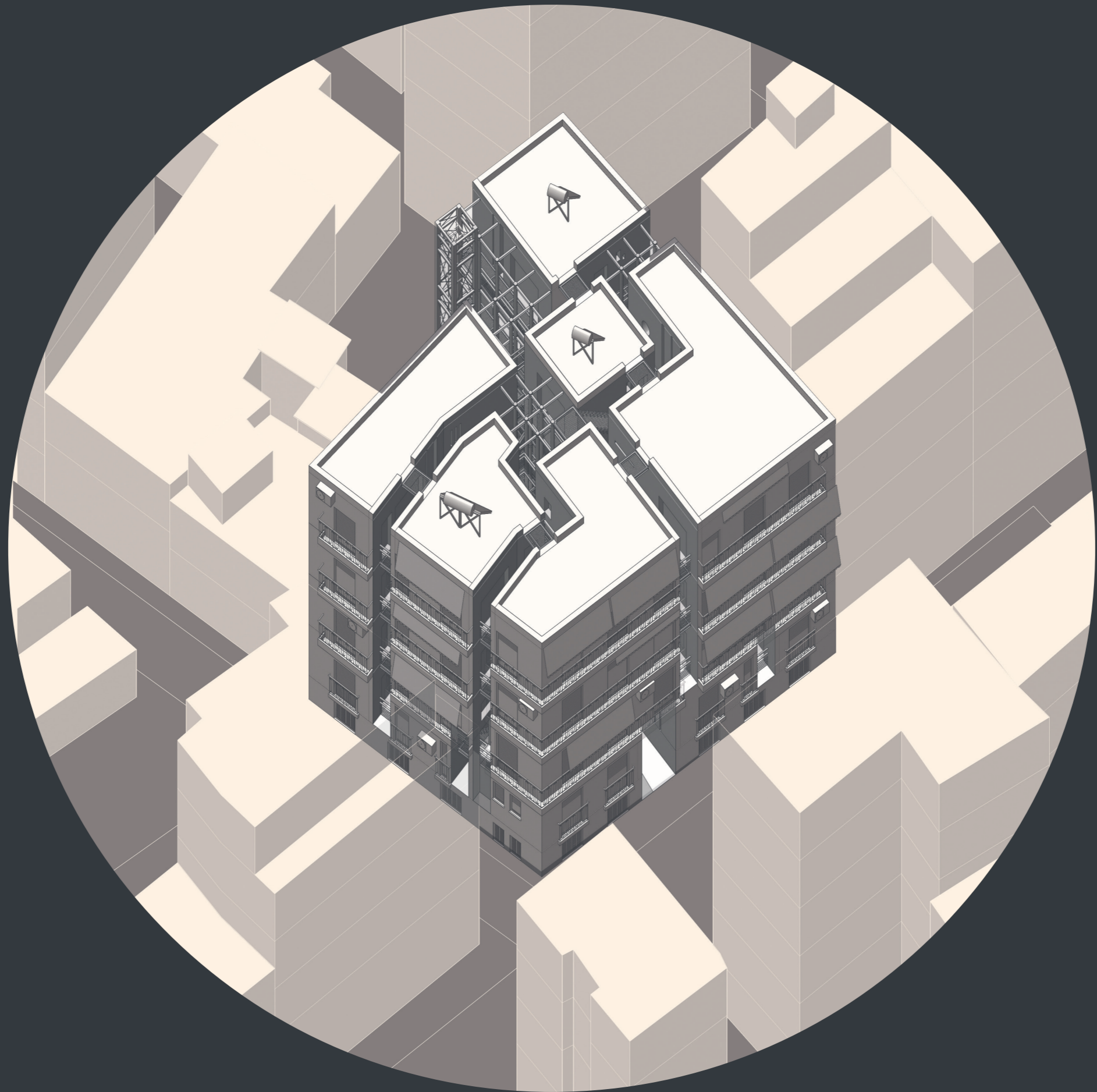

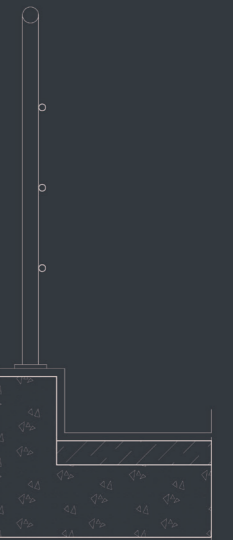
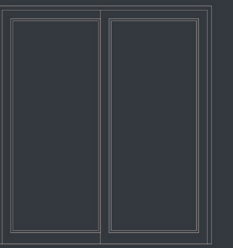
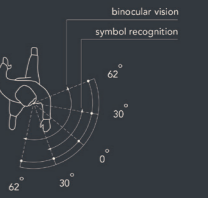
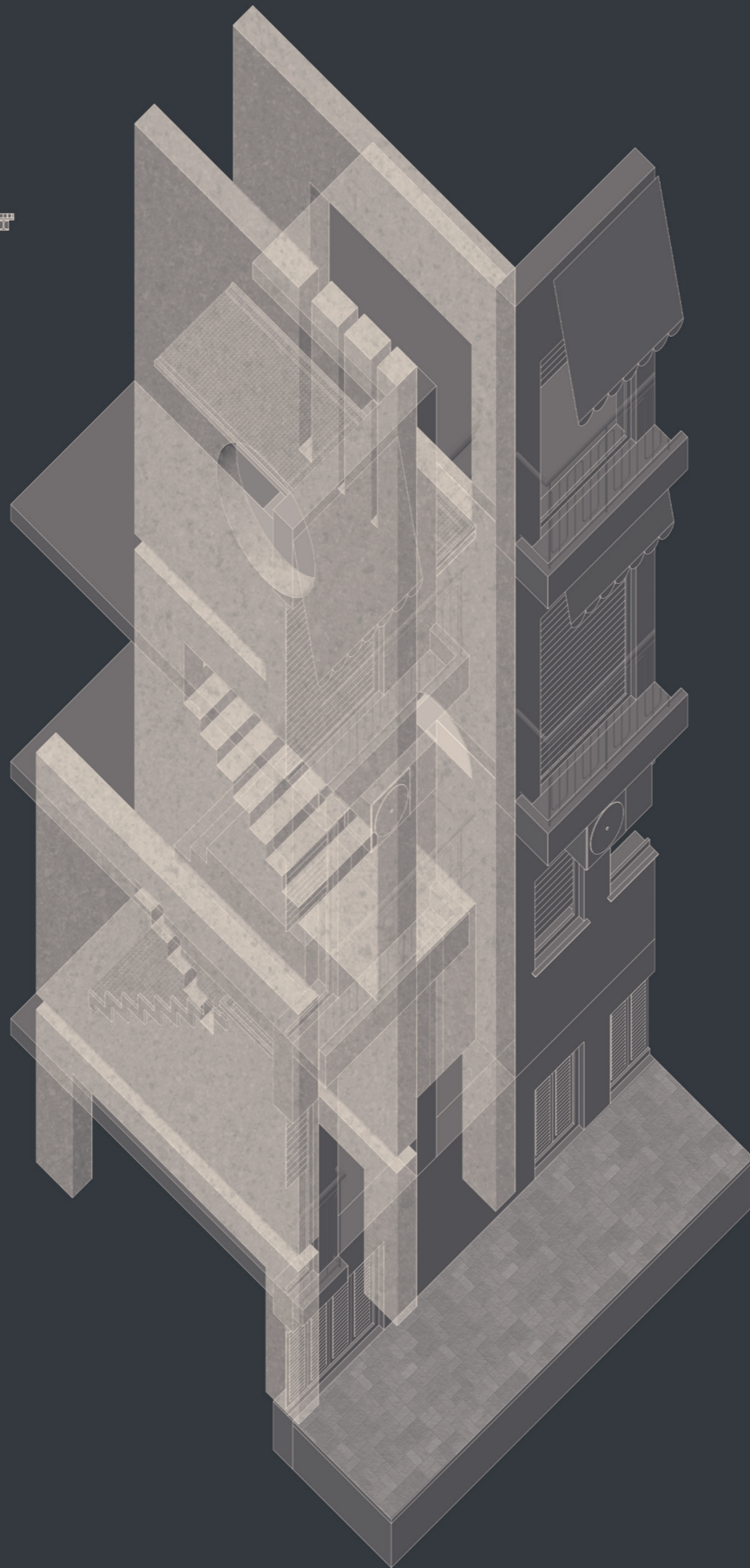
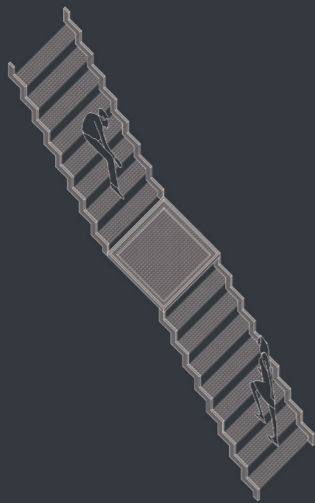
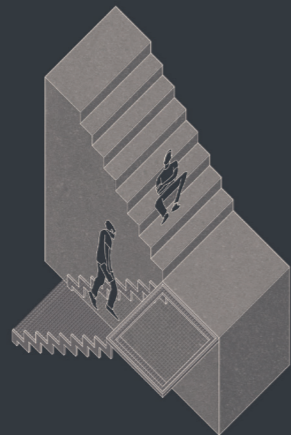
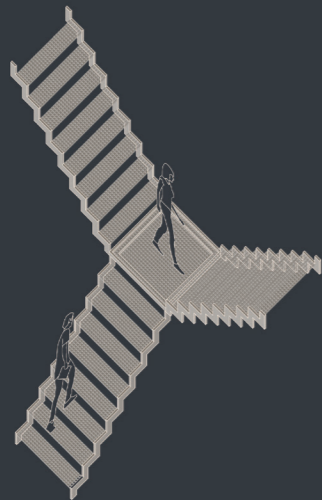
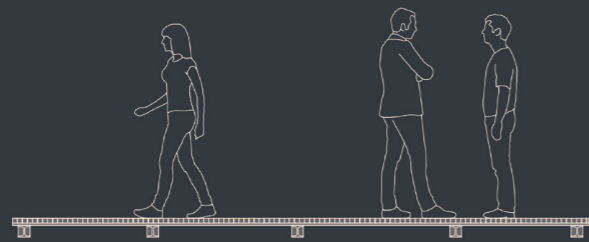

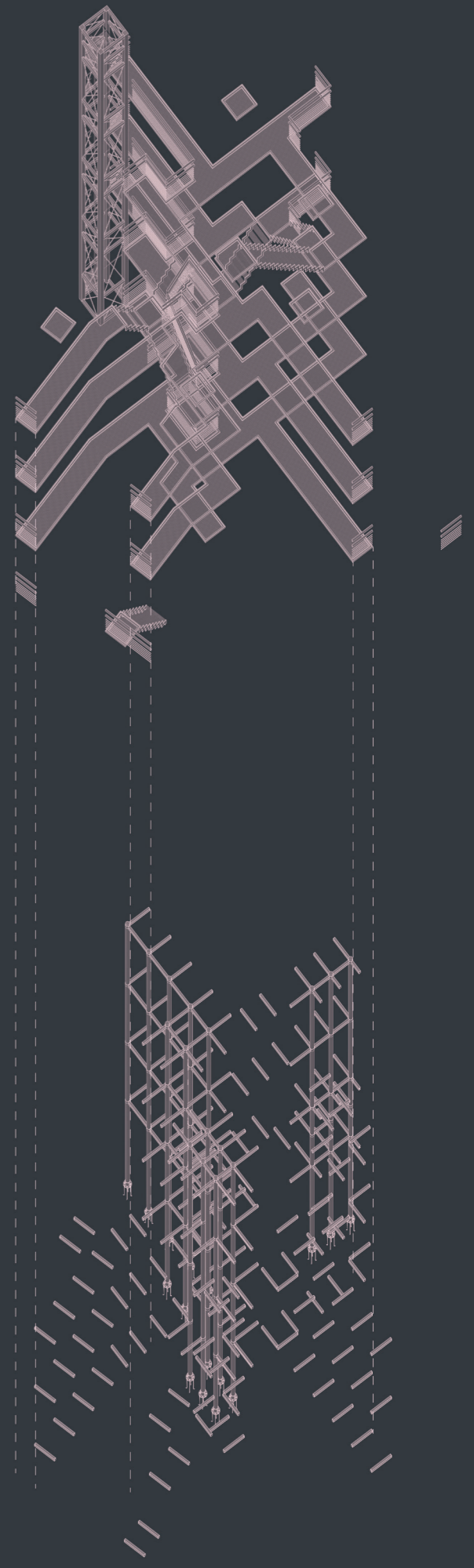
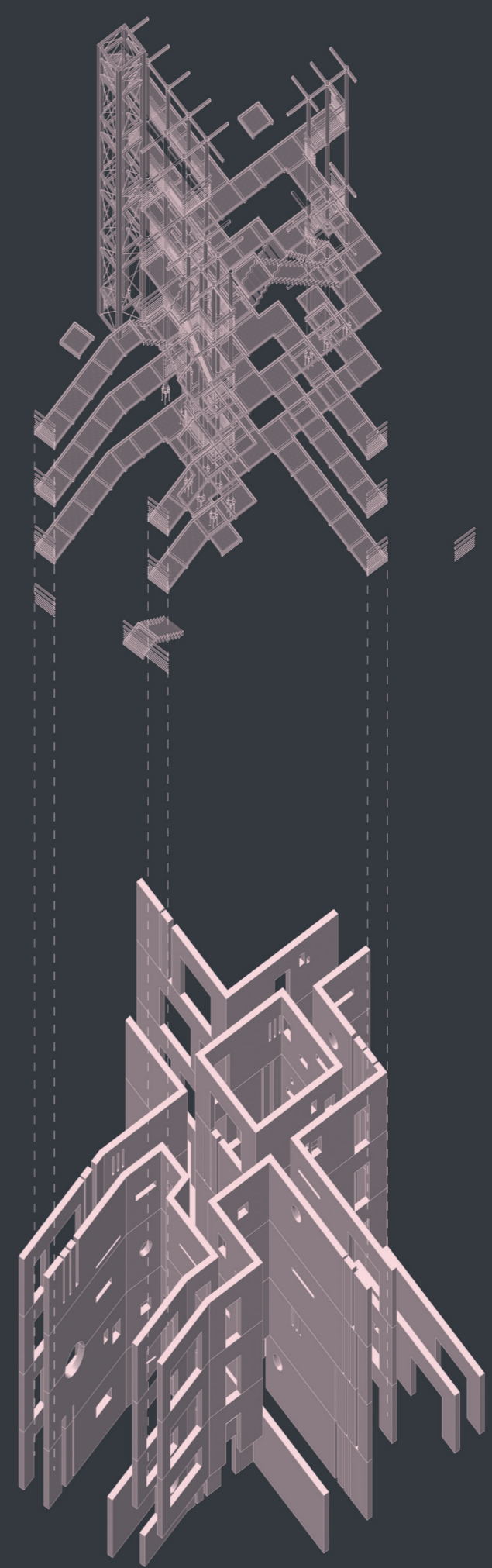
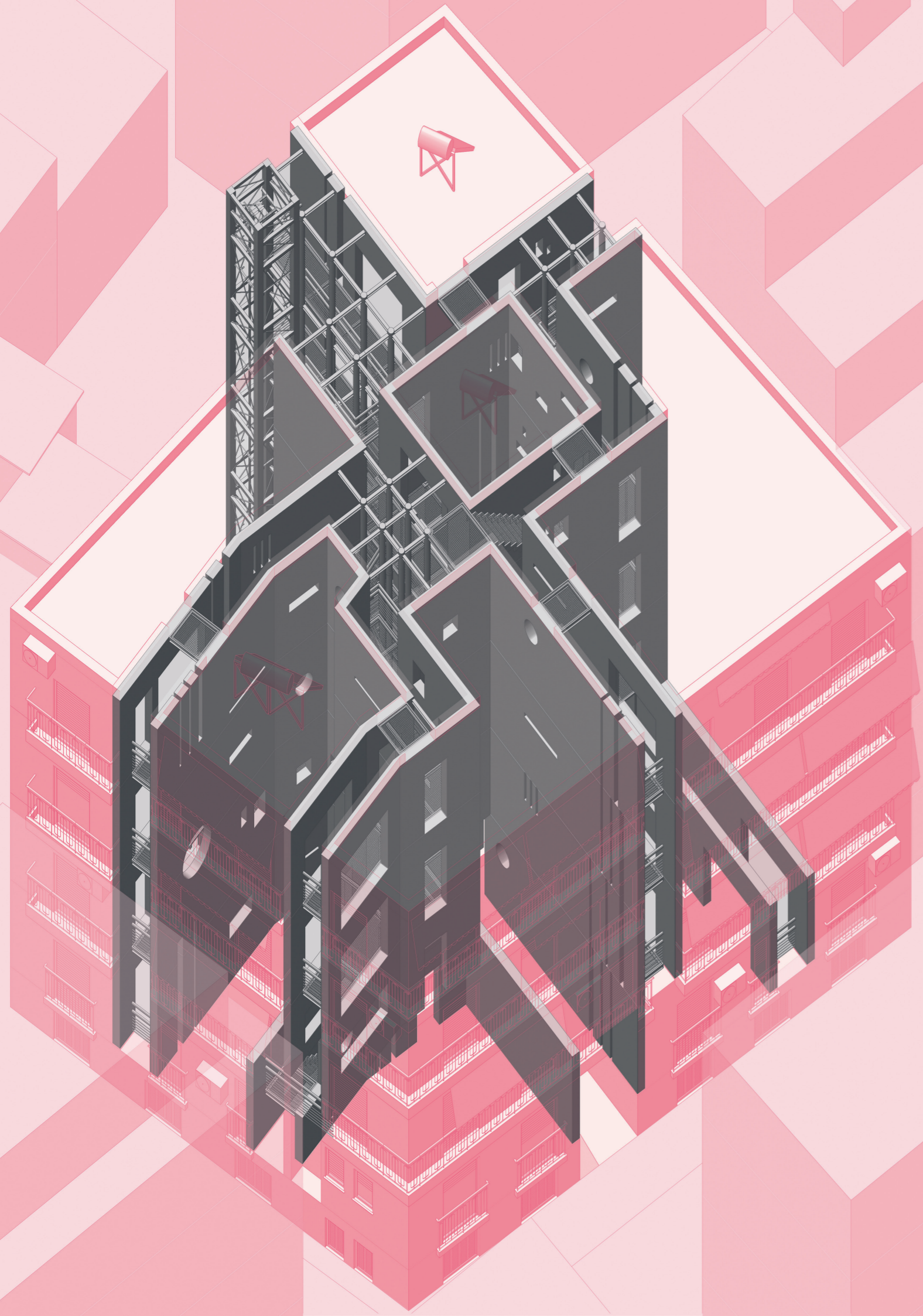

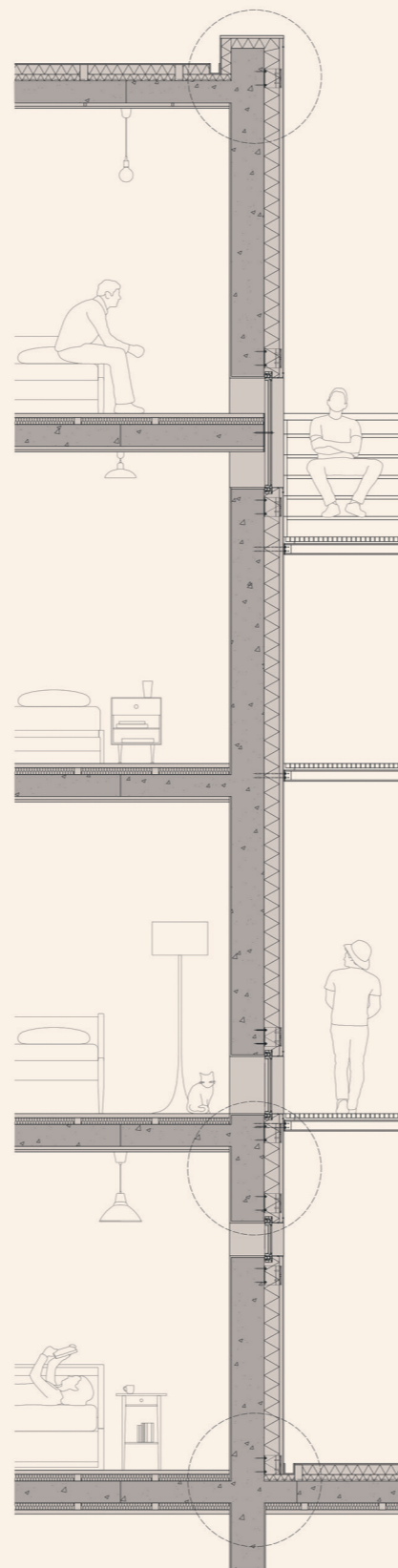
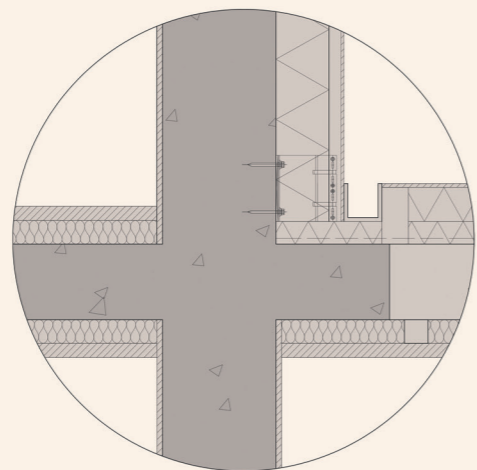
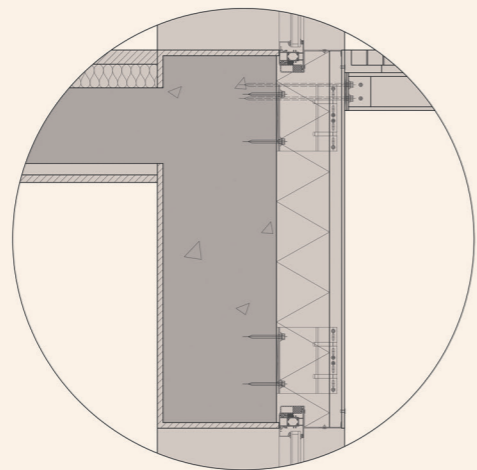
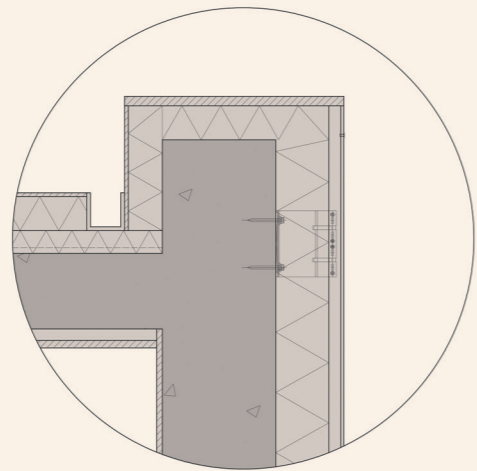





“Once it is no longer the goal of the architect to be the artist of built forms but to offer his services in revealing the virtual desires of spaces, places, trajectories and territories, he will have to undertake the analysis of the relations of individual and collective corporeality by constantly singularising his approach. Moreover, he will have to become an intercessor between these desires, brought to light, and the interests that they thwart. In other words, he will have to become an artist and an artisan of sensible and relational lived experience.”

(Guattari, 1989, 232)

REFERENCES

Baudrillard, J., & Glaser, S. F. (2014). *Simulacra and Simulation*. Ann Arbor: Univ. of Michigan Press.

Bolt, B. (2004). *Art Beyond representation: The performative power of the image*. New York, USA: I.B. Tauris & CO Ltd.

DeLanda, M. (2000). Deleuze, Diagrams, and the Genesis of Form. *Amerikastudien/ American Studies* 45 (1). Heidelberg, Germany: Universitätsverlag Winter GmbH, 33-41.

DeLanda, M. (2013). *A new philosophy of society: Assemblage theory and social complexity*. London, UK: Bloomsbury.

Deleuze, G., & Guattari, F. (1983). *Anti-Oedipus: capitalism and schizophrenia*. Minneapolis, USA: University of Minnesota Press.

Deleuze, G. (2001). Review of Gilbert Simondon's *L'individu et sa genese physico-biologique* (1966). *Pli journal* 12 (4). Coventry, UK: University of Warwick, 43-49.

Gregg, M., Seigworth, G. J. (2010), *The affect theory reader*. North Carolina, USA: Duke University Press.

Guattari, F. (1989), *Architectural Enunciation. Schizoanalytic Cartographies* (Goffey, A., Trans.). London, UK: Bloomsbury, 231-39.

Issaias, P. (2013). The Absence of Plan as a Project: Notes on the Planning development of Modern Athens, 1830–2010. In Pier Vittorio

Aureli (Ed.). *The City as a Project* (pp. 291–331). Berlin, Germany: Ruby Press.

Latour, B. (2009). *Reassembling the social: An introduction to actor-network-theory*. Oxford, UK: Oxford University Press.

Lefebvre, H., & Nicholson-Smith, D. (2009). *The production of space*. Malden, USA: Blackwell.

Liotard, J. F. (1993). *Libidinal economy*. Bloomington and Indianapolis, Indiana: USA University Press.

Massumi, Brian (1992). *A user's guide to capitalism and schizophrenia: Deviations from Deleuze and Guattari*. Cambridge, Massachusetts, USA: The MIT Press.

Massumi, B. (1995). The Autonomy of Affect. *Cultural Critique*, 31. The Politics of Systems and Environments, Part II. Minnesota, USA: University of Minnesota Press, 83-109.

Massumi, B. (2002). *Parables for the Virtual*. North Carolina, USA: Duke University Press.

Ntonou Efstratiadi, A. (2016). Athens urban transformation. *City as organism: New visions for urban life* 1 (1). 22nd

ISUF International Conference. Rome Italy. 22-26 September 2015. Rome, Italy: U+D edition Rome.

Petropoulou C. (2008). "Non/de/re/regulation" and the urban development of Athens (1834 – 2008) (Koutrolidou, P., Siatitsa D., Mermigas, A., Trans.). 18th Congress INURA: Non/De/Re-regulation: limits, exclusions and

claims. Athens, Greece, 2-10 October 2008.

Reiser, J., & Umemoto, N. (2006). *Atlas of novel tectonics*. New York, USA: Princeton Architectural Press.

Simondon, G (2017). *On the Mode of Existence of Technical Objects* (C. Malaspina, J. Rogove, Trans.). Washington, USA: Univocal Publishing. (Original work published 1958).

Simondon, G. (1998). *L'individu et sa genèse physico-biologique*. Grenoble, France: Editions Jérôme Millon. (Original work published 1964).

Simondon, G. (1989). *L'individuation psychique et collective*. Paris, France: Aubier.

Smith, C. L. (2015). The Libidinal Economy of Architecture: Skin, Membrane, and Other Surfaces of Desire. In J. Odgers, M. McVicar, S. Kite (Eds.), *Economy and architecture*. London, UK: Routledge, 108-117.

Smith, D. W. (2012). *Essays on Deleuze*. Edinburgh, UK: Edinburgh University Press.

Spinoza, B. (2001). *Ethics* (W. H. White, Trans.). Ware, UK: Wordsworth Editions

Spurse (2010). *Time Drills: Deep Time Rapid Time Exercises*. spurs press.

Teyssot, G. (2012). *The Diagram as Abstract Machine*. San Paolo, Brazil: VIRUS, 7.

Wigley, M. (1998). *Constants New Babylon: The hyper-architecture of desire*. Rotterdam, the Netherlands: 010 Publishers, Witte de With centre for contemporary art.

Αίσωπος, Γ. (Aesopos, Y.) (2009). *Διάχυτη*

Αθήνα: Δίκτυα, καταναλωτισμός και κρίση. Αθήνα.

Δαμαλά, Α. (Damala., A.), Ζάμπα, Μ. (Zamra, M.), Κορομβλή, Ε. (Koromvli, E.) (1978). Η αστική πολυκατοικία στην Αθήνα, 1920-1940. *Αρχιτεκτονικά θέματα* 1. Αθήνα.

Κόκκινος, Γ. Ν. (Kokkinos, G. N.) (2018). *Η κατοικία στον ελληνικό χώρο από την προϊστορική ως την σύγχρονη εποχή*. Αθήνα.

Μαρμαράς, Β. Μ. (Marmaras, B. M) (1991). *Η αστική πολυκατοικία της μεσοπολεμικής Αθήνας: Η αρχή της εντατικής εκμετάλλευσης του αστικού εδάφους*. Αθήνα: Πολιτιστικό τεχνολογικό ίδρυμα ΕΤΒΑ.

Παπαμίχος, Ν. (Paramichos, N.) (1999). *Αστική κατοικία: Από την πολυκατοικία της αντιπαροχής στα αστικά ακίνητα του χρηματιστηρίου*. 10ο Αρχιτεκτονικό συνέδριο, Δεκέμβριος 1999.

Φιλιππίδης, Δ. (Philippides, D.) (1984), *Νεοελληνική αρχιτεκτονική*. Αθήνα: Μέλισσα.