

a refuge for the minds

Explore Lab
May 2020



Cyriac Levet
MSc4_TU Delft
5143268

P5

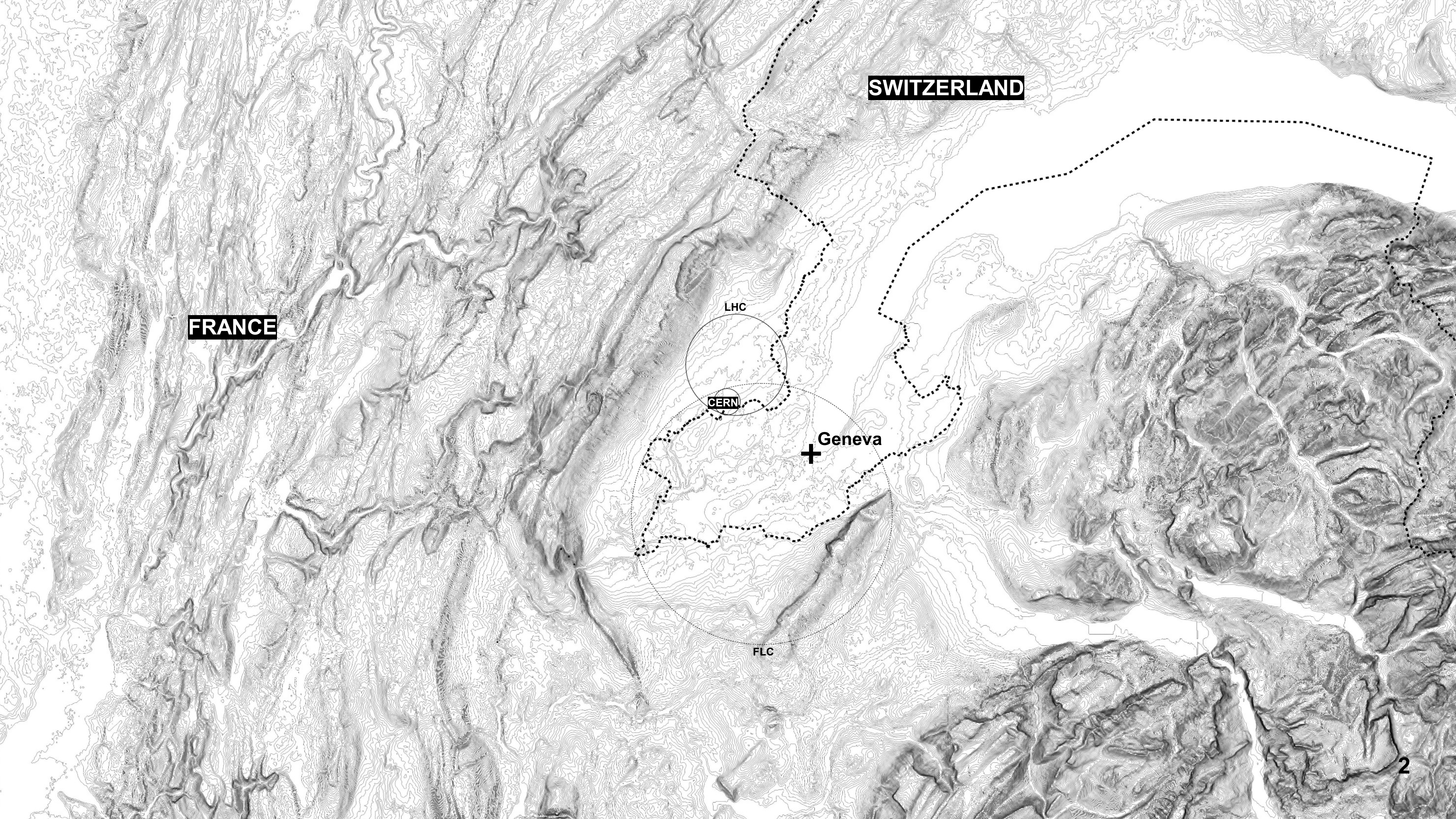

FRANCE

SWITZERLAND

LHC

CERN

+ Geneva

FLC





+
refuge du Curson
alt. 1600m







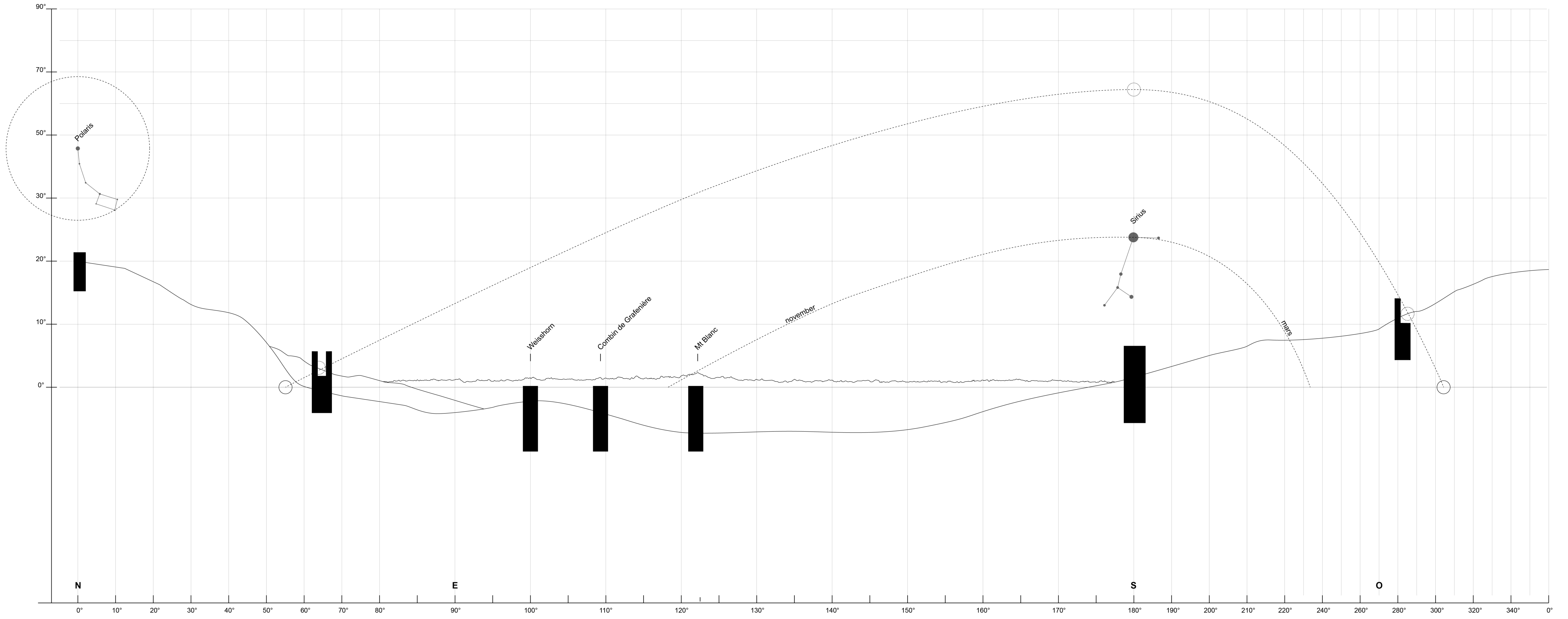



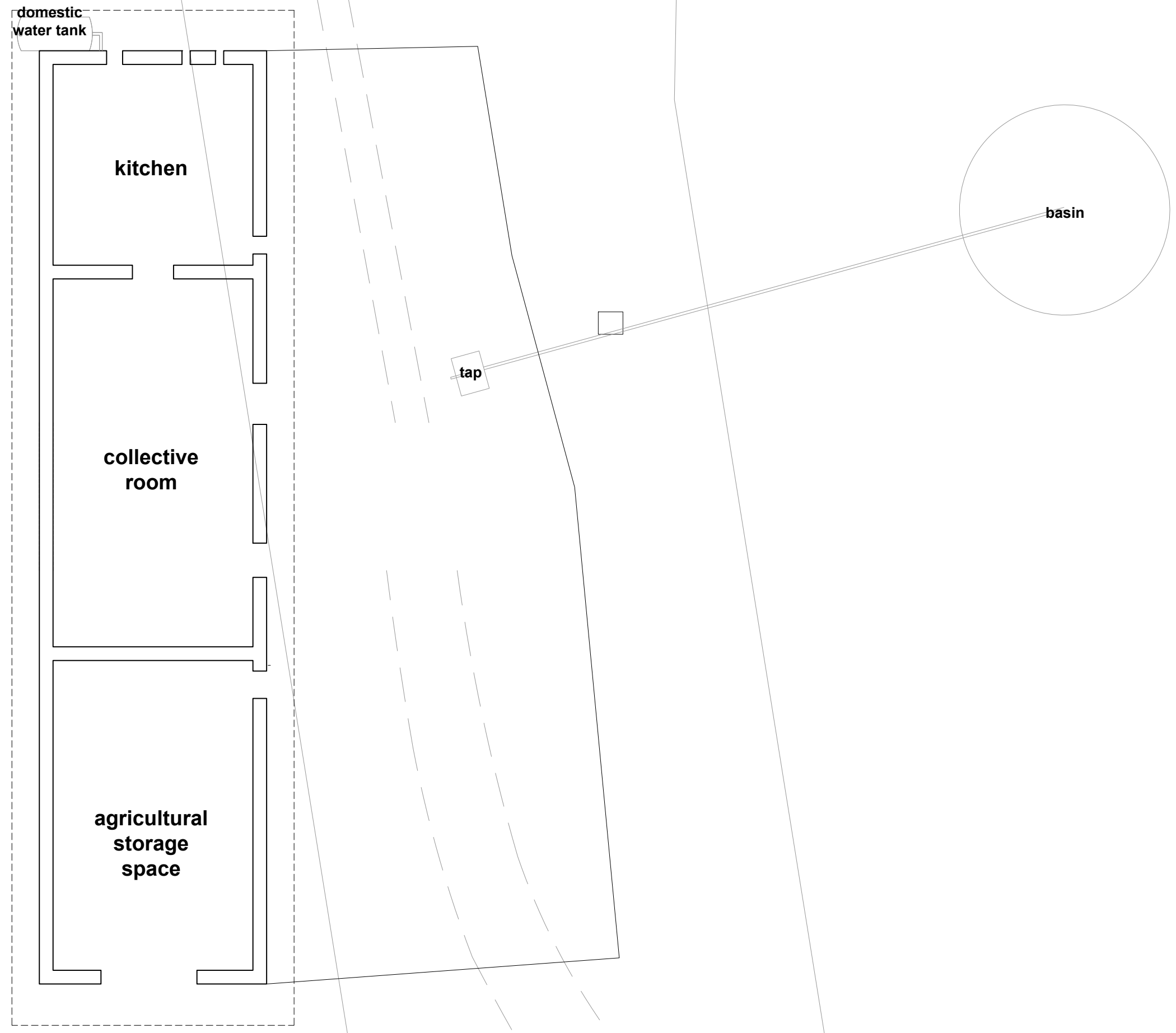





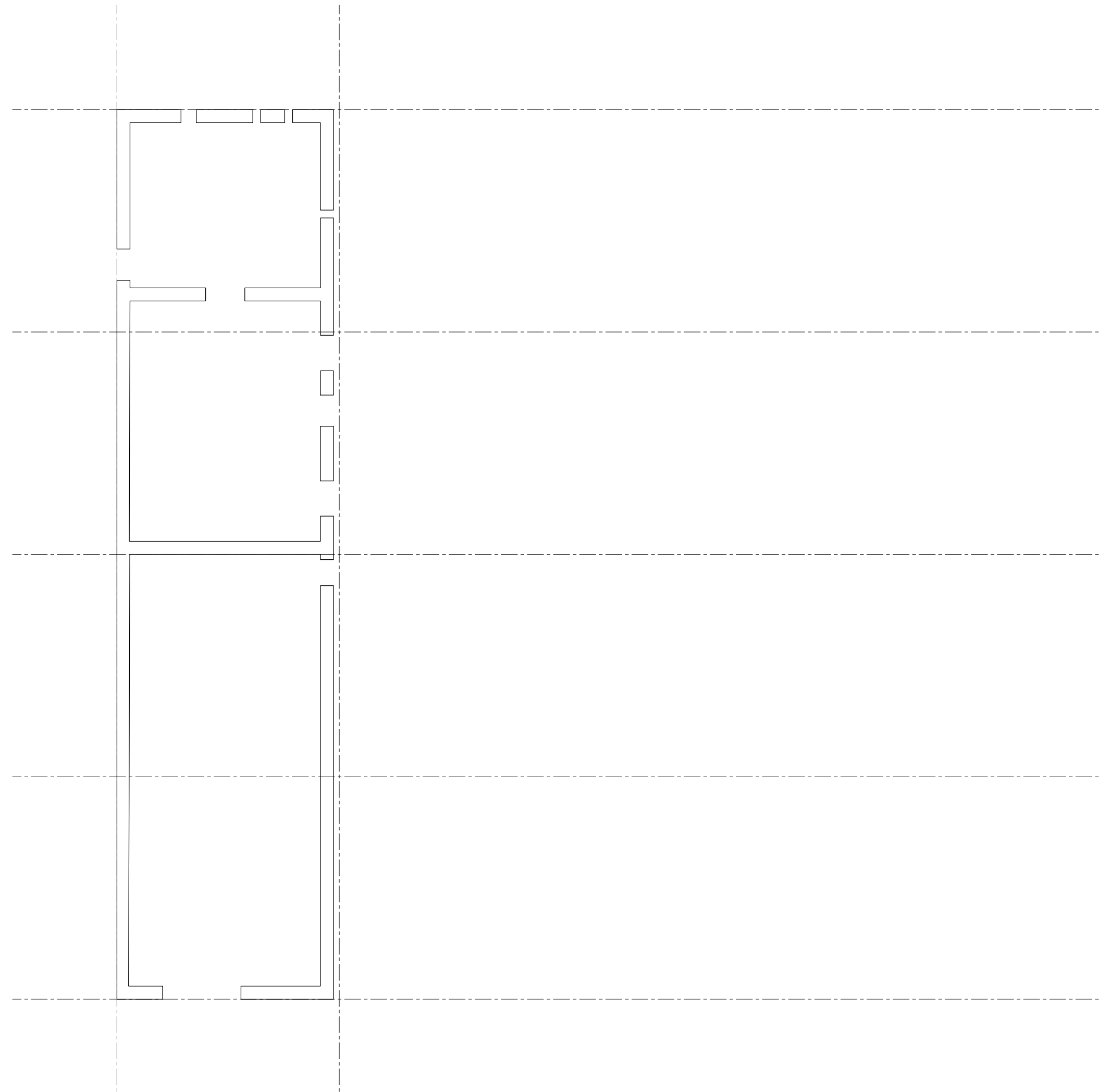

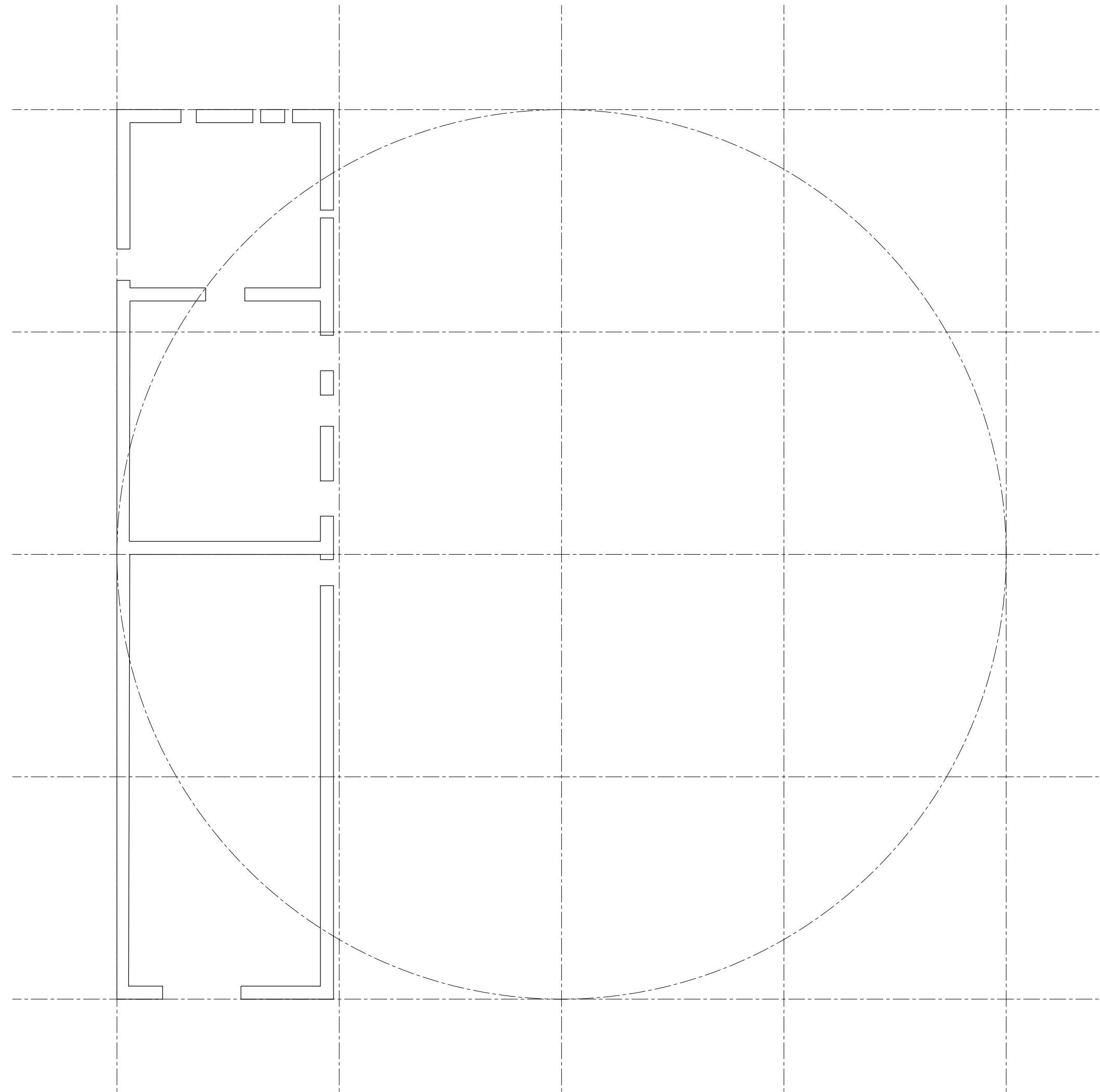

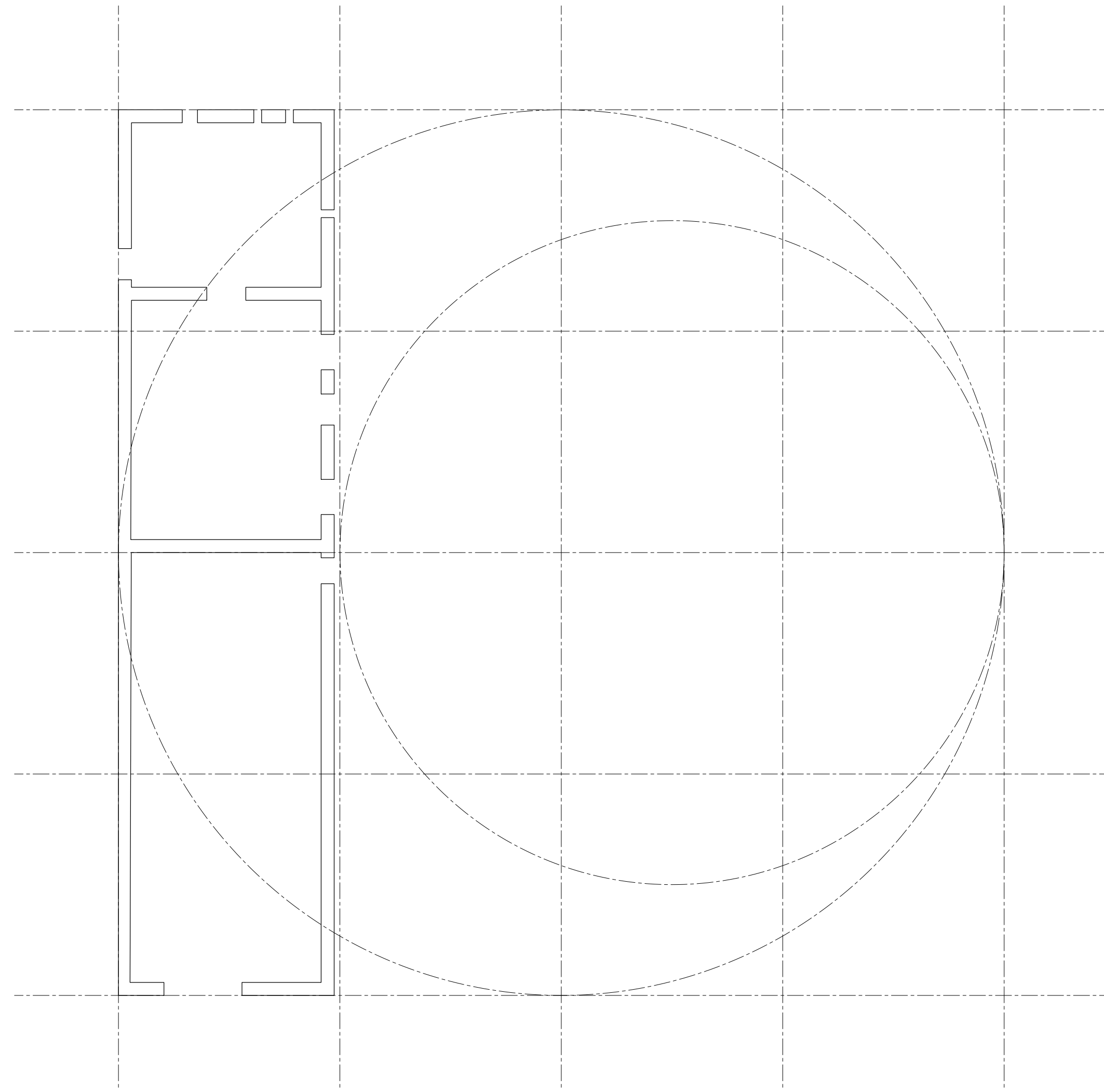

x 3/4

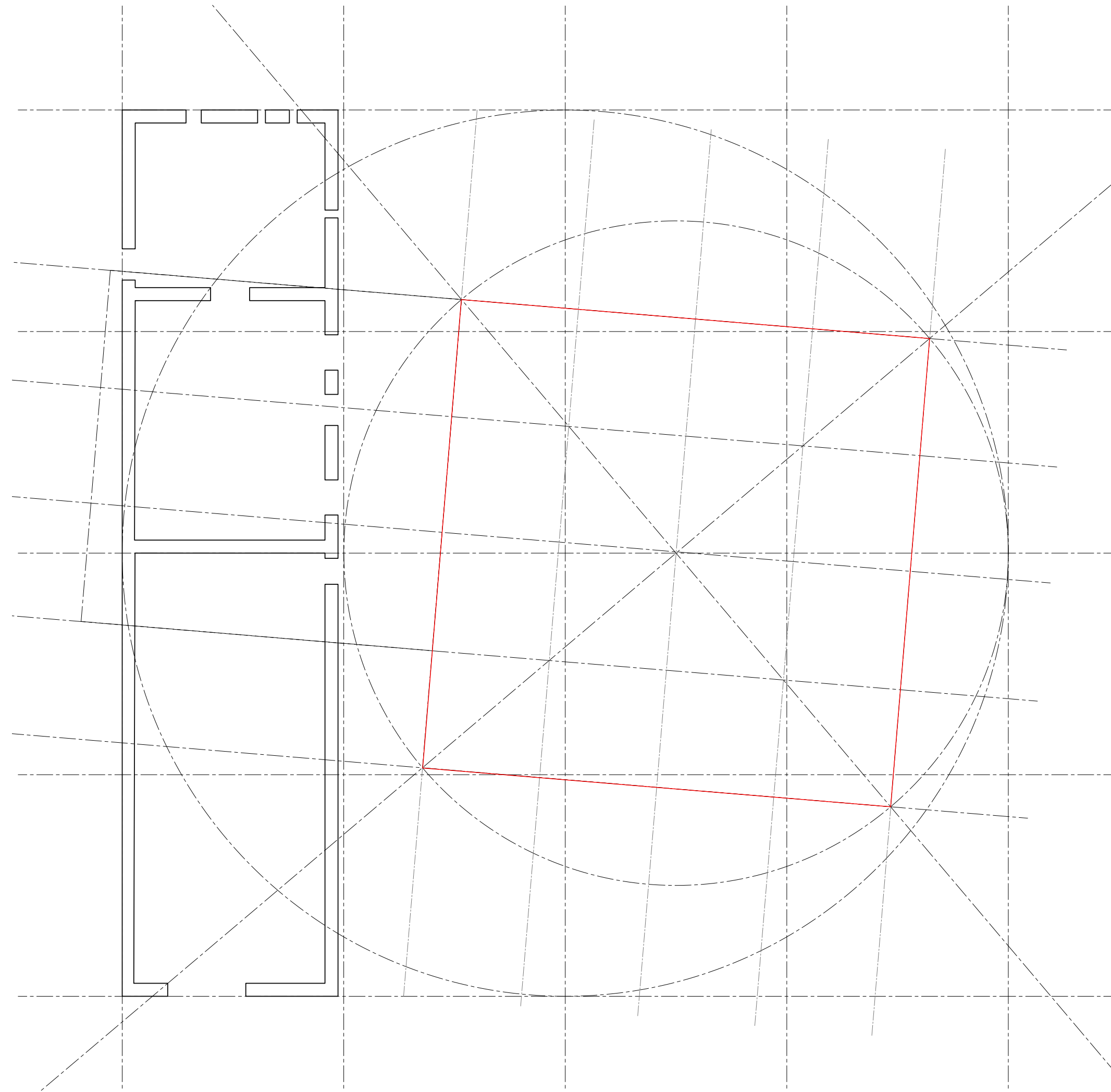

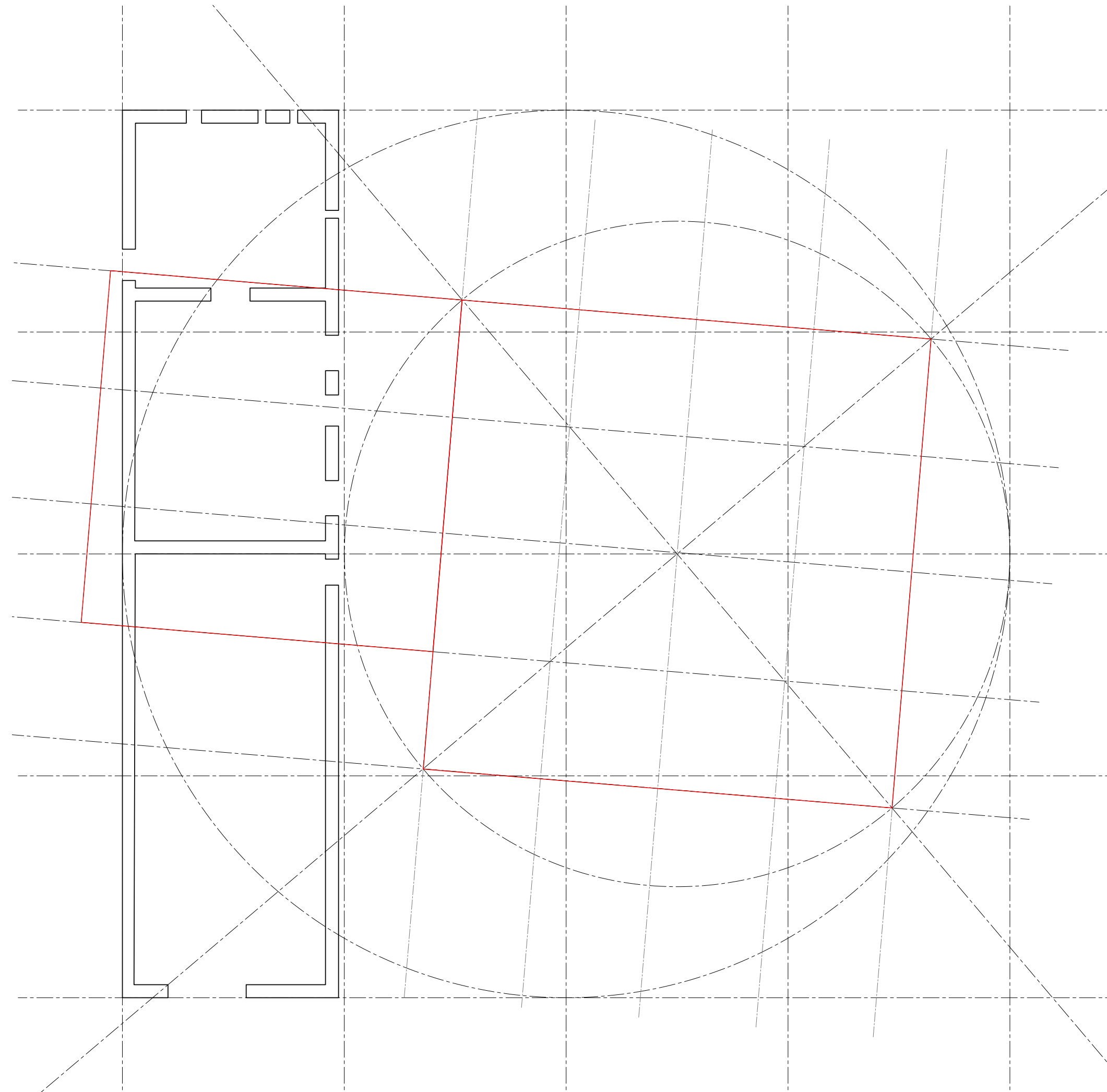

x 3/4

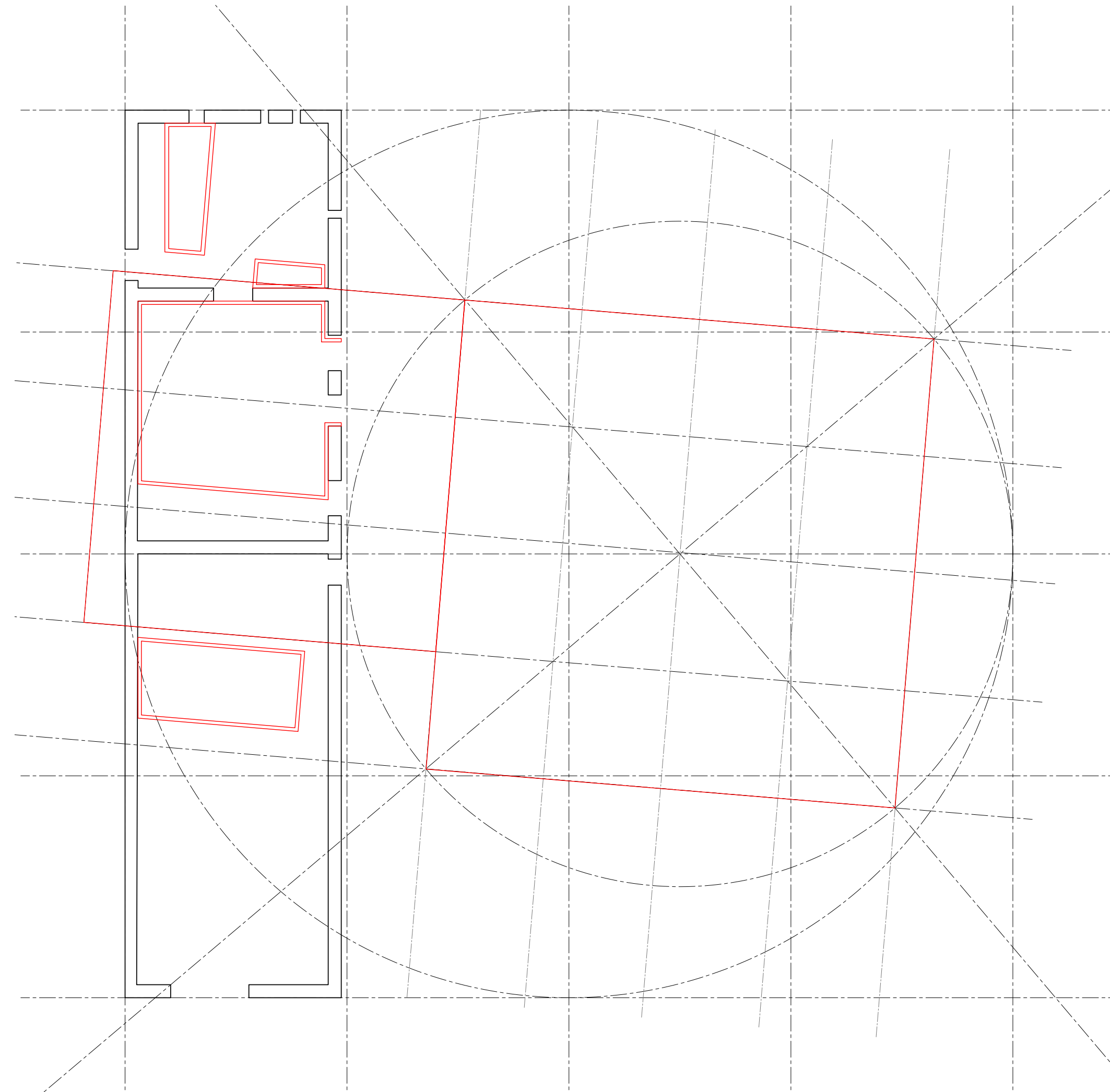

x 3/4

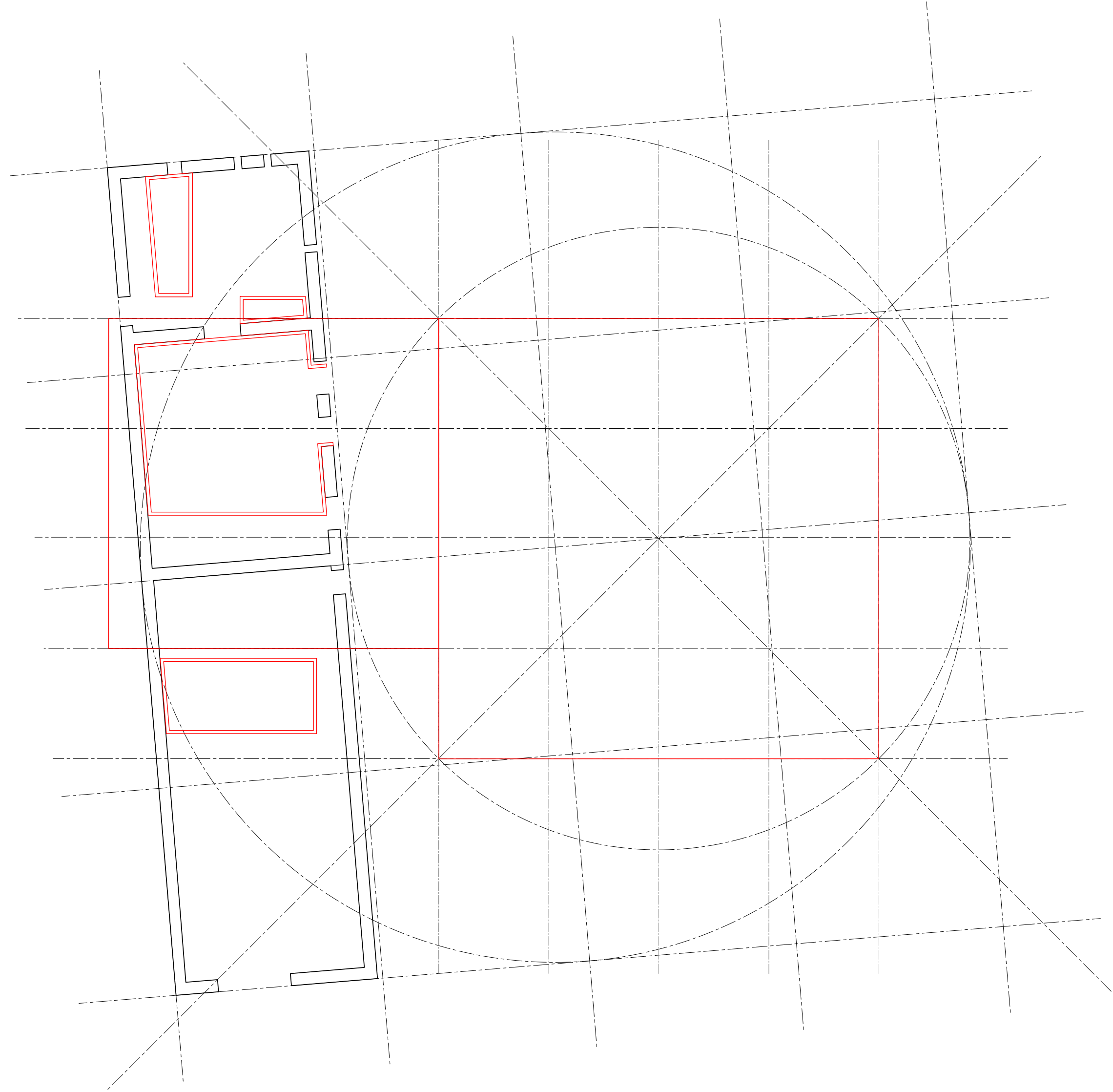

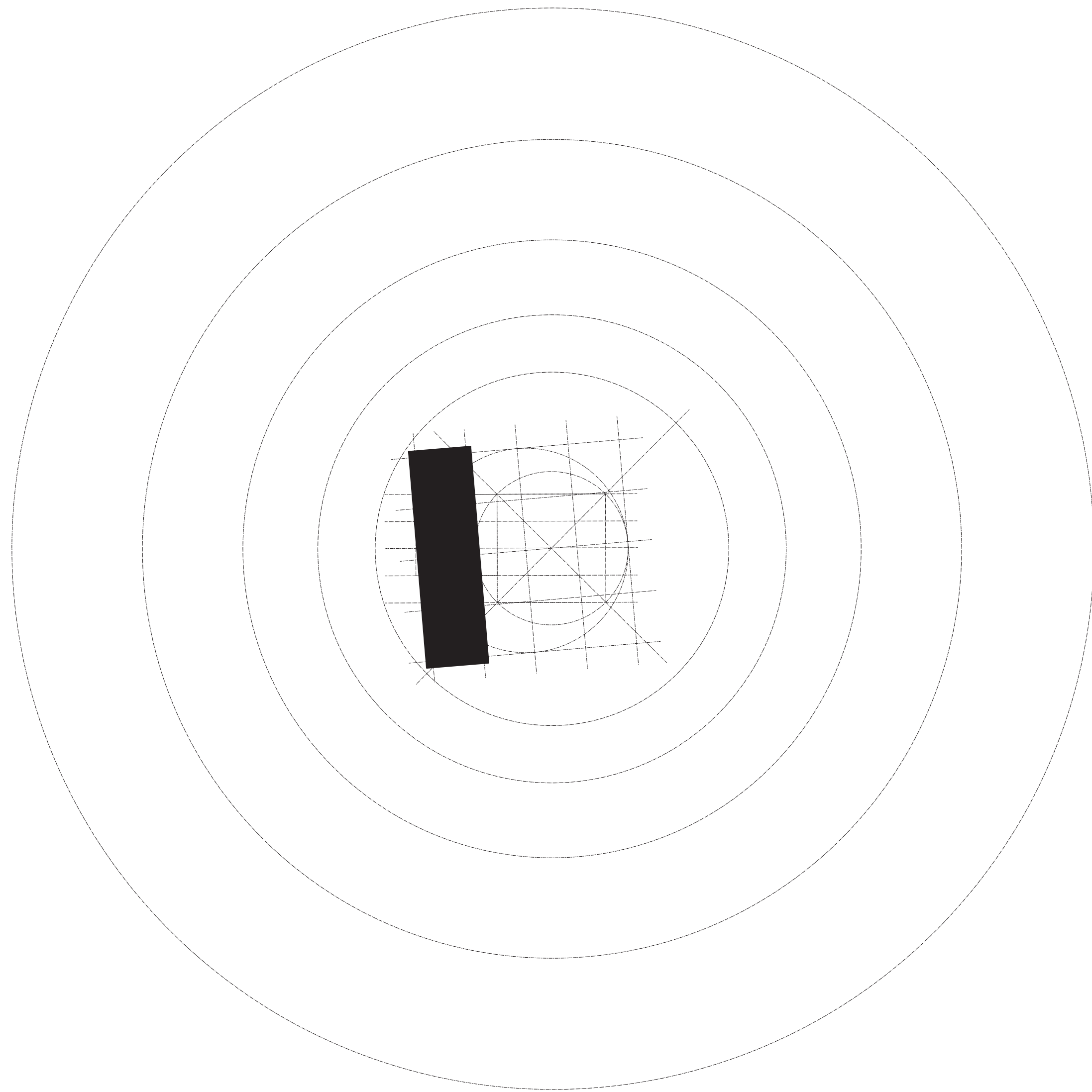

x 4/3

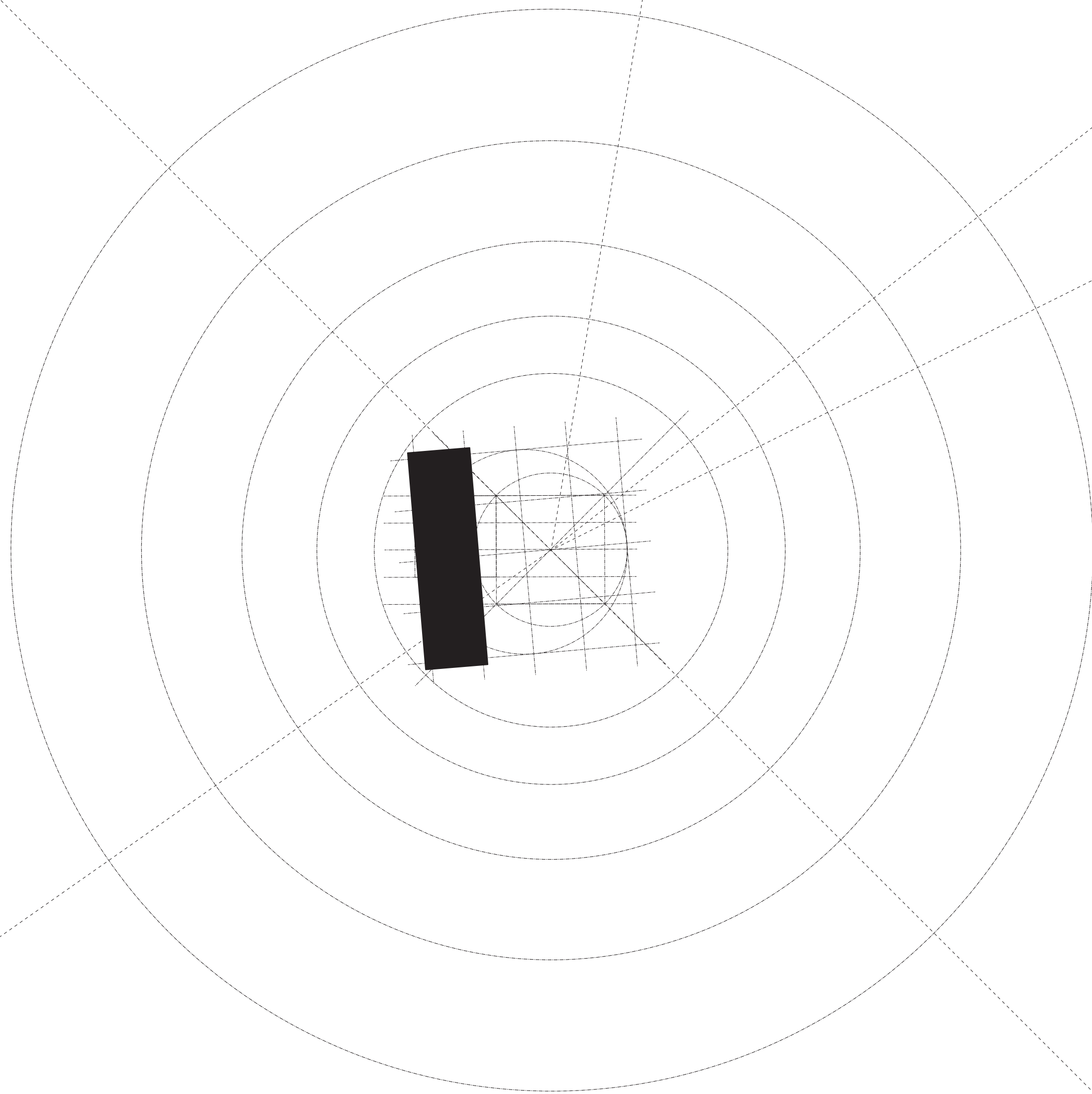

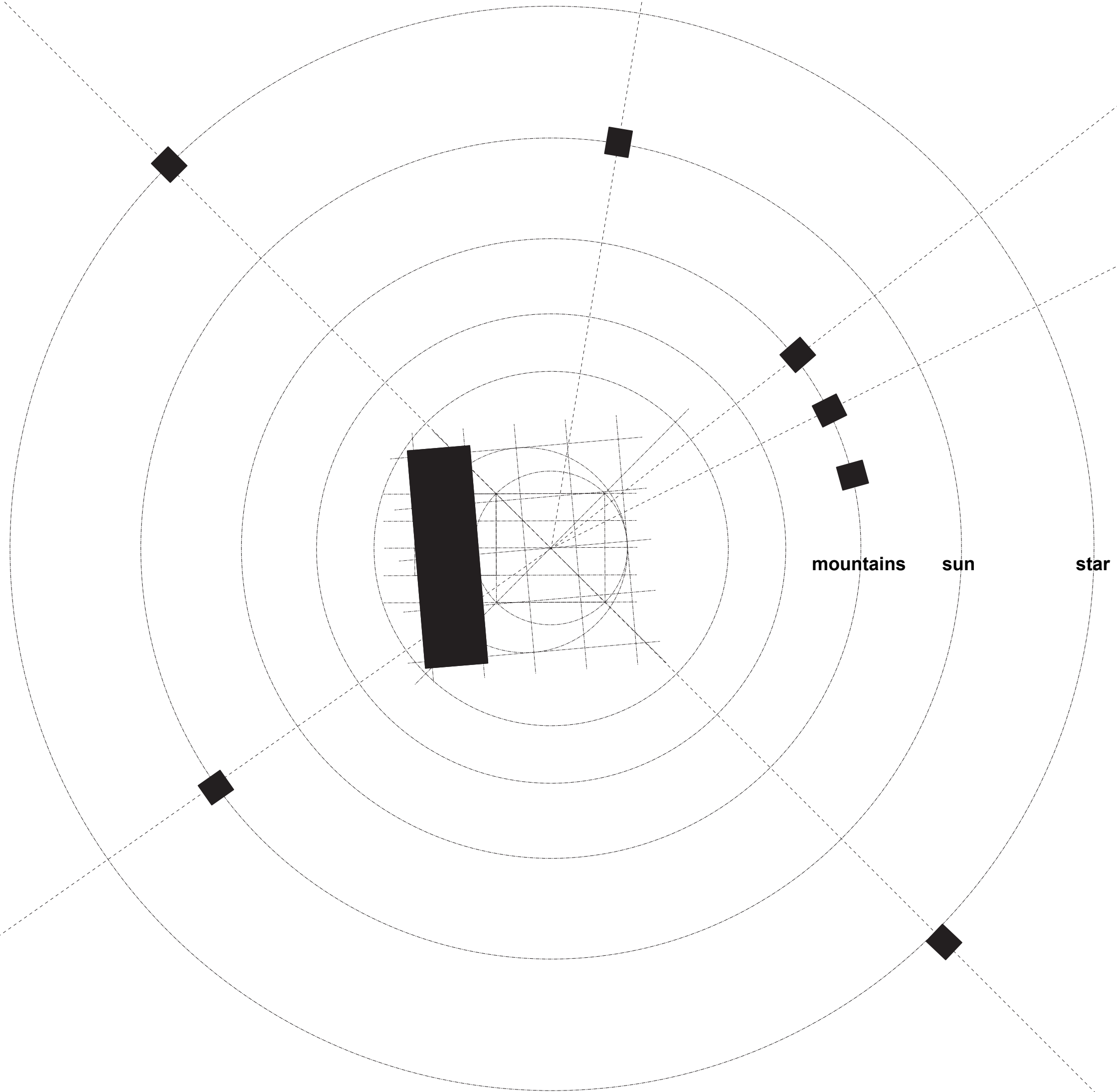

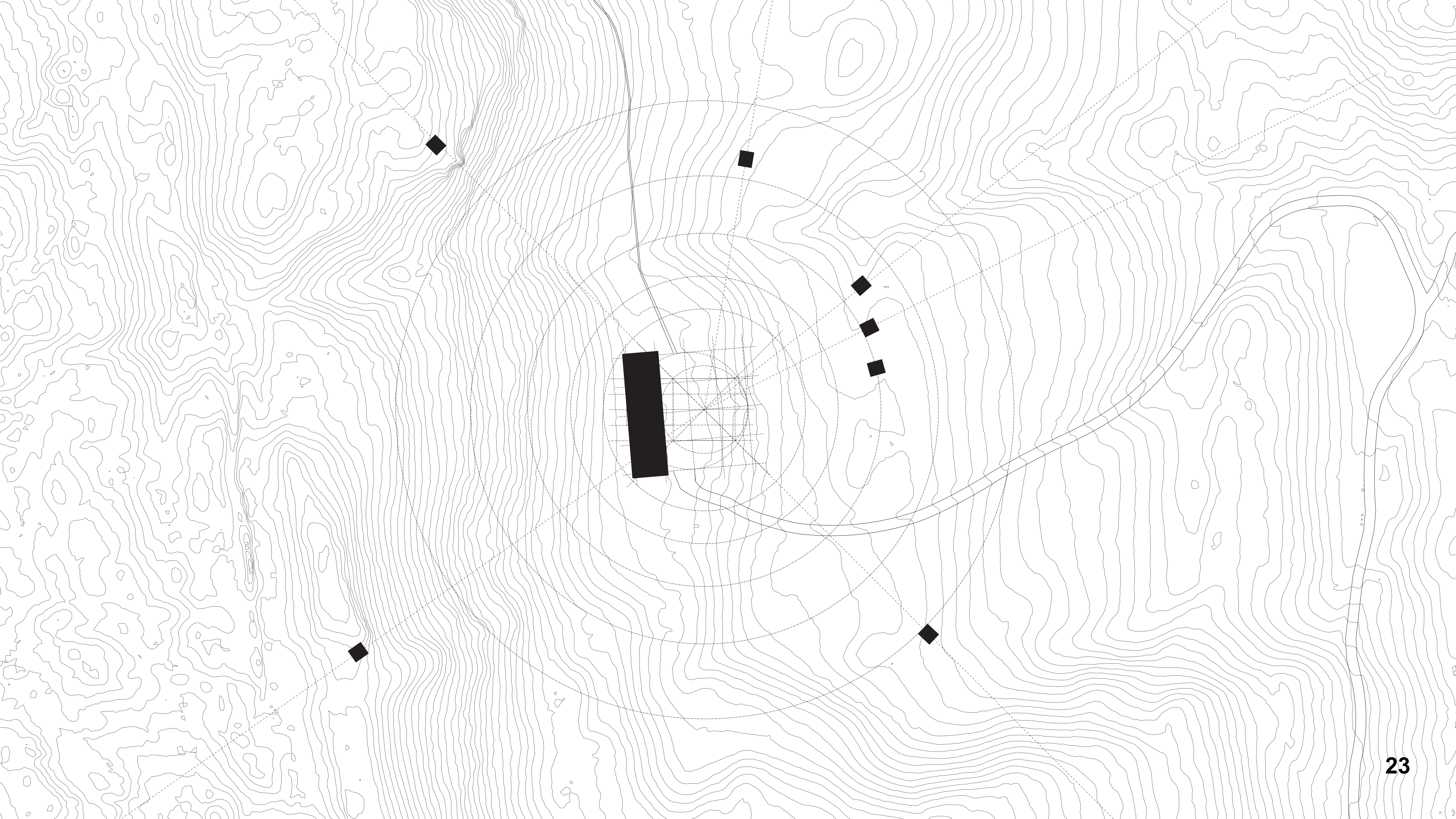

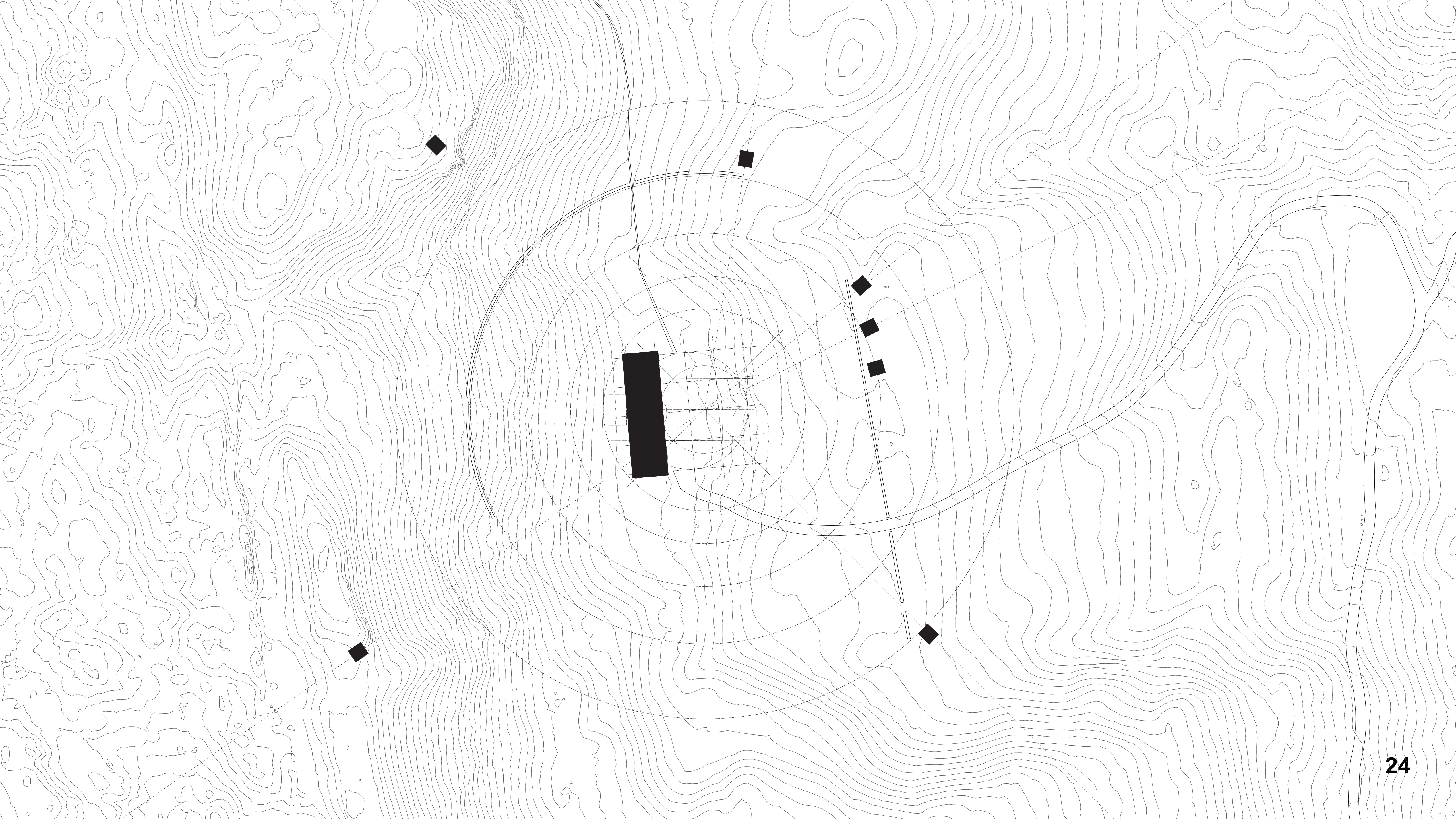

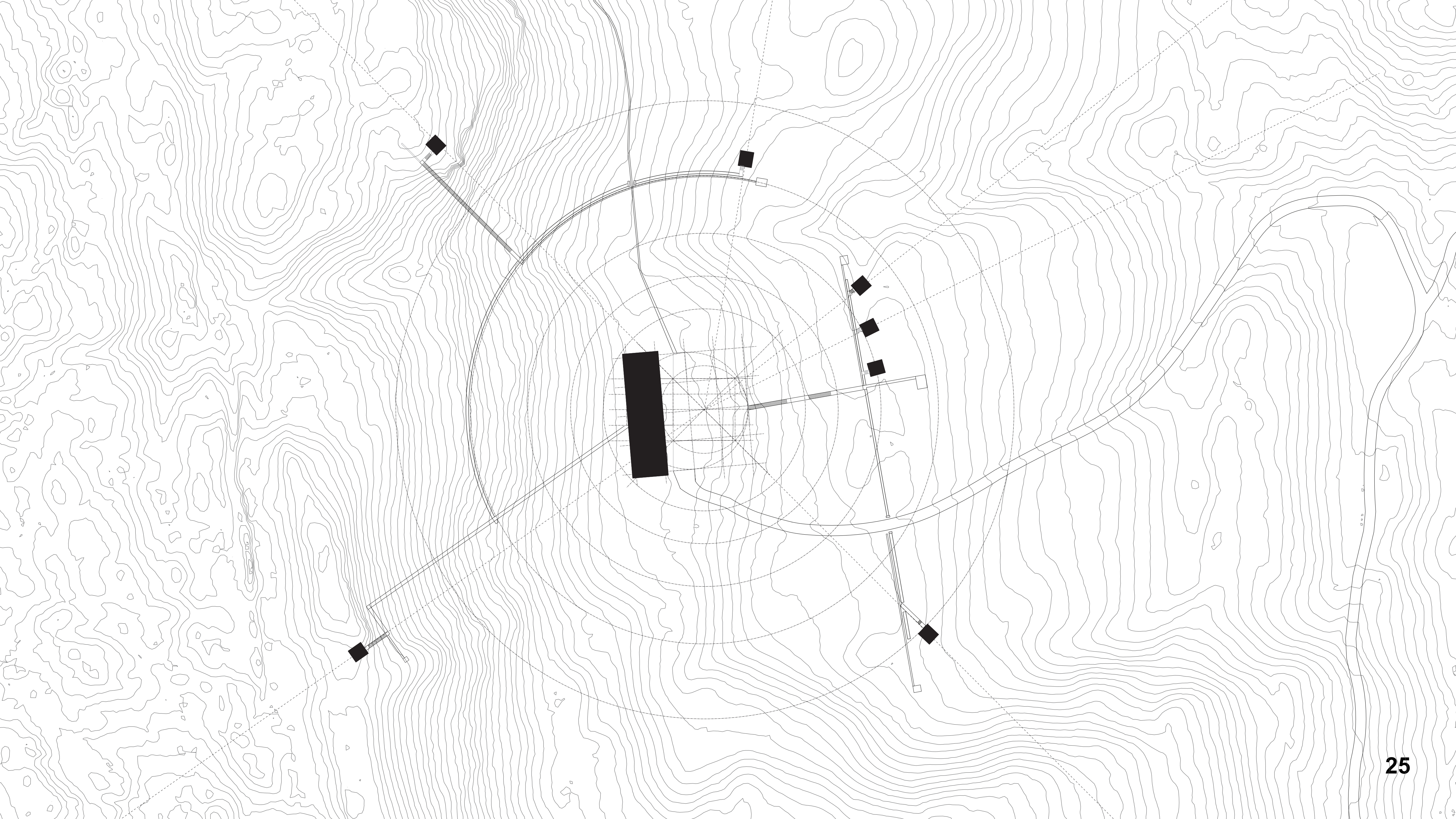



0 10 50m



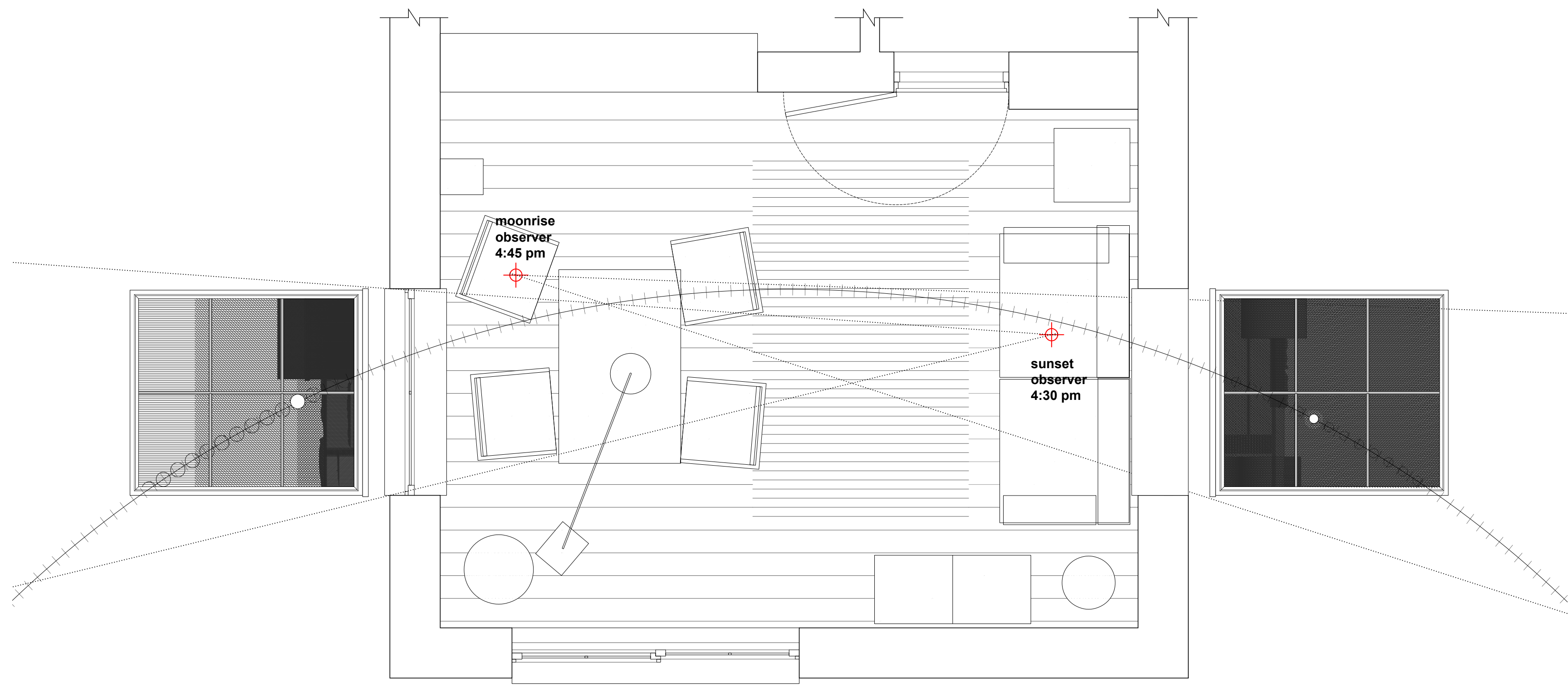

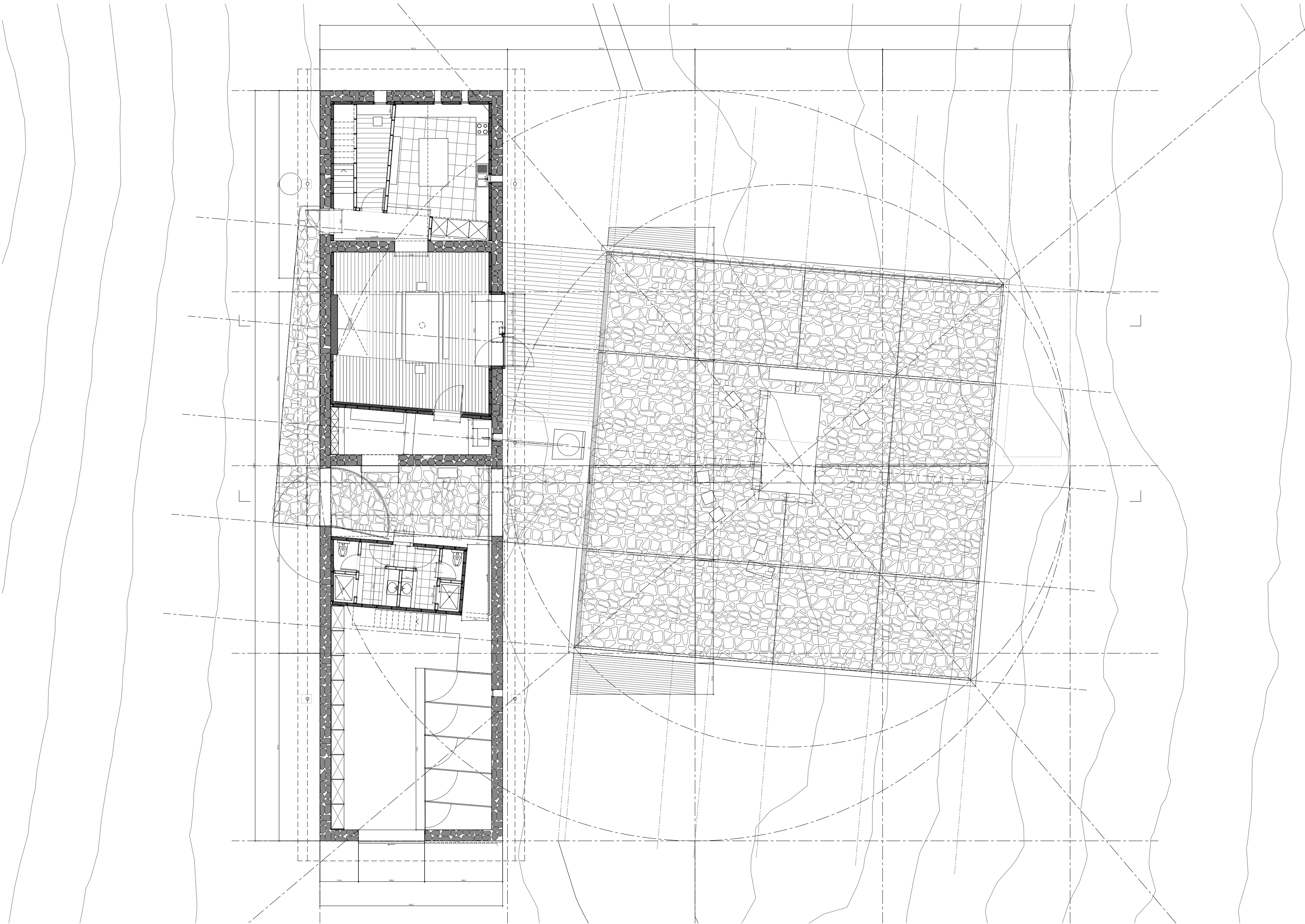

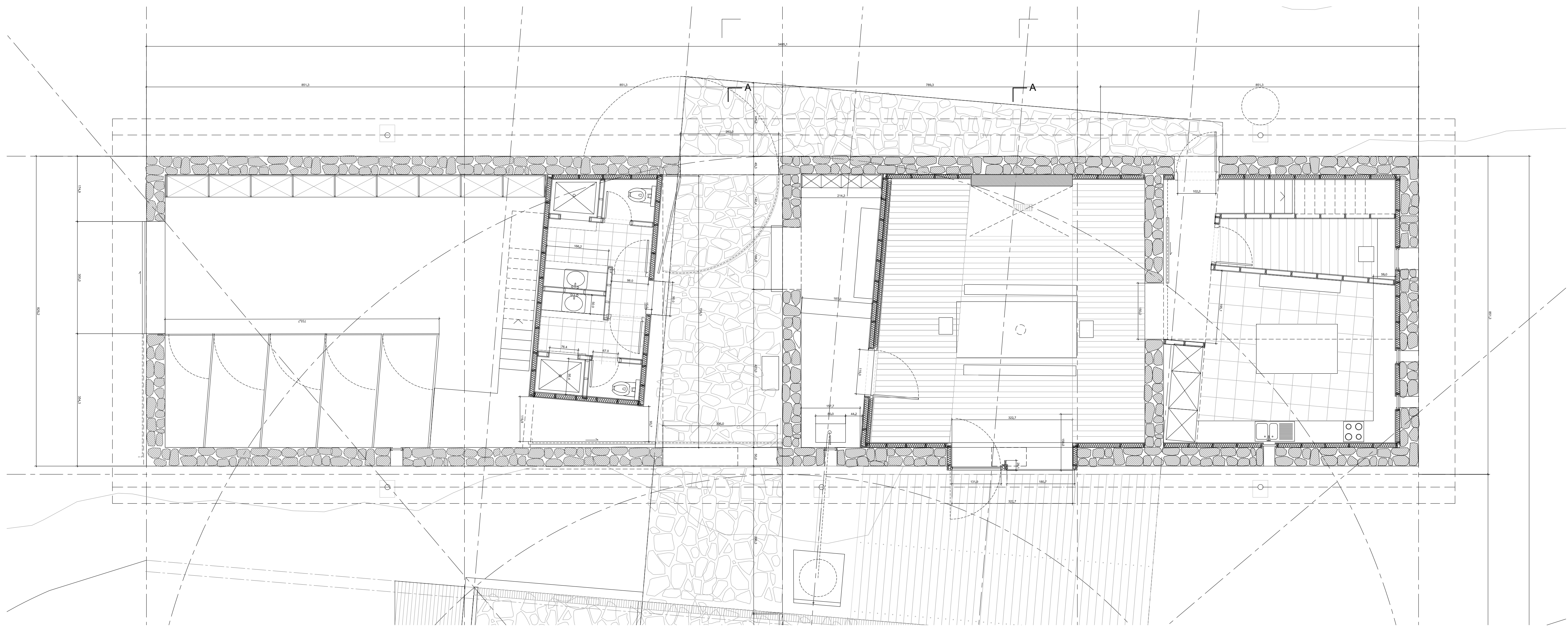

L_A

L_A

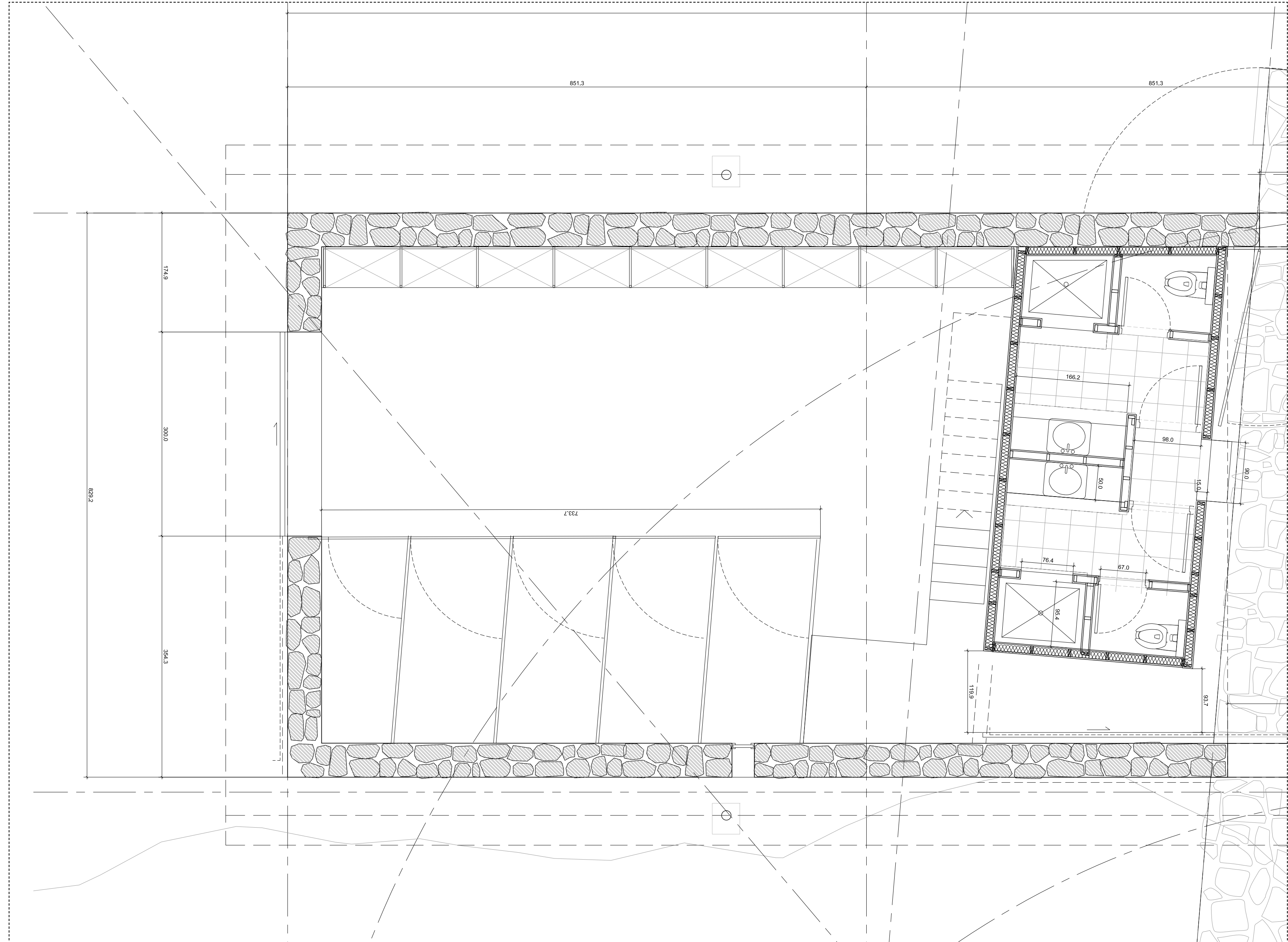

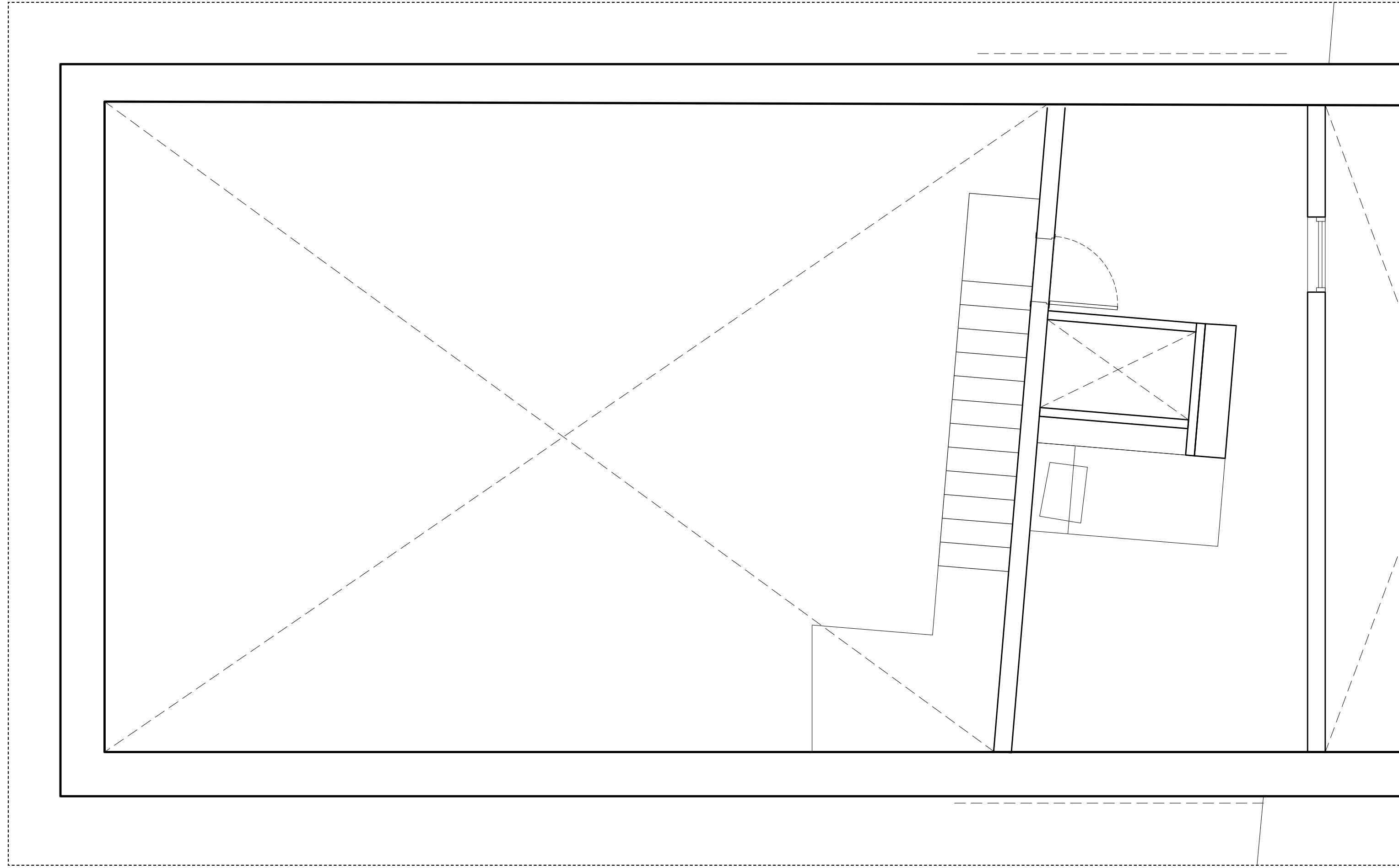

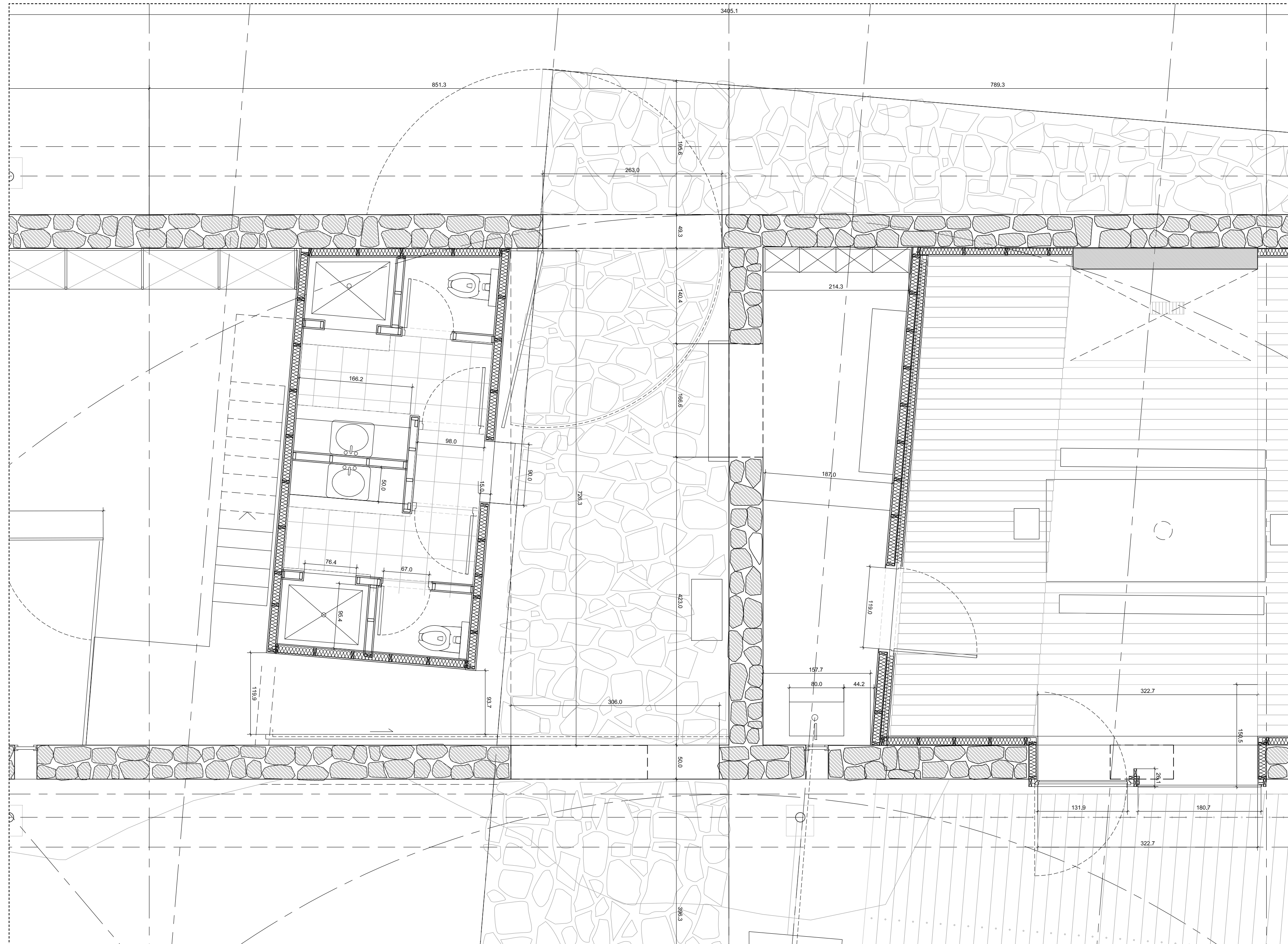







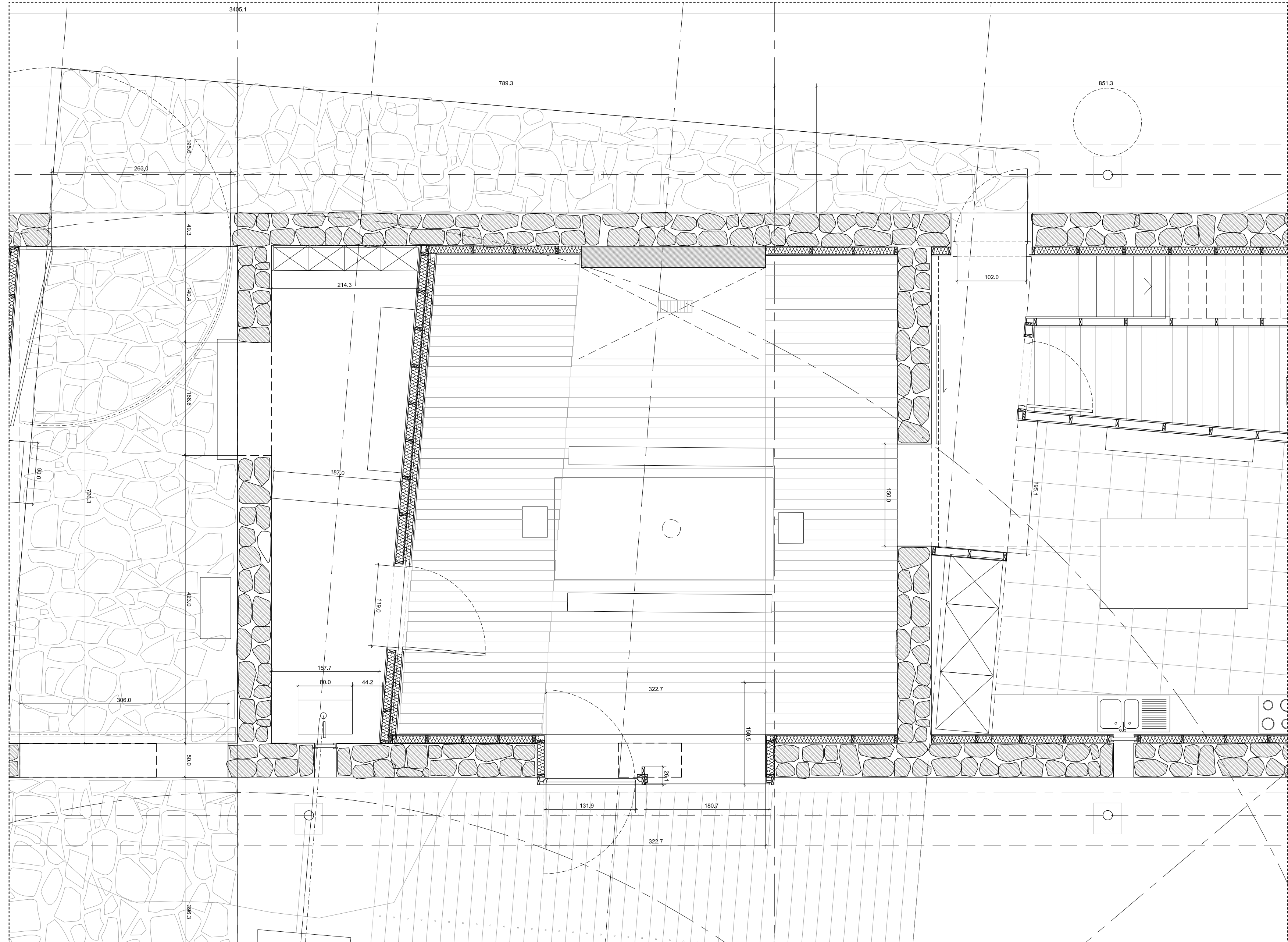

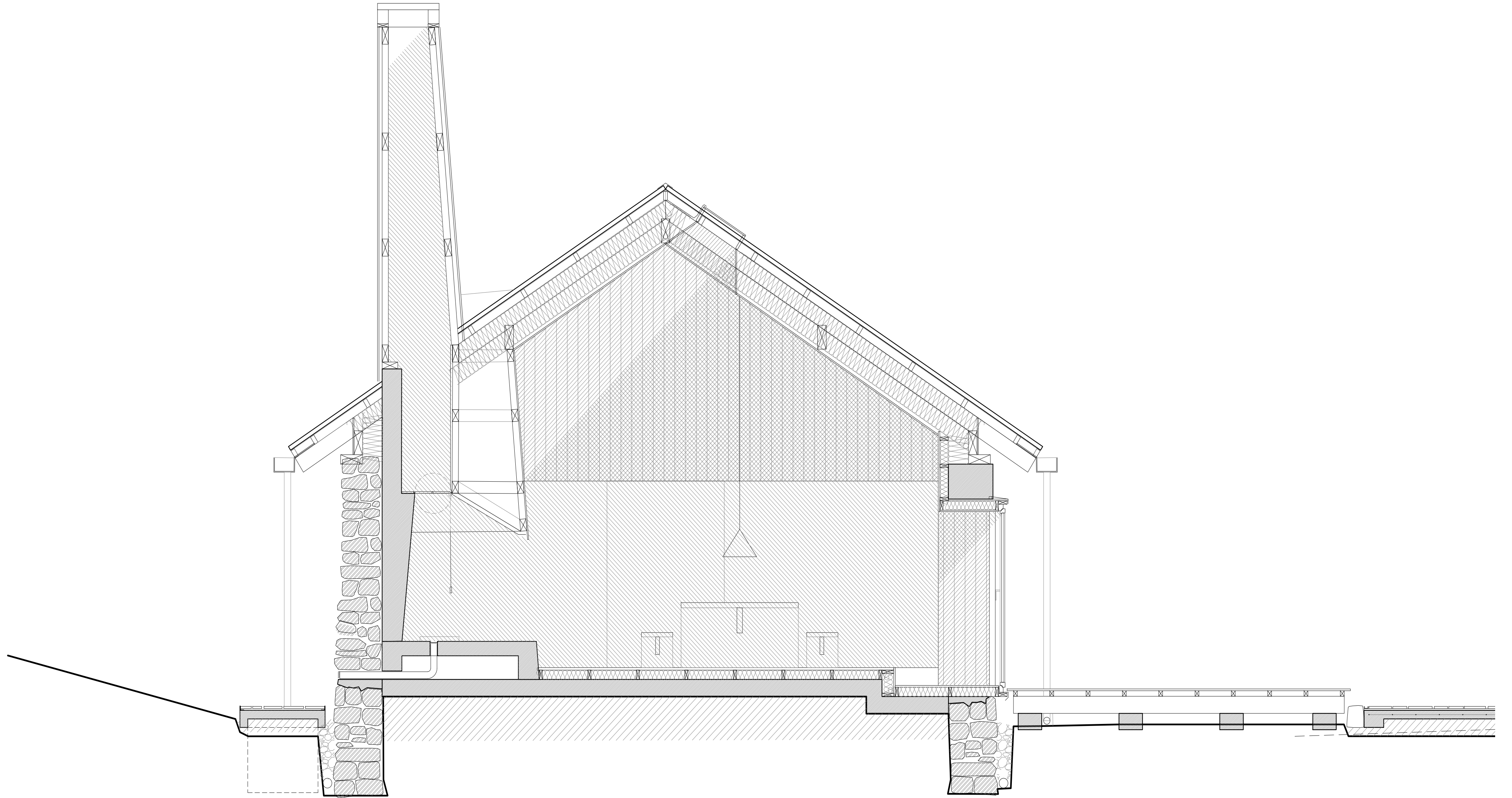





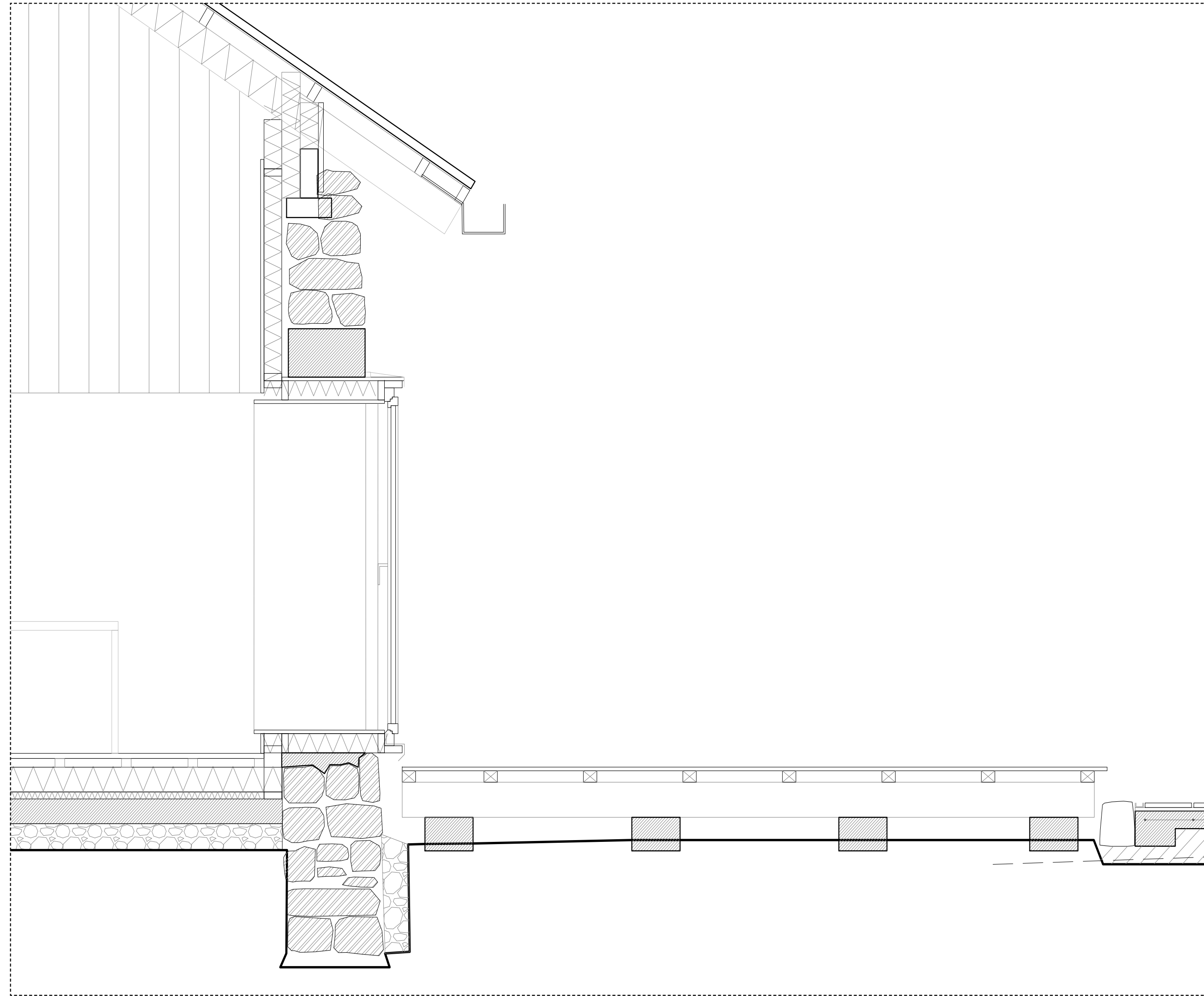

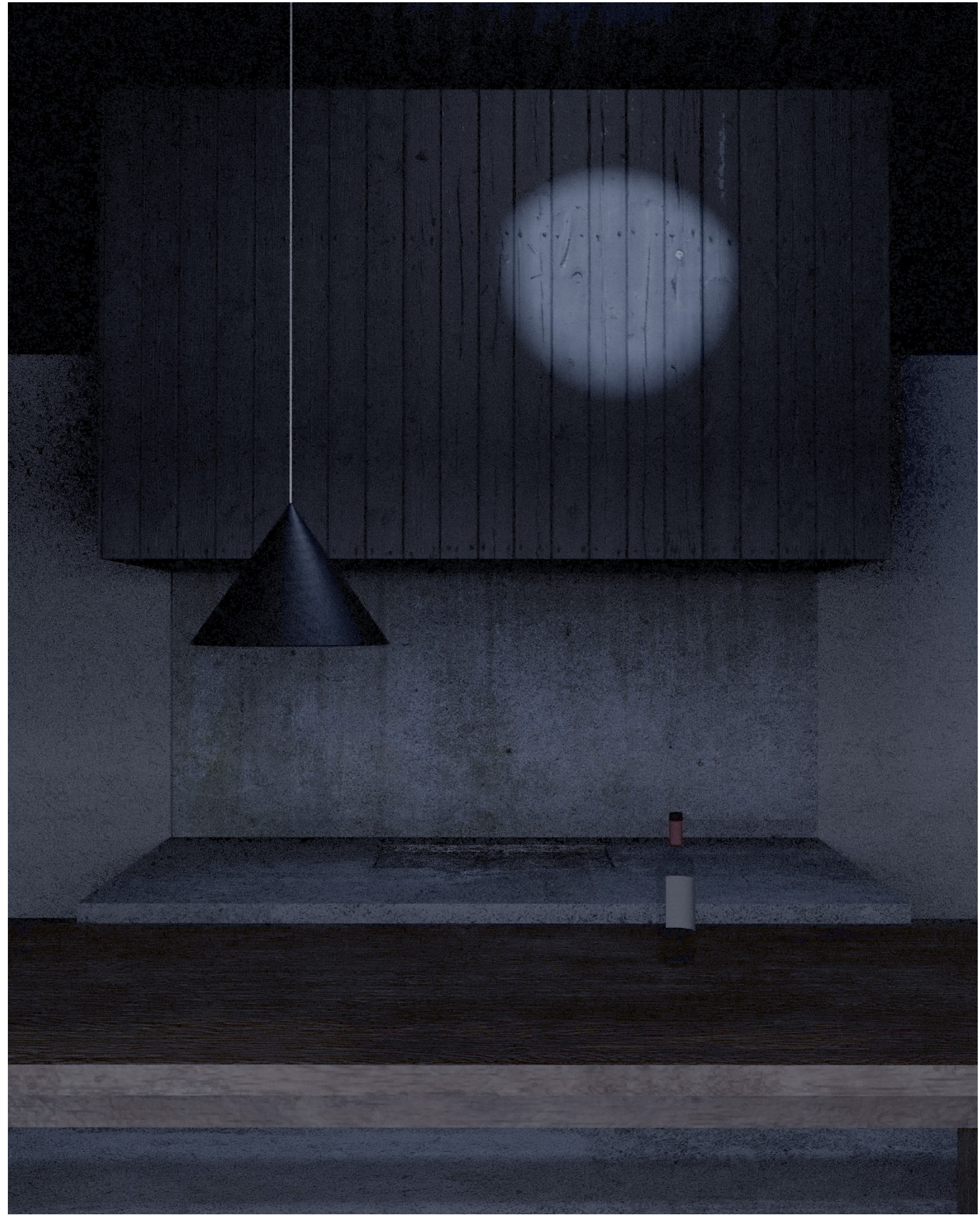

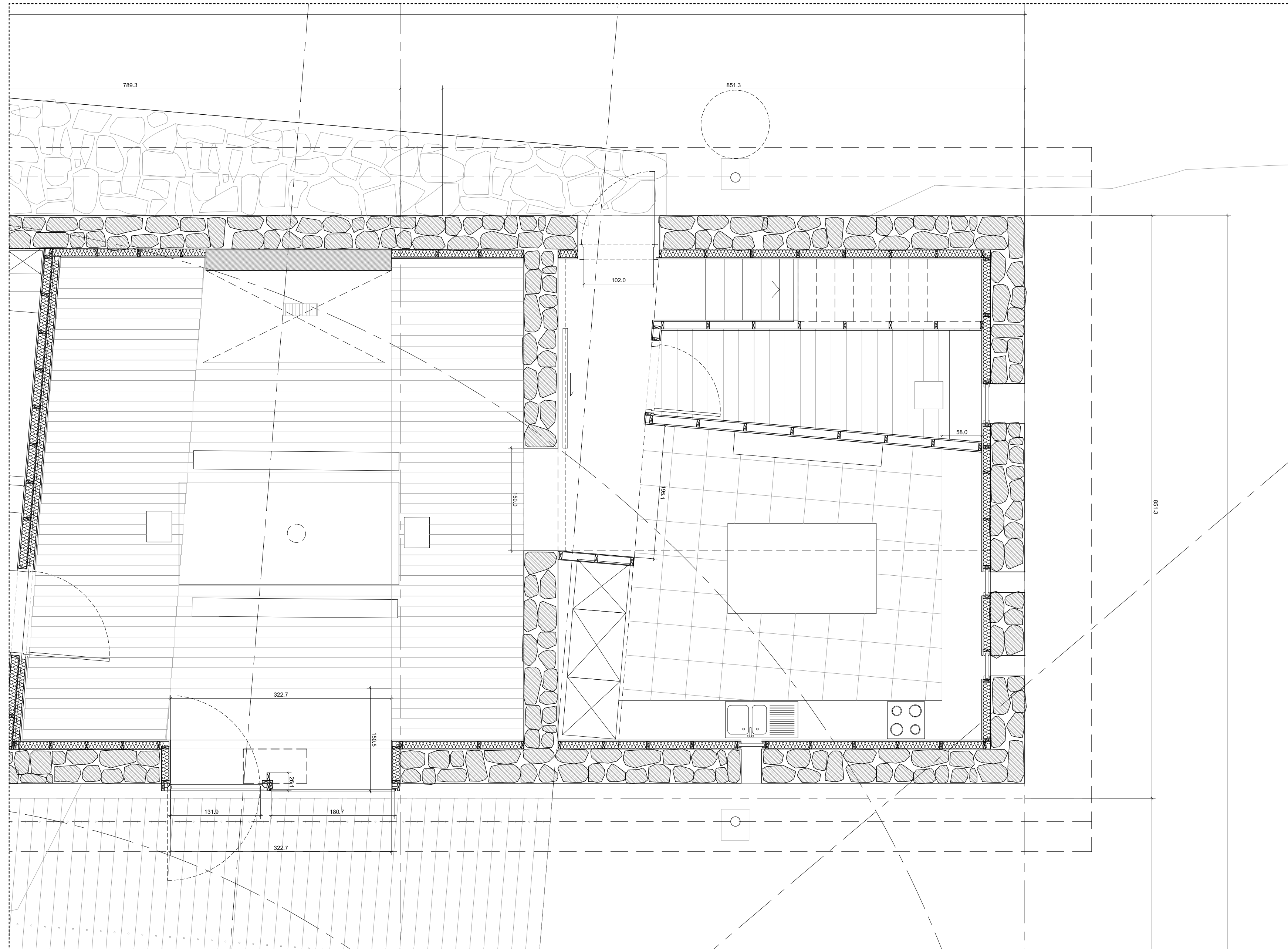

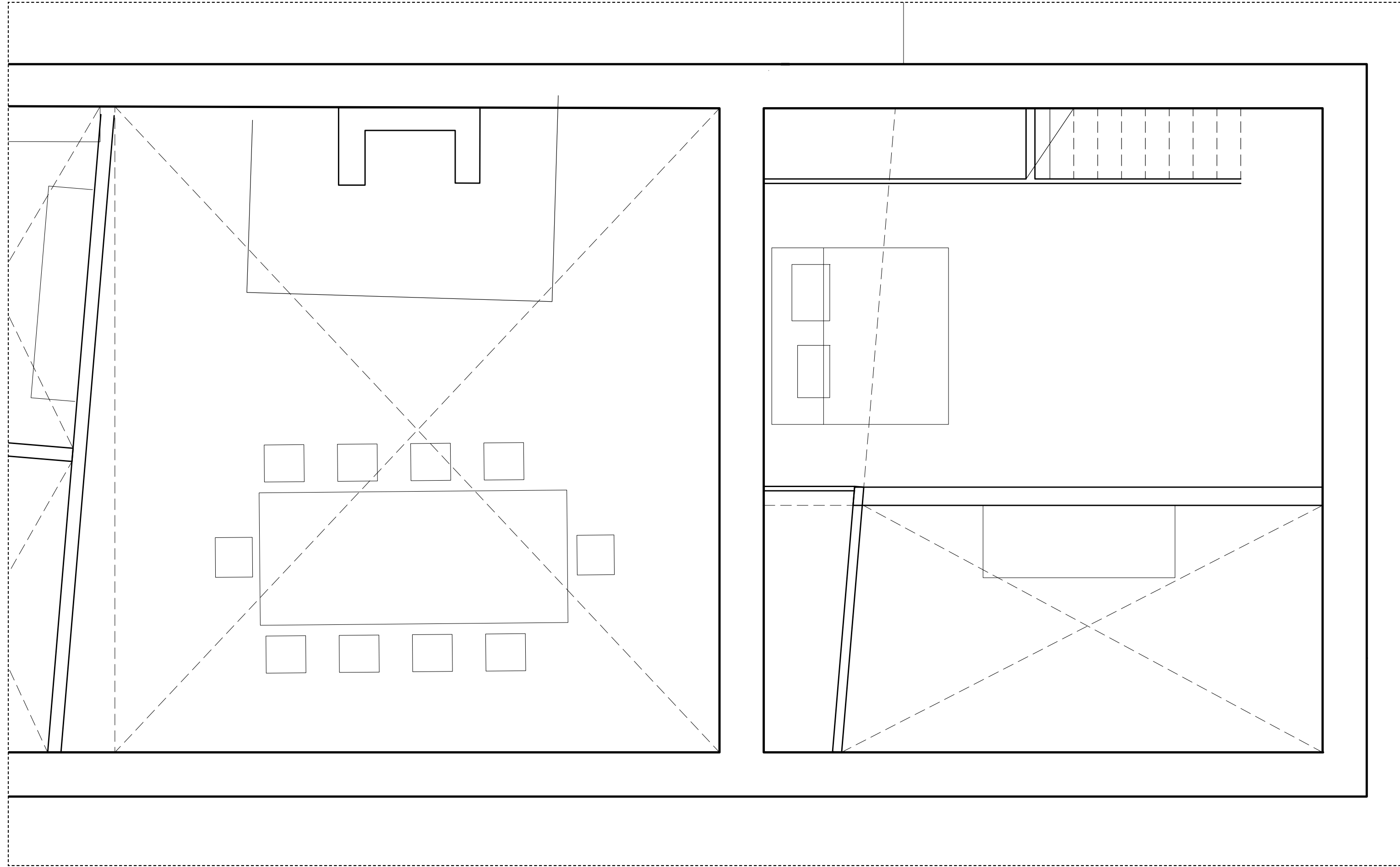

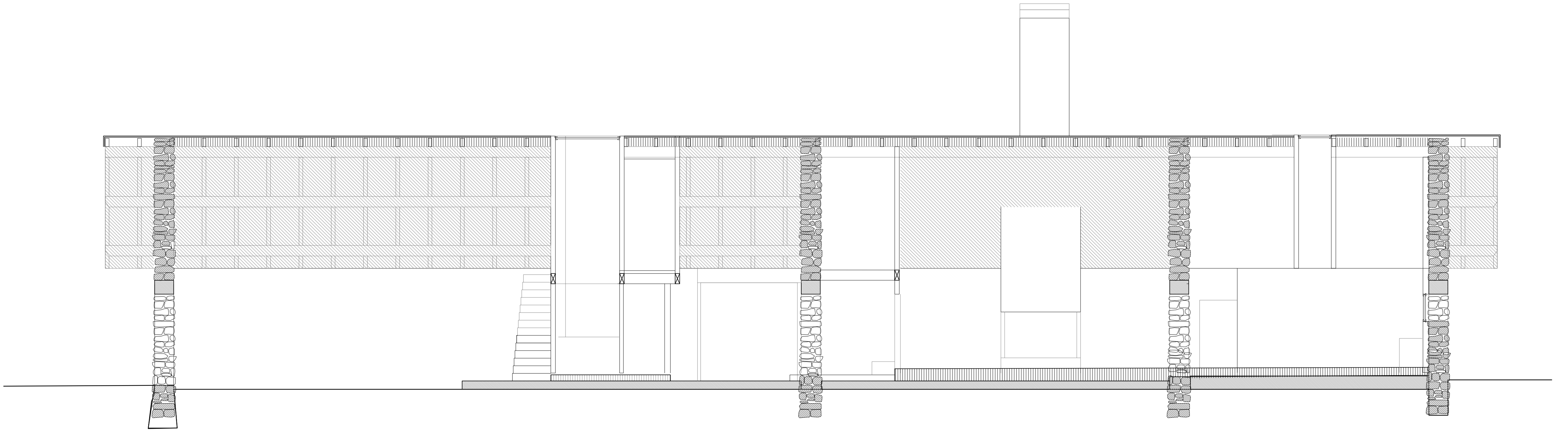

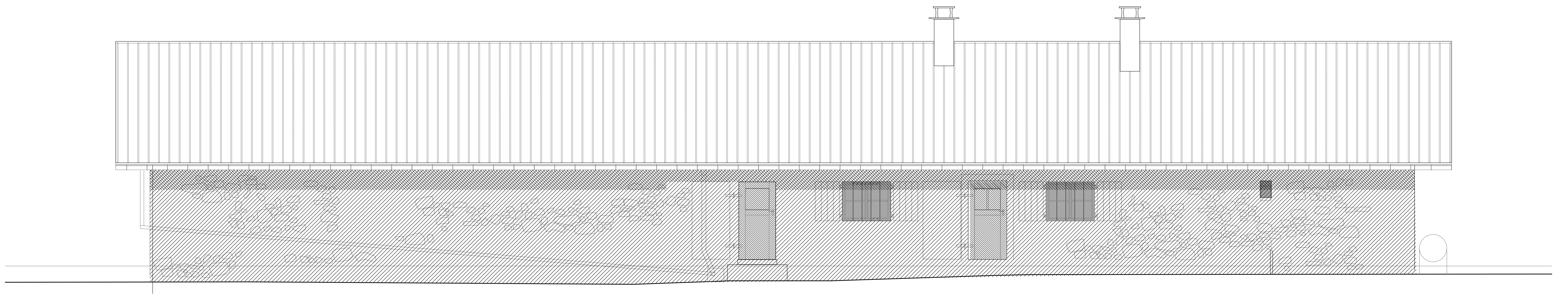

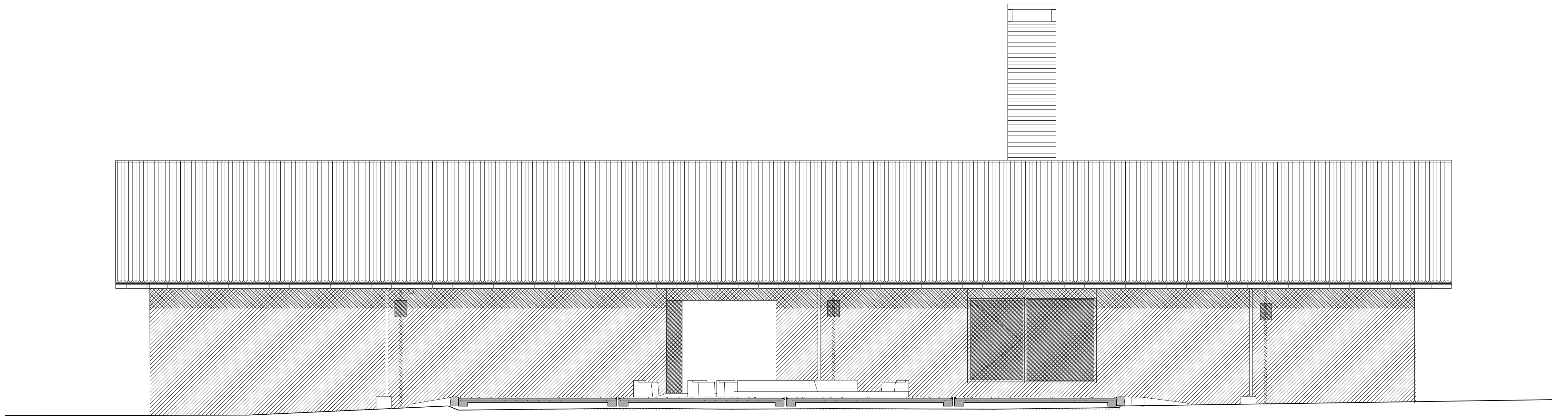

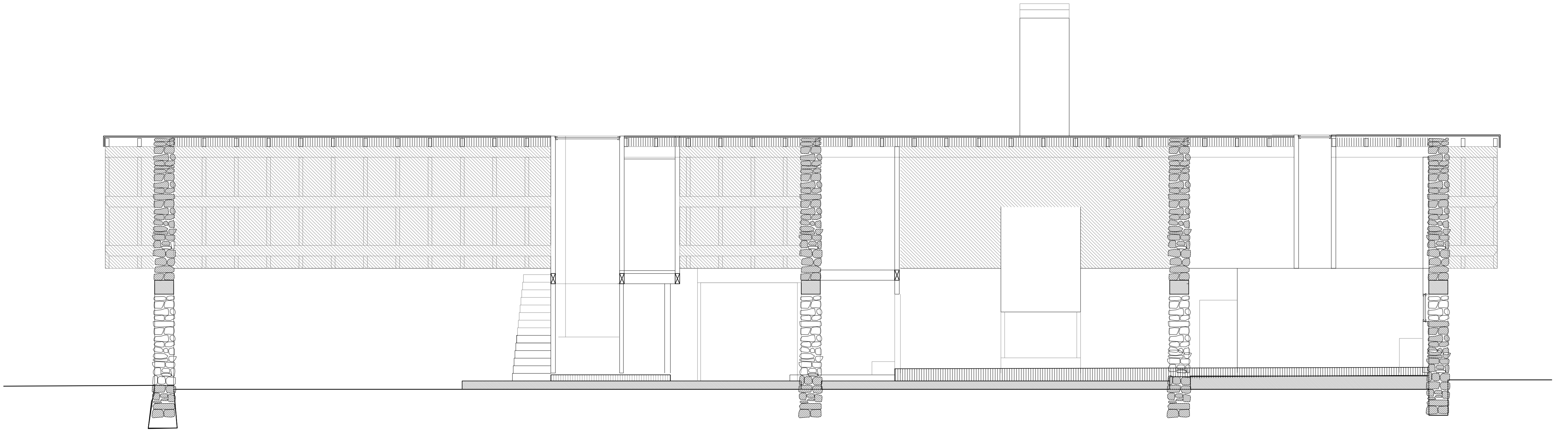

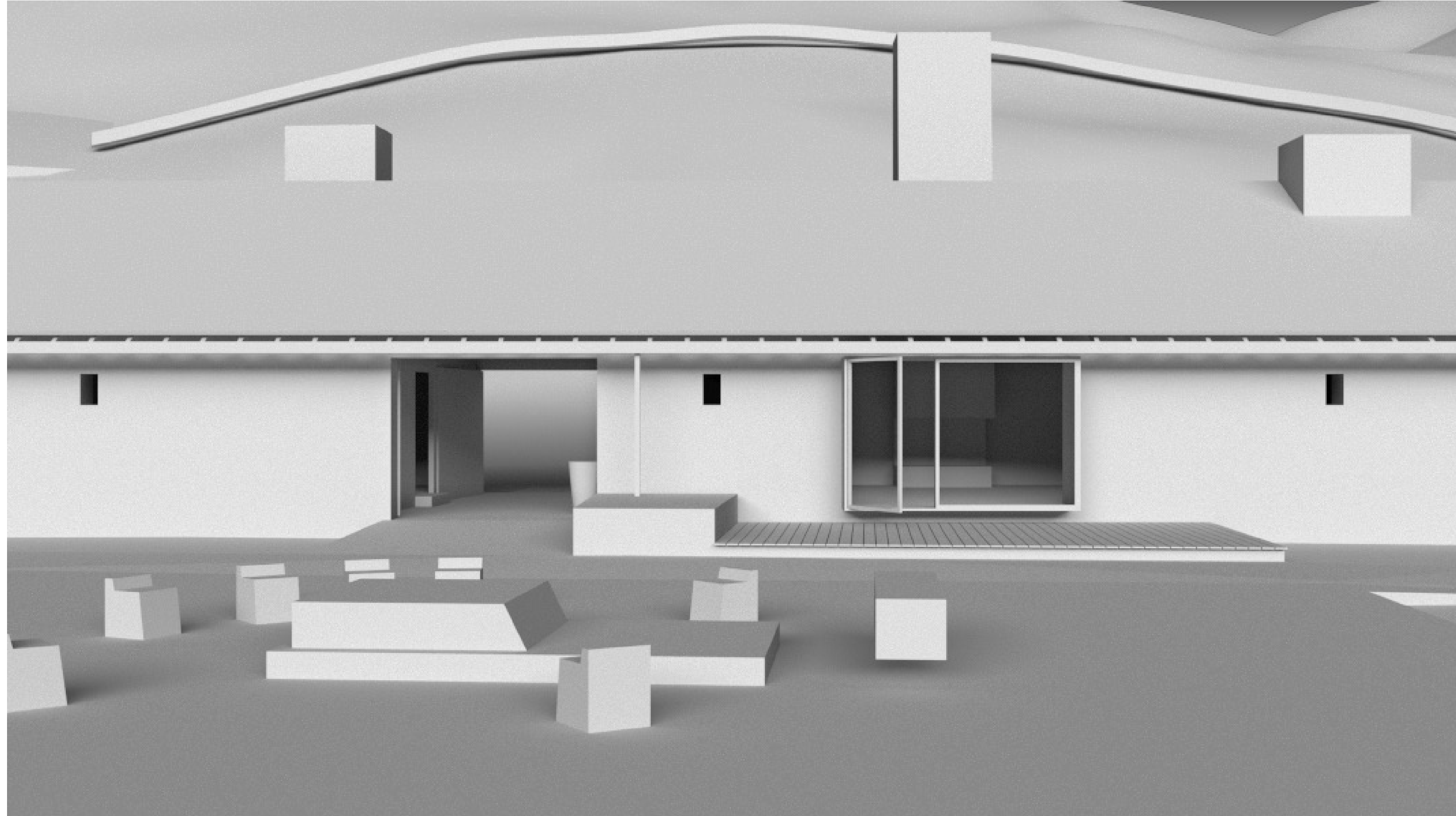

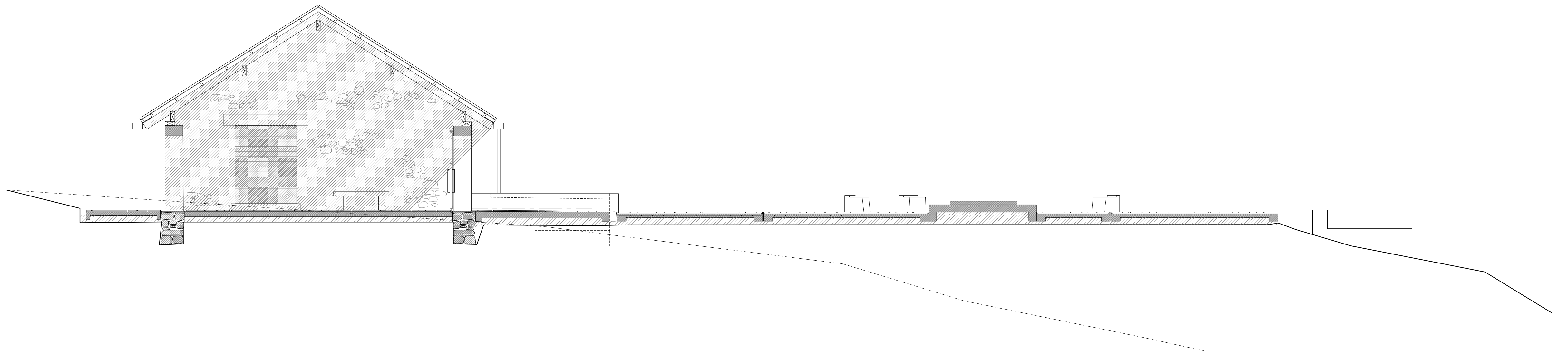



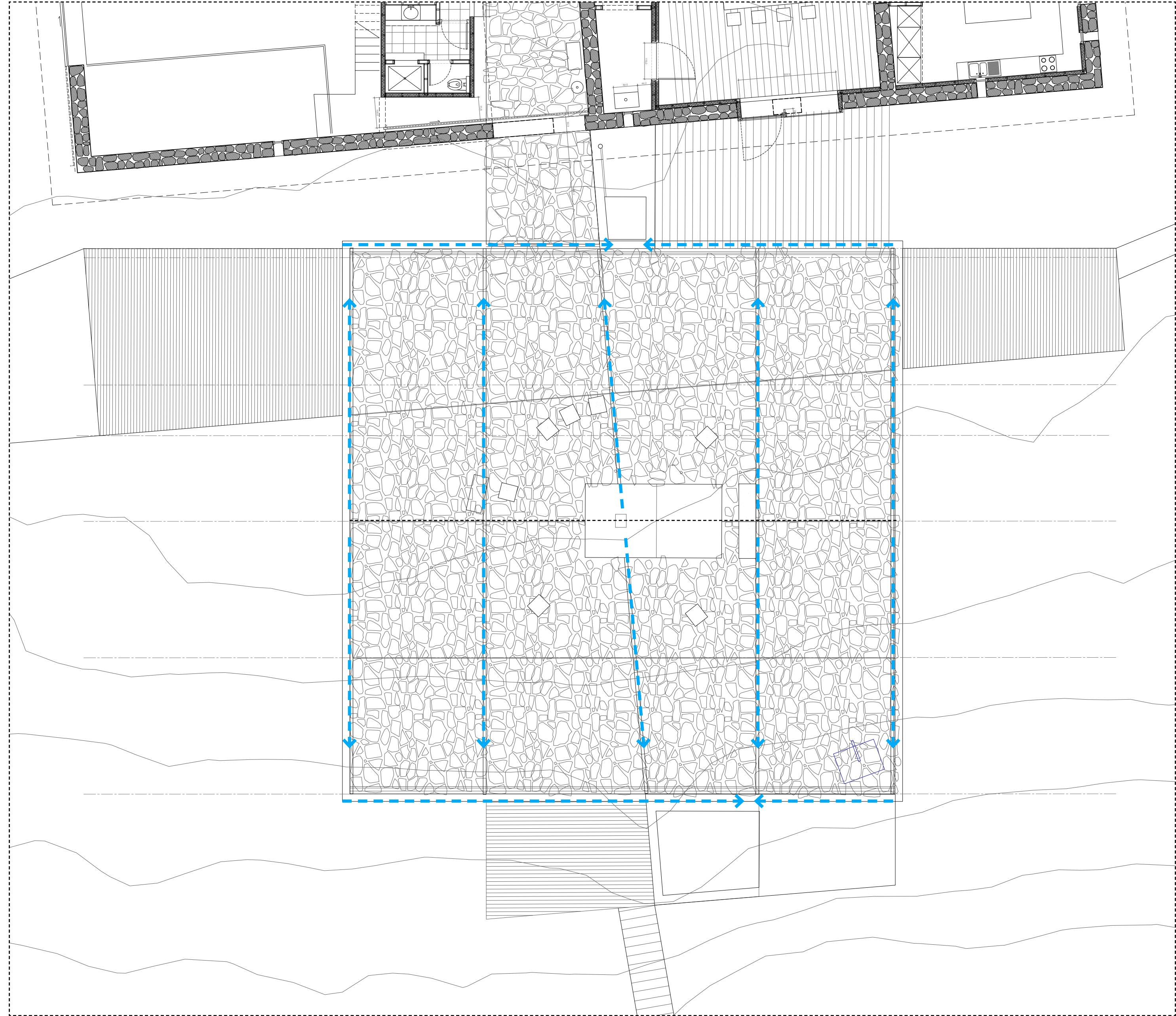

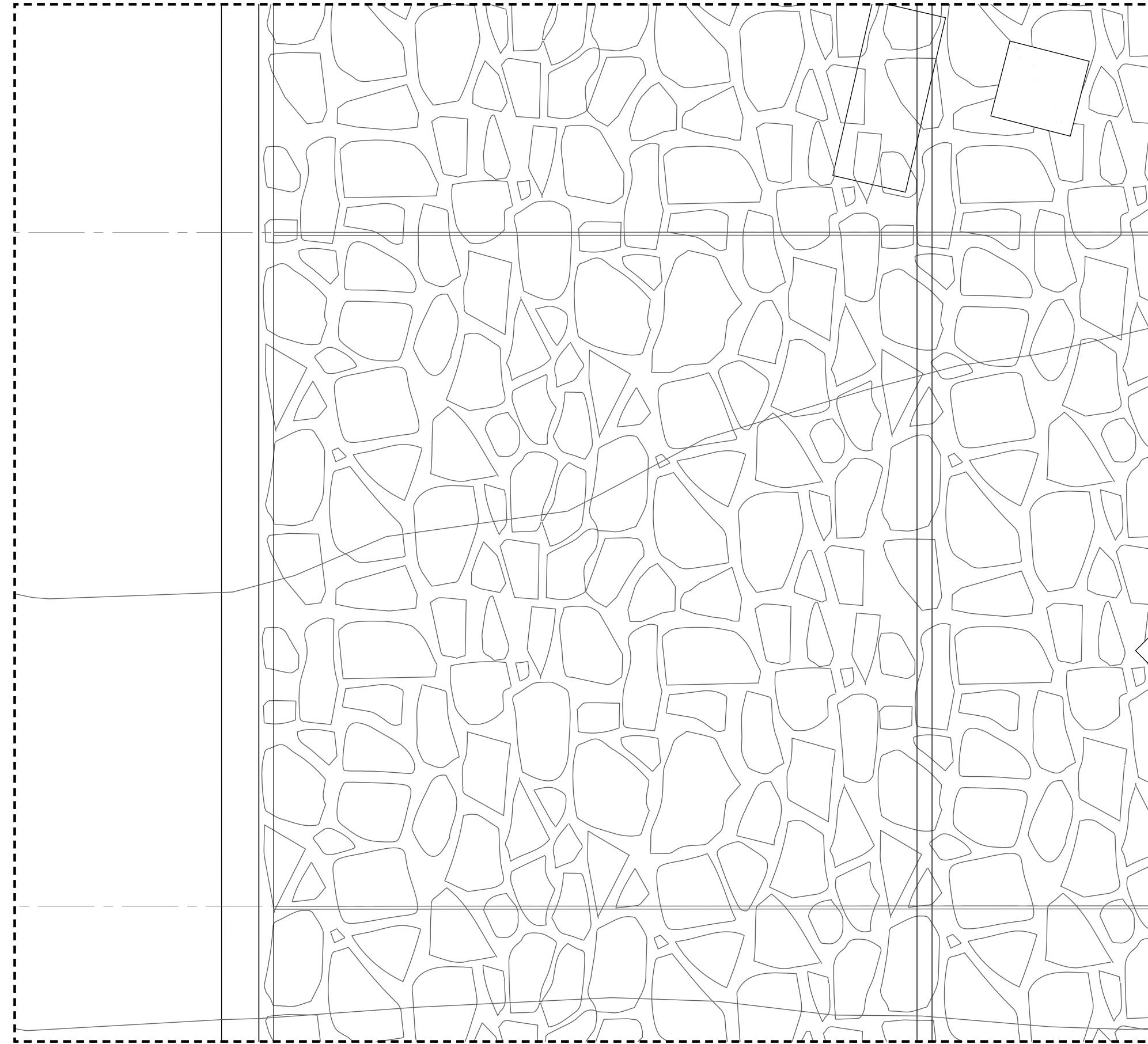

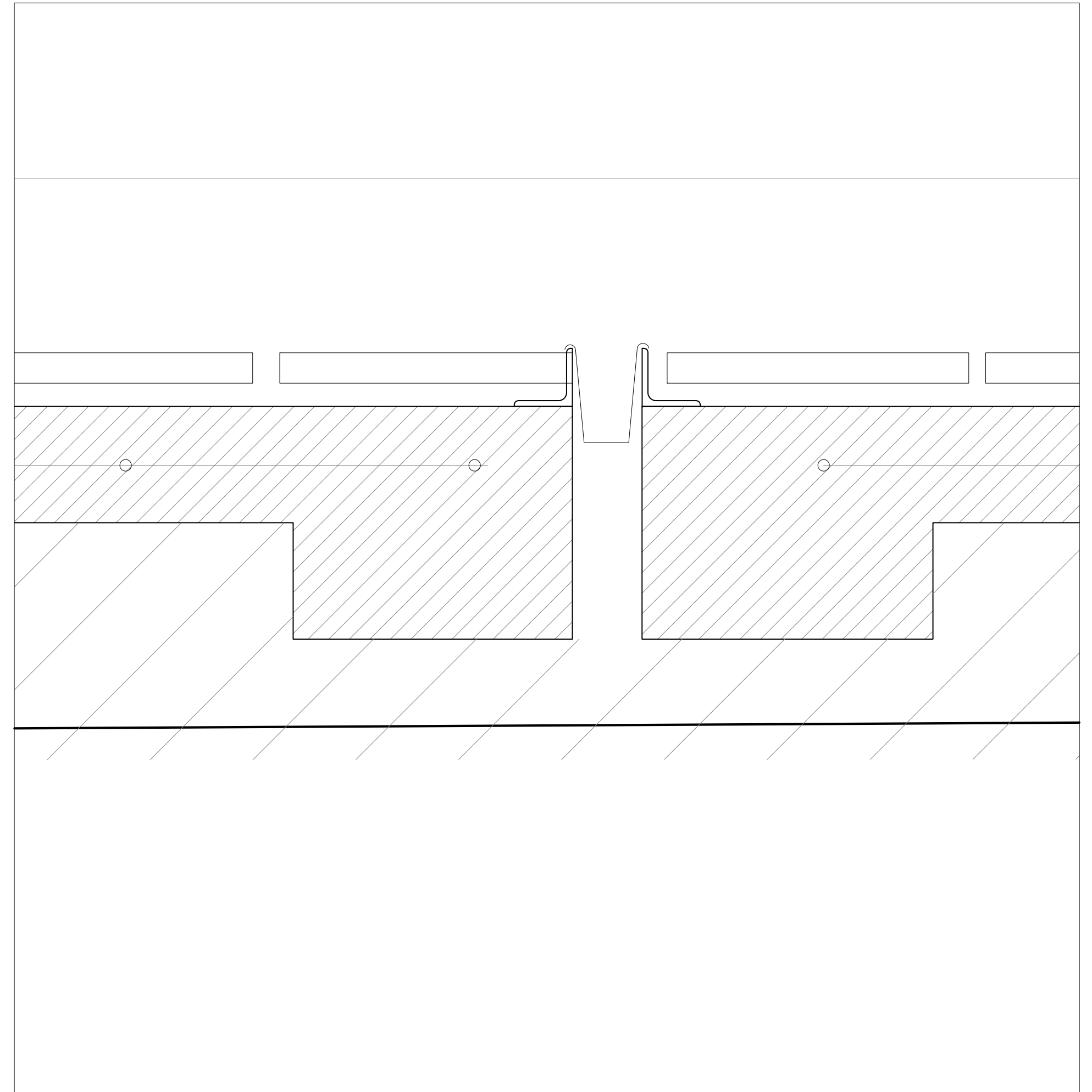
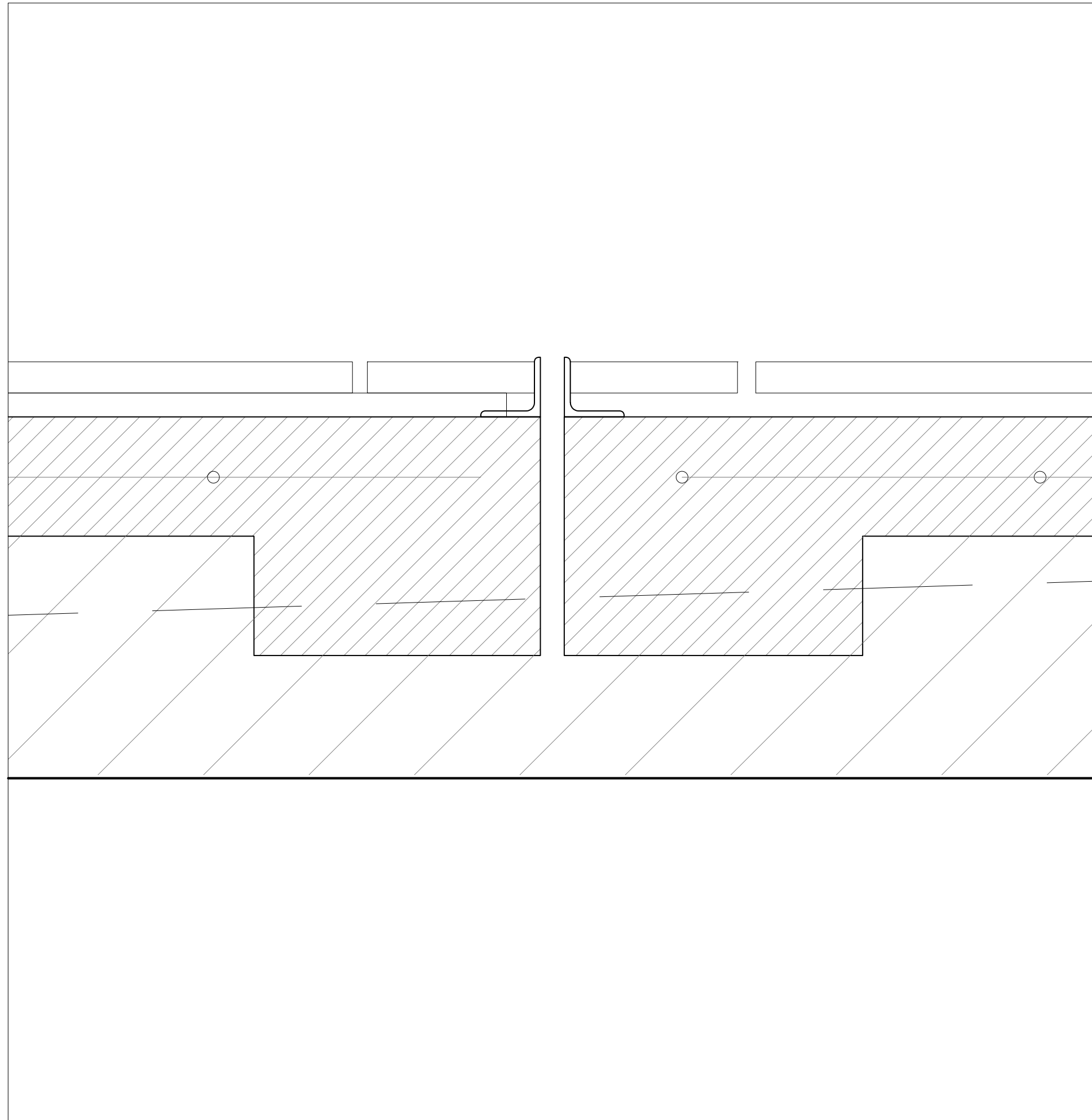



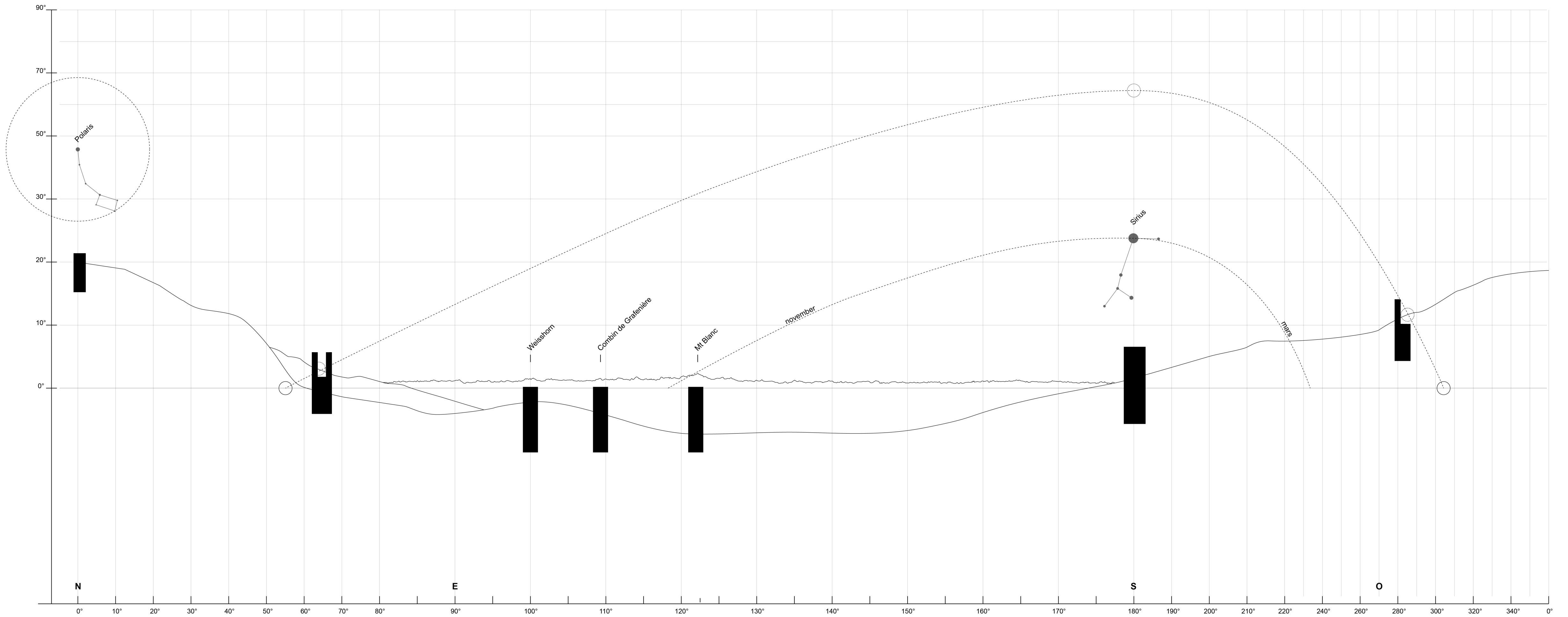







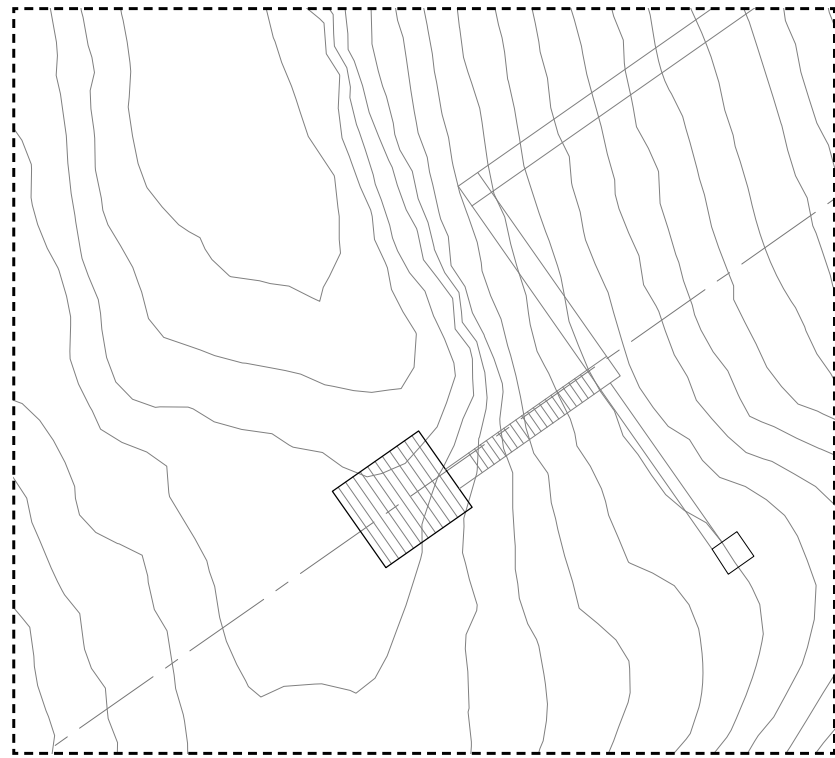

SUN
-
summer solstice sunset

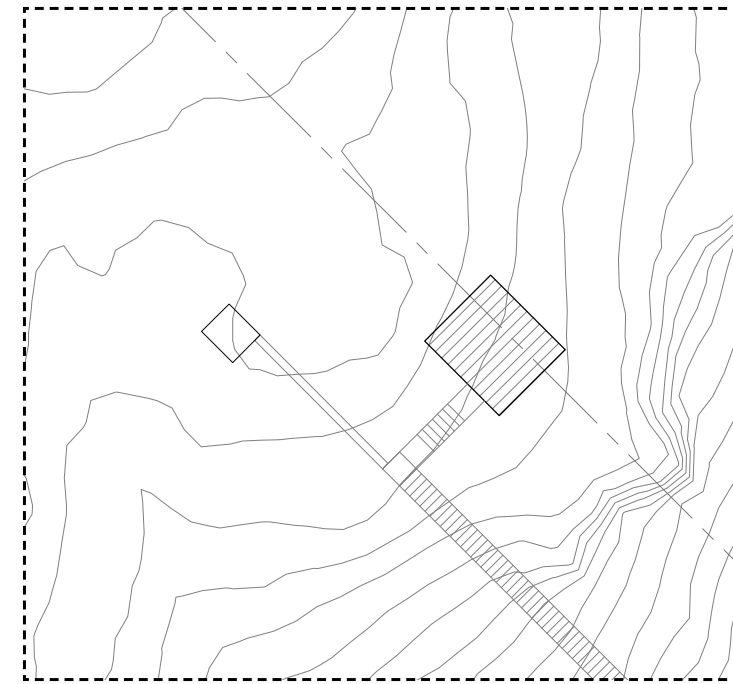

STAR
-
Polaris, north star

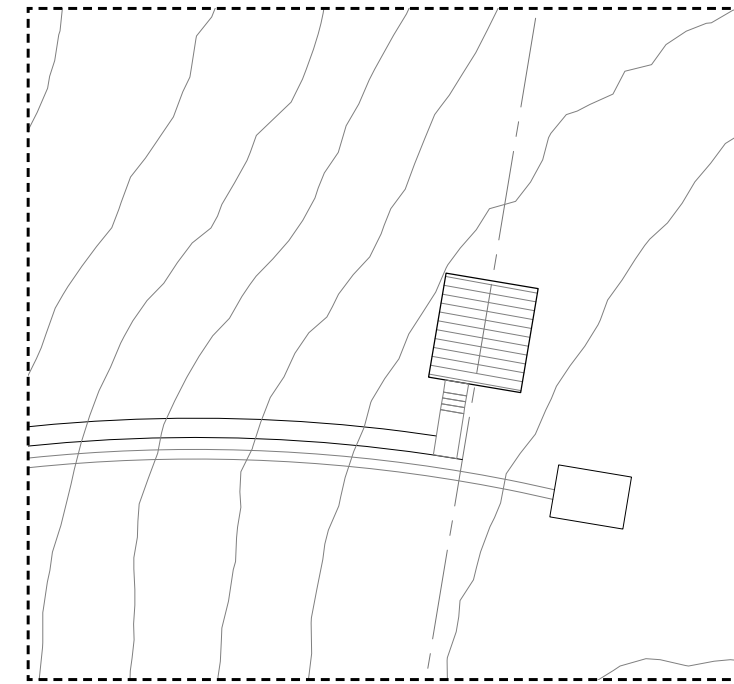

SUN
-
summer solstice sunrise

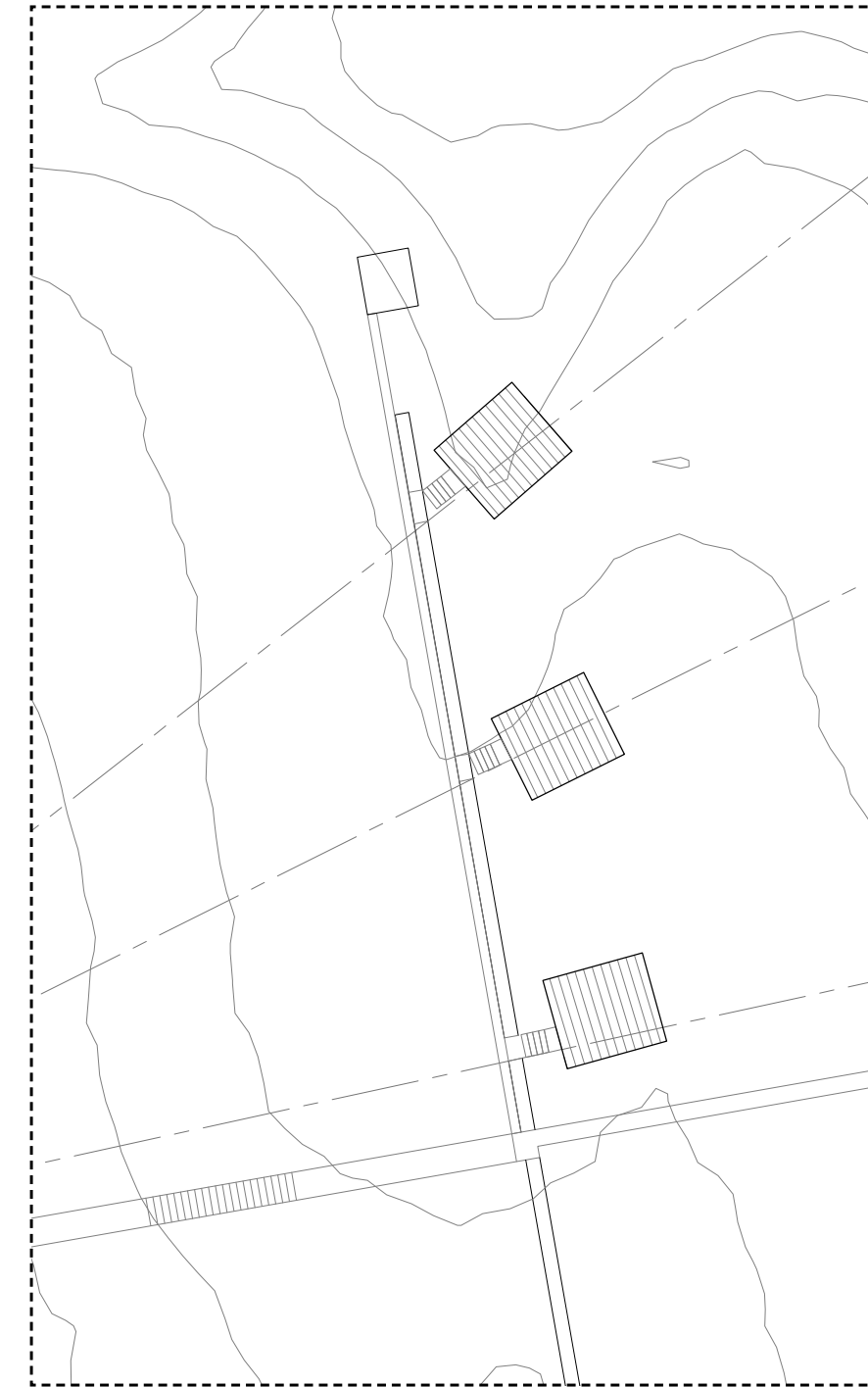

MOUNTAIN
-
Mont Blanc
Combin de Grafenière
Weisshorn

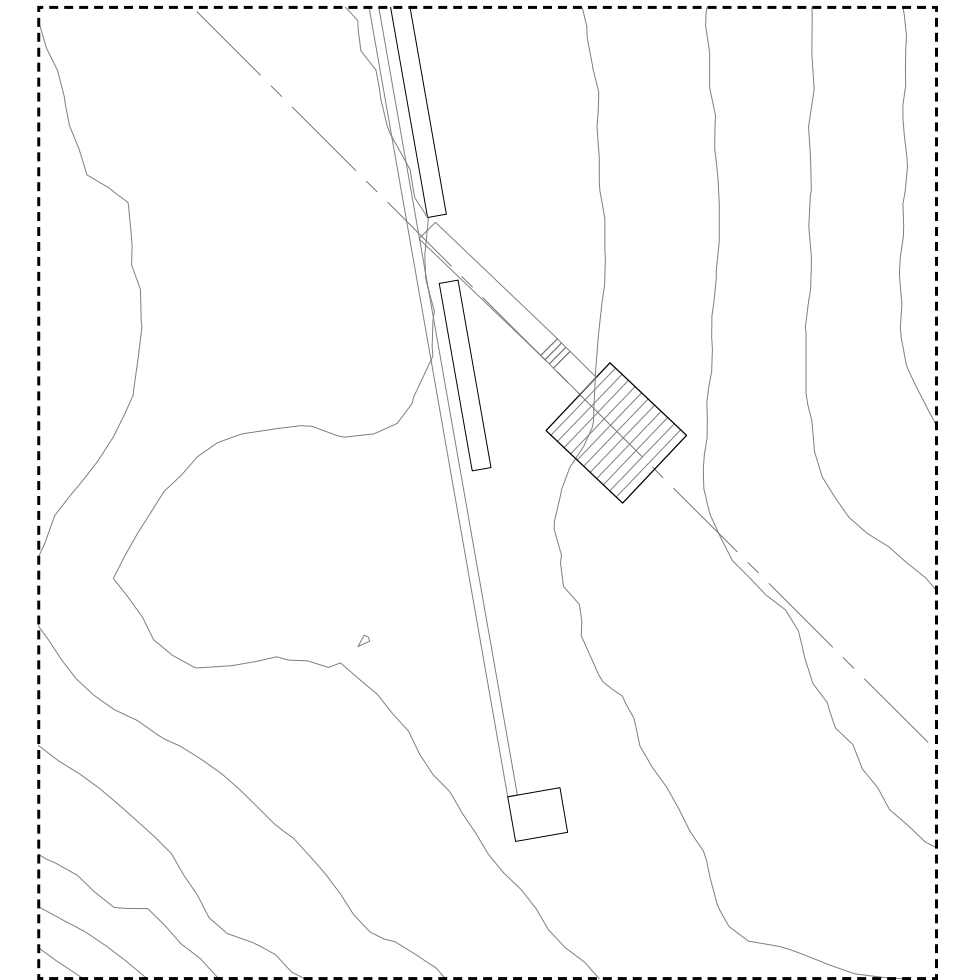

STAR
-
Sirius, brightest star

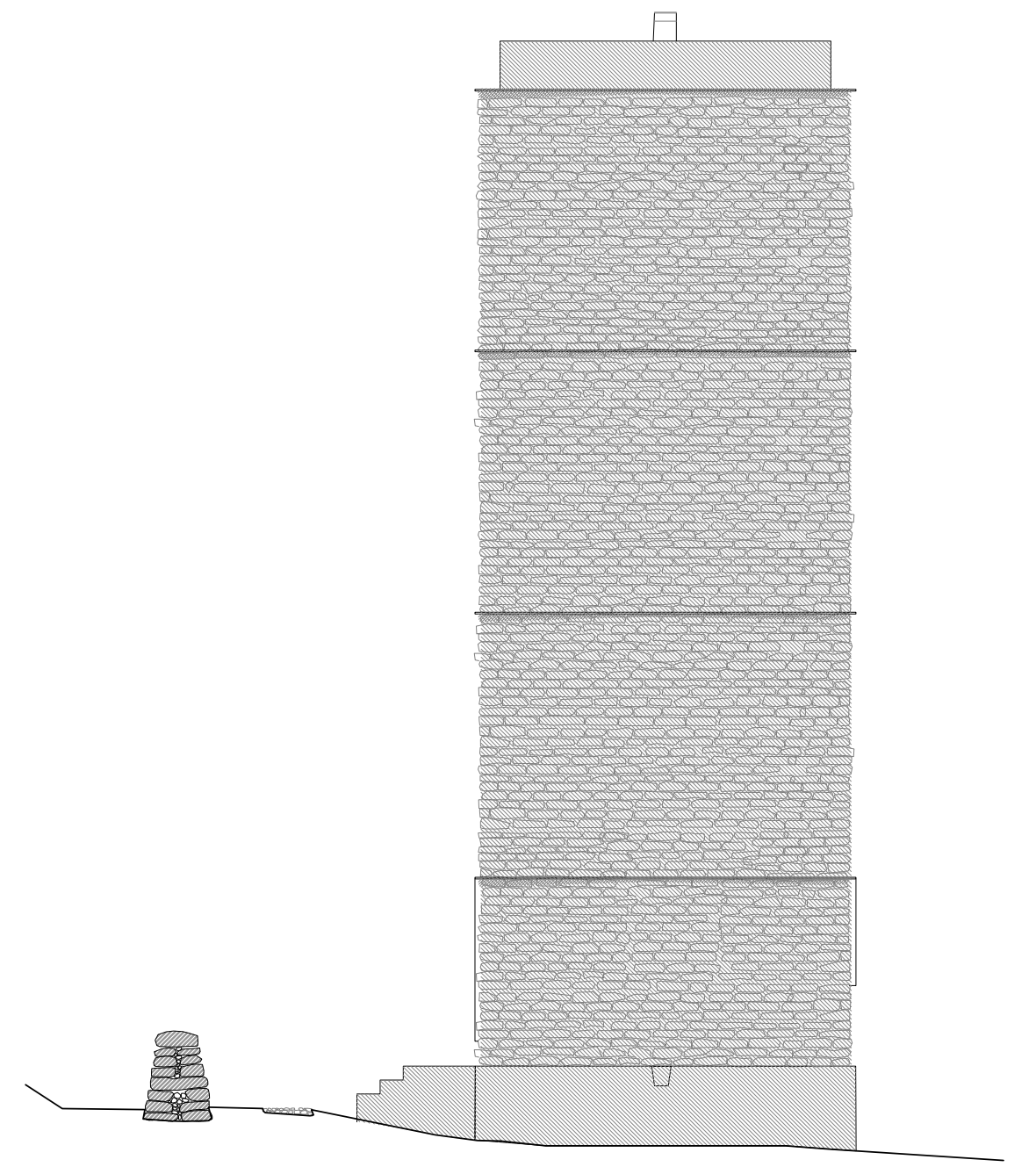
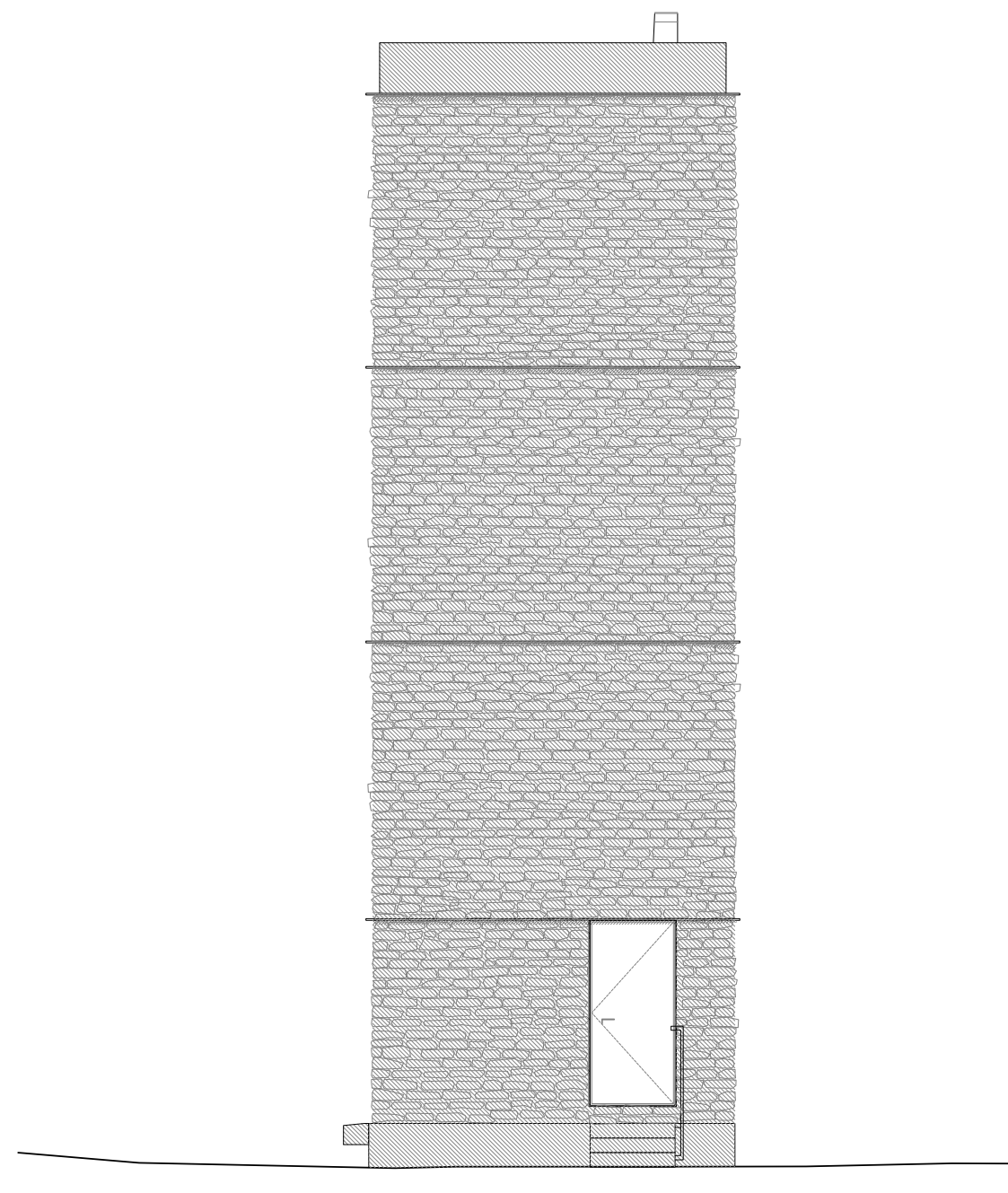
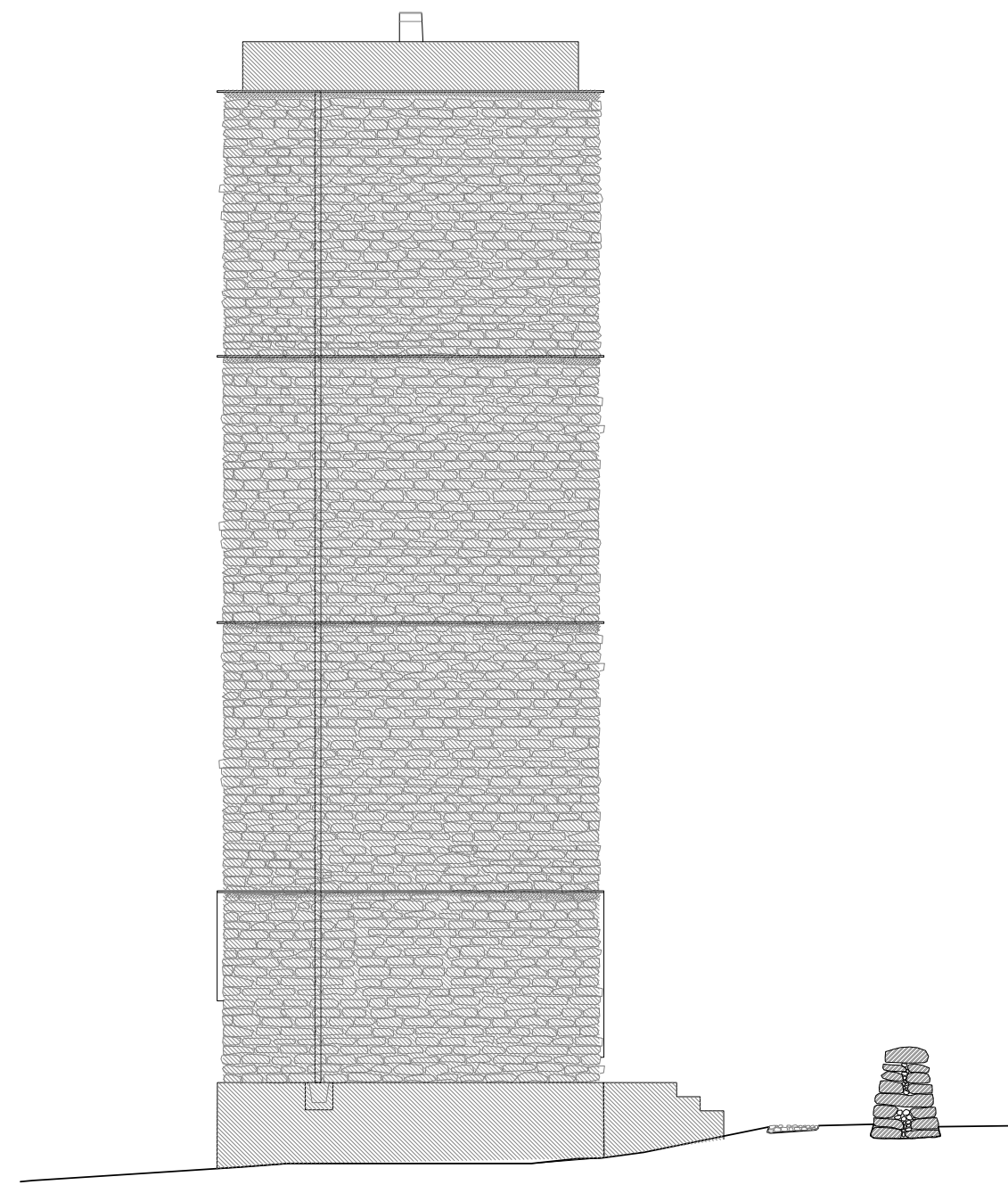
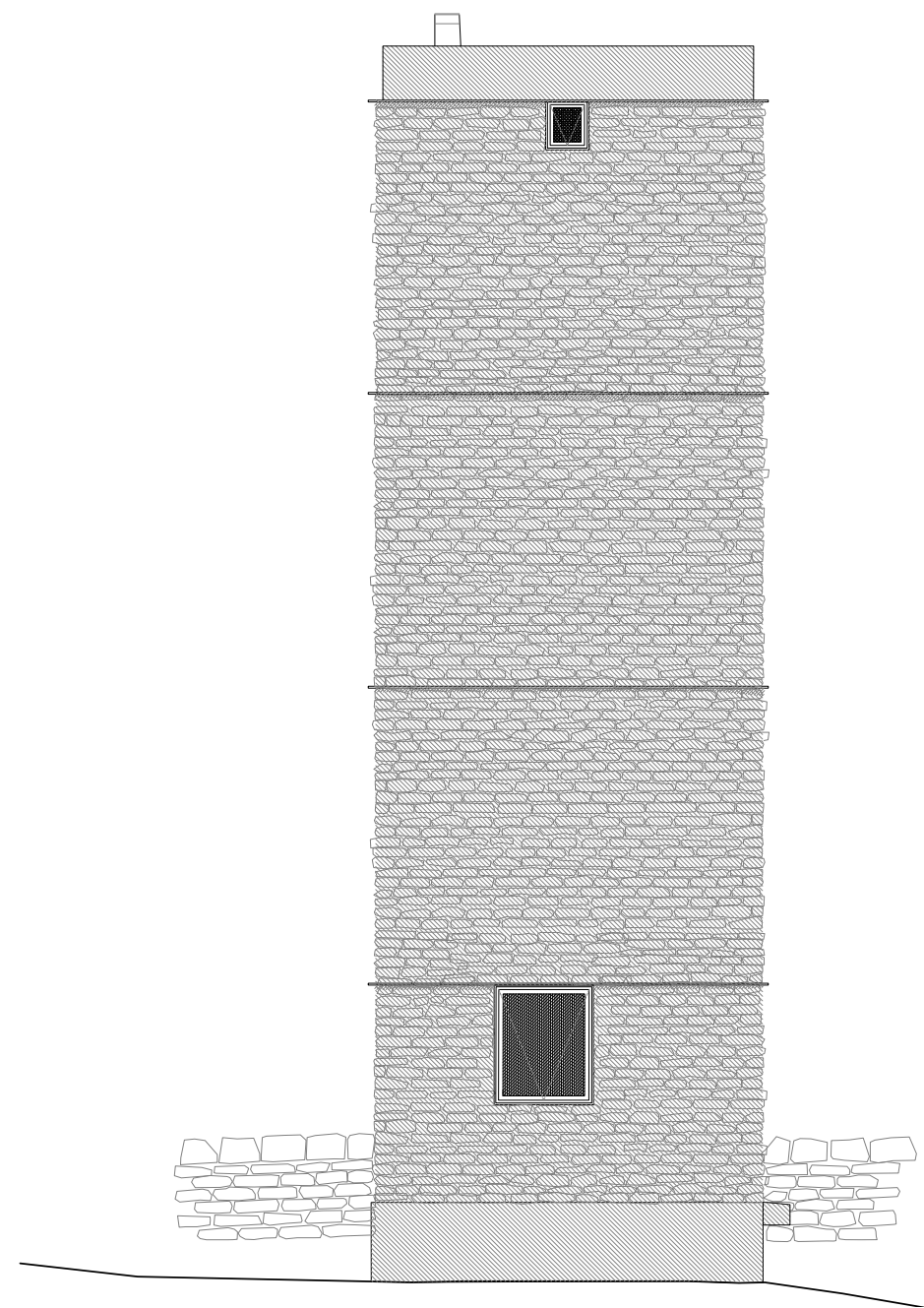







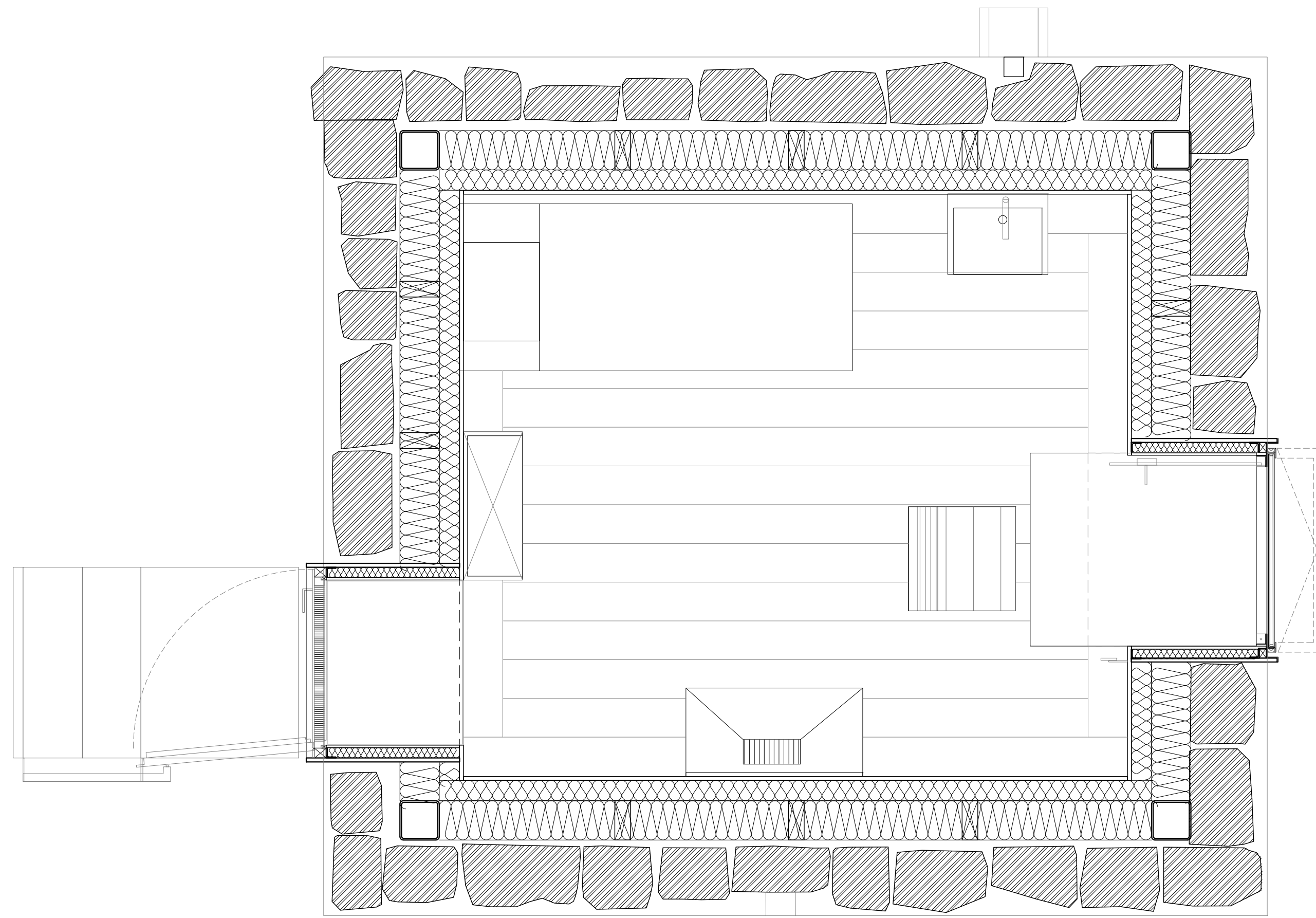
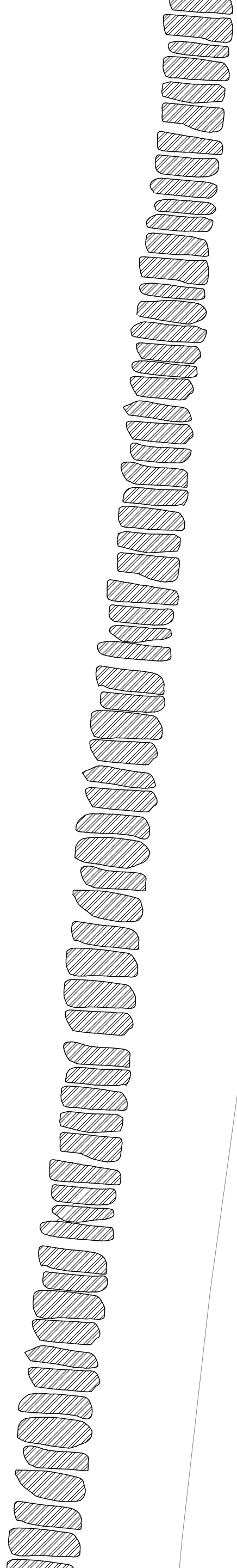

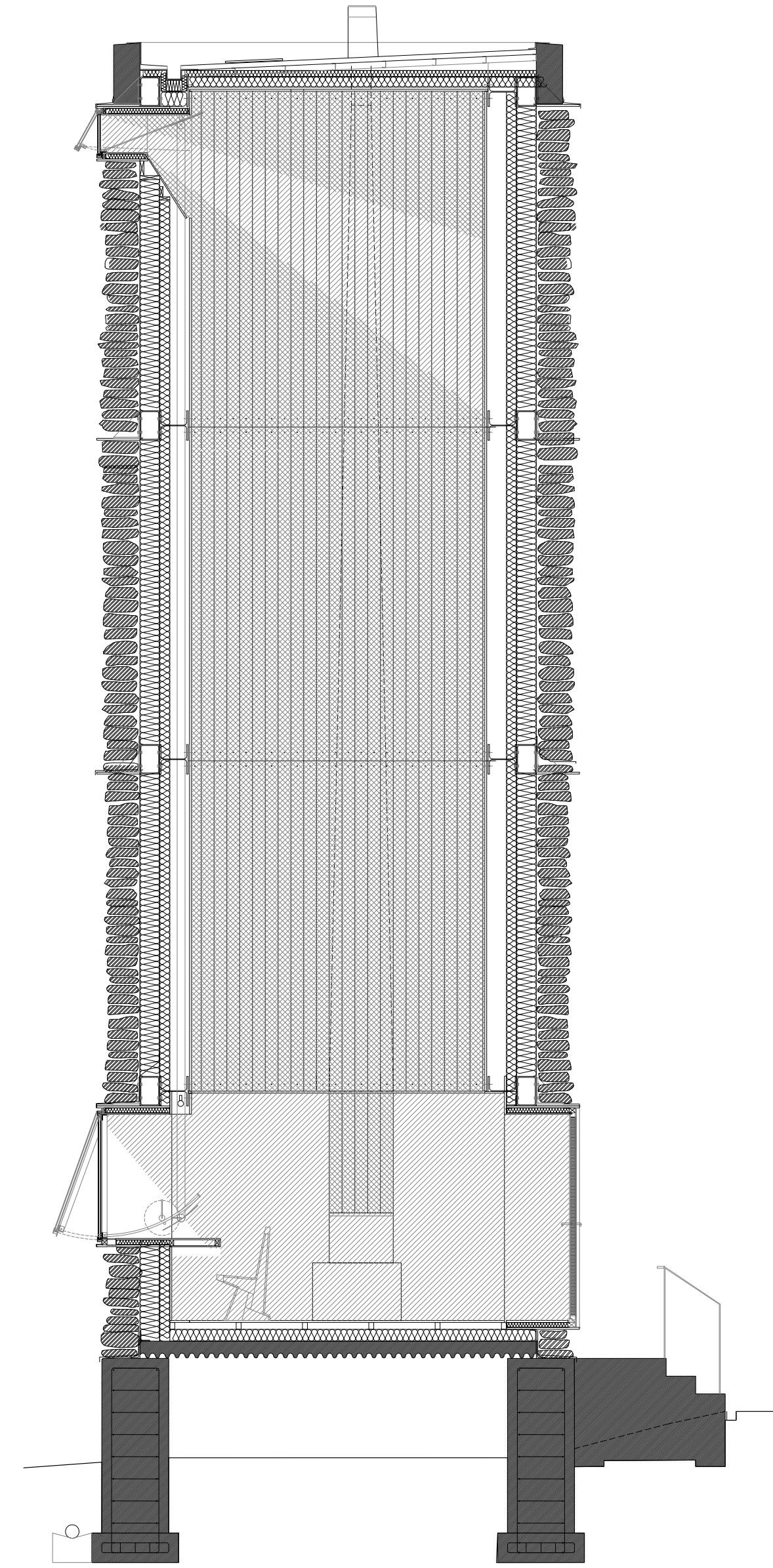
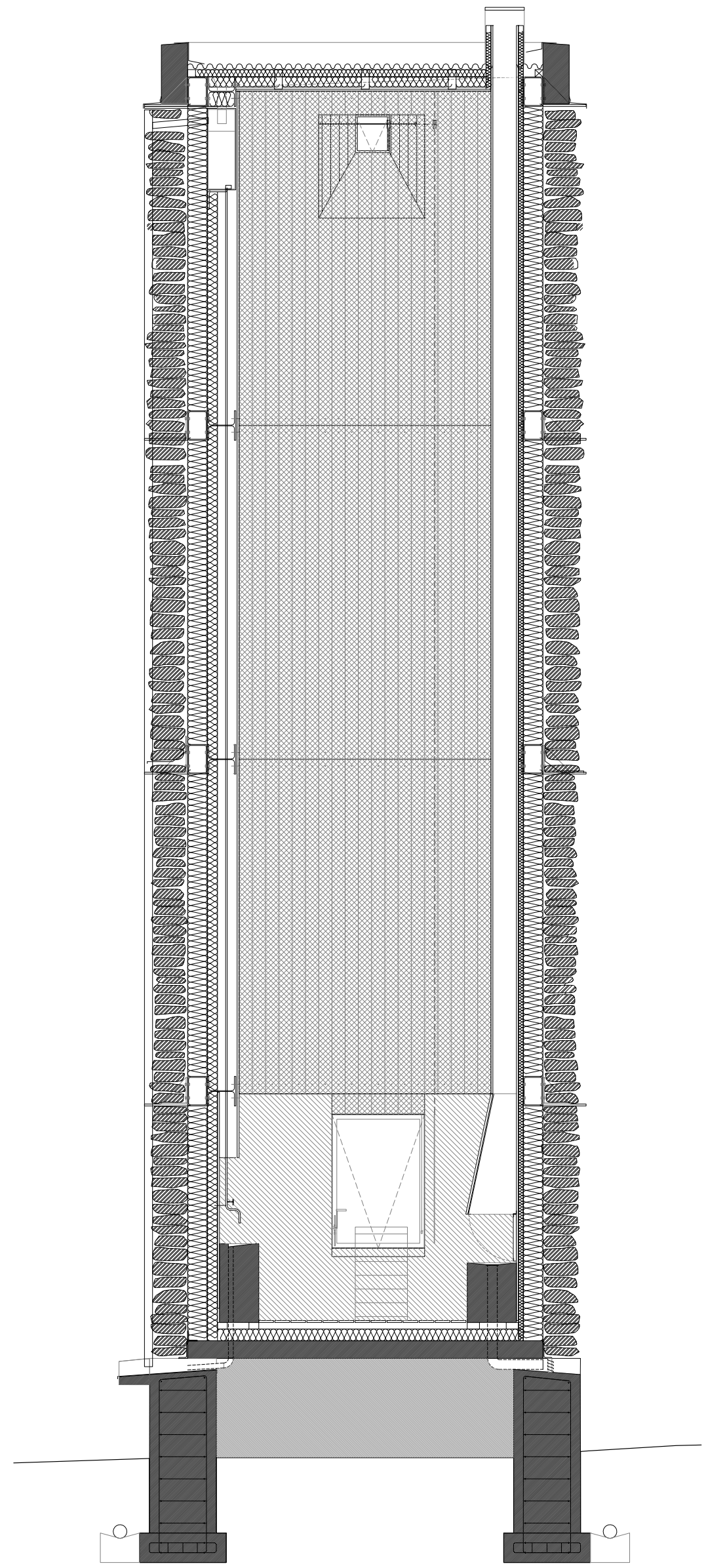

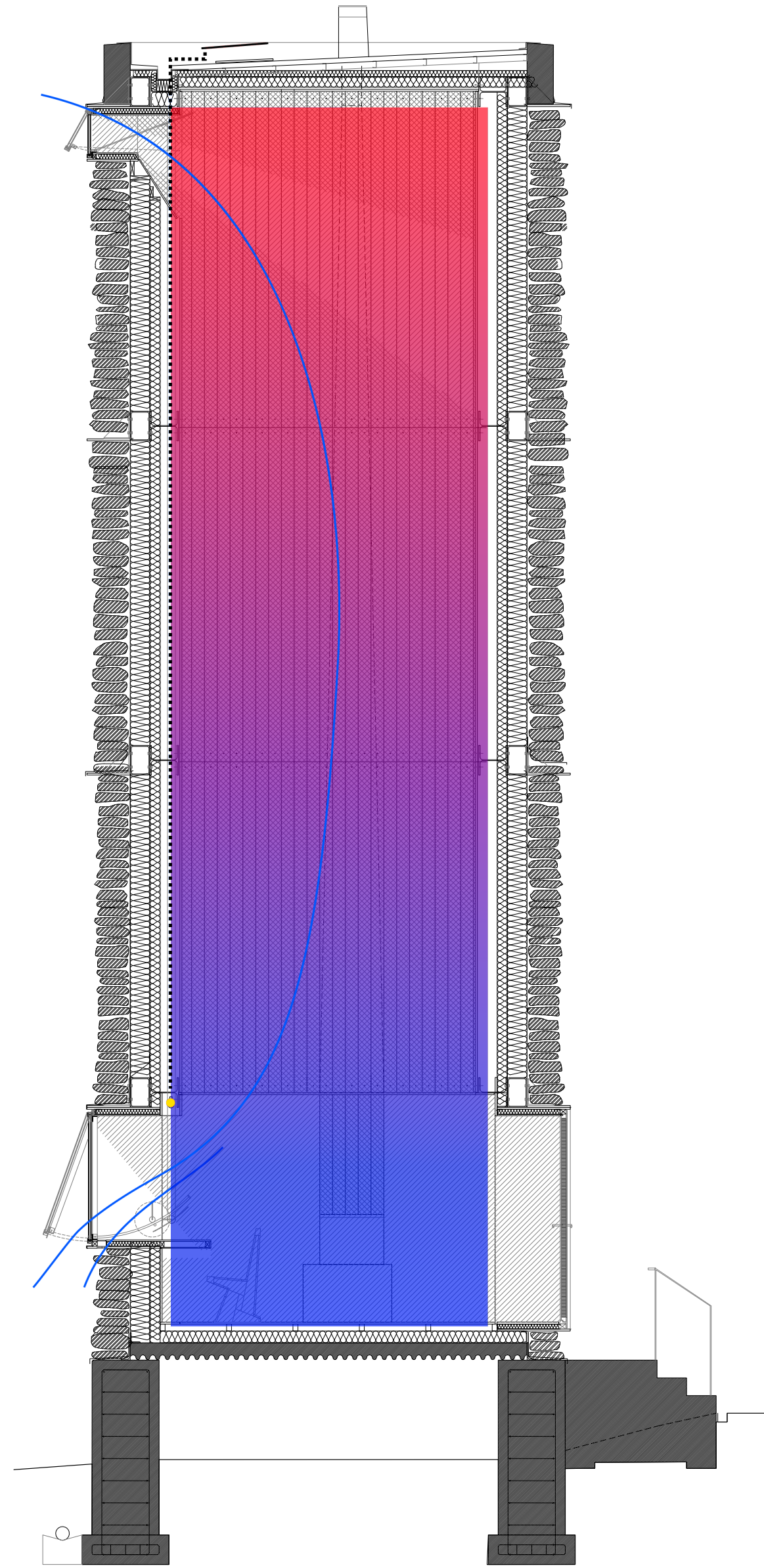
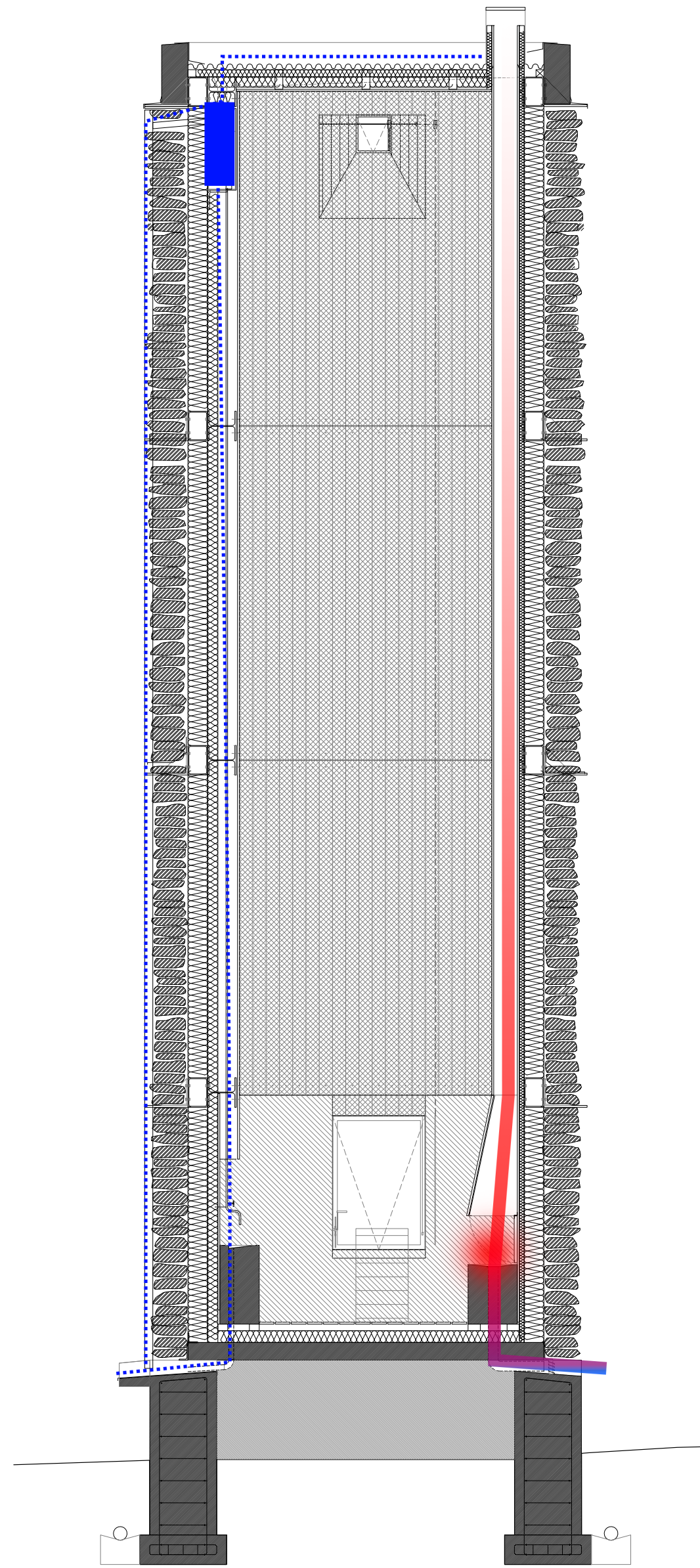

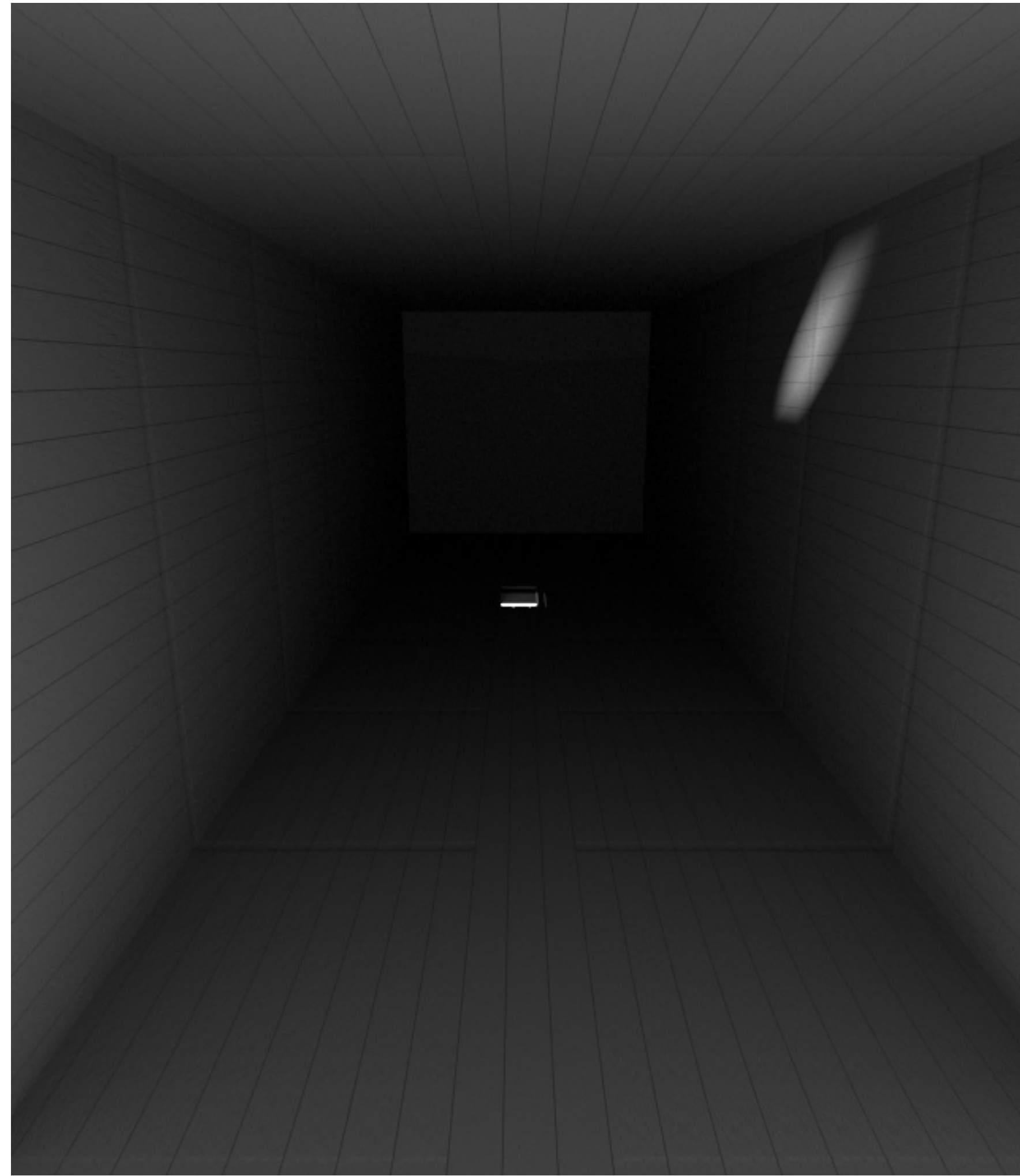





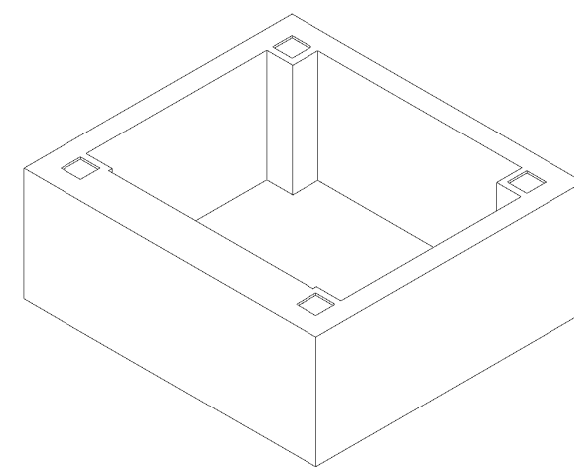

stage 1
fondation, cast in situ
concrete

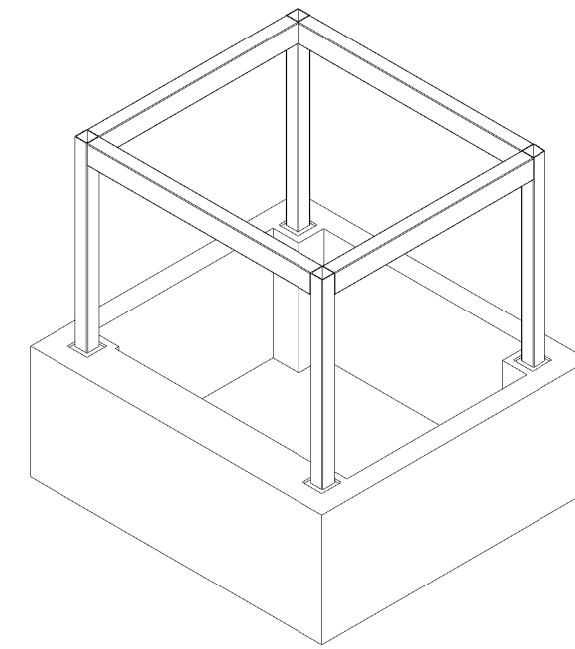

stage 2
elevation of the prefabricated tubular structure,
bolted on concrete

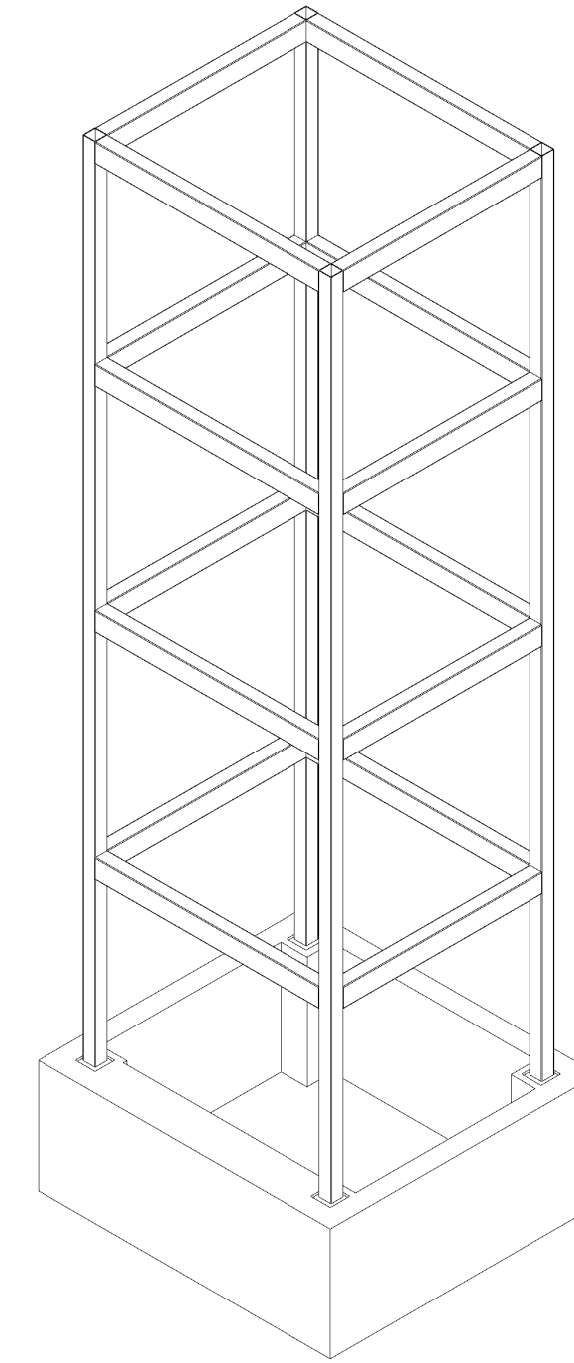

stage 3
assemblage of the several prefabricated pieces that composes the structure

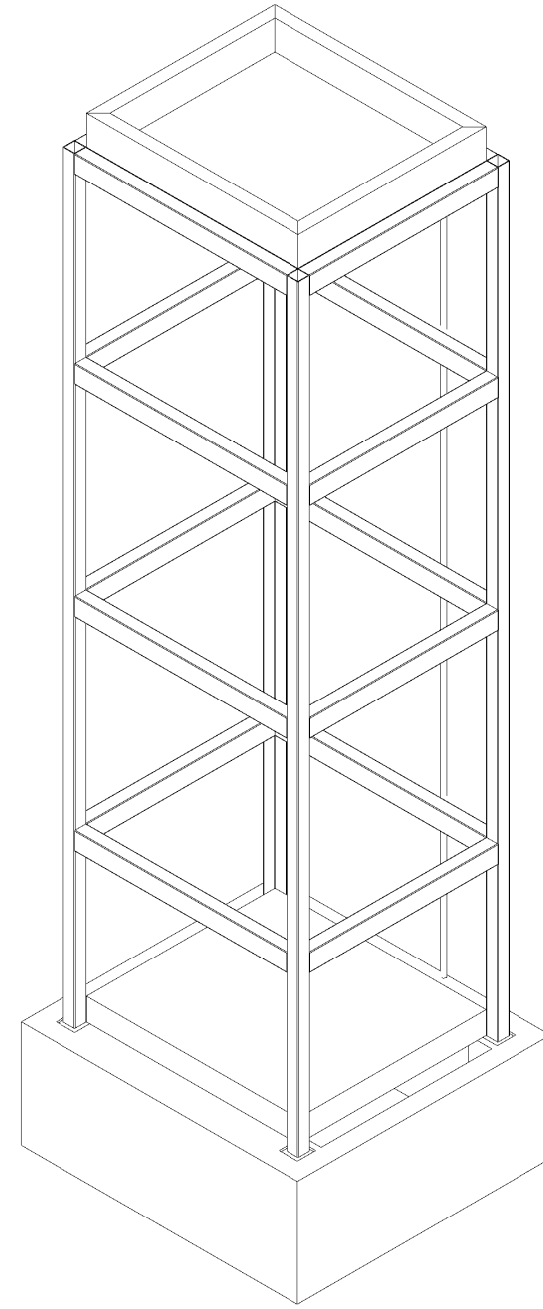

stage 4
cast of slabs on the bottom floor and the top of the structure allowing water to be collected and used for the construction of the stone wall

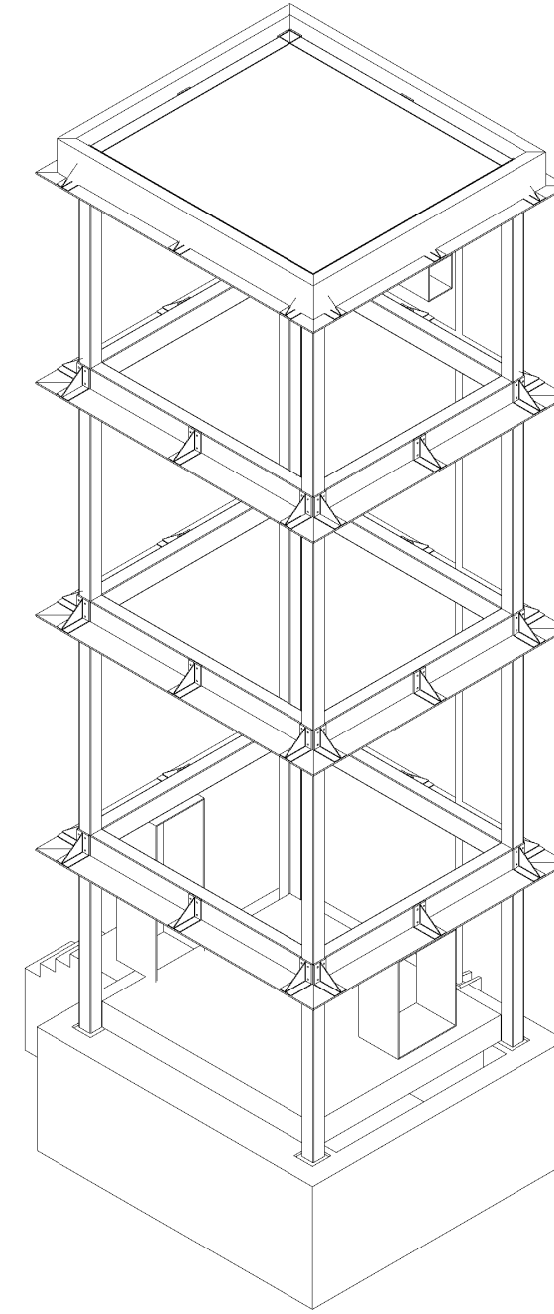

stage 5
hanging of the bolted metal plates partially supporting and stabilizing the stone wall, fixation of the opening frames, windows and doors

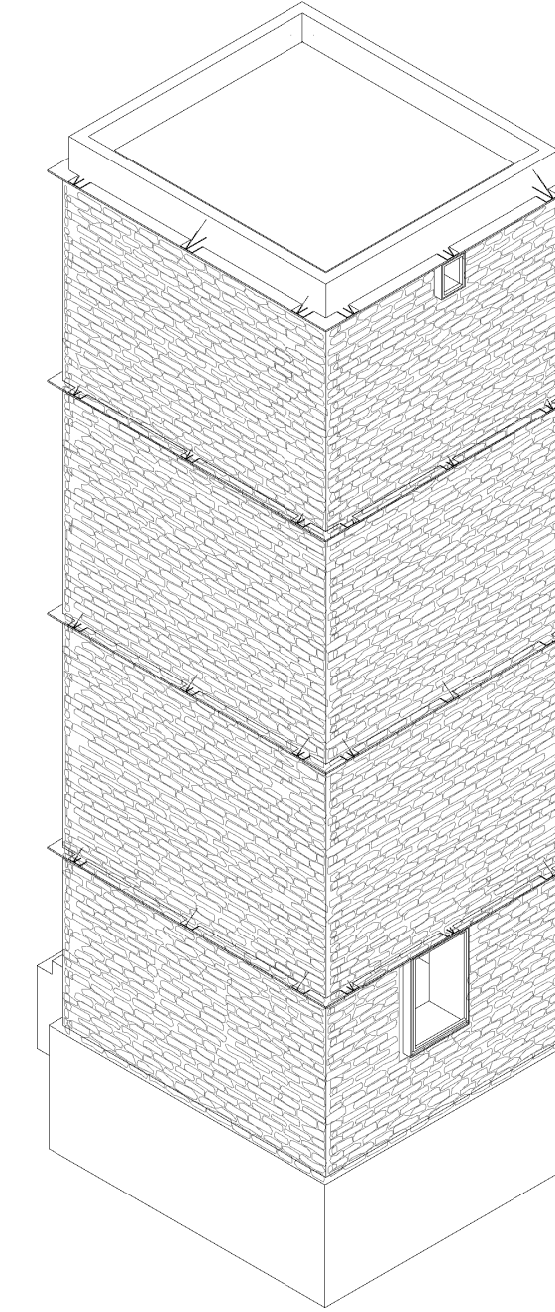

stage 6
stone facade infill thin layer of lime applied between the rocks by local craftsman, insulation and interior cladding

