

# CUTTING EDGE

ELINE STUBERT

| P5 | July 12th 2018 |





# DEVELOPMENTS

## 1. SPORT PERCEPTION



# DEVELOPMENTS

CRITICAL SPORTERS

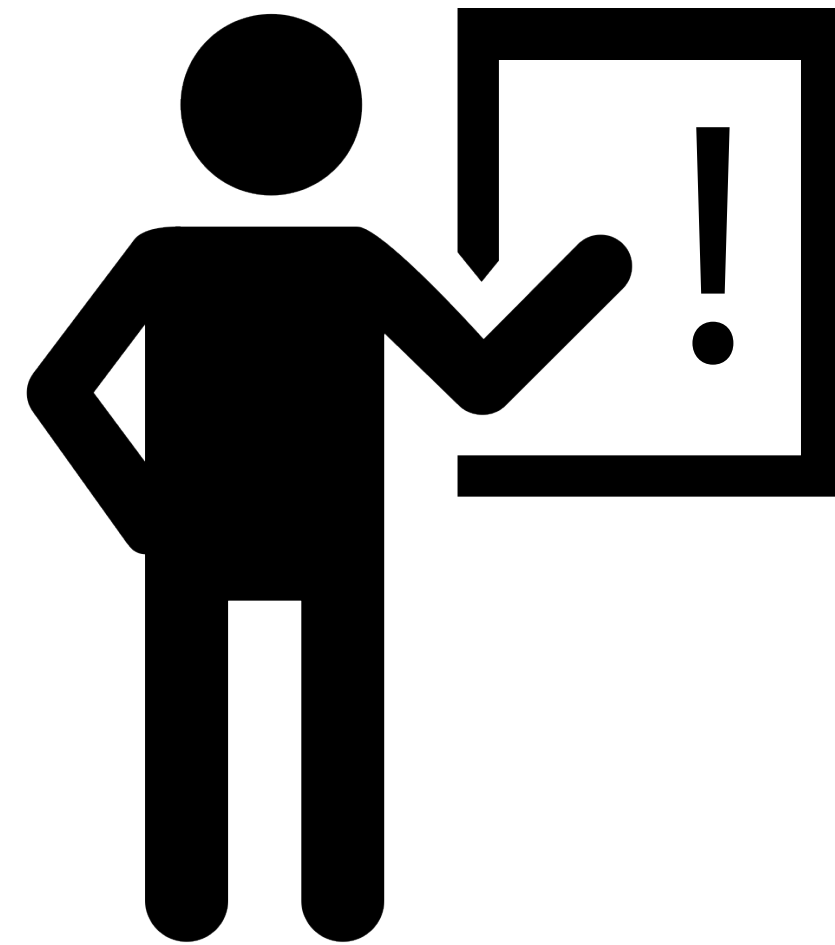

# DEVELOPMENTS

## 2. TRANSITION TOWARDS THE INDOORS

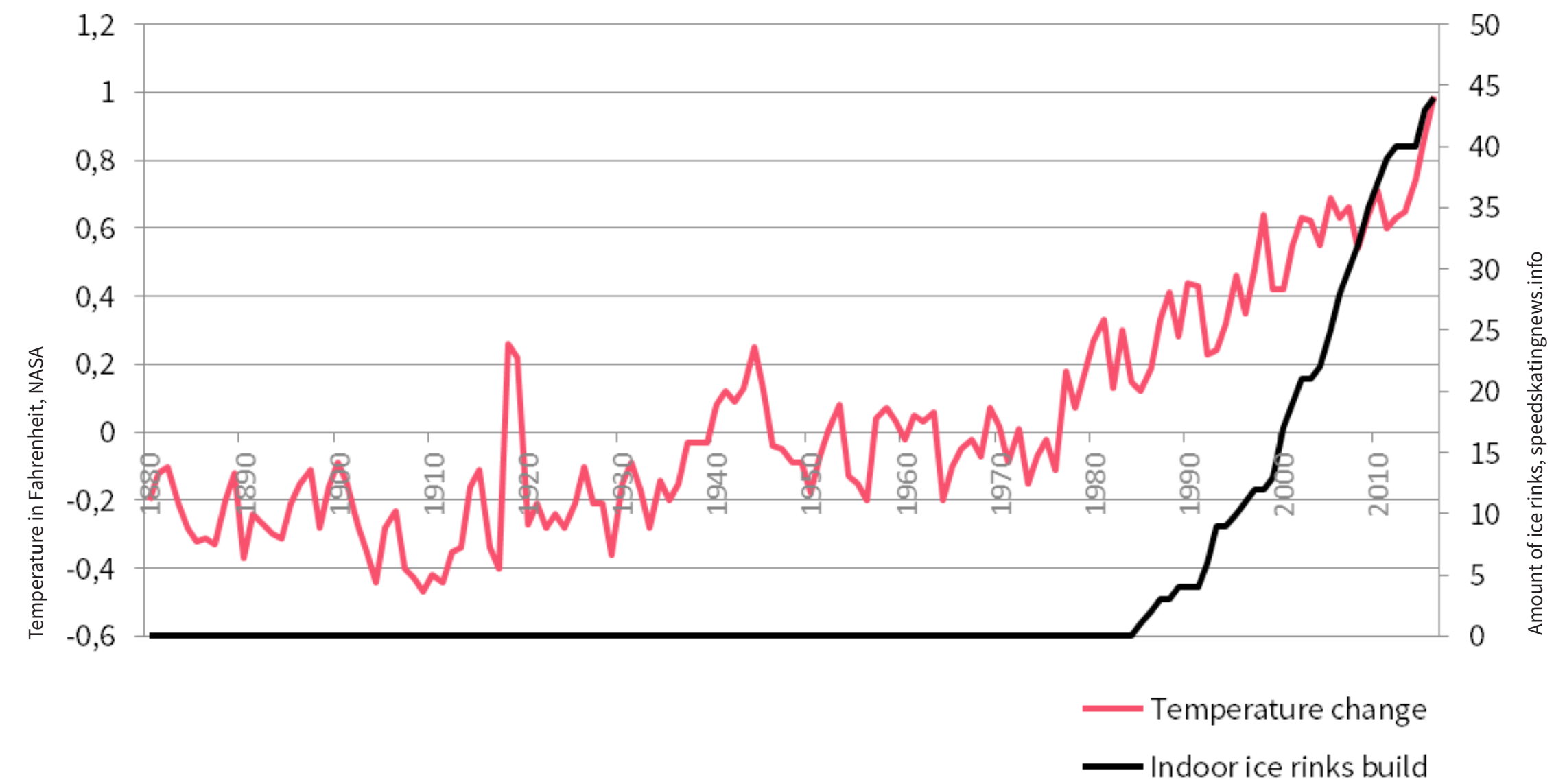

# DEVELOPMENTS

## 2. TRANSITION TOWARDS INDOORS

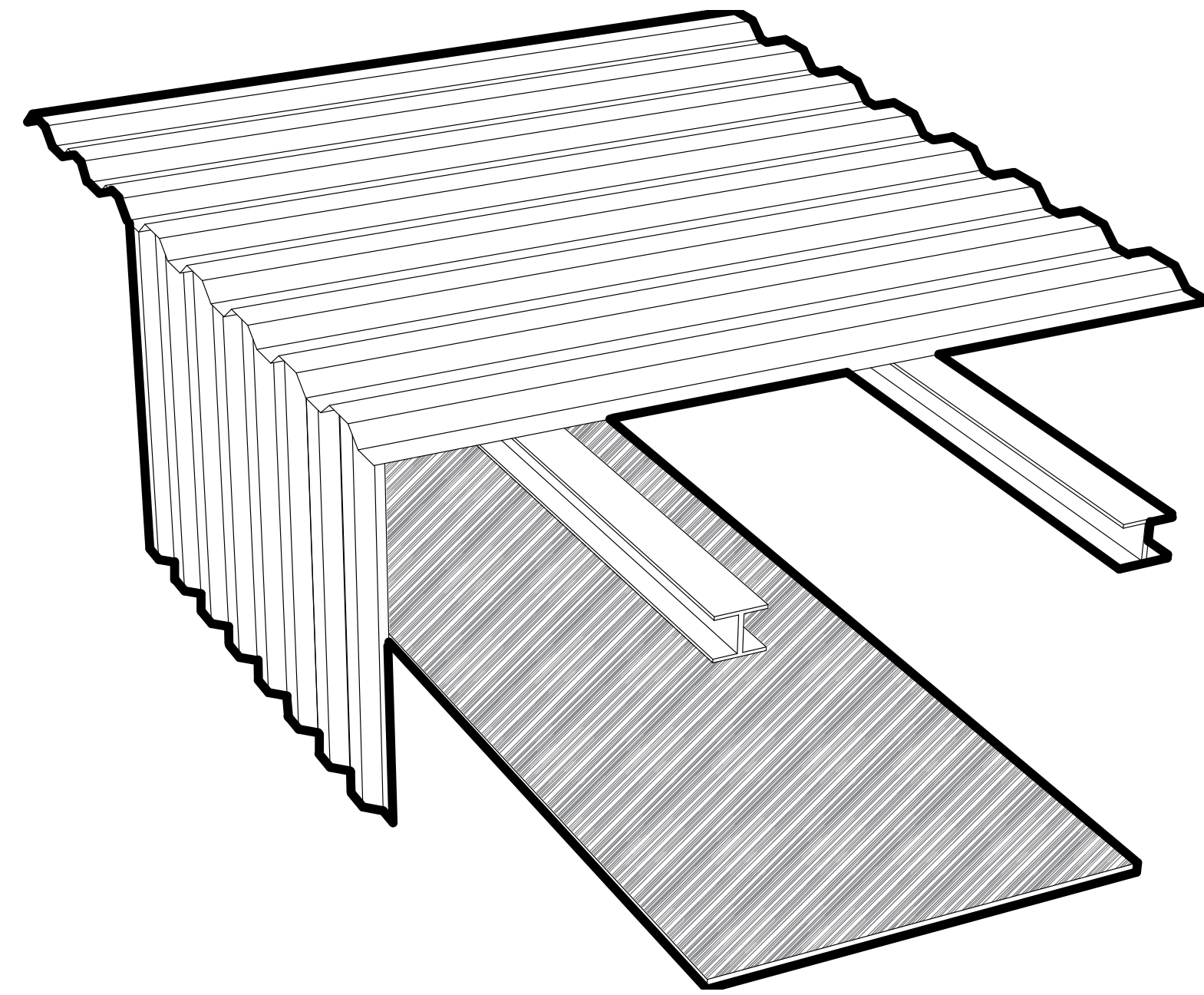

# DEVELOPMENTS

## 2. TRANSITION TOWARDS INDOORS

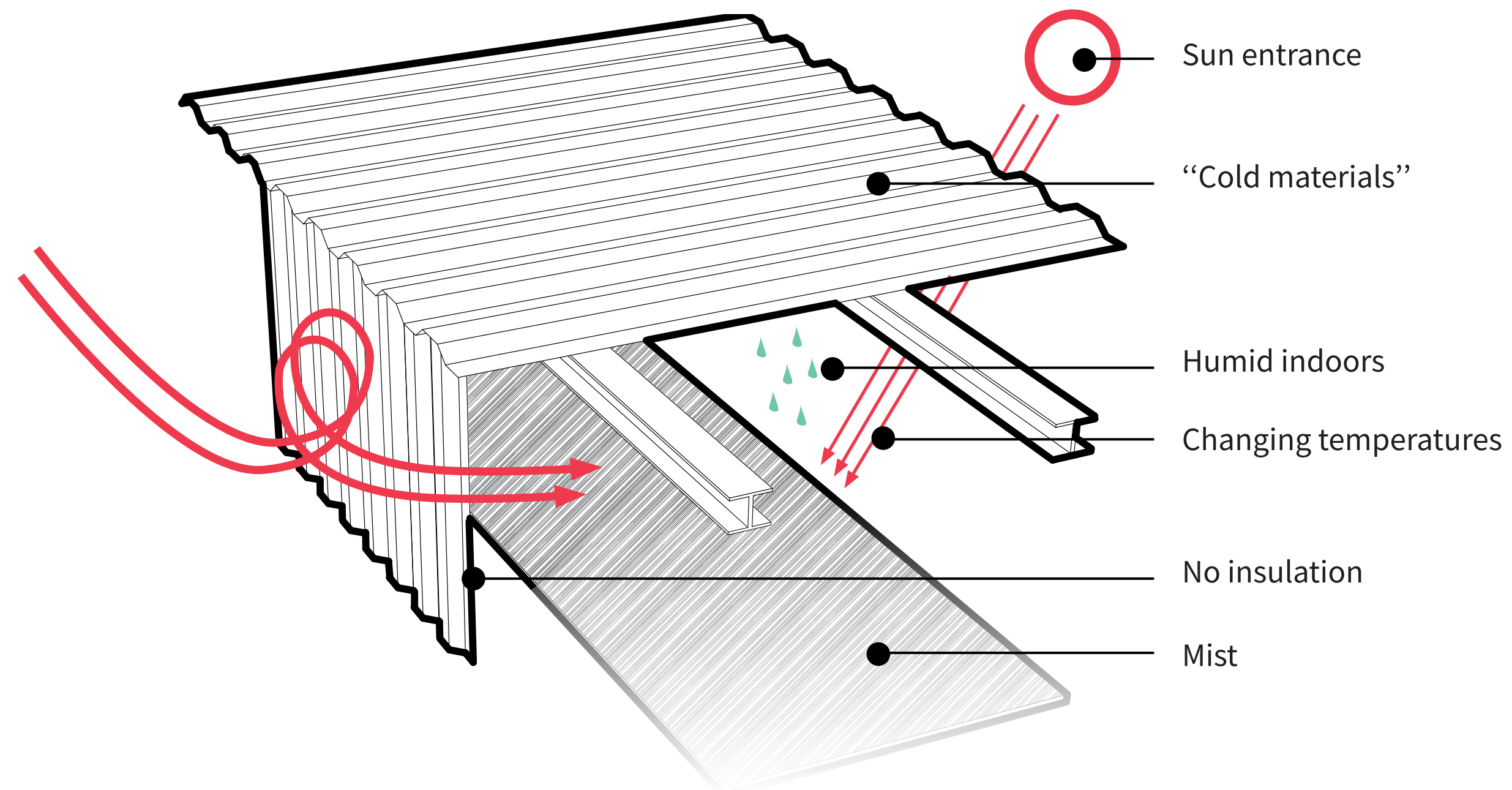

# DEVELOPMENTS

## 2. TRANSITION TOWARDS INDOORS



Het is nu heel erg blauw,  
het lijkt wel een ruimteschip...

NOS.nl

Reputation of 'cold' appearance

# DEVELOPMENTS

## 3. SEASON SPECIFIC BUILDING

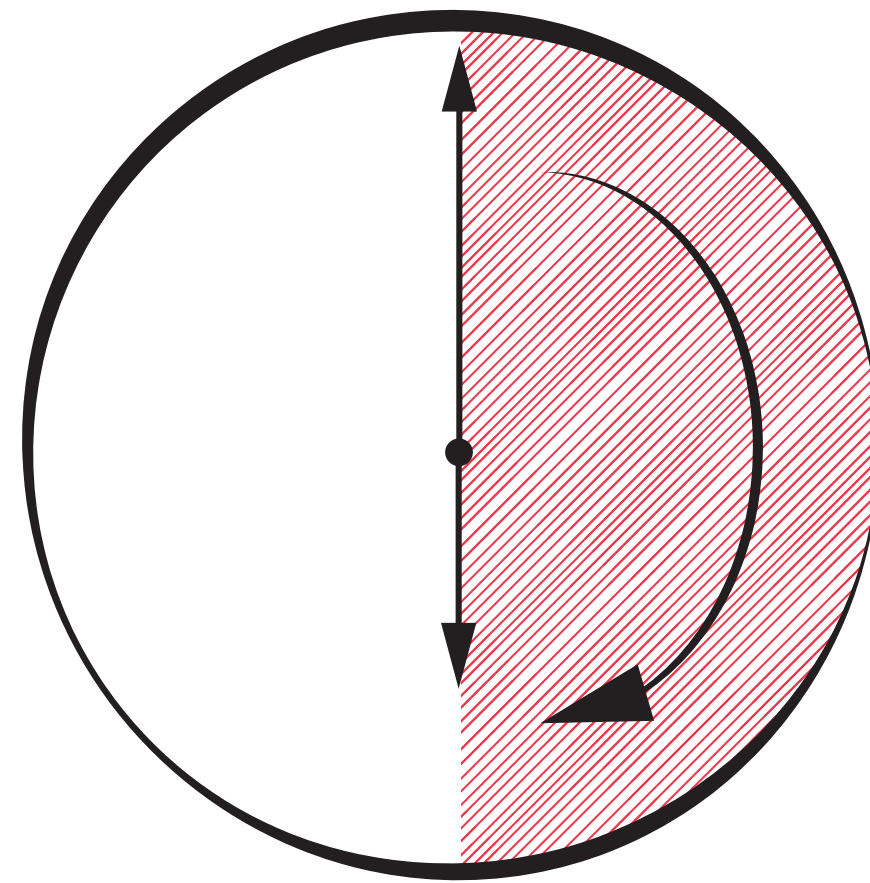

New building typology → Season specific

# DEVELOPMENTS

## 4. PRODUCTION WASTE HEAT

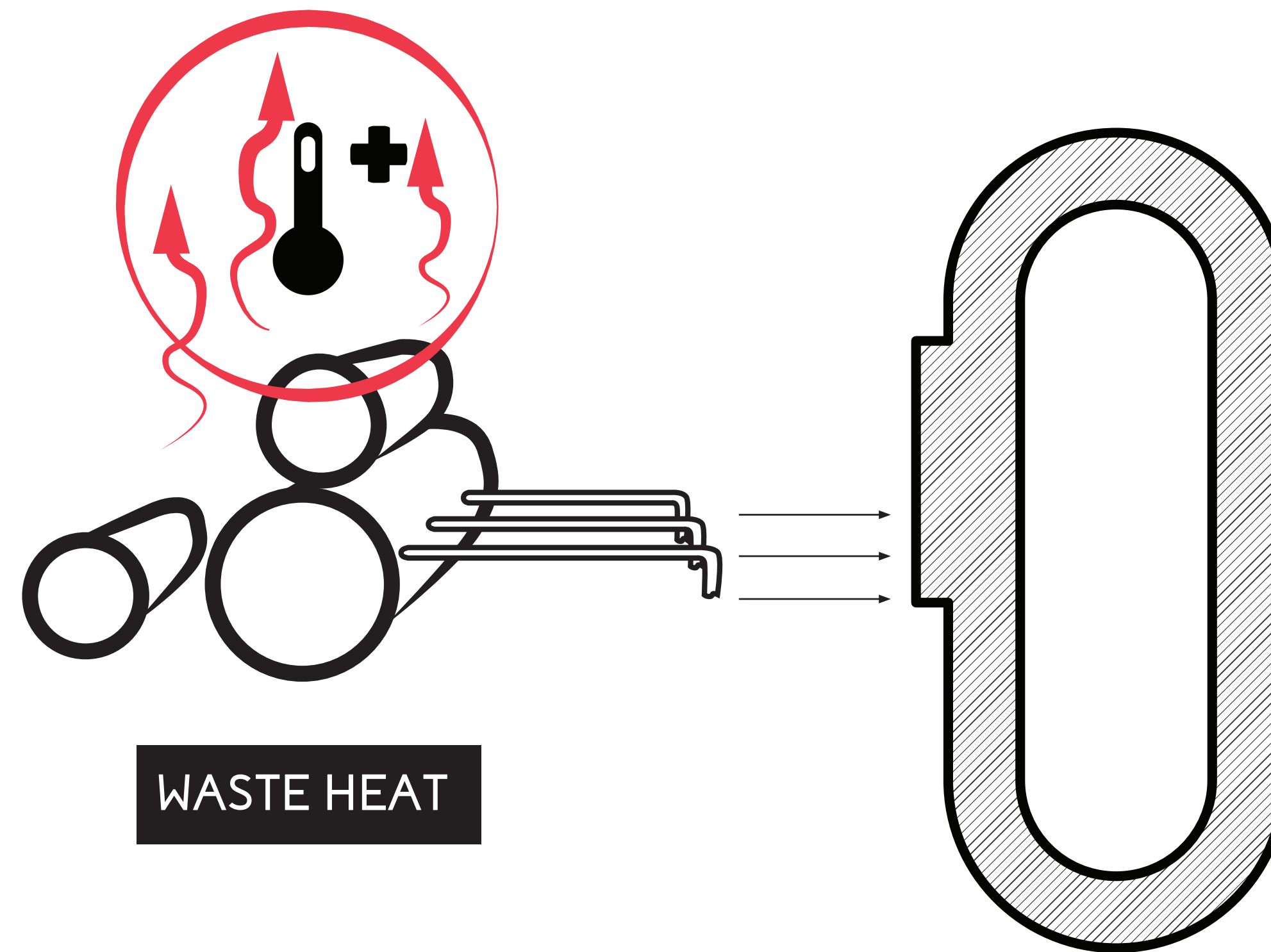

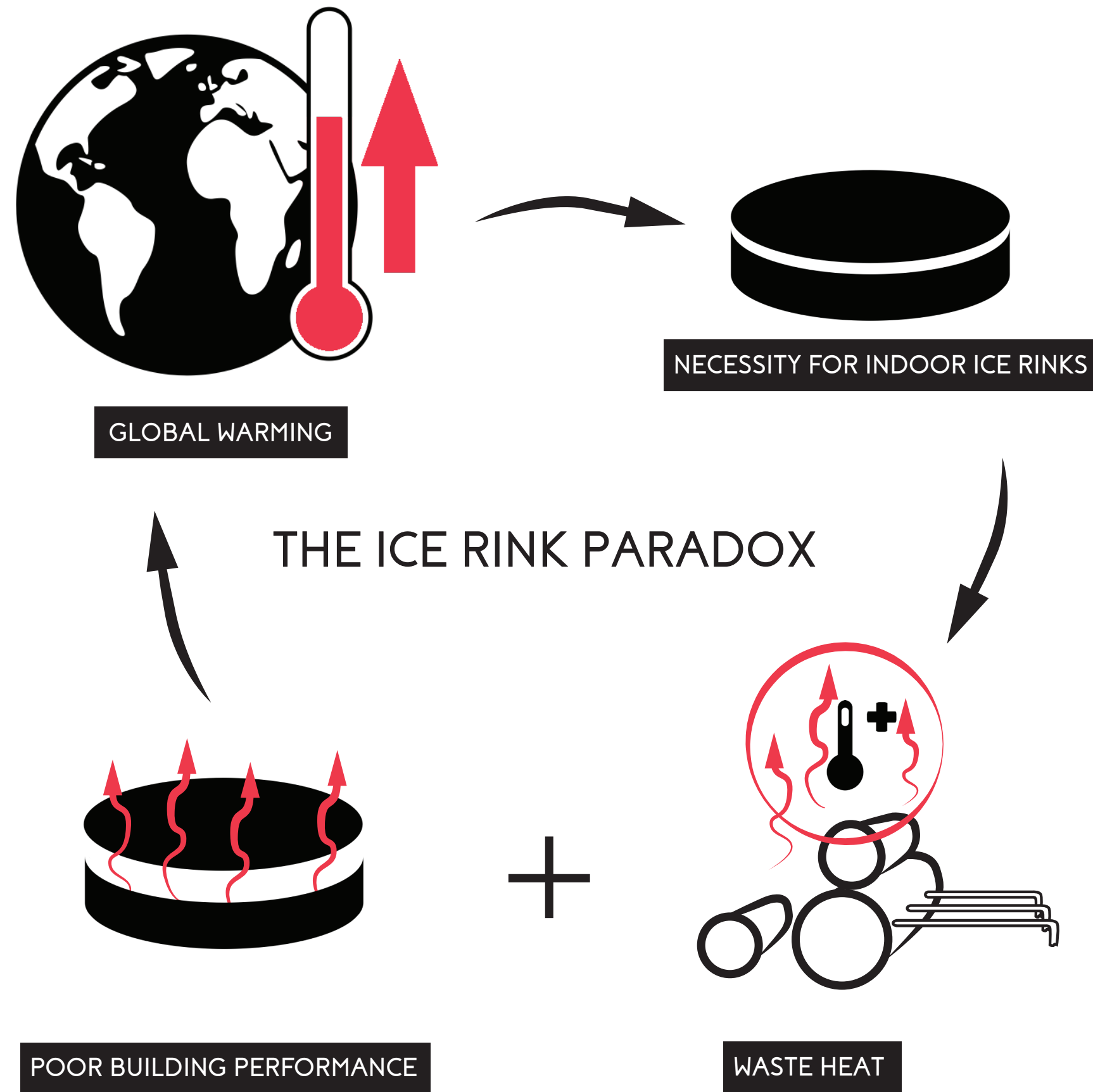

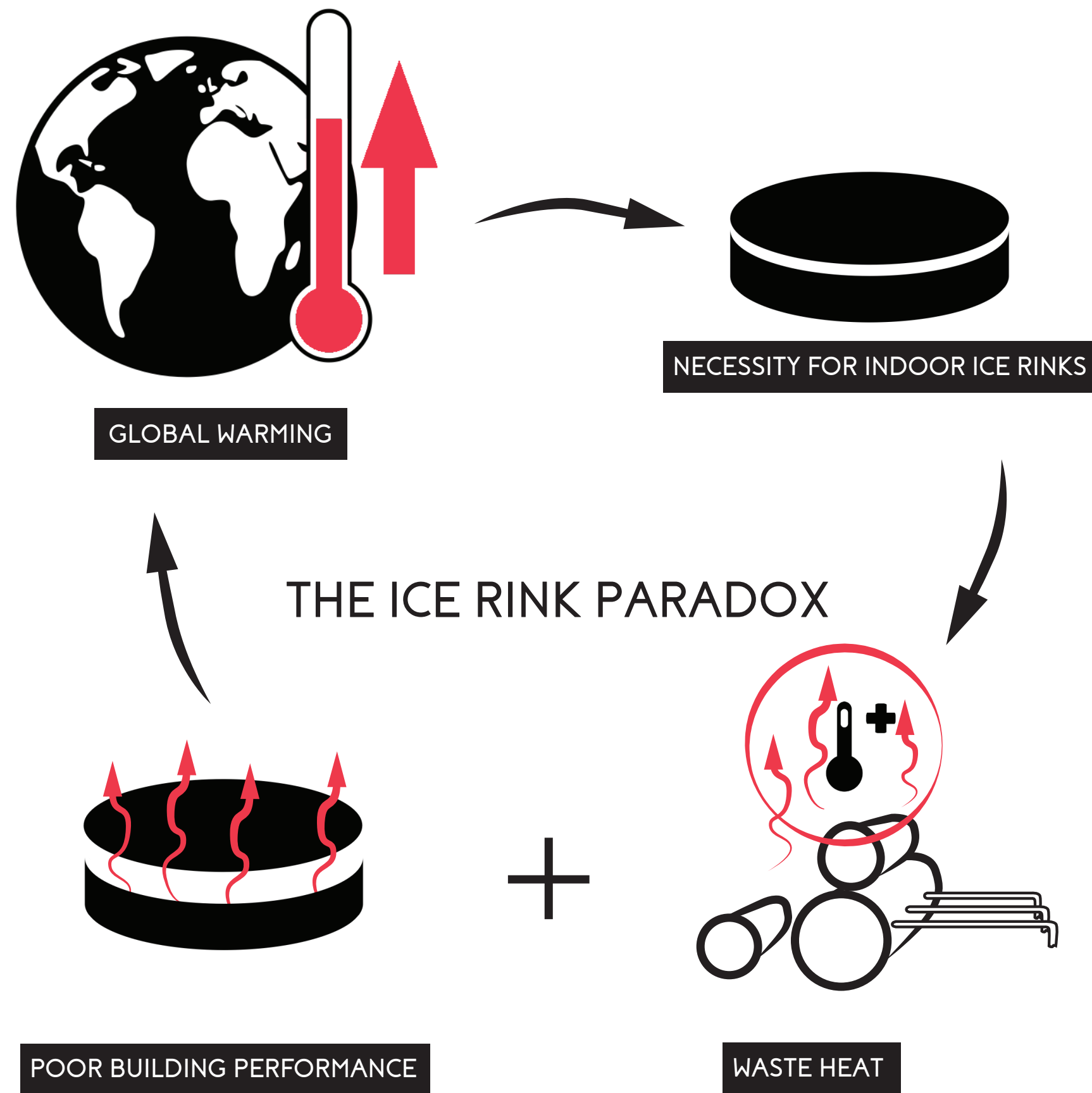

An ice rink emphasizes its reason to exist.

# PROBLEM STATEMENT

## SUMMARY

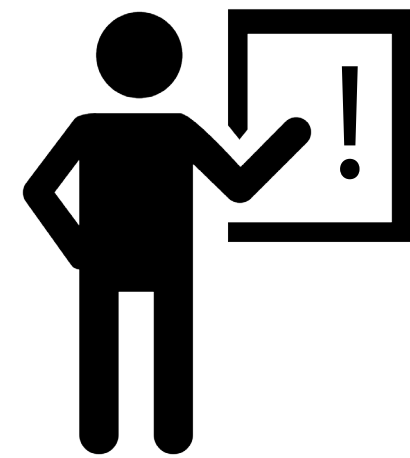

**DEMANDING SPORTERS**

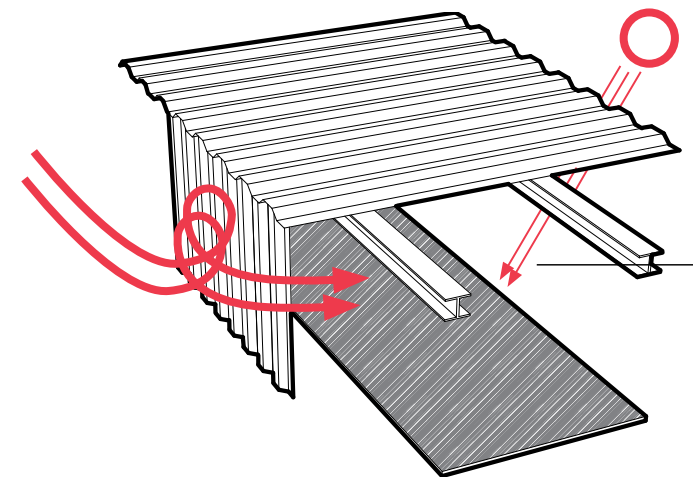

**BAD BUILDING REPUTATION**

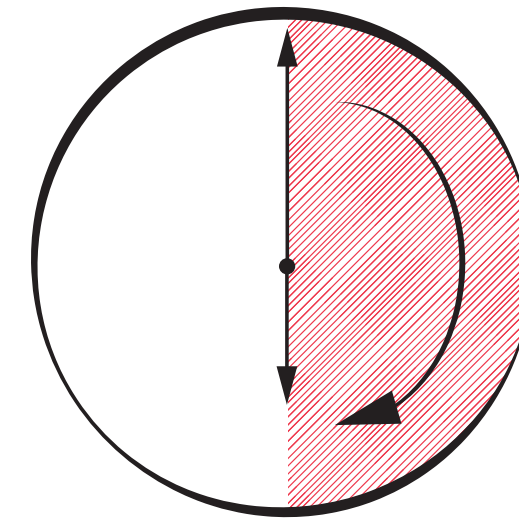

**LOW BUILDING OCCUPATION**

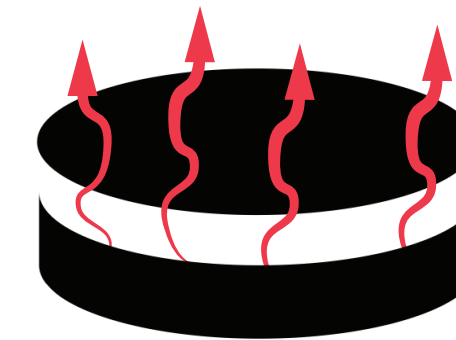

**POOR BUILDING PERFORMANCE**

# PROBLEM STATEMENT

## SUMMARY

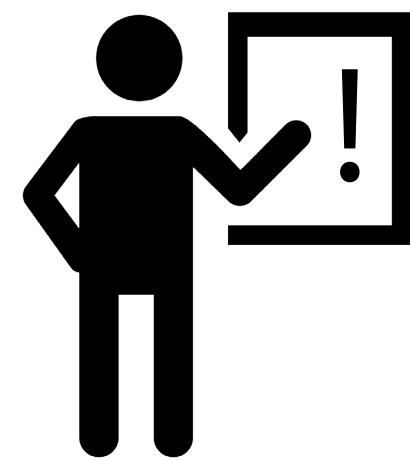

**DEMANDING SPORTERS**

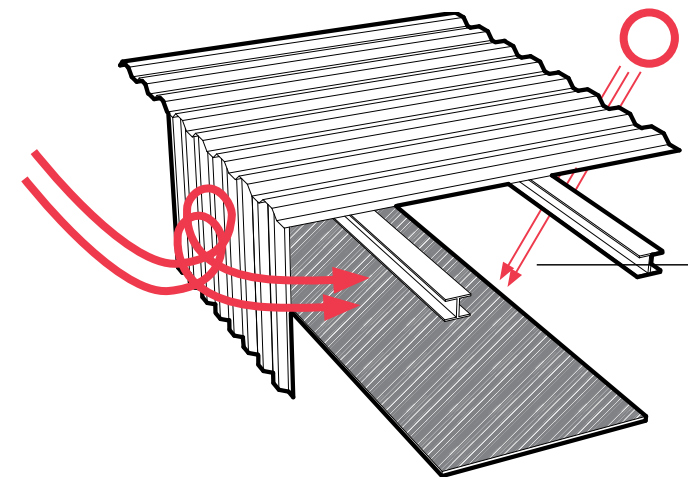

**BAD BUILDING REPUTATION**

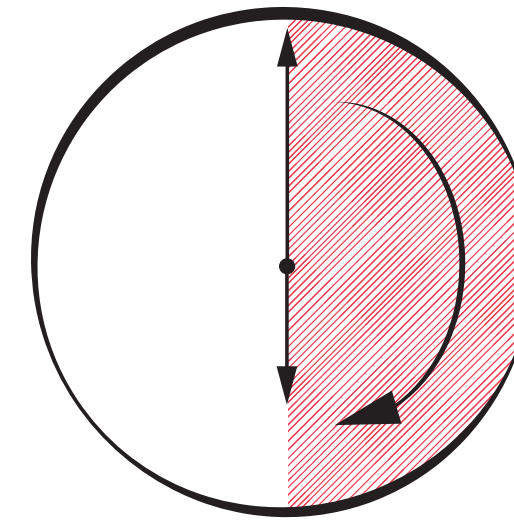

**LOW BUILDING OCCUPATION**

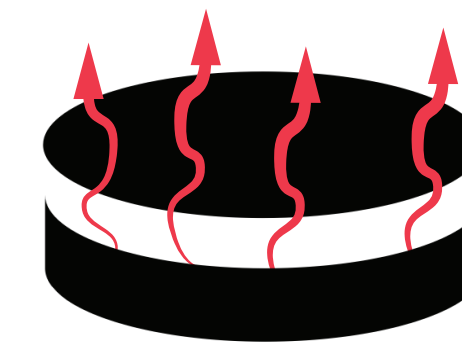

**POOR BUILDING PERFORMANCE**

How to make an ice rink (energy) efficient?

# TABLE OF CONTENT

## **RESEARCH**

METHOD  
CONCLUSIONS

## **DESIGN**

DESIGN ASSIGNMENT

CITY  
CONTEXT  
BUILDING  
CLIMATE  
CONSTRUCTION

## **ENERGY STRATEGY**

## **CONCLUSION**

REFLECTION

RESEARCH

# RESEARCH

MAIN QUESTION

How to integrate energy-saving architectural instruments towards a holistic energy neutral ice rink design.

# RESEARCH

MAIN QUESTION

How to integrate energy-saving architectural instruments towards a holistic energy neutral ice rink design.

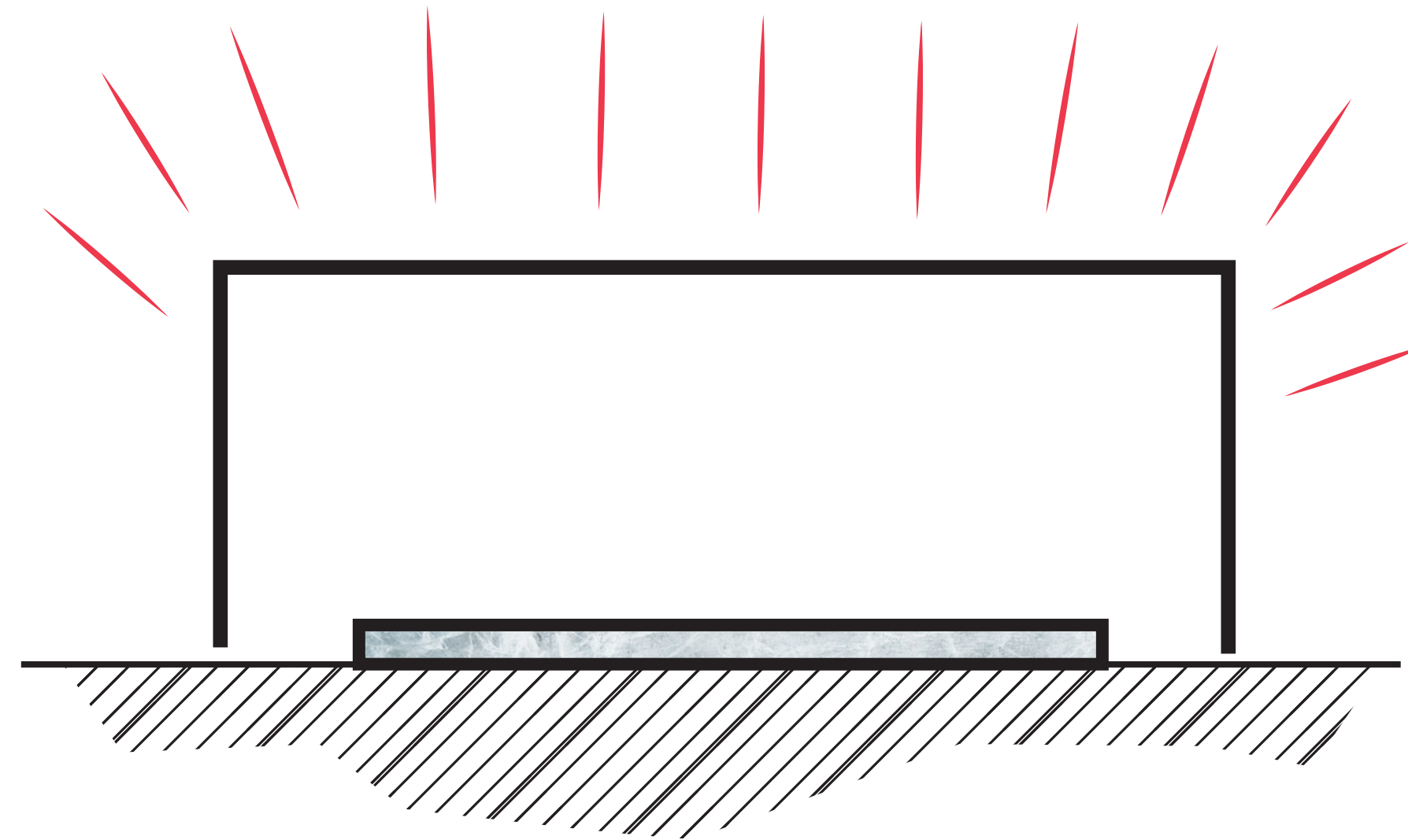

# RESEARCH

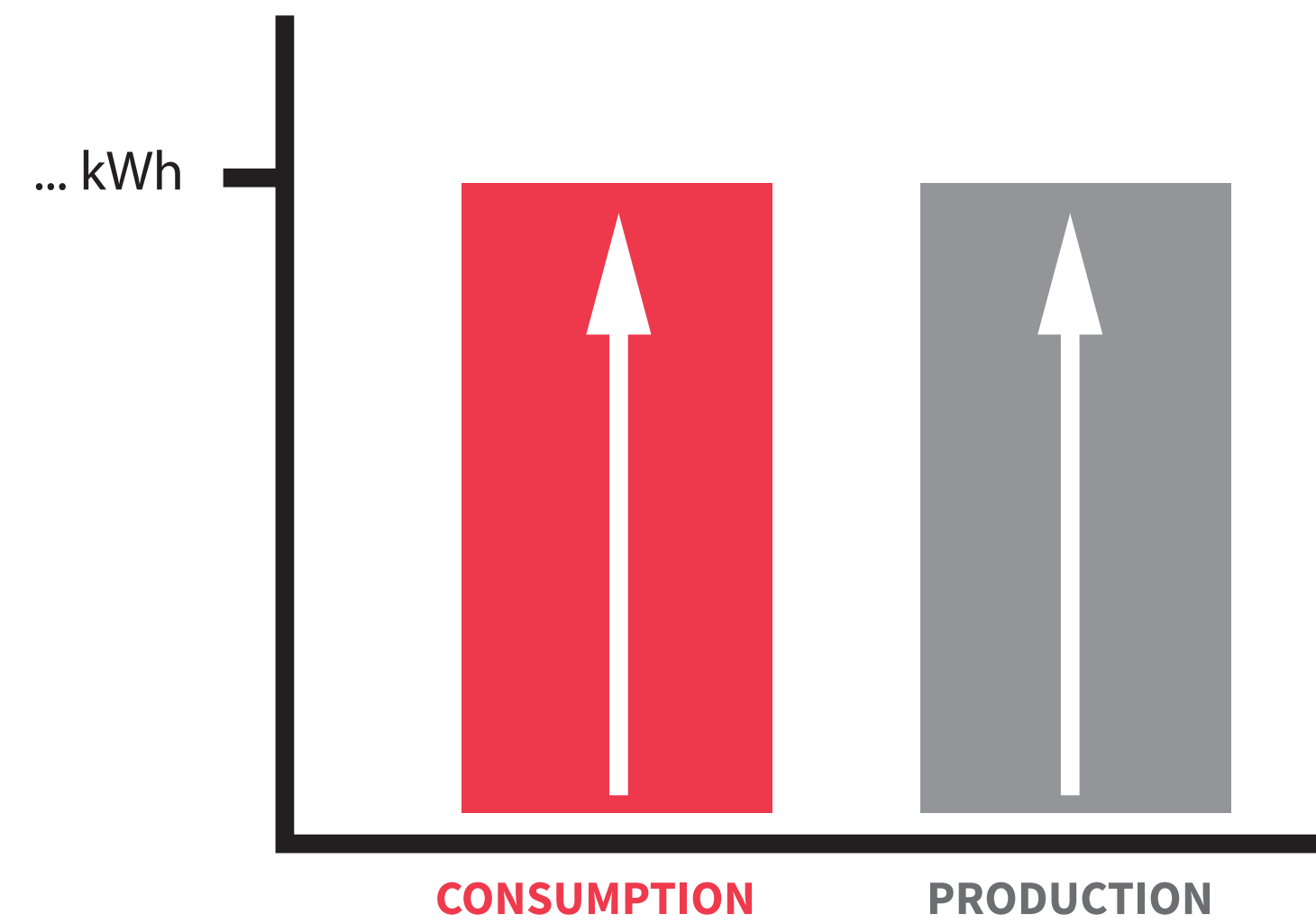

What is energy neutral?

# RESEARCH

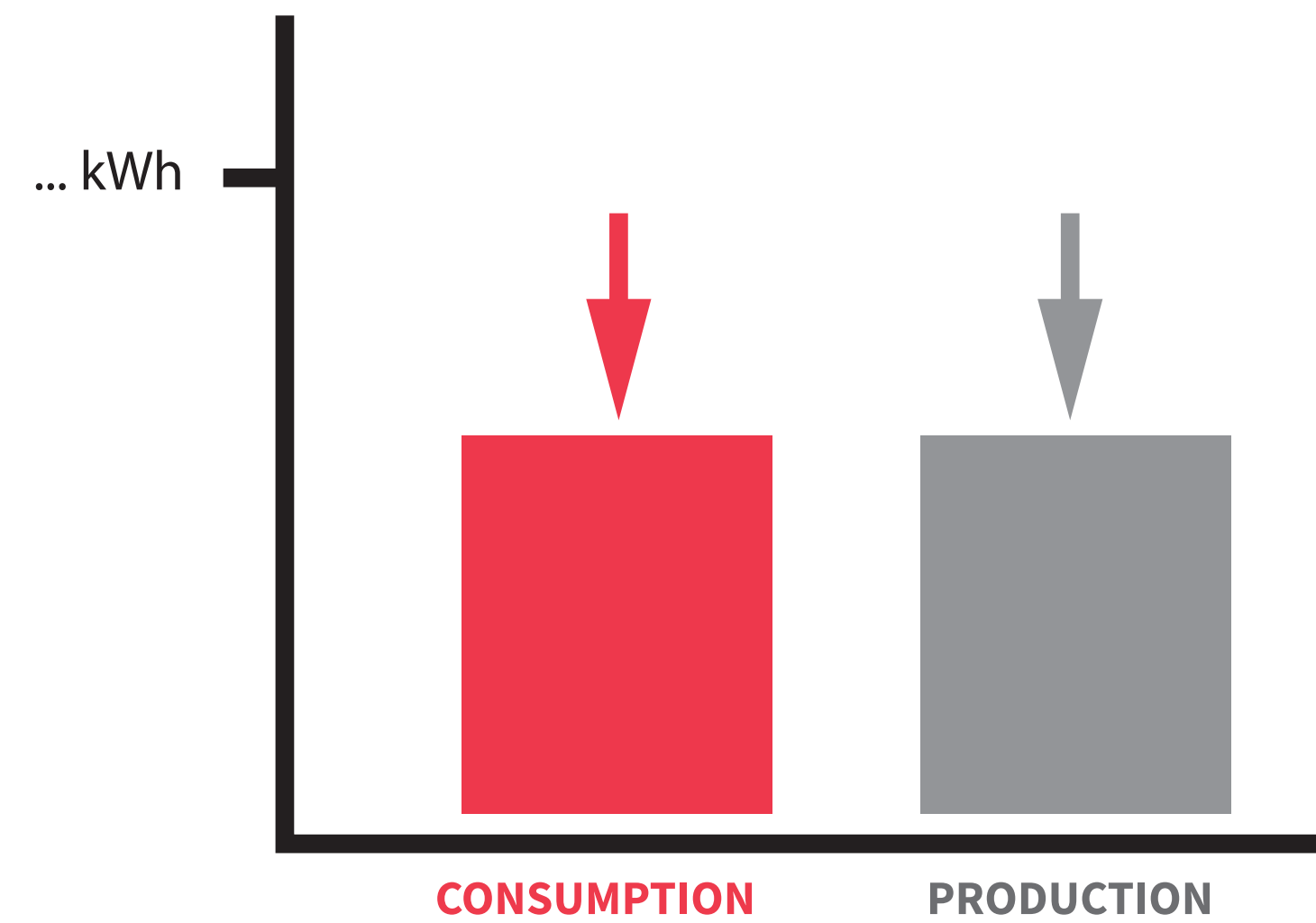

Strategies to lower energy demand

# RESEARCH

SUB QUESTIONS

WHO MAKE USE OF THE BUILDING?



**QUESTIONNAIRE**

WHAT FUNCTIONS CAN BE APPLIED IN SUMMER?



**CASE STUDIES**

WHICH SPACES ARE REQUIRED IN AN ICE RINK?



**CASE STUDIES**

WHAT ARE THE TECHNICAL REQUIREMENTS?



**INTERVIEWS**

+

**LITERATURE**

# RESEARCH

THREE CATEGORIES



# RESEARCH

THREE CATEGORIES



ENERGY EFFICIENCY

# RESEARCH

## RESULTS

### OPERATION DESIGN

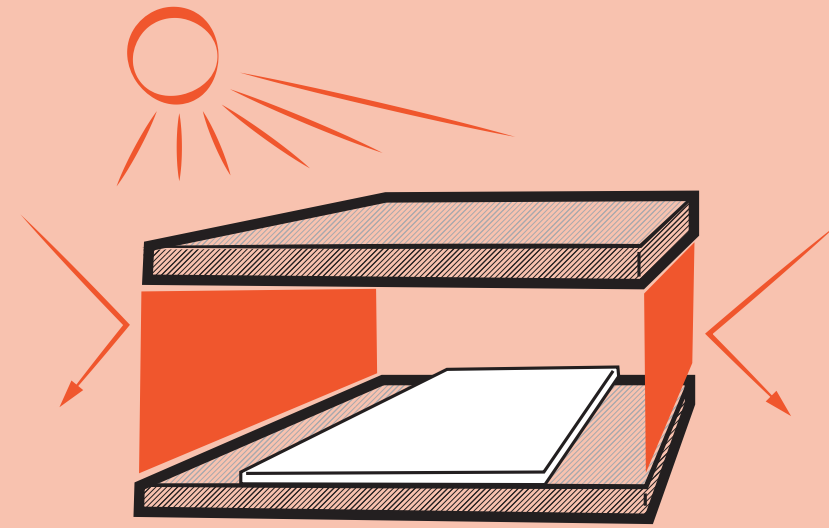

Able to completely block day- and sunlight.

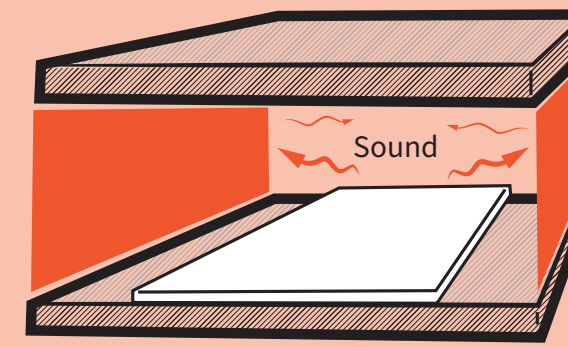

Provide acoustic comfort

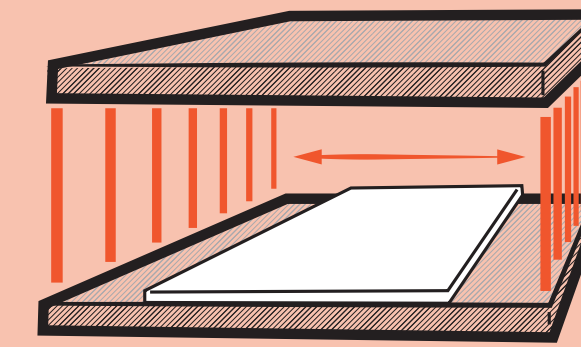

A columnless space

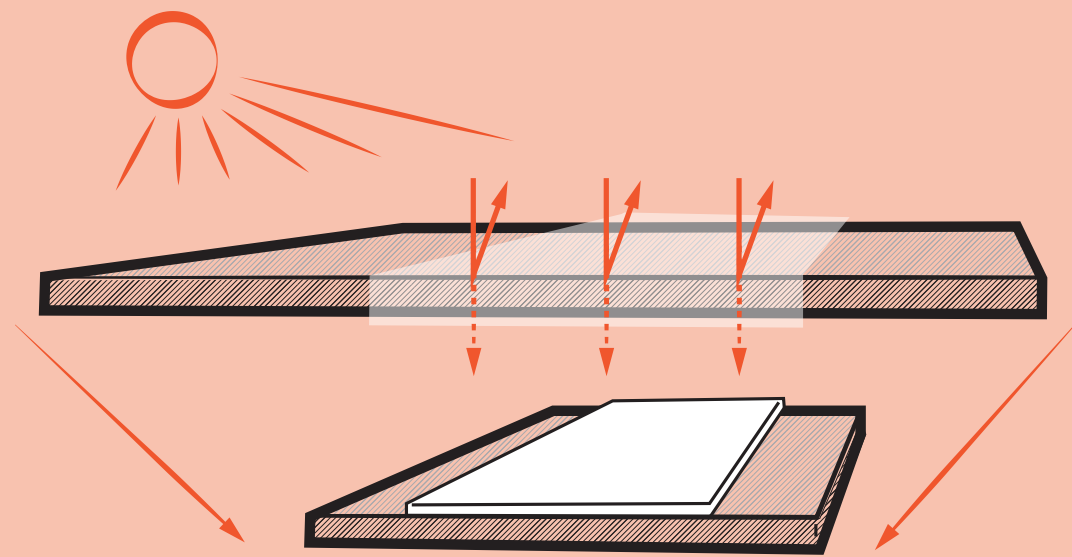

Natural daylight, no direct sunlight

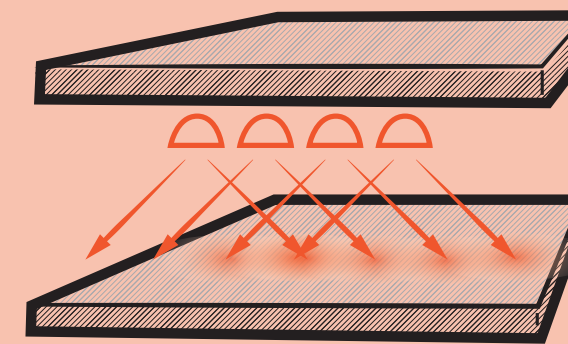

Homogeneous lighting

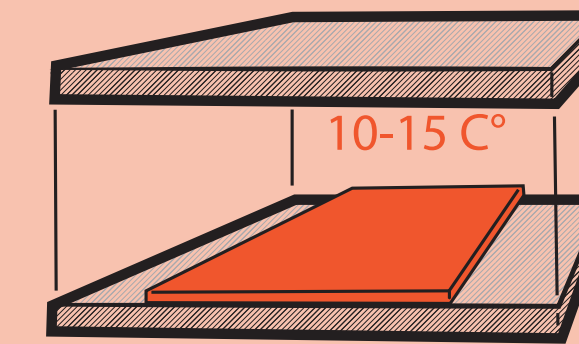

Airtemperature of 10 to 15 degrees.

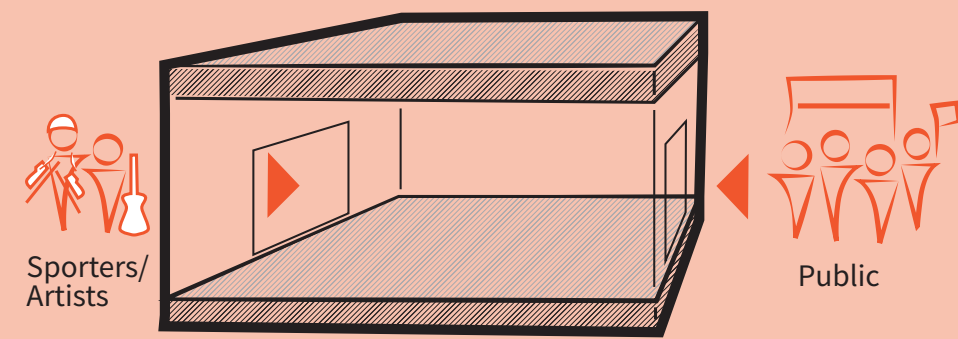

Separate entrance public / private

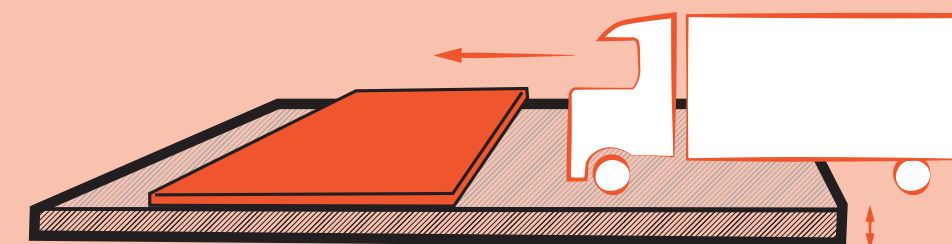

Access trucks

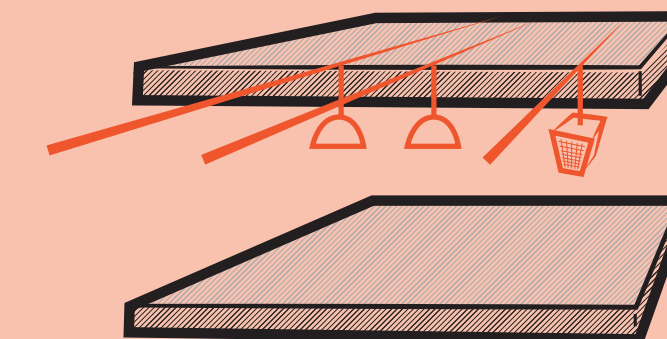

Ceiling can bear light & sound installations

# RESEARCH RESULTS

## OPERATION DESIGN

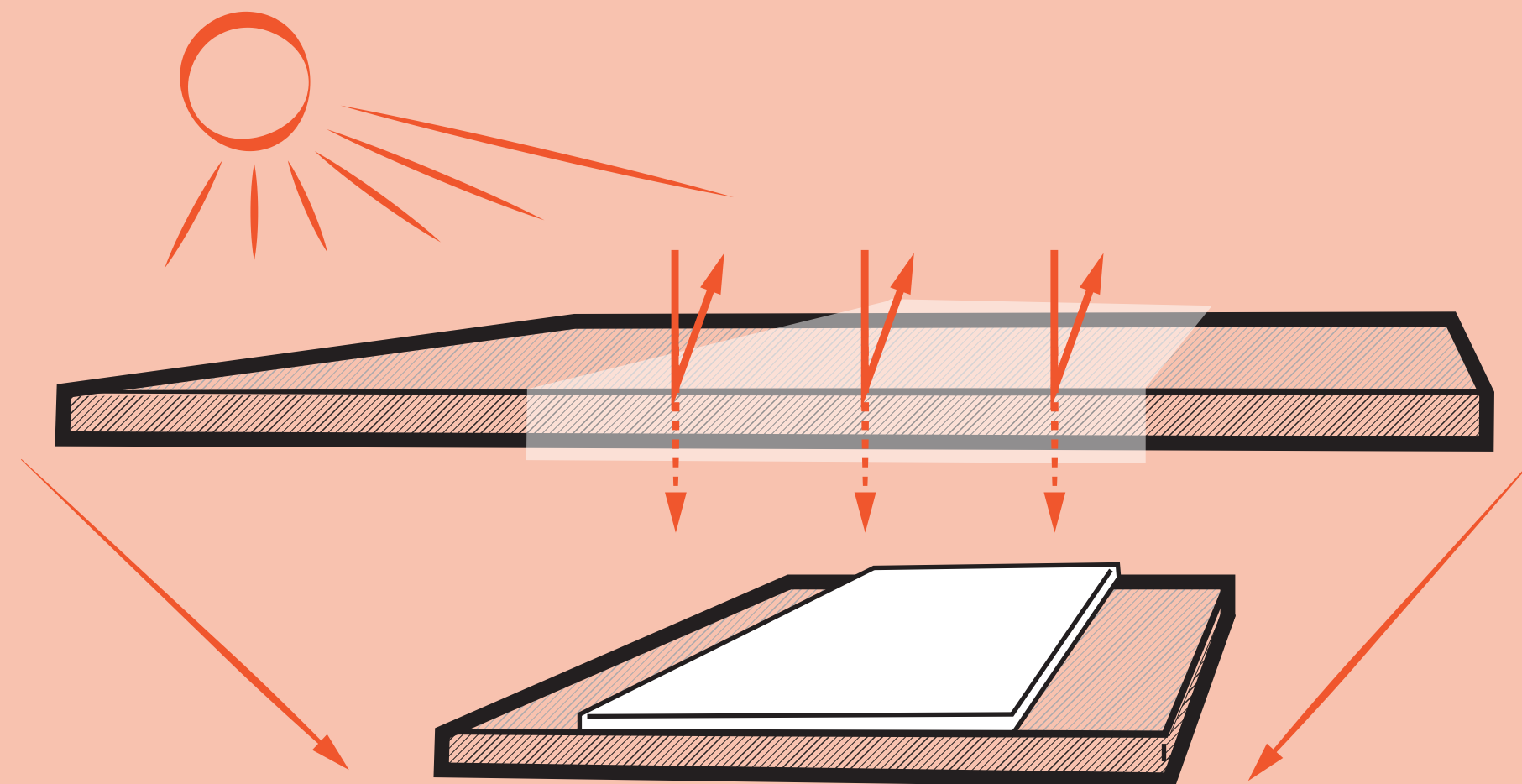

Natural daylight, no direct sunlight

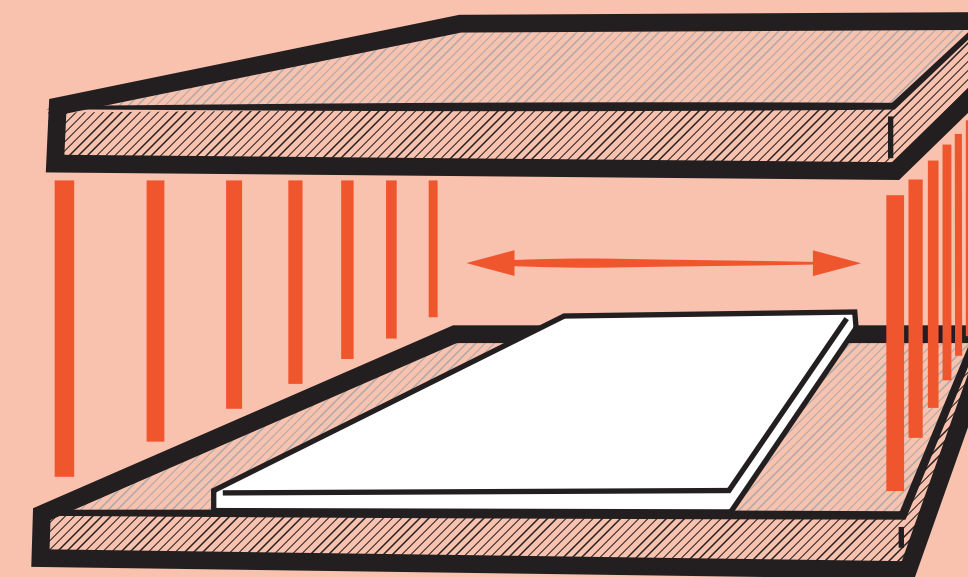

A columnless space

# RESEARCH RESULTS

## SPATIAL DESIGN

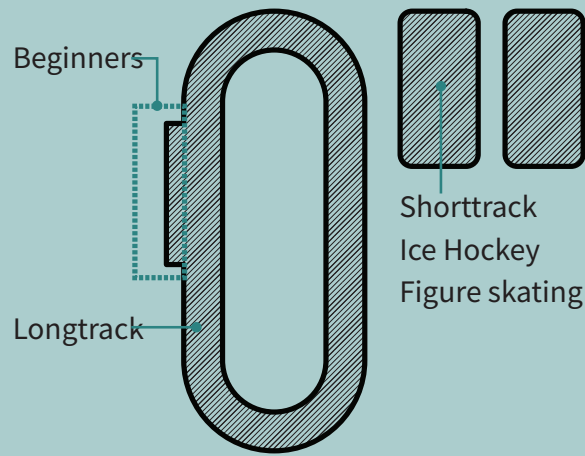

Main program

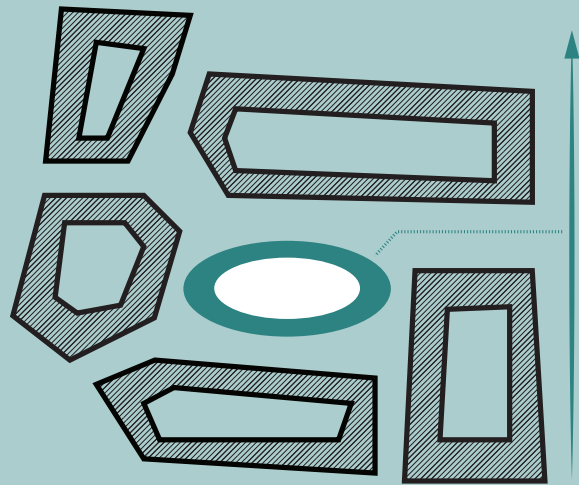

Integration in urban tissue, close to a motorway.

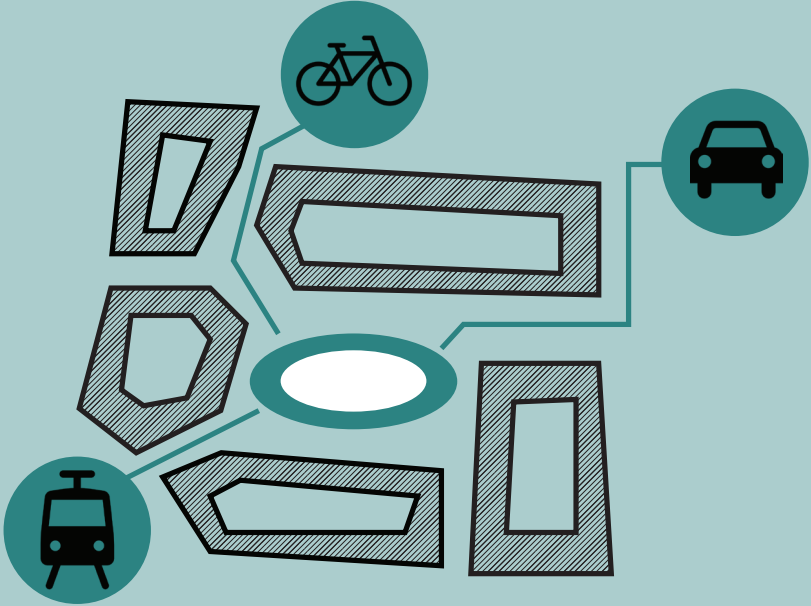

Connected to car roads, public transport and bicycle paths.

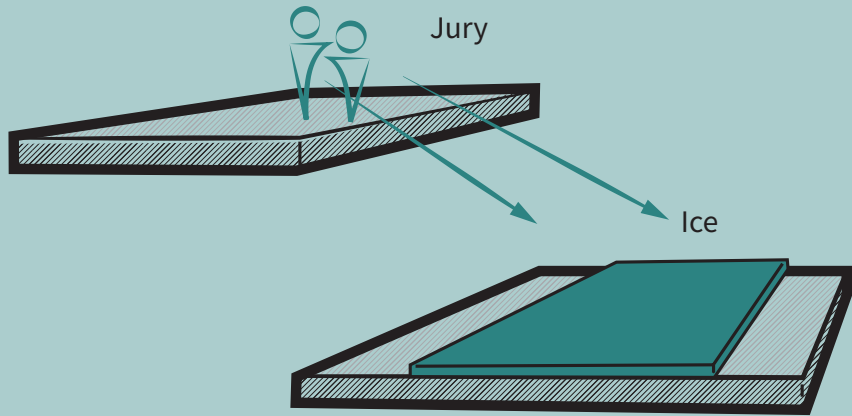

Overlook the ice



Catering facilities close to event space.

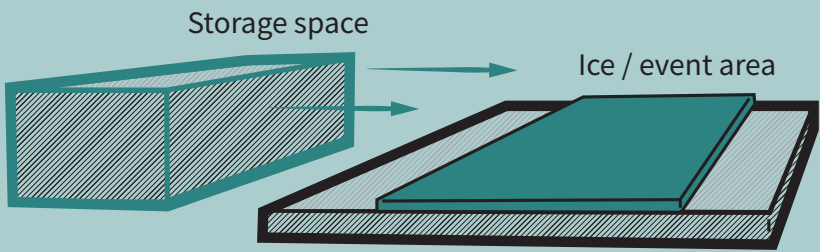

Storage close to the event area.

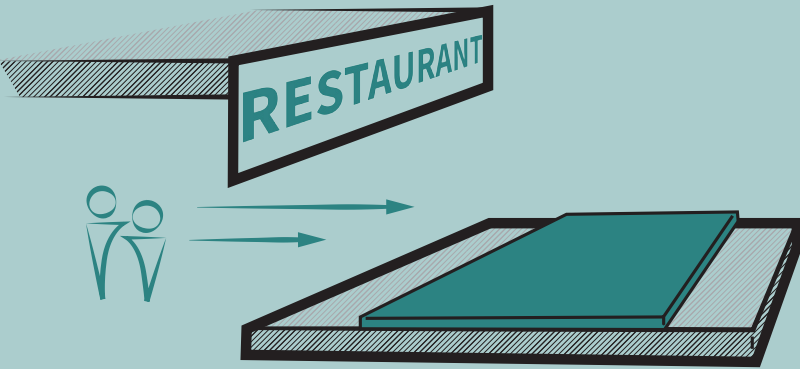

The restaurant should overlook the ice

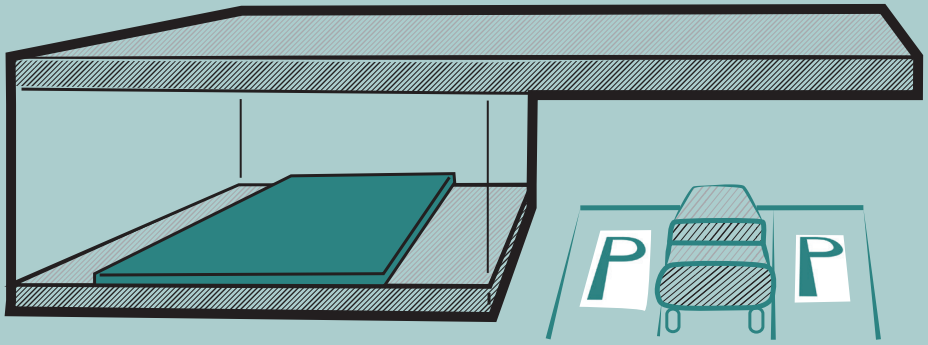

Sufficient parking space in/at building

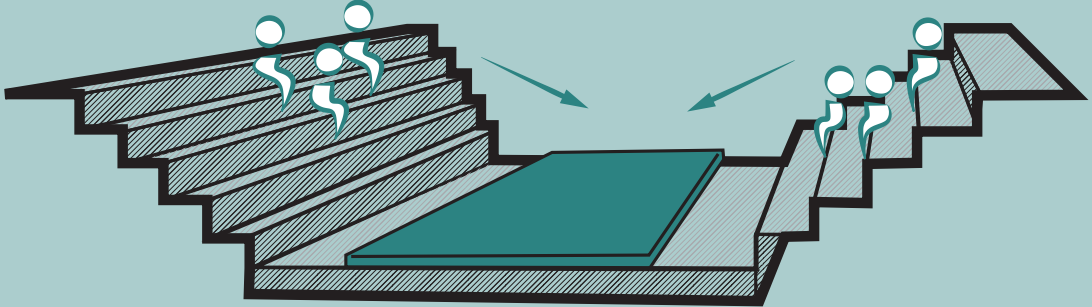

08. The design should provide spectator seats overlooking the event area.

# RESEARCH RESULTS

## SPATIAL DESIGN

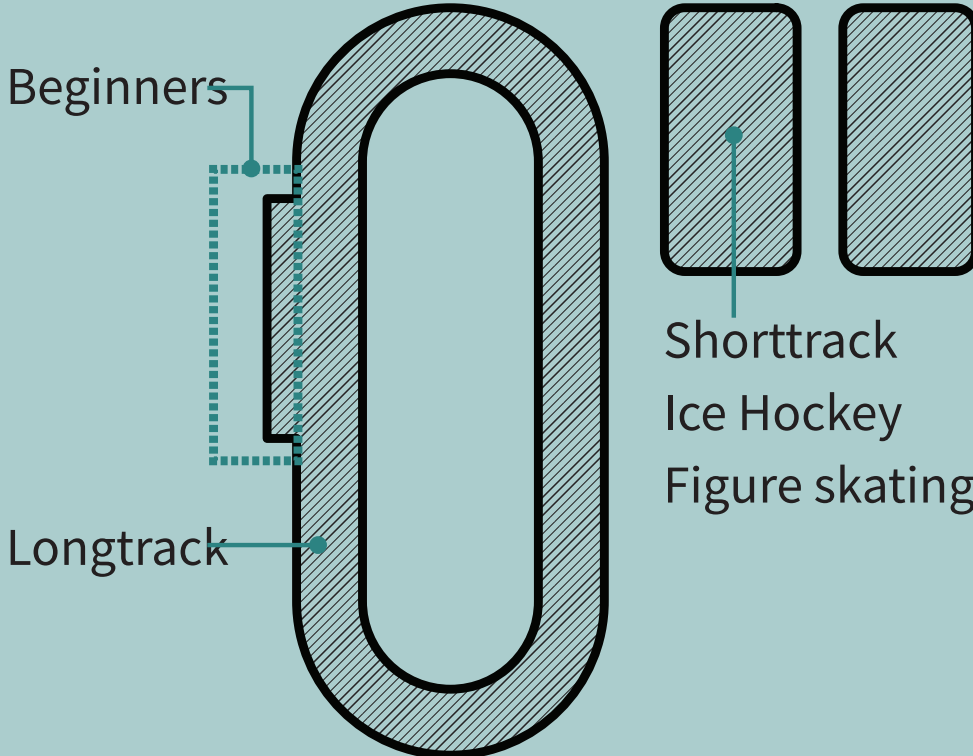

Main program

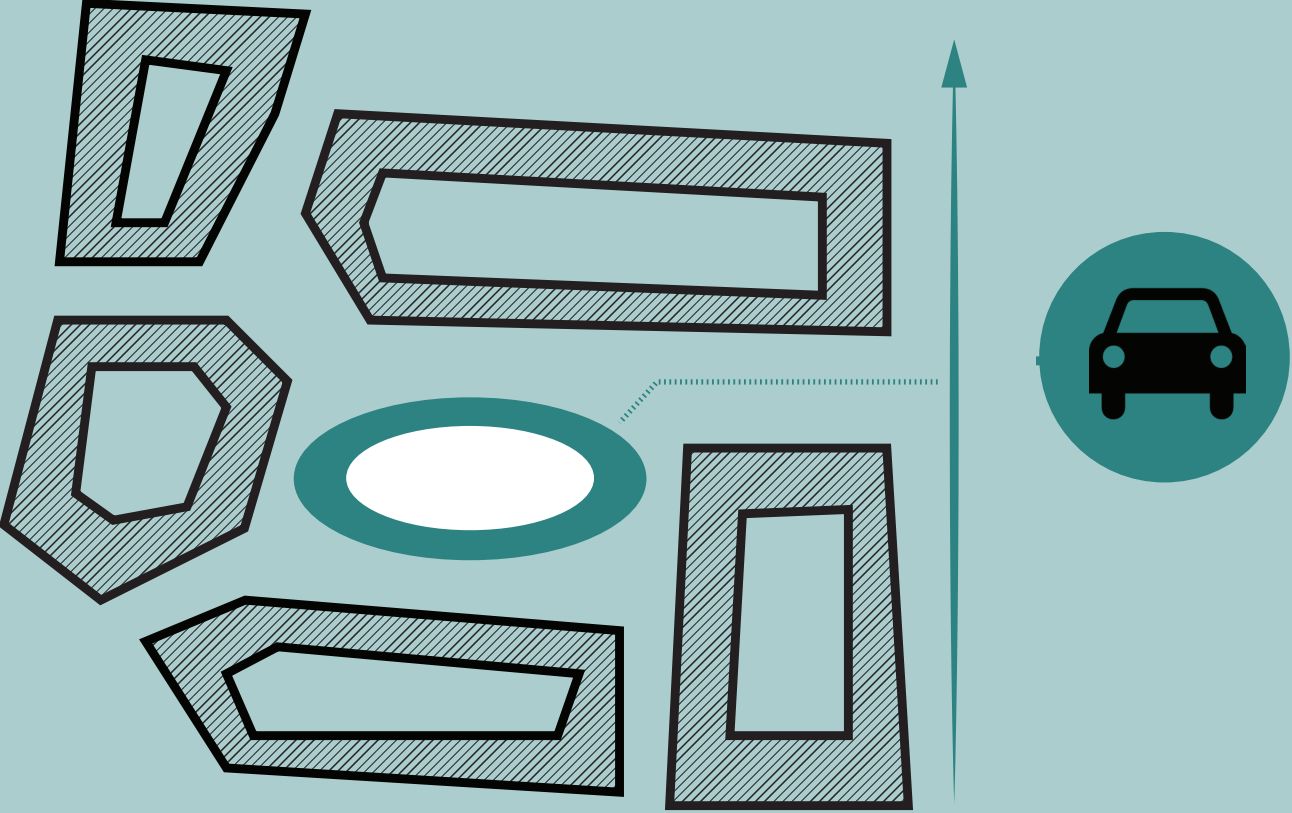

Close to a motorway.

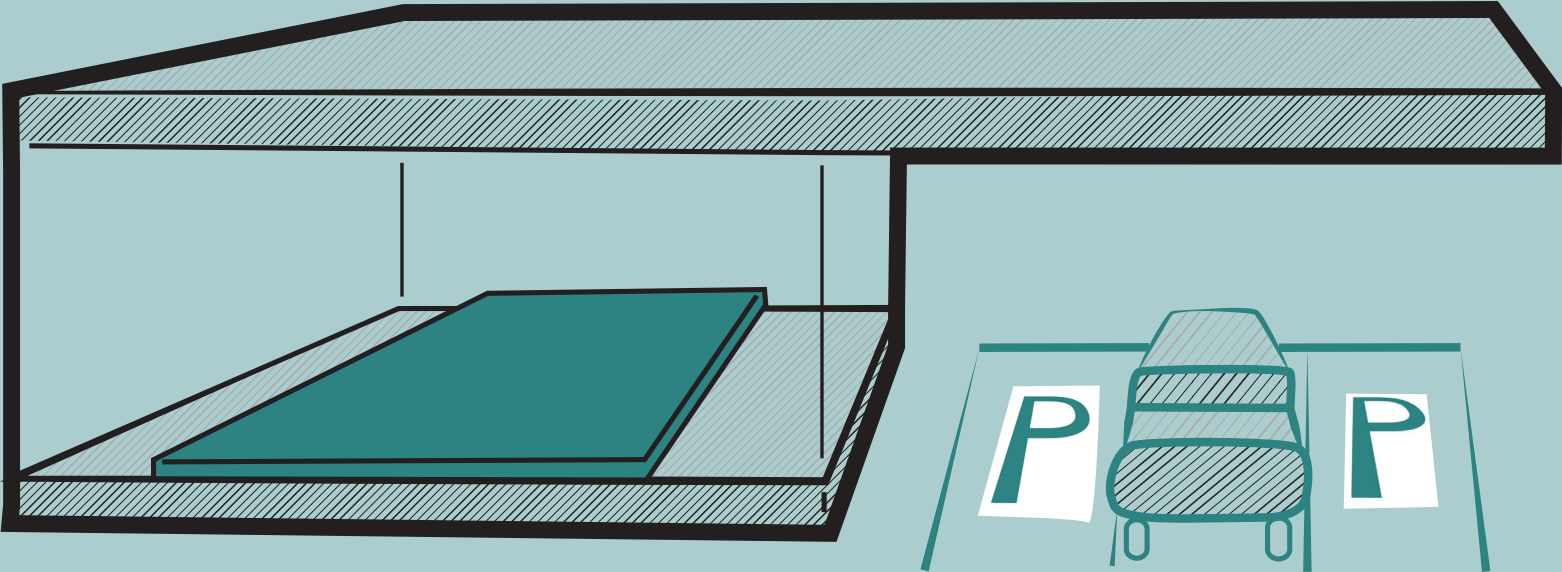

Sufficient parking space in/at building

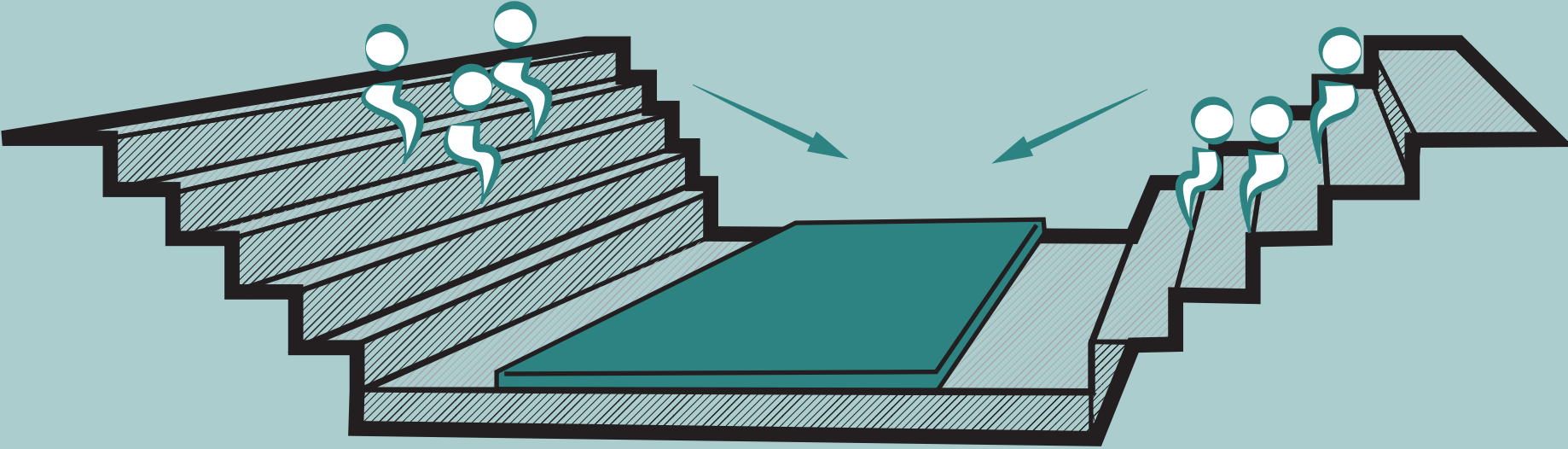

Provides spectator seats

# RESEARCH RESULTS

## TECHNICAL DESIGN

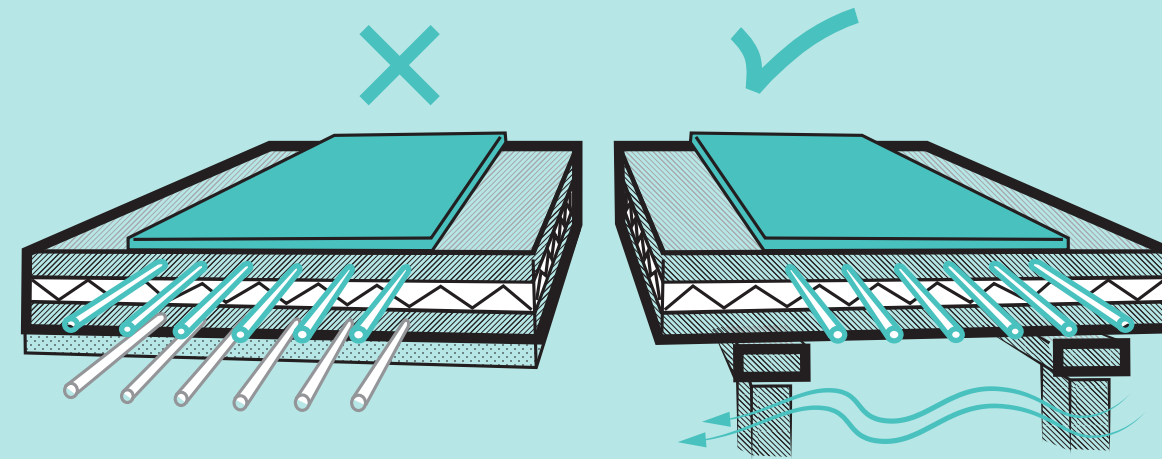

Ventilated elevated foundation

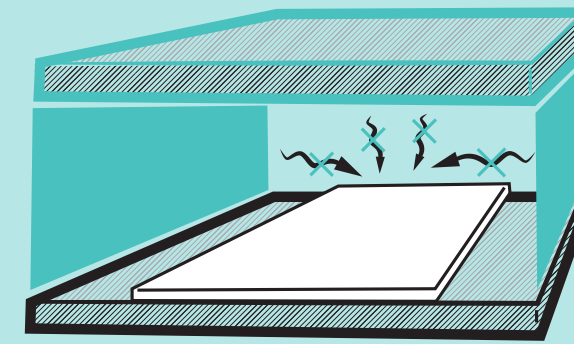

No radiation towards ice

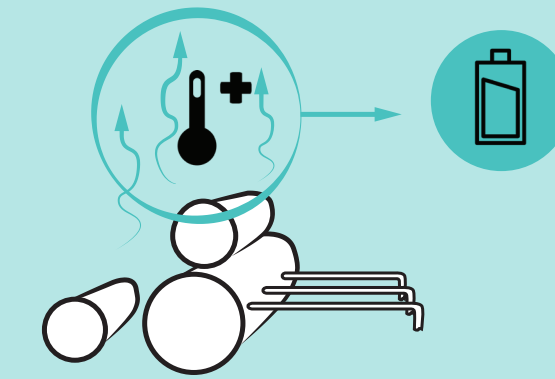

Use waste heat

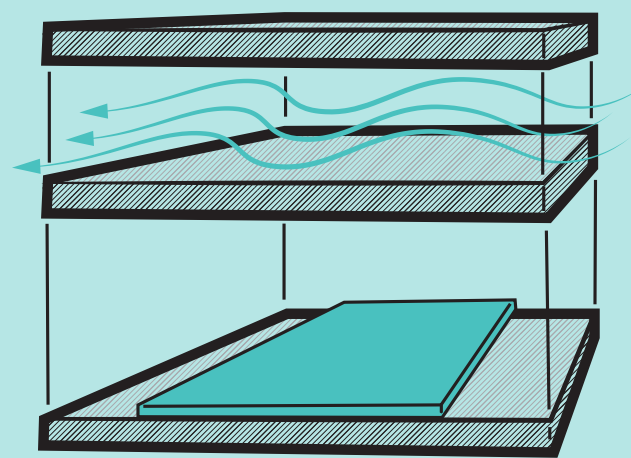

Ventilated roof

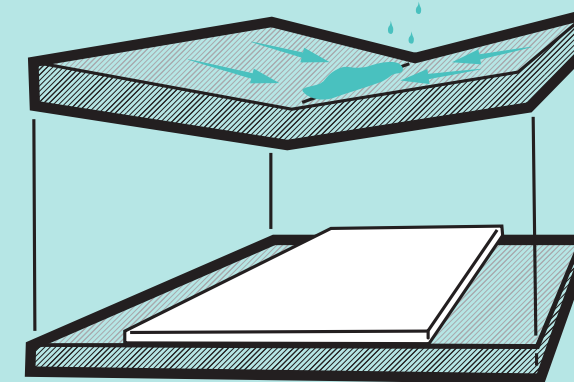

Water collection

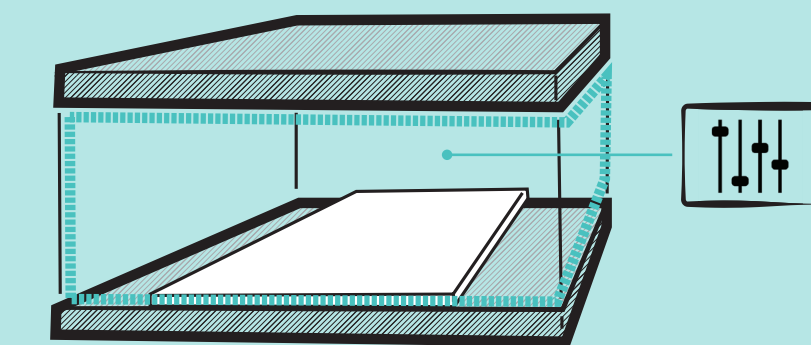

Own micro controllable climate.

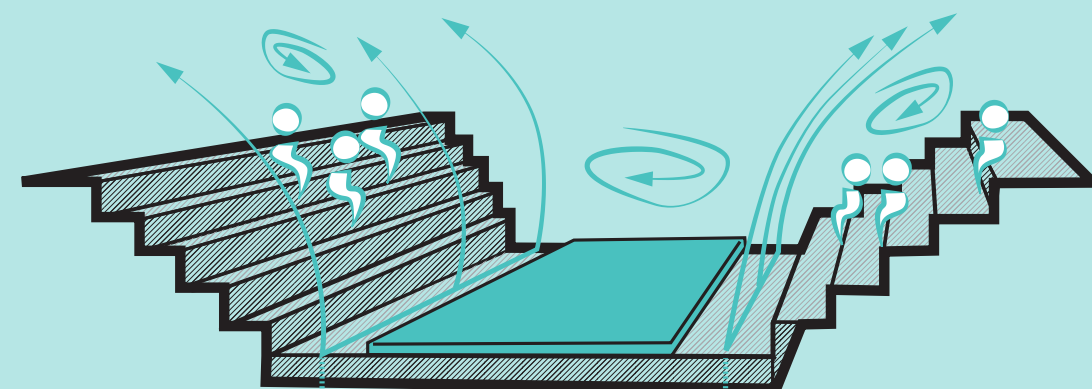

Aircurtain: separate airflows

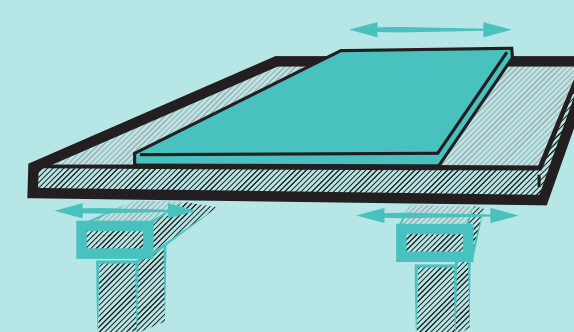

Foundation: Able to expand

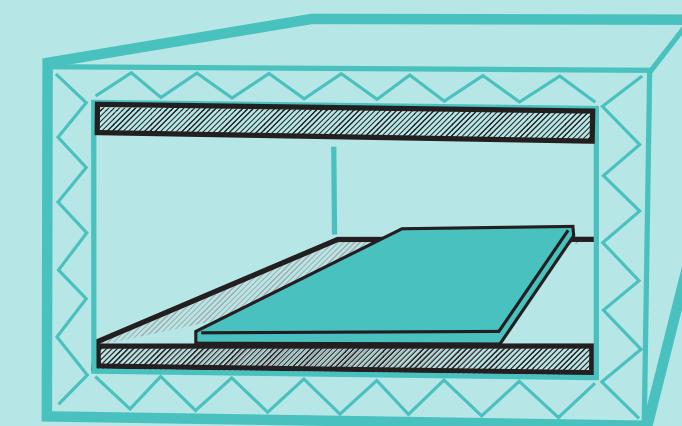

Well insulated

# RESEARCH RESULTS

## TECHNICAL DESIGN

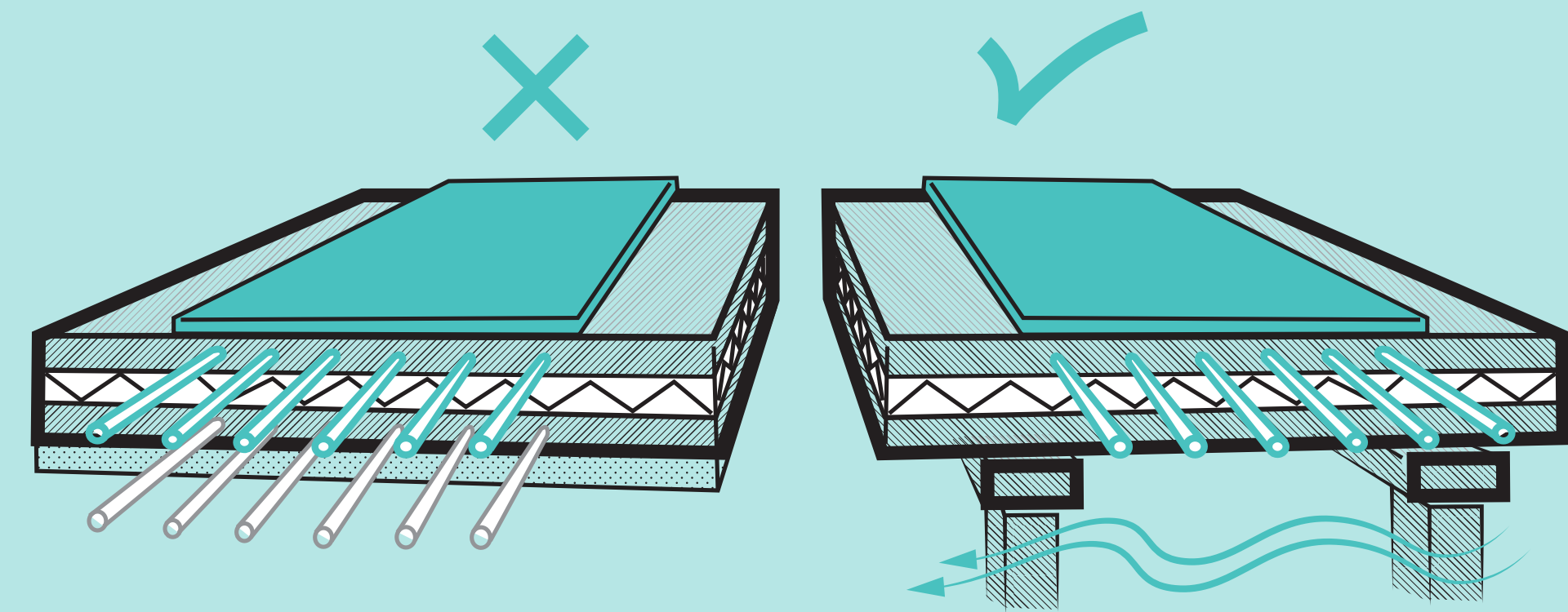

Ventilated elevated foundation

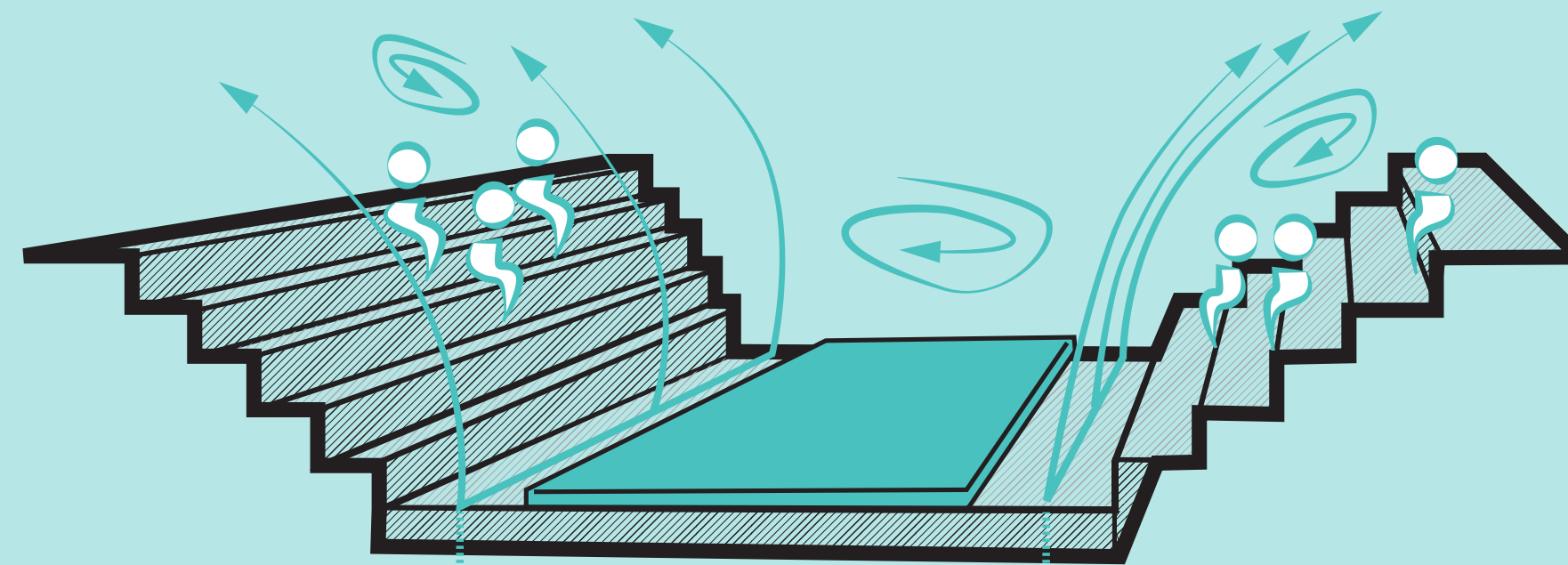

Aircurtain: separate airflows

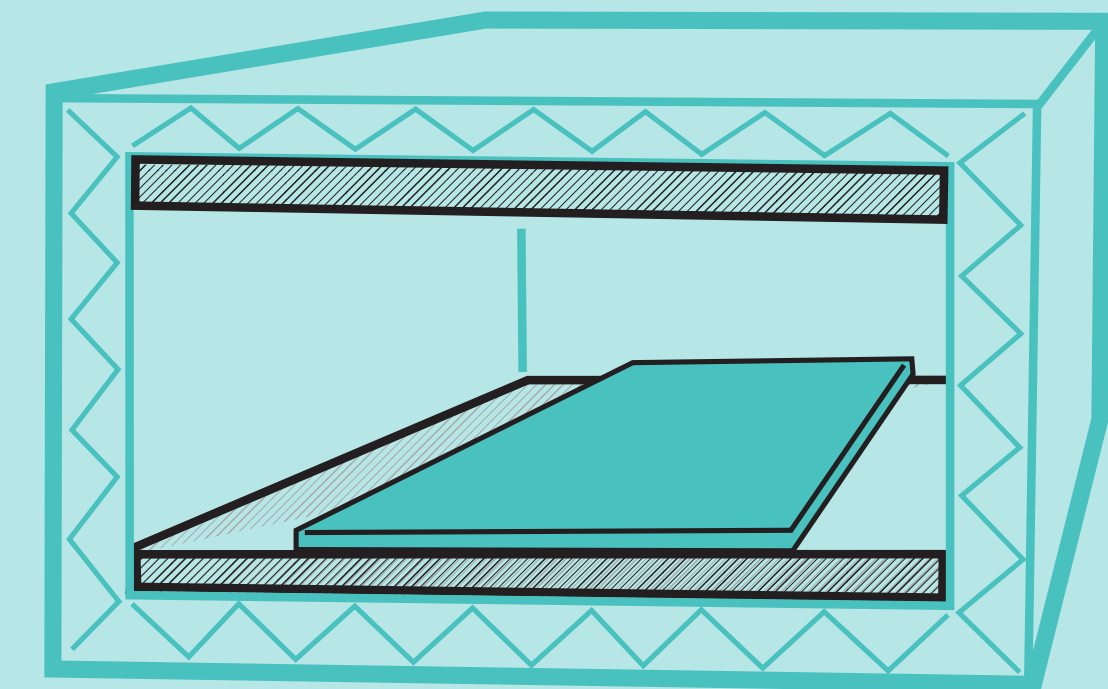

Well insulated



**DESIGN**

# DESIGN ASSIGNMENT

A recreational and competition ice rink in winter



A multifunctional venue in summer



# DESIGN ASSIGNMENT



Recognizable / icon for modern ice skating



Appearance of natural experience

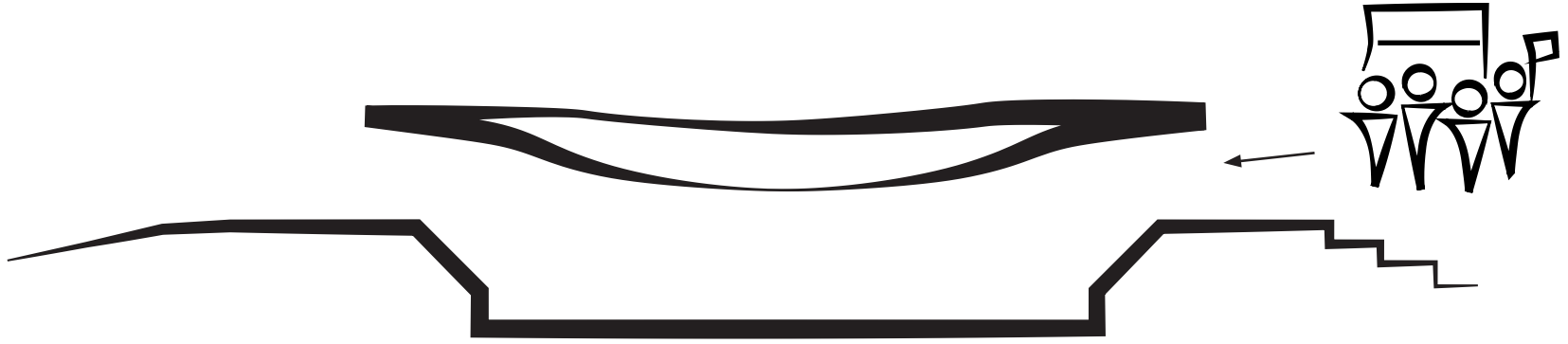

Promoting the sport

**LOCATION**

# LOCATION

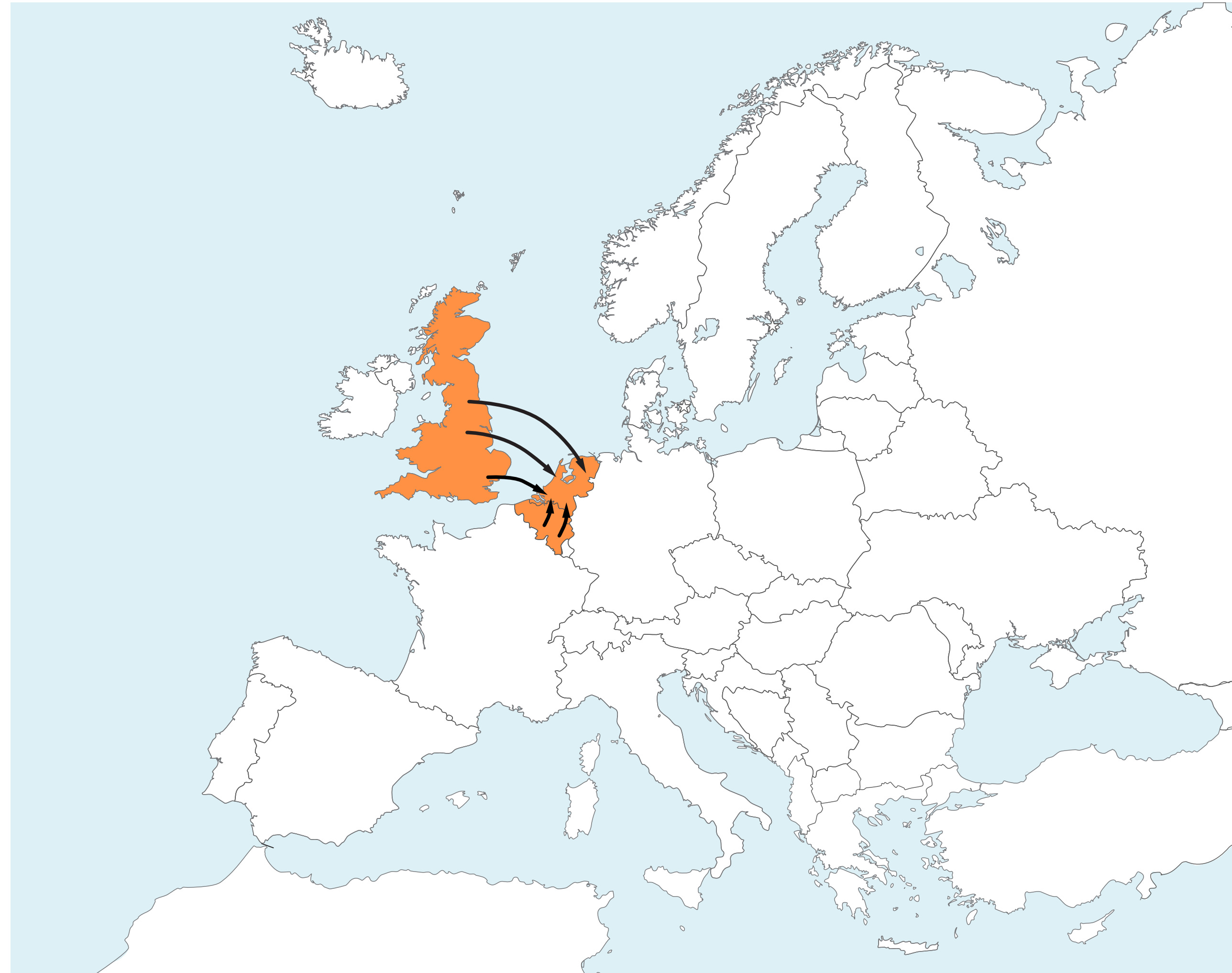

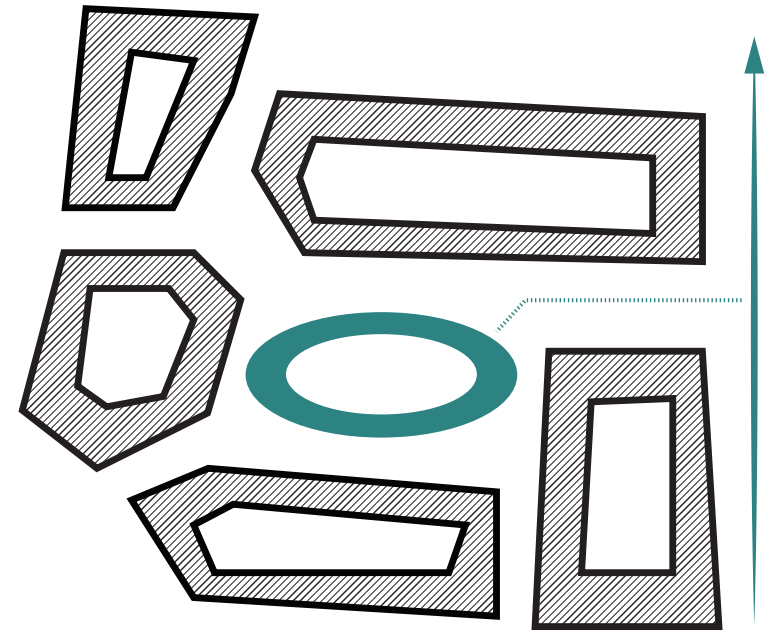

# LOCATION

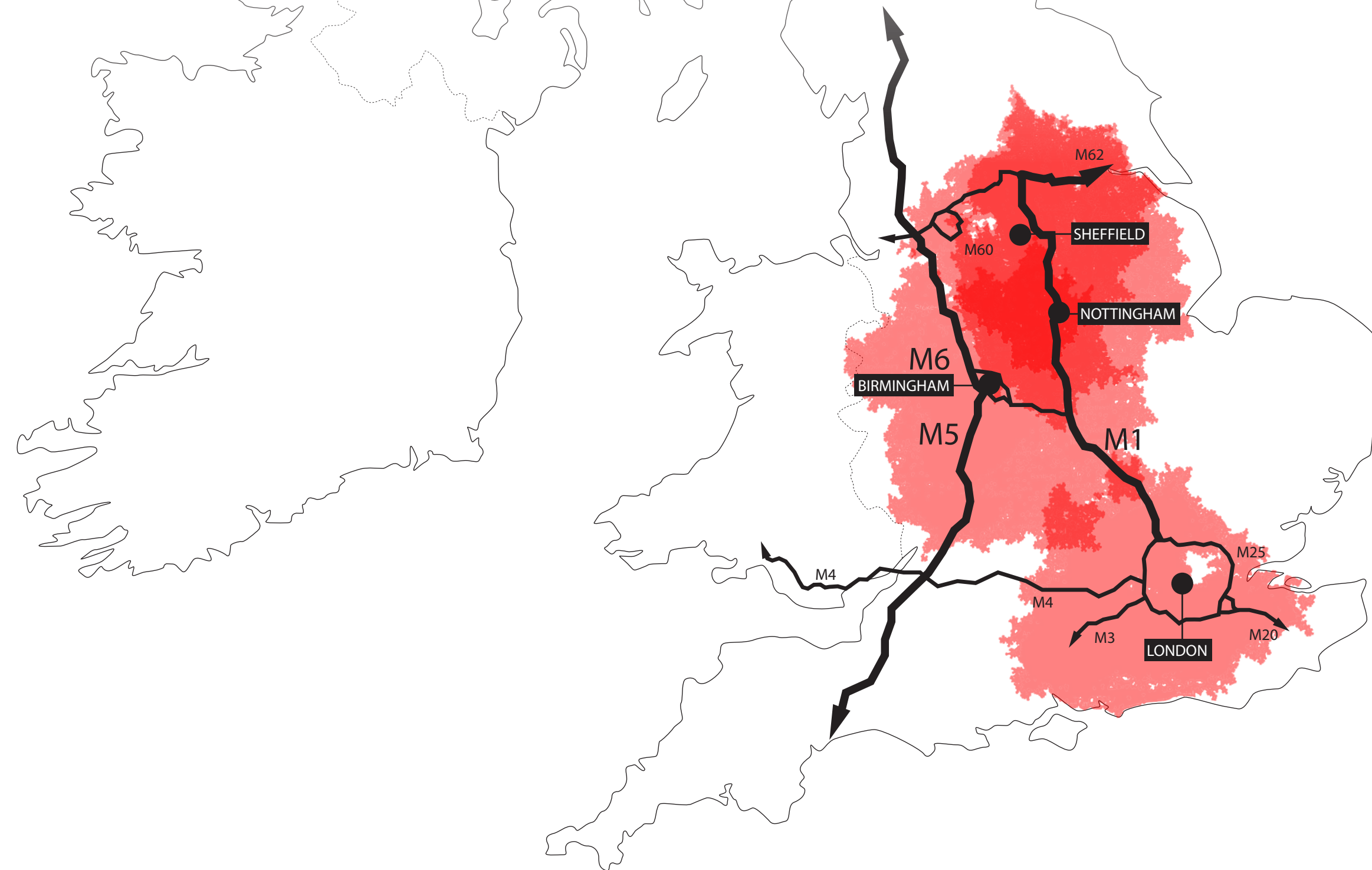

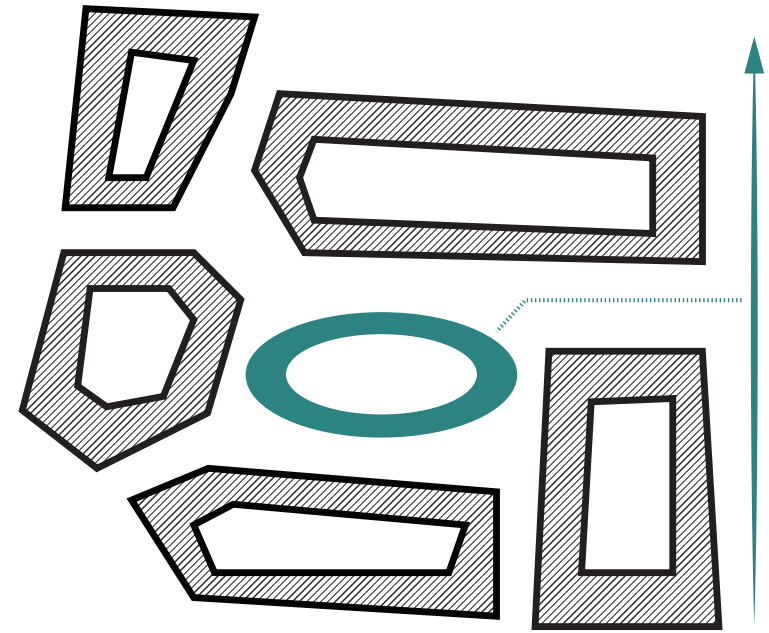

# LOCATION

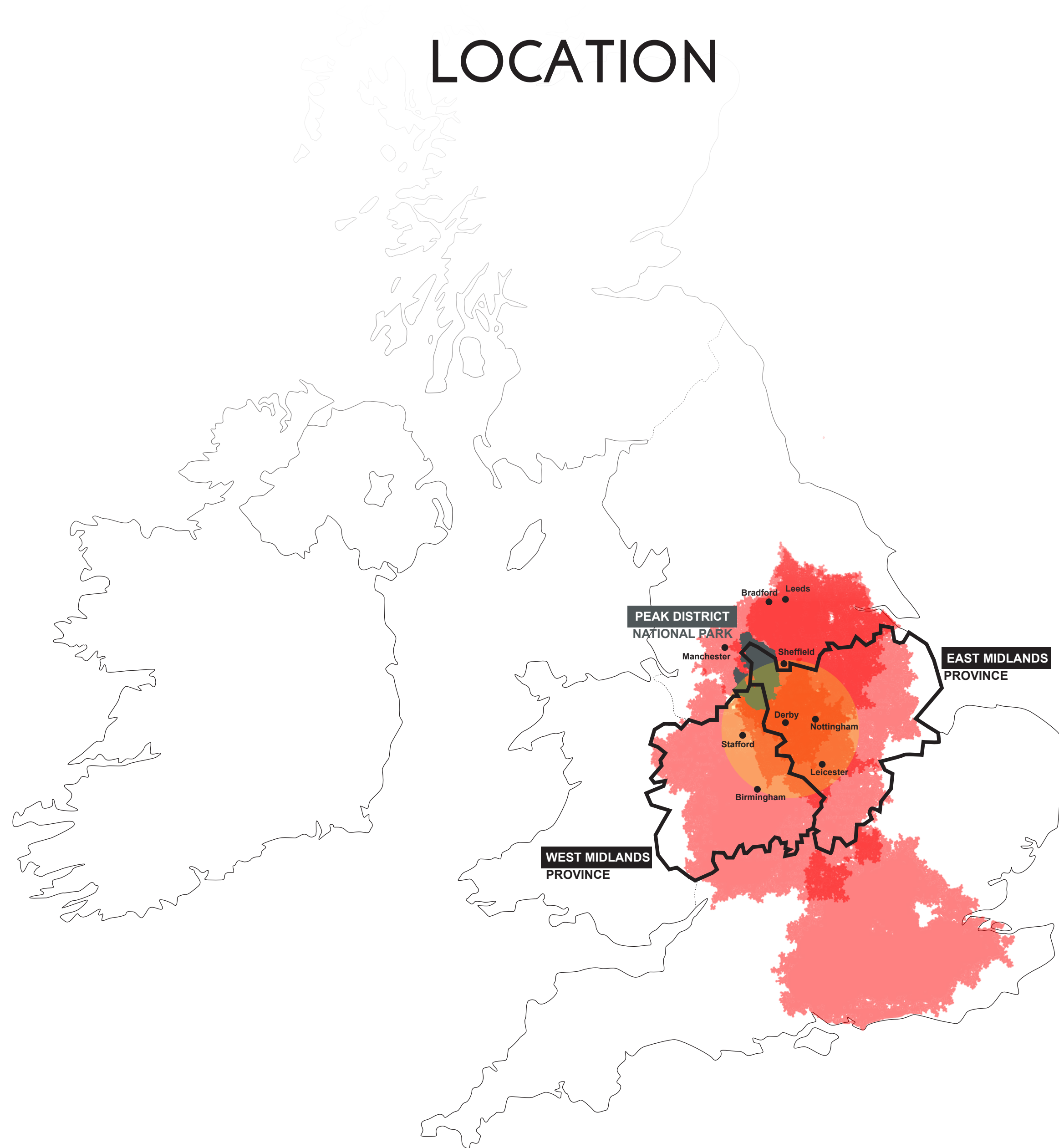



SHEFFIELD HOSPITAL

DON VALLEY

OLYMPIC LEGACY PARK

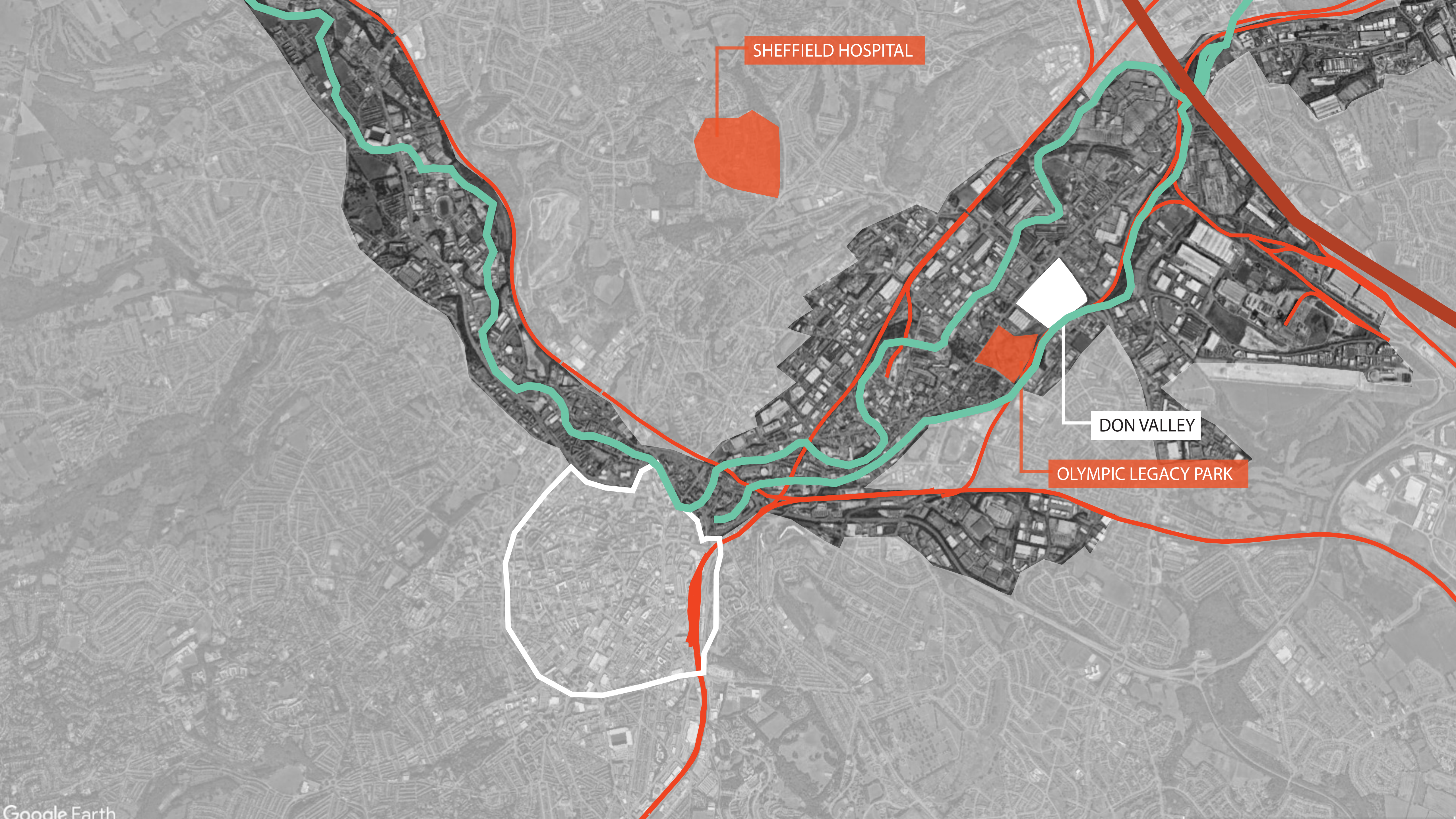



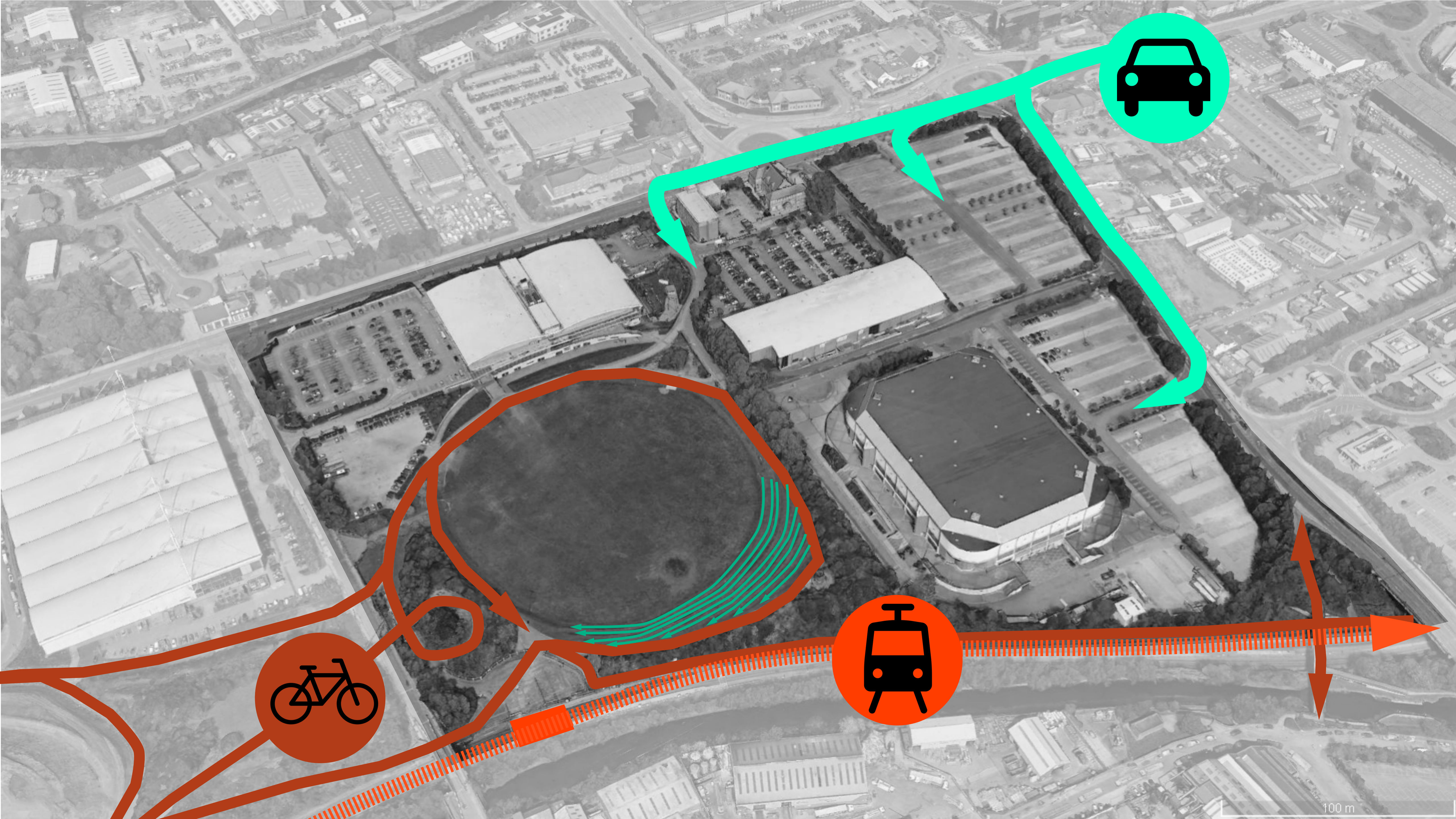

100 m

# URBAN INTEGRATION

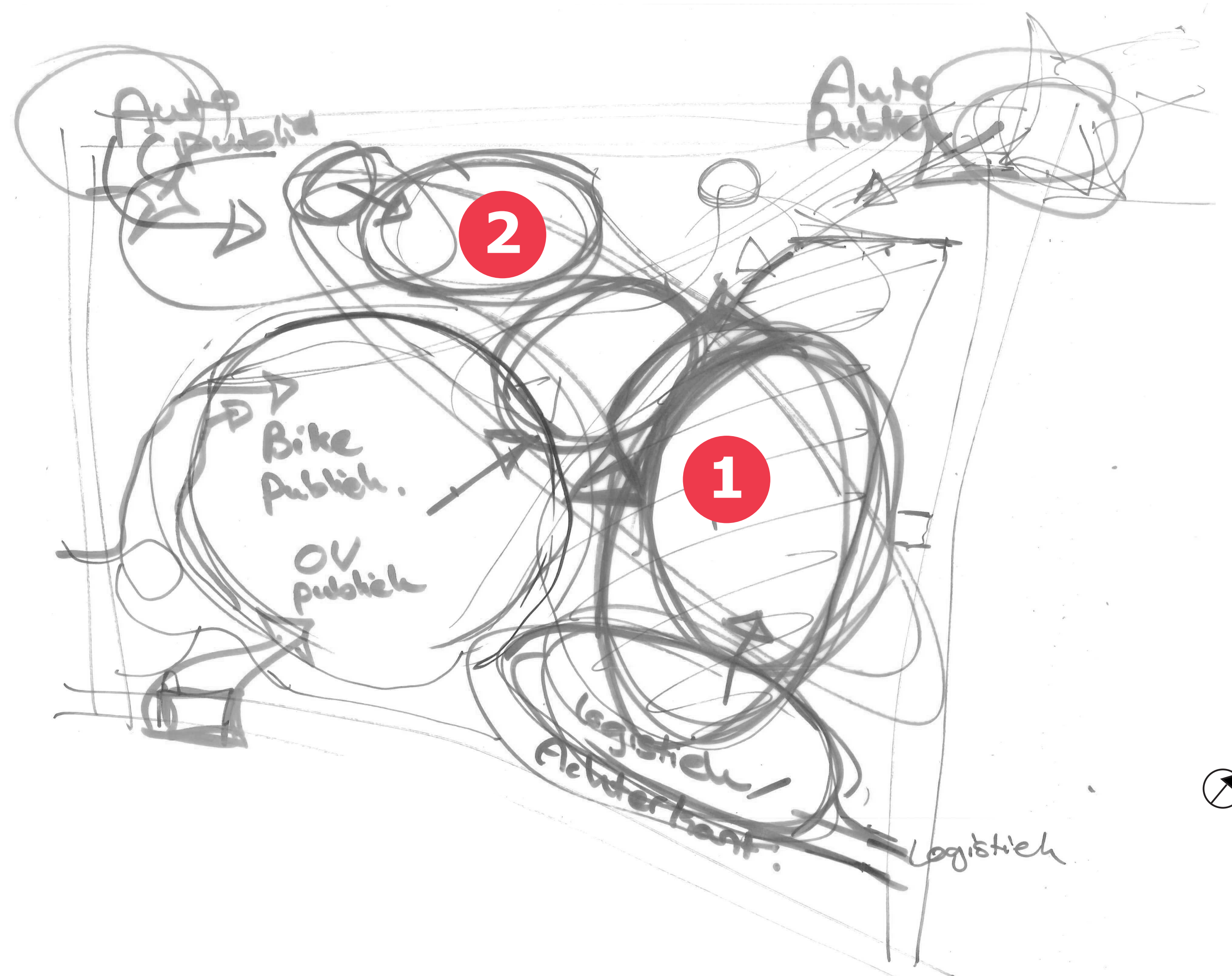

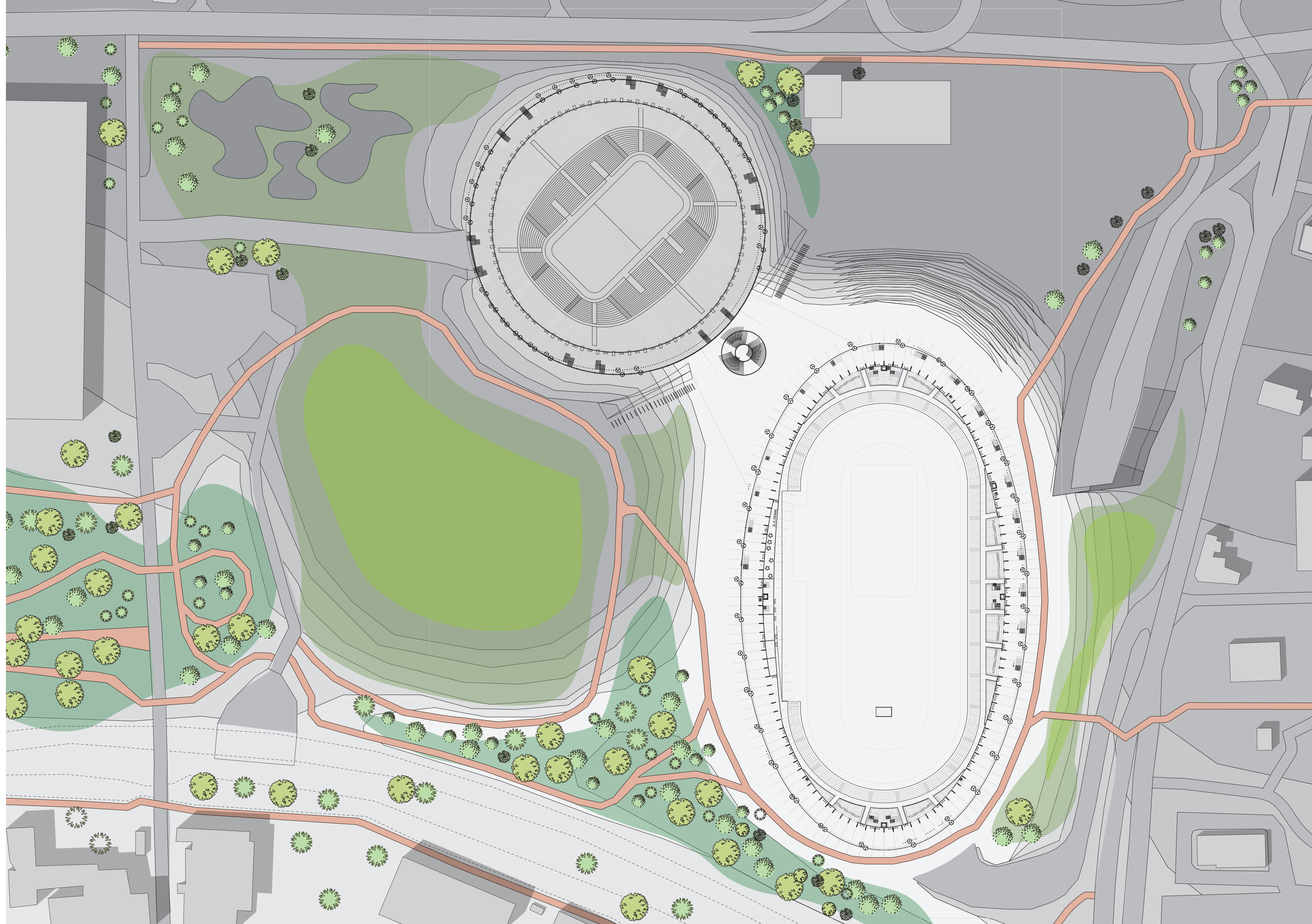

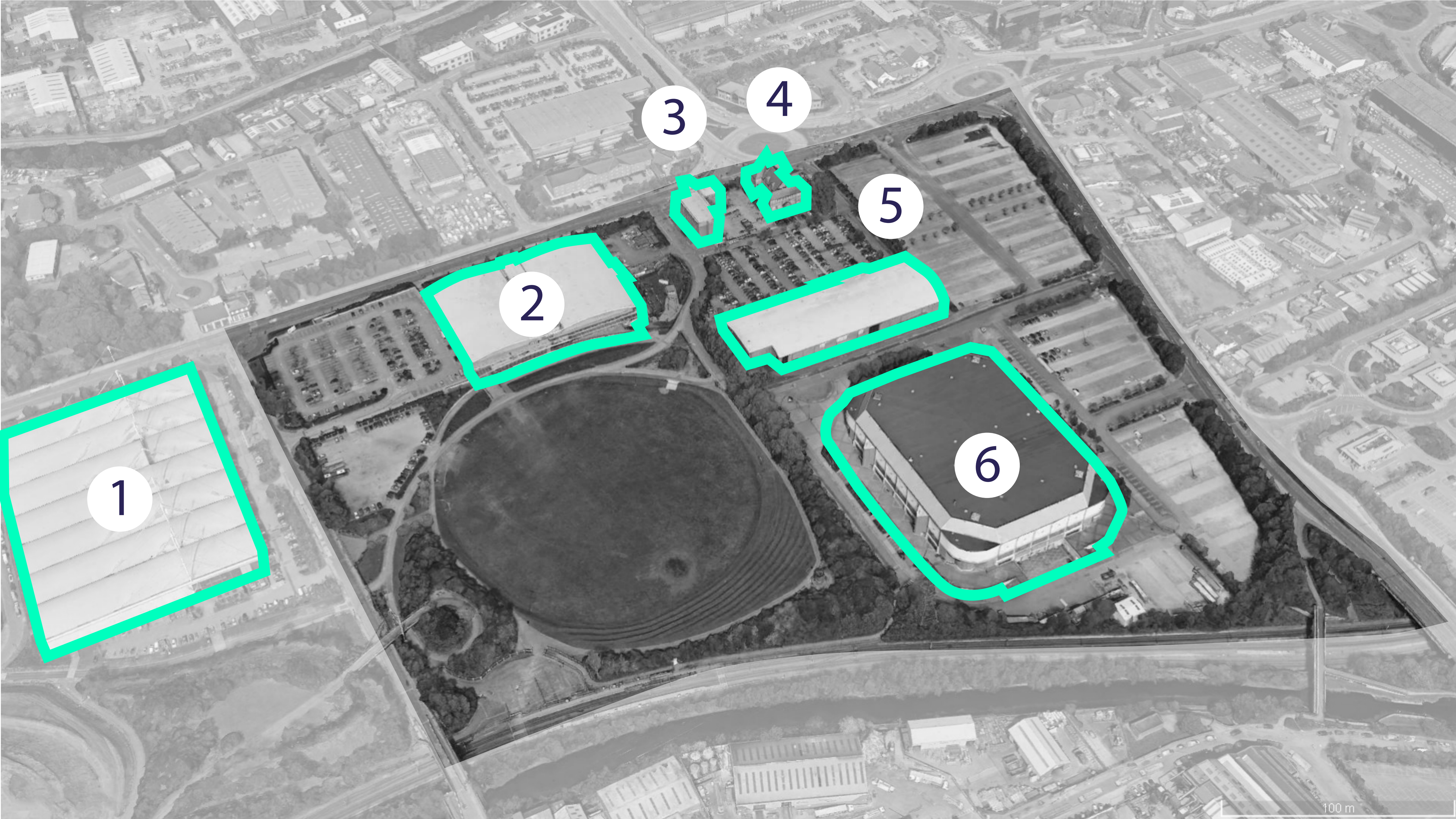

1

2

3

4

5

6

100 m

# PHASE O

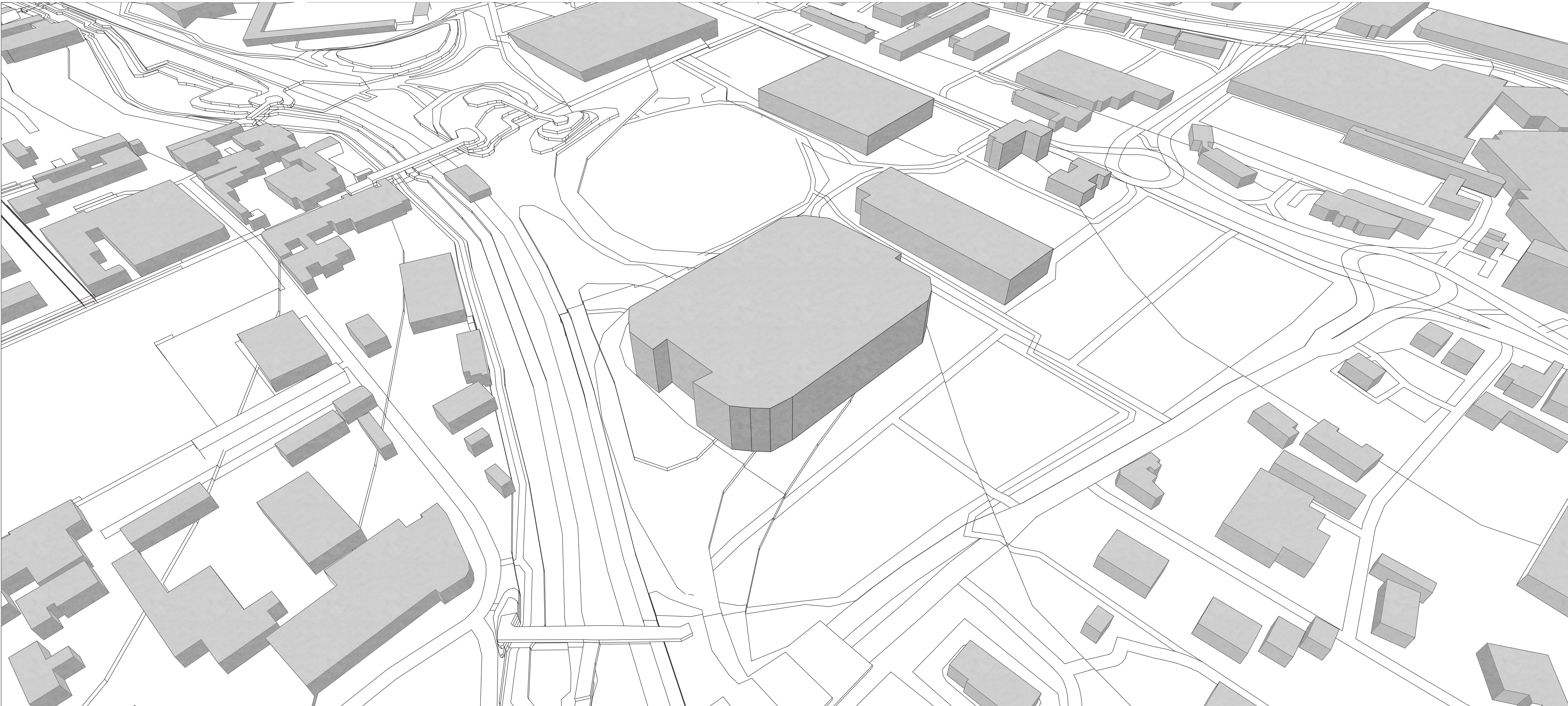

# PHASE 1

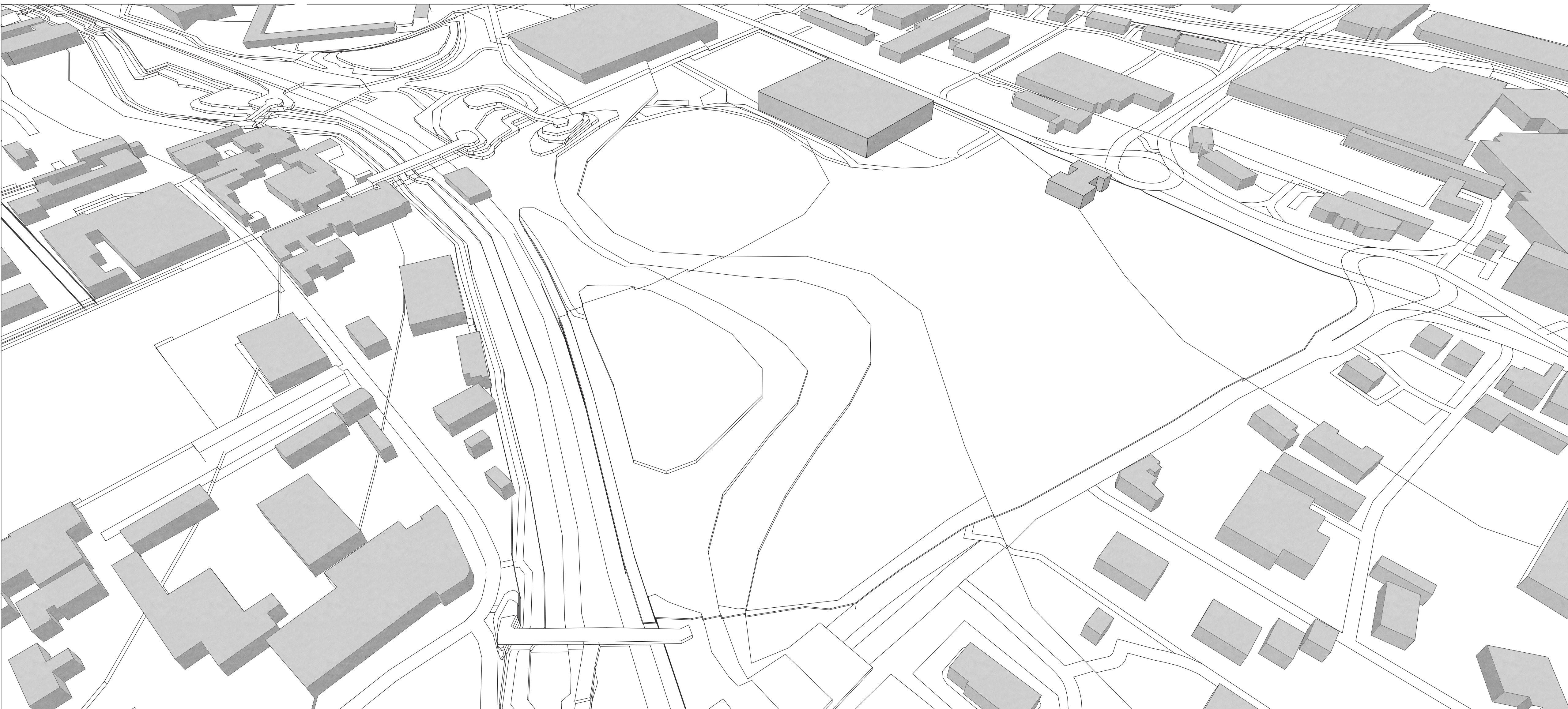

INTRODUCTION

RESEARCH

DESIGN

ENERGY

CONCLUSION

# PHASE 2

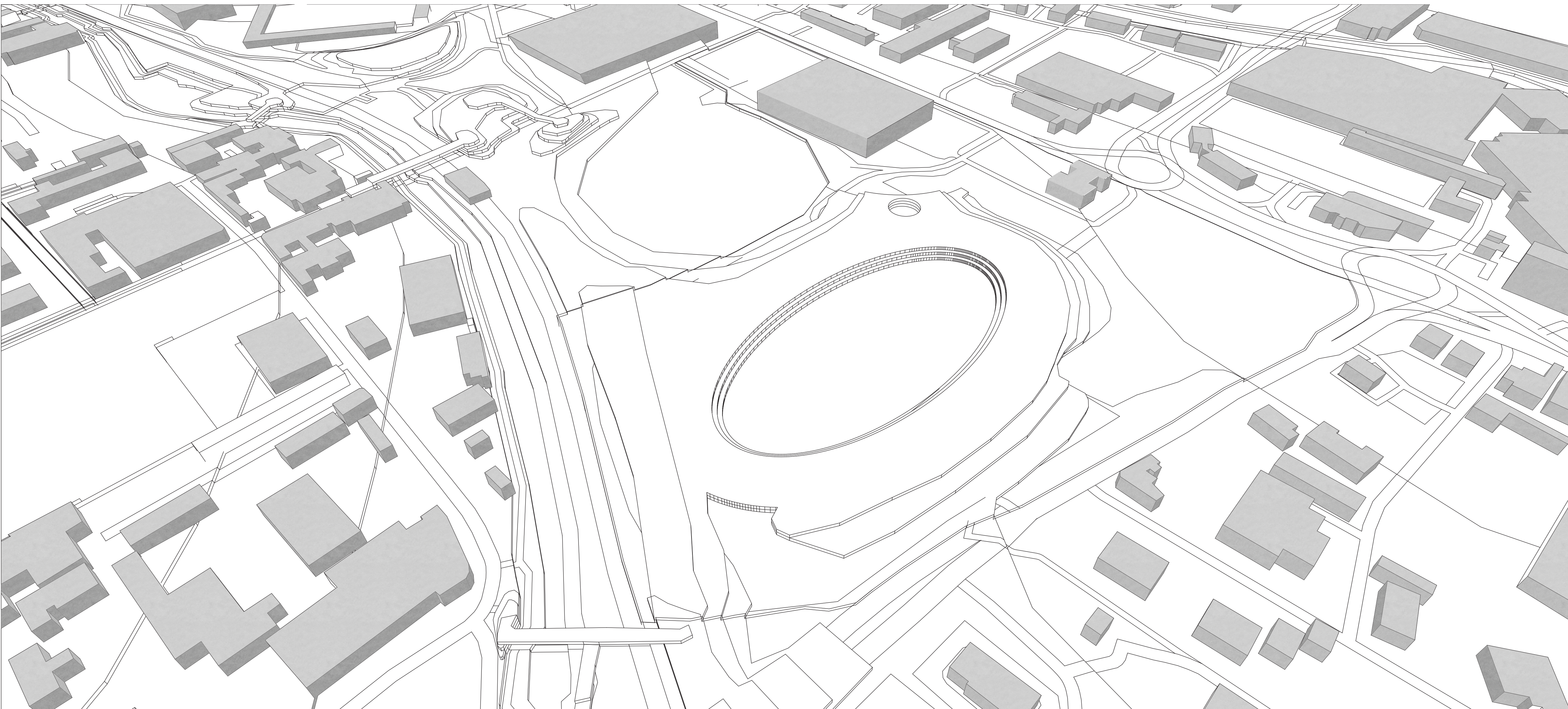

# PHASE 3

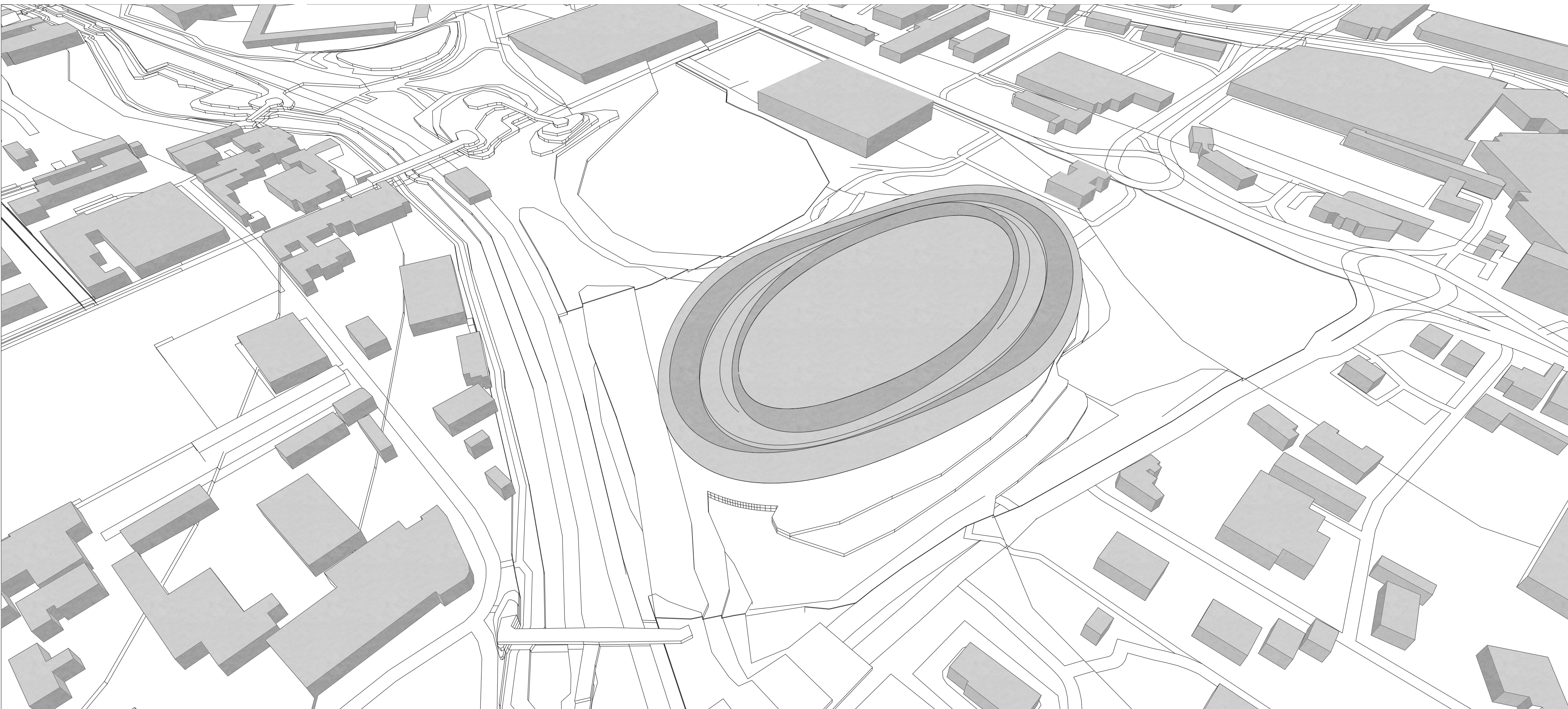

# PHASE 4

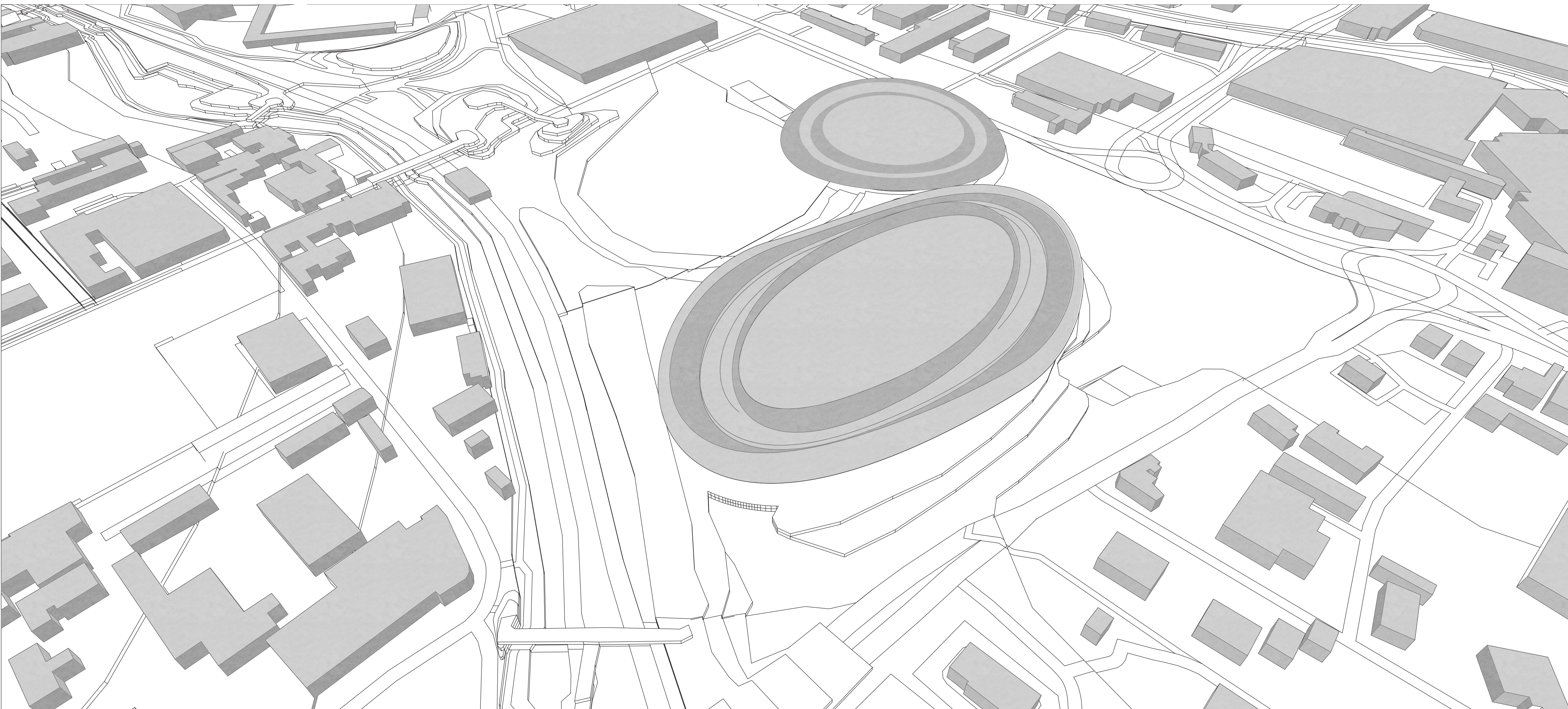

# DETERMINATION FORM

## INSULATING GROUND

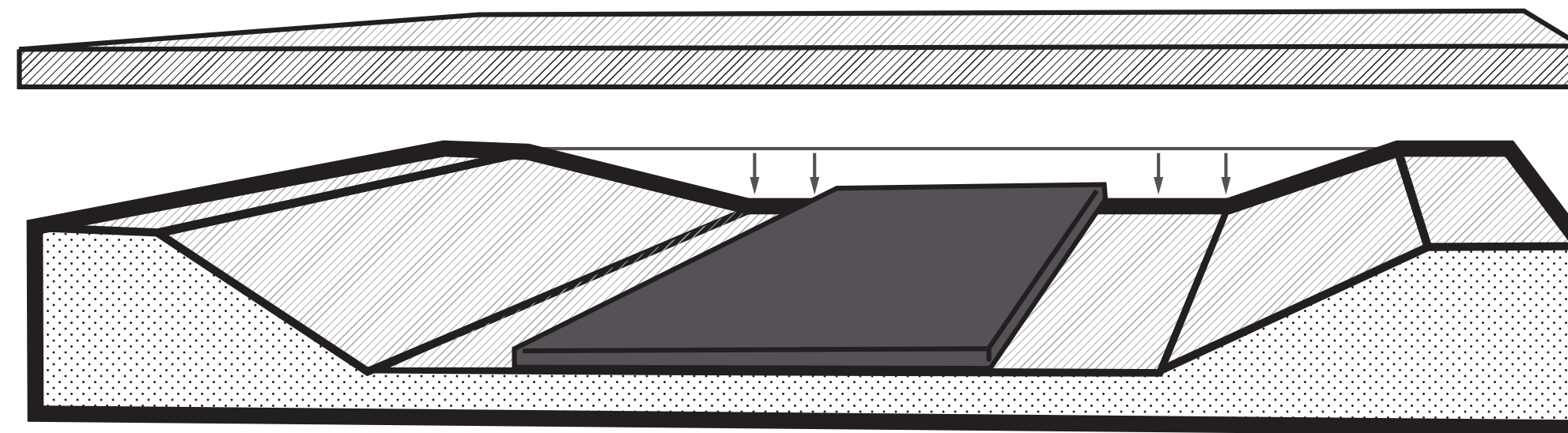

# DETERMINATION FORM

PROTECTION SOLAR RAYS

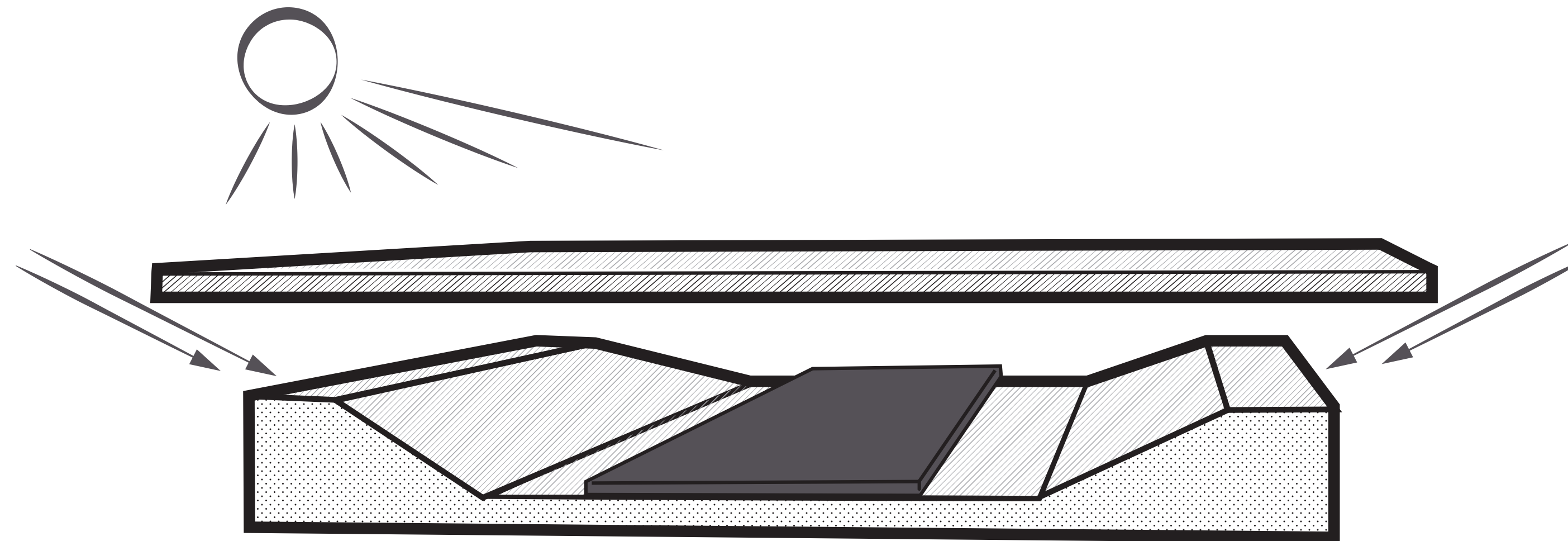

# DETERMINATION FORM

STIMULATE AIRFLOWS

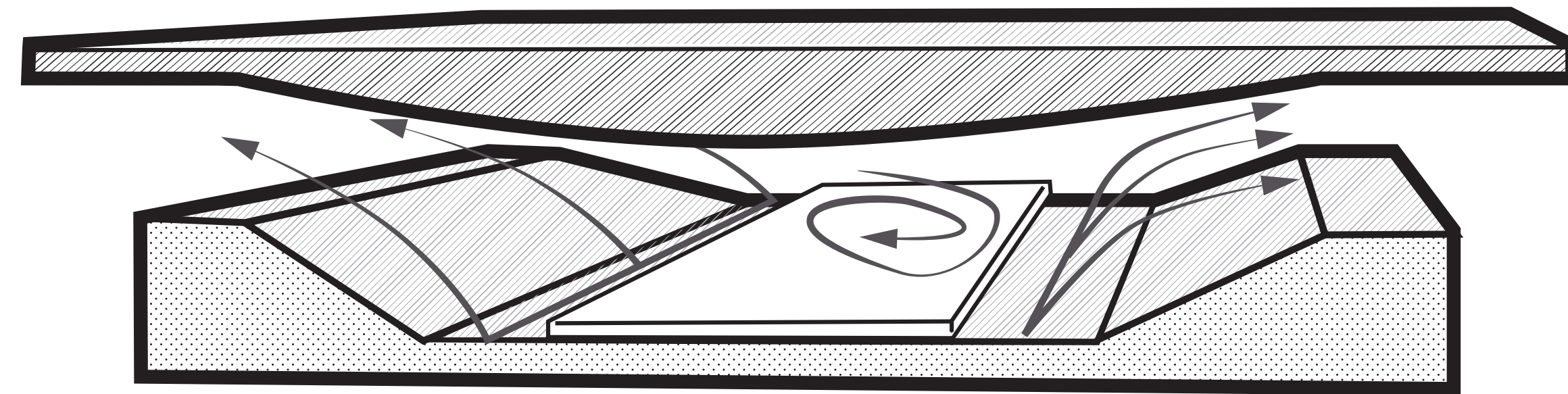

# DETERMINATION FORM

## BUFFER ROOF AND RING

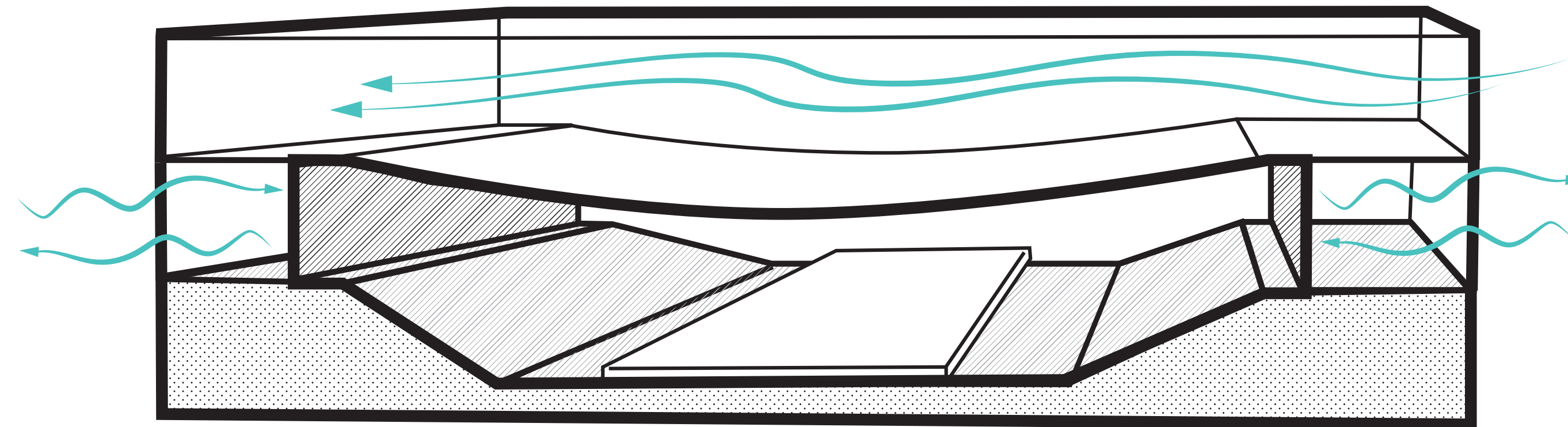

# DETERMINATION FORM

## PROTECTIVE CEILING

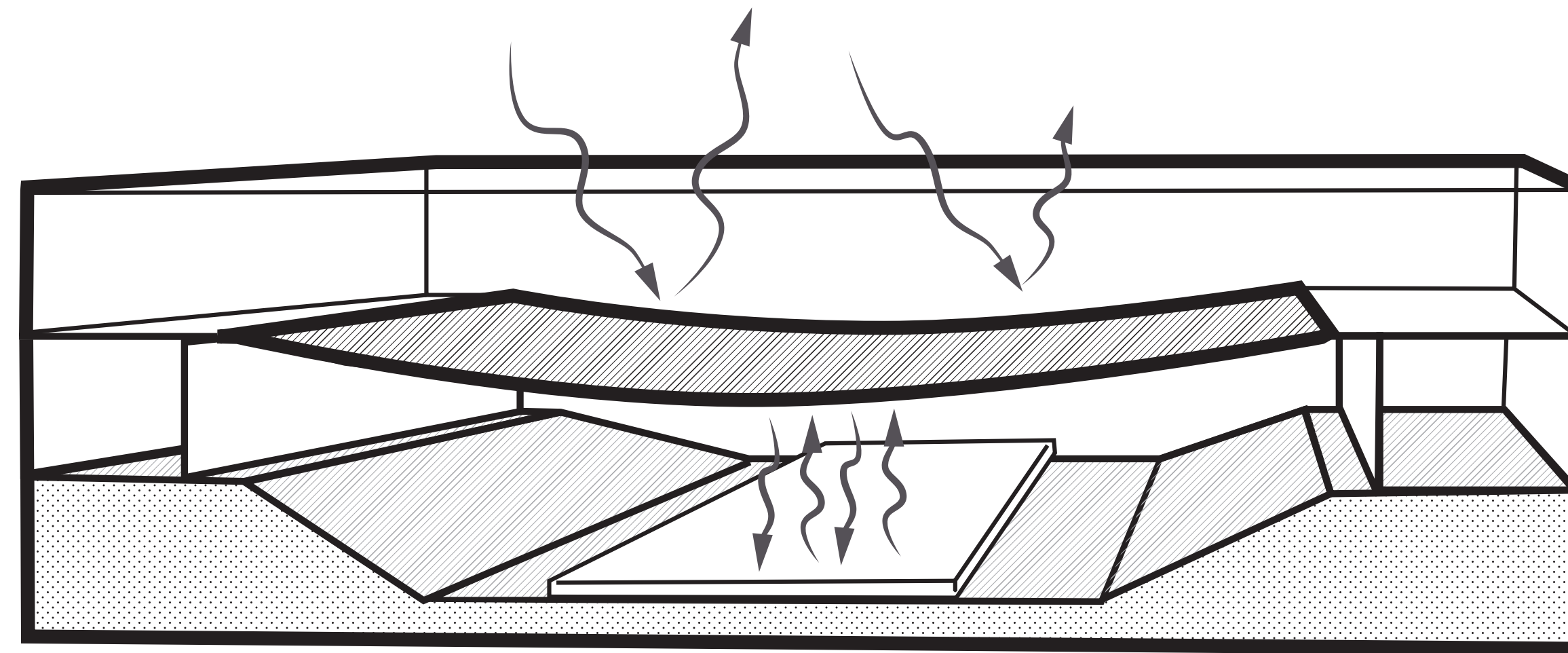
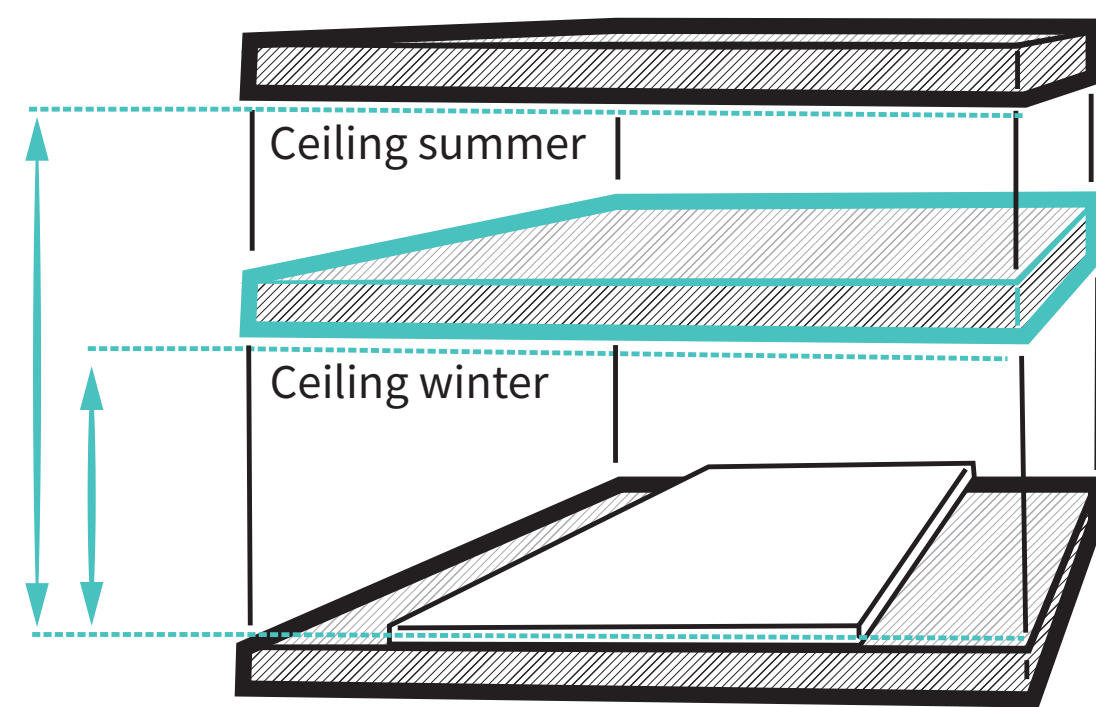

# ROOF AS SERVING OBJECT

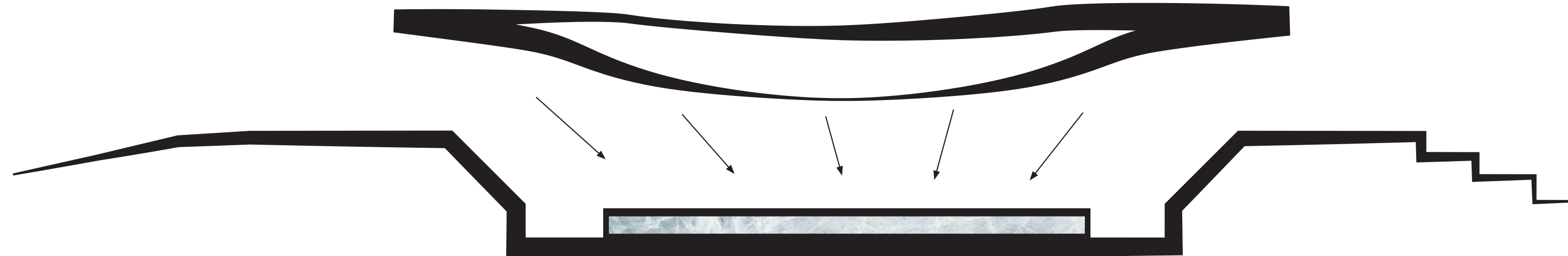

# DETERMINATION FORM

"SKATE MOVEMENT"



# DETERMINATION FORM

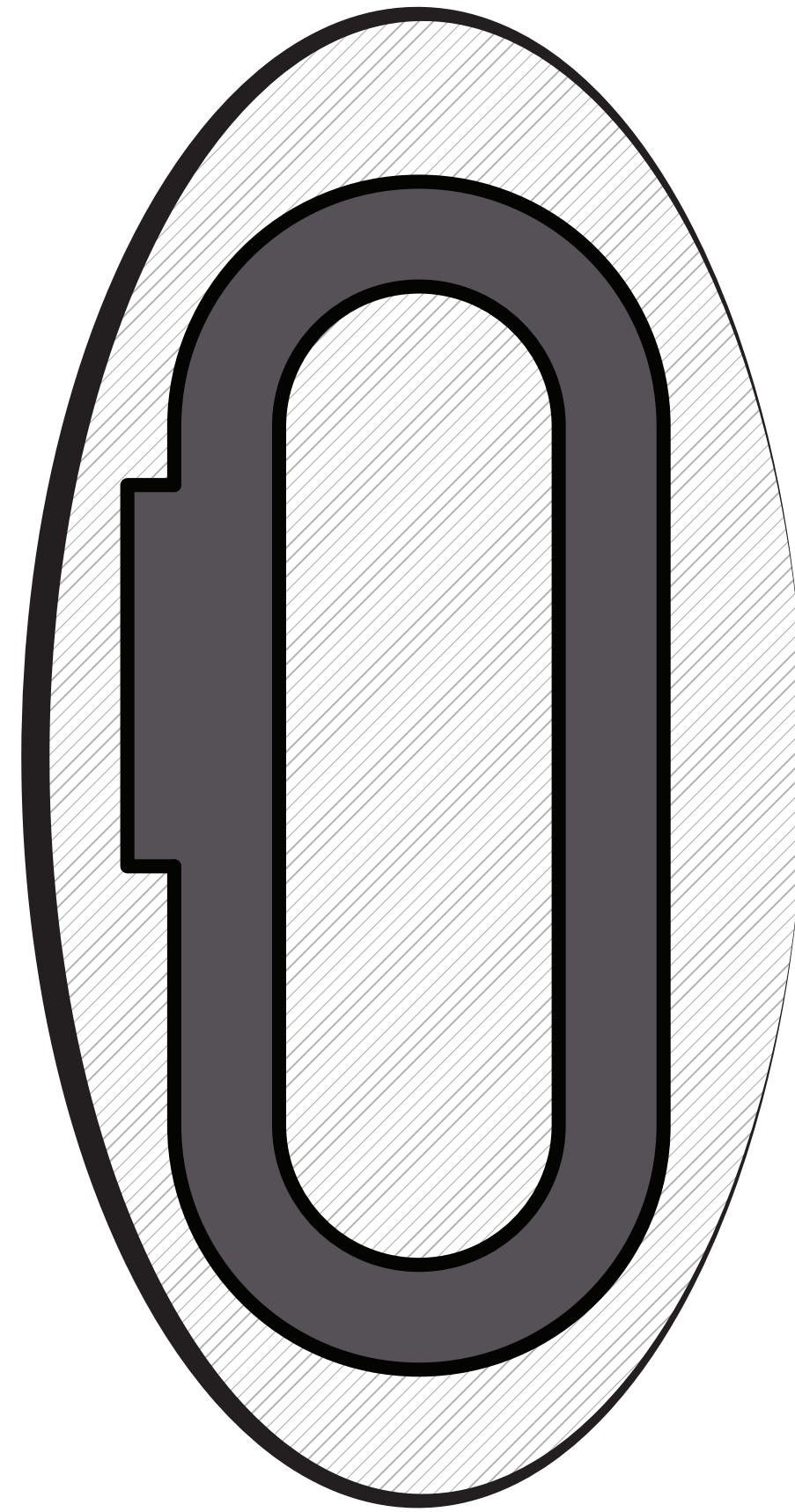

# DETERMINATION FORM



# SPATIAL SET UP

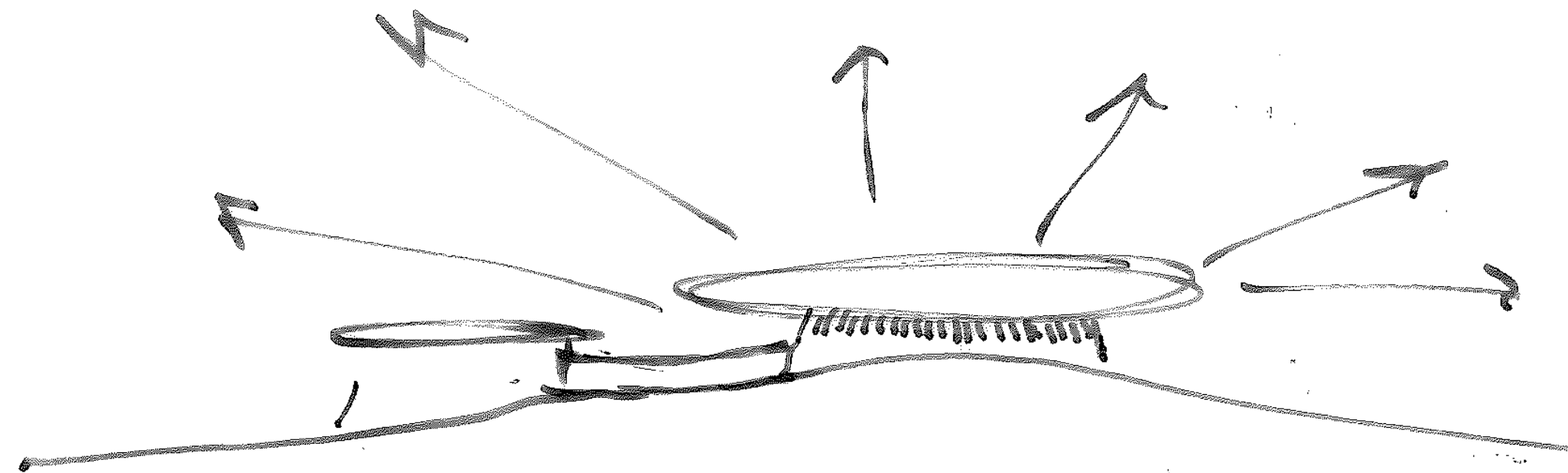

**FOCUS ON 400 METER BUILDING**

# SPATIAL SET UP

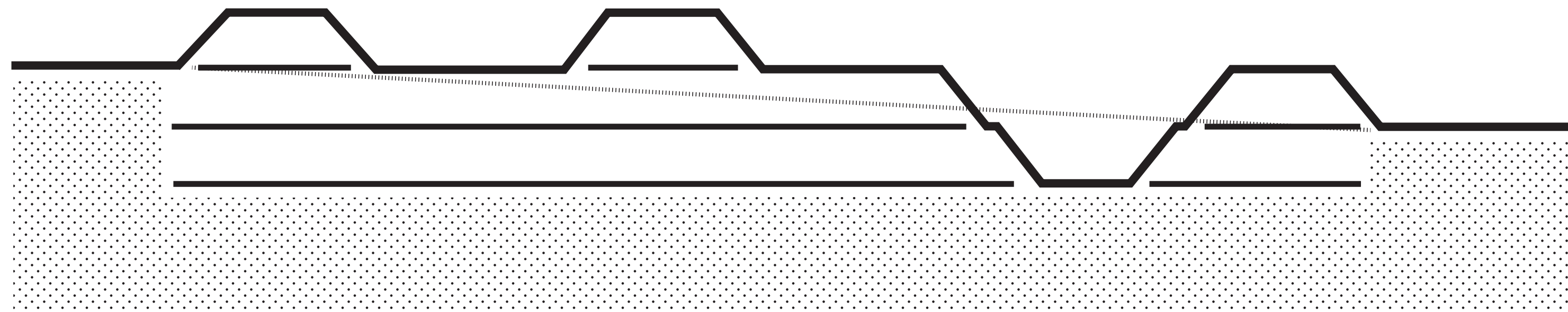

# SPATIAL SET UP

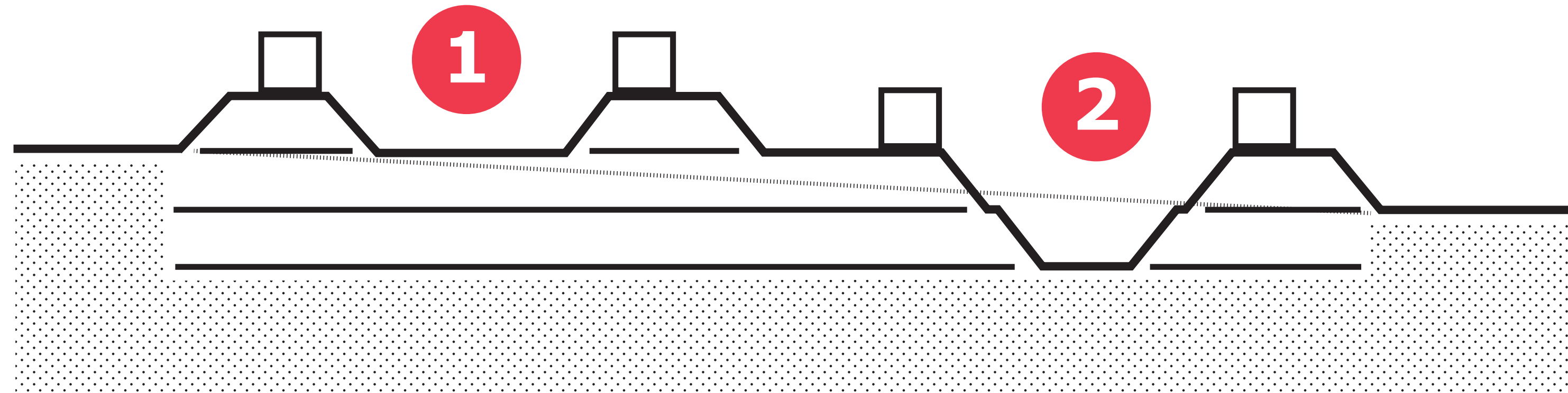

# SPATIAL SET UP

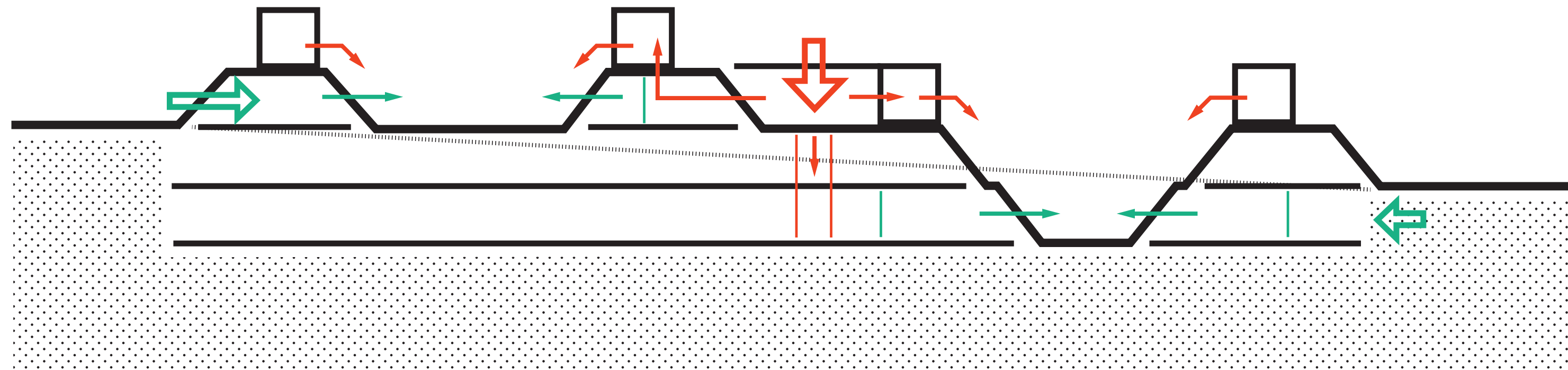

# SPATIAL SET UP

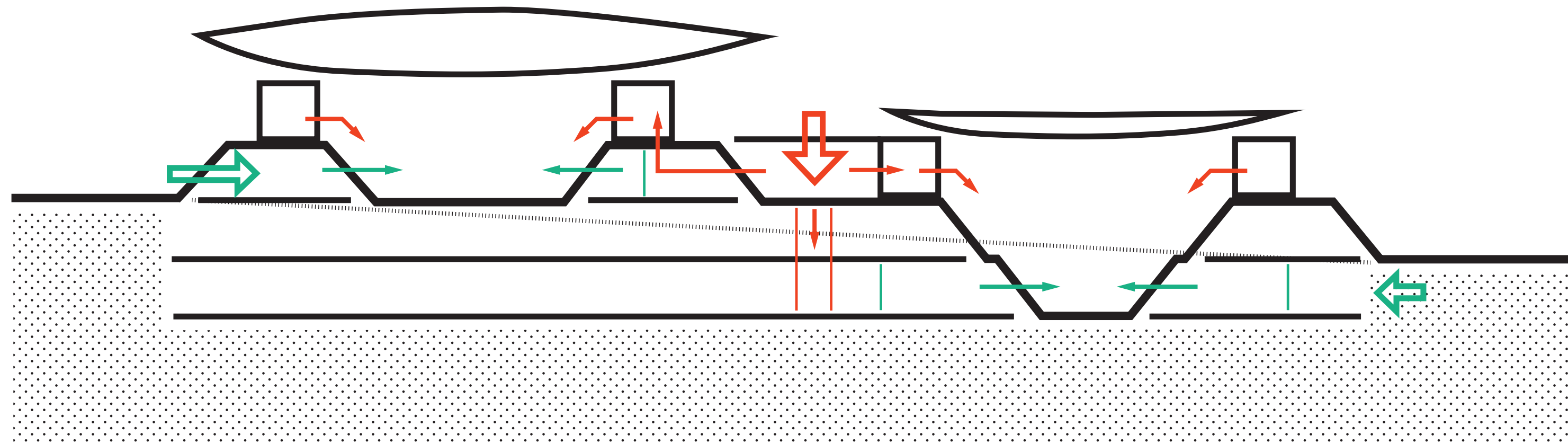
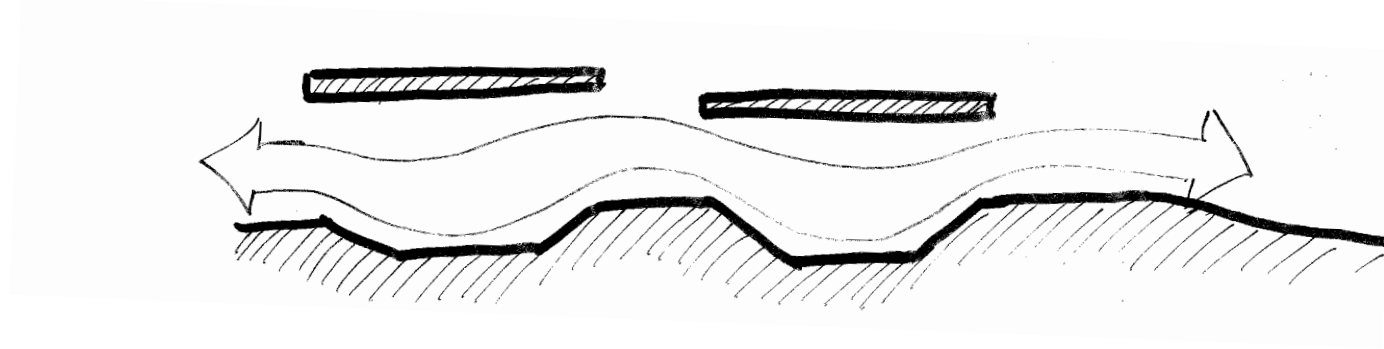

# SPATIAL SET UP

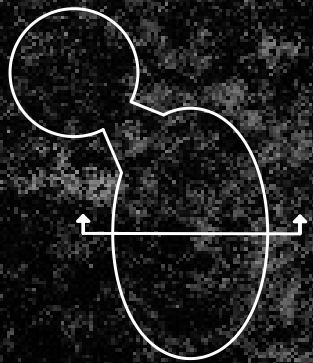
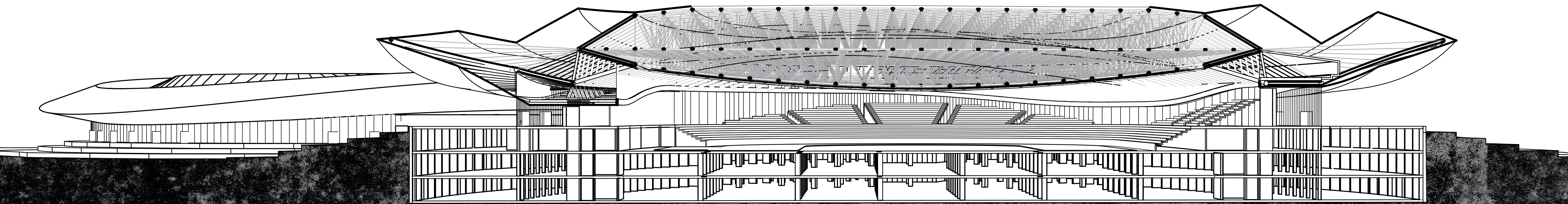

# SPATIAL SET UP

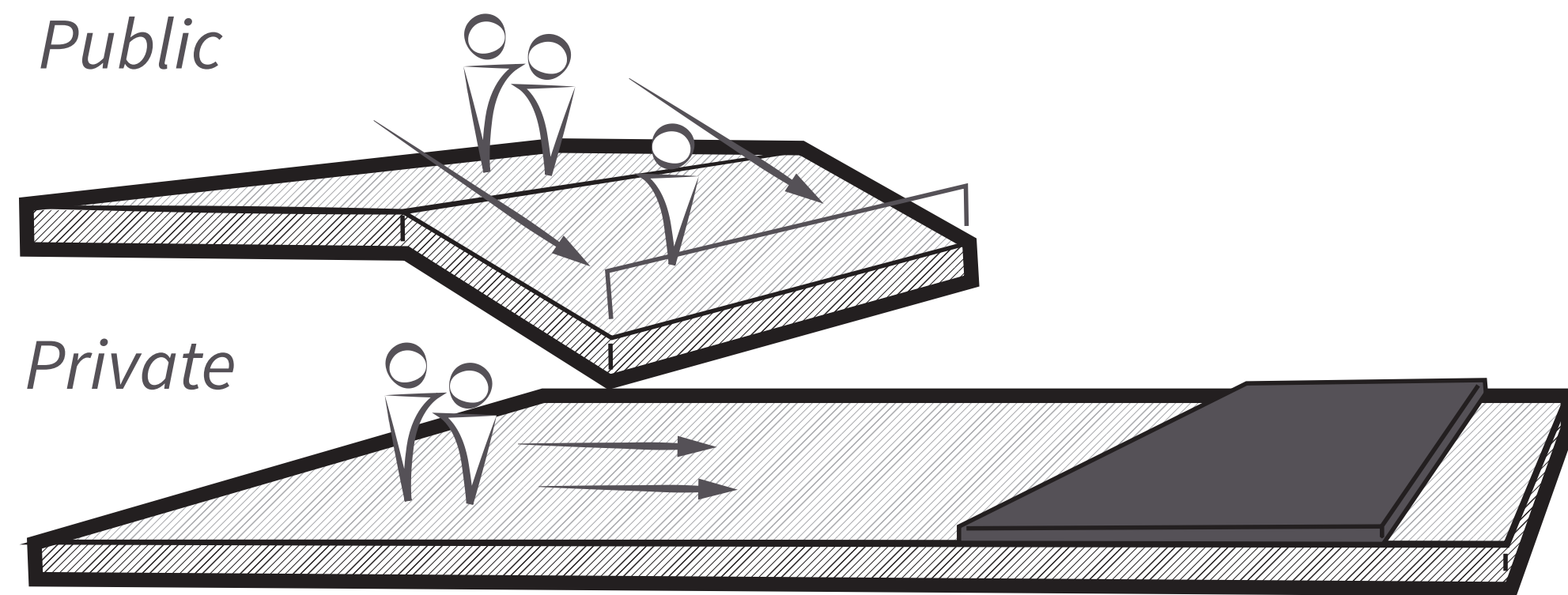

# SPATIAL SET UP

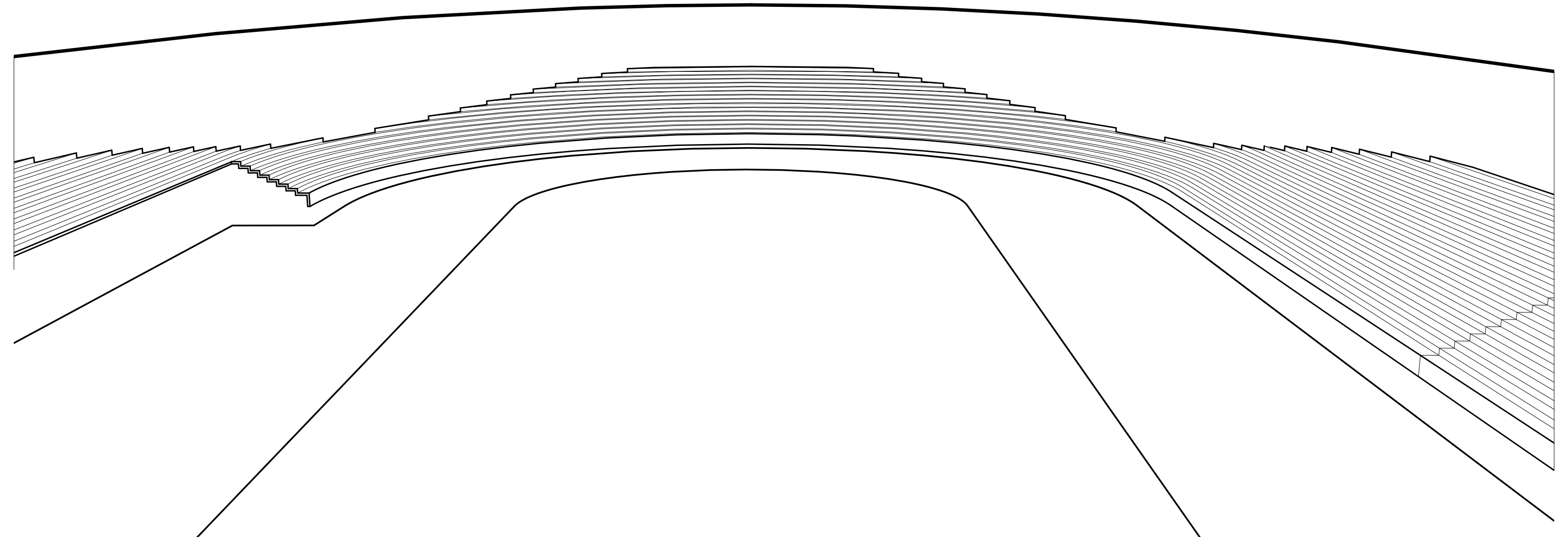
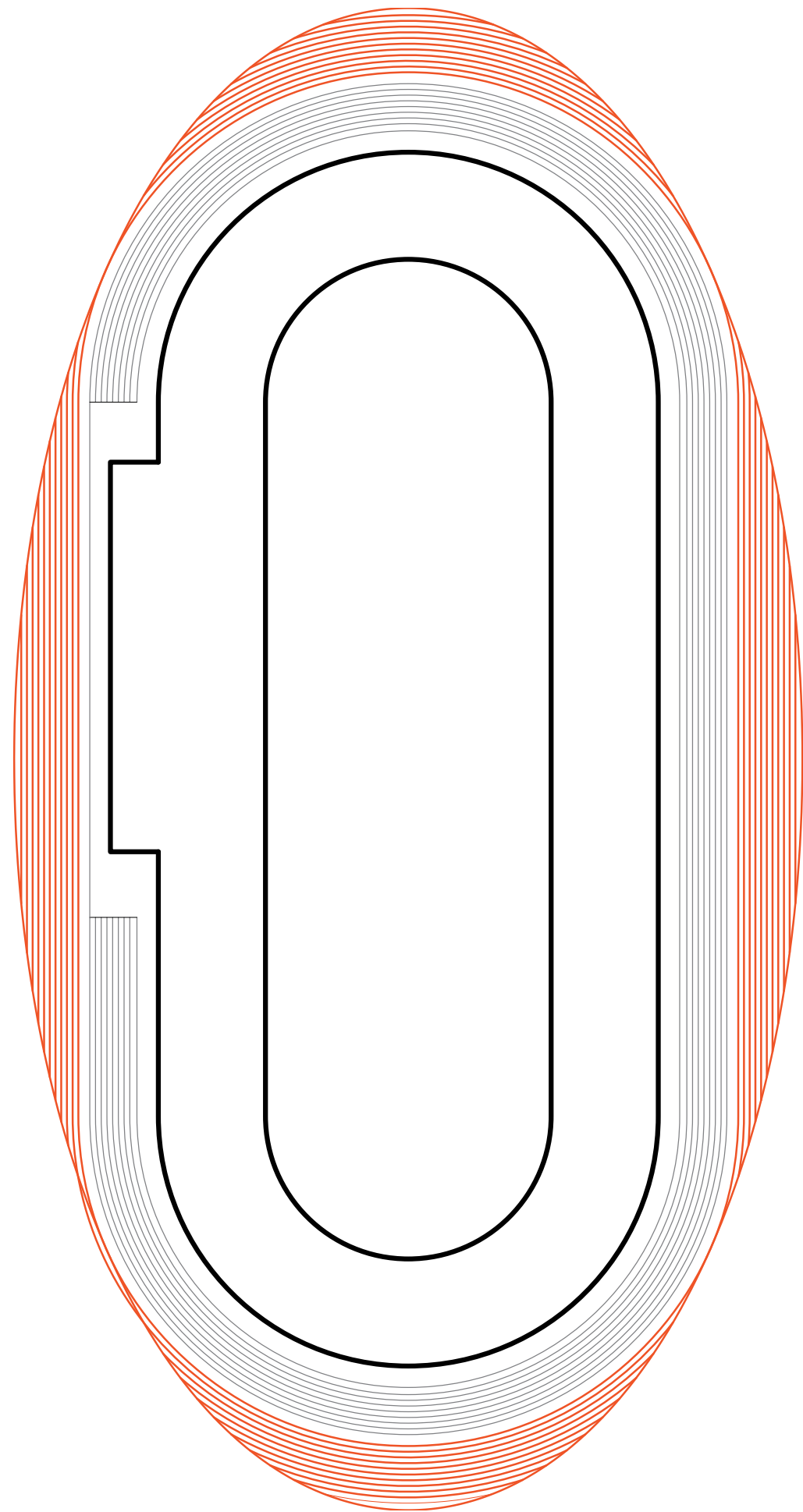

# SPATIAL SET UP

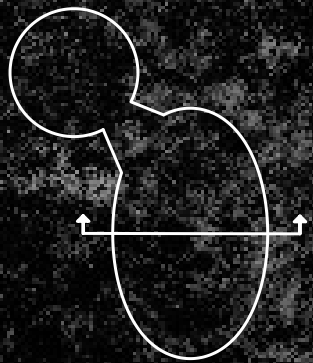
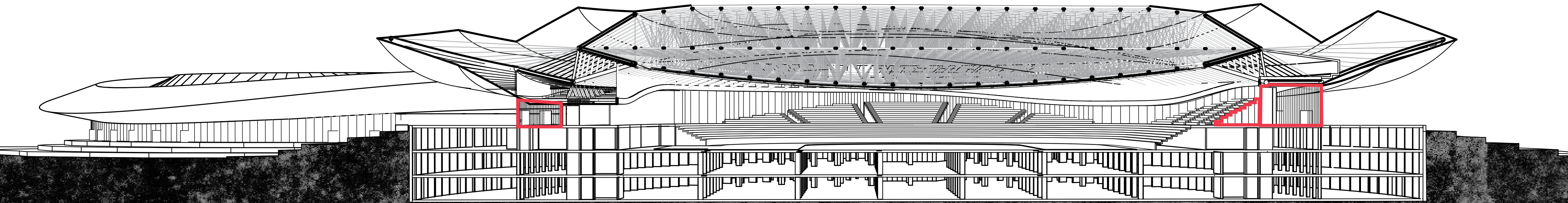

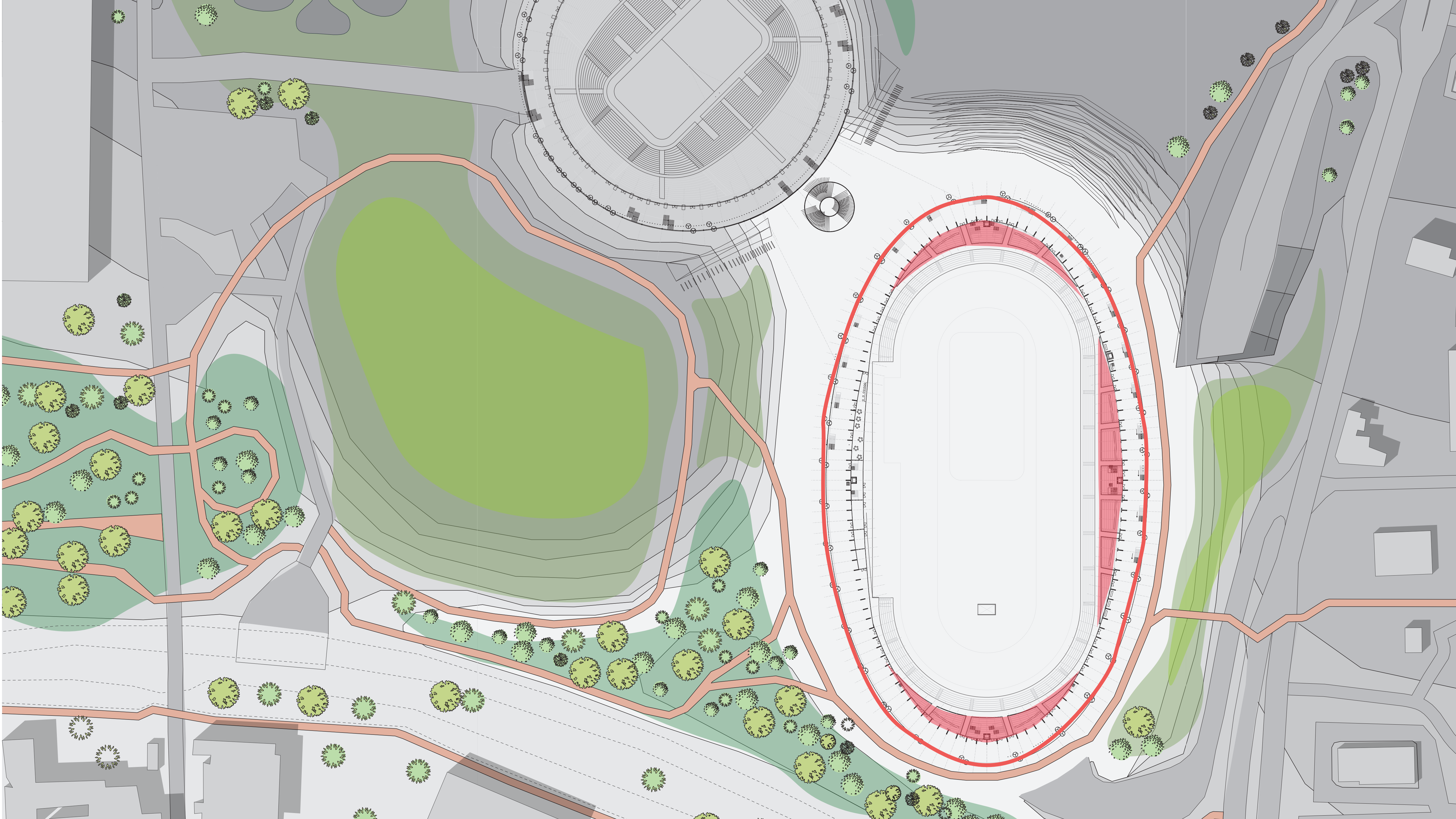

# TRAFFIC RING



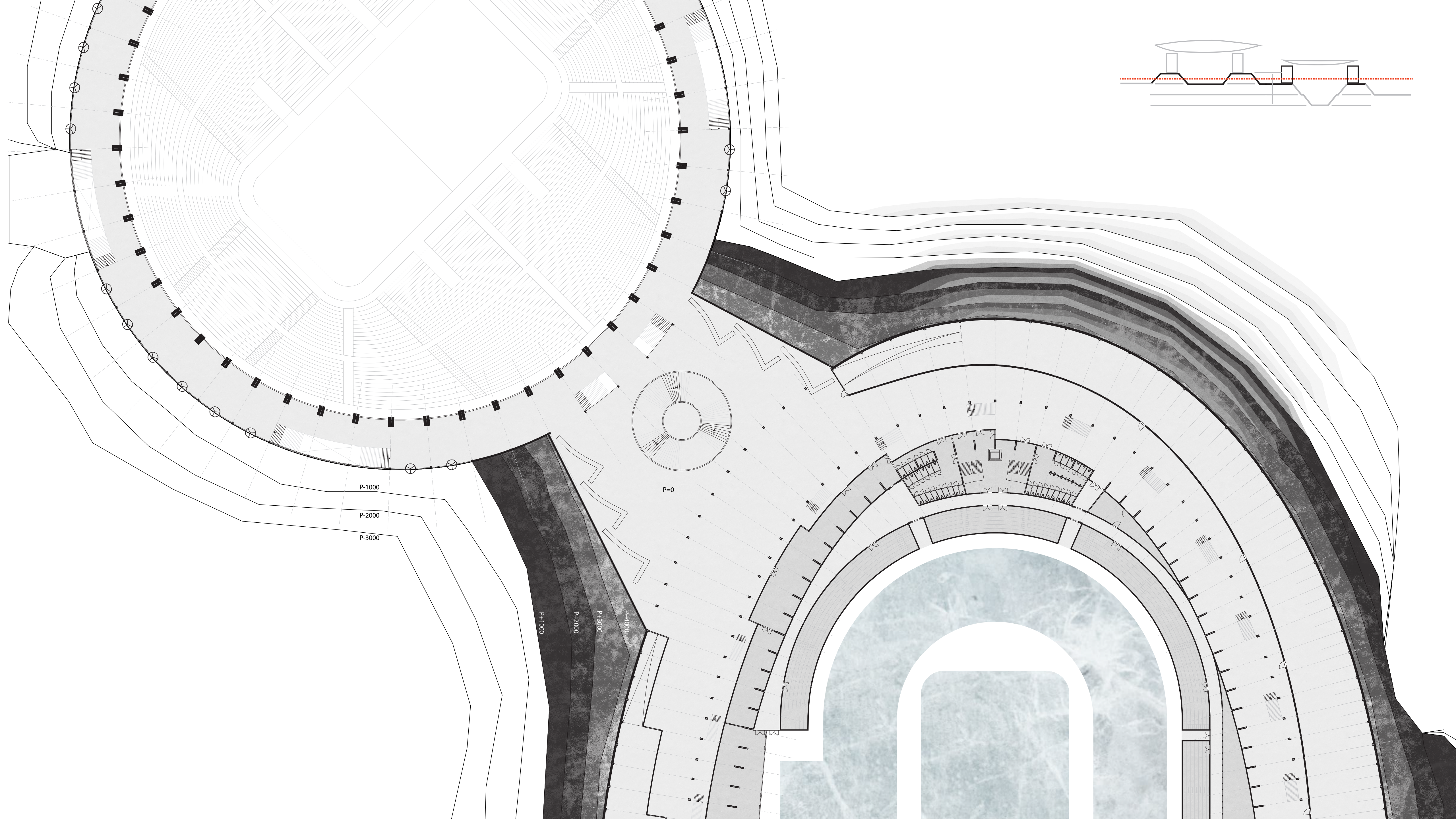
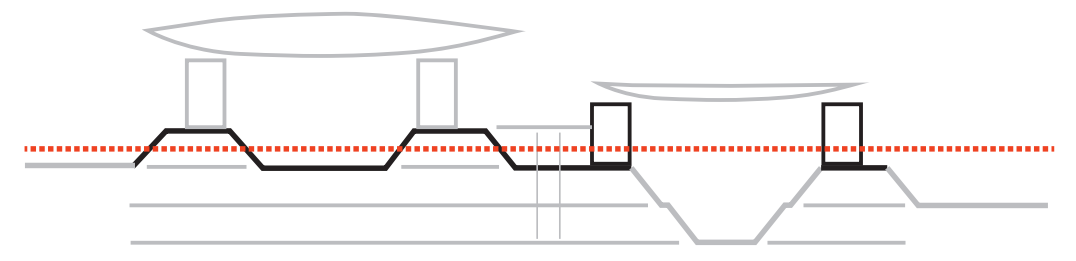

# CONSTRUCTION

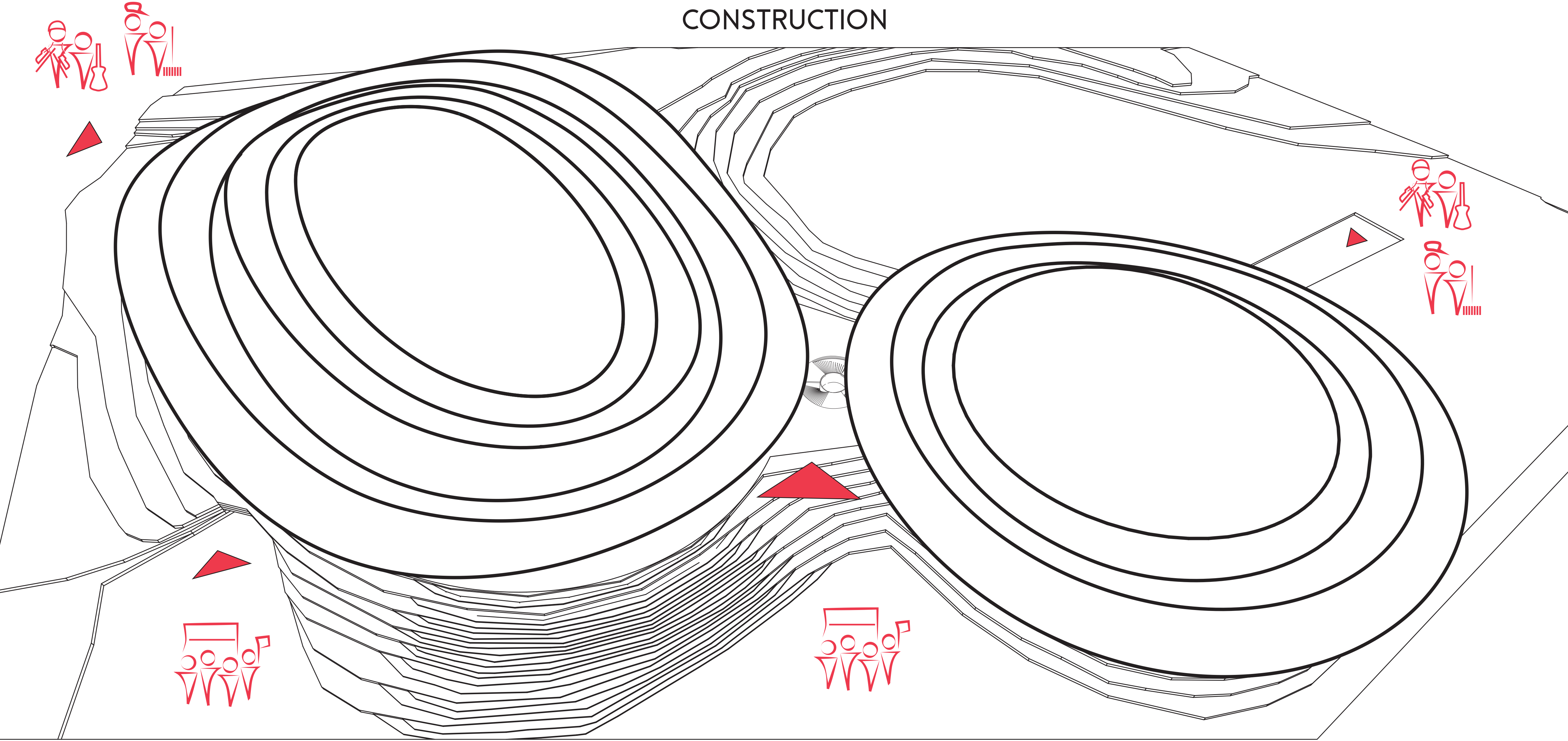

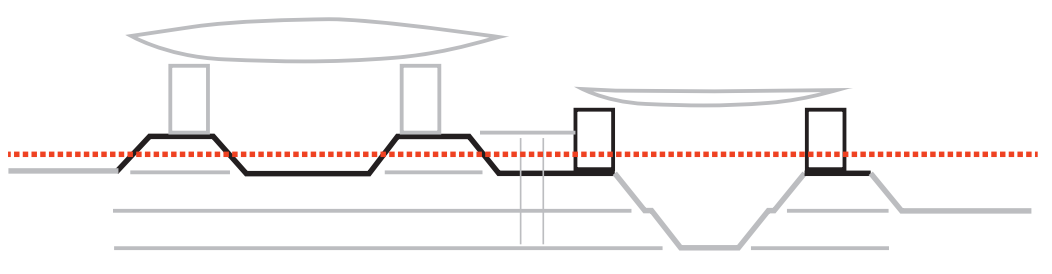
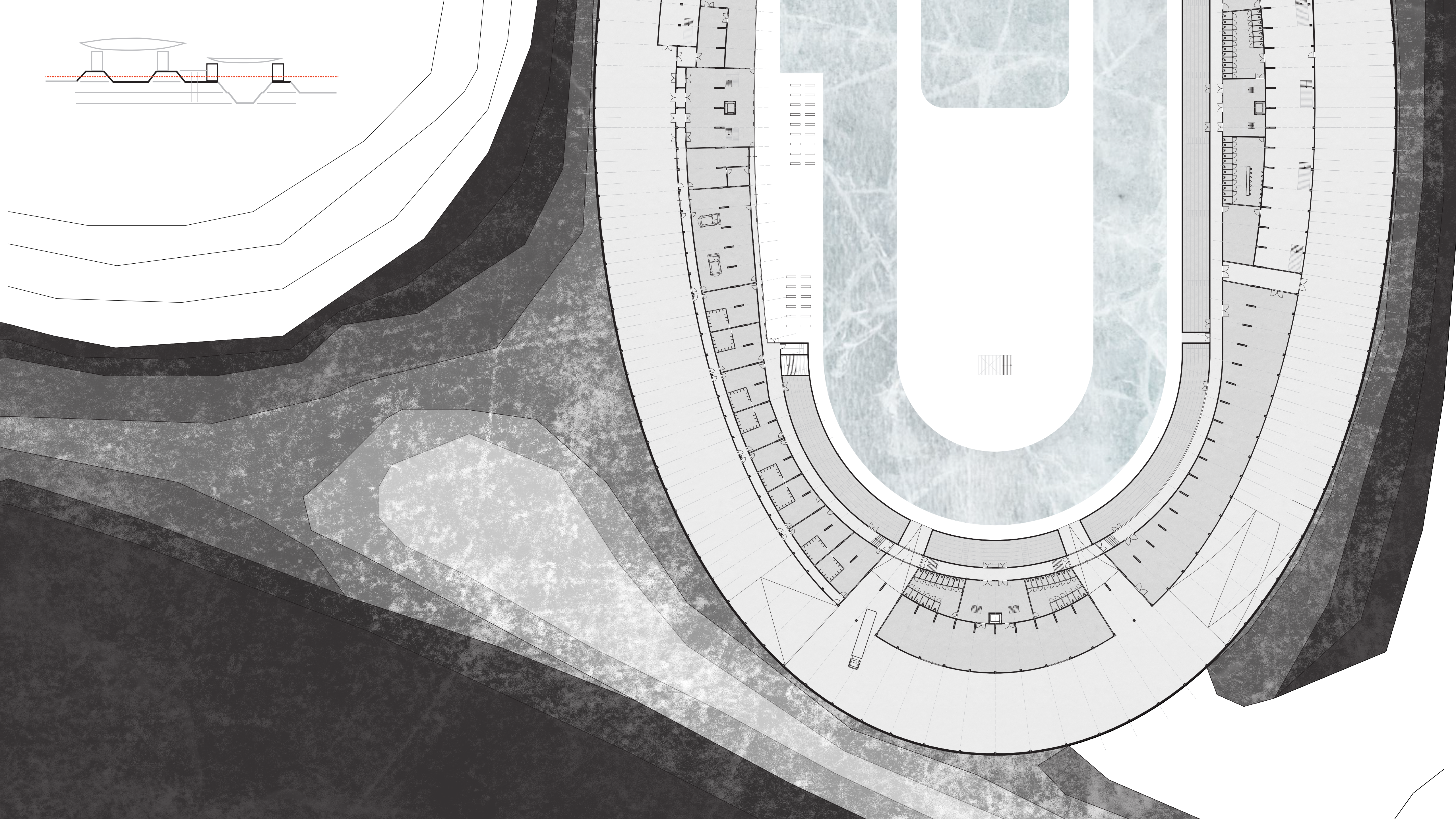

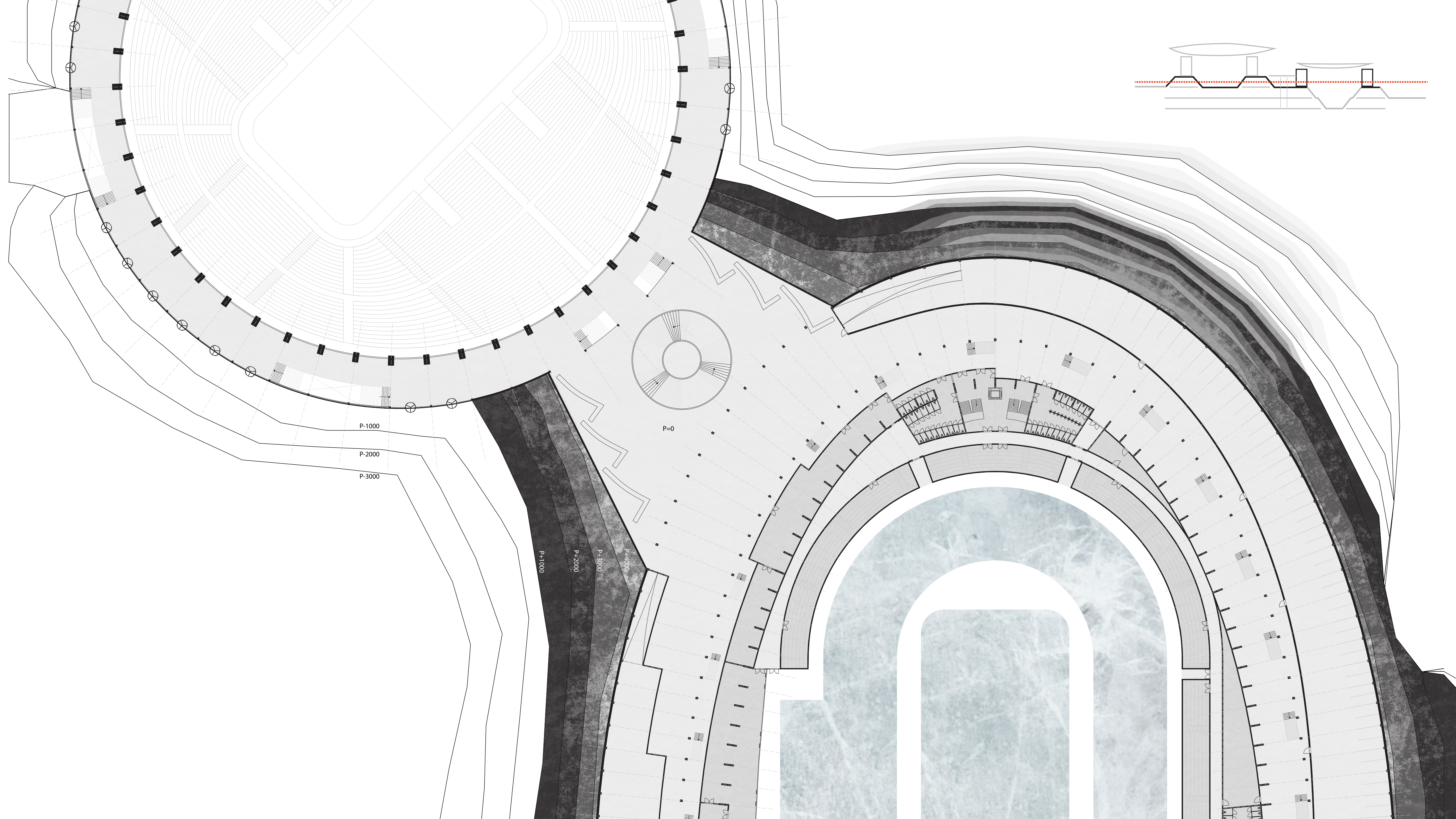
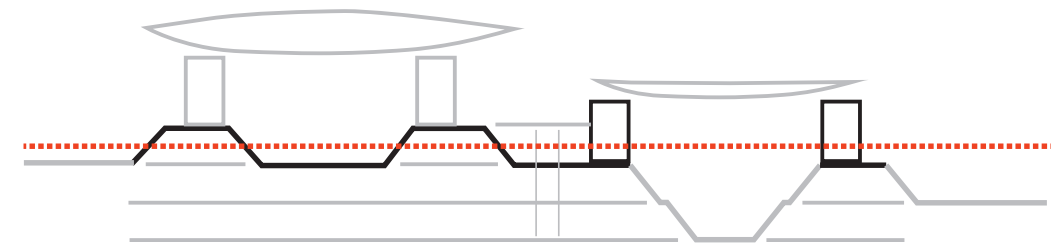

P-1000

P-2000

P-3000

P-0

P-1000

P-2000

P-3000

P-4000

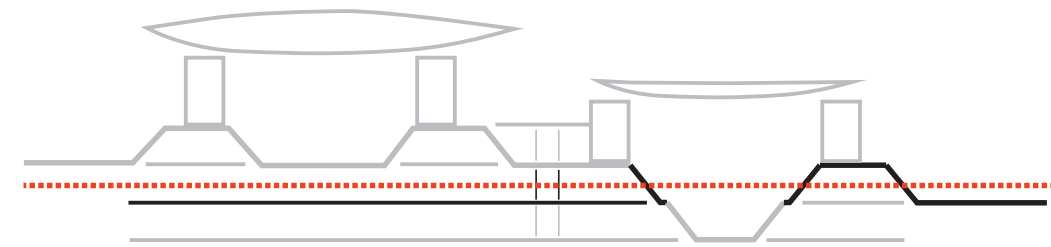
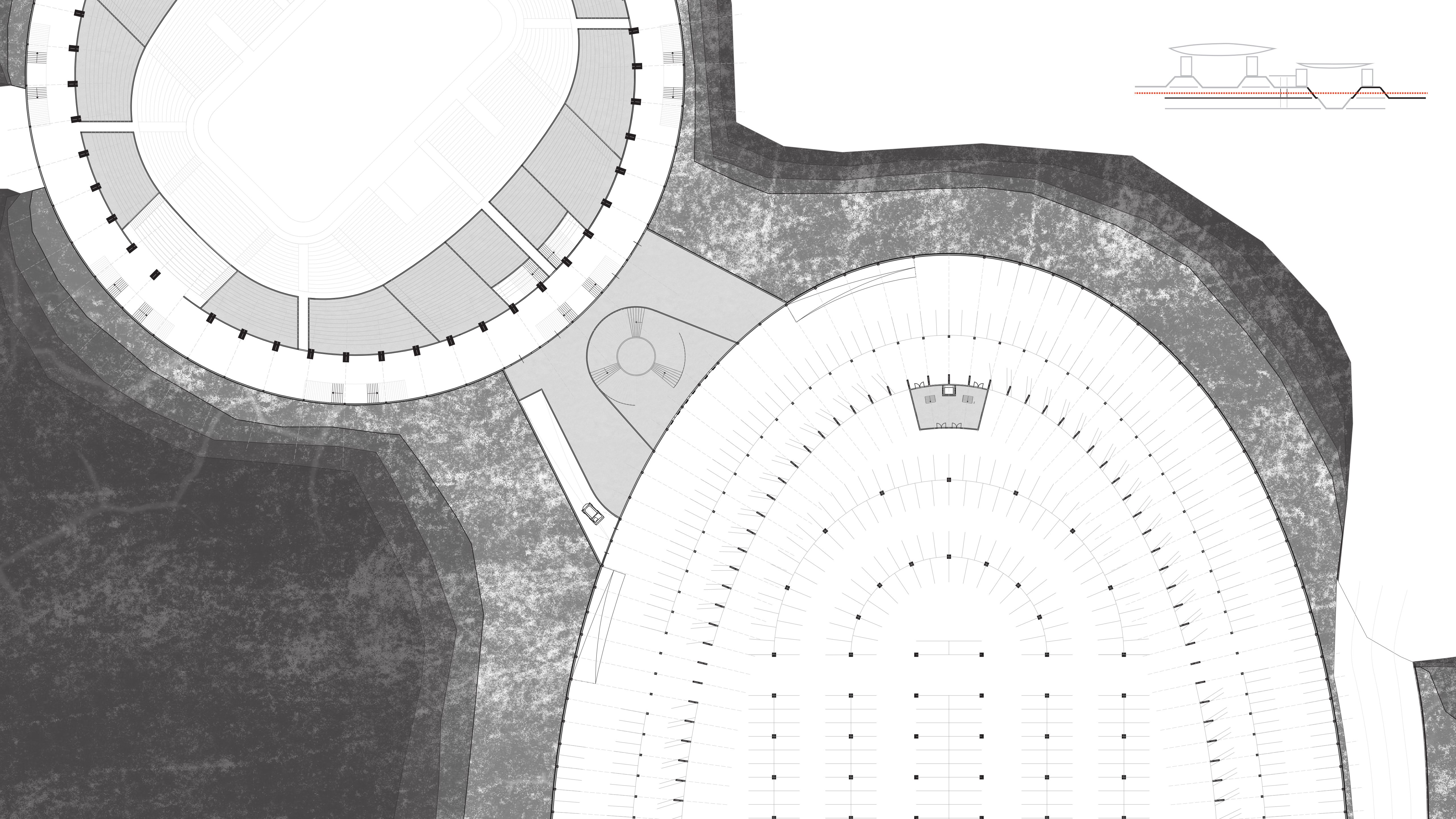

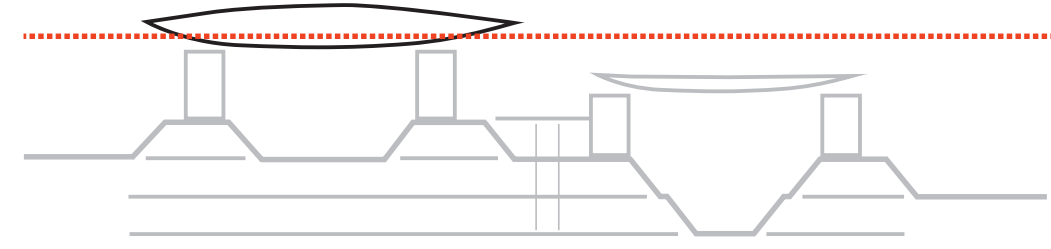
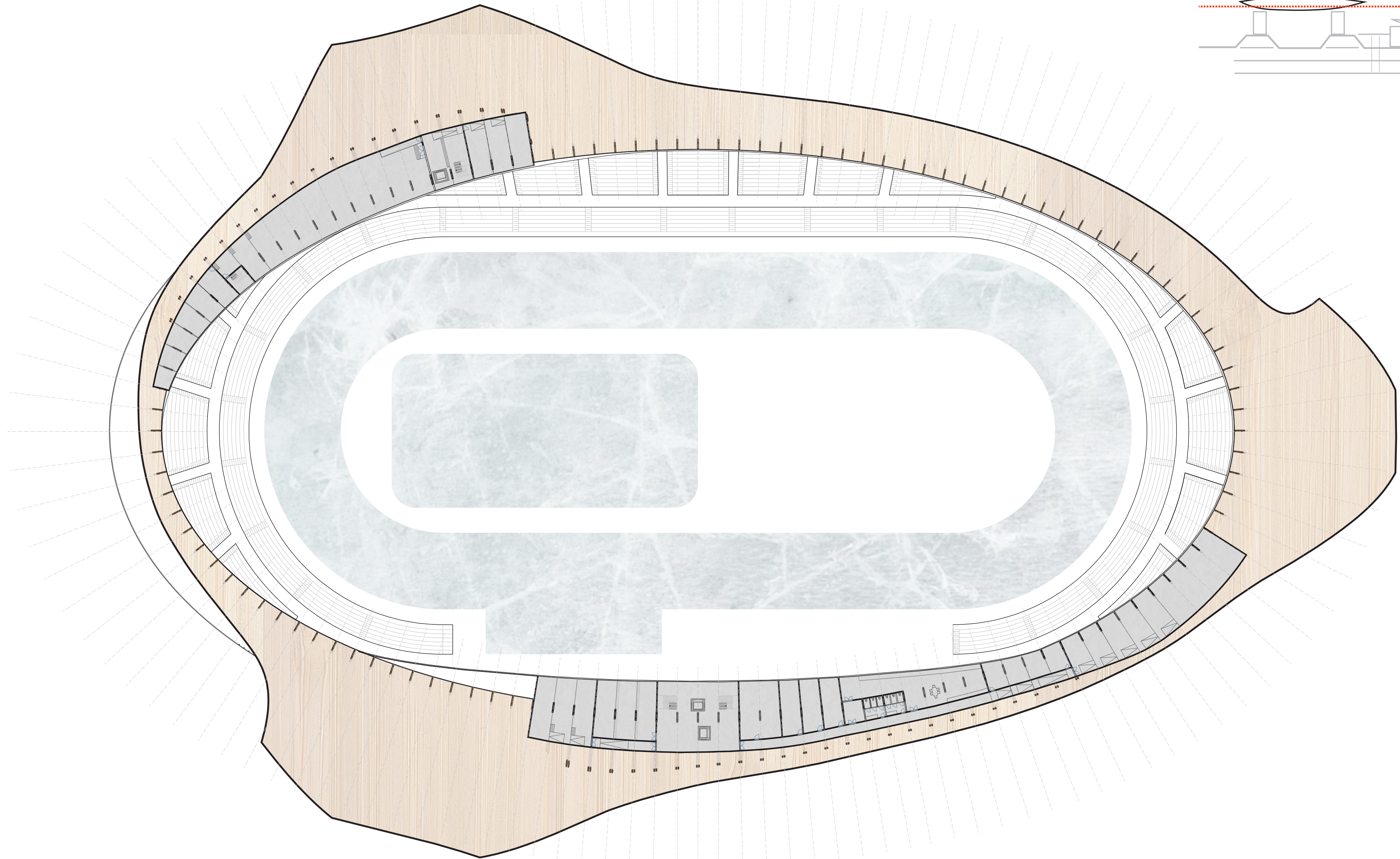

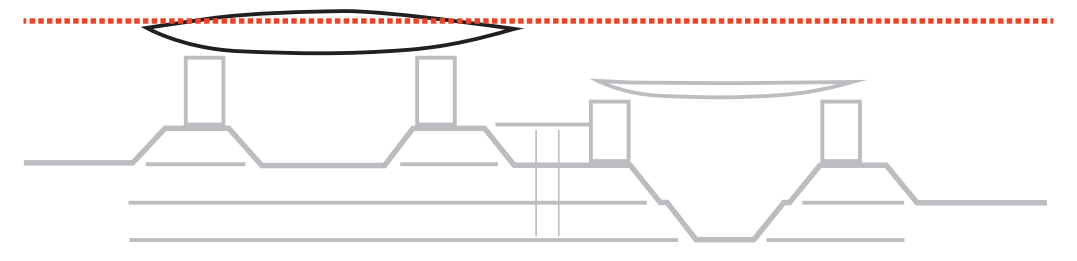
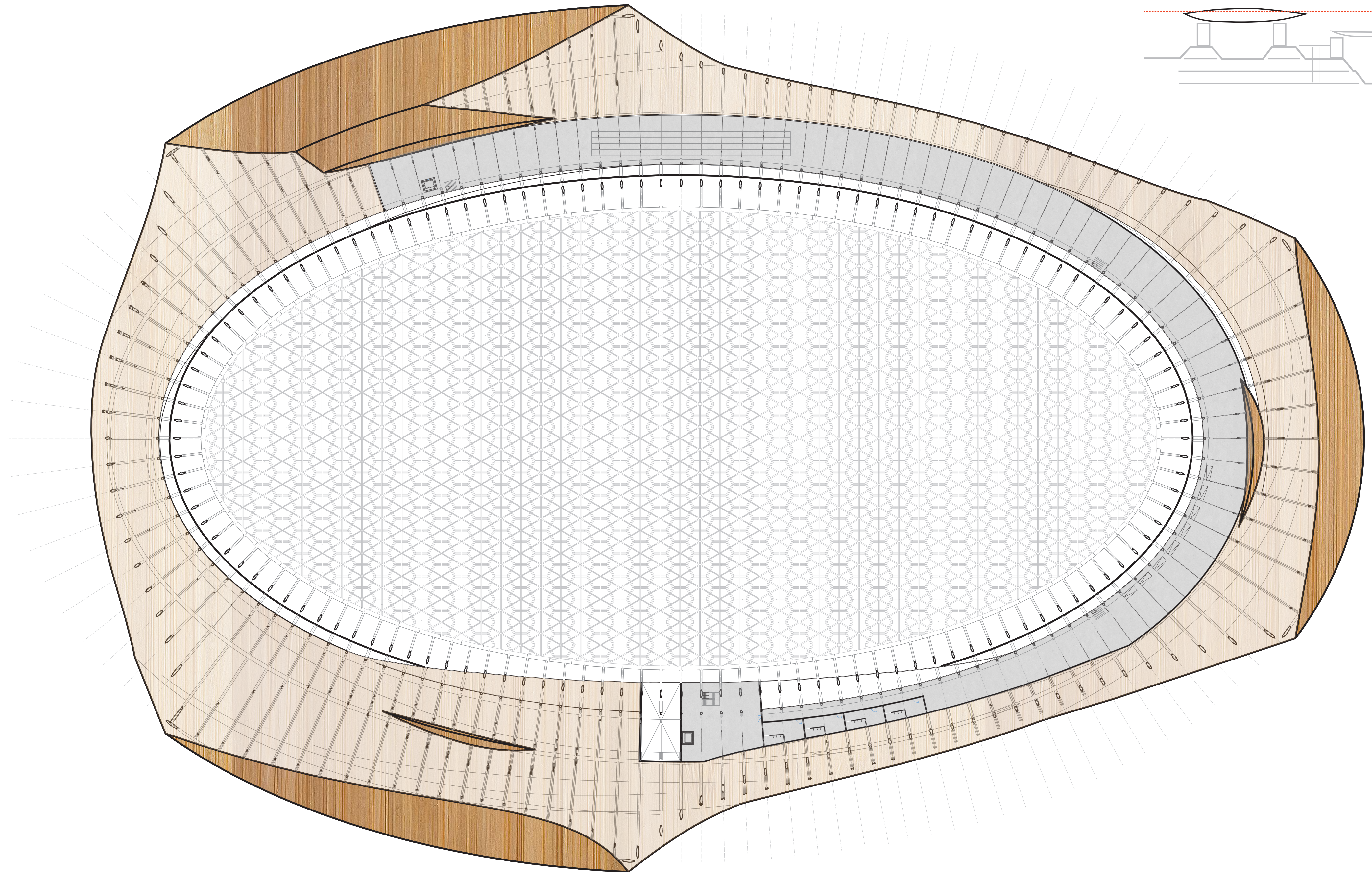

# CONSTRUCTION

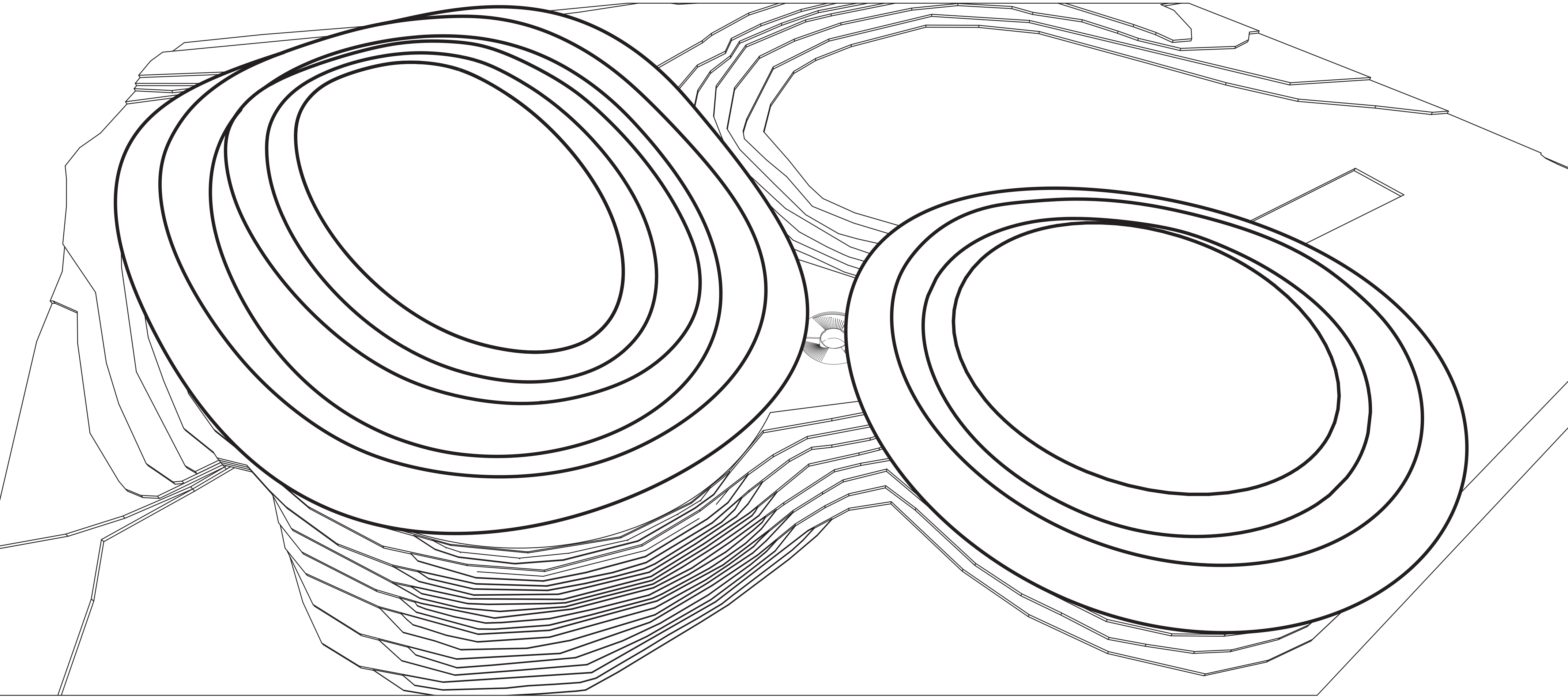

# CONSTRUCTION

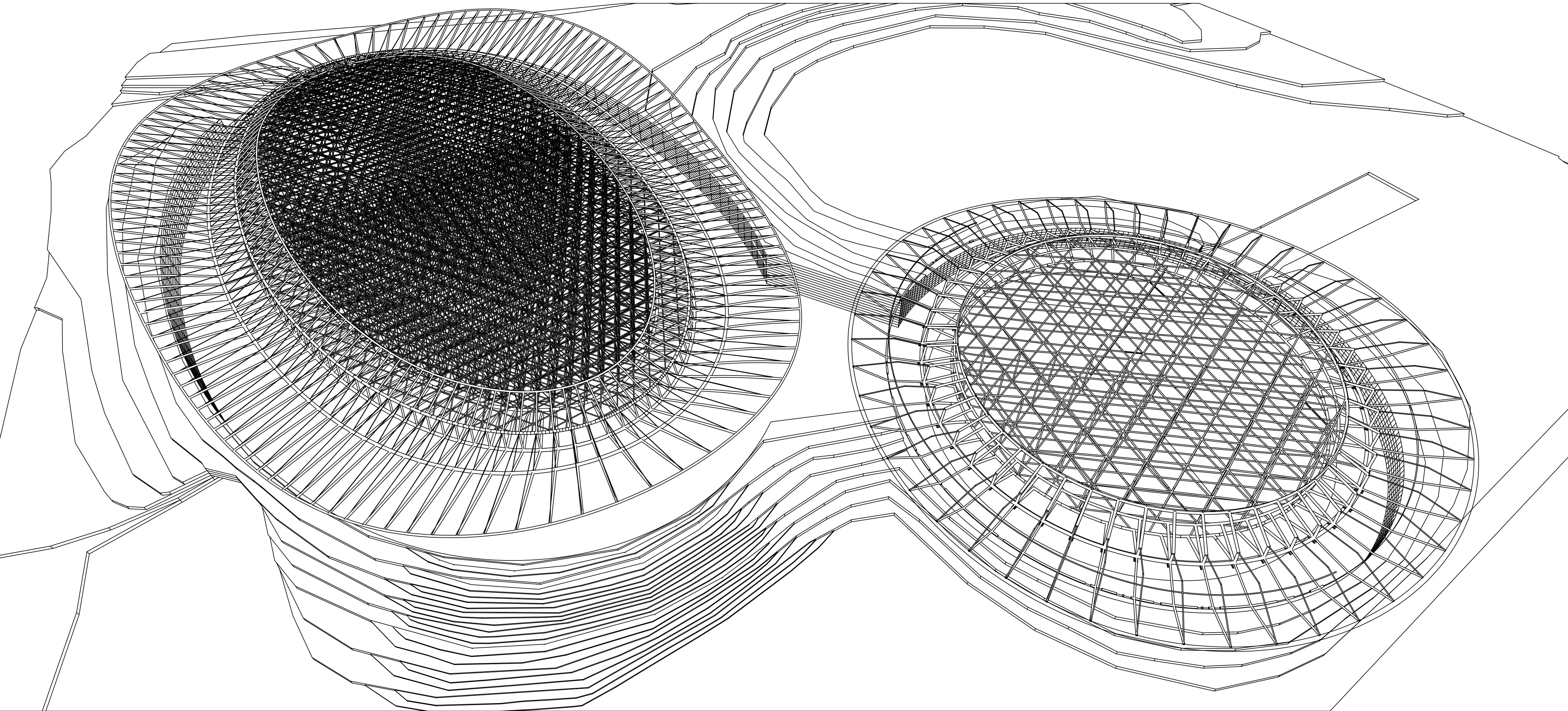

# CONSTRUCTION

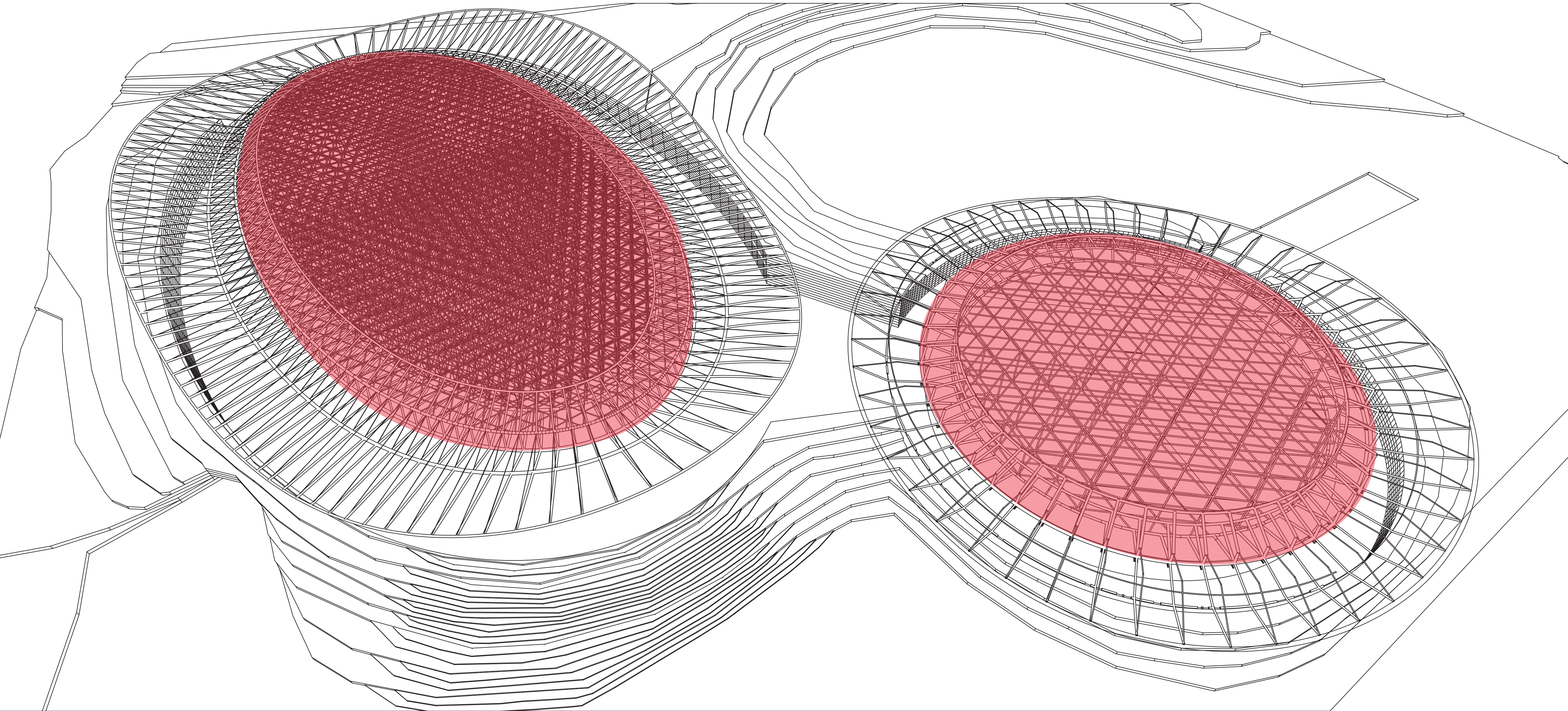

# CONSTRUCTION

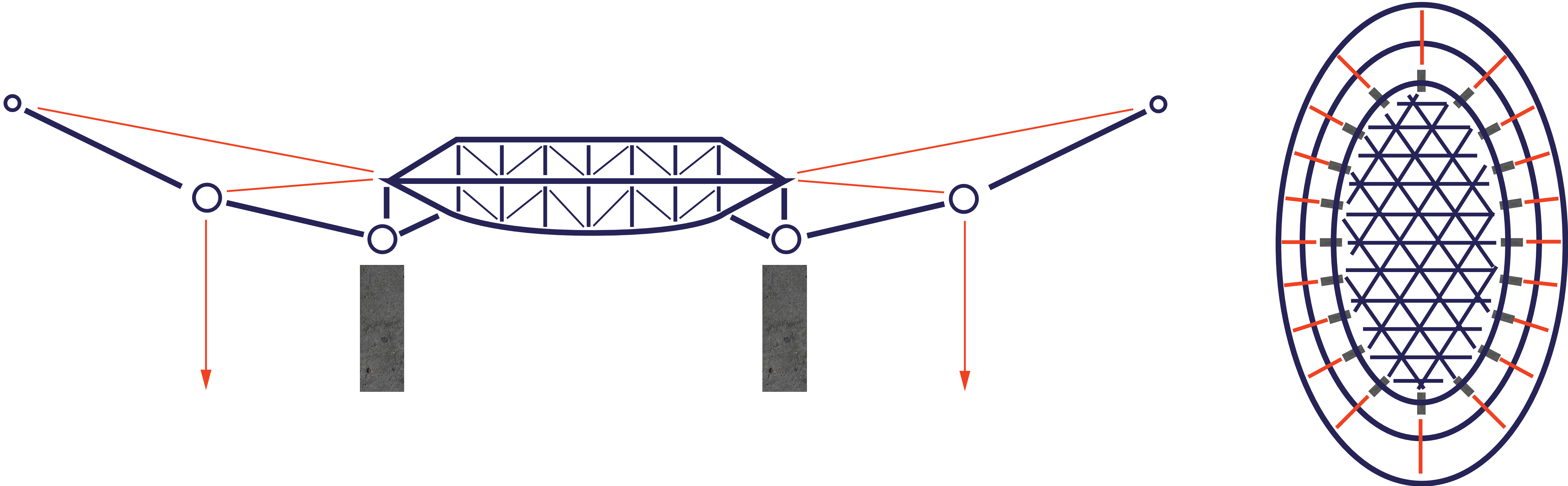

# CONSTRUCTION

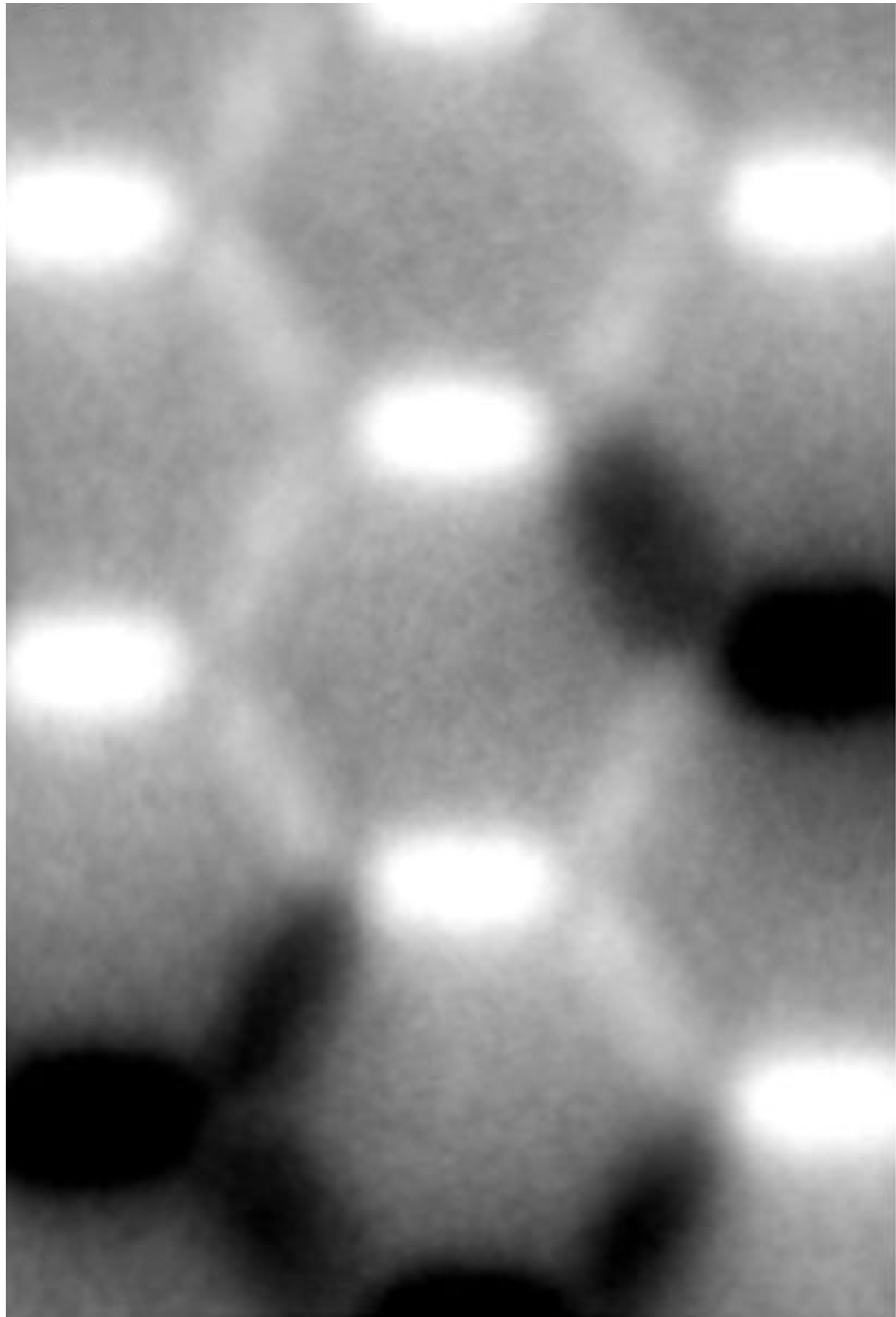

# CONSTRUCTION

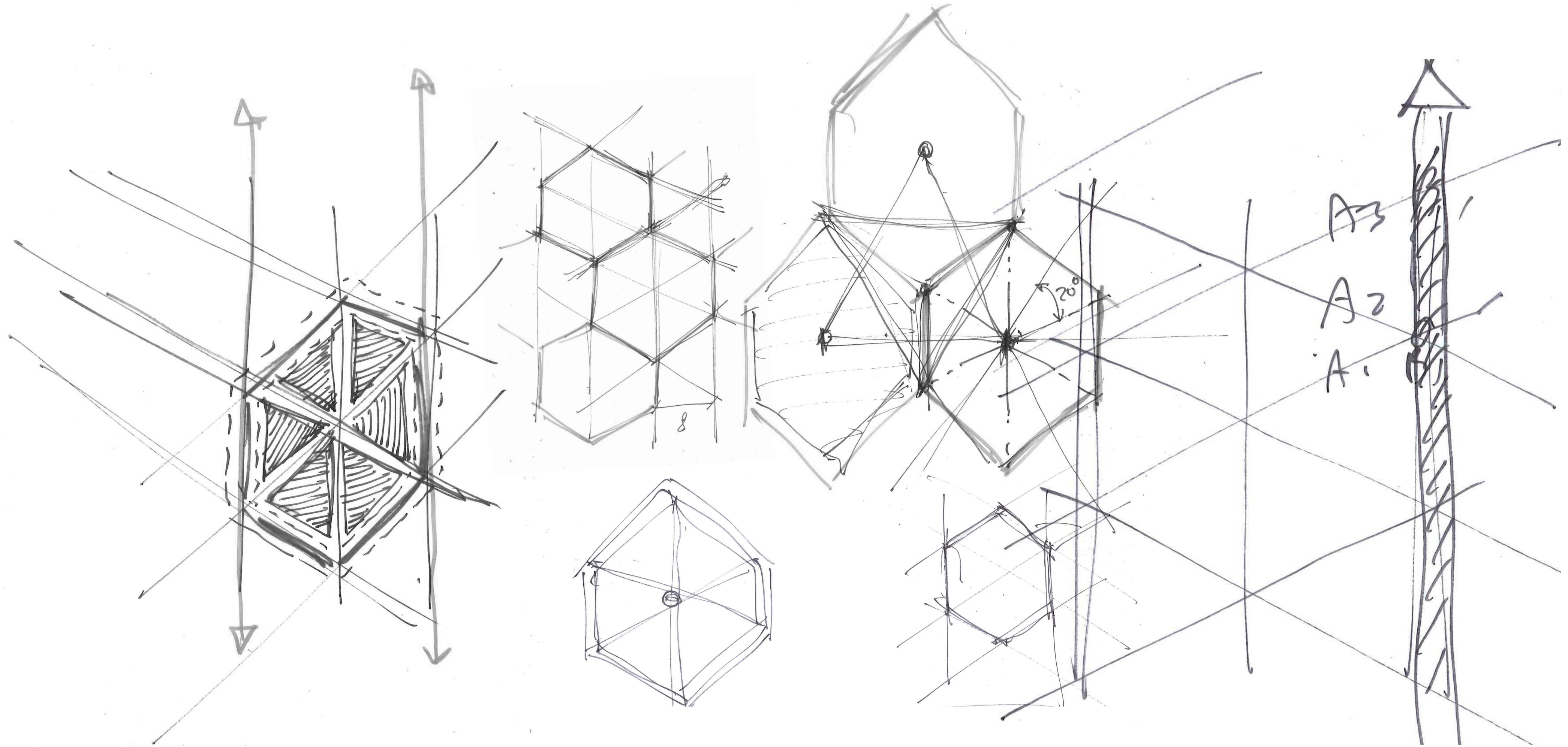

# CONSTRUCTION

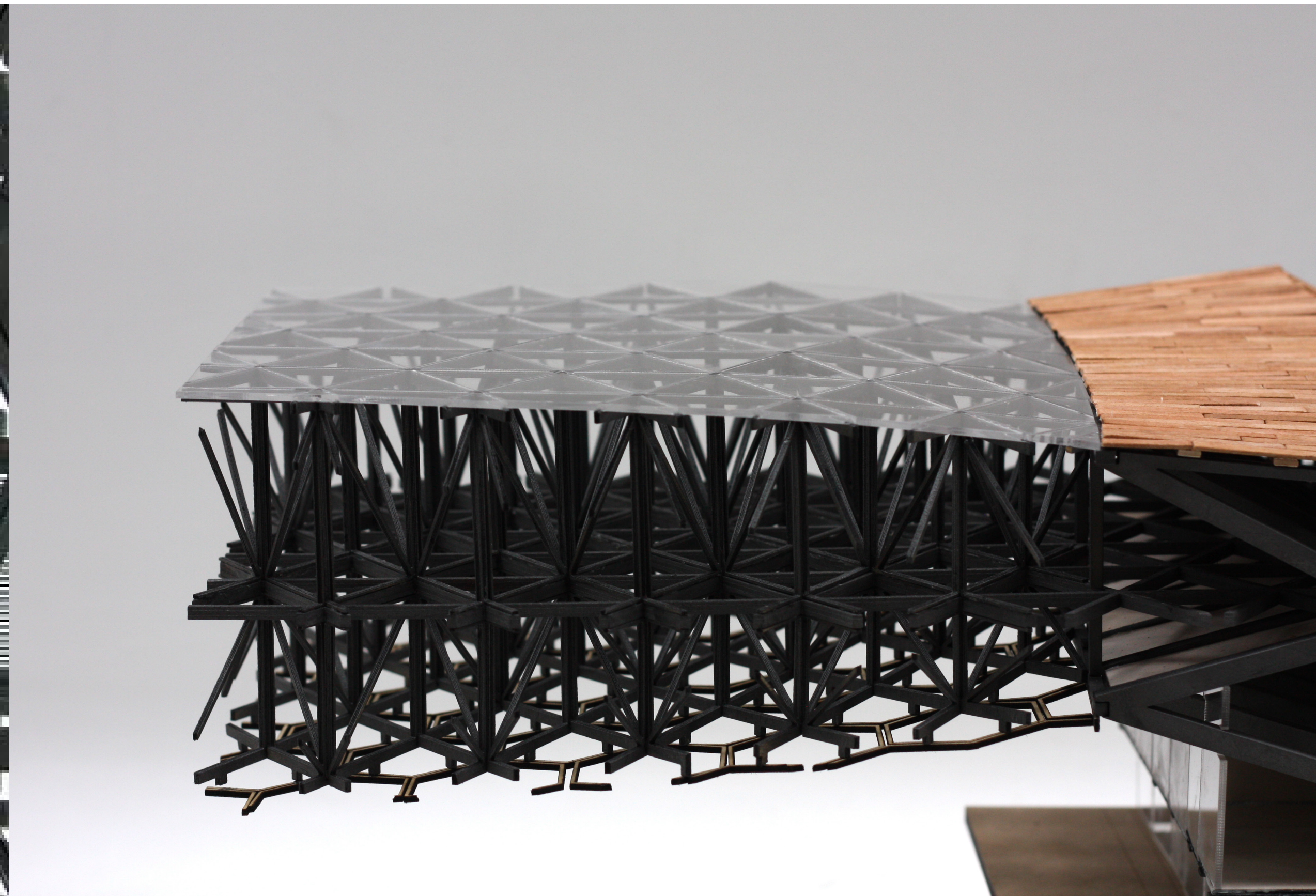
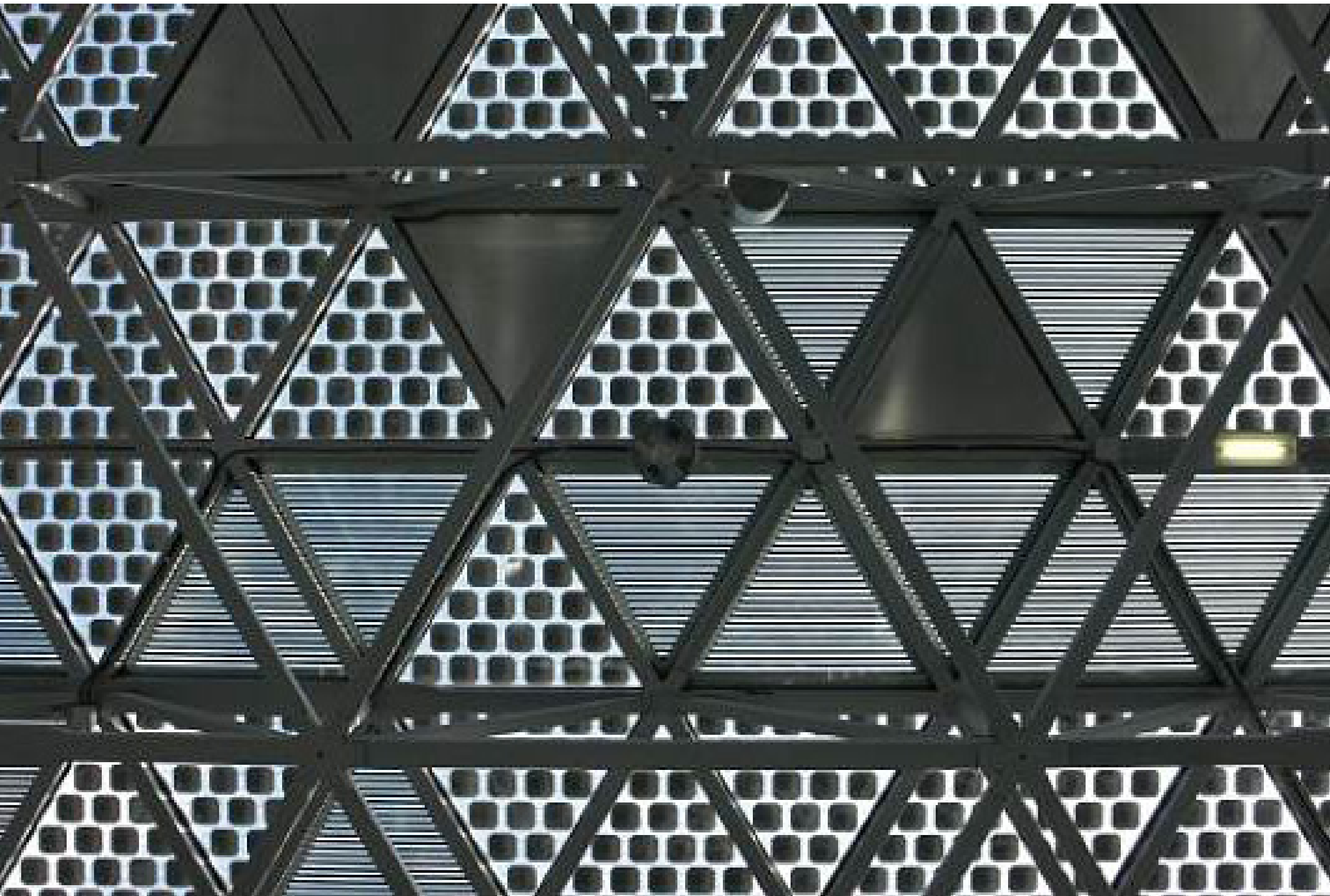

# CONSTRUCTION

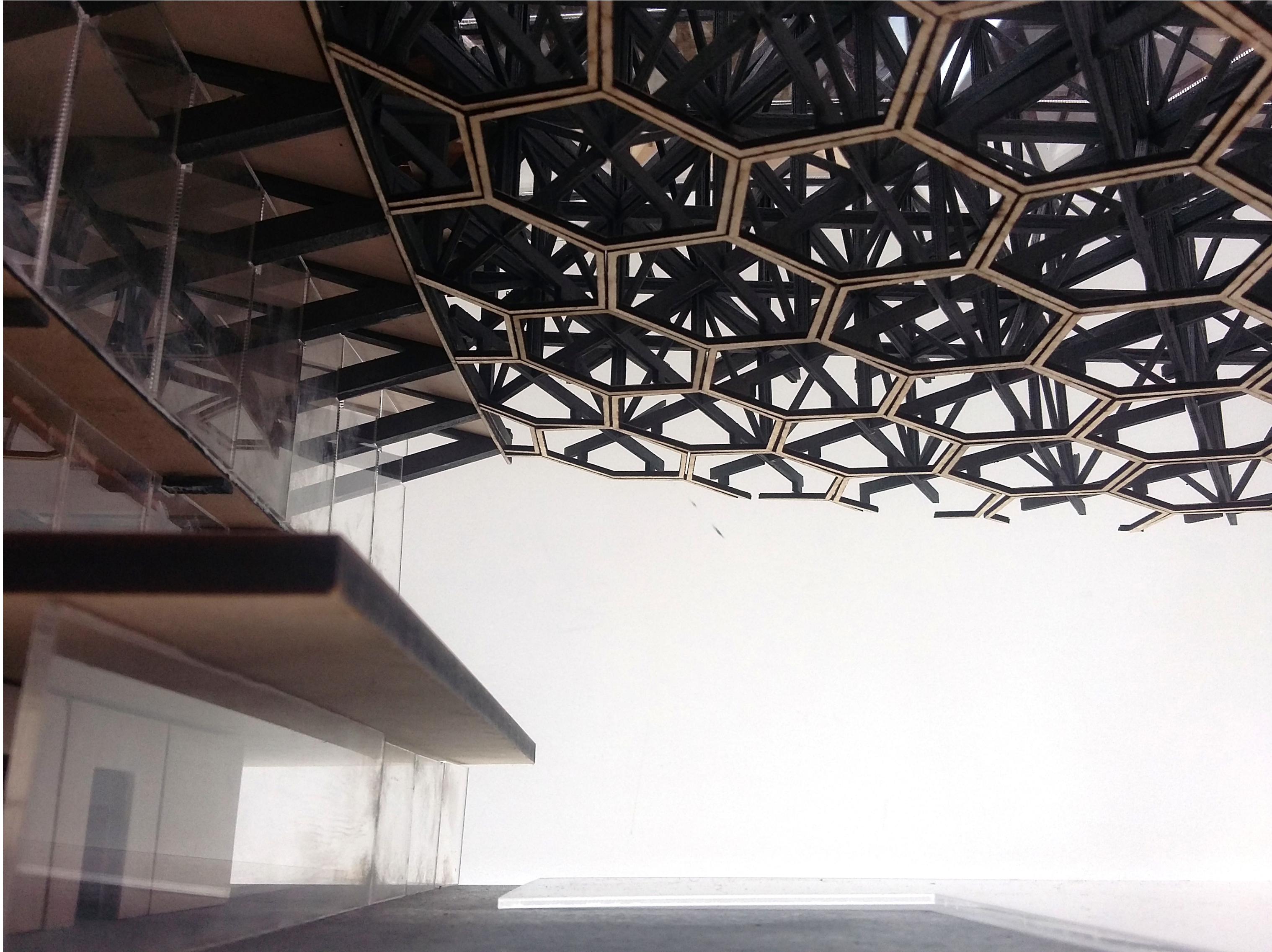

# CONSTRUCTION



# CLIMATE

WINTER

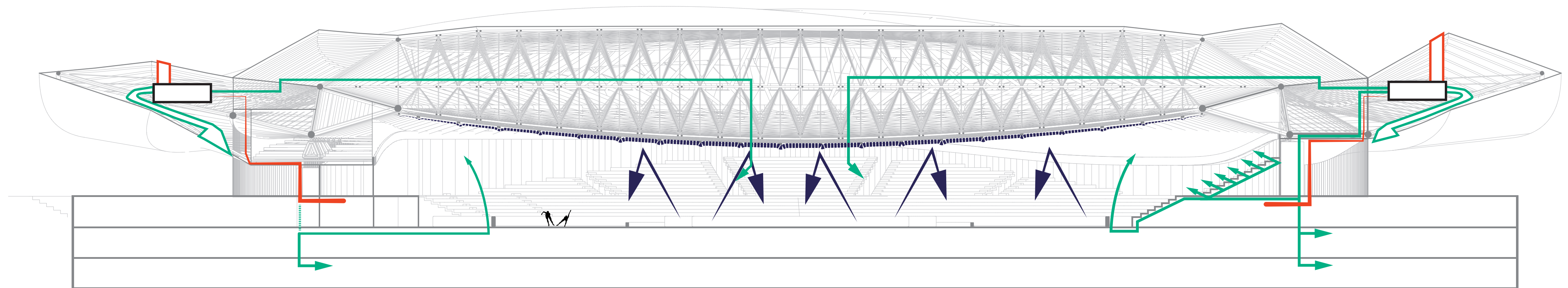

# CLIMATE

SUMMER

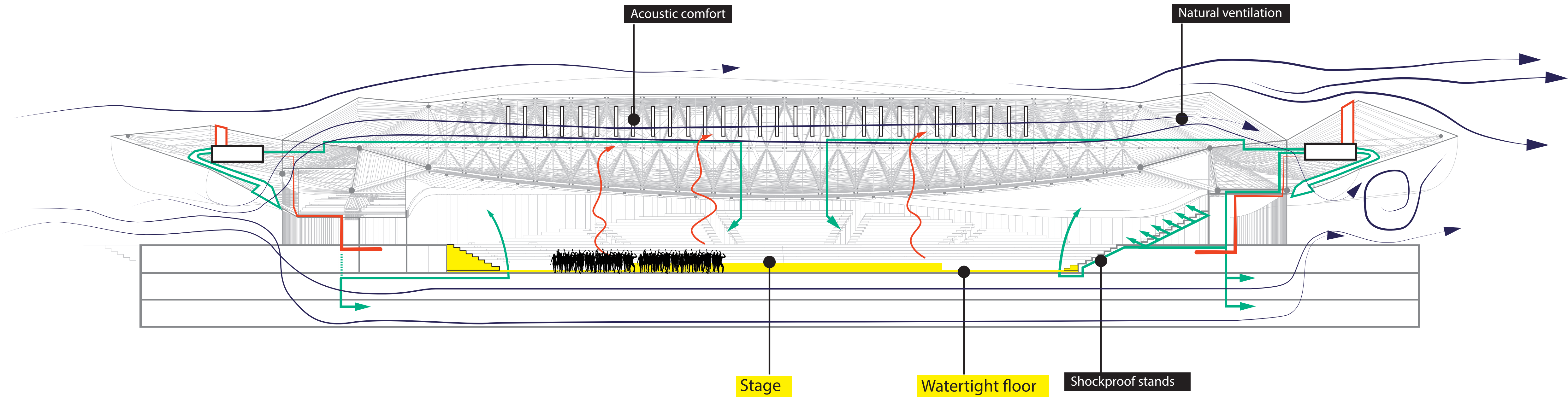

✦ Velocity (m/s) [Pressure (Pa)]

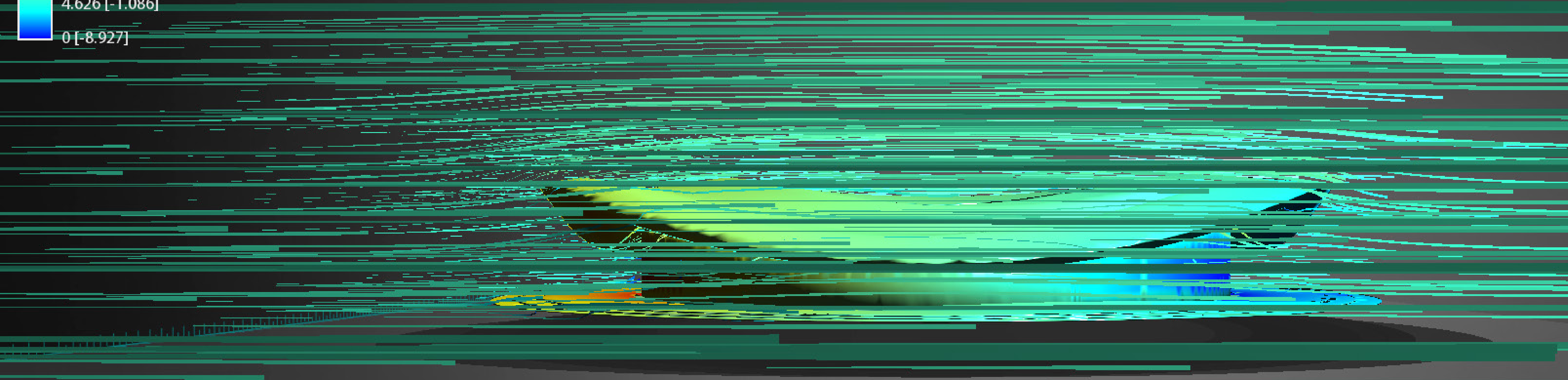
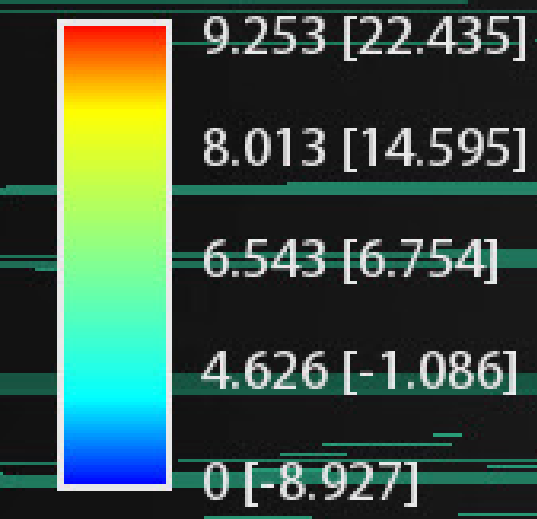

# CLIMATE

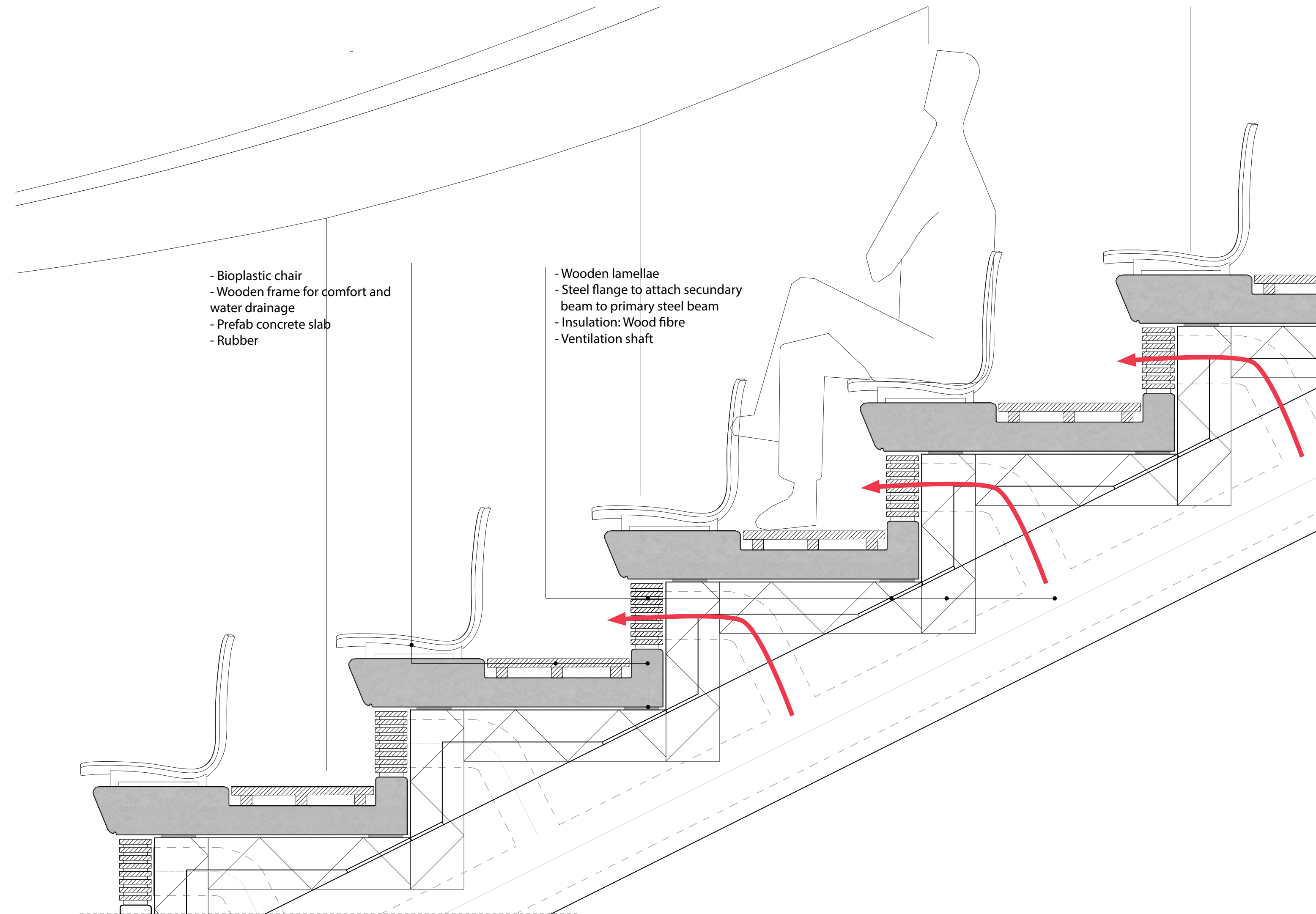

# CLIMATE

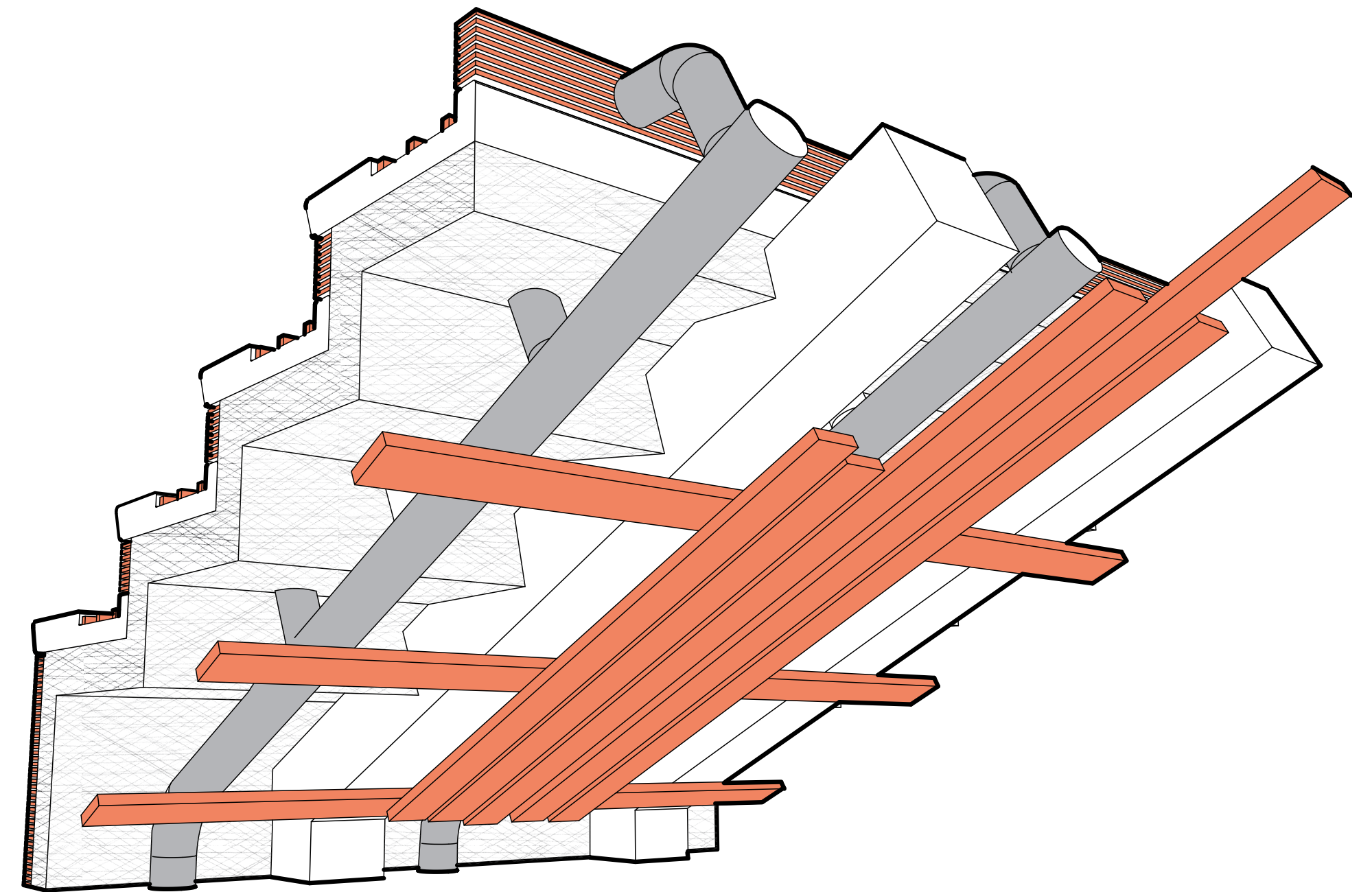
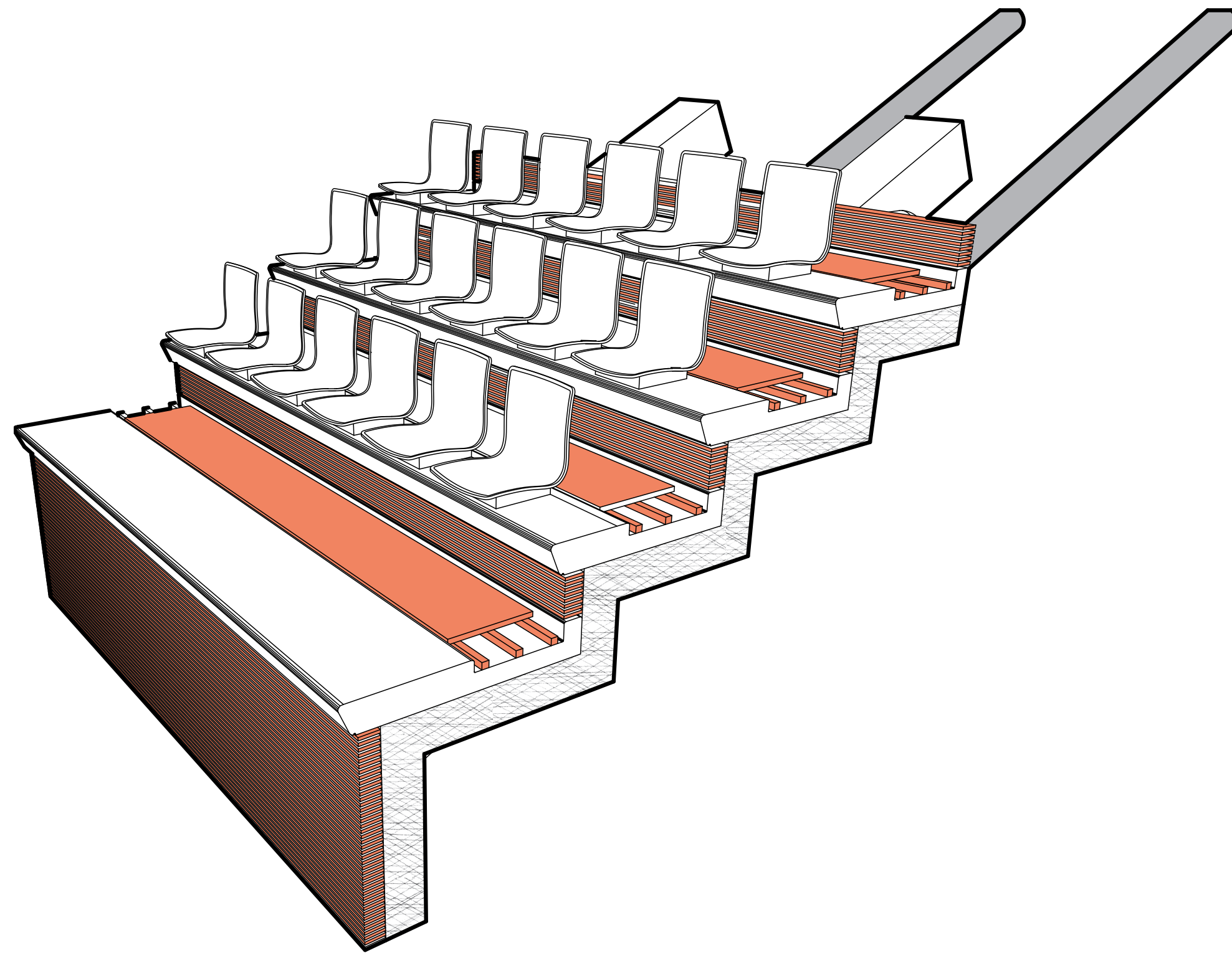

# CLIMATE

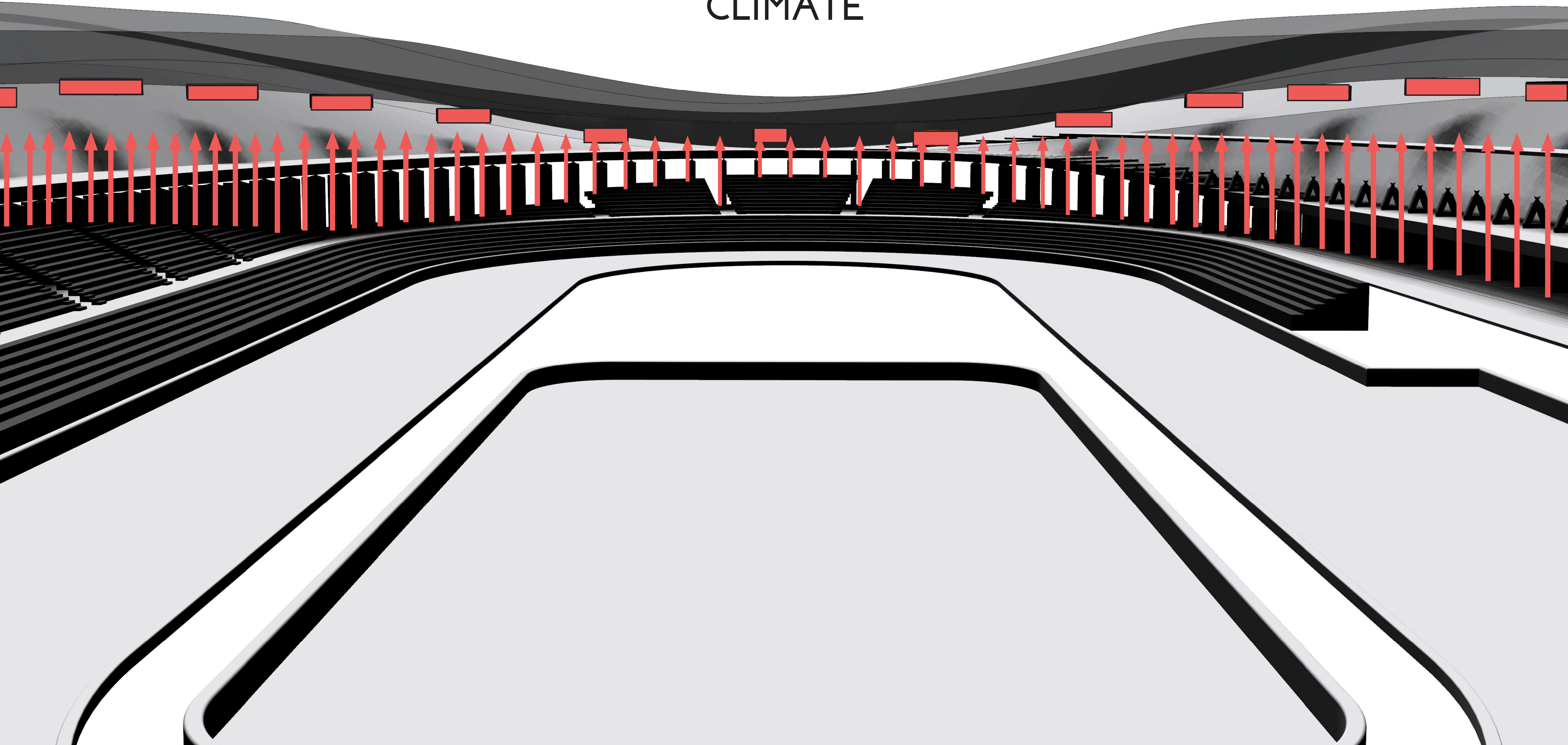

INTRODUCTION

RESEARCH

DESIGN

ENERGY

CONCLUSION

# CLIMATE

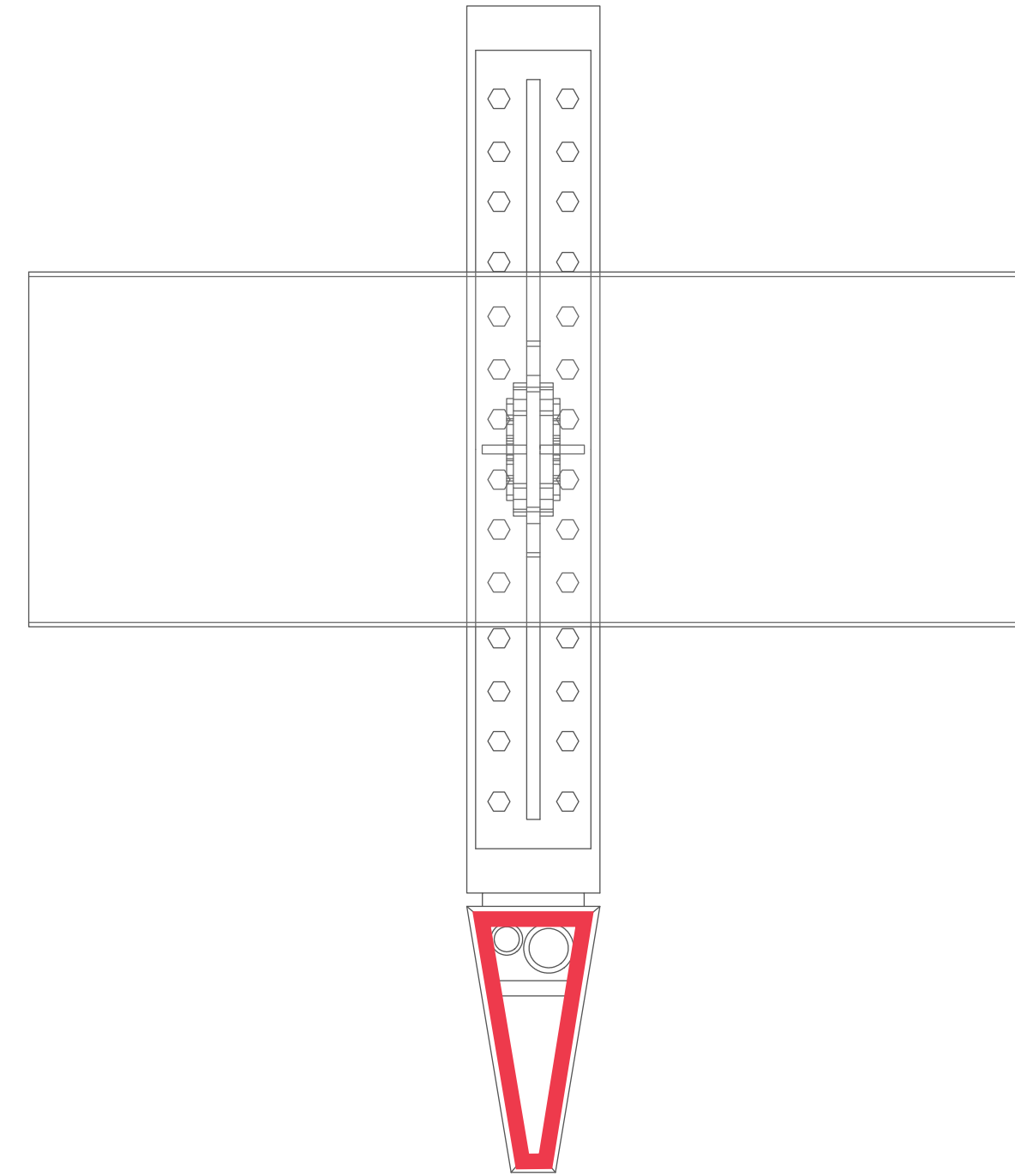
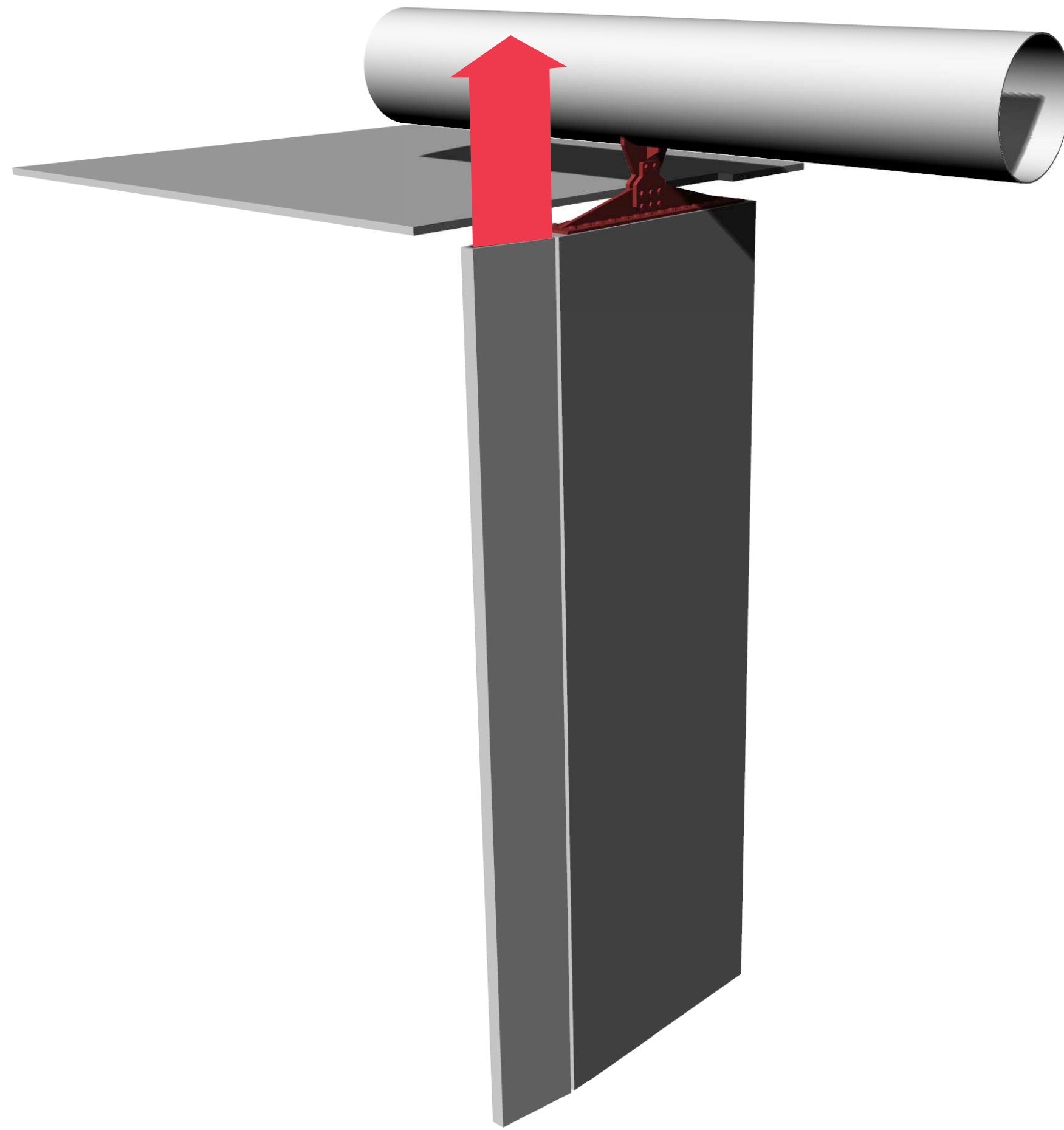

# FACADE CONCEPT

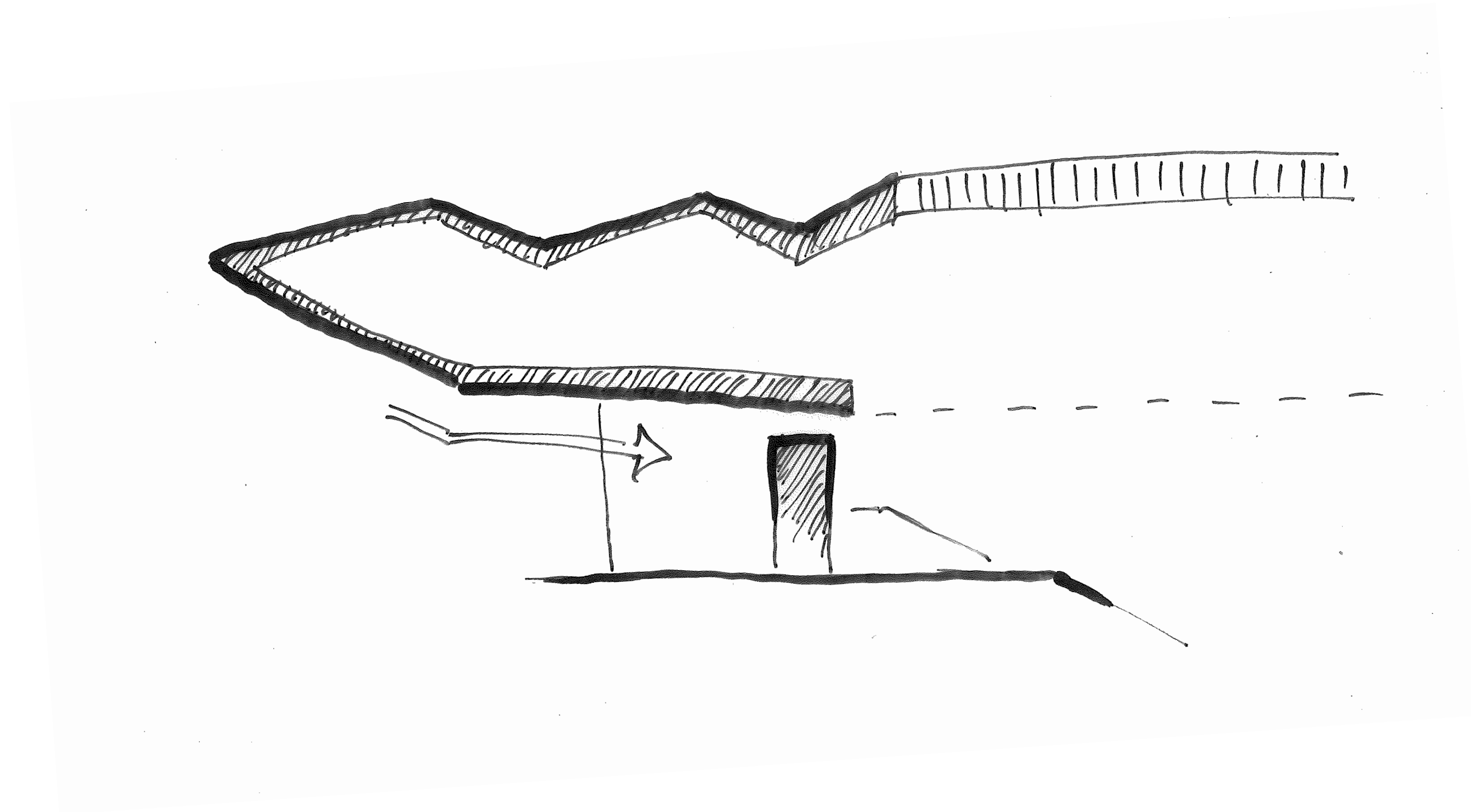

# FACADE CONCEPT

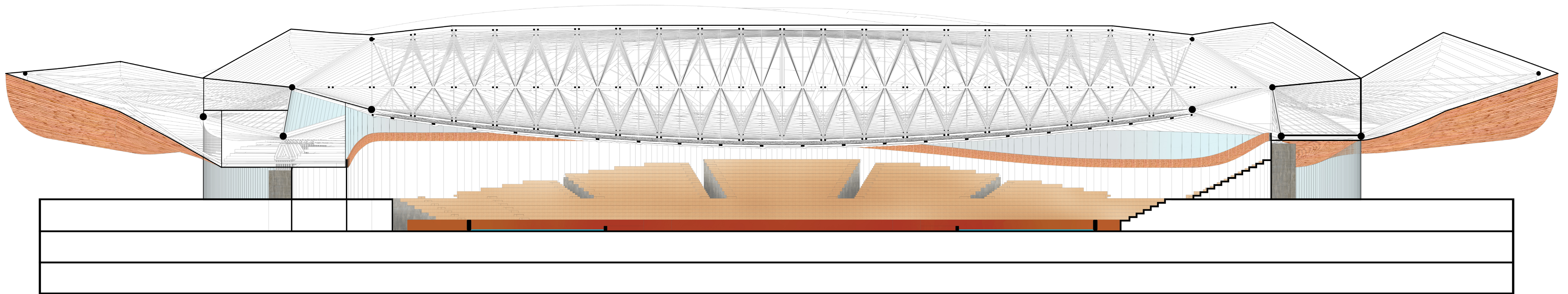

# FACADE

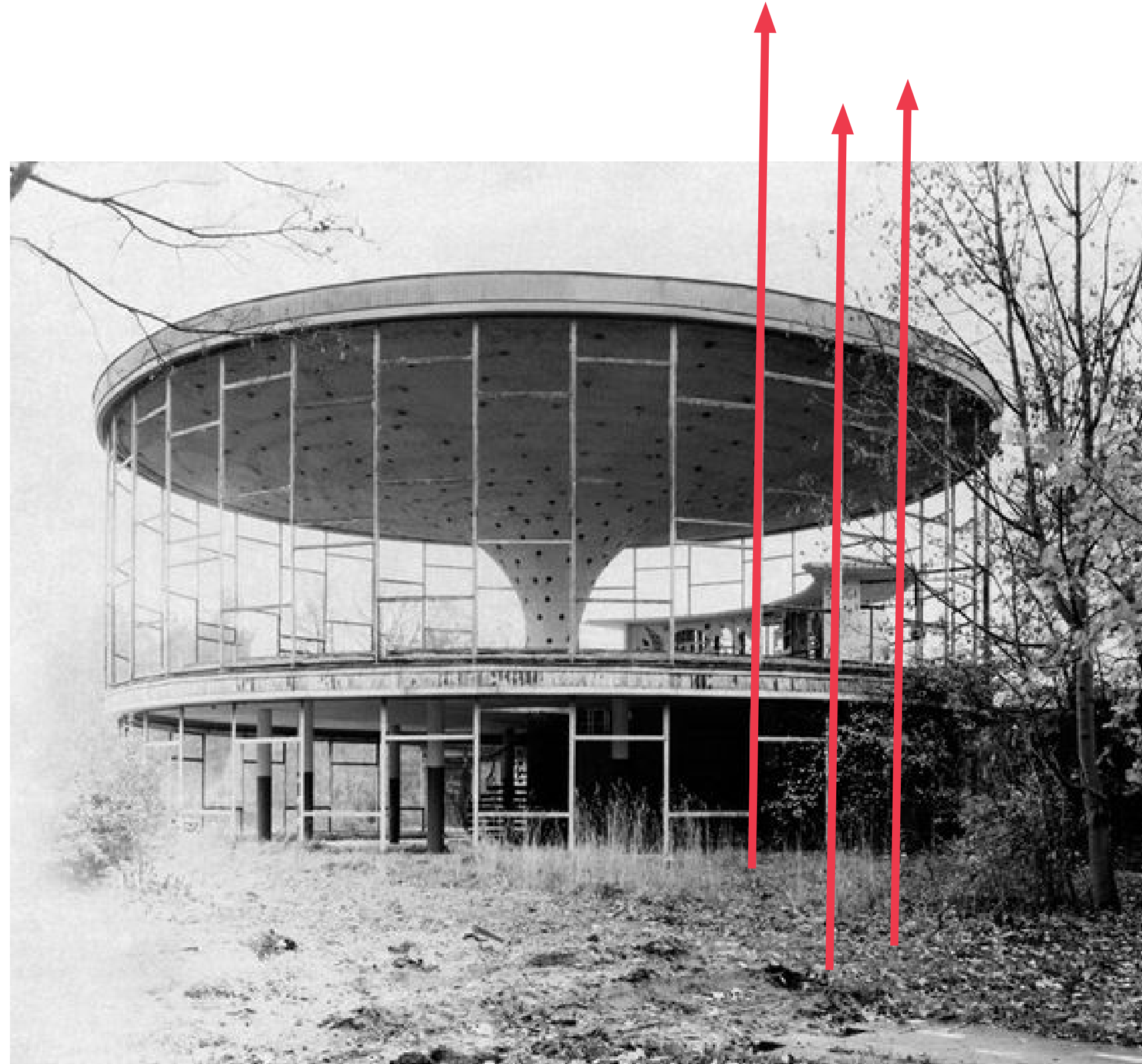









# ENERGY STRATEGY

— CONSUMERS

+ PRODUCERS



ELECTRIC ENERGY

-  Refrigeration plant
-  Lighting
-  Electrical equipment
-  Mechanical ventilation
-  Dehumidifying ventilation
-  Heat pump

-  Natural ventilation
-  Solar panels

THERMAL ENERGY

-  Floor heating / cooling
-  Heating water
-  Resurfacing water heating
-  Heating air

-  Heat district network
-  Refrigeration plant
-  Geothermal storage

# THERMAL ENERGY

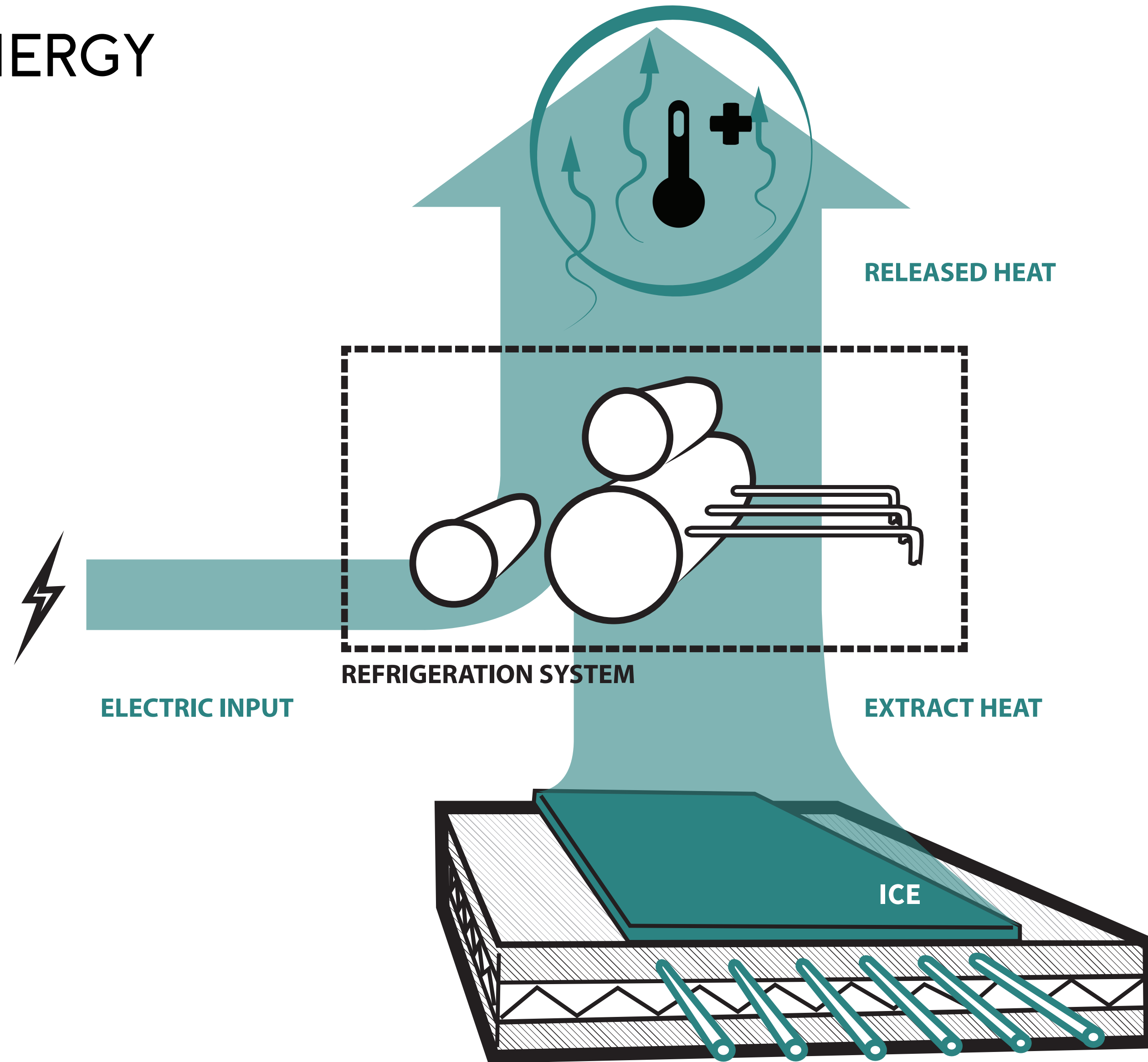

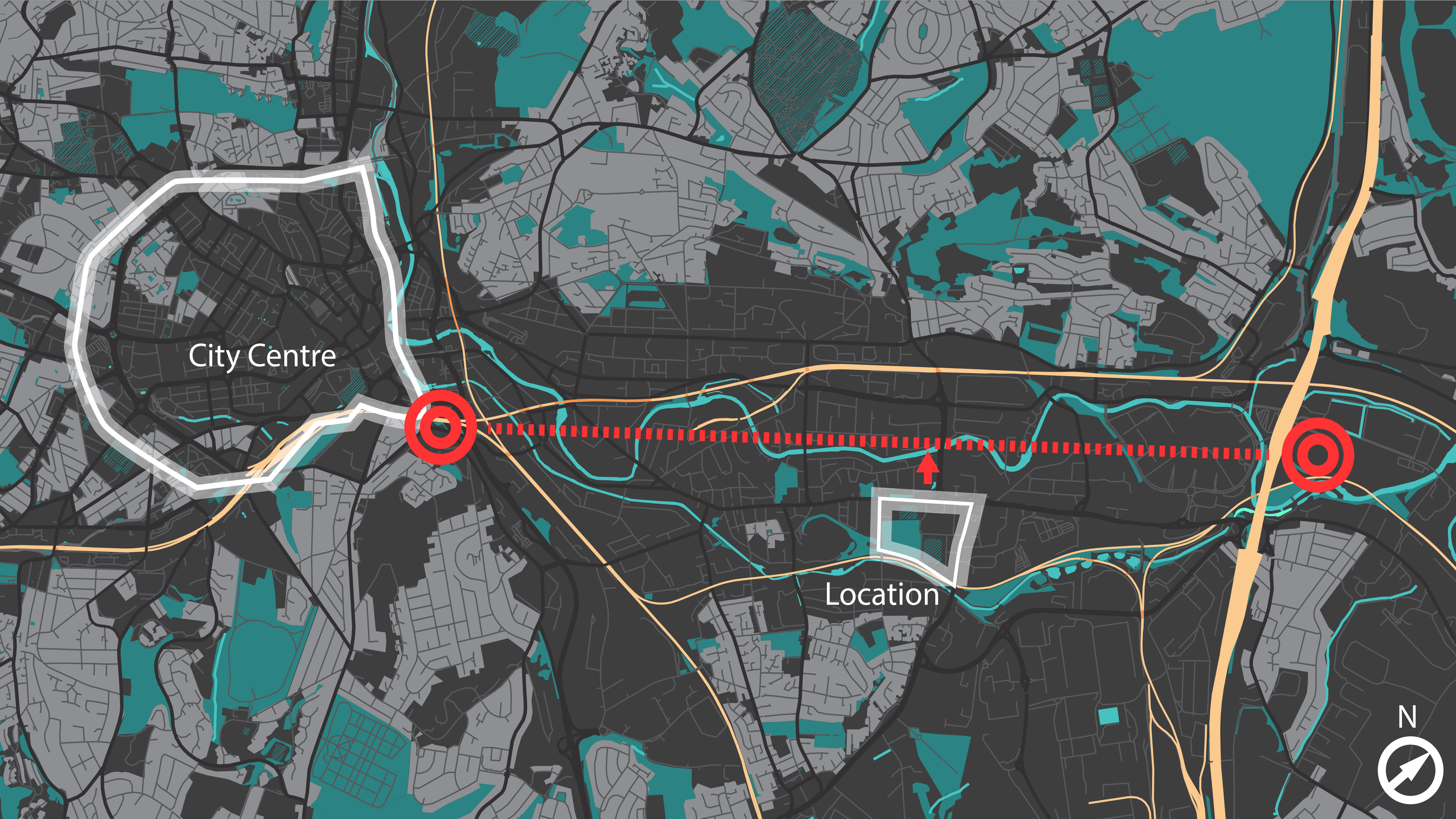

City Centre

Location



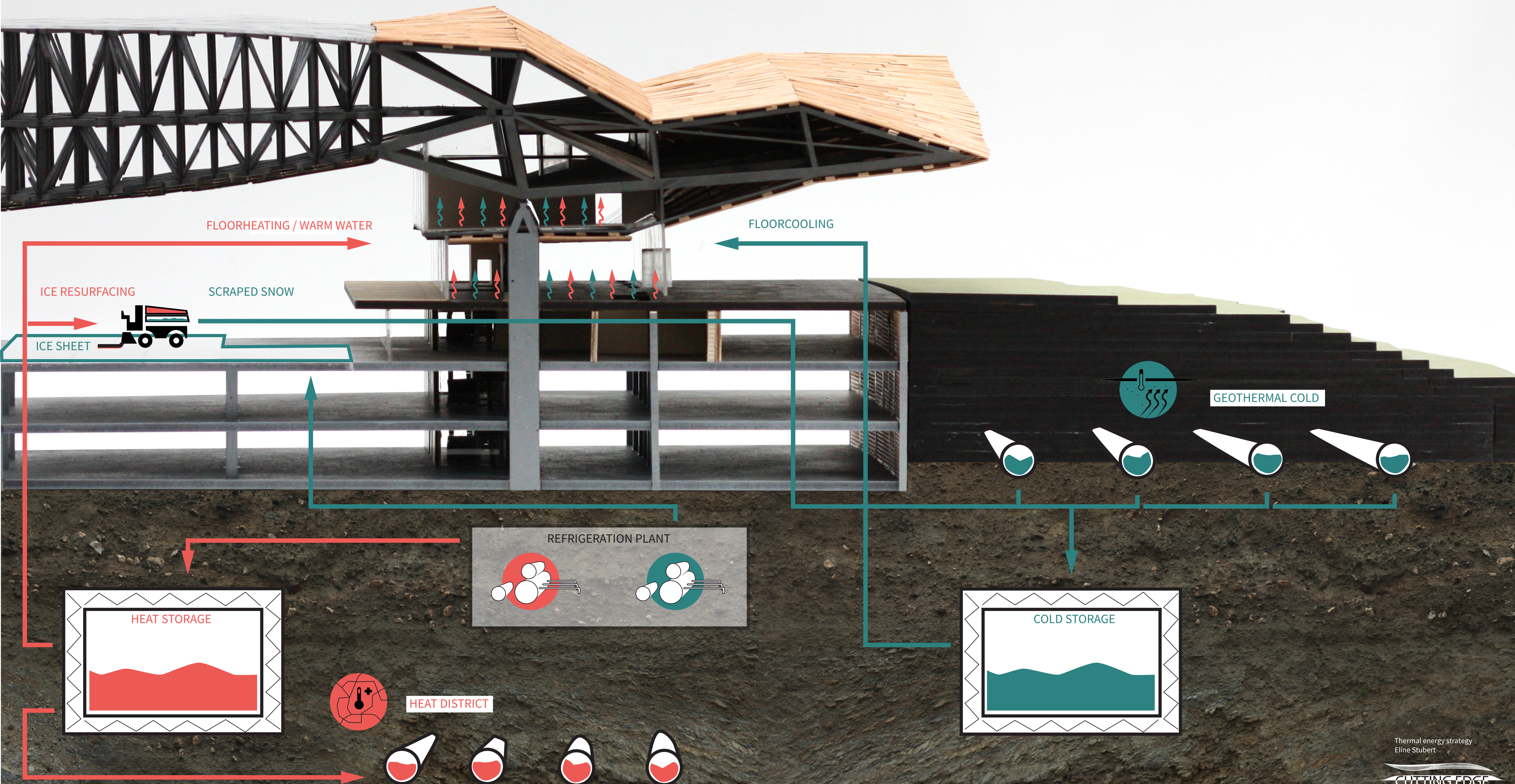

# NATURAL AIRFLOWS

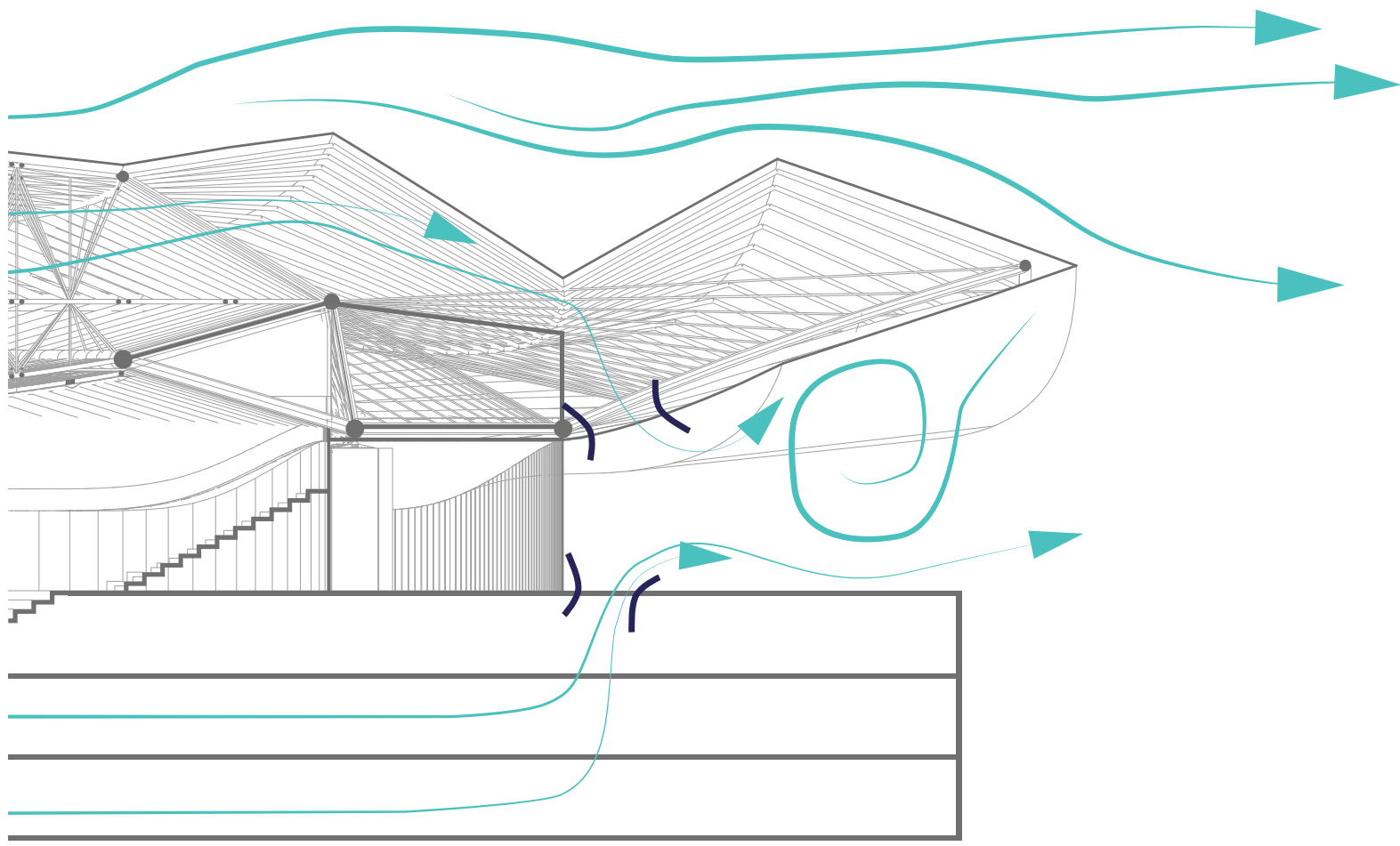
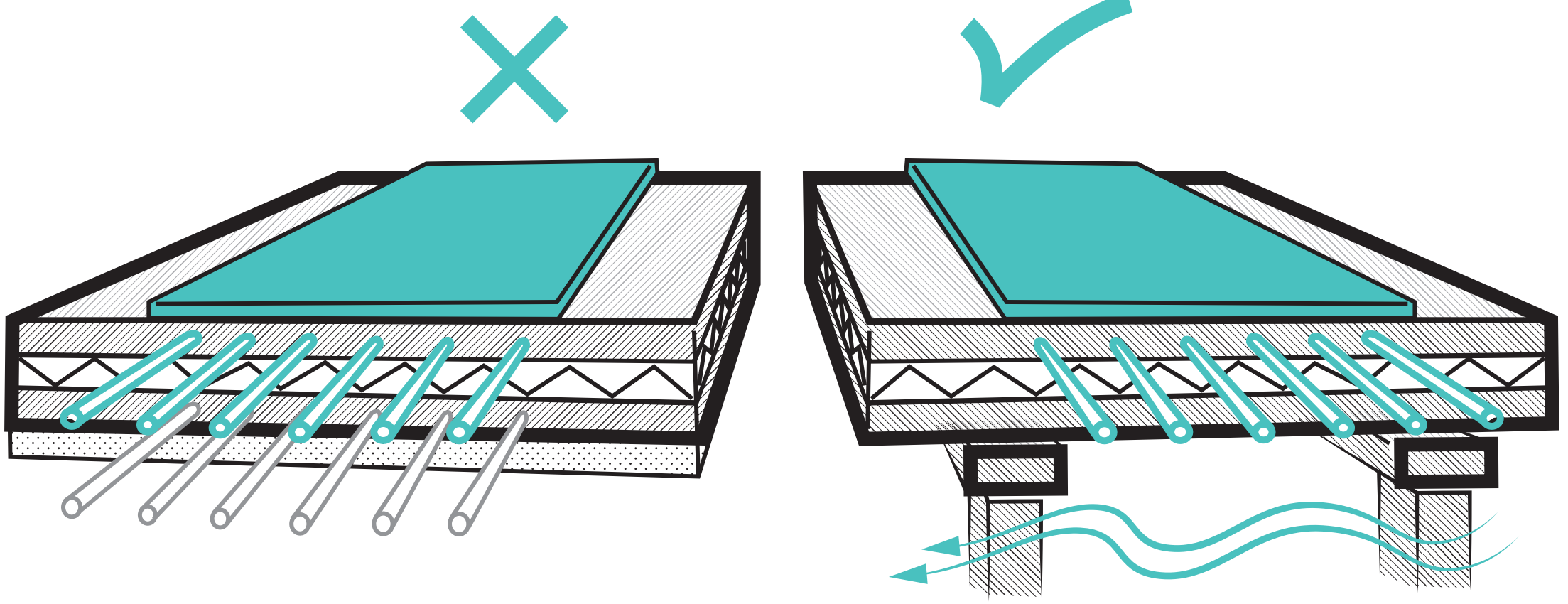
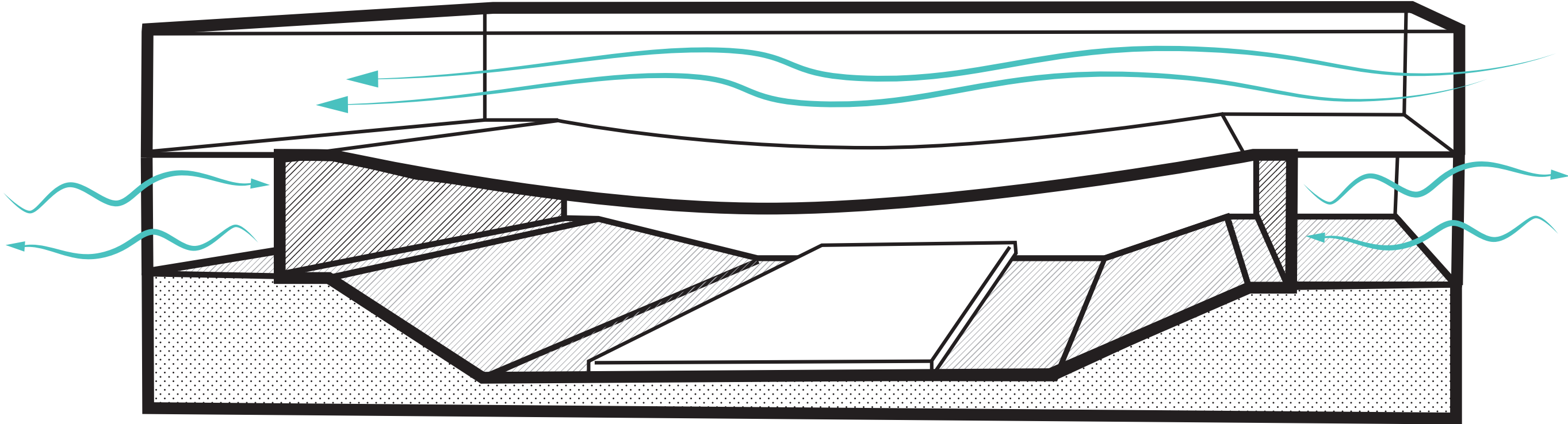

# WELL INSULATED

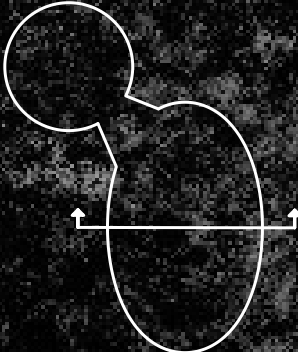
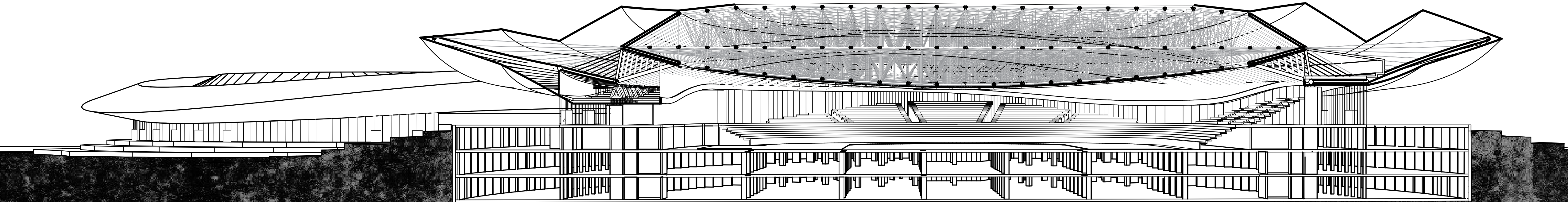
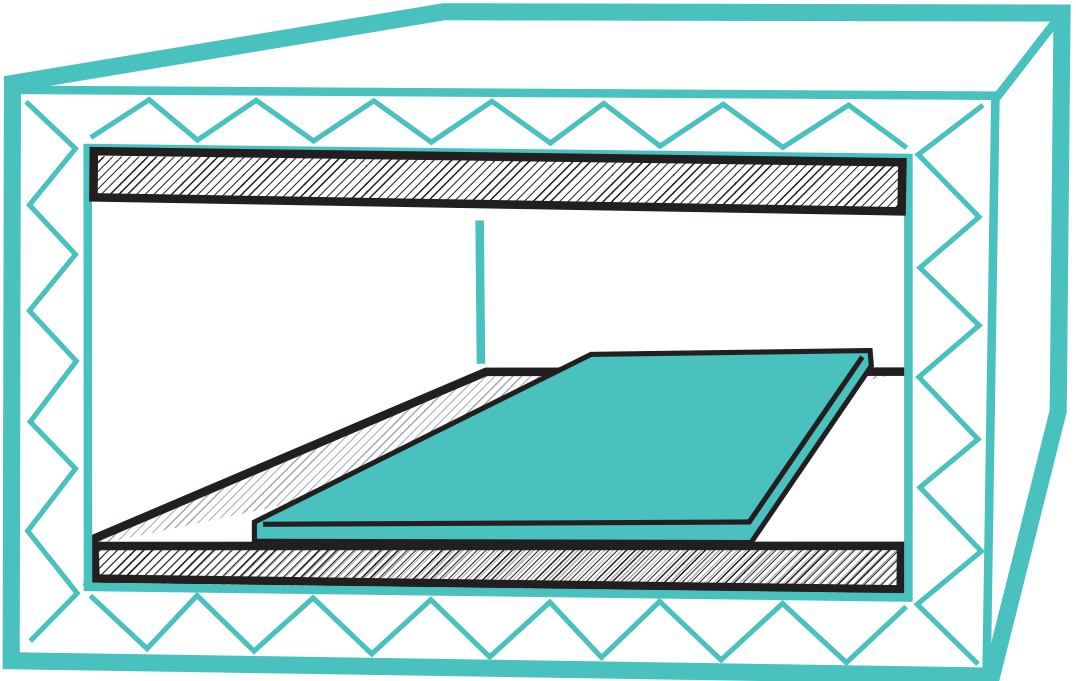

# MAKING USE OF NATURAL DAYLIGHT

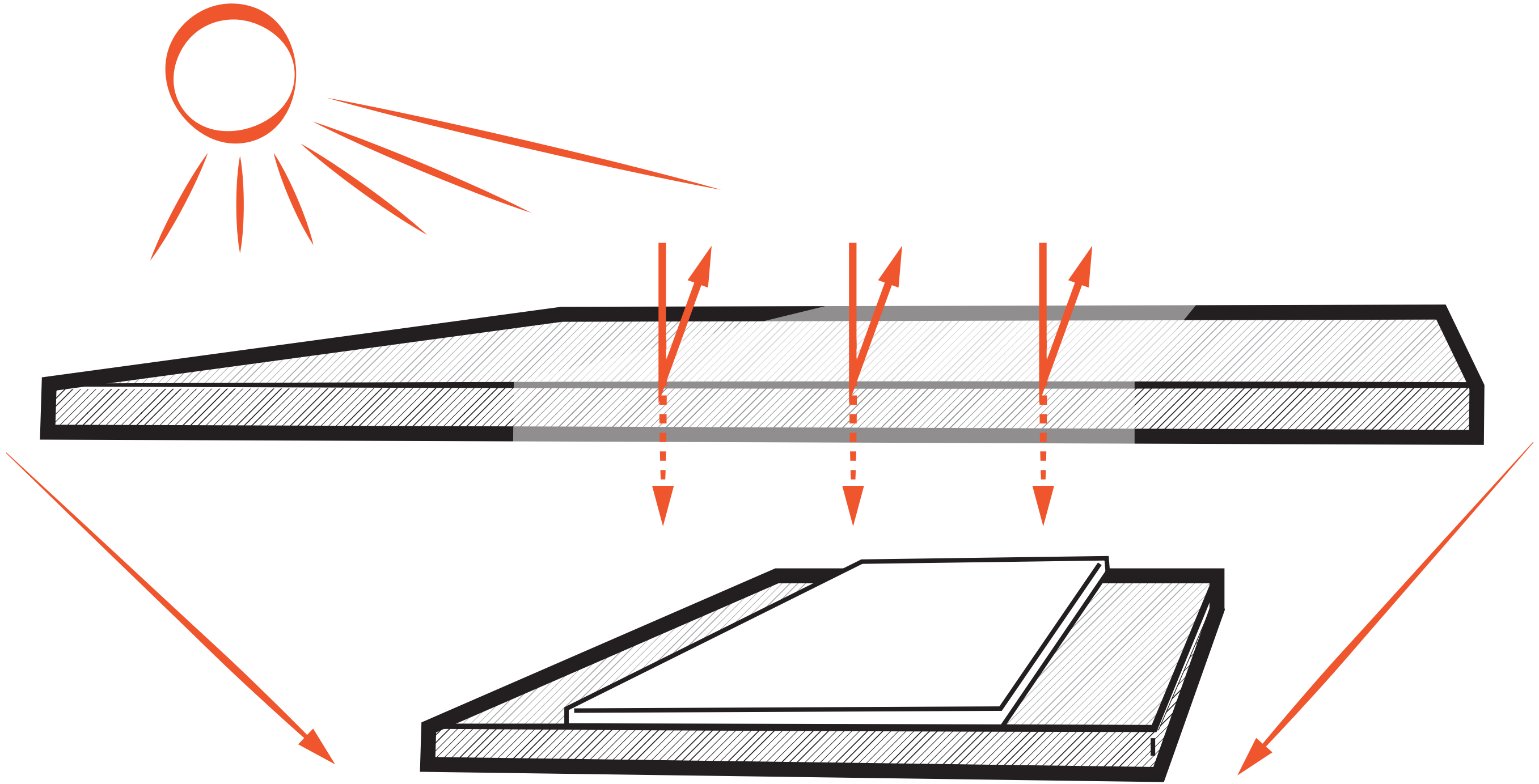

MAKING USE OF NATURAL DAYLIGHT

