

P5 - TRA-DIGITAL HYBRIDS

INZET VAN DIGITALE FABRICATIE BIJ HET MAKEN VAN EEN
HYBRIDE ONTWERP VOOR ONTWIKKELINGSLANDEN

INHOUD

1 // INTRO

2 // PROBLEEMSTELLING

STEDELIJKE VERDICHTING & CONSTRUCTIE KENNIS

3 // ONDERZOEKSVRAAG

OMVANG VAN HET AFSTUDEERPROJECT

4 // TECHNISCH ONDERZOEK

ONDERZOEK & BOUWSYSTEEM

5 // HET BOUWSYSTEEM

CONSTRUCTIE & ASSEMBLAGE

6 // DE ARCHITECTUUR

STRATEGIEEN & PERSPECTIEVEN



2014

INDONESIËRS
250.000.000

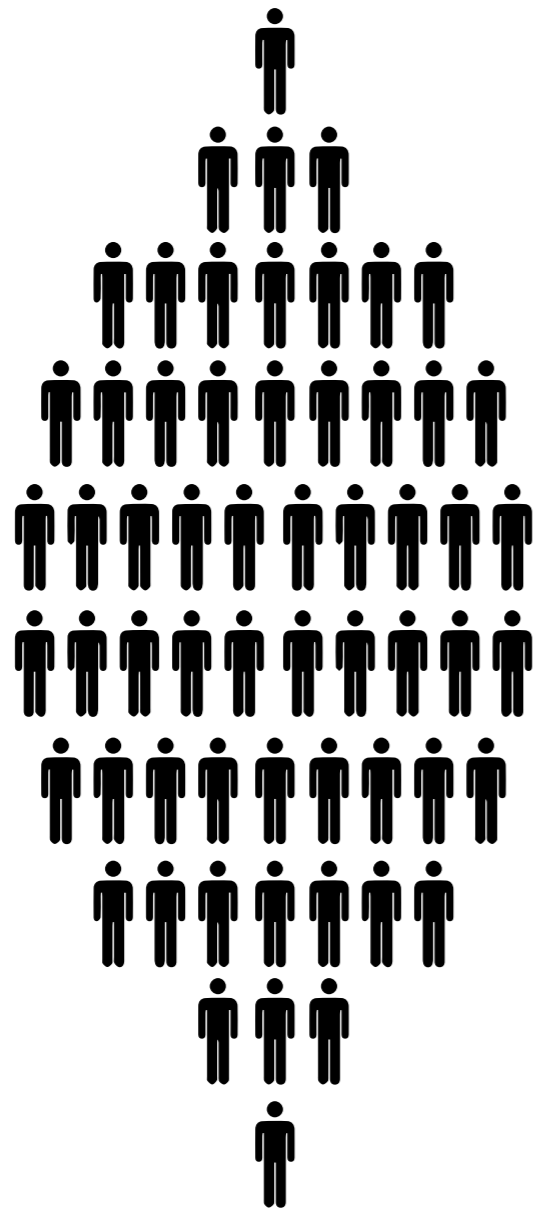

2014

INDONESIËRS
250.000.000

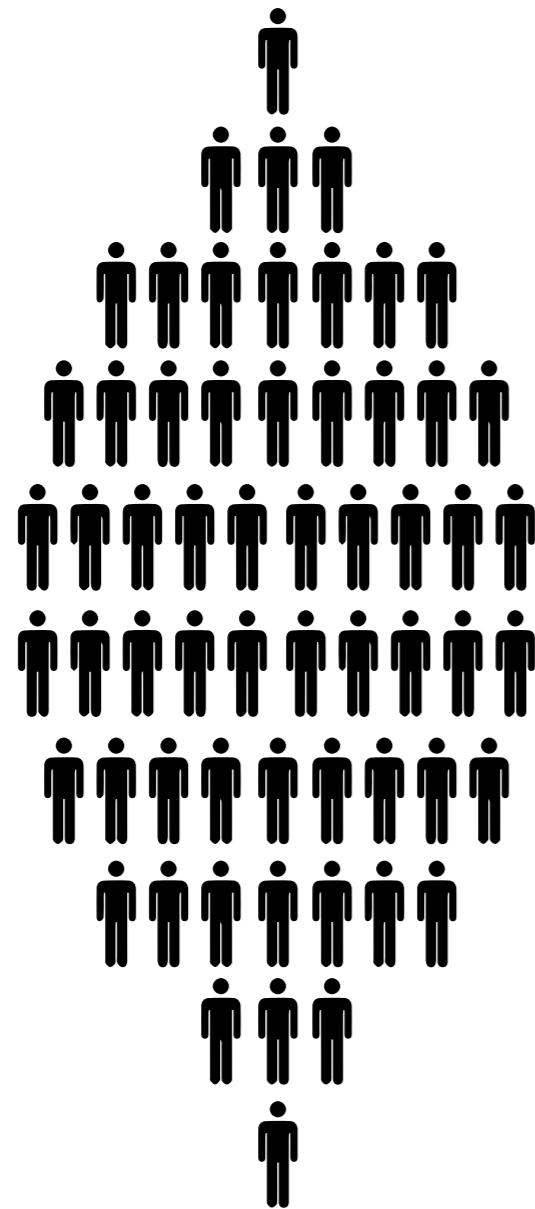

INWONERS STEDEN
125.000.000

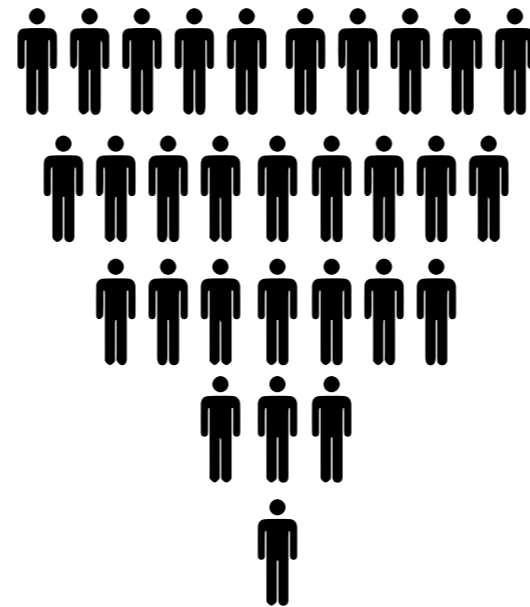

2014

INDONESIËRS
250.000.000

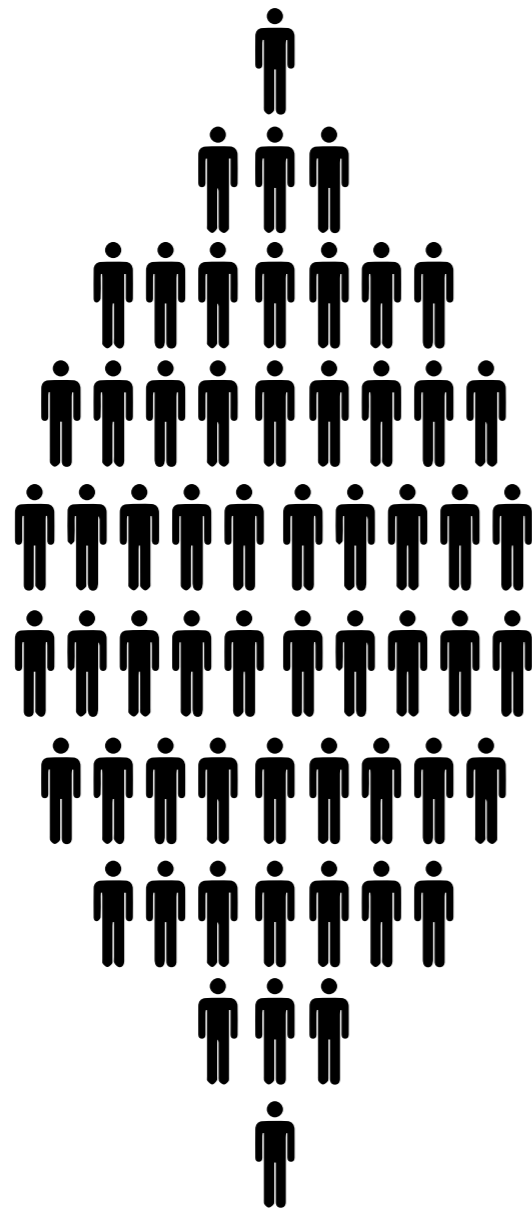

INWONERS STEDEN
125.000.000

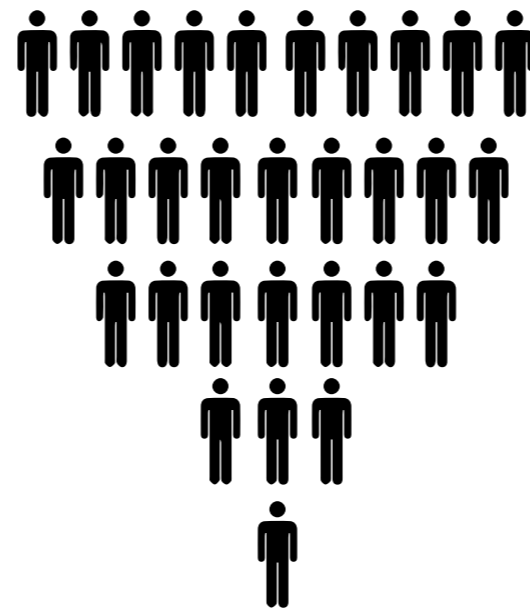

INWONERS KAMPUNG
100.000.000

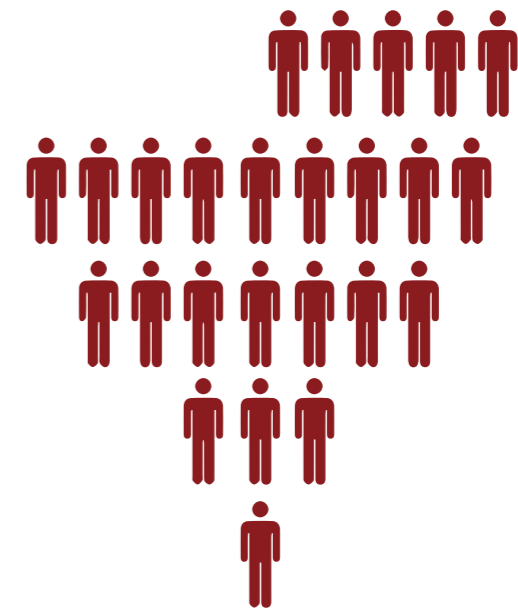

2050

INWONERS KAMPUNG

150.000.000

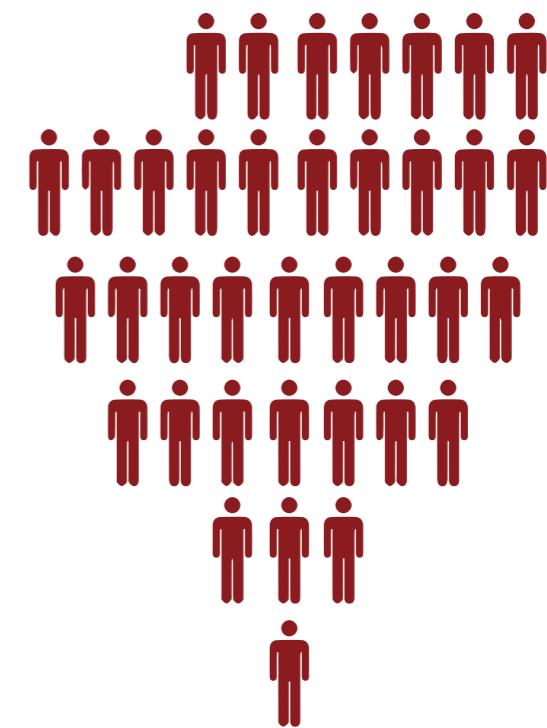

DE KAMPUNG ZIJN WOONGEBIEDEN WELK ONTSTAAN
ZONDER **VOOROPGEZET PLAN** VOOR OFWEL
INFRASTRUCTUUR OF DE GEBOUWDE OMGEVING,
BEWOONT DOOR DE LAGERE INKOMENSKLASSE.



2. PROBLEMEN • KAMPUNG VERDICHTING

% VAN TOTALE BEVOLKING

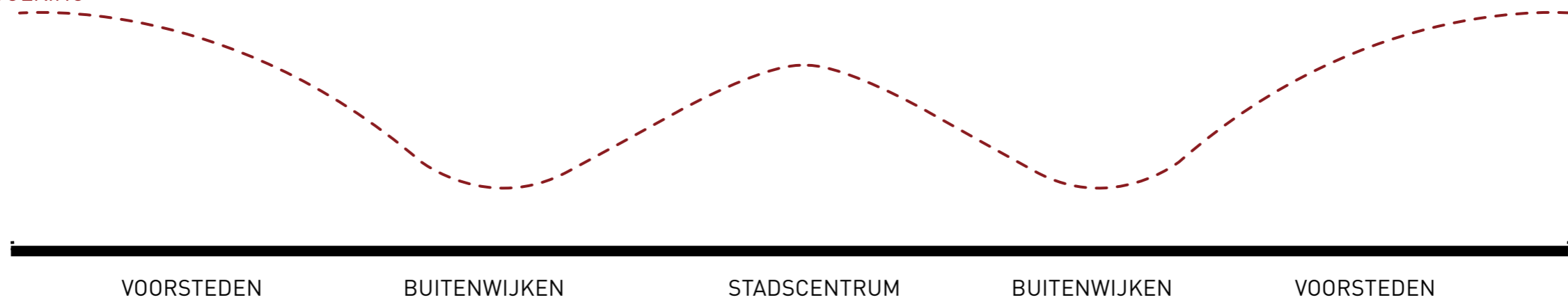

bron: THE WHY FACTORY JAJAKARTA

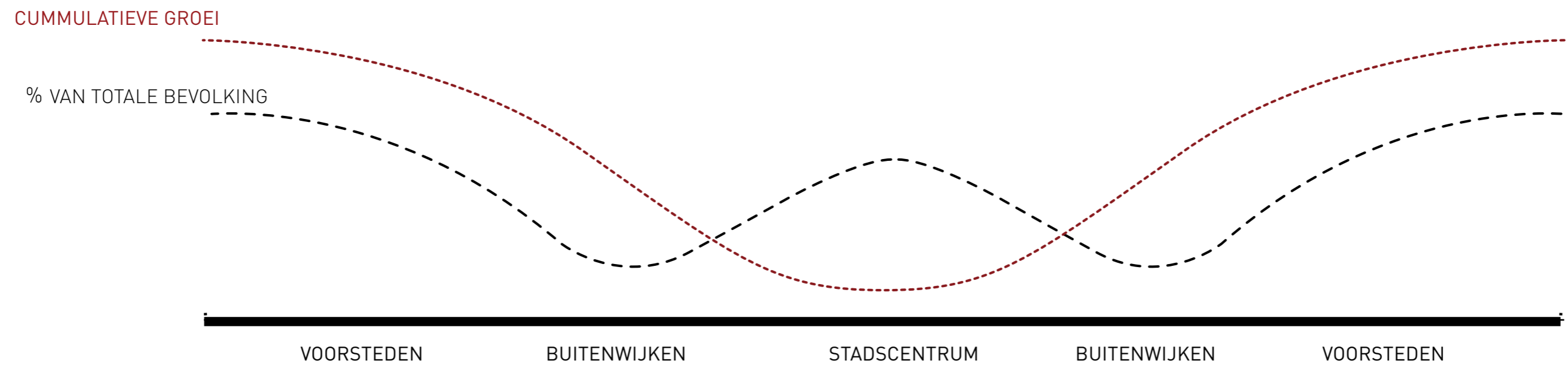

bron: THE WHY FACTORY JAJAKARTA

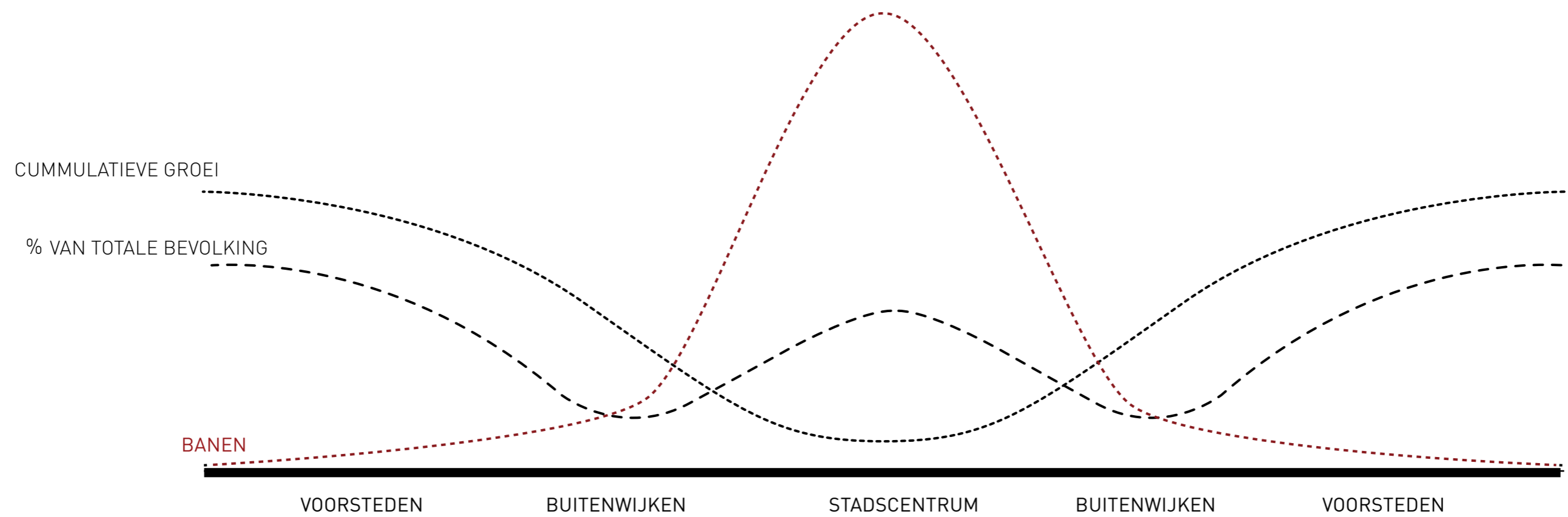

bron: THE WHY FACTORY JAJAKARTA

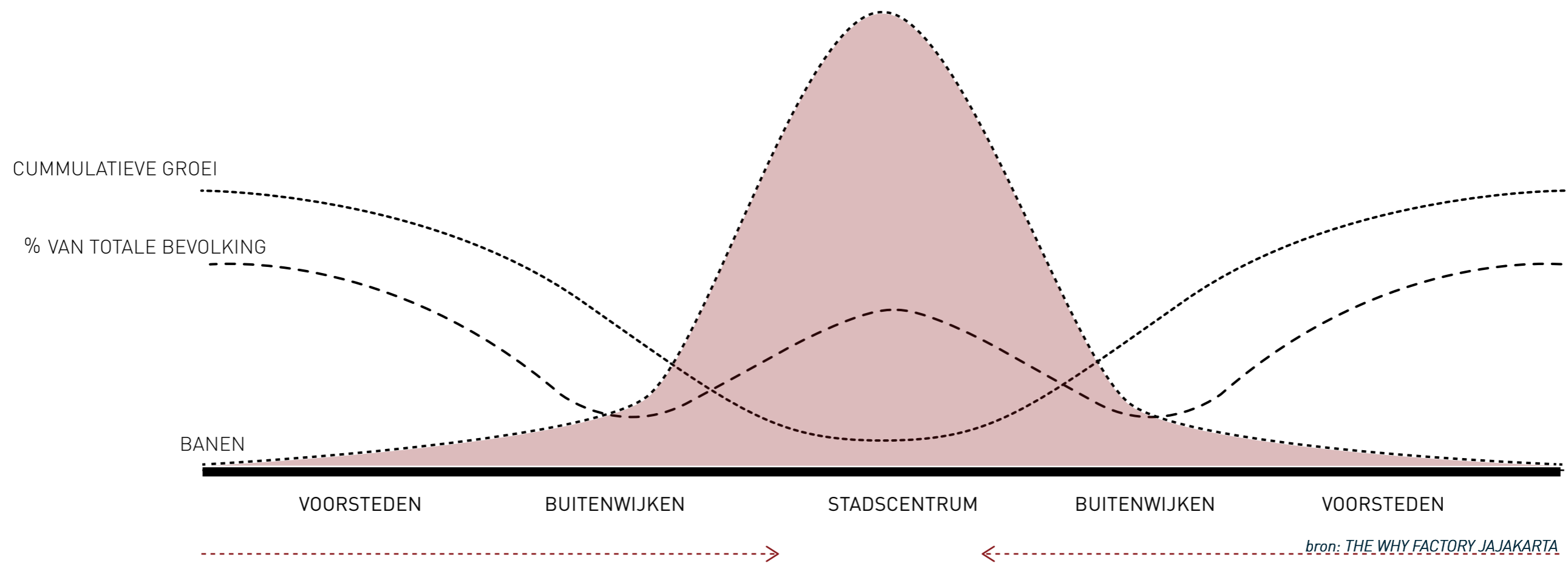

WOON-WERKVERKEER CENTRUM

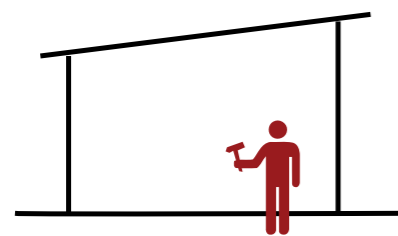

ZELF-BOUW

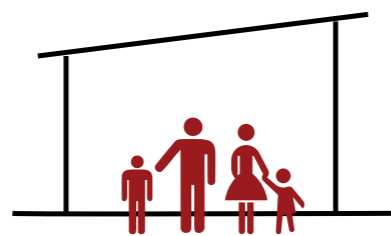

ARMOEDE

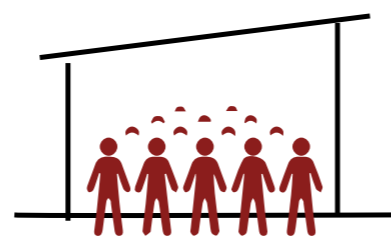

OVERBEVOLKING

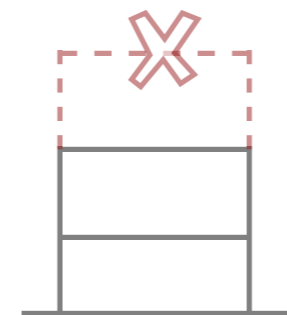

BEPERKTE
BOUWHOOGTE

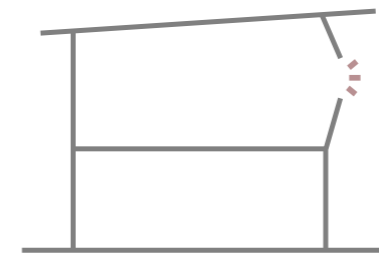

SLECHTE KWALITEIT

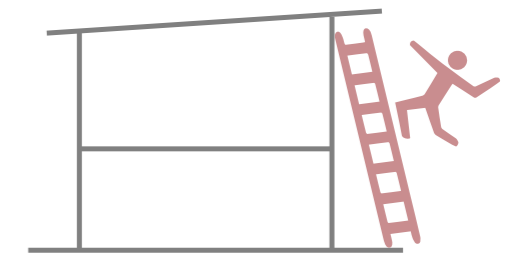

ONVEILIGE CONSTRUCTIE

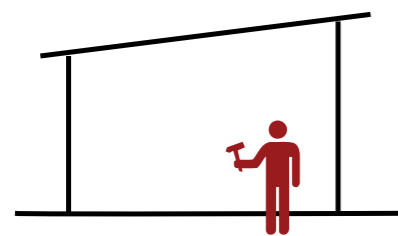

ZELF-BOUW

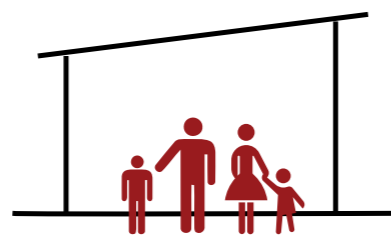

ARMOEDE

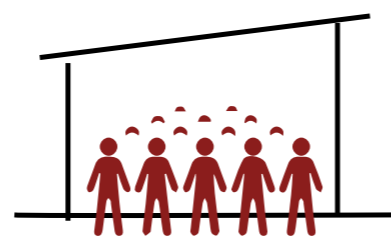

OVERBEVOLKING

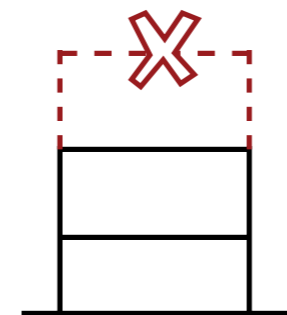

BEPERKTE
BOUWHOOGTE

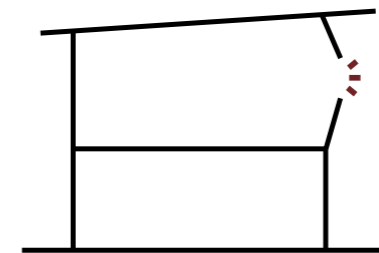

SLECHTE KWALITEIT

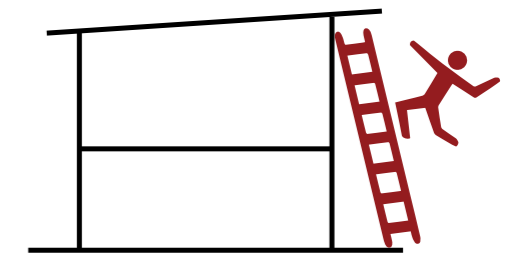

ONVEILIGE CONSTRUCTIE



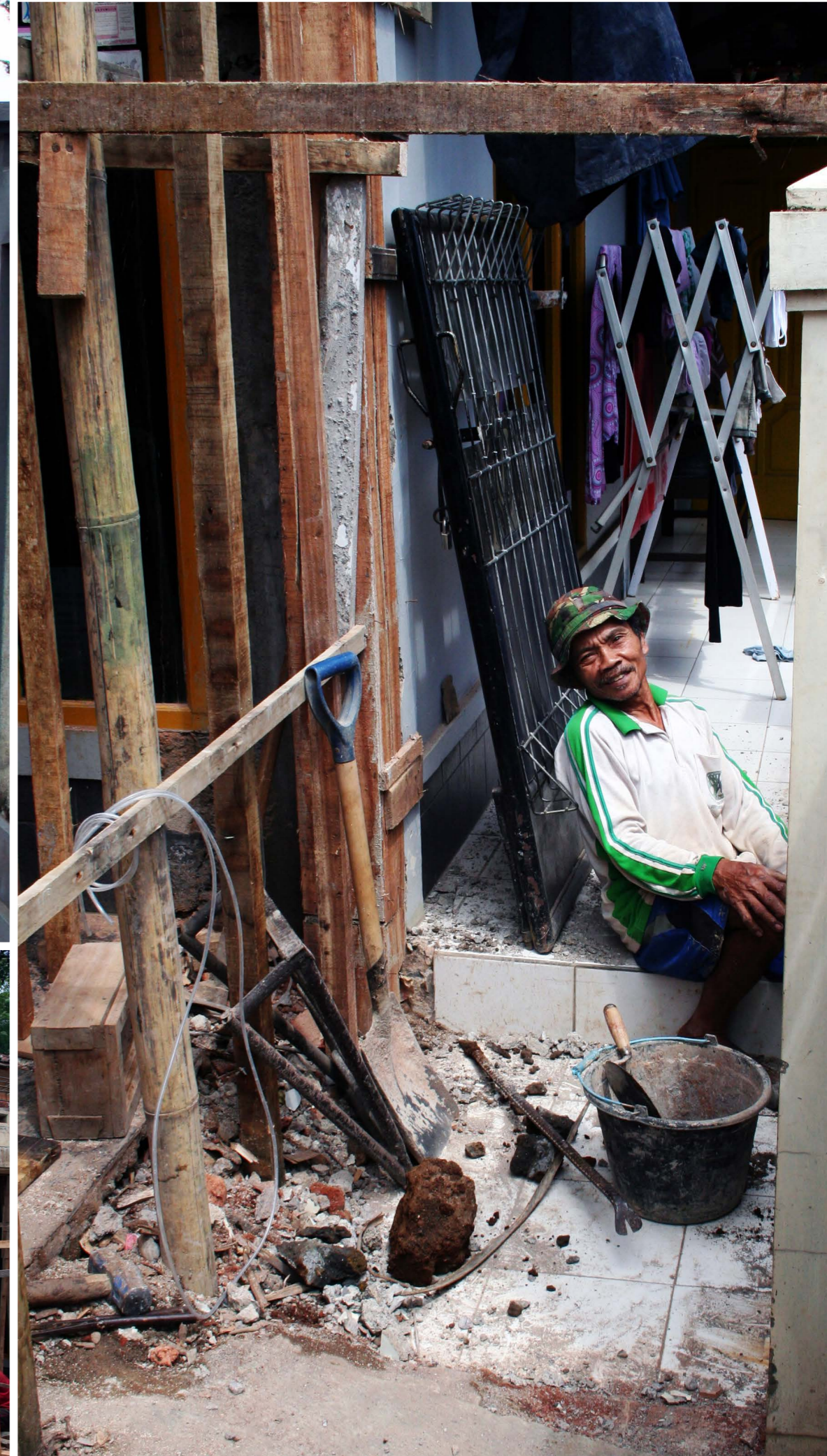

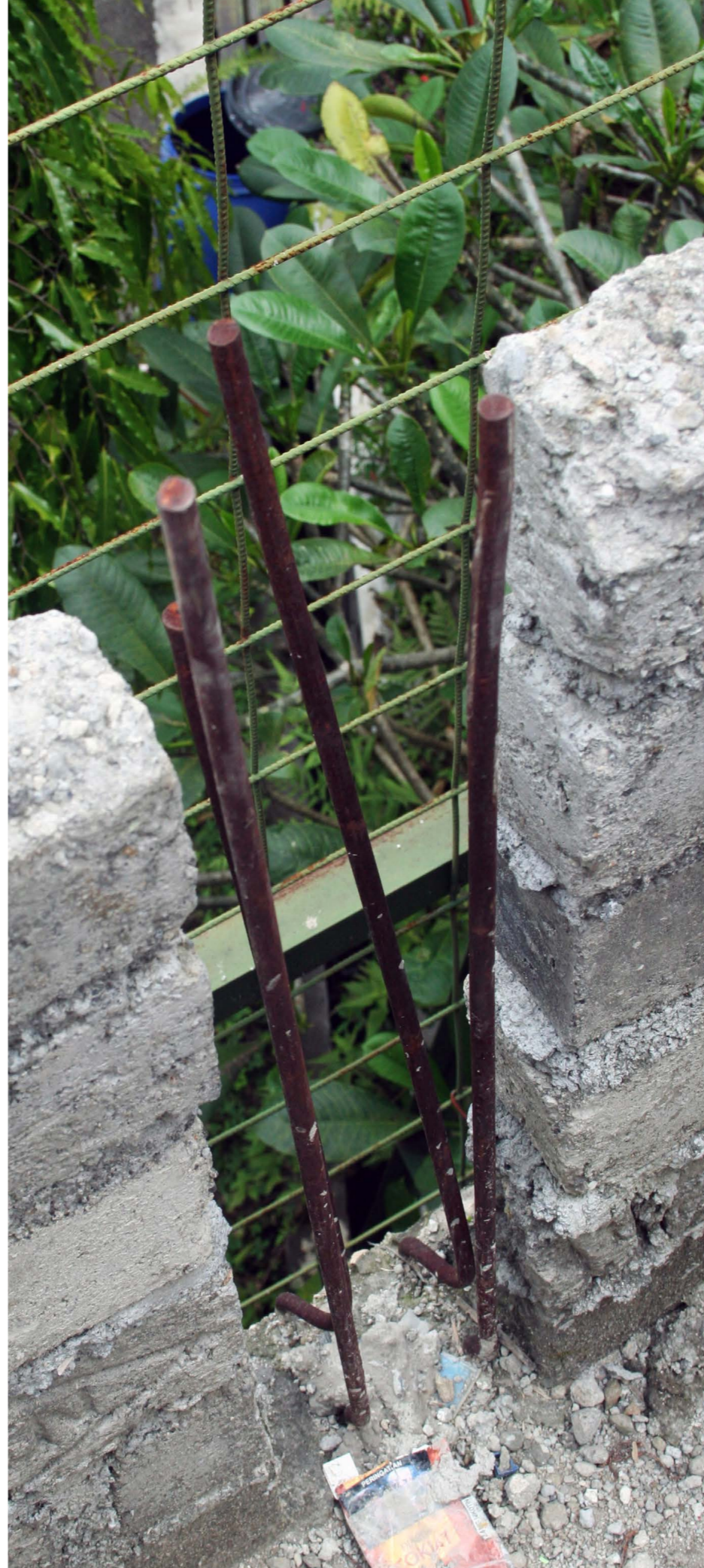

**HOE KAN COMPUTER GESTUURDE PRODUCTIE GEBRUIKT
WORDEN IN HET ONTWERP VAN VEILIGE, DUURZAME EN
BETAALBARE ZELF-BOUW HUISVESTIGING IN DE STEDELIJKE
KAMPUNGS VAN INDONESIA?**

*HOW TO USE THE POTENTIAL OF COMPUTER AIDED
MANUFACTURING (CAM) TO DESIGN SAFE, DURABLE AND
AFFORDABLE SELF-BUILD HOUSING WITHIN THE URBAN
KAMPUNG OF INDONESIA?*

**HOE KAN COMPUTER GESTUURDE PRODUCTIE GEBRUIKT
WORDEN IN HET ONTWERP VAN VEILIGE, DUURZAME EN
BETAALBARE ZELF-BOUW HUISVESTIGING IN DE STEDELIJKE
KAMPUNGS VAN INDONESIA?**

*HOW TO USE THE POTENTIAL OF COMPUTER AIDED
MANUFACTURING (CAM) TO DESIGN SAFE, DURABLE AND
AFFORDABLE SELF-BUILD HOUSING WITHIN THE URBAN
KAMPUNG OF INDONESIA?*



VEILIG +
DUURZAAM



LOCALE
MATERIALEN



LAGE KOSTEN
MATERIALEN



LAGE KOSTEN
MACHINES



PERSONALISEER-
BAAR



MAKKELIJKE
MONTAGE

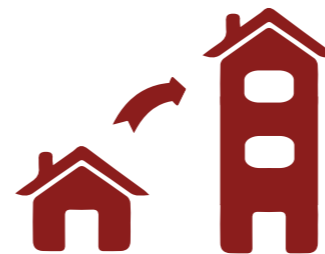

4 - VERDIEPING HOOG



VERPLAATSBAAR IN
DE KAMPUNG



VEILIG +
DUURZAAM



LOCALE
MATERIALEN



LAGE KOSTEN
MATERIALEN



LAGE KOSTEN
MACHINES



PERSONALISEER-
BAAR



MAKKELIJKE
MONTAGE



4 - VERDIEPING HOOG



VERPLAATSBAAR IN
DE KAMPUNG



VEILIG +
DUURZAAM



LOCALE
MATERIALEN



LAGE KOSTEN
MATERIALEN



LAGE KOSTEN
MACHINES



PERSONALISEER-
BAAR



MAKKELIJKE
MONTAGE



4 - VERDIEPING HOOG



VERPLAATSBAAR IN
DE KAMPUNG



VEILIG +
DUURZAAM



LOCALE
MATERIALEN



LAGE KOSTEN
MATERIALEN



LAGE KOSTEN
MACHINES



PERSONALISEER-
BAAR



MAKKELIJKE
MONTAGE



4 - VERDIEPING HOOG



VERPLAATSBAAR IN
DE KAMPUNG



VEILIG +
DUURZAAM



LOCALE
MATERIALEN



LAGE KOSTEN
MATERIALEN



LAGE KOSTEN
MACHINES



PERSONALISEER-
BAAR



MAKKELIJKE
MONTAGE



4 - VERDIEPING HOOG



VERPLAATSBAAR IN
DE KAMPUNG



VEILIG +
DUURZAAM



LOCALE
MATERIALEN



LAGE KOSTEN
MATERIALEN



LAGE KOSTEN
MACHINES



PERSONALISEER-
BAAR



MAKKELIJKE
MONTAGE



4 - VERDIEPING HOOG



VERPLAATSBAAR IN
DE KAMPUNG



VEILIG +
DUURZAAM



LOCALE
MATERIALEN



LAGE KOSTEN
MATERIALEN



LAGE KOSTEN
MACHINES



PERSONALISEER-
BAAR



MAKKELIJKE
MONTAGE



4 - VERDIEPING HOOG



VERPLAATSBAAR IN
DE KAMPUNG



VEILIG +
DUURZAAM



LOCALE
MATERIALEN



LAGE KOSTEN
MATERIALEN



LAGE KOSTEN
MACHINES



PERSONALISEER-
BAAR



MAKKELIJKE
MONTAGE



4 - VERDIEPING HOOG



VERPLAATSBAAR IN
DE KAMPUNG

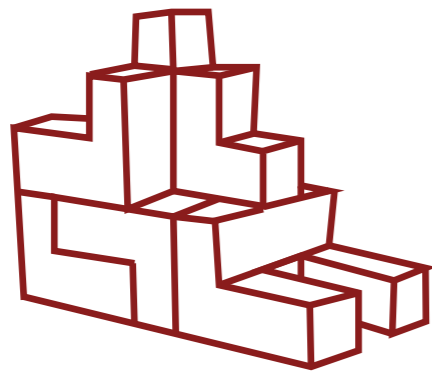

BAKSTEEN // GRIFFITH

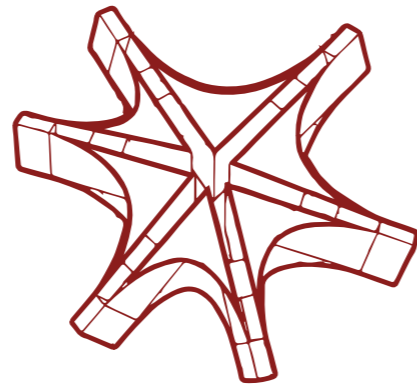

STAAL // CARLOW&CROLLA

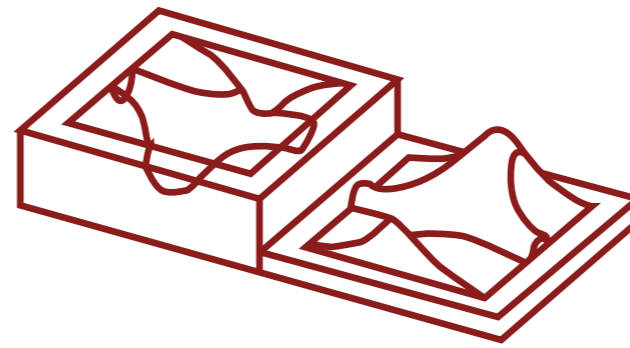

BETON // PEINOVICH

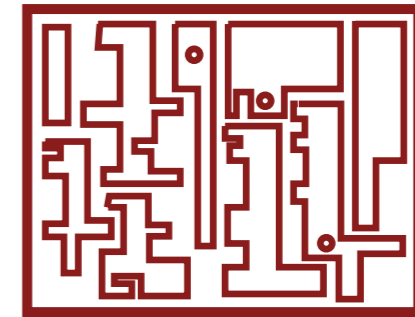

HOUT // SASS

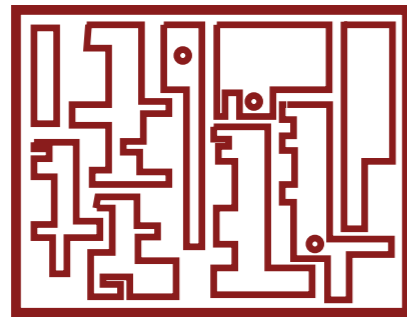

HOUT // STOUTJESDIJK

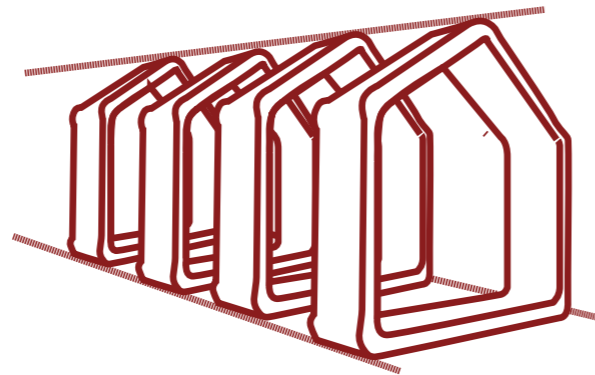

BETON // WINSUN



STOF // ENDESA

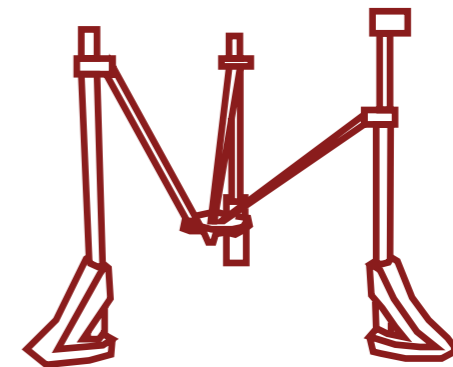

MODDER // WASP

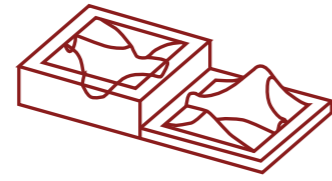

PEINOVICH VS KAMPUNG

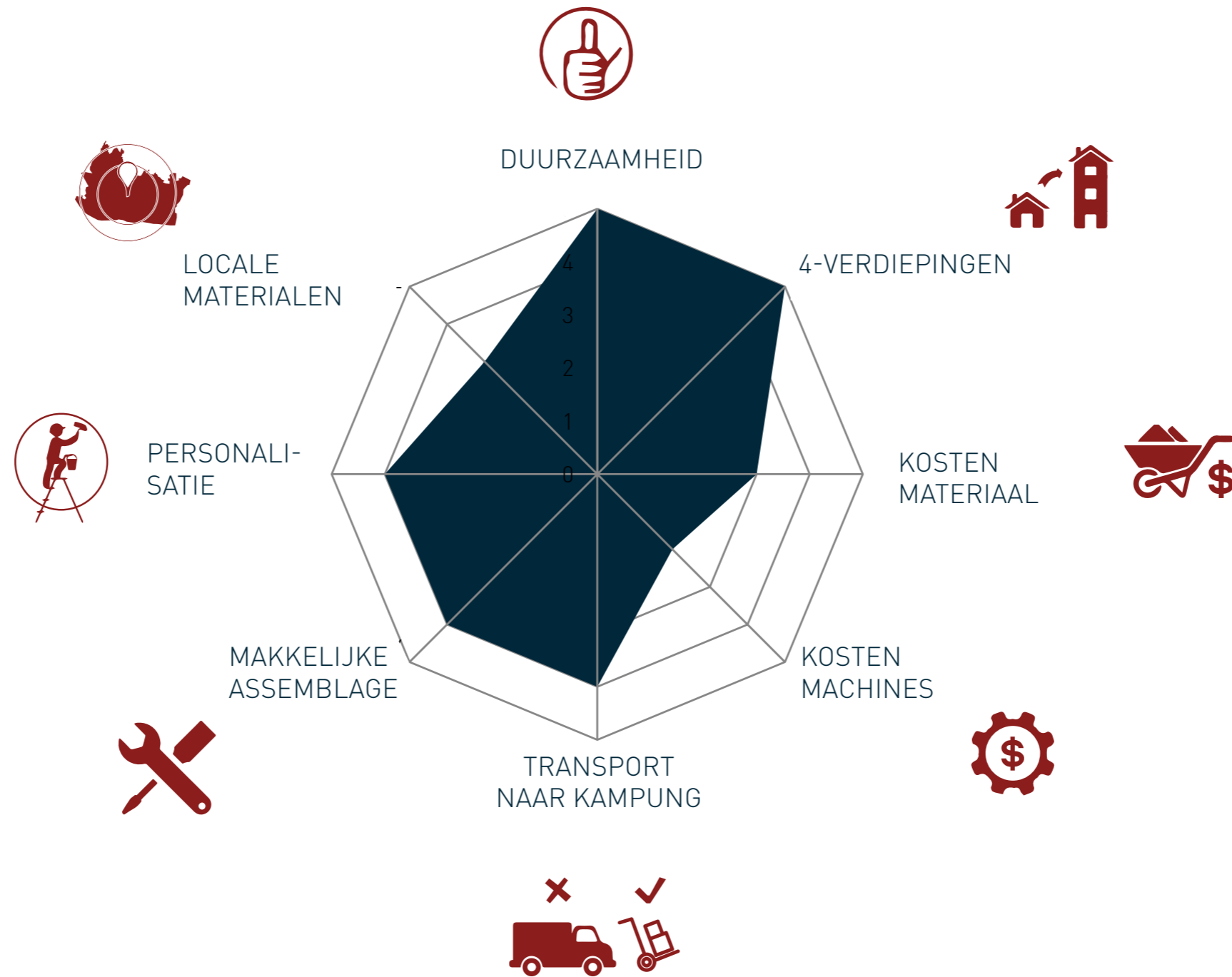

GRIFFITH

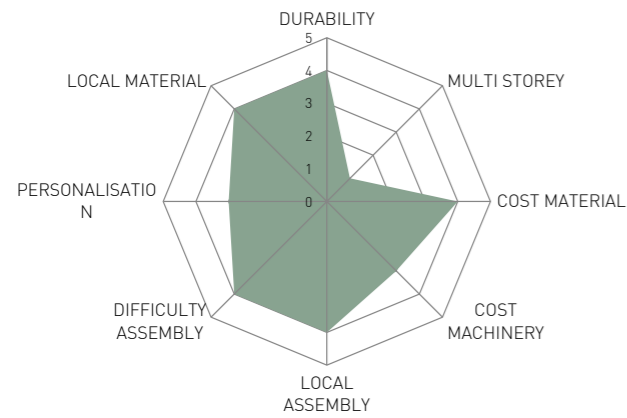

SASS

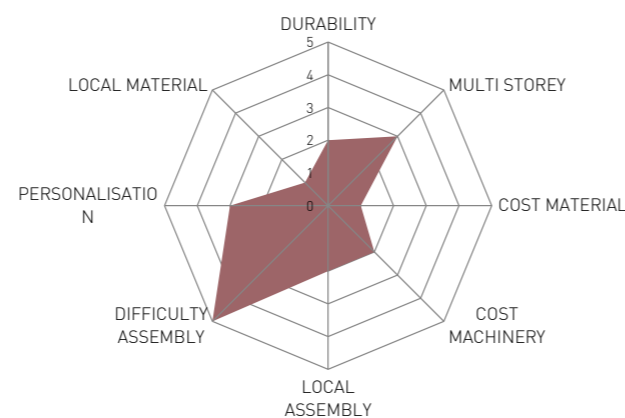

PEINOVICH

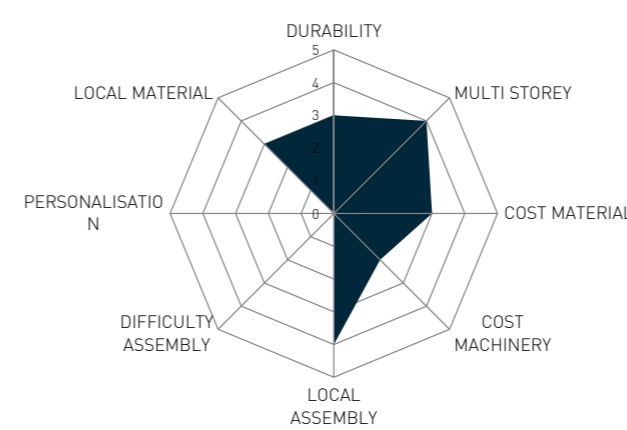

ENDESA

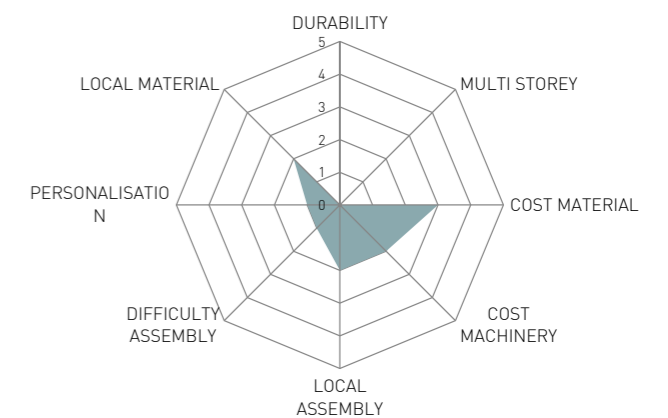

CARLOW & CROLLA

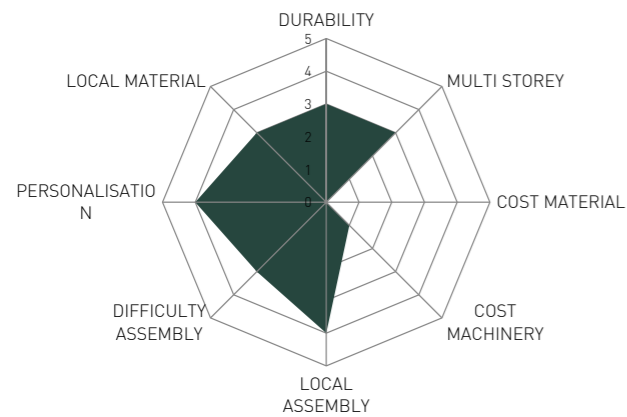

STOUTJESDIJK

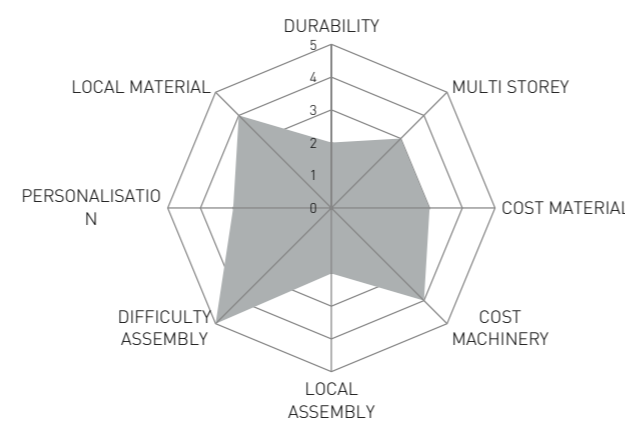

WINSUN

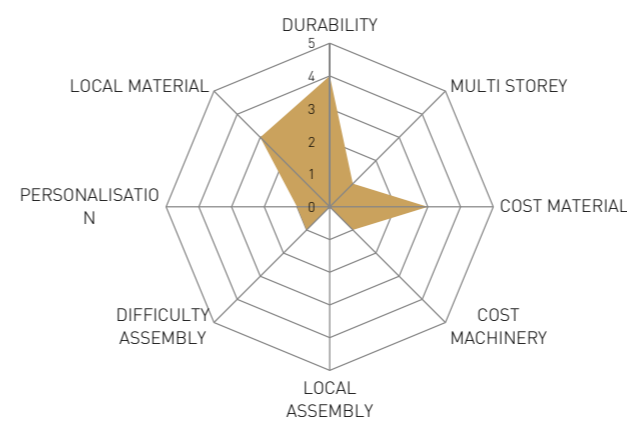

WASP

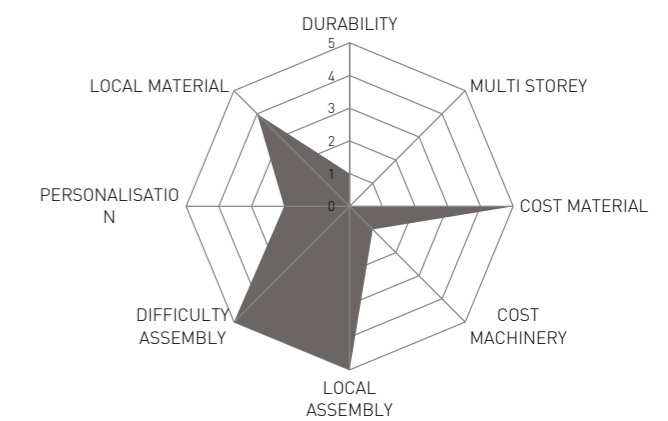

BAKSTEEN // GRIFFITH

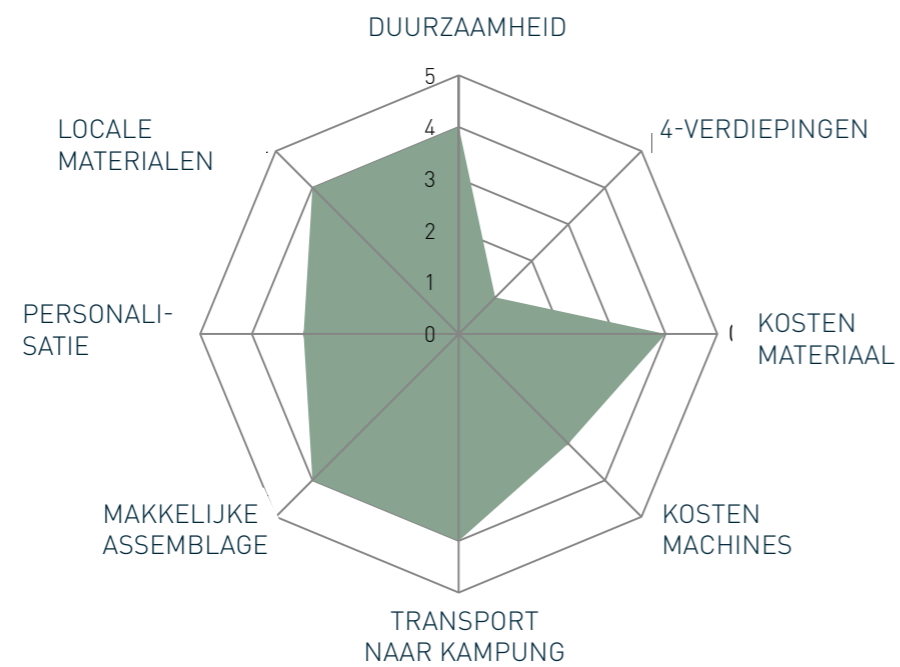

BETON // PEINOVICH

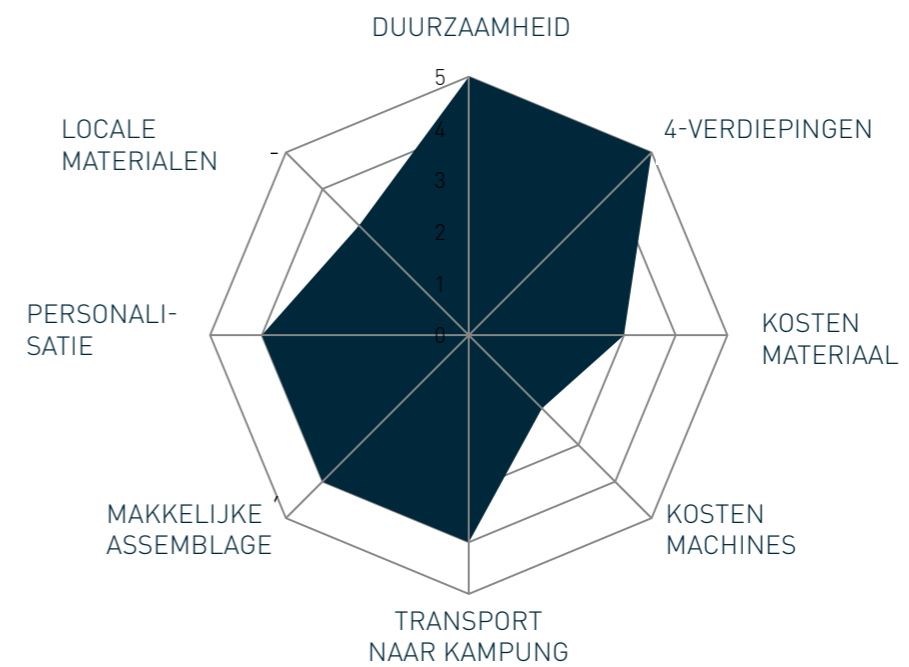
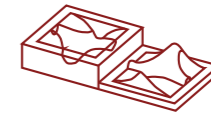

BAKSTEEN // GRIFFITH

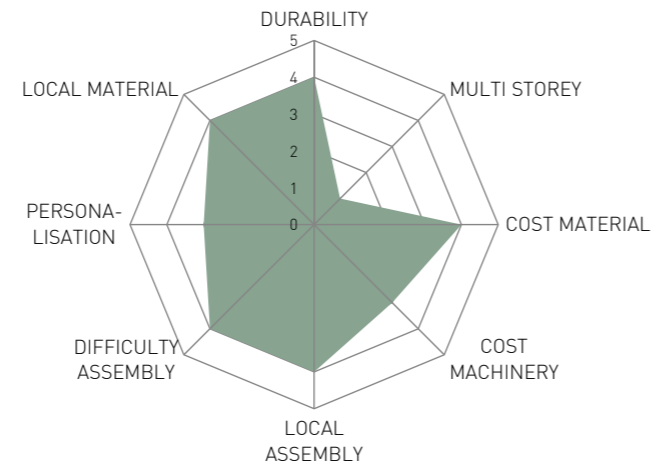

BETON // PEINOVICH

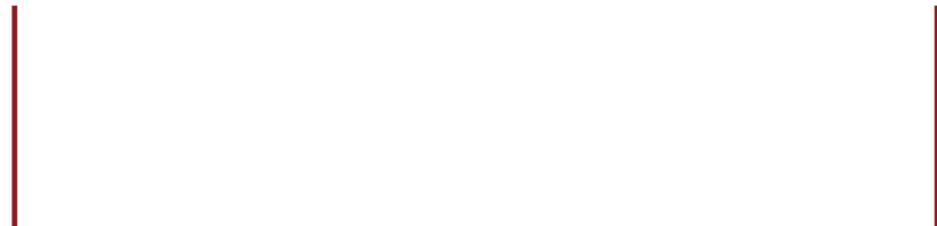
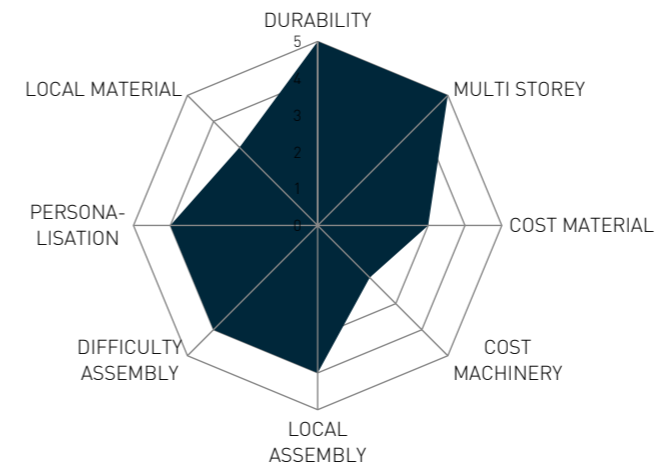
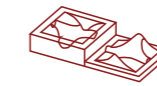

HYBRID BOUWMETHODE

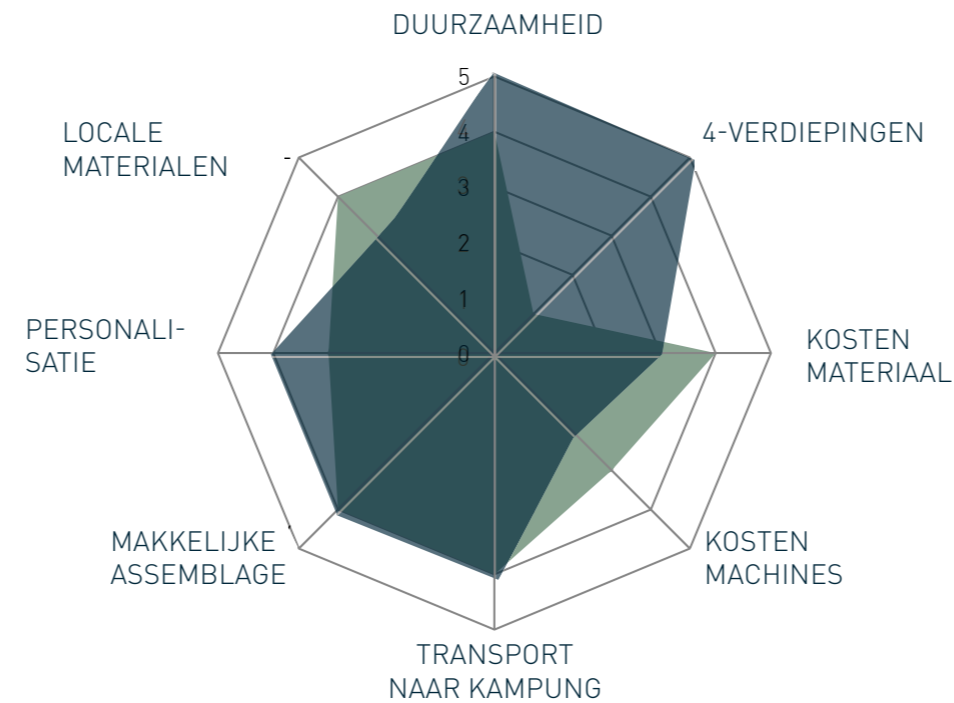

BRICKS // GRIFFITH

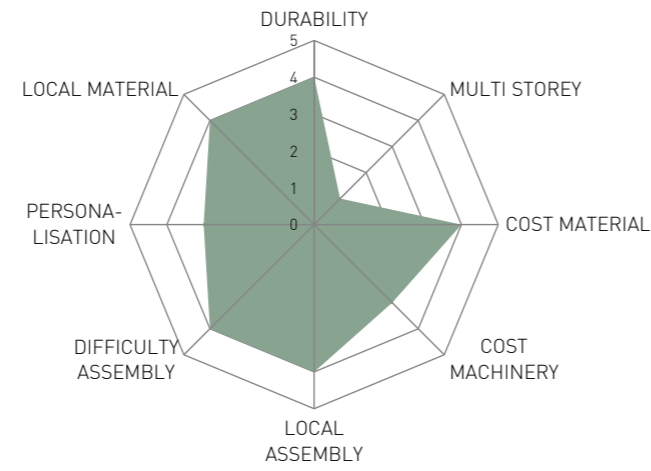

CONCRETE // PEINOVICH

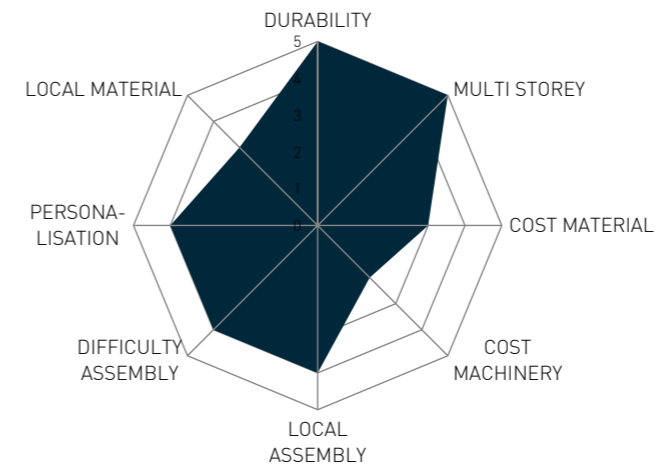
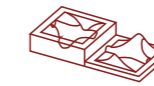

HYBRID BOUWMETHODE

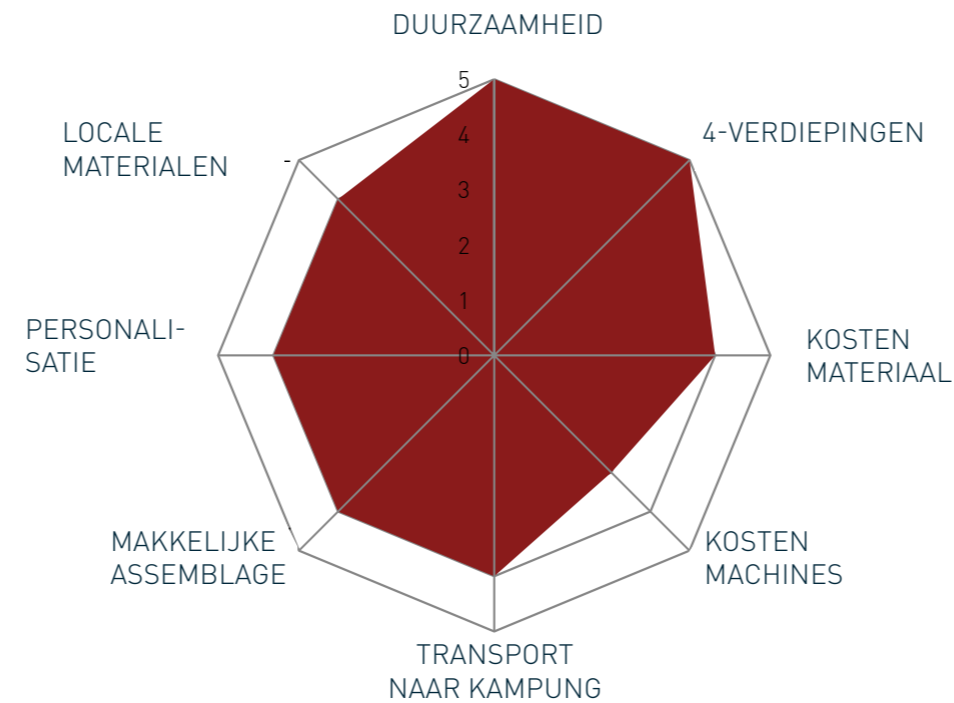

LOCALE BOUWMETHODE

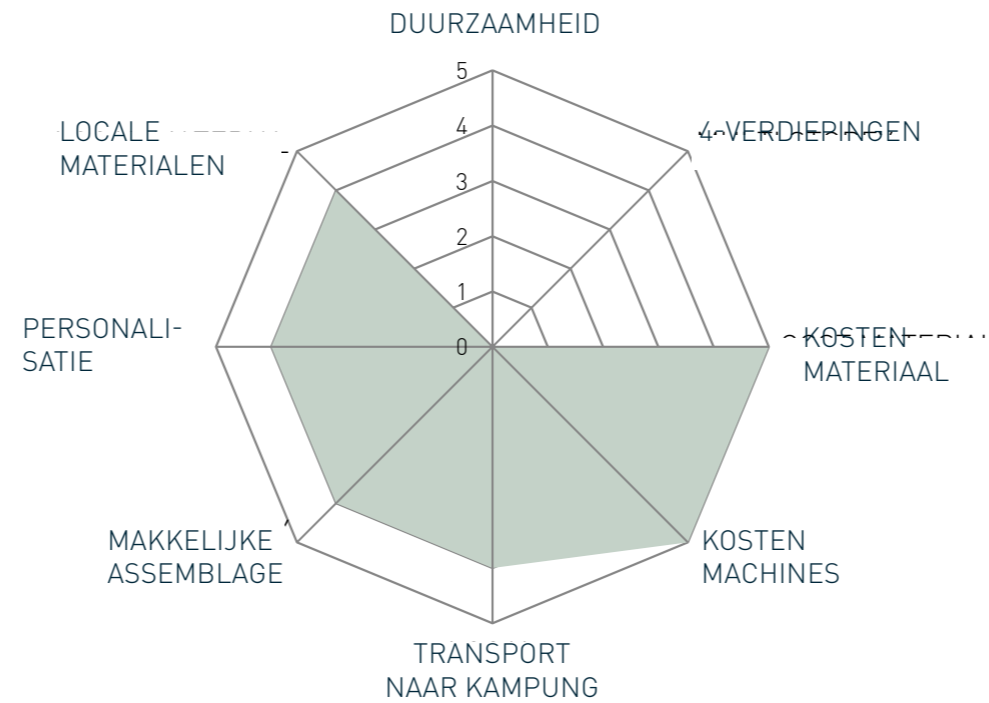

HYBRID BOUWMETHODE

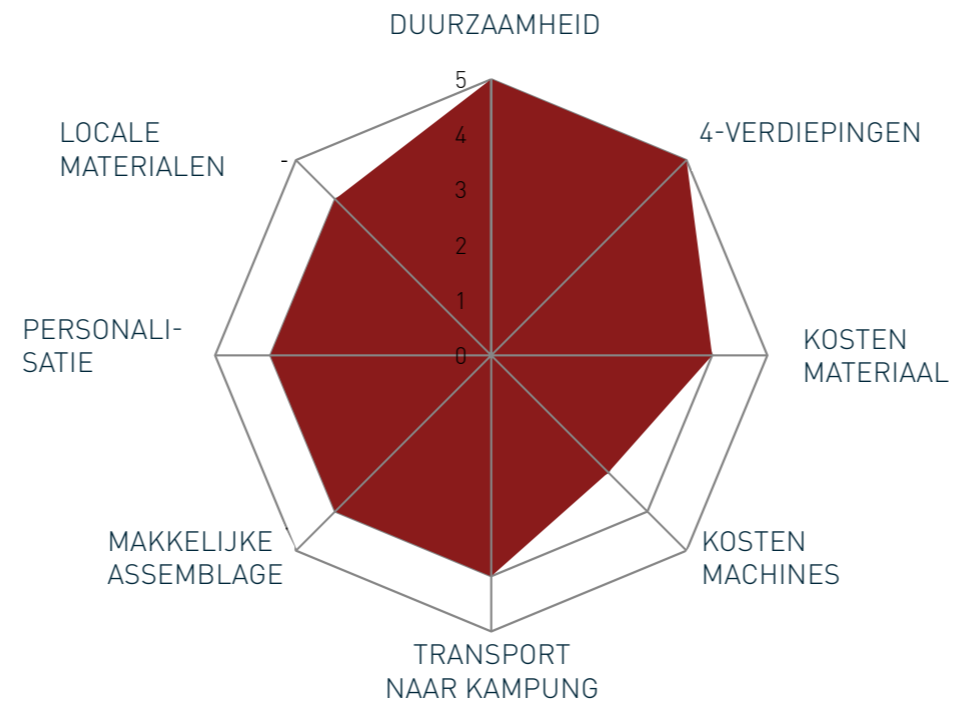

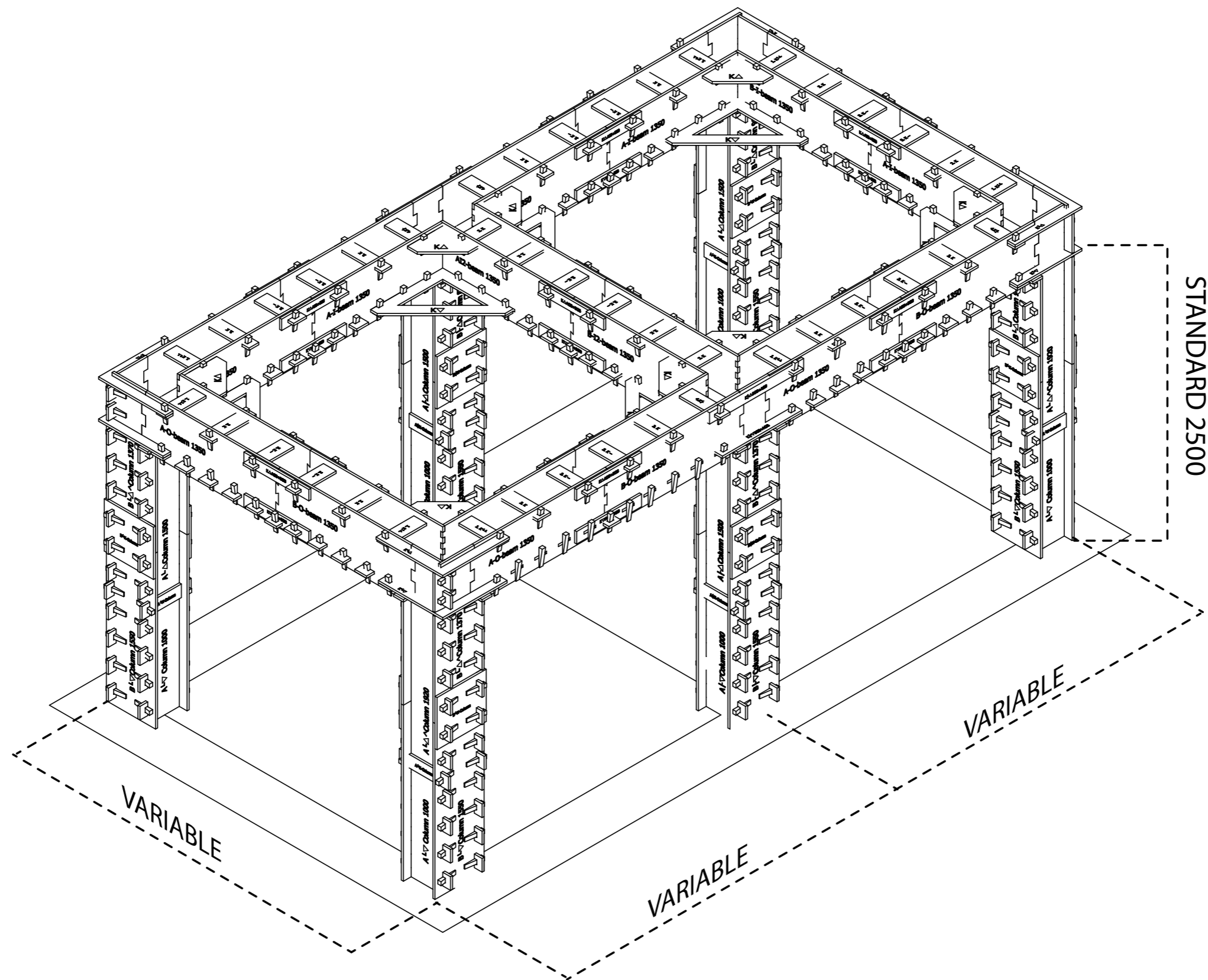

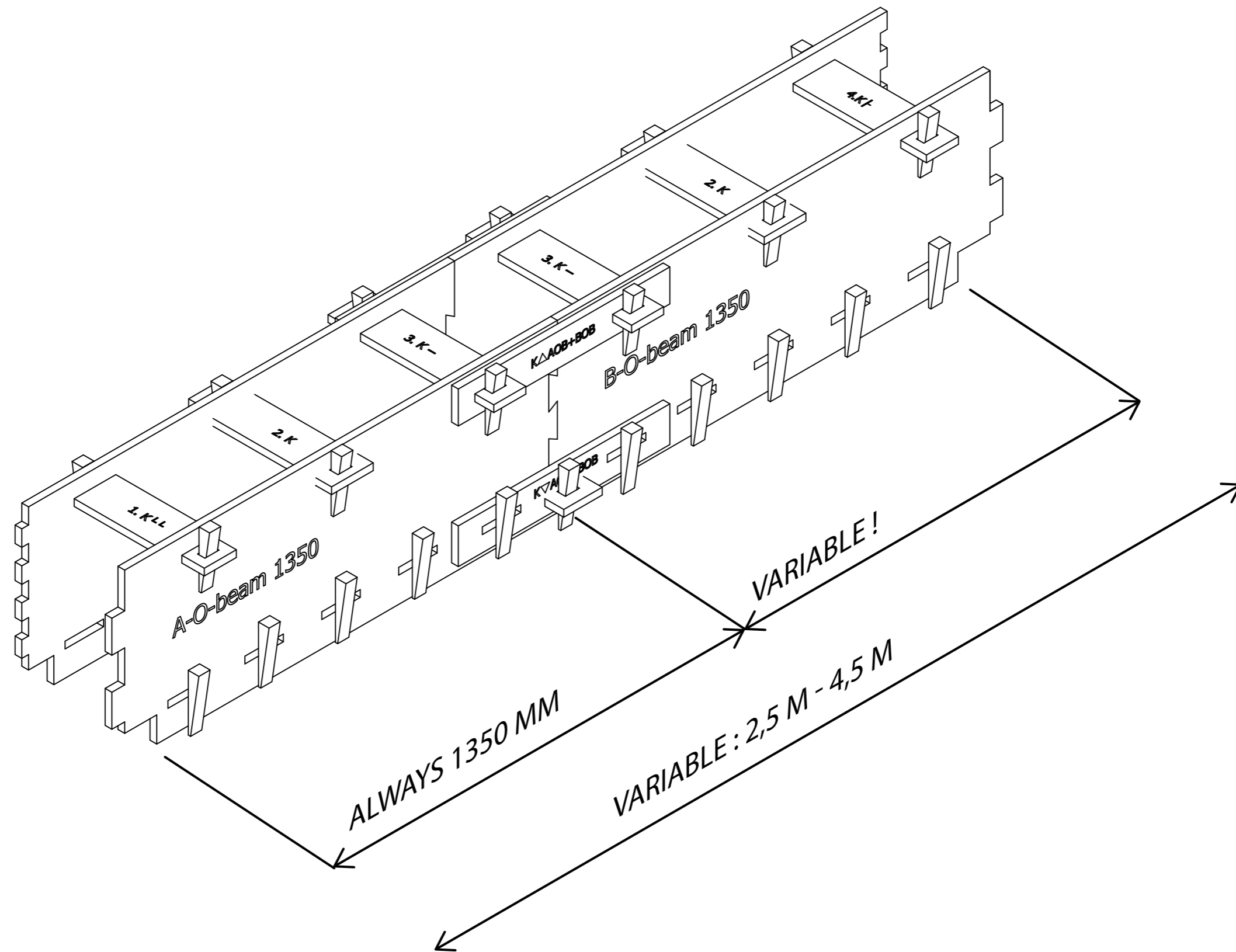

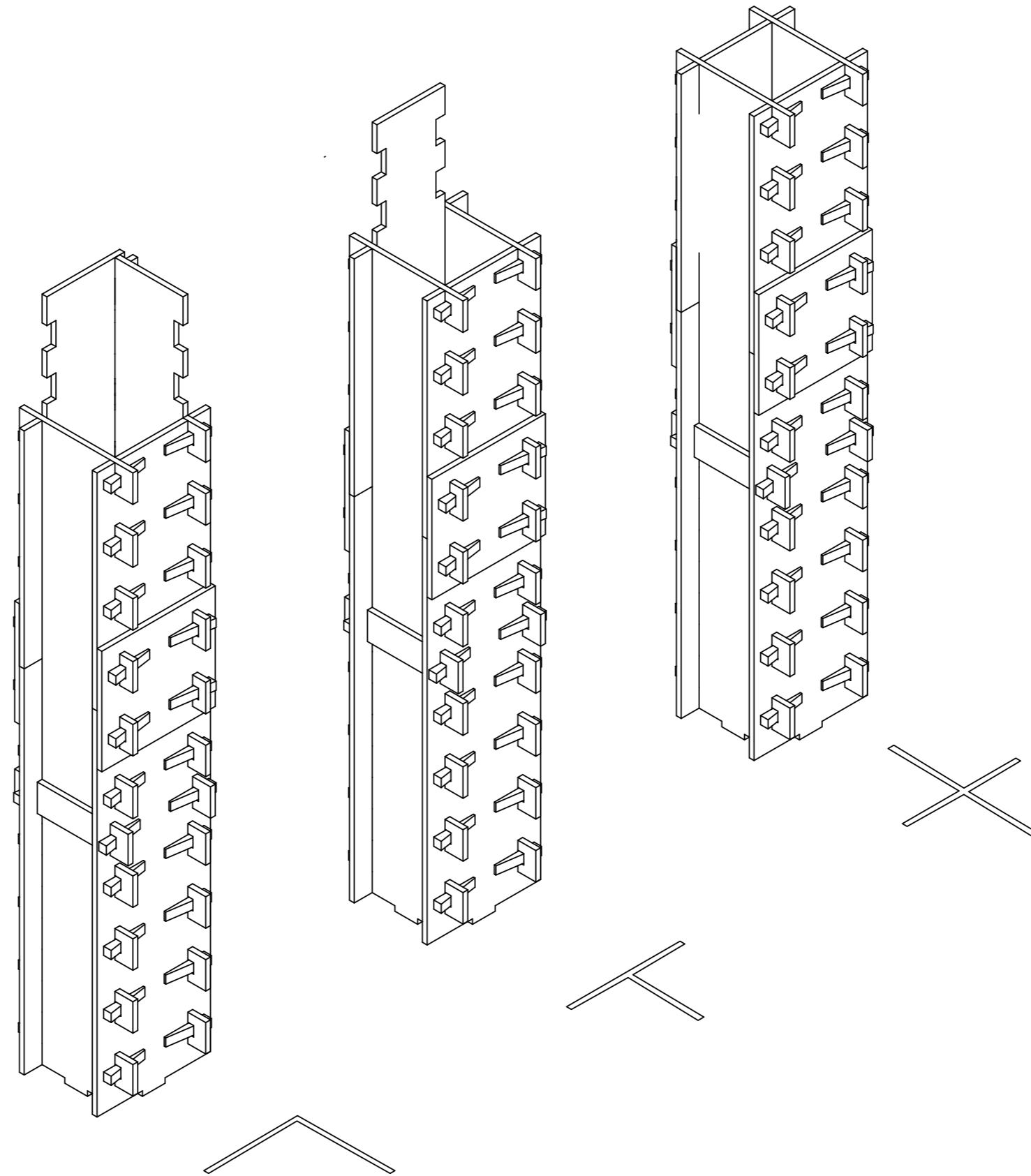

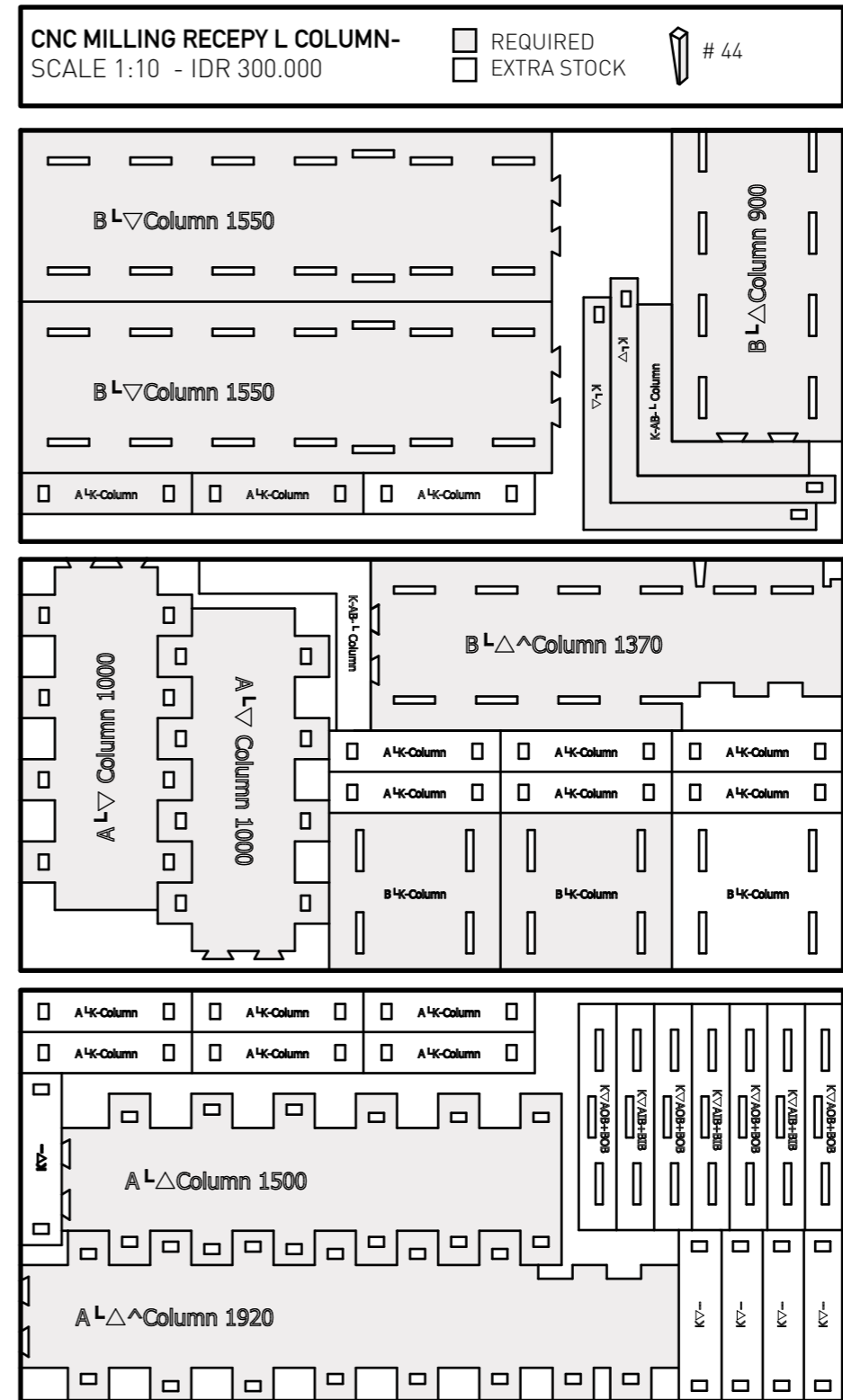
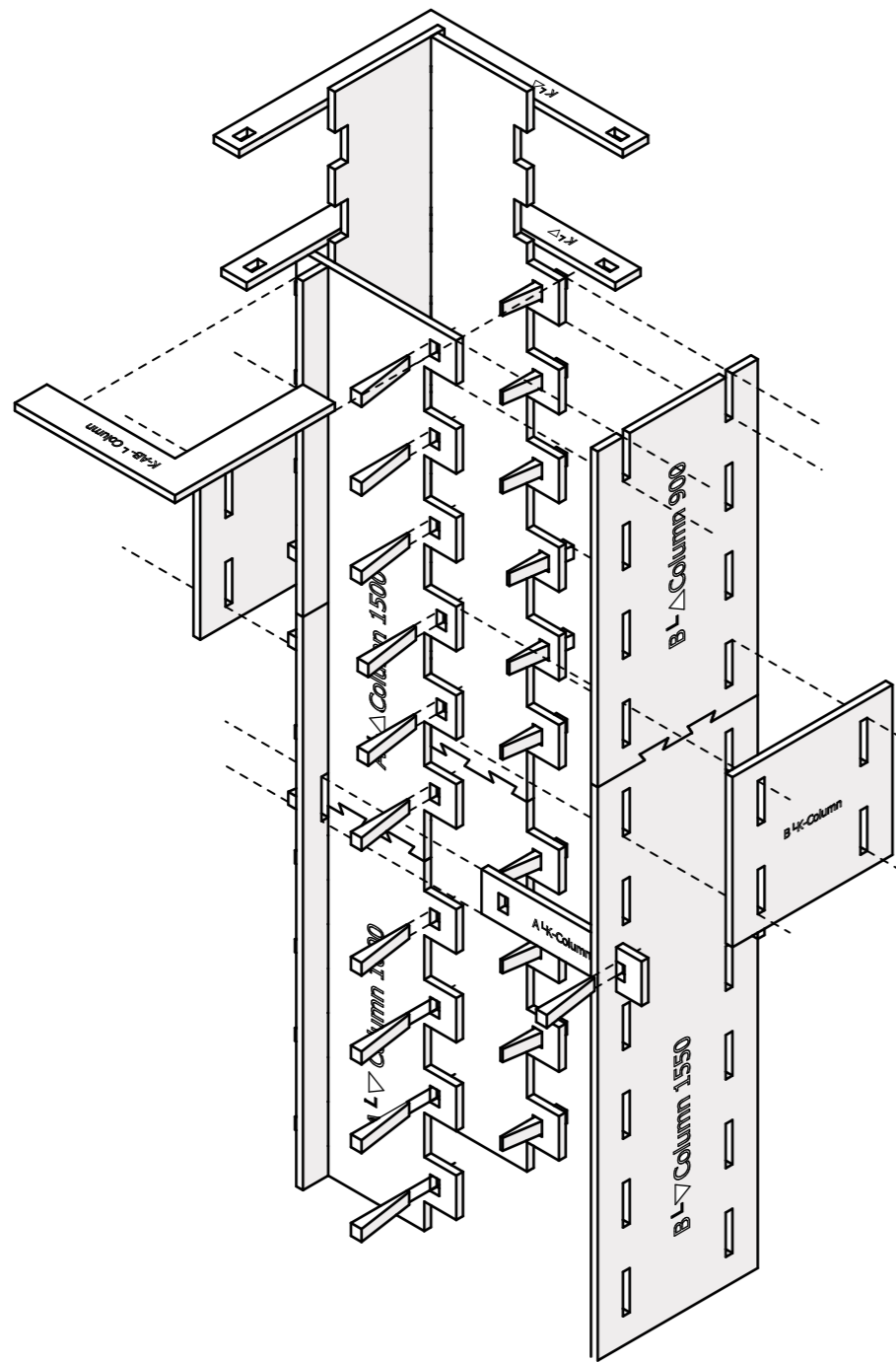

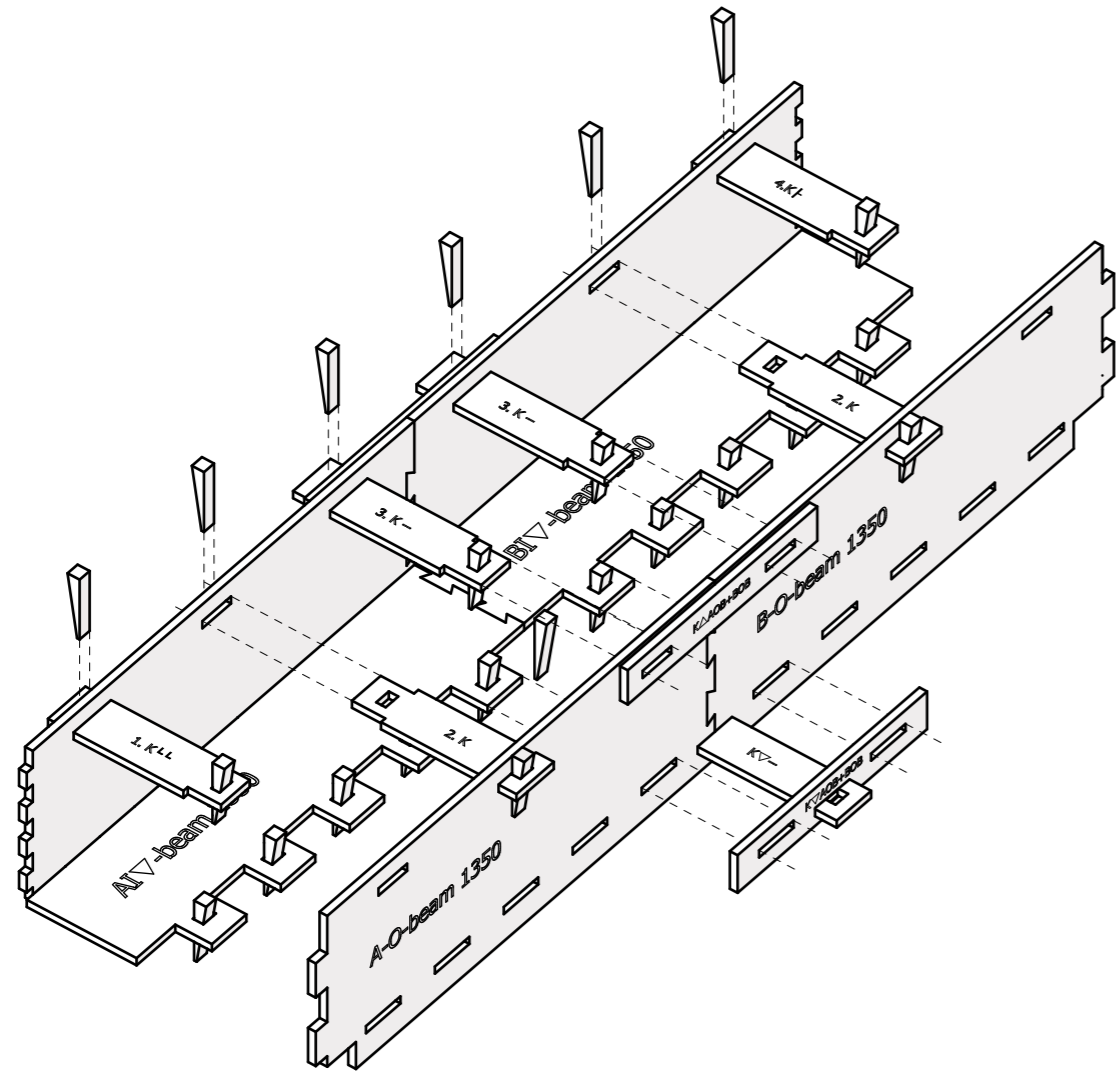

CNC MILLING RECEPY 3-M BEAM
SCALE 1:10

REQUIRED
 EXTRA STOCK

34

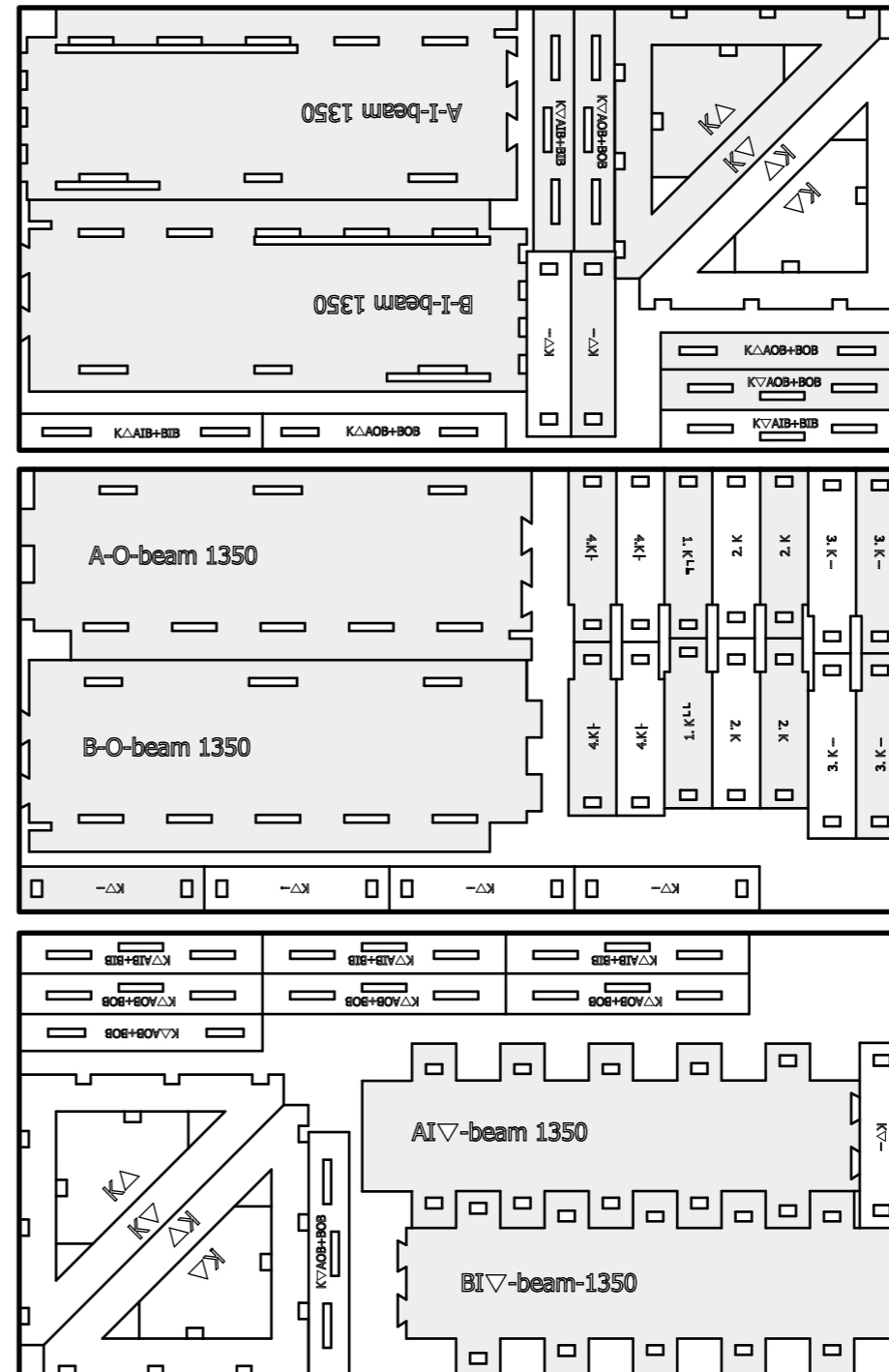

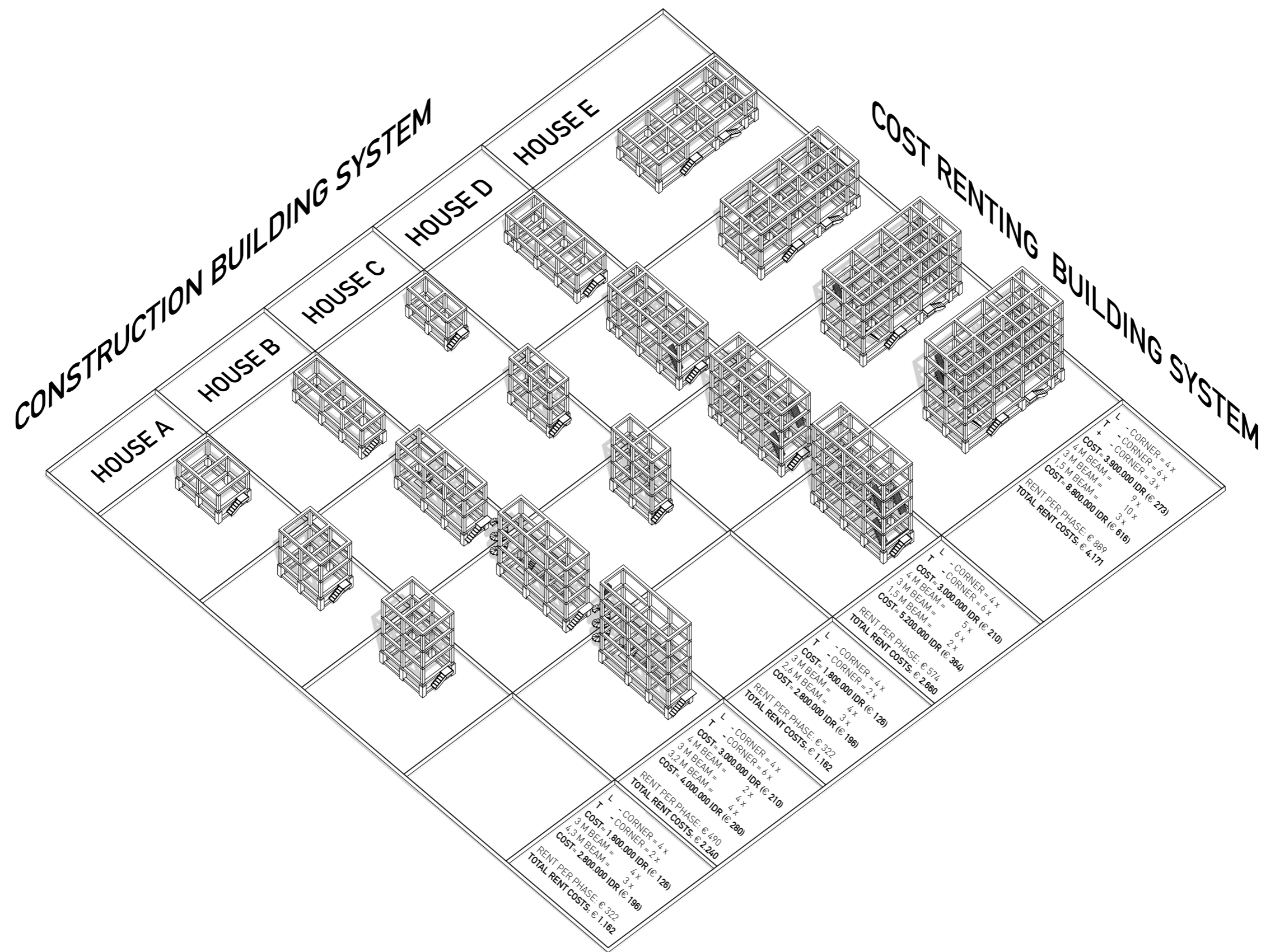

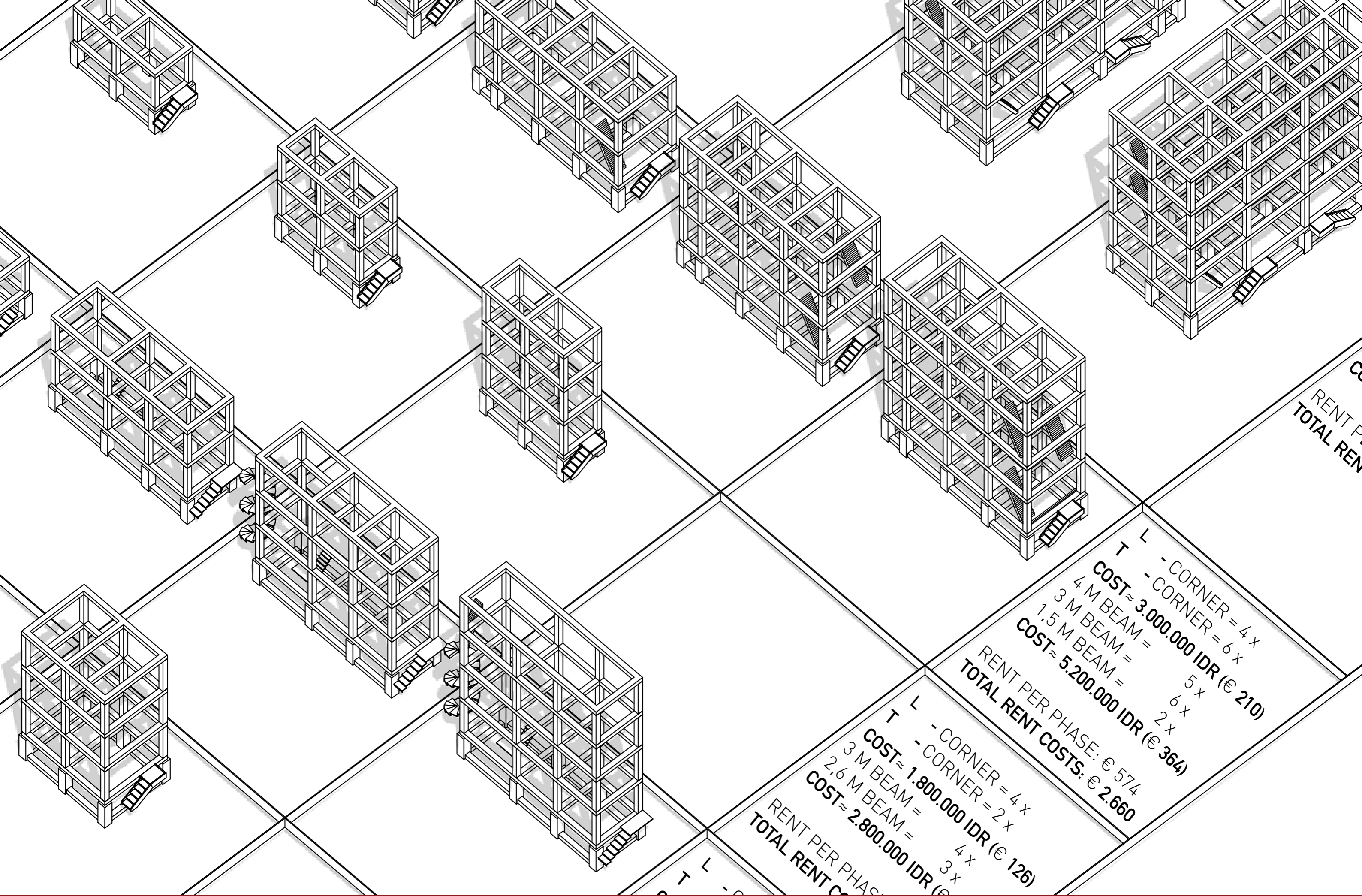

L - CORNER = 4 x
 T - CORNER = 6 x
 COST ≈ 3.000.000 IDR (€ 210)
 4 M BEAM = 5 x
 3 M BEAM = 6 x
 1,5 M BEAM = 2 x
 COST ≈ 5.200.000 IDR (€ 364)
 RENT PER PHASE: € 574
 TOTAL RENT COSTS: € 2.660

L - CORNER = 4 x
 T - CORNER = 2 x
 COST ≈ 1.800.000 IDR (€ 126)
 3 M BEAM = 4 x
 2,6 M BEAM = 3 x
 COST ≈ 2.800.000 IDR (€ 200)
 RENT PER PHASE: € 126
 TOTAL RENT COSTS: € 252

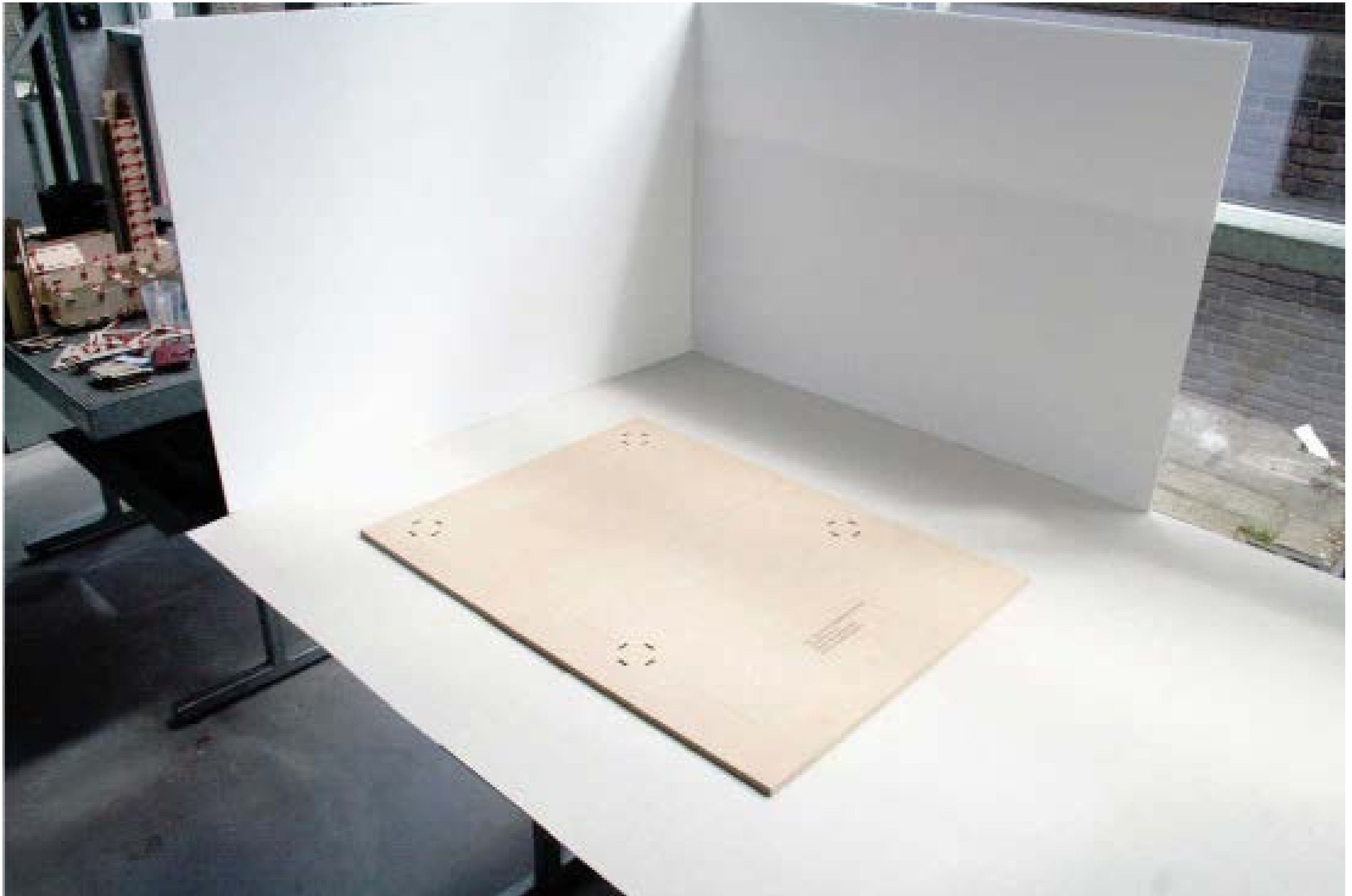

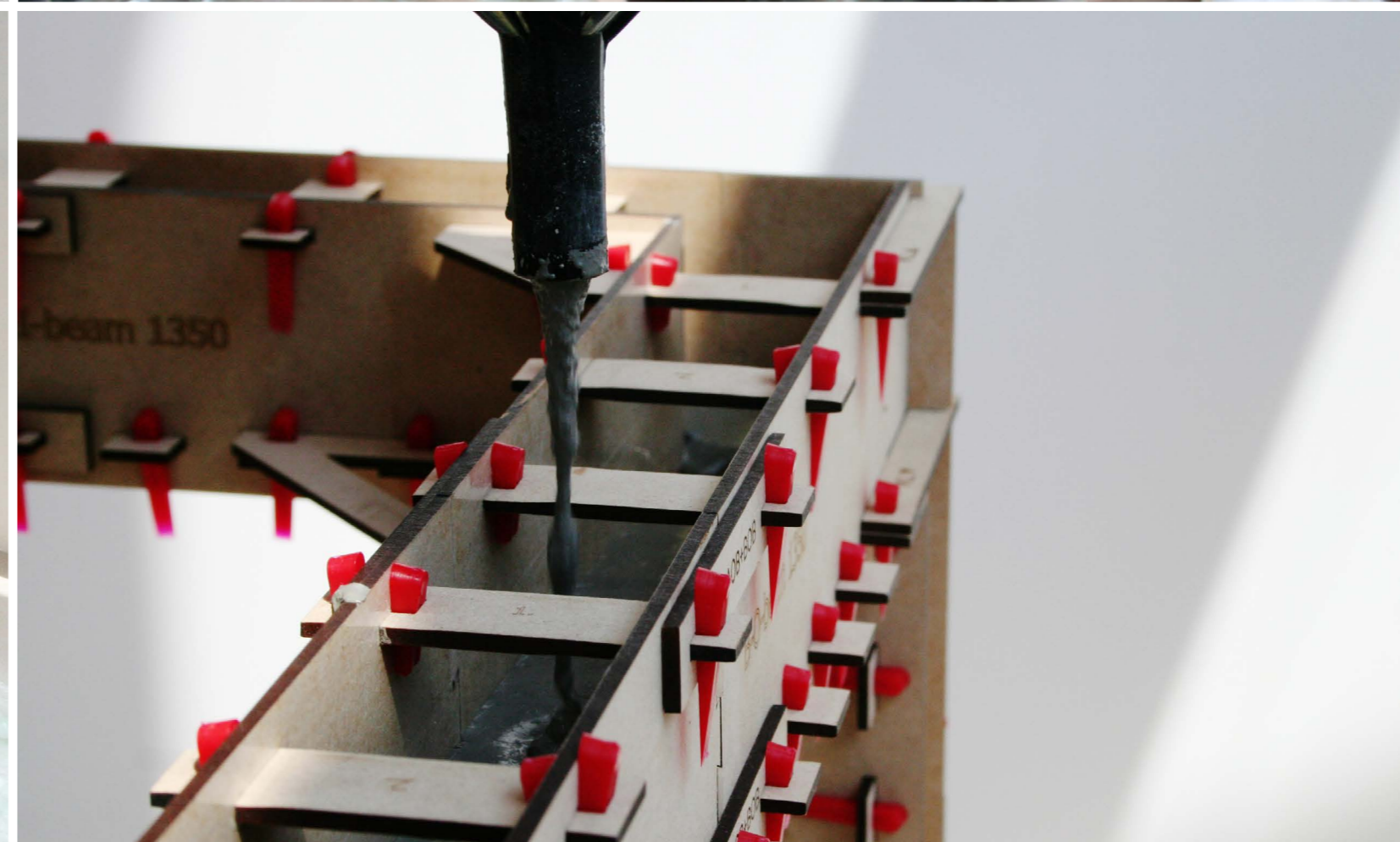
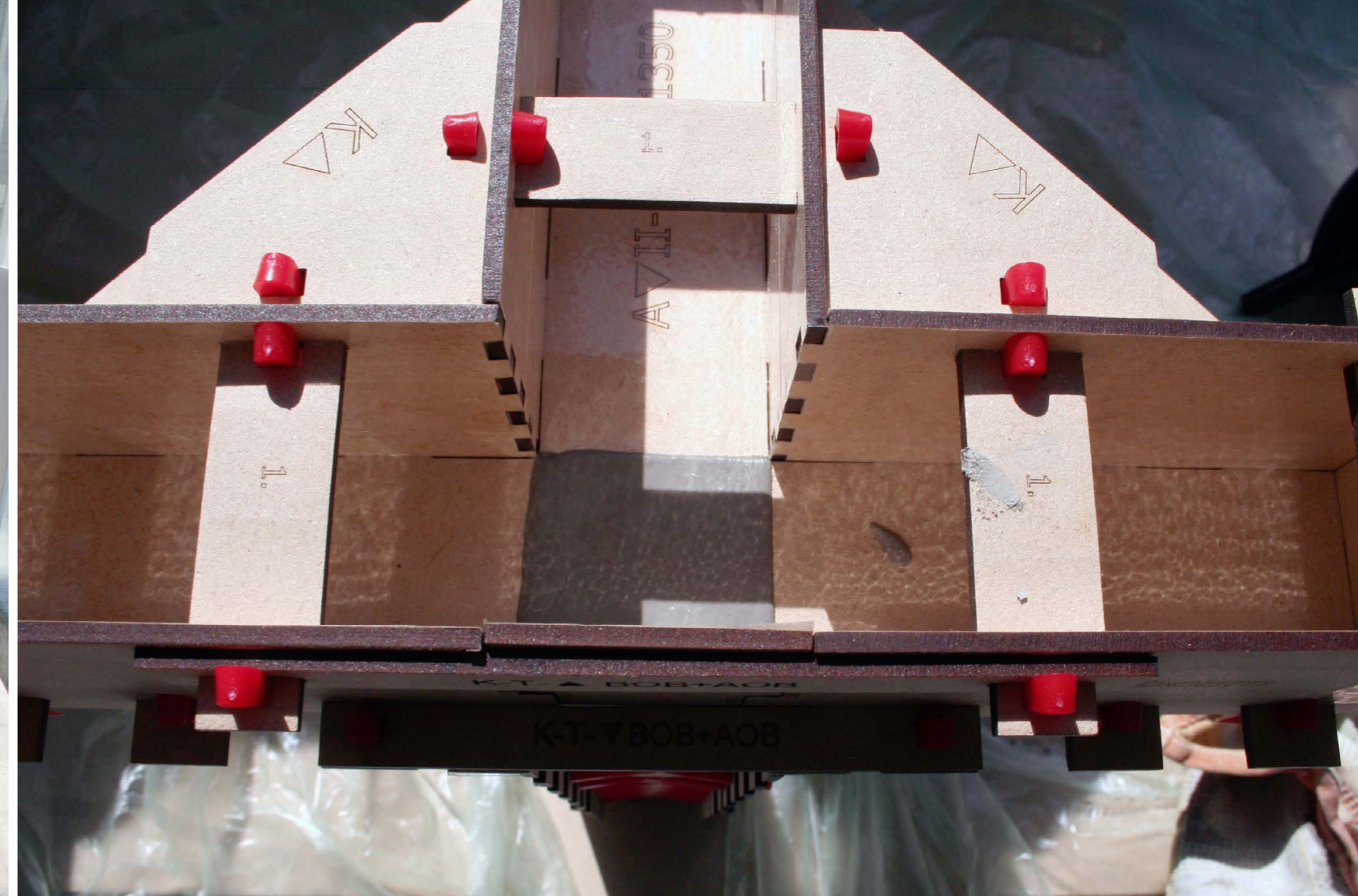



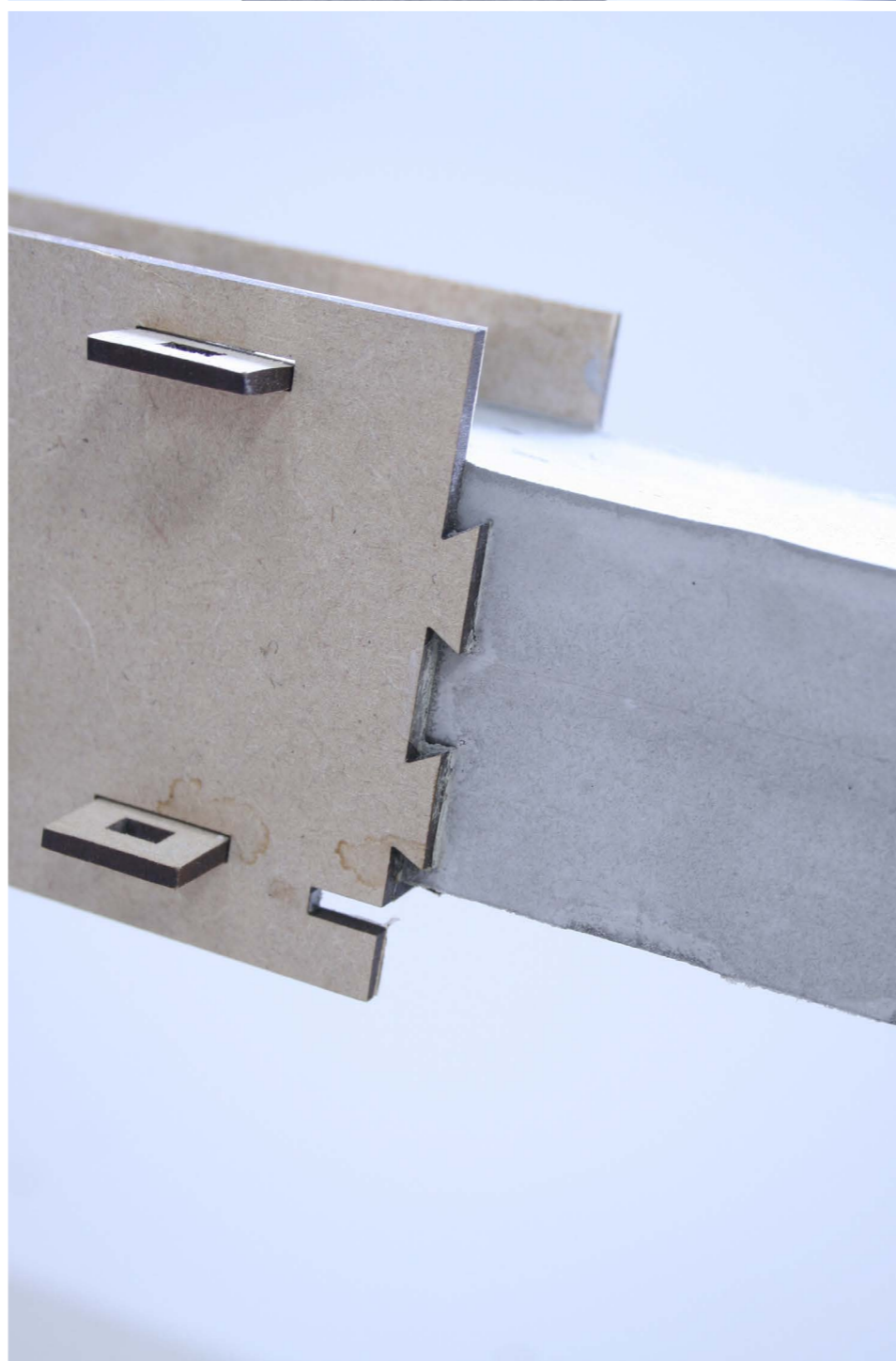
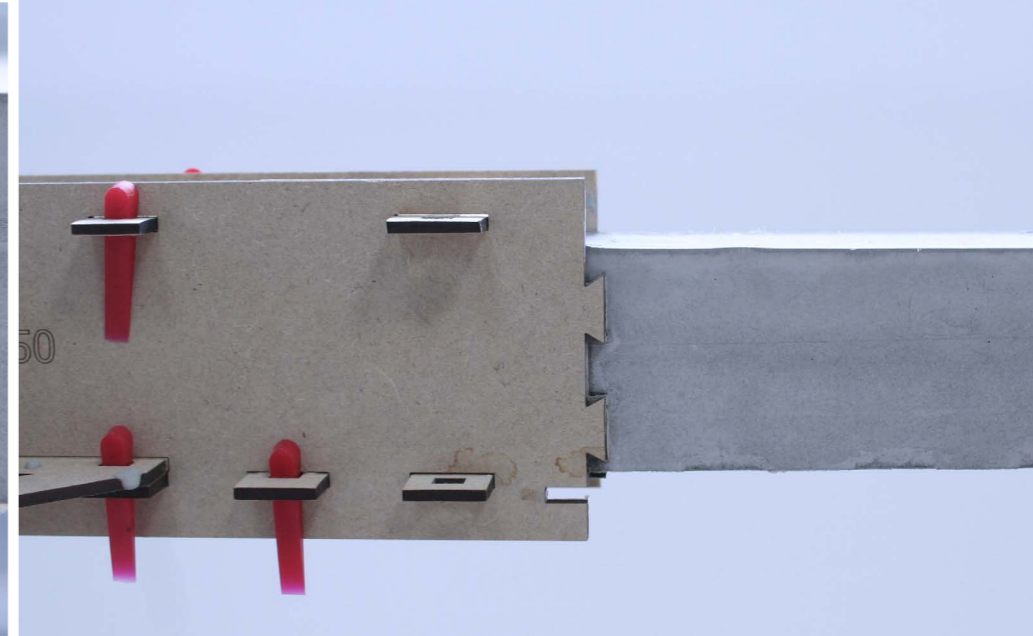
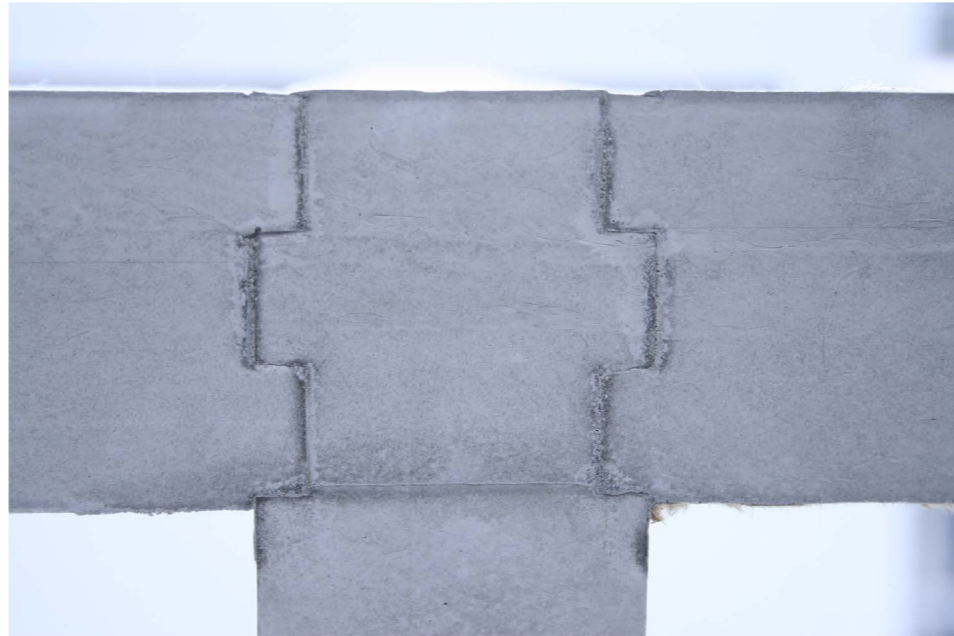



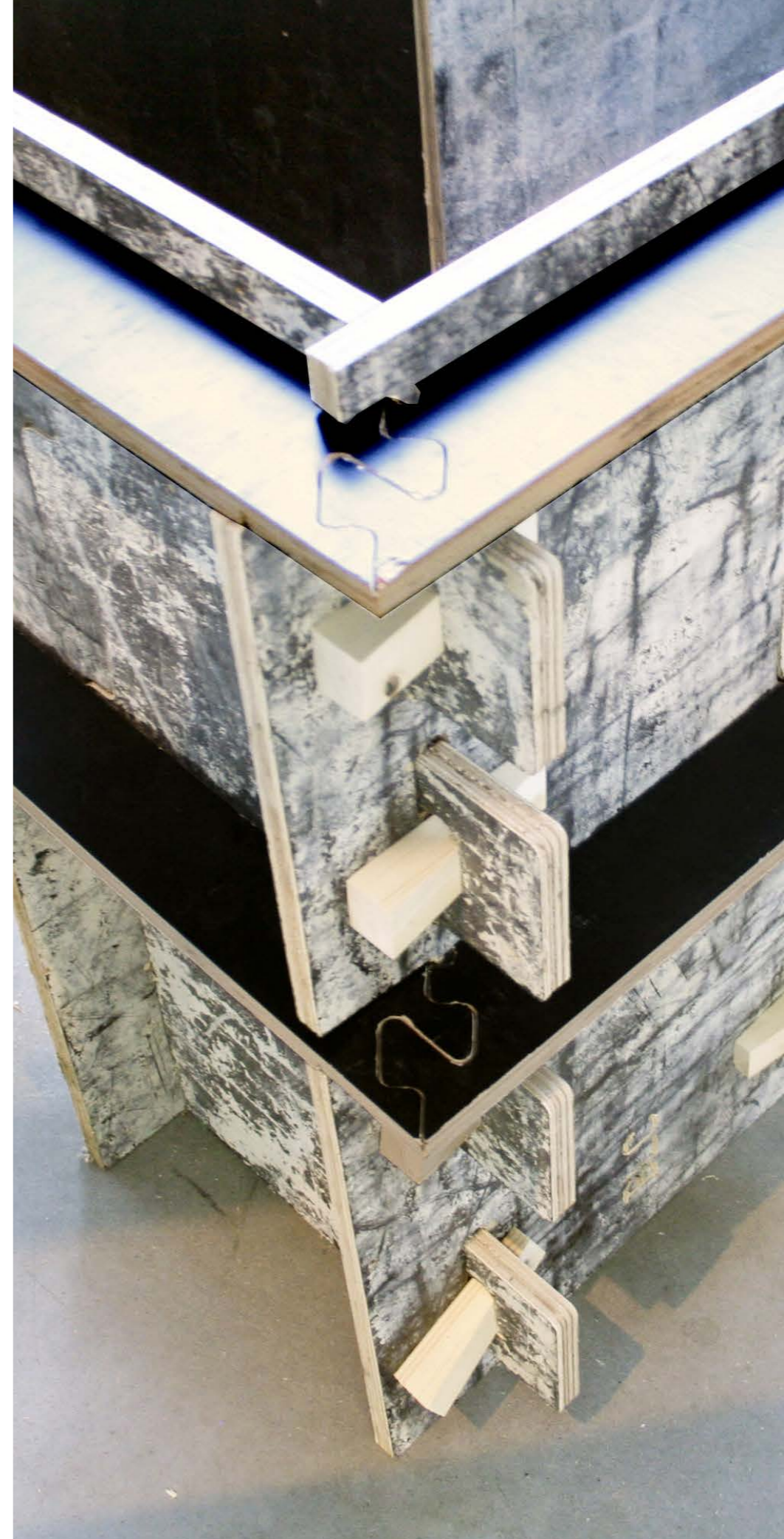

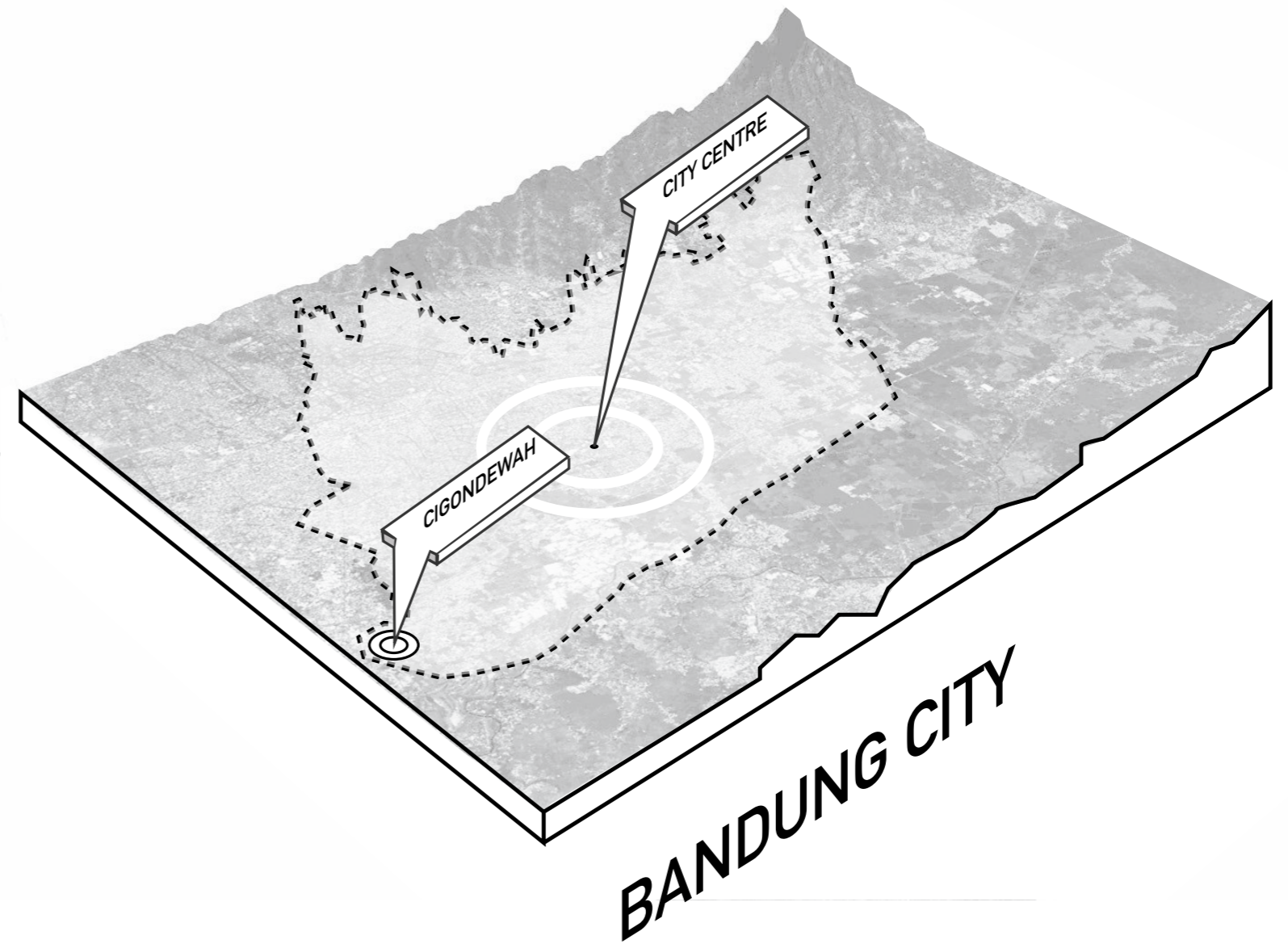
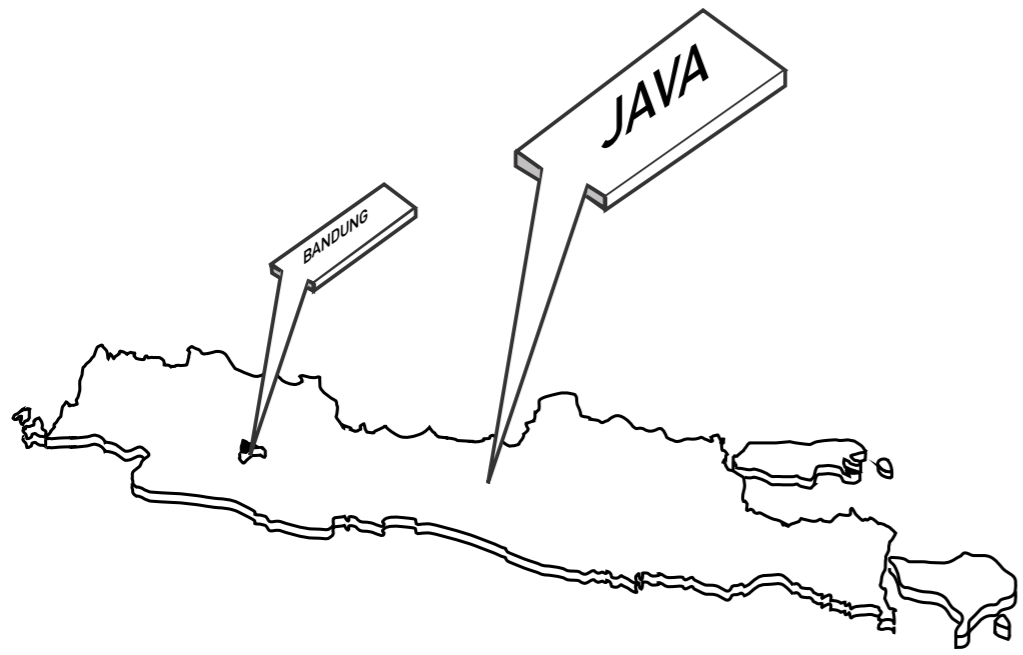

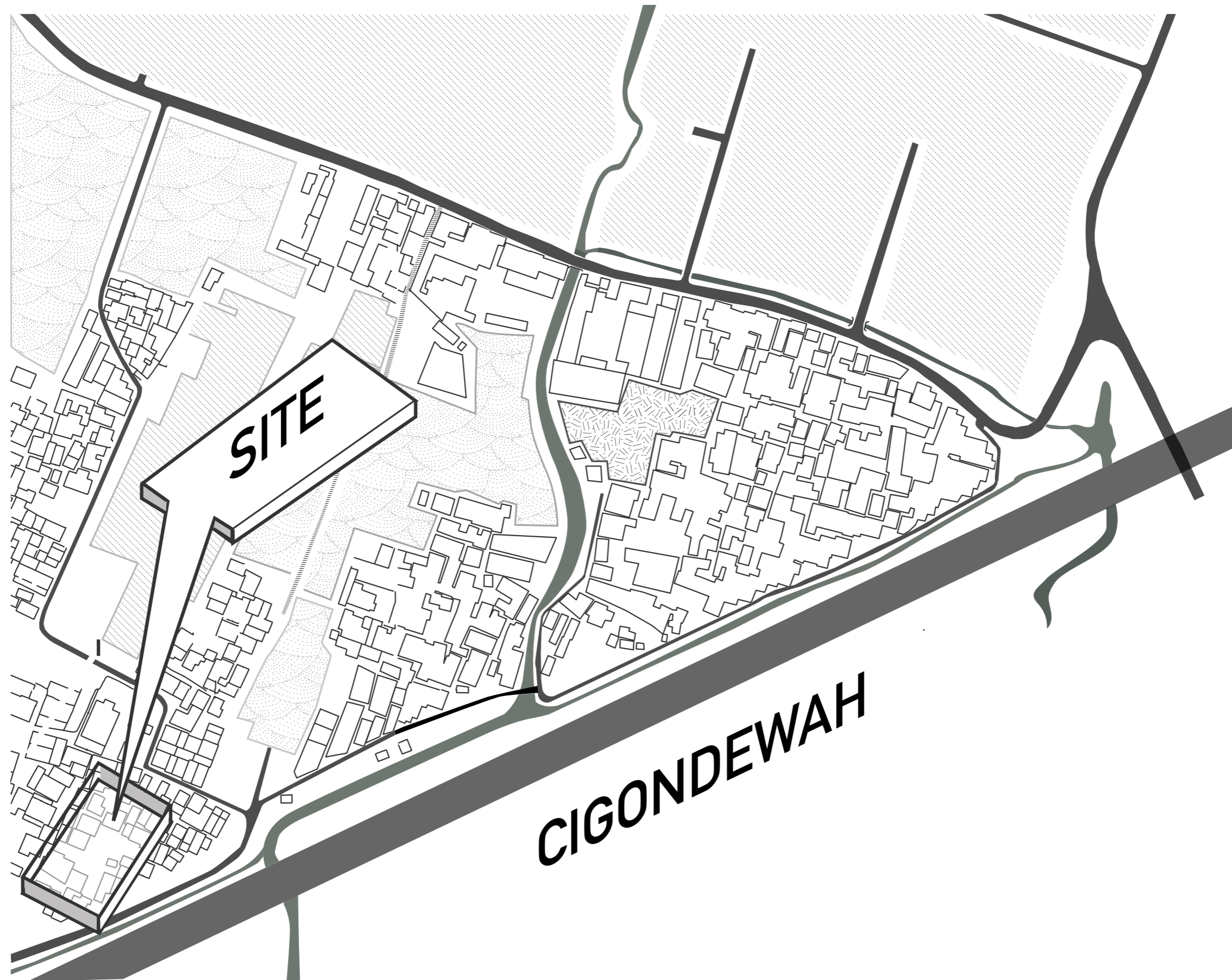

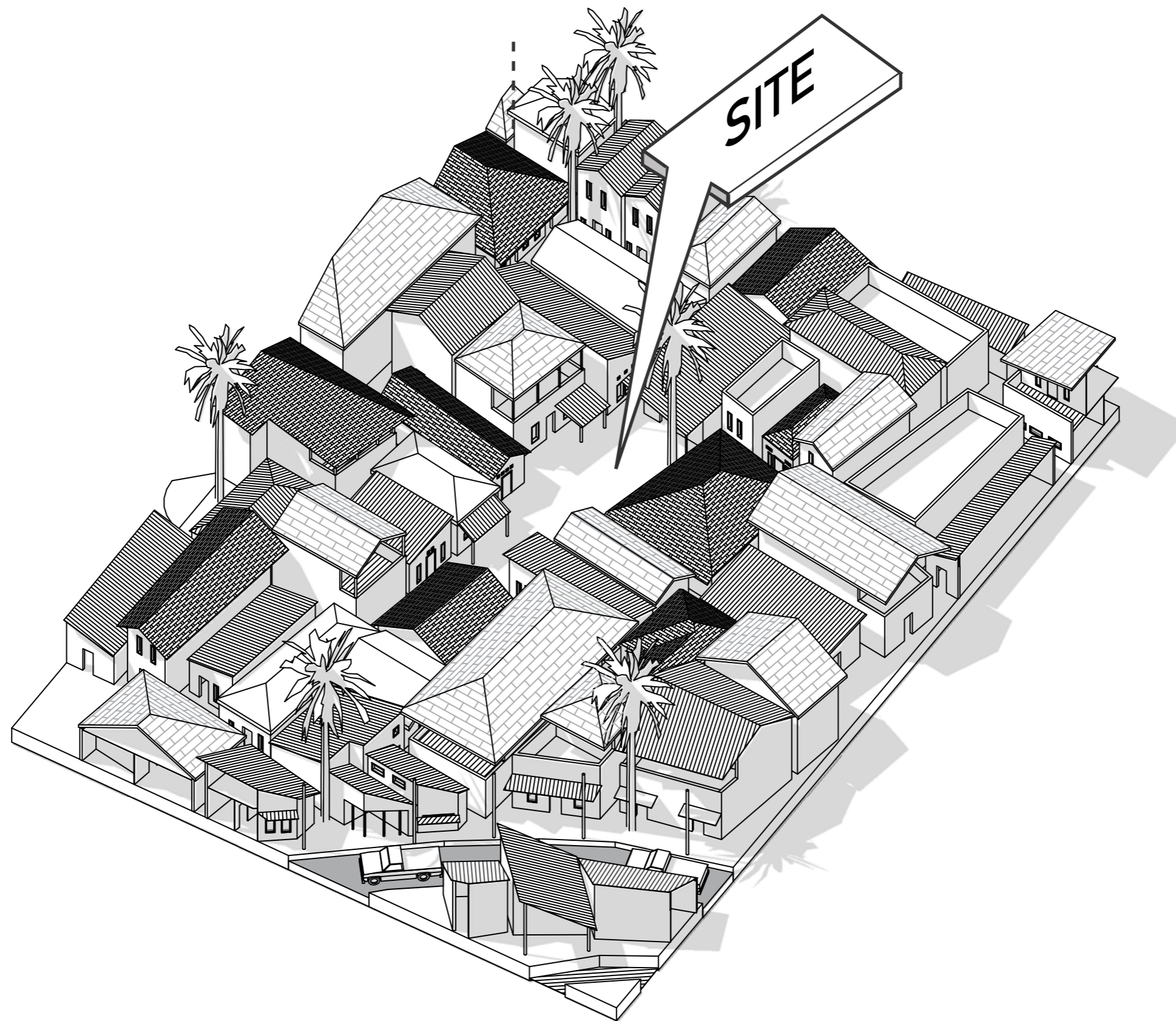

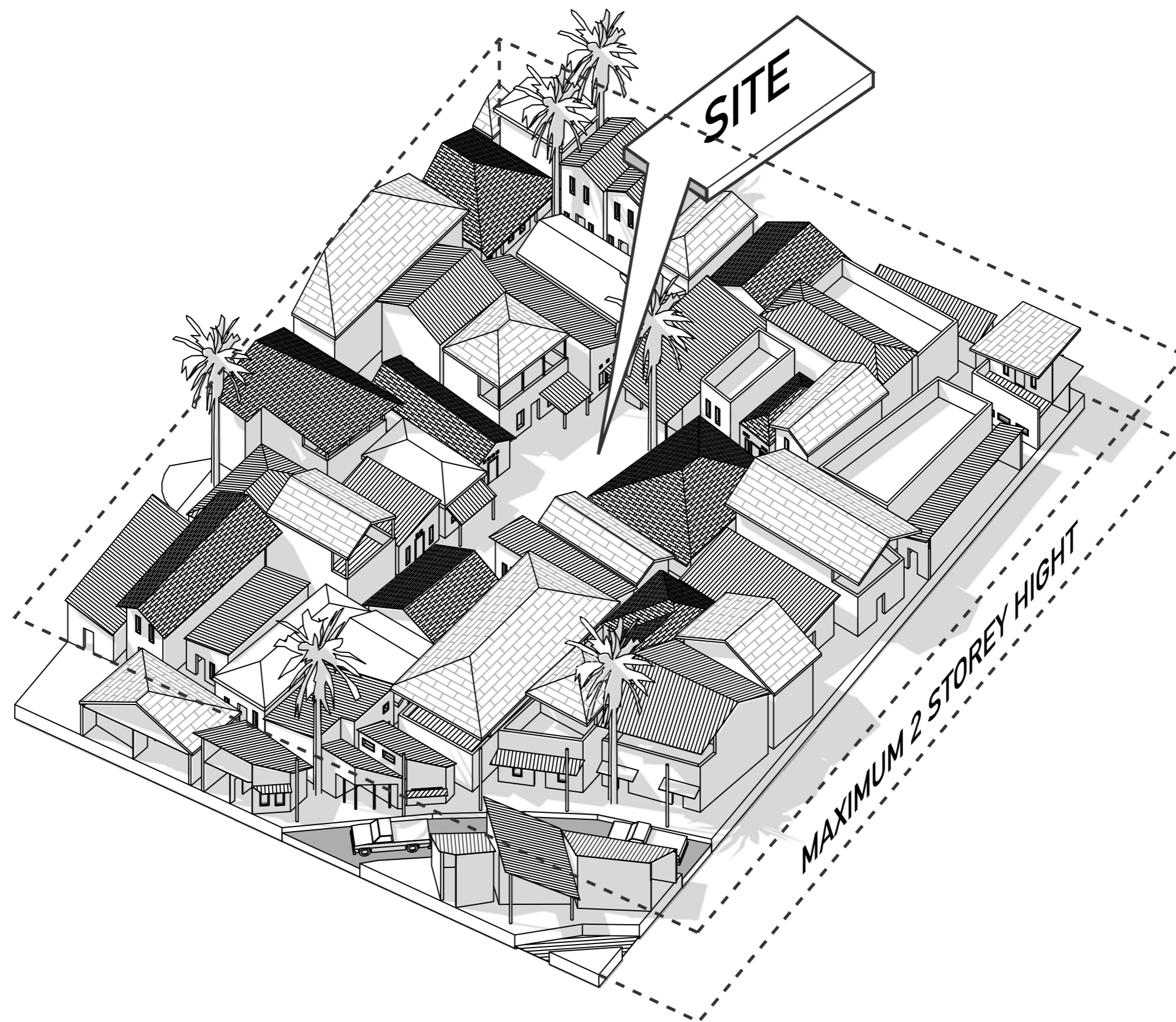

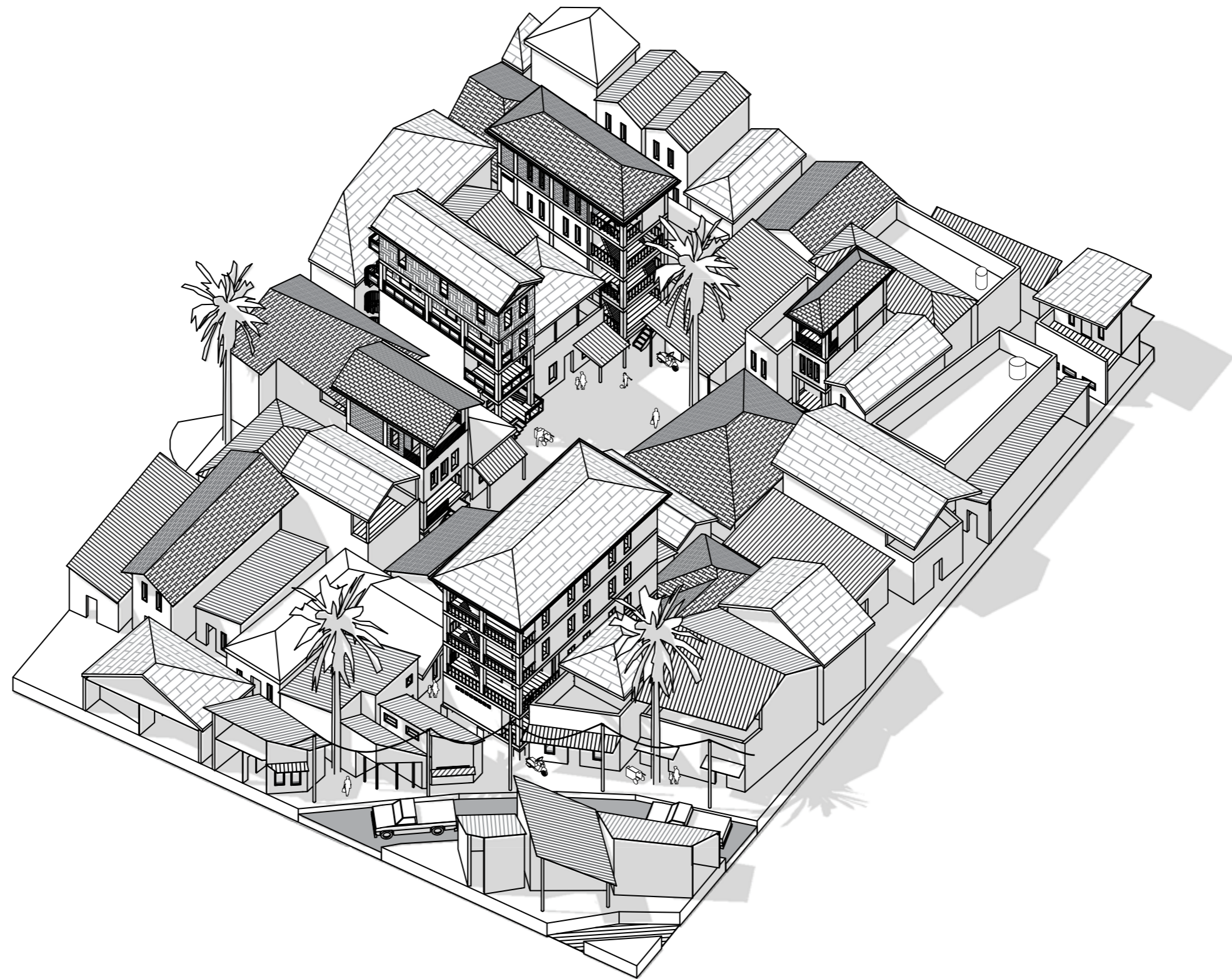

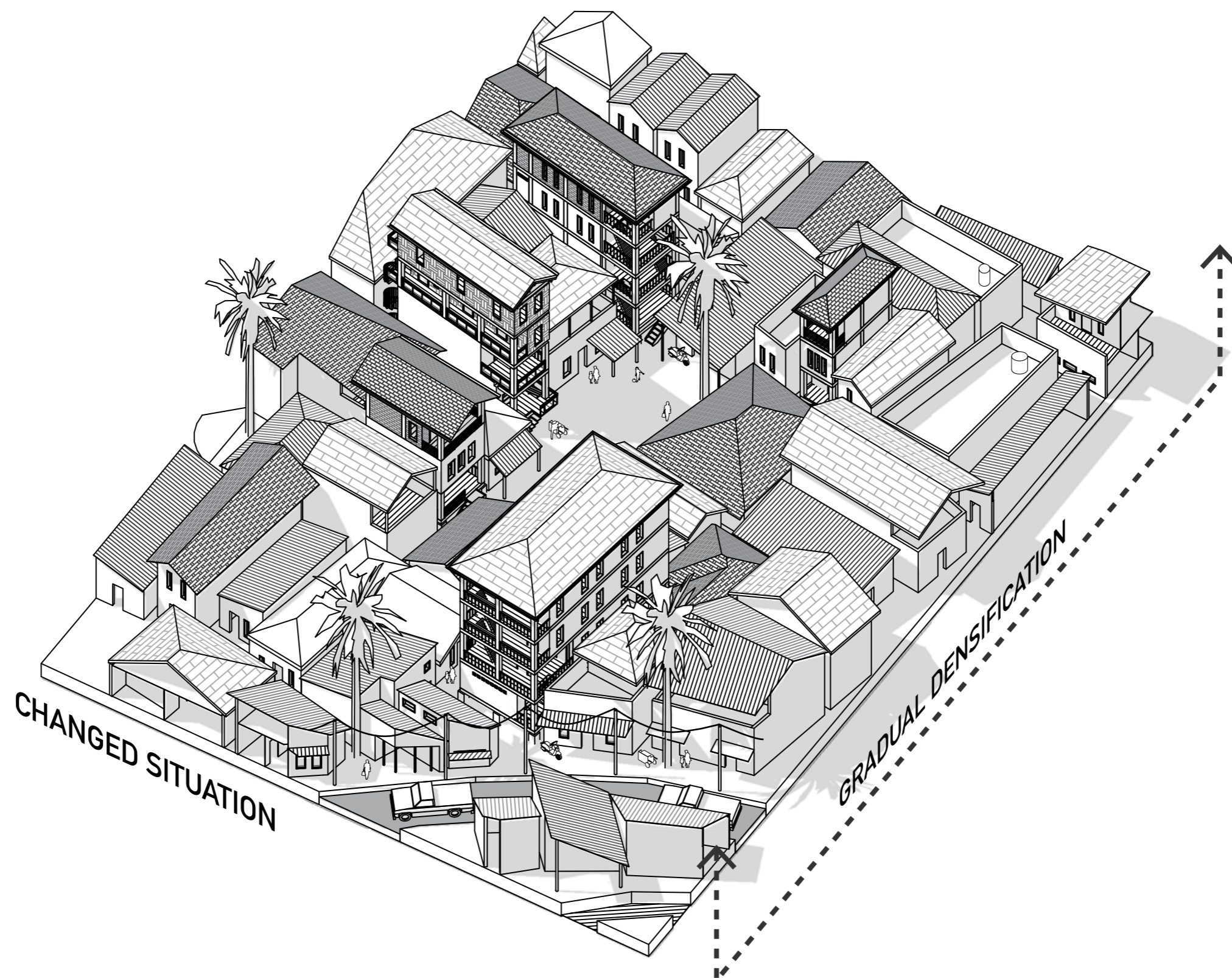

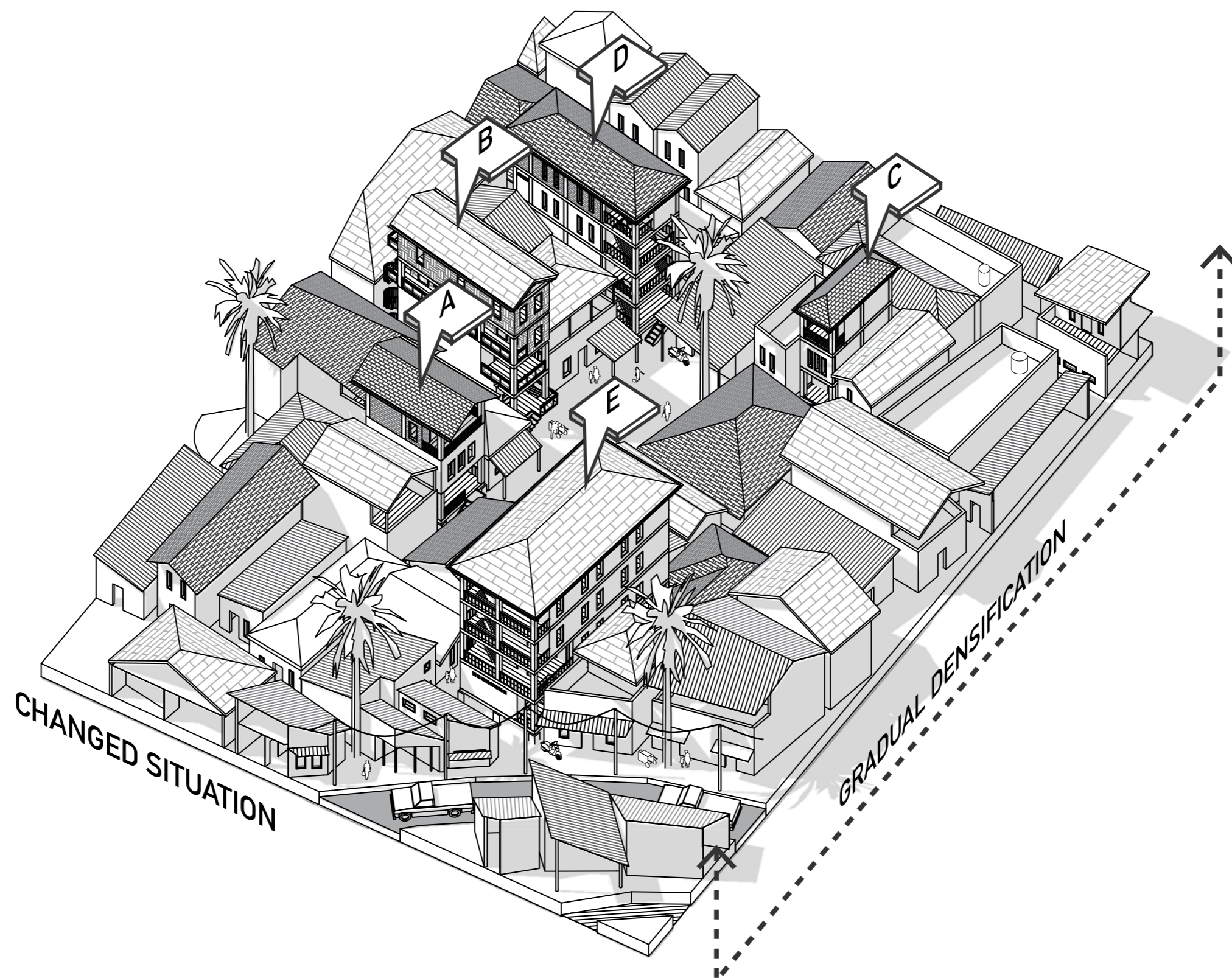

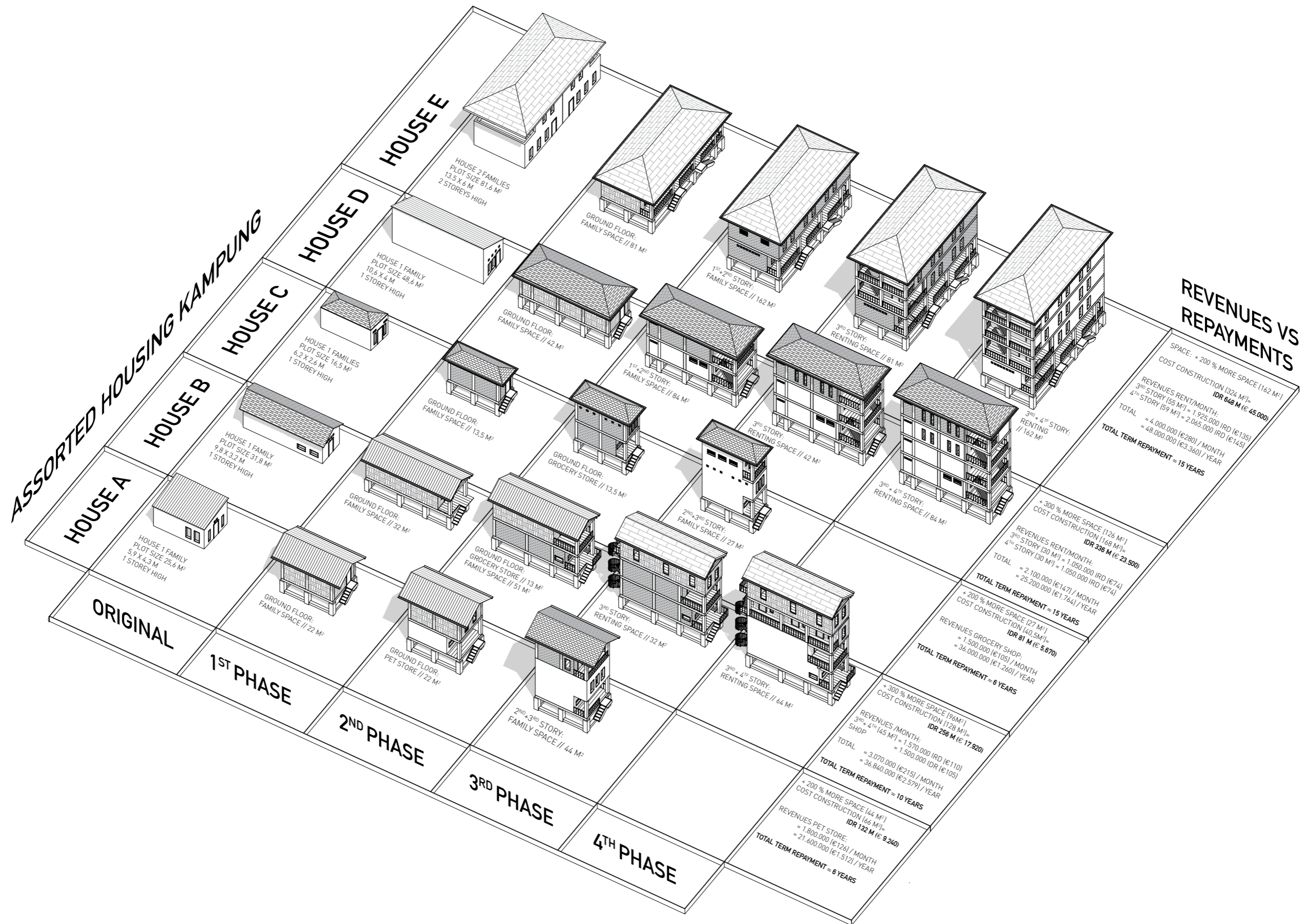

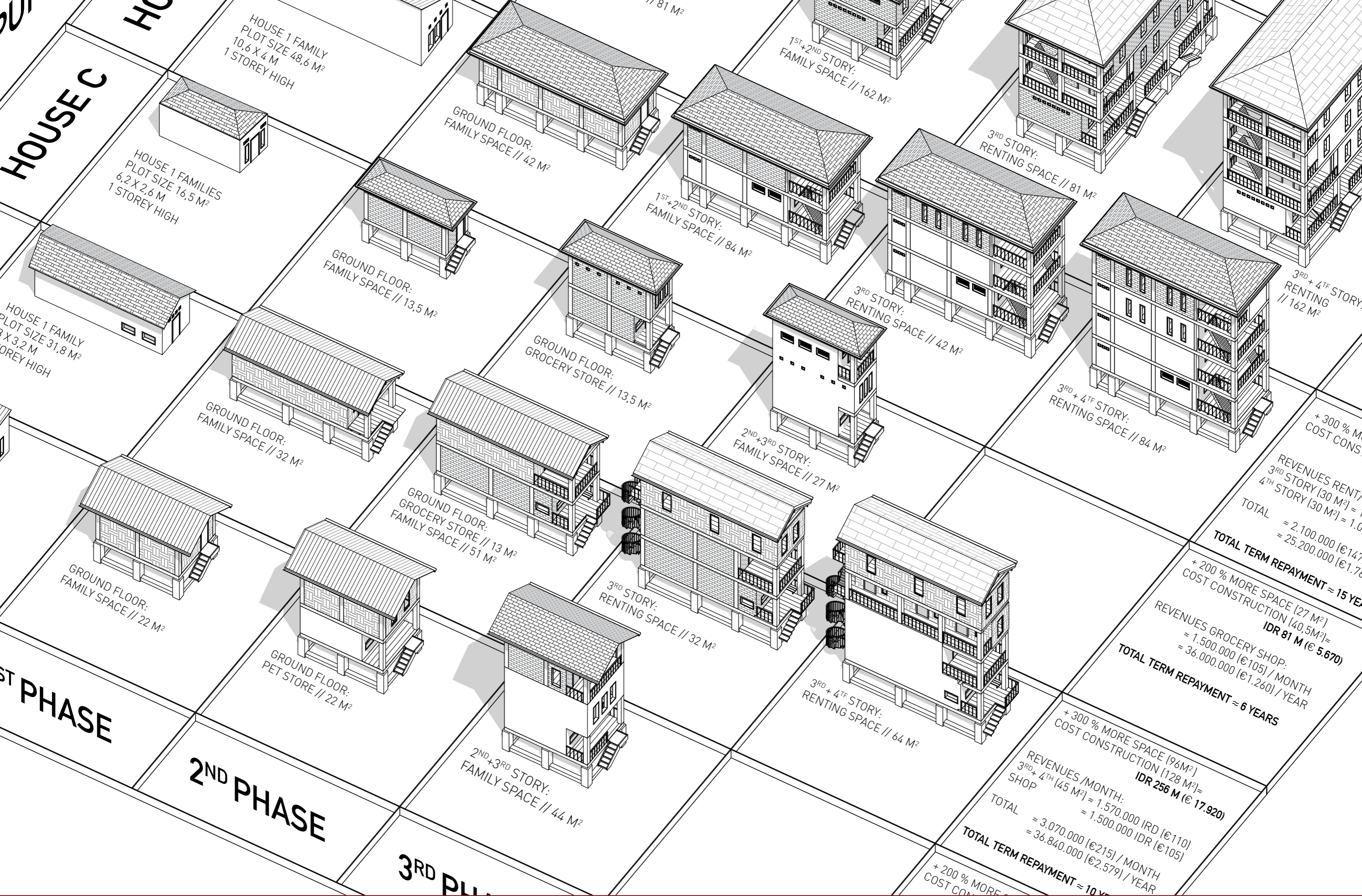



TRA-DIGITAL HUB BANDUNG

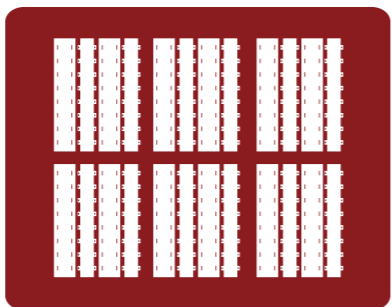
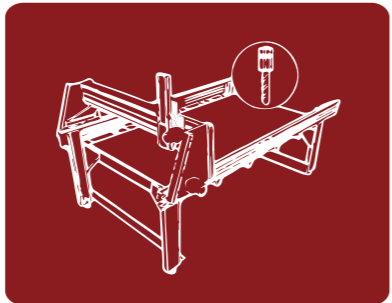
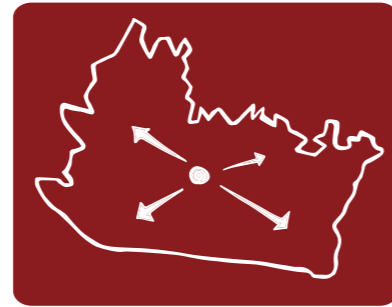
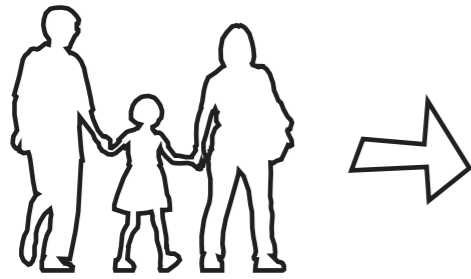

TRA-DIGITAL HUB BANDUNG

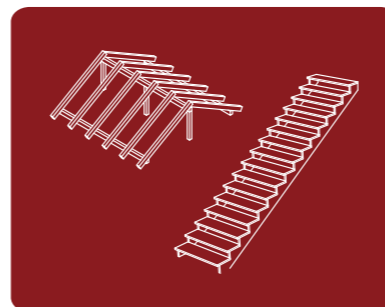
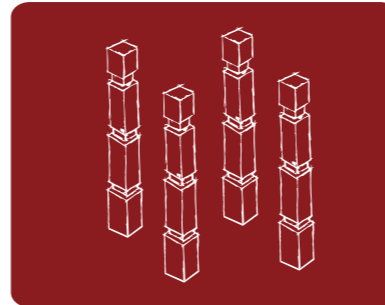
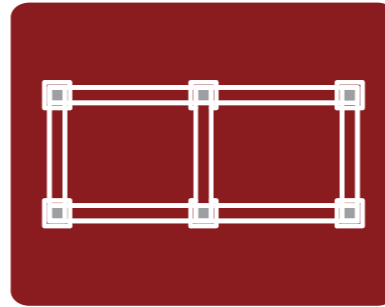
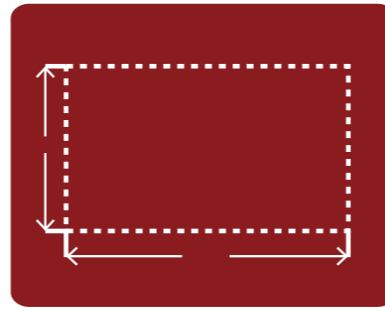
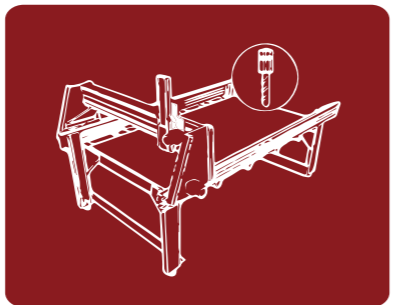

TRA-DIGITAL HUB
BANDUNG

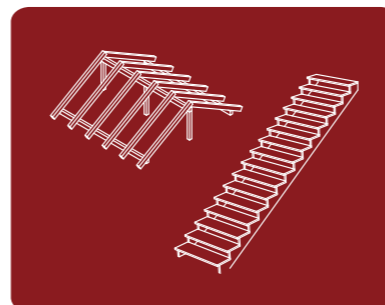
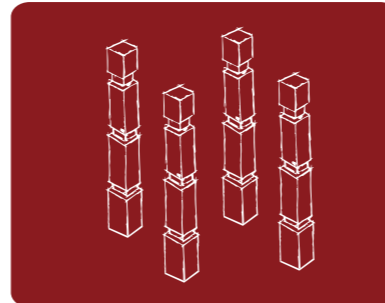
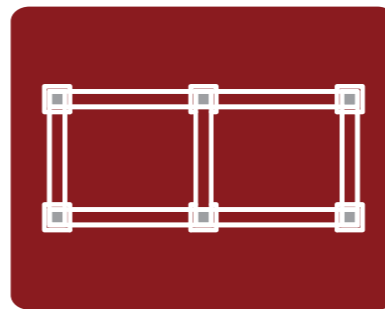
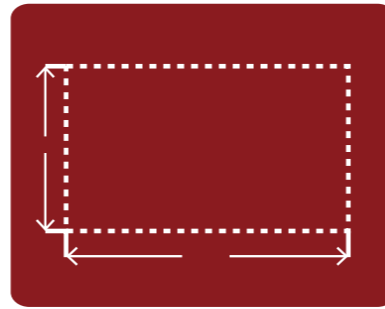
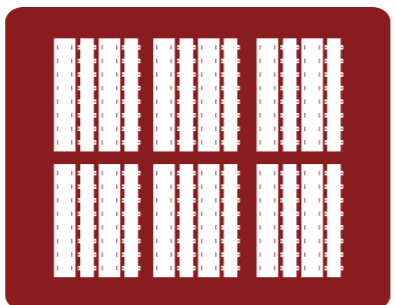
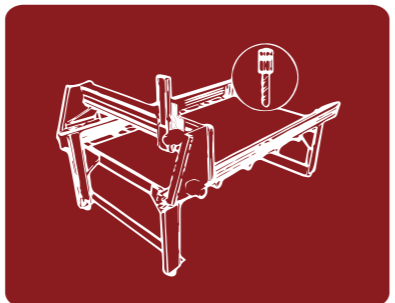

TRA-DIGITAL HUB
BANDUNG

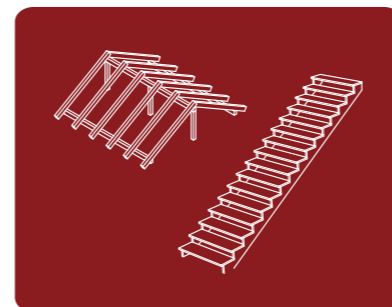
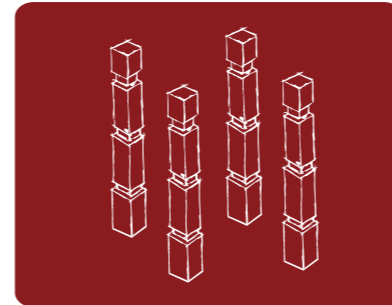
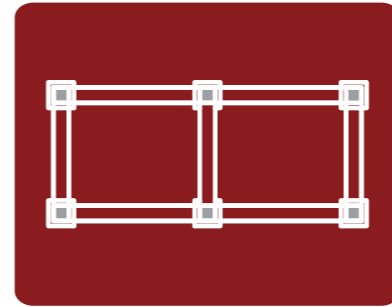
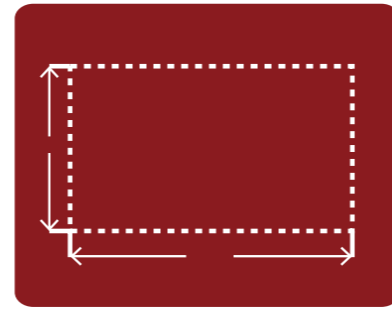
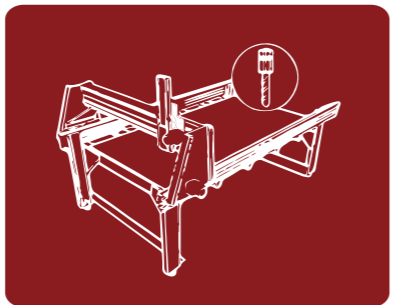
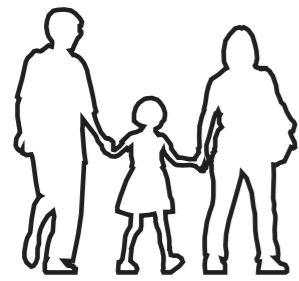

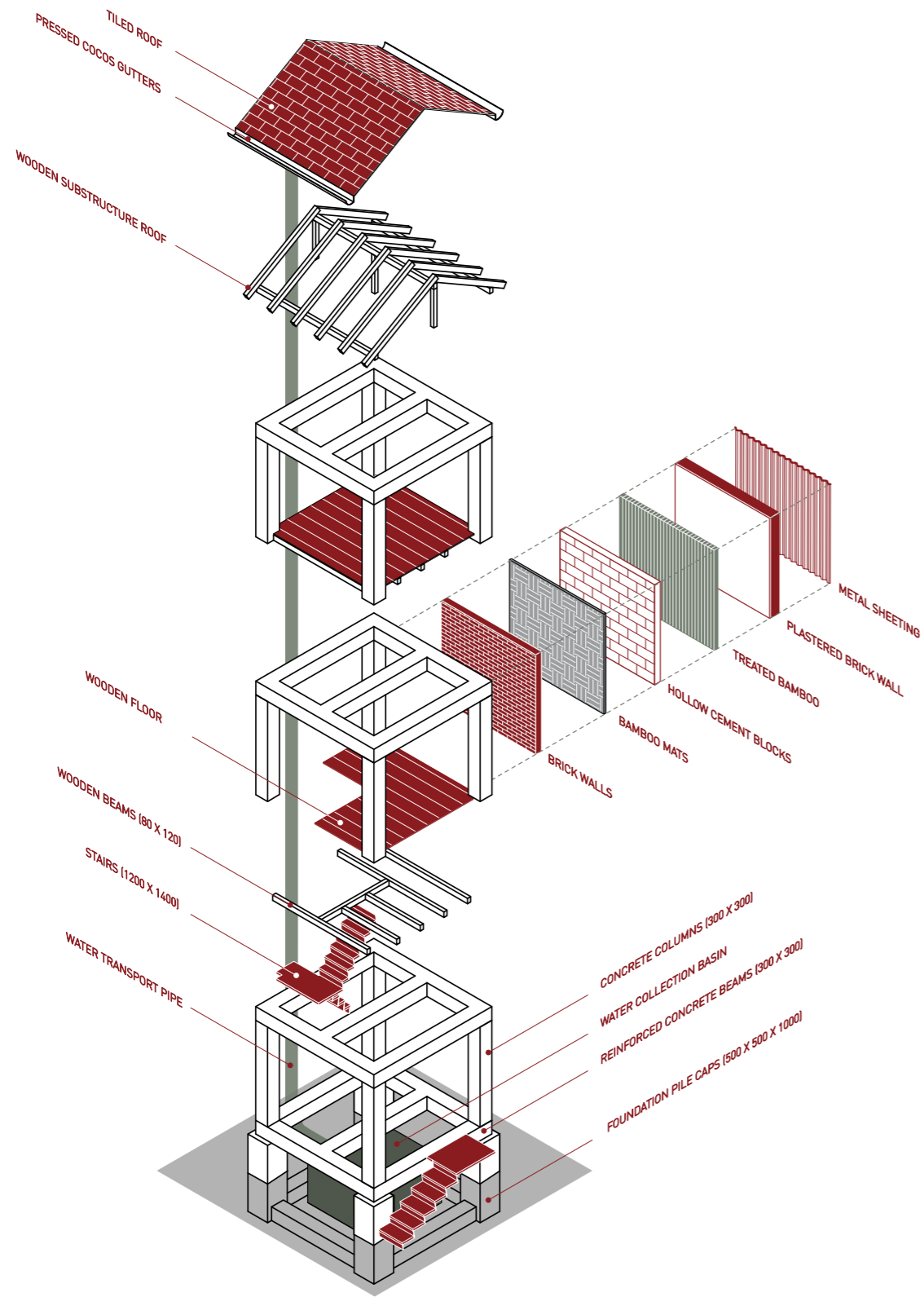

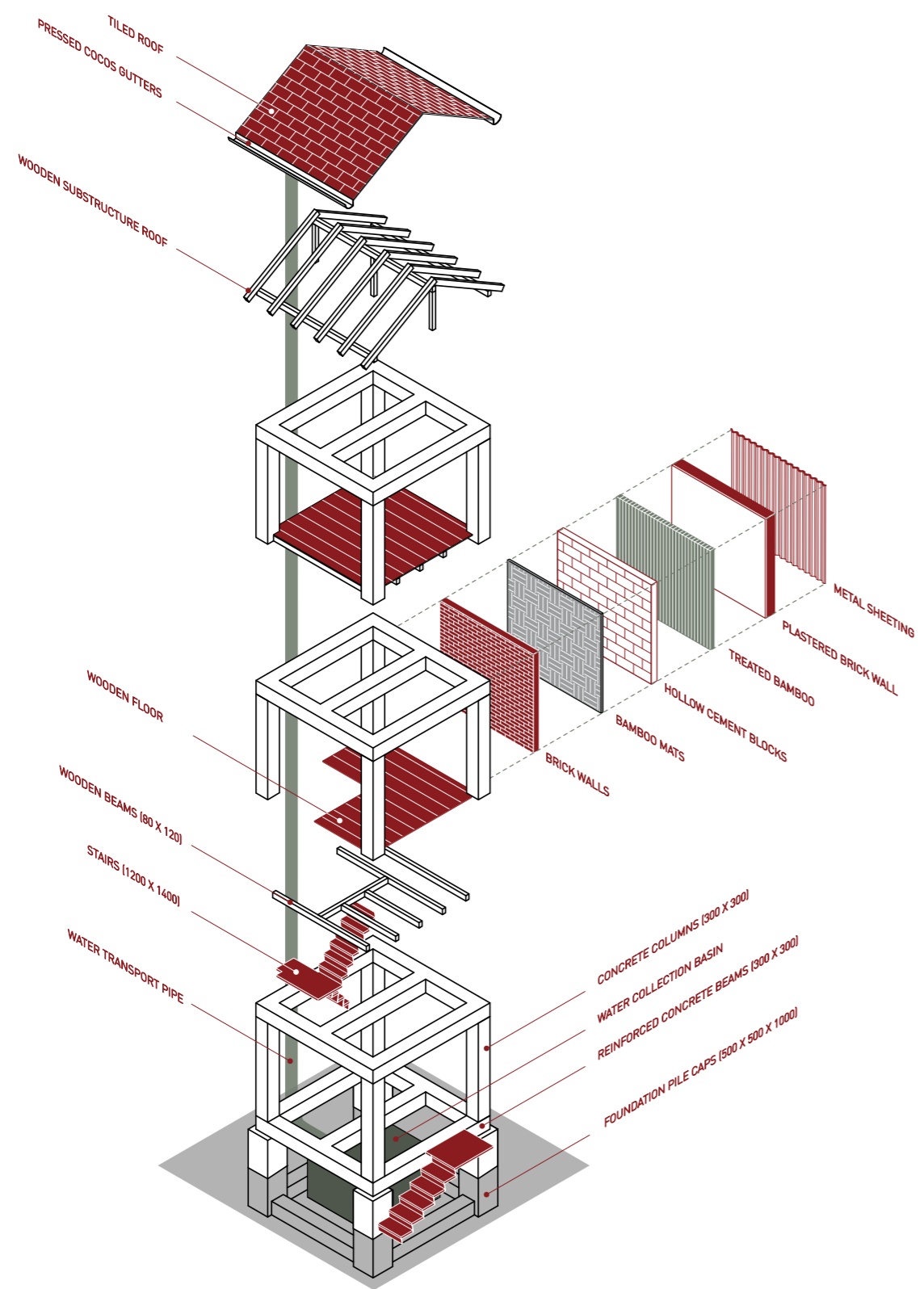

CREATE YOUR OWN HOUSE

BASE CONCRETE FRAME				<p>FORMWORK SYSTEM</p> <p>BAMBOO REINFORCEMENT</p> <p>RENT CNC BEAM: 400.000 IDR (€ 28,-)</p> <p>RENT CNC COLUMN: 300.000 IDR (€ 21,-)</p> <p>RENT SCAFFOLDING 15.000 IDR (€ 1,-) PER MONTH/PIECE</p> <p>REINFORCEMENT BUY PER M³: 30.000 IDR (€ 1,75)</p>				
	GIVE IN PLOT SIZE	CALCULATE CONSTRUCTION						
	DESIGN ROOFS				<p>BUY PER ROOF AND CHOOSE IF YOU WANT TO REUSE FOR EACH PHASE (ONLY THE WOOD + LIGHT STEEL)</p> <p>LIGHT STEEL IDR 150.000 (€10,5)/M²</p> <p>WOODEN ROOF SYSTEM IDR 225.000 (€15,75)/M²</p> <p>DO IT YOURSELF IDR ? (€ ?)/M²</p>			
	FIND FLOORS					<p>USE THE HUB FOR DETAILING CONNECTIONS. ALSO FOR STEEL U-SHOES FOR THE WOODEN FLOORS</p> <p>CHICKEN WIRE IDR 27.000 (€2)/M²</p> <p>STEEL SHEETS (2.10x0.80) IDR 55.000 (€3,85)/SHEET</p> <p>WOODEN FLOOR, KAMPER BANJAH WOOD IDR 6.500.000 (€ 455)/M³</p> <p>DO IT YOURSELF IDR ? (€ ?)/M²</p>		
	PICK STAIRS				<p>FORMWORK CONCRETE FOR RENT, WOODEN STAIRS FOR SALE IN THE HUB.</p> <p>CONCRETE FORMWORK IDR 250.000 (€17,5)/M²</p> <p>WOODEN STAIRS IDR 350.000 (€24,5)/M²</p> <p>DO IT YOURSELF IDR ? (€ ?)/M²</p>			
CHOOSE FACADES							<p>USE THE HUB FOR DETAILING. POSSIBLY FORMWORK FOR CREATIVE BRICKS</p> <p>BRICK</p> <p>BAMBOO MATS</p> <p>HOLLOW CEMENT BLOCKS</p> <p>TREATED BAMBOO</p> <p>PLASTERED BRICK</p> <p>METAL SHEETING</p>	
DOORS & WINDOWS								<p>USE THE HUB FOR CNC MILLING OF DOORS/WINDOWS OR CONNECT WITH SECOND HAND STORES</p> <p>WINDOWS & DOORS</p>

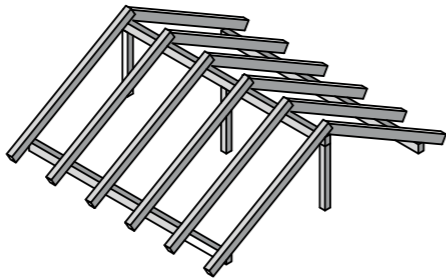
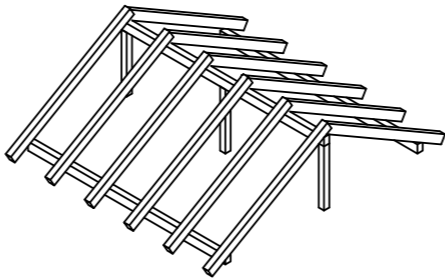
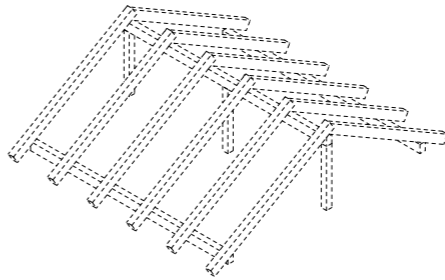
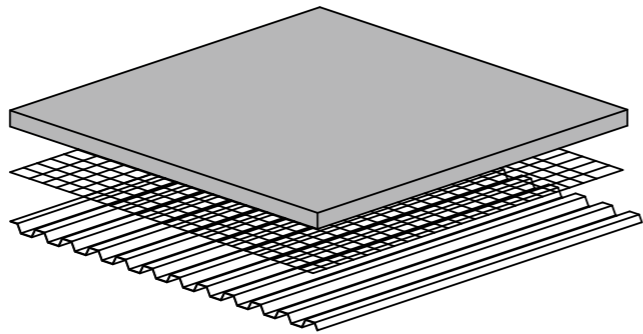
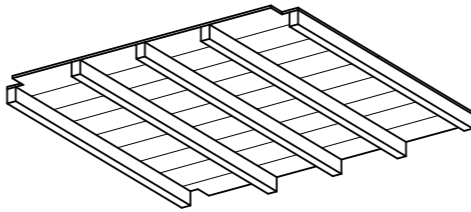
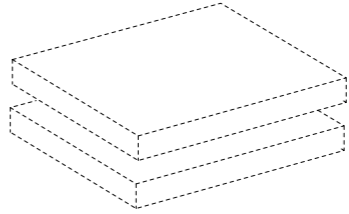
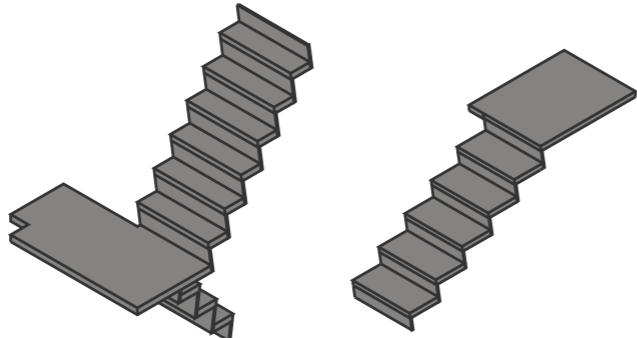
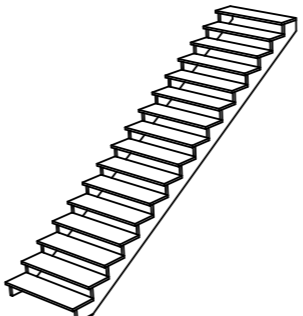
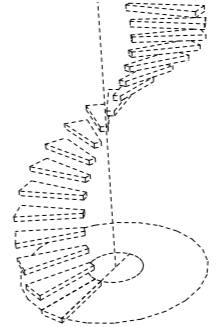
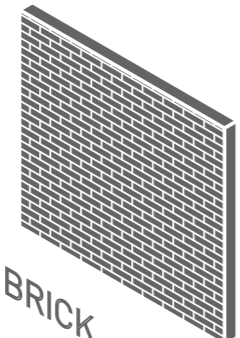
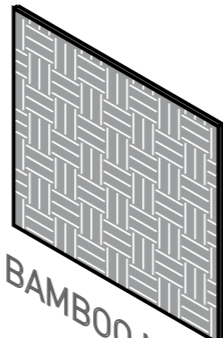
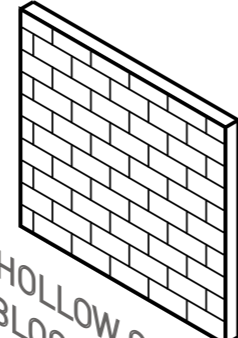
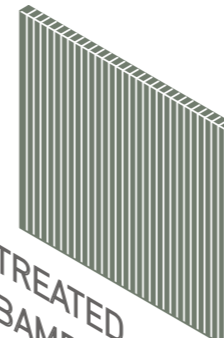
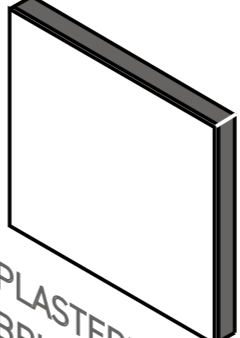
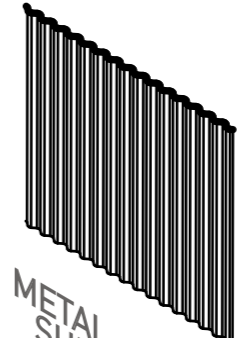
<p>DESIGN ROOFS</p>	 <p>LIGHT STEEL IDR 150.000 (€10,5)/M²</p>	 <p>WOODEN ROOF SYSTEM IDR 225.000 (€15,75)/M²</p>	 <p>DO IT YOURSELF IDR ? (€ ?)/M²</p>	<p>BUY PER ROOF AND CHOOSE IF YOU WANT TO REUSE FOR EACH PHASE (ONLY THE WOOD + LIGHT STEEL)</p>
<p>FIND FLOORS</p>	 <p>CHICKEN WIRE IDR 27.000 (€2)/M²</p> <p>STEEL SHEETS (2.10x0.80) IDR 55.000 (€3,85)/SHEET</p>	 <p>WOODEN FLOOR, KAMPER BANJAH WOOD IDR 6.500.000 (€ 455)/M³</p>	 <p>DO IT YOURSELF IDR ? (€ ?)/M²</p>	<p>USE THE HUB FOR DETAILING CONNECTIONS, ALSO FOR STEEL U-SHOES FOR THE WOODEN FLOORS</p>
<p>PICK STAIRS</p>	 <p>CONCRETE FORMWORK IDR 250.000 (€17,5)/M²</p>	 <p>WOODEN STAIRS IDR 350.000 (€24,5)/M²</p>	 <p>DO IT YOURSELF IDR ? (€ ?)/M²</p>	<p>FORMWORK CONCRETE FOR RENT, WOODEN STAIRS FOR SALE IN THE HUB.</p>
<p>CHOOSE FACADES</p>	 <p>BRICK</p>  <p>BAMBOO MATS</p>  <p>HOLLOW CEMENT BLOCKS</p>  <p>TREATED BAMBOO</p>  <p>PLASTERED BRICK</p>  <p>METAL SHEETING</p>	<p>USE THE HUB FOR DETAILING, POSSIBLY FORMWORK FOR CREATIVE BRICKS</p>		

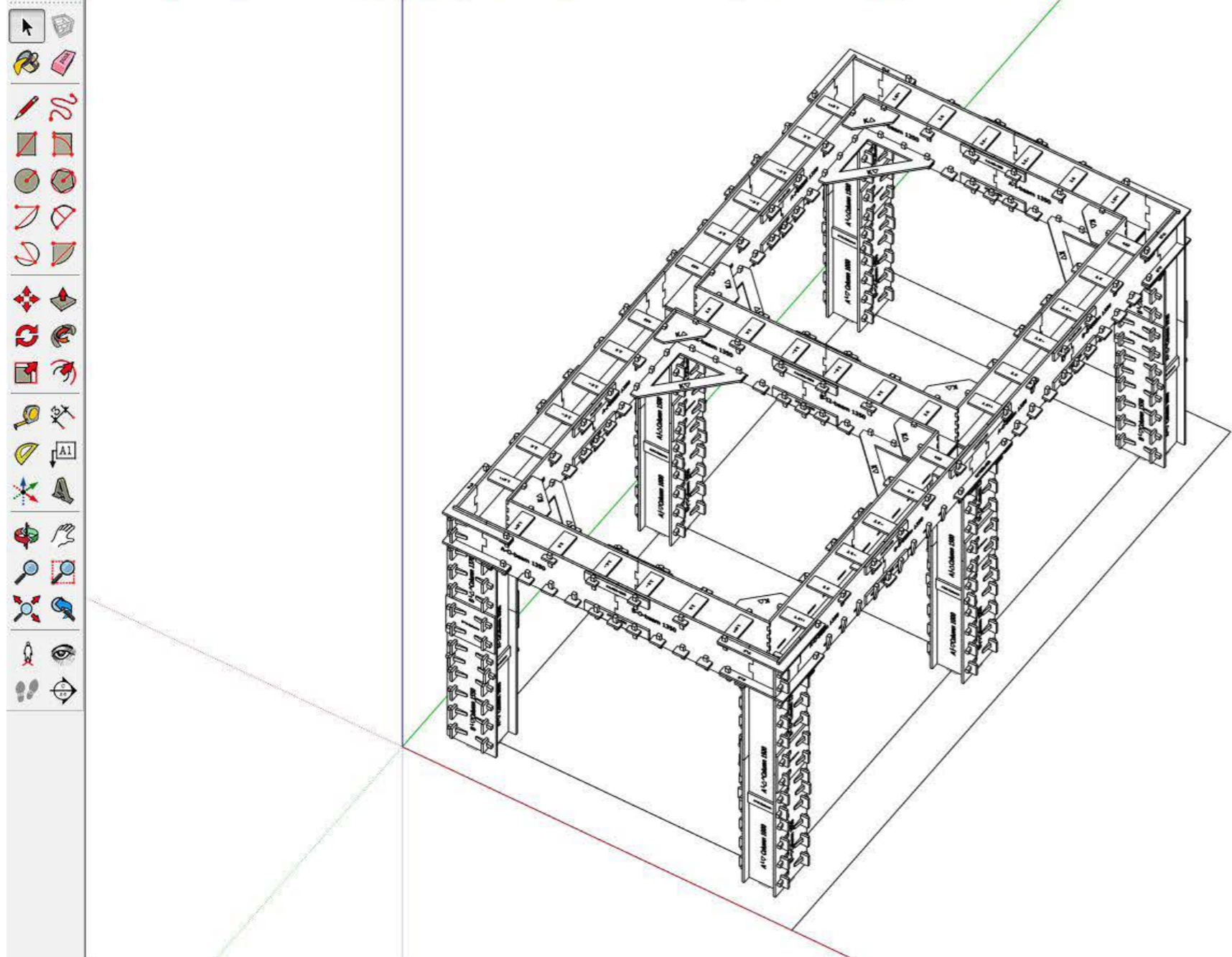

WikiHouse - Download

Blog Press Contact @WikiHouse What is it? Login



WikiHouse ©

- Open library
- Design
- Community
- News
- Support Us

Series

HOUSES	JOINTS	A	B	C	A C	B B	B C
C C	C A C	C B C	OTHER				

Designs - B-Series

[Single sections of WikiHouse - 2.4 metres wide]
[More...](#)



BASIC STUDIO SECTION

Model No. 23002

By:
alastair@research00.net

Verification: structurally checked.

DE TOEKOMST

UN-Habitat (2003) schat dat 23 % van de wereldbevolking in informele gemeenschappen woont; Kampung, Favelas, Pueblos jóvenes of Gekecondo.

Ontwikkelingen ontwikkeld voor Indonesië kunnen relevant zijn voor informele wijken in:

Latijns America	39%
Sub-Sahara Africa	78 %
Zuid-Oost Azië	28%

Volgens voorspellingen zullen in 2020 1.5 miljard mensen in informele wijken wonen.

DE TOEKOMST

UN-Habitat (2003) schat dat **23 % van de wereldbevolking in informele gemeenschappen woont**; Kampung, Favelas, Pueblos jóvenes of Gekecondo.

Ontwikkelingen ontwikkeld voor Indonesië kunnen relevant zijn voor informele wijken in:

Latijns America	39%
Sub-Sahara Africa	78 %
Zuid-Oost Azië	28%

Volgens voorspellingen zullen in 2020 **1.5 miljard** mensen in informele wijken wonen.

VRAGEN?

