

Traffic Safety around Major Forks

A driving simulator study that compares different configurations with the use of surrogate safety measures

Jeroen Hoogvliet

Delft University of Technology



Traffic Safety around Major Forks

A driving simulator study that compares different configurations with
the use of surrogate safety measures

By

J.E. (Jeroen) Hoogvliet

In partial fulfilment of the requirements for the degree of

Master of Science
in Civil Engineering

at the Delft University of Technology,
to be defended publicly on Thursday June 14, 2018 at 12:00.

Graduation committee:

prof. dr. M.P. (Marjan) Hagenzieker (*Chair*)
dr. ir. H. (Haneen) Farah
ir. J. (Jan-Auwke) Verspuij
ir. O. (Olaf) Stroosma
drs. ir. J. (Johan) Vos

TU Delft (CEG-T&P)
TU Delft (CEG-T&P)
Witteveen+Bos
TU Delft (AE-C&O)
Rijkswaterstaat

An electronic version of this thesis is available at <http://repository.tudelft.nl/>.

When reading this report electronically in Acrobat Reader, go to:

View → Page Display → and then select:

Two Page View (or Two Page Scrolling)

Show Cover Page in Two Page View

This is particularly helpful when reading chapter 5 of this report.

PREFACE

This thesis is the graduation work to conclude my Civil Engineering Master at the Delft University of Technology. Although a master thesis is essentially the end product to showcase the knowledge and skills that have been acquired in the course of a study, for me it also represents a completed and successful search for an expertise that has my interest and is in line with my competences. Before starting at the Delft University of Technology, I began my study career at the Hogeschool Rotterdam, where I basically started studying civil engineering in the lack of a study that fitted my interests better. I even almost did a study switch to become a physical therapist after two years in. It was only in my last study year, when I followed the 'Infrastructure and Mobility' minor, that I found something that interested me so much that it raised a natural curiosity and eagerness to learn more. After graduating from the Hogeschool Rotterdam (and after "surviving" the pre-master year) the 'Transport and Planning' master of the Delft University of Technology gave me the possibility to further explore various traffic engineering subjects comprehensively and on a (scientific) level that fitted my competences better. During the master, there were multiple traffic engineering aspects that had my interest but geometrical design of roadways, traffic safety and traffic simulation always were predominant. These three aspects therefore also predominantly shape this thesis, which was carried out at engineering company Witteveen+Bos. I am grateful to Witteveen+Bos for this opportunity, giving me the confirmation that I have completed my journey, and the ability to start a new journey as professional project engineer after my graduation.

This master thesis would not have been completed without the help of all wonderful participants of my driving simulator experiment. Thank you, family members, friends and fellow students, for your time, curiosity and enthusiasm. I find it special that I was not only able to give my loved ones an insight look in my research, but also to make them part of it. Something that would not have been possible without conducting an experiment.

I would like to thank my graduation committee members for all of their guidance during the composing and writing of this thesis. The discussions, your ideas, and your feedback have been invaluable. I feel really fortunate to had such an expert committee on road design, traffic safety and simulation, that at the same time was diverse in the sense of academic background and profession. The whole committee continuously showed enthusiasm for the research objective and method, which motivated me from start to end.

I would also like to thank all (future) colleagues of Witteveen+Bos for their help, input, expertise, pleasant working atmosphere, motivating words, and frequent off-topic talks and discussions that gave a welcome diversion. Since the research included aspects that were new to me, as well as aspects that were quite innovative, I would like to thank numerous colleagues that have helped me in the process. Marco Hovenga for teaching me to work with 3D road design software MXROAD, Martin Dikken for teaching me to work with rendering software 3dsMax, and Maarten 't Hart for all the software-technical support concerning the driving simulator.

Last but not least, I would like to thank my parents and sister for their unconditional support and patience during my entire study career, and my girlfriend for her support at all times and recording all verbal instructions that have been used in the navigation system of the driving simulator.

*Jeroen Eduard Hoogvliet
Maassluis, June 2018*

Background

According to the *Richtlijn Ontwerp Autosnelwegen* (ROA) [1], a major fork is: “a divergence point where the roadway splits into two roadways with a similar design speed; where both roadways include at least one lane of the shared roadway upstream”. While the ROA provides guidelines, eventual major fork design is never set in stone as the ROA gives several configurational options that have the same traffic capacity but differ in the location of the block marking. As example, a 4-2/2 major fork configuration could be modified with a lane addition on the right-side of the mainline roadway and a lane drop on the left-side of the left-diverging roadway, and a 3-1/2 major fork configuration could be flipped horizontally and be given a grade-separated junction downstream of the divergence point. The main difference is that each of the two modifications causes that rightmost traffic going to the left-diverging roadway has one mandatory lane change less than on a standard major fork configuration, and therefore have a lower level of turbulence (that is specified as: “frequency and intensity of individual changes in speed, headways, and lane changes in a certain road segment, over a certain period of time”) [2]. Since a higher level of turbulence relates to lower level of traffic safety, it is expected that drivers on a standard major fork configuration will experience more adverse traffic safety issues than drivers on a modified major fork configuration. In addition, it is expected that a 25% freight traffic condition will magnify this traffic safety difference in comparison with a 0% freight traffic condition due to a greater speed dispersion.

An additional point of attention is the expectancy of drivers on the continuing road design of the left-diverging roadway of major forks. According to its theoretical model, driver expectancy is formed by the road environment and driving experience [3]. From driving experience drivers (subconsciously) know that a single-lane road section of a freeway is always a connector road since single-lane mainline roadways do not exist in the Netherlands. Consequently, a single-lane left-diverging roadway that is also a connector road is automatically and correctly categorized as connector road, while a two-lane left-diverging roadway that is also a connector road is automatically but incorrectly categorized as continuing mainline roadway. This difference in driver expectancy is expected to result in a difference in driving behavior, in which drivers on a two-lane left-diverging roadway are expected to less adapt their driving behavior for a small-radius connector road property (e.g. a small radius) than drivers on a single-lane left-diverging roadway.

Main research questions

In line with the aforementioned expectations, the following two main research questions are formulated:

1. “How does the number of mandatory lane changes by right-most traffic going to the left-diverging roadway of a major fork affect the traffic safety?”
2. “How does the number of traffic lanes on the left-diverging roadway of a major fork, continuing in the same direction as the mainline roadway, affect the traffic safety as it is actually a small-radius connector road?”

The scope of main research question 1 is limited to the major fork configurations discussed in the background: the 4-2/2 major fork configuration in comparison with the 4-3/2-2/2 major fork configuration, and the 3-1/2 major fork configuration in comparison with the 3-2/1 major fork configuration.

Methodology

To answer these questions, two methods that both measure the objective traffic safety were used:

- A **driving simulator experiment** was performed in order to collect vehicle trajectory data around the major forks and small-radius connector roads. 40 participants (aged between 20 and 31) took part, from which everyone drove every design under a freight traffic condition of 0% and 25%. The simulated traffic in the driving simulator environment was modelled using microscopic simulation program VISSIM, which at the same time collected the vehicle trajectories of the simulated traffic and of the participant every tenth of a second. The fixed-base driving simulator of the Delft University of Technology was used to conduct this experiment.
- An **accident data analysis** was performed in order to measure the crash risk of existing road sections. Dutch registered accidents (from BRON data) were filtered by using GIS software in order to only include the road sections that correspond to the designs that are included in the scope.

Results

Focusing on the major fork configurations:

- The driving simulator experiment tend to show less adverse traffic safety issues for the standard major fork configurations than the configurations that include one mandatory lane change less for rightmost traffic going to the left-diverging roadway. However, since the analysis methodology was unable to consider statistical significance, pre-allocating behavior diminished the actual configurational differences between the configurations, the variance in traffic situations between participants caused statistical difficulties, the simulated traffic missed tactical driving behavior around a major fork, and the locations of mandatory lane changes mismatched between participants and simulated traffic, these findings should be queried.
- The accident data analysis showed that the crash risk of the 4-2/2 configurations is 20% higher than that of the 4-3/2 configuration (that replaced the 4-3/2-2/2 configuration in the analysis) and that the crash risk of the 3-1/2 configuration is 100% higher than that of the 3-2/1 configuration. However, the number of included road sections was scarce, the 4-3/2 configurations were found to not honestly reflect 4-3/2-2/2 configurations, and the unequal distribution of block marking lengths between the competitive 3-lane major fork configurations queries these results.

Focusing on the small-radius connector roads:

- The driving simulator experiment showed that participants on the two-lane variant had a higher driving speed and a lower acceleration rate before the start of (and while entering) the small-radius curve, as well as in the small-radius curve itself. Even though the experiment showed that driving experience in the simulator also affects driver expectancy and thus driving behavior, the same results were found independent of the number of small-radius connector road variants that participants already encountered.
- The accident data analysis showed that the average crash risk of the two-lane variants is 50% higher than that of the single-lane variants. Furthermore, the crash risk of both variants follow a bell-curved distribution around the small-radius curve, with both their peak around 200 meters into the small-radius curve. While this analysis did not consider if an included variant was left- or right-curving, an additional analysis showed that the average crash risk of the left-curving two-lane variants is 80% higher than that of the left-curving single-lane variants.

Concluding, no conclusive results are found concerning the different major fork configurations. The corresponding hypotheses can therefore neither be accepted nor rejected. Concerning the small-radius connector roads, both the results of the driving simulator experiment and the accident data analysis suggest that a two-lane variant is less safe than a single-lane variant, which is in line with the hypothesis.

Recommendations

From a scientific standpoint, it is recommended to perform an additional analysis on the collected driving simulator data by means of a Linear Mixed Model (LMM), which has as advantage (over the visual analysis that is performed in this research) that it is able to statistically analyze the effect of every considered factor on every considered output variable simultaneously. Secondly, since the scope of this research was too narrow to affect day-to-day decision-making, it is recommended to do another study that also focuses on the traffic safety of traffic that is going to the right-diverging roadway of the major fork configurations, and another (driving simulator) research that focusses on the traffic safety of right-diverging roadways (of a major fork) that are also (left-curving) small-radius connector roads. Thirdly, it is recommended to do another accident data analysis after a couple of years when there is more accident data available of (the recently new) 4-3/2-2/2 major fork configurations, and to include major fork road section properties and additional crash data.

From a practical standpoint, it is recommended to be hesitant with implementing a 4-3/2-2/2 major fork configuration when there is a high share of freight traffic that splits itself over the left- and right-diverging roadway. The freight traffic distributes itself over the two rightmost lanes, where it creates a blockage for all (faster-driving) traffic going to the right-diverging roadway. Secondly, it is recommended to be hesitant with implementing a major fork of which right-diverging roadway is the through-going mainline roadway and the left-diverging roadway is a two-lane small-radius connector road. As this research confirms the existence and verifies the structure of the driver expectancy model, it is recommended to also consider a design in which the continuing road design of both diverging roadways are switched. Thirdly, it is recommended to be hesitant with using a driving simulator to assess traffic safety when there are too complex interactions between participants and simulated traffic involved. The driving behavior of the participants is greatly dependent on the driving behavior of the simulated traffic, and the truthfulness of the simulated traffic's driving behavior is at least questionable.

TABLE OF CONTENTS

Summary	vii
List of Figures	xiii
List of Tables	xiii
1 Introduction	1
1.1 Background	1
1.2 Problem definition and main research questions	3
1.3 Main research methodology and scope	4
1.4 Report outline	5
2 Literature review	7
2.1 Turbulence.....	7
2.1.1 Turbulence around major forks.....	8
2.1.2 Conditions and impacts of turbulence.....	9
2.2 Driver expectancy	12
2.3 Surrogate safety measures	13
2.3.1 The traffic conflict technique.....	13
2.3.2 Measuring conflict severity.....	14
2.4 Driving simulator	18
2.4.1 Advantages	18
2.4.2 Disadvantages.....	19
3 Research questions	21
4 Methodology	25
4.1 Driving simulator experiment	25
4.1.1 Road design	25
4.1.2 Traffic design.....	28
4.1.3 Simulator design.....	29
4.1.4 Experiment design	30
4.1.5 Analysis methodology	32
4.2 Accident data analysis.....	34
4.2.1 Analysis design.....	34
4.2.2 Analysis methodology	35
5 Results of the driving simulator experiment	37
5.1 4-lane major fork configurations.....	37
5.1.1 0% freight traffic.....	37
5.1.2 25% freight traffic.....	42
5.2 3-lane major fork configurations.....	46
5.2.1 0% freight traffic.....	46
5.2.2 25% freight traffic.....	50
5.3 Small-radius connector road variants.....	54
5.3.1 Only 1 st encounters	54
5.3.2 Only 2 nd , 3 rd and 4 th encounters.....	58
6 Results of the accident data analysis	63
6.1 4-lane major fork configurations.....	63
6.2 3-lane major fork configurations.....	64
6.3 Small-radius connector road variants.....	64
7 Main findings and discussion	67
7.1 Major fork configurations	67
7.1.1 Main findings	67
7.1.2 Discussion.....	68
7.2 Small-radius connector road variants.....	72
7.2.1 Main findings	72
7.2.2 Discussion.....	72

8 Conclusions	75
8.1 Conclusion.....	75
8.1.1 Major fork configurations.....	75
8.1.2 Small-radius connector road variants	77
8.2 Limitations	78
8.3 Recommendations	80
8.3.1 Scientific recommendations	80
8.3.2 Practical recommendations.....	81
8.3.3 Technical recommendations	82
Bibliography	85
Appendices	89

LIST OF FIGURES

Figure 1.1: Comparison between a major fork configuration (top) and an exit-ramp configuration (bottom).....	1
Figure 1.2: A standard unbalanced major fork configuration, as it is advised by the ROA.....	2
Figure 1.3: Comparison between a standard 4-2/2 major fork configuration (top) and a competitive configuration (bottom).....	2
Figure 1.4: Comparison between a standard 3-1/2 major fork configuration (top) and a competitive configuration (bottom).....	2
Figure 1.5: A multilane left-diverging roadway vs. a single-lane left-diverging roadway.....	3
Figure 1.6: The main research methodology.....	4
Figure 1.7: The four researched major forks configurations.....	5
Figure 1.8: The two researched left-diverging roadways that simultaneously are small-radius connector roads.....	5
Figure 2.1: The general concept of turbulence, according to Beinum et al. [2].....	7
Figure 2.2: The tailored theoretical structure of turbulence.....	8
Figure 2.3: The driving maneuvers that occur before, at, and after a major fork.....	9
Figure 2.4: Relationship between annual average daily traffic (AADT) and the number of accidents [7].....	10
Figure 2.5: a power function and an exponential function fitted to data for property-damage-only accidents [21].....	10
Figure 2.6: Relationship between different age groups and their relative accident rates [7].....	11
Figure 2.7: Theoretical model of how the road environment affect traffic safety through driver expectancy [3].....	12
Figure 2.8: the two-lane left-diverging roadway as small-radius connector road (a) and the single-lane variant (b).....	13
Figure 2.9: The conflicts and accidents hierarchy by Amundsen and Hydén [39], Glauz and Migletz [40], and Hydén [41].....	14
Figure 2.10: Schematic illustration of (a) a straight-angle collision course and (b) a parallel collision course [47].....	14
Figure 2.11: Types of potential collisions for a non-perpendicular collision course [45].....	15
Figure 2.12: Relationship between TTC, TET and TIT, in which TTC* represents the TTC threshold value [46].....	15
Figure 2.13: An illustration of PET, which is the time difference between t_1 and t_2 [45].....	17
Figure 2.14: A traffic situation (top figure) and two example PET calculations for merging vehicle O.....	17
Figure 3.1: The two sets of researched major fork configurations.....	21
Figure 3.2: The set of researched left-diverging roadways (simultaneously being small-radius connector roads).....	22
Figure 4.1: The four major fork configurations that should be included in the road design.....	25
Figure 4.2: The test track design (a) and the experimental track design (b).....	26
Figure 4.3: An example of the signage as it is implemented in the road design of the driving simulator.....	27
Figure 6.1: The crash risk for the 4-lane major fork configurations.....	63
Figure 6.2: The crash risk for the 3-lane major fork configurations.....	64
Figure 6.3: The crash risk for the small-radius connector road variants.....	65
Figure 7.1: Theoretical model of how the road environment affect traffic safety through driver expectancy [3].....	73
Figure 8.1: The two sets of major fork designs that are researched in this study.....	75
Figure 8.2: The set of (small-radius) connector roads that is researched in this study.....	77

LIST OF TABLES

Table 4.1: The eight combinations of major fork configuration and percentage of heavy vehicles.....	28
Table 4.2: The four orders of scenarios that participants will encounter.....	32
Table 4.3: Different discontinuities with their turbulence lengths and their measuring point [1].....	35
Table 7.1: Different measures that indicate unsafe driving behavior in comparison between configurations.....	68
Table 7.2: The most-efficient lane distribution at the beginning of the block marking of both configurations.....	71

1

INTRODUCTION

1.1 BACKGROUND

The *Richtlijn Ontwerp Autosnelwegen* (ROA) [1] provides guidelines on the Dutch road design and is used in the (re)designing process of freeways. The main principle of the ROA is to provide a certain basic level of service quality for freeways, which focusses on guaranteeing traffic flow and traffic safety. These two aspects are translated into preferred basic road dimensioning criteria for different freeway design elements, which can be seen as the foundation of the ROA. Although these guidelines should be treated as strict rules, eventual freeway design is never set in stone. Firstly, because deviation from the ROA is not prohibited when it is done with care and a solid underpinning. Secondly, and most importantly, because every situation is unique and the ROA simply cannot cover everything exclusively as a consequence. This results in a degree of freedom in the (re)designing process, which must be filled with research and creativity from traffic engineers.

One of the freeway design elements that is included in the ROA [1] is a major fork. According to the ROA, a major fork is: “a divergence point where the roadway splits into two roadways with a similar design speed; where both roadways include at least one lane of the shared roadway upstream”. The definition implies a certain equality between the diverging roadways of a major fork. A major fork should therefore not be confused with an exit-ramp (see the comparison in Figure 1.1). From a capacity viewpoint, major forks can be either balanced or unbalanced. In a balanced situation, a major fork has an equal number of traffic lanes upstream and downstream of the divergence point. While in an unbalanced situation, a major fork has more lanes downstream than upstream of the divergence point.

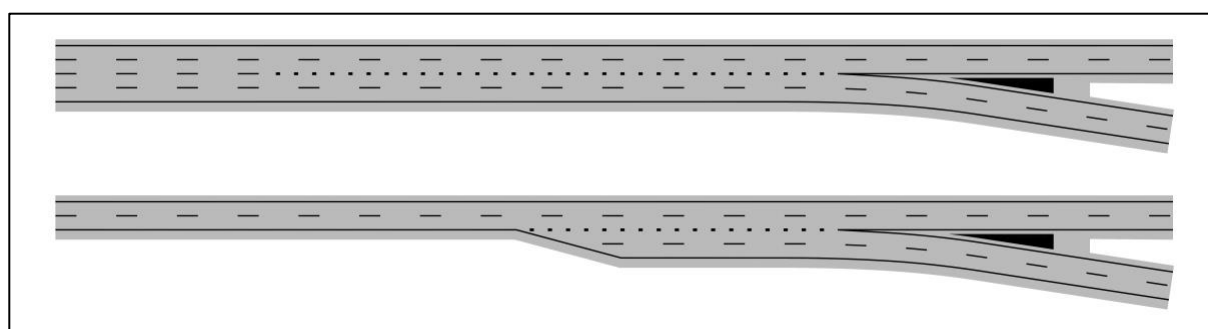

Figure 1.1: Comparison between a major fork configuration (top) and an exit-ramp configuration (bottom)

A great point of attention is the number of mandatory lane changes around major forks by traffic keeping their route. Traffic approaching a major fork and coming from the rightmost lane of the upstream mainline roadway, needs to shift one or more lanes to get to the left-diverging roadway. Next to individual changes in lanes, these maneuvers are accompanied by individual changes in speed and headway (also known as a raised level of turbulence). The ROA [1] especially expresses its concerns on the amount of freight traffic and its share going to the left-diverging roadway. Since freight traffic generally drives with a lower speed on the rightmost lane, speed differences are greater and lead to an increased level of turbulence; thereby decreasing the traffic safety. It also advises to always limit the number of mandatory lane changes by rightmost traffic going to the left-diverging roadway to maximally two.

Nonetheless, the ROA [1] only takes the negative effects of mandatory lane changes into account at unbalanced major forks, and not at balanced major forks. According to the ROA, a balanced major fork

should have a standard configuration in which the block marking splits up the mainline roadway according to the lane-ratio downstream. Assuming that the right-diverging roadway of such a balanced major fork needs two traffic lanes from a capacity viewpoint, rightmost traffic going to the left-diverging roadway needs two mandatory lane changes (as already illustrated in Figure 1.1). While for unbalanced major forks, the ROA discusses the possibility of adding a lane on the left- or right-side of the mainline roadway, in which they state a clear preference for a lane addition to the right-side in order to limit the number of mandatory lane changes. Again, assuming that the right-diverging roadway needs two traffic lanes from a capacity viewpoint, rightmost traffic going to the left-diverging roadway only needs one mandatory lane change (as illustrated in Figure 1.2).

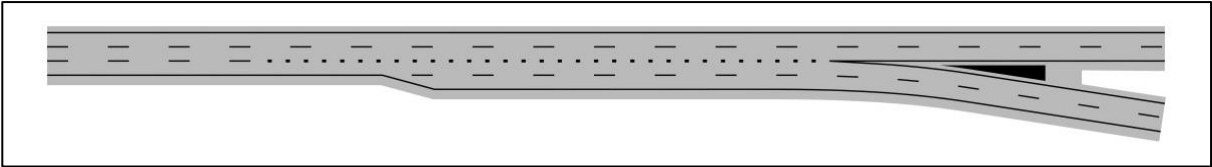

Figure 1.2: A standard unbalanced major fork configuration, as it is advised by the ROA

Although not described in the ROA [1], this trick for unbalanced major forks to cut down the number of mandatory lane changes can also be applied to balanced major forks without affecting the capacity. This is achieved by adding a lane to the right-side of the mainline roadway to limit the number of mandatory lane changes, and by implementing a lane drop on the left-side of the left-diverging roadway to end the major fork with the same amount of total traffic lanes as it started with (as illustrated in Figure 1.3). Theoretically, this kind of configuration works for three-, four- and five-lane balanced major forks, but in practice only appears at four- and five-lane balanced major forks in the Netherlands.

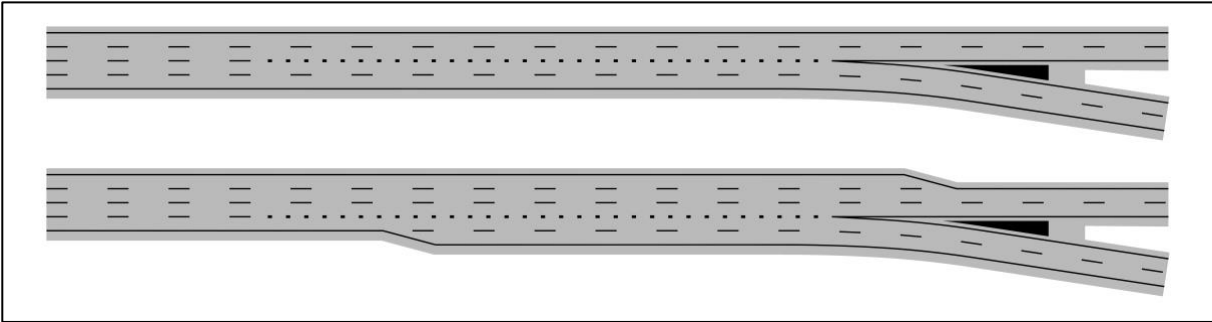

Figure 1.3: Comparison between a standard 4-2/2 major fork configuration (top) and a competitive configuration (bottom)

A completely other approach to limit the number of mandatory lane changes of balanced major forks is to horizontally flip the configuration and add a grade-separated junction to end the major fork with the correct number of traffic lanes on both the left- and right-diverging roadway. (as illustrated in Figure 1.4 but without the additional grade-separated junction). Since this approach only works for balanced major forks with an uneven number of traffic lanes on the mainline roadway, and the ROA advises to always limit the number of mandatory lane changes by rightmost traffic going to the left-diverging roadway to maximally two, this approach can only be applied to balanced major fork designs that have a three-lane mainline roadway.

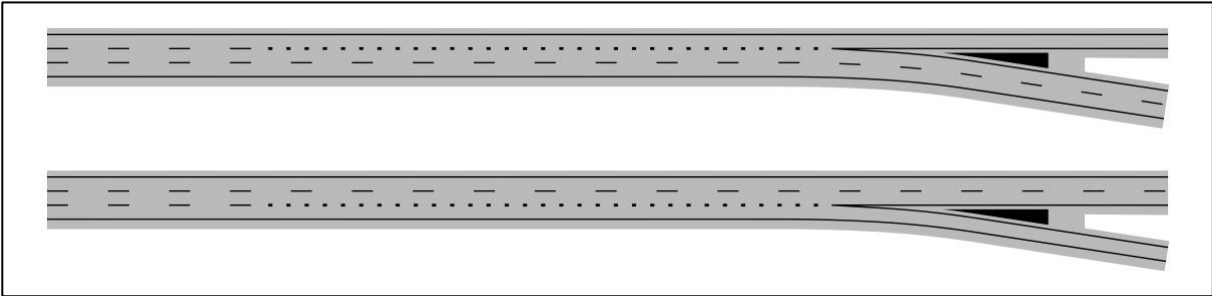

Figure 1.4: Comparison between a standard 3-1/2 major fork configuration (top) and a competitive configuration (bottom)

Putting the actual major fork configuration and its accompanied number of mandatory lane changes for rightmost traffic (and thus turbulence) aside, a second traffic safety issue of major forks could be the amount of traffic lanes on the left-diverging roadway and the potentially faulty expectations that it raises on the continuing road design. To give some background information, Dutch single-lane freeways are always connector roads since normal through-going freeways always minimally include two traffic lanes. This means that a single-lane left-diverging roadway is automatically correctly categorized as connector road by a driver, while a multilane left-diverging roadway is potentially faulty categorized as a continuing mainline roadway. If this multilane left-diverging roadway is actually quickly followed by a road feature that is against drivers' expectations (such as a small-radius connector road in a freeway junction), it could surprise the driver and negatively affect its driving behavior. Figure 1.5 illustrates both situations.

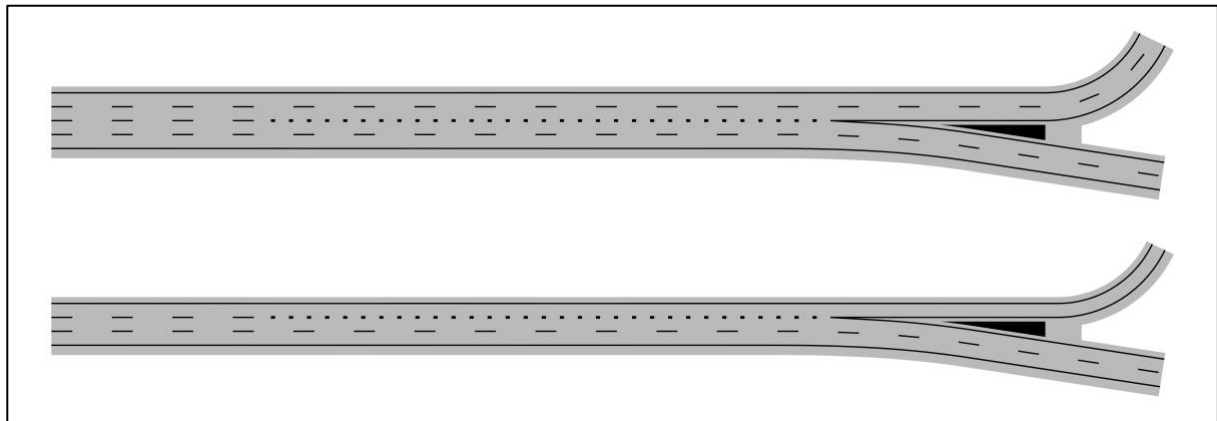

Figure 1.5: A multilane left-diverging roadway vs. a single-lane left-diverging roadway

1.2 PROBLEM DEFINITION AND MAIN RESEARCH QUESTIONS

As already explained in the previous section, a road designer pursues a road design that guarantees traffic flow and traffic safety. In this pursuit, the road designer uses the ROA [1] as a guiding tool but additionally has a lot of freedom left that needs to be filled in with traffic research and creativity. When designing major forks, the ROA states that the number of mandatory lane changes for rightmost traffic going to the left-diverging roadway should be limited to maximally two and in addition it hints that certain traffic conditions (such as the share of freight traffic) should affect a designer's decision on the type of major fork configuration to choose, but underpinning is limited. As a result, most balanced major forks can be configured in two or even three ways that differ in the number of mandatory lane changes for rightmost traffic going to the left-diverging roadway. The first way is the standard design in which the block marking splits up the mainline roadway according to the lane-ratio downstream, the second way is to implement a lane-addition to the right-side of the mainline roadway and a lane drop on the left-diverging roadway, and the third way is to horizontally flip the design and add a grade-separated junction downstream of the divergence point. Whatever configuration a road designer chooses, the traffic capacity is approximately the same; but the real question is whether the traffic safety is also. And furthermore, if it really is the case that the share of freight traffic should affect a designer's decision for a certain configuration, the question is whether there are observable differences in traffic safety between a traffic flow consisting of only passenger cars and a traffic flow with a high share of freight traffic.

Another, somewhat stand-alone, traffic safety question of major forks is the amount of traffic lanes on the left-diverging roadway and the potentially faulty expectations that it raises on the continuing road design. At a major fork, the left-diverging roadway is usually the continuing mainline roadway that does not diverge under an angle, while the right-diverging roadway is usually a connector road that does diverge under a certain angle. However, the exact opposite is appearing more often in the (re)designing processes of Dutch freeways due to location and budget constraints. This means that the left-diverging roadway still does not diverge under an angle but is actually a connector road while the right-diverging roadway still diverges under a certain angle but is actually the continuing mainline roadway. This shift in function could therefore potentially raise faulty expectations on the continuing road design of a multilane left-diverging roadway. While a multilane left-diverging roadway being a connector road is not automatically a problem, the question is whether an unexpected road feature (such as a small-radius curve) is.

The following main research objective is formulated from the problem definition:

to offer (Dutch) road designers and traffic researchers insight into the difference in driving behavior and thus traffic safety of car drivers around competitive balanced major fork designs (with and without left-diverging roadway that is actually a small-radius connector road).

From which the following two main research questions are formulated:

1 *How does the number of mandatory lane changes by right-most traffic going to the left-diverging roadway of a major fork affect the traffic safety?*

2 *How does the number of traffic lanes on the left-diverging roadway of a major fork, continuing in the same direction as the mainline roadway, affect the traffic safety as it is actually a small-radius connector road?*

1.3 MAIN RESEARCH METHODOLOGY AND SCOPE

In order to meet the main research objective, different major fork configurations with the same traffic conditions should be compared with each other on the subject of traffic safety. However, traffic safety is a broad concept and can be measured in multiple ways. Traffic safety is generally divided in objective and subjective traffic safety. Objective safety is the actual number or risk of road accidents, while subjective safety is the feeling or perception of safety, i.e. how people subjectively experience accident risk in traffic. This research will solely focus on objective traffic safety.

The objective traffic safety will be measured by crash risk and driving behavior. The crash risk, which is the number of accidents divided by the exposure, is a direct and evident way of measuring traffic safety, since it is directly obtainable from publicly accessible registered accident data. In contrast, driving behavior does not measure traffic safety directly, as it is just the collection of movements of road users in which traffic accidents are almost always absent. As a consequence, surrogate safety measures are used to measure traffic safety in an indirect way by measuring traffic conflicts instead of traffic accidents (as discussed in Section 2.3). To gather driving behavior data, a driving simulator experiment is the only available and also the best suitable method for this research (as discussed in Section 2.4). This completes the main research methodology as it is illustrated in Figure 1.6.

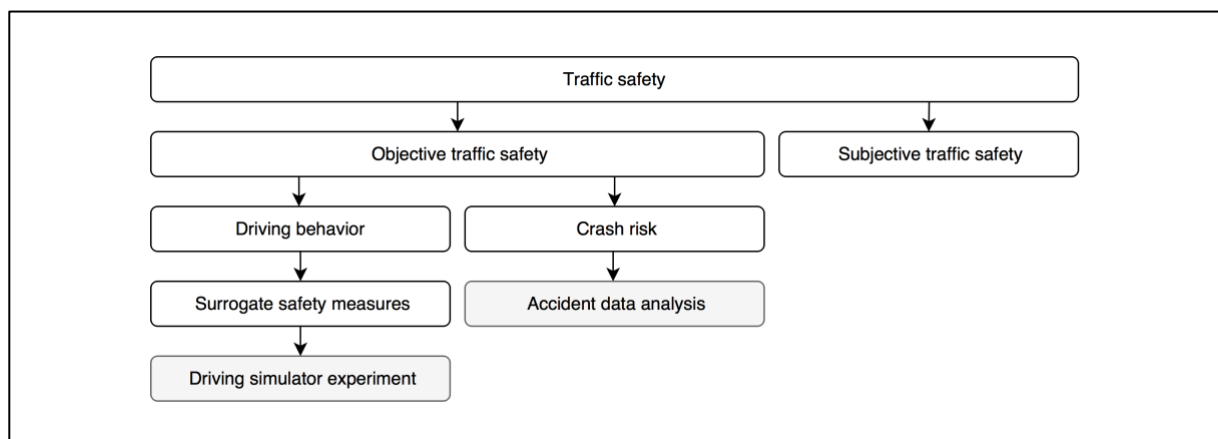

Figure 1.6: The main research methodology

This study will solely focus on major forks that are located on Dutch freeways. This is a conflict-free road category where only motorized vehicles are allowed and a design speed of 120 km/h or 90 km/h is applied. However, the actual speed limit is mostly 100 km/h, but ranges from 80 km/h to 130 km/h; depending on the design speed, road function, and/or environmental reasons.

In relation to main research question 1, the number of mandatory lane changes by right-most traffic going to the left-diverging roadway of a major fork can be controlled by choosing a different major fork

configuration than the standard design. Two configuration types, other than the standard configuration, were introduced in Section 1.1, and are both part of the scope. The first configuration uses a mainline lane addition and a downstream lane drop to lower the number of mandatory lane changes of rightmost traffic going to the left-diverging roadway, and can be applied to three-, four- and five-lane designs. However, the scope of this research is limited to the four-lane design (as illustrated in Figure 1.7) since this one is the most applied on Dutch freeways. The second configuration horizontally flips the major fork design in order to lower the number of mandatory lane changes of rightmost traffic going to the left-diverging roadway, and adds a grade-separated junction to end the major fork with the correct number of traffic lanes on both diverging roadways. As discussed in Section 1.1, this approach only works for balanced major fork designs that have a three-lane mainline roadway. For this reason, the three-lane configurations (as illustrated in Figure 1.7) are added to the scope of this research.

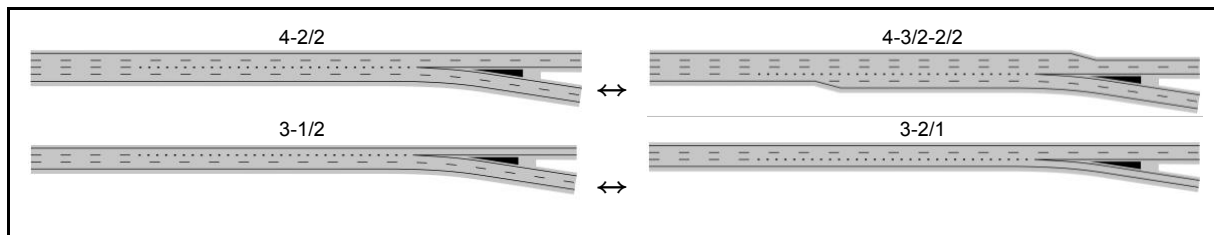

Figure 1.7: The four researched major forks configurations

In relation to main research question 2, the number of traffic lanes on the left-diverging roadway of a major fork potentially affects driver expectancy as it is explained in Section 1.1. A small-radius connector road could therefore be faulty categorized as continuing mainline roadway. Since a single-lane left-diverging roadway is always automatically categorized as connector road, this design should be compared with a multilane configuration. A two-lane configuration would be the best fit because both the single-lane and two-lane small radius connector roads could then simply be implemented in the previous discussed major fork configurations of Figure 1.7. Therefore, the left-diverging roadways (that simultaneously are small-radius connector roads) as they are illustrated in Figure 1.8 are added to the scope of this research.

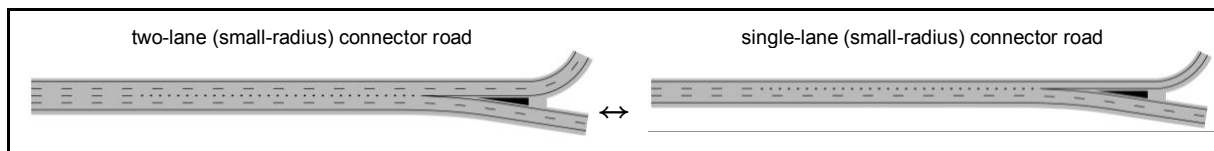

Figure 1.8: The two researched left-diverging roadways that simultaneously are small-radius connector roads

1.4 REPORT OUTLINE

Coming at the end of this introduction, the further outline of this report is the following:

Chapter 2 elaborates on the earlier mentioned phenomena “turbulence” and “driver expectancy”, and discusses the methodology of using and collecting driving behavior to measure traffic safety.

Chapter 3 discusses the research questions of this study. Based on the background and problem definition, this chapter presents the two main research questions, multiple sub-questions that collectively answer the main research questions, and the related hypotheses.

Chapter 4 discusses the general method of the driving simulator experiment and accident data analysis in separate sections, for which it will also end each section with explaining the methodology for analyzing the data that is collected.

Chapter 5 and Chapter 6 present and analyze the results that are obtained by both the driving simulator experiment and accident data analysis, respectively, while Chapter 7 summarizes the main findings and thereafter discusses them.

Chapter 8 presents the final conclusion, the study limitations, scientific and technical recommendations for further research, and practical recommendations for Dutch road designers and traffic engineers.

2

LITERATURE REVIEW

There are some things discussed and assumed in the introduction that deserve some explanation. First of all, this chapter will elaborate on the driving behavior phenomena ‘turbulence’ and ‘driver expectancy’ in Section 2.1 and Section 2.2, respectively, which both explain the driving behavior around the major fork configurations that are included in the scope of this research. These sections will discuss the conditions that influence the phenomena, as well as the impacts these phenomena have on traffic safety. Next, this chapter discusses the use of surrogate safety measures that translate these driving behavior phenomena to quantitative traffic safety values in Section 2.3. It will elaborate comprehensively on the potentially useful and applicable surrogate safety measures, while others are merely shortly introduced. Finally, this chapter will advocate the use of a driving simulator as a tool to collect driving behavior data in Section 2.4. It discusses the strengths and weaknesses of a driving simulator in comparison with other data collection methods, as well as methods to overcome those weaknesses.

2.1 TURBULENCE

Both the Dutch (ROA) and the United States’ design guidelines (AASHTO) mention the occurrence of turbulence on freeways. But where the ROA [1] only mentions turbulence around discontinuities, the AASHTO [4] hints that turbulence is present on all freeway segments but differs in quantity around discontinuities. Beinum et al. [2], who also mention the lack of an explicit definition for turbulence, agrees with the line of reasoning of the ASHTOO and states that turbulence (which they define as *individual changes in speed, headways, and lanes in a certain road segment*) consists of common driver actions such as acceleration, deceleration, and lane changes, that are considered as always present in a traffic stream. It therefore introduces the more useful definition: the level of turbulence, which is defined as: “*frequency and intensity of individual changes in speed, headways, and lane changes in a certain road segment, over a certain period of time*”.

Beinum et al. [2] also introduced the general concept of turbulence, as illustrated in Figure 2.1. It shows that the level of turbulence is affected by certain conditions, while the level of turbulence itself has certain impacts. This general concept of turbulence is used to give structure to this section, while also directly applying it to major fork designs. Turbulence can be broken down into microscopic driver behavior (i.e. movement and interaction of individual entities) and macroscopic effects (i.e. traffic flow characteristics), which are discussed in Section 2.1.1. The certain conditions that affect turbulence around major forks are road geometry, traffic characteristics, and environmental aspects, which are discussed in Section 2.1.2 together with the impact these conditions have on traffic operations and/or traffic safety. Worth mentioning is that these impacts also affect the turbulence (conditions) in a feedback loop, since poorly operating traffic may lead to the reconstruction of some geometric design elements, and unsafe traffic situations lead to cautious driving behavior and/or lower speeds.

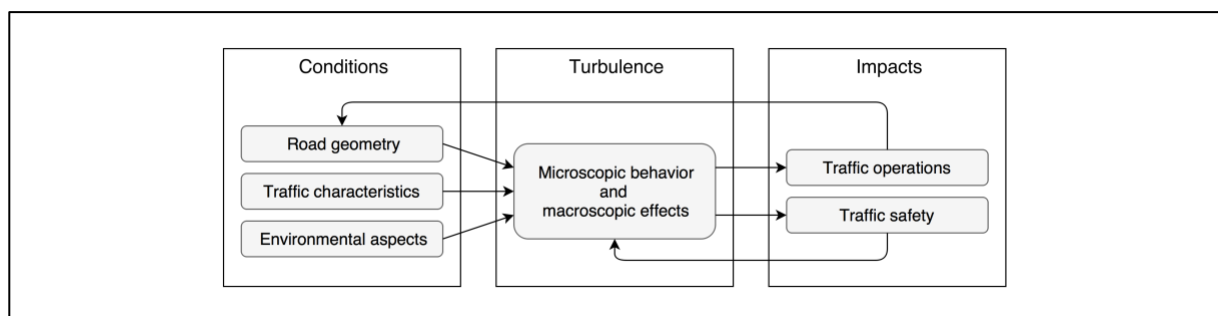

Figure 2.1: The general concept of turbulence, according to Beinum et al. [2]

2.1.1 TURBULENCE AROUND MAJOR FORKS

In addition to the general concept of turbulence, Beinum et al. [2] also introduced a theoretical structure in which turbulence is broken down in four steps: location of occurrence (before, at, and after a discontinuity); driving maneuvers; microscopic (lateral and longitudinal) behavior, and finally; macroscopic effects. The selection and definitions of the individual driving maneuvers differ slightly from research to research [2, 5, 6]. To avoid confusion, Figure 2.2 illustrates the theoretical structure of Beinum et al. that is tailored towards this research, in which the individual driving maneuvers are defined as follows:

Pre-allocating behavior: “the behavior of drivers upstream of the major fork to already change lanes to drive (or keep driving) on a traffic lane that continues in the preferred diverging roadway, even though the position of the driver is not complying with the EU-rule of keeping the rightmost lane possible”;

Mandatory lane changing: “a type of lane change that needs to be performed by the driver to keep following his route, such as changing lanes to get into the proper lane position for going the left- or right-diverging roadway or changing lanes from the leftmost lane to the right before a lane drop”;

Cooperative lane changing: “a type of lane change to the left-adjacent lane in order to make space for a driver on the right-adjacent lane that wants to change lanes to its left-adjacent lane”;

Courtesy yielding: “deceleration by a driver to enlarge the gap between him and the leader in order to make space for a driver on the left- or right-adjacent lane to change lanes into the enlarged gap”;

Keeping-right: “a type of lane change to the right in order to comply with the EU traffic rule of driving at the rightmost lane when possible and safe”;

Relaxation: “deceleration by a driver to enlarge the gap between him and the leader after the driver accepted a smaller gap than normal for a short period of time, caused by lane changes or decelerations around the discontinuity”.

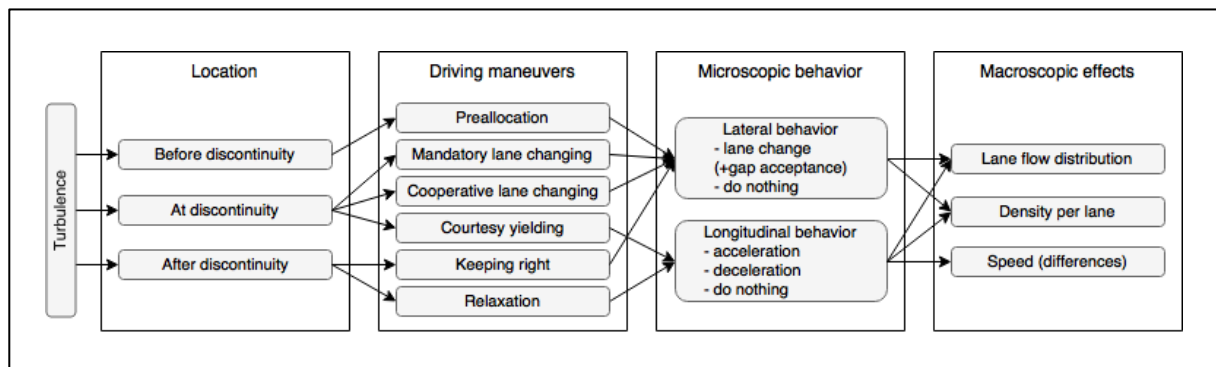

Figure 2.2: The tailored theoretical structure of turbulence

Turbulence around standard major fork configurations

The turbulence before a major fork is solely formed by “pre-allocating behavior”. Taking Figure 2.3 as a reference, traffic on the two rightmost lanes that goes towards the left-diverging roadway is expected to already change lanes to the left, prior to the start of the block marking or overhead signage. Also, traffic that is already on the lane that will continue in their preferred diverging roadway is expected to stay in that lane, even though they have the possibility of “keeping-right”.

The turbulence at a major fork is primarily formed by “mandatory lane changing”. Drivers need to choose a traffic lane that continues in the diverging roadway they need to follow in accordance with their destination. Probably, other vehicles actively react to these mandatory lane changes by creating space for these lane-changing vehicles. These vehicles create space by driving maneuvers such as “cooperative lane changing” (i.e. also changing lanes) or “courtesy yielding” (i.e. decelerating).

The turbulence after a major fork is formed by traffic “relaxation” and “keeping-right”. Since all the mandatory and cooperative lane changes are performed, and the amount of lane changes are decreased, drivers will relax and enlarge the smaller gaps (which they accepted for the short period of time at the major fork) to normal-sized gaps. Also, drivers will much quicker change lanes to the right because the overhead signage and block marking (almost) ended and they therefore do not expect any more mandatory lane changes from traffic on the right-adjacent lanes.

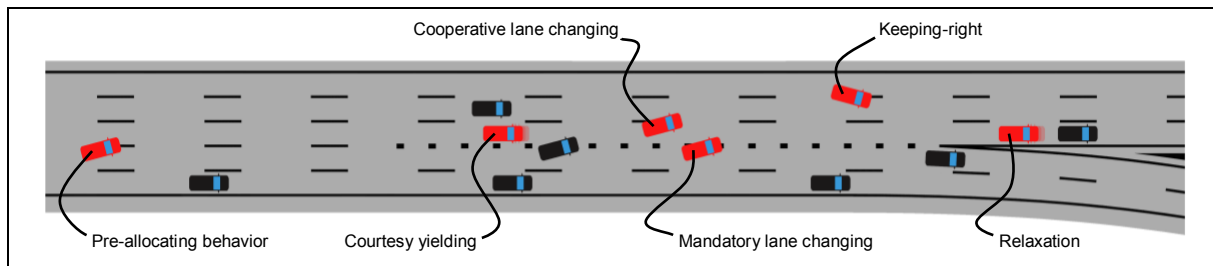

Figure 2.3: The driving maneuvers that occur before, at, and after a major fork

Turbulence around an additional lane drop

Since the scope also includes a major fork design with a lane drop, it is also interesting to list the driving maneuvers that occur there. In short, the driving maneuvers around a lane drop are almost the same as those around a major fork design. To start with the driving maneuvers that match, the turbulence before a lane drop is again solely formed by “pre-allocating behavior” as it is expected that drivers will less likely overtake other vehicles when they need the soon-to-be-ending leftmost lane to do this. Also, the turbulence after a lane drop is solely formed by “relaxation” for the same reason as discussed earlier. Furthermore, the turbulence at a lane drop is primarily formed by “mandatory lane changing” since drivers on the leftmost lane need to perform a lane change in order to keep their route and not end up on the painted gore zone or, even worse, crash into the guardrails. The main difference between the driving maneuvers around a major fork design in comparison with the driving maneuvers around a lane drop are the cooperative driving maneuvers. While “cooperative lane changing” is not expected at all, since a cooperative lane change to the left-adjacent lane would be counterproductive and a cooperative lane change to the right-adjacent lane would in most cases be impossible or uncomfortable, “courtesy yielding” is expected to happen in lesser quantity. Drivers on the right-adjacent lane of the soon-to-be-ending leftmost lane are expected to be less willing to decelerate for mandatory lane changes by daring drivers utilizing the leftmost lane as long as possible than for those drivers that just need to keep their route before and at major forks.

2.1.2 CONDITIONS AND IMPACTS OF TURBULENCE

With Figure 2.1 as reference, certain conditions directly determine the level of turbulence, which in turn directly determines the impacts on traffic operations and traffic safety. With the previous chapter already discussing the raised level of turbulence around major forks, this chapter will solely focus on the different conditions that lead to a raised level of turbulence around major forks, and that can be controlled in a driving simulator experiment. Section 4.1 explains how these conditions are controlled in the design of the driving simulator experiment of this research.

Road geometry

Based on many studies, Elvik et al. [7] found relationships between many geometric features and traffic safety. They found a lower accident risk when increasing the curve radii, decreasing the curve length, improving the superelevation, using transition curves, and decreasing the gradient. However, the relationship between road geometry and traffic safety is complex. It is often the case that specific geometric features are mixed in one design, making it difficult or even impossible to know the contribution of every separate geometric feature on the total effect. Another complex drawback is that road geometry is often paired with differences in road standards, road users, traffic volumes and speeds, making it unclear what effect road geometry exactly has on accident numbers.

Traffic volume

Based on a meta-analysis of 28 studies, Elvik et al. [7] found a positive correlation between the annual average daily traffic (AADT) and the relative number of accidents (as illustrated in Figure 2.4). This relation is not linear as increasing traffic volumes are often related to better road standards and drivers paying more attention. This means that the percentage increase of the number of accidents is less than the percentage increase of traffic volume. However, it is unclear which traffic conditions are taken into account within this meta-analysis. Other research, for example, observed a U-shaped curve representing the crash rate as a function of traffic flow in free-flow conditions [8, 9]. This shape is expected to result from a decrease in single-vehicle crashes in combination with an increase in multiple-vehicle crashes when traffic volume is increased. In addition, multiple studies concluded that crash rates are higher under congested traffic conditions than under free-flow traffic conditions [10, 11, 12].

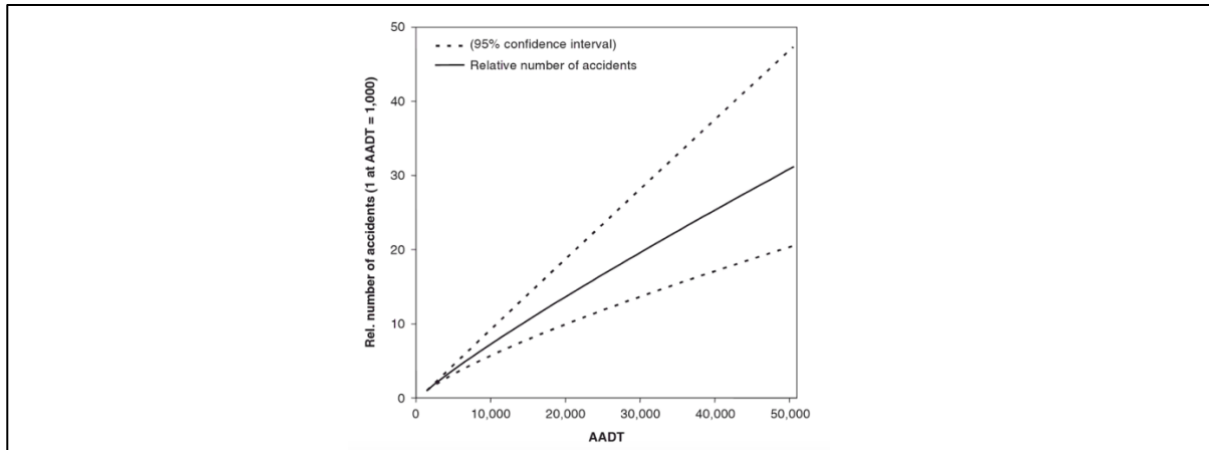

Figure 2.4: Relationship between annual average daily traffic (AADT) and the number of accidents [7]

Speed

Speeding (i.e. having an excessive or inappropriate speed for the situation at hand) is a causation factor in one third of fatal accidents, and an aggravating factor in the severity of all traffic accidents [13]. Speed being an aggravating factor in the severity of all traffic accidents is pretty straightforward as the outcome of a crash is directly related to the kinetic energy that is released during a collision ($E_k=(1/2)mv^2$) [14]. However, the relationship between speed and the risk of a traffic accident is far more complex. On individual vehicle level, literature agrees that faster driving individuals have a higher crash liability [15, 16, 17]. Looking at the case-control study of Kloeden et al. [17], which Aarts & Van Schagen [14] consider to be superior because it controls many confounding factors, crash rates increase exponentially with drivers increasing their speed. On road section level, literature also agrees that an increase in the average speed leads to higher crash rates [18, 19, 20, 21]. According to Nilsson [18], the relationship between the average speed and crash rates is best described by a power function, that later is validated by regression meta-analyses of a large number of before–after and cross-sectional studies [19, 20]. However, a power function implies the same changes in crash rates for the relative same changes in speed, which is argued by Elvik [21] and Hauer & Bonneson [22]. Although the difference between the two function are small, it was concluded that an exponential function fits the data better (see Figure 2.5).

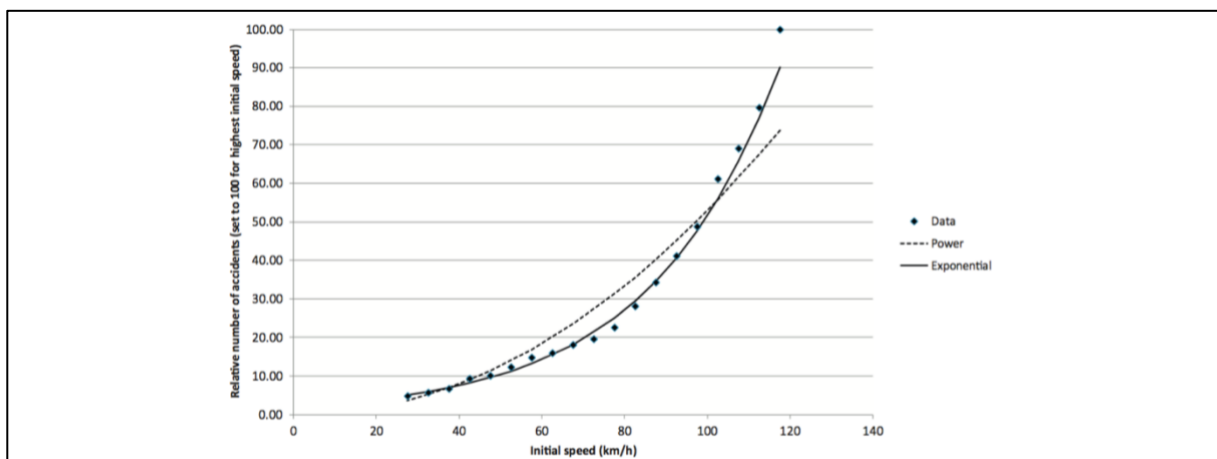

Figure 2.5: a power function and an exponential function fitted to data for property-damage-only accidents [21]

(Percentage of) freight traffic

Focusing on the traffic safety of freight traffic around major forks, an interesting research is that of the *Adviesdienst Verkeer en Vervoer (AVV)* [23], which is the *Advisory Service Traffic and Transport* of Rijkswaterstaat, that looked at truck-related freeway accident data and conducted interviews and questionnaires among truck drivers. From accident data, they concluded that 31% of the accidents are head-tail collisions, 34% side collisions, and 25% one-sided collisions. Head-tail collisions are mostly caused by keeping an insufficient following distance, side collisions by faulty merging and cutting off,

and one-sided collisions by lost cargo. From questionnaires and interviews, the AVV concludes that weaving and lane changing maneuvers by passenger cars and trucks form the most dangerous situations, according to the truck drivers themselves. Respondents indicate that overtaking (25%), merging (18%), and lane changing maneuvers (17%) of other road users cause unsafe traffic situations. The position of the other road user in such situations is mostly in front (32%) or to the left (20%) of the truck. More than 50% of the truck drivers indicate they get cut off by a passenger car minimally one time per week, mostly at on- and off-ramps and during lane changes [24]. Truck drivers indicate that they contribute this to the too high driving speed, last-minute route-choice decisions, late observation of signage, and falsely estimating the distance to trucks by passenger cars. This is in line with the concluding advice of the AVV [23], which also recognizes discontinuities (such as weaving and lane changing roadway segments) as important conflict situations.

As truck drivers themselves already indicate, it is not only the absolute speed of vehicles that is interesting, but also the speed dispersion (i.e. differences in speed) and its effect on crash rates. Early case-control studies in the sixties found a U-curve relationship because vehicles moving 10-20 km/h faster than the modus speed had the lowest crash rate, while vehicles moving 30-50 km/h faster or slower had substantially higher crash rates [25, 26, 27]. Already the RTI [27], but also later studies by Kloeden et al. [28, 17], concluded that the increased risk of slow-driving vehicles is probably overestimated due to inaccurate measuring methods. Another explanation is that the older studies included maneuvering vehicles (that contain other risk factors than those related to speed) in their analyses [14, 7]. Generally, all literature reviewed by Aarts & van Schagen showed increases in crash rates with increases in speed dispersion [14].

Drivers' characteristics

Age and gender are probably the two best well-documented characteristics of drivers in accident records. Elvik et al. [7] used nine studies of different countries (including the Netherlands) that all investigated the relationship between the age and gender of car drivers and their involvement in injury accidents per kilometers of exposure. They concluded that the results of all studies were remarkably similar, and that (injury) accident involvement rate is described by a U-shape function of drivers' age independent of gender (see Figure 2.6). This means that both younger (16-24) and older (65+) drivers have a relative higher accident rate than middle-aged drivers (35-54). According to the *Institute of Road Safety Research* (SWOV, the Netherlands) [29], there are multiple reasons for that why younger drivers experience a higher relative crash rate: an asynchronous development of different parts of the brain, social-psychological factors (e.g. impressing friends with a sporty driving style), cognitive-psychological factors (e.g. earlier distracted and more alcohol- and drug-use than middle-aged drivers), cognitive-perceptual skills (i.e. underestimating traffic situations and overestimating their own skills), and exposure to danger (e.g. driving older cars and driving more at night). Although older drivers generally break traffic rules less often, experience less peer pressure, have a reduced need for sensation, use less alcohol or drugs, and choose to drive under better weather conditions compared to younger and middle-aged drivers, their functional disorders (such as a reduction in vision, hearing, reaction time, and concentration, and dementia) lead to higher crash rates and their physical vulnerability lead to higher risks of injury or fatal accidents [30].

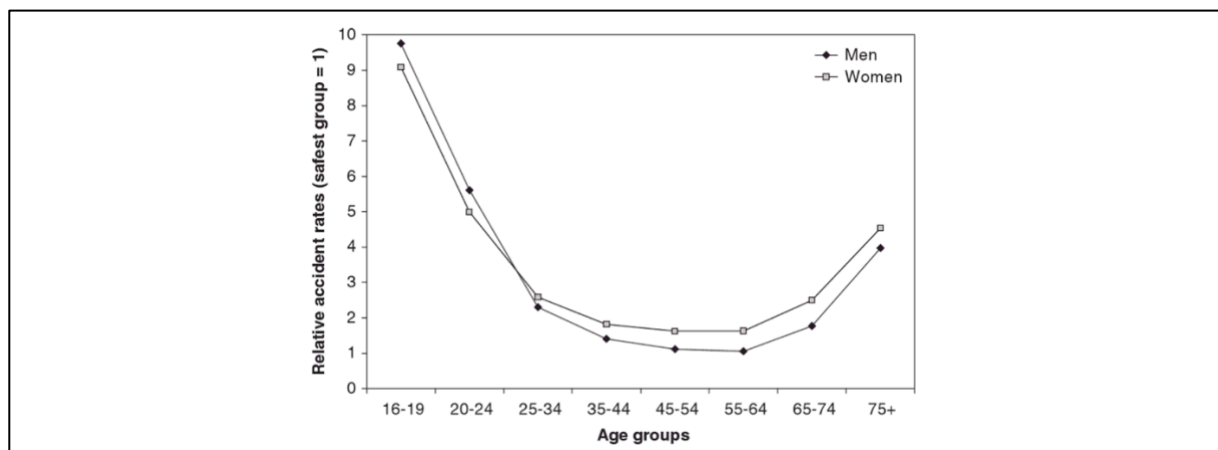

Figure 2.6: Relationship between different age groups and their relative accident rates [7]

2.2 DRIVER EXPECTANCY

Although we have seen in the preceding section that the road environment affects the level of turbulence and thus traffic safety, it also greatly affects driver expectancy and thus traffic safety. Expectancy relates to a driver's readiness to respond to situations, events, and information in predictable and successful ways [31]. The keyword in the definition of driver expectancy is 'predictable', and shows a relationship with the Dutch road safety strategy: Sustainable Safety. The Sustainable Safety vision aims to prevent crashes (or otherwise injury) from occurring with a pro-active approach, and is based on the five principles: functionality, homogeneity, predictability, forgivingness, and state awareness [32]. The principle 'predictability' entails that a road should have a recognizable design. Recognizability is realized when solely the road environment evokes appropriate driving behavior for the specific category of that road, contributing to traffic safety [33]. This chain of events is depicted in Figure 2.7, and is explained in more detail in the following of this section.

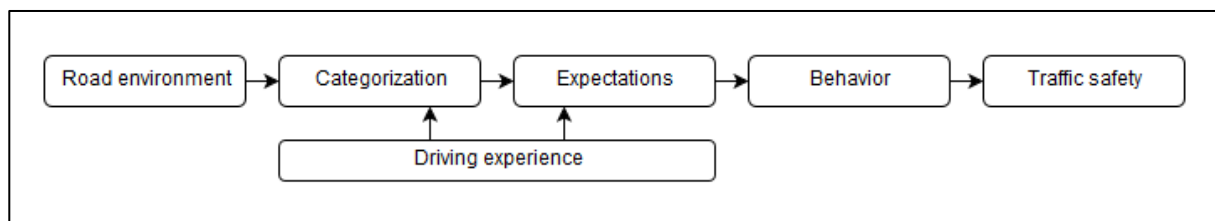

Figure 2.7: Theoretical model of how the road environment affect traffic safety through driver expectancy [3]

From a road design perspective, categorization is the grouping of driving experiences into road categories. There are two general principles for categorization: cognitive economy and perceived world structure [3]. Cognitive economy suggests that road users try to reduce the large number of roads that exist in the 'real' world to a few behaviorally and cognitively relevant road categories. Perceived world structure suggests that road users see the environment as consisting of a set of attributes that are highly correlated and that are not picked randomly. Thus, through experience with the road environment, road users develop a perceived world that contains attributes that are likely to occur in combination. So, in order to categorize a road design, it is not only important that road users are able to distinguish *between* road categories, but that there also exists uniformity *within* road categories [33].

Driving experience does not only support categorizing the road environment, it also activates schemata about what to expect, how to behave and how other road users will behave. If, for instance, a driver categorizes a road environment as a highway (because of physical characteristics such as a four-lane roadway, road markings, an emergency lane, guardrails, blue overhead signs, etc.), that same driver will immediately have expectations regarding other road elements (presence, location and type) and the driving behavior of one's own and others' (speed, maneuvers, safety margins, locations, etc.).

The literature contains numerous claims that approximately 90% of the information that a driver has to process is obtained visually (e.g. [34]). But since the visual system is limited and driving is a relatively complex task, the perception of the road environment will rely on top-down expectations. This means that drivers will perceive events that are in line with their expectations but will overlook events that are not in line with their expectations. By performing two experiments [35, 36], Theeuwes and Hagenzieker demonstrated the existence of this biased search behavior towards those portions of the visual field where the target is expected. Subjects had to search for a target object (e.g. a traffic sign or vehicle) that was either located at a likely (expected) or unlikely (unexpected) location. The results showed that search in the unexpected condition led to more eye movement (since expected positions were scanned first) and was more error prone. This also suggests that drivers' reaction time is higher in unexpected traffic situations, which, in a more simplistic way, is supported by research from Johansson and Rumar [37]. By measuring brake reaction time for expected and unexpected signals, they concluded that the reaction time for expected signals was on average 2/3 seconds, while the reaction time approached 1 second for unexpected signals.

This theoretical model of driver expectancy can directly be applied to the third set of road designs that is discussed in the scope of this research (see Section 1.3). These two designs both include a balanced major fork with a two-lane right-diverging roadway, but differ in the amount of traffic lanes on the left-diverging roadway. Where the first design has a two-lane left-diverging roadway that is also a small-radius connector road (see Figure 2.8a), the second design is a single-lane variant (see Figure 2.8b).

While the left-diverging roadways have a lot of physical characteristics in common (such as diverging under no angle, the presence of asphalt, an emergency lane, road markings, guardrails, long light posts, a chevron sign, and the blue overhead signs along the prior block marking), they differ in the number of traffic lanes. This difference in the number of traffic lanes is expected to lead to a difference in road categorization. Since the ROA [1] states that a mainline roadway should always minimally include two traffic lanes, the single-lane left-diverging roadway is automatically and correctly categorized as connector road, while the two-lane roadway is potentially and faulty categorized as continuing mainline roadway. This difference in categorization is expected to lead to a difference in driver expectancy and thus driving behavior and therefore traffic safety.

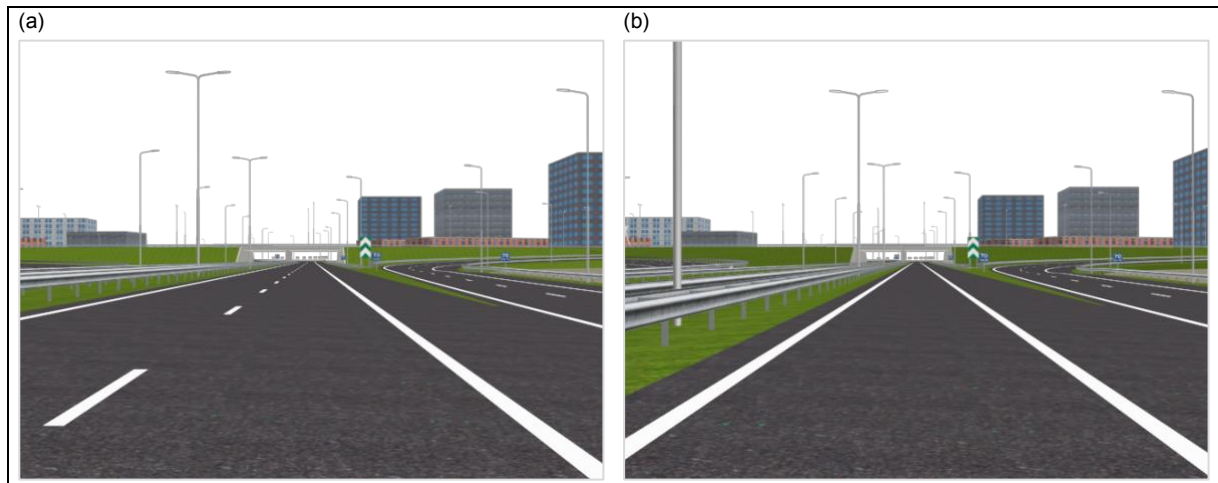

Figure 2.8: the two-lane left-diverging roadway as small-radius connector road (a) and the single-lane variant (b)

2.3 SURROGATE SAFETY MEASURES

A general drawback of driving behavior data is that it not directly measures traffic safety. After all, driving behavior data is just the collection of movements of road users in which traffic accidents are almost always absent. This raises the need for indirect safety measures (i.e. surrogate safety measures) that focus on other safety indicators instead of accidents. This indirect relationship with traffic safety is elaborated in Section 2.3.1, beginning with a short introduction on the origin of surrogate safety measures (SSM). Next, useful and applicable surrogate safety measures are introduced and elaborated in Section 2.3.2, in which there is made a subdivision in SSM that consider longitudinal driving behavior and SSM that consider lateral driving behavior.

2.3.1 THE TRAFFIC CONFLICT TECHNIQUE

The traffic-related branch of surrogate safety measures relates to a procedure called: the *traffic conflict technique* (TCT), which is systematically observing or qualifying evasive actions such as sudden lane-changing or hard braking as a clue to deduce critical situations [38]. Within this definition, ‘critical situations’ could be replaced with ‘traffic conflicts’, which have gotten a unified definition during a workshop in 1977 [39]: “a traffic conflict is an observable situation in which two or more road users approach each other in space and time to such an extent that there is a risk of collision if their movements remain unchanged”. This definition implies that a traffic accident is always preceded by a traffic conflict, but that a traffic conflict only results in a traffic accident if an evasive action is unsuccessful or not undertaken at all.

Several models exist that show the hierarchy between conflicts and accidents. The simplest one is that from Amundsen and Hydén [39], as illustrated in Figure 2.9a. The model considers accidents as a subset of serious conflicts, serious conflicts as a subset of conflicts, and conflicts as a subset of exposure. This model already hints a type of continuity between conflicts and accidents, and differences in probability of occurrence, which is better described by Glauz and Migletz [40]. They introduced, what they call, the nearness-to-collision concept that is illustrated in Figure 2.9b. It suggests that the frequency of different traffic events is distributed over some measure of nearness-to-collision. While the model categorizes most traffic events as ‘not conflicts’ (i.e. exposure), some threshold value of nearness-to-collision is selected that act as the tipping point to the traffic event: ‘conflicts’. The model also shows that even

lower nearness-to-collision values represent more severe conflicts, with the measure being zero or less representing 'collisions' (i.e. accidents). Later, a similar model in the form of a pyramid is introduced by Hydén [41], as illustrated in Figure 2.9c. The pyramid as a whole represents the frequencies of all traffic events, which shows that 'undisturbed passages' are far more common than 'accidents', that only make up a small part of the total pyramid. From bottom to top, the pyramid represents thus a decrease in frequency and an increase in severity. It also shows that next to conflicts, also accidents can have different levels of severity.

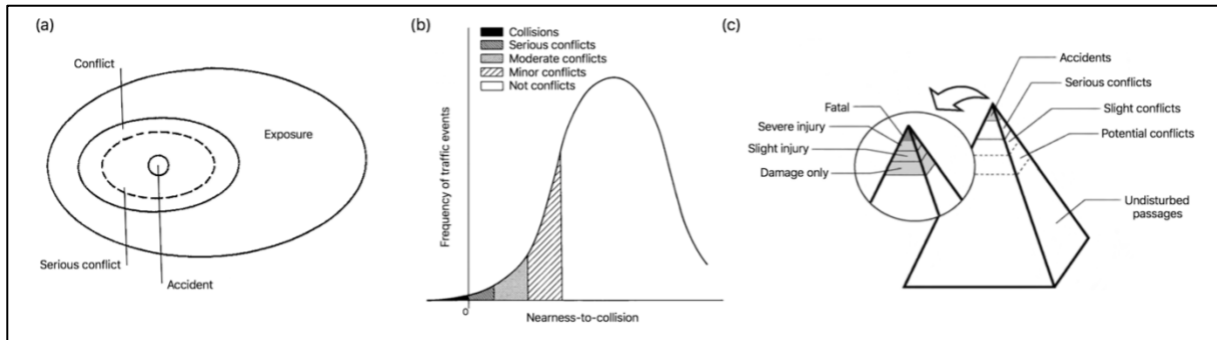

Figure 2.9: The conflicts and accidents hierarchy by Amundsen and Hydén [39], Glauz and Migletz [40], and Hydén [41]

2.3.2 MEASURING CONFLICT SEVERITY

The hypothesis of the continuum relationship between exposure and accidents that the models imply results in the conclusion that there exists a relationship between the number of serious conflicts and accidents [42], which is also validated by Hydén [41]. However, Hydén also mentions that this relation is very much dependent of the definition someone applies to 'serious conflicts'. Because the threshold value between different severity levels of conflicts is rather vague and subjective, the distribution of traffic events over conflict severity levels directly relies on someone's own judgement. Nonetheless, this limitation is less of a problem in this study, because categorization of conflict severity is of less importance than quantification of conflict severity when comparing major fork configurations.

Several surrogate safety measures (SSM) exist that try to quantify conflict severity. The best-known SSM are discussed in this section that is subdivided in two parts. The first part focuses on SSM that are able to quantify longitudinal conflict severity, and the second part focuses on SSM that are able to quantify lateral conflict severity. In both parts, all corresponding SSM are mentioned and compared, but only the SSM that are used in the remainder of this research are elaborately discussed.

Longitudinal conflict severity

The most frequently used SSM is the time-to-collision (TTC), which is found to have many definitions that all imply the same. Two definitions that together provide enough context are: the time required for two road users to collide if no evasive action is taken [43], and; the expected time for two vehicles to collide if they remain at their present speed and on the same path [44]. So basically, in interactions between road users the TTC measure describes how imminent a collision is [45]. TTC is most easily described in situations where vehicles approach each other at a right angle (see Figure 2.10a and Equation 2.1 [45]) or parallel (see Figure 2.10b and Equation 2.2 [46]).

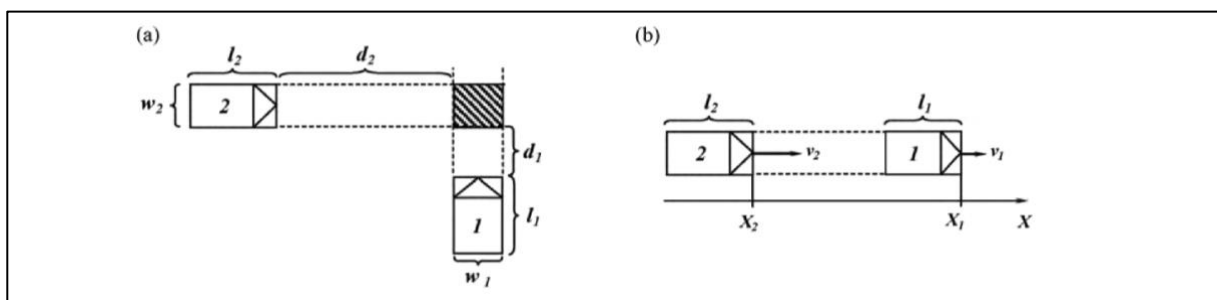

Figure 2.10: Schematic illustration of (a) a straight-angle collision course and (b) a parallel collision course [47]

$$(a) \begin{cases} TTC = \frac{d_2}{v_2} & \text{if } \frac{d_1}{v_1} < \frac{d_2}{v_2} < \frac{d_1 + l_1 + w_2}{v_1} \\ TTC = \frac{d_1}{v_1} & \text{if } \frac{d_2}{v_2} < \frac{d_1}{v_1} < \frac{d_2 + l_2 + w_1}{v_2} \end{cases} \quad (2.1)$$

$$(b) \quad TTC = \frac{X_1 - X_2 - l_1}{v_2 - v_1} \quad \text{if } v_2 > v_1 \quad (2.2)$$

Considering unidirectional freeway traffic, right-angle collision courses probably never occur, while parallel and slight-angle collision courses are very common in car-following and lane-swaying interactions. In cases when vehicles approach each other under a slight angle, all four corner points of both involved vehicles need to be considered separately when determining whether a collision course is present or not [45]. Moreover, different types of collisions are possible for the same (non-perpendicular) collision angle. Basically, these collisions always include a corner of a vehicle and a side of the other vehicle, which results in six different collision types (as illustrated in Figure 2.11) with the possibility of 32 combinations (4 corners*4 sides*2 vehicles) [47]. Calculating a TTC value for these cases is less straightforward because someone should consider a moving point (i.e. the corner of a vehicle) and a moving line section (i.e. the side of a vehicle). The lowest TTC value of all possible combinations is the normative TTC value.

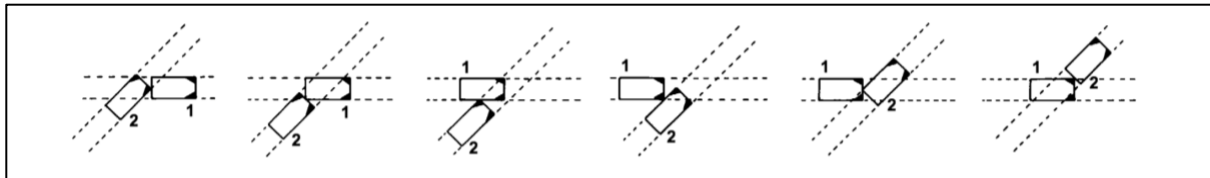

Figure 2.11: Types of potential collisions for a non-perpendicular collision course [45]

Advantages of time-to-collision (TTC) are that it takes both space and time into account, it continuously evolves over the course of a traffic conflict, it has an intrinsic relationship with driver reaction time, and it is easy to compute when analyzing trajectory data [48]. However, when assuming a parallel collision course, TTC does have a couple of limitations. One limitation is that the lowest TTC value is determined over a certain time period for a single conflict, and it therefore does not consider the duration of an increased conflict severity. Minderhoud and Bovy [46] proposed Time Exposed Time-to-collision (TET), an extended TTC measure that is defined as the duration of exposition to safety-critical time-to-collision values (i.e. TTC values below a certain threshold value). However, since the TET measure is not affected by the degree to which TTC values vary below the threshold value, it does not take into account the level of conflict severity. Therefore, Minderhoud and Bovy also proposed the Time Integrated Time-to-collision (TIT), an extended TTC measure that uses the integral of the time-to-collision profile (below a certain TTC threshold value) to express the level of safety (in s²). The relationship between TTC, TET and TIT is illustrated in Figure 2.12. The TTC threshold value basically differentiates risky encounters from safe encounters, and typically varies between 2 and 4 seconds [46, 49]. However, from the literature it is not directly clear which values can be defined as “safe” or “unsafe”, although low values can be interpreted as more unsafe than high values. If the threshold value is too large, many safe car-following scenarios will be judged as unsafe conflict scenarios. If the threshold value is too small, many unsafe car-following scenarios will be judged as safe conflict scenarios, and the measure will lose lots of information by ignoring those observations that are above the threshold value [38].

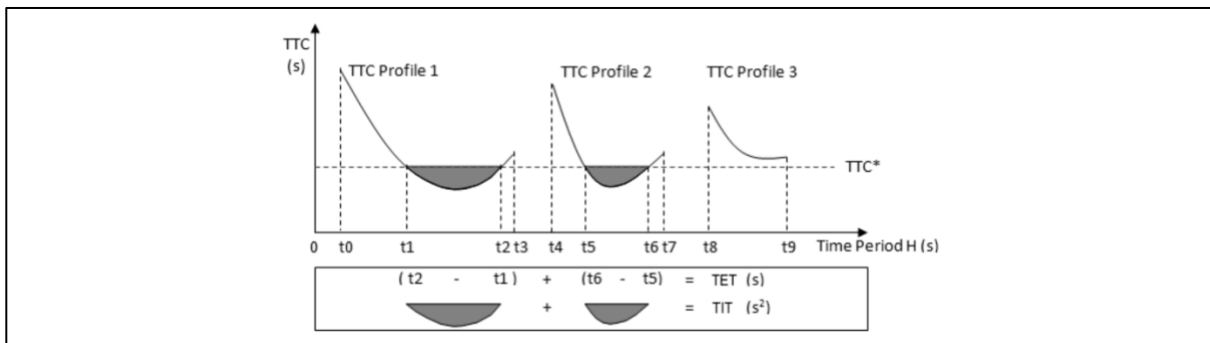

Figure 2.12: Relationship between TTC, TET and TIT, in which TTC* represents the TTC threshold value [46]

Another limitation is that the time-to-collision (TTC) between two vehicles can only be measured when the speed of the following vehicle is higher than that of the leading vehicle. With the same criticism, Vogel [50] states that as surrogate safety measure on its own, TTC is not able to explain the traffic safety situation completely, and needs the time headway (THW) as additional measure. Just like TTC, THW is a longitudinal surrogate safety measure [51]. It is defined as the time difference between two consecutive vehicles in the same traffic lane [38], and is measured as the time between the front of the leading vehicle passing a point on the roadway and the front of the following vehicle passing the same point [50]:

$$THW = t_i - t_{i-1} = \frac{\Delta d}{v_F} \quad (2.3)$$

In which t_i and t_{i-1} are the times the following vehicle and the leading vehicle pass a given point in space respectively, Δd is the relative distance (m) between the fronts of the vehicles, and v_F is the speed (m/s) of the following vehicle.

Assuming equal speeds, TTC cannot be measured even though the headway is unsafely small. The situation only becomes critical when the circumstances change, such as a braking action by the leading vehicle. The combination of TTC and THW therefore says more because it all depends on the combination of the following distance and the action of the leading vehicle. Vogel [50] found independency between THW and TTC of following vehicles and concluded that while a relatively large THW always reflects safe traffic conditions, a relatively small THW at least produces potential danger because only vehicles that travel with short headways have the possibility to produce small TTC values. The THW threshold value, that differentiates risky encounters from safe encounters, varies between 0,6 and 2 seconds in the literature [52]. However, a minimal time headway of 2 seconds is recommended by many European road administrations, including the Netherlands.

A well-known surrogate safety measure that consider longitudinal conflict severity but shows no extra benefit over the earlier mentioned surrogate safety measures is time-to-accident (TTA). TTA is a simplified version of TTC, as it is just a single TTC value at the moment an evasive action is taken by one of the two vehicles [53]. This makes TTA a suitable measure when observing traffic conflicts manually, but less suitable when analyzing vehicle trajectory data because evasive actions are less distinctive, and computers can simply measure TTC for every time step without difficulty.

Another well-known surrogate safety measure that consider longitudinal conflict severity but shows no extra benefit over the earlier mentioned surrogate safety measures is the potential index for collision with urgent deceleration (PICUD). PICUD evaluates the possibility that two consecutive vehicles might collide assuming that the leading vehicle applies its emergency brake. It is a space-based measure because it considers the distance between the two vehicles considered when they completely stop. An advantage of PICUD is that it not only includes the following distance and speed of a following vehicle, but also includes the speed of the leading vehicle. However, a big limitation of PICUD is that it is always an estimation because it requires two predetermined (assumed) parameters: the reaction time and the maximum deceleration rate.

Another well-known surrogate safety measure that consider longitudinal conflict severity but shows no extra benefit over the earlier mentioned surrogate safety measures is the deceleration rate to avoid collision (DRAC). DRAC is defined as the following vehicle's required deceleration to come to a timely stop or attain a matching lead vehicle speed and hence avoid a rear-end collision [54]. Even though the DRAC measure has been explicitly recognized as relevant surrogate safety measure by several studies, Cunto & Saccomanno [54] also mention that researchers have argued that the conventional DRAC measure fails to accurately reflect traffic conflicts and hence identify potential crash situations. Their main argument is that the measure does not take into account the vehicle's braking capability over time for prevailing road and traffic conditions. Cunto & Saccomanno therefore introduced the crash potential index (CPI), which is defined as the probability that a given vehicle's DRAC exceeds its maximum available deceleration rate (MADR) for every time step. However, Since MADR is vehicle- and scenario-specific, it is different for each considered vehicle in the traffic stream, and thus dependent on assumed truncated normal distributions around an average MADR value.

Lateral conflict severity

Although time-to-collision (TTC) could theoretically also be used to measure lateral conflict severity, a limitation is that it only considers the interaction of road users on a collision course. Situations in which road users just miss each other under high speeds and without considerable speed or path changes are therefore not measured, while these are situations that happen frequently when changing lanes. These interactions can be measured with a surrogate safety measure called the post-encroachment-time (PET). PET is defined as the time measured from the moment the first road-user leaves the potential collision point to the moment the other road-user enters this conflicting point [43]. Van der Horst [45] made the definition of PET clearer with Figure 2.13, and the accompanying Equation 2.7.

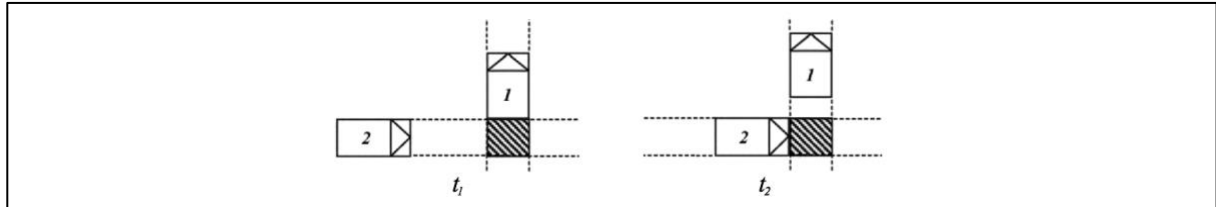

Figure 2.13: An illustration of PET, which is the time difference between t_1 and t_2 [45]

$$PET = t_2 - t_1 \quad (2.4)$$

But, while right-angle interactions are common at urban intersections, they are not on freeways. Zheng et al. [55] proposed a procedure to measure PET during freeway lane change maneuvers. They defined PET during a lane change maneuver as the time difference between the end of the leading vehicle leaving the encroachment line and the front of the following vehicle arriving at the encroachment line. The encroachment line is a virtual line perpendicular to the travel direction, and crosses the intersection point of the lane dividing marker and the lane change trajectory. As shown in Figure 2.14a, there may be as many as four vehicles around the merging vehicle O. For a lane change maneuver, the PET between the merging vehicle O and each of the four adjacent vehicles is calculated, of which the minimum PET is taken as the normative PET of the lane change maneuver. Note that Figure 2.14b and Figure 2.14c only show the calculations of PET between vehicles O and A, and O and C, respectively.

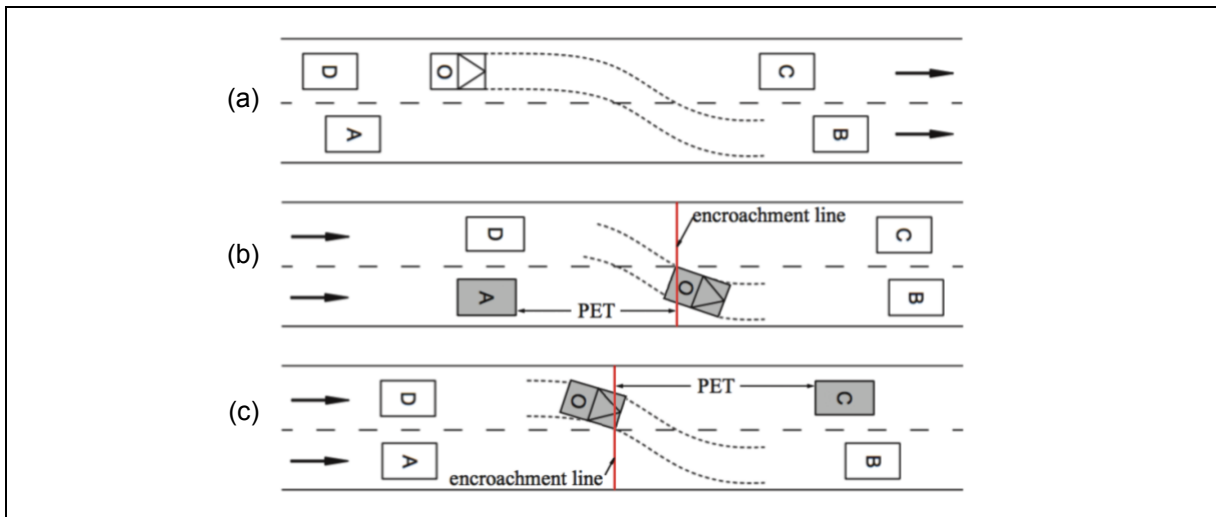

Figure 2.14: A traffic situation (top figure) and two example PET calculations for merging vehicle O

Mullakkal-Babu et al. [51] proposed Equation 2.8 to measure PET during freeway lane changing maneuvers. To measure the chronological variation of PET, they predict the encroachment line and the corresponding PET at every time step, using kinematic prediction with constant velocity assumption:

$$PET = \frac{X^e - X_n}{v_n} - \frac{X^e - X_{n-1}}{v_{n-1}} \quad (2.5)$$

in which X^e is the longitudinal position of the encroachment line, X_n and v_n are the position and velocity of the first vehicle respectively, and X_{n-1} and v_{n-1} are the position and velocity of the second vehicle respectively.

2.4 DRIVING SIMULATOR

A driving simulator experiment is able to let participants drive in a safe environment in which the road design and traffic conditions are controlled by the researcher. The driving environment and the vehicle characteristics of the simulator are mimicked to represent the real world as realistic as possible. Although also other methods exist that collect driving behavior, such as *video cameras* (which collect video footage that is used to generate individual vehicle trajectories) and *instrumented vehicles* (which are vehicles equipped with measuring instruments that record relevant data about the vehicle and surrounding vehicles) [2], a driving simulator is actually the only available and accessible method for this research. However, apart from this constraint, a driving simulator study has several advantages that are discussed in Section 2.4.1, as well as several disadvantages that are discussed in Section 2.4.2, together with methods to overcome these.

2.4.1 ADVANTAGES

The advantages of driving simulators include the ability to control and reproduce simulator conditions, the ease of collecting driver-specific data, and the possibility of letting participants encounter dangerous driving conditions without being physically at risk.

Controllability

One of the main factors affecting research quality is the impossibility of traditional research experiments to conduct controlled experiments in which causal factors are held constant [56]. Traditional research often consists of field experiments in which the researcher is dependent on the characteristics of the site and the conditions during the experiment. This means that in experiments that include site comparisons there are always a multitude of causal factors to be accounted for. But also, performing an experiment multiple times on a fixed location and under the exact same traffic conditions is almost impossible.

These are also exactly the drawbacks of data collection methods such as video cameras and instrumented vehicles, which are directly dependent of the existing road designs and the traffic conditions as they naturally develop. Since in a driving simulator the geometric design and traffic conditions are controlled by the researcher, its advantage is that the experimental environment can be adjusted to the research goals [57, 58]. In addition, controllability also implies reproducibility, which means that a standardized experimental set-up can be created. This ensures the exact same virtual environment for every driving simulator participant and avoids the potential influence of incidental factors.

Data-collection

Another advantage of a driving simulator is the ease of collecting data [57, 58]. First of all, participating an hour in a driving simulator experiment is much more accessible than participating an hour in an instrument vehicle experiment. Second of all, the same computer that controls the environment of the simulation, automatically records the data of the vehicle in relation with the road section configuration and other simulated traffic. Recorded data can include all parameters that relate to travelling conditions (such as location, local speed and acceleration, steering wheel rotation angle, distances to other road users and markings, pitching and rolling angles, etc.) per pre-set time or space interval [57].

Collecting the same type of data from real traffic is far more challenging, since it is really difficult to measure the exact location of a vehicle on the world accurately [58]. Measuring lateral positions of vehicles is for instance challenging for a data collection method using video cameras, since this requires the visibility of road markings while weather conditions, reflection, and shades may affect the quality of the measurement [59]. A data collection method using instrumented vehicles experience the same problems. One study showed that instrumented vehicles were impossible to measure a driver's distance to a stopping line [60], while another study showed that lateral position measurements were of marginally quality [61]. However, a driving simulator was able to measure accurately in both studies.

Safe research environment

A third advantage of a driving simulator is the possibility of conducting experiments in total safety for the participants [57, 58]. It allows the researcher to study driving tasks (such as merging or lane changing) and driving behavior (such as gap acceptance) in a risk-increasing environment (such as high traffic volumes, big speed differences, or bad weather conditions), which is difficult to ethically justify in case

of exposing participants to real risks [62], such as in the case of using video cameras or instrumented vehicles. In these case, a researcher does not control the driving environment, and participants are thus directly exposed to accident risk. One could argue that a participant would be exposed to the risk regardless of the experimental set-up, since methods using video cameras or instrumented vehicles (i.e. naturalistic driving experiments) let participants drive along the routes and during the times as they would normally do.

2.4.2 DISADVANTAGES

The disadvantages of a driving simulator as a data collection method include the lowered behavioral validity and physical validity, and the possibility of participants experiencing simulator sickness. Although data collection methods such as video cameras and instrumented vehicles lack these disadvantages, driving simulators are able to overcome them and change them into merely challenges.

Behavioral validity

A major disadvantage of driving simulators is the need of behavioral validity, which is the extent to which the simulator induces the same driving behaviors that occur when driving in the real world [63]. Any driving simulator experiment should be preceded by questioning whether the behavioral validity is sufficient for the phenomenon to be investigated [64]. This means that a simulator that is only validated on speed, can only answer research questions on speed. The behavioral validation of a specific driving simulator on a specific driving behavior (e.g. braking) on a type of roadway (e.g. freeway) does not allow to be generalized to other types of driving behaviors (e.g. lateral position), type of roadways (e.g. rural road), or other driving simulators [57]. Without behavioral validation, the credibility of the driving simulator results decreases, and one should be careful when extrapolating these results to road design, vehicle design, or traffic regulations.

To make sure that the behavioral validity of a driving simulator is within an acceptable range, the reliability of the recorded simulator measurements need to be verified by comparing it with real world measurements. When the simulator and on-road environments produce the same numerical values, we speak of *absolute validity*; when the simulator and on-road environments produce numerical values that are not identical but are of similar magnitude and in the same direction, we speak of *relative validity* [63]. For a driving simulator to be a useful research tool, relative validity is necessary, and sufficient in case of comparing driving behavior under different controlled traffic conditions [65].

Physical validity

Although the intent of a driving simulator experiment is to mimic the real driving environment and vehicle characteristics as realistic as possible, it will never represent perfect realism. The extent to which the physical components of the simulator correspond to a real on-road vehicle, including the simulator layout, visual displays, and dynamics, is called physical validity [63]. While low-fidelity simulators may evoke unrealistic driving behavior (since participants may become demotivated) and therefore produce invalid research results [58], high-fidelity simulators are able to recreate extremely lifelike driving conditions that enable researchers to obtain data that faithfully reflect driver behavior [57]. But although physical validity is a good starting point for behavioral validity [66], a higher level of physical validity does not automatically lead to a higher level of behavioral validity [60]. In other words, this does not mean that high-fidelity simulators are always preferable to low-fidelity simulators.

When starting up a driving simulator study, one of the most important aspects is that the chosen driving simulator has a balance between efficiency and effectiveness for a specific research question [66]. Efficiency refers to the necessary resources of the simulator (such as costs, time, and personnel), while effectiveness refers the simulator's ability of providing valid data. This means that the level of fidelity should be high enough to meet the required level of effectiveness, while it also should be as low as possible to limit the amount of necessary resources. Simply investing resources to increase a simulator's fidelity (and therefore its effectiveness) is not necessarily a desirable solution, as it adds to the complexity of the device and might hamper experimental control [58]. But simply choosing a low-fidelity simulator for the reason of limiting the amount of necessary resources is also not desirable, since lower levels of fidelity may bring down a simulator's immersion capabilities. Lower levels of immersion cause participants to get detached from the virtual driving environment and result in demotivated participants [58]. It also increases the feeling of invulnerability as there is not any risk or real physical consequences involved [67]. This false sense of safety and responsibility contributes to unrealistic driving behavior [68].

The physical validity of the driving simulator for this research is discussed in Section 4.1.3.

Simulator sickness

Closely related to the physical validity of a driving simulator is simulator sickness, which is a serious concern because it potentially causes confounding data (by affecting the behavioral validity) and influence participant dropout rates [69]. Simulator sickness is labeled as a syndrome, as it includes symptoms like headaches, sweating, a dry mouth, drowsiness, disorientation, vertigo, nausea, dizziness, and vomiting [70]. Several theories exist that explain how and why simulator sickness occurs, with the most prominent one relating to the physical validity of simulators [70]: the *sensory conflict theory*. It states that simulator sickness symptoms arise when cues of the visual system and vestibular system do not match, or do not match one's own past experiences.

Klüver et al. [71] did an extensive literature review on the characteristics that are associated with simulator sickness. In agreement with the prominent sensory conflict theory, they found that most of the studied characteristics are associated with a simulator's physical validity (i.e. simulator- and scenario-specific characteristics). The simulator- and scenario-specific characteristics that were found to increase simulator sickness were a larger field of view, hard braking maneuvers, scenery complexity, maneuver complexity, an increased optic flow, and higher driving speeds. They also concluded that a motion-based simulator alleviates simulator sickness in comparison with a fixed-based simulator, and that a full-scale simulator vehicle alleviates simulator sickness in comparison with a dashboard-only mock-up vehicle. Furthermore, also environmental- and user-specific characteristics were found to affect simulator sickness. Environmental characteristics such as a higher air humidity and a higher room temperature than 21°C increase the chances of developing simulator sickness, and should therefore be controlled. The user-specific characteristics that were found to affect simulator sickness were gender and operating experience. Women tend to experience simulator sickness sooner than men, and a higher operating experience alleviates simulator sickness. Age was not found to correlate with simulator sickness.

Because so many factors can potentially increase the probability of simulator sickness occurring, researchers will not always be able to predict if a participant will experience simulator sickness or not. Therefore, Brooks et al. [70] mention some critical issues that researchers need to consider when conducting a simulator experiment. First of all, they mention the need of obtaining *informed consent* from each research participant, which is basically permission from the participant (who have been received all relevant information, facts, reasonably foreseeable risks or discomforts) to conduct the scientific experiment. Participants should also know that they have the right to withdraw their given consent, and to withdraw their participation of the experiment at any moment. Second of all, Brooks et al. mention the need of *precautionary measures* to prepare researchers for when simulator sickness occurs. They recommend keeping sick bags, plastic gloves, mouthwash, drinks, light snacks, and cleaning products on hand. They also recommend to encourage a participant who suffers from simulator sickness to stay in the lab for a minimum of one hour, as simulator sickness can last (or even become more severe) for a prolonged period of time.

How simulator sickness of participants is tried to keep at a minimal level during the driving simulator experiment is discussed in Section 4.1.4.

3

RESEARCH QUESTIONS

After introducing the two main research questions in Section 1.2, this chapter will formulate the sub-questions and the related hypotheses of both main research questions with the help of the additional background information that is given in Chapter 2. The first main research question focusses on the differences in traffic safety around different major fork designs and is depicted directly below. By the scope that is defined in Section 1.3 this question focusses on the two sets of competitive major fork configurations as they are illustrated in Figure 3.1. These sets contain major fork configurations that are similar in the number of traffic lanes upstream and downstream, but are different in the number of mandatory lane changes that rightmost traffic has to perform to go to the left-diverging roadway.

1 How does the number of mandatory lane changes by right-most traffic going to the left-diverging roadway of a major fork affect the traffic safety?

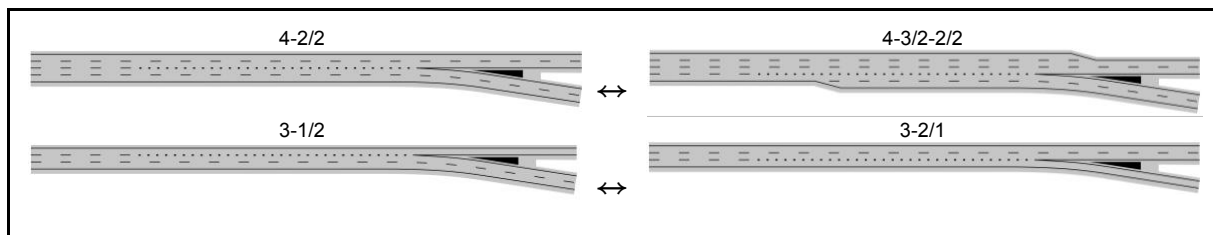

Figure 3.1: The two sets of researched major fork configurations

The first main research question is further subdivided into six sub-questions. For all sub-questions, the general hypothesis is that the major fork designs that include two mandatory lane changes are less safe than the major fork designs that include one mandatory lane change for rightmost traffic going to the left-diverging roadway of a major fork. In addition, a greater share of freight traffic is expected to show even greater differences in traffic safety between configurations. These hypotheses can be underpinned by the turbulence theory as it is worked out in Section 2.1. This theory explains that even though turbulence is always present in a traffic stream, it can differ in quantity. This means that a higher number of mandatory lane changes induce more individual driving maneuvers (especially when there is a greater speed dispersion), which leads to a higher level of turbulence, which in turn leads to a lower level of traffic safety.

The first four sub-questions focus on the probability of road crashes. The probability of road crashes increases with risk increasing driving behavior. Risk increasing behavior can be quantified by surrogate safety measures that measure the conflict-severity between road users on a certain road section. The hypothesis is that major fork configurations that include two mandatory lane changes relate to more unsafe driving behavior than major fork designs that include one mandatory lane change for rightmost traffic going to the left-diverging roadway. This is both expected for a traffic flow with a low share of freight traffic (i.e. 0%) and a traffic flow with a high share of freight traffic (i.e. 25%). Which combination of surrogate safety measures collectively explain the driving behavior and thus traffic safety around the different major fork designs is explained in Section 4.1.5.

1.1a What is the difference in driving behavior between the 4-2/2 major fork configuration and the 4-3/2-2/2 major fork configuration in case of a **0% freight traffic** condition?

1.1b What is the difference in driving behavior between the 3-1/2 major fork configuration and the 3-2/1 major fork configuration in case of a **0% freight traffic** condition?

1.2a What is the difference in driving behavior between the 4-2/2 major fork configuration and the 4-3/2-2/2 major fork configuration in case of a **25% freight traffic** condition?

1.2b What is the difference in driving behavior between the 3-1/2 major fork configuration and the 3-2/1 major fork configuration in case of a **25% freight traffic** condition?

The last two sub-questions focus on the crash risk. Perhaps somewhat self-explanatory, but note that a relative high crash risk relates to a relative lower level of traffic safety, while a relative low crash risk relates to a relative higher level of traffic safety. The hypothesis is that major fork designs that include two mandatory lane changes have a higher crash risk than major fork designs that include one mandatory lane change for rightmost traffic going to the left-diverging roadway.

1.3a What is the difference in crash risk between the 4-2/2 major fork configuration and the 4-3/2-2/2 major fork configuration?

1.3b What is the difference in crash risk between the 3-1/2 major fork configuration and the 3-2/1 major fork configuration?

The second main research question focusses on the differences in traffic safety around two small-radius connector road variants and is depicted directly below. By the scope that is defined in Section 1.3 this question focusses on the set of small-radius connector roads as it is illustrated in Figure 3.2. This set contains two (equally sized) small-radius connector roads that simultaneously are left-diverging roadways of a major fork, but are different in the number of traffic lanes they consist of.

2 How does the number of traffic lanes on the left-diverging roadway of a major fork, continuing in the same direction as the mainline roadway, affect the traffic safety as it is actually a small-radius connector road?

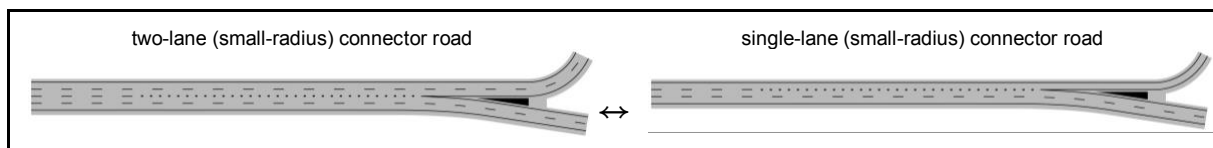

Figure 3.2: The set of researched left-diverging roadways (simultaneously being small-radius connector roads)

This second main research question is further subdivided into two sub-questions. For both sub-questions, the general hypothesis is that the two-lane small-radius connector road is less safe than the single-lane small-radius connector road. This hypothesis can be underpinned by the driver expectancy theory as it is worked out in Section 2.2. This theory explains that drivers on a two-lane left-diverging roadway will automatically and incorrectly categorize their continuing road as a mainline roadway and will therefore less expect a connector road feature (such as a small-radius) in comparison with drivers on a single-lane left-diverging roadway of a major fork. This leads to unwanted driving behavior, which in turn leads to a lower level of traffic safety.

The first sub-question focusses on driving behavior. The hypothesis is that a two-lane small-radius connector road relate to more unsafe driving behavior than a single-lane small-radius connector road. Driving behavior is analyzed with the help of surrogate safety measures as discussed in Section 2.3. Which combination of surrogate safety measures collectively explain the driving behavior and thus traffic safety around small-radius connector roads is explained in Section 4.1.5.

2.2 What is the difference in driving behavior between single- and two-lane small-radius connector roads (that simultaneously are left-diverging roadways of a major fork) in case of a **0% freight traffic** condition?

This sub-question only considers the 0% freight traffic condition. The 25% freight traffic condition is not considered in the analysis of the small-radius connector road variants since slower driving freight traffic is expected to affect the driving behavior of faster driving car traffic (including the participants in the driving simulator) too much to correctly measure the driving behavior affected by the road design.

The last sub-question focusses on the crash risk. The hypothesis is that a two-lane small-radius connector road has a higher crash risk than a single-lane small-radius connector road.

2.1 What is the difference in crash risk between single- and two-lane small-radius connector roads that are also left-diverging roadways of a major fork?

4

METHODOLOGY

To collect driving behavior, multiple methods exist. However, as discussed in Section 2.4, a driving simulator experiment is not just simply the only available method, it also turns out to be the most suitable method for this research. This method is elaborated in Section 4.1, and starts by going in depth on the requirements and final implementation of the road design, traffic design, simulator design and experiment design, and ends with the analysis methodology. To measure crash risk, there only exists one suitable method and that is an accident data analysis. This method is elaborated in Section 4.2, and goes in depth on the accident data source, location selection, and analysis methodology.

4.1 DRIVING SIMULATOR EXPERIMENT

An advantage of a driving simulator is the ability to let participants drive in a safe environment in which road design (discussed in Section 4.1.1) and traffic conditions (discussed in Section 4.1.2) are controlled by the researcher. A weakness is the risk of unrealistic driving behavior, but this can be limited by considering a simulator's physical validity (discussed in Section 4.1.3). As a driving simulator experiment is depending on the voluntariness of people to participate, an experiment design (discussed in Section 4.1.4) was established to guide participants through the experiment in a uniform, effective and responsible way. This chapter ends by elaborating on the analysis methodology in Section 4.1.5.

4.1.1 ROAD DESIGN

In line with the scope of this research and as discussed in Chapter 3, main research question 1 focuses on the turbulence around the two sets of competitive major fork designs as they are illustrated in Figure 3.1, and main research question 2 focuses on driver expectancy around the set of small-radius connector roads as they are illustrated in Figure 3.2. This simply means that the road design of the driving simulator experiment should minimally include these three sets of competitive major fork designs, which are thus six different major fork configurations in total. However, as already discussed in Section 1.3, the major fork designs with the small-radius connector road of main research question 2 are configured in such a way that they can be easily combined with the 4-2/2 and 3-1/2 major fork configurations of main research question 1. Especially since the focus of both main research questions are on other road sections. By combining these major fork designs, it is assumed that the driving behavior around the major fork is not affected by the presence of the small-radius connector road downstream of the major fork. Since the small-radius connector road is not directly visible until participants pass the major fork completely, this assumption is considered reasonable. This means that the road design of the driving simulator experiment only needs to include the four major fork configurations as they are illustrated in Figure 4.1. Note that these four major fork configurations still represent the three sets of competitive major fork designs as they were linked to the two main research questions (see Chapter 3) and as they were defined in the scope of this research (see Section 1.3).

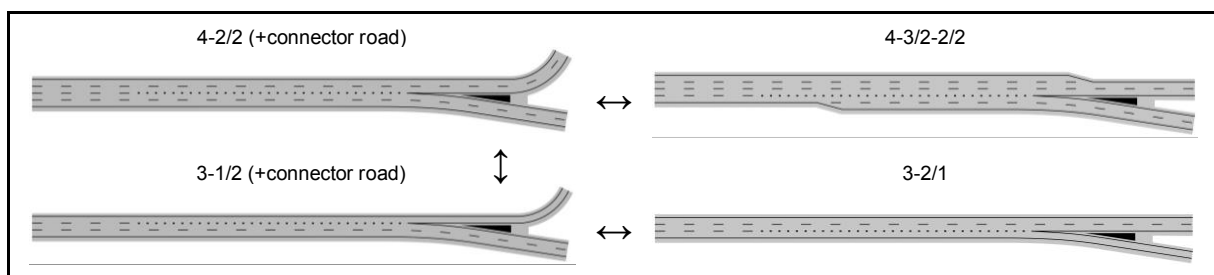

Figure 4.1: The four major fork configurations that should be included in the road design

A road design in which these four major fork configurations are closely followed by each other is undesirable since this is also never the case in the 'real' world and could therefore hint the participants about the objective of this research. By implementing other discontinuities in between, such as mergers and on-and off-ramps, the road design would better resemble a general freeway and could possibly pull the attention away from the major forks and thus the research objective. However, adding other discontinuities also adds considerable length to the road design, which entails other problems. Firstly, it increases the time that participants need to spent in the driving simulator. This is not necessarily a problem, but driving the actual road design is expected to take the vast majority of the total experiment time, and the total experiment time should be as low as possible to increase the voluntariness to participate. Secondly, VISSIM (the software that simulates the surrounding traffic) is limited to a ten by ten-kilometer area, which basically is an inescapable requirement for the road design. VISSIM is more elaborately discussed in Section 4.1.2.

Since it is expected that most of the participants have never driven in a driving simulator before, participants should be able to develop or practice the necessary simulator driving skills. Since one of the two main research questions focusses on driver expectancy, participants need to be able to practice freeway driving without encountering much of the actual major fork designs that are researched. The road design should therefore include a 'test track' that is located separately from the 'experimental track', but should also still minimally include (a different) major fork design with a small-radius connector road. Although the experimental track will exclusively include freeway-driving with a relatively high speed limit, participants should be familiar and comfortable with driving under all driving speeds. For this reason, the test track should include different road categories with different speed limits. By starting on a 30 km/h road in a built-up area and driving towards a 130 km/h freeway via an 80 km/h road outside the built-up area, participants gradually experience higher driving speeds and the corresponding driving characteristics of the simulator such as its road holding and controller sensitivities. Just like the experimental track, the length of the test track cannot be overly long due to constraints in total experiment time. As a consequence, it is expected that even after finishing the test track, participants will still further develop their simulator driving skills while driving on the experimental track. This potentially causes biased results since driving behavior is then not only affected by the road and traffic design, it is also affected by the amount of driving experience in the simulator. The order of the four major fork designs on the experimental track should therefore be randomized between the participants.

As discussed in Section 2.1.2, the contribution that an individual geometric feature has on the total traffic safety is difficult or even impossible to know. So, when designing the different major fork configurations in the driving simulator environment, it is thus important that the road geometry is as simple as possible in order to only measure the turbulence that is formed by the specific major fork configuration. However, since this research only includes comparisons in the scope, it is of more importance that the road geometry is the same in all major fork configurations. This way, the road geometry affects the driving behavior equally in all configurations. Taking this condition into account, the previous road design conditions, and all the relevant road design guidelines [1, 72, 73] has led to a total road network design consisting of an experimental track (as illustrated in Figure 4.2a) and two test tracks (as illustrated in Figure 4.2b).

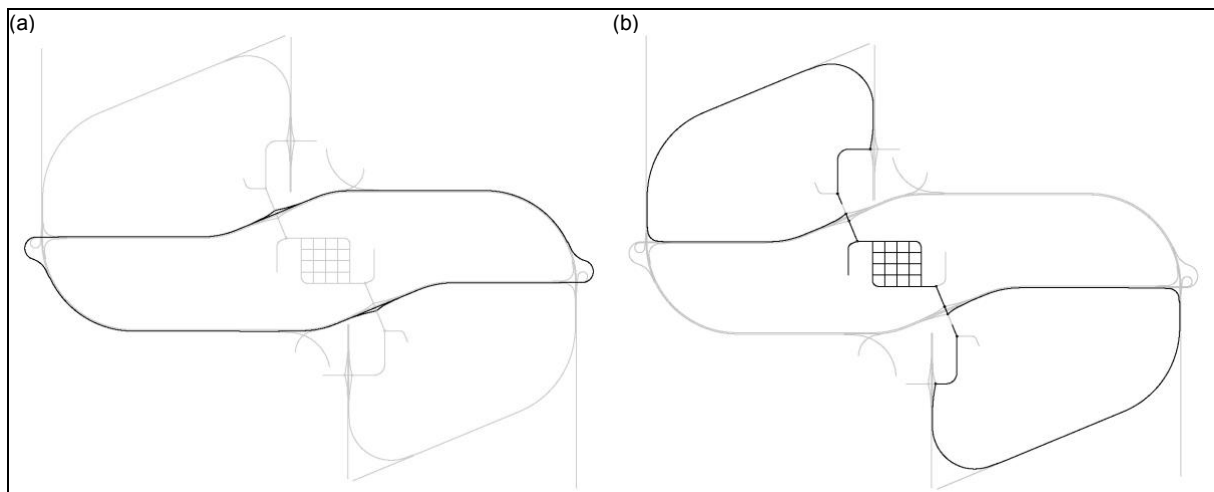

Figure 4.2: The test track design (a) and the experimental track design (b)

The experimental track (as illustrated in Figure 4.2a) is designed as a circular two-carriageway freeway network on which participants will drive exclusively on the outer carriageway (i.e. counterclockwise). The experimental track includes all four major fork configurations that were defined in Figure 4.1, four mergers, two on-ramps, two off-ramps and two junctions. Since the track has an on-ramp on both the south- and north-side, participants can be split equally over both these experimental track entrance points, which will lead to two different orders of major fork configurations that participants will encounter. A more detailed overview with all road geometry dimensions of the experimental track is attached in [Appendix A](#).

The test track (as illustrated in Figure 4.2b) consists of an underlying road network that is connected to two extra freeway networks on the south- and north-side of the experimental track. From a participant's perspective, the experiment starts on the underlying road network where the starting point of the simulation is inside a built-up area with a grid of 30 km/h access roads. This built-up area is connected with both freeway networks via the ring road of the built-up area (designed as a 50 km/h access road) and a little network of 80 km/h distributor roads and roundabouts. While, half of the participants is navigated towards the freeway test track on the south-side, and half of the participants is navigated towards the freeway test track on the north-side, both freeway test tracks are basically the same. To limit the size of the total road network design, each freeway test track includes a major fork design of the experimental track, at which a participant is navigated to the right-diverging roadway to diverge from the experimental track via a small-radius connector road. Each freeway test track is then located separately from the experimental track and continues with another major fork design at which participants are again navigated towards the right-diverging roadway via a small-radius connector road. Each freeway test track is ended with an off-ramp that leads back to the underlying road network.

As discussed in Section 2.4.2, a driving simulator should trigger realistic driving behavior by mimicking the simulated environment as realistic as possible. Next to having a road environment that is designed according to all relevant road design guidelines, the road design is enriched with viaducts, guardrails, road signs, lampposts, portals and (overhead) signage; combined with realistic materials. An impression of the driving simulator environment is attached in [Appendix B](#). While most of the attributes in the driving simulator environment are purely necessary from an aesthetic viewpoint, signage is also necessary from an experimental standpoint. The signage attached to the freeway portals will be used to navigate participants over the road design with the help of verbal instructions. As a consequence, the overhead signage should be designed by the official guidelines for the correct locations, sizes, symbols and font. To not overcomplicate the navigation task, the signage includes existing city names so that the corresponding verbal instructions are easily and maybe even subconsciously remembered. Also, the driving task is even more simplified by ensuring that the participant can follow only one city name over multiple major fork designs. From a topography viewpoint, every major fork design includes signage with a logical combination of existing city names for both the left- and right-diverging roadway. Also, non-existing freeway numbers and exit names are implemented to prevent participants from comparing the road design with a freeway they know from experience and to eliminate faulty expectations that are potentially created. With the help of the guidelines [74, 75], this have led to a signage plan for the experimental track as it is attached in [Appendix C](#).



Figure 4.3: An example of the signage as it is implemented in the road design of the driving simulator

4.1.2 TRAFFIC DESIGN

As we have seen in the previous section, the experimental track includes each of the four major fork configurations of Figure 4.1 once. This means that each participant needs to drive the entire experimental track one time for each traffic condition that needs to be tested. Although the experimental track is designed as short as possible, it would still take roughly 15 minutes to complete. This means that it would take 30 minutes to test two traffic conditions, which is roughly the maximum amount of time the experimental track can take up while limiting the total experiment duration to maximally one hour (including test driving and filling in multiple questionnaires). This is perfectly in line with sub-questions 1.1 and 1.2 that were specified in Chapter 3, and focus on measuring a difference in driving behavior between configurations in (1) a 0% freight traffic condition and (2) a 25% freight traffic condition. So, in order to test these two traffic conditions, each participant will encounter each of the four major fork configurations twice. Once under a low share of freight traffic and once under a high share of freight traffic. This means that they will encounter eight different scenarios in total, as given in an overview in Table 4.1. Since the experimental track includes all four major fork configurations once, the participant needs to drive the total experimental track twice.

Table 4.1: The eight combinations of major fork configuration and percentage of heavy vehicles

	Major fork configuration	Percentage of heavy vehicles
Scenario 1	4-2/2 (+connector road)	0%
Scenario 2	4-3/2-2/2	0%
Scenario 3	3-1/2 (+connector road)	0%
Scenario 4	3-2/1	0%
Scenario 5	4-2/2 (+connector road)	25%
Scenario 6	4-3/2-2/2	25%
Scenario 7	3-1/2 (+connector road)	25%
Scenario 8	3-2/1	25%

Since the objective of this research is to measure traffic safety, and the main research methodology is the use of surrogate safety measures that quantify traffic conflicts, the traffic should be designed in such a way that it stimulates these conflicts throughout the experiment. This does not mean that the traffic should actively create traffic conflicts, but it should contain the right traffic conditions that invite for traffic conflicts to happen. As discussed in Section 2.1.2, there are multiple traffic conditions that affect turbulence and therefore traffic conflicts, with the most prominent one being traffic volume. This section explained that certain traffic volume research concluded that multi-vehicle crashes occur towards the higher end of free-flow traffic conditions instead of the lower end, while other research concluded that the crash rates are higher under congested traffic conditions than under free-flow traffic conditions. However, creating congested traffic conditions result in lower driving speeds and thus undesirable longer experiment durations. So, to design the traffic such that it invites for traffic conflicts to happen, the experiment's intensity/capacity ratio (I/C-ratio) should therefore be as high as possible, without congestion occurring. Another traffic condition that affects turbulence and therefore traffic conflicts is the driving speed (dispersion), as discussed in Section 2.1.2. This section discussed that speeding is both a causation factor and an aggravating factor in traffic accidents, and thus also in traffic conflicts, with crash rates increasing exponentially with drivers increasing their speed. Furthermore, it discussed the negative effects of speed dispersion (i.e. differences in speed) on crash risk and how this is mainly formed by a relatively high share of freight traffic. Especially in the case of major forks, where slow-driving freight traffic on the rightmost lane changes lanes to the left to keep following their route, thereby mixing with the faster driving passenger cars. So, to design the traffic such that it invites for traffic conflicts to happen, both the driving speed for passenger cars and the speed difference between passenger cars and freight traffic should be as large as possible while still being realistic. This results in a driving speed of 130 km/h for passenger cars and a driving speed of 80 km/h for freight traffic.

VISSIM, a microscopic simulation program for modeling multimodal transport operations, is used to simulate the traffic in the driving simulator environment. The traffic volume in VISSIM is determined by doing multiple iterations until the highest traffic volume was found for which no congestion occurred. This I/C-ratio was found to be 0.7 as is defined in the CIA [76], which comes down to 4991 veh/hour/3lanes and 6601 veh/hour/4lanes for a traffic stream with 0% freight traffic, or 3993 veh/hour/3lanes and 5281 veh/hour/4lanes for a traffic stream with 25% freight traffic. Each vehicle that is simulated by VISSIM has its own driving behavior that is based upon a car-following model, lane-changing model, maximum and desired acceleration and deceleration function, desired speed

distribution, vehicle power distribution and vehicle weight distribution. Several of these models and distributions have been modified to better reflect (Dutch) driving behavior at a major fork:

- **Desired driving speed.** As VISSIM is from a German company, and since most of the German freeways do not have a mandatory speed limit but only an advisory speed limit, the standard desired speed distribution includes a relatively high probability for speeds above 130 km/h. For this reason, the desired speed distributions for both car and freight traffic are changed towards more realistic values. Calibrated free-flow driving speeds by Schakel [77] are used to create a new desired speed distribution for car traffic ($V_{\text{desired}} = 123.7$ and $\sigma = 12$) and freight traffic ($V_{\text{desired}} = 85$ and $\sigma = 2.5$).
- **Mandatory lane change location.** The location at a major fork at which the simulated traffic starts executing mandatory lane changes to follow one of the two routes is also a VISSIM setting, and can be adjusted per diverging roadway. Both of these locations are determined iteratively for the 4-lane and 3-lane major fork configurations separately. Various combinations of locations have been tested, in which the combination of locations with the smallest total travel time for the simulated traffic is chosen. In this process, only locations that are within a range of 200 meters from the first overhead signage or the beginning of the block marking have been considered.
- **Car-following and lane-changing.** Visual observation showed that simulated traffic does include some unrealistic individual driving maneuvers. Simulated traffic cuts other traffic off when mandatory lane changing, time headways are relatively small, and traffic overtakes with very minimal speed differences. Calibrated VISSIM parameters by Bosdikou [78] are used to obtain more realistic driving behavior. Bosdikou used real-life vehicle trajectories (collected by a camera mounted on a helicopter) to calibrate the car-following and lane-changing behavior of simulated traffic in VISSIM on weaving areas. Since weaving areas have a lot in common with major forks, visual observations confirmed that these unrealistic individual driving maneuvers were less common and less severe with the adopted VISSIM parameters instead of the standard parameters.

All used VISSIM parameters and settings can be found in [Appendix D](#).

VISSIM has not only the ability to generate the exact same traffic conditions for every new simulation run, it can also generate the exact same traffic situation. This entails that every new simulation run, every generated vehicle is driving with the same driving behavior and is at the same location for every time step in the simulation. This also ensures that voids in the traffic stream (i.e. parts of the traffic stream with a relatively low density of vehicles) are at the same location for every time step in the simulation. Since every participant enters the freeway at roughly the same time step, the VISSIM seeds need to be randomized in order to not let (almost) every participant drive in the same void at the same locations and thus to not let these voids bias the results.

By using a collection of scripts that is developed by engineering company Witteveen+Bos, the vehicles that are simulated in the VISSIM model are not only made visible on the road design in the driving simulator, the driving simulator vehicle is also represented in the VISSIM model. This means that the simulated traffic interacts with the participant by the same models, functions and distributions as it normally does.

4.1.3 SIMULATOR DESIGN

To guide driving simulator researchers, Lee et al. [66] made recommendations by linking different design issues to necessary simulator characteristics and level of fidelity. When considering measuring driver behavior at major fork designs, it categorizes display resolution, control input, and vehicle dynamics as important features; field of view, auditory cues, and motion and vibration as slight important features; and cab realism as not an important feature. They therefore recommend a low- to medium-fidelity driving simulator, which includes anything from a quarter cab with flat-panel screens and 45° to 140° FOV (i.e. field of view) to a free-standing cab with high-resolution front projection screens and 140° to 240° FOV. Jamson [79] adds that for correctly estimating longitudinal speeds in low-fidelity driving simulators, the minimum FOV is 120°.

The in-house driving simulator of the Delft University of Technology is one of the available simulators to conduct this experiment, but more importantly, the only available simulator that meets the requirements of Lee et al. [66]. The fixed-base simulator has three screens that together provide a 180° FOV, a simple dashboard, a haptic steering wheel, all three standard vehicle pedals (clutch, brake and gas), a gear stick, and a car seat with vibration and a seat belt (see [Appendix E](#)). Since the vehicle input and vehicle dynamics are calibrated by comparing it to a real vehicle, all of the important and slight important features that a driving simulator should include according to Lee et al. are included.

Furthermore, the driving simulator is slightly modified to make it more user-friendly. Firstly, the manual transmission is replaced with automatic transmission by reconstructing the gearshift to select automatic transmission modes instead of gears. This is expected to increase the controllability of the vehicle, since participants consequently only need to control the steering wheel, gas pedal and brake pedal. Controlling the gear shift and clutch is not necessary anymore, which cut the necessary tasks almost in half. And since driving in a simulator is different from driving in a real vehicle, every reduction in workload is welcome. Secondly, the driving simulator is equipped with a verbal navigation system. Comparable to a real in-car navigation system, it gives instructions about the route the participants need to follow. The instructions correspond to city names and freeway numbers on the overhead freeway signage (which are discussed in Section 4.1.1), and are timed to coincide with the upstream location of the overhead signage with respect to the divergence point. This has led to the verbal navigation plan as is attached in [Appendix F](#).

4.1.4 EXPERIMENT DESIGN

The experiment design are basically the steps in which participants will actively experience the experiment, from beginning to end. The driving simulator experiment consists of eight experimental components: recruitment, introduction, a first questionnaire, test driving, a second questionnaire, the actual experiment, a third questionnaire, and aftercare.

Recruitment

Participants will be notified of the driving simulator experiment for the first time during the recruitment stage, which will start a couple of weeks prior to the experiment. During this stage, potential participants (e.g. students, university employees, family members, and friends) are invited to participate in the experiment. While students and university employees are recruited by flyers and electronic advertisements on different social media platforms of the Delft University of Technology, family members and friends are simply recruited by a personal message. However, the communicated information is the same in both recruitment methods. It will include a short introduction to the experiment, the total experiment duration, the requirement of having a driver license for minimally one year to participate, location, experiment period, and an easy-to-remember web link to sign up. The web link redirects the participants to an online scheduling tool in which they can see all the possible dates and timeslots for the experiment and which of them are already taken or still free to sign up for. After signing up, the participant automatically gets a confirmation e-mail that includes his or her chosen date and timeslot, location, travel (and parking) directions for car and public transport, check-in instructions, information for cancelling or rescheduling their appointment, contact information, and the request to send an e-mail if anything is unclear. Two days before the appointment the participant is automatically send a reminder with the same content as the confirmation e-mail.

Introduction

At the start of the experiment, the participant is first instructed to read the introduction to the experiment (see [Appendix G](#)). This introduction includes a more elaborate description of the driving simulator experiment by breaking it down into experimental components, and informing the participant what he or she can expect during each of these components (i.e. test driving, the actual experiment, and questionnaires). By already extensively informing a participant on what to expect, a participant is hopefully made less nervous for the experiment. This possibly results in a more relaxed state of mind, closer to the state of mind that a participant usually has when he or she gets in a car to drive.

Together with the introduction, a participant is also given a *statement of consent* form (see [Appendix H](#)), which needs to be signed by the participant. By signing this form, the participant declares that he or she has read, understood and is aware of several issues concerning the experiment. This form also needs to be signed by the responsible researcher who declares that he has, both verbally and in written form, informed the participant about these issues. This means that participants need to be informed sufficient enough to give informed consent, but also inadequate enough to not know the real objective of the experiment. Therefore, participants are informed that the objective of this research is to measure driving behavior on the Dutch freeway and that a driving simulator is the easiest and least expensive method to do so. Extra or more detailed information is not given.

Questionnaire I

After introducing the participants to the experiment and getting their informed consent, the participants are asked to fill in the first questionnaire of three (see [Appendix I](#)). This questionnaire basically consists out of two parts. The first part has 10 questions and focuses on figuring out what type of driver the participant is. These questions include their gender, age, city of residence, primary mode of transportation, driving experience and simulator experience. The second part focuses on determining a baseline level for their physical well-being. As discussed in Section 2.4.2, driving in a simulator can cause simulator sickness, a syndrome that has a lot in common with motion sickness but tends to be less severe and of lower incidence. Next to simulator sickness being a serious concern for the driving simulator experiment (because it potentially causes confounding data and influences participant dropout rates), it is by definition undesirable for the participants (as it includes symptoms such as headaches, disorientation, nausea, dizziness, and even vomiting). By adapting the Pensacola Motion Sickness Questionnaire (MSQ), Kennedy et al. [80] developed the Simulator Sickness Questionnaire (SSQ) to provide a more valid index of overall simulator sickness severity. This questionnaire includes 16 simulator sickness symptoms that are categorized into the three distinct symptom clusters: *Nausea*, *Oculomotor*, and *Disorientation*. Each symptom needs to be scored on a 0-3 scale (with respect to how much each symptom is affecting a participant at that point of time) and is multiplied with a variable of its assigned symptom cluster. A total score is obtained by summing the three scores of the three distinct symptom clusters. By measuring the participants' simulator sickness score pre-experiment, a baseline level is determined that later can be compared with intra- and post-experimental measurements. If a participant scores a symptom of the "Disorientation" cluster (e.g. nausea, blurred vision, dizzy, vertigo) with a 2 or a 3 on the 0-3 scale, the participant is not even allowed to start the experiment. The participants are already made aware of this requirement in the confirmation and reminder e-mail of the driving simulator experiment, where it is advised to cancel or reschedule the booking if the participant is feeling sick on the day of/before the experiment.

Test driving in the simulator

After filling in the first questionnaire, participants are asked to take place in the driving simulator. Although the controller inputs of the driving simulator are almost exactly the same as the inputs of a real vehicle, the responsible researcher will help the participant with adjusting the seat to his or her needs and give instructions on how to operate the steering wheel, pedals, blinkers and gearshift. Even though the participant has read the introduction to the experiment and therefore has already got a clue on what to expect during test driving, the instructions are repeated in order to limit any uncertainties. The participant is asked to drive around in a test environment to get familiar with the driving characteristics of the driving simulator. They are told that their starting position is on the underlying road network and they need to follow the visual and verbal instructions until further notice by the experiment leader.

Questionnaire II

When the participant finishes the test track, he or she is asked to fill in the second questionnaire (see [Appendix J](#)) while keeping seated in the driving simulator. This second questionnaire only includes the second part of the first questionnaire, which is the question to score the 16 symptoms of the Simulator Sickness Questionnaire. Since the participant has already filled in the same question approximately 10 minutes prior, the questions are expected to be easily recalled and to be filled in quickly. The results of this second questionnaire will determine if the participant is advised to stop participating or not. If a participant scores a symptom of the "Disorientation" cluster with a 2 or a 3 on the 0-3 scale (which means it affects the participant moderate or severe), they are strongly advised to not continue the experiment. Since only the participants that scored all symptoms with a 0 or a 1 on the 0-3 scale were allowed test driving, a scale-up suggests that, even during the relatively short drive on the test track that contains relatively little traffic, the symptoms have increased to an uncomfortable level. If the participant would continue the experiment, these symptoms are only likely to increase since the actual experimental phase takes twice as long to complete and contains relatively more traffic and thus stimuli.

Actual experiment

If the participant passed the second questionnaire they will continue to the actual experiment. Again, although the participant is already given the needed instructions in the introduction, they are repeated in order to limit any uncertainties. The participant is asked to follow the visual and verbal instructions to the freeway and on the freeway. They are reminded that there is speed limit of 130 km/h, and they should try to keep this speed as much as possible, unless the traffic signs along the road advise otherwise or if the traffic situation is such that they do not feel comfortable driving the speed limit. They are also told that the total experimental track will take around 30 minutes, but there will be a short break

at each off-ramp they will encounter. Since each participant drives the total experimental track twice, a participant is given three short breaks. These short breaks are implemented to make the driving simulator experiment more robust. When for any reason the software crashes, only the data that was collected between the last break and the crash would be lost. As this is roughly 7,5 minutes (i.e. one fourth of the actual experiment) of data, this part of the actual experiment can easily be repeated, without exceeding the total experiment duration of one hour. A second advantage of these short breaks is the ability to give the eyes of a participant a moment of rest from the simulator screens. With each of the three short breaks, the participant has on average 3 minutes' rest, in which the participant is able to drink some water. Furthermore, the participant is asked about his or her physical well-being but without the need to fill in a questionnaire. Instead, the participant is asked to recall the questionnaire and decide, with the symptoms in mind, whether to continue the experiment or not. A third advantage of these short breaks is the ability to randomize the scenarios of Table 4.1, which are the eight combinations of major fork designs and traffic conditions. As already discussed in the road design, participants can be split up equally over two experimental track entrance points, which will lead to two different orders of major fork designs that participants will encounter. In combination with the short breaks every one fourth of the actual experiment, one could create four different orders of scenarios that participants will encounter (see Table 4.2).

Table 4.2: The four orders of scenarios that participants will encounter

	Order of scenarios
Order 1	Test track (south) – 1 – 2 – 3 – 4 – 5 – 6 – 7 – 8
Order 2	Test track (south) – 5 – 6 – 7 – 8 – 1 – 2 – 3 – 4
Order 3	Test track (north) – 3 – 4 – 1 – 2 – 7 – 8 – 5 – 6
Order 4	Test track (north) – 7 – 8 – 5 – 6 – 3 – 4 – 1 – 2

Questionnaire III and aftercare

After the actual experiment, the simulation is ended but the participant is asked to keep seated in the driving simulator to fill in the first part of third and final questionnaire (see Appendix K). This first part is again the Simulator Sickness Questionnaire with the same 16 symptoms to score as in the first and second questionnaire. Instead of being a criterion to participate in the experiment, this final SSQ is to investigate if the participant can be sent home safely. Simulator sickness can worsen after the experiment and can interfere with participants' real-life driving while driving home for example. If the results do show that there are some simulator sickness symptoms that are scored high, the participant is strongly advised to stay at the driving simulator laboratory until the symptoms decrease. After filling in the first part of the questionnaire, the participant is asked to step out of the driving simulator. Since the participant spent already quite some time in the driving simulator, he or she is offered something to drink (coffee, tea or water) with a little snack. At the same time, they are asked to fill in the second and last part of the questionnaire. This part has an evaluation purpose as it focuses on the driving simulator experience with respect to the participants' real driving experience. On a 5-point scale, participants are asked to score the driving characteristics of the driving simulator with respect to a real vehicle, and to score their driving behavior in the simulator with respect to their real driving behavior. Next to a scoring scale, there is also room to elaborate on the given answer with an open text box. This information could potentially help with the development of both the soft- and hardware side of the driving simulator of the Delft University of Technology for future research.

4.1.5 ANALYSIS METHODOLOGY

The objective is to reach minimally 40 participants for the driving simulator experiment, which comes down to four groups of 10 participants per order of scenarios. As discussed in Section 2.1.2, both age and gender are driver characteristics that influence crash risk. In the case of drivers' age, accident involvement rate is described by a U-shape function independent of gender. This means that both younger and older drivers have a relative higher accident rate than middle-aged drivers. In the case of drivers' gender, men tend to have a relative higher accident rate when considering younger drivers, but this is vice versa when considering middle-aged or older drivers. To not let the age or gender of the participants influence the results, only people under the age of 31 with minimally one year of driving experience on Dutch freeways are recruited, and a 50/50 distribution between men and women should be pursued for each of the four groups.

The analysis should be able to conduct a thorough and complete comparison for the two sets of competitive major fork configurations and the set of small-radius connector road variants. In compliance with sub-questions 1.1 and 1.2 (see Chapter 3), the analysis of the major fork configurations should be

split up in separate analyses that consider the 0% freight traffic condition and the 25% freight traffic condition separately. As also discussed in Chapter 3, the 25% freight traffic condition is not considered in the analysis of the small-radius connector road variants since slower driving freight traffic is expected to affect the driving behavior of faster driving car traffic (including the participants in the driving simulator) too much to correctly measure the driving behavior affected by the road design. However, it is probably necessary to include the experience level of the participants when they encounter a small-radius connector road. Since there are four orders of scenarios (discussed in Section 4.1.4 and Table 4.2) over which participants are equally distributed, it is for both the two-lane and single-lane small-radius connector road possible to subdivide all 40 participants into four groups of ten participants encountering the specific small-radius connector road for the first, second, third and fourth time. With the driver expectancy theory explained in Section 2.2, participants encountering a left-diverging roadway of a major fork (that is actually a small-radius connector road) for the first time are less likely to expect a small-radius connector road since this is also less likely to occur on Dutch freeways. With the same theory, it is plausible that participants encountering this left-diverging roadway for the fourth time during the driving simulator experiment have already so much more driving experience on the experimental road design that their expectations are rightly adjusted. This difference in driver expectancy will therefore lead to a difference in driving behavior. On the other hand, although the first encounter does measure driver expectations in its purest form, the driving behavior could also be easily biased by lower driving simulator skills. The analysis of the small-radius connector roads should therefore be split up in separate analyses that consider the 1st encounter, and the 2nd, 3rd, and 4th encounter separately.

This research focuses on two phenomena: (1) turbulence around major forks, and (2) driver expectancy around small-radius connector roads. Both phenomena can be explained by the driving behavior of the participants and by the interaction the participants have with the simulated traffic. Surrogate safety measures are necessary to translate this interaction (i.e. conflicts) to quantifiable traffic safety. Section 2.3.2 introduced several surrogate safety measures (SSM) that are able to quantify both longitudinal and lateral conflict severity, but only elaborated on the SSM that are best-applicable when focusing on turbulence and driver expectancy. To quantify longitudinal conflict severity, time-to-collision (TTC), Time Exposed Time-to-collision (TET), Time Integrated Time-to-collision (TIT), and time headway (THW) were the best-applicable SSM. To avoid judging just-unsafe car-following scenarios as safe and losing lots of interactions, a TTC threshold value of 6 seconds and a THW threshold of 2 seconds will be used in this research. To quantify lateral conflict severity, post-encroachment-time (PET) was the best-applicable SSM. To better understand how all of these SSM develop, also more general driving characteristics like speed, acceleration rate, lane choice, and lane change location should be taken into account. These general driving characteristics are especially useful when focusing on the driver expectancy around small-radius connector roads, because in those cases it is not only the interaction with other vehicles that determines the level of traffic safety, but also the interaction between the vehicle and the road design.

To collect vehicle trajectories, data of both the driving simulator vehicle and simulated traffic is collected ten times per second using the *direct output* function of VISSIM. With this function, VISSIM automatically generates text files as output files with all the attributes that are selected. To calculate the surrogate safety measures (i.e. TTC, TET, TIT, THW and PET) and more general driving characteristics (i.e. speed, acceleration rate, lane choice, lane change locations), these output files should minimally include the following attributes for every vehicle:

- **Time step [s]**. Gives the time step in the simulation on which the data is collected.
- **Vehicle ID**. Gives the vehicle ID.
- **Vehicle width [m]**. Gives the width of the vehicle.
- **Coordinates front**. Gives the X- and Y-coordinate of the middle of the front of the vehicle.
- **Coordinates rear**. Gives the X- and Y-coordinate of the middle of the rear of the vehicle.
- **Speed [m/s]**. Gives the speed of the vehicle.
- **Acceleration [m/s²]**. Gives the acceleration (or deceleration) of the vehicle.

Next to collecting vehicle attributes every simulation step, also the participant's driving errors are logged. By recording the time on which a participant makes an error, the error log can be used to delete the participant's vehicle trajectory at the major fork configuration on which the error happened. This is a radical measure, but errors make surrogate safety measures impossible to calculate. Errors that are taken into account include tolling of the vehicle, crashing into the guardrails, and continuously swaying over the entire carriageway. Traffic accidents that involve a simulated vehicle are not considered errors and are part of the analysis. Next to errors, also participants that drive slower than 60 km/h on a major

fork configuration are deleted from the analysis. Since the speed limit is 130 km/h on every major fork design from beginning to end, a driving speed below 60 km/h is a substantial deviation that is likely caused by an emergency stop or shock wave traffic jam, and would likely bias the results.

All of the surrogate safety measures and general driving characteristics can be of one or both kinds:

- **Location-specific.** These include lane choice, lane change location, driving speed, acceleration rate, time headway and time-to-collision, and need to be visualized along a major fork configuration or small-radius connector road variant. By putting all of these visualizations underneath each other, different driving behavior trends can be analyzed individually and can also be linked together to get a better total picture of the total traffic situation. This means that they all need to be visualized in a graph that specifies the location on the x-axis. Since the output of the driving simulator is time-specific instead of location-specific, each participant has a different number of total data points per major fork configuration or small-radius connector road variant. Consequently, each design is split in separate sections of 20 to 50 meters (depending on the surrogate safety measure or driving behavior characteristic), after which all data points of a specific participant are averaged out before they are taken into consideration for the total analysis of all 40 participants.
- **Not location-specific.** These include driving speed, acceleration rate, time headway, time-to-collision, Time Exposed Time-to-collision (TET), Time Integrated Time-to-collision (TIT), number of lane changes per participant, accepted gaps, and Post-Encroachment-Time (PET), and need to be visualized in a histogram or boxplot. Instead of comparing trends, these graphs compare complete datasets with each other in terms of mean, median, interquartile range, and shape of distribution. Assuming these datasets are not normally distributed, only the Kolmogorov-Smirnov test and Mann-Whitney U-test are suitable tests to test whether two datasets are of the same distribution or not [81, 82]. But since the datasets that need to be compared are so large (i.e. 4500+), the KS test almost certainly rejects the null hypothesis since small changes in the distributions are easily interpreted as significant. This is because the KS-test is mostly sensitive for changes in the shape, spread, or median of the distributions, which entails that the MWU-test is the better option since this test is mostly sensitive for changes in the medians only. This can be seen from the hypotheses of the MWU-test: $H_0: M_x = M_y$ (null hypothesis) and $H_1: M_x \neq M_y$ (alternative hypothesis), with M_x and M_y being the medians of datasets one and two respectively.

4.2 ACCIDENT DATA ANALYSIS

In the Netherlands, accident data is registered in *Bestand geRegistreerde Ongevallen Nederland* (BRON), which stands for the *Dutch registered accident file*. This product is an open-source file in which traffic accident reports from the police are linked to the digital road network of the *Nationale Wegenbestand* (NWB), which stands for the *National Road file*. For every unique accident, this file contains the freeway number, driving direction, hectometer sign value, cause, number of involved parties, vehicle information of every party, road user characteristics of every party, and the injury severity of every party. At the date of this analysis, BRON includes the registered accident data from 2003 until 2015, of which the 2003 data is essentially unusable since this data cannot be compared with the data of subsequent years due to a change in procedure since 2004.

4.2.1 ANALYSIS DESIGN

Next to the closest hectometer sign value of every unique accident, the data of BRON also includes the accident coordinates and a shapefile that contains a graphically simple but yet geographically accurate representation of the total road network of the Netherlands. This shapefile is a geospatial vector data format for geographic information system (GIS) software. By using such software, such as *Manifold GIS*, accident data can be made geographically visible. This facilitates the filtering of the total BRON data since accident data can easily be isolated from the total data set by zooming in on locations of interest and by drawing a selection box around it. In this research, the locations of interest are major fork road sections and small-radius connector roads that satisfy the following four criteria:

- **Geography.** Since this study only considers the Dutch design guidelines for freeways, only major forks and small-radius connector roads that are located in the Netherlands are taken into account.
- **Scope.** Only freeway configurations that are in line with the scope of both main research questions are taken into account. This means that for main research question 1, the accident data analysis only considers balanced 4-lane major forks (either in a 4-2/2 or 4-3/2-2/2 configuration) and 3-lane major forks (either in a 3-1/2 or 3-2/1 configuration); and that for main research question 2, the

accident data analysis only considers single-lane and two-lane left-diverging roadways (of major forks) that are simultaneously small-radius connector roads.

- **No odd configurations.** Only major fork designs that do not differ too much from each other are considered in the analysis. Especially in the length of the block marking there is a lot of variation, which obstruct mutual comparisons between major fork designs. As a consequence, only the selection of major fork road sections that have a block marking length that differs maximally 400 meters from each other are considered in the analysis.
- **No other discontinuities.** In order to only measure the effects of the major fork as an isolated design element, only major fork designs where other discontinuities are distant far enough are considered in the analysis. A discontinuity in a road design is a transition between different road segments, which is basically a point of divergence or convergence. Discontinuities are for example on- and off-ramps, weaving sections, branch connections, lane drops, lane additions, but also other major forks. These upstream and downstream distances around discontinuities where driving behavior and traffic flow are affected are called turbulence lengths, which the ROA [1] quantifies as presented in Table 4.3.

Table 4.3: Different discontinuities with their turbulence lengths and their measuring point [1]

Location	Design speed		Measuring point
	120 km/h	90 km/h	
upstream of on-ramp	150 m	110 m	point of painted nose
downstream of on-ramp	750 m	550 m	point of painted nose
upstream of off-ramp	750 m	550 m	point of painted nose
downstream of off-ramp	150 m	110 m	point of painted nose
upstream of branch connection	150 m	110 m	point of painted nose
downstream of branch connection	375 m	275 m	point of painted nose
upstream of major fork	150 m	110 m	begin of block marking
downstream of major fork	150 m	110 m	point of painted nose
upstream of lane drop	375 m	275 m	begin of painted gore zone
downstream of lane drop	150 m	110 m	end of painted gore zone
up/downstream of lane additions	-	-	-

The accident data analysis basically includes six freeway segments that can be assigned to three comparison groups: balanced 4-lane major forks (either in a 4-2/2 or 4-3/2-2/2 configuration), 3-lane major forks (either in a 3-1/2 or 3-2/1 configuration) and small-radius connector roads (either in a single-lane or two-lane variant). To make these comparisons fair, the crash risk should be calculated by dividing the number of crashes with the Annual Average Daily Traffic (AADT), which is measured in vehicles per hour. Data from the *Nationale Databank Wegverkeersgegevens* (NDW), which is the *National Data Warehouse for Traffic Information*, is used to collect these average daily traffic volumes. This publicly accessible historical database includes average traffic volumes measured per loop detector, and can be requested by selecting a time period (in days), considered days of the week, and location.

4.2.2 ANALYSIS METHODOLOGY

When comparing configurations with each other, the years of accident data of each considered location should match for a fair comparison. This means that for each comparison group, all locations collectively determine the used timespan in the analysis.

- **Available accident data.** Each comparison is based upon the largest coinciding timespan of consecutive years in which historical accident data is available for all considered locations in that comparison group. This availability does not necessarily depend on BRON, but is rather dependent on the years of existence of every considered location.
- **No major configurational and/or geometric changes.** Since the configuration and road geometry of a freeway section affects driving behavior and thus traffic safety (as discussed in Section 2.1), only the most recent years after a major change in the configuration or geometry of a freeway section should be taken into account. As a result, each comparison is based upon the largest coinciding timespan of consecutive years in which all considered locations in that comparison group minimally exist.

Additionally, the accident distribution along each freeway segment should be taken into account. To do so, the boundaries that define the most upstream and downstream limit in which registered accidents are taken into account should be determined. This means that, when analyzing the major fork designs,

the boundaries should include the total major fork design (i.e. the road section that is covered by the block marking) and the upstream and downstream turbulence length. In the case of the small-radius connector roads, the upstream boundary is determined by the divergence point of the preceding major fork, and the downstream boundary is determined by the end of the small-radius. However, there is also a certain inaccuracy in the BRON data that should be taken into account. As explained, the BRON data contains the freeway number, driving direction and hectometer sign value for every unique accident. Unfortunately, the police only report one hectometer sign value by walking randomly downstream or upstream and writing down the first hectometer sign value they encounter. Since they do not report two successive hectometer sign values, there exists an inaccuracy of maximally 100 meter upstream or downstream of the registered location, which means that BRON applies an accuracy of 200 meter. The boundaries for which registered accident data should be taken into account does thus not only extend with the upstream and downstream turbulence lengths, but also with the inaccuracy of BRON.

5

RESULTS OF THE DRIVING SIMULATOR EXPERIMENT

**When viewing this report electronically, see page iii for the best Acrobat Reader settings to read this chapter.*

The driving simulator experiment included 41 participants in total, of which one participant did not complete the entire experiment. Using the simulator sickness questionnaire, this participant was advised to stop the experiment prematurely, which turned out to be the right decision because the simulator sickness kept developing even after the participant had left the driving simulator vehicle. Consequently, only the results of the other 40 participants are taken into account in this analysis. Since the enrollment stalled after the first 20 participants, the goal of a 50/50 gender distribution was suspended, and the last 20 participants received a gift card for their participation. As a result, the experiment counted 24 males and 16 females, which makes up for a 60/40-distribution. All participants were aged between the 20 and 31 years, and gender was equally distributed over all four orders of scenarios. The results of the questionnaires, and thus more (detailed) information on the 40 participants, are attached in [Appendix L](#).

This chapter presents the results of the driving simulator experiment and is subdivided into three separate analyses. The 4-lane major fork configurations are discussed in Section 5.1, the 3-lane major fork configurations are discussed in Section 5.2, and the small-radius connector road variants are discussed in Section 5.3.

5.1 4-LANE MAJOR FORK CONFIGURATIONS

The analysis of the 4-lane major fork configurations is subdivided into two analyses that consider the 0% freight traffic condition and the 25% freight traffic condition separately in Section 5.1.1 and Section 5.1.2, respectively. Each analysis first focuses on the driving behavior along the 4-2/2 configuration (which is represented by a [blue color](#)), and subsequently on the driving behavior along the 4-3/2-2/2 configuration (which is represented by a [red color](#)) and their differences. The driving behavior is analyzed by subdividing the major fork configurations into intervals that are all considered separately. Each analysis ends with a comparison of driving behavior characteristics and surrogate safety measures that consider the major fork configurations as a whole (which is represented by a [grey color](#)).

5.1.1 0% FREIGHT TRAFFIC

The analysis of the 0% freight traffic condition is linked to the results on pages 40 to 41, which includes Figures 5.1 to 5.11 and Table 5.1.

4-2/2 configuration

- **Considering interval 1 [-1900, -1200]:**

[Figure 5.2a](#) shows that a large proportion of the participants changed lanes in a relatively short time period. It shows that almost all participants were driving in lane 2 and 3 at the start of the considered interval, and in lane 1 and 2 at the end of the considered interval. Since lane 3 was the incorrect lane to follow the route to the left-diverging roadway, these lane changes to the left (as also seen in [Figure 5.3](#)) were mostly mandatory lane changes. At the same time, [Figure 5.4](#) shows an increasing median and upper quartile of the driving speed, and [Figure 5.5](#) shows an increasing upper quartile of the time headway towards the end of the considered interval. These trends are not solely caused by the mandatory lane changes of the participants, since the VISSIM settings (see [Appendix D](#)) show that the location at which participants started executing their mandatory lane changes mismatch the location at which the simulated traffic started executing theirs.

- **Considering interval 2 [-1200, -600]:**

The start of the considered interval marks the spot where other left-diverging traffic started executing mandatory lane changes to lane 2 to follow their route to the left-diverging roadway. Consequently, at the beginning of the considered interval [Figure 5.4](#) shows that median and interquartile range of the driving speed stabilizes, [Figure 5.5](#) shows that the upper quartile of the time headway drops to the lowest values that have been recorded along the entire major fork configuration, and [Figure 5.6a](#) shows a high density of TTC trend lines below the 15 seconds. As a reaction, [Figure 5.2a](#) shows that again a large proportion of the participants changed lanes in a relatively short time period. It shows that almost all participants were driving in lane 2 at the start of the considered interval, and that roughly half of the participants was driving in lane 1 at the end of the considered interval. Since both lanes are the correct lanes to continue the route to the left-diverging roadway, these lane changes were not mandatory but discretionary in order to escape or avoid the conflicts with the other left-diverging traffic on lane 2. By escaping and avoiding the traffic conflicts, [Figure 5.5](#) shows an increase in the median and upper quartile of the time headway, and [Figure 5.6a](#) shows a lowered density of TTC trend lines (below the 15 seconds) towards the end of the considered interval.

- **Considering interval 3 [-600, 150]:**

[Figure 5.5](#) shows that the time headway stabilizes, which indicates that the raised level of turbulence is over. It also continues with a relatively high lower and upper quartile in comparison with both intervals that are previously considered. This is the result of the fact that the traffic volume is equally distributed over the left- and right-adjacent lanes of the block marking, while this was not the case before all mandatory lane changes took place due to the EU traffic rule of keeping-right when possible. [Figure 5.4](#) does show a major drop in the median and lower quartile of the driving speed towards the end of the considered interval, which is probably caused by the fact that the left-diverging roadway is also a small-radius connector road.

4-3/2-2/2 configuration

- **Considering interval 1 [-1900, -1200]:**

At the beginning of the considered interval, [Figure 5.4](#) shows a drop in the median and interquartile range of the driving speed that recovers just before the first overhead signage. Analyzing further, [Figure 5.2b](#) shows that, just like the 4-2/2 configuration, most participants were driving in lane 2 and lane 3 at the start of the considered interval. But unlike the 4-2/2 configuration, these lanes are the correct lanes to continue the route to the left-diverging roadway. Consequently, the lane distribution remains stable for the rest of the considered interval, and [Figure 5.3](#) shows an equal number of lane changes to the left and to the right. However, just like the 4-2/2 configuration, [Figure 5.4](#) shows an increasing median and interquartile of the driving speed, and [Figure 5.5](#) shows an increasing upper quartile of the time headway. Just like the 4-2/2 configuration, this is the result of the mandatory lane changes of the right-diverging simulated traffic.

- **Considering interval 2 [-1200, -600]:**

The start of the considered interval marks the spot where other left-diverging traffic started executing mandatory lane changes to lane 3 to follow their route to the left-diverging roadway. Consequently, at the beginning of the considered interval [Figure 5.4](#) shows that median and lower quartile of the driving speed drops, [Figure 5.5](#) shows that the upper quartile of the time headway drops, and [Figure 5.6b](#) shows a high density of TTC trend lines below the 15 seconds. In comparison with the 4-2/2 configuration, [Figure 5.4](#) not only shows a drop but the median and lower quartile of the driving speed stays significantly lowered for the rest of the considered interval, and [Figure 5.6b](#) not only shows a high density of TTC trend lines below the 15 seconds but also that they occur 200 meters more upstream. The main difference with the 4-2/2 configuration, which also explains these trends is explained by [Figure 5.2b](#), which shows that roughly half of the participants on the 4-3/2-2/2 configuration was driving in lane 3. This lane is closer to the right-side of the mainline roadway and thus closer to the simulated traffic that starts executing mandatory lane changes to the left-diverging roadway, and is also filled with traffic that wants to go the right-diverging roadway but does not have the space (yet) to drive on the right-adjacent side of the block marking.

- **Considering interval 3 [-600, 365]:**

Whereas the driving speed was decreased due to gap-searching right-diverging traffic on the left-adjacent lane of the block marking (i.e. lane 3), [Figure 5.4](#) shows that the median and interquartile range of the driving speed is now increasing to values that were observed at the total beginning of the analysis. By means of a lane addition to the right-side of the mainline roadway, gap-searching right-diverging traffic were given the space to do their mandatory lane change, which gave

participants on the left-adjacent lane of the block marking more and larger gaps and thus the ability to drive with their desired speed. [Figure 5.5](#) even shows above average time headways due to the fact that there are three left-diverging lanes and two right-diverging lanes, while the total traffic is equally distributed over both sides of the block marking. Towards the end of the considered interval, [Figure 5.4](#) shows a steady median driving speed, with at the end (at the location of the lane drop) a little drop that is combined with a drop in the median time headway (as seen in [Figure 5.5](#)) and a high density of TTC trend lines below the 15 seconds (as seen in [Figure 5.6b](#)).

Both configurations as a whole

- [Figure 5.7a](#) and [Figure 5.7b](#) show that the configurations have almost equal driving speed distributions and boxplots. The Mann-Whitney U-test (see [Table 5.1](#)) also indicates that the hypothesis that both medians are from the same distribution cannot be rejected.
- [Figure 5.8a](#) shows that the 4-3/2-2/2 configuration has a higher probability that a participant experienced a time headway below the 2 seconds.
- [Figure 5.9a](#) shows that the 4-3/2-2/2 configuration has a higher probability that a participant experienced a conflict with a time-to-collision below the 6 seconds, while the 4-2/2 configuration shows the lowest outliers of TTC values of 3 seconds and lower.
- [Figure 5.10a](#) and [Figure 5.10b](#) shows that the summed TET and the summed TIT are both higher for the 4-3/2-2/2 configuration, while [Table 5.1](#) shows that the mean TET and TIT values per conflict are both higher for the 4-2/2 configuration.
- [Figure 5.11b](#) shows that, although only the 4-2/2 configuration included participants that needed to execute mandatory lane changes, the 4-3/2-2/2 configuration counted a higher number of total lane changes. In addition, [Table 5.1](#) also shows a higher mean and median of number of lane changes per participant for the 4-3/2-2/2 configuration.
- [Figure 5.11b](#) shows that the 4-2/2 configuration has smaller accepted gaps when lane changing, which are primarily caused by smaller front side gaps (see [Table 5.1](#)), since the 4-3/2-2/2 configuration has larger accepted rear side gaps.
- [Figure 5.11c](#) shows that the 4-2/2 configuration does have a lower mean, median and interquartile range of PET when lane changing.
- Noteworthy is that [Table 5.1](#) shows that one participant is deleted from the results of the 4-3/2-2/2 configuration, which indicates that (at least during one time step of the simulation) this participant drove with a driving speed that was less than 60 km/h on the considered major fork.

Results of the 4-lane major fork configurations (0% freight traffic)

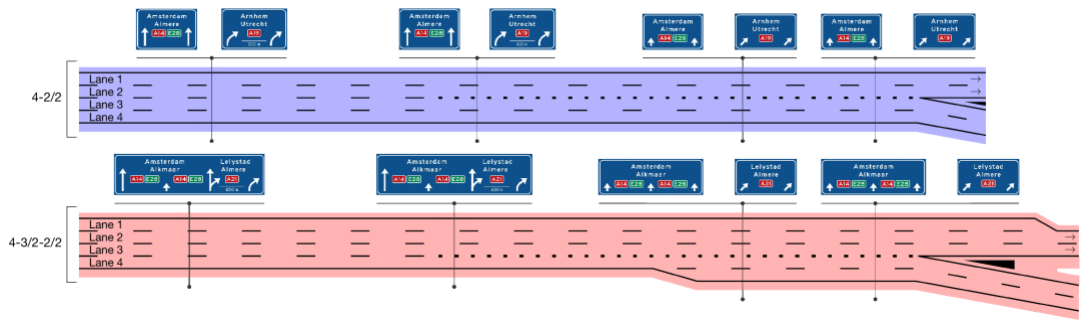

(Fig. 5.1ab)

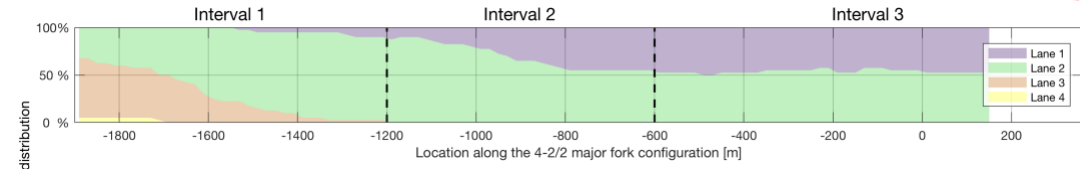

(Fig. 5.2ab)

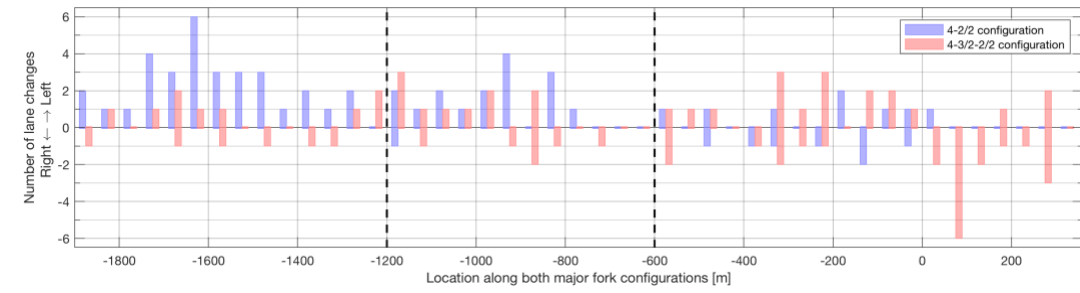
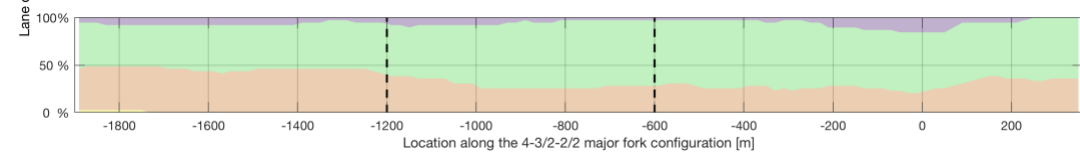

(Fig. 5.3)

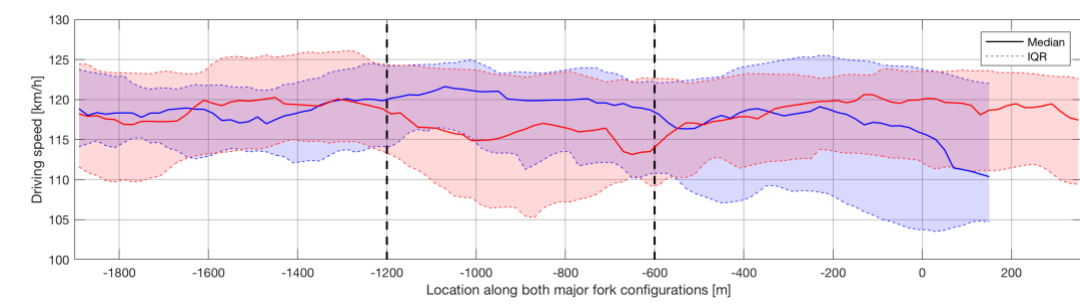

(Fig. 5.4)

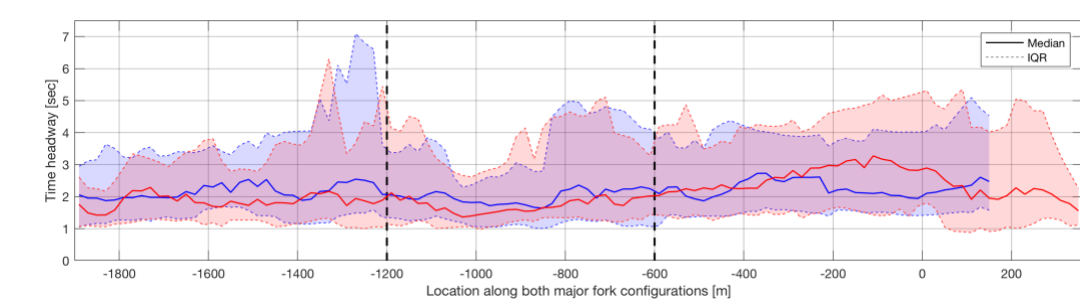

(Fig. 5.5)

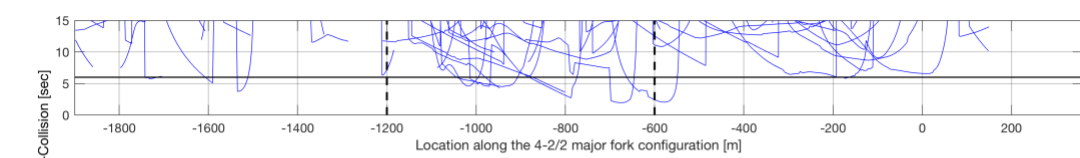

(Fig. 5.6ab)

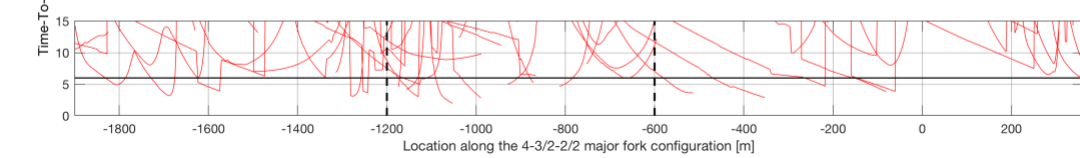

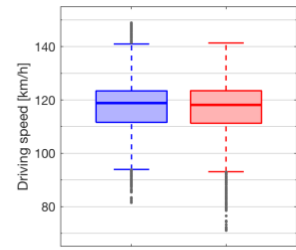
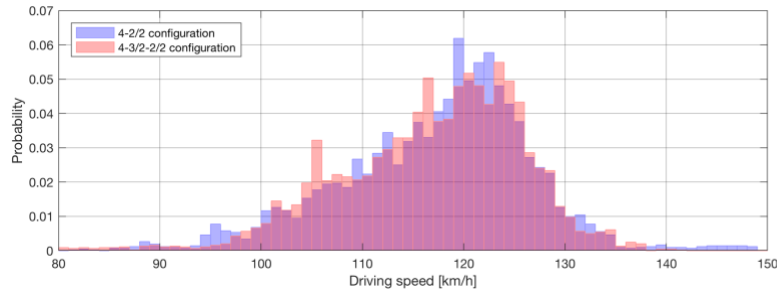

(Fig. 5.7ab)

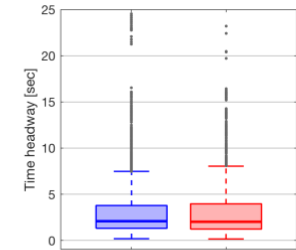
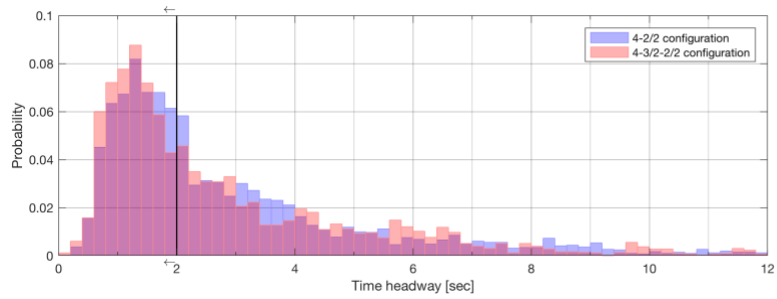

(Fig. 5.8ab)

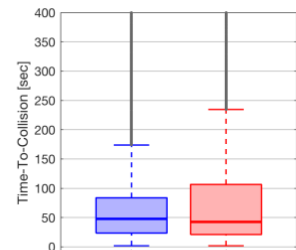
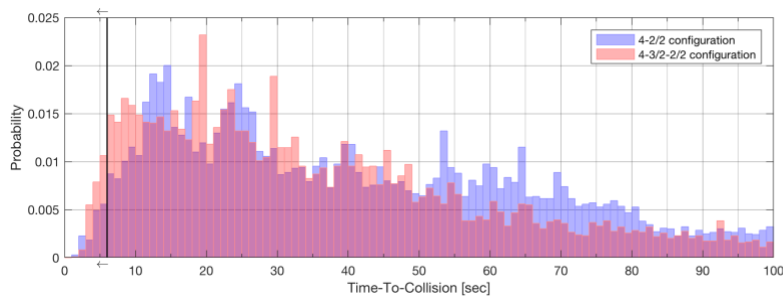

(Fig. 5.9ab)

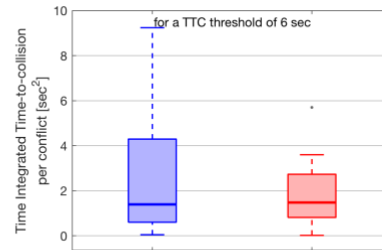
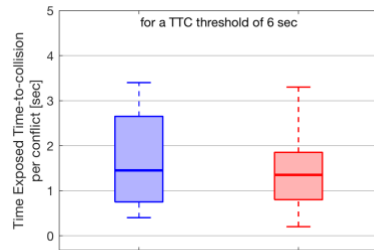

(Fig. 5.10ab)

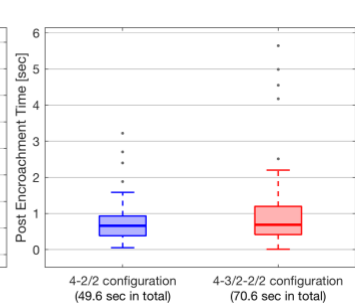
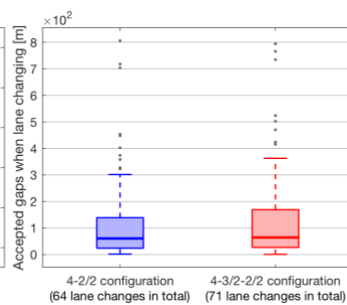
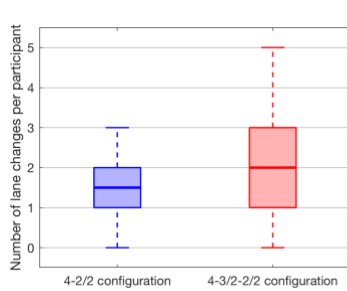

(Fig. 5.11abc)

Table 5.1:

	4-2/2 configuration (0% freight)			4-3/2-2/2 configuration (0% freight)			Mann-Whitney U-test
	mean	median	[IQR]	mean	median	[IQR]	
Driving speed	117.31	118.84	[111.61 - 123.39]	116.76	118.14	[111.27 - 123.46]	$p = 0.050$ indicates that H_0 cannot be rejected
Time headway	3.12	2.09	[1.32 - 3.78]	3.07	2.02	[1.23 - 3.96]	$p = 0.005$ indicates that H_0 is rejected
Time-To-Collision (TTC)	150.56	47.80	[23.52 - 83.66]	315.01	42.62	[21.07 - 106.49]	$p = 0.041$ indicates that H_0 is rejected
TET (TTC threshold of 6sec)	1.69	1.45	[0.75 - 2.65]	1.36	1.35	[0.80 - 1.85]	
TIT (TTC threshold of 6sec)	2.62	1.39	[0.60 - 4.29]	1.80	1.47	[0.81 - 2.73]	
Lane changes (per participant)	1.60	1.50	[1.00 - 2.00]	1.82	2.00	[1.00 - 3.00]	
Accepted gaps	110.59	60.25	[23.73 - 138.60]	120.22	64.01	[26.65 - 168.81]	
Accepted gaps (frontside)	132.52	83.33	[47.25 - 145.60]	115.97	71.69	[37.43 - 166.16]	
Accepted gaps (rearside)	87.57	41.19	[14.46 - 113.45]	124.65	51.59	[18.79 - 175.18]	
Post-Encroachment-Time (PET)	0.78	0.66	[0.38 - 0.93]	0.99	0.69	[0.42 - 1.20]	
Total accidents	0			0			
Total participants	40			39 (1 deleted)			

5.1.2 25% FREIGHT TRAFFIC

The analysis of the 25% freight traffic condition is linked to the results on pages 44 to 45, which includes Figures 5.12 to 5.22 and Table 5.2.

4-2/2 configuration

- **Considering interval 1 [-1900, -1200]:**

Figure 5.13a shows that more participants were driving in lane 2 at the start of the considered interval in comparison with the 0% freight traffic condition (see Figure 5.2a). This seems obvious since the leftmost lanes had become more attractive due to slower-driving freight traffic on the rightmost lanes. It shows that most participants were driving in lane 2, and only a small proportion of the participants in lane 1 and lane 3. As a result, most participants were already driving on the correct lane to continue their route, and mandatory lane changes were nearly absent. Towards the end of the considered interval, Figure 5.15 shows an increasing median and lower quartile of the driving speed, and Figure 5.16 shows an increasing median and upper quartile of the time headway. Again, since the VISSIM settings (see Appendix D) show that this is the location at which simulated traffic started executing mandatory lane changes to the right-diverging roadway, these trends are solely caused by the simulated traffic.

- **Considering interval 2 and interval 3 simultaneously [-1200, -200]:**

The start of the considered interval marks the spot where other left-diverging traffic started executing mandatory lane changes to lane 2 to follow their route to the left-diverging roadway. Consequently, at the beginning of the considered interval Figure 5.15 shows a decrease in the median and interquartile range of the driving speed, Figure 5.16 shows that the median and upper quartile of the time headway drops to the lowest values that have been recorded along the entire major fork configuration, and Figure 5.17a shows a high density of TTC trend lines below the 15 seconds. As a reaction, Figure 5.13a shows that a large proportion of the participants changed lanes in a relatively short time period. It shows that almost all participants were driving in lane 2 at the start of the considered interval, and that roughly three-quarters of the participants was driving in lane 1 at the end of the considered interval. Since both lanes are the correct lanes to continue the route to the left-diverging roadway, these lane changes were not mandatory but discretionary in order to escape or avoid the conflicts with the other left-diverging traffic on lane 2. By escaping and avoiding the traffic conflicts, Figure 5.15 shows that the median and interquartile range of the driving speed stabilizes, Figure 5.16 shows an increase in the median and interquartile range of the time headway, and Figure 5.17a shows a lowered density of TTC trend lines (below the 15 seconds) towards the end of the considered interval.

- **Considering interval 4 [-200, 150]:**

Figure 5.16 shows that the time headway continues with a relatively high lower and upper quartile in comparison with both intervals that are previously considered. This is the result of the fact that the traffic volume is equally distributed over the left- and right-adjacent lanes of the block marking, while this was not the case before all mandatory lane changes took place due to the EU traffic rule of keeping-right when possible.

4-3/2-2/2 configuration

- **Considering interval 1 [-1900, -1200]:**

At the beginning of the considered interval, Figure 5.15 shows a drop in the median and interquartile range of the driving speed that recovers just before the first overhead signage. Analyzing further, Figure 5.13b shows that the center of the lane distribution is shifted towards the leftmost lanes in comparison with the 0% freight traffic condition (see Figure 5.2b), which is obviously caused by slower-driving freight traffic on the rightmost lanes. It also shows that, just like the 4-2/2 configuration, most participants were driving in lane 2, and only a small proportion of the participants in lane 1 and lane 3. But unlike the 4-2/2 configuration, these lanes are the correct lanes to continue the route to the left-diverging roadway, and mandatory lane changes were thus totally absent. Towards the end of the considered interval, Figure 5.15 shows a decreasing lower quartile of the driving speed, Figure 5.16 shows no major increase in the upper quartile of the time headway and Figure 5.17b already shows a high density of TTC trend lines below the 15 seconds. In comparison with the 4-2/2 configuration, the trends of the driving speed and time headway are opposite, and the high density of TTC trend lines occurs 200 meters more upstream. The main difference with the 4-2/2 configuration, which also explains these trends is explained by Figure 5.13b, which shows that a proportion of the participants on the 4-3/2-2/2 configuration was driving in lane 3. This lane is

closer to the right-side of the mainline roadway and thus closer to the simulated (freight) traffic that started executing mandatory lane changes to the left-diverging roadway, and was also filled with (freight) traffic that wanted to go the right-diverging roadway but did not have the space (yet) to drive on the right-adjacent side of the block marking.

- **Considering interval 2 [-1200, -700]:**

The start of the considered interval marks the spot where other left-diverging traffic started executing mandatory lane changes to lane 3 to follow their route to the left-diverging roadway. Consequently, at the beginning of the considered interval [Figure 5.15](#) shows that the lower quartile of the driving speed stays lowered, [Figure 5.16](#) shows that the upper quartile of the time headway drops, and [Figure 5.17b](#) shows a high density of TTC trend lines below the 15 seconds. As a reaction, a relatively small proportion of the participants changed lane to the left in comparison with the 4-2/2 configuration. However, [Figure 5.16](#) shows that it causes for a higher upper quartile of the time headway than the 4-2/2 configuration, which indicates a lower traffic density on lane 1 than the 4-2/2 configuration.

- **Considering interval 3 [-700, -200]:**

[Figure 5.15](#) shows an increasing median and interquartile range of the driving speed, and [Figure 5.16](#) shows an increasing median and lower quartile of the time headway. Since at the same time [Figure 5.13b](#) shows that participants changed from lane 1 to lane 2, this is clearly the result of the lane addition on the right-side of the mainline roadway, and consequently, the decrease in traffic intensity on the left-adjacent lanes of the block marking. In comparison with the 4-2/2 configuration, [Figure 5.17b](#) shows that this interval has a relatively low density of TTC trend lines below the 15 seconds, which indicates that the raised level of turbulence has ended approximately 400 meters earlier.

- **Considering interval 4 [-200, 365]:**

At the lane drop that is located towards the end of the considered interval, [Figure 5.15](#) shows a drop in the median and lower quartile of the driving speed, [Figure 5.16](#) shows a drop in the median and upper quartile of the time headway, and [Figure 5.17b](#) shows a high density of TTC trend lines below the 15 seconds. In comparison, these trends are more severe than the 0% freight traffic condition due to the fact that lane 3 was now primarily filled with slower-driving freight traffic and thus unattractive for faster-driving car traffic.

Both configurations as a whole

- [Figure 5.18a](#) and [Figure 5.18b](#) show that the configurations have almost equal driving speed distributions and boxplots. The Mann-Whitney U-test (see [Table 5.2](#)) also indicates that the hypothesis that both medians are from the same distribution cannot be rejected.
- [Figure 5.19a](#) shows that the 4-3/2-2/2 configuration has a higher probability that a participant experienced a time headway below the 2 seconds.
- [Figure 5.20a](#) shows that the 4-3/2-2/2 configuration has a higher probability that a participant experienced a conflict with a time-to-collision below the 6 seconds, while the 4-2/2 configuration shows the lowest outliers of TTC values of 2 seconds and lower.
- [Figure 5.21a](#) and [Figure 5.21b](#) show that the summed TET and TIT are roughly equal for both configurations, while [Table 5.2](#) shows that the mean TET and TIT values per conflict are both higher for the 4-3/2-2/2 configuration.
- [Figure 5.22b](#) shows that the 4-3/2-2/2 configuration counted a higher number of total lane changes, and [Table 5.2](#) also shows a higher mean and median of number of lane changes per participant for the 4-3/2-2/2 configuration.
- [Figure 5.22b](#) and [Table 5.2](#) show that the 4-3/2-2/2 configuration has smaller accepted gaps when lane changing, while [Figure 5.22c](#) and [Table 5.2](#) show that the 4-2/2 configuration included lane changes with smaller PET values, which indicates that the PET values of the 4-2/2 configuration are primarily formed by the interaction with the leading and following vehicle on the lane that is exited.
- Noteworthy is that [Table 5.2](#) shows that two accidents occurred on the 4-2/2 configuration, which is in line with the TTC outliers that were found in [Figure 5.19a](#). Looking at [Figure 5.17a](#), these accidents probably occurred around 700 meters upstream of the divergence point, which is the location where (freight) traffic entered lane 2 to follow the route to the left-diverging roadway.

Results of the 4-lane major fork configurations (25% freight traffic)

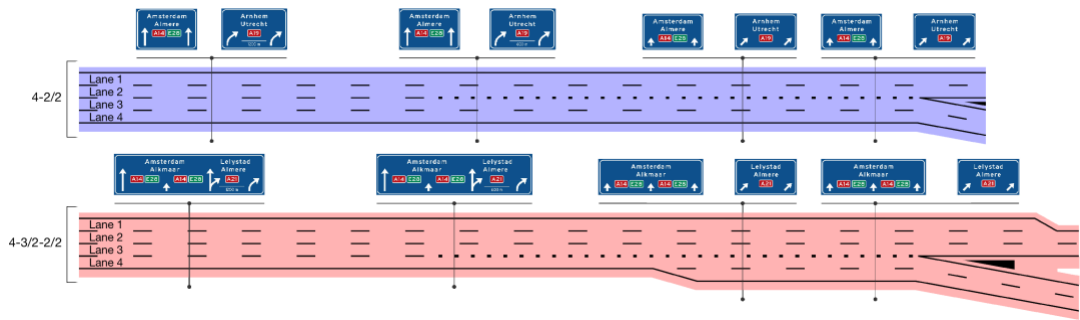

(Fig. 5.12ab)

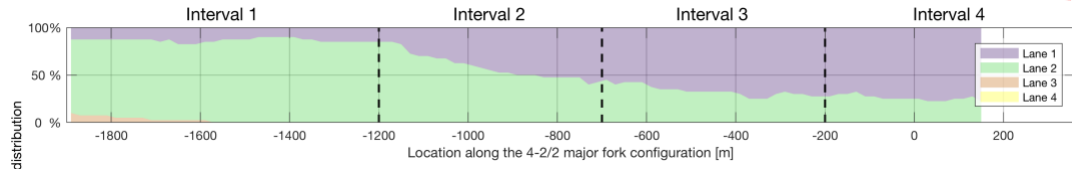

(Fig. 5.13ab)

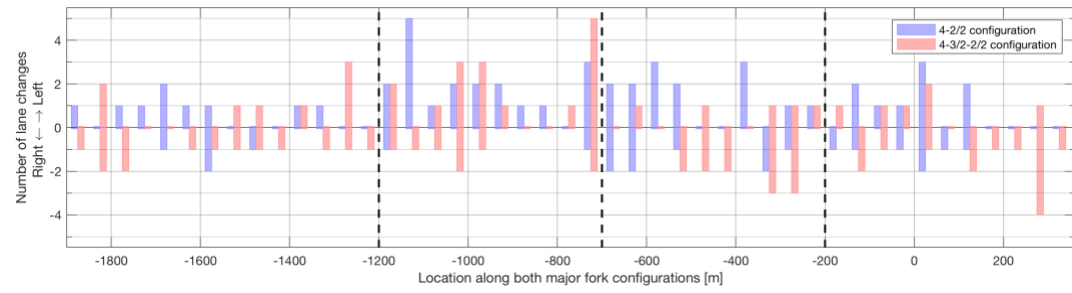
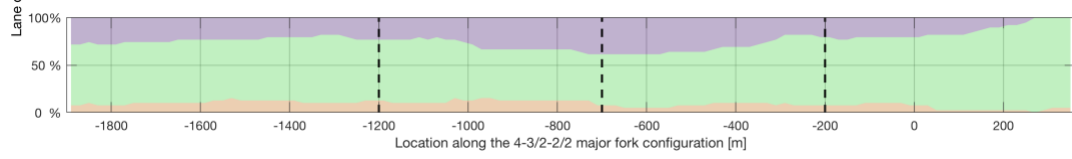

(Fig. 5.14)

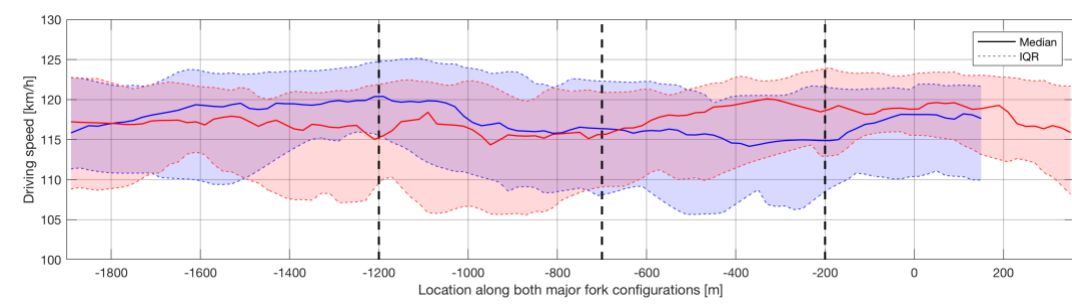

(Fig. 5.15)

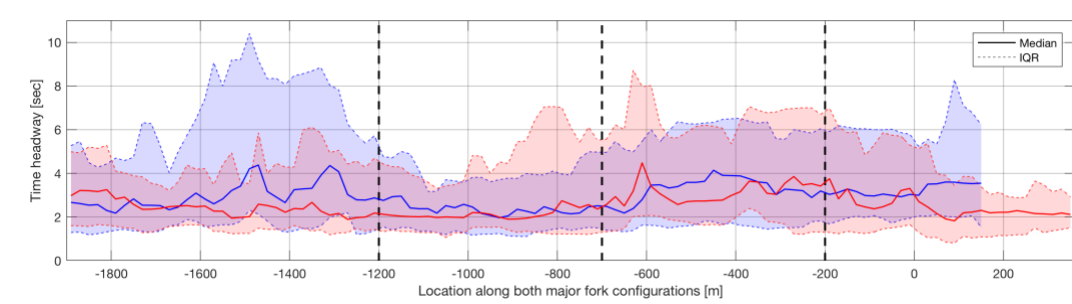

(Fig. 5.16)

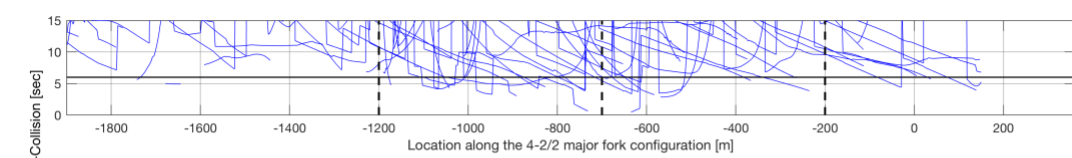

(Fig. 5.17ab)

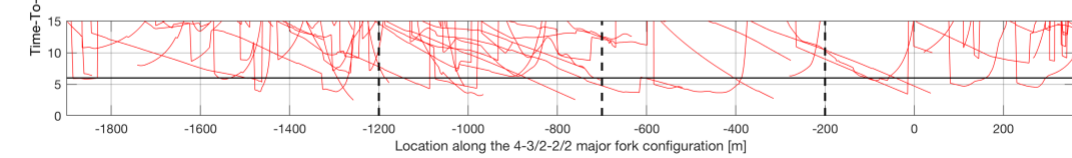

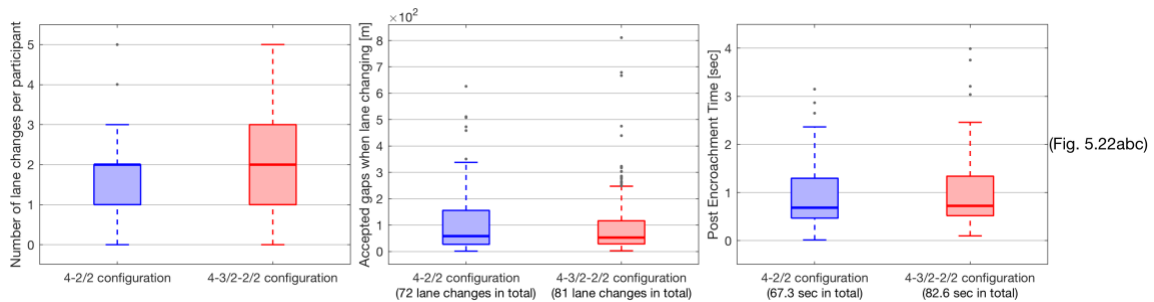
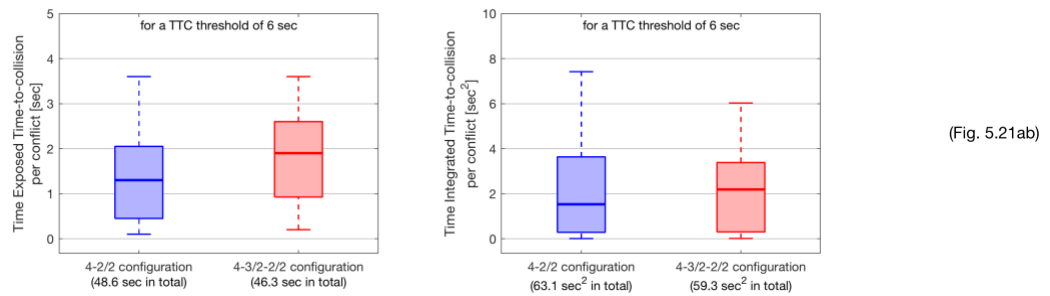
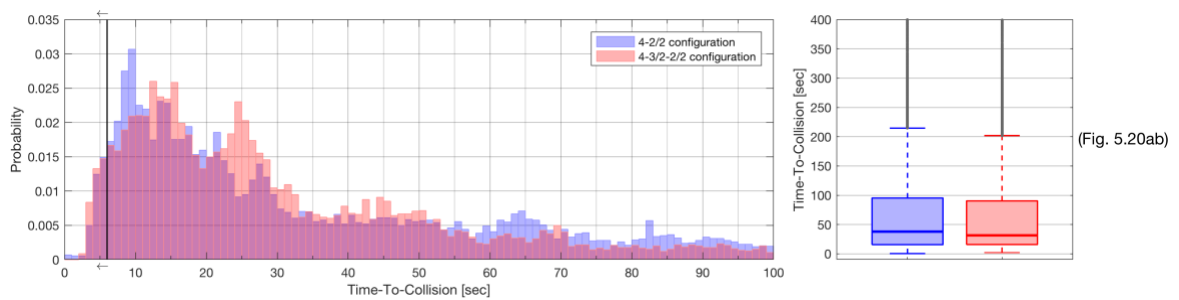
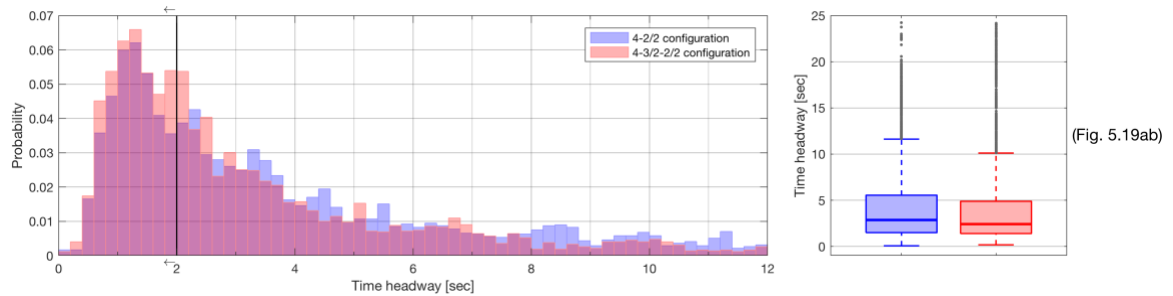
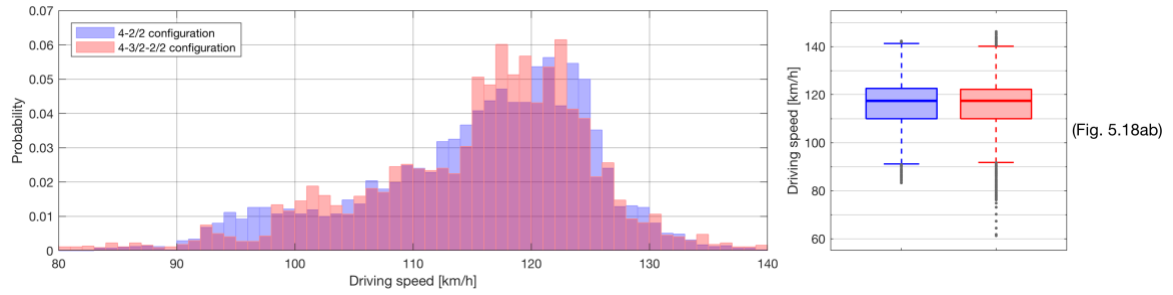

Table 5.2:

	4-2/2 configuration (25% freight)			4-3/2-2/2 configuration (25% freight)			Mann-Whitney U-test
	mean	median	[IQR]	mean	median	[IQR]	
Driving speed	115.51	117.39	[109.96 - 122.58]	115.51	117.42	[109.96 - 122.20]	$p = 0.850$ indicates that H_0 cannot be rejected
Time headway	4.31	2.87	[1.50 - 5.55]	4.22	2.42	[1.40 - 4.89]	$p = 0.000$ indicates that H_0 is rejected
Time-To-Collision (TTC)	211.73	37.96	[15.70 - 95.27]	291.25	31.52	[15.96 - 90.37]	$p = 0.007$ indicates that H_0 is rejected
TET (TTC threshold of 6sec)	1.52	1.30	[0.45 - 2.05]	2.01	1.90	[0.92 - 2.60]	
TIT (TTC threshold of 6sec)	1.97	1.53	[0.29 - 3.63]	2.58	2.19	[0.30 - 3.38]	
Lane changes (per participant)	1.80	2.00	[1.00 - 2.00]	2.08	2.00	[1.00 - 3.00]	
Accepted gaps	108.14	58.44	[27.26 - 155.80]	103.03	52.91	[28.83 - 116.44]	
Accepted gaps (frontside)	112.91	59.43	[33.49 - 169.18]	110.36	59.39	[39.66 - 133.23]	
Accepted gaps (rearside)	103.15	52.51	[24.73 - 126.74]	95.50	45.38	[21.90 - 113.01]	
Post-Encroachment-Time (PET)	0.93	0.68	[0.47 - 1.30]	1.02	0.72	[0.52 - 1.34]	
Total accidents	2			0			
Total participants	40			39 (1 deleted)			

5.2 3-LANE MAJOR FORK CONFIGURATIONS

The analysis of the 3-lane major fork configurations is subdivided into two analyses that consider the 0% freight traffic condition and the 25% freight traffic condition separately in Section 5.2.1 and Section 5.2.2, respectively. Each analysis first focuses on the driving behavior along the 3-1/2 configuration (which is represented by a [blue color](#)), and subsequently on the driving behavior along the 3-2/1 configuration (which is represented by a [red color](#)) and their differences. The driving behavior is analyzed by subdividing the major fork configurations into intervals that are all considered separately. Each analysis ends with a comparison of driving behavior characteristics and surrogate safety measures that consider the major fork configurations as a whole (which is represented by a [grey color](#)).

5.2.1 0% FREIGHT TRAFFIC

The analysis of the 0% freight traffic condition is linked to the results on pages 48 to 49, which includes Figures 5.23 to 5.33 and Table 5.3.

3-1/2 configuration

- **Considering interval 1 [-1300, -900]:**

[Figure 5.24a](#) shows that roughly half of the participants changed lanes in a relatively short time period. It shows that most participants were driving in lane 2 at the start of the considered interval, and in lane 1 at the end of the considered interval. Since lane 2 is the incorrect lane to follow the route to the left-diverging roadway, these lane changes to the left were mandatory lane changes. [Figure 5.25](#) shows the same trend with a peak of lane changes to the left around 1000 meters upstream of the divergence point. At the same time, [Figure 5.26](#) shows a slight increase for the median driving speed and its lower quartile, and [Figure 5.27](#) shows an increase in the time headway's upper quartile. These trends are not solely caused by the mandatory lane changes of the participants, since the VISSIM settings (see [Appendix D](#)) show that the location at which participants started executing their mandatory lane changes mismatch the location at which the simulated traffic started executing theirs.

- **Considering interval 2 [-900, -400]:**

The start of the considered interval marks the spot where other left-diverging traffic started executing mandatory lane changes to lane 1 to follow their route to the left-diverging roadway. Consequently, [Figure 5.26](#) shows that the lower quartile of the driving speed stabilizes, [Figure 5.27](#) shows a drop in the upper quartile of the time headway, and [Figure 5.28a](#) shows a higher density of TTC trend lines that are below the threshold of 6 seconds. Since all the mandatory lane changes by left-diverging traffic were completed, including those of the slowest driving passenger cars, the driving speed of the participants was now fully dependent of the downstream traffic on lane 1 since there are no overtaking possibilities. As a result, [Figure 5.26](#) shows a drop in the median and interquartile range of the driving speed.

- **Considering interval 3 [-400, 150]:**

[Figure 5.26](#) and [Figure 5.27](#) show that participants adjusted to the new situation as the median and interquartile range of the driving speed stabilizes and the median time headway increases again towards the end of the considered interval. The median driving speed and its upper quartile does show a drop towards the end of the considered interval, which is probably caused by the fact that the left-diverging roadway is also a small-radius connector road.

3-2/1 configuration

- **Considering interval 1 [-1300, -900]:**

Just like the 3-1/2 configuration, [Figure 5.24b](#) shows that most participants were driving in lane 2 at the start of the considered interval. But unlike the 3-1/2 configuration, this lane is the correct lane to continue the route to the left-diverging roadway. Consequently, the lane distribution remains stable for the rest of the considered interval, and [Figure 5.25](#) shows an equal number of lane changes to the left and to the right. However, just like the 3-1/2 configuration, [Figure 5.27](#) shows an increasing upper quartile of the time headway. Just like the 3-1/2 configuration, this is the result of the mandatory lane changes of the right-diverging simulated traffic.

- **Considering interval 2 [-900, -400]:**

The start of the considered interval marks the spot where other left-diverging traffic started executing mandatory lane changes to lane 2 to follow their route to the left-diverging roadway. Consequently,

Figure 5.26 shows a drop in the median and lower quartile of the driving speed, Figure 5.27 shows a drop in the median and upper quartile of the time headway, and Figure 5.28b shows a higher density of TTC trend lines that are below the threshold of 6 seconds. These trends are the same as the 3-1/2 configuration but with an earlier onset and, in the case of TTC, with a higher density. This is the result of most participants driving in lane 2 instead of lane 1, which is the middle lane that experienced lane-changing simulated traffic earlier and additionally from both sides. It included entering traffic that needed to go from the rightmost lane to the left-diverging roadway, and also transiting traffic that needed to go from the leftmost lane to the right-diverging roadway. Since left-diverging simulated traffic only needed one mandatory lane change from the rightmost lane, this configuration also recovered earlier from the raised level of turbulence. Already towards the end of the considered interval, Figure 5.28b shows a low density of TTC trend lines below the 15 seconds, Figure 5.26 shows that the median driving speed changes from decreasing to increasing, and Figure 5.27 shows an increasing median and interquartile range of the time headway.

- **Considering interval 3 [-400, 150]:**

Figure 5.26 shows that the median driving speed continues to increase towards values approximately equal to the 3-1/2 configuration, while Figure 5.27 shows that the median time headway is lower for the entire considered interval.

Both configurations as a whole

- Figure 5.29a shows that the driving speed distribution of the 3-2/1 configuration is shifted more to the left than that of the 3-1/2 configuration. Also, Figure 5.29b shows that the median and interquartile range of the boxplot of the 3-2/1 configuration are placed lower than those of the 3-1/2 configuration. In agreement, the Mann-Whitney U-test (see Table 5.3) also indicates that the hypothesis that both medians are from the same distribution is rejected.
- Figure 5.30a shows that the 3-2/1 configuration has a higher probability that a participant experienced a time headway below the 2 seconds. By also looking at Figure 5.27 as a whole, the lowered boxplot and left-shifted distribution of the 3-2/1 configuration are primarily caused by the upper quartile of the 3-2/1 configuration that is consistently lower than the upper quartile of the 3-1/2 configuration.
- Figure 5.31a shows that the 3-1/2 configuration has a higher probability that a participant experienced a conflict with the time-to-collision below the threshold of 6 seconds, while the 3-2/1 configuration shows the lowest outliers of TTC values of 2 seconds and lower (which is also noticeable in Figure 5.28b at the beginning of the [-900, -400] interval).
- Figure 5.32a and Figure 5.32b show that the summed TET and TIT are roughly equal for both configurations, while Table 5.3 shows that the mean and median TET and TIT values per conflict are both higher for the 3-1/2 configuration.
- Figure 5.33a shows that the 3-1/2 configuration had mostly participants with one lane change in total, which is probably the mandatory lane change at the beginning of the configuration. The figure also shows that the 3-2/1 configuration had participants doing more lane changes, but Figure 5.33b shows that this configuration also has a much lower number of total lane changes. Table 5.3 shows that the 3-1/2 configuration has a higher average of lane changes per participant.
- Figure 5.33b, Figure 5.33c and Table 5.3 all show that the 3-2/1 configuration has a lower mean and median of the accepted gaps when lane changing, as well as a lower mean and median of PET when lane changing.
- Noteworthy is Table 5.3 shows that the 3-2/1 configuration included a total of five traffic accidents while the 3-1/2 configuration counted none. Figure 5.28b only explains two of these accidents in the [-900, -400] interval, which indicates that the rest of the accidents are created by simulated traffic hitting a participant at its rear-side around the same location. Since VISSIM does not simulate traffic accidents, these three accidents are created by participants accepting too small gaps with their successor.

Results of the 3-lane major fork configurations (0% freight traffic)

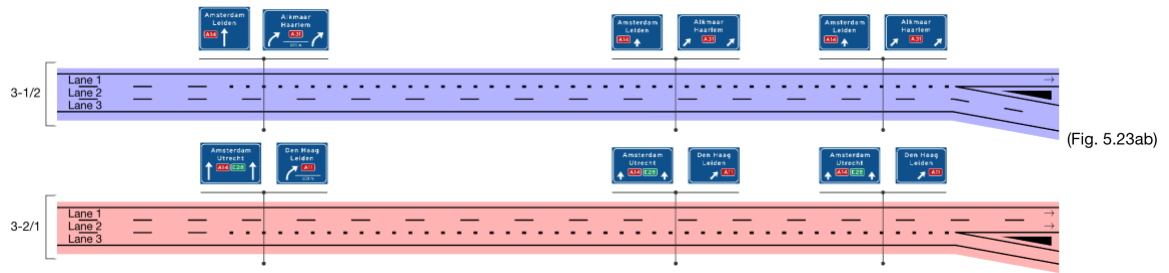

(Fig. 5.23ab)

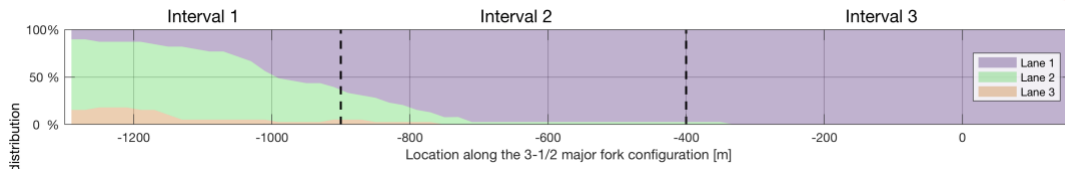

(Fig. 5.24ab)

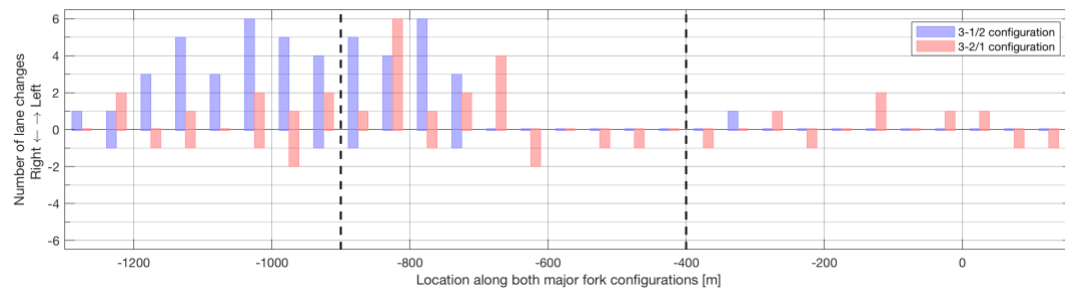
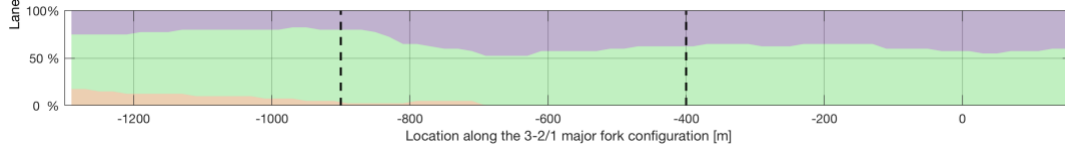

(Fig. 5.25)

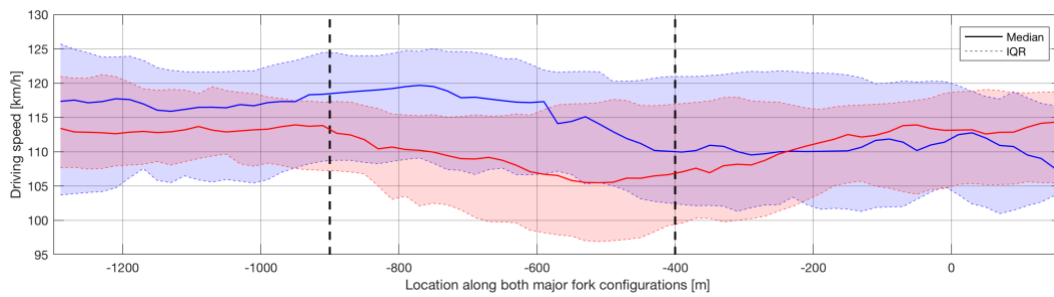

(Fig. 5.26)

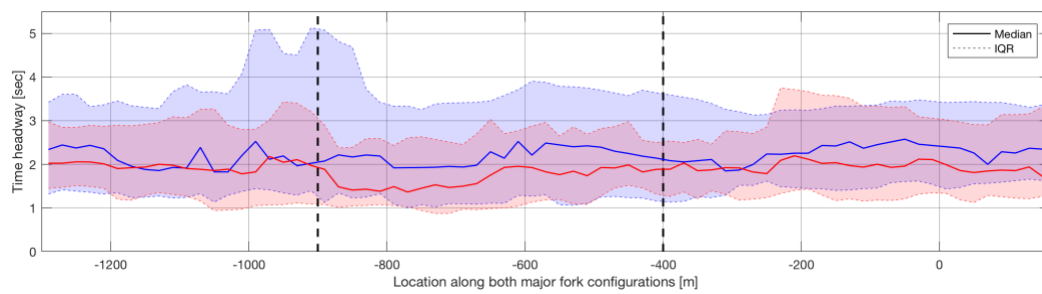

(Fig. 5.27)

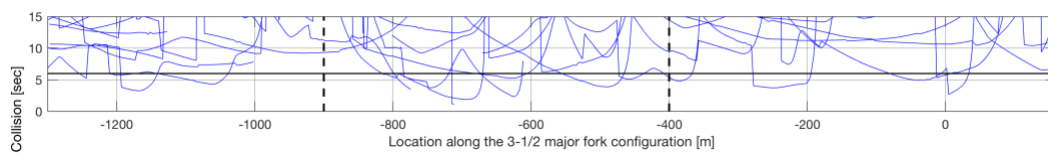

(Fig. 5.28ab)

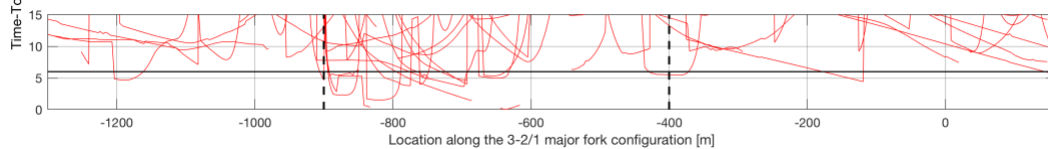

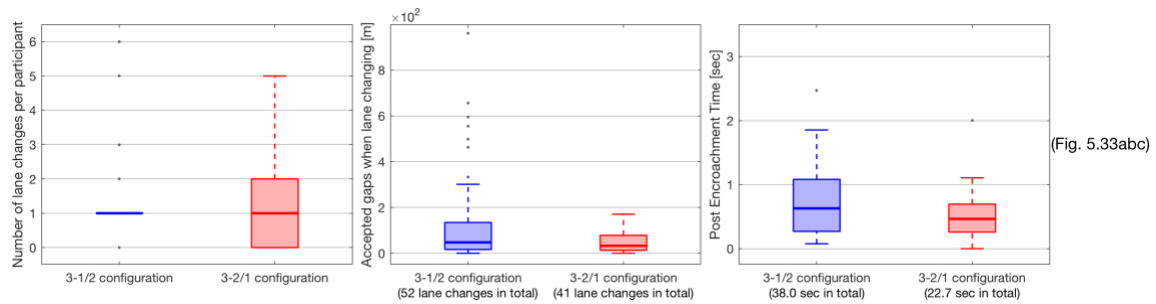
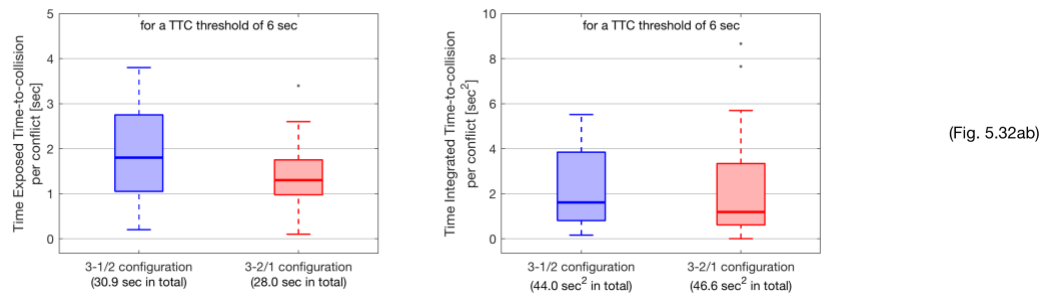
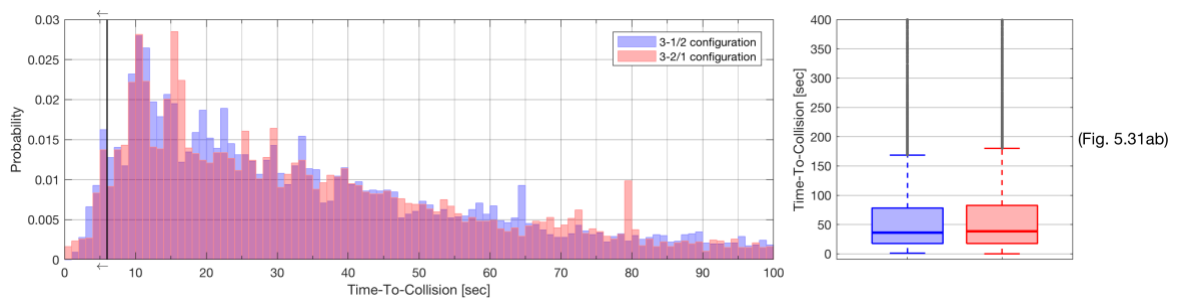
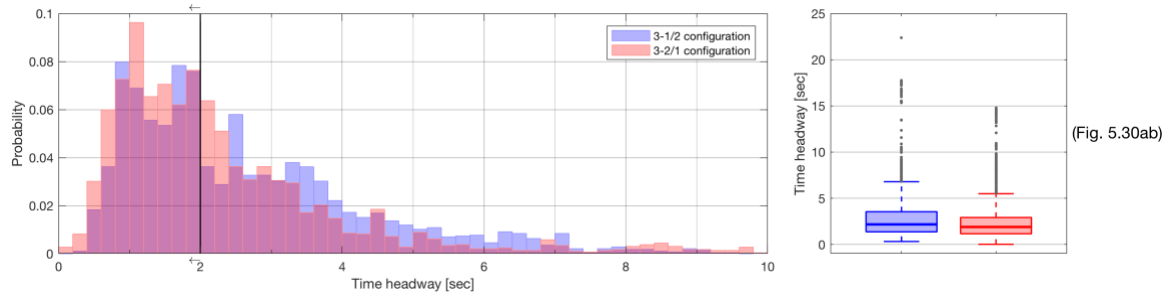
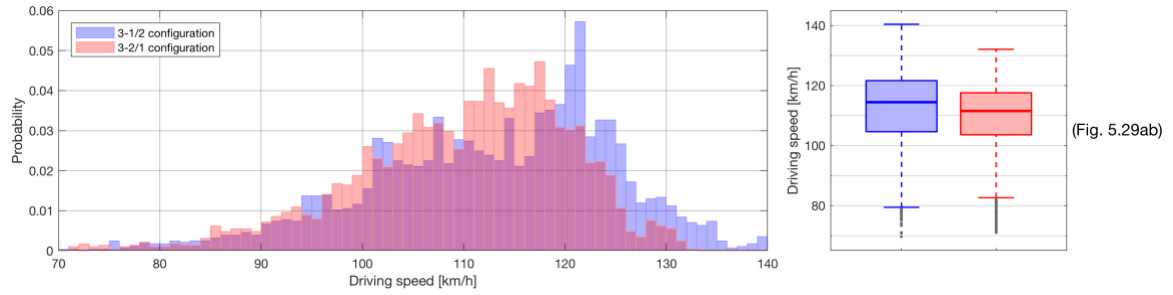

Table 5.3:

	3-1/2 configuration (0% freight)			3-2/1 configuration (0% freight)			Mann-Whitney U-test
	mean	median	[IQR]	mean	median	[IQR]	
Driving speed	112.86	114.47	[104.64 - 121.66]	109.97	111.54	[103.60 - 117.61]	$p = 0.000$ indicates that H_0 is rejected
Time headway	2.78	2.17	[1.37 - 3.54]	2.41	1.90	[1.16 - 2.92]	$p = 0.000$ indicates that H_0 is rejected
Time-To-Collision (TTC)	216.88	36.22	[17.66 - 78.16]	220.02	38.51	[17.71 - 82.68]	$p = 0.000$ indicates that H_0 is rejected
TET (TTC threshold of 6sec)	1.82	1.80	[1.05 - 2.75]	1.33	1.30	[0.97 - 1.75]	
TIT (TTC threshold of 6sec)	2.59	1.61	[0.81 - 3.84]	2.22	1.19	[0.61 - 3.34]	
Lane changes (per participant)	1.33	1.00	[1.00 - 1.00]	1.02	1.00	[0.00 - 2.00]	
Accepted gaps	119.75	47.55	[16.48 - 134.39]	48.71	32.69	[13.16 - 78.22]	
Accepted gaps (frontside)	132.25	53.56	[21.84 - 130.15]	58.13	45.42	[16.54 - 88.85]	
Accepted gaps (rearside)	105.30	40.35	[12.40 - 141.86]	39.51	23.08	[6.24 - 51.95]	
Post-Encroachment-Time (PET)	0.73	0.63	[0.27 - 1.08]	0.52	0.46	[0.26 - 0.70]	
Total accidents	0			5			
Total participants	39 (1 deleted)			40			

5.2.2 25% FREIGHT TRAFFIC

The analysis of the 25% freight traffic condition is linked to the results on pages 52 to 53, which includes Figures 5.34 to 5.44 and Table 5.4.

3-1/2 configuration

- **Considering interval 1 [-1300, -900]:**

Figure 5.35a shows that more participants were driving in lane 1 at the start of the considered interval in comparison with the 0% freight traffic condition (see Figure 5.24a). This seems obvious since the leftmost lanes had become more attractive due to slower-driving freight traffic on the rightmost lanes. However, the observed trend is still the same. It shows that most participants were driving in lane 2 at the beginning of the considered interval, participants needed the same amount of time to lane change, and most of the participants were driving in lane 1 at the end of the considered interval. Towards the end of the considered interval, Figure 5.37 shows a steady median driving speed, and Figure 5.38 shows an increase in the time headway and its interquartile range. Again, since the VISSIM settings (see Appendix D) show that this is the location at which simulated traffic started executing mandatory lane changes to the right-diverging roadway, these trends are solely caused by the simulated traffic.

- **Considering interval 2 [-900, -400]:**

The start of the considered interval marks the spot where other left-diverging traffic started executing mandatory lane changes to lane 1 to follow their route to the left-diverging roadway. Figure 5.37 shows that, unlike the 0% freight traffic condition, the median driving speed is pretty stable. Only towards the end of the considered interval, the median and lower quartile of the driving speed seems to decrease. This indicates that around this point freight traffic started to merge in lane 1, which is 200 meters more downstream than in the 0% freight traffic condition. As a result, Figure 5.38 shows that, along the entire interval, the increased median time headway decreases again towards its starting value. Since the median driving speed stays roughly the same, this means that the free-flowing participants on lane 1 were closing the gap between them and their predecessors. This is also observed in Figure 5.39a, where the long decreasing TTC trend lines represent participants that were slowly closing the gap between them and their predecessors.

- **Considering interval 3 [-400, 150]:**

Figure 5.37 shows a big drop in the median driving speed, and Figure 5.38 shows a steady but low median time headway. These trends are in line with the vanishing TTC trend lines in Figure 5.39a, which indicates that participants had closed the gap between them and their predecessor, and that their driving speeds were now dependent on that of the slow-driving freight traffic since there are no overtaking possibilities.

3-2/1 configuration

- **Considering interval 1 [-1300, -900]:**

Figure 5.35b shows that the center of the lane distribution is shifted towards the leftmost lanes in comparison with the 0% freight traffic condition (see Figure 5.24b), which is obviously caused by slower-driving freight traffic on the rightmost lanes. As a result, all participants were now driving in lane 1 and lane 2 at the start of the considered interval, which are the correct lanes to continue the route to the left-diverging roadway, and mandatory lane changes were totally absent. Towards the end of the considered interval, Figure 5.37 shows an increasing lower quartile of the driving speed, and Figure 5.38 shows an increasing median and upper quartile of the time headway. Just like the 3-1/2 configuration, this is the result of the mandatory lane changes of the right-diverging simulated traffic.

- **Considering interval 2 [-900, -400]:**

The start of the considered interval marks the spot where other left-diverging traffic started executing mandatory lane changes to lane 1 to follow their route to the left-diverging roadway. Figure 5.39 shows that the 3-2/1 configuration has roughly the same TTC trend as the 3-1/2 configuration, but with two main differences. First of all, just like in the 0% freight traffic condition, the figure shows that relatively low TTC trend lines arise earlier and with a higher density. Again, this is the result of the proportion of participants that were driving in lane 2 instead of lane 1, which is the middle lane that experienced lane-changing traffic earlier and additionally from both sides. It included entering traffic that needed to go from the rightmost lane to the left-diverging roadway, and also transiting traffic that needed to go from the leftmost lane to the right-diverging roadway. Second of all, where the 3-1/2 configuration showed long TTC trend lines due to slower-driving freight traffic downstream,

the 3-2/1 configuration misses these due to having the choice of a lane (i.e. lane 1) where no freight traffic was included. Since left-diverging simulated traffic only needed one mandatory lane change from the rightmost lane, this configuration also recovered earlier from the raised level of turbulence. Already towards the end of the considered interval, [Figure 5.39b](#) shows a low density of TTC trend lines below the 15 seconds.

- **Considering interval 3 [-400, 150]:**

[Figure 5.37](#) shows no big changes in the driving speed, as participants had a choice in lanes, and could therefore choose lane 1 with no freight traffic if they wanted.

Both configurations as a whole

- [Figure 5.40a](#) shows that the 3-2/1 configuration has a driving speed distribution that is shifted more to the left than that of the 3-1/2 configuration, and that the 3-1/2 configurations has a second peak in its distribution around 80 km/h. As a result, the 3-1/2 configuration has an interquartile range and lower and upper whisker that extend further than those of the 3-2/1 configuration. Due to this spread, the Mann-Whitney U-test (see [Table 5.4](#)) also indicates that the hypothesis that both medians are from the same distribution cannot be rejected.
- [Figure 5.41a](#) shows that the 3-2/1 configuration has a higher probability that a participant experienced a time headway below the 2 seconds. In agreement, [Figure 5.41b](#) and [Table 5.4](#) also show that the 3-2/1 configuration has a lower mean and median time headway.
- [Figure 5.42a](#) shows that the 3-2/1 configuration has a higher probability that a participant experienced a conflict with a time-to-collision below the threshold of 6 seconds.
- When summing up all conflicts that have TTC values below the threshold of 6 seconds, [Figure 5.43a](#) and [Figure 5.43b](#) show that the 3-1/2 configuration has a higher total TET as well as a higher total TIT. However, looking at the TET and TIT values per conflict, the 3-2/1 configuration has both conflicts of longer duration and conflicts of higher severity.
- [Figure 5.44b](#) shows that, although the 3-2/1 configuration included no participants that needed a mandatory lane change, the total number of lane changes executed are equal. Also, both the mean and median of the number of lane changes per participant is equal (see [Figure 5.44a](#) & [Table 5.4](#)).
- [Figure 5.44b](#) shows that the 3-2/1 configuration has the smallest accepted gaps when lane changing.
- [Figure 5.44c](#) shows that the median PET when lane changing is equal between both configurations, but that the mean PET is lower for the 3-2/1 configuration.

Results of the 3-lane major fork configurations (25% freight traffic)

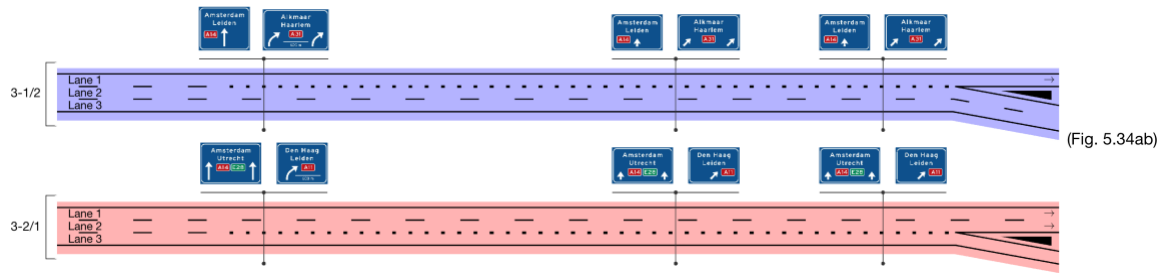

(Fig. 5.34ab)

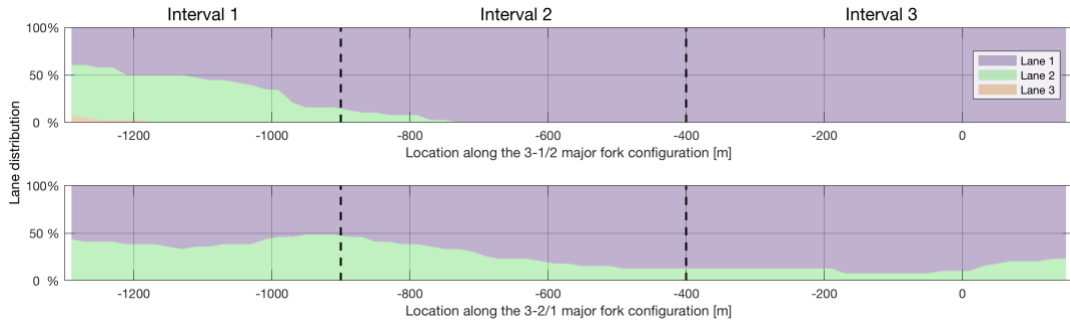

(Fig. 5.35ab)

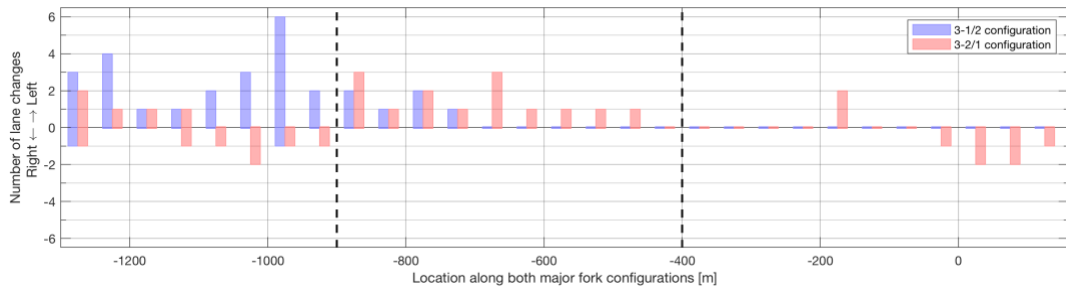

(Fig. 5.36)

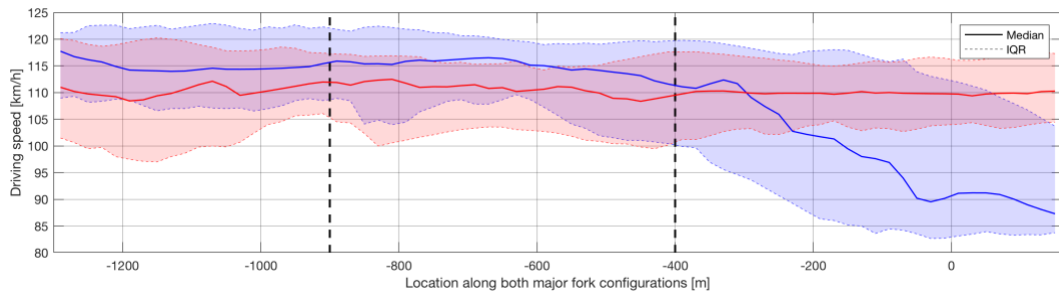

(Fig. 5.37)

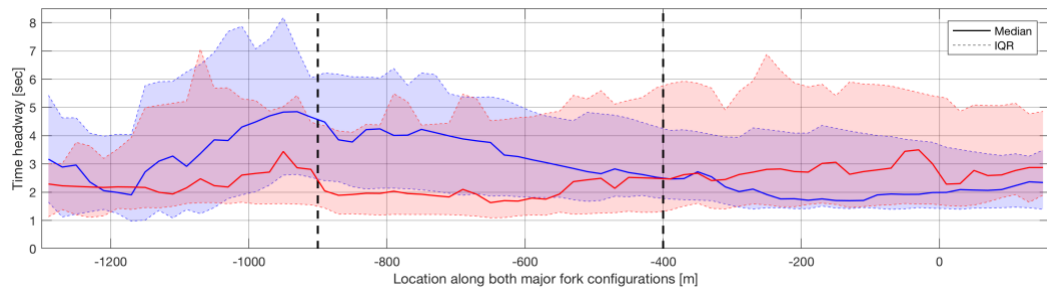

(Fig. 5.38)

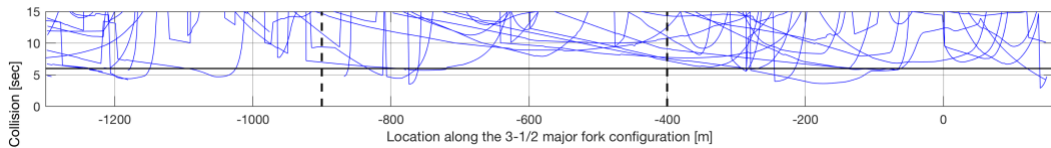

(Fig. 5.39ab)

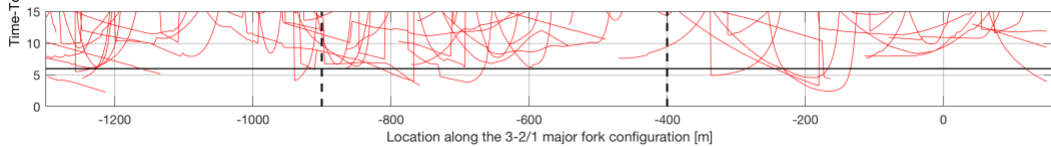

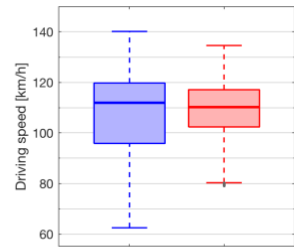
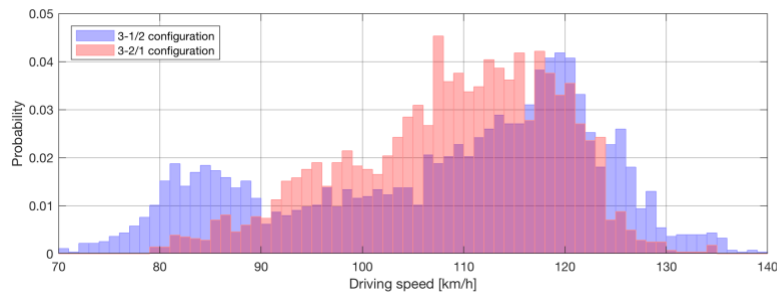

(Fig. 5.40ab)

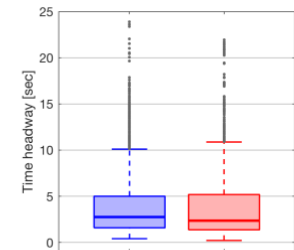
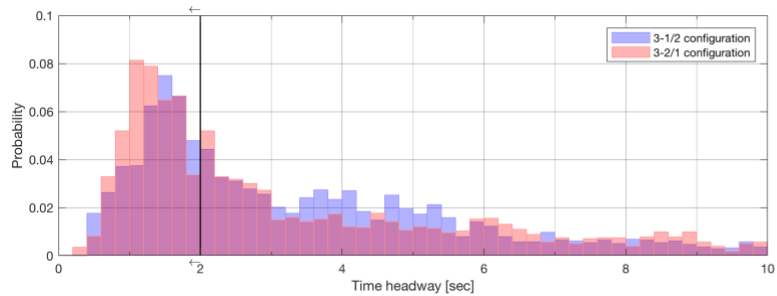

(Fig. 5.41ab)

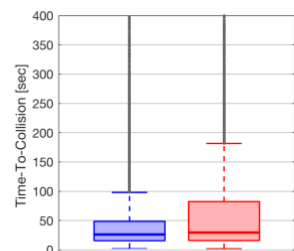
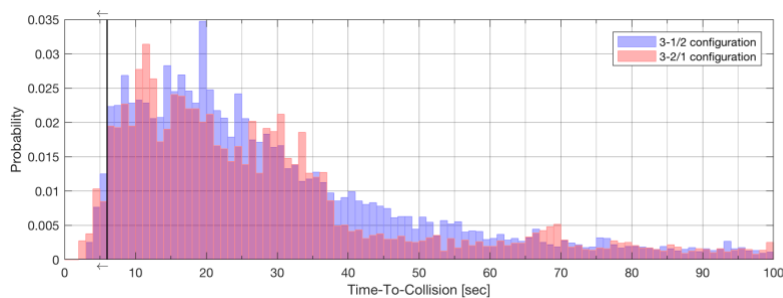

(Fig. 5.42ab)

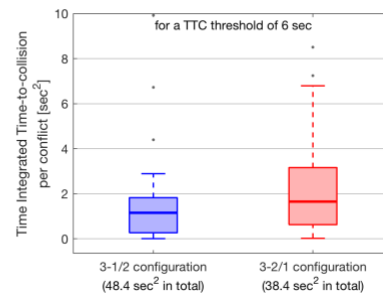
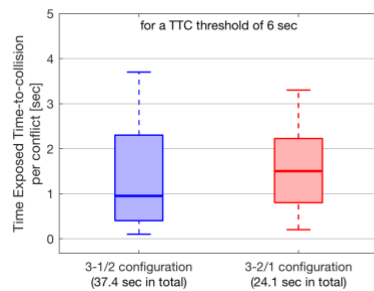

(Fig. 5.43ab)

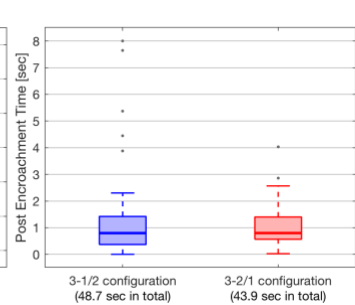
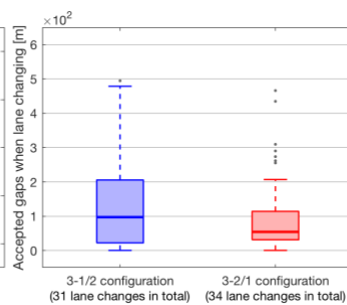
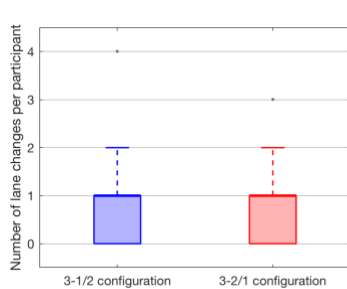

(Fig. 5.44abc)

Table 5.4:

	3-1/2 configuration (25% freight)			3-2/1 configuration (25% freight)			Mann-Whitney U-test
	mean	median	[IQR]	mean	median	[IQR]	
Driving speed	107.64	111.93	[95.85 - 119.74]	109.00	110.21	[102.38 - 117.10]	p = 0.294 indicates that H ₀ cannot be rejected
Time headway	3.87	2.76	[1.59 - 5.00]	3.74	2.36	[1.37 - 5.18]	p = 0.000 indicates that H ₀ is rejected
Time-To-Collision (TTC)	85.72	26.18	[15.67 - 48.57]	210.73	29.52	[15.94 - 82.36]	p = 0.000 indicates that H ₀ is rejected
TET (TTC threshold of 6sec)	1.56	0.95	[0.40 - 2.30]	1.61	1.50	[0.80 - 2.23]	
TIT (TTC threshold of 6sec)	2.02	1.15	[0.26 - 1.82]	2.56	1.65	[0.62 - 3.16]	
Lane changes (per participant)	0.82	1.00	[0.00 - 1.00]	0.87	1.00	[0.00 - 1.00]	
Accepted gaps	156.36	97.39	[22.35 - 205.68]	90.88	54.37	[31.50 - 114.21]	
Accepted gaps (frontside)	191.10	119.58	[44.20 - 246.27]	93.32	53.92	[32.15 - 123.53]	
Accepted gaps (rearside)	109.54	65.28	[5.17 - 202.53]	88.51	63.07	[29.23 - 109.70]	
PET	1.62	0.80	[0.37 - 1.42]	1.07	0.80	[0.57 - 1.40]	
Total accidents	1			1			
Total participants	38 (2 deleted)			39 (1 deleted)			

5.3 SMALL-RADIUS CONNECTOR ROAD VARIANTS

As discussed in Section 4.1.5, the 25% freight traffic condition is not considered in the analysis of the small-radius connector road variants since slower driving freight traffic is expected to affect the driving behavior of faster driving car traffic (including the participants in the driving simulator) too much to correctly measure the driving behavior affected by the geometric design. However, this analysis does consider another variable, which is the experience level of the participants when they encounter a small-radius connector road. With that in mind, this analysis is subdivided into two analyses that consider only the 1st encounters and only the 2nd, 3rd and 4th encounters separately in Section 5.3.1 and Section 5.3.2, respectively. Each analysis first focuses on the driving behavior along the two-lane left-diverging roadway as small-radius connector road (which is represented by a [blue color](#)), and subsequently on the driving behavior along the single-lane variant (which is represented by a [red color](#)) and their differences. The driving behavior is analyzed by subdividing the small-radius connector roads variants into multiple intervals that are all considered separately. Each analysis ends with a comparison of driving behavior characteristics and surrogate safety measures that consider the small-radius connector road variants as a whole (which is represented by a [grey color](#)).

5.3.1 ONLY 1ST ENCOUNTERS

The analysis of the participants that encounter a small-radius connector road for the 1st time is linked to the results on pages 56 to 57, which includes Figures 5.45 to 5.54 and Table 5.5.

Two-lane small-radius connector road

- **Considering interval 1 [-400, -150]:**

[Figure 5.48](#) shows a steady median driving speed and interquartile range. It is only towards the end of the considered interval where the upper quartile starts to decrease slightly, and the lower quartile starts to increase slightly. This is in line with [Figure 5.49](#), which shows a steady median acceleration rate of 0 m/s² along the entire considered interval, but an increasing upper quartile and a decreasing lower quartile towards the end of the considered interval. This shows that the fastest driving participants were slowing down, and that the slowest driving participants were speeding up.

- **Considering interval 2 [-150, 0]:**

[Figure 5.49](#) shows that both the median and upper quartile of the acceleration rate start to decrease at the beginning of the considered interval. Consequently, [Figure 5.48](#) shows that the median driving speed and its interquartile range also start to decrease steadily until 50 meters upstream of the start of the small-radius curve, after which the median driving speed shows a drop of approximately 10 km/h. Simultaneously, [Figure 5.49](#) also shows a drop in the median and lower quartile of the acceleration rate. It even shows a relatively low median acceleration rate when entering the small-radius curve, which indicates that participants entered the curve while still braking.

- **Considering interval 3 [0, 150]:**

[Figure 5.49](#) shows that the median acceleration rate is not as low as it was at the end of the previous interval, but it does show that the lower quartile of the acceleration rate still is for the first 25 meters of the considered interval. It also shows that while the median and interquartile range of the acceleration rate are below 0 m/s² for the majority of the considered interval, the upper quartile shows to increase above the zero-mark after 100 meters in the small-radius curve. Simultaneously, [Figure 5.48](#) shows that the median and interquartile range driving speed is also continuously decreasing in the majority of the small-radius curve itself.

Single-lane small-radius connector road

- **Considering interval 1 [-400, -150]:**

[Figure 5.48](#) shows some differences with the two-lane variant. Already at the beginning of the considered interval, the interquartile range of the driving speed starts decreasing considerably. Towards the end of the considered interval, the median driving speed follows, and ends with being approximately 5 km/h lower than that of the two-lane variant. This trend is in line with [Figure 5.49](#), which shows that the lower quartile of the acceleration rate already starts to decrease at the beginning of the considered interval, and that the median acceleration rate follows towards the end of the considered interval.

- **Considering interval 2 [-150, 0]:**

Figure 5.48 shows that the median driving speed continues to decrease with the same rate as in the previous interval, which is also the same deceleration rate as the two-lane variant. But since the single-lane variant already started decelerating in the previous interval, its median driving speed is also continuously 5 km/h lower than the two-lane variant. Unlike the two-lane variant, Figure 5.49 shows a drop in the acceleration rate's lower quartile, already 75 meters upstream of the start of the small-radius curve. This is approximately 50 meters earlier than the two-lane variant. A little bit more downstream, the median acceleration rate also starts to show this drop, which is 25 meters earlier than the two-lane variant. This drop has not only an earlier onset, the lower quartile shows that it is also more severe than the two-lane variant. As a result, the majority of participants was already done with the necessary deceleration before the start of the small-radius curve, whereas the majority of the participants in the two-lane variant was still decelerating while entering the small-radius curve. Figure 5.48 shows that this earlier and more severe decelerating of the participants on the single-lane variant, also leads to an even bigger difference in median driving speed. The median driving speed is approximately 8 km/h lower than that of the two-lane variant when entering the small-radius curve.

- **Considering interval 3 [0, 150]:**

Figure 5.49 shows that the median and interquartile range of the acceleration rate are continuously higher than those of the two-lane variant. Just like the two-lane variant, it also shows that the median and interquartile range of the acceleration rate are below 0 m/s² for the majority of the considered interval. However, the upper quartile of the acceleration rate shows to increase above the zero-mark after 50 meters in the small-radius curve, which is 50 meters earlier than the two-lane variant. As a result, Figure 5.48 shows that the initial 8 km/h difference in median driving speed at the beginning of the considered interval, is almost dissolved at the end of the considered interval.

Both variants as a whole

- Figure 5.52a and Figure 5.52b show that, for both intervals, the driving speed distribution of the two-lane variant is shifted to the right in comparison with the single-lane variant, which indicates higher driving speeds for the two-lane variant. Also Figure 5.52c shows that, for both intervals, the median, upper quartile and upper whisker of the driving speed is higher for the two-lane variant than the single-lane variant.
- Figure 5.53a shows a higher probability for more conservative acceleration rates (i.e. -0,5 till 0 m/s²) for the single-lane variant before the start of the small-radius curve, and Figure 5.53b shows a higher probability for more conservative and even positive acceleration rates for the single-lane variant in the small-radius curve itself. Figure 5.53c shows the same trends.
- When summing up all conflicts that have TTC values below the threshold of 6 seconds, Figure 5.54a and Figure 5.54b show that the single-lane variant has a higher total TET as well as a higher total TIT than the two-lane variant. However, looking at Figure 5.51b, this is the result of just a single participant that experienced a very low TTC during a relatively long time period.

Result pages of the small-radius connector roads (only 1st encounters)

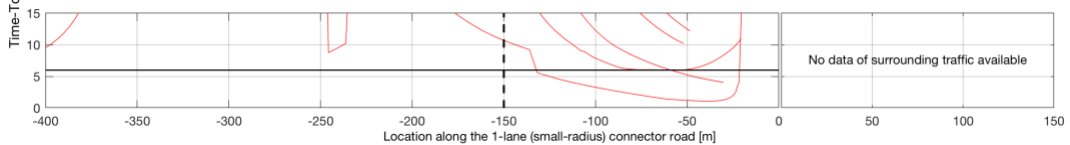
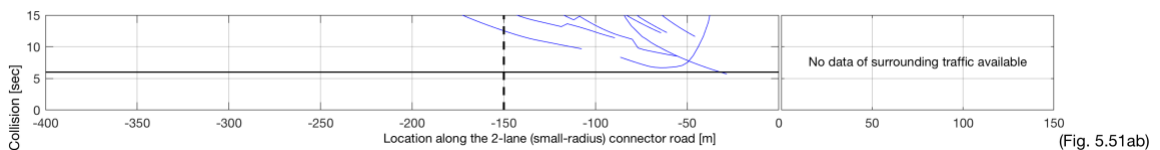
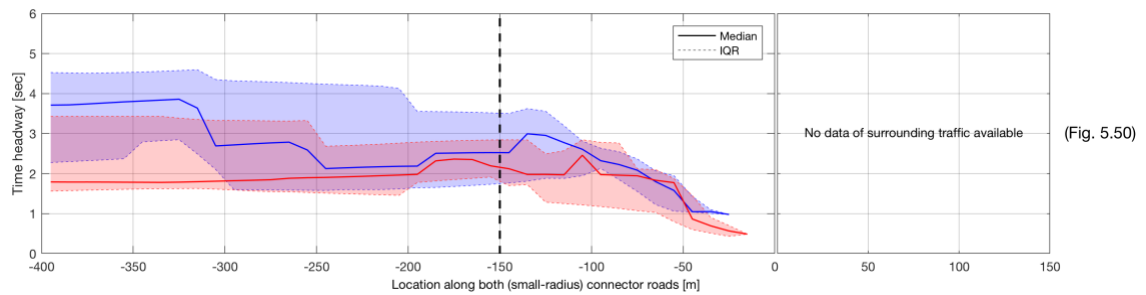
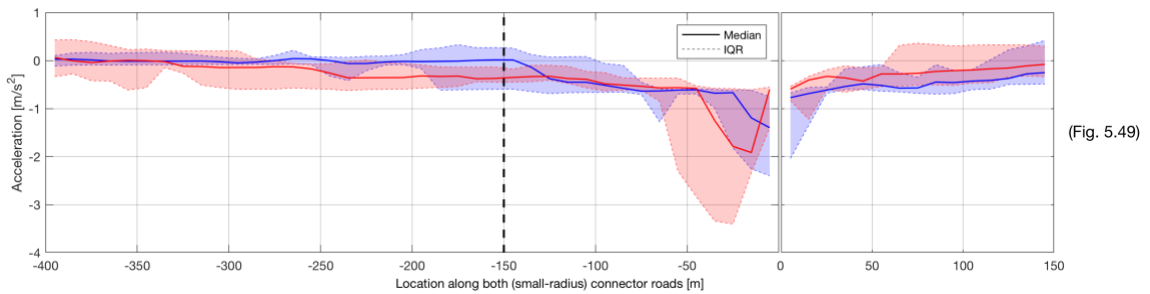
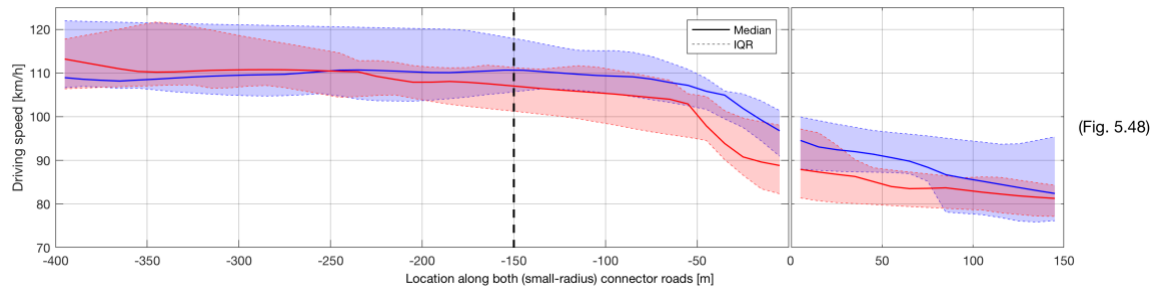
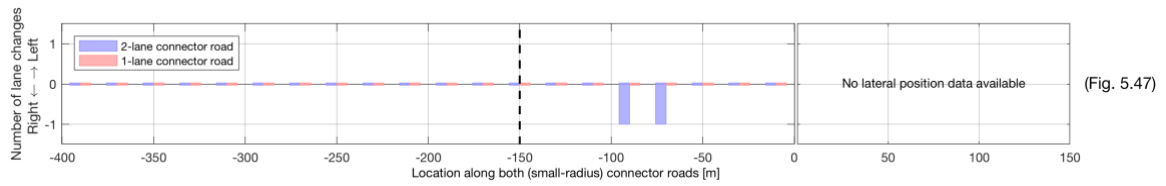
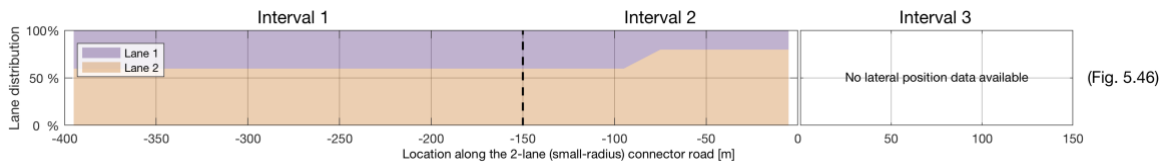
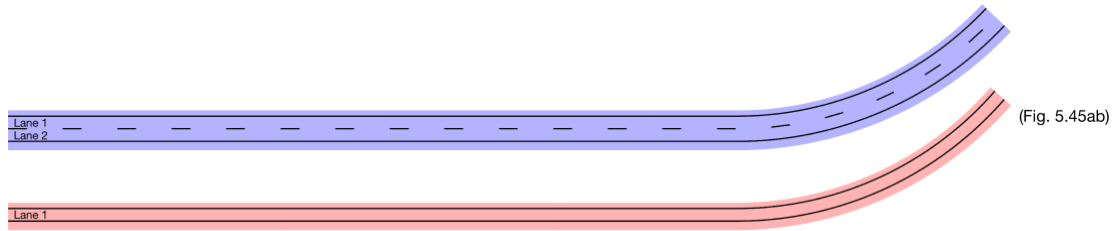

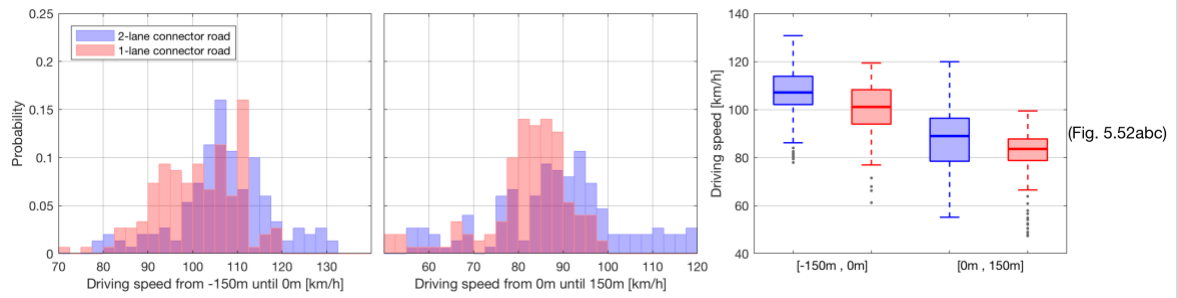

(Fig. 5.52abc)

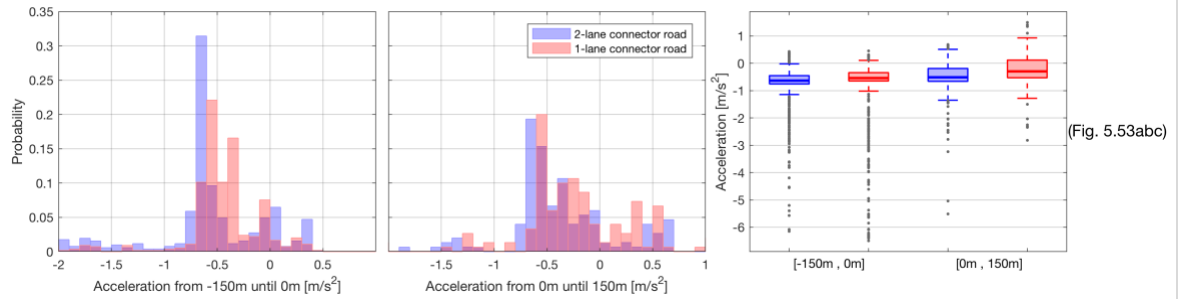

(Fig. 5.53abc)

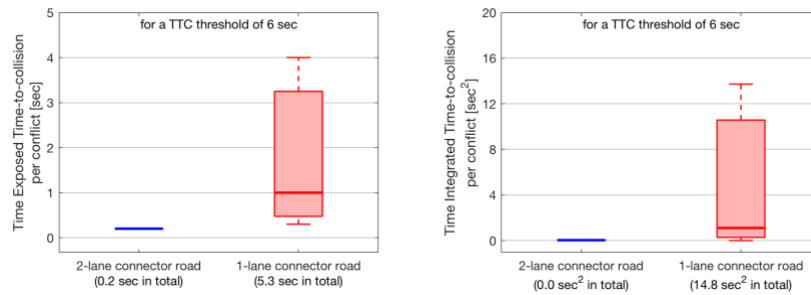

(Fig. 5.54ab)

Table 5.5:

	2-lane variant (only 1 st encounters)				1-lane variant (only 1 st encounters)			
	mean	median	[IQR]		mean	median	[IQR]	
Driving speed [-150m,0m]	107.06	107.14	[102.10	- 113.89]	100.38	101.10	[102.10	- 113.89]
Driving speed [0m,150m]	88.61	89.00	[78.50	- 96.40]	81.13	83.61	[78.80	- 87.79]
Acceleration [-150m,0m]	-0.84	-0.63	[-0.76	- -0.45]	-1.05	-0.54	[-0.65	- -0.34]
Acceleration [0m,150m]	-0.56	-0.51	[-0.66	- -0.19]	-0.25	-0.30	[-0.53	- 0.12]
Time headway [-400m,0m]	2.91	2.65	[1.71	- 4.01]	2.30	1.93	[1.46	- 2.77]
Time-To-Collision (TTC) [-400m,0m]	66.93	23.75	[17.11	- 70.38]	82.57	30.13	[19.02	- 53.93]
TET (TTC threshold of 6sec)	0.20	0.20	[0.20	- 0.20]	1.77	1.00	[0.47	- 3.25]
TIT (TTC threshold of 6sec)	0.04	0.04	[0.04	- 0.04]	4.94	1.11	[0.28	- 10.57]
Lane changes (per participant)	0.20	0.00	[0.00	- 0.00]	0.00	0.00	[0.00	- 0.00]
Total accidents	0				0			
Total participants	10				10			

5.3.2 ONLY 2ND, 3RD AND 4TH ENCOUNTERS

The analysis of the participants that encounter a small-radius connector road for the 2nd, 3^d, and 4th time is linked to the results on pages 60 to 61, which includes Figures 5.55 to 5.64 and Table 5.6.

Two-lane small-radius connector road

- **Considering interval 1 [-400, -200]:**

Figure 5.58 shows a steady median driving speed and an increasing lower quartile, which is in accordance with Figure 5.59 that shows a steady median acceleration rate of approximately 0 m/s² and a positive upper quartile for the majority of the considered interval.

- **Considering interval 2 [-200, 0]:**

Unlike the “only 1st encounters”, Figure 5.59 shows that the interquartile range of the acceleration rate is below zero for the entire considered interval. Consequently, Figure 5.58 shows that the median and interquartile range of the driving speed starts to decrease with an earlier onset, which results in a progressively decreasing trend with an absence of a distinguishable drop in the median driving speed towards the end of the interval. The median driving speed at the end of the interval, and thus at the start of the small-radius curve, is also lower now that the participants have experienced a small-radius connector road before.

- **Considering interval 3 [0, 150]:**

Figure 5.58 shows that the median driving speed stays decreasing towards the end of the considered interval where it becomes stable. Since the median driving speed at the start of the considered interval is already lower than that at the start of the same interval for the “only 1st encounters” analysis, it shows a smaller difference in the median driving speed between the start and the end of the considered interval. This is in line with Figure 5.59, which shows higher acceleration values than the “only 1st encounters” for the entire considered interval.

Single-lane small-radius connector road

- **Considering interval 1 [-400, -200]:**

Figure 5.58 not only shows that the median driving speed is approximately 5 to 10 km/h lower than the two-lane variant for the entire considered interval, it also shows that the median and the interquartile range of the driving speed decreases with a somewhat larger rate than the two-lane variant. This is in line with Figure 5.59, which shows that also the median and interquartile range of the acceleration rate is lower than that of the two-lane variant.

- **Considering interval 2 [-200, 0]:**

Figure 5.58 shows almost exactly the same driving speed trend as the two-lane variant. The difference is primarily in the second 100 meters, where the difference in driving speed is almost halved in comparison with the beginning of the considered interval. Figure 5.59 gives an explanation, as the upper quartile of the acceleration rate is also continuously higher than that of the two-lane variant. This is probably the result of the fact that the median driving speed of the single-lane variant is already 10 km/h lower at the beginning of the considered interval, which makes decelerating just before the start of the small-radius curve less necessary. Just like in the analysis of the two-lane variant, notable is the absence of a distinguishable drop in the median acceleration rate towards the end of the interval, which was visible for the “only 1st encounters”. However, the lower quartiles of the acceleration rate of both variants do still show this drop. Although they have approximately the same shape, participants seem to have stopped decelerating earlier before the start of the single-lane small-radius curve than the start of the two-lane small-radius curve.

- **Considering interval 3 [0, 150]:**

Figure 5.58 shows that the median driving speed starts with an 8 km/h difference between the two-lane variant, and continues to decrease with approximately the same rate as the two-lane variant, which means that the 8km/h difference between the two variants also keeps continuing. However, Figure 5.59 does show higher acceleration values for the single-lane variant; especially in the first 100 meters of the considered interval. This difference is not caused by participants on the single-lane variant, but rather by the fastest driving participants on the two-lane variant since Figure 5.58 shows that the upper quartile of the driving speed on the two-lane variant shows a sharp decrease in the first 50 meters of the considered interval.

Both variants as a whole

- [Figure 5.62a](#) and [Figure 5.62b](#) show that, for both intervals, the driving speed distribution of the two-lane variant is shifted to the right in comparison with the single-lane variant, which indicates higher driving speeds for the two-lane variant. Also [Figure 5.62c](#) shows that the entire boxplots of the two-lane variant are higher in the road section before the start of the small-radius curve, as well as in the small-radius curve itself.
- [Figure 5.63](#) shows that the differences between the variants are smaller than in the case of the “only 1st encounters”, which makes it difficult to observe a trend. Taking [Table 5.6](#) into account, the single-lane variant shows to have a higher mean and median acceleration rate in the last 150 meters before the start of the small-radius curve, as well as the first 150 meters after the start of the small-radius curve.
- [Figure 5.61](#) shows that the two-lane variant has a higher density of low TTC trend lines (below the 15 seconds) than the single-lane variant when considering the [-200, 0] interval. Furthermore, the TTC trend lines for the two-lane variant start to appear more upstream and start to disappear more downstream than the single-lane variant. This indicates that participants on the two-lane variant had higher driving speeds and, at least for the end of the considered interval, also smaller time headways. Two deductions that were already observed earlier in the analysis. When summing up all conflicts that have TTC values below the threshold of 6 seconds, [Figure 5.64a](#) and [Figure 5.64b](#) show that the two-lane variant has a higher total TET as well as a higher total TIT, but that the single-lane variant has larger values per conflict. However, looking at [Figure 5.61b](#), this is the result of just a single participant that experienced low TTC values during a relatively long time period.

Result pages of the small-radius connector roads (only 2nd, 3rd and 4th encounters)

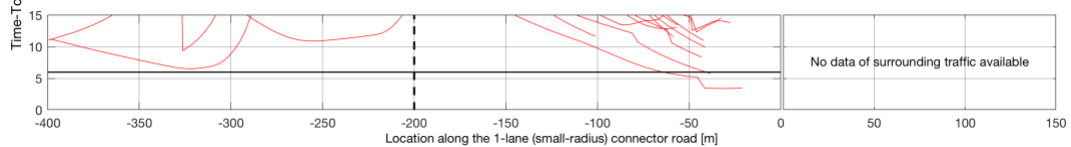
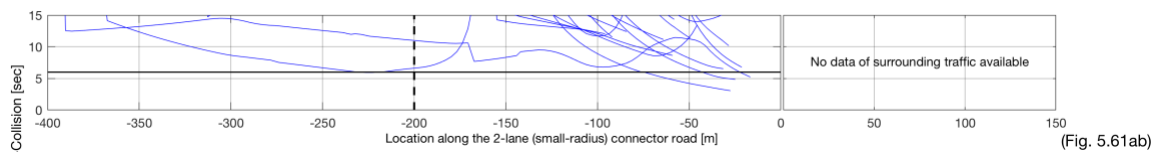
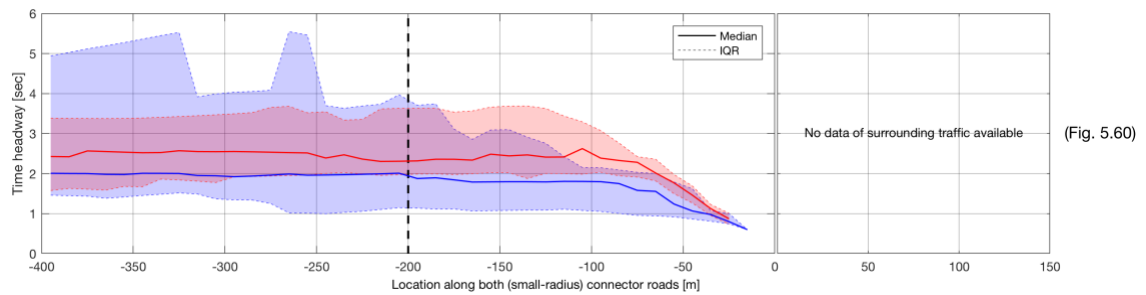
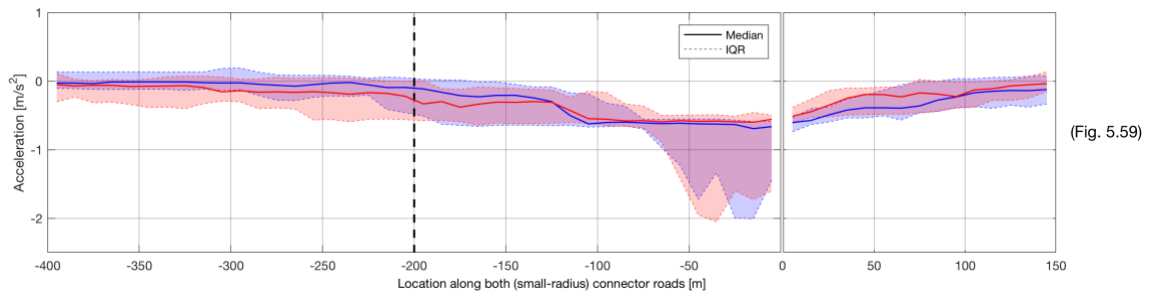
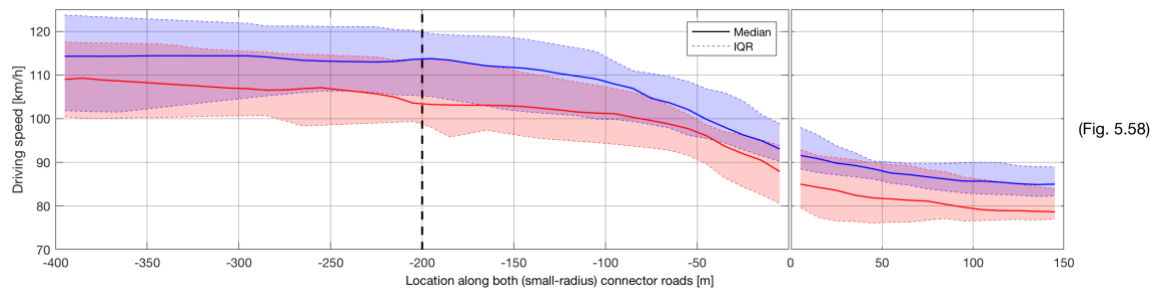
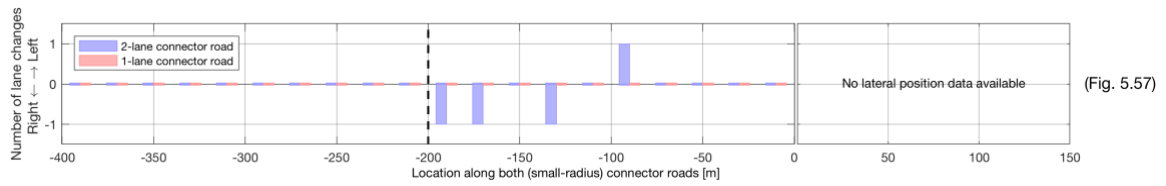
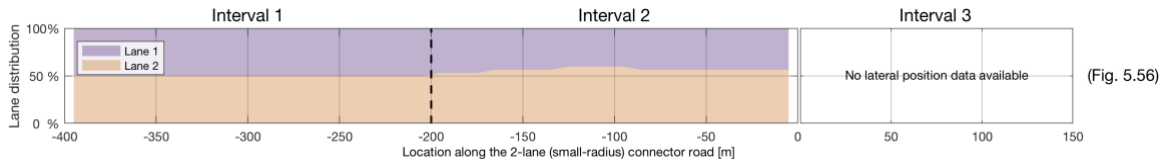
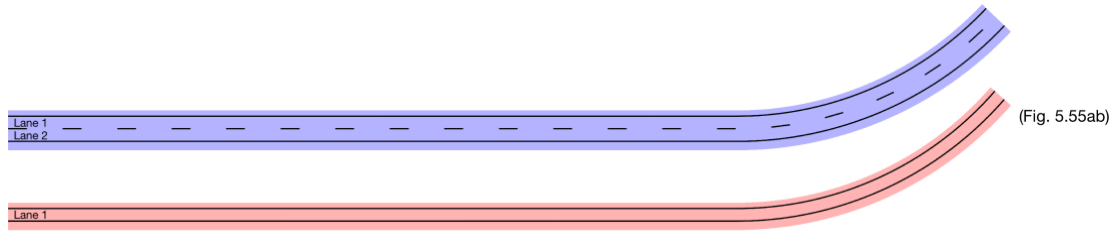

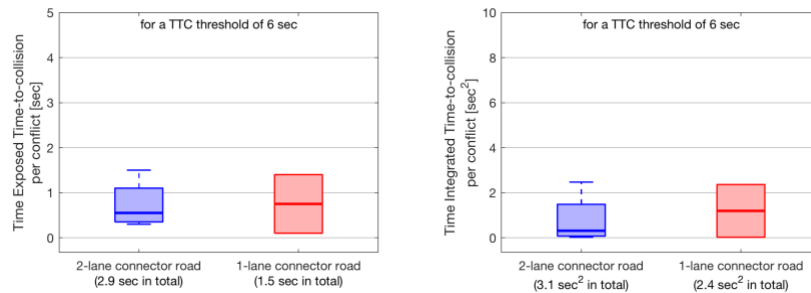
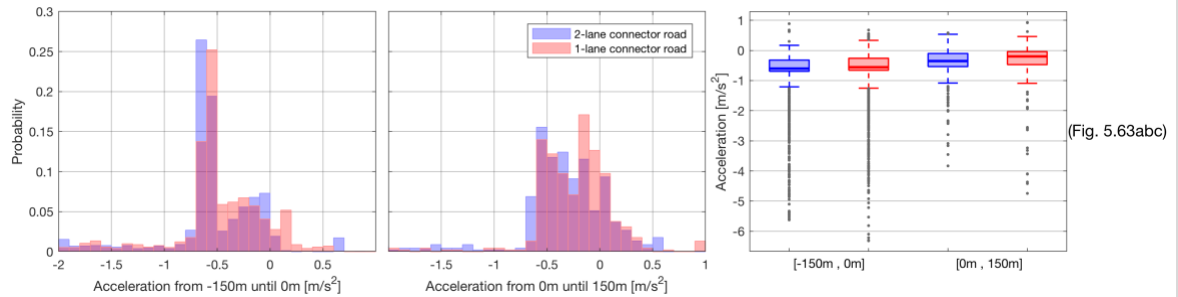
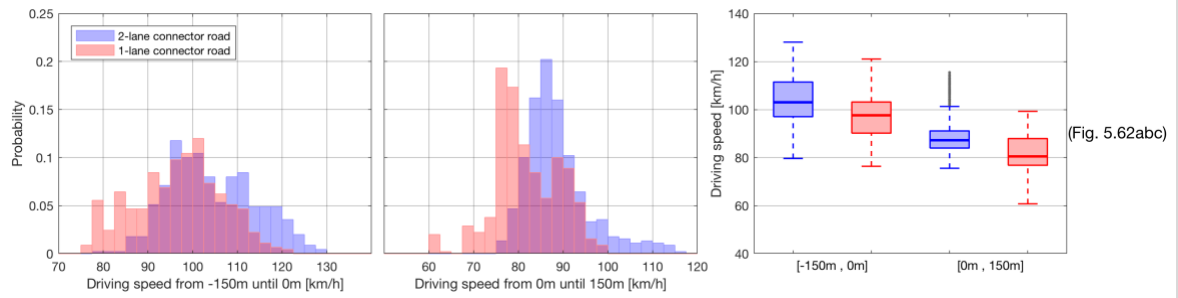

Table 5.6:

	2-lane variant (only 2 nd -4 th encounters)			1-lane variant (only 2 nd -4 th encounters)		
	mean	median	[IQR]	mean	median	[IQR]
Driving speed [-150m,0m]	104.40	103.04	[97.07 - 111.47]	96.73	97.63	[97.07 - 111.47]
Driving speed [0m,150m]	88.70	87.25	[83.99 - 91.13]	81.74	80.52	[76.81 - 87.94]
Acceleration [-150m,0m]	-0.86	-0.60	[-0.69 - -0.32]	-0.76	-0.56	[-0.66 - -0.26]
Acceleration [0m,150m]	-0.37	-0.35	[-0.54 - -0.10]	-0.31	-0.20	[-0.47 - -0.04]
Time headway [-400m,0m]	2.62	1.84	[1.14 - 2.93]	2.85	2.36	[1.83 - 3.39]
Time-To-Collision (TTC) [-400m,0m]	116.44	33.17	[17.29 - 55.38]	146.07	41.90	[23.58 - 97.85]
TET (TTC threshold of 6sec)	0.73	0.55	[0.35 - 1.10]	0.75	0.75	[0.10 - 1.40]
TIT (TTC threshold of 6sec)	0.78	0.31	[0.07 - 1.48]	1.19	1.19	[0.02 - 2.36]
Lane changes (per participant)	0.13	0.00	[0.00 - 0.00]	0.00	0.00	[0.00 - 0.00]
Total accidents	0			0		
Total participants	30			30		

6

RESULTS OF THE ACCIDENT DATA ANALYSIS

With the methodology of the accident data analysis discussed in Section 4.2, this chapter presents and analyzes the results. The chapter is subdivided into three separate analyses, in which the 4-lane major fork configurations are discussed in Section 6.1, the 3-lane major fork configurations are discussed in Section 6.2, and the small-radius connector road variants are discussed in Section 6.3.

6.1 4-LANE MAJOR FORK CONFIGURATIONS

This analysis includes five 4-lane major fork road sections, as they are listed in [Appendix M](#). Since no 4-lane major forks with a 4-3/2-2/2 configuration exist that matched the criteria, 4-lane major forks with just a 4-3/2 configuration were chosen as a replacement. This results in an analysis between three major forks with a 4-2/2 configuration and two major forks with a 4-3/2 configuration. With the use of Google Maps' historical data, it can be stated with certainty that all five major fork road sections already exist since 2013, and did not had any major changes in their configuration or geometric design from 2013 until 2015. For that reason, the total accident data in this analysis is reduced from thirteen calendar years (2003-2015) to three calendar years (2013-2015).

In Figure 6.1, crash risk¹ is visualized on a horizontal axis that represents the location along the considered road sections. Since the location of accidents are linked to the (closest) hectometer sign, the horizontal axis is cut in measurement points that are equally distributed in hectometers, and in which the zero-mark represents the point of divergence. The length of the block marking is on average 1050 meters, but varies between 800 and 1200 meters between the five major fork road sections.

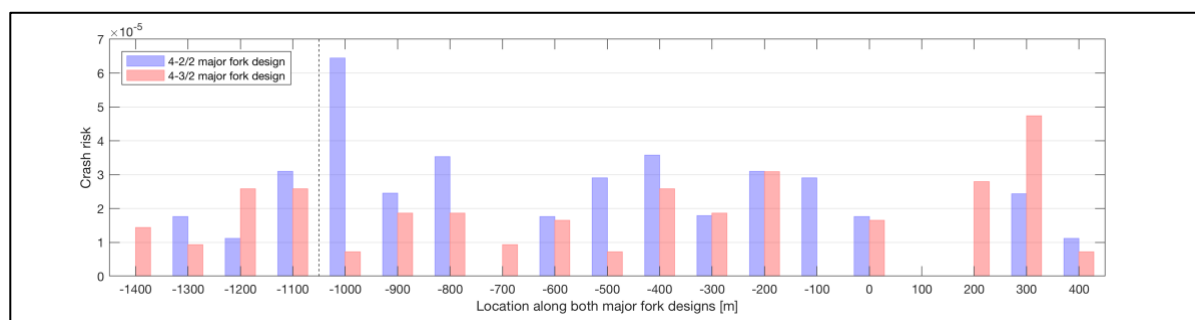

Figure 6.1: The crash risk for the 4-lane major fork configurations

Looking at the results in Figure 6.1, it is difficult to observe a trend. However, both major fork configurations seem to show modest peaks around the beginning and around the middle of the block marking. Looking at absolute numbers instead of trends, the 4-2/2 configuration has on average 15 accidents per road section, while the 4-3/2 configuration shows a higher number of accidents with on average 19,5 accidents per road section. However, the 4-3/2 configuration apparently handles much more traffic volume on average, since the crash risk is the other way around. Whereas the 4-2/2 configuration has a mean crash risk of 0,00040 per road section, the 4-3/2 configuration shows a mean crash risk of 0,00033 per road section.

¹ In this chapter, the crash risk is calculated per considered road section by dividing the number of accidents in the entire timespan (i.e. 3, 7 or 6 years) by the average Annual Average Daily Traffic (AADT) of that timespan.

6.2 3-LANE MAJOR FORK CONFIGURATIONS

This analysis includes four 3-lane major fork road sections, as they are listed in [Appendix M](#). Two of these road sections have a 3-1/2 configuration and two have a 3-2/1 configuration. With the use of Google Maps' historical data, it can be stated with certainty that all four major fork road sections exist since 2009, and did not had any major changes in their configuration or geometric design from 2009 until 2015. For that reason, the total accident data in this analysis is reduced from thirteen calendar years (2003-2015) to seven calendar years (2009-2015).

Just as in the previous section, Figure 6.2 visualizes the crash risk on a horizontal axis that represents the location along the considered road sections, in which the zero-mark represents the point of divergence. For the 3-lane major fork road sections, the length of the block marking is on average 600 meters, but variates between 400 and 800 meters between the four major fork road sections that are included in this analysis.

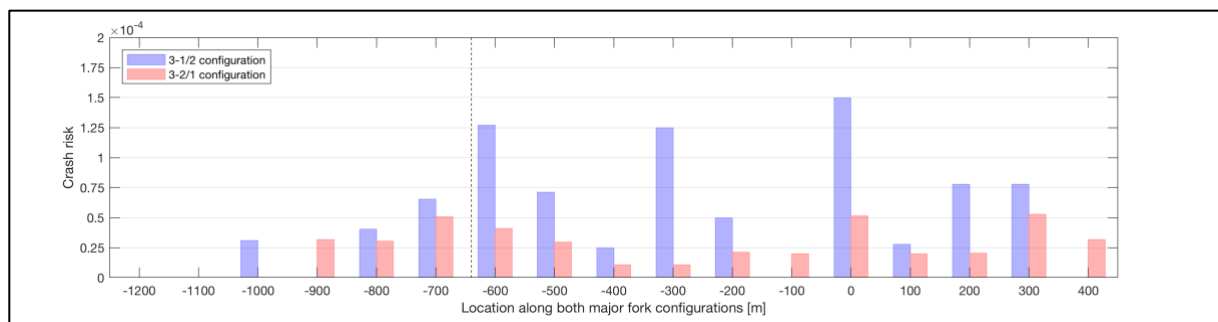

Figure 6.2: The crash risk for the 3-lane major fork configurations

Looking at the results in Figure 6.2, it is difficult to observe a trend. However, both major fork configurations seem to show a peak around the beginning of the block marking and the end of the block marking. Furthermore, the 3-1/2 configuration also shows a peak around the middle of the block marking. Looking at absolute numbers instead of trends, the 3-1/2 configuration shows to have a lower traffic safety in both the number of accidents and crash risk. Whereas the 3-1/2 configuration has on average 33 accidents per road section, the 3-2/1 configuration has on average 20,5 accidents per road section. Additionally, the 3-2/1 configuration also handles much more traffic volume on average, which results in the difference in crash risk being even relatively larger. Whereas the 3-1/2 configuration has a mean crash risk of 0,00087 per road section, the 3-2/1 configuration shows a mean crash risk of 0,00042 per road section.

6.3 SMALL-RADIUS CONNECTOR ROAD VARIANTS

This analysis includes eighteen small-radius connector roads that are also left-diverging roadways of a major fork (as they are listed in [Appendix M](#)); with nine having a two-lane configuration and nine having a single-lane configuration. With the use of Google Maps' historical data, it can be stated with certainty that all eighteen small-radius connector road locations did not had any changes in their geometric design from 2009 until 2014. For that reason, the total accident data is reduced from thirteen calendar years (2003-2015) to six calendar years (2009-2014). Considering these six calendar years, accident data is available for each of the eighteen small-radius connector road locations.

Figure 6.3 visualizes accident data on a horizontal axis that represents the location along the small-radius connector roads. Unlike the major fork configurations, the zero-mark represents the middle of the transition curve, which can also be seen as the start of the small-radius curve. Each small-radius connector road section that is included in the analysis differs in length. The length between a major fork's point of divergence and the start of a small-radius curve variates between 1000 and 100 meters, while the length of all small-radius curves variates between 400 and 700 meters. So, in order to make a fair comparison, only the largest coinciding interval between all eighteen road sections should be taken into account, which is the [-100, 400] interval.

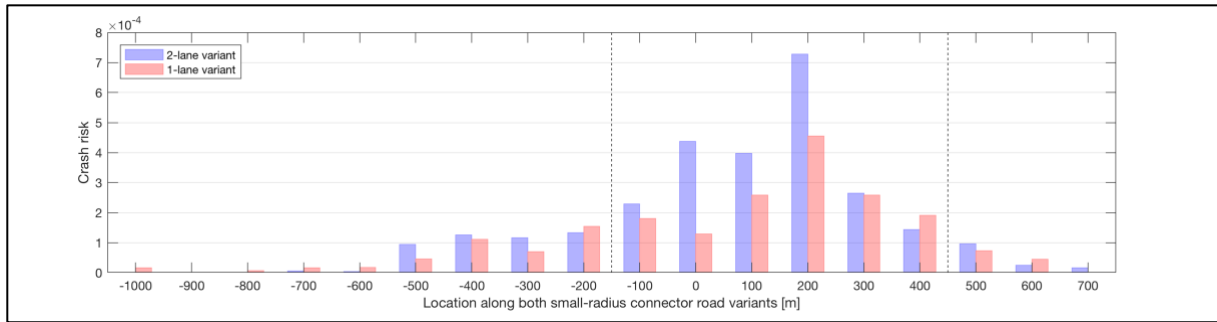

Figure 6.3: The crash risk for the small-radius connector road variants

Looking at the results for the [-100, 400] interval in Figure 6.3, a clear trend is directly observed. A clear peak around the '+200' measurement point is noticeable for both configurations. Furthermore, they both follow a bell curve distribution that is somewhat left skewed for the two-lane variant and somewhat normal distributed for the single-lane variant. But most importantly, the two-lane variant shows a higher crash risk than the single-lane variant for five of the six measurement points in the considered interval. Looking at absolute numbers instead of trends, the two-lane variant shows greater safety issues in all respects for the considered interval. Whereas the two-lane variant has on average 26,1 accidents per road section, the single-lane variant has on average 8,7 accidents per road section. However, the two-lane variant also handles much more traffic volume on average, which lead to a relative smaller difference in crash risk. Whereas the two-lane variant has a mean crash risk of 0,0022 per road section, the single-lane variant shows a mean crash risk of 0,0015 per road section.

7

MAIN FINDINGS AND DISCUSSION

With the results of the driving simulator experiment and accident data analysis presented and analyzed in Chapter 5 and Chapter 6, respectively, this chapter will present and discuss the main findings of both methodologies in Section 7.1 for the major fork configurations, and in Section 7.2 for the small-radius connector road variants.

7.1 MAJOR FORK CONFIGURATIONS

This section is further subdivided into two separate sections. The main findings of the driving simulator experiment and accident data analysis are presented in Section 7.1.1, and are successively discussed in Section 7.1.2.

7.1.1 MAIN FINDINGS

The driving simulator experiment shows specific differences in location-specific surrogate safety measures and driving behavior characteristics that are observed between the competitive major fork configurations. Focusing on both sets of major fork configurations:

- In the 0% freight traffic condition, most participants on the [4-2/2 configuration](#) and [3-1/2 configuration](#) needed to execute at least one mandatory lane change to keep following their route, while all participants on the [4-3/2-2/2 configuration](#) and [3-2/1 configuration](#) needed none.
- In the 25% freight traffic condition, most participants on the [3-1/2 configuration](#) needed to execute at least one mandatory lane change, while all participants on the other configurations needed none.
- Participants that drove on the left-adjacent lane of the block marking on the [4-3/2-2/2 configuration](#) and [3-2/1 configuration](#) automatically drove closer to the right-side edge marking than their competitive configurations. Consequently, in both freight traffic conditions, participants on these configurations experienced the turbulence caused by lane-changing traffic (to go to the left-diverging roadway) earlier and more intense, but also experienced an earlier relief of them.

Focusing on the 4-lane major fork configurations:

- In both freight traffic conditions, the [4-3/2-2/2 configuration](#) showed a higher number of lane changes in total, as well as a higher mean of lane changes per participant (although it did not include participants executing a mandatory lane change).
- In both freight traffic conditions, participants that drove on the left-adjacent lane of the block marking on the [4-3/2-2/2 configuration](#) (before the lane addition) experienced more turbulence (i.e. decreasing driving speed, time headway and TTC) than participants on the left-adjacent lane of the block marking on the [4-2/2 configuration](#) due to being mixed with right-diverging traffic.
- In both freight traffic conditions, participants on the [4-2/2 configuration](#) and [4-3/2-2/2 configuration](#) experienced a relatively higher time headway towards the end of the block marking than at the beginning of the block marking, because traffic was gradually equally distributed over both sides of the block marking towards the divergence point of the major fork. However, the [4-3/2-2/2 configuration](#) showed greater time headways than the [4-2/2 configuration](#), which is explained by the fact that traffic on the left-adjacent side of the block marking was distributed over three lanes instead of two. However, this difference was at the same time suppressed by the lane drop that was located not far downstream.
- While the [4-2/2 configuration](#) did not show a great difference between the 0% and 25% freight traffic condition, the 25% freight traffic condition of the [4-3/2-2/2 configuration](#) did show substantially more adverse traffic safety effects than the 0% freight traffic condition. Firstly, whereas participants on

lane 3 were only mixed with left- and right-diverging car traffic in the 0% freight traffic condition, they were also mixed with left- and right-diverging freight traffic in the 25% freight traffic condition. Secondly, whereas participants did not execute any discretionary lane changes (other than overtaking) in the 0% freight traffic condition, they did execute them in the 25% freight traffic condition to avoid the conflicts on lane 3. Lastly, whereas participants experienced lower time headways and TTC values around the lane drop in the 0% freight traffic condition, they experienced even more severe conditions in the 25% freight traffic condition. This is explained by the fact that the rightmost lane is mostly filled with slow-driving freight traffic, which makes this lane unattractive for the faster-driving car traffic.

Focusing on the 3-lane major fork configurations:

- In the 25% freight traffic condition, the [3-2/1 configuration](#) showed a higher number of lane changes in total, as well as a higher mean of lane changes per participant (although it did not include participants executing a mandatory lane change).
- In both freight traffic conditions, the speed of participants on the [3-1/2 configuration](#) was totally dependent on the simulated traffic. This is explained by the fact that the block marking of this configurations has only one left-adjacent lane, which causes no overtaking possibilities for left-diverging traffic. Whereas this caused steep TTC trend lines and multiple conflicts (TTC below the 6 second threshold) in the 0% freight traffic condition due to merging left-diverging traffic, this caused for long gradual TTC trend lines and less conflicts in the 25% freight traffic condition.

Looking at the surrogate safety measures and driving behavior characteristics that consider the major fork configurations as a whole (and are thus not location-specific), the main findings are summarized in Table 7.1. In this table, a checkmark-symbol below a configuration indicates that this configuration includes the specific measure in comparison with its competitive configuration, and a dot-symbol indicates that there is (almost) no difference between the configurations.

Table 7.1: Different measures that indicate unsafe driving behavior in comparison between configurations

	0% freight traffic		25% freight traffic		0% freight traffic		25% freight traffic	
	4-2/2	4-3/2-2/2	4-2/2	4-3/2-2/2	3-1/2	3-2/1	3-1/2	3-2/1
lower driving speed	✓	.	✓
higher p(THW<2)	.	✓	.	✓	.	✓	.	✓
higher p(TTC<6)	.	✓	.	✓	✓	✓	.	✓
higher summed TET&TIT	.	✓	✓	.
greater mean TET&TIT / conflict	✓	.	.	✓	.	✓	.	✓
more lane changes in total	.	✓	.	✓	✓	✓	.	.
more lane changes / participant	.	✓	.	✓	✓	✓	.	.
smaller accepted gaps	✓	.	.	✓	.	✓	.	✓
smaller PET	✓	.	✓	✓	.	✓	.	✓

* p stands for probability, THW stands for time headway, TTC stands for time-to-collision, TET stands for time exposed time-to-collision, TIT stands for time integrated time-to-collision, and PET stands for post-encroachment time.

** This table is based upon a visual analysis, and therefore does not indicate statistical significance.

The accident data analysis of the major fork configurations shows that:

- When considering the 4-lane major fork configurations, the [4-2/2 configuration](#) has a crash risk that is roughly 20% higher than the crash risk of the 4-3/2 configuration (which was chosen as a replacement for the [4-3/2-2/2 configuration](#)).
- When considering the 3-lane major fork configurations, the [3-1/2 configuration](#) has a crash risk that is roughly 100% higher than the crash risk of the [3-2/1 configuration](#).

7.1.2 DISCUSSION

As discussed in Chapter 3, the general hypothesis is that the major fork configurations that include two mandatory lane changes are less safe than the major fork configurations that include one mandatory lane change for rightmost traffic going to the left-diverging roadway of a major fork. In addition, a greater share of freight traffic is expected to show the same but even greater differences in traffic safety between configurations. In this section, the main findings are held up to the light of these hypotheses, in which the main findings of the driving simulator experiment and the main findings of the accident data analysis are discussed separately.

Driving simulator experiment

Counting the number of checkmarks per configuration in Table 7.1, the non-location-specific surrogate safety measures and driving behavior characteristics indicate that major fork configurations that include one mandatory lane change for rightmost traffic going to the left-diverging roadway are less safe than the configurations that include two mandatory lane changes, which rejects the first hypothesis. Additionally, the main findings indicate that a 25% freight traffic condition gives the major fork configurations that include one mandatory lane change for rightmost traffic going to the left-diverging roadway even more adverse traffic safety issues than a 0% freight traffic condition, which thus rejects the second hypothesis. Even though the main findings of the location-specific surrogate safety measures and driving behavior characteristics are not quantified and therefore less straight forward to interpret or trade off, they at least invite for the same direction of thinking. However, both the analysis methodology and driving simulator experiment had some assumptions and flaws that potentially influenced the results or caused a one-sided perspective.

First of all, the main findings of the driving simulator experiment are obtained by conducting a visual analysis, which is the evaluation of figures by the human eye. This analysis methodology is completely dependent on the available information and the expertise of the person doing the analysis. As the main findings are basically the interpretation of the researcher, there exists a thin line between an opinion and an actual fact, which makes this methodology prone to error. The same holds for the overview table in which the major fork configurations are compared on some surrogate safety measures and driving behavior characteristics that consider the major fork configurations as a whole (see Table 7.1). Allocation of the checkmarks is done by a visual analysis and the choice between a checkmark- or a dot-symbol is dependent of the researcher's opinion. This makes quantifying traffic safety by counting the number of checkmarks prone to error; especially since a checkmark does neither take the absolute difference nor statistical significance of a difference between the configurations into account.

Secondly, at every major fork configuration that participants encountered, participants were directed to the left-diverging roadway. Although this is a point of discussion in itself (since this means that the route to the right-diverging roadway and its accompanied level of turbulence is totally ignored), this repetition in the experiment led to participants showing pre-allocating behavior. Although this had not any effect on the driving behavior of participants at the first couple of major fork configurations of the eight they encountered, the more driving experience in the simulator they had, the more pre-allocating behavior they showed. This means that participants were less likely to obey the EU traffic rule of keeping right when they saw the first overhead signage of a major fork configuration very far downstream. This caused the participants to drive closer the leftmost lane at the start of a major fork configuration and consequently to do less mandatory lane changes. This was especially the case in the 25% freight traffic condition, where almost all participants were already driving on the correct lanes to follow their route to the left-diverging roadway at the start of a major fork configuration; making mandatory lane changes (nearly) absent. Although one could argue that pre-allocating behavior also occurs in reality by driving experience, one should note that the pre-allocating behavior in the simulator was solely formed by the repetition in the experiment. This behavior weakens the comparison since the main difference between the configurations is the number of mandatory lane changes to follow the route to the left-diverging roadway.

Thirdly, each participant experienced a different traffic situation than any other participant on all of the four considered major fork configurations. Even though VISSIM, which simulates the surrounding traffic, has the ability to simulate the same traffic conditions (e.g. traffic intensity) for every participant, every participant drove with a different number and/or formation of simulated vehicles in its vicinity. A certain participant could have been driving an entire major fork configuration with constantly minimally 6 vehicles within a radius of 100 meters, while another participant that was driving the same configuration could have been driving in a void, which basically means he or she had constantly 0 vehicles within a radius of 200 meters. Although these examples are two extremes, each traffic situation between these two extremes had a high probability of occurrence. This means that each participant experienced alternating traffic situations, in which the location and duration of these different traffic situations differed per participant. Although one could argue that this variation in traffic situation is not different from reality, unarguable is the fact that this makes it difficult to observe differences and trends from figures with statistical measures, since driving behavior data of all forty participants is combined.

In addition to the previous paragraph, the effect that a void has on the time headway is different between roadways with a different number of traffic lanes. Assuming that the left-adjacent lanes of a block

marking at a major fork from an individual roadway, there is a time headway difference between participants driving in a void on a 3-1/2 configuration and participants driving in a void on a 3-2/1 configuration. Assuming a low-density void in the simulated traffic stream with 2 generated vehicles per kilometer, an extra participant will on average experience a gap of $(1000/3=)$ 333 meters on the left-adjacent lane of the block marking for the 3-1/2 configuration, and a gap of $(1000/5=)$ 200 meters (when assuming all considered vehicles drive on lane 2) on the left-adjacent lane of the block marking for the 3-2/1 configuration. This shows that the same low traffic density (per lane) on the left-adjacent lanes of the block marking potentially leads to a larger time headway for participants on the 3-1/2 configuration in comparison with participants on the 3-2/1 configuration.

Fourthly, the simulated traffic follows certain longitudinal and lateral driving behavior parameters that control how the simulated traffic behaves, but lacks configurability on more tactical driving maneuvers around convergence and divergence points. The only configurable settings for such a discontinuity are the two upstream locations at which the simulated traffic gets the cue to execute mandatory lane changes to the left- and right-diverging roadway as soon as possible, which were iteratively determined as the locations that had the lowest total travel time for all simulated vehicles (see Section 4.1.2). This lack in complexity caused for single spots (i.e. roughly 400-meter road sections) where almost all mandatory lane changes happened, which potentially caused for a lot more turbulence than there actually is in reality. In addition, this lack in complexity made it also impossible for the simulated traffic to efficiently drive towards the right-diverging roadway of the 4-3/2-2/2 configuration. As soon as the simulated traffic got the cue to follow the right-diverging roadway, which was before the start of the block marking, they all tried to change lanes to the right-adjacent side of the block marking as soon as possible. The simulated traffic was unable to consider the lane addition at the right-side of the mainline roadway around the middle of the block marking, and thus to postpone their mandatory lane change. Only the simulated traffic that did not get the chance to change lanes to the right-adjacent side of the block marking eventually changed lanes after the lane addition. This limitation potentially caused a lot more turbulence on lane 3 than there actually is in reality.

In addition to the previous paragraph, the locations where participants did their mandatory lane change to follow their route to the left-diverging roadway is different from the locations where the simulated traffic did theirs (see [Appendix D](#)). Looking at the results, participants on the 4-lane major fork configurations started lane changing to the left-diverging roadway around 1800 meters downstream of the divergence point, which was 300 meters earlier than the mandatory lane changes of right-diverging simulated traffic and 600 meters earlier than the mandatory lane changes of left-diverging simulated traffic. The same occurred on the 3-lane major fork configurations, where participants started lane changing to the left-diverging roadway around 1200 meters downstream of the divergence point, which was 100 meters earlier than the mandatory lane changes of right-diverging simulated traffic and 300 meters earlier than the mandatory lane changes of left-diverging simulated traffic. As a result of this mismatch, participants that drove on the leftmost lanes experienced a lower traffic density just after the location where the right-diverging simulated traffic got the cue of VISSIM to lane change. This lower traffic density provided bigger gaps in the traffic stream and thus gave the participants the ability to drive with higher driving speeds and a larger time headway, until the location where left-diverging simulated traffic got the cue of VISSIM to lane change. This mismatch caused the 4-2/2 and the 3-1/2 configurations to be safer than the 4-3/2-2/2 and 3-2/1 configurations, respectively, since the block marking of these configurations are located further away from the right-side of the mainline roadway, which caused participants to experience exiting right-diverging simulated traffic earlier and entering left-diverging simulated traffic later.

Fifthly, looking at the results of Section 5.1 and Section 5.2 with more detail, some other trends in the driving behavior of participants stand out that can neither be assigned to the effects of the experiment design nor simulated traffic:

- In both the 0% and 25% freight traffic condition of the 4-3/2-2/2 configuration, a temporarily-lowered median and/or lower quartile of the driving speed is noticeable around the first 200 meters of the total major fork length considered. This drop could be triggered by the first overhead signage of this major fork configuration, which is located after 250 meters. Since this sign is roughly two times the size of any other sign in the driving simulator environment, it also has a resolution that is two times as low. This makes this sign only readable when driving (almost) directly underneath it, while other signs are already readable from a distance of 200 meters. Since the first overhead signage that a participant encounters is also the most important one, it is plausible that participants decelerate when trying to read the first overhead signage and accelerate again when they pass it.

- In the 0% freight traffic condition of the 4-2/2 and 3-1/2 configuration, a drop in the driving speed is noticeable towards the end of the considered major fork lengths. A similarity between these configurations is the fact that their left-diverging roadway is also a small-radius connector road. Although it was assumed in Section 4.1.1 that a downstream small-radius connector road does not affect upstream driving behavior on a major fork since the small-radius connector road is not even visible from the most downstream location of a major fork, it could be that participants that already drove some scenarios on the experimental track know of the existence of the small-radius connector road and adjust their driving speed.

Accident data analysis

The accident data analysis of the major fork configurations shows that the 4-2/2 configuration and the 3-1/2 configuration have a higher crash risk than their competitive configurations, which is in line with the hypothesis that states that major fork configurations on which rightmost traffic needs to perform two mandatory lane changes to go to the left-diverging roadway are less safe than those on which only one mandatory lane change is necessary. However, the accident data analysis had some assumptions and flaws that potentially influenced the results.

First of all, the number of included road sections in the accident data analysis of both the 4-lane and 3-lane major fork configurations are scarce. The analysis of the 4-lane major fork configurations included five road sections in total, and the analysis of the 3-lane major fork configurations included four road sections in total. A comparison with such a low number of included road sections prone to biases, since the effect of outliers are not averaged out, and differences in road geometry, traffic characteristics and environmental factors can influence the result.

Focusing on the 4-lane major fork configurations, a 4-3/2 configuration was chosen as a replacement for the 4-3/2-2/2 configuration, since no 4-lane major forks with a 4-3/2-2/2 configuration exist that match the criteria of the analysis. But claiming that a 4-3/2 configuration is the same as a 4-3/2-2/2 configuration but without the lane drop after the divergence point is not true. First of all, a 4-3/2 configuration has a higher probability of being implemented than a 4-3/2-2/2 (or 4-2/2) configuration when the distribution between the left- and right-diverging roadways is unequal. By simply analyzing the configurations in a very theoretical manner, a 4-3/2 configuration is best suited when processing a 60/40 distribution between the left- and right-diverging roadway, respectively, while a 4-3/2-2/2 configuration is best suited when processing a 50/50 distribution (assuming a relatively high I/C ratio). When considering the road section before the lane addition, and assuming that the total traffic intensity is distributed over all traffic lanes in the most efficient manner (i.e. left-diverging traffic on the leftmost lanes and right-diverging traffic on the rightmost lanes), Table 7.2 shows that the 4-3/2 configuration has mixed traffic on lane 3, while the 4-3/2-2/2 configuration has the ability to split the traffic completely. Although this is a very theoretical approach of thinking since traffic will never distribute itself so efficiently and the number of lane changes are not considered, this makes a 4-3/2 configuration potentially less safe than a 4-3/2-2/2 configuration.

Table 7.2: The most-efficient lane distribution at the beginning of the block marking of both configurations

	4-3/2 configuration		4-3/2-2/2 configuration	
	Left-diverging (60%)	Right-diverging (40%)	Left-diverging (50%)	Right-diverging (50%)
Lane 1	25%		25%	
Lane 2	25%		25%	
Lane 3	10%	15%		25%
Lane 4		25%		25%

In addition, a 4-3/2 configuration has a higher probability of being implemented than a 4-3/2-2/2 (or 4-2/2) configuration when the I/C-ratio is relatively high. Assuming an I/C-ratio below 0.75, a slight unequal distribution between the left- and right-diverging roadway (e.g. a 55/45 distribution) does not make it necessary to implement a 4-3/2 configuration, whereas an I/C-ratio of 0.75 or higher, does make it necessary. This phenomenon is also shown in the results. The 4-3/2 configuration shows a higher number of total accidents, while the 4-2/2 configuration shows a higher crash risk, which indicates that the 4-3/2 configuration indeed handles more traffic volume on average.

Focusing on the 3-lane major fork configurations, the accident data analysis included two 3-1/2 major fork road sections that have a block marking length of 400 and 600 meters, and two 3-2/1 major fork road sections that have a block marking length of 650 and 800 meters (see Appendix M). This not only shows a relatively large variance between the block marking lengths, but also an unfair distribution of

block marking length in the comparison between the two configurations. The two shortest block marking lengths belong to the 3-1/2 major fork road sections, while the two longest block marking lengths belong to the 3-2/1 major fork road sections. Since the number and locations of overhead signage is roughly the same between all four road sections, a shorter block marking length at a major fork road section indicates a shorter timespan in which traffic can perform mandatory lane changes to follow their route to either the left- or right-diverging roadway, which in turn leads to a higher level of turbulence. Taking a closer look at the results of the accident data analysis, the major fork road section with the shortest block marking (i.e. 400 meters) also shows the highest number of total accidents (i.e. 51 accidents in seven years), which is roughly 110% higher than the second major fork road section with the highest number of total accidents. This potentially causes the 3-1/2 configuration to result in being less safe than it actually is in reality.

7.2 SMALL-RADIUS CONNECTOR ROAD VARIANTS

This section is further subdivided into two separate sections. The main findings of the driving simulator experiment and accident data analysis are presented in Section 7.2.1, and are successively discussed in Section 7.2.2.

7.2.1 MAIN FINDINGS

The results of the driving simulator experiment considering the small-radius connector road variants were subdivided in two parts that consider the only 1st encounters of a small-radius connector road by participants, and the 2nd, 3rd and 4th encounters of a small-radius connector road by participants separately. Independent of the number of major forks that participants encountered:

- Participants on the [two-lane variant](#) had a higher driving speed in the last 150 meters before the start of the small-radius curve, as well as in the first 150 meters in the small-radius curve.
- The slowest driving participants on the [two-lane variant](#) even increased their driving speed when they were just 150 to 300 meters (depending on their experience) upstream of the start of the small-radius curve.
- Participants on the [two-lane variant](#) had a lower acceleration rate (i.e. more negative) when entering the small-radius curve.
- Participants on the [two-lane variant](#) had a lower mean, median and interquartile range of the acceleration rate in the first 150 meters of the small-radius curve.

Comparing the results between the group of participants that encountered a small-radius connector road for the 1st time and the group of participants that encountered one for the 2nd, 3rd and 4th time, participants of the second group:

- started to decrease their driving speed more upstream relatively to the start of the small-radius curve, and as a result had a lower median driving speed when entering the small-radius curve.
- did not show a drop in the median driving speed towards the beginning of the small-radius curve, but rather a steady decrease.
- had a lower median driving speed in the entire small-radius curve.
- showed a smaller difference in the median driving speed between the start of the small-radius curve, and 150 meters downstream of the start of the small-radius curve.

The accident data analysis of the small-radius connector road variants showed that the [two-lane variant](#) has a crash risk that is roughly 50% higher than the crash risk of the [single-lane variant](#). Furthermore, the analysis clearly showed that the crash risks of both variants follow a bell-curved distribution around the small-radius curve, with both their peak around 200 meters into the small-radius curve.

7.2.2 DISCUSSION

As discussed in Chapter 3, the general hypothesis is that the two-lane small-radius connector road is less safe than the single-lane small-radius connector road. In this section, the main findings are held up to the light of this hypothesis, in which the main findings of the driving simulator experiment and the main findings of the accident data analysis are discussed separately.

Driving simulator experiment

To start off, the main findings show that the group of participants that encountered a small-radius connector road for the 2nd, 3rd, or 4th time adapted their driving behavior better than the group that encountered one for the 1st time. This clearly demonstrates the existence of the “driving experience” component of the theoretical model of driver expectancy (see Figure 7.1). This model explains that driving behavior is affected by driver expectancy, but that driver expectancy is affected by driving experience. The driving behavior of the group of participants that encounter a small-radius connector road for the 1st time in the driving simulator experiment is thus solely formed by real driving experience, while the driving behavior of the group of participants that encounter a small-radius connector road for the 2nd, 3rd or 4th time in the driving simulator experiment is thus formed by the same real driving experience with driving experience in the simulated environment in addition. Since the road environment in the driving simulator was 100% the same for each encountered small-radius connector road, this observed learning curve is certainly not the same as the learning curve that drivers would typically have. It is therefore obvious that the group of participants that encountered a small-radius connector road for the 1st time is the most critical group and therefore the normative group. However, this group of participants is also less adapted to the driving characteristics of the driving simulator vehicle, which may also have affected the driving behavior.

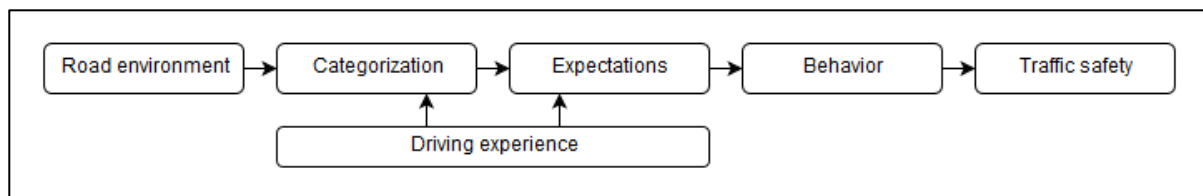

Figure 7.1: Theoretical model of how the road environment affect traffic safety through driver expectancy [3]

Independent of the times a participant encountered a small-radius connector road in the driving simulator experiment, the main findings show that participants on the two-lane variant adapted their driving behavior to undergo the small-radius curve less than the single-lane variant. Since the theory behind the hypothesis is that participants on a two-lane left-diverging roadway will automatically and incorrectly categorize their continuing road as a mainline roadway and will therefore less adapt their driving behavior, this main finding is in line with the hypothesis.

Instead of a difference in driving expectancy, these differences in driving speed and acceleration rate between the two variants could also reflect the fact that there are no overtaking possibilities on the single-lane variant. Although this point of discussion is already made less of a problem by only considering the 0% freight traffic condition, it could be the case that participants on the single-lane variant were held up by their predecessor, which caused their driving speed to drop and made it less necessary for them to decelerate before and/or in the small-radius curve. While this theory seems plausible as the median time headway of the single-lane variant is consistently lower than that of the two-lane variant for the only 1st encounters (see Figure 5.50), the theory is actually busted as the median time headway of the single-lane variant is consistently higher than that of the two-lane variant for the 2nd, 3rd or 4th encounters (see Figure 5.60).

Accident data analysis

The main findings show that the two-lane small-radius connector road (that is also a left-diverging roadway of a major fork) has a higher crash risk than the single-lane variant, which is in line with the hypothesis that drivers on a two-lane variant do less expect a small-radius curve and therefore less adapt their driving behavior. However, looking at the eighteen road sections that were considered (see Appendix M), this analysis only differentiated between the number of lanes that each road section included, while each considered road section has more properties than just that.

Even though all considered small-radius connector roads (that are also left-diverging roadways of a major fork) bear to the left to connect with a perpendicular mainline roadway, they are of two different types. They are either of the type that includes a small-radius curve of 90 degrees to the left, or of the type that includes a small-radius curve of 270 degrees to the right. Depending on the number of traffic lanes they include, these types are formulated as 1L90 or 2L90 for the first type, or as 1R270 or 2R270 for the second type. Looking at the list of all considered small-radius connector roads (see Appendix M), seven out of the nine two-lane variants are of the type L90, and seven out of the nine single-lane variants are of the type R270. So, since approximately 78% of the single-lane variants are of another type than

78% of the two-lane variants, it could also be the case that the accident data analysis showed that a R270 connector road (that is also a left-diverging roadway of a major fork) has a lower number of total accidents and a lower crash risk than a L90 connector road. However, when not considering any R270 small-radius connector road, and thus comparing seven 2L90 variants with two 1L90 variants, the crash risk of the two-lane variant is roughly 80% higher than the crash risk of the single-lane variant. This means that the difference in crash risk is larger when only considering left-curving small-radius connector roads in comparison with an analysis that considers both types simultaneously.

8

CONCLUSIONS

With the results of the driving simulator experiment and accident data analysis discussed in Chapter 7, this chapter will conclude the major findings per sub- and main research question in Section 8.1, discuss the main study limitations in Section 8.2, and give recommendations for further research in Section 8.3.

8.1 CONCLUSION

This section is subdivided into two separate sections. The focus of Section 8.1.1 is on main research question 1, and thus the major fork configurations, whereas the focus of Section 8.1.2 is on main research question 2, and thus on the small-radius connector road variants.

8.1.1 MAJOR FORK CONFIGURATIONS

This first main research question focusses on the traffic safety effects of the number of mandatory lane changes by rightmost traffic going to left-diverging roadway of a major fork. With respect to this research question, the scope of this research was limited to the two comparisons of major fork configurations as they are illustrated in Figure 8.1, and the six sub-questions as they are introduced in the remainder of this section.

As discussed in Chapter 3, the general hypothesis is that the major fork configurations that include two mandatory lane changes are less safe than the major fork configurations that include one mandatory lane change for rightmost traffic going to the left-diverging roadway of a major fork. In addition, a greater share of freight traffic is expected to show even greater differences in traffic safety between configurations. These hypotheses can be underpinned by the turbulence theory as it is worked out in Section 2.1, which explains that even though turbulence is always present in a traffic stream, it can differ in quantity. This means that a higher number of mandatory lane changes induce more individual driving maneuvers (especially when there is a greater speed dispersion), which leads to a higher level of turbulence, which in turn causes a lower level of traffic safety.

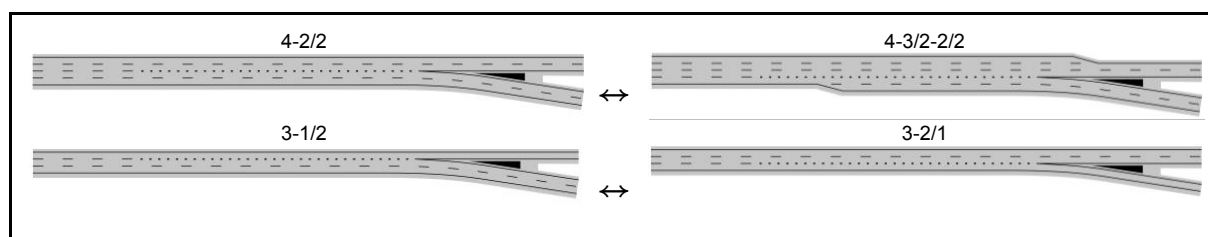

Figure 8.1: The two sets of major fork designs that are researched in this study

1.1a What is the difference in driving behavior between the 4-2/2 major fork configuration and the 4-3/2-2/2 major fork configuration in case of a **0% freight traffic** condition?

1.1b What is the difference in driving behavior between the 3-1/2 major fork configuration and the 3-2/1 major fork configuration in case of a **0% freight traffic** condition?

1.2a *What is the difference in driving behavior between the 4-2/2 major fork configuration and the 4-3/2-2/2 major fork configuration in case of a 25% freight traffic condition?*

1.2b *What is the difference in driving behavior between the 3-1/2 major fork configuration and the 3-2/1 major fork configuration in case of a 25% freight traffic condition?*

To answer sub-questions 1.1 and 1.2 simultaneously, the driving simulator experiment showed that participants driving on the 4-3/2-2/2 or 3-2/1 configuration experienced more adverse traffic safety conflicts than participants driving on one of the competitive configurations, which is thus not in line with the hypothesis. This difference was found for both the 0% and 25% freight traffic condition, with the 25% freight traffic condition resulting in even bigger differences between the competitive major fork configurations, which is also not in line with the hypothesis. However, both the analysis methodology and the driving simulator experiment included so much assumptions and flaws that these main findings should be queried. First of all, the analysis methodology was a visual analysis. This methodology is completely dependent on the interpretation of the researcher, causes that there exists a thin line between opinion and fact, and is therefore prone to error. Secondly, participants were only directed to the left-diverging roadways of the major forks. This caused pre-allocating behavior, which diminished the actual configurational differences between the researched major fork configurations. Moreover, it caused an ignored traffic route along other results could have been obtained. Thirdly, even though the traffic conditions were the same for each participant, the traffic situation (i.e. the number and/or the formation of vehicles in a participant's its vicinity) was not, which caused for statistical difficulties. Additionally, it also caused for a time headway bias in voids between the competitive 3-lane major fork configurations. Fourthly, the used software lacked configurability on more tactical driving maneuvers around major forks, which led to mandatory lane changes of simulated traffic in one spot and consequently in a higher level of turbulence than there actually is in reality. Furthermore, the simulated traffic was unable to be made aware of the lane addition in the 4-3/2-2/2 configuration, which led to a higher level of turbulence upstream of the lane addition than there actually is in reality. In addition, participants did their mandatory lane change at a different location than the simulated traffic, which caused for differences in the location and duration at/in which a raised level of turbulence was measured between the standard and competitive configurations. Taking everything into consideration, no conclusive results are found.

1.3a *What is the difference in crash risk between the 4-2/2 major fork configuration and the 4-3/2-2/2 major fork configuration?*

The accident data analysis showed that the 4-2/2 configuration has a higher crash risk than the 4-3/2 configuration, which is in line with the hypothesis. However, besides the fact that the number of included road sections in this accident data analysis was scarce, a 4-3/2 configuration was chosen as a replacement for the scope of the accident data analysis due to an absence of 4-3/2-2/2 configurations that satisfied the criteria of the accident data analysis. However, a 4-3/2 configuration was shown to have a higher probability of mixed traffic (with different routes) in one traffic lane, which potentially overestimated the crash risk in comparison to a 4-3/2-2/2 configuration. Moreover, all included 4-3/2 configurations had a higher Annual Average Daily Traffic (AADT) than all included 4-2/2 configurations, which certainly underestimated the crash risk in comparison to a 4-3/2-2/2 configuration. Taking everything into consideration, no conclusive results are found.

1.3b *What is the difference in crash risk between the 3-1/2 major fork configuration and the 3-2/1 major fork configuration?*

The accident data analysis showed that the 3-1/2 configuration has a higher crash risk than the 3-2/1 configuration, which is in line with the hypothesis. However, besides the fact that the number of included road sections in this accident data analysis was scarce, the road sections that were included showed great differences in the block marking length between the configurations. The road sections of the 3-1/2 configuration had significantly lower block marking lengths than the other road sections, which makes these road sections automatically less safe. This was also confirmed by the data, which showed that the total number of accidents on one of the two considered 3-1/2 configuration road sections was a big outlier with respect to the three other included road sections. Taking this into consideration, no conclusive results are found.

1 How does the number of mandatory lane changes by right-most traffic going to the left-diverging roadway of a major fork affect the traffic safety?

No conclusive results are found from both the driving simulator experiment and accident data analysis. The general hypothesis that major fork configurations that include two mandatory lane changes are less safe than major fork configurations that include one mandatory lane change for rightmost traffic going to the left-diverging roadway can neither be accepted nor rejected.

8.1.2 SMALL-RADIUS CONNECTOR ROAD VARIANTS

The second main research question focusses on the traffic safety effects of the number of lanes on left-diverging roadways (of major forks) that are actually small-radius connector roads. With respect to this research question, the scope of this research was limited to the small-radius connector road variants as they are illustrated in Figure 8.2, and the two sub-questions as they are introduced in the remainder of this section.

As discussed in Chapter 3, the general hypothesis is that the two-lane small-radius connector road is less safe than the single-lane small-radius connector road. This hypothesis can be underpinned by the driver expectancy theory (see Section 2.2). This theory explains that drivers on a two-lane left-diverging roadway will automatically and incorrectly categorize their continuing road as a mainline roadway and will therefore less expect a connector road feature (such as a small-radius) in comparison with drivers on a single-lane left-diverging roadway of a major fork. This leads to unwanted driving behavior, which in turn leads to a lower level of traffic safety.

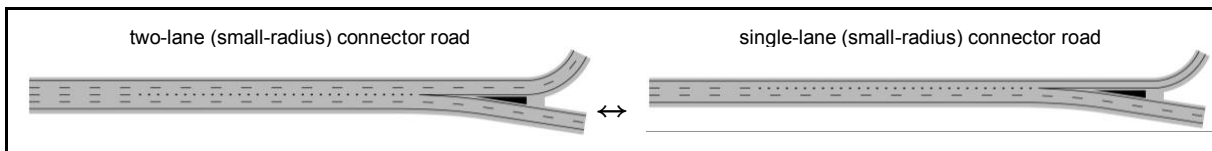

Figure 8.2: The set of (small-radius) connector roads that is researched in this study

2.1 What is the difference in driving behavior between single- and two-lane left-diverging roadways (of major forks) that are actually small-radius connector roads?

To start off, the driving simulator experiment showed that participants that encountered a small-radius connector road before in the experiment adapted their driving behavior to undergo a small-radius curve better than participants that encountered a small-radius connector road for the first time. These results clearly demonstrate the existence of a learning curve and thus the “driving experience” component of the theoretical model of driver expectancy by Theeuwes and van der Horst [3]. However, due to fact that the road environment was exactly the same for each encounter, the learning curve is expected to be much smaller in reality, which makes the 1st encounters normative.

However, independent of the number of encounters, the driving simulator experiment unanimously showed that participants on the two-lane variant adapted their driving behavior to undergo the small-radius curve less than the single-lane variant, which is in line with the hypothesis. Participants on the two-lane variant had a higher driving speed before the start of the small-radius curve of the connector road, as well as in the small-radius curve itself. Moreover, participants on the two-lane variant had a lower acceleration rate while entering the small-radius curve, and also in the entire small-radius curve itself.

2.2 What is the difference in crash risk between single- and two-lane left-diverging roadways (of major forks) that are actually small-radius connector roads?

The accident data analysis showed that the crash risk of both variants follow a bell-curved distribution around the small-radius curve, with both their peak around 200 meters into the small-radius curve, with the peak of the two-lane variant being roughly 50% higher than that of the single-lane variant. Furthermore, the analysis showed that the two-lane small-radius connector road (that is also a left-diverging roadway of a major fork) has a higher crash risk than the single-lane variant, which is in line with the hypothesis. However, while the analysis only differentiated between the number of lanes that

each road section included, it was found that 78% of the single-lane variants are of the type that curve 270 degrees to the right while 78% of the two-lane variants are of the type that curve 90 degrees to the left. However, even when neglecting all types that curve to the right, and thus only taking all road sections that curve 90 degrees to the left into account, the analysis showed that the two-lane small-radius connector road (that is also a left-diverging roadway of a major fork) has a higher crash risk than the single-lane variant, which is thus still in line with the hypothesis.

2 How does the number of traffic lanes on the left-diverging roadway of a major fork, continuing in the same direction as the mainline roadway, affect the traffic safety as it is actually a small-radius connector road?

Both the results of the driving simulator experiment and the accident data analysis suggest that a two-lane left-diverging roadway that is also a (90-degrees left-curving) small-radius connector road, is less safe than a single-lane variant.

8.2 LIMITATIONS

The driving simulator experiment counted 40 participants that were all aged between 20 and 31 years. As discussed in Section 2.1.2, this age group has a relatively high accident risk due to being earlier distracted, underestimating traffic situations, and overestimating their own skills. Additionally, this age group has the highest experience with gaming than any other age group (that is also allowed to drive), which causes them to take more risks since they subconsciously know there are no real dangers other than crashing a virtual vehicle. Since the results are used to compare different configurations with each other, this specific limitation is not expected to have influenced the results. However, due to the small sample size and its specific age group, one should note that the results do not represent the entire driver population of the Netherlands.

It was not checked if the behavioral validity of the driving simulator that was used in this research is within an acceptable range. Without behavioral validation, the credibility of the driving simulator results decreases, and one should be careful when extrapolating these results to road design, vehicle design, or traffic regulations [57]. The driving simulator did meet the recommendations of Lee et al. [66] for physical validity, but although this is a good starting point for having behavioral validity, it is not a certainty. Behavioral validity of a driving simulator can only be determined by comparing the recorded simulator measurements with real world measurements. Even though this comparison is not made, the results of the third questionnaire of the driving simulator experiment do show strong indications for a poor behavioral validity. Focusing on the participants' driving behavior, 43% of the participants indicated that they swayed more than normal, 43% indicated that they drove faster than normal, and 38% indicated that they took more risks than normal. Factors that have affected driving behavior in the driving simulator are discussed below.

The driving characteristics of the simulator vehicle were not the same as the driving characteristics of a real vehicle. According to the third questionnaire of the driving simulator experiment, 70% of the participants indicated that the steering wheel was too sensitive, 35% indicated that the simulator was unable to give them a correct feeling of their driving speed, 28% indicated that the braking pedal reacted differently, and 18% indicated that the gas pedal reacted differently. It is expected that these characteristics are partly caused by wrong settings of the driving simulator's hardware, while they are also partly caused by the absence of gravitational forces. One way or another, these limitations do explain why participants swayed more and drove faster than they would normally do in a real vehicle.

The appearance of the simulated traffic in the driving simulator environment did show some major differences from what a participant would expect:

- The movements of the simulated traffic were different than those of real traffic. The wheels of the simulated vehicles did not rotate, which caused the vehicles to look like they were sliding instead of rolling, and all simulated vehicles synchronously showed a glitch every couple of seconds, which caused the vehicles to look like they were shooting back and forth a couple of decimeters when this happened. These differences may have contributed to a lowered immersion capability of the driving simulator, which potentially causes participants to lose motivation and to show more riskier driving behavior.

- The simulated traffic did miss some key components. First of all, the windows of the simulated vehicles were not transparent. As a result, participants were not able to see through them, which potentially caused larger time headways than normal since only one leading vehicle was observed and not multiple. Second of all, the simulated vehicles did not have braking lights, which potentially caused lower time-to-collision values and greater deceleration rates than normal since the reaction time of participants solely depended on noticing if the following distance to a braking predecessor was decreasing or not.

VISSIM, a microscopic simulation program for modeling multimodal transport operations, was used to simulate the traffic in the driving simulator environment. Although VISSIM has some major advantages in comparison with other software that was available to use in this research, using VISSIM also had some disadvantages:

- Even though the VISSIM parameters and settings from Bosdikou [78] showed more realistic driving behavior than the standard VISSIM parameters and settings, it did still not reflect real driving behavior. Using face validity, simulated traffic seems to: accept too small gaps when mandatory lane changing, accelerate too quickly, overtake with too small driving speed differences, perform more and useless discretionary lane changes, and not perform courtesy yielding. Next to face validity, also the third questionnaire of the driving simulator experiment shows that 35% of the participants indicated that the simulated traffic performed unusual driving behavior.
- By letting the driving simulator and VISSIM communicate, the simulated traffic knew where the participant was driving, and therefore took the participant into account in its driving behavior. However, simulated traffic did not know if the participant wanted to lane change or not. This is because the blinkers of the participant are not communicated to the simulated traffic, and the simulated traffic only “sees” the participant in the lane where the coordinate of the middle of the front of the vehicle of the participant is. This means that when a participant is changing lanes and has already crossed the lane dividing marker with a relatively big proportion of its vehicle but not with the middle of the front of the vehicle, a following vehicle on destination lane will not decelerate or change lanes to make space. Only when a participant crossed the lane dividing marker with the middle of the front of its vehicle, the following vehicle on the destination lane will either decelerate or change lanes. This caused unaware participants to experience smaller accepted rear-side gaps than usual, and even to experience traffic accidents in some cases. Additionally, participants that were aware of the unusual driving behavior were discouraged to change lanes when a vehicle on the destination lane was approaching, even though this vehicle was located respectively far upstream.
- VISSIM only considers the Cartesian coordinate system, which means it specifies a location with a x- and a y-coordinate relative to where the x- and y-axis meet. This makes it difficult to calculate the interaction of participants with the simulated traffic in a curve. Therefore, simulated vehicles were not considered in any computation at the moment they entered a curve. Consequently, towards the beginning of the small-radius curve of a connector road, and towards the end of the 4-3/2-2/2 major fork configuration, the time-to-collision, time headway and post-encroachment-time had a lower probability of a leading vehicle in the calculation, and thus a lower probability to be calculated at all.

Focusing on the road design of the driving simulator experiment, all major fork configurations and small-radius connector roads (up to the start of the small-radius curve) in the experimental track have been designed perfectly straight in order to make the necessary computations relatively easier to perform. Even though the ROA [1] advises to not implement curves at a major fork design, and despite the fact that all straight road sections are shorter than maximally allowed by the ROA, the fact that these road sections are designed perfectly straight makes it harder for participants to observe multiple leading vehicles and thus enhances the limitation of the windows of the simulated traffic not being transparent.

To limit the computational difficulty, some surrogate safety measures were calculated with some assumptions and simplifications:

- The time-to-collision (TTC) is simply calculated by dividing the distance between a participant and its predecessor with the difference in their driving speeds. Although this is the correct way to measure TTC, it neglects the angle of both considered vehicles. Since this research only considers freeways, a type of roadway where almost solely parallel collision courses exist, this simplification only affects the moments at which one of the two vehicles starts or finishes lane changing. These moments are the start and the end of a series of TTC values experienced by a participant.

Assuming a lateral speed of 1 m/s, the time it takes for a vehicle to enter or exit a traffic lane is roughly 1,75 seconds. Assuming a maximum driving speed of 130 km/h (≈ 36 m/s) for a participant, the maximum time and distance a TTC trend line of a participant starts or ends too late or early is thus 1,75 seconds, or $(1,75 \cdot 36 =) 63$ meters.

- The post-encroachment-time (PET) is calculated by first determining the four moments in time at which each of the four corners of the participant's vehicle crosses the lane dividing marker. However, due to the fact that data is only collected every tenth of a second, and the simplification of the calculation to not consider the angle of the vehicle, these moments in time are not determined exactly accurate. Firstly, since each time step is a tenth of a second, the maximum error in the data collection is also a tenth of a second. Secondly, since the angle of the vehicle is not considered, which is maximally $2,58^\circ$ when considering a lateral speed of 1 m/s ($=100$ cm/s) and a driving speed of 80 km/h, the maximum error is 0,2 cm or $(0,2/100 =) 0,002$ seconds. This means that the total error of determining each of the four moments in time at which each of the four corners of the participant's vehicle crosses the lane dividing marker is roughly 0,102 seconds. Since this total error is the maximum time a PET value is calculated too early or late, this error is also the maximum error in each calculation of the four PET values.

Focusing on the accident data analysis, two types of data were not considered:

- Where the analysis did include the absolute and relative number of accidents, it did not include any additional crash data such as the number of parties involved, the severity level, and the type of crashes. This additional data gives an extra dimension to the actual traffic safety level since five accidents with a fatal outcome cannot be equated to five accidents where there is only property damage.
- Where the analysis did include the type of major fork configuration, it did not include any additional road section properties such as the (advisory) speed limit, share of freight traffic, traffic intensity at the time of the accident, and the radii of the small-radius curves. Since all of these variables could potentially have an effect on the number of accidents, some potential correlations are ignored.

8.3 RECOMMENDATIONS

All recommendations can be subdivided into three distinctive kinds: scientific (i.e. recommendations for further research), practical (i.e. recommendations for road designers and/or traffic engineers), and technical (i.e. recommendations when using the same driving simulator).

8.3.1 SCIENTIFIC RECOMMENDATIONS

It is recommended to perform an additional analysis on the results of the driving simulator experiment by using a Linear Mixed Model (LMM). A big advantage of a LMM over the visual analysis that is performed in this research, is that it is able to statistically analyze the effect of every considered factor (i.e. type of major fork configuration and share of freight traffic, or type of small-radius connector road and number of traffic lanes) on every considered output variable (e.g. driving speed, time headway, acceleration rate, time-to-collision, number of lane changes) simultaneously. Next to that, a LMM is not only able to estimate the main effects of these factors on the output variables, it is also able to estimate the interaction effects of these factors on the output variables. Since driving behavior was found to be varying substantially along the major fork configurations and small-radius connector roads, it is recommended to split the total major fork road sections into multiple distinctive road sections and the small-radius connector road sections into two distinctive road sections before adding them as fixed factors to the LLM.

However, additionally performing a Linear Mixed Model or not, the scope of this research was too narrow for the results to really affect day-to-day decision-making of (Dutch) road designers. To elaborate:

- At a major fork configuration, traffic can choose for the left- and right-diverging roadway, depending on the route they need to follow to come to their destination. However, all participants in the driving simulator experiment were directed to the left-diverging roadway for every considered major fork configuration and freight traffic condition. While the main difference between the researched major fork configurations is the number of mandatory lane changes when following the route to the left-diverging roadway (and thus being the most interesting route to compare), repetition in the driving simulator experiment led to pre-allocating behavior which caused participants to already drive in the correct lane to follow the route the left-diverging roadway. This was especially the case in the

25% freight traffic condition, which made the rightmost lanes even less attractive. For that reason, it is recommended to do another research that also focuses on the traffic safety of traffic that is going to the right-diverging roadway. Especially with a high share of freight traffic, this right-diverging traffic needs to execute mandatory lane changes to the right to follow their route, while at the same time half of the slower-driving freight traffic needs to execute mandatory lane changes to the left to follow their route. Following this route to the right-diverging roadway thus includes encountering a traffic stream that is roughly perpendicular, and thus a raised level of turbulence that is not measured in this research.

- The comparison between a single-lane left-diverging roadway (of a major fork) that is also a small-radius connector road and a two-lane variant cannot be considered in a trade-off since the two-lane variant can theoretically process a traffic intensity that is two times as high as the traffic intensity that a single-lane variant can process. When choosing a variant in a road design, the question is not which one is safer, the question is which one gives us an appropriate I/C-ratio. But since this research showed a clear difference in driving behavior between the two variants, it is recommended to do another (driving simulator) research that includes four variants: (1) a single-lane left-diverging roadway (of a major fork) that is also a small-radius connector road, (2) a two-lane variant, (3) a single-lane right-diverging roadway (of a major fork) that is also a small-radius connector road, and (4) a two-lane variant. In addition, all four variants should either be curving to the left or to the right. Focusing on these four variants, there exists a trade-off between the two single-lane variants and the two two-lane variants.

It is recommended to do another accident data analysis after a couple of years. At the moment of this research, only one 4-3/2-2/2 major fork configuration (that satisfy the conditions of Section 4.2.1) exists in the Netherlands, which is also so recently constructed that accident data is not available yet. Luckily (from a research perspective at least), 4-3/2-2/2 major fork configurations are appearing more often in the (re)designing processes of Dutch freeways, which makes it possible to compare accident data with existing 4-2/2 major fork configurations in the future. Additionally, it is recommended to include other aspects of the included major fork road sections as well, such as the speed limits, the traffic intensity at the time of the accident, and the average share of freight traffic.

It is recommended to do the accident data analysis of the small-radius connector roads a second time, but with additional crash data such as number of parties involved, severity level(s), and details on the maneuver(s) prior to the crash. While this research already includes the absolute and the relative number of crashes, the occurrence and seriousness of crashes were not included. Just by analyzing the traffic flow and interactions between vehicles around a small-radius curve, it could for instance be the case that crashes around a single-lane small-radius curve are mostly head-tail collisions, which indicates a shortcoming in the driver expectancy of the following vehicle, while crashes around a two-lane variant are mostly side collisions, which indicates a shortcoming in the skill-based behavior.

8.3.2 PRACTICAL RECOMMENDATIONS

It is recommended to be hesitant with implementing a 4-3/2-2/2 major fork configuration when there is a high share of freight traffic that splits itself over the left- and right-diverging roadway. Since this configuration has only one right-adjacent lane of the block marking upstream of the lane addition, freight traffic distributes itself over the two rightmost lanes. As a result, the freight traffic creates a blockage for all (faster-driving) traffic going to the right-diverging roadway and all left-diverging traffic that drives on the left-adjacent lane of the block marking.

It is recommended to be hesitant when a future road design includes a major fork of which the right-diverging roadway (that diverges under an angle) is a through-going mainline roadway and the left-diverging roadway (that does not have a divergence angle) is also a left-curving two-lane small-radius connector road. As this research confirms the existence and verifies the structure of the driver expectancy model, it is recommended to also consider a major fork design of which the continuing road design of both diverging roadways is switched, which means that the right-diverging roadway (that does diverges under an angle) is also a left-curving two-lane small-radius connector road. Although this research does not directly confirm that the latter design is safer, it is worth a trade-off in which costs, traffic flow and the Dutch road safety strategy: “Sustainable Safety” [32] are taken into account.

When using a driving simulator for traffic safety research in general, one should be careful when implementing too complex interactions between participants and simulated traffic. Even though traffic safety could be purely calculated from a participant’s point of view, it is not only dependent on the driving

behavior of the participant itself, but is also very much dependent on the driving behavior of the simulated traffic and thus the settings and parameters of VISSIM (or any other available microsimulation program). Consequently, one should be careful when extrapolating these results to road design, vehicle design, or traffic regulations. When the driving behavior of the simulated traffic is questionable, it is recommended to only use the available microsimulation program to research traffic safety when the simulated traffic has just a simple interaction with the participant (e.g. freeway-merging behavior with truck platoons) or when the interaction is not the main research measure at all (e.g. driver distraction by road-side advertisements, or the effect of a transition curve).

8.3.3 TECHNICAL RECOMMENDATIONS

When using the driving simulator of the Delft University of Technology in the future:

- It is recommended to assess the behavioral validity of the driving simulator by comparing the recorded simulator measurements with real world measurements. Since the driving behavior data that is collected in this study is primarily collected on road sections with a lot of turbulence, the question is whether the recorded simulator measurements are affected by the driving simulator itself, or by the behavior of simulated traffic. It is therefore recommended to not use the collected data of this research to assess behavioral validity, but to collect new driving behavior data on a road design without discontinuities, and to compare this with a comparable real-life road section.
- When the behavioral validity is for any reason not assessed, it is recommended to at least perform a preliminary study in which participants with no driving simulator experience test multiple settings of the steering wheel and pedals. Trying to approach real driving characteristics (i.e. physical validity) will automatically improve behavioral validity. Since 70% of the participants indicated that the steering wheel was more sensitive than normal, and because the steering wheel of the driving simulator of the Delft University of Technology includes all the necessary tuning options for calibration, this is a point of attention where a lot of improvement can be achieved.
- It is recommended to follow the step-by-step plan that is attached in [Appendix N](#) to create the driving simulator environment and simulated traffic. Using the standard software package of the company that also supplied the hardware of the driving simulator is not recommended since its simplicity limits a researcher's freedom substantially when setting up an experiment. To give some examples, the standard software package does not provide or cannot handle: freedom in radii of curves, superelevation, transition curves, freedom in lane width, freedom in marking width and length, more than approximately 15 other simulated cars, large road networks (e.g. more than five kilometers), and detailed driving behavior characteristics.
- It is recommended to implement air-conditioning in the driving simulator room in order to be able to control the room temperature. The results of the Simulator Sickness Questionnaire showed that sweating was a symptom that was in the top 5 of symptoms that affected the participants before, while and after the driving simulator experiment. Furthermore, it is also expected that a relatively high room temperature also affects symptoms as headaches, nausea, dizziness and vertigo. Consequently, it is recommended to use the same Simulator Sickness Questionnaire (SSQ) to check if controlling the room temperature has a positive effect on the physical well-being of the participants when the driving simulator environment is not or barely changed. The SSQ results of this research are attached in [Appendix L](#).
- It is recommended to make the windows of the simulated traffic transparent, add brake lights to the simulated traffic, and make the wheels of the simulated rotate. Transparent windows would make participants be able to observe multiple leading vehicles instead of one, brake lights would help participants to better observe braking actions by leading vehicles, and rotating wheels would potentially help with the total immersion capability of the driving simulator.

BIBLIOGRAPHY

- [1] Rijkswaterstaat, "Richtlijn voor het Ontwerpen van Autosnelwegen," 2015.
- [2] A. van Beinum, H. Farah, F. Wegman and S. Hoogendoorn, "Critical Assessment of Methodologies for Operations and Safety Evaluation of Freeway Turbulence," *Transportation Research Record: Journal of the Transportation Research Board*, no. 2556, pp. 39-48, 2016.
- [3] J. Theeuwes and R. van der Horst, "Designing Safe Road Systems: A human factors perspective," *Ashgate Publishing Limited*, 2012.
- [4] AASHTO, "A policy on Geometric Design of Highways and Streets," 2011.
- [5] M. Hovenga, "Measuring turbulence distance of acceleration lanes," 2014.
- [6] W. Daamen, M. Loot and S. P. Hoogendoorn, "Emperical Analysis of Merging Behavior at Freeway On-Ramp," *Transportation Research Record: Journal of the Transportation Research Board*, no. 2188, pp. 108-118, 2010.
- [7] R. Elvik, T. Vaa, A. Høy and M. Sørensen, "The handbook of road safety measures: second edition," 2009.
- [8] A. Ceder and L. Livneh, "Relationship between road accidents and hourly traffic flow-I: Analyses and interpretation," *Accident Analysis and Prevention*, no. 14, pp. 19-34, 1982.
- [9] J. Martin, "Relationship between crash rate and hourly traffic flow on interurban motorways," *Accident Analysis and Prevention*, no. 34, pp. 619-629, 2002.
- [10] A. Ceder, "Relationship between road accidents and hourly traffic flow-II: probabilistic approach," *Accident Analysis and Prevention*, no. 14, pp. 35-44, 1982.
- [11] E. C. Sullivan, "Estimating accident benefits of reduced freeway congestion," *Journal of Transportation Engineering*, no. 116, pp. 167-180, 1990.
- [12] B. Persaud and L. Dzvik, "Accident prediction models for freeways," *Transportation Research Record*, no. 1401, pp. 55-60, 1992.
- [13] OECD/ECMT, "Country reports on Safety Performance," 2006.
- [14] L. Aarts and I. van Schagen, "Driving Speed and the Risk of Road Crashes: A Review," *Accident Analysis & Prevention*, vol. 38, no. 2, pp. 215-224, 2006.
- [15] G. Maycock, P. J. Brocklebank and R. D. Hall, "Road layout design standards and driver behavior," *TRL report 332*, 1998.
- [16] A. Quimby, G. Maycock, C. Palmer and S. Buttress, "The factors that influence a driver's choice of speed," *TRL report 325*, 1999.
- [17] C. N. Kloeden, G. Ponte and A. J. McLean, "Travelling speed and the rate of crash involvement on rural roads," *Report No. CR 204*, 2001.
- [18] G. Nilsson, "The effects of speed limits on traffic crashes in Sweden," in *Proceedings of the international symposium on the effects of speed limits on traffic crashes and fuel consumption*, Dublin, 1982.
- [19] G. Nilsson, "Traffic safety dimensions and the power model to describe the effect of speed on safety," 2004.
- [20] R. Elvik, P. Christensen and A. Amundsen, "Speed and road accidents: an evaluation of the Power Model," *TØI report 740*, 2004.
- [21] R. Elvik, "A re-parameterisation of the Power Model of the relationship between the speed of traffic and the number of accidents and accident victims," *Accident Analysis Prevention*, no. 50, pp. 854-860, 2013.
- [22] E. Hauer and J. Bonneson, "An empirical examination of the relationship between speed and road accidents based on data by Elvik, Christensen and Amundsen," *Report Prepared for Project NCHRP 17-25*, 2006.
- [23] M. Kuiken, D. Overkamp and J. Fokkema, "Ongevallen met vrachtauto's op rijkswegen," Rotterdam, 2006.
- [24] M. J. Kuiken and J. Wiercx, "Achtergrond bij ongevallen tussen vrachtauto's en personenauto's," Amersfoort, 2003.
- [25] D. Solomon, "Crashes on main rural highways related to speed, driver and vehicle," *Driver and Vehicle Bureau of Public Roads*, 1964.
- [26] J. A. Cirillo, "Interstate system crash research; study II, interim report II," *Public roads*, 1968.
- [27] Research Triangle Institute, "Speed and accidents," *RTI Project SU-409*, 1970.

- [28] C. N. Kloeden, A. J. McLean, V. M. Moore and G. Ponte, "Travelling speed and the rate of crash involvement on rural roads. Volume 1: findings," *Report No. CR 172*, 1997.
- [29] SWOV, "18- tot en met 24-jarigen: jonge automobilisten," The Hague, 2016.
- [30] SWOV, "Ouderen in het verkeer," The Hague, 2015.
- [31] G. J. Alexander and H. Lunenfeld, "Driver expectancy in highway design and traffic operations," *No. FHWA-TO-86-1*, 1986.
- [32] F. Wegman and L. Aarts, "Advancing Sustainable Safety : National Road Safety Outlook for 2005-2020," SWOV, Leidschendam, 2006.
- [33] SWOV, "Predictability by recognizable road design," Leidschendam, 2012.
- [34] B. L. Hills, "Vision, visibility, and perception in driving," *Perception*, vol. 9, no. 2, pp. 183-216, 1980.
- [35] J. Theeuwes, "Visual search at intersections: An eye-movement analysis," *Vision in Vehicles*, no. 5, pp. 125-134, 1996.
- [36] J. Theeuwes and M. P. Hagenzieker, "Visual search of traffic scenes: On the effect of location expectations," *Vision in Vehicles*, no. 4, pp. 149-158, 1993.
- [37] C. Johansson and K. Rumar, "Driver's brake reaction time," *Human Factors*, vol. 13, no. 1, pp. 22-27, 1971.
- [38] H. Yang, "Simulation-based evaluation of traffic safety performance using surrogate safety measures," *Rutgers The State University of New Jersey-New Brunswick*, 2012.
- [39] F. H. Amundsen and C. Hydén, "Proceedings from the first workshop on traffic conflicts," Oslo, 1977.
- [40] W. D. Glauz and D. J. Migletz, "Application of traffic conflict analysis at intersections," National Cooperative Highway Research Program, 1980.
- [41] C. Hydén, "The development of a method for traffic safety evaluation: the Swedish traffic conflict technique," Lund Institute of Technology, Lund, 1987.
- [42] OECD, "Safety of vulnerable road users," 1998.
- [43] Å. Svensson, "A method for analysing the traffic process in a safety perspective," Department of Traffic Planning and Engineering, Lund University, 1998.
- [44] D. Gettman and L. Head, "Surrogate safety measures from traffic simulation models," *Transportation Research Record: Journal of the Transportation Research Board*, no. 1840, pp. 104-115, 2003.
- [45] A. R. A. van der Horst, "A time-based analysis of road user behaviour in normal and critical encounters," 1990.
- [46] M. M. Minderhoud and P. H. L. Bovy, "Extended time-to-collision measures for road traffic safety assessment," *Accident Analysis and Prevention*, no. 33, pp. 89-97, 2001.
- [47] A. Lareshyn, Å. Svensson and C. Hydén, "Evaluation of traffic safety, based on micro-level behavioural data: Theoretical framework and first implementation," *Accident Analysis and Prevention*, no. 42, pp. 1637-1646, 2010.
- [48] L. Miranda-Moreno, P. St-Aubin and N. Saunier, "An automated surrogate safety analysis at protected highway ramps using cross-sectional and before-after video data," *Transportation Research Part C: Emerging Technologies*, no. 36, pp. 284-295, 2013.
- [49] S. Hirst and R. Graham, "The format and presentation of collision warning," *Ergonomics and Safety of Intelligent Driver Interfaces*, pp. 203-219, 1997.
- [50] K. Vogel, "A comparison of headway and time to collision as safety indicators," *Accident Analysis and Prevention*, no. 35, pp. 427-433, 2003.
- [51] A. F. Mullakkal-Babu, M. Wang, H. Farah, B. van Arem and R. Happee, "Comparative assessment of safety indicators for vehicle trajectories on the highway," *Transportation Research Record: Journal of the Transportation Research Board*, no. 2659, 2017.
- [52] M. de Ruyter, "The road safety of merging tapers," 2016.
- [53] C. Hydén, "Traffic conflicts technique: state-of-the-art," in *Traffic safety work with video-processing*, Transportation Department University Kaiserslautern, 1996.
- [54] F. Cunto and F. F. Saccomanno, "Calibration and validation of simulated vehicle safety performance at signalized intersections," *Accident Analysis and Prevention*, no. 40, pp. 1171-1179, 2008.
- [55] L. Zheng, K. Ismail and X. Meng, "Freeway safety estimation using extreme value theory approaches: a comparative study," *Accident Analysis and Prevention*, no. 62, pp. 32-41, 2014.
- [56] TRB, "Safety research on highway infrastructure and operations," Washington, D.C., 2008.
- [57] F. Bella, "Can driving simulators contribute to solving critical issues in geometric design?," *Transportation Research Record*, no. 2138, pp. 120-126, 2009.

- [58] J. C. de Winter, P. M. van Leeuwen and R. Happee, "Advantages and disadvantages of driving simulators: a discussion," in *Proceedings of measuring behavior*, Utrecht, 2012.
- [59] A. J. Roskam, K. A. Brookhuis, D. de Waard, O. M. Carsten, L. Read, J. Jamson, J. Ostlund, A. Bolling, L. Nilsson, V. Anttila, M. Hoedemaeker, W. H. Janssen, J. Harbluk, E. Johansson, M. Tevell, J. Santos, M. Fowkes, J. Engström and T. Victor, "HASTE Deliverable 1: development of experimental protocol," 2002.
- [60] S. T. Godley, T. J. Triggs and B. N. Fildes, "Driving simulator validation for speed research," *Accident Analysis and Prevention*, no. 34, pp. 589-600, 2002.
- [61] J. Santos, N. Merat, S. Mouta, K. Brookhuis and D. de Waard, "The interaction between driving and in-vehicle information systems," *Transportation Research Part F*, no. 8, pp. 135-146, 2005.
- [62] G. Underwood, D. Crundall and P. Chapman, "Driving simulator validation with hazard perception," *Transportation Research Part F*, no. 14, pp. 435-446, 2011.
- [63] N. Mullen, J. Charlton, A. Devlin and M. Bédard, "Simulator Validity: behaviors observed on the simulator and on the road," in *Handbook of driving simulation for engineering, medicine, and psychology*, Taylor & Francis Group, LLC, 2011, pp. 1301-1318.
- [64] N. A. Kaptein, J. Theeuwes and R. Van der Horst, "Driving simulator validity: some considerations," *Transportation Research Record*, no. 1550, pp. 30-36, 1996.
- [65] J. Törnös, "Driving behaviour in a real and a simulated road-tunnel: a validation study," *Accident Analyses and Prevention*, no. 30, pp. 497-503, 1998.
- [66] J. D. Lee, D. V. McGehee, J. L. Brown, C. M. Richard, O. Ahmad, N. J. Ward, S. Hallmark and J. Lee, "Matching simulator characteristics to highway design problems," *Transportation Research Record*, no. 2248, pp. 53-60, 2011.
- [67] W. D. Käppler, "Views on the role of simulation in driver training," in *The 12th European Annual Conference on Human Decision Making and Manual Control*, Kassel, 1993.
- [68] B. Reimer, L. A. D'ambrosio, J. F. Coughlin, M. E. Kafritsen and J. Biederman, "Using self-reported data to assess the validity of driving simulation data," *Behavior Research Methods*, no. 38, pp. 314-324, 2006.
- [69] S. Cobb, S. Nichols, A. Ramsey and J. Wilson, "Virtual reality-induced symptoms and effects," *Presence*, no. 8, pp. 169-186, 1999.
- [70] J. O. Brooks, R. R. Goodenough, M. C. Crisler, N. D. Klein, R. L. Alley, B. L. Koon, W. C. Logan Jr., J. H. Ogle, R. A. Tyrrell and R. F. Wills, "Simulator sickness during driving simulation studies," *Accident Analysis and Prevention*, no. 42, pp. 788-796, 2010.
- [71] M. Klüver, C. Herrigel, S. Preuß, H. Schöner and H. Hecht, "Comparing the incidence of simulator sickness in five different driving simulators," in *Driving Simulation Conference & Exhibition*, Tübingen, 2015.
- [72] CROW, "ASVV: Aanbevelingen voor verkeersvoorzieningen binnen de bebouwde kom," 2012.
- [73] CROW, "Handboek wegontwerp (series)," 2013.
- [74] Rijkswaterstaat, "Handreiking Bewegwijzeringsschema's: Bewegwijzering autosnelwegen," 2016.
- [75] CROW, "Richtlijn bewegwijzering," 2005.
- [76] Rijkswaterstaat, "Capaciteitswaarden Infrastructuur Autosnelwegen," 2015.
- [77] W. Schakel, "Development, simulation and evaluation of in-car advice on headway, speed and lane," *TRAIL Thesis Series nr. T2015/9*, 2015.
- [78] A. Bosdikou, "Safety analysis in Dutch weaving sections," 2017.
- [79] H. Jamson, "Driving simulation validity: issues of field of view and resolution," in *Driving Simulator Conference*, Paris, 2000.
- [80] R. S. Kenndy, N. E. Lane, K. S. Berbaum and M. G. Lienthal, "Simulator Sickness Questionnaire: An enhanced method for quantifying simulator sickness," *The International Journal of Aviation Psychology*, vol. 3, no. 3, pp. 203-220, 1993.
- [81] J. Frank and J. Massey, "The kolmogorov-smirnov test for goodness of fit," *Journal of the American Statistical Association*, vol. 46, no. 253, pp. 68-78, 1951.
- [82] N. Nachar, "The Mann-Whitney U: A test for assessing whether two independent samples come from the same distribution," *Tutorials in Quantitative Methods for Psychology*, pp. 13-20, 2008.

APPENDICES

- A: Road geometry of the experimental track
- B: Impression of the simulated environment
- C: Signage plan
- D: VISSIM parameters used
- E: Set-up of the driving simulator
- F: Verbal navigation plan
- G: Introduction to the experiment
- H: Statement of informed consent form
- I: Questionnaire I
- J: Questionnaire II
- K: Questionnaire III
- L: Results of the questionnaires
- M: Included road sections in the accident data analysis
- N: Step-by-step plans for the driving simulator environment and simulated traffic

Appendix A

road geometry of the experimental track

(1 page)

The experimental track that is subdivided into multiple distinctive road sections of which their geometric parameters are specified:

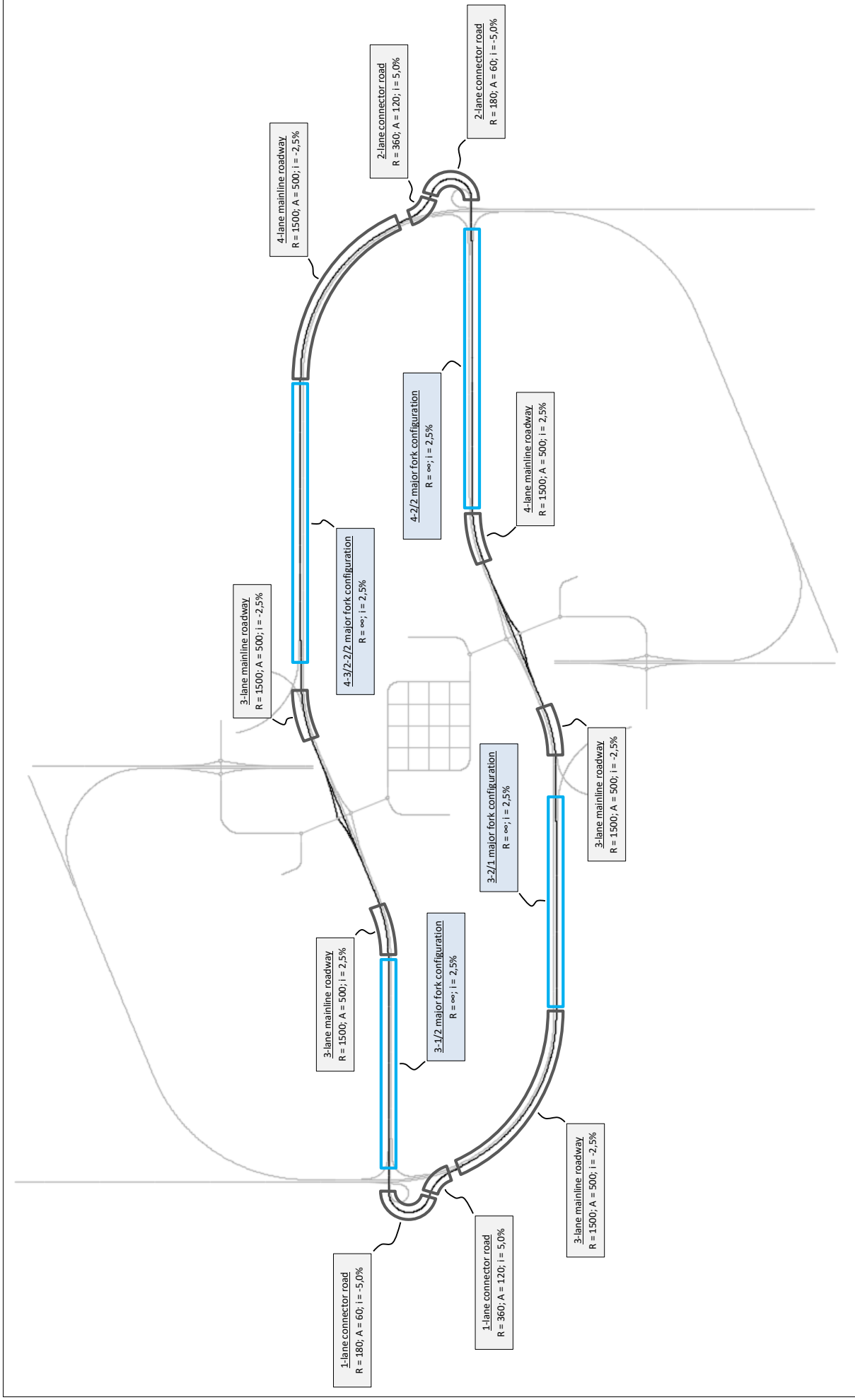

Appendix B

impression of the simulated environment

(4 pages)

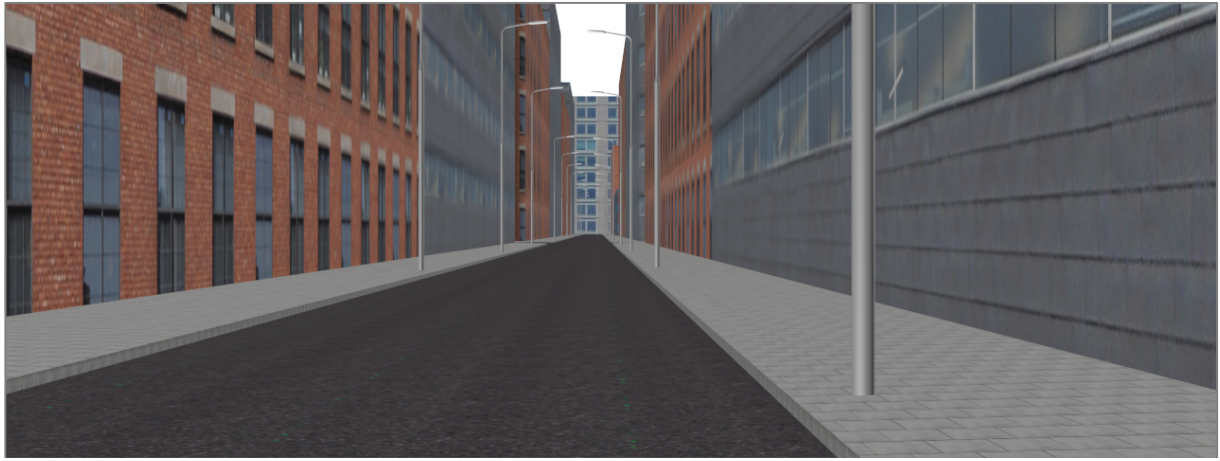

Figure 1: Inside the built-up area of the test track where the starting point of the simulation is

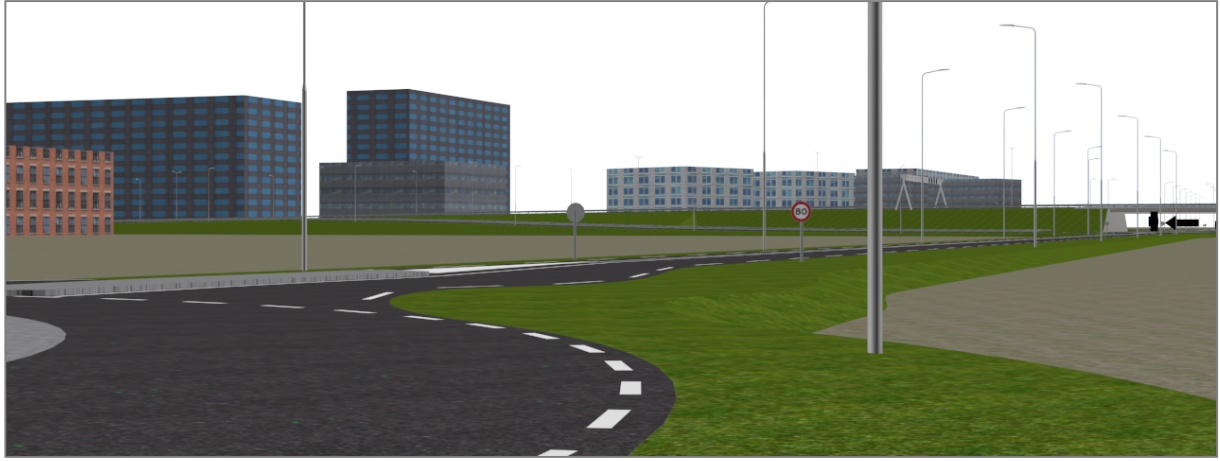

Figure 2: A roundabout and an 80 km/h distributor road just outside the built-up area

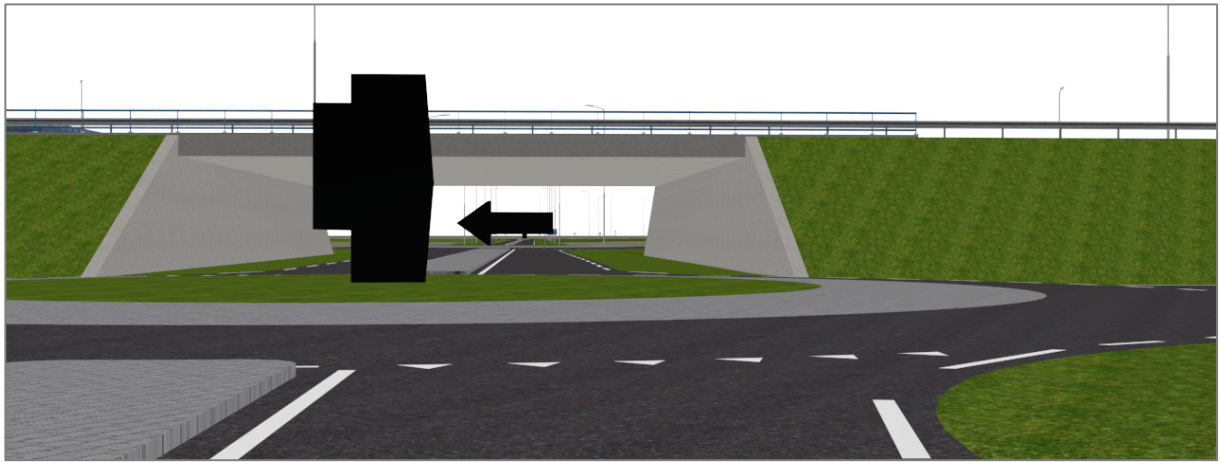

Figure 3: A location where the underlying road network crosses the freeway

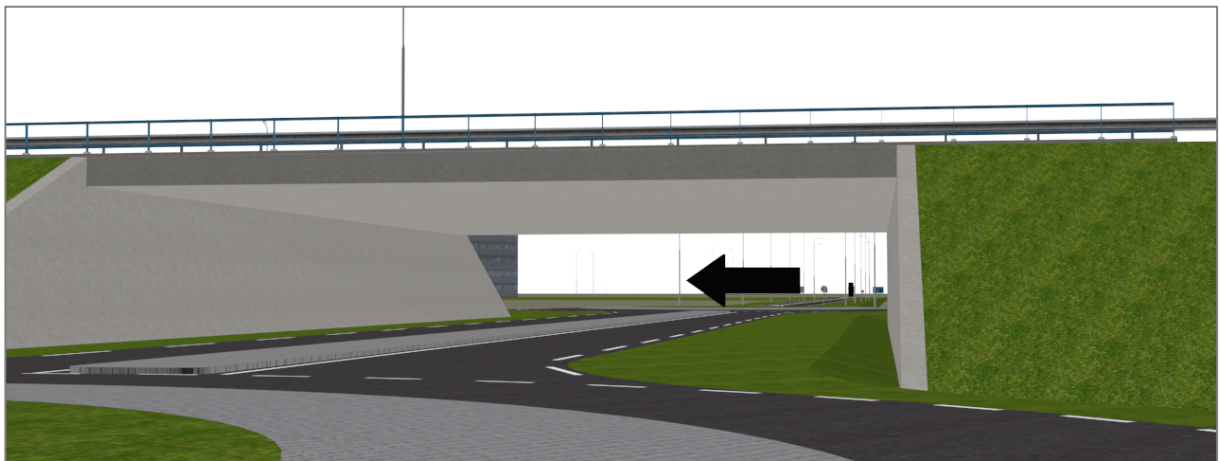

Figure 4: On the roundabouts are big black arrows that help the participants find their way to the freeway

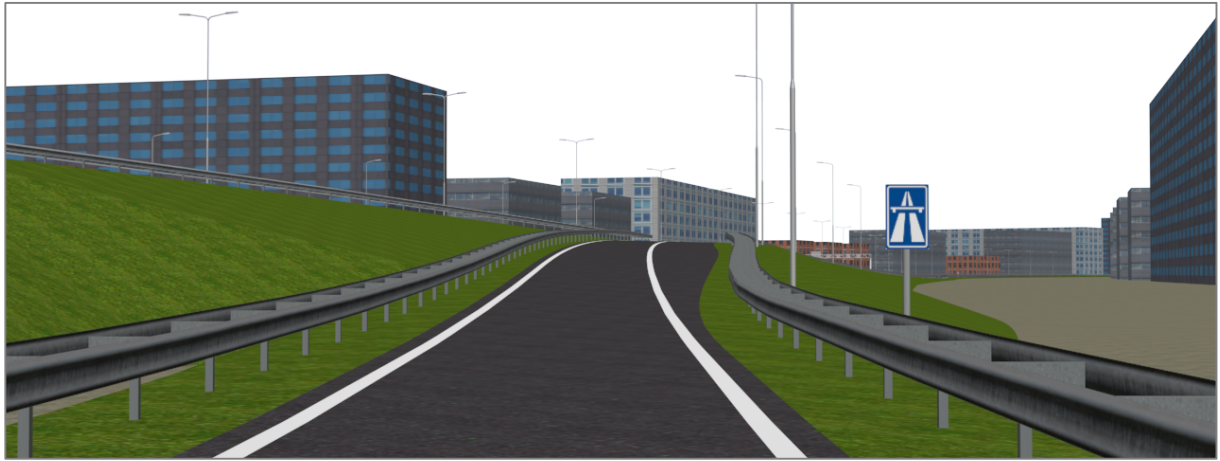

Figure 5: An on-ramp towards the freeway

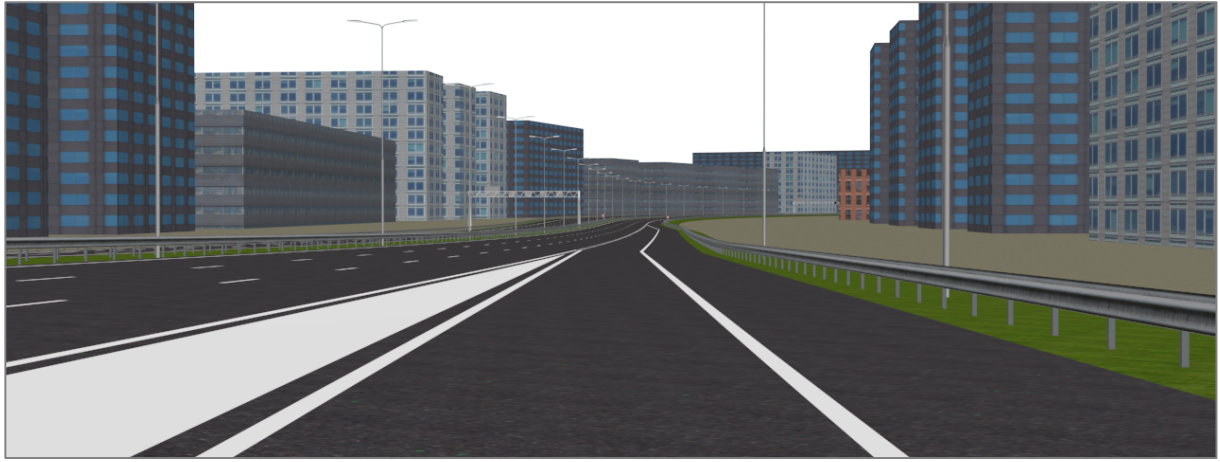

Figure 6: An on-ramp towards the freeway



Figure 7: The first overhead signage of the 3-1/2 configuration



Figure 8: The last overhead signage of the 3-1/2 configuration



Figure 9: The announcement of the single-lane small-radius connector road with an advisory speed limit



Figure 10: The first overhead signage of the 4-2/2 configuration



Figure 11: The announcement of the two-lane small-radius connector road with an advisory speed limit



Figure 12: The signs in the shoulder lane of the mainline roadway, which warn for the small-radius curve



Figure 13: The last part of the road markings that indicate the lane drop on the 4-3/2-2/2 configuration



Figure 14: The last overhead signage (out of three) that indicates an off-ramp

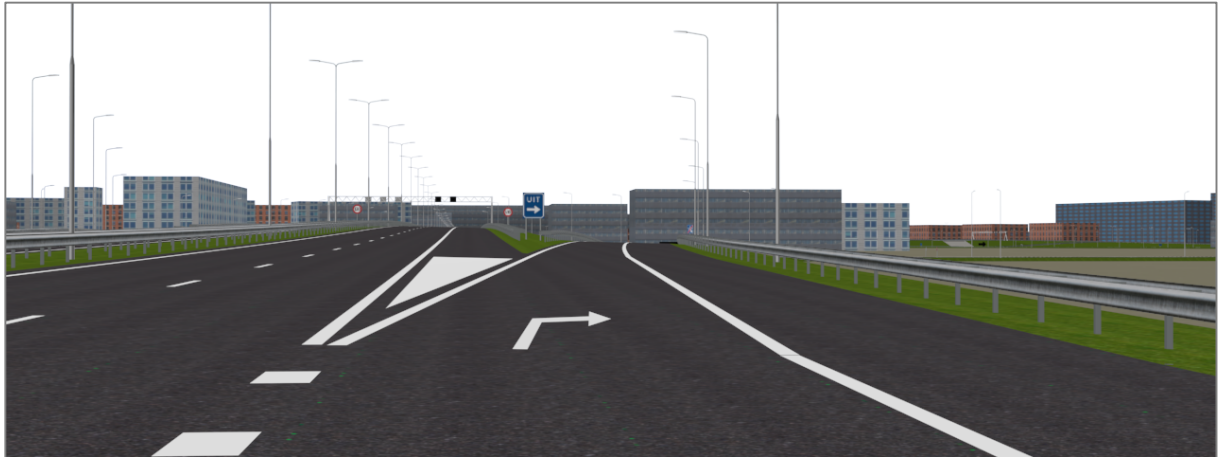

Figure 15: The divergence point of an off-ramp

Appendix C

signage plan

(2 pages)

Overhead signage of the 4-2/2 major fork configuration

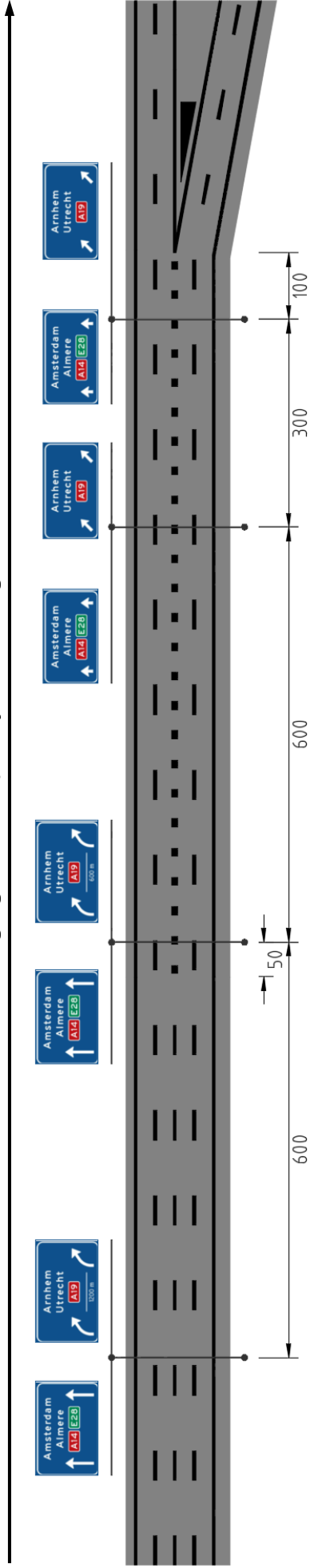

Overhead signage of the 4-3/2/2 major fork configuration

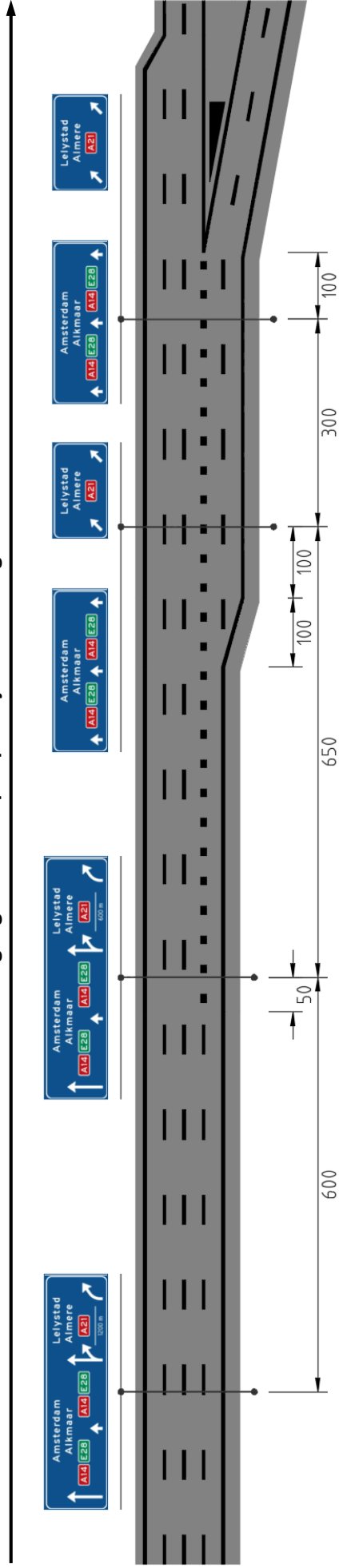

Overhead signage of the 3-1/2 major fork configuration

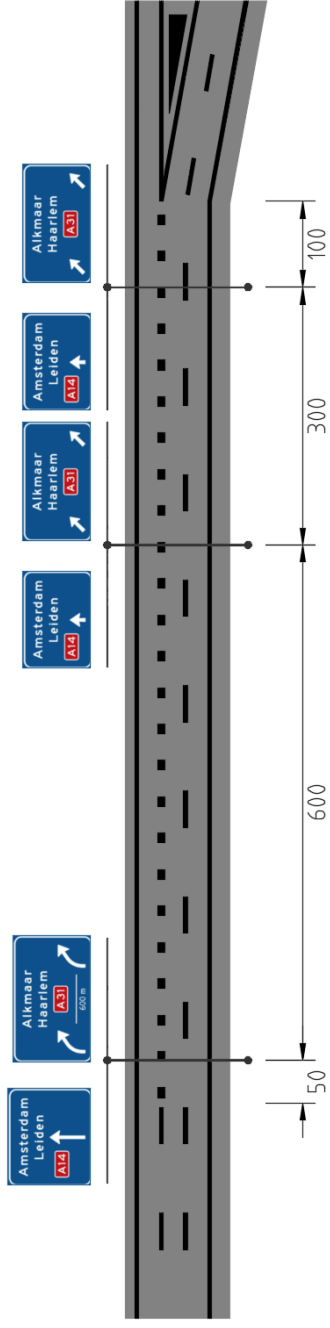

Overhead signage of the 3-2/1 major fork configuration

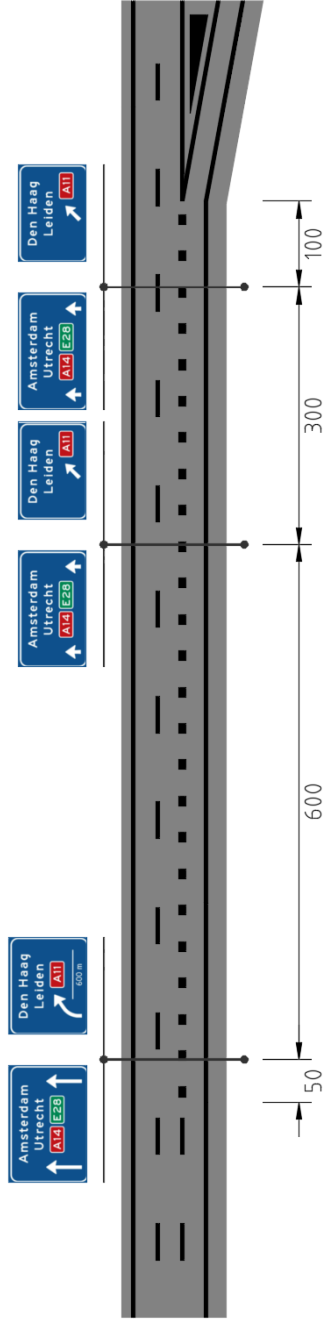

Appendix D

VISSIM parameters used

(2 pages)

Table 1: Driving behavior settings of the freeway sections

Following		
Look ahead distance:		
min.	0,00 m	
max.*	300,00 m	→ 263,16 m
observed vehicles*	10	→ 8
Look back distance:		
min.	0,00 m	
max.	150,00 m	
Temporary lack of attention:		
duration	0 s	
probability	0,00%	
Smooth closeup behavior: <i>not selected</i>		
Standstill distance for static obstacles: <i>not selected</i>		
Car following model and parameters:		
model:	Wiedemann 99	
CC0 (standstill distance)*	1,50 m	→ 2,34 m
CC1 (headway time)*	3	→ 0,5
CC2 ('following' variation)*	4,00 m	→ 3,91 m
CC3 (threshold for entering 'following')*	-8,00	→ -9,87
CC4 (negative 'following' threshold)*	-0,35	→ -1,21
CC5 (positive 'following' threshold)*	0,35	→ 1,00
CC6 (speed dependency of oscillation)	11,44	
CC7 (oscillation acceleration)*	0,25 m/s²	→ 0,24 m/s ²
CC8 (standstill acceleration)	3,50 m/s ²	
CC9 (acceleration with 80 km/h)	1,50 m/s ²	
Lane Change		
General behavior	Slow lane rule	
Necessary lane change (route):		
Maximum deceleration (own)	-4,00 m/s ²	
Maximum deceleration (trailing vehicle)*	-3,00 m/s²	→ -2,35 m/s ²
-1m/s ² per distance (own)	200,00 m	
-1m/s ² per distance (trailing vehicle)	200,00 m	
Accepted deceleration (own)	-0,50 m/s ²	
Accepted deceleration (trailing vehicle)	-0,50 m/s ²	
Waiting time before diffusion: 60,00 s		
Min. headway (front/rear)*	1,00 m	→ 0,83 m
To slower lane if collision time is above	10,00 s	
Safety distance reduction factor*	0,05	→ 0,43
Maximum deceleration for cooperative braking	-3,00 m/s ²	
Overtake reduced speed areas	<i>not selected</i>	
Advanced merging	<i>selected</i>	
Consider subsequent static routing decisions	<i>not selected</i>	
Cooperative lane change*	<i>not selected</i>	→ <i>selected</i>
Maximum speed difference	-	→ 10,80 km/h
Maximum collision time	-	→ 10,00 s
Lateral correction of rear end position: <i>not selected</i>		
Maximum speed	-	
from	-	
until	-	

*These parameters are changed towards values that are adopted from Bosdikou (2017).

Table 2: Lane change settings in the connector properties of the diverging roadways of the major forks

Major fork configuration	Left-diverging roadway		Right-diverging roadway	
	Emergency stop [m]	Lane change [m]	Emergency Stop [m]	Lane change [m]
4-2/2 configuration	10	1200	10	1500
4-3/2-2/2 configuration	10	1200	10	1500
3-1/2 configuration	10	900	10	1100
3-2/1 configuration	10	900	10	1100

Table 3: Desired speed distribution of the car traffic

Probability	Desired driving speed of car traffic
0,00	90,54
0,05	101,44
0,10	105,71
0,15	108,56
0,20	110,86
0,25	112,80
0,30	114,55
0,35	116,19
0,40	117,73
0,45	119,24
0,50	120,70
0,55	122,16
0,60	123,67
0,65	125,21
0,70	126,85
0,75	128,60
0,80	130,54
0,85	132,84
0,90	135,69
0,95	139,96
1,00	150,86

Table 4: Desired speed distribution of the freight traffic

Probability	Desired driving speed of freight traffic
0,00	82,41
0,05	82,90
0,10	83,31
0,15	83,69
0,20	84,04
0,25	84,37
0,35	84,69
0,50	85,00
0,65	85,31
0,75	85,63
0,80	85,96
0,85	86,31
0,90	86,69
0,95	87,10
0,98	87,59
1,00	88,20

Appendix E

set-up of the driving simulator

(1 page)



Figure 1: The driving simulator set-up (screens switched off)



Figure 2: The driving simulator set-up (screens switched on)

Appendix F

verbal navigation plan

(1 page)

The total track on which the numbers on the labels correspond with the navigation instructions in the legend on the left:

- Navigation instructions on the experimental track:**
1. Further on, follow the A14 towards Amsterdam.
 2. After 800 meters, follow the A14 towards Amsterdam.
 3. Follow the A14 towards Amsterdam.
 4. After 600 meters, take the exit towards Spuijddorp.
 5. Take the exit towards Spuijddorp.
 6. After 600 meters, take the exit towards Stoeldam.
 7. Take the exit towards Stoeldam.
- Navigation instructions on the freeway-part of the test track:**
8. Further on, follow the A19 towards Arnhem.
 9. After 800 meters, follow the A19 towards Arnhem.
 10. Follow the A19 towards Arnhem.
 11. Further on, follow the A19 towards Amersfoort.
 12. After 800 meters, follow the A19 towards Amersfoort.
 13. Follow the A19 towards Amersfoort.
 14. Further on, take the exit towards Mardikken.
 15. After 800 meters, take the exit towards Mardikken.
 16. Take the exit towards Mardikken.
 17. Further on, follow the A31 towards Alkmaar.
 18. After 800 meters, follow the A31 towards Alkmaar.
 19. Follow the A31 towards Alkmaar.
- Navigation instructions on the underlying road network (not visualized):**
20. Take a right on the roundabout, first exit.
 21. After 300 meters, go straight on at the roundabout, second exit.
 22. Go straight on at the roundabout, second exit.
 23. Follow the arrows to the freeway.
 24. Take a left on the roundabout, second exit, then, enter the freeway.
 25. Take a left.
 26. Take a right.

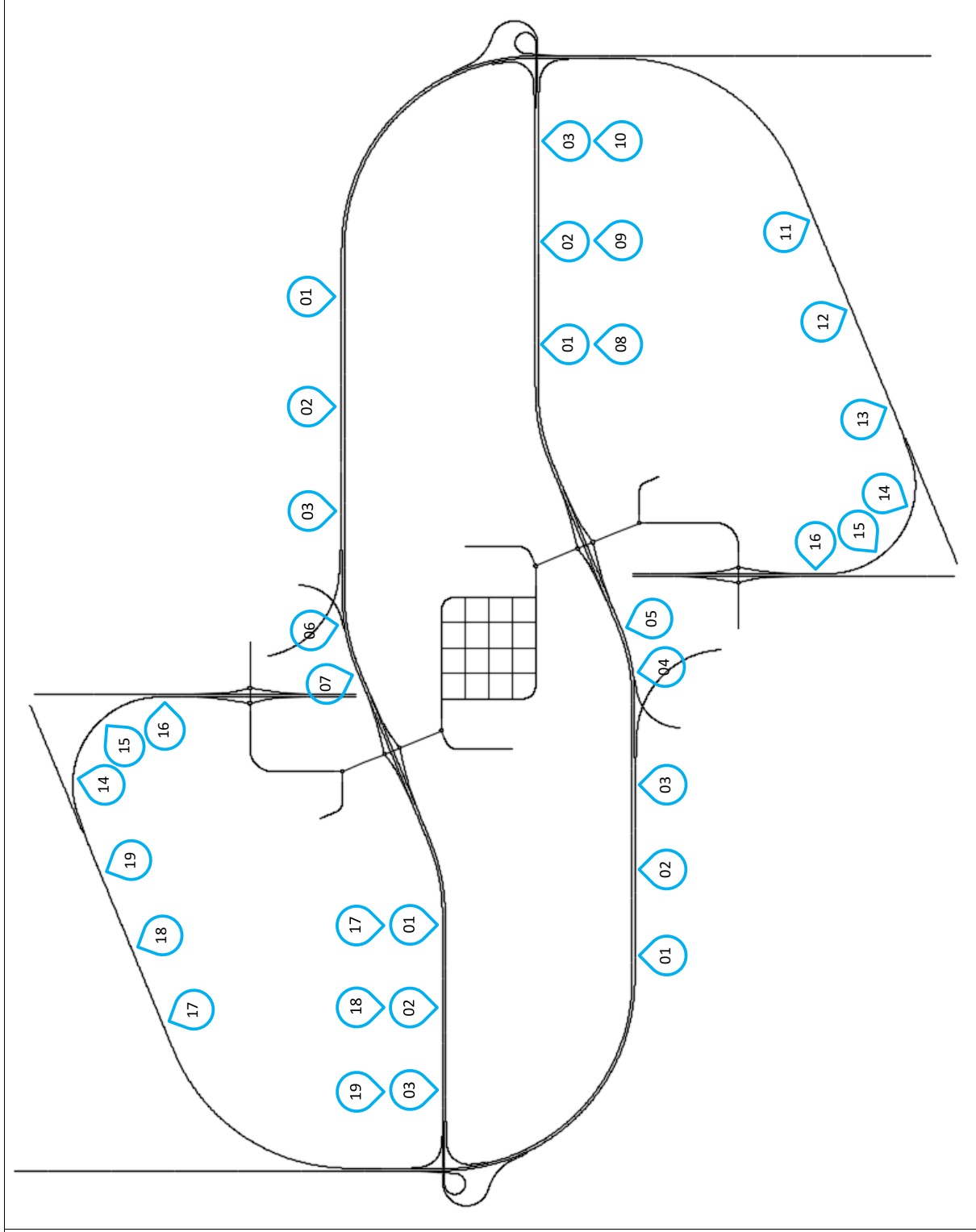

Appendix G

introduction to the experiment

(1 page)

Dear participant,

Thank you for your interest in the driving simulator experiment “Driving behavior on the Dutch freeway”; a collaboration between engineering consultancy Witteveen+Bos and the Delft University of Technology. The objective of this research is to measure the driving behavior on Dutch freeways. Since driving behavior can only be measured on relatively long freeway stretches and does not concentrate itself on one location, measurements on real freeways are often operationally difficult and expensive. A driving simulator does not have these disadvantages. However, it is important that participants in this driving simulator experiment drive the same as they would normally do.

Before you will actually take place in the driving simulator, there are a couple of things you should know:

- During the experiment, you will be asked to fill in three questionnaires. One questionnaire before driving in the simulator, one questionnaire during a break, and one questionnaire after driving in the simulator.
- The experiment will start with a practice round of 10 minutes to learn the vehicle characteristics of the driving simulator. During these 10 minutes, you will drive through a part of a built-up area but primarily on a Dutch freeway route.
- After the practice round, you will drive on a Dutch freeway route for 30 minutes. After each 7.5 minutes, you will get instructions to exit the freeway and follow the instructions to the parking spot to park your car. These short breaks are necessary to give your eyes a short moment of rest from the computer screens. It is preferable that you stay in the driving simulator during each short break.
- During the whole simulation, you will get verbal navigation instructions about the city names and route numbers you need to follow. These instructions will correspond to the signage along and above the road.
- The speed limit on the freeway is 130 km/h. Try to keep this speed limit as much as possible, unless the traffic signs advise otherwise or you don't feel comfortable driving this speed.
- When you start feeling unwell or feel any other discomfort, we strongly recommend to discontinue your participation in the experiment. You can either directly step out of the driving simulator, or just directly close your eyes in order to come to your usual state of fitness. You can do whatever feels the most comfortable in that situation. Either way, try to notify the responsible researcher as soon as possible.
- In case of any questions during the experiment, please ask them to the responsible researcher. In case of any questions after the experiment, please contact the responsible researcher by phone or email:
+316———— (only in case of emergency)¹
————@witteveenbos.com²

^{1,2} The phone number and email address have been depersonalized before adding them as appendix to this report.

Appendix H

statement of informed consent form

(1 page)

STATEMENT OF CONSENT

for participating in the driving simulator study "Driving behavior on the Dutch freeway"

To be filled in by the participant:

- I have read and understood the verbal and written information about the driving simulator study.
- The researcher gave me the opportunity to ask questions concerning the driving simulator study.
- The researcher gave me enough time to carefully consider my participation in the study.
- I am aware of the fact that my participation in the study is entirely voluntary.
- I am aware of the fact that driving in a simulator can cause nausea. As soon as I feel nauseous, or feel any other discomfort, I will report this to the responsible researcher. The researcher will then immediately stop the simulation.
- I understand that I can terminate my participation in the study at any time, without giving reasons, and without any adverse consequences.
- I understand that my personal information and research results will be treated confidentially, and that personal information will be depersonalized after digitalization and destroyed after completion of the study.
- In case of any questions, I know that I can contact the responsible researcher by phone (+316-----) or mail (-----@witteveenbos.com)¹.
- I agree with participation in the aforementioned driving simulator study.

Name:

.....

Date of signature:

...../...../ 2018

Date of birth:

...../...../.....

Signature:

.....

To be filled in by the researcher:

- The undersigned, responsible researcher, declares that the above-mentioned individual was, both verbally and in this written form, informed about the aforementioned driving simulator study.

Name:

.....

Date of signature:

...../...../ 2018

Signature:

.....

¹ The phone number and email address have been depersonalized before adding them as appendix to this report.

Appendix I

questionnaire I

(2 pages)

QUESTIONNAIRE 1

before participating in the driving simulator study "Driving behavior on the Dutch freeway"

A. What type of driver are you?

1. Gender

- Male
- Female

2. What is your age?

3. What is your city of residence?

4. What is your primary mode of transportation?

- Private vehicle
- Public transportation
- Motorcycle
- Walking/cycling
- Other:

5. For how long do you own your driving license?

6. On average, how often did you drive a car in the last 12 months?

- Everyday
- 4 to 6 days a week
- 1 to 3 days a week
- Less than once a month
- Never (*go to question 10*)
- Other:

7. About how many kilometers did you drive in the last 12 months?

If you are not certain, please give the best estimate you can.

- 1 - 1000
- 1001 - 5000
- 5001 - 10000
- 10001 - 25000
- 25001 - 50000
- 50001 - 100000
- More than 100000

8. On which type of road did you drive the most kilometers in the last 12 months?

- On the underlying road network
- On the freeway/motorway

9. In which country did you drive the most kilometers in the last 12 months?

The questionnaire continues on the next page

10. Have you driven in a driving simulator before?

- Yes
- No

B. How correct are the following statements about yourself on this moment?

	Not true				True
1. I am feeling sick right now	<input type="radio"/>	<input type="radio"/>	<input type="radio"/>	<input type="radio"/>	<input type="radio"/>
2. I am in other than my usual state of fitness	<input type="radio"/>	<input type="radio"/>	<input type="radio"/>	<input type="radio"/>	<input type="radio"/>

C. Circle how much each symptom below is affecting you right now.

1. General discomfort	<u>None</u>	<u>Slight</u>	<u>Moderate</u>	<u>Severe</u>
2. Fatigue	<u>None</u>	<u>Slight</u>	<u>Moderate</u>	<u>Severe</u>
3. Headache	<u>None</u>	<u>Slight</u>	<u>Moderate</u>	<u>Severe</u>
4. Eyestrain ¹	<u>None</u>	<u>Slight</u>	<u>Moderate</u>	<u>Severe</u>
5. Difficulty focusing	<u>None</u>	<u>Slight</u>	<u>Moderate</u>	<u>Severe</u>
6. Increased salivation	<u>None</u>	<u>Slight</u>	<u>Moderate</u>	<u>Severe</u>
7. Sweating	<u>None</u>	<u>Slight</u>	<u>Moderate</u>	<u>Severe</u>
8. Nausea	<u>None</u>	<u>Slight</u>	<u>Moderate</u>	<u>Severe</u>
9. Difficulty concentrating	<u>None</u>	<u>Slight</u>	<u>Moderate</u>	<u>Severe</u>
10. Fullness of head ²	<u>None</u>	<u>Slight</u>	<u>Moderate</u>	<u>Severe</u>
11. Blurred vision	<u>None</u>	<u>Slight</u>	<u>Moderate</u>	<u>Severe</u>
12. Dizzy (eyes open)	<u>None</u>	<u>Slight</u>	<u>Moderate</u>	<u>Severe</u>
13. Dizzy (eyes closed)	<u>None</u>	<u>Slight</u>	<u>Moderate</u>	<u>Severe</u>
14. Vertigo ³	<u>None</u>	<u>Slight</u>	<u>Moderate</u>	<u>Severe</u>
15. Stomach awareness ⁴	<u>None</u>	<u>Slight</u>	<u>Moderate</u>	<u>Severe</u>
16. Burping	<u>None</u>	<u>Slight</u>	<u>Moderate</u>	<u>Severe</u>

¹ Eyestrain is the fatigue of the eyes.

² Fullness of head is the awareness of pressure in the head.

³ Vertigo is experienced as loss of orientation with respect to vertical upright.

⁴ Stomach awareness is usually used to indicate a feeling of discomfort which is just short of nausea.

Appendix J

questionnaire II

(1 page)

QUESTIONNAIRE 2

during participating in the driving simulator study "Driving behavior on the Dutch freeway"

A. Circle how much each symptom below is affecting you right now.

1. General discomfort	<u>None</u>	<u>Slight</u>	<u>Moderate</u>	<u>Severe</u>
2. Fatigue	<u>None</u>	<u>Slight</u>	<u>Moderate</u>	<u>Severe</u>
3. Headache	<u>None</u>	<u>Slight</u>	<u>Moderate</u>	<u>Severe</u>
4. Eyestrain ¹	<u>None</u>	<u>Slight</u>	<u>Moderate</u>	<u>Severe</u>
5. Difficulty focusing	<u>None</u>	<u>Slight</u>	<u>Moderate</u>	<u>Severe</u>
6. Increased salivation	<u>None</u>	<u>Slight</u>	<u>Moderate</u>	<u>Severe</u>
7. Sweating	<u>None</u>	<u>Slight</u>	<u>Moderate</u>	<u>Severe</u>
8. Nausea	<u>None</u>	<u>Slight</u>	<u>Moderate</u>	<u>Severe</u>
9. Difficulty concentrating	<u>None</u>	<u>Slight</u>	<u>Moderate</u>	<u>Severe</u>
10. Fullness of head ²	<u>None</u>	<u>Slight</u>	<u>Moderate</u>	<u>Severe</u>
11. Blurred vision	<u>None</u>	<u>Slight</u>	<u>Moderate</u>	<u>Severe</u>
12. Dizzy (eyes open)	<u>None</u>	<u>Slight</u>	<u>Moderate</u>	<u>Severe</u>
13. Dizzy (eyes closed)	<u>None</u>	<u>Slight</u>	<u>Moderate</u>	<u>Severe</u>
14. Vertigo ³	<u>None</u>	<u>Slight</u>	<u>Moderate</u>	<u>Severe</u>
15. Stomach awareness ⁴	<u>None</u>	<u>Slight</u>	<u>Moderate</u>	<u>Severe</u>
16. Burping	<u>None</u>	<u>Slight</u>	<u>Moderate</u>	<u>Severe</u>

¹ Eyestrain is the fatigue of the eyes.

² Fullness of head is the awareness of pressure in the head.

³ Vertigo is experienced as loss of orientation with respect to vertical upright.

⁴ Stomach awareness is usually used to indicate a feeling of discomfort which is just short of nausea.

Appendix K

questionnaire III

(2 pages)

QUESTIONNAIRE 3

after participating in the driving simulator study "Driving behavior on the Dutch freeway"

A. Circle how much each symptom below is affecting you right now.

1. General discomfort	<u>None</u>	<u>Slight</u>	<u>Moderate</u>	<u>Severe</u>
2. Fatigue	<u>None</u>	<u>Slight</u>	<u>Moderate</u>	<u>Severe</u>
3. Headache	<u>None</u>	<u>Slight</u>	<u>Moderate</u>	<u>Severe</u>
4. Eyestrain ¹	<u>None</u>	<u>Slight</u>	<u>Moderate</u>	<u>Severe</u>
5. Difficulty focusing	<u>None</u>	<u>Slight</u>	<u>Moderate</u>	<u>Severe</u>
6. Increased salivation	<u>None</u>	<u>Slight</u>	<u>Moderate</u>	<u>Severe</u>
7. Sweating	<u>None</u>	<u>Slight</u>	<u>Moderate</u>	<u>Severe</u>
8. Nausea	<u>None</u>	<u>Slight</u>	<u>Moderate</u>	<u>Severe</u>
9. Difficulty concentrating	<u>None</u>	<u>Slight</u>	<u>Moderate</u>	<u>Severe</u>
10. Fullness of head ²	<u>None</u>	<u>Slight</u>	<u>Moderate</u>	<u>Severe</u>
11. Blurred vision	<u>None</u>	<u>Slight</u>	<u>Moderate</u>	<u>Severe</u>
12. Dizzy (eyes open)	<u>None</u>	<u>Slight</u>	<u>Moderate</u>	<u>Severe</u>
13. Dizzy (eyes closed)	<u>None</u>	<u>Slight</u>	<u>Moderate</u>	<u>Severe</u>
14. Vertigo ³	<u>None</u>	<u>Slight</u>	<u>Moderate</u>	<u>Severe</u>
15. Stomach awareness ⁴	<u>None</u>	<u>Slight</u>	<u>Moderate</u>	<u>Severe</u>
16. Burping	<u>None</u>	<u>Slight</u>	<u>Moderate</u>	<u>Severe</u>

The questionnaire continues on the next page

¹ Eyestrain is the fatigue of the eyes.

² Fullness of head is the awareness of pressure in the head.

³ Vertigo is experienced as loss of orientation with respect to vertical upright.

⁴ Stomach awareness is usually used to indicate a feeling of discomfort which is just short of nausea.

B. For the next 4 questions, also have your driving experience in the real world in mind.

1. On which scale did you find the driving characteristics of the simulator vehicle to be realistic?

Not realistic

Very realistic

2. In what way did the driving characteristics of the simulator vehicle differ from a real vehicle?

3. On which scale did you find your own driving behavior in the simulator to be similar to your driving behavior in reality?

Not similar

Very similar

4. In what way did your own driving behavior in the simulator differ from your usual driving behavior?

This is the end of the questionnaire, as well as the end of the total experiment. Thank you for participating!

Appendix L

results of the questionnaires

(2 pages)

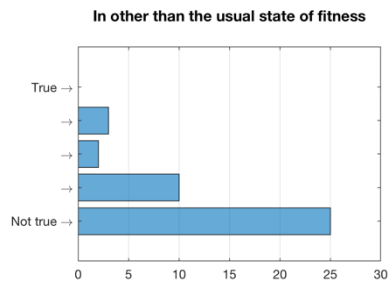
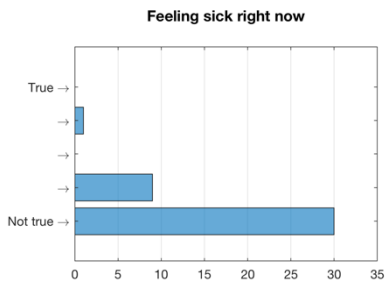
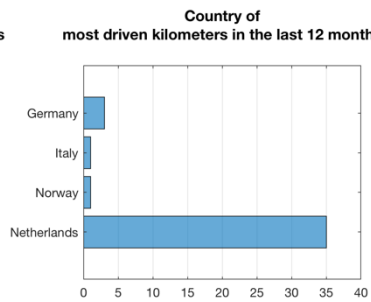
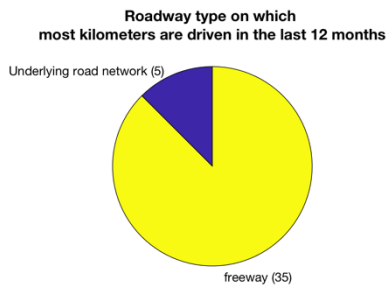
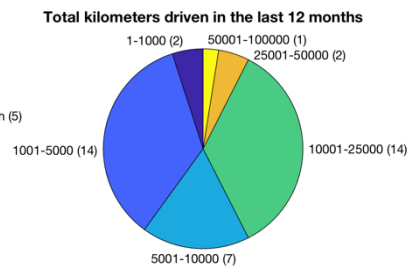
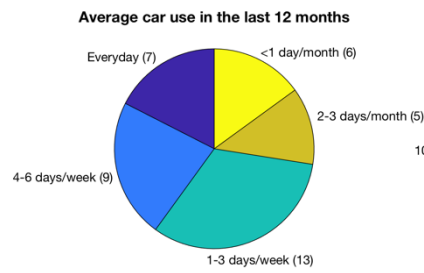
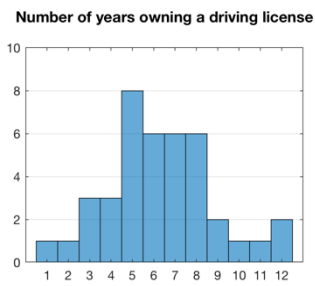
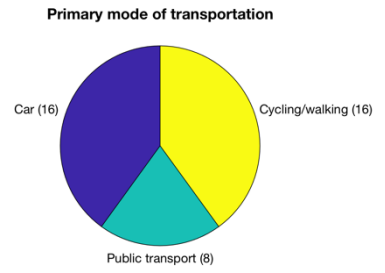
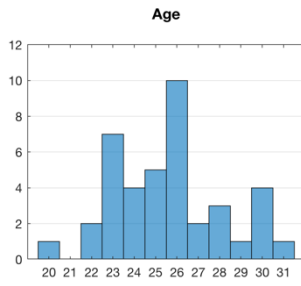
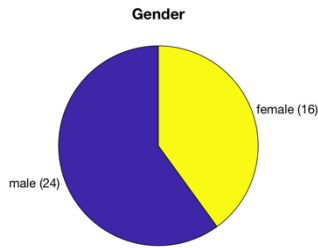

Results Simulator Sickness Questionnaire I (baseline)

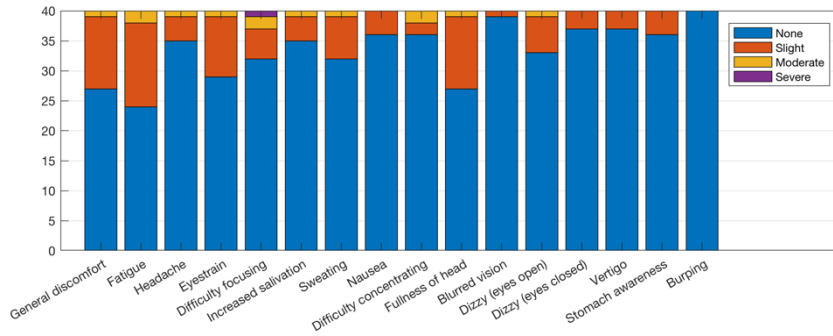

Nausea:
 mean = 10.26
 median = 9.54 [0.00 - 19.08]

Oculomotor:
 mean = 13.08
 median = 7.58 [0.00 - 15.16]

Disorientation:
 mean = 15.66
 median = 13.92 [0.00 - 13.92]

Total score:
 mean = 145.83
 median = 112.42 [32.01 - 180.12]

Results Simulator Sickness Questionnaire II (post-'test track')

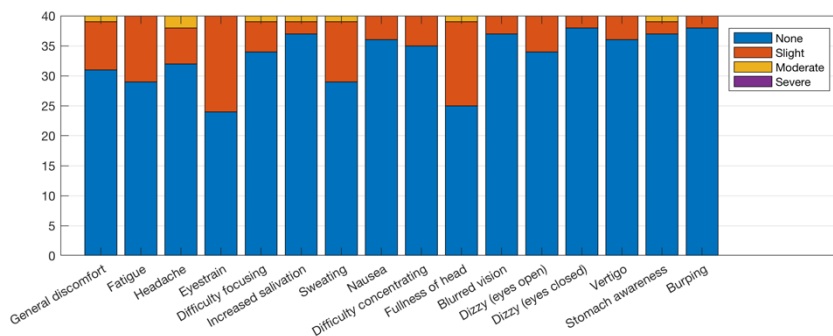

Nausea:
 mean = 9.78
 median = 9.54 [0.00 - 19.08]

Oculomotor:
 mean = 11.75
 median = 7.58 [0.00 - 15.16]

Disorientation:
 mean = 14.62
 median = 13.92 [0.00 - 27.84]

Total score:
 mean = 135.18
 median = 84.08 [32.01 - 180.12]

Results Simulator Sickness Questionnaire III (post-experiment)

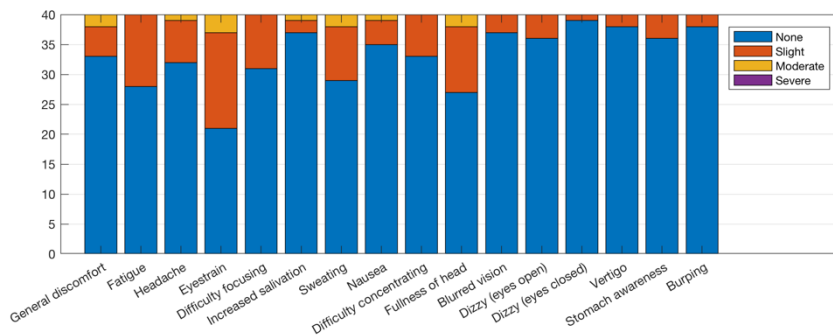

Nausea:
 mean = 10.73
 median = 9.54 [0.00 - 19.08]

Oculomotor:
 mean = 13.45
 median = 7.58 [3.79 - 22.74]

Disorientation:
 mean = 13.92
 median = 13.92 [0.00 - 13.92]

Total score:
 mean = 142.52
 median = 80.41 [52.06 - 190.63]

Driving characteristics of the driving simulator

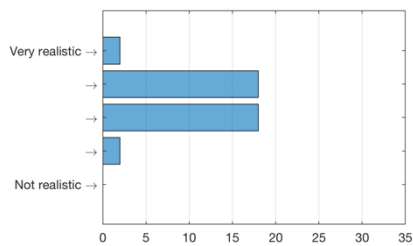

Own driving behavior in the driving simulator

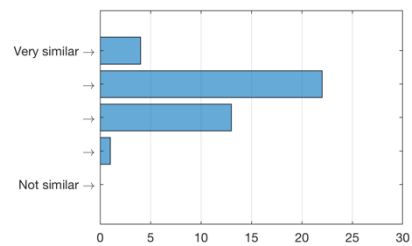

Appendix M

included road sections in the accident data analysis

(1 page)

the five 4-lane major fork road sections that are included in the accident data analysis

#	Name	Type	Freeway nr.	Direction	Start blockmarking [km]	Length blockmarking [m]	Point of divergence [km]	Extra information
1	Ewijk	4-2/2	A50	Li	149,85	1050	148,8	
2	Kerensheide	4-2/2	A2	Re	239,45	850	240,3	Convergence point located 280m upstream
3	Lunetten	4-2/2	A12	Li	64,85	1050	63,8	Entrance ramp located 950m upstream
4	Everdingen	4-3/2	A2	Li	76,35	1050	75,3	
5	Ridderkerk	4-3/2	A15	Li	65,65	1050	64,6	Convergence point located 650m upstream

the four 3-lane major fork road sections that are included in the accident data analysis

#	Name	Type	Freeway nr.	Direction	Start blockmarking [km]	Length blockmarking [m]	Point of divergence [km]	Extra information
1	De Baars	3-1/2	A58	Li	35,1	400	34,7	Convergence point located 500m upstream
2	Diemen (oud)	3-1/2	A9	Li	6,5	600	5,9	Includes a rush-hour lane
3	Ridderkerk	3-2/1	A16	Li	23,65	650	23,0	Convergence point located 500m upstream
4	Rijnsweerd	3-2/1	A27	Li	82,1	800	81,3	Entrance ramp located 360m upstream

the eighteen small-radius connector road sections (that are also left-diverging roadways of a major fork) that are included in the accident data analysis

#	Name	Type*	Freeway nr.	Direction	Point of divergence [km]	Distance to radius [m]	Start radius [km]	Extra information
1	Azelo	1R270	A1	Re	140,8	1000	141,8	
2	Bankhoef	1L90	A326	Li	1,1	100	1,0	Only single-lane on the connector road
3	De Poel	2L90	A256	Li	1,8	300	1,5	
4	De Stok	2L90	A58	Re	93,7	700	94,4	
5	Emmeloord	2L90	A6	Re	111,1	400	111,5	Includes a right-turning curve before it start turning to the left
6	Galder	1R270	A58	Re	62,2	700	62,9	
7	Grijsoord (oud)	1R270	A50	Re	169,3	600	169,9	
8	Holendrecht	2R270	A9	Li	22,6	800	21,8	
9	Klaverpolder	2L70	A17	Li	0,5	500	0,0	The A17 jumps from 0,0(Li) to 30,4(Li)
10	Maanderbroek	2L90	A30	Li	8,2	200	8,0	
11	Markiezaat	1R240	A4	Li	244,2	600	243,6	
12	Neerbosch	2L90	A73	Re	103,9	200	104,1	
13	Noordhoek	1L90	A59	Re	65,2	1100	66,3	
14	Rijkvoort	1R270	A77	Li	2,0	500	1,5	
15	Sabina	1R270	A59	Li	57,6	600	57,0	
16	Sint Annabosch	2L90	A27	Li	2,0	800	1,2	
17	Zonzeel	1R270	A59	Li	89,1	500	88,6	
18	Zoomland	2R270	A58	Re	103,4	600	104,0	

*The type of small-radius connector road is listed as a code, which consists of three components: the number of lanes, the direction of the curve, and the curvature in degrees. For example, the code 1R270 means that it is a 1-lane connector road with a 270° curve to the right.

Appendix N

step-by-step plans for the
driving simulator environment and simulated traffic

(1 page)

Step-by-step plan for creating the driving simulator environment:

1. Use Bentley MXROAD to make the 3D geometry of the edges of the mainline roadway, shoulder lanes and embankments, as well as the lines along which the lane markings, guard rails and light posts should be placed. Make sure that every type of edge or line has its own unique "string code". Make sure that the total design fits within a ten-by-ten-kilometer area, as VISSIM (which simulates the surrounding traffic) is restricted to this size.
2. Use Bentley MXROAD to triangulate all surfaces, with each surface that has a different material in a different model. This means that the embankments and shoulder lanes can be triangulated together since they are both made of grass, but that the mainline roadway should be triangulated separately since that is made of asphalt.
3. Import all edges, lines and surfaces in Autodesk Civil3D. Use the application NedInfra Zicht to place a specific type of marking over a line with the corresponding "string code", and place portals at the locations of interest. The same application can also be used to add the signage and matrix signs to the portals. Make sure that you give every unique sign its own layer.
4. Use the standard Civil3D tools to draw all civil engineering constructions (e.g. viaducts) in 3D, but only at the locations that are directly visible for participants driving on the experimental road design. Again, make sure that every surface that has a unique material is put in a unique layer.
5. Make one last check that every unique (color of) material that is used (e.g. asphalt, grass, marking, concrete, white steel, grey steel, and every unique sign) is put in a different layer. Then import all surfaces and lines into Autodesk 3dsMax.
6. Use Autodesk 3dsMax to give each layer its own material. After that, check the entire environment for missing surfaces. Each surface has a frontside and a backside, and only the frontside is visible to limit the necessary computational power. So, when a surface is not visible, this means that the front- and backside are switched, and that the direction of the normal of the that surface needs to be changed.
7. Use Autodesk 3dsMax's "object-placement style" to import guardrails and light posts along the lines with the corresponding "string code". While guardrails should be added continuously along a line, light posts should be added every 60 meters or so. Note that Autodesk 3dsMax includes these objects by default.
8. Export the entire model as FBX file and make sure that you select the checkbox "animations" in the process. When this checkbox is not selected, materials are not exported.
9. Import the FBX file in Unity, and add a unidirectional light to the scene to make daylight.

Step-by-step plan for creating the simulated traffic:

1. Import the edges of the mainline roadway and the lines of the lane markings in PTV VISSIM, and make sure that the coordinates of the road network match with the coordinates in Unity.
2. Then redraw the entire road network (at least the part where simulated traffic actually drives) with links and connectors, and just let links cross at locations where two roadways in the network also cross. Make sure that every link or connector is of a certain type of roadway (e.g. freeway), and that each type of roadway has the correct driving behavior models and parameters.
3. Add traffic to the network by using "vehicle input" or by implementing an OD-matrix. Make sure that the traffic consists of the vehicle types that you would like to include, and that each vehicle type has the correct distributions (e.g. desired driving speed, acceleration, and power).
4. Make sure that the driving simulator checkbox is selected in the "Network settings" of VISSIM.
5. Add the Witteveen+Bos scripts that connect VISSIM with Unity (and Unity with VISSIM) to the scene and to the player object in your Unity model.