

Distributed Fuzzy and Stochastic Observers for Nonlinear Systems

Zsófia Lendek

Distributed Fuzzy and Stochastic Observers for Nonlinear Systems

Proefschrift

ter verkrijging van de graad van doctor
aan de Technische Universiteit Delft,
op gezag van de Rector Magnificus prof.dr.ir. J.T. Fokkema,
voorzitter van het College van Promoties,
in het openbaar te verdedigen op dinsdag 10 maart 2009 om 10:00 uur
door

Zsófia LENDEK

Master of Science in Control Engineering and Industrial Computing
Technical University of Cluj-Napoca, Roemenië
geboren te Dej, Roemenië.

Dit proefschrift is goedgekeurd door de promotoren:

Prof.dr. R. Babuška, M.Sc.

Prof.dr.ir. B. De Schutter

Samenstelling promotiecommissie:

Rector Magnificus

Prof.dr. R. Babuška, M.Sc.

Prof.dr.ir. B. De Schutter

Prof.dr. H. Werner

Prof.dr. T. M. Guerra

Prof.dr. H. J. Kappen

Prof.dr.ir. S. P. Hoogendoorn

Prof.dr. C. W. Scherer

voorzitter

Technische Universiteit Delft, promotor

Technische Universiteit Delft, promotor

Technische Universität Hamburg-Harburg

Université de Valenciennes

et du Hainaut Cambrésis

Radboud University Nijmegen

Technische Universiteit Delft

Technische Universiteit Delft

disc



This thesis has been completed in partial fulfillment of the requirements of the Dutch Institute for Systems and Control (DISC) for graduate studies. The research described in this thesis was financially supported by Senter, Ministry of Economic Affairs of the Netherlands within the BSIK-ICIS project “Interactive Collaborative Information Systems” (grant no. BSIK03024).

Published and distributed by: Zsófia Lendek

E-mail: z.lendek@tudelft.nl

Web: <http://www.dcsc.tudelft.nl/~zslendek>

ISBN 978-90-9023990-3

Copyright © 2009 by Zsófia Lendek

All rights reserved. No part of the material protected by this copyright notice may be reproduced or utilized in any form or by any means, electronic or mechanical, including photocopying, recording or by any information storage and retrieval system, without written permission of the author.

Printed in the Netherlands

Acknowledgements

I look back to the research done in my PhD with pleasure and I wish these four years hadn't ended. However, the journey is over, and for the great experience I am grateful to a lot of people.

First and foremost, I would have never been able to write my thesis without the constant encouragement, inspiration, and criticism received from my supervisors, Professors Robert Babuška and Bart De Schutter. Thank you for your guidance, ideas, energy to read through and figure out my writings, and for your constant efforts to try and better me.

And thank you, Paula, for making it possible for me to start a PhD.

It was great to work with Thierry Marie Guerra and all the guys from LAMIH. The coffee breaks were not only a relief but often resulted in more ideas than the same time spent in front of the computer.

DCSC provided an excellent research environment, thanks to all the colleagues, staff and students alike. I would like to mention here and thank to Roland Tóth, Alina Tarău, Rudy Negenborn, Diederick Joosten and Arjan van Dijke for the interesting conversations and their help.

I am grateful to my colleagues in the Interactive Collaborative Information Systems project. I also thank the members of my committee for reading through my thesis and providing helpful comments and suggestions: Professors Carsten Scherer, Serge Hoogendoorn, Herbert Werner, Bert Kappen, and of course, Thierry Marie, Bart and Robert.

I would like to thank Lucian for his support and patience. My friends at home – among whom Paula, Sorin, Aur, and Luminița, – who made my holidays great. My family for their support, constant encouragement, and backing me always. And to Brumi, who endured all these years.

Finally, I apologize to and thank those, who contributed in one way or another but are not mentioned here.

Lendek Zsófia
2009 január, Delft

Contents

1	Introduction	1
1.1	Motivation	1
1.2	Thesis focus and contributions	3
1.3	Thesis outline	5
I	Fuzzy observers	7
2	TS fuzzy systems and observers	9
2.1	Introduction	9
2.2	Dynamic TS fuzzy models	10
2.3	Stability conditions for TS fuzzy systems	11
2.4	Fuzzy observers	16
2.4.1	Case 1: State-independent scheduling vector	17
2.4.2	Case 2: State-dependent scheduling vector	18
2.4.3	Design using LMI regions	20
2.5	Summary and concluding remarks	21
3	Cascaded observers	23
3.1	Introduction	23
3.2	Stability of cascaded dynamic systems	24
3.2.1	Preliminaries	24
3.2.2	Partitioning a nonlinear system	25
3.2.3	Stability of cascaded systems	28
3.3	Cascaded TS fuzzy systems	30
3.3.1	Stability of cascaded fuzzy systems	30
3.3.2	Cascaded fuzzy observers	36
3.3.3	Example for cascaded observer design	39
3.4	Summary and concluding remarks	42
4	Distributed observers	45
4.1	Introduction	45
4.2	Decentralized stability analysis of fuzzy systems	46
4.3	Distributed observer design	51
4.3.1	Preliminaries	51

4.3.2	State-independent scheduling vector	53
4.3.3	State-dependent scheduling vector	57
4.4	Example of decentralized observer design	61
4.5	Summary and concluding remarks	65
5	Adaptive observers	67
5.1	Introduction	67
5.2	Polynomial unknown inputs	69
5.2.1	Observer design	69
5.2.2	Bound on errors	73
5.3	Estimation of unmodeled dynamics	77
5.4	Example	80
5.5	Summary and concluding remarks	85
II	Observers for stochastic systems	87
6	Stochastic systems and observers	89
6.1	Introduction	89
6.2	Kalman filters	90
6.2.1	General description	90
6.2.2	Linear Kalman filter	91
6.2.3	Extended Kalman filter	92
6.2.4	Unscented Kalman filter	93
6.2.5	Properties and convergence issues	96
6.3	Particle filters	97
6.4	Summary and concluding remarks	100
7	Cascaded Kalman filters	101
7.1	Introduction	101
7.2	Distributed Kalman filters	102
7.3	Examples	105
7.3.1	Cascaded KFs in open-loop	105
7.3.2	Cascaded KFs in closed-loop	110
7.4	A multi-robot setting	112
7.5	Summary and concluding remarks	116
8	Case studies	119
8.1	Estimation of the overflow losses in a hopper dredger	119
8.1.1	Problem description	119
8.1.2	Dynamic sedimentation model	120
8.1.3	The estimation problem	122
8.1.4	Results for simulated data	124
8.1.5	Results for measured data	128
8.1.6	Conclusions	131
8.2	State estimation for a water treatment plant	131
8.2.1	Introduction	131

8.2.2	The water treatment plant	132
8.2.3	The estimation problem	134
8.2.4	Estimation results	135
8.2.5	Conclusions	138
8.3	Summary and concluding remarks	139
9	Conclusions and future research directions	141
9.1	Summary and conclusions	141
9.2	Main contributions	143
9.3	Open issues and outlook	143
9.3.1	Open issues and future research directions	143
9.3.2	Outlook	144
	Appendices	147
A	Stability criteria	147
B	Obtaining Takagi-Sugeno models by linearization	149
C	Schur complements	151
	Bibliography	153
	Glossary	163
	Summary	167
	Samenvatting	171
	Curriculum vitae	175

Chapter 1

Introduction

This chapter motivates the need for designing observers and introduces the type of nonlinear dynamic systems used in this thesis. Next, the contributions of the thesis are described. The chapter closes with an outline of the thesis.

1.1 Motivation

In order to understand how a system works, one needs to have information on certain important quantities associated with the system. Many problems in decision making, monitoring, and control require the knowledge of the variables, i.e., states and parameters of the process involved. In practical situations, measuring all these quantities may not be possible due to technical or economical reasons. Therefore, estimation of states and parameters in dynamic systems is an important prerequisite for safe and economical process operations. Estimation is an integral part in applications such as process monitoring, fault detection, and process optimization. Moreover, any state feedback control design requires the knowledge of state variables. Therefore, it is necessary to estimate the state variables using an observer from the information available.

Observers use the plant input and output signals to generate an estimate of the plants state, which may be then further employed, for instance in control. Observers can also be used to augment or to replace sensors in a control system. Observers were first proposed and developed by Luenberger in the sixties (Luenberger, 1966). Since the early developments, observers for linear and nonlinear plants with both known and unknown inputs have been developed (Saif and Guan, 1992; Ruiz Vargas and Hemerly, 2001; Bergsten et al., 2001; Welch and Bishop, 2002; Huang and Dey, 2005; Hyun et al., 2006; Besançon, 2006; Priscoli et al., 2006).

In general, the estimation of states and possibly parameters is based on a dynamic system model and a sequence of measurements. For such a purpose, dynamic systems are usually modeled in the state space framework, using a state transition model, which describes the evolution of the states over time, and a measurement model, which relates the measurement to the states. In general, the model of the system is not accurate. Moreover, due to technical limitations, the actuators and sensors, and therefore the measurements are not precise. Therefore, the models are uncertain, or “corrupted by noise”.

In most cases, the noise affecting the actuators, states and/or measurements is not considered significant and is not taken into consideration when analyzing the system or designing an observer. In such cases, it is considered that the system is deterministic and the following description¹ of the system is used:

$$\begin{aligned}\dot{\mathbf{x}}(t) &= \mathbf{f}(\mathbf{x}(t), \mathbf{u}(t), \boldsymbol{\theta}(t)) \\ \mathbf{y}(t) &= \mathbf{h}(\mathbf{x}(t), \mathbf{u}(t), \boldsymbol{\mu}(t))\end{aligned}\tag{1.1}$$

in continuous time, and

$$\begin{aligned}\mathbf{x}_k &= \mathbf{f}(\mathbf{x}_{k-1}, \mathbf{u}_{k-1}, \boldsymbol{\theta}_{k-1}) \\ \mathbf{y}_k &= \mathbf{h}(\mathbf{x}_k, \mathbf{u}_k, \boldsymbol{\mu}_k)\end{aligned}\tag{1.2}$$

in discrete-time, where: k denotes the time step, \mathbf{f} is the state transition function, describing the evolution of the states over time, \mathbf{h} is the measurement function, relating the measurements to the states, \mathbf{x} is the vector of the state variables, \mathbf{u} is the vector of the input or control variables, $\boldsymbol{\theta}$ and $\boldsymbol{\mu}$ are unknown/uncertain parameters, and \mathbf{y} denotes the measurement vector.

If the uncertainty is significant, it may be included in the description of the system evolution:

$$\begin{aligned}\dot{\mathbf{x}}(t) &= \mathbf{f}(\mathbf{x}(t), \mathbf{u}(t), \boldsymbol{\theta}(t), \mathbf{v}(t)) \\ \mathbf{y}(t) &= \mathbf{h}(\mathbf{x}(t), \mathbf{u}(t), \boldsymbol{\mu}(t), \boldsymbol{\eta}(t))\end{aligned}\tag{1.3}$$

in continuous time² and

$$\begin{aligned}\mathbf{x}_k &= \mathbf{f}(\mathbf{x}_{k-1}, \mathbf{u}_{k-1}, \boldsymbol{\theta}_{k-1}, \mathbf{v}_{k-1}) \\ \mathbf{y}_k &= \mathbf{h}(\mathbf{x}_k, \mathbf{u}_k, \boldsymbol{\mu}_k, \boldsymbol{\eta}_k)\end{aligned}\tag{1.4}$$

in discrete time, where \mathbf{v}_{k-1} represents the state transition noise and $\boldsymbol{\eta}_k$ represents the measurement noise.

A probabilistic formulation of the above model may also be used, that is characterized by the probability distribution functions (PDFs)

$$\begin{aligned}p(\mathbf{x}_k | \mathbf{x}_{k-1}, \mathbf{u}_{k-1}, \boldsymbol{\theta}_{k-1}) \\ p(\mathbf{y}_k | \mathbf{x}_k, \mathbf{u}_k, \boldsymbol{\mu}_k)\end{aligned}\tag{1.5}$$

where $p(\mathbf{x}_k | \mathbf{x}_{k-1}, \mathbf{u}_{k-1}, \boldsymbol{\theta}_{k-1})$ represents the probability of the system to transition to the state \mathbf{x}_k , given that at the previous time step $k - 1$ the state vector was \mathbf{x}_{k-1} , the input \mathbf{u}_{k-1} was applied and the parameters were $\boldsymbol{\theta}_{k-1}$. Similarly, $p(\mathbf{y}_k | \mathbf{x}_k, \mathbf{u}_k, \boldsymbol{\mu}_k)$ represents the probability of receiving the measurement \mathbf{y}_k given that the current state is \mathbf{x}_k , the input applied was \mathbf{u}_k and the parameters are $\boldsymbol{\mu}_k$.

Given a state space model, the problem of state estimation arises as soon as the measured output does not coincide with the whole state. The first step in designing an observer is to determine whether the system is observable, i.e., whether the variables of interest can be uniquely determined based on the available model. Unlike for linear systems, there is no

¹In the sequel, for the ease of notation, the explicit time dependence in case of continuous-time systems is omitted.

²A formally correct way of writing the state equation would be

$$d\mathbf{x} = \mathbf{f}(\mathbf{x}(t), \mathbf{u}(t), \boldsymbol{\theta}(t), d\mathbf{v}, dt)$$

systematic procedure to design a state observer for a given nonlinear model. Solutions exist for various cases (Mohler and Bugnon, 1989; Baz, 1992; Julier and Uhlmann, 1997; Aldeen et al., 1998; Bergsten, 2001; Vadigepalli and Doyle, 2003b; Besançon, 2006). The problem becomes more difficult when some parameters in the model are not known exactly either.

In this thesis, in order to design observers for deterministic nonlinear systems, systems represented by Takagi-Sugeno³ (TS) fuzzy models are used, i.e., systems of the form:

$$\begin{aligned}\dot{\mathbf{x}} &= \sum_{i=1}^m w_i(\mathbf{z})(A_i \mathbf{x} + B_i \mathbf{u} + a_i) \\ \mathbf{y} &= \sum_{i=1}^m w_i(\mathbf{z})(C_i \mathbf{x} + d_i)\end{aligned}\tag{1.6}$$

where m is the number of local models, A_i , B_i , C_i , are the matrices and a_i and d_i are the biases of the i th local model, \mathbf{z} is the vector of the scheduling variables, which may depend on the states, inputs, measurements, or other exogenous variables, and $w_i(\mathbf{z})$, $i = 1, 2, \dots, m$ are normalized membership functions, i.e., $w_i(\mathbf{z}) \geq 0$ and $\sum_{i=1}^m w_i(\mathbf{z}) = 1$.

Such a model presents several advantages. The TS model is a universal approximator (Fantuzzi and Rovatti, 1996), and many nonlinear systems can be exactly represented in a compact set of state variables as such (Ohtake et al., 2001). Moreover, (1.6) is the convex combination of local affine models. In addition, many already available stability and design conditions are formulated as linear matrix inequalities (Tanaka and Wang, 1997; Tanaka et al., 1998a), for which efficient algorithms exist that test their feasibility. However, the dimension of the LMI problem may be exponential in the number of the rules. For distributed, large-scale systems such an approach may be computationally unfeasible. Also most existing conditions pertain only the case when the structure and the local models of the fuzzy system are fixed. If the local models change in time, or if external variables other than those represented in the scheduling vector influence the system, different conditions need to be developed.

1.2 Thesis focus and contributions

The objective of this thesis was to develop efficient observer design methods for nonlinear systems. Two types of systems are considered: deterministic nonlinear systems, represented by continuous time Takagi-Sugeno (TS) fuzzy models, and discrete time stochastic systems. For a large-scale or time-varying system, the design and tuning of an observer may be complicated and involve large computational costs. Therefore, before designing an observer, we consider the structure of the system analyzed. For TS systems, three structures are investigated: when the system is in cascaded form, when the system is distributed, and when the system is affected by unknown disturbances. For stochastic systems, the case when the system is in cascaded form is considered. The design of cascaded Kalman filters is investigated from a theoretical point of view and the combination of different estimation methods is studied on application examples. This section motivates and describes our approaches, together with our main contributions.

³Note, that the equations are only a compact mathematical representation corresponding to a set of rules.

Cascaded TS observers

Many physical systems, such as power system, material processing systems, communication and transportation networks are composed of interconnected lower-dimensional subsystems. An important class of these systems can be represented as a cascade of subsystems. If these subsystems are linear, then their stability implies the stability of the whole system. However, this property does not hold in general for nonlinear systems. Therefore, we study the cascade of nonlinear systems represented by TS fuzzy models. We prove that also for cascaded TS systems, the stability of the subsystems imply the stability of the cascade. Therefore, the stability analysis of a cascaded TS system may be performed by analyzing the individual subsystems. We also extend this approach to observer design. A stable observer can be obtained by designing independently observers for the subsystems. We also prove that such a design does not lead to loss of performance in the terms of the estimation error decay-rate.

Distributed TS observers

In many cases, large-scale systems are not cascaded, but distributed, i.e., the influence among the subsystems is not in one way only. In addition, the structure is often not fixed, i.e., subsystems may be added or removed. For such systems, decentralized analysis and design presents several advantages, such as flexibility and easier analysis. Therefore, we consider the stability analysis and observer design for distributed systems, where each subsystem is represented by a TS fuzzy model. We analyze the stability of the overall TS system based on the stability of the subsystems, allowing that new subsystems may be added online. When the structure of the system is not fixed, the influence of the interconnection terms due to the addition of a new subsystem is not known before the subsystem is actually added. Therefore, the newly added subsystem should not influence the stability of the overall system. Also, if a subsystem that was added is removed, the stability of the remaining system is maintained. The approach is extended to observer design. We assume that a fuzzy observer is already designed for an existing subsystem. When a new subsystem, together with the interconnection terms is added, a new observer is designed only for this subsystem. Therefore, the observers are designed sequentially for the subsystems. If a subsystem is removed, the corresponding observer is removed with it. The advantage of this approach is that the observers that have already been designed do not need to be altered.

Adaptive observers

Adaptive observers are observers that simultaneously estimate the states and unknown inputs or parameters of a system. The design of observers in the presence of unknown inputs is an important problem, since in many cases not all inputs are known, and the unknown inputs may represent effects of actuator or plant component failures. Therefore, we consider TS systems that are affected by unknown inputs. Two types of inputs are considered: model mismatch and time-varying disturbances, which can be represented as or approximated by polynomial functions of time. We design observers that simultaneously estimate both the states and unknown inputs. The observer is designed based on the known part of the fuzzy model. Conditions for the asymptotic convergence of the observer are presented and the design guarantees an ultimate bound on the error signal.

Cascaded Kalman filters

In many applications, in order to efficiently analyze the process or to efficiently design observers, one also has to consider the noise that is affecting the states and/or measurements. In such cases, probabilistic estimation methods have to be used. The most well-known and frequently used of these are the Kalman filter (KF), its nonlinear variants, and particle filters (PFs). However, for large-scale system, in particular when subsystems are added online, the application of these methods is time-consuming. We consider combinations of these estimators for stochastic systems that are cascades of subsystems. We compare cascaded and centralized KFs both from a theoretical point of view and on simulation examples.

Cascaded stochastic state estimation

We compare cascaded and centralized stochastic observers on two real-world applications. First, we study the performance of the combination of Unscented KF and PF in a cascaded setting, in order to obtain a better estimate of the overflow losses in a hopper-dredger. In the second application, we use cascaded PFs to estimate the model parameters in a water treatment plant. In both cases, the cascaded filters are easier to tune and obtain better estimation results than a centralized filter, with reduced computational costs.

1.3 Thesis outline

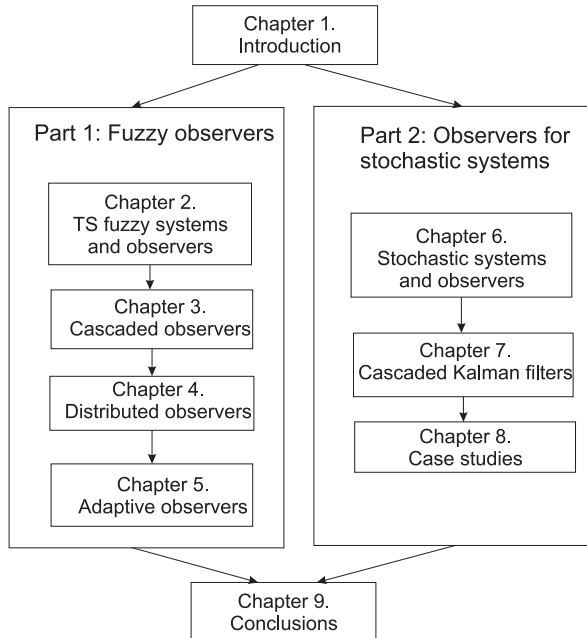

Figure 1.1: A roadmap of the thesis.

Figure 1.1 presents a graphical roadmap depicting the organization of this thesis. The thesis consists of two main parts: Part 1: *Fuzzy observers* and Part 2: *Observers for stochastic*

systems. The first part consists of Chapters 2–5 and the second part of Chapters 6–8. In each part, the first chapter, i.e., Chapter 2 and Chapter 6, respectively, is used to introduce the necessary notations and background. In particular, Chapter 2 introduces the Takagi-Sugeno fuzzy system that is used throughout the first part of the thesis, presents classical stability and observer design conditions, and illustrates these conditions on examples. Chapter 6 presents the stochastic state estimation methods used in the second part of the thesis, namely the Kalman filter, its nonlinear variants, and particle filters.

The subsequent chapters of each part detail the contributions of this thesis. Chapter 3 presents stability analysis and observer design methods for cascaded TS systems. Chapter 4 extends the conditions obtained for cascaded systems to the analysis and observer design of distributed TS systems. The last chapter of Part 1, Chapter 5 considers observer design for TS systems that are influenced by unknown inputs.

The second part of the thesis considers stochastic state estimation in the cascaded setting. Chapter 7 compares cascaded and centralized Kalman filters. Chapter 8 presents two applications in which cascaded stochastic estimators are used.

Chapter 9 contains the conclusions and ideas for future research.

Three appendices are included at the end of this thesis. Appendix A presents stability conditions for nonlinear systems, and is useful to be read before Chapter 2. Appendix B describes how the TS models are obtained from nonlinear models through linearization in the examples of Chapters 3–5. Appendix C introduces the Schur complement that is frequently used in Chapter 4.

Part I

Fuzzy observers

Chapter 2

TS fuzzy systems and observers

This chapter presents the continuous-time dynamic Takagi-Sugeno (TS) fuzzy system that will be employed throughout the first part of the thesis. Conditions for the stability analysis, derived from the direct Lyapunov approach are presented and the design of Thau-Luenberger type fuzzy observers is discussed.

2.1 Introduction

Traditionally, the class of linear, time-invariant systems have dominated the systems and control field. The linearity and time-invariance make these types of systems easy to analyze and design controllers or observers for them. The disadvantage is that such systems fail to describe nonlinear systems globally. An accurate approximation of a nonlinear system can only be expected in the vicinity of an equilibrium point. A large class of nonlinear systems can be well approximated by TS fuzzy models (Takagi and Sugeno, 1985).

The TS fuzzy model consists of a fuzzy rule base. The rule antecedents partition a given subset of the model variables into fuzzy regions. The consequent of each rule is usually a linear or affine model, valid locally in the corresponding region.

Although the local models are often chosen linear or affine, the stability of these local models does not ensure the stability of the overall fuzzy model. Therefore, several stability conditions have been developed for TS fuzzy systems, most of them relying on the feasibility of an associated system of linear matrix inequalities (LMIs) (Tanaka et al., 1998a; Johansson et al., 1999; Bergsten et al., 2001).

In most cases, not all the states of interest of a dynamic system can be measured and therefore, observers need to be designed. A generic method for the design of an observer valid for all types of nonlinear systems has not been found yet. However, several types of observers have been developed for TS fuzzy systems, among which: fuzzy Thau-Luenberger observers (Tanaka and Wang, 1997; Tanaka et al., 1998a,c), reduced-order observers (Bergsten et al., 2001, 2002), and sliding-mode observers (Palm and Bergsten, 2000). In general, the design methods for observers also lead to the feasibility of the associated LMIs.

2.2 Dynamic TS fuzzy models

The TS fuzzy model, originally proposed by Takagi and Sugeno (1985) is composed of an if-then rule base that partitions a space into fuzzy regions called antecedents. The consequent of each rule is a simple functional expression. A rule can be described as follows:

If z_1 is F_1^i and ... and z_r is F_r^i then $\mathbf{y}_i = \mathbf{F}_i(\mathbf{x})$

where the vector \mathbf{z} stands for the premise variables and F_i^j are the antecedent fuzzy sets. The premise variable z_i belongs to a fuzzy set j with a truth value given by the membership function $\eta_{ij} : \mathbb{R} \rightarrow [0, 1]$. Note that the vector of the premise variables \mathbf{z} may depend on the variables \mathbf{x} , \mathbf{y} , or on other exogenous variables. The truth value for the entire rule is determined based on the individual premise variables. Frequently used conjunction operators are *min* and the algebraic product (Kruse et al., 1994):

$$h_i(\mathbf{z}) = \prod_{j=1}^r \eta_{ij}(z_i)$$

This truth value is usually normalized, i.e.,

$$w_i(\mathbf{z}) = \frac{h_i(\mathbf{z})}{\sum_{j=1}^m h_j(\mathbf{z})}$$

assuming that $\sum_{j=1}^m h_j(\mathbf{z}) \neq 0$ and m is the number of the rules. In the remainder of this thesis, $w_i(\mathbf{z})$ is referred to as the normalized membership function. Using $w_i(\mathbf{z})$, the output of the model, \mathbf{y} is expressed as a function of the variables \mathbf{x} and \mathbf{z} as follows

$$\mathbf{y} = \sum_{i=1}^m w_i(\mathbf{z}) \mathbf{F}_i(\mathbf{x}) \quad (2.1)$$

In this thesis, only TS models in the context of dynamic systems are considered. Therefore let a dynamical system be given as:

$$\begin{aligned} \dot{\mathbf{x}} &= \mathbf{f}(t, \mathbf{x}, \mathbf{u}, \boldsymbol{\theta}) \\ \mathbf{y} &= \mathbf{g}(t, \mathbf{x}, \mathbf{u}, \boldsymbol{\mu}) \end{aligned}$$

where \mathbf{f} and \mathbf{g} are functions, $\mathbf{x} \in \mathbb{R}^{n_x}$ is the state vector, $\mathbf{u} \in \mathbb{R}^{n_u}$ is the input vector, $\mathbf{y} \in \mathbb{R}^{n_y}$ is the measurement vector, t denotes the time, and $\boldsymbol{\theta}$ and $\boldsymbol{\mu}$ are parameter vectors. A fuzzy system that approximates the above nonlinear system can be expressed as a set of fuzzy rules of the following form:

If z_1 is F_1^i and ... and z_r is F_r^i then

$$\begin{aligned} \dot{\mathbf{x}}_i &= \widehat{\mathbf{f}}_i(t, \mathbf{x}, \mathbf{u}, \boldsymbol{\theta}) \\ \mathbf{y}_i &= \widehat{\mathbf{g}}_i(t, \mathbf{x}, \mathbf{u}, \boldsymbol{\mu}) \end{aligned}$$

Using (2.1), this leads to

$$\begin{aligned} \dot{\mathbf{x}} &= \sum_{i=1}^m w_i(\mathbf{z}) \widehat{\mathbf{f}}_i(t, \mathbf{x}, \mathbf{u}, \boldsymbol{\theta}) \\ \mathbf{y} &= \sum_{i=1}^m w_i(\mathbf{z}) \widehat{\mathbf{g}}_i(t, \mathbf{x}, \mathbf{u}, \boldsymbol{\mu}) \end{aligned}$$

where the consequents \widehat{f}_i and \widehat{g}_i are less complex than the initial nonlinear functions f and g .

In the general case, $\widehat{f}_i(t, \mathbf{x}, \mathbf{u}, \boldsymbol{\theta})$ and $\widehat{g}_i(t, \mathbf{x}, \mathbf{u}, \boldsymbol{\mu})$ can be non-linear, time varying functions. However, in this thesis only linear or affine dynamic consequents are considered, i.e., TS systems of the form

$$\begin{aligned}\dot{\mathbf{x}} &= \sum_{i=1}^m w_i(\mathbf{z})(A_i \mathbf{x} + B_i \mathbf{u}) \\ \mathbf{y} &= \sum_{i=1}^m w_i(\mathbf{z})C_i \mathbf{x}\end{aligned}$$

or

$$\begin{aligned}\dot{\mathbf{x}} &= \sum_{i=1}^m w_i(\mathbf{z})(A_i \mathbf{x} + B_i \mathbf{u} + a_i) \\ \mathbf{y} &= \sum_{i=1}^m w_i(\mathbf{z})(C_i \mathbf{x} + d_i)\end{aligned}$$

where m is the number of rules, A_i, B_i, C_i, a_i, d_i are the matrices and biases of the i th local model. The vector \mathbf{z} represents the scheduling variables, which may depend on the states, inputs, measurements, or other exogenous variables. In this thesis, for observer design, two cases are considered: 1) the vector \mathbf{z} depends only on measured variables (including input, outputs and exogenous measured variables) and 2) \mathbf{z} is a function of the state variables and possibly also other, measured variables. The membership functions $w_i(\mathbf{z}), i = 1, 2, \dots, m$ are normalized, i.e., $w_i(\mathbf{z}) \geq 0$ and $\sum_{i=1}^m w_i(\mathbf{z}) = 1$. Note that due to the normalized membership functions, the linear (affine) dynamic TS model is in fact a convex combination of local linear (affine) models, which facilitates the stability analysis.

Such models have been proven to be able to approximate on a compact set of variables any nonlinear function to an arbitrary degree of accuracy (Fantuzzi and Rovatti, 1996).

2.3 Stability conditions for TS fuzzy systems

This section presents stability conditions for autonomous TS fuzzy systems:

$$\dot{\mathbf{x}} = \sum_{i=1}^m w_i(\mathbf{z})A_i \mathbf{x} \quad (2.2)$$

where $A_i, i = 1, 2, \dots, m$ represents the i^{th} local linear model, $w_i(\mathbf{z})$ is the corresponding normalized membership function and \mathbf{z} the vector of the scheduling parameters. System (2.2) can also be regarded as a linear parameter varying (LPV) system:

$$\dot{\mathbf{x}} = A(\mathbf{z})\mathbf{x} \quad (2.3)$$

with $A(\mathbf{z}) = \sum_{i=1}^m w_i(\mathbf{z})A_i$.

Note that due to the nonlinearity in the membership functions, the stability of the local models $A_i, i = 1, 2, \dots, m$ does not imply the stability of the system (2.2).

Example 2.1 Consider the following two-rule fuzzy system:

If z is low then $\dot{\mathbf{x}}_1 = A_1 \mathbf{x}$

If z is high then $\dot{x}_1 = A_2x$

with $A_1 = \begin{pmatrix} -3 & 1 \\ 0 & -2 \end{pmatrix}$, $A_2 = \begin{pmatrix} -2 & 0 \\ 16 & -1 \end{pmatrix}$, z an exogenous measured scalar variable, $w_1(z)$, $w_2(z) : [-1, 1] \rightarrow [0, 1]$, $w_1(z) = -0.5z + 0.5$ and $w_2(z) = 1 - w_1(z)$.

Although both local models are stable, the fuzzy system is not stable. It can be easily seen that for instance for $z = 0$, the system becomes $\dot{x} = Ax$, with $A = \begin{pmatrix} -2.5 & 0.5 \\ 8 & -1.5 \end{pmatrix}$, which has a positive eigenvalue 0.12.

Several conditions to verify the stability of a fuzzy system have been derived based on Lyapunov's direct method. These conditions in general rely on the feasibility of an associated system of linear matrix inequalities (LMIs). Since these LMIs in general involve symmetric matrices, in the sequence, $\mathcal{H}(\cdot)$ denotes the symmetric part of a matrix, i.e., $\mathcal{H}(A) = A + A^T$. Also, I denotes the identity matrix of appropriate dimensions. All computations in this thesis have been performed using Matlab. For solving LMIs, yalmip's Löfberg (2004) sedumi solver has been used.

A well-known and frequently used stability condition for TS systems is formulated below (Tanaka et al., 1998a).

Theorem 2.1 System (2.2) is exponentially stable if there exist $P = P^T > 0$ so that $\mathcal{H}(PA_i) < 0$, for $i = 1, 2, \dots, m$. \square

The proof follows immediately using a common quadratic Lyapunov function of the form $V = x^T Px$ and imposing a negative definite derivative.

Example 2.2 Consider the same fuzzy system as in Example 2.1, but with the second local model changed to $A_2 = \begin{pmatrix} -2 & 0 \\ 5 & -1 \end{pmatrix}$ and the same membership functions.

Although both local models are stable, in order to prove the stability of the fuzzy system, one has to find $P = P^T > 0$ so that the LMIs

$$\mathcal{H}(PA_1) < 0$$

$$\mathcal{H}(PA_2) < 0$$

are satisfied. The Lyapunov function is $V = x^T Px$. A solution of the LMIs is $P = \begin{pmatrix} 12.5 & 2.26 \\ 2.26 & 3.46 \end{pmatrix}$, and therefore the system is stable.

Conditions on the convergence rate of system (2.2) were also derived (Tanaka et al., 1998a) from Theorem 2.1:

Theorem 2.2 The convergence rate of system (2.2) is at least α , if there exists $P = P^T > 0$, so that

$$\mathcal{H}(PA_i) + 2\alpha P < 0 \quad i = 1, 2, \dots, m$$

\square

Example 2.3 Consider the fuzzy system in Example 2.2. An approximation of the decay rate for this system can be obtained by solving the generalized eigenvalue problem: find $P = P^T > 0$, maximize α so that

$$\begin{aligned}\mathcal{H}(PA_1 + \alpha P) &< 0 \\ \mathcal{H}(PA_2 + \alpha P) &< 0\end{aligned}$$

The solution yields $\alpha = 0.65$.

Stability conditions similar to those of Theorem 2.1 can be used if the system is subjected to disturbances bounded by the state. Consider the following perturbed fuzzy system:

$$\dot{\mathbf{x}} = \sum_{i=1}^m w_i(\mathbf{z})A_i\mathbf{x} + D\mathbf{f}(t, \mathbf{x}) \quad (2.4)$$

where D is a perturbation distribution matrix and \mathbf{f} is Lipschitz, i.e., there exists $\mu > 0$ so that $\|D\|\|\mathbf{f}(t, \mathbf{x})\| \leq \mu\|\mathbf{x}\|$, for all t and \mathbf{x} . With these assumptions, a sufficient stability condition can be formalized by the following theorem (Bergsten, 2001).

Theorem 2.3 System (2.4) is exponentially stable if there exist matrices $P = P^T$, $Q = Q^T$, so that

$$\begin{aligned}P > 0 \quad Q > 0 \\ \begin{pmatrix} Q - \mu^2 & P \\ P & I \end{pmatrix} > 0 \quad \mathcal{H}(PA_i) < -2Q \quad i = 1, 2, \dots, m\end{aligned} \quad (2.5)$$

where $\|\cdot\|$ denotes the spectral norm for matrices. □

Several variants of the above theorem exist, together with algorithms to compute robustness measures (Bergsten, 2001).

Example 2.4 Consider the fuzzy system in Example 2.2, subjected to the disturbance

$D = I$, $\mathbf{f}(\mathbf{x}) = \begin{pmatrix} 1 & 2 \\ 0 & 1 \end{pmatrix} \begin{pmatrix} x_1 \\ x_2 \end{pmatrix}$, $\mu = 2.41$. The stability of the system can be verified by solving the following LMI problem: find $P = P^T > 0$, $Q = Q^T > 0$, so that

$$\begin{aligned}\mathcal{H}(PA_1) &< -2Q \\ \mathcal{H}(PA_2) &< -2Q \\ \begin{pmatrix} Q - \mu^2 & P \\ P & I \end{pmatrix} &> 0\end{aligned}$$

This LMI problem is feasible and therefore the system is stable.

The above approaches are conservative as they disregard the fact that the fuzzy rules may be valid only in a region of the state-space. Therefore, if the membership functions are functions of the states, and they have bounded support, it is sufficient that $\mathbf{x}^T \mathcal{H}(PA_i)\mathbf{x} < 0$ only where $w_i(\mathbf{x}) > 0$. Stability conditions for the case when the support of each membership function can be bounded, i.e., there exist S_i so that $\mathbf{x}^T S_i \mathbf{x} \geq 0$ where $w_i(\mathbf{x}) > 0$, were derived by Johansson et al. (1999).

The so far presented stability conditions are based on a single quadratic Lyapunov function. Stability conditions can also be derived using other types of Lyapunov functions. For example, a piecewise quadratic Lyapunov function has the form:

$$V(\mathbf{x}) = \max\{\mathbf{x}^T P_1 \mathbf{x}, \mathbf{x}^T P_2 \mathbf{x}, \dots, \mathbf{x}^T P_M \mathbf{x}\} \quad (2.6)$$

Using such a Lyapunov function, one can show that its derivative along the trajectories is negative, and therefore the fuzzy system is stable if the following Proposition holds (Johansson et al., 1999):

Proposition 2.1 *The system (2.2) is stable, if there exists a matrices $P_j = P_j^T > 0$ and scalars $\tau_{ijk} > 0$ such that*

$$\begin{aligned} \mathcal{H}(P_j A_i) + \sum_{k=1}^m \tau_{ijk} (P_j - P_k) &< 0 \\ P_j > 0 \quad \tau_{ijk} &\geq 0 \end{aligned} \quad (2.7)$$

for $i = 1, 2, \dots, m$ and $j = 1, 2, \dots, m$.

Example 2.5 *Consider the fuzzy system of Example 2.2. The stability of the system may be verified using the Proposition 2.1 by solving the bilinear matrix inequality (BMI) problem: find $P_1 = P_1^T > 0$, $P_2 = P_2^T > 0$, $\tau_1, \tau_2 > 0$ so that*

$$\begin{aligned} \mathcal{H}(P_1 A_1) &< 0 \\ \mathcal{H}(P_2 A_2) &< 0 \\ \mathcal{H}(P_1 A_2) + \tau_1 (P_1 - P_2) &< 0 \\ \mathcal{H}(P_2 A_1) + \tau_2 (P_2 - P_1) &< 0 \end{aligned}$$

Note however, that BMIs are much more difficult to solve than LMIs.

Another approach, based on the partitioning the state-space is described by Rantzer and Johansson (2000). This method has been originally developed for piecewise affine systems. Its application to TS systems involves the partitioning of the state-space according to simultaneously activated membership functions. If only one rule is active in some region, i.e., for some values of the scheduling vector, then the corresponding system is linear and the region is called “operating region”. If more than one rule is active, then the corresponding system is the interpolation of the active rules, and the region is denoted as “interpolation region”. Denote the number of regions with r . Then, in each region $k = 1, 2, \dots, r$, the system can be expressed as:

$$\dot{\mathbf{x}} = \sum_{i \in K_k} w_i(\mathbf{z}) A_i \mathbf{x} \quad \mathbf{x} \in X_k \quad (2.8)$$

where K_k denotes the index set of the linear subsystems active in the region X_k , i.e., the fuzzy system (2.2) is reformulated as a continuous, switching system.

Then, using a Lyapunov function of the form $V(\mathbf{x}) = \mathbf{x}^T P_k \mathbf{x}$ whenever $\mathbf{x} \in X_k$, the system (2.2) is stable, under the conditions expressed by the following theorem (Rantzer and Johansson, 2000). Note that if such a Lyapunov functions is used, it is also needed that the function is piecewise continuously differentiable. The Lyapunov matrices are constructed such that the continuity is satisfied.

Theorem 2.4 System (2.8) is stable, if there exist matrices $P_k = P_k^T$, $H = H^T > 0$, F_k , $i = 1, 2, \dots, r$ so that

$$\begin{aligned} P_k &= F_k^T H F_k \\ P_k &> 0 \\ F_k \mathbf{x} &= F_j \mathbf{x} & \forall \mathbf{x} \in X_k \cap X_j \\ \mathcal{H}(P_k A_i) &< 0 & \forall i \in K_k \end{aligned} \quad (2.9)$$

□

For more relaxed conditions, and the computations of the corresponding matrices see (Johansson and Rantzer, 1998; Johansson, 1999). Similar conditions for the discrete-time case are described by Wang and Sun (2005).

Example 2.6 Consider the following switching system (Johansson and Rantzer, 1998)

if $(x_1 > -x_2$ and $x_1 < x_2)$ or $(x_1 > x_2$ and $x_1 < -x_2)$ then $\dot{\mathbf{x}} = A_1 \mathbf{x}$

if $(x_2 > -x_1$ and $x_2 < x_1)$ or $(x_2 > x_1$ and $x_2 < -x_1)$ then $\dot{\mathbf{x}} = A_2 \mathbf{x}$

By analyzing for which values of the state vector the antecedents are satisfied, four regions can be defined:

$x_1 > -x_2$ and $x_1 < x_2$ with $\dot{\mathbf{x}} = A_1 \mathbf{x}$;

$x_1 > x_2$ and $x_1 < -x_2$ with $\dot{\mathbf{x}} = A_1 \mathbf{x}$;

$x_2 > -x_1$ and $x_2 < x_1$ with $\dot{\mathbf{x}} = A_2 \mathbf{x}$ and

$x_2 > x_1$ and $x_2 < -x_1$ with $\dot{\mathbf{x}} = A_1 \mathbf{x}$.

These regions can be characterized by the vector inequalities $F_i \mathbf{x} \succeq 0$, where \succeq denotes that each entry of the vector is non-negative, with

$$F_4 = -F_2 = \begin{pmatrix} -1 & 1 \\ -1 & -1 \end{pmatrix} \text{ and } F_1 = -F_3 = \begin{pmatrix} -1 & 1 \\ 1 & 1 \end{pmatrix}.$$

To verify the stability of the system, one has to solve the LMIs: find $H = H^T > 0$ so that $\mathcal{H}(F_i^T H F_i A_i) < 0$, $i = 1, 2, 3, 4$. Note that there are only four LMIs thanks to the fact that all the regions are operating regions.

In some cases, this method can easily become computationally involved. Consider for instance a fuzzy system with two state variables, where the membership function is computed as the normalized algebraic product of the individual memberships of the states, with the individual membership functions presented in Figure 2.1.

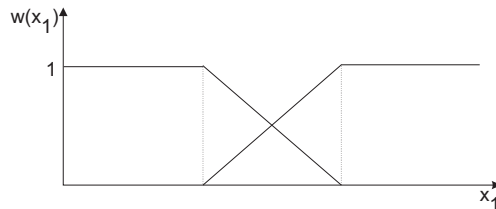

Figure 2.1: Example of membership functions.

The combination of the individual membership functions yields 4 rules, but 9 regions, of which 5 are interpolation regions. The number of LMIs to be solved is $4(\text{for the regions where only one rule is active}) + 2 \cdot 4(\text{in the interpolation regions where two rules are active}) + 4(\text{the}$

interpolation region where all rules are active)= 16. This number is much larger than the number of LMIs to be solved when using a common quadratic Lyapunov functions (4 for this example).

If bounds on the variation of the scheduling vector are known, then Lyapunov functions that depend on the scheduling vector may also be used (Bergsten, 2001). Note that most of the existing stability conditions rely on the feasibility of an LMI problem, for which efficient algorithms exist. However, two shortcomings of the above theorems have to be mentioned: 1) the conditions are conservative and can often lead to infeasible LMIs and 2) the number of LMIs associated in particular to the conditions of Theorem 2.4, can be exponential in the number of local models.

2.4 Fuzzy observers

This section discusses an approach to observer design for TS fuzzy systems. Note that the observability (and similarly controllability) of TS systems is rarely discussed in the literature. TS systems are nonlinear systems, therefore it does seem straightforward to use the observability criteria for nonlinear systems. However, since the observers are in general designed such that each rule has a local gain, it is usually required that the local models are observable instead of the full nonlinear system. Note that in general this requirement is neither sufficient nor necessary for the global system to be observable.

Throughout the first part of this thesis, we consider the affine fuzzy system

$$\begin{aligned}\dot{\mathbf{x}} &= \sum_{i=1}^m w_i(\mathbf{z})(A_i \mathbf{x} + B_i \mathbf{u} + a_i) \\ \mathbf{y} &= \sum_{i=1}^m w_i(\mathbf{z})(C_i \mathbf{x} + d_i)\end{aligned}\tag{2.10}$$

and Thau-Luenberger observer of the form

$$\begin{aligned}\dot{\hat{\mathbf{x}}} &= \sum_{i=1}^m w_i(\hat{\mathbf{z}})(A_i \hat{\mathbf{x}} + B_i \mathbf{u} + a_i + L_i(\mathbf{y} - \hat{\mathbf{y}})) \\ \hat{\mathbf{y}} &= \sum_{i=1}^m w_i(\hat{\mathbf{z}})(C_i \hat{\mathbf{x}} + d_i).\end{aligned}\tag{2.11}$$

Due to the form of the observer (2.11), throughout this thesis it is required and for the design it is implicitly assumed that the local models, i.e., (A_i, C_i) are observable.

Note that when designing an observer, our goal is that the estimated states converge to the real ones, i.e., the error dynamics is asymptotically stable. Depending on the explicit form of the error system given by $\dot{\mathbf{e}} = \dot{\mathbf{x}} - \dot{\hat{\mathbf{x}}}$, the theorems presented in Section 2.3 can be directly applied, or similar conditions may be derived to ensure the stability of the observer. For the analysis, two cases have to be distinguished: 1) the scheduling vector does not depend on the estimated states, in which case $\hat{\mathbf{z}} = \mathbf{z}$ and 2) \mathbf{z} depends also on states to be estimated, in which case the observer uses as part of the scheduling variables the estimated value of the states. The conditions obtained by appropriately modifying Theorem 2.1 are presented here for both cases.

2.4.1 Case 1: State-independent scheduling vector

If the scheduling vector does not depend on the states to be estimated, the observer becomes

$$\begin{aligned}\dot{\hat{\mathbf{x}}} &= \sum_{i=1}^m w_i(\mathbf{z})(A_i \hat{\mathbf{x}} + B_i \mathbf{u} + a_i + L_i(\mathbf{y} - \hat{\mathbf{y}})) \\ \hat{\mathbf{y}} &= \sum_{i=1}^m w_i(\mathbf{z})(C_i \hat{\mathbf{x}} + d_i).\end{aligned}\tag{2.12}$$

and the error system can be written as:

$$\dot{\mathbf{e}} = \sum_{i=1}^m \sum_{j=1}^m w_i(\mathbf{z})w_j(\mathbf{z})(A_i - L_i C_j)\mathbf{e}.\tag{2.13}$$

Basic sufficient stability conditions for this system were derived by Tanaka et al. (1998a), using a Lyapunov function of the form $V(t) = \mathbf{e}^T P \mathbf{e}$, with $P = P^T > 0$. According to these conditions:

Theorem 2.5 *The system (2.13) is stable, if there exists $P = P^T > 0$, $L_i, i = 1, 2, \dots, m$ so that:*

$$\begin{aligned}\mathcal{H}(P(A_i - L_i C_i)) &< 0 \\ \mathcal{H}(P(G_{ij} + G_{ji})) &\leq 0 \\ G_{ij} &= A_i - L_i C_j\end{aligned}\tag{2.14}$$

for any two rules that are simultaneously active¹, i.e., $\forall i, j \in 1, 2, \dots, m$ for which there exists $\mathbf{z} \in \mathcal{D}_{\mathbf{z}}$ such that $w_i(\mathbf{z})w_j(\mathbf{z}) \neq 0$. \square

Example 2.7 *Consider the following two-rule fuzzy system:*

if \mathbf{z} is small then

$$\begin{aligned}\dot{\mathbf{x}}_1 &= \begin{pmatrix} 2 & 2 \\ 0 & -3 \end{pmatrix} \mathbf{x} + \begin{pmatrix} 1 \\ 2 \end{pmatrix} \\ \mathbf{y}_1 &= (1 \ 0) \mathbf{x}\end{aligned}$$

if \mathbf{z} is big then

$$\begin{aligned}\dot{\mathbf{x}}_2 &= \begin{pmatrix} -2 & 1 \\ 1 & -2 \end{pmatrix} \mathbf{x} + \begin{pmatrix} 3 \\ 4 \end{pmatrix} \\ \mathbf{y}_2 &= (1 \ 0) \mathbf{x}\end{aligned}$$

Note that this system is unstable. An exponentially stable observer can be computed by solving the LMI problem: find $P = P^T > 0$, M_1, M_2 so that

$$\begin{aligned}\mathcal{H}(P A_1 - M_1 C) &< 0 \\ \mathcal{H}(P A_2 - M_2 C) &< 0\end{aligned}$$

The observer gains are computed as $L_1 = P^{-1}M_1$, and $L_2 = P^{-1}M_2$, obtaining the values $L_1 = \begin{pmatrix} 1.55 \\ 3.94 \end{pmatrix}$ and $L_2 = \begin{pmatrix} -1.82 \\ 2.36 \end{pmatrix}$.

¹In what follows, for the ease of the notation, this condition will be denoted as $\forall i, j : \exists \mathbf{z} : w_i(\mathbf{z})w_j(\mathbf{z}) \neq 0$.

Note that the above conditions can be relaxed by manipulating the convex sum obtained when imposing the negativeness of the Lyapunov function (Tanaka et al., 1998a; Johansson et al., 1999; Tuan et al., 2001). A well-known condition on the design of the observer for the system (2.2), so that a desired convergence rate or decay rate α of the error is guaranteed, is also presented below (Tanaka et al., 1998a).

Theorem 2.6 *The decay rate of the error system (2.13) is at least α , if there exists $P = P^T > 0$, so that*

$$\begin{aligned} \mathcal{H}(P(A_i - L_i C_i) + 2\alpha P) &< 0 & i = 1, 2, \dots, m \\ \mathcal{H}(P(A_i - L_i C_j)) + 2\alpha P &< 0 & i, j = 1, 2, \dots, m \\ \forall i, j: \exists \mathbf{z}: w_i(\mathbf{z})w_j(\mathbf{z}) &\neq 0 \end{aligned} \quad (2.15)$$

□

Example 2.8 *Consider the fuzzy system from Example 2.7. The observer may be designed so that the error system has a desired decay rate α by solving the LMIs: find $P = P^T > 0$, M_1, M_2 so that*

$$\begin{aligned} \mathcal{H}(PA_1 - M_1 C + \alpha P) &< 0 \\ \mathcal{H}(PA_2 - M_2 C + \alpha P) &< 0 \end{aligned}$$

The observer gains are recovered as in Example 2.7. For instance, solving the above LMI for a desired decay rate $\alpha = 5$ yields the observer gains $L_1 = \begin{pmatrix} -3.9 \\ 15.8 \end{pmatrix}$ and $L_2 = \begin{pmatrix} -6.87 \\ 5.21 \end{pmatrix}$.

2.4.2 Case 2: State-dependent scheduling vector

The second case is when the scheduling vector depends on the states to be estimated. For the simplicity of the notation, only the case with common measurement matrices, i.e., $C_i = C$, $i = 1, 2, \dots, m$ will be considered. Note however, that if the measurement matrix is different for each rule, the observer gains may be designed similarly.

For common measurement matrices, the observer (2.11) becomes:

$$\begin{aligned} \dot{\hat{\mathbf{x}}} &= \sum_{i=1}^m w_i(\hat{\mathbf{z}})(A_i \hat{\mathbf{x}} + B_i \mathbf{u} + a_i + L_i(\mathbf{y} - \hat{\mathbf{y}})) \\ \hat{\mathbf{y}} &= C \hat{\mathbf{x}} \end{aligned} \quad (2.16)$$

and the error system can be expressed as:

$$\dot{\mathbf{e}} = \sum_{i=1}^m w_i(\hat{\mathbf{z}})(A_i - L_i C) \mathbf{e} + \sum_{i=1}^m (w_i(\mathbf{z}) - w_i(\hat{\mathbf{z}}))(A_i \mathbf{x} + B_i \mathbf{u} + a_i) \quad (2.17)$$

Clearly, there is a time-varying difference between the true and estimated states. In order for the estimated states to converge to the real ones, the observer has to be robust enough to deal with this difference. For such a system, sufficient stability conditions were given by Bergsten (2001).

Theorem 2.7 *The error system (2.17) is exponentially stable, if there exist $\mu > 0$, $P = P^T > 0$, $Q = Q^T > 0$ so that for $i = 1, \dots, m$*

$$\begin{aligned} \mathcal{H}(P(A_i - L_i C)) &\leq Q \\ \begin{pmatrix} Q - \mu^2 & P \\ P & I \end{pmatrix} &> 0 \end{aligned} \quad (2.18)$$

$$\|(w_i(\mathbf{z}) - w_i(\hat{\mathbf{z}}))(A_i \mathbf{x} + B_i \mathbf{u} + a_i)\| \leq \mu \|e\|$$

i.e., $(w_i(\mathbf{z}) - w_i(\hat{\mathbf{z}}))(A_i \mathbf{x} + B_i \mathbf{u} + a_i)$ is bounded² by a linear growth³ of e . □

Remark: The conditions of Theorem 2.7 are conservative, due to the worst-case assumption of an unstructured, bounded disturbance. In many cases, an observer will work even though the second condition of the theorem is not satisfied by the computed bound.

Example 2.9 *Consider the fuzzy system*

$$\begin{aligned} \dot{\mathbf{x}} &= w_1(\mathbf{x})(A_1 \mathbf{x} + B_1 u) + w_2(\mathbf{x})(A_2 \mathbf{x} + B_2 u) \\ \mathbf{y} &= (1 \quad 0) \mathbf{x} \end{aligned}$$

with $A_1 = \begin{pmatrix} -2 & 0 \\ 2 & -3 \end{pmatrix}$, $A_2 = \begin{pmatrix} -1 & 3 \\ 2 & -5 \end{pmatrix}$, $B_1 = \begin{pmatrix} 3 \\ 2 \end{pmatrix}$, $B_2 = \begin{pmatrix} 1 \\ 0 \end{pmatrix}$, $w_1(\mathbf{x}) = 0.125(x_1 + x_2 + 4)$, $w_2(\mathbf{x}) = 1 - w_1(\mathbf{x})$, $x_1, x_2 \in [-2, 2]$, $u \in [-0.5, 0.5]$. *Our goal is to design an observer for this system.*

By substituting the values, one gets $\|(w_1(\mathbf{x}) - w_1(\hat{\mathbf{x}}))(A_1 \mathbf{x} + B_1 u)\| \leq 0.125\|e\|$ (3.81 · 4 + 3.6 · 0.5) $\leq 2.2\|e\|$. Similarly, $\|(w_2(\mathbf{x}) - w_2(\hat{\mathbf{x}}))(A_2 \mathbf{x} + B_2 u)\| \leq 3.2\|e\|$. Therefore, $\|(w_i(\mathbf{z}) - w_i(\hat{\mathbf{z}}))(A_i \mathbf{x} + B_i \mathbf{u} + a_i)\| \leq \mu\|e\|$, with $\mu = 3.2$. To design the observer, one needs to solve the LMI: find $P = P^T > 0$, $Q = Q^T > 0$, M_1, M_2 so that

$$\begin{aligned} \mathcal{H}(PA_1 - M_1 C - Q) &\leq 0 \\ \mathcal{H}(PA_2 - M_2 C - Q) &\leq 0 \\ \begin{pmatrix} Q - \mu^2 & P \\ P & I \end{pmatrix} &> 0 \end{aligned}$$

The solution yields $L_1 = P^{-1}M_1 = \begin{pmatrix} -8.09 \\ 0.47 \end{pmatrix}$ and $L_2 = P^{-1}M_2 = \begin{pmatrix} -7.04 \\ 8.36 \end{pmatrix}$.

Although this thesis is not concerned with controllability issues or controller design, it has to be mentioned that TS fuzzy systems are extensively used for state-feedback or output-feedback controller design.

Several authors consider the case of the observer and linear state-feedback controller together and develop relaxed stability conditions for the augmented system. The conditions usually lead to (generalized) eigenvalue problems, possible to be solved using LMIs (Taniguchi et al., 1999b; Tanaka et al., 1998a; Taniguchi et al., 1999a). For the case when the weights depend on the estimated states, the observer and the controller cannot be designed separately (Tanaka and Sano, 1994).

²In this thesis we use $\|f\| \leq \|g\|$ as a shorthand notation for $\|f(t)\| \leq \|g(t)\|, \forall t$

³The bounding constant μ can be found by solving the optimization problem (Khalil, 2002)

$$\mu = \max_{\mathbf{x}, \mathbf{u}, \hat{\mathbf{x}}, \hat{\mathbf{z}}} \left\| \frac{\partial(w_i(\mathbf{z}) - w_i(\hat{\mathbf{z}}))(A_i \mathbf{x} + B_i \mathbf{u} + a_i)}{\partial \mathbf{e}} \right\| = \max_{\mathbf{x}, \mathbf{u}, \hat{\mathbf{x}}} \left\| \frac{\partial(w_i(\mathbf{x}) - w_i(\hat{\mathbf{x}}))(A_i \mathbf{x} + B_i \mathbf{u} + a_i)}{\partial(\mathbf{x} - \hat{\mathbf{x}})} \right\|.$$

Fuzzy observers are usually employed together with a parallel distributed compensation (PDC) controller. A general framework for PDC controllers is given by Wang et al. (2000), while a systematic procedure for fuzzy model construction, rule reduction and robust compensation is presented by Taniguchi et al. (2001). An overview of stability analysis and controller design for discrete time TS systems can be found in (Feng, 2006).

Applications include state estimation for translational oscillations (Tanaka et al., 1998c), backing of a mobile robot with multiple trailers (Tanaka et al., 1998b), and visual servoing (Kadmiry and Bergsten, 2004).

2.4.3 Design using LMI regions

Designing observers based on the conditions presented in Section 2.4 may not give an acceptable performance, since the poles of the observer may be placed at arbitrary locations in the left half-plane. This problem can be avoided by using LMI regions, i.e., constraining the poles of each local model to a specific region. LMI regions can be defined as follows (Chilali and Gahinet, 1996):

Definition 2.1 A subset D of the complex plane is called an LMI region if there exists a symmetric matrix $\alpha \in \mathcal{R}^{m \times m}$ and a matrix $\beta \in \mathcal{R}^{m \times m}$ such that:

$$D = \{z \in \mathcal{C} : f_D(z) < 0\}$$

where

$$f_D(z) = \alpha + z\beta + \bar{z}\beta^T$$

is the characteristic function of the LMI region.

One can easily see that, because of the form of the function $f_D(z)$, LMI regions are convex and symmetric with respect to the real axis. Useful LMI regions include a vertical strip $[d_l, d_u]$ and a conic sector centered in the origin with inner angle θ (Figure 2.2). If all the eigenvalues of a matrix A are located in a region D , then the matrix A is called D -stable.

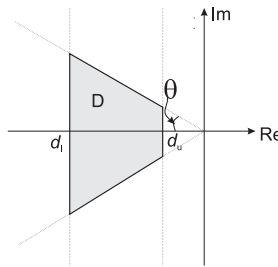

Figure 2.2: LMI regions.

A theorem to ensure D -stability of a matrix A was given by Chilali and Gahinet (1996):

Theorem 2.8 The matrix A is D -stable if and only if there exists $P = P^T > 0$ so that

$$\alpha \otimes P + \beta \otimes AP + \beta^T \otimes (AP)^T < 0$$

where \otimes is the Kronecker product.

In the context of observer design, using LMI regions to ensure the specific D-stability of the observer effectively means adding constraints to the presented LMI problems, more specifically:

$$[\alpha_{j,k}P + \beta_{j,k}P(A_i - L_iC_i) + \beta_{k,j}(A_i - L_iC_i)^T P] < 0$$

$$j, k = 1, 2, \dots, m$$

Here, $\alpha_{j,k}$ and $\beta_{j,k}$ denote the (j, k) th element of the corresponding matrices.

Remark: Note that the upper limit of the vertical strip, d_u , corresponds to the decay rate of Theorem 2.6.

2.5 Summary and concluding remarks

In this chapter, continuous-time dynamic TS fuzzy systems were introduced. A large class of nonlinear systems can be represented or well approximated by TS fuzzy systems. TS fuzzy systems can also be considered as convex combinations of local linear models. Since the stability of these local models does not imply the stability of the whole fuzzy system, several sufficient stability criteria have been developed using Lyapunov's direct method. A general tendency is to obtain LMIs for which mathematical algorithms that test their feasibility exist. Some of the stability conditions have been presented in this chapter.

For TS systems, several types of observers have been developed. In this chapter, a Thau-Luenberger type fuzzy observer has been discussed, together with the design conditions used in this thesis. Regarding the observer design, two cases need to be distinguished, depending on whether or not the scheduling vector is a function of the states to be estimated. When the scheduling vector depends on the states to be estimated, an observer that can handle the mismatch between the true and estimated membership function, has to be designed. Also in this case, the conditions may be formulated as LMIs.

Note that the presented stability and design conditions are only sufficient conditions. A major advantage of these conditions is that they are cast into an LMI form, which is easily solvable. However, this can also be considered a shortcoming of the approaches, since:

- the LMIs may be infeasible, and therefore no conclusive result is obtained;
- the dimension of the LMI problem may be exponential in the number of the rules, and computationally involved, in particular when piecewise Lyapunov functions are considered;
- by obtaining LMIs, conservativeness is introduced;
- most conditions can only be satisfied if all the local models are stable, which in general is not a necessary condition. Depending on the scheduling vector, it is possible, that although a local model is unstable, the equilibrium point is stable.

Note also that both the stability and design conditions (except Theorem 2.3) pertain only the case when the structure and the local models of the fuzzy system are fixed. However, for distributed, large-scale systems such an approach may be computationally unfeasible. Moreover, if the local models change in time, or if external variables other than those represented in the scheduling vector influence the system, the conditions presented here may not be applicable. By analyzing the form of the system considered, it may be possible to relax the stability

and/or design conditions. Such cases are treated to some extent in the following chapters. Approaches to relax the conditions for decentralized TS systems and adaptive observers, to estimate the states of a TS system that changes in time, are presented in the sequel.

Chapter 3

Cascaded observers

This chapter presents an approach to designing observers for cascaded systems. Many systems can be represented as a cascade of several subsystems. In such a case, the observers may also be designed in a cascaded fashion. The first part of the chapter presents stability conditions for cascaded nonlinear systems. The second part derives stability conditions for TS fuzzy systems and extends these for observer design. It is proven that the conventional stability and design conditions can be relaxed while still obtaining the same performance. Parts of this chapter have been published in (Lendek et al., 2007c,b).

3.1 Introduction

Many physical systems, such as power systems, communication networks, economic systems, and traffic networks are interconnections of lower-dimensional subsystems. An important class of these systems, such as material processing systems, chemical processes, can be represented as cascaded subsystems (Seibert and Suarez, 1990; Jankovic et al., 1996; Arcak et al., 2002). Under certain conditions, conclusions referring to the overall cascaded system can be drawn based on the study of the individual subsystems. For instance, for linear systems, the stability of the subsystems implies the stability of the cascaded system. However this property, in general, does not hold for nonlinear or time-varying systems. Even global asymptotic stability of the individual subsystems does not imply the stability of the cascade.

In the literature, the stability of several types of cascaded systems has been studied. Conditions to ensure the overall stability of more general cascades, in which both subsystems are nonlinear, were derived in (Sontag, 1989b; Seibert and Suarez, 1990; Loria and Panteley, 2005). Some of these conditions are presented in the next section.

Stability analysis and observer design in a centralized form is often not feasible for large-scale systems. Therefore, in the context of large-scale processes and distributed systems, decentralized state estimation has been largely studied. The decentralized architecture generally has the form of a network of sensor nodes, each with its own computing capability. Each node computes a local estimate and shares information with other nodes. Computation and communication is distributed over the network and the global estimate is computed by fusing the local results. Several topologies have been proposed, depending on the particular application. In case of large-scale processes (Vadigepalli and Doyle, 2003a,b), the network is

generally in a hierarchical form, with several intermediate nodes and one final fusion node.

This chapter presents the stability analysis of Takagi-Sugeno fuzzy systems, which can be decomposed into cascaded subsystems. It is proven that, in such cases, the stability of the whole system may be analyzed based on the stability of the subsystems. The cascaded approach is extended also to observer design, i.e., observers are designed for TS systems in a cascaded form.

3.2 Stability of cascaded dynamic systems

The first motivation to consider cascaded dynamical systems came from the analysis of the models obtained after input-output linearization (Arcak et al., 2002; Loria and Panteley, 2005). Following this, several stability conditions were derived for different types of subsystems. In this section, the cascaded setting for general nonlinear systems and observers is presented, together with the relevant stability conditions.

3.2.1 Preliminaries

Consider the following general, observable¹ nonlinear system:

$$\begin{aligned} \dot{x}_1 &= f_1(\mathbf{x}, \mathbf{u}) & y_1 &= h_1(\mathbf{x}, \mathbf{u}) \\ \dot{x}_2 &= f_2(\mathbf{x}, \mathbf{u}) & y_2 &= h_2(\mathbf{x}, \mathbf{u}) \\ &\vdots & &\vdots \\ \dot{x}_n &= f_n(\mathbf{x}, \mathbf{u}) & y_m &= h_m(\mathbf{x}, \mathbf{u}) \end{aligned} \quad (3.1)$$

where $\mathbf{x} = [x_1, \dots, x_n]^T$ and $\mathbf{u} = [u_1, \dots, u_l]^T$ and assume that this system can be partitioned into subsystems. For the ease of notation, only two subsystems are considered, without a loss of generality:

$$\begin{aligned} \dot{\mathbf{x}}_1 &= \mathbf{f}_1(\mathbf{x}_1, \mathbf{u}) \\ \mathbf{y}_1 &= \mathbf{h}_1(\mathbf{x}_1, \mathbf{u}) \end{aligned} \quad (3.2)$$

and

$$\begin{aligned} \dot{\mathbf{x}}_2 &= \mathbf{f}_2(\mathbf{x}_1, \mathbf{x}_2, \mathbf{u}) \\ \mathbf{y}_2 &= \mathbf{h}_2(\mathbf{x}_1, \mathbf{x}_2, \mathbf{u}) \end{aligned} \quad (3.3)$$

where $\mathbf{x} = [\mathbf{x}_1^T \ \mathbf{x}_2^T]^T$, $\mathbf{y} = [\mathbf{y}_1^T \ \mathbf{y}_2^T]^T$ and (3.2) is observable. Note that, since both system (3.1) and (3.2) are observable, subsystem (3.3) is also observable. In fact, for subsystem (3.3), \mathbf{x}_1 is an input. In general, such a partition of the model does not necessarily exist. Moreover, if a partition exists, it might not be unique.

Given a particular nonlinear system of the form (3.1), with at least two measurements, if a partitioning into several subsystems is possible, it can be constructed. For two subsystems, the cascaded structure is depicted in Figure 3.1.

If such a partition can be determined, observers may be designed for the subsystems separately, with some observers using the estimates obtained by other observers. For two subsystems, the cascaded observer structure is depicted in Figure 3.2.

¹In this chapter, we consider that the system and the subsystems are uniformly observable, see Definition 2.9 from (Besançon, 2006).

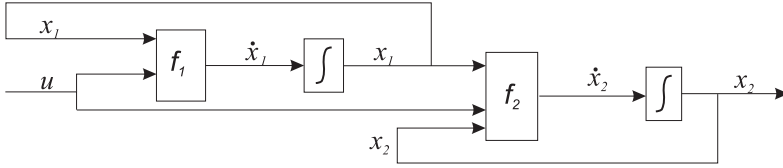

Figure 3.1: Cascaded subsystems.

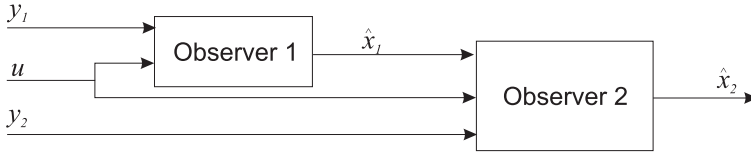

Figure 3.2: Cascaded observers.

3.2.2 Partitioning a nonlinear system

Before designing cascaded observers, one has to determine whether the system considered is the cascade of at least two subsystems. Note that since the given state variables need to be estimated, no coordinate change should be performed. In what follows, an algorithm that determines whether a system is the cascade of two subsystems is presented. This algorithm is based on the observability rank condition. Given the nonlinear system (3.1), for each measurement function, one can determine the variables observable from the respective measurement, thereby constructing sets of observable variables. After these sets are determined, the problem of determining whether the system is cascaded is reduced to that of partitioning the variable sets. The algorithm can be given as follows:

Algorithm 3.1

1. Construct the table presented in Figure 3.1, where $v_{1,i}$, $i = 1, 2, \dots, m$ is the set of state variables that appear in the expression of h_i , $v_{2,i}$, $i = 1, 2, \dots, m$ is the set of state variables that appear in the expression of h_i and $L_{\mathbf{f}}h_i$, etc, and $L_{\mathbf{f}}h$ denotes the Lie derivative² of h with respect to \mathbf{f} .

Table 3.1: Variable table

	h_1	h_2	\dots	h_m
h	$v_{1,1}$	$v_{1,2}$	\dots	$v_{1,m}$
$L_{\mathbf{f}}h$	$v_{2,1}$	$v_{2,2}$	\dots	$v_{2,m}$
$L_{\mathbf{f}}^2h$	$v_{3,1}$	$v_{3,2}$	\dots	$v_{3,m}$
\dots				

²The Lie derivative of a function h with respect to a vector function \mathbf{f} is defined as: $L_{\mathbf{f}}h = \frac{\partial h}{\partial \mathbf{x}} \mathbf{f}$. The second order derivative is $L_{\mathbf{f}}^2h = L_{\mathbf{f}}(L_{\mathbf{f}}h)$, etc.

After a maximum of n steps, these sets cannot expand anymore, $v_{n,i} = v_{n+1,i}$. The “worst” case is an n^{th} order integrator, in which case at each step a new variable appears and the expansion stops at exactly the n^{th} step.

2. Denote with ϕ_i the set of state variables obtained from the derivatives of h_i , $i = 1, 2, \dots, m$. It can be easily seen that, since the system (3.1) observable, $\cup_{i=1}^m \phi_i = \Phi$, where Φ corresponds to the set of all state variables, $\Phi = \{x_1, x_2, \dots, x_n\}$.
3. Group together those measurement equations, which have the same set of variables: $h^i = \{h_k | \phi_k = \phi_i\}$ and delete the doubles. If only one pair (h^i, ϕ_i) remains, the system cannot be partitioned using this algorithm.
4. For each pair (h^i, ϕ_i) for which $\phi_i \neq \Phi$ construct the subsystem

$$\begin{aligned}\dot{\mathbf{x}}^i &= \mathbf{f}^i(\mathbf{x}^i, \mathbf{u}) \\ \mathbf{y}^i &= \mathbf{h}^i(\mathbf{x}^i, \mathbf{u})\end{aligned}\tag{3.4}$$

where \mathbf{x}^i is the vector of the variables in ϕ_i , \mathbf{f}^i is the set of the corresponding functions, \mathbf{h}^i is obtained at step 3. and \mathbf{y}^i are the measurements given by \mathbf{h}^i .

If the system (3.4) is observable, then it can be considered one of the subsystems, and the remaining variables and functions form a second subsystem.

Example 3.1 Consider the following nonlinear system:

$$\begin{aligned}\dot{x}_1 &= f_1(x_1, x_2, x_3) \\ \dot{x}_2 &= f_2(x_2, x_3) \\ \dot{x}_3 &= f_3(x_3, x_4) \\ \dot{x}_4 &= f_4(x_3)\end{aligned}\tag{3.5}$$

$$\begin{aligned}y_1 &= h_1(x_3, x_4) \\ y_2 &= h_2(x_1, x_3) \\ y_3 &= h_3(x_4)\end{aligned}$$

with the assumption that the system (3.5) is observable and the subsystem

$$\begin{aligned}\dot{x}_3 &= f_3(x_3, x_4) \\ \dot{x}_4 &= f_4(x_3)\end{aligned}\tag{3.6}$$

is observable from y_1 .

By looking at this system, one can easily decide that the subsystem (3.6) together with h_1 and h_3 should be the first subsystem and the remaining equations form the second one.

Applying the above algorithm, the following results are obtained.

1. The table for system (3.5) is:
2. We obtain $\phi_1 = \{x_3, x_4\}$, $\phi_2 = \{x_1, x_2, x_3, x_4\}$ and $\phi_3 = \{x_3, x_4\}$.

Table 3.2: Variable table for system (3.5)

	h_1	h_2	h_3
h	$\{x_4, x_3\}$	$\{x_1, x_3\}$	$\{x_4\}$
$L_f h$	$\{x_4, x_3\}$	$\{x_1, x_2, x_4, x_3\}$	$\{x_4, x_3\}$
$L_f^2 h$	$\{x_4, x_3\}$	$\{x_1, x_2, x_4, x_3\}$	$\{x_4, x_3\}$

3. Since $\phi_1 = \phi_3$, group together the measurement equations: $h^1 = \{h_1, h_3\}$ with the corresponding ϕ_1 and $h^2 = \{h_2\}$ with the corresponding ϕ_2 .
4. Only one partition is possible, namely that the first subsystem should be formed by the state equations corresponding to the variables in ϕ_1 and the measurement equations in h^1 . Since the original assumption was that this subsystem is observable, the system can be partitioned.

Remark: For the above example, due to the assumption that (3.6) is observable from h_1 , one could use only the measurement equation h_1 for the subsystem (3.6), i.e., a partitioning of $h^1 = \{h_1\}$, $h^2 = \{h_2, h_3\}$ is also possible. However, that would mean not using all available information, since h_3 would not be used to correct x_4 . For the general case, this is why the h 's corresponding to the same set of equations are grouped together.

Remark: Note that the partitioning of a system, even without loss of information is in general not unique, as illustrated in the following example.

Example 3.2 Consider the system

$$\begin{aligned}\dot{x}_1 &= x_1 + x_3 \\ \dot{x}_2 &= x_2 + x_3 \\ \dot{x}_3 &= u \\ y_1 &= x_1 \\ y_2 &= x_2\end{aligned}$$

This system is observable, and there are two possible ways to divide it: by using as first subsystem

$$\begin{aligned}\dot{x}_1 &= x_1 + x_3 \\ \dot{x}_3 &= u \\ y_1 &= x_1\end{aligned}$$

or, by using as first subsystem

$$\begin{aligned}\dot{x}_2 &= x_2 + x_3 \\ \dot{x}_3 &= u \\ y_1 &= x_2\end{aligned}$$

both being observable. The corresponding variable sets are $\phi_1 = \{x_1, x_3\}$ and $\phi_2 = \{x_2, x_3\}$.

3.2.3 Stability of cascaded systems

It is well-known that the cascade of stable linear systems is stable, since the eigenvalues of the joint system are determined only by the eigenvalues of the individual subsystems. Therefore, the stability of the joint system is determined by the stability of the subsystems. However, the same reasoning does not necessarily hold for nonlinear or time-varying systems. Even global asymptotic stability (GAS) of the decoupled subsystems does not necessarily imply the stability of the cascade.

More general cascades, in which both subsystems are nonlinear, were studied and conditions to ensure overall stability were derived in (Loria and Panteley, 2005). A selection of relevant results is presented below.

Definition 3.1 A continuous function $\alpha : \mathcal{R}^+ \rightarrow \mathcal{R}^+$ belongs to class \mathcal{K} if it is strictly increasing and $\alpha(0) = 0$. If, in addition $\alpha(s) \rightarrow \infty$ when $s \rightarrow \infty$ then α is said to be of class \mathcal{K}_∞ . \square

Definition 3.2 A system $\dot{\mathbf{x}} = \mathbf{f}(\mathbf{x}, \mathbf{u})$ is input-to-state stable (ISS) if and only if there exists a positive definite proper function $V(\mathbf{x})$ and two class \mathcal{K} functions α_1 and α_2 such that

$$(\|\mathbf{x}\| \geq \alpha_1(\|\mathbf{u}\|)) \Rightarrow \left(\frac{\partial V(\mathbf{x})}{\partial \mathbf{x}} \mathbf{f}(\mathbf{x}, \mathbf{u}) \leq -\alpha_2(\|\mathbf{x}\|) \right) \quad (3.7)$$

where $\|\cdot\|$ represents the Euclidian norm. \square

Consider the nonlinear, cascaded, autonomous system

$$\dot{\mathbf{x}}_1 = \mathbf{f}_1(\mathbf{x}_1) \quad (3.8)$$

$$\dot{\mathbf{x}}_2 = \mathbf{f}_2(\mathbf{x}_1, \mathbf{x}_2). \quad (3.9)$$

It has been shown in (Sontag, 1989a) that if

- the functions \mathbf{f}_1 and \mathbf{f}_2 are sufficiently smooth in their arguments,
- system (3.9) is input-to-state-stable with regard to the input \mathbf{x}_1 , and
- system (3.8) and the system

$$\dot{\mathbf{x}}_2 = \mathbf{f}_2(0, \mathbf{x}_2) \quad (3.10)$$

are globally asymptotically stable (GAS),

then the cascade (3.8)-(3.9) is GAS. An equivalent sufficient stability condition is presented by Seibert and Suarez (1990): the cascaded system is GAS, if both subsystems (3.8) and (3.10) are GAS and all trajectories are bounded. The main difficulty with this approach is that in general, boundedness of all the solutions is not easy to determine and the conditions to ensure boundedness may be very conservative.

More relaxed sufficient stability conditions have been derived for systems of the form:

$$\begin{aligned} \dot{\mathbf{x}}_1 &= \mathbf{f}_1(\mathbf{x}_1) \\ \dot{\mathbf{x}}_2 &= \mathbf{f}_2(\mathbf{x}_2) + \mathbf{g}(\mathbf{x}_1, \mathbf{x}_2) \end{aligned} \quad (3.11)$$

assuming that the individual subsystems are GAS and, additionally, certain restrictions related to the continuity and/or slope, apply for the interconnection term \mathbf{g} (Jankovic et al., 1996; Arcak et al., 2002; Chaillet and Loria, 2006). A theorem for ensuring that the cascaded system (3.11) is uniformly GAS (UGAS) (Loria and Panteley, 2005) is presented below.

Assumption 3.1 System (3.10) is UGAS.

Assumption 3.2 There exist constants $c_1, c_2, \mu \geq 0$ and a Lyapunov function $V(t, \mathbf{x}_2)$ for (3.10) such that V is positive definite, radially unbounded, $\dot{V}(t, \mathbf{x}_2) \leq 0$ and

$$\begin{aligned} \left\| \frac{\partial V}{\partial \mathbf{x}_2} \right\| \|\mathbf{x}_2\| &\leq c_1 V(t, \mathbf{x}_2) & \forall \mathbf{x}_2 : \|\mathbf{x}_2\| > \mu \\ \left\| \frac{\partial V}{\partial \mathbf{x}_2} \right\| &\leq c_2 & \forall \mathbf{x}_2 : \|\mathbf{x}_2\| \leq \mu \end{aligned} \quad (3.12)$$

Assumption 3.3 There exist two continuous functions $\theta_1, \theta_2 : \mathcal{R}^+ \rightarrow \mathcal{R}^+$ such that $\mathbf{g}(\mathbf{x})$ satisfies:

$$\|\mathbf{g}(\mathbf{x})\| \leq \theta_1(\|\mathbf{x}_1\|) + \theta_2(\|\mathbf{x}_1\|)\|\mathbf{x}_2\| \quad (3.13)$$

Assumption 3.4 There exists a class \mathcal{K} function $\alpha(\cdot)$ so that for all $t_0 \geq 0$, the trajectories of the system (3.8) satisfy

$$\int_{t_0}^{\infty} \|\mathbf{x}_1(t; t_0, \mathbf{x}_1(t_0))\| dt \leq \alpha(\|\mathbf{x}_1(t_0)\|) \quad (3.14)$$

Theorem 3.1 Let Assumption 3.1 hold and suppose that the trajectories of (3.8) are uniformly globally bounded. If, in addition, Assumptions 3.2–3.4 are satisfied, then the solutions of system (3.11) are uniformly globally bounded. If furthermore, system (3.8) is UGAS, then so is the cascaded system (3.11). \square

Proof: see (Arcak et al., 2002; Loria and Panteley, 2005).

Proposition 3.1 If in addition to the above assumptions systems (3.8) and (3.10) are exponentially stable, then the cascaded system (3.11) is also exponentially stable. \square

Proof: see (Arcak et al., 2002; Loria and Panteley, 2005).

The study of different cases of interconnection terms can be found in (Loria and Panteley, 2005; Arcak et al., 2002), stabilizability conditions were derived in (Bacciotti et al., 1993; Chaillet and Loria, 2006). For observer design for a special type of cascaded SISO system see (Roebenack and Lynch, 2006).

3.3 Cascaded TS fuzzy systems

In this section, cascaded TS fuzzy systems are studied. First, we analyze the stability of a cascaded TS fuzzy system and derive relaxed stability conditions based on the stability of the subsystems. The idea behind this type of stability analysis is that many systems are cascaded (e.g., hierarchical large-scale systems, flow processes), while others may be represented as cascaded subsystems, which are less complex than the original system. Afterwards, the design of cascaded observers is discussed.

The main benefit of this approach is, that it relaxes the conditions imposed by analyzing the system globally. Global analysis may lead to infeasible LMI conditions, even if the system is stable. We propose less conservative stability conditions, which are likely to render the associated LMI problem feasible. Moreover, the dimension of the associated LMI problem is generally reduced.

The results are extended to observer design. We analyze the joint performance of fuzzy observers individually designed for the subsystems. The benefit of this type of estimation is that separate observers can be designed for the individual subsystems, which makes their tuning easier. Moreover, different types of observers can be combined, depending on the subsystem considered. We present a theoretical comparison of the centralized and cascaded fuzzy observers and also compare their performance on an example.

Consider the case when the system matrices of the model (2.2),

$$\dot{\mathbf{x}} = \sum_{i=1}^m w_i(\mathbf{z}) A_i \mathbf{x} \quad (3.15)$$

for each rule $i = 1, 2, \dots, m$ can be written as:

$$A_i = \begin{pmatrix} A_{1i} & 0 \\ A_{21i} & A_{2i} \end{pmatrix}$$

i.e., system (2.2) can be expressed as the cascade of two fuzzy systems:

$$\begin{aligned} \dot{\mathbf{x}}_1 &= \sum_{i=1}^m w_{1i}(\mathbf{z}_1) A_{1i} \mathbf{x}_1 \\ \dot{\mathbf{x}}_2 &= \sum_{i=1}^m w_{2i}(\mathbf{z}_1, \mathbf{z}_2) (A_{21i} \mathbf{x}_1 + A_{2i} \mathbf{x}_2) \end{aligned} \quad (3.16)$$

or, equivalently:

$$\begin{aligned} \dot{\mathbf{x}}_1 &= A_1(\mathbf{z}_1) \mathbf{x}_1 \\ \dot{\mathbf{x}}_2 &= A_{21}(\mathbf{z}_1, \mathbf{z}_2) \mathbf{x}_1 + A_2(\mathbf{z}_1, \mathbf{z}_2) \mathbf{x}_2 \end{aligned} \quad (3.17)$$

with normalized membership functions w_{1i} and w_{2i} , $\mathbf{x} = [\mathbf{x}_1^T, \mathbf{x}_2^T]^T$, $\mathbf{z} = [\mathbf{z}_1^T, \mathbf{z}_2^T]^T$, $A_1(\mathbf{z}_1) = \sum_{i=1}^m w_i(\mathbf{z}_1) A_{1i}$, $A_2(\mathbf{z}_1, \mathbf{z}_2) = \sum_{i=1}^m w_{2i}(\mathbf{z}_1, \mathbf{z}_2) A_{2i}$, and $A_{21}(\mathbf{z}_1, \mathbf{z}_2) = \sum_{i=1}^m w_{2i}(\mathbf{z}_1, \mathbf{z}_2) A_{21i}$.

3.3.1 Stability of cascaded fuzzy systems

In this section, we analyze the stability of system (3.16), assuming that the subsystems

$$\dot{\mathbf{x}}_1 = \sum_{i=1}^m w_{1i}(\mathbf{z}_1) A_{1i} \mathbf{x}_1 \quad (3.18)$$

and

$$\dot{\mathbf{x}}_2 = \sum_{i=1}^m w_{2i}(\mathbf{z}_1, \mathbf{z}_2) A_{2i} \mathbf{x}_2 \quad (3.19)$$

are uniformly globally asymptotically stable (UGAS). For such a case, the following basic result can be formulated.

Theorem 3.2 *If there exist two Lyapunov functions of the form $V_1(\mathbf{x}_1) = \mathbf{x}_1^T P_1 \mathbf{x}_1$ and $V_2(\mathbf{x}_2) = \mathbf{x}_2^T P_2 \mathbf{x}_2$ that prove the stability of the subsystems (3.18) and (3.19), respectively, then the cascaded system (3.16) is also UGAS.*

Proof: Note that the Lyapunov functions $V_1(\mathbf{x}_1) = \mathbf{x}_1^T P_1 \mathbf{x}_1$ and $V_2(\mathbf{x}_2) = \mathbf{x}_2^T P_2 \mathbf{x}_2$ for the subsystems (3.18) and (3.19) satisfy Assumption 3.1 also ensure exponential stability of the individual subsystems, therefore satisfying Assumption 3.4. Moreover, equations (3.16) and (3.17) are special cases of (3.11), where the individual subsystems $\mathbf{f}_1(\mathbf{x}_1)$ and $\mathbf{f}_2(\mathbf{x}_2)$ are represented by fuzzy models. The interconnection term \mathbf{g} is a nonlinear combination of local linear models.

Moreover, Assumption 3.2 is satisfied as: $\forall \mathbf{x}_2 : \|\mathbf{x}_2\| > \mu$,

$$\left\| \frac{\partial V_2}{\partial \mathbf{x}_2} \right\| \|\mathbf{x}_2\| = 2 \|\mathbf{x}_2^T\| \|P_2\| \|\mathbf{x}_2\| \leq 2 \lambda_{\max}(P_2) \|\mathbf{x}_2\|^2 \leq c_1 V_2(\mathbf{x}_2)$$

for any $c_1 \geq \frac{2\lambda_{\max}(P_2)}{\lambda_{\min}(P_2)}$. For the second condition of Assumption 3.2, we have $\forall \mathbf{x}_2 : \|\mathbf{x}_2\| \leq \mu$

$$\left\| \frac{\partial V_2}{\partial \mathbf{x}_2} \right\| = \|2\mathbf{x}_2^T P_2\| \leq 2 \|\mathbf{x}_2\| \|P_2\| \leq 2\mu \lambda_{\max}(P_2) = c_2$$

Consider continuous, positive functions $\theta_1(\|\mathbf{x}_1\|) = \max_{\mathbf{z}} \|A_{21}(\mathbf{z})\| \|\mathbf{x}_1\|$ and $\theta_2(\|\mathbf{x}_1\|) = 0$. By selecting these functions, it is ensured that $\|\mathbf{g}(\mathbf{x})\| = \|\sum_{i=1}^m w_i(\mathbf{z}) A_{21i} \mathbf{x}_1\| \leq \theta_1(\|\mathbf{x}_1\|) + \theta_2(\|\mathbf{x}_1\|) \|\mathbf{x}_2\|$ and therefore Assumption 3.3 is satisfied.

Since the conditions of Theorem 3.1 are satisfied, the cascaded system is UGAS. Furthermore, since these Lyapunov functions ensure exponential stability of the subsystems, based on Proposition 3.1, the cascaded system is also exponentially stable. \square

While it is true that the cascaded system is stable under the above conditions, finding a Lyapunov function valid for the cascaded system is not trivial. A global Lyapunov function of the form:

$$V_0(\mathbf{x}_1, \mathbf{x}_2) = V_1(\mathbf{x}_1) + V_2(\mathbf{x}_2) + \Psi(\mathbf{x}_1, \mathbf{x}_2) \quad (3.20)$$

has been proposed by Jankovic et al. (1996), with V_1 and V_2 being Lyapunov functions for the systems (3.18) and (3.19), respectively. The cross-term $\Psi(\mathbf{x}_1, \mathbf{x}_2)$ has been constructed, under the condition that the cascaded system satisfies Assumptions 3.2 and 3.3.

For the case when the first subsystem is linear, time invariant, Jankovic et al. (1996) proved that the cross-term exists and is continuous, and V_0 is positive definite and radially unbounded. Moreover, if (3.18) is globally exponentially stable, the result can be extended to the system (3.17). The cross-term Ψ is then given by:

$$\Psi(\mathbf{x}_1, \mathbf{x}_2) = \int_0^\infty \frac{\partial V_2}{\partial \mathbf{x}_2}(\tilde{\mathbf{x}}_2(s)) A_{21}(\mathbf{z}(s)) \tilde{\mathbf{x}}_1(s) ds$$

where \tilde{x}_1 and \tilde{x}_2 are the trajectories of systems (3.18) and (3.19), respectively.

In the same way, for Theorems 2.3 and 2.4, the stability conditions presented in Section 2.3 can be relaxed. The new conditions are presented below.

The conditions of Theorem 2.3 can be replaced as follows.

Theorem 3.3 Consider system (3.17) expressed as:

$$\dot{\mathbf{x}} = \begin{pmatrix} A_1(\mathbf{z}_1) & 0 \\ 0 & A_2(\mathbf{z}_1, \mathbf{z}_2) \end{pmatrix} \mathbf{x} + \begin{pmatrix} 0 \\ A_{21}(\mathbf{z}_1, \mathbf{z}_2) \end{pmatrix} \mathbf{x}_1$$

This system is UGAS, if there exist $P_1 = P_1^T > 0$, $P_2 = P_2^T > 0$, so that:

$$\begin{aligned} \mathcal{H}(P_1 A_{1i}) &< 0 \\ \mathcal{H}(P_2 A_{2i}) &< 0 \end{aligned}$$

for $i = 1, 2, \dots, m$. □

The proof is similar to that of Theorem 3.2.

In order to relax the conditions of Theorem 2.4, let K_1 and K_2 be the number of operating and interpolation regions (see Section 2.3) for the individual subsystems, with K_1^i and K_2^j the index sets corresponding to the local models of the subsystems active in the matching region. Note that in general, the number of regions generated in such a way is smaller than the number of regions for the global system, i.e., $K_1 + K_2 \leq K$ and therefore, the number of LMIs to be solved is smaller. Then, the conditions can be expressed as:

Proposition 3.2 The system (3.17) is UGAS, if there exist matrices $P_1^i = (P_1^i)^T > 0$, $P_2^j = (P_2^j)^T > 0$, $H_1 = H_1^T > 0$, $H_2 = H_2^T > 0$, F_1^i , and F_2^j , $i = 1, 2, \dots, K_1$, $j = 1, 2, \dots, K_2$, so that:

$$\begin{aligned} P_1^i &= (F_1^i)^T H_1 F_1^i \\ P_2^j &= (F_2^j)^T H_2 F_2^j \\ F_1^i \mathbf{x}_1 &= F_1^t \mathbf{x}_1 & \forall \mathbf{x}_1 \in X_1^i \cap X_1^t \\ F_2^j \mathbf{x}_2 &= F_2^l \mathbf{x}_2 & \forall \mathbf{x}_2 \in X_2^j \cap X_2^l \\ \mathcal{H}(P_1^i A_{1k}) &< 0 & \forall k \in K_1^i \\ \mathcal{H}(P_2^j A_{2k}) &< 0 & \forall k \in K_2^j \end{aligned} \tag{3.21}$$

□

The proof is similar to that of Theorem 3.2.

Note that the proposed conditions are still only sufficient conditions for the stability of cascaded fuzzy systems. However, by taking advantage of the special form of the system, i.e., by considering the subsystems instead of the overall fuzzy system, the dimension of the associated LMI problem is reduced with respect to Theorems 2.1 and 2.3–2.4, as illustrated by the following example.

Example 3.3 Consider the nonlinear system:

$$\begin{aligned}\dot{x}_1 &= -2x_1 \\ \dot{x}_2 &= -x_2 + x_1 z \cos^2 z\end{aligned}$$

where $z \in [-\pi, \pi]$ is a measured variable. It can be proven that this system is globally asymptotically stable, e.g., by using the Lyapunov function $V = \pi^2 x_1^2/2 + x_2^2$.

A fuzzy approximation of this system can be obtained by linearizing the system around all $z \in \{-\pi, -\pi/2, -\pi/4, 0, \pi/4, \pi/2, \pi\}$. The obtained matrices are:

$$\begin{aligned}A(-\pi) &= \begin{pmatrix} -2 & 0 \\ -\pi & -1 \end{pmatrix} \\ A(-\pi/2) &= A(0) = A(\pi/2) \begin{pmatrix} -2 & 0 \\ 0 & -1 \end{pmatrix} \\ A(-\pi/4) &= \begin{pmatrix} -2 & 0 \\ -\pi/8 & -1 \end{pmatrix} \\ A(\pi/4) &= \begin{pmatrix} -2 & 0 \\ \pi/8 & -1 \end{pmatrix} \\ A(\pi) &= \begin{pmatrix} -2 & 0 \\ \pi & -1 \end{pmatrix}\end{aligned}$$

i.e., there are 5 distinct local linear models. Using Theorem 2.1, this means that 5 LMIs have to be solved, while in case of Theorem 2.4, this number is even larger (11 LMIs). However, using the cascaded approach, the problem is reduced to two one-dimensional LMIs:

$$\begin{aligned}-2P_1 + P_1(-2) &< 0 \\ -1P_2 + P_2(-1) &< 0\end{aligned}$$

As can be seen, by analyzing the subsystems instead of the global fuzzy system, both the number of LMIs and their size can be reduced.

However, the main benefit of the proposed stability conditions is, that while the conditions imposed by conventional methods may lead to an infeasible LMI system, it is still possible to prove stability of the system under study, using the stability conditions presented in this chapter. An example that illustrates this case is presented in what follows.

Example 3.4 Consider the fuzzy system:

$$\dot{\mathbf{x}} = \sum_{i=1}^2 w_i(\mathbf{z}) A_i \mathbf{x} \quad (3.22)$$

with $w_1(\mathbf{z}) \geq 0$, $w_2(\mathbf{z}) \geq 0$, $w_1(\mathbf{z}) + w_2(\mathbf{z}) = 1$, $\forall \mathbf{z}$, and where the state matrices of the local linear models are given as:

$$A_1 = \begin{pmatrix} -0.7 & -1.0 & 0 & 0 & 0 \\ -1.0 & -2.8 & 0 & 0 & 0 \\ -0.1 & -1.8 & -1.4 & 0.6 & 0.0 \\ 0.1 & -0.7 & 0.6 & -3.1 & 0.4 \\ -1.8 & 1.3 & 0.0 & 0.4 & -1.9 \end{pmatrix}$$

and

$$A_2 = \begin{pmatrix} -3.3 & -1.3 & 0 & 0 & 0 \\ -1.3 & -2.6 & 0 & 0 & 0 \\ 0 & 0 & -1.1 & 0.6 & -0.7 \\ 0 & 0 & 0.6 & -5.2 & 1.7 \\ 0 & 0 & -0.7 & 1.7 & -2.0 \end{pmatrix}.$$

The LMI problem

$$\begin{aligned} P &> 0 \\ A_1^T P + P A_1 &< 0 \\ A_2^T P + P A_2 &< 0 \end{aligned}$$

is infeasible, so Theorems 2.1 and 2.3 cannot be applied. The stability of this system can be investigated using Theorem 2.4.

By examining the form of the system matrices, one can easily see that the system can be cascaded, with $\mathbf{x}_1 = [x_1 \ x_2]^T$ and $\mathbf{x}_2 = [x_3 \ x_4 \ x_5]^T$.

Based on Theorem 3.2, the system (3.22) is stable if the individual subsystems are stable. As such, in order to prove the stability of the system (3.22), it is sufficient that the LMI problems

$$\begin{aligned} P_1 &> 0 \\ A_{11}^T P_1 + P_1 A_{11} &< 0 \\ A_{12}^T P_1 + P_1 A_{12} &< 0 \end{aligned}$$

and

$$\begin{aligned} P_2 &> 0 \\ A_{12}^T P_2 + P_2 A_{12} &< 0 \\ A_{22}^T P_2 + P_2 A_{22} &< 0 \end{aligned}$$

are feasible. Using Yalmip's (Löfberg, 2004) sedumi solver one can easily see that it is so.

In the remainder of this section, we study the convergence rate of the system (3.17) with respect to the convergence rate of the individual subsystems (3.18) and (3.19).

Consider the case, when both subsystems are exponentially stable, i.e., there exist $\beta_1, \beta_2, \alpha_1, \alpha_2 > 0$ so that

$$\|\mathbf{x}_1\| \leq \beta_1 \|\mathbf{x}_{10}\| e^{-\alpha_1 t} \quad (3.23)$$

$$\|\mathbf{x}_2\| \leq \beta_2 \|\mathbf{x}_{20}\| e^{-\alpha_2 t} \quad (3.24)$$

Up to now, it has been an open question whether this also meant that the convergence rate of the system (3.17) is $\min\{\alpha_1, \alpha_2\}$: it is valid for linear systems; however, it cannot be proven with a Lyapunov function of the form $V(\mathbf{x}) = V_1(\mathbf{x}_1) + V_2(\mathbf{x}_2)$, where V_1 and V_2 are Lyapunov functions for the individual subsystems. Therefore, other approaches need to be considered.

Consider the joint system (3.17), and assume that there exists a Lyapunov function, $V = \mathbf{x}^T P \mathbf{x}$, $P = P^T > 0$, and $\gamma > 0$, so that:

$$\begin{aligned} \alpha \|\mathbf{x}\|^2 &\leq V \leq \beta \|\mathbf{x}\|^2 \\ \dot{V} = \mathbf{x}^T (A(\mathbf{z})^T P + P A(\mathbf{z})) \mathbf{x} &= -\mathbf{x}^T Q(\mathbf{z}) \mathbf{x} \leq -\gamma \|\mathbf{x}\|^2 \end{aligned}$$

Then the convergence rate γ/β is guaranteed. To have the same convergence rate for the subsystems, it is necessary (in terms of the above conditions) that $P_1 = P_1^T > 0$, $P_2 = P_2^T > 0$ exist so that

- $\alpha \leq \min(\lambda_{\min}(P_1), \lambda_{\min}(P_2))$,
- $\beta \geq \max(\lambda_{\max}(P_1), \lambda_{\max}(P_2))$, and
- $\lambda_{\max}(\text{diag}[A_1(\mathbf{z}_1)^T P_1 + P_1 A_1(\mathbf{z}_1), A_2(\mathbf{z}_2)^T P_2 + P_2 A_2(\mathbf{z}_2)]) \leq -\gamma$

Now it will be proven that, if the subsystems are exponentially stable, the convergence rate of the system (3.17) is also determined by the convergence rate of the individual subsystems (3.18) and (3.19).

Theorem 3.4 *The convergence rate of the system (3.17) is equal to $\max\{-\alpha_1, -\alpha_2\} - \epsilon$, for an arbitrary $\epsilon > 0$ if*

1. system (3.18) is exponentially stable, with convergence rate $-\alpha_1$,
2. system (3.19) is exponentially stable, with convergence rate $-\alpha_2$, and
3. the matrix $A_{21}(\mathbf{z})$ is bounded, i.e., there exists $M \in \mathbb{R}$, so that $\forall \mathbf{z}, \|A_{21}(\mathbf{z})\| \leq M$.

Proof: Condition 1 can be written as $\|\mathbf{x}_1(t)\| \leq k_1 \|\mathbf{x}_{10}\| e^{-\alpha_1 t}$, for some $k_1 > 0$. The solution of the system (3.19) is the homogeneous solution $\mathbf{x}_{2h}(t)$ of the system

$$\dot{\mathbf{x}}_2 = A_{21}(\mathbf{z})\mathbf{x}_1 + A_2(\mathbf{z})\mathbf{x}_2 \quad (3.25)$$

and therefore it satisfies $\|\mathbf{x}_{2h}(t)\| \leq k_2 \|\mathbf{x}_{20}\| e^{-\alpha_2 t}$, for some $k_2 > 0$. The particular solution of equation (3.25) can be expressed as:

$$\mathbf{x}_{2p} = \int_{t_0}^t \mathbf{x}_{2h}(t-s) A_{21}(\mathbf{z}(s)) \mathbf{x}_1(s) ds.$$

Hence,

$$\begin{aligned} \|\mathbf{x}_{2p}\| &= \left\| \int_{t_0}^t \mathbf{x}_{2h}(t-s) A_{21}(\mathbf{z}(s)) \mathbf{x}_1(s) ds \right\| \\ &\leq \int_{t_0}^t \|\mathbf{x}_{2h}(t-s)\| \|A_{21}(\mathbf{z}(s))\| \|\mathbf{x}_1(s)\| ds \\ &\leq \int_{t_0}^t k_2 \|\mathbf{x}_{20}\| e^{-\alpha_2(t-s)} M k_1 \|\mathbf{x}_{10}\| e^{-\alpha_1 s} ds \\ &\leq k_1 k_2 M \|\mathbf{x}_{10}\| \|\mathbf{x}_{20}\| e^{-\alpha_2 t} \int_{t_0}^t e^{(\alpha_2 - \alpha_1)s} ds \end{aligned}$$

If $\alpha_2 \neq \alpha_1$, we have

$$\begin{aligned} \|\mathbf{x}_{2p}\| &\leq k_1 k_2 M \|\mathbf{x}_{10}\| \|\mathbf{x}_{20}\| |\alpha_2 - \alpha_1|^{-1} \cdot e^{-\alpha_2 t} |e^{(\alpha_2 - \alpha_1)t} - e^{(\alpha_2 - \alpha_1)t_0}| \\ &\leq k_1 k_2 M \|\mathbf{x}_{10}\| \|\mathbf{x}_{20}\| |\alpha_2 - \alpha_1|^{-1} |e^{-\alpha_1 t} - c_1 e^{-\alpha_2 t}|. \end{aligned}$$

where $c_1 = e^{(\alpha_2 - \alpha_1)t_0}$.

A bound on the general solution of (3.25) is:

$$\begin{aligned} \|\mathbf{x}_2\| &\leq \|\mathbf{x}_{2h}\| + \|\mathbf{x}_{2p}\| \\ &\leq k_2\|\mathbf{x}_{20}\|e^{-\alpha_2 t} + k_1 k_2 M \|\mathbf{x}_{10}\| \|\mathbf{x}_{20}\| \cdot |\alpha_2 - \alpha_1|^{-1} |e^{-\alpha_1 t} - c_1 e^{-\alpha_2 t}| \\ &\leq c_2 e^{\max\{-\alpha_1, -\alpha_2\}t} \end{aligned}$$

where $c_2 = \max\{k_2\|\mathbf{x}_{20}\|(1+k_1 M \|\mathbf{x}_{10}\||\alpha_2 - \alpha_1|^{-1}c_1), k_1 k_2 \|\mathbf{x}_{10}\| \|\mathbf{x}_{20}\| M |\alpha_2 - \alpha_1|^{-1}\}$.

For $\alpha_1 = \alpha_2 = \alpha$, we have

$$\begin{aligned} \|\mathbf{x}_{2p}\| &\leq k_1 k_2 M \|\mathbf{x}_{10}\| \|\mathbf{x}_{20}\| e^{-\alpha t} (t - t_0) \\ \|\mathbf{x}_2\| &\leq \|\mathbf{x}_{2h}\| + \|\mathbf{x}_{2p}\| \\ &\leq k_2\|\mathbf{x}_{20}\|e^{-\alpha t} + k_1 k_2 M \|\mathbf{x}_{10}\| \|\mathbf{x}_{20}\| e^{-\alpha t} (t - t_0) \\ &\leq c_3 e^{-\alpha t} + c_4 t e^{-\alpha t} \end{aligned} \tag{3.26}$$

with $c_3 = k_2\|\mathbf{x}_{20}\|$ and $c_4 = k_1 k_2 \|\mathbf{x}_{10}\| \|\mathbf{x}_{20}\| M$. For the bound $c_3 e^{-\alpha t} + c_4 t e^{-\alpha t}$ on (3.26) it has been shown that the convergence rate is $\alpha - \epsilon$, for an arbitrary $\epsilon > 0$ (Baddou et al., 2006).

This means that the convergence rate of the system (3.25), and, therefore, of the system (3.17) is determined by the convergence rate of the individual subsystems. \square

3.3.2 Cascaded fuzzy observers

This section presents the cascaded approach applied to observer design for TS fuzzy systems. As before, consider the fuzzy system with normalized membership functions:

$$\begin{aligned} \dot{\mathbf{x}} &= \sum_{i=1}^m w_i(\mathbf{z})(A_i \mathbf{x} + B_i \mathbf{u} + a_i) \\ \mathbf{y} &= \sum_{i=1}^m w_i(\mathbf{z})(C_i \mathbf{x} + d_i) \end{aligned} \tag{3.27}$$

and a fuzzy observer of the form:

$$\begin{aligned} \dot{\hat{\mathbf{x}}} &= \sum_{i=1}^m w_i(\mathbf{z})(A_i \hat{\mathbf{x}} + B_i \mathbf{u} + a_i + L_i(\mathbf{y} - \hat{\mathbf{y}})) \\ \hat{\mathbf{y}} &= \sum_{i=1}^m w_i(\mathbf{z})(C_i \hat{\mathbf{x}} + d_i) \end{aligned} \tag{3.28}$$

Assuming that the system matrices for each rule $i = 1, 2, \dots, m$ can be written as:

$$\begin{aligned} A_i &= \begin{pmatrix} A_{1i} & 0 \\ A_{21i} & A_{2i} \end{pmatrix} \\ C_i &= \begin{pmatrix} C_{1i} & 0 \\ C_{21i} & C_{2i} \end{pmatrix} \end{aligned}$$

observers can be designed individually for each subsystem and each rule, with the overall observer gain having the form $L_i = \begin{pmatrix} L_{1i} & 0 \\ 0 & L_{2i} \end{pmatrix}$, where i denotes the rule number.

Similarly to Section 2.4, two cases are distinguished.

Case 1: State-independent scheduling vector

If the weights do not depend on the states to be estimated, the cascaded error system can be written as:

$$\begin{aligned} \dot{e} &= \sum_{i=1}^m \sum_{j=1}^m w_i(\mathbf{z})w_j(\mathbf{z})(A_i - L_i C_j)e \\ &= \sum_{i=1}^m \sum_{j=1}^m w_i(\mathbf{z})w_j(\mathbf{z}) \begin{pmatrix} A_{1i} - L_{1i}C_{1j} & 0 \\ A_{21i} - L_{2i}C_{21j} & A_{2i} - L_{2i}C_{2j} \end{pmatrix} e. \end{aligned} \quad (3.29)$$

This system is of the form (3.16) for which the stability conditions from Section 3.3.1 can be used. If the C matrix is common for all the rules, the presented theorems can be directly applied.

In the case when the scheduling vector does not depend on the states to be estimated, Theorem 3.4 can also be applied to the design of observers with guaranteed convergence rate.

Using the results on the convergence rate, Theorem 2.6 can be reformulated as follows:

Theorem 3.5 *The decay rate of the error system (3.29) is at least α , if there exist $P_1 = P_1^T > 0$ and $P_2 = P_2^T > 0$, so that for $i = 1, 2, \dots, m$*

$$\begin{aligned} \mathcal{H}(P_1(A_{1i} - L_{1i}C_{1i})) + 2\alpha P_1 &< 0 \\ \mathcal{H}(P_2(A_{2i} - L_{2i}C_{2i})) + 2\alpha P_2 &< 0 \\ \mathcal{H}(P_1(A_{1i} - L_{1i}C_{1j})) + 2\alpha P_1 &< 0 \\ j = 1, 2, \dots, m \quad \forall i, j : \exists \mathbf{z} : w_i(\mathbf{z})w_j(\mathbf{z}) &\neq 0 \\ \mathcal{H}(P_2(A_{2i} - L_{2i}C_{2j})) + 2\alpha P_2 &< 0 \\ j = 1, 2, \dots, m \quad \forall i, j : \exists \mathbf{z} : w_i(\mathbf{z})w_j(\mathbf{z}) &\neq 0 \end{aligned}$$

□

The proof follows directly. The above conditions explicitly state, that in order to design a global observer with a desired convergence rate, it is sufficient to design observers for the subsystems with the same convergence rate.

Case 2: State dependent scheduling vector

Now, consider the case when the parameters \mathbf{z} depend on the states to be estimated, i.e., $\mathbf{z} = \hat{\mathbf{z}}$. For simplicity, only the case with common measurement matrix is considered. Then, the fuzzy system is expressed as

$$\begin{aligned} \dot{\mathbf{x}} &= \sum_{i=1}^m w_i(\mathbf{z})(A_i \mathbf{x} + B_i \mathbf{u} + a_i) \\ \mathbf{y} &= C \mathbf{x}, \end{aligned} \quad (3.30)$$

and the error system can be written as:

$$\begin{aligned} \dot{e} &= \sum_{i=1}^m \begin{pmatrix} w(\hat{\mathbf{z}}_1)(A_{1i} - L_{1i}C_{1i}) & 0 \\ w_i(\hat{\mathbf{z}})(A_{21i} - L_{2i}C_{21i}) & w_i(\hat{\mathbf{z}})(A_{2i} - L_{2i}C_{2i}) \end{pmatrix} e \\ &+ \sum_{i=1}^m \begin{pmatrix} w_{1i}(\mathbf{z}_1) - w_{1i}(\hat{\mathbf{z}}_1) \\ w_{2i}(\mathbf{z}) - w_{2i}(\hat{\mathbf{z}}) \end{pmatrix} (A_i \mathbf{x} + B_i \mathbf{u} + a_i) \end{aligned} \quad (3.31)$$

To ensure the stability of the observer in such a case, Theorem 2.7 can be applied. However, using the results for cascaded systems, relaxed stability conditions are derived. These conditions can be expressed as follows.

Theorem 3.6 *The cascaded error system (3.31) is UGAS, if there exist a Lyapunov function $V_1(\mathbf{x}_1)$, $P_2 = P_2^T > 0$ and two continuous functions $\theta_1, \theta_2 : \mathcal{R}^+ \rightarrow \mathcal{R}^+$ such that:*

1. *The Lyapunov function V_1 ensures exponential stability of the error system*

$$\begin{aligned} \dot{\mathbf{e}}_1 = & \sum_{i=1}^m w_{1i}(\widehat{\mathbf{z}}_1)(A_{1i} - L_{1i}C_{1i})\mathbf{e}_1 + \\ & + (w_{1i}(\mathbf{z}_1) - w_{1i}(\widehat{\mathbf{z}}_1))(A_{1i}\mathbf{x}_1 + B_{1i}\mathbf{u} + a_{1i}), \end{aligned} \quad (3.32)$$

2. *P_2 satisfies $\mathcal{H}(P_2 A_{2i}) < 0$, $i = 1, 2, \dots, m$ and*

3. *$\|\sum_{i=1}^m (w_{2i}(\mathbf{z}_1, \mathbf{z}_2) - w_{2i}(\widehat{\mathbf{z}}_1, \widehat{\mathbf{z}}_2))(A_{21i}\mathbf{x}_1 + A_{2i}\mathbf{x}_2 + B_{2i}\mathbf{u} + a_{2i})\| \leq \theta_1(\|\mathbf{e}_1\|) + \theta_2(\|\mathbf{e}_1\|)\|\mathbf{e}_2\|$.*

Proof: Since $\mathcal{H}(P_2 A_{2i}) < 0$, $i = 1, 2, \dots, m$, V_2 is a Lyapunov function for

$$\dot{\mathbf{e}}_2 = \sum_{i=1}^m w_{2i}(\widehat{\mathbf{z}}_1, \widehat{\mathbf{z}}_2)(A_{2i} - L_{2i}C_{2i})\mathbf{e}_2 \quad (3.33)$$

and this system is UGAS (Assumption 3.1). Let $c_1 = 2\frac{\lambda_{\max}(P_2)}{\lambda_{\min}(P_2)}$, $c_2 = 2\eta\lambda_{\max}(P_2)$. With these constants, Assumption 3.2 is satisfied. The Lyapunov function V_1 satisfies Assumption 3.4.

Now, the interconnection term in the second subsystem can be written as:

$$\begin{aligned} g(\mathbf{e}_1, \mathbf{e}_2) = & \sum_{i=1}^m w_{2i}(\widehat{\mathbf{z}}_1, \widehat{\mathbf{z}}_2)(A_{21i} - L_{2i}C_{2i})\mathbf{e}_1 + \\ & + \sum_{i=1}^m (w_{2i}(\mathbf{z}_1, \mathbf{z}_2) - w_{2i}(\widehat{\mathbf{z}}_1, \widehat{\mathbf{z}}_2))(A_{21i}\mathbf{x}_1 + A_{2i}\mathbf{x}_2 + B_{2i}\mathbf{u} + a_{2i}) \\ \|g(\mathbf{e}_1, \mathbf{e}_2)\| \leq & \sum_{i=1}^m \|w_{2i}(\widehat{\mathbf{z}}_1, \widehat{\mathbf{z}}_2)\| \|A_{21i} - L_{2i}C_{2i}\| \|\mathbf{e}_1\| + \theta_1(\|\mathbf{e}_1\|) + \theta_2(\|\mathbf{e}_1\|)\|\mathbf{e}_2\| \\ \|g(\mathbf{e}_1, \mathbf{e}_2)\| \leq & \tau \|\mathbf{e}_1\| + \theta_1(\|\mathbf{e}_1\|) + \theta_2(\|\mathbf{e}_1\|)\|\mathbf{e}_2\| \\ \|g(\mathbf{e}_1, \mathbf{e}_2)\| \leq & \theta'_1(\|\mathbf{e}_1\|) + \theta_2(\|\mathbf{e}_1\|)\|\mathbf{e}_2\| \end{aligned}$$

where $\theta'_1(\|\mathbf{e}_1\|) = \tau \|\mathbf{e}_1\| + \theta_1(\|\mathbf{e}_1\|)$. With this, Assumption 3.3 (see (3.13)) is satisfied, and based on Theorem 3.1, the cascaded system is UGAS. Moreover, since the first subsystem is exponentially stable, the cascaded system is also exponentially stable (see Proposition 3.1).

□

3.3.3 Example for cascaded observer design

This example of a real-world system (Waurajitti et al., 2000) illustrates the benefits of using the cascaded approach instead of centralized observer design.

Consider the three tanks connected in a cascade as shown in Figure 3.3. Water is pumped from a reservoir into the upper tank (3). From this tank, the water flows to the middle tank (2) and the lower tank (1) and from the lower tank back to the reservoir. The system has one control input u , which is the voltage applied to the motor of the pump and two measured outputs: the water levels h_3 in the upper tank and h_1 in the lowest tank. The flow rate F_{in} , provided by the pump, and the water level h_2 in the middle tank need to be estimated, and therefore, an observer has to be designed. The differential equations describing the dynamics of this system are the following:

$$\begin{aligned}
 \tau \dot{F}_{in} &= -F_{in} + Q_s \cdot u \\
 \dot{h}_3 &= \frac{F_{in}}{A_3} - \frac{s_3 \sqrt{2gh_3}}{A_3} \\
 \dot{h}_2 &= \frac{s_3 \sqrt{2gh_3}}{A_2} - \frac{s_2 \sqrt{2gh_2}}{A_2} \\
 \dot{h}_1 &= \frac{s_2 \sqrt{2gh_2}}{A_1} - \frac{s_1 \sqrt{2gh_1}}{A_1}
 \end{aligned} \tag{3.34}$$

The parameter values are listed in Table 3.3.

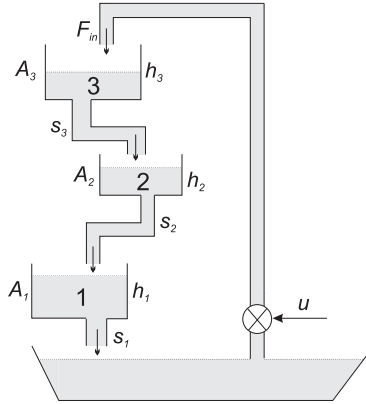

Figure 3.3: Cascaded tanks system.

It is assumed that the tanks have the same height, $h_{\max} = 2$ m, and if a tank is full the overflowing water does not affect the level of the water in the other tanks. Therefore, we have the constraint $\dot{h}_{i,\max} = 0$, and all levels are bounded, $h_i \in [0, h_{\max}]$.

In order to use the proposed design, a TS fuzzy model of the system (3.34) is constructed. To obtain a good coverage of the levels, for each level h_i , four points $h_i \in \{0.1, 0.55, 1.05, 1.6\}$ are chosen, together with appropriate membership functions, as depicted in Figure 5.2. Note that the scheduling vector consists of the levels h_1 , h_2 and h_3 which are the states to be estimated.

Table 3.3: Parameter values used.

Parameter	Symbol	Value	Units
Acceleration due to gravity	g	9.81	m/s^2
Cross-sectional area tank 1	A_1	10	m^2
Cross-sectional area tank 2	A_2	8	m^2
Cross-sectional area tank 3	A_3	9	m^2
Outlet area of tank 1	s_1	0.25	m^2
Outlet area of tank 2	s_2	0.2	m^2
Outlet area of tank 3	s_3	0.3	m^2
Input to flow gain	Q_s	0.336	$\text{m}^3/\text{s}/V$
Motor time constant	τ	3	s

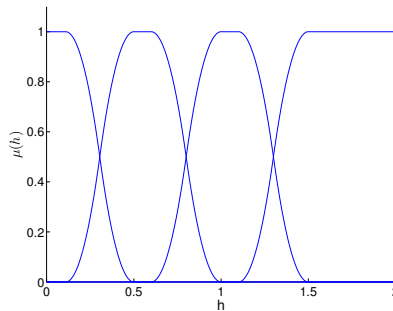

Figure 3.4: Membership functions for the heights.

The system (3.34) is linearized for each combination of the chosen points. Since the linearization is not done in equilibria, the consequents are affine. For instance, the rule obtained by linearizing in $h_1 = 0.55$, $h_2 = 0.1$ and $h_3 = 0.55$ is:

If h_1 is approximately 0.55 and h_2 is approximately 0.1 and h_3 is approximately 0.55, then $\dot{x} = Ax + Bu + a$, with

$$A = \begin{pmatrix} -0.3333 & 0 & 0 & 0 \\ 0.1111 & -0.0995 & 0 & 0 \\ 0 & 0.1120 & -0.1751 & 0 \\ 0 & 0 & 0.1401 & -0.0747 \end{pmatrix} \quad B = \begin{pmatrix} 0.1120 \\ 0 \\ 0 \\ 0 \end{pmatrix}$$

$$a = (0 \quad -0.0547 \quad 0.0441 \quad -0.0271)^T$$

where $x = [F_{\text{in}} \quad h_3 \quad h_2 \quad h_1]^T$. To compute the membership degree of the scheduling vector, the conjunction operator is used.

By examining the form of system (3.34) and the matrices of the fuzzy system, one can easily see that the system can be cascaded, with $x_1 = [F_{\text{in}} \quad h_3]^T$ and $x_2 = [h_2 \quad h_1]^T$. Therefore, observers can be designed separately for the individual subsystems. The observers are designed both for the whole system and the individual subsystems using the same pole-

placement method and conditions. Both observers have the form (2.11), i.e.,

$$\begin{aligned}\dot{\hat{\mathbf{x}}} &= \sum_{i=1}^m w_i(\hat{\mathbf{z}})(A_i \hat{\mathbf{x}} + B_i \mathbf{u} + a_i + L_i(\mathbf{y} - \hat{\mathbf{y}})) \\ \hat{\mathbf{y}} &= \sum_{i=1}^m w_i(\hat{\mathbf{z}})(C_i \hat{\mathbf{x}} + d_i).\end{aligned}$$

To simulate the system, the differential equations of the fuzzy models were discretized with the Euler method, using a sampling period $T = 0.1$ s. The estimated values given by the fuzzy model were saturated at 0 and h_{\max} . The input was randomly generated, and so were the “true” and “estimated” initial states. For the presented cases, the true initial conditions were $[1.7 \ 0.4 \ 0.1 \ 0.4]^T$, while the estimated ones were $[1.5 \ 0.2 \ 1.3 \ 0.8]^T$. The observers were designed using LMI regions (see Section 2.4.3). The regions and the CPU time needed to solve the LMIs for these regions using the sedumi solver of the Yalmip toolbox (Löfberg, 2004) are presented in Table 3.4, for the centralized and cascaded observers. As can be seen, the time needed to solve the LMIs for the centralized observer is, in most cases more than 10 times larger than the time needed for the cascaded observer, due to the larger number of LMI variables that have to be determined: for the centralized system 64 4-by-4 LMIs need to be solved, while for the cascaded approach this number is reduced to 2 times 4 LMIs of dimension 2-by-2.

Table 3.4: LMI regions and the CPU time.

Case	d_l	d_u	θ	Centralized [s]	Cascaded [s]
1	–	–	–	2.73	0.17
2	-10	-2	–	103.00	0.23
3	–	–	$\pi/4$	1.59	0.22
4	-10	-2	$\pi/4$	30.05	0.53
5	–	–	$\pi/36$	1.75	0.31
6	-10	-2	$\pi/36$	33.89	0.53

The estimation errors of F_{in} and h_2 , when using centralized and cascaded observers, for the six cases are presented in Figures 3.5 and 3.6, respectively.

If the LMI region is the entire left half-plane, the cascaded observer converges much faster than the centralized observer (Figures 3.5(a) and 3.6(a)). If the closed-loop poles are restricted to the interval $[-10, -2]$, but there is no restriction on θ (case 2), the imaginary parts of the closed-loop poles of the centralized observer are of the order 10^6 – the observer effectively becomes unusable. Therefore, only the results obtained by the cascaded setting are presented (Figures 3.5(b) and 3.6(b)). If θ is constrained, the performance of the observers is comparable. For no constraints on the real part of the poles (i.e., no vertical strip in Figure 2.2), the estimation error on h_2 of the cascaded observer converges faster (Figures 3.6(c) and 3.6(e)). When both the real part and the damping are constrained, the overshoot of the cascaded observer is slightly larger than that of the centralized one (Figures 3.5(d) and 3.5(f)).

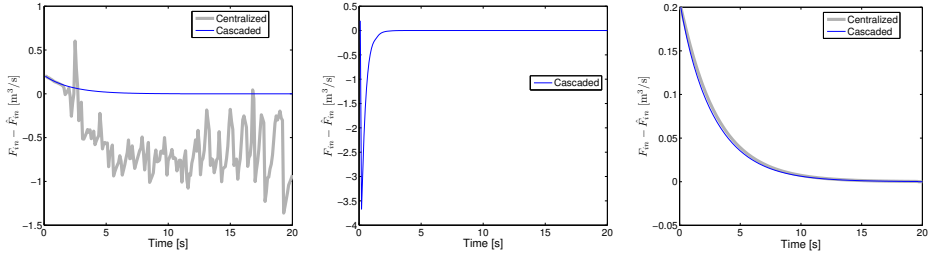

(a) Estimation error for F_{in} , case 1 (b) Estimation error for F_{in} , case 2 (c) Estimation error for F_{in} , case 3

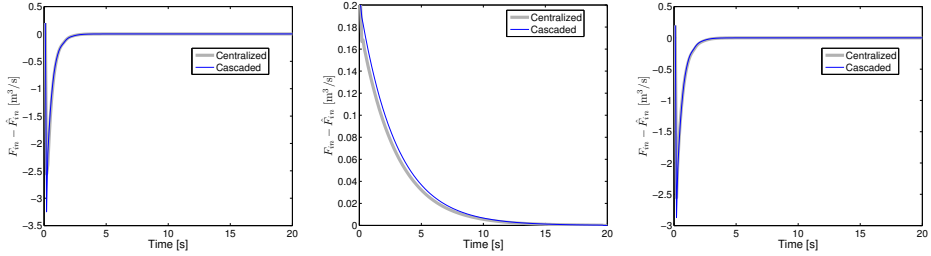

(d) Estimation error for F_{in} , case 4 (e) Estimation error for F_{in} , case 5 (f) Estimation error for F_{in} , case 6

Figure 3.5: Estimation errors for F_{in} centralized and cascaded observers.

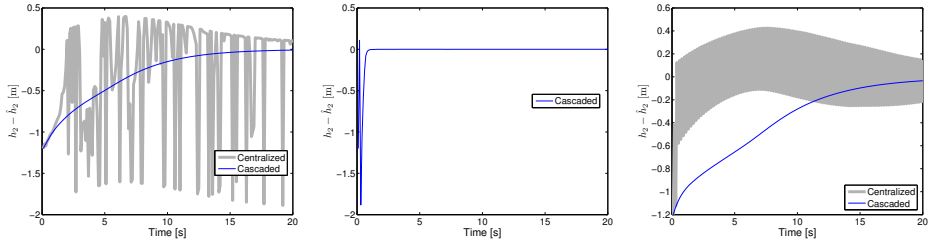

(a) Estimation error for h_2 , case 1 (b) Estimation error for h_2 , case 2 (c) Estimation error for h_2 , case 3

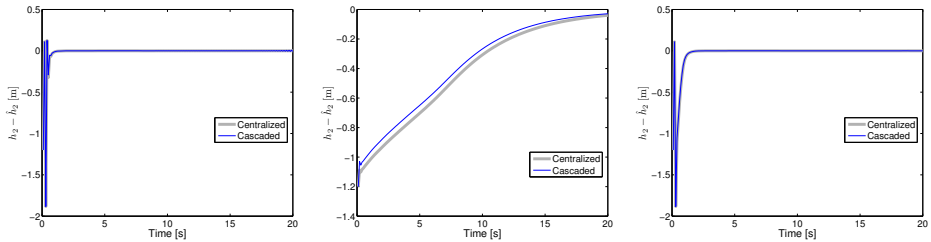

(d) Estimation error for h_2 , case 4 (e) Estimation error for h_2 , case 5 (f) Estimation error for h_2 , case 6

Figure 3.6: Estimation errors for h_2 using centralized and cascaded observers.

3.4 Summary and concluding remarks

In many real-life applications, a complex process model can be decomposed into simpler, cascaded subsystems. This partitioning of a process leads to increased modularity and reduced

complexity of the problem, while also making the analysis easier.

In this chapter, a cascaded approach has been presented for nonlinear systems. In the first part of the chapter, an algorithm for partitioning a nonlinear system and stability conditions for cascaded nonlinear systems have been presented. In the second part, cascaded TS fuzzy systems were considered. Based on the stability conditions for general nonlinear system, more relaxed conditions were derived for TS systems. It has been proven that, similar to linear systems, the exponential stability of the individual subsystems implies the stability of the cascaded system. Moreover, the convergence rate of the cascaded TS system is given by the convergence rate of the individual subsystems. In addition, the cascaded stability analysis relaxes the conventional stability conditions and reduces the dimension of the LMI problems to be solved.

The cascaded setting has also been extended to state estimation. If the system under consideration can be represented as a cascaded of TS fuzzy systems, observers can be designed in a cascaded fashion. This partitioning of a process and observer leads to increased modularity and reduced complexity of the problem, with reduced computational costs. The benefits of studying stability and designing observers based on subsystems have been demonstrated on simulation examples.

Note that although the cascaded stability analysis and observer design have the above enumerated benefits, the Lyapunov functions used are still conservative. Moreover, it is hard to find a Lyapunov function for the whole system, and therefore, the analysis of other performance indices cannot be based on the Lyapunov function of the whole system.

Chapter 4

Distributed observers

The previous chapter has presented stability analysis and observer design for a special case of distributed systems, that may be represented as a cascade of subsystems. In this chapter, a more general case is considered, namely when the subsystems influence each other. Building on the results of the previous chapter, here we consider the distributed stability analysis and observer design for TS fuzzy systems. For large-scale or distributed systems, such an approach presents several advantages compared to the centralized approach, among which easier analysis and design or reduced computational costs. The analysis and design are performed sequentially for the subsystems, allowing for the online addition of new subsystems. LMI conditions are derived, which are easy to solve.

Parts of this chapter have been published in (Lendek et al., 2008a).

4.1 Introduction

In many cases, large-scale or distributed systems are composed of a number of subsystems that influence and are being influenced by each other. For such systems, recently, decentralized analysis and control design has received much attention (Haijun et al., 2006; Liu and Zhang, 2005; Krishnamurthy and Khorrami, 2003; Bavafa-Toosi et al., 2006; Zhang et al., 2006; Liu et al., 2007). For control purposes, the decentralized design presents several advantages: flexibility, fault tolerance, simplified design and tuning. In addition, in many cases, the structure of the overall system is not fixed, i.e., subsystems may be added online, and therefore a centralized analysis and/or design becomes computationally intractable.

Although decentralized control has received much attention (Sandell et al., 1978; Akar and Özgüner, 2000; Jiang, 2000; Krishnamurthy and Khorrami, 2003; Wang and Chai, 2005; Zhang et al., 2006; Bavafa-Toosi et al., 2006) in this context, decentralized state estimation has not been addressed as much as the control problem. For decentralized state estimation, in general an architecture of several sensor nodes is assumed, usually a network of nodes for distributed systems (López-Orozco et al., 2000; Roumeliotis and Bekey, 2002; Schmitt et al., 2002), such that each node shares information with other nodes and computes a local estimate. Observers used include, but are not limited to linear observers (Sundareshan and Elbanna, 1990; Saif and Guan, 1992; Hou and Müller, 1994), Kalman filter variants (Durrant-Whyte et al., 1990; Benigni et al., 2008), and particle filters (Bolic et al., 2004; Coates, 2004).

In this chapter we consider the distributed stability analysis and observer design for a system composed of subsystems. Each subsystem is represented by a TS fuzzy model (Takagi and Sugeno, 1985). The coupling between the subsystems is realized through their states, i.e., the states of a subsystem may influence the dynamics of another subsystem. First, we analyze the stability of the overall TS system based on the stability of the subsystems, allowing that new subsystems may be added online. In such a case, i.e., when the structure of the system is not fixed, the influence of the interconnection terms due to the addition of a new subsystem is not known before the subsystem is actually added. Therefore, the newly added subsystem should be sufficiently robustly stable so that the stability of the overall system is maintained.

Second, the distributed approach is extended to observer design. We assume that a fuzzy observer is already designed for an existing subsystem. When a new subsystem, together with the interconnection terms, which may affect the states and/or measurements is added, a new observer is designed only for this subsystem. Therefore, the observers are designed sequentially for the subsystems. The advantage of this approach is that already designed observers do not need to be altered.

4.2 Decentralized stability analysis of fuzzy systems

Consider a distributed system, with each subsystem being represented by a TS fuzzy model, where the influence of the subsystems is in both directions, i.e., a subsystem influences other subsystems and symmetrically it is influenced by other subsystems. The subsystems are coupled through their states. Assume that the structure of the system is not fixed, i.e., new subsystems may be added online, but the newly added subsystem does not change the local models of the existing subsystems. Note, however, that this assumption allows for the change of the membership functions. In such a case, a centralized re-analysis of the stability of the whole system each time a new subsystem is added or removed may easily become intractable. Therefore, we consider decentralized analysis, based on the stability of the already existing system, the newly added subsystem and the interconnection terms introduced by the new subsystem. Although such an analysis is more restrictive than a centralized one, it has the benefit of reduced computational complexity. For the ease of notation and without loss of generality, only two subsystems are considered. Note, however, that the procedure directly applies for more subsystems if they are added sequentially to the system. The subsystem added (with states \mathbf{x}_1) and the existing system (with states \mathbf{x}_2) are expressed together as:

$$\begin{aligned}\dot{\mathbf{x}}_1 &= \sum_{i=1}^m w_i(\mathbf{z})(A_{1i}\mathbf{x}_1 + A_{12i}\mathbf{x}_2) \\ \dot{\mathbf{x}}_2 &= \sum_{i=1}^m w_i(\mathbf{z})(A_{2i}\mathbf{x}_2 + A_{21i}\mathbf{x}_1)\end{aligned}\tag{4.1}$$

The structure of such a system is presented in Figure 4.1, where S1 and S2 denote the corresponding subsystems.

For such a system, we have formulated the following stability conditions (Lendek et al., 2008a):

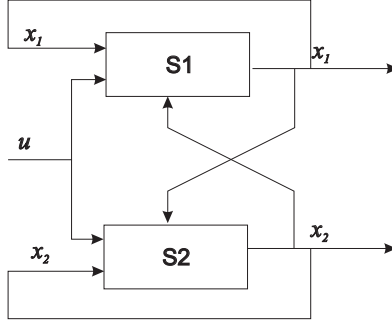

Figure 4.1: Two subsystems (S1 and S2) coupled through their states.

Theorem 4.1 *The system (4.1) is asymptotically stable, if there exist $P_1 = P_1^T > 0$, $P_2 = P_2^T > 0$, $Q_1 = Q_1^T > 0$, $Q_2 = Q_2^T > 0$, so that*

$$\mathcal{H}(P_1 A_{1i}) < -2Q_1 \quad i = 1, 2, \dots, m$$

$$\mathcal{H}(P_2 A_{2i}) < -2Q_2 \quad i = 1, 2, \dots, m$$

$$\lambda_{\min}(Q_1) \geq \max_i \|P_1 A_{12i}\|$$

$$\frac{\lambda_{\min}(\mathcal{H}(P_1 A_{1i}) + 2Q_1)}{\max_i \|P_1 A_{12i}\|} > \frac{\max_i \|A_{21i}^T P_2\|^2}{\lambda_{\min}(Q_2) \lambda_{\min}(\mathcal{H}(P_2 A_{2i}) + 2Q_2)}$$

where $\lambda_{\min}(\cdot)$ is the eigenvalue with the smallest absolute magnitude.

Proof: Consider first the following part of the system (4.1):

$$\begin{aligned} \dot{\mathbf{x}}_1 &= \sum_{i=1}^m w_i(\mathbf{z})(A_{1i} \mathbf{x}_1) \\ \dot{\mathbf{x}}_2 &= \sum_{i=1}^m w_i(\mathbf{z})(A_{2i} \mathbf{x}_2 + A_{21i} \mathbf{x}_1) \end{aligned} \tag{4.2}$$

This is a cascaded system and it is exponentially stable, if there exist $P_1 = P_1^T > 0$, $P_2 = P_2^T > 0$, $Q_1 = Q_1^T > 0$, $Q_2 = Q_2^T > 0$ so that

$$\mathcal{H}(P_1 A_{1i}) < -2Q_1 \quad i = 1, 2, \dots, m$$

$$\mathcal{H}(P_2 A_{2i}) < -2Q_2 \quad i = 1, 2, \dots, m$$

Then, there exists $\alpha \in \mathcal{R}^+$ so that $V_c = \mathbf{x}^T \text{diag}(\alpha P_1, P_2) \mathbf{x}$ is a Lyapunov function for the cascaded system (4.2) and $\dot{V}_c < -2\mathbf{x}^T Q \mathbf{x}$, with $Q = \text{diag}(\alpha Q_1, Q_2)$:

$$\dot{V}_c = \sum_{i=1}^m w_i(\mathbf{z}) \mathbf{x}^T \begin{pmatrix} \alpha \mathcal{H}(P_1 A_{1i}) & A_{21i}^T P_2 \\ P_2 A_{21i} & \mathcal{H}(P_2 A_{2i}) \end{pmatrix} \mathbf{x}$$

For $\dot{V}_c < -2\mathbf{x}^T Q \mathbf{x}$, it is needed that

$$\begin{pmatrix} \alpha \mathcal{H}(P_1 A_{1i}) & A_{21i}^T P_2 \\ P_2 A_{21i} & \mathcal{H}(P_2 A_{2i}) \end{pmatrix} < -2 \begin{pmatrix} \alpha Q_1 & 0 \\ 0 & Q_2 \end{pmatrix}$$

or

$$\begin{pmatrix} \alpha \mathcal{H}(P_1 A_{1i} + Q_1) & A_{21i}^T P_2 \\ P_2 A_{21i} & \mathcal{H}(P_2 A_{2i} + Q_2) \end{pmatrix} < 0$$

Using the Schur complement, we have

$$\alpha \mathcal{H}(P_1 A_{1i} + Q_1) - (A_{21i}^T P_2)(\mathcal{H}(P_2 A_{2i} + Q_2))^{-1} P_2 A_{21i} < 0$$

which is true if α is chosen such that

$$\alpha > \frac{1}{\lambda_{\min}(\mathcal{H}(P_1 A_{1i} + Q_1))} \cdot \frac{\max_i \|A_{21i}^T P_2\|^2}{\lambda_{\min}(\mathcal{H}(P_2 A_{2i} + Q_2))} \quad (4.3)$$

Now, consider the full system (4.1). By using the above constructed V_c as a candidate Lyapunov function for (4.1), we obtain:

$$\begin{aligned} \dot{V}_c &= \sum_{i=1}^m w_i(z) \mathbf{x}^T \left[\begin{pmatrix} \alpha \mathcal{H}(P_1 A_{1i}) & A_{21i}^T P_2 \\ P_2 A_{21i} & \mathcal{H}(P_2 A_{2i}) \end{pmatrix} + \begin{pmatrix} 0 & \alpha P_1 A_{12i} \\ \alpha A_{12i}^T P_1 & 0 \end{pmatrix} \right] \mathbf{x} \\ &< -2\mathbf{x}^T \begin{pmatrix} \alpha Q_1 & 0 \\ 0 & Q_2 \end{pmatrix} \mathbf{x} + 2\mathbf{x}^T \alpha \max_i \|I P_1 A_{12i}\| \mathbf{x} \\ &< -2\mathbf{x}^T \begin{pmatrix} \alpha(Q_1 - \max_i \|P_1 A_{12i}\| I) & 0 \\ 0 & Q_2 - \alpha \max_i \|P_1 A_{12i}\| I \end{pmatrix} \mathbf{x} \end{aligned}$$

which leads to the conditions

$$\lambda_{\min}(Q_1) > \max_i \|P_1 A_{12i}\| \quad (4.4)$$

$$\lambda_{\min}(Q_2) > \alpha \max_i \|P_1 A_{12i}\| \quad (4.5)$$

Combining (4.3) and (4.5), we get that such an α exists and therefore V_c is a Lyapunov function for the whole system if

$$\frac{\lambda_{\min}(Q_2)}{\max_i \|P_1 A_{12i}\|} > \frac{\max_i \|A_{21i}^T P_2\|^2}{\lambda_{\min}(\mathcal{H}(P_1 A_{1i} + Q_1)) \lambda_{\min}(\mathcal{H}(P_2 A_{2i} + Q_2))}$$

or

$$\frac{\lambda_{\min}(\mathcal{H}(P_1 A_{1i} + Q_1))}{\max_i \|P_1 A_{12i}\|} > \frac{\max_i \|A_{21i}^T P_2\|^2}{\lambda_{\min}(Q_2) \lambda_{\min}(\mathcal{H}(P_2 A_{2i} + Q_2))} \quad \square$$

Remark: If A_{12i} , $i = 1, 2, \dots, m$ or A_{21i} , $i = 1, 2, \dots, m$ are zero, then based on Theorem 3.2, the system (4.1) is stable if the individual subsystems are stable, and the last two conditions are not needed.

If one analyzes the stability of the two subsystems at the same time, the conditions of Theorem 4.1 are necessarily nonlinear. However, in the scenario considered in this chapter, i.e., the stability analysis of a TS fuzzy system when a new subsystem is added to system that is already known to be stable, the conditions can be verified using the following algorithm:

Algorithm 4.1

1. We assume that the existing system,

$$\dot{\mathbf{x}}_2 = \sum_{i=1}^m A_{2i} \mathbf{x}$$

is already proven to be stable using a quadratic Lyapunov function and therefore P_2 and Q_2 such that $\mathcal{H}(P_2 A_{2i}) < -2Q_2$ have been computed. Thanks to this, when adding the new subsystem, with the interconnection terms, the value of

$$\gamma = \frac{\max_i \|A_{2i}^T P_2\|^2}{\lambda_{\min}(Q_2) \lambda_{\min}(\mathcal{H}(P_2 A_{2i} + Q_2))}$$

can be computed.

2. Now, for the added subsystem and the corresponding interconnection terms we have the conditions:

$$\mathcal{H}(P_1 A_{1i}) < -2Q_1 \quad i = 1, 2, \dots, m$$

$$\lambda_{\min}(Q_1) \geq \max_i \|P_1 A_{12i}\|$$

$$\lambda_{\min}(\mathcal{H}(P_1 A_{1i} + Q_1)) > \gamma \max_i \|P_1 A_{12i}\|$$

which are satisfied if the LMIs:

$$\mathcal{H}(P_1 A_{1i} + Q_1) \leq -t_1 I \quad i = 1, 2, \dots, m$$

$$Q_1 \geq t_2 I$$

$$\begin{pmatrix} t_2 I & \max_i \|A_{12i}\| P_1 \\ \max_i \|A_{12i}\| P_1 & t_2 I \end{pmatrix} > 0 \quad (4.6)$$

$$\begin{pmatrix} t_1 I & \gamma \max_i \|A_{12i}\| P_1 \\ \gamma \max_i \|A_{12i}\| P_1 & t_1 I \end{pmatrix} > 0$$

are feasible. Moreover, if one takes into consideration that new subsystems may be added to the whole system (4.1), the analysis of the new subsystem is made easier by minimizing the expression:

$$\frac{\|P_1\|}{\lambda_{\min}(Q_1) \lambda_{\min}(\mathcal{H}(P_1 A_{1i} + Q_1))}$$

This can be achieved by solving the LMI problem: find $P_1 = P_1^T > 0$, $Q_1 = Q_1^T > 0$, and maximize $\alpha_1, \alpha_2, \alpha_3$ subject to (4.6) and

$$-P_1 > \alpha_1 I$$

$$Q_1 > \alpha_2 I$$

$$\mathcal{H}(P_1 A_{1i} + Q_1) > \alpha_3 I$$

The above-presented sequential method is only needed if a bound on the interconnection terms is not known before adding a new subsystem. However, if $c_k = \max_{ij} \|A_{kij}\|$, i.e., a

bound on the interconnection terms is known beforehand, the analysis of the subsystems can be decoupled by analyzing the last condition of Theorem 4.1:

$$\frac{\lambda_{\min}(\mathcal{H}(P_1 A_{1i} + Q_1))}{\max_i \|P_1 A_{12i}\|} > \frac{\max_i \|A_{21i}^T P_2\|^2}{\lambda_{\min}(Q_2) \lambda_{\min}(\mathcal{H}(P_2 A_{2i} + Q_2))}$$

$$\lambda_{\min}(\mathcal{H}(P_1 A_{1i} + Q_1)) \lambda_{\min}(Q_2) \lambda_{\min}(\mathcal{H}(P_2 A_{2i} + Q_2)) > \max_i \|P_1 A_{12i}\| \max_i \|A_{21i}^T P_2\|^2$$

The third condition of Theorem 4.1 already states that

$$\lambda_{\min}(Q_1) \geq \max_i \|P_1 A_{12i}\|$$

If Q_2 is similarly restricted, i.e., the condition

$$\lambda_{\min}(Q_2) \geq \max_i \|P_2 A_{21i}\|$$

is imposed, then the last condition of Theorem 4.1 becomes

$$\begin{aligned} \lambda_{\min}(\mathcal{H}(P_1 A_{1i} + Q_1)) \lambda_{\min}(Q_2) \lambda_{\min}(\mathcal{H}(P_2 A_{2i} + Q_2)) &> \lambda_{\min}(Q_1) \lambda_{\min}^2(Q_2) \\ \lambda_{\min}(\mathcal{H}(P_1 A_{1i} + Q_1)) \lambda_{\min}(\mathcal{H}(P_2 A_{2i} + Q_2)) &> \lambda_{\min}(Q_1) \lambda_{\min}(Q_2) \end{aligned}$$

which is satisfied if

$$\begin{aligned} \lambda_{\min}(\mathcal{H}(P_1 A_{1i} + Q_1)) &> \lambda_{\min}(Q_1) \\ \lambda_{\min}(\mathcal{H}(P_2 A_{2i} + Q_2)) &> \lambda_{\min}(Q_2) \end{aligned}$$

The condition can be summarized as:

Theorem 4.2 *The distributed system (4.1) is exponentially stable, if there exist $P_1 = P_1^T > 0$, $P_2 = P_2^T > 0$, $Q_1 = Q_1^T > 0$, $Q_2 = Q_2^T > 0$, so that*

$$\begin{aligned} \lambda_{\min}(\mathcal{H}(P_1 A_{1i} + Q_1)) &> \lambda_{\min}(Q_1) \\ \lambda_{\min}(\mathcal{H}(P_2 A_{2i} + Q_2)) &> \lambda_{\min}(Q_2) \\ \lambda_{\min}(Q_1) &\geq \max_i \|P_1 A_{12i}\| \\ \lambda_{\min}(Q_2) &\geq \max_i \|P_2 A_{21i}\| \end{aligned}$$

where $\lambda_{\min}(\cdot)$ is the eigenvalue with the smallest absolute magnitude. \square

Note that these conditions are more conservative than those of Theorem 4.1. By imposing for both subsystems that $\lambda_{\min}(Q_i) \geq \max_j \|P_i A_{ikj}\|$, $i, j = 1, 2$, it is required that each subsystem “dominates” the influence from the other subsystem. As stated in Theorem 4.1, if the newly added subsystem “dominates” both interconnection terms, while the second subsystem is stable, it is enough to ensure the stability of the whole system.

Theorem 4.2, similarly to current results for stability analysis and stabilization of fuzzy large scale systems (Uang and Chen, 2000; Hsiao and Hwang, 2002; Wang and Luoh, 2004; Wang and Chai, 2005; Tseng, 2008) is comparable to perturbation methods with weak coupling (see (Sandell et al., 1978) and the references therein). In fact, the assumption that the coupling is “weak enough”, compared to the dynamics of the individual subsystems is necessary for the controller (or the analysis) to be decoupled.

In contrast, Theorem 4.1 and the resulting Algorithm 4.1, is comparable to methods developed for strong coupling, i.e., only one of the subsystems has to converge quickly enough so that stability is preserved. This approach can also be thought of as an asymmetrical weak coupling, i.e., only one of the influences has to be weak enough for stability to be preserved.

4.3 Distributed observer design

This section presents the decentralized approach applied to observer design for TS fuzzy systems.

4.3.1 Preliminaries

Consider a distributed system where each subsystem is represented by a TS fuzzy model, to which new subsystems may be added online, and an asymptotically stable observer needs to be designed for the whole system. We consider distributed design, where an observer is designed for each newly added subsystem, without modifying the already existing observers, so that the overall observer is stable.

Note that we only consider observer design and do not assume that the subsystems are stabilized or controlled at a known value (i.e., the states are not at some known constant value). However, we assume that the estimated states are communicated among the subsystems that influence each other. This means that the communication graph of the subsystems should be the same as the interconnection graph, i.e., if a subsystem A influences another subsystem B, then subsystem A should also communicate its estimated states to the subsystem B.

For the ease of notation and without loss of generality, only two subsystems are considered. The observer structure is depicted in Figure 4.2.

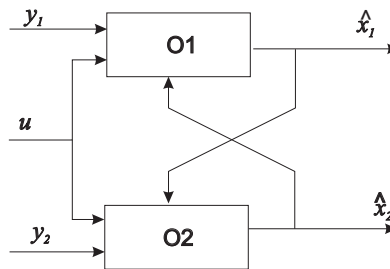

Figure 4.2: Decentralized observer for two subsystems.

Consider a fuzzy system that consists of two subsystems:

$$\begin{aligned}\dot{\mathbf{x}}_1 &= \sum_{i=1}^m w_i(\mathbf{z})(A_{1i}\mathbf{x}_1 + B_{1i}\mathbf{u} + A_{12i}\mathbf{x}_2) \\ \mathbf{y}_1 &= \sum_{i=1}^m w_i(\mathbf{z})(C_{11i}\mathbf{x}_1 + C_{12i}\mathbf{x}_2)\end{aligned}\tag{4.7}$$

$$\begin{aligned}\dot{\mathbf{x}}_2 &= \sum_{i=1}^m w_i(\mathbf{z})(A_{2i}\mathbf{x}_2 + B_{2i}\mathbf{u} + A_{21i}\mathbf{x}_1) \\ \mathbf{y}_2 &= \sum_{i=1}^m w_i(\mathbf{z})(C_{22i}\mathbf{x}_2 + C_{21i}\mathbf{x}_1)\end{aligned}$$

and the observer is of the form:

$$\begin{aligned}\dot{\hat{\mathbf{x}}}_1 &= \sum_{i=1}^m w_i(\hat{\mathbf{z}})(A_{1i}\hat{\mathbf{x}}_1 + B_{1i}\mathbf{u} + A_{12i}\hat{\mathbf{x}}_2 + L_{1i}(\mathbf{y}_1 - \hat{\mathbf{y}}_1)) \\ \hat{\mathbf{y}}_1 &= \sum_{i=1}^m w_i(\hat{\mathbf{z}})(C_{11i}\hat{\mathbf{x}}_1 + C_{12i}\hat{\mathbf{x}}_2)\end{aligned}\tag{4.8}$$

$$\begin{aligned}\dot{\hat{\mathbf{x}}}_2 &= \sum_{i=1}^m w_i(\hat{\mathbf{z}})(A_{2i}\hat{\mathbf{x}}_2 + B_{2i}\mathbf{u} + A_{21i}\hat{\mathbf{x}}_1 + L_{2i}(\mathbf{y}_2 - \hat{\mathbf{y}}_2)) \\ \hat{\mathbf{y}}_2 &= \sum_{i=1}^m w_i(\hat{\mathbf{z}})(C_{22i}\hat{\mathbf{x}}_2 + C_{21i}\hat{\mathbf{x}}_1)\end{aligned}$$

The goal is to design the observer gains L_{1i} , $i = 1, 2, \dots, m$ for each rule of the subsystem with states \mathbf{x}_1 so that (4.8) is a stable observer, given that the gains L_{2i} , $i = 1, 2, \dots, m$ have already been designed such that the observer

$$\begin{aligned}\dot{\hat{\mathbf{x}}}_2 &= \sum_{i=1}^m w_i(\hat{\mathbf{z}})(A_{2i}\hat{\mathbf{x}}_2 + B_{2i}\mathbf{u} + L_{2i}(\mathbf{y}_2 - \hat{\mathbf{y}}_2)) \\ \hat{\mathbf{y}}_2 &= \sum_{i=1}^m w_i(\hat{\mathbf{z}})C_{22i}\hat{\mathbf{x}}_2\end{aligned}$$

is stable for the second subsystem without the interconnection terms:

$$\begin{aligned}\dot{\mathbf{x}}_2 &= \sum_{i=1}^m w_i(\mathbf{z})(A_{2i}\mathbf{x}_2 + B_{2i}\mathbf{u}) \\ \mathbf{y}_2 &= \sum_{i=1}^m w_i(\mathbf{z})C_{22i}\mathbf{x}_2\end{aligned}$$

The system structure considered is characterized by coupling both in states and measurements. Such a system is presented in Figure 4.3. Two cases are distinguished, according to whether or not the scheduling vector depends on some of the states to be estimated.

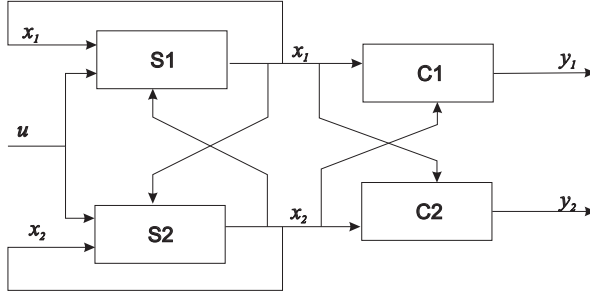

Figure 4.3: Two subsystems coupled through their states and measurements.

4.3.2 State-independent scheduling vector

Distributed observer design

If the scheduling vector does not depend on the states to be estimated, the error systems can be expressed as:

$$\begin{aligned} \dot{e}_1 &= \sum_{i=1}^m \sum_{j=1}^m w_i(z)w_j(z)[A_{1i}e_1 + A_{12i}e_2 - L_{1i}C_{1j}e] \\ e_{y1} &= \sum_{i=1}^m w_i(z)C_{1i}e \end{aligned} \quad (4.9)$$

$$\begin{aligned} \dot{e}_2 &= \sum_{i=1}^m \sum_{j=1}^m w_i(z)w_j(z)[A_{2i}e_2 + A_{21i}e_1 - L_{2i}C_{2j}e] \\ e_{y2} &= \sum_{i=1}^m w_i(z)C_{2i}e \end{aligned}$$

where $C_{1i} = [C_{11i} \ C_{12i}]$ and $C_{2i} = [C_{21i} \ C_{22i}]$, or

$$\dot{e} = \sum_{i=1}^m \sum_{j=1}^m w_i(z)w_j(z) \begin{pmatrix} A_{1i} - L_{1i}C_{11j} & A_{12i} - L_{1i}C_{12j} \\ A_{21i} - L_{2i}C_{21j} & A_{2i} - L_{2i}C_{22j} \end{pmatrix} e \quad (4.10)$$

Note that since $L_{1i}, i = 1, 2, \dots, m$ need to be designed, a simple special case is when there exist $P_1 = P_1^T > 0$ and L_{1i} , so that $\mathcal{H}(P_1(A_{1i} - L_{1i}C_{11j})) < 0$ and $A_{12i} - L_{1i}C_{12j} = 0 \ \forall i, j : \exists z : w_i(z)w_j(z) \neq 0$. In this case the error system (4.10) is cascaded, further restrictions are not necessary, and the stability conditions can be summarized as the consequence of Theorem 3.2:

Corollary 4.1 *The error system (4.10) is asymptotically stable if there exist $P_1 = P_1^T > 0$, $P_2 = P_2^T > 0$, $L_{1i}, L_{2i}, i = 1, 2, \dots, m$ so that $\forall i, j : \exists z : w_i(z)w_j(z) \neq 0$*

$$\mathcal{H}(P_1(A_{1i} - L_{1i}C_{11j})) < 0$$

$$\mathcal{H}(P_2(A_{2i} - L_{2i}C_{22j})) < 0$$

$$A_{12i} - L_{1i}C_{12j} = 0$$

□

Note that the third condition of Corollary 4.1 is more likely to be satisfied if the measurement matrix is common for the rules of a subsystem and the coupling is present only in measurements. However, in general this is not the case and it is not possible to find such L_{1i} . Therefore, the results from Section 4.2 can be appropriately modified:

Corollary 4.2 *The error system (4.10) is exponentially stable, if there exist $L_{1i}, L_{2i}, i = 1, 2, \dots, m, P_1 = P_1^T > 0, P_2 = P_2^T > 0, Q_1 = Q_1^T > 0, Q_2 = Q_2^T > 0$, so that*

$$\begin{aligned} \mathcal{H}(P_1 G_{1ij}) &< -2Q_1 \quad \forall i, j : \exists \mathbf{z} : w_i(\mathbf{z})w_j(\mathbf{z}) \neq 0 \\ \mathcal{H}(P_2 G_{2ij}) &< -2Q_2 \quad \forall i, j : \exists \mathbf{z} : w_i(\mathbf{z})w_j(\mathbf{z}) \neq 0 \\ \lambda_{\min}(Q_1) &\geq \max_{ij} \|P_1 G_{12ij}\| \\ \frac{\lambda_{\min}(\mathcal{H}(P_1 G_{1ij} + Q_1))}{\max_{ij} \|P_1 G_{12ij}\|} &> \frac{\max_{ij} \|P_2 G_{21ij}\|^2}{\lambda_{\min}(Q_2)\lambda_{\min}(\mathcal{H}(P_2 G_{2ij} + Q_2))} \end{aligned}$$

where $G_{1ij} = A_{1i} - L_{1i}C_{11j}$, $G_{2ij} = A_{2i} - L_{2i}C_{22j}$, $G_{12ij} = A_{12i} - L_{1i}C_{12j}$, $G_{21ij} = A_{21i} - L_{2i}C_{21j}$, and λ_{\min} denotes the eigenvalue with the smallest absolute magnitude. □

LMI conditions

Note that Corollary 4.2 leads to a sequential implementation, similar to Algorithm 4.1. Once a stable observer is designed for the subsystem

$$\begin{aligned} \dot{\mathbf{x}}_2 &= \sum_{i=1}^m w_i(\mathbf{z})(A_{2i}\mathbf{x}_2 + B_{2i}\mathbf{u}) \\ \mathbf{y}_2 &= \sum_{i=1}^m w_i(\mathbf{z})C_{22i}\mathbf{x}_2 \end{aligned}$$

the matrices P_2, Q_2 , and the gains $L_{2i}, i = 1, 2, \dots, m$ are known, and therefore, G_{2ij} can be computed. After adding the interconnection terms, $G_{21ij}, i = 1, 2, \dots, m, j = 1, 2, \dots, m$ also the ratio

$$\gamma = \frac{\max_{ij} \|P_2 G_{21ij}\|^2}{\lambda_{\min}(Q_2)\lambda_{\min}(\mathcal{H}(P_2 G_{2ij} + Q_2))}$$

can be computed. The conditions of Corollary 4.2 are then reduced to finding $L_{2i}, i = 1, 2, \dots, m, P_1 = P_1^T > 0, Q_1 = Q_1^T > 0$, so that for $i = 1, 2, \dots, m, j = 1, 2, \dots, m$

$$\begin{aligned} \mathcal{H}(P_1 G_{1ij}) &< -2Q_1 \\ \lambda_{\min}(Q_1) &\geq \max_{ij} \|P_1 G_{12ij}\| \\ \lambda_{\min}(\mathcal{H}(P_1 G_{1ij} + Q_1)) &> \gamma \max_{ij} \|P_1 G_{12ij}\| \end{aligned}$$

which are satisfied if

$$\begin{aligned} \mathcal{H}(P_1 G_{1ij} + Q_1) &< 0 \\ Q_1 &\geq \max_{ij} \|P_1 G_{12ij}\| I \\ \mathcal{H}(P_1 G_{1ij} + Q_1) &< -\gamma \max_{ij} \|P_1 G_{12ij}\| I \end{aligned}$$

These conditions, in turn are satisfied if the following LMI is feasible, with the change of variables $M_i = P_1 L_{1i}$: find $L_{2i}, i = 1, 2, \dots, m, P_1 = P_1^T > 0, Q_1 = Q_1^T > 0, t_1 > 0, t_2 > 0, M_i, i = 1, 2, \dots, m$, so that for $i = 1, 2, \dots, m, j = 1, 2, \dots, m$

$$\begin{aligned} \mathcal{H}(P_1 A_{1i} - M_i C_{1i} + Q_1) &< -t_1 I \\ Q_1 &> t_2 I \\ \begin{pmatrix} t_2 I & P_1 A_{12i} - M_i C_{21j} \\ (P_1 A_{12i} - M_i C_{21j})^T & t_2 I \end{pmatrix} &> 0 \\ \begin{pmatrix} t_1 I & P_1 \gamma A_{12i} - M_i \gamma C_{21j} \\ (P_1 \gamma A_{12i} - M_i \gamma C_{21j})^T & t_1 I \end{pmatrix} &> 0 \end{aligned}$$

The steps can be summarized as:

Algorithm 4.2

1. For the existing observer of the subsystem

$$\begin{aligned} \dot{\mathbf{x}}_2 &= \sum_{i=1}^m w_i(\mathbf{z})(A_{2i} \mathbf{x}_2 + B_{2i} \mathbf{u}) \\ \mathbf{y}_2 &= \sum_{i=1}^m w_i(\mathbf{z}) C_{22i} \mathbf{x}_2 \end{aligned}$$

compute

$$\bar{\gamma} = \frac{\|P_2\|^2}{\lambda_{\min}(Q_2) \lambda_{\min}(\mathcal{H}(P_2 G_{2ij} + Q_2))}$$

2. When the new subsystem and corresponding interconnection terms are added, compute $\gamma = \bar{\gamma} \max_{i,j} \|G_{21ij}\|^2$. To design the observer for this subsystem, solve the LMI problem: find $L_{2i}, i = 1, 2, \dots, m, P_1 = P_1^T > 0, Q_1 = Q_1^T > 0, t_1 > 0, t_2 > 0, M_i, i = 1, 2, \dots, m$, so that for $i = 1, 2, \dots, m, j = 1, 2, \dots, m$

$$\begin{aligned} \mathcal{H}(P_1 A_{1i} - M_i C_{1i} + Q_1) &< -t_1 I \\ Q_1 &> t_2 I \\ \begin{pmatrix} t_2 I & P_1 A_{12i} - M_i C_{21j} \\ (P_1 A_{12i} - M_i C_{21j})^T & t_2 I \end{pmatrix} &> 0 \\ \begin{pmatrix} t_1 I & P_1 \gamma A_{12i} - M_i \gamma C_{21j} \\ (P_1 \gamma A_{12i} - M_i \gamma C_{21j})^T & t_1 I \end{pmatrix} &> 0 \end{aligned}$$

Decoupled observer design

Note that Algorithm 4.2 is useful if no bound on the interconnection terms is known before the subsystem is added. If a bound on $A_{12i}, A_{21i}, C_{21i}, C_{12i}, i = 1, 2, \dots, m$ is known beforehand, the design can be decoupled starting with the first subsystem, by analyzing the last condition of Corollary 4.2. Although the following manipulations introduce conservativeness, the design is decoupled, and LMI conditions are obtained.

Let us impose a condition similar to that of the third condition of Corollary 4.2 to the second subsystem, i.e.,

$$\lambda_{\min}(Q_2) \geq \max_{ij} \|P_2 G_{21ij}\|$$

Then, we obtain

$$\frac{\max_{ij} \|P_2 G_{21ij}\|^2}{\lambda_{\min}(Q_2) \lambda_{\min}(\mathcal{H}(P_2 G_{2ij} + Q_2))} \leq \frac{\max_{ij} \|P_2 G_{21ij}\|}{\lambda_{\min}(\mathcal{H}(P_2 G_{2ij} + Q_2))}$$

an expression that is similar to that of the reciprocal of the first part of the fourth condition of Corollary 4.2, i.e.,

$$\frac{\lambda_{\min}(\mathcal{H}(P_1 G_{1ij} + Q_1))}{\max_{ij} \|P_1 G_{12ij}\|}$$

By imposing for both subsystems

$$\frac{\lambda_{\min}(\mathcal{H}(P_k G_{kij} + Q_k))}{\max_{ij} \|P_k T_{kij}\|} > 1$$

where T_{kij} is the interconnection term influencing the subsystem k , $T_{kij} = A_{kpi} - L_{ki} C_{kpj}$, $k = 1, 2$, the conditions are decoupled. This result can be summarized as:

Corollary 4.3 *The error system (4.10) is exponentially stable, if there exist L_{kij} , $i = 1, 2, \dots, m$, $j = 1, 2, \dots, m$, $P_k = P_k^T > 0$, $Q_k = Q_k^T > 0$ so that $\forall i, j : \exists z : w_i(z) w_j(z) \neq 0$*

$$\begin{aligned} \mathcal{H}(P_k G_{kij}) &< -2Q_k \\ \lambda_{\min}(Q_k) &\geq \max_i \|P_k T_{kij}\| \\ \lambda_{\min}(\mathcal{H}(P_k G_{kij} + Q_k)) &> \max_{ij} \|P_k T_{kij}\| \end{aligned} \quad (4.11)$$

where $G_{kij} = A_{ki} - L_{ki} C_{kij}$, $T_{kij} = A_{kpi} - L_{ki} C_{kpj}$ is the interconnection term that influences the subsystem k , L_{ki} , $i = 1, 2, \dots, m$ are the observer gains of the k th subsystem, and λ_{\min} denotes the eigenvalue with the smallest absolute magnitude. \square

Note that the above conditions are not LMIs. By imposing that

$$\lambda_{\min}(\mathcal{H}(P_k G_{kij} + Q_k)) > \lambda_{\min}(Q_k)$$

and that $t_{km}I \leq Q_k \leq t_{kM}I$, the conditions (4.11) are satisfied if

$$\begin{aligned} t_{km}I &\leq Q_k \leq t_{kM}I \\ \mathcal{H}(P_k G_{kij} + Q_k) &< -t_{kM}I \quad t_{km}I \geq \max_{ij} \|P_k T_{kij}\| \end{aligned} \quad (4.12)$$

Recall, that the interconnection term T_{kij} is in fact $T_{kij} = A_{kpi} - L_{ki} C_{kpj}$, i.e., the interconnection term in the error dynamics. However, only the bounds on the interconnection terms in the subsystems are known, i.e., $\mu_{Ak} = \max_{pi} \|A_{kpi}\|$ and $\mu_{Ck} = \max_{pi} \|C_{kpi}\|$, where k is the number of the current subsystem, $k = 1, 2$. Therefore, let Q_k be the sum of two positive definite matrices, $Q_k = Q_{kA} + Q_{kC}$, which satisfy

$$\begin{aligned} Q_{kA} &\geq \mu_{Ak} \|P_k\| I \\ Q_{kC} &\geq \mu_{Ck} \max_i \|P_k L_{ki}\| I \end{aligned}$$

The conditions above may be expressed as LMIs:

$$\begin{aligned}
 Q_{kA} &\geq t_1 I \\
 Q_{kC} &\geq t_2 I \\
 \begin{pmatrix} t_1 I & \mu_{Ak} P_k \\ \mu_{Ak} P_k & t_1 I \end{pmatrix} &\geq 0 \\
 \begin{pmatrix} t_2 I & \mu_{Ck} M_{ki} \\ \mu_{Ck} M_{ki}^T & t_2 I \end{pmatrix} &\geq 0
 \end{aligned}$$

where $M_{ki} = P_k L_{ki}$.

Now, the conditions are not only decoupled, but also expressed as LMIs. The result is summarized as:

Theorem 4.3 *The error system (4.10) is exponentially stable, if there exist M_{ki} , $i = 1, 2, \dots, m$, $P_k = P_k^T > 0$, $Q_k = Q_k^T$, $t_1 > 0$, $t_2 > 0$, $t_{kM} > 0$, $t_{km} > 0$, so that $\forall i, j : \exists \mathbf{z} : w_i(\mathbf{z})w_j(\mathbf{z}) \neq 0$*

$$\begin{aligned}
 t_{km} I &\leq Q_k \leq t_{kM} I \\
 \mathcal{H}(P_k G_{kij} + Q_k) &< -t_{kM} I \\
 t_{km} I &\geq Q_{kA} + Q_{kC} \\
 Q_{kA} &\geq t_1 I \\
 Q_{kC} &\geq t_2 I \\
 \begin{pmatrix} t_1 I & \mu_{Ak} P_k \\ \mu_{Ak} P_k & t_1 I \end{pmatrix} &\geq 0 \\
 \begin{pmatrix} t_2 I & \mu_{Ck} M_{ki} \\ \mu_{Ck} M_{ki}^T & t_2 I \end{pmatrix} &\geq 0
 \end{aligned} \tag{4.13}$$

□

Note however, that this result can only be used if a bound on the possible interconnection term is known. Also, the same remark is valid, as for Theorem 4.1, i.e., the conditions of Theorem 4.3 are more conservative than those of Corollary 4.2.

4.3.3 State-dependent scheduling vector

Consider now the case when the scheduling vector depends on the states to be estimated. For the simplicity of notation, only the case when the measurement matrices are common for all the rules of a subsystem is presented. Note, however, that if the measurement matrices are different for each rule, the observers can be designed in a similar fashion.

The error system (similarly to Section 4.3.2) can be expressed as:

$$\begin{aligned}\dot{\mathbf{e}}_1 &= \sum_{i=1}^m w_i(\hat{\mathbf{z}})[A_{1i}\mathbf{e}_1 + A_{12i}\mathbf{e}_2 - L_{1i}C_1\mathbf{e}] \\ &\quad + \sum_{i=1}^m (w_i(\mathbf{z}) - w_i(\hat{\mathbf{z}}))(A_{1i}\mathbf{x}_1 + B_{1i}\mathbf{u} + A_{12i}\mathbf{x}_2) \\ \mathbf{e}_{y1} &= C_1\mathbf{e}\end{aligned}\tag{4.14}$$

$$\begin{aligned}\dot{\mathbf{e}}_2 &= \sum_{i=1}^m w_i(\hat{\mathbf{z}})[A_{2i}\mathbf{e}_2 + A_{21i}\mathbf{e}_1 - L_{2i}C_2\mathbf{e}] \\ &\quad + \sum_{i=1}^m (w_i(\mathbf{z}) - w_i(\hat{\mathbf{z}}))(A_{2i}\mathbf{x}_2 + B_{2i}\mathbf{u} + A_{21i}\mathbf{x}_1) \\ \mathbf{e}_{y2} &= C_2\mathbf{e}\end{aligned}$$

or

$$\begin{aligned}\dot{\mathbf{e}} &= \sum_{i=1}^m w_i(\hat{\mathbf{z}}) \begin{pmatrix} A_{1i} - L_{1i}C_{11} & A_{12i} - L_{1i}C_{12} \\ A_{21i} - L_{2i}C_{21} & A_{2i} - L_{2i}C_{22} \end{pmatrix} \mathbf{e} \\ &\quad + \sum_{i=1}^m (w_i(\mathbf{z}) - w_i(\hat{\mathbf{z}})) \begin{pmatrix} A_{1i}\mathbf{x}_1 + B_{1i}\mathbf{u} + A_{12i}\mathbf{x}_2 \\ A_{2i}\mathbf{x}_2 + B_{2i}\mathbf{u} + A_{21i}\mathbf{x}_1 \end{pmatrix}\end{aligned}\tag{4.15}$$

In case of a centralized observer design in general it is assumed that

$$\Delta = \sum_{i=1}^m (w_i(\mathbf{z}) - w_i(\hat{\mathbf{z}})) \begin{pmatrix} A_{1i}\mathbf{x}_1 + B_{1i}\mathbf{u} + A_{12i}\mathbf{x}_2 \\ A_{2i}\mathbf{x}_2 + B_{2i}\mathbf{u} + A_{21i}\mathbf{x}_1 \end{pmatrix}$$

is Lipschitz in \mathbf{e} , i.e., $\|\Delta\| \leq \mu\|\mathbf{e}\|$. This condition can also be formulated as $\Delta = F\mathbf{e}$, with F an uncertainty, $\|F\| \leq \mu$. Consider now the distributed observer design. For the already existing subsystem the error is

$$\begin{aligned}\dot{\mathbf{e}}_2 &= \sum_{i=1}^m w_i(\hat{\mathbf{z}})[A_{2i}\mathbf{e}_2 - L_{2i}C_{22}\mathbf{e}_2] + \sum_{i=1}^m (w_i(\mathbf{z}) - w_i(\hat{\mathbf{z}}))(A_{2i}\mathbf{x}_2 + B_{2i}\mathbf{u}) \\ \mathbf{e}_{y2} &= C_{22}\mathbf{e}_2\end{aligned}\tag{4.16}$$

where $\bar{\mathbf{z}}$ depends *only* on the states of this subsystem. For this subsystem, there already exists a condition on the model-observer mismatch, i.e., $\|\bar{\Delta}\| = \|\sum_{i=1}^m (w_i(\bar{\mathbf{z}}) - w_i(\hat{\bar{\mathbf{z}}})) (A_{2i}\mathbf{x}_2 + B_{2i}\mathbf{u})\| \leq \mu_2\|\mathbf{e}_2\|$. When a new subsystem is introduced, both \mathbf{z} and Δ change. In order to keep the symmetry and have condition similar to that of centralized observer design, in this chapter we require that Δ is expressed as

$$\sum_{i=1}^m (w_i(\mathbf{z}) - w_i(\hat{\mathbf{z}})) \begin{pmatrix} A_{1i}\mathbf{x}_1 + B_{1i}\mathbf{u} + A_{12i}\mathbf{x}_1 \\ A_{2i}\mathbf{x}_2 + B_{2i}\mathbf{u} + A_{21i}\mathbf{x}_1 \end{pmatrix} = \begin{pmatrix} F_1 & F_{12} \\ F_{21} & F_2 \end{pmatrix} \mathbf{e}\tag{4.17}$$

and the uncertainties are bounded:

$$\begin{aligned}
 \|F_{12}\| &\leq \mu_{12} \\
 \|F_1\| &\leq \mu_1 \\
 \|F_{21}\| &\leq \mu_{21} \\
 \|F_2\| &\leq \mu_2
 \end{aligned} \tag{4.18}$$

Considering a distributed observer design for such a system, the following stability conditions can be formulated:

Corollary 4.4 *The error system (4.15) is asymptotically stable, if there exist $P_1 = P_1^T > 0$, $P_2 = P_2^T > 0$, $Q_1 = Q_1^T > 0$, $Q_2 = Q_2^T > 0$, L_{1i}, L_{2i} , $i = 1, 2, \dots, m$ so that (4.17) and (4.18) are satisfied and*

$$\begin{aligned}
 \mathcal{H}(P_2(G_{2i} + F_2)) &< -2Q_2 \quad i = 1, 2, \dots, m \\
 \mathcal{H}(P_1G_{1i}) &< -2Q_1 \quad i = 1, 2, \dots, m \\
 \lambda_{\min}(\mathcal{H}(Q_1 + P_1F_1)) &> \max_i \|P_1(G_{12i} + F_{12})\| \\
 \frac{\lambda_{\min}(\mathcal{H}(P_1G_{1i} + Q_1))}{\max_i \|P_1(G_{12i} + F_{12})\|} &> \frac{\max_i \|P_2(G_{21i} + F_{21})\|^2}{\lambda_{\min}(Q_2)\lambda_{\min}(\mathcal{H}(P_2(G_{2i} + F_2) + Q_2))}
 \end{aligned}$$

where $G_{1i} = A_{1i} - L_{1i}C_{11}$, $G_{2i} = A_{2i} - L_{2i}C_{21}$, $G_{12i} = A_{12i} - L_{1i}C_{12}$, $G_{21i} = A_{21i} - L_{2i}C_{21}$, and λ_{\min} denotes the eigenvalue with the smallest absolute magnitude.

Proof: Consider first the following part of the system (4.15):

$$\begin{aligned}
 \dot{e}_c &= \sum_{i=1}^m w_i(\hat{z}) \begin{pmatrix} (A_{1i} - L_{1i}C_{11})e_{1c} \\ A_{2i}e_{2c} + A_{21i}e_{1c} - L_{2i}C_{2e} \end{pmatrix} \\
 &+ \sum_{i=1}^m (w_i(z) - w_i(\hat{z})) \begin{pmatrix} 0 \\ A_{2i}x_2 + B_{2i}u + A_{21i}x_1 \end{pmatrix}
 \end{aligned} \tag{4.19}$$

This is a cascaded system and it is asymptotically stable, if the conditions of Theorem 3.6 are satisfied. First, we prove, that for this cascaded system, exponential stability can be achieved by using somewhat more conservative conditions: if there exist $P_1 = P_1^T > 0$, $P_2 = P_2^T > 0$, $Q_1 = Q_1^T > 0$, $Q_2 = Q_2^T > 0$, $\mu_2 \geq 0$, $\mu_{21} \geq 0$, F_2, F_{21} so that

$$\begin{aligned}
 \mathcal{H}(P_1G_{1i}) &< -2Q_1 \quad i = 1, 2, \dots, m \\
 \sum_{i=1}^m (w_i(z) - w_i(\hat{z})) &(A_{2i}x_2 + B_{2i}u + A_{21i}x_1) = (F_{21} \quad F_2) e_c \\
 \|F_{21}\| &\leq \mu_{21} \\
 \|F_2\| &\leq \mu_2 \\
 \mathcal{H}(P_2(G_{2i} + F_2)) &< -2Q_2 \quad i = 1, 2, \dots, m
 \end{aligned}$$

with $G_{1i} = A_{1i} - L_{1i}C_{11}$ and $G_{2i} = A_{2i} - L_{2i}C_{21}$.

Note that the condition $\mathcal{H}(P_2(G_{2i} + F_2)) < -2Q_2$ ensures that the already existing error system is exponentially stable. Moreover, when the new (error) subsystem is “plugged

in", the bound on F_2 should not change, i.e., although the new subsystem influences the membership functions, it should not influence the model-observer mismatch of the second subsystem.

The above conditions also ensure that there exists $\alpha \in \mathcal{R}^+$ so that $V_c = e_c^T \text{diag}(\alpha P_1, P_2) e_c$ is a Lyapunov function for (4.19) and $\dot{V}_c < -2e_c^T Q e_c$, with $Q = \text{diag}(\alpha Q_1, Q_2)$ and $G_{21i} = A_{21i} - L_{2i} C_{21}$. To prove this, consider the Lyapunov function

$$V_c = e_c^T \begin{pmatrix} \alpha P_1 & 0 \\ 0 & P_2 \end{pmatrix} e_c$$

The derivative can be computed as:

$$\dot{V}_c = \sum_{i=1}^m w_i(\hat{z}) e_c^T \mathcal{H} \begin{pmatrix} \alpha P_1 G_{1i} & 0 \\ P_2(G_{21i} + F_{21}) & P_2(G_{2i} + F_2) \end{pmatrix} e_c$$

For $\dot{V}_c < -2e_c^T Q e_c$, it is needed that

$$\begin{pmatrix} \alpha \mathcal{H}(P_1 G_{1i}) & (G_{21i} + F_{21})^T P_2 \\ P_2(G_{21i} + F_{21}) & \mathcal{H}(P_2(G_{2i} + F_2)) \end{pmatrix} < -2 \begin{pmatrix} \alpha Q_1 & 0 \\ 0 & Q_2 \end{pmatrix}$$

which amounts to

$$\begin{pmatrix} \alpha \mathcal{H}(P_1 G_{1i} + Q_1) & (G_{21i} + F_{21})^T P_2 \\ P_2(G_{21i} + F_{21}) & \mathcal{H}(P_2(G_{2i} + F_2) + Q_2) \end{pmatrix} < 0$$

Using the Schur complement, we obtain

$$\alpha \mathcal{H}(P_1 G_{1i} + Q_1) - (G_{21i} + F_{21})^T P_2 (\mathcal{H}(P_2(G_{2i} + F_2) + Q_2))^{-1} P_2 (G_{21i} + F_{21}) < 0$$

which is satisfied by any α chosen such that

$$\alpha > \frac{1}{\lambda_{\min}(\mathcal{H}(P_1 G_{1i} + Q_1))} \cdot \frac{\max_i \|P_2(G_{21i} + F_{21})\|^2}{\lambda_{\min}(\mathcal{H}(P_2(G_{2i} + F_2) + Q_2))} \quad (4.20)$$

Now, consider the full error system (4.15), together with the assumptions

$$\begin{aligned} \sum_{i=1}^m (w_i(\mathbf{z}) - w_i(\hat{\mathbf{z}}))(A_{1i} \mathbf{x}_1 + B_{1i} \mathbf{u} + A_{12i} \mathbf{x}_1) &= (F_1 \quad F_{12}) e \\ \|F_{12}\| &\leq \mu_{12} \\ \|F_1\| &\leq \mu_1 \end{aligned} \quad (4.21)$$

Note that these assumptions, together with

$$\begin{aligned} \sum_{i=1}^m (w_i(\mathbf{z}) - w_i(\hat{\mathbf{z}}))(A_{2i} \mathbf{x}_2 + B_{2i} \mathbf{u} + A_{21i} \mathbf{x}_1) &= (F_{21} \quad F_2) e_c \\ \|F_{21}\| &\leq \mu_{21} \\ \|F_2\| &\leq \mu_2 \end{aligned} \quad (4.22)$$

are effectively equivalent to those that would be used in the centralized design (see Theorem 2.3).

By using the above constructed $V = V_c$ as a candidate Lyapunov function for (4.15), we obtain:

$$\begin{aligned} \dot{V} &= \sum_{i=1}^m w_i(\hat{z}) e^T \left(\begin{pmatrix} \alpha \mathcal{H}(P_1 G_{1i}) & G_{21i}^T P_2 \\ P_2 G_{21i} & \mathcal{H}(P_2 G_{2i}) \end{pmatrix} + \begin{pmatrix} 0 & \alpha P_1 G_{12i} \\ \alpha G_{12i}^T P_1 & 0 \end{pmatrix} \right) e \\ &+ e^T \begin{pmatrix} \alpha \mathcal{H}(P_1 F_1) & \alpha P_1 F_{12} \\ \alpha (P_1 F_{12})^T & 0 \end{pmatrix} e \\ &< -e^T \mathcal{H} \begin{pmatrix} \alpha(Q_1 + P_1 F_1) & 0 \\ 0 & Q_2 \end{pmatrix} e + 2e^T [\alpha \max_i \|P_1(G_{12i} + F_{12})\|] I e \\ &< -e^T \begin{pmatrix} \alpha \mathcal{H}(Q_1 + P_1 F_1 - \alpha \max_i \|P_1(G_{12i} + F_{12})\| I) & 0 \\ 0 & \mathcal{H}(Q_2 - \alpha \max_i \|P_1(G_{12i} + F_{12})\| I) \end{pmatrix} e \end{aligned}$$

which leads to the conditions

$$\lambda_{\min}(\mathcal{H}(Q_1 + P_1 F_1)) > \max_i \|P_1(G_{12i} + F_{12})\| \quad (4.23)$$

$$\lambda_{\min}(Q_2) > \alpha \max_i \|P_1(G_{12i} + F_{12})\| \quad (4.24)$$

Combining (4.20) and (4.24), we get that such an α exists, and $V = V_c$ is a Lyapunov function if

$$\frac{\lambda_{\min}(Q_2)}{\max_i \|P_1(G_{12i} + F_{12})\|} > \frac{\max_i \|P_2(G_{21i} + F_{21})\|^2}{\lambda_{\min}(\mathcal{H}(P_1 G_{1i} + Q_1)) \lambda_{\min}(\mathcal{H}(P_2(G_{2i} + F_2) + Q_2))}$$

or

$$\frac{\lambda_{\min}(\mathcal{H}(P_1 G_{1i} + Q_1))}{\max_i \|P_1(G_{12i} + F_{12})\|} > \frac{\max_i \|P_2(G_{21i} + F_{21})\|^2}{\lambda_{\min}(Q_2) \lambda_{\min}(\mathcal{H}(P_2(G_{2i} + F_2) + Q_2))}$$

□

Note that for this case (i.e., the scheduling vector depending on states to be estimated), a cascaded error system can only be obtained in special cases. As in Section 4.3.2, the conditions of Corollary 4.4 can be implemented in a two-step algorithm, similarly to Algorithm 4.2. If a bound on the interconnection terms is known in advance, a decomposed design is also possible, similar to that given in Theorem 4.3.

4.4 Example of decentralized observer design

Here we give a numerical example to illustrate the decentralized observer design. Consider a decentralized system, composed of four subsystems, as presented in Figure 4.4.

Part of the states of each subsystem is measured, and the interconnections are realized among the state functions. The individual subsystems and the interconnections are described as follows:

1. Subsystem 1: The scheduling variable z_1 is an exogenous measured variable, with the membership functions presented in Figure 4.5.

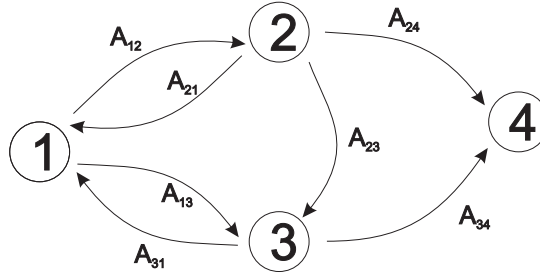

Figure 4.4: Four subsystems with their interconnections.

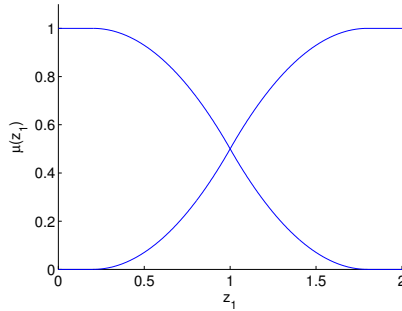

Figure 4.5: Membership function of z_1 .

Rule 1: If z_1 is small then

$$\begin{aligned}\dot{\mathbf{x}}_1 &= \begin{pmatrix} -1 & 1 \\ 2 & 3 \end{pmatrix} \mathbf{x}_1 + \begin{pmatrix} 1 \\ 2 \end{pmatrix} u \\ y_1 &= (1 \ 0) \mathbf{x}_1\end{aligned}$$

Rule 2: If z_1 is big then

$$\begin{aligned}\dot{\mathbf{x}}_1 &= \begin{pmatrix} 2 & 3 \\ 0 & -4 \end{pmatrix} \mathbf{x}_1 + \begin{pmatrix} 1 \\ 2 \end{pmatrix} u \\ y_1 &= (1 \ 0) \mathbf{x}_1\end{aligned}$$

2. Subsystem 2: The scheduling variable z_2 is x_{22} , a state to be estimated, with membership functions presented in Figure 4.6. The states are also assumed bounded, $x_{21}, x_{22} \in [-2, 2]$.

Rule 1: If z_2 is not zero then

$$\begin{aligned}\dot{\mathbf{x}}_2 &= \begin{pmatrix} -0.5 & 1.5 \\ 0 & -1 \end{pmatrix} \mathbf{x}_2 + \begin{pmatrix} 0.1 \\ 0.1 \end{pmatrix} \\ \mathbf{y}_2 &= \begin{pmatrix} 1 & 10 \\ 0.1 & 0 \end{pmatrix} \mathbf{x}_2\end{aligned}$$

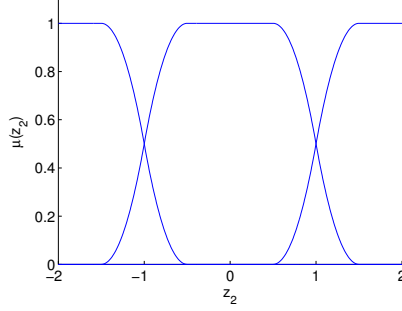
 Figure 4.6: Membership function of z_2 .

Rule 2: If z_2 is around zero then

$$\begin{aligned}\dot{\mathbf{x}}_2 &= \begin{pmatrix} 0.5 & 3 \\ 0 & 1 \end{pmatrix} \mathbf{x}_2 + \begin{pmatrix} 0 \\ 0.1 \end{pmatrix} \\ \mathbf{y}_2 &= \begin{pmatrix} 1 & 10 \\ 0.1 & 0 \end{pmatrix} \mathbf{x}_2\end{aligned}$$

The interconnection terms are as follows:

If z_1 is small and x_{22} is around zero then: $A_{12}^1 = \begin{pmatrix} 0.1 & 0.8 \\ 0.5 & 0 \end{pmatrix}$, $A_{21}^1 = \begin{pmatrix} 0.2 & 0.3 \\ 0.1 & 0 \end{pmatrix}$.

If z_1 is big and x_{22} is around zero then: $A_{12}^2 = \begin{pmatrix} -0.3 & 0.1 \\ 0.2 & 0.3 \end{pmatrix}$, $A_{21}^1 = \begin{pmatrix} -0.2 & -0.3 \\ 0.1 & 0 \end{pmatrix}$.

Otherwise there is no direct influence among the subsystems 1 and 2.

3. Subsystem 3: The scheduling variable z_3 is an exogenous measured variable, with the same type of membership function as z_1 .

Rule 1: If z_3 is small then

$$\begin{aligned}\dot{\mathbf{x}}_3 &= \begin{pmatrix} 1 & 2 \\ 3 & -3 \end{pmatrix} \mathbf{x}_3 + \begin{pmatrix} 3 \\ 4 \end{pmatrix} u \\ \mathbf{y}_3 &= (1 \ 2)\mathbf{x}_3\end{aligned}$$

Rule 2: If z_3 is big then

$$\begin{aligned}\dot{\mathbf{x}}_3 &= \begin{pmatrix} -2 & 0 \\ 2 & 2 \end{pmatrix} \mathbf{x}_3 + \begin{pmatrix} 3 \\ 4 \end{pmatrix} u \\ \mathbf{y}_3 &= (1 \ 2)\mathbf{x}_3\end{aligned}$$

The interconnection terms are as follows:

If z_3 is big then: $A_{13}^1 = \begin{pmatrix} 0.4 & 0.3 \\ 0.8 & 0 \end{pmatrix}$.

If z_1 is big and z_3 is small then: $A_{31}^1 = \begin{pmatrix} 0.2 & -0.3 \\ 0.1 & 0 \end{pmatrix}$.

if z_2 is around zero then: $A_{32}^1 = \begin{pmatrix} -0.2 & 0.1 \\ 0 & -0.1 \end{pmatrix}$.

Otherwise, there is no direct influence among the subsystems 1 and 3 and 2 and 3, respectively.

4. Subsystem 4: The scheduling variable z_4 depends on \mathbf{x}_4 , $z_4 = \mathbf{x}_{41} + \mathbf{x}_{42} + 4$, and the membership functions are $w_1(z_4) = 0.125(\mathbf{x}_{41} + \mathbf{x}_{42} + 4)$ (corresponding to “ z_4 is small”), and $w_2(z_4) = 1 - w_1(z_4)$ (“ z_4 is big”). The states are bounded, $\mathbf{x}_{41}, \mathbf{x}_{42} \in [-2, 2]$ and the input is bounded $u \in [-0.5, 0.5]$.

Rule 1: If z_4 is small then

$$\begin{aligned} \dot{\mathbf{x}}_4 &= \begin{pmatrix} -2 & 0 \\ 2 & -3 \end{pmatrix} \mathbf{x}_4 + \begin{pmatrix} 3 \\ 2 \end{pmatrix} u \\ y_4 &= (1 \ 0) \mathbf{x}_4 \end{aligned}$$

Rule 2: If z_4 is big then

$$\begin{aligned} \dot{\mathbf{x}}_4 &= \begin{pmatrix} -1 & 3 \\ 2 & -1 \end{pmatrix} \mathbf{x}_4 + \begin{pmatrix} 1 \\ 0 \end{pmatrix} u \\ y_4 &= (1 \ 0) \mathbf{x}_4 \end{aligned}$$

The interconnection terms are as follows:

If rule 1 is active then: $A_{42}^1 = \begin{pmatrix} 0.1 & 0.5 \\ 0.8 & 1 \end{pmatrix}$.

If rule 2 is active then: $A_{43}^1 = \begin{pmatrix} 0.2 & 0.5 \\ -0.5 & 0 \end{pmatrix}$.

Otherwise, there is no direct influence among the subsystems 1 and 4, 2 and 4, and 3 and 4.

The observers are designed sequentially, based on the conditions of Corollaries 4.2 and 4.4. First, an observer is designed for Subsystem 1, without further conditions. Second, an observer is designed for Subsystem 2, taking into account the interconnection terms with Subsystem 1. Third, an observer is designed for Subsystem 3, considering the interconnection terms with Subsystems 1 and 2. Finally, an observer is designed for Subsystem 4. These steps are illustrated in Figure 4.7. Note that subsystems 2' and 4 are cascaded, and therefore, based on stability conditions for cascaded systems, it is sufficient that the independent observers are stable.

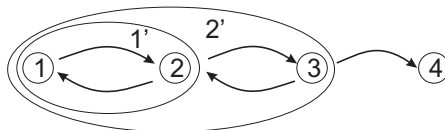

Figure 4.7: Ordering of subsystems for observer design.

A typical error trajectory can be seen in Figure 4.8. The system was simulated using the “ode23tb” method (trapezoidal rule with second order backward difference formula) for

solving ordinary differential equations of Matlab. This particular trajectory was computed for a randomly generated input and (where applicable) a random scheduling vector, with the true initial state being $[1 \ 2 \ -1 \ 3 \ -1 \ 1 \ 1 \ -1]^T$ and the estimated initial state being zero. As expected, the error converges asymptotically to zero. Note that the error for the second subsystem converges very fast. This is due to two reasons: 1) the scheduling variable of this subsystem is a state to be estimated, and the observer has to be robust enough to handle the model mismatch and 2) at the same time the observer has to comply with the restrictions imposed by the interconnections to the first subsystem.

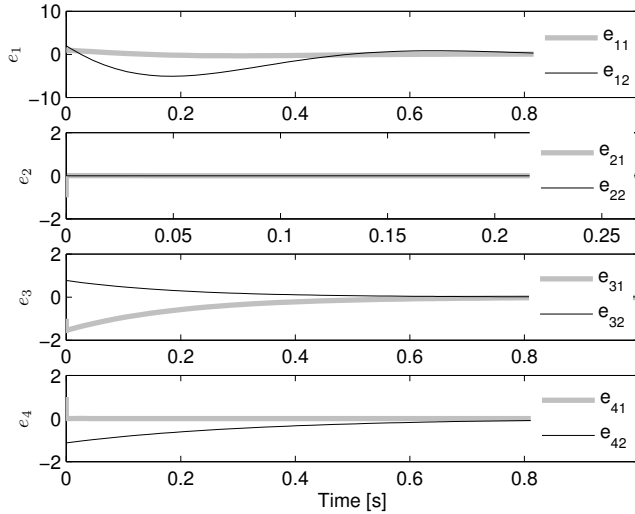

Figure 4.8: Error for the subsystems with decentralized design.

If the subsystems are added sequentially, and a bound on the interconnection terms is not known before the subsystem is added, one has to redesign a centralized observer each time a subsystem is added. A model of the centralized system can be obtained by taking all possible combinations of the interconnected subsystems and an observer can be designed for this system. This means that both the number of rules and the dimension of the LMI problem to be solved increase in every step: for the first subsystem, 2 LMIs of dimension 2 has to be solved, when the second subsystem is added, 4 LMIs of dimension 4, for the third subsystem 8 LMIs of dimension 6, and finally, when the fourth is added, 16 LMIs of dimension 8 need to be solved.

4.5 Summary and concluding remarks

Many physical systems, such as power systems, communication and distribution networks, economic systems, and traffic networks are composed of lower-dimensional subsystems that are interconnected. In this chapter, the stability of such decentralized systems has been studied for the case when the subsystems are represented as TS fuzzy systems. We proposed a method to sequentially analyze the stability of and design observers for TS fuzzy subsystems.

The proposed approach reduces the dimension of the problem to be solved, by analyzing the stability of the overall system based on the individual subsystems and the strength of the interconnection terms. We have also extended this setting to state estimation. Observers can be designed for the individual subsystems sequentially. Such a design has the advantage that the observer does not need to be redesigned every time a subsystem is added/removed.

A shortcoming of the method as it is presented is that it relies on the existence of a common quadratic Lyapunov function. Moreover, the derivation of LMI conditions, although facilitating the easier design, introduce conservativeness. Note however, that similar, less conservative, although notably more complex conditions may be derived by using piecewise quadratic Lyapunov functions.

Chapter 5

Adaptive observers

Many processes change slowly enough in time so that this change does not need to be considered when designing observers or controllers. However, in some cases, the change is considerable and may be due to the degradation of parts of the system, actuator failures, or unknown inputs or disturbances that should be detected as soon as possible. Therefore, in this chapter we propose a method to design observers for systems represented by TS fuzzy models, that are affected by unknown inputs. The observer designed is able to simultaneously estimate both the states and the unknown inputs affecting the system. We consider two types of inputs: 1) polynomials in time, such as a bias in the model or an unknown ramp input acting on the model and 2) unmodeled dynamics. The observer is designed based on the known part of the fuzzy model. Conditions for the asymptotic convergence of the observer are presented and the design guarantees an ultimate bound on the error signal.

5.1 Introduction

Adaptive observers are observers that simultaneously estimate the states and unknown parameters, by processing the measurements online. For SISO LTI systems, the adaptive observer design has been largely investigated, see (Narendra and Annaswamy, 1989) and the references therein.

For nonlinear systems, a general approach, both in adaptive controller and observer design (Park and Park, 2003; Tong et al., 2004; Park et al., 2005; Ho et al., 2005; Wang and Chai, 2005) is to assume that the system is SISO and in observer canonical form. By using a quadratic Lyapunov function, ensuring strictly positive real conditions, the Kalman-Yakubovic-Popov lemma is applied and the adaptive laws are deduced from the Lyapunov synthesis. A shortcoming of these observers is that they do not incorporate prior information (such as an approximate model) and cannot be used when physical states have to be estimated, or when a model is not in a canonical form. Robust versions of these adaptive observers have also been derived for systems affected by a bounded disturbance, by adding a robustness term (Park et al., 2001; Park and Park, 2003; Park et al., 2005; Wang and Chai, 2005; Labiod and Guerra, 2007). In many cases, when using both an observer and a controller, the robustness term is incorporated in the controller instead, to deal with the approximation error and disturbances (Tong et al., 2004; Ho et al., 2005). Results for MIMO systems include high

gain observers (Zhang and Xu, 2001), special observer canonical forms of the system (Zhu and Pagilla, 2003; Wang and Luoh, 2004), linearly parameterized neural networks (Ruiz Vargas and Hemerly, 2001; Hovakimyan et al., 2002) and observers based on a known linear part of the model (Ha and Trinh, 2004). A linear observers used for a nonlinear system in general can be used only in a small neighborhood of the linearization point. Moreover, such an observer can only deal with constant or slowly varying inputs (Xiong and Saif, 2003).

The design of observers in the presence of unknown inputs is an important problem, since in many cases not all the inputs are known (Xiong and Saif, 2003; Pertew et al., 2005, 2006). For instance, in machine tool and manipulator applications, the cutting force exerted by the tool or the exerting force/torque of the robot is needed, but it is very difficult or expensive to measure (Corless and Tu, 1998; Ha and Trinh, 2004). Load estimation in e.g., electricity distribution networks (Sheldrake, 2005), or wind turbines (Li and Chen, 2005) is necessary for proper planning and operation. In biomechanics, the myoskeletal system can be regarded as a dynamic system, where segment positions and trajectories are the system outputs and joint torques are the non-measurable inputs (Guelton et al., 2008). In traffic control, time-varying parameters have to be tracked, which can be regarded as unknown inputs (Wang and Papa-georgiou, 2005). In chaotic systems, for chaos synchronization and secure communication, one has to estimate not only the state, but also the input signal (Liao and Huang, 1999). The class of adaptive observers has received considerable interest in fault detection and identification, where the unknown inputs represent the effect of actuator failures or plant components and its presence has to be detected as soon as possible. However, many of these methods only detect the fault, but do not estimate it (Marx et al., 2007). However, in most cases, the system considered in these approaches is LTI. In this chapter, polynomial unknown inputs, such as biases in the model or an unknown ramp input acting on the model and uncertainty in the model dynamics are considered for TS fuzzy systems. The objective is to estimate the state and the unknown input from the available input and output information.

The idea behind this type of design is that, in practice, a TS representation of a nonlinear system may be obtained by identifying LTI models in different operation points. However, such models are often inaccurate. We develop a method to design observers for TS fuzzy systems with unknown polynomial inputs or unmodeled dynamics. By estimating the unknown inputs or unmodeled dynamics, the accuracy of the available models can be improved. The observers are designed based on the already identified model, such that, together with an appropriate update law estimating the unknown inputs, they ensure the convergence of the estimation error.

The fuzzy system considered is of the form

$$\begin{aligned}\dot{\mathbf{x}} &= \sum_{i=1}^m w_i(\mathbf{z})(A_i \mathbf{x} + B_i \mathbf{u} + a_i + M_i \mathbf{d}) \\ \mathbf{y} &= \sum_{i=1}^m w_i(\mathbf{z}) C_i \mathbf{x}\end{aligned}\tag{5.1}$$

where $A_i, B_i, M_i, a_i, C_i, i = 1, 2, \dots, m$ are known and the vector \mathbf{d} is an unknown input. This input can represent disturbances acting on the process, effects of uncertain dynamics or actuator failures. The matrices $M_i, i = 1, 2, \dots, m$ may be considered selection matrices, i.e., some disturbance may affect only some of the states. We consider two types of unknown inputs: 1) polynomials in time and 2) unmodelled dynamics. Our goal is to design

a stable observer to simultaneously estimate both the state vector \mathbf{x} and the unknown input \mathbf{d} . Throughout this section, it is assumed that

Assumption 5.1 *The matrices M_i , $i = 1, 2, \dots, m$ have full column rank, and $\text{rank}(CM_i) = \text{rank}(M_i)$, $i = 1, 2, \dots, m$.*

While this assumption is somewhat restrictive, it is necessary for the estimation of the unknown input with the proposed observer. The observer considered is of the form:

$$\begin{aligned}\hat{\dot{\mathbf{x}}} &= \sum_{i=1}^m w_i(\hat{\mathbf{z}})(A_i\hat{\mathbf{x}} + B_i\mathbf{u} + a_i + M_i\hat{\mathbf{d}} + L_i(\mathbf{y} - \hat{\mathbf{y}})) \\ \hat{\mathbf{y}} &= \sum_{i=1}^m w_i(\hat{\mathbf{z}})C_i\hat{\mathbf{x}} \\ \hat{\dot{\mathbf{d}}} &= f(\hat{\mathbf{d}}, \mathbf{w}(\hat{\mathbf{z}}), \hat{\mathbf{x}}, \mathbf{y})\end{aligned}\tag{5.2}$$

where L_i , $i = 1, 2, \dots, m$, are the gain matrices to be designed for each rule, and f , the update law for \mathbf{d} , should be determined so that (5.2) is a stable observer.

Two main cases can be distinguished, depending on whether or not the scheduling vector depends on the states to be estimated. The observer design is considered in both cases.

5.2 Polynomial unknown inputs

In this section, we consider the case when the unknown input is or can be approximated by a polynomial function in time. Such inputs may represent biases in the model, time-varying disturbances acting on the process, or the degradation in time or even failure of actuators. Conditions to design a fuzzy observer and a bound on the estimation error are derived.

5.2.1 Observer design

Consider the TS fuzzy system of the form

$$\begin{aligned}\dot{\mathbf{x}} &= \sum_{i=1}^m w_i(\mathbf{z})(A_i\mathbf{x} + B_i\mathbf{u} + M_i\mathbf{d} + a_i) \\ \mathbf{y} &= \sum_{i=1}^m w_i(\mathbf{z})C_i\mathbf{x}\end{aligned}\tag{5.3}$$

where there exists $p \in \mathbb{N}$ so that $\mathbf{d}^{(p)} = 0$, where $\mathbf{d}^{(p)}$ denotes the p th order derivative of \mathbf{d} , i.e., the unknown input is a $p-1$ -th order polynomial in time. It is assumed that the states, the unknown input \mathbf{d} , and the derivatives of \mathbf{d} are observable from \mathbf{y} . Two cases are considered, depending on whether or not the scheduling vector \mathbf{z} depends on the states to be estimated.

Case 1: State-independent scheduling vector

If \mathbf{z} does not depend on $\hat{\mathbf{x}}$, then the following result can be formulated:

Theorem 5.1 *The estimation error using the observer*

$$\begin{aligned}
 \dot{\hat{\mathbf{x}}} &= \sum_{i=1}^m w_i(\mathbf{z}) [A_i \hat{\mathbf{x}} + B_i \mathbf{u} + L_i (\mathbf{y} - \hat{\mathbf{y}}) + M_i \widehat{\mathbf{d}} + \mathbf{a}_i] \\
 \hat{\mathbf{y}} &= \sum_{i=1}^m w_i(\mathbf{z}) C_i \hat{\mathbf{x}} \\
 \dot{\widehat{\mathbf{d}}^{(p-1)}} &= \sum_{i=1}^m w_i(\mathbf{z}) \Lambda_{i,p} (\mathbf{y} - \hat{\mathbf{y}}) \\
 \dot{\widehat{\mathbf{d}}^{(k)}} &= \sum_{i=1}^m w_i(\mathbf{z}) (\Lambda_{i,k} (\mathbf{y} - \hat{\mathbf{y}}) + \widehat{\mathbf{d}}^{(k+1)}) \\
 &\text{for } k = 0, \dots, p-2
 \end{aligned} \tag{5.4}$$

is exponentially stable if there exist $P = P^T > 0$, L_i , $\Lambda_{i,k}$, $i = 1, 2, \dots, m$, $j = 1, 2, \dots, m$, $k = 1, 2, \dots, p$ so that

$$\mathcal{H} \left(P \begin{pmatrix} A_i - L_i C_j & M_i & 0 & \cdots & 0 \\ -\Lambda_{i,1} C_j & 0 & I & \cdots & 0 \\ \vdots & \vdots & \vdots & \ddots & \vdots \\ -\Lambda_{i,p} C_j & 0 & 0 & \cdots & 0 \end{pmatrix} \right) < 0 \tag{5.5}$$

$$\forall i, j : \exists \mathbf{z} : w_i(\mathbf{z}) w_j(\mathbf{z}) \neq 0$$

Proof: An extended error system, containing both state error, the input error $\bar{\mathbf{d}} = \mathbf{d} - \widehat{\mathbf{d}}$, and the derivatives of the input error, $\dot{\bar{\mathbf{d}}^{(i)}} = \dot{\mathbf{d}}^{(i)} - \dot{\widehat{\mathbf{d}}^{(i)}}$, $i = 0, 2, \dots, p-1$ can be expressed as:

$$\dot{\mathbf{e}}_a = \begin{pmatrix} \dot{\bar{\mathbf{d}}} \\ \dot{\bar{\mathbf{d}}^{(1)}} \\ \vdots \\ \dot{\bar{\mathbf{d}}^{(p-1)}} \end{pmatrix} = \sum_{i=1}^m w_i(\mathbf{z}) \sum_{j=1}^m w_j(\mathbf{z}) \begin{pmatrix} A_i - L_i C_j & M_i & 0 & \cdots & 0 \\ -\Lambda_{i,1} C_j & 0 & I & \cdots & 0 \\ \vdots & \vdots & \vdots & \ddots & \vdots \\ -\Lambda_{i,p} C_j & 0 & 0 & \cdots & 0 \end{pmatrix} \begin{pmatrix} \bar{\mathbf{d}} \\ \bar{\mathbf{d}}^{(1)} \\ \vdots \\ \bar{\mathbf{d}}^{(p-1)} \end{pmatrix} \tag{5.6}$$

Using a quadratic Lyapunov function for the extended error vector $V = \mathbf{e}_a^T P \mathbf{e}_a$, the derivative is

$$\dot{V} = \sum_{i=1}^m w_i(\mathbf{z}) \sum_{j=1}^m w_j(\mathbf{z}) \mathbf{e}_a^T \mathcal{H} \left(P \begin{pmatrix} A_i - L_i C_j & M_i & 0 & \cdots & 0 \\ -\Lambda_{i,1} C_j & 0 & I & \cdots & 0 \\ \vdots & \vdots & \vdots & \ddots & \vdots \\ -\Lambda_{i,p} C_j & 0 & 0 & \cdots & 0 \end{pmatrix} \right) \mathbf{e}_a$$

which is negative definite if the condition (5.5) is satisfied. \square

Note that the design is equivalent with design an observer for the extended error vector, as illustrated in the following example.

Example 5.1 Consider a two-rule fuzzy system, with state matrices $A_1 = \begin{pmatrix} -3 & 1 \\ 2 & 2 \end{pmatrix}$ and $A_2 = \begin{pmatrix} 2 & 1 \\ 1 & -2 \end{pmatrix}$ and a common measurement matrix $C = \begin{pmatrix} 1 & 3 \\ 0 & 2 \end{pmatrix}$, with the scheduling vector being an exogenous measured variable. The system is affected by a linear input $\mathbf{d} = \begin{pmatrix} d_1 \\ d_2 \end{pmatrix}$, i.e., $M_1 = I$ and $M_2 = I$. In order to design an observer that estimates both the states and the input, the following LMI problem needs to be solved: find $P = P^T > 0$, G_1 , G_2 so that

$$\mathcal{H} \left(P \begin{pmatrix} A_1 & I & 0 \\ 0 & 0 & I \\ 0 & 0 & 0 \end{pmatrix} - G_1 \begin{pmatrix} I & 0 & 0 \end{pmatrix} \right) < 0$$

$$\mathcal{H} \left(P \begin{pmatrix} A_2 & I & 0 \\ 0 & 0 & I \\ 0 & 0 & 0 \end{pmatrix} - G_2 \begin{pmatrix} I & 0 & 0 \end{pmatrix} \right) < 0$$

The observer gains are computed as $\begin{pmatrix} L_1 \\ \Lambda_1^1 \\ \Lambda_1^2 \end{pmatrix} = P^{-1}G_1$ and $\begin{pmatrix} L_2 \\ \Lambda_2^1 \\ \Lambda_2^2 \end{pmatrix} = P^{-1}G_2$. A solution of the above LMI gives

$$\begin{pmatrix} L_1 \\ \Lambda_1^1 \\ \Lambda_1^2 \end{pmatrix} = \begin{pmatrix} -0.5884 & 205.6828 \\ -406.6004 & 612.1064 \\ 3.2036 & 140.3529 \\ -290.3166 & 437.0766 \\ 1.1431 & 80.0786 \\ -163.5865 & 245.9513 \end{pmatrix} \quad \text{and} \quad \begin{pmatrix} L_2 \\ \Lambda_2^1 \\ \Lambda_2^2 \end{pmatrix} = \begin{pmatrix} 4.4116 & -13.8436 \\ 16.4525 & -24.4729 \\ 3.2036 & -10.2950 \\ 10.9792 & -14.8670 \\ 1.1431 & -4.8079 \\ 6.1865 & -8.7082 \end{pmatrix}$$

In order to design observers with a desired convergence rate α , Theorem 2.2 can be applied.

Corollary 5.1 The estimation error of the observer (5.4) converges with a rate at least α if there exists $P = P^T > 0$, L_i , $\Lambda_{i,k}$, $i = 1, 2, \dots, m$, $j = 1, 2, \dots, m$, $k = 1, 2, \dots, p$ so that

$$\mathcal{H} \left(P \begin{pmatrix} A_i - L_i C_j & M_i & 0 & \cdots & 0 \\ -\Lambda_{i,1} C_j & 0 & I & \cdots & 0 \\ \vdots & \vdots & \vdots & \ddots & \vdots \\ -\Lambda_{i,p} C_j & 0 & 0 & \cdots & 0 \end{pmatrix} \right) + 2\alpha P < 0 \quad (5.7)$$

$$\forall i, j : \exists \mathbf{z} : w_i(\mathbf{z})w_j(\mathbf{z}) \neq 0$$

The proof follows directly. \square

Example 5.2 Consider the fuzzy system from Example 5.1 for which an observer has to be designed so that the decay rate of the error is at least $\alpha = 1$. For this, the following LMI

problem needs to be solved: find $P = P^T > 0$, G_1 , G_2 so that

$$\begin{aligned} \mathcal{H}\left(P \begin{pmatrix} A_1 & I & 0 \\ 0 & 0 & I \\ 0 & 0 & 0 \end{pmatrix} - G_1 \begin{pmatrix} I & 0 & 0 \end{pmatrix} + P\right) < 0 \\ \mathcal{H}\left(P \begin{pmatrix} A_2 & I & 0 \\ 0 & 0 & I \\ 0 & 0 & 0 \end{pmatrix} - G_2 \begin{pmatrix} I & 0 & 0 \end{pmatrix} + P\right) < 0 \end{aligned}$$

The observer gains are computed as in Example 5.1 and the solution yields

$$\begin{pmatrix} L_1 \\ \Lambda_1^1 \\ \Lambda_1^2 \end{pmatrix} = \begin{pmatrix} 4.9462 & -56.3686 \\ 100.8986 & -146.3747 \\ 27.3107 & -198.7996 \\ 315.6670 & -459.8452 \\ 26.5414 & -195.5050 \\ 311.3856 & -453.8077 \end{pmatrix} \quad \begin{pmatrix} L_2 \\ \Lambda_2^1 \\ \Lambda_2^2 \end{pmatrix} = \begin{pmatrix} 9.9462 & -11.3877 \\ -5.0634 & 10.5681 \\ 27.3107 & -31.2895 \\ -19.3532 & 42.6851 \\ 26.5414 & -30.2668 \\ -19.0907 & 41.9068 \end{pmatrix}$$

Case 2: State-dependent scheduling vector

A similar observer can also be designed if z depends on \hat{x} . For the simplicity of the notation, only the case when the measurement matrix is common for all rules is presented. Note, however, that if the measurement matrices are different for the rules, the observer can be designed in a similar way.

The observer considered is of the form

$$\begin{aligned} \dot{\hat{x}} &= \sum_{i=1}^m w_i(\hat{z}) [A_i \hat{x} + B_i u + L_i(\mathbf{y} - \hat{\mathbf{y}}) + M_i \hat{\mathbf{d}} + a_i] \\ \hat{\mathbf{y}} &= C \hat{x} \\ \dot{\widehat{\mathbf{d}}^{(p-1)}} &= \sum_{i=1}^m w_i(\hat{z}) \Lambda_{i,p}(\mathbf{y} - \hat{\mathbf{y}}) \\ \dot{\widehat{\mathbf{d}}^{(j-1)}} &= \sum_{i=1}^m w_i(\hat{z}) (\Lambda_{i,j}(\mathbf{y} - \hat{\mathbf{y}}) + \widehat{\mathbf{d}}^{(j+1)}) \\ &\text{for } j = 1, \dots, p-1 \end{aligned} \tag{5.8}$$

The extended error system may be expressed as:

$$\begin{aligned} \dot{e}_a &= \sum_{i=1}^m w_i(\hat{z}) \begin{pmatrix} A_i - L_i C & M_i & 0 & \dots & 0 \\ -\Lambda_{i,1} C & 0 & I & \dots & 0 \\ \vdots & \vdots & \vdots & \ddots & \vdots \\ -\Lambda_{i,p} C & 0 & 0 & \dots & 0 \end{pmatrix} \begin{pmatrix} e \\ \bar{\mathbf{d}} \\ \vdots \\ \bar{\mathbf{d}}^{(p-1)} \end{pmatrix} \\ &+ \sum_{i=1}^m ((w_i(\mathbf{z}) - w_i(\hat{z}))(I \ 0 \ \dots \ 0)^T \cdot (A_i \mathbf{x} + B_i \mathbf{u} + M_i \mathbf{d} + a_i)) \end{aligned} \tag{5.9}$$

Assuming that $\|\Delta\| = \|(w_i(\mathbf{z}) - w_i(\hat{z}))(A_i \mathbf{x} + B_i \mathbf{u} + M_i \mathbf{d} + a_i)\| \leq \mu \|e\|$, and therefore $\|\Delta\|$ is also Lipschitz in e_a , with the same Lipschitz constant μ , the stability conditions become:

Corollary 5.2 *The error system (5.9) is asymptotically stable, if there exist P , L_i , Λ_i^j , $i = 1, 2, \dots, m$, $j = 1, 2, \dots, p$ so that*

$$\mathcal{H} \left(P \begin{pmatrix} A_i - L_i C & M_i & 0 & \cdots & 0 \\ -\Lambda_{i,1} C & 0 & I & \cdots & 0 \\ \vdots & \vdots & \vdots & \ddots & \vdots \\ -\Lambda_{i,p} C & 0 & 0 & \cdots & 0 \end{pmatrix} \right) < Q \quad (5.10)$$

$$\|(w_i(\mathbf{z}) - w_i(\hat{\mathbf{z}}))(A_i \mathbf{x} + B_i \mathbf{u} + M_i \mathbf{d} + a_i)\| \leq \mu \|e\|$$

$$\begin{pmatrix} Q - \mu^2 & P \\ P & I \end{pmatrix} > 0$$

The proof follows directly. \square

Example 5.3 *Consider the fuzzy system from Example 2.9, i.e.,*

$$\dot{\mathbf{x}} = w_1(\mathbf{x})(A_1 \mathbf{x} + B_1 u) + w_2(\mathbf{x})(A_2 \mathbf{x} + B_2 u)$$

$$\mathbf{y} = \begin{pmatrix} 1 & 0 \end{pmatrix} \mathbf{x}$$

with $A_1 = \begin{pmatrix} -2 & 0 \\ 2 & -3 \end{pmatrix}$, $A_2 = \begin{pmatrix} -1 & 3 \\ 2 & -5 \end{pmatrix}$, $B_1 = \begin{pmatrix} 3 \\ 2 \end{pmatrix}$, $B_2 = \begin{pmatrix} 1 \\ 0 \end{pmatrix}$, $w_1(\mathbf{x}) = 0.125(x_1 + x_2 + 4)$, $w_2(\mathbf{x}) = 1 - w_1(\mathbf{x})$, $x_1, x_2 \in [-2, 2]$, $u \in [-0.5, 0.5]$. *Our goal is to design an observer for this system, assuming that there is a bias in the model, i.e., $\mathbf{d} = [d_1 \ d_2]^T$, with d_1, d_2 constants and $M_1 = M_2 = 1$.*

As presented in Example 2.9, $\|(w_1(\mathbf{x}) - w_1(\hat{\mathbf{x}}))(A_1 \mathbf{x} + B_1 u)\| \leq 2.2 \|e\|$, and $\|(w_2(\mathbf{x}) - w_2(\hat{\mathbf{x}}))(A_2 \mathbf{x} + B_2 u)\| \leq 3.2 \|e\|$, therefore, $\|(w_i(\mathbf{z}) - w_i(\hat{\mathbf{z}}))(A_i \mathbf{x} + B_i \mathbf{u} + a_i)\| \leq \mu \|e\|$, with $\mu = 3.2$. To design the observer, one needs to solve the LMI problem: find $P = P^T > 0$, $Q = Q^T > 0$, G_1, G_2 so that

$$\mathcal{H} \left(P \begin{pmatrix} A_1 & I \\ 0 & 0 \end{pmatrix} - G_1 \begin{pmatrix} C & 0 \end{pmatrix} - Q \right) \leq 0$$

$$\mathcal{H} \left(P \begin{pmatrix} A_2 & I \\ 0 & 0 \end{pmatrix} - G_2 \begin{pmatrix} C & 0 \end{pmatrix} - Q \right) \leq 0$$

$$\begin{pmatrix} Q - \mu^2 & P \\ P & I \end{pmatrix} > 0$$

The observer gains are computed as in Example 5.1 and the solution yields

$$\begin{pmatrix} L_1 \\ \Lambda_1^1 \end{pmatrix} = \begin{pmatrix} -6.8552 \\ 1.0315 \\ 2.3726 \\ 0.3719 \end{pmatrix} \quad \begin{pmatrix} L_2 \\ \Lambda_2^1 \end{pmatrix} = \begin{pmatrix} -7.2546 \\ 12.1031 \\ 2.2011 \\ -0.1839 \end{pmatrix}$$

5.2.2 Bound on errors

In most cases, the unknown input is not polynomial, but it is often possible to determine a bound on some derivative of it. Therefore, consider the case when there exists $p \in \mathbb{N}$ so

that $\mathbf{d}^{(p)}$ is bounded by a known constant, i.e., $\|\mathbf{d}^{(p)}\| < \mu_d$, and $\mathbf{d}^{(j)}$, $j = 1, 2, \dots, p$ are observable from \mathbf{y} . In this case, only the input-to-state stability (see Chapter 3) of the observer can be guaranteed, but it is possible to compute a bound on the estimation error. Again, two cases are distinguished, depending on whether or not the scheduling vector depends on the states to be estimated.

Case 1: State-independent scheduling vector

If the scheduling vector does not depend on $\hat{\mathbf{x}}$, the error system can be written as:

$$\dot{\mathbf{e}}_a = \sum_{i=1}^m w_i(\mathbf{z}) \sum_{j=1}^m w_j(\mathbf{z}) \begin{pmatrix} A_i - L_i C_j & M_i & 0 & \cdots & 0 \\ -\Lambda_{i,1} C_j & 0 & I & \cdots & 0 \\ \vdots & \vdots & \vdots & \ddots & \vdots \\ -\Lambda_{i,p} C_j & 0 & 0 & \cdots & 0 \end{pmatrix} \mathbf{e}_a + \begin{pmatrix} 0 \\ 0 \\ 0 \\ \vdots \\ \mathbf{d}^{(p)} \end{pmatrix} \quad (5.11)$$

Note that in the previous section, the disturbance was assumed to be a $p - 1$ th order polynomial and therefore $\mathbf{d}^{(p)} = 0$.

Theorem 5.2 *The error described by (5.11) is ultimately bounded by a ball with radius*

$$\gamma = \sqrt{\frac{\lambda_{\max}(P) \lambda_{\max}(P) \mu_d}{\lambda_{\min}(P) \sigma \lambda_{\min}(Q)}} \quad (5.12)$$

if there exist $P = P^T > 0$, $Q = Q^T > 0$, L_i , $\Lambda_{i,k}$, $i = 1, 2, \dots, m$, $k = 1, 2, \dots, p$, $j = 1, 2, \dots, m$ so that

$$\begin{aligned} & \|\mathbf{d}^{(p)}\| < \mu_d \\ & \mathcal{H} \left(P \begin{pmatrix} A_i - L_i C_j & M_i & 0 & \cdots & 0 \\ -\Lambda_{i,1} C_j & 0 & I & \cdots & 0 \\ \vdots & \vdots & \vdots & \ddots & \vdots \\ -\Lambda_{i,p} C_j & 0 & 0 & \cdots & 0 \end{pmatrix} \right) < -2Q \\ & \forall i, j : \exists \mathbf{z} : w_i(\mathbf{z}) w_j(\mathbf{z}) \neq 0 \end{aligned} \quad (5.13)$$

for $i = 1, 2, \dots, m$, where $\sigma \in (0, 1)$ and λ_{\min} and λ_{\max} denote the smallest and largest eigenvalues, respectively.

Proof: Consider a quadratic Lyapunov function for the extended error vector, $V = \mathbf{e}_a^T P \mathbf{e}_a$. Then,

$$\begin{aligned} \dot{V} &= \sum_{i=1}^m w_i(\mathbf{z}) \sum_{j=1}^m w_j(\mathbf{z}) \mathbf{e}_a^T \mathcal{H} \left(P \begin{pmatrix} A_i - L_i C_j & M_i & 0 & \cdots & 0 \\ -\Lambda_{i,1} C_j & 0 & I & \cdots & 0 \\ \vdots & \vdots & \vdots & \ddots & \vdots \\ -\Lambda_{i,p} C_j & 0 & 0 & \cdots & 0 \end{pmatrix} \right) \mathbf{e}_a \\ &+ \sum_{i=1}^m w_i(\mathbf{z}) 2 \mathbf{e}_a^T P \left(0 \ 0 \ 0 \ \cdots \ \mathbf{d}^{(p)} \right)^T \\ &\leq -2\lambda_{\min}(Q) \|\mathbf{e}_a\|^2 + 2\lambda_{\max}(P) \|\mathbf{e}_a\| \mu_d \\ &\leq -2(1 - \sigma) \lambda_{\min}(Q) \|\mathbf{e}_a\|^2 - 2(\sigma \lambda_{\min}(Q)) \|\mathbf{e}_a\|^2 - \lambda_{\max}(P) \|\mathbf{e}_a\| \mu_d \end{aligned}$$

where $\sigma \in (0, 1)$ is arbitrarily chosen and $Q = Q^T$ is a positive definite matrix such that (5.17) is satisfied. Then, \dot{V} is negative definite if

$$\begin{aligned} \sigma \lambda_{\min}(Q) \|e_a\|^2 - \lambda_{\max}(P) \|e_a\| \mu_d &> 0 \\ \|e_a\| &> \frac{\lambda_{\max}(P) \mu_d}{\sigma \lambda_{\min}(Q)} \end{aligned}$$

Since it is also true, that $\lambda_{\min}(P) \|e_a\|^2 \leq V \leq \lambda_{\max}(P) \|e_a\|^2$, it can be concluded that $\|e_a\|$ converges exponentially to a ball with radius

$$\gamma = \sqrt{\frac{\lambda_{\max}(P)}{\lambda_{\min}(P)} \frac{\lambda_{\max}(P) \mu_d}{\sigma \lambda_{\min}(Q)}} \quad (5.14)$$

which is a global uniform ultimate bound on the estimation error (Khalil, 2002). \square

Remark: This bound can be minimized by using the relaxation given by Tuan et al. (2001) and solving the following LMI problem:

Find $P, L_i, \Lambda_i^k, i = 1, 2, \dots, m, j = 1, 2, \dots, m, k = 1, 2, \dots, p$ and maximize $\alpha_1, \alpha_2, \alpha_3$ subject to:

$$\begin{aligned} \Gamma_{ij} &= \mathcal{H} \left(P \begin{pmatrix} A_i - L_i C_j & M_i & 0 & \cdots & 0 \\ -\Lambda_{i,1} C_j & 0 & I & \cdots & 0 \\ \vdots & \vdots & \vdots & \ddots & \vdots \\ -\Lambda_{i,p} C_j & 0 & 0 & \cdots & 0 \end{pmatrix} \right) \\ P &= P^T > 0 \\ \Gamma_{ii} &> 0 \\ \frac{2}{m-1} \Gamma_{ii} + \Gamma_{ij} + \Gamma_{ji} &< -\alpha_3 I \\ \forall i, j : \exists z : w_i(z) w_j(z) &\neq 0 \\ -P &> -\alpha_2 I \\ P &> \alpha_1 I \end{aligned} \quad (5.15)$$

for all $i = 1, 2, \dots, m$.

Example 5.4 Consider the fuzzy system from Example 5.1. By solving the LMI problem above, the bound obtained is $\gamma = 3.84 \mu_d / \sigma$, where μ_d is a bound on \mathbf{d} and $\sigma \in (0, 1)$.

Case 2: State dependent scheduling vector

A similar, though notably more conservative bound can be found in the case when \mathbf{z} is a function of $\hat{\mathbf{x}}$. For the simplicity of the notation, the computation is presented for the case when the measurement matrices are common for all the rules. The following results can be formulated.

Theorem 5.3 The error described by (5.9) is ultimately bounded by a ball with radius

$$\gamma = \sqrt{\frac{\lambda_{\max}(P)}{\lambda_{\min}(P)} \frac{\lambda_{\max}(P) \mu_d}{\sigma(\lambda_{\min}(Q) - \mu \lambda_{\max}(P))}} \quad (5.16)$$

if there exist $P = P^T > 0$, $Q = Q^T > 0$, L_i , $\Lambda_{i,k}$, $i = 1, 2, \dots, m$, $k = 1, 2, \dots, p$, so that

$$\begin{aligned} & \|\mathbf{d}^{(p)}\| < \mu_{\mathbf{d}} \\ & \mathcal{H} \left(P \begin{pmatrix} A_i - L_i C & M_i & 0 & \cdots & 0 \\ -\Lambda_{i,1} C & 0 & I & \cdots & 0 \\ \vdots & \vdots & \vdots & \ddots & \vdots \\ -\Lambda_{i,p} C & 0 & 0 & \cdots & 0 \end{pmatrix} \right) < -2Q \end{aligned} \quad (5.17)$$

for $i = 1, 2, \dots, m$, where $\sigma \in (0, 1)$ and λ_{\min} and λ_{\max} denote the smallest and largest eigenvalues, respectively.

Proof: Using a quadratic Lyapunov function for the extended error vector, $V = \mathbf{e}_a^T P \mathbf{e}_a$. We obtain

$$\begin{aligned} \dot{V} &= \sum_{i=1}^m w_i(\mathbf{z}) \mathbf{e}_a^T \mathcal{H} \left(P \begin{pmatrix} A_i - L_i C & M_i & 0 & \cdots & 0 \\ -\Lambda_{i,1} C & 0 & I & \cdots & 0 \\ \vdots & \vdots & \vdots & \ddots & \vdots \\ -\Lambda_{i,p} C & 0 & 0 & \cdots & 0 \end{pmatrix} \right) \mathbf{e}_a \\ &+ \sum_{i=1}^m w_i(\mathbf{z}) 2 \mathbf{e}_a^T P \begin{pmatrix} 0 & 0 & 0 & \cdots & \mathbf{d}^{(p)} \end{pmatrix}^T \\ &+ \sum_{i=1}^m (w_i(\mathbf{z}) - w_i(\hat{\mathbf{z}})) (I \ 0 \ \cdots \ 0)^T (A_i \mathbf{x} + B_i \mathbf{u} + M_i \mathbf{d}) \\ &\leq -2\lambda_{\min}(Q) \|\mathbf{e}_a\|^2 + 2\lambda_{\max}(P) \mu \|\mathbf{e}_a\|^2 + \lambda_{\max}(P) \|\mathbf{e}_a\| \mu_{\mathbf{d}} \\ &\leq -2(1 - \sigma) (\lambda_{\min}(Q) - \mu \lambda_{\max}(P)) \|\mathbf{e}_a\|^2 \\ &\quad - 2(\sigma (\lambda_{\min}(Q) - \mu \lambda_{\max}(P))) \|\mathbf{e}_a\|^2 - \lambda_{\max}(P) \|\mathbf{e}_a\| \mu_{\mathbf{d}} \end{aligned}$$

where $\sigma \in (0, 1)$ is arbitrarily chosen and $Q = Q^T$ is a positive definite matrix such that (5.17) is satisfied. Then, \dot{V} is negative definite if

$$\begin{aligned} & \sigma (\lambda_{\min}(Q) - \mu \lambda_{\max}(P)) \|\mathbf{e}_a\|^2 - \lambda_{\max}(P) \|\mathbf{e}_a\| \mu_{\mathbf{d}} > 0 \\ & \|\mathbf{e}_a\| > \frac{\lambda_{\max}(P) \mu_{\mathbf{d}}}{\sigma (\lambda_{\min}(Q) - \mu \lambda_{\max}(P))} \end{aligned}$$

Since $\lambda_{\min}(P) \|\mathbf{e}_a\|^2 \leq V \leq \lambda_{\max}(P) \|\mathbf{e}_a\|^2$, it can be concluded that $\|\mathbf{e}_a\|$ converges exponentially to a ball with radius

$$\gamma = \sqrt{\frac{\lambda_{\max}(P)}{\lambda_{\min}(P)} \frac{\lambda_{\max}(P) \mu_{\mathbf{d}}}{\sigma (\lambda_{\min}(Q) - \mu \lambda_{\max}(P))}} \quad (5.18)$$

□

This bound can also be minimized using the conditions (5.15), together with the condition $\lambda_{\min}(Q) > \mu \lambda_{\max}(P)$.

5.3 Estimation of unmodeled dynamics

Consider now the problem of estimating the states of a fuzzy system in the presence of unmodeled dynamics, i.e., the the fuzzy system is of the form

$$\begin{aligned}\dot{\mathbf{x}} &= \sum_{i=1}^m w_i(\mathbf{z})(A_i \mathbf{x} + B_i \mathbf{u} + M_i(A_{\delta_i} \mathbf{x} + B_{\delta_i} \mathbf{u} + \theta_i)) \\ \mathbf{y} &= C \mathbf{x}\end{aligned}\quad (5.19)$$

where $A_i, B_i, M_i, i = 1, 2, \dots, m$ are known and Assumption 5.1 holds. The matrices $A_{\delta_i}, B_{\delta_i}$ and the vectors $\theta_i, i = 1, 2, \dots, m$ are unknown, but $A_{\delta_i}, i = 1, 2, \dots, m$ are bounded by a known bound $\mu_{\max}, \max \|A_{\delta_i}\| \leq \mu_{\max}$. This corresponds to the situation when part of the true dynamics is unmodeled. The goal is to determine sufficient conditions and to design an asymptotically stable observer to estimate \mathbf{x} and also the constant matrices $A_{\delta_i}, B_{\delta_i}$ and the vector $\theta_i, i = 1, 2, \dots, m$. Therefore, our goal is to estimate the unknown dynamics.

For the simplicity of the computations, we present only the case when the measurement matrix is common for all rules of the model. Note however, that if the measurement matrices differ for each rule, the observer can be designed in a similar way. Two cases are considered, depending on whether or not the scheduling vector \mathbf{z} depends on the states to be estimated.

Case 1: State-independent scheduling vector

Consider first the case when the scheduling vector does not depend on states to be estimated. An observer of the following form is considered:

$$\begin{aligned}\dot{\hat{\mathbf{x}}} &= \sum_{i=1}^m w_i(\mathbf{z})(A_i \hat{\mathbf{x}} + B_i \mathbf{u} + L_i(\mathbf{y} - \hat{\mathbf{y}}) + M_i(\hat{A}_{\delta_i} \hat{\mathbf{x}} + \hat{B}_{\delta_i} \mathbf{u} + \hat{\theta}_i)) \\ \hat{\mathbf{y}} &= C \hat{\mathbf{x}} \\ \dot{\hat{A}}_{\delta_i} &= f_i(\hat{A}_{\delta_i}, \mathbf{w}(\mathbf{z}), \hat{\mathbf{x}}, \mathbf{y}) \\ \dot{\hat{B}}_{\delta_i} &= g_i(\hat{B}_{\delta_i}, \mathbf{w}(\mathbf{z}), \hat{\mathbf{x}}, \mathbf{y}, \mathbf{u}) \\ \dot{\hat{\theta}}_i &= h_i(\hat{\theta}_i, \mathbf{w}(\mathbf{z}), \hat{\mathbf{x}}, \mathbf{y})\end{aligned}\quad (5.20)$$

where $L_i, i = 1, 2, \dots, m$ are the gain matrices for each rule, and the update laws $f_i, g_i, h_i, i = 1, 2, \dots, m$ will be determined so that the (5.20) is a stable observer.

The error system when using the observer (5.20) can be expressed as:

$$\begin{aligned}\dot{\mathbf{e}} &= \sum_{i=1}^m w_i(\mathbf{z})[(A_i - L_i C + A_{\delta_i}) \mathbf{e} + M_i(\bar{A}_{\delta_i} \hat{\mathbf{x}} + \bar{B}_{\delta_i} \mathbf{u} + \bar{\theta}_i)] \\ \mathbf{e}_y &= C \mathbf{e}\end{aligned}\quad (5.21)$$

with $\bar{A}_{\delta_i} = A_{\delta_i} - \hat{A}_{\delta_i}, \bar{B}_{\delta_i} = B_{\delta_i} - \hat{B}_{\delta_i}, \bar{\theta}_i = \theta_i - \hat{\theta}_i$.

Consider first the following part of the error expressed in (5.21):

$$\dot{\tilde{\mathbf{e}}} = \sum_{i=1}^m w_i(\mathbf{z})(A_i - L_i C + A_{\delta_i}) \tilde{\mathbf{e}} \quad (5.22)$$

Since a bound on $A_{\delta i}$, $i = 1, 2, \dots, m$ is known, i.e., $\max \|A_{\delta i}\| \leq \mu_{\max}$, stability conditions for perturbed fuzzy systems can be used to render (5.22) stable and to design the gain matrices L_i (Bergsten, 2001): find $P = P^T > 0$, $Q = Q^T > 0$, L_i , $i = 1, 2, \dots, m$ so that

$$\begin{aligned} \mu_{\max} &\leq \frac{\lambda_{\min}(Q)}{\lambda_{\max}(P)} \\ \mathcal{H}(P(A_i - L_i C)) &\leq -2Q \end{aligned} \quad (5.23)$$

Consider now a Lyapunov function of the form

$$V = e^T P e + \sum_{i=1}^m \text{tr}(\bar{A}_{\delta i}^T \bar{A}_{\delta i}) + \sum_{i=1}^m \text{tr}(\bar{B}_{\delta i}^T \bar{B}_{\delta i}) + \sum_{i=1}^m (\bar{\theta}_i^T \bar{\theta}_i)$$

for the error system (5.21), so that P satisfies (5.23). Then,

$$\begin{aligned} \dot{V} &= \sum_{i=1}^n w_i(z) e^T [(A_i - L_i C + A_{\delta i})^T P + P(A_i - L_i C + A_{\delta i})] e \\ &\quad + 2e^T P \sum_{i=1}^m w_i(z) M_i \bar{A}_{\delta i} \hat{x} + 2e^T P \sum_{i=1}^m w_i(z) M_i \bar{B}_{\delta i} u \\ &\quad + 2e^T P \sum_{i=1}^m w_i(z) M_i \bar{\theta}_i - 2 \sum_{i=1}^m \text{tr}(\dot{\hat{A}}_{\delta i}^T \bar{A}_{\delta i}) - 2 \sum_{i=1}^m \text{tr}(\dot{\hat{B}}_{\delta i}^T \bar{B}_{\delta i}) - 2 \sum_{i=1}^m (\dot{\hat{\theta}}_i^T \bar{\theta}_i) \\ &= \sum_{i=1}^n w_i(z) e^T G_i e + 2 \sum_{i=1}^m (\text{tr}(\hat{x} e^T P M_i w_i(z) \bar{A}_{\delta i}) - \text{tr}(\dot{\hat{A}}_{\delta i}^T \bar{A}_{\delta i})) \\ &\quad + 2 \sum_{i=1}^m (\text{tr}(u e^T P M_i w_i(z) \bar{B}_{\delta i}) - \text{tr}(\dot{\hat{B}}_{\delta i}^T \bar{B}_{\delta i})) + 2 \sum_{i=1}^m (e^T P M_i w_i(z) \bar{\theta}_i - \dot{\hat{\theta}}_i^T \bar{\theta}_i) \\ &= \sum_{i=1}^n w_i(z) e^T G_i e + 2 \sum_{i=1}^m \text{tr}((\hat{x} e^T P M_i w_i(z) - \dot{\hat{A}}_{\delta i}^T) \bar{A}_{\delta i}) \\ &\quad + 2 \sum_{i=1}^m \text{tr}((u e^T P M_i w_i(z) - \dot{\hat{B}}_{\delta i}^T) \bar{B}_{\delta i}) + 2 \sum_{i=1}^m (e^T P w_i(z) - \dot{\hat{\theta}}_i^T) \bar{\theta}_i \end{aligned}$$

with $G_i = \mathcal{H}(P(A_i - L_i C + A_{\delta i}))$.

Since $V > 0$ and from (5.23) $G_i < 0$, for $i = 1, 2, \dots, m$, \dot{V} is rendered negative definite if $\text{tr}((\hat{x} e^T P M_i w_i(z) - \dot{\hat{A}}_{\delta i}^T) \bar{A}_{\delta i}) = 0$, $\text{tr}((u e^T P M_i w_i(z) - \dot{\hat{B}}_{\delta i}^T) \bar{B}_{\delta i})$ and $e^T P M_i w_i(z) - \dot{\hat{\theta}}_i^T = 0$, for $i = 1, 2, \dots, m$. These equations lead to the update laws:

$$\begin{aligned} \dot{\hat{A}}_{\delta i} &= w_i(z) M_i^T P e \hat{x}^T \\ \dot{\hat{B}}_{\delta i} &= w_i(z) M_i^T P e u^T \\ \dot{\hat{\theta}}_i &= w_i(z) M_i^T P e \end{aligned} \quad (5.24)$$

Note, that in general e is not directly available. However, due to Assumption 5.1, i.e., that $\text{rank}(C M_i) = \text{rank}(M_i)$, $i = 1, 2, \dots, m$, there exist matrices Λ_i , $i = 1, 2, \dots, m$ so that

$\Lambda_i C = M_i^T P$: $\Lambda_i = M_i^T PC^\dagger$, where C^\dagger denotes the Moore-Penrose pseudoinverse of C . Hence, $M_i^T P e = \Lambda_i C e = M_i^T PC^\dagger e_y$.

Therefore, the update laws can be expressed as:

$$\begin{aligned}\dot{\hat{A}}_{\delta i} &= w_i(\mathbf{z})M_i^T PC^\dagger e_y \hat{\mathbf{x}}^T \\ \dot{\hat{B}}_{\delta i} &= w_i(\mathbf{z})M_i^T PC^\dagger e_y \mathbf{u}^T \\ \dot{\hat{\theta}}_i &= w_i(\mathbf{z})M_i^T PC^\dagger e_y\end{aligned}\quad (5.25)$$

If every rule is active for a sufficient amount of time, both the error system and the estimates of the unknown matrices are asymptotically stable. It can easily be seen that, assuming nonzero and varying \mathbf{x} , \mathbf{u} , the only invariant set of the error system (5.21) is $e = 0$, $\bar{A}_{\delta i} = 0$, $\bar{B}_{\delta i} = 0$, and $\bar{\theta}_i = 0$. If $w_i(\mathbf{z})$, $i = 1, 2, \dots, m$ are sufficiently smooth, and the fuzzy model is defined on a compact set of variables, then, based on Barbalat's lemma and LaSalle's invariance principle (Khalil, 2002), the dynamics (5.21), together with the update laws above are asymptotically stable.

The results can be summarized as follows:

Theorem 5.4 *The observer (5.20), together with the update laws (5.25) is asymptotically stable, if there exist P , L_i , $i = 1, 2, \dots, m$ so that*

$$\begin{aligned}P &> 0 \\ \mathcal{H}(P(A_i - L_i C)) &< -2Q \quad i = 1, 2, \dots, m \\ \mu_{\max} &\leq \frac{\lambda_{\min}(Q)}{\lambda_{\max}(P)}\end{aligned}\quad (5.26)$$

□

Case 2: State-dependent scheduling vector

Consider now the case when \mathbf{z} depends on $\hat{\mathbf{x}}$. The error system (5.21) becomes

$$\begin{aligned}\dot{e} &= \sum_{i=1}^m w_i(\hat{\mathbf{z}})[(A_i - L_i C + A_{\delta i})e + M_i(\bar{A}_{\delta i}\hat{\mathbf{x}} + \bar{B}_{\delta i}\mathbf{u} + \bar{\theta}_i)] \\ &+ \sum_{i=1}^m (w_i(\mathbf{z}) - w_i(\hat{\mathbf{z}})) \cdot (A_i \mathbf{x} + B_i \mathbf{u} + M_i(A_{\delta i} \mathbf{x} + B_{\delta i} \mathbf{u} + \theta_i)) \\ e_y &= C e\end{aligned}\quad (5.27)$$

Under the assumption that $\|(w_i(\mathbf{z}) - w_i(\hat{\mathbf{z}}))(A_i \mathbf{x} + B_i \mathbf{u} + M_i(A_{\delta i} \mathbf{x} + B_{\delta i} \mathbf{u} + \theta_i))\| \leq \mu \|e\|$, combining the conditions in Theorems 2.7 and 5.4, we get:

Corollary 5.3 *The error system (5.27), together with the update laws*

$$\begin{aligned}\dot{\hat{A}}_{\delta i} &= w_i(\hat{\mathbf{z}})M_i^T PC^\dagger e_y \hat{\mathbf{x}}^T \\ \dot{\hat{B}}_{\delta i} &= w_i(\hat{\mathbf{z}})M_i^T PC^\dagger e_y \mathbf{u}^T \\ \dot{\hat{\theta}}_i &= w_i(\hat{\mathbf{z}})M_i^T PC^\dagger e_y\end{aligned}\quad (5.28)$$

is asymptotically stable, if there exist $P, L_i, i = 1, 2, \dots, m$ so that

$$\begin{aligned}
 & P > 0 \\
 & \mathcal{H}(P(A_i - L_i C)) < -Q \quad i = 1, 2, \dots, m \\
 & \|(w_i(\mathbf{z}) - w_i(\hat{\mathbf{z}})) \cdot (A_i \mathbf{x} + B_i \mathbf{u} + M_i(A_{\delta i} \mathbf{x} + B_{\delta i} \mathbf{u} + \theta_i))\| \leq \mu \|\mathbf{e}\| \\
 & \begin{pmatrix} Q - \mu^2 & P \\ P & I \end{pmatrix} > 0
 \end{aligned} \tag{5.29}$$

□

The proof follows directly.

Remark: Note that if the measurement matrix is different for each rule of the fuzzy model, the update laws for the matrices of the unknown dynamics can still be expressed as (5.24). Update laws similar to (5.25) can be derived if there exist $(\sum_{i=1}^m w_i(\mathbf{z})C_i)^\dagger, \forall \mathbf{z}$ (Case 1), and $(\sum_{i=1}^m w_i(\hat{\mathbf{z}})C_i)^\dagger, \forall \hat{\mathbf{z}}$ (Case 2), $i = 1, 2, \dots, m$. Then, the update laws are

$$\begin{aligned}
 \hat{A}_{\delta i} &= w_i(\mathbf{z})M_i^T P \left(\sum_{i=1}^m w_i(\mathbf{z})C_i \right)^\dagger \mathbf{e}_y \hat{\mathbf{x}}^T \\
 \hat{B}_{\delta i} &= w_i(\mathbf{z})M_i^T P \left(\sum_{i=1}^m w_i(\mathbf{z})C_i \right)^\dagger \mathbf{e}_y \mathbf{u}^T \\
 \hat{\theta}_i &= w_i(\mathbf{z})M_i^T P \left(\sum_{i=1}^m w_i(\mathbf{z})C_i \right)^\dagger \mathbf{e}_y
 \end{aligned} \tag{5.30}$$

if the scheduling vector does not depend on the states to be estimated (Case 1) and

$$\begin{aligned}
 \hat{A}_{\delta i} &= w_i(\hat{\mathbf{z}})M_i^T P \left(\sum_{i=1}^m w_i(\hat{\mathbf{z}})C_i \right)^\dagger \mathbf{e}_y \hat{\mathbf{x}}^T \\
 \hat{B}_{\delta i} &= w_i(\hat{\mathbf{z}})M_i^T P \left(\sum_{i=1}^m w_i(\hat{\mathbf{z}})C_i \right)^\dagger \mathbf{e}_y \mathbf{u}^T \\
 \hat{\theta}_i &= w_i(\hat{\mathbf{z}})M_i^T P \left(\sum_{i=1}^m w_i(\hat{\mathbf{z}})C_i \right)^\dagger \mathbf{e}_y
 \end{aligned} \tag{5.31}$$

if the scheduling vector depends on $\hat{\mathbf{x}}$ (Case 2) and the observer gains are given by (5.26) and (5.29), respectively.

Remark: The results can also be applied if the unknown matrices are piecewise constant.

5.4 Example

We illustrate the proposed design method on a simulation example. The plant under consideration is the dynamic model of a missile, adopted from Nichols et al. (1993), illustrated in Figure 5.1. The nonlinear state-space equations are:

$$\begin{aligned}
 \dot{\alpha} &= K_\alpha M C_n(\alpha, \delta, M) \cos(\alpha) + q \\
 \dot{q} &= K_q M^2 C_m(\alpha, \delta, M)
 \end{aligned} \tag{5.32}$$

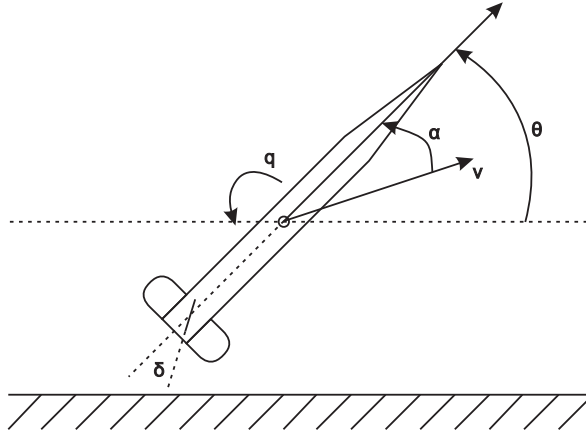

Figure 5.1: Schematic representation of a missile.

Table 5.1: Plant variables.

α	Angle of attack [deg]
q	Pitch rate [deg/s]
M	Mach number
δ_c	Commanded tail fin deflection [deg]
δ	Actual tail fin deflection [deg]

Table 5.2: Plant parameters.

$P_0 = 973.3$	Static pressure at 20000 feet [lbs/ft ²]
$S = 0.44$	Surface area [ft ²]
$m = 13.98$	Mass[slugs]
$v_s = 1036.4$	Speed of sound at 20000 feet [ft/s]
$d = 0.75$	Diameter [ft]
$I_y = 182.5$	Pitch moment of inertia [slug ft ²]
$\omega_a = 225$	
$K_\alpha = (\pi/180)0.7P_0S/(mv_s)$	
$K_q = (\pi/180)0.7P_0Sd/I_y$	
$a_n = 0.000103$ [deg ⁻³]	$a_m = 0.000215$ [deg ⁻³]
$b_n = -0.00945$ [deg ⁻²]	$b_m = -0.0195$ [deg ⁻²]
$c_n = -0.1696$ [deg ⁻¹]	$c_m = -0.051$ [deg ⁻¹]
$d_n = -0.034$ [deg ⁻¹]	$d_m = -0.206$ [deg ⁻¹]

The plant variables are given in Table 5.1, and the parameters in Table 5.2.

The Mach number M is an exogenous scheduling variable. The angle of attack α and the

pitch rate $q = \dot{\theta}$ are measured. The aerodynamic coefficients are expressed as:

$$\begin{aligned} C_n(\alpha, \delta, M) &= \text{sgn}(\alpha)[a_n|\alpha|^3 + b_n|\alpha|^2 + c_n(2 - M/3)|\alpha|] + d_n\delta \\ C_m(\alpha, \delta, M) &= \text{sgn}(\alpha)[a_m|\alpha|^3 + b_m|\alpha|^2 + c_m(-7 + 8M/3)|\alpha|] + d_m\delta \end{aligned}$$

The dynamics of the tail fin actuator are described by a first-order linear model:

$$\dot{\delta} = \omega_a\delta + \omega_a\delta_c$$

In order to use the proposed design, a TS fuzzy model of the system (5.32) is constructed. For the Mach number M , five points $M \in \{2, 2.5, 3, 3.5, 4\}$ and for the angle of attack seven points $\alpha \in \{-15, -10, -5, 0, 5, 10, 15\}$ are chosen as centers of the membership functions. The membership functions for M are depicted in Figure 5.2. The scheduling vector consists of the Mach number M and the angle of attack α , which is also a state to be estimated. An example of a rule is:

If M is approximately 3 and α is approximately 5 then $\dot{x}_i = Ax + Bu + a$, with

$$\begin{aligned} A &= \begin{pmatrix} -0.0012 & 1.0 & 0.0 \\ -0.0445 & 0 & -0.0399 \\ 0 & 0 & -225.0 \end{pmatrix} \\ B &= (0 \quad 0 \quad 225.0)^T \\ a &= (0.0056 \quad 0.0839 \quad 0)^T \end{aligned}$$

where $x = [\alpha \quad q \quad \delta]^T$.

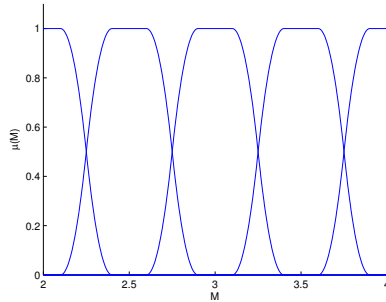

Figure 5.2: Membership functions for the Mach number M .

The consequent models in the fuzzy rules are obtained by linearizing the system for each combination of the chosen M and α . Since the linearization is not done in equilibria, the consequents are affine. To compute the membership degree of the scheduling vector, the algebraic product operator is used.

To simulate the system, the input was randomly generated. For the considered estimations (unmodeled dynamics and unknown input, respectively), the initial conditions for the nonlinear system were $[15 \quad 2.3 \quad 3]^T$, while the initial conditions used for the states and parameters to be estimated were zero. The LMIs were solved using the Yalmip toolbox (Löfberg,

2004). The unknown input/unmodelled dynamics is assumed to affect α and q , therefore

$$M_i = \begin{pmatrix} 1 & 0 \\ 0 & 1 \\ 0 & 0 \end{pmatrix}, i = 1, 2, \dots, m.$$

First, the TS model obtained by linearization is adapted, so that it better approximates the nonlinear model. Afterwards, it is assumed that an unknown input, that has to be estimated, is acting on the states.

1) *Improving the accuracy of the TS model:* Since the consequents in the fuzzy rules were obtained by linearizing the nonlinear model, the local models represent the nonlinear system exactly only in the linearization points, i.e., in the centers of the membership functions. When more than one membership function is activated, the accuracy of the TS model decreases. In order to obtain a better approximation of the nonlinear system, first an observer to estimate the unmodeled dynamics was designed, according to Theorem 5.4. This observer estimates the states and updates the system matrices according to equation (5.25). The estimation error for the states is presented in Figure 5.3. As can be seen, the estimated states converge to the states of the nonlinear system. As a result of using this observer, the rule corresponding to the approximation in $M = 3$ and $\alpha = 5$ has been changed to:

If M is approximately 3 and α is approximately 5 then $\dot{x}_i = Ax + Bu + a$, with

$$A = \begin{pmatrix} 0.0496 & 1.1488 & 0.0062 \\ -0.0164 & -0.0179 & -0.0402 \\ 0 & 0 & -225.0 \end{pmatrix}$$

$$B = \begin{pmatrix} -0.0032 & -0.0003 & 225.0 \end{pmatrix}^T$$

$$a = \begin{pmatrix} 0.00475 & -0.0031 & 0 \end{pmatrix}^T$$

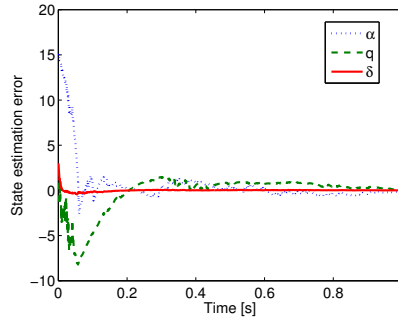

Figure 5.3: Estimation of unmodeled dynamics: state estimation error.

2) *Unknown input estimation:* Now assume that an unknown input d is acting on α and q . Three cases are considered, as follows.

In the first case, d is constant, $d = [5 \ 10]^T$. The observer is designed based on the conditions of Theorem 5.1, with the first derivative of the unknown input being already zero, i.e., correctly assuming a bias in the model. The state estimation error is presented in Figure 5.4(a). The unknown input and its estimate is presented in Figure 5.4(b). Both the estimated states and input converge to the correct ones, as expected.

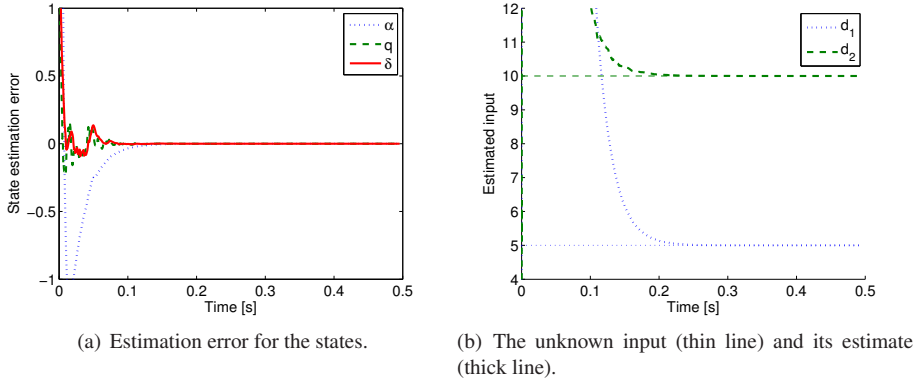

Figure 5.4: Estimation results for constant input.

In the second case, \mathbf{d} is a second-order polynomial in time, $\mathbf{d} = [5 \ 10]^T t^2 + [3 \ 1]^T t + [2 \ 4]^T$. The observer is designed in the same manner as for the \mathbf{d} in constant case, but using three derivatives. The estimation error for the states is presented in Figure 5.5(a) and the unknown inputs and their estimate in Figure 5.5(b). The estimated states and inputs converge to the correct states and inputs as expected.

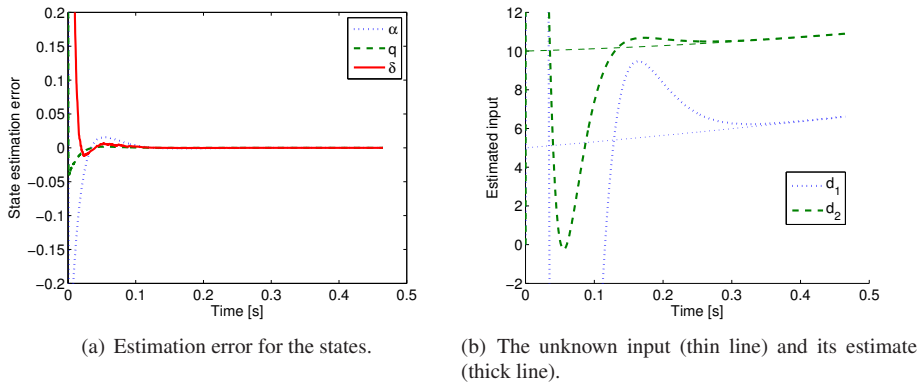

Figure 5.5: Estimation results for second order input.

The last case considered is with the true unknown input \mathbf{d} acting on the system being non-polynomial, given by $\mathbf{d} = [1 \ 3]^T \sin(t) + [4 \ 2]^T \cos(t)$, but the observer is computed by (incorrectly) assuming a linear input, i.e., a ramp. The estimation error for the states is presented in Figure 5.6(a) and the unknown inputs and their estimate in Figure 5.6(b). The estimated input does not converge exponentially to the exact value of the true input (see Figure 5.7), but only to a ball around it. The ultimate upper bound on the error (state and input), computed for this observer is $38.6 \cdot \|\mathbf{d}\|/\sigma$ with $\|\mathbf{d}\| \leq 8$ the norm of the input and σ arbitrarily chosen in $(0, 1)$. However, based on the estimation errors presented in Figures 5.6(a) and 5.7, one can conclude that for this example the computed bound is very conservative.

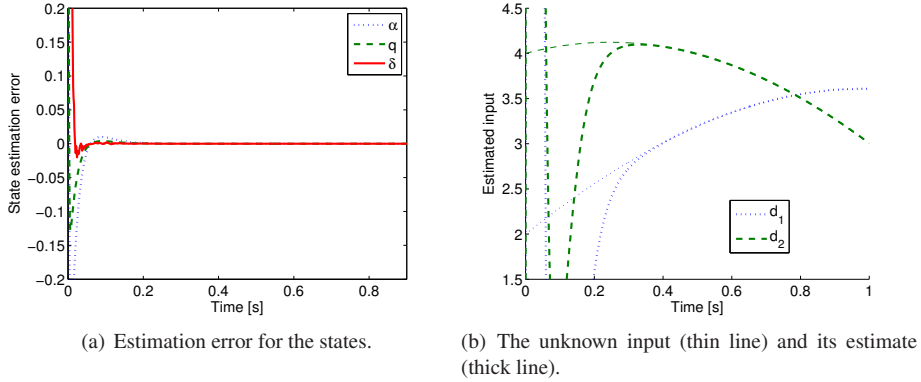

Figure 5.6: Estimation results for non-polynomial input.

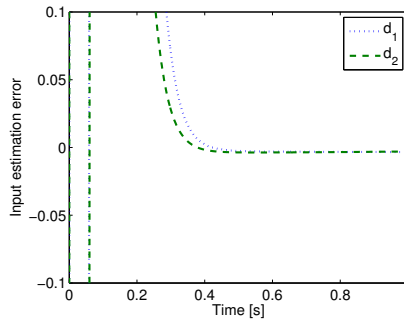

Figure 5.7: Input estimation error.

5.5 Summary and concluding remarks

In this chapter a method for designing observers that estimate the state and unknown inputs of TS fuzzy systems has been proposed. Design of unknown input observers is important in practice, since in many cases not all the inputs are known. These unknown inputs can represent disturbances acting on the process, effects of unmodeled dynamics, or actuator failures. The observer presented in this chapter is designed based on the known part of the fuzzy model. Sufficient conditions have been given for the stability of the observer and the computation of the observer gains was based on solving a system of LMIs. For the case when the unknown inputs are represented or approximated by polynomial functions of time, we derived sufficient conditions that guarantee the exponential convergence of the error and also an ultimate bound on the error signal. In the case of estimating unmodeled dynamics, sufficient conditions have been given for the asymptotic convergence of the observer. The design methods have been illustrated on an example of a missile. The simulation results show that the proposed observer is able to estimate both the states and inputs simultaneously.

Two shortcomings of the presented approach have to be noted. First, for the estimation of unmodelled dynamics, prerequisites are that an upper bound on the state matrix of the un-

modelled dynamics is known, that Assumption 5.1 is satisfied, and that a robust observer can be designed. Moreover, the presented method only guarantees asymptotic stability. The second shortcoming is that the methods rely on the existence of a common quadratic Lyapunov function, which introduces conservativeness in itself. Note however, that similar, less conservative, although more complex conditions may similarly be derived for piecewise quadratic Lyapunov functions.

Part II

Observers for stochastic systems

Chapter 6

Stochastic systems and observers

In the first part of the thesis, we dealt with deterministic nonlinear systems, represented by TS fuzzy models. In this second part we consider cascaded state estimation in discrete time stochastic systems. This chapter reviews the Kalman filter (KF), two of its nonlinear variants, and particle filters (PFs) for state estimation in discrete-time stochastic systems. The linear KF, Extended Kalman Filter (EKF), Unscented Kalman Filter (UKF), and PFs are briefly described, and based on the available literature, their advantages and shortcomings are presented.

6.1 Stochastic state estimation

In the first part of the thesis, we assumed that the model under study is deterministic, i.e., no noise is affecting the system or the noise is not significant enough to be taken into consideration when analyzing the system or designing observers for it. However, depending on the application considered, this is not always the case. The noise influencing the process may be relevant, and in order to obtain a useful estimate, probabilistic methods need to be used. In this part of the thesis, we consider such systems. In contrast with the first part, we also assume that the system evolves in discrete time. It is considered that both the states and the measurements may be corrupted by noise. In what follows, for applications, the explicit form of the system evolution¹ is used, with the noise explicitly represented:

$$\begin{aligned} \mathbf{x}_k &= \mathbf{f}(\mathbf{x}_{k-1}, \mathbf{u}_{k-1}, \boldsymbol{\theta}_{k-1}, \mathbf{v}_{k-1}) \\ \mathbf{y}_k &= \mathbf{h}(\mathbf{x}_k, \mathbf{u}_k, \boldsymbol{\mu}_k, \boldsymbol{\eta}_k) \end{aligned} \tag{6.1}$$

where k denotes the current time step, \mathbf{f} is the state transition model, describing the evolution of the states, \mathbf{h} is the measurement model, relating the measurement to the states, \mathbf{x} is the vector of the state variables, \mathbf{u} is the vector of the input and/or control variables, $\boldsymbol{\theta}$ and $\boldsymbol{\mu}$ are unknown/uncertain parameters, \mathbf{y} denotes the measurements, \mathbf{v}_{k-1} represents the state transition noise and $\boldsymbol{\eta}_k$ represents the measurement noise.

¹Note that the state and measurement models may also depend explicitly on the time (step). For the ease of notation, however, this is not denoted explicitly in Chapters 6–8.

A probabilistic formulation in the following form may also be used:

$$p(\mathbf{x}_k | \mathbf{x}_{k-1}, \mathbf{u}_{k-1}, \boldsymbol{\theta}_{k-1})$$
$$p(\mathbf{y}_k | \mathbf{x}_k, \mathbf{u}_{k-1}, \boldsymbol{\mu}_k)$$

where $p(\mathbf{x}_k | \mathbf{x}_{k-1}, \mathbf{u}_{k-1}, \boldsymbol{\theta}_{k-1})$ represents the conditional probability distribution function (PDF) of the current state \mathbf{x}_k , given the state \mathbf{x}_{k-1} , input \mathbf{u}_{k-1} and parameters $\boldsymbol{\theta}_{k-1}$ at the previous time step $k - 1$ and $p(\mathbf{y}_k | \mathbf{x}_k, \mathbf{u}_{k-1}, \boldsymbol{\mu}_k)$ represents the PDF of the current measurement \mathbf{y}_k given the current state, input and parameters. For the ease of notation, in the remainder of the thesis, we denote these PDFs only as $p(\mathbf{x}_k | \mathbf{x}_{k-1})$ and $p(\mathbf{y}_k | \mathbf{x}_k)$.

Filtering or estimation can be defined as the problem of estimating the states of a system, given its model and a set of noisy measurements of some quantities related to the states. Model inaccuracy can also be considered as noise.

The most well-known and widely used probabilistic estimation methods are the KF and its basic extension to nonlinear systems, the EKF (Kalman, 1960; Welch and Bishop, 2002). However, these filters have severe limitations and may become unstable even for linear processes. Over the last years, PFs (Doucet et al., 2000; Arulampalam et al., 2002) have been extensively studied. These filters have been successfully applied to state estimation problems (Nait-Charif and McKenna, 2004) and allow the handling of nonlinear, non-Gaussian systems. In this chapter, these estimation methods are briefly presented.

In many cases, model (6.1) is not exact and contains uncertain parameters. In this part of the thesis, parameter estimation is not handled separately, but it is assumed that the parameter variation can be represented as a stochastic process (e.g., can be well approximated by a random walk model), and that the estimation can be performed on the states augmented with the parameter.

6.2 Kalman filters

For a linear process, the KF provides an efficient means to estimate the states so that the filter also minimizes the mean of the squared error. KFs may be used to estimate current states, predict future states or smooth an already estimated trajectory. These filters in general assume Gaussian noise and approximate the posterior with a Gaussian distribution, by computing its mean and covariance. A Gaussian (or normal) distribution is usually assumed because it remains linear under linear transformations and its mean, mode, and median have the same value. Moreover, an arbitrary distribution can be approximated as an (infinite) sum of Gaussian distributions. In addition, for any distribution for which only the mean and the variance are known, there exists a normal distribution with the same parameters. KFs are essentially deterministic, in the sense that, given the state transition model, the measurement model and a Gaussian distribution of the corrupting noise, the estimates are determined using a deterministic procedure.

6.2.1 General description

In the case of linear systems, corrupted by white Gaussian noise, the KF is proved to be an optimal filter in the least mean square sense (Kalman, 1960), i.e., the filter minimizes the covariance of the error. The KF is a recursive algorithm that incorporates all the provided

information (model and observations) and processes the available measurements to estimate the current state of the system. The filter works in two steps: prediction and update. The *prediction* step uses the system model and the information available so far in order to predict the states of the process. This step is also known as the time update step, as it projects the current state forward in time. The *update* step uses the latest (noisy) measurement to correct the projected state. This step is also known as measurement update, since it incorporates the information brought by the new measurement.

The KF works under the assumption that both the state transition noise and measurement noise are white and Gaussian. If this assumption is removed, i.e., the noises are considered arbitrary, the KF can be shown to be the best (minimum error variance) filter from the class of linear unbiased filters (Welch and Bishop, 2002).

While the KF is optimal only in the case of linear systems corrupted by white Gaussian noise, several extensions to nonlinear systems exist: the EKF, which is based on linearizing the models around the current states, or the family of sigma-point KFs, which approximate the distribution of the states.

The recursive algorithms for the KF, EKF and UKF are presented below (Welch and Bishop, 2002; Julier and Uhlmann, 1997). For the computational derivation of the filters, see (Kalman, 1960; Julier and Uhlmann, 1997; Welch and Bishop, 2002).

6.2.2 Linear Kalman filter

The KF addresses the problem of estimating the state $\mathbf{x}_k \in \mathbb{R}^n$ of a linear discrete-time process:

$$\begin{aligned}\mathbf{x}_k &= A\mathbf{x}_{k-1} + B\mathbf{u}_{k-1} + \mathbf{v}_{k-1} \\ \mathbf{y}_k &= C\mathbf{x}_k + \boldsymbol{\eta}_k\end{aligned}\tag{6.2}$$

with \mathbf{x}_0 (initial state) and P_0 (initial covariance of the states) known or previously estimated.

The inputs \mathbf{v} and $\boldsymbol{\eta}$ are random variables, representing the process and measurement noise, respectively. These random variables are assumed to be independent, white, and normally distributed $\mathbf{v}_{k-1} \sim \mathcal{N}(0, Q)$ and $\boldsymbol{\eta}_k \sim \mathcal{N}(0, R)$. In general, the process and measurement noise covariance matrices (Q and R), the state transition matrix A , the input matrix B , and the measurement matrix C can change at every time step; however, here, they are assumed constant to simplify the notation. The objective is to recursively estimate or filter the state \mathbf{x}_k based on the available measurement \mathbf{y}_k .

The KF works in two steps, prediction:

$$\begin{aligned}\mathbf{x}_{k|k-1} &= A\hat{\mathbf{x}}_{k-1} + B\mathbf{u}_{k-1} \\ P_{k|k-1} &= AP_{k-1}A^T + Q\end{aligned}\tag{6.3}$$

and update or correction:

$$\begin{aligned}\hat{\mathbf{x}}_k &= \mathbf{x}_{k|k-1} + K_k(\mathbf{y}_k - C\mathbf{x}_{k|k-1}) \\ P_k &= (I - K_kC)P_{k|k-1}(I - K_kC)^T + K_kRK_k^T\end{aligned}\tag{6.4}$$

where $\hat{\mathbf{x}}_k$ (P_k) refers to the estimate of the states (covariance) obtained by using all the measurements up to k . The Kalman gain K_k is computed at each step k so that it minimizes

the error covariance P_k . This is obtained by minimizing the trace² of P_k at every step:

$$\begin{aligned} \frac{\partial(\text{tr}(P_k))}{\partial K_k} &= -2CP_{k|k-1} + 2(CP_{k|k-1}C^T + R)K_k^T = 0 \\ \implies K_k &= P_{k|k-1}C^T(CP_{k|k-1}C^T + R)^{-1} \end{aligned} \quad (6.5)$$

Then, assuming that at step $k - 1$ the error covariance is P_{k-1} , the covariance and the Kalman gain at step k can be expressed as:

$$\begin{aligned} P_k &= (I - K_kC)(AP_{k-1}A^T + Q)(I - K_kC)^T + K_kRK_k^T \\ K_k &= (AP_{k-1}A^T + Q)C^T(C(AP_{k-1}A^T + Q)C^T + R)^{-1} \end{aligned} \quad (6.6)$$

A generic KF algorithm is summarized in Algorithm 6.1.

Algorithm 6.1 Kalman filter

Input: $u, y, Q, R, A, B, C, \mathbf{x}_0, P_0$

Output: $\hat{\mathbf{x}}, P$

for $k = 1, 2, \dots$ **do**

Prediction:

$$\mathbf{x}_{k|k-1} = A\hat{\mathbf{x}}_{k-1} + B\mathbf{u}_{k-1} \quad \{\text{predict states}\}$$

$$P_{k|k-1} = AP_{k-1}A^T + Q \quad \{\text{predict covariance}\}$$

Update:

$$K_k = P_{k|k-1}C^T(CP_{k|k-1}C^T + R)^{-1} \quad \{\text{compute Kalman gain}\}$$

$$\hat{\mathbf{x}}_k = \mathbf{x}_{k|k-1} + K_k(\mathbf{y}_k - C\mathbf{x}_{k|k-1}) \quad \{\text{correct states}\}$$

$$P_k = (I - K_kC)P_{k|k-1}(I - K_kC)^T + K_kRK_k^T \quad \{\text{correct covariance}\}$$

end for

Note that if the state matrices, state-transition noise covariance, and measurement noise covariance are constant, both the estimation error covariance and the Kalman gain eventually converges to a final value and remains constant. If this is the case, they may be computed off-line and the final value can be used as the Kalman gain. However, in this case, the estimation is no longer optimal.

6.2.3 Extended Kalman filter

The KF is optimal only when dealing with linear processes and white Gaussian noise. However, since the publication of the Kalman's seminal paper (Kalman, 1960), the filter has been the subject of extensive research and applications, particularly in the area of autonomous robots, assisted navigation, and sensor data fusion (Lee et al., 1995; Dorfmüller-Ulhaas, 2003; Caron et al., 2006). In order to cope with nonlinear systems, many variants of Kalman's original formulation have been developed: the EKF, the information filter, and the family of sigma-point Kalman filters (van der Merwe and Wan, 2003b). Of these, probably still the most widely used is the EKF, which assumes the following nonlinear model:

$$\begin{aligned} \mathbf{x}_k &= \mathbf{f}(\mathbf{x}_{k-1}, \mathbf{v}_{k-1}) \\ \mathbf{y}_k &= \mathbf{h}(\mathbf{x}_k, \boldsymbol{\eta}_k) \end{aligned} \quad (6.7)$$

²For derivatives of matrices with respect to matrices, see (Jan R. Magnus, 1999) and the references therein.

with \mathbf{x}_0 and P_0 known or estimated, and \mathbf{v}_{k-1} and $\boldsymbol{\eta}_k$ zero mean Gaussian noises with known covariances Q_k and R_k , respectively.

The EKF linearizes the model at every step around the current estimate. In practice, one cannot know the value of the corrupting noise \mathbf{v}_{k-1} and $\boldsymbol{\eta}_k$, but it is possible to approximate the state and measurement vector without the noise. Thus, the following matrices are defined:

$$\begin{aligned} F_k &= \frac{\partial \mathbf{f}}{\partial \mathbf{x}}(\mathbf{x}_{k-1}, 0) \\ G_k &= \frac{\partial \mathbf{f}}{\partial \mathbf{v}}(\mathbf{x}_{k-1}, 0) \\ H_k &= \frac{\partial \mathbf{h}}{\partial \mathbf{x}}(\mathbf{x}_k, 0) \\ D_k &= \frac{\partial \mathbf{h}}{\partial \boldsymbol{\eta}}(\mathbf{x}_k, 0) \end{aligned} \quad (6.8)$$

Note that using these approximations, the distributions of the state variables are no longer normal. Therefore, the EKF is simply a heuristic estimator. Moreover, in order to obtain a good approximation, these matrices have to be recomputed at every step. After that, the linear KF is applied to this linearized model.

The prediction stage becomes:

$$\begin{aligned} \mathbf{x}_{k|k-1} &= \mathbf{f}(\widehat{\mathbf{x}}_{k-1}, 0) \\ P_{k|k-1} &= F_k P_{k-1} F_k^T + G_k Q_{k-1} G_k^T \end{aligned} \quad (6.9)$$

The update equations are:

$$\begin{aligned} K_k &= P_{k|k-1} H_k^T (H_k P_{k|k-1} H_k^T + D_k R_k D_k^T)^{-1} \\ \mathbf{x}_k &= \mathbf{x}_{k|k-1} + K_k (\mathbf{y}_k - \mathbf{h}(\mathbf{x}_{k|k-1}, 0)) \\ P_k &= (I - K_k H_k) P_{k|k-1} \end{aligned} \quad (6.10)$$

Although the EKF is the most used KF (Maybeck, 1979; Lee et al., 1995; Caron et al., 2006), especially in tracking, navigation, and localization problems, when the nonlinearity is not smooth, the filter easily diverges.

6.2.4 Unscented Kalman filter

The fundamental problem of the EKF is that the distributions of the random variables will no longer be normal after undergoing a nonlinear transformation. A variant of the KF that preserves the normal distribution up to the second order of the Taylor expansion while propagated through a nonlinear function was developed by Julier and Uhlmann (1997).

The UKF belongs to the family of the sigma-point KFs (van der Merwe et al., 2001), and it is based on the unscented transformation. The unscented transformation computes the statistics of a random variable that undergoes a nonlinear transformation. To compute the statistics, a number of weighted samples called ‘‘sigma points’’ are chosen deterministically, so that they completely capture the mean and covariance of the random variable, i.e., their mean is \mathbf{x}_0 and their variance is P_0 , respectively.

Assume that an n_x -dimensional random variable \mathbf{x} has to be propagated through the nonlinear function \mathbf{g} in order to generate \mathbf{y} :

$$\mathbf{y} = \mathbf{g}(\mathbf{x})$$

Assume also that \mathbf{x} has a known mean \mathbf{x}_0 and a known covariance P_x . In this case, a number of $2n_x + 1$ sigma points can be generated deterministically, so that they capture the mean and variance. One method to generate the sigma points is the following:

$$\begin{aligned} \mathcal{X}_0 &= \mathbf{x}_0 & w_0 &= \kappa / (n_x + \kappa) \\ \mathcal{X}_i &= \mathbf{x}_0 + [\sqrt{(n_x + \kappa)P_x}]_i & w_i &= 1 / [2(n_x + \kappa)] \quad i = 1, 2, \dots, n_x \\ \mathcal{X}_i &= \mathbf{x}_0 - [\sqrt{(n_x + \kappa)P_x}]_i & w_i &= 1 / [2(n_x + \kappa)] \quad i = n_x + 1, \dots, 2n_x \end{aligned} \quad (6.11)$$

where κ is a scaling parameter, $[\sqrt{(n_x + \kappa)P_x}]_i$ is the i^{th} row of the matrix square root of $(n_x + \kappa)P_x$, and w_i is the weight associated to the i^{th} sample.

The sigma points are now propagated through the nonlinear function \mathbf{g} : $\mathcal{Y}_i = \mathbf{g}(\mathcal{X}_i)$, $i = 0, 1, \dots, 2n_x$. The mean and covariance are estimated as:

$$\begin{aligned} \mathbf{y}_0 &= \sum_{i=0}^{2n_x} w_i \mathcal{Y}_i \\ P_y &= \sum_{i=0}^{2n_x} w_i (\mathcal{Y}_i - \mathbf{y}_0)(\mathcal{Y}_i - \mathbf{y}_0)^T \end{aligned} \quad (6.12)$$

The unscented transformation is illustrated in Figure 6.1.

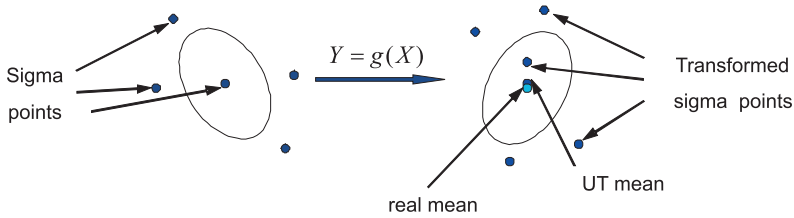

Figure 6.1: Unscented transformation.

In order to apply the KF using the unscented transformation, the state variables are augmented with the state transition and measurement noise, and the state covariance with the state transition and measurement covariance:

$$\begin{aligned} \mathbf{x}_k^a &= [\mathbf{x}_k^T \quad \mathbf{v}_k^T \quad \boldsymbol{\eta}_k^T]^T \\ P^a &= \text{diag}([P_k \quad Q_k \quad R_k]) \end{aligned}$$

The sigma points are generated from the augmented state and covariance.

The prediction is extended, since the sigma points have to be computed and propagated through the state transition model to predict the new states. The predicted states also have to be propagated through the measurement model in order to predict the measurement. The equations are the following:

First the sigma points are computed

$$\mathcal{X}_{k-1}^a = [\mathbf{x}_{k-1}^a \quad \mathbf{x}_{k-1}^a + \sqrt{(n_a + \kappa)P_{k-1}^a} \quad \mathbf{x}_{k-1}^a - \sqrt{(n_a + \kappa)P_{k-1}^a}]$$

based on the augmented state vector:

$$\mathcal{X}_{k-1}^a = [\mathcal{X}_{k-1}^x \quad \mathcal{X}_{k-1}^v \quad \mathcal{X}_{k-1}^\eta]$$

These sigma points are propagated through the state transition model:

$$\mathcal{X}_{k|k-1} = \mathbf{f}(\mathcal{X}_{k-1}^x, \mathcal{X}_{k-1}^v)$$

to obtain the sigma points corresponding to the predicted state, which is computed as:

$$\mathbf{x}_{k|k-1} = \sum_{i=0}^{2n_a} w_i \mathcal{X}_{i,k|k-1}$$

The covariance of the predicted state is also computed from the transformed sigma points:

$$P_{k|k-1} = \sum_{i=0}^{2n_a} w_i (\mathcal{X}_{i,k|k-1} - \mathbf{x}_{k|k-1})(\mathcal{X}_{i,k|k-1} - \mathbf{x}_{k|k-1})^T$$

In order to have an accurate prediction of the measurement, the sigma points corresponding to the predicted state are propagated through the measurement model:

$$\mathcal{Y}_{k|k-1} = \mathbf{h}(\mathcal{X}_{k|k-1}, \mathcal{X}_{k-1}^\eta)$$

From these, twice propagated points, the predicted measurement

$$\mathbf{y}_{k|k-1} = \sum_{i=0}^{2n_a} w_i \mathcal{Y}_{i,k|k-1}$$

and the covariance of the predicted measurements

$$P_{yy} = \sum_{i=0}^{2n_a} w_i (\mathcal{Y}_{i,k|k-1} - \mathbf{y}_{k|k-1})(\mathcal{Y}_{i,k|k-1} - \mathbf{y}_{k|k-1})^T$$

are computed. Combining the sigma points corresponding to the predicted state with those corresponding to the predicted measurement, the cross-correlation matrix is determined:

$$P_{xy} = \sum_{i=0}^{2n_a} w_i (\mathcal{X}_{i,k|k-1} - \mathbf{x}_{k|k-1})(\mathcal{Y}_{i,k|k-1} - \mathbf{y}_{k|k-1})^T$$

The procedure of updating the predicted state remains the same as for the KF. The Kalman gain is computed as:

$$K_k = P_{xy}P_{yy}^{-1}$$

The predicted state is corrected as follows

$$\hat{\mathbf{x}}_k = \mathbf{x}_{k|k-1} + K_k(\mathbf{y}_k - \mathbf{y}_{k|k-1})$$

Algorithm 6.2 Unscented Kalman filter

Input: u, y, Q, R, f, h
Output: x, P
for $k = 1, 2, \dots$ **do**
Prediction:

$$\mathbf{x}_{k-1}^a = [\mathbf{x}_{k-1}^T \mathbf{v}_{k-1}^T \boldsymbol{\eta}_{k-1}^T]^T \quad \{\text{augment states}\}$$

$$P_{k-1}^a = \text{diag}[P_{k-1} \ Q_{k-1} \ R_{k-1}] \quad \{\text{augment covariance}\}$$

$$\mathcal{X}_{k-1}^a = [\mathbf{x}_{k-1}^a \quad \mathbf{x}_{k-1}^a + \sqrt{(n_a + \kappa)P_{k-1}^a} \quad \mathbf{x}_{k-1}^a - \sqrt{(n_a + \kappa)P_{k-1}^a}] \quad \{\text{compute sigma points}\}$$

$$\mathcal{X}_{k|k-1} = f(\mathcal{X}_{k-1}^x, \mathcal{X}_{k-1}^v) \quad \{\text{propagate sigma points}\}$$

$$\mathbf{x}_{k|k-1} = \sum_{i=0}^{2n_a} w_i \mathcal{X}_{i,k|k-1} \quad \{\text{predicted next state}\}$$

$$P_{k|k-1} = \sum_{i=0}^{2n_a} w_i (\mathcal{X}_{i,k|k-1} - \mathbf{x}_{k|k-1})(\mathcal{X}_{i,k|k-1} - \mathbf{x}_{k|k-1})^T \quad \{\text{predict covariance}\}$$

$$\mathcal{Y}_{k|k-1} = h(\mathcal{X}_{k|k-1}, \mathcal{X}_{k-1}^\eta) \quad \{\text{propagate transformed sigma points}\}$$

$$\mathbf{y}_{k|k-1} = \sum_{i=0}^{2n_a} w_i \mathcal{Y}_{i,k|k-1} \quad \{\text{predicted measurement}\}$$

$$P_{yy} = \sum_{i=0}^{2n_a} w_i (\mathcal{Y}_{i,k|k-1} - \mathbf{y}_{k|k-1})(\mathcal{Y}_{i,k|k-1} - \mathbf{y}_{k|k-1})^T \quad \{\text{predicted measurement covariance}\}$$

$$P_{xy} = \sum_{i=0}^{2n_a} w_i (\mathcal{X}_{i,k|k-1} - \mathbf{x}_{k|k-1})(\mathcal{Y}_{i,k|k-1} - \mathbf{y}_{k|k-1})^T \quad \{\text{cross-correlation matrix}\}$$

Update:

$$K_k = P_{xy} P_{yy}^{-1} \quad \{\text{Kalman gain}\}$$

$$\hat{\mathbf{x}}_k = \mathbf{x}_{k|k-1} + K_k (\mathbf{y} - \mathbf{y}_{k|k-1}) \quad \{\text{correct the state}\}$$

$$P_k = P_{k|k-1} + K_k P_{yy} K_k^T \quad \{\text{correct the covariance}\}$$

end for

and the covariance is corrected by

$$P_k = P_{k|k-1} + K_k P_{yy} K_k^T$$

A generic UKF algorithm is given in Algorithm 6.2.

The presented procedure is a general form of the UKF. For special cases, such as additive state transition and/or measurement noise, the computational complexity may be reduced, since, in such cases it is not necessary to include the additive noise in the augmented vector and matrix (Julier and Uhlmann, 1997).

The UKF is a rather general solution for nonlinear state estimation, but it cannot be used successfully in all situations. The filter may collapse due to the lack of robustness: the estimated posterior covariance can increase in an unbounded fashion in case of model-plant mismatch.

6.2.5 Properties and convergence issues

In order to implement a KF, first the state transition and measurement noise covariance need to be determined. In general these noise covariances are considered constant. However, in some

cases (e.g., actuator or sensor degradation or fault) they might vary in time, and have to be tuned online. In an actual implementation, the measurement noise covariance is determined before filtering.

The state transition noise covariance is more difficult to determine. Sometimes even a poor model can produce acceptable results, if enough uncertainty is considered, i.e., the state transition noise covariance is large enough to account for the model mismatch. In either case, the covariances may be tuned. This is usually performed offline.

Note that since the EKF is essentially a heuristic method, there is no guarantee that the estimate will converge. The EKF generally diverges due to two causes:

1. the random variables are no longer normal after the nonlinear transformation and this effect is increased at every step.
2. due to the linearization, the correction is performed wrongly, in particular if the non-linearity is not mild.

In some cases, these collapses may be prevented by the UKF. Since the UKF uses the nonlinear model equations, it is more accurate than the EKF. Note that the UKF is not restricted to Gaussian noises. Depending on the particular application considered, the fact that a matrix square root has to be computed instead of having to linearize the model at each step might be an advantage, in particular for non-smooth models. Its superior performance has been reported in many publications, such as (van der Merwe et al., 2001; van der Merwe and Wan, 2003a; Li et al., 2004).

However, not in all cases the UKF can be used successfully. While theoretically it can handle non-Gaussian noise, this is not always the case in practice, in particular with multi-modal distributions.

6.3 Particle filters

KFs represent the distribution of random variables by their mean and covariance. However, for arbitrary distributions or nonlinear processes, this representation is not sufficient for a reliable estimation and there is no general method to compute the resulting distribution analytically. Therefore, these methods may become unstable for highly nonlinear processes. This is why the PFs approximate the distributions by samples, which can be easily computed with, rather than by a compact parametric form.

The PF uses probabilistic models for the state transition function and the measurement function (Doucet et al., 2000; Arulampalam et al., 2002):

$$p(\mathbf{x}_k | \mathbf{x}_{k-1}), \quad p(\mathbf{y}_k | \mathbf{x}_k).$$

The objective is to recursively construct the posterior PDF $p(\mathbf{x}_k | \mathbf{y}_k)$ of the state, given the measured output \mathbf{y}_k and assuming conditional independence of the measurements in consecutive time steps. The PF works in two stages:

1. The *prediction stage* uses the state-transition model to predict the state PDF one step ahead. The PDF obtained is called the *prior*.
2. The *update stage* uses the current measurement to correct the prior via the Bayes rule. The PDF obtained after the update is called the *posterior*.

PFs represent the PDF by N random samples (particles) \mathbf{x}_k^i with their associated weights w_k^i , $i = 1, 2, \dots, N$, normalized so that $\sum_{i=1}^N w_k^i = 1$. At time instant k , the posterior obtained in the previous step, $p(\mathbf{x}_{k-1}|\mathbf{y}_{k-1})$, is represented by N samples \mathbf{x}_{k-1}^i and the corresponding weights w_{k-1}^i , $i = 1, 2, \dots, N$. To approximate the posterior $p(\mathbf{x}_k|\mathbf{y}_k)$, N new samples \mathbf{x}_k^i and weights w_k^i , $i = 1, 2, \dots, N$ are generated. Samples \mathbf{x}_k^i are drawn from a (chosen) *importance density function* $q(\mathbf{x}_k^i|\mathbf{x}_{k-1}^i, \mathbf{y}_k)$, and the weights are updated, using the current measurement \mathbf{y}_k

$$\tilde{w}_k^i = w_{k-1}^i \frac{p(\mathbf{y}_k|\mathbf{x}_k^i)p(\mathbf{x}_k^i|\mathbf{x}_{k-1}^i)}{q(\mathbf{x}_k^i|\mathbf{x}_{k-1}^i, \mathbf{y}_k)} \quad (6.13)$$

and normalized

$$w_k^i = \frac{\tilde{w}_k^i}{\sum_{j=1}^N \tilde{w}_k^j}.$$

If the importance density $q(\mathbf{x}_k|\mathbf{x}_{k-1}, \mathbf{y}_k)$ is chosen equal to the state-transition PDF, $p(\mathbf{x}_k|\mathbf{x}_{k-1})$, the weight update equation (6.13) becomes:

$$\tilde{w}_k^i = w_{k-1}^i p(\mathbf{y}_k|\mathbf{x}_k^i).$$

The use of the transition prior as the importance density is a common choice (Arulampalam et al., 2002) and it has the advantage that it can be easily sampled and the weights are easily evaluated.

The posterior PDF is represented by the set of weighted samples, conventionally denoted by:

$$p(\mathbf{x}_k|\mathbf{y}_k) = \sum_{i=1}^N w_k^i \delta(\mathbf{x}_k - \mathbf{x}_k^i)$$

where δ is the Dirac delta measure.

The PF algorithm is summarized in Algorithm 6.3 and illustrated in Figure 6.2. A common problem of PF is the particle degeneracy: after several iterations, all but one particle will have negligible weights. Therefore, particles must be resampled. A standard measure of the degeneracy is the effective sample size:

$$N_{\text{eff}} = \frac{1}{\sum_{i=1}^N (w_k^i)^2}$$

If N_{eff} drops below a specified threshold $N_T \in [1, N]$, particles are resampled (Fearnhead, 1998) by using Algorithm 6.4.

The state estimate is in general computed as the weighted mean of the particles:

$$\hat{\mathbf{x}}_k = \sum_{i=1}^N w_k^i \mathbf{x}_k^i.$$

In some cases, however, the weighted mean cannot be considered a correct estimate of the state, since no guarantees exist that the posterior is unimodal. Due to the approximation of the posterior with weighted samples, a large number of samples are necessary for good performance. Hence, the algorithm is computationally involved, and not suitable for fast processes.

For more details on particle filters, refer to (Doucet et al., 2000; Arulampalam et al., 2002).

Algorithm 6.3 Particle filter**Input:** $p(\mathbf{x}_k|\mathbf{x}_{k-1}), p(\mathbf{y}_k|\mathbf{x}_k), p(\mathbf{x}_0), N, N_T$ **Initialize:****for** $i = 1, 2, \dots, N$ **do** Draw a new particle: $\mathbf{x}_1^i \sim p(\mathbf{x}_0)$ Assign weight: $w_1^i = \frac{1}{N}$ **end for****At every time step** $k = 2, 3, \dots$ **for** $i = 1, 2, \dots, N$ **do** Draw a particle from importance distribution: $\mathbf{x}_k^i \sim p(\mathbf{x}_k^i|\mathbf{x}_{k-1}^i)$ Use the measured y_k to update the weight: $\tilde{w}_k^i = w_{k-1}^i p(\mathbf{y}_k|\mathbf{x}_k^i)$ **end for**Normalize weights: $w_k^i = \frac{\tilde{w}_k^i}{\sum_{j=1}^N \tilde{w}_k^j}$ **if** $\frac{1}{\sum_{i=1}^N (w_k^i)^2} < N_T$ **then**

Resample using Algorithm 6.4.

end if**Algorithm 6.4** Resampling**Input:** $\{(\mathbf{x}^i, w^i)\}_{i=1}^N$ **Output:** $\{(\mathbf{x}_{\text{new}}^i, w_{\text{new}}^i)\}_{i=1}^N$ **for** $i = 1, 2, \dots, N$ **do** Compute cumulative sum of weights: $w_c^i = \sum_{j=1}^i w_k^j$ **end for**Draw u_1 from $\mathcal{U}(0, \frac{1}{N})$ **for** $i = 1, 2, \dots, N$ **do** Find \mathbf{x}^{+i} , the first sample for which $w_c^i \geq u_i$. Replace particle i : $\mathbf{x}_{\text{new}}^i = \mathbf{x}^{+i}, w_{\text{new}}^i = \frac{1}{N}$ $u_{i+1} = u_i + \frac{1}{N}$ **end for**

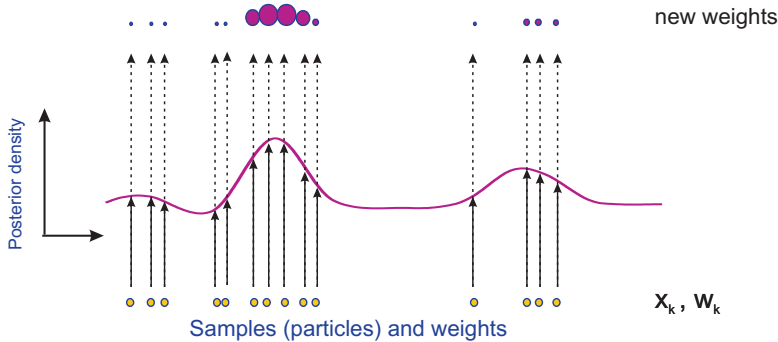

Figure 6.2: Propagation of particles.

6.4 Summary and concluding remarks

In this chapter, the KF, two of its nonlinear variants, the EKF and the UKF, and PFs have been presented for state estimation for stochastic processes. These methods use a state transition model that describe the evolution of states over time, and a measurement model that relates the measurements to the states.

The most well-known variant of the KF is the linear KF. Although it has severe limitations and becomes unstable for nonlinear or non-Gaussian processes, it provides an efficient means to estimate the states of a linear stochastic process, so that it also minimizes the covariance of the estimation error.

Its most used extension for nonlinear systems, the EKF, is based on the linearization of the system at each moment around the current estimate. However, when dealing with highly nonlinear systems, where the linearization is valid only in a very restricted space, this filter is likely to diverge.

A more accurate extension of the Kalman filter to nonlinear systems, is the Unscented Kalman filter, which uses the true nonlinear model. The performance of the UKF may be far superior or similar to that of the EKF, depending on the application considered.

Particle filters have an important advantage over KFs: they can handle highly nonlinear processes, as well as arbitrary distributions. Note, however, that PFs are computationally involved.

Recently, several new methods have been developed to make PFs more efficient by solving the problem of particle degeneration and obtaining a better importance density: density assisted PFs (Djurić et al., 2004), resampling after obtaining the observation (Wu et al., 2006), and combination with other approaches (Shi and Han, 2007; Cheng and Bondon, 2008; Wu et al., 2008). Although methods for a more time-efficient implementation (Hong et al., 2007) have also been investigated, due to the large number of particles in general needed, online estimation using PFs still represent a challenge.

Chapter 7

Cascaded Kalman filters

In this chapter, the cascaded design of linear Kalman filters is discussed. If (at least) the deterministic part of a linear system, that is observable, but corrupted by zero-mean Gaussian noise, is a cascade of subsystems, then cascaded KFs may be designed. Although theoretically these observers do not achieve the same performance as a centralized KF, examples indicate that in practical applications the cascaded design has several advantages. The performance of the KF designed for the system as a whole and the cascaded KFs are compared theoretically and on several examples.

Parts of this chapter have been published in (Lendek et al., 2007a, 2008c).

7.1 Introduction

For large-scale systems, in particular when subsystems may be added or removed online, the design and re-design of a centralized observer may not be computationally feasible. In Chapter 3, we have investigated whether a sequential stability analysis and observer design is possible for cascaded system represented by TS fuzzy models. As demonstrated, such a design is not only possible, but it does not lead to performance loss in terms of the estimation error decay-rate.

In this chapter, we study whether such an observer design is also possible for cascaded, discrete time stochastic systems. Since for linear Gaussian systems the KF is optimal, we analyze whether this optimality is preserved if KFs are designed in a cascaded manner.

Note that many nonlinear systems may be expressed as or approximated by the cascade of linear (time-varying) subsystems. If the measurements are such that these subsystems are observable, for these linear systems KFs may be used, instead of a complex and possibly hard to design observer that has to be found for the centralized system. Naturally, such an approximation may introduce performance loss. To obtain a fair comparison, in this chapter we assume that a linear system is the cascade of linear subsystems. Therefore, consider the following observable linear MIMO system:

$$\begin{aligned} \mathbf{x}_k &= A\mathbf{x}_{k-1} + B\mathbf{u}_{k-1} \\ \mathbf{y}_k &= C\mathbf{x}_k \end{aligned} \tag{7.1}$$

and assume that this system can be partitioned into subsystems. For the ease of notation, only two subsystems are considered, $\mathbf{x} = [\mathbf{x}_1^T \ \mathbf{x}_2^T]^T$ and $\mathbf{y} = [\mathbf{y}_1^T \ \mathbf{y}_2^T]^T$:

$$\begin{aligned} \mathbf{x}_{1k} &= A_1 \mathbf{x}_{1k-1} + B_1 \mathbf{u}_{k-1} \\ \mathbf{y}_{1k} &= C_1 \mathbf{x}_{1k} \end{aligned} \tag{7.2}$$

and

$$\begin{aligned} \mathbf{x}_{2k} &= A_2 \mathbf{x}_{2k-1} + B_2 \mathbf{u}_{k-1} + A_{21} \mathbf{x}_{1k-1} \\ \mathbf{y}_{1k} &= C_2 \mathbf{x}_{2k} + C_{21} \mathbf{x}_{1k} \end{aligned} \tag{7.3}$$

so that (7.2) is observable. Similarly to Section 3.2.1, since both systems (7.1) and (7.2) are observable, this also means that the subsystem (7.3) is observable for given \mathbf{x}_{1k} and \mathbf{x}_{1k-1} .

The necessary and sufficient condition for the existence of a partition is that the A and C matrices can be transformed into block triangular forms. Note that, if the partition exists, it might not be unique, as illustrated in the following example.

Example 7.1 Consider the system

$$\begin{aligned} x_{1k} &= x_{1k-1} + x_{3k-1} & y_{1k} &= x_{1k} \\ x_{2k} &= x_{2k-1} + x_{3k-1} & y_{2k} &= x_{2k} \\ x_{3k} &= u_{k-1} \end{aligned}$$

This system is observable, and there are two possible ways to partition it: by using as the first subsystem

$$\begin{aligned} x_{1k} &= x_{1k-1} + x_{3k-1} & y_{1k} &= x_{1k} \\ x_{3k} &= u_{k-1} \end{aligned}$$

or, by using as the first subsystem

$$\begin{aligned} x_{2k} &= x_{2k-1} + x_{3k-1} & y_{2k} &= x_{2k} \\ x_{3k} &= u_{k-1} \end{aligned}$$

Both subsystems are observable.

In this section, we study the conditions under which Kalman-type filters can be designed for the two subsystems so that the performance of the cascaded filters is the same as that of a single KF for system (7.1).

7.2 Distributed Kalman filters

Consider the linear system (6.2), corrupted with zero-mean Gaussian noise and assume that the system can be written in the form

$$\begin{aligned} \begin{pmatrix} \mathbf{x}_{1k} \\ \mathbf{x}_{2k} \end{pmatrix} &= \begin{pmatrix} A_1 & 0 \\ A_{21} & A_2 \end{pmatrix} \begin{pmatrix} \mathbf{x}_{1k-1} \\ \mathbf{x}_{2k-1} \end{pmatrix} + \begin{pmatrix} B_1 \\ B_2 \end{pmatrix} \mathbf{u}_{k-1} + \begin{pmatrix} \mathbf{v}_{1k-1} \\ \mathbf{v}_{2k-1} \end{pmatrix} \\ \begin{pmatrix} \mathbf{y}_{1k} \\ \mathbf{y}_{1k} \end{pmatrix} &= \begin{pmatrix} C_1 & 0 \\ C_{21} & C_2 \end{pmatrix} \begin{pmatrix} \mathbf{x}_{1k} \\ \mathbf{x}_{2k} \end{pmatrix} + \begin{pmatrix} \boldsymbol{\eta}_{1k} \\ \boldsymbol{\eta}_{2k} \end{pmatrix} \end{aligned} \tag{7.4}$$

i.e., as two cascaded subsystems. Our goal is to design separate observers for the two subsystems, so that the cascaded observers have the same error covariance as the KF designed for the joint system. In order to have a truly cascaded system, here we assume that the covariance matrices are block-diagonal, i.e., $Q = \begin{pmatrix} Q_1 & 0 \\ 0 & Q_2 \end{pmatrix}$ and $R = \begin{pmatrix} R_1 & 0 \\ 0 & R_2 \end{pmatrix}$. While this condition appears restrictive, in practice one rarely knows the true cross-covariances and it is often assumed that the covariance matrix is diagonal (Hue et al., 2002; Aja-Fernandez et al., 2003).

Since our goal is to design separate observers for the two subsystems, while still minimizing the error covariance, we use separate KFs for each subsystem. The first subsystem can be expressed as:

$$\begin{aligned} \mathbf{x}_{1k} &= A_1 \mathbf{x}_{1k-1} + B_1 \mathbf{u}_{k-1} + \mathbf{v}_{1k-1} \\ \mathbf{y}_{1k} &= C_1 \mathbf{x}_{1k} + \boldsymbol{\eta}_{1k} \end{aligned} \quad (7.5)$$

which is a linear system, with $\mathbf{v}_{1k-1} \sim \mathcal{N}(0, Q_1)$ and $\boldsymbol{\eta}_{1k} \sim \mathcal{N}(0, R_1)$ and the deterministic input \mathbf{u} . In order to minimize the error covariance for the first subsystem, the Kalman filter presented in Section 6.2.2 is used. Then, for the first subsystem (with the deterministic input \mathbf{u}), the covariance and the gain at each time step can be written as

$$\begin{aligned} P_{1k} &= (I - K_{1k} C_1)(A_1 P_{1k-1} A_1^T + Q_1)(I - K_{1k} C_1)^T + K_{1k} R_1 K_{1k}^T \\ K_{1k} &= (A_1 P_{1k-1} A_1^T + Q_1) C_1^T (C_1 (A_1 P_{1k-1} A_1^T + Q_1) C_1^T + R_1)^{-1} \end{aligned} \quad (7.6)$$

The second subsystem can be expressed as:

$$\begin{aligned} \mathbf{x}_{2k} &= A_2 \mathbf{x}_{2k-1} + B_2 \mathbf{u}_{k-1} + A_{21} \mathbf{x}_{1k-1} + \mathbf{v}_{2k-1} \\ \mathbf{y}_{1k} &= C_2 \mathbf{x}_{2k} + C_{21} \mathbf{x}_{1k} + \boldsymbol{\eta}_{2k} \end{aligned} \quad (7.7)$$

with $\mathbf{v}_{k-1} \sim \mathcal{N}(0, Q_2)$ and $\boldsymbol{\eta}_{2k} \sim \mathcal{N}(0, R_2)$, the deterministic input \mathbf{u} and the stochastic variable \mathbf{x}_1 . Depending on the type of estimate required, two cases can be distinguished.

Case 1: Use \mathbf{x}_1 as another **deterministic input** besides \mathbf{u} for the second subsystem. This amounts to approximating the random variable \mathbf{x}_1 with its mean value when using it in the second subsystem. If the estimation is done for control purposes, usually the mean value, not the distribution of the estimate is needed. Therefore, it is plausible that only the estimated value (without the covariance) is transmitted to the second subsystem. In this case, the Kalman filter can be used also for this subsystem, and the expression for the covariance and the gain are given by

$$\begin{aligned} P_{2k} &= (I - K_{2k} C_2)(A_2 P_{2k-1} A_2^T + Q_2)(I - K_{2k} C_2)^T + K_{2k} R_2 K_{2k}^T \\ K_{2k} &= (A_2 P_{2k-1} A_2^T + Q_2) C_2^T (C_2 (A_2 P_{2k-1} A_2^T + Q_2) C_2^T + R_2)^{-1} \end{aligned} \quad (7.8)$$

Note that the computed error covariance is not equal to the true error covariance for the second subsystem.

Case 2: If the covariance of the estimates is also available, then \mathbf{x}_1 can be considered as a **stochastic input**, with estimated covariance P_{1k} , for the second subsystem. For this case, a Kalman-type gain can be computed by minimizing the trace of the error covariance for the

second subsystem, given that \mathbf{x}_1 is a stochastic variable with a known covariance matrix P_1

$$\begin{aligned}
 0 &= -2C_2(A_2P_{2k-1}A_2^T + A_{21}P_{1k-1}A_{21}^T + Q_2) + 2(C_2(A_2P_{2k-1}A_2^T + \\
 &\quad A_{21}P_{1k-1}A_{21}^T + Q_2)C_2^T + R_2)K_{2k}^T + 2C_{21}P_{1k-1}C_{21}^T K_{2k}^T \\
 K_{2k} &= (C_2(A_2P_{2k-1}A_2^T + A_{21}P_{1k-1}A_{21}^T + Q_2))^T \cdot ((C_2(A_2P_{2k-1}A_2^T + \\
 &\quad A_{21}P_{1k-1}A_{21}^T + Q_2)C_2^T + R_2 + C_{21}P_{1k-1}C_{21}^T)^{-1})^T
 \end{aligned} \tag{7.9}$$

The covariance for \mathbf{x}_2 is calculated as

$$\begin{aligned}
 P_{2k} &= (I - K_{2k}C_2)(A_2P_{2k-1}A_2^T + A_{21}P_{1k-1}A_{21}^T + Q_2)(I - K_{2k}C_2)^T + \\
 &\quad K_{2k}R_2K_{2k}^T + K_{2k}C_{21}P_{1k-1}(K_{2k}C_{21})^T
 \end{aligned} \tag{7.10}$$

where P_{2k} is the true covariance obtained for the states of the second subsystem.

In both cases, the observer gain and the covariance matrix for the whole system are expressed as:

$$K = \begin{pmatrix} K_1 & 0 \\ 0 & K_2 \end{pmatrix} \quad P = \begin{pmatrix} P_1 & 0 \\ 0 & P_2 \end{pmatrix} \tag{7.11}$$

However, only in the second case (if \mathbf{x}_1 is considered a stochastic input), the covariance matrix for the joint system equals the true covariance obtained by the observers.

Proposition 7.1 *The cascaded setting achieves the same error covariance as the centralized Kalman filter if and only if the subsystems are decoupled, i.e., in (7.4), $A_{21} = 0$, $C_{21} = 0$, $R_{12} = 0$ and $Q_{12} = 0$.*

Proof: It is straightforward to see that if the subsystems are independent, then the cascaded KF is equivalent to the centralized KF.

For the “only if” part, the error covariance has to be minimized by a block-diagonal Kalman gain at every step, i.e., (6.5) has to be satisfied by a block-diagonal K_k . For the ease of notation and calculus, assume first that $P_{k|k-1}$ and R are block-diagonal, i.e., $P_{k|k-1} = \begin{pmatrix} P_1 & 0 \\ 0 & P_2 \end{pmatrix}$ and $R = \begin{pmatrix} R_1 & 0 \\ 0 & R_2 \end{pmatrix}$.

For such $P_{k|k-1}$ and R we get that the trace is minimized if:

$$\begin{pmatrix} C_1P_1 - (C_1P_1C_1^T + R_1)K_{1k}^T & C_1P_1C_{21}^T K_{2k}^T \\ C_{21}P_1 - C_{21}P_1C_{21}^T K_{1k}^T & C_2P_2 - C_{21}P_1C_{21}^T K_{1k}^T + (C_2P_2C_2^T + R_2)K_{2k}^T \end{pmatrix} = 0$$

i.e.,

$$C_1P_1 - (C_1P_1C_1^T + R_1)K_{1k}^T = 0 \tag{7.12}$$

$$C_2P_2 - C_{21}P_1C_{21}^T K_{1k}^T + (C_2P_2C_2^T + R_2)K_{2k}^T = 0 \tag{7.13}$$

$$C_1P_1C_{21}^T K_{2k}^T = 0 \tag{7.14}$$

$$C_{21}P_1 - C_{21}P_1C_{21}^T K_{1k}^T = 0 \tag{7.15}$$

Note that (7.12) and (7.13) are satisfied by the Kalman gains given by (7.6) and (7.9). However, (7.14) and (7.15) for any P_1 and K_{1k} are satisfied only if $C_{21} = 0$.

Now, recall that if the prediction step is realized for the whole system, $P_{k|k-1}$ is not block-diagonal, but obtained as

$$P_{k|k-1} = \begin{pmatrix} P_{11} & P_{12} \\ P_{12}^T & P_{21} \end{pmatrix} = \begin{pmatrix} A_1 P_{11k-1} A_1^T + Q_{11} & A_1 P_{11k-1} A_{21}^T + A_1 P_{12k-1} A_2^T + Q_{12} \\ \left(A_1 P_{11k-1} A_{21}^T + A_1 P_{12k-1} A_2^T + Q_{12} \right)^T & A_{21} (P_{11k-1} A_{21}^T + P_{12k-1} A_2^T) + A_2 (P_{21k-1} A_{21}^T + P_{22k-1} A_2^T) + Q_2 \end{pmatrix} \quad (7.16)$$

The block-diagonal form is obtained only if $A_1 P_{11k-1} A_{21}^T + A_1 P_{12k-1} A_2^T + Q_{12} = 0$, which is satisfied for any A_1, A_2 only if $A_{21} = 0, P_{12k-1} = 0$ and $Q_{12} = 0$.

Summarizing, the error covariance of the whole system can be minimized for any system and any covariance matrices by a block-diagonal Kalman gain if and only if the subsystems are decoupled, i.e., $A_{21} = 0, C_{21} = 0, R_{12} = 0$, and $Q_{12} = 0$. \square

Since the distributed filters obtain the same performance as the centralized KF if and only if the subsystems are decoupled, in general, the distributed observers will not minimize the joint covariance. However, in practice, the performance of the centralized and distributed observers is comparable, as illustrated in the following section.

7.3 Examples

In this section, three examples are presented to compare the performance of the cascaded and centralized KFs, both in open-loop and closed-loop control.

7.3.1 Cascaded KFs in open-loop

Here an example is presented to compare the performance of the cascaded and centralized observers, in open-loop control. The first observer (O1) uses the available input, u and the output of the first subsystem, y_1 , to estimate the states of the subsystem, \hat{x}_1 . The second observer (O2) uses the input u , the output of the second subsystem, y_2 , and the estimated states of the first subsystem, \hat{x}_1 , to estimate the states of the second subsystem, \hat{x}_2 . Such a setting is depicted in Figure 7.1.

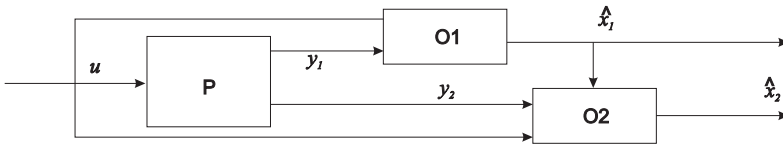

Figure 7.1: Cascaded observers in open-loop.

Consider the following, randomly generated discrete-time system:

$$\begin{aligned} x_k &= Ax_{k-1} + Bu_{k-1} + \mathbf{v}_{k-1} \\ y_k &= Cx_k + \eta_k \end{aligned}$$

with

$$\begin{aligned}
 A &= \begin{pmatrix} -0.2034 & 0 & 0 \\ -0.8520 & -0.3182 & -1.2951 \\ 0.0218 & 0.5776 & 0.9522 \end{pmatrix} \\
 B &= \begin{pmatrix} 1 \\ 0 \\ 0 \end{pmatrix} \quad C = \begin{pmatrix} 1 & 0 & 0 \\ 0 & 1 & 0 \end{pmatrix} \\
 \mathbf{v}_{k-1} &\sim \mathcal{N}(0, Q) \quad Q = \begin{pmatrix} 0.6818 & 0.2244 & 0.0577 \\ 0.2244 & 0.2796 & 0.1039 \\ 0.0577 & 0.1039 & 0.2263 \end{pmatrix} \\
 \boldsymbol{\eta}_k &\sim \mathcal{N}(0, R) \quad R = \begin{pmatrix} 0.1679 & 0.0616 \\ 0.0616 & 0.1204 \end{pmatrix}
 \end{aligned} \tag{7.17}$$

It can be easily seen that the deterministic part of the system is the cascaded of two subsystems. However, the noise covariance matrices are not. Therefore, two cases are considered.

- a) Since the cascaded filters do not take into account the cross-covariance between the subsystems, in order to ensure the exact same conditions, consider for both the KF and the cascaded filters the following block diagonal part of the noise covariances:

$$\begin{aligned}
 \bar{Q} &= \begin{pmatrix} 0.6818 & 0 & 0 \\ 0 & 0.2796 & 0.1039 \\ 0 & 0.1039 & 0.2263 \end{pmatrix} \\
 \bar{R} &= \begin{pmatrix} 0.1679 & 0 \\ 0 & 0.1204 \end{pmatrix}
 \end{aligned} \tag{7.18}$$

The input signal is presented in Figure 7.2. Using the centralized Kalman filter, after 300 steps, we obtain:

$$\begin{aligned}
 P &= \begin{pmatrix} 0.1349 & 0.0004 & 0.0015 \\ 0.0004 & 0.1091 & -0.0438 \\ 0.0015 & -0.0438 & 0.4804 \end{pmatrix} \\
 K &= \begin{pmatrix} 0.8036 & 0.0036 \\ 0.0026 & 0.9060 \\ 0.0090 & -0.3640 \end{pmatrix}
 \end{aligned}$$

while for the cascaded subsystems:

$$\begin{aligned}
 P_c &= \begin{pmatrix} 0.1350 & 0 & 0 \\ 0 & 0.1078 & -0.0461 \\ 0 & -0.0461 & 0.4646 \end{pmatrix} \\
 K_c &= \begin{pmatrix} 0.8037 & 0 \\ 0 & 0.8982 \\ 0 & -0.3921 \end{pmatrix}
 \end{aligned}$$

if x_1 is considered to be a deterministic input (Case 1) and

$$P_c = \begin{pmatrix} 0.1350 & 0 & 0 \\ 0 & 0.1091 & -0.0438 \\ 0 & -0.0438 & 0.4812 \end{pmatrix}$$

$$K_c = \begin{pmatrix} 0.8037 & 0 \\ 0 & 0.9059 \\ 0 & -0.3921 \end{pmatrix}$$

if x_1 is considered to be a stochastic input (Case 2).

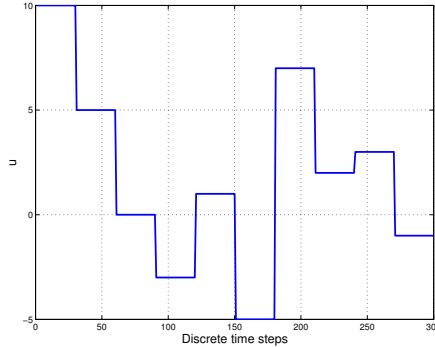

Figure 7.2: Input used for the distributed filters in open-loop.

Histograms of the residuals obtained for x_3 (the state which is not measured) with the centralized Kalman filter, and for both cases of the distributed filters are presented in Figure 7.3. The statistics of the distributions of the residuals for all states and observers are given in Table 7.1. It can be seen that the performance of the cascaded observers is comparable with that of the centralized observer.

Table 7.1: Statistics of the residuals when the centralized and distributed observers use the same covariance matrix.

State	Method	Mean	Standard deviation
x_1	centralized	-0.0032	0.1890
	cascaded	-0.0033	0.1889
x_2	centralized	-0.0105	0.1246
	cascaded deterministic	-0.0103	0.1262
	cascaded stochastic	-0.0113	0.1318
x_3	centralized	0.0420	0.4022
	cascaded deterministic	0.0397	0.4035
	cascaded stochastic	0.0420	0.4024

- b) The Kalman filter uses the true noise covariances (7.17), while the cascaded filters neglect the cross-covariance between the subsystems and consider only (7.18). The same input is used as that in the previous case.

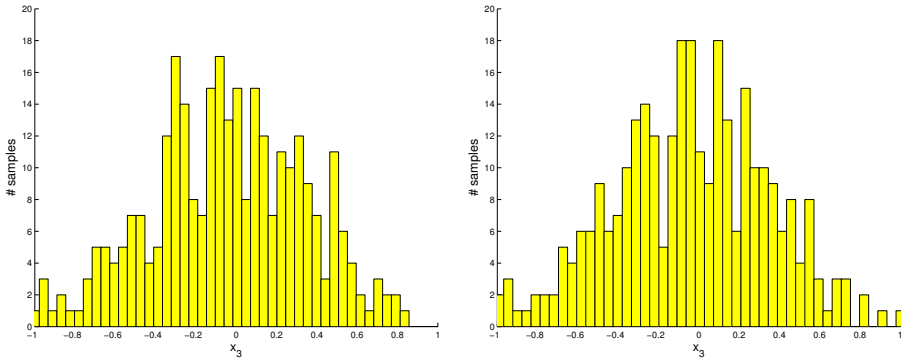

(a) Residuals for x_3 with the centralized Kalman filter. (b) Residuals for x_3 with the cascaded Kalman filter and deterministic input (case 1).

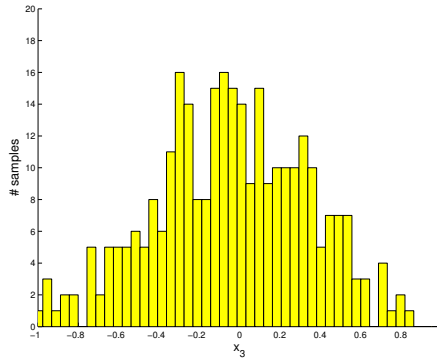

(c) Residuals for x_3 with the cascaded Kalman filter and stochastic input (case 2).

Figure 7.3: Results when the centralized and cascaded filters use the same covariance matrix.

The histogram of the residuals obtained for x_3 is presented in Figure 7.4. The statistics of the distributions of the residuals for all states and observers are given in Table 7.2.

Table 7.2: Statistics of residuals with the cascaded Kalman filter discarding the cross-covariance.

State	Method	Mean	Standard deviation
x_1	centralized	-0.0077	0.2058
	cascaded	-0.0076	0.2058
x_2	centralized	-0.0074	0.1406
	deterministic	-0.0106	0.1444
	stochastic	-0.0106	0.1522
x_3	centralized	-0.0070	0.3757
	deterministic	0.0072	0.4393
	stochastic	0.0077	0.4365

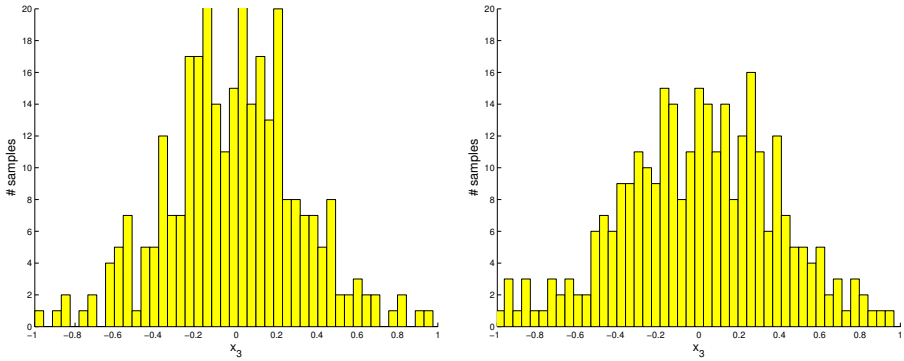

(a) Residuals for x_3 with centralized Kalman filter. (b) Residuals for x_3 with cascaded Kalman filter and deterministic input.

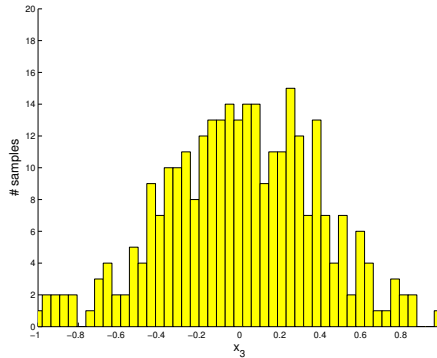

(c) Residuals for x_3 with cascaded Kalman filter and stochastic input.

Figure 7.4: Results with discarded cross-covariances.

For this case, the final covariance and the Kalman gain obtained after 300 steps by the centralized Kalman filter are

$$P = \begin{pmatrix} 0.1350 & 0.0496 & 0.0098 \\ 0.0496 & 0.1074 & -0.0359 \\ 0.0098 & -0.0359 & 0.4214 \end{pmatrix}$$

$$K = \begin{pmatrix} 0.8036 & 0.0002 \\ -0.0399 & 0.9126 \\ 0.2064 & -0.4036 \end{pmatrix}$$

while those obtained by the cascaded observers are the same as in the previous case.

The statistics of the residuals confirm that the centralized filter performs slightly better and hence, the cascaded filters are suboptimal. However, the difference between the residuals is minimal, even if x_1 obtained from the first subsystem is considered as a deterministic input, and the computed covariance is not the correct one.

7.3.2 Cascaded KFs in closed-loop

Here two examples are presented to compare the performance of the cascaded and centralized observers, in closed-loop control. For this purpose, a stabilizing state-feedback control law L is designed based on the system model. Since not all the states are measured, and the control input is computed based on the states estimated by KFs. Such a setting is depicted in Figure 7.5.

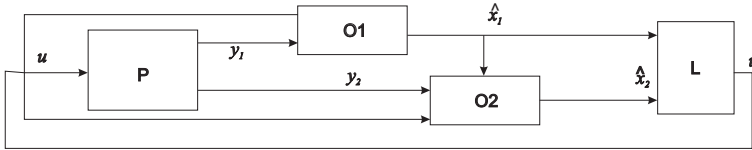

Figure 7.5: Cascaded observers in closed-loop.

Example 1: Consider the following, randomly generated discrete-time system:

$$\mathbf{x}_k = A\mathbf{x}_{k-1} + B u_{k-1} + \mathbf{v}_{k-1}$$

$$\mathbf{y}_k = C\mathbf{x}_k + \boldsymbol{\eta}_k$$

$$A = \begin{pmatrix} 1.1274 & 0 & 0 \\ 0.0639 & 0.9091 & 0.0391 \\ 0.1381 & -0.2306 & 1.0020 \end{pmatrix}$$

$$B = \begin{pmatrix} 0.1 \\ 0 \\ 0 \end{pmatrix} \quad C = \begin{pmatrix} 1 & 0 & 0 \\ 0 & 1 & 0 \end{pmatrix}$$

$$\mathbf{v}_{k-1} \sim \mathcal{N}(0, Q) \quad Q = \begin{pmatrix} 0.0097 & 0.0026 & 0.0032 \\ 0.0026 & 0.0066 & 0.0002 \\ 0.0032 & 0.0002 & 0.0128 \end{pmatrix}$$

$$\boldsymbol{\eta}_k \sim \mathcal{N}(0, R) \quad R = \begin{pmatrix} 0.0035 & 0.0078 \\ 0.0078 & 0.0118 \end{pmatrix}$$

for which a stabilizing state feedback control with constant gain $L = [9.3853 \ 16.2397 \ 3.2858]$ has been computed.

The deterministic part of the system is decomposed. The cascaded filters do not take into account the noise covariances between the subsystems. Now the control is applied for four different cases:

1. the states are known, and the controller is applied directly;
2. the first two states are measured, and the control input is computed based on the estimate given by a centralized KF;
3. the first two states are measured, and the control input is computed based on the estimate given by a cascaded Kalman-type filter, with the second subsystem considering the estimates of the first subsystem as stochastic inputs;

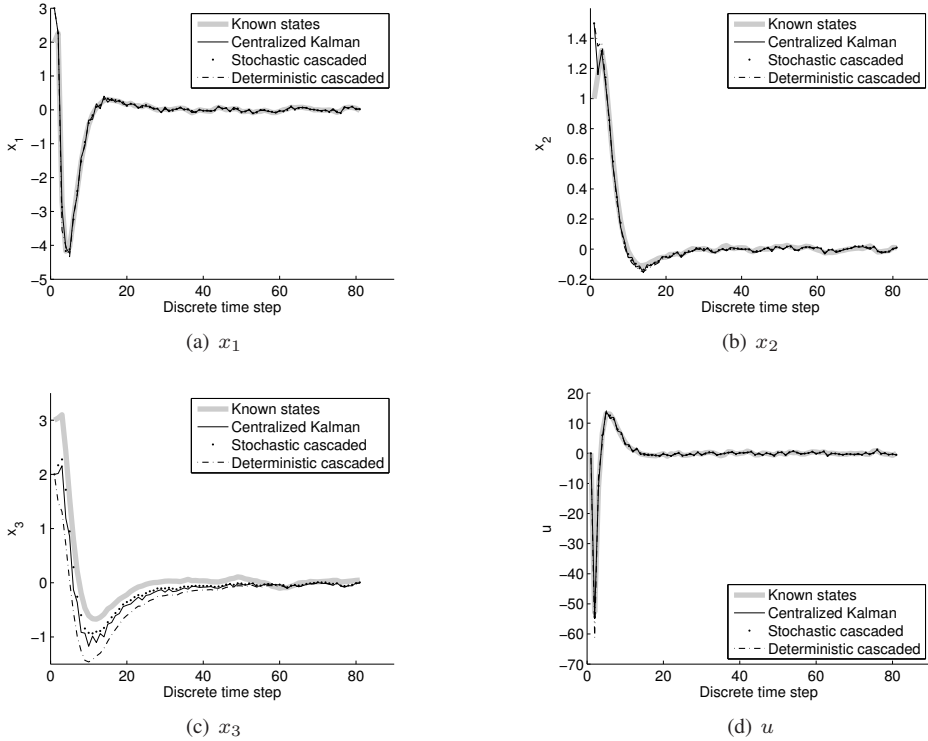

Figure 7.6: Example 1 state estimates in closed-loop with different observers (state feedback without observer, Kalman, stochastic cascaded, deterministic cascaded).

4. the first two states are measured, and the control is computed based on the estimate given by a cascaded Kalman-type filter, with the second subsystem considering the estimates of the first subsystem as deterministic inputs.

The results obtained can be seen in Figure 7.6. The estimation error for the first two states, which are measured, is very small. However, for the third state the estimate of the cascaded observers converges more slowly than the estimate of the centralized one.

Example 2: Consider the following, randomly generated discrete-time system:

$$\begin{aligned} \mathbf{x}_k &= A\mathbf{x}_{k-1} + B u_{k-1} + \mathbf{v}_{k-1} \\ \mathbf{y}_k &= C\mathbf{x}_k + \boldsymbol{\eta}_k \end{aligned}$$

$$A = \begin{pmatrix} 1.1137 & 0 & 0 \\ 0.0087 & 1.0829 & 0.0117 \\ 0.0170 & -0.0009 & 1.0909 \end{pmatrix}$$

$$B = \begin{pmatrix} 0.1 \\ 0 \\ 0 \end{pmatrix} \quad C = \begin{pmatrix} 1 & 0 & 0 \\ 0 & 1 & 0 \end{pmatrix}$$

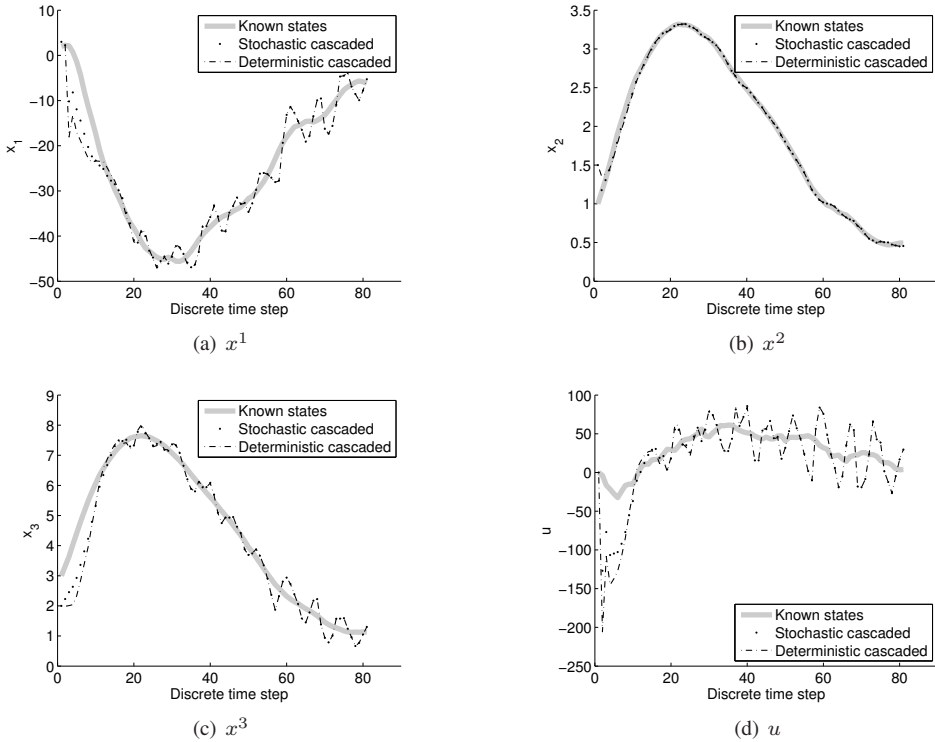

Figure 7.7: Example 2 state estimates in closed-loop with different observers (state feedback without observer, stochastic cascaded, deterministic cascaded). The system using the centralized Kalman filter is unstable in this case.

for which a stabilizing state feedback control with constant gain $L = [5.1743 \ 298.9764 \ -106.2475]$ has been computed. The state and measurement noises have the same covariance as in the previous example. Note that this system with this control law, when the centralized KF is applied, becomes unstable.

The estimates of the states using the distributed observers can be seen in Figure 7.7. While the estimate is noisy, and this noise also affects the control law, the system does not become unstable.

7.4 A multi-robot setting

Robotic teams or multi-robot systems are one of the most popular application domains for multi-agent systems. In such a system, the agents are robots, that have to perform some task, while moving in general in a two-dimensional space. Several types of tasks have been considered in the literature (Simmons and Koenig, 1995; Jetto et al., 1999), among which: navigation, area sweeping, multi-target observation, object transportation, robotic soccer, pursuit, etc. In this section, we consider robot navigation. In navigation, the goal of each robot is to find its way from a starting position to a final goal position.

We consider the following simple scenario: three robots navigate in a two-dimensional spatial domain, being able to move in the x and y directions. One of the robots is the “leader”. Its task is to navigate into a predefined position. The other two robots have to maintain a certain configuration with respect to the leader’s position. Robot 2 follows Robot 1, while maintaining a safe distance both in terms of position and velocity. Robot 3 has to maintain its relative position to both Robot 1 and 2. Moreover, only limited information of the robots’ states is available. Therefore, the robots need to estimate their own states. The robots are able to communicate their own estimated states.

Each robot’s dynamic is modeled as a two-dimensional double-integrator with damping dynamics. The control input is an acceleration vector. Each robot measures its own position, but not the velocity. Moreover, the velocity of the robots is limited so that they avoid collision. Individual state-feedback control laws were designed for each robot for desired navigation, without taking into account that the states and measurements are corrupted by noise.

The system can be described by the following equations, where x_i denotes the position on the x coordinate of the robot i , y_i the position on the y coordinate of the robot i , v_{xi} the velocity in direction x , v_{yi} the velocity in the y direction, and z_i the measurement vector.

- Robot 1 is independent of the other two, and it measures its own position:

$$\begin{aligned} \begin{pmatrix} x_{1,k+1} \\ v_{x1,k+1} \end{pmatrix} &= \begin{pmatrix} 1 & T \\ 0 & 1 \end{pmatrix} \begin{pmatrix} x_{1,k} \\ v_{x1,k} \end{pmatrix} + \begin{pmatrix} 0 \\ 1 \end{pmatrix} u_{x1,k} \\ \begin{pmatrix} y_{1,k+1} \\ v_{y1,k+1} \end{pmatrix} &= \begin{pmatrix} 1 & T \\ 0 & 1 \end{pmatrix} \begin{pmatrix} y_{1,k} \\ v_{y1,k} \end{pmatrix} + \begin{pmatrix} 0 \\ 1 \end{pmatrix} u_{y1,k} \\ z_{1,k+1} &= \begin{pmatrix} x_{1,k+1} \\ y_{1,k+1} \end{pmatrix} \end{aligned}$$

- Robot 2 moves relative to Robot 1 and also measures its position relative to Robot 1.

$$\begin{aligned} \begin{pmatrix} x_{2,k+1} \\ v_{x2,k+1} \end{pmatrix} &= \begin{pmatrix} 1 & T \\ c_1 T & 1 \end{pmatrix} \begin{pmatrix} x_{2,k} \\ v_{x2,k} \end{pmatrix} + \begin{pmatrix} 0 \\ 1 \end{pmatrix} u_{x2,k} + \begin{pmatrix} 0 & -T \\ -c_1 T & 0 \end{pmatrix} \begin{pmatrix} x_{1,k} \\ v_{x1,k} \end{pmatrix} \\ \begin{pmatrix} y_{2,k+1} \\ v_{y2,k+1} \end{pmatrix} &= \begin{pmatrix} 1 & T \\ c_2 T & 1 \end{pmatrix} \begin{pmatrix} y_{2,k} \\ v_{y2,k} \end{pmatrix} + \begin{pmatrix} 0 \\ 1 \end{pmatrix} u_{y2,k} + \begin{pmatrix} 0 & -T \\ -c_2 T & 0 \end{pmatrix} \begin{pmatrix} y_{1,k} \\ v_{y1,k} \end{pmatrix} \\ z_{2,k+1} &= \begin{pmatrix} x_{2,k+1} - x_{1,k+1} \\ y_{2,k+1} - y_{1,k+1} \end{pmatrix} \end{aligned}$$

- Robot 3 uses information from both the first and second robot:

$$\begin{aligned} \begin{pmatrix} x_{3,k+1} \\ v_{x3,k+1} \end{pmatrix} &= \begin{pmatrix} 1 & T \\ c_3 T & 1 \end{pmatrix} \begin{pmatrix} x_{3,k} \\ v_{x3,k} \end{pmatrix} + \begin{pmatrix} 0 \\ 1 \end{pmatrix} u_{x3,k} + \begin{pmatrix} 0 & -T \\ -c_3 T & 0 \end{pmatrix} \begin{pmatrix} x_{1,k} \\ v_{x1,k} \end{pmatrix} \\ \begin{pmatrix} y_{3,k+1} \\ v_{y3,k+1} \end{pmatrix} &= \begin{pmatrix} 1 & T \\ c_4 T & 1 \end{pmatrix} \begin{pmatrix} y_{3,k} \\ v_{y3,k} \end{pmatrix} + \begin{pmatrix} 0 \\ 1 \end{pmatrix} u_{y3,k} + \begin{pmatrix} 0 & -T \\ -c_4 T & 0 \end{pmatrix} \begin{pmatrix} y_{2,k} \\ v_{y2,k} \end{pmatrix} \\ z_{3,k+1} &= \begin{pmatrix} x_{3,k+1} - x_{1,k+1} \\ y_{3,k+1} - y_{2,k+1} \end{pmatrix} \end{aligned}$$

A schematic representation of the robots’ problem is depicted in Figure 7.8, where black denotes measured variables and grey denotes variables to be estimated.

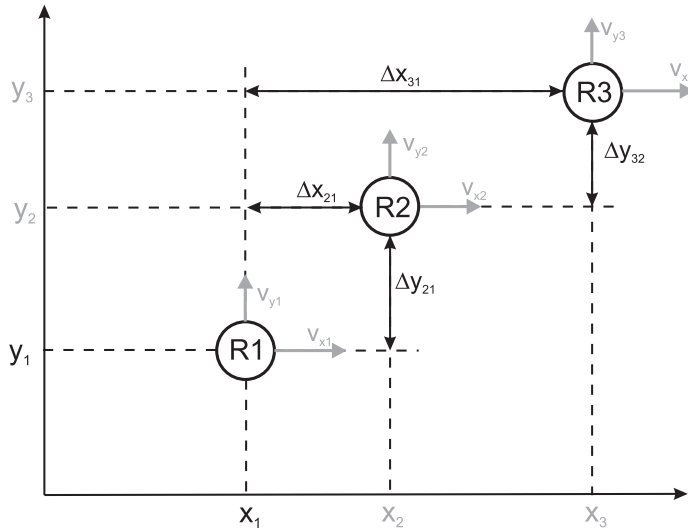

Figure 7.8: Measured (black) and estimated (grey) variables in the robot problem.

The joint system can be expressed as a linear, discrete-time system, with 12 states, 6 inputs and 6 measurements. In order to use a Kalman filter, it is assumed that both the states and measurements are corrupted by a zero-mean, Gaussian noise, with covariance Q and R , respectively, with $Q = 0.1I$ and $R = 0.1I$ known. For each robot i , a state-feedback control law has been designed, with gain $L = \begin{bmatrix} 15.8384 & 1.7799 & 0.0292 & 0.0017 \\ 0.0292 & 0.0017 & 15.3136 & 1.7501 \end{bmatrix}$, the control input depending only on their own states. The results obtained for three cases are compared: the feedback is applied to known states, a centralized Kalman filter is used to estimate the states, and distributed Kalman filters are used, with each robot relying on the estimates of the others.

The true initial states are: $[x_1 \ v_{x1} \ y_1 \ v_{y1}]^T = [5 \ 1 \ -2 \ 0]^T$, $[x_2 \ v_{x2} \ y_2 \ v_{y2}]^T = [1 \ 0 \ 3 \ -1]^T$, and $[x_3 \ v_{x3} \ y_3 \ v_{y3}]^T = [10 \ -2 \ 0 \ 1]^T$, while the estimated initial states are: $[x_1 \ v_{x1} \ y_1 \ v_{y1}]^T = [-3 \ 0 \ 1 \ 0]^T$, $[x_2 \ v_{x2} \ y_2 \ v_{y2}]^T = [5 \ 0 \ 6 \ 0]^T$, and $[x_3 \ v_{x3} \ y_3 \ v_{y3}]^T = [-8 \ 0 \ -2 \ 0]^T$. The parameters used are: $T = 0.05$, $c_1 = 0.1$, $c_2 = 0.02$, $c_3 = 3$, and $c_4 = 0.5$.

The estimates of the velocities, which are not measured, are presented in Figure 7.9. It can be seen that the results obtained with the centralized and distributed filters are comparable. This is also proven by the statistics of the residuals (see Table 7.3). The estimates of the positions are not shown, since the (relative) positions are measured.

The motion of the three robots in the space is presented in Figure 7.10. A major advantage of this cascaded observer setting is that if another robot is introduced in the system, as long as the robots that are already in the system do not depend on it, the current observers do not need further tuning.

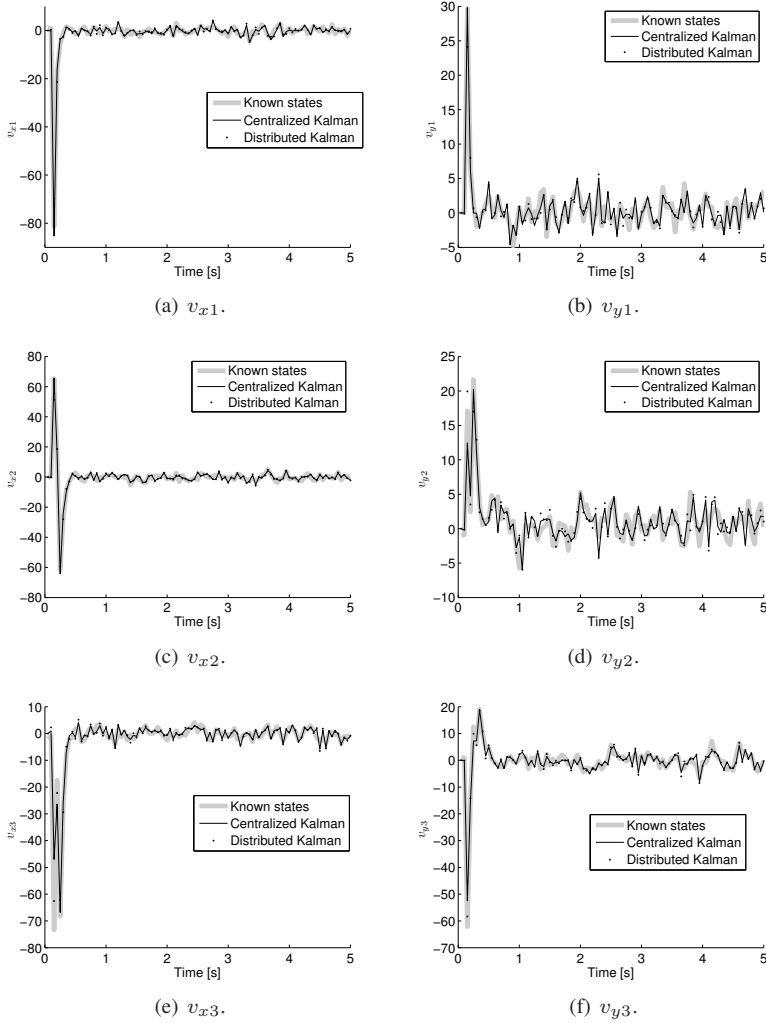

Figure 7.9: Estimates of the robots' velocities with different observers (state feedback without observer, centralized KF, distributed KF).

Table 7.3: Statistics of residuals of the robots' states.

State	Mean of residual (centr.)	Mean of residual (distr.)	Std. of residual (centr.)	Std. of residual (distr.)
x_1	0.0719	0.0857	0.8048	0.8067
v_{x1}	0.0604	-0.0679	1.2227	1.7737
y_1	-0.0305	-0.0390	0.3092	0.3124
v_{y1}	-0.0070	0.0746	1.3144	1.4192
x_2	-0.0294	-0.0417	0.4155	0.4286
v_{x2}	-0.0815	0.0265	1.7042	2.2757
y_2	-0.0322	-0.0294	0.3184	0.3222
v_{y2}	-0.0281	0.0087	1.6413	1.8272
x_3	0.2001	0.1876	1.8103	1.8041
v_{x3}	-0.2039	-0.1037	3.5789	2.6460
y_3	0.0221	0.0213	0.2316	0.2289
v_{y3}	-0.0106	-0.0067	1.6806	1.6695

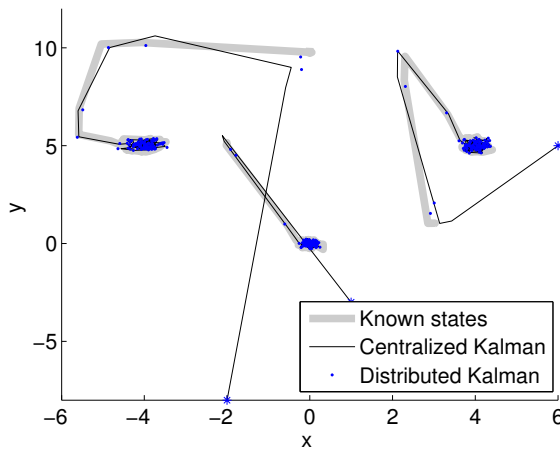

Figure 7.10: Robots' motion in space.

7.5 Summary and concluding remarks

For cascaded linear systems, distributed, Kalman-like filters can be designed. In such a case, the observers are optimal for the individual subsystems, and the joint estimation error converges to a zero-mean Gaussian. However, the joint estimate of the state is in theory suboptimal. Theoretical results show that the cascaded KFs can be jointly optimal, if and only if the subsystems are independent.

Based on the examples, however, the performance of the centralized KF and cascaded filters are comparable. Moreover, our simulations show that for certain cases, in closed-loop the cascaded observers perform better than the KF. This is because when using a cascaded ob-

server, the estimation error of the second subsystem does not affect the first one. In addition, by using the cascaded approach, a modular implementation is possible and the computational costs are reduced.

In many cases, a nonlinear system may be decomposed into a cascade of linear and nonlinear subsystems. If such a decomposition is feasible, then it is also possible to combine different observers, depending on the complexity of the subsystem under consideration. Such applications are presented in the next chapter.

Chapter 8

Case studies

In this chapter, two applications are presented for which cascaded observers are used. While the previous chapter addressed cascaded linear systems, here nonlinear models are considered, which are, in addition, corrupted by non-Gaussian noise. The first application described is the estimation of overflow losses in a hopper dredger. The system is uncertain and highly nonlinear, and the information on the amount of overflow losses is needed for both the decision support system and automatic control. The second application concerns a water treatment plant. In order to implement quality control of such a plant, an accurate dynamic model should be available. However, the reaction dynamics and model characteristics depend nonlinearly on the temperature, which is reflected in uncertain model characteristics. Therefore, we propose the online estimation of the uncertain parameters in order to improve model characteristics.

Parts of this chapter have been published in (Lendek et al., 2008b,c,d).

8.1 Estimation of the overflow losses in a hopper dredger

The estimation of overflow losses is an essential step toward the optimization of the separation process in the hopper, which is of vital importance for the improvement of dredging efficiency and accuracy. In the considered process, the measured variables are heavily corrupted by noise. The system is highly nonlinear, and for global state estimation a particle filter would be required, which implies high computational costs. However, the model can be represented as two cascaded subsystems, which allows the use of two observers. For these observers the combinations of UKF and PF are considered and the four possible combinations in the distributed setting are compared with the performance of a centralized PF for the whole system, both on simulated and experimental data.

8.1.1 Problem description

Information on the amount of overflow losses is essential both for decision support and automatic control. Unfortunately, these losses cannot be reliably measured, due to the presence of air in the overflow pipe. However, as shown in this chapter, they can be estimated by using mathematical models and the available on-line measurements.

Before stating the estimation problem, the principle of the dredging process is briefly explained. The dredger uses a drag head to excavate soil from the sea bottom. A mixture of soil and water is transported through a pipe to the hopper, which is a large cargo hold inside the ship (see Figure 8.1).

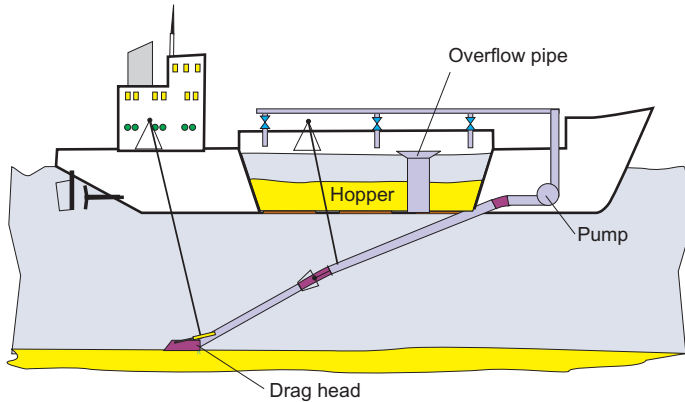

Figure 8.1: Schematic drawing of a hopper dredger.

The soil gradually settles at the bottom of the hopper, while excess water (in fact low-density mixture) is discharged through an overflow pipe the level of which can be adjusted. As the height of the settled sand layer rises, so does the concentration of the overflow mixture and eventually the overflow losses become so high that it is no longer economical to continue dredging. The ship then sails back to deliver the load. After the sand is discharged, the ship sails again to the dredging location and the whole cycle repeats.

The efficiency of the sedimentation process heavily depends on the type of soil and is influenced by the flow-rate and density of the incoming mixture and the manner the overflow pipe is controlled. An important factor in the optimization of the dredging performance is the minimization of the overflow losses. In the literature, a number of sedimentation models have been proposed (Camp, 1946; van Rhee, 2002). However, these models cannot be used as a basis for control or optimization of the dredging process. The reason is that they are based on detailed (often partial differential equations) modeling of the physical phenomena and often contain too many uncertain parameters. Therefore, simplified models have to be used, along with advanced signal processing and estimation techniques.

8.1.2 Dynamic sedimentation model

The sedimentation process in a hopper dredger can be described by a model with three state variables: the total mass in the hopper m_t , the total volume V_t of the mixture in the hopper and the mass of the sand bed m_s (see Figure 8.2).

While the first two variables can be derived from on-line measurements (the ship draught and the total level in the tank h_t , respectively), the mass of the sand bed is not measurable. The flow rate Q_i of the incoming mixture and the overflow height h_o are the manipulated inputs and the incoming mixture density ρ_i is in this context regarded as a measured distur-

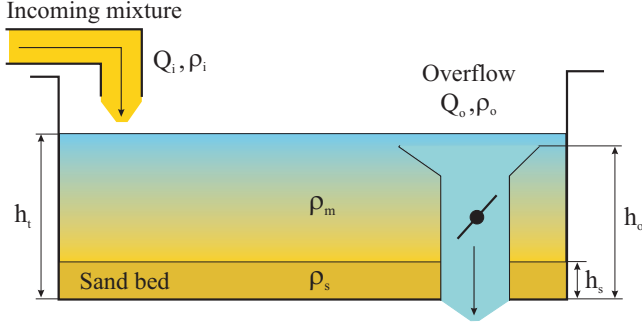

Figure 8.2: The sedimentation process in the hopper.

bance. The volume and mass balance equations are given by:

$$\dot{V}_t = Q_i - Q_o \quad (8.1)$$

$$\dot{m}_t = Q_i \rho_i - Q_o \rho_o. \quad (8.2)$$

The rate of material sedimentation is a function of the settling velocity (f_s) and the scouring (erosion) effects (f_e)

$$\dot{m}_s = f_s(\rho_m) f_e(Q_o, h_m). \quad (8.3)$$

The overflow rate Q_o , the density ρ_o and the functions in (8.3) are in general modeled using static relationships as detailed below.

If the outgoing mixture flows freely through the overflow pipe, the overflow rate Q_o is given by

$$Q_o = k_o \max(h_t - h_o, 0)^{\frac{3}{2}} \quad (8.4)$$

where k_o is an uncertain parameter depending on shape and circumference of the overflow pipe. However, if the overflow pipe is full (e.g., because the valve inside the pipe is engaged), the following model must be used:

$$Q_o = k'_o \sqrt{2g \max(h_t - h_o, 0)}. \quad (8.5)$$

Since it is difficult to determine when the models switch, there is some uncertainty in the modeling of the overflow rate. Moreover, due to the model's switching nature, it is not straightforward to estimate its parameters.

To model the overflow density ρ_o , the density profile in the mixture above the sand bed must be described. Generally, this profile can be approximated as a decreasing function of the height above the sand, but the exact form of this function is highly uncertain and time varying. In this chapter, the following saturated affine approximation is used:

$$\rho_o = \max(\rho_s - k_\rho(h_o - h_s), \rho_w). \quad (8.6)$$

The slope k_ρ must be determined at every time instant such that the average mixture density ρ_m , computed from the mass-balance relations, equals to the average of the density profile:

$$\rho_m = \frac{1}{h_m} \int_{h_s}^{h_t} \max(\rho_s - k_\rho(h - h_s), \rho_w) dh$$

with $h_m = h_t - h_s$. Solving this constraint for the model (8.6) yields the following equation for the slope:

$$k_\rho = \begin{cases} \frac{2(\rho_s - \rho_m)}{h_m} & \text{for } \rho_m > \frac{1}{2}(\rho_w + \rho_s) \\ \frac{(\rho_s - \rho_w)^2}{2h_m(\rho_m - \rho_w)} & \text{otherwise} \end{cases}$$

where the average mixture density is given by:

$$\rho_m = \frac{m_t - m_s}{V_t - \frac{m_s}{\rho_s}} = \frac{\rho_s(m_t - m_s)}{V_t \rho_s - m_s}.$$

Validation based on measured data has shown that this model is not very accurate, but it suffices for the tuning and first evaluation of the particle filter.

The settling function f_s describes how the rate of sedimentation depends on the undisturbed settling velocity v_s and the mixture density:

$$f_s(\rho_m) = A \rho_s v_s \frac{\rho_m - \rho_w}{\rho_s - \rho_m} \left(\frac{\rho_q - \rho_m}{\rho_q - \rho_w} \right)^\beta. \quad (8.7)$$

The scouring function f_e describes the effect of erosion on the sand bed due to the flow in the mixture (which is considered to be equal to the overflow rate in steady state):

$$f_e(Q_o, h_m) = \max \left(1 - \frac{Q_o^2}{k_c h_m^2}, 0 \right). \quad (8.8)$$

The parameters of the entire model may be determined by fitting the outputs of the simulation model to real data from a ship, by using non-linear least-squares optimization (Braaksma et al., 2007).

8.1.3 The estimation problem

In order to estimate at each time step the overflow density and flow-rate, the volume and mass balance equations were discretized by using the Euler method:

$$V_{t,k} = V_{t,k-1} + T(Q_{i,k-1} - Q_{o,k-1}) \quad (8.9)$$

$$m_{t,k} = m_{t,k-1} + T(Q_{i,k-1} \rho_{i,k-1} - Q_{o,k-1} \rho_{o,k-1}) \quad (8.10)$$

where the sampling period is $T = 5$ s, which is also the sampling period of the on-board data acquisition system. These state equations are augmented with a random-walk model for Q_o and ρ_o :

$$Q_{o,k} = Q_{o,k-1} + \epsilon_{Q,k-1} \quad (8.11)$$

$$\rho_{o,k} = \rho_{o,k-1} + \epsilon_{\rho,k-1} \quad (8.12)$$

The corrupting noises $\epsilon_{Q,k-1}$ and $\epsilon_{\rho,k-1}$ are considered zero-mean Gaussians ($\epsilon_{x_i,k} \sim \mathcal{N}(0, \nu_{x_i})$), and their standard deviations ν_{x_i} are determined experimentally. The motivation for this choice results from the process description in Section 8.1.2. The sedimentation models are based on empirical modeling of the physical phenomena and contain too many uncertain parameters. By using a random walk model, the use of the uncertain overflow model

(8.4)-(8.5), the settling and scouring functions (8.7)-(8.8), and the uncertain parameters is circumvented. The augmented state, input and output vectors are defined as:

$$x = \begin{pmatrix} V_t \\ m_t \\ Q_o \\ \rho_o \end{pmatrix}, \quad u = \begin{pmatrix} Q_i \\ \rho_i \end{pmatrix}, \quad y = \begin{pmatrix} V_t \\ m_t \end{pmatrix}$$

Measurements are available for the inputs Q_i and ρ_i and the outputs V_t and m_t . The objective is to estimate Q_o and ρ_o on-line.

Note, that in this particular case, the estimation model is described as:

$$\begin{aligned} \mathbf{x}_k &= \mathbf{f}(\mathbf{x}_{k-1}) + \mathbf{v}_{k-1} \\ \mathbf{y}_k &= \mathbf{h}(\mathbf{x}_{k-1}) + \boldsymbol{\eta}_k \end{aligned}$$

where \mathbf{v}_k and $\boldsymbol{\eta}_k$ are zero mean Gaussian noises, with covariances Q and R , respectively. The equivalent probabilistic model is expressed as:

$$\begin{aligned} p(\mathbf{x}_k | \mathbf{x}_{k-1}) &= \mathcal{N}(\mathbf{x}_k; \mathbf{f}(\mathbf{x}_{k-1}); Q) \\ p(\mathbf{y}_k | \mathbf{x}_k) &= \mathcal{N}(\mathbf{y}_k; \mathbf{h}(\mathbf{x}_k); R) \end{aligned}$$

Using the above estimation model, a centralized PF has already been successfully implemented in the data acquisition and monitoring system of a hopper dredger (Babuška et al., 2006). In this thesis, different observers are compared in terms of their performance. The following cases are considered:

1. A centralized observer to simultaneously estimate the values of both Q_o and ρ_o , see Figure 8.3.

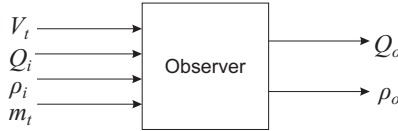

Figure 8.3: Centralized observer.

2. Cascaded observers: the first observer estimates Q_o based on the volume balance (8.9), and the second estimates ρ_o based on the mass balance (8.10) and on the values obtained for Q_o by the first observer, see Figure 8.4.

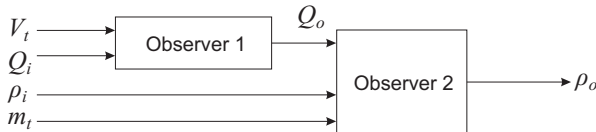

Figure 8.4: Cascaded observers.

Note that the models (8.9)-(8.12) only approximate the underlying true process. If the data were generated based on these models, a Kalman filter could be used. For the data generated from the sedimentation model, however, the results obtained by the Kalman filter are too noisy and the Kalman filter becomes unstable for the experimental data.

It was found that the UKF cannot simultaneously estimate both Q_o and ρ_o . Therefore, for the centralized observer, only the PF is considered, while in the cascaded setting both the PF and the UKF are used. The observers are first applied to the simulated data and then, with the same parameters, to real measured data.

Remark: There is one more setting of observers that was considered for this specific application: independent observers. In this setting, one uses two observers: the first estimates Q_o based on the volume balance (8.9). The second estimates $Q_o\rho_o$ based on the mass balance (8.10). The value of ρ_o can be computed afterwards by dividing the estimate of $Q_o\rho_o$ by the estimate of Q_o obtained by the first observer. However, when working with experimental data, the computation of ρ_o means dividing noisy variables and leads to large errors and therefore the results are not presented here.

8.1.4 Results for simulated data

Recall that the model used for simulation is the one presented in Section 8.1.2, while the one used for estimation is:

$$\begin{aligned} V_{t,k} &= V_{t,k-1} + T(Q_{i,k-1} - Q_{o,k-1}) + \epsilon_{V,k-1} \\ m_{t,k} &= m_{t,k-1} + T(Q_{i,k-1}\rho_{i,k-1} - Q_{o,k-1}\rho_{o,k-1}) + \epsilon_{m,k-1} \\ Q_{o,k} &= Q_{o,k-1} + \epsilon_{Q,k-1} \\ \rho_{o,k} &= \rho_{o,k-1} + \epsilon_{\rho,k-1} \end{aligned} \tag{8.13}$$

with $\epsilon_{V,k} \sim \mathcal{N}(0, \nu_V)$, $\epsilon_{m,k} \sim \mathcal{N}(0, \nu_m)$, $\epsilon_{Q,k} \sim \mathcal{N}(0, \nu_Q)$, $\epsilon_{\rho,k} \sim \mathcal{N}(0, \nu_\rho)$ and $\mathcal{N}(0, \nu)$ being a zero-mean, ν^2 covariance Gaussian random noise.

For this simulation, only the inputs Q_i and ρ_i are fed with experimental data, corrupted by noise. The remaining variables are computed in simulation without adding noise.

The results obtained with the different configurations of observers are compared to the simulated values of ρ_o and Q_o . The standard deviations of the state transition and measurement noise are given in Table 8.1. The particle filter used 1000 samples, with resampling at a threshold of $N_T = 900$. The presented results are the average of 30 simulations.

Table 8.1: Standard deviations used in the estimation model (8.13).

Variable	State transition	Measurement
V_t [m ³]	0	10
m_t [kg]	3000	12000
Q_o [m ³ /s]	0.25	–
ρ_o [kg/m ³]	5	–

Centralized particle filter

The results obtained with a particle filter, based on the model (8.13) are presented in Figure 8.5. The maximum standard deviation computed point-wise for 30 trajectories of the state estimated by the particle filter, is 0.1 for Q_o and 5.1 for ρ_o .

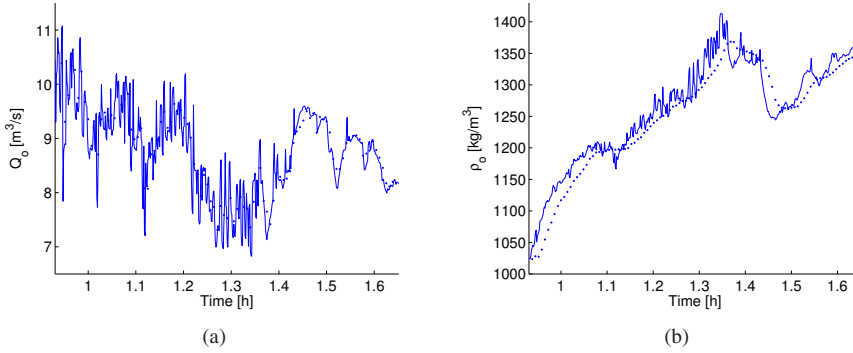

Figure 8.5: Centralized observer: results for Q_o (a) and ρ_o (b) using the particle filter (solid line – simulated data, dotted line – estimate).

The residuals are computed as the difference between the simulated and estimated values of Q_o and ρ_o , respectively. The distribution of the residuals is presented in Figure 8.6, while their statistics are given in Table 8.2.

Table 8.2: Statistics of residuals for the centralized PF.

	Mean	Standard deviation
Q_o [m^3/s]	-0.0135	0.5863
ρ_o [kg/m^3]	11.6858	22.6426

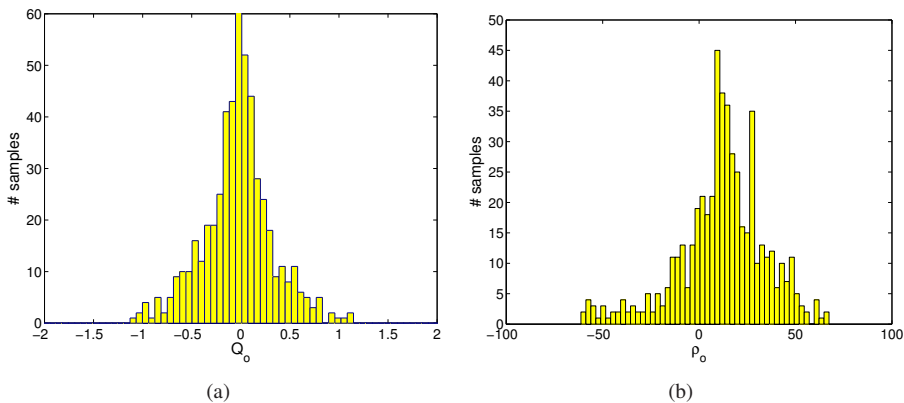

Figure 8.6: Centralized observer: residuals for Q_o (a) and ρ_o (b).

Cascaded observers

This setting involves two observers in a cascade. The first one estimates Q_o using the volume balance (8.9) and a random walk model for Q_o . The second observer estimates ρ_o based on the mass balance (8.10), a random walk model for ρ_o , and the result obtained for Q_o by the first observer (see also Figure 8.4). Two types of filters are compared: the Unscented Kalman Filter and the Particle Filter.

The dynamic model is decomposed into two subsystems. The first observer uses the model

$$\begin{aligned} V_{t,k} &= V_{t,k-1} + T(Q_{i,k-1} - Q_{o,k-1}) + \epsilon_{V,k-1} \\ Q_{o,k} &= Q_{o,k-1} + \epsilon_{Q,k-1} \end{aligned} \quad (8.14)$$

where V_t is the measured output. The second observer uses the model

$$\begin{aligned} m_{t,k} &= m_{t,k-1} + T(Q_{i,k-1}\rho_{i,k-1} - Q_{o,k-1}\rho_{i,k-1}) + \epsilon_{m,k-1} \\ \rho_{o,k} &= \rho_{o,k-1} + \epsilon_{\rho,k-1} \end{aligned} \quad (8.15)$$

where m_t is the measured output.

The results obtained for Q_o are presented in Figure 8.7. As one can see, the results obtained by the UKF and PF are comparable.

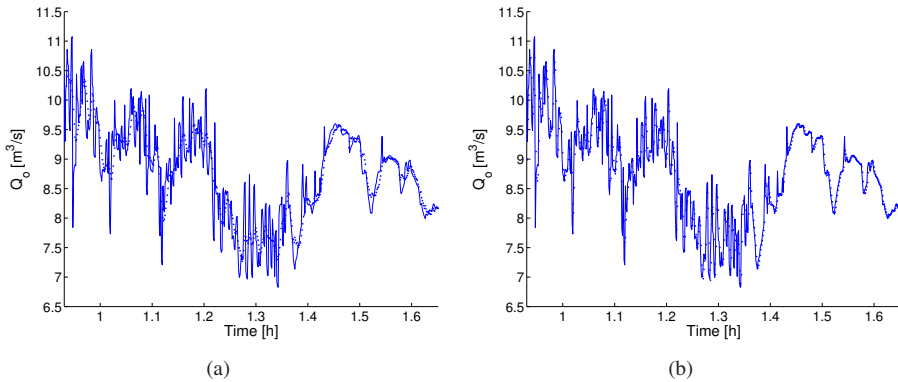

Figure 8.7: Cascaded observers: results for Q_o using PF (a) and UKF (b) (solid line – simulated data, dotted line – estimate).

The maximum standard deviation computed point-wise for the 30 Monte Carlo simulations, is 0.095. The statistics of the residuals' distributions are given in Table 8.3. These statistics are comparable with those obtained with the centralized observer.

Table 8.3: Statistics of residuals of Q_o [m^3/s].

	Mean	Standard deviation
PF	0.0094	0.5953
UKF	0.0222	0.5582

For the cascaded observer the following combinations are considered: UKF for both Q_o and ρ_o , PF for both Q_o and ρ_o , UKF for Q_o and PF for ρ_o , and PF for Q_o and UKF for ρ_o . In

what follows, the observer setting is denoted as observer 1 - observer 2, i.e. PF-PF denotes that PF is used for both Q_o and ρ_o , UKF-PF means that UKF is used for Q_o and PF for ρ_o , etc.

The results obtained for ρ_o using Q_o estimated by PF and UKF are presented in Figure 8.8. The maximum point-wise standard deviation of 30 Monte Carlo simulations for ρ_o , based on the results of Q_o given also by PF is 5.8, while for ρ_o based on based on the results of Q_o given by UKF is 2.96. The distribution of the residuals is given in Figure 8.9. The statistics of the residuals can be found in Table 8.4.

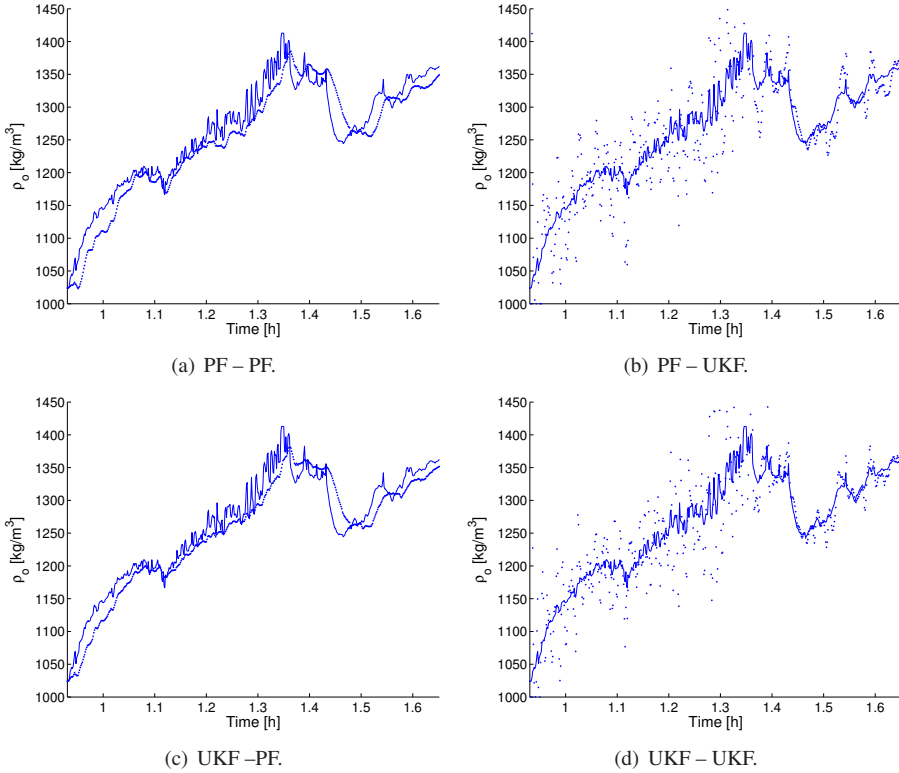

Figure 8.8: Estimates of ρ_o with the four possible filter combinations (solid line – simulated data, dotted line – estimate).

Table 8.4: Statistics of residuals of ρ_o [kg/m³].

Q_o	ρ_o	Mean	Standard deviation
PF	PF	12.1986	25.1174
PF	UKF	0.3354	54.3970
UKF	PF	10.6790	21.5436
UKF	UKF	-1.2536	54.2936

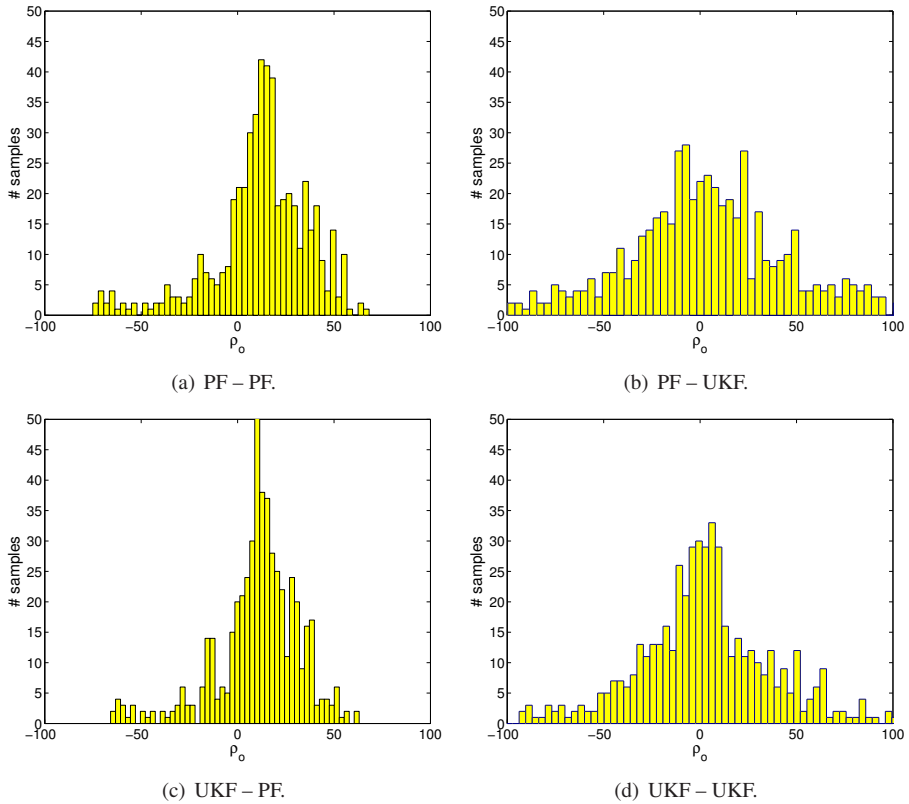

Figure 8.9: Cascaded observers: residuals for the estimates of ρ_o .

Discussion

For simulated data, a good estimate is obtained with the centralized observer (particle filter) for Q_o , but the estimate of ρ_o is delayed relative to the one simulated (Figure 8.5).

For the cascaded observers, considering only the mean of the residuals (Table 8.4), one can conclude that the UKF performs the best for the estimation of ρ_o , much better than the centralized observer or the PF. However, considering the standard deviations (Table 8.4 and Figure 8.9), one can see that the estimates of ρ_o obtained by UKF are much noisier than those obtained by the PF, both centralized and cascaded. Comparing the results obtained by PF for ρ_o with the centralized observer (Table 8.2), it can be seen that using a combination of two particle filters leads to approximately the same results as the centralized filter. However, the best result, based on the statistics presented in Tables 8.3 and 8.4 is obtained with cascaded observers, the combination UKF for Q_o and PF for ρ_o .

8.1.5 Results for measured data

For the experimental data, the same model and parameter values are considered as for the simulated data and the same combinations of observers. The presented results for the particle filter are the average of 30 simulations.

Since no measurements of Q_o and ρ_o are available, the results are compared to the values of ρ_o and Q_o computed directly from the volume and mass balance, i.e., equations (8.9)-(8.10). The overflow rate and the density are computed as:

$$Q_{o,k} = Q_{i,k} - \frac{1}{T}(V_{t,k} - V_{t,k-1})$$

$$\rho_{o,k} = \frac{Q_{i,k}\rho_{i,k} - \frac{1}{T}(m_{t,k} - m_{t,k-1})}{Q_{o,k}}. \quad (8.16)$$

As the result of this computation is very noisy, a first-order anti-causal low-pass filter was applied to the measured data before computing Q_o and ρ_o , with an experimentally chosen cut-off frequency of 0.05 Hz.

Centralized observer

The results obtained with the centralized observer (particle filter) are presented in Figure 8.10. A reasonably good estimate is obtained for ρ_o , but the estimate of Q_o is noisy. The maximum standard deviation computed point-wise over the 30 Monte Carlo simulations is 1.76 for Q_o and 42.87 for ρ_o .

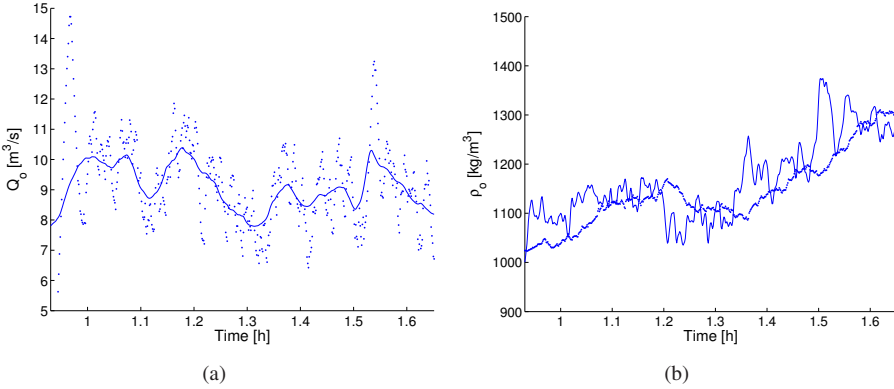

Figure 8.10: Centralized observer: results for Q_o (a) and ρ_o (b) using the particle filter (solid line – computed by (8.16), dotted line – estimate).

Cascaded observers

The results obtained by the UKF and PF for Q_o are presented in Figure 8.11. The estimate of Q_o obtained by the UKF is noisier than that obtained by the PF, but comparable to the result obtained by the centralized observer. The maximum sample-wise standard deviation of the Monte Carlo simulations for Q_o is 0.55.

For the cascaded setting, the previous four combinations, i.e., PF-PF, PF-UKF, UKF-UKF, and UKF-PF are considered. The results obtained for ρ_o with the four combinations are presented in Figure 8.12. The sample-wise maximum standard deviation of the 30 Monte Carlo simulations for ρ_o , based on the results of Q_o given also by PF is 36.91, while for ρ_o based on the results of Q_o given by UKF is 36.05.

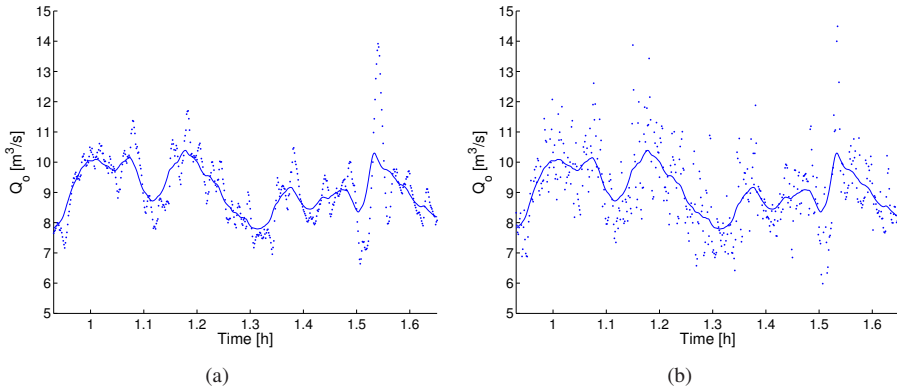

Figure 8.11: Cascaded observers: results for Q_O using PF (a) and UKF (b) (solid line – computed by (8.16), dotted line – estimate).

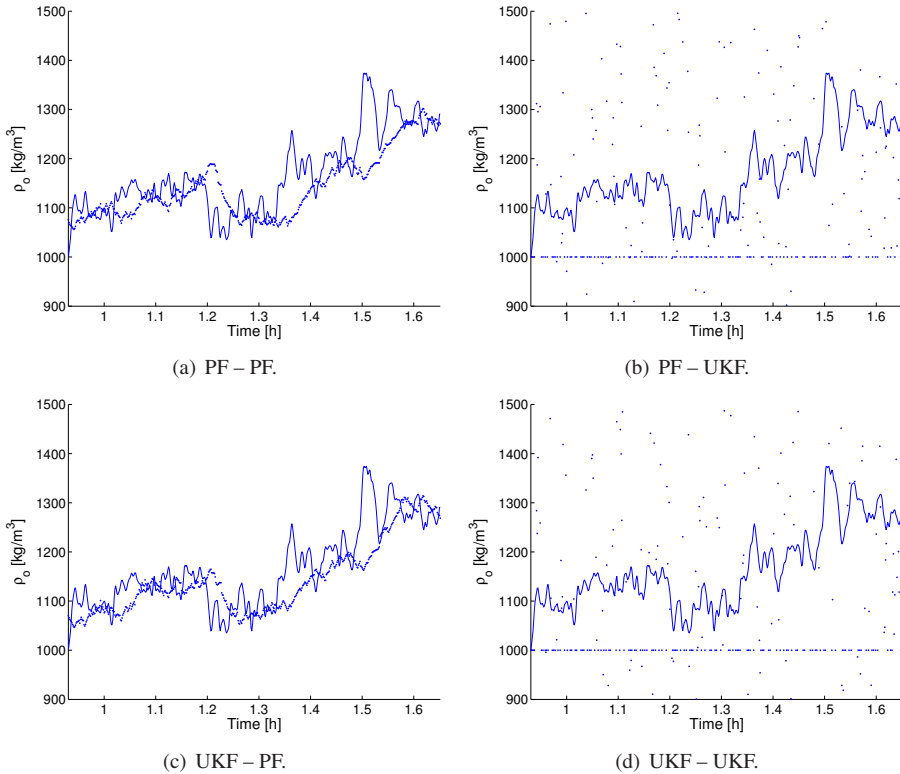

Figure 8.12: Cascaded observers: estimates of ρ_O using the four possible combinations (solid line – computed by (8.16), dotted line – estimate).

Discussion

For measured data, a centralized observer (Figure 8.10) obtains a reasonably good estimate for ρ_O , but the estimate of Q_O is noisier than the one computed by using (8.16).

From Figure 8.12 it can be seen that the UKF cannot handle the estimation of ρ_o , probably due to the high noise level of the measured variables. By using the combinations of PF–PF and UKF–PF, approximately the same results are obtained for ρ_o . These results are also comparable to those obtained by a PF as the centralized observer.

8.1.6 Conclusions

A distributed observer setting has been applied to the estimation of overflow losses in a hopper dredger. The results were compared with those obtained by the centralized observer. The overflow losses, represented by the overflow mixture density, are estimated on the basis of the measured total hopper volume, hopper mass, incoming mixture density, and flow rate.

The proposed approach uses straightforward nonlinear mass balance equations and does not rely on complex overflow and sedimentation models that contain uncertain parameters and empirical functional relationships.

The performance was evaluated in simulations and with real measurements. The simulation results for this application clearly indicate the best combination: cascaded observers, using UKF or PF for the simpler subsystem (flow rate) and PF for the more complex one (density).

8.2 State estimation for a water treatment plant

Advanced online quality control of drinking water treatment plants requires reliable models. The available models in general involve temperature-dependent, uncertain parameters, which can only be measured in laboratory conditions. The available measurement is that of the pH, which is a highly nonlinear combination of the system states. We propose to estimate the uncertain model parameters using this measurement. Since the model is nonlinear, a PF is used, and thanks to the model properties, the estimation is performed in a cascaded manner. The performance is evaluated both for simulated and real-world data.

8.2.1 Introduction

In drinking water production and distribution, there is an increased interest in advanced control using online flow and level measurements. However, in the current practice advanced control methods are mainly used for water quantity control. The increased use of these measurements has led to the optimization of the produced and distributed water quantity (Bakker et al., 2003; Hill et al., 2005).

Advanced semi-online water quality measurements have also become more common, although, currently they are predominantly used for monitoring. Such measurements include for instance pH and UV spectra measurements.

Previous research (van Schagen et al., 2006) has shown that before implementing advanced control strategies in drinking water production, it is recommended to investigate the trade-off between the number of necessary measurements, the accuracy of the measurements, and the effort for maintaining the measurement devices. The sensors must be able to perform under industrial circumstances, and ensure very small variations in water quality. If new measurements that do not meet these conditions are used in online control, they can worsen the performance of the process.

A measure to describe the super-saturation of calcium carbonate in water is the Saturation Index (SI), which is defined as the pH offset at which the actual calcium concentration is in equilibrium with the carbonate concentration (see van Schagen et al. (2007) and the references therein). An SI below zero will cause the concrete of the installation to dissolve. An SI above 0.3 will cause scaling on the equipment of the installation, which may result in malfunction of the valves and dosing units. The difference between a high and low SI is therefore about 0.3. The accuracy of the pH measurement is restricted and the process conditions change in time.

The research reported here involves one of the water treatment plants (WTPs) of Amsterdam, WTP Weesperkarspel. Together with the WTP Leiduin it produces all the drinking water for the city of Amsterdam (400 Ml/day). The Weesperkarspel plant treats seepage water from a polder with eight process steps (stages) in cascade: coagulation, 100 days retention in a lake water reservoir, acid dosage (HCl), rapid sand filtration (RSF), ozone, pellet softening, biologically activated carbon, and slow sand filtration.

In the current situation, the SI is controlled using only pH measurements. Due to the setup of the treatment plant (with a long retention time in the lake), the water quality parameters change slowly. However, the reaction dynamics and model characteristics in each process step depend nonlinearly on the temperature, which is reflected in uncertain model parameters. To improve SI control a reliable dynamic model should be constructed. This research aims to improve the model characteristics based on the pH measurements available in the process. In order to improve the model, we consider the online estimation of these uncertain parameters for two stages: acid dosage and RSF.

We propose a method for the online estimation of the uncertain reaction constants of the acid dosage and the RSF stages, in order to improve the model characteristics. Due to the nonlinear and uncertain nature of the process, we use PFs. Since the process steps are in a cascade, the parameter estimation is performed in a cascaded manner.

8.2.2 The water treatment plant

Most models developed for water treatment plants are steady-state models, and they are used for the design of the installation. In this chapter we consider a dynamic model that describes the effect of chemical dosing and reactions through the m-alkalinity (M) and p-alkalinity (P). Neither these alkalinities, nor the reaction rates or disturbances can be measured directly. The available measurement is that of the pH, which is a nonlinear function of M and P .

In the current situation, the pH at different stages is kept at fixed values to achieve a desired SI. The desired pH is based on laboratory measurements of M and P and the current temperature. Therefore, the true SI is only controlled at the sampling rate of the laboratory measurements, with a delay of several days. In reality, the process parameters vary with the temperature and other, non-measured disturbances. Moreover, the concentrations of interests cannot be directly measured. This effectively means that changes in process performance/process input can only be detected with a delay of several days. In order to determine the current state of the process, online estimation is needed. This will also give direct feedback to the operators, instead of a delayed evaluation.

Therefore, the goal is to determine M and P online, based on the measured pH and the reactant added at different steps in the treatment process together with the reaction rates at the treatment steps.

In drinking water production, the pH is mainly determined by the carbonic equilibrium (Wiechers et al., 1975):

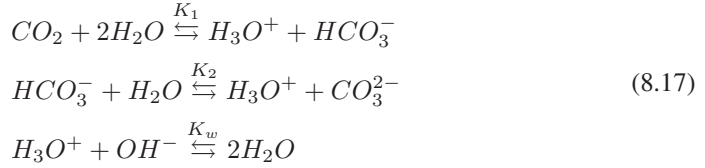

where K_1 , K_2 and K_w are temperature-dependent reaction constants.

The reaction rates of these equilibria are high, and it is therefore assumed that the carbonic fractions are always in equilibrium. The pH (H_3O^+ activity) changes when one of the other concentrations changes due to a reaction. To model the equilibrium, the alkalinities M and P are used. The actual concentrations can be found by solving the following system of equations (van Schagen et al., 2007):

$$\begin{aligned}
 M &= 2[CO_3^{2-}] + [HCO_3^-] + [OH^-] - [H_3O^+] \\
 P &= [CO_3^{2-}] - [CO_2] + [OH^-] - [H_3O^+] \\
 K_1 &= f^2[HCO_3^-][H_3O^+][CO_2]^{-1} \\
 K_2 &= f^4[CO_3^{2-}][H_3O^+][HCO_3^-]^{-1} \\
 K_w &= f^2[H_3O^+][OH^-]
 \end{aligned} \tag{8.18}$$

where f is a parameter depending on the ionic strength of the water and $[.]$ denotes concentration. This system of five equations can be solved as soon as two variables are known. It can also be used to make a simple model of the treatment plant with respect to the pH, by describing the effect of dosage and reactions on M and P and deducing the (nonlinear) relation to the pH. For the relevant range between 7 and 11 the relation is plotted in Figure 8.13. The measured pH values are normally between 7.6 and 8.6.

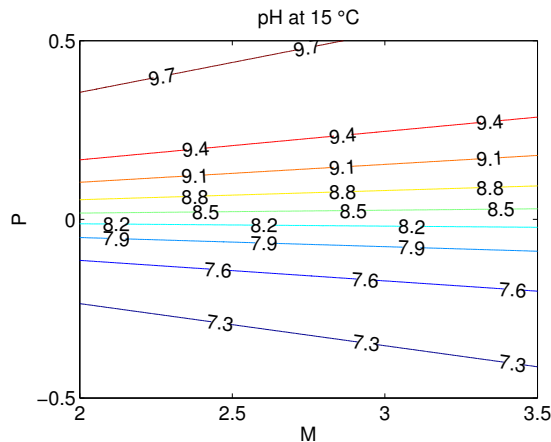

Figure 8.13: Dependence of the pH on M and P at $15^\circ C$.

The dynamic model for M and P can be expressed as:

$$\begin{aligned}\dot{M} &= \frac{F}{V}(M_{\text{prev}} - M) + \frac{F}{V}f_M(r_{\text{in}}) - R_M(M, P, r, \tau) \\ \dot{P} &= \frac{F}{V}(P_{\text{prev}} - P) + \frac{F}{V}f_P(r_{\text{in}}) - R_P(M, P, r, \tau) \\ \dot{r} &= \frac{F}{V}(r_{\text{in}} - r) - R_r(M, P, r, \tau)\end{aligned}$$

where F is the flow, V is the water volume in the corresponding process step, r is the concentration of the reactant in the water, r_{in} is the concentration of the reactant added to the water, R_M , R_P and R_r describe the influence of the temperature on the reactions in the treatment step and depend on the temperature τ . The functions f_M and f_P are the instantaneous changes in M and P due to the dosage of chemicals, and M_{prev} and P_{prev} are the M and P values from the previous treatment stage (van Schagen et al., 2006).

8.2.3 The estimation problem

We consider the estimation of the parameters for the HCl dosage stage and the RSF stage, for which the functions f_M , f_P , R_M , R_P and R_r for the treatment stages of interest are presented in Table 8.5. In the HCl dosage stage, reactions take place due to the added HCl , with the reaction “constant” k_{12} depending heavily on the temperature. During the RSF stage, NH_4 is biologically degraded. The biology uses PO_4 already in the water. The reaction constants again depend on the temperature.

Table 8.5: Functions used in the estimation model.

Stage	f_M	f_P	R_M	R_P	R_r
HCl dosage	$-r_{\text{in}}$	$-r_{\text{in}}$	0	$k_{12}(P + 0.05)$	0
RSF	0	0	k_3r	k_3r	r
Transportation	0	0	0	0	—

The functions f_M and f_P are considered to be linear in r_{in} , and R_M , R_P and R_r are approximated by linear combinations of M , P and r . The parameters k_i change in each treatment step, and in general they depend on the temperature. The measurements are the pH values after each stage.

For each treatment stage, the initial states are the M and P values from the previous stage and the dosing r_{in} . The concentration in each stage refers to the different chemical added. The change during the stage in the M and P numbers depends on the dosing, the reactant already in the water, and the temperature. The measurement is the pH after the treatment stage.

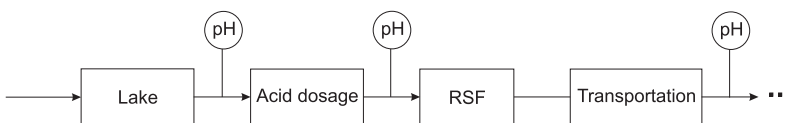

Figure 8.14: Stages of interest.

Since measurements are only available after the water resulting from RSF has been transported, as illustrated in Figure 8.14, we need to consider the RSF and transportation models as one stage. This is why Table 8.5 also contains a “Transportation” stage. It is assumed that the reactions due to the reactant added in a stage are restricted to the corresponding stage.

Due to the nonlinear nature of both the state transition and the measurement model, a nonlinear estimator is needed. Trials have shown that neither the EKF, nor the UKF are able to handle the estimation when measured data is used. Therefore, PFs have been applied. Thanks to the cascaded form of the system, the filters have been also applied in cascades.

8.2.4 Estimation results

The particle filter was first tested for simulated data and afterwards applied to measured data. In all cases, the estimation is cascaded and particle filters are used.

Results using simulation data

The model was simulated using noisy measured flow (F) and reactant (r) data, and both the states and the measurements were corrupted by zero-mean, Gaussian noise.

The initial values were randomly generated. For each process step, both the states and measurements are assumed to be corrupted by a zero-mean Gaussian noise, with known noise covariances. The state transition noise covariance in each stage is 0.005 for M , P , and r and 0.01 for the unknown parameter. The measurement noise covariance is 0.05, which is approximately the measurement error. To simulate the continuous model, a fourth-order Runge-Kutta numerical integration method was used.

Since the water quality parameters in the lake are practically constant, the M_{prev} and P_{prev} for the first HCl dosage are known and constant. The models for each stage and the corresponding results are presented below. For each stage, 50 particles were used, with resampling at $N_T = 45$. To estimate the unknown parameters, a random walk model is used.

HCl dosage stage

The model used for both simulation and estimation purposes is:

$$\begin{aligned}\dot{M} &= \frac{F}{V}(M_{\text{prev}} - M) - \frac{F}{V}r_{\text{in}} \\ \dot{P} &= \frac{F}{V}(P_{\text{prev}} - P) - \frac{F}{V}r_{\text{in}} - k_{12}(P + 0.05) \\ \dot{r} &= \frac{F}{V}(r_{\text{in}} - r)\end{aligned}\tag{8.19}$$

When generating the data, $k_{12} = 0.1$ was used. The estimation result for the unknown parameter is presented in Figure 8.15(a). As can be seen, the estimate, albeit slowly, converges to the true value.

Rapid Sand Filtration stage

The model used for both simulation and estimation purposes is:

$$\begin{aligned} \dot{M} &= \frac{F}{V}(M_{\text{prev}} - M) - k_3 r \\ \dot{P} &= \frac{F}{V}(P_{\text{prev}} - P) - k_3 r \\ \dot{r} &= \frac{F}{V}(r_{\text{in}} - r) - r \end{aligned} \tag{8.20}$$

When generating the data, $k_3 = 3$ was used. The estimation result for the unknown parameter is presented in Figure 8.15(b). As one can see from the presented results, the estimates converge to the true values. The maximum standard deviation computed point-wise over the 30 simulations is below 0.01 for all the estimated states and below 0.001 for the estimated reaction constants.

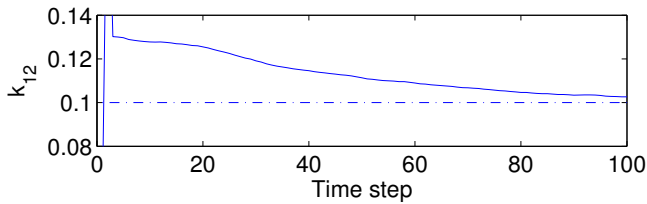

(a) Parameter convergence for acid dosage.

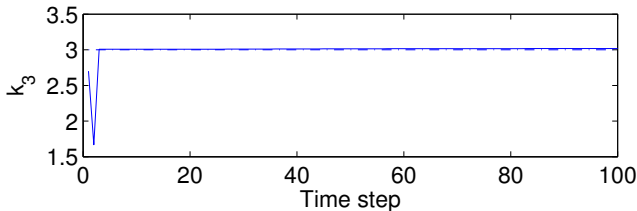

(b) Parameter convergence for RSF.

Figure 8.15: *HCl* and RSF estimation results.

Results using measured data

The simulation results give confidence that using a particle filter the process parameters can be identified based on the measured pH and the measured dosing.

To verify this assumption unfiltered real-world data from the full-scale plant are used. The reactant dosage in the *HCl* dosage stage, the pH after the dosage stage, the incoming NH_4 concentration in the RSF stage, the pH after transportation, and the temperature are measured every minute. The results are obtained for a situation where the reactant and flow through the treatment plant are changed, due to operational changes.

HCl dosage stage

Since before the *HCl* dosage, the water is in equilibrium with the CO_2 in the air, the M and P numbers stabilize at $M = 3.7$ and $P = -0.05$, respectively. These are the inputs

M_{prev} and P_{prev} for the HCl dosage stage. The added reactant is measured, and so is the pH at the end of the stage. The states M , P , r and the reaction constant k_{12} need to be estimated. The particle filter uses 100 particles, with resampling at $N_T = 90$. The state transition noise covariance for M , P and r was 0.00005, while for the random walk model of k_{12} it was 0.002. The measurement noise covariance used was 0.05. The results are presented in Figure 8.16. With these tuning parameters the prediction of the pH after dosing is very accurate, but the reaction rate varies too quickly. This variation cannot be explained by physical phenomena and therefore it is concluded that the error in the pH measurement must be larger.

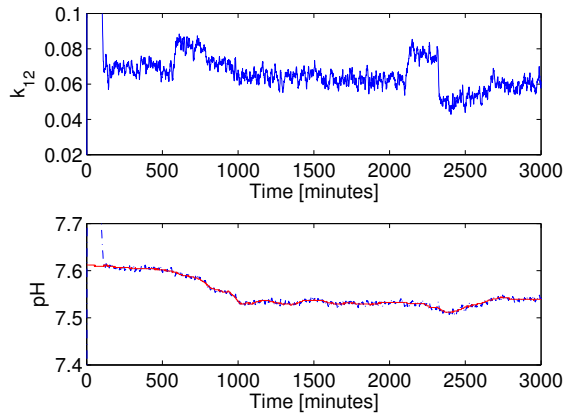

Figure 8.16: Estimation results for the first acid dosage - experimental data (solid line - measured, dashed - predicted).

In a second run the accuracy of the pH measurement was changed to 0.2 and the covariance of the random walk model of k_{12} was changed to 0.0001. The results of this run are shown in Figure 8.17. The pH is within the expected deviation from the measured pH, and the process parameters stabilize at a constant value. However, in simulation, the pH varies more rapidly than in the real-world measurements. An explanation is a possible extra mixing in the HCl dosage stage that is not modeled in the current model.

RSF stage and transportation.

Since a measurement of the pH is only available after transportation of the water obtained in the RSF stage, the two stages have to be taken together. Reactant is added only in the RSF stage, where the inputs are the M and P numbers at the end of the HCl dosage stage. The transportation only delays the M and P s obtained at the end of the RSF stage. The model is

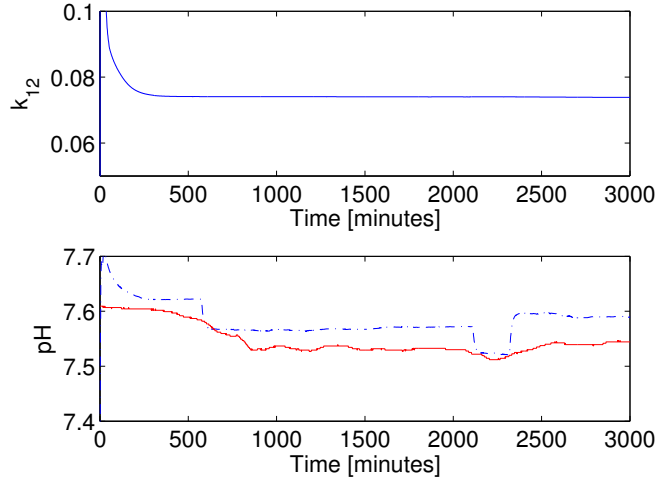

Figure 8.17: Estimation results for the first acid dosage - experimental data (solid line - measured, dashed - predicted).

given by:

$$\begin{aligned}
 \dot{M}_2 &= \frac{F}{V_2}(M_1 - M_2) \\
 \dot{P}_2 &= \frac{F}{V_2}(P_1 - P_2) \\
 \dot{M}_1 &= \frac{F}{V_1}(M_{\text{prev}} - M_1) - k_3 r \\
 \dot{P}_1 &= \frac{F}{V_1}(P_{\text{prev}} - P_1) - k_3 r \\
 \dot{r} &= \frac{F}{V_1}(r_{\text{in}} - r) - r
 \end{aligned} \tag{8.21}$$

The measured pH is a nonlinear combination of M_2 and P_2 . Besides the states, the parameter k_3 also has to be estimated. The values used for M_{prev} and P_{prev} are those estimated in the previous stage. The particle filter uses 100 particles, with resampling at $N_T = 90$. The state transition noise covariances are 0.00005 for M_1 , M_2 , P_1 , P_2 , and r , and 0.0002 for the random walk model of k_3 . The measurement noise covariance is again increased to 0.2.

Part of the estimated results is presented in Figure 8.18. The estimation results for this case (Figure 8.18) show that the convergence to the correct pH value is slower than in the simulated case, but again the process parameter converges to a constant parameter. The difference between the estimated and measured pH however is not explained by the model.

8.2.5 Conclusions

In drinking water production and distribution there is an increased interest in advanced control using online data. However, in the current situation only the pH at different stages is

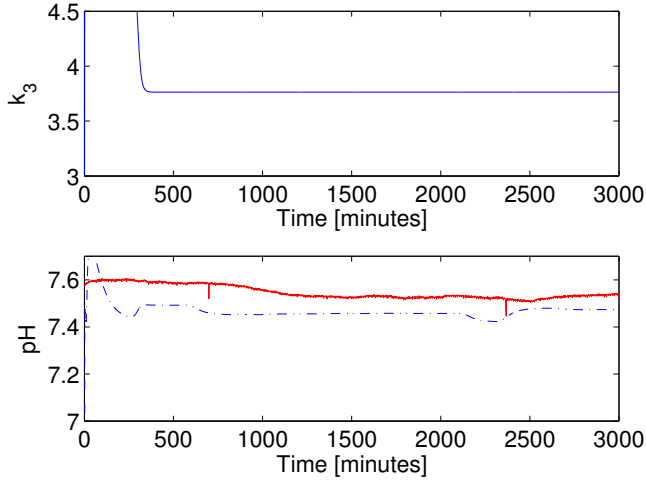

Figure 8.18: Estimation results for RSF and transportation - experimental data (solid line - measured, dash-dotted - predicted).

measured. Based on these measurements, a particle filter was applied to the estimation of reaction constants for two stages of a water treatment plant.

Estimation was performed both on simulated data and using data from the full-scale installation. It has been shown that the theoretical accuracy of the pH measurements does not hold in practice, and that an accuracy of 0.2 for the pH measurement must be used. If that accuracy is taken into account, “constant” process parameters are changing gradually and the pH is within the defined range.

The results are encouraging, but, at the same time, they show that SI cannot be controlled solely by one pH measurement. To guarantee that the desired SI is kept, it is necessary to implement redundant pH measurements (to increase accuracy) or to use a model-based approach to identify erroneous measurement data.

8.3 Summary and concluding remarks

This chapter has presented the application of cascaded state estimation for two real-world processes. In both cases, the model is nonlinear and non-Gaussian, and the variables of interest, although needed for advanced control, cannot be measured online. Therefore, they have to be estimated. Due to the nonlinearity and the uncertainty of the models and the noise affecting the measurements, a centralized estimation involves the use of a particle filter with a large number of samples, which implies high computational costs. By employing the cascaded approach, different observers can be combined. With the increased modularity, the complexity of the problem is reduced, which leads to reduced computational costs. Moreover, since the design and tuning of the observers becomes easy, the overall performance is also increased.

Chapter 9

Conclusions and future research directions

In this thesis we have proposed and studied techniques to design observers for nonlinear systems. Two types of systems have been considered: deterministic nonlinear systems represented by Takagi-Sugeno (TS) fuzzy models, and cascaded stochastic systems. For TS fuzzy models, we have discussed both stability analysis and observer design, for cascaded, distributed and adaptive systems. For cascaded stochastic processes, the performance of Kalman filters has been discussed from a theoretical point of view and the combination of different stochastic observers has been evaluated on two real-world applications.

This chapter summarizes our findings and discusses future research directions in observer design for nonlinear systems.

9.1 Summary and conclusions

In the first part of the thesis, we have studied TS fuzzy systems and propose observer design methods for such systems. First, we have discussed TS fuzzy systems that are the cascade of several subsystems. We have given an algorithm for partitioning a nonlinear observable system into cascaded observable subsystems to determine whether a system is a cascade of subsystems. For cascaded fuzzy systems, we have proven that under mild conditions, the stability of the whole system is implied by the stability of the subsystems. Therefore, if a TS fuzzy system is the cascade of TS subsystems, the stability of the whole system can be analyzed based on the stability of the subsystems. The cascaded analysis relaxes the stability conditions and it also reduces the computational costs. We have also extended the cascaded approach to observer design. By designing observers independently, a decentralized observer for the whole system is obtained. Such a decentralized observer has the same error decay rate as an observer designed for the whole system, i.e., the same performance can be obtained with reduced computational costs.

While many processes are cascaded (e.g., material processing, flow processes), most systems are not cascaded, but distributed, i.e., the subsystems influence one another. When considering cascaded systems, we exploit the property that the influence among the subsystems is in one direction only. Since in general this is not the case, we have also studied the

possibility of analyzing the stability and designing observers for distributed TS systems in a fashion similar to cascaded systems, i.e., sequentially for the subsystems. We have considered distributed TS systems with a structure that changes in time, i.e., subsystems can be added to or removed from the system online. Given such a system, its stability can be determined by sequentially analyzing the subsystems and the strength of the interconnection terms. Assuming that the already analyzed part of the system is proven to be exponentially stable, we have derived conditions for the stability of the newly added subsystems and the interconnection terms, so that the whole system maintains stability. The approach has been extended to observer design. Given that a stable observer has already been designed for a part of the system, when a new subsystem, together with the interconnection terms, is added, an observer is designed only for the new subsystem. We have developed conditions to design the new observer in such a manner that the already existing observers do not need to be modified, and the global observer is stable.

In the last chapter of the first part of the thesis, we have considered adaptive TS systems. Two kinds of uncertainties are considered: changes in the local linear models and disturbances that are polynomial functions of time. In the case when the local models change slowly in time, we have designed an observer that asymptotically estimates the true local models. For the case of time-varying disturbances, we have assumed that these disturbances can be represented as or approximated by polynomial functions of time, that have a known order. When the disturbance is represented by a polynomial, an observer can be designed that estimates the disturbance with an exponential convergence to the true signal value. If the disturbance is only approximated by a polynomial function of time, the estimate converges exponentially to a region that lies within a bound of the true value.

In the second part of the thesis we have presented combinations of stochastic observers for cascaded stochastic systems. First, we have given a theoretical comparison of Kalman filters (KFs) designed for cascaded subsystems, and KFs designed for the cascaded system as a whole. We have proven that the cascaded KFs are jointly optimal and therefore have the same performance as a centralized KF, if and only if the subsystems are independent. Next, we have studied the performance of cascaded observers on simulation examples and real-world applications. The examples indicate that although the cascaded KFs are theoretically not optimal, their performance is comparable to that of a centralized KF. Moreover, when the system is controlled, simulations indicate that the cascaded filters perform better than the centralized filters. An explanation for this is that by using cascaded observers, the estimation error on one subsystem does not influence the other subsystem. We have also considered two real-world applications, the estimation of the overflow losses in a hopper dredger and the estimation of model parameters of a water treatment plant. Note that our goal in these applications is to obtain the best estimate of the current state, and not a distribution of the estimate of the current state, as was the case for the KFs. The models describing these applications are nonlinear and the noise affecting the processes are non-Gaussian. By employing the cascaded approach, an unscented Kalman filter (UKF) and a particle filter (PF) are combined to obtain a better estimate of the overflow losses in a hopper-dredger. In the second application, PFs are used in cascade to estimate the model parameters in a water treatment plant. By using the cascaded approach and combining different observers, the complexity of the estimation problem and therefore the computational costs are significantly reduced.

We conclude that by determining the structure of the model available, that is, cascaded,

distributed, or time-varying, and incorporating this information in the observer design leads to easier analysis and design, better performance, and reduced computational costs.

9.2 Main contributions

The main contributions of this thesis can be summarized as follows:

- We have proven that under mild conditions, the stability of a cascaded TS fuzzy system is implied by the stability of the individual subsystems. Based on this property, we have also derived an observer design method for cascaded TS systems.
- We have proposed a method to design observers for a distributed TS fuzzy system to which subsystems are added online sequentially, by considering each subsystem as it is added.
- We have designed observers that can simultaneously estimate both the states of a TS system and unknown inputs that are represented as or approximated by polynomial functions of time. Conditions for the convergence of the observer have been presented and the design guarantees an ultimate bound on the estimation error.

9.3 Open issues and outlook

This section presents some important open issues concerning the techniques presented in this thesis, as well as more fundamental open problems in the field of state estimation.

9.3.1 Open issues and future research directions

Several open issues regarding the approaches presented in this thesis were mentioned in the previous chapters. This section summarizes these issues.

The first part of the thesis concerned the stability analysis and observer design for TS fuzzy systems. Among the issues that remain to be investigated we mention the following.

- We have investigated the performance of the designed cascaded observers for TS fuzzy systems in the terms of the decay rate of the estimation error. However, other performance indices, (e.g., overshoot, integral error) can also be defined, and the cascaded and centralized approaches could also be compared based on these indices.
- We have also considered decentralized stability analysis and observer design for TS systems. The decentralized approach has several benefits, such as modularity or easier design. However, similarly to the cascaded approach, an issue that remains to be investigated is how the centralized and distributed approaches compare in terms of performance indicators.
- When considering time-varying TS fuzzy systems, we have assumed that the membership functions are known, that their structure is fixed, and that only the parameters of the local models change in time. The design of an adaptive observer for the case when

the membership functions change as well, or when there is a model mismatch in the membership functions, remains to be investigated. In such a case, not only the model parameters, but also the membership functions have to be adapted. Moreover, the use of adaptive observers for decentralized (cascaded, distributed) systems could also be investigated.

- Our results have been illustrated on numerical examples. They should also be applied on real-world processes.

The second part of the thesis has investigated the possibility and benefits of cascaded state estimation for cascaded stochastic systems. Some directions that may be explored in the future are the following.

- The performance of cascaded and centralized KFs has been compared. The performance gain or loss using other types of stochastic filters could also be investigated.
- Since the extended KF is essentially a heuristic method, it does not have any convergence guarantees. However, the UKF is accurate up to the second-order Taylor series expansion. A possible issue to be investigated is whether this property also holds for cascaded UKFs.
- For PFs, bounds exist on the approximation error between the true and the estimated distribution, given the number of particles used. It could also be investigated whether similar bounds hold for the cascade of PFs.
- The presented applications have demonstrated the benefits of cascaded state estimation in two real-life stochastic processes. They also indicate that the approach may be successfully used for other real-world applications. Therefore, other applications should be explored in the future.

9.3.2 Outlook

Next to the open issues mentioned in the previous section, we identify several more general research questions and some promising directions that may help to solve these. Some of these directions are discussed in this section.

- In this thesis it is assumed that the observer gains have the same membership functions as the TS model. It could be investigated whether a different choice of membership functions for the observer can result in less conservative conditions and how the membership functions have to be chosen. A promising direction is the use of membership function dependent Lyapunov functions.
- Most of the results for TS systems in this thesis rely on the existence of a common quadratic Lyapunov function. Such a requirement is conservative and may not be applicable for certain models (e.g., when one of the local models is unstable). Investigation of the use of piecewise quadratic or piecewise linear Lyapunov functions for observer design is a promising direction.

- For the approaches in this thesis, we have required that every local model of the TS fuzzy system is stable (in case of stability analysis) or observable (in case of observer design). However, in general such a requirement is neither a sufficient, nor a necessary condition for the whole system to be stable or observable. When more than one rule is active, depending on the current value of the membership function, the system may be stable, even though one of the active local models is unstable. In such a case, a quadratic Lyapunov function cannot be used to determine stability, as the most existing conditions become unfeasible. However, membership function or scheduling vector dependent Lyapunov functions may help to derive less conservative conditions.
- To test stability and to design observers, usually LMIs are derived from nonlinear conditions. However, in order to arrive to these LMIs, in general conservativeness is introduced. In order to introduce less conservativeness, bilinear matrix inequalities may be derived instead of LMIs. Algorithms and methods for solving efficiently nonlinear matrix inequalities and eigenvalue problems are also needed.
- The results for TS systems in this thesis concern only the observer design for continuous-time systems. How similar conditions may be derived for the purpose of state-feedback or output-feedback control and for discrete-time TS systems still needs to be investigated. Methods similar to those employed in this thesis could be the first step in solving this issue.
- We have considered in the first part of the thesis only deterministic TS systems. The case when (part of) the states or measurements are corrupted by noise should also be investigated. For instance, when the local models are corrupted by noise, the observer gains may be determined in a fashion similar to KFs, while ensuring the stability of the observer.
- State estimation for general nonlinear systems should also be explored. Since TS systems are able to approximate a nonlinear system to an arbitrary degree of accuracy, they could represent the first step into this direction. If a bound is known on the approximation error, robust observers could be derived that are also valid for the nonlinear system, or a bound on the estimation error may be deduced.

Appendix A

Stability criteria

The following theorems can be found in Khalil (2002), Chapters 4.1 and 4.5. Consider the autonomous nonlinear system

$$\dot{\mathbf{x}} = \mathbf{f}(\mathbf{x}) \quad \mathbf{x} \in \mathcal{D} \quad (\text{A.1})$$

with an equilibrium point in \mathbf{x}_0 .

Theorem A.1 Lyapunov stability: *If there exists a continuously differentiable function $V : \mathcal{D} \rightarrow \mathbb{R}$ such that*

$$\begin{aligned} V(\mathbf{x}_0) &= 0 \\ V(\mathbf{x}) &> 0 \quad \forall \mathbf{x} \in \mathcal{D} \setminus \{\mathbf{x}_0\} \\ \dot{V}(\mathbf{x}) &\leq 0 \end{aligned} \quad (\text{A.2})$$

then the equilibrium point \mathbf{x}_0 is stable.

Theorem A.2 Asymptotic stability: *If there exists a continuously differentiable function $V : \mathcal{D} \rightarrow \mathbb{R}$ such that*

$$\begin{aligned} V(\mathbf{x}_0) &= 0 \\ V(\mathbf{x}) &> 0 \quad \forall \mathbf{x} \in \mathcal{D} \setminus \{\mathbf{x}_0\} \\ \dot{V}(\mathbf{x}_0) &= 0 \\ \dot{V}(\mathbf{x}) &< 0 \quad \forall \mathbf{x} \in \mathcal{D} \setminus \{\mathbf{x}_0\} \end{aligned} \quad (\text{A.3})$$

then the equilibrium point \mathbf{x}_0 is asymptotically stable. Furthermore, if V is radially unbounded, then \mathbf{x}_0 is globally asymptotically stable.

Theorem A.3 Exponential stability: *If there exists a function V that proves asymptotic stability and in addition there exists $\alpha > 0$ so that*

$$\dot{V}(\mathbf{x}) \leq -\alpha V(\mathbf{x}) \quad (\text{A.4})$$

for some neighborhood of \mathbf{x}_0 then \mathbf{x}_0 is exponentially stable. If (A.4) holds globally, then \mathbf{x}_0 is globally exponentially stable.

In what follows, consider the nonlinear system

$$\dot{\mathbf{x}} = \mathbf{f}(t, \mathbf{x}) \quad \mathbf{x} \in \mathcal{D} \tag{A.5}$$

that is piecewise continuous in t , locally Lipschitz in \mathbf{x} , and has an equilibrium point in \mathbf{x}_0 .

Theorem A.4 Uniform stability: *If there exists a continuously differentiable function $V : [0, \infty) \times \mathcal{D} \rightarrow \mathbb{R}$ and two continuous positive definite functions $W_1(\mathbf{x})$ and $W_2(\mathbf{x})$, such that*

$$\begin{aligned} W_1(\mathbf{x}) &\leq V(t, \mathbf{x}) \leq W_2(\mathbf{x}) \\ \frac{\partial V}{\partial t} + \frac{\partial V}{\partial \mathbf{x}} \mathbf{f}(t, \mathbf{x}) &\leq 0 \quad \forall t, \mathbf{x} \end{aligned} \tag{A.6}$$

then the equilibrium point \mathbf{x}_0 is uniformly stable.

Theorem A.5 Uniform asymptotic stability: *If there exists a continuously differentiable function $V : [0, \infty) \times \mathcal{D} \rightarrow \mathbb{R}$ and three continuous positive definite functions $W_1(\mathbf{x})$, $W_2(\mathbf{x})$ and $W_3(\mathbf{x})$, such that*

$$\begin{aligned} W_1(\mathbf{x}) &\leq V(t, \mathbf{x}) \leq W_2(\mathbf{x}) \\ \frac{\partial V}{\partial t} + \frac{\partial V}{\partial \mathbf{x}} \mathbf{f}(t, \mathbf{x}) &\leq -W_3(\mathbf{x}) \quad \forall t, \mathbf{x} \end{aligned} \tag{A.7}$$

then the equilibrium point \mathbf{x}_0 is uniformly asymptotically stable (UAS). If moreover, $W_1(\mathbf{x})$ is radially unbounded, then \mathbf{x}_0 is globally uniformly asymptotically stable (GUAS).

Remark: The above theorems present only sufficient conditions. If a function V that satisfies the conditions cannot be found, it only means that no conclusion can be drawn regarding the stability of the equilibrium point on the basis of these theorems.

Appendix B

Obtaining Takagi-Sugeno models by linearization

In this thesis we assume that for the purpose of observer design, a fuzzy model or a nonlinear model of the process considered is directly available. Given a nonlinear model, a fuzzy approximation is obtained by linearizing the nonlinear model. This is in fact a Taylor series expansion in different representative points, which may or may not be equilibria.

Consider a dynamic nonlinear system expressed as

$$\begin{aligned}\dot{\mathbf{x}} &= \mathbf{f}(\mathbf{x}, \mathbf{u}, \boldsymbol{\theta}) \\ \mathbf{y} &= \mathbf{h}(\mathbf{x}, \mathbf{u}, \boldsymbol{\theta})\end{aligned}\tag{B.1}$$

where $\mathbf{x} \in \mathcal{X}$ is the vector of state variables, $\mathbf{y} \in \mathcal{Y}$ is the vector of measurements, $\mathbf{u} \in \mathcal{U}$ is the input vector, and $\boldsymbol{\theta} \in \mathcal{D}$ represents parameters.

Our goal is to obtain an approximation of the nonlinear system (B.1) as a set of m rules: R_i : If \mathbf{z} is around \mathbf{z}_i then

$$\begin{aligned}\dot{\mathbf{x}} &= A_i \mathbf{x} + B_i \mathbf{u} + a_i \\ \mathbf{y} &= C_i \mathbf{x} + D_i \mathbf{u} + d_i\end{aligned}$$

or of the form

$$\begin{aligned}\dot{\mathbf{x}} &= \sum_{i=1}^m w_i(\mathbf{z})(A_i \mathbf{x} + B_i \mathbf{u} + a_i) \\ \mathbf{y} &= \sum_{i=1}^m w_i(\mathbf{z})(C_i \mathbf{x} + D_i \mathbf{u} + d_i)\end{aligned}\tag{B.2}$$

where $A_i, B_i, a_i, C_i, D_i, d_i$ are the matrices and biases of the local linear models, \mathbf{z} is the scheduling vector that determines which of the rules are active at a certain moment, and $w_i(\mathbf{z}), i = 1, 2, \dots, m$ are the normalized membership functions.

First, one has to decide which variables describe the nonlinearities, i.e., which variables should be the scheduling variables (\mathbf{z} is a selection of inputs, states, and parameters). Second, a sufficient amount m of linearization points $\mathbf{z}_i, i = 1, 2, \dots, m$ has to be chosen, together with a partition of the space $\mathcal{X} \times \mathcal{U} \times \mathcal{D}$ and the corresponding membership functions $\varphi_i, i = 1, 2, \dots, m$. Note that by increasing the number of well-chosen approximation points,

the approximation accuracy of the fuzzy model increases. However, the choices above are highly application dependent (Kruse et al., 1994). The consequent matrices are obtained as:

$$\begin{aligned} A_i &= \left. \frac{\partial \mathbf{f}}{\partial \mathbf{x}} \right|_{\mathbf{z}_{i,0}} & B_i &= \left. \frac{\partial \mathbf{f}}{\partial \mathbf{u}} \right|_{\mathbf{z}_{i,0}} \\ C_i &= \left. \frac{\partial \mathbf{h}}{\partial \mathbf{x}} \right|_{\mathbf{z}_{i,0}} & D_i &= \left. \frac{\partial \mathbf{h}}{\partial \mathbf{u}} \right|_{\mathbf{z}_{i,0}} \end{aligned} \quad (\text{B.3})$$

where $|_{\mathbf{z}_{i,0}}$ denotes the evaluation of the expression on the left in the value corresponding to \mathbf{z}_i for \mathbf{x} , \mathbf{u} and θ that are scheduling variables and 0 for those states and inputs that are not in \mathbf{z} .

If the linearization is not done in equilibria, affine terms also need to be added:

$$\begin{aligned} a_i &= \mathbf{f}(\mathbf{x}, \mathbf{u}, \theta)|_{\mathbf{z}_{i,0}} - A_i \mathbf{x}|_{\mathbf{z}_{i,0}} - B_i \mathbf{u}|_{\mathbf{z}_{i,0}} \\ d_i &= \mathbf{h}(\mathbf{x}, \mathbf{u}, \theta)|_{\mathbf{z}_{i,0}} - C_i \mathbf{x}|_{\mathbf{z}_{i,0}} - D_i \mathbf{u}|_{\mathbf{z}_{i,0}} \end{aligned} \quad (\text{B.4})$$

In order to obtain the TS system of the form (B.2), the membership functions are normalized as follows

$$w_i(\mathbf{z}) = \frac{\varphi_i(\mathbf{z})}{\sum_{j=1}^m \varphi_j(\mathbf{z})} \quad (\text{B.5})$$

Then, the TS fuzzy model can be expressed as

$$\begin{aligned} \dot{\mathbf{x}} &= \sum_{i=1}^m w_i(\mathbf{z})(A_i \mathbf{x} + B_i \mathbf{u} + a_i) \\ \mathbf{y} &= \sum_{i=1}^m w_i(\mathbf{z})(C_i \mathbf{x} + D_i \mathbf{u} + d_i) \end{aligned} \quad (\text{B.6})$$

A convenient advantage of the fuzzy approximation obtained by linearization is that the local models retain the properties of the nonlinear system in the linearization points, i.e., if \mathbf{z}_i is locally observable and/or accessible in the nonlinear system, then the affine model obtained by linearization in the respective point is also observable and/or accessible.

Appendix C

Schur complements

Consider a symmetric, positive definite matrix A , partitioned as:

$$A = \begin{pmatrix} A_{11} & A_{12} \\ A_{12}^T & A_{22} \end{pmatrix}$$

The Schur complement of the submatrix A_{11} is

$$A_{22} - A_{12}^T A_{11}^{-1} A_{12}$$

and the Schur complement of the submatrix A_{22} is

$$A_{11} - A_{12} A_{22}^{-1} A_{12}^T$$

These complements have the properties (Zhang, 2005)

$$A_{11} - A_{12} A_{22}^{-1} A_{12}^T > 0$$

$$A_{22} - A_{12}^T A_{11}^{-1} A_{12} > 0$$

Using the Schur complement it is possible to rewrite quadratic matrix inequalities of the form $Q(\mathbf{x}) - R(\mathbf{x})S(\mathbf{x})^{-1}R(\mathbf{x}) > 0$, where $Q(\mathbf{x}) = Q(\mathbf{x})^T > 0$ and $S(\mathbf{x}) = S(\mathbf{x})^T > 0$ as the following linear matrix inequality:

$$\begin{pmatrix} Q(\mathbf{x}) & R(\mathbf{x}) \\ R(\mathbf{x})^T & S(\mathbf{x}) \end{pmatrix} > 0$$

Bibliography

- Aja-Fernandez, S., Alberola-Lopez, C., and Ruiz-Alzola, J. (2003). A fuzzy-controlled Kalman filter applied to stereo-visual tracking schemes. *Signal Processing*, 83(1):101–120.
- Akar, M. and Özgüner, U. (2000). Decentralized techniques for the analysis and control of Takagi-Sugeno fuzzy systems. *IEEE Transactions on Fuzzy Systems*, 8(6):691–704.
- Aldeen, M., Lau, K.-H., and Marsh, J. (1998). A decentralised observer for interconnected systems. In *UKACC International Conference on Control '98*, volume 1, pages 348–352, Swansea, UK.
- Arcak, M., Angeli, D., and Sontag, E. (2002). A unifying integral ISS framework for stability of nonlinear cascades. *SIAM Journal of Control and Optimization*, 40(6):1888–1904.
- Arulampalam, S., Maskell, S., Gordon, N. J., and Clapp, T. (2002). A tutorial on particle filters for on-line nonlinear/non-Gaussian Bayesian tracking. *IEEE Transactions on Signal Processing*, 50(2):174–188.
- Babuška, R., Lendek, Zs., Braaksma, J., and de Keizer, C. (2006). Particle filtering for on-line estimation of overflow losses in a hopper dredger. In *Proceedings of the American Control Conference*, pages 5751–5756, Minneapolis, Minnesota, USA.
- Bacciotti, A., Boieri, P., and Mazzi, L. (1993). Linear stabilization of nonlinear cascade systems. *Mathematics of Control, Signals and Systems*, 6(2):146–165.
- Baddou, A., Naib, M., Tadeo, F., and Benzaouia, A. (2006). On improving the convergence rate of linear continuous-time systems subject to asymmetrically constrained control. *Mathematical Problems in Engineering*, 2006:Article ID 89429, 14 pages. doi:10.1155/MPE/2006/89429.
- Bakker, M., van Schagen, K., and Timmer, J. (2003). Flow control by prediction of water demand. *Journal of Water Supply: Research And Technology-AQUA*, Vol 52(6):417–424.
- Bavafa-Toosi, Y., Ohmori, H., and Labibi, B. (2006). A generic approach to the design of decentralized linear output-feedback controllers. *Systems & Control Letters*, 55(4):282–292.
- Baz, A. (1992). A neural observer for dynamic systems. *Journal of Sound and Vibration*, 152(2):227–243.

- Benigni, A., Ghisla, U., D'Antona, G., Monti, A., and Ponci, F. (2008). A decentralized observer for electrical power systems: Implementation and experimental validation. In *IEEE Instrumentation and Measurement Technology Conference Proceedings*, pages 859–864, Vancouver, Canada.
- Bergsten, P. (2001). *Observers and controllers for Takagi-Sugeno fuzzy systems*. PhD thesis, Örebro University, Sweden.
- Bergsten, P., Palm, R., and Driankov, D. (2001). Fuzzy observers. In *Proceedings of the 10th IEEE International Conference on Fuzzy Systems*, volume 2, pages 700–703, Melbourne, Australia.
- Bergsten, P., Palm, R., and Driankov, D. (2002). Observers for Takagi-Sugeno fuzzy systems. *IEEE Transactions on Systems, Man and Cybernetics, Part B*, 32(1):114–121.
- Besaçon, G. (2006). *Advanced Topics in Control Systems Theory*, chapter 2. Observer design for nonlinear systems, pages 61–89. Springer-Verlag London.
- Bolic, M., Djuric, P. M., and Hong, S. (2004). Resampling algorithms and architectures for distributed particle filters. *IEEE Transactions on Signal Processing*, 53(7):2442–2450.
- Braaksma, J., Klaassens, J., Babuska, R., and de Keizer, C. (2007). A computationally efficient model for predicting overflow mixture density in a hopper dredger. *Terra et Aqua*, 106(16):16–25.
- Camp, T. (1946). Sedimentation and the design of settling tanks. *Transactions of the American Society of Civil Engineers*, 111:895–936.
- Caron, F., Duflos, E., Pomorski, D., and Vanheeghe, P. (2006). GPS/IMU data fusion using multisensor Kalman filtering: introduction of contextual aspects. *Information Fusion*, 7(2):221–230.
- Chaillet, A. and Loria, A. (2006). Necessary and sufficient conditions for uniform semiglobal practical asymptotic stability: Application to cascaded systems. *Automatica*, 42(11):1899–1906.
- Cheng, Q. and Bondon, P. (2008). A new unscented particle filter. In *IEEE International Conference on Acoustics, Speech and Signal Processing, 2008.*, pages 3417–3420.
- Chilali, M. and Gahinet, P. (1996). H_∞ design with pole placement constraints: An LMI approach. *IEEE Transactions on Automatic Control*, 41(3):358–367.
- Coates, M. (2004). Distributed particle filters for sensor networks. In *3rd International Symposium on Information Processing in Sensor Networks*, pages 99–107, Berkeley, California.
- Corless, M. and Tu, J. (1998). State and input estimation for a class of uncertain systems. *Automatica*, 34(6):757–764.
- Djurić, P. M., Bugallo, M. F., and Miguez, J. (2004). Density assisted particle filters for state and parameter estimation. In *Proceedings of the IEEE 29th International Conference on Acoustics, Speech and Signal Processing (ICASSP'2004)*, volume 2, pages 701–704.

- Dorfmueller-Ulhaas, K. (2003). Robust optical user motion tracking using a Kalman filter. Technical Report 2003-6, Klaus Dorfmueller-Ulhaas, Augsburg University. mm-werkstatt.informatik.uni-augsburg.de/files/publications/38/squint2.pdf.
- Doucet, A., Godsill, S., and Andrieu, C. (2000). On sequential Monte Carlo sampling methods for Bayesian filtering. *Statistics and Computing*, 10(3):197–208.
- Durrant-Whyte, H., Rao, B., and Hu, H. (1990). Toward a fully decentralized architecture for multi-sensor data fusion. In *Proceedings of the IEEE International Conference on Robotics and Automation*, volume 2, pages 1331–1336, Cincinnati, Ohio.
- Fantuzzi, C. and Rovatti, R. (1996). On the approximation capabilities of the homogeneous Takagi-Sugeno model. In *Proceedings of the Fifth IEEE International Conference on Fuzzy Systems*, pages 1067–1072, New Orleans, Louisiana.
- Fearnhead, P. (1998). *Sequential Monte Carlo methods in filter theory*. PhD thesis, University of Oxford, UK.
- Feng, G. (2006). A survey on analysis and design of model-based fuzzy control systems. *IEEE Transactions on Fuzzy Systems*, 14(5):676–697.
- Guelton, K., Delprat, S., and Guerra, T.-M. (2008). An alternative to inverse dynamics joint torques estimation in human stance based on a Takagi-Sugeno unknown-inputs observer in the descriptor form. *Control Engineering Practice*, 16(12):1414–1426.
- Ha, Q. P. and Trinh, H. (2004). State and input simultaneous estimation for a class of nonlinear systems. *Automatica*, 40(10):1779–1785.
- Haijun, G., Tianping, Z., and Qikun, S. (2006). Decentralized model reference adaptive sliding mode control based on fuzzy model. *Journal of Systems Engineering and Electronics*, 17(1):182–186.
- Hill, B., Conrad, S., Kidder, H., and Riddle, R. (2005). Optimal control of water distribution. In *Proceedings of the 2nd International Conference on Instrumentation, Control and Automation*, Busan, South Korea.
- Ho, H., Wong, Y., Rad, A., and Lo, W. (2005). State observer based indirect adaptive fuzzy tracking control. *Simulation Modelling Practice and Theory*, 7(13):646–663.
- Hong, S., Lee, J., Athalye, A., Djuric, P., and Cho, W.-D. (2007). Design methodology for domain specific parameterizable particle filter realizations. *Circuits and Systems I: Regular Papers, IEEE Transactions on*, 54(9):1987–2000.
- Hou, M. and Müller, P. C. (1994). Design of decentralized linear state function observers. *Automatica*, 30(11):1801–1805.
- Hovakimyan, N., Calise, A., and Madyastha, V. (2002). An adaptive observer design methodology for bounded nonlinear processes. In *Proceedings of the 41st IEEE Conference on Decision and Control*, volume 4, pages 4700–4705, Las Vegas, Nevada.
- Hsiao, F.-H. and Hwang, J.-D. (2002). Stability analysis of fuzzy large-scale systems. *Systems, Man, and Cybernetics, Part B, IEEE Transactions on*, 32(1):122–126.

- Huang, M. and Dey, S. (2005). Distributed state estimation for hidden Markov models with dynamic quantization and rate allocation. In *16th IFAC World Congress*, volume 16, Prague, Czech Republic.
- Hue, C., Cadre, J. L., and Perez, P. (2002). Tracking multiple objects with particle filtering. *IEEE Transactions on Aerospace and Electronic Systems*, 38(3):791–812.
- Hyun, C.-H., Kim, J.-H., Kim, E., and Park, M. (2006). Adaptive fuzzy observer based synchronization design and secure communications of chaotic systems. *Chaos, Solitons & Fractals*, 27(4):930–940.
- Jan R. Magnus, H. N. (1999). *Matrix Differential Calculus with Applications in Statistics and Econometrics*. John Wiley & Sons.
- Jankovic, M., Sepulchre, R., and Kokotovic, P. (1996). Constructive Lyapunov stabilization of nonlinear cascade systems. *IEEE Transactions on Automatic Control*, 41(12):1723–1735.
- Jetto, L., Longhi, S., and Vitali, D. (1999). Localization of a wheeled mobile robot by sensor data fusion based on a fuzzy logic adapted Kalman filter. *Control Engineering Practice*, 7(6):763–771.
- Jiang, Z.-P. (2000). Decentralized and adaptive nonlinear tracking of large-scale systems via output feedback. *IEEE Transactions on Automatic Control*, 45(11):2122–2128.
- Johansson, M. (1999). *Piecewise linear control systems*. PhD thesis, Department of Automatic Control, Lund Institute of Technology, Sweden.
- Johansson, M. and Rantzer, A. (1998). Computation of piecewise quadratic Lyapunov functions for hybrid systems. *IEEE Transactions on Automatic Control*, 43(4):555–559.
- Johansson, M., Rantzer, A., and Arzen, K. (1999). Piecewise quadratic stability of fuzzy systems. *IEEE Transactions on Fuzzy Systems*, 7(6):713–722.
- Julier, S. J. and Uhlmann, J. K. (1997). A new extension of the Kalman filter to nonlinear systems. In *Proceedings of 11th International Symposium on Aerospace/Defense Sensing, Simulation and Controls*, pages 182–193, Orlando, Florida.
- Kadmiry, B. and Bergsten, P. (2004). Robust fuzzy gain scheduled visual-servoing with sampling time uncertainties. In *Proceedings of the IEEE International Symposium on Intelligent Control*, volume 1, pages 239–245, Taipei, Taiwan.
- Kalman, R. E. (1960). A new approach to linear filtering and prediction problems. *Transactions of the ASME—Journal of Basic Engineering*, 82(1):35–45.
- Khalil, H. K. (2002). *Nonlinear Systems*. Prentice-Hall, Upper Saddle River, New Jersey, USA.
- Krishnamurthy, P. and Khorrami, F. (2003). Decentralized control and disturbance attenuation for large-scale nonlinear systems in generalized output-feedback canonical form. *Automatica*, 39(11):1923–1933.

- Kruse, R., Gebhardt, J. E., and Klowon, F. (1994). *Foundations of Fuzzy Systems*. John Wiley & Sons, Inc., New York, USA.
- Labiod, S. and Guerra, T. M. (2007). Adaptive fuzzy control of a class of SISO nonaffine nonlinear systems. *Fuzzy Sets and Systems*, 158(10):1126–1137.
- Lee, J. W., Kim, M. S., and Kweon, I. S. (1995). A Kalman filter based visual tracking algorithm for an object moving in 3D. In *Proceedings of the IEEE/RSJ International Conference on Intelligent Robots and Systems*, volume 1, pages 342–347, Pittsburgh, Pennsylvania.
- Lendek, Zs., Babuška, R., and B. De Schutter (2008a). Stability analysis and observer design for decentralized TS fuzzy systems. In *Proceedings of the IEEE International Conference on Fuzzy Systems*, pages 631–636, Hong Kong, China.
- Lendek, Zs., Babuška, R., Braaksma, J., and de Keizer, C. (2008b). Decentralized estimation of overflow losses in a hopper-dredger. *Control Engineering Practice*, 16(4):392–406.
- Lendek, Zs., Babuška, R., and De Schutter, B. (2007a). Distributed Kalman filtering for multi-agent systems. In *Proceedings of the European Control Conference*, volume 1, pages 2193–2200, Kos, Greece.
- Lendek, Zs., Babuška, R., and De Schutter, B. (2007b). Stability of cascaded fuzzy systems and observers. Accepted for publication in *IEEE Transactions on Fuzzy Systems*.
- Lendek, Zs., Babuška, R., and De Schutter, B. (2007c). Stability of cascaded Takagi-Sugeno fuzzy systems. In *Proceedings of the IEEE International Conference on Fuzzy Systems*, volume 1, pages 505–510, London, UK.
- Lendek, Zs., Babuška, R., and De Schutter, B. (2008c). Distributed Kalman filtering for cascaded systems. *Engineering Applications of Artificial Intelligence*, 21(3):457–469.
- Lendek, Zs., van Schagen, K., Babuška, R., Veersma, A., and De Schutter, B. (2008d). Cascaded parameter estimation for a water treatment plant using particle filters. In *Preprints 17th IFAC World Congress*, pages 10857–10862, Seoul, Korea.
- Li, D. D. and Chen, C. (2005). A novel approach to estimate load factor of variable-speed wind turbines. *IEEE Transactions on Power Systems*, 20:1186–1188.
- Li, P., Zhang, T., and Ma, B. (2004). Unscented Kalman filter for visual curve tracking. *Image and Vision Computing*, 22(2):157–164.
- Liao, T. L. and Huang, N. S. (1999). An observer based approach for chaotic synchronization with applications to secure communications. *IEEE Transactions on Circuits and Systems*, 46:1144–1150.
- Liu, S.-J., Zhang, J.-F., and Jiang, Z.-P. (2007). Decentralized adaptive output-feedback stabilization for large-scale stochastic nonlinear systems. *Automatica*, 43(2):238–251.
- Liu, X. and Zhang, H. (2005). Stability analysis of uncertain fuzzy large-scale system. *Chaos, Solitons & Fractals*, 25(5):1107–1122.

- Löfberg, J. (2004). YALMIP: a toolbox for modeling and optimization in MATLAB. In *Proceedings of the CACSD Conference*, pages 284–289, Taipei, Taiwan.
- López-Orozco, J. A., de la Cruz, J. M., Besada, E., and Ruiprez, P. (2000). An asynchronous, robust, and distributed multisensor fusion system for mobile robots. *International Journal of Robotics Research*, 19(12):914–932.
- Loria, A. and Panteley, E. (2005). *Advanced Topics in Control Systems Theory*, chapter Cascaded nonlinear time-varying systems: Analysis and design, pages 23–64. Springer Berlin / Heidelberg.
- Luenberger, D. G. (1966). Observers for multivariable systems. *IEEE Transactions on Automatic Control*, 11(2):190–197.
- Marx, B., Koenig, D., and Ragot, J. (2007). Design of observers for Takagi-Sugeno descriptor systems with unknown inputs and application to fault diagnosis. *IET Control Theory & Applications*, 1(5):1487–1495.
- Maybeck, P. S. (1979). *Stochastic models, estimation, and control*, volume 1 of *Mathematics in Science and Engineering*, chapter Why stochastic models, estimation and control, pages 1–16. Academic Press.
- Mohler, R. and Bugnon, J. (1989). A nonlinear system perspective and guaranteed state estimation. In *IEEE International Symposium on Circuits and Systems*, volume 3, pages 1607–1610, Portland, Oregon.
- Nait-Charif, H. and McKenna, S. J. (2004). Tracking poorly modelled motion using particle filters with iterated likelihood weighting. In *Proceedings of the Asian Conference on Computer Vision Systems*, pages 156–161, Jeju, Korea.
- Narendra, K. S. and Annaswamy, A. M. (1989). *Stable Adaptive Systems*. Prentice-Hall, Inc., Upper Saddle River, New Jersey, USA.
- Nichols, R., Reichert, R., and Rugh, W. (1993). Gain scheduling for H-infinity controllers: A flight control example. *IEEE Transactions on Control Systems Technology*, 2(2):69–79.
- Ohtake, H., Tanaka, K., and Wang, H. (2001). Fuzzy modeling via sector nonlinearity concept. In *Proceedings of the Joint 9th IFSA World Congress and 20th NAFIPS International Conference*, volume 1, pages 127–132, Vancouver, Canada.
- Palm, R. and Bergsten, P. (2000). Sliding mode observer for a Takagi-Sugeno fuzzy system. In *Proceedings of the 9th IEEE International Conference on Fuzzy Systems*, volume 2, pages 665–670, San Antonio, Texas.
- Park, J.-H. and Park, G.-T. (2003). Adaptive fuzzy observer with minimal dynamic order for uncertain nonlinear systems. *IEE Proceedings- Control Theory and Applications*, 150:189–197.
- Park, J.-H., Park, G.-T., Kim, S.-H., and Moon, C.-J. (2005). Output-feedback control of uncertain nonlinear systems using a self-structuring adaptive fuzzy observer. *Fuzzy Sets and Systems*, 151(1):21–42.

- Park, J.-H., Yoon, P.-S., and Park, G.-T. (2001). Robust adaptive observer using fuzzy systems for uncertain nonlinear systems. In *Proceedings of the 10th IEEE International Conference on Fuzzy Systems*, volume 2, pages 749–752, Melbourne, Australia.
- Pertew, A., Marquez, H., and Zhao, Q. (2005). H_∞ synthesis of unknown input observers for non-linear Lipschitz systems. *International Journal of Control*, 78(15):1155–1165.
- Pertew, A., Marquez, H., and Zhao, Q. (2006). H_∞ observer design for Lipschitz nonlinear systems. *IEEE Transactions on Automatic Control*, 51(7):1211–1216.
- Priscoli, F. D., Marconi, L., and Isidori, A. (2006). Adaptive observers as nonlinear internal models. *Systems & Control Letters*, 55(8):640–649.
- Rantzer, A. and Johansson, M. (2000). Piecewise linear quadratic optimal control. *IEEE Transactions on Automatic Control*, 45(4):629–637.
- Roebenack, K. and Lynch, A. (2006). Observer design using a partial nonlinear observer canonical form. *International Journal of Applied Mathematics and Computer Science*, 16(3):333–343.
- Roumeliotis, S. and Bekey, G. (2002). Distributed multirobot localization. *IEEE Transactions on Robotics and Automation*, 18(5):781–795.
- Ruiz Vargas, J. and Hemerly, E. (2001). Adaptive observers for unknown general nonlinear systems. *IEEE Transactions on Systems, Man and Cybernetics, Part B*, 31(5):683–690.
- Saif, M. and Guan, Y. (1992). Decentralized state estimation in large-scale interconnected dynamical systems. *Automatica*, 28(1):215–219.
- Sandell, N., Varaiya, P., Athans, M., and Safonov, M. (1978). Survey of decentralized control methods for large scale systems. *IEEE Transactions on Automatic Control*, 23(2):108–128.
- Schmitt, T., Hanek, R., Beetz, M., Buck, S., and Radig, B. (2002). Cooperative probabilistic state estimation for vision-based autonomous mobile robots. *IEEE Transactions on Robotics and Automation*, 18(5):670–684.
- Seibert, P. and Suarez, R. (1990). Global stabilization of nonlinear cascade systems. *Systems & Control Letters*, 14(4):347–352.
- Sheldrake, A. L. (2005). *Estimation of Plant Electrical Load*, chapter 1, pages 1–18. John Wiley and Sons.
- Shi, Y. and Han, C. (2007). The divided difference particle filter. In *10th International Conference on Information Fusion, 2007.*, pages 1–7.
- Simmons, R. and Koenig, S. (1995). Probabilistic robot navigation in partially observable environments. In *Proceedings of the 14th International Joint Conference on Artificial Intelligence*, pages 1080–1087, Montreal, Canada.
- Sontag, E. (1989a). Remarks on stabilization and input-to-state stability. In *Proceedings of the 28th IEEE Conference on Decision and Control*, pages 1376–1378, Tampa, Florida.

- Sontag, E. D. (1989b). Smooth stabilization implies coprime factorization. *IEEE Transactions on Automatic Control*, 34(4):435–443.
- Sundareshan, M. K. and Elbanna, R. M. (1990). Design of decentralized observation schemes for large-scale interconnected systems: Some new results. *Automatica*, 26(4):789–796.
- Takagi, T. and Sugeno, M. (1985). Fuzzy identification of systems and its applications to modeling and control. *IEEE Transactions on Systems, Man, and Cybernetics*, 15(1):116–132.
- Tanaka, K., Ikeda, T., and Wang, H. (1998a). Fuzzy regulators and fuzzy observers: relaxed stability conditions and LMI-based designs. *IEEE Transactions on Fuzzy Systems*, 6(2):250–265.
- Tanaka, K., Kosaki, T., and Wang, H. (1998b). Backing control problem of a mobile robot with multiple trailers: fuzzy modeling and LMI-based design. *IEEE Transactions on Systems, Man and Cybernetics*, 28(3):329–337.
- Tanaka, K. and Sano, M. (1994). On the concepts of regulator and observer of fuzzy control systems. In *Proceedings of the Third IEEE Conference on Fuzzy Systems*, volume 2, pages 767–772, Orlando, Florida.
- Tanaka, K., Taniguchi, T., and Wang, H. (1998c). Model-based fuzzy control of TORA system: fuzzy regulator and fuzzy observer design via LMIs that represent decay rate, disturbance rejection, robustness, optimality. In *Proceedings of the 7th IEEE International Conference on Fuzzy Systems*, volume 1, pages 313–318, Anchorage, Alaska.
- Tanaka, K. and Wang, H. (1997). Fuzzy regulators and fuzzy observers: a linear matrix inequality approach. In *Proceedings of the 36th IEEE Conference on Decision and Control*, volume 2, pages 1315–1320, San Diego, California.
- Taniguchi, T., Tanaka, K., Ohtake, H., and Wang, H. (2001). Model construction, rule reduction, and robust compensation for generalized form of Takagi-Sugeno fuzzy systems. *IEEE Transactions on Fuzzy Systems*, 9(4):525–538.
- Taniguchi, T., Tanaka, K., Yamafuji, K., and Wang, H. (1999a). A new PDC for fuzzy reference models. In *Proceedings of the IEEE International Conference on Fuzzy Systems*, volume 2, pages 898–903, Seoul, Korea.
- Taniguchi, T., Tanaka, K., Yamafuji, K., and Wang, H. (1999b). Nonlinear model following control via Takagi-Sugeno fuzzy model. In *Proceedings of the American Control Conference*, volume 3, pages 1837–1841, San Diego, California.
- Tong, S., Li, H.-X., and Wang, W. (2004). Observer-based adaptive fuzzy control for SISO nonlinear systems. *Fuzzy Sets and Systems*, 148(3):355–376.
- Tseng, C.-S. (2008). A novel approach to H_∞ decentralized fuzzy-observer-based fuzzy control design for nonlinear interconnected systems. *IEEE Transactions on Fuzzy Systems*, 16(5):1337–1350.

- Tuan, H., Apkarian, P., Narikiyo, T., and Yamamoto, Y. (2001). Parameterized linear matrix inequality techniques in fuzzy control system design. *IEEE Transactions on Fuzzy Systems*, 9(2):324–332.
- Uang, H.-J. and Chen, B.-S. (2000). Fuzzy decentralized controller and observer design for nonlinear interconnected systems. In *The Ninth IEEE International Conference on Fuzzy Systems*, volume 2, pages 945–948.
- Vadigepalli, R. and Doyle, F. J. (2003a). Structural analysis of large-scale systems for distributed state estimation and control applications. *Control Engineering Practice*, 11(8):895–905.
- Vadigepalli, R. and Doyle, F.J., I. (2003b). A distributed state estimation and control algorithm for plantwide processes. *IEEE Transactions on Control Systems Technology*, 11(1):119–127.
- van der Merwe, R., de Freitas, J. F. G., and Doucet, A. (2001). The unscented particle filter. In *Advances in Neural Information Processing Systems*, Cambridge, Massachusetts. MIT Press.
- van der Merwe, R. and Wan, E. (2003a). Gaussian mixture sigma-point particle filters for sequential probabilistic inference in dynamic state-space models. In *Proceedings of the IEEE International Conference on Acoustics, Speech and Signal Processing*, pages 701–704, Hong Kong.
- van der Merwe, R. and Wan, E. (2003b). Sigma-point Kalman filters for probabilistic inference in dynamic state-space models. In *Workshop on Advances in Machine Learning*, Montreal, Canada.
- van Rhee, C. (2002). *On the sedimentation process in a suction hopper dredger*. PhD thesis, TU Delft, The Netherlands.
- van Schagen, K., Bakker, M., Rietveld, L., Veersma, A., and Babuška, R. (2006). Using online quality measurements in drinking water process control. In *Proceedings of the AWWA WQTC Conference*, pages 1–7, Denver, Colorado.
- van Schagen, K., Rietveld, L., and Babuška, R. (2007). Dynamic modelling for optimisation of pellet softening. *Journal of Water Supply: Research and Technology-AQUA*, accepted for publication.
- Wang, H., Li, J., Niemann, D., and Tanaka, K. (2000). T-S fuzzy model with linear rule consequence and PDC controller: a universal framework for nonlinear control systems. In *Proceedings of the Ninth IEEE International Conference on Fuzzy Systems*, volume 2, pages 549–554, San Antonio, Texas.
- Wang, W.-J. and Luoh, L. (2004). Stability and stabilization of fuzzy large-scale systems. *IEEE Transactions on Fuzzy Systems*, 12(3):309–315.
- Wang, W.-J. and Sun, C.-H. (2005). Relaxed stability and stabilization conditions for a TS fuzzy discrete system. *Fuzzy Sets and Systems*, 156(2):208–225.

- Wang, Y. and Chai, T. (2005). Output-feedback control of uncertain nonlinear systems using adaptive fuzzy observer. In *Proceedings of the American Control Conference*, volume 4, pages 2613–2618, Portland, Oregon.
- Wang, Y. and Papageorgiou, M. (2005). Real-time freeway traffic state estimation based on extended kalman filter: A general approach. *Transportation Research B*, 39(2):141–167.
- Waurajitti, N., Ngamwiwit, J., and Prempraneerach, Y. (2000). Adaptive fuzzy sliding mode controller for two cascaded tanks level control. In *Proceedings of TENCON 2000*, volume 2, pages 592–597, Kuala Lumpur, Malaysia.
- Welch, G. and Bishop, G. (2002). An introduction to the Kalman filter. Technical Report TR 95-041, Department of Computer Science, University of North Carolina, NC, USA.
- Wiechers, H., Sturrock, P., and Marais, G. (1975). Calcium carbonate crystallization kinetics. *Water Research*, 15(9):835–845.
- Wu, H., Sun, F., and Liu, H. (2008). Fuzzy particle filtering for uncertain systems. *Fuzzy Systems, IEEE Transactions on*, 16(5):1114–1129.
- Wu, L., Deng, Z., and Jia, P. (2006). A post-resampling based particle filter for online bayesian estimation and tracking. In *The Sixth World Congress on Intelligent Control and Automation, 2006.*, volume 1, pages 4331–4334.
- Xiong, Y. and Saif, M. (2003). Unknown disturbance inputs estimation based on a state functional observer design. *Automatica*, 39(8):1389–1398.
- Zhang, F., editor (2005). *The Schur Complement and Its Applications*. Numerical methods and algorithms. Springer.
- Zhang, H., Li, C., and Liao, X. (2006). Stability analysis and H_{inf} controller design of fuzzy large-scale systems based on piecewise Lyapunov functions. *IEEE Transactions on Systems, Man and Cybernetics, Part B*, 36(3):685–698.
- Zhang, Q. and Xu, A. (2001). Implicit adaptive observers for a class of nonlinear systems. In *Proceedings of the American Control Conference*, volume 2, pages 1551–1556, Arlington, Virginia.
- Zhu, Y. and Pagilla, P. (2003). Adaptive controller and observer design for a class of nonlinear systems. In *42nd IEEE Conference on Decision and Control*, volume 2, pages 1687–1692, Maui, Hawaii.

Glossary

Conventions

The following conventions are used:

- The standard control-theoretic conventions are used. For instance, the state is denoted by \mathbf{x} , the control action by \mathbf{u} , the process dynamics by \mathbf{f} , the measurements by \mathbf{y} , and the measurement function by \mathbf{h} .
- All the vectors used in this thesis are column vectors. The transpose of a vector is denoted by the superscript T . For instance, the transpose of \mathbf{x} is \mathbf{x}^T .
- Boldface notation is used for vector or matrix functions, e.g., \mathbf{f} is a vector function.
- For all the examples in this thesis, the measurement units of variables are mentioned only once in the text, when the variables are introduced, after which they are omitted. Time measurements are always accompanied by units, however.

List of symbols and notations

Below, a list is given containing the mathematical symbols and notations that are used most frequently in this thesis.

General notations

I	identity matrix
0	zero matrix
\mathcal{H}	Hermitian of a matrix $\mathcal{H}(A) = A + A^T$
$A > 0$	A is positive definite (matrix)
$a \geq 0$	each entry of the vector a is non-negative
\hat{s}	estimated value
\dot{s}	derivative of the signal
$\ \cdot\ $	norm of a vector/ induced norm of a matrix
\mathcal{N}	Gaussian distribution
$p(\cdot)$	probability density

Dynamic systems

x	state vector
u	input vector
y	output vector
θ, ν	unknown parameter vectors
f	state transition function
h	measurement function
v	state transition noise
η	measurement noise
A	state transition matrix
B	input matrix
C	measurement matrix
t	time
k	time step

Takagi-Sugeno fuzzy systems

i, j	indices for local linear models
m	number of local linear models
z	vector of scheduling variables
w	normalized membership function
e	error vector
a_i	bias in the i th local model
d_i	measurement bias of the i th local model
P	Lyapunov matrix
V	Lyapunov function
L_i	observer gain of the i th local model

Kalman and particle filters

Q	state transition covariance
R	measurement covariance
P	error covariance
K	Kalman gain
$s_{k k-1}$	predicted value at step k
\mathcal{X}, \mathcal{Y}	sigma point
N	number of particles
N_T	resampling threshold
x_k^i	i th particle at time step k
w_k^i	weight of the i th particle at time step k
$x_k^i \sim p(\cdot)$	particle i is drawn from a probability density p at step k

List of abbreviations

This list below collects the abbreviations used most frequently in this thesis.

TS	Takagi-Sugeno
LMI	linear matrix inequality
KF	linear Kalman filter
EKF	extended Kalman filter
UKF	unscented Kalman filter
PF	particle filter
PDF	probability density function

Summary

Many problems in decision making, control, and monitoring require that all variables of interest, usually states and parameters of the system, are known at all times. However, in practical situations, not all variables are measurable or they are not measured due to technical or economical reasons. Therefore, these variables need to be estimated using an observer, based on a model of the system and measured data. For such a purpose, dynamic systems are often modeled in the state space framework, using a state transition model, which describes the evolution of the states over time; and a measurement model, which relates the measurements to the states. In some cases, these models also consider random external disturbances influencing the process. While for linear systems several solutions to estimate the unknown variables exist, state estimation for general nonlinear systems still represents a challenge.

This thesis develops efficient observer design methods for nonlinear systems. Two types of systems are considered: deterministic nonlinear systems, represented by Takagi-Sugeno (TS) fuzzy models, and stochastic systems. For a large-scale or time-varying system, the design and tuning of an observer may be complicated and may involve large computational costs. By taking into account the specific properties of the system (such as cascaded, distributed, or time-varying), the observer design becomes easier and the computational costs are reduced.

In the first part of the thesis, we consider nonlinear systems represented by TS fuzzy models, and investigate three system structures: cascaded systems, distributed systems, and systems affected by unknown disturbances.

The motivation for investigating the cascaded and distributed structures comes from large-scale systems. Many large-scale systems, such as power networks, material processing systems, communication and transportation networks are composed of interconnected lower-dimensional subsystems. An important class of these systems can be represented as a cascade of subsystems. We study the cascade of nonlinear systems represented by TS fuzzy models. For cascaded TS systems with normalized membership functions we prove that the stability of the subsystems implies the stability of the cascade. Therefore, the stability analysis of a cascaded TS system may be performed by analyzing the individual subsystems. This approach is also extended to observer design. In order to design observers for the cascaded TS system it is sufficient to design observers for the subsystems. We also show that a cascaded design does not lead to the loss of performance in the terms of the estimation error decay rate. Therefore, the cascaded approach reduces the computational costs, while preserving the performance of the observer. In order to determine whether a nonlinear system is a cascade of subsystems, we give an algorithm that partitions a nonlinear system into cascaded subsystems.

However, large-scale systems are in general not cascaded, but distributed, i.e., the influence among the subsystems is not unidirectional. In addition, the structure is often not fixed, i.e., subsystems may be added or removed on-line. For such systems, decentralized analysis and design present several advantages, such as flexibility and easier analysis. Therefore, we consider the stability analysis and observer design for distributed systems where each subsystem is represented by a TS fuzzy model. The conditions previously obtained for cascaded TS systems are extended to distributed TS systems. We analyze the stability of the overall TS system based on the stability of the subsystems, allowing that new subsystems may be added on-line. When the structure of the system is not fixed, the influence of the interconnection terms due to the addition of a new subsystem is not known before the subsystem is actually added. Moreover, even though the new subsystem is stable, the interconnection terms may have a destabilizing effect. Therefore, we derive conditions on the strength of the interconnection terms so that the stability of the overall system is maintained. Next, the approach is extended to observer design. We assume that a fuzzy observer is already designed for an existing subsystem or a collection of subsystems. When a new subsystem, together with the interconnection terms is added, a new observer is designed only for this subsystem. Since the already analyzed parts of the system or designed observers do not need to be analyzed or designed again, the computational costs are reduced.

We also study TS systems that are influenced by unknown inputs (disturbances) or that change over time. The design of observers in the presence of unknown inputs is an important problem, since in many cases not all the inputs are known. The unknown inputs may also represent effects of actuator or plant component failures. Two types of inputs are considered in this thesis: model-plant mismatch and time-varying disturbances that can be represented as or approximated by polynomial functions of time. Based on the known part of the fuzzy model, we design observers that simultaneously estimate both the states and the unknown inputs. In case of a polynomial input, the observer guarantees an exponential convergence of the error to zero. When the input is only approximated by a polynomial function of time, a bound on the estimation error is derived. If the disturbance is due to a model mismatch, the true model is estimated, with an asymptotic convergence of the error to zero.

In the second part of the thesis, we consider stochastic systems, and investigate the combination of different observers for cascaded stochastic systems.

In many applications, in order to efficiently analyze the process or to efficiently design observers, one also has to consider the noise that is affecting the states or the measurements. In such cases, probabilistic estimation methods have to be used. The most well-known of these are the Kalman filter (KF), its nonlinear variants, the extended and unscented KF, and particle filters (PFs). We consider combinations of KFs for stochastic systems that are cascades of subsystems. We compare cascaded and centralized KFs both from a theoretical point of view and on simulation examples. If the KFs are designed independently for the subsystems, the individual KFs are optimal for the subsystems. Our theoretical results show that the cascaded KFs are jointly optimal and therefore have the same performance as a centralized KF for all possible inputs and outputs if and only if the subsystems are decoupled. However, simulation results indicate that for practical purposes, the performance of the centralized and cascaded KFs is comparable.

We also compare cascaded and centralized stochastic observers on two real-world applications, namely the estimation of the overflow losses in a hopper dredger and the estimation of the model parameters in a water treatment plant. In both cases, the models are nonlinear

and non-Gaussian, and the states of interest are not measurable. By employing the cascaded approach, an unscented KF and a PF are combined to obtain a better estimate of the overflow losses in a hopper dredger. In the second application, PFs are used in cascade to estimate the model parameters in a water treatment plant. In both cases, the cascaded filters are easier to tune and yield better estimation results than a centralized filter, with reduced computational costs.

The thesis closes with some concluding remarks and a discussion on important open issues regarding the approaches studied. Additionally, some fundamental unsolved issues in state estimation are discussed, and promising research directions to address these issues are suggested.

Samenvatting

Een groot aantal problemen op het gebied van de besliskunde, regeling en *monitoring* vereisen dat alle relevante variabelen — in het algemeen zijn dit de toestanden en de parameters van het systeem — op elk moment bekend zijn. In de praktijk zijn echter niet alle variabelen meetbaar of kunnen ze niet gemeten worden omwille van technische of economische beperkingen. Daarom moeten deze variabelen geschat worden met een schatter (*observer*) op basis van een model van het systeem en gemeten data. Hiertoe worden dynamische systemen vaak gemodelleerd in toestandsruimte-vorm, met een toestandsovergangsmodel, dat de evolutie van de toestand in de tijd beschrijft, en een meetmodel, dat de metingen relateert aan de toestanden. Soms bevatten de modellen ook willekeurige externe verstoringen die het proces beïnvloeden. Terwijl er voor lineaire systemen verscheidene oplossingen bestaan om de onbekende variabelen te schatten, is toestandsschatting voor algemene niet-lineaire systemen nog steeds een grote uitdaging.

In dit proefschrift worden methoden ontwikkeld voor het ontwerpen van schatters voor niet-lineaire systemen. Hierbij worden twee types van systemen beschouwd: deterministische niet-lineaire systemen beschreven door middel van Takagi-Sugeno (TS) *fuzzy* modellen, en stochastische systemen. Voor een grootschalig of tijdsvariërend systeem kan het ontwerpen en instellen van een schatter zeer ingewikkeld zijn en gepaard gaan met hoge rekenkosten. Door gebruik te maken van specifieke eigenschappen van het systeem (zoals cascade-, gedistribueerde of tijdsvariërende structuur) wordt het ontwerpen van een schatter eenvoudiger en worden de vereiste rekenkosten gereduceerd.

In het eerste deel van het proefschrift beschouwen we niet-lineaire systemen beschreven door middel van TS *fuzzy* modellen en onderzoeken we drie systeemstructuren: cascade-systemen, gedistribueerde systemen en systemen onderworpen aan onbekende verstoringen.

De motivatie voor het onderzoeken van cascade- en gedistribueerde structuren komt voort uit grootschalige systemen. Vele grootschalige systemen, zoals elektriciteitsnetwerken, materiaalverwerkingssystemen, communicatienetwerken en transportnetwerken bestaan uit lagerdimensionale deelsystemen die met elkaar verbonden zijn. Een belangrijke klasse van dergelijke systemen kan beschreven worden als een cascade van deelsystemen. Wij bestuderen cascades van niet-lineaire systemen die beschreven kunnen worden door TS *fuzzy* modellen. Voor cascade TS systemen met genormaliseerde lidmaatschapsfuncties bewijzen wij dat stabiliteit van de deelsystemen de stabiliteit van de cascade impliceert. De stabiliteitsanalyse van een cascade TS systeem kan dus uitgevoerd worden door de individuele deelsystemen te analyseren. Wij breiden deze methode ook uit naar het ontwerpen van schatters. Om een schatter voor een cascade TS systeem te ontwerpen, volstaat het dan om schatters te ontwerpen voor de deelsystemen. Wij tonen ook aan dat een cascade-ontwerp niet resulteert in een

vermindering van de prestatie in termen van de afnamesnelheid van de schattingsfout. Dit betekent dat de cascade-aanpak leidt tot een vermindering van de rekenkosten met behoud van de prestatie van de schatter. Om te kunnen bepalen of een gegeven niet-lineair systeem al dan niet een cascade is van deelsystemen, geven wij ook een algoritme dat een niet-lineair systeem partitioneert in een cascade van deelsystemen.

In het algemeen zijn grootschalige systemen echter geen cascade-systemen maar wel gedistribueerd, d.w.z. dat de beïnvloeding tussen deelsystemen niet unidirectioneel is maar in twee richtingen werkt. Bovendien ligt de structuur vaak niet vast, d.w.z. dat deelsystemen *on-line* verwijderd of toegevoegd kunnen worden. Voor dergelijke systemen bieden gedecentraliseerde analyse en gedecentraliseerd ontwerp verscheidene voordelen zoals grotere flexibiliteit en eenvoudigere analyse. Daarom beschouwen wij de stabiliteitsanalyse en het ontwerp van schatters voor gedistribueerde systemen waarbij elk deelsysteem beschreven wordt door een TS *fuzzy* model. De voorwaarden die eerder verkregen werden voor cascade TS systemen worden uitgebreid naar gedistribueerde TS systemen. Wij analyseren de stabiliteit van het volledige TS systeem gebaseerd op de stabiliteit van de deelsystemen, waarbij nieuwe deelsystemen *on-line* mogen worden toegevoegd. Als de structuur van het systeem niet vastligt, dan is de invloed van de verbindingstermen ten gevolge van de toevoeging van een nieuw deelsysteem niet bekend voordat het deelsysteem effectief toegevoegd wordt. Bovendien kunnen de verbindingstermen een destabiliserend effect hebben, zelfs indien het nieuwe deelsysteem op zichzelf wel stabiel is. Daarom leiden wij voorwaarden af voor de sterkte van de verbindingstermen zodanig dat de stabiliteit van het volledige systeem behouden blijft. Vervolgens wordt de methode uitgebreid naar het ontwerp van schatters. Wij veronderstellen dat er reeds een TS *fuzzy* schatter ontwikkeld is voor een bestaand deelsysteem of een verzameling van deelsystemen. Wanneer een nieuw deelsysteem wordt toegevoegd, samen met de verbindingstermen, dan wordt er enkel voor dit deelsysteem een nieuwe schatter ontworpen. Aangezien de reeds eerder geanalyseerde delen van het systeem niet meer opnieuw geanalyseerd hoeven te worden en aangezien de reeds eerder ontworpen schatters niet meer opnieuw ontworpen hoeven te worden, worden de rekenkosten gereduceerd.

Wij bestuderen ook TS systemen die beïnvloed worden door onbekende ingangssignalen (verstoringen) of die veranderen in de tijd. Het ontwerpen van schatters in de aanwezigheid van onbekende ingangssignalen is een belangrijk probleem aangezien in vele gevallen niet alle ingangssignalen bekend zijn. De onbekende ingangssignalen kunnen ook de effecten van storingen in de actuatoren of in onderdelen van het systeem beschrijven. In dit proefschrift worden twee types van ingangssignalen beschouwd: (1) afwijkingen tussen het model en het systeem en (2) tijdsvariërende verstoringen die beschreven of benaderd kunnen worden door polynomiale functies van de tijd. Op basis van het bekende deel van het *fuzzy* model ontwerpen wij schatters die tegelijkertijd de toestanden en de onbekende ingangen schatten. In het geval van een polynomiaal ingangssignaal garandeert de schatter een exponentiële convergentie van de schattingsfout naar nul. Voor het geval dat de ingang enkel benaderd kan worden door een polynomiale functie van de tijd, wordt een bovengrens op de schattingsfout afgeleid. Als de verstoring het gevolg is van een modelafwijking, dan kan het echte model geschat worden met een asymptotische convergentie van de schattingsfout naar nul.

In het tweede deel van het proefschrift worden stochastische systemen beschouwd en onderzoeken wij de combinatie van verschillende schatters voor een cascade van stochastische systemen.

Om op een efficiënte manier een proces te analyseren en op een efficiënte manier schatters

te ontwerpen, moet bij vele toepassingen ook rekening gehouden worden met de ruis op de toestanden en de metingen. In dergelijke gevallen moeten probabilistische schattingsmethoden gebruikt worden. De bekendste onder deze methoden zijn het Kalman filter (KF) en zijn niet-lineaire varianten: het uitgebreide en het *unscented* KF, alsmede *particle filters* (PF's). Wij beschouwen combinaties van KF's voor stochastische systemen die een cascade zijn van deelsystemen en wij vergelijken cascade-KF's en gecentraliseerde KF's zowel vanuit theoretisch oogpunt als door middel van simulatie-voorbeelden. Als de KF's onafhankelijk van elkaar ontworpen worden voor de deelsystemen, dan zijn de individuele KF's optimaal voor de deelsystemen. Onze theoretische resultaten tonen aan dat de cascade-KF's gezamenlijk optimaal zijn en dus voor alle mogelijke ingangs- en uitgangssignalen dezelfde prestatie opleveren als het gecentraliseerde KF als en slechts als de deelsystemen ontkoppeld zijn. Simulatieresultaten tonen echter aan dat vanuit een praktisch oogpunt de prestaties van het gecentraliseerde KF en de cascade-KF's vergelijkbaar zijn.

Wij vergelijken ook cascade- en gecentraliseerde stochastische schatters voor twee fysieke voorbeelden, met name de schatting van overvloeiverliezen in een hopperzuiger en de schatting van modelparameters voor een waterzuiveringsinstallatie. In beide gevallen zijn de modellen niet-lineair en niet-Gaussisch en zijn de relevante toestanden niet meetbaar. Met behulp van de cascade-aanpak combineren we een *unscented* KF en een PF om een betere schatting van de overvloeiverliezen in een hopperzuiger te verkrijgen. In de tweede toepassing worden PF's in cascade gebruikt om de modelparameters voor een waterzuiveringsinstallatie te schatten. In beide gevallen zijn de cascade-filters gemakkelijker in te stellen en leveren ze betere schattingen op dan een gecentraliseerd filter en vergen ze bovendien minder rekenkosten.

Het proefschrift eindigt met een aantal afsluitende opmerkingen en een discussie over belangrijke open problemen in verband met de bestudeerde methoden. Daarnaast worden ook nog een aantal fundamentele onopgeloste problemen op het gebied van de toestandsschatting bediscussieerd en worden enkele veelbelovende onderzoeksrichtingen aangegeven om deze problemen aan te pakken.

Curriculum vitae

Zsófia Lendek was born in 1980 in Dej, Romania. In 1998, she graduated from the Báthory István high school, Computer Science specialization. She then studied Control Engineering at the Technical University of Cluj-Napoca, Romania, where she obtained her Master of Science (in its equivalent form of a 5-year Engineer's Diploma) in 2003, and Computer Science at the Babeş-Bolyai University, where she obtained a Bachelor of Science in 2004. Her theses were entitled "Modeling and Simulation of the ^{15}N Isotopes Separation Process by Ion Exchange" and "Vowel Recognition using Neural Networks", respectively. She also enrolled in a postgraduate program on Automatic Control at the Technical University of Cluj-Napoca, from which she graduated in 2004.

Since 2005, Zsófia Lendek has been working on her PhD project at the Center for Systems and Control of the Delft University of Technology, the Netherlands. Her PhD research has dealt with stability and observer design for Takagi-Sugeno fuzzy systems and cascaded stochastic systems, and has been performed under the supervision of Prof.dr. Robert Babuška, M.Sc. and Prof.dr.ir. Bart De Schutter. She collaborated with Prof. dr. Thierry Marie Guerra, whom she visited in 2008 at Université de Valenciennes, France. During her PhD project, Zsófia Lendek obtained the DISC certificate for fulfilling the course program requirements of the Dutch Institute for Systems and Control.

Zsófia Lendek's research interests include state estimation for nonlinear systems and Takagi-Sugeno fuzzy observers for decentralized and adaptive systems.

