

*

Disassembly assessment framework for enhanced reclamation of façade systems.

Student

Sarah Droste

5584655

First Mentor

Mauro Overend

Structural Design & Mechanics

Second Mentor

Marcel Bilow

Façade & Building Product Innovation

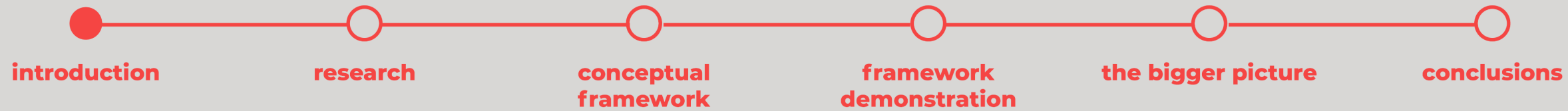

introduction

environmental impact of the construction sector

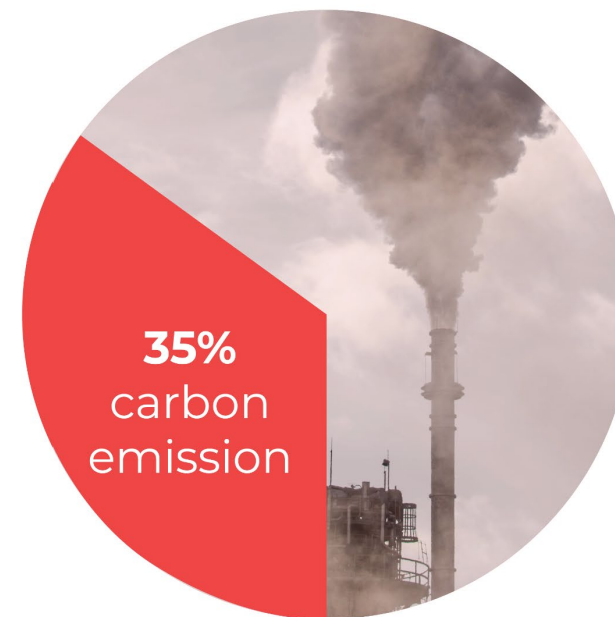
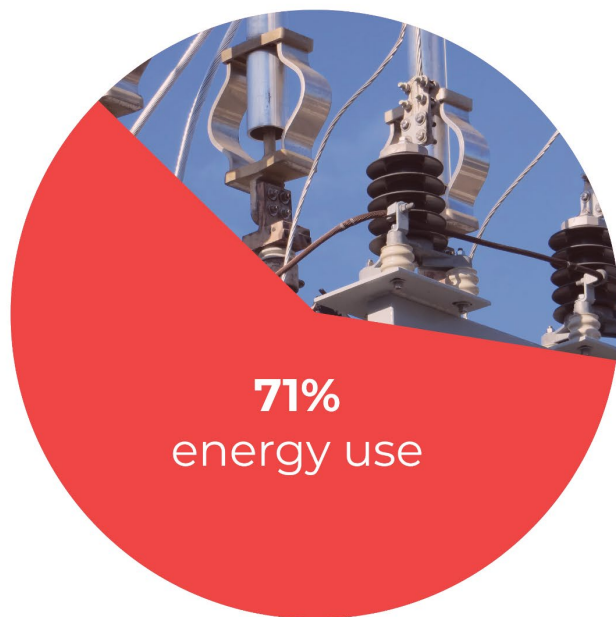

Source: European Environmental Agency, 2022

introduction

carbon emissions in buildings

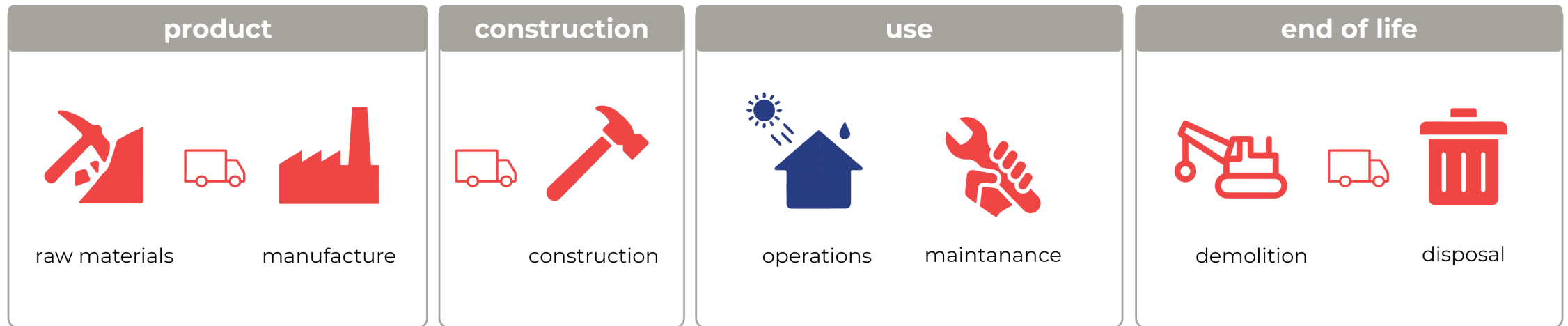

embodied carbon

operational carbon

Source: Adapted from (Carbon Leadership Forum, 2020)

introduction

carbon emissions in buildings

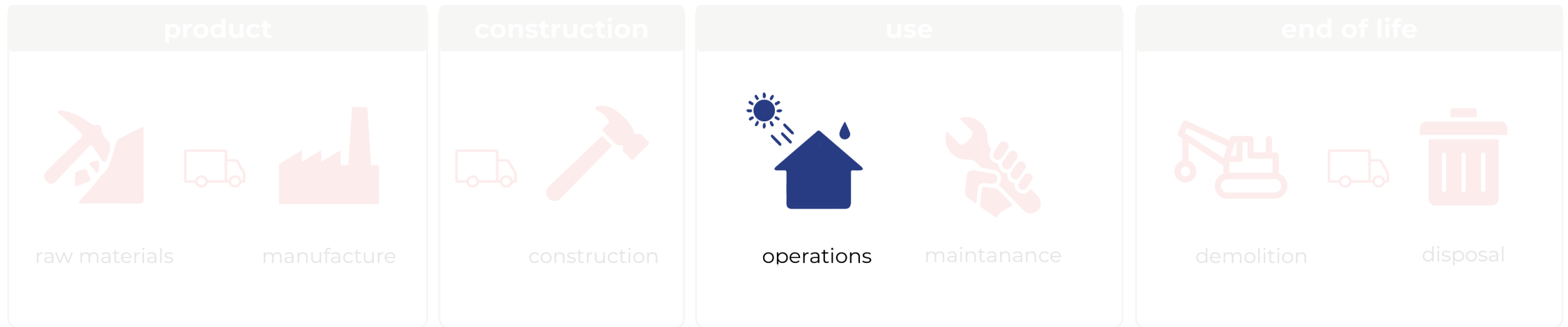

Source: Adapted from (Carbon Leadership Forum, 2020)

introduction

introduction

buildings facades become more complex material assemblies

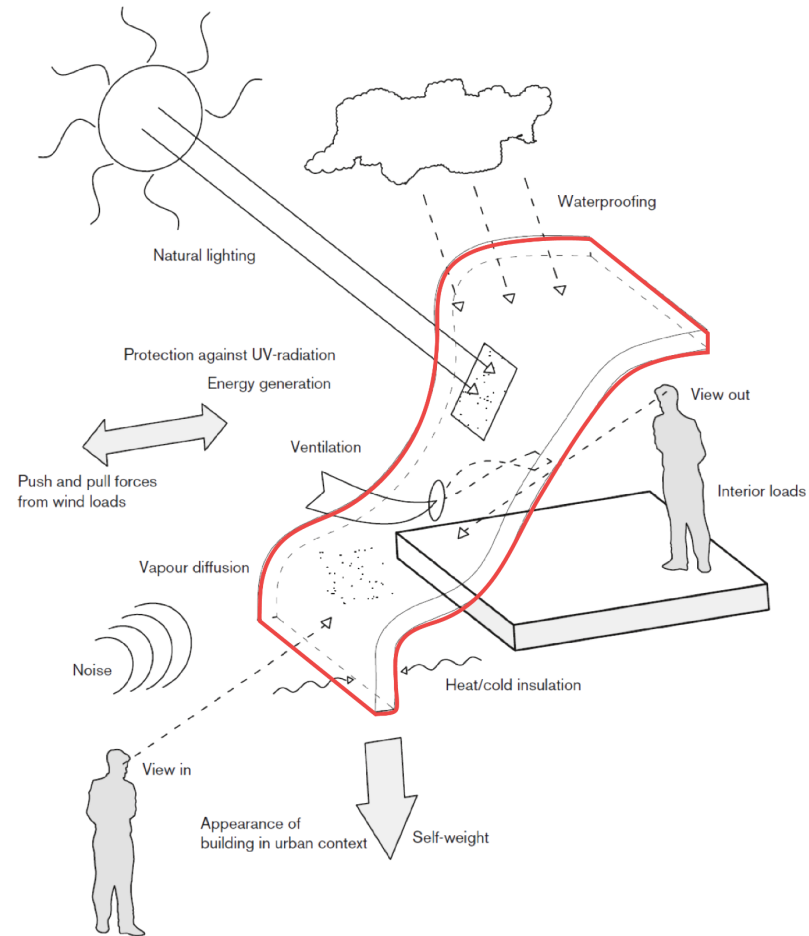

Source: Adapted from (Klein, 2013)

introduction

introduction

buildings facades become more complex material assemblies



textiles

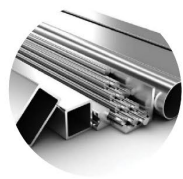

aluminium



silicones



internal blinds



**vintegrated
ventialtion systems**



plastics



bolts and screws



insulation

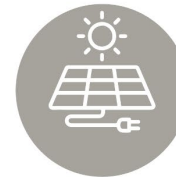

energy harvesting

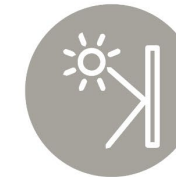

**solar control
glazing**



steel

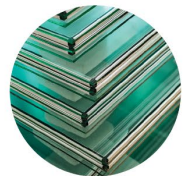

insulated glass



epdm



timber



external shading

introduction

reducing operational carbon = increasing embodied carbon



Source: www.webpage.com

introduction

facades have a typically short lifespan



functional reasons

intended use by
designer ends



economic reasons

replacement is cheaper
than maintenance



technical reasons

product undergoes
deterioration and loses
performance



aesthetic reasons

changes in aesthetic
requirements

introduction

glass facades



Source: <https://unsplash.com>

introduction

introduction

typical end of life scenario



Source: <https://eu.jsonline.com/videos/news/2019/02/12/bradley-center-facade-demol->

introduction

introduction

focus on design for disassembly

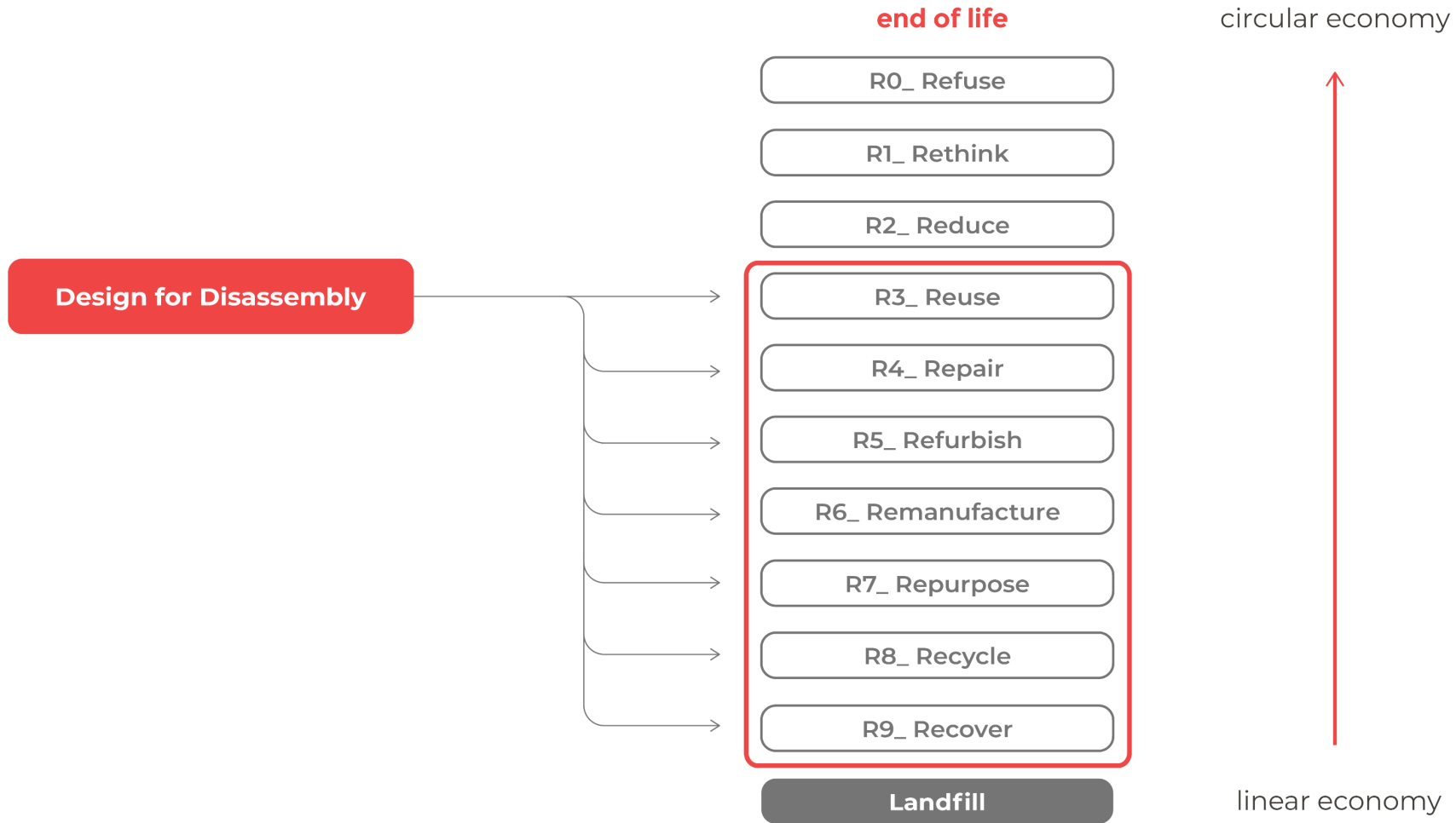

introduction

“Choices made during conceptual and technical design can affect **up to 80%** of a building’s environmental impact.”

Source: Morini et al., 2019

problem statement

current scenario in the facade industry

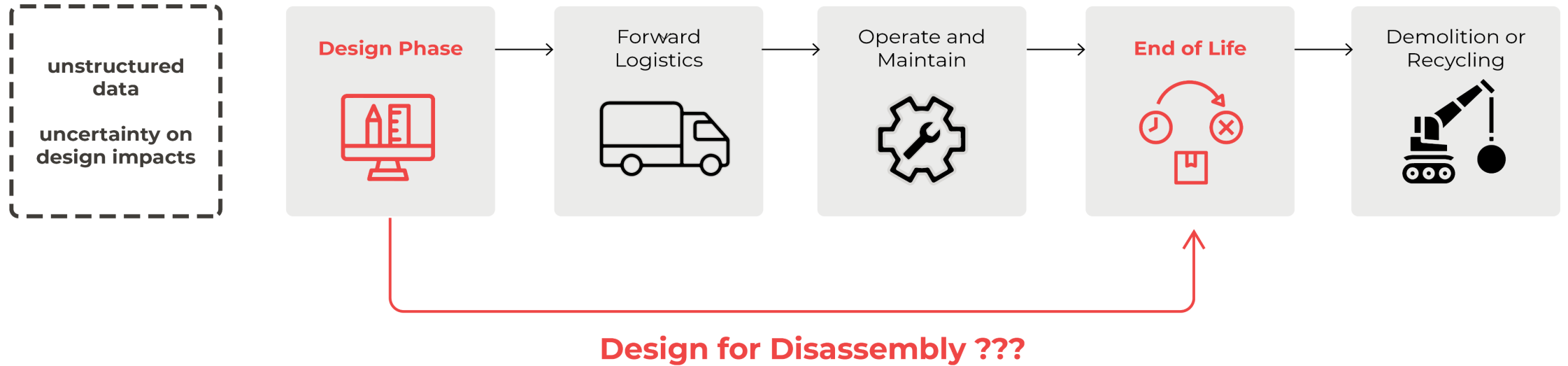

research question

How can a **disassembly assessment framework** be developed to evaluate the **influence of design for disassembly on material reclamation potential** of stick system facades?

research methodology

design science research



research output

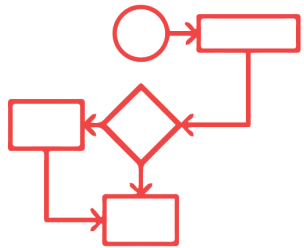

assessment
process map



structured
information



disassembly
assessment method
based on design

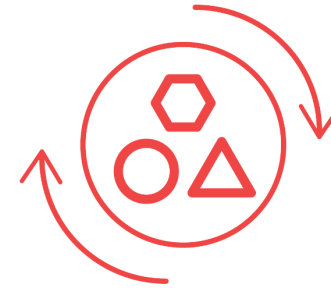

reclamation potential



the bigger picture

circular lifecycle of a facade

proposed scenario

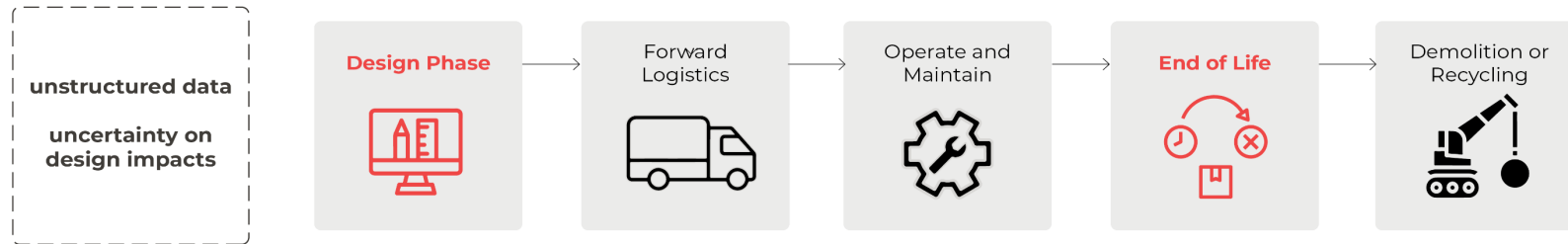

proposed scenario

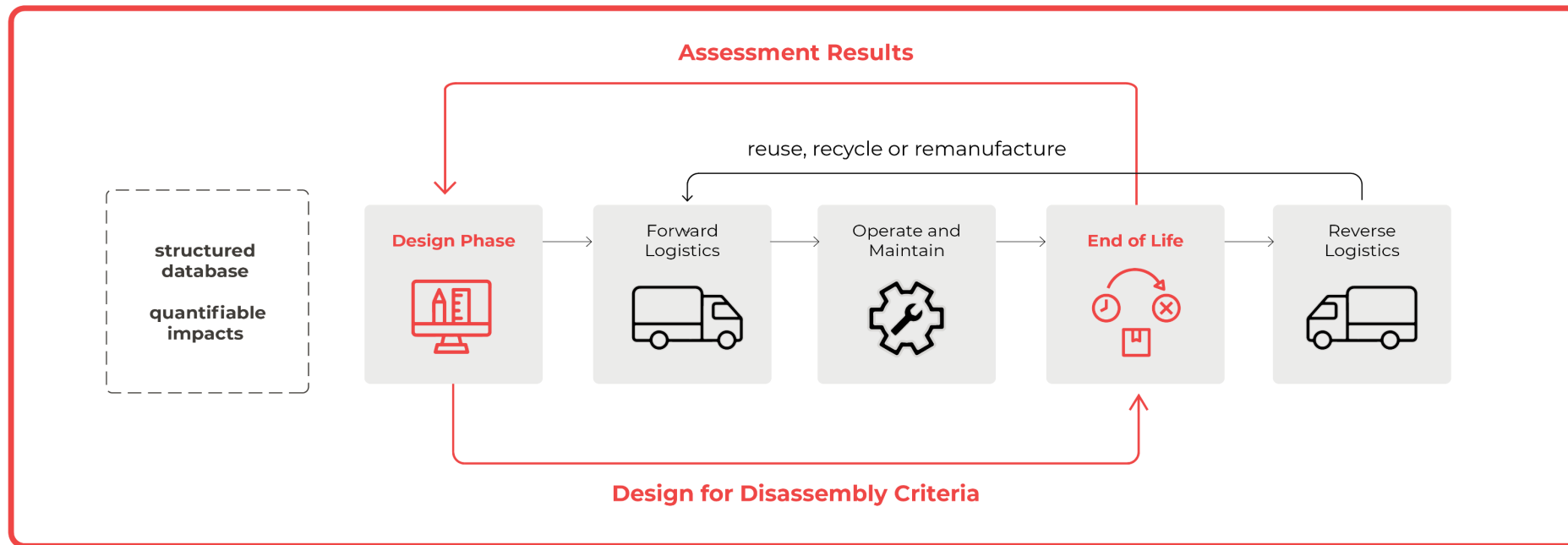

conceptual framework

disassembly assessment

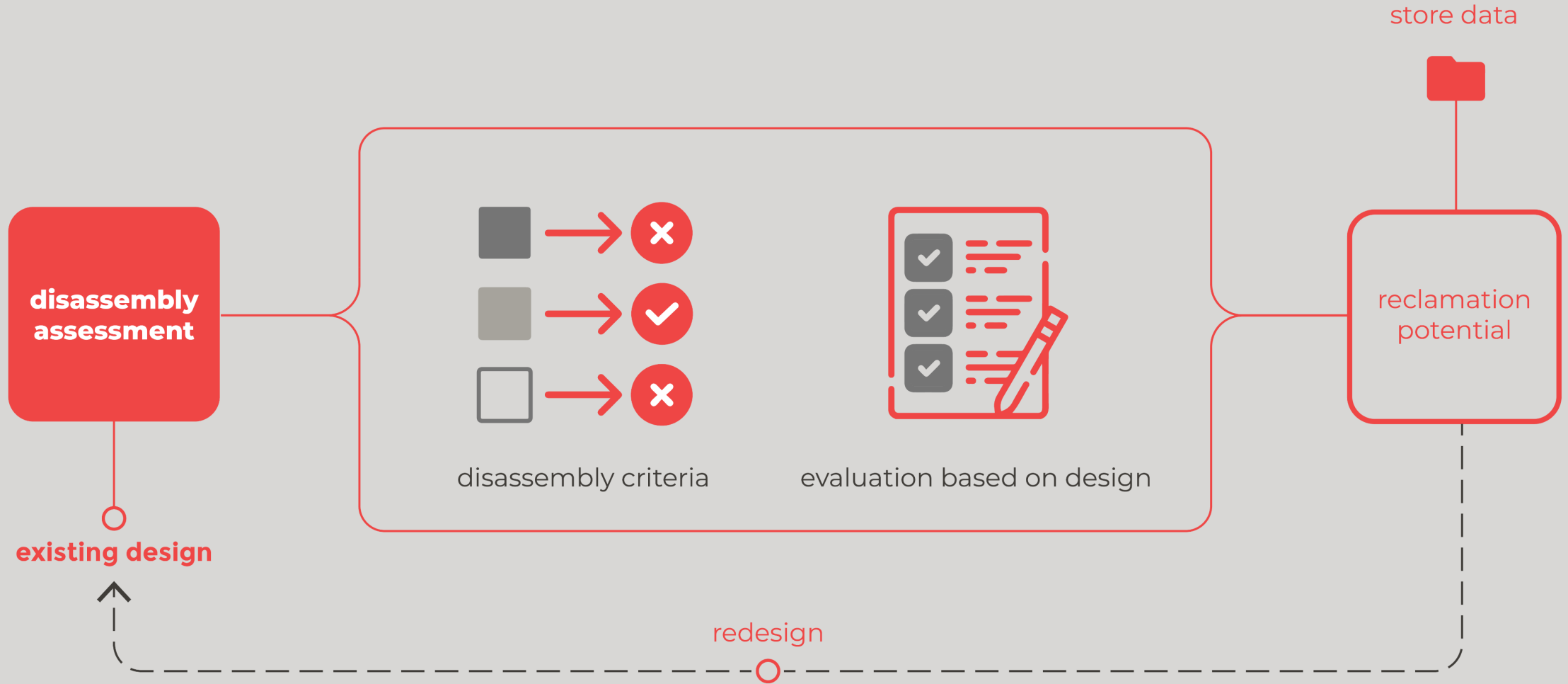

conceptual framework

what is reclamation potential?



conceptual framework

what are the criteria?



disassembly potential

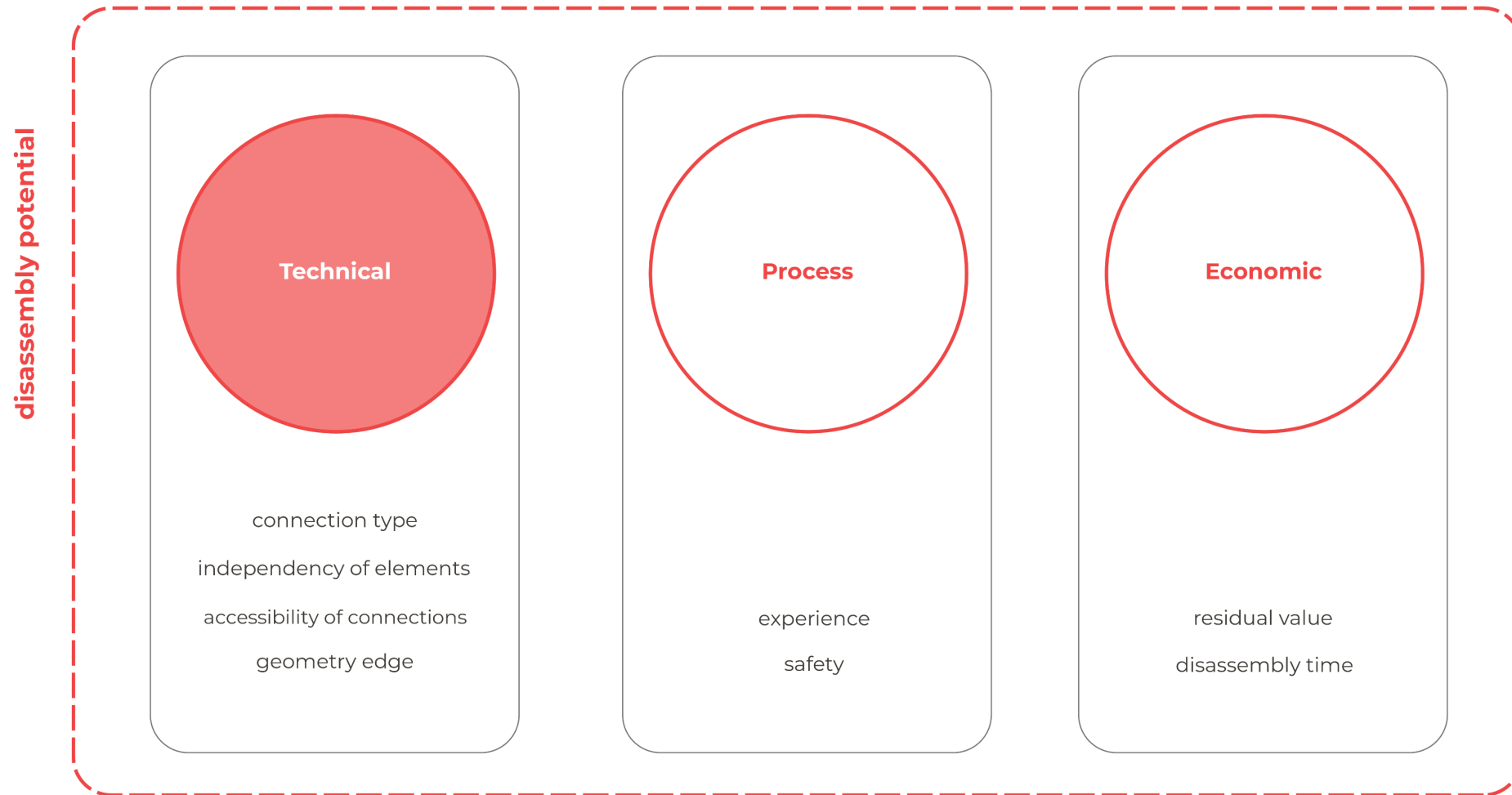

disassembly potential

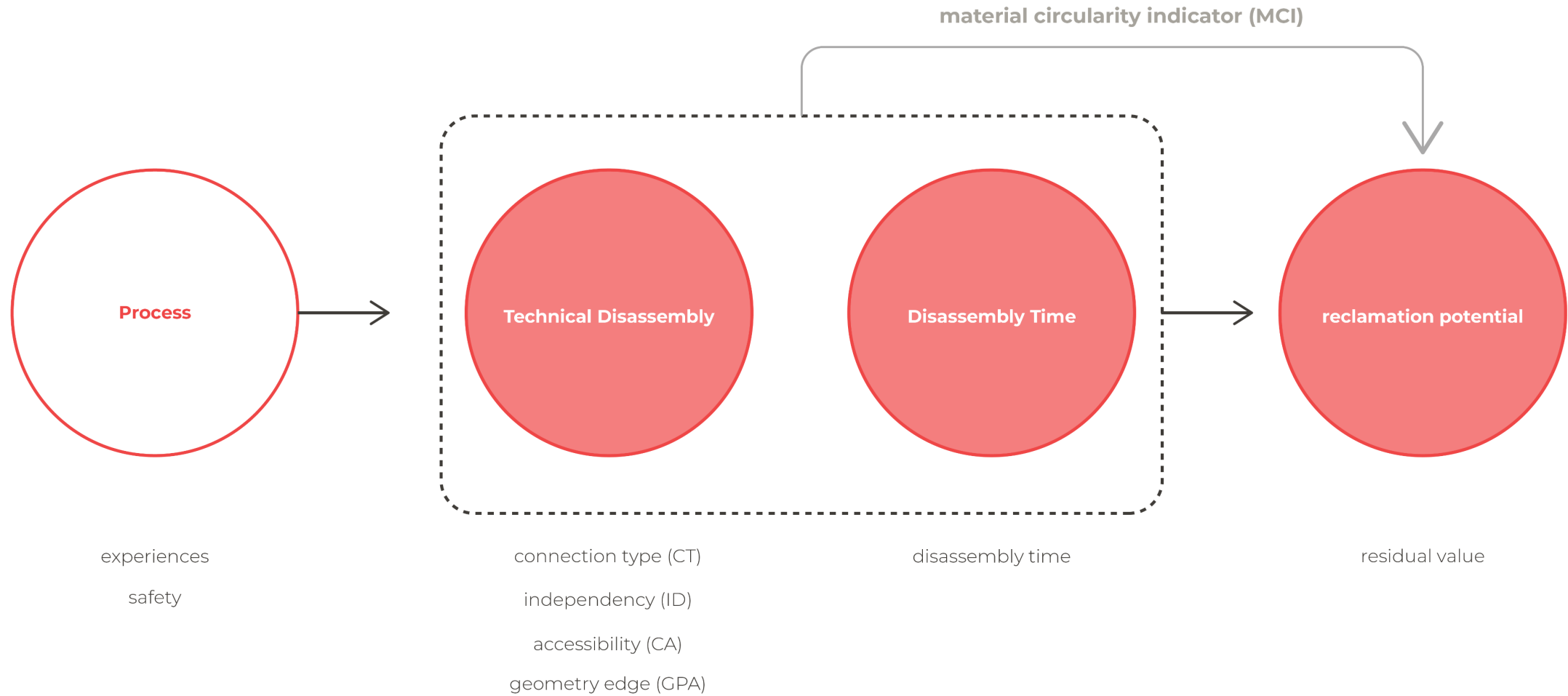

conceptual framework

selected criteria

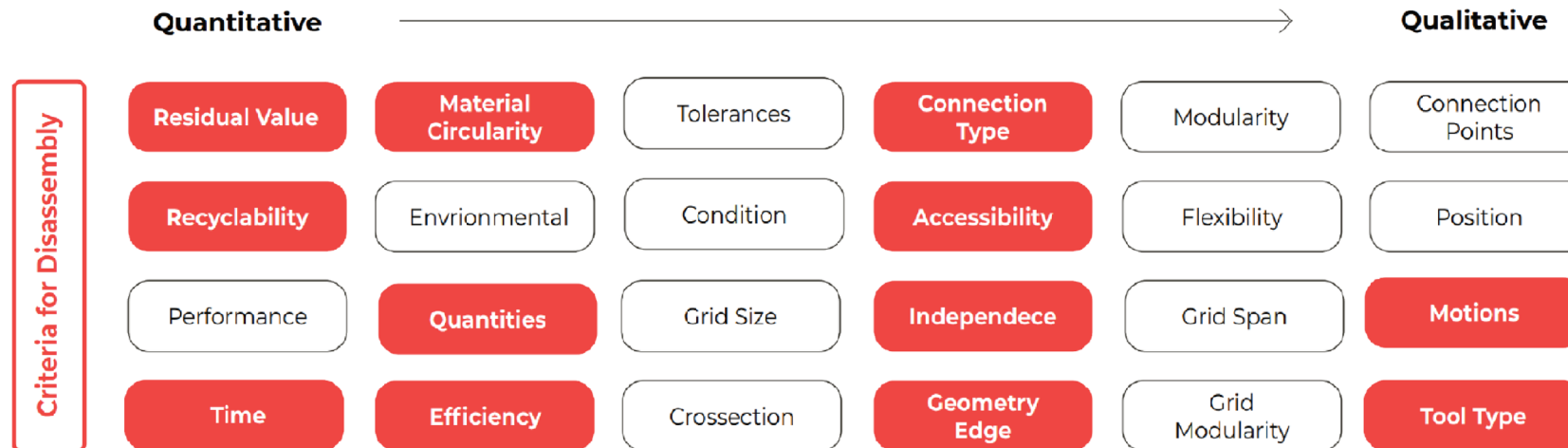

conceptual framework

selected criteria

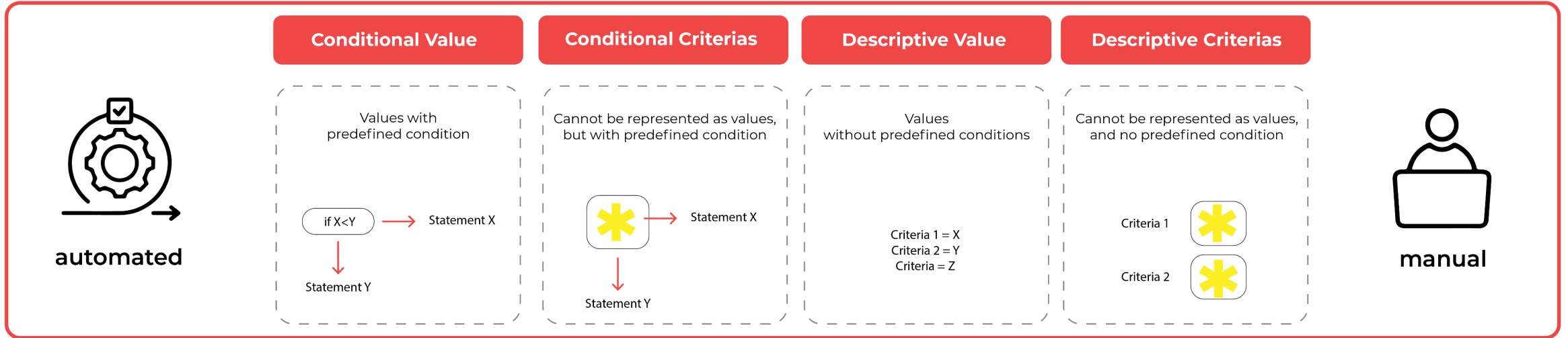

Quantitative

Qualitative

Criteria for Disassembly	Residual Value	Material Circularity	Tolerances	Connection Type	Modularity	Connection Points
	Recyclability	Environmental	Condition	Accessibility	Flexibility	Position
	Performance	Quantities	Grid Size	Independence	Grid Span	Motions
	Time	Efficiency	Cross-section	Geometry Edge	Grid Modularity	Tool Type

conceptual framework

how can it be processed?

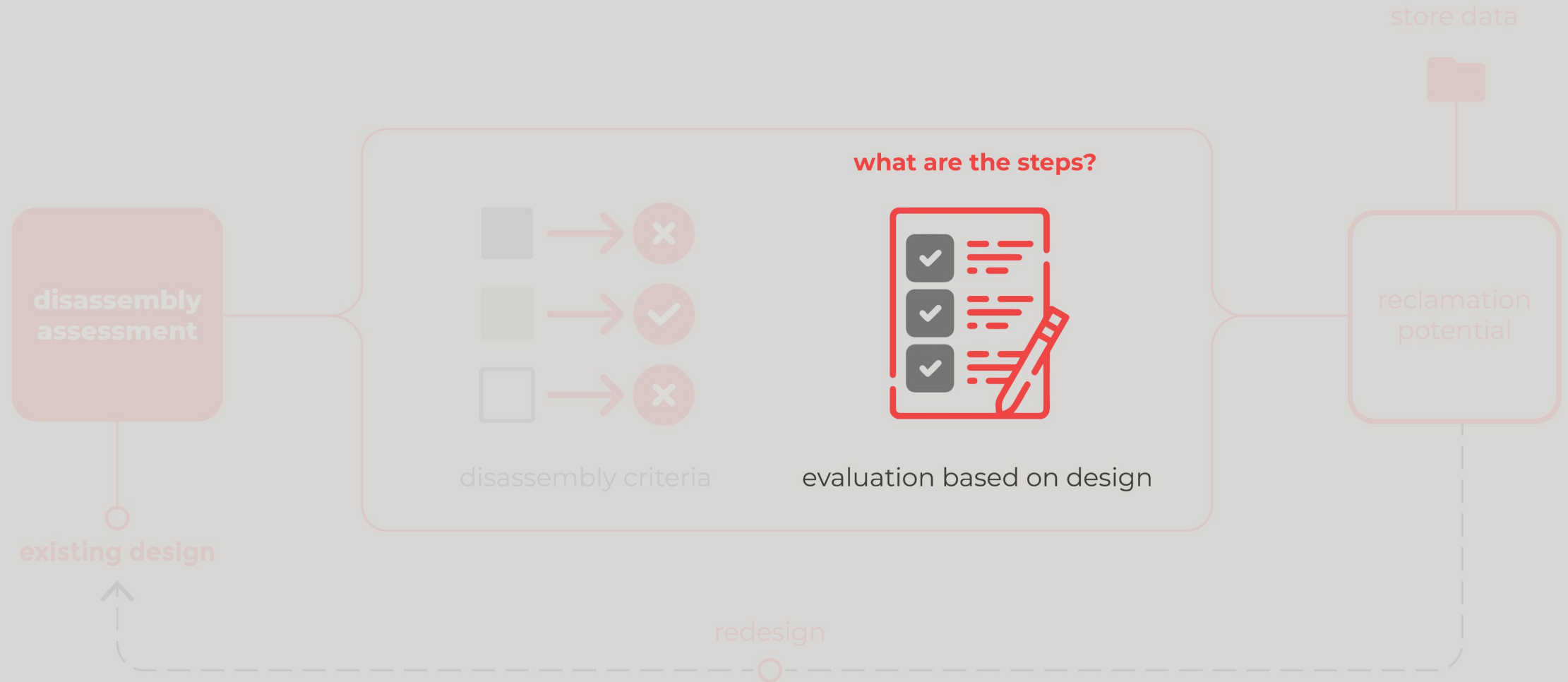

conceptual framework

process map

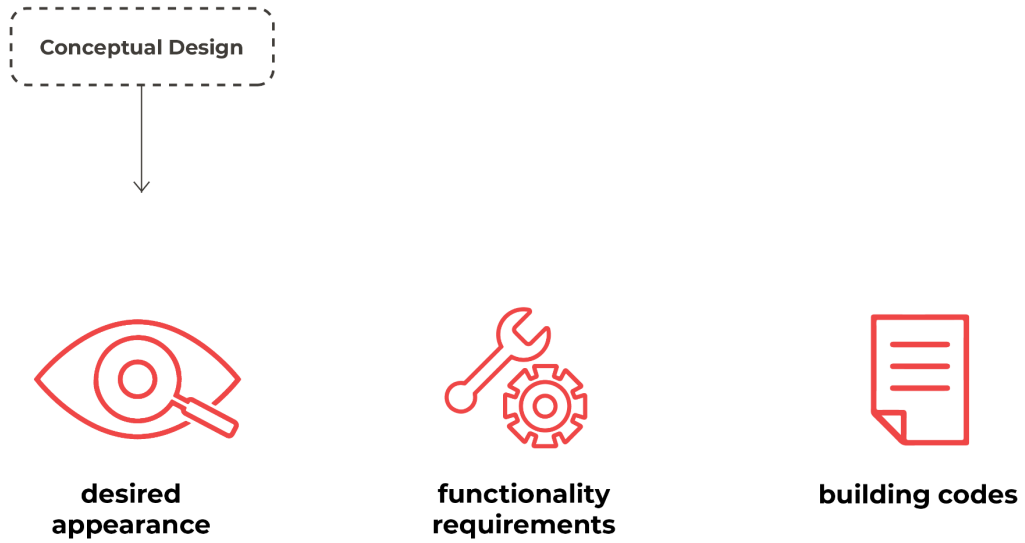

conceptual framework

process map

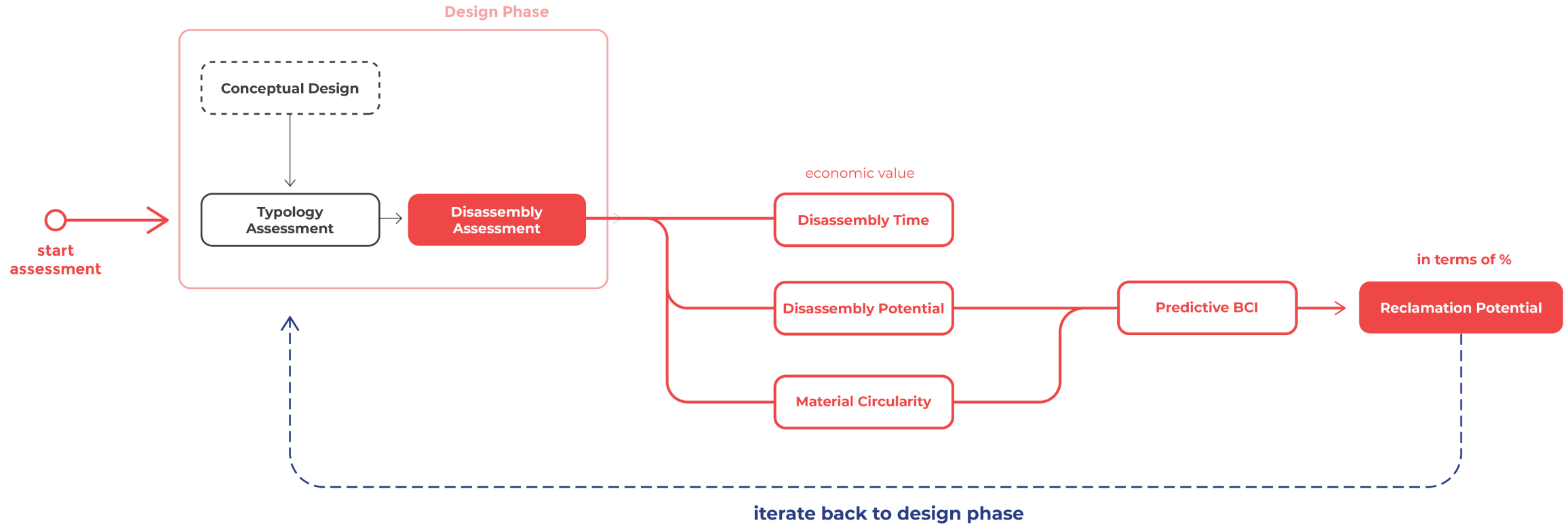

conceptual framework

process map

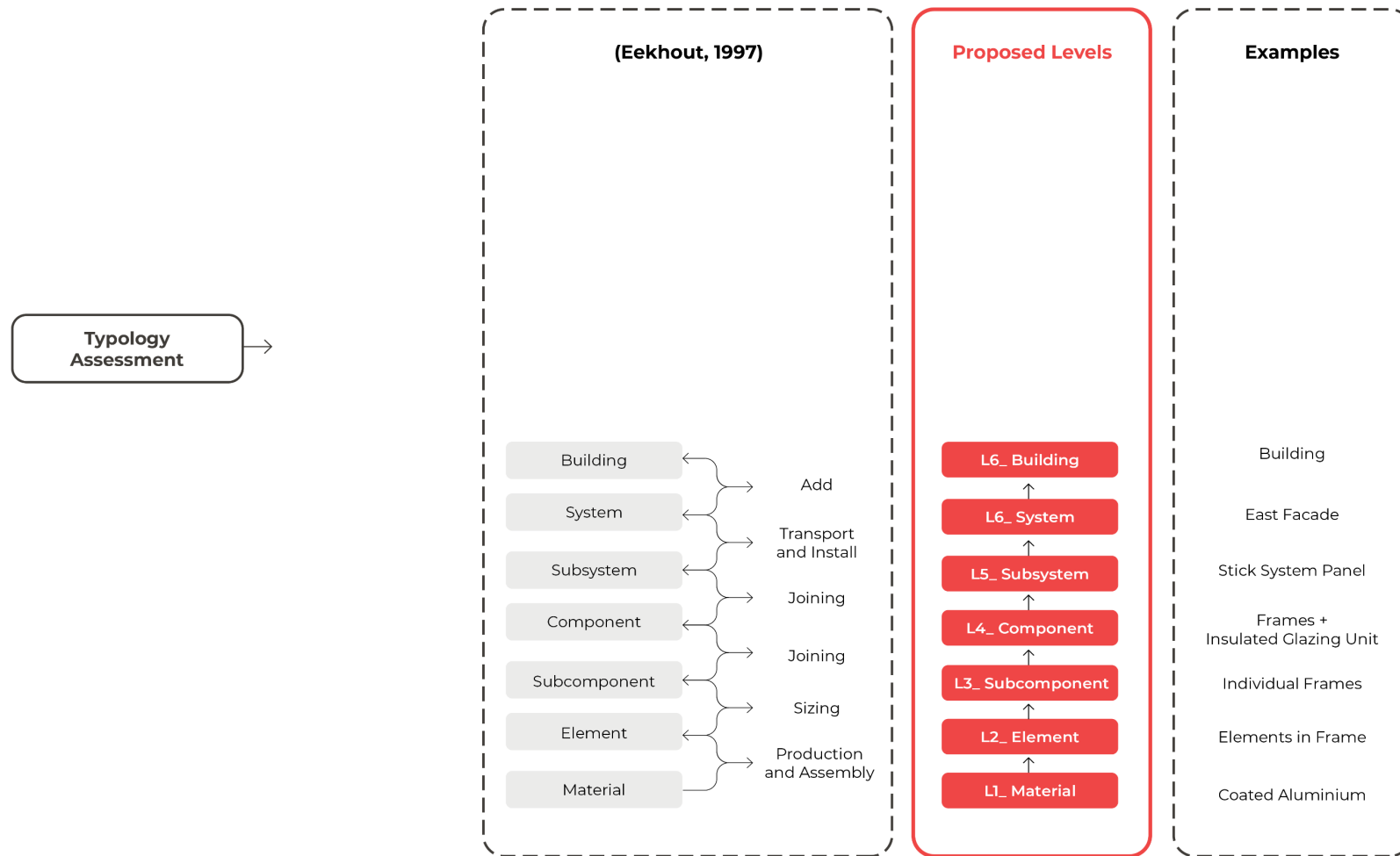

conceptual framework

process map

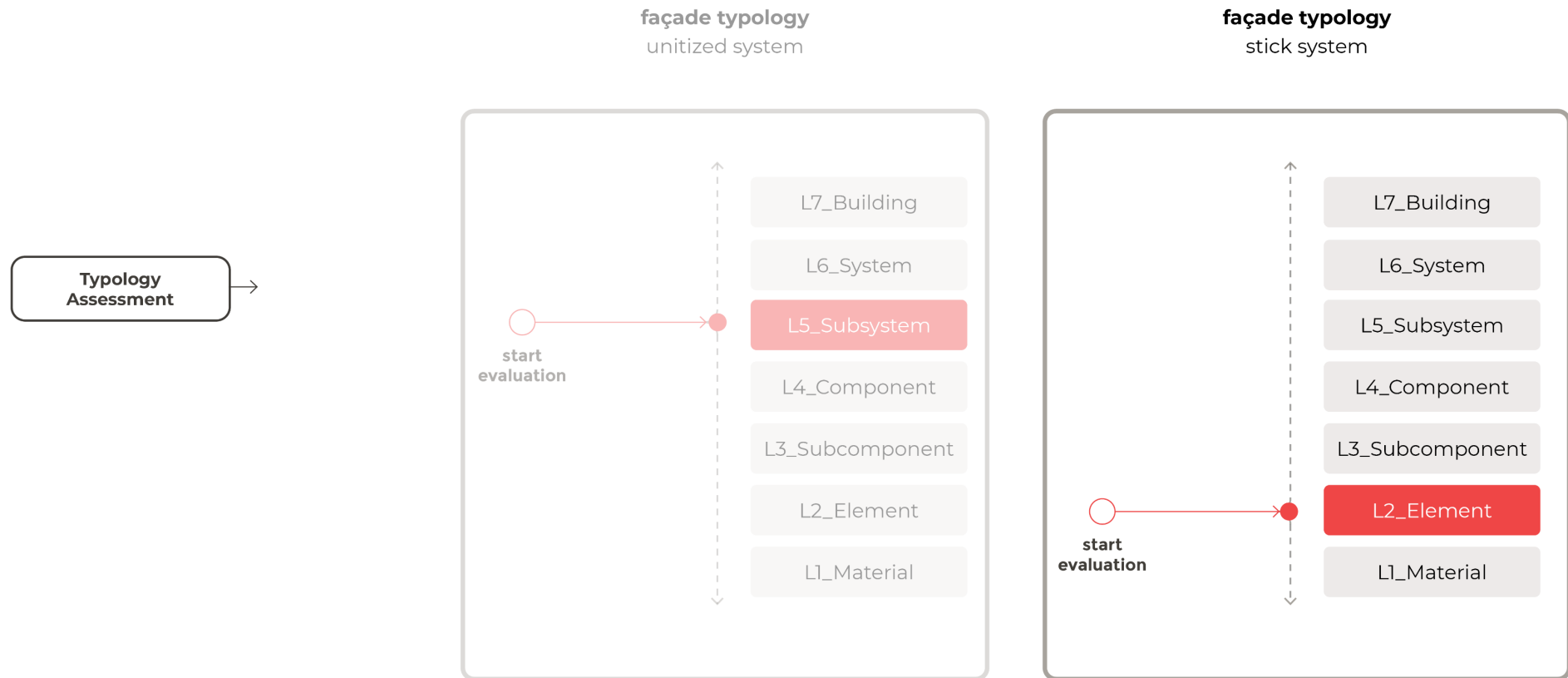

conceptual framework

process map

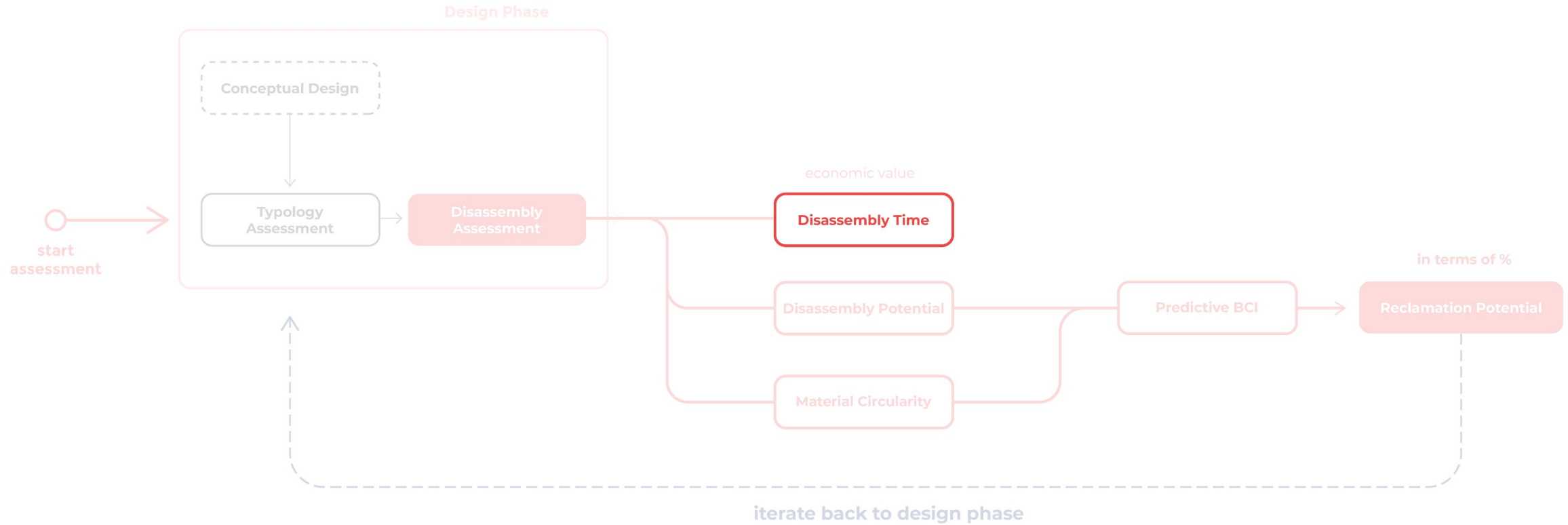

conceptual framework

process map

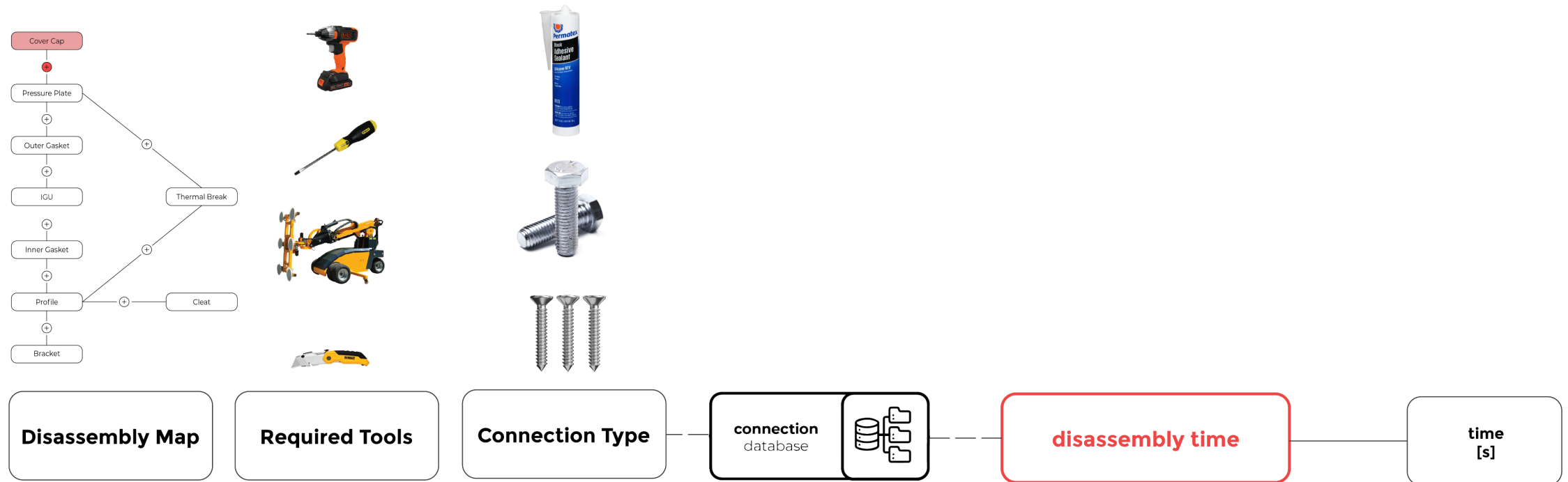

conceptual framework

process map

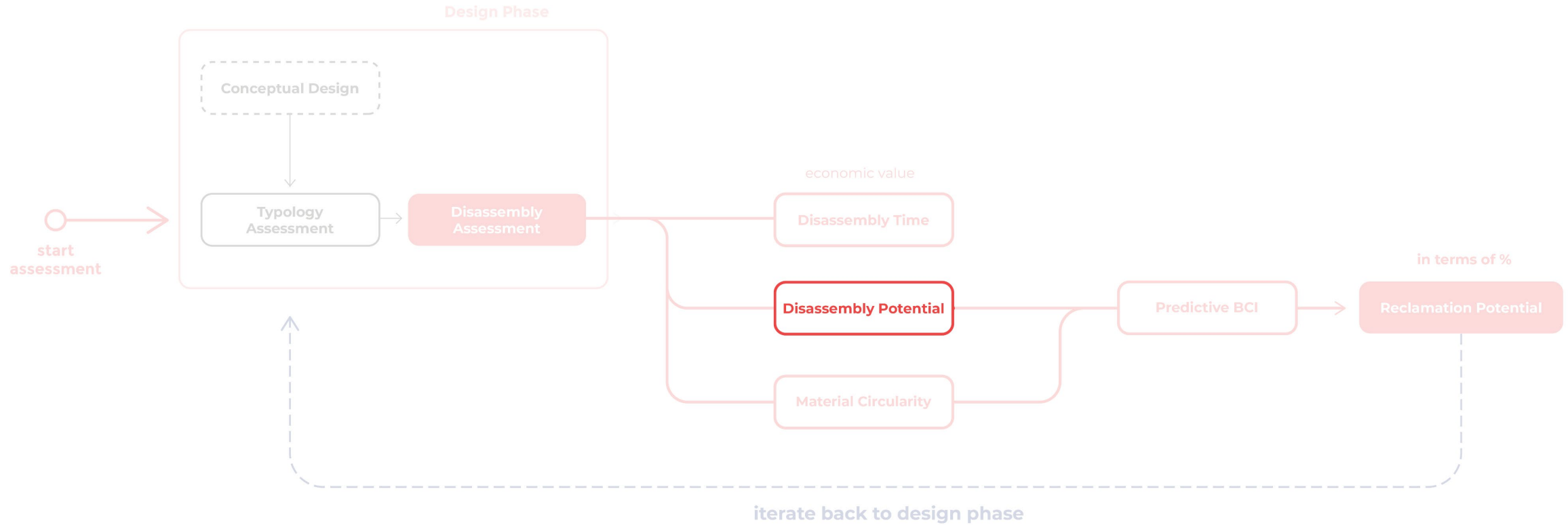

conceptual framework

process map

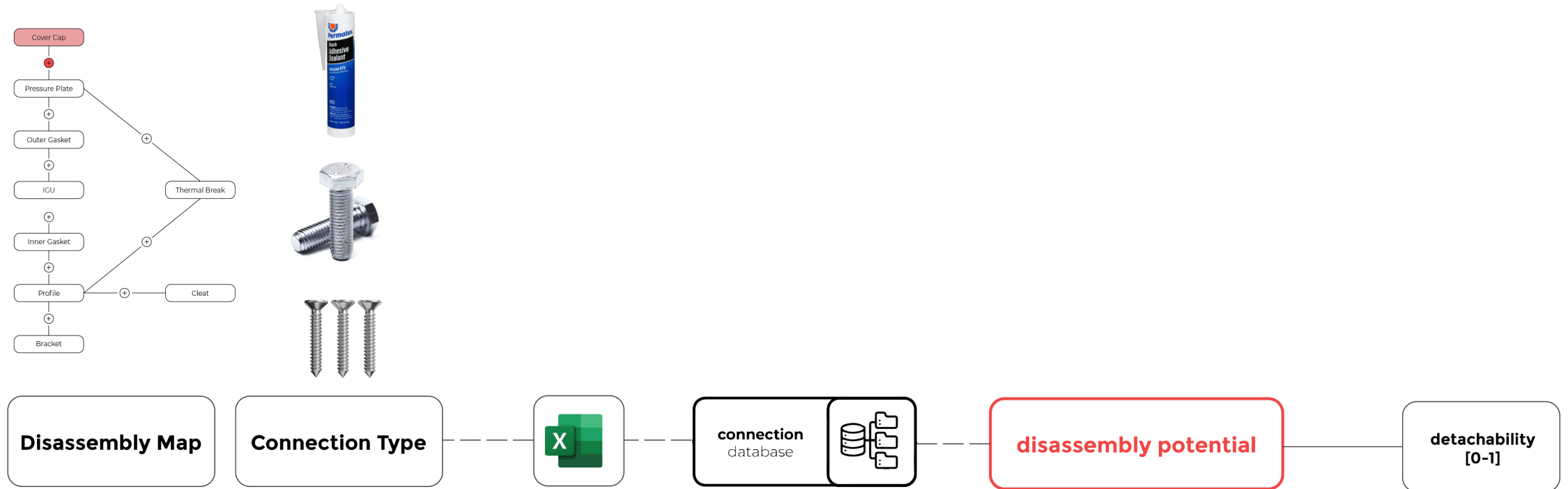

conceptual framework

process map

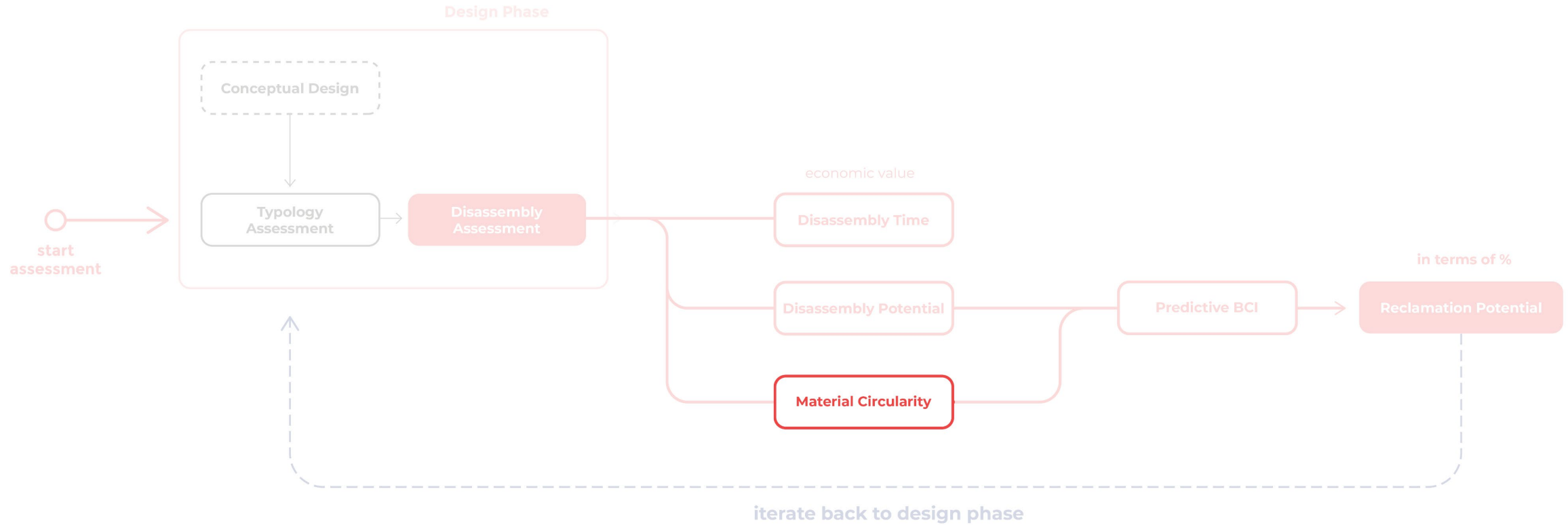

conceptual framework

material flows in aluminium stick system facades

% recycling efficiency

% to recycling

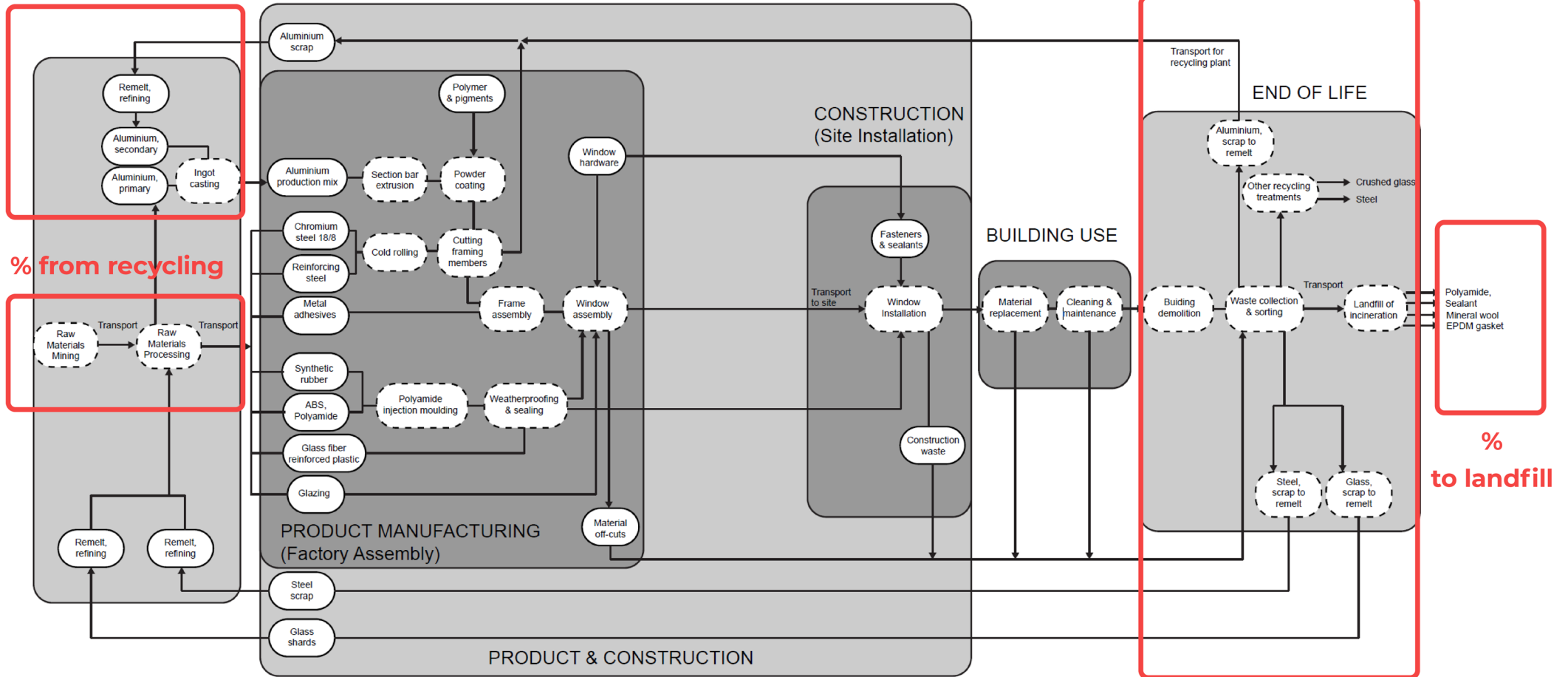

framework demonstration

conceptual framework

process map

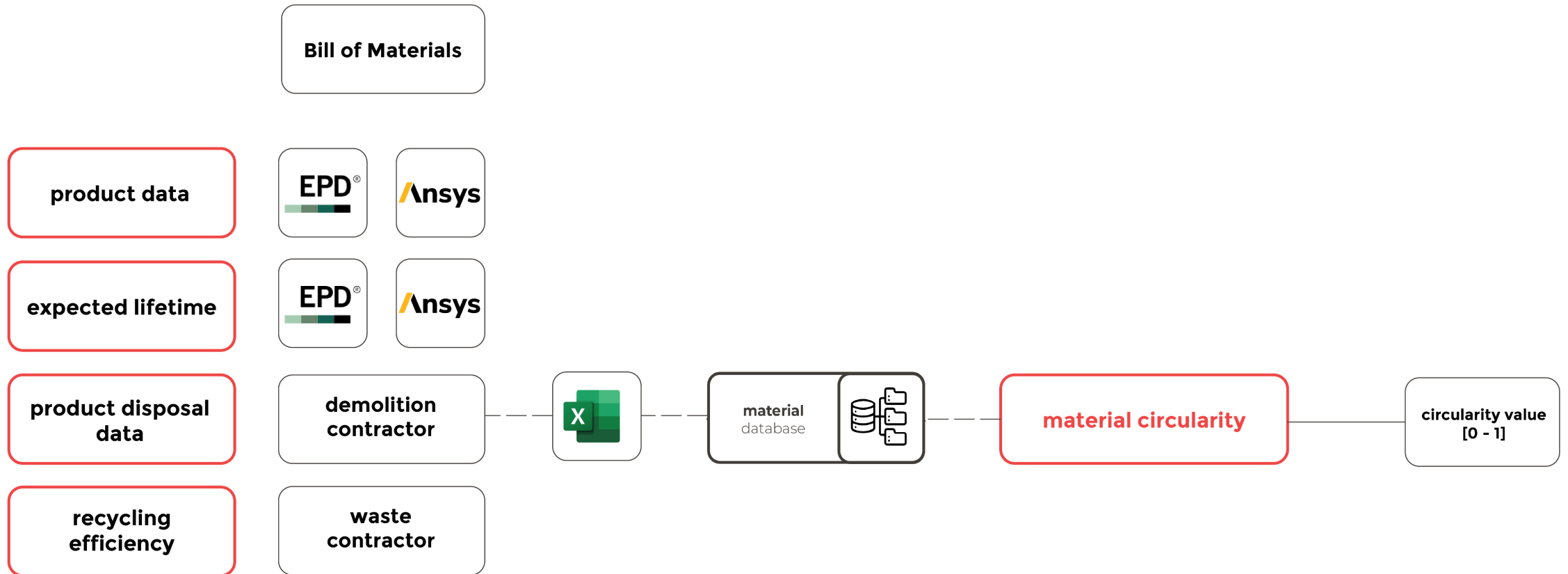

conceptual framework

process map

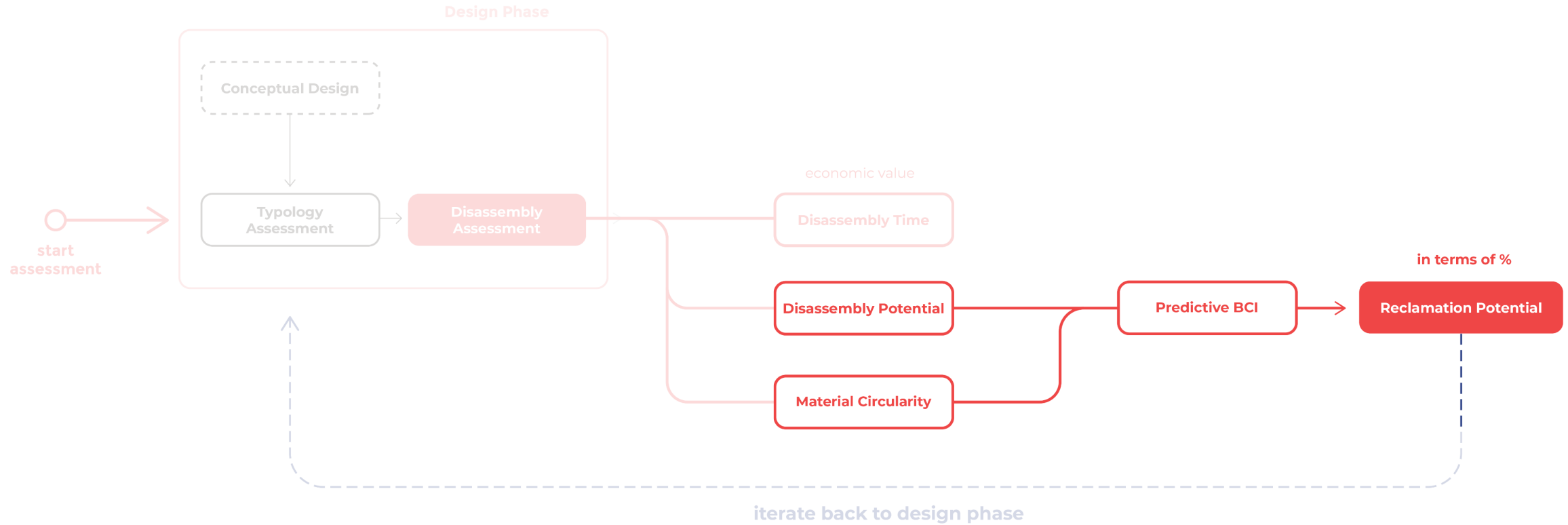

conceptual framework

what information is needed?

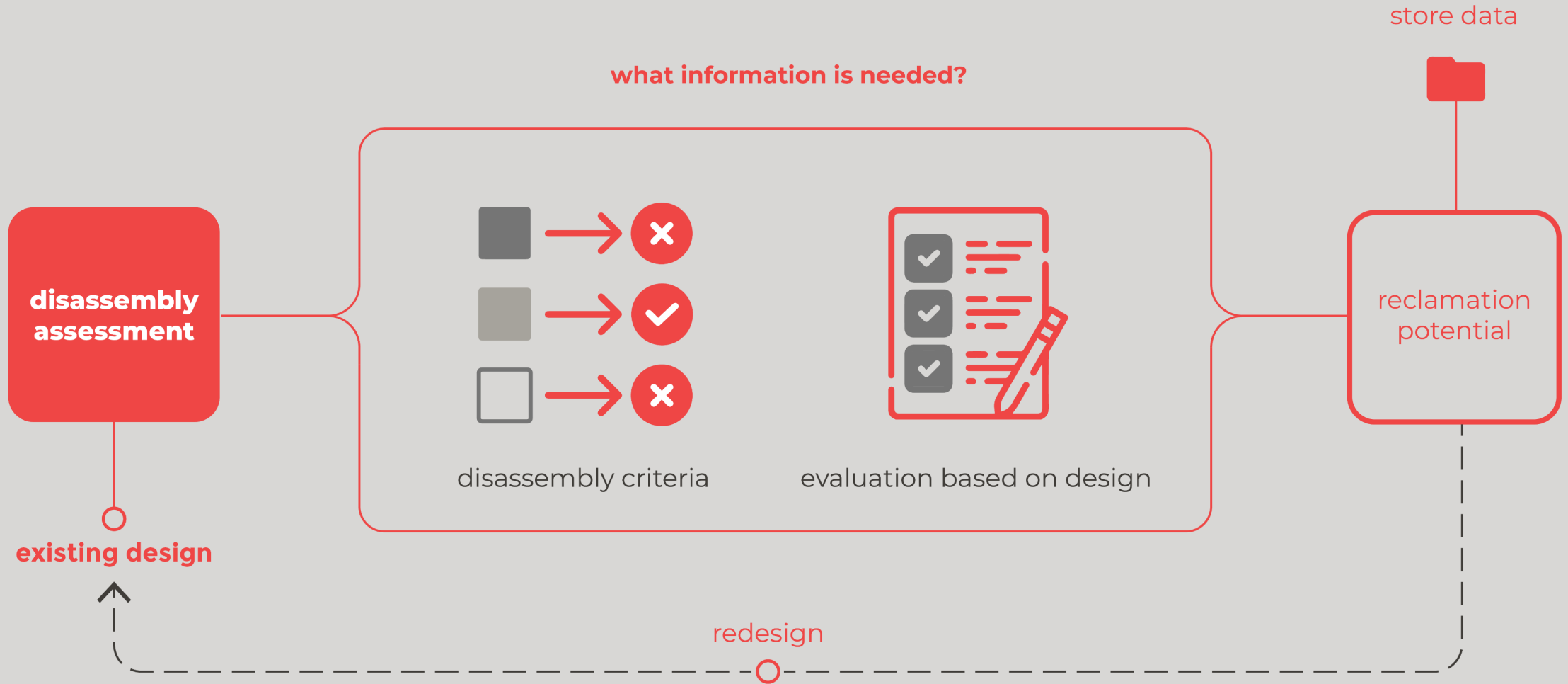

conceptual framework

information structure

organization	item	description
source	CE Download Portal EPD Manual Input	CE marks available through supplier Download portal from companies Environmental Product Declaration In form of Excel tables
type	Documents Drawings Value Text Multiple	Information from Word documents or PDF CAD Files and BIM Models Unit Characters when type is n/a
hierarchy level	L1_ Material L2_ Element L3_ Subcomponent L4_ Component L5_ Subsystem L6_ System L7_ Building	Materials used for the products. Elements which are produced from the materials. Combination of elements General combination of subcomponents For instance, a facade panel For instance, building skin Building location and relevant data
category	Design Data Environmental Data Manufacturing Data Material Properties	Based on the categories proposed by (Heinrich, et al., 2019)

conceptual framework

stakeholder involvement

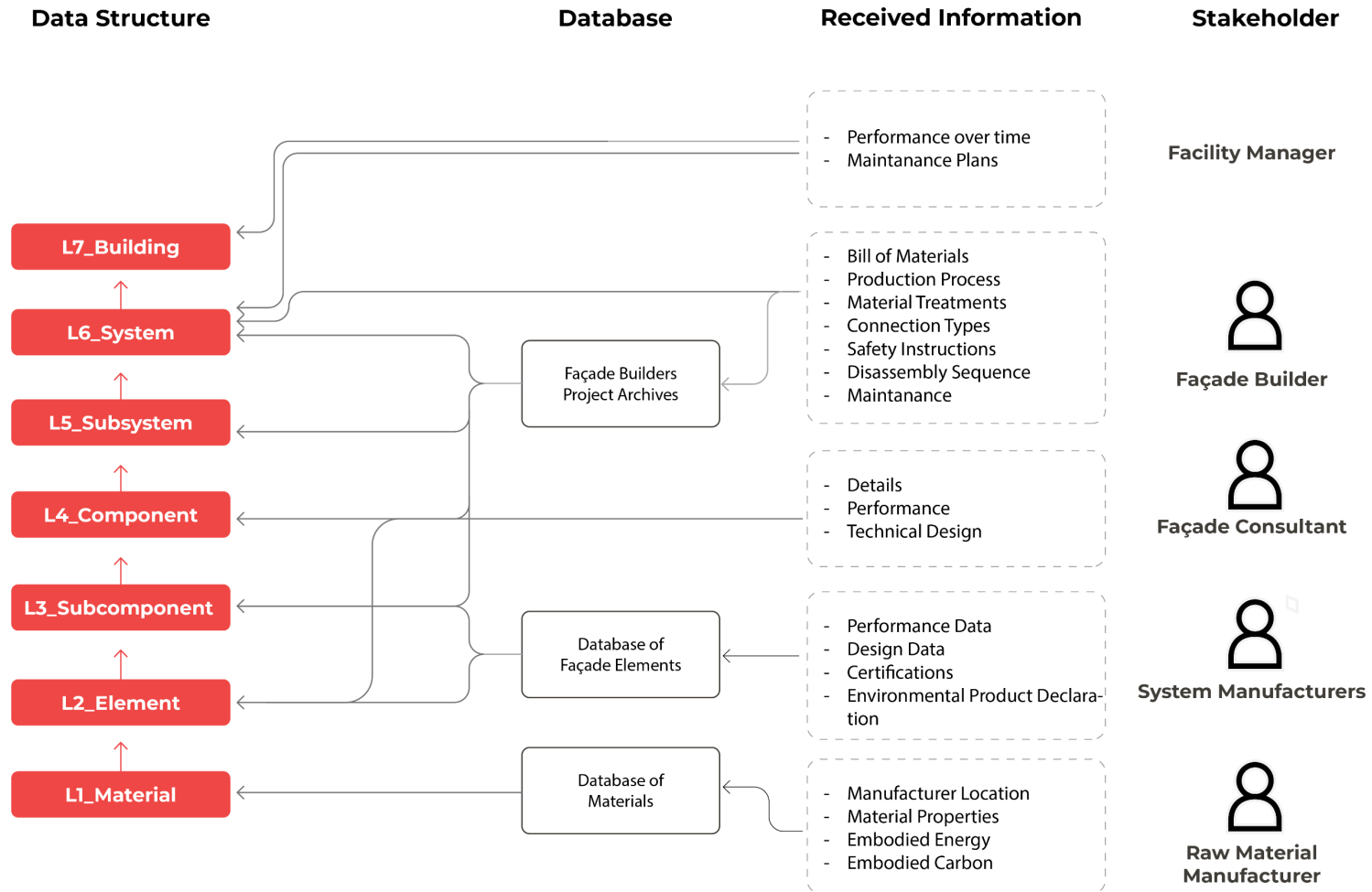

framework demonstration

Triodos Bank | Octatube



Source: Octatube

framework demonstration

framework demonstration

Triodos Bank | Octatube



Source: Octatube

framework demonstration

framework demonstration

Triodos Bank | Octatube



Source: Octatube

framework demonstration

framework demonstration

information received

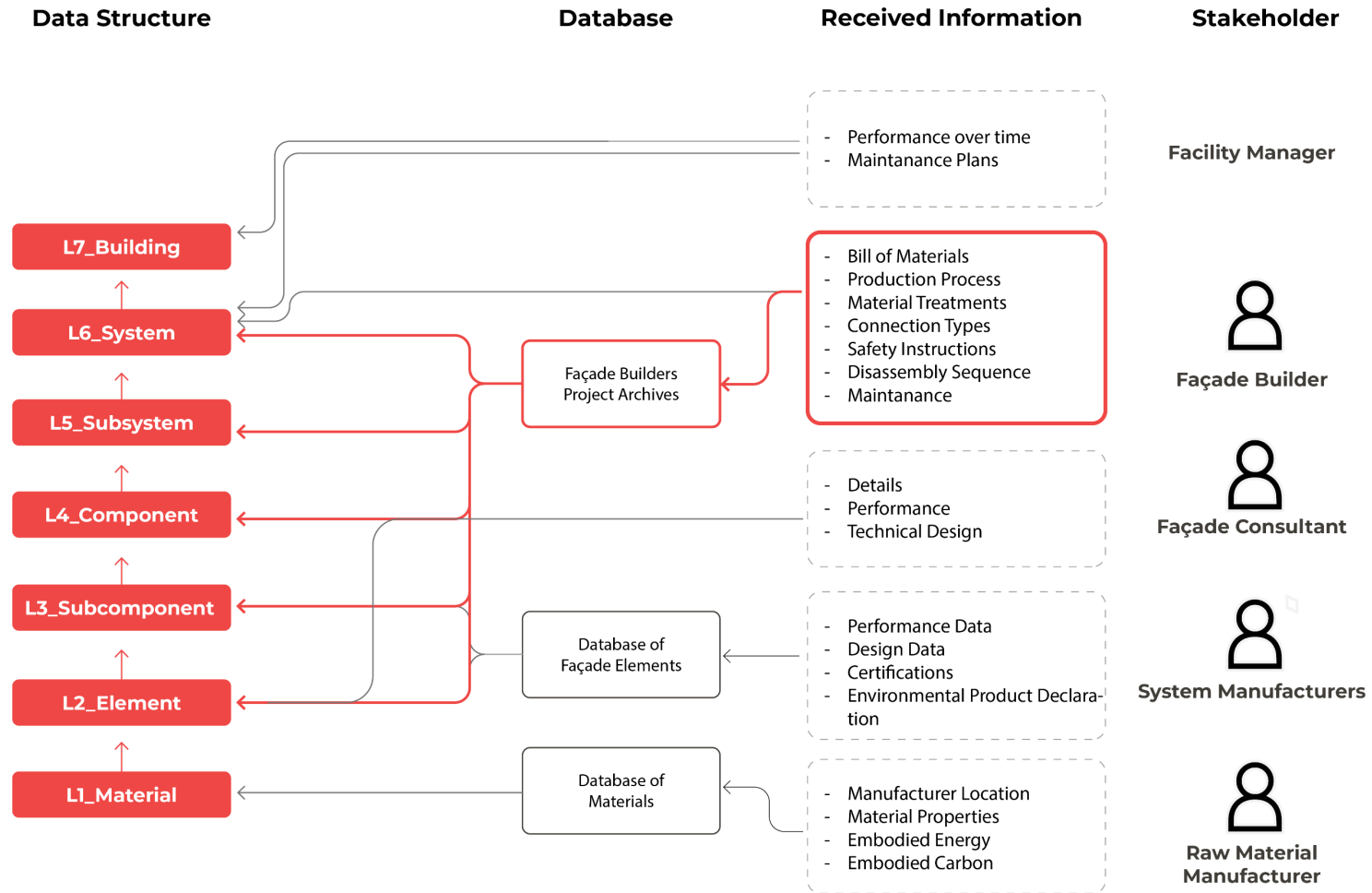

framework demonstration

Triodos Bank | Octatube

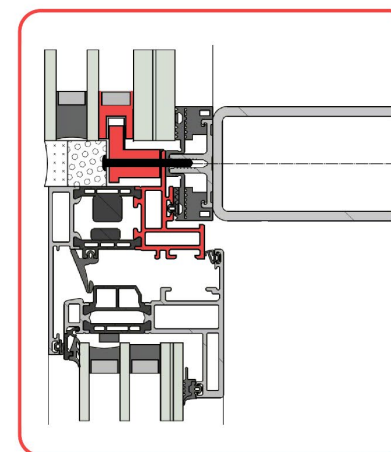
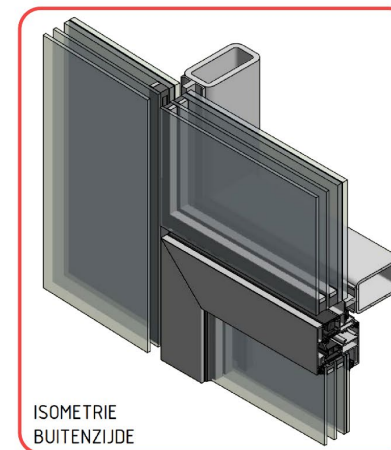

Source: Octatube

framework demonstration

framework demonstration

connection identification and disassembly mapping

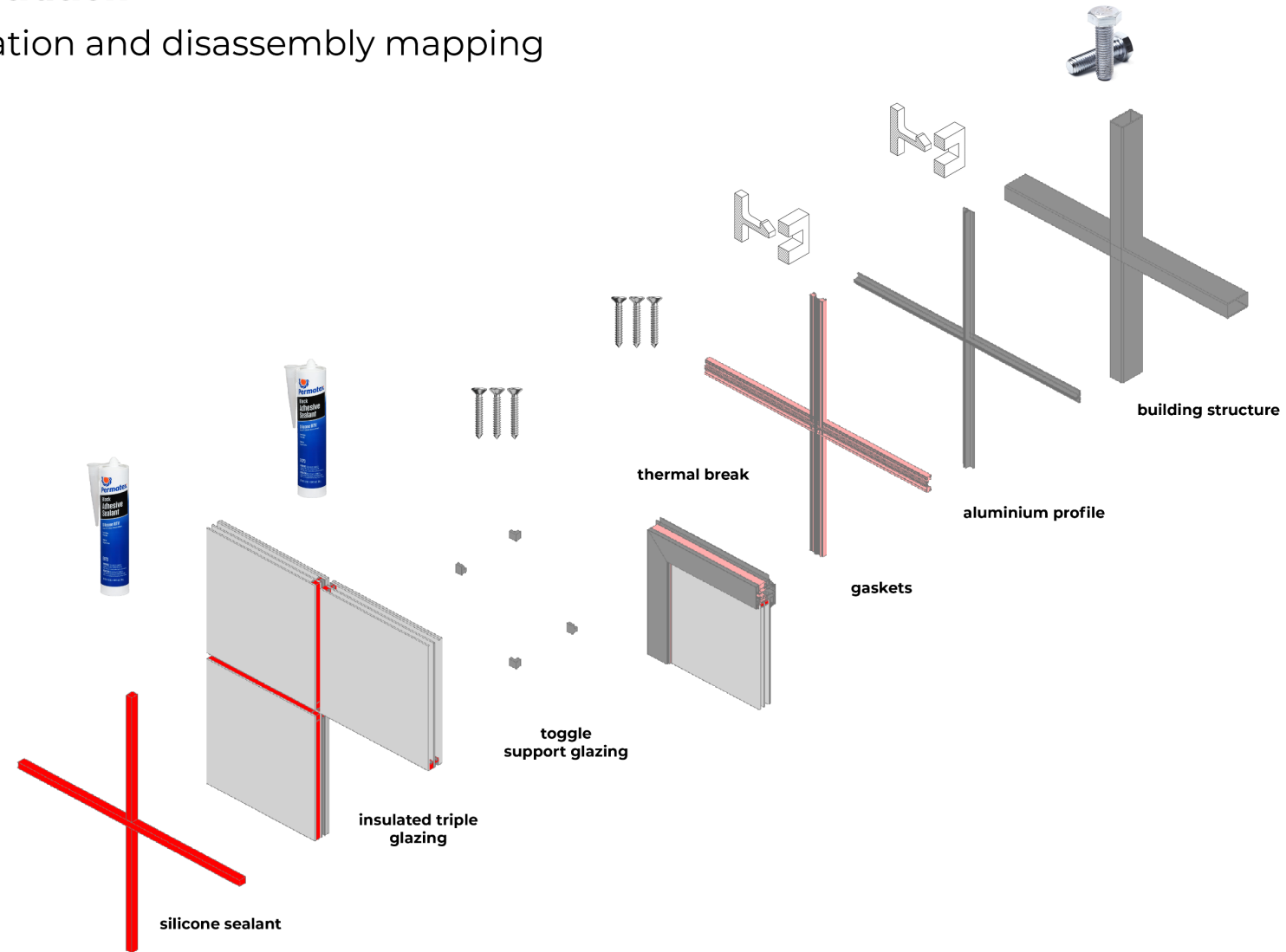

framework demonstration

scenarios construction

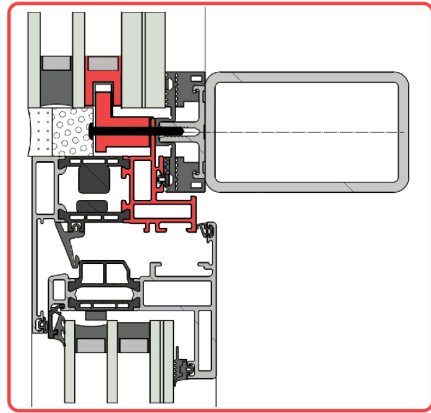

original design

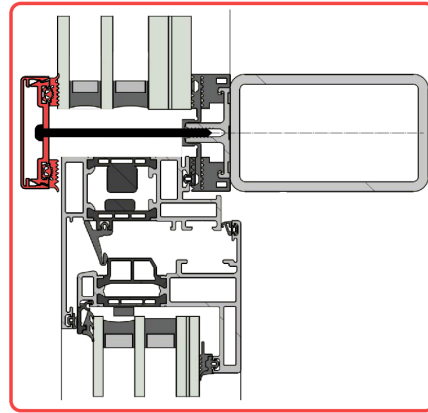

scenario 01

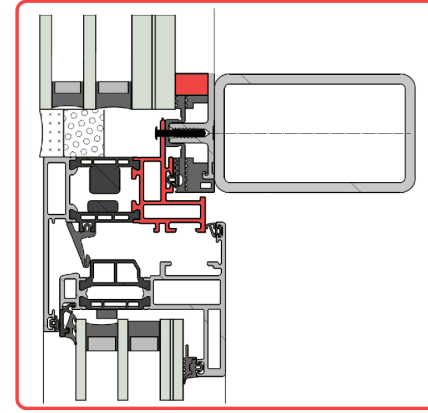

scenario 02

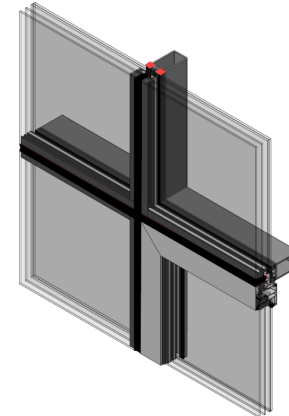
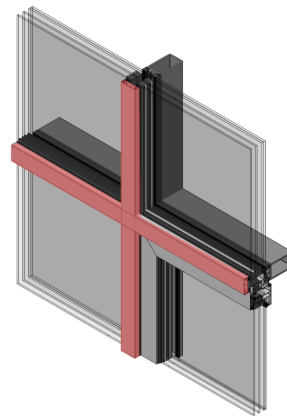
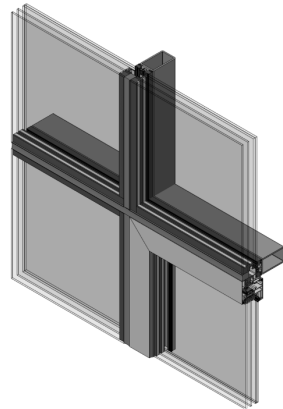

framework demonstration

material composition

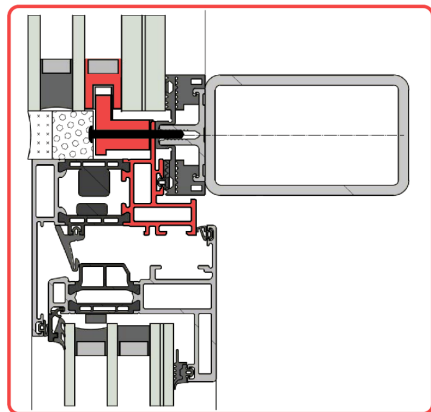

original design

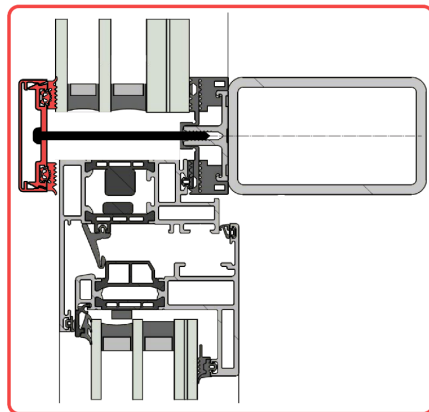

scenario 01

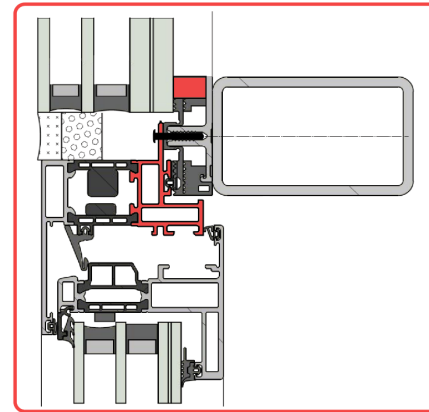

scenario 02

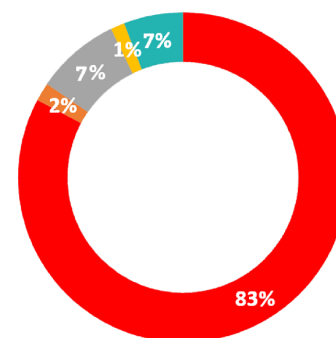
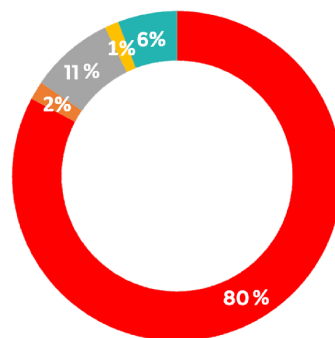
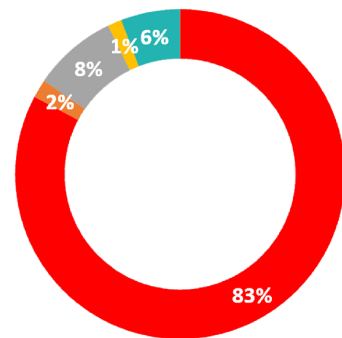

■ glazing ■ gaskets ■ aluminium ■ polyamide ■ silicone sealant ■ butyl seal

framework demonstration

process map

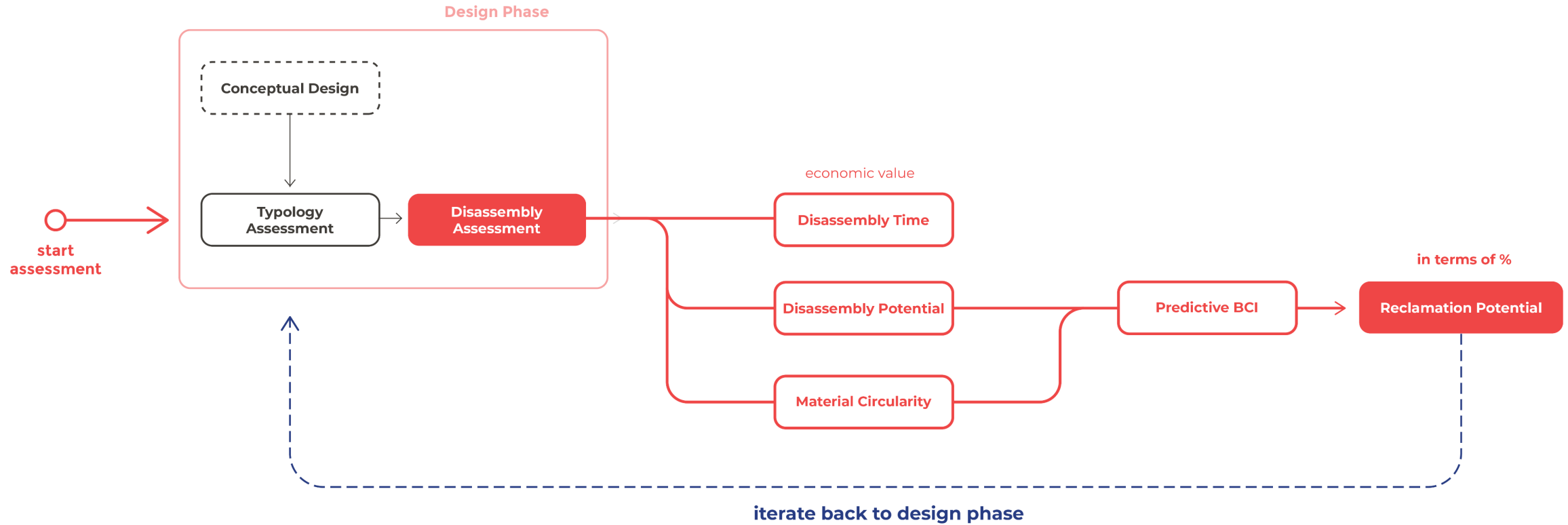

framework demonstration

process map

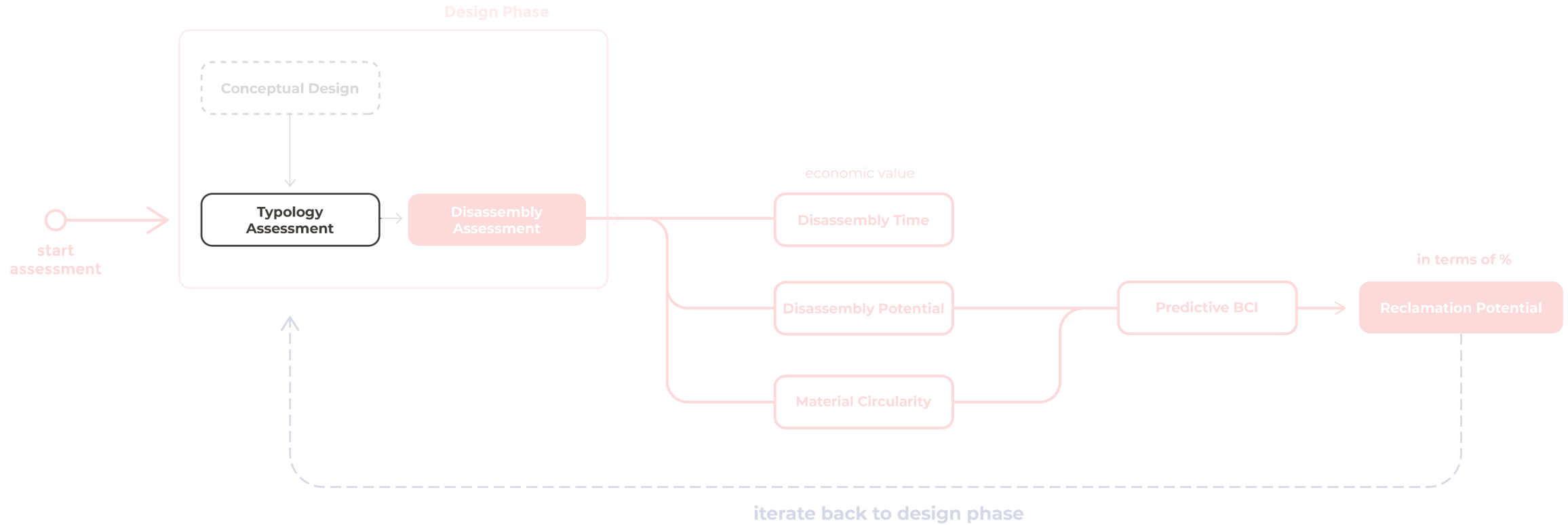

framework demonstration

identification of instances

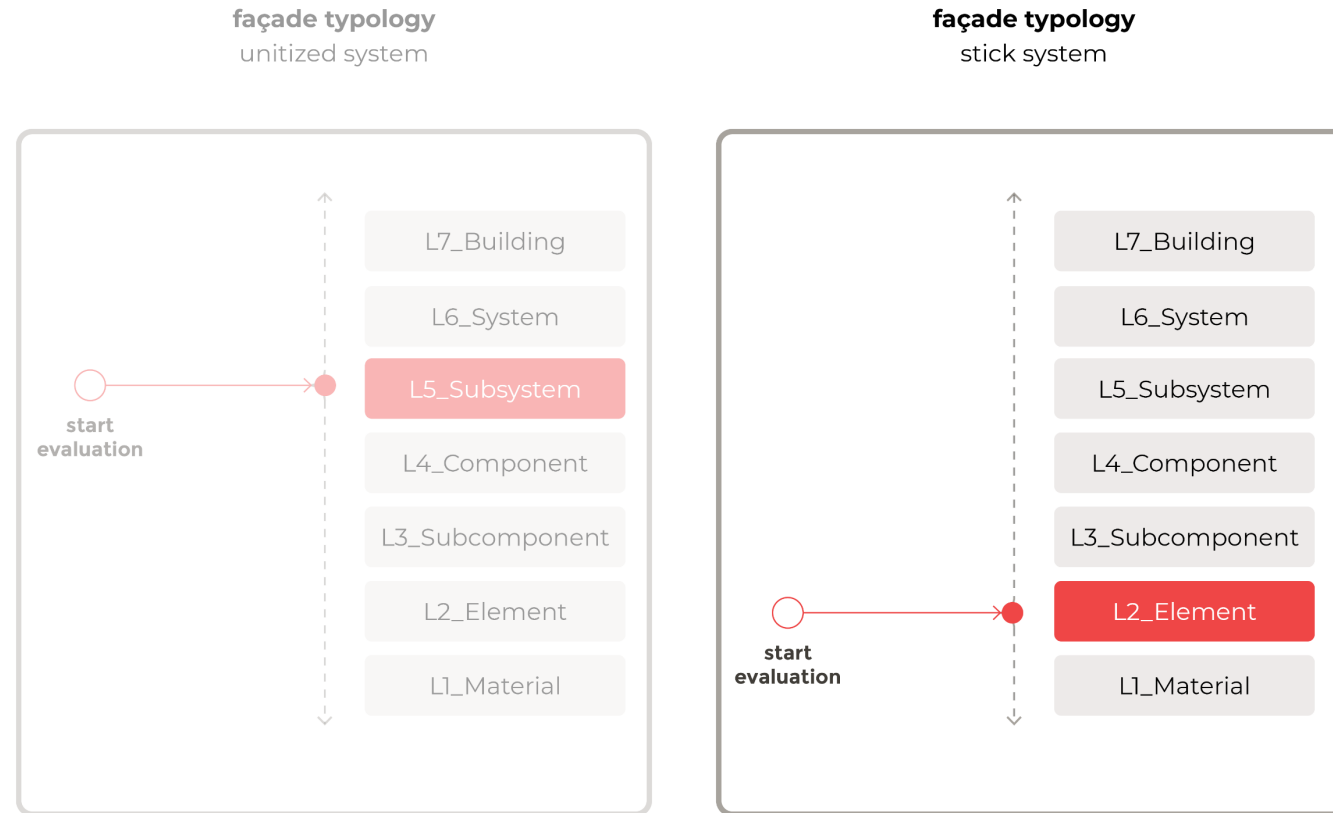

framework demonstration

identification of instances

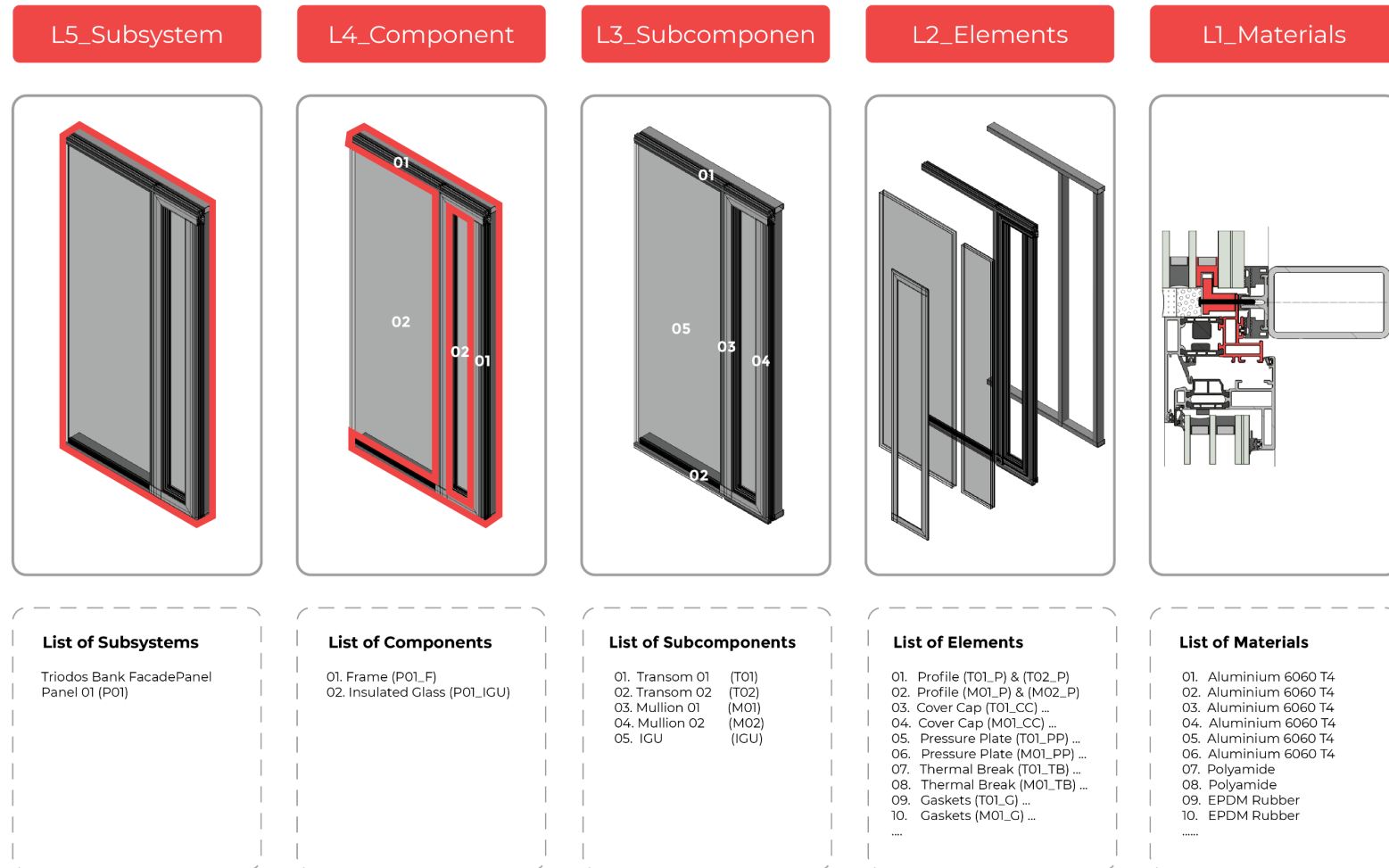

framework demonstration

identification of instances

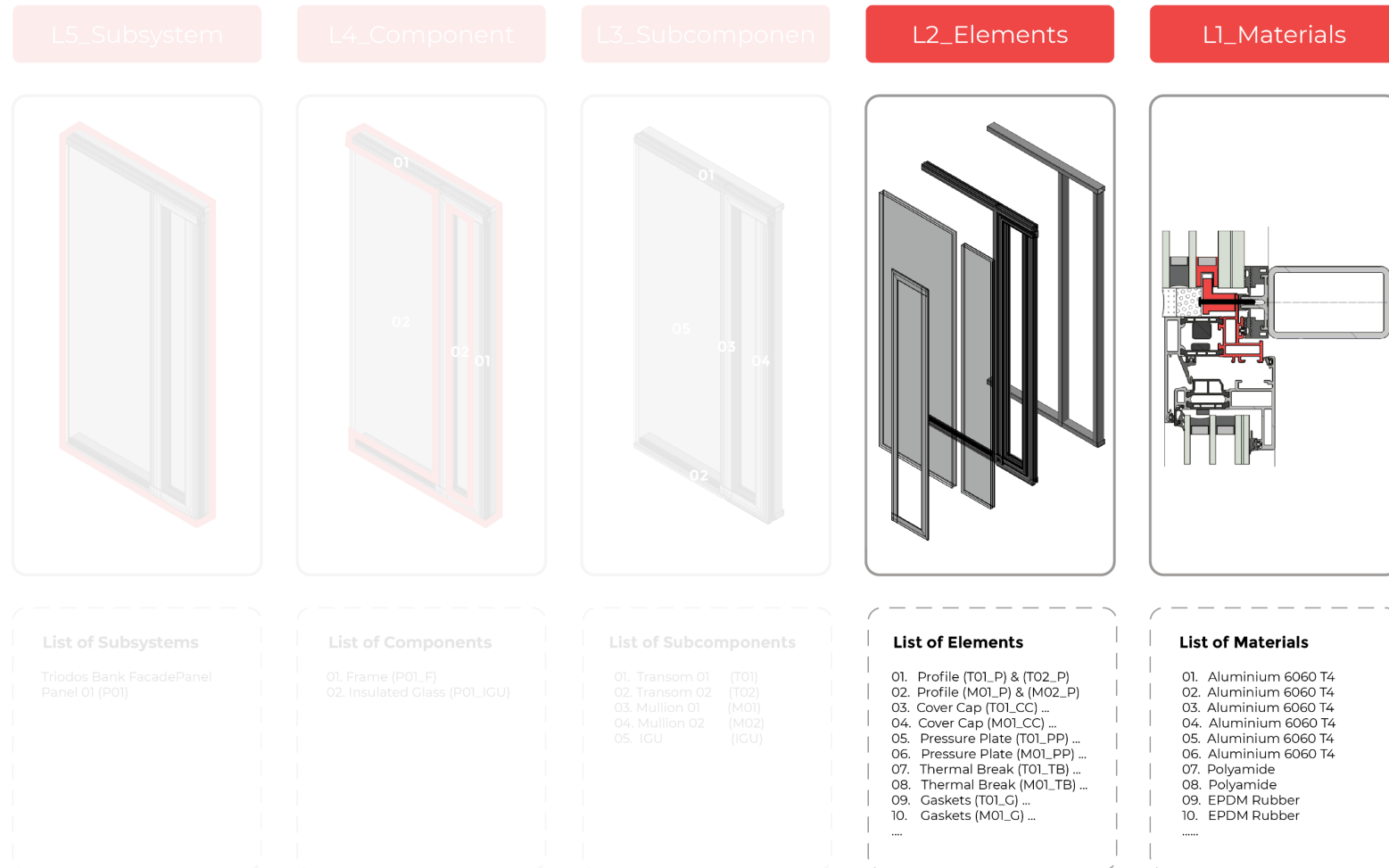

framework demonstration

process map

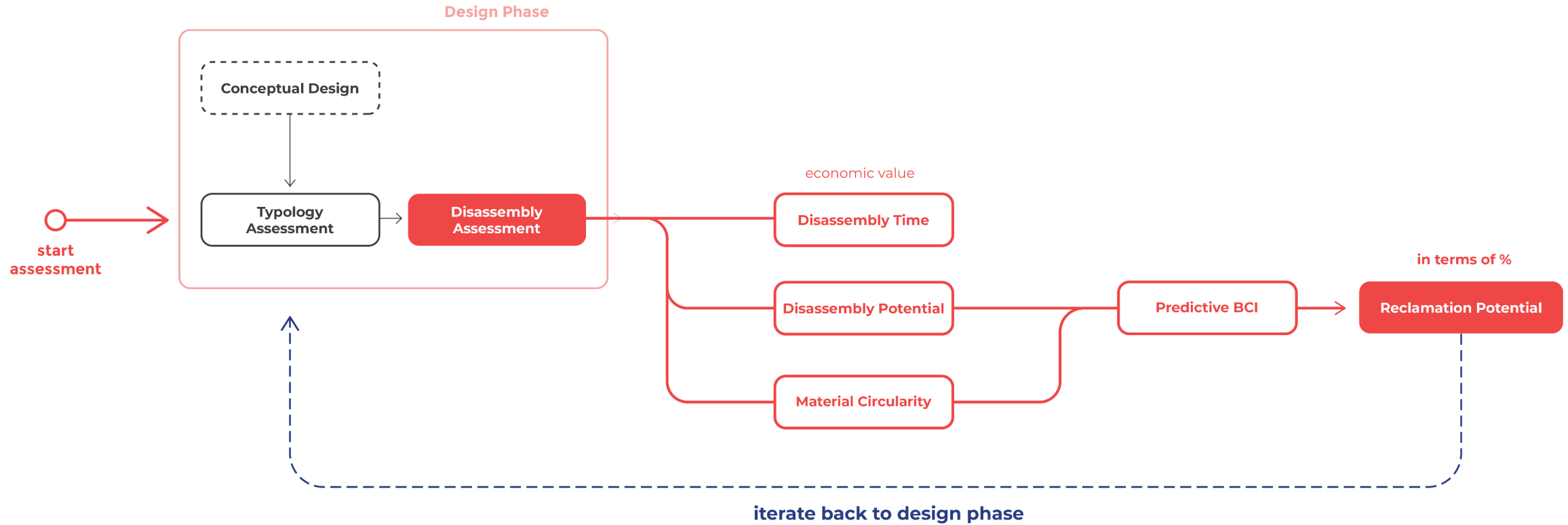

framework demonstration

process map

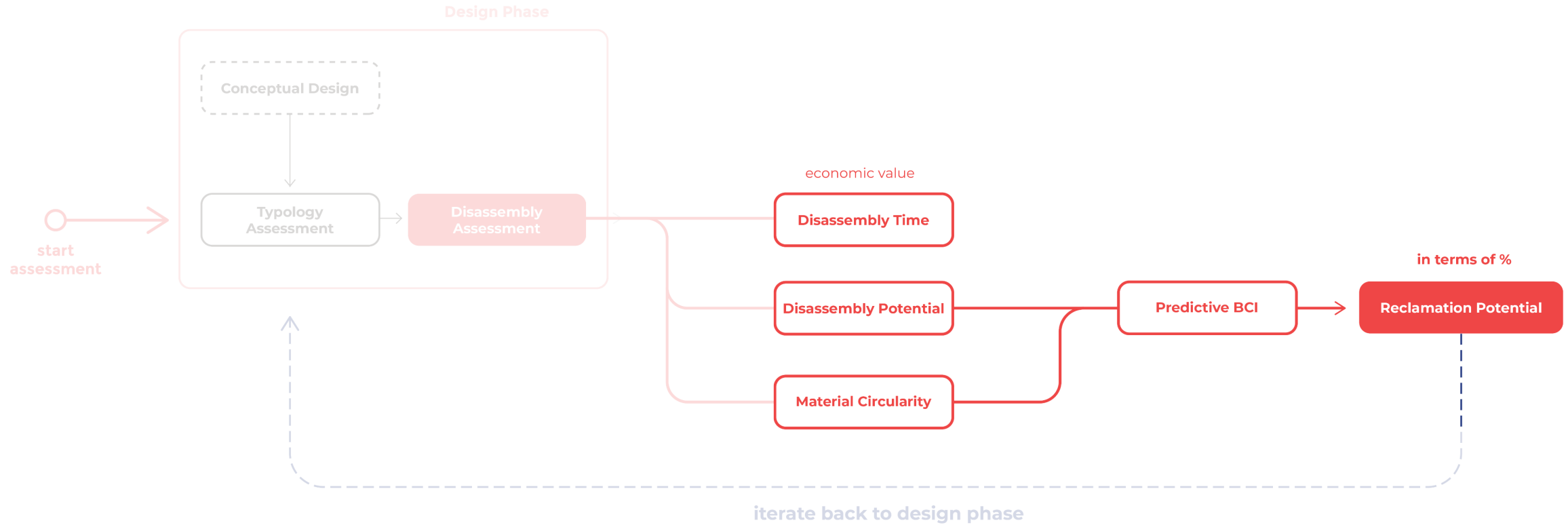

framework demonstration

benchmarking

original design

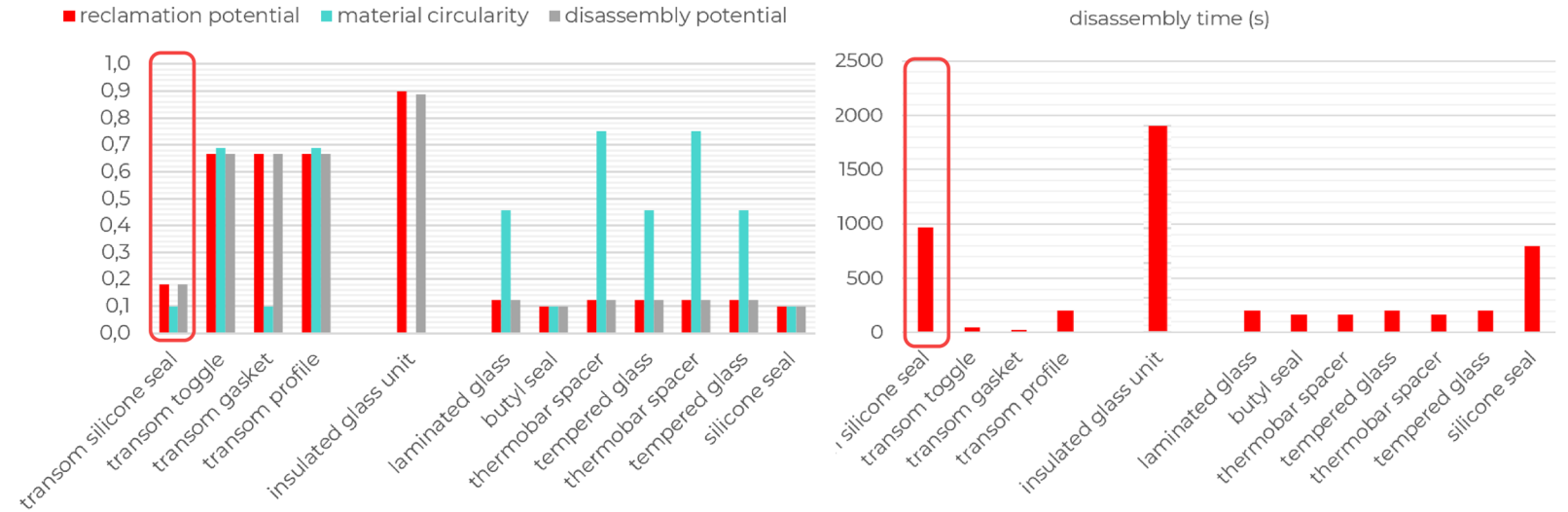
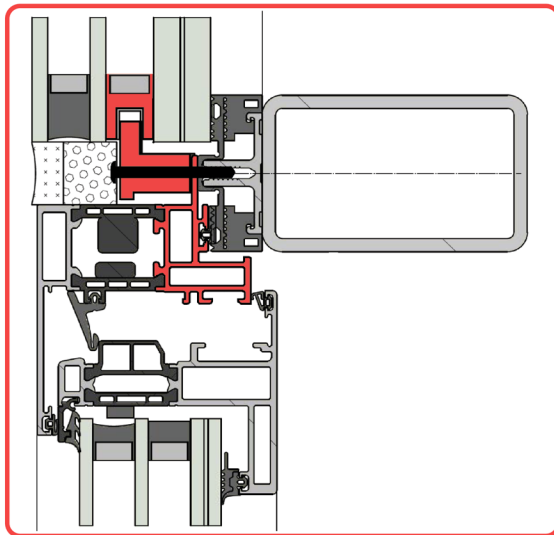

framework demonstration

benchmarking

scenario 01

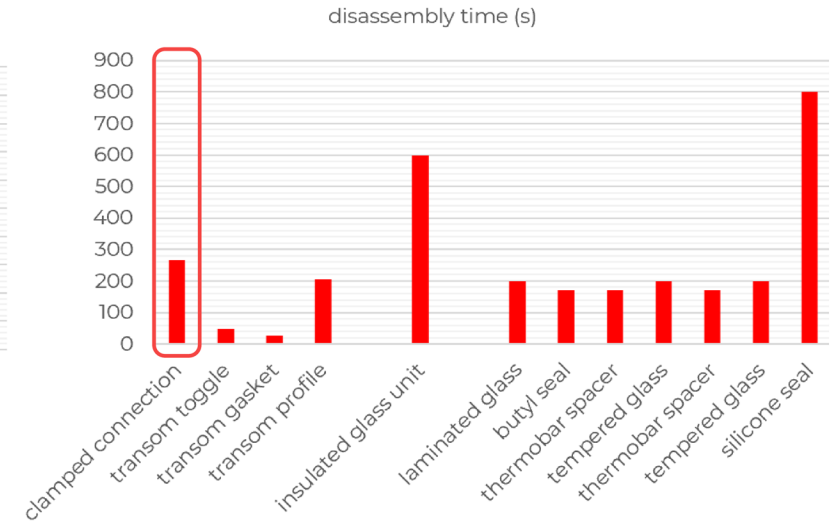
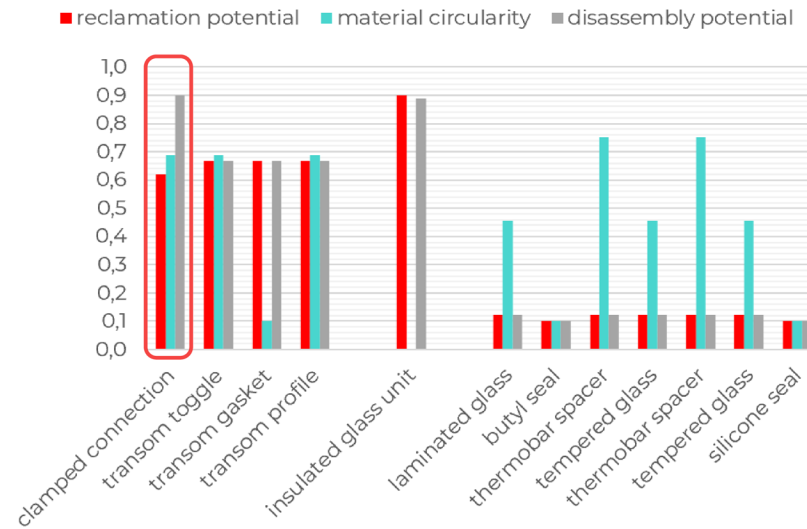
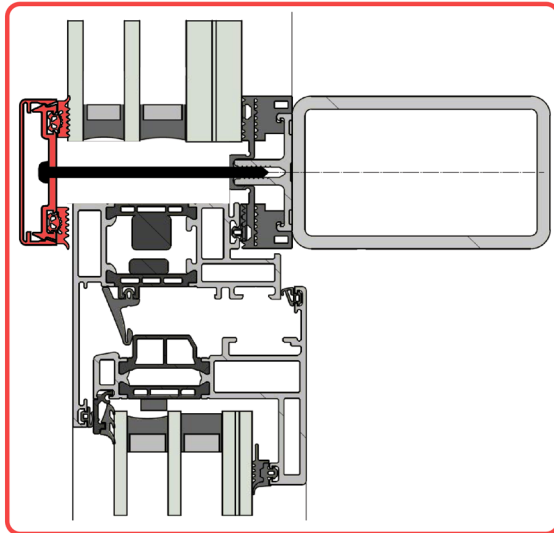

framework demonstration

benchmarking

scenario 02

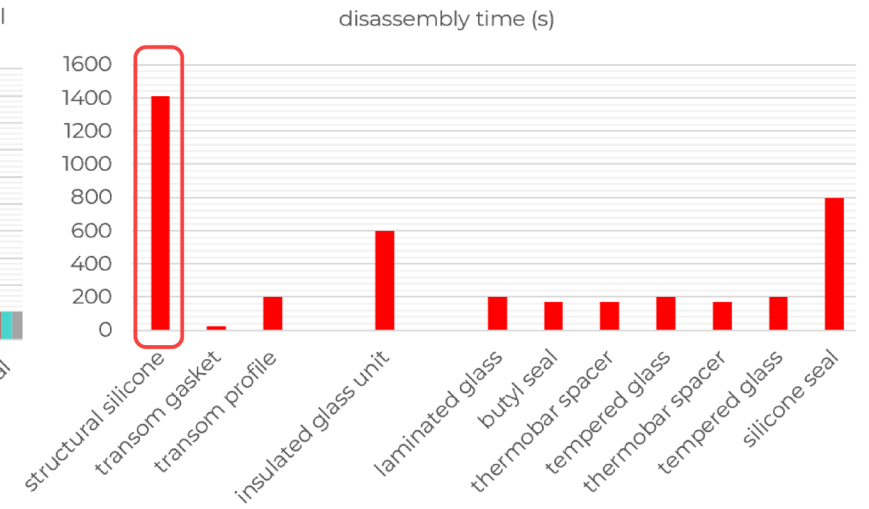
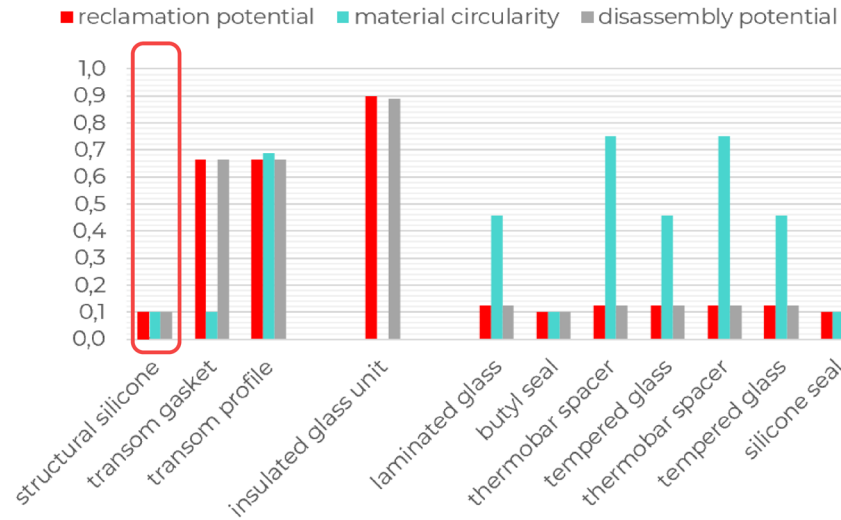
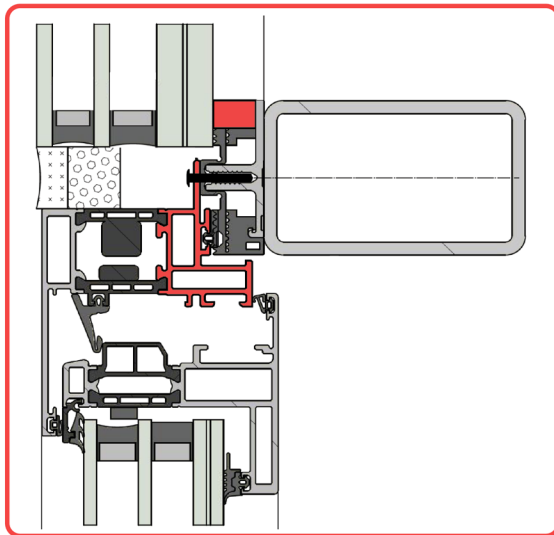

framework demonstration

process map

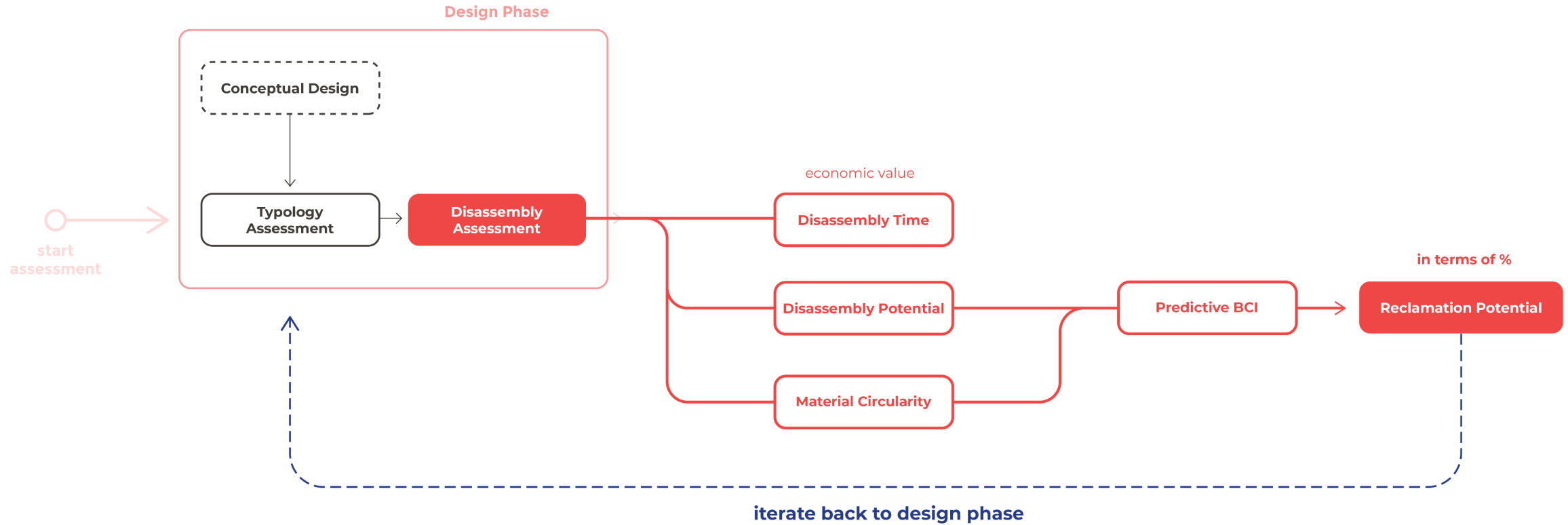

framework demonstration

design improvement

original design

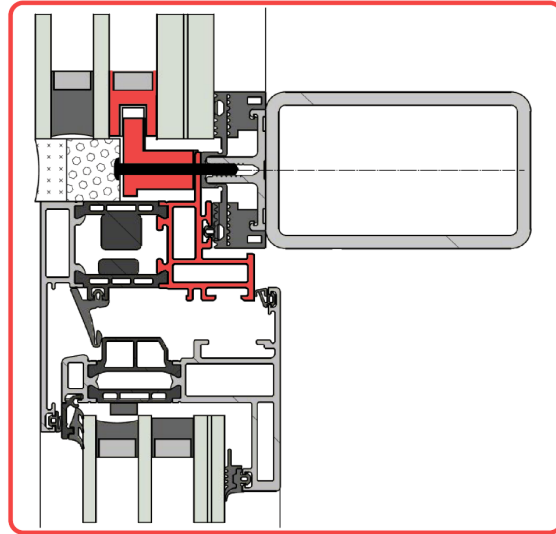

improved design

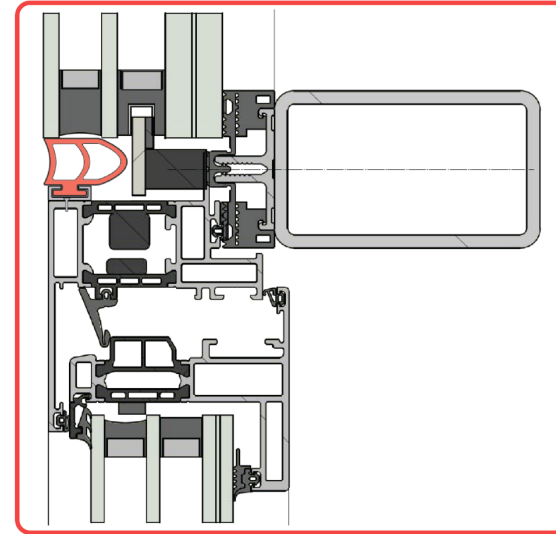

framework demonstration

benchmarking

original design

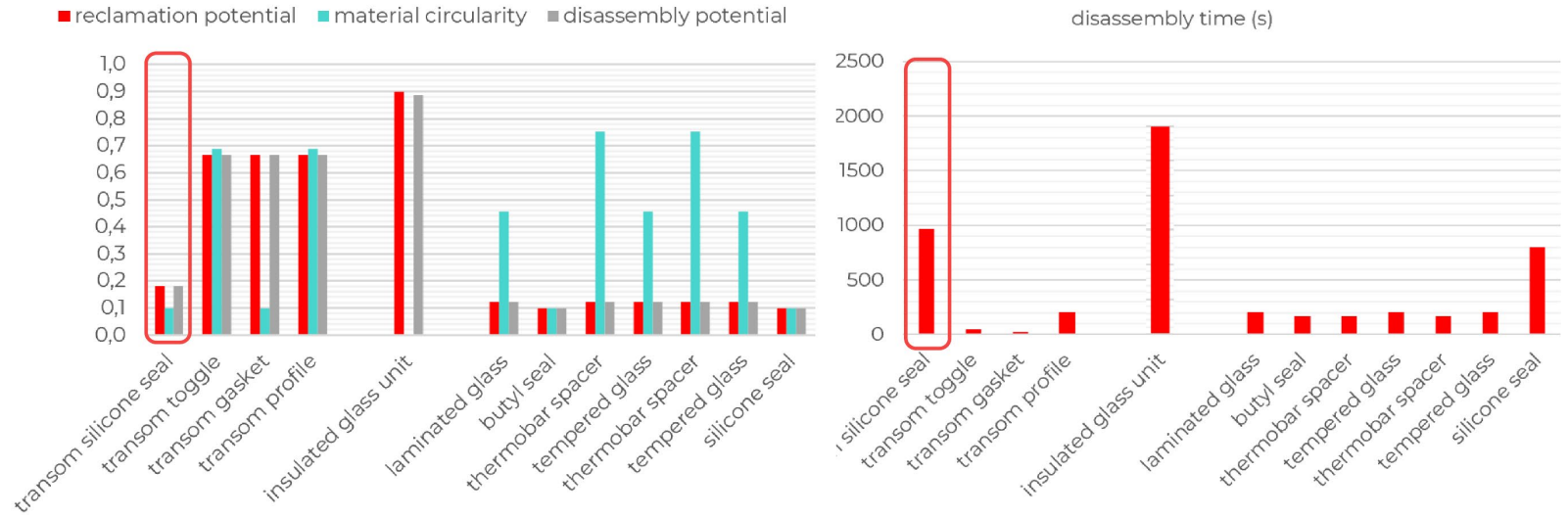
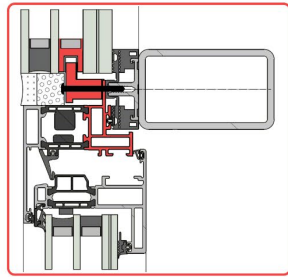

improved design

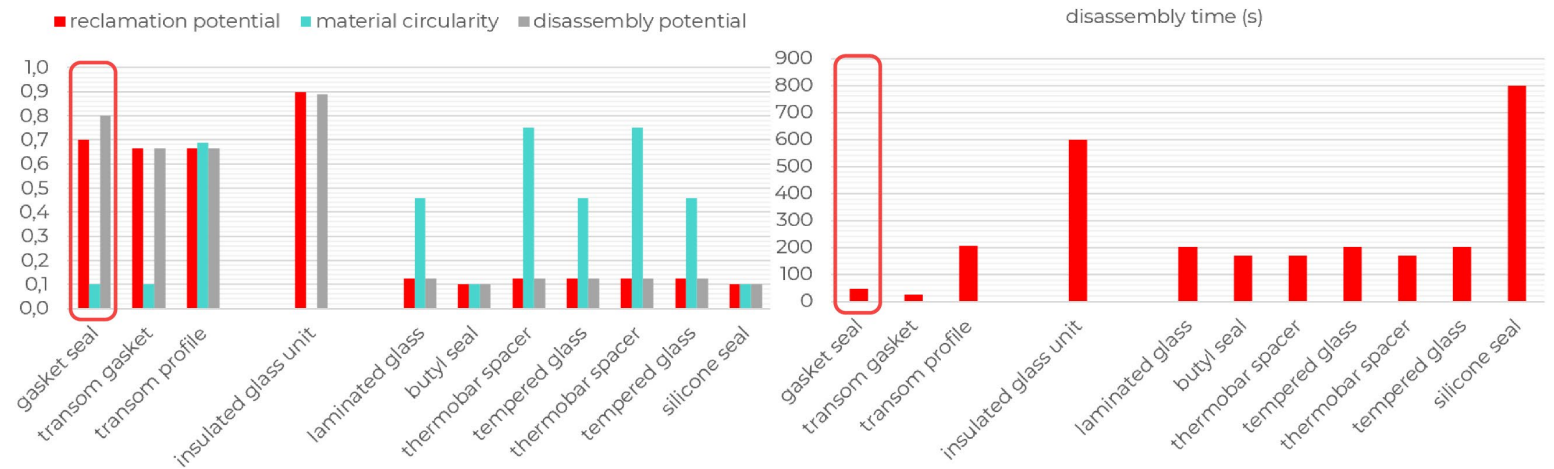
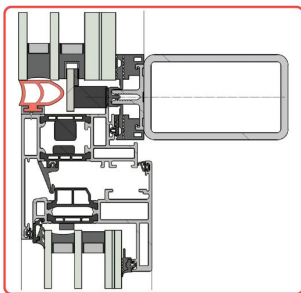

framework demonstration

aesthetic implications

original design

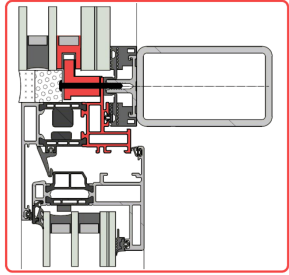

improved design

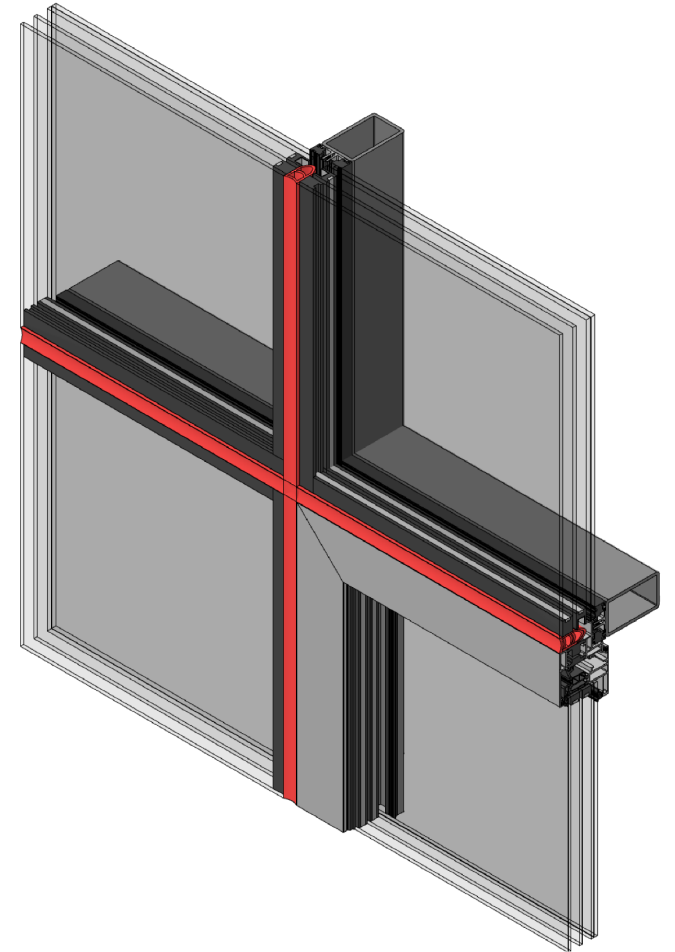
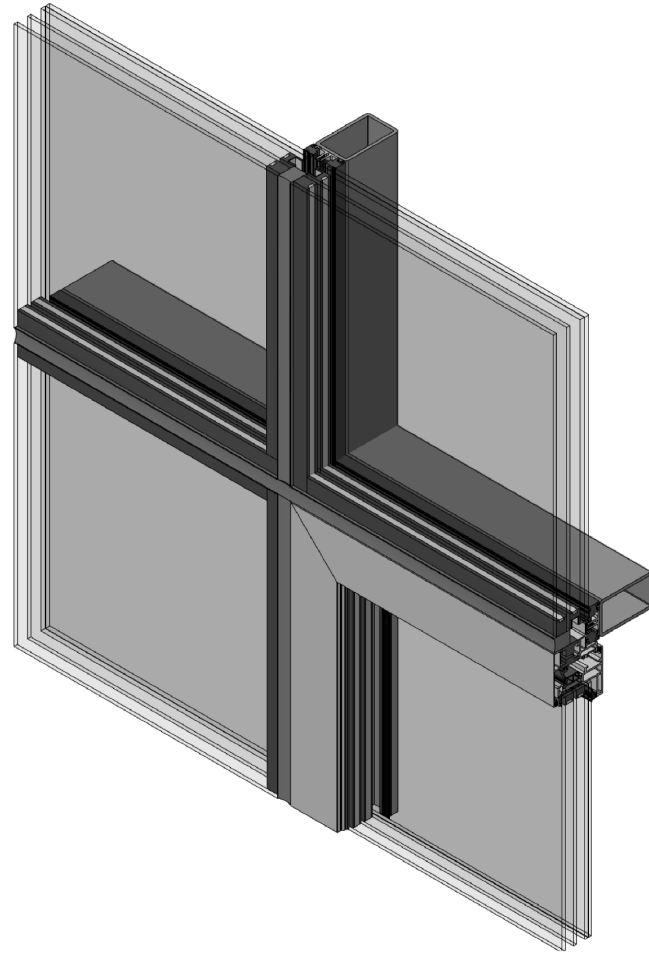
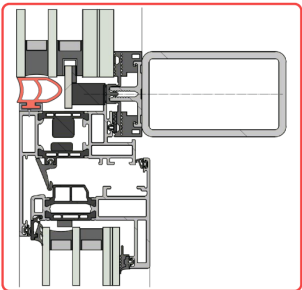

framework demonstration

design improvement

original design

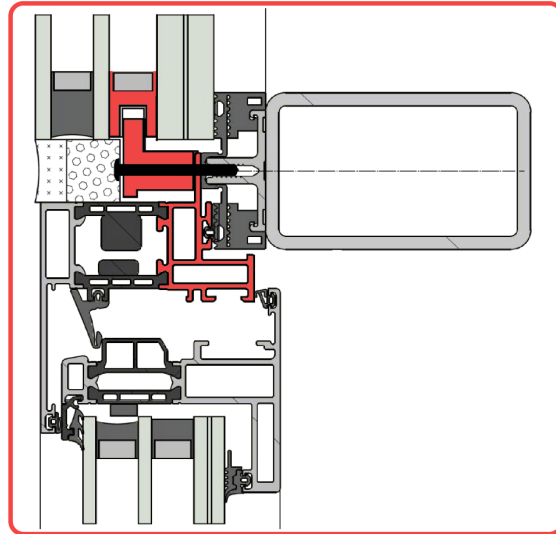

improved design

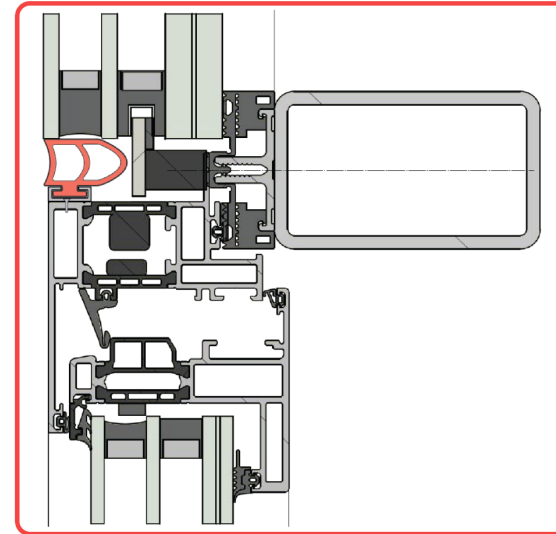

less tools

from cutter to hands

no adhesives

from silicone to gasket

same aesthetics

no external elements

framework demonstration

benchmarking

original design

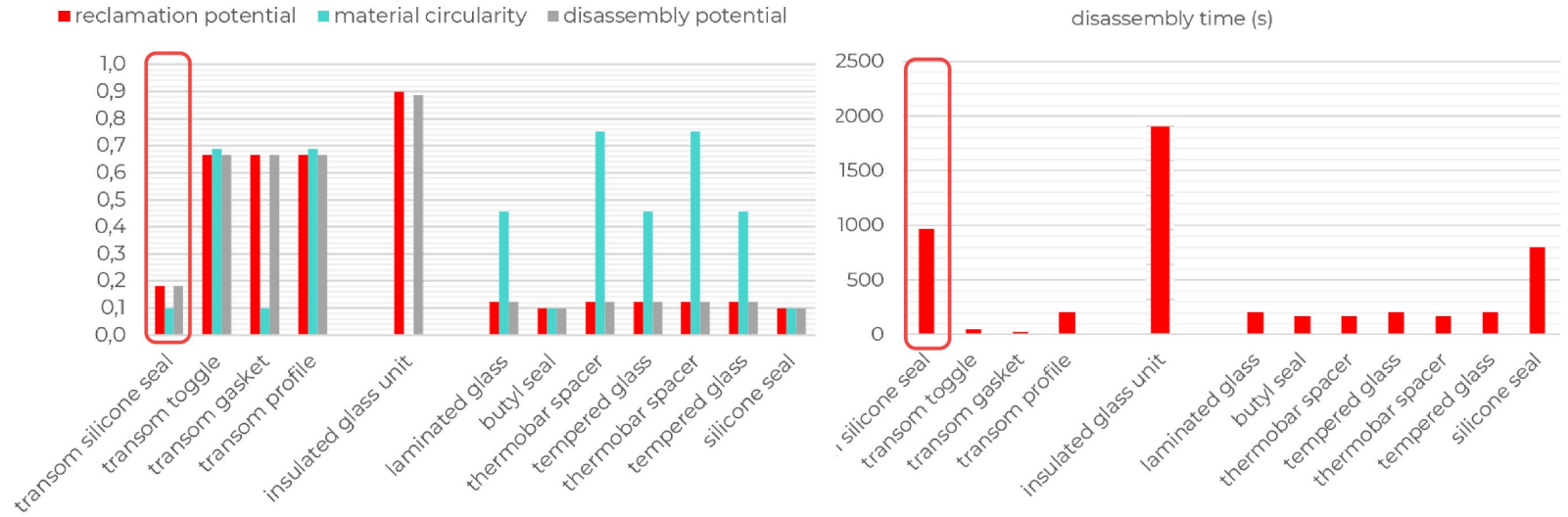
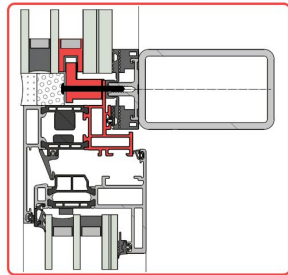

improved design

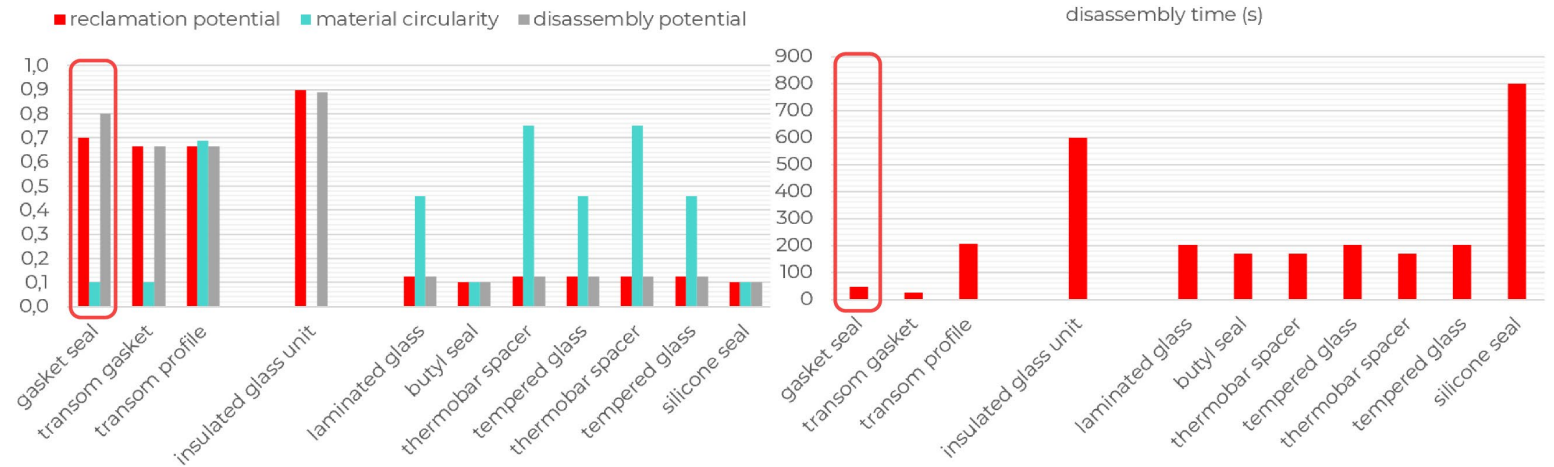
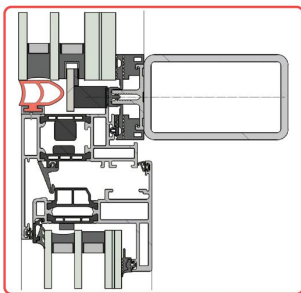

framework demonstration

aesthetic implications



Source: Octatube

framework demonstration

user output

disassembly potential

Design Phase
EoL Phase

L1_ Material
L2_ Element
L3_ Subcomponent
L4_ Component
L5_ Subsystem
L6_ System
L7_ Building

Input

ID
M01_CC

Instance ID

Common Name
Mullion Cover Cap

Common Name

Connection Type

+

1

Connection Accessibility

+

1

Independence

+

1

Geometry Product Edge

+

1

Disassembly Map

Output

Connection Type (CT)
 Connection Accessibility (CA)
 Independence (ID)
 Geometry of Product Edge (GPE)
Disassembly Potential (DPP)

user output

disassembly potential

Design Phase
EoL Phase

L1_ Material
L2_ Element
L3_ Subcomponent
L4_ Component
L5_ Subsystem
L6_ System
L7_ Building

Input

ID
Instance ID DGU_LG

Common Name Laminated Glass

Connection Type

Connection Accessibility

Independence

Geometry Product Edge

Disassembly Map

Output

Metric	Score
CT	0,40
CA	0,10
ID	0,10
GPE	0,10
DPP	0,10

Connection Type (CT)
 Connection Accessibility (CA)
 Independence (ID)
 Geometry of Product Edge (GPE)
Disassembly Potential (DPP)

user output

reclamation potential

Design PhaseEoL Phase

L1_ Material**L2_ Element**L3_ SubcomponentL4_ ComponentL5_ SubsystemL6_ SystemL7_ Building

Input

ID

Instance ID M01_CC

Common Name Mullion Cover Cap

Material Circularity Indicator (MCI)

0,67

Linear Flow Indicator (LFI)

0,29

Disassembly Potential

1

Assessment Input

Disassembly Map

```
graph TD; CC[Cover Cap] --- P[Pressure Plate]; CC --- OG[Outer Gasket]; CC --- TB[Thermal Break]; P --- IGU[IGU]; OG --- IGU; OG --- TB; IGU --- PS[Primary Seal]; IGU --- SS[Secondary Seal]; IGU --- S[Spacer]; IGU --- IG[Inner Gasket]; PS --- SS; S --- LG[Laminated Glass]; IG --- P[Profile]; SB[Setting Block] --- P; P --- B[Bracket]; P --- C[Cleat];
```

Output

77% reclamation for reuse/recycle

0,32 kg reclamation for reuse/recycle

user output

reclamation potential

Design Phase | EoL Phase

L1_ Material | **L2_ Element** | L3_ Subcomponent | L4_ Component | L5_ Subsystem | L6_ System | L7_ Building

Input

ID: DGU_LG
Common Name: Laminated Glass

Material Circularity Indicator (MCI): 0,55

Linear Flow Indicator (LFI): 0,5

Disassembly Potential: 0,12

Disassembly Map

```
graph TD; CC[Cover Cap] -- "+" --> PP[Pressure Plate]; PP -- "+" --> OG[Outer Gasket]; OG -- "+" --> IGU[IGU]; IGU -- "+" --> ISG[Inner Gasket]; ISG -- "+" --> P[Profile]; P -- "+" --> B[Bracket]; CC -- "+" --> TB[Thermal Break]; PP -- "+" --> TB; OG -- "+" --> TB; IGU -- "+" --> TB; ISG -- "+" --> TB; P -- "+" --> TB; P -- "+" --> SB[Setting Block]; P -- "+" --> C[Cleat]; IGU -- "+" --> S[Spacer]; S -- "+" --> LG[Laminated Glass]; S -- "+" --> SS[Secondary Seal]; SS -- "+" --> PS[Primary Seal];
```

Output

52% reclamation for reuse/recycle

12,26 kg reclamation for reuse/recycle

the bigger picture

who can use it and who does it benefit?

can be the same party

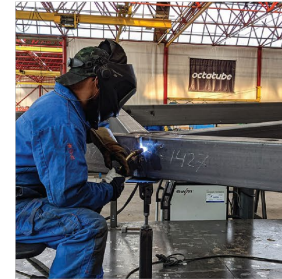
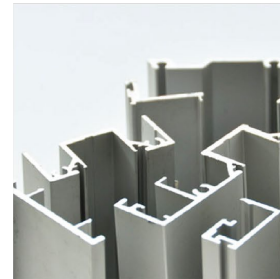
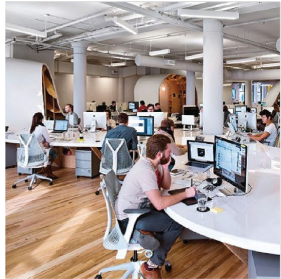

Architect

Facade Consultant

Material Manufacturer

System Provider

Facade Contractor

Developer/ Owner

Improving architectural sustainable practices

Consulting developers and architects on **decision making**

Receiving a higher volume of materials for **recycling processes**

Improving system design for **reversible connections**

Additional **Facade Disassembly Service** in their portfolio

Desires a building with a **maintenance strategy** and **longevity** (technically & financially)

the bigger picture

integrating end of life assessment

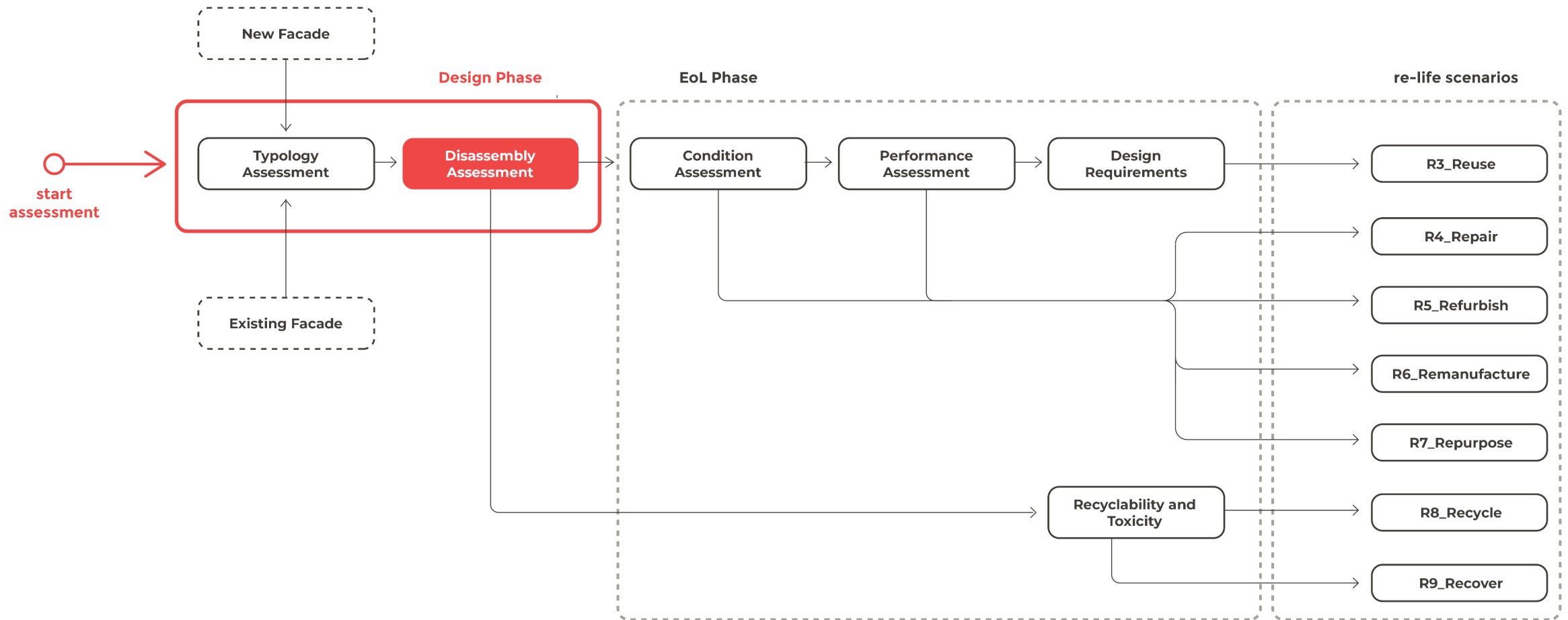

the bigger picture

end of life reclamation potential

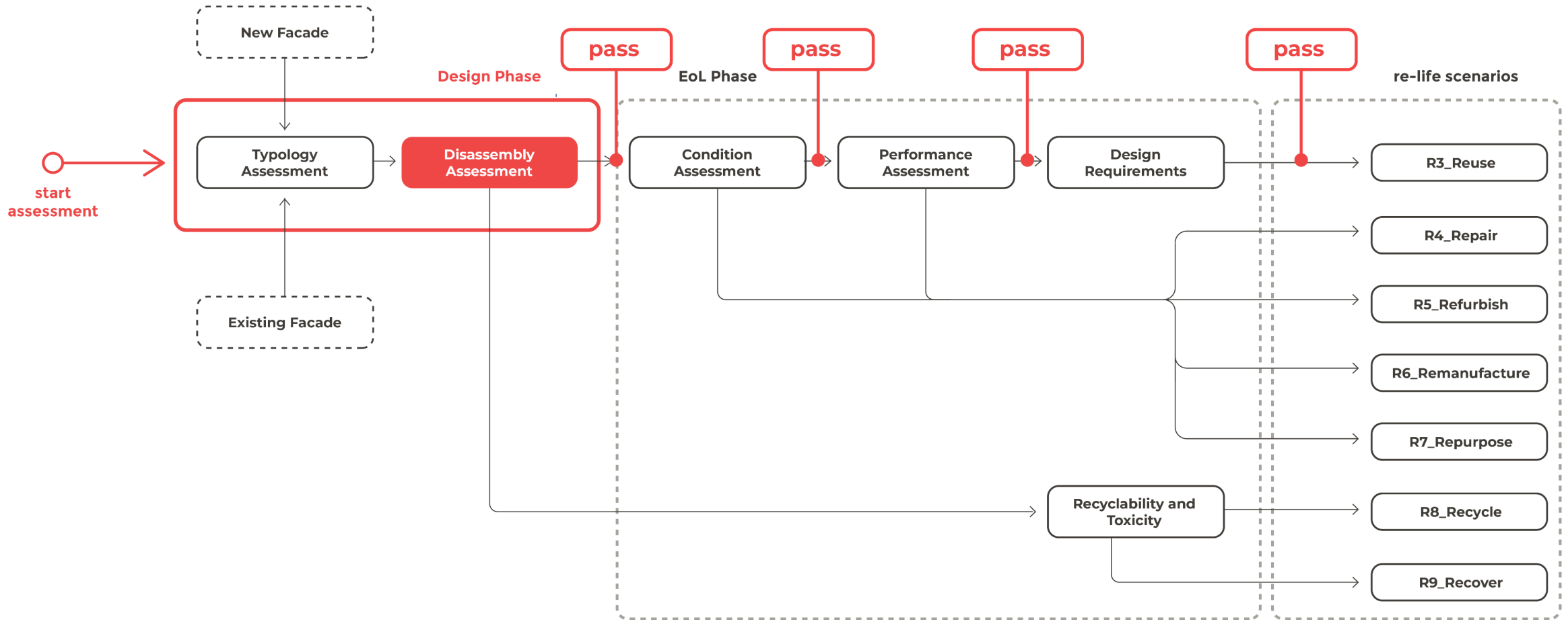

the bigger picture

end of life reclamation potential

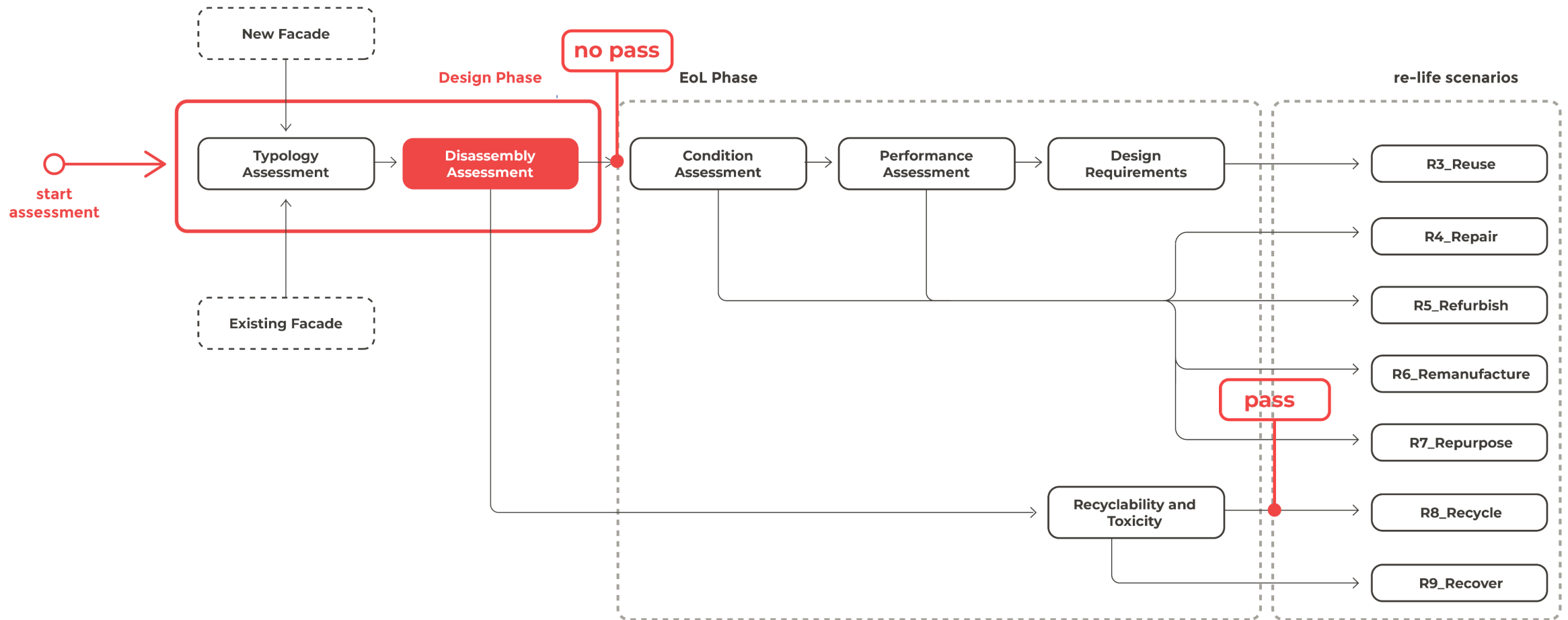

conclusions

further research

- 1. Test framework on case studies to create a database on connection disassembly times.**
- 2. Test process on other facade typologies to validate efficacy for design improvements.**
- 3. Reclamation in terms of environmental impact.**
there is a missing link between accounting for design for disassembly in environmental impact assessments.
- 4. Assess Economic Implications.**

Source: www.webpage.com

conclusions

conclusions

limitations

- 1. Information on disassembly times is scarce, assumptions had to be made.**
- 2. Information from Environmental Product Declarations are not in all cases complete. Granta EduPack was used to supplement missing information.**
- 3. The real reclamation potential should be assessed with experts in the demolition sector.**

conclusions

recommendations

design strategies	
minimize disassembly time	ensure common tools reduce disassembly tasks
make components accessible	avoid destructive disassembly methods due to inaccessibility
aim for high disassembly potential	higher detachability translates to easier removal of materials in good condition for reuse
reclamation potential	design for highest reclamation potential in facade systems
reuse materials	make designs as easy to disassemble as possible to increase reclamation potential

process strategies	
data transparency	ensure data sources are reliable
store information	structure information in databases for future disassembly operations
involve stakeholders	involve stakeholders to increase awareness
predict outcomes	designing while being able to predict the outcome in terms of reclamation potential

Source: www.webpage.com

conclusions

scientific relevance



design
optimizations

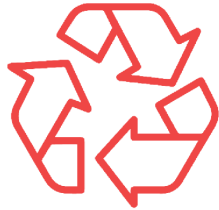

recycling and
material **reclamation**



outlook for
digitalization

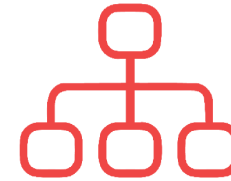

framework
design

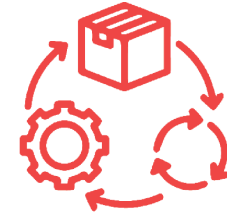

link to
life cycle assessment

conclusions

societal relevance



highlight
design barriers



promote resource
efficiency



reduction of
demolition waste



regulatory
implications



stakeholder
awareness

conclusions

answering research question

How can a disassembly assessment framework be developed to evaluate the influence of design for disassembly on material reclamation potential of stick system facades?

This research developed a disassembly assessment framework and applied it on several case studies of a stick system facades to test the efficacy. Information regarding materials, connection types, disassembly time can inform stakeholders on the reclamation potential of materials at the End of Life of a facade system. This information can be used for financial and environmental purposes.

The framework emphasizes the significance of structured data, comprehensive assessment methods, and the consideration of challenges in time consuming assessment frameworks.

Dank u wel!

