



Delft University of Technology

Faculty of Civil Engineering

Master Thesis in Structural Engineering (Concrete Structures)

Structural connections in circular concrete

Author:

M. Volkov

Graduation committee:

Prof. ir. R. Nijssen

Ir. J. M. Houben

Dr. H.M. Jonkers

Ir. P. Lagendijk (external)

Ir. A. Glias (external)

Structural connections in circular concrete

A study about the jointing methods for “second-hand” concrete elements

MSc Graduation Thesis

Mykyta Volkov

October 2019

Department of Structural Engineering
Faculty of Civil Engineering and Geosciences
Delft University of Technology
www.tudelft.nl

Abstract

Several researches have been done in the last decade about the possibility to “give a new life” to the second-hand reinforced concrete elements of a certain building which has been (fully/partly) disassembled. However, not often the actual technical detailing of their reuse practice are addressed.

This study is primarily focused on proposing the most suitable solutions to what concerns the reintegration of these structural second-hand parts into a “host” structure, which can contain other reused elements or can be a mixture of new and second-hand parts.

The overall approach to the previously mentioned task is structured as follows:

- Four structural systems have been considered to formulate the input list of elements for which re-connection approaches need to be formulated;
- Connection approaches have been formulated for the elements which have been considered suitable for a potential reuse;
- Selected connection methods from the ones formulated above have been studied in detail, assuming to embed them in a hypothetical office building made partially of second-hand elements.

From the first part it has been assumed that common columns, shallow beams, load bearing wall panels and one way slabs such as hollow core slabs and plank-floors can be potentially reused. In the second phase several connection approaches have been formulated, highlighting briefly their constructional details and specifying their advantages and drawbacks. Some of these resulted in having different degrees of overall complexity. In any case the proposed designs are requiring more investigation before being actually put in practice, since, for some methods a significantly different design from the one used for traditional connections was used. In the last part, regarding the case study of selected jointing methods, it was chosen to address three approaches: the connection of a second-hand column to the foundation block, a splice joint on a column and a complete study of a columns-to-shallow beams node.

In final result it has been deduced that, even if the feasibility regarding the use of second-hand elements requires a careful preliminary assessment and a detailed study about the cost-effectiveness of the details, the proposed connections could be potentially successfully embedded in a new structures.

This point has been also confirmed by the positive output results obtained at the end of the analysis of the case-study.

Contents

1. Introduction	5
1.1. Project presentation	5
1.1.1. Research questions	6
1.1.2. Research methodology	6
1.2. Motivation behind the research	6
1.2.1. Importance of the word “circular”	6
1.2.2. Incompleteness of traditional way of recycling	8
1.2.3. Environmental aspects	8
1.2.4. Economic aspects	9
2. Literature research about the general reuse practice	10
2.1. Steps leading to the reuse of an element	10
2.1.1. Pre-disassembling phase	10
2.1.2. Disassembling phase	10
2.1.3. Assessment of the elements	13
2.1.4. Transportation of the elements	13
2.1.5. Storage of the elements	14
2.2. Attempts to achieve demountability	14
2.3. Achievements in the reuse practice	17
3. The “donor” structural systems	19
3.1. Hollow core slab floors on load bearing walls	19
3.1.1. Generalities	19
3.1.2. Reusability features of hollow core slabs	20
3.1.3. Reusability features of load-bearing walls	20
3.2. Columns bearing directly two-ways flat slabs	20
3.2.1. Generalities	20
3.2.2. Reusability features of flat slabs	22
3.2.3. Reusability features of columns	22
3.3. Columns bearing shallow beams with one-way slabs	22
3.3.1. Generalities	22
3.3.2. Reusability features of plank-floors	24
3.3.3. Reusability features of shallow beams	24
3.4. Steel columns bearing integrated steel beams with hollow core slab	25
3.4.1. Generalities	25
4. The importance of structural connections and governing prescriptions	27
4.1. The features of structural connections	27
4.2. Generalities about the possible reconnection methods	28
4.3. Prescriptions from the Eurocode	28
4.3.1. Shear verification at the interface between concrete cast at different times	29
4.3.2. Anchorage length of longitudinal reinforcements	30
4.3.3. Lap length of longitudinal reinforcement	31
4.3.4. Shear reinforcement concentration in the overlap zone	32

5.	Reconnecting second-hand columns.....	33
5.1.	<i>Second-hand column foot, splice and node connections</i>	33
5.1.1.	Common methods for connecting newly made columns to the foundation block	33
5.1.2.	Common methods for achieving a splice joint.....	35
5.1.3.	Common methods for column to beam node connection	35
5.1.4.	Limitations and boundaries of second-hand elements	36
5.1.5.	Connection design proposals.....	37
6.	Reconnecting second-hand shallow beams.....	63
6.1.	<i>Second-hand shallow beam-to-column and the splice connections</i>	63
6.1.1.	Common methods for connecting shallow beams to columns	63
6.1.2.	Common methods for performing beam splice connections	64
6.1.3.	Limitations and boundaries of second-hand elements	64
6.1.4.	Connection design proposals.....	66
7.	Reconnecting second-hand load-bearing wall elements	75
7.1.	<i>Horizontal connection of second-hand wall elements</i>	75
7.1.1.	Common methods for connecting newly made elements.....	75
7.1.2.	Limitations and boundaries of second-hand elements	76
7.1.3.	Connection design proposals.....	76
7.2.	<i>Vertical connection of second-hand wall elements</i>	80
7.2.1.	Common methods for connecting newly made elements.....	80
7.2.2.	Limitations and boundaries of second-hand elements	81
7.2.3.	Connection design proposals.....	83
8.	Reconnecting second-hand floors.....	88
8.1.	<i>Second-hand hollow core slab to wall, shallow beam and integrated steel beam end-connection</i>	88
8.1.1.	Common method for connecting newly made hollow core slabs	88
8.1.2.	Limitations and boundaries of second-hand elements	89
8.1.3.	Connection design proposals.....	90
8.2.	<i>Longitudinal connection between adjacent hollow core slabs</i>	98
8.2.1.	Common methods for connecting newly made elements.....	99
8.2.2.	Limitations and boundaries of second-hand elements	100
8.2.3.	Connection design proposal	100
8.3.	<i>Second-hand one-way plank-floor to shallow beam connection</i>	103
8.3.1.	Common methods for connecting newly made elements.....	103
8.3.2.	Limitations and boundaries of second-hand elements	104
8.3.3.	Connection design proposal	105
9.	Numerical case study	107
9.1.	<i>Introduction of the project</i>	107
9.2.	<i>The “Second-hand building”</i>	108
9.2.1.	Generalities, modelling and assumptions.....	108
9.2.2.	Geometry of the building	110
9.2.3.	Loads and load combinations.....	110
9.2.4.	External constraints and internal boundary conditions	111
9.3.	<i>Classification and properties of the elements</i>	112
9.3.1.	Floor/roof elements.....	113
9.3.2.	Wall elements	113

9.3.3.	Beam elements	113
9.3.4.	Column elements	117
9.4.	<i>Reconnection of second-hand elements</i>	119
9.4.1.	Second-hand shallow beams to second-hand columns node	120
9.4.2.	Splice connection between two second-hand columns	134
9.4.3.	Second-hand column to foundation block.....	141
9.5.	<i>Conclusions and remarks about the case-study</i>	147
9.5.1.	Second-hand shallow beams and second-hand columns node.....	147
9.5.2.	Splice connection between two second-hand columns	148
9.5.3.	Second-hand column to foundation block.....	148
10.	Conclusions.....	149
10.1.	<i>Excursus over the studied elements</i>	149
10.1.1.	Second-hand columns.....	149
10.1.2.	Second-hand shallow beams	149
10.1.3.	Second-hand wall elements	150
10.1.4.	Second-hand hollow core floors.....	150
10.2.	<i>Final remarks</i>	150
11.	Bibliography	152

1. Introduction

1.1. Project presentation

At the end of the lifespan of a permanent structure, it is not very common in the engineering practice to hear the word “deconstruction” or “disassembling” instead of the word “demolition”, and when it regards concrete structures, it seems almost to be often a taboo topic. However, if we want to achieve a truly sustainable process and to talk about the circularity of the concrete life, it is necessary to get use to these words. Should we maybe treat the permanent structures as some kind of “long-lasting temporary structure”? Should we put more efforts and investments in achieving a “ready-to-disassemble” way of building? These questions can easily become rhetoric, if we think about the environmental impact cuts and the increased cost-effectiveness that can be obtained by studying and developing new techniques and by considering the concrete circularity potentials. The lifespan of properly made concrete elements may reach even 200 years, and this should be a warning sign for the builders, that the reuse practice is not an utopia.

Many examples can be made in civil engineering of situations in which this reusability can be successfully applied. Let’s consider for example that a portion of a highway road should be deviated and the current one is ready to be dismantled: the bridges over this road can be disassembled and the concrete beams can be reused to build another bridge or even a totally different structure.

A big research about the reusability features of concrete elements has been carried out in the 2013 by Ir. A. Glias, during his master thesis project called The “Donor Skelet”. In his work, a lot of procedural steps and recommendations have been described in detail.

This graduation work, besides of giving a general introduction and the existing research outputs on the “circularity” of concrete, will be focused on a formulation of recommendations about the design of structural connections between elements taken out from “donor” structures and the rest of the elements of the host-structure (built ex-novo or eventually also second-hand).

In other words, the topic of this thesis is how, in practice, to “give a new life” to second-hand elements by reintegrating them in a new structure.

The structural systems which are considered to be disassembled, so those which will be the “donors” of elements to be reused, are the ones that can be found more frequently in the current office buildings in the Netherlands. These are:

- Load-bearing walls with hollow core slab floors;
- Integrated steel beams carrying hollow core slab;
- Column structure bearing two-way flat slab;
- Shallow beams supporting one-way cast in-situ slab.

During the first phase of the research the reuse in the same and in other structural systems will be addressed, giving all the possible recommendations about the way to reconnect the second-hand elements to the rest of the structure.

During the second phase of this work, the analysis of the behaviour of selected joints among the ones presented in the first phase will be carried on, by considering them embedded in a hypothetical structure (office building) designed according to the Eurocode.

1.1.1. Research questions

As already mentioned in the project overview part, this work will rotate around the following central question:

- For each structural element extracted from the four structural systems presented before, how to perform the re-connection with the rest of the structure in which it will be embedded in its “second life”?

The previous central question can be split in other sub-queries which may arise while trying to find a coherent answer. Some examples of these questions can be:

- What are the boundaries of the second-hand elements respect to newly-made precast elements?
- What is the level of complexity for a certain connection between second-hand elements?

1.1.2. Research methodology

The research will be conducted using the following methods:

- First of all a detailed study of the available literature (which consists of books, journal articles and web-resources) will be performed, which will allow the author to formulate his first own conceptions about the topic;
- The opinion of experts in concrete structures will be heard, in order to have an idea of the correctness of the conceptual design previously formulated;
- FEM modelling (SCIA Engineer) will be used for the computation of the cross sectional actions;
- Calculations of the case study will be performed by hand and with the help of Excel spreadsheets;

Recommendations and verifications of the Eurocode will be used to give advice of the correct way to proceed with the re-connection.

1.2. Motivation behind the research

In this section some aspects which contributed to motivate the research and stimulate the enthusiasm for the topic will be addressed.

1.2.1. Importance of the word “circular”

Nowadays, there is worldwide a tendency and a willingness to achieve the so called “Circular economy” (which is in contrast with the “Linear economy”), and which is aimed to reuse/recycle as much as possible, minimizing with this the waste. People which are supporting the idea of the circular economy tend to assert that, with a good management of resources and of the process, it can be achieved at the same price and the same effort as the linear one (Circular economy, s.d.).

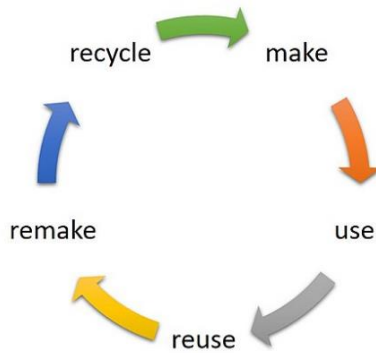

Figure 1.1 – The Circular Economy concept (Circular economy, s.d.)

To what concerns the construction practice, there is a tendency to inherit the same approach. The linear life-span steps of a traditional construction can be divided in the following phases:

- I. Excavation of raw materials;
- II. Production of (half) products;
- III. Assembly of final functional product;
- IV. Use of the product;
- V. Demolition of the product;
- VI. Landfilling or waste.

These can be seen in the Figure 1.2.

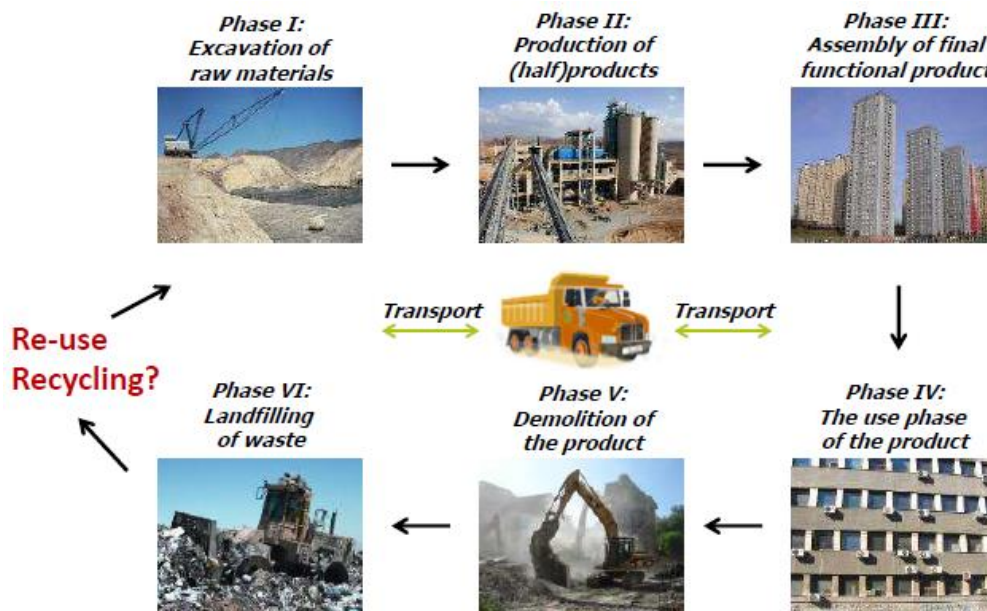

Figure 1.2 – Phases of the linear/circular lifespan (Jonkers, 2016)

These can be grouped in the following way (Jonkers, 2016):

- Phases I to III: “Cradle to gate” process;
- Phases I to VI: “Cradle to grave” process;
- Circularity: “Cradle to cradle” process.

The goal of the circular way of building is to propose the achievement of the following:

- A. Reduction to a possible extent of phases I, II and VI;
- B. Substitution to a possible extent of the Phase V with a “Disassembling of the product” phase;

C. Closure of the loop by drawing an arrow from the Phase V (modified as at point B.) and the Phase III;

By achieving these three conditions, a real circularity of the construction process can be reached.

1.2.2. Incompleteness of traditional way of recycling

To produce the concrete there is the need worldwide of a lot of gravel every year. There is the need of square kilometres of excavations, and of energy for the transportation. Nowadays one of the possible ways to reduce the need of new gravel excavation is to “recycle” old parts of the buildings. The demolished concrete and masonry parts go to a crusher and after that, the gravel is separated from the unneeded parts like for example the steel reinforcement, wooden parts or sheeting. At this point the recycled gravel is selected according to the particle sizes which are usually ranging from 2mm up to 16mm.



Figure 1.3 – Demolition process to gravel (Recycling concrete)

During this recycle practice there’s still the need for new binders and the amount of the recycled gravel part with respect to the total amount of gravel in the mixture of a new structural part is often limited to a worldwide average of about 40%. The Dutch standards allow a maximum content of recycled concrete aggregate up to 20% of the total mass, if no extra tests are made. However, above 20%, specific tests are required (Dutch NEN 5950, 1995).

The parts which are not suitable as gravel for new structural and non-structural elements are often used as subgrade for the roads or other types of infrastructure (Recycling concrete, s.d.).

However, even if this traditional way of recycling the concrete contributes to make the building industry more circular, it is not what is meant with the word “circular” in the title of this Thesis. In fact, it is very far from the practice of reusing entire structural parts, which is in all the cases, not a simple procedure. The reuse of entire structural parts would result in a much more drastic reduction of the wasted material.

1.2.3. Environmental aspects

During the design and the construction process, the 3 points of the below scheme, also called “The 3R” should be kept in mind.

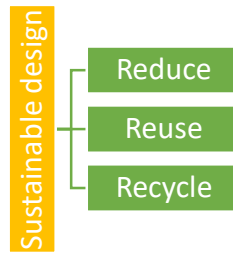

Figure 1.4 – The 3R of a sustainable design

This Thesis project will be focused on the “Reuse” point, but consequently it is also affects the “Reduce” point since the fact that the reuse of whole concrete parts will lead to a reduction in construction waste. This can be schematically summarized in the Figure 1.5.

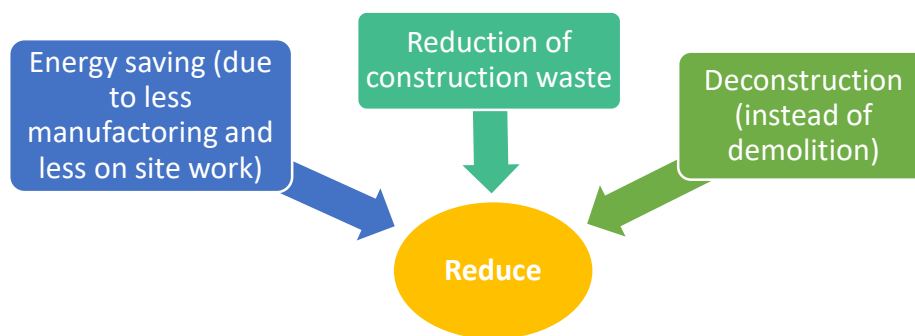

Figure 1.5 – The “Reduce” aspects

Recently some researches about the environmental aspect of the concrete elements were carried out at TU Delft. After performing an LCA on a building made of reused concrete elements and the same building made of concrete elements which contain recycled gravel, it was shown that the reuse process leads to a reduction of the environmental impact by 75%. (Glias, The "Donor Skelet", 2013)

1.2.4. Economic aspects

Even if, when talking about reusing second-hand elements, the cost reduction advantage can be a very attractive idea, the real situation is more complex respect to what one can think. In fact, different costs should be taken into account, of which the principal are referred to:

- Costs of the tests and of the assessments;
- Demolition costs;
- Transportation costs;
- Storage costs;
- Adaptation and shaping for the new structure costs.

Keeping these costs under a certain level is not always an easy task, and it is easily understandable that in order to find clients to whom to sell these elements, their prices should be much lower with respect to the equivalent new parts.

The last researches on the topic show that the difference in costs between a structure built with new materials and the one made for 64% of reused elements is of about 10%. (Glias, The "Donor Skelet", 2013)

2. Literature research about the general reuse practice

Nowadays there is still a great lack of codes and instructions which can be used to determine if and how a whole reinforced concrete element can be reused in another structure.

The key-aspects about the general reuse practice will be now here addressed. This is done since, before talking about the connections between second-hand elements, it is important to understand how these elements became available for the connection design. These aspects will not be discussed going deeply in all the details, but the main features definitely worth to be mentioned.

2.1. Steps leading to the reuse of an element

When an element is disassembled, in order for it to be reused, few important steps should be followed in order not to make some very costly mistakes in the building phase.

2.1.1. Pre-disassembling phase

Before the start of the “real” disassembling phase, some preliminary actions are required. The project of disassembling (which can be with partial demolition) should include the following documents:

- A general description of the building;
- A structural description of the building;
- A preliminary assessment of the technical properties of each element;
- A preliminary assessment of the technical condition of each element;
- List of the elements and the inventory of the parts to be reused;
- Ways to perform the building disassembling.

Despite of the frequent use of standardized structural systems in the construction of the buildings (even in the past decades), very often some changes have been made to the structure already on the building site, so they cannot be seen on the drawings and calculations of the building to disassemble. In other words, it can be said that every structure is somehow “unique”, and should be directly studied, analysing all the components and the details, sometimes directly on site.

2.1.2. Disassembling phase

As it can be easily understood, the first practical step after the preliminary assessment of the actual conditions of a reinforced concrete element is a correctly done disassembling process. In general, the deconstruction process is perhaps one of the most problematic aspects in the reuse practice. The disassembling process of concrete buildings is totally different from the disassembling process of, for example, steel structures, where elements can be often detached “just” by untightening few bolts. The situation is further complicated by the fact that nowadays there are no codes or prescriptions about the correct and the most suitable way to disassemble a concrete structure and to prepare it for a future reuse.

It should also be added that, according to recent studies, the disassembling phase has 60% extra costs respect to the demolition of the same structure (Naber, 2012).

Before starting the actual disassembling of structural elements, usually, the building should be reduced only to its load-bearing parts. This is also frequently done before traditional demolishing old buildings, and, even if in this case it should be done with more care in order not to damage structural reusable parts, there are no specific prescriptions to be suggested for this procedure. The disassembling of any kind of structure usually goes from the upper parts of a building to the lower ones. In the majority (but not in all) of cases, the disassembling process of a reinforced concrete structure requires the cutting of concrete. Since the fact that the reinforced concrete is not a monolithic material but, as from its name, it's composed of concrete part and reinforcement part, some problems may arise. The cut is usually performed in a "net" way, therefore the reinforcement bars are not protruding out of the cross-section, but, in the majority of cases, to achieve a suitable effectiveness during the reconnection process, as it will be explained in the next paragraphs, the reinforcement continuity should be ensured, and this condition is not so easily achievable.

In order to efficiently cut the concrete different tools are available on the market. Nowadays, the most used techniques to cut the concrete are:

- Diamond blade saw;
- Abrasive saw (also called "cut-off saw");
- Wire saw;
- Diamond wire saw;
- Electromechanical jackhammer;
- Pneumatic hammer;
- Chipping hammer;
- High pressure water.

Of the above cutting techniques, one of the most suitable for the disassembling process is the diamond saw, because it is quite precise (in order to avoid damages to other elements) and economic. However the drawback of the diamond saw is the excessive noise generated during its use. (Luiken, 2000)



Figure 2.1 – Two sizes of diamond saws (SCON 12) (Concrete saws)

In the future, the concrete cutting techniques may develop drastically, and one day it will maybe be possible to see concrete-eating robots, like the ones on the render shown in the Figure 2.2.



Figure 2.2 – The future of concrete sawing (Szondy, 2013)

The correct choice of the disconnection point is also very important.

Many factors should be considered, before taking such a decision. Some of the aspects that should be accounted for, are:

- Internal forces and moments in the element at the point of a potential disconnection;
- Safety of the rest of the structure after the element disconnection;
- Rebar position inside the element;
- Available room for the disassembling procedure;

To what concerns structural considerations, in general principle, the disassembling of a statically determinate element is much easier. This is due to the fact that no bending moment is present at the supports, which are often chosen as disconnection points and in most of the cases, no redistribution of forces or moments will take place in the donor structure after the extracting of the element.

It should also be kept into account that not always the disassembling of an element goes exactly as planned. Sometimes the cut surface of the element to reuse is not as smooth and as straight as expected. In fact, in the disassembling phase, chipping of the angles may occur, due to the increase of shear stresses during the cutting process. This can be repaired by replicating the missing reinforcement and by covering it with mortar. (Asam C. , 2006) An example is shown in the Figure 2.3.

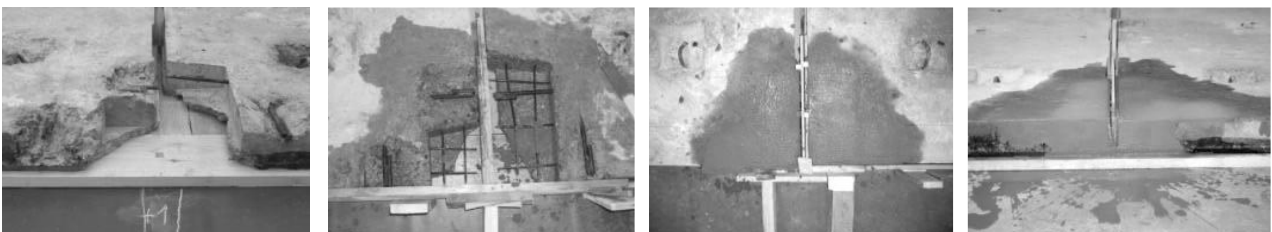

Figure 2.3 – Damages due to disassembling and their repair (Asam C. , 2006)

When possible, it is useful to use the same brigade of workers during the disassembling and during the reassembling phases. In this way they will be more careful in handling the element, which they will have to reassemble afterwards (Gliás, The "Donor Skelet", 2013).

2.1.3. Assessment of the elements

As mentioned previously, the preliminary assessment starts in-situ, before the demolition process starts, but more complete testing is required on the actual elements to be reused. Therefore, after the disassembling had taken place, an expert has to perform all the necessary laboratory and in-situ tests in order to assess the real conditions of the element and release a certificate, which confirms the possibility for the element to be reused. The most important parameters of an element to be assessed are the durability and strength after the end of the service life in the “donor” structure.

Even if the original bearing capacity and the complete specifications of the element at the construction time are known, the following relevant aspects which could have had negative influence have to be considered:

- The environmental conditions in which the original structure operated during its lifespan (mostly for the “external” elements which are exposed to the environmental conditions);
- The influence of time on the materials of the element;
- Maintenance which eventually took place;
- Eventual openings created during its lifespan;
- Eventual repairs.

The knowledge of these aspects can be decisive in order to assess the current state of the concrete (and eventually of the reinforcement, tendons, etc...). The fatigue behaviour of the concrete is not taken into account in any way when dealing with building for residential or office use, because there is no relevant cyclic loading in buildings thought for office or residential use.

The assessment procedures can require some time, advanced equipment and knowledge which implies some non-neglectable investments, but if these are done not on each individual element but on groups of similar parts located in similar environment, this step becomes much more cost-effective.

The main tests to be done in-situ are usually Schmidt hammering, Windsor probe test, ground penetrating radar, and of course simple visual inspection. While the laboratory tests to be done are usually the following: carbonation test (only for the elements which are directly exposed to climatic effects), strength tests on cores.

2.1.4. Transportation of the elements

After an element have been disassembled it can be transported to the new building site or just stored to wait its future use (Glias, The "Donor Skelet", 2013).

The transportation process is an aspect which has a bad influence on the reutilization practice. In fact, the transportation process has a financial cost and an environmental impact which is a drawback of the reutilization process.

A progressive minimization of the transportation impact can be obtained with the general spreading of the reuse practice itself. If the practice will become more popular and of a wider use, statistically, the offer and the demand locations of used elements will become physically closer one to each other, and the transportation distances will reduce drastically.



Figure 2.4 – Securing of second-hand slabs before their transportation (Asam C. , 2006)

2.1.5. Storage of the elements

If a second-hand element is not brought directly to the construction site where it will have its second life, this should be stored somewhere. Large warehouses as the ones that are usually storing the precast elements are perfect for this task, but of course, the longer is the period for which an element is stored and the higher will be its final cost, since the room for the storage may be quite expensive.



Figure 2.5 – Storage of second-hand slabs (Kristinsson, Hendriks, Kowalczyk, & te Dorsthorst, 2001)

2.2. Attempts to achieve demountability

Since the seventies to nowadays, some attempts to achieve an easy, fast and modular way of building with concrete took place. This reflected also in some thoughts of the designers of these systems to achieve the demountability, since the used connections were suitable for this aspect. In this paragraph, the most relevant modular systems will be presented.

It should be said that all of these methods were based on the structural system made of precast flat slabs on precast columns, and, in principle, they differed only by the way in which these elements were connected between each other. The connections of these building systems can

surely be seen as a starting point for the development of ways of jointing second-hand elements with the rest of the structure.

- *MXB-5 Building System*

The MXB-5 concept is based on dry-mounting method. The precast columns arrive to the construction site already with steel plates on both ends. The floors have anchor-holes in order to be jointed by means of bolts directly to the columns.

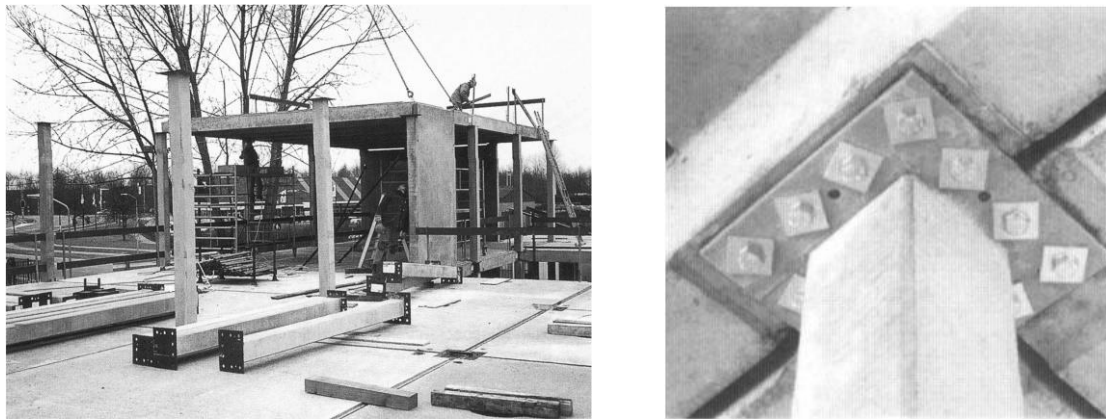

Figure 2.6 – MXB-5 mounting on site and column-slabs connection detail (Van Dijk, Boedianto, & Kowalczyk)

- *Bestcon-30 Building System*

In the upper part of the column, four reinforcement bars are left protruding. The precast slabs have holes to host the bars from the columns. Once that the floors are well positioned, the connection is sealed with mortar.



Figure 2.7 – Bestcon-30 column-slabs connection details (Van Dijk, Boedianto, & Kowalczyk)

- *CD20 Building System*

On the column ends, steel plates with four pins are present. These pins are meant to be inserted into the holes of metallic corners, present on each of the four slabs which the column is supporting. The metallic corners have slots which have to be grouted in order to have a solid connection. This system, developed in the 1978 is still available on the market.

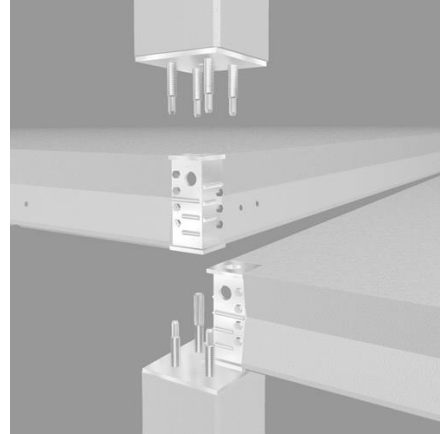

Figure 2.8 – CD20 overall view (Van Dijk, Boedianto, & Kowalczyk) and connection detail (The CD20 building construction system)

- *Moducon 2000 Building System*

On the top of the columns there are four insert bolts, while the floor of this system is made of traditionally reinforced cassette-type elements, with longitudinal and transversal ribs. The slabs have openings in the corners, through which the bolts are inserted. In the lower part of each column there are slots for fitting the bolts from the lower's floor column.



Figure 2.9 – Moducon 2000 on-site mounting and overall view (Bouwsystemen in de scholenbouw: Moducon-2000, 1999)

- *SMT Building System*

In the upper and in the lower part of the columns there are steel dowels. On these, the precast slab with holes in the corners is positioned, and then the mortar is poured in order to fill the opening with the inserted dowel. This system is similar to Bestcon-30.

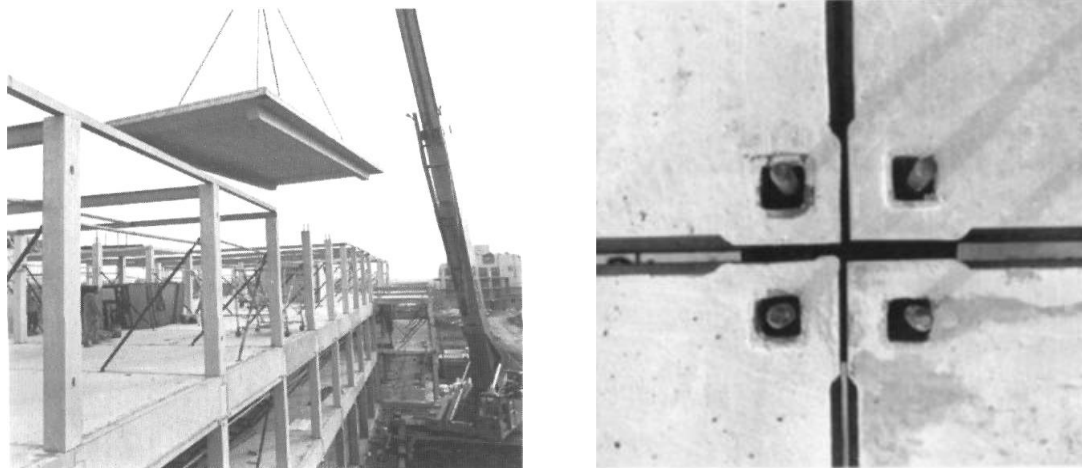

Figure 2.10 – SMT on-site mounting and column-slabs connection detail (Van Dijk, Boedianto, & Kowalczyk)

2.3. Achievements in the reuse practice

Not many examples of putting in practice the reuse process have been seen in the past, however, some of them took place. In this section the most relevant cases will be presented, which will help the reader to understand the current situation.

- *Apartment building in Middelburg*

In the Dutch city Middelburg, an apartment building was 15 years old when it was chosen in 1986 to apply the reuse of its elements instead of demolishing it. The decision to proceed in this direction was that due to social problems, the occupancy of the building was too low.



Figure 2.11 – Middelburg apartment building before the disassembling (Kristinsson, Hendriks, Kowalczyk, & te Dorsthorst, 2001)

The original building was 11-floor high. The plan consisted in demounting the upper floors, in order to leave one 4-storey building and with the reused elements rebuild one 4-storey building and one 3-storey one.

The demounting of the building was estimated to be possible because the connections between reinforced concrete elements were not grouted, but just dry-mounted. Only two saw cuts were required to free the floors from the walls.

Even if it turned out to be a quite expensive project respect to a potentially newly built building (Coenen, 1990), this reuse project was successfully carried out from an engineering point of view.

- *Apartment building in Maassluis*

In the year 2000, in the Dutch city Maassluis, another disassembling project took place. The addressed building was called “Elementumflats” and it was built after the World War II. Even if there was the choice to renovate the existing building or to build a new/reused one, the second option have been chosen. The upper floors were disassembled, leaving just the ground floor and the second floor. But in the end, no reassembling took place, for several reasons (logistics, financial issues with government subsidies, etc..)



Figure 2.12 - The main structure after removing the upper floors (Naber, 2012)

So, after all, this reuse project can be rated as “failed” because no reuse phase took place, but only a careful disassembling, which in this case can be seen as equivalent to a partial demolition.

- *Small residential house in Mehrow*

Another successful example of reuse of second-hand elements, took place in the city Mehrow (near Berlin), in Germany. The elements to be reused have been taken from several disassembled buildings, which were initially built according to the “Plattenbau” technique. The final reduction in terms of costs, respect to the possibility if the same house potentially would have been built with new elements, was quantified to be 30%. (Stacey, 2011)



Figure 2.13 – Mehrow house building procedure and final result (Asam C. , 2006)

3. The “donor” structural systems

In this chapter, the four structural systems where the second-hand elements to be connected come from, will be briefly presented. For each of these, first of all a quick introduction will be given, in order to remind the reader their key features, and afterwards a reflection about the “reusability” will be made, evaluating the strong and the weak points of the potential reuse practice of each element, still keeping in mind that this Thesis is intended to be more focused on the design of structural connections with second-hand elements involved rather than on the disconnection phase one of the latter.

As mentioned before, the choice of these four structural systems was mainly dictated by the fact that they can be more often found in old office buildings (category of buildings with the highest vacancy rate in the Netherlands), which otherwise would undergo the complete demolishing.

3.1. Hollow core slab floors on load bearing walls

3.1.1. Generalities

The first structural system, which is here introduced, regards buildings made with fully precast elements: load-bearing precast walls as vertical structural elements and hollow core slabs as horizontal elements. This way of building became very popular since the ‘80s and the percentage of buildings built with this structural type is still growing over the cast in-situ way of building. Today this is the mostly diffused method for constructing office buildings in the Netherlands.

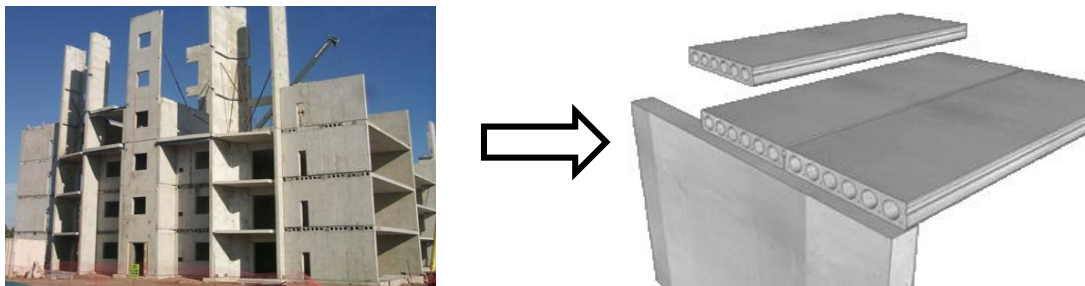

Figure 3.1 – Hollow core slabs on load bearing walls structural system (Off-Site And Modular Construction Explained) (Schokbeton Saramac - Connections hollow core slabs, n.d.)

This structural system ensures quick building process (also because of the possibility of all-weather building) and a cleaner building site. Some general features regarding the involved elements are:

- The hollow core slabs have usually a thickness which goes from 200mm (for spans 0-9m) up to 400mm (for spans of 12-18m). They can have a structural topping (thickness of 50-70mm, with reinforcement inside), finishing topping 20-30mm (with no reinforcement inside) or not having any topping at all.
- The load bearing walls are elements of around 3,5-4m high and around 7,2m long with a thickness ranging between 180 and 200mm.
- The structural joints in this kind of structures are usually cast in situ and they can be of a great variety of types.

3.1.2. Reusability features of hollow core slabs

From different existing studies, it is known that the hollow core slabs are one of the most suitable parts that can be potentially reused. It is perhaps easier to reuse hollow core slabs deriving from office buildings in low residential houses. (Naber, 2012) Of course, the level of this easiness depends on many factors, such as:

- Right (or easily adjustable) dimensions and properties between the second-hand slab and the one that is needed in the new construction;
- Compliance of the technical features with the new codes;
- Eventual presence and type of the original topping layer and its function;
- Type of the original connection with the load-bearing wall;
- Type of the connection of the slab with adjacent slabs;
- Condition of the slab.

It should be also considered how many block-outs and other openings are designed to be made in the floors of the new construction. In order to efficiently reuse the hollow core slabs, there should not be many block-outs in the new design (Naber, 2012).

To what concerns the topping layer, this can either be removed or not, before the disassembling begins. However, due to the fact, that the topping covers the joints between the slabs and due to the fact, that it adds extra weight to the slab to reuse, the best solution is to remove it before the reuse process starts (Glias, The "Donor Skelet", 2013)

3.1.3. Reusability features of load-bearing walls

One of the limiting features for their active reuse is the presence of the openings such as doors and windows, which are seldom compatible with the required openings in the "new" structure. So, if the structure in which the second-hand will be reused was not designed keeping into account that the elements will come from a certain structure, this can be a problem, which however can be solved by closing-up these openings (it should in any case taken into account that this requires efforts and therefore extra costs).

It should also be kept in mind that the external walls may be often exposed to climate effects, so they have to be carefully assessed before their reuse takes place.

However, if the properties of the second-hand element are all as requested, or, if during the new design, the availability of a certain types of walls was known and this was considered, the walls can be successfully reused.

3.2. Columns bearing directly two-ways flat slabs

3.2.1. Generalities

This structural system is composed mainly of two load-bearing elements: reinforced concrete columns and slabs. There are no beams involved, but the load is transferred from the slab directly to the column. This kind of slabs are two-way reinforced.

One of the main advantages of this type of construction is the fact that the net height of each floor is not reduced by the beam's depth. This structural type is also aesthetically quite nice to see and gives a lot of freedom to the work of the architects and engineers.

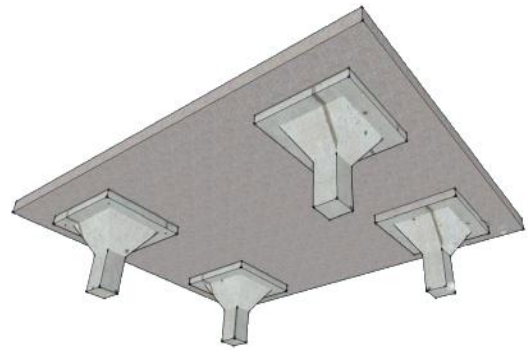
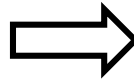

Figure 3.2 – Two-way slabs on columns structural system (Types of Economical Floor Systems for Reinforced Concrete Buildings)

The punching action of the column is an effect that should be always taken into account in this case, and, for this purpose, the column heads (also called “capitals”) or/and drop panels at the column-slab interface have always an important “role in the game”.

Some general features regarding the involved elements are:

- The two-way slabs can be with or without shear reinforcement. It should be always kept in mind that the failure of flat slabs without shear reinforcement is brittle, and this can be very dangerous in practice.

It has been also found that very often the slabs can carry compressive loads from the columns much larger than the uniaxial compressive strength of the concrete they are made of. This is due to the fact that, there is a kind of concrete confinement to a certain extent from the reinforcement in the slab. (Guidotti, Fernandez Ruiz, & Muttoni, 2011) A generic representation of such slab is shown in Figure 3.3.

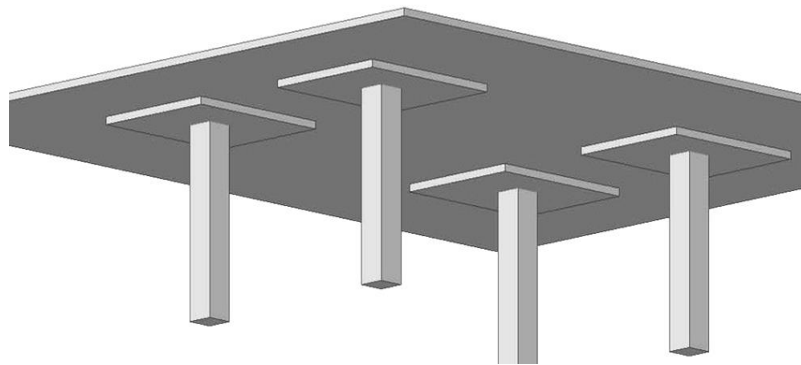

Figure 3.3 – Representation of a generic flat slab with drop-panels (Flat Slab Diagram)

- The two-way slabs are laying directly on the columns, to which they are transmitting the self-load and the load from the various actions. These columns can be precast as well as cast in-situ. In any case, they have longitudinal and transversal reinforcement inside which is designed to fulfil the requirements of the structure and comply with the codes valid at the moment of the construction of the building.

Usually, columns for this kind of purpose, are cast in high-strength concrete.

A generic representation of such column, its reinforcement and its cross-section is shown in Figure 3.4.



Figure 3.4 – Representation of a generic concrete column (Slenderness Effects for Concrete Columns in Sway Frame - Moment Magnification Method)

3.2.2. Reusability features of flat slabs

In this graduation project it has been decided to rate the flat slabs as elements which cannot undergo a cost- and effort- effective reuse process. This is due to the fact that these cast in-situ elements are usually made particularly “on-size” for every singular structure, with precise support locations and precise internal disposition of reinforcement. Even if the cutting of the column from the bottom of the capital/drop panel and the subsequent reconnection of it could be theoretically possible (even with the same methods as for second-hand splice joints which will be mentioned further on), the reconnection of such a two way panel in the span directly to another panel (by ensuring also continuity of actions) would be an extremely laborious procedure, and therefore it will not be addressed.

3.2.3. Reusability features of columns

The columns are elements which can relatively easily be disassembled and consequently reused. In this case the most suitable point where to disconnect the column from the slab element is right under the drop panel or under the capital if this is present. This is the most suitable location because in this way the slab remains without any column protrusions and is almost “ready” to be reconnected to a new column without the need to remove the remaining concrete of the column.

3.3. Columns bearing shallow beams with one-way slabs

3.3.1. Generalities

Another structural system, which can also be found very frequently in vacant Dutch office buildings, consists of columns bearing wide beams with one-way slabs laying on top. This way of building is often encountered for several reasons, the main one can be that respect to the traditional use of deep beams or T-beams, there is no reduction of the free floor height. In the Figure 3.5 a real structure of this kind with its schematization can be seen.

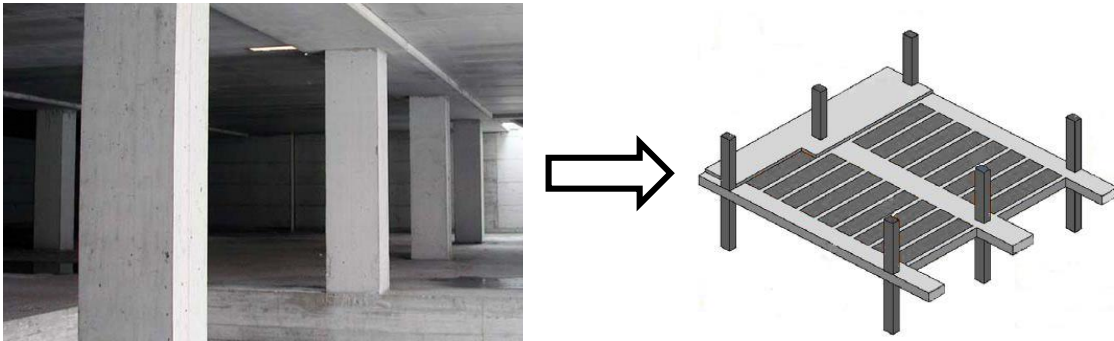

Figure 3.5 – Shallow beam on columns structural system (Conforti, Minelli, & Plizzari, 2013)

Some general features regarding the involved elements are:

- The slabs spanning between shallow beams may be of many different types (also hollow core slabs), but the one, which will be addressed here, is the so-called plank floor (sometimes also referred as “filigree slab”). The span of this kind of slabs is usually not very large (3 to 6 meters), and the suitable live loads is around 3 to 5 kN/m^2 . This has its bottom layer precast with steel lattice girders embedded in concrete, while the top layer is usually cast in-situ. The volume between the lattice girders can often be filled with polystyrene or other lightweight fillings, which allows leaving empty voids inside the slab once that it is completed. Beside of the steel lattice girders, the slab has reinforcement bars in the precast layer and, also in the cast in-situ layer. In Figure 3.6 a filigree slab with its internal reinforcement is shown.

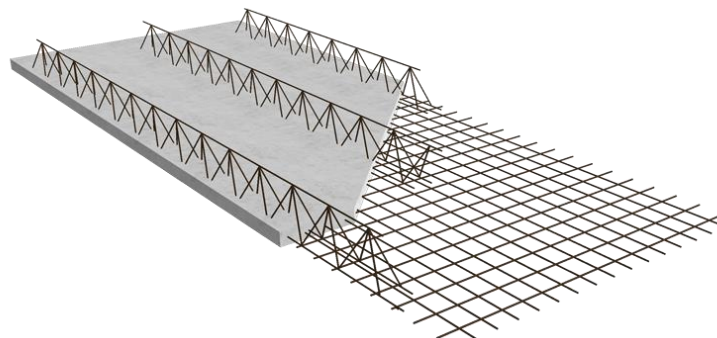

Figure 3.6 – Model of a filigree slab showing its internal reinforcement (Products)

While, to what concerns the eventual fillings (still keeping in mind that this type of weight reduction is not very common), some methods are shown in the Figure 3.7.

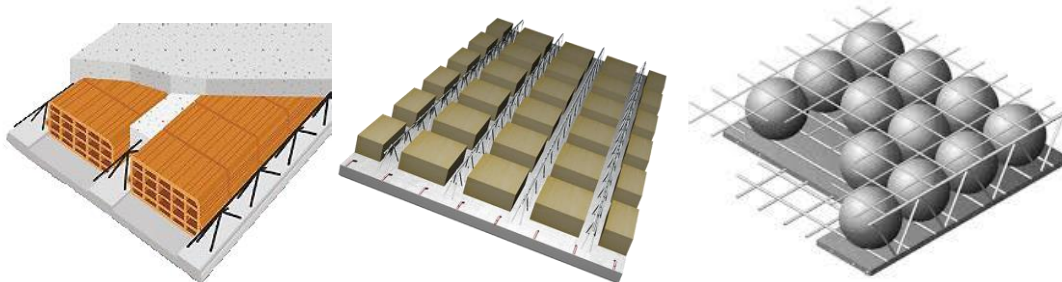

Figure 3.7 – Eventual weight-reduction elements (Filigree Slabs)

- The shallow beams addressed in this circumstances can be half-precise, as shown in the Figure 3.8.



Figure 3.8 – Half-precaster beam

Their upper part is not usually precast in order to be able to laterally connect to it more easily the slab elements (hollow core slabs or plank-floors as in this case).

- The shallow beams are laying on the columns, to which they are transmitting the self-load and the load from the plank-floors. The same considerations already mentioned in the previous section about columns supporting two-way slabs are valid also here.

3.3.2. Reusability features of plank-floors

As it can be easily understood, the slab that we find in a building to disassemble, does not look like the one shown in the picture above, but has the top concrete layer attached monolithically to the precast part and to the lattice girders. This top layer cannot be removed because of its bond with the steel bars, and the plank-floor is a monolithic element at this stage of its lifespan.

3.3.3. Reusability features of shallow beams

The shallow beams are often designed to have a continuous behaviour and not to be simply supported on one span. It is known that a continuous beam has a bending moment diagram as the one shown in Figure 3.9.

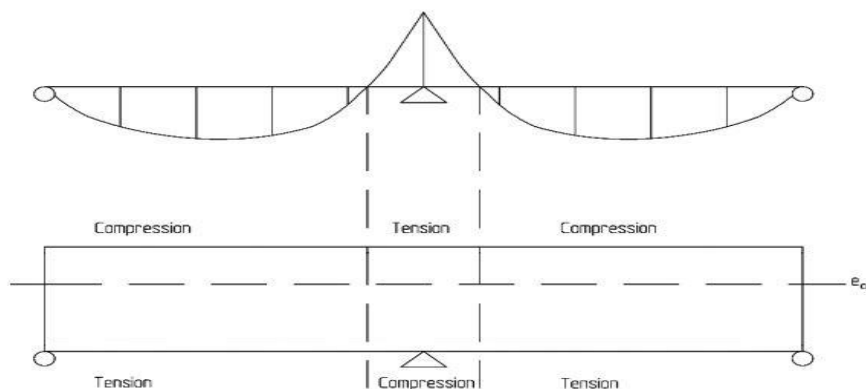

Figure 3.9 – Generic two-span beam bending moment diagram

It can be technically very difficult to disassemble such an element, cutting it at the positions where the bending is not zero because of the fact that during the cutting procedure we would have to deal with the fact that the beam can brake at a certain moment of the disassembling. At this point, it should be considered, that, before the disassembling of a continuous beam, it might be necessary to apply a load from the bottom of the beam upwards in both the spans in order to balance the self-load of the beam and to bring the bending moment to zero at the point of disconnection.

An option can also be to cut it at the position where the bending moment is actually zero, in this case is also more likely that less reinforcement is present in the cross-section.

3.4. Steel columns bearing integrated steel beams with hollow core slab

3.4.1. Generalities

This fourth structural system, which is hereby presented, consists of steel columns supporting integrated steel beams to which the loads from hollow core slab are transmitted.

Some advantages of this structural system may be the features such as fast construction process and no evident limitation to the height of the building.

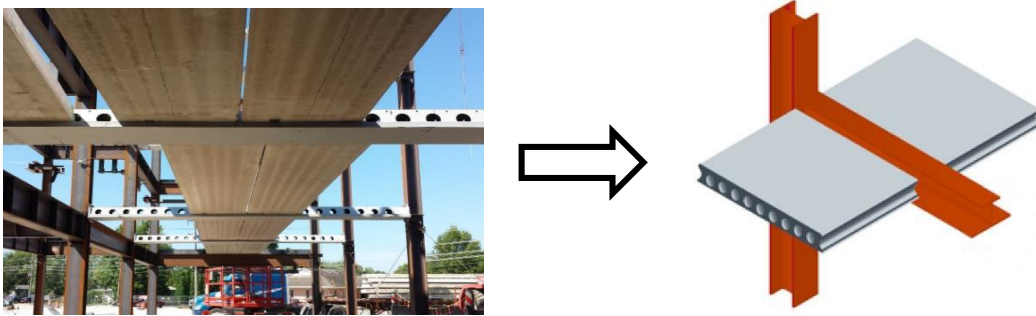

Figure 3.10 – Hollow core slabs on integrated steel beam structural system (Framing Schematics)

Some general features are:

- To what concerns the hollow core slabs used in this structural system, the same exact considerations, which have already been mentioned previously during the description of the hollow core slabs on load-bearing walls, apply also here. Usually the slab spans up to 9m. Concrete topping is generally used to embed the steel beam and create a completely monolithic structure.

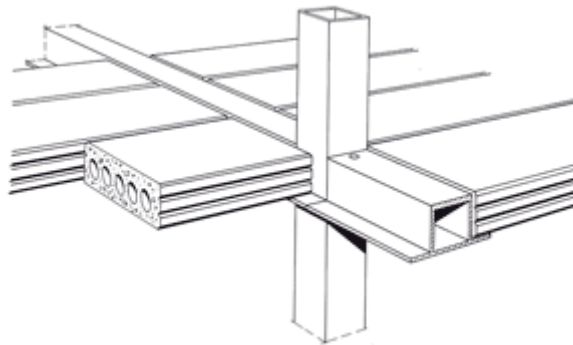

Figure 3.11 – Hollow core slabs on THQ steel beams (Opwarming geïntegreerde liggers, s.d.)

Of course, it should be kept into account that this time the type of connection between the slab and the integrated steel beam is different, however, this will be analysed further on in the dedicated chapter.

- The beams for the purpose of this kind of “integration” are also known as “slim floor beams”, this is because they minimize the floor depth. The length of the beams goes up to 7,5m. The “normal” fire resistance of the beam itself is usually around 60 minutes (for the open sections) but this can be extended by applying boards or intumescent coating to the lower flange.

On the market is available a huge variety of beams with different cross sections. Some of the most common ones are showed in Figure 3.12.

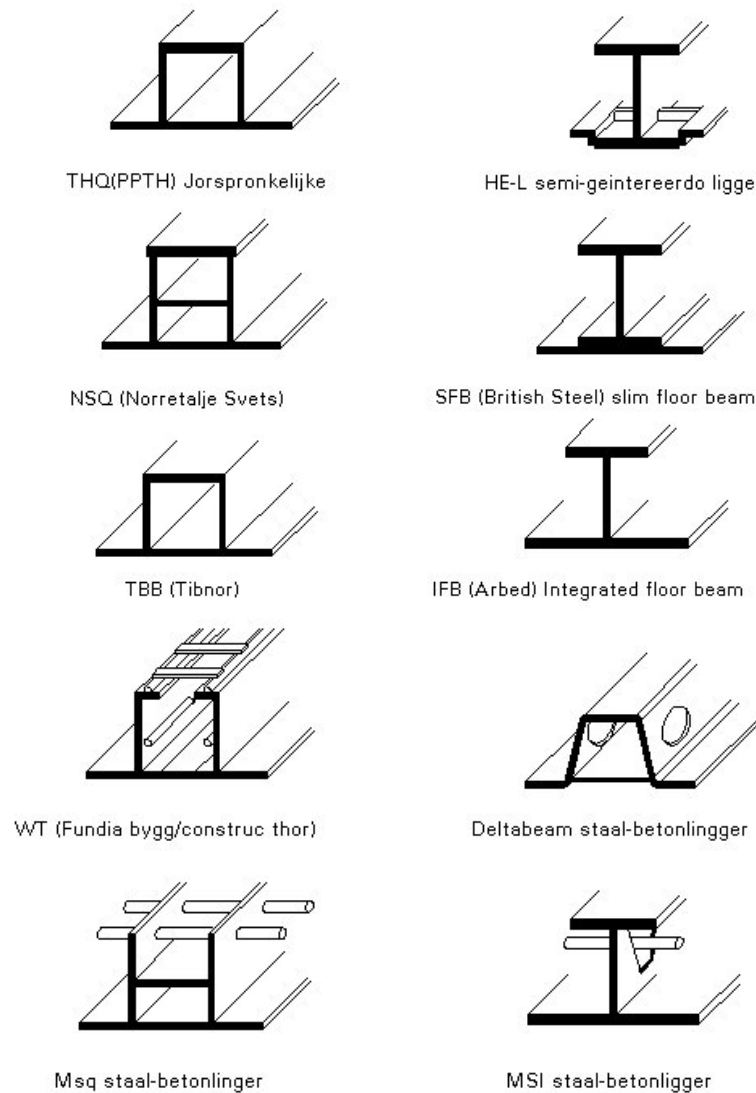

Figure 3.12 – Varieties of steel beams for use with concrete slabs (Lecture 14.7: Anatomy of Multi-Storey Buildings)

Torsional failure of the beam is very dangerous during the construction phase, when the beam is loaded unequally on the sides. To what concerns this aspect, beams with closed sections are behaving much better, since the fact that such sections are less vulnerable to torsional problems.

In this study it is assumed that in the second-hand building which have to be disassembled, simple I-beams are used.

- Even if the integrated steel beams can be also supported by concrete columns or load-bearing walls, the columns of this structural system in this graduation work are considered to be closed-section steel profiles. The configuration of such columns is not related anyhow to the reuse process of the hollow core slabs, which a donor structure can offer, and therefore, these elements will not be subject of any attention.

4. The importance of structural connections and governing prescriptions

Once that an element has been detached from the structure it belonged to during its first “life” and it reaches the structure in which it has to be integrated, the real crucial question can be asked: “How the embedding of this second-hand part can practically can be done?” Of course, in real life, this question should not arise at the time when the part reaches the new building site, but much before, and to be precise, when the engineer decides that a certain piece can be structurally suitable for a certain new construction.

The modification/adaptation of a second-hand element to be embedded, can take place (Glias, The "Donor Skelet", 2013):

- On the deconstruction site (if the new use of the element is known);
- At the storage site;
- At the new construction site.

It should be said that, in general, to make the reuse process cost-effective, every element should undergo as less adaptation procedure as it is possible (Naber, 2012). And this adaptation should be possibly done not on the building site because of its potential impact on the erection speed (Lagendijk P. , 2019).

As it is well known, in most of the constructions, the connections between structural elements are details, which can make the difference between a safe and effective design and a total fail, and this is what this thesis will address the most.

The connection should be as simple as it is possible, but capable of accomplishing the functions for which it has been designed.

4.1. The features of structural connections

The connections are perhaps the details that deserve more attention while designing a structure. The most crucial features of the connections, subdivided in two main groups, are here briefly mentioned (CUR-VB, 1985):

1. Features regarding the function of a connection:
 - The connection should have sufficient strength;
 - Connections which transmit bending, should be sufficiently rigid but also enough deformation capacity in order to guarantee redistribution of moments under extreme conditions;
 - Absorption of creep and shrinkage should be guaranteed;
 - Hinged connections should guarantee enough freedom of rotation;
 - Fire and corrosion resistance should be guaranteed.
2. Features regarding the realization of a connection:
 - Simplicity of a connection is often a priority;
 - Inspection of the realized connection should always be done;
 - The connection should accommodate the dimensional tolerances of the elements, as well as erection tolerances (Lagendijk P. , 2019)
 - Costs, aesthetics and production possibilities should be taken into account during the design of the connection;

Even if in this graduation work, better than the word “connection”, the word “reconnection” should be used, the previously mentioned points for a reliable connection do not change.

4.2. Generalities about the possible reconnection methods

As already mentioned before, in the nowadays engineering codes, such as the Eurocode, there are no prescriptions to what regards the jointing of reused element. Many of the connection methods, which will be presented, are actually adaptations of the techniques used to connect common precast elements. This is mainly because, after all, second-hand elements, which arrive to the building site of a new structure, are in fact precast (in a factory or in the previous building site). However, the differences between second-hand elements and the newly precast ones are actually significant, one of the main ones is that during usual pre-casting, the steel reinforcement or other metallic parts are in place before pouring concrete, while in case of reused elements, a solution for using the existing reinforcement or for adding other parts to already cured concrete should be developed.

The first step can be the definition of the general types of possible connections between reused elements and the rest of the structure, and this can be mostly of two types: wet, and dry. However, besides of the actual “connection” step, it should be also identified the method of adaptation of the second-hand element for being reused, which will be here divided in two general categories: with added provisions (plates, anchors, bars) or without the latter.

Therefore we come to the following combinations:

- a) Cast in-situ wet connection without any added provisions;
- b) Cast in-situ wet connection with added provisions (plates/anchors);
- c) Dry connection without any added provisions;
- d) Dry connection with added provisions (plates/anchors).

The type of connection (a) is mostly possible in case when the original reinforcement of the element is not sawn at the same position when the concrete is sawn.

The type of connection (b) is often possible when the reinforcement bars are cut together with the concrete, so, usually some steel parts have to be inserted and/or added.

The type of connection (c), so a dry connection with an element, which have been just extracted (often by sawing concrete and reinforcement) from another structure, without any added provisions, is usually very difficult to put in practice, this can be imagined, for example, for a second-hand simply supported beam which does not require a lot of bonding in the host-structure, however even in that case it is necessary to anchor it in place by its bottom reinforcement, which is very difficult to be done without any grouting process. One of the solution to achieve this type of connection might be however to predispose the second-hand element for a sort of purely mechanical dowel-type connection.

The type of connection (d) can be usually performed on second-hand elements which have been considerably adapted (process which is usually done not in-situ).

4.3. Prescriptions from the Eurocode

In order to give a new life to a second-hand element, the latter should fulfil some important structural requirements. As it is known, for most civil engineering requirements, the most used code in Europe is the Eurocode (EC).

In the Netherlands, the old office buildings were designed mainly according to two old codes, respectively the VB 1974/1984 and VBC, while nowadays, the requirement is to have the elements designed according to the Eurocode, so, many times this can bring to some difficulties during the reuse process.

At this point, an engineer can potentially do two things in order to convince a client to take into consideration the idea about reuse practice:

1. Prove with modelling and calculations that a certain part is as safe and reliable, as it is a newly-designed part according to current codes;
2. Adapt a second-hand part designed according to old codes, to the Eurocode requirements.

This Thesis is focused on the second one of these, even if in practice, also the first approach worth to be considered, and sometimes it may even result to be the more convenient one (this requires deeper investigations, which are not part of this graduation work).

For this reason (and for the reason that in the case study which will be presented further on these prescriptions are applied) in this paragraph some of the relevant prescriptions from the Eurocode, which are more likely to be taken into account during the design of joints with second-hand elements, will be presented. The usual shear (with presence of shear reinforcement), bending and bending-normal force interaction verifications will not be presented here, since they are absolutely the same as for newly-made elements.

4.3.1. Shear verification at the interface between concrete cast at different times

Since very often the gap between the second-hand element (or a portion of it) and the element to which the latter is jointed is grouted in-situ, we will have contact between concrete cast at different times. For this purpose, in the section 6.2.5 of the EN 1992.1.1 a verification is prescribed. The procedure which is shown here regards a second-hand element grouted head-to-head to another element (second-hand or newly-cast) with an interface layer of newly-cast concrete:

$$v_{Edi} \leq v_{Rdi}$$

Where:

$$v_{Rdi} = c f_{ctd} + \mu \sigma_n + \rho f_{yd} (\mu \sin \alpha + \cos \alpha) \leq 0,5 v f_{cd}$$

And:

- v_{Edi} is the design value of the shear stress given by $\frac{N_{Ed} \cos \alpha + V_{Ed} \sin \alpha}{hb_i}$;
- ρ is given by $\frac{A_s + A_s'}{hb_i}$;
- $v = 0,6 \left[1 - \frac{f_{ck}}{250} \right]$;
- To what concerns c and μ they are taken respectively 0,4 and 0,7 because the interface surface is considered to be "Rough", which means that it has at least 3mm roughness at a distance of 40mm from each other (the surface is roughened for this purpose).

All the above with reference to the scheme in Figure 4.1.

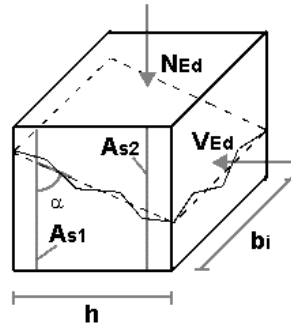

Figure 4.1 – The interface location to be considered in the calculation (Shear strength in concrete joints - Eurocode 2)

Attention should be paid to assuming always the correct interface area (in this case given by $h \cdot b_i$). It is not so obvious which is the actual contact area.

4.3.2. Anchorage length of longitudinal reinforcements

Very often, during the design of a connection between second-hand elements, the anchorage of the longitudinal reinforcement of the latter inside the part to which is connected should be provided. The second-hand element will very likely not have enough protruding reinforcement to meet the anchorage length requirement, however there are few solutions to this, such as welding bars to the existing reinforcement or drilling coupling holes aside to this. In any case, the following anchorage length, specified in section 8.4 of EN 1992.1.1 should be met:

$$l_{bd} = \alpha_1 \alpha_2 \alpha_3 \alpha_4 \alpha_5 l_{b,rqd} \geq l_{b,min}$$

The basic required anchorage length is given by:

$$l_{b,rqd} = \frac{\phi \sigma_{sd}}{4 f_{bd}}$$

Where:

- σ_{sd} is the actual design stress in the reinforcement bar, at the position where the anchorage is measured from;
- f_{bd} is the ultimate bond strength, and is given by $2,25\eta_1\eta_2f_{ctd}$;
- f_{ctd} is the design value of concrete tensile strength;
- η_1 is related to the bond conditions. It's equal to 1,0 when "good" conditions are obtained, and to 0,7 for all other cases;
- η_2 is related to the bar diameter. It's equal to 1,0 when the diameter is lower or equal to 32mm, and it's equal to $\frac{132-\phi}{100}$ when it is larger than 32mm.

To what concerns the α -coefficients, these are given in the Table 4.1:

Influencing factor	Type of anchorage	Reinforcement bar	
		In tension	In compression
Shape of bars	Straight	$\alpha_1 = 1,0$	$\alpha_1 = 1,0$
	Other than straight (see Figure 8.1 (b), (c) and (d))	$\alpha_1 = 0,7$ if $c_d > 3\phi$ otherwise $\alpha_1 = 1,0$ (see Figure 8.3 for values of c_d)	$\alpha_1 = 1,0$
Concrete cover	Straight	$\alpha_2 = 1 - 0,15 (c_d - \phi) / \phi$ $\geq 0,7$ $\leq 1,0$	$\alpha_2 = 1,0$
	Other than straight (see Figure 8.1 (b), (c) and (d))	$\alpha_2 = 1 - 0,15 (c_d - 3\phi) / \phi$ $\geq 0,7$ $\leq 1,0$ (see Figure 8.3 for values of c_d)	$\alpha_2 = 1,0$
Confinement by transverse reinforcement not welded to main reinforcement	All types	$\alpha_3 = 1 - K\lambda$ $\geq 0,7$ $\leq 1,0$	$\alpha_3 = 1,0$
Confinement by welded transverse reinforcement*	All types, position and size as specified in Figure 8.1 (e)	$\alpha_4 = 0,7$	$\alpha_4 = 0,7$
Confinement by transverse pressure	All types	$\alpha_5 = 1 - 0,04p$ $\geq 0,7$ $\leq 1,0$	-
where: $\lambda = (\Sigma A_{st} - \Sigma A_{st,min}) / A_s$ ΣA_{st} cross-sectional area of the transverse reinforcement along the design anchorage length l_{bd} $\Sigma A_{st,min}$ cross-sectional area of the minimum transverse reinforcement = $0,25 A_s$ for beams and 0 for slabs A_s area of a single anchored bar with maximum bar diameter K values shown in Figure 8.4 p transverse pressure [MPa] at ultimate limit state along l_{bd}			
* See also 8.6: For direct supports l_{bd} may be taken less than $l_{b,min}$ provided that there is at least one transverse wire welded within the support. This should be at least 15 mm from the face of the support.			

Table 4.1 – α -coefficients according to Eurocode 2

The values of K, are the ones of the Figure 4.2:

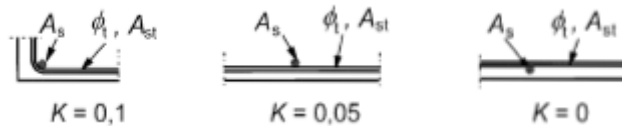

Figure 4.2 – K-coefficient according to Eurocode 2

And $l_{b,min}$ is the minimum anchorage length if no other limitation is applied. For anchorages in tension it is $l_{b,min} \geq \max\{0,3l_{b,rqd}; 10\phi; 100mm\}$, while for anchorages in compression it is $l_{b,min} \geq \max\{0,6l_{b,rqd}; 10\phi; 100mm\}$.

More details about the anchorage prescriptions can be found directly in the Eurocode.

4.3.3. Lap length of longitudinal reinforcement

When a second-hand element such as a column or a beam is reused in a new structure, continuity of its reinforcement has very likely to be ensured with the element to which it is connected and therefore, if for example coupling holes are chosen to be used, the required lap length for a correct transmission of forces should be provided. Therefore, according to section 8.7 of EN 1992.1.1, the design lap length is given by:

$$l_0 = \alpha_1 \alpha_2 \alpha_3 \alpha_5 \alpha_6 l_{b,rqd} \geq l_{0,min}$$

Where:

- $l_{0,min}$ is given by $\max\{0,3\alpha_6 l_{b,rqd}; 15\phi; 200\text{mm}\}$;
- α_6 is given by $\left(\frac{\rho_1}{25}\right)^{0,5}$ but not exceeding 1,5 nor less than 1,0;
- ρ_1 is the percentage of reinforcement lapped with $0,65l_0$ from the centre of the lap length.

While the spacings for the overlapping of the bars, are schematized in the Figure 4.3.

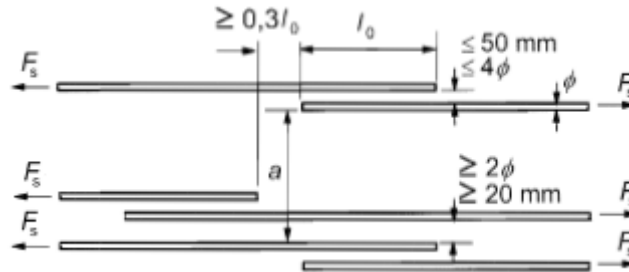

Figure 4.3 – Lap lengths and spacings according to EC2

More details about the force transmission prescriptions can be found directly in the Eurocode.

4.3.4. Shear reinforcement concentration in the overlap zone

Another prescription that may become of difficult appliance is the one given in section 8.7.4 of the EN 1992.1.1. This states that the transverse reinforcement is required in the tension zones to resist transverse tension forces. The shear reinforcement disposition as shown in the Figure 4.4 should be adopted if the diameter of lapped bars is greater than 20mm.

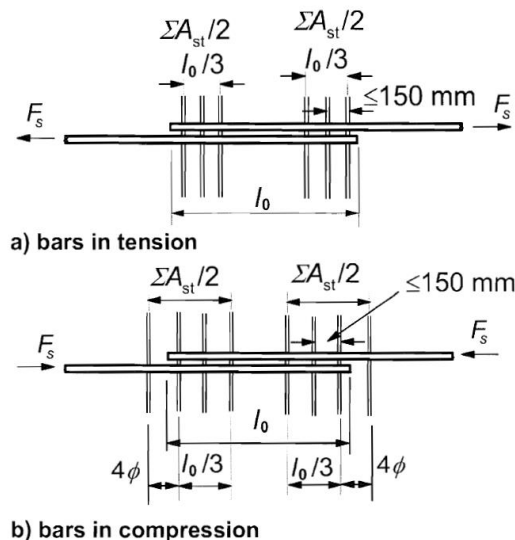

Figure 4.4 – Shear reinforcement concentration scheme according to EC2

Where:

- $\sum A_{st}$ is the sum of all legs parallel to the layer of the spliced reinforcement.

However if the diameter of the lapped bars is lower than 20mm, or the percentage of lapped bars is lower than 25% the normal shear reinforcement present in the section is considered to be sufficient, and the above rules are not required.

5. Reconnecting second-hand columns

This section will deal with the connection of second-hand columns to the rest of the structure. The columns which are here addressed are considered to come from one of the three structural systems which were presented before. Usually it should not be very relevant whether the second-hand column that we have was initially precast or, if it have been cast in-situ, since during its reuse, it can be considered that we deal with a precast element in any case, and the approach for reconnecting it is nearly the same in both cases.

5.1. Second-hand column foot, splice and node connections

In this section, the jointing possibilities between a second-hand column and the foundation block, between two columns and between a second-hand column and the point where the latter meets the beams will be addressed.

The foot connection is present almost in all the buildings with structural systems having concrete columns as structural elements, a splice joint can be needed, for example, when a second-hand column is shorter than the required length, and it has to be jointed though to a “new” column or to another second-hand element, while a connection of a second-hand column to a node with beams involved is necessary to allow a correct force transmission between the members in the node. In any case, they all deserve a great attention and efficient solutions.

This section (as also the further ones regarding the reconnection of the other structural elements) will have a well-defined structure.

- First of all the common methods for connecting newly made prefabricated elements will be addressed, in order to remind to the reader the most common s methods to deal with precast elements nowadays.
- At this point the drawbacks and the limitations of the use of second-hand elements will be one by one listed and discussed.
- After the previous two points have been addressed, some new design proposals for connecting the second-hand elements will be formulated. At the end of each design proposal the potential advantages and the drawbacks will be stated. Moreover, a grade regarding the easiness of putting in practice of the design will be assigned at the end of each connection approach (this grading will range between “Simple”, “Medium complexity” and “Complex”, and it will be subjectively assigned by the author of this Thesis considering the overall procedure of adaptation of the second-hand element and the actual connection in-situ).

Some of the formulated connection designs for the joints will be addressed in detail in the Chapter 9, since they will be embedded in a hypothetical structure and assessed to a sufficient degree to state that the proposed design is feasible and can be actually put in practice.

5.1.1. Common methods for connecting newly made columns to the foundation block

First of all, the foot joint in case of new precast elements will be addressed.

This can be done in many ways, however, the following two are perhaps the most used ones:

- a. Connection trough anchored end-plate;
- b. Grouted connection by means of coupling sleeves.

These two methods are shown in the Figure 5.1a and 5.1b.

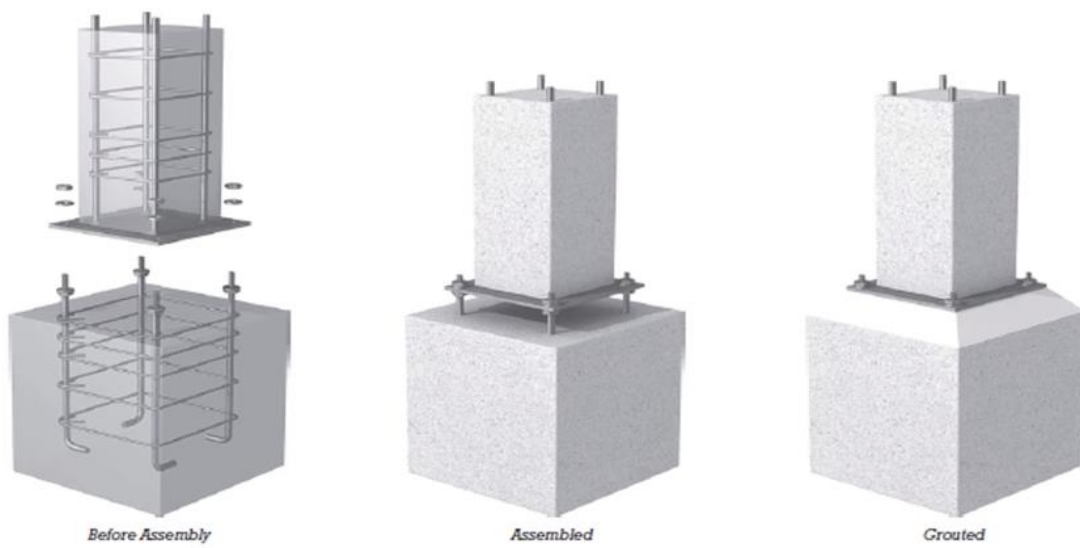

Figure 5.1a – Method (a) (Allen & Iano, 2013)

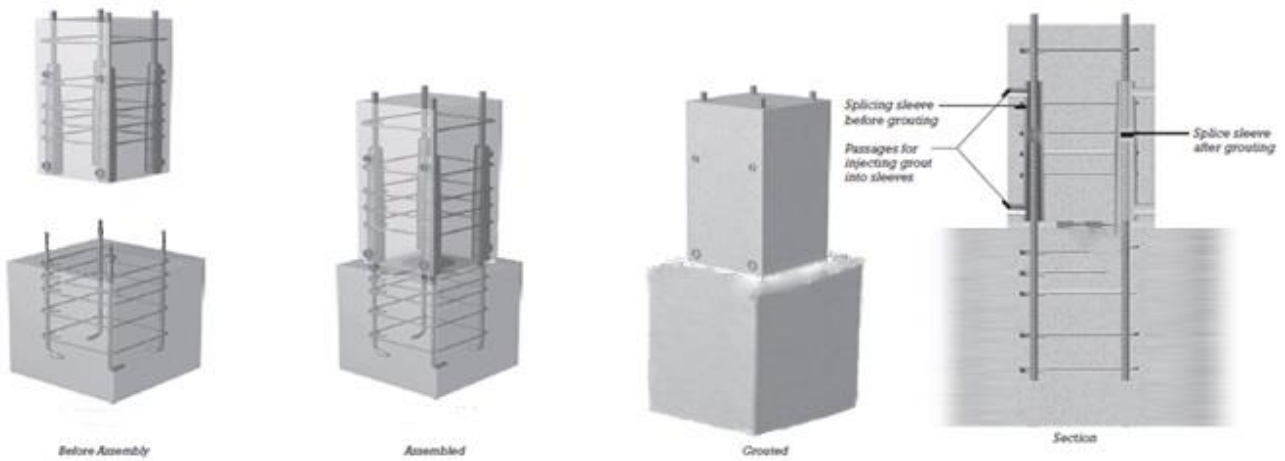

Figure 5.1b – Method (b) (Allen & Iano, 2013)

In the picture above, to what concerns the method (b), a simple concrete sleeve coupling is shown, however, sometimes, a steel splice sleeve is used instead just of having a hole inside the concrete member. This metallic sleeve, has two openings on its side, which remain open after casting the concrete: one is needed for pouring the concrete inside, and the other one is for expelling air and for determining when the coupler is completely filled. The reinforcement bar has often a threaded connection with the coupler. An example of the coupler itself and how is embedded into the concrete is shown in the Figure 5.2.

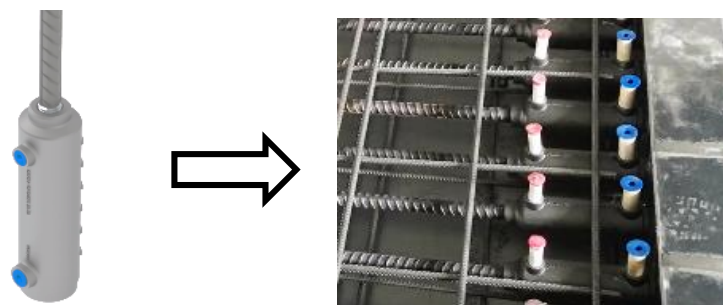

Figure 5.2 – Steel coupler

5.1.2. Common methods for achieving a splice joint

The splice joints on columns are not a common practice (Lagendijk P. , 2019), however sometimes several methods for performing them have been applied, and these will be recalled further on in this work during the proposals of new connection methods:

- a. Connection trough concrete-anchored end-plates on both the ends;
- b. Grouted connection by means of coupling sleeves.

These two methods are shown in the Figures 5.3a and 5.3b.

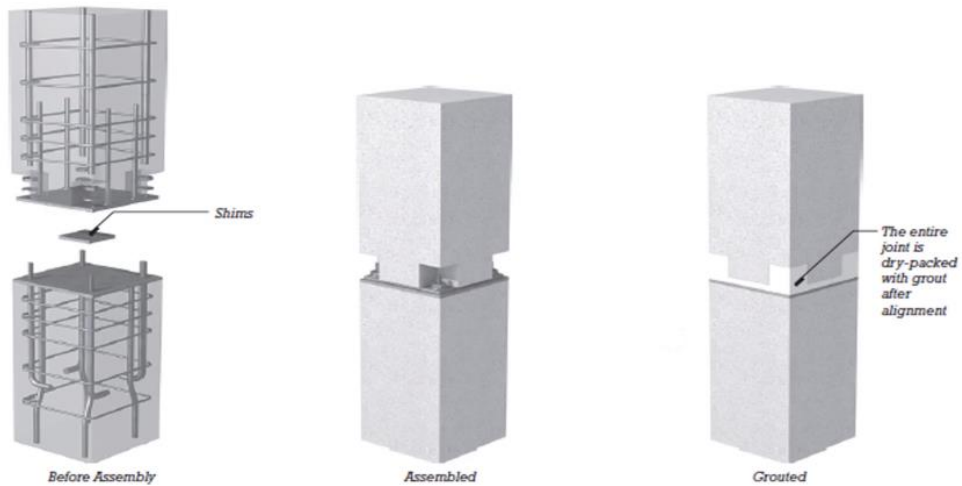

Figure 5.3a – Method (a) (Allen & Iano, 2013)

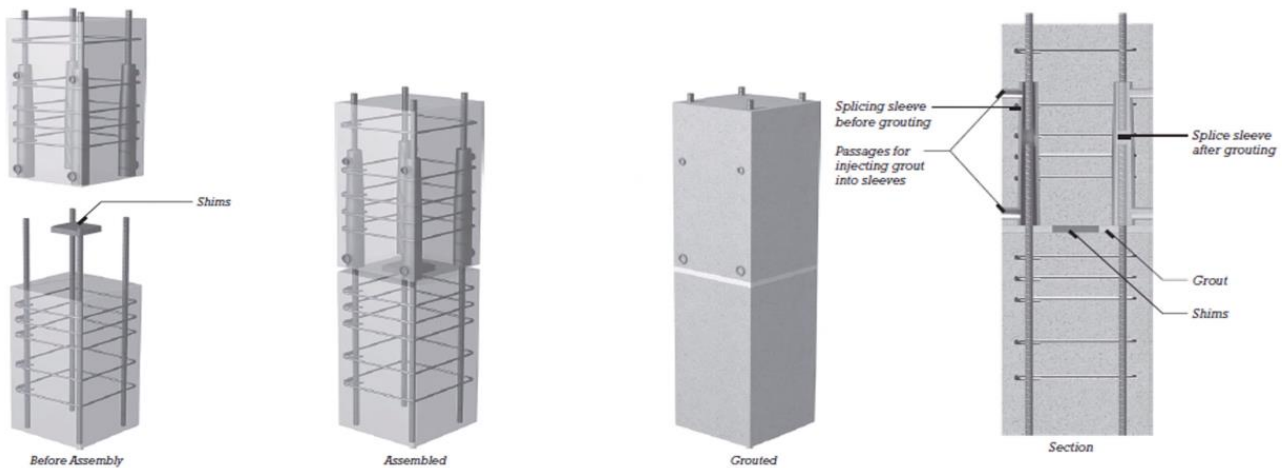

Figure 5.3b – Method (b) (Allen & Iano, 2013)

5.1.3. Common methods for column to beam node connection

It should be said that in common practice (referred to the use of precast elements), this type of joints is not very common, since usually only the splice joints are present between the columns, while the beams lay on the corbels which are specifically designed for this use, and the connection with the connection with the upper part of the column is located at another position. This is shown in the Figure 5.4.

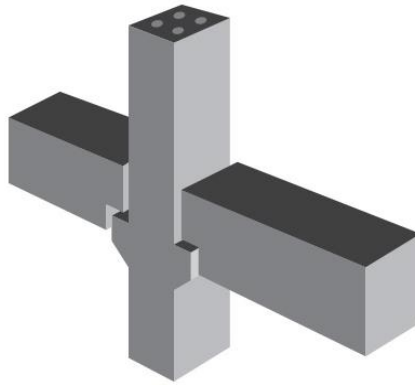

Figure 5.4 – Beams laying on corbels

While in this Thesis is assumed that the column elements to be reused are not provided with corbels, and therefore it should be figured out how to arrange the connection where the beams meet the column.

5.1.4. Limitations and boundaries of second-hand elements

In this paragraph, the drawbacks of second-hand column elements once they have been removed from the “donor” structure and need to be embedded in a new structure will be presented.

5.1.4.1. Laborious achievement of reinforcement continuity

In most of the connections that can be thought of, continuity of the longitudinal reinforcement should be ensured between the reused second-hand column element and the rest of the structure (in this case with the foundation block), two main conceptual approaches to predispose the end of a generic structural element can be thought of. These are the following:

a) *Steel-avoiding adaptation – protruding reinforcement*

The element is cut out from the donor structure with a net cut, but successively in a portion of its ends, the concrete is “carefully” removed in a way that its reinforcement bars are left protruding. At this point, the element can be treated almost as a normal precast element, since these reinforcement bars can be used to ensure the connection, potentially without any added steel bar or provision. However, this implies the fact that the element will be shorter, because, even if it will be cut at the end of the span, some space to bare the reinforcement is required. Also high costs due to very precise modification of the beam’s end have to be accounted for.

b) *Net cut – need for additional steel bars/provisions*

The element is cut from the donor structure in a way that no protruding reinforcement bars are left outside to be part of the connection node, its ends have to be modified and adapted for being easily connected to the hosting structure. There could potentially be many ways to do this, and these will be presented further on, but the majority of them require the drilling of the column and adding of connection bars/anchors and/or steel plates. This implies again that extra costs for qualified personnel, tools and steel parts are to be expected. However, the

positive aspect of the absence of protruding steel parts is that it allows using the whole span of the element.

5.1.4.2. *Eventual presence of useless connection bars*

Inside the second-hand column element there could be the presence of several bars and/or steel provisions, which have no structural role. These elements can be the ones, which originally connected the column to the ground or to the beams/floors. This fact should be kept in mind when the column gets predisposed for a reconnection: these be interfering with holes, which need to be drilled during connection procedure, or with the baring procedure of the longitudinal reinforcement of the column.

5.1.5. **Connection design proposals**

In this section few proposals for new design of second-hand connections will be formulated for both the joint locations (foot joint and splice joint). In the presentation of the foot joints, the foundation block is assumed to be newly made, while to what concerns the splice joints, only one of the elements will be assumed as second-hand during the presentations of the design, however the same element adaptation and the same procedure can be also applied for the complementary element of the joint if this one is also second-hand.

One of the most used approaches to find suitable methods for reconnecting second-hand elements will be to recall the previously mentioned connection methods for new elements, and propose some kind of adaptations to those.

5.1.5.1. *Connection in sleeve couplers*

This methodology for connecting second-hand elements can be applied to all the three joint locations: the foot joint, the splice joint and column to columns-beams node. Therefore each of these three joint locations will be addressed separately.

5.1.5.1.1. **Foot joint**

The first connection that is hereby proposed is directly concerned with the connection (b) presented in the section 5.1.1. For the realization of such connection with brand new precast column elements, the predisposition for the couplers is usually thought of before manufacturing the column and the coupling holes are left free, or, if steel couplers are used, these are placed in their final positions before casting. While, during the adaptation of a second-hand column for its reuse, the latter is already a hardened and monolithic concrete element, and the creation of the couplers could become the hardest part of the connection.

In general, the joint can be categorized as a “compression joint with combined actions”, and the acting forces it should resist are the ones shown in the Figure 5.5.

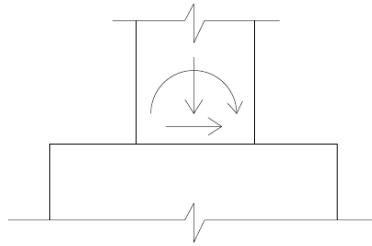

Figure 5.5 – Loads to be carried-out by the connection

The procedure for the adaptation and the connection of the second-hand column is hereby described, giving the phases for a correct realization. It is presumed that the disassembling stage has been correctly completed, and the required length of the column to be connected has been achieved. The steps for the accomplishment of this connection are the following:

1. Perform the drilling of the coupling holes respecting all the requirements;
2. Perpendicularly to each coupling hole, there is the need to drill one hole in the wall of the second-hand column for expelling the air out of it during the grouting procedure. This hole should intersect the coupling sleeve in its top part. After doing this, the adaptation part of the column is completed;
3. Lower the column over the rods sticking out of the foundation, inserting the connection rods/anchors of the foundation block into the coupling holes;
4. Insert the shim plate in between the column to be jointed and the foundation block;
5. The column should be kept braced;
6. Inject low-shrinkage concrete under pressure all around the gap between the foundation block and the column. Make sure that the sleeves are fully grouted. This is achieved when the concrete has filled the air expelling openings.
7. Once that the concrete is hardened and full bond is achieved between the anchors and the column, the desired connection is achieved.

Of the previous phases, the ones from 1 to 3 are more suitable to be done in the factory. The final layout is very similar to the method (b) shown in section 5.1.1.

- *Conceptual representation*

In the Figures 5.6a and 5.6b (not to scale, meant only for a conceptual visualization), a schematic representation is shown.

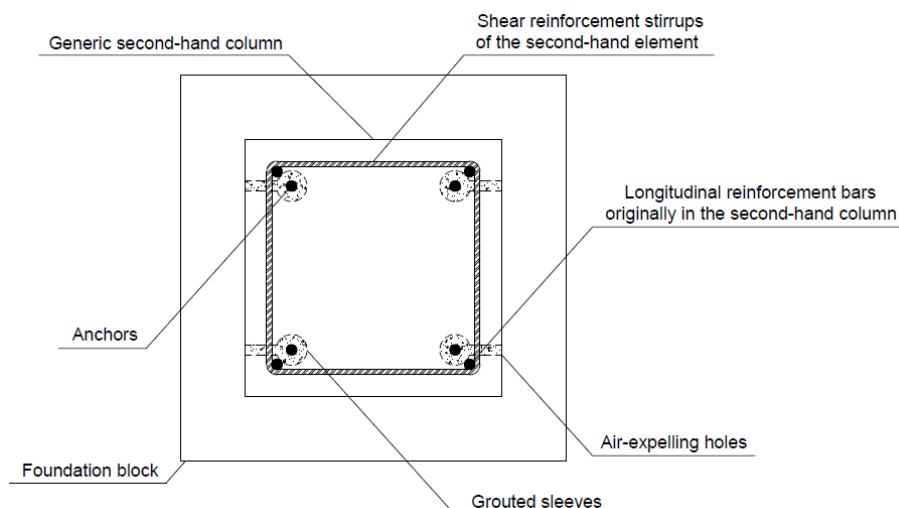

Figure 5.6a – Cross-sectional view of the connection at the interface position

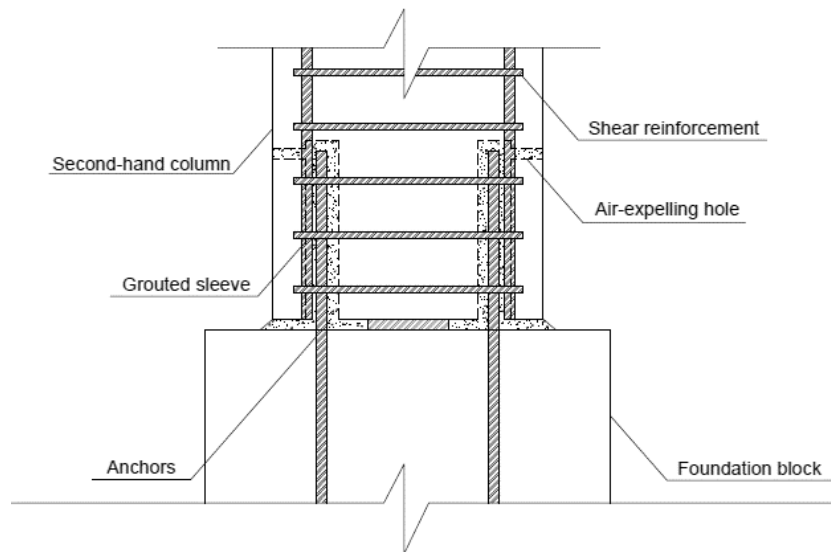

Figure 5.6b – Lateral view of the connection zone

In the final result, the second-hand column after the adaptation procedure should look similarly to the one shown in the Figure 5.7 (on which is actually shown a newly made precast column element, but is still a good visualization also for representing a second-hand case).



Figure 5.7 – Coupling sleeves in a column end (FIB, 2008)

At this point some of the key-aspects worth to be paid attention on will be addressed more in detail.

- *Sleeve holes and air expelling holes*

In order to obtain the desired coupling holes in the end of the column, the use of drilling equipment is required. The drilling operation itself, can be very similar to the core extracting procedure, and the same equipment can be potentially used, however, the hole can even be of a lower diameter, while the depth is usually higher. The Figure 5.8 shows the drilling in action.



Figure 5.8 – Drilling procedure of sleeve holes (Rafa Adventure, s.d.) (Adamas homepage, s.d.)

As it can be seen from the cross-sectional drawing, the most suitable position for performing the sleeve holes is inside the perimeter of the shear stirrups of the column, which should coincide with the exact corner of the cut-away.

In order to be able to fill each coupling sleeve, a lateral perpendicular aeration hole is needed for each sleeve coupler. These can be drilled as shown in the section regarding a similar connection for second-hand beams. An important consideration is that this hole should not interfere with any steel reinforcement parts.

- *Shim plates*

As it is done for such connection between new elements, inserting a shim plate is also necessary. This shim plate is needed to level the column, to bring it to the exact height and to ensure some space between the second-hand element and the one already in place so that it can consequently be filled with mortar or concrete. The maximum levelling allowance is usually of 50mm.

- *Shape of the stirrups*

When the sleeve has to be created, it is not suitable to cut the transversal reinforcement stirrups during the drilling procedure. In the Figure 5.9 the three most common ways to bend the stirrup ends are shown, between these, the only one fully suitable for this connection method is the layout (a).

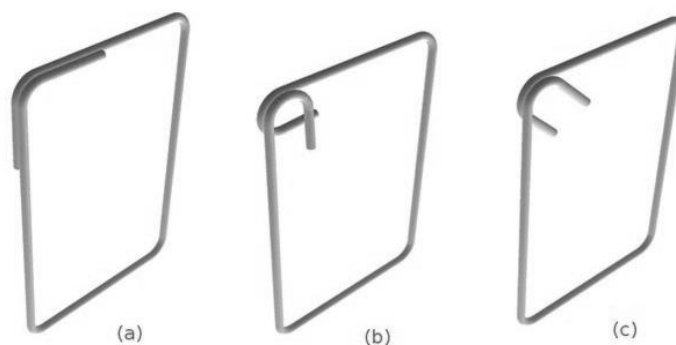

Figure 5.9 – Shapes of the stirrups

In general, also with other layouts of the stirrup ends this connection method can be adopted, however in those cases, the drilling machine could potentially face a damage. An option can be

also to perform the sleeve holes not right in the corners of the stirrups, but a little shifted in one of the two directions or towards the centre of the cross-section. In any case, the maximum spacing between overlapped longitudinal bars should be respected, in order to ensure the correct transmission of forces.

The eventual option to perform the coupling holes outside the stirrup perimeter and locate there the coupling bars/anchors, would, in the majority of cases, imply the necessity to add an increased cover all around the column region where these bars are located (a similar connection method will be presented further on in this study).

- *Grouting of the gap and of the coupling sleeves*

The grouting of the connection is the last step of the connection procedure. It should also be kept in mind that the grouting material is quite expensive, this is due to the fact that it should be at least of the same strength grade as the one of the elements, and, which is even more important, it should have a low-shrinkage property. This last feature is very important, since, if it is not met, the creep/shrinkage behaviour between newly cast concrete and the second-hand element may occur, causing cracks. Also the correct grouting equipment and the setting of the site is important, since this type of grouting is meant to be done under high pressure. Some confinement of the grouting concrete around the gap at the column base may also be required, since the concrete material which is injected is very liquid.

- *Adaptation of the foundation block*

The foundation block, to which the second-hand element has to be jointed, has also to be predisposed eventually for such connection. The connecting rods, which will be inserted into the sleeves of the second-hand part, are usually embedded into the foundation block at the time of its casting (in-situ or precast) and they can be:

- i. Part of the bending reinforcement of the foundation block;
- ii. Anchors apart from the foundation block reinforcement;

- *Advantages, drawbacks and complexity rating*

In the Table 5.1 the advantages and the drawbacks of this connection method are briefly summarized.

Advantages	Drawbacks
No added steel provisions	Need of a precise concrete drilling
Completely monolithic result	Not suitable for eventual further reuse
Aesthetically attractive	

Table 5.1 – Advantages and drawbacks of the proposed design

This connection can be rated to have a “Medium complexity”. This rating is assigned due to the fact that even if the required materials are quite common and can be reachable easily on the market, the adaptation and the connection procedures can be relatively laborious (since precise drilling and grouting are required). A possible optimization that can be done is a reduction of the reinforcement bars that have actually to be connected through sleeve couplers, however the minimum required reinforcement area (according to the Eurocode) should be fulfilled in any case.

5.1.5.1.2. Splice joint

It comes now to the designing procedure of a splice joint by using the coupling sleeves presented in the section concerned with the foot joint. This time, the proposed connection will try to “emulate” the method (b) shown in section 5.1.2. As it can be understood, the difference with the foot connection joint with the same approach is that this time the existing part consists in one of the column portions. The forces to be transmitted between the two column parts are the same as the ones that had to be transmitted between the foundation block and the second-hand column connected to it.

The procedure for the adaptation and the connection is not very different from the previous one: The steps are the following:

1. Perform the drilling of the coupling holes respecting all the requirements;
2. Perpendicularly to each coupling hole, there is the need to drill one hole in the wall of the second-hand column for expelling the air out of it during the grouting procedure. This hole should intersect the coupling sleeve in its top part. After doing this, the creation of coupling sleeves is completed;
3. Insert the shim plate in between the column to be jointed and the foundation block;
4. Insert the connection rods/anchors of the existing column into the coupling holes;
5. Inject concrete under pressure all around the gap between the two column parts. Make sure that the sleeves are fully grouted. This is achieved when the concrete has filled the air expelling openings.
6. Once that the concrete is hardened, the desired connection is achieved.

Exactly the same considerations already mentioned for the foot joint to what concerns the sleeve couplers with air expelling holes, the shim plates, and the shape of the stirrups are valid also in this case, so, they will not be repeated.

- *Conceptual representation*

In the Figure 5.10 a generic positioning of the coupling sleeves with the connection rods is shown.

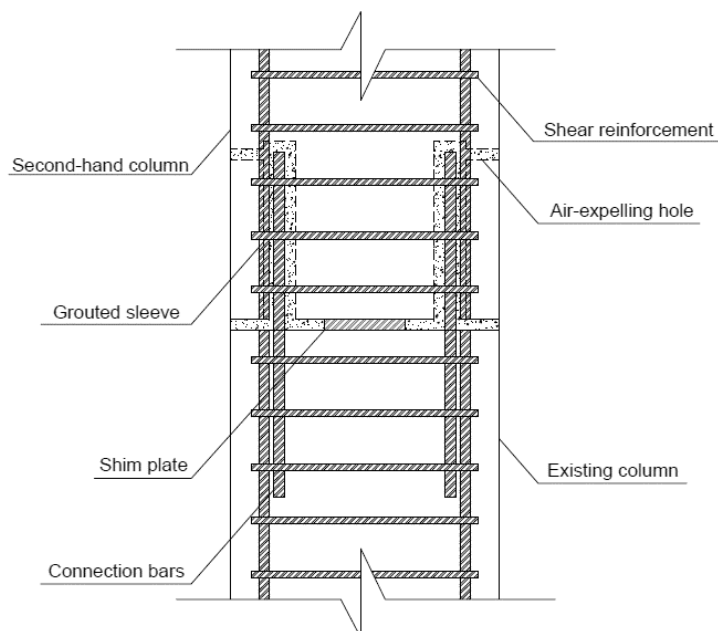

Figure 5.10 – Lateral view of the connection zone

- *Adaptation of the coupled column*

The column, to which the second-hand element has to be attached, has also to be predisposed eventually for such connection. The connecting rods, which will be inserted into the sleeves of the second-hand part, can be:

- a. Embedded inside the existing column during its casting (in-situ or precast);
- b. Added to the existing column with the same procedure as for the second-hand elements;
- c. Part of the longitudinal reinforcement of the existing column.

The last option mentioned above can be adopted when the second-hand column has a larger cross-section, so, when for example it is necessary to cast a new portion of a column above a second-hand one, and this new portion should have a smaller cross-sectional dimensions or diameter, in case of a circular cross section. This can be seen schematically in the Figure 5.11.

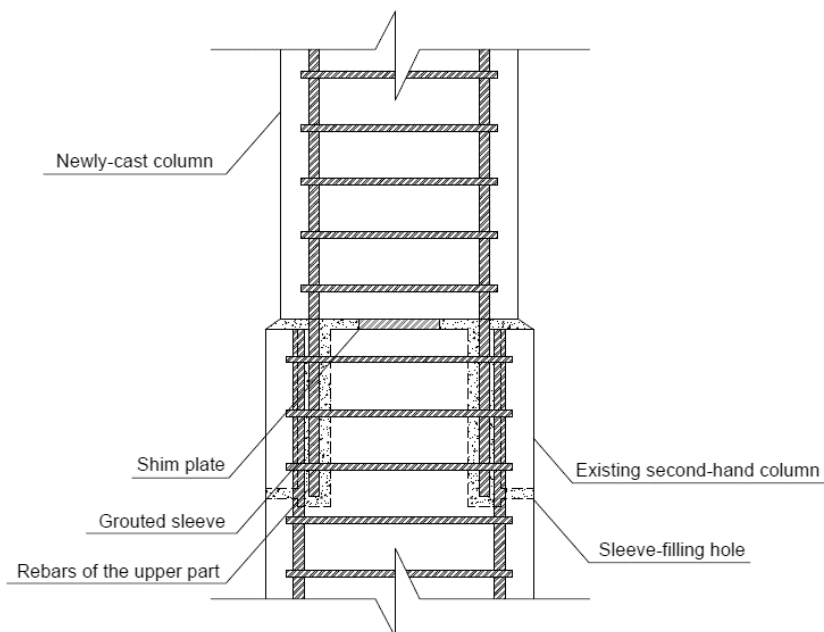

Figure 5.11 – Lateral view of the connection zone

- *Advantages, drawbacks and complexity rating*

In the Table 5.2 the advantages and the drawbacks of this connection method are briefly summarized.

Advantages	Drawbacks
No added steel provisions	Need for a precise concrete drilling
Completely monolithic result	Non suitable for eventual further reuse
Aesthetically attractive	

Table 5.2 – Advantages and drawbacks of the proposed design

As for the foot joint, also this connection is rated to be of “Medium complexity” for the same reasons (need to drill precise coupling and filling holes).

5.1.5.1.3. Column to column-beam node

The connection by means of sleeve couplers can be successfully applied also for connecting the beam to the column-beam node. In this section the connection of the bottom column to the node is presented. The actions transmitted to the node are the ones showed in the Figure 5.12.

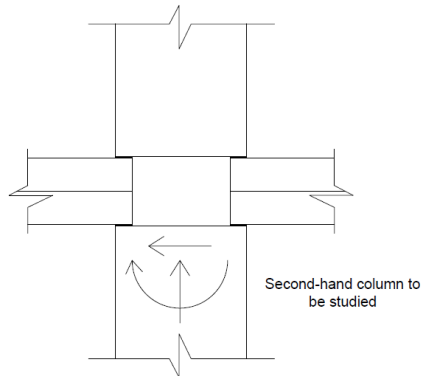

Figure 5.12 – Actions transmitted by the connection

The complete manufacturing of this beam-column-column-beam joint can be considered to be built up of 3 different connections (to be executed in the following order):

- i. Bottom column connection (presented in this section);
- ii. Beam to column connection (with one of the methods presented in section 6.1.4);
- iii. Top column connection (with the same method as the one shown in 5.1.5.1.1).

The connection here presented is, in final result only the grouting of the bars inside the column top, however also this phase requires attention.

Another aspect is that this time the joint is filled from below. So, the perpendicular hole to the coupling sleeve this time is not an air expelling hole but a filling hole, and therefore it should have a higher diameter. Only the sleeve couplers will be filled with the grouting concrete (very liquid and with a reduced size of the aggregates), while the gap between the beams will be filled with “traditional” concrete because this is more cost effective and has more feasibility advantages because of the higher viscosity of concrete.

The procedure for the adaptation and the connection is the following:

1. Perform the drilling of the coupling holes respecting all the requirements;
2. Perpendicularly to each coupling hole, there is the need to drill one hole in the wall of the second-hand column for filling the joint during the grouting procedure. This hole should intersect the coupling sleeve in its bottom part. After doing this, the creation of coupling sleeves is completed;
3. Insert the connection bars into the coupling holes;
4. Inject concrete under pressure into the filling holes. Make sure that the sleeves are fully grouted;
5. Once that the concrete is hardened, the desired connection is achieved.

Exactly the same considerations already mentioned for the foot joint to what concerns the sleeve couplers, and the shape of the stirrups are valid also in this case, so, they will not be repeated.

- *Conceptual representation*

In the Figure 5.13 (not to scale, meant only for a conceptual visualization), a schematic representation of the connection is shown. The whole node is shown, even if in this section only

the insertion of the coupling bars and their grouting is addressed (while, as said before, to what concerns the connection of the beams to the node, please refer to section 6.1.4).

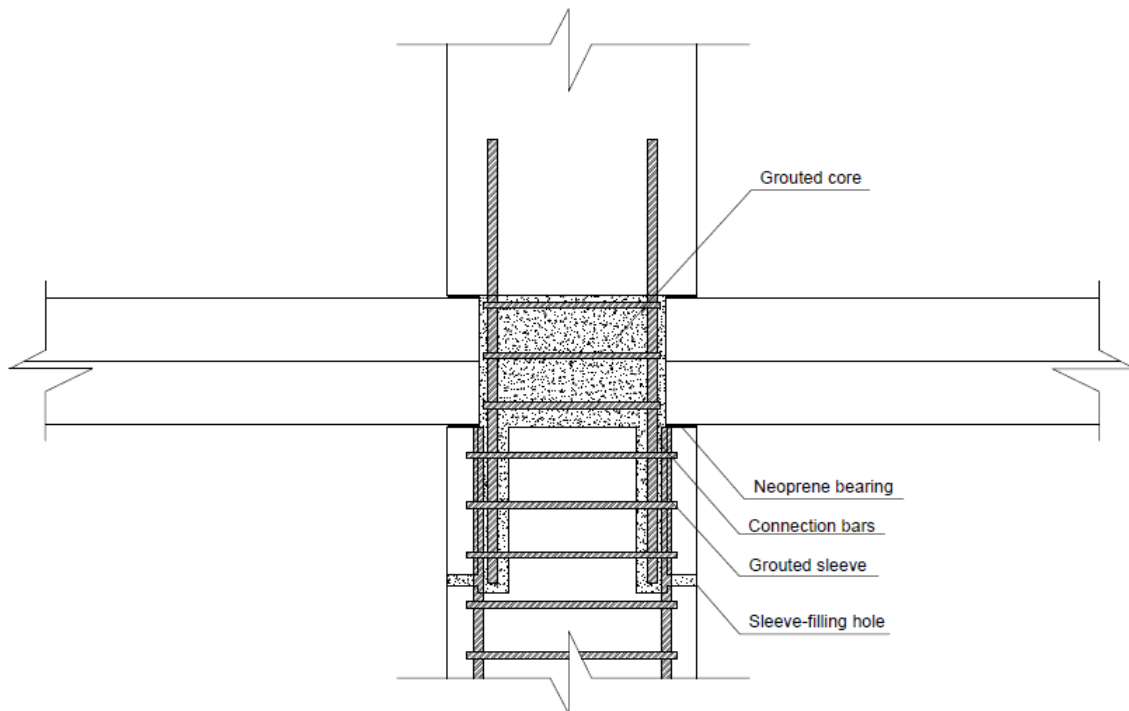

Figure 5.13 – Lateral view of the whole node

- *Advantages, drawbacks and complexity rating*

In the Table 5.3 the advantages and the drawbacks of this connection method are briefly summarized.

Advantages	Drawbacks
No added steel provisions	Need for a precise concrete drilling
Completely monolithic result	Non suitable for eventual further reuse
Aesthetically relatively attractive	

Table 5.3 – Advantages and drawbacks of the proposed design

As for the foot joint and the splice joint, also now this one is rated to be of “Medium complexity” for the same motivation (need to drill precise coupling and filling holes).

In the Chapter 9 of this graduation work this joint will be embedded in a hypothetical office building constructed by using several second-hand elements. Therefore it will be studied in detail and checked according to the Eurocode.

5.1.5.2. *Connection by means of adding steel column shoes*

The connection approach can be applied to a foot joint and to a splice joint, therefore the section will be split into two parts.

5.1.5.2.1. *Foot joint*

It comes now to a connection proposal which requires the embedment of such steel provisions as the steel “column shoes”. These may provide a solution to achieve a solid connection between the foot of the column and the foundation block.

Again, the joint can be categorized as a “compression joint with combined actions”, and the acting forces it should resist are the ones shown in Figure 5.14.

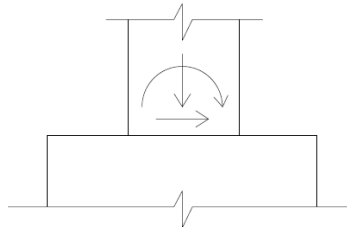

Figure 5.14 – Actions transmitted by the connection

Once again, a difficulty that can be encountered, is concerned with the methods, which can be used to insert the anchors of the steel shoes into the second-hand column, and their bonding into the concrete. However, as already mentioned during the explanation of similar procedure for other elements, this kind of adaptation can be done in a specialized factory, since there could be no suitable conditions for it to be done on the building site.

Hereby, the procedure of adaptation is described, giving the steps for a correct realization. The basis for the application of these steps is a correctly completed disassembling phase of the column, with the achievement of the required length. The stages for accomplishment of this connection are the following:

1. Cut away 4 cubic or cylindrical parts of concrete from the angles of the column foot, the obtained niches can be called “pockets”.
2. Drill 4 holes with a diameter larger than the anchoring rods of the shoe, in the angles of the pockets;
3. Perpendicularly to each anchoring hole, there is the need to drill a hole in the wall of the column for expelling the air during the grouting procedure. After doing this, the creation of coupling sleeves is completed;
4. Insert the 4 anchoring rods in the holes;
5. Inject concrete under pressure from the bottom of the sleeve hole (from where the shoe anchoring rods were inserted). Make sure that the sleeves are fully grouted. This is achieved when the concrete has filled the air expelling openings.
6. Once that the concrete is hardened and full bond is achieved between the shoe anchors and the column, the second-hand element modification phase is completed;
7. Insert now the shim plate between the foundation block and the second-hand column;
8. Lay down the column on the threaded anchors;
9. Tighten the nuts;
10. Grout the gap between the elements.

All the same considerations to what concerns the installation of the column shoes inside the second-hand column as the ones seen in the previous sections for installing the anchors/connection bars are valid also here (because after all, the anchors of the column shoes have to be considered as connection bars).

- *Conceptual representation*

In the Figures 5.15a and 5.15b (not to scale, meant only for a conceptual visualization), a schematic representation of the connection is shown.

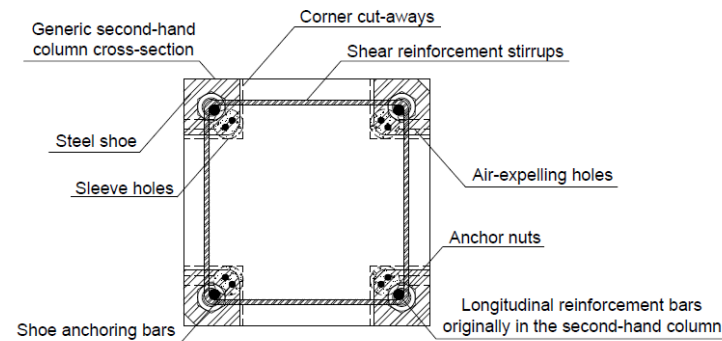

Figure 5.15a – Cross-sectional view of the connection at the column shoes level

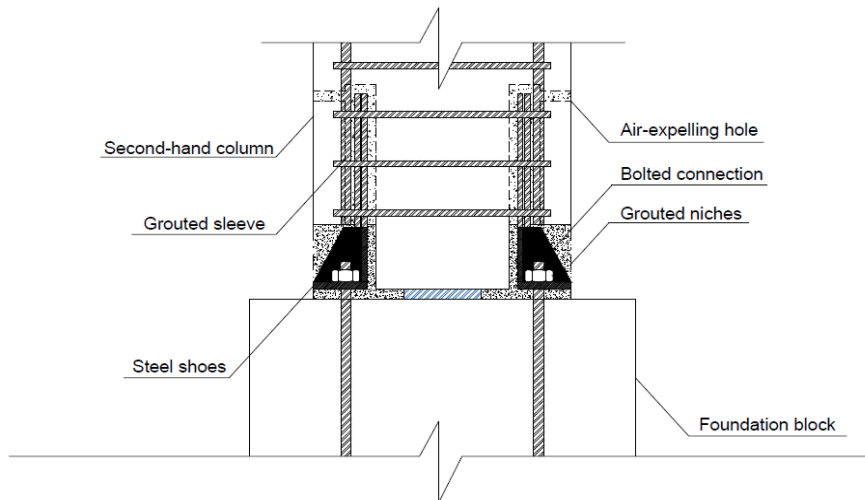

Figure 5.15b – Lateral view of the connection zone

A photograph of workers during the installation with this method (in this case a precast column with column shoes is shown but after the adaptation process of the column is ended, the column can be considered almost as a precast element) is shown in Figure 5.16.



Figure 5.16 – Workers installing a precast column with column shoes (Circulariteit, 2018)

- *Column shoes*

As already seen for the previous connection method, for a correct transmission of eventual tensile (but also compressive) forces between the reinforcement bars of the second-hand column and the steel shoes, the distance between the bars and the overlapping length prescribed by the Eurocode should be respected. The most suitable position for performing the shoe-anchoring hole is inside the perimeter of the shear stirrups of the column, which should coincide as much as possible with the corner of the cut-away. On the market are available several different column shoes, which can be used for this connection.



Figure 5.17 – Varieties of “column-shoes” (Peikko products - overview, s.d.)

All the adaptation procedure of the column (cutting of the edges, drilling, shoes inserting and grouting) is more suitable to be done in a factory, since it requires high precision of manufacture.

- *Adaptation of the foundation block*

The foundation block, to which the second-hand element has to be jointed, has of course to be predisposed for such connection. The threaded end anchors, to which the second-hand element will be bolted, are usually embedded into the foundation block at the time of its casting (in-situ or precast), they have to be correctly designed, in order to efficiently transmit the forces to the reinforcement of the foundation block. Therefore, their overlap and anchorage length should be calculated.

- *Advantages, drawbacks and complexity rating*

Even if on the first sight it seems to be not wise to embed column shoes in a second-hand column when it is possible to directly insert anchors inside the coupling holes, even because a lot of effort should be also spent on performing the shoe-pockets in the corners of the column. However this way of jointing allows the column to be reused further on in the future, the column is more easily installed on site, and more ductility is provided to the whole connection, since steel parts are involved in it.

In the Table 5.4 the advantages and the drawbacks of this connection method are briefly summarized.

Advantages	Drawbacks
Easy mounting on site	Need of a precise concrete drilling/cutting
Possibility for an easy further reuse	Need of steel provisions
	Failure of shoes may be accounted for

Table 5.4 – Advantages and drawbacks of the proposed design

This joint can be rated as “Complex”, because of the fact that even if the actual connection phase is quite easy, the adaptation of the column is very laborious and require costly provisions and precise drilling and cutting of concrete parts.

5.1.5.2.2. Splice joint

The approach by using the so called “column shoes” is suitable also for connecting together two parts of the columns. Once again this joint can be categorized as a “compression joint with combined actions”, and the acting forces to be resisted by the connection are exactly the ones as for the connection between the foundation block and the column.

Hereby, the procedure of adaptation and connection are described, giving the steps for a correct realization. The basis for the application of these steps is a correctly completed disassembling phase of the column, with the achievement of the required length. The stages for accomplishment of this connection are the following:

1. Cut away 4 cubic or cylindrical parts of concrete from the angles of the column foot;
2. Drill 4 holes with a diameter larger than the anchoring rod of the shoe, in the angles of the created pockets;
3. Perpendicularly to each anchoring hole, there is the need to drill a hole in the wall of the column for expelling the air during the grouting procedure. After doing this, the creation of coupling sleeves is completed;
4. Insert the 4 anchoring rods in the holes;
5. Inject concrete under pressure from the bottom of the sleeve hole (from where the shoe anchoring rods were inserted). Make sure that the sleeves are fully grouted. This is achieved when the concrete has filled the air expelling openings.
6. Once that the concrete is hardened and full bond is achieved between the shoe anchors and the column, the second-hand element modification phase is completed;
7. Insert now the shim plate between the column parts;
8. Lay down the column on the threaded anchors;
9. Tighten the nuts;
10. Grout the gap between the elements.

All the same considerations to what concerns the column shoes and their installation inside the second-hand column as the ones seen in the previous sections are valid also here.

- Conceptual representation

In the figure 5.18 a generic positioning of the shoe-anchoring sleeves, the cut-aways and the shoes itself are shown.

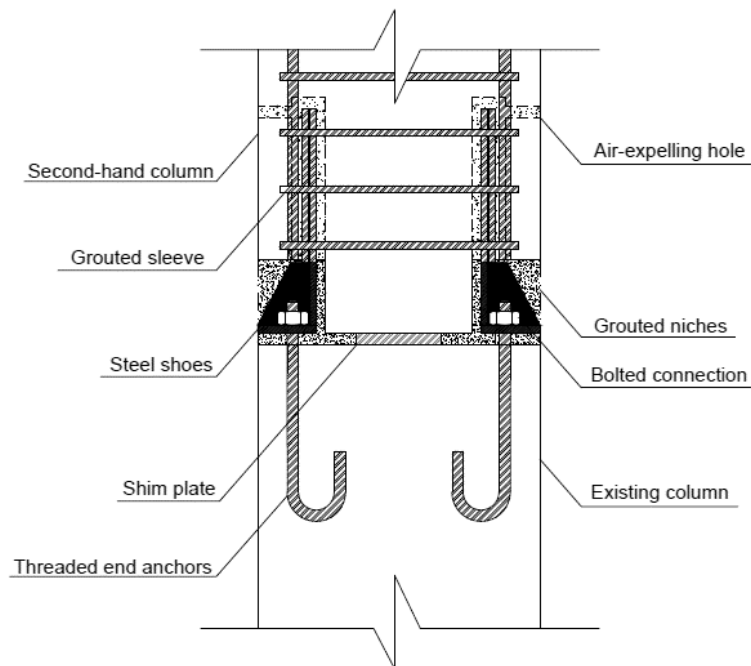

Figure 5.18 – Lateral view of the connection zone

- *Adaptation of the existing column*

As it is shown in the picture showing the conceptual representation, the bottom column part is the one that is assumed to be newly made. As in the previous section for the case of the adaptation of the foundation block, also this newly made column part has of course to be predisposed for such connection. The threaded end anchors, to which the second-hand element will be bolted, are usually embedded into the existing column part at the time of its casting (in-situ or precast), they have to be correctly designed, in order to efficiently transmit the forces to the reinforcement of the existing element. Therefore, their overlap and anchorage length should be calculated. If the existing column part is also second-hand, the threaded anchors might be embedded in it, for example, with the same method (by means of sleeve couplers) as shown in the section 5.1.5.1.3.

- *Advantages, drawbacks and complexity rating*

In the Table 5.5 the advantages and the drawbacks of this connection method are briefly summarized

Advantages	Drawbacks
Easy mounting on site	Need of a precise concrete drilling
Possibility for an easy further reuse	Need of steel provisions
	Failure of shoes may be accounted for

Table 5.5 – Advantages and drawbacks of the proposed design

This joint, as the related column foot one, can be rated as “Complex”, because of the same reasons.

5.1.5.3. *Connection by means of a steel end-plate*

As for the previous jointing method, the connection is designed for the foot joint and for the splice joint, therefore the section will be split in two different sub-sections.

5.1.5.3.1. Foot joint

Another option in order to connect the column to the foundation block is to add to the end of the second-hand element a steel plate, which will have, from its side, a bolted connection with the anchors of the foundation block. This steel plate could be attached to the concrete column mainly in two different ways:

- i. By means of steel connection bars previously welded to the plate and attached to the column by means of couplers (similarly as described in 5.1.3.1). The ready-to-use plate with the connection bars before its installation would look similarly to the one shown in the Figure 5.19.



Figure 5.19 – Steel plate with pre-welded bars (FIB, 2008)

- ii. By welding it directly to the longitudinal reinforcement bars of the second-hand column.

The second one of these options will be addressed here, since the fact that it would be less reasonable to perform a bolted connection through a plate if all the work to drill the couplers have to be done.

However, in order to weld correctly a plate to the existing reinforcement a certain bared portion of it should be obtained.

The foundation block, by its side, has to be predisposed for this type of connection with the column, by inserting steel anchors with threaded ends before casting the concrete.

Also this joint can be categorized as a “compression joint with combined actions”, and the acting forces to be resisted are the ones shown in the Figure 5.20.

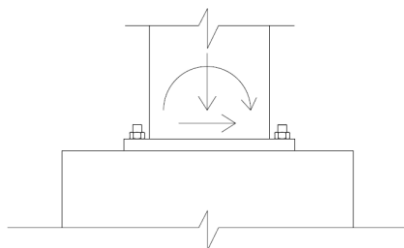

Figure 5.20 – Actions transmitted by the connection

A difficulty that may be encountered here is concerned with the breaking of concrete avoiding the reinforcement, and a precision welding of the plate to the longitudinal reinforcement. This

procedure of adaptation can be done in a specialized factory, since there could be no suitable conditions for it to be done on the building site.

Hereby, the procedures of adaptation and connection are described, giving the steps for a correct realization. The basis for the application of these steps is a correctly completed disassembling phase of the column and the achieving of the required length (incremented by the end margin, called e_m , where the concrete will be removed). The stages for the accomplishment of this connection are the following:

1. The end margin quantity e_m should be bared in order to obtain a portion of free longitudinal reinforcement, the eventual shear reinforcement should also be removed (it will be replaced further on). This is done in order to be able to reach with the welding equipment the point where the end-plate will be welded;
2. Weld the longitudinal reinforcement bars to the previously prepared steel end-plate;
3. Replace the (eventually) removed shear stirrups with new ones;
4. Re-cast this part of the column with new concrete. At this point, the adaptation phase is accomplished. After this, the second-hand element looks exactly as in the connection between precast elements (a) presented before.
5. One of these two options may now be chosen:
 - A. Insert the shim plate between the column and the foundation block
 - B. Adjust the levelling nuts on the anchors
6. Lay down the column on the threaded anchors;
7. Tighten the nuts;
8. Grout the gap between the elements.

The margin quantity of concrete which should be "trimmed" avoiding the steel bars (as mentioned in the step 1), is represented in the Figure 5.21.

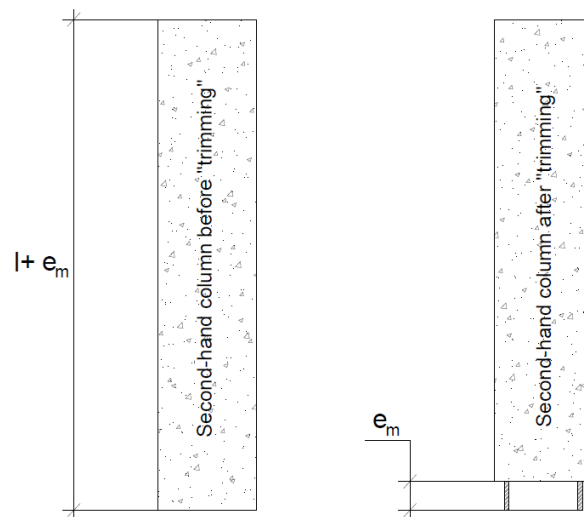

Figure 5.21 – Column before and after trimming (Phase 1) respectively

The final layout of the connection is exactly the same as the connection meant for prefabricated columns shown in section 5.1.1 at the point (a).

The same considerations made for the shim plate, for the grouting concrete and for the adaptation of the foundation block which were made in for the previous connection proposals are valid also here, however some other aspects of the connection will be now addressed more in detail.

- *Conceptual representation*

In the Figures 5.22a and 5.22b (not to scale, meant only for a conceptual visualization), a schematic representation of the connection is shown.

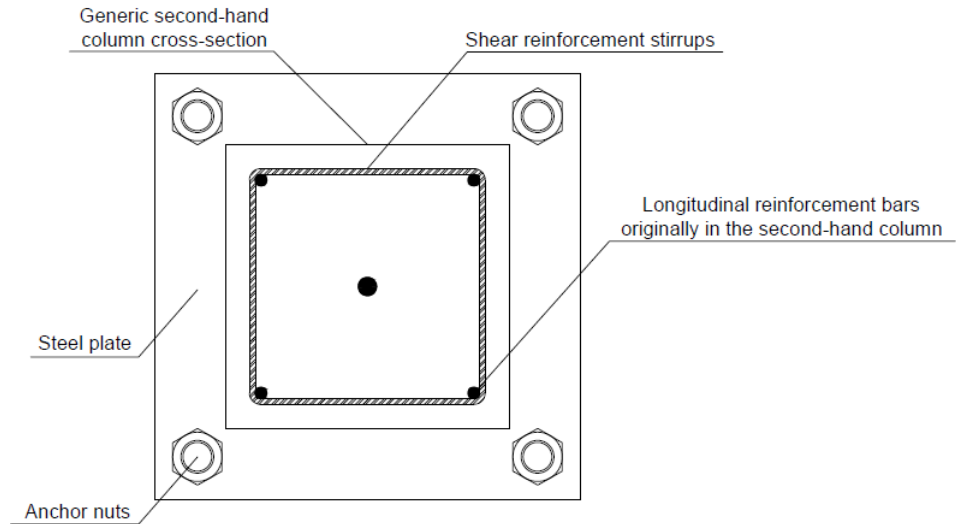

Figure 5.22a – Cross-sectional view of the connection at the connection plate level

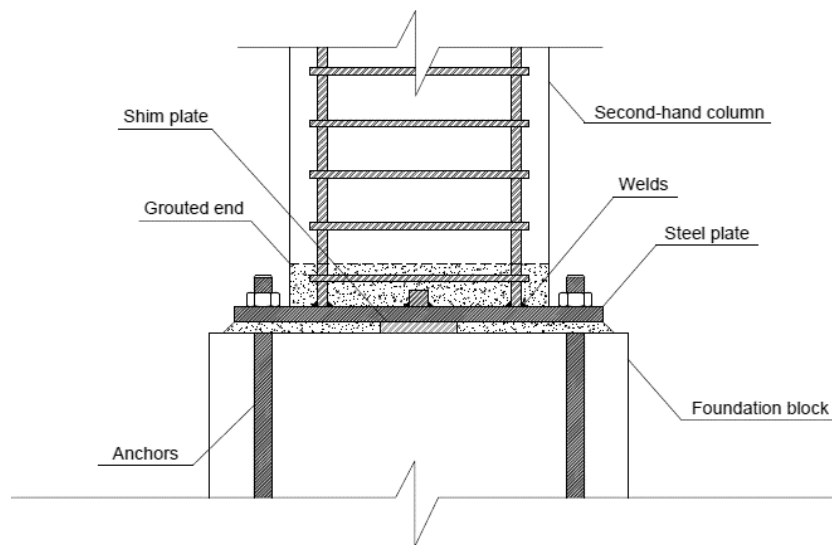

Figure 5.22b – Lateral view of the connection zone

- *End-plate*

This joint can be considered very similar to a common foot joint of a steel column. However, usually at a column foot the compressive force is so high that no tensile force will act in any part of the section nor in the plate even if we consider the bending moment due to normal force eccentricity summed up to the compression. Therefore according to EN 1993.1.8, the verifications that should be performed for the plate are:

- Bolt shear verification;
- Bearing resistance of the plate.

However, since the bars are welded to the plate, also these welds should be checked according to the prescribed checks of the Eurocode 3.

- *Advantages, drawbacks and complexity rating*

In the Table 5.6, the advantages and the drawbacks of this connection method are briefly summarized.

Advantages	Drawbacks
No need to drill sleeves	Need to bare the reinforcement
Easy on-site assembling	Precision and quality welding is necessary
	Failure possibility of plate, bolts, welds should be accounted for

Table 5.6 – Advantages and drawbacks of the proposed design

The connection can be rated as a joint with “Medium complexity”, since the fact that the adaptation of the second-hand column requires the manufacturing of the plate and precise execution of the welds, however the installation is very simple.

5.1.5.3.2. Splice joint

The same approach as the one presented for the foot joint, can be adapted also for a splice joint. This is once again categorized as a “compression joint with combined actions”, and the transmitted actions are the same as between the column and the foundation block.

The procedures of adaptation and connection is also very similar to the one proposed for the foot connection. The steps are the following:

1. The end margin quantity e_m should be bared in order to obtain a portion of free longitudinal reinforcement, the eventual shear reinforcement should also be removed (it will be replaced further on). This is done in order to be able to reach with the welding equipment the point where the end-plate will be welded;
2. Weld the longitudinal reinforcement bars to the previously prepared steel end-plate;
3. Replace the (eventually) removed shear stirrups with new ones;
4. Re-cast this part of the column with new concrete. At this point, the adaptation phase is accomplished. After this, the second-hand element looks exactly as in the connection between precast elements (a) presented before.
5. Lay down the column on the existing part;
6. Insert the bolts in the holes;
7. Tighten the nuts.

The final layout of the connection is slightly similar to the connection meant between prefabricated columns shown in section 5.1.2 at the point (a). The same considerations about the features of the connection made for the foot connection are valid also here.

- *Conceptual representation*

In the Figure 5.23 (not to scale, meant only for a conceptual visualization), a schematic representation of the connection is shown.

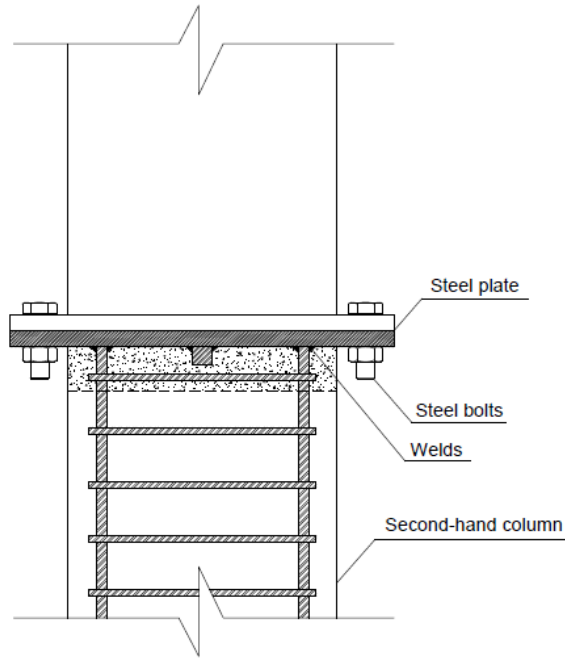

Figure 5.23 – Lateral view of the connection zone

- *Advantages, drawbacks and complexity rating*

In the Table 5.7, the advantages and the drawbacks of this connection method are briefly summarized:

Advantages	Drawbacks
No need to drill sleeves	Need to bare the reinforcement
Easy on site assembling	Precision and quality welding is necessary
	Failure of plate, bolts, welds should be accounted for

Table 5.7 – Advantages and drawbacks of the proposed design

The connection can be once again rated as a joint with “Medium complexity”, for the same reasons as the foot joint.

The embedment of this connection in a hypothetical structure in which second-hand elements are used will be made in the chapter 9, showing also the verifications that should be done for it according to the Eurocode.

5.1.5.4. *Connection by re-casting the concrete cover*

Also this connection can be applied to the foot joint and the splice joint, therefore, once again, the section will be split in two sub-sections.

5.1.5.4.1. *Foot joint*

The idea behind this connection method is the following: perform a partial concrete removal from the second-hand element in order to be able to overlap its longitudinal reinforcement and therefore to ensure easily and efficiently the transmission of forces through it. This would prevent the workers from performing precise drilling of holes, and it would not prescribe the use of any added steel part.

Once again this can be categorized as a “compression joint with combined action”, and the acting forces are shown in the Figure 5.24.

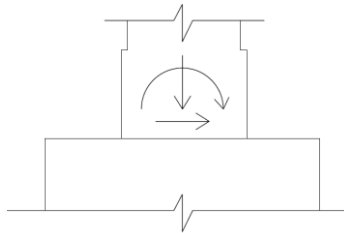

Figure 5.24 – Actions transmitted by the joint

As for the previously presented connection, a difficulty that may be encountered here is concerned with the breaking of concrete avoiding the reinforcement. This procedure of adaptation would better be done in a specialized factory, since there could be no suitable conditions for it to be done on the building site. Another drawback consists in an increased column foot size at the position of the overlap since the connection rods are positioned externally respect to the existing reinforcement of the second-hand column and in most of the cases, the original concrete cover would not have enough thickness in the overlap region.

Hereby, the procedures of adaptation and connection are described, giving the steps for a correct realization. The basis for the application of these steps is a correctly completed disassembling phase of the column. The stages for the accomplishment of this connection are the following:

1. Brake the concrete cover in the region where the overlap of the reinforcements is planned, avoiding the reinforcement bars itself;
2. Position the shim plate on the previously prepared place for the column;
3. Position the column in its final location, with the foundation anchors just externally beside of each longitudinal reinforcement;
4. Replace the (eventually) removed shear stirrups with new ones;
5. Re-cast this part of the column with new concrete. At this point, both the adaptation and the connection phases are completed;

- *Conceptual representation*

In the Figures 5.25a and 5.25b, a generic schematic representation of the joint is shown.

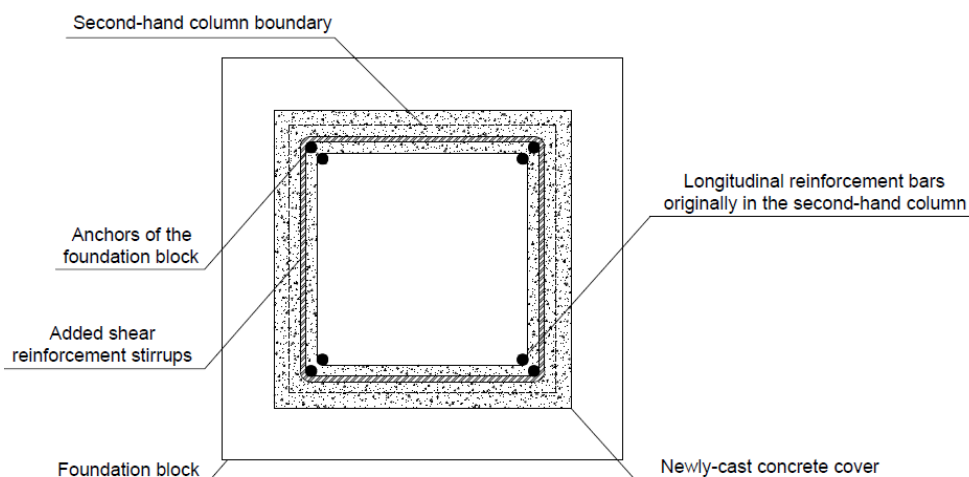

Figure 5.25a – Cross-sectional view in the increased-cover zone

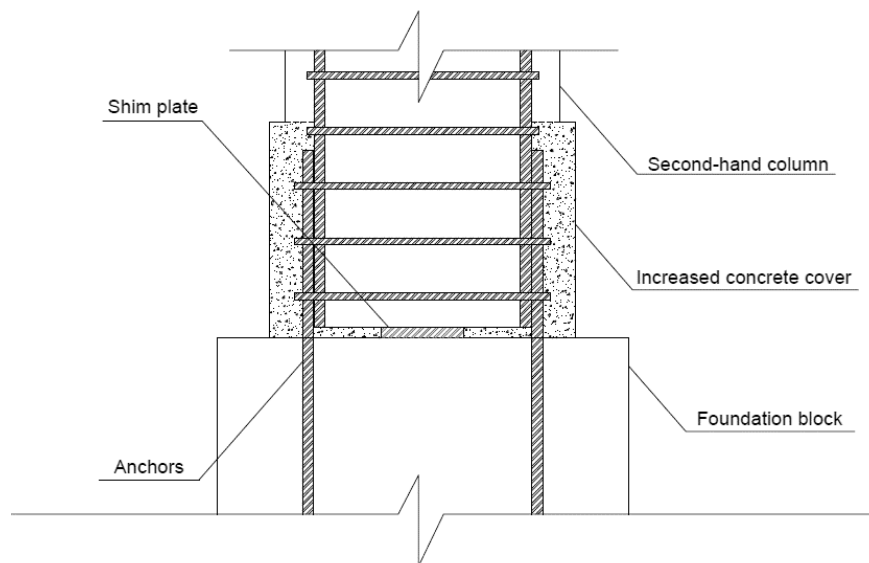

Figure 5.25b – Lateral view of the connection zone

- *Adaptation of the foundation block*

To what concerns the adaptation of the foundation block, the same considerations valid for the connection by means of coupling holes applies also here. Therefore, the connection rods can be part of the bending reinforcement of the foundation block, or separate anchors apart from the foundation block reinforcement.

- *Variations of the proposed design*

Another option could be not to remove the existing stirrups in the connection zone, but to leave them in place and position the anchors just outside of their perimeter, adding shear stirrups also outside of the latter (Legendijk P. , 2019). One drawback of this might be the fact that an increased concrete cover is needed. This situation is represented in the Figure 5.26.

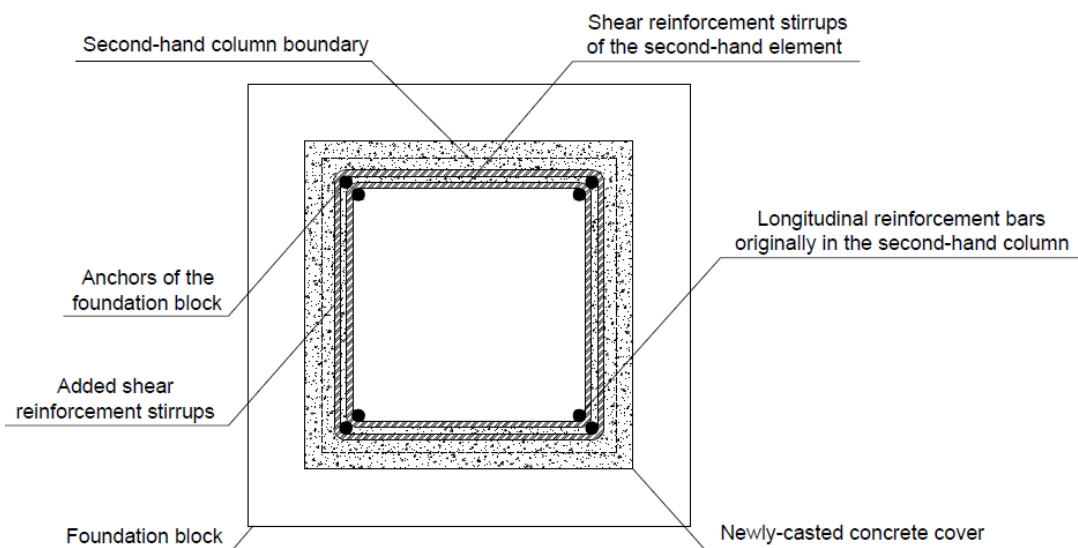

Figure 5.26 – Cross-sectional view in the increased-cover zone (with anchors outside the existing stirrups)

- *Advantages, drawbacks and complexity rating*

This connection can be considered to be the one with the best relation between the easiness of putting it in practice and its effectiveness and adaptability. In fact, braking only the external cover of the reinforcement is not a complicated procedure, but it allows us to easily fulfil all the overlapping/anchoring requirements for the bars. Another very important aspect is that if the transversal reinforcement of the second-hand column is not enough for the required use, this can be easily added before recasting the concrete cover. This last aspect can be very important in some circumstances, and this is the only connection method to allow a so easy procedure of adding extra reinforcement.

In the Table 5.8, the advantages and the drawbacks of this connection method are briefly summarized:

Advantages	Drawbacks
Less precise concrete cut is needed	Formwork required
No sleeves drilling is needed	Increased concrete cover
Allows for reinforcement inspection	Aesthetically relatively unattractive

Table 5.8 – Advantages and drawbacks of the proposed design

The overall joint can be rated as “Simple”, since the fact that the adaptation of the second-hand column and its installation does not require a big effort. Also the required materials are quite common and can be easily find on the market.

5.1.5.4.2. Splice joint

Also a splice joint can be created by means of using connection bars between a second-hand element and a newly cast one or between two second-hand elements. In this section it will be proposed to adopt this approach for the case when the existing column has a larger cross section, which is the best condition for the appliance of this type of connection. The procedure steps for the adaptation and the connection by using this approach are the same as the ones mentioned in the section about the foot joint, therefore they will not be repeated here.

- *Conceptual representation*

In the Figure 5.27, a generic schematic representation of the joint is shown.

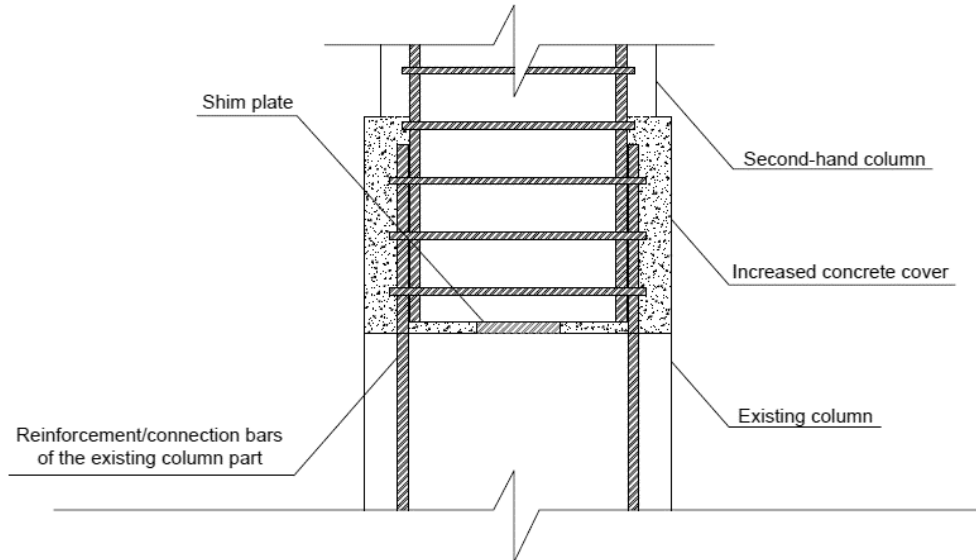

Figure 5.27 – Lateral view of the connection zone

- *Adaptation of the existing column element*

To what concerns the adaptation of the existing column element, the bars that will be overlapped in the re-cast part of the second-hand element can be:

- Part of the reinforcement of the existing column element;
- Connection bars which are inside the existing element on purpose for being connected in this way.

In any case, all the considerations about the overlap length and about the anchorage length shown in the sections 4.3.2 to 4.3.4 should be respected.

- *Advantages, drawbacks and complexity rating*

In the Table 5.9, the advantages and the drawbacks of this connection method are briefly summarized.

Advantages	Drawbacks
Less precise concrete cut is needed	Formwork required
No sleeves drilling is needed	Increased concrete cover
Allows for reinforcement inspection	Aesthetically relatively unattractive

Table 5.9 – Advantages and drawbacks of the proposed design

As for the column foot connection, also this joint can be rated as “Simple”, for the same reasons.

5.1.5.5. *Connection in external concrete “pocket”*

This kind of connection method is suitable only for the foot joint, therefore the section will not be split in sub-sections. Once again, it comes now to an adaptation of the usual design of newly-made elements. The concept is the following: in order to reuse second-hand columns, predispose a reinforced concrete “sleeve” (also called “pocket”), which will host the second-hand column.

As before, this joint can be categorized as a “compression joint with combined actions”, and the acting forces to be resisted by the connection are the ones in the Figure 5.28.

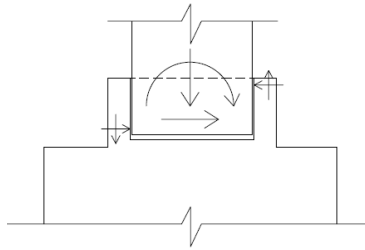

Figure 5.28 – Actions transmitted by the connection

One of the advantages of this design could be that the second-hand column would not need any adaptation (besides of a precise on-size cutting) at the bottom end. Possible drawbacks can however be the fact that this reinforced concrete sleeve has to be manufactured precisely for a certain second-hand element and that this connection can be aesthetically unattractive due to the presence of the wider sleeve respect to the rest of the column.

A technical reason, which can be, at the first view, a big brake to the efficiency of this joining method, is the fact that the maximum distance between longitudinal reinforcement bars is not fulfilled, since it would be in this case equal to the concrete cover of the original second-hand element. At this point, the doubt about the performance of the tensile force transmission may arise. However, as already mentioned previously, before talking about the transmission of tensile forces, it should be investigated whether these will arise at all.

Hereby, the procedures of adaptation and connection are described, giving the steps for a correct realization. The basis for the application of these steps is a correctly completed disassembling phase of the column. The stages for the accomplishment of this connection are the following:

1. Predispose a reinforced concrete sleeve with the internal diameter slightly larger than the column itself and with holes for grouting in the bottom part of it;
2. Position the shim plate on the spot for the column, in order to keep the end of the column slightly elevated for an efficient grouting;
3. Lower the column in its final location inside the sleeve;
4. Grout the column inside this reinforced concrete sleeve by injecting concrete through the holes.

- *Conceptual representation*

In the Figure 5.29 a schematic representation of the joint is shown.

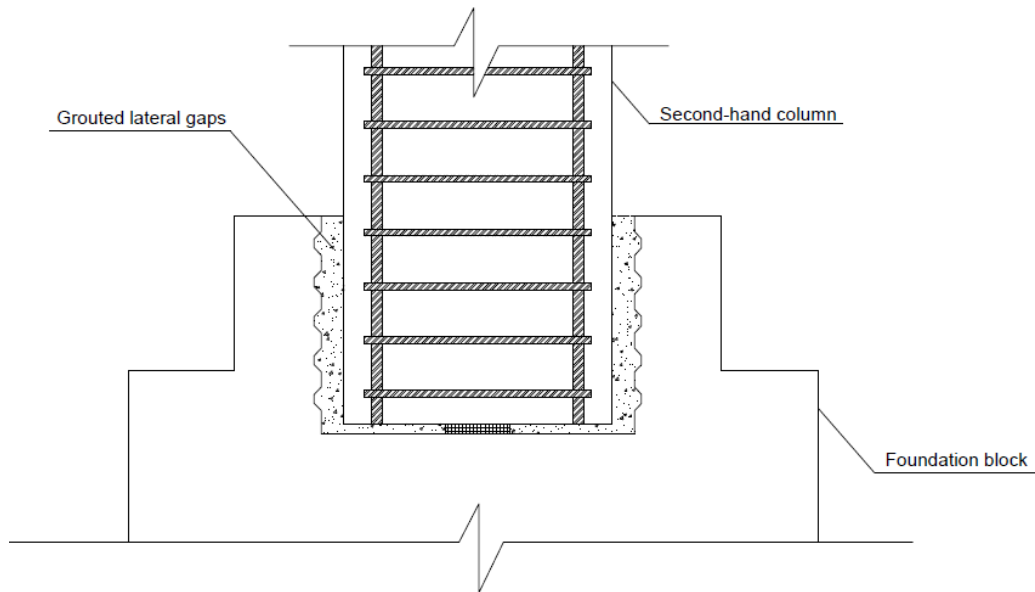

Figure 5.29 – Scheme of the proposed design

- *Adaptation of the foundation block*

The concrete pocket can be precast or cast in-situ. In the upper part the gap between the second-hand column and the pocket walls should be of 75mm.

The depth of the column in the pocket d_c is related to the height of the column cross section and to the ratio between the acting bending moment and the acting normal force on the column in the following manner (Bruggeling & Huyghe, 1991):

$$\frac{M}{N} < 0,15h \text{ implies that } d_c > 1,2h$$

$$\frac{M}{N} > 2,00h \text{ implies that } d_c > 2,0h$$

This referred to the scheme in the Figure 5.30.

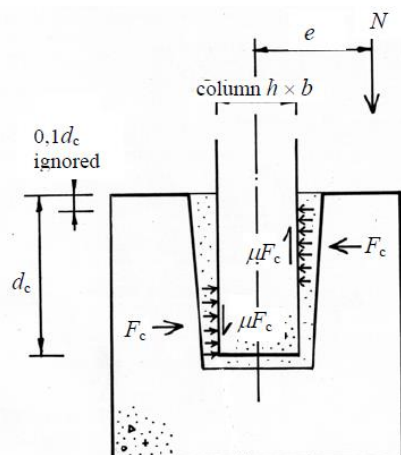

Figure 5.30 – Scheme of the actions on the column portion inside the pocket (FIB, 2008)

As from the picture above, the moment acting on the column is now decomposed into compressive forces and shear forces acting on the column portion inside the pocket.

The pocket with ribbed walls (in order to provide shear capacity) in which the column will be inserted should look similarly to what is shown in the Figure 5.31.



Figure 5.31 – A column pocket ready to host a column (FIB, 2008)

- *Variation of the proposed design*

A variation to the proposed design could be the solution to perform the pockets underneath the ground floor level. In this way the design could be aesthetically more attractive.

- *Advantages, drawbacks and complexity rating*

In the Table 5.10 the advantages and the drawbacks of this connection method are briefly summarized.

Advantages	Drawbacks
Very limited column adaptation	Formwork required (for the foundation block)
No sleeves drilling is needed	Laborious foundation adaptation in general
Simple installation	Aesthetically unattractive (if pocket above floor level)

Table 5.10 – Advantages and drawbacks of the proposed design

The connection can be rated as a joint with “Medium complexity”, since the fact that even if the second-hand column does not require almost any adaptation procedure, the preparation of a suitable “pocket” may require a lot of time and materials.

6. Reconnecting second-hand shallow beams

This chapter, as the previous one, will be related to the design of structural connections for second-hand elements, and it will address the design of connections involving second-hand shallow beams. The type of beams that will be studied in this section is the so-called “half-beam”, so a beam, which had initially the bottom part precast, while the top part was cast in-situ. This is assumed to come from one of the structural systems presented in Chapter 3.

6.1. Second-hand shallow beam-to-column and the splice connections

In this section the design of second-hand shallow beam-to-column and of splice connections will be addressed. The used approach to the topic and the structure of the section are the same as the ones adopted previously for the study of the connections for second-hand columns (presentation of connections for brand new elements, reflection on the limitations of second-hand elements and formulation of suitable conceptual design).

6.1.1. Common methods for connecting shallow beams to columns

In the chapter about the columns, many examples of jointing methods between precast elements have been shown, and many of the proposed designs for new connections were based on these, while when it comes to show how a shallow half-beam is jointed to a column the method shown in the Figure 6.1 is maybe one of the most commonly used.

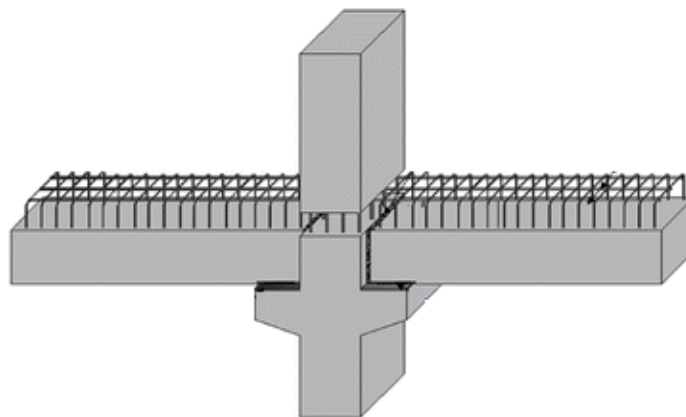

Figure 6.1 – Half-beams on corbels

If the continuity of bending moment between the beams is meant to be ensured (which is commonly the case), the connection bars are positioned between the top reinforcement of the two beams (making it pass through the longitudinal reinforcement of the column). When the connection is grouted and the concrete is hardened, the output is a monolithic node, transmitting bending moments between the beams in a reliable way, while the column acts as a simple support.

The above picture shows us the node, as it looks before concreting the top part of the beams and the gap in the column, however at the moment when the beam has to be reused, it is a monolithic element and cannot be brought to the initial condition by removing the cast in-situ concrete, for obvious reasons. Therefore, the presentation of this connection between newly made half-beams is useful for having an idea of what to expect from a shallow beam once that it is disassembled, but it does not give us any indication to what concerns the design of a possible second-hand

connection (even because as it has been assumed in the previous chapter, the available second-hand column for being reused is not provided with corbels). Thus, completely new approaches respect to the existing ones has to be looked for when dealing with second-hand elements.

6.1.2. Common methods for performing beam splice connections

The splice joint between newly made shallow beams (and between beams in general) is a very uncommon practice and therefore no examples of this can be mentioned here. However, since the second-hand beams for being reused can have lower spans than the required ones in the host-structure, there could be definitely the need for thinking about such type connection. It should also mentioned, the fact that if we are in presence of a beam that has a continuous behaviour over two or more spans, this type of connection may have the advantage that it could be done in the position where the bending moment is zero (or in any case where it has a low value), and in this way there will be no need for large overlapping length between the reinforcement bars of the jointed elements.

6.1.3. Limitations and boundaries of second-hand elements

The main possible limitations of a second-hand shallow beam element to be jointed are now here presented.

6.1.3.1. Need for a totally different approach respect to new elements

As it was previously mentioned, a completely new approach should be figured out for connection methods to use for second-hand shallow beams respect to brand new ones, because the element in its second use is completely different from how it was before its “first life”.

6.1.3.2. Laborious achievement of reinforcement continuity

As it has been done previously for the case of second-hand columns, the following two main conceptual approaches to predispose the end of a shallow beam can be thought of:

- a) Steel-avoiding adaptation – protruding reinforcement
- b) Net cut – need for additional steel bars/provisions

Both these adaptation procedures will be addressed in the section dedicated to new joints proposals.

6.1.3.3. Eventual insufficiency of shear reinforcement

At the points of intersection between the beams and the columns, there is usually a very high shear force acting on the beam. According to many (recent and less recent) codes, to counteract to this, lower spacing between transversal reinforcement bars is often used in these high shear locations. The application of this principle for a new beam can be seen in the Figure 6.2.

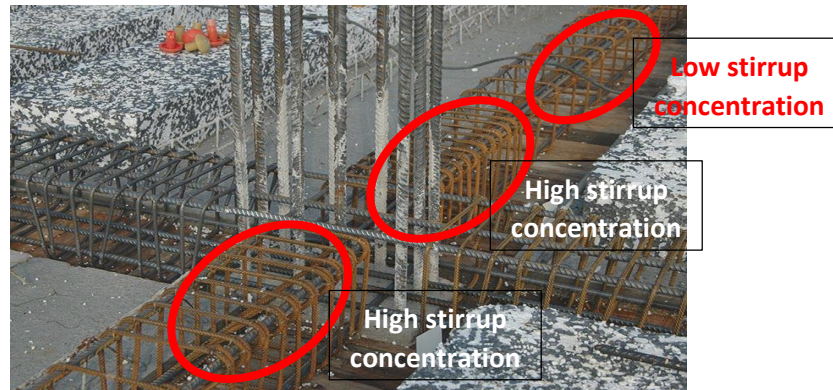

Figure 6.2 – Stirrup concentration in the beam

Therefore, when a second-hand beam is cut at a certain distance from its original joining point with the column, a question may arise: “is there enough shear reinforcement at the ends of the beam once that this beam is disassembled?” In any case, if the beam is reused to its total length, this problem will not arise, while if the beam is reused partially and the shear verifications are critical, external reinforcement (carbon fibre strips or steel provisions) might be added in order to overcome the problem (of course if this is cost-efficient).

6.1.3.4. *Eventual presence of useless connection bars*

As for the case of second-hand column elements, also inside the second-hand shallow beam, there could be the presence of several bars, which have no structural role. These bars can be the ones, which originally connected the floor to the beam or also the ones needed for the previous connection of the beam to the column, etc.... This should be kept in mind when the beam elements are getting predisposed for a reconnection: these bars can be interfering with holes/voids, which need to be drilled during connection procedure.

6.1.3.5. *Modification of the structural scheme*

The beams are often designed to have a continuous behaviour across the columns, however due to several feasibility reasons, during the disassembling phase it is necessary to reduce them back to one-span elements. These elements can be reassembled to have a simply supported behaviour or to re-acquire again a continuous behaviour. However, obviously, the internal bending moment and the shear forces change from one structural system to another, even if the same load is applied in the two spans. This is schematically shown in the Figure 6.3.

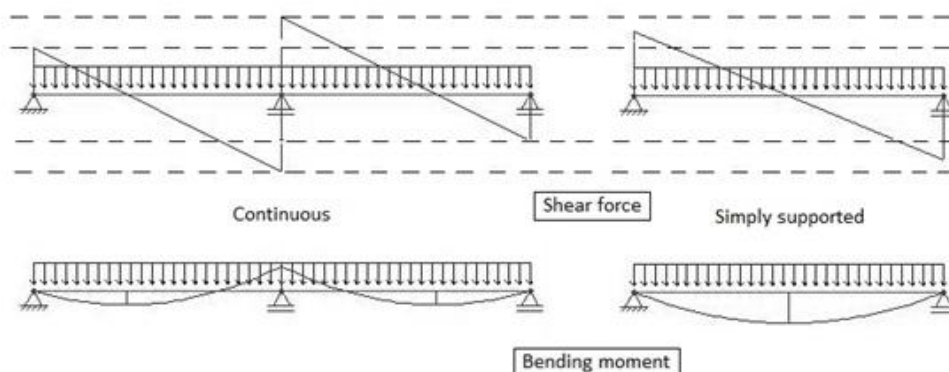

Figure 6.3 – Differences between continuous and simply-supported structural schemes

This implies that, if a beam was extracted from a continuous structural scheme, the best option, structurally speaking, would be to re-integrate it in the new structure by providing bending moment resistance at the connections in order not to have higher actions in some parts of the beam. However, a reconnection that allows for the transmission of bending moment is very difficult to achieve in case of second-hand elements. Both the possibilities will be addressed in the next section.

6.1.4. Connection design proposals

In this section some proposals for new design of second-hand connections will be formulated for both the joint locations (at the column location and splice joint). In the presentation of all the joints, only one of the beams will be assumed as second-hand, however the same element adaptation and the same procedure can be usually also applied for the complementary elements of the joint if these are also second-hand. For each connection method it will be specified if this presuppose a simply-supported behaviour of the beam over the supports or if this is meant to have a continuous static scheme.

6.1.4.1. Connection by anchoring the bottom reinforcement (simply-supported)

This connection method is referred only to the jointing of a beam to the so called “column-beam node” but it is not suitable for a splice joint between beams. The first thing that should be said is that it presuppose that the beam has been modelled as simply-supported over the column, this makes it mostly a “compression joint”, because the shear force of the beam is transferred under the form of compression to the column. Therefore, the scheme of transferred forces looks like in the Figure 6.4.

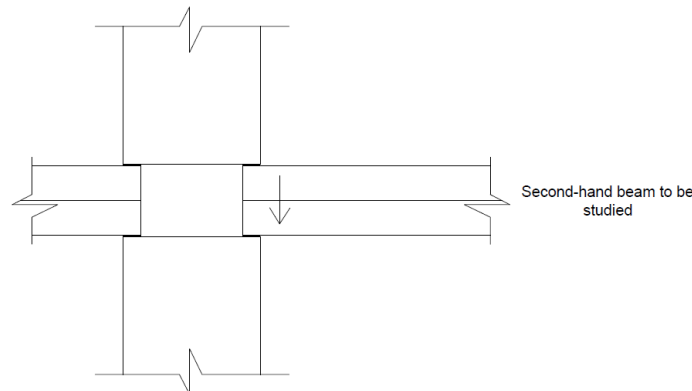

Figure 6.4 – Actions to be transmitted by the connection

The idea behind this connection approach is that the shear force is transmitted to the bottom column by anchoring the bottom reinforcement to the (grouted) core of the node. It has been chosen to position the beam on a “step” (edge of the column), with a neoprene bearing in between, but this is done just to facilitate the assembling of the joint. The only load that the bearing should be capable of withstanding is the self-load of the beam during the assembling. The beam cannot be assumed to be supported only by the edge of the column for the reason that in that case we would need to refer to the part of the Eurocode concerned with the design of precast elements (ENV 1992-1-3) where all the required spacings for such a case are given, and these are very likely not to be compatible with our case.

However, since it is assumed that the beam has been cut-out from the donor structure in a net-way, no protruding reinforcement bars are present for being anchored, therefore something should be done for obtaining these. The chosen option for achieving this, is to drill-away a small portion of concrete around the bottom bars and afterwards use mechanical (threaded) steel couplers, which will be attached to their protruding parts.

Hereby, the procedures of adaptation and connection are described, giving the steps for a correct realization. The basis for the application of these steps is a correctly completed disassembling phase of the beam. The stages for the accomplishment of this connection are the following:

1. The end surface of the second-hand beam, should be roughened (if is not rough enough by itself after the cutting out of the element from the “donor” structure). This is done in order to ensure sufficient bond with the new concrete which will come in contact with the second-hand beam when the core of the node will be grouted.
 2. A small amount of concrete around the bottom reinforcement bars of the end of the beam should be bared in order to obtain a portion of free longitudinal reinforcement, to be able to cut the thread and to install successfully the coupler;
 3. On site, the coupler and the anchorage bar can now be installed. After this phase, the element adaptation is considered to be completed.
 4. Install the neoprene bearings in the correct position on the column edge;
 5. Make the beam assume its final position on the edge of the column;
 6. Grout the core with low-shrinkage concrete;
 7. Once the grouting concrete is hardened, the connection can be considered to be achieved.
- Some aspects of the connection will be addressed further on more in detail.

- *Conceptual representation*

In the Figure 6.5 (not to scale, meant only for a conceptual visualization), a schematic representation of the connection is shown.

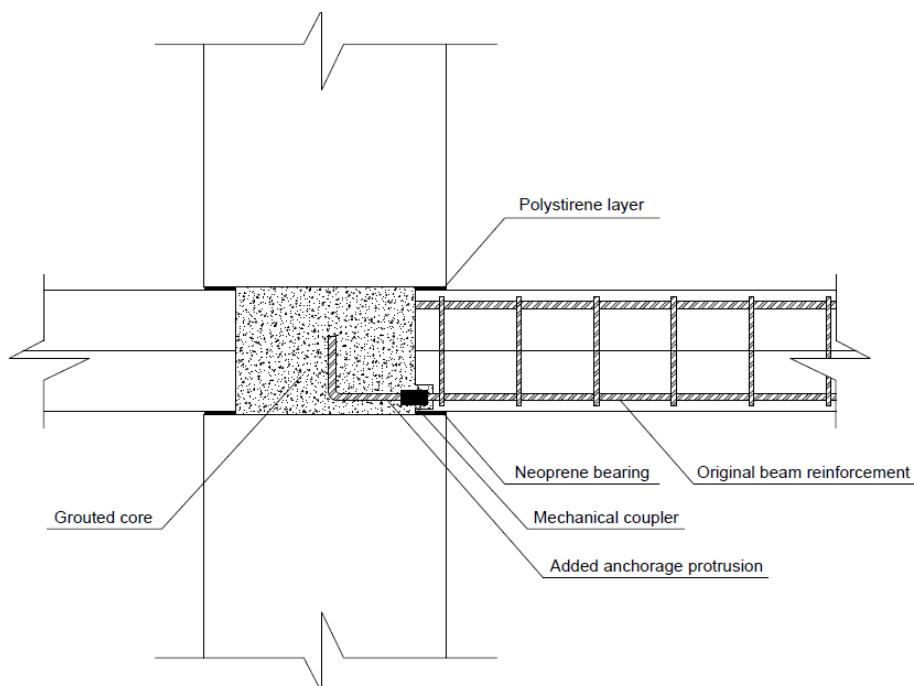

Figure 6.5 –Scheme of the proposed connection

- *Unintended restraint action*

As for newly made connections between elements, which ends are assumed simply supported during the design phase, also now great attention should be put to the unintended restraint actions. So, it should be taken into account that some bending moments could eventually occur at positions where this was not meant to be during the design. It can be more intuitively seen from the schematization shown in Figure 6.6.

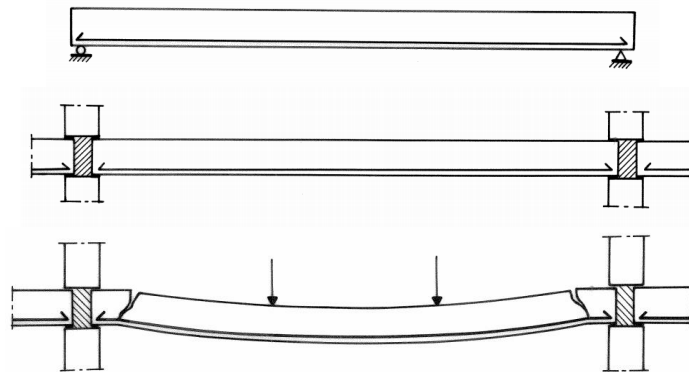

Figure 6.6 – Unintended restraint action principle (FIB, 2008)

In order to overcome the problem, between the beam and the slab, a neoprene strip should be placed in order to allow for some rotations and to avoid direct contact between the two parts, which can cause the break of some concrete pieces, as shown in the Figure 6.7.

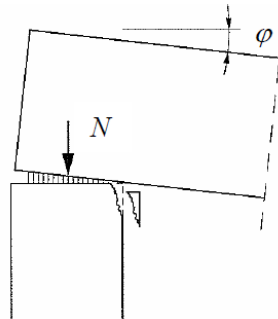

Figure 6.7 – Breaking of the column edge due to beam rotation (FIB, 2008)

There is a great variety of bearings meant explicitly for this purpose available on the market. In order to choose the correct one, usually further study is required.

If, as in the case analysed in this section, a top column is meant to be part of the node, sufficient rotation capacity should be ensured to the beams also by the top column. This can be done by inserting a thin layer of foam, polystyrene, etc...

- *Anchorage length of the bottom bars*

According to the prescriptions of the EN 1992.1.1, the bottom reinforcement of a beam at its end support (so without an intended clamping), should be anchored by an amount l_{bd} (the calculation procedure of this has been presented in the section 4.3.2), which is measured as it is shown in the Figure 6.8.

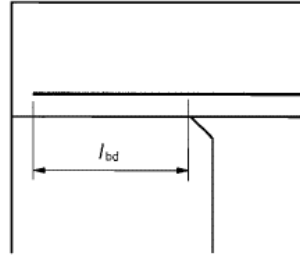

Figure 6.8 – The end-support anchorage length

- *Threaded couplers*

As mentioned before, for connecting the anchors to the bottom reinforcement of the beam the steel threaded couplers are chosen. These are available of many different sizes and varieties (straight thread, tapered thread, etc...) on the market. A thread cutting machine is used for obtaining the threaded end of the second-hand reinforcement.



Figure 6.9 – Threaded steel coupler (Tapered thread rebar coupler)

Also other types of connection between the protruding existing bars and the added anchoring part are possible, one example could be a simple welding, however, this kind of connection has been chosen because of the feature that in this way the anchoring part can be added directly in-situ, so the transportation to the building site of the second-hand beam element may be done without any long protruding parts.

- *Variations of the proposed design*

The proposed design may withstand also some variations. For example, different ways of connecting the bottom reinforcement protrusion to the core of the node might be thought of: it can be also welded or coupled by means of bolted steel couplers.

- *Advantages, drawbacks and complexity rating*

In the Table 6.1 the advantages and the drawbacks of this connection method are briefly summarized.

Advantages	Drawbacks
Easy design	Need to bare the reinforcement
Easy on site connection	Need for adding couplers
No reduction of beam length	

Table 6.1 – Advantages and drawbacks of the proposed design

This connection approach, together with the one for the columns mentioned in the section 5.1.5.3.3 will be addressed more in detail in Chapter 9, regarding the case study about the embedding of presented structural joints in a hypothetical structure.

The complexity of the connection can be rated as “Simple”, since the fact that the adaptation phase of the second-hand beam requires the braking of the concrete around the bottom reinforcement bars and the adding of threaded couplers, however the installation is very simple.

6.1.4.2. Intermediate connection by linking top reinforcement bars (continuous behaviour)

The second approach that will be hereby presented, regards the ensuring of a solid connection between the top reinforcement bars of the two beams, in order to guarantee the full transmission of the bending moment between the two involved beam parts. This approach is suitable only for an intermediate joint over the column.

The connection between the second-hand beam and the column-beam node (“intermediate support”) will be now addressed. The actions which are now assumed to pass between the two beams are shown in the Figure 6.10.

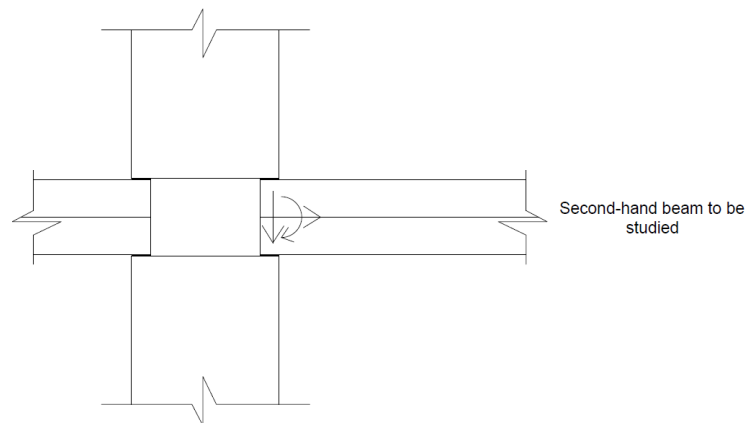

Figure 6.10 – Actions to be transmitted by the connection

The connection between the top bars is assumed to be achieved by means of baring their ends from the concrete (avoiding carefully the reinforcement bars), and welding to them connection bars which will terminate inside the previously predisposed beam in front of it.

A similar result may be reached with the creation of sleeve holes inside the ends of the beam (as it has been shown for coupling the reinforcement between two column elements in the section 5.1.5.1), however due to the fact that there would be too many problems regarding the assembling sequence (laborious insertion of bars inside the couplers between the beams), it has been chosen not to use this approach.

To what concerns the bottom bars, these should be anchored inside the (grouted) core of the node at least to a length equal to 10ϕ , as required in the point (2) of the section 9.2.1.5 of the EN 1992.1.1. Therefore, for the bottom bars the same approach as the one presented in the section 6.1.4.1 will be used.

As for the previous connection proposal, it should be highlighted that the beams are not laying on the column edges, and the only load that they may transmit to the latter is their self-weight during the assembling phase, since from the moment when the core is grouted and the concrete is hardened, all the actions will be transmitted directly through the core, and the neoprene bearings are meant only to provide sufficient rotation capacity to the beam (even if this time, since the beam has a continuous behaviour, the rotations of the beam will be very small).

The procedure for the adaptation and connection of the second-hand shallow beam is hereby described, giving the phases for a correct realization. It is presumed that the disassembling stage has been correctly completed, and the required length of the element (incremented by the end margin, called e_m , where the concrete will be removed) has been achieved. The steps for the achievement of this connection are the following:

1. The end margin quantity e_m of concrete should be removed in order to obtain a portion of free longitudinal reinforcement (top and bottom bars), the eventual shear reinforcement should also be removed, if this is present;
2. The “new” end surface that is obtained, should be roughened (if is not rough enough naturally after the concrete removal procedure). This is done in order to ensure sufficient bond with the new concrete which will come in contact with the second-hand beam when the core of the node will be grouted.
3. At this point the anchorage element can be welded to the bottom bars of the beam. This is more likely to be done in the factory in order to avoid welding on site.
4. Install the neoprene bearings in the correct position on the column edge;
5. Lower the beam, making it assume its final position on the bearings;
6. Install the preliminarily-cut to the correct length connection bars in their final position, between the top reinforcement bars, ready to be welded;
7. Perform the welds between the connection rods and the protrusions of the second-hand element and between the connection rods and the protrusions of the existing beam, respecting all the requirements;
8. Grout the core of the node with low-shrinkage concrete;
9. Once the grouting concrete is hardened, the connection can be considered to be achieved.

- *Conceptual representation*

In the Figure 6.11 (not to scale, meant only for a conceptual visualization), a schematic representation of the connection is shown.

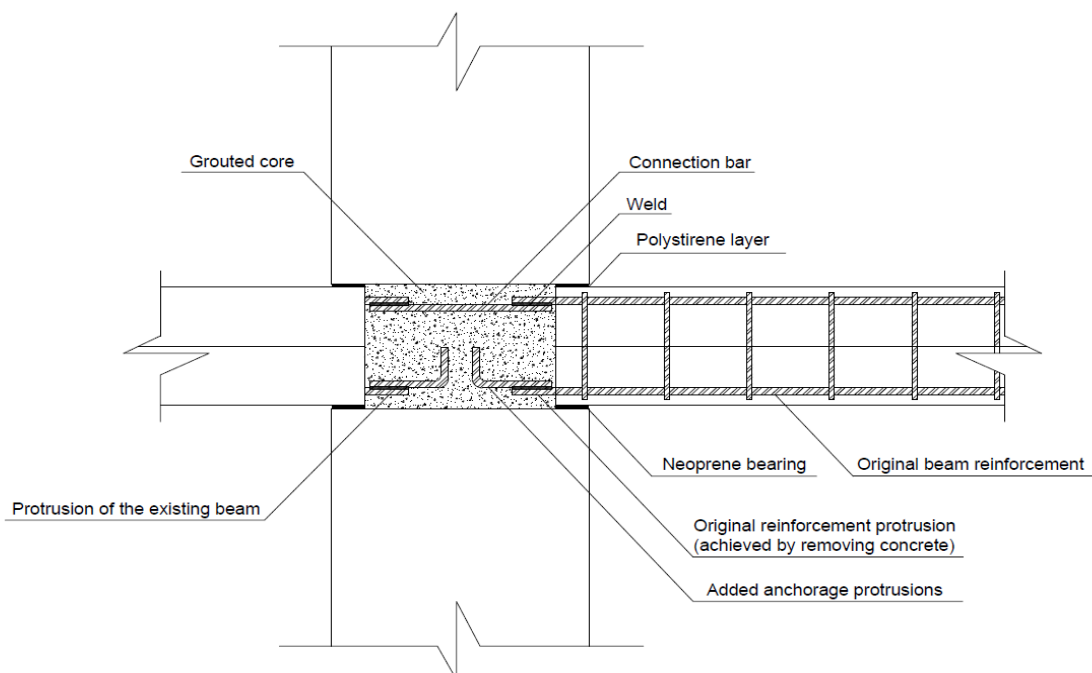

Figure 6.11 – Scheme of the proposed connection

- *Welds with the connection bar*

The welds between the reinforcement of the second-hand beam and the connection bar should be done by calculating the length of the weld on the basis of the maximum acting stress inside the bars. These welds, as it can be understood, need to be done by a qualified personnel directly on the building site, when the beam is already in its final position laying on the bearing over the column. The Figure 6.12 shows how welds between two reinforcement bars may look like.



Figure 6.12 – A generic representation of a welded connection between bars

- *Adaptation of the complementary beam*

To what concerns the beam to which the addressed second-hand element will have to transfer the actions, this also should be adapted to the connection. It should also withstand the roughening of the end surface, since, just as the second-hand element it will have to be in contact with newly-cast concrete of the core. As already mentioned in the beginning of this section, the complementary beam is considered to be newly made, in this case, the protruding bars to which the connection rods will be welded can be embedded into the concrete at the moment of the casting of the beam (in-situ or during the prefabrication), respecting all the overlapping and the anchoring requirements. If the complementary beam would have been second hand, it could withstand the same adaptation as the one mentioned in this section in order to be ready for the jointing. It is in any case very important that in final result, the connection bars are aligned between the reinforcements of the beams, in other words no oblique connection bars are allowed, because dangerous strut-and-tie mechanisms can otherwise occur.

- *Advantages, drawbacks and complexity rating*

In the Table 6.2, the advantages and the drawbacks of this connection method are briefly summarized.

Advantages	Drawbacks
Aesthetically attractive	Need to bare the reinforcement
Relatively simple on-site montage	Precision and quality welding is necessary
	Failure of the welds should be accounted for
	Reduction of second-hand beam length
	Mostly applicable between beams with similar bar layouts

Table 6.2 – Advantages and drawbacks of the proposed design

The connection can be assumed to have a “Medium complexity” since it is not simple to remove the concrete precisely avoiding the concrete and because a precise welding is required on site, however the overall procedure does not require complex materials and the montage procedure does not require particular skills from the workers brigade.

6.1.4.3. Splice connection by linking top and bottom reinforcement bars

This time the splice joint with the use of connection bars welded between the top and the bottom reinforcement bars is addressed. The actions which are assumed to be transmitted between the two beams are showed in Figure 6.13.

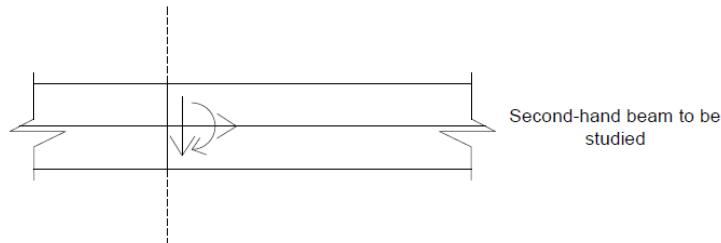

Figure 6.13 – Actions transmitted by the connection

Once again the connection between the bars of the two beam elements is assumed to be achieved by means of baring their ends from the concrete (avoiding carefully the reinforcement bars), and welding to them connection bars.

The procedure for the adaptation and connection of the second-hand shallow beam is hereby described, giving the phases for a correct realization. The actual connection between the two parts is assumed to be done on the building site. Once again, it is presumed that the disassembling stage has been correctly completed, and the required length of the element (incremented by the end margin, called e_m , where the concrete will be removed) has been achieved. The steps for the achievement of this connection are the following:

1. The end margin quantity e_m of concrete should be removed in order to obtain a portion of free longitudinal reinforcement (top and bottom bars), the eventual shear reinforcement should also be removed, if this is present;
2. The “new” end surface that is obtained, should be roughened (if is not rough enough by itself after the concrete removal procedure). This is done in order to ensure sufficient bond with the new concrete which will come in contact with the second-hand beam when the core of the node will be grouted. After this phase, the element adaptation is considered to be completed.
3. Install the jacks which will support the two beam portions during the execution of the connection;
4. Make the beam assume its final position on the jacks;
5. Install the preliminarily-cut to the correct length connection bars in their final position, between the top and the bottom reinforcement, ready to be welded;
6. Perform the welds between the connection rods and the protrusions of the second-hand element and between the connection rods and the protrusions of the existing beam, respecting all the requirements;
7. Mount the formworks to the correct shape;
8. Grout the core/gap between the beams with low-shrinkage concrete;
9. Once the grouting concrete is hardened, the jacks can be removed and the connection can be considered to be achieved.

Same considerations about the unintended restraint action, welds between the connection bars and the adaptation of the complementary beam mentioned for the intermediate connection are valid also here. Some aspects will be now discussed more in detail.

- *Conceptual representation*

In the Figure 6.14 (not to scale, meant only for a conceptual visualization), a schematic representation of the connection is shown.

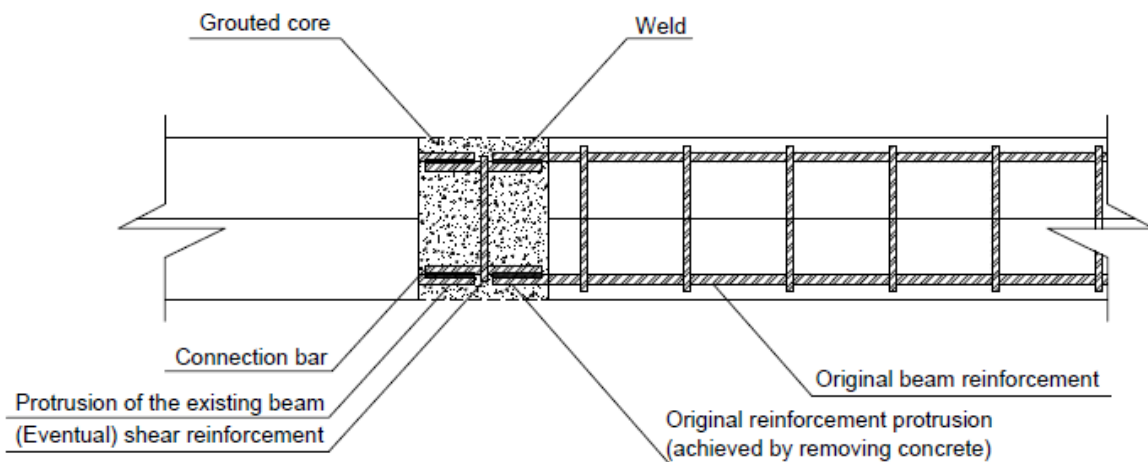

Figure 6.14 – Scheme of the proposed connection

As it can be noticed, respect to the joint at the intermediate support made with the same approach, this time there might be the need to add also eventual shear reinforcement stirrup(s). This is because in the case of the intermediate support, the column is taking the shear force of the beam, while now the shear force is supposed to be transferred to the complementary part of the beam.

- *Advantages, drawbacks and complexity rating*

In the Table 6.3, the advantages and the drawbacks of this connection method are briefly summarized.

Advantages	Drawbacks
Aesthetically attractive	Need to bare the reinforcement
Relatively simple on-site montage	Precision and quality welding is necessary
	Failure of the welds should be accounted for
	Need for in-span formwork
	Reduction of second-hand beam length
	Mostly applicable between beams with similar bar layouts

Table 6.3 – Advantages and drawbacks of the proposed design

The connection can be assumed to have a “Medium complexity” since it is not simple to remove the concrete precisely avoiding the concrete and because a precise welding is required on site, however the overall procedure does not require complex materials and the montage procedure does not require particular skills from the workers brigade.

7. Reconnecting second-hand load-bearing wall elements

This chapter will deal with the connection of a second-hand wall element to the rest of the structure. The type of second-hand wall that is addressed in this section is a precast wall panel with two reinforcement layers (which has been presented in the Chapter 3).

7.1. Horizontal connection of second-hand wall elements

It comes now to address the horizontal connection of a second-hand wall element to the foundation block or to another element. As done in the previous sections, the element to which the second-hand wall will be connected, is assumed to be newly made (for the sake of simplicity), however if this would have been also second-hand (only in case of the other wall element, since this graduation project does not address the reuse of the foundation blocks), it could withstand the same adaptation procedure as the one that will be here presented.

The used approach to the topic and the structure of the section are the same as the ones adopted previously for the study of the connections for second-hand columns and beams (presentation of connections for brand new wall elements, reflection on the limitations of second-hand elements and formulation of suitable conceptual design).

7.1.1. Common methods for connecting newly made elements

The same methods for performing the connection between the foundation block and the precast element and between two precast elements are usually applied. Different methods could be listed here, however, it has been chosen to address only the most widely spread one. This consists in embedding, at the time of casting the element in the factory, of mechanical steel couplers, which are connected by means of a threaded heads to bars inside the wall. At the moment of their installation on-site, the coupling bars protruding from the element to which the wall has to be connected are inserted in these couplers and then grouted with low shrinkage concrete from the filling hole, until the coupler is completely filled, letting the air be expelled from the top opening in the coupler. This approach for connecting brand new wall elements is used for both the shear walls and simple load-bearing walls. The “x-ray” visualization of the wall with the couplers looks as in the Figure 7.1.

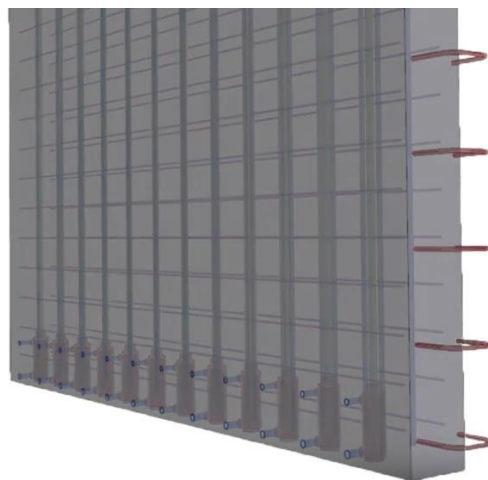

Figure 7.1 – A precast wall element ready to be connected (Precast element connection on a residential project using Groutec)

This connection design is very similar to the connection for precast columns which was previously presented in the section 5.1.1.

7.1.2. Limitations and boundaries of second-hand elements

Mostly the same limitations as the ones that have been mentioned in the Chapter 5 for second-hand column elements are also valid for the case of second-hand walls.

1.1.2.1. Laborious achievement of reinforcement continuity

In most of the connections that can be thought of, continuity of the longitudinal reinforcement should be ensured between the reused second-hand wall element and the rest of the structure (in this case with the foundation block), two main conceptual approaches to predispose the end of a generic structural element can be thought of. These are the following:

- a. Steel-avoiding adaptation – protruding reinforcement made available
- b. Net cut – need for additional steel bars/provisions

1.1.2.2. Eventual presence of useless connection bars and provisions

Inside the second-hand element there could be the presence of several bars and/or other provisions, which have no structural role. These can be for example the steel couplers which have been shown to be present usually in new precast elements. This fact should be kept in mind when the wall gets predisposed for a reconnection: these elements can be interfering with holes, which need to be drilled during connection procedure.

7.1.3. Connection design proposals

The design proposals for connecting the second-hand element are now here presented.

7.1.3.1. Connection in sleeve couplers

This methodology for connecting second-hand elements can be applied to all the connection to the foundation block and to another (top or bottom) wall element. Therefore, in order to address more precisely the two (in any case very similar) cases, it has been decided to split the section in two sub-sections.

7.1.3.1.1. Wall base connection

The first connection that is hereby proposed can be considered to be similar with the connection presented in the section 7.1.1. However, this time the connection will not be performed in steel couplers, since these cannot be easily embedded in an already cast monolithic wall, but into sleeve coupling holes, drilled in the wall end. This approach recalls directly the same method used for connecting second-hand columns as shown in the section 5.1.1.

Also now, the joint can be categorized as a “compression joint with combined actions”, and the acting forces it should resist (in plane of the wall) are the ones shown in the Figure 7.2.

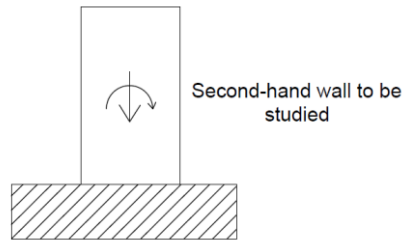

Figure 7.2 – Actions transmitted by the connection

The procedure for the adaptation and the connection of the second-hand wall is hereby described, giving the phases for a correct realization. It is presumed that the disassembling stage has been correctly completed, and the required dimensions of the wall element to be connected has been achieved. The steps for the accomplishment of this connection are the following:

1. Perform the drilling of the coupling holes respecting all the requirements;
2. Perpendicularly to each coupling hole, there is the need to drill one hole in the wall in the lower part of the sleeve, and one (of a smaller diameter) in the upper one. The first hole will be used for grouting the sleeve while the second one will be used for expelling the air. It is of vital importance that both these holes intersect the coupling sleeve with sufficient precision.
3. The end-surface of the second-hand wall should be roughened enough to ensure a sufficient bond with the concrete which will be used to grout the connection. After doing this, the adaptation phase of the wall is considered to be completed;
4. Insert thin shim plates in between the wall to be jointed and the foundation block in order to allow for a small gap in between the wall end and the foundation. This gap is needed in order to acquire head-to head bond;
5. Lay down the wall inserting the connection bars/anchors of the foundation block into the coupling holes;
6. The wall should be still kept braced;
7. Inject low-shrinkage concrete under pressure in the filling holes of the couplers. Make sure that the sleeves and the head-to-head gap are fully grouted. This is achieved when the concrete has filled the air expelling openings.
8. Once that the concrete is hardened and full bond is achieved between the anchors and the column, the desired connection is achieved.

Of the previous phases, the ones from 1 to 3 are more suitable to be done in the factory.

It should be added that the sleeve holes must be close enough to the vertical reinforcement of the wall, in order to guarantee the correct force transfer. The same considerations already mentioned in the section 5.1.1 to what concerns the length of the sleeves to be achieved, the drilling of sleeve holes and the air expelling holes may be considered to be valid also now.

- *Conceptual representation*

In the Figure 7.3 (not to scale, meant only for a conceptual visualization), a schematic representation is shown (cross-section view of the wall is presented because it gives a better idea about the connection).

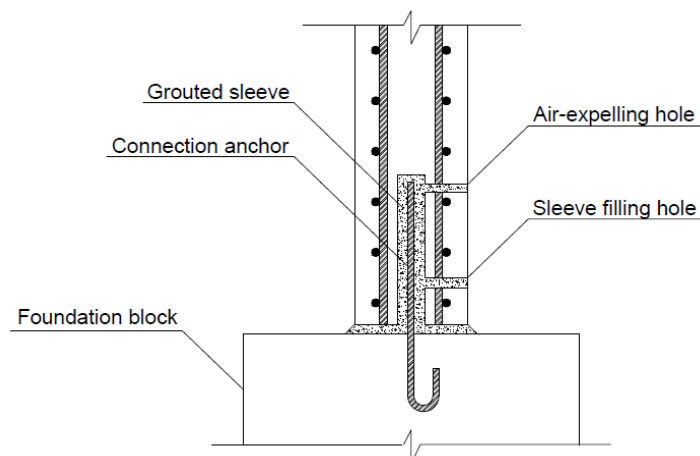

Figure 7.3 – Scheme of the proposed design

In the final result, the second-hand wall end after the adaptation procedure should look similarly to the one shown in the Figure 7.4 (on which is actually shown a newly made precast wall element with steel couplers, but is still a good visualization also for representing a second-hand case).



Figure 7.4 – Precast wall ready to be assembled (Precast element connection on a residential project using Groutec)

- *Adaptation of the foundation block*

The foundation block, to which the second-hand element has to be jointed, has also to be predisposed eventually for such connection. The connecting rods, which will be inserted into the sleeves of the second-hand wall, are usually embedded into the foundation block at the time of its casting (in-situ or precast). To what concerns the surface of the foundation block which will be in contact with freshly cast concrete, this one should be roughened enough to be able to achieve a good bond with the concrete cast in the interface between the foundation and the interface.

- *Advantages, drawbacks and complexity rating*

In the Table 7.1 the advantages and the drawbacks of this connection method are briefly summarized.

Advantages	Drawbacks
No added steel provisions	Need for a precise concrete drilling
Common on site mounting procedure	Not suitable for eventual further reuse
Aesthetically attractive	

Table 7.1 – Advantages and drawbacks of the proposed design

This connection can be rated to have a “Medium complexity”. This rating is assigned due to the fact that even if the required materials are quite common and can be reachable easily on the

market, the adaptation may result to be quite laborious (since precise drilling and grouting are required). This is however compensated by the fact that the on-site mounting procedure is almost the same as for brand new elements, as shown in the section 7.1.1.

7.1.3.1.2. Wall-to-wall horizontal connection

It is now assumed that we have to joint together a second-hand wall element on the top of another wall element. For the sake of simplicity, no slabs connected to the node are considered (which will be addressed in detail in the next chapter). The bottom precast wall element to which the addressed wall is considered to be connected is assumed to be newly made.

Exactly the same transmission of forces, the connecting procedure and the same considerations as for the connection with the foundation block are valid also here, therefore they will not be repeated

- *Conceptual representation*

In the Figure 7.5 (not to scale, meant only for a conceptual visualization), a schematic representation is shown (cross-section view of the wall is presented because it gives a better idea about the connection).

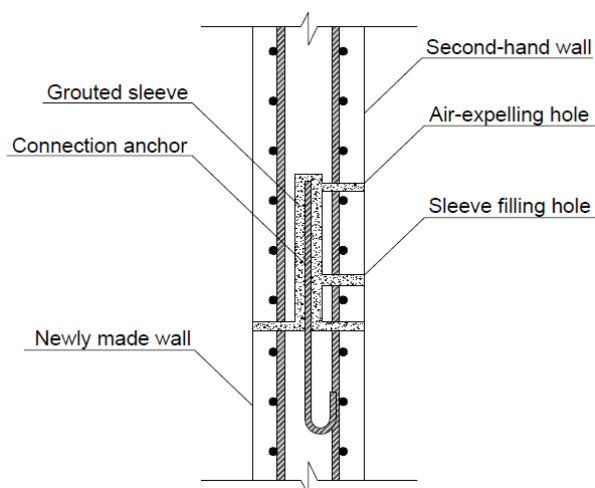

Figure 7.5 – Scheme of the proposed design

- *Adaptation of the complementary wall element*

The bottom wall element on top of which the second-hand part is considered to be connected, has also to be predisposed eventually for such connection. The connecting rods, which will be inserted into the sleeves of the second-hand wall, have to be embedded into the foundation block at the time of its casting. And, as before, the surface which will be in contact with new concrete has to be roughened.

- *Advantages, drawbacks and complexity rating*

In the Table 7.2, the advantages and the drawbacks of this connection method are briefly summarized.

Advantages	Drawbacks
No added steel provisions	Need for a precise concrete drilling
Common on site mounting procedure	Not suitable for eventual further reuse
Aesthetically attractive	Compromised out-of-plane stability

Table 7.2 – Advantages and drawbacks of the proposed design

As it can be seen from the table above, one of the drawbacks can be the fact that, since the connection is done by means of only one row of connection bars, it behaves almost as a hinge for out-of plane rotation and this should be kept in mind while putting it in practice. Therefore perpendicular walls should be present to ensure global stability to the structure. This connection can be rated to have a “Medium complexity” for the same reasons as the wall-to-foundation connection.

7.2. Vertical connection of second-hand wall elements

Hereby the vertical joint between a second-hand wall element and an existing part of a similar wall will be addressed, giving all the conceptual advices on how to achieve a solid reconnection. It will be now important to distinguish the connections between the ones suitable for a shear walls and the ones to be used between simple wall elements. As previously, the element to which the second-hand wall will be connected, is assumed to be newly made (for the sake of simplicity), however if this would have been also second-hand, it could withstand the same adaptation procedure. Same structure of the section and same studying approach will be used.

7.2.1. Common methods for connecting newly made elements

As said before, it is important to differentiate between connections, which allow a shear-wall behaviour and the ones that do not. The shear wall allows for transferring lateral loads, and makes the wall to behave as a kind of a bracing system.

7.2.1.1. Connection between shear walls

One of the most used methods to connect shear wall elements is the one based on the following principle: loops of reinforcement bars at the end of the elements are predisposed to host a vertical connection bar going through. Everything is grouted after the correct alignment. These reinforcing loops at the point of the connection create the shear capacity. A representation of a similar connection is shown in the Figure 7.6.

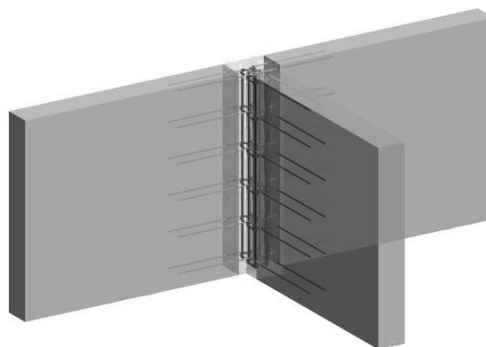

Figure 7.6 – Shear-resistant connection between three wall elements (Connections to last, s.d.)

The schematic representation of a similar connection with “shear keys” between two wall elements under 180° is shown on a closer scale in the Figure 7.7.

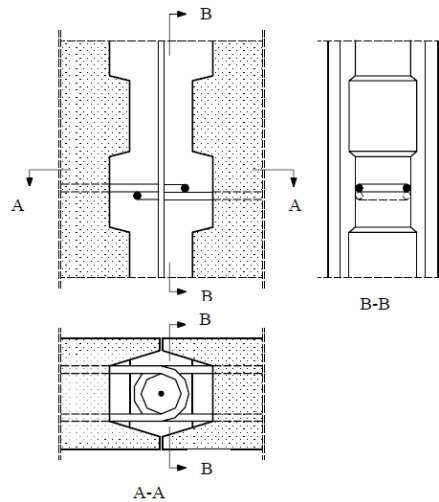

Figure 7.7 – Shear-resistant connection scheme (FIB, 2008)

7.2.1.2. Connection between simple wall elements

The most common method to connect two wall elements which do not require to resist to vertical shear force, is the one by jointing together the connection plates (appositely predisposed in the wall sides at the moment of their manufacturing). In fact, during the production of the precast wall, small, anchored steel plates (usually by means of studs) are added, and when two adjacent elements have to be jointed, this plates are jointed together. The in-situ connection may occur by means of bolting together these two plates of two adjacent elements or by welding them, as shown respectively in the Figures 7.8a and 7.8b.

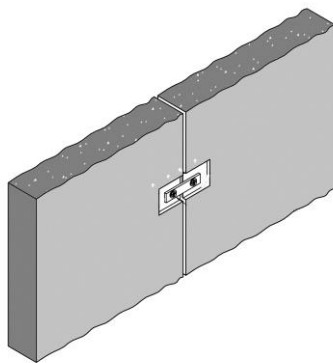

Figure 7.8a – Connection by means of a bolted plate

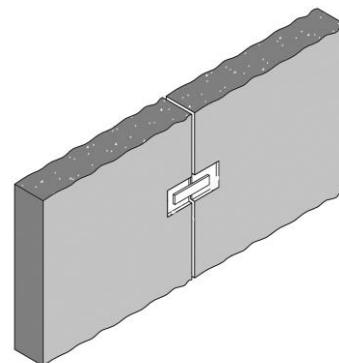

Figure 7.8b – Connection by means of a welded plate

Sometimes even no connection at all between precast wall elements might be put in practice. This can be also done between second-hand elements, but it will not be addressed in detail in this study.

7.2.2. Limitations and boundaries of second-hand elements

The main possible limitations of a second-hand wall element to be jointed are now here presented.

7.2.2.1. *Absence of indentation on the connection surface (only valid for shear walls)*

When a wall portion is cut away from its original structure, this is done by performing a straight cut, which implies that the surface of the second-hand element is smooth, as it is showed in Figure 7.9.

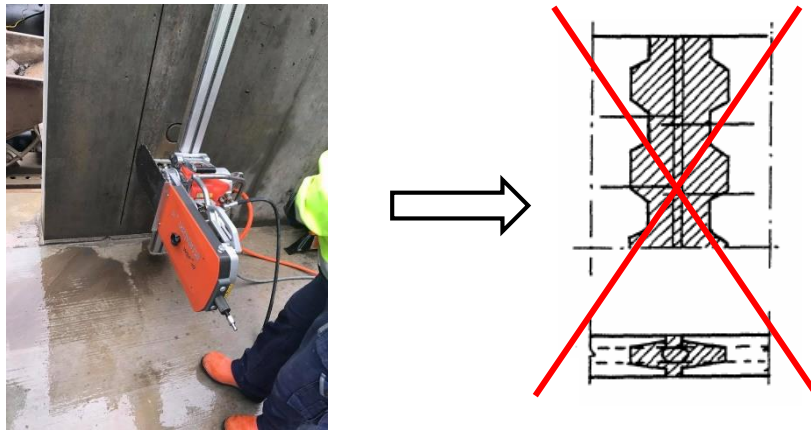

Figure 7.9 – Absence of indentation due to a straight cut

This absolutely an inconvenient situation, since the fact that the shear resistance of a connection made with such a smooth surface would be much lower compared to an indented one. The slip response due to the same acting shear stress on the connection in case of a smooth surface is significantly increased as it is shown in the Figure 7.10.

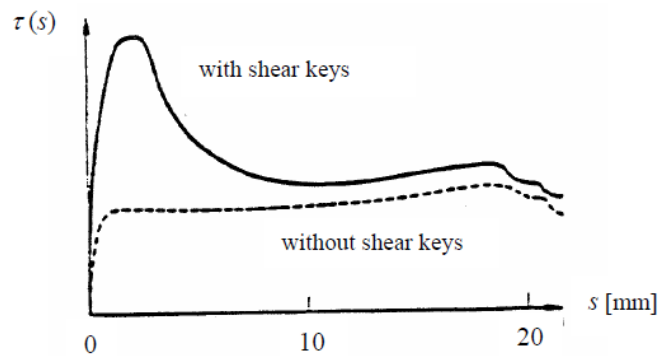

Figure 7.10 – Shear stress – slip response graph (SBI, 1979)

This problem will tried to be solved in the new connection design proposals.

7.2.2.2. *Absence of the necessary protruding steel provisions*

Once again, due to the fact that during the deconstruction phase, the concrete walls are sawn with a “net cut” (unless the technique of avoiding steel bars is used), there will not be any protruding steel bars nor hooks (for shear walls) protruding outside the concrete. Since these parts are necessary for the correct bond and transmission of forces between the elements, they will need to be added in one way or another. However, in case of the embedded steel plate, the latter is still there after the disassembling process occurs. As it was already seen from the previous chapters, embedding steel provisions into an already cast concrete in a second time is always a quite laborious procedure.

7.2.3. Connection design proposals

7.2.3.1. Connection by re-casting a whole side portion (shear-wall behaviour)

It comes now to the first connection proposal. First of all the type of joint with the force to be transmitted should be defined: this case can be considered mostly as a “shear joint”, and the actions to which the joint should be able to resist are shown in the Figure 7.11.

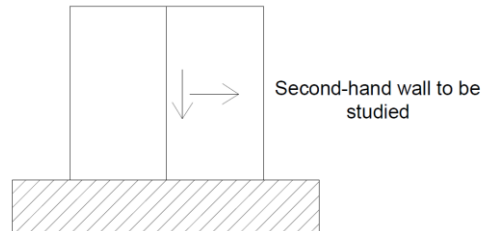

Figure 7.11 – Actions transmitted by the connection

Because of the limitations presented above, it is quite complicated to achieve the same force transmission between the wall elements as in the case of newly made parts, without re-casting a portion of the wall. For this reason, the first choice here adopted regards the achieving of the same wall side configuration as in a new element, by means of:

- Ensuring reinforcement continuity with added connection bar loops;
- Re-casting the end of the final portion of the wall side to bond the connection bars in concrete.

The reinforcement continuity will be obtained by welding the horizontal reinforcement of the second-hand wall to the bars, which are bent to form the connection loop. The re-casting of concrete will involve some formwork to provide a suitable shape to the indented wall sides.

The procedure for the adaptation and connection of a second-hand wall element for this type of connection and the connection itself is hereby described, giving the phases for a correct realization. It is presumed that the disassembling stage has been correctly completed. The steps are:

1. Remove the concrete from the end of the wall in order to obtain a portion of free horizontal reinforcement. The amount of concrete to be removed is dictated by the length of the welds to be performed successively (which from its side depends on the forces to transmit and on the diameter of the bars);
2. Adjust the length of the protruding reinforcement bars to be adequate for being efficiently welded to connection bars;
3. The surface of the second-hand wall which will be in contact with the newly cast concrete, should be adequately roughened in order to be able to have a sufficient bond with the latter;
4. Weld the connection bars of the friction-resistant strip to all the needed protruding reinforcement bars;
5. Cast the concrete in the region where the connection bars were placed, to the friction-resistant strip;
6. Once the concrete is hardened, the wall element looks like a newly made one;
7. Now, the vertical jointing bar can be inserted in the loops between such two wall elements and the whole connection can be concreted;
8. Once the concrete is hardened the desired connection is achieved.

- *Conceptual representation*

In the Figure 7.12 (not to scale, meant only for a conceptual visualization), a schematic representation of the connection is shown.

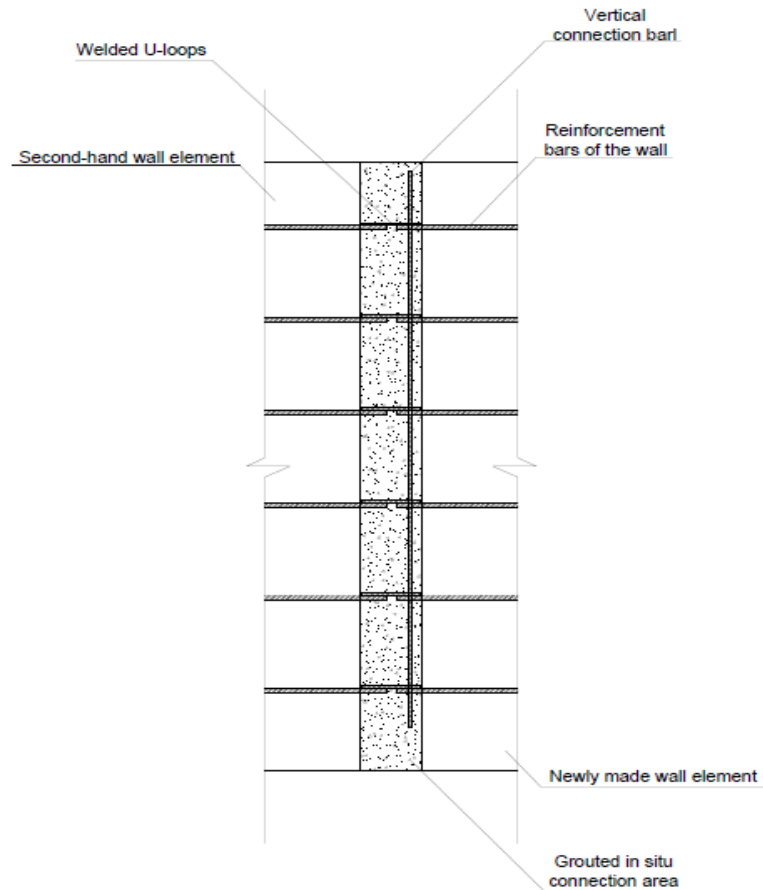

Figure 7.12 – Scheme of the proposed design

- *Steel connection loops with shear resistant strip*

A big variety of parts for being used in this connection method, are available on the market. They look close to the part shown in the Figure 7.13.

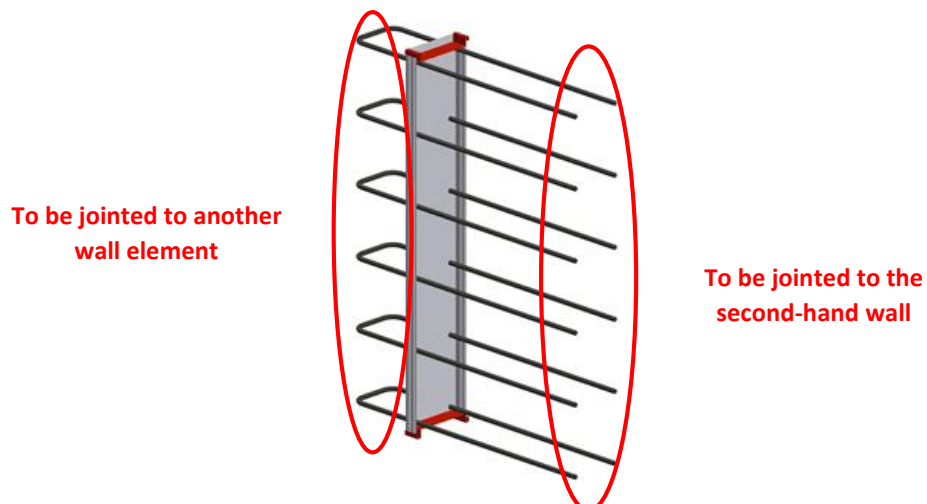

Figure 7.13 – Shear-resistant strip (Ruwa, s.d.)

The strip through which the connection bars are pre-inserted can also have different shapes. The most suitable for a vertical joint between two shear walls are the ones with the indentation as shown in the Figure 7.14.

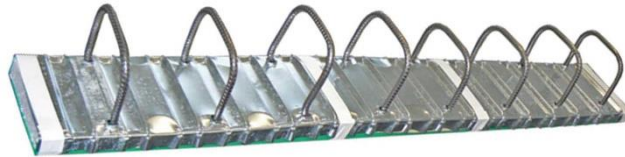

Figure 7.14 – Shear-resistant strip (closer look to the indentations)

The Eurocode 2 gives the following requirements to what concerns an indented joint geometry. These are represented in Figure 7.15.

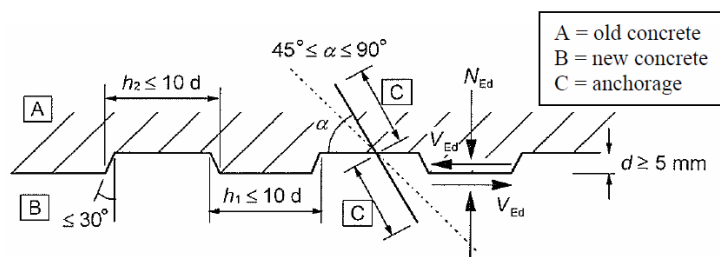

Figure 7.15 – Required dimensions for the indentations

The shear verification for “interface between concrete cast at a different time” is required in case of this connection. The procedure for this verification can be found in the Eurocode 2 in the paragraph 6.2.5.

- *Adaptation of the complementary wall*

The wall to which the second-hand element is considered to be connected, is assumed to be newly made, and therefore, with the connection loops protruding from the wall side when it reaches the construction site.

- *Advantages, drawbacks and complexity rating*

In the Table 7.3 the advantages and the drawbacks of this connection method are briefly summarized.

Advantages	Drawbacks
Final result reminds a newly made element	Need to remove concrete from a wall portion
Aesthetically attractive	Need for a precise welding
	Need to re-cast a wall portion
	Need for added steel provisions

Table 7.3 – Advantages and drawbacks of the proposed design

This connection can be certainly rated as “Complex”, because of the fact that baring and recasting such a relatively big portion of concrete is a very laborious procedure.

7.2.3.2. Connection by connecting the embedded plates (simple precast walls)

This time, the proposed connection will have a very simple nature. In fact it recalls directly the method presented for new elements.

It is assumed that during the disassembling phase the steel plate, which was bolted or welded between the two jointed wall elements, is un-welded, un-bolted or just cut. Subsequently, once that the element is on the construction site where it will have its second life, a new plate will be re-welded or re-bolted between the wall elements ensuring so the requested connection.

The forces that the joint has to withstand are the ones shown in the Figure 7.16.

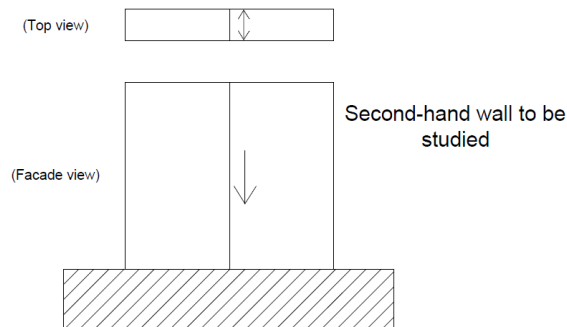

Figure 7.16 – Actions transmitted by the connection

As it can be seen from the picture above, also the shear between the walls is shown to be transmitted. This is because, depending on the dimensions of the joints, also a little bit of shear can be withstood (Lagendijk P. , 2019).

The procedure for the adaptation and connection of a second-hand wall element for this type of connection and the connection itself is hereby described, giving the phases for a correct realization. It is presumed that the disassembling stage has been correctly completed, and the embedded steel plates are still in their place on the side of the wall. It is also assumed that the second-hand wall element is already horizontally connected in the bottom location (perhaps with one of the techniques proposed in the previous section), but it is still shored. The steps are:

1. Perform the weld between the plates of the two wall elements / ensure the bolted connection between the two wall elements;
2. Grout the niches containing the embedded plates with the transversally welded element.

No representation is required in this case, since the connection looks just like it was shown in section 7.2.1.2.

- Adaptation of the complementary wall

The wall to which the second-hand element is considered to be connected, is assumed to be newly made, and therefore, with the embedded connection plates already in the correct position (at the same height as in the second-hand element. However, if this is not the case, and the complementary wall is also a second-hand element, two scenarios may arise:

- a. The complementary wall portion is exactly the one from which the wall to be connected was connected also in the donor structure;
- b. The complementary wall has been disassembled from another structure or from another location of the same donor structure.

To what concerns the case (a), no problems should arise, since the connection plates are at the same height and can be easily coupled. If instead we have the case (b), the situation is slightly more complicated, since some kind of anchorage with the wall have to be ensured. One solution to this might be to drill a hole from side to side of the wall the wall for bolting the plate, or just to embed an anchor (which however would give a relatively low load capacity (Legendijk P. , 2019)) to which the connection strip can be bolted, as shown schematically in the Figure 7.17.

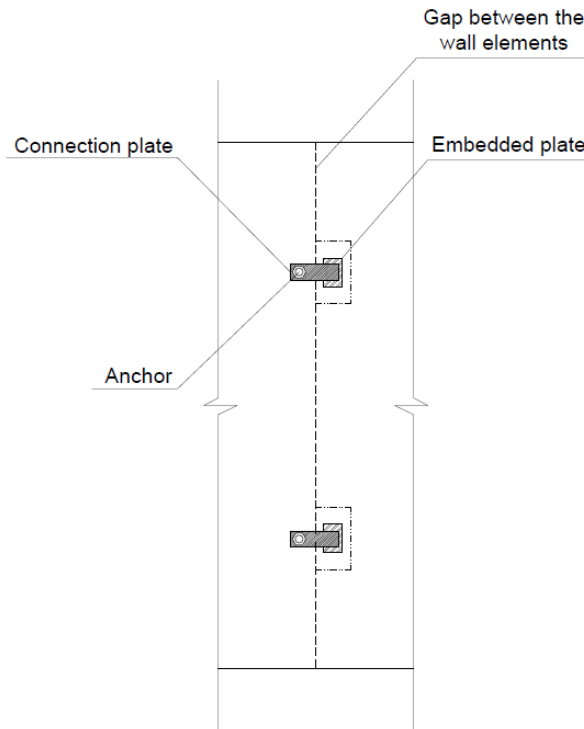

Figure 7.17 – Scheme of the proposed design

- *Advantages, drawbacks and complexity rating*

In the Table 7.4, the advantages and the drawbacks of this connection method are briefly summarized.

Advantages	Drawbacks
Extremely simple design	Need for a performing on-site welding
Identical to the usual method	Eventual need to drill the wall
Aesthetically attractive	

Table 7.4 – Advantages and drawbacks of the proposed design

This connection can be certainly rated as “Simple”, because it is in final result the common method for connecting newly made walls, and is very easy to put in practice.

8. Reconnecting second-hand floors

This chapter will be focused on the reconnection of second-hand floors. For “floors” in this section the following elements will be meant:

- Second-hand hollow core slabs (deriving from the structural system with load-bearing walls, and the ones deriving from the structural system with integrated steel beams, which was presented in Chapter 3);
- Cast in-situ one-way “plank-floor” slabs (deriving from the structural system where shallow beams are carrying such type of floors, which was presented in Chapter 3).

The chapter will have more or less the same structure as the previous ones, and will first address the end connection of second-hand hollow core slab to a wall, to a shallow beam and to a steel I-profile; then then longitudinal connection between second-hand hollow core slabs will be presented; at last the one-way slab to shallow beam connection will be addressed.

8.1. Second-hand hollow core slab to wall, shallow beam and integrated steel beam end-connection

In this section, the connection of a second-hand hollow core slab to a wall, a shallow beam and to an integrated steel I-beam will be studied. The addressed second-hand slab is assumed to be deriving from the structural system where it was supported by load-bearing walls or from the one where it was carried by integrated steel beams, because these are two of the four systems from which all the elements studied in this graduation project are considered to come from. However, since the hollow core slabs are usually connected in the donor structure in similar ways from system to system, to what regards the reconnection phase, it is not very relevant from which structural system the slab is deriving.

8.1.1. Common method for connecting newly made hollow core slabs

As in the previous sections, first of all, the common methods for connecting a “new” hollow core slab will be presented.

8.1.1.1. Connection to a wall

The precast hollow core slab can be jointed to the wall in several different ways. However the one that consists in positioning the connection bars into the hollowed-out cores which will be successively grouted is perhaps the most widely used one. This method is shown briefly in the Figure 8.1.

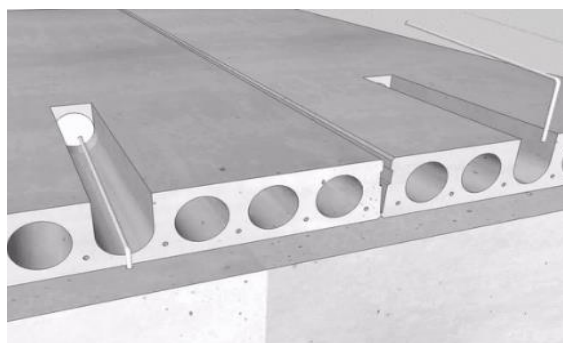

Figure 8.1 – Connection to wall in hollowed-out cores (Schokbeton Saramac - Connections hollow core slabs, s.d.)

8.1.1.2. Connection to a shallow beam

The situation is very similar to the connection to a concrete wall (connection bars in hollow cores), however, this time in the top part of the beam is usually present some sticking out reinforcement stirrups in the middle of which the connection bars are letting pass, as it is shown in the Figure 8.2.

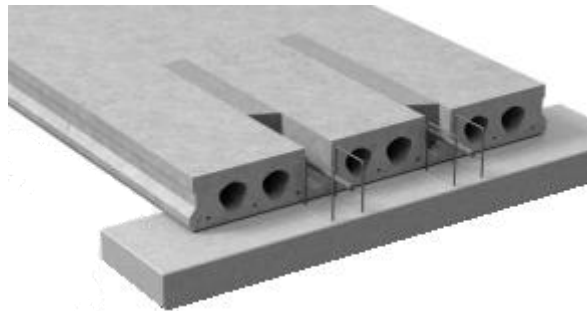

Figure 8.2 – Connection to beam in hollowed-out cores

8.1.1.3. Connection to a steel I-beam

The variety of shapes of integrated steel beams is nowadays very wide and for each of these shapes, the possible connection repertoire with a hollow core slab is also very broad. In this section only the joint with an I-beam will be addressed, for which also the connection in hollowed out cores is one of the most diffused ones. A representation of this is shown in the Figure 8.3.

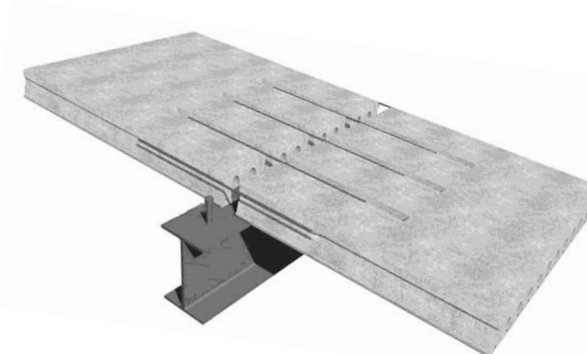

Figure 8.3 – Connection to steel beam in hollowed-out cores

8.1.2. Limitations and boundaries of second-hand elements

8.1.2.1. Non-hollow cores issue

During the reuse of a hollow core slab, few of the previously hollow cores, are not hollow anymore, since they have been originally connected with the methods seen before, and this should be kept in mind when designing a new connection.

Some of the possibilities to solve this issue can be the following:

- Brake the concrete-filled cores in the top part to a certain extent, place the steel bars inside and pour concrete in order to fill the hollow core and to provide bond to the bars.
- Drill sleeve-holes (in the cutting plane), achieving the correct anchorage length, place the steel bar inside and pour the concrete through holes made into the surface of the slab

perpendicular to the deep hole. Two holes should be made: one for pouring concrete, and the other one to create an output for the air (and to indicate when the sleeve is full of concrete).

- Since the fact that usually not all the cores were filled with concrete to create a connection, the still hollow cores may be used to host the steel connection bars and to create though a solid connection. In this case, the second-hand hollow core slab can be seen just as a new one.
- Whether the needed slab for the second-hand use is shorter than the one available in the donor structure, it could be suitable to saw the slab to the extent where all the cores are empty, though to take the central part of it.

8.1.3. Connection design proposals

The new joint design proposals for connecting second-hand hollow core slabs will be now addressed.

8.1.4.1. Connection in hollowed-out cores

The first approach for connecting a second-hand hollow core slab is the one that recalls directly the previously introduced approach for newly made elements. The use of such a common technique can be done quite effectively in case of the hollow core slabs, since the fact that after the disassembling, the reused elements look very similar to new ones. This is also suitable because such an approach has been carefully tested and they are shown to be reliable over the time and the on-site workers are already instructed about how to put it in practice. It does not require a lot of presentation, since it is very common on practice, however it will be briefly introduced since use of second-hand slabs is made instead of new ones. The section will be split into three sub-sections, regarding respectively the connection to a wall, the one to a shallow beam and to an integrated steel I-beam.

8.1.4.1.1. End-connection to a wall

The connection to a wall by means of the previously explained technique will be now addressed. For the sake of simplicity and to highlight the connection between the wall rather than the one with the complementary slab, it has been decided to address the slab-wall node with the slab on one side only.

The actions to which the connection should be able to resist are the ones shown in the Figure 8.4.

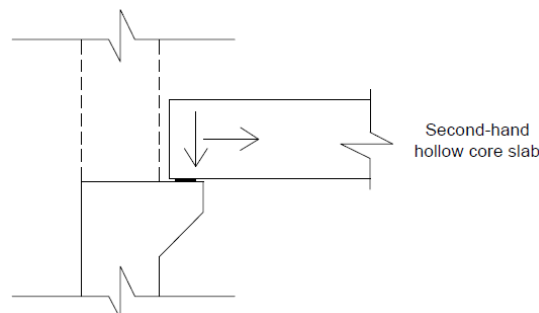

Figure 8.4 – Actions transmitted by the connection

The procedure for the adaptation and the actual connection of a second-hand hollow core slab is hereby described, giving the phases for a correct realization. It is presumed that the disassembling stage has been correctly completed, the topping has been removed and the required length of the element has been achieved. The steps though are the following:

1. Brake the top part of the hollow cores in which the connection bars are planned to be grouted (usually around two per slab) to the required length.
2. Block the hollow core in which the bars will be positioned with a plastic cap to the length which has to be grouted. This is required to prevent the grouting concrete from spreading along all the hollow core. After this phase the adaptation phase of the HCS may considered to be concluded;
3. Install the neoprene bearings in their final position on the corbel;
4. Position the slab in its correct position, laying on the bearings;
5. Insert the preliminarily-prepared connection bars in the cores;
6. Weld the connection bars to the reinforcement bars of the wall;
7. Block at the end the hollowed-out core in which the connection bars are positioned with plastic caps, in order to prevent the concrete from pouring out;
8. Grout hollowed-out cores;
9. When the upper floor wall element will be installed and also the gap wall-slab is grouted, the desired connection can be considered achieved.

Some aspects will be discussed further on more in detail.

- *Conceptual representation*

In the Figure 8.5 (not to scale, meant only for a conceptual visualization), a schematic representation of the connection is shown.

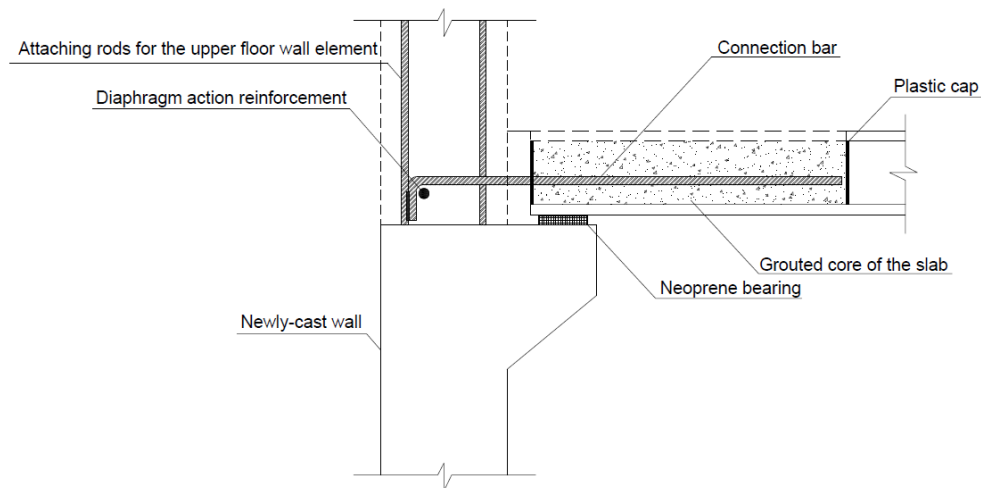

Figure 8.5 – Scheme of the proposed design

- *Braking the top of the “connection cores”*

It was already mentioned during the execution procedure, that the cores in which the connection bars will have to be inserted have to be adapted for the purpose by literally breaking the concrete in their top part. This phase is not necessary for newly made HCS, because the top openings are already predisposed for connection purposes. While in case of a second-hand slab these have to be performed with a saw or a jackhammer, paying attention not to cause any damage to other

parts of the slab. It should be also highlighted that, if some slabs are not hollow because they have been filled with concrete for connection purposes during their previous life, it is better simply to choose the ones that are hollow, otherwise the procedure of emptying these cores may become too laborious.

- *Adaptation of the wall*

The wall is assumed to be a new element, therefore, it is assumed that the corbel is located in the required position, and the reinforcement bars are sticking out of the upper cross-section. To what concerns the location of the bearing pads on which the slab will lay, these should be dimensioned as prescribed by the ENV 1992-1-3, with all the required spacings a , a_1 , a_2 and a_3 , etc...

The adaptation of a second-hand wall for this kind of connection may result in a too laborious adaptation procedure, and therefore it is unadvised for this approach.

- *Advantages, drawbacks and complexity rating*

In the Table 8.1, the advantages and the drawbacks of this connection method are briefly summarized:

Advantages	Drawbacks
Simple/common design	Not particularly suitable for further reuse
Aesthetically attractive	Not suitable for use with second-hand wall

Table 8.1 – Advantages and drawbacks of the proposed design

The overall complexity rating that can be assigned to this joint is: “Simple”. This rating has been assigned due to the fact that the only procedure to be done for adapting the slab to its reuse (besides removing its topping part) is to brake the top of the hollow cores in which the connection bars will be inserted.

8.1.4.1.2. End-connection to a shallow beam

Now the connection of a second-hand slab to a newly-made shallow beam with the approach of using connection bars in hollowed-out cores will be addressed. A beam with HCS on both the sides (which is common for the case of a shallow beam) will be now studied.

The forces to which the connection has to resist are the ones shown in the Figure 8.6.

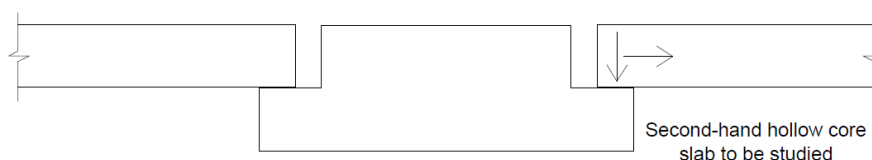

Figure 8.6 – Actions transmitted by the connection

The neoprene bearings have to be used in order to guarantee rotation without interfering with the flange of the shallow beam on which the slab is laying.

The procedure for the adaptation and the actual connection of the second-hand hollow core slab is hereby described, giving the phases for a correct realization. It is presumed that the

disassembling stage has been correctly completed, the topping has been removed and the required length of the element has been achieved. The steps though are the following:

1. Brake the top part of the hollow cores in which the connection bars are planned to be grouted (usually around two per slab) to the required length;
2. Block the hollow core in which the bars will be positioned with a plastic cap to the length which has to be grouted. This is required to prevent the grouting concrete from spreading along all the hollow core. After this phase the adaptation phase of the HCS may considered to be concluded;
3. Install the neoprene bearings in their final position on the flange of the beam;
4. Position the slab in its correct position, laying on the bearings;
5. Insert the preliminarily-prepared connection bars in the cores (making it pass in the middle of the protruding stirrups of the uncast part of the shallow beam), ready to be grouted;
6. Grout the cores with connection bars inside and the gaps between the beam wall and the hollow core slab;
7. When the concrete used to grout the connection is hardened, the desired connection is achieved.

The same consideration about the braking of the top part of the cores to be connected is valid also now. Some aspects will be however discussed further on more in detail.

- *Conceptual representation*

In the Figure 8.7 (not to scale, meant only for a conceptual visualization), a schematic representation of the connection is shown.

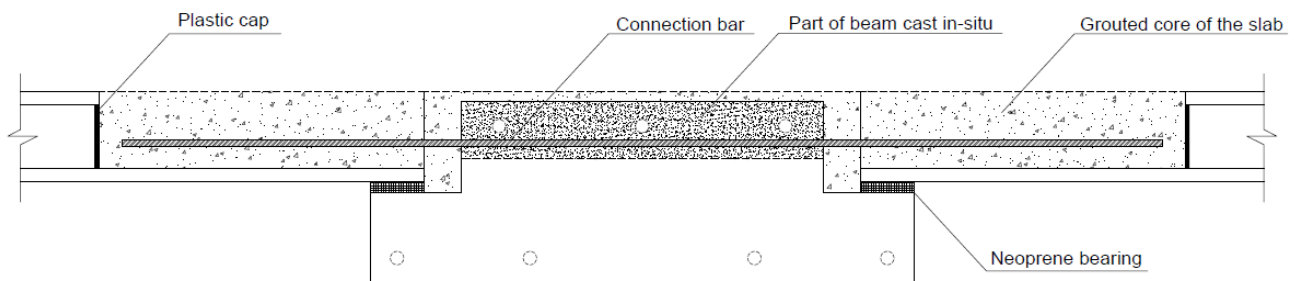

Figure 8.7 – Scheme of the proposed design

- *Adaptation of the beam*

The beam is considered to be new, so the upper part of it is cast in situ, and therefore the connection bar can be easily inserted between its reinforcement in the upper part and grouted in the final position. However, if we had a second-hand beam instead, the procedure had to be much more complicated, since the whole beam would have been a monolithic piece and its careful adaptation would have been required. The procedure to achieve a result similar to the previous one could involve the performing of “U-voids” perpendicularly to the top surface of the shallow beam. These U-voids should be performed as close as possible to the top reinforcement longitudinal bars (again paying a lot of attention not to damage the latter). The situation in case of a second-hand shallow beam would look as shown in the Figure 8.8.

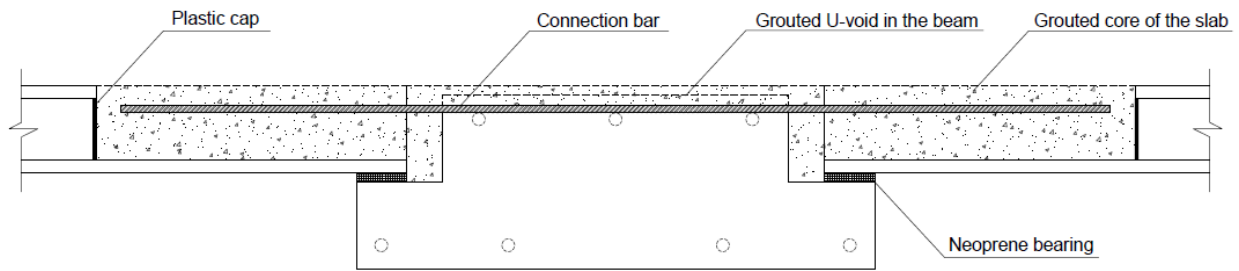

Figure 8.8 –Scheme of the proposed design in case of a second-hand beam

Once again, to what concerns the location of the bearings on which the slab will lay, these should be dimensioned as prescribed by the ENV 1992-1-3.

All the parts of the shallow beam which are in contact with newly cast concrete, should have been previously adequately roughened, in order for it to achieve sufficient bond with the latter.

- *Advantages, drawbacks and complexity rating*

In the Table 8.2, the advantages and the drawbacks of this connection method are briefly summarized:

Advantages	Drawbacks
Simple/common design	Need to perform U-voids into the shallow beam
Aesthetically attractive	Not particularly suitable for further reuse

Table 8.2 – Advantages and drawbacks of the proposed design

The overall complexity rating that can be assigned to this joint is: “Simple”. This rating however, can be assigned if the beam to which the slabs have to be connected is newly cast, because otherwise the adaptation of the beam would result in a laborious procedure with a significant increase of complexity.

8.1.4.1.3. End-connection to an integrated steel beam

The same connection approach consisting in grouting connection bars inside the hollow cores of the slab is applied for the connection with integrated steel beams as well. The addressed detail can mainly be considered a “compression joint” however also axial force is acting. The actions prevented by the end connection are showed in Figure 8.9.

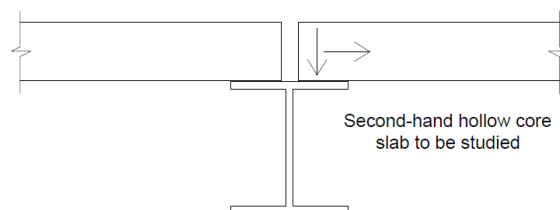

Figure 8.9 – Actions transmitted by the connection

The neoprene bearings are indispensable also in this case, in order for the slab not to have any contact with the flange of the beam in case of big rotation angles.

The output design of this connection is exactly the one shown in the section 8.1.1.3

The procedure for the adaptation and the actual connection of the second-hand hollow core slab is hereby described, giving the phases for a correct realization. It is presumed that the disassembling stage has been correctly completed, the topping has been removed and the required length of the element has been achieved. The steps though are the following:

1. Brake the top part of the hollow cores in which the connection bars are planned to be grouted (usually around two per slab) to the required length;
2. Block the hollow cores in which the bars will be positioned with a plastic cap to the length which has to be grouted. This is required to prevent the grouting concrete from spreading along all the hollow core. After this phase the adaptation phase of the HCS may considered to be concluded;
3. Install the neoprene bearings in their final position on the flange of the beam;
4. Position the slab in its correct position, laying on the bearings;
5. Insert the preliminarily-prepared connection bars in the cores (making it pass in the middle of the protruding shear studs welded on the top of the I-beam), ready to be grouted;
6. Grout the cores with connection bars inside and the gaps between the hollow core slabs;
7. When the concrete used to grout the connection is hardened, the desired connection is achieved.

The same consideration about the braking of the top part of the cores to be connected is valid also now. Some aspects will be discussed further on more in detail.

- *Conceptual representation*

In the Figure 8.10 (not to scale, meant only for a conceptual visualization), a schematic representation of the connection is shown.

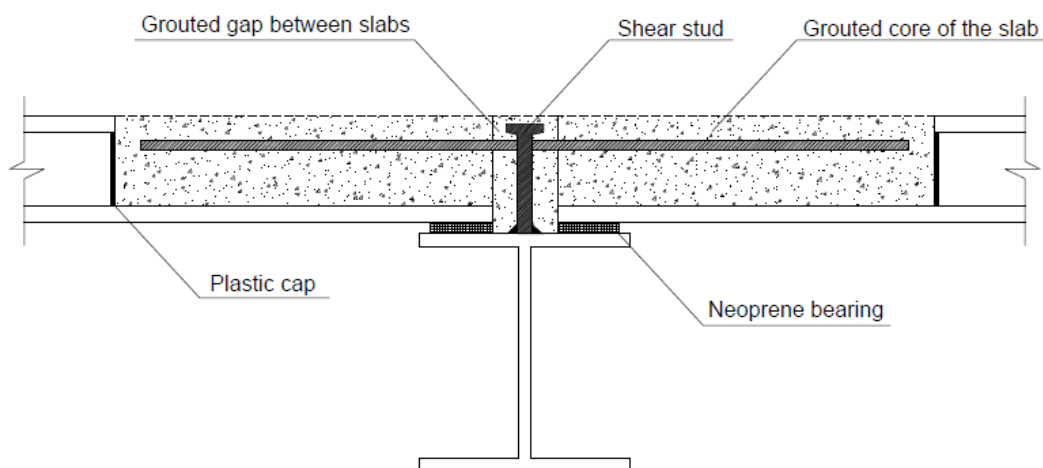

Figure 8.10 – Scheme of the proposed design

- *Adaptation of the integrated steel beam*

The steel beam is assumed to be brand new, with shear studs welded on top of it. The welds have usually to be performed in a specialized factory by qualified personnel. The amount and the size of the studs should be carefully calculated.

- *Advantages, drawbacks and complexity rating*

In the Table 8.3, the advantages and the drawbacks of this connection method are briefly summarized:

Advantages	Drawbacks
Simple/common design	Need for added shear studs on the beam
Aesthetically attractive	Not particularly suitable for further reuse

Table 8.3 – Advantages and drawbacks of the proposed design

The overall complexity rating that can be assigned to this joint is: “Simple”. This rating has been assigned due to the fact that the only procedure to be done for adapting the slab to its reuse in a common way (besides removing its topping part) is to brake the top of the hollow cores in which the connection bars will be inserted.

8.1.4.2. Connection to a wall by means of an L-profile

This approach is based once again on the following concept: an L-shaped steel plate is bolted to the wall and the second-hand hollow core slab is lowered on it, and successively connected by installing a longitudinal connection bar attached by means of a threaded coupler to the anchor responsible also for bearing the L-profile itself.

First of all, let’s take a look on the actions prevented by this kind of end connection. These are showed in Figure 8.11.

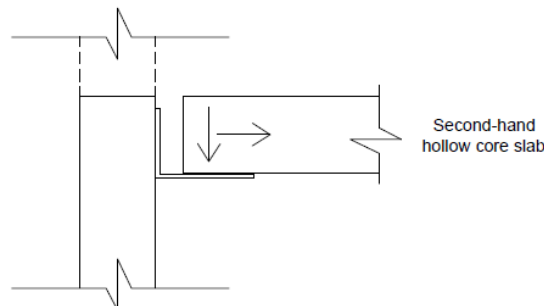

Figure 8.11 – Actions transmitted by the connection

This jointing method would allow performing connections at any height of the wall, regardless of what is the wall element height. Other points that worth to be considered in favour of this connection are the facts that the L-profile can potentially be reused further on in its lifespan and that some more ductility and rotation capacity are guaranteed thanks to the steel profile.

The procedure for the adaptation and the actual connection of the second-hand hollow core slab is hereby described, giving the phases for a correct realization. It is presumed that the disassembling stage has been correctly completed, the topping has been removed and the required length of the element has been achieved. The steps though are the following:

1. Brake the top part of the hollow cores in which the connection bars are planned to be grouted (usually around two per slab) to the required length.
2. Block the hollow core in which the bars will be positioned with a plastic cap to the length which has to be grouted. This is required to prevent the grouting concrete from spreading along all the hollow core. After this phase the adaptation phase of the HCS may considered to be concluded;

3. Connect the previously prepared L-profile to the wall by tightening the nuts, on the previously embedded in the wall anchors.
 4. Lower the slab on the L-profile;
 5. Screw on the same anchor which is used for connecting the L-profile to the wall the threaded steel couplers;
 6. Insert the connection bars into the hollowed-out holes;
 7. Screw the connection bars into the threaded couplers;
 8. Grout from above the cores with the anchors and the wall-slab gap;
 9. When the concrete is hardened, the desired connection is achieved.
- Some aspects will be discussed further on more in detail.

- *Spacing and conceptual representation*

In the Figure 8.12, the conceptual design of the connection is shown.

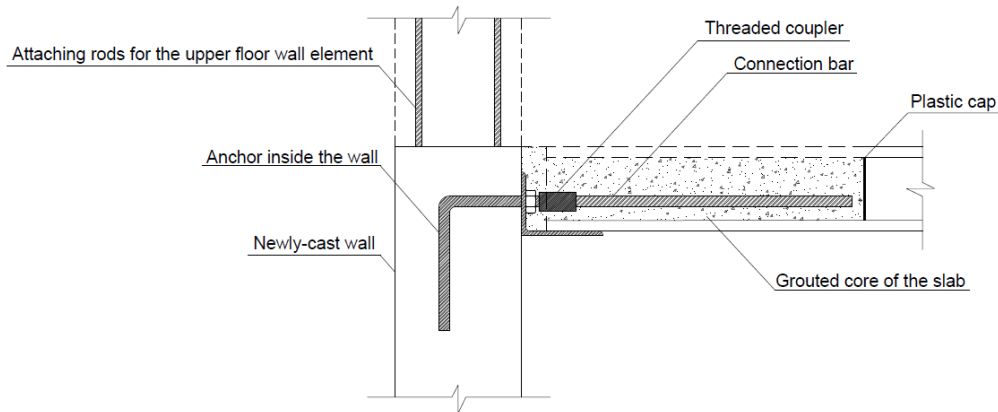

Figure 8.12 – Scheme of the proposed design

- *L-shaped steel plate*

The L-shaped steel plate can be, after all, a simple L-profile, which are commercially very diffused, so there is no need to shape it on size. Its thickness and the position of the holes need however to be carefully studied and verified according to the mechanical behaviour.

- *Threaded couplers*

The threaded couplers to be used in this connection are the same as the ones already presented in section 6.1.4.1. This coupling method for between the connection bars and the embedded anchors has been chosen in order not to have to perform welds on site (which may require qualified personnel).

- *Adaptation of the wall*

As mentioned before, the wall to which the L-profile is meant to be bolted, is assumed to be newly made. Therefore the anchor with the threaded end is considered to have been embedded during the wall casting phase. If we were in presence of a second-hand wall, the embedment of the threaded anchor could result in a laborious procedure, however this is still feasible (one of the solutions can be to drill the wall from part to part and bolt the inserted anchor also from outside

of the wall (paying attention to the punching shear action of the bolt head, which should in any case have a washer of an adequate diameter).

- *Advantages, drawbacks and complexity rating*

In the Table 8.4, the advantages and the drawbacks of this connection method are briefly summarized:

Advantages	Drawbacks
Adds freedom of architectural design	Added steel provisions
Ductile joint behaviour	Aesthetically unattractive
	Dimensioning of the L-profile needed

Table 8.4 – Advantages and drawbacks of the proposed design

The overall complexity rating that can be assigned to this joint is: “Medium complexity”. This rating has been assigned due to the fact that even if the only procedure to be done for adapting the slab to its reuse (besides removing its topping part) is to brake the top of the hollow cores in which the connection bars will be inserted, the wall to which the slab has to be bolted needs to be predisposed with an embedded anchor in advance. Moreover the adding of a (drilled) L-profile is required, and this can influence on the cost-effectiveness.

8.2. Longitudinal connection between adjacent hollow core slabs

In this section, the longitudinal connection between hollow core slabs will be addressed. This connection deserves a lot of attention, since it is responsible for transferring vertical and horizontal shear forces, which are acting between the two slab elements. The vertical component of shear, as it will be explained further on, is the one of more interest for this study and it is due to various dead and live loads applied vertically to the slab. While the horizontal component is due mostly to the “diaphragm action”, to which the structural system is subjected. These are shown respectively in Figures 8.13a and 8.13b.

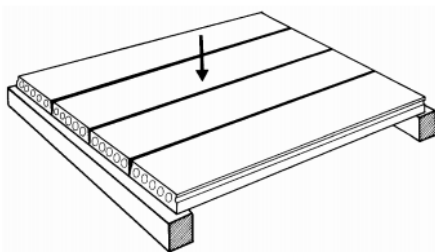

Figure 8.13a – Vertical actions on slabs (FIB, 2008)

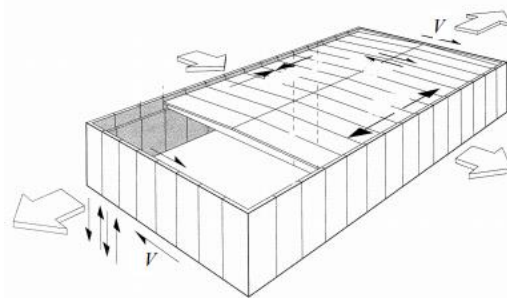

Figure 8.13b – Horizontal actions on slabs (FIB, 2008)

In newly made joints, the vertical shear in the connection is resisted by the so-called “keyed joint”, which looks like shown in the Figure 8.14.

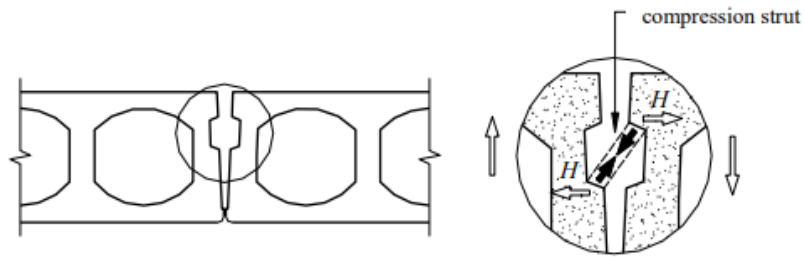

Figure 8.14 – Lateral void and the forces acting on it (FIB, 2008)

While, the horizontal component of the shear force will be resisted by bars transversal to the slab orientation as in the Figure 8.15.

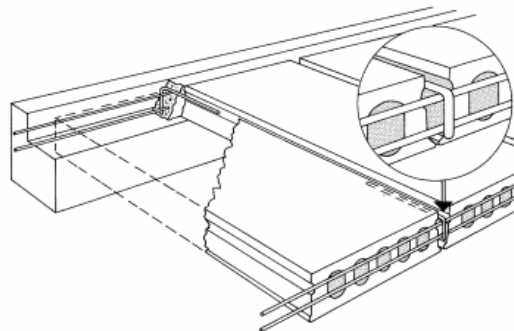

Figure 8.15 – Diaphragm action bars (FIB, 2008)

8.2.1. Common methods for connecting newly made elements

The most common way of jointing two hollow core slabs presuppose the insertion of a steel bar in between the lateral voids of the elements to be jointed. This is represented in the Figure 8.16.



Figure 8.16 – Common method for connecting adjacent slabs

It should be also said that also the connection by inserting steel bars in gaskets can be of a “continuous” type across a wall element or for connecting the slab to the wall as shown respectively in the Figures 8.17a and 8.17b.

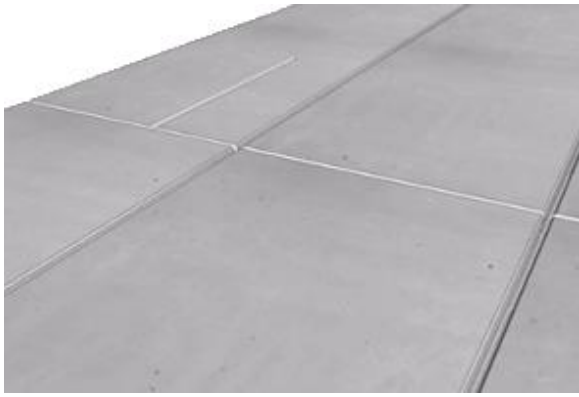

Figure 8.17a – Continuous type of connection

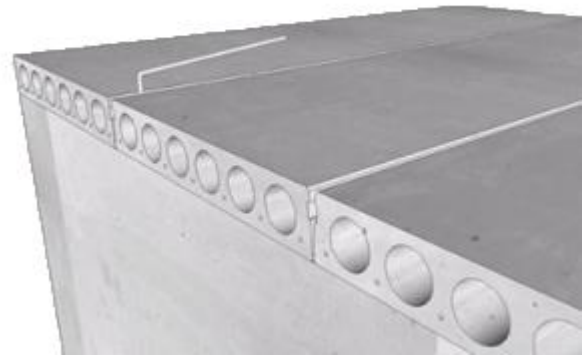

Figure 8.17b – Connection in gaskets to a wall

8.2.2. Limitations and boundaries of second-hand elements

The possible limitations will now be addressed.

8.2.2.1. Absence of the lateral “keyed” void

As it was introduced above, a new hollow core slab has a not very deep void or/and a slight step along its border, while a reused one is usually cut straight and in this way the method (a) which was previously mentioned, cannot be put in practice. This situation is represented in the Figure 8.18.

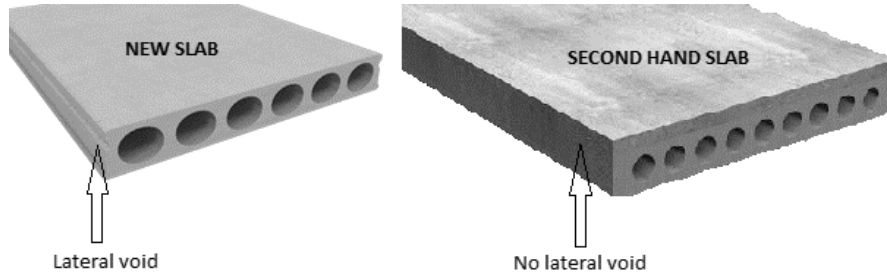

Figure 8.18 – Presence and absence of the lateral void

During the design proposals for connections between second-hand elements, this will be taken into account, and a solution will be found.

8.2.3. Connection design proposal

The proposed designs of how to achieve the desired connection will now be addressed here.

8.2.3.1. Connection in “C-gaps”

In order to solve the issue with the absence of the void on the side of the slabs, the following approach can be adopted: the sloped longitudinal cut is performed intersecting a hollow core (this is addressed as the “C-gap”). Doing this, a similar strut-and-tie mechanism as the one, which usually acts in presence of a factory gap, might be valid.

The procedure for the adaptation and connection of a second-hand hollow core slab is hereby described, giving the phases for a correct realization. It is presumed that the disassembling stage has been correctly completed, the topping of the slab has been removed and the required length of the element has been achieved. The steps for the accomplishment of this connection are the following:

1. The longitudinal side of the slab need to have a slight angle (exact slope requires further studies) with the vertical. This slope should be achieved by cutting the side (if this has not been done during the disassembling phase). The cut should pass through a portion of a hollow core, in order to obtain a C-shaped void;
2. Insert the preliminarily cut steel bar into the achieved void, ready to be grouted;
3. Grout the C-gap with low-shrinkage concrete;
4. When the concrete used to grout the connection is fully hardened, the desired connection is achieved.

The output design of this connection is very similar to the one between new elements, shown in the section 8.2.1.

- *Conceptual representation*

In the Figure 8.19 (not to scale, meant only for a conceptual visualization), a schematic representation of the connection is shown.

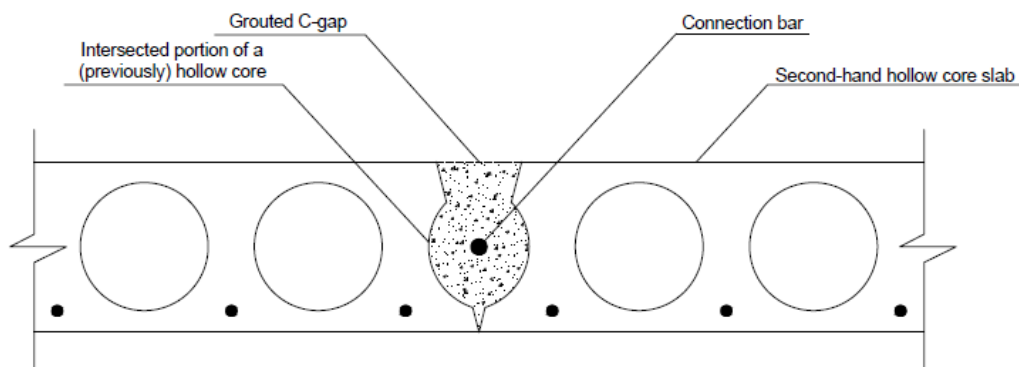

Figure 8.19 – Scheme of the proposed design

The functioning of this design in terms of strut-and-tie mechanism can be visualized as shown in the Figure 8.20.

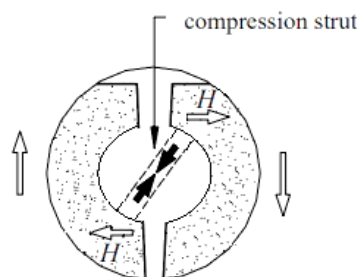

Figure 8.20 – Strut-and-tie mechanism in presence of a circular void/core

- *Advantages, drawbacks and complexity rating*

In the Table 8.6, the advantages and the drawbacks of this connection method are briefly summarized:

Advantages	Drawbacks
Simple design	Not suitable for further reuse
No added steel provisions	Requires further studies on its effectiveness
Aesthetically attractive	

Table 8.6 – Advantages and drawbacks of the proposed design

The overall connection complexity is rated as “Simple” since both the adaptation phase and the on-site assembling are not representing particular difficulties.

8.2.3.2. Connection in “V-gaps” with added steel plate

The second solution that is presented in this study consists in the use of steel plates for helping jointing together laterally two adjacent slabs and ensure the correct transferring mechanism for shear forces.

The procedure for the adaptation of a second-hand hollow core slab for this type of connection is hereby described, giving the phases for a correct realization. It is presumed that the disassembling stage has been correctly completed. The steps for the achievement of this connection are the following:

1. The longitudinal cut side of the slab need to have a certain angle with the vertical. This slope should be achieved by cutting the side under a certain slope (if this has not been done during the disassembling phase);
2. Drill the required number of holes in the top and bottom faces of the side hollow core for the attachment of the longitudinal plate between slabs;
3. Drill the concrete filling holes (in the top face) for grouting the anchors of the longitudinal jointing plate;
4. Position the previously prepared bottom steel plate with holes in its final position between two slabs and insert the anchors;
5. Grout, through the filling holes, to all its length, the involved cores which are hosting the anchors of the longitudinal slab jointing plate;
6. Grout the V-gap with the eventual connection bar inside;
7. Wait for the concrete to harden;
8. Position the previously prepared top steel plate with holes in its final position on the sticking out anchors and tighten the nuts. The connection may be considered as achieved after this phase.

- *Conceptual representation*

In the Figure 8.21 (not to scale, meant only for a conceptual visualization), a schematic representation of the connection is shown.

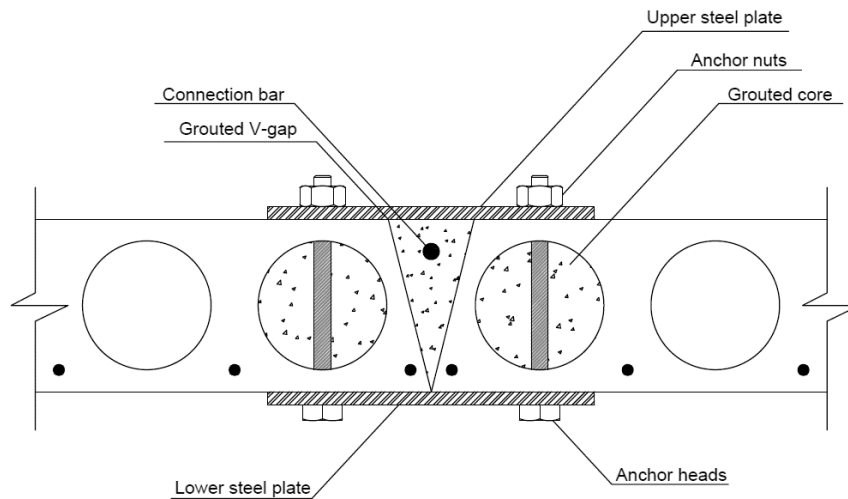

Figure 8.21 – Scheme of the proposed design

- Improved horizontal shear resistance

Due to the continuous plates along the bottom of the whole connection, a high grade of resistance to the horizontal shear action is also offered, which adds extra effectiveness to this type of connection.

- Advantages, drawbacks and complexity rating

In the Table 8.6, the advantages and the drawbacks of this connection method are briefly summarized:

Advantages	Drawbacks
Ductile joint behaviour	Need of precise drilling
Relatively suitable for further reuse	Added steel provisions
Good horizontal shear resistance	Aesthetically unattractive

Table 8.6 – Advantages and drawbacks of the proposed design

This joint has been rated as “Complex” due to the amount of operations to be done for the adaptation of the second-hand elements, due to the large amount of added steel provisions and to the complex on-site mounting procedure.

8.3. Second-hand one-way plank-floor to shallow beam connection

This section will deal with the connection of second-hand plank-floor (called also “half-slab” or “filigree slab”) elements to a shallow beam. The shallow beam can be newly made or eventually also second-hand, however in this section, for simplicity reasons it will assumed to be newly made. The main features of the shallow half-beam and of the one way slab have been reminded in the Chapter 3.

8.3.1. Common methods for connecting newly made elements

First of all it should be highlighted that in case of a plank-floor we are dealing with a composite slab. However, at the moment of its reuse, the top concrete layer which was casted in-situ during

its first use, is already present (because, as it was explained in chapter 3, it cannot be removed in any way). As for the case of shallow beams, also in this situation it is difficult to base the design of connections for second-hand elements on the connection methods used for brand new elements during their first use, for the simple reason that, during the initial connection procedure in the “donor” structure, half of the slab was cast in-situ, while at the beginning of the building process with second-hand elements the slab is fully cast and monolithic.

Once again, for having a better visualization of the original connection it is useful to introduce the most common way of jointing such type of slabs. In the Figure 8.22, slabs laid on the flanges of a precast shallow beam are shown.

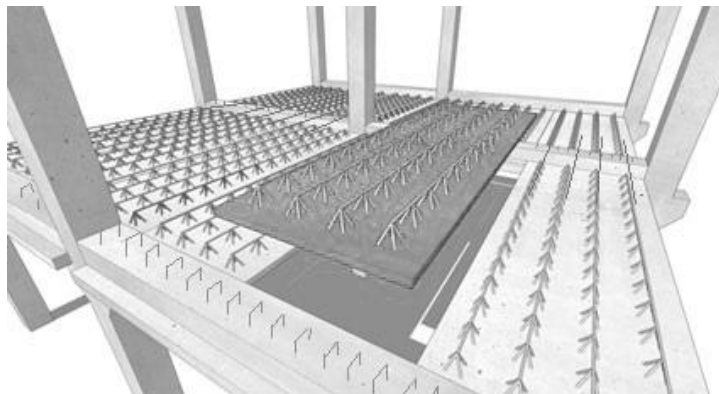

Figure 8.22 – Installations of newly made plank floors

After this step, the connection bars are put in their final position across the stirrups protruding from the upper part of the beam. Finally, the top layer of the slab is casted, covering also the protruding stirrups of the beam with the connection bars across them.

8.3.2. Limitations and boundaries of second-hand elements

The limitations for the case of a second-hand two-way slab are quite restrictive. Here they will be listed and briefly explained.

8.3.2.1. *Need for a totally different approach respect to new elements*

As it was previously mentioned for the half-beam, also now it is possible to state that a completely new approach should be figured out for connection methods to use for second-hand slabs respect to brand new ones.

8.3.2.2. *Laborious achievement of reinforcement continuity*

Continuity of the longitudinal reinforcement (or at least the anchorage of the latter inside the element to which the slab is connected, if the connected end is considered to be simply-supported) should be ensured. The same two main conceptual approaches to predispose the end of a second-hand one way slab for a reconnection that have been already introduced for the case of the columns and the shallow beams are valid also here:

- a) Steel-avoiding adaptation – protruding reinforcement available
- b) Net cut – need for additional steel bars/provisions

8.3.2.3. Modification of the structural scheme

The plank-floors are often designed to have a continuous behaviour across the beams in their “first life”, just as it was mentioned for the beams which are often designed to be continuous across the column supports, however, also in this case, due to several feasibility reasons, during the disassembling phase it is necessary to reduce them back to one-span elements. These elements can be reassembled to have a simply supported behaviour or to re-acquire again a continuous behaviour, but the same drawbacks about the modification already mentioned for the case of the beam applies also here.

8.3.3. Connection design proposal

It comes now to present some ideas regarding the possible ways to achieve the required connection.

8.3.3.1. Connection in “U-voids”

The first method to perform a joint between a second-hand plank-floor and the shallow beam, which is hereby proposed, regards the creation of voids with a U-shape (from which their name) in the top part of the second-hand slab. The floors will be therefore connected with the beam by means of inserting connection rods inside these voids. The structural scheme which they will undergo in case of such a connection is the simply-supported one.

The actions to which the joint has to withstand are the ones of the Figure 8.23.



Figure 8.23 – Action transmitted by the joint

The procedure for the adaptation of a second-hand plank-floor is hereby described, giving the main phases for a correct realization. It is presumed that the disassembling stage has been correctly completed, and the required length of the element has been achieved. The steps for the achievement of this connection are the following:

1. Perform U-voids in the upper part of the slab;
2. Position the plank-floor on the flange of the shallow beam;
3. Insert the connection bars in each void;
4. Grout the voids with the bars inside with low-shrinkage concrete;
5. When the concrete is hardened and full bond is achieved between the rods and the floor, the desired connection is achieved.

- Conceptual representation

In the Figures 8.24a and 8.24b (not to scale, meant only for a conceptual visualization), a schematic representation of the connection is shown (also the slab on the left is represented to be connected with the same method).

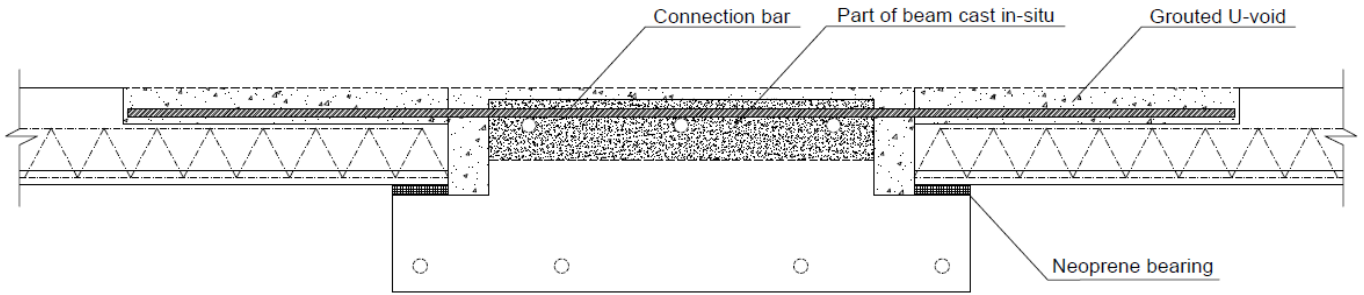

Figure 8.24a – Scheme of the proposed design

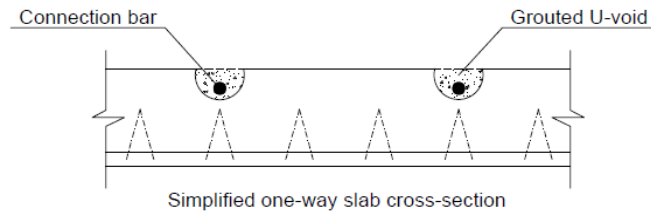

Figure 8.24b – Portion of the cross-section of the slab in the connection zone

- U-voids

The U-void mentioned here can be performed by using a jackhammer, but paying always attention not to damage the existing reinforcement inside the element. In any case their depth should be compliant with the required concrete cover over the connection bars that will be inserted.

- Advantages, drawbacks and complexity rating

In the Table 8.7, the advantages and the drawbacks of this connection method are briefly summarized:

Advantages	Drawbacks
Relatively simple design	Need for a precise concrete breaking
Simple on-site installation	Non suitable for eventual further reuse
Most of the adaptation is done in factory	

Table 8.7 – Advantages and drawbacks of the proposed design

This joint can be considered to have “Medium complexity” because of the fact that even if precise U-voids have to be performed during the preparation phase, the on-site mounting is quite simple and does not require particular skills from the workers brigade.

9. Numerical case study

9.1. Introduction of the project

The numerical case study which will be addressed in this graduation project, regards the embedment of some of the joints proposed in the chapters 5 to 8 into a hypothetical structure designed according to the Eurocode (and the Dutch NEN). It is important to highlight that this case study is meant to demonstrate the structural feasibility of the proposed connections rather than to perform detailed dimensioning and calculations about strictly all their components.

It is assumed that there are some initial requirements for the structure to be built. The requested structural system, the geometry and the materials should be as much common and “usual” as possible for a simple modern office building like the ones that are used to be built in the Netherlands nowadays. Therefore, the basic requested features of this (partly) “second-hand” building” are specified in the Table 9.1.

Feature	Requirement
Type of building	Office use
Number of floors	10
Floor height	3,5-4m
Main beam spans	7m
Transversal beam spans	7m
Structural scheme	HCS on beams supported by columns

Table 9.1 – Basic features of the building

The project can be conceptually divided in the following steps:

- a) General design of the “second-hand” building;
- b) Selection of the second-hand/new elements to be used in the new building;
- c) Design and verification of the connections necessary for embedding the second-hand elements.

In the step (a), the design of a hypothetical building, partly made of reused elements, will be presented.

During the step (b), the elements of the building to be built are presented. It also specified that these can have two sources:

- “Smartly invented” second-hand element¹;
- Traditional newly-made element (precast or cast in-situ).

After the first two phases, a linear analysis using FEM software (Nemetschek SCIA Engineer 19) is performed and the acting forces and moments at the positions of the connections are calculated.

¹ Invented taking into account its approximate resistance capacity for the addressed building type and by respecting all the requirements for the reinforcement and its positioning inside the section (minimum concrete cover, minimum bar dimension and minimum and maximum reinforcement area were checked). The detailed calculations for the cross-section properties can be found in the Appendices 1, 2 and 3.

In the phase (c) the detailed design of each connection is shown, and its verification is performed in this last step. Of course, not all the joints will be addressed in this study, but only the selected ones, which will be presented further on.

According to A. Glias, in order to efficiently identify an element to be reused, the definition of the so-called “EID” (Element Identity) is necessary. This consists in the definition of the data showed in the Tables 9.2a and 9.2b

GENERAL		MATERIAL		TYPE	SECTION	DIMENSIONS	
Address	Construction year Label Quantity Level	Type of concrete	Type of steel	Precast	Rectangular L Tee Inverted Tee	Span (L)	
Construction year				Pre-stressed		Overall height(H)	
Label				Post-tensed		Width (W)	
Quantity				Cast-in-situ			
Level							
REINFORCEMENT		SECTION		DAMAGES	LOAD	MODIFICATION	PROPERTIES
Amount		Effective depth (d)		Location	Max.	Sawing	Weight
Area		Cover		Type	Moment	Drilling	Volume
Location		Area		Severity	Max.	Protection	
					Shear		

Table 9.2a – EID for the beams

GENERAL		MATERIAL		TYPE	SECTION	DIMENSIONS	
Address	Construction year Label Quantity Level	Type of concrete	Type of steel	Precast	Rectangular Round	Clear height (L)	
Construction year				Pre-stressed		Section height (H)	
Label				Post-tensed		Width (W)	
Quantity				Cast-in-situ			
Level							
REINFORCEMENT		SECTION		DAMAGES	LOAD	MODIFICATION	PROPERTIES
Amount		Effective depth (d)		Location	Max. Axial	Sawing	Weight
Area		Cover		Type		Drilling	Volume
Location		Area		Severity			

Table 9.2b – EID for the columns

Therefore, during the phase (b), for the elements which were assumed to be second-hand, a hypothetical EID will be formulated.

9.2. The “Second-hand building”

Now that the elements to be reused are presented, before talking about the connections itself, the structure in which to embed them deserves attention.

9.2.1. Generalities, modelling and assumptions

As seen before, the structural system of the building in which to reuse the second-hand elements is the following: columns are bearing the beams on which the hollow core slabs are transmitting the loads. In the Figure 9.1, a general representation of the building can be seen (the slabs are shown in red, the walls are green with blue cores, the beams are orange and the columns are blue).

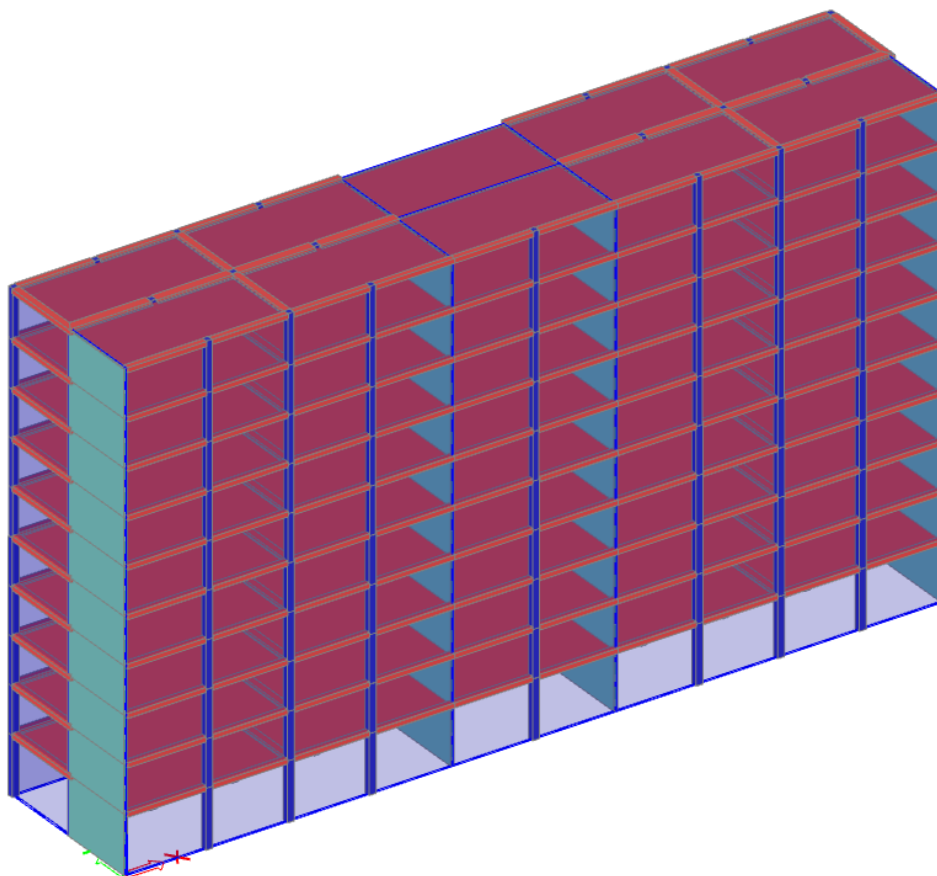

Figure 9.1 – General rendering of the building

The stability is mostly provided by the core walls. Stability walls for actions perpendicular to the longitudinal building direction are also provided at the sides of the building. The positions of the walls are highlighted with red lines in the Figure 9.2.

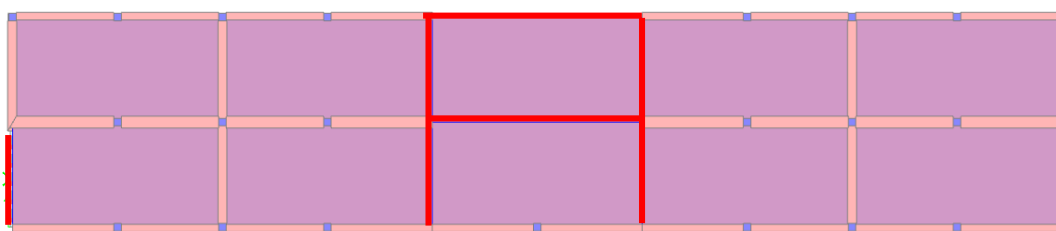

Figure 9.2 – Location of the shear walls

The modelling of the structure has mainly the purpose to assess the forces and the moments acting on the members at the connection points, and therefore no detailed definition of all the reinforcements or non-structural elements has been made. The assumptions that were made, are the following:

- No openings for doors or windows were considered in the walls;
- No stairs have been modelled;
- The real cross sections of the elements have been carefully defined in the model, but in order to consider the effect of the steel reinforcement, an approximation about the stiffness of the elements has been made, affecting the "manual" change of the modulus of elasticity;
- No dynamic loads are considered in the model;

- Only linear analysis will be performed;
- No second order effects are taken into account.

9.2.2. Geometry of the building

As mentioned previously, the office building has 10 floors. The ground floor has a height of 5m while the other floors have heights of 4m. The resulting height of the structure is so equal to 41m, its length is 70m (10 spans x 7m) and its width is 14m (2 spans x 7m). A representation of the structure is shown in the Figure 9.3.

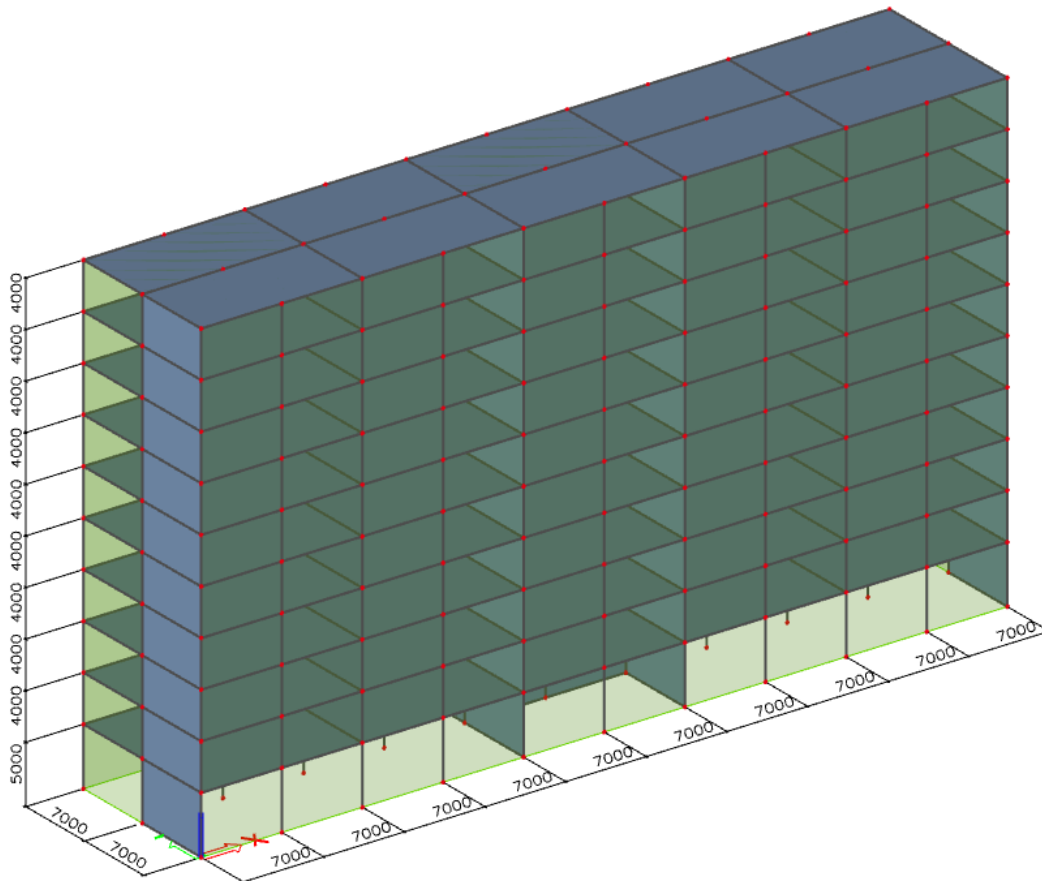

Figure 9.3 – Dimensions of the building

9.2.3. Loads and load combinations

The loads on the structure are:

- Self-weight of the elements (calculated by SCIA directly);
- Permanent loads ($q_{k, floor} = 2,0 \text{ kN/m}^2$ and $q_{k, roof} = 1,0 \text{ kN/m}^2$);
- Variable loads ($q_{k, floor} = 2,5 \text{ kN/m}^2$ and $q_{k, roof} = 0,5 \text{ kN/m}^2$);
- Snow load ($s_k = 0,7 \text{ kN/m}^2$);
- Wind load ($v_{b,0} = 29,5 \text{ m/s}$, terrain category II, $c_{pe,10}$);

The Figures 9.4a, 9.4b and 9.4c show respectively the permanent, variable and snow loads applied to the structure, while, to what concerns to wind loads, these are generated automatically in SCIA, but are not shown in a graphical way.

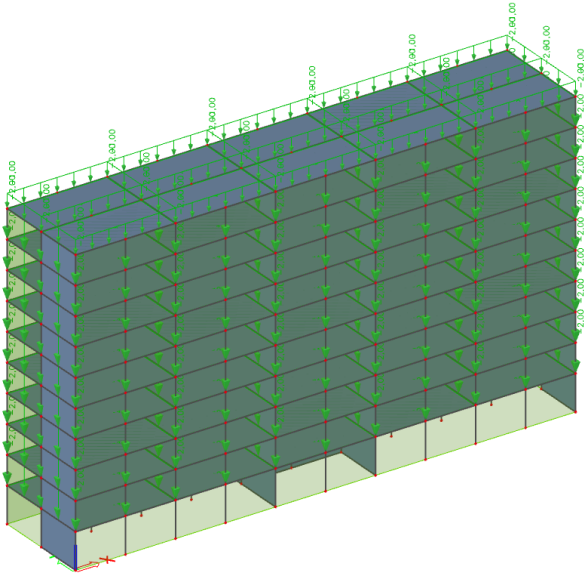

Figure 9.4a – Permanent loads on the building

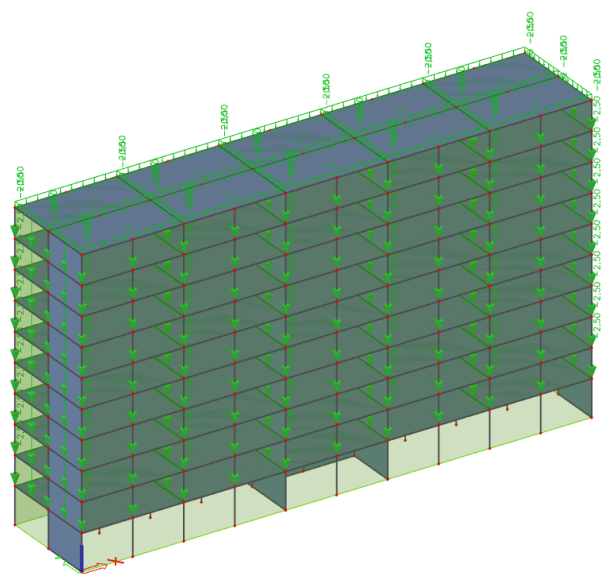

Figure 9.4b – Variable loads on the building

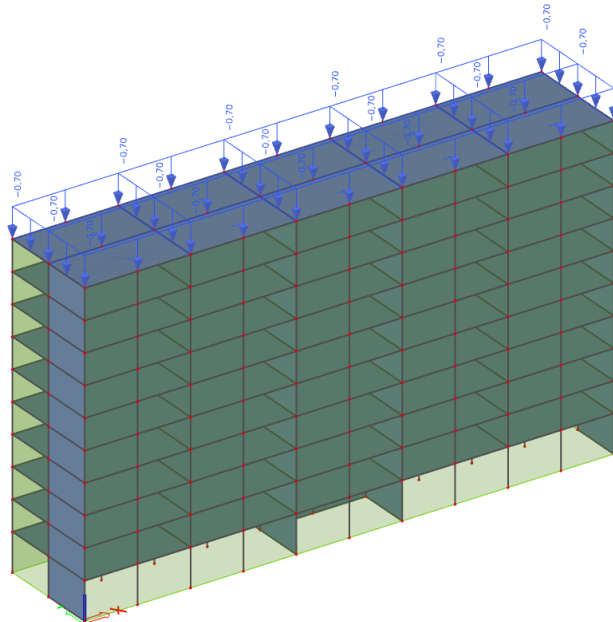

Figure 9.4c – Snow loads on the building

The used load combinations for ULS and SLS are considered automatically in SCIA Engineer according to the Eurocode:

$$\left\{ \begin{array}{l} \sum_{j \geq 1} \gamma_{G,j} G_{k,j} + \gamma_P P + \gamma_{Q,1} \psi_{0,1} Q_{k,1} + \sum_{i > 1} \gamma_{Q,i} \psi_{0,i} Q_{k,i} \\ \sum_{j \geq 1} \xi_j \gamma_{G,j} G_{k,j} + \gamma_P P + \gamma_{Q,1} Q_{k,1} + \sum_{i > 1} \gamma_{Q,i} \psi_{0,i} Q_{k,i} \end{array} \right.$$

9.2.4. External constraints and internal boundary conditions

In this paragraph, the general boundary conditions of the structure and of the single elements which are used during the modelling will be introduced.

The external constraints at the foot connection of the elements with the foundation block are the following:

- The columns are free to rotate around the X axis (the one longitudinal to the span of the building) but they are clamped to what concerns the rotation around Y axis (the one transversal to the span of the building);
- Simply supported walls.

Internally, the situation is the following:

- All the slabs are considered to have hinged connection with the beams;
- All the walls are considered to have a shear-resistant vertical connection between each other, however the in-plane moment is not transmitted between the walls;
- All the beams are considered to be simply supported on single spans. To what concerns the use of one or another structural scheme for reusing the beams, this can be a topic for long discussion, since the fact that in the original building to which the second-hand elements belonged, they probably had a continuous scheme, while during the reconnection it is not so easy to say which behaviour should be assigned to them.
- All the columns are modelled as continuous from the bottom to the top of the building. This implies that all the connections between two beam parts in a node with beams and also the eventual splice connections should allow the full transmission of forces and moments.

The visualization of the external constraints and of the internal line supports on the panel edges are shown respectively in the Figures 9.5a and 9.5b.

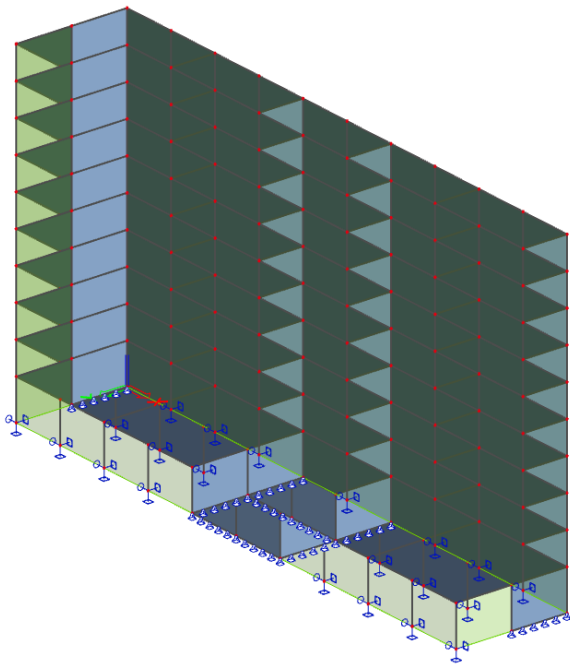

Figure 9.5a – External constraints

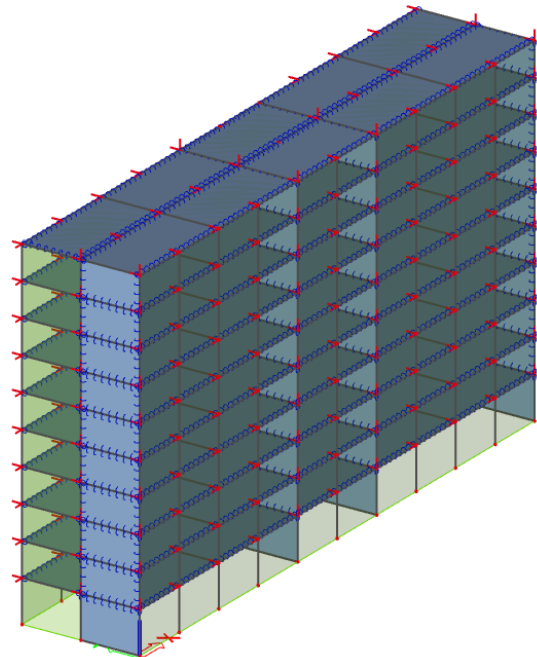

Figure 9.5b – Internal constraints

9.3. Classification and properties of the elements

As previously mentioned, in this section the elements to be used for the new office building will be presented. Each category of structural parts will be addressed separately and it will be said whether the elements are new or reused.

The exact characteristics (such as all the details about the reinforcement, etc...) of the elements will not be specified in this section, since that the only scope of the present element definition is to allow the FEM software to calculate the forces that are acting on the connections which will be presented further on. To take into account the overall (or “homogenized”) characteristics of the reinforced concrete elements, without any modelled reinforcement inside, the overall stiffness has to be defined, and this has been done by setting manually the modulus of elasticity in SCIA Engineer to (Glias, 2019):

- $E = 5.000MPa$ to what concerns hollow core slabs;
- $E = 15.000MPa$ to what concerns beams, columns and walls.

These values will provide good approximation for the overall functioning of the structure.

9.3.1. Floor/roof elements

It comes now to select the elements to be used as floors and roof of the building. In the Table 9.3 the general features of the elements are specified.

Feature	Value
New/second-hand	New
Element	One way slab
Type	Hollow core slab
Thickness	200mm

Table 9.3 – General properties of the element

Since these elements are newly made, they are not subject of this study and no detailed properties will be specified for them.

9.3.2. Wall elements

In order to guarantee the stability of the building, wall elements are necessary. In the Table 9.4 the general features of the elements are specified.

Feature	Value
New/second-hand	New
Element	Shear wall
Type	Double-reinforced
Thickness	300mm

Table 9.4 – General properties of the element

Since these elements are newly made, they are not subject of this study and no detailed properties will be specified for them.

9.3.3. Beam elements

The beam elements to be used in the structure will be now addressed. The beams which are supposed to be used in the structure are of three types: central shallow beams (carrying hollow core slabs on two sides), edge beams (2 sub-types; carrying hollow core slabs on one side only) and beams transversal to the spanning of the previous two types of beams (2 sub-types; only

responsible for the stability of the whole structure and for carrying the shear action from the hollow core slabs).

9.3.3.1. Central beams

The “central beams” which are here addressed are, as mentioned before, beams that are bearing the hollow core slabs on both sides. In the Table 9.5 the general features of the elements are specified.

Feature	Value
New/second-hand	Second-hand
Element	Central beam
Type	Shallow beam

Table 9.5 – General properties of the element

The shape of the cross-section is shown in Figure 9.6.

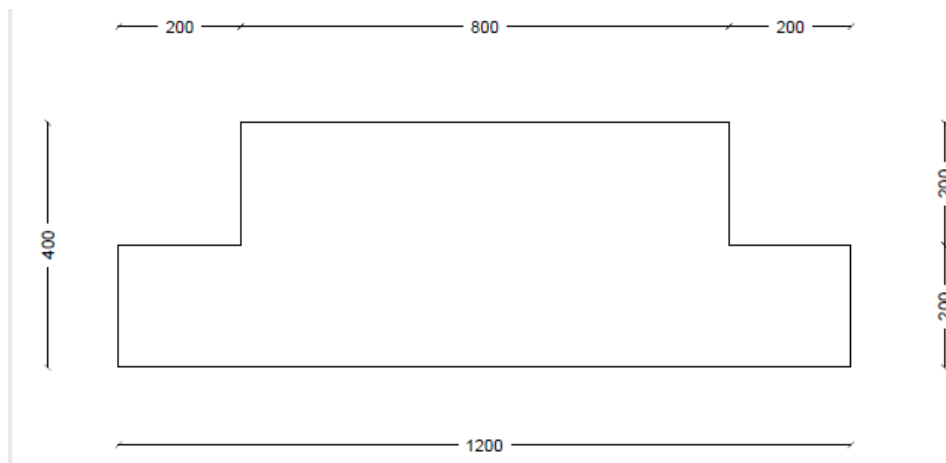

Figure 9.6 – Cross-section of the element

The amount of the elements is assumed to be sufficient to cover the need of the entire structure. This element will be used in the detailed study of the connections, and therefore, further on, its EID and the detailed properties of its cross section at the position of the joint will be presented.

9.3.3.2. Edge beams (ground floor to 4th floor)

The “edge beams” which are here addressed are the beams that are bearing the hollow core slabs just on one side. In the Table 9.6 the general features of the elements are specified.

Feature	Value
New/second-hand	New
Element	Edge beam
Type	L - shaped

Table 9.6 – General properties of the element

The shape of the cross-section is shown in the Figure 9.7.

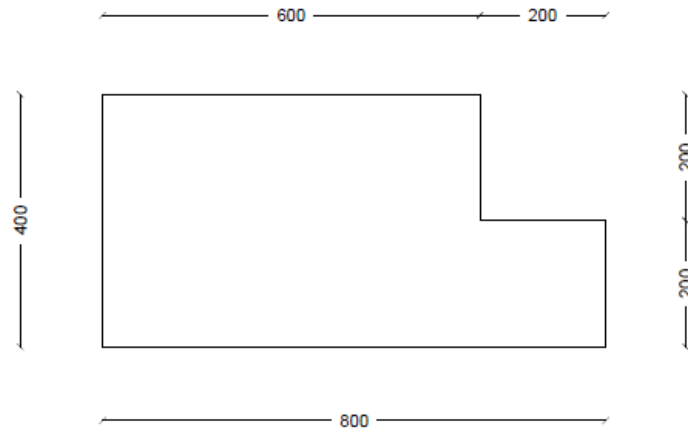

Figure 9.7 – Cross-section of the element

No EID of the elements is formulated in this case since the elements are not second-hand.

9.3.3.3. *Edge beams (floors 5th to 9th)*

The “edge beams” which are here addressed are the beams that are bearing the hollow core slabs just on one side. In the Table 9.7 the general features of the elements are specified.

Feature	Value
New/second-hand	New
Element	Edge beam
Type	L - shaped

Table 9.7 – General properties of the element

The shape of the cross-section is shown in the Figure 9.8.

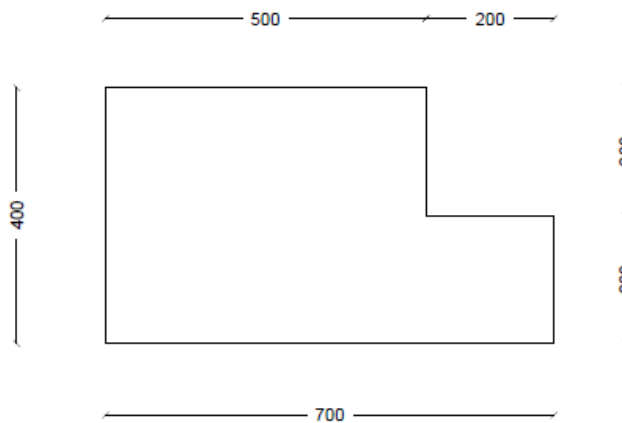

Figure 9.8 – Cross-section of the element

No EID of the elements is formulated in this case since the elements are not second-hand.

9.3.3.4. *Internal transversal beams*

For “transversal beams”, the beams that are running longitudinally to the hollow core slabs are meant. No actual vertical load is transmitted to these beams directly since the fact that the hollow

core slabs are just one-way elements, but they are bearing the vertical and horizontal shear force from the adjacent slab. In the Table 9.8 the general features of the elements are specified.

Feature	Value
New/second-hand	New
Element	Internal transversal beam
Type	Reversed T - shaped

Table 9.8 – General properties of the element

The shape of the cross-section is shown in the Figure 9.9.

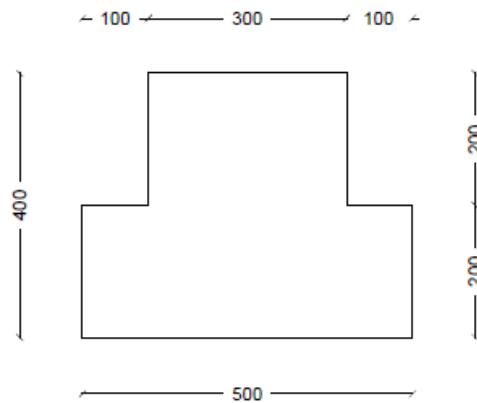

Figure 9.9 – Cross-section of the element

No EID of the elements is formulated in this case since the elements are not second-hand.

9.3.3.5. Edge transversal beams

For “transversal beams”, the beams that are running longitudinally to the hollow core slabs are meant. No actual vertical load is transmitted to these beams directly since the fact that the hollow core slabs are just one-way elements, but they are bearing the vertical and horizontal shear force from the adjacent slab. In the Table 9.9 the general features of the elements are specified.

Feature	Value
New/second-hand	New
Element	Edge transversal beam
Type	L - shaped

Table 9.9 – General properties of the element

The shape of the cross-section is shown in Figure 9.10.

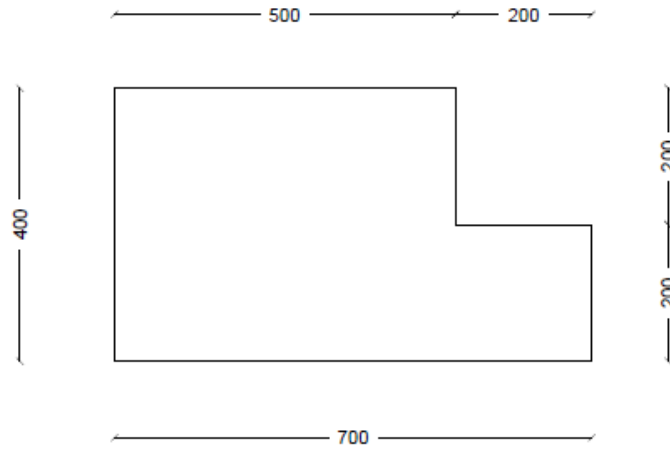

Figure 9.10 – Cross-section of the element

No EID of the elements is formulated in this case since the elements are not second-hand.

9.3.4. Column elements

The column elements that are used in this project are of three types: internal columns from ground floor to floor 4, internal columns from floor 5 to floor 9 and external columns. The distinction between the internal columns of the lower floors and the upper floors is done because of the fact that the lower columns need to bear more compressive force, therefore their cross-section should be bigger. The details of all of these elements will be now addressed.

9.3.4.1. Internal columns (ground floor to 4th floor)

The columns which are here addressed are the ones that are bearing the central shallow beam and they are present from the ground level up to the 4th floor in the whole building. In the Table 9.10 the general features of these elements are specified.

Feature	Value
New/second-hand	Second-hand
Element	Column
Type	Internal column (ground to 4 th floor)

Table 9.10 – General properties of the element

The shape of the cross-section is shown in Figure 9.11.

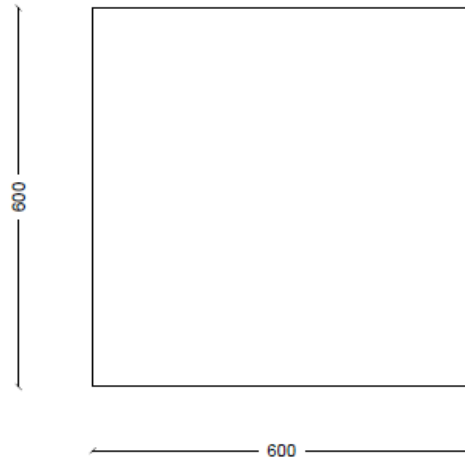

Figure 9.11 – Cross-section of the element

The amount of the elements is assumed to be sufficient to cover the need of the entire structure. This element will be used in the detailed study of the connection, and therefore, further on, the detailed properties of its cross section at the position of the joint will be presented.

9.3.4.2. *Internal columns (floors 5th to 9th)*

The columns which are here addressed are the internal columns from the 5th floor up to the 9th floor. In the Table 9.11 the general features of these elements are specified.

Feature	Value
New/second-hand	Second-hand
Element	Column
Type	Internal column (floors 5 th to 9 th)

Table 9.11 – General properties of the element

The cross sectional details taken from the picture of the original drawings are shown in the Figure 9.12.

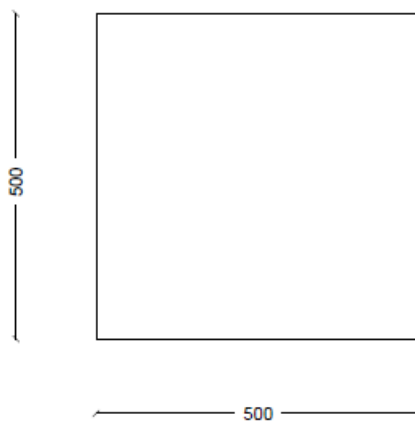

Figure 9.12 – Cross-section of the element

The amount of the elements is assumed to be sufficient to cover the need of the entire structure. This element will be used in the detailed study of the connection, and therefore, further on, the detailed properties of its cross section at the position of the joint will be presented.

9.3.4.3. External columns

The columns which are here addressed are all the external columns. In the Table 9.12 the general features of these elements are specified.

Feature	Value
New/second-hand	Second-hand
Element	Column
Type	External columns

Table 9.12 – General properties of the element

The cross sectional details taken from the picture of the original drawings are shown in the Figure 9.13.

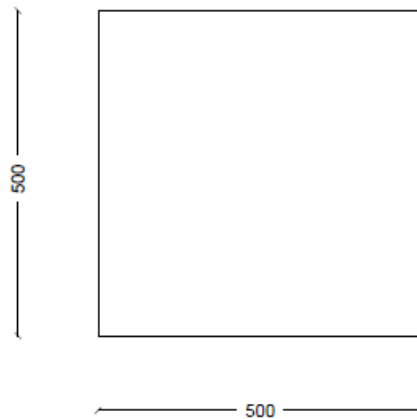

Figure 9.13 – Cross-section of the element

The amount of the elements is assumed to be sufficient to cover the need of the entire structure. This element will be used in the detailed study of the connection, and therefore, further on, the detailed properties of its cross section at the position of the joint will be presented.

9.4. Reconnection of second-hand elements

It comes now to the part of the case study directly concerned with the main topic of this Thesis: the embedding of the previously presented connections for second-hand elements into the new building.

The following connections between the specified elements and with the specified methodologies will be addressed:

1. Second-hand shallow beams to second-hand columns main node:

- Second-hand columns are connected by means of grouted coupling holes (continuity of forces and moments is guaranteed between bottom and top column elements of the node);
- Second-hand beams are laid down on column edges and connected to the node only by anchoring their bottom reinforcement bars (since they are considered to be simply supported).

2. Splice connection between two second-hand column elements:

- Second-hand column elements are connected by means of welding of a steel plate to the existing reinforcement of second-hand elements and using bolts to create bond.
3. Foot connection of a second-hand column to the foundation block:
- Second-hand column element is connected to the foundation block by means of breaking the concrete cover in its lower part, positioning connection bars (anchors) externally to the existing reinforcement and by recasting the concrete cover again.
- These connections are highlighted by the red circle on the Figure 9.14.



Figure 9.14 – Identification of the joints to be studied

9.4.1. Second-hand shallow beams to second-hand columns node

9.4.1.1. Introduction to the connection

As previously mentioned, the first connection that will now be addressed in detail is the one between second-hand shallow beams (left and right), the second-hand columns (top and bottom), and transversal newly cast beams (which will not be considered as subject of this case study). A rough representation of the joint can be seen from a SCIA Engineer visualization in Figure 9.15, however, this is meant just to give an idea of the configuration of the elements, while the detailed drawings will be presented further on.

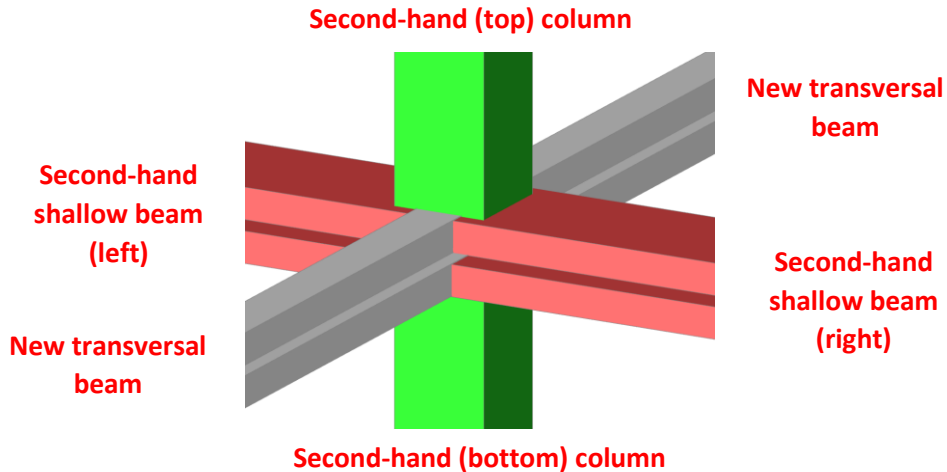

Figure 9.15 – Identification of the elements of the joint

The actions to be transmitted between the bottom and the top column elements are:

- Normal compressive force;
- Shear force;
- Bending moment (as from the modelling of these elements, only the moment acting in the direction of the spanning of the beams is considered).

While the beams, are transmitting to the bottom column:

- Vertical shear force.

Therefore, the columns can be considered as completely continuous through the node, while the beams are just simply-supported.

The chosen location for the joint to be studied is identified as the position I-2 on the building grid, between the ground and the 1st floors.

9.4.1.2. Elements involved

The elements which will be involved into the connection have been already briefly presented in the previous sections, however it is now necessary to address them more in detail. To sum up, these elements are:

- Second-hand left shallow beam element;
- Second-hand right shallow beam element;
- Second-hand top internal ground floor column element;
- Second-hand bottom internal ground floor column element;
- New transversal beam elements.

The most relevant data about the cross-sections and about the materials of the second-hand elements will be now presented. More detailed dimensions and values can be found in the Appendix 1A and Appendix 1B.

9.4.1.2.1. Shallow beam elements (left and right)

The shallow beams to be used in the connection will now be presented. The most relevant part for this case study is, of course, the end of the element, because this will be involved in its connection. In the Figure 9.16 a detailed representation of the end cross-section is shown.

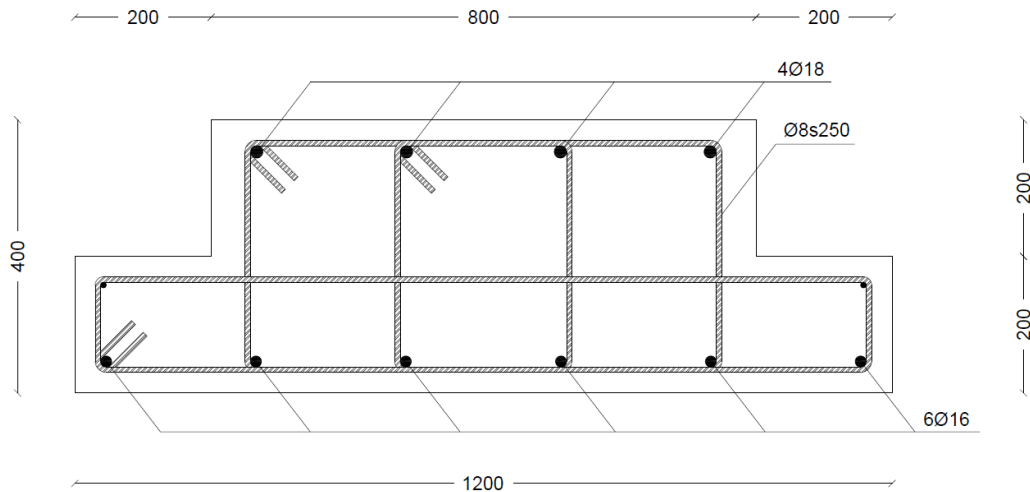

Figure 9.16 – End cross-section of the shallow beams

As it can be seen, we have reinforcement bars in the upper and in the lower part. Because of this bar configuration, it is deduced that in the donor structure to which it belonged, these were continuous across at least one intermediate support. However, in this new structure, the beam will be connected as simply supported. In the cross-section located at the span, more bars may be present in the bottom part to resist the in-span bending moment.

Since this element is second-hand, its EID should be defined before using it in a new structure, which will also contribute to introduce better the main features of it. In the Table 9.13 the parameters are shown.

General/source	Material	Type	Section	Dimensions
“Smartly invented”	C30/37 B 500B	Partly precast at its first use	Shallow beam	1200x400mm

Reinforcement (at the studied end)	End-section details	Damages	Load	Modification	Properties
Upper: 4Ø18 Lower: 6Ø16 Transversal: Ø8s250	d=353mm c=30mm	None	N.A.	Sawing and baring a portion of bottom bars	N.A.

Table 9.13 – EID of the shallow beam

The section was invented taking into account its approximate resistance capacity and by respecting all the requirements for the reinforcement and its positioning inside the section (minimum concrete cover, minimum bar dimension and minimum and maximum reinforcement area were checked). The detailed calculations can be found in the Appendix 1A.

9.4.1.2.2. Column elements (top and bottom)

The end cross-section of the column to be involved in the connection is presented in the Figure 9.17.

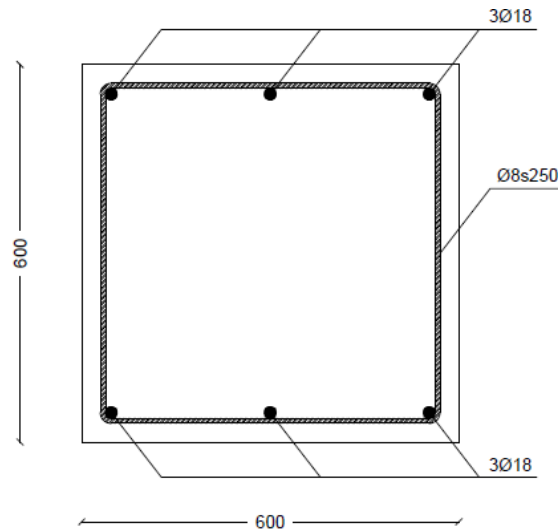

Figure 9.17 – End cross-section of the columns

Since this element is second-hand, as already done for the previous element its EID should be defined before using it in a new structure. This is presented in Table 9.14.

General/source	Material	Type	Section	Dimensions
“Smartly invented”	C30/37 B 500B	Cast in-situ in first use	Square	600x600mm

Reinforcement (at the studied end)	End-section details	Damages	Load	Modification	Properties
Upper: 3Ø18 Lower: 3Ø18 Transversal: Ø8s250	d=553mm c=30mm	None	N.A.	Sawing + drilling	N.A.

Table 9.14 – EID of the column

The section was invented taking into account its approximate resistance capacity and by respecting all the requirements for the reinforcement and its positioning inside the section (minimum concrete cover, minimum bar dimension and minimum and maximum reinforcement area were checked). The longest column (5m) has been also briefly checked to be resistant to buckling. All these detailed calculations can be found in the Appendix 1B and Appendix 3.

9.4.1.3. Internal actions at the connection position

By considering the actions on the elements calculated with SCIA Engineer (and checked also with rough hand-calculation), and by accounting to the fact that the two column elements and the two beam elements have the same properties respectively, it has been decided to perform the checks only on the bottom column connection to the node and on the right beam connection to the node. The resulting extreme internal forces and moments in ULS near the node position are shown in Table 9.15.

Element	N_{Ed} (kN)	V_{Ed} (kN)	M_{Ed} (kNm)
Bottom column	5013	1,50	3,20
Right beam	0	250,88	0

Table 9.15 – Actions at the end of each element

To what concerns the beam, it is also important to consider the bending moment in the span, since its end should be verified to be resistant to a bending moment equal to a portion of the latter, therefore in the Table 9.16 the in-span moments are shown.

Element	$M_{Ed,span}$ (kNm)
Right beam	439,03

Table 9.16 – Maximum in-span moments

It should be also considered that during the construction phase, the shear at the beam support due to the self-weight should be checked, since the beam lays on the column edge in this phase and this can be susceptible to breaking. The maximum value of this shear force at the support is shown in the Table 9.17.

Element	$V_{Ed,sl}$ (kN)
Right beam	34,34

Table 9.17 – Maximum shear forces at the support due to self-load

While to what concerns the column, it should be kept in mind that during the verification of the cross-section to the interaction bending-compression, the eccentricity of the compression force should be accounted for.

9.4.1.4. Conceptual scheme of the adopted beam-to-node connection

As mentioned in the previous paragraph, it was chosen to address the right beam-to-node joint, since the fact that the left one is connected in exactly the same (specular) way. The information about the general procedure for performing this joint has already been given in the theoretical part of this thesis, dedicated to the conceptual proposals of joints for second-hand elements, therefore it will not be repeated for this joint in particular. The final connection looks as in the Figure 9.18 (not to scale, only meant for method presentation purposes).

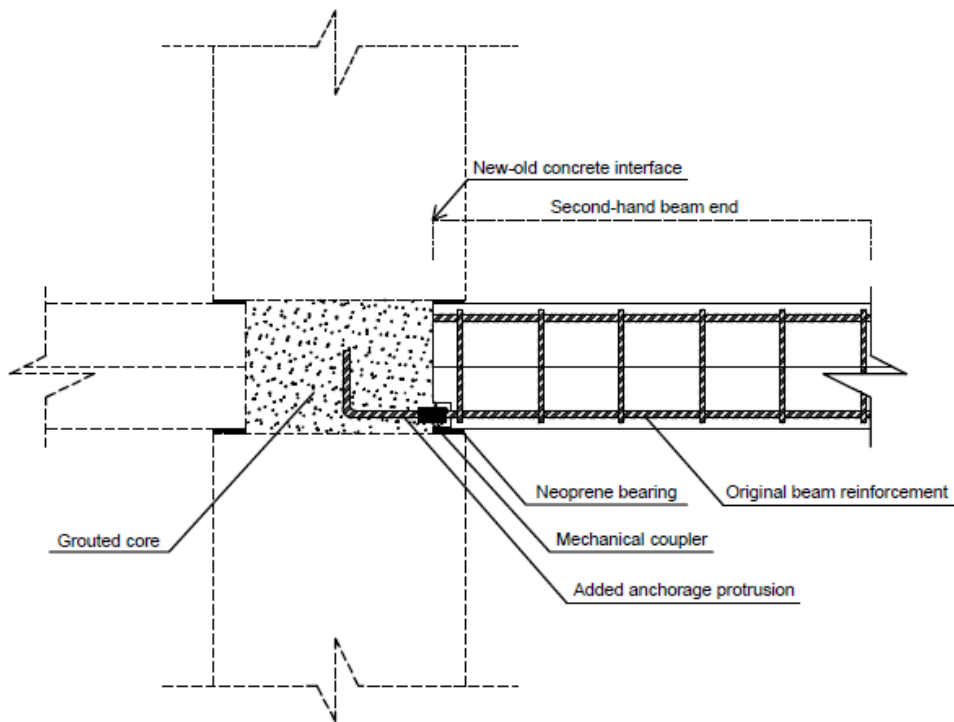

Figure 9.18 – Beam-to-node connection scheme

As it can be seen in the picture above, two “zones” of the joint are explicitly highlighted, namely the second-hand beam end and the new-old concrete interface. This is done because the further verifications will be addressed to these two areas.

For the connection of the anchorage protrusion to the existing bottom reinforcement of the beam, in this case, the threaded mechanical couplers are proposed. However, these anchorage elements can be also welded to the existing reinforcement after partially braking the concrete around the bars. Both of these adaptations are more likely to be done in a factory rather than on the building site.

The use of adequate neoprene bearings is very important here, since the beam should be provided with enough rotational capacity in order to behave as modelled in the FEM software.

The dimensioning and verifications of both the couplers and the bearings is omitted in this case study because the latter is meant only to state the feasibility of the proposed design.

The materials required for the entire connection and their basic specifications are briefly summarized in the Table 9.18.

Component	Amount	Specifications
Left beam connection anchors	2	φ16, B500B
Right beam connection anchors	2	φ16, B500B
Steel mechanical couplers	4	To fit φ16, EN certified
Left beam neoprene bearings	2	EN certified
Right beam neoprene bearings	2	EN certified
Concrete	-	C50/60, low shrinkage

Table 9.18 – List of needed materials

9.4.1.5. Conceptual scheme of the adopted column-to-node connection

Also for the case of the connection of the second-hand column, it was chosen to address for the detailed study purposes only the bottom part since this one is subjected to higher actions. The top part will be connected with exactly the same method as the one presented here. As before, it should be said that the detailed connection method will not be repeated for this joint in particular, since it was mentioned before.

The final connection looks as in the Figure 9.19 (not to scale, only meant for method presentation purposes).

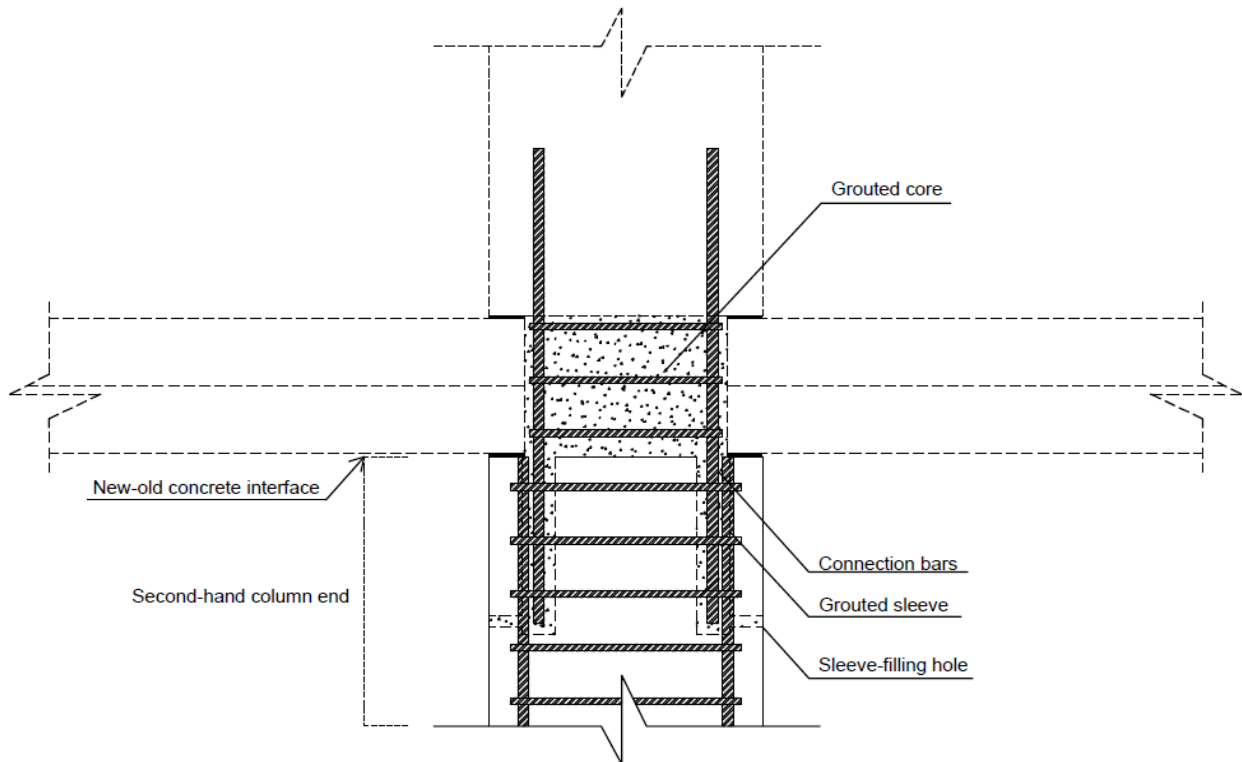

Figure 9.19 – Column-to-node connection scheme

As it can be seen in the picture above, two “zones” of the joint are explicitly highlighted, namely the second-hand column end and the new-old concrete interface. This is done because the further verifications will be addressed to these areas.

The second-hand column end cross-section has been already introduced in the section dedicated to the involved elements in the connection, while in Figure 9.20 the detailed cross-section in the zone where the connection bars are located is shown.

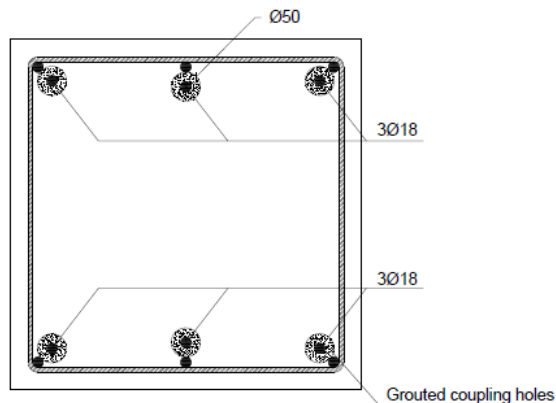

Figure 9.20 – Cross-sectional view of the sleeves' zone

The materials required for the entire connection and their basic specifications are briefly summarized in the Table 9.19.

Component	Amount	Specifications
Bottom/top column connection bars	3+3	φ18, B500B
Transversal column reinforcement	2	φ8, B500B
Concrete	-	C50/60, low shrinkage

Table 9.19 – Materials needed for the connection

To what concerns the building procedure, this is the one already mentioned in the connection proposal part of this graduation work.

9.4.1.6. Verifications and anchorage length of the beam-to-node connection

All the required verifications for this connection method will be now addressed. They will address only the connection zone, since it has been assumed that the second-hand beam elements involved in the connection itself are capable of bearing the required loads and has successfully passed all the checks in the span and at the connection on the other end.

Only the most relevant values will be explicitly shown, while to what concerns all the intermediate steps and detailed intermediate values, reference should be made to the calculation sheet which can be found in the Appendix 1A.

9.4.1.6.1. Bending verification of the end cross-section

As already introduced before, even if the beam has been modelled as simply-supported, in the section 9.2.1.2 of the EN 1992.1.1 is stated that the end cross-section of the beam needs to withstand to a bending moment equal to $\beta_1 \cdot M_{Ed,span}$ (in ULS) which arises due to partial fixity at the (end) supports. In our case, the values for bending moment at the end cross-section shown in Table 9.20 are obtained.

Parameter	Symbol	Value	Units
Moment in the span	$M_{Ed,span}$	439,03	kNm
Reduction coefficient	β_1	0,15	-
Partial fixity moment at the end section	$M_{Ed,pf}$	135,85	kNm

Table 9.20 – End-moment due to partial fixity

The shift of the bending moment line should also be taken into account, as specified in the section 9.2.1.3 of the EN 1992.1.1. This is summarized in the Table 9.21.

Parameter	Symbol	Value	Units
Slope of the shear reinforcement	α	90	°
Slope of the concrete struts	θ	25	°
Inner lever arm	z	318	mm
Shifting amount	α_1	341	mm
Moment at the end section due to shifting	$M_{Ed,sb}$	70	kNm

Table 9.21 – End-moment due to partial shifting of the moment line

At this point, the verification is performed as prescribed by the EN 1992.1.1 in the section 6.1. The results shown in Table 9.22 have been obtained.

Parameter	Symbol	Value	Units
Position of the neutral axis	x_u	42,66	mm
Resisting bending moment	M_{Rd}	150,90	kNm
Acting total bending moment	M_{Ed}	135,85	kNm
Unity check	U.C.	0,90	-

Table 9.22 – Intermediate values and outcome of the verification

The verification is therefore fulfilled.

9.4.1.6.2. Shear verification of the end cross-section

The shear verification for the end cross-section of the beam is performed in compliance with the section 6.2.3 of the EN 1992.1.1. The main values and the results are summarized in the Table 9.23:

Parameter	Symbol	Value	Units
Shear strength of the shear reinforcement	$V_{Rd,s}$	267,88	kN
Maximum shear strength	$V_{Rd,max}$	1028,00	kN
Acting shear at the beam end	V_{Ed}	250,88	kN
Unity check	U.C.	0,94	-

Table 9.23 – Intermediate values and outcome of the verification

The verification is therefore fulfilled.

9.4.1.6.3. Shear verification at the interface between concrete cast at different times

The shear verification at the interface between concrete cast at different times is performed (even if most of the shear force is taken by the column before it can reach the interface location between “old” and “new” concrete) in compliance with the section 6.2.5 of the EN 1992.1.1. The area of the connection to which this verification is addressed is highlighted in the Figure 9.21.

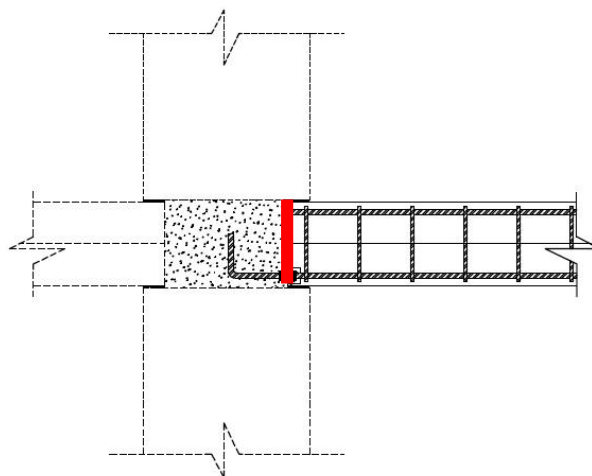

Figure 9.21 – Addressed cross-section

The main values and the results are summarized in the Table 9.24.

Parameter	Symbol	Value	Units
Slope of the anchorage	α	90	°
Assumed surface type	-	Rough	-
Roughness factor	c	0,4	-
Roughness factor	μ	0,7	-
Strength reduction factor	ν	0,53	
Design shear strength at the interface	v_{Rdi}	1,29	MPa
Acting shear stress at the interface	v_{Edi}	1,05	MPa
Unity check	U.C.	0,81	-

Table 9.24 – Intermediate values and outcome of the verification

The verification is therefore fulfilled.

9.4.1.6.4. Bearing capacity of the concrete under the beam (shear due to self-load)

This simple verification is meant to check whether the portion of the column on which the beam is supported during the installation phase, when only the self-load is acting, is capable of bearing the shear force of the beam at the support. No influence of the longitudinal reinforcement of the column is taken into account, even if the supporting portion contains three reinforcement bars $\phi 18$.

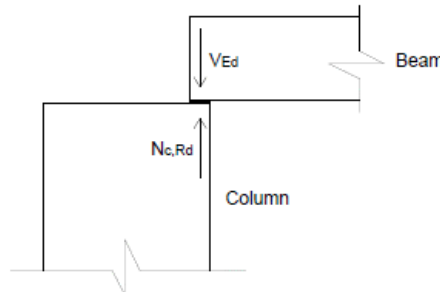

Figure 9.22 – Verification model

Where:

$$V_{Ed,sl} \leq N_{c,Rd}$$

In the Table 9.25 the main values and results are collected.

Parameter	Symbol	Value	Units
Width of the column under the beam	b_c	600	mm
Depth of the bearing surface under the beam	d_b	48	mm
Concrete grade of the column	-	C30/37	-
Bearing strength of the column portion	$N_{c,Rd}$	576,00	kN
Acting shear force due to self-load	$V_{Ed,sl}$	34,34	kN
Unity check	U.C.	0,06	-

Table 9.25 – Intermediate values and outcome of the verification

The verification is therefore fulfilled.

9.4.1.6.5. Design anchorage length of the added anchoring bars

The anchorage length of the bottom bars which will be grouted inside the perimeter of the column is calculated according to section 8.4.4 of the EN 1992.1.1. The bars are not in tension (eventually can have some compression inside). As from the previous representation, the bars are standard bent, so the following case applies:

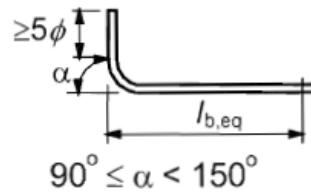

Figure 9.23 – Anchorage part definition

Numerically, we have the values showed in the Table 9.26:

Parameter	Symbol	Value	Units
Bond conditions	-	Good	-
Bond condition coefficient	η_1	1,00	-
Bar diameter coefficient	η_2	1,00	-
Design stress in the reinforcement bar	σ_{sd}	434,78	MPa
Coefficient K	K	0,1	-
Bars in tension/compression	-	Tension	-
Anchorage type	-	Other	-
Distance c,d	c_d	38	mm
Shape of bars coefficient	α_1	1,00	-
Concrete cover coefficient	α_2	1,00	-
Confinement by not welded reinforcement coefficient	α_3	0,93	-
Confinement by welded reinforcement coefficient	α_4	1,00	-
Confinement by transverse pressure coefficient	α_5	1,00	-
Minimum anchorage length	$l_{b,min}$	160	mm
Anchorage length	l_{bd}	376	mm
Minimum length of the bent	5ϕ	80	mm
Bending angle	α	90	°

Table 9.26 – Intermediate values and outcome of the calculation

Therefore, the values above have to be applied into the design.

9.4.1.7. Verifications and anchorage/overlapping lengths of the column-to-node connection

As already done for the beam-to-node connection, the verifications needed to check this kind of connection will be now performed. The following verifications will address only the connection zone, since it has been assumed that the second-hand column elements involved in the

connection itself are capable of bearing the required loads and has successfully passed all the checks in the span and at the connection on the other end. Once again, only the main and most relevant values and results will be shown, while the integral calculation procedure can be found in the Appendix 1B.

9.4.1.7.1. *Bending-compression interaction verification at the column end*

The first check which is hereby presented, regards the verification of the bending acting together with compression. The acting normal force have been already presented at 9.3.1.3, while the acting moment should be increased by considering the fact that compression force is acting with an eccentricity. Therefore, we have the situation as in Table 9.27.

Parameter	Symbol	Value	Units
Eccentricity	e_0	20	mm
Total acting moment	$M_{Ed,tot}$	103,45	kNm

Table 9.27 – Final end-moment calculation

To what concerns the strength of the cross-section, this time a resistance domain should be built for the column end cross-section, using extreme situations to which the column can be subjected. Therefore, the five points which are used to build this domain are:

1. Section under uniform tension;
2. Section under pure bending;
3. Yielding steel and concrete at ultimate strain;
4. Bottom reinforcement unloaded;
5. Uniformly compressed section.

By studying these five situations, and considering the actions on the cross-section the Graph 9.1 has been obtained.

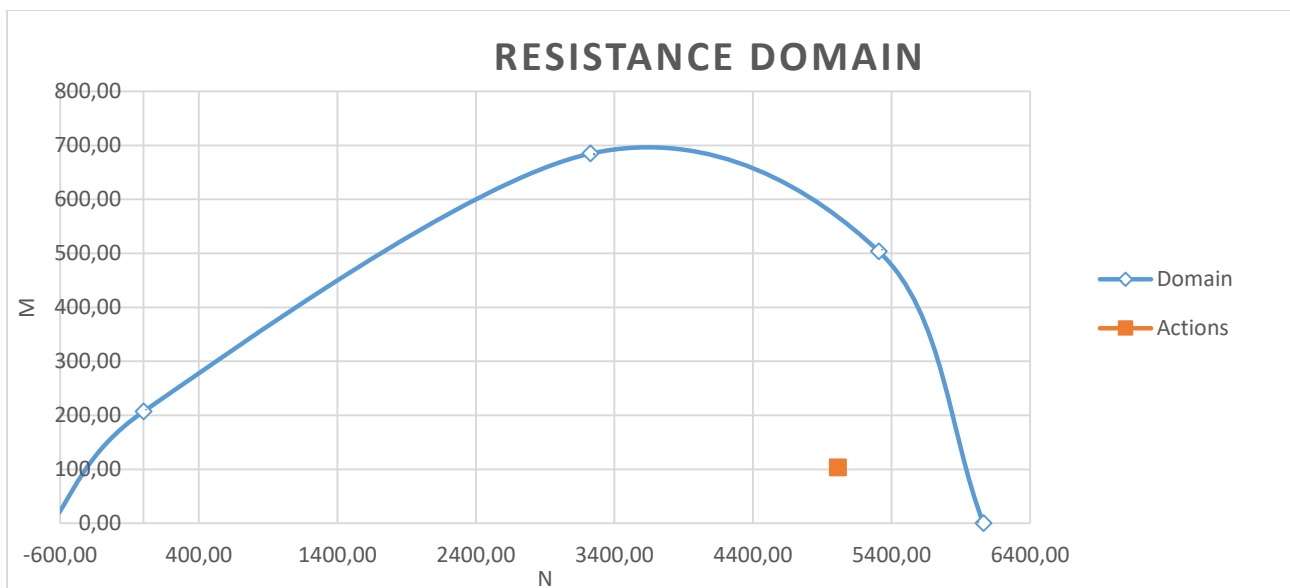

Graph 9.1 – Actions and the resistance domain

As it can be seen, the actions are located inside the domain, the verification is therefore fulfilled.

9.4.1.7.2. Bending-compression interaction verification in the interface zone

While the previous verification regarded the column cross-section, this time the addressed cross section is the one of the core of the node (the one in between the two beams). This cross-section is reduced compared to the one of the column, because the beam supports subtract space to the latter, and therefore this check is also required. The same considerations about the acting moment and the points for building the domain are valid also here. The output situation is the one showed in Graph 9.2.

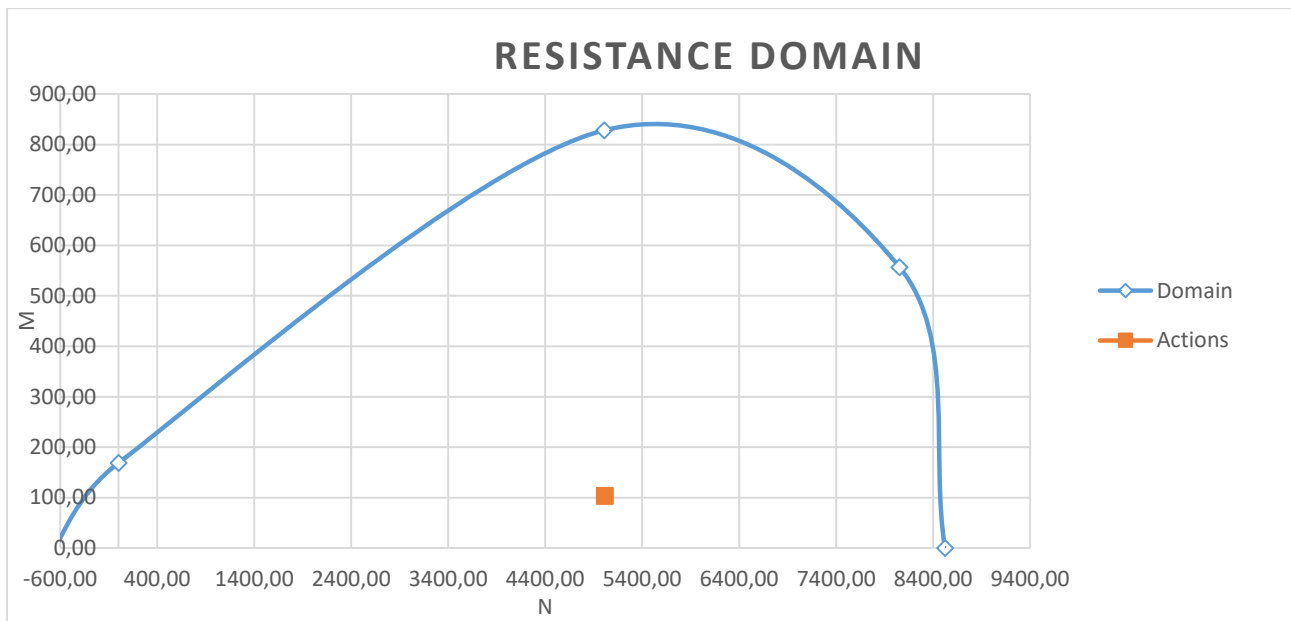

Graph 9.2 – Actions and the resistance domain

Even if the interface cross-section is smaller than the actual cross-section of the column itself, the verification is even more widely fulfilled. This is due to the fact that the concrete grade used to concrete the core of the node is higher than the grade of the concrete of the column.

9.4.1.7.3. Shear verification in the interface zone

The shear verification is performed only in the interface zone, because this one has a smaller cross-section and therefore it is the critical one. The check is performed in compliance with the section 6.2.3 of the EN 1992.1.1. The main values and the results are summarized in the Table 9.28.

Parameter	Symbol	Value	Units
Slope of the shear reinforcement	α	90	°
Slope of the concrete struts	θ	25	°
Shear strength of the shear reinforcement	$V_{Rd,s}$	156,33	kN
Maximum shear strength	$V_{Rd,max}$	1024,84	kN
Acting shear at the beam end	V_{Ed}	1,45	kN
Unity check	U.C.	0,01	-

Table 9.28 – Intermediate values and outcome of the verification

The verification is widely fulfilled.

9.4.1.7.4. Shear verification at the interface between concrete cast at different times

The shear verification at the interface between concrete cast at different times is performed in compliance with the section 6.2.5 of the EN 1992.1.1. The interface area addressed in this verification is the one highlighted in the Figure 9.24.

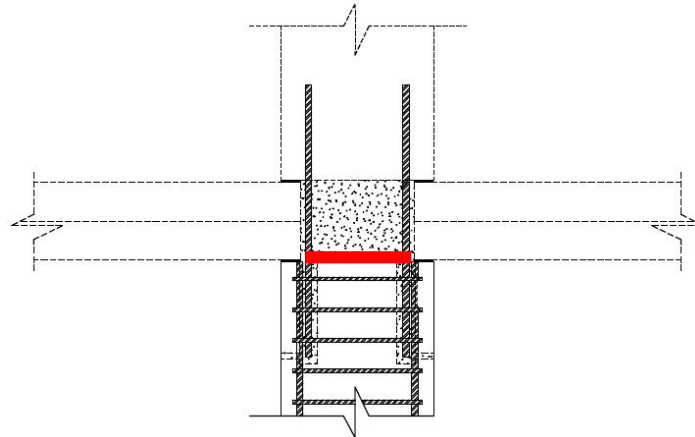

Figure 9.24 – Addressed cross-section

The main values and the results are summarized in the Table 9.29.

Parameter	Symbol	Value	Units
Slope of the anchorage	α	90	°
Assumed surface type	-	Rough	-
Roughness factor	c	0,4	-
Roughness factor	μ	0,7	-
Strength reduction factor	v	0,53	
Design shear strength at the interface	v_{Rdi}	5,28	MPa
Acting shear strength at the interface	v_{Edi}	0,74	MPa
Unity check	U.C.	0,00	-

Table 9.29 – Intermediate values and outcome of the verification

The verification is widely fulfilled.

9.4.1.7.5. Design anchorage length of the connection bars

The anchorage length of the connection bars which will be grouted inside the coupling holes of the column is calculated according to section 8.4.4 of the EN 1992.1.1. The bars are all in compression. As from the previous representation, this time the bars are straight. Numerically, we have the values and the results summarized in the Table 9.30.

Parameter	Symbol	Value	Units
Bond conditions	-	Good	-
Bond condition coefficient	η_1	1,00	-
Bar diameter coefficient	η_2	1,00	-
Design stress in the reinforcement bar	σ_{sd}	434,78	MPa

Coefficient K	K	0,1	-
Bars in tension/compression	-	Compression	-
Anchorage type	-	Straight	-
Shape of bars coefficient	α_1	1,00	-
Concrete cover coefficient	α_2	1,00	-
Confinement by not welded reinforcement coefficient	α_3	1,00	-
Confinement by welded reinforcement coefficient	α_4	1,00	-
Confinement by transverse pressure coefficient	α_5	1,00	-
Minimum anchorage length	$l_{b,min}$	275	mm
Anchorage length	l_{bd}	458	mm

Table 9.30 – Intermediate values and outcome of the calculation

Therefore, the above anchorage length has to be applied in the design.

9.4.1.7.6. Overlapping length and lap distance of the bars

The overlapping length has now to be calculated. This will be done according to the procedure of the section 8.7.3 of the EN 1992.1.1. Numerically, we have the values and the results summarized in the Table 9.31.

Parameter	Symbol	Value	Units
Percentage of reinforcement lapped with $0,65l_0$	ρ_1	100	%
Bars lap coefficient	α_6	1,5	-
Minimum lap length	$l_{0,min}$	270	mm
Design lap length	l_0	688	mm
Maximum distance between two bars	$\min(5\varphi, 50\text{mm})$	50	mm

Table 9.31 – Intermediate values and outcome of the calculation

9.4.1.7.7. Transverse reinforcement in the lap zone

Since the bars in the cross section have all a diameter which is lower than 20mm, no considerations should be done about the concentration of transversal reinforcement in the lap zone (according to section 8.7.4 of the EN 1992.1.1).

9.4.2. Splice connection between two second-hand columns

9.4.2.1. Introduction to the connection

The splice joint, by its definition, is located at a certain point along the height of the column. The method of connection which was chosen to address here is the one consisting of adding a steel end-plate to each of the ends of the second-hand column elements and consequently to provide bond between the plates by means of steel bolts. In the Figure 9.25, a simple schematic representation of this connection can be seen, to make help the reader visualizing the concept.

Second-hand (top) column

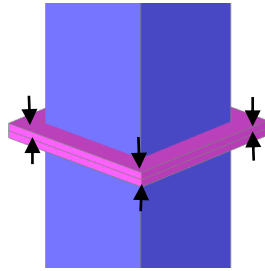

Second-hand (bottom) column

Figure 9.25 – Definition of the connected elements

The actions to be transmitted through the connection are:

- Normal compressive force;
- Shear force;
- Bending moment (as from the modelling of these elements, only the moment acting in the direction of the spanning of the beams is considered).

So, a full continuity of actions should be ensured through the connection.

The chosen location for the joint to be studied is identified as K-3 on the plan of the building, and is located on the column of the 9th floor. The compressive normal force acting in the upper floor column is relatively low, and its eventual interaction with a consistent bending moment may cause tension in some parts of the connection, for this reason, it has been chosen (and it is generally advised) to locate the joint in a position where the bending moment is minimal (which is at a height 1,7m from the floor of the last storey) in order to avoid tension in the plate/bolts and therefore arising of additional failure modes.

9.4.2.2. Elements involved

As before, it is now necessary to address the involved elements more in detail. The splice connection is assumed to be performed between two column elements with identical cross-sectional properties. Therefore, the involved elements are:

- Second-hand 9th floor external top column element;
- Second-hand 9th floor external bottom column element.

The most relevant data about the cross-sections and about the materials of the column will be now presented (more detailed data can be found in the Appendix).

9.4.2.2.1. Column elements (top and bottom)

The column on which the splice connection is planned to be designed, is the external column of the building, so is not the same one which was involved in the column-beams node previously studied (which addressed the internal column). This time it has a smaller cross-section, as it can be seen in the Figure 9.26.

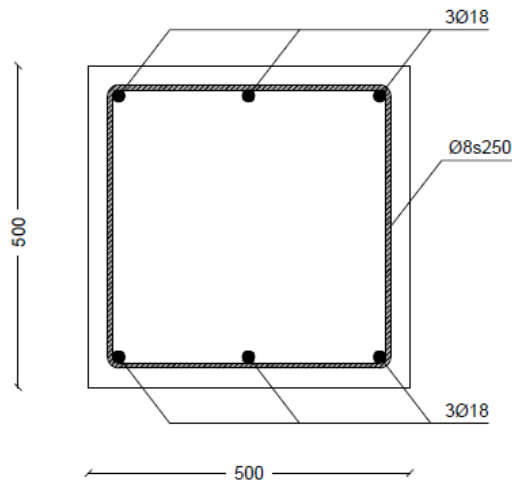

Figure 9.26 – End cross-section of the columns

Once again, since this element is second-hand, its EID should be defined before using it in a new structure. This is showed in Table 9.32.

General/source	Material	Type	Section	Dimensions
“Smartly invented”	C30/37 B 500B	Cast in-situ in first use	Square	500x500mm

Reinforcement (at the studied end)	End-section details	Damages	Load	Modification	Properties
Upper: 3Ø18 Lower: 3Ø18 Transversal: Ø8s250	d=453mm c=30mm	None	N.A.	Sawing + drilling	N.A.

Table 9.32 – EID of the column

The section was invented taking into account its approximate resistance capacity and by respecting all the requirements for the reinforcement and its positioning inside the section (minimum concrete cover, minimum bar dimension and minimum and maximum reinforcement area were checked). The detailed calculations can be found in the Appendix 2.

9.4.2.3. Internal actions at the connection position

The extreme ULS internal forces and moments in the column at the splice location, calculated with SCIA Engineer, are now addressed, therefore the actions at the joint position are summarized in the Table 9.33.

$N_{Ed,max}$ (kN)	$N_{Ed,min}$ (kN)	V_{Ed} (kN)	M_{Ed} (kNm)
100	62	26	4,5

Table 9.33 – Actions at the end of the column

The value of the minimal compression force $N_{Ed,min}$ is also accounted for in this case to check whether there might be any tensile forces in some parts of the joint. The above values will be used to perform the checks of the connection.

By accounting to the fact that the two column elements (top and bottom) have the same properties, it has been decided to perform the checks only on the bottom column element connection since the top one will be connected exactly symmetrically.

9.4.2.4. Conceptual scheme of the adopted connection

As mentioned in the previous paragraph, it was chosen to address only the bottom part of the joint, since the fact that the top one is connected in exactly the same way with the same characteristics and the same acting forces.

The information about the general procedure for performing this joint has already been given in the theoretical part of this thesis, dedicated to the conceptual proposals of joints for second-hand elements, therefore it will not be repeated for this joint in particular.

The final connection looks as in the Figure 9.27 (not to scale, only meant for method presentation purposes).

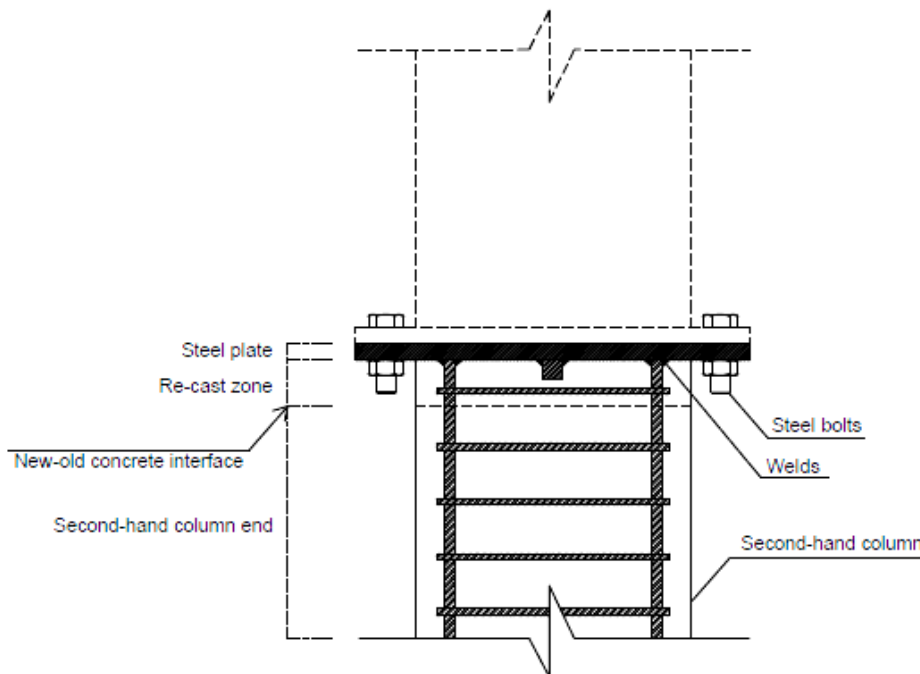

Figure 9.27 – Scheme of the connection

As it can be seen in the picture above, as for the previous connections, four “zones” of the joint are explicitly highlighted, namely the second-hand column end, the re-cast zone, the new-old concrete interface and the steel plate. This is done because the further verifications will be addressed to these areas. The second-hand column end cross-section has been already introduced in the section dedicated to the involved elements, the re cast zone looks exactly the same, while in the Figure 9.28 the detailed drawing of the used steel plate with a thickness of 20mm is presented.

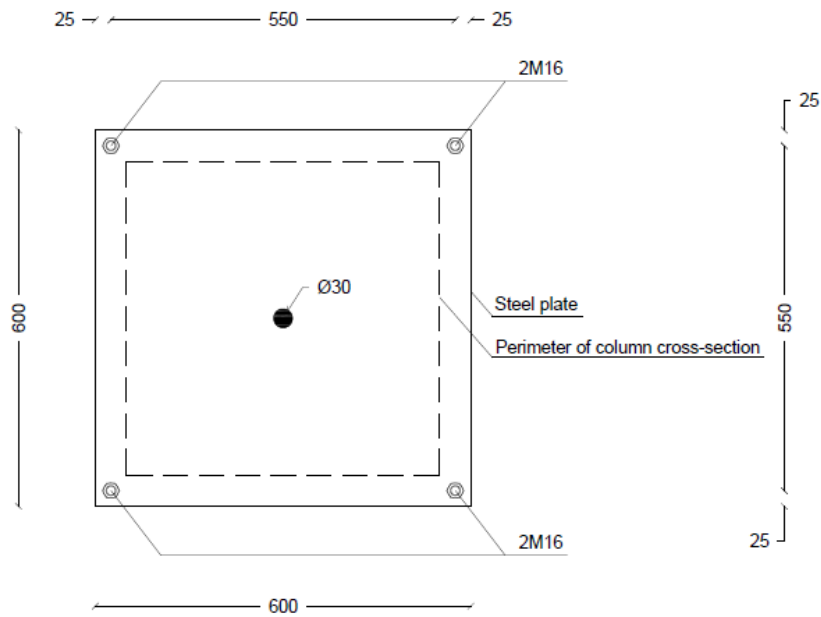

Figure 9.28 – End-plate dimensions

The materials that are used for the entire connection and their specifications are briefly summarized in the Table 9.34.

Component	Amount	Specifications
Plate	2	S355, 600x600x20mm
Bolts with nuts	4	M16, 8.8
Welding steel	-	S355
Transversal reinforcement	2	$\phi 8$, B500B
Concrete	-	C50/60, low shrinkage

Table 9.34 – Materials needed for the connection

9.4.2.5. Verifications of the connection

The verifications to be performed regard the reinforced concrete, the welds between the reinforcement and the steel plate, the steel plate itself and the bolts. The following verifications will address only the connection zone, since it has been assumed that the second-hand column elements involved in the connection itself are capable of bearing the required loads and has successfully passed all the checks in the span and at the connection on the other end. As already mentioned in the dedicated section for the previous connection, only the most relevant values and results will be shown, while the integral calculation procedure can be found in the Appendix 2.

9.4.2.5.1. Bending-compression interaction verification of the column end

The first check which is hereby presented, regards the verification of the bending acting together with compression in the 'last' second-hand column cross-section. The verification is performed only at the column end, because:

- The second-hand column element itself has a lower grade concrete than the concrete used for re-casting the part between the second-hand element and the steel plate;
- The cross-section of the column element is the same as the re-cast part;
- The same reinforcement is present in the re-cast part.

For the above mentioned reasons the column end is the critical location for this verification. The acting normal force have been already presented at 9.3.2.3, while the acting moment should be increased by considering the fact that compression force is acting with an eccentricity, as it can be seen from the Table 9.35.

Parameter	Symbol	Value	Units
Eccentricity	e_0	20	mm
Total acting moment	$M_{Ed,tot}$	6,51	kNm

Table 9.35 – Total acting moment calculation

In the section 9.3.1.7.1, the six situations to be studying for building the resistance domain have been already addressed. In this case we have the situation showed in Graph 9.3.

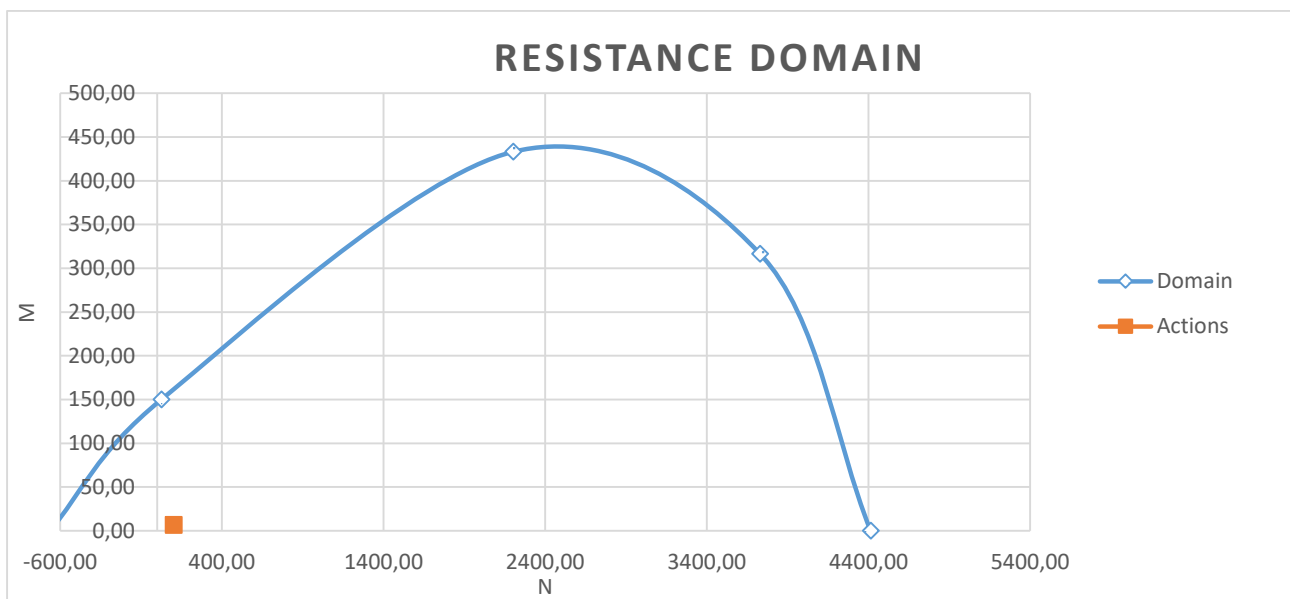

Graph 9.3 – Actions and the resistance domain

As it can be seen, the actions are located inside the domain, the verification is therefore fulfilled.

9.4.2.5.2. Shear verification at the column end

For the same reasons mentioned for the previous verification, the column end is the critical location also for this check as well. The check is performed in compliance with the section 6.2.3 of the Eurocode 2. The main values and the results are summarized in the Table 9.36.

Parameter	Symbol	Value	Units
Slope of the shear reinforcement	α	90	°
Slope of the concrete struts	θ	25	°
Shear strength of the shear reinforcement	$V_{Rd,s}$	137,51	kN
Maximum shear strength	$V_{Rd,max}$	824,52	kN
Acting shear at the beam end	V_{Ed}	25,86	kN
Unity check	U.C.	0,19	-

Table 9.36 – Intermediate values and outcome of the verification

The verification is therefore fulfilled.

9.4.2.5.3. Shear verification at the interface between concrete cast at different times

The shear verification at the interface between concrete cast at different times is performed in compliance with the section 6.2.5 of the EN 1992.1.1. The interface cross-section is the one highlighted in the Figure 9.29.

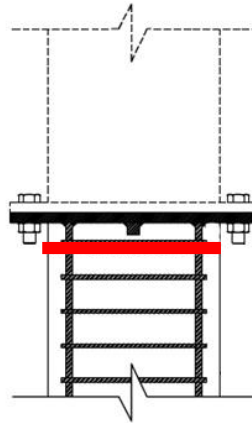

Figure 9.29 – Addressed cross-section

The main values and the results are summarized in the Table 9.37:

Parameter	Symbol	Value	Units
Slope of the anchorage	α	90	°
Assumed surface type	-	Rough	-
Roughness factor	c	0,4	-
Roughness factor	μ	0,7	-
Strength reduction factor	ν	0,53	
Design shear strength at the interface	v_{Rdi}	2,57	MPa
Acting shear strength at the interface	v_{Edi}	0,10	MPa
Unity check	U.C.	0,04	-

Table 9.37 – Intermediate values and outcome of the verification

The verification is widely fulfilled.

9.4.2.5.4. Verification of the welds reinforcement bars - plate

Also the welds should be verified in this connection. This will be done according to section 4.5.3 of the EN 1993.1.8 In this case we will have all the six reinforcement bars of the cross-section of the column welded to the plate. Since no parts of the cross-section are subjected to tension, the only action on the welded bars will be the shear (which is considered to be equally divided between the welds). The main values and the results are summarized in the Table 9.38.

Parameter	Symbol	Value	Units
Correlation factor	β_w	0,9	-
Weld throat	a	7	mm
Ultimate strength of the weld material	f_u	490	MPa
Shear force acting on each reinforcement bar	$V_{Ed,\phi}$	4,31	kN
Tangential stress in the weld	$\tau_{//}$	21,78	MPa

Unity check	U.C.	0,09	-
--------------------	-------------	-------------	----------

Table 9.38 – Intermediate values and outcome of the verification

The verification is widely fulfilled.

9.4.2.5.5. Bearing resistance of the plate

Since there is shear force acting on the bolts, the plate should be also checked to be capable of withstanding it. The check is performed according to tab. 3.4 of the EN 1993.1.8. The acting shear force on the connection is considered to be taken equally by each of the 4 bolts. The main values and the results are summarized in the Table 9.39.

Parameter	Symbol	Value	Units
Edge distance 1	e_1	25	mm
Edge distance 2	e_2	25	mm
Spacing 1	p_1	550	mm
Spacing 2	p_2	550	mm
Parameter α_d	α_d	0,52	
Parameter α_b	α_b	0,52	
Parameter k_1	k_1	2,5	
Ultimate strength of the plate	f_u	490	MPa
Bearing resistance of the plate	$F_{b,Rd}$	142,92	kN
Shear force acting on each bolt	$F_{v,Ed}$	6,47	kN
Unity check	U.C.	0,05	-

Table 9.39 – Intermediate values and outcome of the verification

The verification is widely fulfilled.

9.4.3. Second-hand column to foundation block

9.4.3.1. Introduction to the connection

The last connection to be addressed is the foot connection between the column base and the foundation block. The method of connection which was chosen to be applied here is the one consisting of braking the concrete cover around the existing longitudinal reinforcement and by adding externally of its perimeter the connection bars and then to re-cast the concrete cover (which will be wider at this point due to the fact that it should protect also the connection bars). This connection was introduced in 8.2.3.4. In the Figure 9.30, a conceptual representation of the connection, meant for better conceptual visualization, can be seen.

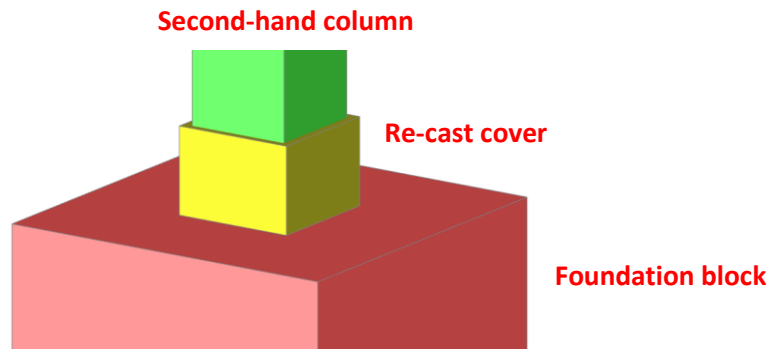

Figure 9.30 – Definition of the connected elements

The actions to be transmitted through the connection are once again:

- Normal compressive force;
- Shear force;
- Bending moment (with the same consideration that only the action in the direction of the spanning of beams is considered).

The chosen location for the joint to be studied is already partly defined by its name, however, the column which will be addressed during the verification phase is the one located at the position C-2 on the building plan. It was chosen to address this element because it is one of the foot nodes where the highest compressive force acts.

9.4.3.2. Elements involved

The involved elements in this connection are:

- Second-hand internal ground floor column element;
- Foundation block.

The ground floor internal column is exactly the same 600x600mm column which was already defined during the presentation of the second-hand beams to second-hand columns connection, and therefore there is no need to introduce further data about it. While, to what concerns the foundation block to which the column has to be connected, this is considered to be newly cast, and it is not subject of this thesis.

9.4.3.3. Internal actions in the member

The extreme internal forces and moments at ULS at the foot of the column calculated with SCIA Engineer are now addressed, therefore the actions at the joint position are summarized in the Table 9.40.

$N_{Ed,max}$ (kN)	$N_{Ed,min}$ (kN)	V_{Ed} (kN)	M_{Ed} (kNm)
5066	2517	1,45	5

Table 9.40 – Actions at the end of the column

These actions will be used to perform all the necessary connection checks.

Once again, as it has been done for the previous connections, it should be kept in mind that during the verification of the cross-section to the interaction bending-compression, the eccentricity of the compression force should be accounted for.

9.4.3.4. Conceptual scheme of the adopted connection

All the information about the general procedure for performing this joint has already been given in the theoretical part of this thesis, dedicated to the conceptual proposals of joints for second-hand elements, therefore it will not be repeated for this joint in particular.

The final connection looks as in Figure 9.31 (not to scale, only meant for method presentation purposes).

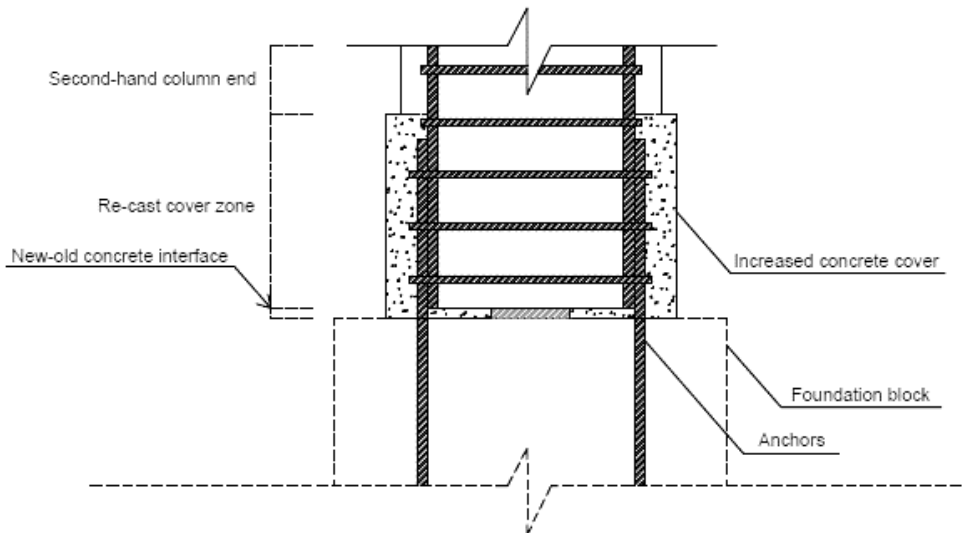

Figure 9.31 – Scheme of the connection

As it can be seen in the picture above, as for the previous connections, three “zones” of the joint are explicitly highlighted, namely the second-hand column end, the re-cast cover zone and the new-old concrete interface. This is done because the further verifications will be addressed to these areas.

The second-hand column end cross-section has been already introduced in the section dedicated to the involved elements, while in Figure 9.32 the detailed cross-section in the re-cast cover zone is presented.

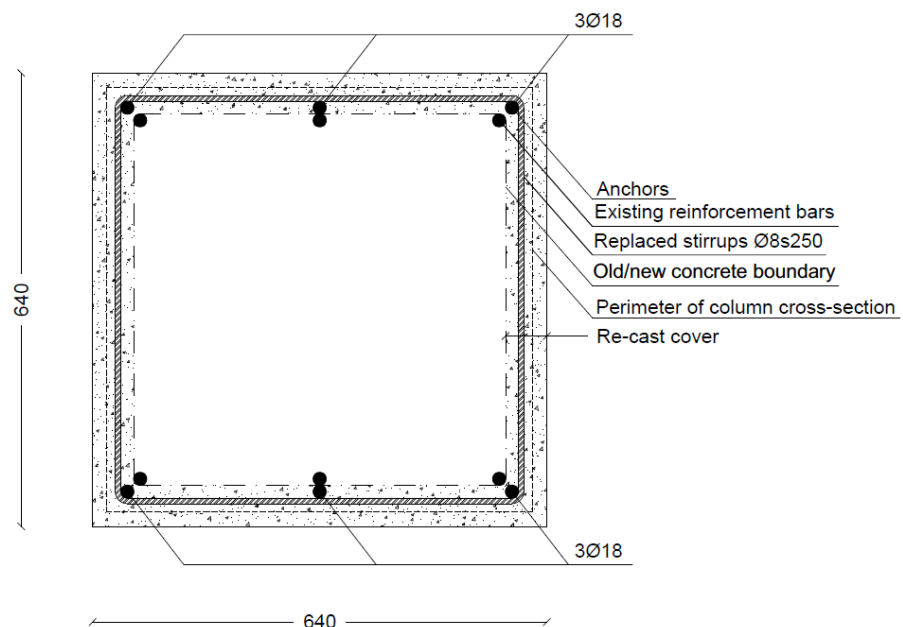

Figure 9.32 – Cross-sectional view in the re-cast cover zone

Another aspects requires attention: an adequate shim plate should be used in order to guarantee a good and balanced levelling and concreting under the column. However, the dimensioning and verifications of the shim plate is omitted in this case study because the latter is meant only to state the feasibility of the proposed design (and only an assumed thickness of around 20mm is recommended to be used).

The materials required for the entire connection and their basic specifications are briefly summarized in the Table 9.41.

Component	Amount	Specifications
Anchors	3+3	φ18, B500B
Transversal reinforcement	2	φ8, B500B
Steel shim plate	1	S355, 20mm
Concrete	-	C50/60, low shrinkage

Table 9.41 – Materials needed for the connection

9.4.3.5. Verifications, anchorage and lap length of the connection

The required checks to assess the joint will be now addressed. The following verifications will address only the connection zone, since it has been assumed that the second-hand column element involved in the connection itself is capable of bearing the required loads and has successfully passed all the checks in the span and at the connection on the other end. Once again, only the most relevant values and results will be shown, while the integral calculation procedure can be found in the Appendix 3.

9.4.3.5.1. Bending-compression interaction verification of the end cross-section

The first check which is hereby presented, regards the verification of the bending acting together with compression. There is no need to study the interface zone for the interaction of bending with compression, because:

- The “new” concrete in the interface zone is of a higher grade;
- The cross-section in the interface zone is larger due to the increased concrete cover;
- There is the same amount of reinforcement is in the interface zone;

Therefore the column end section is the critical one to what concerns the bending-compression interaction.

The acting normal force have been already presented at 9.3.3.3, while the acting moment should be increased by considering the fact that compression force is acting with an eccentricity, as shown in Table 9.42.

Parameter	Symbol	Value	Units
Eccentricity	e_0	20	mm
Total acting moment at the column end	$M_{Ed,tot}$	105,98	kNm

Table 9.42 – Total acting moment calculation

In the section 9.3.1.7.1, the five situations to be studying for building the resistance domain have been already addressed. In this case the situation looks as showed in Graph 9.4.

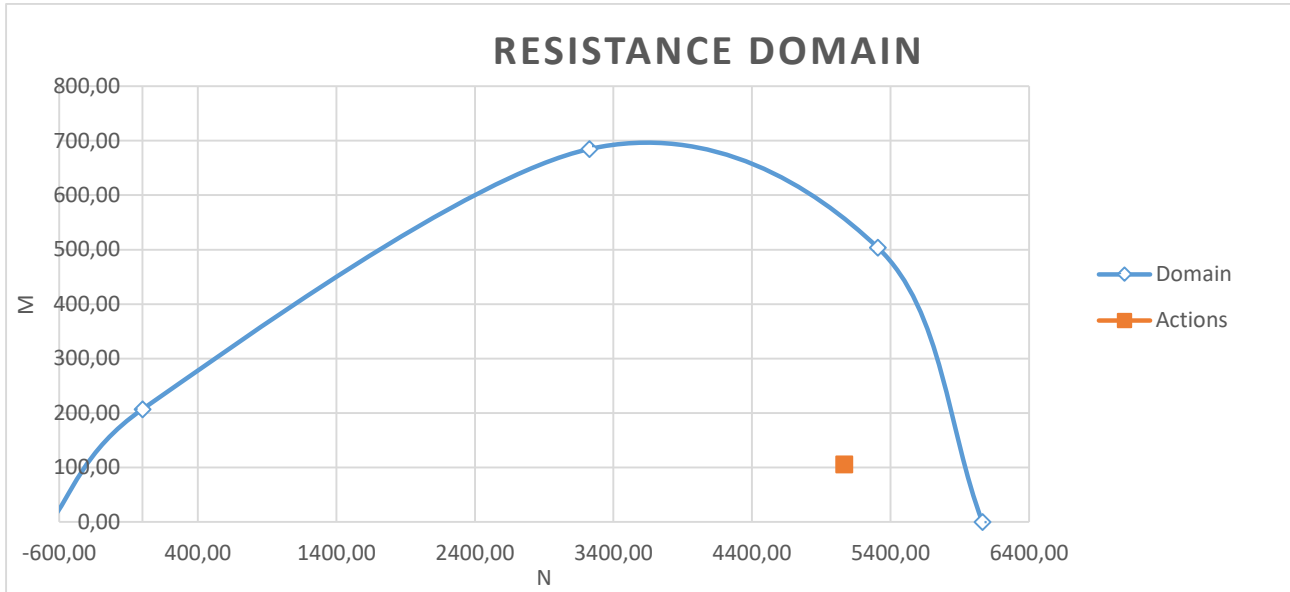

Graph 9.4 – Actions and the resistance domain

As it can be seen, the actions are located inside the domain, the verification is therefore fulfilled.

9.4.3.5.2. Shear verification at the column end

The shear verification is performed only at the column end, for the same three reasons mentioned in the previous verification. The check is performed in compliance with the section 6.2.3 of the Eurocode 2. The main values and the results are summarized in the Table 9.43.

Parameter	Symbol	Value	Units
Slope of the shear reinforcement	α	90	°
Slope of the concrete struts	θ	25	°
Shear strength of the shear reinforcement	$V_{Rd,s}$	179,40	kN
Maximum shear strength	$V_{Rd,max}$	1376,89	kN
Acting shear at the beam end	V_{Ed}	1,45	kN
Unity check	U.C.	0,01	-

Table 9.43 – Intermediate values and outcome of the verification

The verification is widely fulfilled.

9.4.3.5.3. Shear verification at the interface between concrete cast at different times

The shear verification at the interface between concrete cast at different times is performed in compliance with the section 6.2.5 of the EN 1992.1.1. The interface cross-section is the one highlighted in the Figure 9.33.

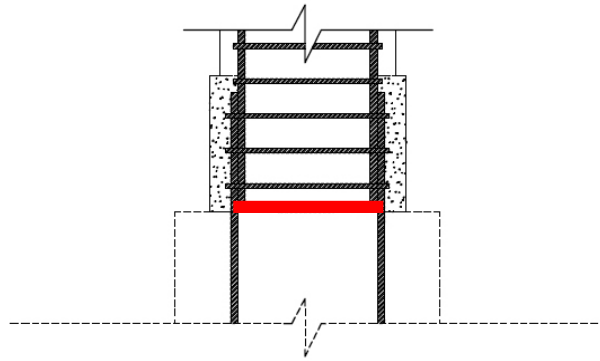

Figure 9.33 – Addressed cross-section

The main values and the results are summarized in the Table 9.44.

Parameter	Symbol	Value	Units
Slope of the anchorage	α	90	°
Assumed surface type	-	Rough	-
Roughness factor	c	0,4	-
Roughness factor	μ	0,7	-
Strength reduction factor	ν	0,53	
Design shear strength at the interface	v_{Rdi}	5,28	MPa
Acting shear strength at the interface	v_{Edi}	0,01	MPa
Unity check	U.C.	0,00	-

Table 9.44 – Intermediate values and outcome of the verification

The verification is widely fulfilled.

9.4.3.5.4. Design anchorage length of the anchors/connections bars

The anchorage length of the connection bars which will be running externally to the existing longitudinal reinforcement of the column is calculated according to section 8.4.4 of the EN 1992.1.1. The bars are all in compression. As from the previous representation, the bars are straight. Numerically, we have the values and the results shown in Table 9.45.

Parameter	Symbol	Value	Units
Bond conditions	-	Good	-
Bond condition coefficient	η_2	1,00	-
Bar diameter coefficient	η_2	1,00	-
Design stress in the reinforcement bar	σ_{sd}	434,78	MPa
Coefficient K	K	0,1	-
Bars in tension/compression	-	Compression	-
Anchorage type	-	Straight	-
Shape of bars coefficient	α_1	1,00	-
Concrete cover coefficient	α_2	1,00	-
Confinement by not welded reinforcement coefficient	α_3	1,00	-
Confinement by welded reinforcement coefficient	α_4	1,00	-
Confinement by transverse pressure coefficient	α_5	1,00	-
Minimum anchorage length	$l_{b,min}$	275	mm

Anchorage length	l_{bd}	458	mm
-------------------------	----------	------------	-----------

Table 9.45 – Intermediate values and outcome of the calculation

Therefore, the above anchorage length has to be applied in the design.

9.4.3.5.5. Overlapping length and lap distance of the bars

The overlapping length has now to be calculated. This will be done according to the procedure of the section 8.7.3 of the EN 1992.1.1. Numerically, we have the values and the results shown in Table 9.46.

Parameter	Symbol	Value	Units
Percentage of reinforcement lapped with $0,65l_0$	ρ_1	100	%
Bars lap coefficient	α_6	1,5	-
Minimum lap length	$l_{0,min}$	270	mm
Design lap length	l_0	686	mm
Maximum distance between two bars	$min(5\phi, 50mm)$	50	mm

Table 9.46 – Intermediate values and outcome of the calculation

9.4.3.5.6. Transverse reinforcement in the lap zone

As already seen for the splice connection, since the bars in the cross section have all a diameter which is lower than 20mm, no considerations should be done about the concentration of transversal reinforcement in the lap zone (according to section 8.7.4 of the EN 1992.1.1).

9.5. Conclusions and remarks about the case-study

At this point, after having analysed all the three connections, some conclusions can be drawn. The overall look at the verification results can indicate us what to improve, what instead can be considered to be over-dimensioned and which general remarks can be made. The three connections will be analysed one by one in this section.

9.5.1. Second-hand shallow beams and second-hand columns node

To what concerns the connection of the second-hand beam to the node, the following conclusions can be made:

- The shear verification at the beam end is the governing check, and it has a 94% utilisation ratio. If we had a different native configuration of shear reinforcement in the second-hand beam, the check could not be fulfilled, and in that case the beam could undergo some quite laborious procedure of increasing the shear resistance (e.g. adding external steel provisions or carbon fibre reinforcement).
- Also the bending moment check at the beam end gives quite high results: 90%.

To what concerns the connection of the second-hand column to the node, the following conclusions can be made:

- The load-bearing element in between the bottom and top column parts is the cast in-situ reinforced core. This core has a smaller area than the columns itself and for this reason can become a critical part. In our case this is compensated by a higher grade

concrete (C50/60) used for grouting, but if for example the concrete C30/37 had to be used, the compression-bending interaction check would not have been verified anymore on the same cross-section.

- Since the bars in the cross-section have all a diameter which is lower than 20mm, no considerations should be done about the concentration of transversal reinforcement in the lap zone but if according to the relative verification, we needed a transverse reinforcement concentration, this could bring some difficulties, because since the adding of shear reinforcement cannot be done internally of a second-hand element, this would have to be done externally and it would require more design and calculations about it.

9.5.2. Splice connection between two second-hand columns

Now the splice connection is taken into account, for which the following remarks can be made:

- The plate thickness is assumed to be 20mm, but the only check which it was involved in, shown that it is utilised only by 5%, therefore a lower thickness can be used.
- The bolts are assumed to be M16, however the required bolts can have even a smaller diameter, since they are working only in shear, and their utilisation ratio is only 11%.
- In general the column properties are quite generous for such a connection.

9.5.3. Second-hand column to foundation block

At last, the following conclusions can be made for the connection between the second-hand column and the foundation block:

- The governing check here is the compression-bending interaction, from the Graph 9.4 it can be seen that the column is utilised at around 80%.
- The total number of anchors to which the second-hand column foot is connected is 6, but since the section is all in compression, the unity checks performed in the interface zone between the column and the foundation block would give an even lower utilisation ratio than the one seen for the check of the column end. Therefore, this might let the designer think that even 4 bars (one bar per corner of the second-hand column) would be sufficient, but this is not the case, because the minimum total reinforcement area requirement would not be fulfilled (according to section 9.5.2. of EN 1992.1.1).
- The internal shear verification is widely fulfilled in our case since the acting shear force is very low, but if during the embedment of a similar connection into another structure, the need for more shear capacity would arise, we can easily deal with it, by adding more shear reinforcement before re-casting back the concrete cover.

10. Conclusions

It comes now to draw some conclusions about the whole study. These will regard the theoretical part as well as the numerical case-study.

10.1. Excursus over the studied elements

In this section the “output” elements from the four structural systems presented in the Chapter 3 will be once again addressed, reviewing briefly their re-connection features.

10.1.1. Second-hand columns

To what concerns the re-connection of second-hand columns addressed in Chapter 5, the first thing that should be said is that most of their reconnection methods could be based on the ones used for newly made precast elements. The adaptation procedure of the beam may be more or less laborious, relatively costly and time consuming, however the on-site installation procedures are very likely to be quite simple and common. The positive aspect is that the most of the adaptation procedures (usually the key ones) can be done in a factory where there is commonly the availability of suitable environment, tools, machines and qualified personnel.

There might be the necessity to perform splice-joints which are not very common for the case of concrete columns, but the connection approach that can be applied for these might also be “borrowed” from the precast elements practice.

Sometimes very precise drilling or high-pressured water concrete removal might be required and this can bring extra costs. Also the fact that pressurized grout injection system is required to fill the coupling sleeves, may be a potential weak point of the connection approaches which presuppose the connection by means of this method (and also the very liquid and low-shrinkage concrete to be used for grouting these coupling holes have relatively high costs).

10.1.2. Second-hand shallow beams

Two methods have been presented in Chapter 6 to what concerns the reconnection of a second-hand shallow beam to a column. No analogy could be made between these methods and the methods for connecting new precast elements. In both the cases the beam had to withstand an adaptation of different degrees of complexity, in order to obtain a portion of existing longitudinal reinforcement bars to which the connection rods or anchors may be attached.

In theory, if during the disassembling process, the reinforcement of the element to be extracted could be left protruding (even to a relatively limited extent) outside of the ends of the beam, in order for these to be coupled to anchor or connection bars, a lot of time and costs for the removal of concrete from around the bars might be saved. Of course, this would imply more efforts during the disassembling phase, and it is not in general always possible.

Both the proposed methods imply a slight reduction of the cross-section of the column in the zone of the core of the node. The resistance of this zone should be studied separately from the column-end one. As expected, and as it has been highlighted by the results obtained from the case-study, shear may in general represent the critical action for the case of a beam. For the presented connection methods (but also for potential other similar ones formulated on their basis) the shear resistance of the interface between old and new concrete should be carefully addressed.

10.1.3. Second-hand wall elements

The reconnection of second-hand wall elements which was addressed in Chapter 7, should be addressed by considering their horizontal connections (top and bottom), as well as the vertical ones (with other adjacent wall elements).

To what concerns the horizontal connection methods, a similar approach to the one presented for second-hand columns (by means of coupling sleeves) was found out to be suitable. The same remarks valid for the columns are valid also here (laborious element adaptation but relatively easy on-site assembling).

For the vertical connections it should be said that the complexity level depends on the aspect whether a shear-wall behaviour should be reached or not. Ensuring a vertical shear connection is not in general an easy task, once again, because of the lack of protruding reinforcement bars outside of the second-hand element after the disassembling and also because of the missing shear indentation on the sides of the elements. If no vertical shear resistance is required, no particular difficulties should usually arise.

10.1.4. Second-hand hollow core floors

To what concerns the reconnection of second-hand floors presented in Chapter 8, distinction should be made between the reconnection of second-hand hollow core slabs and the plank-floors.

10.1.4.1. Hollow core slabs

As for the case of second-hand wall elements, also the reconnection of hollow core slabs should be addressed by considering the connection of the slab perpendicularly to its spanning direction and longitudinally to the latter.

In general it can be said that the adaptation of a second-hand hollow core slab for a to-wall or to-beam connection is a relatively simple procedure, it does not require complex tools or specialized personnel. The installation techniques are mostly the same as for new elements.

From the structural point of view, it should be said that to what concerns the to-wall or to-beam joints, the connection mechanism can be easily achieved with the same techniques as for the case of new elements (horizontal connection bar inserted in hollow cores).

For the longitudinal joint, the proposed approaches were not very close to the existing techniques, these are quite laborious and have high degrees of complexity.

10.1.4.2. Plank-floors

For the case of the plank-floors, there are, for obvious reasons (since they are half-cast before their "first life"), no precast methods which could serve as a basis for new connection approaches. Only one method of reconnection was presented for this case: the one based on positioning the connection rods into previously prepared U-voids. This method can be considered to come from the hollow core slab connection practice. It cannot be considered as particularly complicated, but is quite unusual for these kind of elements.

10.2. Final remarks

Many connection approaches have been developed and presented in this graduation work, many details and aspects have been addressed, and these were in-fact the actual answer to the central

research question (about founding possible connection methods for each element couplings) mentioned at the beginning of this study, which in this case cannot be answered briefly but it required four chapters of this graduation project. However, even if the basis for a structural feasibility have been defined, every connection approach needs to be assessed with a higher attention before putting it in practice.

To what concerns the first sub-research question about the boundaries of the second-hand elements, these have also been addressed for each element in the respective chapters, but, in general the commonly encountered limitations can be schematized as shown in Figure 10.1.

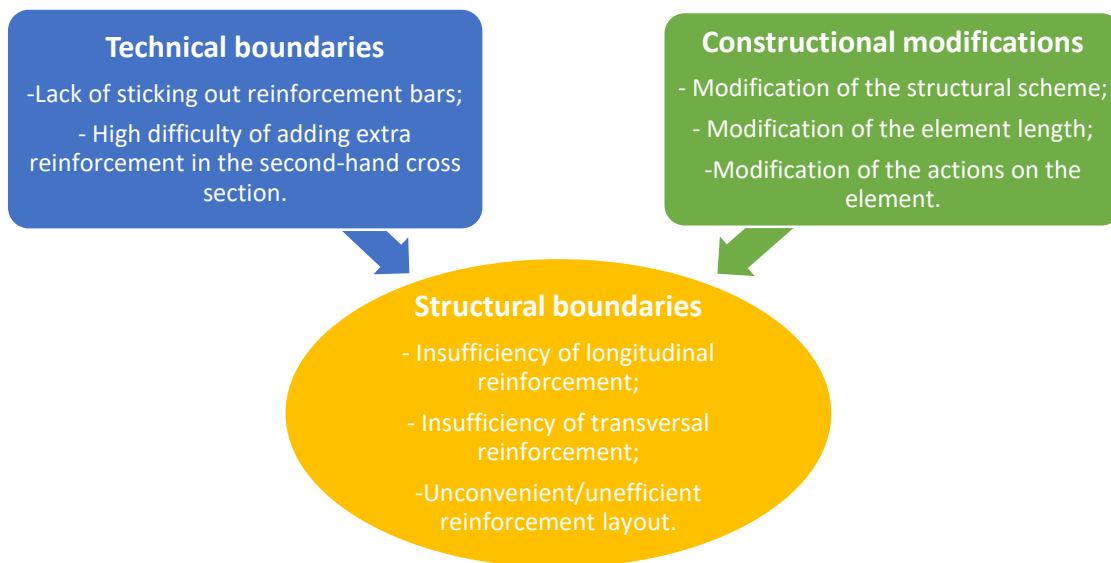

Figure 10.1 – Scheme concerning the boundaries of second-hand elements

Concerning the second sub-research question about the general complexity level of each connection approach, at the end of each design proposal in chapters from 5 to 8, the potential advantages and the drawbacks have been stated, and considering these, three levels of complexity have been assigned (subjectively by the author on the basis of the procedure of connection, used provisions, etc...):

- “Simple”;
- “Medium complexity”;
- “Complex”.

The recommendation of the author, besides of the structural aspects (but still based on the latter) is that cost- and time-effectiveness of connection methods between second-hand elements should be very carefully studied before taking into consideration the use of such elements in general. In fact, as seen from this work the predisposition of reused elements might be quite laborious sometimes and can make the difference between the reasonability and non-reasonability of using second-hand elements.

In any case, this graduation work has been developed in order to become one of the first steps towards the active reuse of concrete elements, and to spread the belief of the author not only in the feasibility of solid connections but also in the possibility to achieve a circular way of building.

11. Bibliography

- (s.d.). Taken from TBS Struture: <https://tubisiderstruture.it/sistema-prem.php>
- (s.d.). Taken from Ruwa: <http://www.ruwa-ag.ch/ebea/produkteuebersicht/ebea-bewa-euro-euro-id/ebea-bewa-bewehrungsanschluss/bewa-typ-a.html>
- Adamas homepage.* (s.d.). Taken from Adamas: <https://www.adamas.pro/en>
- Advantages and disadvantages of flat slabs?* (s.d.). Taken from iamcivilengineer.com: <https://www.iamcivilengineer.com/advantages-and-disadvantages-of-flat/>
- Allen, E., & Iano, J. (2013). *Fundamentals of Building Construction : Materials and Methods.*
- Asam, C. (2006). *IEMB - Endbericht zum Forschungsprojekt.*
- Asam, C. (2006). Reuse possibilities of dismantled building elements.
- Bouwsystemen in de scholenbouw: Moducon-2000. (1999). *Cement.*
- Bruggeling, & Huyghe. (1991).
- Circular economy.* (s.d.). Taken from Wikipedia: https://en.wikipedia.org/wiki/Circular_economy
- Circulariteit. (2018). *Cement.*
- Coenen. (1990).
- Concrete saws.* (s.d.). Taken from Ace Cutting Equipment: <https://acecutting.com/collections/concrete-saws>
- Conforti, Minelli, & Plizzari. (2013). Wide-shallow beams with and without steel fibres: A peculiar behaviour in shear and flexure. *Composites Part B: Engineering.*
- Connections to last.* (s.d.). Taken from Concrete issues: <https://www.concreteissues.com/en/stories/1-18/connections-to-last/>
- CUR-VB. (1985). *Demountable construction in precast concrete.*
- Dilger, W. H. (2000). Flat slab-column connections. University of Calgary, Canada.
- Dolkemade, E. (2018). *Reuse of monolithic concrete floors.*
- Dutch NEN 5950.* (1995).
- FIB. (2008). *Structural connections for precast concrete buildings.*
- Filigree Slabs.* (s.d.). Taken from NordImpianti: <https://www.nordimpianti.com/Concrete-Elements/Filigree-Slabs>
- Flat Slab Diagram.* (s.d.). Taken from www.civilengineer-egy.com
- Floor slab.* (s.d.). Taken from www.vollert.de: <https://www.vollert.de/en/product-areas/solutions-for-precast-concrete-production/precast-concrete-parts-in-construction/beton-halbfertigteile-fuer-gebaeude/floor-slab/>
- Framing Schematics.* (s.d.). Taken from SteelConstruction.info: https://www.steelconstruction.info/Framing_schematics

- Glias, A. (2013). *The "Donor Skelet"*. Delft.
- Glias, A. (2019).
- Guidotti, R., Fernandez Ruiz, M., & Muttoni, A. (2011). Behaviour and design of slab-column joints. Prague.
- Jonkers, H. (2016). Materials and ecological engineering. Delft.
- Kamariya, & Tilva. (2018). Comparative Study of Flat Slab with and Without Punching Shear. *IRJET*.
- Kibert, C., Chini, A., & Languell, J. (2001). Deconstruction as an essential component of sustainable construction.
- Kristinsson, J., Hendriks, C., Kowalczyk, T., & te Dorsthorst, B. (2001). Reuse of secondary elements: utopia or reality., (p. 11). Delft.
- Lagendijk, P. (2018). Details in concrete (part 2). In *Building structures 2 lecture slides*. Delft.
- Lagendijk, P. (2019). Ir.
- Lecture 14.7: Anatomy of Multi-Storey Buildings*. (s.d.). Taken from <http://fgg-web.fgg.uni-lj.si/~pmoze/ESDEP/master/wg14/l0700.htm>
- Luiken, R. (2000). *Demontabel Bouwen en Hergebruik*.
- Naber, N. (2012). *Reuse of hollow core slabs from office buildings to residential buildings*.
- Off-Site And Modular Construction Explained*. (s.d.). Taken from WBDG: <https://www.wbdg.org/resources/site-and-modular-construction-explained>
- Opwarming geïntegreerde liggers*. (s.d.). Taken from Brand informatie systeem: https://www.brandveiligmetstaal.nl/pag/336/6a2_opwarming_ge%C3%AFntegreerde_liggers.html
- Peikko products - overview*. (s.d.). Taken from YouTube: <https://www.youtube.com/watch?v=pG9IS7JylqE&frags=wn>
- Precast element connection on a residential project using Groutec*. (s.d.). Taken from <https://www.youtube.com/watch?v=34YjzeBCFDg>
- Products*. (s.d.). Taken from Mitau Prefab: <https://www.mitauprefab.com/products/>
- Rafa Adventure*. (s.d.). Taken from Rafaproject: <http://www.rafaproiect.ro/news%20service.html>
- Rebar couplers*. (s.d.). Taken from CMT group: <https://www.cmt.co.uk/rebar-couplers>
- Recycling concrete*. (s.d.). Taken from YouTube: <https://www.youtube.com/watch?v=TNNPLQkqipE&t=202s>
- Recycling concrete*. (s.d.). Taken from Recycling concrete (You Tube): <https://www.youtube.com/watch?v=TNNPLQkqipE&t=203s>
- SBI. (1979).
- Schmidt hammer*. (s.d.). Taken from PCTE: <https://www.pcte.com.au/original-schmidt-hammer>
- Schokbeton Saramac - Connections hollow core slabs*. (s.d.). Taken from <http://www.saraschok.com/en/connections-hollow-slabs>
- SCON 12*. (s.d.). Taken from Gappower: <https://www.gappower.com/12-Cut-Off-Saw-Rental-in-Coatesville-PA-Lancaster-PA-and-Chester-County-PA/item/SCON12>

- Shear strength in concrete joints - Eurocode 2.* (s.d.). Taken from Civil Calculation:
https://calculocivil.com/eu/ec2/shear_join/calc?construction_joint
- Slenderness Effects for Concrete Columns in Sway Frame - Moment Magnification Method.* (s.d.). Taken from StructurePoint: <https://structurepoint.org/pdfs/Slender-Concrete-Columns-Sway-Frame-Moment-Magnification-ACI318-14-W.htm>
- Stacey, M. (2011). *Concrete: a studio design guide.*
- Structural Joints in Precast Concrete.* (s.d.). Taken from YouTube:
<https://www.youtube.com/watch?v=uiQzx1YFOBs&t=262s>
- Szondy, D. (2013). *ERO demolition robot concept recycles on the fly.* Taken from New Atlas:
<https://newatlas.com/ero-robot-demolition/28299/>
- Tapered thread rebar coupler.* (s.d.). Taken from Aleono: <https://www.aleono.com/product/standard-taper-threaded-coupler/>
- The CD20 building construction system.* (s.d.). Taken from www.cd20.nl:
<https://www.cd20.nl/en/systems/CD20BuildingSystem.php#.XLjwxjAzbDc>
- Types of Economical Floor Systems for Reinforced Concrete Buildings.* (s.d.). Taken from The Constructor:
<https://theconstructor.org/structural-engg/economical-slab-floor-systems-buildings/19458/>
- Van Dijk, K., Boedianto, P., & Kowalczyk, A. (s.d.). State of the art deconstruction in the Netherlands.
- Van Paassen, A., & Ijsseldijk, G. (s.d.). Bouwen in prefab beton.
- Windsor HP Probe System.* (s.d.). Taken from Humboldt mfg: <https://www.humboldtmfg.com/windsor-hp-probe-system-2.html>