

TACTICS OF THE OTHER EVERYDAY

FROM

URBAN SCENOGRAPHY

TO

A LIBRARY

OF DIGITAL CULTURE

Mengzhe Tang

Public Building, Border Conditions Studio

Tutors: Marc Schoonderbeek, Oscar Rommens, Pierre Jennen, Sang Lee



The Color of Pomegranates

Urban Scenography

research
observation
theory

imagination
mapping
drawing

space
modeling

Library of Digital Culture

architectural
design

Building
Technology

1. Dérive
2. Frames and Associations I:
Analyzing Urban Scenography
3. Frames and Associations II:
Drawing the Fragmented Stories
4. Modeling:
Spatial Translations
5. Site
Site as Narratives
6. Program
Program and Narratives
7. Actualization

Urban Scenography

(De)constructing the (Sur)reality

1. Dérive

In Yerevan

A PHOTOGRAPHIC RESEARCH

Of Urban scenography

DÉRIVE

Everyday



Mundane



Small



Mystic



Surreal



BEYOND A PHOTOGRAPHIC RESEARCH

Places/ Selections

DÉRIVE

Courtyard

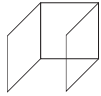

Street

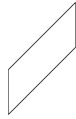

Market

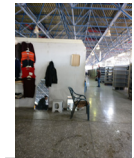
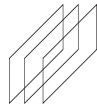

2. Frames and Associations I

Analyzing Urban Scenography

AN INTERDISCIPLINE RESEARCH

Theatre/ Architecture/ Urbanism

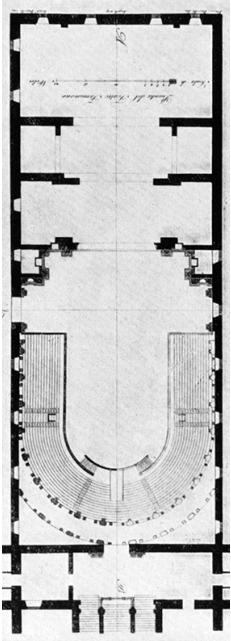

FRAME:

A spatial agency: between the real world (the audience) and the fictitious other world (the stage).

Glass and mirrors: spatial assemblages via reflection and transparency.

FRAMES AND ASSOCIATIONS I

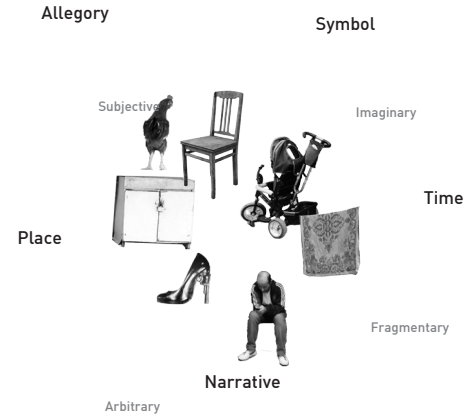

ASSOCIATION:

The power of *imagination*.

Other times, places, narratives, symbols, allegories and etc.



FRAMES

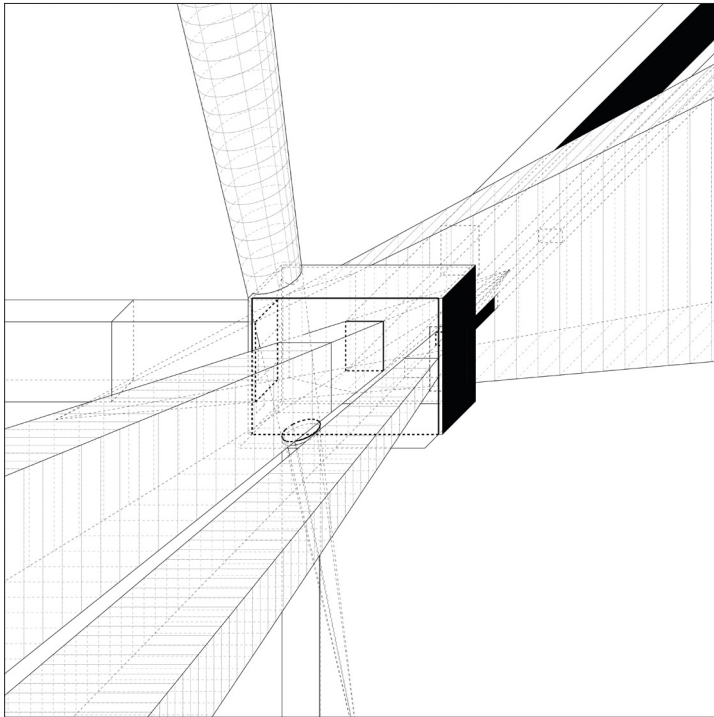

ASSOCIATIONS

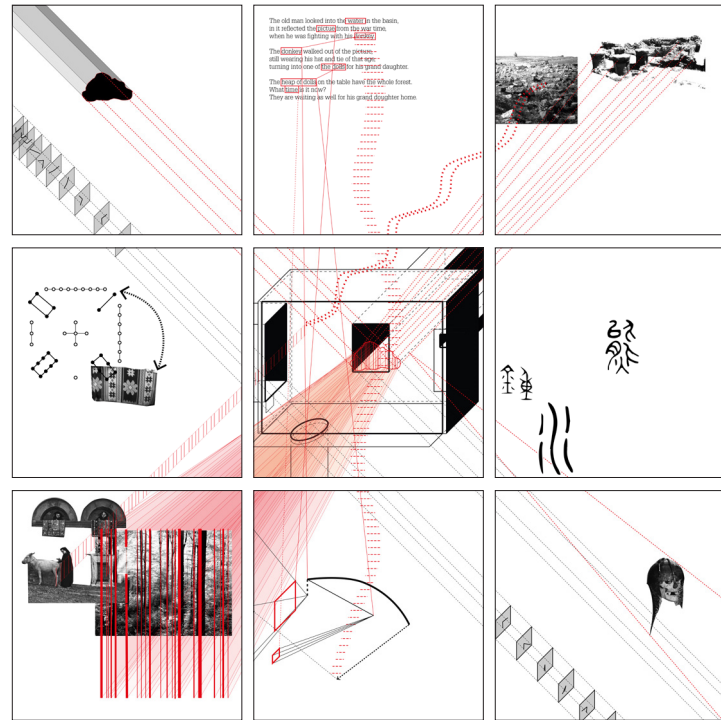



FRAMES

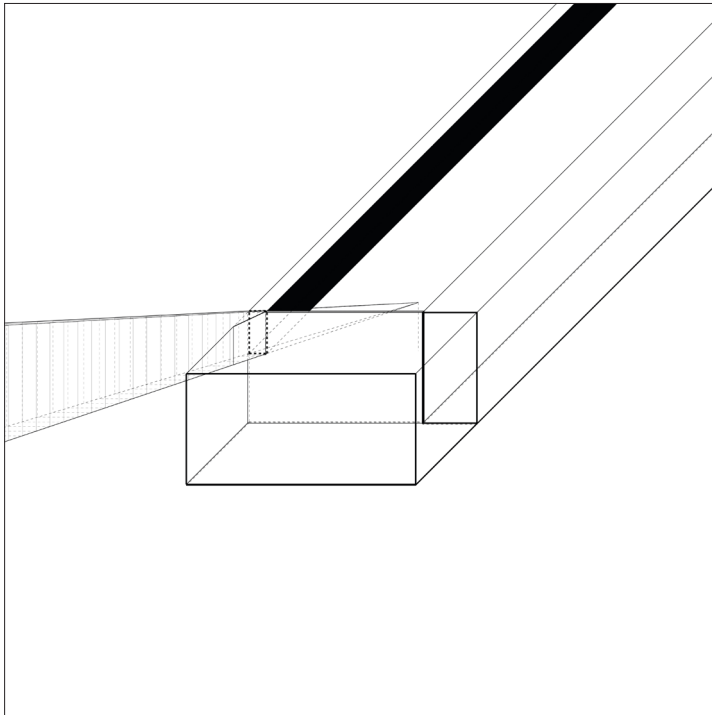

ASSOCIATIONS

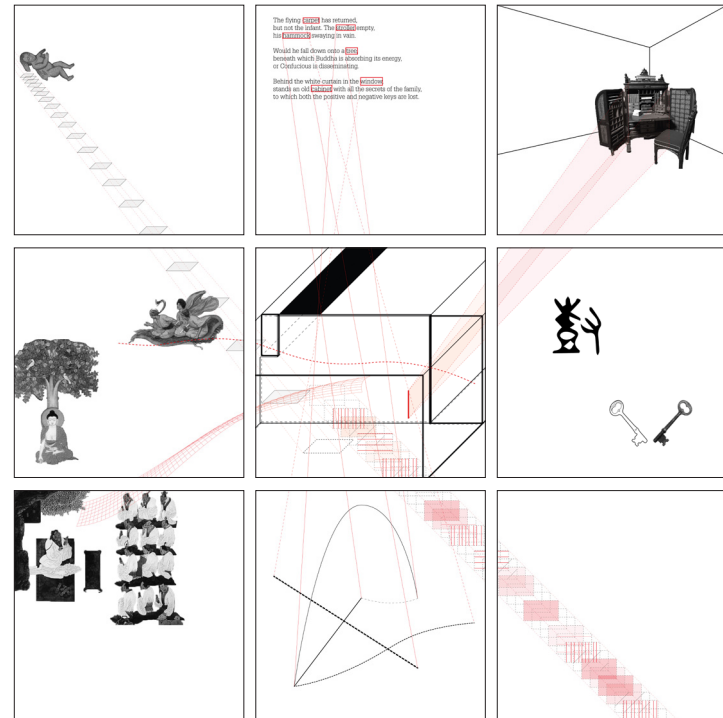



FRAMES

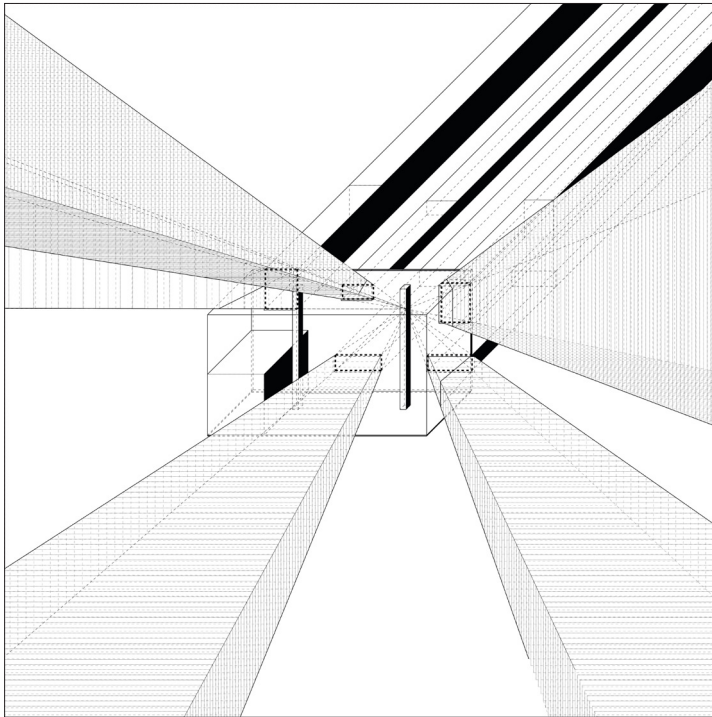

ASSOCIATIONS

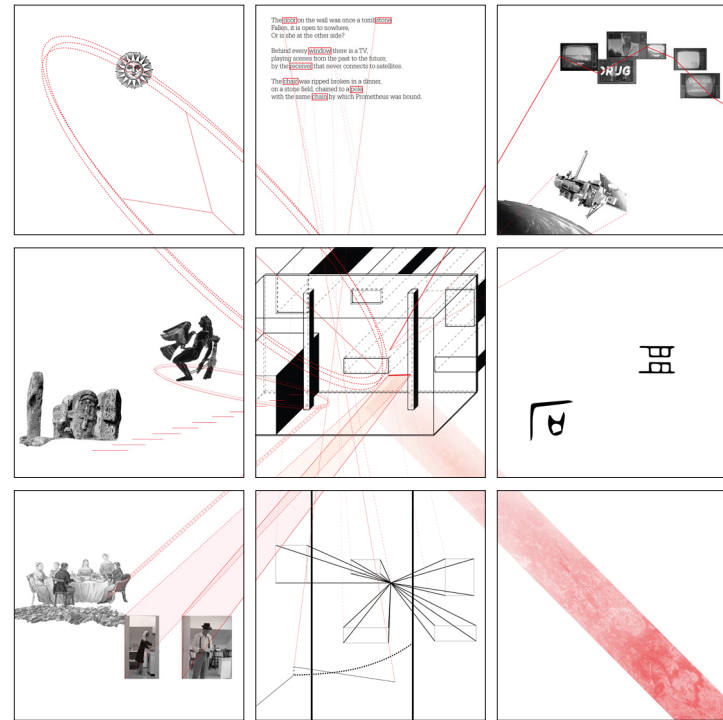



FRAMES

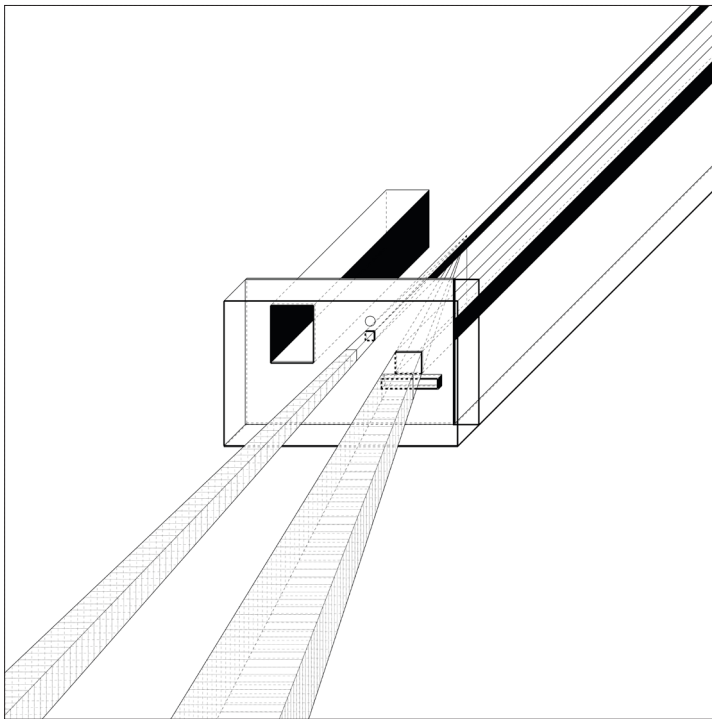

ASSOCIATIONS

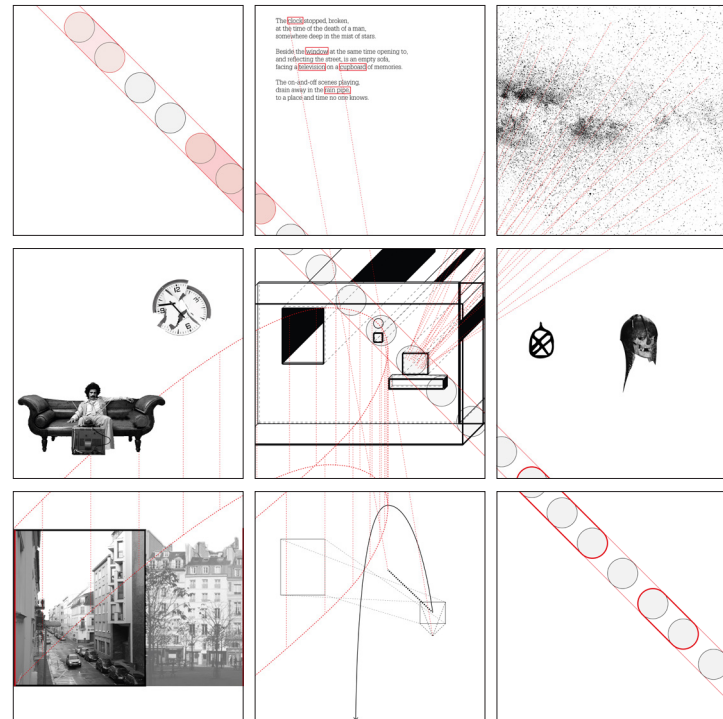



FRAMES

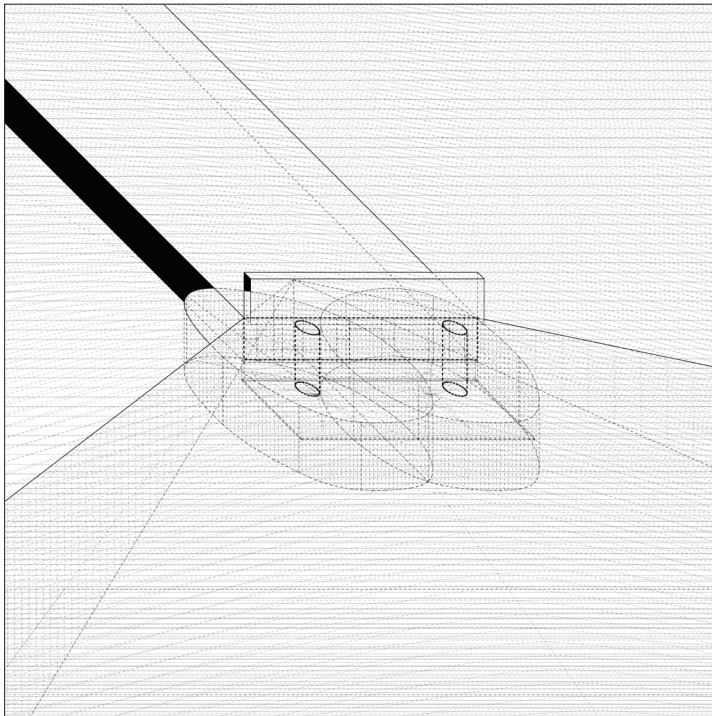

ASSOCIATIONS

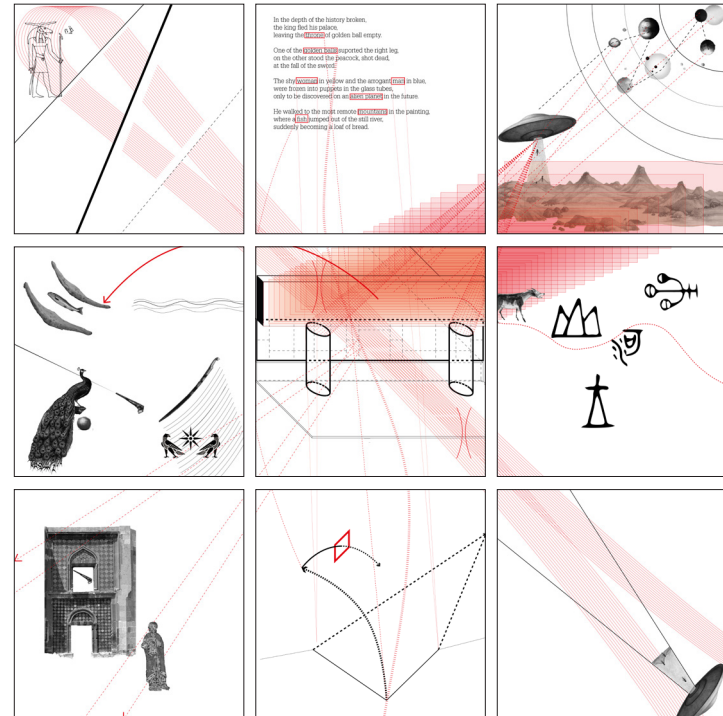

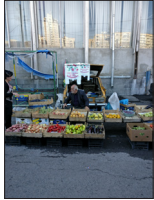

FRAMES

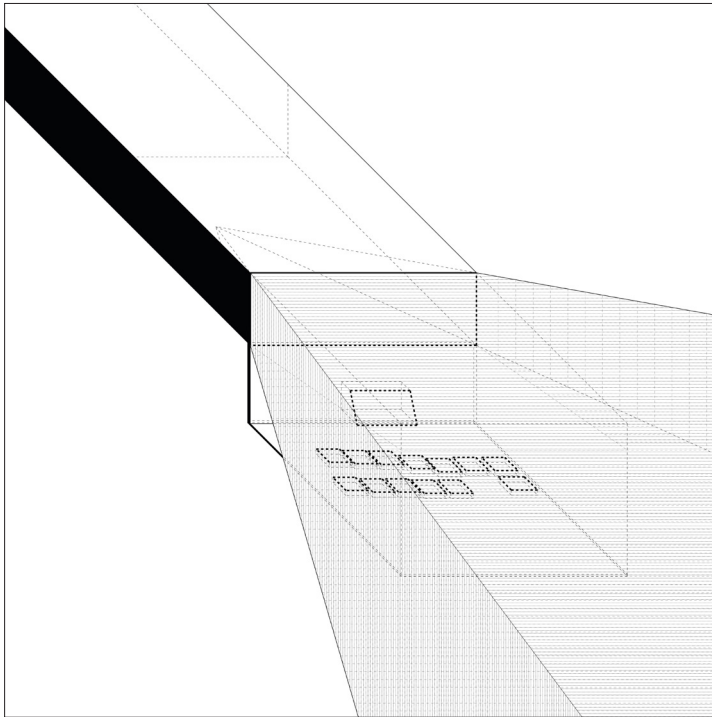

ASSOCIATIONS

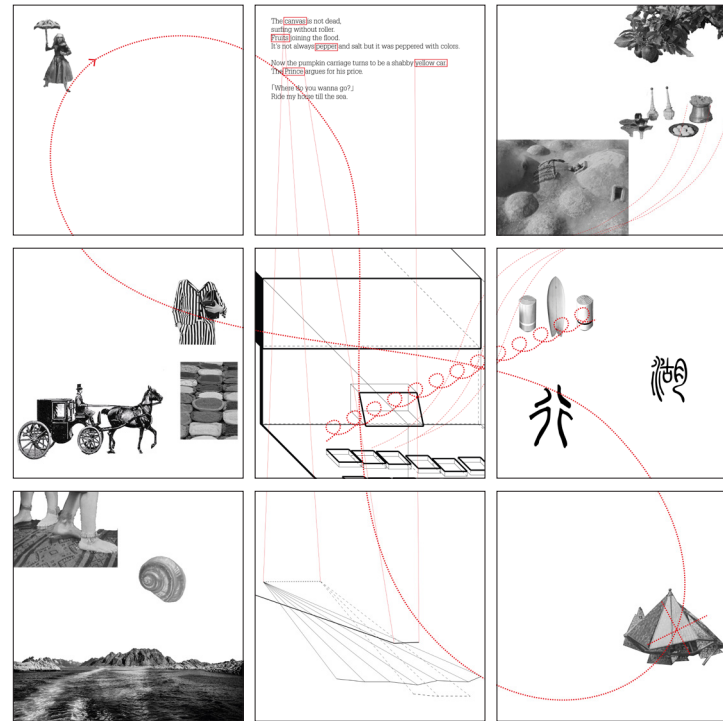



FRAMES

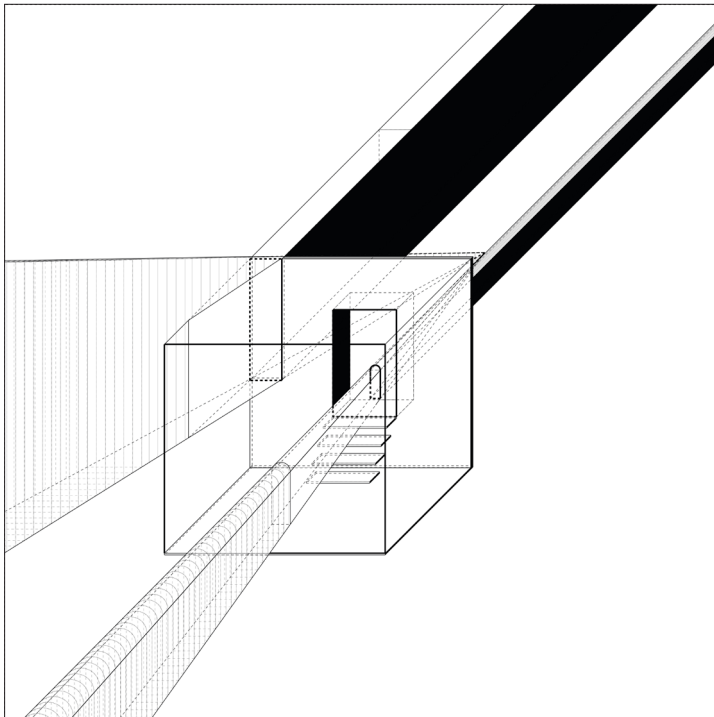

ASSOCIATIONS

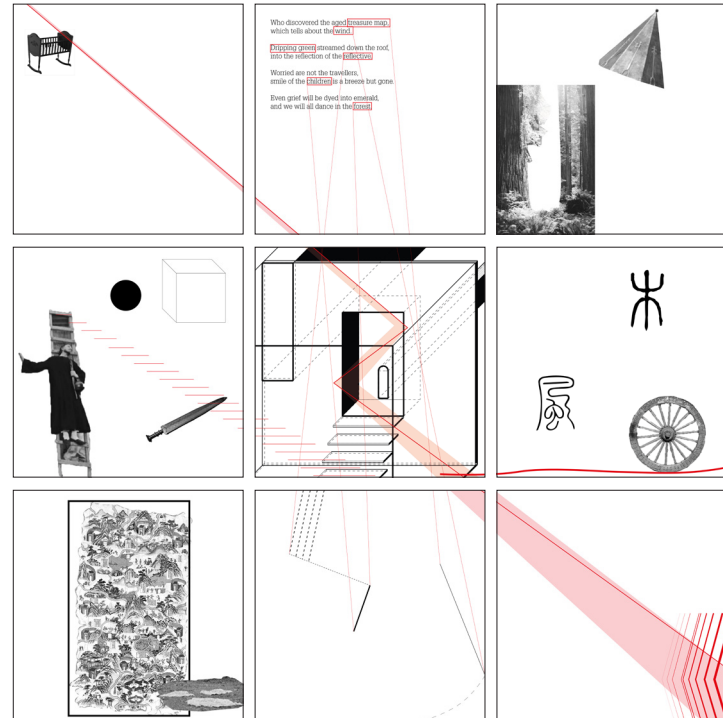



FRAMES

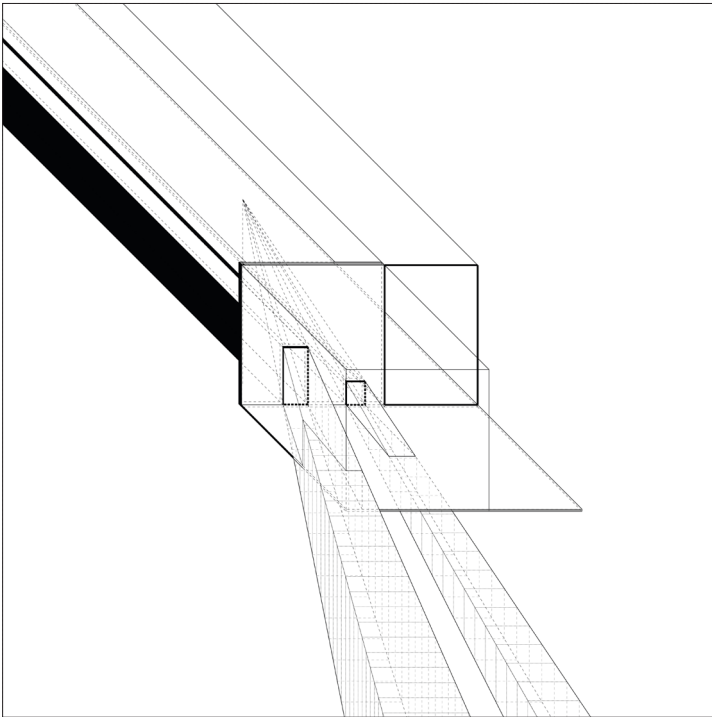

ASSOCIATIONS

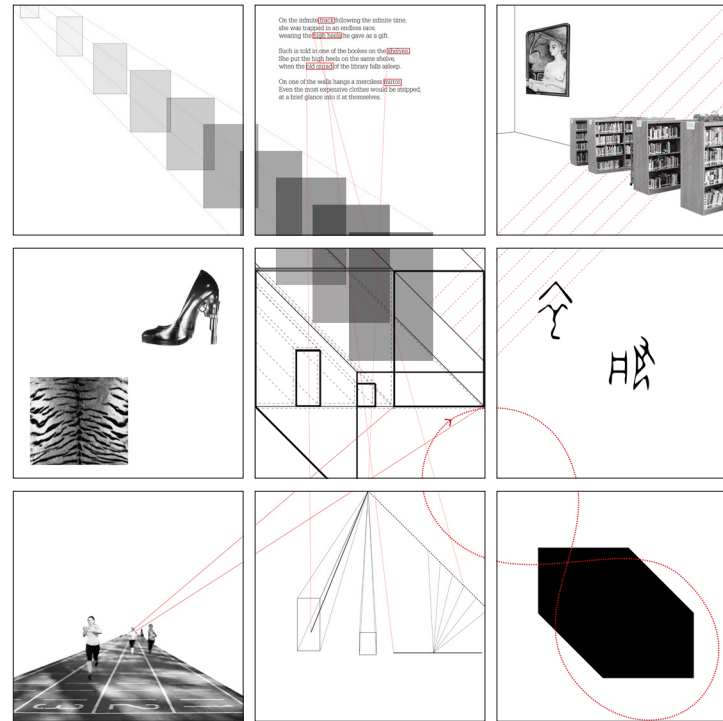



FRAMES

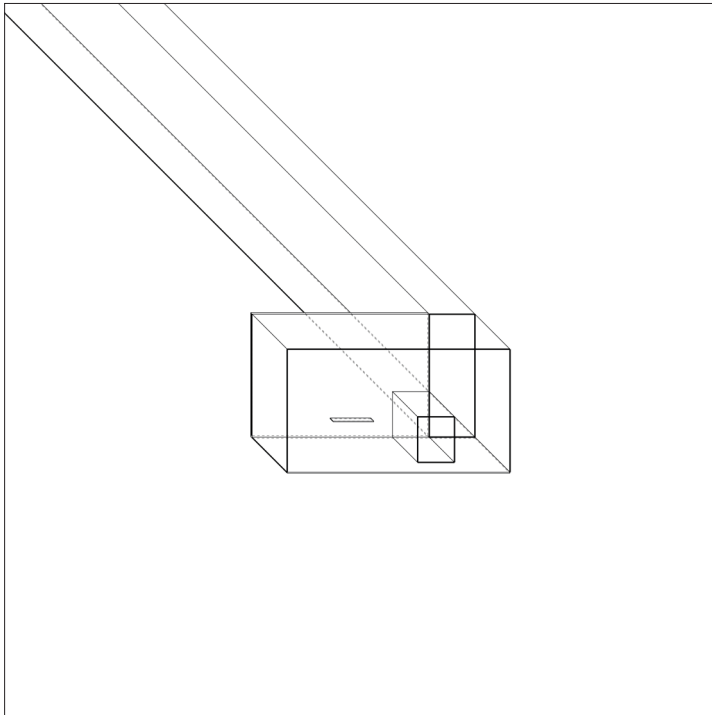

ASSOCIATIONS

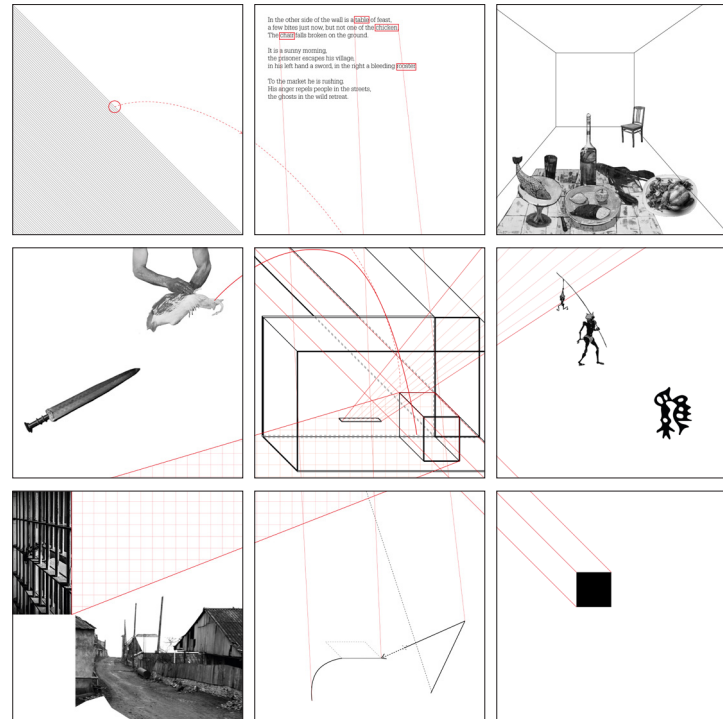

3. Frames and Associations II

Drawing the Fragmented Stories

NARRATIVE ASSOCIATIONS

Pieces of Stories Lost Elsewhere at Another Time

COURTYARD:

The Old Man, His Granddaughter, or the War

The old man looked into the water in the basin,
In it reflected the picture from the imaginary war.
At a time before the clocks,
He remembered to be a soldier on his donkey,
Fighting whoever in the endless rocky fields.

The donkey left the lonely chapel,
Wearing a hat and a tie,
Petrified either before or after death itself.
When numbers turn into patterns.

The heap of bears abandons the whole forest.
What time is it now?
They are waiting as well for his granddaughter home.

She's not Home, a TV room or a Dinner

The door on the wall was once a tombstone.
Fallen, folded, and open to nowhere,
Or is she on the other side?

But behind every window there is a TV,
Connected as every room is,

Playing scenes of from sunrise to sunset.
The receiver never succeeds connecting to satellites.

The chair was ripped broken when she sat in a dinner,
In a stone field of hard stones.
It was chained to a pole that erodes as time does.
But never does the chain, after bounding Prometheus.

The Lost Infant, a Tree or the Secret Family

The flying carpet has returned,
But not the infant. The stroller empty,
His hammock swaying in vain.

Would he fall down onto a tree?
Beneath Buddha is contemplating
Or Confucius is talking,
Of the shrinking history.

Behind the white curtain,
Hides in the corner an old cabinet
With all the secrets of the family,
Accumulated like time,
To which both the positive and negative keys are lost.

STREET:

The Fleeing King, His Ruins, Two Aliens or a Fish

In the depth of the history broken,
The king fled his palace, ruined so soon,
Leaving the throne of golden balls empty.

One of the golden balls supported the right leg,
On the other stood a peacock, shot dead,
At the slow fall of the sword.

The shy woman in yellow and the arrogant man in blue,
Found themselves frozen puppets in two glass tubes,
Only to talk again on two alien planets in two separate
futures.

He walked on to the most remote mountains in the painting,
Where a fish jumped out of the still river,
Suddenly becoming a loaf of bread.

Death of a Man and His Room

The clock stopped, three times,

Shattered at the end of the man's death,
Somewhere deep and dark in the mist of stars.

Beside the window at the same time opening to,
and from the street, is a sofa empty,
facing a television on an open cupboard of memories.

The intermittent scenes he watched,
Are draining away from the rain pipe,
to places and times separated and unknown.

The Treasure Map of Wind and the Forest

Who discovered the aged treasure map,
which tells about the wind.

Dripping green streamed down the roof,
into the reflection of the reflective.

Worried are not the travellers,
smile of the children is a breeze but gone.

Even grief will be dyed into emerald,
and we will all dance in the forest.

MARKET:

Flooded Fruits, a Yellow Car or a Horse

The canvas is not dead,
surfing without roller.
Fruits joining the flood.
It's not always pepper and salt but it was peppered with color.

Now the pumpkin carriage turns to be a shabby yellow car.
The Prince argues for his price.

“Where do you wanna go?”
Ride my horse till the sea.

Her Infinite Race, His Gift, or the Library with a Mirror

On the infinite track following the cyclic time,
She was racing an endless race,
Wearing the high heel that he gave as a gift.

Such is told in one of the books on the shelves.
She put the high heel on the same one,
As the old guard of the library falls asleep,
Into his solid black dream of what's yet to come.

On one of the walls hangs a merciless mirror.

Even as strong as a piece of tiger skin would melt away,
At a brief glance into it at themselves.

A Feast, an Escaping Prisoner, or His Revenge

On the other side of the wall is a table of feast,
Aroma filling up the empty room.
A few bites just now, yet where's the chicken?
A chair falls broken on the ground.

It is a sunny morning,
When the prisoner escapes his village.
In his left hand a sword, in the right a bleeding rooster.

Toward the market he's rushing.
Bleating howls repel people on the streets,
Ghosts in the wild retreat.

Combining Frames with Associations

*Constructing Imaginary and Surreal
Scenography I:*

Interconnected frames

Each frame -- one subnarrative

The associative objects: reconfigured
into the frames, according to the
narratives.

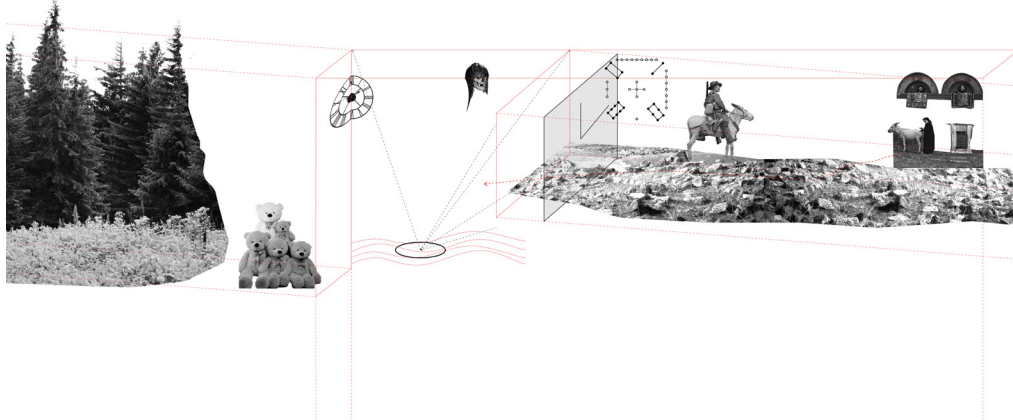

The Old Man, His Granddaughter, or the War

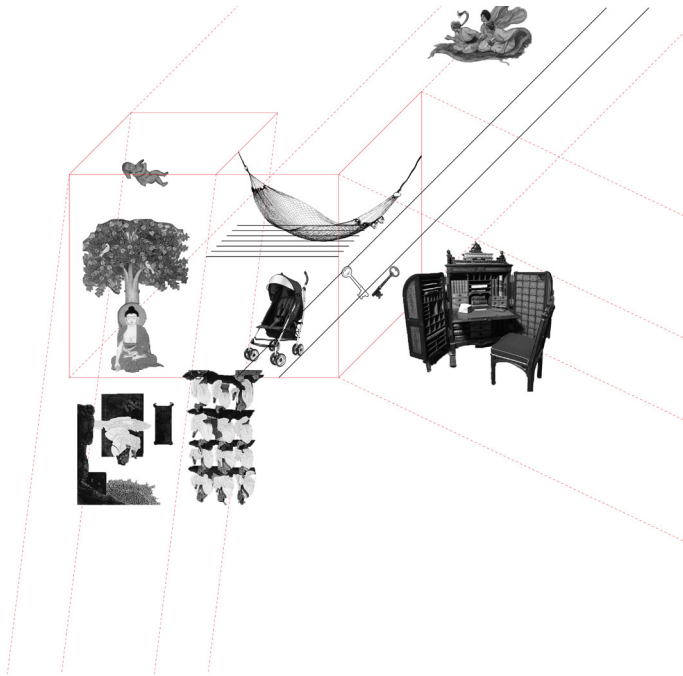

The Lost Infant, a Tree or the Secret Family

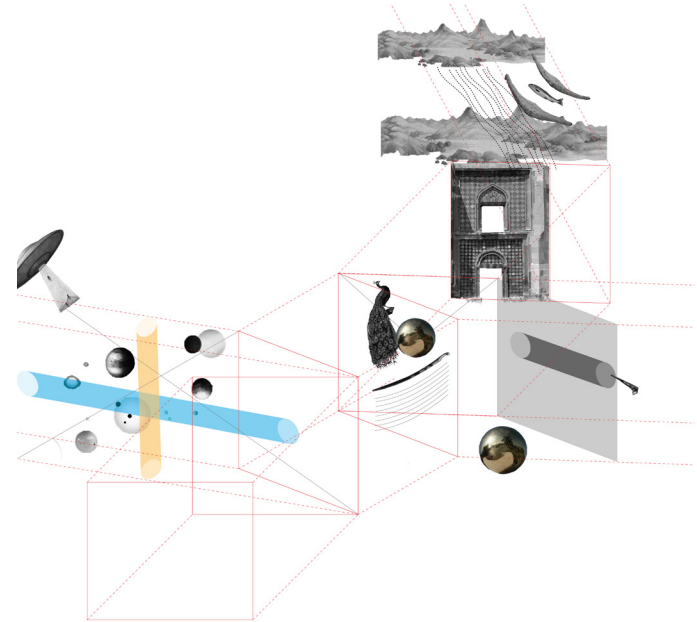

The Fleeing King, His Ruins, Two Aliens or a Fish

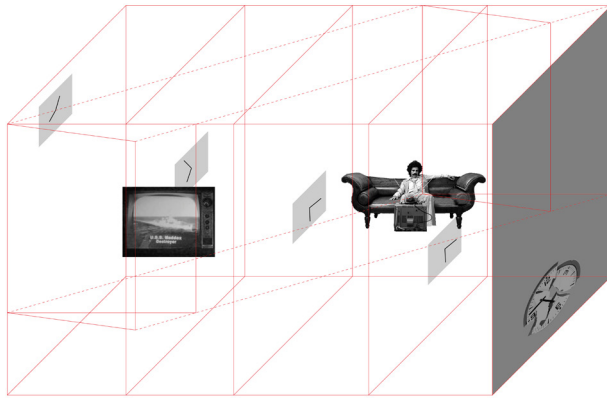

Death of a Man and His Room

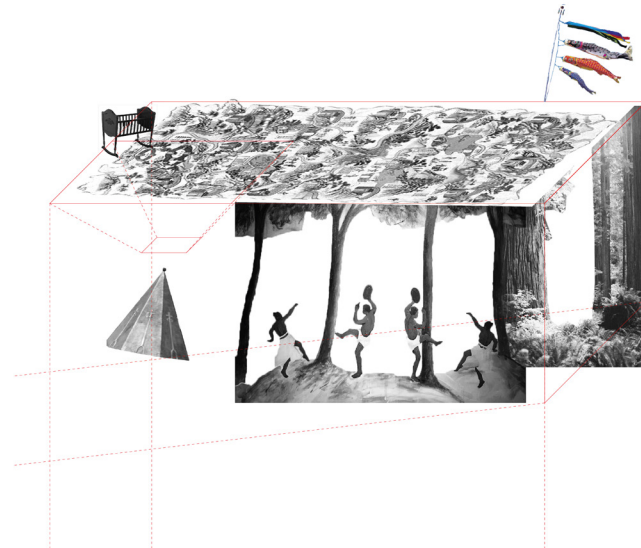

The Treasure Map of Wind and the Forest

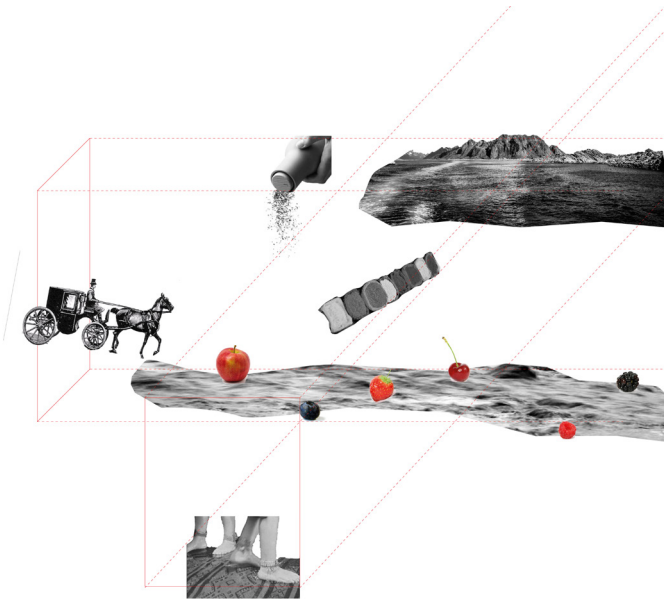

Flooded Fruits, a Yellow Car or a Horse

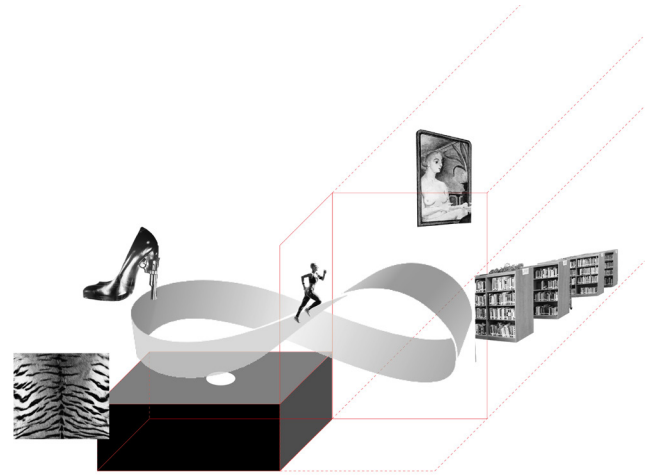

Her Infinite Race, His Gift, or the Library with a Mirror

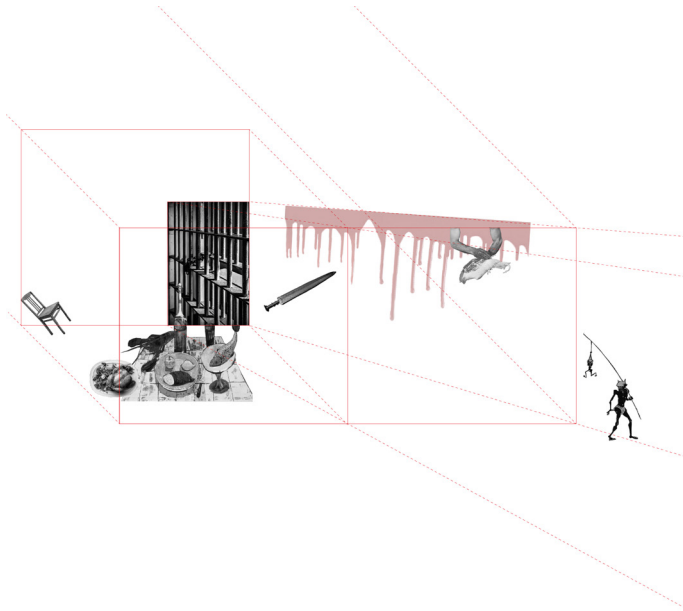

A Feast, an Escaping Prisoner, or His Revenge

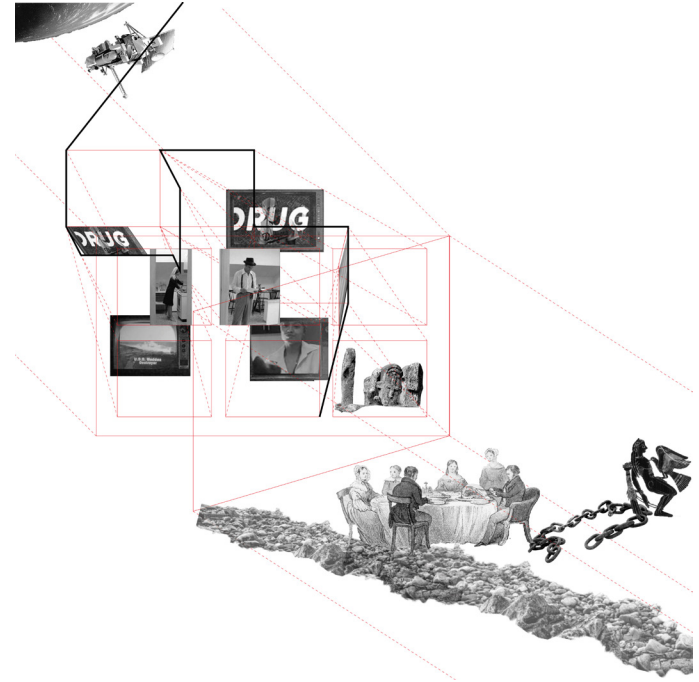

She's not Home, a TV room or a Dinner

4. Modeling

Spatial Translations

Constructing Imaginary and Surreal Scenography II:

-Frames

Wooden frameworks, glass panels, mirrors, openings...

-Effects of reflection, transparency, translucency, shadows...

Multiplying, contradicting, or distorting the perception of the actual space.

-Explicit architectural (spatial) elements

-Ambiguous and unspecified elements

-Gestural translations

Manipulating materials

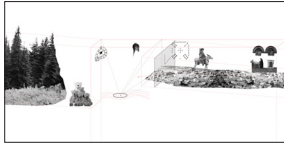

The Old Man, His Granddaughter, or the War

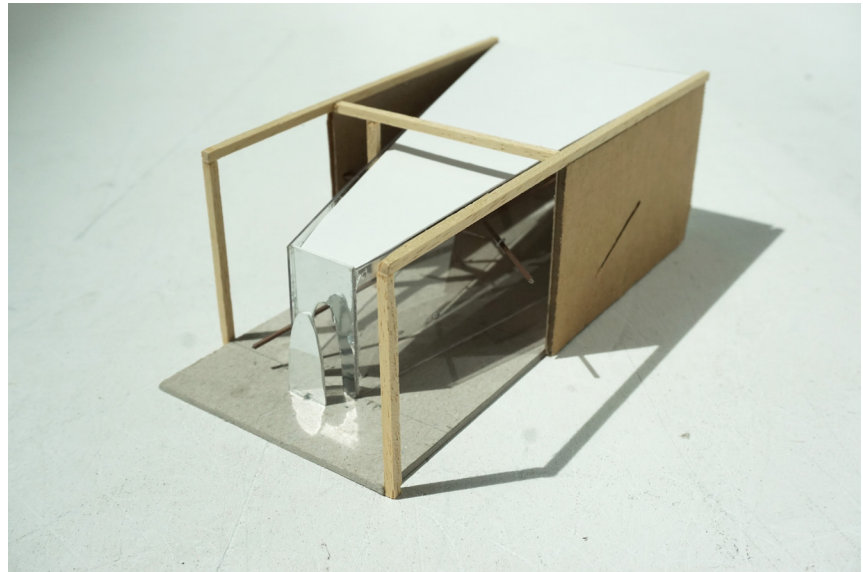
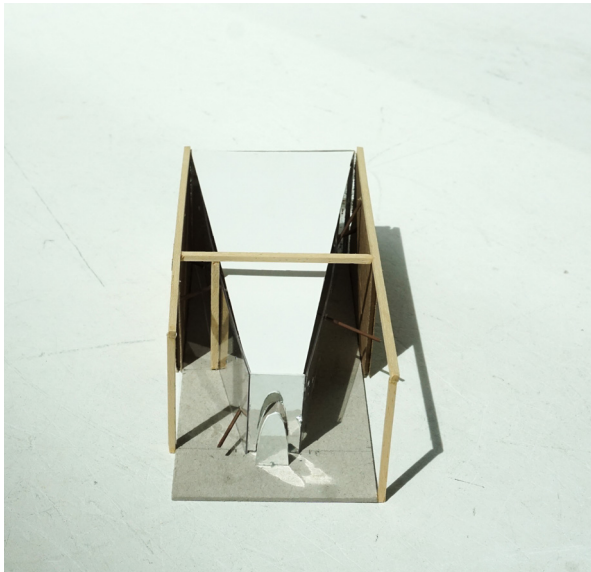

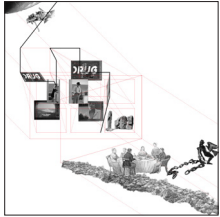

She's not Home, a TV room or a Dinner

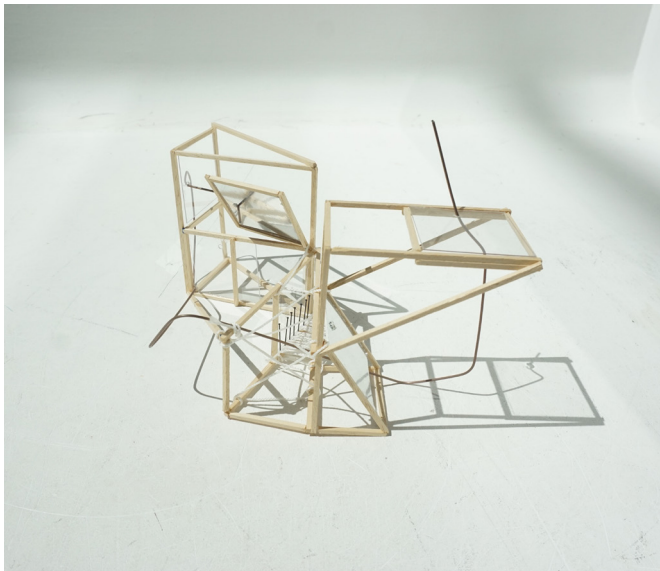

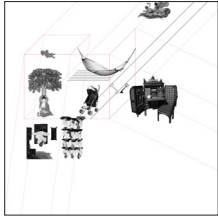

The Lost Infant, a Tree or the Secret Family

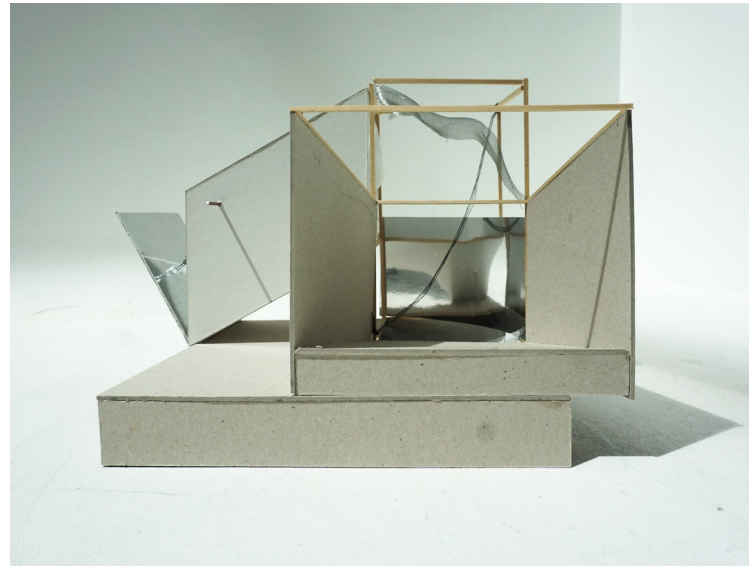

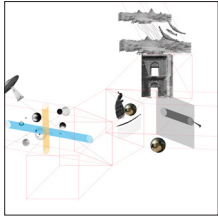

The Fleeing King, His Ruins, Two Aliens or a Fish

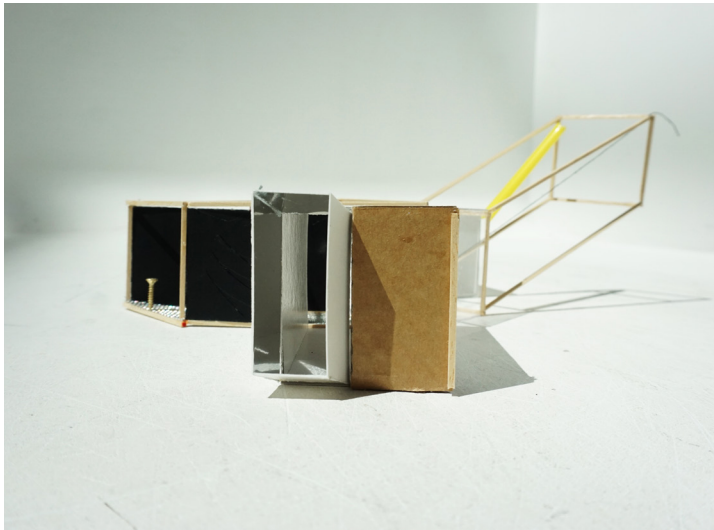

Death of a Man and His Room

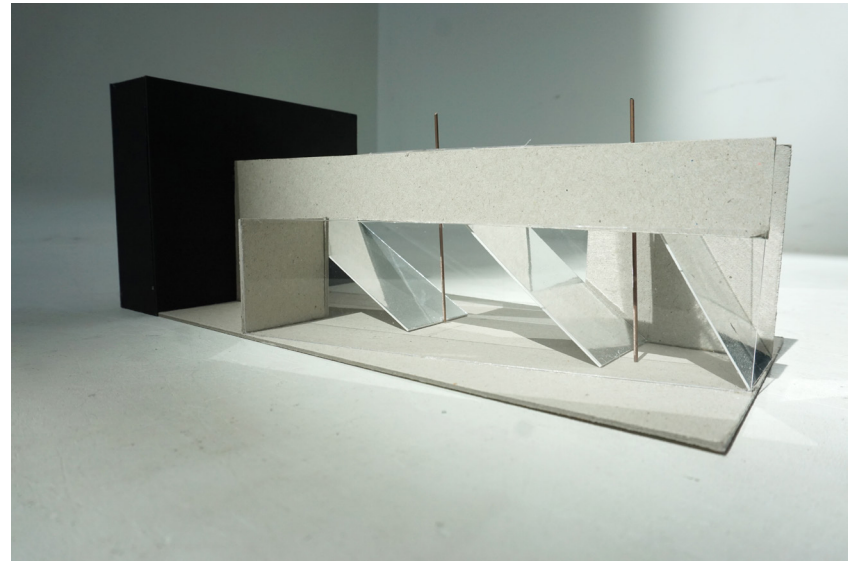
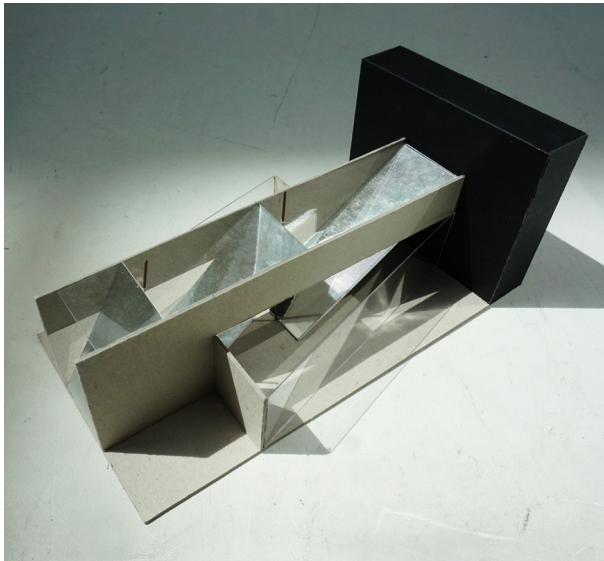
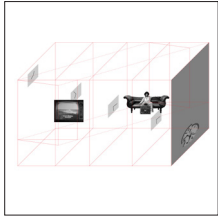

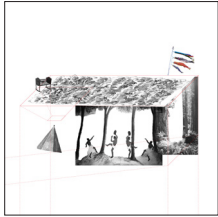

The Treasure Map of Wind and the Forest

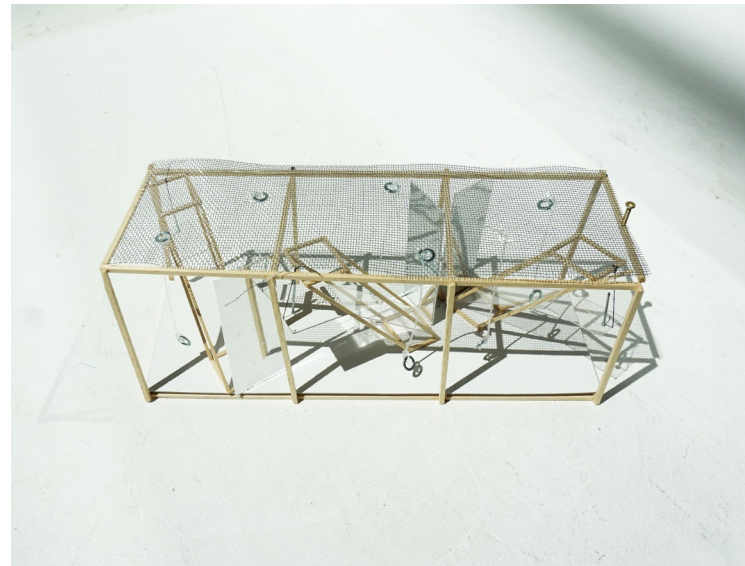

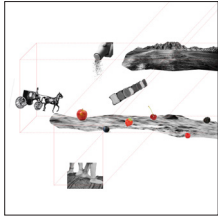

Flooded Fruits, a Yellow Car or a Horse

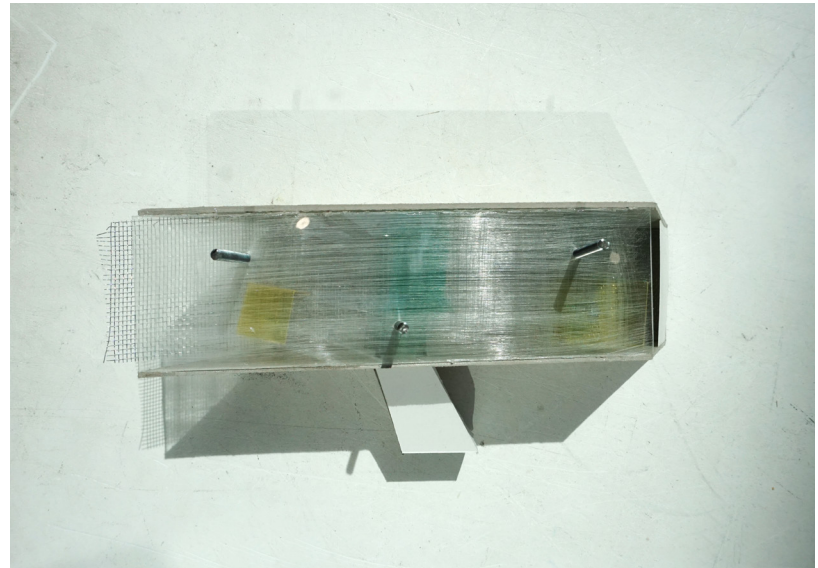
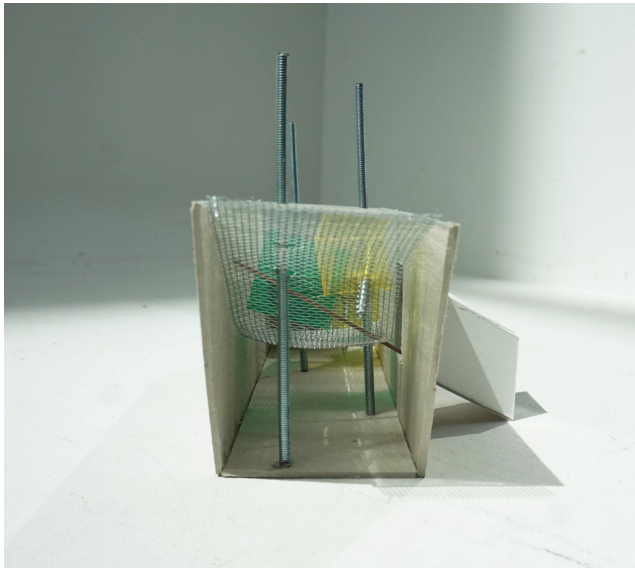

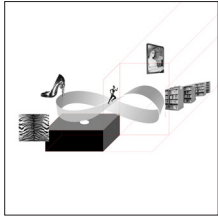

Her Infinite Race, His Gift, or the Library with a Mirror

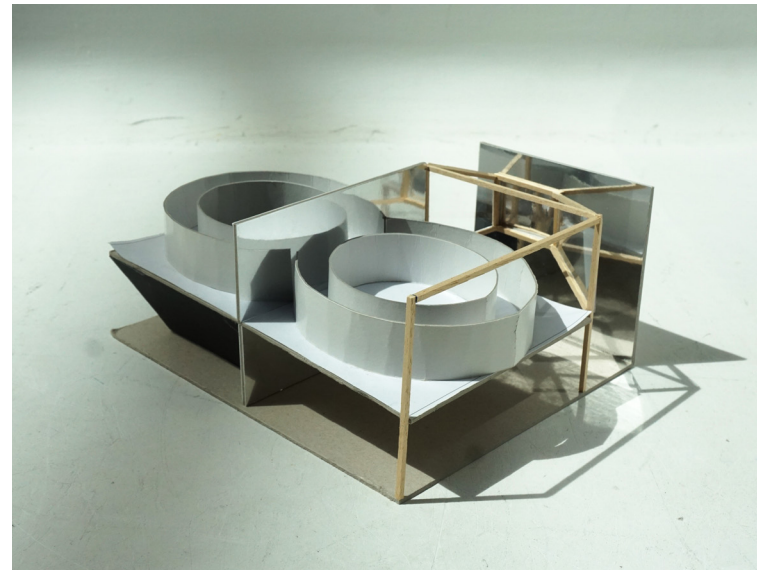
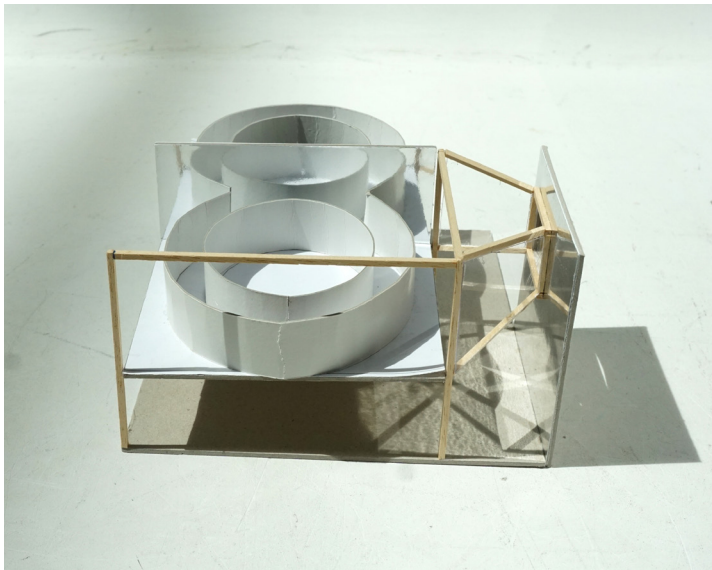

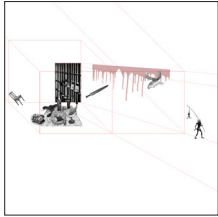

A Feast, an Escaping Prisoner, or His Revenge

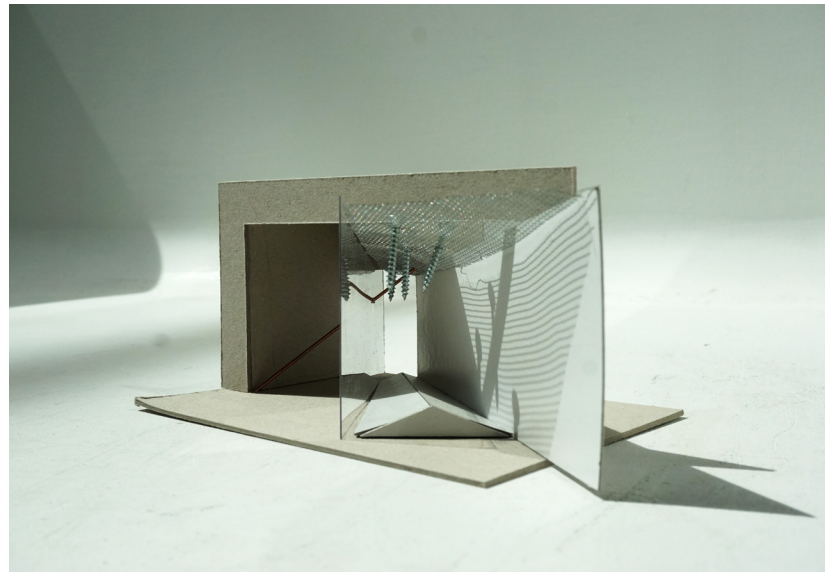
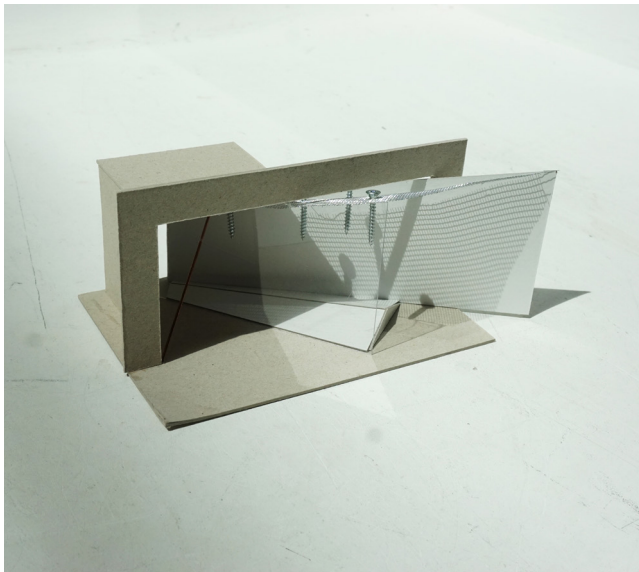

Library of Digital Culture

A Heterotopia of Virtuality

Urban Scenography

The Other

Surreality

The OTHER in the common and the ordinary.

Framings and Associations: deconstructs and reconstructs reality into surreality.

Framings establish spatial **assemblages**.
Associations construct the other world.

A library as a heterotopia: a place of a collection of OTHER times and places.

A library of digital culture is thus a Heterotopia of VIRTUALITY.

Virtuality is not only the unreal, but **potentiality** of multiplicity and otherness.

The Virtual

Heterotopia

Library of Digital Culture

Methodological continuation

5. Site

Site as Narratives

TWO OPPOSITIONS AND FOUR LINES

BULKY, INSTITUTIONAL, POWERFUL

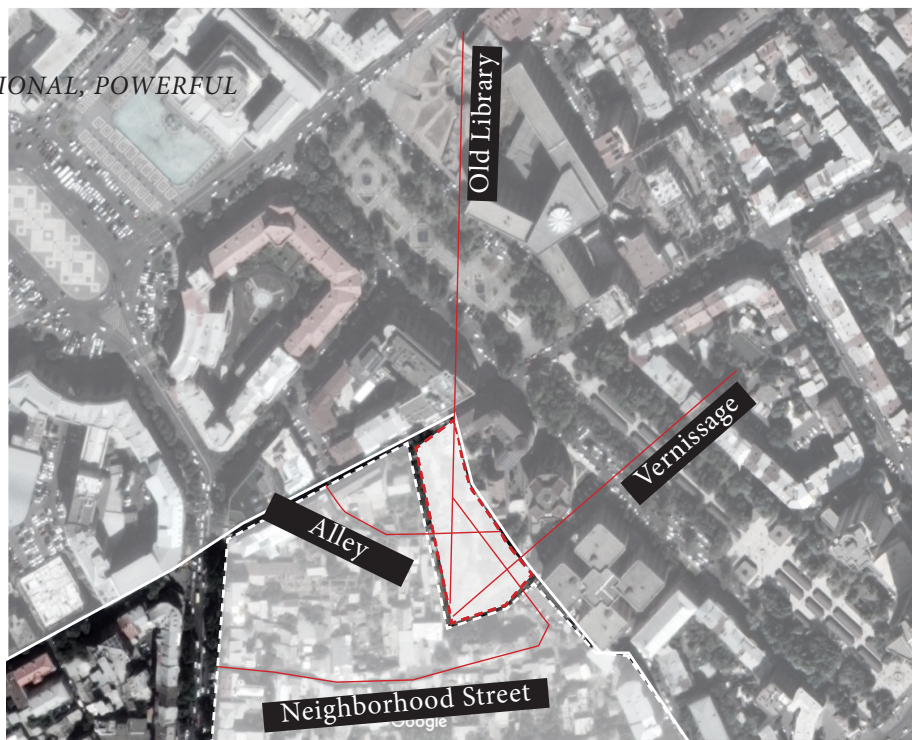

FRAGMENTED, SMALL SCALE, INFORMAL

SITE

Three Weaves of the Site

Alley:

After the five vodkas,
Each with a brush of color on his palette,
The old painter is put to sleep,
In an empty broken dream chair.

As the little khachkar swings through the still shadows
Of history, in silence.

The infant slips down the aged easel,
Out of the painting into the alley,
Where people discover distant fruits in an abandoned yellow car.

Small street:

In the wooden cabin at one end of the street,
Works a sewing machine that never stops.

Out of the waving pedal walk the pants,
Out of the pecking needle the shirts.
On their way feeling to the other end of the street,
The pants lost their shirts.

The chess board is caged in the middle.
Black and white pieces frozen,
On their way of returning to their sides.
Even the glasses and cigarettes can't keep the diminishing records

SITE

in the notebook.

Vernissage:

Lines of refined windows between refined tufa
Extend from the depth of museum of history.
Behind some windows a tie,
some an eye.

Wind lifts up the draperies,
Under the shivering shadows.
Unveiled is the bustling market,
Endless hats find their endless heads,
Confronted with the flowing gaze of the tourists.

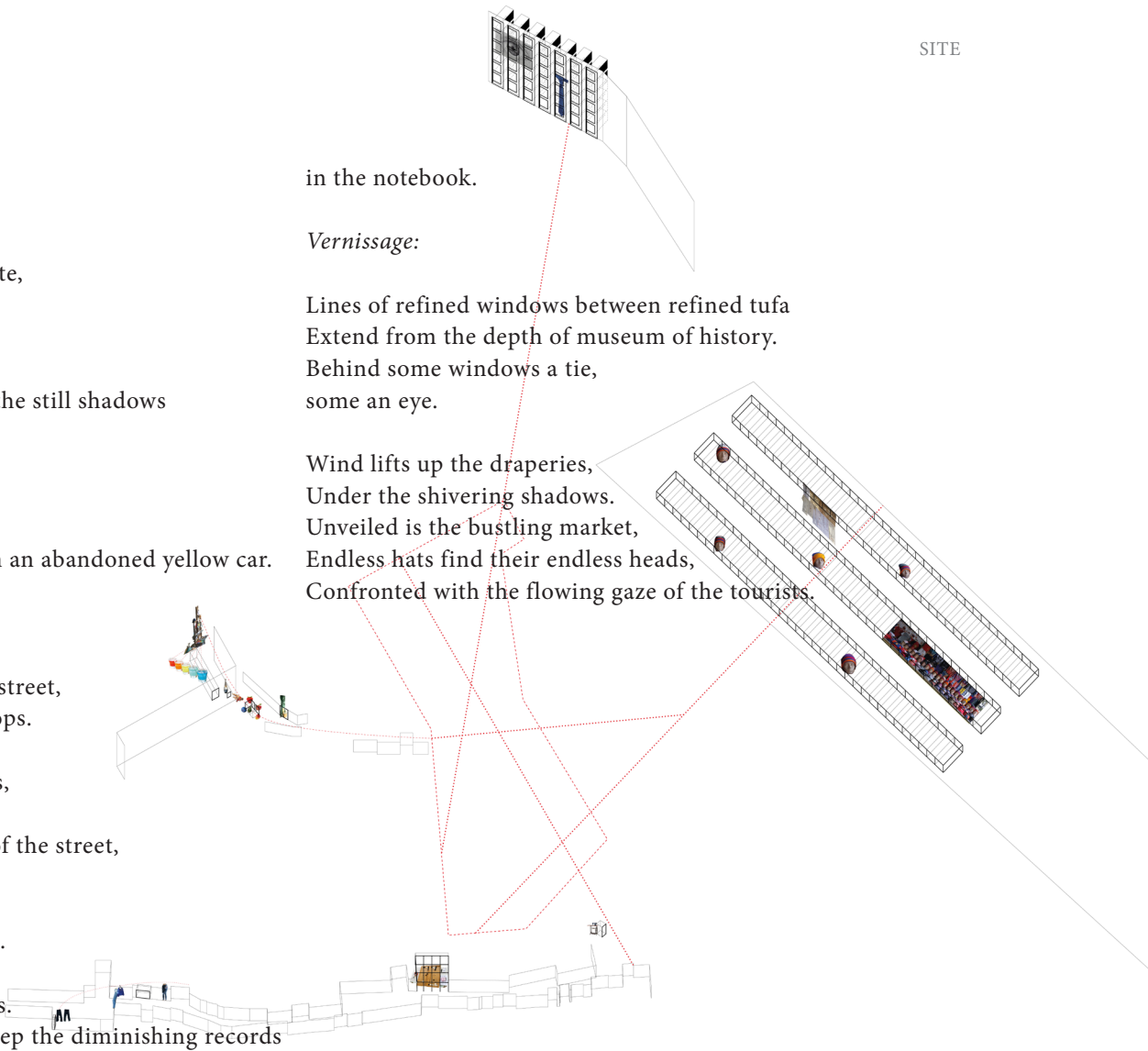

SITE

SITE

Projecting Narratives on Site

Context: continuation and cuts-in as somewhere else.

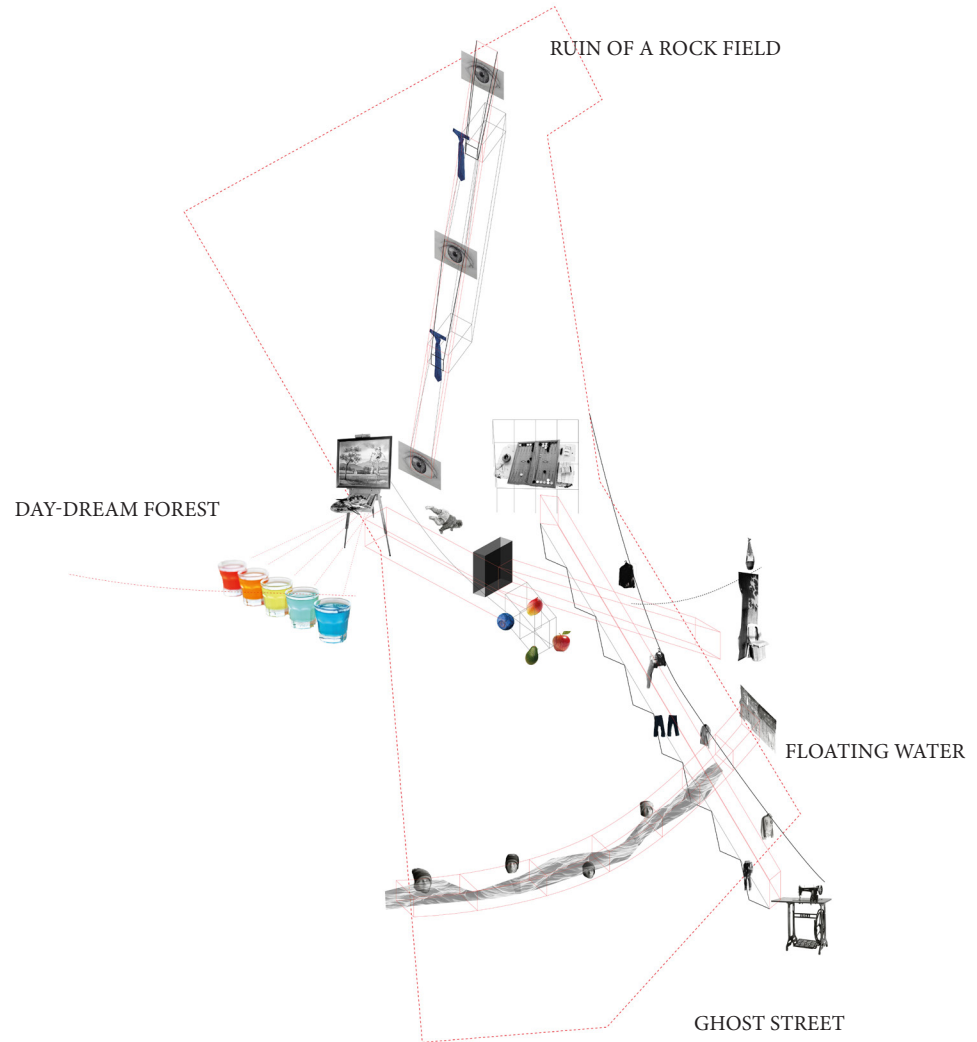

Routes of Organization.

6. Program

Program and Narratives

LIBRARY OF DIGITAL CULTURE

Exposition:

Books	<i>Day-dream Forest</i>	<i>Ruin of a Rock Field</i>
Videos	<i>Ghost Street</i>	
Audios	<i>Floating Water</i>	

Retrieval:

Books	<i>Flooded Fruits, a Yellow Car or a Horse</i>
Videos	<i>Death of a Man and His Room</i>
Audios	<i>The Treasure Map of Wind and the Forest</i>

<i>Exhibition/ Open Space</i>	<i>The Old Man, His Granddaughter, or the War</i>
-------------------------------------	---

<i>Education + Production:</i>	<i>The Fleeing King, His Ruins, Two Aliens or a Fish</i>
Digital Workshops	
Video Facilities	
Audio Facilities + Recording	
Auditorium	

<i>Compact Stacks</i>	<i>Her Infinite Race, His Gift, or the Library with a Mirror</i>
-----------------------------	--

<i>Administration/ Technical Support</i>	<i>She's not Home, a TV room or a Dinner</i>
--	--

<i>Outdoor Tribune</i>	<i>The Lost Infant, a Tree or the Secret Family</i>
------------------------------	---

<i>Entrance + Lobby</i>	<i>A Feast, an Escaping Prisoner, or His Revenge</i>
-------------------------------	--

PROGRAM

Overall Organization

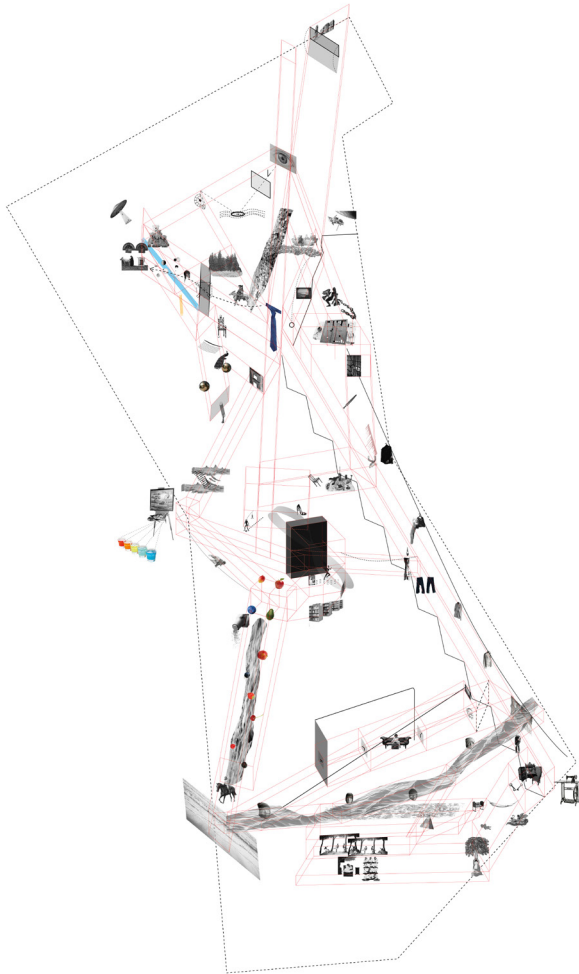

Design diagram: Frames and Associations reconfigured

PROGRAM

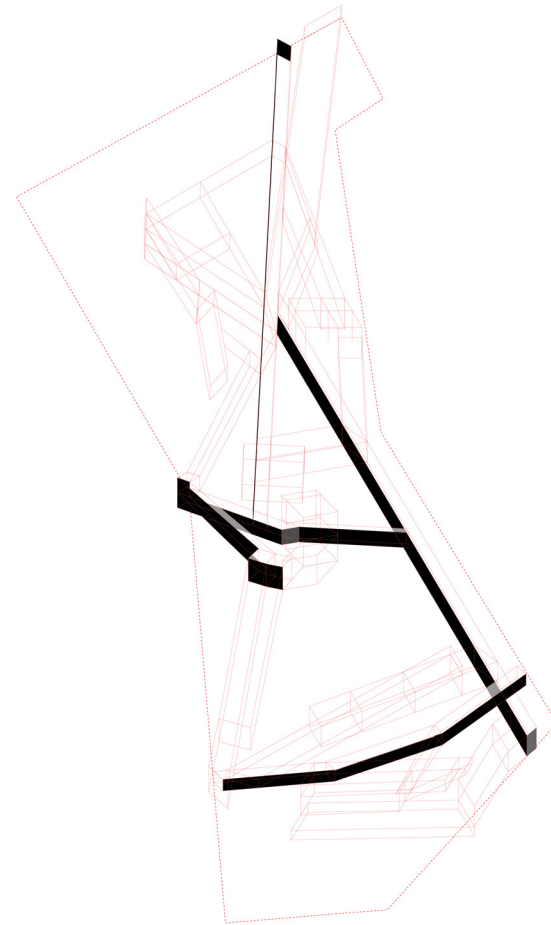

Organizational paths of exposition

Programs dissected

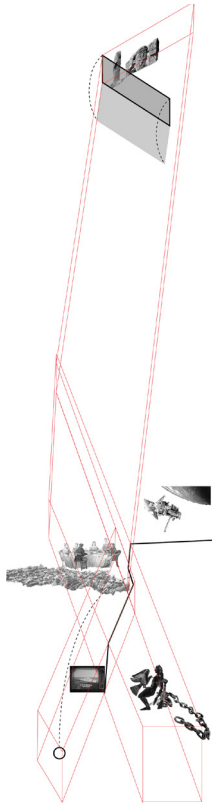

Administration+ technical support

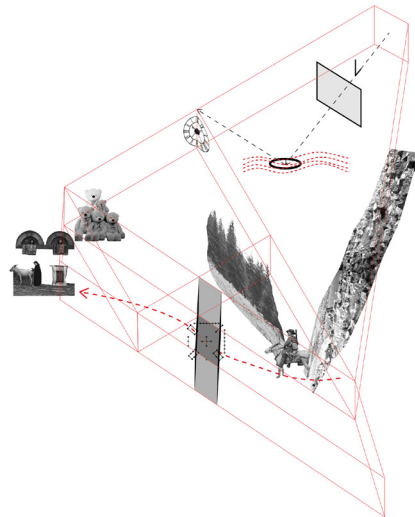

Exhibition/ Open Space

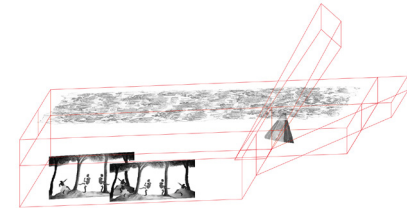

Audio Retrieval

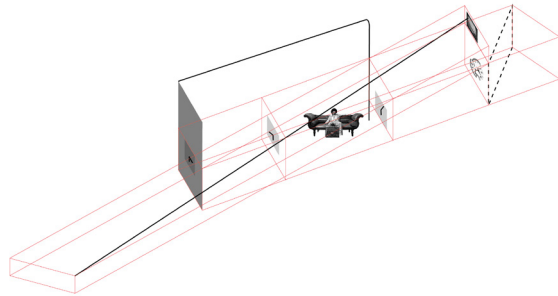

Video Retrieval

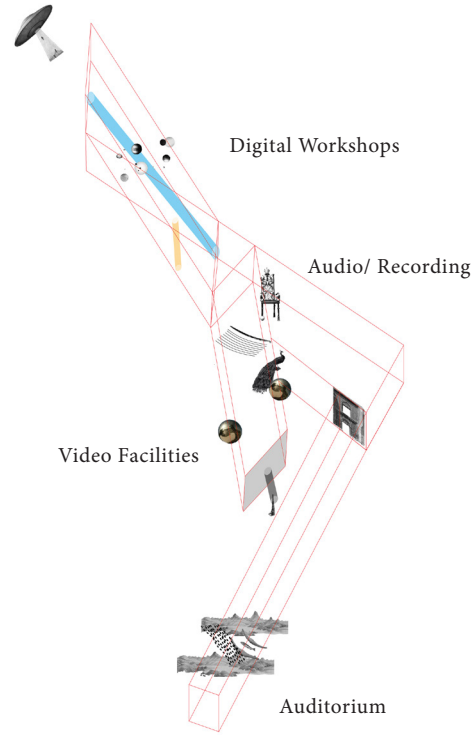

Education + Production

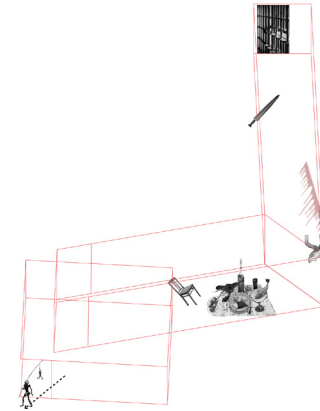

Entrance/ Lobby

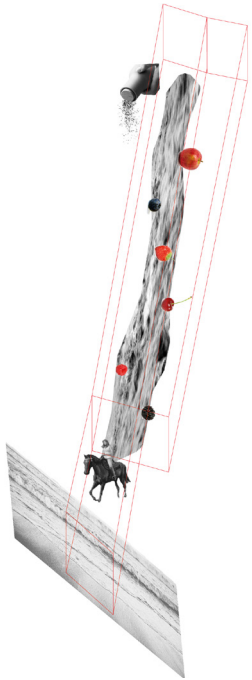

Book Retrieval/ Reading

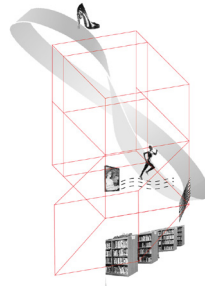

Compact Storage

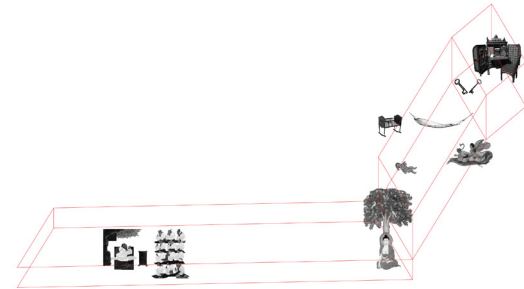

Outdoor Tribune

8. Actualization

Towards a Real Building

MODELING

ACTUALIZATION

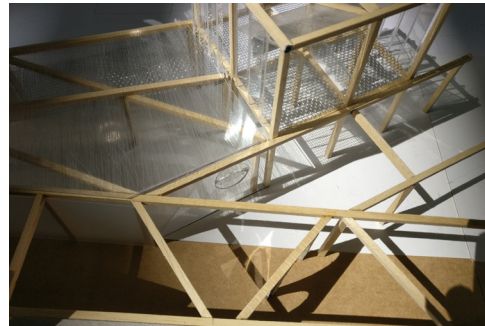

Methodology:
Spatial translation of the drawing

-Multiple presence of frames

-Transparency, reflections, shadows

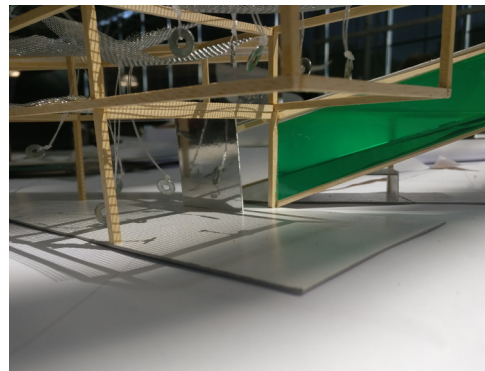
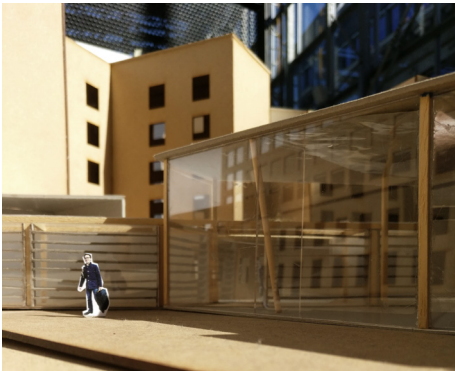

-Objects

-Manipulations

Sense of virtuality:
the potentiality of multiplicity and
otherness





IMPLANTATION

Site Plan

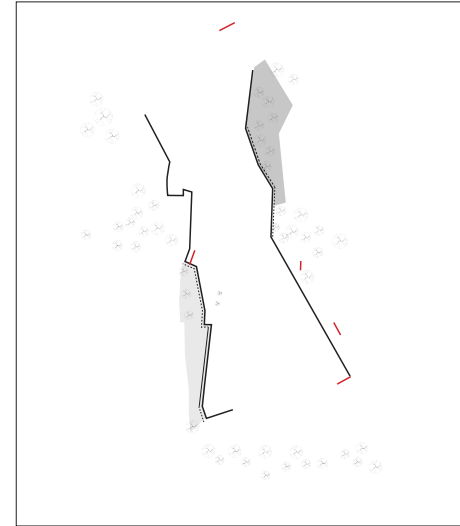

ACTUALIZATION



-  Edges of the building on both sides
-  Transparency and reflection
-  Close in-between space:
Reflections mediated by foliage
-  -Sudden transitions

STRUCTURE

Frames

ACTUALIZATION

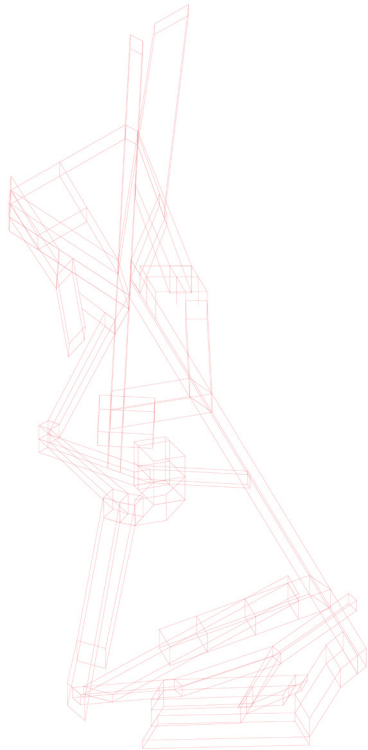

Frame Diagram

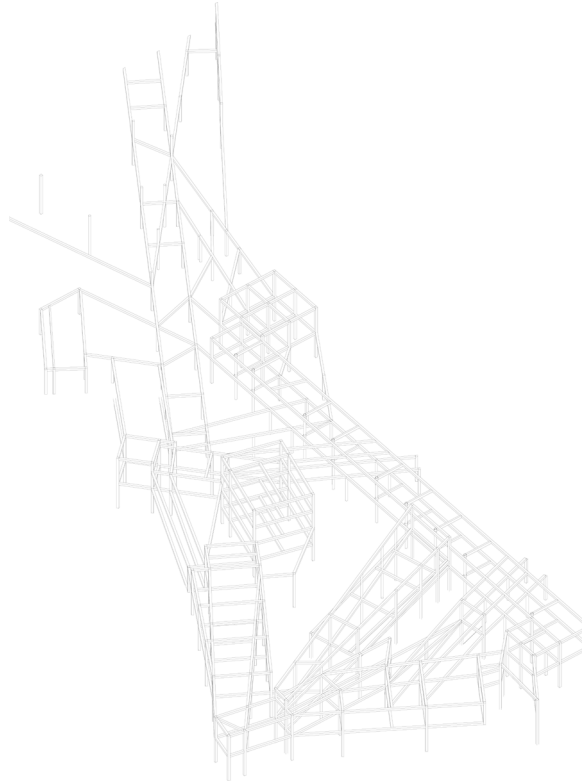

Structure Framework

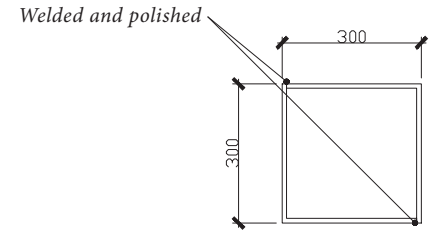

Beam/ Column Section

-Three-dimensionally neutral framings:

Beams/Columns: 300 x 300 mm

Steel

White

-Additional Supports (Mullions)

PLAN

Plan: Ground Floor



ACTUALIZATION

Plan: 1st Floor

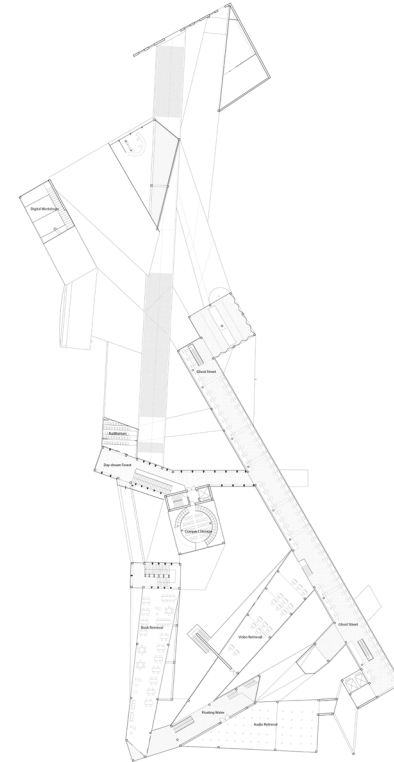

SECTION

Section Through Exposition Routes Unfolded 1-1

ACTUALIZATION



Rambling, sequential experience of the routes, multiplied by various kinds of frames opening to different realities.

「 Sudden
cuts-in
of the
contextual
realities 」

ELEVATION

ACTUALIZATION

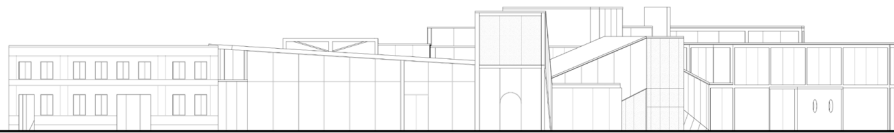

North



East

PARTS

Day-dream Forest

ACTUALIZATION

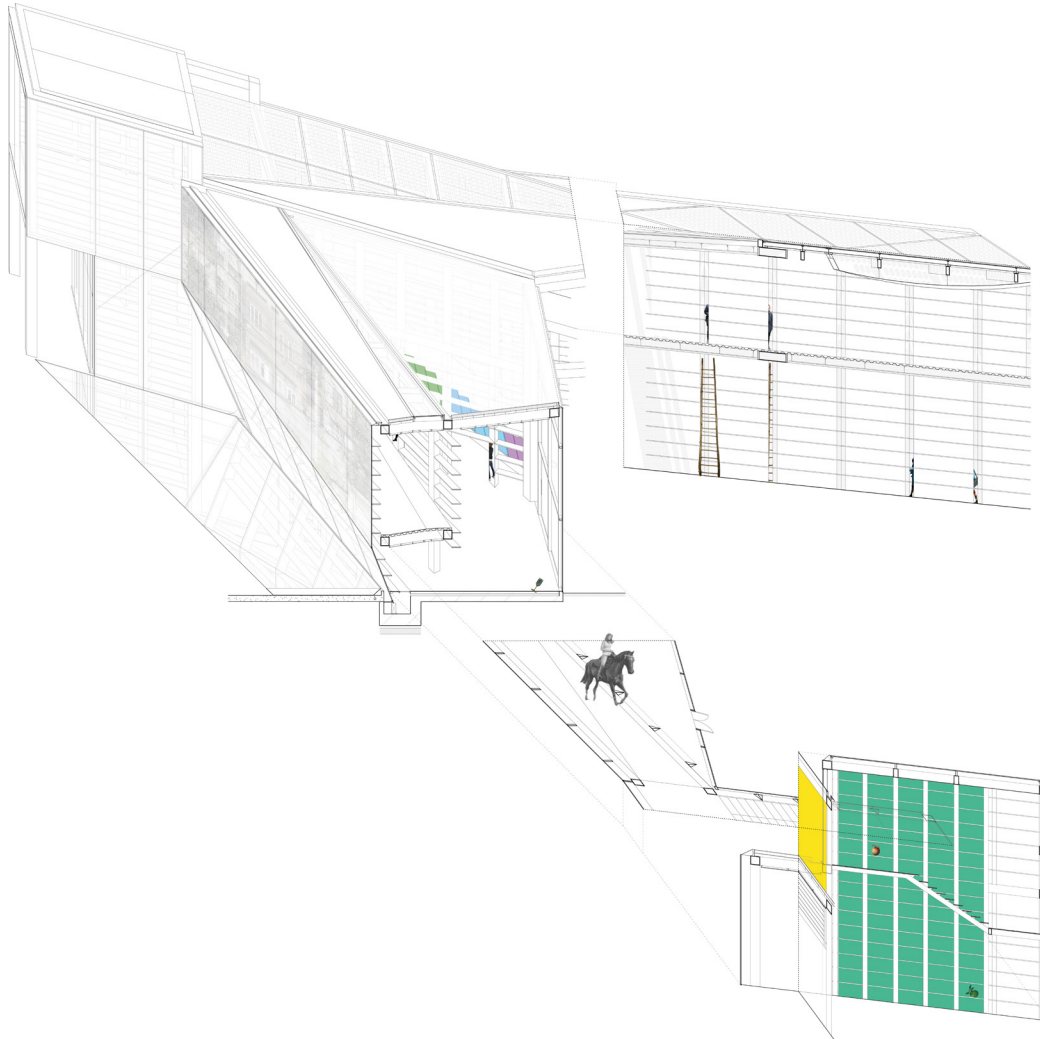

Combining drawing techniques

Frames

Transparency

Reflections

(Parts of) mirrored figures

Alien objects

The glass is shattered
Two apples float above the green
glass,
When a horse walks down the
ramp of mirrors.

Ghost Street



A sewing machine works next to
the revolving glass,
A peacock stops on the curved
mirror,
A coat falls onto ground.

Video Retrieval

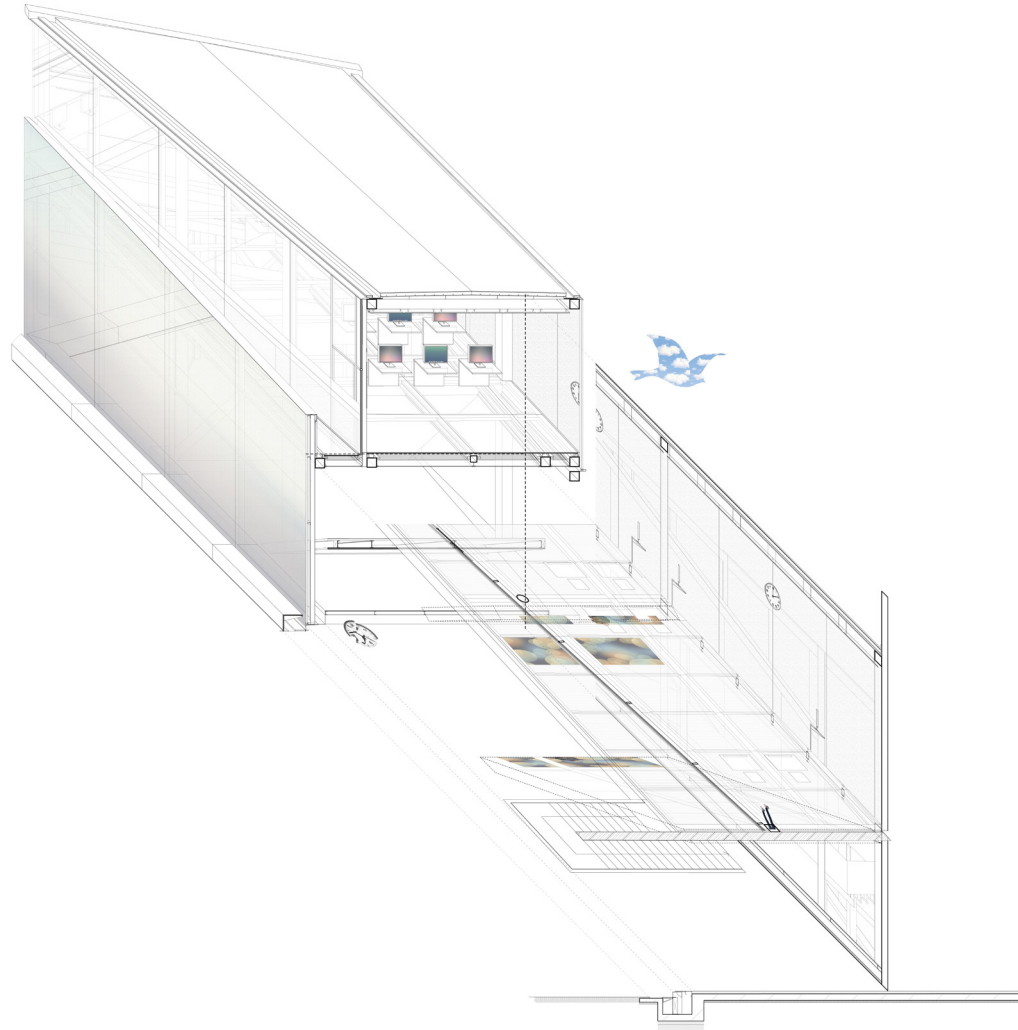

Two clocks stop at two different times,
Another falls on the floor, shattered,
When the bird flies away
To become the sky

DETAIL

Material and Ventilation

Double layered laminated acrylic glazing

Mirror

Metal walk-on gratings

Polished aluminium chair surface

Polished concrete floor

Natural ventilation with heat exchanger

Ghost Street

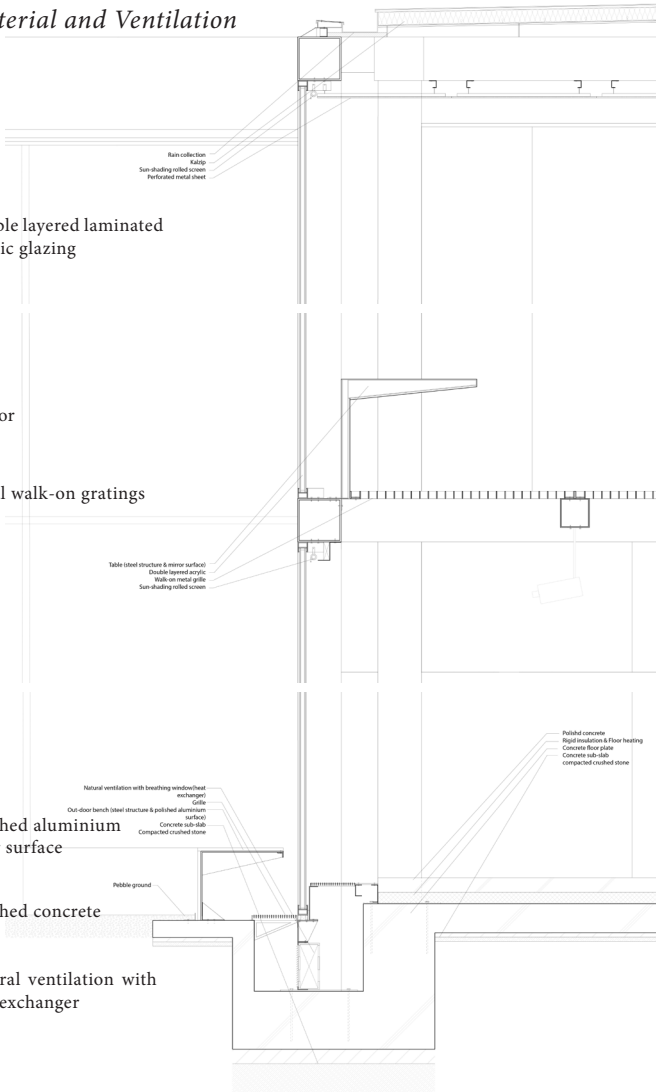

ACTUALIZATION

Double layered laminated acrylic glazing

Walk-on waffled acrylic floor sheet

Adjustable metal mesh sun-shading

Polycarbonate sheet

Mirror

Polished aluminium chair surface

Natural ventilation with heat exchanger

Video Retrieval

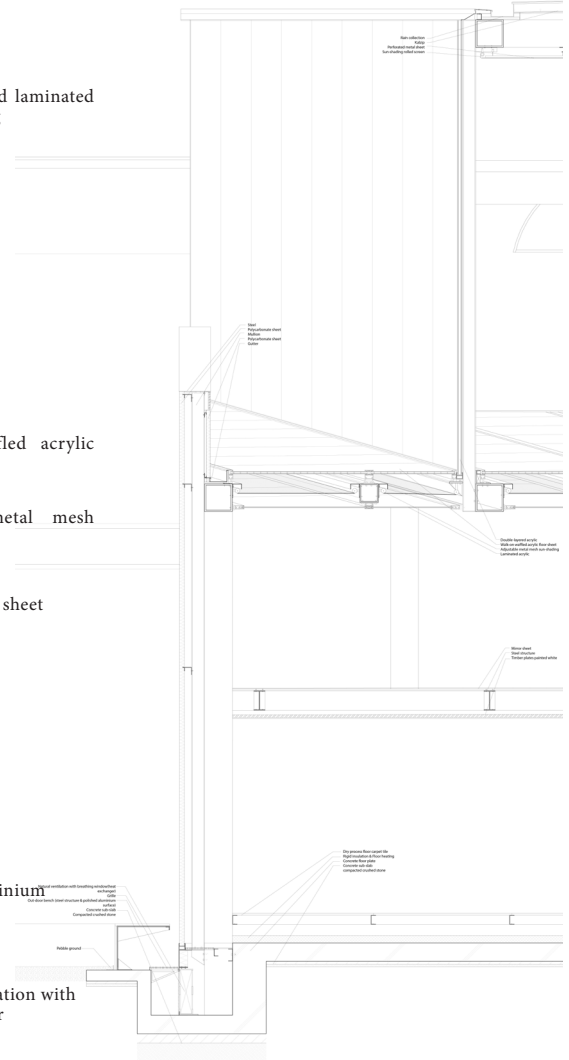

CLIMATE AND ENERGY

Glazing Roof

ACTUALIZATION

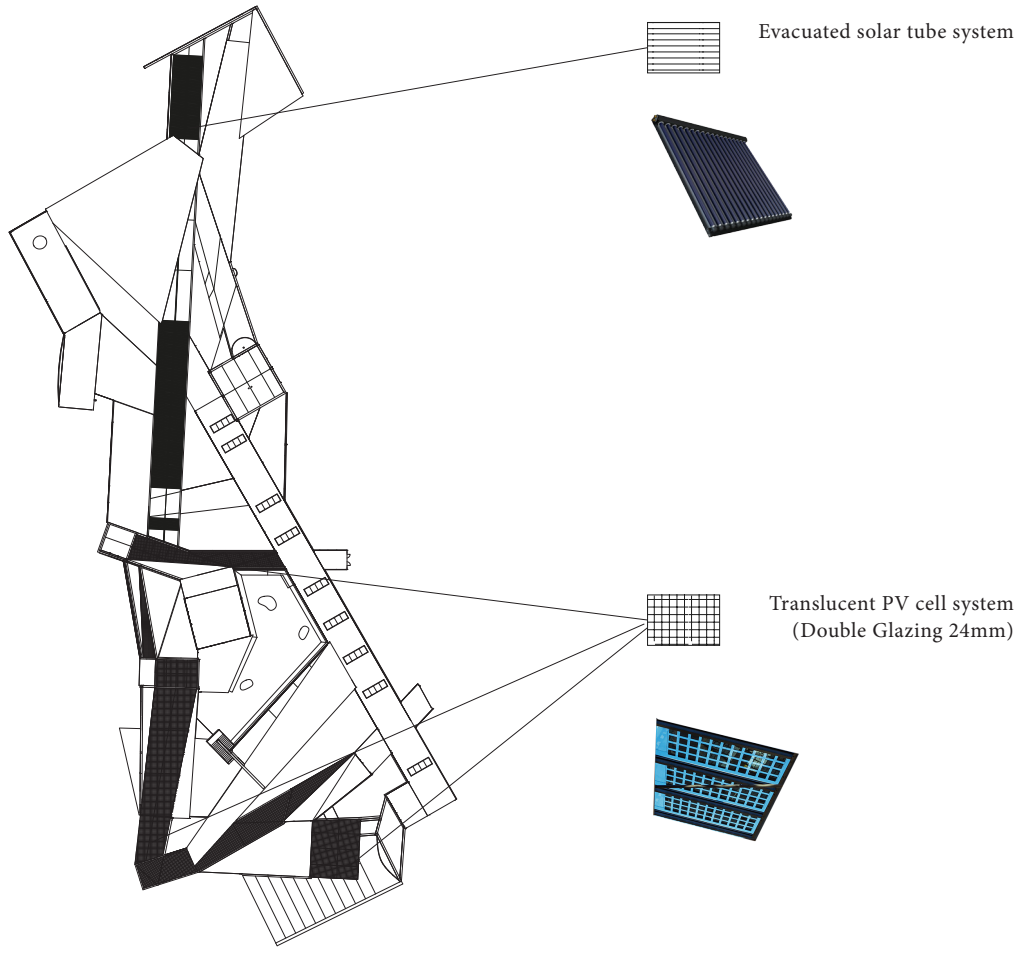

Sunshading
Energy Production
Shadows

Estimated energy yield:

- Evacuated solar tube system: 165620 kWh/m²a
- PV cell system: 1900 W (pmp)

VISUALIZATION

ACTUALIZATION

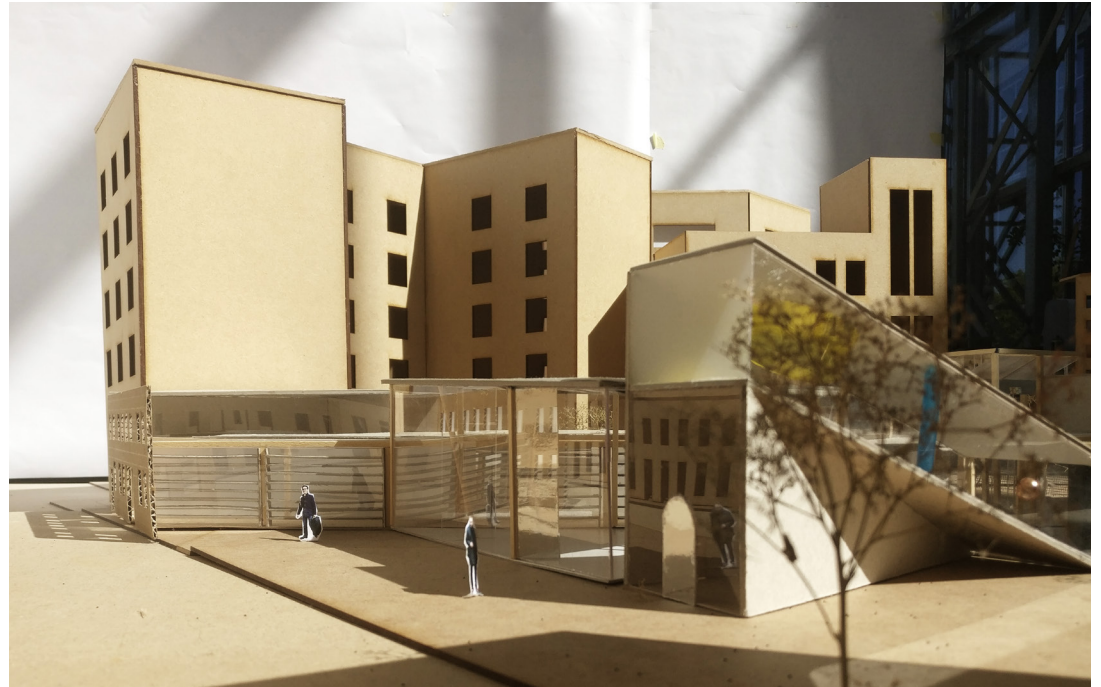
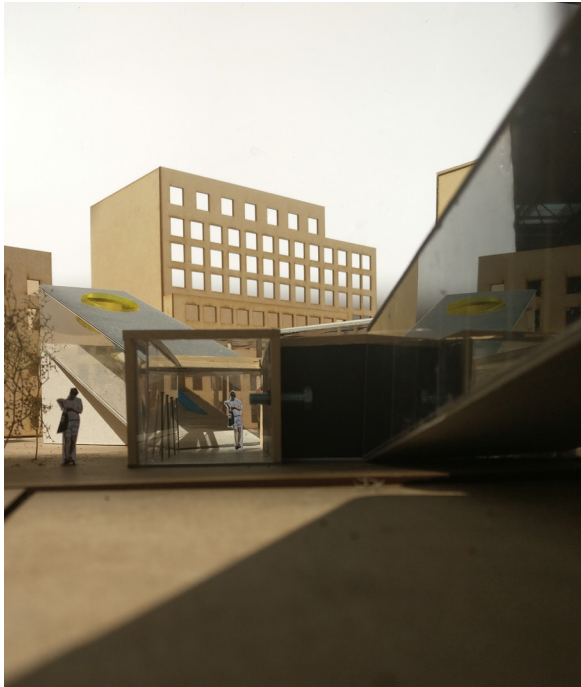

Ruin of a Rock Field





Ghost Street

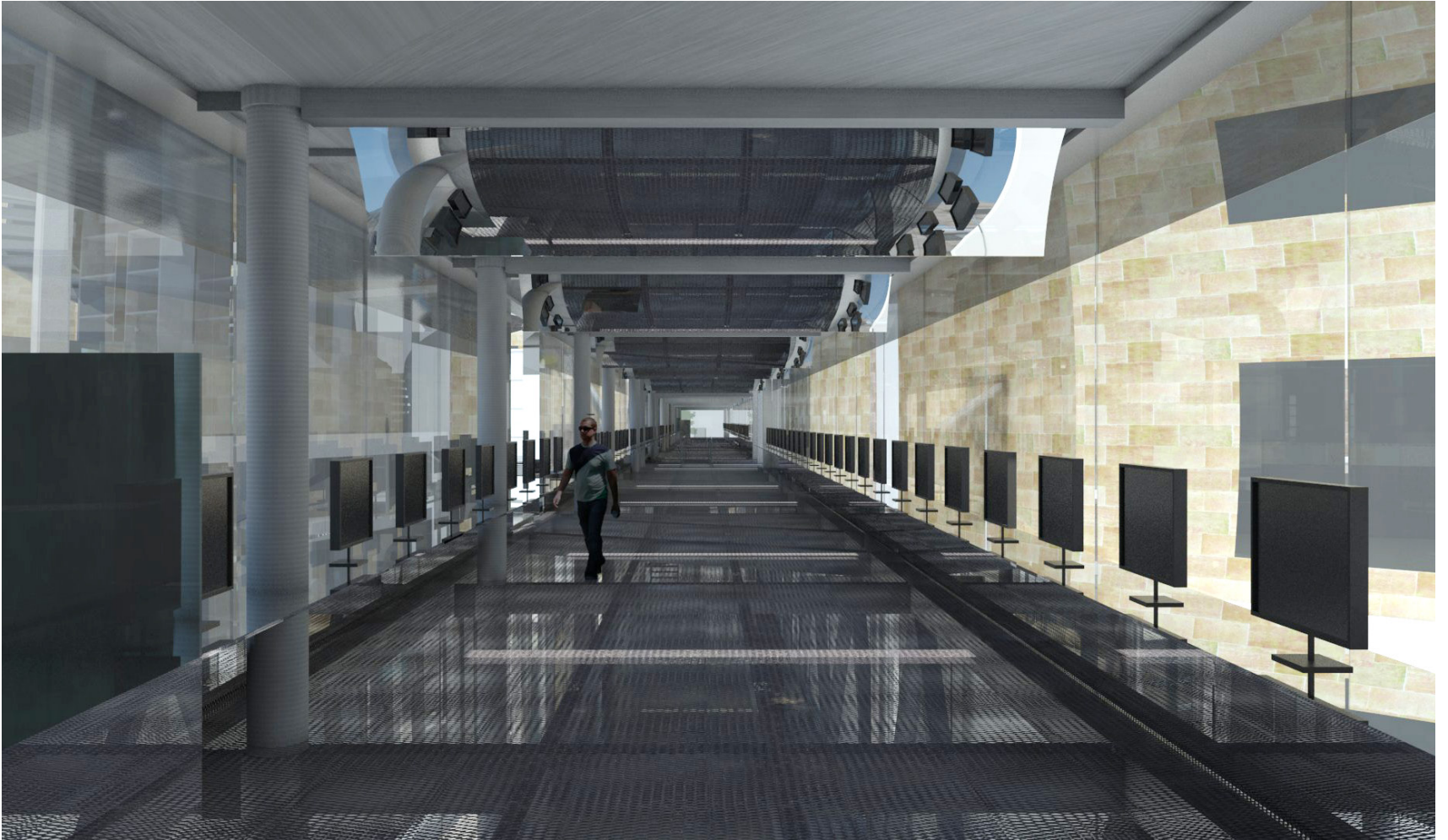

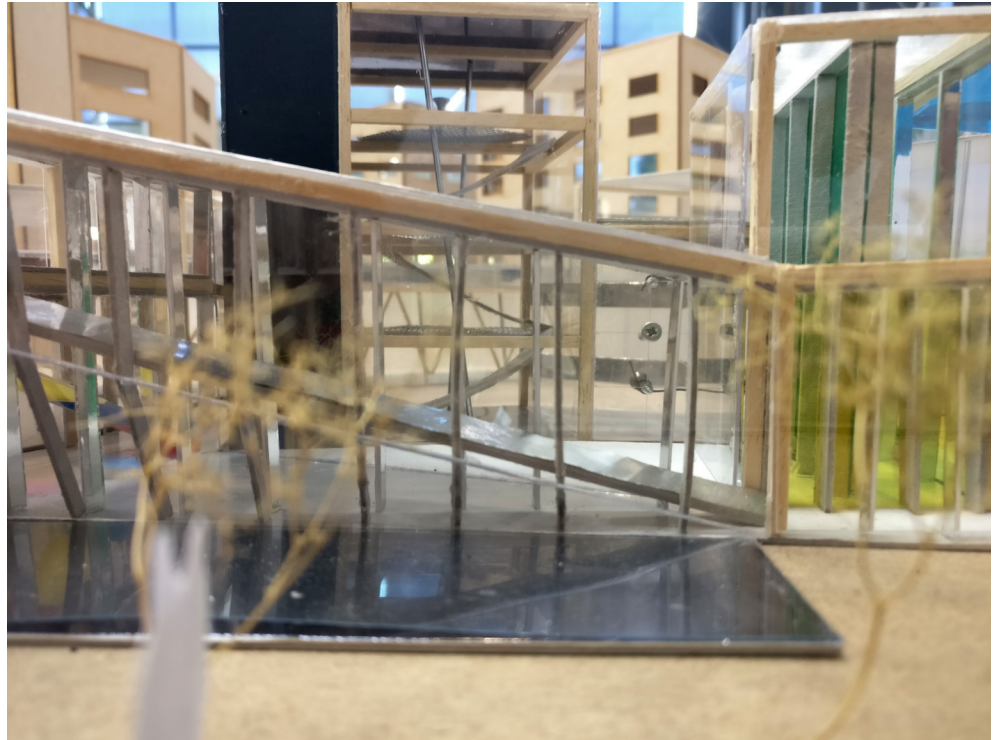

Day-dream Forest

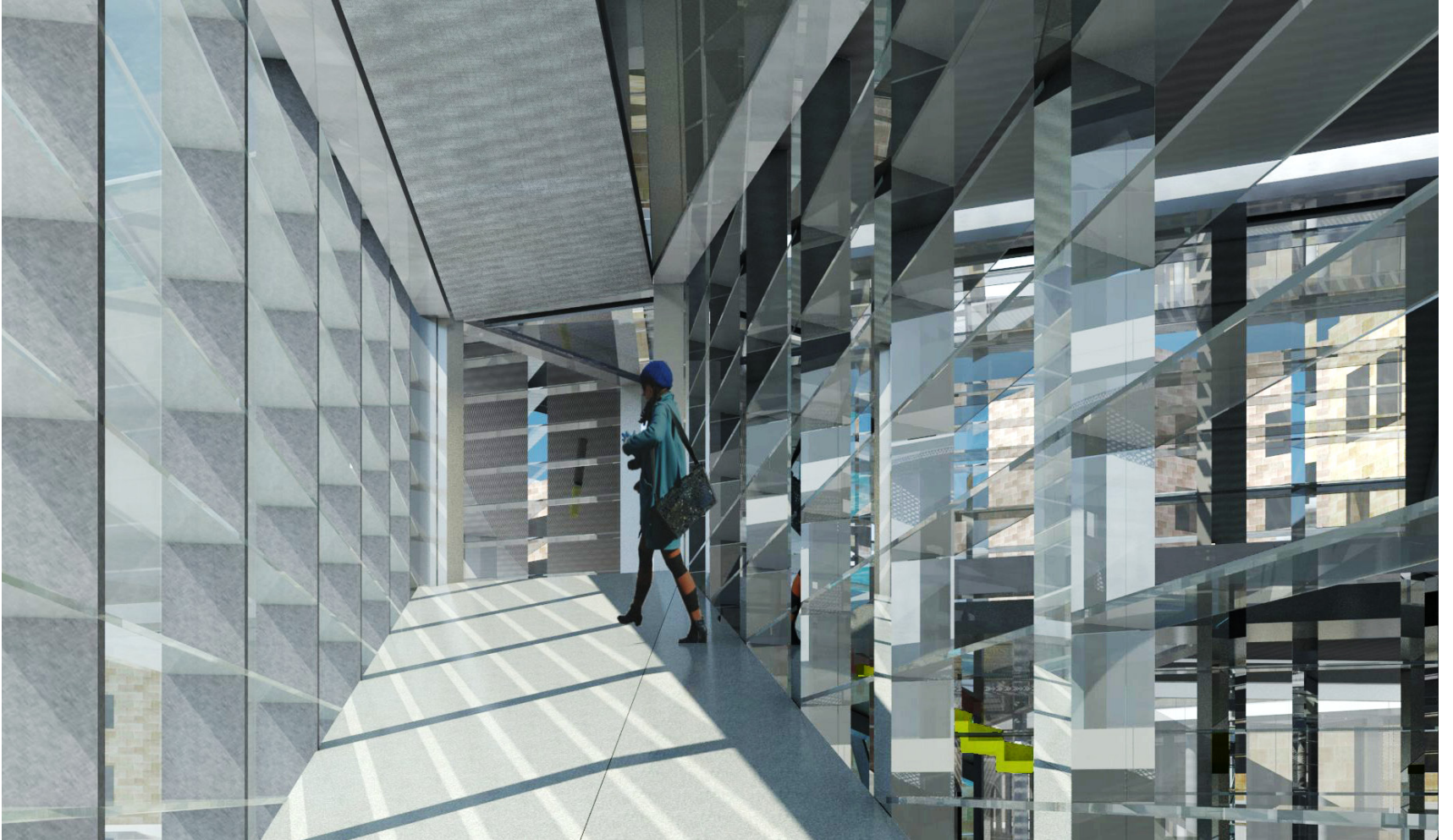

Day-dream Forest



THANK YOU!