

Architecture as facilitating agent: exploring architecture's position in spatial relationships through festival spaces



Architecture as facilitating agent: exploring architecture's position in spatial relationships through festival spaces

Program

An introduction to festival spaces	Location	Festival I.	The process
Why they matter	Preparing the site	Festival II.	What's next
Problems faced by the industry			
Establishing the role of the architect in festival spaces	Spatial interventions	Other set ups	Reflecion

Research -
An introduction to
festival spaces

Design -
Program & structure

Experience -
The first trials

Closing act

An introduction to festival spaces

why they are interesting spaces to investigate spatial relationships



A temporarily constructed space

An introduction to festival spaces

why they are interesting spaces to investigate spatial relationships



A temporarily constructed space

An introduction to festival spaces

why they are interesting spaces to investigate spatial relationships



A temporarily constructed space

Collectively writing the story of the space

An introduction to festival spaces

why they are interesting spaces to investigate spatial relationships



A temporarily constructed space

Collectively writing the story of the space

a safe space: expression and experimentation

An introduction to festival spaces

Their characteristics and why they are interesting spaces to investigate spatial relationships



A temporarily constructed space

Collectively writing the story of the space

a safe space: expression and experimentation

Temporality

Co-authorship

Performativity

Research

Why they matter
For people, place and society

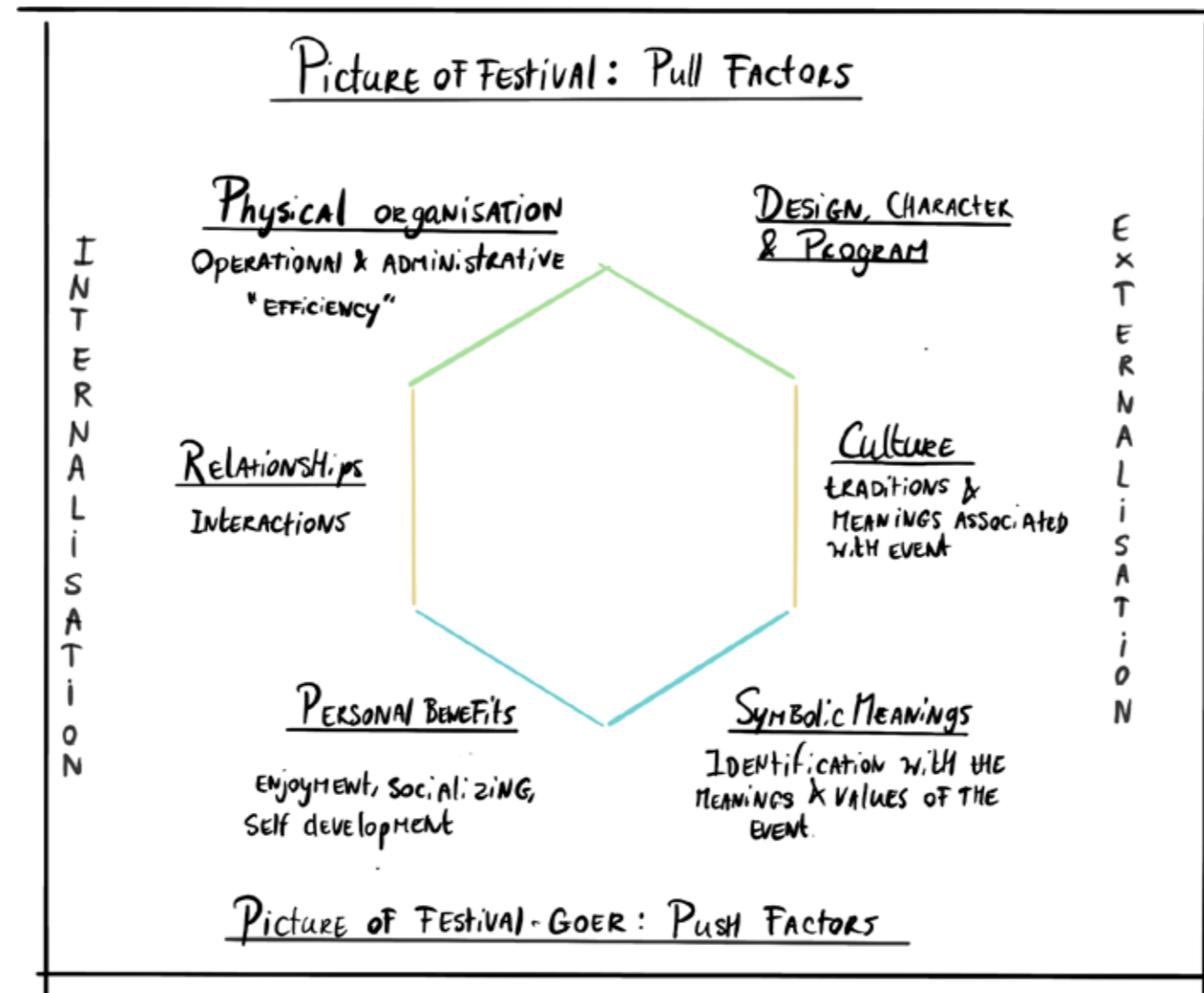

The prism of event experience, Morgan 2007

They foster well-being, social inclusion, and connection

'Music festivals broadly create this sense of community that in my mind is unmatched across any other events space. You know, it's a completely non-judgmental space. It's a space where people can express themselves in any way that they want. And especially in this post-COVID world that social cohesion is really, really important. It's also a bit of a rite of passage for out of high school and before you become a fully-fledged adult.'

(Logistics/operations)

Why they matter

For people, place and society

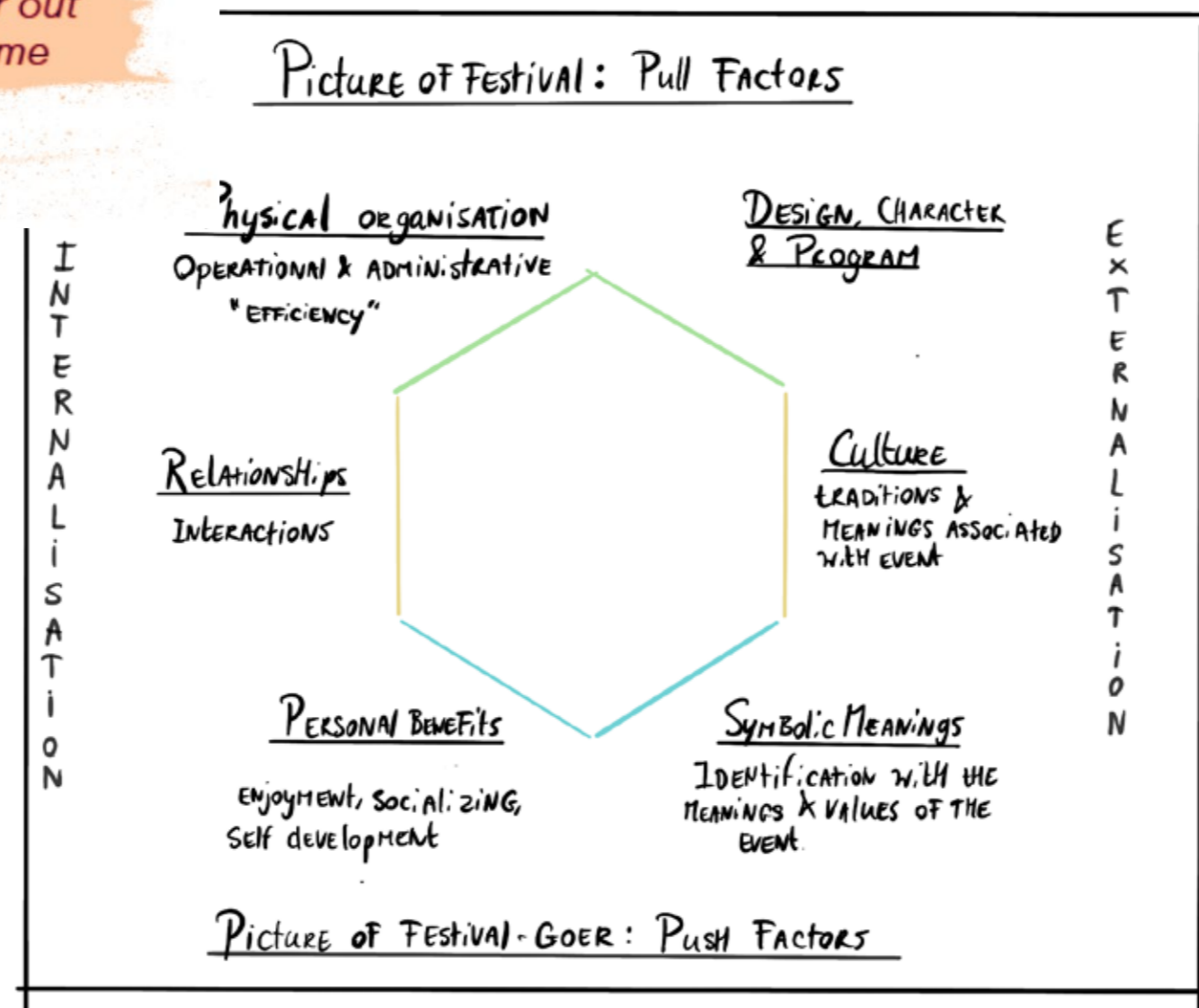

The prism of event experience, Morgan 2007

They foster well-being, social inclusion, and connection

And are platforms for protest, play, and experimenting with alternative value systems and ways of doing

'Music festivals broadly create this sense of community that in my mind is unmatched across any other events space. You know, it's a completely non-judgmental space. It's a space where people can express themselves in any way that they want. And especially in this post-COVID world that social cohesion is really, really important. It's also a bit of a rite of passage for out of high school and before you become a fully-fledged adult.'

(Logistics/operations)

Why they matter

For people, place and society

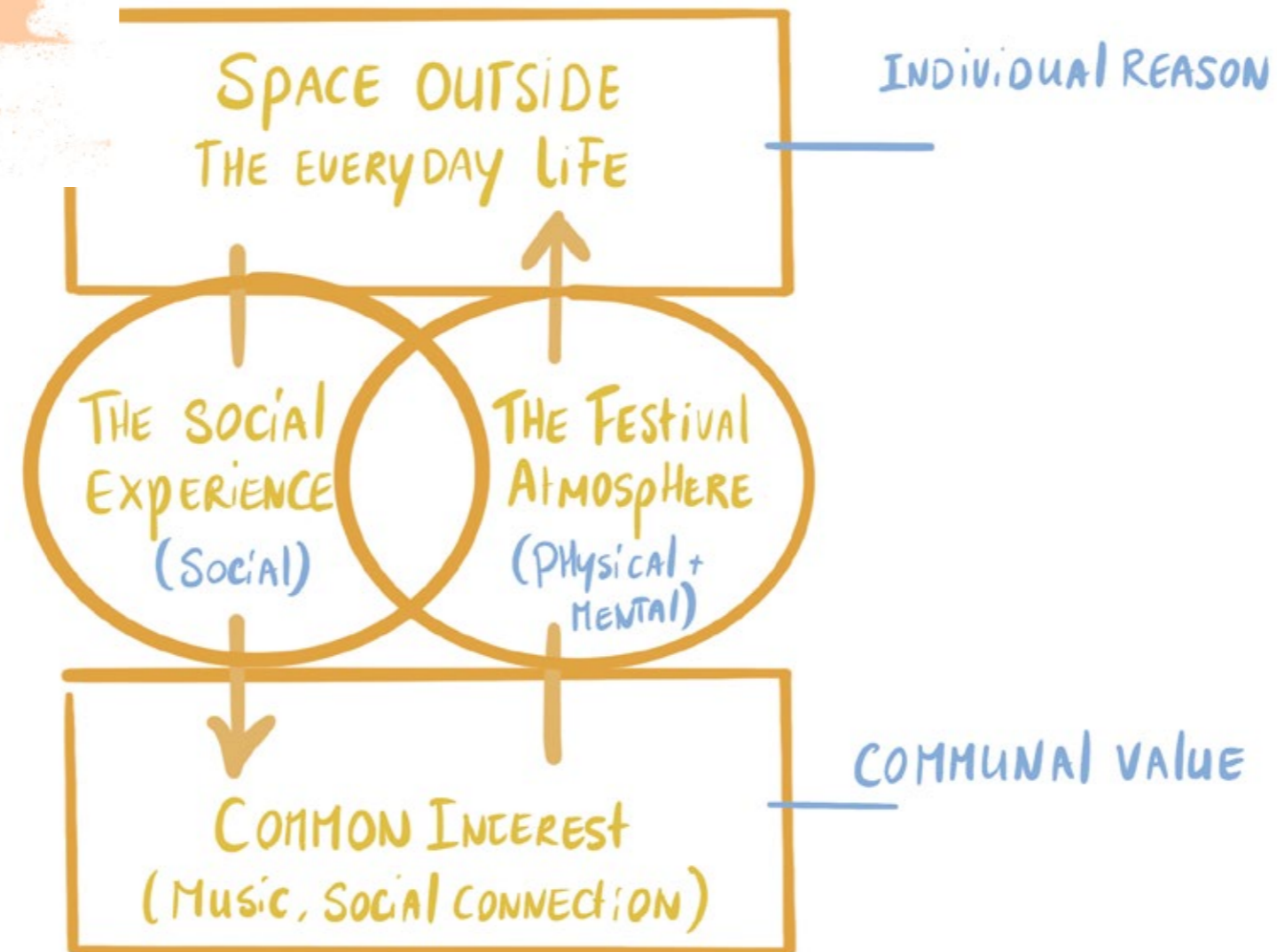

- Escape and Relaxation
- Socialization,
- Novelty
- Cultural enrichment,
- Education,
- Hedonism and co-creation

Problems faced by the industry

Their value is often overlooked

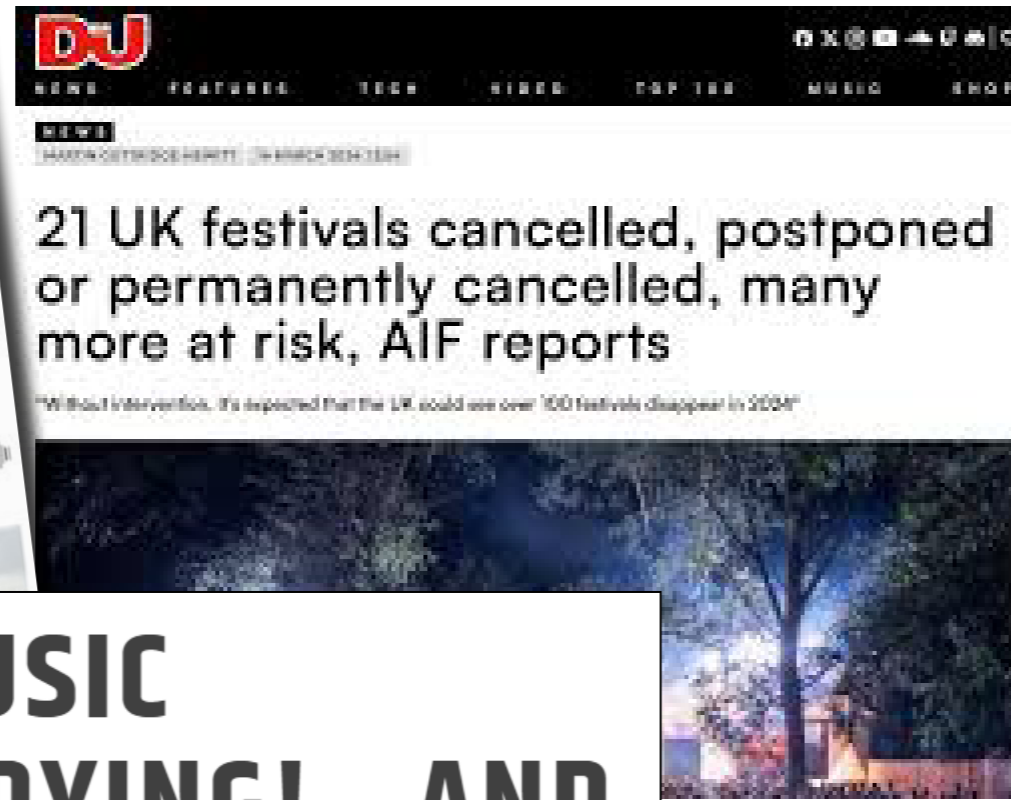

AUSTRALIA'S MUSIC FESTIVALS ARE DYING! ..AND IT'S NOT BECAUSE PEOPLE STOPPED DANCING

Once upon a time, music festivals were the beating heart of an Australian summer. You'd scrape together your last \$280, brave the dust or mud or both, and get spiritually reborn somewhere between a D-floor mosh pit and a \$14 souvlaki stand. They were sweaty, euphoric, chaotic – and they were ours.

Now? The stages are silent. The porta-loos are packed away. And the only thing hitting higher notes than a festival DJ are the insurance premiums.

The emphasis has often been on financial gain and what benefits they produce for the local area

Problems faced by the industry

Their value is often overlooked



AUSTRALIA'S MUSIC FESTIVALS ARE DYING! ..AND IT'S NOT BECAUSE PEOPLE STOPPED DANCING

Once upon a time, music festivals were the beating heart of an Australian summer. You'd scrape together your last \$280, brave the dust or mud or both, and get spiritually reborn somewhere between a D-floor mosh pit and a \$14 souvlaki stand. They were sweaty, euphoric, chaotic – and they were ours.

Now? The stages are silent. The porta-loos are packed away. And the only thing hitting higher notes than a festival DJ are the insurance premiums.

Overlooking the importance of having these spaces outside of the every day to escape to

Problems faced by the industry

Operation costs and management

535

music festivals were held in the 2022-23 financial year, including ticketed and free, commercial and community-run.

75%

of music festivals **were first held in the last 13 years**, that is, between 2010 and 2023.

One in ten

music festivals have been in operation for **30 years or more**.

47%

of festival organisers say **rising operational costs** have a severe or major impact on their festival.

39%

of festival organisers say **lack of funding and grants available** has a severe or major impact on their festival.

The two key regulatory barriers for festival organisers are **navigating planning and/or local government/council requirements and navigating police and/or security requirements**.

Problems faced by the industry

Operation costs and management

Competition

Rise in popularity

Short lifespan

535

music festivals were held in the 2022-23 financial year, including ticketed and free, commercial and community-run.

75%

of music festivals **were first held in the last 13 years**, that is, between 2010 and 2023.

One in ten

music festivals have been in operation for **30 years or more**.

47%

of festival organisers say **rising operational costs** have a severe or major impact on their festival.

39%

of festival organisers say **lack of funding and grants available** has a severe or major impact on their festival.

The two key regulatory barriers for festival organisers are **navigating planning and/or local government/council requirements and navigating police and/or security requirements**.

Operation costs through the roof

Not enough funding

increasing difficulties with requirements

Problems faced by the industry

Ticketsales and proximity

Sustainability, weather and cancellations - especially for smaller festivals

Competition

Rise in popularity

Short lifespan

535

music festivals were held in the 2022-23 financial year, including ticketed and free, commercial

75%

of music festivals were first held in the last 13 years, that is, between 2010 and 2023.

One in ten

music festivals have been in operation for 30 years or more.

The main barriers young Australians experience are:

- **cost of tickets/entry** (56% compared to 55% of Australians aged 25 and over)
- **events being too far away or not near where they live** (42% compared to 39% of Australians aged 25 and over)
- **difficulty finding the time** (37% compared to 24% of Australians aged 25 and over).

4
of
sc
costs have a severe or major impact on their festival.

and grants available has a severe or major impact on their festival.

and/or local government/council requirements and navigating police and/or security requirements.

Operation costs through the roof

Not enough funding

increasing difficulties with requirements

Establishing the role of the architect in festival spaces



Festival characteristics

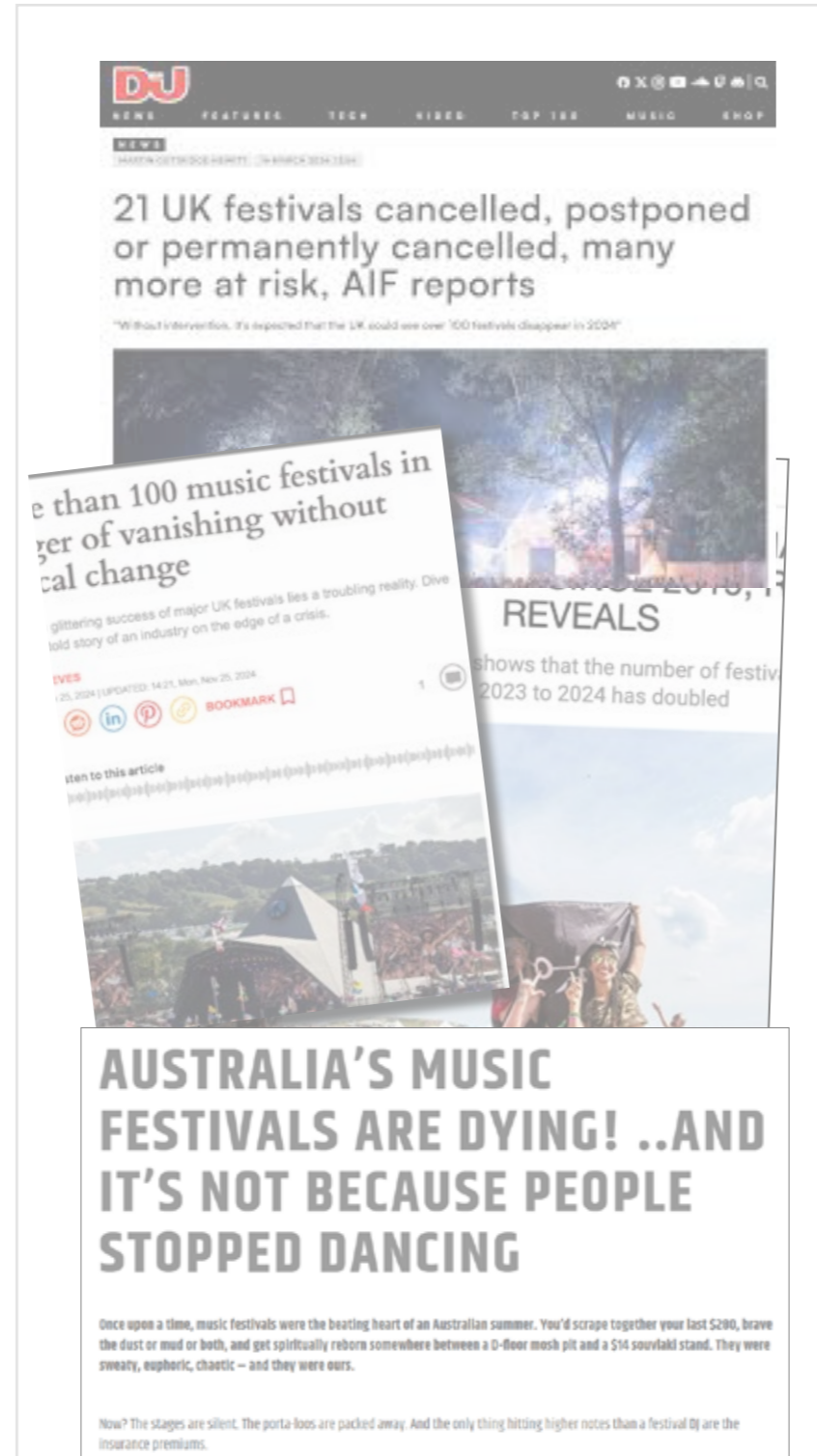

Why they matter



Establishing the role of the architect in festival spaces

Establishing the role of the architect in festival spaces

What happens at a festival space and what is the architects' place?

Very little research on how these environments can be shaped

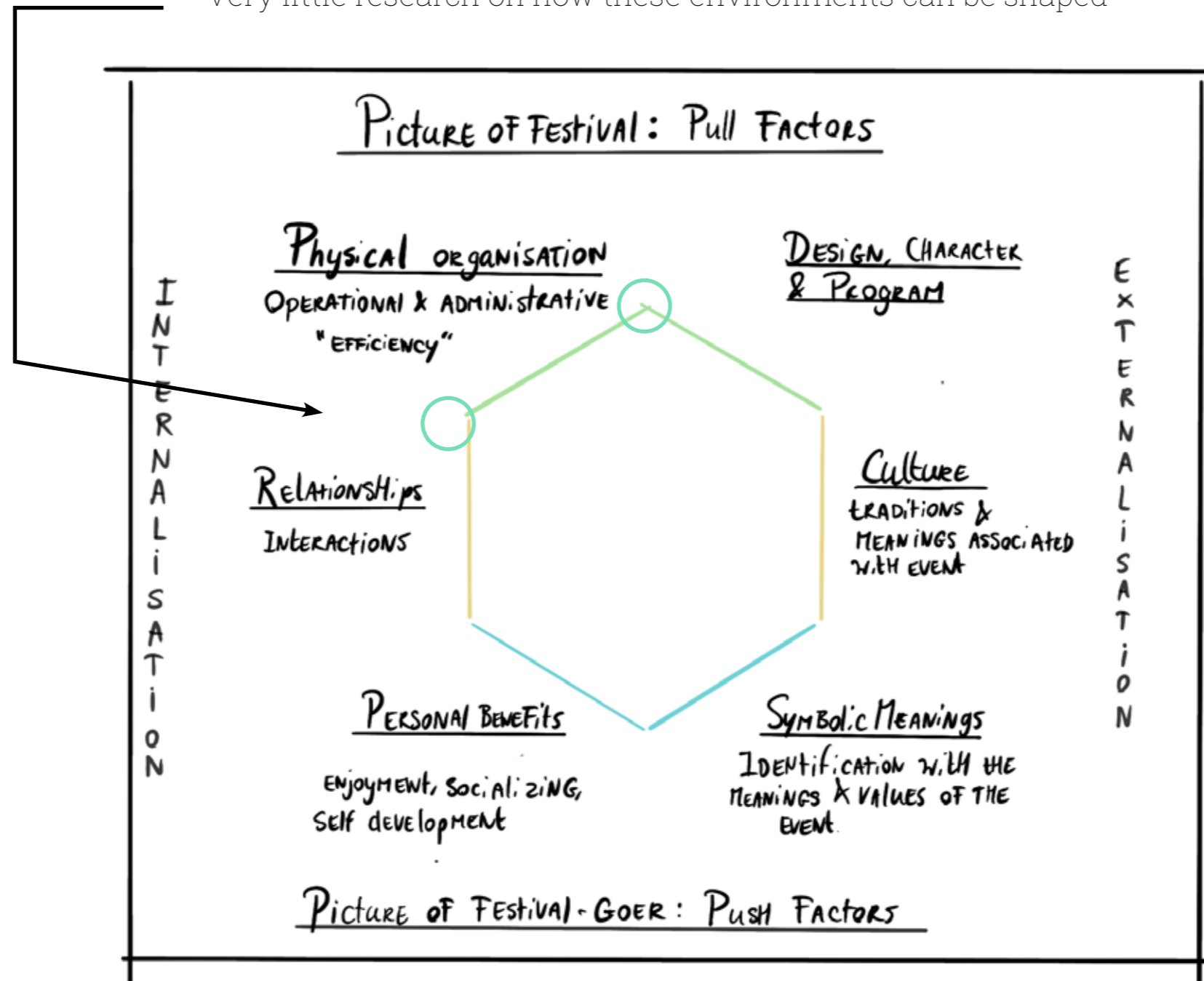

The prism of event experience , (adapted) Morgan, 2007.

Establishing the role of the architect in festival spaces

What happens at a festival space and what is the architects' place?

Very little research on how these environments can be shaped

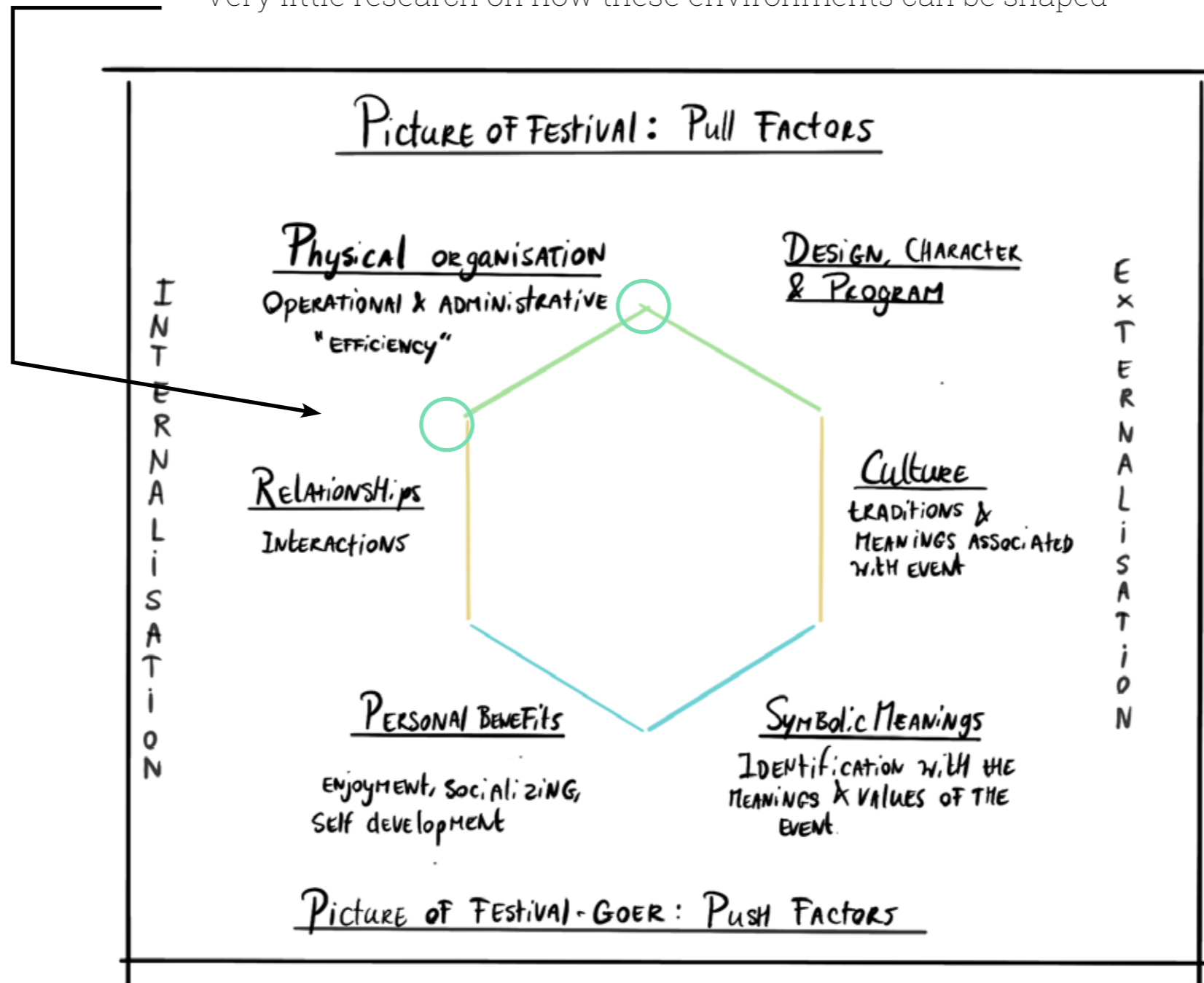

The prism of event experience , (adapted) Morgan, 2007.

The mediator between the needs of the local place, event organisers and the attendees

Establishing the role of the architect in festival spaces

What happens at a festival space and what is the architects' place?

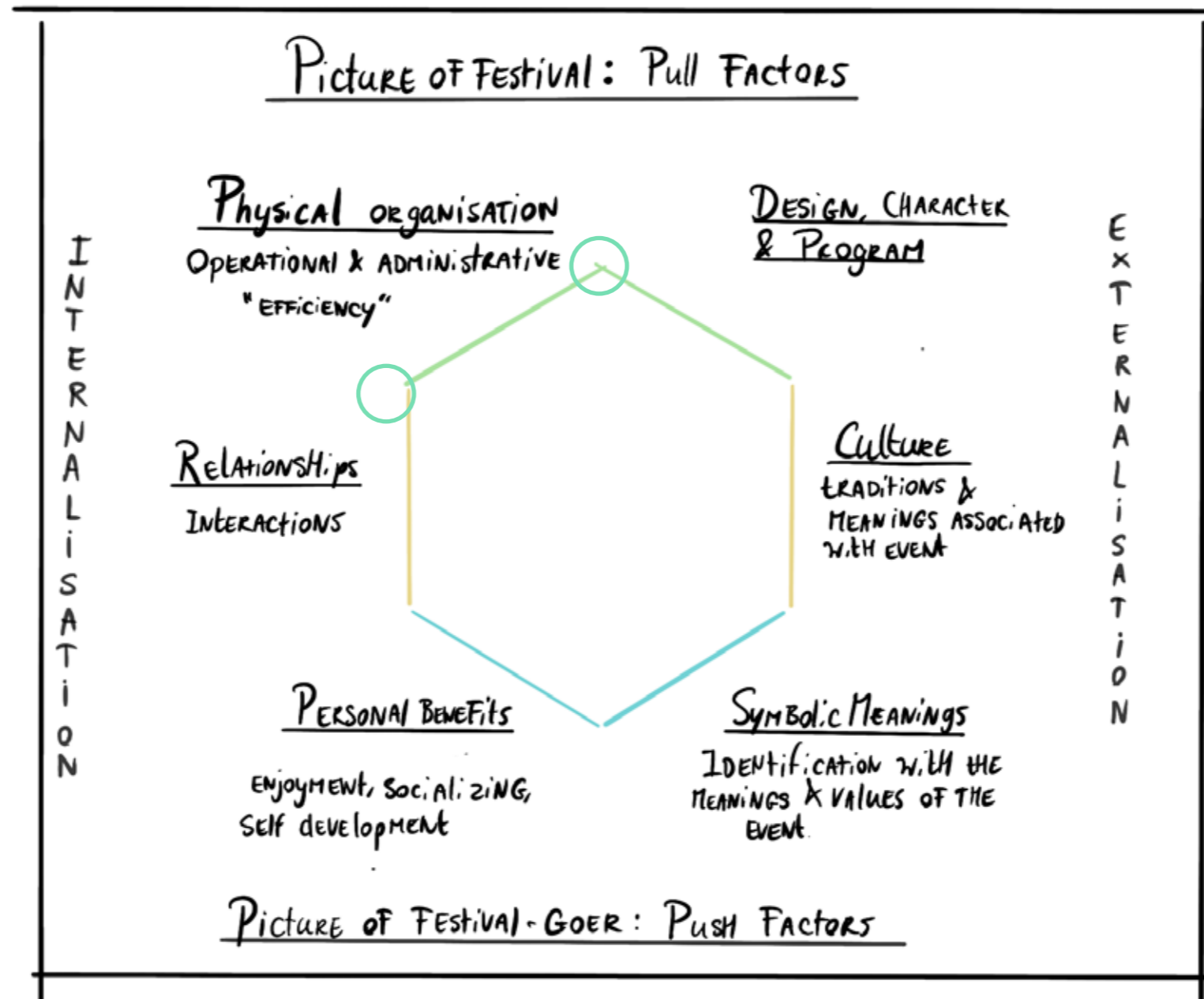

The prism of event experience , (adapted) Morgan, 2007.

The mediator between the needs of the local place, event organisers and the attendees
Facilitator of experience, use of space, encounters and interactions through lay out and program

Establishing the role of the architect in festival spaces

What happens at a festival space and what is the architects' place?

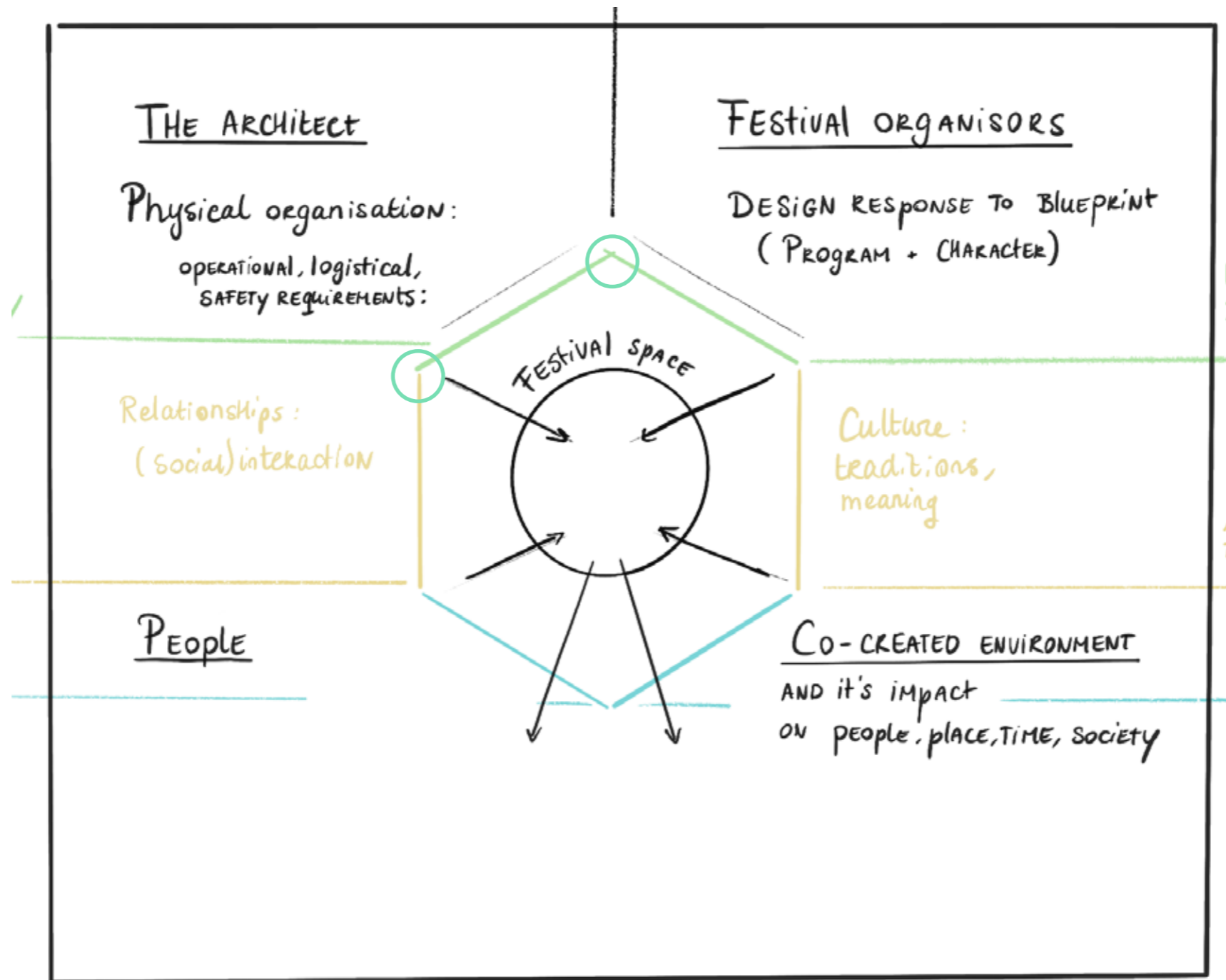

The prism of event experience , (adapted) Morgan, 2007.

The mediator between the needs of the local place, event organisers and the attendees
Facilitator of experience, use of space, encounters and interactions through a system of spatial interventions

Establishing the role of the architect in festival spaces

Investigating the role of spatial design on experience and behaviour



Accessibility

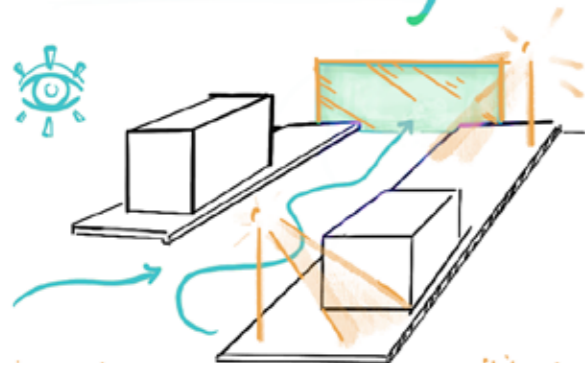

Props

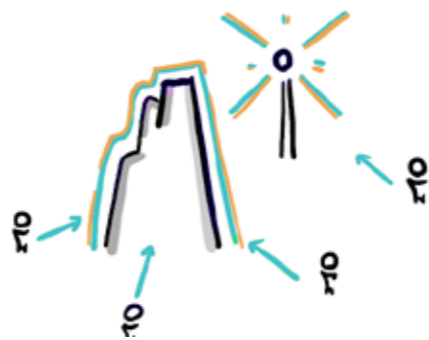

ENCLOSURES & AREAS

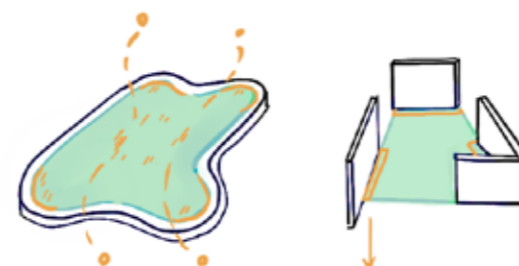

EDGES & THRESHOLDS

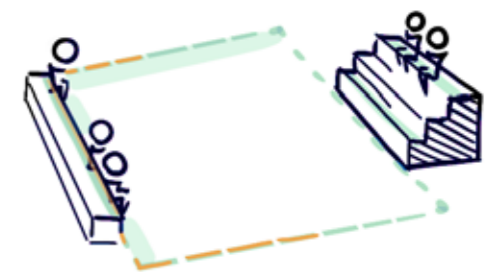

Spatial factors that influence our interactions, experiences and behaviours

Establishing the role of the architect in festival spaces

Investigating the role of spatial design on experience and behaviour



LINKAGE & FAMILIARITY

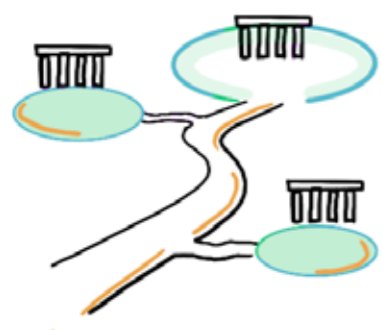

NATURAL LANDSCAPE



COMFORT



LIVELINESS



Spatial factors that influence our interactions, experiences and behaviours

Establishing the role of the architect in festival spaces

Investigating the role of spatial design on experience and behaviour

Accessibility

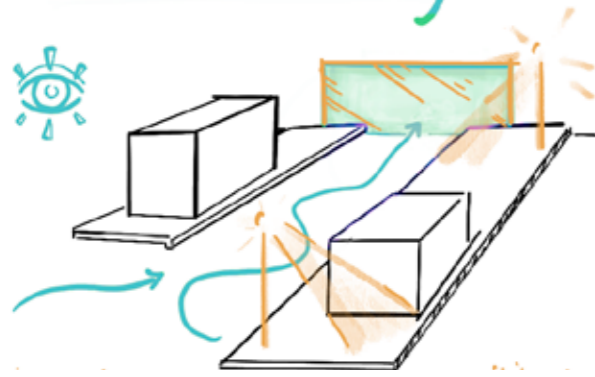

Props

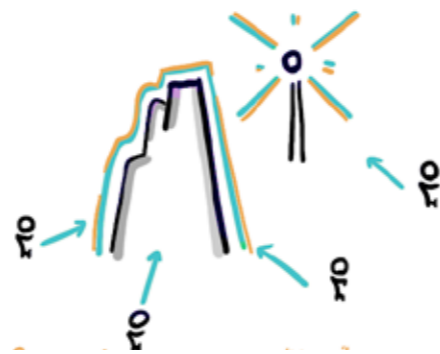

ENCLOSURES & AREAS

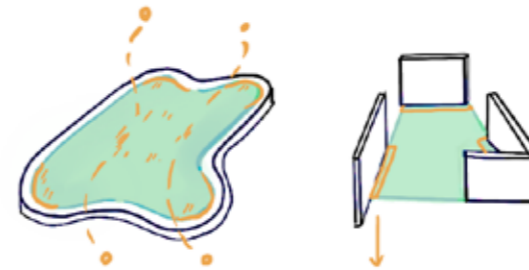

EDGES & THRESHOLDS

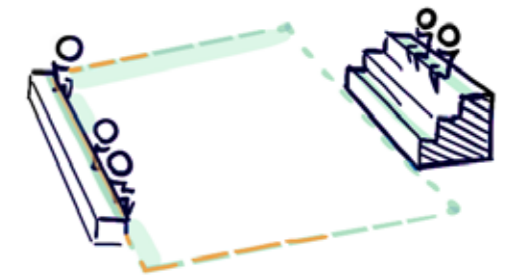

LINKAGE & FAMILIARITY

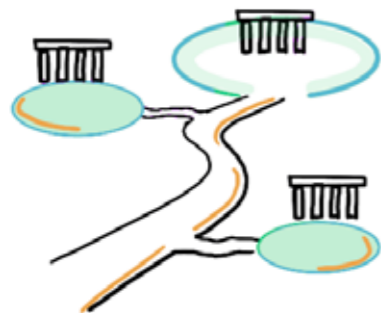

NATURAL LANDSCAPE



COMFORT



LIVELINESS



Spatial factors that influence our interactions, experiences and behaviours

Establishing the role of the architect in festival spaces

Applying spatial design factors with industry requirements

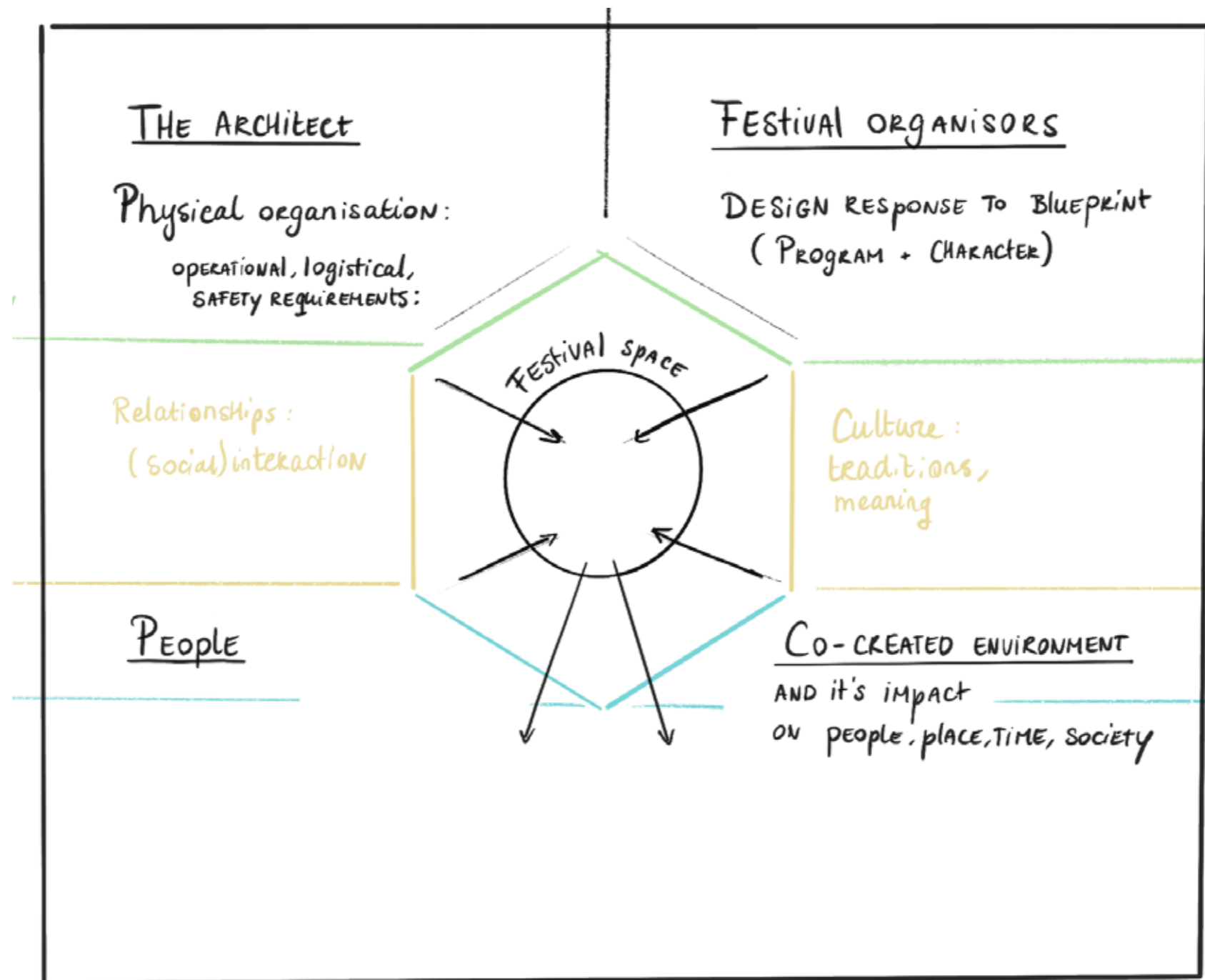

The prism of event experience , (adapted) Morgan, 2007.

The facilitator of the frame, combining spatial and structural knowledge, industry needs and requirements and inviting people to engage through a system of spatial interventions

Establishing the role of the architect in festival spaces

Applying spatial design factors with industry requirements

municipal and logistical requirements

organisers' wants and needs

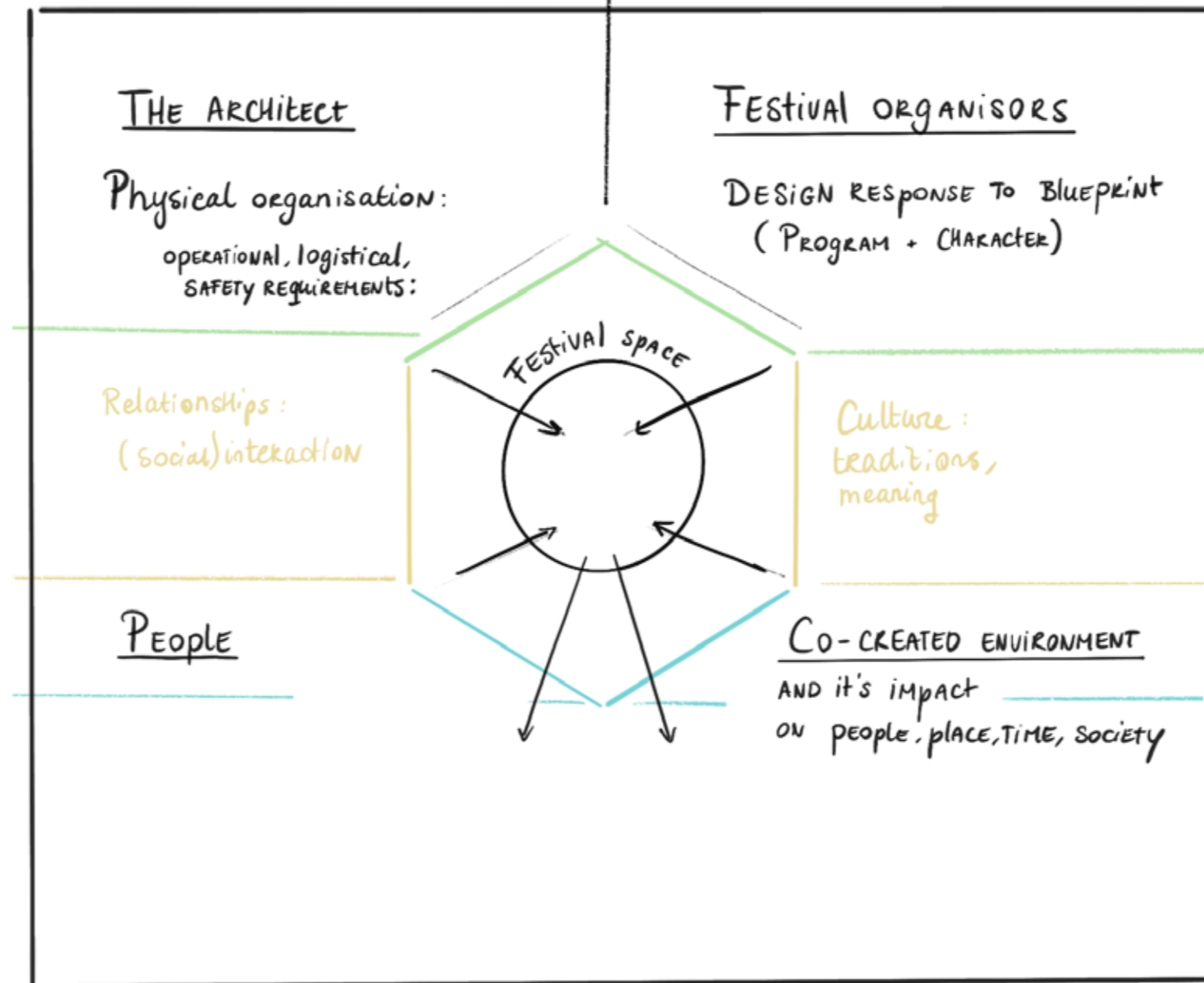

The prism of event experience , (adapted) Morgan, 2007.

The facilitator of the frame, combining spatial and structural knowledge, industry needs and requirements and inviting people to engage through a system of spatial interventions

Architecture as facilitating agent: exploring architecture's position in spatial relationships through festival spaces

Program

An introduction to festival spaces	Location	Festival I.	The process
Why they matter	Preparing the site	Festival II.	What's next
Problems faced by the industry			
Establishing the role of the architect in festival spaces	Spatial interventions	Other set ups	Reflecion

Research -
An introduction to
festival spaces

Design -
Program & structure

Experience -
The first trials

Closing act

Location

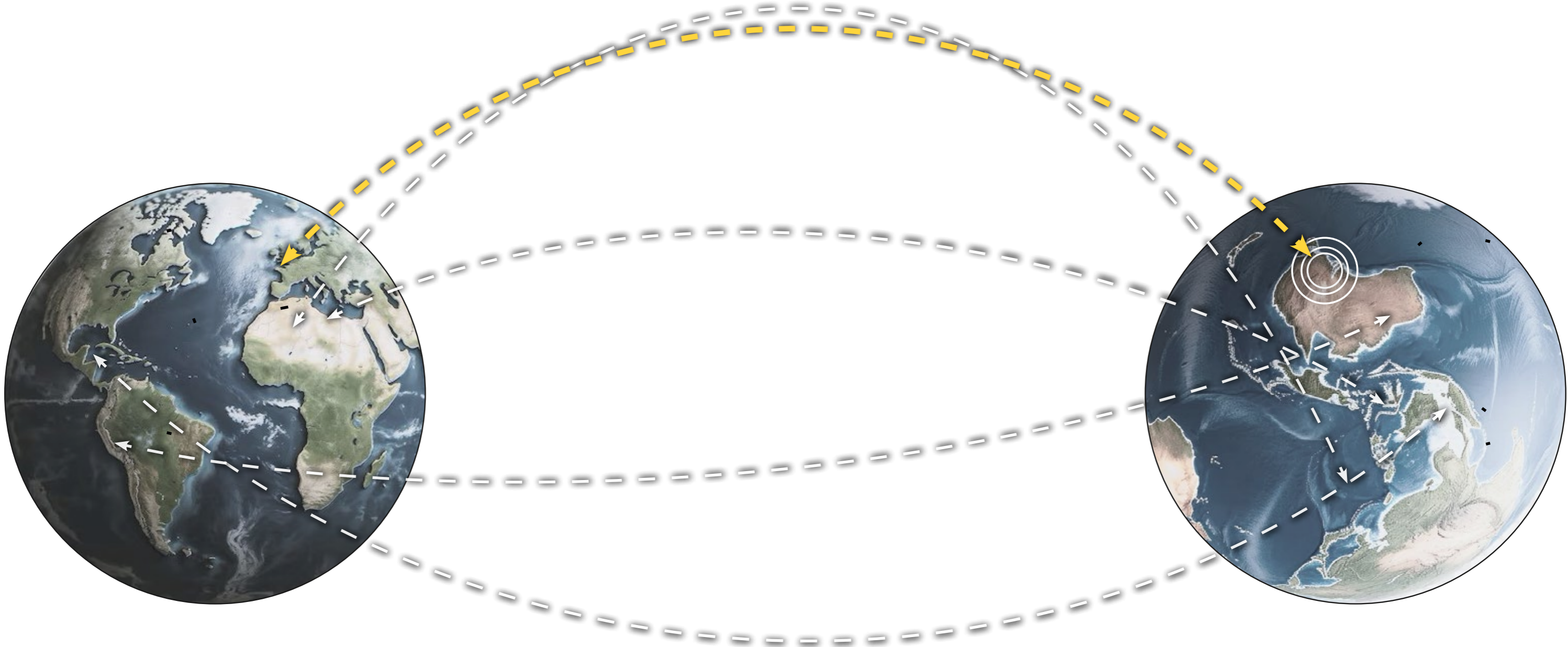

Birrarung Marr, Melbourne, Australia

Location



Birrarung Marr, Melbourne, Australia

Location

Infrastructural knot

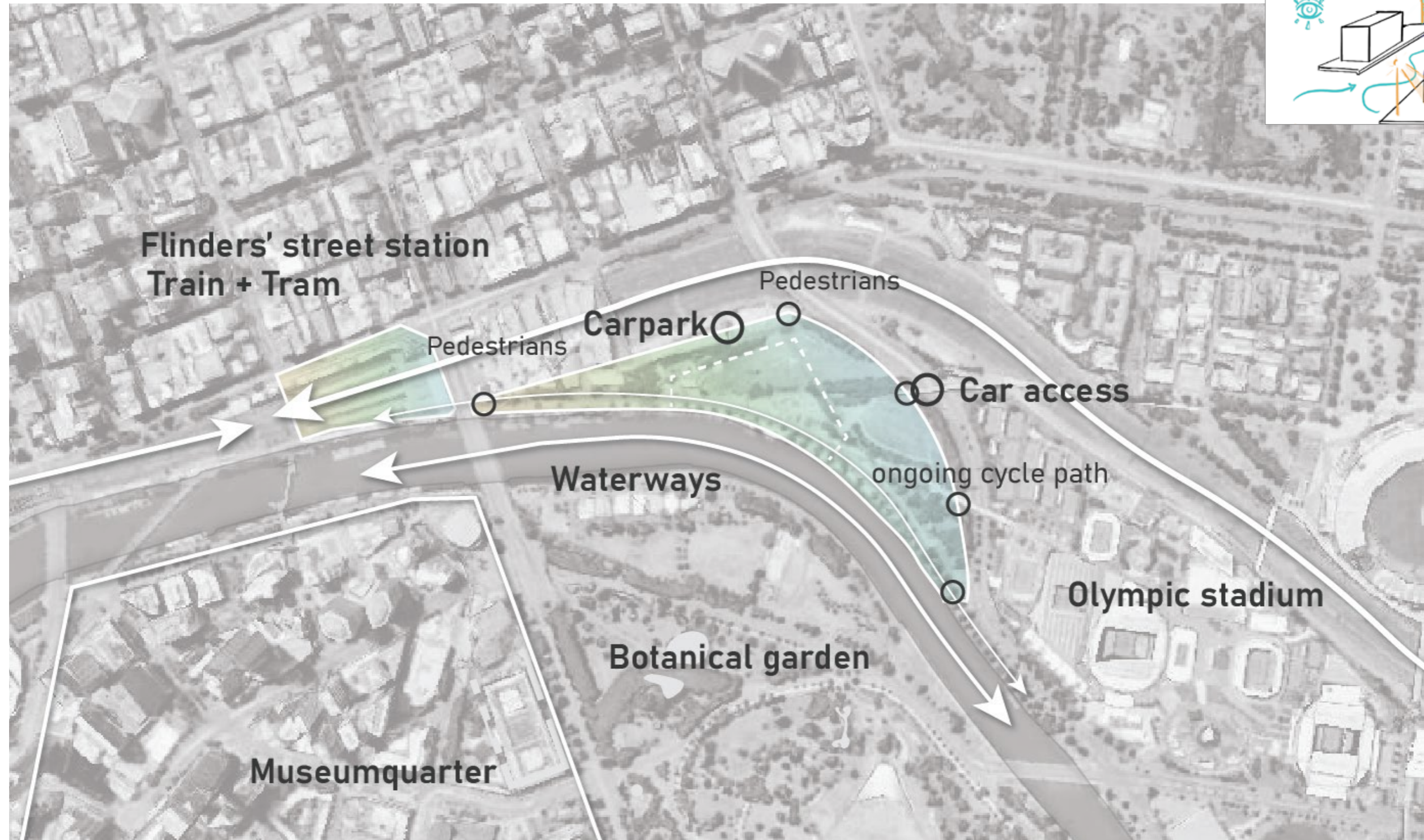

Birrarung Marr, Melbourne, Australia

Location

Historically a place of gathering, celebrations and significant site for first nations people of the kulin nation



Artpiece of place, Reimagining Birrarung, artist unknown

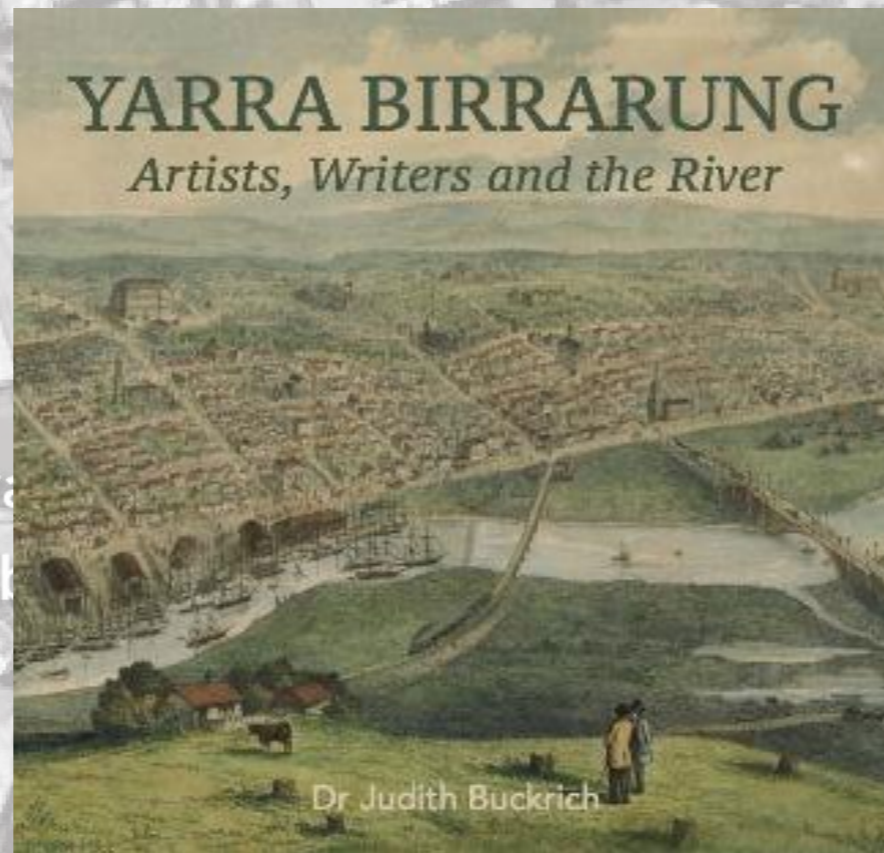

Importance of river

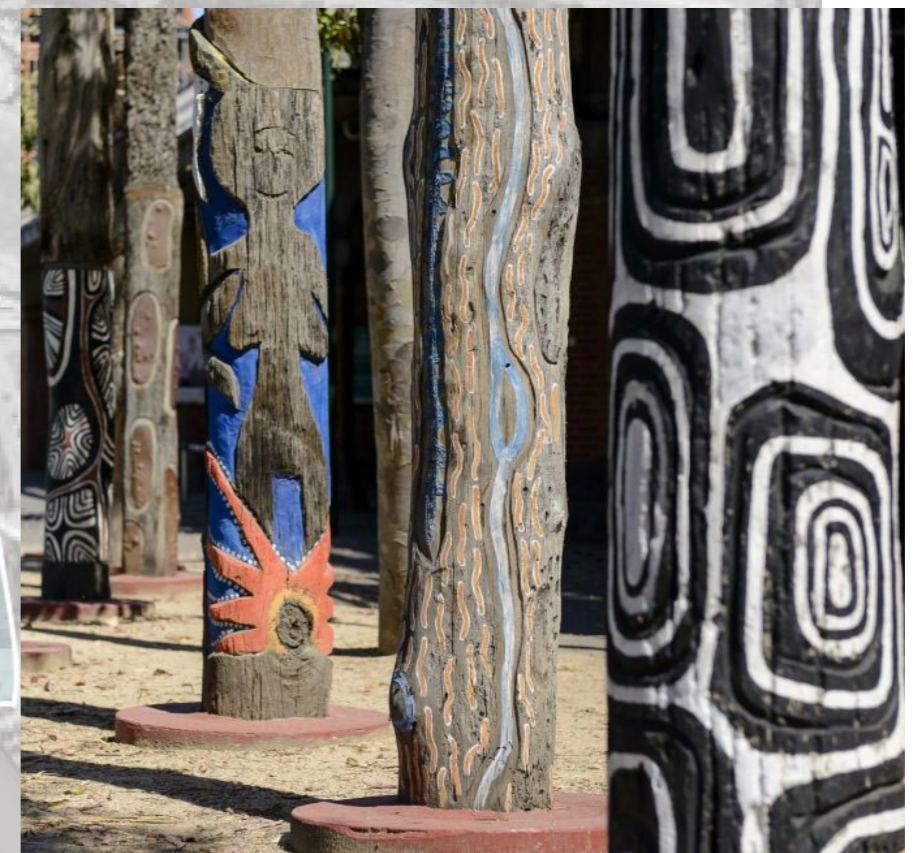

Contemporary indigenous totems

Birrarung Marr, Melbourne, Australia

Location

Forward to now: A public gravelfield in the heart of the city

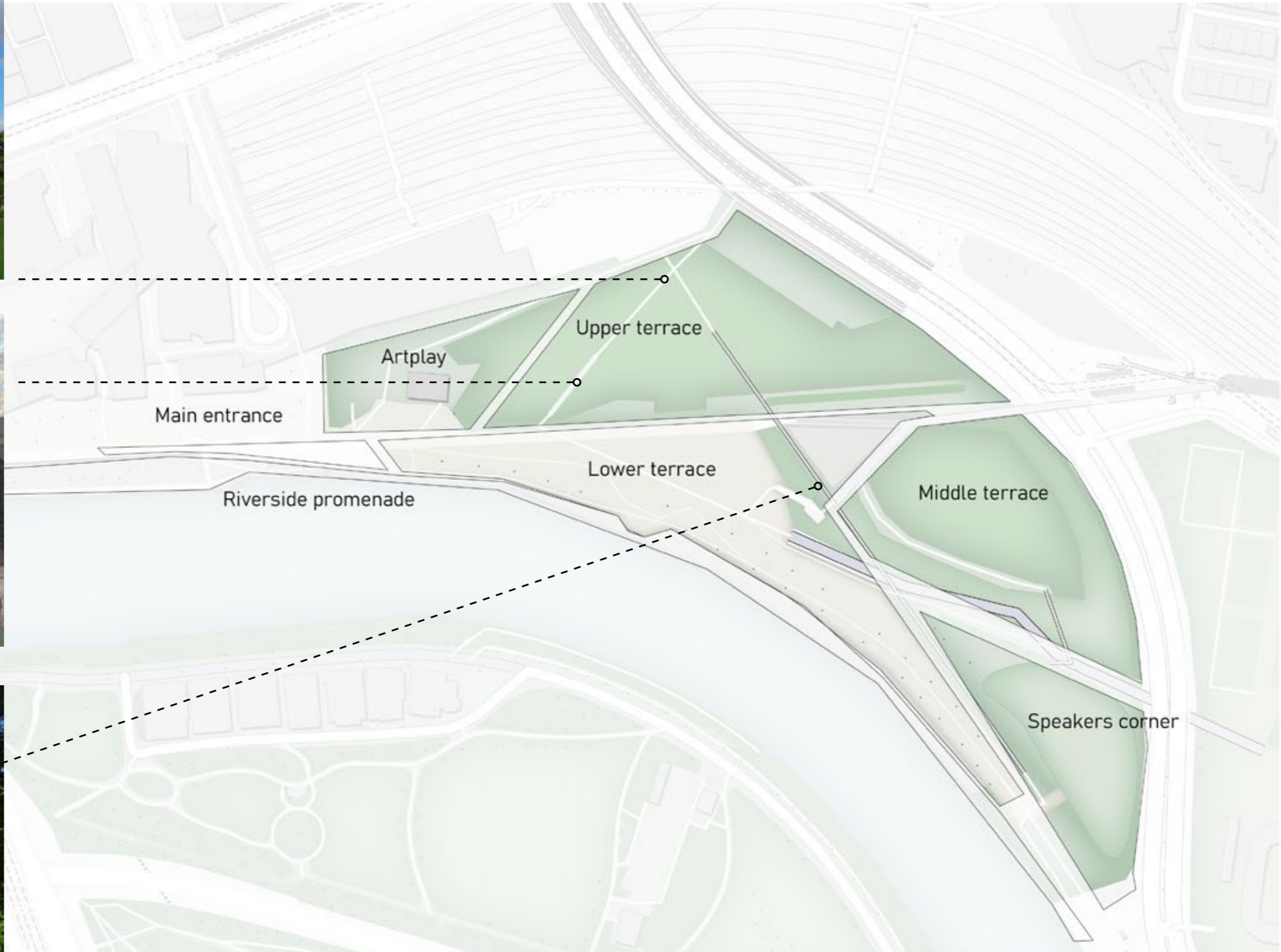

Birrarung Marr, Melbourne, Australia

Location

some cultural remains and monuments on site



Totems on site



Birrarung Wilam



Speakers' corner

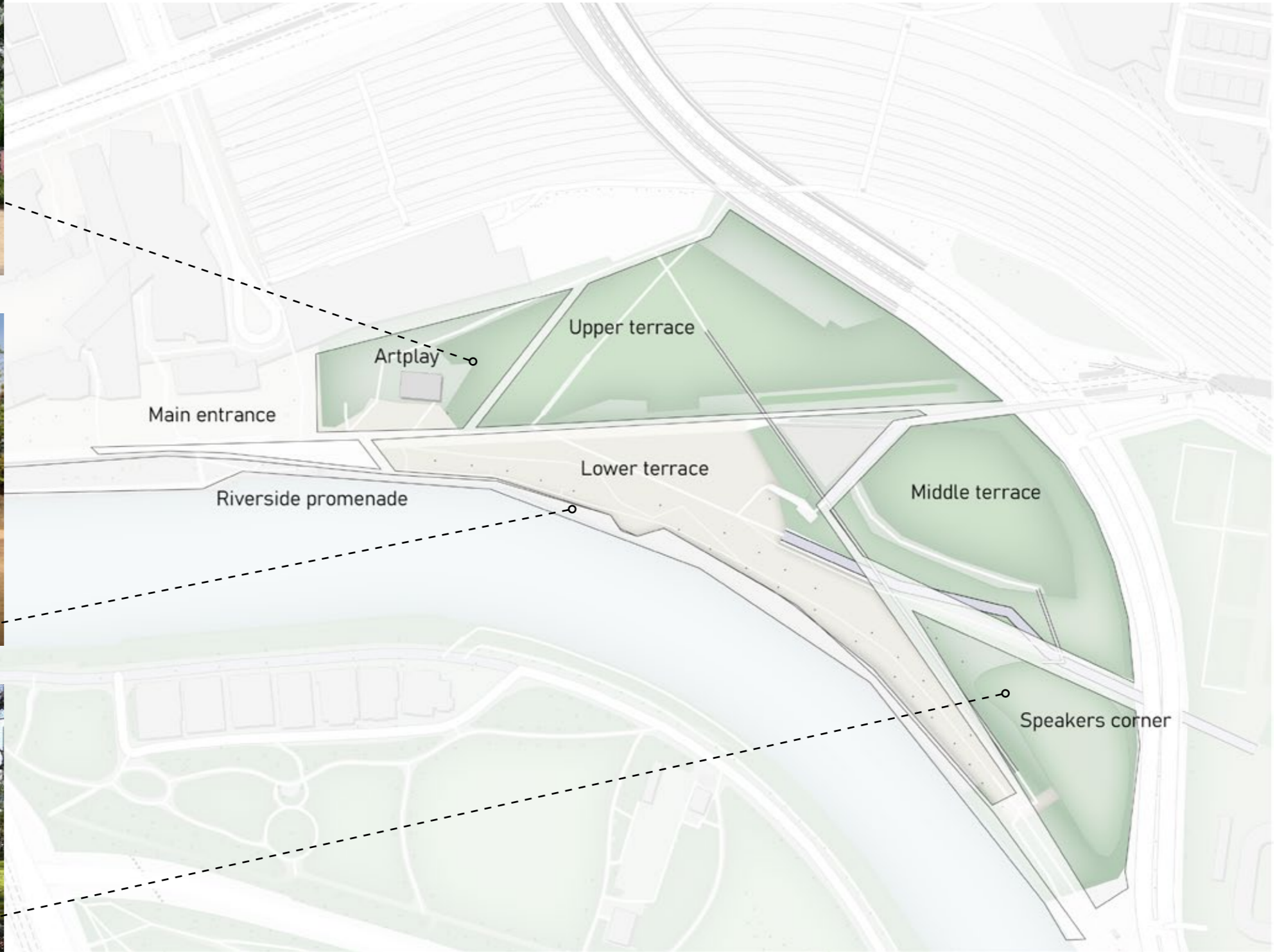

Birrarung Marr, Melbourne, Australia

Location

Climate and landscape

Wind, seasons and sunlight

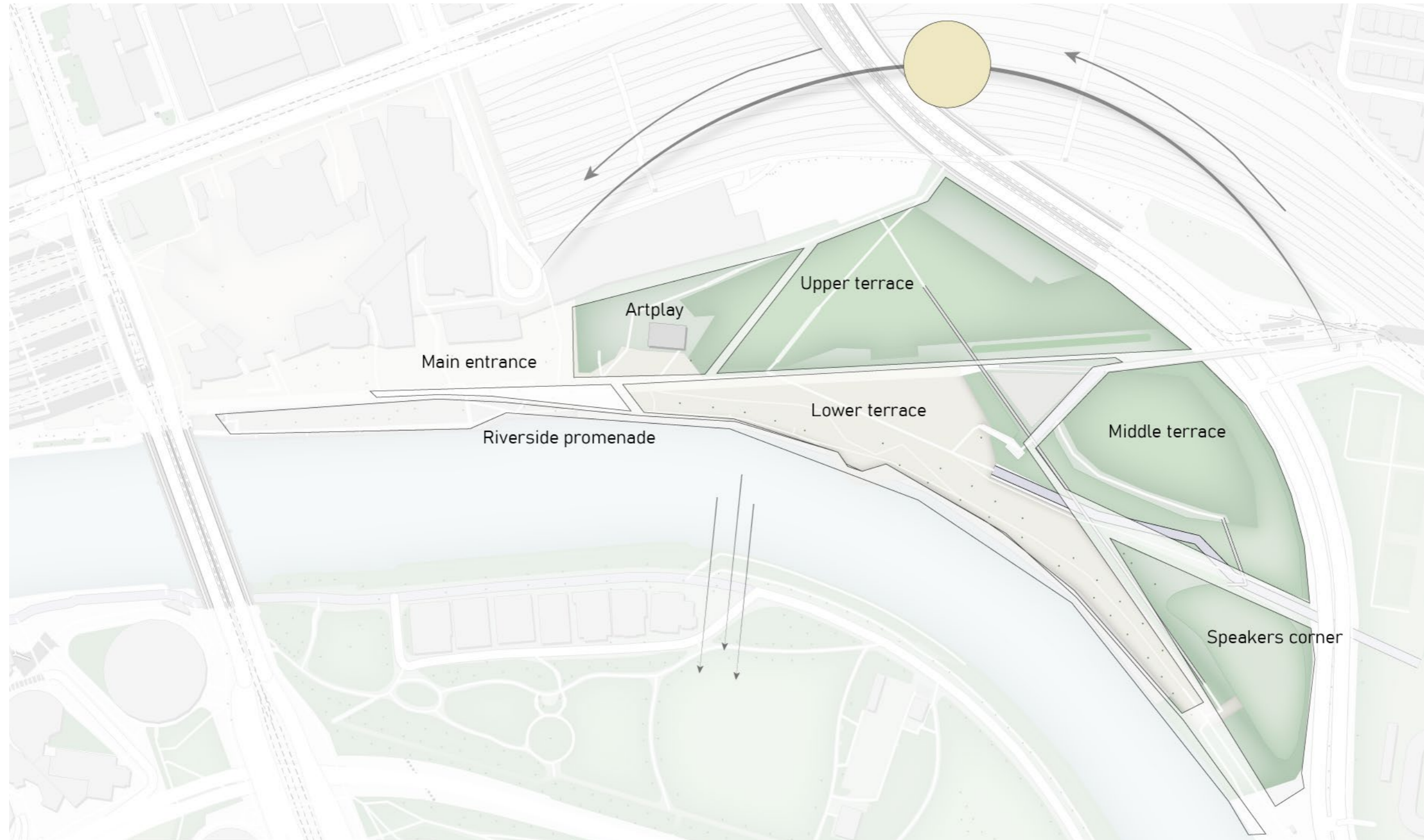

Birrarung Marr, Melbourne, Australia

Location

Climate and landscape
Winter

Wind, seasons and sunlight

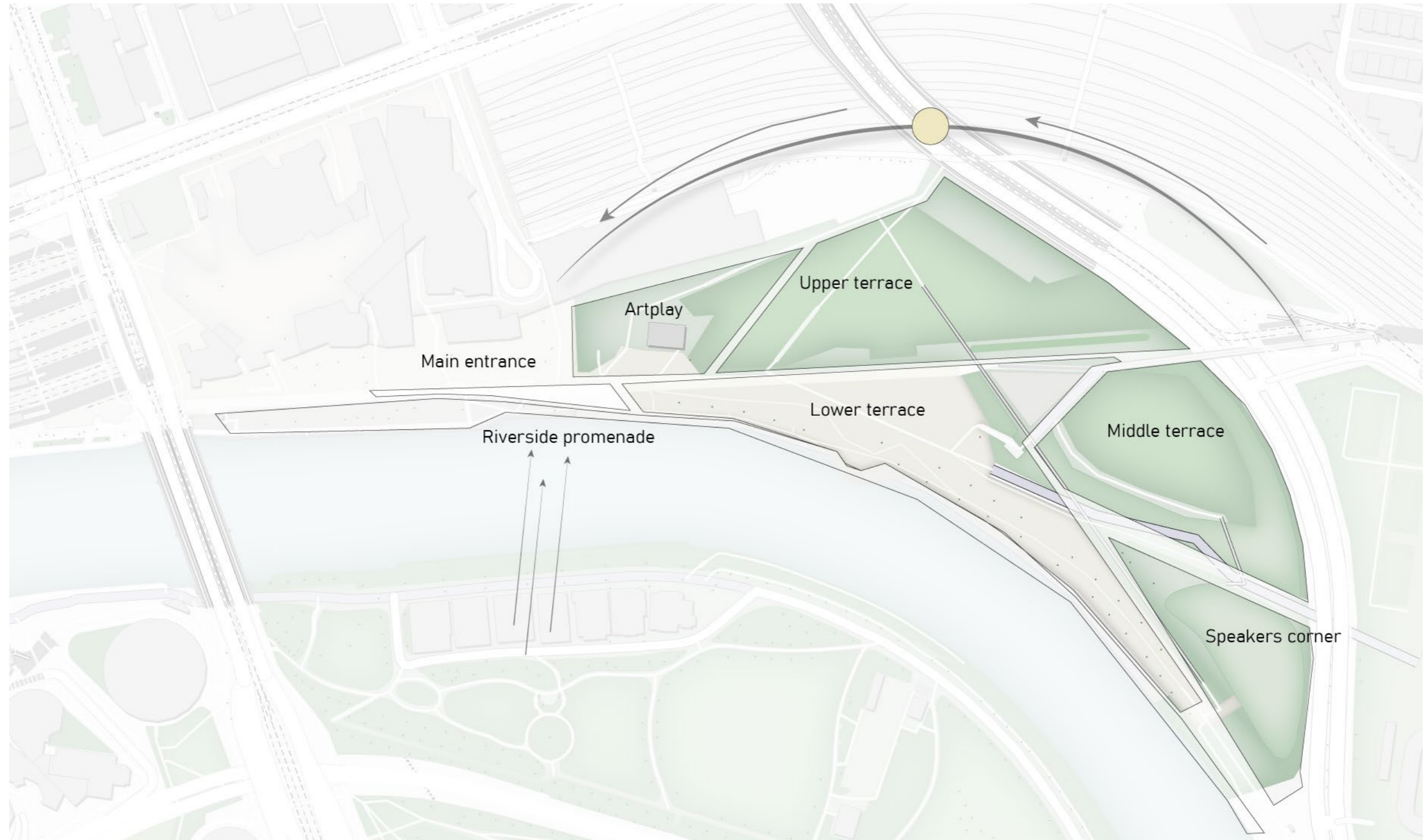

Location

Climate and landscape
Winter

Wind, seasons and sunlight



Wurjunderi seasons

Location

Climate and landscape

Sandy, silty loam, and vertisol



Preparing the site

Landscape interventions to prepare for future use

Preparing the site

Landscape interventions to prepare for future use

Terrain boundaries

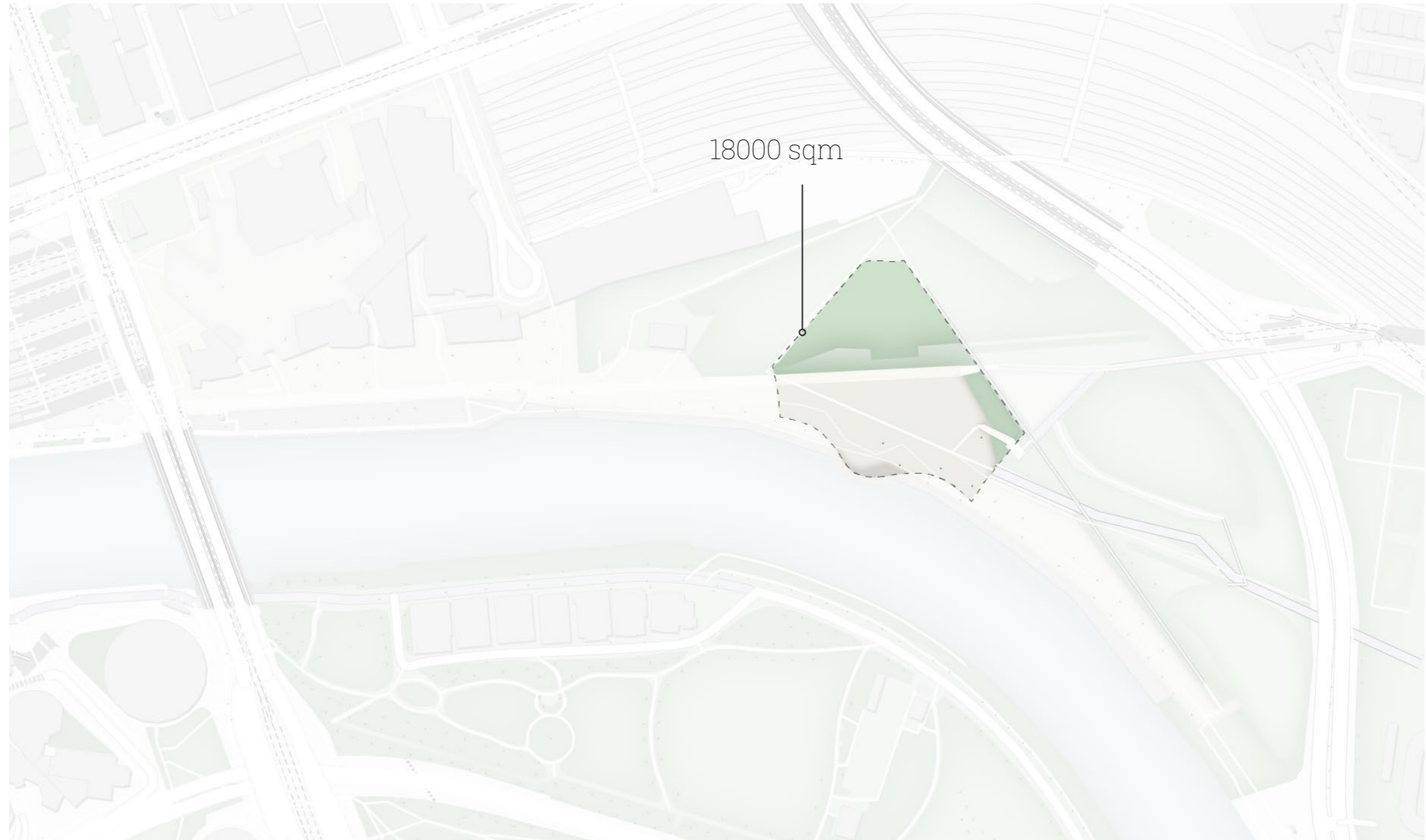

Crowd safety - comfort - accessibility

Preparing the site

Landscape interventions to prepare for future use

Potential expansion

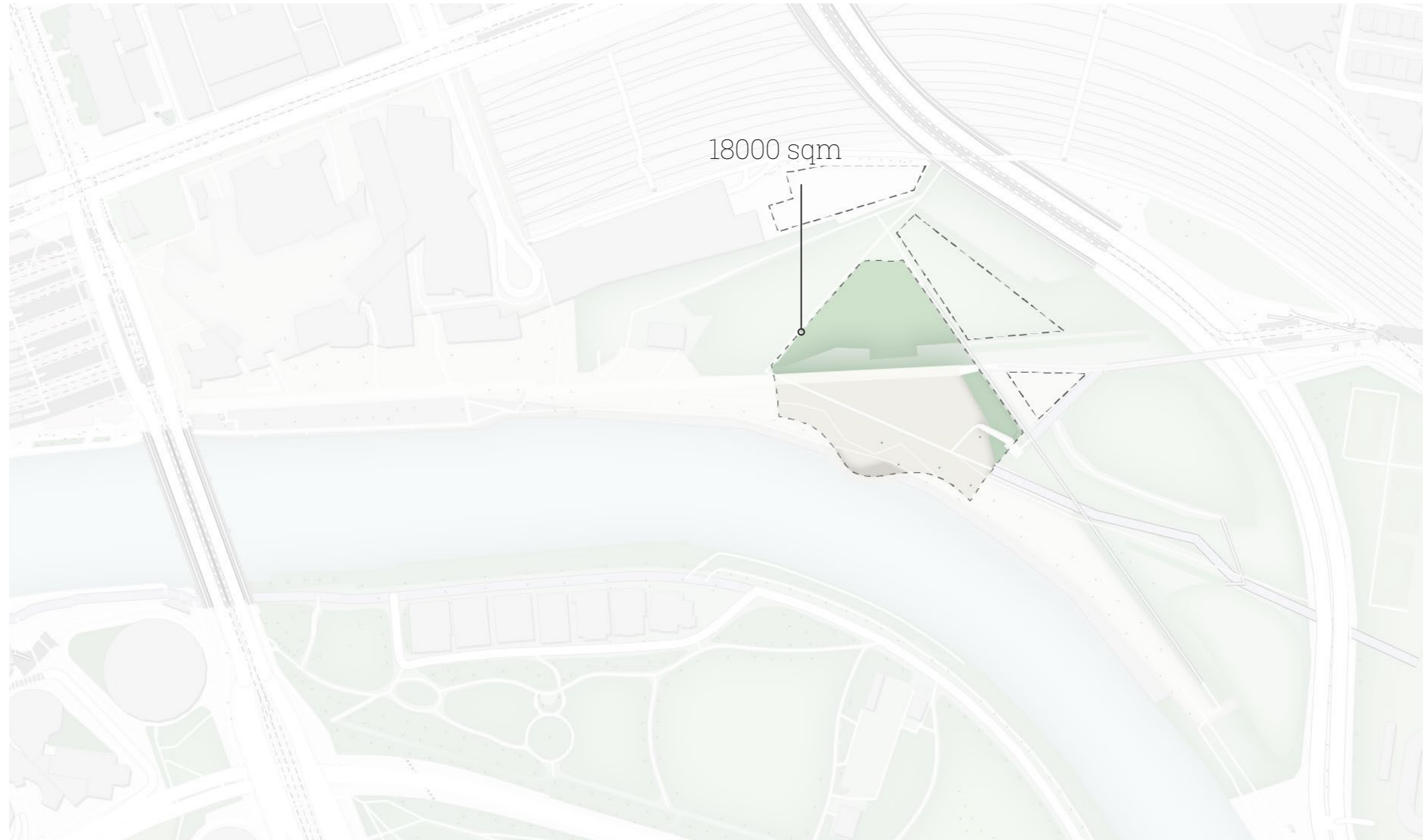

Preparing the site

Landscape interventions to prepare for future use

Capacity and flow

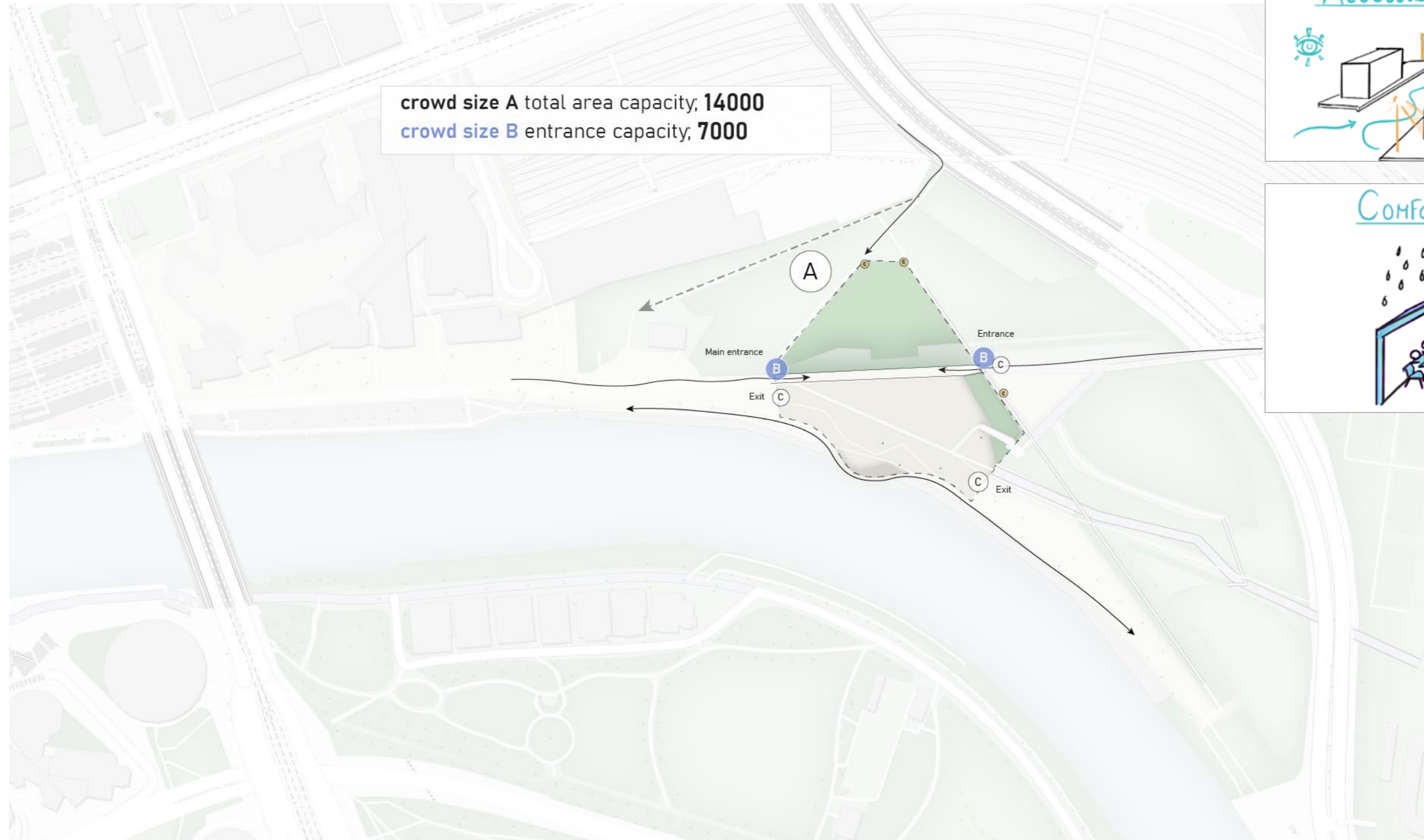

Based on event safety handbooks

Spatial interventions

Landscape - Facilities and program - Facilitating infrastructure - the invitation

Spatial interventions

Landscape

Proofing the terrain for use

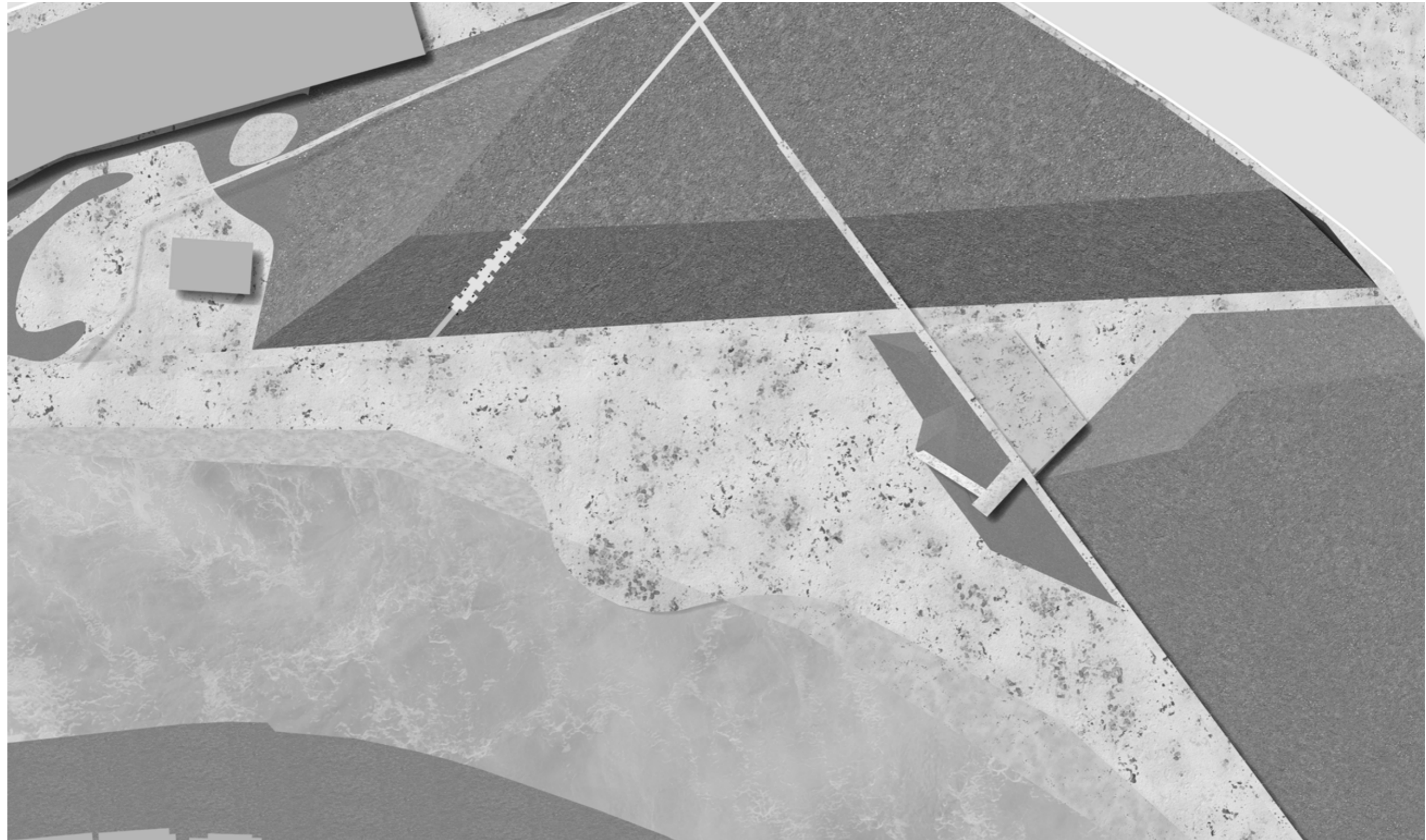

1:400 siteplan

Spatial interventions

Landscape

adjusting groundcover

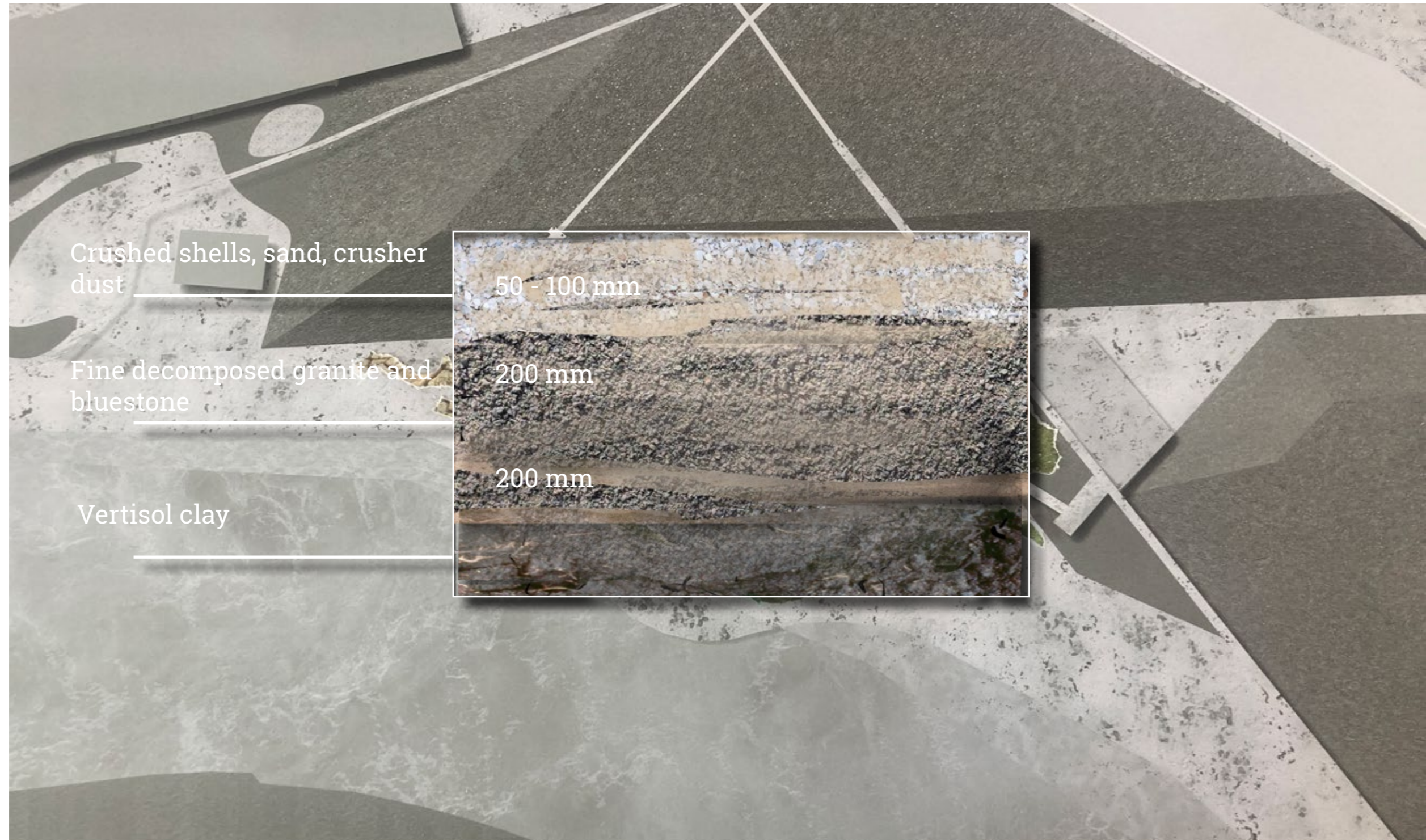

1:400 siteplan

Spatial interventions

Landscape

Creating naturally formed paths through use

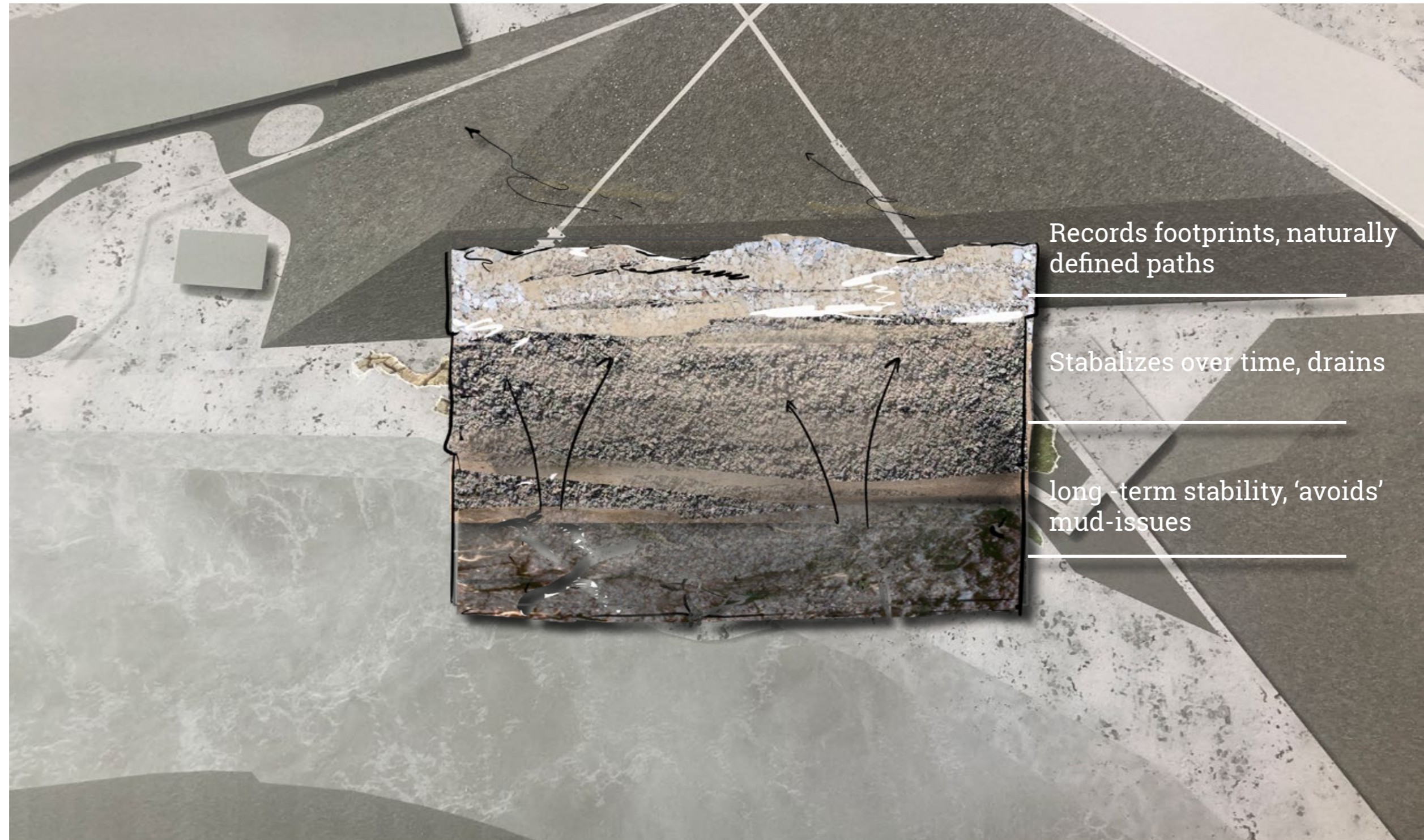

1:400 siteplan

Spatial interventions

Landscape

adjusting groundcover



Woodchips

Image of model

French drainage

Spatial interventions

Landscape



Entrance of site, naturally excavating the path

Spatial interventions

Landscape

12 meter wide

??? meter wide

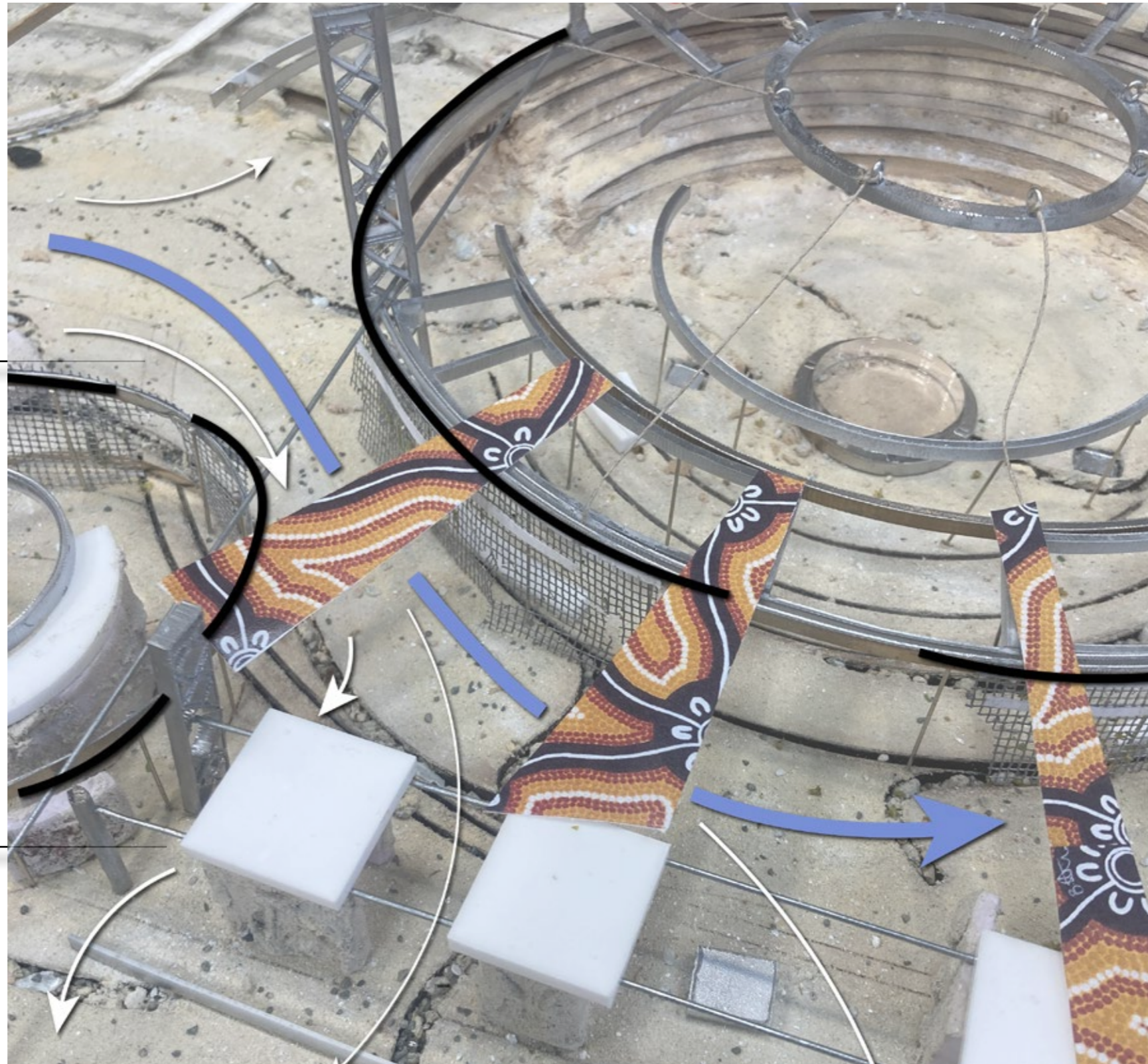

Main thoroughfare 12 meter wide - all other paths are made by users

Spatial interventions

Landscape

12 meters wide

??? meters wide

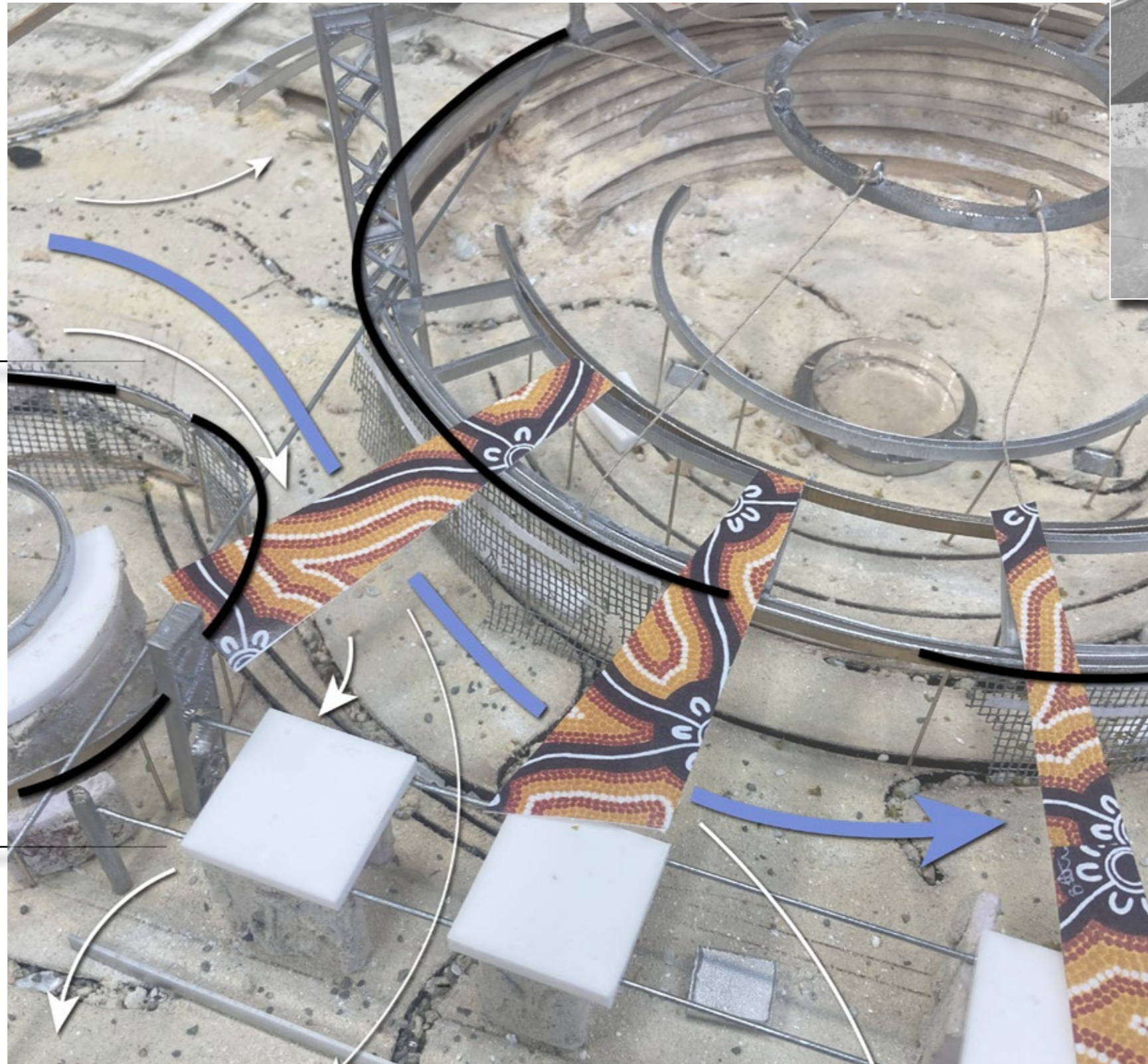

But likely to be in between nodes

Main thoroughfare 12 meter wide - all other paths are made by users

Spatial interventions

Landscape

Planting resilient shrubs



Kangaroo grass



Kidney weed



Weeping grass

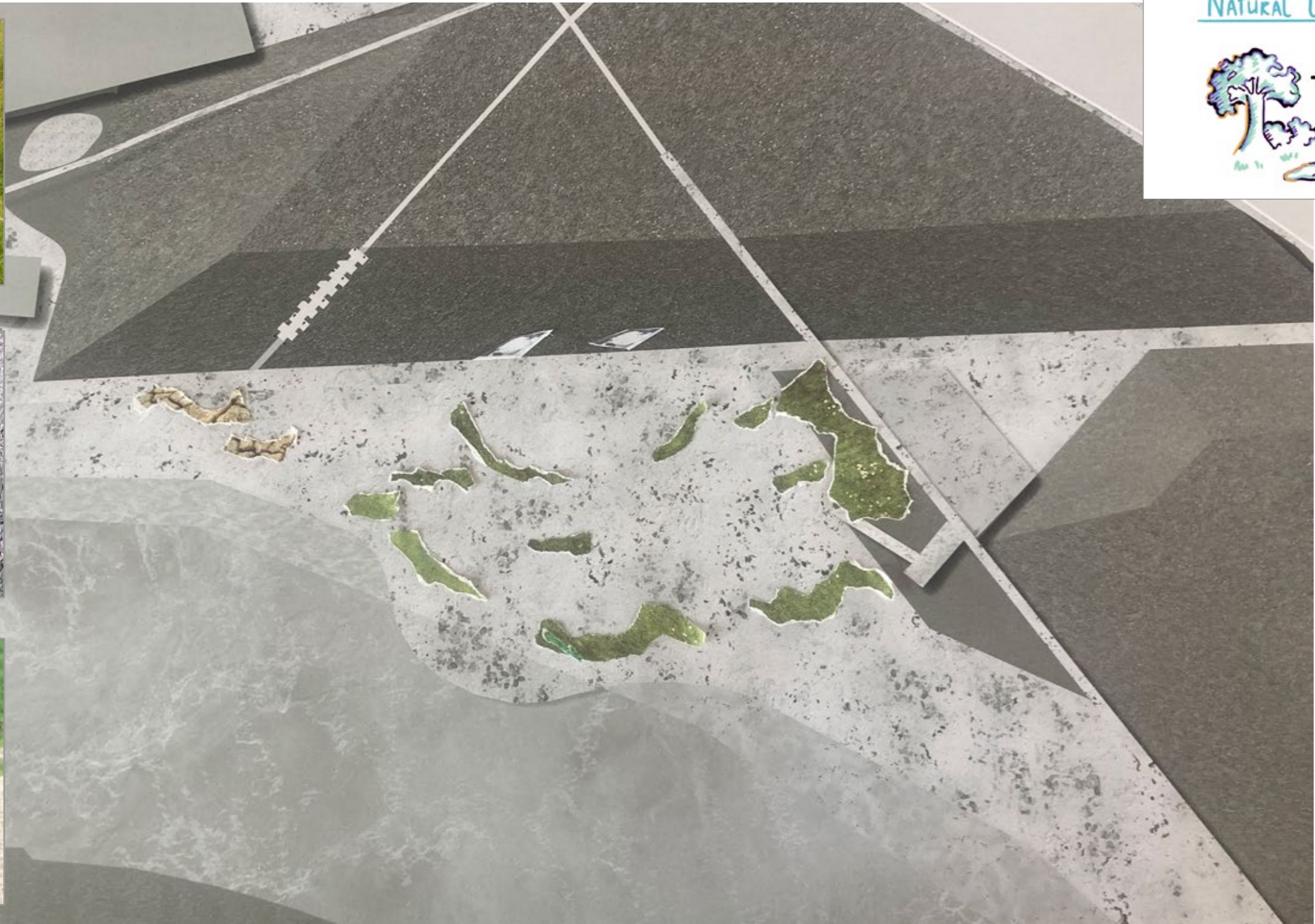

1:400 siteplan - collage

Spatial interventions

Landscape

And seasonal vegetation



Native reed (Phragmites)



Snow gum (eucalyptus)



Mana gum (eucalyptus)

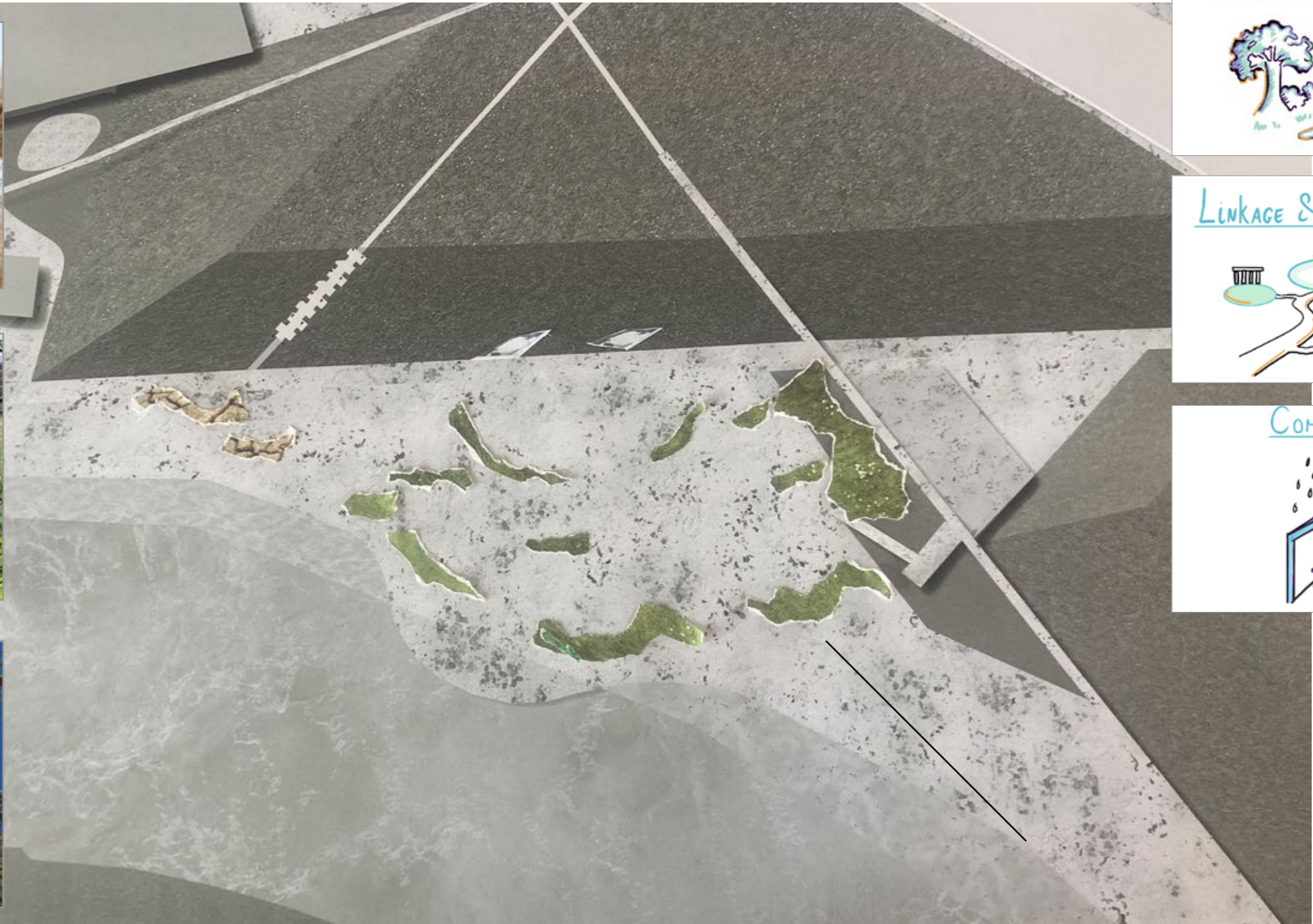

1:400 siteplan - collage



Spatial interventions

Landscape

Connection to historical context



Totems marking sites' use



Eel painting around site



Possum skin cloth

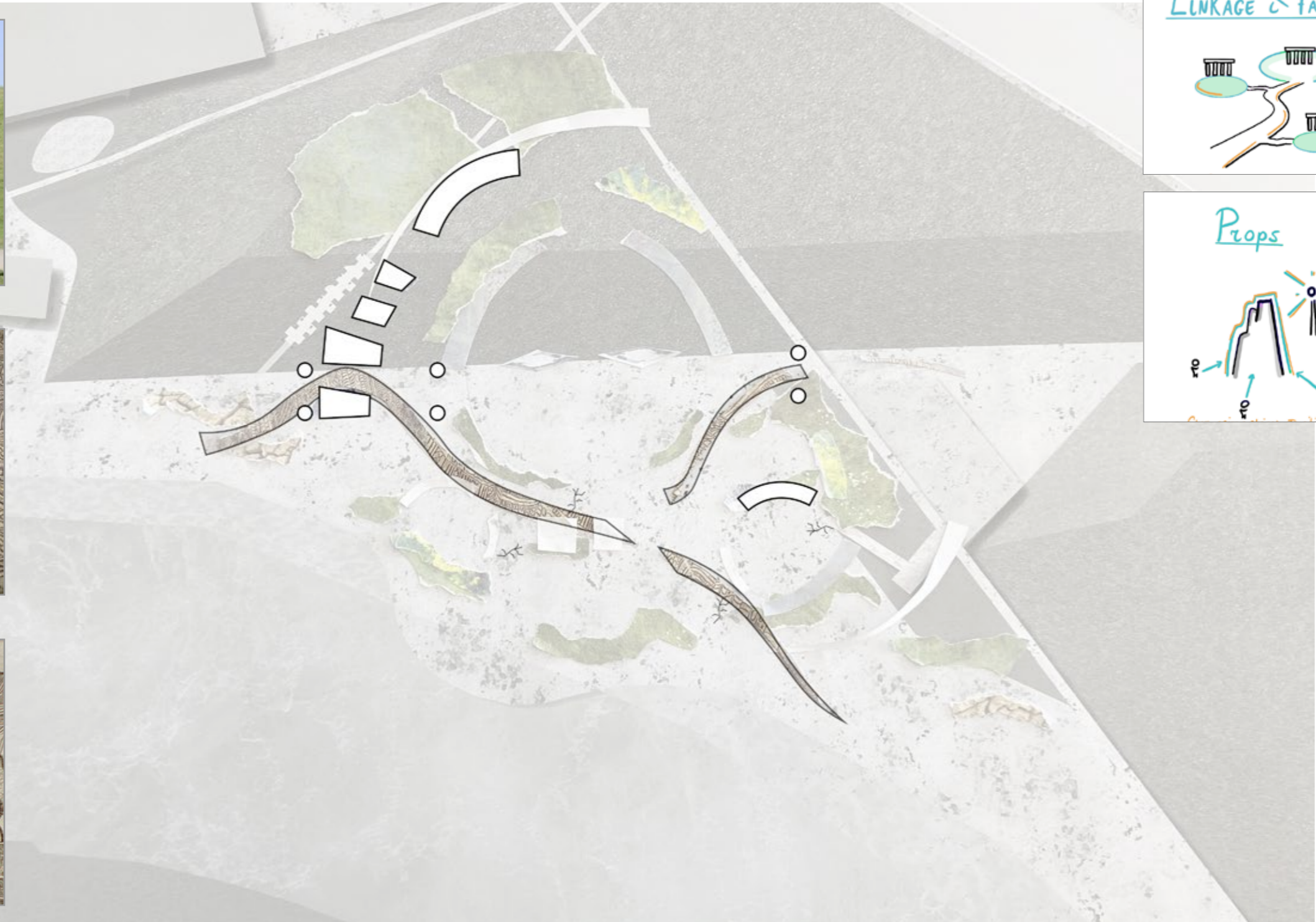

1:400 siteplan - collage

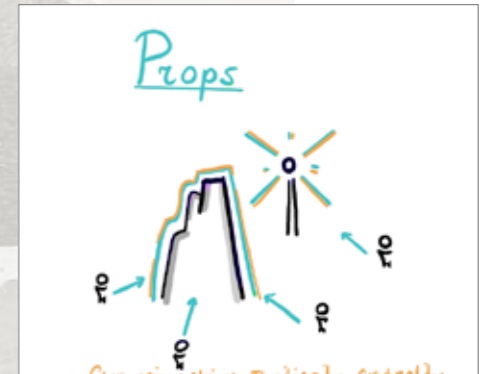

Spatial interventions

Landscape

Creating a 'soft' boundary for closing off the site

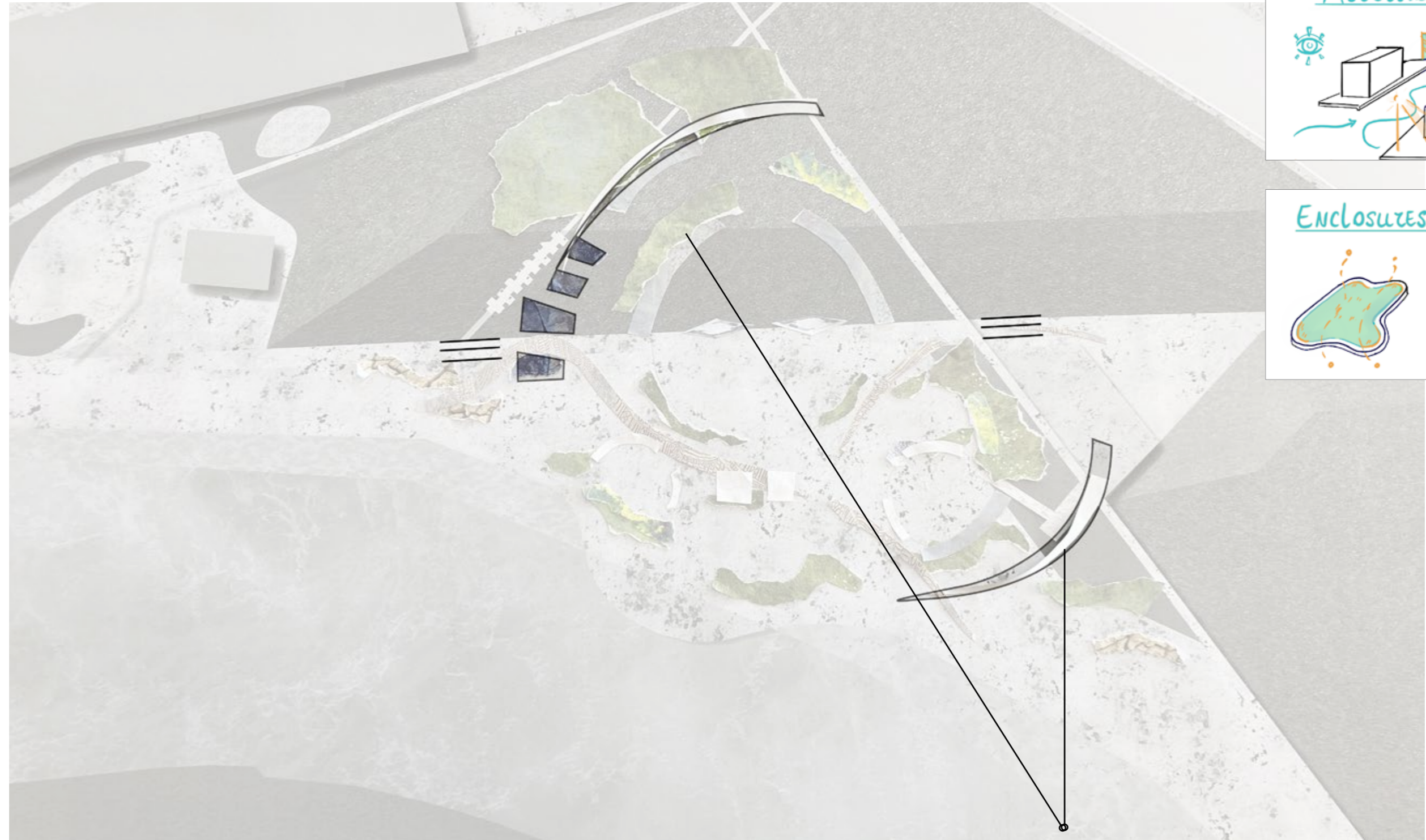

1:400 siteplan - collage

Lined with solar panels

Spatial interventions

Landscape



Perspective view of entrance

Spatial interventions

Landscape - **Facilities and program** - Facilitating infrastructure - the invitation

Spatial interventions

Facilities and program

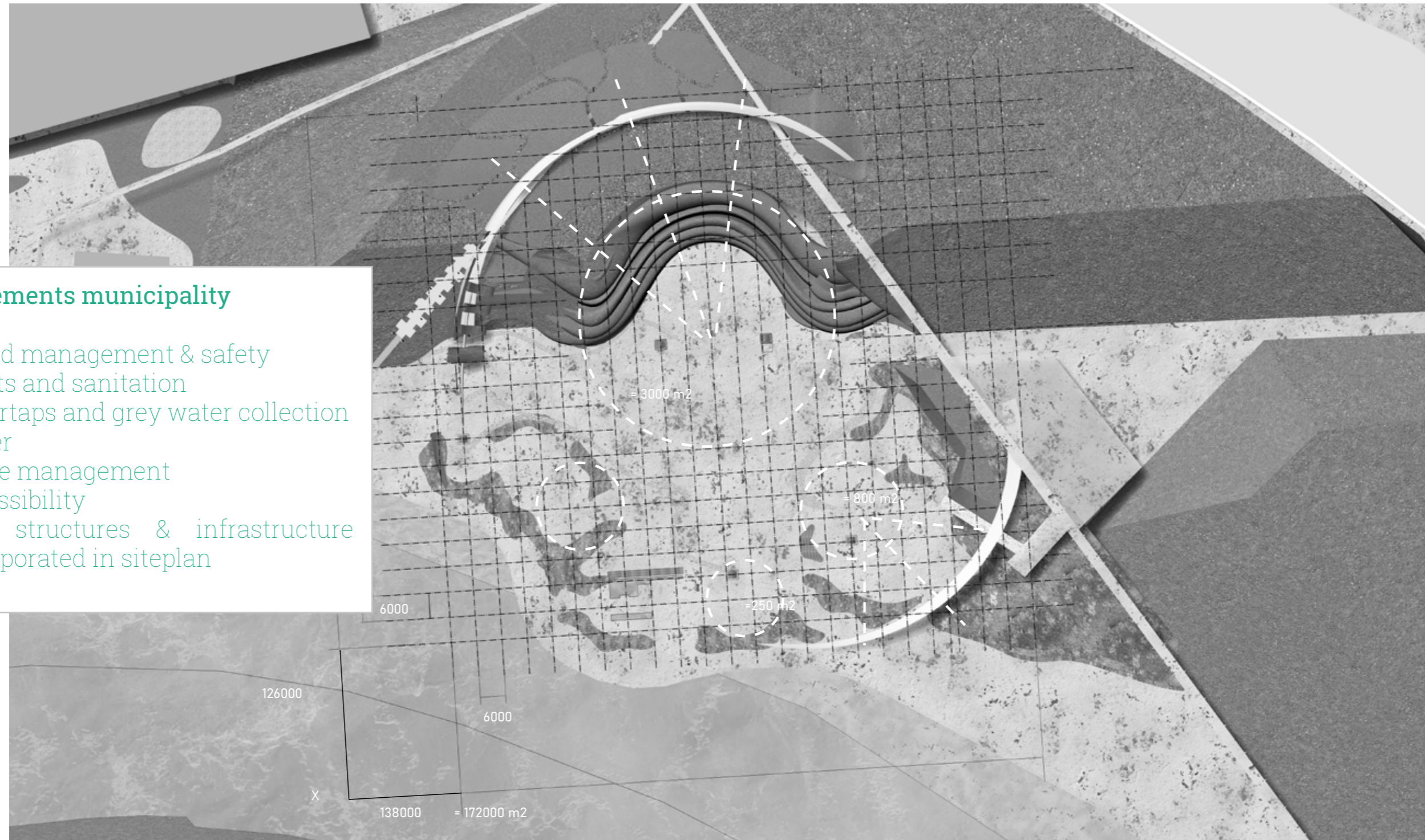

Requirements municipality

- Crowd management & safety
- Toilets and sanitation
- Watertaps and grey water collection
- Power
- Waste management
- Accessibility
- Safe structures & infrastructure incorporated in siteplan

Implementing permanent facilities based on municipal requirements, festival organisers' needs, and people's experiences

Spatial interventions

Facilities and program

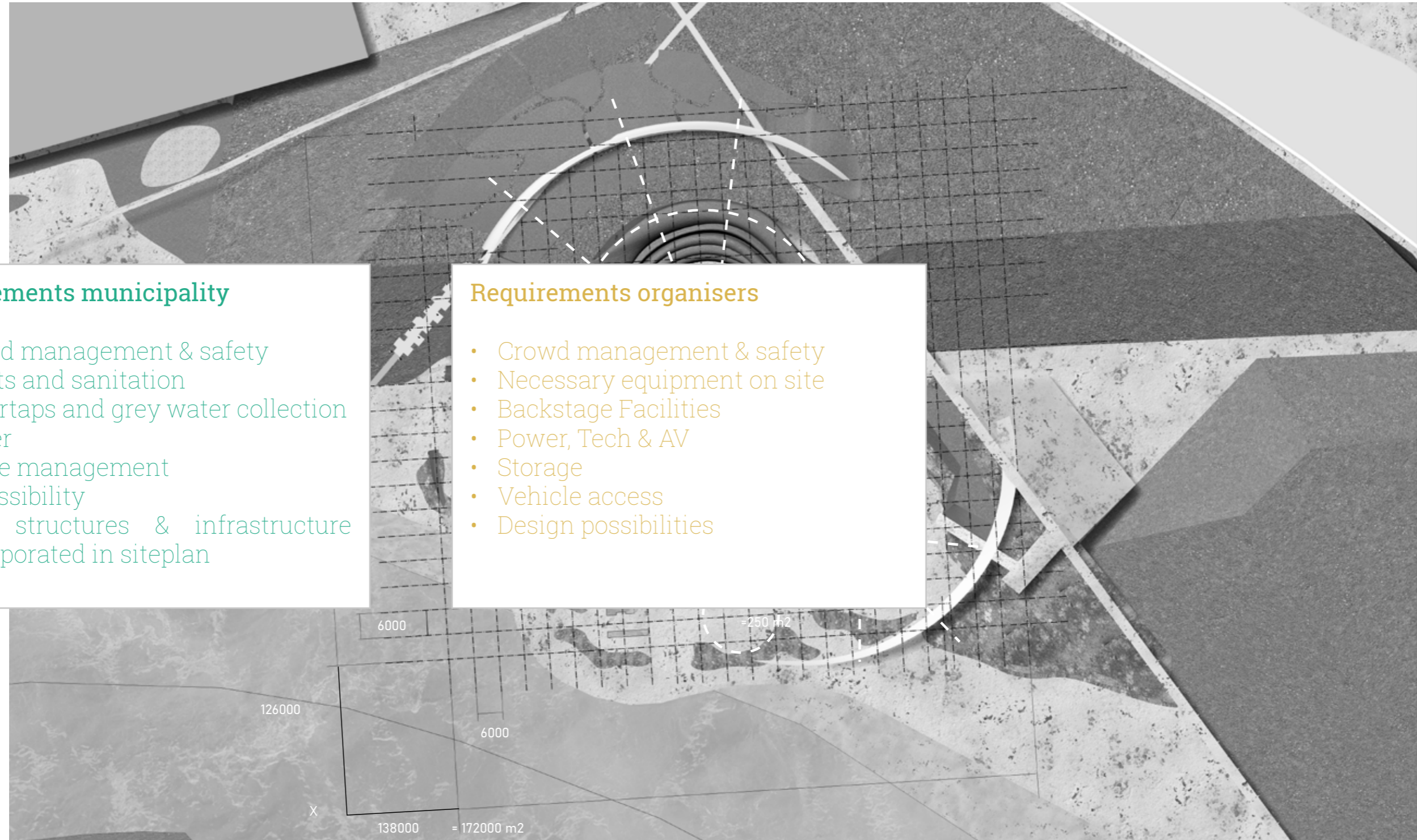

Requirements municipality

- Crowd management & safety
- Toilets and sanitation
- Watertaps and grey water collection
- Power
- Waste management
- Accessibility
- Safe structures & infrastructure incorporated in siteplan

Requirements organisers

- Crowd management & safety
- Necessary equipment on site
- Backstage Facilities
- Power, Tech & AV
- Storage
- Vehicle access
- Design possibilities

Implementing permanent facilities based on municipal requirements, festival organisers' needs, and people's experiences

Spatial interventions

Facilities and program

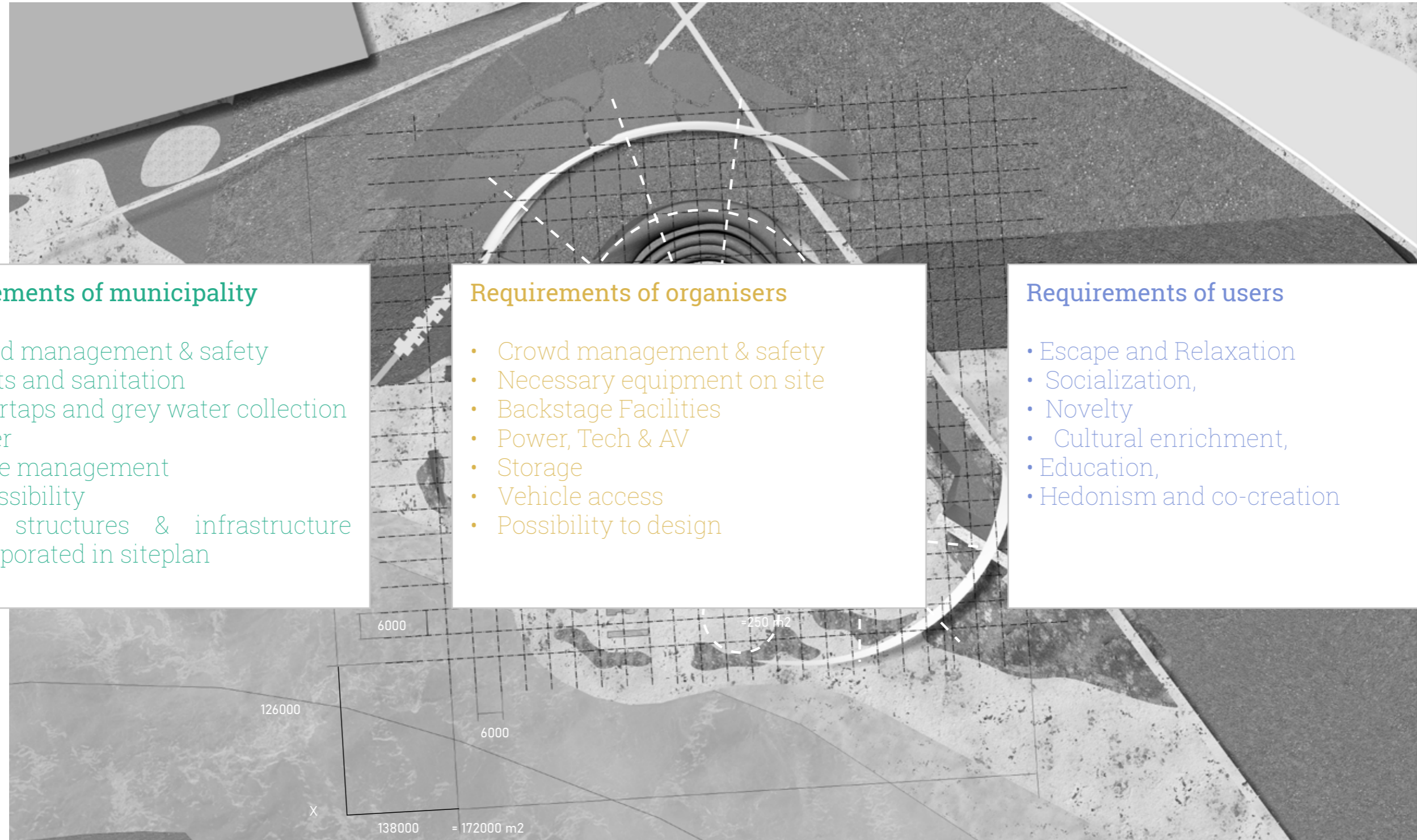

Requirements of municipality

- Crowd management & safety
- Toilets and sanitation
- Watertaps and grey water collection
- Power
- Waste management
- Accessibility
- Safe structures & infrastructure incorporated in siteplan

Requirements of organisers

- Crowd management & safety
- Necessary equipment on site
- Backstage Facilities
- Power, Tech & AV
- Storage
- Vehicle access
- Possibility to design

Requirements of users

- Escape and Relaxation
- Socialization,
- Novelty
- Cultural enrichment,
- Education,
- Hedonism and co-creation

Implementing permanent facilities based on municipal requirements, festival organisers' needs, and people's experiences

Spatial interventions

Facilities and program



1:400 siteplan - designing areas of activity

Implementing permanent facilities based on municipal requirements, festival organisers' needs, and people's experiences

Spatial interventions

Facilities and program

Permanent interventions on site



1:400 siteplan; 'permanent' facilities, program and experiential characteristics

Spatial interventions

Facilities and program



1:400 siteplan; 'permanent' facilities, storage, toilet, waterbasins; stones



Model - permanent facilities

Spatial interventions

Facilities and program

Responding to organisers' requirements

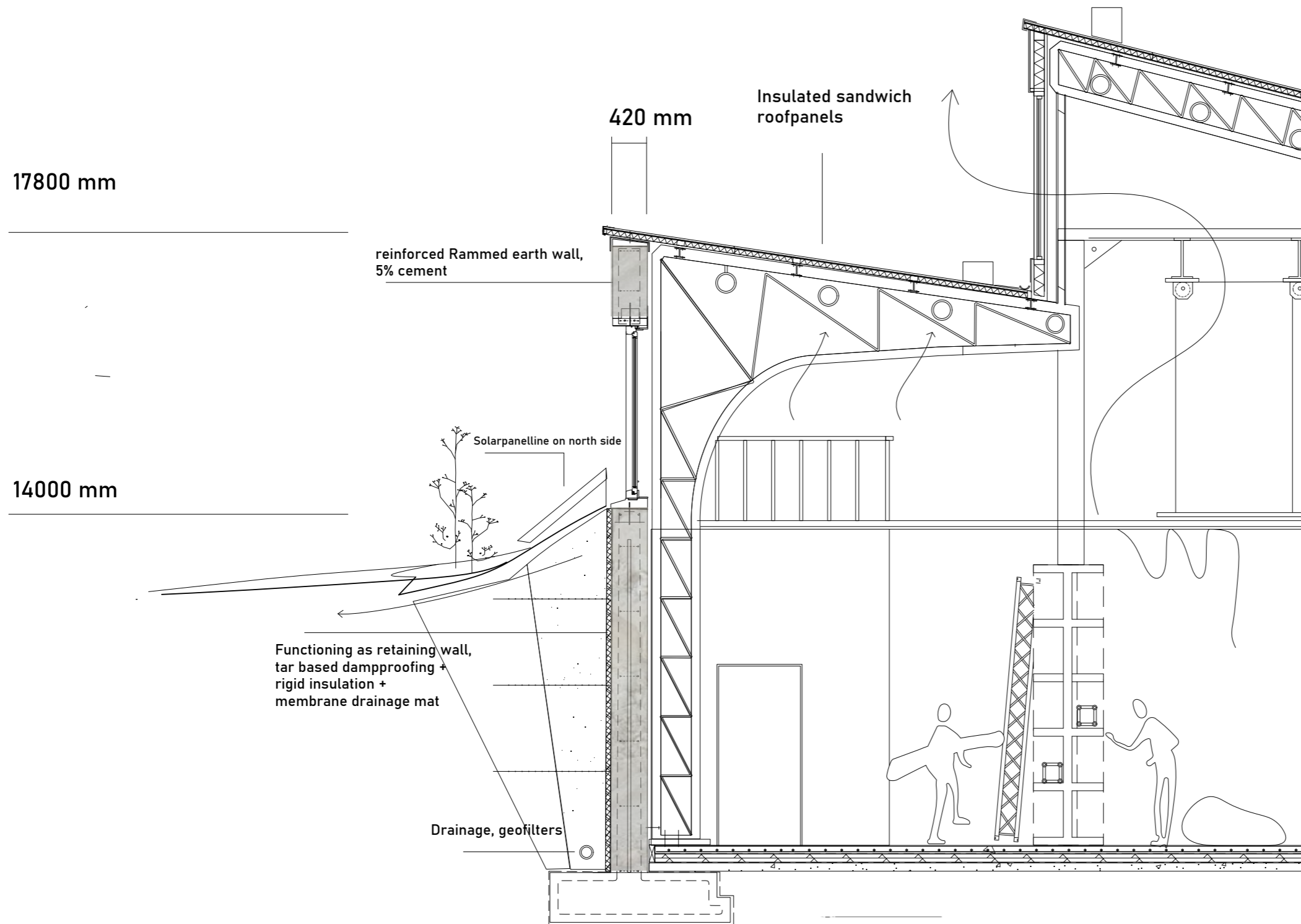

Storage with necessary equipment, section B.a



Elevation of storage

Spatial interventions

Facilities and program

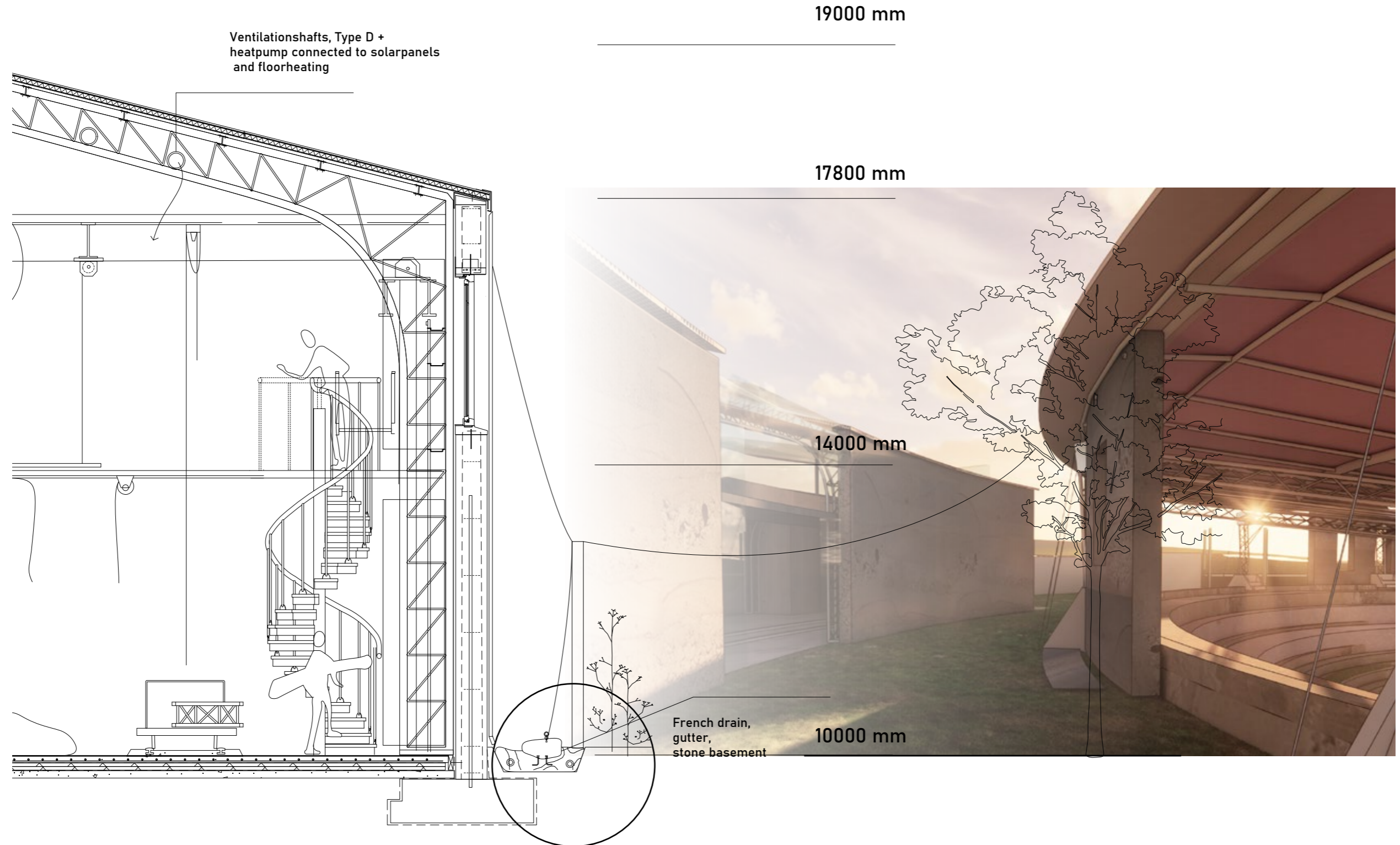

Storage with necessary equipment, section B.b

Stonebasement with hook - column

Perspective of amphitheatre

Spatial interventions

Facilities and program

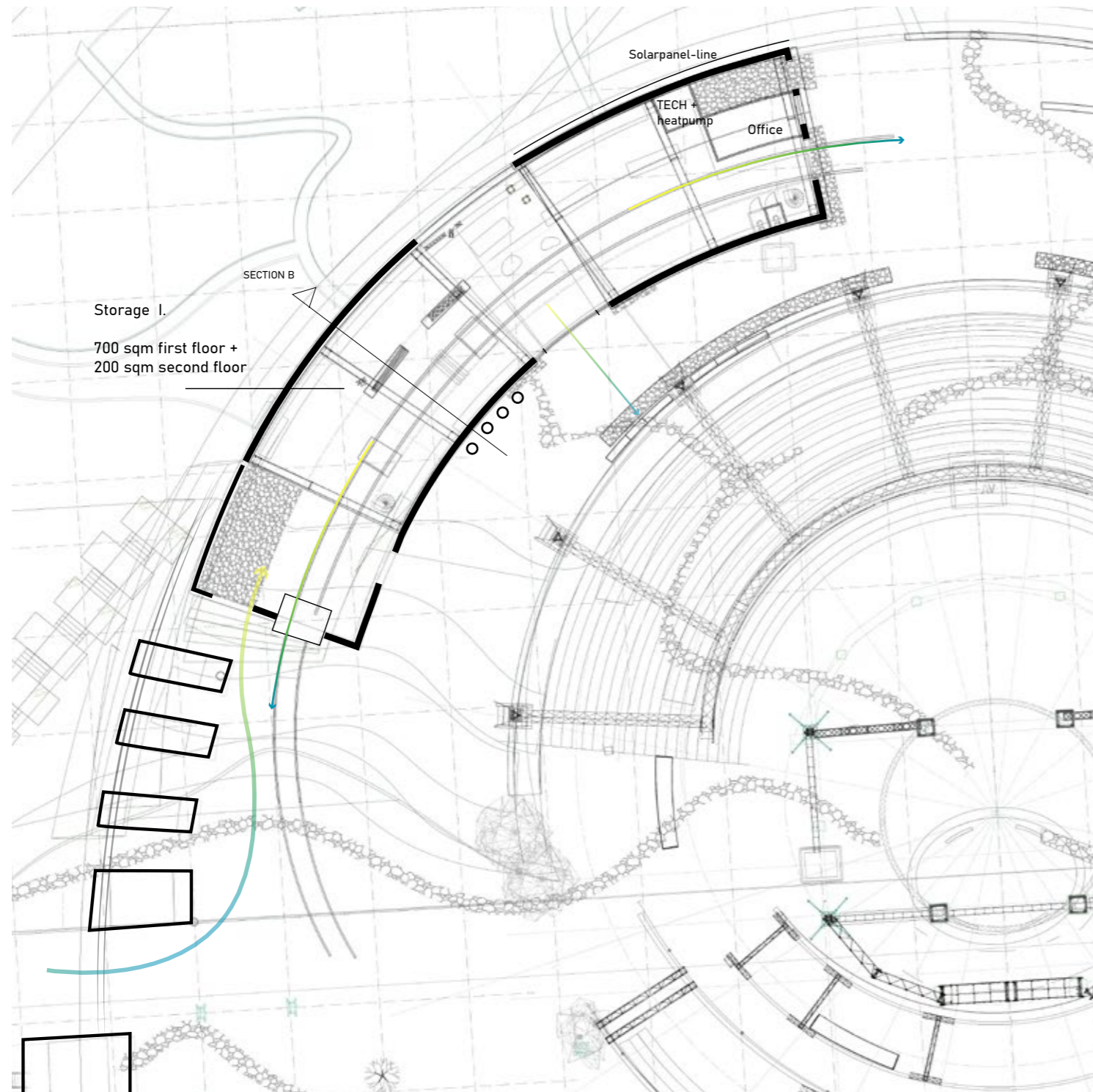

1:200 siteplan; storage

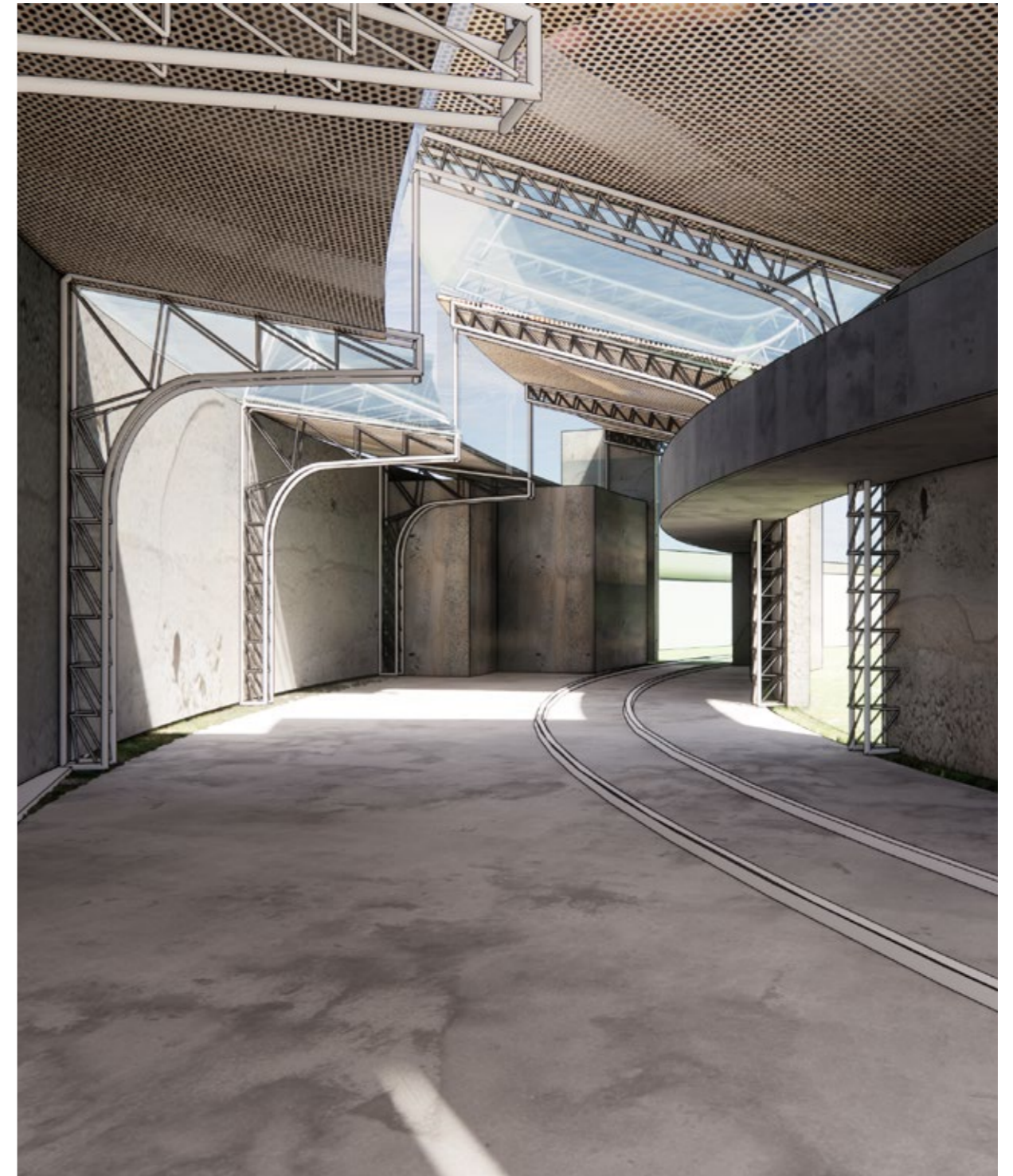

An empty storage

Spatial interventions

Facilities and program



model: experiential characteristics



Model: experiential characteristics

Spatial interventions

Landscape - Facilities and program - **Facilitating infrastructure** - the invitation

How spatial design facilitates different types of events, people and sizes

Spatial interventions

Facilitating infrastructure - powerplan

Generators buried in ground (operable)

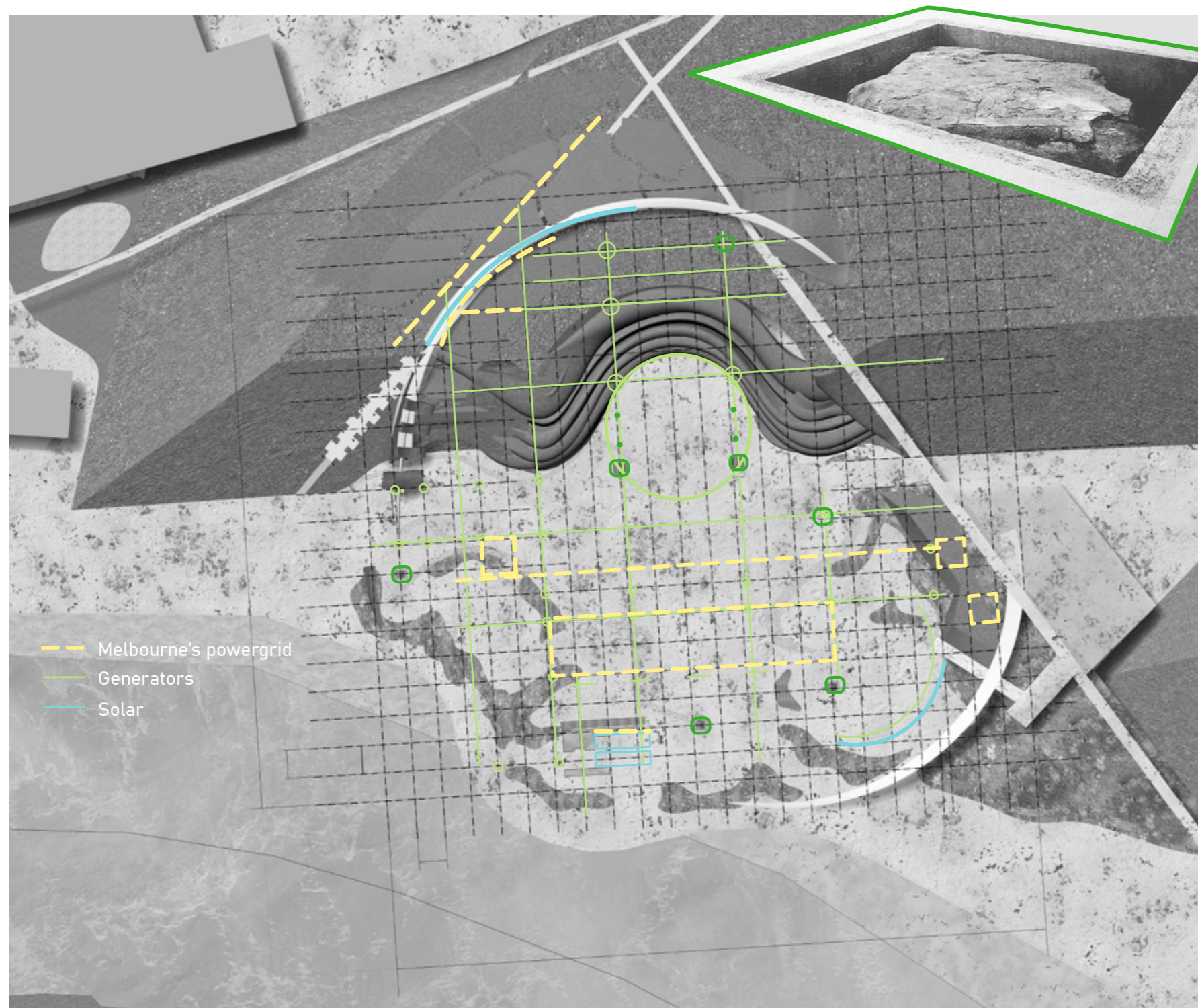

1:400 siteplan; powergrid, generators and solar

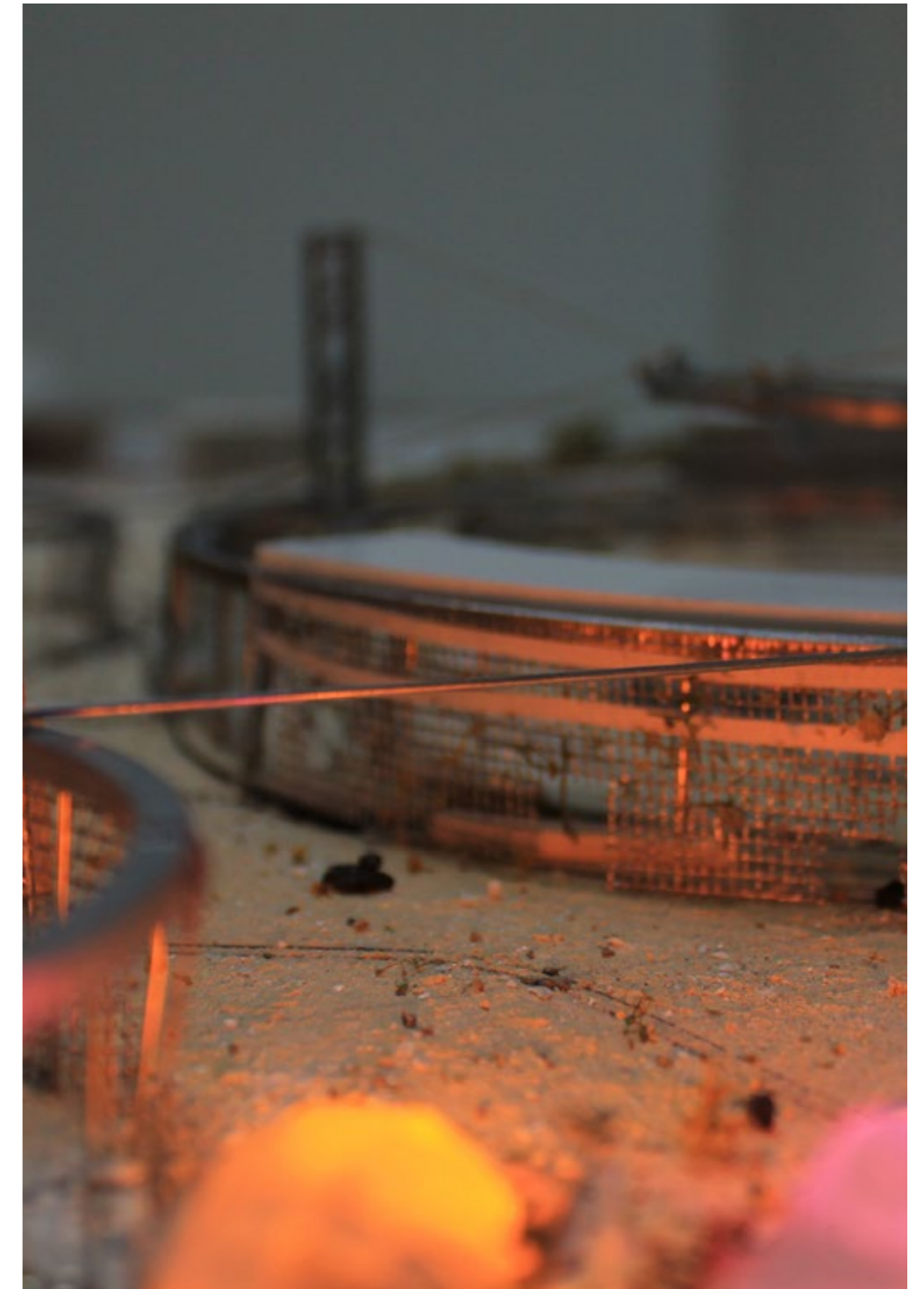

Model: power and light

Spatial interventions

Facilitating infrastructure - irrigation, waterpoints, misting system

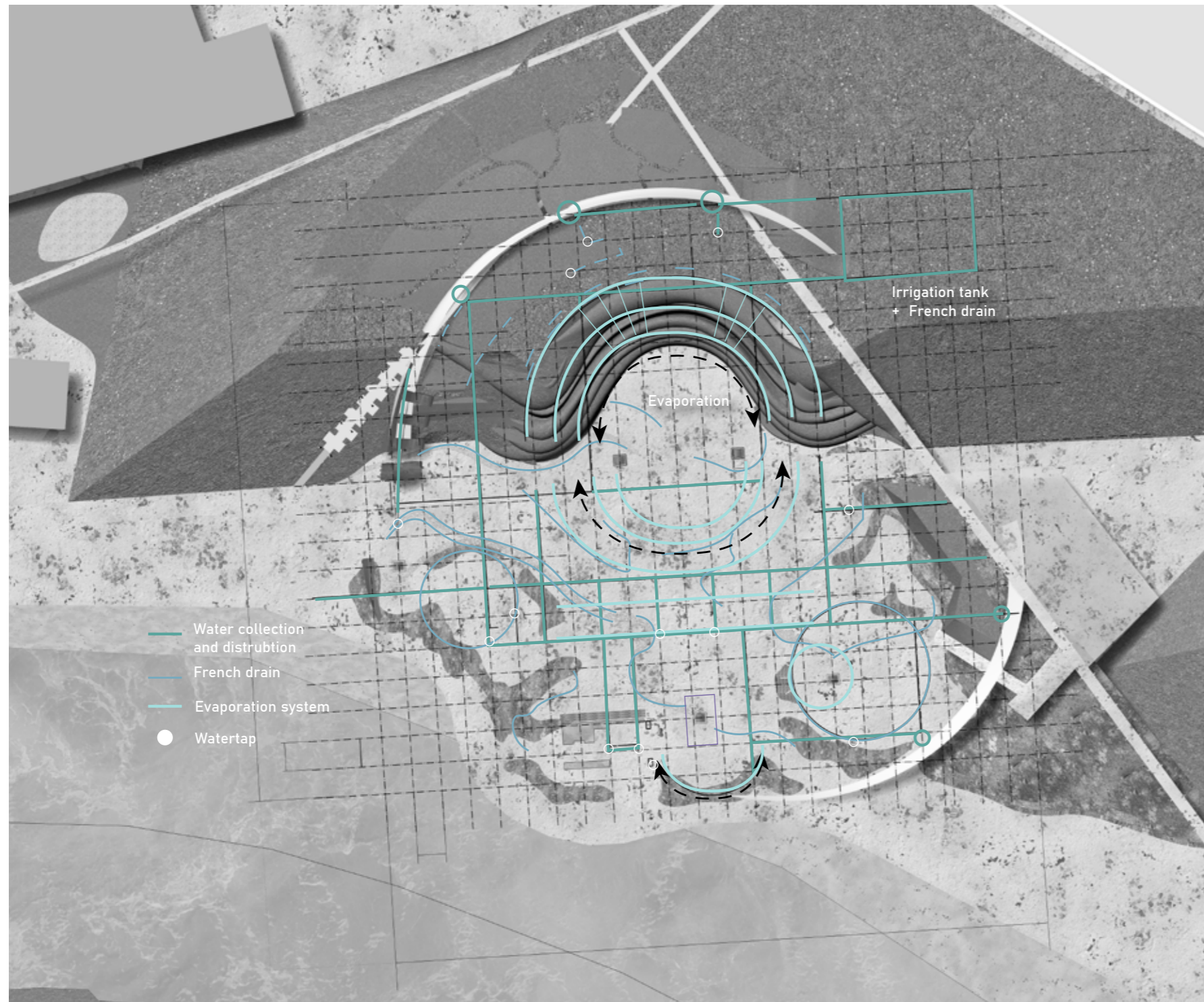

1:400 siteplan; water infrastructure



Waterbasin on site

Spatial interventions

Facilitating infrastructure - transportation of objects

Transporting objects

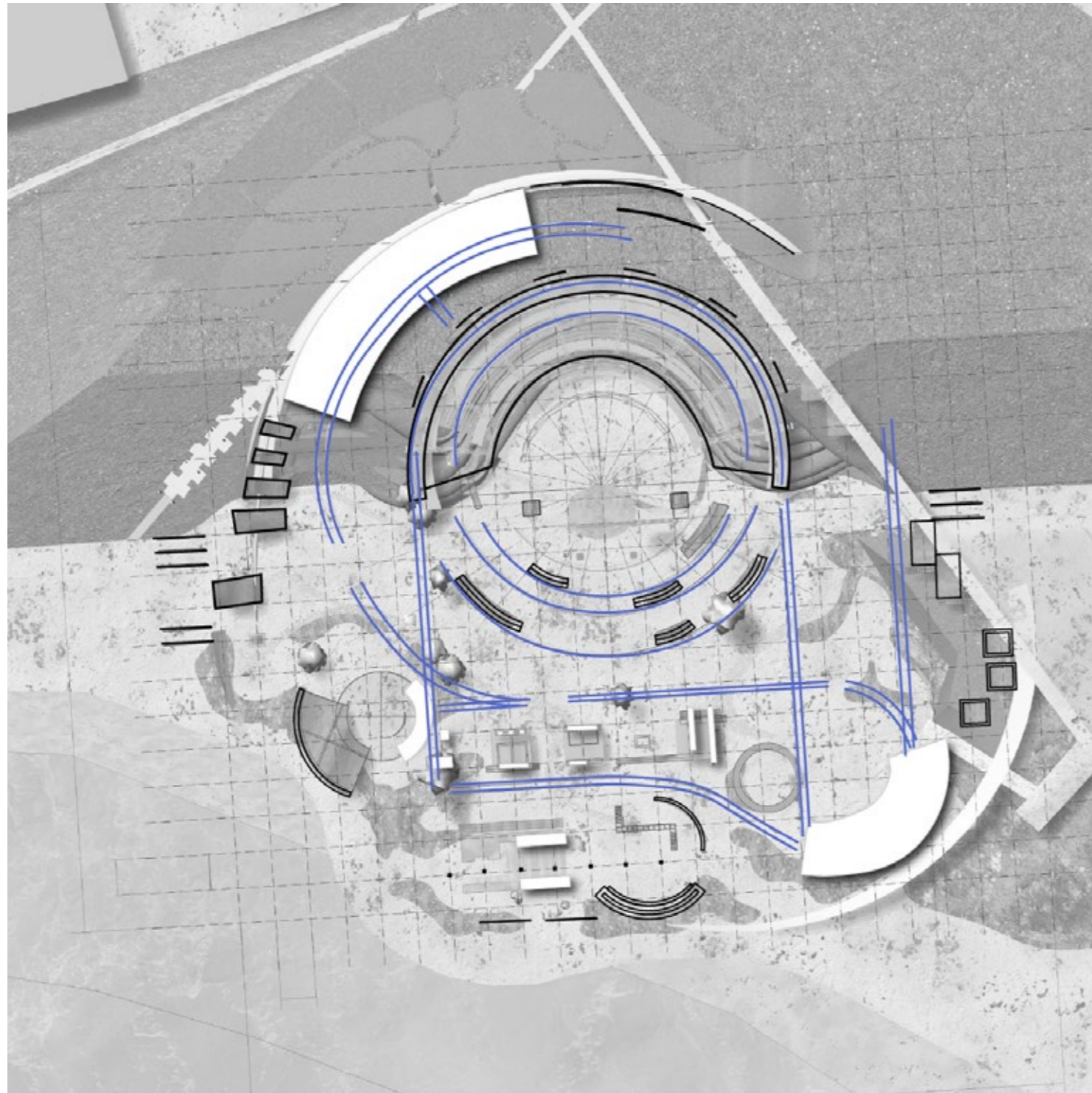

1:400 siteplan; use of left over trainrails



Modelperspective of railsystem

Spatial interventions

Facilitating infrastructure - space maker or breaker

Creating open, semi-open or closed spaces

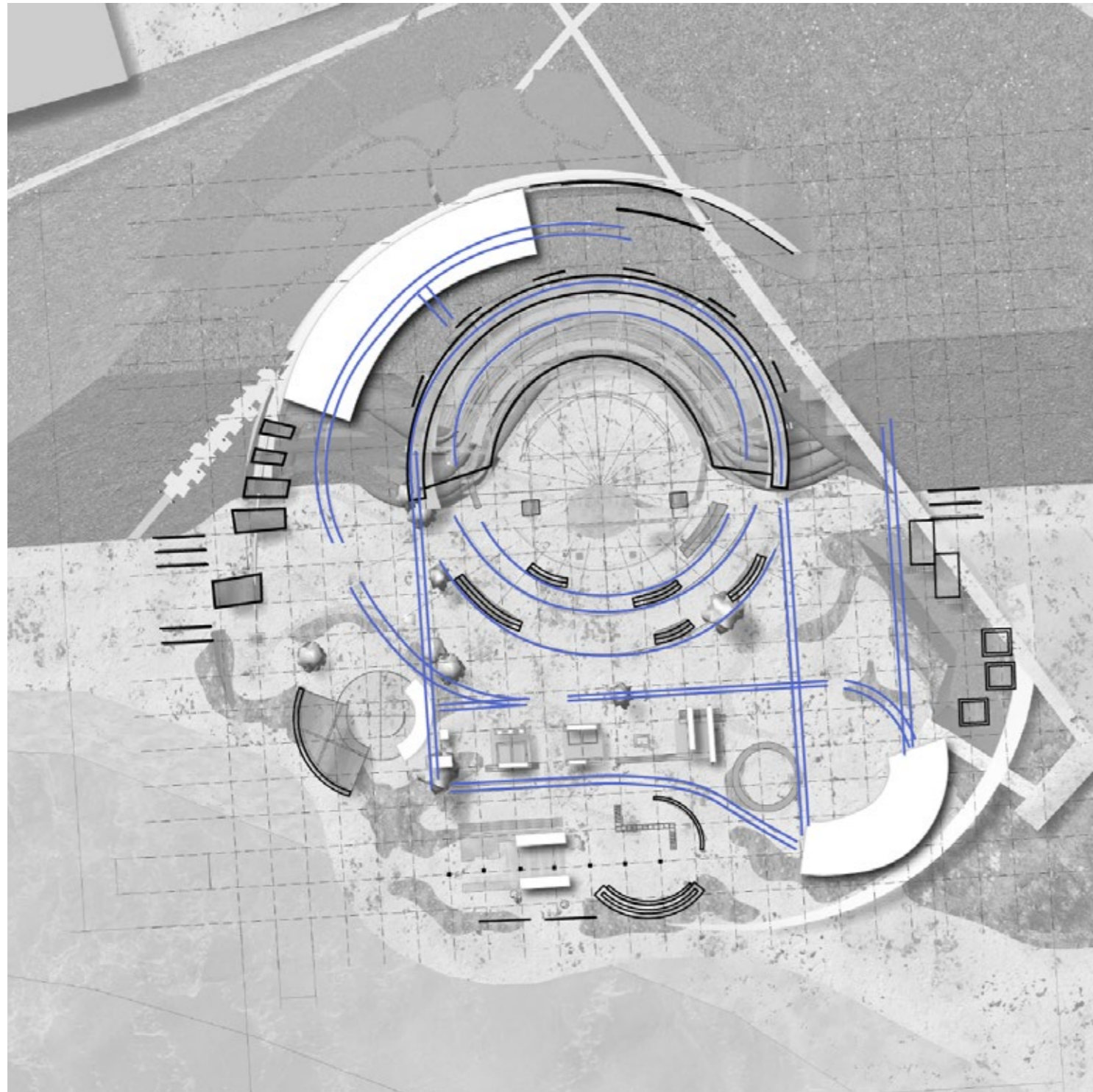

1:400 siteplan; use of left over trainrails



Model: opening or closing of spaces

Spatial interventions

Facilitating infrastructure - spacedivider

Rails and stones

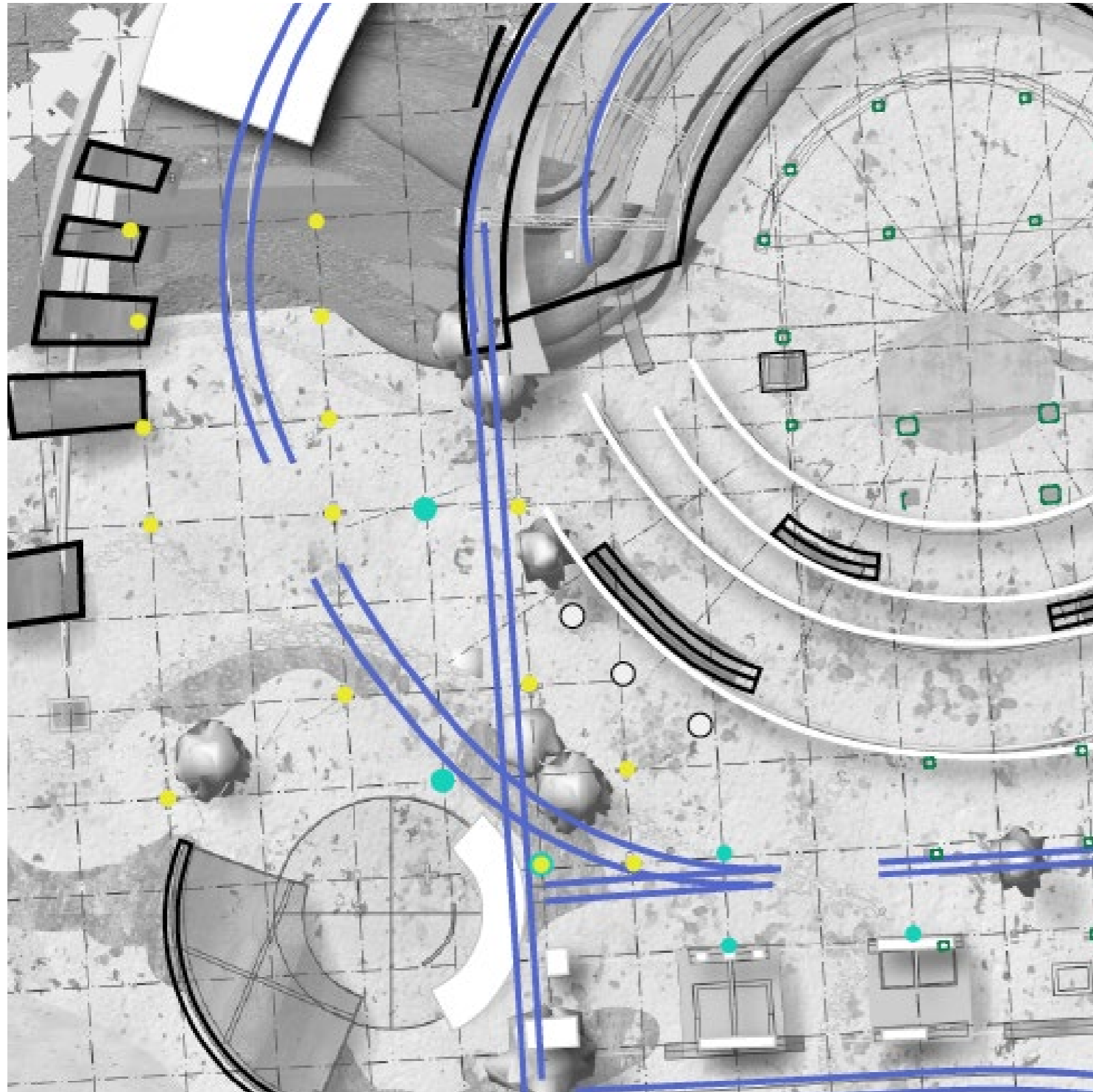

1:400 siteplan; Stones and baseplates

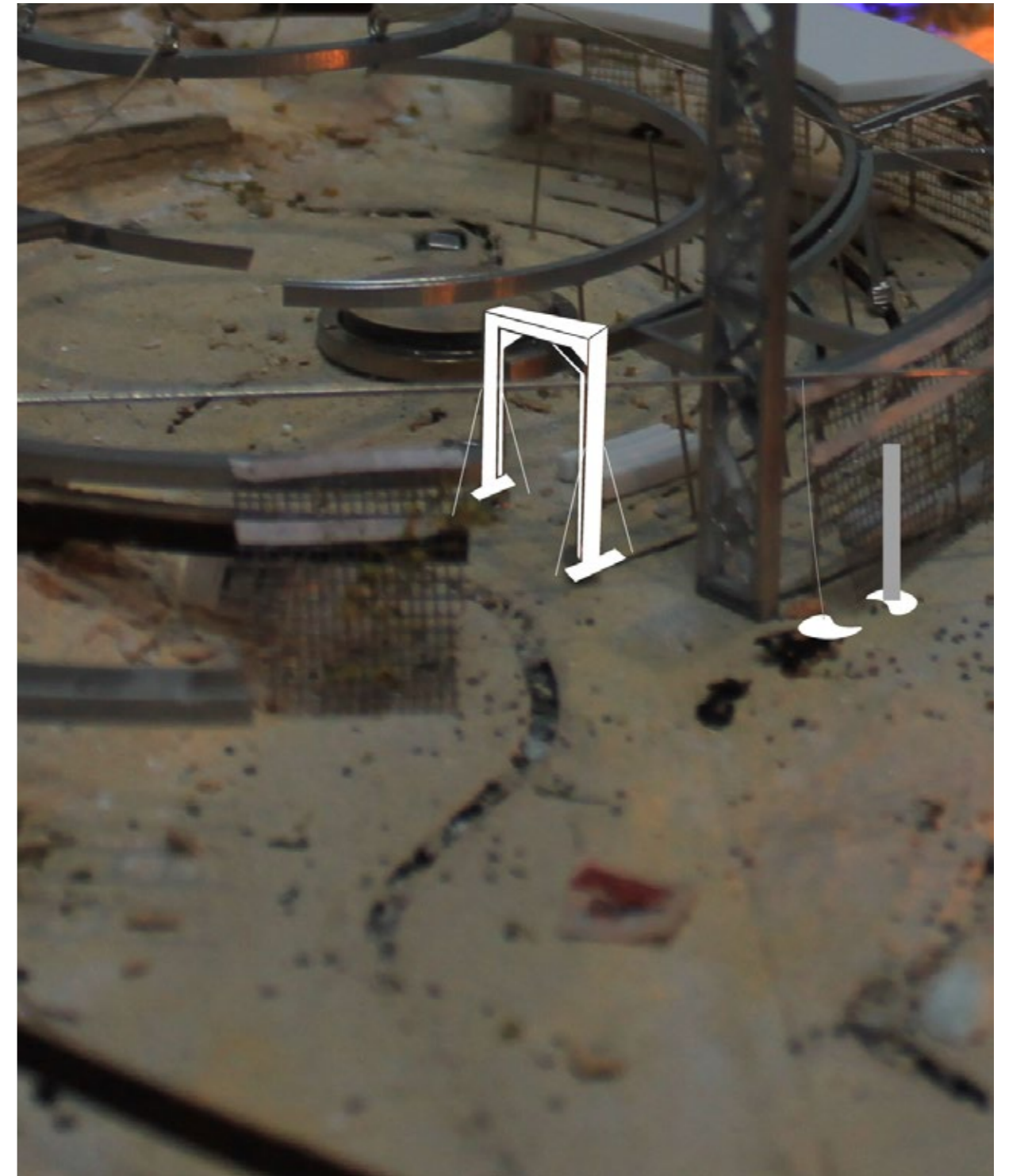

Model: amphitheatre

Spatial interventions

Landscape - Facilities and program - Facilitating infrastructure - **the invitation**

The invitation

the intention communicated through material, symbolic and formal expression
and the values of temporality, co-authorship and performativity

'Permanent' interventions



Rammed earth walls with larger aggregate
- carving possibilities

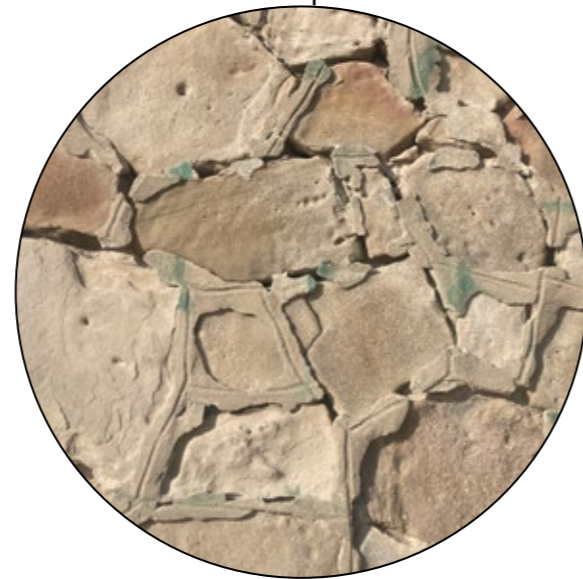

Stone foundations

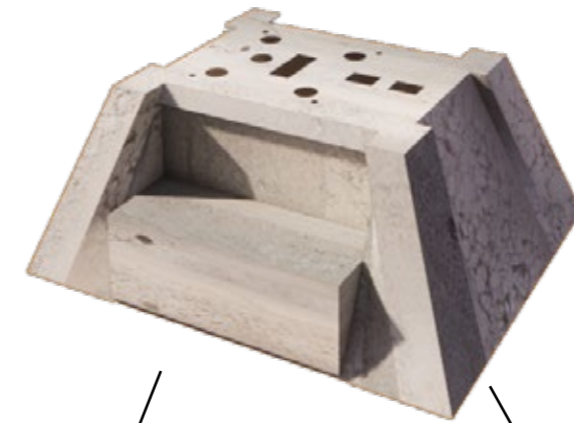

Baseplates, seats, etc.
-porous in some places
designed to cater to adaptable elements

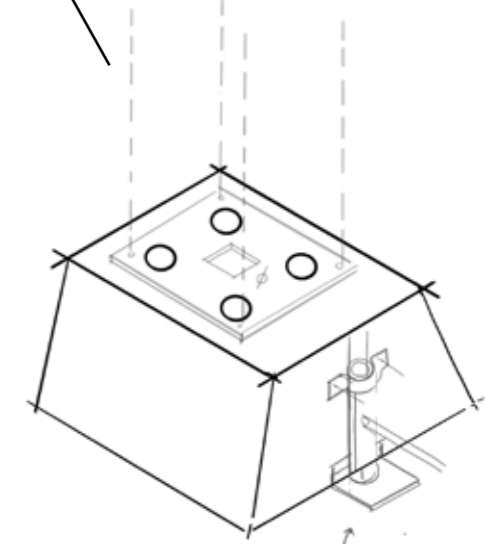
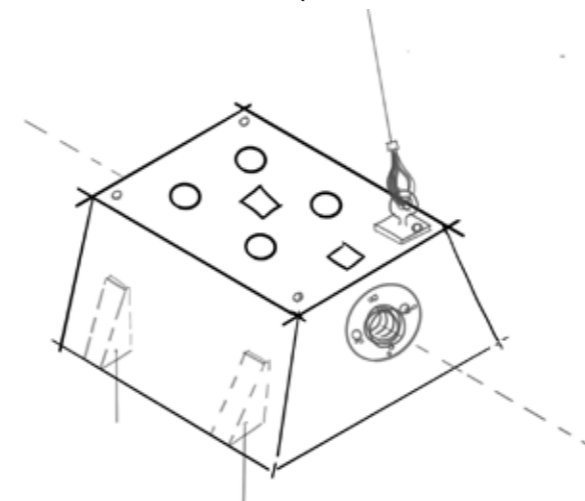

Research

Design

The invitation

the intention communicated through material, symbolic and formal expression
and the values of temporality, co-authorship and performativity

Permanent elements

40 - 100 years



Rammed earth walls with larger aggregate
- carving possibilities

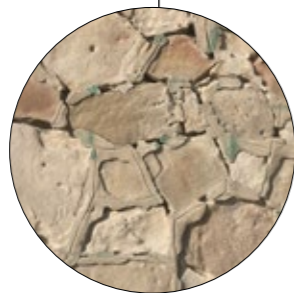

Stone foundations

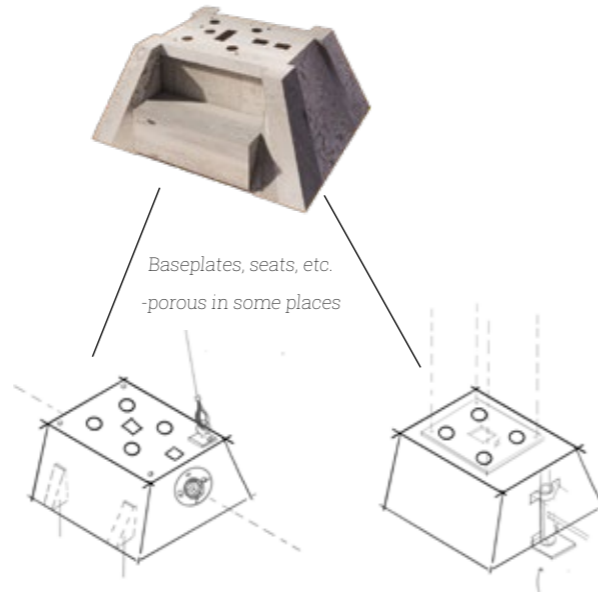

Baseplates, seats, etc.
-porous in some places

Facilitating infrastructure

10 - 40 years

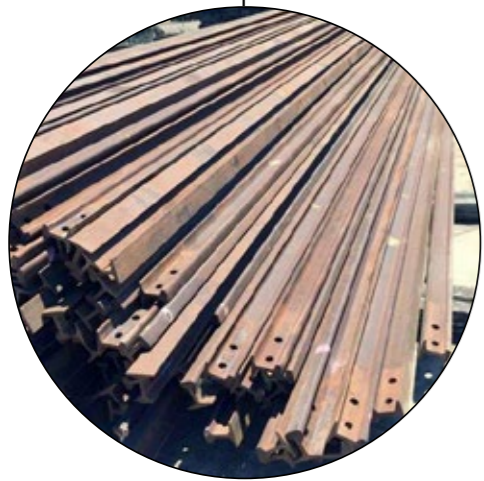

Rails

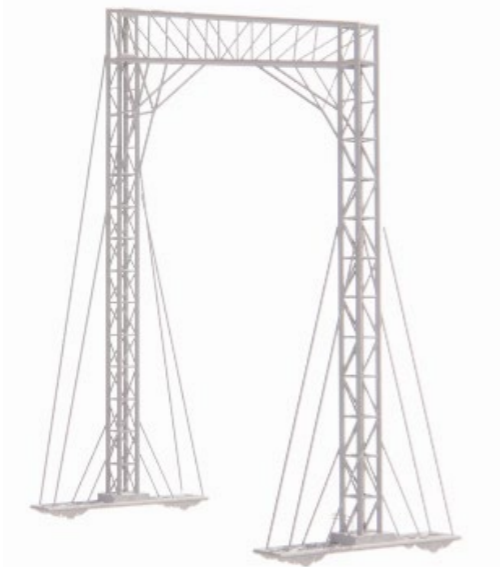

Scaffolding on rails

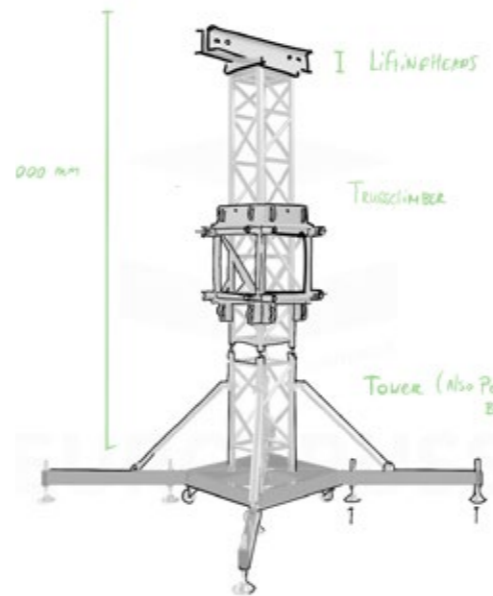

Research

Design

The invitation

the intention communicated through material, symbolic and formal expression
and the values of temporality, co-authorship and performativity

Permanent elements

40 - 100 years



Rammed earth walls with larger aggregate
- carving possibilities

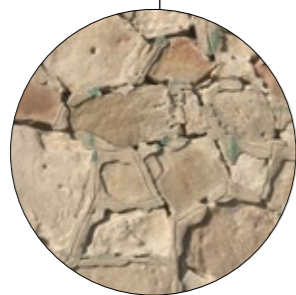

Stone foundations



Baseplates, seats, etc.
-porous in some places

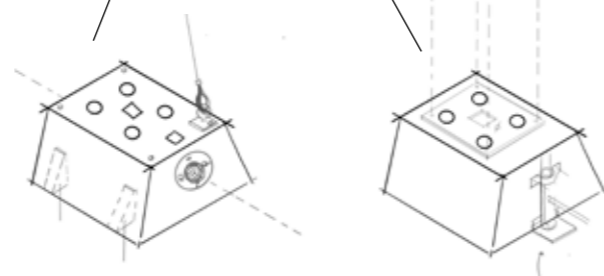

Facilitating infrastructure

10 - 40 years

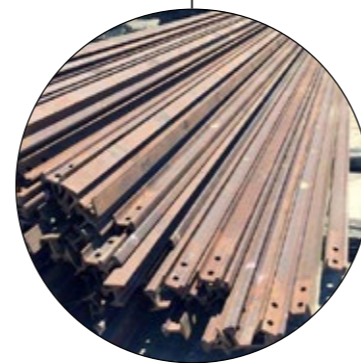

Rails

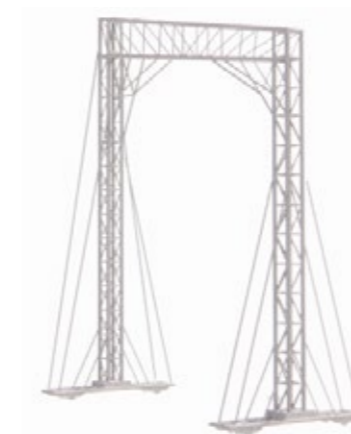

Scaffolding on rails

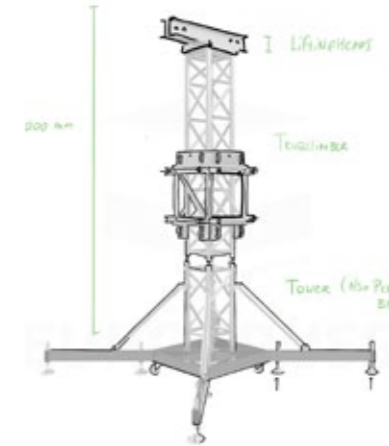

Invitational elements

From moment to moment - from festival to festival



Open-ended columns



Moveable bases



Fillable gabion walls

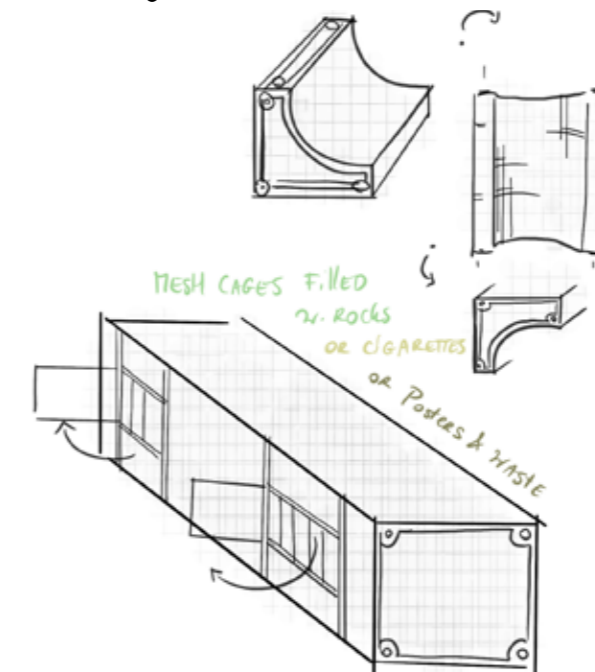

Research

Design

The invitation

The curated invitation by the architect to co-create the festival space;

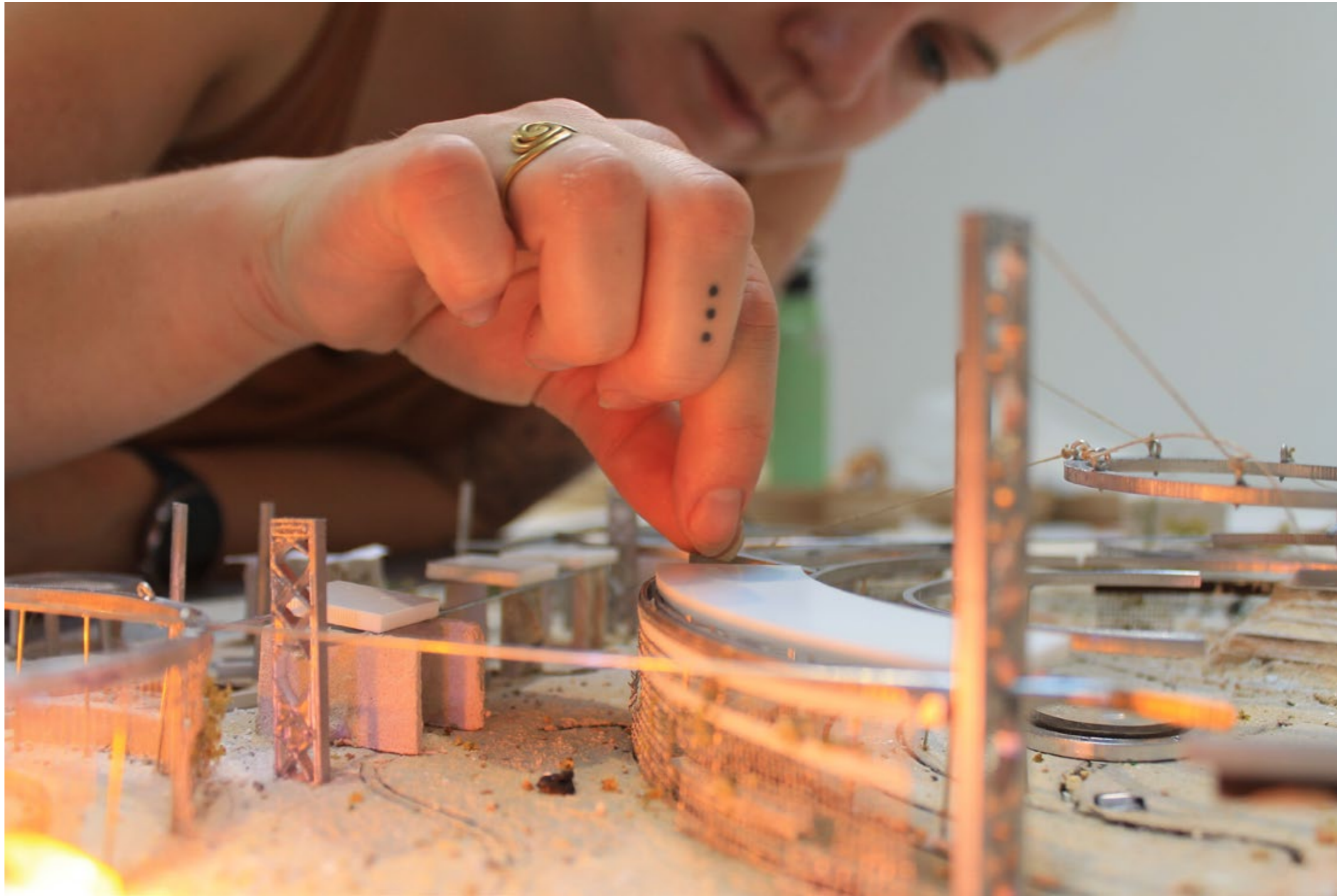

2028

Research

Design

Architecture as facilitating agent: exploring architecture's position in spatial relationships through festival spaces

Program

An introduction to festival spaces	Location	Festival I.	The process
Why they matter	Preparing the site	Festival II.	What's next
Problems faced by the industry			
Establishing the role of the architect in festival spaces	Spatial interventions	Other set ups	Reflecion

Research -
An introduction to festival spaces

Design -
Program & structure

Experience -
The first trials

Closing act

Festival I.

Preparing the site for the event

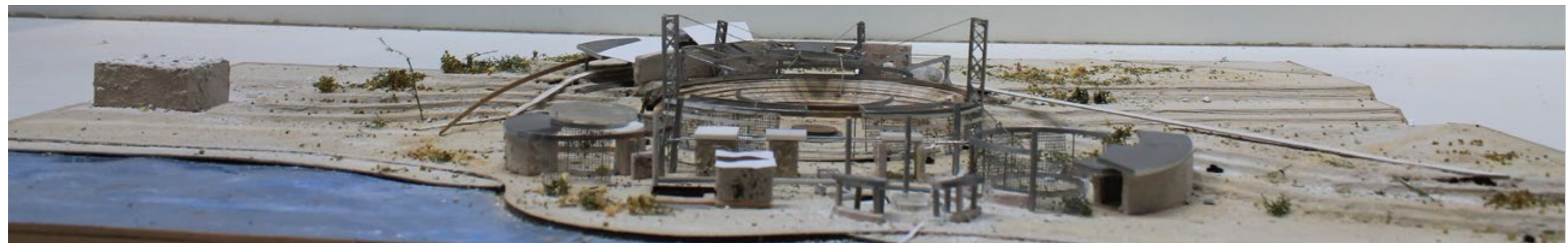

The first trial

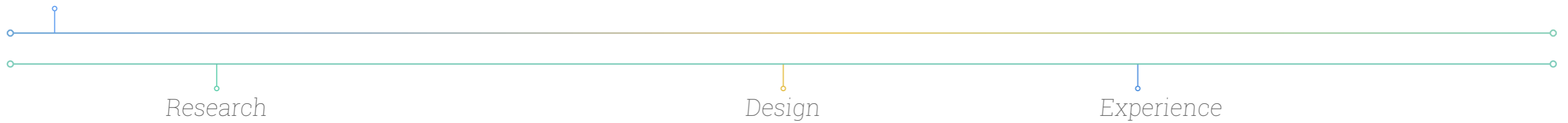

Festival I.
co-creating the festival space



The first trial

Timelapse of the first set up



Research

Design

Experience

Share the spirit festival

January 26th, 2028

sitemap

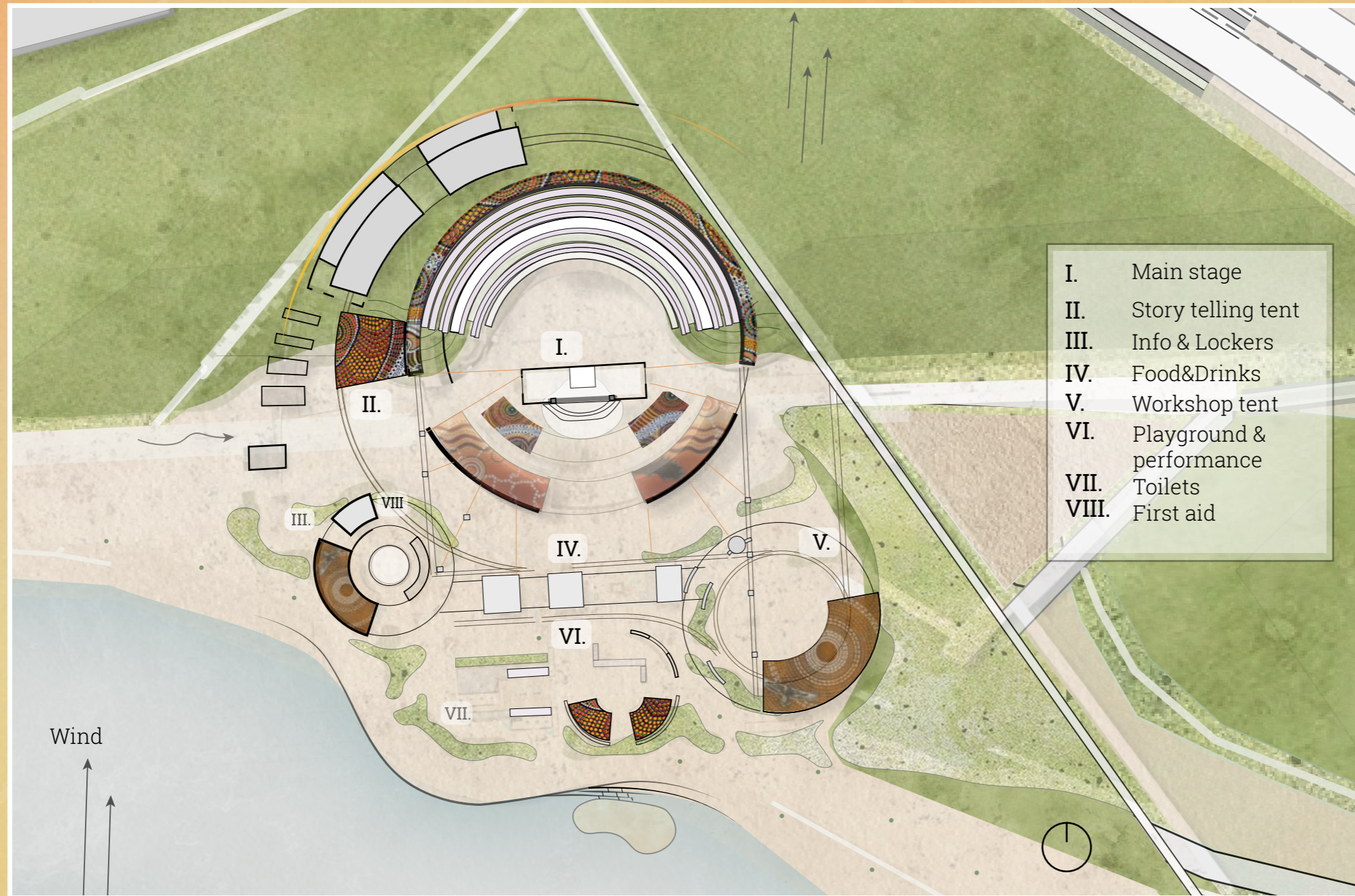

Site conditions

Sunny, hot day

Free event
12.00 - 21.00

Open,
First nations
festival,
All age groups

Small - midsize
500 - 2000 people

Wear sunscreen
and stay
hydrated

Share the spirit festival

January 26th, 2028

Time	Main stage	Story telling tent	Workshop station
12.00	Welcome to country <i>Aunty joy Murphy</i>		
13.00	Yung Warriors		
14.00			Bush Medicine 101
15.00	The Koori Collective	"Echoes of Country" <i>Uncle Ray</i>	
16.00		Blackfire	Djirri Djirri Dancers
17.00	Mulga Bore Hard Rock Band	"Songlines Unfold" <i>Byron K.</i>	
18.00			Bush Medicine 101
19.00		"Rivers and Resistance" <i>Alinta Rose</i>	
20.00	Closing Ceremony <i>Aunty Carolyn N'arweet Briggs</i>		Wattle weaving workshop
- 21.30			

Festival I.

Share the spirit - hot summer day

Setting it up

Smoking ceremony

Breaking it down



The first trial

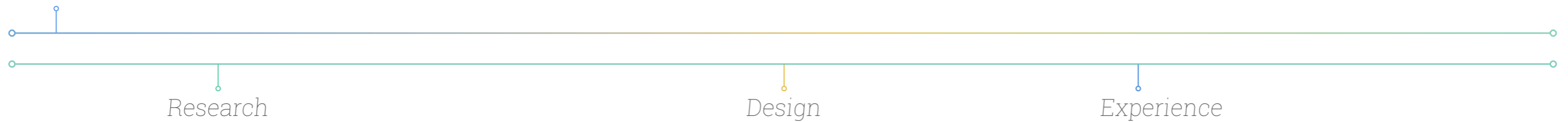

Festival I.

Share the spirit - hot summer day

Setting it up

Smoking ceremony

Breaking it down



The first trial

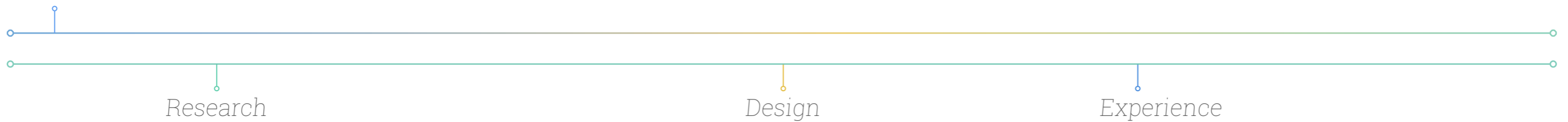

Festival I.

Share the spirit - hot summer day



The first trial

Section of rails bedding

Perspective; rails locked position

Research

Design

Experience

Festival I.

Share the spirit - hot summer day

Setting it up

Smoking ceremony

Breaking it down



The first trial

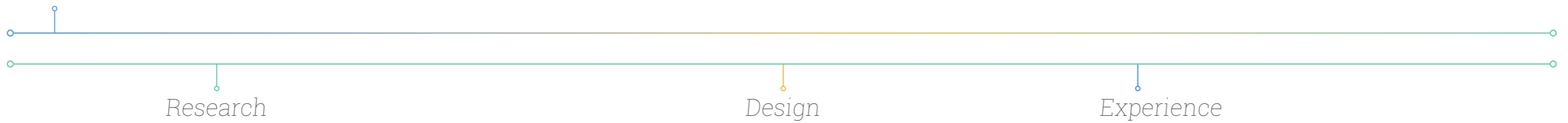

Festival I.

Share the spirit - hot summer day

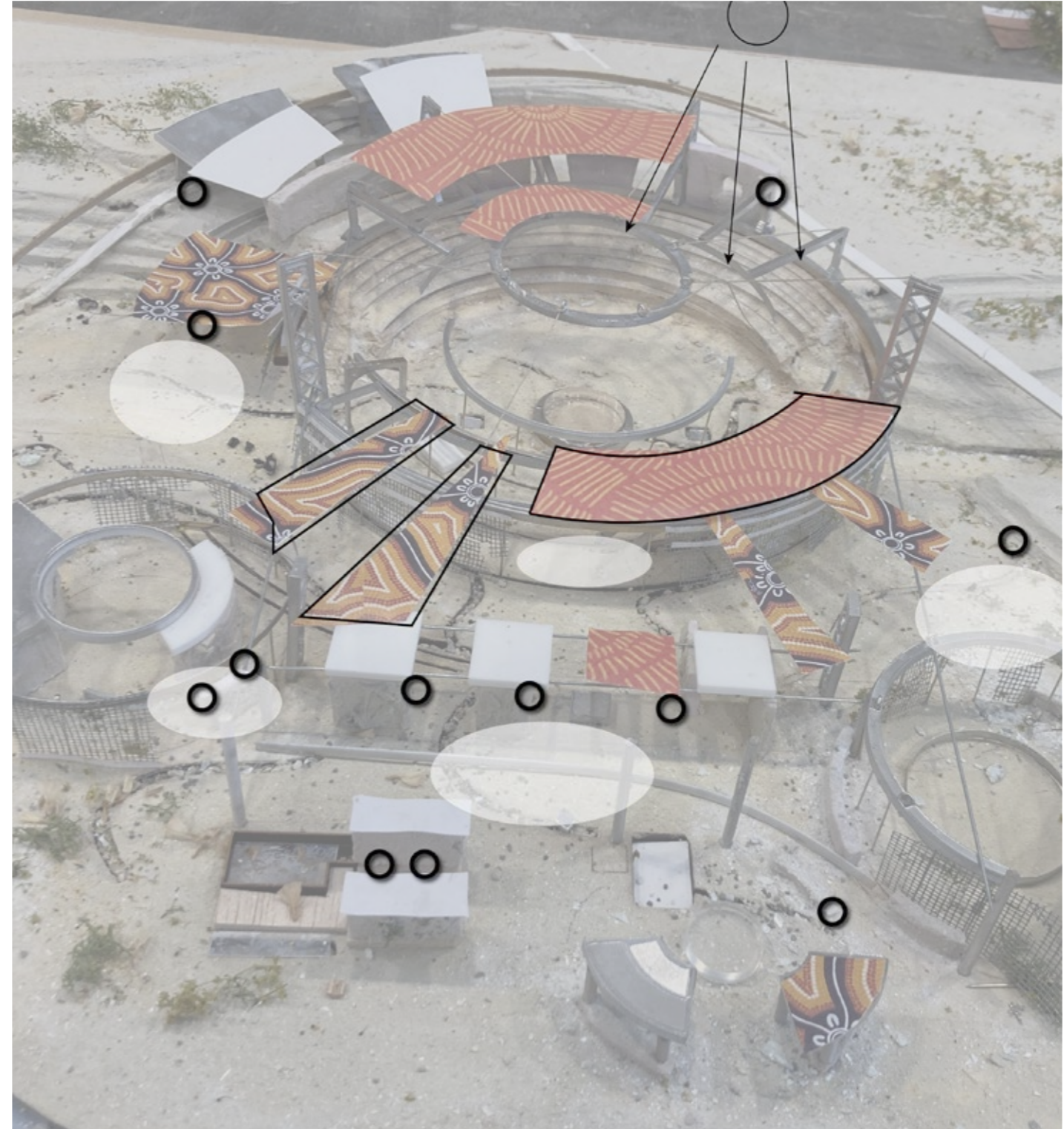

The first trial Misting fans, shade, positioned with dominant winddirection in summer

waterpoints and shade provide other areas of activity.

Festival I.

Share the spirit - hot summer day

Setting it up

Smoking ceremony

Breaking it down

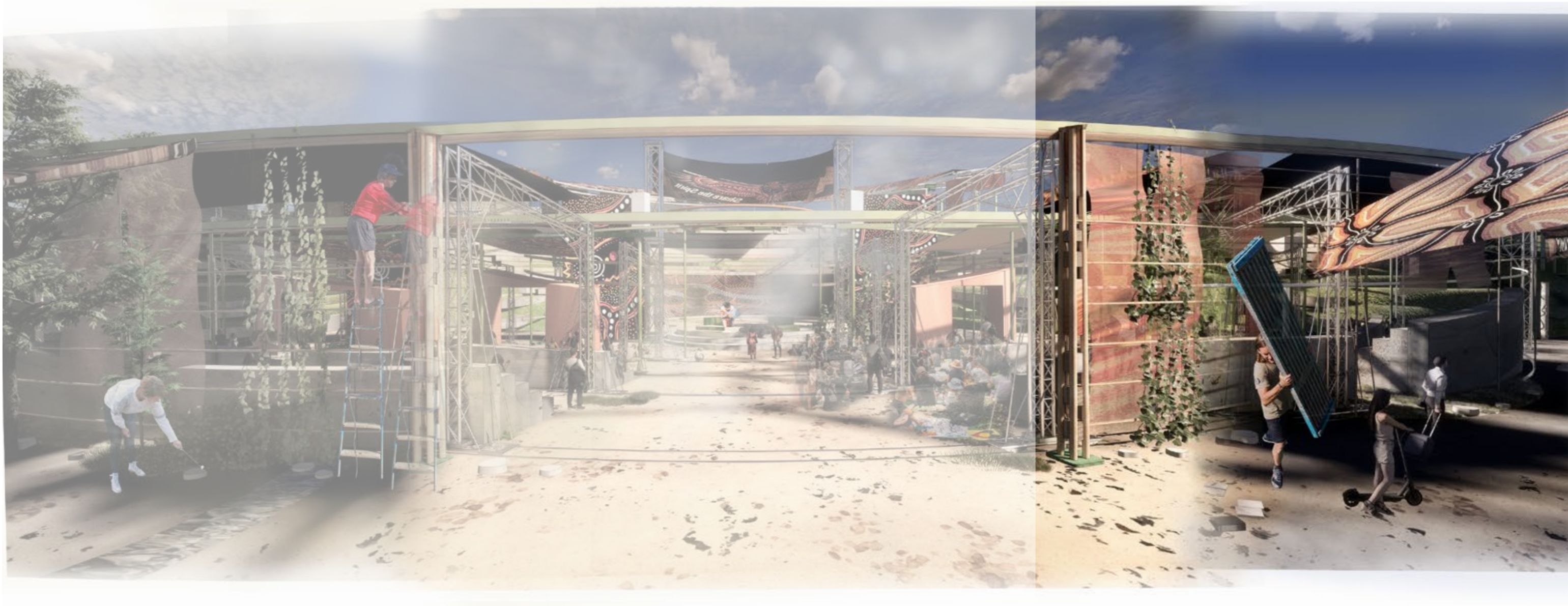

The first trial

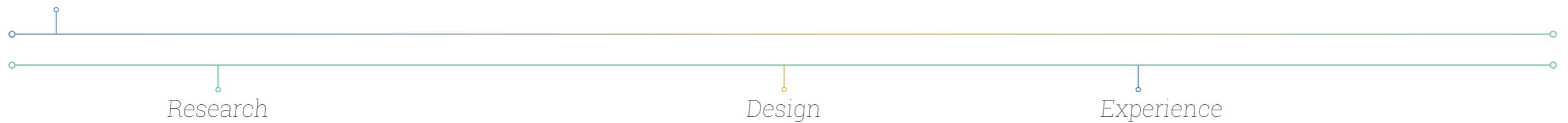

Festival I.

Share the spirit - hot summer day

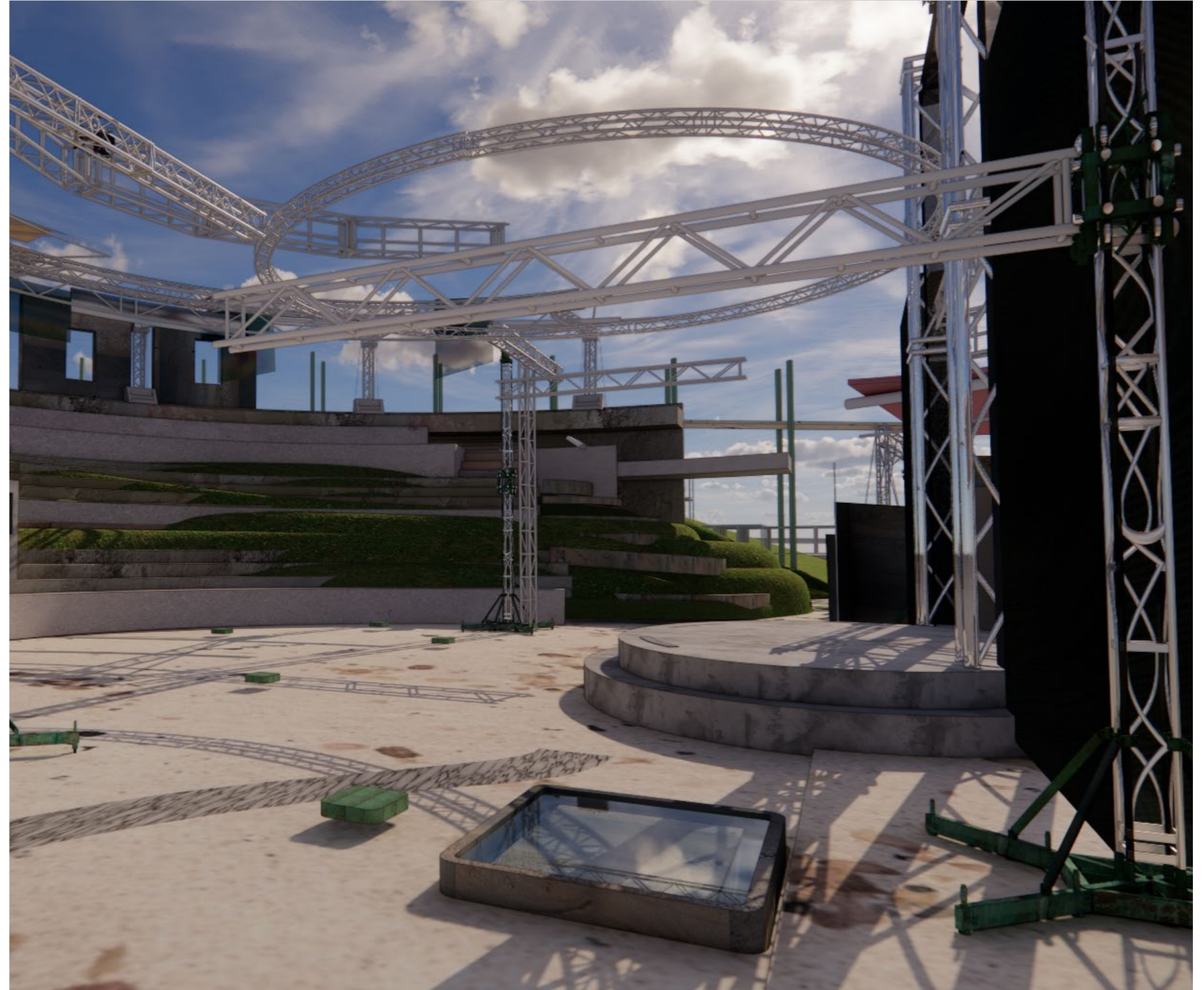

The first trial
Deaching columns and sails

And getting rid of all scaffolding

Research

Design

Experience

Festival I.

Share the spirit - hot summer day



The first trial

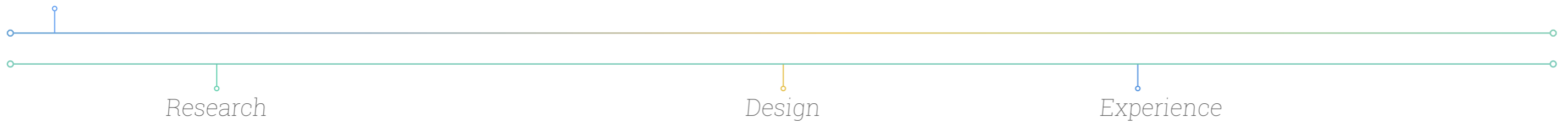

Festival II.

Preparing the site for the event



The first trial

The second trial



Research

Design

Festival II.

Preparing the site for the event



The first trial

The second trial

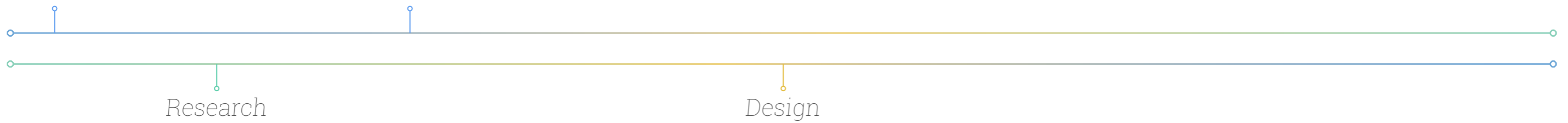

Melbourne Rising

October 19th

Day 1

Time	Echo stage	Tiny desk stage	Indigo garden	The liminal lane
12.00	Welcome to country <i>Aunty Donna</i>			
13.00	Triple R presents Daytripper ft. Clara Slewa, Hal Langley	Theatre collective Rookie numbers	Stand up comedy mc. Sam Campbell	Kick-off radio: Triple R
14.00				
15.00				Gregory Porter
16.00				
17.00	Caroline Pollachek	LETTUCE	Vinyl Revival	Japanese Breakfast (Indie Pop)
18.00				
19.00	Missy Higgins	Methyl Ethyl		Night Trade Social Hub
20.00	Mount Kimbie			
21.00	Maribou state ft. that Sax guy	Nightcap Experimental	Barry can swim	
22.00				

Melbourne rising

October 19th-25th, 2028

Program

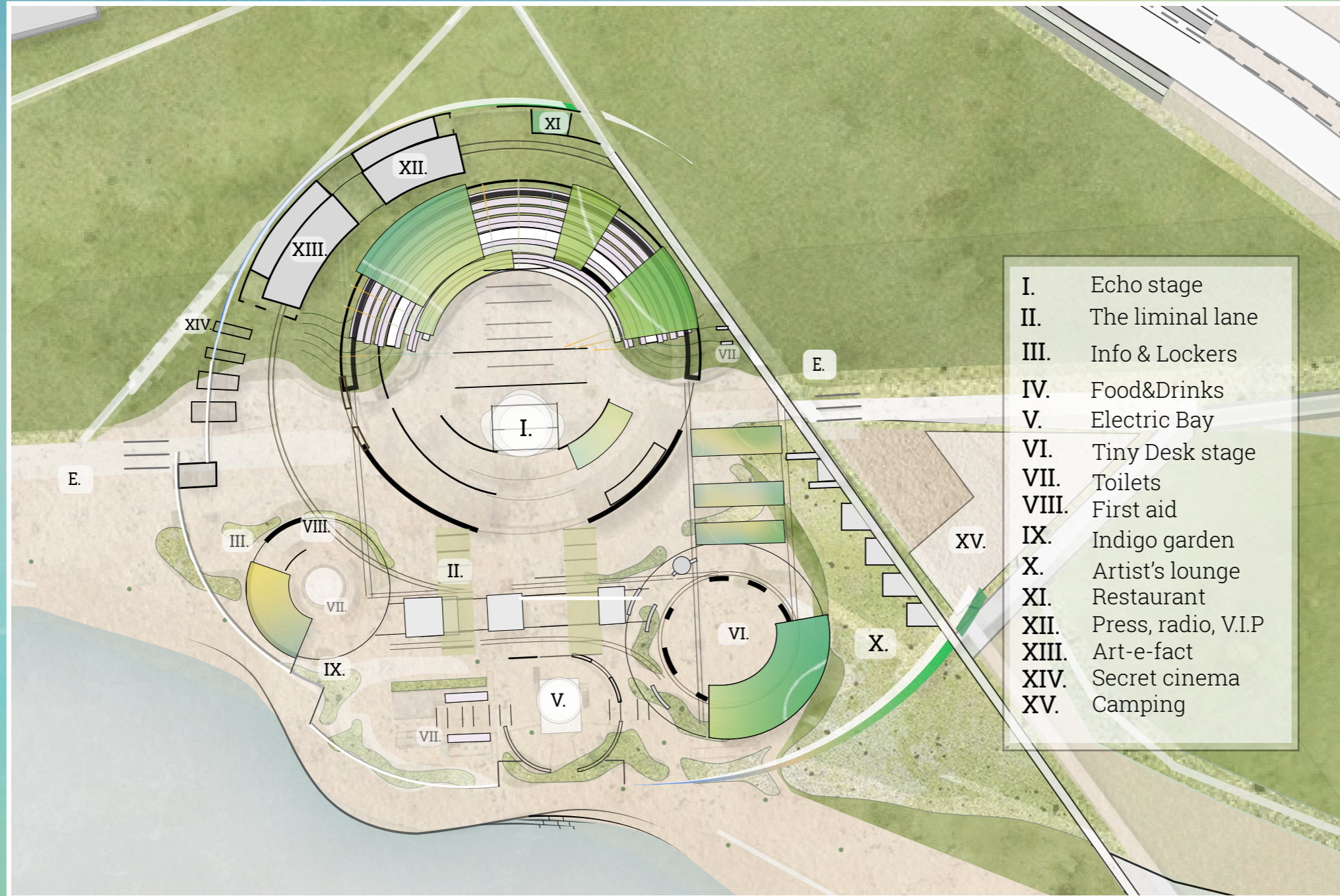

Site conditions

Dusk - quiet

Ticketed

7000 - 10000
people, large, mul-
tiple days
- windy

20 - 22 degrees

Comedy, Fringe &
Jazz

Festival II.

Melbourne rising

Different use of elements and lights



view from the outside



attaching rigging to nodes and adjustable columns
Putting a lot of baseblocks around site

The first trial

The second trial

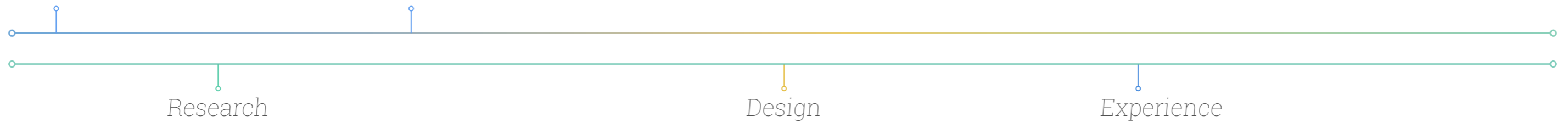

Festival II.
Melbourne rising

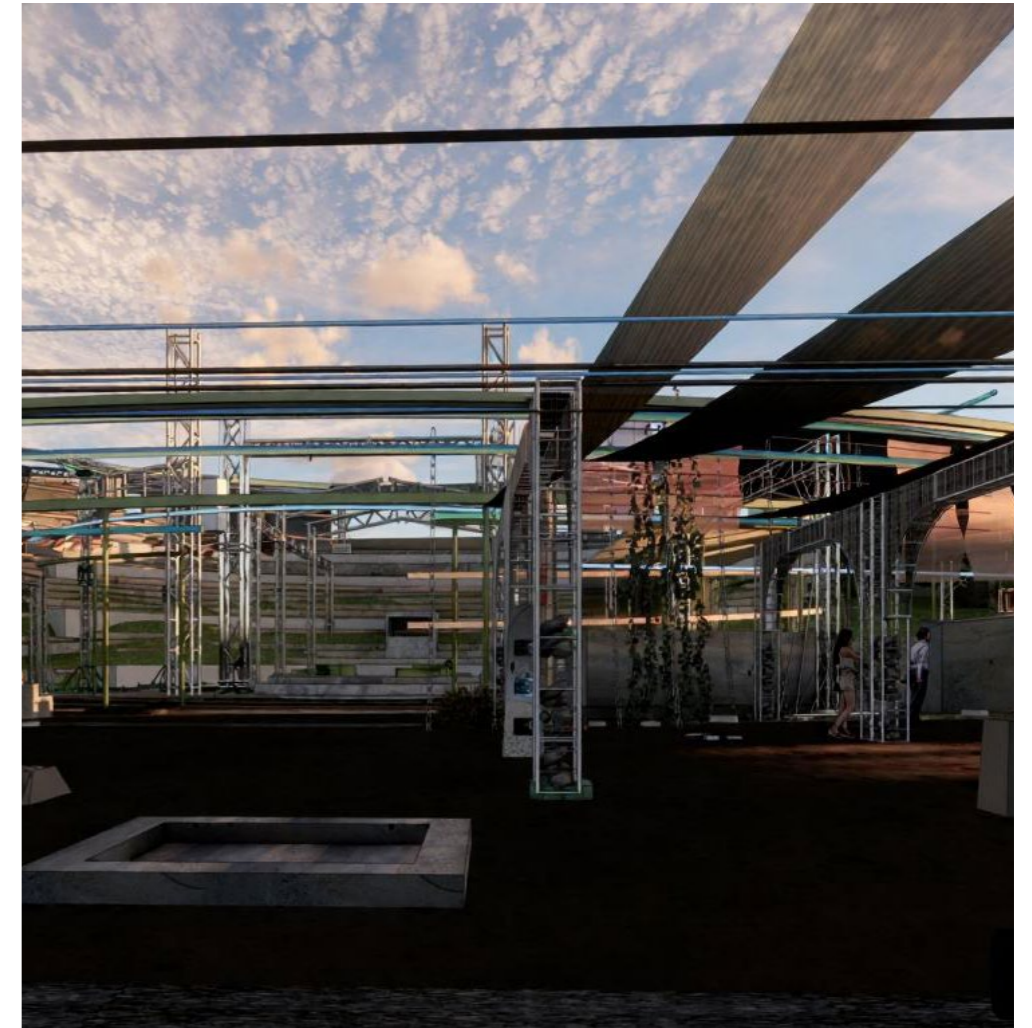
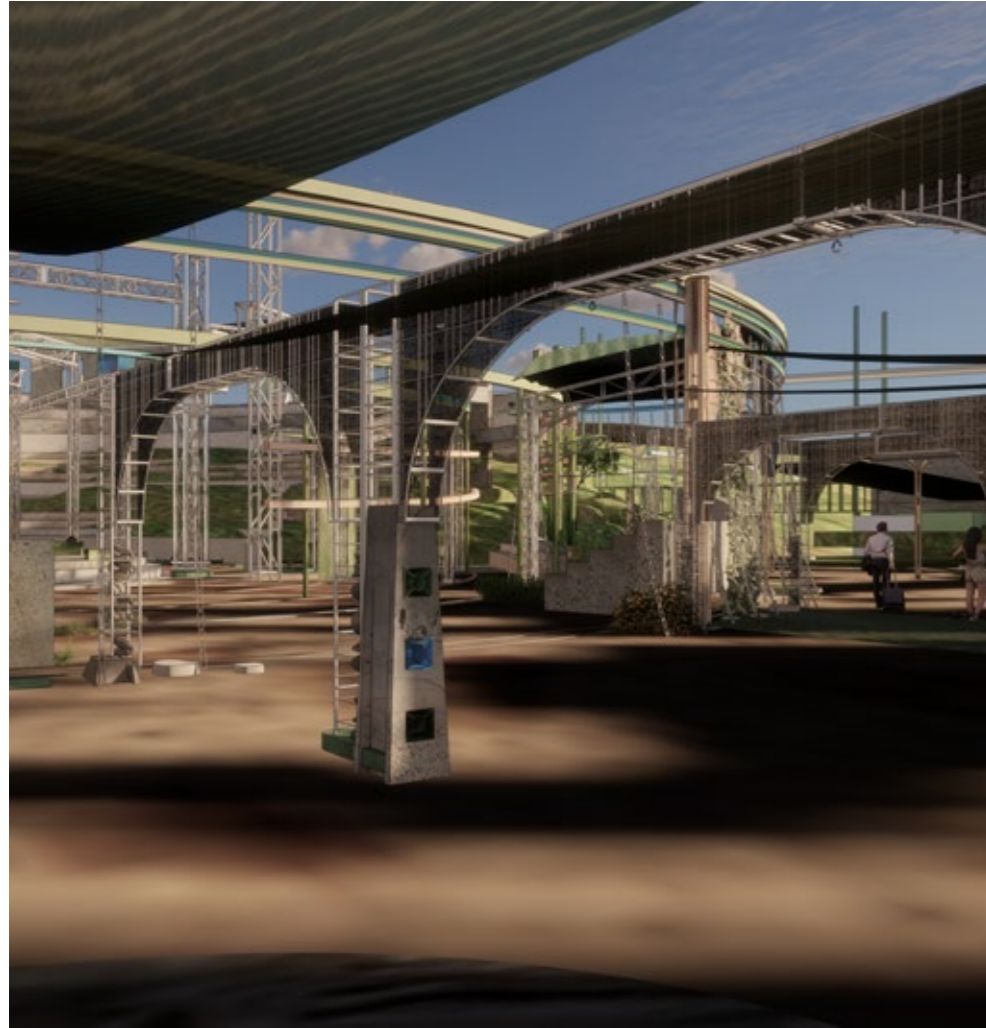

And other site setups and possibilities

Frost.bite - Monoblockparty

June 28th, 2028

Program



Site conditions

Cold winter/rainy/
misty/windy

Ticketed - late

Caters to:
Punk&rock/
GARAGE

Small - midsize
2000 people

Other set ups

The Monoblockparty



Architecture as facilitating agent: exploring architecture's position in spatial relationships through festival spaces

Program

An introduction to festival spaces	Location	Festival I.	The process
Why they matter	Preparing the site	Festival II.	What's next
Problems faced by the industry			
Establishing the role of the architect in festival spaces	Spatial interventions	Other set ups	Reflecion

Research -
An introduction to
festival spaces

Design -
Program & structure

Experience -
The first trials

Closing act

The process



an interdisciplinary project

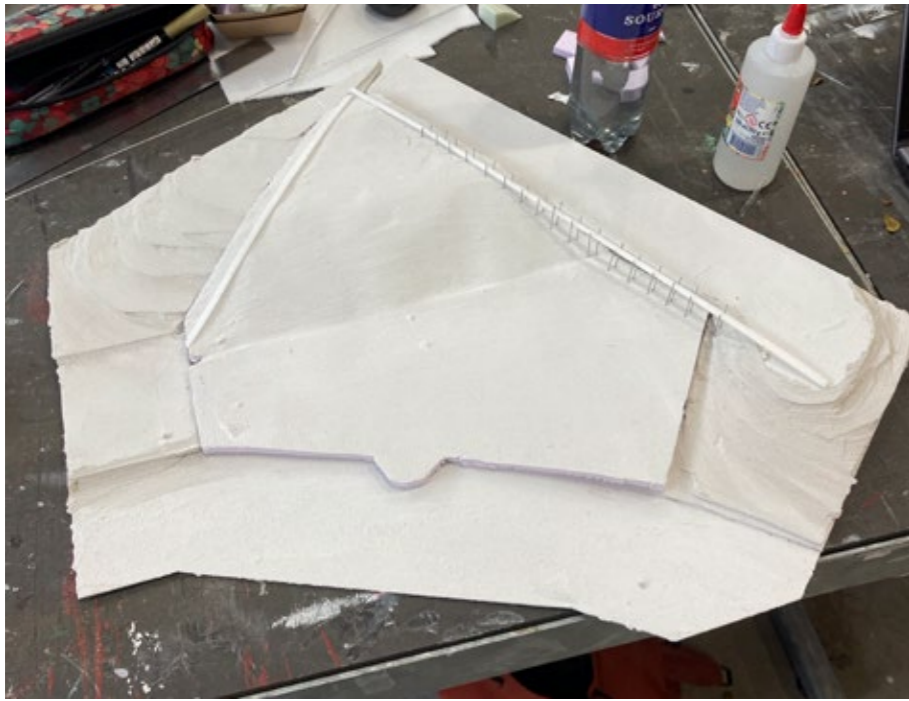

The process

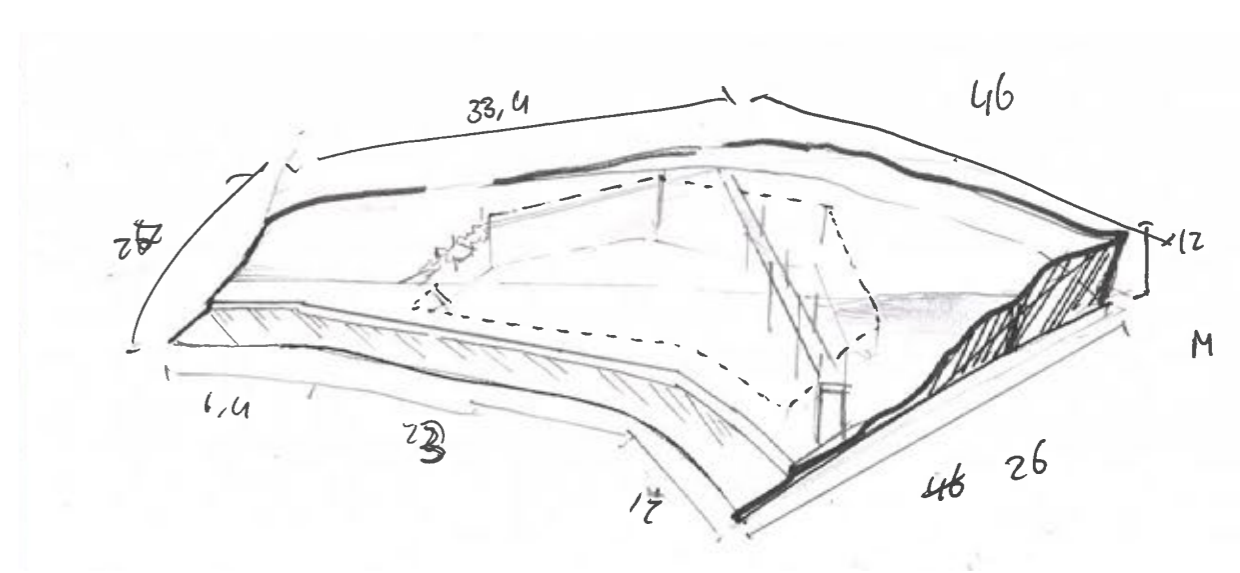

The testingmodel

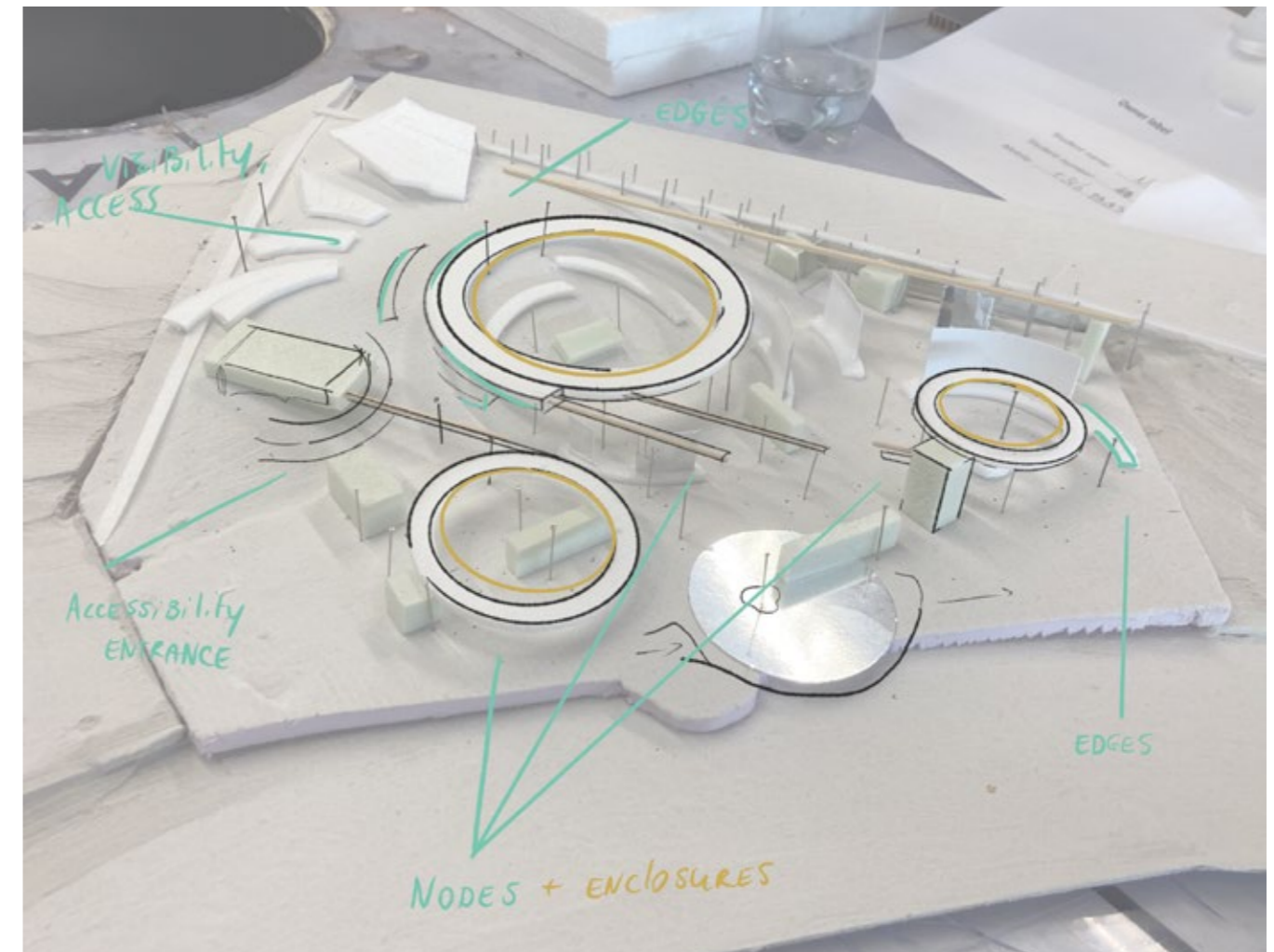

The process



an interdisciplinary process

What is next

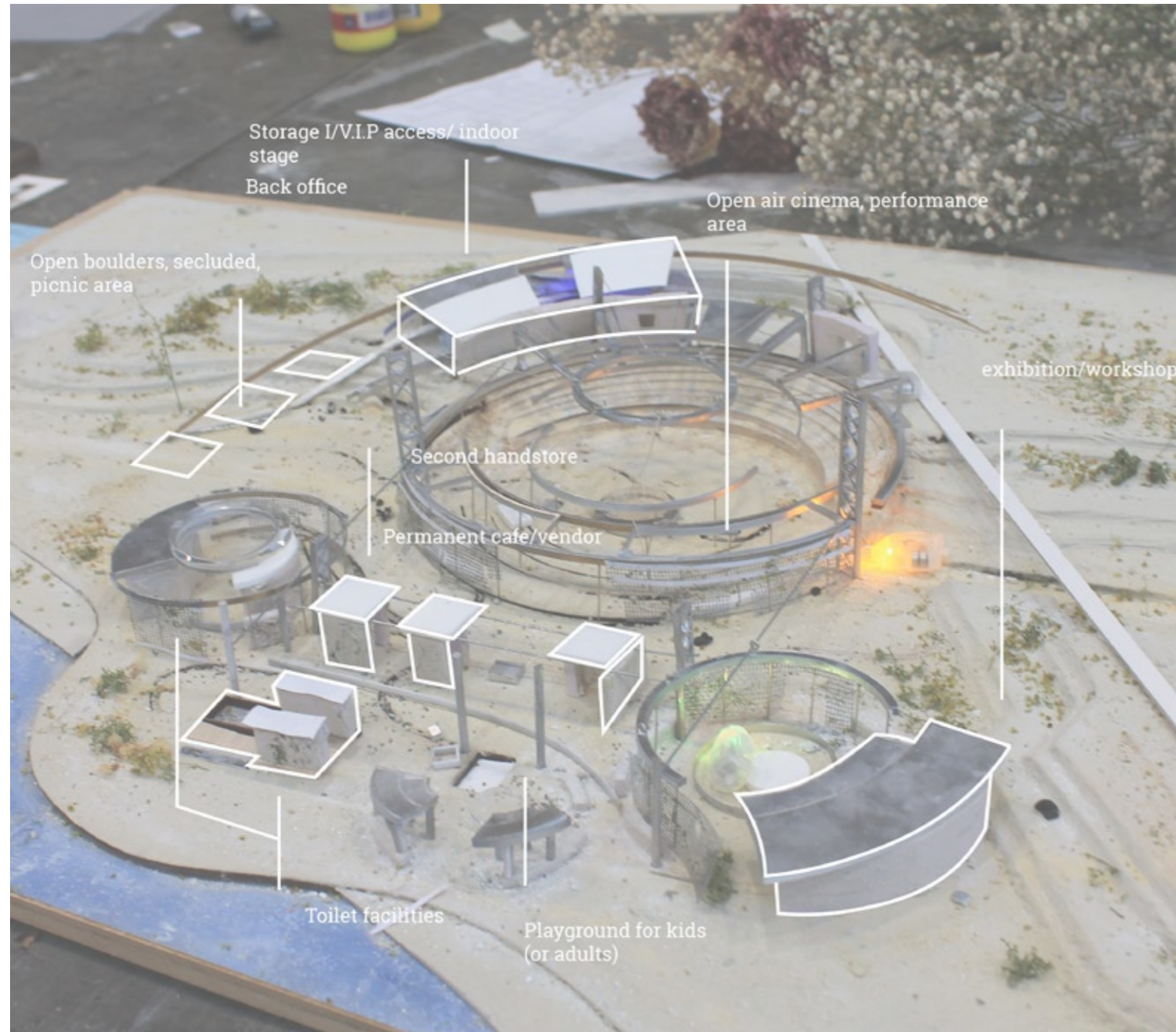

Program when there is no festival on



Overlapping them all at once

Reflection

